

Under the Paperwork Reduction Act of 1995, no persons are required to respond to a collection of information unless it contains a valid OMB control number.

<b>Application Data Sheet 37 CFR 1.76</b>		Attorney Docket Number	STRATOS.029A
		Application Number	
Title of Invention	SYSTEM AND METHOD FOR ADVERTISEMENT TRANSMISSION AND DISPLAY		
The application data sheet is part of the provisional or nonprovisional application for which it is being submitted. The following form contains the bibliographic data arranged in a format specified by the United States Patent and Trademark Office as outlined in 37 CFR 1.76. This document may be completed electronically and submitted to the Office in electronic format using the Electronic Filing System (EFS) or the document may be printed and included in a paper filed application.			

**Secrecy Order 37 CFR 5.2**

<input type="checkbox"/>	Portions or all of the application associated with this Application Data Sheet may fall under a Secrecy Order pursuant to 37 CFR 5.2 (Paper filers only. Applications that fall under Secrecy Order may not be filed electronically.)
--------------------------	---

**Applicant Information:**

<b>Applicant 1</b>					
<b>Applicant Authority</b>		<input checked="" type="radio"/> Inventor		<input type="radio"/> Legal Representative under 35 U.S.C. 117	
				<input type="radio"/> Party of Interest under 35 U.S.C. 118	
<b>Prefix</b>	<b>Given Name</b>	<b>Middle Name</b>	<b>Family Name</b>	<b>Suffix</b>	
	Kelly	M.	Christensen		
<b>Residence Information (Select One)</b> <input checked="" type="radio"/> US Residency <input type="radio"/> Non US Residency <input type="radio"/> Active US Military Service					
<b>City</b>	Marina Del Rey	<b>State/Province</b>	CA	<b>Country of Residence</b>	US
<b>Citizenship under 37 CFR 1.41(b)</b>		US			
<b>Mailing Address of Applicant:</b>					
<b>Address 1</b>		4712 Admiralty Way			
<b>Address 2</b>					
<b>City</b>	Marina Del Rey	<b>State/Province</b>	CA		
<b>Postal Code</b>	90292	<b>Country</b>	US		
<b>Applicant 2</b>					
<b>Applicant Authority</b>		<input checked="" type="radio"/> Inventor		<input type="radio"/> Legal Representative under 35 U.S.C. 117	
				<input type="radio"/> Party of Interest under 35 U.S.C. 118	
<b>Prefix</b>	<b>Given Name</b>	<b>Middle Name</b>	<b>Family Name</b>	<b>Suffix</b>	
	John	Phillip	Hansen		
<b>Residence Information (Select One)</b> <input checked="" type="radio"/> US Residency <input type="radio"/> Non US Residency <input type="radio"/> Active US Military Service					
<b>City</b>	Austin	<b>State/Province</b>	TX	<b>Country of Residence</b>	US
<b>Citizenship under 37 CFR 1.41(b)</b>		US			
<b>Mailing Address of Applicant:</b>					
<b>Address 1</b>		6637 Whitemarsh Valley Walk			
<b>Address 2</b>					
<b>City</b>	Austin	<b>State/Province</b>	TX		
<b>Postal Code</b>	78746	<b>Country</b>	US		
<b>Applicant 3</b>					
<b>Applicant Authority</b>		<input checked="" type="radio"/> Inventor		<input type="radio"/> Legal Representative under 35 U.S.C. 117	
				<input type="radio"/> Party of Interest under 35 U.S.C. 118	
<b>Prefix</b>	<b>Given Name</b>	<b>Middle Name</b>	<b>Family Name</b>	<b>Suffix</b>	
	Thomas		Mock		
<b>Residence Information (Select One)</b> <input checked="" type="radio"/> US Residency <input type="radio"/> Non US Residency <input type="radio"/> Active US Military Service					
<b>City</b>	Sheffield	<b>State/Province</b>	PA	<b>Country of Residence</b>	US

<b>Application Data Sheet 37 CFR 1.76</b>	Attorney Docket Number	STRATOS.029A
	Application Number	
Title of Invention	SYSTEM AND METHOD FOR ADVERTISEMENT TRANSMISSION AND DISPLAY	

Citizenship under 37 CFR 1.41(b)	US		
<b>Mailing Address of Applicant:</b>			
Address 1	16 First Mill Street		
Address 2			
City	Sheffield	State/Province	PA
Postal Code	16347	Country	US
All Inventors Must Be Listed - Additional Inventor Information blocks may be generated within this form by selecting the Add button.			<input type="button" value="Add"/>

**Correspondence Information:**

Enter either Customer Number or complete the Correspondence Information section below. For further information see 37 CFR 1.33(a).			
<input type="checkbox"/> An Address is being provided for the correspondence information of this application.			
Customer Number	20995		
Email Address	efiling@kmob.com	<input type="button" value="Add Email"/>	<input type="button" value="Remove Email"/>

**Application Information:**

Title of the Invention	SYSTEM AND METHOD FOR ADVERTISEMENT TRANSMISSION AND DISPLAY		
Attorney Docket Number	STRATOS.029A	Small Entity Status Claimed	<input checked="" type="checkbox"/>
Application Type	Nonprovisional		
Subject Matter	Utility		
Suggested Class (if any)		Sub Class (if any)	
Suggested Technology Center (if any)			
Total Number of Drawing Sheets (if any)		Suggested Figure for Publication (if any)	5A

**Publication Information:**

<input type="checkbox"/> Request Early Publication (Fee required at time of Request 37 CFR 1.219)
<input type="checkbox"/> <b>Request Not to Publish.</b> I hereby request that the attached application not be published under 35 U.S.C. 122(b) and certify that the invention disclosed in the attached application <b>has not and will not</b> be the subject of an application filed in another country, or under a multilateral international agreement, that requires publication at eighteen months after filing.

**Representative Information:**

Representative information should be provided for all practitioners having a power of attorney in the application. Providing this information in the Application Data Sheet does not constitute a power of attorney in the application (see 37 CFR 1.32). Enter either Customer Number or complete the Representative Name section below. If both sections are completed the Customer Number will be used for the Representative Information during processing.			
Please Select One:	<input checked="" type="radio"/> Customer Number	<input type="radio"/> US Patent Practitioner	<input type="radio"/> Limited Recognition (37 CFR 11.9)

Under the Paperwork Reduction Act of 1995, no persons are required to respond to a collection of information unless it contains a valid OMB control number.

<b>Application Data Sheet 37 CFR 1.76</b>		Attorney Docket Number	STRATOS.029A
		Application Number	
Title of Invention	SYSTEM AND METHOD FOR ADVERTISEMENT TRANSMISSION AND DISPLAY		
Customer Number	20995		

### Domestic Benefit/National Stage Information:

This section allows for the applicant to either claim benefit under 35 U.S.C. 119(e), 120, 121, or 365(c) or indicate National Stage entry from a PCT application. Providing this information in the application data sheet constitutes the specific reference required by 35 U.S.C. 119(e) or 120, and 37 CFR 1.78(a)(2) or CFR 1.78(a)(4), and need not otherwise be made part of the specification.

Prior Application Status	Pending	<input type="button" value="Remove"/>	
Application Number	Continuity Type	Prior Application Number	Filing Date (YYYY-MM-DD)
	non provisional of	61/026449	2008-02-05

Additional Domestic Benefit/National Stage Data may be generated within this form by selecting the **Add** button.

### Foreign Priority Information:

This section allows for the applicant to claim benefit of foreign priority and to identify any prior foreign application for which priority is not claimed. Providing this information in the application data sheet constitutes the claim for priority as required by 35 U.S.C. 119(b) and 37 CFR 1.55(a).

<input type="button" value="Remove"/>			
Application Number	Country <sup>1</sup>	Parent Filing Date (YYYY-MM-DD)	Priority Claimed
			<input type="radio"/> Yes <input checked="" type="radio"/> No

Additional Foreign Priority Data may be generated within this form by selecting the **Add** button.

### Assignee Information:

Providing this information in the application data sheet does not substitute for compliance with any requirement of part 3 of Title 37 of the CFR to have an assignment recorded in the Office.

**Assignee 1**

If the Assignee is an Organization check here.

Prefix	Given Name	Middle Name	Family Name	Suffix

**Mailing Address Information:**

Address 1			
Address 2			
City		State/Province	
Country <sup>1</sup>	US	Postal Code	
Phone Number		Fax Number	
Email Address			

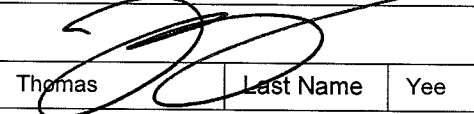
Additional Assignee Data may be generated within this form by selecting the **Add** button.

### Signature:

A signature of the applicant or representative is required in accordance with 37 CFR 1.33 and 10.18. Please see 37 CFR 1.4(d) for the form of the signature.

Under the Paperwork Reduction Act of 1995, no persons are required to respond to a collection of information unless it contains a valid OMB control number.

<b>Application Data Sheet 37 CFR 1.76</b>		Attorney Docket Number	STRATOS.029A
		Application Number	
Title of Invention	SYSTEM AND METHOD FOR ADVERTISEMENT TRANSMISSION AND DISPLAY		

Signature				Date (YYYY-MM-DD)	2009-02-05
First Name	Thomas	Last Name	Yee	Registration Number	57013

This collection of information is required by 37 CFR 1.76. The information is required to obtain or retain a benefit by the public which is to file (and by the USPTO to process) an application. Confidentiality is governed by 35 U.S.C. 122 and 37 CFR 1.14. This collection is estimated to take 23 minutes to complete, including gathering, preparing, and submitting the completed application data sheet form to the USPTO. Time will vary depending upon the individual case. Any comments on the amount of time you require to complete this form and/or suggestions for reducing this burden, should be sent to the Chief Information Officer, U.S. Patent and Trademark Office, U.S. Department of Commerce, P.O. Box 1450, Alexandria, VA 22313-1450. DO NOT SEND FEES OR COMPLETED FORMS TO THIS ADDRESS. **SEND TO: Commissioner for Patents, P.O. Box 1450, Alexandria, VA 22313-1450.**



## Privacy Act Statement

The Privacy Act of 1974 (P.L. 93-579) requires that you be given certain information in connection with your submission of the attached form related to a patent application or patent. Accordingly, pursuant to the requirements of the Act, please be advised that: (1) the general authority for the collection of this information is 35 U.S.C. 2(b)(2); (2) furnishing of the information solicited is voluntary; and (3) the principal purpose for which the information is used by the U.S. Patent and Trademark Office is to process and/or examine your submission related to a patent application or patent. If you do not furnish the requested information, the U.S. Patent and Trademark Office may not be able to process and/or examine your submission, which may result in termination of proceedings or abandonment of the application or expiration of the patent.

The information provided by you in this form will be subject to the following routine uses:

1. The information on this form will be treated confidentially to the extent allowed under the Freedom of Information Act (5 U.S.C. 552) and the Privacy Act (5 U.S.C. 552a). Records from this system of records may be disclosed to the Department of Justice to determine whether the Freedom of Information Act requires disclosure of these records.
2. A record from this system of records may be disclosed, as a routine use, in the course of presenting evidence to a court, magistrate, or administrative tribunal, including disclosures to opposing counsel in the course of settlement negotiations.
3. A record in this system of records may be disclosed, as a routine use, to a Member of Congress submitting a request involving an individual, to whom the record pertains, when the individual has requested assistance from the Member with respect to the subject matter of the record.
4. A record in this system of records may be disclosed, as a routine use, to a contractor of the Agency having need for the information in order to perform a contract. Recipients of information shall be required to comply with the requirements of the Privacy Act of 1974, as amended, pursuant to 5 U.S.C. 552a(m).
5. A record related to an International Application filed under the Patent Cooperation Treaty in this system of records may be disclosed, as a routine use, to the International Bureau of the World Intellectual Property Organization, pursuant to the Patent Cooperation Treaty.
6. A record in this system of records may be disclosed, as a routine use, to another federal agency for purposes of National Security review (35 U.S.C. 181) and for review pursuant to the Atomic Energy Act (42 U.S.C. 218(c)).
7. A record from this system of records may be disclosed, as a routine use, to the Administrator, General Services, or his/her designee, during an inspection of records conducted by GSA as part of that agency's responsibility to recommend improvements in records management practices and programs, under authority of 44 U.S.C. 2904 and 2906. Such disclosure shall be made in accordance with the GSA regulations governing inspection of records for this purpose, and any other relevant (i.e., GSA or Commerce) directive. Such disclosure shall not be used to make determinations about individuals.
8. A record from this system of records may be disclosed, as a routine use, to the public after either publication of the application pursuant to 35 U.S.C. 122(b) or issuance of a patent pursuant to 35 U.S.C. 151. Further, a record may be disclosed, subject to the limitations of 37 CFR 1.14, as a routine use, to the public if the record was filed in an application which became abandoned or in which the proceedings were terminated and which application is referenced by either a published application, an application open to public inspections or an issued patent.
9. A record from this system of records may be disclosed, as a routine use, to a Federal, State, or local law enforcement agency, if the USPTO becomes aware of a violation or potential violation of law or regulation.

**SYSTEM AND METHOD FOR ADVERTISEMENT  
TRANSMISSION AND DISPLAY**

CROSS-REFERENCE TO RELATED APPLICATIONS

[0001] The present application claims the benefit under 35 U.S.C. 119(c) to U.S. Provisional Application No. 61/026,449, filed February 5, 2008, which is hereby incorporated by reference in its entirety, including specifically but not limited to the systems and methods relating to advertisement transmission and display.

BACKGROUND

Field

[0002] The invention relates generally to media advertising and in particular to systems and methods for associating an advertising media signal with another media signal.

Description of the Related Art

[0003] In advertising, it is generally desirable to associate products with specific characteristics, such as associating a brand of car with quality engineering. Another example is associating a brand of beverage with the characteristic of happiness or lifestyle as exhibited by smiling people. Creating such associations in the minds of potential customers may generally increase the chance that a potential customer will choose to purchase a product that is associated with a favorable characteristic. Celebrities and other images often exhibit favorable characteristics. Therefore, an advertisement may be more effective if the product advertisement is associated with an image of a celebrity or other media element exhibiting favorable characteristics.

SUMMARY

[0004] In certain embodiments, a method for associating multiple media signals, comprising in no particular order: obtaining information about a first media signal; analyzing the information about the first media signal; selecting at least one second media signal to be correlated with the first media signal based on at least one criteria; assigning a unique identifier that is specific to the transmission of the selected second media signal, wherein at least the unique identifier is stored in a database; transmitting at least the second media signal and the unique identifier to a user device, wherein the user device outputs the first media

signal and the second media signal to a user; receiving a user response from the user in relation to the second media signal wherein the user response includes at least the unique identifier; and correlating at least the unique identifier in the database.

**[0005]** In some embodiments, a method for combining multiple media signals in a device, comprising in no particular order: obtaining a first media signal by the device; outputting a first media content comprised in the first media signal to a user of the device; obtaining a second media signal by the device; obtaining a criteria correlated to the second media signal; evaluating the criteria in reference to the user of the device; and outputting at least a second media content comprised in the second media signal to the user of the device, wherein in the second media content outputted is determined at least in part based on the evaluation of the criteria.

**[0006]** In certain embodiments, a user device system capable of combining multiple media signals comprising: a first receiver module configured to receive at least a first media signal from a first transmitter; a second receiver module configured to receive at least a second media signal and a unique identifier correlated to the second media signal; an output module configured to output a primary media content from the first media signal and output a secondary media content from the second media signal; an input module capable of receiving at least a user input; and a transmitting module capable of transmitting at least the user input and the unique identifier to a computer server, wherein the computer server has access to a database containing at least the unique identifier.

**[0007]** In some embodiments, a method for associating multiple media signals, comprising in no particular order: obtaining information about a first media signal; analyzing the information about the first media signal; selecting at least one second media signal to be correlated with the first media signal based on at least one criteria; assigning a unique identifier that is specific to the transmission of the selected second media signal, wherein at least the unique identifier is stored in a database; transmitting at least the second media signal and the unique identifier to a user device, wherein the user device outputs the first media signal and the second media signal to a user; and transmitting the unique identifier to a third party.

**[0008]** For purposes of this summary, certain aspects, advantages, and novel features of the invention are described herein. It is to be understood that not necessarily all such advantages may be achieved in accordance with any particular embodiment of the invention. Thus, for example, those skilled in the art will recognize that the invention may be embodied or carried out in a manner that achieves one advantage or group of advantages as taught herein without necessarily achieving other advantages as may be taught or suggested herein.

#### BRIEF DESCRIPTION OF THE DRAWINGS

**[0009]** The foregoing and other features, aspects and advantages of the present invention are described in detail below with reference to the drawings of various embodiments, which are intended to illustrate and not to limit the invention. The drawings comprise the following figures in which:

**[0010]** FIGURE 1 illustrates a high-level overview of one embodiment of a media enhancement system.

**[0011]** FIGURES 1A-1C illustrate signals and identifiers correlated and transmitted in between elements of one embodiment of a media enhancement system.

**[0012]** FIGURE 1D illustrates identifiers correlated, transmitted and stored in a database in relation to elements of one embodiment of a media enhancement system.

**[0013]** FIGURE 2 illustrates a block diagram of one embodiment of a user device connected to a media association system via a network.

**[0014]** FIGURE 3 illustrates one embodiment of a user device with a user interface, connected to a media association system.

**[0015]** FIGURE 3A illustrates one embodiment of an alternative display portion of a user interface.

**[0016]** FIGURE 4 illustrates a flow-chart diagram of one embodiment of a method for a device providing media to a user.

**[0017]** FIGURE 4A illustrates a detailed flow-chart diagram of one embodiment of a method for a device providing media to a user.

**[0018]** FIGURE 5 illustrates a block diagram of one embodiment of a media association system.

[0019] FIGURE 5A illustrates a more detailed block diagram of one embodiment of a media association system.

[0020] FIGURE 6 illustrates a flow-chart diagram of one embodiment of a method for choosing media to provide to user devices.

[0021] FIGURE 7 illustrates one embodiment of a media enhancement system in the context of one embodiment of a broadcast response and business system.

[0022] FIGURE 8 illustrates one embodiment of a conditional access portal for establishing operations criteria, filters and conditions for the control, transmission, presentation, response to and reporting of media content activity.

#### DETAILED DESCRIPTION

[0023] The disclosure herein provides systems and methods for a media enhancement system configured to associate a secondary media signal (for example, the secondary media signal can comprise an advertisement) to a primary media signal (for example, a radio broadcast). The disclosure herein additionally provides systems and methods for a media enhancement system that enables the generating, transmitting, displaying, and/or responding to a plurality of associated and/or unassociated secondary media signals, based on a primary media content from a primary media signal, user characteristics (for example, demographic and/or geographic information), and/or third-party preferences (for example, the goals of advertisers). The secondary media signals can be used to enhance the primary media content already being provided to the user on a user device. The secondary media signals can also be used to create psychological associations or relationships with the primary media content already being provided to the user.

[0024] For example, in one embodiment, a radio station transmits a song that is received by a user enabled-device, such as a cellular phone with a radio. The transmitted song is transmitted in a first media signal. The song is analyzed by a media association system to determine what prospective media elements can be associated with the song. The user enabled-device obtains and/or receives from the media association system a secondary media signal that is separate and/or discrete from the first media signal. For example, the secondary media signal could be an advertisement for a particular truck. As the user enabled-device is playing a song obtained from the first media signal, the user enabled-device displays

the media content in the second media signal, wherein the media content can be a still or moving picture of the advertised truck. In another embodiment, as the user enabled-device is playing a song obtained from the first media signal, the user enabled-device displays the media content obtained from the second media signal, wherein the media content can be a still or moving picture with user selectable audio of the advertised truck wherein the first audio track could be paused upon selection.

**[0025]** Additional information could be associated with the first media signal and/or the secondary media signal. For example, additional information could be obtained by the user enabled-device in the form of a text message that offers a test drive of the advertised truck at a local truck dealer. A third media signal could be obtained or received by the user enable-device providing the address information and/or direction to the nearest truck dealer based on the GPS location of the user enabled-device. As an alternative to GPS, triangulation or other similar method may also be used to locate the user-enabled device. Accordingly, one or more media signals can be associated with the first media signal.

**[0026]** In one embodiment, the system provides logic and/or a user interface to allow users to select the form of desired media. For example, the user can select to receive textual, graphical, and/or audio media content based on the user's location. For example, if the user is in an environment that is not conducive to generating audio, such as in some transit systems, libraries, and/or schools, then the system could generate graphical and/or textual media content, and no audio media content.

**[0027]** In another embodiment, the first media signal provides and/or sends programming and/or other media content, the second media signal provides and/or sends additional information about the programming from a source other than the originator of the first media signal, and/or the third media signal (from a third party source) could provide and/or send unique media content to be associated with the first media signal and/or the second media signal. For example, a radio broadcast is received as the first media signal by a user device comprising an analog or digital receiver. The user device also receives the second media signal through for example, GPRS, EVDO and/or HSDPA over a wireless network, wherein the second media signal comprises additional information about the broadcast, such as an artist name, a title, an advertisement, an advertiser, a purchase option, a

voting option, and/or other interactive options available and/or related to the first media signal. The user device also receives the third media signal comprising comments sourced through a peer to peer relationship received from other user devices relaying comments, opinions, and/or other additional information about the first and/or second media signals.

**[0028]** In one embodiment, the system comprises a computational device that receives a streamed internet transmission sourced from a radio station, a radio receiver that receives the first media stream from the radio station, a user device such as a cell phone capable of presenting to the user a media stream, and/or a storage device that could be connected via a network to at least a computational device and/or the user device/cell phone. The storage device is configured to present the multiple media streams that are available. The computational device is configured to perform an analysis of the first media stream. Based on user selectable criteria, the computational device is configured to select from the storage device which available media stream is to be associated with the first media stream. The storage device is configured to use the network connection to send the selected additional media stream to the cell phone.

**[0029]** The cell phone is configured to display the additional media stream. When the user changes the radio status (for example, changes station and/or turns off the device), the additional media stream on the cell phone could be continued, the user or device could alert the computational device of the status change to be used in future analysis, and/or the radio could automatically communicate with the computational device regarding the changed status. The computational device is configured to continuously monitor and/or detect changes in the media streams from the radio station (for example, one song followed by another song) via the internet streaming of the radio station transmission.

**[0030]** In one embodiment, the first media signal and the advertisement message could be integrated into the same transmission. The media association system could associate the first media signal with the advertisement message before the broadcast of the first media signal is completed. In another embodiment, the first media signal and the advertisement message are separate and discrete. In another embodiment, the first media signal is intercepted before reaching the user device and the advertisement message is added to the first media signal and sent on to the user device. In all three of the above embodiments,

where the first media signal and advertisement message are discrete, integrated or combined after interception, the device receives both the first media signal and the advertisement message and presents them to the user.

**[0031]** In one embodiment, the first media signal and the second media signal are integrated into the same transmission. In one embodiment, the first media signal and the second media signal are separate and discrete. In one embodiment, the first media signal is intercepted before reaching the user device and the second media signal is added to the first media signal and sent on to the user device. In one embodiment, the user can respond to the second media signal. In one embodiment, the user response is to the first media signal sender. In one embodiment, the user response is to the second media signal sender. In one embodiment, the user response is to a third party. In one embodiment, the media content of the second media signal is selected based on demographic information of the user, status of the user device (such as make, model, geographic location and/or other pertinent information) and/or other like criteria. In one embodiment, the second media signal is transmitted to the user device prior to the transmission of the first media signal. In one embodiment, the media content of the second media signal is stored in the user device. In one embodiment, the stored media content of the second media signal is communicated to the user based on a media association system integrated into the user device. In one embodiment, a third signal is sent to the user device indicating which, if any, stored media content should be communicated to the user.

**[0032]** As used herein, the terms “media” or “media content” are broad terms that comprise any form of content, including without limitation, graphics, videos, sounds, text, text messages, interactive applications, vibrations, television and/or radio programming, podcasts, movies, songs, games, telephone conversations, speeches, news, information, advertisements, polls votes, personal messages, and/or other physical manifestations capable of communicating a concept or idea.

**[0033]** Similarly, the terms “hear,” “view,” “read,” “feel,” “sense,” their synonyms, and their alternative conjugations should be used interchangeably when referring to any form of media. When one sensory verb is used in connection with one form of media, it will be clear that other forms of media could be used in conjunction with other sensory



verbs (such as “hear a sound” is interchangeable with “view a graphic”). Similarly, the terms “display,” “present,” their synonyms, and their alternative conjugations should be used interchangeably and be broadly interpreted as providing media to be sensed by the user.

**[0034]** The terms “media signal,” “broadcast stream,” or “media stream” are broad terms that comprise broadcasts or transmissions from AM/FM radio, Digital radio, IBOC, Satellite, Cable, Analog television, Digital Television, HSDPA (3G), UMTS, CDMA, internet, WiFi, other broadcast stations/entities, and/or other media conveyance methodologies such as direct wire connections. Media signals can be unique media streams. Further, the foregoing terms also comprise data signals or data streams from servers or devices that stream data and/or media to other devices or servers. For example, a radio device can receive a first media signal comprising music media content being played by a radio station, and the radio device can also receive simultaneously, serially, or otherwise a second media signal comprising an advertisement sent by an advertisement server or media association system.

**[0035]** Further, the term “program” is a broad term that comprises a portion of a media signal in any media form, or combinations thereof. This can comprise for example a discrete song, a series of songs, a truncated song, a song followed by or preceded by commentary, a song accompanied with graphical images and/or video, a song accompanied by text, combinations thereof, and/or analogous portions of other forms of media. Other examples can include, but are not limited to: discrete media elements comprising video and/or audio, a series of media elements, a portion of a media element, a media element followed by, or preceded by commentary, a media element accompanied with fixed graphical images, video, and/or audio, a media element accompanied by text, combinations thereof, and/or analogous portions of other forms of media.

**[0036]** Further, the term “sensor” is a broad term that comprises any mechanism for converting an external stimulus and/or characteristic into a simplified signal, comprising buttons, keyboards, joysticks, touch-screens, thermometers, electrocardiographs, cameras and other photo sensors, microphones, a mouse, trackpad and/or trackball, mice, styluses, GPS systems, and/or other sensors. These sensors can output to electromagnetic signals, optical

displays, audio outputs, vibrators, signal carried by wire, and/or any other externally detectable response.

**[0037]** Further, the term “communication methods” as used herein broadly refers to protocols, standards, conventions, and/or the like for communicating. This comprises hypertext transfer protocol (“HTTP”), file transfer protocol (“FTP”), amplitude/frequency modulation (“AM/FM”), general packet radio service (“GPRS”), evolution-data optimized (“EVDO”), short message service (“SMS”), radio broadcast data system (“RBDS”), Bluetooth<sup>®</sup>, digital radio mondiale (“DRM”), in band on channel (“IBOC”), high speed download packet access (“3G” and/or “HSDPA”), other forms of broadcast, telephony, peer-to-peer networking/protocol, and/or the like. Additionally, “communication methods” could comprise various physical means for conveying information comprising nonexclusively electromagnetic waves (for example, radio or light), sound waves, cables, and/or the like. “Communication methods” also comprises indirect methods, such as a first communication to an intermediary via HTTP, followed by a communication from the intermediary to a receiver by a television signal. It should be understood that specific communication methods could be interchangeable in the context of this disclosure.

**[0038]** Further, the term “communications element” as used herein broadly refers to devices, elements, machines, and/or structures capable of using communication methods. Examples comprise radio transmitters, receivers, transceivers, cellular phones, internet-capable computers, Ethernet cards, wireless adapters, and/or the like.

**[0039]** Further, the term “broadcast” as used herein broadly refers to media distributed publicly over a communication method, comprising without limitation terrestrial radio, over-the-air (or terrestrial) television, cable, satellite, internet downloading, WIFI, internet streaming, other communications by electro-magnetic waves, and/or the like.

**[0040]** Further, in general the word “module,” as used herein, refers to logic embodied in hardware and/or firmware, and/or to a collection of software instructions, possibly having entry and/or exit points, written in a programming language, such as, for example, Java, and/or the Java Platform-Micro Edition (Java ME, and/or J2ME), comprising the Java Specification Request 234 (JSR 234) Advanced Multimedia Supplements. Other

programming languages comprise without limitation COBOL, CICS, Lua, C and/or C++ and an application program including pseudo code interpretable instructions. A software module may be compiled and linked into an executable program, installed in a dynamic link library, and/or may be written in an interpreted programming language such as, for example, BASIC, Perl, PHP and/or Python. It will be appreciated that software modules may be callable from other modules and/or from themselves, and/or may be invoked in response to detected events and/or interrupts. Software instructions may be embedded in firmware, such as an erasable programmable read-only memory (EPROM). It will be further appreciated that hardware modules may be comprised of connected logic units, such as gates and/or flip-flops, and/or may be comprised of programmable units, such as programmable gate arrays and/or processors. The modules described herein are preferably implemented as software modules, but may be represented in hardware and/or firmware. Generally, the modules described herein refer to logical modules that may be combined with other modules or divided into sub-modules despite their physical organization or storage.

**[0041]** The terms “computer,” “computer server,” “computing system,” “computer clients,” “servers,” or “computing system devices” as used herein are interchangeable terms, and the terms broadly refer, without limitation, to a machine that manipulates data according to a list of instructions or the like.

**[0042]** Further, the terms “response transmission,” “responses,” “click-through's,” or “status report” are broad terms that include any of the communication means described above to transfer information from the device to other components of the system such as the media association system, first transmitter, message entity, control monitoring system, ancillary device or other primary devices. The information can include, but is not limited to, aspects of the device such as being turned off, being turned on, accessing a different media signal; status of reception of a first media signal, an advertising signal, an associated media signal, a related media signal and/or an identifier (a unique identifier, content, device, user, advertising signal, first media signal, broadcaster, message entity and/or identifying other aspects of the system); device capabilities, including but not limited to parameters associated with first media signal, advertisement signal, associated media signal, and/or related media signal presentation (display, audio, vibration), user input capabilities, communication

capabilities; device status such as location, motion, use patterns, capabilities being utilized, ambient environment; and/or user status.

**[0043]** The terms “rules,” “criteria,” “conditional filters,” “programmable filters,” “filters,” “association criteria,” “logic and rules of operation,” or “advertisement criteria” are broad terms that comprise without limitation determinate control over the following: access, creation, organization, communication, presentation and display to users, dissemination, pricing, device and signal availability, user device media signal presentation and correlation to programming and/or programmable filters, and/or conditions to be applied to the media signals.

**[0044]** The terms “unique event identifier,” or “unique identifier” as used herein are broad terms that refer to any means for identifying a specific instance of a broadcast stream, transmission and/or media signal. As used herein, when the terms "unique identifier" or "unique event identifier" are used in specificity it is to establish preeminence of operation amongst identifiers. It is not intended to limit or exclude the presence or use of other identifier elements, content and/or classes. The term “identifier” or “identifies” as used herein are a broad terms that refer to a representation of that which is being identified. The identifier may include, but is not limited to, at least the unique identifier and may further comprise identification of other elements, contents and/or classes. Such elements may comprise: an advertisement, related media, associated media, device, language user of a device, and/or first media signals. Such contents may comprise: a first media signal, related media, associated media, device, language, user of a device, and/or first media signal. And/or such classes may comprise: a class of a first media signal, advertisement, related media, associated media, device, language, user of a device, and/or first media signal. The unique event identifier and/or identifiers are preferably implemented as a part of a database that allows for the storage and/or retrieval of the identifier and/or data associated with the identifier. By means of the unique event identifier and/or identifiers, reports can be generated on the performance of various aspects of the system such as who, what, when, where, why, which, and/or how an event within the system occurred, including the number of times an event within the system occurred; locations for events; what prompted an event; devices, signals and/or users associated with events and/or means associated with the events.

## Media Enhancement System

[0045] FIGURE 1 depicts one embodiment of a media enhancement system for transmitting and/or displaying advertisements and/or other media content, wherein the system comprises but is not limited to a first transmitter 3, control management system 100, a media association system 2, a primary device 4, an ancillary device(s) 5, and an advertisement entity 6.

[0046] Referring to FIGURE 1, the first transmitter 3 can be a radio station broadcasting through an antenna tower via modulated electromagnetic waves. In other embodiments, the first transmitter 3 comprises but is not limited to a broadcaster broadcasting content over the internet (for example, by UDP, TCP/IP, HTML, HTTP, and/or the like), a broadcaster broadcasting content through a cable line, satellite and/or through other communication methods. Additionally, the first transmitter 3 can comprise a computer connected to the internet so as to transmit information to a more limited set of receivers, such as to a set of internet protocol addresses email addresses, instant messenger accounts, and/or the like. Thus, as further examples the first transmitter 3 can comprise an instance of peer-to-peer software, an interactive web-based video game, a website with controlled access, and/or the like. The first transmitter 3 can also comprise a telephone and/or wireless connection, so as to transmit information by phone, cellular phone, and/or other wired or wireless communication. The first transmitter 3 can also comprise a connection to some other element, such as a serial connection, capable of any form of communication method. Additionally, the first transmitter 3 can comprise an encryption module to limit access to a first media signal 111, as illustrated in FIGURE 1A. Generally, the first transmitter 3 comprises a communications element. By an indirect or direct communication method, the first transmitter 3 sends a first media signal 111 that is received by the primary device 4.

[0047] The primary device 4 illustrated in FIGURE 1 may be a portable device, such as a radio, television, digital media player, GPS unit, multi purpose displays, cellular phone, laptop computer, personal digital assistant, transceiver, transmitter, receiver, and/or the like. The primary device 4 may also be a non-portable device, such as a desktop computer, television, land-line telephone, and/or the like. The primary device 4 can display the media content in the first media signal 111 and/or transmit the first media signal to one or

more ancillary devices 5, which may take the form of any device such as those defined for primary device 4 or an adjunct to a primary device 4 such as a personal computer, server, digital media player docking station, video player, printer, clock, telephone, answering machine, recorder, remote control and/or the like. The ancillary device can be portable, mobile such as a radio in a car or fixed in place. The ancillary devices 5 can then display the media content in the first media signal 111 and/or transmit the first media signal back to the primary device 4. When the ancillary device 5 comprises a communications element capable of retransmitting the first media signal 111, the first media signal may be viewed on the primary device 4 at a later time without requiring data storage on the primary device 4. When the ancillary device 5 comprises a communications element capable of retransmitting the first media signal 111, the first media signal and/or information identifying the first media signal 111, may be viewed on the ancillary device 5 at a later time without requiring data storage on the primary device 4. The first media signal 111 that is transmitted from the first transmitter 3 to the primary device 4 can contain any form(s) of media in digital and/or analog formats.

**[0048]** Also illustrated in FIGURE 1, the primary and/or ancillary devices 4, 5 can transmit information back to the first transmitter 3 by either the same communication method or by a different communication method. For example, the first media signal 111 sent by the first transmitter 3 can comprise a talk radio program soliciting responses to a poll. The primary and/or ancillary devices 4, 5, can respond by, for example, placing a phone call to the first transmitter 3, when either the primary or ancillary device is capable of telephony. Alternatively, the first transmitter 3 can comprise a computer connected to the internet, sending a first media signal 111 instant message advertising an upcoming pay-per-view television program. The primary device 4 may comprise a computer configured to receive this instant message and upon receiving a user response transmit the message to an ancillary device 5. The ancillary device 5 can comprise a television with interactive capabilities, such that upon receiving the message from the primary device 4 the ancillary device 5 can request the pay-per-view television program from the first transmitter 3. The first transmitter 3 can then send the television program directly to the ancillary device 5. It will be clear that other communication methods between the first transmitter 3 and the primary and/or ancillary devices 4, 5 are possible.

**[0049]** Referring to FIGURE 1, similar transmissions and/or interactions can be made between the first transmitter 3 and the media association system 2 and/or the advertisement entity 6. The media association system 2 and the advertisement entity 6 can each comprise the same forms as those identified for the primary and/or ancillary devices 4, 5 and/or the first transmitter 3. In one embodiment, the media association system 2 may comprise a radio signal receiver connected to a computer that is connected to the internet. The media association system 2 can then receive and/or identify the media content in the first media signal 111. For example, the media association system 2 can identify the media content as a particular song or particular program. As illustrated in FIGURE 1B, media association system 2 can use this information to send or transmit a secondary or related media signal 114, such as information regarding the media content of the first media signal 111, to the primary device 4 and/or the ancillary devices 5 through an internet connection. The secondary or related media signal 114 can be provided by any communication method described herein, and the secondary or related media signal 114 can either be the same or different type of communication method used to transmit the first media signal 111.

**[0050]** In one embodiment, as illustrated in FIGURE 1, the first transmitter 3 and the media association system 2 can be combined into a single system with one part performing the functions of the first transmitter 3 and another part performing the functions of the media association system 2. The communications, processing, memory, and/or other components of such a combined system can be shared between the different parts or be separate.

**[0051]** As illustrated in FIGURE 1, the primary device 4 and/or ancillary device 5 can also send signals back to the media association system 2 and/or to the control management system 100. For example, if the related media signal 114 sent by the media association system 2 to the devices 4, 5 comprises purchasing information for a song present in the first media signal 111, the primary and/or ancillary devices 4, 5 can provide a purchase request to the media association system 2. The media association system 2 can then transmit the purchase request to the first transmitter 3, to a third party for fulfillment, and/or to the control management system 100. The response transmission sent back to the media association system 2 and/or the control management system 100 can comprise: the response

to a first media signal 111 and/or a unique identifier 115 obtained from first media signal 111, a response to an advertisement media signal 113, and/or a unique identifier 115 obtained from advertisement media signal 113, (and/or a user identifier, a device identifier etc), a user selection from a list of options and/or the status of the device (including but not limited to the presentation of the first media signal, presentation of the advertisement signal, changing which first transmitter 3 is being received, the device turning on or off).

**[0052]** Referring to FIGURE 1, the advertisement entity 6 can make similar communications with the primary and/or ancillary devices 4, 5, the first transmitter 3, as well as the media association system 2, to a third party for more information, and/or to the control management system 100. For example, the advertisement entity 6 can send an advertisement signal 113 to the media association system 2, for the purpose of having it provided by the media association system 2 to the primary and/or ancillary devices 4, 5. The advertisement entity 6 can also send advertisement criteria to the media association system 2, such that the advertisement signal 113 is provided to the primary and/or ancillary devices 4, 5 upon them receiving a specific song from the first transmitter 3 in the first media signal 111. The advertisement signal 113 can comprise, for example, graphical media along with an interactive purchasing option for the advertisement entity's product. A user of the primary and/or ancillary devices 4, 5 can respond to the advertisement signal 113 with a purchase order in the form of an interactive response sent back to the media association system 2, to a third party for fulfillment/more information or the control management system 100, and/or directly to the advertisement entity 6.

**[0053]** As illustrated in FIGURE 1, the advertisement entity 6 can also communicate with the first transmitter 3, to a third party for fulfillment/more information. and/or the control management system 100. As illustrated in FIGURE 1A, for example, the first transmitter 3 can send to the advertisement entity 6 a current and/or future schedule of the media content to be contained in the first media signal 111. As illustrated in FIGURE 1B the advertisement entity 6 can then use this information to determine the advertisement media content 113 it transmits to the media association system 2. In another embodiment, as illustrated in FIGURE 1A, the first transmitter 3 can send to the control management system 100 a current and/or future schedule of the media content to be contained in the first media



signal 111. As illustrated in FIGURE 1B, the control management system 100 can then use this information to determine the advertisement media content 113 it transmits to the media association system 2.

#### The First Media Signal

**[0054]** Referring to FIGURE 1A, the first transmitter 3 can send a first media signal 111 to the primary device 4 and/or ancillary device 5. FIGURE 1A also illustrates an embodiment of a first media signal 111 transmitted from the first transmitter 3 to the primary device 4, the media association system 2, and the advertisement entity 6. The first media signal 111 can comprise any type of media as set forth herein.

**[0055]** In some embodiments the first media signal 111 can be integrated or transmitted together with a secondary or associated media signal 112 and/or identifier 115 (as illustrated in FIGURE 1A) or the first media signal 111 can be transmitted separately from the associated media signal 112 and/or identifier 115. The associated media signal 112 can comprise information and/or data related to or about the media contents in the first media signal 111, such as the title, author, artist, album, ad, advertiser, length, date of creation, language identifier, checksum, error checking/correction and/or other relevant information, or the associated media signal 112 can comprise associated media content, such as album cover art, accompanying music, lyrics and/or other media content. When the associated media signal 112 is integral with the first media signal 111 the two signals can be combined into a single signal transmitted with, for example, alternating information or data packets (as illustrated in FIGURE 1A) over a single frequency or physical data connection.

**[0056]** The associated media signal 112 can be transmitted integrally with the first media signal 111 via a communication method. Alternatively, when the two signals are separate they can be transmitted on distinct frequencies, through distinct physical connections, at distinct times, and/or through distinct communication methods (for example, one by physical connection and the other by electromagnetic waves). Integrally combining a first media signal 111 with an associated media signal 112 can ensure that all, substantially all, or some of devices that receive the first media signal 111 can also receive the associated media signal 112. In some cases, when the first media signal 111 and the associated media signal 112 are not integral or are sent as separate media signals, then a unique identifier 115

can be assigned to the first media signal 111 and/or the associated media signal 112. In other embodiments, the identifier is not a unique identifier. In some embodiments, the unique identifier 115 is specific to the transmission of the first media signal 111 and/or the associated media signal 112. In another embodiment, the unique identifier 115 is tied to the specific instance of each media content segment conveyed via the first media signal 111. In another embodiment, the unique identifier 115 is tied to the specific instance of each media content segment conveyed via the associated media signal 112.

**[0057]** As illustrated in FIGURE 1D, the unique identifier 115 is database-linked thereby allowing a user (for example, a user of the control management system 100, media association system 2 and/or advertisement entity 6) to conduct a search or lookup of the information identified by the unique identifier 115 to determine the location, the user device, the time of transmittal, the program and/or media content in the first media signal, the available options for response to the user of the device, and/or other identifying characteristic information. Identifiers illustrated in FIGURE 1D are representative but not limited to identifiers, elements, content and/or classes of identifiers used in the media enhancement system. As depicted in FIGURE 8, the control management system 100 can comprise a conditional access user interface that allows programmable filters and/or conditions to be applied to the control, transmission, presentation and/or response to media content. The frequency of media content presentation, the duration of media content presentation, cost of click through responses to third parties by end users using primary device 4 and/or ancillary device 5, cost or pricing for use of the media association system 2, the conditions of response to media content presentation, the defined parameters controlling the relationship between first media signal 111 and associated media signal 112 and the language relating to the media content is controlled by conditions set in the control management system 100.

**[0058]** Conditional filters established and/or controlled in the control management system server 100 may include but not be limited to: geographic location, time of day, language, source of broadcast transmission, account establishment for participation by third parties, cost of click throughs, cost of media content presentation, cost of reporting frequency of media content presentation, number of times media content presentation occurred, responses generated from media content presentation, demographic information

associated with media content presentation and response, reporting results of media content presentation and response, noticeability of messages and/or advertisements by the user, demographic of the user, frequency of presentation, duration of presentation, size of the graphic and/or video presented, compression of the audio presented, combinations of the same, or the like. In addition, logic and rules of operation for presentation can be maintained by the control management system 100. Conditional filters established and/or controlled in the control management system server 100 can also modulate and/or determine features of the primary device 4, features of the ancillary device 5 and/or availability of communication means.

**[0059]** As illustrated in FIGURE 1A, an identifier 115 can also be used when the first media signal 111 and associated media signal 112 are integral. The identifier 115 can serve to identify both signals, or only one of these signals and/or media content segments within a signal.

**[0060]** Again referring to FIGURES 1, 1A the first media signal 111 from the first transmitter 3 can come in the form of an electromagnetic wave (for example, traditional radio, digital radio and/or television signals, WiFi, satellite, cellular phone signals, and/or the like), electronic and/or fiber-optic transmission over cable lines (such as, land-line telephones, cable television, DSL, other internet connections, and/or the like), and/or other communication methods.

**[0061]** Although the first media signal 111, as depicted in FIGURE 1A, is transmitted to the primary device 4, the media association system 2, and the advertisement entity 6, it is clear that the first media signal 111 could further be transmitted to any number of devices or entities, as well as the ancillary devices 5 including the control management system 100.

#### The Advertisement Signal

**[0062]** Referring back to FIGURE 1, both the media association system 2 and the advertisement entity 6 can provide an advertisement media signal 113 to the primary and/or ancillary devices 4, 5. The advertisement media signal 113 can be provided by any of the communication methods disclosed herein, and/or can comprise any form of media content.

**[0063]** FIGURE 1B and FIGURE 1C illustrate the media association system 2 transmitting the advertisement media signal 113 and the related media signal 114 to the primary and/or ancillary devices 4, 5. Similar to the first media signal 111, the related media signal 114 and/or the advertisement media signal 113 can comprise graphics, video, audio, and/or text. Additionally, similar to the first media signal 111, the related media signal 114 and/or the advertisement media signal 113 can be interactive in nature, allowing back-and-forth communication between the primary device 4 and the media association system 2, the advertisement entity 6 and the control management system 100. For example, the advertisement media signal 113 may comprise games, polls or votes, message boards, discounts, digital coupons, premiums, options to purchase related products, and/or other interactive activities. Further, the first media signal 111 can also be associated with a plurality of advertisement media signals 113 to be selectively played throughout the duration of the first media signal 111.

**[0064]** Along with the advertisement media signal 113, the advertisement entity 6 in FIGURE 1 can provide advertisement criteria, associated with said advertisement signal 113, for determining when said advertisement signal 113 should be provided to the primary and/or ancillary devices 4, 5 and/or conditions of presentation to a user. To facilitate the assignment and/or sending of an advertisement media signal 113 with a first media signal 111, a unique identifier 115 can be provided to each media signal (the first media signal 111, the advertisement media signal 113, and/or the related media signal 114), and/or each instance of each signal or content media segment. Similarly, media signals can additionally or alternatively be assigned one or more non-unique identifiers 115 to classify said media signals for similar purposes, such as an identifier for all, substantially all, or some instances of advertisement media signals 113 with a given graphical image, all, substantially all, or some signals provided in a given time period, all, substantially all, or some signals provided to a given device, all, substantially all, or some signals originating from a given source, or other purpose. These identifiers 115 can be stored in a database and/or other location such as the control management system 100, along with other relevant information. The unique identifier 115 can be used by the media association system 2, the advertisement entity 6, the first transmitter 3, and/or the primary and/or ancillary devices 4, 5 and/or the control

management system 100 as discussed further below, to track and/or record the results of any given signal as well as to determine whether the signal should be provided to the primary and/or ancillary devices 4, 5 and/or the user. Presentation of advertisement signal 113 on primary devices 4 and/or ancillary devices 5 may be different for each user even when receiving the same first media signal 111 depending on the age, gender, language, location, time of day, type of device, user preferences, user affiliations, combinations of the same, or the like as defined by criteria established in the control management system 100, the media association system 2 and/or the advertisement entity 6.

[0065] Again referring to FIGURE 1B, the advertisement media signal 113 transmitted by the advertisement entity 6 can contain a unique and/or non-unique identifier 115, along with further associated data integrated with the signal. For example, the advertisements media signal 113 may be immediately preceded by or immediately follow a data signal with the advertisement signal's unique identifier 115, identifiers 115, and/or advertisement criteria. The advertisement media signal 113 may also be associated with a separate data signal also sent by the advertisement entity 6, for example, in a simultaneous transmission or in a later transmission. The signals can be associated by their time of transmission, use of identifiers 115, or any other characteristics.

[0066] The identifier 115 associated with the first media signal 111, associated media 112, advertisement signal 113, and/or related media 114, could each be separate and/or discrete from each other. The identifier 115 associated with the first media signal 111, associated media 112, advertisement signal 113, and/or related media 114, could be the same identifier.

[0067] In one embodiment, the advertisement media signal 113 can be conveyed to the primary device 4 and/or ancillary device 5 prior to transmission of the first media signal 111. Along with the advertisement signal 113, the identifier 115 can contain association criteria for the advertisement signal 113. The primary device 4 and/or the ancillary device 5 can store the advertisement signal 113 and the identifier 115. Examples of such association criteria include, but is not limited to, the ability to recognize a particular first media signal by its identifier 115, demographic information the advertisement signal 113 is appropriate for, information to match the demographics of the advertisement signal 113 with

a first media signal 111, and/or similar information. When a first media signal 111 and identifier 115 is received by the primary device 4 and/or the ancillary device 5, then the association criteria could be applied. For example, an advertisement signal 113 identified as appropriate for people over 40 years of age could be indicated by the identifier 115, could have been received earlier and stored in the primary device 4 and/or ancillary device 5. A first media signal 111 could be received by the primary device 4 and/or ancillary device 5, along with the identifier 115 indicating the first media signal 111 is directed primarily at people over 40. The association criteria could check the storage on primary device 4 and/or ancillary device 5, determine that advertisement signal 113 is appropriate for presentation with first media signal 111 and then have either the primary device 4 and/or ancillary device 5 to present the advertisement signal 113 at the same time or substantially the same time as the first media signal 111 is presented to the user of the primary device 4 and/or ancillary device 5. In some embodiments, the advertisement signal 113 may be presented at a different time than the first media signal 111. Similarly, in another embodiment the advertisement signal 113 and a corollary identifier 115 are associated with a first media signal 111. The first media signal 111 and the corollary identifier 115 are received and stored by the primary device 4 and/or ancillary device 5. When the primary device 4 and/or ancillary device 5 receives the first media signal 111 with the first media identifier 115 corollary to the advertisement signal identifier 115, the association criteria would check the stored information on primary device 4 and/or ancillary device 5 to determine that advertisement signal 113 is appropriate for presentation with first media signal 111. Validation is confirmed because the advertisement signal identifier 115 and first media identifier 115 correlate. Next, the primary device 4 and/or ancillary device 5 present the advertisement signal media signal 113 at the same time or nearly the same time as the first media signal 111 is presented to the user of primary device 4 and/or ancillary device 5.

**[0068]** The methods and systems of user sign up and/or opt in to web based portals for the purpose of managing content selection, advertising response follow up and/or account management are further described in detail in U.S. Patent Application No. 10/806,084, filed March 22, 2004, titled "BROADCAST RESPONSE METHOD AND SYSTEM," which is incorporated by reference in its entirety.

### Related Media Signal

[0069] As illustrated in FIGURES 1, 1A, 1B, 1C, the media association system 2 can also provide media as a service to the user and/or for its own benefit. The related media signal 114 sent from the media association system 2 to the primary device 4 and/or ancillary devices 5 can comprise any form of media content which may or may not be related to the first media signal 111 and/or the advertisement media signal 113. For example, the related media signal 114 may comprise album art and/or a music video relating to a first media signal 111 that comprises a song. Additionally, the related media signal 114 can comprise text, such as a song's author, title, album, producer, lyrics, music notation, purchasing information, and/or other information. It will be clear that the related media signal 114 can also comprise interactive media, advertisements and/or any other form of media. It will also be clear that the related media signal 114 may be related to other criteria, such as criteria related to the user. For example, the related media signal 114 can comprise a reminder pre-programmed by the user, and/or other reminders such as a reminder to pay a service bill. Thus, the related media signal 114 can be related to the first media signal, the user, the media association system 2, the advertisement signal 113, and/or any other relevant element.

[0070] Again referring to FIGURES 1, 1B, 1C, the related media signal 114 can be provided from the media association system 2 by any communication method discussed herein. This may be the same means or a different means from that which is used to transmit the advertisement media signal 113 and/or the first media signal 111. Additionally, like the foregoing media signals, the related media signal 114 may also be associated with a unique or non-unique identifier 115.

[0071] As illustrated in FIGURES 1B, 1C the advertisement signal 113 and the related media signal 114 can be sent integrally or separately, as can the first media signal 111 and associated media signal 112.

### Response Signals

[0072] As illustrated in FIGURE 1, the primary and/or ancillary devices 4, 5 can also send signals to the first transmitter 3, the media association system 2, control management system 100 and/or the advertisement entity 6. As discussed above, these signals from the primary and/or ancillary devices 4, 5 can comprise responses to interactive media

signals. Additionally, the primary and/or ancillary devices 4, 5 can also transmit user data in response to or independent of signals received by the primary and/or ancillary devices 4, 5. The primary device 4 can transmit user behavior, such as when the user changes a channel, turns the device on or off, changes the volume, and/or any other parameter. Primary and/or ancillary devices 4, 5 equipped with GPS systems and/or other geographical positioning systems, such as those offered by Google<sup>®</sup>, can also report location, direction of motion, and/or speed. Primary and/or ancillary devices 4, 5 further equipped with other sensors can detect other information or data about the user and/or the user's location and/or environment. Such information can advantageously be used by the media association system 2 to decide what media and/or advertisements to be sent to the primary and/or ancillary devices 4, 5 in order to obtain a reaction from the user in general, and/or what media and/or advertisements are likely to elicit a positive reaction at a given time and/or when the user is in a given state or environment, as further discussed below.

[0073] Additionally, as depicted in FIGURE 1, the ancillary devices 5 can convey data from the primary device 4 to the media association system 2. For example, if the primary device 4 is a radio-enabled cellular phone and an ancillary device 5 is a personal computer, the primary device 4 can collect data and later upload that data to the personal computer through a data transfer protocol, such as Bluetooth<sup>®</sup>, which in turn can send the user data through a network connection to the media association system 2. The ancillary device 5 can comprise superior bandwidth, storage capacity, and/or processing power relative to the primary device 4, allowing the ancillary device 5 to transmit more complex data to the media association system 2.

[0074] As further illustrated in FIGURE 1, the primary and/or ancillary devices 4, 5 can also provide similar communications with the advertisement entity 6 and/or the first transmitter 3, and/or the control management system 100 as disclosed for the media association system 2. Thus, the primary and/or ancillary devices 4, 5 can be equipped to receive multiple media signals from either of these sources, and respond thereto in the same way as done with the media association system 2. It is additionally possible for the primary and/or ancillary devices 4, 5 to communicate with any of the other entities indirectly through the media association system 2.



[0075] The methods and systems of processing responses or broadcast responses are further described in detail in U.S. Patent Application No. 10/806,084, filed March 22, 2004, titled "BROADCAST RESPONSE METHOD AND SYSTEM," which is incorporated by reference in its entirety.

[0076] Referring to FIGURE 1, it is clear that system 1 could encompass multiple first transmitters 3, primary devices 4, ancillary devices 5, media association systems 2 and/or message entities 6. The introduction of multiple components in system 1 can increase the versatility of the communication connections. As an example, when primary device 4 is receiving a first media signal 111 from a first transmitter 3, then the advertisement signal 113 can be handled using the media association system 2. But when the primary device 4 changes device status to receive a different first media signal 111 from a different first transmitter 3, then advertisement signal 113 may need to switch and be obtained from a different media association system 2. This switch can occur in several different ways depending on how the communications are conducted. As an example, the change from first transmitter 3 to the different first transmitter 3 can be a change in tuning frequency, change in the method of communication with first transmitter 3, sending a message to first transmitter 3 and/or the different first transmitter 3 and/or other action. With the change from first transmitter 3 to the different first transmitter 3, the primary device 4 and/or ancillary device 5 can have already stored and/or obtained data indicating which media association system 2 corresponds to the different first transmitter 3 and how to establish communication with the appropriate media association system 2. Alternatively, the associated media 112 can indicate which media association system 2 will have the advertisement signal 113 for the primary device 4 and/or ancillary device 5. Alternatively, the media association system 2 can have a gateway system associated with it such that all communication from the primary device 4 and/or ancillary device 5 can be sent through the gateway. Then the media association system 2 can have sub-modules associated with the different first transmitters 3. When the primary device 4 and/or ancillary device 5 indicates a device status change, the appropriate media association system 2 sub-modules can be informed so they can stop sending advertisement signal 113 associated with the current first transmitter 3 and begin sending advertisement signal 113 associated with the different first transmitter 3. Alternatively, when the current media association system

2 receives the device status change from primary device 4 and/or ancillary device 5 indicating a change from receiving the current first transmitter 3 to receiving the different first transmitter 3, then current media association system 2 can inform the different media association system 2 of the change, stop sending advertisement signal 113 to primary device 4 and/or ancillary device 5, and the different media association system 2 can begin sending advertisement signal 113 to primary device 4 and/or ancillary device 5. Alternatively, primary device 4 and/or ancillary device 5 can communicate with the control management system 100 all device status changes such as device turning on or off, device changing stations and/or the like. The control management system 100 could then coordinate among the media association systems 2 for which of them will communicate with the primary device 4 and/or ancillary device 5. Alternatively, the primary device 4 and/or ancillary device 5 can send device status change information to some or all media association systems 2 allowing them to determine which one of them should communicate with primary device 4 and/or ancillary device 5.

### **Primary Device**

#### **Computing System Components**

[0077] FIGURE 2 illustrates an embodiment of a primary device 4. The primary device 4 comprises a computing system 400, which comprises a computer system suitable for controlling and/or communicating with the media association system 2, the advertisement entity 6, the first transmitter 3, the control management system 100 and other third parties for which the primary device 4 is designed to communicate (for example, the internet 7). The components and/or connections disclosed below for computing system 400 can also be used to implement the other modules, systems, and/or devices described herein.

[0078] The computing system 400 comprises a central processing unit (CPU) 404, which may comprise a microprocessor and/or baseband chip. The computing system 400 further comprises a memory 405, such as random access memory (RAM) for temporary storage of information and/or a read only memory (ROM) for permanent storage of information, and a mass storage device 401, such as a hard drive, diskette, flash memory, and/or optical media storage device. Typically, the modules of the computing system 400 are connected to the computer system 400 using a standards based bus system. In other embodiments, the standards based bus system could be Peripheral Component Interconnect

(PCI), Microchannel, SCSI, Industrial Standard Architecture (ISA), Baseband Bus and Extended ISA (EISA) architectures, and/or other proprietary bus system for example.

**[0079]** In one embodiment, the computing system 400 comprises one or more commonly available input/output (I/O) devices and/or interfaces 403, such as a keyboard, mouse, touchpad, four-way navigation button, other sensors, wireless technologies such as Bluetooth, WiFi, Infrared, and/or a printer. In one embodiment, the I/O devices and/or interfaces 403 comprise one or more display devices, such as a monitor or display that allows the visual presentation of media and/or options to a user. More particularly, a display device provides for the presentation of GUIs, application software data, multimedia presentations, menus and/or any other form of media or decision lists. In the embodiment of FIGURE 2, the I/O devices and/or interfaces 403 also provide a communications interface to various external devices. The computing system 400 may also comprise one or more multimedia devices 402, such as speakers, video cards, graphics accelerators, microphones, vibrators, and/or other devices capable of presenting media.

#### Computing System Device/Operating System

**[0080]** The computing system 400 may operate on a variety of computing devices, such as, for example, a server, a Windows server, a Mac server, a Structure Query Language server, a Unix server, Linux server, a personal computer, a mainframe computer, a laptop computer, a cell phone, a personal digital assistant, a kiosk, an audio player, combinations of the same, or the like. The computing system 400 is generally controlled and coordinated by operating system software, such as z/OS, Windows 95, Windows 98, Windows NT, Windows 2000, Windows XP, Windows Vista, Linux, Unix, SunOS, Solaris, Palm, Windows Mobile, Symbian, Blackberry, Android, Mac OS X and/or the like. Other operating systems may also be compatible. In other embodiments, the computing system 400 may be controlled by a proprietary operating system. Operating systems control and schedule computer processes for execution, perform memory management, provide file system, networking, and I/O services, and/or provide a user interface, such as a graphical user interface (GUI), among other things.

#### Network

[0081] In the embodiment of FIGURE 2, the computing system 400 communicates with a network 410, such as one or more of a LAN, WAN, cellular network, public switched telephone network, and/or the Internet, for example, via a wired, wireless, or combination of wired and wireless, communication link 415. The network 410 communicates with various computing devices and/or other electronic devices via wired and/or wireless communication links. In the embodiment of FIGURE 2, the network 410 is communicating with the media association system 2, the advertisement entity 6, the first transmitter 3, the internet 7, the ancillary devices 5, and/or other entities 10 with which any of the preceding elements are configured to communicate.

[0082] Access to the display selection module 406 of the computer system 400 by the media association system 2 may be through a web-enabled user access point such as a computer, cellular phone, laptop, and/or other device capable of connecting to the network 410. Such a device may have a browser module implemented as a module that uses text, graphics, audio, video, and/or other media to present data and to allow interaction with data via the network 410. The browser module may be implemented as a combination of an all, substantially all, or some points addressable display such as a cathode-ray tube (CRT), a liquid crystal display (LCD), organic light emitting diode (OLED), a rear-projection display, a plasma display, or other types and/or combinations of output devices to present media to the user. In addition, the browser module may be implemented to communicate with input devices 403 and may also comprise software with the appropriate interfaces which allow a user to access data through the use of stylized screen elements such as, for example, menus, windows, dialog boxes, toolbars, and/or controls (for example, radio buttons, check boxes, sliding scales, combinations of the same, or the like). Furthermore, the browser module may communicate with a set of input and/or output devices to receive signals from the user. The input device(s) may be connected and designed to interpret outputs from sensors comprised on the primary device 4. The output device(s) may comprise a speaker, a display screen, a printer, and/or a voice synthesizer. In addition a touch screen may act as a hybrid input/output device. In another embodiment, a user may interact with the system more directly such as through a system terminal connected to the primary device 4 without

communications over the Internet, a WAN, LAN, and/or similar network capable of a communication method.

#### Other Systems

[0083] In addition to the systems that are illustrated in FIGURE 2, the network 410 may communicate with other data sources and/or other computing devices. The computing system 400 may also comprise one or more internal and/or external media sources. For example, any of the media provided by the sources described herein may be stored in whole or in part in the computing system 400 or may be stored in whole or in part on ancillary devices 5 or the media association system 2. In some embodiments, one or more of the data repositories and/or the data sources may be implemented using a relational database, such as DB2, Sybase, Oracle, CodeBase, MySQL, PHP and/or Microsoft® SQL Server as well as other types of databases such as, for example, a flat file database, an entity-relationship database, object-oriented database, and/or a record-based database.

[0084] It will be clear that any ancillary devices 5 can comprise the same organizational structure as the primary device 4, as described in this section.

#### User Interface

[0085] FIGURE 3 illustrates a user interface of an embodiment of a primary device 4. When primary device 4 receives the first media signal 111 through a receiver 455 and/or wire data connection 470, the contents of first media signal 111 can be presented along with related information to the user on primary device 4. For example, if the first media signal 111 comprises a radio program the primary device 4 can play the audio signal to the user through speaker 453. In some embodiments, the primary device 4 can modify the program by changing the volume and/or pitch, overlaying other audio effects, pausing and resuming the program, and/or if the program has been recorded the primary device 4 can fast-forward or skip through the program. Analogous effects could be made on a television signal, comprising overlaying related content in a discrete section of the screen or mixing distinct audio signals with distinct video signals. It will be clear that further modifications could be made by the primary device 4 prior to viewing by the user for other forms of media. It will also be clear that the modifications need not be limited by the form of media viewed.

Thus, for example, some embodiments can add graphics to a purely audio media signal, or add audio to a purely graphical media signal.

[0086] More specifically, the embodiment of a primary device presented in FIGURE 3 is a radio-enabled cellular phone with a display panel 450. When tuned to a radio station the first transmitter 3, the display panel 450 can show information relating to the radio program being played, and the information can be acquired from an associated media signal 112 and/or from the media association system 2. In FIGURE 3, the upper portion of the display panel 451 can comprise textual information corresponding to the music being played on the radio, comprising the name of the artist, title of the song or media content, and/or time remaining in the song or media content. However, the display could also comprise other information comprising the record label or logo, the price of the album or media content, related news, lyrics, radio station logo, advertiser logo or message, and/or sponsored information or other information that users may desire to see while listening to the radio station. Additionally, the display can comprise album art, a music video, and/or any other form of media (graphical, textual and/or otherwise). In this embodiment, the information is provided in an upper panel 451 but it could also be provided in other portions of the display panel 450. It will additionally be clear that this information need not be static, but can instead scroll across the screen, periodically rotate through a set of distinct images and/or messages, and/or comprise other visual effects. It will further be clear that the images on the upper panel 451 could be associated with other media provided along with the radio signal, such as a brief ping and/or vibration when a new image is presented. Control and/or presentation logic of the graphic and/or audio information presented via display panel 450, upper panel 451, lower panel 452, and/or speaker 453 is established and maintained through the use criteria established in the control management system 100 and/or rules of operation established in the media association system 2.

[0087] The lower panel 452 of the display panel in FIGURE 3 displays an advertisement signal 113. In the illustrated embodiment, the lower panel 452 displays a textual advertisement signal 113. However, like the related media signal 114 displayed on the upper panel 451, the advertisement signal 113 can comprise any sort of media which can be provided as a static image, scrolling images, text, overlaid audio, interactive media, video,

and/or other forms of media. Notably, the advertisement signal 113 need not be presented through the display panel, but could alternatively be presented through the speaker, a vibration system, and/or any other primary device output 402, 403.

[0088] In other embodiments, it will be advantageous to provide the related media signal 114 and the advertisement signal 113 to the display panel 450 separately as in FIGURE 3, or to provide the related media signal 114 in a distinct display panels 450, or to alternate what is displayed, such that only one signal or media content segment is displayed in the display panel 450 at any one time. For example, the display panel 450 can comprise two separate panels, one for presenting the related media signal 114 and the other for presenting the advertisement signal 113. This may be advantageous for allowing viewers to quickly and more easily identify the information they wish to find. In other embodiments, one signal is brighter than another or one display should be turned off while the other remains on. Considering these alternative embodiments, it will also be clear that the primary device 4 need not display both an advertisement signal 113 and a related media signal 114 at the same time. As an example, the primary device 4 may provide a related media signal 114 or provide an advertisement signal 113. As another example, the primary device 4 may provide a toggle button 462 allowing a user to toggle between displays of the advertisement signal 113 and the related media signal 114. It may be advantageous to set the display panel 450 to show the advertisement signal 113 by default, and then to display the data signal upon activation of the toggle button 462. The display panel 450 can then return to displaying the advertisement signal 113 upon the occurrence of some criteria such as a re-activation of the toggle button 462 or the passage of a certain amount of idle time. In another embodiment, advertisement signal 113 may be presented using display panel 450, upper panel 451 or lower panel 452 depending on various pricing scenarios determining value of the presentation area based on criteria such as: noticeability of the message or presentation by the user, age or gender of the user, frequency of presentation, duration of presentation, size of the graphic or video presented, compression of the audio presented, combinations of the same, or the like. Logic and rules of operation for presentation can be established through use of a conditional access portal in the control management system 100 or media association system 2 or a logical operative of both. Presentation of advertisement signal 113 on primary devices 4

and/or ancillary devices 5 may be unique for each user even when receiving the same first media signal 111 depending on criteria such as: age, gender, language, location, time of day, type of device, user preferences, user affiliations, combinations of the same, or the like.

**[0089]** Referring further to FIGURE 3, in some embodiments, the related media signal 114 and/or the advertisement signal 113 may be provided using the same display means as the first media signal 111. In FIGURE 3, the first media signal 111 may comprise audio along with video and/or graphical media content. In this instance the display panel 450 can be further subdivided, such that the primary device 4 can present each graphical signal (first media signal 111, advertisement signal 113, and/or related media signals 114) all, substantially all, or some on the same display panel 450. In other embodiments, the primary device 4 can be configured by the user or through the media association system 2 to adopt a set of display criteria, which instructs the computing system 400 what should be displayed and how.

**[0090]** An alternative display is illustrated in FIGURE 3A. The primary device 3 can present the advertisement signal 113 and the related media signal 114 overlaid on the first media signal 111. The display selection module 406 can comprise criteria for the placement of the advertisement signal 113 and/or the related media signal 114 so as to optimize the viewing experience. This may involve placing the signals in set positions on the periphery of the first media signal 111, dynamically changing their placement according to characteristics of the first media signal 111, and/or the like.

**[0091]** More generally, as illustrated in FIGURES 3 and 3A, the advertisement and/or related media signals 113, 114 can be provided in the interstices of a first media signal 111. These interstices can be based on time, location, content and/or form of media. Alternatively, the advertisement and/or related media signals 113, 114 can be provided overlapping with the first media signal 111.

**[0092]** Referring back to FIGURE 3, the primary device 4 comprises a plurality of buttons 462. In addition to buttons 462, some embodiments can comprise other input sensors to allow user input. These sensors 403 allow the primary device 4 to provide interactive media contained in the related media signal 114, advertisement media signal 113, and/or the first media signal 111. The sensors 403 can communicate with the computing system 400 (as



illustrated in FIGURE 2) which can then create a device response signal sent to the media association system 2 through the network 410. The media association 2 can respond to that with another related media signal 114 or advertisement signal 113, which can be displayed to the user so as to create a truly interactive experience for the user. Alternatively, this interactive signal set could be provided to the primary device 4 in the initial related media signal 114 or advertisement signal 113, such that the primary device 4 can respond to input from sensors (such as the buttons 462) without needing to communicate with the media association system 2. The interactive signal set can also configure the primary device 2 to communicate with ancillary devices 5, through the ancillary devices 5 to the media association system 2, through the media association system 2 to the ancillary devices 5, through either of these to other entities, or directly with other entities so as to create an interactive experience for the user. It will further be clear that an interactive signal set can comprise some combination of these communication methods.

**[0093]** As illustrated in FIGURE 3, above the display panel 450 the primary device 4 comprises a speaker 453 and below the display panel 450 the primary device 4 comprises a microphone 461. Other input sensors and/or output modules can be provided through a connection to an ancillary device 5. For example, if a media signal 114 and/or an advertisement media signal 113 cannot viewed on the primary device 4, then a user can view the media signal 114 and/or the advertisement media signal 113 on an ancillary device 5. In other embodiment, the primary device 4 will modify the media signal 114 and/or an advertisement media signal 113 in order to display the media content on the primary device 4. Additionally, the primary device can also ignore the media signal 114 and/or an advertisement media signal 113 if the media content cannot be displayed on the primary device 4.

**[0094]** As further depicted in FIGURE 3, the primary device 4 can be connected to an ancillary device 5, depicted here as a personal computer connected by a wire data connection 470. The first media signal 111 can be stored using a mass storage device 401 on the primary device 4 (depicted in FIGURE 2) and/or on an ancillary device 5 comprising similar mass storage device. The ancillary device 5 can receive the first media signal 111 and the advertisement signal 113 directly from the first transmitter 3 and/or the media association

system 2. Alternatively, the ancillary device 5 can receive the first media signal 111 and the advertisement signal 113 indirectly through the primary device 4 or some other agent. The ancillary device 5 need not acquire both signals from the same source. For example, if a user wishes to listen to a radio broadcast at a later time the user could configure an ancillary device 5 to record said first media signal 111. This configuration could be implemented indirectly through the interface on the primary device 4 or directly on an interface on the ancillary device 5. Then, the first media signal 111 could later be viewed on the primary device 4 after transmitting the recorded first media signal 111 from the ancillary device 5 to the primary device 4. Alternatively the first media signal 111 could be viewed directly on the ancillary device 5, such as when the ancillary device 5 comprises a home entertainment system. In the foregoing, the advertisement signal 113 and the related media signal 114 can be recorded, transferred, and viewed just as done with the first media signal 111. Accordingly, the advertisement signal 113 and the related media signal 114 can remain associated with the first media signal 111.

**[0095]** The primary and/or the ancillary devices 4, 5 in FIGURE 3 can be in regular communication with the media association system 2, and accordingly a first media signal 111 stored for later viewing can be associated with an advertisement signal 113 distinct from the advertisement signal 113 associated with the first media signal 111 when viewed in real time. Whether the advertisement signal 113 is preserved or changed upon storage of the first media signal 111 can be determined by advertisement placement criteria, discussed further below. The primary device 4 can replace the advertisement signal 113 when the advertised product, service, cause, and/or event is geographically and/or temporally specific, such as presenting an advertisement for a restaurant intended to be shown slightly before lunch time to those likely to be near the given restaurant at that time of day. The advertisement signal 113 can also be replaced upon the occurrence of other criteria, such as a given user response, age, gender, language, location, time of day, type of device, user preferences, user affiliations, popularity, political affinity, cultural affinity, and/or the like. Similar actions can be made on the related media signal 114.

**[0096]** Although the embodiment described in this section is a radio-enabled cellular phone, it will be clear that other devices can be provided in accordance with the

invention. For example, the primary device 4 could comprise a WiFi enabled receiver, laptop computer, personal digital assistant, desktop computer, television, and/or any other device capable of receiving media, displaying media, transmitting data, and sensing user inputs.

[0097] FIGURE 4 illustrates a flow chart showing the actions performed by the primary device 4. The primary device 4 can receive media and/or a configuration from one of its inputs and/or through a communication method. The primary device 4 can then use the media and the configuration to choose output media. The output media can be stored and/or presented to the user. Storage of the output media could be dependent on the attributes of the primary device 4, the first media signal 111, user preferences and/or similar criteria. The user can then respond to the output media. The user's response can then cause the primary device 4 to perform an action.

[0098] FIGURE 4A illustrates a more detailed flow chart showing the actions performed by the primary device 4. It will be clear that the same actions could be provided by the ancillary devices 5. When being turned on, the primary device 4 can receive a variety of inputs, comprising a first media signal 111, a related media signal 114, an advertisement signal 113, a user input, a configuration signal, and/or stored media. Each of these signals can comprise or be translatable into media that can be provided to the user. Examples of this comprise media provided through the media signals, stored media, pre-programmed media responses to user inputs, media responses to new configurations, and/or the like. Additionally, the inputs can cause a change of the primary device's configuration, such as by a signal from the media association system 2, advertisement entity 6, the first transmitter 3, an ancillary device 5, the control management system 100 and/or other sources. Such a signal may comprise machine readable code, or instructions for machine readable code already on the primary device. Alternatively, user inputs could alter the configuration of the primary device in a similar manner.

[0099] Referring further to FIGURE 4A and FIGURE 2, the display selection module 406 can use the incoming media, user inputs, and/or its own configuration to choose output media. For example, a computer may be configured by the user to a "mute" setting, and when the computer receives an incoming media signal with both audio and video, the computer may output the video and not the audio. In another example, an interactive

television system may receive multiple video signals from both a first transmitter 3 and a media association system 2. The interactive television system can also receive a configuration signal from the media association system 2 with criteria stating what a user may and may not watch. The interactive television system could then, upon user input for selecting a channel, either display the video signal on that channel from the first transmitter, or instead an advertisement media signal 113 from the media association system 2 if the user is not permitted to view that channel. Further configurations could overlay advertisement and/or the related media signals 113, 114 on a first media signal 111. Additionally, the display selection module 406 can be configured to store one or more media signals for later viewing.

[0100] When presented with the output media, the user can provide a response, as illustrated in FIGURE 4A. The user response can be based on intentional action or inaction, and/or the response can be caused by the user or the user's environment. The response can comprise user reactions or user commands, detected by the primary device's sensors. These responses can then be used by the primary device 4 to change its output criteria, choose media to be stored, or choose to perform some other action of which the device is capable. Additionally, the primary device 4 can relay these responses, or some function thereof, to the media association system 2, the advertisement entity 6, the first transmitter 3, the ancillary device 5, the control management system 100 and/or the like. For example, the primary device 4 can report to the media association system 2 when the user chooses to view the first media signals 111 from a different first transmitter 3 (for example, the user changes stations).

#### Media association system

[0101] Referring back to FIGURE 1, the media association system 2 can comprise the device components illustrated for the primary device 4 as depicted in FIGURE 2. The media association system 2 can also be a plurality of media association systems 2, wherein each device performs similar and/or distinct functions to be described below.

[0102] FIGURE 5 illustrates a block diagram of an embodiment of the media association system 2. The media association system 2 can receive from the first transmitter 3, the first media signal 111 or information related to the first media signal 111. This can be used by the media signal identifier module 280 to identify the contents of the first media

signal 111, or certain characteristics thereof. That information can then be forwarded to a related media processing module 250, which can then choose what media content to forward to a primary device 4, and put said media in proper form for transmission.

**[0103]** As further depicted in FIGURE 5, a media association system 2 can also receive advertisement signals 113 and/or advertisement criteria from an advertisement entity 6. This information, along with information from the media signal identifier module 280, can be provided to an advertisement processing module 251, which uses the information to perform functions that can be similar to or different from those performed by the related media processing module 250. The media association system 2 can use the information related to a first media signal 111, an advertisement signal 113, and/or the advertisement criteria, and using or processing the information to select media to be sent to the primary device 4. In one embodiment, advertisement criteria is created and/or managed in the control management system 100. In another embodiment, advertisement criteria is created and/or managed in the advertisement entity 6. In another embodiment, advertisement criteria is created and/or managed through combined use of the control management system 100 and the advertisement entity 6.

**[0104]** FIGURE 5A illustrates a block diagram of a more detailed embodiment of a media association system 2. As depicted in FIGURE 5A, the media association system 2 can send information to the primary device 4 and/or to any ancillary devices 5. These communications can be established through communications element 223 comprising any of the communication methods discussed, or the like. The communication methods used can be the same, or can be different between each communications element 223 for each direction of communication. Advantageously, the media association system 2 can transmit directly to a given primary and/or ancillary device 4, 5, thus customizing content to that device and/or that user.

**[0105]** Further, as depicted in FIGURE 5A, the communications need not be specifically directed toward one primary or ancillary device 4, 5 or specifically directed toward the media association system 2. For example, the media association system 2 can send a related media signal 114 or advertisement signal 113 through communications elements 223 to a plurality of primary devices 4 and/or ancillary devices 5, such as by

broadcast radio whether analog or digital, satellite, cable, HSDPA, GPRS, a publicly available internet website, and/or some other openly accessible medium and/or communication method. Similarly, the signal can be sent directly to a given primary and/or ancillary device 4, 5, but not necessarily customized to the device. If desirable, the signal can then be customized by the primary and/or ancillary device 4, 5 via a display selection module 406 on the primary and/or ancillary device 4, 5 (depicted in FIGURE 2), such that a portion of the related media and/or advertisement signals 113 are presented to the user. The signal ultimately presented to the user can frequently and/or periodically be customized for said user by the display selection module 406, which can be downloaded from the media association system 2, edited by the media association system 2 via a data signal (for example, from the media association system 2), edited by the user, edited through use of a conditional access portal and/or database server such as the control management system 100, and/or modified in some other way.

**[0106]** The media association system 2 as depicted in FIGURE 5A provides a related media signal 114 to the primary and/or ancillary devices 4, 5 via a communications element 223. The communications element 223 can use a communication method to provide media to the primary and/or ancillary devices 4, 5, and to receive information from said devices. The related media signal 114 sent via the communications element 223 can be determined by a related media processing module 250. The related media processing module 250 can receive information from the media signal identifier module 280, the communications element 223, the internet 7, and/or other sources. These connections allow the related media processing module 250 to acquire information not stored on the media association system's mass storage device (not shown) or in the information transmitted by the first transmitter 3 (discussed below). For example, in the context of an SMS message as a first media signal 111, the related phone number and/or the text of the message might not fully identify the identity of the sender. In this example, the related media processing module 250 may connect to a remote phone listings database to associate the phone number with a sender name, address, and/or other relevant information. As another example, in the context of radio the first media signal 111 may come with an accompanying RBDS and/or RDS signal, but not with album art. If the memory storage unit does not store album art or does

not store album art for the particular song being played, then the media association system 2 can access the internet 7 to automatically download the album art and prepare it for transmission to the primary and/or ancillary devices 4, 5.

**[0107]** The related media processing module 250 in FIGURE 5A can also perform the task of deciding what media to provide to different primary and/or ancillary devices 4, 5. The related media processing module 250 can use a set of user display criteria, based on pre-determined user preferences, bandwidth restrictions, broadcaster preference, artist preference, copyright access, the media association system's operator's preference, age, gender, language, location, time of day, type of device, user preferences, user affiliations, political affinity, cultural affinity, popularity, and the like, and/or any other criteria discussed herein. Notably, embodiments equipped for communication from the primary and/or ancillary devices 4, 5 to the media association system 2 can update these criteria based on a user response constantly or intermittently, via the communications element 223.

**[0108]** The related media processing module 250 depicted in FIGURE 5A can also prepare the related media for transmission to the primary and/or ancillary devices 4, 5. Such preparation can comprise encryption, compression, reformatting, and/or any other data processing method that can change the size, form, accessibility, and/or content of the related media signal 114. Such steps can reduce bandwidth requirements, restrict access to the related media signal 114, and allow it to be viewed on the primary and/or an ancillary devices 4, 5 capable of viewing media in a certain set of formats.

**[0109]** As illustrated in FIGURE 5A, the related media processing module 250 can obtain and/or receive information relating to the first media signal 111 from the media signal identifier module 280. The media signal identifier module 280 can obtain and/or receive information relating to the first media signal 111 from the first transmitter 3 via either the receiver 220 and/or the communications element 221. The communications element 221 can allow two-way communication between the media association system 2 and the first transmitter 3, while the receiver 220 can allow one-way communication, such as by receiving a publicly available radio or television signal. Two-way communications allow the media association system 2 to request specific information and provide the first transmitter 3 with information regarding user responses, discussed further below. The media signal identifier

module 280 is also connected to the internet 7, allowing the media signal identifier module 280 to obtain outside information to identify the first media signal 111. Although not illustrated in FIGURE 5, the media signal identifier module 280 can also receive similar information from the primary and/or ancillary devices 4, 5. When the media signal identifier module 280 cannot obtain sufficient information from the first transmitter 3 to identify the first media signal 111, the media signal identifier module 280 can obtain further information related to the first media signal 111 from the primary and/or ancillary devices 4, 5.

**[0110]** In addition to or in place of the related media signal 114, as illustrated in FIGURE 5A the media association system 2 can send an advertisement signal 113 to the primary and/or ancillary devices 4, 5 in the same ways that the related media signal 114 can be sent. The advertisement signal 113 is determined by an advertisement processing module 251. The advertisement processing module 251 receives information regarding the first media signal 111, or a representation thereof such as a identifier 115, from the media signal identifier module 280. Additionally, the advertisement processing module 251 receives advertisement signals 113 and/or advertisement criteria from advertising entities 6 through an advertiser communications element 222. The advertisement processing module 251 can also receive feedback from the primary and/or ancillary devices 4, 5 via the communications element 223. The advertisement processing module can then use the advertisement criteria from the advertisement entity 6, information regarding the first media signal 111 from the media signal identifier module 280, and/or signals transmitted from the primary and/or ancillary devices 4, 5 to determine which advertisement media to send to the primary and/or ancillary devices 4, 5. The advertisement processing module 251 can be substantially similar to the related media processing module, or it can comprise other elements. As with the related media signal 114, the advertisement signal 113 can be stored in a memory storage unit on the primary and/or ancillary devices 4, 5, or be modified by the primary and/or ancillary devices 4, 5, prior to presentation to the user. In one embodiment information identifying the first media signal 111, the advertisement signal 113, the related media signal 114, the unique identifier 115, time of receipt and/or interactive selection options such as organization of options in a menu system can be stored in a memory storage unit on the primary and/or ancillary devices 4,5 for retrieval at a later time and display by as desired by the user. Key



word search capabilities and/or time based first-in-last-out methodologies can be employed for ease of access.

[0111] The media association system 2 depicted in FIGURE 5A can provide an advertisement entity 6 interface through communications 222, further discussed below. This interface can comprise a conditional access website and/or web portal, WAP portal, form letter, automated phone system, and/or some other mechanism for allowing advertisement entities 6 to automatically send advertisement criteria and/or signals and receive feedback from the media association system 2. In one embodiment, the media association system 2 may operate discretely from the control management system 100. In another embodiment, the media association system 2 may operate in logical combination with the control management system 100. In another embodiment, the media association system 2 can operate as a portion of the control management system 100.

[0112] As illustrated in FIGURE 5A, the media association system 2 can additionally comprise one or more report modules 260, 261 connected to the communications element 223. The report modules 260, 261 allow the media association system 2 to transmit user feedback from the primary and/or ancillary devices 4, 5 to the first transmitter 3, the control management system 100 and/or the advertisement entity 6. The report modules 260, 261 can condense, transform, encrypt, and/or otherwise change the form or content of this data (customizable for each) before passing it along to the first transmitter 3, the control management system 100 and/or the advertisement entity 6. The first transmitter 3, the control management system 100 and/or the advertisement entity 6 can then use this information to determine what signals and/or criteria to provide to the primary and/or ancillary devices 4, 5, and/or to the media association system 2.

[0113] FIGURE 6 illustrates a flow diagram for an embodiment of the media association system 2. The system can be started by turning on the power, providing a command to start a given software module, or the like. The media association system 2 can then receive information relating to the first media signal 111, the advertisement signal 113, and/or the advertisement criteria. Information obtained relating to the first media signal 111 can comprise data related to the media signal's current programming, further comprising but not limited to the title of the program, artists, advertiser, ad, song, movie, program length,

start times, end times, other information relevant to the program, and/or simply the program itself. The foregoing information pertaining to the programs can also be transmitted by the first transmitter 3. If the first transmitter 3 transmits the foregoing related information in a signal publicly available, then the media association system 2 can advantageously retrieve the information without requiring a separate communications link with the first transmitter 3. Additionally, the primary and/or ancillary devices 4, 5 can obtain this information independent of the media association system 2. The information related to the first media signal 111 need not be transmitted from the first transmitter 3 constantly, and could instead be transmitted at regular or irregular intervals, in which case the media association system 2 can store said information in a memory storage unit.

**[0114]** In the case where the only information available is the actual first media signal 111, or when the associated media signals 112 are otherwise inaccessible, the step of identifying the first media signal illustrated in FIGURE 6 can comprise using the first media signal 111 itself to identify the contents of the media signal. For example, a radio station may verbally announce the title of a song prior to playing said song, and therefore the media signal identifier module 280 can use a voice-recognition module or a person listening to the broadcast to input or identify the contents of the first media signal 111. Alternatively, the media signal identifier module 280 could maintain a database containing recordings of content that might be presented by a first transmitter 3, and use statistical and/or non-statistical methods to compare the transmitted first media signal 111 and/or recorded content to identify the contents of the first media signal 111. Methods for identifying first media signal 111 contents can comprise human recognition, least-squares spectral analysis (LSSA), hash sums, or other operations comparing the first media signal to recorded content. Similar operations can also be performed without a full recording of the content, but instead appropriate information related to the content. When other information regarding the first media signal 111 is available, using these methods can also be used for redundancy and/or error-checking.

**[0115]** In some instances it may not be necessary to fully identify the first media signal 111 as illustrated in FIGURE 6. For example, to choose appropriate accompanying signals it may be sufficient to identify the genre or topic of the first media signal 111 such as

sporting events, political events, weather and/or news topic. As such, the media association system 2 can identify some characteristic of the first media signal 111. When the foregoing is not possible, the accompanying media can be chosen based on default criteria.

[0116] Referring to FIGURE 6, once the first media signal 111 has been sufficiently identified the media association system 2 can collect and/or store the information and/or data related to the media signal 111 to be eventually provided to the primary and/or ancillary devices 4, 5. This related media can comprise media also transmitted by the first transmitter 3, media stored in a mass storage device on the media association system 2, or media collected from other sources such as the internet, other data connections, and/or by physical means.

[0117] FIGURE 6 illustrates that after the media association system 2 has collected related media, the media association system 2 can prepare a related media signal 114. This can involve editing, truncating, reordering, combining, and/or performing similar operations on the related media signal 114. Additionally, it can involve putting the related media signal 114 in a proper format, as done by the related media processing module 250 in FIGURE 5A. Criteria or the filter for choosing what related media to provide to the primary and/or ancillary devices 4, 5, and in what format to do so, can comprise settings chosen by the user and reported by a primary and/or ancillary device 4, 5, and other data about the user further discussed below.

[0118] The device responses depicted in FIGURE 6 provide information used to amend criteria for preparing the related media signal 114. Thus, the media association system 2 can amend and/or calibrate criteria continuously, with the possibility of converging on a set of criteria that is optimal for each user or any given subset of users according to criteria discussed further below. The responses can be modified, condensed, encrypted, and/or transformed in some other way prior to transmission between any element and/or module.

[0119] Also in FIGURE 6, the media association system 2 can receive at least one advertisement signal 113 and/or advertisement criteria from an advertisement entity 6. The media association system 2 can use this information, and possibly also the identity of the first media signal, to choose an advertisement media signal 113 to be transmitted to the primary

and/or ancillary devices 4, 5 based on preselected criteria. This advertisement media signal 113 can then be prepared for transmission and, with or without the related media signal 114, sent to the devices 4, 5. Alternatively, the related media signal 114 can be sent without an advertisement signal 113. The criteria or filter for choosing an advertisement signal 113 can be constantly refined. In general, the method for providing an advertisement signal 113 can comprise any of the methods by which the related media signal 114 can be provided, although they do not need to be provided in the same way in any single embodiment.

**[0120]** To determine rules for choosing which advertisement media signals 113 to provide to the devices at any given time, advertisement entities 6 provide a set of advertisement criteria as illustrated in FIGURE 6. The advertisement criteria can associate a given advertisement signal 113 and/or advertisement identifier 115 to certain content, users, times, geographies, sources, and/or other categories. Criteria or filter relating to content can comprise the title of a program, artist, producer, length, genre, lyrics, and/or keywords therein, and/or other characteristics. Criteria or filter relating to users can comprise demographic data, such as age, sex, income, race, zodiac sign, type of device, time of day, location, language, affiliations and/or club memberships, marital status, religion, cultural affinity, political affinity, popularity, user preference, place of residence, hometown, and/or other data.

**[0121]** Other demographic data comprises media event history of the user, media event history of the device, media stream content history, media stream transmitter history, alternate media stream content history, device history, prior interactions of the user based on past associations, promotional campaigns, previous, on going, and/or anticipated future events, demographic information associated with the source of the first media signal 111, demographic information associated with the collective users of the first media signal 111, demographic information from research providers, and/or the like.

**[0122]** Other criteria includes, but is not limited to, media stream producers, media stream artists, media stream consumers, benefits of associating one media stream with another, professional studies or psychographic data, availability, costs, signal strength, opportunity costs, geographic information, contractual obligations, intellectual property rights, genre, and/or the like. Criteria relating to users can further comprise data collected by

the devices, such as choosing to turn off the device, change the volume, change the station, and/or provide any other response, upon receiving a first media signal 111, a related media signal 114, and/or an advertisement media signal 113.

**[0123]** Criteria relating to times can comprise the length, date and/or time of transmission at the source, date and/or time of reception at the user device, date and/or time of viewing of a given media signal, as well as date and/or time relative to of the media signal relative to other media signals, including but not limited to prior, current, or future transmissions of media signals, date and/or time of prior, current, or future events, date and/or time of one criteria relative to another criteria, and/or the like.

**[0124]** Criteria related to geography can comprise the location and/or past locations of the first transmitter 3, the advertisement entity 6, the primary and/or ancillary devices 4, 5, or the user's home, place of work, billing address, and/or other locations associated with the user. Storing the primary and/or ancillary device's 4, 5 past location histories can indicate travel habits as well as current direction, language in a location, velocity, and/or regional associations. Criteria relating to source can comprise characteristics of the first transmitter 3, comprising first transmitter identity, signal strength, signal quality, signal type; for example, digital vs. analog, media form, usual genre, Nielsen ratings, and/or other characteristics. Other criteria sources can comprise the advertisement entity's 6 willingness to pay, the related advertisement media signals 113 (such as package advertisements or advertising campaigns), the advertised products, services, causes, and/or events that conflict with the interests of another advertisement entity 6, and/or the interests of the operator of the media association system 2, and/or any other criteria.

**[0125]** The foregoing should not be considered an exhaustive list of possible criteria for choosing what advertisement media signal 113 is sent or provided to a given device 4, 5. The foregoing criteria or filter elements can be used singularly or in combination with each other. The criteria used to determine the media content to be associated with the first media signal 111 can involve the assignment of weighting factors to some criteria, and/or can be dynamic changed, for example, where the status of one criterion determines the weight to assign to another criterion. Access to criteria selection and/or weighting factors could be through the use of the internet, data entry, paper, telephone, text messaging, and/or

any other means of conveying information into the system. The analysis can be static where the criteria are evaluated independently of each other. The analysis can change with time, events, and/or the like.

**[0126]** In some embodiments, the analysis comprises the ability to anticipate criteria conflicts and/or the ability to resolve criteria conflicts. An example of a criteria conflict would be demonstrated when a filter or criteria dictates that two discrete secondary media signals be paired with a single first media signal. Resolution can be made by prioritizing one of the secondary media signals over the other; using additional criteria to resolve the conflict; dividing the association of the secondary media streams to the first media stream by time, location, demographics, language, number of devices, randomness, or the like. The division does not have to be equal, and/or can favor one media signal over another.

**[0127]** To provide an advertisement selection process, some embodiments are configured to analyze user responses reported by the primary and/or ancillary devices 4, 5 to amend the advertisement selection process criteria (as well as the related media signal selection criteria). In some embodiments, it is advantageous to first condense advertisement criteria parameters and/or data collected by the devices into a variety of statistics, such as the estimated probability of a given response to a given signal or the estimated revenue from a given signal. To further improve data mining capabilities, some primary and/or ancillary devices 4, 5 can send to the media association system 2 over communications element 223 a complete report similar to a keystroke log combined with a log of viewed media, data, and/or advertisements. In other embodiments the foregoing data is condensed before transmission.

**[0128]** When receiving the response data from the primary and/or ancillary devices 4, 5, the advertisement processing module 251 can use various statistical methods to estimate the likely success of a given advertisement media signal 113 and/or related media signal 114. Success can be measured by user responses, such as eliciting or obtaining an increase in volume, not eliciting or obtaining a decrease in volume, eliciting a sale of an advertised product, a charge for each user response or click through to an advertiser or other results. Statistical techniques used can comprise generalized least squares regression, profit models, logic models, and/or other linear statistical techniques, as well as non-linear

statistical methods. It may also be advantageous to comprise interactions between distinct variables, such as the effect of one variable on the effect of another variable on the success criteria. In other embodiments, other techniques could be used comprising holistic and/or non-mathematical methods.

[0129] It will be clear that these methods for measuring the anticipated user response to advertisement media signals 113 can also be used to measure the anticipated user response to related media signals 114 and/or first media signals 111. Such methods allow the media association system 2 to advantageously provide optimal signals desirable to users, thus enhancing the value of the product.

[0130] Taking all, substantially all, or some of these criteria together, the related media and/or advertisement processing modules 250, 251 can choose advertisement and/or related media signals 114 optimized for achieving a certain goal. Such goals may comprise boosting responses to advertisement media signals 113, increasing viewing by users, increasing revenue from advertisement entities 6, increasing user responses or click throughs to advertisement media signals 113 to increase per response revenue and/or other goals.

[0131] Additionally, the media association system 2 in FIGURE 5A and/or the signal selection process in FIGURE 6 can be modified such that the advertisement signal 113 is selected knowing its accompanying related media signal 114, the related media signal is selected knowing its accompanying advertisement signal 113, or the two are selected as a pair. Such a system will be advantageous in that the two signals (advertisement message 113 and related media signal 114) can be coordinated to avoid clashing colors, excessive stimuli, and/or other coordination problems. However, choosing the signals independently can sometimes require fewer computational resources by providing a smaller number of choices to be considered. Thus, the media association system 2 can be configured to choose the signals in any of these ways, depending on its available resources.

[0132] The process depicted in FIGURE 6 of selecting an advertisement signal 113 to coincide with a given portion of the first media signal 111 can cause the advertised product, cause, or idea to become psychologically associated with the content of the first media signal. It may be desirable to provide the advertisement media signal 113 to the primary device 4 prior to the termination of the desired portion of the first media signal 111,

so as to enhance the psychological connection between the two media signals. However, providing the advertisement media signal 113 shortly before or after the related first media signal 111 can still have an effect. Similarly, if a first media signal 111 is sufficiently memorable and the advertisement media signal 113 is sufficiently related, it may be desirable to provide an advertisement signal 113 a set time period after the first media signal 111 so as to evoke positive memories. Providing an advertisement media signal 113 in anticipation of a first media signal 111 can also provide benefits in accordance with the invention, such as to promote a future media program on the same or a different station or a program transmitted by an entirely different communication method.

**[0133]** The method depicted in FIGURE 6 can provide the advertisement signal 113 from a source distinct from the first transmitter 3. This allows one to associate advertisement signals 113 not necessarily the same as advertisement signals 113 provided by the first transmitter 3. Thus, for example, a radio transmission without graphical advertisements from the first transmitter 3 can be augmented with graphical advertisements provided by the media association system 2. Alternatively, a television broadcast from the first transmitter 3 can have advertisements specifically determined by the media association system 2, perhaps targeted to a specific region, market, language, age, gender, political party, cultural affinity, and/or set of viewers. The media association system 2 can thus tailor advertisement media signals 113 to each individual, independent of or in conjunction with the first transmitter 3.

#### Advertisement Entity

**[0134]** Referring back to FIGURE 1, the advertisement entity 6 can comprise corporations, companies, partnerships, agencies, firms, organizations, public entities, non-profit organizations, individuals, and/or any other entity, including the operator of the media association system 2 and/or the first transmitter 3. Similarly, the advertisement signals 113 can advocate a product, service, cause, and/or event, promote awareness of an idea or issue, and/or comprise any other form of communication method. In some embodiments, the advertisement media signal 113 can be assigned a unique advertisement identifier 115 to facilitate communication, data processing, and/or data mining.



**[0135]** The communications between the advertisement entity 6 and the media association system 2, depicted in FIGURES 1 and 5A can go through an interface provided by the communications element 222. The interface can comprise a webpage or web portal, WAP portal, paper form, automated telephone system, a person, and/or any other form capable of transmission through a communication method. Through the interface, the advertisement entity 6 can set advertisement criteria discussed above, such as when a given advertisement signal 113 should be provided. Additionally, the interface can allow the advertisement entity 6 to upload or send new advertisement media signals 113 remotely. Thus, an advertisement entity 6 can constantly update its advertisement media signals 113. The interface can also provide information back to the advertisement entity 6 from the media association system 2, comprising billing information and usage and/or response feedback from the primary and/or ancillary devices 4, 5. This information can be provided in whole, or in condensed forms such as numerical statistics, pie charts, bar graphs, text, and/or any other media. As with the related media signal 114 and the primary device 4, the interface with the advertisement entity 6 can be determined by criteria deriving from either the advertisement entity 6 and/or the media association system 2. The interface can further comprise modules that allow a user to access data through the use of stylized screen elements such as, for example, menus, windows, dialog boxes, toolbars, controls (for example, radio buttons, check boxes, sliding scales, combinations of the same, or the like), and/or the like.

**[0136]** With reference to FIGURE 7, the various embodiments of the media enhancement system may be used in a variety of systems and/or contexts. FIGURE 7 illustrates such an example context. In the illustrated example, a plurality of broadcast sources 120 broadcast various media content in a plurality of broadcast streams, which are received by the broadcast scanning system 160. In one embodiment, the broadcast scanning system 160 is configured to: analyze the broadcast streams received from the plurality of broadcast sources 120 to obtain or identify the media content transmitted in the broadcast streams; obtain additional information about the media content if available; and/or assign a unique event identifier 115 specific to the broadcast of each specific broadcast stream. In one embodiment, the broadcast scanning system 160 transmits the unique event identifier 115 to the media association (advertisement) system 1102. Methods and systems of how the

broadcast scanning system 160 obtain or generate the unique event identifier 115 are disclosed in detail in co-pending U.S. Patent Application No. \_\_\_\_\_, filed \_\_\_\_\_, titled "SYSTEM, METHOD, AND DEVICES FOR SCANNING BROADCASTS," which is incorporated by reference in its entirety. In one embodiment, the broadcast scanning system 160 stores the unique event identifier 115 in the unique event identifier database 1111. In one embodiment, the unique event identifier 115 that is stored in the unique event identifier database 1111 is database linked with the corresponding and/or associated content and/or content identifiers that are stored in the content database 1103.

**[0137]** Referring to FIGURE 7, in one embodiment, the broadcast scanning system 160 further broadcasts or transmits over a network to the broadcast receiving systems 140. In one embodiment, the unique event identifier 115 is transmitted through the internet and/or over a wireless/cellular network to a mobile device operating a software application (for example, a Java J2ME software application) capable of accessing the internet through the wireless/cellular network. After a broadcast receiving system 140 receives a broadcast stream from a broadcast source 120, and receives a corresponding unique event identifier 115 from the broadcast scanning system 160, the broadcast receiving system 140 is configured to receive a user selection or user input. After the broadcast receiving system 140 receives the user selection or user input, the broadcast receiving system 140 is configured, in one embodiment, to transmit to the broadcast response and business system 1101 at least the unique event identifier 115 and/or a user identifier.

**[0138]** In further reference to FIGURE 7, in one embodiment, the broadcast response and business system 1101 is configured to connect to the unique event identifier database 1111 in order to perform a database lookup of the received unique event identifier 115. From the database lookup, the broadcast response system 1101 can determine the broadcast source, the time and date of the broadcast, and/or the content associated with the broadcast. The broadcast response system 1101 is configured in one embodiment to locate in the content database 1103 the content and if available, the content identifier associated with the broadcast based on the database lookup. In one embodiment, the broadcast response system 1101 is configured to store the user selection or the user response in the response database 1105.

**[0139]** With reference to FIGURE 7, if the user selected to purchase the content associated with the unique event identifier 115, then the broadcast response system 1101 is configured in one embodiment to verify the user identifier in the consumer database 1107, which stores, for example, user name, address, demographic data, and/or other similar user information. The broadcast response system 1101 in one embodiment is configured to store the purchase event in the purchase database 1109. The purchase database 1109 is configured to store, for example, past user purchases, user credit card information, user billing information, user preferences, user telephone information for billing the user cellular account, age, gender, location, mobile operator, receiving device model and/or the like. In one embodiment, the broadcast response system 1101 is configured to transmit the purchase selection to the fulfillment system 1113. The fulfillment system 1113 can also be configured to ship from a supplier 1117 to the user a physical product, for example, a CD or book, and in other embodiments, the fulfillment system 1113 is configured to inform the user where to download the content, or electronically transmits the content to the user.

**[0140]** Referring to FIGURE 7, in one embodiment, the data mining and reporting system 1115 is configured to connect to the content database 1103, the response database 1105, the consumer database 1107, the purchase database 1109, and/or the unique event identifier database 1111 to conduct data mining and/or reporting. In one embodiment, the data mining and reporting system 1115 is configured to identify based on the unique event identifier 115 the broadcast source, the broadcast segment, and/or the time and date of the broadcast segment that produced the most user responses in a given period.

**[0141]** As illustrated in FIGURE 7, in one embodiment, the media association (advertisement ad) system 1102 is configured to receive the unique event identifier 115 from the broadcast scanning system 160. The media association system 1102 in one embodiment is configured to identify the content associated with the unique event identifier 115 by performing a database lookup using the unique event identifier database 1111 and/or the content database 1103. The media association system 1102 can also be configured to compare the content with a database to determine whether an associated media stream or content should be transmitted to broadcast receiving systems 140 that are displaying or outputting the content associated with the unique event identifier 115. For example, the

media association system 1102 is configured in one embodiment to display an advertisement next to a graphic representing a music artist and/or advertiser featured in the content received from a broadcast source 120 and outputted on the broadcast receiving system 140.

**[0142]** Conditional language, such as, among others, “can,” “could,” “might,” or “may,” unless specifically stated otherwise, or otherwise understood within the context as used, is generally intended to convey that certain embodiments include, while other embodiments do not include, certain features, elements and/or steps. Thus, such conditional language is not generally intended to imply that features, elements and/or steps are in any way required for one or more embodiments or that one or more embodiments necessarily include logic for deciding, with or without user input or prompting, whether these features, elements and/or steps are included or are to be performed in any particular embodiment.

**[0143]** In certain embodiments, the acts, methods, and processes described herein are implemented within, or using, software modules (programs) that are executed by one or more general purpose computers. The software modules may be stored on or within any suitable computer-readable medium. It should be understood that the various steps may alternatively be implemented in-whole or in-part within specially designed hardware. The skilled artisan will recognize that not all calculations, analyses and/or optimization require the use of computers, though any of the above-described methods, calculations or analyses can be facilitated through the use of computers.

**[0144]** Although the foregoing systems and methods have been described in terms of certain preferred embodiments, other embodiments will be apparent to those of ordinary skill in the art from the disclosure herein. Additionally, other combinations, omissions, substitutions and modifications will be apparent to the skilled artisan in view of the disclosure herein. While certain embodiments of the inventions have been described, these embodiments have been presented by way of example only, and are not intended to limit the scope of the inventions. Indeed, the novel methods and systems described herein may be embodied in a variety of other forms without departing from the spirit thereof. Further, the disclosure herein of any particular feature, aspect, method, property, characteristic, quality, attribute, element, or the like in connection with an embodiment can be used in all other

embodiments set forth herein. Accordingly, other combinations, omissions, substitutions and modifications will be apparent to the skilled artisan in view of the disclosure herein.

WHAT IS CLAIMED IS:

1. A method for associating multiple media signals, comprising in no particular order:
  - obtaining information about a first media signal;
  - analyzing the information about the first media signal;
  - selecting at least one second media signal to be correlated with the first media signal based on at least one criteria;
  - assigning a unique identifier that is specific to the transmission of the selected second media signal, wherein at least the unique identifier is stored in a database;
  - transmitting at least the second media signal and the unique identifier to a user device, wherein the user device outputs the first media signal and the second media signal to a user;
  - receiving a user response from the user in relation to the second media signal wherein the user response includes at least the unique identifier; and
  - correlating at least the unique identifier in the database.
2. The method of claim 1, wherein the obtaining the first media signal and the transmitting the second media signal are performed using different communications methods.
3. The method of claim 1, wherein at least one additional media signal beyond the second media signal is transmitted to the device.
4. The method of claim 1, wherein the first media signal is disseminated through a second device.
5. The method of claim 1, wherein the first media signal and the second media signal are outputted to the user on the same device.
6. The method of claim 1, wherein the first media signal comprises a radio broadcast and the second media signal comprises a graphic image.
7. The method of claim 1, further comprising generating a report wherein at least a portion of the report generation uses at least the unique identifier and the database.
8. The method of claim 1, wherein the first media signal is publicly available and the second media signal is transmitted to a specific user device.

9. The method of claim 1, further comprising transmitting to the user device a third media signal, wherein the second media signal is at the request of the user device and the third media signal is at the request of an advertisement entity.

10. The method of claim 1, wherein the at least one criteria is modified according to the return user response.

11. The method of claim 10, wherein the at least one association criteria is modified continuously.

12. A method for combining multiple media signals in a device, comprising in no particular order:

obtaining a first media signal by the device;

outputting a first media content comprised in the first media signal to a user of the device;

obtaining a second media signal by the device;

obtaining a criteria correlated to the second media signal;

evaluating the criteria in reference to the user of the device; and

outputting at least a second media content comprised in the second media signal to the user of the device, wherein in the second media content outputted is determined at least in part based on the evaluation of the criteria.

13. The method of claim 12, further comprising communicating the obtainment of the first media signal to a media signal association system.

14. The method of claim 12, further comprising communicating the status of the device to a media signal association system.

15. The method of claim 12, further comprising obtaining a unique identifier specific to the instance of the outputting of the second media signal; detecting a user response to the second media content and transmitting at least the unique identifier to a computer server, wherein the computer server has access to a database containing at least the unique identifier.

16. A user device system capable of combining multiple media signals comprising:

a first receiver module configured to receive at least a first media signal from a first transmitter;

a second receiver module configured to receive at least a second media signal and a unique identifier correlated to the second media signal;

an output module configured to output a primary media content from the first media signal and output a secondary media content from the second media signal;

an input module capable of receiving at least a user input; and

a transmitting module capable of transmitting at least the user input and the unique identifier to a computer server, wherein the computer server has access to a database containing at least the unique identifier.

17. The user device of claim 16 further comprising an output selection module capable of limiting the output of the primary and secondary media content based on a criteria.

18. The user device of claim 16 further comprising a mass storage device capable of storing at least one of one the media content.

19. A method for associating multiple media signals, comprising in no particular order:

obtaining information about a first media signal;

analyzing the information about the first media signal;

selecting at least one second media signal to be correlated with the first media signal based on at least one criteria;

assigning a unique identifier that is specific to the transmission of the selected second media signal, wherein at least the unique identifier is stored in a database;

transmitting at least the second media signal and the unique identifier to a user device, wherein the user device outputs the first media signal and the second media signal to a user; and

transmitting the unique identifier to a third party.

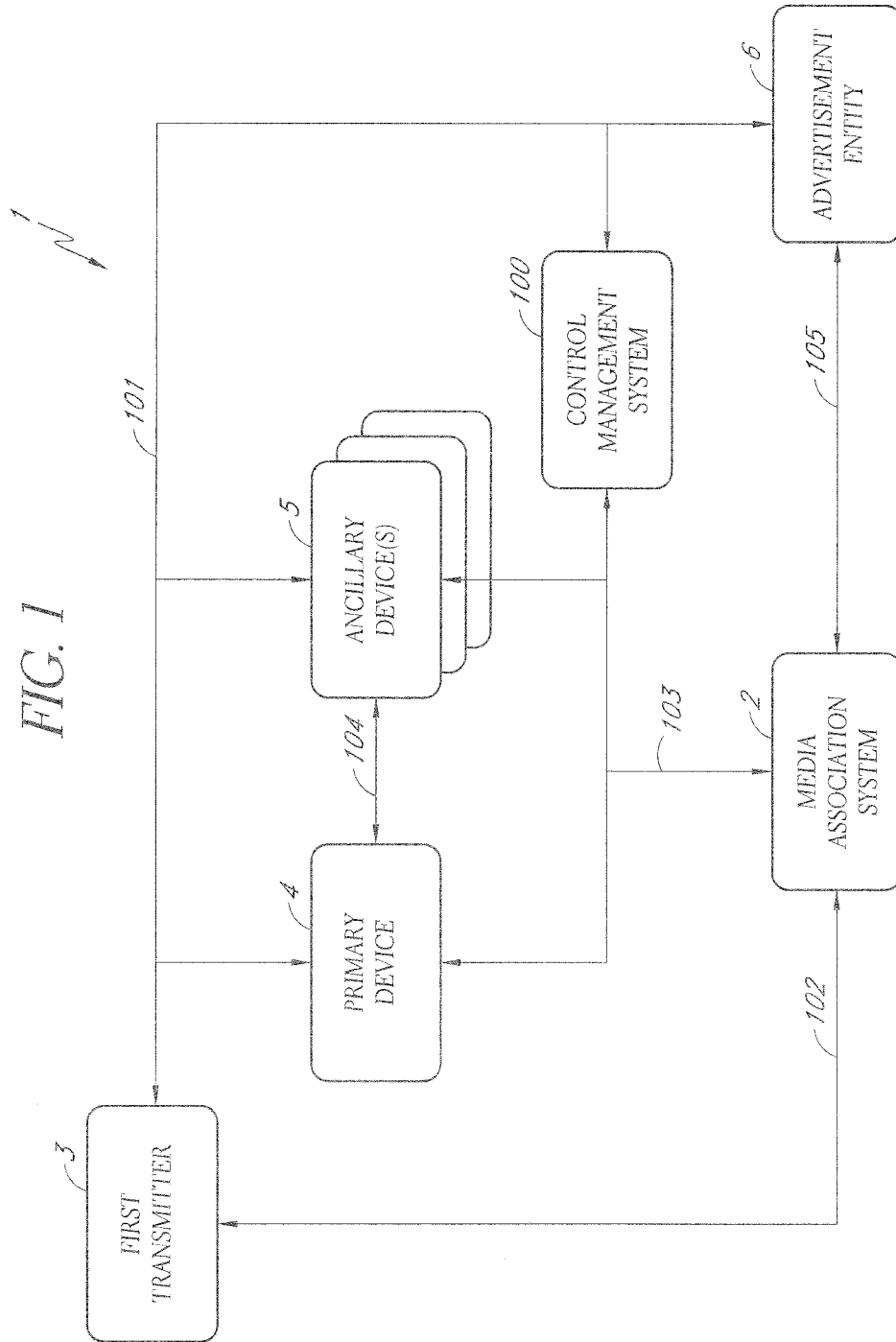


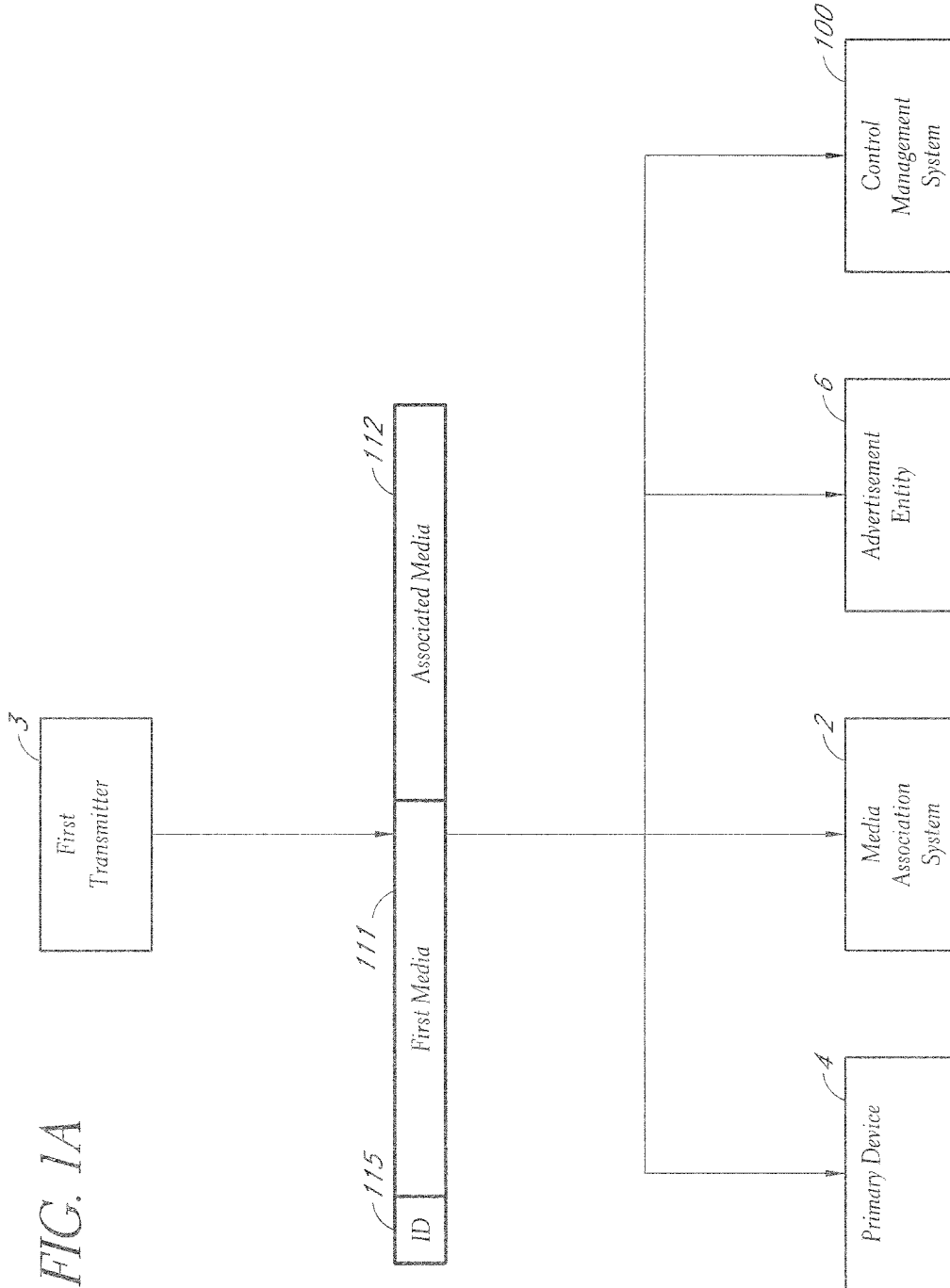
## **SYSTEM AND METHOD FOR ADVERTISEMENT**

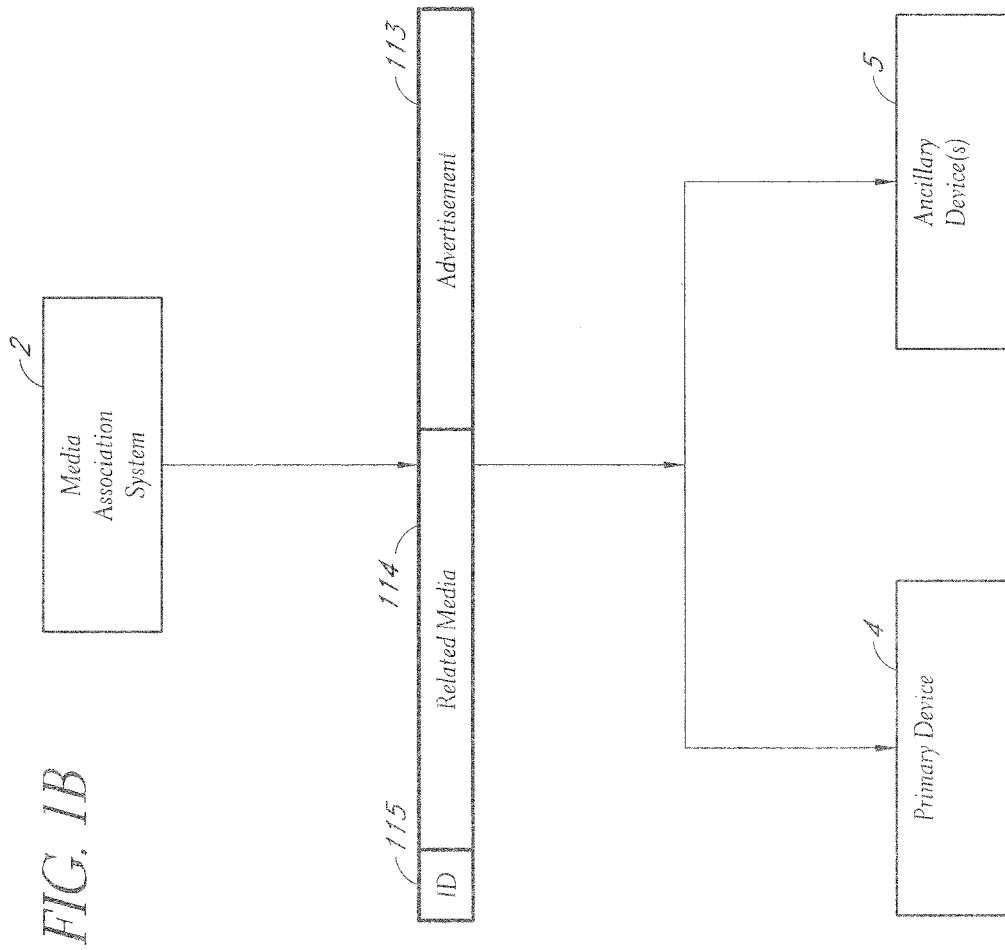
### **TRANSMISSION AND DISPLAY**

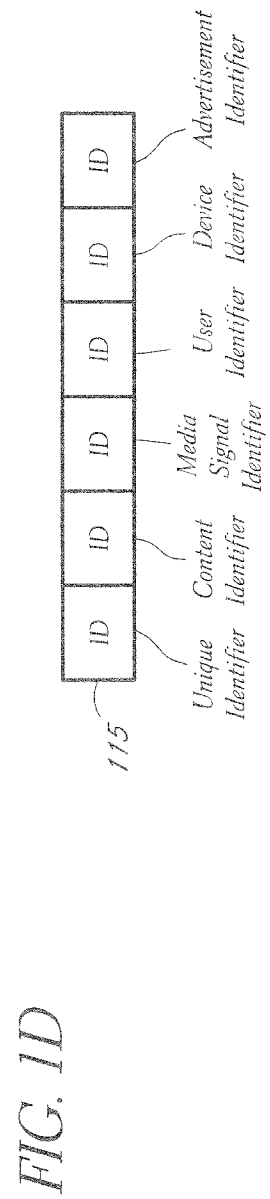
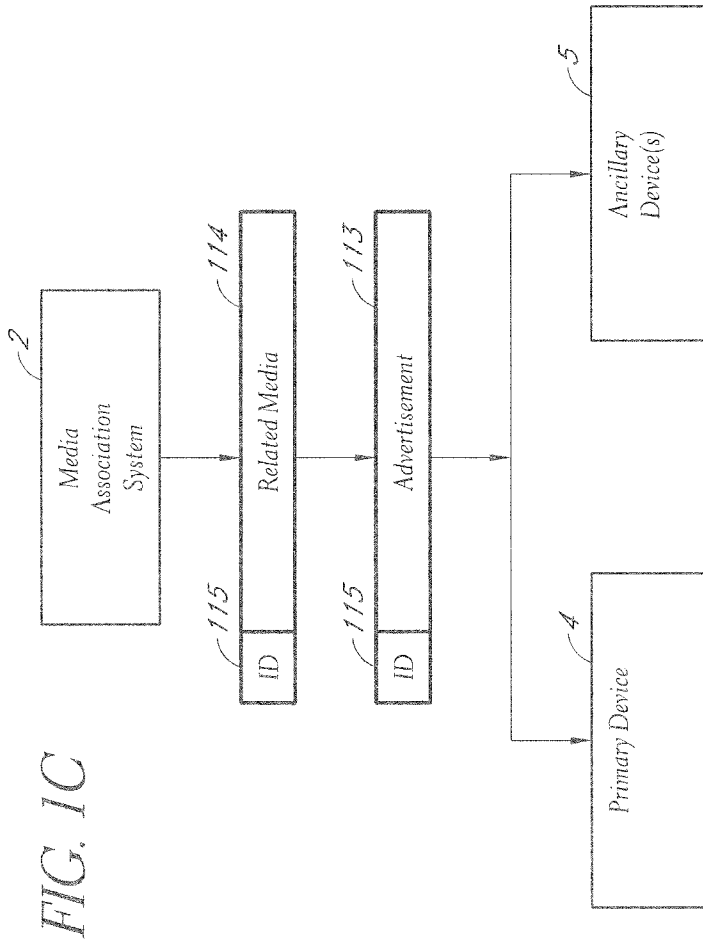
#### **ABSTRACT OF THE DISCLOSURE**

The disclosure herein provides systems and methods for a media enhancement system configured to associate a secondary media signal (for example, the secondary media signal can comprise an advertisement) to a primary media signal (for example, a radio broadcast). The disclosure herein additionally provides systems and methods for a media enhancement system that enables the generating, transmitting, displaying, and/or responding to a plurality of associated and/or unassociated secondary media signals, based on a primary media content from a primary media signal, user characteristics (for example, demographic and/or geographic information), and/or third-party preferences (for example, the goals of advertisers). The secondary media signals can be used to enhance the primary media content already being provided to the user on a user device. The secondary media signals can also be used to create psychological associations or relationships with the primary media content already being provided to the user.



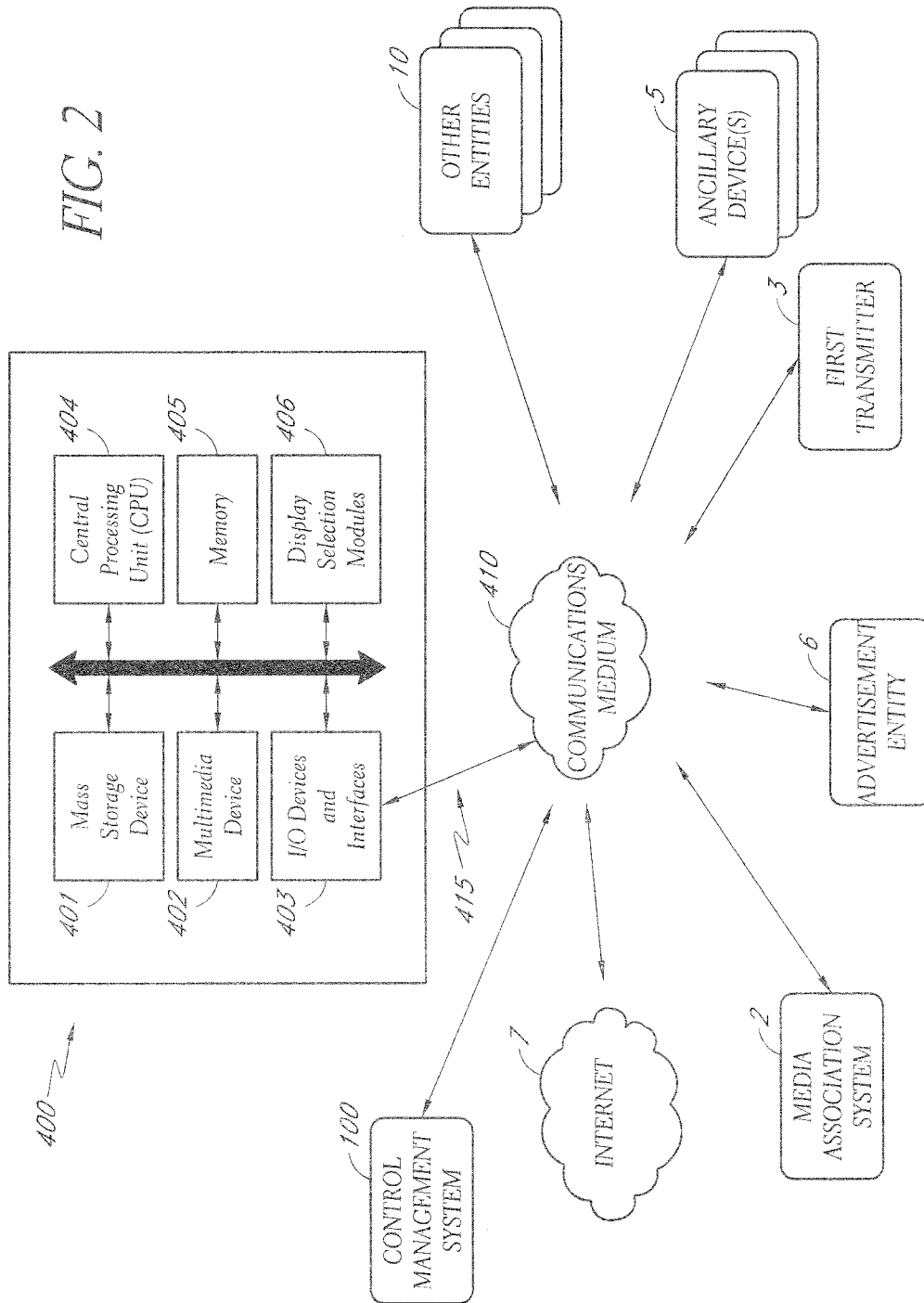


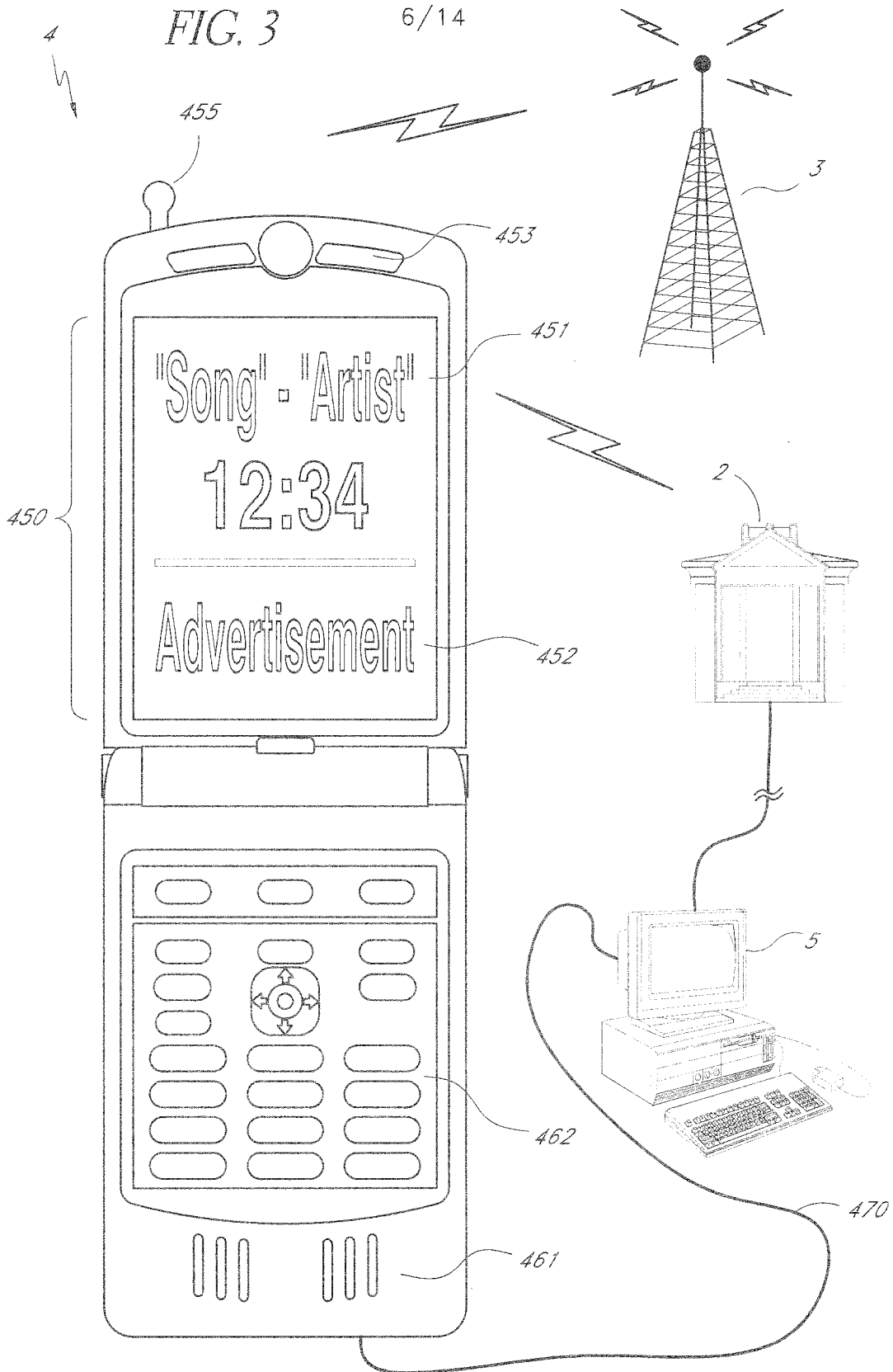




5/14

FIG. 2





7/14

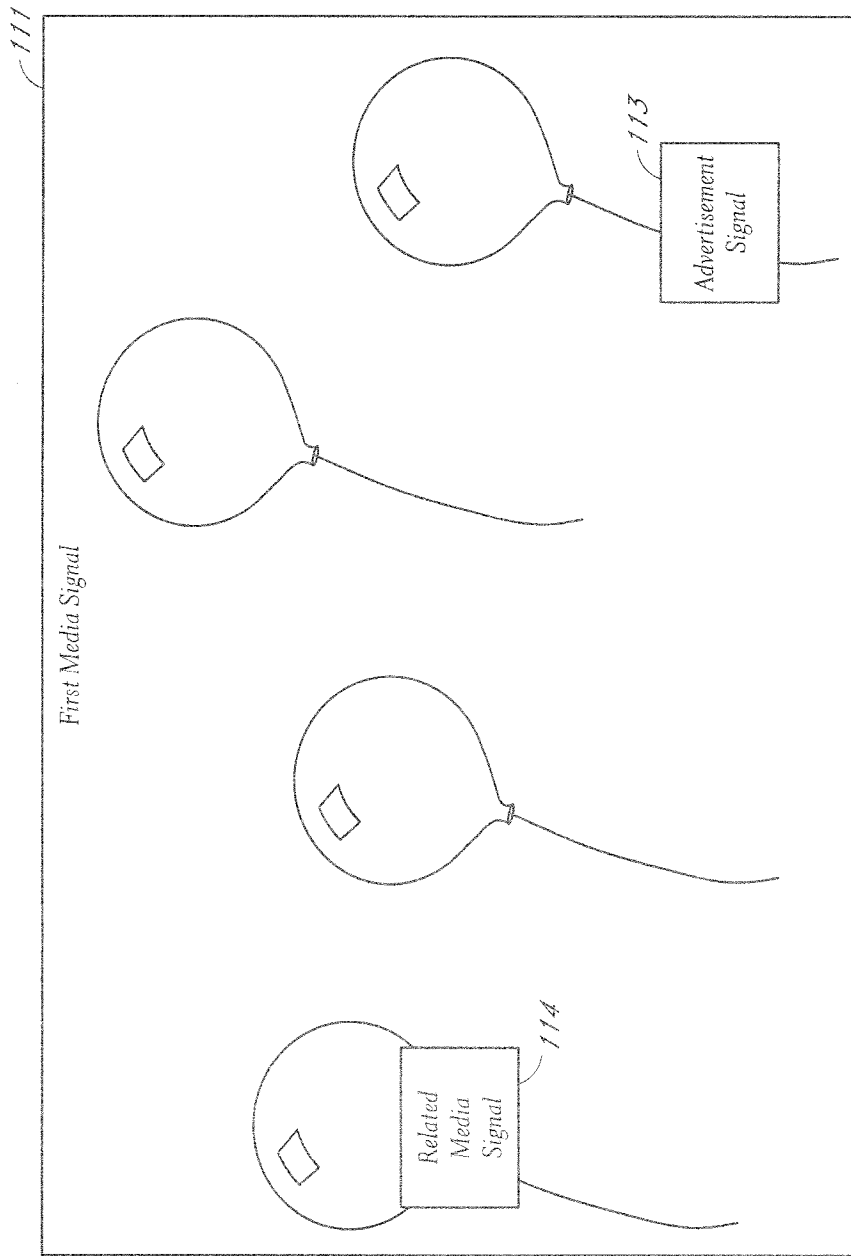
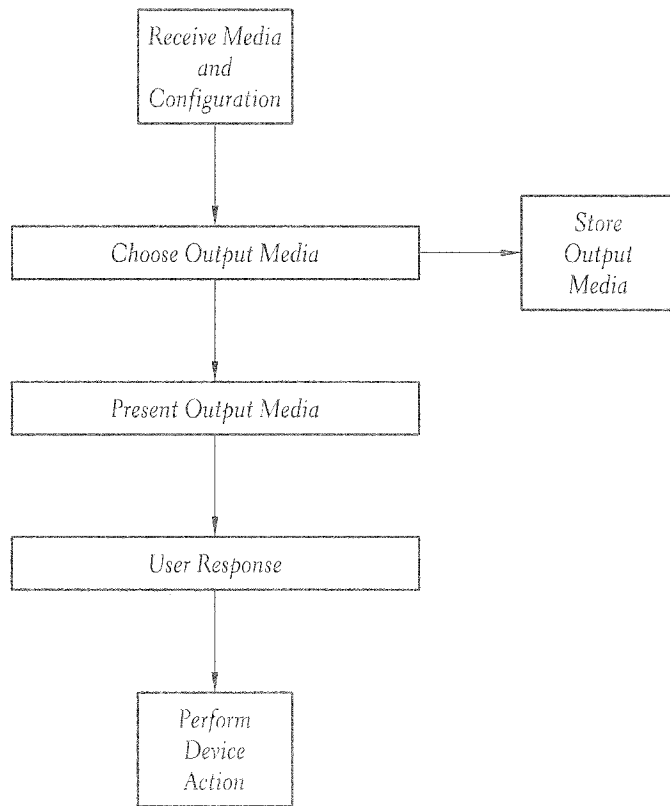


FIG. 3A



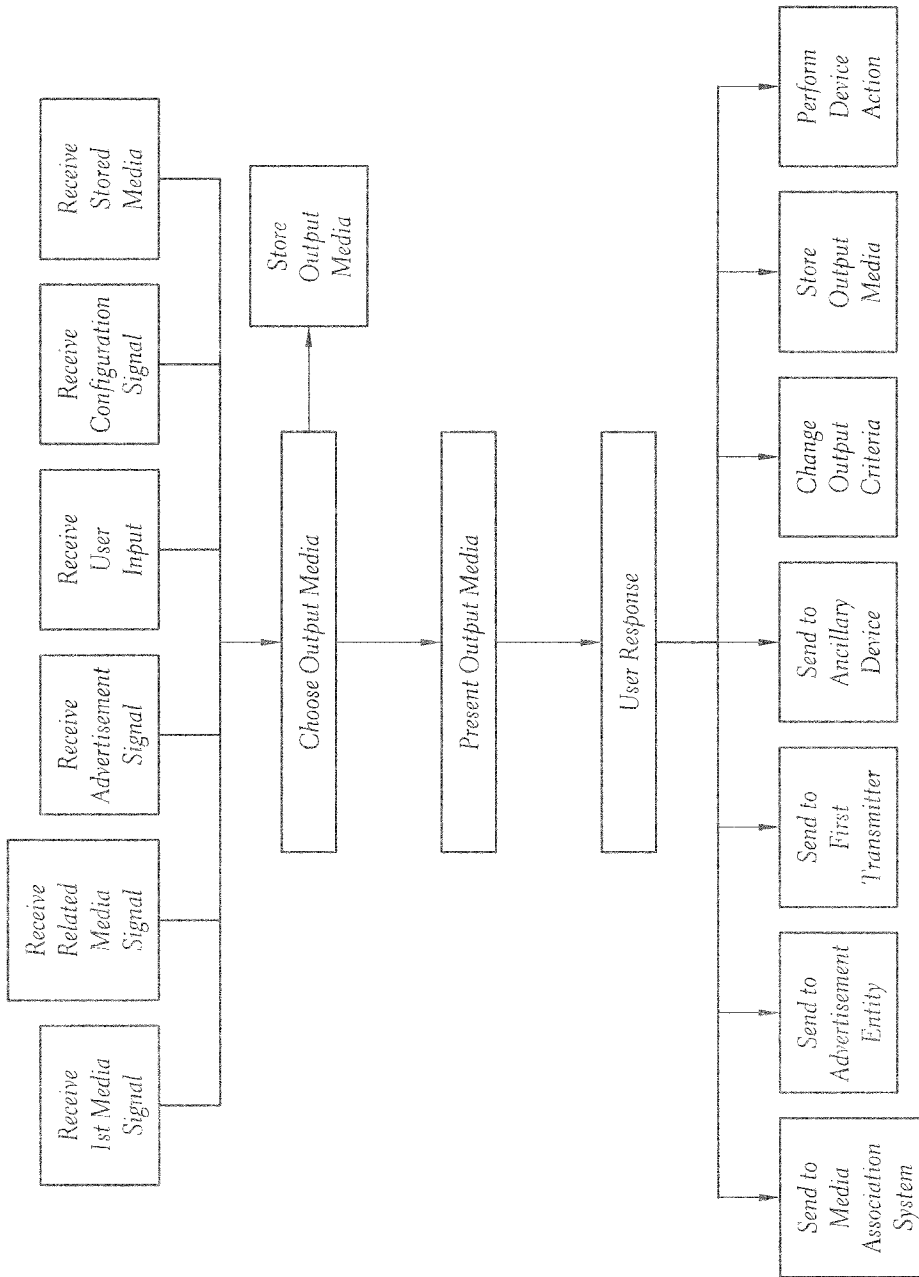
8/14

FIG. 4



9/14

FIG. 4A



10/14

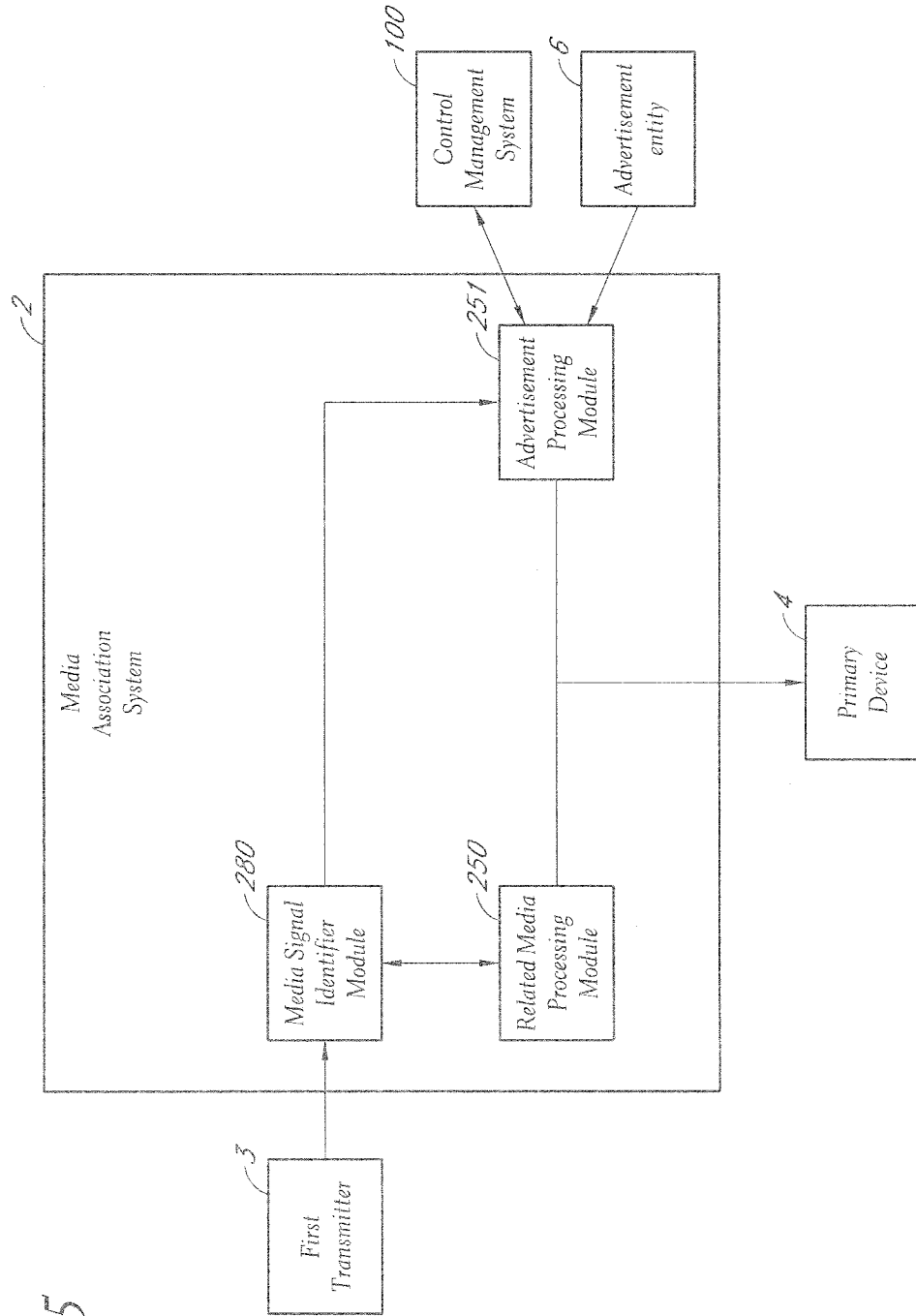


FIG. 5

11/14

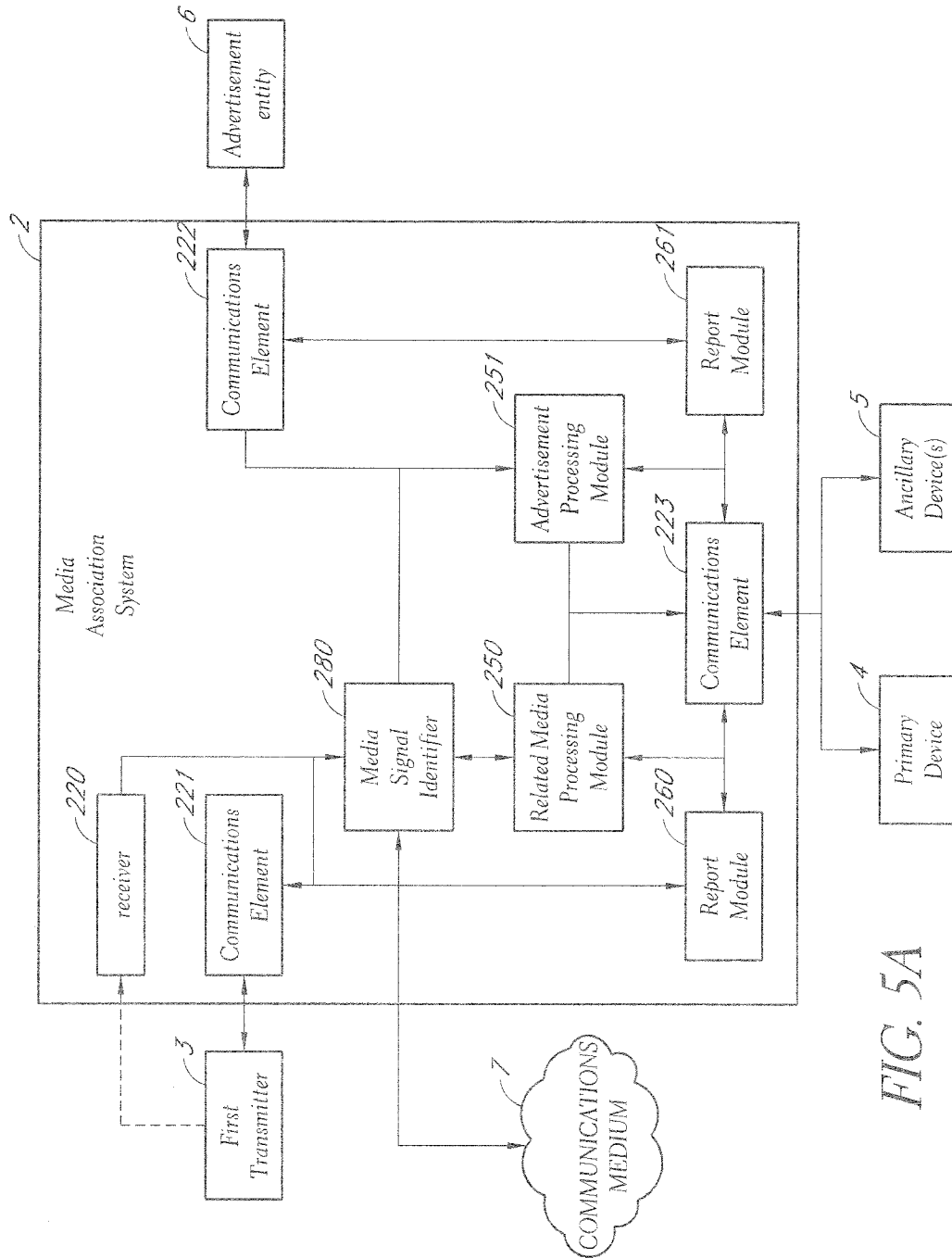
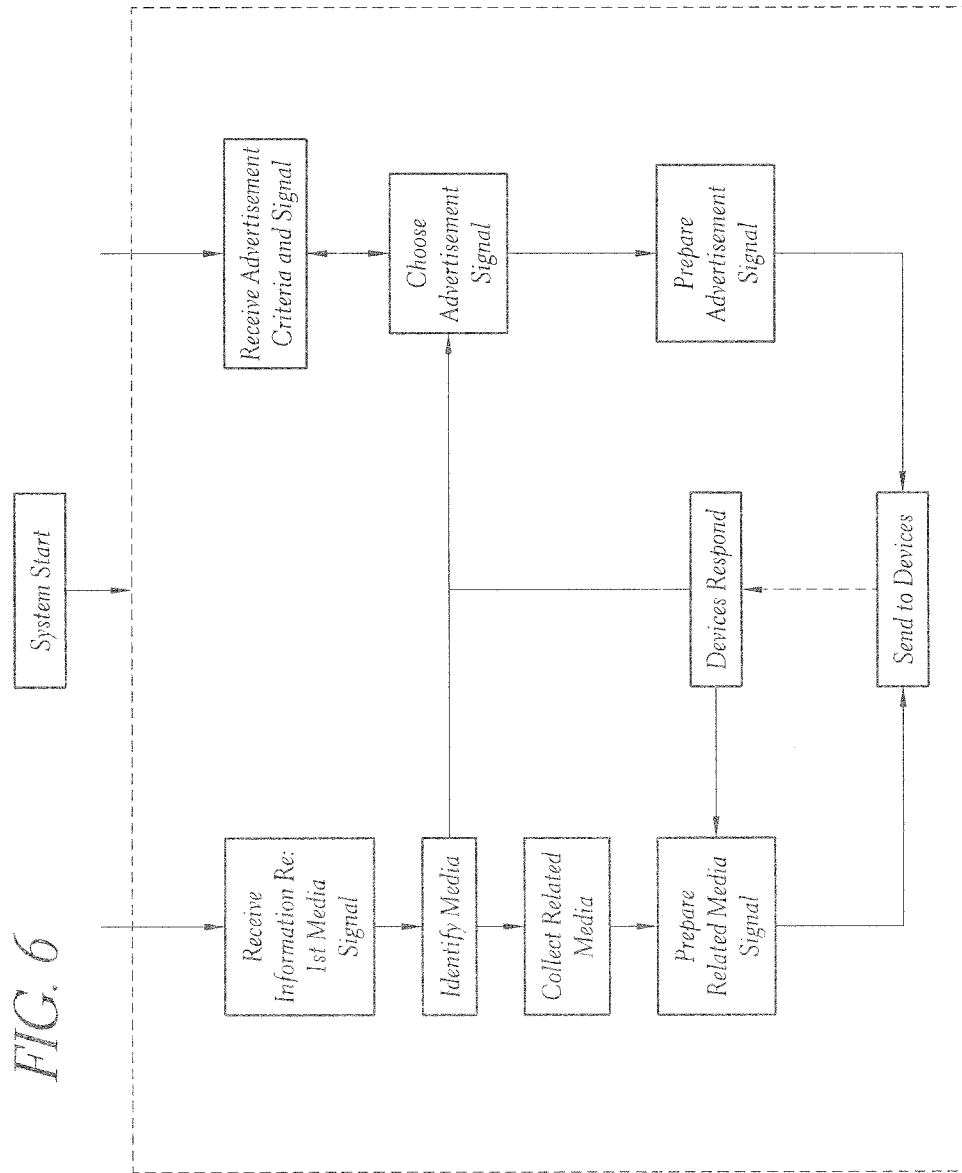


FIG. 5A

12/14



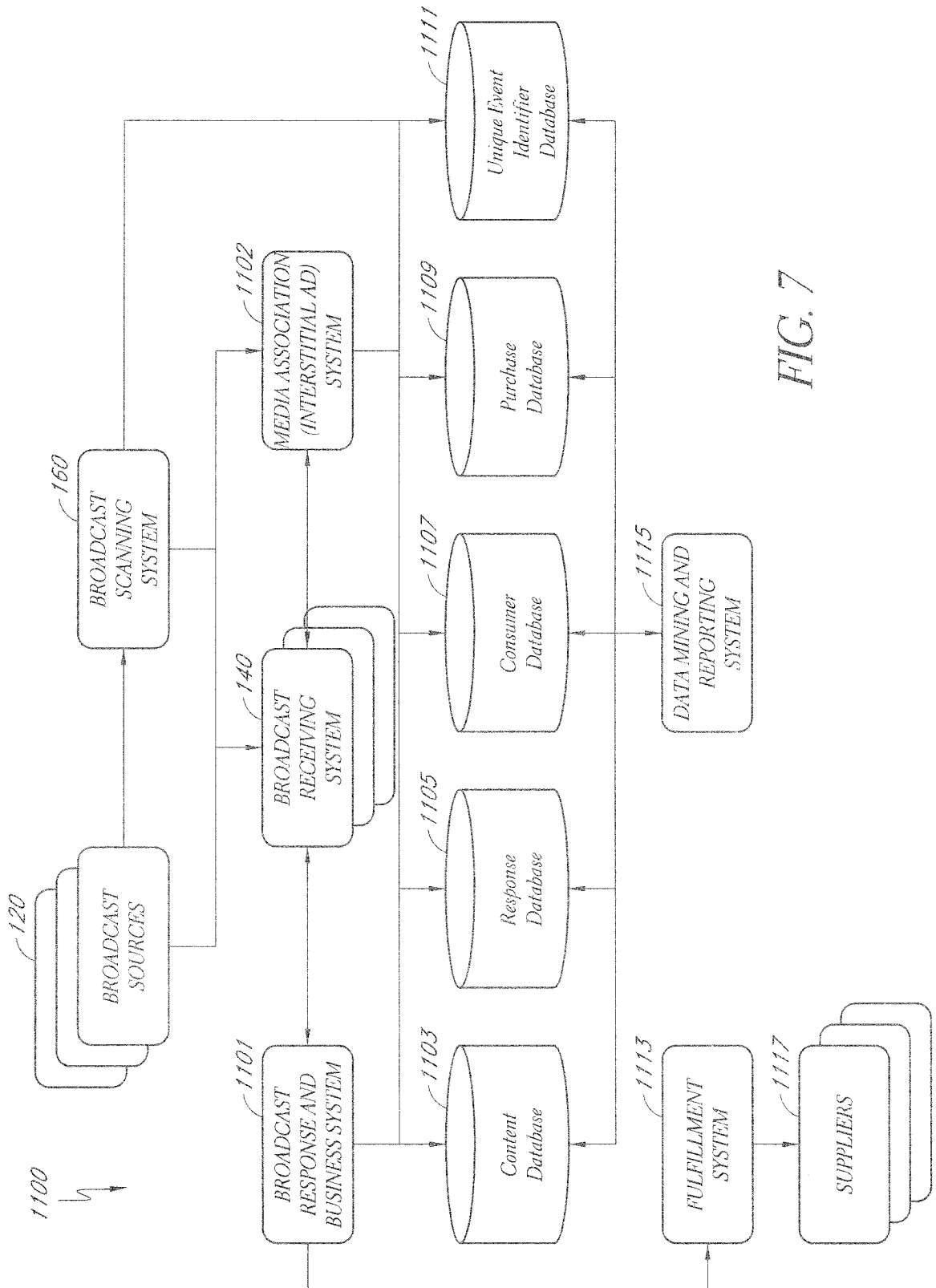


FIG. 7

FIG. 8

14/14

[Add a Campaign](#) | [Campaigns](#) | [Clients](#) | [Ad Graphics](#) | | [My Profile](#) | [Log Out](#)

Welcome back, Kelly Christensen

## Campaigns

[← Back to Campaigns](#)

Step 1  Step 2  Step 3  Step 4  Step 5

Choose a Client Campaign Information Demographics Select Stations Review and Launch

### Step 2: Campaign Information

#### Campaign Details [?](#)

Client Name: **Digital Muse**

Campaign Name: **Advertisement Entity**

Campaign Types:

- Click Throughs (\$0.12 per 100 clicks)
- Interstitial (\$10.00 per 1000 views)
- More Info (\$0.50 per click)
- On Air Ad (\$0.12 per 100 clicks)
- Primary Banner (\$10.00 per 1000 view)
- Qualified Lead (\$50.00 per lead)
- Splash Screen (\$25.00 per 1000 views)

Notes:

#### Schedule [?](#)

Begins: **02-05-2009 (Thu)** Ends: **-- ONGOING --**

Between the hours of: **--247--** and: **--247--**

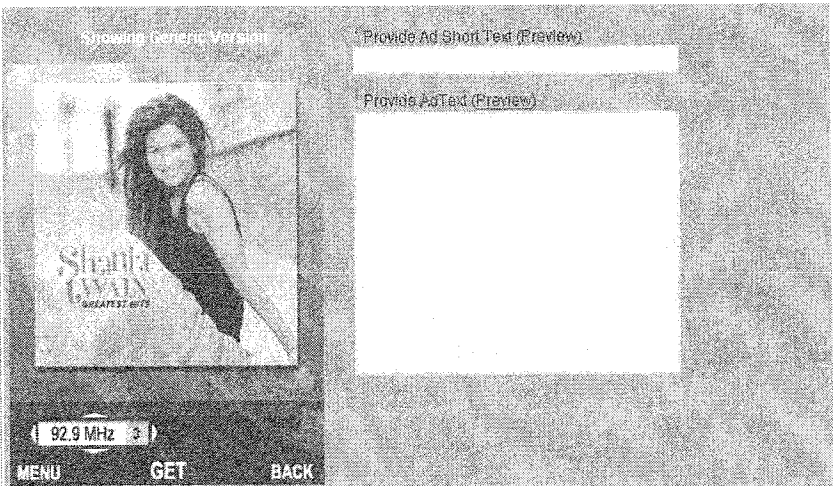
Advertise Now!  [?](#)

Handset Calendar Scheduling  [?](#)

#### Generic Ad Details [?](#)

Provide Ad Short Text (Preview)

Provide Ad Text (Preview)



#### Ad Response Details [?](#)

Bar Code ASCII (Code 39) **Product**

Handset Response URL **http://wap.product.com**

Web Response URL **http://www.product.com**

## Electronic Acknowledgement Receipt

<b>EFS ID:</b>	4743954
<b>Application Number:</b>	12366535
<b>International Application Number:</b>	
<b>Confirmation Number:</b>	7989
<b>Title of Invention:</b>	SYSTEM AND METHOD FOR ADVERTISEMENT TRANSMISSION AND DISPLAY
<b>First Named Inventor/Applicant Name:</b>	Kelly M. Christensen
<b>Customer Number:</b>	20995
<b>Filer:</b>	Thomas Yee/Valerie Jones
<b>Filer Authorized By:</b>	Thomas Yee
<b>Attorney Docket Number:</b>	STRATOS.029A
<b>Receipt Date:</b>	05-FEB-2009
<b>Filing Date:</b>	
<b>Time Stamp:</b>	18:50:25
<b>Application Type:</b>	Utility under 35 USC 111(a)

### Payment information:

Submitted with Payment	no
------------------------	----

### File Listing:

Document Number	Document Description	File Name	File Size(Bytes)/ Message Digest	Multi Part /.zip	Pages (if appl.)
1	Application Data Sheet	29ads_20090205142803.pdf	305943 <small>f8402cc434df49c273d1b2d188eee57f3bb33f21</small>	no	5

### Warnings:

### Information:



This is not an USPTO supplied ADS fillable form

2		29spec_20090205142855.pdf	3412123	yes	56
			d314c1283b66e94a12a12e3b1f73b77023181ce2		

**Multipart Description/PDF files in .zip description**

Document Description	Start	End
Specification	1	52
Claims	53	55
Abstract	56	56

**Warnings:**

**Information:**

3	Drawings-only black and white line drawings	20090205144254.pdf	2175750	no	14
			4b99b890a8f14c8dcf544380bd836eae393474aa		

**Warnings:**

**Information:**

**Total Files Size (in bytes):** 5893816

**This Acknowledgement Receipt evidences receipt on the noted date by the USPTO of the indicated documents, characterized by the applicant, and including page counts, where applicable. It serves as evidence of receipt similar to a Post Card, as described in MPEP 503.**

**New Applications Under 35 U.S.C. 111**

**If a new application is being filed and the application includes the necessary components for a filing date (see 37 CFR 1.53(b)-(d) and MPEP 506), a Filing Receipt (37 CFR 1.54) will be issued in due course and the date shown on this Acknowledgement Receipt will establish the filing date of the application.**

**National Stage of an International Application under 35 U.S.C. 371**

**If a timely submission to enter the national stage of an international application is compliant with the conditions of 35 U.S.C. 371 and other applicable requirements a Form PCT/DO/EO/903 indicating acceptance of the application as a national stage submission under 35 U.S.C. 371 will be issued in addition to the Filing Receipt, in due course.**

**New International Application Filed with the USPTO as a Receiving Office**

**If a new international application is being filed and the international application includes the necessary components for an international filing date (see PCT Article 11 and MPEP 1810), a Notification of the International Application Number and of the International Filing Date (Form PCT/RO/105) will be issued in due course, subject to prescriptions concerning national security, and the date shown on this Acknowledgement Receipt will establish the international filing date of the application.**

Filing Date: 02/05/09

Approved for use through 7/31/2006. OMB 0651-0032  
U.S. Patent and Trademark Office; U.S. DEPARTMENT OF COMMERCE

Under the Paperwork Reduction Act of 1995, no persons are required to respond to a collection of information unless it displays a valid OMB control number.

PATENT APPLICATION FEE DETERMINATION RECORD Substitute for Form PTO-875					Application or Docket Number <b>12/366,535</b>	
<b>APPLICATION AS FILED – PART I</b>						
(Column 1)		(Column 2)			SMALL ENTITY	
FOR	NUMBER FILED	NUMBER EXTRA			RATE (\$)	FEE (\$)
BASIC FEE (37 CFR 1.16(a), (b), or (c))	N/A	N/A			N/A	<b>165</b>
SEARCH FEE (37 CFR 1.16(k), (l), or (m))	N/A	N/A			N/A	<b>270</b>
EXAMINATION FEE (37 CFR 1.16(o), (p), or (q))	N/A	N/A			N/A	<b>110</b>
TOTAL CLAIMS (37 CFR 1.16(i))	<b>19</b>	minus 20 =			x\$26	x\$52
INDEPENDENT CLAIMS (37 CFR 1.16(h))	<b>4</b>	minus 3 = <b>1</b>			x\$110	x\$220
APPLICATION SIZE FEE (37 CFR 1.16(s))	If the specification and drawings exceed 100 sheets of paper, the application size fee due is \$270 (\$135 for small entity) for each additional 50 sheets or fraction thereof. See 35 U.S.C. 41(a)(1)(G) and 37 CFR					
MULTIPLE DEPENDENT CLAIM PRESENT (37 CFR 1.16(j))						
					195	390
					<b>TOTAL</b>	<b>655</b>
* If the difference in column 1 is less than zero, enter "0" in column 2.						
<b>APPLICATION AS AMENDED – PART II</b>						
(Column 1)		(Column 2)		(Column 3)		
AMENDMENT A	CLAIMS REMAINING AFTER AMENDMENT	MINUS	HIGHEST NUMBER PREVIOUSLY PAID FOR	PRESENT EXTRA		
	Total (37 CFR 1.16(i))	*	Minus **	=		
	Independent (37 CFR 1.16(h))	*	Minus ***	=		
	Application Size Fee (37 CFR 1.16(s))					
	FIRST PRESENTATION OF MULTIPLE DEPENDENT CLAIM (37 CFR 1.16(j))					
				SMALL ENTITY		
				RATE (\$)	ADDITIONAL FEE (\$)	
				X =		
				X =		
				N/A		
				<b>TOTAL</b>		
				ADD'T FEE		
				OTHER THAN SMALL ENTITY		
				RATE (\$)	ADDITIONAL FEE (\$)	
				X =		
				X =		
				N/A		
				<b>TOTAL</b>		
				ADD'T FEE		
				OTHER THAN SMALL ENTITY		
				RATE (\$)	ADDITIONAL FEE (\$)	
				X =		
				X =		
				N/A		
				<b>TOTAL</b>		
				ADD'T FEE		
* If the entry in column 1 is less than the entry in column 2, write "0" in column 3.						
** If the "Highest Number Previously Paid For" IN THIS SPACE is less than 20, enter "20".						
*** If the "Highest Number Previously Paid For" IN THIS SPACE is less than 3, enter "3".						
The "Highest Number Previously Paid For" (Total or Independent) is the highest number found in the appropriate box in column 1.						

This collection of information is required by 37 CFR 1.16. The information is required to obtain or retain a benefit by the public which is to file (and by the USPTO to process) an application. Confidentiality is governed by 35 U.S.C. 122 and 37 CFR 1.14. This collection is estimated to take 12 minutes to complete, including gathering, preparing, and submitting the completed application form to the USPTO. Time will vary depending upon the individual case. Any comments on the amount of time you require to complete this form and/or suggestions for reducing this burden, should be sent to the Chief Information Officer, U.S. Patent and Trademark Office, U.S. Department of Commerce, P.O. Box 1450, Alexandria, VA 22313-1450. DO NOT SEND FEES OR COMPLETED FORMS TO THIS ADDRESS. SEND TO: Commissioner for Patents, P.O. Box 1450, Alexandria, VA 22313-1450.

If you need assistance in completing the form, call 1-800-PTO-9199 and select option 2.

1. 12. 16. 19.

Volkswagen Exhibit 1002



UNITED STATES PATENT AND TRADEMARK OFFICE

UNITED STATES DEPARTMENT OF COMMERCE
United States Patent and Trademark Office
Address: COMMISSIONER FOR PATENTS
P.O. Box 1450
Alexandria, Virginia 22313-1450
www.uspto.gov

Table with 4 columns: APPLICATION NUMBER (12/366,535), FILING OR 371(C) DATE (02/05/2009), FIRST NAMED APPLICANT (Kelly M. Christensen), ATTY. DOCKET NO./TITLE (STRATOS.029A)

CONFIRMATION NO. 7989

FORMALITIES LETTER



20995
KNOBBE MARTENS OLSON & BEAR LLP
2040 MAIN STREET
FOURTEENTH FLOOR
IRVINE, CA 92614

Date Mailed: 02/24/2009

NOTICE TO FILE MISSING PARTS OF NONPROVISIONAL APPLICATION

FILED UNDER 37 CFR 1.53(b)

Filing Date Granted

Items Required To Avoid Abandonment:

An application number and filing date have been accorded to this application. The item(s) indicated below, however, are missing. Applicant is given TWO MONTHS from the date of this Notice within which to file all required items and pay any fees required below to avoid abandonment.

- The statutory basic filing fee is missing. Applicant must submit \$82 to complete the basic filing fee for a small entity.
The oath or declaration is missing. A properly signed oath or declaration in compliance with 37 CFR 1.63, identifying the application by the above Application Number and Filing Date, is required.
Note: If a petition under 37 CFR 1.47 is being filed, an oath or declaration in compliance with 37 CFR 1.63 signed by all available joint inventors, or if no inventor is available by a party with sufficient proprietary interest, is required.

The application is informal since it does not comply with the regulations for the reason(s) indicated below.

The required item(s) identified below must be timely submitted to avoid abandonment:

- Replacement drawings in compliance with 37 CFR 1.84 and 37 CFR 1.121(d) are required. The drawings submitted are not acceptable because:
Numbers, letters, and reference characters on the drawings must measure at least 0.32 cm (1/8 inch) in height. See Figure(s) 1A-1C, 2-9.

Applicant is cautioned that correction of the above items may cause the specification and drawings page count to exceed 100 pages. If the specification and drawings exceed 100 pages, applicant will need to submit the required application size fee.

The applicant needs to satisfy supplemental fees problems indicated below.

The required item(s) identified below must be timely submitted to avoid abandonment:

- Additional claim fees of **\$110** as a small entity, including any required multiple dependent claim fee, are required. Applicant must submit the additional claim fees or cancel the additional claims for which fees are due.
- To avoid abandonment, a surcharge (for late submission of filing fee, search fee, examination fee or oath or declaration) as set forth in 37 CFR 1.16(f) of **\$65** for a small entity in compliance with 37 CFR 1.27, must be submitted with the missing items identified in this notice.

**SUMMARY OF FEES DUE:**

Total additional fee(s) required for this application is **\$637** for a small entity

- **\$82** Statutory basic filing fee.
- **\$65** Surcharge.
- The application search fee has not been paid. Applicant must submit **\$270** to complete the search fee.
- The application examination fee has not been paid. Applicant must submit **\$110** to complete the examination fee for a small entity in compliance with 37 CFR 1.27.
- Total additional claim fee(s) for this application is **\$110**
  - **\$110** for **1** independent claims over 3.

Replies should be mailed to:

Mail Stop Missing Parts  
Commissioner for Patents  
P.O. Box 1450  
Alexandria VA 22313-1450

Registered users of EFS-Web may alternatively submit their reply to this notice via EFS-Web.

<https://portal.uspto.gov/authenticate/AuthenticateUserLocalEPF.html>

For more information about EFS-Web please call the USPTO Electronic Business Center at **1-866-217-9197** or visit our website at <http://www.uspto.gov/ebc>.

If you are not using EFS-Web to submit your reply, you must include a copy of this notice.

/mduong/

---

Office of Data Management, Application Assistance Unit (571) 272-4000, or (571) 272-4200, or 1-888-786-0101



UNITED STATES PATENT AND TRADEMARK OFFICE

UNITED STATES DEPARTMENT OF COMMERCE
United States Patent and Trademark Office
Address: COMMISSIONER FOR PATENTS
P.O. Box 1450
Alexandria, Virginia 22313-1450
www.uspto.gov

Table with 7 columns: APPLICATION NUMBER, FILING or 371(c) DATE, GRP ART UNIT, FIL FEE REC'D, ATTY. DOCKET NO, TOT CLAIMS, IND CLAIMS. Row 1: 12/366,535, 02/05/2009, 2627, 0.00, STRATOS.029A, 19, 4

CONFIRMATION NO. 7989

20995
KNOBBE MARTENS OLSON & BEAR LLP
2040 MAIN STREET
FOURTEENTH FLOOR
IRVINE, CA 92614

FILING RECEIPT



Date Mailed: 02/24/2009

Receipt is acknowledged of this non-provisional patent application. The application will be taken up for examination in due course. Applicant will be notified as to the results of the examination. Any correspondence concerning the application must include the following identification information: the U.S. APPLICATION NUMBER, FILING DATE, NAME OF APPLICANT, and TITLE OF INVENTION. Fees transmitted by check or draft are subject to collection. Please verify the accuracy of the data presented on this receipt. If an error is noted on this Filing Receipt, please submit a written request for a Filing Receipt Correction. Please provide a copy of this Filing Receipt with the changes noted thereon. If you received a "Notice to File Missing Parts" for this application, please submit any corrections to this Filing Receipt with your reply to the Notice. When the USPTO processes the reply to the Notice, the USPTO will generate another Filing Receipt incorporating the requested corrections

Applicant(s)

Kelly M. Christensen, Marina Del Rey, CA;
John Phillip Hansen, Austin, TX;
Thomas Mock, Sheffield, PA;

Power of Attorney: None

Domestic Priority data as claimed by applicant

This appln claims benefit of 61/026,449 02/05/2008

Foreign Applications

If Required, Foreign Filing License Granted: 02/17/2009

The country code and number of your priority application, to be used for filing abroad under the Paris Convention, is US 12/366,535

Projected Publication Date: 08/06/2009

Non-Publication Request: No

Early Publication Request: No

\*\* SMALL ENTITY \*\*

**Title**

SYSTEM AND METHOD FOR ADVERTISEMENT TRANSMISSION AND DISPLAY

**Preliminary Class**

360

**PROTECTING YOUR INVENTION OUTSIDE THE UNITED STATES**

Since the rights granted by a U.S. patent extend only throughout the territory of the United States and have no effect in a foreign country, an inventor who wishes patent protection in another country must apply for a patent in a specific country or in regional patent offices. Applicants may wish to consider the filing of an international application under the Patent Cooperation Treaty (PCT). An international (PCT) application generally has the same effect as a regular national patent application in each PCT-member country. The PCT process **simplifies** the filing of patent applications on the same invention in member countries, but **does not result** in a grant of "an international patent" and does not eliminate the need of applicants to file additional documents and fees in countries where patent protection is desired.

Almost every country has its own patent law, and a person desiring a patent in a particular country must make an application for patent in that country in accordance with its particular laws. Since the laws of many countries differ in various respects from the patent law of the United States, applicants are advised to seek guidance from specific foreign countries to ensure that patent rights are not lost prematurely.

Applicants also are advised that in the case of inventions made in the United States, the Director of the USPTO must issue a license before applicants can apply for a patent in a foreign country. The filing of a U.S. patent application serves as a request for a foreign filing license. The application's filing receipt contains further information and guidance as to the status of applicant's license for foreign filing.

Applicants may wish to consult the USPTO booklet, "General Information Concerning Patents" (specifically, the section entitled "Treaties and Foreign Patents") for more information on timeframes and deadlines for filing foreign patent applications. The guide is available either by contacting the USPTO Contact Center at 800-786-9199, or it can be viewed on the USPTO website at <http://www.uspto.gov/web/offices/pac/doc/general/index.html>.

For information on preventing theft of your intellectual property (patents, trademarks and copyrights), you may wish to consult the U.S. Government website, <http://www.stopfakes.gov>. Part of a Department of Commerce initiative, this website includes self-help "toolkits" giving innovators guidance on how to protect intellectual property in specific countries such as China, Korea and Mexico. For questions regarding patent enforcement issues, applicants may call the U.S. Government hotline at 1-866-999-HALT (1-866-999-4158).

**LICENSE FOR FOREIGN FILING UNDER**

**Title 35, United States Code, Section 184**

**Title 37, Code of Federal Regulations, 5.11 & 5.15**

**GRANTED**

The applicant has been granted a license under 35 U.S.C. 184, if the phrase "IF REQUIRED, FOREIGN FILING LICENSE GRANTED" followed by a date appears on this form. Such licenses are issued in all applications where the conditions for issuance of a license have been met, regardless of whether or not a license may be required as

set forth in 37 CFR 5.15. The scope and limitations of this license are set forth in 37 CFR 5.15(a) unless an earlier license has been issued under 37 CFR 5.15(b). The license is subject to revocation upon written notification. The date indicated is the effective date of the license, unless an earlier license of similar scope has been granted under 37 CFR 5.13 or 5.14.

This license is to be retained by the licensee and may be used at any time on or after the effective date thereof unless it is revoked. This license is automatically transferred to any related applications(s) filed under 37 CFR 1.53(d). This license is not retroactive.

The grant of a license does not in any way lessen the responsibility of a licensee for the security of the subject matter as imposed by any Government contract or the provisions of existing laws relating to espionage and the national security or the export of technical data. Licensees should apprise themselves of current regulations especially with respect to certain countries, of other agencies, particularly the Office of Defense Trade Controls, Department of State (with respect to Arms, Munitions and Implements of War (22 CFR 121-128)); the Bureau of Industry and Security, Department of Commerce (15 CFR parts 730-774); the Office of Foreign Assets Control, Department of Treasury (31 CFR Parts 500+) and the Department of Energy.

**NOT GRANTED**

No license under 35 U.S.C. 184 has been granted at this time, if the phrase "IF REQUIRED, FOREIGN FILING LICENSE GRANTED" DOES NOT appear on this form. Applicant may still petition for a license under 37 CFR 5.12, if a license is desired before the expiration of 6 months from the filing date of the application. If 6 months has lapsed from the filing date of this application and the licensee has not received any indication of a secrecy order under 35 U.S.C. 181, the licensee may foreign file the application pursuant to 37 CFR 5.15(b).

Please Direct All Correspondence to Customer Number 20995

**RESPONSE TO FORMALITIES NOTICE**

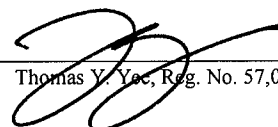
Applicant : Christensen et al.  
 App. No : 12/366,535  
 Filed : February 5, 2009  
 For : SYSTEM AND METHOD FOR  
 ADVERTISEMENT TRANSMISSION  
 AND DISPLAY  
 Art Unit : 2627  
 Conf. # : 7989

CERTIFICATE OF EFS WEB TRANSMISSION

I hereby certify that this correspondence, and any other attachment noted on the automated Acknowledgement Receipt, is being transmitted from within the Pacific Time zone to the Commissioner for Patents via the EFS Web server on:

4/23/2009

(Date)



Thomas Y. Yee, Reg. No. 57,013

**Mail Stop Missing Parts  
Commissioner for Patents  
P.O. Box 1450  
Alexandria, VA 22313-1450**

Dear Sir:

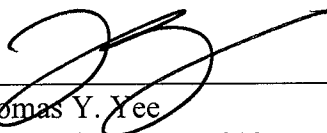
The above-captioned application was filed without a Declaration and/or filing fees. Enclosed in compliance with 37 CFR 1.53(f) are the following.

- (X) A Declaration
- (X) Corrected Drawings in 14 pages
- (X) General Power of Attorney
- (X) Statement Under 37 CFR § 3.73(b) and copy of Assignment.

The present application qualifies for small entity status under 37 CFR § 1.27.

- (X) Fees will be paid via EFS Web. Extension of time is requested by payment of any extension fee.

The Commissioner is hereby authorized to charge any additional fees which may be required, now or in the future, or credit any overpayment, to Account No. 11-1410.



Thomas Y. Yee  
 Registration No. 57,013  
 Attorney of Record  
 Customer No. 20,995  
 (949) 760-0404



**DECLARATION FOR UTILITY OR DESIGN APPLICATION  
UNDER 37 CFR 1.63**

Docket No.: STRATOS.029A

Page 1 of 2

Title: SYSTEM AND METHOD FOR ADVERTISEMENT TRANSMISSION AND DISPLAY  
Inventors: Kelly M. Christensen, John Phillip Hansen, and Thomas Mock

Please Direct All Correspondence to Customer Number 20995

---

This Declaration is directed to the invention that:

Was filed as Serial No. 12/366,535 filed on February 5, 2009

As a below named inventor:

I believe the inventor(s) named below to be the original and first inventor(s) of the subject matter which is described and claimed and for which a patent is sought;

I have reviewed and understand the contents of the above-identified application, including the claims, and any amendment filed herewith or identified above;

I acknowledge the duty to disclose information which is material to patentability as defined in 37 CFR 1.56;

I hereby declare that all statements made herein of my own knowledge are true and that all statements made on information and belief are believed to be true; and further that these statements were made with the knowledge that willful false statements and the like so made are punishable by fine or imprisonment, or both, under Section 1001 of Title 18 of the United States Code and that such willful, false statements may jeopardize the validity of the application or any patent issued thereon.

---

Full name of **first** inventor: Kelly M. Christensen

Signature:  Date: 2-12-2009

Citizenship: U.S.

Residence Address: 4712 Admiralty Way, Marina Del Rey, California 90292

Full name of **second** inventor: John Phillip Hansen

Signature: \_\_\_\_\_ Date: \_\_\_\_\_

Citizenship: U.S.

Residence Address: 6637 Whitmarsh Valley Walk Austin, Texas 78746

**DECLARATION FOR UTILITY OR DESIGN APPLICATION  
UNDER 37 CFR 1.63**

Docket No.: STRATOS.029A

Page 2 of 2

Title: SYSTEM AND METHOD FOR ADVERTISEMENT TRANSMISSION AND DISPLAY

Inventors: Kelly M. Christensen, John Phillip Hansen, and Thomas Mock

Please Direct All Correspondence to Customer Number 20995

---

Full name of **third** inventor: Thomas Daniel Mock

Signature: \_\_\_\_\_ Date: \_\_\_\_\_

Citizenship: U.S.

Residence Address: 16 First Mill Street, Sheffield, Pennsylvania 16347

Send Correspondence To:  
KNOBBE, MARTENS, OLSON & BEAR, LLP  
**Customer No. 20,995**

6602454

**DECLARATION FOR UTILITY OR DESIGN APPLICATION  
UNDER 37 CFR 1.63**

Docket No.: STRATOS.029A

Page 1 of 2

Title: SYSTEM AND METHOD FOR ADVERTISEMENT TRANSMISSION AND DISPLAY

Inventors: Kelly M. Christensen, John Phillip Hansen, and Thomas Mock

Please Direct All Correspondence to Customer Number 20995

This Declaration is directed to the invention that:

Was filed as Serial No. 12/366,535 filed on February 5, 2009

As a below named inventor:

I believe the inventor(s) named below to be the original and first inventor(s) of the subject matter which is described and claimed and for which a patent is sought;

I have reviewed and understand the contents of the above-identified application, including the claims, and any amendment filed herewith or identified above;

I acknowledge the duty to disclose information which is material to patentability as defined in 37 CFR 1.56;

I hereby declare that all statements made herein of my own knowledge are true and that all statements made on information and belief are believed to be true; and further that these statements were made with the knowledge that willful false statements and the like so made are punishable by fine or imprisonment, or both, under Section 1001 of Title 18 of the United States Code and that such willful, false statements may jeopardize the validity of the application or any patent issued thereon.

Full name of first inventor: Kelly M. Christensen

Signature: \_\_\_\_\_ Date: \_\_\_\_\_

Citizenship: U.S.

Residence Address: 4712 Admiralty Way, Marina Del Rey, California 90292

Full name of second inventor: John Phillip Hansen

Signature: John P. Hansen Date: 2-12-09

Citizenship: U.S.

Residence Address: 6637 Whitmarsh Valley Walk Austin, Texas 78746

**DECLARATION FOR UTILITY OR DESIGN APPLICATION  
UNDER 37 CFR 1.63**

Docket No.: STRATOS.029A

Page 2 of 2

Title: SYSTEM AND METHOD FOR ADVERTISEMENT TRANSMISSION AND DISPLAY  
Inventors: Kelly M. Christensen, John Phillip Hansen, and Thomas Mock

Please Direct All Correspondence to Customer Number 20995

---

Full name of **third** inventor: Thomas Daniel Mock

Signature:

Thomas Daniel Mock

Date:

18 February 2009

Citizenship:

U.S.

Residence Address:

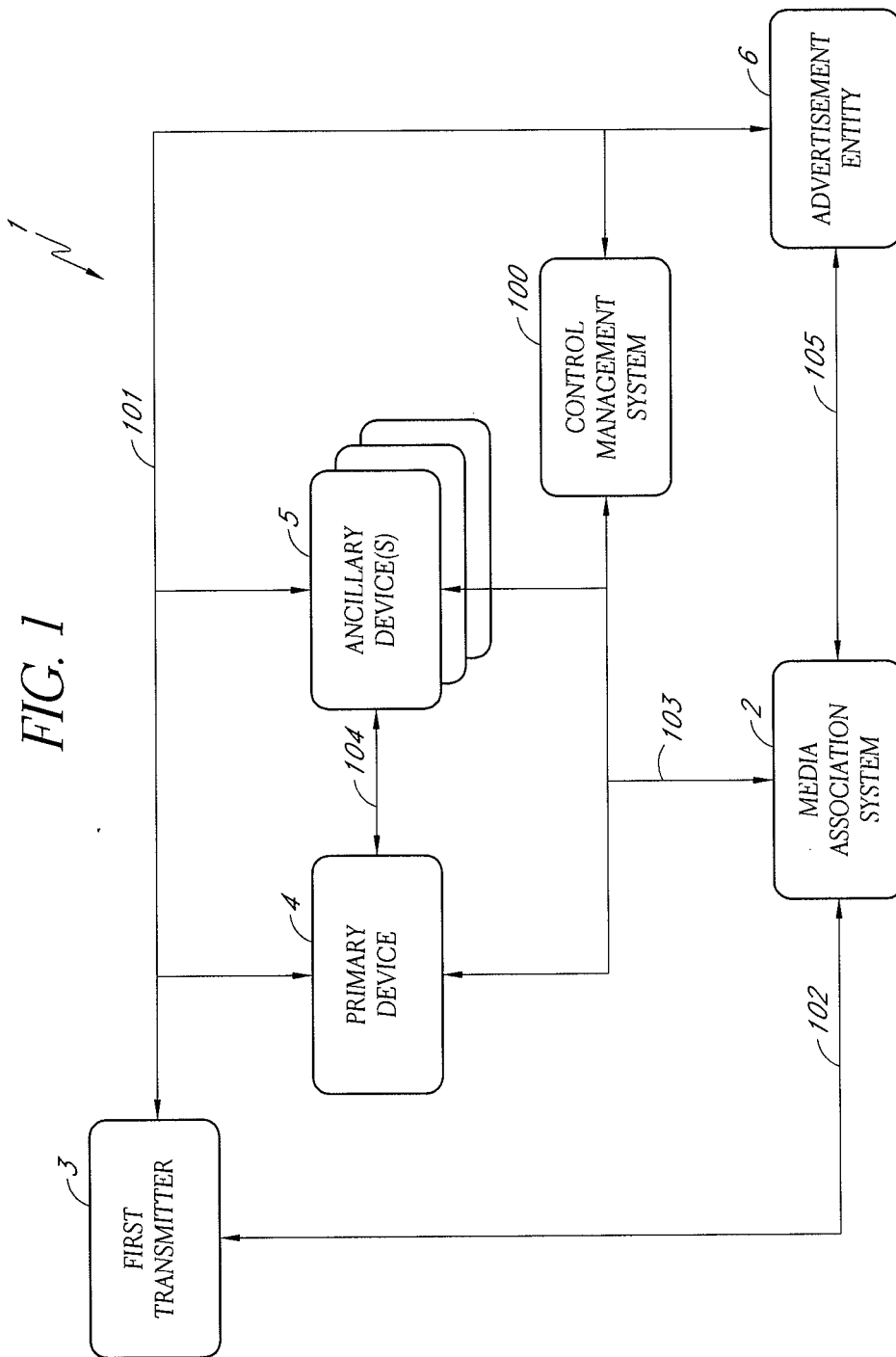
16 First Mill Street, Sheffield, Pennsylvania 16347

Send Correspondence To:

**KNOBBE, MARTENS, OLSON & BEAR, LLP**

**Customer No. 20,995**

6602454



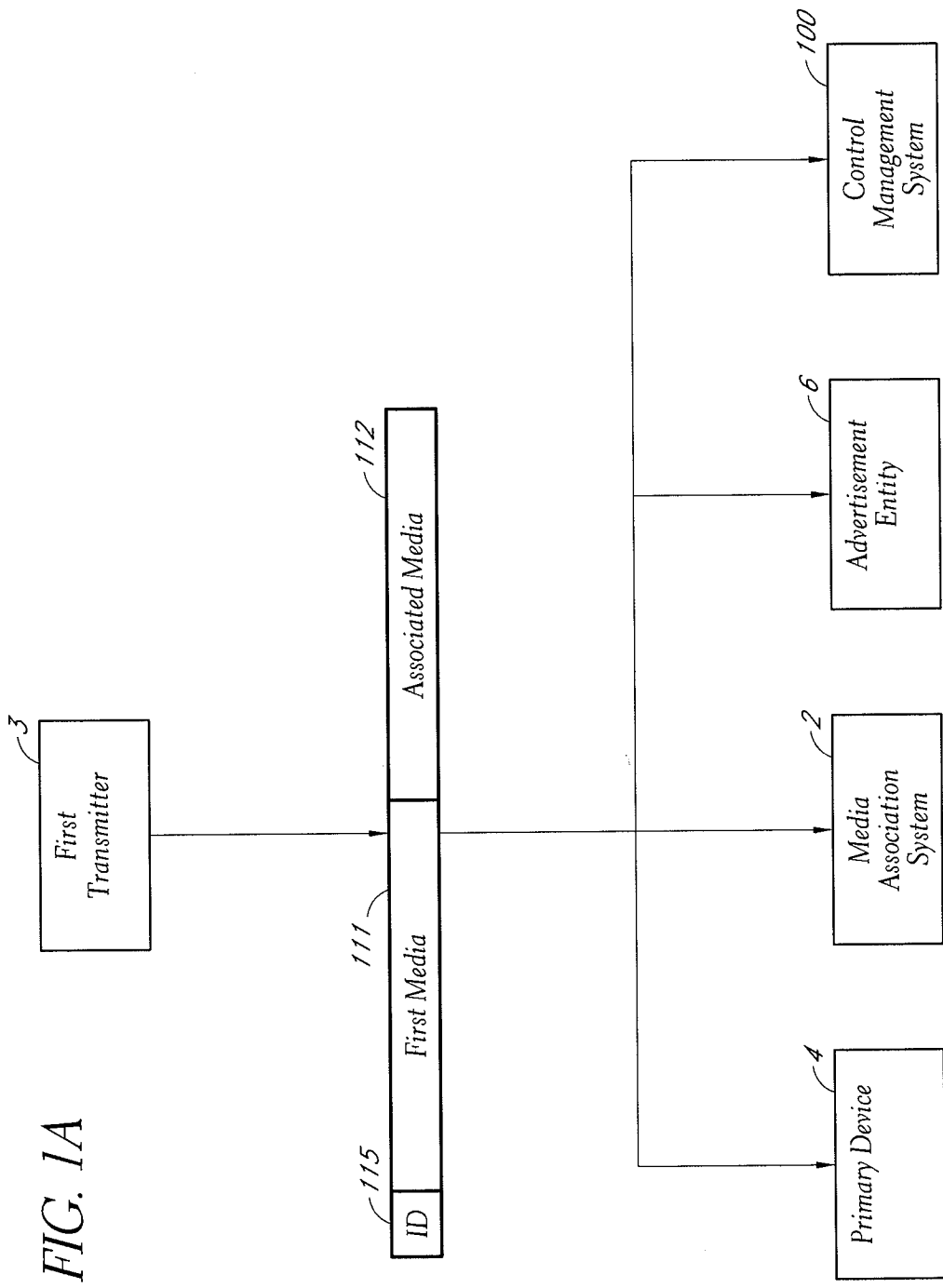
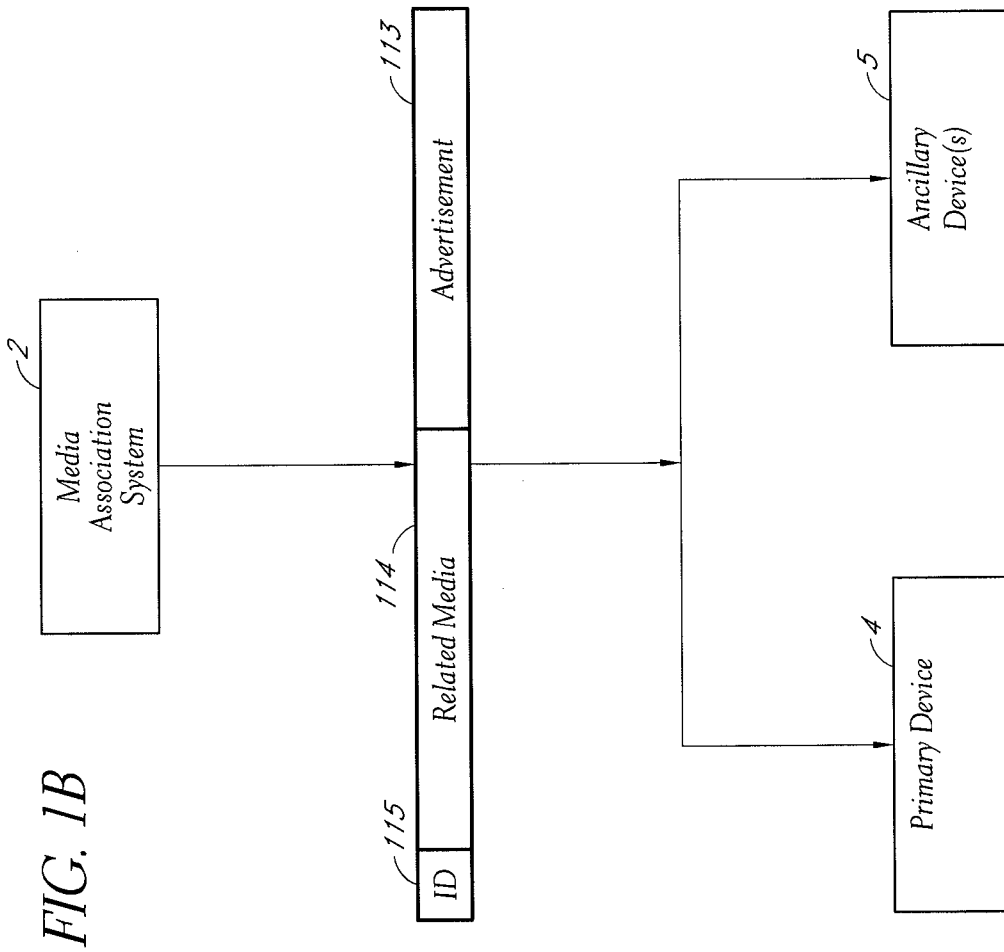
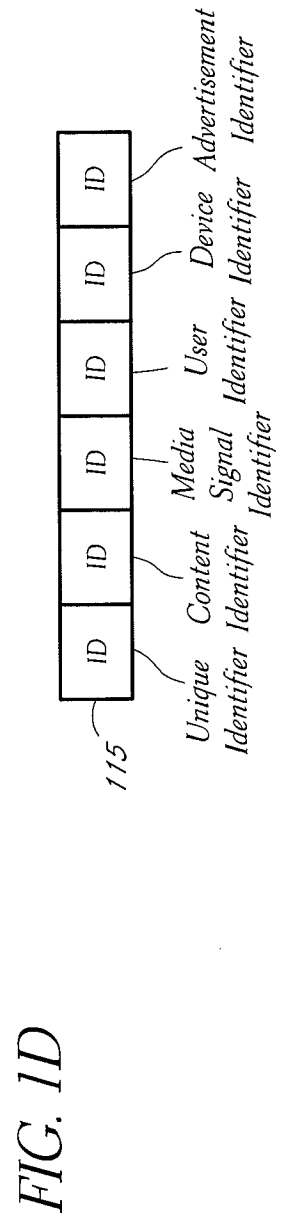
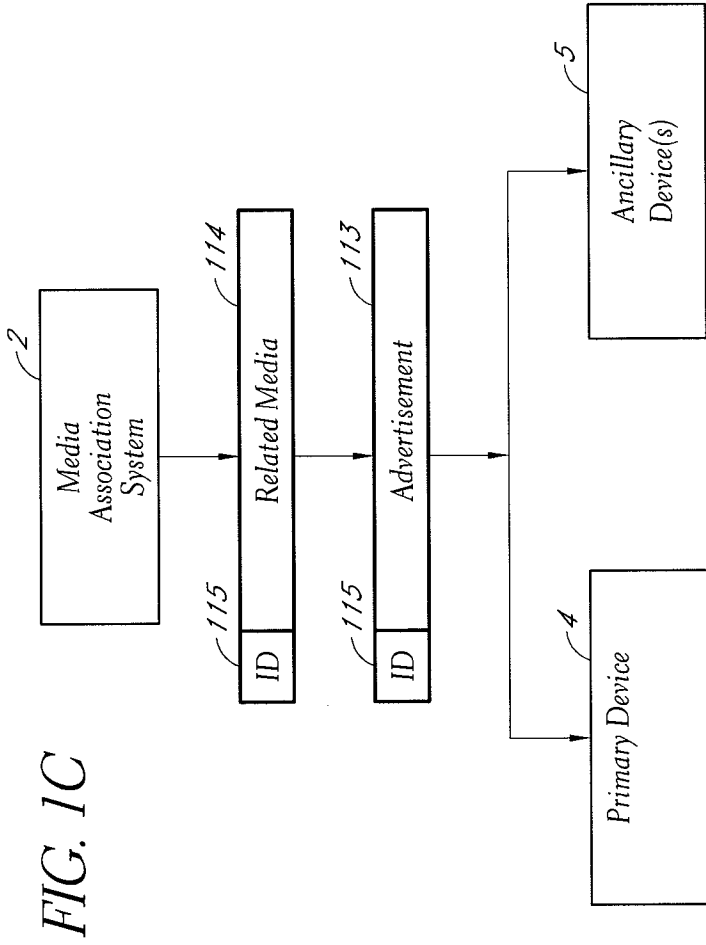


FIG. 1A

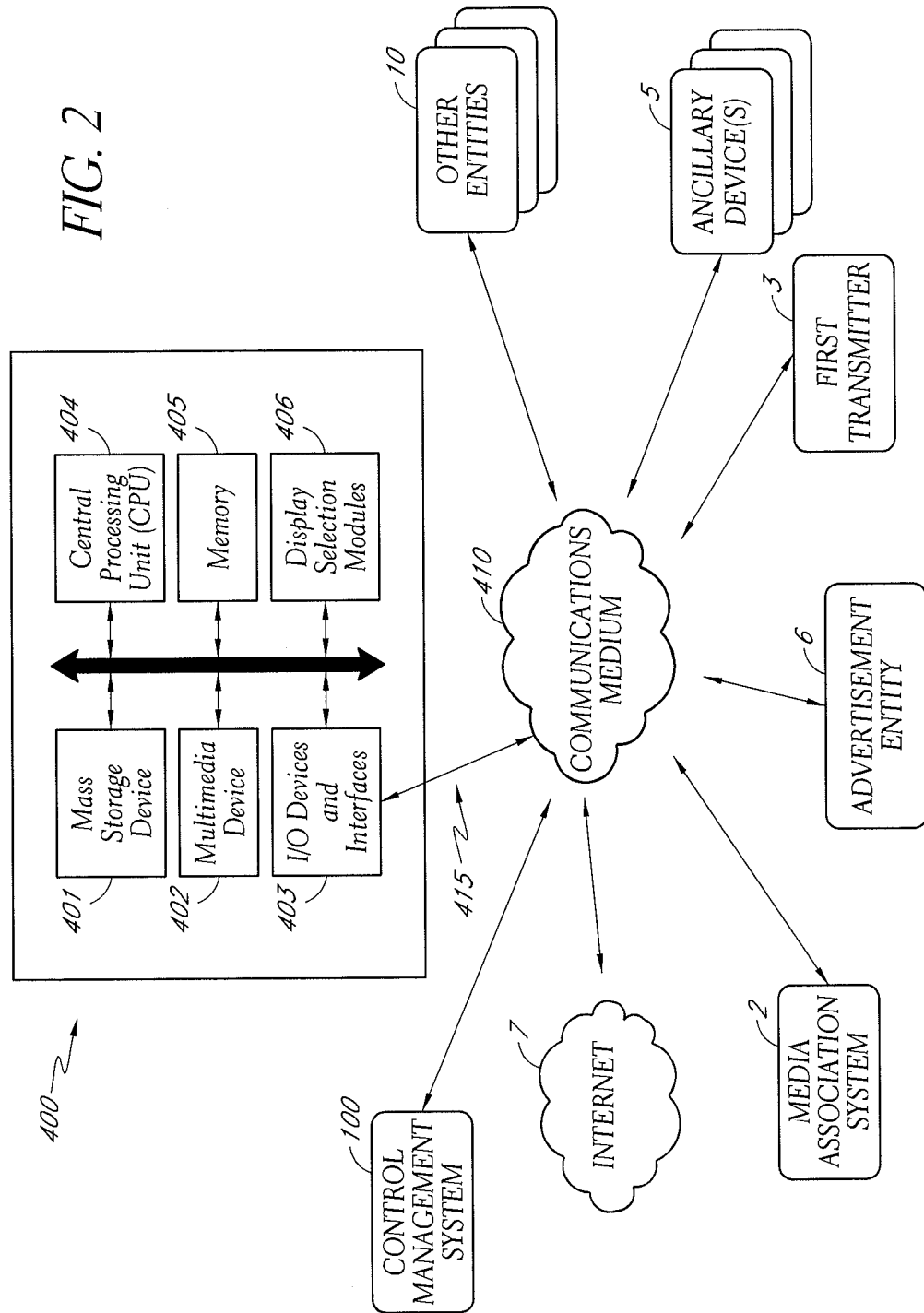


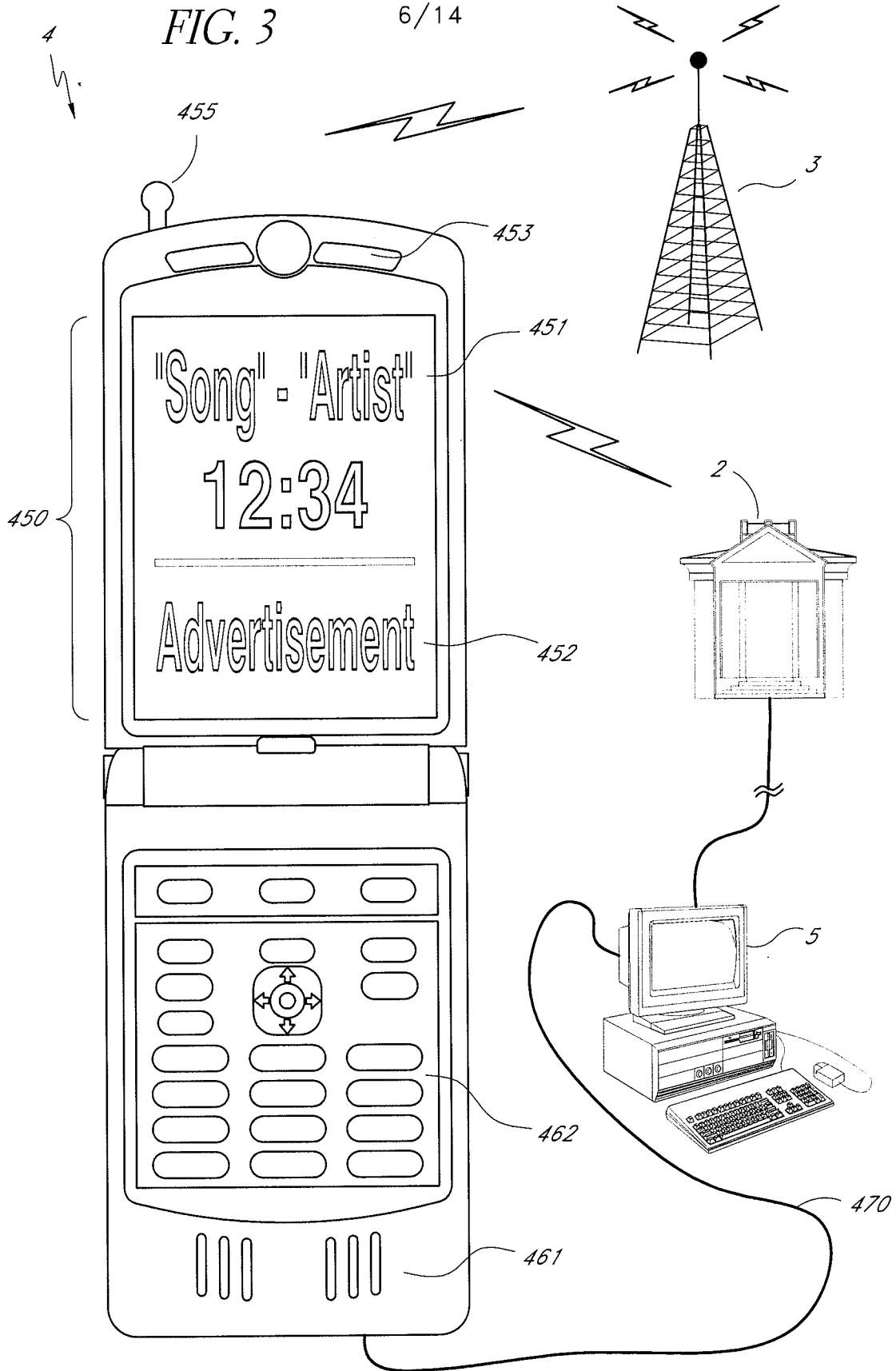




5/14

FIG. 2





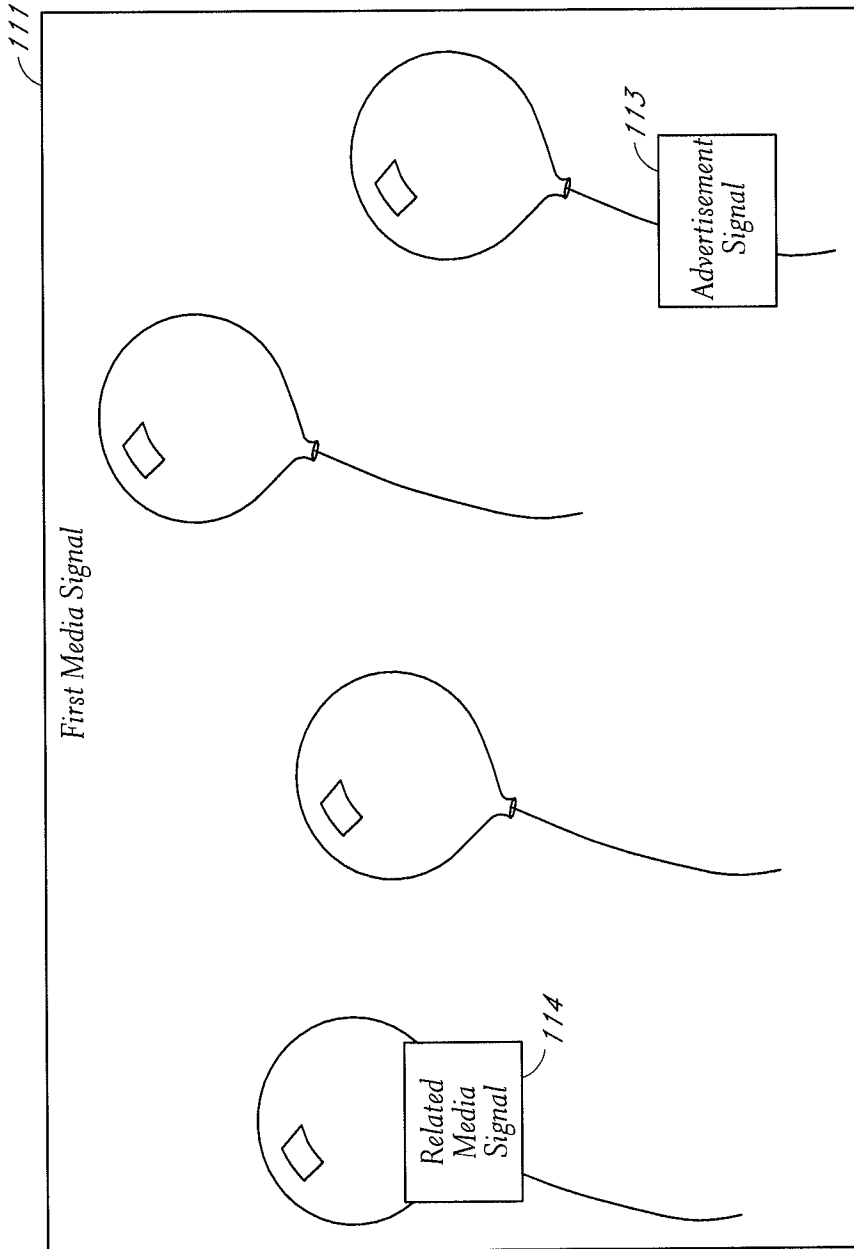
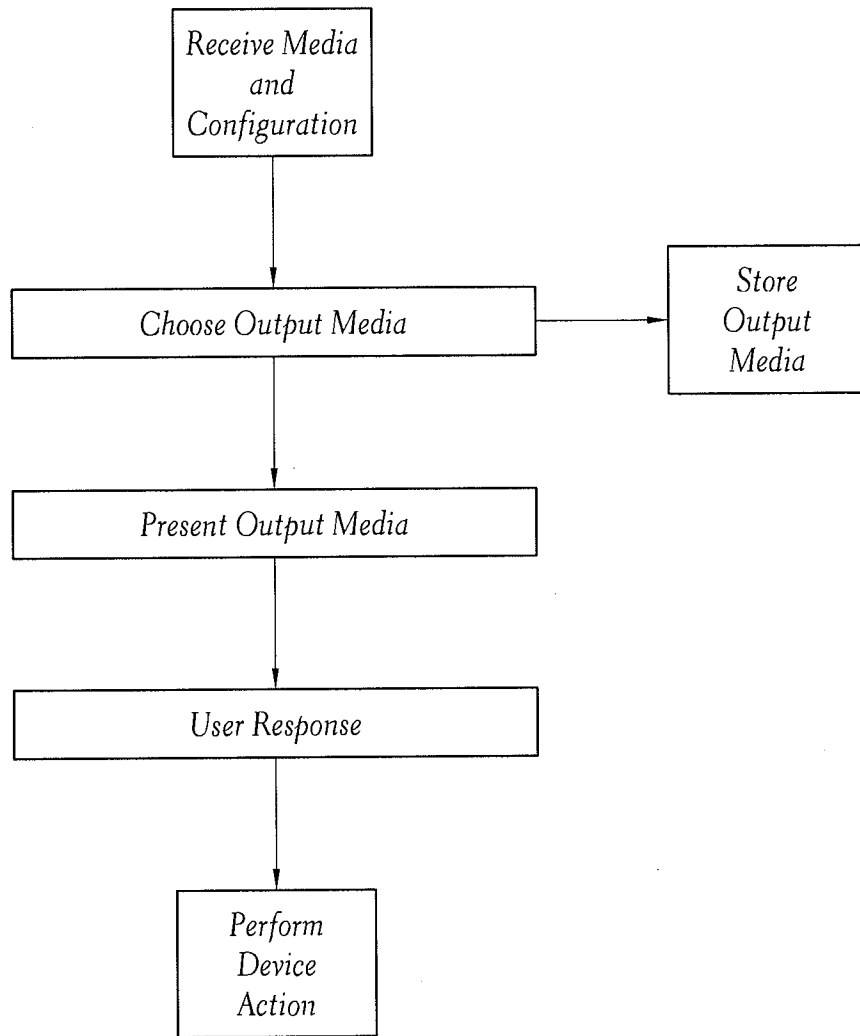


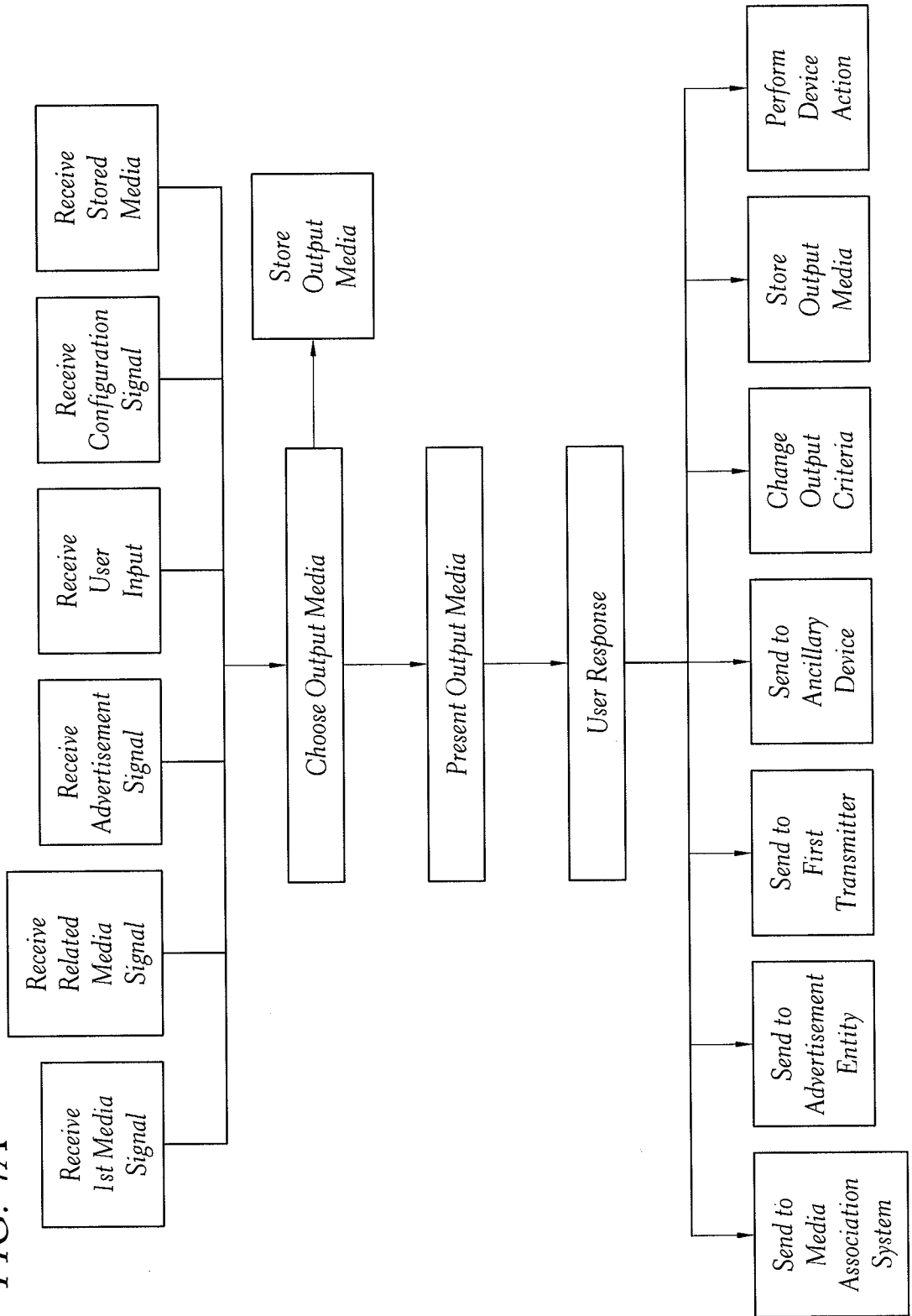
FIG. 3A

FIG. 4



9/14

FIG. 4A



10/14

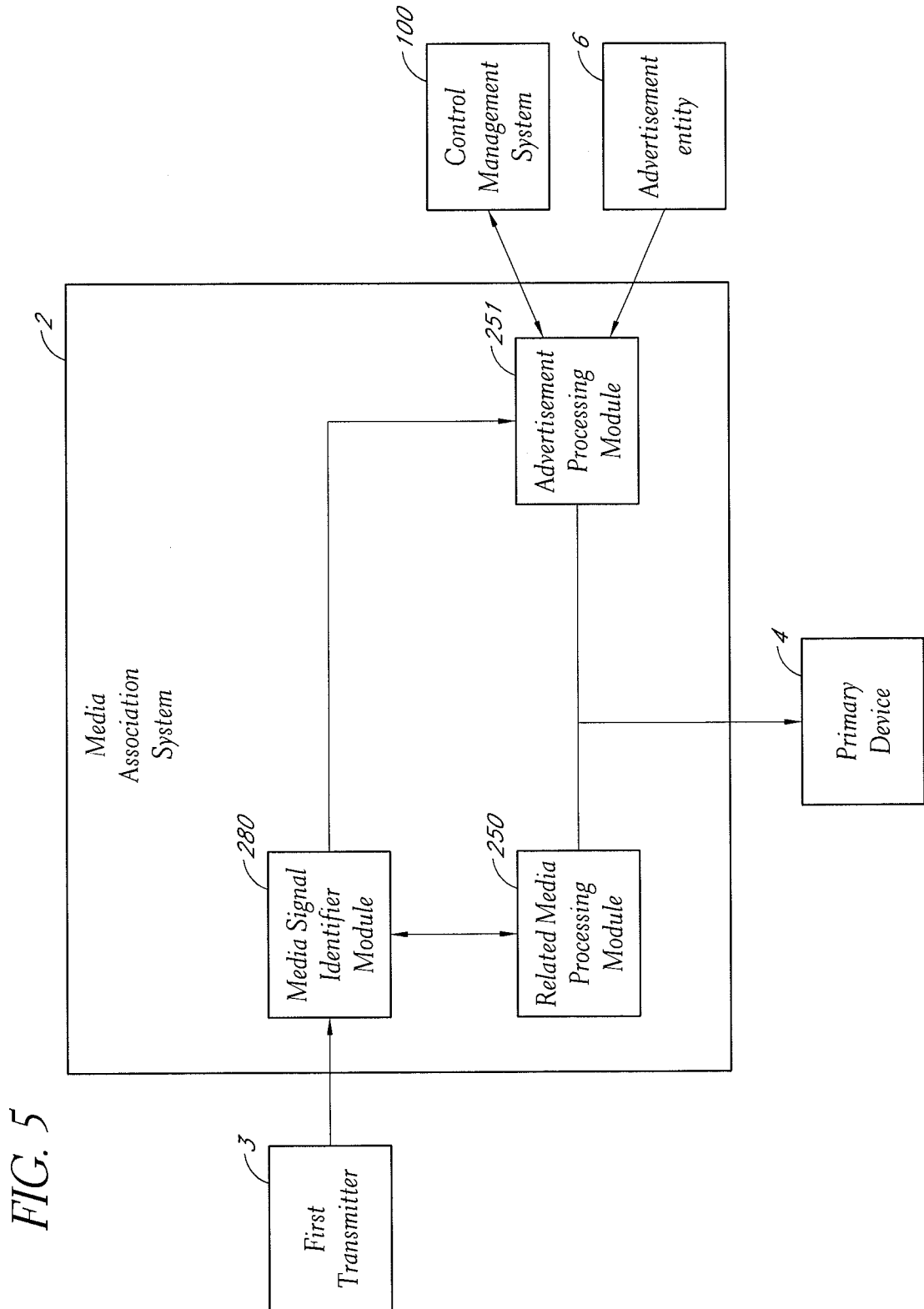


FIG. 5

11/14

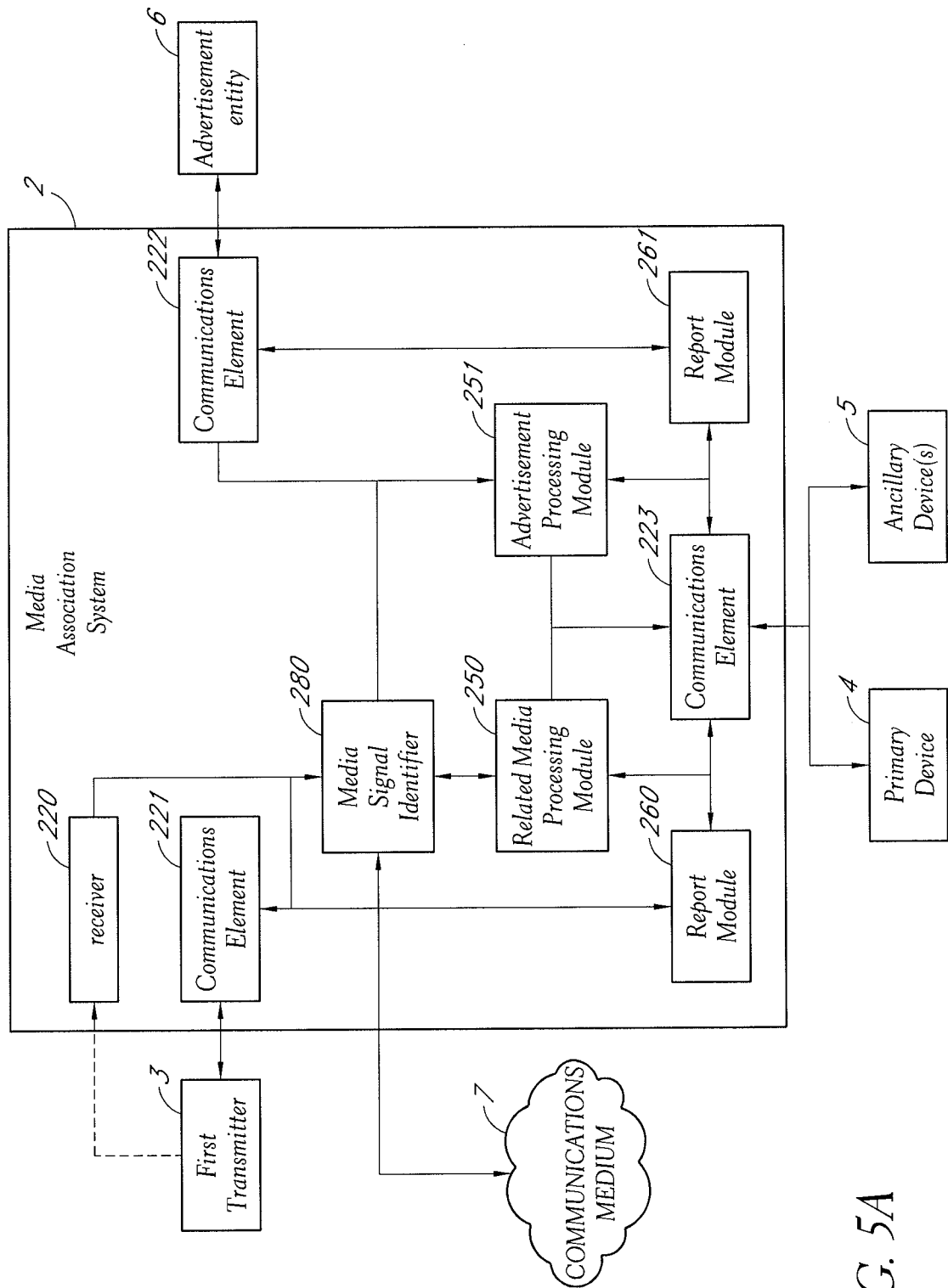


FIG. 5A

12/14

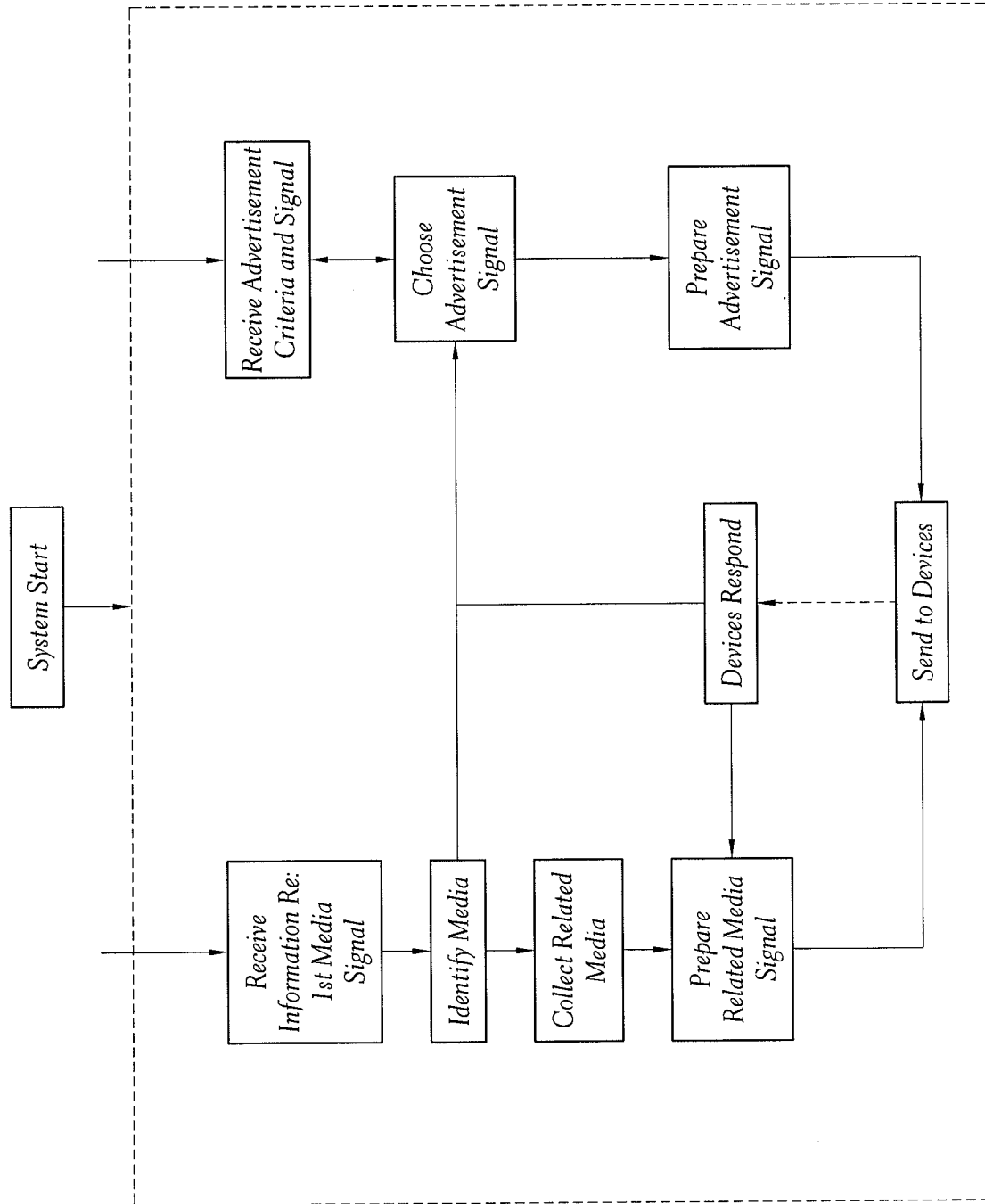


FIG. 6



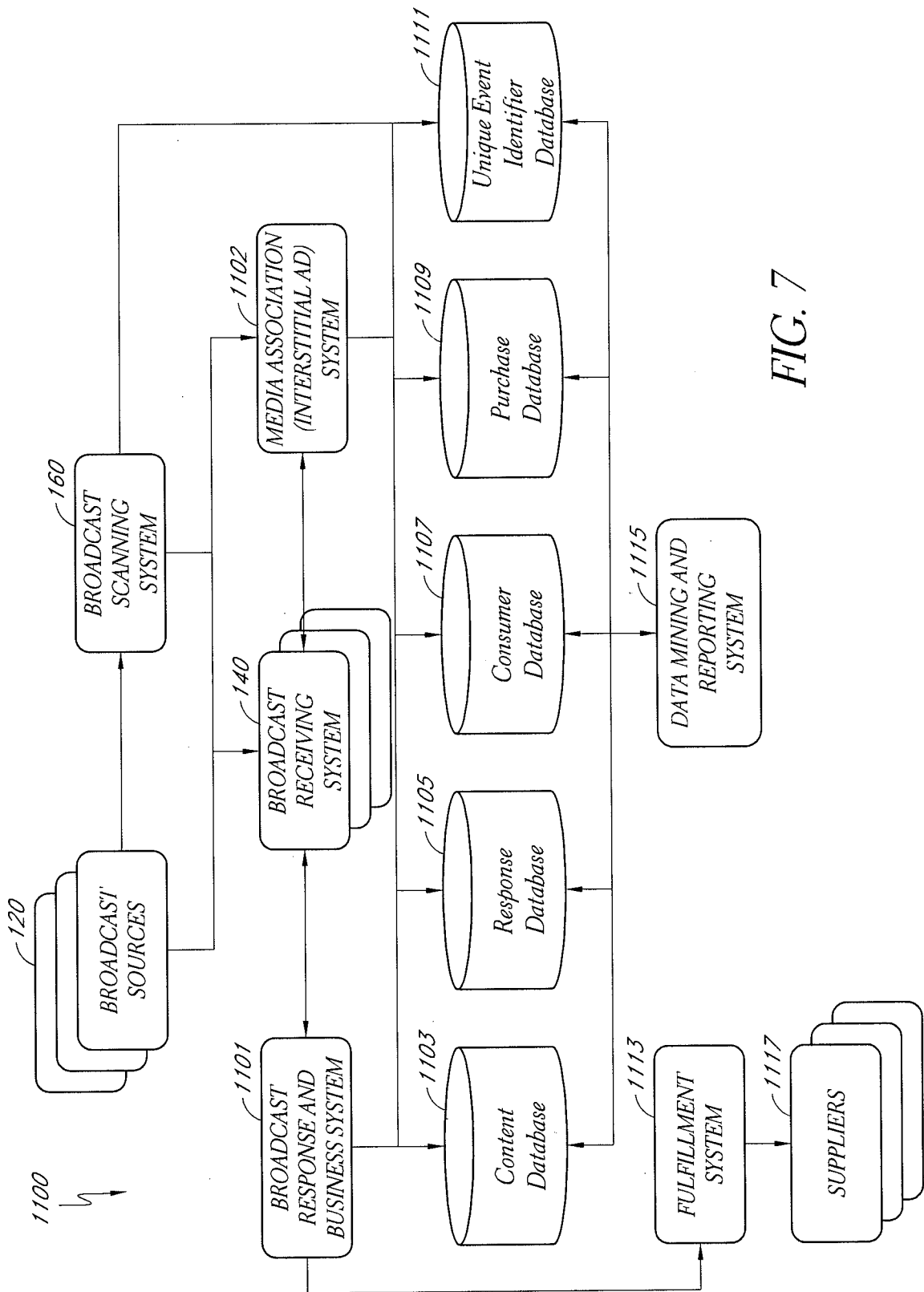


FIG. 7

[Add a Campaign](#) | [Campaigns](#) | [Clients](#) | [Ad Graphics](#) | [My Profile](#) | [Log Out](#)

Welcome Back, Customer

Campaigns

[<< Back to Campaigns](#)

- Step 1 *Choose a Client*
- Step 2 *Campaign Information*
- Step 3 *Demographics*
- Step 4 *Select Stations*
- Step 5 *Review and Launch*

Step 2: Campaign Information

Campaign Details (?)

Client Name: Digital Muse

\*Campaign Name:

\*Campaign Types:

- Click Throughs (\$0.12 per 100 clicks)
- Interstitial (\$10.00 per 1000 views)
- More Info (\$0.50 per click)
- On Air Ad (\$0.12 per 100 clicks)
- Primary Banner (\$10.00 per 1000 views)
- Qualified Lead (\$50.00 per lead)
- Splash Screen (\$25.00 per 1000 views)

Notes:

Schedule (?)


\*Begins:  Ends:

Between the hours of:  and:

Advertise Now!  (?)

Handset Calendar Scheduling  (?)

Generic Ad Details (?)

<p>Showing Generic Version</p> <div style="text-align: center;">  </div> <p style="text-align: center;">◀ 92.9 MHz 3 ▶</p> <p style="text-align: center;">MENU    GET    BACK</p>	<p>* Provide Ad Short Text (Preview)</p> <input style="width: 100%;" type="text"/> <p>* Provide Ad Text (Preview)</p> <div style="border: 1px solid black; height: 80px; width: 100%;"></div>
--	---

Ad Response Details (?)

Bar Code ASCII (Code 39)

Handset Response URL

Web Response URL

◀ PREV

Step 2: Campaign Information

NEXT ▶

**REVOCATION  
AND  
GENERAL POWER OF ATTORNEY**

Commissioner for Patents  
P.O. Box 1450  
Alexandria, VA 22313-1450

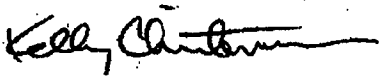
Dear Sir:

The undersigned is an empowered representative of the Assignee and hereby appoints the registrants of Knobbe, Martens, Olson & Bear, LLP, **Customer No. 20,995**, as attorneys and agents to represent the Assignee before the United States Patent and Trademark Office (USPTO) in connection with any and all patent applications assigned to the Assignee according to the USPTO assignment records or assignment documents supplied with an accompanying Statement Under 37 CFR § 3.73(b). This appointment is to be to the exclusion of the inventor(s) and his attorney(s) in accordance with the provisions of 37 CFR § 3.71.

Submission of this paper in connection with any matter of the below named assignee, together with a statement under 37 CFR 3.73(b), shall serve to revoke any previous powers of attorney in that matter.

A Statement Under 37 CFR § 3.73(b), signed by a registrant of Knobbe, Martens, Olson & Bear, LLP, is attached setting forth a full chain of title for the subject application owned by the Assignee named below.

Please recognize or change the correspondence address for the application identified in the attached Statement to **Customer No. 20,995**.

By:  Date: Feb 24, 2009

Name: Kelly Christensen Title: CEO

Assignee: STRATOSAUDIO, INC.  
1800 Century Park East, Suite 600

Address: Century City, California 90067

**STATEMENT UNDER 37 CFR § 3.73(b)  
ESTABLISHMENT OF ASSIGNEE**

Applicant	: Christensen et al.
App. No.	: 12/366,535
Filed	: February 5, 2009
For	: SYSTEM AND METHOD FOR ADVERTISEMENT TRANSMISSION AND DISPLAY
Examiner	: Unknown
Group Art Unit	: 2627

Commissioner for Patents  
P.O. Box 1450  
Alexandria, VA 22313-1450

Dear Sir:

This document is being filed with a copy of a Power of Attorney signed by the Assignee. This Statement sets forth the chain of title of the above-identified application.

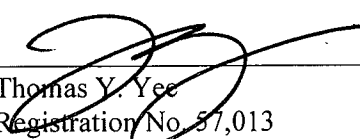
STRATOSAUDIO, INC., a Corporation, is the Assignee of the entire right, title, and interest of the above-referenced application by virtue of:

The attached copy of the Assignment being forwarded to the Recordation Branch concurrently under separate cover.

The undersigned is an agent of Customer Number 20995 and is authorized to act on behalf of the Assignee. Please recognize or change the correspondence address for the above-identified application to **Customer No. 20995.**

Respectfully submitted,  
KNOBBE, MARTENS, OLSON & BEAR, LLP

Dated: 4/23/2009

By:   
Thomas Y. Yee  
Registration No. 57,013  
Attorney of Record  
Customer No. 20995  
(949) 760-0404

**ASSIGNMENT AGREEMENT**

THIS ASSIGNMENT AGREEMENT ("Agreement") is effective as of the 5th day of February, 2008 and is by Kelly M. Christensen, a U.S. citizen residing at 4712 Admiralty Way Marina Del Rey, California 90292; John Phillip Hansen, a U.S. citizen residing at 6637 Whitemarsh Valley Walk Austin, Texas 78746; and Thomas Daniel Mock, a U.S. citizen residing at 16 First Mill Street, Sheffield, Pennsylvania 16347 ("ASSIGNOR").

WHEREAS, ASSIGNOR has conceived of an invention ("Invention") disclosed in a patent application entitled SYSTEM AND METHOD FOR ADVERTISEMENT TRANSMISSION AND DISPLAY and filed in the United States Patent and Trademark Office, on February 5, 2009 as Application No. 12/366,535 ("Application");

WHEREAS, STRATOSAUDIO, INC., a Delaware corporation having offices at 1800 Century Park East, Suite 600 Century City, California 90067 ("ASSIGNEE") desires to acquire and confirm the entire right, title, and interest in and to the Invention and the Application, as well as all related intellectual property rights as further set forth herein.

NOW, THEREFORE, for good and valuable consideration, the receipt and sufficiency of which is hereby acknowledged, ASSIGNOR agrees to assign and does hereby assign, transfer, and set over to ASSIGNEE, its successors, legal representatives, and assigns, to the extent not already done so to ASSIGNEE, the entire right, title, and interest throughout the world in and to each of the following:

A. The Invention, including without limitation any improvements thereto, whether conceived and/or reduced to practice by ASSIGNOR alone or jointly with anyone else;

B. The Application, including without limitation any of ASSIGNOR'S inventions that may be disclosed therein, and any other applications in which the Invention is disclosed; all provisional and nonprovisional applications relating to the Application or claiming the benefit thereof that have been or may hereafter be filed in the United States or in any foreign country and all continuations, divisionals, and continuations in part of the Application (collectively, "Related Applications"); and all U.S. and foreign patents which may be granted on the Application and the Related Applications, and all reissues, re-examinations, and extensions of such patents.

C. Any other related intellectual property rights such as, but not limited to, copyright rights, copyrightable subject matter, know how, trade secrets, copyright registrations, reproduction rights, and waives any and all moral rights under 17 U.S.C. § 106A or otherwise.

D. Those items of ASSIGNOR'S tangible property embodying or describing the Invention, including without limitation all documents, drawings, prototypes, models, test results, designs, materials, computer programs and data, and the like, which, if not presently in the possession of ASSIGNEE, will be delivered to ASSIGNEE immediately upon request.

E. All causes of action for infringement of, all damages for, and all remedies for all rights related to the Invention, the Application, and/or the Related Applications, and all legal rights to enforce the same against third parties and to retain the entire proceeds therefrom, whether accruing before or after this Assignment.

ASSIGNOR AGREES, without further consideration or compensation, to communicate to ASSIGNEE, its successors, legal representatives, and assigns any facts of which ASSIGNOR has knowledge respecting the Invention, Application, or Related Applications; to assist in the preparation of

any other applications relating to the invention, to testify in any legal proceeding; to sign all documents, make all rightful oaths and declarations; and to generally do everything possible to aid ASSIGNEE, its successors, legal representatives, and assigns in obtaining and enforcing patents for the Invention in all countries. ASSIGNEE agrees to reimburse ASSIGNOR'S reasonable expenses in carrying out his/her obligations under this Agreement, but only upon ASSIGNEE'S prior written approval of such expenses which in no event shall include ASSIGNOR'S time or legal expense.

AND ASSIGNOR FURTHER AGREES AS FOLLOWS:

A. This Agreement is binding on ASSIGNOR, its officers, agents, employees, heirs, successors, assigns, affiliates, and those entities acting under its direction and control, and shall inure to the benefit of ASSIGNEE, its successors and assigns. This Agreement, and the rights and obligations arising hereunder, are not assignable or transferable by ASSIGNOR, by operation of law or otherwise, and any attempt to do so shall be null and void. This Agreement is fully assignable by ASSIGNEE. The obligations set forth in this Agreement shall survive the term of any employment agreement or any other affiliation between the ASSIGNEE and ASSIGNOR.

B. If ASSIGNOR cannot be located or is unable or unwilling to sign documents as required hereunder, ASSIGNOR agrees to and does hereby appoint ASSIGNEE as ASSIGNOR'S attorney-in-fact for the limited purpose of executing all documents and performing all other acts necessary to give effect and legality to the provisions of this Agreement. ASSIGNOR acknowledges that this appointment is coupled with an interest and is irrevocable.

C. This Agreement shall be governed and construed in accordance with the laws of the state of California, U.S.A. without regard to conflicts of law provisions. The exclusive jurisdiction for any legal proceeding regarding this Agreement shall be in the in the state or federal courts of California, in the county of Orange, and the parties expressly agree that jurisdiction and venue are proper in said courts. In the event that any legal action becomes necessary to enforce or interpret the terms of this Agreement, the prevailing party shall be entitled, in addition to its court costs, to such reasonable attorneys' fees, expert witness fees and legal expenses as shall be fixed by a court of competent jurisdiction.

D. ASSIGNOR acknowledges that, to the best of his or her knowledge, the Invention is patentable, and further agrees not to take any action, or to assist or request any third party, in, challenging or opposing, on any grounds whatsoever, ASSIGNEE'S rights granted under this Agreement, or the validity or enforceability of such rights. ASSIGNOR further acknowledges that ASSIGNEE'S patent counsel presenting this Agreement does not represent ASSIGNOR personally, and ASSIGNOR has the right to seek independent counsel of his or her choosing. No course of conduct or dealing between the parties shall act as an amendment, modification or waiver of any provision of this Agreement, and only an amendment, modification or waiver which is contained in a written agreement signed by both ASSIGNEE and ASSIGNOR shall be effective.

*(The remainder of this page is intentionally left blank. The signature page(s) follows.)*

IN TESTIMONY WHEREOF, I hereunto set my hand and seal this 12<sup>th</sup> day of February, 2009

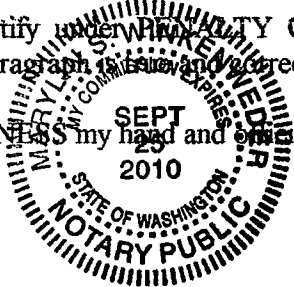
Kelly M. Christensen  
Kelly M. Christensen

STATE OF Washington  
COUNTY OF Snohomish ss.

On 2.12.2009, before me, Marylin D. Winkenweder notary public, personally appeared Kelly M. Christensen who proved to me on the basis of satisfactory evidence to be the person whose name is subscribed to the within instrument, and acknowledged to me that Kelly M. Christensen executed the same in Kelly M. Christensen's authorized capacity, and that by Kelly M. Christensen's signature on the instrument the person, or the entity upon behalf of which the person acted, executed the instrument.

I certify under PENALTY OF PERJURY under the laws of the State of California that the foregoing paragraph is true and correct.

WITNESS my hand and official seal.



[SEAL]

Marylin D. Winkenweder  
Notary Signature

IN TESTIMONY WHEREOF, I hereunto set my hand and seal this 12<sup>th</sup> day of February, 2009.

\_\_\_\_\_  
John Phillip Hansen

STATE OF \_\_\_\_\_ }  
COUNTY OF \_\_\_\_\_ } ss.

On \_\_\_\_\_, before me, \_\_\_\_\_, notary public, personally appeared John Phillip Hansen who proved to me on the basis of satisfactory evidence to be the person whose name is subscribed to the within instrument, and acknowledged to me that John Phillip Hansen executed the same in John Phillip Hansen's authorized capacity, and that by John Phillip Hansen's signature on the instrument the person, or the entity upon behalf of which the person acted, executed the instrument.

I certify under PENALTY OF PERJURY under the laws of the State of California that the foregoing paragraph is true and correct.

WITNESS my hand and official seal.

[SEAL]

\_\_\_\_\_  
Notary Signature

Application No.: 12/366,535  
Filing Date: February 5, 2009

**ASSIGNMENT AGREEMENT**  
Client Code: STRATOS.029A  
Page 4

IN TESTIMONY WHEREOF, I hereunto set my hand and seal this \_\_\_\_\_ day of \_\_\_\_\_, 20\_\_.

\_\_\_\_\_  
Thomas Daniel Mock

STATE OF                    )  
                                  ) ss.  
COUNTY OF                )

On \_\_\_\_\_, before me, \_\_\_\_\_, notary public, personally appeared Thomas Daniel Mock who proved to me on the basis of satisfactory evidence to be the person whose name is subscribed to the within instrument, and acknowledged to me that Thomas Daniel Mock executed the same in Thomas Daniel Mock's authorized capacity, and that by Thomas Daniel Mock's signature on the instrument the person, or the entity upon behalf of which the person acted, executed the instrument.

I certify under PENALTY OF PERJURY under the laws of the State of California that the foregoing paragraph is true and correct.

WITNESS my hand and official seal.

[SEAL]

\_\_\_\_\_  
Notary Signature

6602393



**ASSIGNMENT AGREEMENT**

THIS ASSIGNMENT AGREEMENT ("Agreement") is effective as of the 5th day of February, 2008 and is by Kelly M. Christensen, a U.S. citizen residing at 4712 Admiralty Way Marina Del Rey, California 90292; John Phillip Hansen, a U.S. citizen residing at 6637 Whitmarsh Valley Walk Austin, Texas 78746; and Thomas Daniel Mock, a U.S. citizen residing at 16 First Mill Street, Sheffield, Pennsylvania 16347 ("ASSIGNOR").

WHEREAS, ASSIGNOR has conceived of an invention ("Invention") disclosed in a patent application entitled SYSTEM AND METHOD FOR ADVERTISEMENT TRANSMISSION AND DISPLAY and filed in the United States Patent and Trademark Office, on February 5, 2009 as Application No. 12/366,535 ("Application");

WHEREAS, STRATOSAUDIO, INC., a Delaware corporation having offices at 1800 Century Park East, Suite 600 Century City, California 90067 ("ASSIGNEE") desires to acquire and confirm the entire right, title, and interest in and to the Invention and the Application, as well as all related intellectual property rights as further set forth herein.

NOW, THEREFORE, for good and valuable consideration, the receipt and sufficiency of which is hereby acknowledged, ASSIGNOR agrees to assign and does hereby assign, transfer, and set over to ASSIGNEE, its successors, legal representatives, and assigns, to the extent not already done so to ASSIGNEE, the entire right, title, and interest throughout the world in and to each of the following:

A. The Invention, including without limitation any improvements thereto, whether conceived and/or reduced to practice by ASSIGNOR alone or jointly with anyone else;

B. The Application, including without limitation any of ASSIGNOR'S inventions that may be disclosed therein, and any other applications in which the Invention is disclosed; all provisional and nonprovisional applications relating to the Application or claiming the benefit thereof that have been or may hereafter be filed in the United States or in any foreign country and all continuations, divisionals, and continuations in part of the Application (collectively, "Related Applications"); and all U.S. and foreign patents which may be granted on the Application and the Related Applications, and all reissues, re-examinations, and extensions of such patents.

C. Any other related intellectual property rights such as, but not limited to, copyright rights, copyrightable subject matter, know how, trade secrets, copyright registrations, reproduction rights, and waives any and all moral rights under 17 U.S.C. § 106A or otherwise.

D. Those items of ASSIGNOR'S tangible property embodying or describing the Invention, including without limitation all documents, drawings, prototypes, models, test results, designs, materials, computer programs and data, and the like, which, if not presently in the possession of ASSIGNEE, will be delivered to ASSIGNEE immediately upon request.

E. All causes of action for infringement of, all damages for, and all remedies for all rights related to the Invention, the Application, and/or the Related Applications, and all legal rights to enforce the same against third parties and to retain the entire proceeds therefrom, whether accruing before or after this Assignment.

ASSIGNOR AGREES, without further consideration or compensation, to communicate to ASSIGNEE, its successors, legal representatives, and assigns any facts of which ASSIGNOR has knowledge respecting the Invention, Application, or Related Applications; to assist in the preparation of

any other applications relating to the invention, to testify in any legal proceeding; to sign all documents, make all rightful oaths and declarations; and to generally do everything possible to aid ASSIGNEE, its successors, legal representatives, and assigns in obtaining and enforcing patents for the Invention in all countries. ASSIGNEE agrees to reimburse ASSIGNOR'S reasonable expenses in carrying out his/her obligations under this Agreement, but only upon ASSIGNEE'S prior written approval of such expenses which in no event shall include ASSIGNOR'S time or legal expense.

**AND ASSIGNOR FURTHER AGREES AS FOLLOWS:**

A. This Agreement is binding on ASSIGNOR, its officers, agents, employees, heirs, successors, assigns, affiliates, and those entities acting under its direction and control, and shall inure to the benefit of ASSIGNEE, its successors and assigns. This Agreement, and the rights and obligations arising hereunder, are not assignable or transferable by ASSIGNOR, by operation of law or otherwise, and any attempt to do so shall be null and void. This Agreement is fully assignable by ASSIGNEE. The obligations set forth in this Agreement shall survive the term of any employment agreement or any other affiliation between the ASSIGNEE and ASSIGNOR.

B. If ASSIGNOR cannot be located or is unable or unwilling to sign documents as required hereunder, ASSIGNOR agrees to and does hereby appoint ASSIGNEE as ASSIGNOR'S attorney-in-fact for the limited purpose of executing all documents and performing all other acts necessary to give effect and legality to the provisions of this Agreement. ASSIGNOR acknowledges that this appointment is coupled with an interest and is irrevocable.

C. This Agreement shall be governed and construed in accordance with the laws of the state of California, U.S.A. without regard to conflicts of law provisions. The exclusive jurisdiction for any legal proceeding regarding this Agreement shall be in the in the state or federal courts of California, in the county of Orange, and the parties expressly agree that jurisdiction and venue are proper in said courts. In the event that any legal action becomes necessary to enforce or interpret the terms of this Agreement, the prevailing party shall be entitled, in addition to its court costs, to such reasonable attorneys' fees, expert witness fees and legal expenses as shall be fixed by a court of competent jurisdiction.

D. ASSIGNOR acknowledges that, to the best of his or her knowledge, the Invention is patentable, and further agrees not to take any action, or to assist or request any third party, in, challenging or opposing, on any grounds whatsoever, ASSIGNEE'S rights granted under this Agreement, or the validity or enforceability of such rights. ASSIGNOR further acknowledges that ASSIGNEE'S patent counsel presenting this Agreement does not represent ASSIGNOR personally, and ASSIGNOR has the right to seek independent counsel of his or her choosing. No course of conduct or dealing between the parties shall act as an amendment, modification or waiver of any provision of this Agreement, and only an amendment, modification or waiver which is contained in a written agreement signed by both ASSIGNEE and ASSIGNOR shall be effective.

*(The remainder of this page is intentionally left blank. The signature page(s) follows.)*

IN TESTIMONY WHEREOF, I hereunto set my hand and seal this \_\_\_\_\_ day of \_\_\_\_\_, 20\_\_.

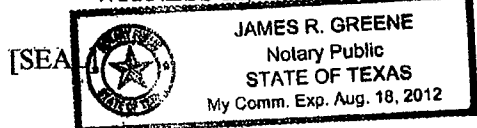
\_\_\_\_\_  
Kelly M. Christensen

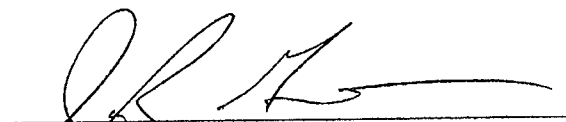
STATE OF \_\_\_\_\_ }  
  } ss.  
COUNTY OF \_\_\_\_\_ }

On \_\_\_\_\_, before me, \_\_\_\_\_, notary public, personally appeared Kelly M. Christensen who proved to me on the basis of satisfactory evidence to be the person whose name is subscribed to the within instrument, and acknowledged to me that Kelly M. Christensen executed the same in Kelly M. Christensen's authorized capacity, and that by Kelly M. Christensen's signature on the instrument the person, or the entity upon behalf of which the person acted, executed the instrument.

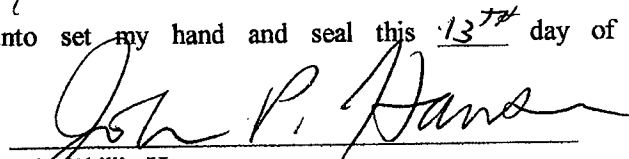
I certify under PENALTY OF PERJURY under the laws of the State of California that the foregoing paragraph is true and correct.

WITNESS my hand and official seal.



  
\_\_\_\_\_  
Notary Signature

IN TESTIMONY WHEREOF, I hereunto set my hand and seal this 13<sup>th</sup> day of FEBRUARY, 2009

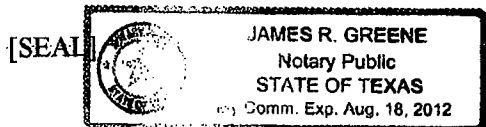
  
\_\_\_\_\_  
John Phillip Hansen


STATE OF \_\_\_\_\_ }  
  } ss.  
COUNTY OF \_\_\_\_\_ }

On 2-13-09, before me, ROBERT GREENE, notary public, personally appeared John Phillip Hansen who proved to me on the basis of satisfactory evidence to be the person whose name is subscribed to the within instrument, and acknowledged to me that John Phillip Hansen executed the same in John Phillip Hansen's authorized capacity, and that by John Phillip Hansen's signature on the instrument the person, or the entity upon behalf of which the person acted, executed the instrument.

I certify under PENALTY OF PERJURY under the laws of the State of California that the foregoing paragraph is true and correct.

WITNESS my hand and official seal.



  
\_\_\_\_\_  
Notary Signature

Application No.: 12/366,535  
Filing Date: February 5, 2009

ASSIGNMENT AGREEMENT  
Client Code: STRATOS.029A  
Page 4

IN TESTIMONY WHEREOF, I hereunto set my hand and seal this \_\_\_\_\_ day of \_\_\_\_\_, 20\_\_.

\_\_\_\_\_  
Thomas Daniel Mock

STATE OF }  
                  } ss.  
COUNTY OF }

On \_\_\_\_\_, before me, \_\_\_\_\_, notary public, personally appeared Thomas Daniel Mock who proved to me on the basis of satisfactory evidence to be the person whose name is subscribed to the within instrument, and acknowledged to me that Thomas Daniel Mock executed the same in Thomas Daniel Mock's authorized capacity, and that by Thomas Daniel Mock's signature on the instrument the person, or the entity upon behalf of which the person acted, executed the instrument.

I certify under PENALTY OF PERJURY under the laws of the State of California that the foregoing paragraph is true and correct.

WITNESS my hand and official seal.

[SEAL]

\_\_\_\_\_  
Notary Signature

6602393

**ASSIGNMENT AGREEMENT**

THIS ASSIGNMENT AGREEMENT ("Agreement") is effective as of the 5th day of February, 2008 and is by Kelly M. Christensen, a U.S. citizen residing at 4712 Admiralty Way Marina Del Rey, California 90292; John Phillip Hansen, a U.S. citizen residing at 6637 Whitemarsh Valley Walk Austin, Texas 78746; and Thomas Daniel Mock, a U.S. citizen residing at 16 First Mill Street, Sheffield, Pennsylvania 16347 ("ASSIGNOR").

WHEREAS, ASSIGNOR has conceived of an invention ("Invention") disclosed in a patent application entitled SYSTEM AND METHOD FOR ADVERTISEMENT TRANSMISSION AND DISPLAY and filed in the United States Patent and Trademark Office, on February 5, 2009 as Application No. 12/366,535 ("Application");

WHEREAS, STRATOSAUDIO, INC., a Delaware corporation having offices at 1800 Century Park East, Suite 600 Century City, California 90067 ("ASSIGNEE") desires to acquire and confirm the entire right, title, and interest in and to the Invention and the Application, as well as all related intellectual property rights as further set forth herein.

NOW, THEREFORE, for good and valuable consideration, the receipt and sufficiency of which is hereby acknowledged, ASSIGNOR agrees to assign and does hereby assign, transfer, and set over to ASSIGNEE, its successors, legal representatives, and assigns, to the extent not already done so to ASSIGNEE, the entire right, title, and interest throughout the world in and to each of the following:

A. The Invention, including without limitation any improvements thereto, whether conceived and/or reduced to practice by ASSIGNOR alone or jointly with anyone else;

B. The Application, including without limitation any of ASSIGNOR'S inventions that may be disclosed therein, and any other applications in which the Invention is disclosed; all provisional and nonprovisional applications relating to the Application or claiming the benefit thereof that have been or may hereafter be filed in the United States or in any foreign country and all continuations, divisionals, and continuations in part of the Application (collectively, "Related Applications"); and all U.S. and foreign patents which may be granted on the Application and the Related Applications, and all reissues, re-examinations, and extensions of such patents.

C. Any other related intellectual property rights such as, but not limited to, copyright rights, copyrightable subject matter, know how, trade secrets, copyright registrations, reproduction rights, and waives any and all moral rights under 17 U.S.C. § 106A or otherwise.

D. Those items of ASSIGNOR'S tangible property embodying or describing the Invention, including without limitation all documents, drawings, prototypes, models, test results, designs, materials, computer programs and data, and the like, which, if not presently in the possession of ASSIGNEE, will be delivered to ASSIGNEE immediately upon request.

E. All causes of action for infringement of, all damages for, and all remedies for all rights related to the Invention, the Application, and/or the Related Applications, and all legal rights to enforce the same against third parties and to retain the entire proceeds therefrom, whether accruing before or after this Assignment.

ASSIGNOR AGREES, without further consideration or compensation, to communicate to ASSIGNEE, its successors, legal representatives, and assigns any facts of which ASSIGNOR has knowledge respecting the Invention, Application, or Related Applications; to assist in the preparation of

any other applications relating to the invention, to testify in any legal proceeding; to sign all documents, make all rightful oaths and declarations; and to generally do everything possible to aid ASSIGNEE, its successors, legal representatives, and assigns in obtaining and enforcing patents for the Invention in all countries. ASSIGNEE agrees to reimburse ASSIGNOR'S reasonable expenses in carrying out his/her obligations under this Agreement, but only upon ASSIGNEE'S prior written approval of such expenses which in no event shall include ASSIGNOR'S time or legal expense.

**AND ASSIGNOR FURTHER AGREES AS FOLLOWS:**

A. This Agreement is binding on ASSIGNOR, its officers, agents, employees, heirs, successors, assigns, affiliates, and those entities acting under its direction and control, and shall inure to the benefit of ASSIGNEE, its successors and assigns. This Agreement, and the rights and obligations arising hereunder, are not assignable or transferable by ASSIGNOR, by operation of law or otherwise, and any attempt to do so shall be null and void. This Agreement is fully assignable by ASSIGNEE. The obligations set forth in this Agreement shall survive the term of any employment agreement or any other affiliation between the ASSIGNEE and ASSIGNOR.

B. If ASSIGNOR cannot be located or is unable or unwilling to sign documents as required hereunder, ASSIGNOR agrees to and does hereby appoint ASSIGNEE as ASSIGNOR'S attorney-in-fact for the limited purpose of executing all documents and performing all other acts necessary to give effect and legality to the provisions of this Agreement. ASSIGNOR acknowledges that this appointment is coupled with an interest and is irrevocable.

C. This Agreement shall be governed and construed in accordance with the laws of the state of California, U.S.A. without regard to conflicts of law provisions. The exclusive jurisdiction for any legal proceeding regarding this Agreement shall be in the in the state or federal courts of California, in the county of Orange, and the parties expressly agree that jurisdiction and venue are proper in said courts. In the event that any legal action becomes necessary to enforce or interpret the terms of this Agreement, the prevailing party shall be entitled, in addition to its court costs, to such reasonable attorneys' fees, expert witness fees and legal expenses as shall be fixed by a court of competent jurisdiction.

D. ASSIGNOR acknowledges that, to the best of his or her knowledge, the Invention is patentable, and further agrees not to take any action, or to assist or request any third party, in, challenging or opposing, on any grounds whatsoever, ASSIGNEE'S rights granted under this Agreement, or the validity or enforceability of such rights. ASSIGNOR further acknowledges that ASSIGNEE'S patent counsel presenting this Agreement does not represent ASSIGNOR personally, and ASSIGNOR has the right to seek independent counsel of his or her choosing. No course of conduct or dealing between the parties shall act as an amendment, modification or waiver of any provision of this Agreement, and only an amendment, modification or waiver which is contained in a written agreement signed by both ASSIGNEE and ASSIGNOR shall be effective.

*(The remainder of this page is intentionally left blank. The signature page(s) follows.)*

IN TESTIMONY WHEREOF, I hereunto set my hand and seal this \_\_\_\_ day of \_\_\_\_\_, 20\_\_.

\_\_\_\_\_  
Kelly M. Christensen

STATE OF }  
                  } ss.  
COUNTY OF }

On \_\_\_\_\_, before me, \_\_\_\_\_, notary public, personally appeared Kelly M. Christensen who proved to me on the basis of satisfactory evidence to be the person whose name is subscribed to the within instrument, and acknowledged to me that Kelly M. Christensen executed the same in Kelly M. Christensen's authorized capacity, and that by Kelly M. Christensen's signature on the instrument the person, or the entity upon behalf of which the person acted, executed the instrument.

I certify under PENALTY OF PERJURY under the laws of the State of California that the foregoing paragraph is true and correct.

WITNESS my hand and official seal.

[SEAL]

\_\_\_\_\_  
Notary Signature

IN TESTIMONY WHEREOF, I hereunto set my hand and seal this \_\_\_\_ day of \_\_\_\_\_, 20\_\_.

\_\_\_\_\_  
John Phillip Hansen

STATE OF }  
                  } ss.  
COUNTY OF }

On \_\_\_\_\_, before me, \_\_\_\_\_, notary public, personally appeared John Phillip Hansen who proved to me on the basis of satisfactory evidence to be the person whose name is subscribed to the within instrument, and acknowledged to me that John Phillip Hansen executed the same in John Phillip Hansen's authorized capacity, and that by John Phillip Hansen's signature on the instrument the person, or the entity upon behalf of which the person acted, executed the instrument.

I certify under PENALTY OF PERJURY under the laws of the State of California that the foregoing paragraph is true and correct.

WITNESS my hand and official seal.

[SEAL]

\_\_\_\_\_  
Notary Signature

IN TESTIMONY WHEREOF, I hereunto set my hand and seal this 18th day of  
FEBRUARY 20 09

Thomas Daniel Mock  
Thomas Daniel Mock

STATE OF PA. }  
COUNTY OF Warren } ss.

On Feb. 18, 2009, before me, Christie L. Humphrey, notary public, personally appeared Thomas Daniel Mock who proved to me on the basis of satisfactory evidence to be the person whose name is subscribed to the within instrument, and acknowledged to me that Thomas Daniel Mock executed the same in Thomas Daniel Mock's authorized capacity, and that by Thomas Daniel Mock's signature on the instrument the person, or the entity upon behalf of which the person acted, executed the instrument.

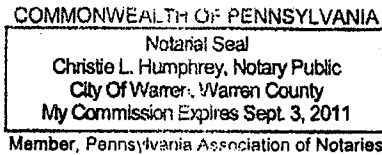
I certify under PENALTY OF PERJURY under the laws of the State of California that the foregoing paragraph is true and correct.

WITNESS my hand and official seal.

[SEAL]

Christie L. Humphrey  
Notary Signature

6602393





## Electronic Patent Application Fee Transmittal

<b>Application Number:</b>	12366535
<b>Filing Date:</b>	05-Feb-2009
<b>Title of Invention:</b>	SYSTEM AND METHOD FOR ADVERTISEMENT TRANSMISSION AND DISPLAY
<b>First Named Inventor/Applicant Name:</b>	Kelly M. Christensen
<b>Filer:</b>	Thomas Yee/Will Nguyen
<b>Attorney Docket Number:</b>	STRATOS.029A

Filed as Small Entity

### Utility under 35 USC 111(a) Filing Fees

Description	Fee Code	Quantity	Amount	Sub-Total in USD(\$)
<b>Basic Filing:</b>				
Utility filing Fee (Electronic filing)	4011	1	82	82
Utility Search Fee	2111	1	270	270
Utility Examination Fee	2311	1	110	110

### Pages:

### Claims:

Independent claims in excess of 3	2201	1	110	110
-----------------------------------	------	---	-----	-----

### Miscellaneous-Filing:

Late filing fee for oath or declaration	2051	1	65	65
---	------	---	----	----

Description	Fee Code	Quantity	Amount	Sub-Total in USD(\$)
<b>Petition:</b>				
<b>Patent-Appeals-and-Interference:</b>				
<b>Post-Allowance-and-Post-Issuance:</b>				
<b>Extension-of-Time:</b>				
<b>Miscellaneous:</b>				
			<b>Total in USD (\$)</b>	<b>637</b>

## Electronic Acknowledgement Receipt

<b>EFS ID:</b>	5209910
<b>Application Number:</b>	12366535
<b>International Application Number:</b>	
<b>Confirmation Number:</b>	7989
<b>Title of Invention:</b>	SYSTEM AND METHOD FOR ADVERTISEMENT TRANSMISSION AND DISPLAY
<b>First Named Inventor/Applicant Name:</b>	Kelly M. Christensen
<b>Customer Number:</b>	20995
<b>Filer:</b>	Thomas Yee/Quyen Lieu
<b>Filer Authorized By:</b>	Thomas Yee
<b>Attorney Docket Number:</b>	STRATOS.029A
<b>Receipt Date:</b>	23-APR-2009
<b>Filing Date:</b>	05-FEB-2009
<b>Time Stamp:</b>	19:53:57
<b>Application Type:</b>	Utility under 35 USC 111(a)

### Payment information:

Submitted with Payment	yes
Payment Type	Credit Card
Payment was successfully received in RAM	\$637
RAM confirmation Number	5368
Deposit Account	111410
Authorized User	KNOBBE MARTENS OLSON AND BEAR

The Director of the USPTO is hereby authorized to charge indicated fees and credit any overpayment as follows:

Charge any Additional Fees required under 37 C.F.R. Section 1.16 (National application filing, search, and examination fees)

Charge any Additional Fees required under 37 C.F.R. Section 1.17 (Patent application and reexamination processing fees)

Volkswagen Exhibit 1002

<b>File Listing:</b>					
<b>Document Number</b>	<b>Document Description</b>	<b>File Name</b>	<b>File Size(Bytes)/ Message Digest</b>	<b>Multi Part /.zip</b>	<b>Pages (if appl.)</b>
1	Applicant Response to Pre-Exam Formalities Notice	STRATOS-029A_MpartsTransmittal.pdf	47123 9037d639787511d82a27ecfd125713ce4f8b7730	no	1
<b>Warnings:</b>					
<b>Information:</b>					
2	Oath or Declaration filed	STRATOS-029A_Declaration.pdf	163145 07e3dea010fb175853596e7b61f8d0af984fed36	no	4
<b>Warnings:</b>					
<b>Information:</b>					
3	Drawings-only black and white line drawings	STRATOS-029A_Drawings.pdf	371902 1201c4123cf212227464e256ac4e1d54d7a27741	no	14
<b>Warnings:</b>					
<b>Information:</b>					
4	Power of Attorney	STRATOS-029A_GENPOA.pdf	50463 ed2736bc5d78d11e4144a5a5351e4d8634052d1f	no	1
<b>Warnings:</b>					
<b>Information:</b>					
5	Assignee showing of ownership per 37 CFR 3.73(b).	STRATOS-029A_STMNT373.pdf	40015 7299c697c0ee8d8d7bdf77c19db10032fee015f	no	1
<b>Warnings:</b>					
<b>Information:</b>					
6	Assignee showing of ownership per 37 CFR 3.73(b).	STRATOS-029A_Assignment.pdf	788011 aeaf11ea6a9fe6c5b55ef352c7a33ea5015aa397	no	12
<b>Warnings:</b>					
<b>Information:</b>					
7	Fee Worksheet (PTO-875)	fee-info.pdf	38490 e863eb00a157c5df1a9feb6f7ce8157c47dbc319	no	2
<b>Warnings:</b>					
<b>Information:</b>					
<b>Total Files Size (in bytes):</b>			1499149		

**This Acknowledgement Receipt evidences receipt on the noted date by the USPTO of the indicated documents, characterized by the applicant, and including page counts, where applicable. It serves as evidence of receipt similar to a Post Card, as described in MPEP 503.**

**New Applications Under 35 U.S.C. 111**

**If a new application is being filed and the application includes the necessary components for a filing date (see 37 CFR 1.53(b)-(d) and MPEP 506), a Filing Receipt (37 CFR 1.54) will be issued in due course and the date shown on this Acknowledgement Receipt will establish the filing date of the application.**

**National Stage of an International Application under 35 U.S.C. 371**

**If a timely submission to enter the national stage of an international application is compliant with the conditions of 35 U.S.C. 371 and other applicable requirements a Form PCT/DO/EO/903 indicating acceptance of the application as a national stage submission under 35 U.S.C. 371 will be issued in addition to the Filing Receipt, in due course.**

**New International Application Filed with the USPTO as a Receiving Office**

**If a new international application is being filed and the international application includes the necessary components for an international filing date (see PCT Article 11 and MPEP 1810), a Notification of the International Application Number and of the International Filing Date (Form PCT/RO/105) will be issued in due course, subject to prescriptions concerning national security, and the date shown on this Acknowledgement Receipt will establish the international filing date of the application.**



UNITED STATES PATENT AND TRADEMARK OFFICE

UNITED STATES DEPARTMENT OF COMMERCE
United States Patent and Trademark Office
Address: COMMISSIONER FOR PATENTS
P.O. Box 1450
Alexandria, Virginia 22313-1450
www.uspto.gov

Table with 6 columns: APPLICATION NUMBER, FILING or 371(c) DATE, GRP ART UNIT, FIL FEE REC'D, ATTY. DOCKET NO, TOT CLAIMS, IND CLAIMS. Row 1: 12/366,535, 02/05/2009, 2627, 637, STRATOS.029A, 19, 4

CONFIRMATION NO. 7989

UPDATED FILING RECEIPT

20995
KNOBBE MARTENS OLSON & BEAR LLP
2040 MAIN STREET
FOURTEENTH FLOOR
IRVINE, CA 92614



Date Mailed: 05/06/2009

Receipt is acknowledged of this non-provisional patent application. The application will be taken up for examination in due course. Applicant will be notified as to the results of the examination. Any correspondence concerning the application must include the following identification information: the U.S. APPLICATION NUMBER, FILING DATE, NAME OF APPLICANT, and TITLE OF INVENTION. Fees transmitted by check or draft are subject to collection. Please verify the accuracy of the data presented on this receipt. If an error is noted on this Filing Receipt, please submit a written request for a Filing Receipt Correction. Please provide a copy of this Filing Receipt with the changes noted thereon. If you received a "Notice to File Missing Parts" for this application, please submit any corrections to this Filing Receipt with your reply to the Notice. When the USPTO processes the reply to the Notice, the USPTO will generate another Filing Receipt incorporating the requested corrections

Applicant(s)

Kelly M. Christensen, Marina Del Rey, CA;
John Phillip Hansen, Austin, TX;
Thomas Daniel Mock, Sheffield, PA;

Power of Attorney: The patent practitioners associated with Customer Number 20995

Domestic Priority data as claimed by applicant

This appln claims benefit of 61/026,449 02/05/2008

Foreign Applications

If Required, Foreign Filing License Granted: 02/17/2009

The country code and number of your priority application, to be used for filing abroad under the Paris Convention, is US 12/366,535

Projected Publication Date: 08/13/2009

Non-Publication Request: No

Early Publication Request: No

\*\* SMALL ENTITY \*\*

**Title**

SYSTEM AND METHOD FOR ADVERTISEMENT TRANSMISSION AND DISPLAY

**Preliminary Class**

360

**PROTECTING YOUR INVENTION OUTSIDE THE UNITED STATES**

Since the rights granted by a U.S. patent extend only throughout the territory of the United States and have no effect in a foreign country, an inventor who wishes patent protection in another country must apply for a patent in a specific country or in regional patent offices. Applicants may wish to consider the filing of an international application under the Patent Cooperation Treaty (PCT). An international (PCT) application generally has the same effect as a regular national patent application in each PCT-member country. The PCT process **simplifies** the filing of patent applications on the same invention in member countries, but **does not result** in a grant of "an international patent" and does not eliminate the need of applicants to file additional documents and fees in countries where patent protection is desired.

Almost every country has its own patent law, and a person desiring a patent in a particular country must make an application for patent in that country in accordance with its particular laws. Since the laws of many countries differ in various respects from the patent law of the United States, applicants are advised to seek guidance from specific foreign countries to ensure that patent rights are not lost prematurely.

Applicants also are advised that in the case of inventions made in the United States, the Director of the USPTO must issue a license before applicants can apply for a patent in a foreign country. The filing of a U.S. patent application serves as a request for a foreign filing license. The application's filing receipt contains further information and guidance as to the status of applicant's license for foreign filing.

Applicants may wish to consult the USPTO booklet, "General Information Concerning Patents" (specifically, the section entitled "Treaties and Foreign Patents") for more information on timeframes and deadlines for filing foreign patent applications. The guide is available either by contacting the USPTO Contact Center at 800-786-9199, or it can be viewed on the USPTO website at <http://www.uspto.gov/web/offices/pac/doc/general/index.html>.

For information on preventing theft of your intellectual property (patents, trademarks and copyrights), you may wish to consult the U.S. Government website, <http://www.stopfakes.gov>. Part of a Department of Commerce initiative, this website includes self-help "toolkits" giving innovators guidance on how to protect intellectual property in specific countries such as China, Korea and Mexico. For questions regarding patent enforcement issues, applicants may call the U.S. Government hotline at 1-866-999-HALT (1-866-999-4158).

**LICENSE FOR FOREIGN FILING UNDER**

**Title 35, United States Code, Section 184**

**Title 37, Code of Federal Regulations, 5.11 & 5.15**

**GRANTED**

The applicant has been granted a license under 35 U.S.C. 184, if the phrase "IF REQUIRED, FOREIGN FILING LICENSE GRANTED" followed by a date appears on this form. Such licenses are issued in all applications where the conditions for issuance of a license have been met, regardless of whether or not a license may be required as

set forth in 37 CFR 5.15. The scope and limitations of this license are set forth in 37 CFR 5.15(a) unless an earlier license has been issued under 37 CFR 5.15(b). The license is subject to revocation upon written notification. The date indicated is the effective date of the license, unless an earlier license of similar scope has been granted under 37 CFR 5.13 or 5.14.

This license is to be retained by the licensee and may be used at any time on or after the effective date thereof unless it is revoked. This license is automatically transferred to any related applications(s) filed under 37 CFR 1.53(d). This license is not retroactive.

The grant of a license does not in any way lessen the responsibility of a licensee for the security of the subject matter as imposed by any Government contract or the provisions of existing laws relating to espionage and the national security or the export of technical data. Licensees should apprise themselves of current regulations especially with respect to certain countries, of other agencies, particularly the Office of Defense Trade Controls, Department of State (with respect to Arms, Munitions and Implements of War (22 CFR 121-128)); the Bureau of Industry and Security, Department of Commerce (15 CFR parts 730-774); the Office of Foreign Assets Control, Department of Treasury (31 CFR Parts 500+) and the Department of Energy.

**NOT GRANTED**

No license under 35 U.S.C. 184 has been granted at this time, if the phrase "IF REQUIRED, FOREIGN FILING LICENSE GRANTED" DOES NOT appear on this form. Applicant may still petition for a license under 37 CFR 5.12, if a license is desired before the expiration of 6 months from the filing date of the application. If 6 months has lapsed from the filing date of this application and the licensee has not received any indication of a secrecy order under 35 U.S.C. 181, the licensee may foreign file the application pursuant to 37 CFR 5.15(b).





UNITED STATES PATENT AND TRADEMARK OFFICE

UNITED STATES DEPARTMENT OF COMMERCE  
United States Patent and Trademark Office  
Address: COMMISSIONER FOR PATENTS  
P.O. Box 1450  
Alexandria, Virginia 22313-1450  
www.uspto.gov

APPLICATION NUMBER	FILING OR 371(C) DATE	FIRST NAMED APPLICANT	ATTY. DOCKET NO./TITLE
12/366,535	02/05/2009	Kelly M. Christensen	STRATOS.029A

**CONFIRMATION NO. 7989**

**POA ACCEPTANCE LETTER**



20995  
KNOBBE MARTENS OLSON & BEAR LLP  
2040 MAIN STREET  
FOURTEENTH FLOOR  
IRVINE, CA 92614

Date Mailed: 05/06/2009

**NOTICE OF ACCEPTANCE OF POWER OF ATTORNEY**

This is in response to the Power of Attorney filed 04/23/2009.

The Power of Attorney in this application is accepted. Correspondence in this application will be mailed to the above address as provided by 37 CFR 1.33.

/tnnguyen/

Office of Data Management, Application Assistance Unit (571) 272-4000, or (571) 272-4200, or 1-888-786-0101



UNITED STATES PATENT AND TRADEMARK OFFICE

UNITED STATES DEPARTMENT OF COMMERCE
United States Patent and Trademark Office
Address: COMMISSIONER FOR PATENTS
P.O. Box 1450
Alexandria, Virginia 22313-1450
www.uspto.gov

Table with 4 columns: APPLICATION NUMBER (12/366,535), FILING OR 371(C) DATE (02/05/2009), FIRST NAMED APPLICANT (Kelly M. Christensen), ATTY. DOCKET NO./TITLE (STRATOS.029A)

CONFIRMATION NO. 7989

PUBLICATION NOTICE

20995
KNOBBE MARTENS OLSON & BEAR LLP
2040 MAIN STREET
FOURTEENTH FLOOR
IRVINE, CA 92614



Title:SYSTEM AND METHOD FOR ADVERTISEMENT TRANSMISSION AND DISPLAY

Publication No.US-2009-0204640-A1
Publication Date:08/13/2009

NOTICE OF PUBLICATION OF APPLICATION

The above-identified application will be electronically published as a patent application publication pursuant to 37 CFR 1.211, et seq. The patent application publication number and publication date are set forth above.

The publication may be accessed through the USPTO's publically available Searchable Databases via the Internet at www.uspto.gov. The direct link to access the publication is currently http://www.uspto.gov/patft/.

The publication process established by the Office does not provide for mailing a copy of the publication to applicant. A copy of the publication may be obtained from the Office upon payment of the appropriate fee set forth in 37 CFR 1.19(a)(1). Orders for copies of patent application publications are handled by the USPTO's Office of Public Records. The Office of Public Records can be reached by telephone at (703) 308-9726 or (800) 972-6382, by facsimile at (703) 305-8759, by mail addressed to the United States Patent and Trademark Office, Office of Public Records, Alexandria, VA 22313-1450 or via the Internet.

In addition, information on the status of the application, including the mailing date of Office actions and the dates of receipt of correspondence filed in the Office, may also be accessed via the Internet through the Patent Electronic Business Center at www.uspto.gov using the public side of the Patent Application Information and Retrieval (PAIR) system. The direct link to access this status information is currently http://pair.uspto.gov/. Prior to publication, such status information is confidential and may only be obtained by applicant using the private side of PAIR.

Further assistance in electronically accessing the publication, or about PAIR, is available by calling the Patent Electronic Business Center at 1-866-217-9197.

Office of Data Management, Application Assistance Unit (571) 272-4000, or (571) 272-4200, or 1-888-786-0101

<b>INFORMATION DISCLOSURE STATEMENT BY APPLICANT</b>	Application No.	12/366,535
	Filing Date	February 5, 2009
	First Named Inventor	Kelly M. Christensen
	Art Unit	2164
<i>(Multiple sheets used when necessary)</i>	Examiner	Belix M. Ortiz
SHEET 1 OF 5	Attorney Docket No.	STRATOS.029A

U.S. PATENT DOCUMENTS					
Examiner Initials	Cite No.	Document Number Number - Kind Code (if known) Example: 1,234,567 B1	Publication Date MM-DD-YYYY	Name of Patentee or Applicant	Pages, Columns, Lines Where Relevant Passages or Relevant Figures Appear
	1	4,926,255	05-15-1990	Von Kohorn	
	2	5,134,719	07-28-1992	Mankovitz	
	3	5,303,393	04-12-1994	Noreen et al.	
	4	5,438,355	08-01-1995	Palmer	
	5	5,444,769	08-22-1995	Koen et al.	
	6	5,539,635	07-23-1996	Larson, Jr.	
	7	5,548,828	02-20-1996	Kozaki, et al.	
	8	5,557,541	09-17-1996	Schulhof et al.	
	9	5,579,537	11-26-1996	Takahisa	
	10	5,661,787	08-26-1997	Pocock	
	11	5,708,478	01-13-1998	Tognazzini	
	12	5,752,159	05-12-1998	Faust et al.	
	13	5,857,156	01-05-1999	Anderson	
	14	5,872,589	02-16-1999	Morales	
	15	5,905,865	05-18-1999	Palmer et al.	
	16	5,907,793	05-25-1999	Reams	
	17	5,991,601	11-23-1999	Anderson	
	18	5,991,737	11-23-1999	Chen	
	19	6,036,086	03-14-2000	Sizer, II et al.	
	20	6,098,106	08-01-2000	Philyaw et al.	
	21	6,202,210	03-13-2001	Ludtke	
	22	6,286,140	09-04-2001	Ivanyi	
	23	6,446,262	09-03-2002	Malaure et al.	
	24	6,463,469	10-08-2002	Yavitz	
	25	6,473,792	10-29-2002	Yavitz et al	
	26	6,507,727	01-14-2003	Henrick	
	27	6,578,047	06-10-2003	Deguchi	
	28	6,611,201	08-26-2003	Bishop et al.	
	29	6,658,232	12-02-2003	Johnson	

Examiner Signature	Date Considered
*Examiner: Initial if reference considered, whether or not citation is in conformance with MPEP 609. Draw line through citation if not in conformance and not considered. Include copy of this form with next communication to applicant.	

T<sup>1</sup> - Place a check mark in this area when an English language Translation is attached.

Volkswagen Exhibit 1002

<b>INFORMATION DISCLOSURE STATEMENT BY APPLICANT</b>	Application No.	12/366,535
	Filing Date	February 5, 2009
	First Named Inventor	Kelly M. Christensen
	Art Unit	2164
<i>(Multiple sheets used when necessary)</i>	Examiner	Belix M. Ortiz
SHEET 2 OF 5	Attorney Docket No.	STRATOS.029A

U.S. PATENT DOCUMENTS					
Examiner Initials	Cite No.	Document Number Number - Kind Code (if known) Example: 1,234,567 B1	Publication Date MM-DD-YYYY	Name of Patentee or Applicant	Pages, Columns, Lines Where Relevant Passages or Relevant Figures Appear
	30	6,725,022	04-20-2004	Clayton et al.	
	31	6,829,486	12-07-2004	McKenna et al.	
	32	6,888,457	03-03-2005	Wilkinson et al.	
	33	6,928,423	08-09-2005	Yamanaka	
	34	6,941,154	09-06-2005	Ritter	
	35	6,957,041	10-18-2005	Christensen et al.	
	36	6,987,734	01-17-2006	Hundemer	
	37	6,990,312	01-24-2006	Gioscia et al.	
	38	7,054,653	05-30-2006	Järvi et al.	
	39	7,088,950	08-08-2006	Tassberg et al.	
	40	7,110,714	09-19-2006	Kay et al.	
	41	7,149,541	12-12-2006	Rautila	
	42	7,158,753	01-02-2007	Kagan et al.	
	43	7,190,971	03-13-2007	Kagan et al.	
	44	7,194,235	03-20-2007	Nykanen et al.	
	45	7,260,842	08-21-2007	Hirayama	
	46	7,266,343	09-04-2007	Yli-juuti et al.	
	47	7,299,194	11-20-2007	Manganaris et al.	
	48	7,313,359	12-25-2007	Steelberg et al.	
	49	7,313,360	12-25-2007	Steelberg et al.	
	50	7,415,430	08-19-2008	Christensen et al.	
	51	7,500,256	03-03-2009	Ohmae et al.	
	52	7,647,609	01-12-2010	Wachtfogel et al.	
	53	7,773,939	08-10-2010	Christensen et al.	
	54	2001/0031013	10-18-2001	Stetzler et al.	
	55	2002/0026474	02-28-2002	Wang et al.	
	56	2002/0046407	04-18-2002	Franco	
	57	2002/0133824	09-19-2002	Mensch	
	58	2002/0178441	11-28-2002	Hashimoto	

Examiner Signature	Date Considered
*Examiner: Initial if reference considered, whether or not citation is in conformance with MPEP 609. Draw line through citation if not in conformance and not considered. Include copy of this form with next communication to applicant.	

T<sup>1</sup> - Place a check mark in this area when an English language Translation is attached.

Volkswagen Exhibit 1002

<b>INFORMATION DISCLOSURE STATEMENT BY APPLICANT</b>	Application No.	12/366,535
	Filing Date	February 5, 2009
	First Named Inventor	Kelly M. Christensen
	Art Unit	2164
<i>(Multiple sheets used when necessary)</i>	Examiner	Belix M. Ortiz
SHEET 3 OF 5	Attorney Docket No.	STRATOS.029A

<b>U.S. PATENT DOCUMENTS</b>					
Examiner Initials	Cite No.	Document Number Number - Kind Code (if known) Example: 1,234,567 B1	Publication Date MM-DD-YYYY	Name of Patentee or Applicant	Pages, Columns, Lines Where Relevant Passages or Relevant Figures Appear
	59	2003/0086694	05-08-2003	Davidsson	
	60	2003/0097338	05-22-2003	Mankovich et al.	
	61	2003/0200543	10-23-2003	Burns	
	62	2004/0205810	10-14-2004	Matheny et al.	
	63	2005/0021744	01-27-2005	Haitsuka	
	64	2006/0174261	08-03-2006	Cline Jr. et al.	
	65	2006/0184960	08-17-2006	Horton et al.	
	66	2007/0155311 (STRATOS.001C2)	07-05-2007	Christensen et al.	
	67	2007/0198353	08-23-2007	Behringer et al.	
	68	2007/0226146	09-27-2007	Ruul	
	69	2008/0049704	02-28-2008	Witteman et al.	
	70	2009/0104870 (STRATOS.001C1C1)	04-23-2009	Christensen et al.	
	71	2009/0104872 (STRATOS.001C1C2)	04-23-2009	Christensen et al.	
	72	2009/0177736 (STRATOS.022A)	07-09-2009	Christensen et al.	
	73	2009/0183208 (STRATOS.030A)	12-12-2008	Christensen et al.	
	74	2009/0205000 (STRATOS.028A)	08-13-2009	Christensen et al.	
	75	U.S. App. No. 10/806,084 (Our reference STRATOS.006A)	Filing Date 03-22-2004	Christensen et al.	
	76	U.S. App. No. 12/897,509 (Our reference STRATOS.006C1)	Filing Date 10-04-2010	Christensen et al.	

<b>FOREIGN PATENT DOCUMENTS</b>						
Examiner Initials	Cite No.	Foreign Patent Document Country Code-Number-Kind Code Example: JP 1234567 A1	Publication Date MM-DD-YYYY	Name of Patentee or Applicant	Pages, Columns, Lines Where Relevant Passages or Relevant Figures Appear	T <sup>1</sup>
	77	CA 2 316 925	07-15-1999	Swisscom AG		
	78	DE 196 27 308	01-02-1998	Mihatsch		
	79	DE 44 27 046	02-01-1996	Goldscheider et al.		
	80	EP 0713335	05-22-1996	AT&T Corp.		
	81	JP 08-139624	05-31-1996	Yoshio et al.		X
	82	JP 10-135855	05-22-1998	Tetsujiro et al.		

Examiner Signature	Date Considered
--------------------	-----------------

\***Examiner:** Initial if reference considered, whether or not citation is in conformance with MPEP 609. Draw line through citation if not in conformance and not considered. Include copy of this form with next communication to applicant.

T<sup>1</sup> - Place a check mark in this area when an English language Translation is attached.

Volkswagen Exhibit 1002

<b>INFORMATION DISCLOSURE STATEMENT BY APPLICANT</b>	Application No.	12/366,535
	Filing Date	February 5, 2009
	First Named Inventor	Kelly M. Christensen
	Art Unit	2164
<i>(Multiple sheets used when necessary)</i>	Examiner	Belix M. Ortiz
SHEET 4 OF 5	Attorney Docket No.	STRATOS.029A

**FOREIGN PATENT DOCUMENTS**

Examiner Initials	Cite No.	Foreign Patent Document Country Code-Number-Kind Code Example: JP 1234567 A1	Publication Date MM-DD-YYYY	Name of Patentee or Applicant	Pages, Columns, Lines Where Relevant Passages or Relevant Figures Appear	T <sup>1</sup>
	83	JP 2000292182	10-20-2000	Akio		
	84	Korean Patent Publication No. 10-1996-0033096	09-17-1996			
	85	Korean Patent Publication No. 10-1998-0078248	11-16-1998			
	86	WO 1990/000847	01-25-1990	Insight Telecast, Inc.		
	87	WO 1992/014222	08-20-1992	Tait et al.		
	88	WO 1994/002909	02-03-1994	Whinhall Limited		
	89	WO 1997/021291	06-12-1997	Pocock		
	90	WO 1997/042724	11-13-1997	Digital D.J. Inc.		
	91	WO 1997/045814	12-04-1997	Vazvan		
	92	WO 1999/018518	04-15-1999	Polash		
	93	WO 1999/035771	07-15-1999	Swisscom AG		
	94	WO 1999/043109	08-26-1999	TTP Communications Ltd		
	95	WO 1999/035809	07-15-1999	Connexus Corporation		
	96	WO 2000/019662	04-06-2000	Radiowave.com, Inc.		
	97	WO 2000/078050	12-21-2000	United Video Properties, Inc.		
	98	WO 2001/001331	01-04-2001	Digimarc Corporation		
	99	WO 2001/057759	08-09-2001	Minushkin		
	100	WO 2001/077779	10-18-2001	Morphics Technology, Inc.		
	101	WO 2002/023773	03-21-2002	Stratos Audio		
	102	WO 2006/122028	11-16-2006	Root Markets Inc.		
	103	WO 2008/002000	01-03-2008	Electronics and Telecommunications Research Institute		

**NON PATENT LITERATURE DOCUMENTS**

Examiner Initials	Cite No.	Include name of the author (in CAPITAL LETTERS), title of the article (when appropriate), title of the item (book, magazine, journal, serial, symposium, catalog, etc.), date, page(s), volume-issue number(s), publisher, city and/or country where published.	T <sup>1</sup>
	104	"Bookmark Your World", 1999-2000 Xenote, www.xenote.com	
	105	"Sirus to Add 'Instant Buy' Button," March 13, 2000, Twice, V 15, n 7, p. 28.	

Examiner Signature	Date Considered
--------------------	-----------------

\***Examiner:** Initial if reference considered, whether or not citation is in conformance with MPEP 609. Draw line through citation if not in conformance and not considered. Include copy of this form with next communication to applicant.

T<sup>1</sup> - Place a check mark in this area when an English language Translation is attached.

Volkswagen Exhibit 1002

<b>INFORMATION DISCLOSURE STATEMENT BY APPLICANT</b>	Application No.	12/366,535
	Filing Date	February 5, 2009
	First Named Inventor	Kelly M. Christensen
	Art Unit	2164
<i>(Multiple sheets used when necessary)</i>	Examiner	Belix M. Ortiz
SHEET 5 OF 5	Attorney Docket No.	STRATOS.029A

**NON PATENT LITERATURE DOCUMENTS**

Examiner Initials	Cite No.	Include name of the author (in CAPITAL LETTERS), title of the article (when appropriate), title of the item (book, magazine, journal, serial, symposium, catalog, etc.), date, page(s), volume-issue number(s), publisher, city and/or country where published.	T <sup>1</sup>
	106	Jan. 25, 2000, Showcase 2000 - Xenote Press Release re Xenote iTag, www.xenote.com/html/press/releases.html	
	107	International Search Report and Written Opinion for International Application No. PCT/US2009/03349, Notification mailed June 23, 2009. (STRATOS.029VPC)	

9798042

Examiner Signature	Date Considered
<p><b>*Examiner:</b> Initial if reference considered, whether or not citation is in conformance with MPEP 609. Draw line through citation if not in conformance and not considered. Include copy of this form with next communication to applicant.</p>	

T<sup>1</sup> - Place a check mark in this area when an English language Translation is attached

Volkswagen Exhibit 1002

(12)

(21) 2 316 925

(22) 06.01.1999

(51) Int. Cl.<sup>6</sup>: H04H 9/00

(85) 27.06.2000

(86) PCT/CH99/00006

(87) WO99/35771

(30) 24/98 CH 09.01.1998

(71) SWISSCOM AG,  
Alte Tiefenaustrasse 6, 3050 BERN, XX (CH).

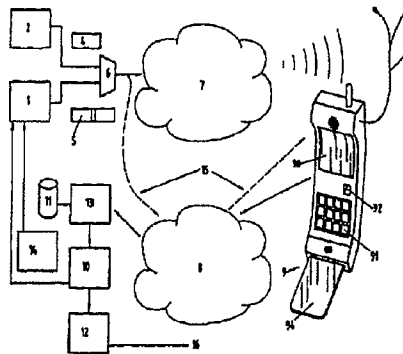
(72) RITTER, RUDOLF (CH).

(74) MACRAE & CO.

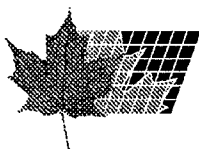
(54) PROCEDE DE TELECOMMUNICATION INTERACTIVE  
(54) METHOD FOR INTERACTIVE TELECOMMUNICATION

(57)

The invention relates to a telecommunication method comprising the following steps: integration of programme-related digital data into a TV or radio programme and transmission of said programme; reception and playback of the programme by a mobile telephone combined with a TV or radio receiving system, where the receiving system comprises a chip card reader into which the user of the receiving system can insert a SIM card to identify himself; display of at least one option corresponding to the integrated digital data on a display of the receiving system and selection of an option by the user of the receiving system; preparation of a message corresponding to the selected option by the SIM card, where the message prepared comprises at least one data field from the digital data being received; transmission of the above message by a bidirectional mobile telephone network to a server; automatic user identification by a server, whereby the user identification process uses information stored in the identification card and transmitted by the above bidirectional telecommunications network; linking of at least some received data with user-specific data.







(72) RITTER, RUDOLF, CH

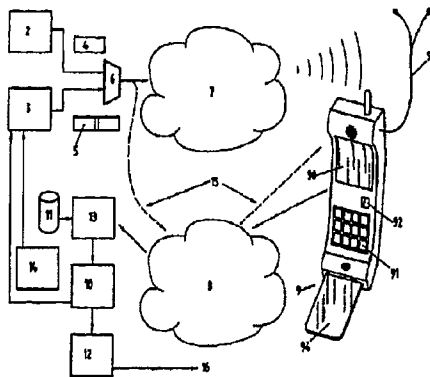
(71) SWISSCOM AG, CH

(51) Int. Cl. <sup>6</sup> H04H 9/00

(30) 1998/01/09 (24/98) CH

(54) **PROCEDE DE TELECOMMUNICATION INTERACTIVE**

(54) **METHOD FOR INTERACTIVE TELECOMMUNICATION**



(57) L'invention concerne un procédé de télécommunication comprenant les étapes suivantes: intégration de données numériques accompagnant le programme dans un programme télévisé ou radio et émission dudit programme; réception et restitution dudit programme par l'intermédiaire d'un appareil radio mobile, combiné avec un système récepteur télévisuel ou radio, le système récepteur comprenant un lecteur de carte à puce dans lequel l'utilisateur dudit système peut introduire une carte à module d'identification d'abonné, afin de présenter son identité; affichage sur un système d'affichage du système récepteur, d'au moins une option correspondant aux données numériques intégrées, et sélection d'une option par l'utilisateur du système de réception; préparation par la carte à module d'identification d'abonné d'un message correspondant à l'option retenue, le message préparé comprenant au moins un champ de données issu des données numériques reçues; transmission à un serveur du message cité par l'intermédiaire d'un réseau radio mobile bidirectionnel; identification automatique de l'utilisateur par le serveur, cette identification utilisant une information mémorisée dans la carte d'identification et transmise par ledit réseau de télécommunication bidirectionnel; combinaison d'au moins quelques unes des données reçues avec des données propres à l'utilisateur.

(57) The invention relates to a telecommunication method comprising the following steps: integration of programme-related digital data into a TV or radio programme and transmission of said programme; reception and playback of the programme by a mobile telephone combined with a TV or radio receiving system, where the receiving system comprises a chip card reader into which the user of the receiving system can insert a SIM card to identify himself; display of at least one option corresponding to the integrated digital data on a display of the receiving system and selection of an option by the user of the receiving system; preparation of a message corresponding to the selected option by the SIM card, where the message prepared comprises at least one data field from the digital data being received; transmission of the above message by a bidirectional mobile telephone network to a server; automatic user identification by a server, whereby the user identification process uses information stored in the identification card and transmitted by the above bidirectional telecommunications network; linking of at least some received data with user-specific data.





**PCT**  
 WELTORGANISATION FÜR GEISTIGES EIGENTUM  
 Internationales Büro  
 INTERNATIONALE ANMELDUNG VERÖFFENTLICHT NACH DEM VERTRAG ÜBER DIE  
 INTERNATIONALE ZUSAMMENARBEIT AUF DEM GEBIET DES PATENTWESENS (PCT)

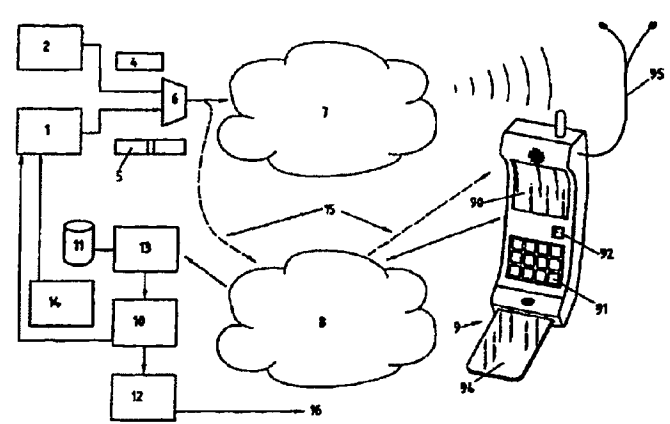
<p>(51) Internationale Patentklassifikation <sup>6</sup> :  <b>H04H 9/00</b></p>	<p><b>AI</b></p>	<p>(11) Internationale Veröffentlichungsnummer: <b>WO 99/35771</b>                  (43) Internationales Veröffentlichungsdatum: <b>15. Juli 1999 (15.07.99)</b></p>
<p>(21) Internationales Aktenzeichen: <b>PCT/CH99/00006</b>                  (22) Internationales Anmeldedatum: <b>6. Januar 1999 (06.01.99)</b>                  (30) Prioritätsdaten:                      <b>24/98</b>                      <b>9. Januar 1998 (09.01.98)</b>                      <b>CH</b>                  (71) Anmelder (für alle Bestimmungsstaaten ausser US): <b>SWISS-COM AG [CH/CH]; Viktoriastrasse 21, CH-3050 Bern (CH).</b>                  (72) Erfinder; und                  (75) Erfinder/Anmelder (nur für US): <b>RITTER, Rudolf [CH/CH]; Rossweidweg 8, CH-3052 Zollikofen (CH).</b>                  (74) Anwalt: <b>BOVARD AG; Optingenstrasse 16, CH-3000 Bern 25 (CH).</b></p>	<p>(81) Bestimmungsstaaten: <b>AL, AM, AT, AT (Gebrauchsmuster), AU, AZ, BA, BB, BG, BR, BY, CA, CH, CN, CU, CZ, CZ (Gebrauchsmuster), DE, DE (Gebrauchsmuster), DK, DK (Gebrauchsmuster), EE, EE (Gebrauchsmuster), ES, FI, FI (Gebrauchsmuster), GB, GD, GE, GH, GM, HR, HU, ID, IL, IN, IS, JP, KE, KG, KP, KR, KZ, LC, LK, LR, LS, LT, LU, LV, MD, MG, MK, MN, MW, MX, NO, NZ, PL, PT, RO, RU, SD, SE, SG, SI, SK, SK (Gebrauchsmuster), SL, TJ, TM, TR, TT, UA, UG, US, UZ, VN, YU, ZW, ARIPO Patent (GH, GM, KE, LS, MW, SD, SZ, UG, ZW), eurasisches Patent (AM, AZ, BY, KG, KZ, MD, RU, TJ, TM), europäisches Patent (AT, BE, CH, CY, DE, DK, ES, FI, FR, GB, GR, IE, IT, LU, MC, NL, PT, SE), OAPI Patent (BF, BJ, CF, CG, CI, CM, GA, GN, GW, ML, MR, NE, SN, TD, TG).</b></p> <p><b>Veröffentlicht</b>  <i>Mit internationalem Recherchenbericht.</i></p>	

(54) Title: **METHOD FOR INTERACTIVE TELECOMMUNICATION**

(54) Bezeichnung: **VERFAHREN ZUR INTERAKTIVEN TELEKOMMUNIKATION**

(57) Abstract

The invention relates to a telecommunication method comprising the following steps: integration of programme-related digital data into a TV or radio programme and transmission of said programme; reception and playback of the programme by a mobile telephone combined with a TV or radio receiving system, where the receiving system comprises a chip card reader into which the user of the receiving system can insert a SIM card to identify himself; display of at least one option corresponding to the integrated digital data on a display of the receiving system and selection of an option by the user of the receiving system; preparation of a message corresponding to the selected option by the SIM card, where the message prepared comprises at least one data field from the digital data being received; transmission of the above message by a bidirectional mobile telephone network to a server; automatic user identification by a server, whereby the user identification process uses information stored in the identification card and transmitted by the above bidirectional telecommunications network; linking of at least some received data with user-specific data.



## Telecommunication Method

The present invention relates to a telecommunication method and to a receiving system for carrying out this method. The invention relates in particular  
5 to a telecommunication method which can be utilized on a broadcast channel.

The most widespread broadcast systems are purely monodirectional and therefore have no backward channel by means of which the receiver could send response messages to the sender. That is the case, for example, in most radio and TV broadcast systems. If the receiver, e.g. the radio listener or the  
10 television viewer, would like to react to a program or to a commercial, he must therefore have recourse to some other telecommunications system, e.g. his telephone. If, for example, a product is advertised on television, the interested customer must immediately make a note of the address or telephone number of the supplier and call him later manually. The customer must then identify  
15 himself to the supplier and indicate by telephone the product which interests him. This procedure is extremely complicated and error-prone. For this reason, most broadcast systems are not entirely suitable for prompting the receiver to make spontaneous purchases during or just after a commercial. Moreover, it is difficult to design TV or radio programs in which immediate feedback from the  
20 receiver is needed.

Adding accompanying digital data to a radio or television program is likewise already known. In television systems, digital data can thus be transmitted during the vertical raster interval. An appropriate hardware and software device in the receiver's television set or PC makes it possible to  
25 decode these digital data, to select them, and to store them or display them on the receiver's screen. In radio systems, the transmission of program-accompanying data in addition to the radio programs is used above all with digital radio systems of the DAB (digital audio broadcasting) type. DAB technology makes it possible in this way to transmit both radio programs and  
30 accompanying services (program associated data, PAD). DAB receivers containing a data decoder and a respective display are commercially available.

TV program channel, this channel for program-accompanying data is only monodirectional.

Broadcast channels having a backward channel whereby digital data are sent between a server and a number of receivers, e.g. by means of a push channel on the Internet, have meanwhile also become known. According to the user's choice and interests, these digital data can then be stored and/or filtered in the user's receiving system. For example, a complete information program can be transmitted to the user, who then decides, for instance, to display or store only the information pertaining to sports articles or politics. With these systems, the receivers can receive a program passively and respond only when, for example, they want more information on a subject or when they want to order a product. As is well known, however, it is difficult to identify users reliably on the Internet, so that this method is not entirely suitable for transmitting confidential or security-sensitive data, such as product or remittance orders, to the sender or to a supplier. Furthermore, the user must have a minimum knowledge of computer technology in order to take advantage of an offer transmitted through a push-channel in the media program. For instance, the user must compose an E-mail message containing his own identification, a description of the product to be ordered, and the identification of the chosen supplier. Hence this method is rather lengthy and troublesome. Moreover, possible errors made by the user or arising through problems with the transmission in the telecommunications network are not easy to locate. The result is a substantial percentage of orders which cannot be carried out because, for instance, the particulars from the user have been entered incompletely or erroneously.

Described in the patent application EP 426 542 A1 is a method for direct marketing via a television network as well as a device for carrying out the method. According to the teaching disclosed in EP 426 542 A1, television receivers are equipped with chip-card readers, and information received from a sender, which contains product identification, is processed in a chip-card inserted into the chip-card reader, information received and user authentication data stored on the chip-card being processed together, and the result of this processing is displayed on the television screen when the television viewer enters a command. To order

AMENDED PAGE

2a

a product, the television viewer can communicate the said result to the sender in a delayed way, for example by means of post or telephone, or immediately, for example via a cable network, according to the teaching disclosed in EP 426 542

5 A1.

It is therefore the object of the present invention to provide a telecommunications system which avoids the above-mentioned drawbacks.

This object is attained, according to the invention, by means of a method and a system having the features of the respective independent claims, preferred  
10 embodiments being presented moreover in the dependent claims.

15

20

**AMENDED PAGE**

By means of the inventive system and method, the receiver can automatically compose and transmit messages not only to the sender, but also to other partners, e.g. to suppliers of advertised products.

5           The invention will be better understood with the aid of the description, given by way of example and illustrated by the figures, whereby:

Fig. 1 shows a schematic view of the system according to the invention;

Fig. 2 shows a schematic view of the structure of the order code transmitted;

10           Fig. 3 shows a screen view generated on the display of the user's receiving system by the inventive Java applet; and

Fig. 4 is a flow chart indicating the various steps carried out upon reception of such an applet in the receiving system.

15           Fig. 1 shows schematically the system components which can be utilized for carrying out the inventive method. The individual elements will now be described in detail:

20           Reference numeral 1 represents a marketing-on-line studio. Here individual order numbers 52 are prepared, packed with Java applets 50 (Java is a registered trademark of Sun Microsystems), and assigned to one or more transmission blocks. These messages will be explained below with reference to Fig. 2.

25           In a transmission studio 2, media programs are prepared and divided into transmission blocks. A transmission block may, for instance, correspond to an advertisement, a piece of music, a radio play, a commercial, a film, a Web site, etc. The transmission studio may, for example, be a radio studio, a TV studio,

or an Internet server.

Transmitted transmission blocks 4 are combined at 6 with assigned messages 5 and sent out over a broadcast channel 7. Depending upon the application, broadcast channel 7 may, for example, be an FM broadcasting network, a TV broadcasting network, or an Internet push channel. Alternatively, the transmission blocks 4, e.g. advertising messages, and the respective messages 5 may also be sent out over a conventional mobile communication network 8, as indicated by arrow 15.

10

The transmitted media program is received by a receiving system 9 according to the present invention. The receiving system 9 may, for example, be a mobile telecommunications device having an integrated radio receiver. With this system, the user may telephone quite conventionally over a mobile radio network 8, e.g. a GSM network, or use it as a conventional FM receiver instead, e.g. to listen to radio programs by means of headphones 95. In a modification, the receiving system has a television receiver instead of or in addition to the radio receiver for viewing television programs on a display 90 of the mobile apparatus. Mobile radio apparatus provided with an adequate screen, e.g. for video telephone applications, are commercially available; one skilled in the art can easily integrate a TV tuner in such a mobile videophone apparatus so that television can also be viewed with this system. The mobile radio functions and the radio or TV functions can be operated individually or in combination. In the case of individual operation, the radio or TV receiver can be operated like a conventional individual apparatus. In the case of combined operation, the FM radio or TV receiver is operative, and the mobile radio component is on standby or in communication mode. By means of a special key 92, the user, upon receiving an interesting message, can activate the execution of the applet 5 and the screen display shown in Fig. 3.

20  
25  
30

The receiving system 9 may also consist of a radio and/or TV receiver with additional mobile radio communication components integrated in the

housing. It is equally possible to integrate the mobile radio components in a remote control for a television set or for some other broadcast receiver. Furthermore, the receiving system may also consist of a computer, e.g. a PC or a palmtop, with integrated reception means for radio, TV, and/or Internet, as well as communication means for a mobile radio network 8. As will be explained below, however, the inventive method can also be carried out with a conventional mobile radio device 9, e.g. a GSM terminal.

The receiving system 9 preferably contains in addition means known per se for sending and receiving SMS (short message system) and/or USSD (unstructured supplementary service data) short messages, as well as filter means known per se for recognizing and temporarily storing special short messages, preferably according to the SICAP method described, among other things, in European Patent No. 0 689 368. Encryption and signature means are preferably present as well in order to decode short messages received and to encode and sign short messages to be sent out. The TTP method may be utilized as an encryption method, for example, or else decryption means functioning according to a point-to-point method.

The receiving system 9 can further transmit a short message having an order number to a server 13 over the mobile radio network 8. The server 13 combines the received order number with user identification data from a subscriber data base 11. These user identification data contain at least the full name and address of the subscriber. The user identification data preferably also contain the user's language, his bank connection and/or credit card company, subscribed services, etc. The subscriber data base 11 is preferably the data base of the operator of the telecommunications network 8 for administering the subscribers. Its contents are therefore extremely reliable in principle. It may also contain a temporary address of the subscriber. In a modification, the subscriber data base contains the user identification data only of users who have subscribed to the inventive system.



The receiving system 9 contains user identification means, preferably chip-card reading means, for identifying the user of the receiving system by means of an identification card. Such chip-card reading means are customary, among other things, in GSM mobile apparatus provided with SIM (subscriber identification module) cards. However, other identification cards, e.g. cards known by the name of OpenCard, may also be used, depending upon the receiving system.

The server 13 then combines at least some of the information contained in the short message entered by the user with the user identifications in order to complete the identification of the user not fully transmitted.

The server 13 is connected to a product/information supplier data base 10. It is via this data base that the functions of the system are controlled. It preferably newly contains a user profile. The data combined in the server 13 are sent by means of this data base to the logistics center 12 of the respective supplier, who then delivers the ordered products or information to the user 16.

A data warehouse server 14 analyzes the messages received from the user 9 <sic. 16> and hence draws up user profiles which allow marketing at the point-to-point level. The users may then load a user profile or a group of offered profiles on their identification card 94 so that they can also be directly addressed in the broadcast process.

The user may also order a profile for himself and have it assigned to him, e.g. by means of a special order message or on line by means of a computer.

The process which takes place in the elements 9 to 14 is described in more detail in the patent application PCT/CH96/00464, the contents of which are incorporated here.

30

Fig. 2 shows the structure of the message 5. The order number 52 itself is packed together with the respective Java code 50. This Java applet is received by the SIM card 94 in the mobile apparatus 9, having Java capability, which consequently carries out an interactive process with the user. The Java code 50 is transmitted only between the sender 1 and the mobile apparatus so that this interactive process takes place between the SIM card 9 <sic. 94> having Java capability and the user, but not between the mobile apparatus 9 and the server 13. Instead of Java, the applets may naturally also be written in some other object-oriented computer language.

The message 5 further comprises a user profile 510 drawn up in the studio 1, by means of which profile the data of interest to the user are filtered in the SIM card 94. For example, when the invention is utilized for securities trading, the user profile may, for instance, correspond to a segment of securities in an automatic trading system. The data-processing means in the SIM card 9 <sic. 94> can then automatically prepare a short message for the server 13 if buying or selling signals occur. The user then has the option of carrying out a respective process.

The user profile may be drawn up in the data warehouse 14 by the user himself or by combination. By means of a personal user profile, it becomes possible to indicate to a user the specific products in which he is really interested.

For example, the user may send a short message asking the logistics center 12 for a list of profiles and detail segments, which is displayed on his screen 90. Alternatively, a user profile may also be ordered on line with a PC or other computer. The user profile ordered is, for instance, stored in a user profile table in the secured area of the SIM card 94 and is used for selecting applets containing the information of interest. The user profile table can preferably not be modified by the user directly via the mobile apparatus.

Field 525 contains only a designator F for the order number 52. Fields 526, 527, and 528 contain separators. Field 521 contains a product supplier indication for the product or information offered. This designator preferably consists of a predefined abbreviation of the supplier's name. In order for the user to be able to understand this abbreviation, the supplier's full name is preferably transmitted as well as a link file (500) in the applet 50.

Field 522 contains the product identification, e.g. a product number. The product offered preferably corresponds to the transmission block 4 sent out simultaneously. For instance, if a piece of music is broadcast on the FM channel, various products pertaining to that piece of music may be offered simultaneously on the data channel or on DAB as an option in a menu, e.g. for ordering a CD, or sheet music, or tickets to a concert, etc. This mechanism controlled by the studio 1 may also be designed dynamically.

In addition to the product number 522, a link file 501 to one or more product identifications 502, 502', etc. in plain text and in several languages is preferably transmitted in the applet 50 and, if need be, displayed on the screen 90. The product identification is preferably provided with a language flag 503, 503', etc. This makes it possible for the product name to be set to the user's language by means of the language flag on the user-specific Java SIM card.

Field 523 (CS) contains a check sum or a parity sum in order to catch any errors in field 52. If such an error occurs at the level of the server 13, the user is prompted to repeat his entry.

The check sum is established by means of any known error-checking or error-correction algorithm from field 521 and 522. For example, a parity-check algorithm may be used for establishing the value of the check sum 523. The number of characters in the check sum depends upon the algorithm used and

on the maximum accepted error quota.

Finally, field 524 contains an indication concerning the desired transaction. This process can be controlled interactively by the user to enter  
5 whether he would like to order a product (ORDER) or whether he would just like to ask for information, for instance. If the receiving system is also linked to the Internet, a code W may also be entered in order to set the apparatus directly to a corresponding Web page. By means of a terminal identification IMEI in the receiving system, the Java applet can recognize whether the system has  
10 access to the Internet and whether the W option code must also be offered.

Furthermore, by means of options in field 524, the desired product quantity (M) and the preferred mode of payment (Z) can be selected.

15 This division of information in the short-message order is given only by way of example, for other ways of dividing it are quite conceivable. Moreover, the various data fields may be mixed, encrypted, and/or signed in order to guarantee confidentiality. The information may also be divided up into different short messages sent in succession.  
20

Fig. 3 shows diagrammatically the screen 90 during execution of a message which has passed through the filter. In this example, the whole order number 52 is interactively depicted. Under the abbreviated supplier designator 521, the full supplier identification 500 is displayed. Using a cursor 900, the  
25 user can choose one of a number of products 522, 522', 522", ... in a list box in area 901. The name of the chosen product is permanently shown in plain text in field 502. Similarly, the Java applet permits selection of the transaction possibilities (order or information), the desired quantity (M), and the mode of payment (Z) by means of a menu, the chosen option always being explained in  
30 plain text in the text area 902 of the screen.

The sequence of operations will now be described in detail. In the case of a mobile apparatus combined with a radio receiver, advertising programs, music, news, etc., are sent out on the broadcast channel 7. At the same time, the order number 52, preferably packed with applet 50, is also sent out on the available data channel. If an offer or a piece of music appeals to the user, he can press the F-key 92 in order to activate the execution of the applet and the screen display of Fig. 3. With the cursor, the user can then pick out an operation, e.g. from the list boxes, and in this way enter a command; depending upon the supplier, only a single option, e.g. a single product which can be ordered, may be displayed instead.

If the user selects a transaction code which does not relate just to information, an interactive process preferably follows so that the user's authenticity can be ensured. This process may take place directly on the card 94, e.g. by means of TTP (trusted third party) or PTP (point-to-point) resources on the card, or interactively in a security server (not shown).

In the case of a mobile apparatus combined with a television receiver or a multifunctional computer, the sequence of operations is analogous. In that case, however, the receiving system may also be linked to the Internet and display Web pages. The system may thereby be set directly to the respective Web page.

The inventive method may also be used with ordinary mobile apparatus which do not contain any additional broadcast channel receivers, as already indicated by arrow 15 in Fig. 1. In that case, messages are sent out from a central office 2 to several or all users over the normal mobile radio network 8 in the broadcast method. In this modification, it is advisable to work with user profiles so that the information reaches only those users who are interested in it or those who have subscribed to a respective service.

The method implemented in the receiving system 9 upon receipt of a message 5 will now be described with reference to Fig. 4.

5 The receiving system has receiving means for receiving a media program sent out over a broadcast channel and program-accompanying data, and reproduction means for playing the received media program back to the user. The receiving system can thereby receive transmitted messages 5 and applets 50 as program-accompanying data (step 20).

10 The messages 5 received are then evaluated, this evaluation taking place even when the mobile radio part of the receiving system is switched off or in standby mode. If a message with an order number 52 is received (designated by the designator 525), the user profile is evaluated (test 21). If the order number received does not correspond to any customer profile, the  
15 process is terminated (step 23); otherwise, this code is further processed. If the mobile apparatus is switched on (test 24), the applet 50 is directly displayed on the display 90 (step 25). The user may then, for example, order products or ask for information, as described above (step 29).

If, on the contrary, the mobile apparatus is switched off, the message 5  
20 received or just the applet 50 is filed in a buffer (not shown) on the SIM card 94 or in the receiving system 9 (step 26). Only later, when the mobile apparatus is switched on (27), is the applet 50 executed and the information displayed (step 28), so that the user may order products or ask for information (step 29).

**Claims**

1. Telecommunication method comprising the following steps:

receiving by means of a suitable telecommunications mobile device (9),  
which contains a radio receiver and/or a television receiver, digital data (5) sent  
5 out over a broadcast channel (7, 8), which data are transmitted as program-  
accompanying data (5) in a media program (4), the telecommunications mobile  
device including an identification (94) card by which the user of the  
telecommunications mobile device (9) is identified,

displaying information, corresponding to the received digital data, on a  
10 display (90) of the telecommunications mobile device (9),

entering of a command by the user,

preparing a message corresponding to the entered command, the  
prepared message including at least one data field (521, 522, 524) from the  
digital data (5) received and an identification of the user determined from the  
15 identification card,

sending the prepared message over a mobile radio network (8).

2. Telecommunication method in accordance with claim 1, wherein said  
media program (4) is reproduced by the telecommunications mobile device (9).

3. Telecommunication method in accordance with one of the preceding  
20 claims, wherein the displayed information contains at least one menu from  
which a command can be selected.

4. Telecommunication method in accordance with one of the preceding  
claims, wherein the digital data can contain applets (50) which are executed by

**AMENDED PAGE**

the telecommunications mobile device (9).

5 5. Telecommunication method in accordance with one of the preceding claims, wherein, when the components needed for processing and displaying these data are switched off, the digital data received are temporarily stored in a buffer and not processed until these components are switched on.

6. Telecommunication method in accordance with one of the preceding claims, wherein the digital data received are packed in messages (5) which are first evaluated in order to determine whether they must be displayed.

10 7. Telecommunication method in accordance with claim 6, wherein the received messages (5) which are not of interest to the user are sorted out with the aid of a user profile stored in the memory of the telecommunications mobile device (9).

8. Telecommunication method in accordance with one of the preceding claims, wherein the digital data (5) are transmitted in a radio channel (7).

15 9. Telecommunication method in accordance with one of the preceding claims, wherein the digital data (5) are transmitted in a TV channel (7).

10. Telecommunication method in accordance with one of the preceding claims, wherein the prepared message is a SMS message.

20 11. Telecommunication method in accordance with one of the preceding claims, wherein the prepared message is a USSD message.

12. Telecommunication method in accordance with one of the preceding claims, wherein the prepared message is signed.

13. Telecommunication method in accordance with one of the

**AMENDED PAGE**



preceding claims, wherein the prepared message is encrypted.

14. Telecommunications mobile device (9) comprising mobile radio components by means of which the telecommunications mobile device (9) can be utilized in a mobile radio network (8), and which telecommunications mobile  
5 device (9) comprises an identification card (94) in order to identify the user of the telecommunications mobile device (9), wherein it further comprises:

a radio receiver and/or a television receiver for receiving a media program (4), sent out over a broadcast channel (7), and program-accompanying data (5),

10 reproducing means (90, 95) for playing back to the user the media program received,

message-preparing means for preparing and sending over the mobile radio network (8) messages including at least one data field (521, 522, 524) from the program-accompanying data (5) and an identification of the user.

15 15. Telecommunications mobile device (9) in accordance with claim 14, wherein the mobile radio components comprise a GSM mobile device.

16. Telecommunications mobile device (9) in accordance with one of the claims 14 or 15, wherein the identification card is a SIM card (94) capable of executing the applets (50) transmitted in the program-accompanying data  
20 (5).

17. Telecommunications mobile device (9) in accordance with one of the claims 14 to 16, wherein the message-preparing means are capable of preparing and sending SMS messages.

18. Telecommunications mobile device (9) in accordance with one of  
25 the claims 14 to 17, wherein the message-preparing means are capable of

**AMENDED PAGE**

preparing and sending USSD messages.

19. Telecommunications mobile device (9) in accordance with one of  
the claims 14 to 18, further comprising a key (92) for causing information,  
corresponding to the digital data received, to be displayed on a display (90) of  
5 the telecommunications mobile device (9).

10

15

**AMENDED PAGE**

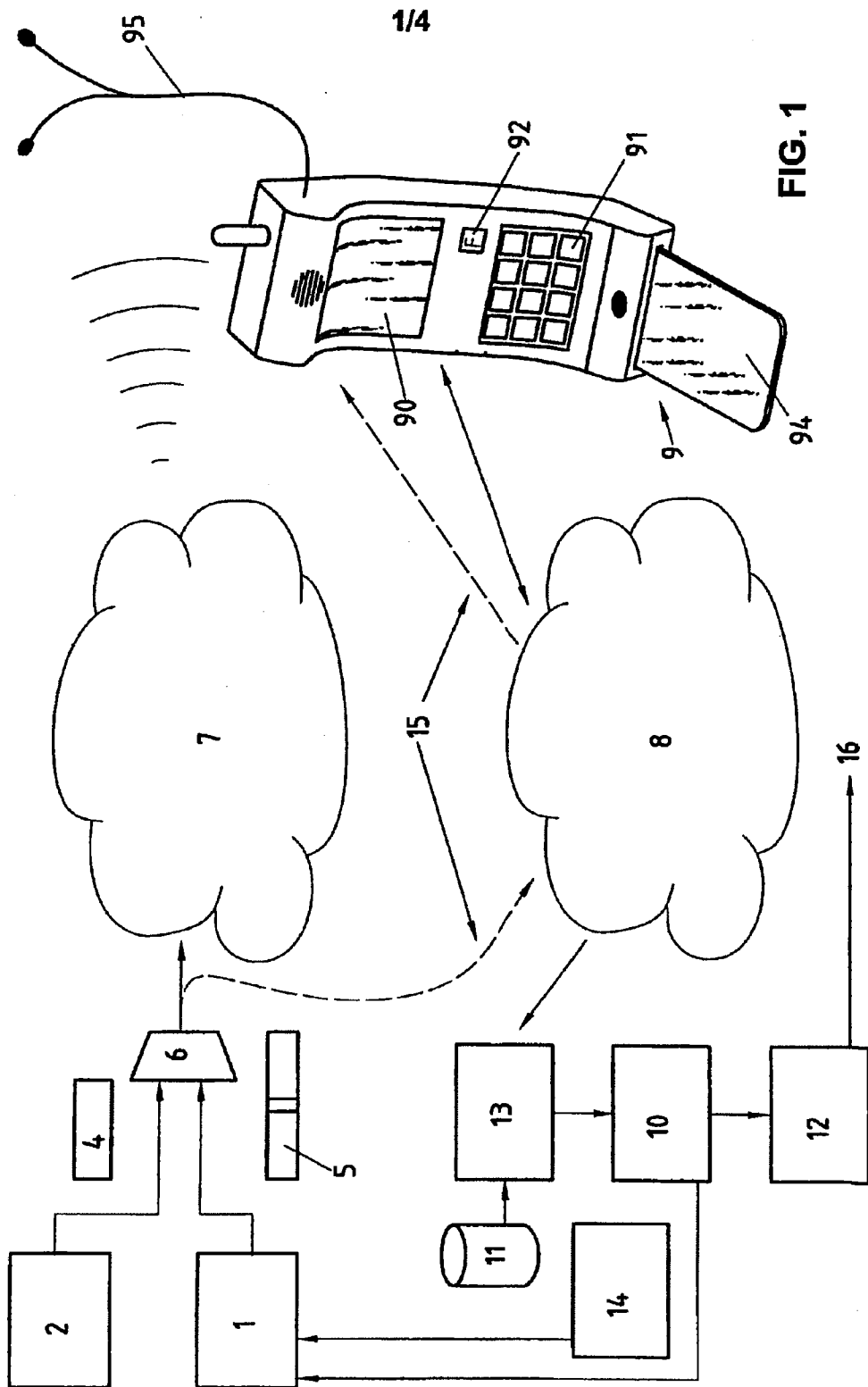


FIG. 1

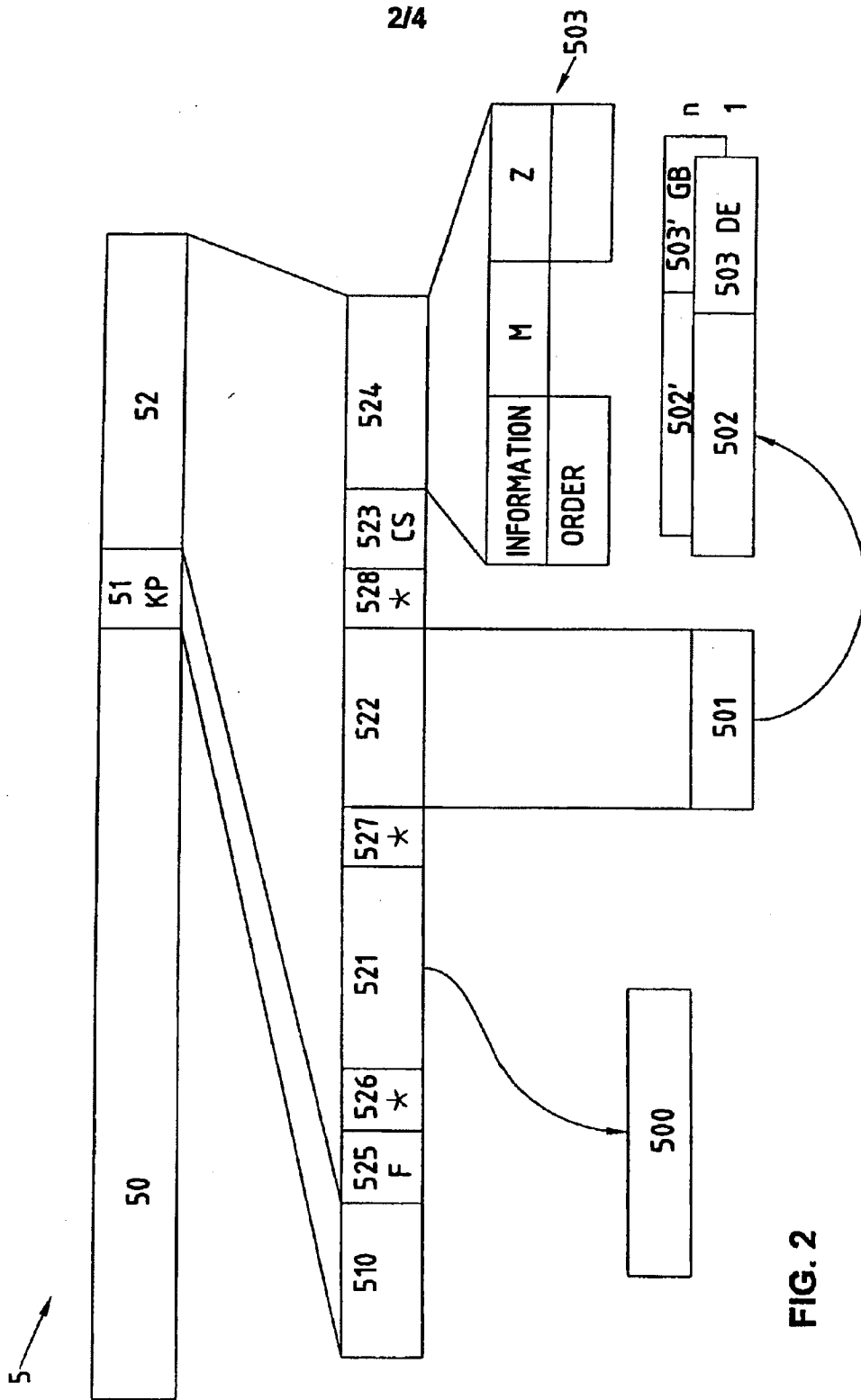


FIG. 2

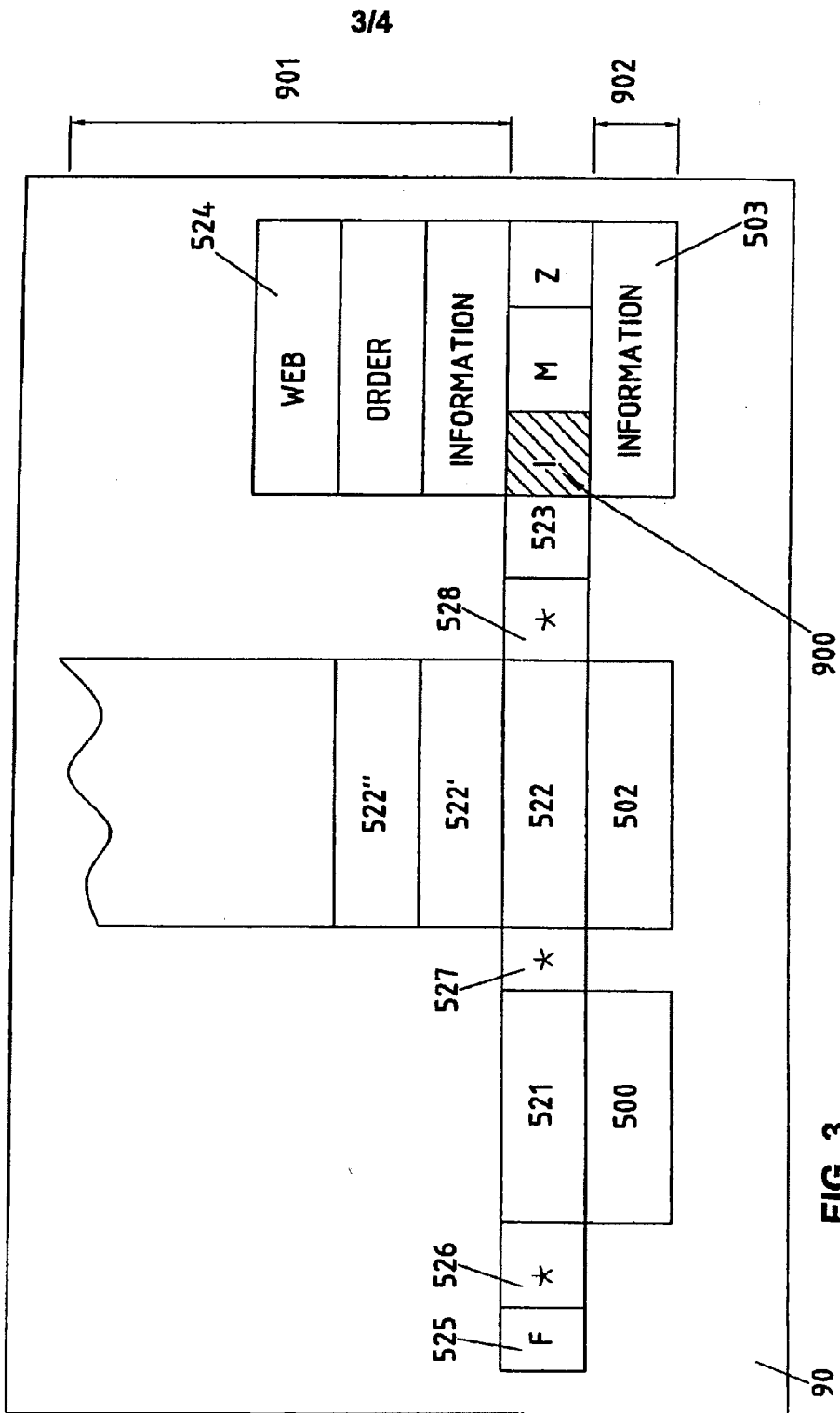


FIG. 3

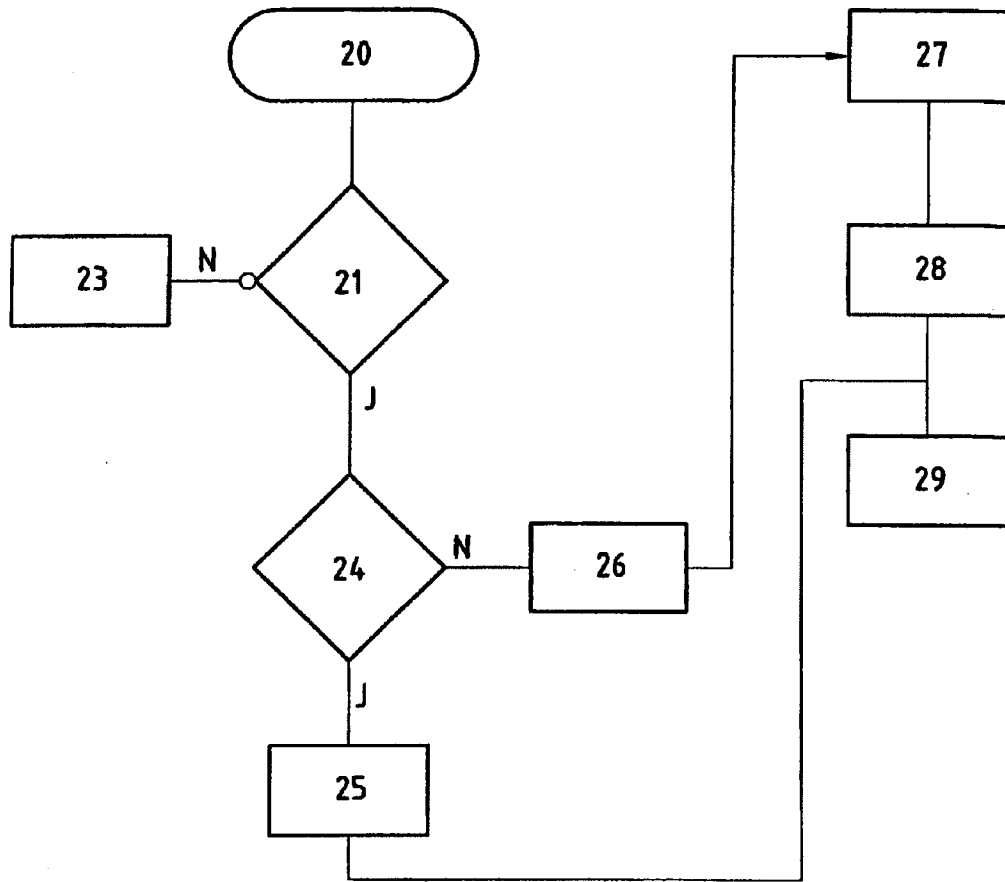


FIG. 4



19 BUNDESREPUBLIK  
DEUTSCHLAND



DEUTSCHES  
PATENTAMT

# Offenlegungsschrift DE 196 27 308 A 1

51 Int. Cl. 9:  
H 04 M 1/00  
H 04 M 11/06  
H 04 L 9/32  
G 07 F 19/00

21 Aktenzeichen: 196 27 308.0  
22 Anmeldetag: 27. 6. 96  
43 Offenlegungstag: 2. 1. 98

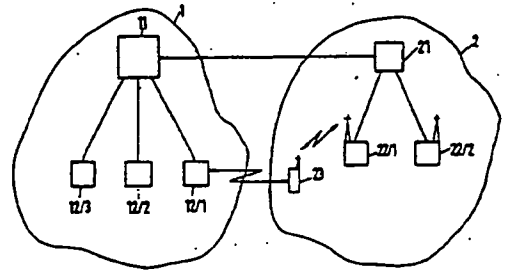
DE 196 27 308 A 1

71 Anmelder:  
Mannesmann AG, 40213 Düsseldorf, DE  
  
74 Vertreter:  
P. Meissner und Kollegen, 14199 Berlin

72 Erfinder:  
Mihatsch, Peter, Dr., 71069 Sindelfingen, DE

## 54 Kommunikationsgerät zur Übertragung von Buchungsbefehlen

57 Die Erfindung betrifft ein Kommunikationssystem zur Übertragung von Buchungsbefehlen, das untereinander zumindest virtuell vernetzte, zentrale und dezentrale Einrichtungen umfaßt, wobei an dezentralen Einrichtungen eingebaute, nutzerindividuelle Buchungsbefehle auf ihre Legitimation geprüft und an zentrale Einrichtungen zur Verarbeitung weitergeleitet werden.  
Die Erfindung ist dadurch gekennzeichnet,  
- daß Mittel eines unabhängigen zweiten Kommunikationssystems (2) mit ortsfesten Einrichtungen (21, 22/1, 22/2) und mit diesen verschlüsselt kommunizierenden, tragbaren Kommunikationseinrichtungen (23) vorgesehen sind,  
- daß die ortsfesten Einrichtungen (21, 22/1, 22/2) des zweiten Kommunikationssystems (2) mit den zentralen Einrichtungen (11) des ersten Kommunikationssystems (1) zumindest temporär verbindbar sind,  
- daß mit den tragbaren Kommunikationseinrichtungen (23) des zweiten Kommunikationssystems (2) nutzerindividuelle Buchungsbefehle in einer der zentralen Einrichtungen (11) des ersten Kommunikationssystems (1) vorlegitimierbar sind,  
- daß ein vorlegitimierter verschlüsselter Buchungscodex zumindest temporär in der tragbaren Kommunikationseinrichtungen (23) des zweiten Kommunikationssystems (2) speicherbar ist und  
- daß der vorlegitimierte verschlüsselte Buchungscodex unabhängig vom ersten und zweiten Kommunikationssystem (1, 2) zur tatsächlichen Buchung an eine dezentrale Einrichtung (12/1 bis 12/3) des ersten Kommunikationssystems (1)



DE 196 27 308 A 1

Die folgenden Angaben sind den vom Anmelder eingereichten Unterlagen entnommen  
BUNDESDRUCKEREI 10. 97 702 051/720

6/25

## Beschreibung

Die Erfindung betrifft ein Kommunikationssystem zur Übertragung von Buchungsbefehlen nach dem Oberbegriff des Patentanspruchs 1.

Derartige Kommunikationssysteme sind durch offenkundige Vorbenutzung bekannt.

Dazu ist eine Vielzahl von geldwerten Chipkarten, wie Telefonkarten, Kundenkarten, Kreditkarten usw. im Umlauf, die durch temporäres Einfügen in eine von einer zentralen Buchungseinrichtung örtlich abgesetzten dezentralen Einrichtung zur Bezahlung einer Ware oder Dienstleistung geeignet sind. Nachteiligerweise sind diese geldwerten Chipkarten regelmäßig von enger Zweckbindung, beispielsweise sind Telefonkarten ausschließlich zum Telefonieren unter Nutzung von Endgeräten eines einzigen Telefonunternehmens geeignet, und in Verbindung mit dezentralen Einrichtungen unterschiedlichen Komforts benutzbar. Darüber hinaus ist das Abhandenkommen einer derartigen geldwerten Chipkarte regelmäßig von monetärem Verlust begleitet. Weiterhin unterliegen diese Chipkarten aus Haftungsgründen betragsmäßigen Wertbeschränkungen, die ihre Brauchbarkeit weitgehend limitieren.

Darüber hinaus ist unter dem Begriff des sogenannten "Homebanking" ein Kommunikationssystem zur Übertragung von Buchungsbefehlen bekanntgeworden, bei dem der Benutzer dieses System unter Verwendung eines Personalcomputers mit Modem über eine Telefonverbindung Buchungsbefehle an eine zentrale Buchungseinrichtung überträgt. Die dazu erforderlichen technischen Einrichtungen sind nur eingeschränkt transportabel. Darüber hinaus ermangelt es diesem Verfahren an der Möglichkeit der Barauszahlung. Weiterhin sind die Vorkehrungen zum Schutz gegen unlegitimierte Zugriffe zumindest lückenhaft.

Der Erfindung liegt daher die Aufgabe zugrunde, ein Kommunikationssystem der gattungsgemäßen Art anzugeben, das einen komfortablen Zugriff bei höchstmöglicher Sicherheit gegen unlegitimierte Zugriffe sowie eine breite Akzeptanz ermöglicht.

Erfindungsgemäß wird diese Aufgabe mit den Mitteln des Patentanspruchs 1 gelöst. Vorteilhafte Ausgestaltungen der Erfindung sind in den Patentansprüchen 2 bis 6 beschrieben.

Die Erfindung geht dabei von einem für sich bekannten Kommunikationssystem zur Übertragung von Buchungsbefehlen aus, das untereinander zumindest virtuell vernetzte, zentrale und dezentrale Einrichtungen umfaßt wobei die an den dezentralen Einrichtungen eingebaren, nutzerindividuellen Buchungsbefehle auf ihre Legitimation geprüft und an zentrale Einrichtungen zur Verarbeitung weitergeleitet werden.

Der Kern der Erfindung besteht darin, daß ein unabhängiges zweites Kommunikationssystem vorgesehen ist, das aus ortsfesten Einrichtungen und mit diesen verschlüsselt kommunizierenden, tragbaren Kommunikationseinrichtungen besteht. Dabei sind die ortsfesten Einrichtungen des zweiten Kommunikationssystems mit den zentralen Einrichtungen des Kommunikationssystems zur Übertragung von Buchungsbefehlen zumindest temporär verbindbar. Mit den tragbaren Kommunikationseinrichtungen des zweiten Kommunikationssystems sind nutzerindividuelle Buchungsbefehle in einer der zentralen Einrichtungen des Kommunikationssystems zur Übertragung von Buchungsbefehlen vorlegitimierbar. Weiterhin ist vorgesehen, daß ein vorlegitimierter, verschlüsselter Buchungscode zumindest

temporär in der tragbaren Kommunikationseinrichtung des zweiten Kommunikationssystems speicherbar ist und daß der vorlegitimierte verschlüsselte Buchungscode unabhängig vom ersten und vom zweiten Kommunikationssystem zur tatsächlichen Buchung an eine dezentrale Einrichtung des ersten Kommunikationssystems übertragbar ist.

Ein durch einen Nutzer initiiertes Buchungsbefehl wird mit den Mitteln der tragbaren Kommunikationseinrichtung des zweiten Kommunikationssystems eingegeben. Dazu ist die tragbare Kommunikationseinrichtung mit einer Tastatur und vorzugsweise einer Anzeigevorrichtung ausgestattet. Der Buchungsbefehl wird innerhalb des zweiten Kommunikationssystems mit der dem zweiten Kommunikationssystem immanenten Verschlüsselung zu einer ortsfesten Einrichtung des zweiten Kommunikationssystems übertragen und an eine zentrale Einrichtung des Kommunikationssystems zur Übertragung von Buchungsbefehlen weitergeleitet.

Der Zugang des Nutzers zur Diensten des zweiten Kommunikationssystems ist durch einen mehrstufigen Identifizierungsprozeß gegen unlegitimierte Zugriffe abgesichert. Dazu werden seitens der ortsfesten Einrichtungen des zweiten Kommunikationssystems die Endgerätenummer der tragbaren Kommunikationseinrichtung, die Teilnehmernummer des Nutzers, die auf einem wechselbaren Modul innerhalb der tragbaren Kommunikationseinrichtung gespeichert ist, und die persönliche Identifikationsnummer des Nutzers abgefragt. Infolge dieses mehrstufigen Identifizierungsprozesses gilt der unlegitimierte Zugang zum zweiten Kommunikationssystem bei bestimmungsgemäßem Gebrauch als ausgeschlossen. Vorzugsweise ist das zweite Kommunikationssystem ein Mobilkommunikationssystem auf der Basis des GSM-Standards.

Vorteilhafterweise wird bei höchstmöglicher Sicherheit gegen unlegitimierte Zugriffe ein hoher Grad an Komfort realisiert, da bekannte tragbare Kommunikationseinrichtungen so geringe Volumina aufweisen, daß sie ständig mitgeführt werden können.

Als zusätzlicher positiver Effekt ist anzusehen, daß mit einem einzigen mitzuführenden Gerät, das zum Zwecke der verbalen und Daten-Kommunikation ohnehin bereits eine weite Verbreitung gefunden hat, ergänzend Buchungsgeschäfte durchführbar sind.

Die Erfindung wird nachstehend anhand eines Ausführungsbeispiels unter Berücksichtigung von vorteilhaften Ausgestaltungen näher erläutert.

In der einzigen Figur sind ein Kommunikationssystem 1 zur Übertragung von Buchungsbefehlen mit einer zentralen Einrichtung 11 und drei dezentralen Einrichtungen 12/1 bis 12/3 dargestellt, die derart miteinander vernetzt sind, daß jede dezentrale Einrichtung 12/1 bis 12/3 mit der zentralen Einrichtung 11 verbunden ist. Diese Verbindung kann dauerhaft oder auch auf Anforderung temporär geschaltet sein.

Weiterhin ist ein zweites Kommunikationssystem 2 mit ortsfesten Einrichtungen 21, 22/1 und 22/2 und tragbaren Kommunikationseinrichtungen 23 dargestellt, das als Mobilkommunikationssystem ausgeführt ist. Dabei sind die ortsfesten Einrichtungen 21, 22/1 und 22/2 permanent miteinander verbunden. Bestimmungsgemäß wird bedarfsweise eine Verbindung zwischen der tragbaren Kommunikationseinrichtung 23 und einer der ortsfesten Einrichtungen 22/1 und 22/2 hergestellt, die eine Funkverbindung mit verschlüsselter Datenübertragung ist.

Die ortsfeste Einrichtung 21 des Kommunikationssy-



stems 2 ist mit der zentralen Einrichtung 11 des Kommunikationssystems 1 zur Übertragung von Buchungsbefehlen verbunden. Diese Verbindung kann permanent oder auf Anforderung temporär geschaltet sein.

Ein nutzerindividueller Buchungsbefehl wird auf der Tastatur der tragbaren Kommunikationseinrichtung 23 eingegeben und über die ortsfesten Einrichtungen 22/1 und 21 des Mobilkommunikationssystems 2 an die zentrale Einrichtung 11 des Kommunikationssystems 1 zur Übertragung von Buchungsbefehlen übertragen. Bei vorliegender Zugangsvoraussetzung des Nutzers zum Kommunikationssystem 1 zur Übertragung von Buchungsbefehlen wird der empfangene Buchungsbefehl mit der zentralen Einrichtung 11 vorlegitimiert und als vorlegitimierter Buchungscodex über die ortsfesten Einrichtungen 21 und 22/1 des Mobilkommunikationssystems an die tragbare Kommunikationseinrichtung 23 übertragen und in der tragbaren Kommunikationseinrichtung zumindest temporär zwischengespeichert.

Da die Legitimation des Nutzers bereits beim Zugang zum Mobilkommunikationssystem 2 mehrstufig geprüft wird, ist vorteilhafterweise eine zusätzliche Legitimation des Nutzers gegenüber der zentralen Einrichtung 11 des Kommunikationssystems 1 zur Übertragung von Buchungsbefehlen entbehrlich. Dabei ist als weiterer Vorteil anzusehen, daß sich die Anzahl der durch den Nutzer zu merkenden Zugangs- und Identifizierungsschlüssel verringert, wodurch die Gefahr von Verwechslungen und Fehlidentifizierungen sinkt. Dieses Merkmal ist insbesondere im Hinblick auf die in üblichen Systemen sicherheitstechnisch begründete, eng begrenzte Anzahl von Zugangsversuchen bedeutsam.

Zur tatsächlichen Erlangung einer Ware oder Dienstleistung wird der vorlegitimierte, verschlüsselte Buchungscodex, der in der tragbaren Kommunikationseinrichtung 23 zwischengespeichert ist, unabhängig vom ersten und zweiten Kommunikationssystem 1 und 2 zur tatsächlichen Buchung an eine dezentrale Einrichtung 12/1 des Kommunikationssystems 1 zur Übertragung von Buchungsbefehlen übertragen.

Dazu ist vorgesehen, daß die tragbare Kommunikationseinrichtung 23 des Mobilkommunikationssystems und die dezentrale Einrichtung 12/1 des Kommunikationssystems 1 zur Übertragung von Buchungsbefehlen über eine drahtlose, kurzreichweitige Kommunikationsanordnung untereinander verbindbar sind, wobei die tragbare Kommunikationseinrichtung 23 mindestens mit Sendemitteln und die dezentrale Einrichtung 12/1 mindestens mit Empfangsmitteln ausgestattet ist.

In vorteilhafter Ausgestaltung der Erfindung ist diese drahtlose, kurzreichweitige Kommunikationsanordnung durch eine Infrarotverbindung dargestellt. Die dazu erforderlichen technischen Mittel zeichnen sich vorteilhafterweise durch sehr geringe Volumina und Versorgungsanforderungen aus, so daß diese vorteilhaft in bekannte tragbare Kommunikationseinrichtungen integrierbar sind.

In alternativer Ausgestaltung der drahtlosen, kurzreichweitigen Kommunikationsanordnung ist vorgesehen, diese als Ultraschallverbindung auszuführen. Die dazu erforderlichen technischen Mittel weisen dieselben vorteilhaften Eigenschaften wie die Infrarotverbindung auf.

In weiterer Ausgestaltung der Erfindung ist vorgesehen, daß der vorlegitimierte, verschlüsselte Buchungscodex entsprechend den Algorithmen im Verkehr zwi-

schen den zentralen und dezentralen Einrichtungen 11 und 12/1 bis 12/3 verschlüsselt ist.

Vorteilhafterweise ist der an die dezentrale Einrichtung 12/1 übertragene Buchungscodex durch die dezentrale Einrichtung 12/1 direkt verarbeitbar, so als wäre er von der zentralen Einrichtung 11 desselben Kommunikationssystems 1 übertragen worden.

In weiterführender Ausgestaltung der Erfindung ist vorgesehen, den vorlegitimierten verschlüsselten Buchungscodex entsprechend den Algorithmen im Verkehr zwischen den ortsfesten Einrichtungen 21, 22/1 und 22/2 und den mit diesen verschlüsselt kommunizierenden, tragbaren Kommunikationseinrichtungen 23 des Mobilkommunikationssystems 2 verschlüsselt zu übertragen. Mit anderen Worten ist der vorlegitimierte Buchungscodex, der bereits unter Anwendung von Mitteln im Kommunikationssystem 1 zur Übertragung von Buchungsbefehlen gemäß diesem System verschlüsselt ist, während seiner Übertragung innerhalb des Mobilkommunikationssystems 2 ein weiteres Mal, also überlagert verschlüsselt.

Vorteilhafterweise wird durch diese doppelte Verschlüsselung der unlegitimierte Zugang zu vorlegitimierten Buchungscodes zumindest erheblich erschwert, so daß aufgrund der weitgehenden Sicherheitsvorkehrungen eine breite Akzeptanz ermöglicht wird.

#### Bezugszeichenliste

- 1 Kommunikationssystem zur Übertragung von Buchungsbefehlen
- 11 zentrale Einrichtung
- 12/1 bis 12/3 dezentrale Einrichtungen
- 2 zweites Kommunikationssystem
- 21, 22/1, 22/2 ortsfeste Einrichtungen
- 23 tragbare Kommunikationseinrichtung

#### Patentansprüche

1. Kommunikationssystem zur Übertragung von Buchungsbefehlen, das untereinander zumindest virtuell vernetzte, zentrale und dezentrale Einrichtungen umfaßt wobei an dezentralen Einrichtungen eingebare, nutzerindividuelle Buchungsbefehle auf ihre Legitimation geprüft und an zentrale Einrichtungen zur Verarbeitung weitergeleitet werden, dadurch gekennzeichnet,

– daß Mittel eines unabhängigen zweiten Kommunikationssystems (2) mit ortsfesten Einrichtungen (21, 22/1, 22/2) und mit diesen verschlüsselt kommunizierenden, tragbaren Kommunikationseinrichtungen (23) vorgesehen sind,

– daß die ortsfesten Einrichtungen (21, 22/1, 22/2) des zweiten Kommunikationssystems (2) mit den zentralen Einrichtungen (11) des ersten Kommunikationssystems (1) zumindest temporär verbindbar sind,

– daß mit den tragbaren Kommunikationseinrichtungen (23) des zweiten Kommunikationssystems (2) nutzerindividuelle Buchungsbefehle in einer der zentralen Einrichtungen (11) des ersten Kommunikationssystems (1) vorlegitimierbar sind,

– daß ein vorlegitimierter verschlüsselter Buchungscodex zumindest temporär in der tragbaren Kommunikationseinrichtungen (23) des zweiten Kommunikationssystems (2) spei-

cherbar ist und

- daß der vorlegiti-  
mierte verschlüsselte Bu-  
chungscode unabhängig vom ersten und zwei-  
ten Kommunikationssystem (1, 2) zur tatsäch-  
lichen Buchung an eine dezentrale Einrichtung 5  
(12/1 bis 12/3) des ersten Kommunikationssy-  
stems (1) übertragbar ist.

2. Kommunikationssystem nach Anspruch 1, da-  
durch gekennzeichnet, daß die Kommunika-  
tionseinrichtungen (23) des zweiten Kommunika-  
tionssystems (2) und die dezentrale Einrichtung 10  
(12/1 bis 12/3) des ersten Kommunikationssystems  
(1) über eine drahtlose, kurzreichweitige Kommu-  
nikationsanordnung miteinander verbindbar sind,  
wobei die Kommunikationseinrichtungen (23) 15  
mindestens mit Sendemitteln und die dezentrale  
Einrichtung (12/1 bis 12/3) mindestens mit Emp-  
fangsmitteln ausgestattet ist.

3. Kommunikationssystem nach Anspruch 2, da-  
durch gekennzeichnet, daß die drahtlose, kurz- 20  
reichweitige Kommunikationsanordnung durch eine  
Infrarotverbindung dargestellt ist.

4. Kommunikationssystem nach Anspruch 2, da-  
durch gekennzeichnet, daß die drahtlose, kurz- 25  
reichweitige Kommunikationsanordnung durch eine  
Ultraschallverbindung dargestellt ist.

5. Kommunikationssystem nach Anspruch 1, da-  
durch gekennzeichnet, daß der vorlegiti-  
mierte verschlüsselte Buchungscode entsprechend den Algo-  
rithmen im Verkehr zwischen den zentralen und 30  
dezentralen Einrichtungen (11 und 12/1 bis 12/3)  
verschlüsselt ist.

6. Kommunikationssystem nach den Ansprüchen 1  
und 5, dadurch gekennzeichnet, daß der vorlegiti-  
mierte verschlüsselte Buchungscode entsprechend 35  
den Algorithmen im Verkehr zwischen den ortsfes-  
ten Einrichtungen (21, 22/1, 22/2) und mit diesen  
verschlüsselt kommunizierenden, tragbaren Kom-  
munikationseinrichtungen (23) des zweiten  
Kommunikationssystems (2) verschlüsselt über- 40  
tragbar ist.

Hierzu 1 Seite(n) Zeichnungen

45

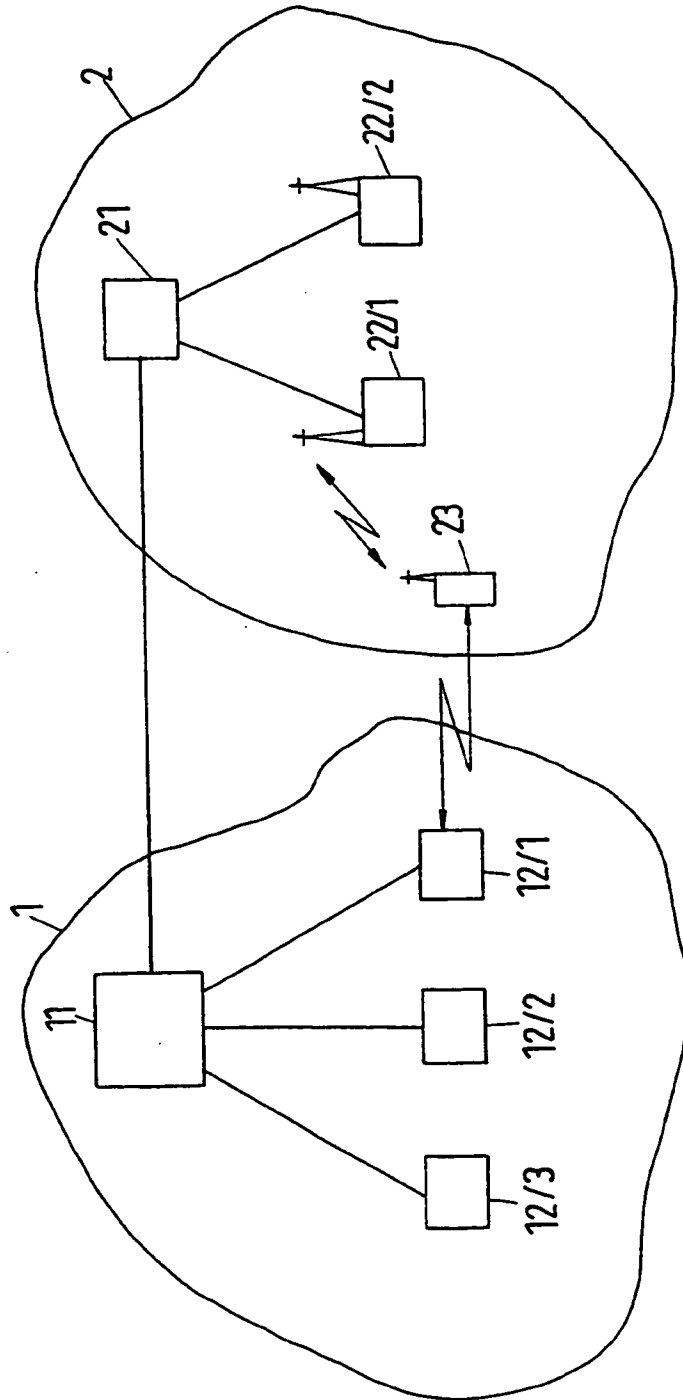
50

55

60

65

- Leerseite -



702 061/720

19 BUNDESREPUBLIK  
DEUTSCHLAND



DEUTSCHES  
PATENTAMT

12 Offenlegungsschrift  
10 DE 44 27 046 A 1

61 Int. Cl.<sup>8</sup>:  
H 04 N 5/445  
H 04 N 7/08  
H 04 M 1/26

21 Aktenzeichen: P 44 27 046.1  
22 Anmeldetag: 29. 7. 94  
43 Offenlegungstag: 1. 2. 96

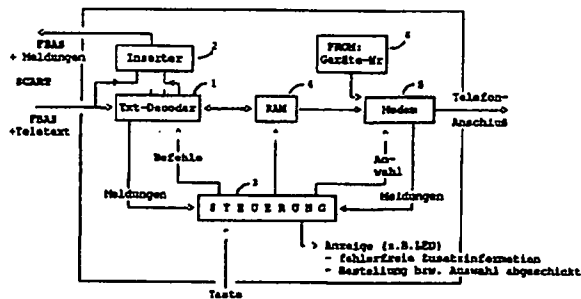
DE 44 27 046 A 1

71 Anmelder:  
Fridley Technologies Ltd., British Virgin Islands, VG  
74 Vertreter:  
Konle, T., Dipl.-Ing., Pat.-Anw., 81247 München

72 Erfinder:  
Goldscheider, Daniel, Wien, AT; Eitz, Gerhard, 85586 Poing, DE; Eichhorn, Roland, 80634 München, DE

64 Verfahren zum Wiedergeben von in einem Fernseh- oder Hörfunk-Programmsignal enthaltenen Zusatzinformationen

57 Um das Bestellen von Produkten, die im Fernsehen oder Hörfunk präsentiert werden, für den Fernseh- bzw. Hörfunkeinsteiger so einfach wie möglich zu machen und gleichzeitig die für eine Bestellung erforderliche Rechtsicherheit zu gewährleisten, wird vorgeschlagen, Zusatzinformationen, insbesondere in Form von Schrift und ggf. von Grafikelementen, innerhalb des Programmsignals in zeitlicher Korrelation zu dessen Programminhalt zu übertragen und empfangenseitig für eine bestimmte Dauer zwischengespeichert. Auf einen ersten Befehl des Benutzers wird eine in der zuletzt empfangenen Zusatzinformation enthaltene Klarschrift und ggf. Grafikinformatio für eine bestimmte Zeitdauer wiedergegeben. Während der Wiedergabe der Klarschrift und ggf. der Grafikinformatio wird auf einen zweiten Befehl des Benutzers aus der zuletzt zwischengespeicherten Zusatzinformation eine der Klarschrift und ggf. Grafikinformatio zugeordnete Bestell- oder Auswahlinformation entnommen und an eine Wählvermittlungseinrichtung (z. B. Modem) weitergeleitet.



DE 44 27 046 A 1

Die Erfindung bezieht sich auf ein Verfahren gemäß dem Oberbegriff des Patentanspruchs 1. Ein derartiges Verfahren ist aus Rundfunktechnischen Mitteilungen, Heft 1, 1978 "Anlage zur Aufbereitung und Einblendung von Untertiteln nach dem englischen Teletext-Standard" bekannt.

Aus der vorgenannten Literaturstelle ist es bekannt, bei fremdsprachigem Fernsehton oder für Gehörlose in das Fernsehbild Untertitel einzublenden. Die eingeblendeten Untertitel sind dabei zeitlich mit dem Fernsehbild korreliert.

Es ist ferner bekannt, in Fernseh-Werbesendungen Produkte vorzustellen, und am Ende der Werbesendung getrennt für jedes Land die Preise und die Telefonnummern anzugeben, unter welchen die zuvor erworbenen Produkte bestellt werden können. Dieses sogenannte "Teleshopping" hat jedoch den Nachteil, daß vom Fernsehteilnehmer die betreffenden Telefonnummern mitgeschrieben werden müssen; außerdem leidet der unmittelbare Bezug zwischen der fernsehmäßigen Präsentation des Produktes und der Anzeige von Preis und Telefonnummer. Hinzu kommt, daß der Fernsehteilnehmer, nachdem er die Telefonnummer abgeschrieben hat, einen telefonischen Bestellvorgang durchführen muß, was dann, wenn viele Fernsehteilnehmer gleichzeitig bestellen wollen, eine Vielzahl von Wählversuchen erforderlich macht.

Die Aufgabe der Erfindung besteht darin, ein Verfahren der eingangs erwähnten Art für den Bestellvorgang von Produkten nutzbar zu machen, um das Bestellen für den Teilnehmer so einfach wie möglich zu machen und gleichzeitig die für eine Bestellung erforderliche Rechtssicherheit zu gewährleisten.

Diese Aufgabe wird erfindungsgemäß durch die kennzeichnenden Merkmale des Patentanspruchs 1 gelöst.

Vorteilhafte Ausgestaltungen und Weiterbildungen des erfindungsgemäßen Verfahrens nach Anspruch 1 ergeben sich aus den Unteransprüchen.

Die Erfindung beruht auf der Überlegung, dem Fernseh- oder Hörfunkteilnehmer per Knopfdruck die Möglichkeit zu geben, bei der bildlichen oder akustischen Präsentation von Produkten oder Dienstleistungen eine Klarschriftinformation abzurufen, welche ihm durch Einblendung in das Fernsehbild bzw. Wiedergabe auf einem Display am Empfänger sichtbar gemacht wird. Insbesondere handelt es sich bei der Klarschriftinformation um nähere Angaben über das Produkt einschließlich Preis, welche für eine Kaufentscheidung des Teilnehmers erforderlich sind. Zur Bestellung braucht der Teilnehmer nur noch ein weiteres Mal auf eine spezielle Taste seines Empfängers bzw. dessen Fernbedienung zu drücken, worauf der Bestellvorgang automatisch ausgelöst wird. Ferner erhält der Teilnehmer nach Auslösung eines Bestellvorganges eine Quittiermeldung.

Die Erfindung wird anhand eines in den Zeichnungen dargestellten Ausführungsbeispiels näher erläutert. Es zeigen

Fig. 1a und Fig. 1b zwei Teletextseiten mit dann enthaltenen Zusatzinformationen;

Fig. 2 eine empfangenseitige Einrichtung nach der Erfindung zur Dekodierung der Zusatzinformation,

Fig. 3 eine Darstellung der zeitlichen Aufeinanderfolge zwischen einzelnen Fernsehbeiträgen und den zugehörigen Zusatzinformationen, und

Fig. 4 eine Darstellung der zeitlichen Aufeinanderfol-

ge zwischen der Anzeige der Klarschriftinformation und der den Zeitfenstern zur Auslösung eines Bestellvorgangs bzw. der Übermittlung einer Auswahlinformation.

Die für eine Bestellung bzw. eine Auswahl notwendigen Daten werden als Zusatzinformation zeitlich korreliert zum Fernsehprogramm auf Teletextseiten ähnlich wie Untertitel mit bestimmten Seitennummern gesendet, die der Empfangseinrichtung bekannt sind. Das in Fig. 1a dargestellte Beispiel ("Rotes Sommerkleid für DM 19,95") enthält eine Klarschrift-Information, eine Telefon-Nummer und eine Produkt-Nummer zur Bestellung des Sommerkleids. Alternativ kann, wie Fig. 1b zeigt, anstelle der Produkt-Nummer eine Nummer für eine Auswahlidentifikation, beispielsweise für eine anonyme Umfrage ("Gewinnt XYZ die nächste Wahl?") übertragen werden.

In Fig. 2 ist ein Blockschaltbild einer Empfangseinrichtung nach der Erfindung dargestellt, die extern aufgestellt und mit einem Fernsehgerät über ein Scart-Kabel verbunden ist. Über das Scart-Kabel wird das empfangene Fernsehsignal mit den Teletextdaten aus dem Fernsehgerät auf einen in der Empfangseinrichtung eingebauten Teletext-Dekoder und einen Inserter geführt. Der Teletext-Dekoder 1 detektiert aus den einlaufenden Teletext-Daten diejenigen Seiten, die von einer Steuerung angefordert werden und untersucht den Seiteninhalt der selektierten Seiten (sh. Fig. 1a oder Fig. 1b) nach einer Zusatzinformation.

Eine in ein Fernsehgerät eingebaute Empfangseinrichtung nach der Erfindung ist ähnlich wie eine Empfangseinrichtung mit Scart-Kabel aufgebaut. Bei der eingebauten Empfangseinrichtung entfällt der Inserter und die RGB-Signale am Ausgang des Teletext-Dekoders werden direkt über einen Schalter und entsprechende Verstärker auf den Fernsehbildschirm gegeben.

Wird eine fehlerfreie Zusatzinformation von dem Teletext-Decoder 1 festgestellt, so erfolgt eine Zwischenspeicherung in einem RAM-Speicher, eine Meldung an die Steuerung 3 und eine entsprechende Anzeige für den Benutzer, beispielsweise durch Blinken einer grünen LED-Anzeige. Bei bereits in Fernsehempfängern integrierten Empfangseinrichtungen nach der Erfindung ist es auch denkbar, eine entsprechende Signalisierung an der Gehäusefrontseite des Fernsehgerätes vorzunehmen.

Außerdem kann dem Benutzer das Vorhandensein von einer Zusatzinformation dadurch signalisiert werden, daß beispielsweise ein Logogramm vom Teletext-Dekoder generiert, vom Inserter in das Fernsehsignal eingestanz, über das Scart-Kabel zum Fernsehgerät zurückgeführt und auf dem Bildschirm zusammen mit dem gewählten Programm in einer Ecke auf dem Bildschirm angezeigt wird.

Sind nun Zusatzinformationen vorhanden und betätigt der Benutzer eine Taste, die der Empfangseinrichtung zugeordnet ist und die entweder am Gehäuse der Empfangseinrichtung oder an der Fernbedienung des Fernsehgerätes oder der erfindungsgemäßen Empfangseinrichtung angeordnet sein kann, so wird ein entsprechendes Steuersignal an die Steuerung übermittelt, die daraufhin den Teletext-Dekoder 1 veranlaßt, die zuletzt zwischengespeicherte Zusatzinformation aus dem RAM 4 zu laden und die darin enthaltene Klarschriftinformation (Fig. 1a, 1b) über den Inserter auf dem Bildschirm des Fernsehgerätes anzuzeigen.

Wird die Taste ein zweites Mal vom Benutzer gedrückt, so wird aus der im RAM 4 zwischengespeicher-

ten Zusatzinformation die Telefonnummer (Fig. 1a, 1b) in ein Modem übergeben und ein Wählvorgang ausgelöst. Vom Modem 5 führt eine entsprechende Telefonleitung aus der Empfangseinrichtung nach der Erfindung auf einen Telefonanschluß des Benutzers. Ist die Verbindung mit dem angewählten Teilnehmer hergestellt, werden bei einer Bestellinformation die Produktnummer (Fig. 1a) für das gewünschte Produkt zusammen mit einer Geräte-Nummer zur Identifikation des Benutzers aus einem PROM-Speicher übertragen. Enthält dagegen die Zusatzinformation eine Auswahlidentifikations-Nummer (Fig. 1b), so wird nur sie, ohne Geräte-Nummer, zur Wahrung der Anonymität des Benutzers dem angewählten Teilnehmer übermittelt.

Die erfolgreiche Übertragung der Daten wird vom Modem an die Steuerung signalisiert, die wiederum eine entsprechende Meldung an den Teletext-Dekoder zur Anzeige auf dem Bildschirm abgibt. Außerdem ist eine entsprechende Anzeige auf einer zugeordneten LED-Anzeige oder am Fernsehgerät bei einer eingebauten Empfangseinrichtung denkbar.

Kann dagegen vom Modem keine Verbindung hergestellt werden, so erfolgt eine Wiederholung des Wahlvorgangs nach einer Zeitspanne, die von einem Zufallsgenerator in der Steuerung bestimmt wird. Diese Vorgehensweise ist insbesondere zur zeitlichen Entzerrung von Anwahlwiederholungen notwendig, die auftreten können, wenn bei vielen Empfangseinrichtungen zum gleichen Zeitpunkt ein Bestellvorgang bzw. ein Auswahlvorgang vom Benutzer ausgelöst wird (beispielsweise bei einem Preisausschreiben "Die ersten zehn Anrufer gewinnen").

Zur Verdeutlichung der Erfindung werden die zeitlichen Aufeinanderfolgen der einzelnen Fernsehbeiträge mit den zugehörigen Zusatzinformationen und die möglichen Bestell- bzw. Auswahlmöglichkeiten näher in Fig. 3 und Fig. 4 gezeigt.

Fig. 3 (a) zeigt zwei aufeinanderfolgende Werbeprogramme "Spot A" und "Spot B". In Fig. 3 (b) sind die Zusatzinformationen "A" für "Spot A" und "B" für "Spot B" dargestellt, die beispielsweise alle  $t_0 = 20$  sec. übertragen werden.

Das Eintreffen der Zusatzinformation und damit die Möglichkeit, direkt zu reagieren und das Angebot wahrzunehmen, wird dem Benutzer durch eine entsprechende Anzeige signalisiert, beispielsweise durch Eintasten eines Logogramms in das betreffende Programm. Wird dagegen keine Zusatzinformation beispielsweise für mehr als  $t_1 = 30$  sec. von der Empfangseinrichtung detektiert, wird die Anzeige wieder gelöscht (Fig. 4 (a)).

Beim ersten Tastendruck des Benutzers (Fig. 4 (b)) wird die Klarschrift-Information aus der Zusatzinformation "A" in das laufende Werbeprogramm "Spot A" eingeblendet. Beim Eintreffen der Zusatzinformation "B" wechselt die Anzeige automatisch und es werden die zu "Spot B" gehörenden Klarschrift-Informationen angezeigt. Die Klarschrift-Information zu "Spot B" wird vom Bildschirm gelöscht, wenn nach dem ersten Tastendruck innerhalb von beispielsweise  $t_2 = 100$  sec. kein zweiter Tastendruck erfolgt.

Um auszuschließen, daß bei einem unvorhergesehenen Wechsel der Zusatzinformation eine Bestellung des falschen Produkts bzw. eine falsche Auswahl erfolgt, ist vorgesehen, nach einem Wechsel für beispielsweise  $t_3 = 2$  sec. einen etwaigen zweiten Tastendruck zur Auslösung des Bestellvorgangs bzw. der Auswahl zu ignorieren (Fig. 4 (c)).

Bei einem Bestellvorgang (Fig. 1a) erhält der ange-

wählte Teilnehmer (z. B. eine Kreditkartenorganisation) die Produkt-Nummer und die Geräte-Nummer; er identifiziert den Bestellenden anhand der Geräte-Nummer, gibt Adresse, Kontoverbindung und angefordertes Produkt an eine für die Auslieferung zuständige Stelle weiter und regelt ggf. die Bezahlung. Ein Auswahlvorgang (Fig. 1b) läuft ähnlich wie ein Bestellvorgang ab; es erfolgt nur keine Übermittlung der Geräte-Nummer zur Identifikation des Benutzers.

Ein erfolgreicher Bestell- bzw. Auswahlvorgang und eine erfolgreiche Übermittlung der Bestell- bzw. Auswahl-daten wird dem Benutzer von der Empfangseinrichtung in geeigneter Weise angezeigt.

Anstelle einer fernsehmäßigen Übertragung der Zusatzinformation und deren Einblendung in ein Fernsehbild ist es ebensogut möglich, die Zusatzinformation in einem Hörfunk-Programmsignal zu übertragen und auf einem Display am Hörfunkempfänger wiederzugeben. Insbesondere eignet sich hierfür wegen der großen Übertragungskapazität ein digitales Hörfunk-Programmsignal. In Betracht kommt aber auch ein mit RDS-(Radio-Daten-System)-Signal versehenes analoges Hörfunk-Programmsignal (FM- und AM-Signal), da das RDS-Signal noch nichtbelegte Kennungen aufweist, welche für die erfindungsgemäße Zusatzinformation genutzt werden können.

#### Patentansprüche

1. Verfahren zum Wiedergeben von in einem Fernseh- oder Hörfunkprogrammsignal enthaltenen Zusatzinformationen, insbesondere in Form von Schrift und ggf. von Grafikelementen, welche innerhalb des Programmsignals in zeitlicher Korrelation zu dessen Programminhalt übertragen und empfängerseitig decodiert werden, dadurch gekennzeichnet, daß die empfangenen Zusatzinformationen empfängerseitig für eine bestimmte Dauer zwischengespeichert werden, daß auf einen ersten Befehl des Benutzers eine in der zuletzt empfangenen Zusatzinformation enthaltene Klarschrift und ggf. Grafikinformaton für eine bestimmte Zeitdauer wiedergegeben wird, und daß während der Wiedergabe der Klarschrift und ggf. der Grafikinformaton auf einen zweiten Befehl des Benutzers aus der zuletzt zwischengespeicherten Zusatzinformation eine der Klarschrift und ggf. Grafikinformaton zugeordnete Bestell- oder Auswahlinformation entnommen und an eine Wählvermittlungseinrichtung (z. B. Modem) weitergeleitet wird.
2. Verfahren nach Anspruch 1, dadurch gekennzeichnet, daß im Wiedergabebetrieb bei einem Wechsel der Zusatzinformationen die Auslösung des zweiten Befehls für eine bestimmte Zeitdauer gesperrt wird.
3. Verfahren nach Anspruch 1 oder 2, dadurch gekennzeichnet, daß die empfangsseitige Zwischenspeicherung einer Zusatzinformation dem Benutzer, zumindest für eine festgelegte Zeitdauer, optisch signalisiert wird.
4. Verfahren nach einem der Ansprüche 1 bis 3, dadurch gekennzeichnet, daß die Bestellinformation eine Produktkennung und eine Telekommunikationsnummer, ggf. in codierter Form, enthält, und daß die Wählvermittlungseinrichtung einen Wählvorgang entsprechend der Telekommunikationsnummer durchführt und bei aufgebauter Telekommunikationsverbindung die Produktkennung zu-

- sammen mit einer Benutzerkennung an den gerufenen Teilnehmer überträgt.
5. Verfahren nach Anspruch 4, dadurch gekennzeichnet, daß die entnommene Produktkennung und die entnommene Telekommunikationsnummer zwischengespeichert werden und daß die Benutzerkennung dauerhaft gespeichert ist. 5
6. Verfahren nach Anspruch 4 oder 5, dadurch gekennzeichnet, daß bei fehlerfreier Übertragung der Produkt- und der Benutzerkennung der gerufene Teilnehmer eine Quittiermeldung an die Wahlvermittlungseinrichtung rücküberträgt. 10
7. Verfahren nach Anspruch 6, dadurch gekennzeichnet, daß die rückübertragene Quittiermeldung an der Wiedergabeeinrichtung in geeigneter Weise angezeigt wird. 15
8. Verfahren nach Anspruch 6, dadurch gekennzeichnet, daß die rückübertragene Quittiermeldung eine optische und/oder akustische Signalisierung auslöst. 20
9. Verfahren nach einem der Ansprüche 4 bis 8, dadurch gekennzeichnet, daß bei erfolglosem Vermittlungsversuch oder bei fehlerhafter Übertragung der Produkt- und der Benutzerkennung die Wahlvermittlungseinrichtung einen erneuten Vermittlungs- und Übertragungsversuch nach einer Wartezeit durchführt, welche entsprechend einem Zufallsgesetz bestimmt wird. 25
10. Verfahren nach einem der Ansprüche 4 bis 9, dadurch gekennzeichnet, daß ein Wahlvorgang nur dann erfolgt, wenn die Benutzung der Wahlvermittlungseinrichtung vom berechtigten Benutzer freigegeben ist. 30
11. Verfahren nach einem der Ansprüche 1 bis 3, dadurch gekennzeichnet, daß die Auswahlinformation eine Auswahlidentifikation und eine Telekommunikationsnummer, ggf. in codierter Form, enthält, und daß die Wahlvermittlungseinrichtung einen Wahlvorgang entsprechend der Telekommunikationsnummer durchführt und bei aufgebauter Telekommunikationsverbindung die Auswahlidentifikation an den gerufenen Teilnehmer überträgt. 35
12. Verfahren nach Anspruch 11, dadurch gekennzeichnet, daß die entnommene Auswahlidentifikation und die entnommene Telekommunikationsnummer zwischengespeichert werden. 40
13. Verfahren nach Anspruch 11 oder 12, dadurch gekennzeichnet, daß bei fehlerfreier Übertragung der Auswahlidentifikation der gerufene Teilnehmer eine Quittiermeldung an die Wahlvermittlungseinrichtung rücküberträgt. 45
14. Verfahren nach Anspruch 13, dadurch gekennzeichnet, daß die rückübertragene Quittiermeldung an der Wiedergabeeinrichtung in geeigneter Weise angezeigt wird. 50
15. Verfahren nach Anspruch 13, dadurch gekennzeichnet, daß die rückübertragene Quittiermeldung eine optische und/oder akustische Signalisierung auslöst. 55
16. Verfahren nach einem der Ansprüche 11 bis 15, dadurch gekennzeichnet, daß erfolglosem Vermittlungsversuch oder bei fehlerhafter Übertragung der Auswahlidentifikation die Wahlvermittlungseinrichtung einen erneuten Vermittlungs- und Übertragungsversuch nach einer Wartezeit durchführt, welche entsprechend einem Zufallsgesetz bestimmt wird. 60
- 65



Rotes Sommerkleid für 15.95 DM
Produkt-Nummer    Telefon-Nummer

Fig. 1a

Umfrage: Gewinnt XYZ die nächste Wahl ??
Identifik.-Nr.    Telefon-Nummer

Fig. 1b

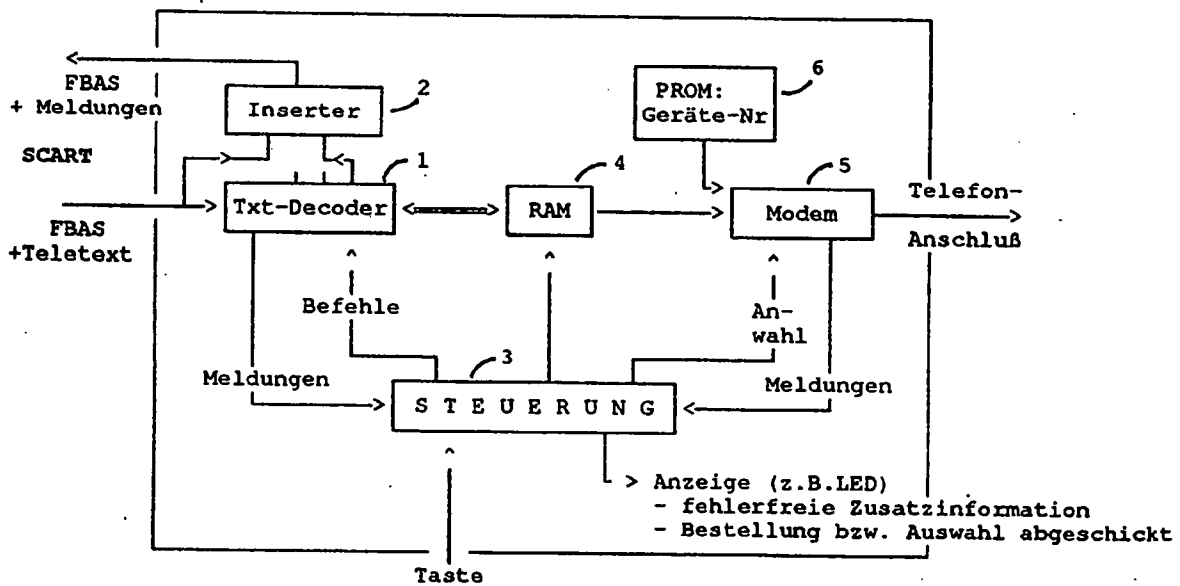


Fig. 2

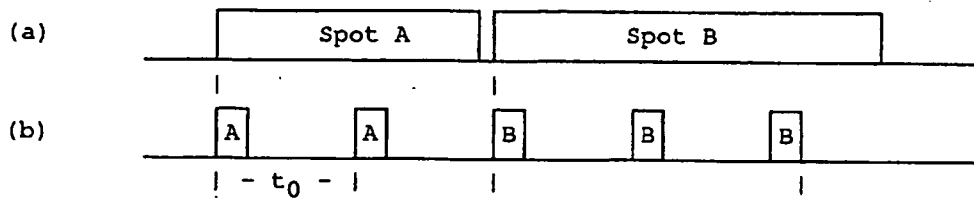


Fig. 3

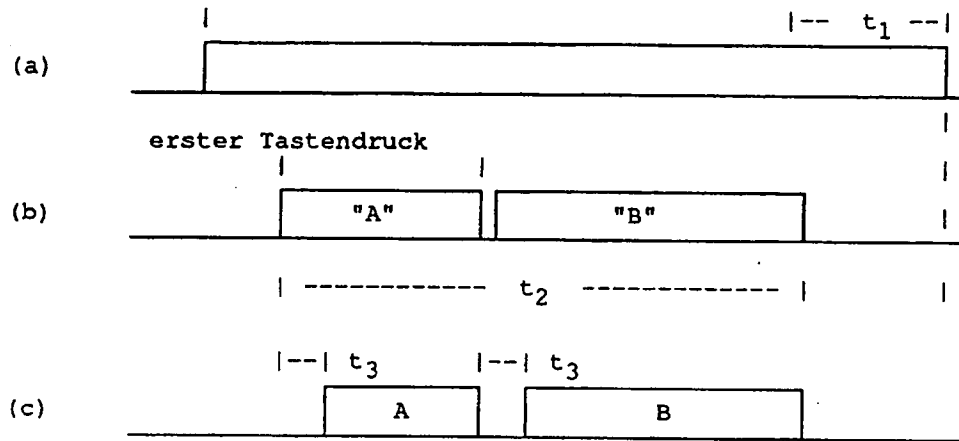


Fig. 4



(12) **EUROPEAN PATENT APPLICATION**

(43) Date of publication:  
**22.05.1996 Bulletin 1996/21**

(51) Int Cl.<sup>6</sup>: **H04N 7/08**

(21) Application number: **95307885.4**

(22) Date of filing: **06.11.1995**

(84) Designated Contracting States:  
**DE ES FR GB**

- **Herbst, Steven M.**  
**Bernardsville, New Jersey 07924 (US)**
- **Sizer II, Theodore**  
**Little Silver, New Jersey 07739 (US)**

(30) Priority: **15.11.1994 US 339538**

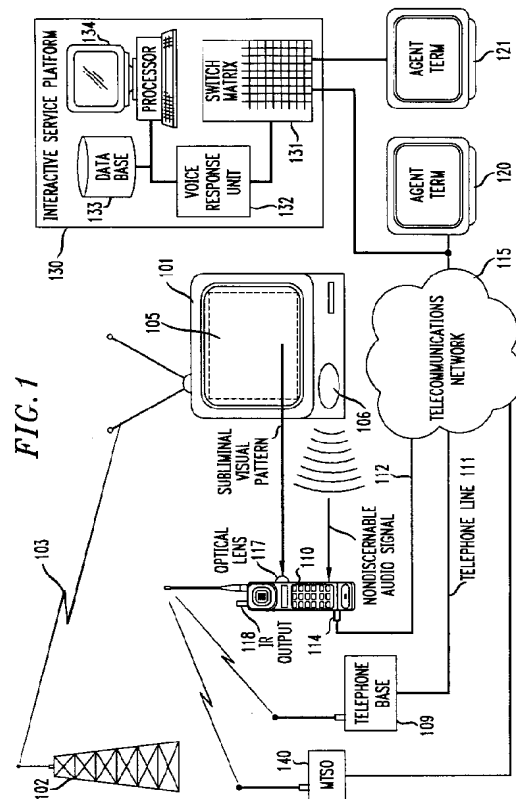
(71) Applicant: **AT&T Corp.**  
**New York, NY 10013-2412 (US)**

(74) Representative:  
**Buckley, Christopher Simon Thirsk et al**  
**AT&T (UK) LTD.,**  
**AT&T Intellectual Property Division,**  
**5 Mornington Road**  
**Woodford Green, Essex IG8 0TU (GB)**

- (72) Inventors:
- **August, Katherine G.**  
**Matawan, New Jersey 07747 (US)**
  - **Caldwell, Charles D.**  
**Cliffwood Beach, New Jersey 07735 (US)**

(54) **System and method for wireless capture of encoded data transmitted with a television, video or audio signal and subsequent initiation of a transaction using such data**

(57) A device (110) which can be portable and therefore used in conjunction with several different data sources is arranged for wireless capture of encoded non-perceptible data directly from a light emitting device, such as a television (101) or other video and/or audio output device. The data is part of the ordinary program displayed by the device (101) and yet indiscernible by a viewer or listener. The indiscernible data may be information needed to order those services or products, including prices, delivery intervals, shipping details, coupon offers, and so-on. After capture, the device includes a memory arranged to store the data for later use, and communications circuitry (114 or 118) arranged to output at least portions of the data (or data derived from the captured data) to a remote agent or device (120, 121), such as via a telephone call (via 140 or 109 or 112) or a data transfer to a point of sale device.



## Description

### Field of the Invention

This invention relates to a device and a method for the wireless capture of encoded non-perceptible data from a light emitting device such as a television or other video and/or audio output device, and subsequent use of the captured data to initiate a transaction, such as placing a telephone call and transmitting a message to a remote agent or automated attendant, or delivering the data to a point of sale agent directly or indirectly via a telecommunications connection, or to operate another device.

### Background of the Invention

In a copending application entitled "System and Method of Capturing Encoded Data Transmitted Over a Communications Network in a Video System" filed on behalf of Isenberg and Tuomenoksa on March 18, 1994, Serial No. 08/210802 and assigned to the same assignee as the present application, it was recognized that non-perceptible information can be encoded in a television program, captured in a "set top box", and thereafter used to make telephone calls. The set top box is an electrical device that is "hard-wired" directly in the circuit between the video services network and the television set (as a stand alone unit or alternatively as part of the television set itself) and thus, unfortunately, is not portable. Also, the set top box is dedicated to one particular television (or other video source) and thus cannot be shared among several sources. Finally, the user of the set top box may be uncertain as to the nature of the information captured therein.

### Summary of the Invention

In accordance with our invention, a device which can be portable and therefore used in conjunction with several different data sources is arranged for wireless capture of encoded non-perceptible data directly from a light emitting device, such as a television or other video and/or audio output device. The data is part of the ordinary program displayed by the device and yet indiscernible by a viewer or listener. As an example, a television monitor may be located in a kiosk or other public area, and display a program advertising selected services and products. The indiscernible data may be information needed to order those services or products, including prices, delivery intervals, shipping details, coupon offers, and so-on.

Capture can be effected by decoding subliminally modulated video broadcast signals, in a manner suggested in U. S. Patent 4,807,031, issued on February 21, 1989, to R. S. Broughton, et al., the teachings of which are incorporated herein by reference. Alternatively, a modulated carrier, which, for example, can be an

amplitude shift keyed (ASK) or frequency shift keyed (FSK) signal having its primary frequency components at a frequency (e.g. 25 kHz) not usually present in a conventional television signal, can be added only to the luminance component of a television signal, and the data can thereafter be captured using bandpass filtering and an ASK or FSK receiver. After capture, the device includes a memory arranged to store the data for later use, and communications circuitry arranged to output at least portions of the data (or data derived from the captured data) to a remote agent or device, such as via a telephone call or a data transfer to a point of sale device.

In accordance with the present invention, the encoded non-perceptible data includes associated dialing, routing, or identification information, so that other portions of the captured data can be transmitted to an appropriate final destination or device. In this context, the final destination can be (a) a remote location, such as a platform arranged to process and consummate transactions, or (b) a point of sale system or other device (e.g., TV, stereo, VCR Plus, smart mouse device, etc.). The other portions of the captured data that constitutes a payload to be communicated to the final destination or device, can, for example, be product or coupon information that is related to the display from which the non-perceptible data was captured, or programming or control data.

Further in accordance with the present invention, the capture device includes a built-in display, such as an LCD display, and the encoded non-perceptible data includes display information, so that at least portions of the captured data can be discerned by a user of the device, and the user can thus be kept informed as to the operation of the device. The memory and the communications circuitry in the capture device are advantageously arranged so that, in a transaction initiated by the device using captured information, a two-way dialog may be initiated between the user and an agent at a remote terminal or a POS system, and information may be transmitted to and stored in the device for later retrieval.

### Brief Description of the Drawing

The present invention will be more fully appreciated by consideration of the following Detailed Description, which should be read in light of the accompanying drawing in which:

- Fig. 1 is a schematic drawing of one embodiment of a system arranged in accordance with the present invention for wireless capture of encoded data transmitted with a television signal;
- Fig. 2 is a block diagram illustrating the components of capture device 110 of Fig. 1;
- Fig. 3 is a diagram illustrating the format of captured data; and
- Fig. 4 is a flow diagram of the process by which data

embedded in a subliminal visual or non-audible message is captured and used.

### **Detailed Description**

Referring first to Fig. 1, there is shown a schematic drawing of one embodiment of the present invention arranged for the wireless capture of encoded non-perceptible data from a light emitting device such as television 101, and subsequent use of the captured data to initiate a transaction which might be handled by a person at an agent terminal 120, or a person at another terminal 121 that is supported by an interactive service platform 130.

A television signal is received by television 101 via over-the-air transmission, as from transmission tower 102 via a transmission link 103, or alternatively is supplied by a cable TV connection, or from a VCR/video-tape. The video portion of the television signal is displayed on the picture tube or other visual display area 105 of a monitor, computer or a television 101, while the audio portion of the television signal is played through or by projected from speaker 106. Associated with the program that is seen and/or heard by a viewer/listener is non-discernible encoded data that is transmitted as part of the audio and/or video signal. For example, the program may be an advertisement for a service or product, and the indiscernible data may create a subliminal visual pattern on the visual display area, that when properly received and decoded, contains information needed to order those services or products, including prices, delivery intervals, shipping details, coupon offers, and so-on.

Encoding, transmission and decoding of non-discernible data may be accomplished as described in a patent application entitled "System and Method for Encoding Digital Information in a Television Signal" filed on behalf of T. Sizer and assigned to the same assignee as the present application, which co-pending application is incorporated herein by reference. Briefly, it was found using a spectrum analyzer on a typical video signal, that there are comparatively large frequency components at the line rate and at the frame rate and its harmonics, but that between these frequencies, there are other frequency bands in which little information is carried. One such frequency band is between 15 and 30 kHz. By adding a low level carrier signal or tone at a frequency in this band, say 25kHz, the video image is not degraded, but a properly tuned decoder can receive and decode the encoded information. In this way, digital information can be subliminally inserted in a video signal by adding to the video signal an amplitude shift keyed (ASK) or frequency shift keyed (FSK) carrier signal, and the digital information can later be recovered using ASK or FSK decoding. Encoded data can also be inserted in a television signal and recovered by a receiver that responds to the picture displayed on the television, in the manner described in patent 4,807,031 cited above.

The program displayed on television 101 is sensed

by a portable capture device 110, which is described in more detail in connection with Fig. 2. When the non-discernible encoded data is part of the video signal, such sensing takes the form of light from display area 105 being collected by an optical lens 117, while when the non-discernible encoded data is part of the audio signal, such sensing takes the form of sound from speaker 106 being collected by a microphone (211 in Fig. 2). In either event, there is a wireless communication of the information from television 101 to capture device 110 such that the encoded data is "viewed" or "heard" rather than being transmitted through a wired connection, or through a more conventional radio frequency communication.

In addition to receiving non-discernible encoded data, capture device 110 has the capability of (a) storing the encoded data, (b) transmitting (or otherwise outputting) the encoded data (or information retrieved using such data) to a remote location or device, and (c) displaying the encoded data to a user. The data may include information for initiating a transaction or originating a telephone call, as well as additional information (e. g., price and ordering information) associated with the television program being displayed on television 101. The remote location may be agent terminals 120 or 121, interactive service platform 130, or a point of sale system, and the communication between the capture device 110 and the remote location may be one-way or two-way.

In the case where encoded data is to be output from capture device 110 via a telephone call, the call may be initiated and transacted in one of several ways, as illustrated in Fig. 1. First, the data may be transmitted over a wireless link to an associated telephone base station 109 that is, in turn, connected to a telephone line 111 that is part of a telecommunications network 115. Communication between capture device 110 and base station 109 may be accomplished in a variety of ways; as an example, the same signaling and transmission can be used as is presently used in communication between a cordless telephone handset and its associated base station. Second, capture device 110 may be directly connected to a telephone line 112 through an interface that includes a standard telephone jack 114. Third, capture device 110 may include the functionality of a cellular telephone, so that the data may be communicated to a remote location via a wireless call placed to a mobile telephone switching office (MTSO) 140, which is in turn connected to telecommunications network 115.

As explained more fully in connection with Fig. 2, capture device 110 may include a dual tone multi-frequency (DTMF) transceiver arranged to generate a series of audible tones. Accordingly, a fourth way to initiate a telephone call would apply portions of the data to the transmitter (tone generator) portion of the DTMF transceiver. Capture device 110 may then be placed in juxtaposition with the microphone portion of a conventional telephone handset, such that the audible tones generated in capture device 110 are acoustically coupled

through the handset to receivers in telecommunications network 115.

Capture device 110 can also output encoded data directly, without making a telephone call. This is useful in conjunction with a point of sale system or the like, which includes a docking station or other interface to which the capture device may be connected, or an IR receiving device or a device responding to DTMF.

If an outgoing telephone call is initiated by capture device 110, the call can illustratively be routed through telecommunications network 115 directly to an agent terminal 120, or to an interactive service platform 130 to which is connected another agent terminal 121. When a connection is completed to platform 130, the call may be routed by a switch matrix 131 to a voice response unit 132 that operates under the control of a processor 134. Information included in the captured encoded data can be provided to the attendants, or processor 134 can perform a look-up and retrieval operation in database 131, using encoded data as a key, in order to effectuate a desired transaction.

For certain transactions, information connected with a transaction may also be transmitted from service platform 130 to capture device 110, either for display to a user, storage for later use, or output to a point of sale system or device. This information may, for example, be confirmation information, indicating that a transaction has been effected, or details regarding a just completed transaction, such as ticket information relating to a travel reservation.

Referring now to Fig. 2, there is shown a block diagram illustrating in more detail the components in one embodiment of capture device 110 of Fig. 1. If the encoded non-perceptible data is inserted in the video portion of a television signal, the images displayed on visual display area 105 are captured by optical lens 117 and an associated photodetector 203, which is arranged to supply an electrical signal to filter/receiver 215 representing the image. On the other hand, if the encoded non-perceptible data is inserted in the audio portion of a television signal, the output from speaker 106 is captured by a microphone 211 and an associated amplifier 213, which is arranged to supply an electrical signal to filter/receiver 215 representing the sound energy. In either event, the encoded non-perceptible data is decoded in filter/receiver 215 in a manner consistent with the manner in which the original data was encoded. Thus, filter/receiver 215 can be arranged to perform the same functionality as the elements illustrated in Fig. 4 of the above referenced Broughton et al. patent, or, alternatively, the operation of filter/receiver 215 can be as described in conjunction with Figs. 4 or 7 in copending application of T.Sizer. In each instance, it is noted that capture device 110 receives and recovers encoded data by "watching" or "listening to" the output of television 101 (or another similar display device), and that the capture device 110 is not connected to television 101 or the other display device by a cable or wires.

The output of filter/receiver 215, representing the data captured by capture device 110, is applied to a microprocessor 220, which is arranged to perform various data processing and control functions in coordination with programs stored in an associated memory 221 as well as inputs received from a user of capture device 110. Generally speaking, capture device 110 may operate in an active or a passive mode. In the active mode, capture device 110 responds only to user initiated capture commands. In the passive mode, capture device 110 captures all of the data sent to it while in that mode. In either mode, captured data may be routed by microprocessor to memory 221 and stored for use at a later time, as determined by the user. The captured data may also be displayed on a display 225, such as a liquid crystal display, so that a user will be aware of exactly what information was captured.

The control programs contained in memory 221 can implement numerous functions, which, broadly speaking, can be categorized as (a) functions relating to data capture, such as SAVE and AUTOSAVE functions, (b) functions relating to output of already captured data, such as DIAL and SEND DATA functions, (c) functions relating to memory manipulation, such as the RECALL and DELETE functions. The above enumerated functions are initiated when respective buttons 241 - 246 are activated, and the activation signal output from a button is applied to microprocessor 220 via a button interface 240. Each of the functions is discussed below.

When the SAVE function is initiated by activation of button 241, capture device 110 is in the active mode, and the encoded data contained in the current audio or video output of television 101 is captured. This is accomplished, for example, by activating optical lens 117 and photo detector 203, or microphone 211 and amplifier 213, for a relatively brief period of time, typically on the order of several seconds, so that encoded data associated with the current program being displayed on display area 105 or played through the loudspeaker 106 is processed by filter/receiver 215 and stored in memory 221. A visual or auditory cue may be contained in the video or audio program, to indicate to a user of a capture device that there is data to be captured. When the SAVE function is activated, microprocessor 220 may be arranged to control display 225 so as to indicate the current status, e.g., that the capture device is in the process of receiving and capturing data. When the data has been captured, microprocessor 220 may be arranged to control display 225 so as to actually display some or all of the data, so that the user is now aware of information that had theretofore been subliminal and indiscernible. The display can also indicate that the device is "aimed" correctly.

When the AUTOSAVE function is initiated by activation of button 244, capture device 110 is in the passive mode. In this mode, capture device 110 captures a series of encoded data that may be contained in each of a series of programs that can be viewed/heard on tele-

vision 101. This is accomplished, for example, by activating optical lens 117 and photo detector 203, or microphone 211 and amplifier 213, for a relatively long period of time, typically on the order of several minutes or hours. Encoded data captured from the various programs being displayed on display area 105 or played through loudspeaker 106 over a long period of time are processed by filter/receiver 215 and stored in memory 221. As with the SAVE function, when the AUTOSAVE function is activated, microprocessor 220 may be arranged to control display 225 so as to indicate the current status, e.g., that the capture device is in the process of receiving and capturing data.

When a user of capture device 110 desires to use any of the data stored in memory 221, including data stored a result of the AUTOSAVE function, the contents of memory 221 may be retrieved and displayed on display 225 by initiating the RECALL function upon activating button 245. This permits a user to be aware of exactly what information was previously captured and stored. Through this function, the user will be able to selectively peruse or scroll through the stored data, so as to retain or use selected portions thereof. Activation of button 246 initiates the DELETE function, whereby portions of the data stored in memory 221 are selectively erased. In order to conserve and thereby "recycle" to storage capacity of memory 221, microprocessor 220 may also be arranged to manage the contents in memory 221, so that the oldest information stored therein could be cycled out and deleted as new information is captured and stored.

Turning now to consideration of the use of already captured data, it is an important functionality of capture device 110 to permit such data to be output upon a command from a user. Such data, when output, can be used to (a) make a telephone call, and, when the call is answered, to provide information to a live or automated attendant that receives the call, or (b) initiate a transaction, such as by interacting with a special purpose terminal or kiosk arranged to receive the stored data, or a device such as a VCR Plus or a stereo. In accordance with the arrangement shown in Fig. 2, data output via a telephone call can be initiated in several ways.

First, captured data can be routed by microprocessor 220 from memory 221 to a modem 246 and then to a base station interface 250, so that the information can be communicated to telephone base 109 of Fig. 1. This in turn allows a conventional telephone call to be originated from telephone base 109.

Second, captured data can be routed through modem 246 to a wire interface 253, which allows capture device 110 to be physically connected to a terminal or docking station for information off loading.

Third, captured data can be routed to a DTMF transceiver 247, which includes a tone generator arranged to output DTMF tones. These tones can be directly connected to a telephone line 112 via a standard connection such as RT11 jack 114. Alternatively, capture device 110

can be placed in juxtaposition with the microphone in a telephone handset, and the audible tones can be applied and used much like an audible frequency autodialer.

Fourth, captured data can be routed through modem 246 to a cellular telephone 252, which can initiate a cellular call. When a cellular connection is completed, the captured data can be output in encoded form or as audible tones.

For each of the arrangements just described, a telephone call may be originated using the DIAL function. This function is initiated by activation of button 242. With this function, dialing or routing information, which is part of the data captured by capture device 110 and now stored in memory 221, is retrieved. This information is then further processed, so that a telephone call can be initiated. In some instances, a call is originated by application of stored data to DTMF transceiver 247, so that audible tones can be output. In other instances, a data call can be initiated by appropriately formatting stored data. In yet other instances, such as when a cellular call is dialed, stored dialing information may be applied to an outgoing number register. The exact manner in which information is output from capture device 110 can vary, in accordance with several embodiments of the present invention.

While the DIAL function is used to output certain captured information needed to initiate a telephone call (or other data output function), the SEND DATA function, initiated by activation of button 243, is used to output other portions of the captured data stored in memory 221, pertaining, for example, to a transaction that the user desires to make. This additional data is retrieved from memory 221 and appropriately transmitted, depending upon the manner and type of telephone call involved. Thus, data may be output either via base station interface 250 to telephone base 109, or via RJ 11 jack 114 onto telephone line 112, or via cellular phone 252 to MTSO 140. Note that if output occurs directly, without a telephone call, the SEND DATA function may cause information from memory 221 to be output via wire interface 253. During the SEND DATA function, the information being output may also be displayed on display 225. This allows a person using the capture device to identify the information that was captured, and use the information in an actual transaction.

It is to be noted here that capture device 110 of Fig. 2 may optionally include an automatic speech recognition circuit 245, an infrared (IR) transmitter 235, a handset 230 and a keypad 247. The purpose of IR transmitter 235 is to allow captured data to be output directly to a device such as a point of sale system or a VCR or the like, via infrared transmission. The purpose of speech recognition circuit 245 is to convert captured data to spoken phrases, which can be played to a user or to an attendant after a telephone call is initiated. The purpose of handset 230 and keypad 247 is to allow capture device 110, in addition to being used in accordance with

the present invention, to be used to complete conventional dialed telephone calls.

In one application of the present invention, a televised advertisement for a product includes additional ordering or "coupon" information embedded in a subliminal visual pattern within the video image displayed on visual display area 105. The coupon information describes the item(s) offered for sale, the regular price, the coupon value, and contains additional information needed for ordering. This embedded information is transmitted between television 101 and capture device 110 at a rate such as 60 bits per second, that is sufficient such that the necessary information can be transmitted in a very brief period of time. In the application just described, the embedded product information, dialing number, coupon information and necessary checkbits together comprise approximately 2,000 bits of information, so that between three and four seconds would be required for transmission. Once the coupon information is stored in capture device 110, the user of the capture device can supplement the coupon information with user entered data which can be entered using keypad 247. This supplemental information may include credit card or other billing information pertaining to the user, as an example.

As shown in Fig. 3, the information represented by the encoded data can be organized in several fields. Using the coupon application as an example, a first field 301 contains a telephone number which may be used to originate a telephone call in order to order the product to which the coupon applies. Illustratively, this will be a toll-free or "800" number. Other information associated with the coupon can include a product description in field 303, an expiration date in field 305, the time that the advertisement was televised in field 307, the number of the television channel running the ad in field 309, and a serial number for the ad in field 311, identifying either or both the particular ad and its sequence in an ad campaign. It is to be noted that various other information can also be included in the information illustrated in Fig. 3, such as keywords or attributes describing the received encoded data, as well as information indicating that a product is available in particular colors or sizes. The keywords would be useful in retrieving from memory 221, information relating to specific products or advertisers.

The process by which information embedded in a subliminal visual or audible message is captured and used is illustrated in flow diagram form in Fig. 4. As indicated previously, two general modes of operation are contemplated, namely a "passive" mode and an "active" mode, both of which follow a "start" step 401.

In the passive mode, a user desires to operate capture device 110 in an unattended manner, and to capture all of the encoded data that may be subliminally displayed on a display device 105 or output from speaker 106 over a relatively long period of time, typically several minutes or hours, until the user, at some later time, desires to discontinue or terminate the capture. This mode

is initiated using AUTOSAVE functionality, by activating button 244. When this is done, a positive response is obtained in step 502, so that data capture, storage and display, all as described below in connection with step 507, occur. While in the passive mode, capture is terminated by subsequent activation of the same button 224.

In the active mode, a user operates capture device 110 in real time, typically while viewing a video display or listening to an audio presentation. During the display or presentation, the user sees or hears a corresponding televised advertisement or other indication that imperceptible information is available for capture. The user may, at this time, be instructed to activate SAVE button 241, or the user may know, from previous experience, how to use the device. When button 241 is activated, a positive result occurs in step 503, thereby capturing the imperceptible encoded data, displaying all or a portion of the data on display 225, and storing same in memory 221, all in step 507. Until the SAVE button is activated, capture device 110 may be in a "wait state" 505.

The user of capture device 110 determines that the appropriate data has been captured by reviewing the information seen in display 225. After the captured data has been reviewed and determined to be correct, activation of the DIAL button 242 on the portable capture device 110 in step 509 initiates step 513, by which stored dialing and/or routing information, illustratively in field 401 of Fig. 4, is recalled from memory 221. A call is then originated launched, such by transmitting the dialing information from memory 221 through base station interface 250 to base station 109 and thence to telephone line 111 and telecommunications network 115 to interactive service platform 130. The call may be a local or long distance call, made using a "plain old telephone service" (POTS) line; alternatively, a toll-free call may be launched using an 800 number. Desirably, automatic number identification (ANI), caller ID, and other features available in the telecommunications network may be used to provide additional information to the called party, in addition to the captured data that is transmitted in succeeding steps in the process. Until the DIAL button is activated, capture device 110 may be in a "wait state" 511.

After the call has been originated, a determination is made in step 515 that the call has been answered and that the SEND DATA button 243 has been pushed. (Until the SEND DATA button is activated, capture device 110 may be in a "wait state" 517.) When a positive result occurs in step 515, information contained in fields 403-411 is transmitted to the called destination in step 519. As stated previously, from the point of view of the called party, the information received includes details concerning the advertised product, the identity of the caller, and other information associated with the item that was initially displayed or mentioned on the television program. Advantageously, the advertiser will know more about their customer than ever before. This is because the advertiser will be able to determine from the



transmitted information which advertisement drew the business, how long it took the caller to respond to the ad. and the geographic location of the callers, based upon ANI or caller ID. It will be easy to tell which ads in a campaign are most successful.

In accordance with one optional arrangement of the present invention, when data is captured and stored in step 507, the newly collected data is compared with previously stored data. When a match is found, any duplicate data is dropped. In addition, the information in various fields is examined, to assure that the data captured is in the appropriate format. If an error is detected in any data, the information may be deleted, and "new" data collected. This is accomplished by repeating capture step 507 several times.

In another application of the present invention, an interactive television capability is provided in connection with a game show or television drama. For a game show, an audience would be asked to vote on various aspects of the game. This could include questions such as which person should go on a date with the contestant, or which singer is the best? The audience would be instructed to press the "SAVE" button on their capture device at the appropriate time specified for their choice. The viewers vote would then be cast by depressing the DIAL button, communicating with the game show host, and then transmitting information indicating the vote by depressing the SEND DATA button. Alternately, one number could be transmitted and an automated interactive voice platform such as the InfoWorx™ platform available from AT&T could offer options to the caller. These calls could be toll free calls, or, alternatively, billed to the caller.

In yet another application of the present invention, a video on demand capability can be provided. A viewer sees a video he or she would like to see advertised on a previewing network. An instruction to press the DIAL button on the capture device is made on the previewing channel to indicate to the viewer that he or she can press the button to order a particular video. The call would be placed to a voice response system used to reserve the video on demand. Information about which video the caller wanted to see is sent over the phone lines once the call is connected. The caller would merely have to acknowledge the order and select a time slot.

The present invention can also be employed in the context of programming of a VCR, particularly where the user already has the capabilities provided by VCR Plus, a product that is commercially available. In this embodiment, a code sequence associated with and representing a particular television show constitutes the information included in a televised advertisement. When the ad is viewed, the viewer can press the SAVE button and send the sequences to the VCR Plus using IR transmitter 235.

While the portability of capture device 110 is advantageous, it is to be noted that in some arrangements, the functions of capture device 110 and telephone base 109 may be combined in a single stationary unit, which

might resemble a cordless telephone base station. In this event, the functionality of capture device 110 would be included in the stationary unit, and that unit would be arranged, in the manner previously described, to collect information from the visual display area 105 and to provide storage of the collected information. In this arrangement, the stationary unit could also be adapted to utilize input devices such as optical character recognition (OCR) or scanners that would provide an additional method of inputting telephone numbers and coupon and/or product information. The hand piece of this stationary unit would be used to place a call and send the data.

The present invention is not limited to live televised programs, but can also be operated in conjunction with stored video programs played from a VCR. In this arrangement, advertisements and other encoded information is included in videos at the time they are recorded or at the time they are mastered and put onto video cassettes. A viewer watching a video with such an ad can respond immediately to reserve another video, purchase one of the items advertised, or order catalogs automatically. When a program containing subliminally encoded data is viewed, the viewer simply presses the DIAL button, launching a telephone call, and then presses the SEND DATA button, sending captured data, such as product information, to an agent, who can verify the order using the additional information that was captured or stored in the device.

The portability of the present invention can be used to advantage in implementing what can, in effect, be called a "Roaming Bulletin Board". A user can be attending a conference or traveling through the airport where kiosks or bulletin boards are set up. In the case of a conference, an attendee would walk through the conference viewing the displays. When the attendee sees a display of interest, he or she points the capture device towards the display, and captures the non-discernible encoded data from either the displayed image or the sound output. Later, the user launches a telephone call to the telephone number specified and included in the captured data, and sends out coupon information that is also part of the captured data.

It is further to be noted that the present invention can be used in the context of automobiles and mobile telephones. When a capture device in accordance with the invention is placed in a car, it can receive and capture non-discernible encoded data contained in the audio output of the car radio. The captured data can include a toll free or conventional telephone number for originating a mobile cellular telephone call from the car. The call may be placed to an interactive service platform, and additional captured data, such as coupon or similar information, can then be used to effectuate a transaction.

Various modifications and adaptations of the present invention will be apparent to those skilled in the art. For example, the functions provided by the present

invention may be combined with those used in a personal digital assistant (PDA) or a laptop computer. If desired, a simultaneous voice and data (SVD) modem of the type available now from AT&T could be provided in capture device 110 to allow communication both by voice and data transfer, at the same time. Various functions can also be added to the processes and applications described. For example, telephone base 109 may be programmed to dial a number or series of numbers at specific times, when certain amounts of information or data have been collected, or based upon some criteria. Capture device 110 could then send collected information "in bulk" to interactive service platform 130. For this purpose, modem 246 could be used, so as to send the information more efficiently.

**Claims**

- 1. Apparatus for initiating a transaction, comprising
  - means arranged for wireless capture of data directly from an audio/visual display, said data being indiscernible by a viewer or listener, and means arranged to transfer at least portions of said data to a separate transaction processor to initiate said transaction.
- 2. The invention defined in claim 1 wherein said data includes dialing information for originating a telephone call, and wherein said transfer means includes means for initiating said telephone call using said dialing information.
- 3. The invention defined in claim 1 wherein said apparatus further includes
  - means responsive to said capture means for storing said data, and wherein said transfer means includes means for coupling information from said storing means directly to a separate transaction processor.
- 4. The invention defined in claim 1 wherein said capture means is in a portable capture device and said transfer means is in a base station, and wherein said apparatus further includes means for transferring information from said portable capture device to said base station.
- 5. The invention defined in claim 1 wherein said audio/visual display includes non-perceptible encoded data, and wherein said capture means is arranged to receive and decode said encoded data.
- 6. The invention defined in claim 5 wherein said non-perceptible encoded data includes an amplitude

shift keyed (ASK) or frequency shift keyed (FSK) carrier signal added to a television signal, and wherein capture is effected by detecting and decoding said carrier signal.

- 7. A system for capturing data comprising
  - means for wireless capture of indiscernible data embedded in an audio/video display; and means for outputting at least portions of said captured indiscernible data to a remote device via a telephone call.
- 8. Apparatus for initiating a transaction relating to a program appearing on a television display, said apparatus comprising
  - means arranged for wireless capture of data directly from said television display, said data being indiscernible to a viewer of said television display;
  - means responsive to said captured data for obtaining a telephone number, said telephone number being associated with a remote location arranged to perform transactions associated with said program appearing on said television display;
  - means for initiating a telephone call using said telephone number; and
  - means for transmitting to said remote location, during said telephone call, additional information contained in said captured data, said additional information also pertaining to said program.
- 9. A system for responding to a televised advertisement, comprising
  - means for embedding non-discernible information in said advertisement, said information including (a) a telephone number for a remote processor arranged to process orders for the items displayed in said advertisement, and (b) other information relating to said items displayed in said advertisement;
  - means arranged for wireless capture of said non-discernible information directly from said televised advertisement; and
  - means responsive to said captured information for (a) placing a telephone call using said telephone number and (b) transmitting said other information to said remote processor via said telephone call.
- 10. A method for initiating a transaction, comprising the steps of
  - capturing data directly from an audio/visual dis-

play, said data being indiscernible by a viewer or listener, and transferring at least portions of said data to a separate transaction processor to initiate said transaction.

5

11. The method defined in claim 10 wherein said data includes dialing information for originating a telephone call, and wherein said transferring step includes initiating said telephone call using said dialing information.

10

12. A method for capturing data comprising

capturing, using wireless capture, indiscernible data embedded in an audio/video display; and outputting at least portions of said captured indiscernible data to a remote device via a telephone call.

15

20

13. A method for initiating a transaction relating to a program appearing on a television display, said method comprising steps of

using wireless capture data directly from said television display, said data being indiscernible to a viewer of said television display; responsive to said captured data, obtaining a telephone number, said telephone number being associated with a remote location arranged to perform transactions associated with said program appearing on said television display; initiating a telephone call using said telephone number; and transmitting to said remote location, during said telephone call, additional information contained in said captured data, said additional information also pertaining to said program.

25

30

35

40

14. A method for responding to a televised advertisement, comprising the steps of

embedding non-discernible information in said advertisement, said information including (a) a telephone number for a remote processor arranged to process orders for the items displayed in said advertisement, and (b) other information relating to said items displayed in said advertisement; capturing, using wireless capture, said non-discernible information directly from said televised advertisement; and responsive to said captured information, (a) placing a telephone call using said telephone number and (b) transmitting said other information to said remote processor via said telephone call.

45

50

55

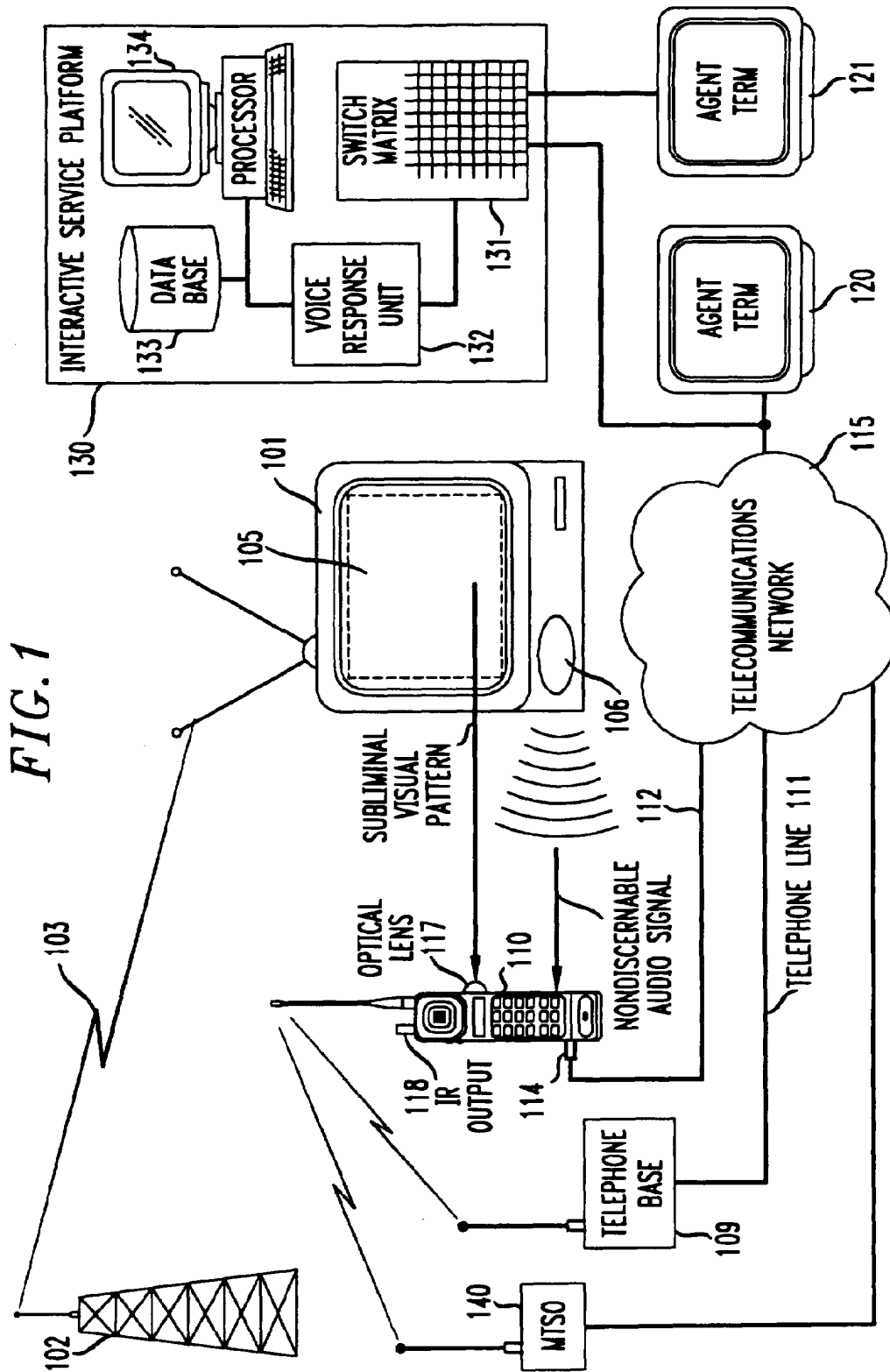


FIG. 1

FIG. 2

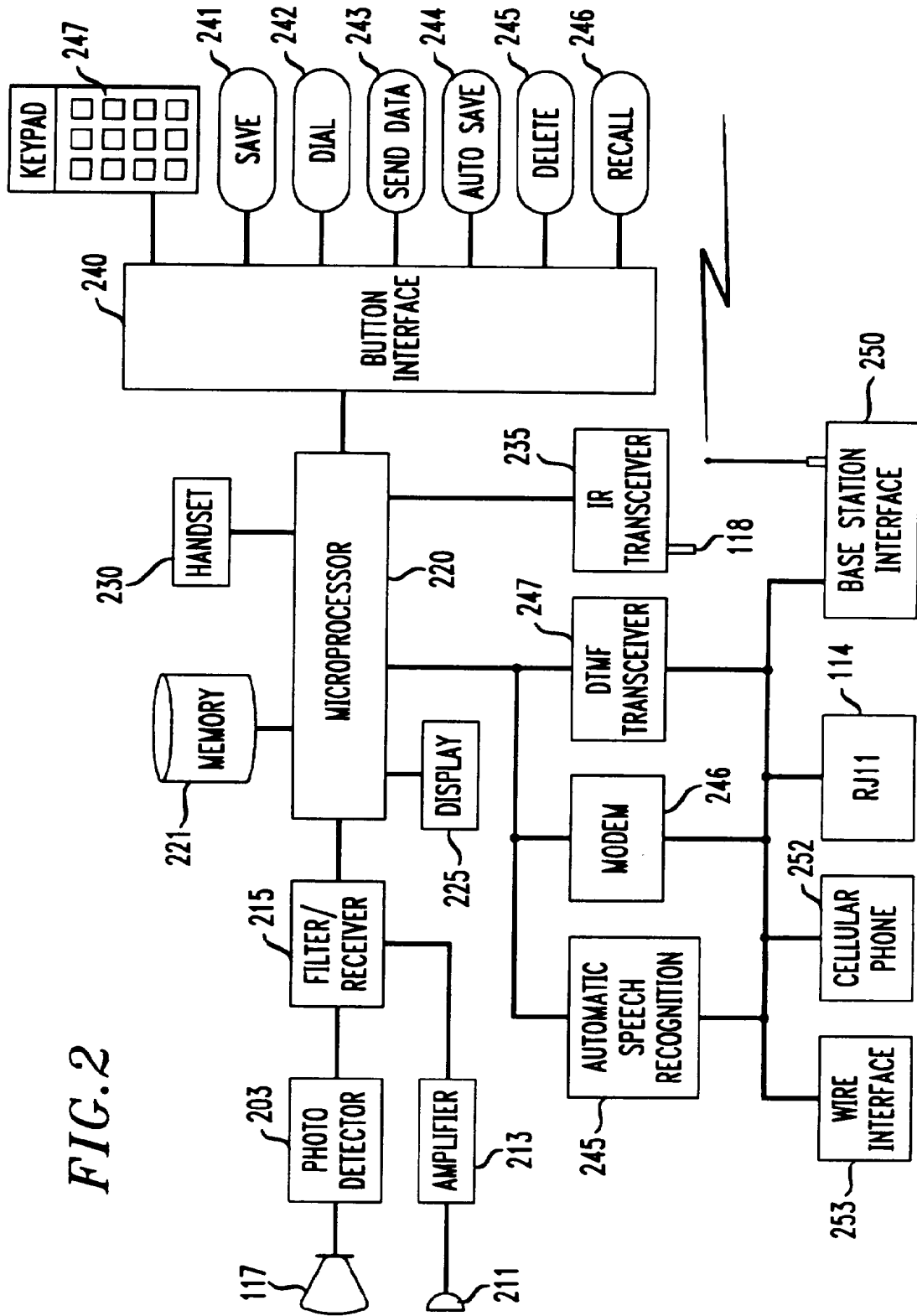


FIG. 3

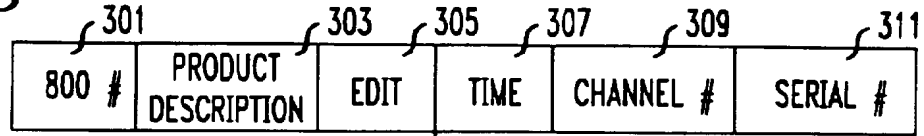
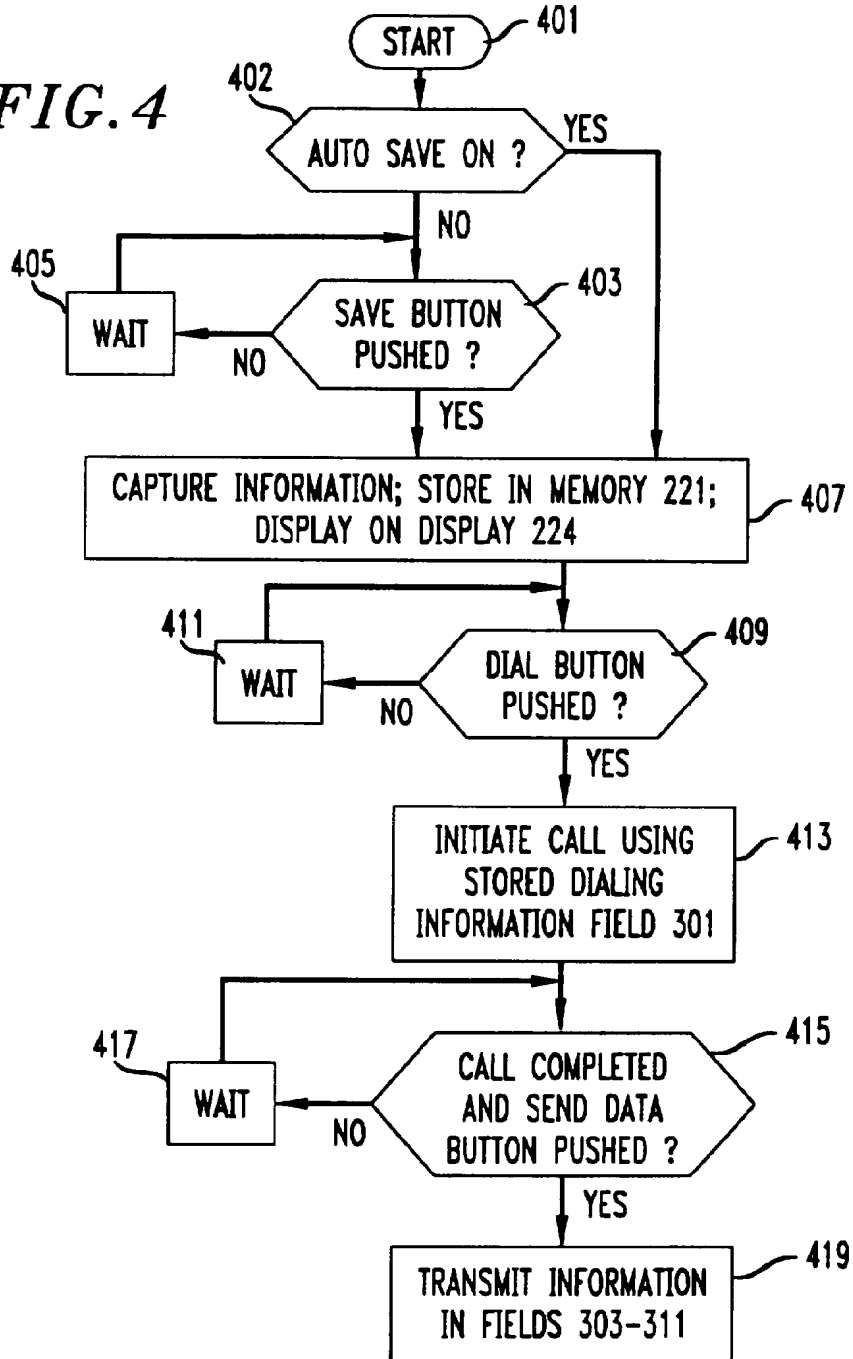


FIG. 4



\* NOTICES \*

JPO and INPIT are not responsible for any damages caused by the use of this translation.

1. This document has been translated by computer. So the translation may not reflect the original precisely.
2. \*\*\*\* shows the word which can not be translated.
3. In the drawings, any words are not translated.

---

CLAIMS

---

[Claim(s)]

[Claim 1] A multiplex-broadcasting receiving set comprising provided with a multiplex-broadcasting demodulation section which recovers auxiliary information from multiplex broadcasting which carried out multiplex [ of the auxiliary information ] to main information: An alphabetic-information-storage part which memorizes text in auxiliary information to which it restored in said multiplex-broadcasting demodulation section.  
A telephone number extraction part which extracts a telephone number from the inside of text memorized by this alphabetic-information-storage part.  
A character display which displays text memorized by a telephone number extracted by this telephone number extraction part or said alphabetic-information-storage part.  
A telephone number sending part which sends out a telephone number and an autodial indication signal corresponding to text displayed on a telephone number or this character display displayed on this character display.

[Claim 2] A multiplex-broadcasting receiving set comprising provided with a multiplex-broadcasting demodulation section which recovers auxiliary information from multiplex broadcasting which carried out multiplex [ of the auxiliary information ] to main information: An alphabetic-information-storage part which memorizes text in auxiliary information to which it restored in said multiplex-broadcasting demodulation section.  
A telephone number extraction part which extracts a telephone number from the inside of text memorized by this alphabetic-information-storage part.  
A character display which displays text memorized by a telephone number extracted by this telephone number extraction part or said alphabetic-information-storage part.  
An autodial control section which generates a dial pulse based on a telephone number corresponding to text displayed on a telephone number or this character display displayed on

this character display.

[Claim 3]A multiplex-broadcasting receiving set characterized by said multiplex broadcasting being an FM multiplex broadcast in claim 1 or claim 2.

[Claim 4]A multiplex-broadcasting receiving set providing an identification-code-information storage parts store of device each which carries out identification-code-information memory in claim 3, and transmitting this identification code information after a dial.

[Claim 5]A multiplex-broadcasting receiving set receiving multiplex broadcasting which carried out multiplex [ of the auxiliary information ] to main information, and dialing based on telephone number information and dial directions information in auxiliary information.

---

[Translation done.]



\* NOTICES \*

JPO and INPIT are not responsible for any damages caused by the use of this translation.

- 1.This document has been translated by computer. So the translation may not reflect the original precisely.
- 2.\*\*\*\* shows the word which can not be translated.
- 3.In the drawings, any words are not translated.

---

DETAILED DESCRIPTION

---

[Detailed Description of the Invention]

[0001]

[Industrial Application]This invention relates to the device which receives especially an FM multiplex broadcast about the device in which multiplex-broadcasting reception is possible.

[0002]

[Description of the Prior Art]Conventionally, an FM multiplex broadcast is received and what displays the text, graphic information, etc. is considered. In the conventional FM multiplex broadcast receiving set, when telephone number information had been transmitted as information and it was going to call to this telephone number for example, it was dialing, looking at the telephone number displayed on the indicator.

[0003]

[Problem(s) to be Solved by the Invention]However, when dialed according to the telephone number displayed on the indicator of the conventional FM multiplex broadcast receiving set, the telephone number hung, the mistake etc. happened and it had the problem of making the 3rd person trouble. When the conventional FM multiplex broadcast receiving set was mounted and it called to the telephone number displayed on an indicator, the frequency where a cellular phone and a car telephone are used was high, and it increased, also when dialing during a run of a car, and it also had the problem of bringing an obstacle to the safety at the time of a run of a car.

[0004]This invention is made in view of said problem, and simplifies complicated dial control, and an object of this invention is to prevent the credit mistake in a telephone.

[0005]

[Means for Solving the Problem]Multiplex-broadcasting receiving set of this invention provided with a multiplex-broadcasting demodulation section which recovers auxiliary information from multiplex broadcasting which carried out multiplex [ of the auxiliary information ] to main

information is characterized by that claim 1 comprises the following.

An alphabetic-information-storage part which memorizes text in auxiliary information to which it restored in a multiplex-broadcasting demodulation section.

A telephone number extraction part which extracts a telephone number from the inside of text memorized by alphabetic-information-storage part.

A character display which displays text memorized by a telephone number extracted by telephone number extraction part or said alphabetic-information-storage part.

A telephone number sending part which sends out a telephone number and an autodial indication signal corresponding to text displayed on a telephone number displayed on a character display, or a character display.

[0006] Multiplex-broadcasting receiving set of this invention provided with a multiplex-broadcasting demodulation section which recovers auxiliary information from multiplex broadcasting which carried out multiplex [ of the auxiliary information ] to main information is characterized by that claim 2 comprises the following.

An alphabetic-information-storage part which memorizes text in auxiliary information to which it restored in a multiplex-broadcasting demodulation section.

A telephone number extraction part which extracts a telephone number from the inside of text memorized by alphabetic-information-storage part.

A character display which displays text memorized by a telephone number extracted by telephone number extraction part or said alphabetic-information-storage part.

An autodial control section which generates a dial pulse based on a telephone number corresponding to text displayed on a telephone number displayed on a character display, or a character display.

[0007] Multiplex-broadcasting receiving set of this invention provided with an FM multiplex broadcast demodulation section which recovers auxiliary information from an FM multiplex broadcast which carried out multiplex [ of the auxiliary information ] to main information is characterized by that claim 3 comprises the following.

An alphabetic-information-storage part which memorizes text in auxiliary information to which it restored in an FM multiplex broadcast demodulation section.

A telephone number extraction part which extracts a telephone number from the inside of text memorized by alphabetic-information-storage part.

A character display which displays text memorized by a telephone number extracted by telephone number extraction part or said alphabetic-information-storage part.

A telephone number sending part which sends out a telephone number and an autodial indication signal corresponding to text displayed on a telephone number displayed on a

character display, or a character display. Or an autodial control section which generates a dial pulse based on a telephone number corresponding to text displayed on a telephone number displayed on a character display, or a character display.

[0008]An alphabetic-information-storage part which memorizes text in auxiliary information which recovered claim 4 from an FM multiplex broadcast which carried out multiplex [ of the auxiliary information ] to main information in an FM multiplex broadcast demodulation section in a multiplex-broadcasting receiving set provided with an FM multiplex broadcast demodulation section which restores to auxiliary information, A telephone number extraction part which extracts a telephone number from the inside of text memorized by alphabetic-information-storage part, A character display which displays text memorized by a telephone number extracted by telephone number extraction part or said alphabetic-information-storage part, a telephone number sending part which sends out a telephone number and an autodial indication signal corresponding to text displayed on an identification-code-information storage parts store of device each which carries out identification-code-information memory, and a telephone number displayed on a character display or a character display -- or, An autodial control section which generates a dial pulse based on a telephone number corresponding to text displayed on a telephone number displayed on a character display or a character display is provided, Identification code information memorized by identification-code-information storage parts store after a dial is transmitted.

[0009]Claim 5 receives multiplex broadcasting which carried out multiplex [ of the auxiliary information ] to main information, and dials it based on telephone number information and dial directions information in auxiliary information.

[0010]

[Function]According to claim 1, telephone number information is extracted from the text of multiplex broadcasting, and it is transmitted to telephone with an autodial function for the dial information of the extracted telephone number based on a dial instruction input part. According to claim 2, autodial is carried out to the telephone number which extracted telephone number information from the text of multiplex broadcasting, and was extracted based on the dial instruction input part.

[0011]According to claim 3, autodial is carried out to the telephone number which extracted telephone number information from the text of the FM multiplex broadcast, and was extracted based on the dial instruction input part. According to claim 4, since an identification code can be transmitted, the communications-partner point can recognize this device. According to claim 5, multiplex broadcasting is received and it can call to the telephone number in the information.

[0012]

[Example]The example of the FM multiplex broadcast receiving set of this invention is described referring to drawing 1 thru/or drawing 6. First, the 1st example of the FM multiplex broadcast receiving set of this invention is described, referring to drawing 1.

[0013]The FM multiplex broadcast demodulation section to which 1 receives an FM multiplex broadcast via an antenna, and it restores in drawing 1, 2 is constituted by storages, such as RAM, a hard disk, a magneto-optical disc, The alphabetic-information-storage part which extracts and memorizes only text from the signal to which it restored by the FM multiplex broadcast demodulation section 1, The telephone number extraction part which extracts a telephone number from the text 3 is remembered to be by the alphabetic-information-storage part 2, The character display which displays the telephone number extracted by the text which 4 is constituted by LCD, CRT, a plasma display, etc. and is memorized by the alphabetic-information-storage part 2, and the telephone number extraction part 3, The dial instruction input part provided with the button which performs the directions which dial the telephone number as which 5 was displayed on the character display 4 at least, The telephone number sending part which sends out the telephone number which extracted 6 by the telephone number extraction part 3 based on directions of the dial instruction input part 5, and the signal of autodial directions to the telephone 11 with an autodial function via an interface (I/F) and a cable, and 7 comprise a CPU etc., It is a main control part which controls each function of the FM multiplex broadcast receiving set of this invention in generalization.

[0014]In the FM multiplex broadcast, the telephone number information for a request shall be sent as multiple sentence character information simultaneously with the speech information of a musical program, and the telephone number shall be added after the character string telephone number information suggests telephone numbers, such as a "telephone" and "TEL", saying. Recovery processing is carried out by the FM multiplex broadcast demodulation section 1, it separates into speech information, and a figure and text, and a figure and text are supplied to the FM multiplex broadcast received via the antenna by the alphabetic-information-storage part. Suppose that explanation is omitted about processing of speech information in this example.

[0015]The alphabetic-information-storage part 2 memorizes the figure and text supplied from the FM multiplex broadcast demodulation section 1. The telephone number extraction part 3 always carries out comparison detection of the character string which suggests telephone numbers, such as a "telephone" and "TEL", extracts 9 figures of numbers which continue after that thru/or 10 figures as a telephone number from the text memorized by the alphabetic-information-storage part 2, and stores them temporarily in the memory (not shown) which the telephone number extraction part 3 manages.

[0016]The telephone number extracted by the telephone number extraction part 3 is supplied and displayed on the character display 4. Information other than a telephone number is also

supplied and displayed on the character display 4 from the alphabetic-information-storage part 2. It is displayed that the telephone number of "request is 03-3456-7890 in the character display 4." When telephoning the telephone number of the request displayed on the character display 4, the operator of this FM multiplex broadcast receiving set pushes the dial indicating button of the dial instruction input part 5. A push on a dial indicating button will output a dial indication signal to the main control part 7 from the dial instruction input part 5.

[0017]The main control part 7 will be controlled to transmit now the telephone number information currently displayed on the character display 4 to the telephone number sending part 6, if a dial indication signal is detected. The telephone number sending part 6 will transmit autodial control information and telephone number information to the telephone 11 with an autodial function via general-purpose I/F (for example, RS-232C), if telephone number information is received from the telephone number extraction part 3. This telephone control information is an AT command, a V.25bis command, etc. The method of telephone control may be control not only by what transmits the telephone control information shown in this example but the signal wire using exclusive I/F, such as for example, making autodial (start by making into "H" the signal wire which sent telephone number information and was defined beforehand). Of course, the telephone 11 does not need to say that it is what can carry out autodial based on the telephone control by the signal wire which used this exclusive I/F. When connected with a public line via a private branch exchange etc., the dial information (for example, "0") which shows outside line connection may be added to the beginning of telephone number information.

[0018]The telephone 11 calls to this telephone number based on dial control information and telephone number information. After calling to the target telephone number, when connected with a partner, an operator can talk using the telephone 11. A cable or radio may be sufficient as the telephone 11. Next, the 2nd example of the FM multiplex broadcast receiving set of this invention is described, referring to drawing 2.

[0019]In drawing 2, since the attached number 1 thru/or 5 and 7 are drawing 1, the name, and the function, it omits explanation. The dialing circuit which performs autodial to the telephone number which 8 was connected to the public line and extracted by the telephone number extraction part 3 based on directions of the dial instruction input part 5, It is the autodial control section provided with the voice circuit which enables transmission and reception of the sound in a public line (operator) via the call device (not shown) constituted with an earphone, a microphone, etc. A public network may be a wired network or may be a radio network.

[0020]The telephone number information for a request shall be sent to the 2nd example as multiple sentence character information simultaneously [ in an FM multiplex broadcast ] with the speech information of a musical program like the 1st example. The telephone number shall be added after the character string telephone number information suggests telephone

numbers, such as a "telephone" and "TEL", saying. Recovery processing is carried out by the FM multiplex broadcast demodulation section 1, it separates into speech information, and a figure and text, and a figure and text are supplied to the FM multiplex broadcast received via the antenna by the alphabetic-information-storage part. Suppose that explanation is omitted about processing of speech information in this example.

[0021]The alphabetic-information-storage part 2 memorizes the figure and text supplied from the FM multiplex broadcast demodulation section 1. The telephone number extraction part 3 always carries out comparison detection of the character string which suggests telephone numbers, such as a "telephone" and "TEL", extracts 9 figures of numbers which continue after that thru/or 10 figures as a telephone number from the text memorized by the alphabetic-information-storage part 2, and stores them temporarily in the memory (not shown) which the telephone number extraction part 3 manages.

[0022]The telephone number extracted by the telephone number extraction part 3 is supplied and displayed on the character display 4. Information other than a telephone number is also supplied and displayed on the character display 4 from the alphabetic-information-storage part 2. It is displayed that the telephone number of "request is 03-3456-7890 in the character display 4." When telephoning the telephone number of the request displayed on the character display 4, the operator of this FM multiplex broadcast receiving set pushes the dial indicating button of the dial instruction input part 5. A push on a dial indicating button will output a dial indication signal to the main control part 7 from the dial instruction input part 5.

[0023]The main control part 7 will control the autodial control section 8 now to the telephone number currently displayed on the character display 4 to dial, if a dial indication signal is detected. The autodial control section 8 will start autodial to this telephone number, if telephone number information is received from the telephone number extraction part 3. After calling to the target telephone number, when connected with a partner, it can talk with call devices (not shown) which an operator can connect to the autodial control section 8, such as an earphone and a microphone. When connected with a public line via a private branch exchange etc., it may be made to start autodial based on what added the dial information (for example, "0") which shows outside line connection to the beginning of telephone number information.

[0024]In the above FM multiplex broadcast receiving sets, since it is not necessary to recognize a telephone number and can dial, the credit mistake in a telephone can be prevented. Since it can dial only by operating a dial indicating button when telephoning the target telephone number, also when operation of an operator becomes easy and dials into an automobilism, it is ceased to cause trouble.

[0025]These shall be removed when "("and")" and "-" are added to the information on a telephone number at the time of extraction of the telephone number in the telephone number

extraction part 3. Although 9 figures of numbers which continue after the character string which suggests a telephone number thru/or 10 figures are made into the telephone number in this example, the arbitrary digit numbers which do not restrict to this example and were set up beforehand may be sufficient.

[0026]Next, the identification code of device each is set as the FM multiplex broadcast receiving set indicated in the 1st example or 2nd example, and the shopping system using an FM multiplex broadcast is explained according to drawing 3 and drawing 4. This example explains the shopping system of CD for music (compact disk). In drawing 3, since the attached numbers 1 thru/or 7 are drawing 1, the name, and the function, they omit explanation. 9 is an identification code storage parts store which memorizes the identification code information uniquely given to device each. An operator may input by a key input means (not shown) etc., may receive an identification code from a predetermined partner via a public line, and may also write the identification code memorized by the identification code storage parts store 9 in the identification code storage parts store 9.

[0027]In drawing 4, the FM multiplex broadcasting stations where 41 broadcasts CD information etc., the FM multiplex broadcast receiving set which showed 42 to drawing 3 which is the placing terminal in which the identification code was memorized beforehand, and 43 are goods centers which ship products according to the ordering information from a placing terminal. Simultaneously with the music dedicated by CD, from FM multiplex broadcasting stations 41, text, such as a telephone number etc. of the goods center 43 which is the product code, the trade names (CD title name, a singer name, etc.), and the object for order of the CD, is sent as multiple sentence character information. The telephone number shall be added after the character string telephone number information suggests telephone numbers, such as a "telephone" and "TEL", saying.

[0028]The placing terminal 42 receives the FM multiplex broadcast from FM multiplex broadcasting stations 41, and displays the product code and trade names of CD (CD title name, a singer name, etc.) on the character display 4. Speech information (music) shall be outputted from the voice response system which is not illustrated. Text is memorized by the alphabetic-information-storage part 2 only fixed time (for example, 24 hours) at this time.

[0029]When it is thought that the operator of the placing terminal 42 will purchase the goods displayed on the character display 4, it is an order key (in this example.). By pushing the dial indicating button of the dial instruction input part 5, it calls to the telephone number of the goods center 43 corresponding to the merchandise information displayed on the character display 4 (refer to drawing 5). The placing terminal 42 is connected with the ordering processing device (not shown) of the goods center 43 by the telephone 11 via a public network. Then, the placing terminal 42 transmits the product code of the goods currently displayed on the present character display 4, and the placing terminal identification code

memorized by the identification code storage parts store 9. As for the placing terminal 42 and the ordering processing device of the goods center 43, communication shall be performed using publicly known communication procedures, such as HDLC, and this communication procedure shall be memorized by the main control part 7 in the ordering processing device of the goods center 43, and a placing terminal.

[0030]In the goods center 43, when the customer data corresponding to an identification code are managed and there is an order of goods, it is a system which ships an ordered commodity to the address corresponding to the sent identification code. Although the shopping system using an FM multiplex broadcast explained using the FM multiplex broadcast receiving set shown in the placing terminal in the 1st example, it is clear to become the same placing terminal by forming the identification code storage parts store 9 in the FM multiplex broadcast receiving set shown in the 2nd example.

[0031]

[Effect of the Invention]In claim 1, since it is not necessary to recognize a telephone number and can dial, the credit mistake in a telephone can be prevented and trouble is not made to the 3rd person. Since it can dial only by operating a dial indicating button when telephoning the target telephone number, safety is secured, also when operation of an operator tends to become easy and tends to dial into an automobilism. Commercial telephone can be used and the cost cut of the multiplex-broadcasting receiving set of this invention can be aimed at.

[0032]In claim 2, since it is not necessary to recognize a telephone number and can dial, the credit mistake in a telephone can be prevented and trouble is not made to the 3rd person. Since it can dial only by operating a dial indicating button when telephoning the target telephone number, safety is secured, also when operation of an operator tends to become easy and tends to dial into an automobilism. Since the telephone function is built in, from the case where commercial telephone is used, an equipment configuration can be simplified and portability also improves.

[0033]It can use for an FM multiplex broadcast in claim 3. In claim 4, since the FM multiplex broadcast receiving set of this invention is discriminable, it can use for various services to be identified. In claim 5, it can dial using the information on multiplex broadcasting.

---

[Translation done.]



\* NOTICES \*

JPO and INPIT are not responsible for any damages caused by the use of this translation.

- 1.This document has been translated by computer. So the translation may not reflect the original precisely.
- 2.\*\*\*\* shows the word which can not be translated.
- 3.In the drawings, any words are not translated.

---

TECHNICAL FIELD

---

[Industrial Application]This invention relates to the device which receives especially an FM multiplex broadcast about the device in which multiplex-broadcasting reception is possible.

---

[Translation done.]

\* NOTICES \*

JPO and INPIT are not responsible for any damages caused by the use of this translation.

- 1.This document has been translated by computer. So the translation may not reflect the original precisely.
- 2.\*\*\*\* shows the word which can not be translated.
- 3.In the drawings, any words are not translated.

---

PRIOR ART

---

[Description of the Prior Art]Conventionally, an FM multiplex broadcast is received and what displays the text, graphic information, etc. is considered. In the conventional FM multiplex broadcast receiving set, when telephone number information had been transmitted as information and it was going to call to this telephone number for example, it was dialing, looking at the telephone number displayed on the indicator.

---

[Translation done.]

\* NOTICES \*

JPO and INPIT are not responsible for any damages caused by the use of this translation.

- 1.This document has been translated by computer. So the translation may not reflect the original precisely.
- 2.\*\*\*\* shows the word which can not be translated.
- 3.In the drawings, any words are not translated.

---

EFFECT OF THE INVENTION

---

[Effect of the Invention]In claim 1, since it is not necessary to recognize a telephone number and can dial, the credit mistake in a telephone can be prevented and trouble is not made to the 3rd person. Since it can dial only by operating a dial indicating button when telephoning the target telephone number, safety is secured, also when operation of an operator tends to become easy and tends to dial into an automobilism. Commercial telephone can be used and the cost cut of the multiplex-broadcasting receiving set of this invention can be aimed at.

[0032]In claim 2, since it is not necessary to recognize a telephone number and can dial, the credit mistake in a telephone can be prevented and trouble is not made to the 3rd person. Since it can dial only by operating a dial indicating button when telephoning the target telephone number, safety is secured, also when operation of an operator tends to become easy and tends to dial into an automobilism. Since the telephone function is built in, from the case where commercial telephone is used, an equipment configuration can be simplified and portability also improves.

\* NOTICES \*

JPO and INPIT are not responsible for any damages caused by the use of this translation.

- 1.This document has been translated by computer. So the translation may not reflect the original precisely.
- 2.\*\*\*\* shows the word which can not be translated.
- 3.In the drawings, any words are not translated.

---

TECHNICAL PROBLEM

---

[Problem(s) to be Solved by the Invention]However, when dialed according to the telephone number displayed on the indicator of the conventional FM multiplex broadcast receiving set, the telephone number hung, the mistake etc. happened and it had the problem of making the 3rd person trouble. When the conventional FM multiplex broadcast receiving set was mounted and it called to the telephone number displayed on an indicator, the frequency where a cellular phone and a car telephone are used was high, and it increased, also when dialing during a run of a car, and it also had the problem of bringing an obstacle to the safety at the time of a run of a car.

[0004]This invention is made in view of said problem, and simplifies complicated dial control, and an object of this invention is to prevent the credit mistake in a telephone.

---

[Translation done.]

\* NOTICES \*

JPO and INPIT are not responsible for any damages caused by the use of this translation.

- 1.This document has been translated by computer. So the translation may not reflect the original precisely.
- 2.\*\*\*\* shows the word which can not be translated.
- 3.In the drawings, any words are not translated.

---

MEANS

---

[Means for Solving the Problem]Multiplex-broadcasting receiving set of this invention provided with a multiplex-broadcasting demodulation section which recovers auxiliary information from multiplex broadcasting which carried out multiplex [ of the auxiliary information ] to main information is characterized by that claim 1 comprises the following.

An alphabetic-information-storage part which memorizes text in auxiliary information to which it restored in a multiplex-broadcasting demodulation section.

A telephone number extraction part which extracts a telephone number from the inside of text memorized by alphabetic-information-storage part.

A character display which displays text memorized by a telephone number extracted by telephone number extraction part or said alphabetic-information-storage part.

A telephone number sending part which sends out a telephone number and an autodial indication signal corresponding to text displayed on a telephone number displayed on a character display, or a character display.

[0006]Multiplex-broadcasting receiving set of this invention provided with a multiplex-broadcasting demodulation section which recovers auxiliary information from multiplex broadcasting which carried out multiplex [ of the auxiliary information ] to main information is characterized by that claim 2 comprises the following.

An alphabetic-information-storage part which memorizes text in auxiliary information to which it restored in a multiplex-broadcasting demodulation section.

A telephone number extraction part which extracts a telephone number from the inside of text memorized by alphabetic-information-storage part.

A character display which displays text memorized by a telephone number extracted by telephone number extraction part or said alphabetic-information-storage part.

An autodial control section which generates a dial pulse based on a telephone number

corresponding to text displayed on a telephone number displayed on a character display, or a character display.

[0007] Multiplex-broadcasting receiving set of this invention provided with an FM multiplex broadcast demodulation section which recovers auxiliary information from an FM multiplex broadcast which carried out multiplex [ of the auxiliary information ] to main information is characterized by that claim 3 comprises the following.

An alphabetic-information-storage part which memorizes text in auxiliary information to which it restored in an FM multiplex broadcast demodulation section.

A telephone number extraction part which extracts a telephone number from the inside of text memorized by alphabetic-information-storage part.

A character display which displays text memorized by a telephone number extracted by telephone number extraction part or said alphabetic-information-storage part.

A telephone number sending part which sends out a telephone number and an autodial indication signal corresponding to text displayed on a telephone number displayed on a character display, or a character display. Or an autodial control section which generates a dial pulse based on a telephone number corresponding to text displayed on a telephone number displayed on a character display, or a character display.

\* NOTICES \*

JPO and INPIT are not responsible for any damages caused by the use of this translation.

- 1.This document has been translated by computer. So the translation may not reflect the original precisely.
- 2.\*\*\*\* shows the word which can not be translated.
- 3.In the drawings, any words are not translated.

---

OPERATION

---

[Function]According to claim 1, telephone number information is extracted from the text of multiplex broadcasting, and it is transmitted to telephone with an autodial function for the dial information of the extracted telephone number based on a dial instruction input part. According to claim 2, autodial is carried out to the telephone number which extracted telephone number information from the text of multiplex broadcasting, and was extracted based on the dial instruction input part.

[0011]According to claim 3, autodial is carried out to the telephone number which extracted telephone number information from the text of the FM multiplex broadcast, and was extracted based on the dial instruction input part. According to claim 4, since an identification code can be transmitted, the communications-partner point can recognize this device. According to claim 5, multiplex broadcasting is received and it can call to the telephone number in the information.

---

[Translation done.]

\* NOTICES \*

JPO and INPIT are not responsible for any damages caused by the use of this translation.

- 1.This document has been translated by computer. So the translation may not reflect the original precisely.
- 2.\*\*\*\* shows the word which can not be translated.
- 3.In the drawings, any words are not translated.

---

EXAMPLE

---

[Example]The example of the FM multiplex broadcast receiving set of this invention is described referring to drawing 1 thru/or drawing 6. First, the 1st example of the FM multiplex broadcast receiving set of this invention is described, referring to drawing 1.

[0013]The FM multiplex broadcast demodulation section to which 1 receives an FM multiplex broadcast via an antenna, and it restores in drawing 1, 2 is constituted by storages, such as RAM, a hard disk, a magneto-optical disc, The alphabetic-information-storage part which extracts and memorizes only text from the signal to which it restored by the FM multiplex broadcast demodulation section 1, The telephone number extraction part which extracts a telephone number from the text 3 is remembered to be by the alphabetic-information-storage part 2, The character display which displays the telephone number extracted by the text which 4 is constituted by LCD, CRT, a plasma display, etc. and is memorized by the alphabetic-information-storage part 2, and the telephone number extraction part 3, The dial instruction input part provided with the button which performs the directions which dial the telephone number as which 5 was displayed on the character display 4 at least, The telephone number sending part which sends out the telephone number which extracted 6 by the telephone number extraction part 3 based on directions of the dial instruction input part 5, and the signal of autodial directions to the telephone 11 with an autodial function via an interface (I/F) and a cable, and 7 comprise a CPU etc., It is a main control part which controls each function of the FM multiplex broadcast receiving set of this invention in generalization.

[0014]In the FM multiplex broadcast, the telephone number information for a request shall be sent as multiple sentence character information simultaneously with the speech information of a musical program, and the telephone number shall be added after the character string telephone number information suggests telephone numbers, such as a "telephone" and "TEL", saying. Recovery processing is carried out by the FM multiplex broadcast demodulation section 1, it separates into speech information, and a figure and text, and a figure and text are



supplied to the FM multiplex broadcast received via the antenna by the alphabetic-information-storage part. Suppose that explanation is omitted about processing of speech information in this example.

[0015]The alphabetic-information-storage part 2 memorizes the figure and text supplied from the FM multiplex broadcast demodulation section 1. The telephone number extraction part 3 always carries out comparison detection of the character string which suggests telephone numbers, such as a "telephone" and "TEL", extracts 9 figures of numbers which continue after that thru/or 10 figures as a telephone number from the text memorized by the alphabetic-information-storage part 2, and stores them temporarily in the memory (not shown) which the telephone number extraction part 3 manages.

[0016]The telephone number extracted by the telephone number extraction part 3 is supplied and displayed on the character display 4. Information other than a telephone number is also supplied and displayed on the character display 4 from the alphabetic-information-storage part 2. It is displayed that the telephone number of "request is 03-3456-7890 in the character display 4." When telephoning the telephone number of the request displayed on the character display 4, the operator of this FM multiplex broadcast receiving set pushes the dial indicating button of the dial instruction input part 5. A push on a dial indicating button will output a dial indication signal to the main control part 7 from the dial instruction input part 5.

[0017]The main control part 7 will be controlled to transmit now the telephone number information currently displayed on the character display 4 to the telephone number sending part 6, if a dial indication signal is detected. The telephone number sending part 6 will transmit autodial control information and telephone number information to the telephone 11 with an autodial function via general-purpose I/F (for example, RS-232C), if telephone number information is received from the telephone number extraction part 3. This telephone control information is an AT command, a V.25bis command, etc. The method of telephone control may be control not only by what transmits the telephone control information shown in this example but the signal wire using exclusive I/F, such as for example, making autodial (start by making into "H" the signal wire which sent telephone number information and was defined beforehand). Of course, the telephone 11 does not need to say that it is what can carry out autodial based on the telephone control by the signal wire which used this exclusive I/F. When connected with a public line via a private branch exchange etc., the dial information (for example, "0") which shows outside line connection may be added to the beginning of telephone number information.

[0018]The telephone 11 calls to this telephone number based on dial control information and telephone number information. After calling to the target telephone number, when connected with a partner, an operator can talk using the telephone 11. A cable or radio may be sufficient as the telephone 11. Next, the 2nd example of the FM multiplex broadcast receiving set of this

invention is described, referring to drawing 2.

[0019]In drawing 2, since the attached number 1 thru/or 5 and 7 are drawing 1, the name, and the function, it omits explanation. The dialing circuit which performs autodial to the telephone number which 8 was connected to the public line and extracted by the telephone number extraction part 3 based on directions of the dial instruction input part 5, It is the autodial control section provided with the voice circuit which enables transmission and reception of the sound in a public line (operator) via the call device (not shown) constituted with an earphone, a microphone, etc. A public network may be a wired network or may be a radio network.

[0020]The telephone number information for a request shall be sent to the 2nd example as multiple sentence character information simultaneously [ in an FM multiplex broadcast ] with the speech information of a musical program like the 1st example. The telephone number shall be added after the character string telephone number information suggests telephone numbers, such as a "telephone" and "TEL", saying. Recovery processing is carried out by the FM multiplex broadcast demodulation section 1, it separates into speech information, and a figure and text, and a figure and text are supplied to the FM multiplex broadcast received via the antenna by the alphabetic-information-storage part. Suppose that explanation is omitted about processing of speech information in this example.

[0021]The alphabetic-information-storage part 2 memorizes the figure and text supplied from the FM multiplex broadcast demodulation section 1. The telephone number extraction part 3 always carries out comparison detection of the character string which suggests telephone numbers, such as a "telephone" and "TEL", extracts 9 figures of numbers which continue after that thru/or 10 figures as a telephone number from the text memorized by the alphabetic-information-storage part 2, and stores them temporarily in the memory (not shown) which the telephone number extraction part 3 manages.

[0022]The telephone number extracted by the telephone number extraction part 3 is supplied and displayed on the character display 4. Information other than a telephone number is also supplied and displayed on the character display 4 from the alphabetic-information-storage part 2. It is displayed that the telephone number of "request is 03-3456-7890 in the character display 4." When telephoning the telephone number of the request displayed on the character display 4, the operator of this FM multiplex broadcast receiving set pushes the dial indicating button of the dial instruction input part 5. A push on a dial indicating button will output a dial indication signal to the main control part 7 from the dial instruction input part 5.

[0023]The main control part 7 will control the autodial control section 8 now to the telephone number currently displayed on the character display 4 to dial, if a dial indication signal is detected. The autodial control section 8 will start autodial to this telephone number, if telephone number information is received from the telephone number extraction part 3. After calling to the target telephone number, when connected with a partner, it can talk with call

devices (not shown) which an operator can connect to the autodial control section 8, such as an earphone and a microphone. When connected with a public line via a private branch exchange etc., it may be made to start autodial based on what added the dial information (for example, "0") which shows outside line connection to the beginning of telephone number information.

[0024]In the above FM multiplex broadcast receiving sets, since it is not necessary to recognize a telephone number and can dial, the credit mistake in a telephone can be prevented. Since it can dial only by operating a dial indicating button when telephoning the target telephone number, also when operation of an operator becomes easy and dials into an automobilism, it is ceased to cause trouble.

[0025]These shall be removed when "("and")" and "-" are added to the information on a telephone number at the time of extraction of the telephone number in the telephone number extraction part 3. Although 9 figures of numbers which continue after the character string which suggests a telephone number thru/or 10 figures are made into the telephone number in this example, the arbitrary digit numbers which do not restrict to this example and were set up beforehand may be sufficient.

[0026]Next, the identification code of device each is set as the FM multiplex broadcast receiving set indicated in the 1st example or 2nd example, and the shopping system using an FM multiplex broadcast is explained according to drawing 3 and drawing 4. This example explains the shopping system of CD for music (compact disk). In drawing 3, since the attached numbers 1 thru/or 7 are drawing 1, the name, and the function, they omit explanation. 9 is an identification code storage parts store which memorizes the identification code information uniquely given to device each. An operator may input by a key input means (not shown) etc., may receive an identification code from a predetermined partner via a public line, and may also write the identification code memorized by the identification code storage parts store 9 in the identification code storage parts store 9.

[0027]In drawing 4, the FM multiplex broadcasting stations where 41 broadcasts CD information etc., the FM multiplex broadcast receiving set which showed 42 to drawing 3 which is the placing terminal in which the identification code was memorized beforehand, and 43 are goods centers which ship products according to the ordering information from a placing terminal. Simultaneously with the music dedicated by CD, from FM multiplex broadcasting stations 41, text, such as a telephone number etc. of the goods center 43 which is the product code, the trade names (CD title name, a singer name, etc.), and the object for order of the CD, is sent as multiple sentence character information. The telephone number shall be added after the character string telephone number information suggests telephone numbers, such as a "telephone" and "TEL", saying.

[0028]The placing terminal 42 receives the FM multiplex broadcast from FM multiplex

broadcasting stations 41, and displays the product code and trade names of CD (CD title name, a singer name, etc.) on the character display 4. Speech information (music) shall be outputted from the voice response system which is not illustrated. Text is memorized by the alphabetic-information-storage part 2 only fixed time (for example, 24 hours) at this time. [0029]When it is thought that the operator of the placing terminal 42 will purchase the goods displayed on the character display 4, it is an order key (in this example.). By pushing the dial indicating button of the dial instruction input part 5, it calls to the telephone number of the goods center 43 corresponding to the merchandise information displayed on the character display 4 (refer to drawing 5). The placing terminal 42 is connected with the ordering processing device (not shown) of the goods center 43 by the telephone 11 via a public network. Then, the placing terminal 42 transmits the product code of the goods currently displayed on the present character display 4, and the placing terminal identification code memorized by the identification code storage parts store 9. As for the placing terminal 42 and the ordering processing device of the goods center 43, communication shall be performed using publicly known communication procedures, such as HDLC, and this communication procedure shall be memorized by the main control part 7 in the ordering processing device of the goods center 43, and a placing terminal.

[0030]In the goods center 43, when the customer data corresponding to an identification code are managed and there is an order of goods, it is a system which ships an ordered commodity to the address corresponding to the sent identification code. Although the shopping system using an FM multiplex broadcast explained using the FM multiplex broadcast receiving set shown in the placing terminal in the 1st example, it is clear to become the same placing terminal by forming the identification code storage parts store 9 in the FM multiplex broadcast receiving set shown in the 2nd example.

---

[Translation done.]

\* NOTICES \*

JPO and INPIT are not responsible for any damages caused by the use of this translation.

- 1.This document has been translated by computer. So the translation may not reflect the original precisely.
- 2.\*\*\*\* shows the word which can not be translated.
- 3.In the drawings, any words are not translated.

---

DESCRIPTION OF DRAWINGS

---

[Brief Description of the Drawings]

[Drawing 1]It is a functional block diagram of the 1st example of the receiving set at the time of using the multiplex-broadcasting receiving set of this invention for an FM multiplex broadcast.

[Drawing 2]It is a functional block diagram of the 2nd example of \*\*\*\*\* at the time of using the multiplex-broadcasting receiving set of this invention for an FM multiplex broadcast.

[Drawing 3]It is a functional block diagram when the multiplex-broadcasting receiving set of this invention is used for the placing terminal of a shopping system.

[Drawing 4]It is a mimetic diagram showing one example of the shopping system using the multiplex-broadcasting receiving set of this invention.

[Drawing 5]It is a mimetic diagram showing one example at the time of using the multiplex-broadcasting receiving set of this invention for a shopping system.

[Description of Notations]

- 1 FM multiplex broadcast demodulation section
- 2 Alphabetic-information-storage part
- 3 Telephone number extraction part
- 4 Character display
- 5 Dial instruction input part
- 6 Telephone number sending part
- 7 Main control part
- 8 Autodial control section
- 9 Identification code storage parts store
- 11 Telephone
- 41 FM multiplex broadcasting stations
- 43 Goods center

---

[Translation done.]

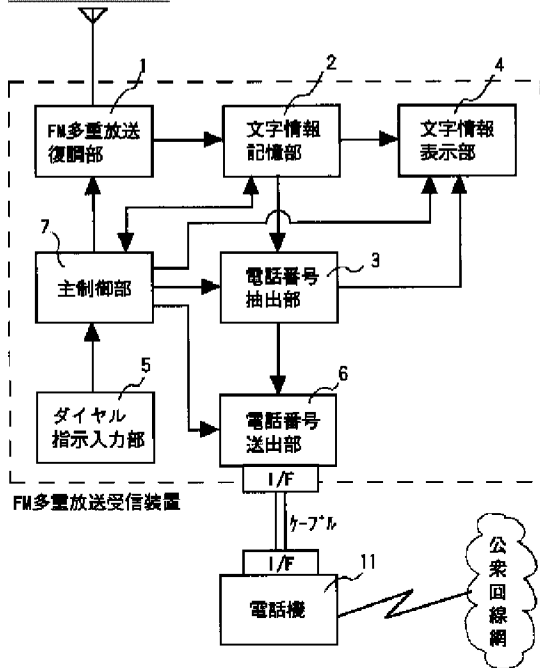
## \* NOTICES \*

JPO and INPIT are not responsible for any damages caused by the use of this translation.

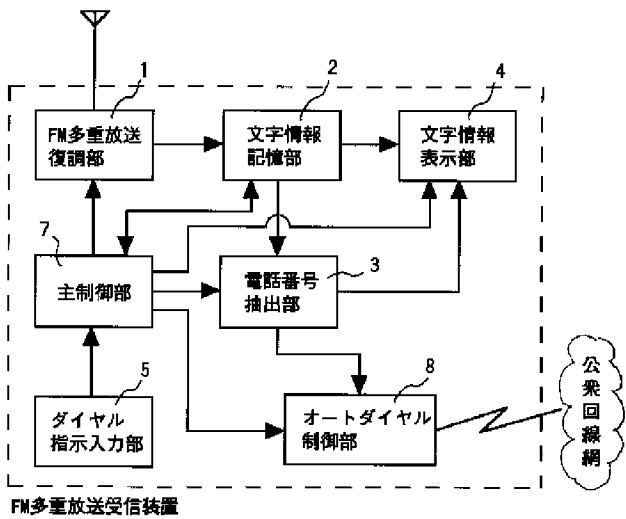
1. This document has been translated by computer. So the translation may not reflect the original precisely.
2. \*\*\*\* shows the word which can not be translated.
3. In the drawings, any words are not translated.

## DRAWINGS

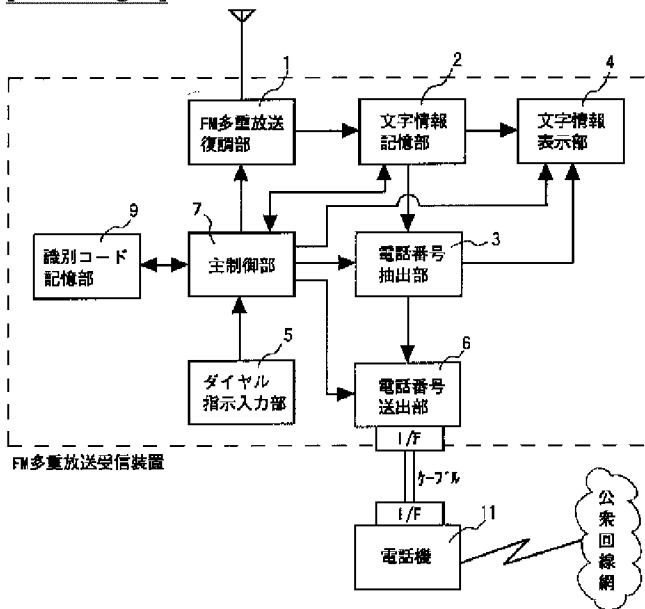
[Drawing 1]



[Drawing 2]

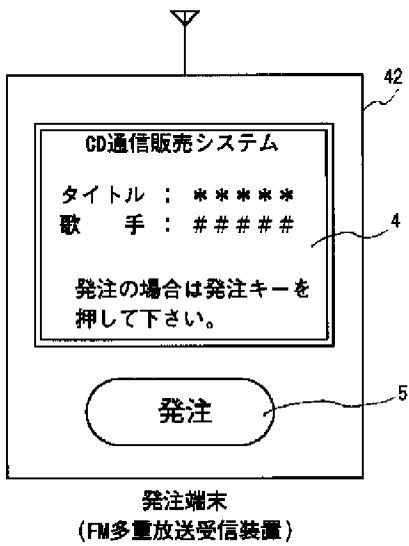


[Drawing 3]

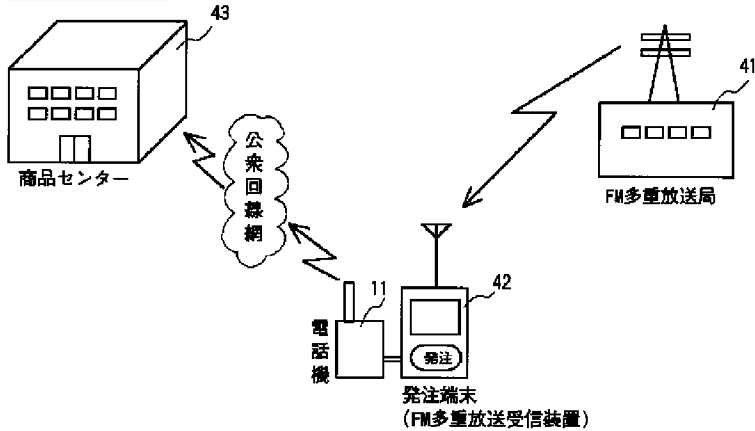


[Drawing 5]





[Drawing 4]



[Translation done.]

(19) 日本国特許庁 (JP)

(12) 公開特許公報 (A)

(11) 特許出願公開番号

特開平10-135855

(43) 公開日 平成10年(1998) 5月22日

(51) Int.Cl. <sup>4</sup>	識別記号	F I	
H 0 4 B	1/16	H 0 4 B	1/16 G
H 0 4 H	1/00	H 0 4 H	1/00 C
	1/02		E
H 0 4 Q	9/00	H 0 4 Q	9/00 F
	3 0 1		3 0 1 E

審査請求 未請求 請求項の数11 OL (全 4 頁)

(21) 出願番号	特願平8-286982	(71) 出願人	000002185 ソニー株式会社 東京都品川区北品川6丁目7番35号
(22) 出願日	平成8年(1996)10月29日	(72) 発明者	近藤 哲二郎 東京都品川区北品川6丁目7番35号 ソニー株式会社内
		(72) 発明者	奥村 裕二 東京都品川区北品川6丁目7番35号 ソニー株式会社内

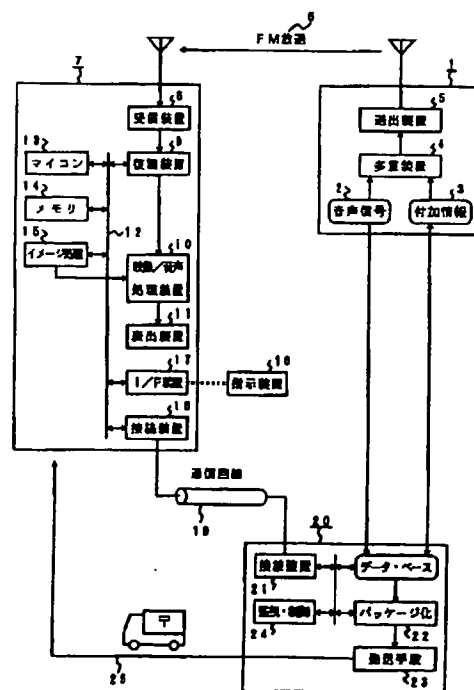
(54) 【発明の名称】 情報受信装置及び情報送信装置並びに情報伝送方法

(57) 【要約】

【課題】 音声放送等に種々のデータを多重化することにより、受信端末装置の制御等を可能とする。

【解決手段】 放送局から放送電波に、放送中の映像又は音声信号の識別コード、演奏時間、著作権所有者、販売価格、又は、販売元等の付加情報を多重化して伝送する。そしてこの伝送された付加情報を受信した者は、必要に応じて、所定の手続きで、放送中の映像信号等の販売事業者から映像等のソースを購入する。

【効果】 受信者において、所望の楽曲等の購入にかかる費用等が付加情報により確認できるほか、通信回線による販売事業者等への接続や、発注等にかかる作業負担を、付加情報の利用で軽減できる。



## 【特許請求の範囲】

【請求項1】 放送局から放送電波に多重化して送信される情報を受信する情報受信装置であって、前記多重化して送信される情報は、放送中の映像又は音声信号の付加情報であることを特徴とする情報受信装置。

【請求項2】 請求項1記載の情報受信装置であって、前記付加情報は、前記放送中の映像又は音声信号の識別コード、演奏時間、著作権所有者、販売価格、又は、販売元であることを特徴とする情報受信装置。

【請求項3】 放送電波に多重化して情報を送信する情報送信装置であって、前記多重化して送信する情報は、放送中の映像又は音声信号の付加情報であることを特徴とする情報送信装置。

【請求項4】 請求項3記載の情報送信装置であって、前記付加情報は、前記放送中の映像又は音声信号の識別コード、演奏時間、著作権所有者、販売価格、又は、販売元であることを特徴とする情報送信装置。

【請求項5】 請求項1記載の情報受信装置であって、前記情報受信装置は、前記放送中の映像又は音声信号のソースを販売する事業者と情報の授受を行うための通信手段を有することを特徴とする情報受信装置。

【請求項6】 請求項2記載の情報受信装置であって、前記情報受信装置は、前記放送中の映像又は音声信号のソースを販売する事業者と情報の授受を行うための通信手段を有することを特徴とする情報受信装置。

【請求項7】 請求項5記載の情報受信装置であって、更に、前記付加情報を記憶する手段と、前記記憶した付加情報を編集し発注用データを作成するデータ作成手段とを有することを特徴とする情報受信装置。

【請求項8】 放送局から放送電波に多重化して情報を伝送する情報伝送方法であって、前記多重化して伝送する情報は、放送中の映像又は音声信号の付加情報であることを特徴とする情報伝送方法。

【請求項9】 請求項8記載の情報伝送方法であって、前記付加情報は、前記放送中の映像又は音声信号の識別コード、演奏時間、著作権所有者、販売価格、又は、販売元であることを特徴とする情報伝送方法。

【請求項10】 請求項8記載の情報伝送方法であって、前記付加情報を一時的に記憶し、前記記憶した付加情報の履歴に基づいて伝送された信号を編集し選択する編集工程を有することを特徴とする情報伝送方法。

【請求項11】 請求項10記載の情報伝送方法であって、更に、前記編集工程の結果を基に映像又は音声信号のソースを配布する工程を有することを特徴とする情報伝送方法。

## 【発明の詳細な説明】

## 【0001】

【発明の属する技術分野】本発明は、映像/音声信号にデータを多重化して放送するシステムに関する。

## 【0002】

【従来の技術】従来、FMラジオ放送等において、FM多重データ放送が行われていた。これは、特開平8-149023号公報に記載されているように、通常のFM番組音声信号に多重化して、その番組と連動した文字情報等を放送するものである。

## 10 【0003】

【発明が解決しようとする課題】しかし、従来のFM多重データ放送は、文字コードの伝送による、受信装置における情報の文字表示を目的としており、伝送されたデータにより受信端末装置の制御を行う等のサービス形態はこれまでなかった。

【0004】本発明の課題は、音声放送等に種々のデータを多重化することにより、受信端末装置の制御等を可能とする情報受信装置及び情報送信装置並びに情報伝送方法を提供することである。

## 20 【0005】

【課題を解決するための手段】上記目的を達成するために、本発明の情報受信装置は、放送局から放送電波に、放送中の映像又は音声信号の識別コード、演奏時間、著作権所有者、販売価格、又は、販売元等の付加情報を多重化して送信される情報を受信するものである。上記目的を達成するために、本発明の情報送信装置は、放送電波に、放送中の映像又は音声信号の識別コード、演奏時間、著作権所有者、販売価格、又は、販売元等の付加情報を多重化して送信するものである。上記目的を達成するために、本発明の情報伝送方法は、放送電波に、放送中の映像又は音声信号の識別コード、演奏時間、著作権所有者、販売価格、又は、販売元等の付加情報を多重化して伝送するものである。

## 【0006】

【発明の実施の形態】以下、本発明を図面を参照して具体的に説明する。図1は、本発明の好ましい実施の形態を示すブロック図である。放送局1は、通常のFMラジオ放送である音声による音声信号2に、例えば、現在放送している楽曲の識別コード、演奏時間、著作権所有者、販売価格、販売事業者等のデータからなる付加情報3を、主たる音声信号2を受信する上で妨害を与えぬよう、例えば、FM文字多重放送のように受信端末で分離可能な方式により、多重装置4にて多重化した後、送出装置5より放送信号として送出する。送出されたFM放送信号は、放送手段6により受信端末装置7に供給される。

【0007】受信端末装置7の受信装置8により受信された放送信号は、復調装置9において、通常のFMラジオ放送信号に関しては、映像/音声処理装置10において音声処理された後、表出装置11の、例えば、スピー

カ等からなる音声表出手段により、受信者（図示せず）に供給される。

【0008】他方、音声信号に多重、重畳された付加情報3は、復調装置9において所定の信号形式に複合化された後、バス12を介し、マイクロプロセッサ13に供給される。マイクロプロセッサ13は、受信者（図示せず）が指示装置16の操作により送信した制御命令を受信するインターフェース装置17や、受信した番組付加情報データを一時格納するメモリ14、番組付加情報データを映像/音声化するイメージ処理装置15、販売事業者20と通信回線19とバス12を介して接続されている。

【0009】いま、受信者（図示せず）が、表出装置11より表出される音声番組中の楽曲を聴き、この楽曲或いは、例えば、演奏者等が異なる等の派生形態に関し、CDや磁気録音メディア等のパッケージメディアの形態での購入、或いは、通信回線19を介して、蓄積装置（図示せず）への配信を希望した場合、以下の操作及び手続きを行う。

【0010】まず、受信者（図示せず）は、希望する楽曲の購入価格、演奏時間、派生形態の有無等を付加情報から得るため、指示装置16の操作によりマイクロプロセッサ13に指令を出し、これらの情報を認識可能な形態で表出装置11に表示させる。ここで、マイクロプロセッサ13は、付加情報のメモリ14への格納と、複数の楽曲にかかる演奏時間、購入価格等を蓄積する演算処理や、放送による演奏順序によらず受信者が意図する順序への並べ替え、選択楽曲の削除といった編集作業を行うという処理機能をあわせて有し、受信者の指令によりこれを行う。

【0011】購入を希望する単一の楽曲或いは複数の楽曲からなるパッケージの選択、編集作業を終了した後、受信者の指示装置16による指示を受け、マイクロプロセッサ13は、付加情報中の販売事業者20に関する情報を基に、接続装置18を操作し、通信回線19を介してこれと接続し、受信者情報を含む購入依頼データを送信する。

【0012】販売事業者20は、接続装置21を介して受けた購入依頼のデータを基に、楽曲及びそれに付随する情報が蓄積されたデータベースを検索及び操作し、該当する楽曲をパッケージ化手段22によりCDや磁気録

音メディア等のパッケージメディア化し、発送手段23を経た後、郵送等の配信手段25にて受信者に供給する。これらのデータの流れは、監視・制御手段24によって監視され、制御される。但し、受信者が希望した楽曲の組み合わせが、いわゆる楽曲集の形態で販売事業者20等が予め提示し、パッケージ化した物と一致する場合には、新たなパッケージ化は行わない。パッケージによる供給の他、受信者の希望によっては、接続装置21、通信回線19を介し、楽曲データとして受信者に配信する。

【0013】尚、上記発明の実施の形態では、FM放送の場合のみを示したが、本発明に係る情報受信装置及び情報送信装置並びに情報伝送方法はこれに限るものでなく、AM放送、デジタル放送等の任意の放送形態であってもよいことはいうまでもない。

【0014】

【発明の効果】以上の説明から明らかなように、本発明の情報受信装置及び情報送信装置並びに情報伝送方法によれば、FM放送等にデータを多重化することにより、受信者において、所望の楽曲等の購入にかかる費用等が付加情報により確認できるほか、通信回線による販売事業者等への接続や、発注等にかかる作業負担を、付加情報の利用で軽減でき、これにより、現に受信している楽曲を鍵に、選択、発注を行うため、楽曲等の取扱商品のデータベースや検索システムを受信者側において持つ必要がなくなる他、個人レベルで行われていた複数のCDからのテープ編集を事業者側に一本化して行うことが可能となる。

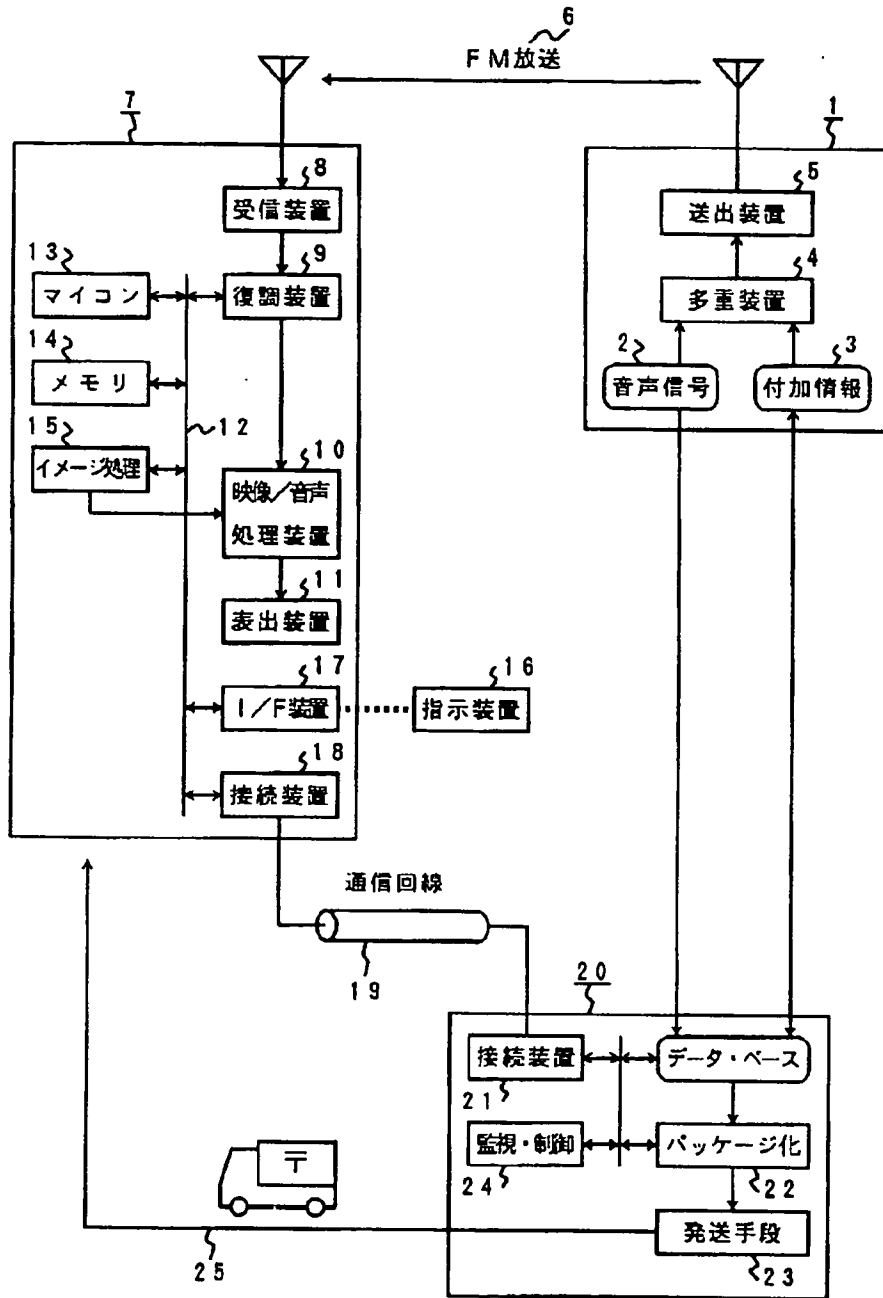
【図面の簡単な説明】

【図1】 本発明の好ましい実施の形態を示すブロック図である。

【符号の説明】

1…放送局、2…音声信号、3…付加情報、4…多重装置、5…送出装置、6…放送手段、7…受信端末装置、8…受信装置、9…復調装置、10…映像/音声処理装置、11…表出装置、12…バス、13…マイクロプロセッサ、14…メモリ、15…イメージ処理装置、16…指示装置、17…インターフェース装置、18…接続装置、19…通信回線、20…販売事業者、21…接続装置、22…パッケージ化手段、23…発送手段、24…監視・制御手段、25…配信手段

【図1】



DERWENT-ACC-NO: 1998-354040  
DERWENT-WEEK: 199831  
COPYRIGHT 1999 DERWENT INFORMATION LTD

TITLE: Information receiver for FM radio data broadcast - receives audio signal along with additional information multiplexed and transmitted from FM broadcast station

PATENT-ASSIGNEE: SONY CORP[SONY]

PRIORITY-DATA: 1996JP-0286982 (October 29, 1996)

PATENT-FAMILY:

PUB-NO	PUB-DATE	LANGUAGE	PAGES
MAIN-IPC			
JP 10135855 A	May 22, 1998	N/A	004
H04B 001/16			

APPLICATION-DATA:

PUB-NO	APPL-DESCRIPTOR	APPL-NO
APPL-DATE		
JP10135855A	N/A	1996JP-0286982
October 29, 1996		

INT-CL\_(IPC): H04B001/16; H04H001/00 ; H04H001/02 ; H04Q009/00

ABSTRACTED-PUB-NO: JP10135855A

BASIC-ABSTRACT: The information receiver (7) receives a broadcast electric wave transmitted by an FM radio broadcasting station (1). This broadcast station multiplexes various additional information such as identification code of audio signal, selling price and agency, copy write owner to the audio signal and transmits the multiplexed signal. This transmitted information is sent to a selling agent (20) who responds in response to the obtained information.

ADVANTAGE - Reduces work load by providing additional information. Avoids use of database and searching systems for handling goods.

CHOSEN-DRAWING: Dwg.1/1

TITLE-TERMS:

INFORMATION RECEIVE FM RADIO DATA BROADCAST RECEIVE AUDIO SIGNAL ADD  
INFORMATION MULTIPLEX TRANSMIT FM BROADCAST STATION

DERWENT-CLASS: W03

EPI-CODES: W03-B08;

SECONDARY-ACC-NO:  
Non-CPI Secondary Accession Numbers: N1998-277166



PATENT ABSTRACTS OF JAPAN

(11) Publication number: 2000292182 A

(43) Date of publication of application: 20.10.00

(51) Int. Cl. **G01C 21/00**  
**G08G 1/09**  
**G08G 1/0969**  
**G09F 21/04**  
**H04B 7/26**  
**H04Q 7/34**  
**H04H 1/00**

(21) Application number: 11100172

(71) Applicant: DENTSU INC

(22) Date of filing: 07.04.99

(72) Inventor: IIJIMA AKIO

(54) **ADVERTISEMENT SYSTEM FOR MOVABLE BODY AND ADVERTISEMENT INFORMATION-REPORTING METHOD FOR MOVABLE BODY**

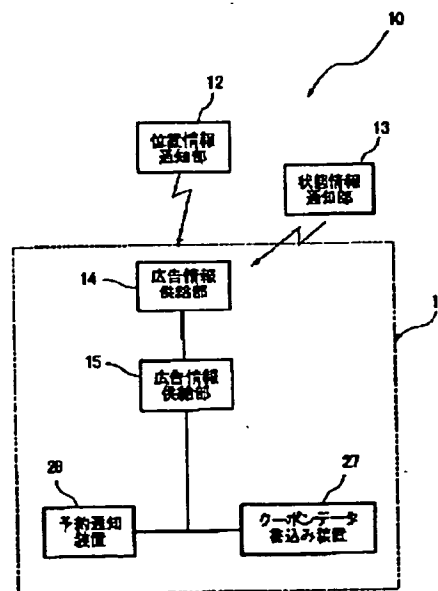
target into a smart card, presents the card to a service store and receives service based on the coupon data. Also, a reservation-reporting device 28 makes reservation/reservation purchase or the like to an advertisement target service store.

(57) Abstract:

COPYRIGHT: (C)2000,JPO

**PROBLEM TO BE SOLVED:** To enable a passenger to view or listen to advertisement information in a safer state and to reserve to purchase an advertisement target by storing a received advertisement data signal and at the same time verifying advertisement information that matches the position of a movable body for reporting to the passenger.

**SOLUTION:** An advertisement information data is transmitted from a broadcasting electronic wave to a movable body 11, and a data is stored at a storage that is mounted to the monitor of the receiver of an advertisement information-reporting part 15 that is installed at the movable body 11. When the movable body 11 enters an advertisement target area by verifying the position of the movable body 11 using a GPS, the advertisement information-reporting part 15 reports the advertise information to a passenger by voices and images. A coupon data-writing device 27 downloads the coupon data of the advertisement





(19) 대한민국특허청(KR)  
(12) 공개특허공보(A)

(51) Int. Cl.<sup>6</sup>  
H04N 7/20

(11) 공개번호 특1998-078248  
(43) 공개일자 1998년11월16일

(21) 출원번호	특1997-015719
(22) 출원일자	1997년04월26일
(71) 출원인	삼성전자 주식회사 윤종용 경기도 수원시 팔달구 매탄동 416번지
(72) 발명자	장순모 경기도 수원시 팔달구 원천동 주공 아파트 107동 1302호
(74) 대리인	임팽섭, 정현영, 최재희

심사결과 : 있음

(54) 셋탑박스의 아날로그/디지털방송 수신장치

요약

개시된 내용은 하나의 셋탑박스로 아날로그 방송과 디지털 방송 모두를 수신하여 화면에 선택적으로 표시하여 주는 셋탑박스의 아날로그/디지털방송 수신 장치에 관한 것이다.

본 발명은, 위성방송 튜너를 통해 수신된 방송파의 간섭을 제거하는 다이플렉서와, 상기 간섭이 제거된 방송파에서 디지털 신호의 대역을 검출하는 필터수단과, 상기 검출된 방송파를 디지털로 변환하고 진폭 변조하는 직각진폭 변조수단과, 상기 변조된 방송파 데이터의 오류를 정정하는 자동오류 정정수단 및 상기 정정된 방송파 데이터를 직각위상이동 변조수단의 위상이동 변조신호에 따라 비디오 데이터와 오디오 데이터로 복원 처리하는 엠팩 처리수단으로 이루어진 셋탑박스에 있어서; 상기 다이플렉서에서 얻어진 방송파중 아날로그 주파수 대역의 신호를 복조하여 비디오신호와 오디오신호로 분리하는 복조수단; 상기 복조된 아날로그 비디오신호가 혼화된 경우 이를 원래의 신호로 역혼화 시키는 역혼화수단; 복조된 아날로그 오디오신호를 음성다중 처리하는 음성다중처리수단; 및 상기 역혼화수단 및 음성다중 처리수단에서 얻어진 아날로그 비디오신호와 오디오신호 및 상기 엠팩처리수단에서 얻어진 비디오 데이터와 오디오 데이터중 어느 하나의 비디오와 오디오를 선택하여 출력하는 적어도 하나 이상의 선택수단을 포함한 것을 그 특징으로 한다.

도표도

도 2

명세서

도면의 간단한 설명

도 1은 종래 셋탑박스의 디지털 수신장치를 보인 블록도.

도 2는 본 발명 셋탑박스의 아날로그/디지털방송 수신장치의 설명에 제공되는 실시예 블록도.

도 3은 본 발명을 설명하기 위한 하이브리드 피버 커브 통신망 구조인 경우 입력되는 주파수 대역을 보인 도.

<도면의 주요부분에 대한 부호의 설명>

201 : 위성방송 튜너	202 : 다이플렉서
203 : 필터부	204 : 아날로그/디지털 변환부
205 : 직각진폭 변조부	206 : 자동오류 정정부
207 : 직각위상이동 변조부	208 : 복조부
209 : 음성다중처리부	210 : 역혼화부
211 : 엠팩처리부	

발명의 상세한 설명

발명의 목적

발명이 속하는 기술분야 및 그 분야의 종래기술

본 발명은 셋톱박스의 아날로그/디지털방송 수신에 관한 것으로, 더욱 상세하게는 고품질 텔레비전 등과 같은 디지털 전송방식을 사용하는 장치에서 프로그램 제공자 또는 서비스 제공자에서 제공되는 지상파 방송 또는 아날로그 케이블 방송을 시청자의 취향에 따라 선택적으로 수신이 가능하도록 하는 셋톱박스의 아날로그/디지털방송 수신 장치에 관한 것이다.

최근 정보미디어의 급격한 발전으로 인하여 정보(데이터)를 아날로그형태로 전송하는 방식에서 디지털형태로 전송하는 방식으로 전환되고 있다.

이때, 동일한 시간내에 보다 많은 정보를 전송하여야 한다는 요구에 부응하여, 'MPEG'이라는 데이터 압축 규정에 의해 데이터를 압축하여 전송하게 된다.

MPEG은(Moving Picture Experts Group :미디어 통합계 동영상압축의 국제 표준)의 약자로서, 통신·방송·저장미디어·컴퓨터 분야에서 공통으로 사용하기 위한 디지털 동영상 부호화(압축), 음향부호화 그리고 다중·분리방식에 관하여 ISO(International Organization for Standardization: 국제표준화기구)에 의해 표준화된 부호화방식이다.

이러한 MPEG은 오디오 비주얼(Audio Visual) 즉, 음향신호와 동영상 및 정지영상을 고도의 압축률로 압축하여 전송함으로써, 방송에서는 다채널화와 고품질의 전송효과를 얻을 수 있고, 저장미디어에서는 점유량 감소와 저가격의 저장미디어에 멀티미디어정보를 기록할 수 있는 효과를 얻을 수 있으며, 통신미디어에서는 저렴한 가격에 멀티미디어통신을 수행할 수 있다는 장점을 얻을 수 있으므로, 최근 멀티미디어시대의 핵심기술로 자리잡고 있다.

한편, 일반적인 텔레비전은 아날로그방송 신호를 신호처리하도록 규격화되어 있는데, 위성방송 및 기타 디지털방송 방식이 보급됨에 따라 사용자가 아날로그 방식의 텔레비전을 통하여 디지털방송신호를 시청할 수 있도록, MPEG 규정에 따라 압축·전송된 디지털방송신호를 신호처리하여 아날로그방송신호로 변환하기 위해 '디지털 셋 탑 박스(Set Top Box)'라 불리는 별도의 변환장치가 제공된다.

상기 디지털 셋 탑 박스는 프로그램 제공자 또는 서비스 제공자, 즉 다시 말해서, 각 방송국 또는 유선 방송국, 예컨대 케이블 텔레비전 및 위성방송 등과 같은 디지털형태의 비디오신호를 아날로그형태의 비디오신호로 변환하여 텔레비전에 신호처리가 가능한 방송방식으로 변환하는 장치로서, 최근 디지털방식의 방송신호를 시청하기 위한 소비자의 욕구에 힘입어 급속하게 보급되고 있다.

따라서 각 방송국 또는 유선 방송국에서는 주지하다시피, 서비스의 프로그램아날로그 신호를 디지털 신호로 변환하여 제공하게 된다.

이 변환된 데이터는 많은 정보를 전달하기 위해서 소정의 압축방식에 의해 압축된 후에 통신망을 통하여 가입자측으로 전달 된다.

상기 가입자측에는 상기와 같은 디지털 셋탑박스가 구비되어 상기 전달된 디지털 데이터를 수신하여 이를 아날로그 신호로 변환한 후에 모니터에 디스플레이 하게 된다.

이와 같이 각 방송국 또는 유선방송국에서 압축되어 전송되는 디지털 신호를 아날로그신호로 처리하여 모니터에 표시하는 장치로서는 도 1과 같은 수신장치가 있다.

도 1에 제시된 장치를 종래 셋톱박스의 디지털방송 수신장치의 예로서, 설명한다.

상기 셋톱박스의 디지털 수신장치는, 각 방송국 또는 유선 방송국에서 송출되어 입력단자(100)를 통해 입력되는 압축된 혼성(Hybrid) 방송파(carrier) 신호를 해당 채널의 주파수로 동조하고 그 동조된 방송파 신호의 진폭을 외부로부터 입력되는 위상이동 변조신호의 크기에 비례하여 변화시키는 위성방송 튜너(101)와, 상기 위성방송 튜너(101)를 통해 동조되어 얻어진 방송파중에서 비디오 신호와 오디오신호의 상호 간섭을 제거하고 상기 위상이동 변조신호를 위성방송 튜너(101)로 제공하는 다이플렉서(102)와, 상기 다이플렉서(102)로부터 얻어진 방송파 신호를 필터링하여 디지털신호 대역만을 추출하는 필터부(103)와, 상기 필터부(103)에서 추출된 아날로그신호를 디지털신호로 변환하여, 출력하는 아날로그/디지털 변환부(104)와, 상기 아날로그/디지털 변환부(104)로부터 주파수가 같고 위상이 서로 90도 차이나는 두 개의 방송파신호를 입력받아 유한개의 값을 가질 수 있는 두 개의 미산신호로 각각 진폭 변조하여 출력하는 직각진폭 변조부(QAM: Quadrature Amplitude Modulation)(105)와, 인접 채널간의 간섭에 의해 발생되는 오류를 보정하기 위해 상기 직각진폭 변조부(105)에서 변조되어 입력되는 방송파 데이터 포맷을 읽어 정보들을 토대로 정정하여 패킷단위로 출력하는 자동오류 정정부(106)와, 상기 위성방송 튜너(101)를 통해 입력되는 방송파의 순간 위상을 변화시키기 위해 상기 위상이동 변조신호를 다이플렉서(102)를 통해 위성방송 튜너(101)에 제공하는 직각위상 이동변조부(107)와, 상기 자동오류 정정부(106)를 통하여 입력되는 비디오 데이터 및 오디오 데이터를 상기 직각위상 이동변조부(107)의 위상이동 변조신호에 따라 복원하여 메모리부(110)에 저장함과 아울러 원래의 복합비디오 신호(CPSV) 및 오디오신호(ADS)로 변환하여 각각 비디오 출력단자(112) 및 오디오출력단자(113)로 출력하는 앰프 처리부(108)와, 상기 앰프처리부(108)에서 복원된 디지털 복합비디오 신호(CPSV) 및 오디오신호(ADS)를 고주파신호로 변조하여 출력단자(111)를 통해 텔레비전 수상기로 제공되는 고주파 변조부(109)로 구성된다.

이와 같이 구성된 종래 셋톱박스의 디지털 방송 수신장치는, 잘 알려진 바와 같이, 각 방송국 또는 유선 방송국에서 프로그램에 대한 디지털 비디오신호와 오디오신호가 압축 혼성되어 입력단자(100)를 통해 방송파 신호로 입력되면, 위성방송 튜너(101)는, 상기 입력단자(100)를 통해 수신되어 입력되는 압축된 혼성 방송파(carrier) 신호를 해당 채널의 주파수로 동조하고 그 동조된 방송파 신호의 진폭을 이후에 설명될 직각위상이동 변조부(107)의 위상이동 변조신호의 크기에 비례하여 변화시키게 된다.

그리고, 상기 위성방송 튜너(101)를 통해 상기 진폭 변화된 방송파 신호는 다이플렉서(102)로 제공된다.

상기 다이플렉서(102)는, 상기 위성방송 튜너(101)를 통해 동조되어 얻어진 방송파 신호 중에서 압축된 비디오 신호와 오디오신호의 상호 간섭을 제거하여 필터부(103)에 제공함과 아울러 상기 직각위상이동 변조부(107)에서 발생된 위상이동 변조신호를 상기 위성방송 튜너(101)로 제공하게 된다.

한편, 상기 필터부(103)는 상기 다이플렉서(102)로부터 입력되는 반송파 신호를 필터링하여 디지털 신호 대역, 즉 다시 말해서 450MHz 내지 700MHz 대역만을 검출하게 된다.

상기 필터부(103)를 통해 검출된 아날로그 성분의 반송파 신호는 아날로그/디지털 변환부(104)를 통해 디지털 신호로 변환된 후에 직각진폭 변조부(105)에 제공된다.

상기 직각진폭 변조부(105)는 상기 아날로그/디지털 변환부(104)로부터의 주파수가 같고 위상이 서로 90도 차이나는 두 개의 디지털 반송파 데이터를 입력받아 이들 두 개의 이산신호로 각각 진폭 변조하게 된다.

상기 직각진폭 변조부(105)를 통해 진폭 변조된 반송파 데이터는 자동오류 정정부(106)에서 인접 채널간의 간섭에 의해 발생하는 오류가 보정되어 원래의 비디오 및 오디오 패킷 데이터로 엠팩처리부(108)에 제공된다.

한편, 상기 직각위상이동 변조부(107)에서는 위상이동 변조신호가 발생되어 엠팩처리부(108)에 제공된다.

따라서, 상기 엠팩처리부(108)는 상기 자동오류 정정부(106)에서 입력되는 비디오 데이터 및 오디오 데이터를 상기 직각위상이동 변조부(107)의 위상이동 변조신호에 동기 복원하여 이를 메모리부(110)에 저장하고 아울러 또한 원래의 복합비디오 신호(CPSV) 및 오디오 신호(ADS)로 엠팩처리하여 각각의 비디오 출력단자(112) 및 오디오 출력단자(113)를 통해 출력하고 또한 고주파 변조부(109)에 제공하게 된다.

상기 고주파 변조부(109)는 엠팩처리부(108)에서 엠팩 처리된 복합비디오 신호(CPSV)와 오디오 신호(ADS)를 고주파 신호로 변조하여 이를 다시 출력단자(111)를 통해 텔레비전 수상기로 제공함으로써, 시청자는 칼라수상관을 통해 디지털 방송을 시청할 수가 있게 된다.

그리고, 상기 비디오 출력단자(112) 및 오디오 출력단자(113)로 출력된 복합비디오 신호 및 오디오 신호는 디지털 비디오 디스크 플레이어 또는 디지털 브이씨에에 제공되어 자기기록 매체에 기록이 된다.

**발명이 이루고자 하는 기술적 과제**

그러나, 전술한 종래의 셋톱박스의 디지털 방송 수신장치는, 잘 알려진 바와 같이, 수신된 방송신호 및 케이블 신호가 디지털 신호인 경우에는 이를 수신하여 칼라수상관에 표시를 하여 주지만, 만약 지상파 방송이나 또는 아날로그 케이블 방송인 경우에 있어서, 그 아날로그 신호를 직접 수신하는 것이 불가능하다는 것을 알 수 있다.

따라서, 종래의 셋톱박스의 구성으로서는, 지상파 또는 케이블 방송에서 전송되는 아날로그 신호의 수신이 불가능하여 부득이 셋톱박스를 통해 디지털 방송만을 시청해야 하는 문제점을 내제하고 있다.

따라서, 지상파 방송 또는 아날로그 케이블 방송의 시청 불가상태 없이 종래의 것과 동등 이상의 아날로그/디지털 방송 수신이 가능한 셋톱박스의 수신장치가 바람직하다.

따라서, 본 발명은 전술한 종래의 기술에서, 셋톱박스가 가지는 지상파 방송 또는 아날로그 케이블 방송의 수신 불가 상태를 배제한 것으로, 본 발명의 한 견지로서, 하나의 셋톱박스로 아날로그 방송과 디지털 방송 모두를 수신하여 화면에 표시하여 주도록 하는 셋톱박스의 아날로그/디지털 방송 수신 장치를 제공할에 그 목적이 있다.

본 발명의 다른 견지로서, 아날로그 방송과 디지털 방송 모두를 수신하여 시청자의 선택에 의해 어느 하나의 방송을 화면에 표시하여 주도록 하는데 그 목적이 있다.

본 발명의 또다른 견지로서, 하나의 셋톱박스를 통해 아날로그 방송과 디지털 방송을 수신하도록 하여 편리성을 제공하고 텔레비전 수상기와의 호환성을 유지시켜 주도록 하는데 그 목적이 있다.

본 발명의 또다른 견지로서, 셋톱박스에 음성다중 기능을 부여하여 수신된 음성신호를 다중 처리하도록 하는데 그 목적이 있다.

본 발명의 또다른 견지로서, 셋톱박스에 디스크해블링(descrambling; 역혼화) 기능을 부여하여 수신된 신호가 스크램블링이 걸려 있을 경우 이를 역혼화시켜 화면에 표시하여 주도록 하는데 그 목적이 있다.

**발명의 구성 및 작용**

상기와 같은 목적들을 달성하기 위한 본 발명의 일 측면에 따른 셋톱박스의 아날로그/디지털 방송 수신 장치는, 위성방송 튜너를 통해 수신된 반송파의 간섭을 제거하는 다이플렉서; 상기 간섭이 제거된 반송파에서 디지털 신호의 대역을 검출하는 필터수단; 상기 검출된 반송파를 디지털로 변환하고 진폭 변조하는 직각진폭 변조수단; 상기 변조된 반송파 데이터의 오류를 정정하는 자동오류 정정수단; 상기 정정된 반송파 데이터를 직각위상이동 변조수단의 위상이동 변조신호에 따라 비디오 데이터와 오디오 데이터로 복원 처리하는 엠팩 처리수단으로 이루어진 셋톱박스에 있어서; 상기 다이플렉서에서 얻어진 반송파중 아날로그 주파수 대역의 신호를 복조하여 아날로그의 비디오신호와 오디오신호로 분리하는 복조수단; 및 상기 분리된 아날로그 비디오신호 및 오디오신호와 상기 엠팩처리수단의 비디오 데이터 및 오디오 데이터중 어느 하나의 비디오와 오디오를 선택하여 출력하는 제 1, 제 2선택수단을 포함한 것을 그 특징으로 한다.

상기 본 발명에 의한 셋톱박스의 아날로그/디지털 방송 수신 장치에 있어서, 상기 제 1, 제 2선택수단은, 한 번의 조작에 의해 연동되어 아날로그 비디오신호와 오디오신호 및 디지털 비디오신호와 오디오신호를 각기 선택하는 것이 바람직하다.

상기 본 발명에 의한 셋톱박스의 아날로그/디지털 방송 수신 장치에 있어서, 상기 제 1선택수단이 아날로그 비디오신호를 선택 시에 제 2선택수단은, 디지털 오디오신호를, 상기 제 1선택수단이 디지털 비디오신호를 선택 시에 제 2선택수단은, 아날로그 오디오신호를 선택하는 것이 바람직하다.

상기와 같은 목적들을 달성하기 위한 본 발명의 다른 측면에 따른 셋톱박스의 아날로그/디지털 방송 수신

장치는, 위성방송 튜너를 통해 수신된 방송파의 간섭을 제거하는 다이플렉서; 상기 간섭이 제거된 방송파에서 디지털 신호의 대역을 검출하는 필터수단; 상기 검출된 방송파를 디지털로 변환하고 진폭 변조하는 직각진폭 변조수단; 상기 변조된 방송파 데이터의 오류를 정정하는 자동오류 정정부; 상기 정정된 방송파 데이터를 직각위상이동 변조수단의 위상이동 변조신호에 따라 비디오 데이터와 오디오 데이터로 복원 처리하는 임팩 처리수단으로 이루어진 셋톱박스에 있어서; 상기 다이플렉서에서 얻어진 방송파중 아날로그 주파수 대역의 신호를 복조하여 아날로그의 비디오신호와 오디오신호로 분리하는 복조수단; 상기 복조된 아날로그 비디오신호가 혼화된 경우 이를 원래의 신호로 역혼화시키는 역혼화수단; 상기 복조된 아날로그 오디오신호를 음성다중 처리하는 음성다중 처리수단; 및 상기 역혼화수단 및 음성다중 처리수단에서 얻어진 아날로그 비디오신호 및 오디오신호와 상기 임팩처리수단에서 얻어진 비디오 데이터 및 오디오 데이터 중 어느 하나의 비디오와 오디오를 선택하여 출력하는 제 1, 제 2선택수단을 포함한 것을 그 특징으로 한다.

이와 같이하면, 하나의 셋톱박스로 아날로그 방송과 디지털 방송 모두를 수신하여 시청자의 선택에 의해 어느 하나의 방송을 화면에 표시해 주게됨을 알 수 있다.

그 결과, 하나의 셋톱박스를 통해 아날로그 방송과 디지털 방송을 수신함으로써, 사용상의 편리성이 제공될 뿐 아니라 텔레비전 수상기와와의 호환성이 유지되는 이점이 있는 것이다.

또한 아울러 부가적인 음성다중 기능과 역혼화 기능을 통해 음성다중 처리와 혼화된 정보를 풀어서 시청할 수가 있는 이점이 있다.

그리고, 본 발명의 실시 예로는 다수개가 존재할 수 있으며, 이하에서는 가장 바람직한 실시예에 대하여 상세히 설명하고자 한다.

이 바람직한 실시예를 통해 본 발명의 목적, 특징 및 이점을 보다 잘 이해할 수 있게 된다.

이하, 첨부한 도면을 참조하여 본 발명에 의한 셋톱박스의 아날로그/디지털방송 수신 장치의 바람직한 실시예를 상세히 설명한다.

또한, 본 발명은 디지털방송을 수신하는 여러 가지의 수신장치, 예컨대 고화질 텔레비전 수상기 등에 적용할 수 있다.

그래서, 설명에 사용되는 도 2는 특정한 셋톱박스가 아니고 여러 가지 디지털방송 수신장치에 착안한 도면이다.

또한, 이하의 설명에서는 일반 아날로그 텔레비전 수상기에 셋톱박스의 아날로그/디지털방송 수신장치를 사용한 예를 고려한다.

도 2는 본 발명 셋톱박스의 아날로그/디지털방송 수신장치의 설명에 제공되는 실시예 블록도이다.

본 실시예에 따르면, 각 방송국 또는 유선 방송국에서 송출되어 입력단자(200)를 통해 입력되는 아날로그 방송 또는 디지털방송의 압축된 혼성 방송파를 해당 채널의 주파수로 동조하고 그 동조된 방송파 신호의 진폭을 외부로부터 입력되는 위상이동 변조신호의 크기에 비례하여 변화시키는 위성방송 튜너(201)와, 상기 위성방송 튜너(201)를 통해 동조되어 입력되는 방송파중에서 비디오 신호와 오디오신호의 상호 간섭을 제거하고 상기 위상이동 변조신호를 위성방송 튜너(201)로 제공하는 다이플렉서(202)와, 상기 다이플렉서(202)를 통해 입력되는 방송파중에서 디지털신호 대역만을 추출하는 필터부(203)와, 상기 필터부(203)에서 추출된 아날로그신호를 디지털신호로 변환하여 출력하는 아날로그/디지털 변환부(204)와, 상기 아날로그/디지털 변환부(204)로부터 주파수가 같고 위상이 서로 90도 차이나는 두 개의 방송파를 입력받아 미상신호로 각각 진폭 변조하여 출력하는 직각진폭 변조부(205)와, 인접 채널간의 간섭에 의해 발생하는 오류를 보정하기 위해 상기 직각진폭 변조부(205)에서 변조되어 입력되는 방송파 데이터 포맷을 정정하여 패킷단위로 출력하는 자동오류 정정부(206)와, 상기 위성방송 튜너(201)를 통해 입력되는 방송파의 순간 위상을 변화시키기 위해 상기 위상이동 변조신호를 다이플렉서(202)를 통해 위성방송 튜너(201)에 제공하는 직각위상이동 변조부(207)와, 상기 자동오류 정정부(206)를 통하여 입력되는 비디오 데이터 및 오디오 데이터를 상기 직각위상이동 변조부(207)의 위상이동 변조신호에 따라 복원하여 메모리부(218)에 저장함과 아울러 원래의 복합비디오 신호(CPSV) 및 오디오신호(ADS)로 변환하여 출력하는 임팩처리부(211)와, 상기 다이플렉서(202)에서 입력되는 방송파중 아날로그 주파수 대역의 신호를 추출·복조하여 아날로그의 비디오신호와 오디오신호로 분리·출력하는 복조부(208)와, 상기 복조부(208)에서 복조된 아날로그 비디오신호가 혼화된 경우 이 신호를 원래의 신호로 역혼화시키는 역혼화부(210)와, 상기 복조부(208)에서 복조된 아날로그 오디오신호가 음성다중일 경우 이 신호를 음성다중 처리하여 출력하는 음성다중 처리부(209)와, 상기 역혼화부(210)에서 입력되는 아날로그 비디오신호와 상기 임팩처리부(211)에서 입력되는 디지털 복합 비디오신호(CPSV)중 어느 하나의 비디오신호를 선택하여 비디오 출력단자(216)로 선택하여 출력하는 제 1선택부(212)와, 상기 음성다중 처리부(209)에서 처리된 아날로그 오디오신호와 상기 임팩처리부(211)에서 입력되는 디지털 오디오신호(ADS)중 어느 하나의 오디오신호를 선택하여 오디오 출력단자(217)로 출력하는 제 2선택부(213)와, 상기 제 1, 제 2선택부(212), (213)에서 선택된 아날로그 또는 디지털 비디오신호 및 오디오신호를 고주파신호로 변조하여 출력단자(215)를 통해 텔레비전 수상기로 제공하는 고주파 변조부(214)로 구성한다.

그리고, 도 3은 본 발명을 설명하기 위한 하이브리드 피버 커브(Hybrid Fiber Curb) 통신망 구조인 경우 입력되는 주파수 대역을 보인 도이다.

이하에, 도 3을 참조하여 본 발명의 바람직한 실시예를 더욱 구체적으로 설명한다.

먼저, 각 방송국 또는 유선 방송국에서 도 3과 같은 프로그램에 대한 디지털 비디오신호와 오디오신호가 압축 혼성되어 입력단자(200)를 통해 방송파신호로 입력되면 위성방송 튜너(201)는, 상기 입력단자(200)를 통해 수신되어 입력되는 압축된 혼성 방송파신호를 해당 채널의 주파수로 동조하고 그 동조된 방송파 신호의 진폭을 이후에 설명될 직각위상이동 변조부(207)의 위상이동 변조신호의 크기에 비례하여 변화시키게 된다.

즉 다시 말해서, 상기 도 3의 주파수 대역에서, 5MHz 내지 30MHz까지는 텔레폰 및 간섭 서비스(T/I ; Telephone and Interactive Service)대역이고, 54MHz 내지 450MHz까지는 아날로그 비디오 신호 대역이며, 450MHz 내지 700MHz까지는 압축된 디지털 비디오신호 대역이며, 700MHz 내지 750MHz까지는 디지털 텔레폰 대역이다.

따라서, 상기 위성방송 튜너(201)는 상기와 같은 주파수 대역을 갖는 반송파 신호를 해당 채널로 동조하게 된다.

상기 위성방송 튜너(201)를 통해 상기 해당 채널로 동조되고 진폭 변화된 반송파 신호는 다이플렉서(202)로 제공된다.

상기 다이플렉서(202)는 상기 위성방송 튜너(201)를 통해 동조되어 얻어진 반송파 신호중에서 압축된 비디오 신호와 오디오신호의 상호 간섭을 제거하여 필터부(203) 및 이후에 설명될 복조부(208)에 제공할과 아울러 상기 직각위상이동 변조부(207)에서 발생된 위상이동 변조신호를 상기 위성방송 튜너(201)로 제공하게 된다.

상기 필터부(203)는 상기 다이플렉서(202)로부터 입력되는 반송파 신호를 필터링하여 디지털신호 대역, 즉 다시 말해서 압축된 450MHz 내지 700MHz 대역만을 추출하여 아날로그/디지털 변환부(204)에 제공하게 된다.

상기 필터부(203)를 통해 추출된 아날로그 성분의 반송파 신호는 아날로그/디지털 변환부(204)를 통해 디지털 신호로 변환된 후에 직각진폭 변조부(205)에 제공된다.

상기 직각진폭 변조부(205)는 상기 아날로그/디지털 변환부(204)로부터의 주파수가 같고 위상이 서로 90도 차이나는 두 개의 디지털 반송파 데이터를 입력받아 이를 두 개의 미산신호로 각각 진폭 변조하여 자동오류 정정부(206)에 제공하게 된다.

상기 자동오류 정정부(206)는 위성방송 튜너(202)로부터의 인접 채널간 간섭에 의해 발생하는 오류를 보정하여 비디오 및 오디오 패킷 데이터로 엠팩처리부(208)에 제공한다.

따라서, 상기 엠팩처리부(208)는 상기 자동오류 정정부(106)에서 입력되는 비디오 데이터 및 오디오 패킷 데이터를 상기 직각위상이동 변조부(207)에서 발생되어 입력되는 위상이동 변조신호에 동기·복합하여 이를 메모리부(218)에 저장하고 또한 원래의 복합비디오 신호(CPSV) 및 오디오 신호(ADS)로 엠팩처리하여 디지털 비디오 신호는 제 1선택부(212)에, 디지털 오디오신호는 제 2선택부(213)에 제공하게 된다.

한편, 상기 복조부(208)는 다이플렉서(202)에서 입력되는 도 3과 같은 주파수 대역에서 아날로그신호 대역을, 즉 다시 말해서 54MHz 내지 450MHz의 반송파신호를 원래의 신호로 복조하여 아날로그 비디오신호와 오디오신호를 분리 출력하게 된다.

상기 분리된 아날로그 오디오신호는 음성다중 처리부(209)에 제공되고, 비디오신호는 역혼화부(210)에 제공된다.

그리고, 상기 음성다중 처리부(209)는 상기 복조부(208)에서 입력되는 신호가 음성다중일 경우에는 음성 다중처리하고 음성다중이 아닐 경우에는 신호 처리 없이 바로 제 2선택부(213)에 제공하게 된다.

또한, 상기 역혼화부(210)는 상기 복조부(208)에서 입력되는 아날로그 비디오신호가 스크램블링(혼화)이 걸려 있을 경우에는 디스크램블링(역혼화)하고 스크램블링이 걸려 있지 않은 경우에는 바로 제 1선택부(212)에 제공하게 된다.

따라서, 상기 제 1선택부(212)는 사용자에 의해 상기 엠팩처리부(211)에서 입력되는 디지털 복합비디오신호(CPSV)와 역혼화부(210)에서 입력되는 아날로그 복합 비디오신호중 어느 한 신호를 선택하여 비디오 출력단자(215)로 출력함과 아울러 고주파 변조부(214)에 제공하고, 제 2선택부(213) 역시 사용자에 의해 상기 엠팩처리부(211)의 디지털 오디오신호(ADS)와 음성다중처리부(209)의 아날로그 오디오신호중 어느 한 신호를 선택하여 오디오 출력단자(217)로 출력함과 아울러 고주파 변조부(214)에 제공하게 된다.

상기 고주파 변조부(214)는 입력된 아날로그 또는 디지털 비디오/오디오신호를 고주파신호에 변조시켜 출력단자(215)를 통해 텔레비전 수상기에 제공함으로써, 시청자는 그 텔레비전 수상기의 칼라수상관을 통해 디지털 방송 또는 아날로그 방송을 시청할 수가 있게 된다.

그리고, 상기 비디오 출력단자(216) 및 오디오 출력단자(217)로 출력된 복합비디오 신호(CPSV) 및 오디오 신호(ADS)는 디지털 비디오 디스크 플레이어 또는 디지털 브이씨알에 제공되어 자기기록 매체에 기록이 된다.

상기 적용예의 결과에서, 알 수 있듯이 상기 엠팩처리부(211)에서 출력되는 디지털 방송의 비디오신호와 오디오신호 또는 역혼화부(210) 및 음성다중처리부(209)에서 출력되는 아날로그 방송의 비디오신호와 오디오신호를 사용자의 선택에 의해 시청하게 됨을 알 수 있다.

한편, 비교 예로서, 종래의 구성, 즉 다시 말해서 셋탑박스의 엠팩처리부를 통해 디지털방송의 비디오신호와 오디오신호를 엠팩 처리하여 화면을 시청하던 것과는 달리 본 발명은 아날로그 방송을 수신하기 위한 복조부와 제 1, 제 2선택부를 사용하였기 때문에 지상파 또는 케이블 방송에서 전송되는 아날로그 신호는 물론 디지털 방송까지 수신이 가능하다.

이 결과에서, 본 발명이 의하면 하나의 셋탑박스를 통해 아날로그 방송과 디지털 방송을 모두 수신함으로써, 사용상의 편리성 및 텔레비전 수상기와와의 호환성이 유지된다는 것을 알 수 있다.

그리고, 상기에서 본 발명의 특정한 실시예가 설명 및 도시되었지만 본 발명이 당업자에 의해 다양하게 변형되어 실시될 가능성이 있는 것은 자명한 일이다.

이와 같은 변형된 실시 예들은 본 발명의 기술적 사상이나 전망으로부터 개별적으로 이해되어져서는 안되

며, 이와 같은 변형된 실시 예들은 본 발명의 첨부된 특허청구범위 안에 속한다 해야 할 것이다.

**발명의 효과**

상술한 설명으로부터 분명한 것은, 본 발명의 셋톱박스의 아날로그/디지털방송 수신 장치에 의하면, 하나의 셋톱박스로 지상파 방송이나 또는 아날로그 케이블 방송을 모두 수신함으로써 사용상의 편리성이 제공되고 경제성 및 텔레비전 수상기와의 호환성이 유지되는 효과가 있다는 것이다.

또한, 부가적인 기능으로서, 음성다중 기능과 역혼화 기능을 통해 음성다중 처리와 암호화된 정보를 해독하여 시청할 수가 있는 효과가 있다는 것이다.

**(57) 청구의 범위**

**청구항 1**

위성방송 튜너를 통해 수신된 방송파의 간섭을 제거하는 다이플렉서와, 상기 간섭이 제거된 방송파에서 디지털 신호의 대역을 검출하는 필터수단과, 상기 검출된 방송파를 디지털로 변환하고 진폭 변조하는 직각진폭 변조수단과, 상기 변조된 방송파 데이터의 오류를 정정하는 자동오류 정정수단 및 상기 정정된 방송파 데이터를 직각위상이동 변조수단의 위상이동 변조신호에 따라 비디오 데이터와 오디오 데이터로 복원 처리하는 엠팩 처리수단으로 이루어진 셋톱박스에 있어서;

상기 다이플렉서에서 얻어진 방송파중 아날로그 주파수 대역의 신호를 복조하여 비디오신호와 오디오신호로 분리하는 복조수단; 및

상기 분리된 아날로그 비디오신호와 오디오신호와 상기 엠팩처리수단의 비디오 데이터 및 오디오 데이터 중 어느 하나의 비디오와 오디오신호를 선택하여 출력하는 적어도 하나 이상의 선택수단을 포함한 것을 특징으로 한 셋톱박스의 아날로그/디지털방송 수신 장치.

**청구항 2**

제 1 항에 있어서,

상기 선택수단은, 두 비디오신호와 오디오신호중 어느 한 비디오신호와 오디오신호를 각각 선택하는 두 개의 제 1,제 2선택수단을 갖는 것을 특징으로 한 셋톱박스의 아날로그/디지털방송 수신 장치.

**청구항 3**

제 2 항에 있어서,

상기 제 1,제 2선택수단은, 한 번의 조작에 의해 연동되어 아날로그 비디오신호와 오디오신호 및 디지털 비디오신호와 오디오신호를 각기 선택하는 것을 특징으로 한 셋톱박스의 아날로그/디지털방송 수신 장치.

**청구항 4**

제 2 항에 있어서,

상기 제 1선택수단이 아날로그 비디오신호를 선택 시에 제 2선택수단은, 디지털 오디오신호를, 상기 제 1 선택수단이 디지털 비디오신호를 선택 시에 제 2선택수단은, 아날로그 오디오신호를 선택하는 것을 특징으로 한 셋톱박스의 아날로그/디지털방송 수신 장치.

**청구항 5**

위성방송 튜너를 통해 수신된 방송파의 간섭을 제거하는 다이플렉서와, 상기 간섭이 제거된 방송파에서 디지털 신호의 대역을 검출하는 필터수단과, 상기 검출된 방송파를 디지털로 변환하고 진폭 변조하는 직각진폭 변조수단과, 상기 변조된 방송파 데이터의 오류를 정정하는 자동오류 정정수단 및 상기 정정된 방송파 데이터를 직각위상이동 변조수단의 위상이동 변조신호에 따라 비디오 데이터와 오디오 데이터로 복원 처리하는 엠팩처리수단으로 이루어진 셋톱박스에 있어서;

상기 다이플렉서에서 얻어진 방송파중 아날로그 주파수 대역의 신호를 복조하여 비디오신호와 오디오신호로 분리하는 복조수단;

상기 복조된 아날로그 비디오신호가 혼화된 경우 이를 원래의 신호로 역혼화 시키는 역혼화수단;

복조된 아날로그 오디오신호를 음성다중 처리하는 음성다중처리수단; 및 상기 역혼화수단 및 음성다중 처리수단에서 얻어진 아날로그 비디오신호와 오디오신호와 상기 엠팩처리수단에서 얻어진 비디오 데이터와 오디오 데이터중 어느 하나의 비디오와 오디오를 선택하여 출력하는 적어도 하나 이상의 선택수단을 포함한 것을 특징으로 한 셋톱박스의 아날로그/디지털방송 수신 장치.

**청구항 6**

제 5 항에 있어서,

상기 선택수단은, 두 비디오신호와 오디오신호중 어느 한 비디오신호와 오디오신호를 각각 선택하는 두 개의 제 1,제 2선택수단을 갖는 것을 특징으로 한 셋톱박스의 아날로그/디지털방송 수신 장치.

**청구항 7**

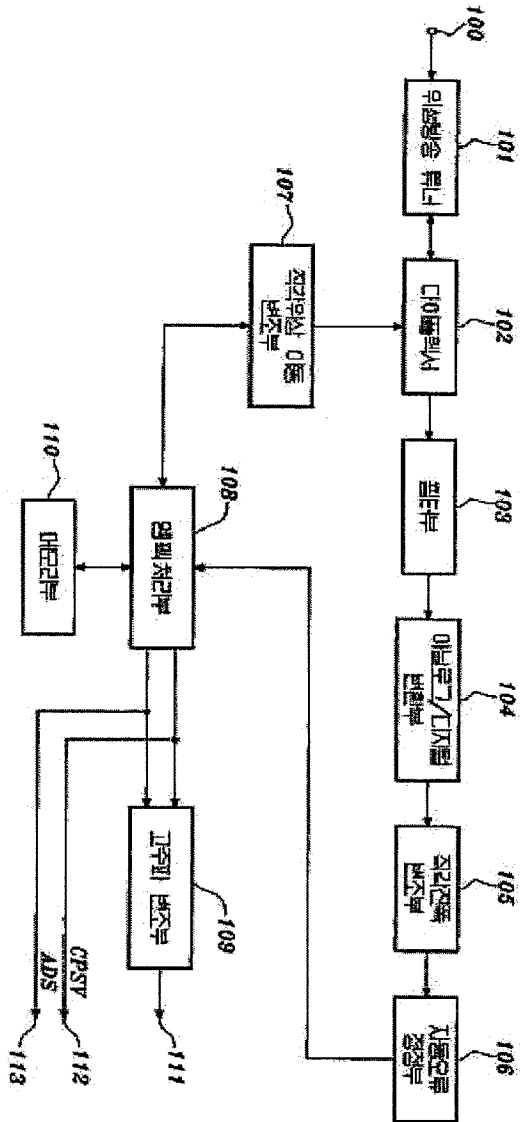
제 6 항에 있어서,

상기 제 1,제 2선택수단은, 한 번의 조작에 의해 연동되어 아날로그 비디오신호와 오디오신호 및 디지털

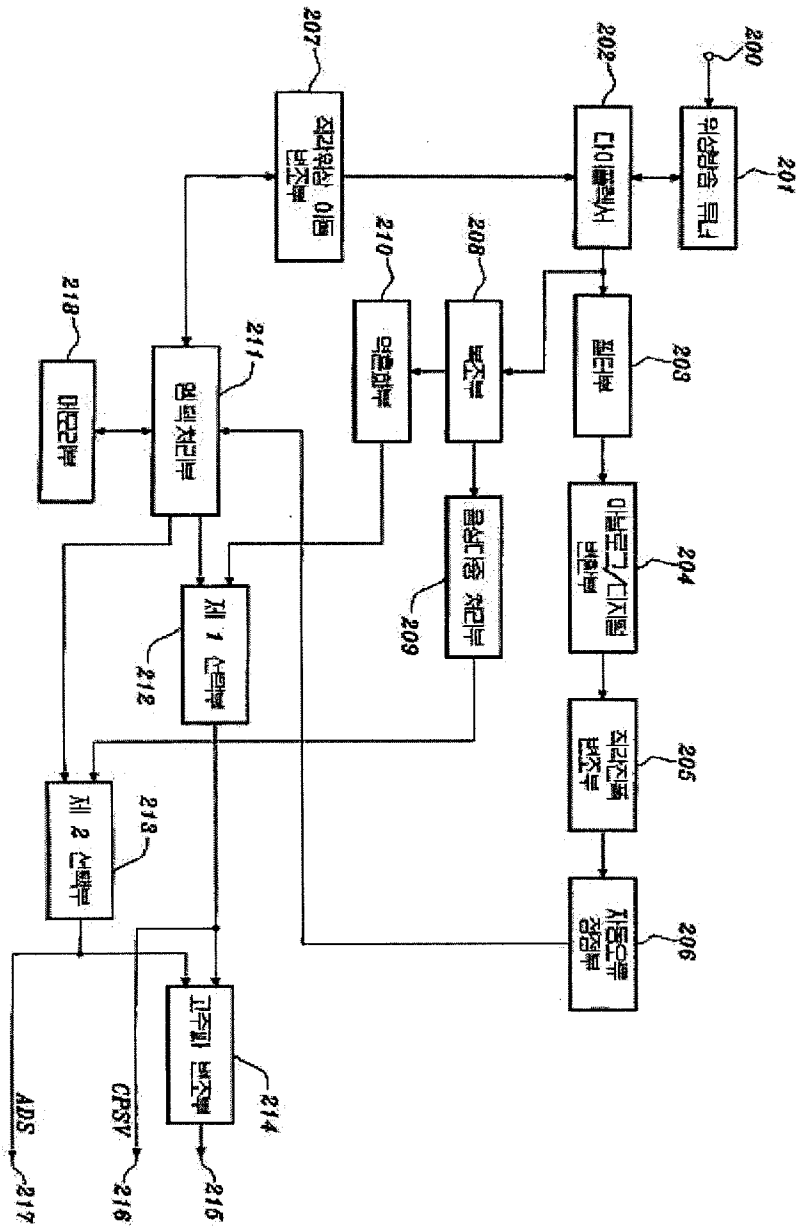
비디오신호와 오디오신호를 각기 선택하는 것을 특징으로 한 셋톱박스의 아날로그/디지털방송 수신 장치.

도면

도면1

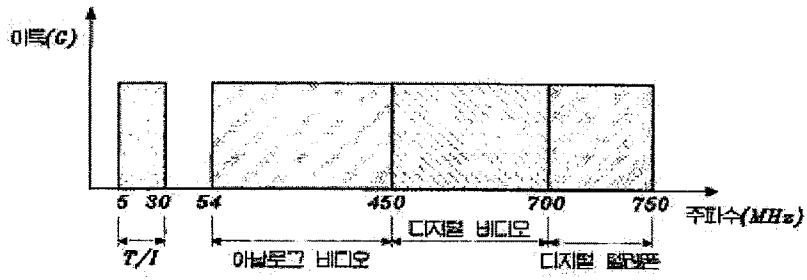


도 82





도면3



(19) 대한민국특허청(KR)  
(12) 공개특허공보(A)

(51) Int. Cl.<sup>6</sup>  
H04N 7/00

(11) 공개번호 특1996-0033096  
(43) 공개일자 1996년09월17일

(21) 출원번호	특1995-0029626
(22) 출원일자	1995년09월12일
(30) 우선권주장	95-021699 1995년02월09일 일본(JP)
(71) 출원인	미쓰비시덴키 가부시끼가이샤 기따오까 다까시 일본국 도쿄도 지요다쿠 마루노우치 2-2-3 우라까미 도꾸미찌 일본국 가나가와켄 가마꾸라시 오후나 5-1-1 미쯔비시덴끼 가부시끼가이샤 통신 시스템 연구소 내 마쯔자끼 가즈히로 일본국 가나가와켄 가마꾸라시 오후나 5-1-1 미쯔비시덴끼 가부시끼가이샤 통신 시스템 연구소 내 가또 요시야끼 일본국 가나가와켄 가마꾸라시 오후나 5-1-1 미쯔비시덴끼 가부시끼가이샤 통신 시스템 연구소 내 오히라 히데오 일본국 가나가와켄 가마꾸라시 오후나 5-1-1 미쯔비시덴끼 가부시끼가이샤 통신 시스템 연구소 내
(72) 발명자	백남기
(74) 대리인	백남기

심사청구 : 있음

(54) 멀티미디어 정보처리 시스템

요약

디지털화된 비디오 신호, 오디오 신호 및 그 외의 데이터가 부호화 되고 다중화된 후 전송되고 저장되며, 전송된 신호 또는 저장된 신호는 분리된 후 복호되어 비디오 신호, 오디오 신호 및 그 외의 데이터를 생성하는 멀티미디어 정보처리 시스템에 관한 것으로서, 미디어 정보의 선택에서부터 전송 처리 또는 기록 처리까지를 포함하는 일련의 처리과정에서 방송 시스템, 통신 시스템 및 컴퓨터 내의 저장 시스템들의 사이의 데이터 교환 서비스의 범용성이 향상되고, 하드웨어 구조가 단순화되며, 부가 기능의 추가 등이 용이하게 실행되고, 송신기에서 미디어 수의 변화, 각 미디어의 송신 속도의 변화 및 각 미디어의 유무 등을 용통성 있게 다루는 것에 의해 각 미디어의 정보가 효과적으로 다중화되는 멀티미디어 정보처리 시스템을 제공하기 위해, 멀티미디어 정보의 전송 또는 저장을 실행하는 멀티미디어 정보처리 시스템으로서, 여러개의 미디어정보를 입력하고, 각 미디어 단위로 정보를 부호화하고, 미디어 식별, 패킷등기 및 동기설정을 위한 보조정보를 부가하고, 다른 시스템과 호환성을 가진 신호형식으로 구성된 요소 패킷을 생성하는 정보원 부호화 수단, 정보원 부호화 수단이 출력하는 각각의 미디어에 대한 요소 패킷의 속도 정합과 다중화를 실행하고 시스템 사이의 호환성을 갖는 신호형식으로 다중화 스트림을 생성하는 패킷 다중화수단 및 전송 미디어 또는 저장 미디어에 따라 다중화 스트림을 변환하고 전송 신호를 출력하는 전송 처리수단을 포함하는 멀티미디어 정보처리 시스템이 마련된다. 이것에 의해, 방송, 통신, 컴퓨터 내의 저장 등의 서비스 사이의 데이터 교환이 용이하게 실행될 수 있고, 하드웨어 구조는 단순화되며, 부가 기능 등의 용이하게 추가됨에 따라 다양한 응용이 개발될 수 있다.

대표도

도1

발명서

[발명의 명칭]

멀티미디어 정보처리 시스템

[도면의 간단한 설명]

제1도는 본 발명의 제1의 실시예에 따른 멀티미디어 정보처리 시스템 내의 송신기의 구조를 도시하는 블록도

본 내용은 요부공개 건이므로 전문 내용을 수록하지 않았음.

**(57) 청구의 범위**

**청구항 1**

멀티미디어 정보의 전송 또는 저장을 실행하는 멀티미디어 정보처리 시스템으로서, 여러개의 미디어정보를 입력하고, 각 미디어 단위로 정보를 부호화하고, 미디어 식별, 패킷동기 및 동기설정을 위한 보조정보를 부가하고, 다른 시스템과 호환성을 가진 신호형식으로 구성된 요소 패킷을 생성하는 정보원 부호화 수단, 상기 정보원 부호화 수단이 출력하는 각각의 미디어에 대한 요소 패킷의 속도 정합과 다중화를 실행하고 시스템사이의 호환성을 갖는 신호형식으로 다중화 스트림을 생성하는 패킷 다중화수단 및 전송 미디어 또는 저장 미디어에 따라 상기 다중화 스트림을 변화하고 전송신호를 출력하는 전송 처리수단을 포함하는 멀티미디어 정보처리 시스템.

**청구항 2**

제1항에 있어서, 상기 정보원 부호화수단은 요소 미디어 내의 미디어 정보를 편집하는 요소 미디어 선택 수단, 상기 요소 미디어 정보의 양을 감소시키는 정보원부호화수단 및 상기 정보원 부호화수단의 출력을 입력하여 요소패킷을 생성하는 요소패킷 생성수단을 포함하는 멀티미디어 정보처리 시스템.

**청구항 3**

제1항에 있어서, 상기 패킷 다중화 수단을 미디어 정보에 대응하는 미디어 식별과 패킷 재생의 동기 등을 위해 부가 정보를 추가하는 패킷 생성수단 및 다중화 스트림을 생성하기 위해 요소패킷의 속도 정합과 다중화를 실행하는 패킷 다중화수단을 포함하는 멀티미디어 정보처리 시스템.

**청구항 4**

제1항에 있어서, 상기 전송 처리수단은 전송 미디어 또는 저장 미디어에 따라 에러를 정정하는 부호화 수단, 상기 에러정정 부호화 수단의 데이터를 출력하도록 전송 프레임링을 처리하는 전송 프레임 생성수단 및 전송 또는 기록하기 위해 상기 전송 프레임 생성수단의 출력 데이터를 변조하는 변조수단을 포함하는 멀티미디어 정보처리 시스템.

**청구항 5**

제1항에 있어서, 상기 정보원 처리수단 또는 상기 패킷 다중화 수단의 동작 모드를 변조시키는 응용 프로그램을 갖는 소프트웨어 처리수단을 또 포함하는 멀티미디어 정보처리 시스템.

**청구항 6**

제1항에 있어서, 상기 패킷 다중화 수단이 미디어 정보에 대응하는 미디어 식별, 패킷 동기 및 동기 설정을 위한 부가적 정보를 부가하여 고정 길이의 패킷을 생성하고, 속도 정합을 실행하면서 고정 길이의 패킷을 하나의 단위로 사용해서 다중화하는 멀티미디어 정보처리 시스템.

**청구항 7**

제1항에 있어서, 상기 전송 처리수단이 다중화 스트림에 대해 TCP/UDP/XTP처리를 실행한 후, IP 처리를 실행하여 다중화 스트림을 인터넷 프로토콜 전송로로 보내는 멀티미디어 정보처리 시스템.

**청구항 8**

제1항에 있어서, 요소패킷을 하나의 단위로 해서 하나 이상의 정보원 부호화 처리수단에 의해 생성된 요소 패킷을 저장하는 요소패킷 저장수단, 상기 요소패킷 저장수단에 저장된 요소패킷의 어드레스를 기억하는 어드레스 관리수단 및 상기 어드레스 관리수단에 의해 지시된 요소패킷을 상기 요소패킷 저장수단에서 패킷 다중화 수단으로 출력하는 요소패킷 송신수단을 또 포함하는 멀티미디어 정보처리 시스템.

**청구항 9**

제1항에 있어서, 패킷 다중화 수단에 의해 생성된 다중화 스트림을 저장하는 다중화 스트림 저장수단, 상기 다중화 스트림 저장수단에 저장된 상기 다중화 스트림의 어드레스를 기억하는 다중화 스트림 관리수단 및 다중화 스트림 관리수단에 의해 나타낸 다중화 스트림을 상기 다중화 스트림 저장수단에 상기 전송 처리 수단으로 출력하는 다중화 스트림 전송수단을 또 포함하는 멀티미디어 정보처리 시스템.

**청구항 10**

멀티미디어 정보의 전송 또는 저장을 실행하는 멀티미디어 정보처리 시스템으로서, 다중화 스트림을 출력하도록 상기 전송 미디어의 특성에 따라 전송 미디어에 적합한 형식으로 전송된 패킷 다중화 신호를 복호하는 수신 처리수단, 각 미디어 단위로 미디어 정보를 생성하는 데 필요한 요소패킷을 다중화 스트림에서 분리하는 패킷 분리수단 및 각 미디어 단위로 분리 요소패킷의 정보원 복호를 실행하고, 미디어 식별, 패킷 동기 및 재생 동기를 실행하도록 부가된 부가 정보에 따른 미디어 정보를 재생하는 정보원 복호처리수단을 포함하는 멀티미디어 정보처리 시스템.

**청구항 11**

제10항에 있어서, 상기 수신 처리수단은 전송 미디어의 특성에 따라 패킷 다중화 신호를 복조하는 복조수단, 프레임 분리를 실행하도록 상복조수단의 출력 신호에서 전송 프레임 동기를 설정하는 전송 프레임 재생수단 및 에러정정 복호를 실행하도록 상기 전송 프레임 재생수단의 출력으로부터 에러정정 프레임 동기를 설정하고, 다중화 스트림을 출력하는 에러정정 복호수단을 포함하는 멀티미디어 정보처리 시스템.

**청구항 12**

제11항에 있어서, 정정할 수 없는 에러가 발생한 경우, 에러정정 복호수단은 에러가 존재하는 영역을 나타내는 정정 생성신호를 상기 패킷분리수단으로 다중화 스트림에 부가해서 출력하는 멀티미디어 정보처리 시스템.

**청구항 13**

제11항에 있어서, 정정할 수 없는 에러가 발생한 경우, 상기 에러정정 복호수단은 에러가 존재하는 영역을 나타내는 정정 생성신호를 상기 정보원 복호처리수단으로 다중화 스트림에 부가해서 출력하는 멀티미디어 정보처리 시스템.

**청구항 14**

제10항에 있어서, 상기 정보원 복호수단은 부가 정보와 부호화 요소 미디어정보를 분리하는 패킷 분리수단, 상기 부호화요소 미디어정보를 복호하는 정보원 복호수단 및 상기 정보원 복호수단이 출력하는 복호 요소 미디어정보를 동기시켜 미디어 정보를 생성하는 복호 데이터 재구성수단을 포함하는 멀티미디어 정보처리 시스템.

**청구항 15**

제10항에 있어서, 상기 정보원 복호처리 수단 또는 상기 패킷 분리수단의 동작모드를 변화시키는 응용 프로그램을 갖는 소프트웨어 처리수단을 또 포함하는 멀티미디어 정보처리 시스템.

**청구항 16**

제10항에 있어서, 상기 패킷 분리수단은 하나의 요소패킷을 단위로 사용해서 다중화된 다중화 스트림을 각 요소패킷 단위로 분리하고, 각 요소패킷을 상기 정보원 복호 처리수단으로 출력하는 멀티미디어 정보처리 시스템.

**청구항 17**

제10항에 있어서, 상기 패킷 분리수단은 분리된 요소패킷이 하나의 단위로써 포함된 고정길이의 패킷을 사용해서 다중화된 다중화 스트림을 고정길이의 패킷 단위로 분리하여 요소패킷을 재구성하고, 각 요소를 상기 정보원 복호처리수단에 출력하는 멀티미디어 정보처리 시스템.

**청구항 18**

제10항에 있어서, 상기 수신처리단은 인터넷 프로토콜 전송로에서 전송된 데이터의 IP처리를 실행하는 후 TCP/UDP/XTP처리를 실행하여 패킷 다중화 스트림을 수신하는 멀티미디어 정보처리 시스템.

**청구항 19**

제10항에 있어서, 상기 패킷분리수단은 분리된 요소패킷을 저장하는 수신된 요소패킷 저장부, 상기 수신된 요소패킷 저장부에 저장된 요소패킷의 어드레스를 기억하는 수신 프로그램 관리수단 및 상기 수신된 프로그램 관리수단에서 지시된 프로그램을 실행하는데 필수적인 요소패킷을 상기 수신 요소패킷 저장부에서 상기 정보원 복호처리수단으로 출력하는 수신 요소패킷 리드수단을 포함하는 멀티미디어 정보처리 시스템.

**청구항 20**

멀티미디어 정보의 전송 또는 저장을 실행하는 멀티미디어 정보처리 시스템으로서, 패킷으로 다중화되고 전송 미디어에 적합한 형식으로 전송된 패킷 다중화 신호를 하나 이상의 전송 미디어에서 입력하고 각 전송 미디어의 다중화 스트림을 생성하는 수신 처리부, 패킷 다중화 스트림을 매 전송미디어 마다 요소패킷으로 분리하는 패킷분리수단, 요소패킷을 하나의 다중화 스트림으로 재다중화하는 패킷 재다중화 수단 및 상기 패킷 재다중화 수단이 출력하는 상기 다중화 스트림을 전송 미디어의 특성에 따라 전송신호로써 송신 미디어에 출력하는 전송처리수단을 포함하는 멀티미디어 정보처리 시스템.

**청구항 21**

각각 다른 형식의 신호의 정보원 부호화를 실행하여 각각의 부호화 비트열을 생성하는 정보원 부호화처리 수단, 신호의 형식을 식별하는 식별정보와 각각의 부호화 비트열을 고정길이의 패킷단위로 저장하여 고정길이의 패킷열을 생성하는 미디어 다중화수단, 상기 고정 길이의 패킷열 내의 고정 길이의 패킷의 소정의 수를 다양한 데이터와 함께 소정의 크기의 프레임으로 설정하는 구조 다중화 수단 및 상기 구조 다중화수단에서 출력된 프레임 열에 대해 전송 미디어에 적합한 전송 프레임을 갖는 전송 신호를 생성하는 전송 처리수단을 포함하는 멀티미디어 정보처리 시스템.

**청구항 22**

제21항에 있어서, 상기 구조 다중화 수단을 제어정보, 지시정보 또는 클럭정보의 데이터로 고정 길이의 패킷을 다중화하는 멀티미디어 정보처리 시스템.

**청구항 23**

다양한 데이터와 함께 각각의 소정의 크기의 프레임 내에 소정의 수의 고정 길이의 패킷의 전송 프레임 열을 갖는 송신 신호를 수신하고, 다중화 비트열을 재생하는 수신 처리수단, 상기 다중화 비트열에서 고정길이의 패킷열과 다양한 데이터를 재생하는 구조 분리수단, 고정 길이의 패킷열에서 고정 길이의 패킷을 인출하고, 신호형식을 식별하는 식별 정보에 대응하는 부호화 비트열을 재생하는 미디어 분리수단 및 상기 부호화 비트열을 복호하여 응용 또는 미디어의 차이에 따른 각각의 신호 등의 각각의 다른 형식의 신호를

재생하는 정보원 복호 처리수단을 포함하는 멀티미디어 정보처리 시스템.

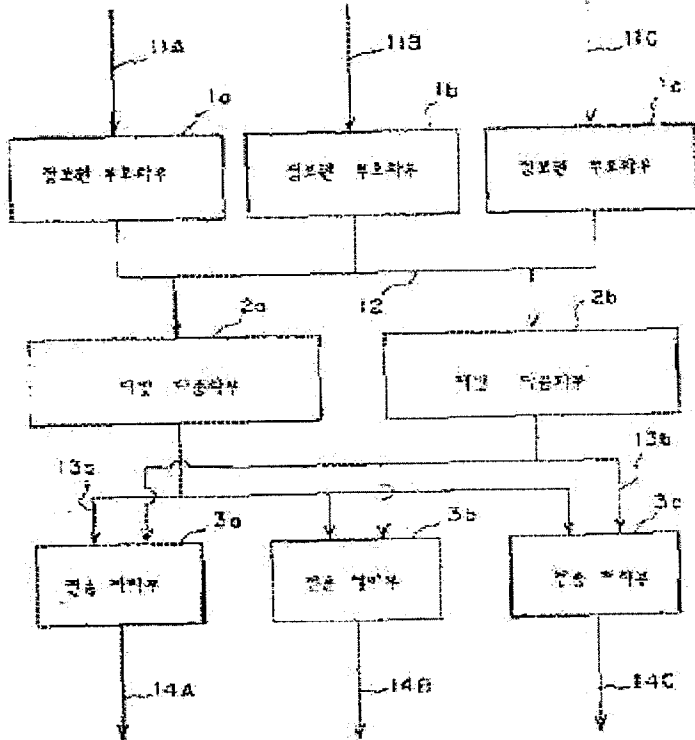
청구항 24

제23항에 있어서, 상기 구조 분리수단이 제어정보, 지시정보 또는 클럭정보 등과 같은 다양한 데이터와 구조 내에서 다중화된 고정 길이의 패킷을 분리하는 멀티미디어 정보처리 시스템.

※ 참고사항 : 최초출원 내용에 의하여 공개하는 것임.

도면

도면1

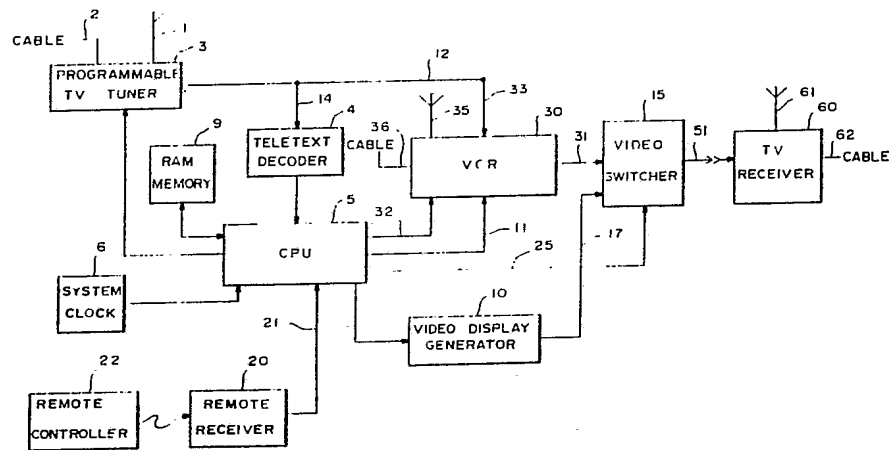




INTERNATIONAL APPLICATION PUBLISHED UNDER THE PATENT COOPERATION TREATY (PCT)

<p>(51) International Patent Classification 4 : H04N 7/087, 7/04, G11B 27/02 H04H 1/00</p>	<p>A1</p>	<p>(11) International Publication Number: <b>WO 90/00847</b> (43) International Publication Date: 25 January 1990 (25.01.90)</p>
<p>(21) International Application Number: PCT/US89/02927 (22) International Filing Date: 10 July 1989 (10.07.89) (30) Priority data: 219,971 15 July 1988 (15.07.88) US (71) Applicant: INSIGHT TELECAST, INC. [US/US]; 1496 Cherrywood Drive, San Mateo, CA 94403 (US). (72) Inventor: YOUNG, Patrick ; 1496 Cherrywood Drive, San Mateo, CA 94403 (US). (74) Agents: NISHIMURA, Keiichi et al.; Flehr, Hohbach, Test, Albritton &amp; Herbert, Four Embarcadero Center, Suite 3400, San Francisco, CA 94111-4187 (US).</p>		<p>(81) Designated States: AT (European patent), AU, BE (European patent), CH (European patent), DE (European patent), FR (European patent), GB (European patent), IT (European patent), JP, KR, LU (European patent), NL (European patent), SE (European patent).  <b>Published</b> <i>With international search report.</i> <i>With amended claims.</i></p>

(54) Title: SYSTEM AND PROCESS FOR VCR SCHEDULING



(57) Abstract

A VCR schedule controller receives broadcast data over antenna (1) or cable (2) by a programmable tuner (3), which is connected to a teletext receiver (4). The teletext receiver (4) is connected to a microprocessor (5). Microprocessor output (11) is connected to a video display generator (10), used to create text for television receiver (60) to display a message from the microprocessor (5). After processing embedded data in a broadcast, the microprocessor (5) generates a cue for display on TV receiver (60). Remote control receiver (20) receives a command from a remote controller (22) from a viewer input in response to the cue. Remote control receiver (20) supplies a control signal to cause the microprocessor to store the embedded data in memory (9). The microprocessor then issues a message to the display generator (10) as an acknowledgement of the viewer input. The microprocessor (5) monitors the system clock (6) and compares it with stored schedules from the embedded supplemental data. When the system time corresponds to one of the scheduled times, the microprocessor (5) sets the programmable tuner (3) to the stored channel and initiates recording on VCR (30).

**FOR THE PURPOSES OF INFORMATION ONLY**

Codes used to identify States party to the PCT on the front pages of pamphlets publishing international applications under the PCT.

AT	Austria	ES	Spain	MG	Madagascar
AU	Australia	FI	Finland	ML	Mali
BB	Barbados	FR	France	MR	Mauritania
BE	Belgium	GA	Gabon	MW	Malawi
BF	Burkina Fasso	GB	United Kingdom	NL	Netherlands
BG	Bulgaria	HU	Hungary	NO	Norway
BJ	Benin	IT	Italy	RO	Romania
BR	Brazil	JP	Japan	SD	Sudan
CA	Canada	KP	Democratic People's Republic of Korea	SE	Sweden
CF	Central African Republic	KR	Republic of Korea	SN	Senegal
CG	Congo	LI	Liechtenstein	SU	Soviet Union
CH	Switzerland	LK	Sri Lanka	TD	Chad
CM	Cameroon	LU	Luxembourg	TG	Togo
DE	Germany, Federal Republic of	MC	Monaco	US	United States of America
DK	Denmark				

- 1 -

## SYSTEM AND PROCESS FOR VCR SCHEDULING

## CROSS REFERENCE TO RELATED INVENTION

This invention relates to an improvement in the invention described in my earlier U.S. Patent 4,706,121, issued November 10, 1987 and entitled "TV Schedule System and Process."  
5

## BACKGROUND OF THE INVENTION

1. Field of the Invention:

The present invention further relates generally to a system and process in which television supplemental data is embedded in a televised broadcast and, on cue, the viewer can store the supplemental data. Such supplemental data can include schedule information, such as time, channel, program name and program type. The stored data is used to program a VCR automatically for recording a supplemental televised program as defined by the schedule information.  
10  
15

2. Description of the Prior Art:

The above-referenced related patent describes a system and process which allows user selection of broadcast programs from schedule information for presentation to a television set and/or recording by a VCR. The prior art discussed in that patent and of record in its application shows a variety of systems and processes for increasing the functionality of a television set and/or a VCR.  
20  
25



- 2 -

While a number of such systems and processes are known in this art, none of these systems and processes deal with a way to provide supplemental information about material being broadcast to a viewer. An example of such supplemental information that would be of substantial interest to certain viewers is further information on a product that is advertised during a regular broadcast. Such commercial time is very expensive, particularly during prime time or televised sporting events with very large audiences, so that commercials have a typical length of from 30 seconds to one minute. For many advertised products, viewers need more information than can be provided during the commercials on, for example, features, prices and local availability before they make a decision to purchase the product. The ability to provide such supplemental information selectively to viewers who desire it would be of substantial value to advertisers and other suppliers of televised information.

## SUMMARY OF THE INVENTION

Accordingly, it is an object of this invention to provide a system and process which will allow a viewer to select interactively to receive supplemental information related to material in a television broadcast.

It is another object of the invention to provide such a system and process which will provide the supplemental information for recording when broadcast time is inexpensive.

It is a further object of the invention to provide such a system and process which will allow viewers to select supplemental information from a menu.

It is another object of the invention to provide a VCR schedule controller that provides an improved index of recorded material on a tape.

The attainment of these and related objects may be achieved through use of the novel system and process for

- 3 -

VCR scheduling herein disclosed. A system and process for VCR scheduling in accordance with this invention has a recording device, a broadcast receiver and a data processor connected to the recording device and to the broadcast receiver. The data processor includes means for presenting a cue on the broadcast receiver during the broadcast. A means is connected to the data processor for receiving a user response to the cue. A means responsive to the user response to the cue controls the recording device to record the supplemental information.

A process for presenting supplemental information about a broadcast in accordance with the invention includes providing a cue during a broadcast indicating the availability of supplemental information relating to the broadcast. A response to the cue is received from the user. The supplemental information is supplied to the user after receiving the cue response from the user. Preferably, the supplemental information is broadcast at a later time. Schedule information for the supplemental information is provided with the broadcast. The schedule information is stored after the user response to the cue and used to record the supplemental information with a recording device when the supplemental information is broadcast.

This apparatus allows supplemental information to be delivered to the viewer selectively, at a time that is beneficial and convenient for broadcasters, and retrieved by the viewer in a prompt and convenient way. One method of sending supplemental data is using the video blanking interval (VBI) segment of the video signal to carry teletext-formatted data. A teletext receiver-based apparatus is used to decode the supplemental data.

The cue may be a caption on the screen, an audio signal or message, an indicator on the apparatus, or anything that can alert the viewer. The cue may be generated selectively by the apparatus, based on the

- 4 -

content of the supplemental data received, or the cue may be contained in the normal televised video picture or sound. The viewer responds to the cue by pushing a key on a remote controller, by a switch on the apparatus, by  
5 making a loud sound, or by any other means that will activate the system to store the supplemental data in memory.

When the viewer successfully stores the data on cue, the system may issue an acknowledgement. This may be  
10 another caption, an audio signal or message, or anything else to inform the viewer that the response to the cue has been entered. The system will then automatically tune the VCR to the scheduled channel and time defined by the supplemental data.

15 The attainment of the foregoing and related objects, advantages and features of the invention should be more readily apparent to those skilled in the art, after review of the following more detailed description of the invention, taken together with the drawings, in which:

20

#### BRIEF DESCRIPTION OF THE DRAWINGS

Figure 1 is a block diagram of a system for VCR scheduling in accordance with the invention.

25 Figure 2 is a block diagram of another system for VCR scheduling in accordance with the invention.

#### DETAILED DESCRIPTION OF THE INVENTION

Turning now to the drawings, more particularly to Figure 1, there is shown a block diagram of an integrated  
30 VCR schedule controller in accordance with the invention. In this embodiment, the controller is provided built into a VCR, but it can also be provided separate from the VCR, such as by using the remote facility of the VCR to provide inputs to the VCR.

35 Broadcast data is received over antenna 1 or cable 2 by a programmable tuner 3, which has an output connected

- 5 -

to input 14 of a teletext receiver 4. The teletext receiver may be a Sears Caption Decoder. The output of the teletext receiver 4 is connected to a microprocessor 5. Microprocessor output 11 is connected to a video display generator 10, used to create text for television receiver 60. Video switcher 15 connects the display generator 10 output 17 to the TV receiver 60 to display a message from the microprocessor 5.

The microprocessor 5 has a random access memory 9 and a system clock/calendar 6. After processing the embedded data, the microprocessor 5 generates a cue by outputting a symbol or message to the display generator 10 for display on TV receiver 60. Remote control receiver 20 receives a command from a remote controller 22 from a viewer input in response to the cue. Remote control receiver 20 is connected to an input line 21 and supplies a control signal to cause the microprocessor to store the embedded data in memory 9. The microprocessor then issues a message to the display generator 10 as an acknowledgement of the viewer input.

The cue can be implemented in many ways other than through the microprocessor 5. The simplest is an audio or visual stimulus that is part of the sound or video portion of the broadcast. In this case, both the display generator 10 and the video switcher 15 are unnecessary. The provision of the cue separate from the sound or video portion of the broadcast, such as in the VBI, which is then added to the sound or video portion of the signal provided to the TV receiver 60 by the microprocessor, is not distracting to viewers without the system of this invention.

The microprocessor 5 monitors the system clock 6 and compares it with the stored schedules from the embedded supplemental data. When the system time corresponds to one of the scheduled times, the microprocessor 5 sets the programmable tuner 3 to the stored channel and initiates

- 6 -

recording on VCR 30 by a control signal on line 32. The VCR receives its signal from antenna 35 or cable 36.

In addition to obtaining schedule information as part of a broadcast, in a system 90 as shown in Figure 2, the  
5 schedule information can be received by a computer 5 using a modem 94 and processed by the computer 5. Based on user selections, one or more program schedule listings is stored in computer memory. At the time of the broad-  
casts, the computer 5 activates a VCR 30 for recording of  
10 the selected programs. Serial output port 32 of the computer 5 connects to a control bus of the VCR 30 to turn on the VCR, control channel selection and enable recording of the program.

The system 90 incorporates a feature for automatical-  
15 ly converting television guide station listings to channel selections for cable users. To eliminate need to convert station listings to local channel numbers each time the VCR 30 is to be programmed for unattended recording, a memory is provided so that the user only needs to enter  
20 the conversion once. After that, the conversion is handled by the computer 5. An entry table is provided on-screen requesting the user to enter a cable channel number corresponding to each station name or number. Alternatively, both the station name or number and the cable  
25 number may be read from a bar-code conversion guide, using a bar-code reader. In either method, the conversion data is stored in a table in memory. During unattended recording, the channel number corresponding to the station name is used by the computer 5 to control channel selec-  
30 tion on the VCR 30. With such a conversion stored locally in the system 90, cable schedule information can be supplied under cable channel names (e.g., ESPN) on a regional or national basis and selection of the appropriate local channel number for that cable service made by  
35 the controller 90.

- 7 -

The system 90 uses electronic indexing for automatic retrieval of programs. During recording, the location of the program is identified by a capstan counter with a digital readout. This index information identifying where a program to be recorded is stored into a log along with the name of the program. During playback, the VCR 30 will automatically go to the indexed location and start playback.

Line 101 from the VCR 30 is a serial bus containing the index data. It is connected to a serial input port of the computer 5. Search is made by comparing the present index value and the stored index value. Search is completed when the index value from the VCR 30 matches the stored index value.

The system 90 also provides self-indexed cassette recordings. At the start of each cassette tape, a complete description of the start and end positions of every program recorded on the cassette is stored along with the program names. During playback, this information is read by the teletext decoder of the VCR 30 and presented on the screen, allowing the user to identify quickly what is recorded and to access the desired program automatically. Access is made by name selection from the log.

During recording, a complete log is created for each tape as described above. Before the tape is removed from the VCR 30, the tape is rewound to the start, and the log information is recorded onto video blanking interval (VBI) tracks of the tape using a VBI data encoder 110 of the type described in my above-referenced issued patent. Line 102 is a serial output from the computer 5 to the VBI encoder 110 and line 103 is the video signal with the embedded log information connecting to the video input port of the VCR 30. While the log information is recorded, the VCR 30 receives its signals from the antenna input 35 to the video input.

- 8 -

During playback, a VBI teletext decoder 108 receives data from the VCR on line 107, which is the video output port of VCR 30. After decoding, the data is received on line 106 by computer 5 on a second input port. Other than  
5 as shown and described, the construction and operation of the Figure 2 embodiment of the invention is the same as that of the Figure 1 embodiment.

Further details on implementing systems of this invention are available in my above-referenced issued  
10 patent, the disclosure of which is incorporated by reference herein.

It should now be apparent to those skilled in the art that a novel VCR schedule system and process capable of achieving the stated objects of the invention has been  
15 provided. The system and process allows interactive selection by a viewer of further information related to information being broadcast, which may be made with a menu selection. The further information can be broadcast for recording by a viewer at a different time, when broadcast  
20 time is less costly and/or underutilized.

It should further be apparent to those skilled in the art that various changes in form and details of the invention as shown and described may be made. It is  
25 intended that such changes be included within the spirit and scope of the claims appended hereto.

- 9 -

**WHAT IS CLAIMED IS:**

1. A system to allow interactive selection for presentation to a user of supplemental information pertaining to a broadcast, which comprises a recording device, a broadcast receiver, a data processor connected to said recording device and to said broadcast receiver, said data processor including means for presenting a cue on the broadcast receiver during the broadcast, means connected to the data processor for receiving a user response to the cue, and means responsive to the user response to the cue for controlling said recording device to record the supplemental information.

2. The system to allow interactive selection for presentation to a user of supplemental information pertaining to a broadcast of Claim 1 in which the supplemental information is broadcast at a later time, schedule information for the supplemental information is provided with the broadcast, and said data processor is configured to store the schedule information in response to the user response to the cue and to use the schedule information to record the supplemental information with said recording device when the supplemental information is broadcast.

3. The system to allow interactive selection for presentation to a user of supplemental information pertaining to a broadcast of Claim 2 in which said recording device is a video cassette recorder and said broadcast receiver is a television set.

4. The system to allow interactive selection for presentation to a user of supplemental information pertaining to a broadcast of Claim 1 in which said data processor is further configured to provide acknowledgment to the user of the user response to the cue.



- 10 -

5           5.    The system to allow interactive selection for presentation to a user of supplemental information pertaining to a broadcast of Claim 1 in which said data processor is further configured to provide a menu display to the user in response to a user response to the cue and to receive user menu selections.

10           6.    The system to allow interactive selection for presentation to a user of supplemental information pertaining to a broadcast of Claim 1 in which said system includes means for creating and storing an index of recorded material.

15           7.    The system to allow interactive selection for presentation to a user of supplemental information pertaining to a broadcast of Claim 6 in which said system includes means for recording the index on a tape including the recorded material.

20           8.    A system for recording and indexing broadcast information, which comprises a recording device for receiving and recording the broadcast information, means for receiving and storing schedule information, a data processor connected to said recording device, said data processor including means for creating and storing an index of location and identification of recorded broadcast information from index inputs received from the schedule information and from said recording device.

30           9.    A system for recording and indexing broadcast information, which comprises a recording device for receiving and recording the broadcast information, a data processor connected to said recording device, and data processor including means for creating and storing an index of recorded broadcast information, said system

35

- 11 -

including means for recording the index on a recording medium including the recorded material.

5           10. The system for recording and indexing broadcast information of Claim 9 in which said system includes means for selecting broadcast information for recording from schedule information and said means for creating and storing the index is configured to compile the index from the schedule information.

10

          11. A process to allow interactive selection for presentation to a user of supplemental information pertaining to a broadcast, which comprises providing a cue during a broadcast indicating the availability of supplemental information relating to the broadcast, receiving a response to the cue from the user, and supplying the supplemental information to the user after receiving the cue response from the user.

15

          12. The process to allow interactive selection for presentation to a user of supplemental information pertaining to a broadcast of Claim 11 in which the supplemental information is broadcast at a later time, schedule information for the supplemental information is provided with the broadcast, the process further comprising storing the schedule information after the user response to the cue and using the schedule information to record the supplemental information with a recording device when the supplemental information is broadcast.

20

25

30

          13. The process to allow interactive selection for presentation to a user of supplemental information pertaining to a broadcast of Claim 11 additionally comprising providing acknowledgment to the user of the user response to the cue.

35

- 12 -

14. The process to allow interactive selection for presentation to a user of supplemental information pertaining to a broadcast of Claim 11 additionally comprising providing a menu display to the user in response to a user response to the cue, receiving user menu selections, and supplying the supplemental information in accordance with the user menu selections.

15. The process to allow interactive selection for presentation to a user of supplemental information pertaining to a broadcast of Claim 11 additionally comprising creating and storing an index of recorded material.

16. The process to allow interactive selection for presentation to a user of supplemental information pertaining to a broadcast of Claim 15 additionally comprising recording the index on a tape including the recorded material.

17. A process for recording and indexing broadcast information, which comprises receiving and recording the broadcast information, creating and storing an index of recorded broadcast information, and recording the index on a recording medium including the recorded material.

18. The process for recording and indexing broadcast information of Claim 17 additionally comprising selecting broadcast information for recording from schedule information and in which the index is created from the schedule information.

19. The system of Claim 8 in which said means for creating and storing an index is configured to store at least a title of the broadcast information as the index input from the schedule information.

- 13 -

20. The system of Claim 19 in which said means for  
creating and storing an index is configured to store at  
least a numeric location of the recorded information as  
5 the index input from the recording device.

## AMENDED CLAIMS

[received by the International Bureau  
on 18 December 1989 (18.12.89);  
original claims 1-20 replaced by amended claims 1-20 (5 pages)]

1. A system which comprises a recording device, a broadcast receiver, and a data processor connected to said recording device and to said broadcast receiver, characterized by said system allowing interactive selection for presentation to a user of supplemental broadcast information pertaining to a primary broadcast, said data processor including means for presenting a cue on the broadcast receiver during the primary broadcast at a first time, means connected to the data processor for receiving a user response to the cue, and means responsive to the user response to the cue for controlling said recording device to record the supplemental broadcast information at a second time later than the first time.

2. The system to allow interactive selection for presentation to a user of supplemental broadcast information pertaining to a primary broadcast of Claim 1 further characterized in that schedule information for the supplemental broadcast information is provided with and in addition to the primary broadcast, and said data processor is configured to store the schedule information in response to the user response to the cue and to use the schedule information to record the supplemental broadcast information with said recording device when the supplemental broadcast information is broadcast.

3. The system to allow interactive selection for presentation to a user of supplemental broadcast information pertaining to a primary broadcast of Claim 2 further characterized in that said recording device is a video cassette recorder and said broadcast receiver is a television set.

4. The system to allow interactive selection for presentation to a user of supplemental broadcast informa-

tion pertaining to a primary broadcast of Claim 1 further characterized in that said data processor is configured to provide acknowledgment to the user of the user response to the cue.

5           5. The system to allow interactive selection for presentation to a user of supplemental broadcast information pertaining to a primary broadcast of Claim 1 further characterized in that said data processor is configured to provide a menu display to the user in response to a user  
10 response to the cue and to receive user menu selections.

6. The system to allow interactive selection for presentation to a user of supplemental broadcast information pertaining to a primary broadcast of Claim 1 further characterized in that said system includes means for  
15 creating and storing an index of recorded material.

7. The system to allow interactive selection for presentation to a user of supplemental broadcast information pertaining to a primary broadcast of Claim 6 further characterized in that said system includes means for  
20 recording the index on a tape including the recorded material.

8. A system for recording broadcast information, including a recording device for receiving and recording the broadcast information, means for receiving and storing  
25 schedule information and a data processor connected to said recording device, characterized by said data processor including means for creating and storing an index of location and identification of recorded broadcast information from index inputs received from the schedule information  
30 and from said recording device.

9. A system for recording and indexing broadcast information, which comprises a recording device for receiving and recording the broadcast information and a data processor connected to said recording device, characterized in that said data processor includes means for creating and storing an index of recorded broadcast information and said system includes means for recording the index on a recording medium including the recorded material.

10. The system for recording and indexing broadcast information of Claim 9 further characterized in that said system includes means for selecting broadcast information for recording from schedule information and said means for creating and storing the index is configured to compile the index from the schedule information.

11. A process including providing a primary broadcast and receiving the primary broadcast, characterized by the process allowing interactive selection for presentation to a user of supplemental broadcast information pertaining to the primary broadcast, the process including the steps of providing a cue during the primary broadcast at a first time indicating the availability at a second time later than the first time of the supplemental broadcast information relating to the primary broadcast, receiving a response to the cue from the user, and supplying the supplemental broadcast information to the user at the second time after receiving the cue response from the user.

12. The process to allow interactive selection for presentation to a user of supplemental broadcast information pertaining to a primary broadcast of Claim 11 further characterized in that schedule information for the supplemental broadcast information is provided with the

primary broadcast, the process further comprising storing the schedule information after the user response to the cue and using the schedule information to record the supplemental broadcast information with a recording device  
5 when the supplemental broadcast information is broadcast.

13. The process to allow interactive selection for presentation to a user of supplemental broadcast information pertaining to a primary broadcast of Claim 11 further characterized by providing acknowledgment to the user of  
10 the user response to the cue.

14. The process to allow interactive selection for presentation to a user of supplemental broadcast information pertaining to a primary broadcast of Claim 11 further characterized by providing a menu display to the user in  
15 response to a user response to the cue, receiving user menu selections, and supplying the supplemental broadcast information in accordance with the user menu selections.

15. The process to allow interactive selection for presentation to a user of supplemental broadcast information pertaining to a primary broadcast of Claim 11 further characterized by recording the supplemental program  
20 information, creating an index of the recorded supplemental program information and storing the index.

16. The process to allow interactive selection for presentation to a user of supplemental broadcast information pertaining to a primary broadcast of Claim 15 further characterized by recording the index on a tape including  
25 the recorded supplemental program information.

17. A process for recording broadcast information, which comprises receiving and recording the broadcast  
30 information, characterized by creating and storing an

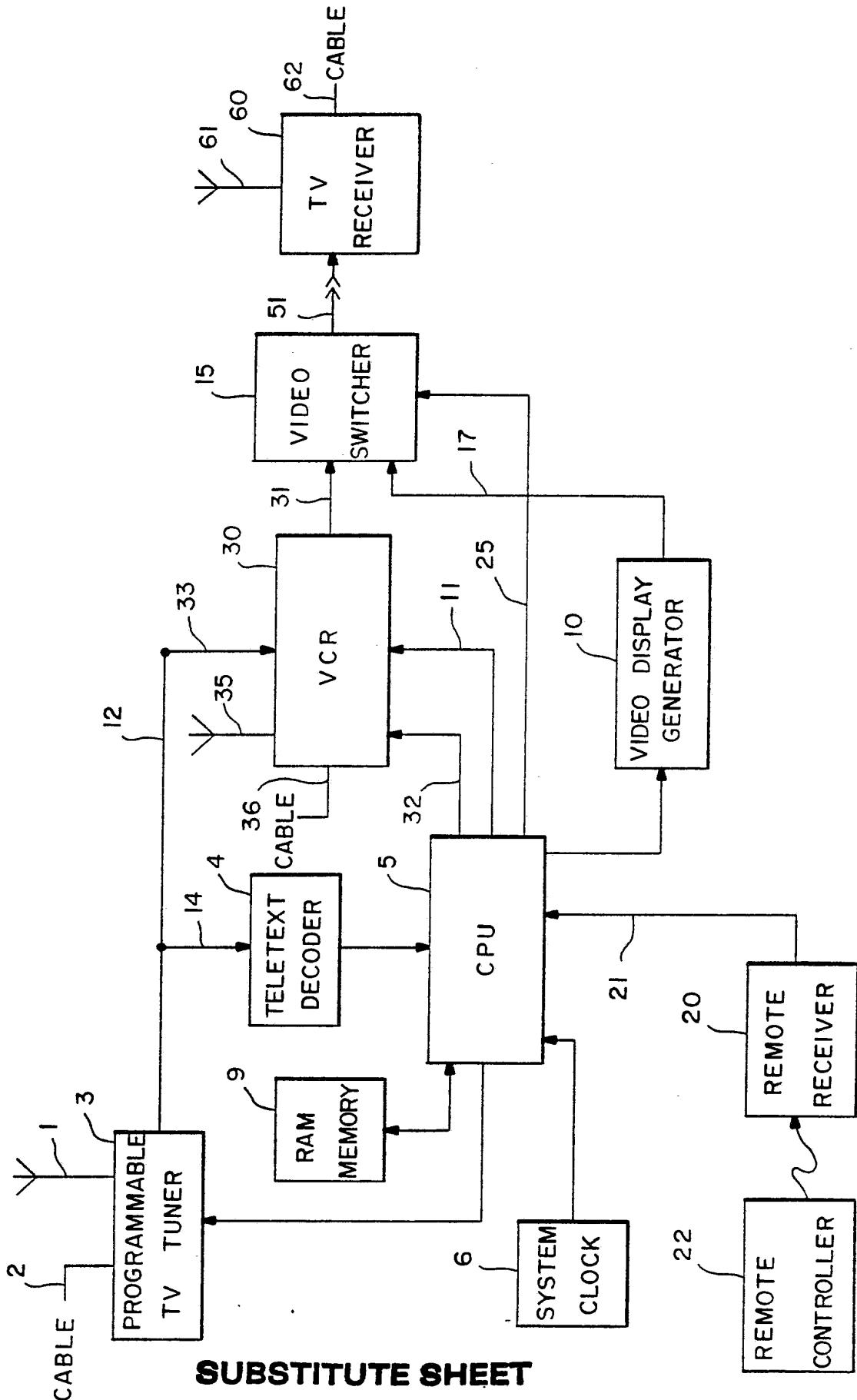


index of the recorded broadcast information, and recording the index on a recording medium including the recorded broadcast information.

5 18. The process for recording and indexing broadcast information of Claim 17 further characterized by selecting broadcast information for recording from schedule information and creating the index from the schedule information.

10 19. The system for recording and indexing broadcast information of Claim 8 further characterized in that said means for creating and storing an index is configured to store at least a title of the broadcast information as the index input from the schedule information.

15 20. The system for recording and indexing broadcast information of Claim 19 further characterized in that said means for creating and storing an index is configured to store at least a numeric location of the recorded information as the index input from the recording device.



**SUBSTITUTE SHEET**

**FIG. 1**

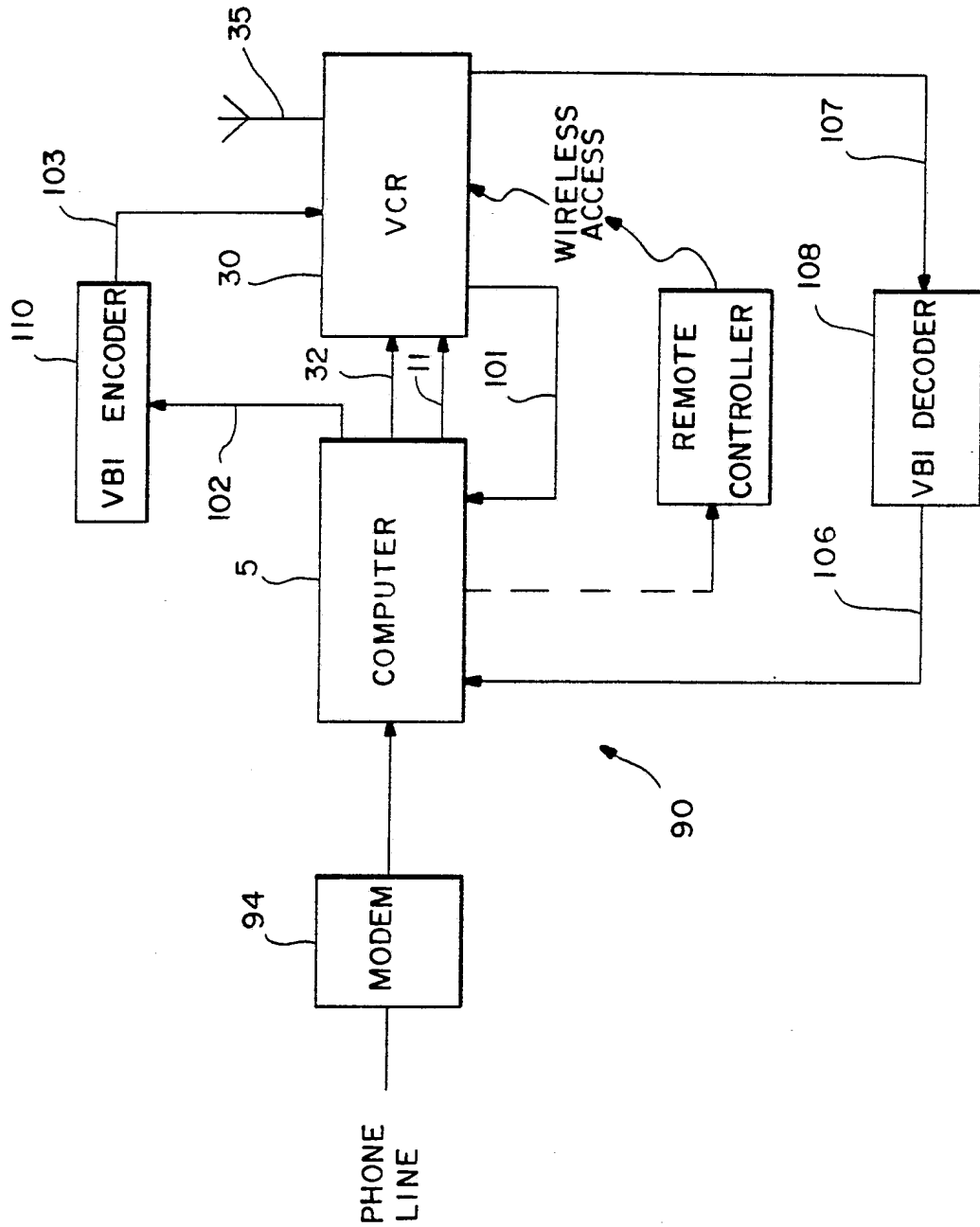


FIG.— 2

SUBSTITUTE SHEET

# INTERNATIONAL SEARCH REPORT

International Application No. PCT/US 89/02927

<b>I. CLASSIFICATION OF SUBJECT MATTER</b> (if several classification symbols apply, indicate all) <sup>6</sup>		
According to International Patent Classification (IPC) or to both National Classification and IPC		
IPC(4): H04N 7/087, 7/04; G11B 27/02; H04H 1/00		
US. CL.: 358/86, 142, 147; 360/13, 72.1; 455/2, 4		
<b>II. FIELDS SEARCHED</b>		
Minimum Documentation Searched <sup>7</sup>		
Classification System	Classification Symbols	
U.S.	358/85, 86, 142, 146, 147, 194.1, 311, 335, 908 360/13, 69, 72.1, 72.2 455/2, 4	
Documentation Searched other than Minimum Documentation to the Extent that such Documents are Included in the Fields Searched <sup>8</sup>		
<b>III. DOCUMENTS CONSIDERED TO BE RELEVANT <sup>9</sup></b>		
Category <sup>*</sup>	Citation of Document, <sup>11</sup> with indication, where appropriate, of the relevant passages <sup>12</sup>	Relevant to Claim No. <sup>13</sup>
X	WO, A 88/04507 (Chambers) British Broadcasting Corporation 16 June 1988 See Entire Document	1-5, 11-14
&,A	US, A 4,706,121 (Young) 10 November 1987	1-7, 11-16
P,A	GB, A 2,207,314 (Kinghorn) Philips Electronic and Associated Industries Limited 25 January 1989	
A	US, A 4,305,101 (Yarbrough et al.) 08 December 1981	
P,A	US, A 4,821,102 (Ichikawa et al.) 11 April 1989	
A	GB, A 2,185,670 (Calif) 22 July 1987	
<p><sup>*</sup> Special categories of cited documents: <sup>10</sup></p> <p>"A" document defining the general state of the art which is not considered to be of particular relevance</p> <p>"E" earlier document but published on or after the international filing date</p> <p>"L" document which may throw doubts on priority claim(s) or which is cited to establish the publication date of another citation or other special reason (as specified)</p> <p>"O" document referring to an oral disclosure, use, exhibition or other means</p> <p>"P" document published prior to the international filing date but later than the priority date claimed</p> <p>"T" later document published after the international filing date or priority date and not in conflict with the application but cited to understand the principle or theory underlying the invention</p> <p>"X" document of particular relevance; the claimed invention cannot be considered novel or cannot be considered to involve an inventive step</p> <p>"Y" document of particular relevance; the claimed invention cannot be considered to involve an inventive step when the document is combined with one or more other such documents, such combination being obvious to a person skilled in the art.</p> <p>"&amp;" document member of the same patent family</p>		
<b>IV. CERTIFICATION</b>		
Date of the Actual Completion of the International Search		Date of Mailing of this International Search Report
04 October 1989		20 OCT 1989
International Searching Authority		Signature of Authorized Officer
ISA/US		<i>Michael Parker</i> Michael Parker

**FURTHER INFORMATION CONTINUED FROM THE SECOND SHEET**

V.  **OBSERVATIONS WHERE CERTAIN CLAIMS WERE FOUND UNSEARCHABLE <sup>1</sup>**

This international search report has not been established in respect of certain claims under Article 17(2) (a) for the following reasons:

1.  Claim numbers \_\_\_\_\_ because they relate to subject matter <sup>1</sup> - not required to be searched by this Authority, namely:
  
2.  Claim numbers \_\_\_\_\_, because they relate to parts of the international application that do not comply with the prescribed requirements to such an extent that no meaningful international search can be carried out <sup>1</sup>, specifically:
  
3.  Claim numbers \_\_\_\_\_, because they are dependent claims not drafted in accordance with the second and third sentences of PCT Rule 6.4(a).

VI.  **OBSERVATIONS WHERE UNITY OF INVENTION IS LACKING <sup>2</sup>**

This International Searching Authority found multiple inventions in this international application as follows:

- I. Claims 1-7 and 11-16 drawn to recording supplemental data in response to a user's response to a cue classified in Class 358 subclass 147.
- II. Claims 8, 9 and 17-20 drawn to a recording device recording an index of received and recorded information classified in class 360 subclass 13.

1.  As all required additional search fees were timely paid by the applicant, this international search report covers all searchable claims of the international application. **Telephone Practice**
2.  As only some of the required additional search fees were timely paid by the applicant, this international search report covers only those claims of the international application for which fees were paid, specifically claims:
  
3.  No required additional search fees were timely paid by the applicant. Consequently, this international search report is restricted to the invention first mentioned in the claims; it is covered by claim numbers:
  
4.  As all searchable claims could be searched without effort justifying an additional fee, the International Searching Authority did not invite payment of any additional fee.

Remark on Protest

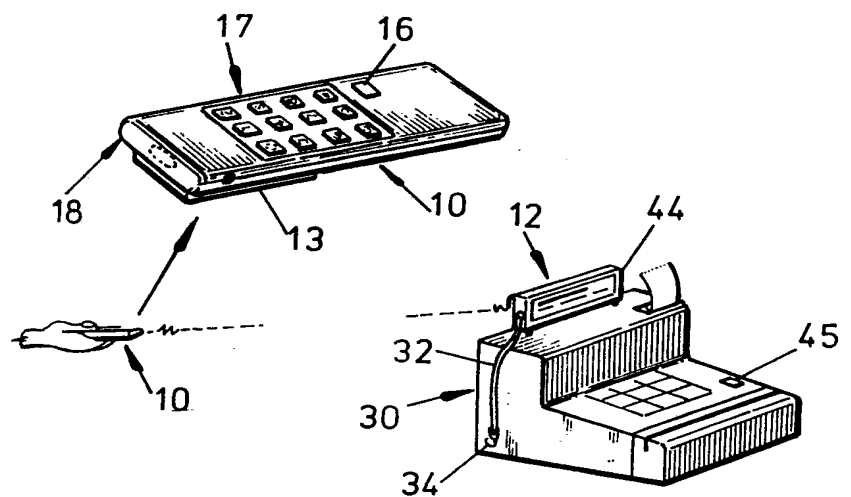
- The additional search fees were accompanied by applicant's protest.  
 No protest accompanied the payment of additional search fees.



INTERNATIONAL APPLICATION PUBLISHED UNDER THE PATENT COOPERATION TREATY (PCT)

<p>(51) International Patent Classification <sup>5</sup> : <b>G07F 7/10</b></p>	<p><b>A1</b></p>	<p>(11) International Publication Number: <b>WO 92/14222</b> (43) International Publication Date: 20 August 1992 (20.08.92)</p>
<p>(21) International Application Number: PCT/GB92/00181 (22) International Filing Date: 31 January 1992 (31.01.92) (30) Priority data: 9102104.8 31 January 1991 (31.01.91) GB  (71)(72) Applicants and Inventors: TAIT, Robert, Alan, Reid [GB/GB]; TAIT, Elizabeth, Mary [GB/GB]; 5 Bridge-castle, Westfield, Bathgate, East Lothian EH48 3DU (GB).  (74) Agent: NAISMITH, Robert, Stewart; Cruikshank &amp; Fair-weather, 19 Royal Exchange Square, Glasgow G1 3AE (GB).</p>		<p>(81) Designated States: AT (European patent), AU, BE (Euro-pean patent), CA, CH (European patent), DE (Euro-pean patent), DK (European patent), ES (European pa-tent), FR (European patent), GB, GB (European patent), GR (European patent), HU, IT (European patent), JP, LU (European patent), MC (European patent), NL (Eu-ropean patent), SE (European patent), US.  <b>Published</b> <i>With international search report.</i> <i>Before the expiration of the time limit for amending the claims and to be republished in the event of the receipt of amendments.</i></p>

(54) Title: NON-CONTACTING TRANSACTION SYSTEM



(57) Abstract

A non-contacting transaction system as described which includes a hand-held device (10) which contains information unique to the user and which, when actuated by the user, generates a wireless signal which is picked up by a receiver (12). In a preferred arrangement, the transmitter (10) contains the user's code and has a keypad (17) for the user to insert a personal identification number (PIN) code. The receiver (12) is coupled via a transmission line to a local system where the user's code and PIN number and details of the purchase, received from the vendor, are registered against the user's number so that billing can be carried out subsequently. The receiver (10) can include a means for checking (27) and for rectifying the correctness of the code and PIN number prior to transmitting the data via the modem to the central system. Various embodiments of the invention are described; for example, the device is flexible and the PIN number could be required for all transactions to minimise fraud. Each transmitter may be provided with a terminal to allow an input to the memory for changing details of the user's account and charge number. To prove ownership of the transmitter, the owner's name, telephone number, car registration number etc. may also be fused in the memory along with the credit card number. This information would be displayed only to the vendor who could ask the person who was using the transmitter to identify himself by name, PIN, telephone number or car registration as proof of identity.

**FOR THE PURPOSES OF INFORMATION ONLY**

Codes used to identify States party to the PCT on the front pages of pamphlets publishing international applications under the PCT.

AT	Austria	FI	Finland	MI	Mali
AU	Australia	FR	France	MN	Mongolia
BB	Barbados	GA	Gabon	MR	Mauritania
BE	Belgium	GB	United Kingdom	MW	Malawi
BF	Burkina Faso	GN	Guinea	NL	Netherlands
BG	Bulgaria	GR	Greece	NO	Norway
BJ	Benin	HU	Hungary	PL	Poland
BR	Brazil	IE	Ireland	RO	Romania
CA	Canada	IT	Italy	RU	Russian Federation
CF	Central African Republic	JP	Japan	SD	Sudan
CG	Congo	KP	Democratic People's Republic of Korea	SE	Sweden
CH	Switzerland	KR	Republic of Korea	SN	Senegal
CI	Côte d'Ivoire	LI	Liechtenstein	SU	Soviet Union
CM	Cameroon	LK	Sri Lanka	TD	Chad
CS	Czechoslovakia	LU	Luxembourg	TG	Togo
DE	Germany	MC	Monaco	US	United States of America
DK	Denmark	MG	Madagascar		
ES	Spain				

NON-CONTACTING TRANSACTION SYSTEM

The present invention relates to apparatus for logging data of transactions and particularly, but not exclusively, the invention relates to apparatus for recording cashless financial transactions.

It is now widely accepted that purchasing goods or services in the domestic sector is more efficiently carried out if the purchase transaction does not use cash. Cash is often perceived as, at best, cumbersome and, at worst, an unnecessary risk to personal safety, for example, from muggings and also financially, from theft. Current trends are to move towards a "cashless society" and the momentum of this trend is gaining the support nationally and internationally.

The existence of credit cards goes quite a long way to meet the ideal requirements in respect of cashless transactions. For example, it contains the owner's identity number imprinted on a magnetic strip on the back of the card, together with the owner's name embossed on the front of the card. A holograph of the owner's signature is written on the back of the card and is the only means of confirming the correct ownership of the card.

Nevertheless, the present type of credit card has severe limitations in providing the ideal solution for a cashless transaction. For such a transaction to



commence, the credit card must physically come into contact with either a paper voucher on which the embossed details are transferred by carbon copy or the card must be physically passed through a swipe machine so that the magnetic strip is electro-magnetically read by a magnetic head. Both of these techniques require intimate physical contact of a machine with a credit card. The next step in the transaction is for the owner of the credit card to append his signature on the paper voucher. The vendor in the transaction compares, or should compare, the signature on the back of the card with that on the voucher. Assuming that there is a fair degree of resemblance between the signatures, the vendor then accepts that the transaction is complete. In order for the card owner's account to be debited, the vendor either sends copies of the carbon slips to the credit card company or the information from the magnetic swipe reader is electronically stored and usually transmitted over a telephone link. In the former case, one of the problems is loss of credit card slips or even damage to the slips such as to render details of the credit card unusable, with the result that the owner's account does not get debited and this results in a loss to the vendor. In the case of a card swipe machine, the information is periodically scanned from a central computer which polls all the swipe machines to which it is linked and the details of the transaction are then fed to a central

storage location where the information is then entered into the user's account and a bill is then prepared and sent to the user.

One problem with the existing system is that card fraud is very easily perpetrated. This is mainly because the signature appears on the reverse side of the card. A signature can generally be perfected by repeated copying so that it appears similar to that on the card. The unauthorised user of the card can then forge the signature to complete a fraudulent transaction. Even if a stolen or lost card is reported, there is often considerable time before all premises and businesses accepting that type of card are notified. In the case of a swipe card, notification is carried out remotely and periodically over the telephone line. Nevertheless, a professional criminal is able to verify whether the card is still valid with minimal risk and to use the card on a day-to-day basis with minimal risk of being apprehended.

A further disadvantage of existing credit card systems is that it is not possible to use the card without physical contact. Therefore, it is not presently feasible to use a credit card for parking, for paying tolls on a toll road or bridge or the like and in such situations, cash is still the preferred method of payment.

An object of the present invention is to obviate or mitigate at least one of the aforementioned disadvantages.

This is achieved by providing a hand-held transmitter

which contains information unique to the user and which, when actuated by the user, generates a wireless signal which is picked up by a receiver. In a preferred arrangement, the transmitter contains the user's code and has a keypad for the user to insert a personal identification number (PIN) code. The receiver is coupled via a transmission line to a local system where the user's code and PIN number and details of the purchase, received from the vendor, are registered against the user's number so that billing can be carried out subsequently.

The receiver can include a means for checking and for rectifying the correctness of the code and PIN number prior to transmitting the data via the modem to the central system. The device is flexible and the PIN number could be required for all transactions to minimise fraud. Each transmitter may be provided with a terminal to allow an input to the memory for changing details of the user's account and charge number. To prove ownership of the transmitter, the owner's name, telephone number, car registration number etc. may also be fused in the memory along with the credit card number. This information would be displayed only to the vendor who could ask the person who was using the transmitter to identify himself by name, PIN, telephone number or car registration as proof of identity.

An object of the present invention is to obviate or

mitigate at least one of the aforementioned disadvantages.

According to one aspect of the present invention, there is provided a non-contacting transaction system comprising,

transmitter means having a memory for storage of data identifying the user therein, and a transmitter for transmitting the stored data to a remote location upon actuation of the transmitter means by the user, and

receiver means for receiving the transmitted data and having indicator means for indicating that the data transmitted is received and that the transaction can proceed.

Preferably, the transmitter means includes a keypad for the user to insert details of a PIN number. Conveniently, the transmitter means includes a terminal coupled to said memory whereby the transmitter can be coupled to a control means whereby the information in said memory may be changed or supplemented.

The transmitter includes a switch actuatable by the user which results in the stored data being continually transmitted or transmitted in bursts during the transmitting actuation.

Conveniently, the receiver may be coupled by a modem or the like over the telephone network to a central data processing and storage unit where details of the transactions are allocated to the user's account for subsequent billing.

Alternatively, the receiver may include disk storage means or other suitable mass storage means for storing validated transactions for subsequent despatching of the stored transaction data to the central data processing and storage unit at a later date.

Conveniently, the receiver includes a display for displaying to the vendor the transmitted information. Advantageously, the receiver includes parity and code check means for rectifying the correctness of the received code prior to transmitting it to the modem.

According to another aspect of the invention, there is provided a transmitter for use in a non-contacting transaction system, said transmitter comprising a memory for storing data identifying the user, a transmitter coupled to the memory for wireless transmission of said stored data to a remote location, and switch means actuatable by the user for causing said stored data to be transmitted.

Preferably, the transmitter includes a keypad for the user to insert details of a personal identification number (PIN), and said data being transmitted only if the correct PIN number is keyed in.

Conveniently, the transmitter includes a terminal coupled to the memory whereby the transmitter can be coupled to a control means to change the information in said memory.

Preferably also, the transmitter includes a plurality

of keys representative of different user accounts and the user can nominate which account a transaction is to be attributed to by selecting the appropriate key.

The transmitter is an infra-red transmitter.

Alternatively, the transmitter may include a remote telephone console interfaced to said memory and keys whereby a user may remotely conduct a transaction using radio frequency communications or any part of the electro-magnetic spectrum for communications.

According to a further aspect of the invention, there is provided a receiver for use in a non-contacting transaction system, said receiver comprising a data receiver for receiving a wireless transmission, means for indicating that the data has been received, means for processing the received data for display, means for verifying the correctness of the data received, and display means for displaying to a vendor details of the user stored in said transmitter.

Preferably, the receiver is coupled to a card swipe machine. Conveniently, the receiver and/or card swipe machine are coupled to a cellular telephone network for receiving said data by radio frequency communication. Conveniently, the receiver may be coupled by a modem or the like over the telephone network to a central data processing and storage unit where details of the transactions are allocated to the user's account for subsequent billing.

Alternatively, the receiver may include disk storage means or other suitable storage means for storing validated transactions for subsequent despatching of the stored transaction data to the central data processing and storage unit at a later date.

Thus, the invention provides a considerable improvement over existing cash cards to satisfy requirements for cashless transactions. The invention permits cashless transactions to be performed in a non-contacting fashion and it provides a secure method of checking and verifying the identity of the vendor without requiring signatures.

These and other aspects of the present invention will become apparent from the following description when taken in combination with the accompanying drawings in which:-

Fig. 1 is a diagrammatic view of a system consisting of a transmitter and a receiver shown coupled to a card swipe machine in accordance with one aspect of the present invention;

Fig. 2 is a diagrammatic view of an alternative transmitter similar to that shown in Fig. 1 and which includes a keyboard and a set of credit card select buttons;

Fig. 3a and 3b are schematic block diagrams of the transmitter and receiver, respectively shown in Fig. 1;

Fig. 4 is a schematic block diagram of the transmitter shown in Fig. 2;

Fig 5 is a schematic block diagram of an alternative transmitter similar to that of Figs. 1 and 2, but which has no keypad;

Fig. 6 depicts a flow chart of the operation of the transmitter and receiver conducted by a user in the pursuit of purchasing a commodity using the transmitter and receiver shown in Fig. 1;

Fig. 7 and Fig. 8 depict flow charts which are similar to Fig. 6, but using the transmitters of Fig 2 and Fig. 3 respectively, and

Fig. 9 is a circuit diagram of an embodiment of an infra-red transmitter in accordance with the present invention.

Reference is first made to Fig. 1 of the drawings which depicts a hand-held transmitter 10 and receiver 12 in accordance with the first embodiment of the invention. As will be later described in detail, the transmitter 10, when actuated, transmits information about the user which is received by the receiver 12 and used to initiate the transaction. The transmitter is about 10cm long and has a clip 13 for securing in a pocket or the like. The transmitter has a switch 16 and an infra-red filter 18 at one end of the transmitter. The transmitter also has a keypad 17 which enables high value transactions to be carried out by combining the stored credit card or account number with a personal identification number (PIN).

Reference is also made to Fig. 3a, 3b and Fig. 6 of



the drawings which are a schematic block diagram of the transmitter and receiver circuits and a flow chart of the operations involved in a transaction using the transmitter/receiver arrangement of Fig. 1. The transmitter 10 contains a programmable read only memory (PROM) chip 20 in which the owner's personal credit number (i.e. similar to a credit card number or bank number etc.) is electronically stored. The owner's name or other identifying number such as vehicle registration number or community charge number, is also stored. When the switch 16 is depressed, power is applied to the circuit from the battery 22 and the information contained in the PROM 20 is only transferred in parallel using the clock 24, to the shift register 26 only if the correct PIN number is inserted via the keypad 17. The keyed-in PIN number is compared in comparator 27 with the fused PIN number, and only if they match is the information transferred to shift register 26. The identity part of the fused data, for example, the vendee's name or community charge number or driving licence number, can be checked as previously mentioned. This further improves the security as the PIN number is known only to the user and will provide at least the same level of security as with a bank charge card for use with High Street terminals and the like. the information received in the shift register 26 is then transferred to the infra-red transmitter 28, in serial form, and clocked by the clock 24 for transmission. The

infra-red filter 18 is a notch filter selected to best suit infra-red transmission.

Thus, in practice, the vendee or user can transfer his personal credit details in a non-contacting, remote fashion in the infra-red waveband. Of course, it will be appreciated that transmission might be in any suitable part of the electro-magnetic spectrum, not necessarily at infra-red wavelengths.

The transmitted data is received by the receiver 12 which is coupled to a conventional card swipe machine 30 by a cable and connector 32,34 respectively. As best seen from the receiver schematic block diagram in Fig. 3b, the data is received by a suitable infra-red receiver 36 in serial form and the receiver then assembles the data into parallel format for the shift register 38. The parallel data is checked for parity in the code corrector 40 and any precoded format of data using a protocol circuit 42 prior to being transferred to the card swipe machine 30.

Thus, the information in the transmitter is passed from the transmitter to the receiver and then to the card swipe machine without contact or from suffering from the aforementioned disadvantages.

The operation of the system in a cashless transaction is best described with reference to the flow chart shown in Fig. 6 of the drawings. The receiver 12 on the card swipe machine has a display panel 44 which displays the

contents of the identity part of the message, for example, the name of the user or vendee once the transmission is complete. Provided that the display panel 44 is out of sight of the vendee, the vendor can read the identity part of the message and verify with the vendee as to the contents of this part of the message, as shown in step 8 of Fig. 6. Assuming that the vendee is the owner of the transmitter, only he knows the detail of the identity part of the message and can give the correct answer. This can be readily checked by the vendor by simply comparing the answer with that displayed on the panel; step 9. If the vendor is satisfied of the user's identity, he then authorises the transaction to proceed by actuating a button 45 on the card swipe machine which accepts the user's transmitted data; step 10. Of course, if the vendee is not the owner of the transmitter, then the vendor can terminate the transaction, step 13. If, in fact, the vendee is not the owner of the transmitter, then only access to sophisticated electronic equipment would be required to interrogate the transmitter to enable misuse of the transmitter. Although this is, in theory, possible it is most unlikely that this facility would be available to criminals to carry out widespread fraud and the security achieved is far superior to that of comparing signatures.

Reference is now made to Figs, 2, 4 and 7 of the accompanying drawings which describe a further embodiment

of the invention. The transmitter 10a shown in Fig. 2 is similar to that shown in Fig. 1 in which like numerals denote like parts, but with the suffix 'a' added and which includes a facility for using the transmitter 10a with more than one credit card. This is achieved by providing a set of card select buttons 50, each of which can be selected by the user (step 3a, Fig. 7) in order to designate a particular transaction to a particular credit card. In this case, the individual owns several credit cards and wishes to have one transmitter to operate on behalf of all of the credit cards. Each card select button allows the operator to select the credit card which he wishes to use to complete the transaction. As shown in Fig. 4, the switches 50 are coupled to the PROM 20a and to the other components which contain the details appropriate to the card selected. Once the particular button has been depressed, the operation of the device is identical to that described with reference to Fig. 1.

The device can be used for low value transactions such as paying parking charges, paying tolls and the like and as security codes are regularly updated any loss and unauthorised use is likely to be insignificant. Moreover, the transaction is likely to be fully mechanised for the vendor. Reference is now made to Fig. 5 of the accompanying drawings which are for a transmitter of generally similar size and shape to the transmitter 10 shown in Fig. 1 except that it does not have a key-pad.

- 14 -

The circuit elements in Fig. 5 are referred to by like numerals, but by suffix 'b' added and operate in the same way. From Fig. 5 it will be seen that the basic operation is similar to the transmitter of Fig. 1 except that a PIN number is not employed. An example of how this circuit might be implemented is shown in Fig. 9. It comprises electronic elements where each and every one form part of the industry standard. ICs 1A and B might be a 74ALS14 or any suitable package containing 6 Schmitt trigger invertors; IC 2 is a 22V10 or any similar Programmable Array Logic configured to drive IC 3, an NMC9306, a 512-bit programmable serial read only memory. The resistors and capacitors are 1/4 watt, 5 percent tolerance components; a nominal 6 volt battery is employed. The light emitting diode D1 is similar to those used in television channel changers. The user's credit card number and the encryption element are fused in IC 3. These data are configured in an auto-clocking code, a 3 from 9 code being an example, ready for transmission. Implementation might also employ micro-processors/micro-controllers to reduce the component count within the transmitter. There are many such devices available, an example being COP8720C, or a COP424C with an accompanying NMC9306.

The receiver might be configured round a bar-code reader. One example is the Hewlett-Packard HBCR8500 which contains all the necessary electronics to convert

the data from the transmitter to ASCII, an international standard compatible with the majority of peripherals and swipe card machines.

Reference is now made to Figs. 5 and 8 of the accompanying drawings which are for a transmitter generally similar in size and shape to the transmitter 10 shown in Fig. 1 except that it does not have a keypad. The circuit elements in Fig. 5 are referred to by like numerals, but with the suffix 'b' added and operate in the same way. From Figs. 5 and 8 it will be seen that the basic operation is similar to the transmitter of Fig. 1 except that a PIN number is not entered, that is, step 5 is omitted. This device can be used for low value transactions such as paying parking charges, paying tolls and the like and as the security codes are regularly updated any loss and unauthorised use is likely to be insignificant.

It will be appreciated that various modifications may be made to the embodiments hereinbefore described without departing from the scope of the invention. For example, two chips may be combined in a transmitter; one chip containing the user's credit information, PIN number and the like, and a second chip containing an encryption algorithm so that the data transmitted is encrypted for more secure communications. Each receiver would have a corresponding chip with a decryption algorithm so that the transmitted information can be decoded and the stored

- 16 -

information displayed to the vendor. The size and shape of the transmitter may be varied and, in fact, depending on manufacturing technology, the transmitter may be credit card shaped to fit in a wallet or the like. The transmitter on such a credit card shape could also contain a keycard and credit card selector keys. The device and system could be used other than for financial transactions; it could be used to control entry or access to secure areas and the like, with the user's code (PIN) being verified at a local or central location.

The communication medium could be radio frequency (r.f.) sound or ultrasound suitable for carrying the necessary information to initiate a transaction, although it is believed that infra-red is the most suitable. A further modification is the addition of r.f. circuits to the transmitter and receiver so that the user is able to complete transactions remotely, in a similar manner to the operation of cardless cellular telephones. Thus, cinema theatre tickets and the like, could be ordered using the transmitter, and shopping could be done remotely with the receiver processing the order and automatically debiting the user's account.

The principal advantage of the invention is that it improves the security of cashless transactions and allows the transactions to be completed in a non-contacting fashion. Furthermore, it provides a more secure method of checking identity of the user without requiring

- 17 -

signatures. In addition, a single transmitter can be used to complete transactions for various cards and the transactions can be performed for purchasing any type of goods or service, including parking, paying tolls and the like which is not hitherto been possible with existing credit cards.



CLAIMS

1. A non-contacting transaction system comprising, transmitter means having a memory for storage of data identifying the user therein, and a transmitter for transmitting the stored data to a remote location upon actuation of the transmitter means by the user, and receiver means for receiving the transmitted data and having indicator means for indicating that the data transmitted is received and that the transaction can proceed.
2. A system as claimed in claim 1 wherein the transmitter means includes a keypad for the user to insert details of a PIN number.
3. A system as claimed in claim 1 or claim 2 wherein the transmitter means includes a terminal coupled to said memory whereby the transmitter is coupled to a control means whereby the information in said memory is alterable.
4. A system as claimed in claim 2 or claim 3 wherein the transmitter includes a switch actuatable by the user which results in the stored data being continually transmitted or transmitted in bursts during the transmitting actuation.
5. A system as claimed in any preceding claim wherein the receiver is coupled by a modem or the like over the telephone network to a central data processing and storage unit where details of the transactions are allocated to the user's account for subsequent billing.

- 19 -

6. A system has claimed in any one of claims 1- 4 wherein the receiver includes disk storage means or other suitable mass storage means for storing validated transactions for subsequent despatching of the stored transaction data to the central data processing and storage unit at a later date.

7. A system as claimed in any preceding claim wherein the receiver includes a display for displaying to the vendor the transmitted information.

8. A system as claimed in any preceding claim wherein the receiver includes parity and code check means for rectifying the correctness of the received code prior to transmitting it to the modem.

9. A transmitter for use in a non-contacting transaction system, said transmitter comprising a memory for storing data identifying the user, a transmitter coupled to the memory for wireless transmission of said stored data to a remote location, and switch means actuatable by the user for causing said stored data to be transmitted.

10. A transmitter as claimed in claim 9 wherein the transmitter includes a keypad for the user to insert details of a personal identification number (PIN), and said data being transmitted only if the correct PIN number is keyed in.

11. A transmitter as claimed in claim 9 or claim 10 wherein the transmitter includes a terminal coupled to the memory whereby the transmitter can be coupled to a control

- 20 -

means to change the information in said memory.

12. A transmitter as claimed in any one of claims 9 - 11 wherein the transmitter includes a plurality of keys representative of different user accounts and the user can nominate which account a transaction is to be attributed to by selecting the appropriate key.

13. A transmitter as claimed in any one of claims 9 - 12 wherein the transmitter is an infra-red transmitter.

14. A transmitter as claimed in any one of claims 9 - 15 wherein the transmitter may include a remote telephone console interfaced to said memory and keys whereby a user may remotely conduct a transaction using radio frequency communications or any part of the electro-magnetic spectrum for communications.

15. A receiver for use in a non-contacting transaction system, said receiver comprising a data receiver for receiving a wireless transmission, means for indicating that the data has been received, means for processing the received data for display, means for verifying the correctness of the data received, and display means for displaying to a vendor details of the user stored in said transmitter.

16. A receiver as claimed in claim 15 wherein the receiver is coupled to a card swipe machine.

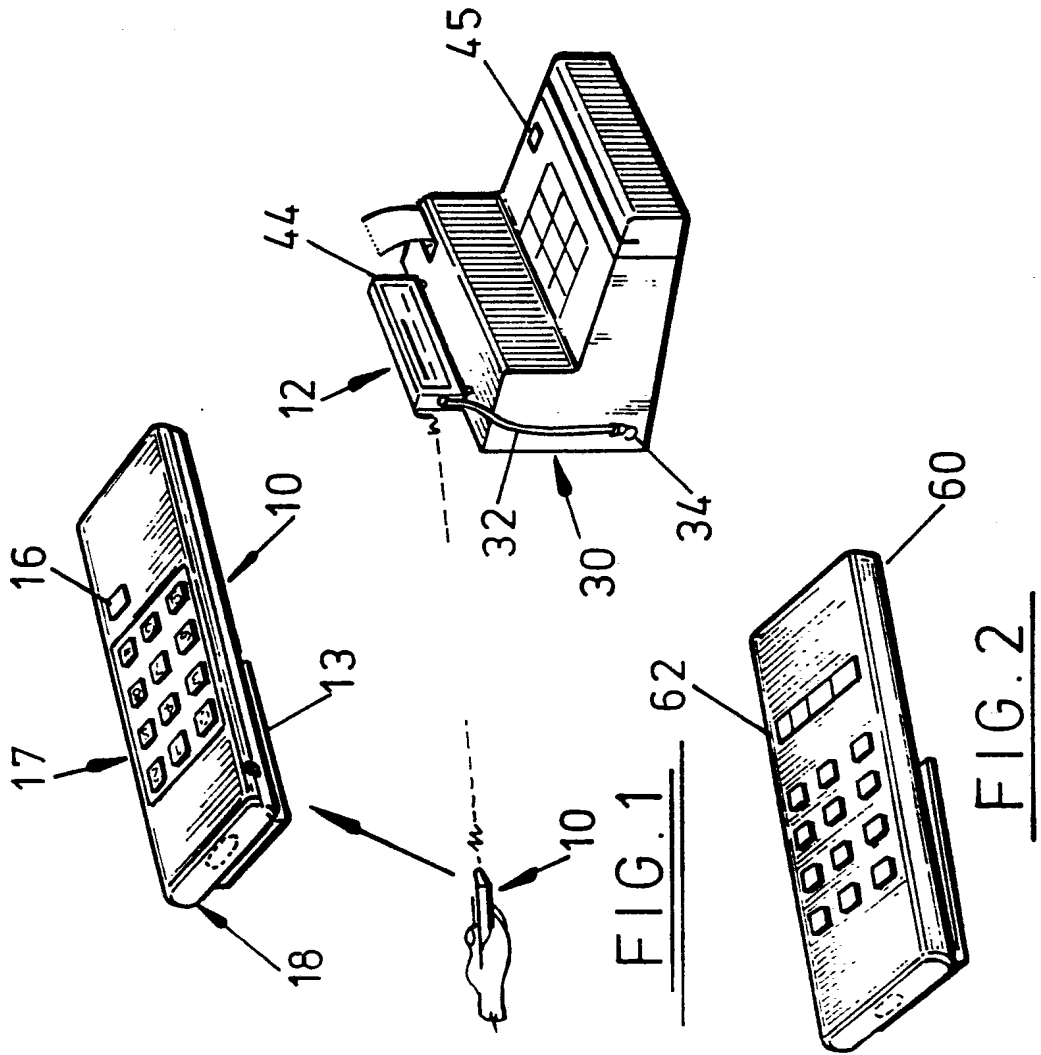
17. A receiver as claimed in claim 15 or 16 wherein the receiver and/or card swipe machine are coupled to a cellular telephone network for receiving said data by

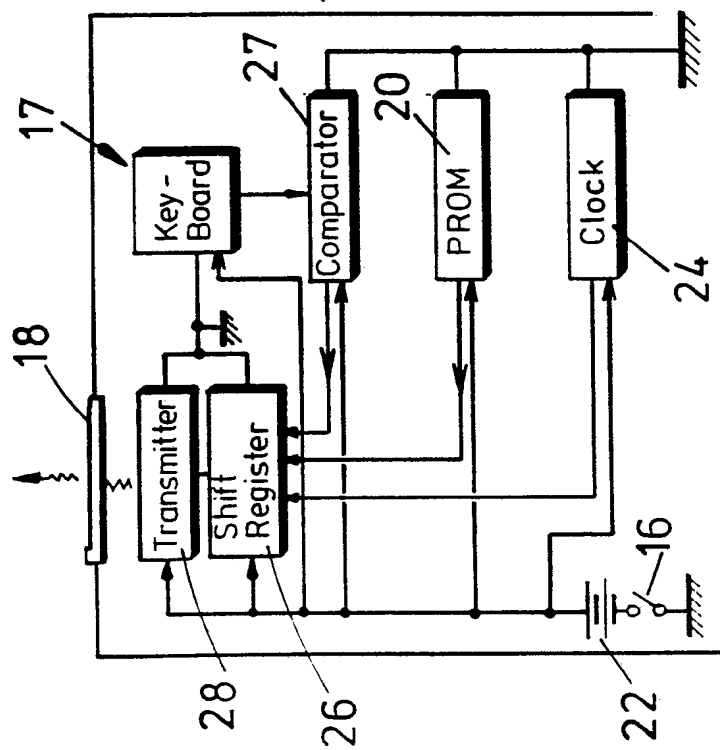
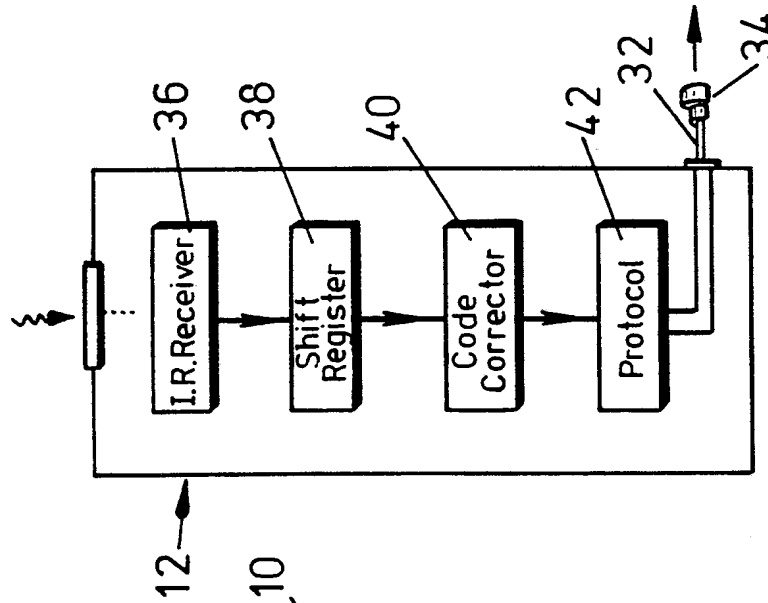
- 21 -

radio frequency communication.

18. A receiver as claimed in any one of claims 15 - 17 wherein the receiver is coupled by a modem or the like over the telephone network to a central data processing and storage unit where details of the transactions are allocated to the user's account for subsequent billing.

19. A receiver as claimed in any one of claims 15 - 17 wherein the receiver includes disk storage means or other suitable storage means for storing validated transactions for subsequent despatching of the stored transaction data to the central data processing and storage unit at a later date.





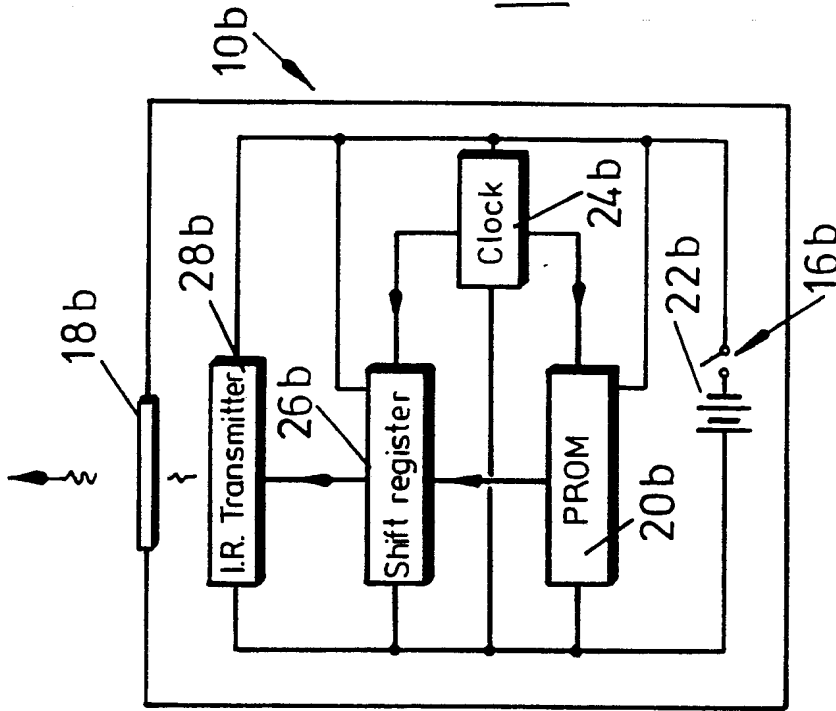


FIG. 5

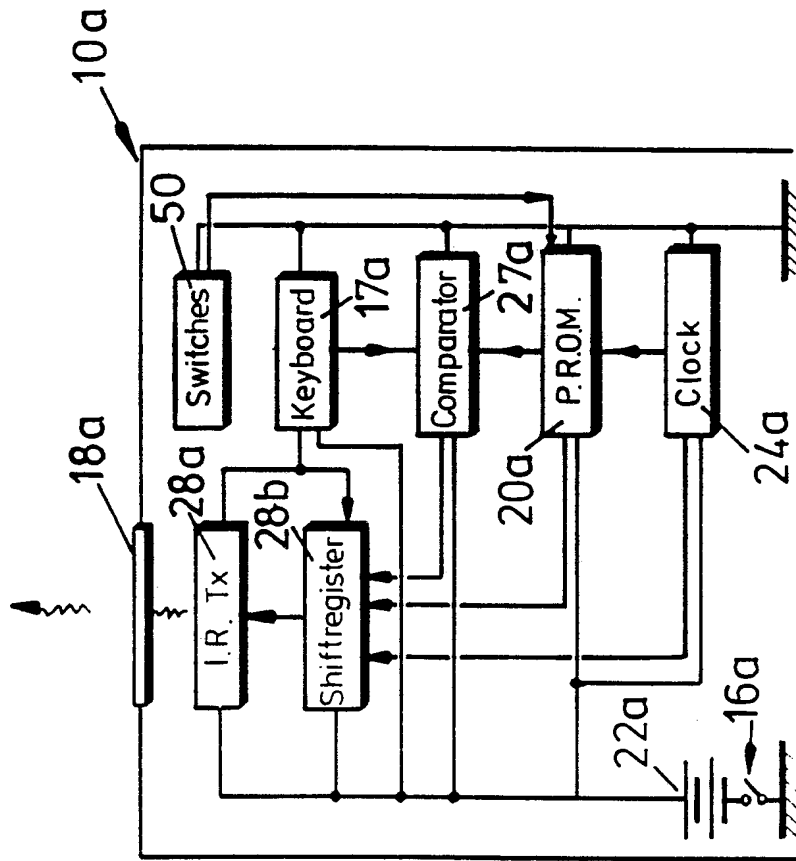


FIG. 4

4 / 7

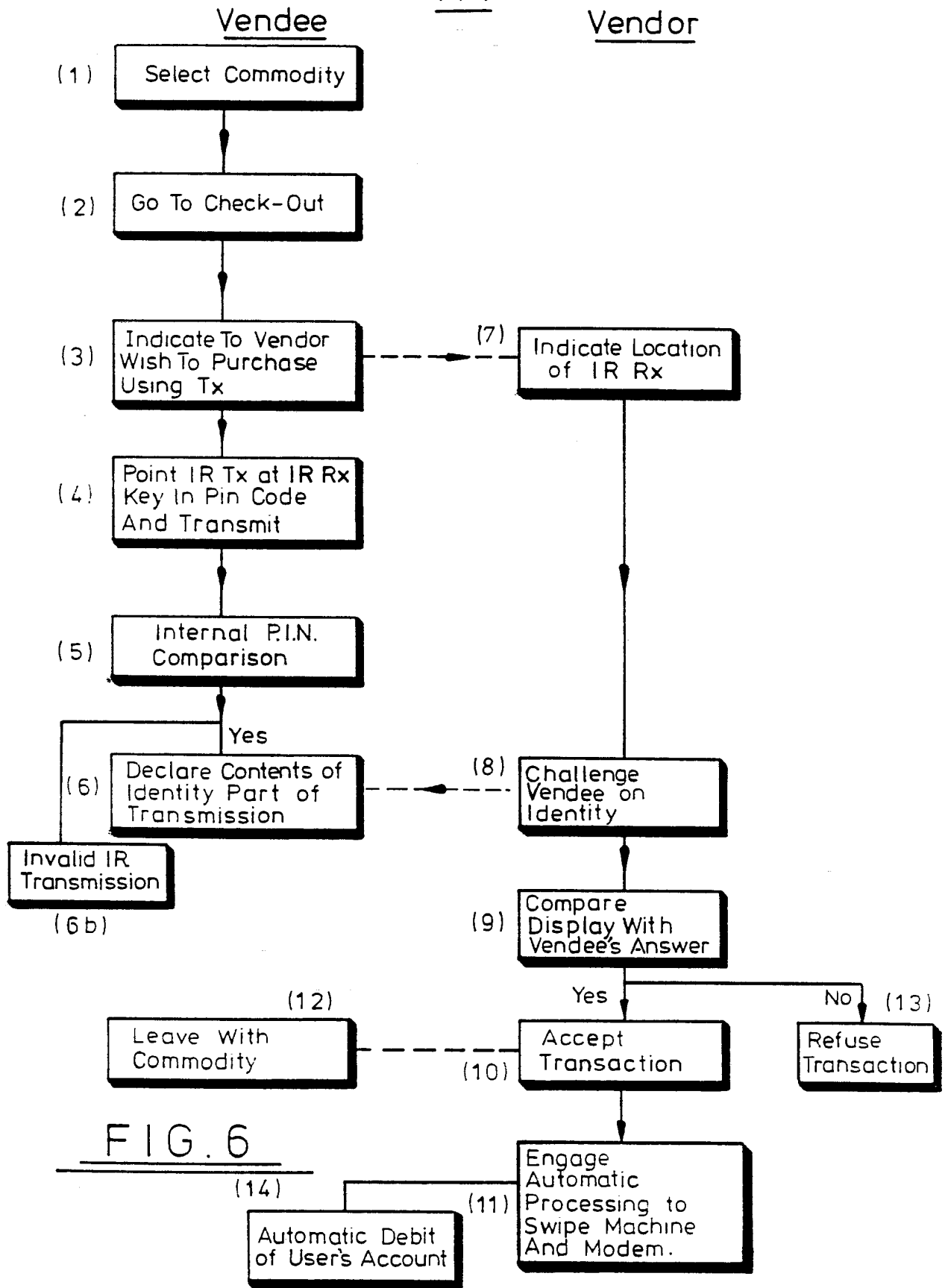


FIG. 6



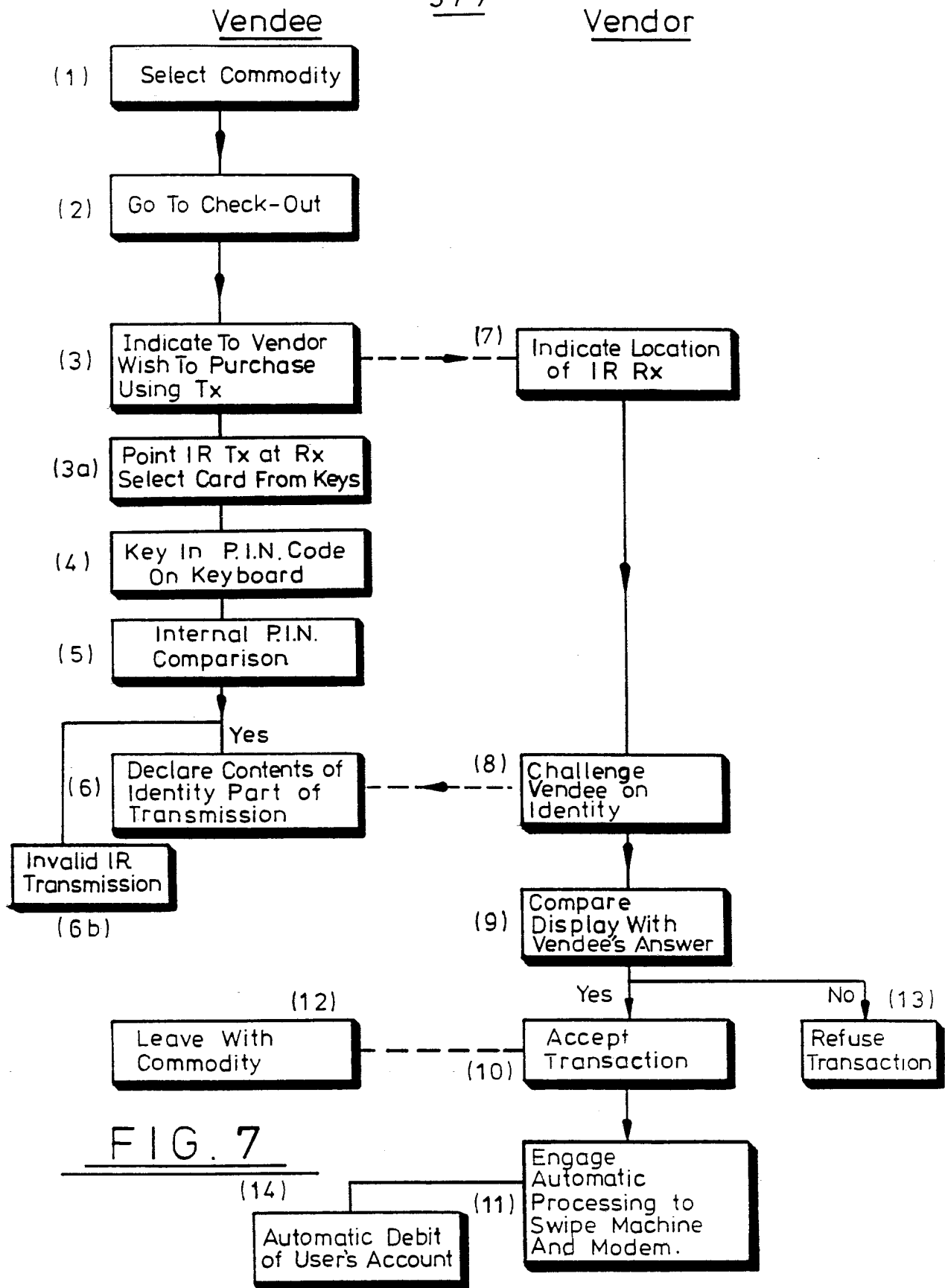


FIG. 7

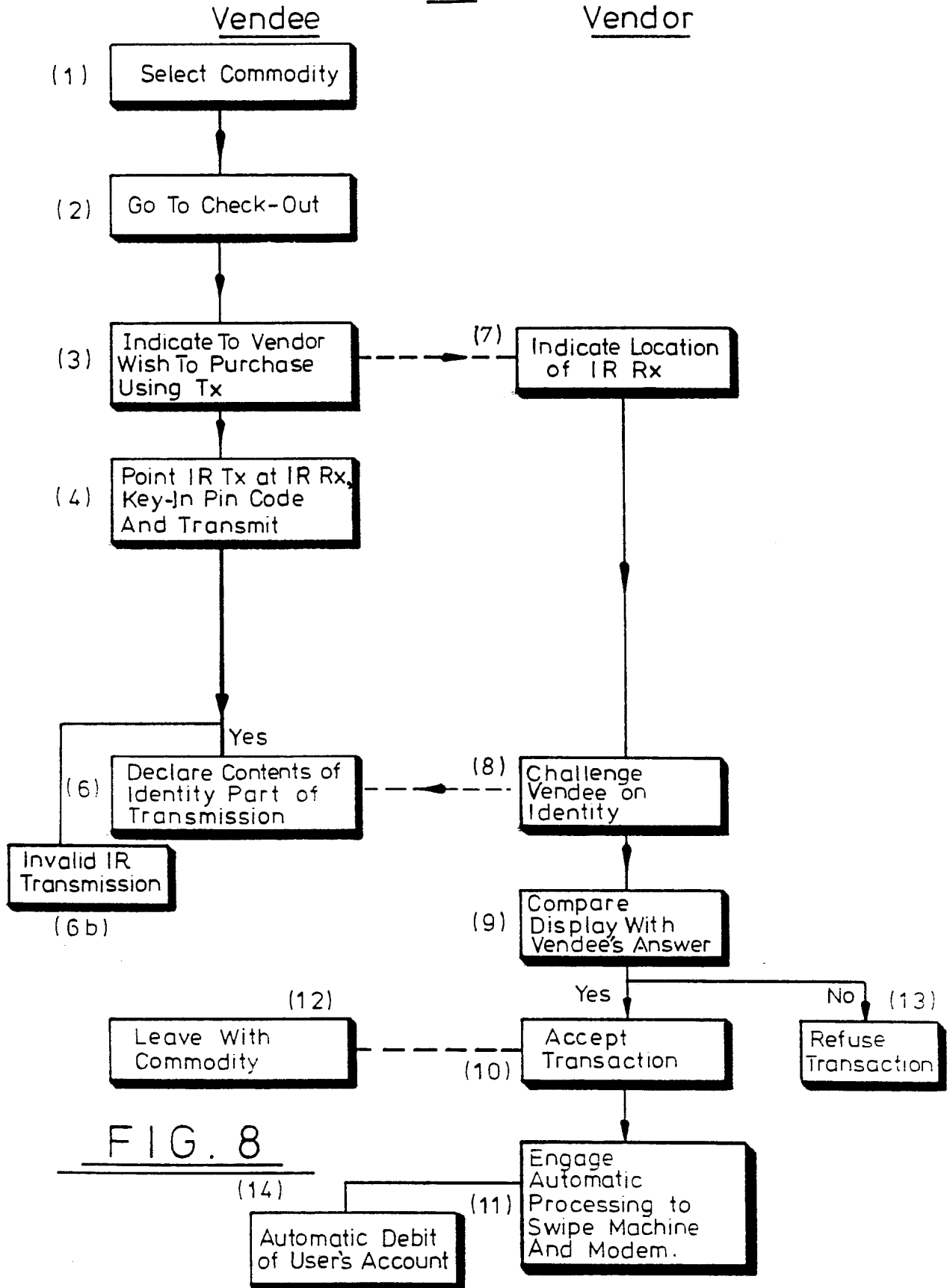


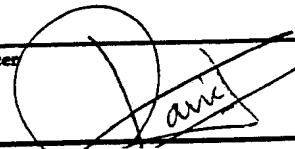
FIG. 8



INTERNATIONAL SEARCH REPORT

PCT/GB 92/00181

International Application

<b>I. CLASSIFICATION OF SUBJECT MATTER</b> (if several classification symbols apply, indicate all) <sup>6</sup> According to International Patent Classification (IPC) or to both National Classification and IPC Int.Cl. 5 G07F7/10		
<b>II. FIELDS SEARCHED</b> Minimum Documentation Searched <sup>7</sup>		
Classification System	Classification Symbols	
Int.Cl. 5	G07F ;	G06K ; G07C
Documentation Searched other than Minimum Documentation to the Extent that such Documents are Included in the Fields Searched <sup>8</sup>		
<b>III. DOCUMENTS CONSIDERED TO BE RELEVANT<sup>9</sup></b>		
Category <sup>10</sup>	Citation of Document, <sup>11</sup> with indication, where appropriate, of the relevant passages <sup>12</sup>	Relevant to Claim No. <sup>13</sup>
X	US,A,4 800 543 (R. LYNDON-JAMES) 24 January 1989 see abstract; claims; figures 1,4,5 see column 2, line 19 - line 62	1,9,13, 15
A	see column 5, line 22 - column 6, line 58	2,5-7, 10,12,18
X	US,A,4 757 185 (Y. ONISHI) 12 July 1988 see the whole document	1
A		2,10,12, 15
X	EP,A,0 159 539 (SIEMENS) 30 October 1985 see the whole document	1,2,9, 10,13
A		3,11,12, 15
	---	---
		---/---
<sup>10</sup> Special categories of cited documents : "A" document defining the general state of the art which is not considered to be of particular relevance "E" earlier document but published on or after the international filing date "L" document which may throw doubts on priority claim(s) or which is cited to establish the publication date of another citation or other special reason (as specified) "O" document referring to an oral disclosure, use, exhibition or other means "P" document published prior to the international filing date but later than the priority date claimed "T" later document published after the international filing date or priority date and not in conflict with the application but cited to understand the principle or theory underlying the invention "X" document of particular relevance; the claimed invention cannot be considered novel or cannot be considered to involve an inventive step "Y" document of particular relevance; the claimed invention cannot be considered to involve an inventive step when the document is combined with one or more other such documents, such combination being obvious to a person skilled in the art. "&" document member of the same patent family		
<b>IV. CERTIFICATION</b>		
Date of the Actual Completion of the International Search	Date of Mailing of this International Search Report	
21 MAY 1992	11. 06. 92	
International Searching Authority	Signature of Authorized Officer	
EUROPEAN PATENT OFFICE	DAVID J. Y. H. 	

III. DOCUMENTS CONSIDERED TO BE RELEVANT (CONTINUED FROM THE SECOND SHEET)		Relevant to Claim No.
Category <sup>a</sup>	Citation of Document, with indication, where appropriate, of the relevant passages	
A	US,A,4 601 011 (A. GRYNBERG) 15 July 1986 see abstract; figures ---	1,2,5,9, 10,14
A	EP,A,0 402 182 (R. PARIENTI) 12 December 1990 see abstract; claims; figures see column 4, line 34 - column 6, line 20 ---	1,7,9, 13,15
A	WO,A,8 603 869 (NCR) 3 July 1986 see abstract; claims; figures see page 5, line 20 - page 7, line 20 see page 22, line 16 - page 27, line 26 ---	1-3,5,6, 9-12,14, 15,17-19
A	EP,A,0 174 016 (CASIO COMPUTER) 12 March 1986 ---	
A	GB,A,2 192 665 (NEIMAN SECURITY PRODUCTS) 20 January 1988 ---	

**ANNEX TO THE INTERNATIONAL SEARCH REPORT  
ON INTERNATIONAL PATENT APPLICATION NO. GB 9200181  
SA 55949**

This annex lists the patent family members relating to the patent documents cited in the above-mentioned international search report. The members are as contained in the European Patent Office EDP file on The European Patent Office is in no way liable for these particulars which are merely given for the purpose of information. 21/05/92

Patent document cited in search report	Publication date	Patent family member(s)	Publication date
US-A-4800543	24-01-89	AU-A- 2645188	08-06-89
		EP-A- 0319297	07-06-89
		JP-A- 2002974	08-01-90
-----	-----	-----	-----
US-A-4757185	12-07-88	JP-A- 62254265	06-11-87
-----	-----	-----	-----
EP-A-0159539	30-10-85	DE-A- 3412663	17-10-85
		JP-A- 60230284	15-11-85
-----	-----	-----	-----
US-A-4601011	15-07-86	DE-A- 3248400	28-07-83
		GB-A- 2114791	24-08-83
-----	-----	-----	-----
EP-A-0402182	12-12-90	None	
-----	-----	-----	-----
WO-A-8603869	03-07-86	US-A- 4634845	06-01-87
		US-A- 4689478	25-08-87
		CA-A- 1240068	02-08-88
		EP-A, B 0207125	07-01-87
		JP-T- 62501239	14-05-87
		CA-A, C 1253626	02-05-89
-----	-----	-----	-----
EP-A-0174016	12-03-86	JP-A- 61067192	07-04-86
		DE-A- 3585188	27-02-92
		FR-A- 2570207	14-03-86
		US-A- 4697072	29-09-87
-----	-----	-----	-----
GB-A-2192665	20-01-88	None	
-----	-----	-----	-----

EPO FORM P0479

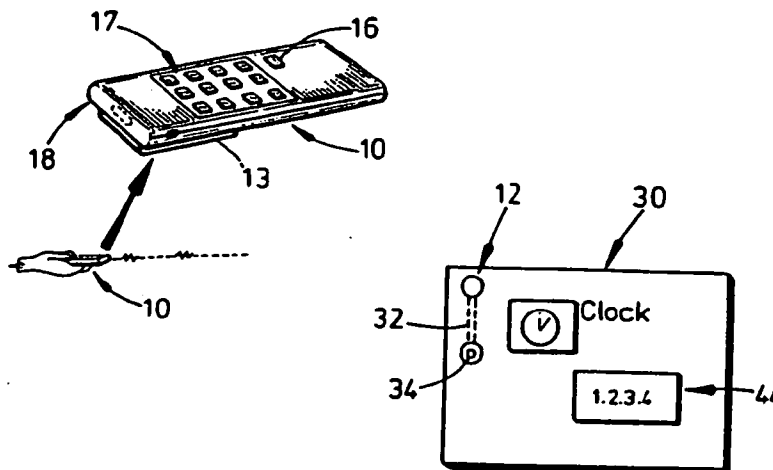
For more details about this annex : see Official Journal of the European Patent Office, No. 12/82



INTERNATIONAL APPLICATION PUBLISHED UNDER THE PATENT COOPERATION TREATY (PCT)

<p>(51) International Patent Classification <sup>5</sup> : G06K 7/00, 17/00</p>	<p>A1</p>	<p>(11) International Publication Number: WO 94/0290 (43) International Publication Date: 3 February 1994 (03.02.94)</p>
<p>(21) International Application Number: PCT/GB93/01526 (22) International Filing Date: 21 July 1993 (21.07.93) (30) Priority data: 9215706.4 23 July 1992 (23.07.92) GB (71) Applicant (for all designated States except US): WHIN-HALL LIMITED [GB/GB]; 5 Bridgecastle Gardens, Bridgecastle, Westfield, Bathgate, West Lothian EH48 3DU (GB). (72) Inventors; and (75) Inventors/Applicants (for US only) : TAIT, Robert, Allen, Reid [GB/GB]; TAIT, Elizabeth, Mary [GB/GB]; 5 Bridgecastle Gardens, Bridgecastle, Westfield, Bathgate, West Lothian EH48 3DU (GB).</p>		<p>(74) Agents: McCALLUM, William, Potter et al.; Cruikshan &amp; Fairweather, 19 Royal Exchange Square, Glasgow G3AE (GB). (81) Designated States: AU, CA, GB, HU, JP, US, European patent (AT, BE, CH, DE, DK, ES, FR, GB, GR, IE, IT, LU, MC, NL, PT, SE). <b>Published</b> <i>With international search report.</i></p>

(54) Title: NON-CONTACTING TRANSACTION SYSTEM FOR TICKETING



(57) Abstract

A non-contacting transaction system for ticketing is described which consists of a hand-held transmitter (10) which contains information unique to the user and which, when actuated by the user, generates a wireless signal which is picked up by a receiver (12). In a preferred arrangement, the transmitter (10) contains the user's code and has a keypad (17) for the user to insert a personal identification number (PIN) code. This PIN might be a series of digits or the owners telephone number, car registration number or any code preferred by the owner. The detectors of the receiver are coupled via a transmission line to a local system where the user's code and PIN number and details of the purchase, received from the vendor, are registered against the user's number so that billing can be carried out subsequently. The local system can include a means for checking and for rectifying the correctness of the code and PIN number prior to transmitting the data via the modem to the central system. The device is flexible and the PIN number could be required for all transactions to minimize fraud. Each transmitter may be provided with a terminal to allow an input to the memory for changing details of the user's account and charge number.

**FOR THE PURPOSES OF INFORMATION ONLY**

Codes used to identify States party to the PCT on the front pages of pamphlets publishing international applications under the PCT.

AT	Austria	FR	France	MR	Mauritania
AU	Australia	GA	Gabon	MW	Malawi
BB	Barbados	GB	United Kingdom	NE	Niger
BE	Belgium	GN	Guinea	NL	Netherlands
BF	Burkina Faso	GR	Greece	NO	Norway
BG	Bulgaria	HU	Hungary	NZ	New Zealand
BJ	Benin	IE	Ireland	PL	Poland
BR	Brazil	IT	Italy	PT	Portugal
BY	Belarus	JP	Japan	RO	Romania
CA	Canada	KP	Democratic People's Republic of Korea	RU	Russian Federation
CF	Central African Republic	KR	Republic of Korea	SD	Sudan
CG	Congo	KZ	Kazakhstan	SE	Sweden
CH	Switzerland	LJ	Liechtenstein	SI	Slovenia
CI	Côte d'Ivoire	LK	Sri Lanka	SK	Slovak Republic
CM	Cameroon	LU	Luxembourg	SN	Senegal
CN	China	LV	Latvia	TD	Chad
CS	Czechoslovakia	MC	Monaco	TC	Togo
CZ	Czech Republic	MG	Madagascar	UA	Ukraine
DE	Germany	ML	Mali	US	United States of America
DK	Denmark	MN	Mongolia	UZ	Uzbekistan
ES	Spain			VN	Viet Nam
FI	Finland				



- 1 -

NON-CONTACTING TRANSACTION SYSTEM FOR TICKETING

The present invention relates to apparatus for logging data of transactions and particularly, but not exclusively, the invention relates to apparatus for conducting cashless financial transactions.

It is now widely accepted that purchasing goods or services in the domestic sector is more efficiently carried out if the purchase transaction does not use cash. Cash is often perceived as, at best, cumbersome and, at worst, an unnecessary risk to personal safety, for example, from muggings and also financially, from theft. Current trends are to move towards a "cashless society" and the momentum of this trend is gaining in support nationally and internationally.

Credit cards fall short of meeting all requirements in cashless transactions. For example, as regards security, a credit card contains the owner's identity number imprinted on a magnetic strip on the back of the card, together with the owner's name embossed on the front of the card. A holograph of the owner's signature is written on the back of the card and is the only means of confirming the correct ownership of the card.

Nevertheless, the present type of credit card has severe limitations in providing the ideal solution for a cashless transaction. For such a transaction to commence, the credit card must physically come into

- 2 -

contact with either a paper voucher on which the embossed details are transferred by carbon copy or the card must be physically passed through a swipe machine so that the magnetic strip is electro-magnetically read by a magnetic head. Both of these techniques require intimate physical contact of a machine with a credit card. The next step in the transaction is for the owner of the credit card to append his signature on the paper voucher. The vendor in the transaction compares, or should compare, the signature on the back of the card with that on the voucher. Assuming that there is a fair degree of resemblance between the signatures, the vendor then accepts that the transaction is complete. In order for the card owner's account to be debited, the vendor either sends copies of the carbon slips to the credit card company or the information from the magnetic swipe reader is electronically stored and usually transmitted over a telephone link. In the former case, one of the problems is loss of credit card slips or even damage to the slips such as to render details of the credit card unusable, with the result that the owner's account does not get debited and this results in a loss to the vendor. In the case of a card swipe machine, the information is periodically scanned from a central computer which polls all the swipe machines to which it is linked and the details of the transaction are then fed to a central storage location where the information is then entered

- 3 -

into the user's account and a bill is then prepared and sent to the user.

One problem with the existing system is that card fraud is very easily perpetrated. This is mainly because the signature appears on the reverse side of the card. A signature can generally be perfected by repeated copying so that the end result appears similar to that on the card. The unauthorised user of the card can then forge the signature to complete a fraudulent transaction. Even if a stolen or lost card is reported, there is often considerable time before all premises and businesses accepting that type of card are notified. In the case of a swipe card, notification is carried out remotely and periodically over the telephone line. Nevertheless, a professional criminal is able to verify whether the card is still valid with minimal risk and to use the card on a day-to-day basis with minimal risk of being apprehended.

A further disadvantage of existing credit card systems is that it is not possible to use the card without physical contact. Therefore, it is not presently feasible to use a credit card for conducting a low value transaction, such as purchasing a ticket for the parking of a car or admission to a sports function, admission to a metro or any other public transportation system, and in such situations, cash is still the preferred method of payment.

An object of the present invention is to obviate or

- 4 -

mitigate at least one of the aforementioned disadvantages.

This is achieved by providing a hand-held transmitter which contains information unique to the user and which, when actuated by the user, generates a wireless signal which is picked up by a receiver. In a preferred arrangement, the transmitter contains the user's code and has a keypad for the user to insert a personal identification number (PIN) code. This PIN might be a series of digits or the owners telephone number, car registration number or any code preferred by the owner. The detectors of the receiver are coupled via a transmission line to a local system where the user's code and PIN number and details of the purchase, received from the vendor, are registered against the user's number so that billing can be carried out subsequently.

The local system can include a means for checking and for rectifying the correctness of the code and PIN number prior to transmitting the data via the modem to the central system. The device is flexible and the PIN number could be required for all transactions to minimise fraud. Each transmitter may be provided with a terminal to allow an input to the memory for changing details of the user's account and charge number. To prove ownership of the transmitter, the owner's name, telephone number, car registration number etc. may also be fused in the memory along with the credit card number. In the case where there is doubt in the ownership of the transmitter,

- 5 -

the vendor might ask the person who was using the transmitter to identify himself by either name, PIN, telephone number or car registration as proof of identity.

An object of the present invention is to obviate or mitigate at least one of the aforementioned disadvantages.

According to one aspect of the present invention, there is provided a non-contacting transaction system comprising,

transmitter means having a memory for storage of data identifying the user therein, and a transmitter for transmitting the stored data to a remote location upon actuation of the transmitter means by the user, and

receiver means for receiving the transmitted data and also having indicator means for indicating that the data transmitted is received and that the transaction can proceed.

Preferably, the transmitter means includes a keypad for the user to insert details of a PIN number.

Conveniently, the non-contacting transaction system is a car-park ticketing system.

The transmitter includes a switch actuatable by the user which results in the stored data being continually transmitted or transmitted in bursts during the transmitting actuation.

Conveniently, the receiver or local system may be coupled by a modem or the like over the telephone network to a central data processing and storage unit where

- 6 -

details of the transactions are allocated to the user's account for subsequent billing.

Alternatively, the local system may include disk storage means or other suitable mass storage means for storing validated transactions for subsequent despatching of the stored transaction data to the central data processing and storage unit at a later date.

Conveniently, the receiver includes a display for displaying to the vendee his PIN in the transmitted information. Advantageously, the receiver includes parity and code check means for rectifying the correctness of the received code prior to transmitting it to the modem.

According to another aspect of the invention, there is provided a transmitter for use in a non-contacting transaction system, said transmitter comprising a memory for storing data identifying the user, a transmitter coupled to the memory for wireless transmission of said stored data to a remote location, and switch means actuatable by the user for causing said stored data to be transmitted.

Preferably, the transmitter includes a keypad for the user to insert details of a personal identification number (PIN), and said data being transmitted only if the correct PIN number is keyed in.

Preferably also, the transmitter includes a plurality of keys representative of different user accounts and the user can nominate which account a transaction is to be

- 7 -

attributed to by selecting the appropriate key.

The transmitter is an infra-red transmitter.

Alternatively, the transmitter may include a remote telephone console interfaced to said memory and keys whereby a user may remotely conduct a transaction using radio frequency communications or any part of the electro-magnetic spectrum for communications.

According to a further aspect of the invention, there is provided a receiver for use in a non-contacting transaction system, said receiver comprising a data receiver for receiving a wireless transmission, means for indicating that the data has been received, means for processing the received data for display, means for verifying the correctness of the data received, and display means for displaying to a vendor details of the user stored in said transmitter.

Preferably, the receiver is a car-park ticketing machine.

Preferably, the local system is coupled to the elements which combined comprise a card swipe machine. Conveniently, the receiver and/or card swipe machine are coupled to a cellular telephone network for receiving said data by radio frequency communication. Conveniently, the receiver may be coupled by a modem or the like over the telephone network to a central data processing and storage unit where details of the transactions are allocated to the user's account for subsequent billing.

Alternatively, the receiver may include disk storage means, or random access memory (RAM) or other suitable storage means for storing validated transactions for subsequent despatching of the stored transaction data to the central data processing and storage unit at a later date.

Thus, the invention provides a considerable improvement over existing cash cards to satisfy requirements for cashless transactions. The invention permits cashless transactions to be performed in a non-contacting fashion.

These and other aspects of the present invention will become apparent from the following description when taken in combination with the accompanying drawings in which:-

Fig. 1 is a diagrammatic view of a system consisting of a transmitter and a receiver shown coupled to a car-park ticketing machine in accordance with one aspect of the present invention;

Fig. 2 is a diagrammatic view of an alternative transmitter similar to that shown in Fig. 1 and which includes a keyboard and a set of credit card select buttons;

Fig. 3a and 3b are schematic block diagrams of the transmitter and receiver, respectively shown in Fig. 1;

Fig. 4 is a schematic block diagram of the transmitter shown in Fig. 2;

Fig 5 is a schematic block diagram of an alternative



- 9 -

transmitter similar to that of Figs. 1 and 2, but which has no keypad;

Fig. 6 depicts a flow chart of the operation of the transmitter and receiver conducted by a user in the pursuit of purchasing a ticket using the transmitter and receiver shown in Fig. 1;

Fig. 7 and Fig. 8 depict flow charts which are similar to Fig. 6, but using the transmitters of Fig 2 and Fig. 3 respectively, and

Fig. 9 is a circuit diagram of an embodiment of an infra-red transmitter in accordance with the present invention.

Reference is first made to Fig. 1 of the drawings which depicts a hand-held transmitter 10 and receiver 12 in accordance with the first embodiment of the invention. As will be later described in detail, the transmitter 10, when actuated, transmits information about the user which is received by the receiver 12 and used to initiate the transaction. The transmitter is about 10cm long and has a clip 13 for securing in a pocket or the like. The transmitter has a switch 16 and an infra-red filter 18 at one end of the transmitter. The transmitter also has a keypad 17 which enables high value transactions to be carried out by combining the stored credit card or account number with a personal identification number (PIN).

Reference is also made to Fig. 3a, 3b and Fig. 6 of the drawings which are a schematic block diagram of the

- 10 -

transmitter and receiver circuits and a flow chart of the operations involved in a transaction using the transmitter/receiver arrangement of Fig. 1. The transmitter 10 contains a programmable read only memory (PROM) chip 20 in which the owner's personal credit number (i.e. similar to a credit card number or bank number etc.) is electronically stored. The owner's name or other identifying number such as vehicle registration number or community charge number, is also stored. When the switch 16 is depressed, power is applied to the circuit from the battery 22 and the information contained in the PROM 20 is only transferred in parallel using the clock 24, to the shift register 26 only if the correct PIN number is inserted via the keypad 17. The keyed-in PIN number is compared in comparator 27 with the fused PIN number, and only if they match is the information transferred to shift register 26. The identity part of the fused data, for example, the vendee's name or community charge number or driving licence number, can be checked as previously mentioned. This further improves the security as the PIN number is known only to the user and will provide at least the same level of security as with a bank charge card for use with High Street terminals and the like. The information received in the shift register 26 is then transferred to the infra-red transmitter 28, in serial form, and clocked by the clock 24 for transmission. The infra-red filter 18 is a notch filter selected to best

- 11 -

suit infra-red transmission.

Thus, in practice, the vendee or user can transfer his personal credit details in a non-contacting, remote fashion in the infra-red waveband. Of course, it will be appreciated that transmission might be in any suitable part of the electro-magnetic spectrum, not necessarily at infra-red wavelengths.

The transmitted data is received by the receiver 12 which is coupled to a conventional car-park ticketing machine 30 by an internal cable and connector 32,34 respectively. As best seen from the receiver schematic block diagram in Fig. 3b, the data is received by a suitable infra-red receiver 36 in serial form and the receiver then assembles the data into parallel format for the shift register 38. The parallel data is checked for parity in the code corrector 40 and any precoded format of data using a protocol circuit 42 prior to being transferred to the ticketing machine 30.

Thus, the information in the transmitter is passed from the transmitter to the receiver and then to the ticketing machine without contact or from suffering from the aforementioned disadvantages.

The operation of the system in a cashless transaction is best described with reference to the flow chart shown in Fig. 6 of the drawings. The receiver 12 on the ticketing machine has a display panel 44 which displays the contents of the identity part of the message, for

- 12 -

example, the name of the user or vendee once the transmission is complete. This vendee can check that transmission has occurred and all validity checks made by reading the contents of display panel 44, as shown in step 4 of Fig. 6. Assuming that the vendee is the owner of the transmitter, only he knows the detail of the identity part of the message and knows the correct code to key in. If, in fact, the vendee is not the owner of the transmitter, then only access to sophisticated electronic equipment would be required to interrogate the transmitter to enable misuse of the transmitter. Although this is, in theory, possible it is most unlikely that this facility would be available to criminals to carry out widespread fraud and the security achieved is far superior to that of comparing signatures.

Reference is now made to Figs, 2, 4 and 7 of the accompanying drawings which describe a further embodiment of the invention. The transmitter 10a shown in Fig. 2 is similar to that shown in Fig. 1 in which like numerals denote like parts, but with the suffix 'a' added and which includes a facility for using the transmitter 10a with more than one credit card. This is achieved by providing a set of card select buttons 50, each of which can be selected by the user (step 2a, Fig. 7) in order to designate a particular transaction to a particular credit card. In this case, the individual owns several credit cards and wishes to have one transmitter to operate on

- 13 -

behalf of all of the credit cards. Each card select button allows the operator to select the credit card which he wishes to use to complete the transaction. As shown in Fig. 4, the switches 50 are coupled to the PROM 20a and to the other components which contain the details appropriate to the card selected. Once the particular button has been depressed, the operation of the device is identical to that described with reference to Fig. 1.

The device can be used for low value transactions such as paying parking charges, ticketing for metros and the like and as security codes are regularly updated any loss and unauthorised use is likely to be insignificant. Moreover, the transaction is likely to be fully mechanised for the vendor. Reference is now made to Fig. 5 of the accompanying drawings which are for a transmitter of generally similar size and shape to the transmitter 10 shown in Fig. 1 except that it does not have a key-pad. The circuit elements in Fig. 5 are referred to by like numerals, but by suffix 'b' added and operate in the same way. From Fig. 5 it will be seen that the basic operation is similar to the transmitter of Fig. 1 except that a PIN number is not employed. Moreover, the transmitted word would be a unique number and correlated to the user's identity by the software contained in the receiving apparatus. An example of how this circuit might be implemented is shown in Fig. 9. It comprises electronic elements where each and every one form part of

- 14 -

the industry standard. ICs 1A and B might be a 74ALS14 or any suitable package containing 6 Schmitt trigger invertors; IC 2 is a 22V10 or any similar Programmable Array Logic configured to drive IC 3, an NMC9306, a 512-bit programmable serial read only memory. The resistors and capacitors are 1/4 watt, 5 percent tolerance components; a nominal 6 volt battery is employed. The light emitting diode D1 is similar to those used in television channel changers. The user's credit card number and the encryption element are fused in IC 3. These data are configured in an auto-clocking code, a 3 from 9 code being an example, ready for transmission. Implementation might also employ micro-processors/micro-controllers to reduce the component count within the transmitter. There are many such devices available, an example being COP8720C, or a COP424C with an accompanying NMC9306.

The receiver might be configured round a bar-code reader. One example is the Hewlett-Packard HBCR8500 which contains all the necessary electronics to convert the data from the transmitter to ASCII, an international standard compatible with the majority of peripherals and swipe card machines.

Reference is now made to Figs. 5 and 8 of the accompanying drawings which are for a transmitter generally similar in size and shape to the transmitter 10 shown in Fig. 1 except that it does not have a keypad.

- 15 -

The circuit elements in Fig. 5 are referred to by like numerals, but with the suffix 'b' added and operate in the same way. From Figs. 5 and 8 it will be seen that the basic operation is similar to the transmitter of Fig. 1 except that a PIN number is not entered, that is, step 3 is omitted. This device can be used for low value transactions such as paying parking charges, paying tolls and the like and as the security codes are regularly updated any loss and unauthorised use is likely to be insignificant.

It will be appreciated that various modifications may be made to the embodiments hereinbefore described without departing from the scope of the invention. For example, two chips may be combined in a transmitter; one chip containing the user's credit information, PIN number and the like, and a second chip containing an encryption algorithm so that the data transmitted is encrypted for more secure communications. Each receiver would have a corresponding chip with a decryption algorithm so that the transmitted information can be decoded and validation completed by the local system. The size and shape of the transmitter may be varied and, in fact, depending on manufacturing technology, the transmitter may be credit card shaped to fit in a wallet or the like. The transmitter on such a credit card shape could also contain a keycard and credit card selector keys. The device and system could be used other than for financial

- 16 -

transactions; it could be used to control entry or access to secure areas and the like, with the user's code (PIN) being verified at a local or central location.

The communication medium could be radio frequency (r.f.) sound or ultrasound suitable for carrying the necessary information to initiate a transaction, although it is believed that infra-red is the most suitable. A further modification is the addition of r.f. circuits to the transmitter and receiver so that the user is able to complete transactions remotely, in a similar manner to the operation of cardless cellular telephones. Thus, cinema theatre tickets and the like, could be ordered using the transmitter, and shopping could be done remotely with the receiver processing the order and automatically debiting the user's account.

The principal advantage of the invention is that it improves the security of cashless transactions and allows the transactions to be completed in a non-contacting fashion. Furthermore, it provides a more secure method of checking identity of the user without requiring signatures. In addition, a single transmitter can be used to complete transactions for various cards and the transactions can be performed for purchasing any type of goods or service, parking tickets, paying tolls and the like which is not hitherto been possible with existing credit cards.



CLAIMS

1. A non-contacting transaction system comprising,  
transmitter means having a memory for storage of data identifying the user therein, and a transmitter for transmitting the stored data to a remote location upon actuation of the transmitter means by the user, and  
receiver means for receiving the transmitted data and also having indicator means for indicating that the data transmitted is received and that the transaction can proceed.
2. A system as claimed in claim 1 wherein the transmitter means includes a keypad for the user to insert details of a PIN number.
3. A system as claimed in claim 1 or claim 2 wherein the non-contacting transaction system is a car-park ticketing system.
4. A system as claimed in any preceding claim wherein the transmitter includes a switch actuatable by the user which results in the stored data being continually transmitted or transmitted in bursts during the transmitting actuation.
5. A system as claimed in any preceding claim wherein the receiver or local system is coupled to a modem or the like over the telephone network to a central data processing and storage unit where details of the transactions are allocated to the user's account for

subsequent billing.

6. A system as claimed in any one of claims 1 to 4 wherein the receiver or local system includes disk storage means or other suitable mass storage means for storing validated transactions for subsequent despatching of the stored transaction data to the central data processing and storage unit at a later date.

7. A system as claimed in any preceding claim wherein said receiver means includes a display for displaying to the vendee his PIN in the transmitted information.

8. A system as claimed in any preceding claim wherein said the receiver means includes parity and code check means for rectifying the correctness of the received code prior to passing it to the modem.

9. A transmitter for use in a non-contacting transaction system, said transmitter comprising a memory for storing data identifying the user, a transmitter coupled to the memory for wireless transmission of said stored data to a remote location, and switch means actuatable by the user for causing said stored data to be transmitted.

10. A transmitter as claimed in claim 9 wherein the transmitter includes a keypad for the user to insert details of a personal identification number (PIN), and said data being transmitted only if the correct PIN number is keyed in.

11. A transmitter as claimed in claim 10 wherein the transmitter includes a plurality of keys representative of

- 19 -

different user accounts and the user can nominate which account a transaction is to be attributed to by selecting the appropriate key.

12. A transmitter as claimed in claim 9, 10 or 11 wherein the transmitter is an infra-red transmitter.

13. A transmitter as claimed in claim 9, 10 or 11 wherein the transmitter includes a remote telephone console interfaced to said memory and keys to enable a user to remotely conduct a transaction using radio frequency communications or any part of the electro-magnetic spectrum for communications.

14. A receiver for use in a non-contacting transaction system, said receiver comprising a data receiver for receiving a wireless transmission, means for indicating that the data has been received, means for processing the received data for display, means for verifying the correctness of the data received, and display means for displaying to a vendor details of the user stored in said transmitter.

15. A receiver as claimed in claim 14 wherein the receiver is a car-park ticketing machine.

16. A receiver as claimed in claim 14 or claim 15 wherein the non-contacting transaction system is coupled to the elements which combined comprise a card swipe machine.

17. A receiver as claimed in claim 16 wherein the receiver and/or card swipe machine are coupled to a cellular telephone network for receiving said data by

- 20 -

radio frequency communication.

18. A receiver as claimed in any preceding claim wherein the receiver is coupled by a modem or the like over the telephone network to a central data processing and storage unit where details of the transactions are allocated to the user's account for subsequent billing.

19. A receiver as claimed in one of claims 15 to 17 wherein the receiver includes disk storage means, or random access memory (RAM) or other suitable storage means for storing validated transactions for subsequent despatching of the stored transaction data to the central data processing and storage unit at a later date.

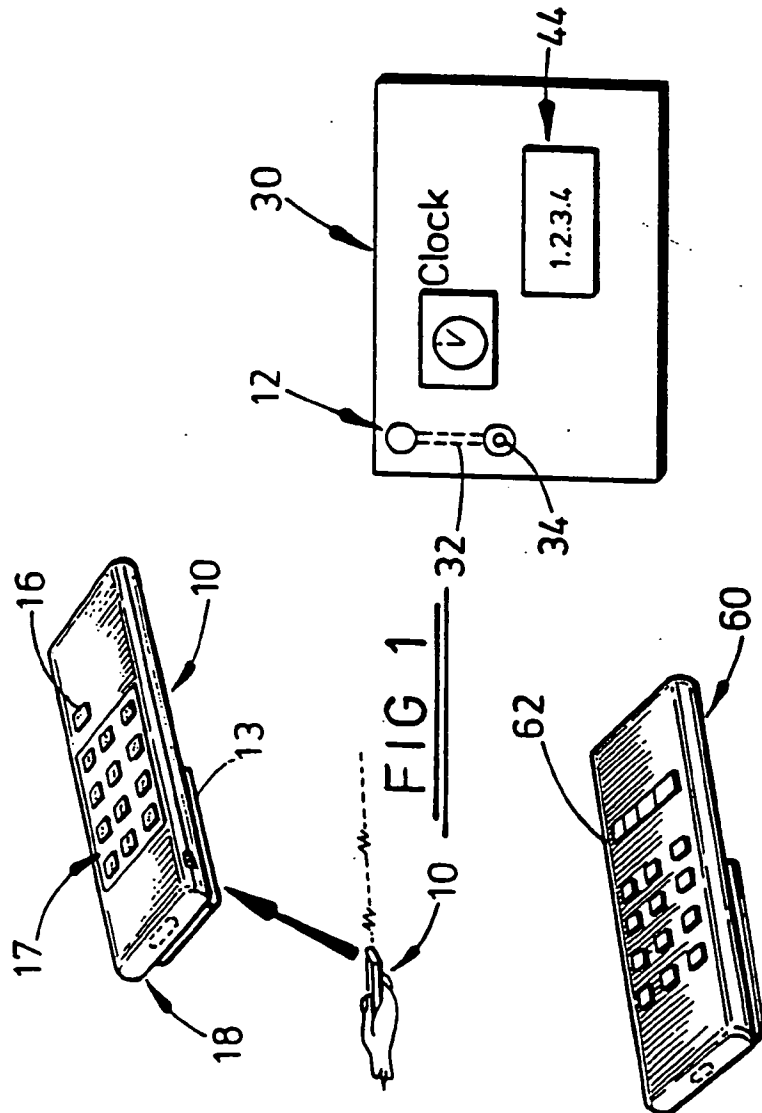


FIG 1

FIG.2

**SUBSTITUTE SHEET**

217

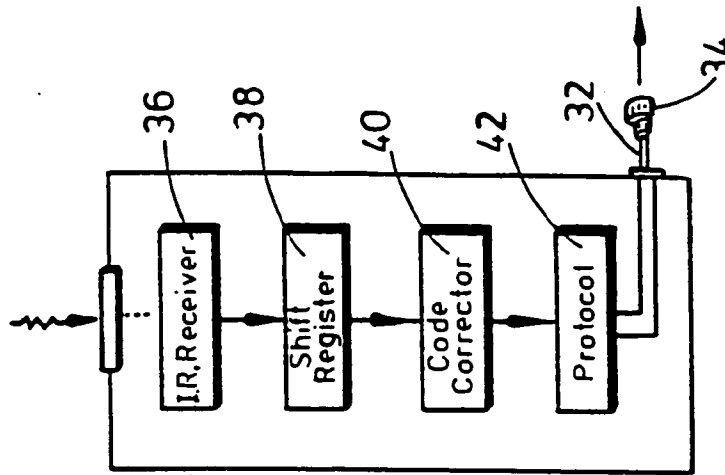


FIG 3b

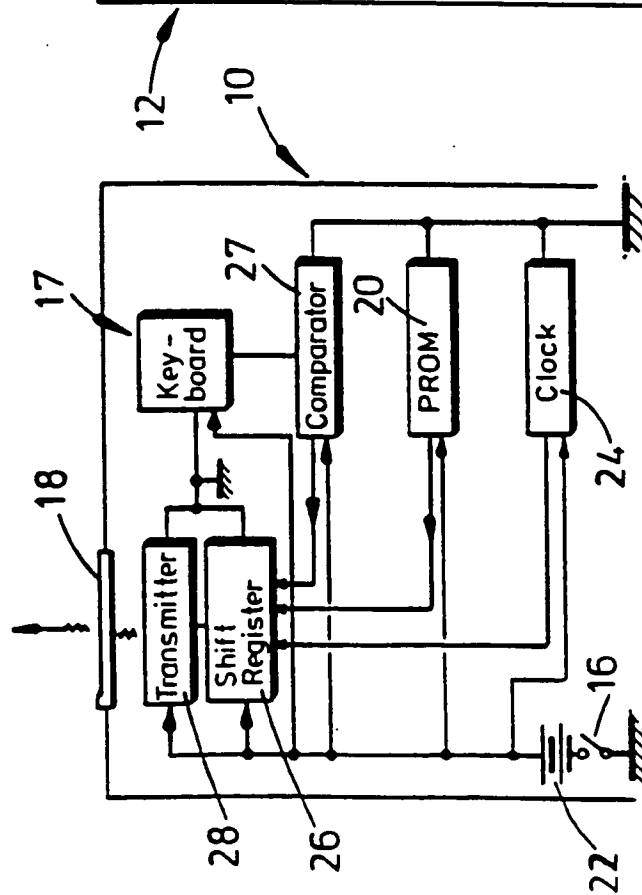


FIG. 3a

**SUBSTITUTE SHEET**

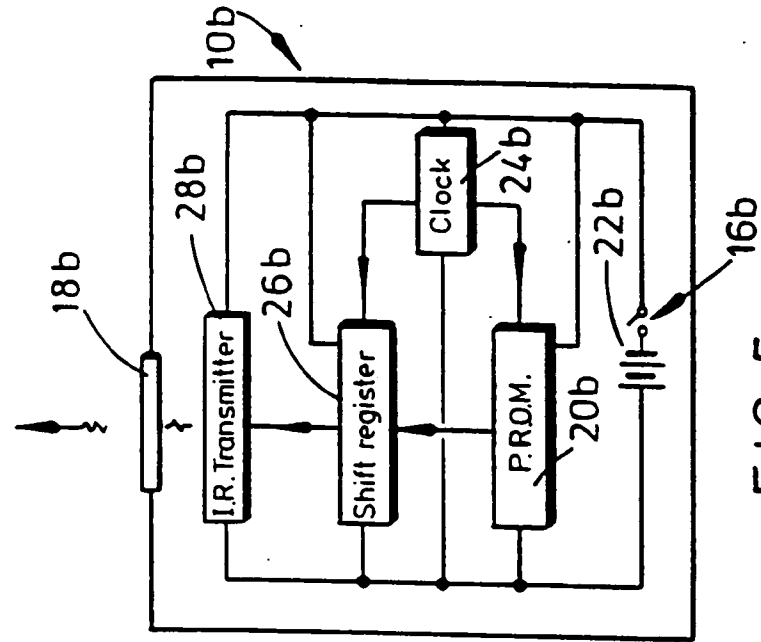


FIG. 5

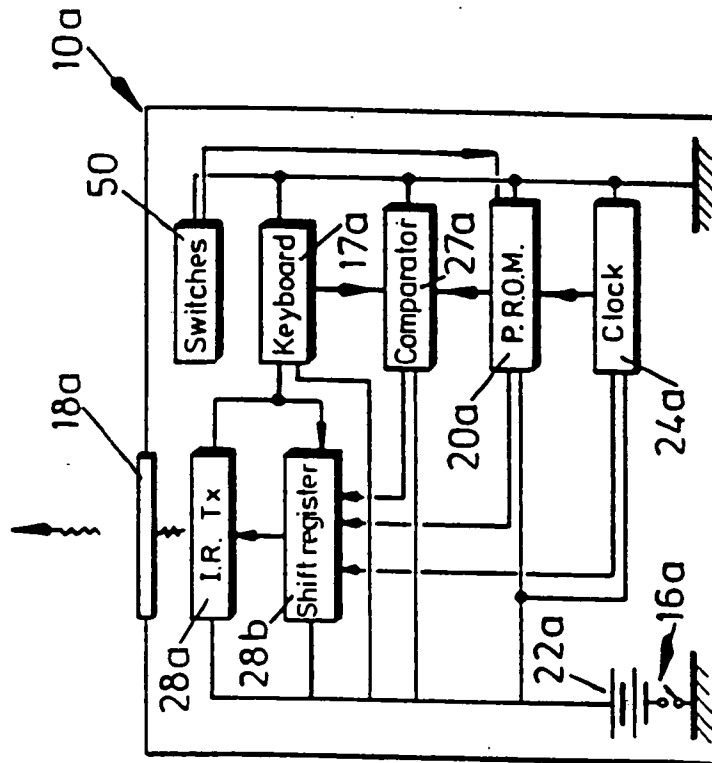


FIG. 4

SUBSTITUTE SHEET

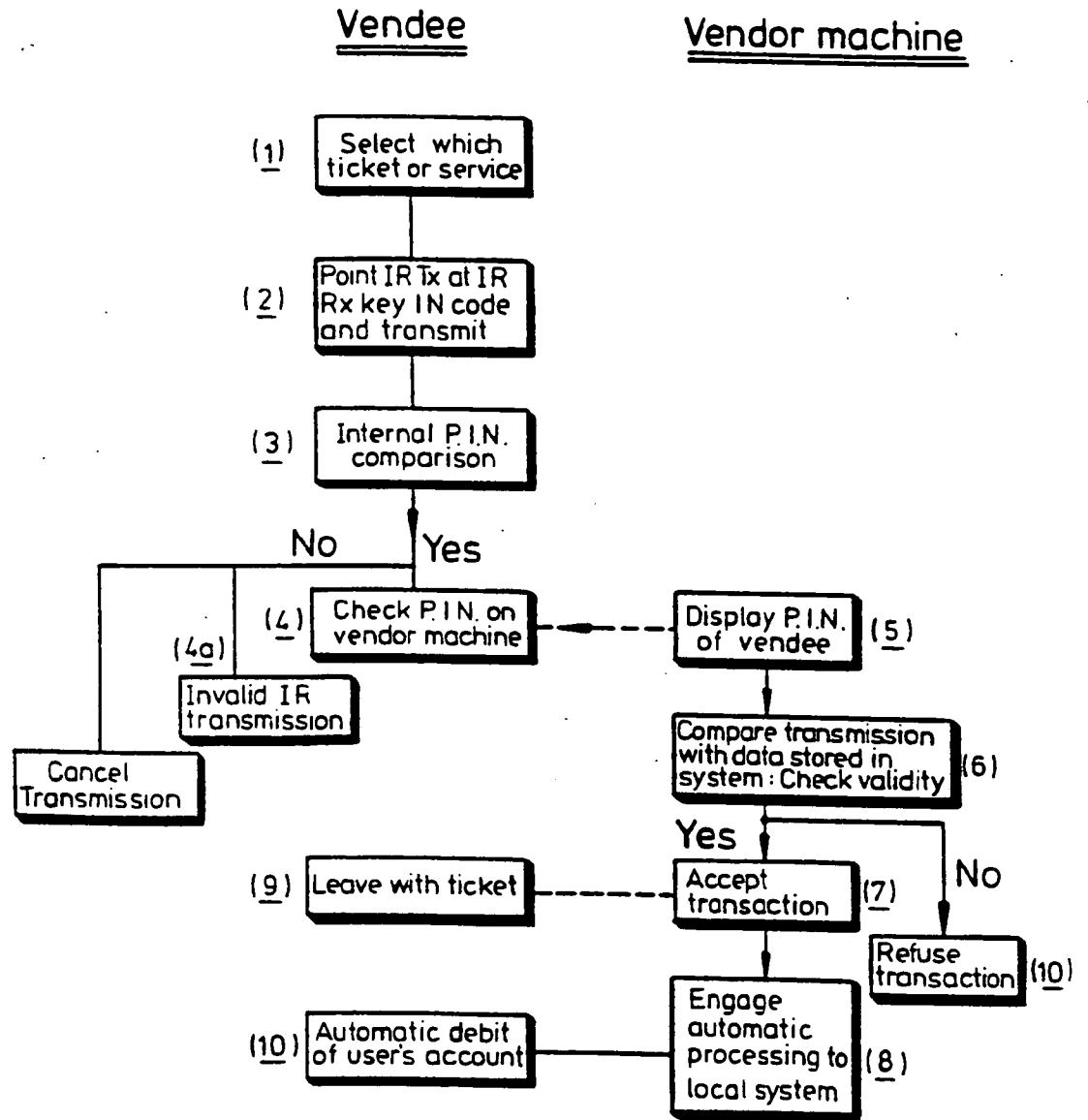


FIG. 6



5 / 7

Vendee

Vendor machine

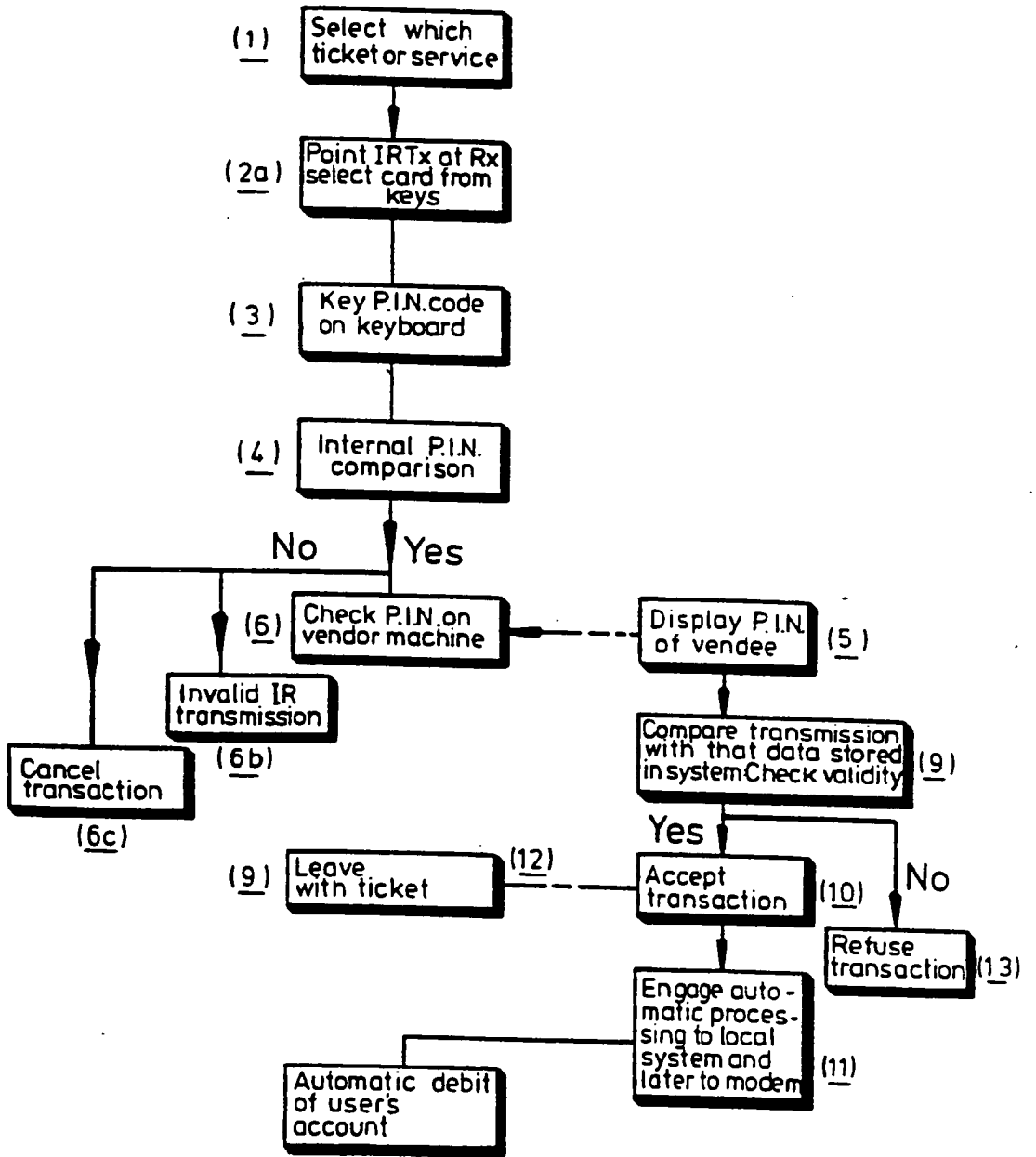


FIG. 7

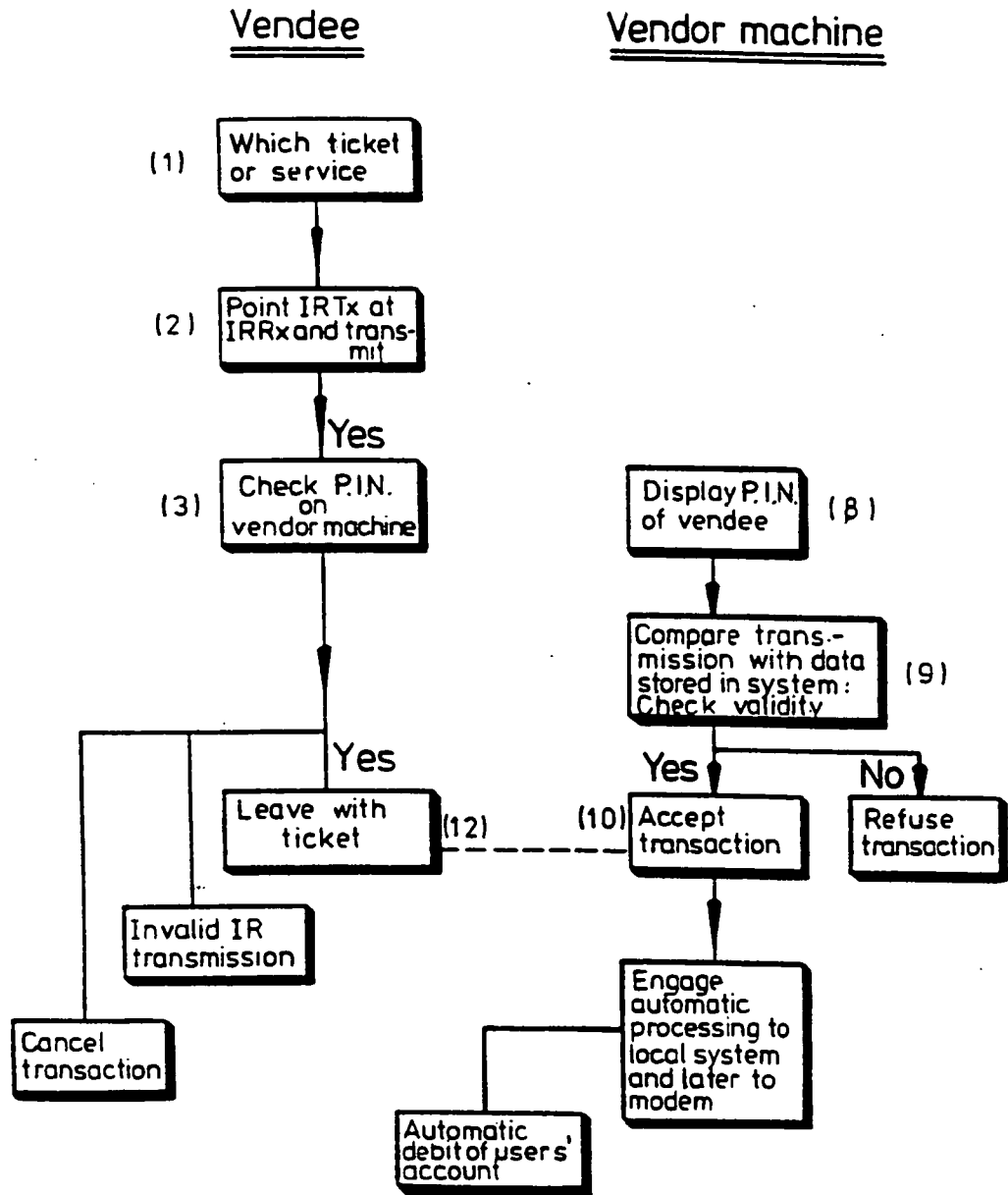


FIG. 8

**SUBSTITUTE SHEET**

717

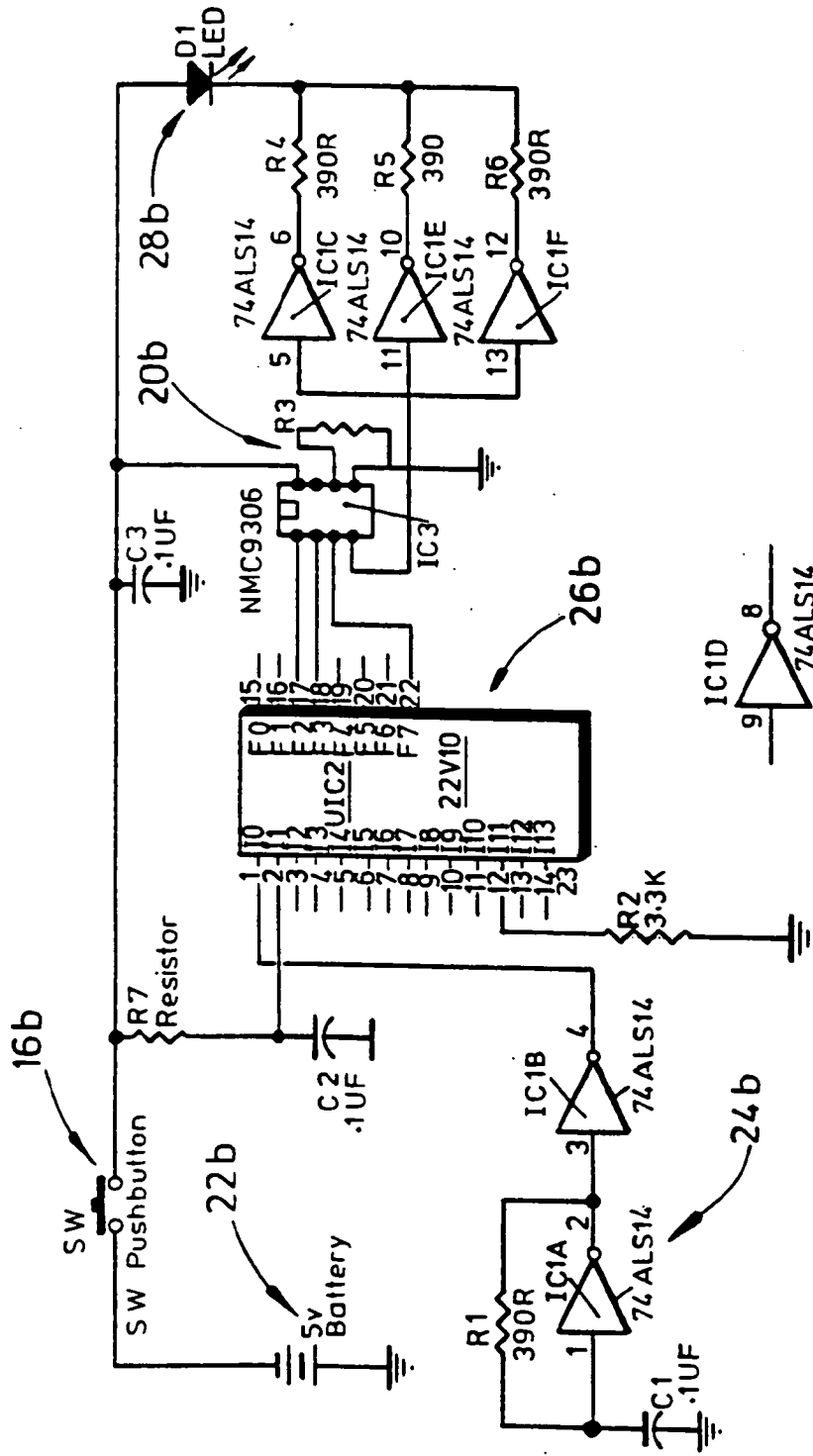


FIG. 9

SUBSTITUTE SHEET

**INTERNATIONAL SEARCH REPORT**

International Application No

PCT/GB 93/01526

<b>I. CLASSIFICATION OF SUBJECT MATTER</b> (if several classification symbols apply, indicate all) <sup>6</sup>		
According to International Patent Classification (IPC) or to both National Classification and IPC		
Int.Cl. 5 G06K7/00; G06K17/00		
<b>II. FIELDS SEARCHED</b>		
Minimum Documentation Searched <sup>7</sup>		
Classification Systems	Classification Symbols	
Int.Cl. 5	G06K	
Documentation Searched other than Minimum Documentation to the Extent that such Documents are Included in the Fields Searched <sup>8</sup>		
<b>III. DOCUMENTS CONSIDERED TO BE RELEVANT<sup>9</sup></b>		
Category <sup>10</sup>	Citation of Document, <sup>11</sup> with indication, where appropriate, of the relevant passages <sup>12</sup>	Relevant to Claim No. <sup>13</sup>
X	US,A,4 277 837 (STUCKERT,P.E) 7 July 1981  see column 1, line 51 - line 61 see column 1, line 66 - line 68 see column 2, line 1 - line 3 see column 3, line 12 - line 16 see column 3, line 28 - line 32 see column 9, line 65 - line 68 see column 10, line 1 - line 11 see column 14, line 67 - line 68 see column 15, line 1 - line 12 see claim 1	1,2,5, 8-10,13, 18
A	---	-/--  15
<p><sup>10</sup> Special categories of cited documents :<sup>10</sup></p> <p>"A" document defining the general state of the art which is not considered to be of particular relevance</p> <p>"E" earlier document but published on or after the international filing date</p> <p>"L" document which may throw doubts on priority claim(s) or which is cited to establish the publication date of another citation or other special reason (as specified)</p> <p>"O" document referring to an oral disclosure, use, exhibition or other means</p> <p>"P" document published prior to the international filing date but later than the priority date claimed</p> <p>"T" later document published after the international filing date or priority date and not in conflict with the application but cited to understand the principle or theory underlying the invention</p> <p>"X" document of particular relevance; the claimed invention cannot be considered novel or cannot be considered to involve an inventive step</p> <p>"Y" document of particular relevance; the claimed invention cannot be considered to involve an inventive step when the document is combined with one or more other such documents, such combination being obvious to a person skilled in the art.</p> <p>"Δ" document member of the same patent family</p>		
<b>IV. CERTIFICATION</b>		
Date of the Actual Completion of the International Search	Date of Mailing of this International Search Report	
05 OCTOBER 1993	12. 10. 93	
International Searching Authority	Signature of Authorized Officer	
EUROPEAN PATENT OFFICE	HERSKOVIC M.	

Form PCT/ISA/210 (second sheet) (January 1983)

IPL DOCUMENTS CONSIDERED TO BE RELEVANT (CONTINUED FROM THE SECOND SHEET)		
Category *	Citation of Document, with indication, where appropriate, of the relevant passages	Relevant to Claims No.
X	WO,A,8 603 869 (NCR CORP.) 3 July 1986  see page 1 see page 6 see page 7 see claims 1,2,4,7,8 ---	1,2,5, 9-12,14, 18
A	US,A,4 800 543 (LYNDON-JAMES,R. ET AL) 24 January 1989 see the whole document ---	1,2,4, 11,12,14
A	US,A,4 639 583 (ZEROWIN,J.H.) 27 January 1987 see the whole document -----	6,19

**ANNEX TO THE INTERNATIONAL SEARCH REPORT  
ON INTERNATIONAL PATENT APPLICATION NO.**

GB 9301526  
SA 77021

This annex lists the patent family members relating to the patent documents cited in the above-mentioned international search report. The members are as contained in the European Patent Office EDP file on  
The European Patent Office is in no way liable for these particulars which are merely given for the purpose of information. 05/10/93

Patent document cited in search report	Publication date	Patent family member(s)	Publication date
US-A-4277837	07-07-81	CA-A- 1111567	27-10-81
		DE-A, C 2852941	05-07-79
		FR-A, B 2413721	27-07-79
		GB-A, B 2011671	11-07-79
		JP-C- 1220759	26-07-84
		JP-A- 54094855	26-07-79
		JP-B- 58053784	01-12-83
		NL-A- 7812390	03-07-79
		SE-A- 7812924	01-07-79
WO-A-8603869	03-07-86	US-A- 4634845	06-01-87
		US-A- 4689478	25-08-87
		CA-A- 1240068	02-08-88
		EP-A, B 0207125	07-01-87
		JP-T- 62501239	14-05-87
		CA-A, C 1253626	02-05-89
US-A-4800543	24-01-89	AU-A- 2645188	08-06-89
		EP-A- 0319297	07-06-89
		JP-A- 2002974	08-01-90
US-A-4639583	27-01-87	None	

EPO FORM P0479

For more details about this annex : see Official Journal of the European Patent Office, No. 12/82



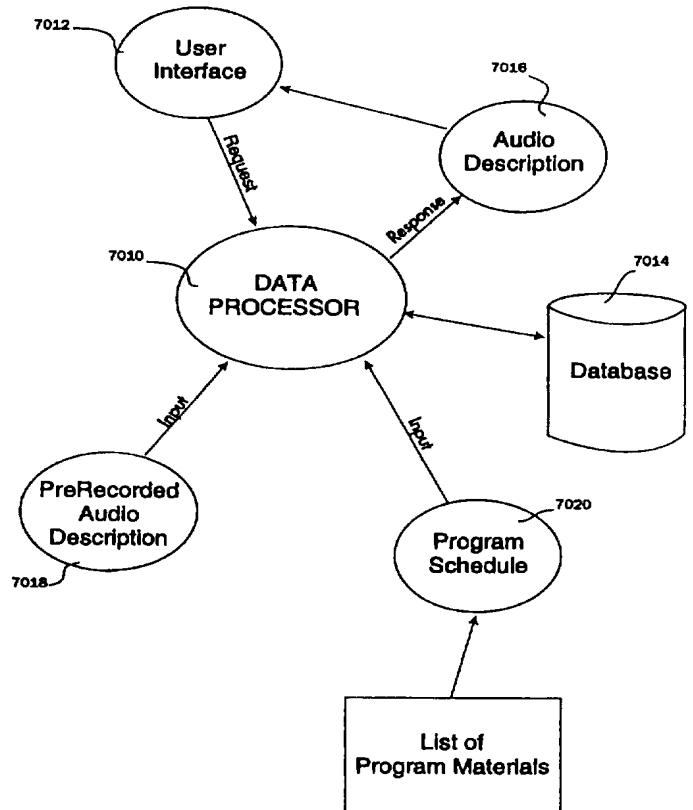
INTERNATIONAL APPLICATION PUBLISHED UNDER THE PATENT COOPERATION TREATY (PCT)

<p>(51) International Patent Classification <sup>6</sup> : <b>H04L</b></p>	<p><b>A2</b></p>	<p>(11) International Publication Number: <b>WO 97/21291</b> (43) International Publication Date: 12 June 1997 (12.06.97)</p>
<p>(21) International Application Number: PCT/CA96/00794 (22) International Filing Date: 2 December 1996 (02.12.96) (30) Priority Data: 2,164,231 1 December 1995 (01.12.95) CA (71)(72) Applicant and Inventor: POCOCK, Michael [CA/CA]; 485 Queens Avenue, London, Ontario N6B 1Y3 (CA).</p>		<p>(81) Designated States: AU, BR, JP, MX, US, Eurasian patent (AM, AZ, BY, KG, KZ, MD, RU, TJ, TM), European patent (AT, BE, CH, DE, DK, ES, FI, FR, GB, GR, IE, IT, LU, MC, NL, PT, SE). <b>Published</b> <i>Without international search report and to be republished upon receipt of that report.</i></p>

(54) Title: A SYSTEM FOR ON-DEMAND REMOTE ACCESS TO A SELF-GENERATING AUDIO RECORDING, STORAGE, INDEXING AND TRANSACTION SYSTEM

(57) Abstract

The system allows radio broadcast listeners to use a telephone to connect to a database that contains prerecorded audio descriptions (e.g. spoken text and/or music) of material played by the radio station. The database is indexed by the radio station's program schedule or play-list to allow the user to select a particular audio description of interest (e.g. the song currently airing, the song last played, etc.). Hearing the audio description over the telephone ensures the listener that the requested selection is in fact correct. By using the telephone DTMF touch tone controls, the listener can place an order to purchase the selected material over the telephone.



**FOR THE PURPOSES OF INFORMATION ONLY**

Codes used to identify States party to the PCT on the front pages of pamphlets publishing international applications under the PCT.

<b>AM</b>	Armenia	<b>GB</b>	United Kingdom	<b>MW</b>	Malawi
<b>AT</b>	Austria	<b>GE</b>	Georgia	<b>MX</b>	Mexico
<b>AU</b>	Australia	<b>GN</b>	Guinea	<b>NE</b>	Niger
<b>BB</b>	Barbados	<b>GR</b>	Greece	<b>NL</b>	Netherlands
<b>BE</b>	Belgium	<b>HU</b>	Hungary	<b>NO</b>	Norway
<b>BF</b>	Burkina Faso	<b>IE</b>	Ireland	<b>NZ</b>	New Zealand
<b>BG</b>	Bulgaria	<b>IT</b>	Italy	<b>PL</b>	Poland
<b>BJ</b>	Benin	<b>JP</b>	Japan	<b>PT</b>	Portugal
<b>BR</b>	Brazil	<b>KE</b>	Kenya	<b>RO</b>	Romania
<b>BY</b>	Belarus	<b>KG</b>	Kyrgyzstan	<b>RU</b>	Russian Federation
<b>CA</b>	Canada	<b>KP</b>	Democratic People's Republic of Korea	<b>SD</b>	Sudan
<b>CF</b>	Central African Republic	<b>KR</b>	Republic of Korea	<b>SE</b>	Sweden
<b>CG</b>	Congo	<b>KZ</b>	Kazakhstan	<b>SG</b>	Singapore
<b>CH</b>	Switzerland	<b>LI</b>	Liechtenstein	<b>SI</b>	Slovenia
<b>CI</b>	Côte d'Ivoire	<b>LK</b>	Sri Lanka	<b>SK</b>	Slovakia
<b>CM</b>	Cameroon	<b>LR</b>	Liberia	<b>SN</b>	Senegal
<b>CN</b>	China	<b>LT</b>	Lithuania	<b>SZ</b>	Swaziland
<b>CS</b>	Czechoslovakia	<b>LU</b>	Luxembourg	<b>TD</b>	Chad
<b>CZ</b>	Czech Republic	<b>LV</b>	Larvia	<b>TG</b>	Togo
<b>DE</b>	Germany	<b>MC</b>	Monaco	<b>TJ</b>	Tajikistan
<b>DK</b>	Denmark	<b>MD</b>	Republic of Moldova	<b>TT</b>	Trinidad and Tobago
<b>EE</b>	Estonia	<b>MG</b>	Madagascar	<b>UA</b>	Ukraine
<b>ES</b>	Spain	<b>ML</b>	Mali	<b>UG</b>	Uganda
<b>FI</b>	Finland	<b>MN</b>	Mongolia	<b>US</b>	United States of America
<b>FR</b>	France	<b>MR</b>	Mauritania	<b>UZ</b>	Uzbekistan
<b>GA</b>	Gabon			<b>VN</b>	Viet Nam



**A SYSTEM FOR ON-DEMAND REMOTE ACCESS  
TO A SELF-GENERATING AUDIO RECORDING,  
STORAGE, INDEXING AND TRANSACTION SYSTEM**

**Technical Field**

The present invention relates generally to a method and apparatus to enable a broadcast listener to automatically purchase a music product such as a record album, cassette tape or compact disk without the intervention of an operator after hearing a music piece played on a radio station or music television station. More specifically, the preferred embodiment of the invention utilizes a programmed data processor, a digitally stored audio database containing the names of musical artists and groups, the names of pieces which have been recorded on the musical products, musical excerpts of these pieces, and a telephone system to replay this descriptive information through a telephone connection to a potential purchaser. This method utilizes the program schedule from a local radio station indicating when pieces will be played, a digital recording facility to automatically record excerpts of the music pieces played, a telephone system to decode DTMF tones from a touch tone telephone and an interface to a data communications network for communication with remote databases and computers.

**Background Art**

Radio networks offer the most significant marketing medium for the music industry to create awareness for music titles and artists. But music products such as records, cassettes and compact disks (CDs) are inconvenient to purchase at the time when the consumer has the maximum impulse to buy, after hearing a musical piece on the radio.

Additionally, the inability to automate many of the key functions of a radio based, direct marketing sales operation make it cost prohibitive for a single radio station to establish a direct marketing service linked to the music they broadcast. Station operators offer different programming in each market area making it unsuitable to link their stations into a national music retail network. As well, regulatory limitations curtail the number of stations a radio operator can own in a major market thereby limiting the number of listeners below the critical mass necessary to operate a profitable direct marketing music business.

Radio broadcasters provide no means to fulfil the impulse purchase nature of the radio business. When a radio listener hears a music piece they wish to purchase they must listen for, and remember, the artists name and title of the song. In many instances it is inconvenient to write this information down for future reference. In order to purchase the music product containing the song heard on the radio the consumer must be further motivated to travel to a music store to proceed with the purchase process. At the music store the

potential purchaser must determine if the selected music product is in stock and assess the pricing information.

The consumer is further constrained because they are unable to preview the songs on the music product they are considering because the music products are packaged and cannot be played at the store. The potential purchaser must remember and continue to be motivated by the music piece heard on the radio broadcast, possibly from days ago, and hope the other pieces recorded on the album are of sufficient interest to justify the purchase. The inconvenience and inability to sustain the impulse impetus severely impacts the purchase process.

Radio networks are unable to capitalize on the direct marketing opportunities they initiate through impulse music purchases because of the high cost of creating a direct marketing operation. Coordinating and tracking the music aired with the music products to be sold, recording of musical excerpts to be previewed, customer service operations and order fulfilment are all high overhead activities requiring a large dedicated staff with a separate skill set than radio station personnel. The cost for a radio station to establish a direct marketing operation far exceeds the returns from the music selling proceeds derived from a single radio station.

Cable television shopping networks have successfully developed large direct marketing networks based on national coverage by telecasting their programming over many cable companies reaching millions of potential purchasers.

Radio station operators are unable to market music products in the same manner because station operators broadcast different music programming in each market preventing the linking of these stations into a common national market.

Radio is the most widely received broadcast medium throughout the world. The problems as previously described have prevented radio networks from being utilized for a mass media, direct marketing, music retail business.

### Disclosure of Invention

In view of the foregoing, one objective of this invention is to resolve the problems which inhibit the successful development of a direct marketing music business for the radio industry. In this regard, it should be apparent that there exists a need in the art for a method of operating an automated system which tracks radio audio segments enabling radio broadcast listeners to select, preview and purchase a music product containing the music piece listened to for a radio broadcast.

It is therefore an object of this invention to provide an automated transaction system to record and track radio audio segments enabling a radio listener to use their telephone to recall and preview, on-demand, music pieces previously broadcast thereby assisting the listener in the purchase of a music product such as a record album, cassette or CD. The invention provides the

consumer with a timely method to purchase a musical product by supplying all of the required information to conveniently make a music product purchase.

It is another object of the invention to provide a method for an automated transaction system to service multiple radio broadcasts simultaneously, thereby creating a mass radio audience for the direct marketing of music.

These and other objects are achieved by a method of and apparatus for tracking and recording a radio broadcast using a telephone interface connected to a programmed data processor such that when a potential purchaser calls a designated telephone number advertised by the radio station, for example 1-800-RECORDS, a telephone interface provides the listener with the name of the musical artist and the song titles in the reverse order played during the broadcast, starting with the current piece played. The selection, from the current artist played, to the music product the potential purchaser wants to order, is controlled by the potential purchaser using the touch tone telephone keys or voice input. When the potential purchaser reaches the song and artist of interest, further details can be related such as the other songs recorded on the album, pricing, availability and delivery information.

The invention can playback through the telephone, on instructions from the caller, excerpts or the entire song, as broadcast over the radio network, to assist the caller with the purchasing process.

When the potential purchaser indicates they are ready to order, the automated order system obtains the correct name and shipping address by accessing a name and address database responsive to the consumers telephone number or credit card information. The system also records the consumer's credit card information and obtains credit authorization. The invention then transmits the complete order to the fulfilment warehouse for shipment of the musical product to the purchaser.

It is a further object of this invention to provide a method and apparatus whereby multiple radio stations can be supported simultaneously, offering services on a local, regional or national basis providing the economies of scale and mass audience to support the sales volume necessary to operate a profitable direct marketing service. When a potential purchaser dials the advertised number such as 1-800-RECORDS they are directed by audio prompts to indicate by touch tone entry or voice input the call letters for the radio station to which they are listening. The audio prompts are provided by a telephone interface that is connected to a programmed data processor which performs database functions. The potential purchaser's telephone number, input by the caller or supplied by the telephone company's (ANI) Automatic Number Identification service, is compared to all the radio station broadcast coverage zones offered by the participating radio stations. This comparison determines the radio stations within the broadcast range of the caller, providing a limited set of radio stations for the programmed data processor to sort and search based on the callers input of the station call letters. The input of the station call letters enables the programmed data processor to select the correct station

program schedule and related information. Thus a large number of radio stations, dispersed locally, regionally, nationally and internationally can be supported by one automated system.

The inventive method also includes the step of efficiently selecting the correct radio station based on touch tone input. Although, each of the telephone keys 2 through 9 have three related alphabetical characters, callers need only to input four telephone key strokes for the four station call letters. The programmed data processor only recognizes the input for the participating radio stations broadcasting in the callers area as determined by the telephone number and broadcast coverage comparison previously described.

It is a further object of this invention to automate the manual and time-consuming functions. The inputting of the radio station play schedule in advance of the broadcast as well as the tracking of the program schedule during the broadcast day requires significant overhead if undertaken manually. As the service expands, and many radio stations are added to the service, the tracking of the various program schedules becomes unmanageable from a manual standpoint.

One component of the method and apparatus of the invention is a system for management of the radio station's program schedule. A radio station's program schedule is produced days and sometimes weeks in advance of broadcast. The program schedule is organized chronologically in the order musical pieces are broadcast and includes information such as the title of the song, the recording artist and group, as well as the day and time the piece is to be broadcast. A radio station broadcasts hundreds of musical pieces each day and the input of the program schedule by an operator is both time-consuming and prone to manual input error. The present invention enables the automation of the program schedule input by utilizing a data communications link and a communications interface such as a facsimile interface to receive the program schedule directly from the radio station into the programmed data processor. The communication interface such as a facsimile board is resident in the programmed data processor and in conjunction with a imaging software, such as a character recognition package, automatically interprets and directly stores the stations program schedule and associated information on a programmed data processor.

The radio station program schedule contains timetable information as well as information describing the music pieces played such as the title, artist and group name. The program schedule is accessed by a audio description creation system which is connected to the programmed data processor. The audio description creation system creates the audio description heard by the caller over the telephone when inquiring about a particular music piece. The audio description information describes the music piece outlined in the program schedule and the music product containing the music piece, along with other related information such as product pricing. The audio description creation system digitally records the audio and is connected to various input devices such as a compact disc player, cassette player, digital audio tape and a microphone. An announcer accesses the program schedule file on a display screen

and reads the description information into the microphone creating the audio description file for each music piece. The announcer has access to previous recordings stored in an audio description archive which can be accessed via a data input terminal connected to the audio description creation system enabling previously recorded audio descriptions to be referenced.

It is another object of the invention to automate the recording and storing of the music excerpts for the music pieces outline in the program schedule. These audio segments can be accessed by the potential purchaser to assist in the purchase process and to verify to the caller they are purchasing the music product containing the music piece listened to during the radio broadcast. The automated record and store process is accomplished by inserting a signal such as a tone or pulse at the beginning of each music piece broadcast. A receiver is tuned to the broadcast containing the music pieces to be recorded and a signal detector triggers the digital recording of the piece by the programmed data processor. The music piece is recorded for a specified time such as ten seconds providing an audio segment of the music piece.

Coordination of the audio description file with the program schedule is accomplished through a synchronized time schedule whereby the program schedule file and the recording of the audio segments on the programmed data processor are initiated at the same time. Each station's program schedule is stored in chronological order enabling the coordination. Another method of implementing the signal insertion enables information to be encoded as part of the selection signal and decoded into data for use by a programmed data processor. Information such as the program schedule number or music piece number can be incorporated into the selection signal enabling the coordination of the audio description with the program schedule. Information can be encoded into the selection signal through means such as multiple pulses or combination of tones and pulses.

The invention also provides the information for a potential purchaser to automatically order a music product without having heard one of the pieces through a radio broadcast. For instance when the potential purchaser dials the telephone number a telephone system audibly requests the potential purchaser to touch 1 on their touch tone telephone if they want to order a music piece they have just heard played on the radio, or touch 2 if they want to order a music product from the automated music catalogue. If the potential purchaser touches 2 the invention will then proceed to determine the musical product to be ordered by asking the potential purchaser to select the type of music and to input the artists name or group name using the touch tone telephone keys. Once the correct artist or group is determined the system can reference all the music products performed by that artist or group and provide the potential purchaser with the names of the music album and the recording media available such as CD, record or cassette along with pricing. Further information can also be made available such as the names of the pieces of each piece recorded on each music product along with excerpts to preview each song. The invention conveniently

provides all the information required to make a purchase. Some of this information is not available even at the record store.

When the potential purchaser indicates they wish to buy a particular music product the system determines the shipping address and credit authorization and then places the order for the music product with the fulfilment warehouse.

In the case where more than one main artist or group performed on a music product or the purchase process was too complex, the potential purchaser can be bridged to an operator who can obtain and input any required data and assist the caller through the purchase process.

The invention can also be utilized with other broadcast services such as a music television telecast. Viewers of music television program or channel, access the invention in the same manner as previously described but enter the station designation such as call letters, channel number or advertised pseudo-name enabling the invention to recall the pertinent program schedule relating to the viewed television program or channel. The audio portion of the music broadcast, would be recorded and utilized to assist the viewer in the purchasing process. The invention can simultaneously support orders originating from both radio listeners and television viewers.

Other applications of the invention are also possible. The broadcast can consist of content other than music whereby products are advertised within a broadcast and the invention enables listeners to select, preview and purchase items advertised for sale over the network. The audio segments for these products would be recorded in the same manner as previously described for the music pieces and the products would match the program schedule as input prior to the broadcast.

The invention also extends to a digital as well as analog broadcast format whereby the selection signals are digital signals inserted into a digital broadcast.

The foregoing features of the invention, as well as the advantages provided thereby, are explained in greater detail hereinafter with reference to preferred embodiments illustrated in the accompanying drawings.

#### **Brief Description of the Drawings**

Figure 1 is a block diagram of the self-generating audio recording, storage, indexing and transaction system according to the present invention;

Figure 2 illustrates an example of a Program Schedule reference file;

Figure 3 illustrates an Artist and Group Name reference file;

Figure 4 illustrates the telephone area and exchange code, station call letter code and touch tone input database file;

Figure 5 is a table and map of North American telephone area codes;

Figure 6 is the touch tone telephone keypad lay out; and

Figure 7 is an entity relationship diagram illustrating some of the principles of the invention.

Best Mode for Carrying Out the Invention

In order to explain the present invention in detail, reference will be made in particular to Figure 1.

In Figure 1, the reference number 1000 designates the radio station schedule input terminal device located at a remote radio station that can communicate with the programmed data processor 1010, located at the central site 1025, and input the program schedule of music to be broadcast on the remote radio station. In the preferred embodiment the radio station schedule input terminal 1000 is the computer system at the radio station that schedules the time of play for both commercials and musical program content. This terminal device 1000 is equipped with a modem and a communications program so that it can automatically dial the communications interface 1050 of the programmed data processor 1010 and input the program schedule including the artists name, name of the musical piece, and the date and time the music is to be played. This information can be coded to reduce the transmission time as there could be hundreds of music pieces broadcast each day.

Alternatively the radio station schedule can be automatically input by FAX (facsimile) using a computer or typewritten print out of the stations program schedule to transmit the stations schedule from the local FAX machine at the radio station to the central site 1025. At the central site 1025, the FAX receiver is a FAX board mounted within either a stand alone personal computer or the programmed data processor 1010 that would sequentially provide each incoming FAX message with its own identification number prior to storing the FAX digitally on the computer systems hard drive. In the process of setting up the FAX call a hand shake protocol is established between the sending and receiving FAX machines such that the receiving FAX machine can determine, by error free data transfer, the telephone number of the transmitting FAX machine. Alternatively, the station's FAX number can be established through, the telephone company supplied, (ANI) Automatic Number Identification service. The programmed data processor 1010 utilizes this telephone number as an index to select the optimal algorithm to convert the FAX images to data. For example, message number 101 assigned by the FAX receiving board is associated with radio station WHAM FM because of the stations digitized telephone number received in the hand shake protocol. The programmed data processor 1010 then accesses the interpretation protocol that matches the FAXed data for WTAM FM to convert the character images sent from the radio station FAX into ASCII characters to be stored on the programmed data processor 1010 in the program schedule file 1060.

For example, radio station WTAM FM could utilize a computer printer that produced text in the Roman font. Each line on their schedule begins with time of play, followed by duration, artist name, then the name of the music piece. A different radio station, identified through the handshake protocol by their telephone number as WPAT AM, utilizes a different scheduling computer to print out their program schedule using the Tudor font highlighting the artist name first, followed by the musical piece, time of play and duration. Because the

programmed data processor 1010 knows the identity of the sending FAX machine it can apply the optimum algorithm to interpret the text font and determine from the text placement the contents of the page. This approach enables the programmed data processor 1010 to automatically file the FAXed program schedule of the remote radio station in a fixed digital format in the program schedule file 1060 associated with a particular radio station. An example of the format to which the program schedule files are processed is illustrated in Figure 2.

Alternatively, the terminal device 1000 could be a nonprogrammable terminal or data source connected via a network to the communications interface 1050, interacting on line to input the program schedule. The program schedule data could also be input using a touch tone telephone with voice prompting when connected to the telephone interface 1020 or input by voice into a section of the telephone interface that recognized spoken numbers and words through voice recognition. A coded version of the radio station program schedule makes the input easier and quicker. The schedule data could also be read over the telephone to an operator who would input the data. As this program schedule data is received from all of the participating radio stations it is stored in the program schedule 1060 of the programmed data processor 1010.

Music television channels and other telecasters can also utilize the above-mentioned methods to forward and store their program schedules for use by the system.

Other station specific information such as a station's top ten music listing or most requested hits can also be input in the above mentioned manner.

The digitized audio description file 1070 is created using the audio description creation system 1080 which is connected to the programmed data processor 1010. The audio description creation system consists of a set of audio input devices, such as a CD player 1085, cassette player 1086, record player 1087, audio tape player 1088 and microphone 1089 for an announcer to record audio descriptions.

The audio description file 1070 consists of the audio description information describing the music piece and an audio segment consisting of an excerpt of the music piece. The audio description information corresponds to the audio recording of the text description of each music piece listed in the program schedule stored in the program schedule file 1060. The announcer uses the display screen 1081 to recall the program schedule from the programmed data processor 1010 for each radio station. As well, additional information concerning the music piece such as the name of the music product containing the music piece and pricing can be input into the creation system via the attached data input terminal 1082 or personal computer and stored on the audio description creation system available to the announcer for audio recording.

For example, the station program schedule, after receipt from a participating radio station, would be loaded onto the audio description creation system 1020. The program schedule file 1060, an example of which is referenced in Figure 2, contains the station code or identifier for the station 2000, field



1, date and period of the program schedule broadcast 2005 field 2, number of music pieces in the time period 2010 field 3, chronological schedule number 2015 field 4, time of broadcast for a particular music piece 2020 field 5, artist or group name 2025 field 6, title of the music piece 2030 field 7 and the pointer to data file 2035 field 8. Parts of this schedule information can be coded to reduce the transmission time from the radio station to the system. For example, a particular artist or group would be listed in a reference table with an artist or group number followed by a music piece reference number for the song broadcast. The coded entry would be made in the program schedule at the radio station and FAXed to the central site 1025. A standardized music reference system can be utilized by all reference table based stations or customized tables implemented whereby the station reference table conversion is conducted by the programmed data processor 1010 when the imaging and interpolation process occurs for the incoming program schedules. If a customized music reference table is utilized by a station then a copy of the table would be resident on, or available to, the audio description creation system 1020 to conduct the conversion into artist and song title information.

Once a station's program schedule is stored on the system it can be updated if changes are required. To accommodate updates, access will be provided to the program schedule file stored on the system. This access will enable station personnel to use their touch tone telephone to call into the Now Music system and utilize their telephone keypad to modify the program schedule.

By calling into the telephone interface 1020, station staff can step through their current play-list with the song titles or chronological play-list numbers verbally related back to the caller using text-to-speech processing. The text-to-speech technology is well adapted for this application and is included as part of the telephone interface 1020. For example, the \* key on the telephone will delete a song from the current play-list while the # key can add or insert an entry. The # key would be followed by a music reference number which relates to a song, artist and album title contained in the previously described, coded music reference table. After entering any changes the new program schedule information would be verbally related back to the caller confirming the play-list changes.

For the purposes of recording the music title portion of the audio description, the audio description creation system 1080 performs an initial sort of the music pieces listed in the program schedules to remove redundant entries for the same artist and music piece. The artist name 2025 field 6 and the name of the music piece 2030 field 7 contained in the program schedule 1060, or the code representing it, is compared to the data description archive file 1066 containing all previous listings for which audio descriptions already exist. The announcer is then presented, on the display screen 1081, with the listings that require an audio description. The announcer then reads the artist's name and title of the music piece into the microphone 1089 and stores them in the

audio description file 1070 while at the same time updating the audio description archive file 1084.

Information not contained in the program schedule such as pricing, album name or other background can be input by the data input terminal 1082, prior to audio recording, and stored as part of the data description archive file 1066 to be included in the audio description by the announcer.

The music product containing the music piece outlined in the program schedule can then be loaded into its respective player such as a CD player 1085, on the audio description creation system 1080 and the audio segment digitized, compressed and stored into its associated audio description file 1070 while also updating the audio description archive file 1084. The audio segment can consist of an excerpt of the music piece or the entire music piece.

The announcer would then depress the space bar or other key of the display terminal 1082 to indicate completion of that audio input and the linking of the entry in the program schedule with the corresponding audio description. The link is made through a database which utilizes the pointer to data file, 2035 field 8, which is added to each music piece in the program schedule and references the corresponding audio and data description.

The announcer can then proceed with the next descriptive item of that musical product which would be displayed on the display screen 1081 for the announcer to record onto the system. This process can be repeated for each piece recorded on the musical product and referenced in the database by product name. Both the audio description archive file 1084 and the data description archive file 1066 are automatically updated with the new entries.

Instead of using a staff announcer's voice to provide the audio description it is possible to have the recording artist provide their own music descriptions on a recording medium such as an audio tape and have it sent to the creation system site to be input and included as part of the audio description via the audio tape recorder 1088. Alternatively, recording artists can provide song and album introductions utilizing the recording capabilities of the telephone interface 1020 by using their touch tone telephone 1030 to follow special voice prompts to record personalized messages directly on the system.

When the audio descriptions for all of program schedule entries and potentially for all of the new music products have been processed by the audio description creation system 1080, the digital audio description file 1070 on the programmed data processor 1010 is updated with the new audio descriptions contained in the audio description archive file 1084. As well, the data file 1065 is also updated with the new files contained in the data description archive file 1066. The program schedule 1060 is updated with the revised schedule containing the pointer to data file 2035 field 8 linking to the corresponding audio and data description.

Acquiring the music products and manually recording the music pieces is both expensive and time-consuming. The system offers a method for

automatically recording the audio segments of the music pieces broadcast. This is accomplished by digitally recording the music in real time directly from the broadcast and storing the recorded segments into the associated audio description file **1070** on the programmed data processor **1010**.

In the radio industry, recordable media, such as Digital Audio Tape (DAT) or digital hard drives are used to prerecord many hours of music for preparation and play by radio stations. The music on the digital media is prepared in accordance with a station's program schedule. Existing technology enables a signal such as a pulse or DTMF tone to be recorded on the DAT and included with the broadcast to trigger remote audio and video equipment. This capability is commonly used in the radio and television industries to trigger equipment remotely for the broadcast of advertisements.

According to the invention, the automated record and store process is accomplished by inserting a selection signal such as a tone or pulse at the beginning of each music piece to be recorded from the broadcast. In Figure 1 the receiver **1090** is connected to the signal detector **1091** which is connected to the programmed data processor **1010**. The receiver **1090** receives the broadcast containing the music pieces to be recorded and a signal detector **1091**, when it detects the appropriate signal, triggers the digital recording of the piece by the programmed data processor **1010**. The recording of the music piece continues for a specified time, such as ten seconds, providing an excerpt of each music piece denoted by the selection signal. The digitizing facility can be part of the signal detector **1091** or contained within the programmed data processor **1010**.

An additional signal can be included to notify the programmed data processor **1010** to stop recording rather than a timer based approach. Having a signal start and stop the recording function enables the entire music piece to be recorded whereby the additional signal is appended to the end of the music piece.

The real-time recording of the music piece is linked to the program schedule **1060** enabling the recorded audio segment to be stored in the correct audio description file. The recording of the music pieces is initially time synchronized with the program schedule for each station. A receiver **1090** and signal detector **1091** is dedicated to each station requiring real-time recording. Knowing the station code or identifier that the receiver is dedicated to, the programmed data processor **1010** loads the correct program schedule **1060**, for the station it is recording, based on the station code **2000** field 1, and the current time and period of broadcast **2005** field 2. The system clock is used by the programmed data processor to locate the current music piece played as indicated in the program schedule, using the time of broadcast **2020** field 5. The incoming audio segment, as detected by the signal detector **1091** is recorded into its corresponding audio description file **1070** as referenced by the pointer to data file **2035** field 8 in its program schedule **1070**. After the initial synchronization, the recording of the music pieces into the audio description file **1070** follows in chronological order with the program schedule

for that particular station. For example, if synchronization between the incoming audio segments and the current program schedule occurred with the first music piece listed in the program schedule as indicated by the chronological schedule number 2015 field 4, then the next audio segment detected would be recorded into the audio description file corresponding to the next program schedule listing containing the chronological schedule number of two.

When the programmed data processor 1010 reaches the last listing in a program schedule it loads the next schedule for that particular station and proceeds to synchronize and record when the next audio segment is detected. Establishing the last listing in a program schedule can be accomplished in various ways such as comparing the number of music pieces in the time period 2010 field 3 and the chronological schedule number 2015 field 4 for the current listing. If the two fields match, the next program schedule is loaded for synchronization with the next incoming audio segment. Another method of detecting the end of a program schedule involves the addition of a delineator at the end of the program listing which when reached causes the loading of the new program schedule. Alternatively or as well, a delineator signal can be added to the broadcast signaling the programmed data processor to refer to the next program schedule.

Specific signals or multiple signals can be inserted for various purposes such as to synchronize the program schedule with the automatic recording of the music pieces. When creating the program schedule the station can indicate the time of the synchronizing signal and upon receiving the program schedule, the programmed data processor 1010 automatically interprets the signal placement along with the rest of the program schedule information. Many stations currently utilize a beginning of the hour signal for advertising purposes and this beginning of the hour signal can be detected by the programmed data processor and utilized to synchronize the program schedule.

Another method of implementing the selection signal enables information to be encoded as part of the inserted signal and converted into data by the signal detector 1091. Information such as a program schedule number or a music piece reference number can be incorporated into the selection signal enabling the coordination of the program schedule 1060 with the recording of the music pieces into the correct audio description file 1070. The selection signal information can be encoded in the inserted signal through various means such as multiple tones or a combination of tones and pulses. For example, when DAT tapes are prepared containing the music for a days broadcast, a signal such as DTMF tones can be inserted prior to each music piece whereby the program schedule number accompanies the music piece in the broadcast. This signal information could be sent before, during or after the music piece is broadcast.

For example, the 46th music piece in a program schedule can be preceded by the tones representing a 4 and 6. The signal detector 1091 would detect and decode the signal and pass the information to the programmed data processor 1010. The programmed data processor 1010 would reference the chronological schedule number

2015 field 4, within the current program schedule and record the audio segment into the correct audio description file 1070.

The encoding and inserting of information in the broadcast can be utilized in several ways. A coded music piece reference number indicating the title and artist name can be inserted into the broadcast and received, detected and decoded for use by the programmed data processor 1010 to coordinate the recording of the audio description and the synchronization of the program schedule.

In an alternate method of operating the system, the insertion of information such as the music piece reference number enables the system to create the program schedule as the broadcast occurs. This is accomplished by creating a reference table as previously described whereby a station inserts the music piece reference number according to a standardized or station specific music reference table which is known to the radio station and stored on the programmed data processor 1010.

If the music piece reference number refers to an audio description not available on the programmed data processor 1010 then the programmed data processor can access the audio description archive file 1084 to retrieve the associated audio description. For operation without a predefined program schedule, utilizing the insertion of a music piece reference number, the audio description archive file 1084 can be located on the programmed data processor 1010 to provide more efficient operation.

The selection signal or other information, can be sent as data with the broadcast signal through methods such as the side band frequency of the broadcast signal or as digital data contained within a digital radio transmission or digital television signal.

As well, the selection signal can be utilized to pass messages in real-time to the programmed data processor 1010 such as in the case whereby a disc jockey at a broadcast station manually inserts a specific signal as part of the broadcast. The signal is decoded by the signal detector 1091 and passed to the programmed data processor 1010, relaying messages such as to skip a music piece and continue with the next listing in the program schedule thereby instructing the programmed data processor to skip the current listing in the program schedule.

The real-time insertion of information into the broadcast enables radio stations that conduct live or request shows, to insert information such as a music piece reference number with the music piece broadcast, enabling the programmed data processor 1010 to locate the corresponding audio description or trigger the recording facility if necessary.

The selection signal methodology also applies in the case of a music television channel, music video program or a music station associated with a television telecast such as provided through a cable television telecast, satellite broadcast or television signals distributed via the telephone network.

The selection signal is inserted into the audio portion of the signal and detected and potentially decoded as previously described.

An alternate signaling method enables video information to be inserted and detected as the selection signal. In the case of video signaling, the receiver 1090 becomes a television receiver and the signal detector and decoder is a video decoder able to decode the embedded video signal contained within the broadcast.

In some cases, broadcast stations are unable to insert a signal into their broadcast in which case an alternate data communications facilities can be established, such as a modem and a telephone line, to transmit the real-time information to the communications interface 1050 thereby enabling the programmed data processor 1010 to locate the corresponding audio description or trigger the recording facility.

If a request show runs throughout the day the communications costs for an external data facility can become significant. In an alternate method of operating the system, a polling procedure can be implemented for the transmission of the program schedule and station specific information. With the polling method, the disc jockey inputs the program schedule onto the schedule input device 1000 such as a personal computer which stores the information locally at the broadcast station. When a customer call is received at the telephone interface 1020 requesting station specific information such as the last song broadcast, the communications interface 1050 utilizes a data communications facility, such as a modem and telephone line, to connect with the remote schedule input device 1000 located at the broadcast station. A data file transfer is then conducted whereby the station's information such as the program schedule is transferred to the programmed data processor 1010 which reformats the information and stores it in the program schedule file 1060. The telephone interface 1020 then relates the requested station specific information to the caller. Program schedule information for a predetermined time, such as the last hour, can be included when the data file transfer is received from the remote schedule input terminal 1000. If multiple customer calls are received by the telephone interface 1020 requesting the same station specific information or requesting information which is already available to the programmed data processor 1010 then the information can be accessed without re-initiating communications with the remote schedule input terminal 1000. This polling method is for request shows which broadcast for long durations and when customer calls do not occur for every song.

The audio description archive file 1084 can be updated at the end of a recording period such as the end of the day by up-loading the audio segments and audio descriptions recorded from the broadcast in the audio description file 1070 that do not already exist in the archive. Music pieces, whether prerecorded when the artist name and titles are recorded by the announcer, or real-time recorded from the broadcast, are recorded once and can be referenced by multiple program schedules, multiple times within a given program schedule

and further referenced if needed for other station specific information such as a station's top ten song listing. Each audio description is filed in the audio description archive file 1084 contained on the audio description creation system 1080. The audio description archive file 1084 enables easy reference and repeated use of the audio descriptions. This is significant from an efficiency standpoint because in most cases a relatively limited number of music pieces receive the majority of the broadcast play. The archive files 1084, 1083, and 1066 can be located locally on the programmed data processor 1010 or remotely connected by a data communications facility.

The audio description creation system 1080 is also the means to create the area code and call letter file 1075, which when located on the programmed data processor 1010, is the basis for determining the call letters of the radio station being listened to by the potential purchaser.

For example each of the approximately 130 telephone company area codes, see Figure 5, have less than 999 unique local exchange codes. Each telephone exchange code defines a small portion of the geographic area of the telephone area code that it is located in, such that a specific exchange code can only exist in one city or town for that particular area code. Similarly, cellular and other wireless telephone services such as PCS (Personal Communications Services) have identification codes relating to cell and transmitter locations with defined geographic limits. Every radio station has an area of signal coverage that is publicly available on maps such that for every exchange code it can be determined which radio stations provide coverage within the boundaries of a particular exchange. For example, in area code 519, exchanges 293, 526, 765, 773, 565, 644, 523, 228, 482, 233, 234, 237, 268, 762, 235, 769, 287, 524, 238, 225, 269, 262, 263, 666, 247, 229, 652, 227, 289, 264, 232, 294, 874, 243, 782, 785, 631, 633, 527, 522, 764, 775, 866, 245, 296, 461, 693, 768, 236 are located in an area surrounding London, Ontario, Canada and these following exchanges are within the London city limits 432, 433, 434, 438, 439, 451, 452, 453, 455, 471, 472, 473, 641, 643, 645, 649, 657, 659, 660, 661, 663, 667, 668, 672, 673, 679, 681, 685, 686 and from these exchanges the following radio stations can be heard CBBL FM, CBCL FM, CIXX FM, CJBC FM, CJBK AM, CJBX FM, CIQM FM, CKSL AM, CFPL AM in London and CHLO AM in St. Thomas and CBEG FM, CHOK AM, CKJD AM, CJFI FM in Sarnia. By organizing this information in a database it is possible to determine from touch tone input, the call letters of the radio station listened to even though the touch tone keys have three alphabetic characters on each key as illustrated in Figure 6.

The area code and call letter file and database structure are illustrated in Figure 4 where the area code 4000 and the local exchange digits 4010 are the first two data fields followed by a third field 4020 which indicates the maximum number of radio stations that can be satisfactorily heard in that area and exchange code. A radio station is described in the next set of four fields which are repeated for each radio station. 4030, field 4 contains the numeric values of the touch tone keys that match the letters of the radio

stations call letters. For instance WPAT FM would appear as 9728 where the number 9 is contained on the touch tone key corresponding to the letters WXY. **4040** field 5 contains a 0 if the station is AM station or a 1 if FM. **4050** field 6 contains a number 0 to 9 indicating the type of radio station such as country, pop or rock. **4060** field 7 contains a pointer to an audio description of the station call letters so that the potential purchaser can be prompted with the station call letters combined with the type of station in the event the purchaser forgets the call letters. The radio station call letter fields would be arranged in sorted order to improve the speed of the retrieval.

The system would know in advance as part of the database that the first two stations listed in the above example, CBBL FM and CBCL FM have the same touch tone numeric values 22252 and would audibly ask the caller to select the correct station once it detected this conflict.

To determine the radio station call letters the potential purchaser's telephone area and exchange code digits are used as a retrieval key against the area code and call letter file **1075** to retrieve the set of radio station call letters that could be heard from that telephone exchange. The potential purchaser is asked to use the telephone to input the station call letters. The call letter numbers from the area code and call letter file **1075** are then compared with the numeric values of the station call letters input by the potential purchaser. If a match is established the system can then proceed to determine which music has been played on the selected radio station or what station specific information is requested. If a match is not found the potential purchaser can be verbally prompted with the types of radio stations in that area code and exchange, for example touch 1 for country, 2 for pop, which when selected, will allow the system to further prompt the potential purchaser with the radio station call letters that match the selected type of station. If this process does not determine the radio station, the potential purchaser can be bridged to a customer service operator, located at a customer service data terminal, **1040** to determine and input the radio station call letters.

As well as station call letters, other identifiers can be utilized in place of or in conjunction with the station call letters, for example, a radio station frequency number, television channel call letters, cable or television station number or advertised station descriptor. This entails an expanded version of the area code and call letter file referenced in Figure 4 whereby **4030**, field 4 includes the touch tone numbers for additional identifiers.

In some cases, a music genre, such as rock or classical can be used as a station identifier whereby the caller is prompted by the telephone interface **1020** to use the touch tone telephone **1030** to make a selection corresponding to the music genre of the station listened to. This identification information in combination with the caller's telephone area and exchange code information significantly narrows and identifies the affiliates within the caller's broadcast range. If multiple affiliates exist with overlapping broadcast ranges



within the same music genre then a narrowed list of stations can be presented to the caller for the final selection of the station listened to by the caller.

Additionally, station operators may request their own specific telephone number for their listeners to access the service, in which case the called number would identify the station and enable the programmed data processor to recall the appropriate program schedule or station specific information.

The audio description creation system **1080** is also the means to create an artist name archive file **1083** which is updated every time a new artist adds a musical product. This artists name archive file **1083** updates the artists name file **1078** on the programmed data processor **1010** each time it is updated. The artists name file **1078** contains the touch tone key combinations and other related information for each artist or group name. This file is also partitioned into as many segments as a potential purchaser can identify as separate sets or styles of music. For example, 5 partitions can be created by dividing all artists or groups into the categories of soft rock, hard rock, pop, easy listening and country. Each of these categories can then be divided into single artists or groups. Then the artist and group names are converted into the numeric values of the touch tone keys that match the alphabetic characters of their names. For example, the letters A,B,C would all be represented by the number 2 which is the numeric value of the touch tone key containing them. A generalized version of this file is described in Figure 3 where **3000** field 1 contains a number between 1 and 5 representing the type or category of music. **3005** field 2 contains a 0 for an artist or 1 indicating a group. **3010** field 3 contains the name of the artist in touch tone representation of the ASCII characters of their name. Since the characters Q and Z and Space do not appear on the touch tone telephone keypad the number 1 is used to indicate either Q or Z and the number 0 is used to denote a space. The potential purchaser would be informed of these keyboard characteristics when prompted to input the artist or group name. **3020** field 4 would contain a pointer to the artist or group name in the data file **1065** referencing the pointers to all the musical products for the artist or group as well as pointers to the audio description of the artist's name, the names of the artist's musical products, the various pieces included in the musical products and musical excerpts of these pieces contained in the audio description file **1070**.

When the updated program schedule **1060**, data file **1065**, area code and call letter file **1075**, artists name file **1078**, and audio description file **1070** have been loaded on to the programmed data processor **1010** along with the program to initialize and control the data processor, the system is ready to receive telephone calls ordering music products.

Referencing Figure 1, the potential purchaser uses a touch tone telephone **1030** to dial an advertised number such as 1-800-RECORDS (equivalent to 1-800-732-6737) to be connected to the telephone interface **1020**. The telephone interface **1020** uses audio prompts to ask the potential purchaser to use the

touch tone keys to input their telephone number including the area code. Alternatively, this information can be supplied or verified by the telephone company ANI (Automatic Number Identification) service.

After receiving the telephone number the system asks the potential purchaser to touch 1 if they heard the music piece of interest on a radio station, or to touch 2 if they plan to order a music product not recently heard on the radio station.

If the potential purchaser touched 1 the telephone interface 1020 would ask the potential purchaser to input the call letters of the radio station to which they were listening, including AM and FM designations if necessary. Since the basic radio station call letters are four characters and each of the touch tone telephone keys with an alphabetical listing contain three possible characters, the potential for confusion as to which radio station identifier was input is very large. One of the concepts of the invention is to eliminate this confusion by using the caller's telephone area code and the mutually exclusive exchange code digits. This area and exchange code information enables the system to determine which city the call originated from and compare the caller input with a select group of radio station call letters consisting of only the stations participating in the service from that area. The request for the input of AM and FM designations would be requested when an equivalent set of base call letters, such as WPAT FM and WPAT AM, provide a potential conflict.

If the potential purchaser cannot remember the station call letters it is possible to use the area and exchange code digits to retrieve station descriptions from the area code and call letter file 1075 to verbally prompt the user with the call letters or station identifier for the affiliate stations available from their city. This audio prompting could also include general station descriptions such as Country and Western or Rock to help determine the exact station listened to.

Once the system has determined which radio station was listened to, the system can search the station's program schedule to determine the current piece being played and provide the prospective purchaser with the first level of description such as the artist's name. The telephone interface then directs the potential purchaser to touch 1 if it is the music piece in which they are interested or touch the 2 key to hear an excerpt of the music piece broadcast to confirm the music piece of interest or touch the number key # on their telephone to relate information for the previous piece of music played on the broadcast.

With each touch of the number key (#) the system would step back through each piece of music previously broadcast or telecast until the potential purchaser touched 1 to indicate reaching the music piece of interest. Listeners can also, through the telephone, enter the time they listened to a song to speed the retrieve process for those callers that were significantly delayed in calling the service.

Upon reaching the music piece of interest, the system audibly informs the potential purchaser of the formats available for the music product

selected, such as CD, cassette tape or record album and provide the pricing, shipping and other details.

The system would then ask the potential purchaser to touch the asterisk key \* on the touch tone telephone 1030 if they want to order the music product. Alternatively they can press the number key # if they want more details.

If the potential purchaser touches the number key # the other musical pieces on the product would be described and, if requested, excerpts could be played so that the potential purchaser had all the required information to make the purchase. Pressing the asterisk key \* begins the order process.

When the asterisk key \* is pressed to order the musical product, the system would use the caller's telephone number to determine the shipping address. The system accomplishes this by requesting the communications interface 1050 to connect to an outside database 1090 to provide the address associated with the caller's telephone number. This address could also be obtained from a local CD ROM, attached to the programmed data processor 1010, that contains the street addresses for the respective telephone numbers. If the caller requests a different shipping address, they can leave a voice message on the audio response system 1025 or be connected to a customer service operator.

As the address retrieval process is proceeding, the telephone interface 1020 audibly requests the purchaser to input their credit card number on the touch tone telephone 1030. The programmed data processor 1010 then directs the communications interface 1050 to contact the credit card issuer 1095 and obtain a credit authorization number which would enable the system to subsequently invoice the customers credit card account upon shipment.

With the shipping address and credit authorization known, the programmed data processor 1010 directs the communications interface 1050 to connect to the fulfilment warehouse 2000 and place the order for the requested music product. If the product is not in stock the fulfilment warehouse computer informs the programmed data processor 1010 through the communications interface 1050 which then instructs the telephone interface 1020 to inform the customer of the out of stock condition.

Once it has been determined that the product is in stock an order is placed with all the information to ship the product and create the appropriate records to invoice the purchaser and record the transaction for further accounting and statistical purposes.

In each of these steps, if the caller experiences problems not easily handled by inputting information via the touch tone telephone the caller can be connected through the telephone interface 1020 to a customer service operator, who would obtain the required information verbally for input into the system via the customer service data terminal 1040. The customer service operator has complete control of the session with the caller once the bridge connection has been made. For example, the customer service operator, can over the telephone, play the recorded excerpts for the caller, obtain and enter

shipping addresses or explain credit problems. In general the customer service operator is the last resort when the automatic system is unable to complete the order process.

The system will also support orders from callers not directed by a broadcast but interested in purchasing a music product. For example, the potential purchaser can initially, upon calling, be prompted to press the number 2 on their touch tone telephone indicating they were not a radio listener but wished to use the automated music catalogue service whereby the system would proceed to automatically determine the required musical product and provide all the information, including the playing of music excerpts, to enable the potential purchaser to order a selected music album. The system accomplishes this by narrowing the scope of possible music products by first asking the potential purchaser to touch 1 if the artist or group is soft rock, touch 2 if hard rock, touch 3 for blues and touch 4 for country, then to indicate whether the music product is recorded by a group or single artist. Then the telephone interface 1020 requests the artists name followed by a terminator key such as the number key #, to be input using the touch tone keys on the telephone 1030. The type of music and the numeric representation of the artist or group name is combined together as a retrieval key. Matching the retrieval key with the artists name file 1078 provides access to the pointer for the selected artist's name in the data file 1065. The data file 1065 contains a pointer to the artist's name in the audio description file 1070 for the telephone interface 1020 to audibly relate the artist or group name and ask the potential purchaser to confirm the selection of the correct artist or group, using the touch tone keys.

Once the correct artist has been identified the system retrieves the names of musical products for the selected artist stored in the data file 1065 and relates them in the reverse order of their release. These names have pointers to audio descriptions in the audio description file 1070, which when played to the potential purchaser, assist in determining which music product is of interest. By using the touch tone keys, the potential purchaser can hear excerpts from any music product until satisfied they have all the required information to initiate the purchasing process by touching the asterisk key \*. Once the asterisk key \* is depressed the system will automatically proceed with the purchase process as previously described.

It is contemplated that a 1-900 telephone number can be used for the service where the potential purchaser would be charged by their telephone company for the telephone call on either a per call or duration basis.

It is further anticipated that record and music clubs can use this invention to assist in describing and selling their products. As well, record stores can use this invention to allow potential customers to hear excerpts from the musical products over telephone lines. These services could be offered from one central site or through smaller local distributed systems networked together.

In both of the above-mentioned examples the music product number or unit code can be used to access the album index of possible pieces to be previewed, thereby reducing the retrieval time to obtain the music information required to make a purchase.

It is further contemplated that specific components of the system can be located remotely and networked to provide a distributed approach to reduce communications costs. For example, the telephone interface 1020 can contain local file storage capabilities and be located remotely from the programmed data processor 1010 such that the telephone interface, and its audible response and preview functions, can be located in major cities.

Additionally, access to the system can be provided by personal computer whereby a communications network address such as an Internet address would be promoted by a broadcaster. A personal computer user would access the system through the system's communication interface 1050 and would use personal computer commands instead of touch tone telephone input to preview and order music. The personal computer would communicate utilizing digital data and access the digital audio files available to the programmed data processor 1010.

The personal computer user would be directed to navigate throughout the system through voice or visual prompts provided through the personal computer.

It is further envisioned that the system would store, index and record a combined audio and video signal, such as a music video, recorded from a telecast such as a cable or satellite broadcast in the same manner as previously described for a radio broadcast but utilizing digital video capture facilities.

A terminal device such as a personal computer would access the system via a network connected to the communication interface 1050 to access audio and video information as broadcast or as outlined in a telecaster's program schedule. The audio and video portions of the signal would be stored in separate files or in a manner maintaining access to the audio by telephone users of the system.

The system could further be utilized in conjunction with a billing facility such as a 900 telephone number to enable terminal users such as personal computer user to review a music video channel's program schedule in order to receive and store specific information locally on their personal computer.

Having now described the preferred embodiment of the invention, reference will be made to Figure 7, which gives an overview of some of the principles of the present invention. As illustrated, the present invention employs data processor 7010 which is provided with a suitable user interface 7012. In the presently preferred embodiment, the user interface is integrated with the existing telephone and communications infrastructure, so that persons may interact with the system using conventional DTMF telephone equipment or other terminal equipment such as personal computer as described above. Connected to data processor 7010 is a subsystem 7018 for providing prerecorded audio or combined audio and video descriptions of the program material (e.g.

recorded music) that the caller may wish to purchase. Subsystem 7018 may be implemented using hard disk storage, optical storage, digital audio tape (DAT) storage, or the like. The program material (e.g. recorded music) may be prerecorded from the media played over the air, or it may be prerecorded from the live broadcast using a suitable AM, FM or television receiver and suitable digitizing (analog to digital conversion) equipment. Also connected to data processor 7010 is a program schedule input system 7020, which may be any suitable means for inputting the program schedule, play list or station specific information identifying what program materials have been or will be broadcast, including optical character recognition equipment for inputting program schedules or play lists provided in printed form and telefacsimile equipment for inputting the program schedule or play list information via FAX.

Data processor 7010 is further provided with a database system 7014 for storing the program schedule, suitable data or pointers from which the prerecorded description may be obtained, reconstructed or generated. An audio description subsystem 7016 is coupled to data processor 7010 to provide the selected audio description to the user via the user interface 7012. The audio description subsystem may include digital to analog conversion equipment for converting digitally prerecorded audio description information into an analog form suitable for distributing serially over the telephone. Alternatively or additionally, the audio description subsystem may include synthesis equipment for performing text to speech conversion on text data files for the creation of audio description information.

The audio description information may also include video information either stored on the audio description subsystem 7016 or on a separate subsystem connected to the data processor 7010.

While the invention has been described with regard to the presently preferred embodiment, it will be understood that the invention is capable of certain modification without departing from the spirit of the invention as set forth in the appended claims.

I claim:

1. A computer-implemented audio information system to provide users with audible information concerning program materials disseminated according to a program list, comprising:

a processing system for execution by a computer;

a user interface coupled to said processing system, said user interface providing means for placing user inquiries regarding the program material;

a database coupled to said processing system;

a first input means coupled to said processing system for inputting information reflecting audio descriptions of said program materials;

a second input means coupled to said processing system for inputting program list information regarding a plurality of program material items; and

an audio description output means coupled to said processing system and to said user interface;

said processing system having:

means for correlating said audio descriptions of program material with said program list information and for storing said correlated audio descriptions and program list information in said database;

means for responding to a user inquiry, placed through said user interface, about an item in said program list, by retrieving a selected audio description from said database; and

means for further responding to said user inquiry by causing said audio description output means to produce an audible message based on said selected audio description.

2. The audio information system of Claim 1 wherein said processing system is a computer program running on said computer.

3. The audio information system of Claim 1 wherein said user interface includes a mechanism for coupling said user interface to a touch tone telephone.

4. The audio information system of Claim 1 wherein said user interface further includes a telephone interface and wherein said user inquiries are placed using telephone DTMF codes entered through said touch tone telephone.

5. The audio information system of Claim 1 wherein said first input means includes a radio receiver.

6. The audio information system of Claim 1 wherein said first input means further includes an audio signal digitizer.

7. The audio information system of Claim 1 wherein said first input means further includes a device for extracting said audio descriptions from prerecorded program materials.

8. The audio information system of Claim 1 wherein said second input means includes an optical character recognition system.

9. The audio information system of Claim 1 wherein said second input means further includes a telefacsimile transceiver.

10. The audio information system of Claim 1 wherein said audio description output means includes a text to speech conversion device.

11. The audio information system of Claim 1 wherein said audio description output means further includes a digital to analog conversion device.

12. A system for on-demand remote access to a self-generating, audio recording, storing, indexing and transacting system comprising:

at least one broadcast unit, said at least one broadcast unit allowing audio broadcast to remote locations and informing said remote locations of a telephone number;

an emission device providing a selection signal to said at least one broadcast unit;

a telephone interface device providing audio descriptive data to a programmed data processor, said audio descriptive data received via a telephone connection, said audio descriptive data at least one broadcast identifier, said programmed data processor including a data input unit for receiving a program schedule;

a reception device providing reception for said audio broadcast;

a detection device providing signal detection for said selection signal from said audio broadcast;

a storage device digitally recording, compressing and storing detected audio segments on said programmed data processor;

an audio description creation device comprising input devices selected from the group consisting of a compact disc player, a tape cassette player, a digital audio tape device, a videotape player, a multi-track audio tape recorder, a microphone and a data input device, said data input device creating an audio description file;

a communication device coupled to said programmed data processor enabling access with remote databases and computers for credit authorization and placement of orders;

a responsive device responding to the receipt of said at least one broadcast identifier, generating information in a first database and directing said program schedule and said audio descriptive data; and



a data processor attachment device coupled to said telephone interface device, said detection device and said communication device, said data processor attachment device directing said telephone interface device to communicate said audio descriptive data in a reverse chronological order to said remote locations.

13. The system in Claim 12 further comprising a timer controlling recording time of said detected audio segments, wherein only portions of musical pieces or audio programs is recorded.

14. The system in Claim 12 wherein said selection signal provides a reference point within said program schedule.

15. The system in Claim 12 wherein said program schedule is encoded and broadcast as said selection signal.

16. The system in Claim 12 wherein said selection signal occurs at the beginning of said audio segments to be recorded.

17. The system in Claim 12 wherein said selection signal occurs at the beginning and the end of said audio segments.

18. The system in Claim 12 wherein said selection signal comprises at least one of or a combination of a DTMF tone, a frequency tone or a time delay queuing pause.

19. The system in Claim 12 wherein said selection signal is contained within a signal not including said audio broadcast.

20. The system in Claim 12 wherein said selection signal further comprises at least one digital signal.

21. The system in Claim 12 wherein said selection signal is contained within a video broadcast.

22. The system in Claim 12 wherein said reception device comprises a radio receiver, a digital radio receiver, a television receiver, a cable converter, a digital cable receiver, a satellite receiver or a personal computer.

23. The system in Claim 12 wherein said audio broadcast is received by said telephone connection and transferred to said telephone interface.

24. The system in Claim 12 wherein said detection device includes a decoder device for obtaining numeric data from said selection signal for use by said programmed data processor.

25. The system in Claim 24 wherein said numeric data includes information relating to said program schedule or said audio descriptive data.

26. The system in Claim 12 wherein said audio descriptive data is stored on a separate system than said programmed data processor.

27. The system in Claim 12 wherein said audio descriptive data is stored on said telephone interface.

28. The system of Claim 12 wherein said audio description creation unit includes a text to speech conversion device.

29. The system of Claim 12 wherein said data processor includes a text to speech conversion device.

30. The system in Claim 12 wherein the said audio broadcast informs said remote locations of a common telephone number associated with said audio broadcast.

31. The system in Claim 12 wherein the said audio broadcast informs said remote locations of a specific telephone number associated with said audio broadcast.

32. The system in Claim 12 wherein said at least one broadcast unit includes a radio broadcast.

33. The system in Claim 12 wherein said at least one broadcast unit further includes a digital radio broadcast.

34. The system in Claim 12 wherein said at least one broadcast unit further includes a video broadcast.

35. The system in Claim 12 wherein a caller enters information using keys on a telephone, said telephone interface includes a conversion device for converting DTMF tones to numeric data for utilization by said programmed data processor.

36. The telephone interface of Claim 12 wherein said telephone interface includes a voice recognition device to acquire information from said caller.

37. The system in Claim 12 wherein said telephone interface receives said at least one broadcast identifier selected from the group consisting of a station tuning frequency, station call letters, a television channel allocation, a cable subscriber identification or a predetermined identifier.

38. The system in Claim 12 wherein said telephone interface receives said program schedule such that said caller enters information using said keys on said telephone or voice recognition to input a number representation referenced from a master listing of said audio pieces wherein said number representation is entered in a corresponding order of play over said at least one broadcast unit.

39. The system in Claim 12 wherein said audio description creation device is configured through a separate system comprising:

at least one computer system containing audio authoring software;  
input unit comprising a compact disc player, a digital audio tape, a multi-track audio tape recorder, a microphone and a cassette tape player;  
a communication unit transferring digital files to said programmed data processor;

an audio storage unit digitally compressing said audio descriptive data; and

a data input and display unit connected to said at least one computer system.

40. The system in Claim 39 wherein said audio description creation device creates said audio segments.

41. The system in Claim 39 wherein said communications unit communicates said audio descriptive data relating to said program schedule.

42. The system in Claim 39 wherein said communications unit includes said telephone connection, said program schedule is input via said telephone.

43. The system in Claim 39 wherein said communications unit receives said audio description information.

44. The system in Claim 12 wherein said data input unit includes a facsimile (FAX) machine or FAX interface board coupled to said programmed data processor to receive said program schedule.

45. The method in Claim 12 wherein said programmed data processor utilizes optical character recognition (OCR) to automatically interpret a facsimiled version of said program schedule.

46. The system in Claim 12 wherein said communications device receives said audio descriptive data.

47. The system in Claim 12 wherein said communications device consists of a data input terminal, personal computer or an input facility connected through a communications network.

48. The system in Claim 12 wherein said program schedule comprises a video schedule.

49. The system in Claim 12 wherein all apparatus is located at said at least one broadcast unit.

50. The system in Claim 12 wherein said broadcast unit informs said remote locations of a communications network address.

51. A method to provide a self-generating audio recording, storage, indexing and transaction system for remote listeners of a radio or television broadcast comprising the steps of:

broadcasting at least one radio or television signal on which signal a telephone number is advertised;

inserting of selection signal into said broadcast signal;

accepting of telephone input from said listener of said radio or television signal who provide at least the broadcast identifier of said radio station or television signal;

receiving of said radio or television signal;

detecting of said selection signal from within said radio or television broadcast;

digital recording, compression and storage of the detected audio segment;

provision of communications means for the input of the radio or television station program schedule into the programmed data processor;

receiving of input from input devices selected from the group consisting of a compact disc player, a tape cassette player, a digital audio tape device, a videotape player, a multi-track audio tape recorder, a microphone and auxiliary data input devices for the creation of a audio description file;

communicating means coupled to the programmed data processor enabling access with remote databases and computers for credit authorization and placement of orders;

generating of information in a first database responsive to receipt of a broadcast identifier, directing said audio program schedule and audio description information;

use of a programmed data processor coupled to the telephone interface, signal detection means and the communication means directing the

telephone interface to communicate to said listener the audio description information for said radio or television broadcast.

52. The method in Claim 51 wherein said broadcast identifier is spoken through a telephone and is manually input via a data terminal into said system.

53. The method in Claim 51 wherein a voice recognition device receives input from said listeners corresponding to said radio or television station identifier.

54. The method in Claim 51 wherein said broadcast identifier is selected from a group consisting of a station tuning frequency, station call letters, a channel allocation, a cable subscriber identification or a predetermined identifier.

55. The method in Claim 51 wherein said audio description file contains digital data relating to audio describing the title and artist of a listing in said program schedule.

56. The method in Claim 51 wherein said audio description file contains digital data describing the title of said program schedule listing and an audio segment.

57. The method in Claim 51 wherein said audio description information is created using text to speech translation to convert said program schedule listing or station specific information into an audio format.

58. The method in Claim 51 wherein said audio description information is transmitted by said communications mechanism and received by a personal computer device.

59. The method in Claim 51 whereby said telephone interface or said communications mechanism receive at least the music category of the broadcast station.

60. A system for on-demand remote access to a self-generating, audio indexing and transacting system comprising:  
at least one broadcast unit, said at least one broadcast unit allowing audio broadcast to remote locations and informing said remote locations of a telephone number;  
an emission device providing a selection signal to said at least one broadcast unit;  
a telephone interface device providing audio descriptive data to a programmed data processor, said audio descriptive data received via a telephone

connection, said audio descriptive data at least one broadcast identifier, said programmed data processor including a data input unit for receiving a program schedule;

a reception device providing reception for said audio broadcast;

a detection device providing signal detection for said selection signal from said audio broadcast;

an audio description creation device comprising input devices selected from the group consisting of a compact disc player, a tape cassette player, a digital audio tape device, a videotape player, a multi-track audio tape recorder, a microphone and a data input device, said data input device creating an audio description file;

a communication device coupled to said programmed data processor enabling access with remote databases and computers for credit authorization and placement of orders;

a responsive device responding to the receipt of said at least one broadcast identifier, generating information in a first database and directing said program schedule and said audio descriptive data; and

a data processor attachment device coupled to said telephone interface device, said detection device and said communication device, said data processor attachment device directing said telephone interface device to communicate said audio descriptive data to said remote locations.

61. The system in Claim 60 wherein said communications device receives the said program schedule.

62. The system in Claim 60 wherein said audio description creation device includes a text-to-speech conversion system.

63. The system in Claim 60 wherein said programmed data processor further includes a text to speech conversion device for relating said audio description information to said listeners.

64. The system in Claim 60 wherein said audio broadcast unit informs said remote locations of a communications network address associated with said audio broadcast.

65. The system in Claim 60 wherein said audio broadcast unit includes a radio transmitter.

66. The system in Claim 60 wherein said audio broadcast unit further includes a television transmitter.

67. The system in Claim 60 wherein said at least one broadcast unit includes a video broadcast comprising both video and audio.

68. The system in Claim 60 wherein said at least one broadcast unit further includes a satellite transmitter.

69. The system in Claim 60 wherein said at least one broadcast unit further includes a cable television head end.

70. The system in Claim 60 wherein said at least one broadcast unit further includes a fiber optic head end and distribution network.

71. The system in Claim 60 wherein said at least one broadcast unit further includes a low power television transmitter.

72. The system in Claim 60 wherein said at least one broadcast unit further includes a digital video broadcast.

73. The system in Claim 60 wherein said programmed data processor directs said telephone interface for information from said listener utilizing computer generated voice prompts.

74. The system in Claim 60 wherein said telephone interface receives touch tone input or automatic number identification (ANI) relating to a caller telephone number.

75. The system in Claim 60 wherein said telephone interface receives said program schedule such that said caller enters information using said keys on said telephone or voice recognition to input a number representation referenced from a master listing.

76. The system in Claim 60 wherein said telephone interface receives and digitally stores said caller authorization and billing information.

77. The system in Claim 60 wherein said telephone interface connects said caller to a customer support operator.

78. The system in Claim 60 wherein said audio description creation device is configured through a separate system comprising:

- at least one computer system containing audio authoring software;
- input unit comprising a compact disc player, a digital audio tape, a multi-track audio tape recorder, a microphone and a cassette tape player;
- a communication unit transferring digital files to said programmed data processor;

- an audio storage unit digitally compressing said audio descriptive data; and

- a data input and display unit connected to said at least one computer system.

79. The system in Claim 78 wherein said audio description creation device creates said audio segments.

80. The system in Claim 60 wherein said program schedule comprises a video schedule.

81 The system in Claim 60 wherein all apparatus is located at said at least one broadcast unit.

82. A method to provide a self-generating audio storage, indexing and transaction system for remote listeners of a radio or television broadcast comprising the steps of:

broadcasting of at least one radio or television signal on which signal a telephone number is advertised;

inserting of a selection signal into said broadcast signal;

accepting of telephone input from said listener of said radio or television signal who provide at least the broadcast identifier of said radio station or television signal;

receiving of said radio or television signal;

detecting of said selection signal from within said radio or television broadcast;

provision of communications means for the input of the radio or television station program schedule into the programmed data processor;

receiving of input from input devices selected from the group consisting of a compact disc player, a tape cassette player, a digital audio tape device, a videotape player, a multi-track audio tape recorder, a microphone and auxiliary data input devices for the creation of a audio description file;

communicating means coupled to the programmed data processor enabling access with remote databases and computers for credit authorization and placement of orders;

generating of information in a first database responsive to receipt of a broadcast identifier, directing said audio program schedule and audio description information;

use of a programmed data processor coupled to the telephone interface, signal detection means and the communication means directing the telephone interface to communicate to said listener the audio description information for said radio or television broadcast.

83. The method in Claim 82 wherein said audio description file contains the digital data describing the title and artist of said program schedule listing.



84. The method in Claim 82 wherein said audio description file contains digital data describing the title and artist of said program schedule listing and an audio segment.

85. The method in Claim 82 whereby said broadcast identifier is a music category or music genre of said broadcast unit.

86. A system for on-demand remote access to a self-generating, audio storing, indexing and transacting system comprising:

at least one broadcast unit, said at least one broadcast unit allowing audio broadcast to remote locations and informing said remote locations of a telephone number;

a telephone interface device providing audio descriptive data to a programmed data processor, said audio descriptive data received via a telephone connection, said audio descriptive data at least one broadcast identifier, said programmed data processor including a data input unit for receiving a program schedule;

an audio description creation device comprising input devices selected from the group consisting of a compact disc player, a tape cassette player, a digital audio tape device, a videotape player, a multi-track audio tape recorder, a microphone and a data input device, said data input device creating an audio description file;

a communication device coupled to said programmed data processor enabling access with remote databases and computers for credit authorization and placement of orders;

a responsive device responding to the receipt of said at least one broadcast identifier, generating information in a first database and directing said program schedule and said audio descriptive data; and

a data processor attachment device coupled to said telephone interface device and said communication device, said data processor attachment device directing said telephone interface device to communicate said audio descriptive data to said remote locations.

87. The system in Claim 86 wherein said audio description creation device is configured through a separate system comprising:

at least one computer system containing audio authoring software;

an input unit comprising a compact disc player, a digital audio tape, a multi-track audio tape recorder, a microphone and a cassette tape player;

a communication unit transferring digital files to said programmed data processor;

an audio storage unit digitally compressing said audio descriptive data; and

a data input and display unit connected to said at least one computer system.

88. The system of Claim 87 wherein said audio description creation means further includes a text to speech conversion device.

89. The system of Claim 86 wherein said data processor attachment device includes a text to speech conversion device.

90. The system in Claim 86 wherein the communications unit communicates said audio descriptive data relating to said program schedule.

91. The system in Claim 86 wherein said communications unit receives said program schedule.

92. A method to provide a self-generating audio storage, indexing and transaction system for remote listeners of a radio or television broadcast comprising the steps of:

broadcasting of at least one radio or television signal on which signal a telephone number is advertised;

accepting of telephone input from said listener of said radio or television signal who provide at least the broadcast identifier of said radio station or television signal;

provision of communications means for the input of the radio or television station program schedule into the programmed data processor;

receiving of input from input devices selected from the group consisting of a compact disc player, a tape cassette player, a digital audio tape device, a videotape player, a multi-track audio tape recorder, a microphone and auxiliary data input devices for the creation of a audio description file;

communicating means coupled to the programmed data processor enabling access with remote databases and computers for credit authorization and placement of orders;

generating of information in a first database responsive to receipt of a broadcast identifier, directing said audio program schedule and audio description information;

use of a programmed data processor coupled to the telephone interface and the communication means directing the telephone interface to communicate to said listener the audio description information for said radio or television broadcast.

93. The method in Claim 92 wherein said audio description file includes an audio device describing a selected title in said program schedule.

94. The method in Claim 92 wherein said audio description file includes an audio device describing title and audio segment in said program schedule.

95. The method in Claim 92 wherein said audio description file is created using text to speech translation to convert a program schedule listings or station specific information into an audio format.

96. A method to identify an audio broadcast for a broadcast listener by utilizing a combination of said broadcast listeners telephone number and station call letters comprising:

obtaining said broadcast listener telephone number including area and exchange code utilizing touch tone telephone input or through ANI (Automatic Number Identification);

obtaining broadcast identifier input by said broadcast listener utilizing touch tone telephone input;

creating a file on a programmed data processor organized by area code, the three telephone exchange digits and the call letters for stations that can be received for an area and telephone exchange code;

utilizing said broadcast listener area and exchange telephone codes to determine which said broadcast identifier match the said broadcast identifier input by the said broadcast listener.

97. The method in Claim 96 wherein said broadcast listener enters a AM or FM designation on the touch tone telephone to resolve a conflict when more than one station have the same call letters.

98. The method in Claim 96 wherein said telephone interface receives said at least one broadcast identifier selected from the group consisting of a station tuning frequency, station call letters, a television channel allocation, a cable subscriber identification or a predetermined identifier.

99. A method of identifying a radio station being listened to using a combination of a listeners telephone number and the music genre or category of the radio or television station, comprising the steps of:

obtaining a listeners telephone number and area code by touch tone input by the listener or through ANI (Automatic Number Identification);

creating a file on the programmed data processor organized by area code, the three telephone exchange digits and the genre or music category of the participating stations able to be received by a potential listener in each area code and telephone exchange;

prompting a listener to input through the touch tone telephone the genre or music category of the radio station listened to;

prompting of the potential purchaser to select the correct station call letters from an audio description of only those stations within reception distance, that match the selected station type.

100. The audio information system in Claim 1 wherein said audio description further includes video information.

101. The audio information system in Claim 1 wherein said user interface includes means for coupling to a personal computer.

102. The audio information system in Claim 1 wherein said audio description output means relates audio and video information.

103. The audio information system in Claim 1 wherein said user interface further includes a computer interface and said user inquiries are placed using commands entered through a keypad.

104. The audio information system in Claim 1 wherein said first input means further includes a television receiver device.

105. The audio information system in Claim 1 wherein said first input means further includes an video signal digitizer device.

106. The audio information system in Claim 1 wherein said audio description output means transmits digital information relating to a textual message.

107. The audio information system of Claim 1 wherein said audio description output means transmits digital information for storage on said user interface.

108. The audio information system of Claim 1 wherein said first input means includes means for extracting audio and video description from prerecorded material.

109. The system of Claim 12 wherein said communications means produces digital information to be stored on a user interface comprising a personal computer.

110. The system of Claim 12 wherein said communications means produces digital information relating to a textual message based on said selected audio or video description.

111. The system of Claim 12 wherein said audio description further includes video.

112. The system of Claim 12 wherein said recording means includes a video signal digitizer device.

113. The system of Claim 12 wherein said audio description creation means further includes a video signal digitizer device.

114. The system of Claim 60 wherein said communications means produces digital information to be stored on a user interface comprising a personal computer.

115. The system of Claim 60 wherein said communications means produces digital information relating to a visual message based on said selected audio or video description.

116. The system of Claim 60 wherein said audio description creation means includes a video signal digitizer device.

117. The system of Claim 115 wherein said communications means transmits digital information to be stored on said user interface comprising a personal computer.

118. The system of Claim 115 wherein said communications means transmits digital information relating to a textual message based on said selected audio or video description.

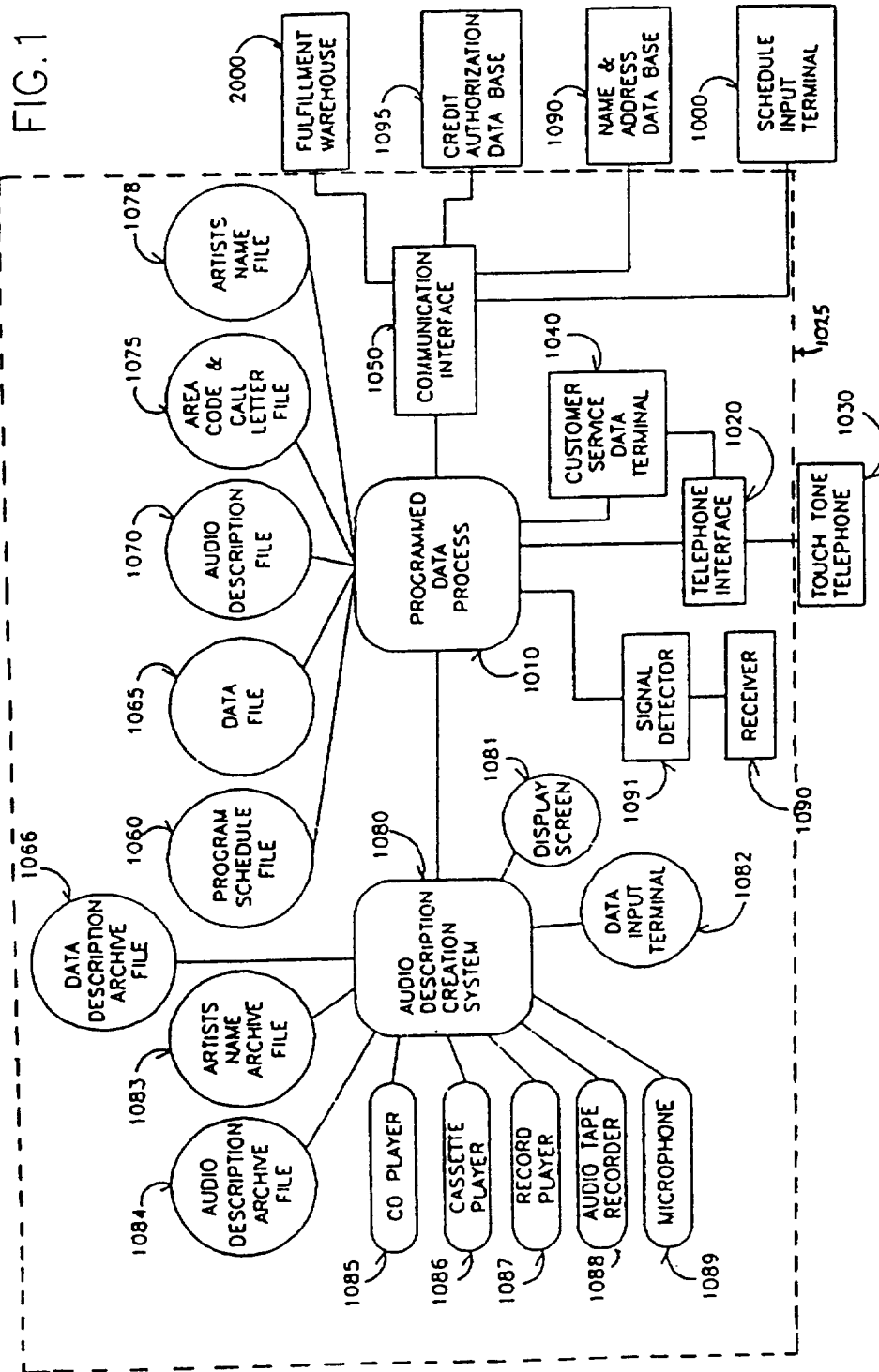


FIG. 2

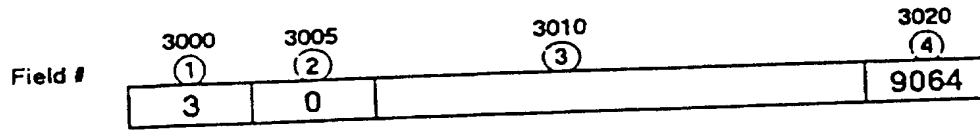
Field #	2000	2005	2010	2015	2020	2025	2030	2035
①	9728	80694	176	001	032406			9064
②								
③								
④								
⑤								
⑥								
⑦								
⑧								

Next Music Piece Broadcast

Program Schedule File 1060

- Field #
- ① Station call letters as numeric values of touchtone keys.
  - ② Date and period of broadcast.
  - ③ Number of music pieces in the time period.
  - ④ Chronological schedule number.
  - ⑤ Time of broadcast
  - ⑥ Artist or group name.
  - ⑦ Title of music piece.
  - ⑧ Pointer to data file.

FIG. 3



Artist Name File 1078

- Field #
- ① Category of Music. ie Pop, Rock
  - ② Artist or Group indicator. ie 0 for artist
  - ③ Name of Artist in touch tones
  - ④ Pointer to Artist or Group Name in Data File 1065



FIG. 4

Field #	4000	4010	4020	4030	4040	4050	4060	next station in area code and exchange				last station			
	(1)	(2)	(3)	(4)	(5)	(6)	(7)	(4)	(5)	(6)	(7)	(4)	(5)	(6)	(7)
	123	306	3	9728	1	3	49062								
	123	309	2												
	123	322	5												
	123	338	2												

Area Code and Call Letter File and Database Structure

- Field #
- (1) Telephone area code
  - (2) Telephone exchange code ( within previous Area Code )
  - (3) Maximum number of radio stations with signal coverage in the outlined area and exchange code
  - (4) Numeric values of touch tone telephone keys that match the letters of the radio station call letters
  - (5) AM or FM indicator
  - (6) Category of music indicator
  - (7) Pointer to the audio description for the station call letters.

# CANADA - USA

Canada and the United States are divided into more than 100 telephone areas, identified by a three-figure Area Code. Fig. 5

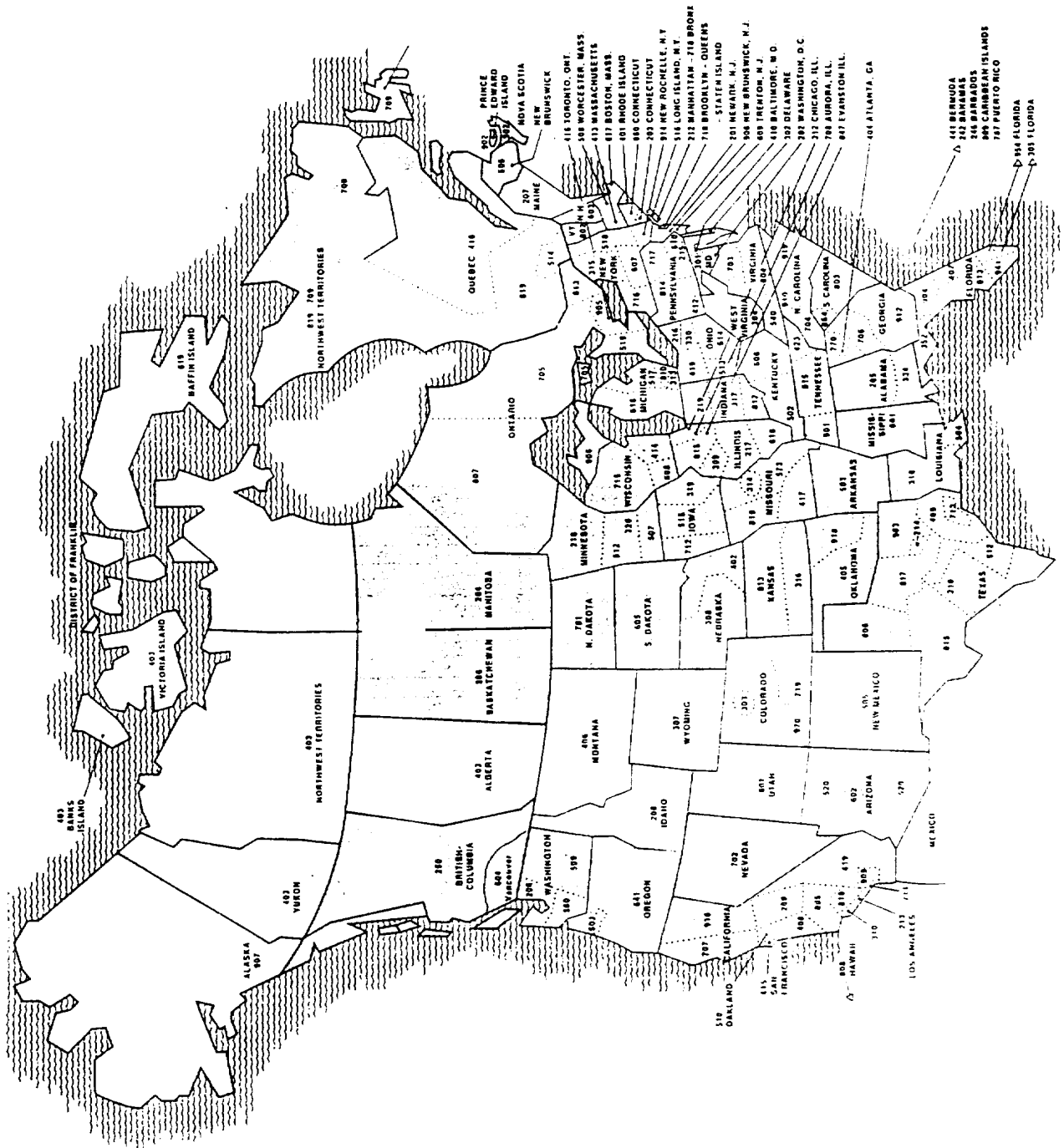
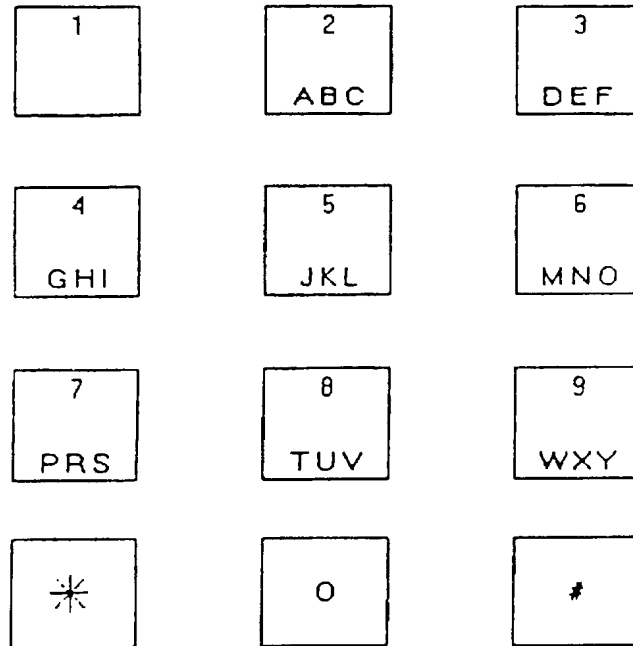
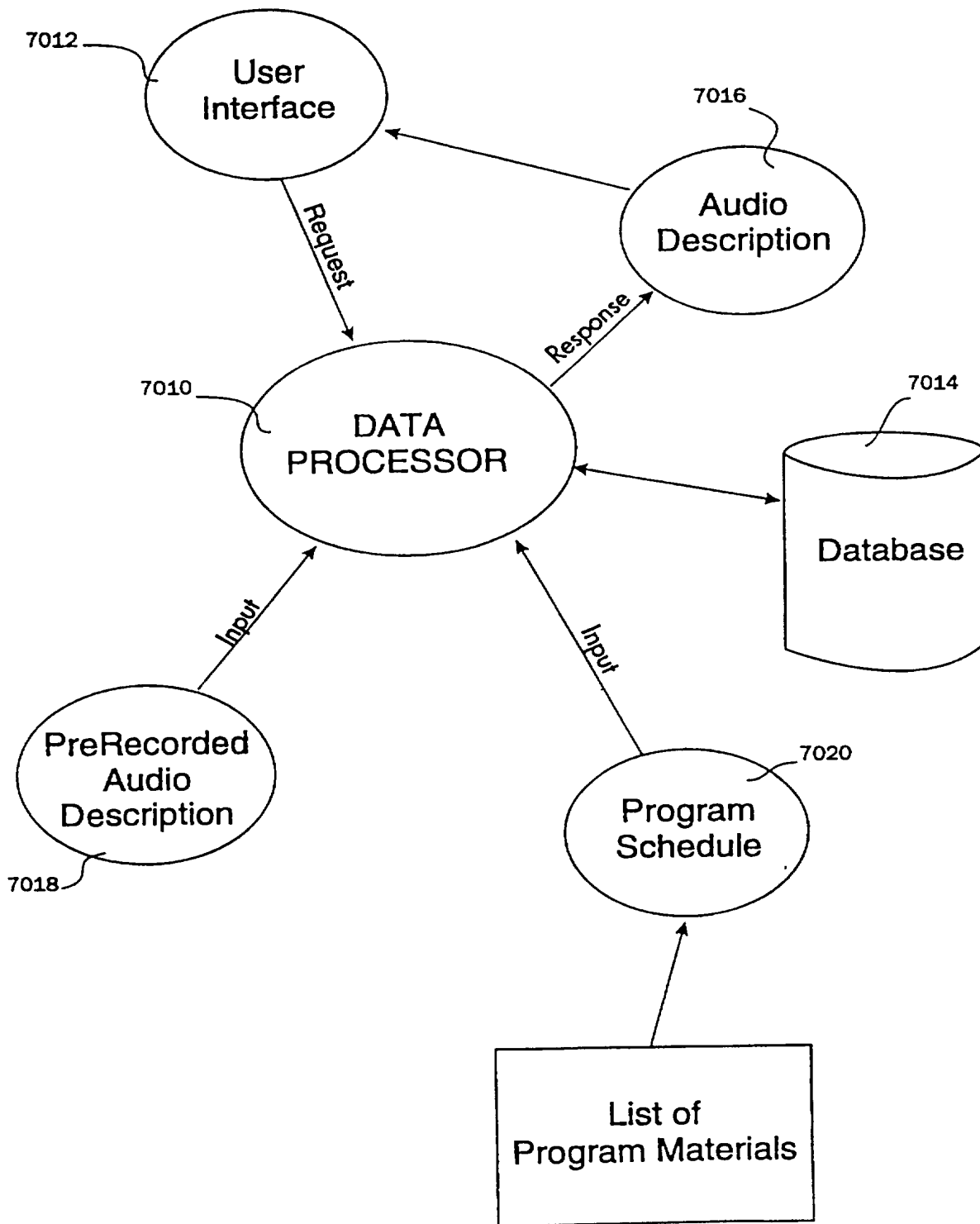


FIG. 6



NOTE: The letter Q and Z are not contained on the keypad. In this embodiment the key containing the number 1 is used to denote a Q or Z. The key containing O is used to denote a space where required.

# Figure 7





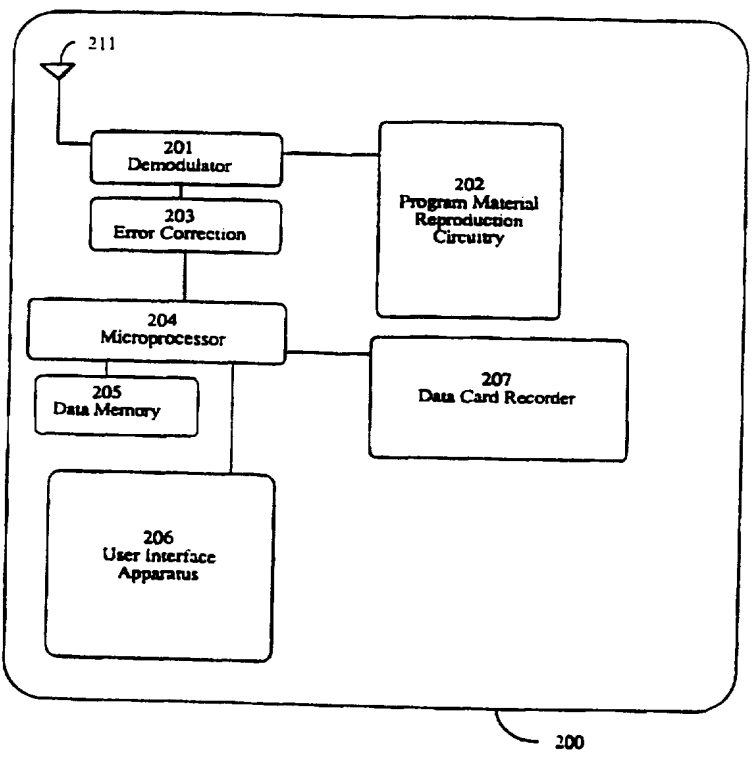
INTERNATIONAL APPLICATION PUBLISHED UNDER THE PATENT COOPERATION TREATY (PCT)

<p>(51) International Patent Classification <sup>6</sup> : <b>H04H 1/00</b></p>	<p><b>A1</b></p>	<p>(11) International Publication Number: <b>WO 97/42724</b> (43) International Publication Date: 13 November 1997 (13.11.97)</p>
<p>(21) International Application Number: PCT/US97/07485 (22) International Filing Date: 2 May 1997 (02.05.97) (30) Priority Data: 08/643,801 6 May 1996 (06.05.96) US (71) Applicant: DIGITAL D.J. INCORPORATED [US/US]; 1375 McCandless Drive, Milpitas, CA 95035 (US). (72) Inventors: TAKAHISA, Tsutomu; 111 Saratoga Avenue #2305, Santa Clara, CA 95051 (US). HASEGAWA, Koyo; 3-7-9, Nishi-Ikebukuro, Toshimaku, Tokyo 171 (JP). (74) Agents: MEYER, Stuart, P. et al.; Fenwick &amp; West LLP, Suite 700, Two Palo Alto Square, Palo Alto, CA 94306 (US).</p>		<p>(81) Designated States: AL, AM, AT, AU, AZ, BA, BB, BG, BR, BY, CA, CH, CN, CU, CZ, DE, DK, EE, ES, FI, GB, GE, GH, HU, IL, IS, JP, KE, KG, KP, KR, KZ, LC, LK, LR, LS, LT, LU, LV, MD, MG, MK, MN, MW, MX, NO, NZ, PL, PT, RO, RU, SD, SE, SG, SI, SK, TJ, TM, TR, TT, UA, UG, UZ, VN, YU, ARIPO patent (GH, KE, LS, MW, SD, SZ, UG), Eurasian patent (AM, AZ, BY, KG, KZ, MD, RU, TJ, TM), European patent (AT, BE, CH, DE, DK, ES, FI, FR, GB, GR, IE, IT, LU, MC, NL, PT, SE), OAPI patent (BF, BJ, CF, CG, CI, CM, GA, GN, ML, MR, NE, SN, TD, TG).</p> <p><b>Published</b> <i>With international search report. Before the expiration of the time limit for amending the claims and to be republished in the event of the receipt of amendments.</i></p>

(54) Title: DATA BROADCAST SYSTEM WITH MULTIPLE-TUNER RECEIVER

(57) Abstract

A broadcast transmitting and receiving system includes a receiver having multiple tuners. A data tuner receives a data stream indicating the type of programming being broadcast by one or more stations. Based on information in the data stream, the frequency of operation of a sound tuner is adjusted to provide the user with a desired type of programming. Various modes of operation are provided, some employing a user interface and others being operable without user intervention.



**FOR THE PURPOSES OF INFORMATION ONLY**

Codes used to identify States party to the PCT on the front pages of pamphlets publishing international applications under the PCT.

<b>AL</b>	Albania	<b>ES</b>	Spain	<b>LS</b>	Lesotho	<b>SI</b>	Slovenia
<b>AM</b>	Armenia	<b>FI</b>	Finland	<b>LT</b>	Lithuania	<b>SK</b>	Slovakia
<b>AT</b>	Austria	<b>FR</b>	France	<b>LU</b>	Luxembourg	<b>SN</b>	Senegal
<b>AU</b>	Australia	<b>GA</b>	Gabon	<b>LV</b>	Latvia	<b>SZ</b>	Swaziland
<b>AZ</b>	Azerbaijan	<b>GB</b>	United Kingdom	<b>MC</b>	Monaco	<b>TD</b>	Chad
<b>BA</b>	Bosnia and Herzegovina	<b>GE</b>	Georgia	<b>MD</b>	Republic of Moldova	<b>TG</b>	Togo
<b>BB</b>	Barbados	<b>GH</b>	Ghana	<b>MG</b>	Madagascar	<b>TJ</b>	Tajikistan
<b>BE</b>	Belgium	<b>GN</b>	Guinea	<b>MK</b>	The former Yugoslav Republic of Macedonia	<b>TM</b>	Turkmenistan
<b>BF</b>	Burkina Faso	<b>GR</b>	Greece	<b>ML</b>	Mali	<b>TR</b>	Turkey
<b>BG</b>	Bulgaria	<b>HU</b>	Hungary	<b>MN</b>	Mongolia	<b>TT</b>	Trinidad and Tobago
<b>BJ</b>	Benin	<b>IE</b>	Ireland	<b>MR</b>	Mauritania	<b>UA</b>	Ukraine
<b>BR</b>	Brazil	<b>IL</b>	Israel	<b>MW</b>	Malawi	<b>UG</b>	Uganda
<b>BY</b>	Belarus	<b>IS</b>	Iceland	<b>MX</b>	Mexico	<b>US</b>	United States of America
<b>CA</b>	Canada	<b>IT</b>	Italy	<b>NE</b>	Niger	<b>UZ</b>	Uzbekistan
<b>CF</b>	Central African Republic	<b>JP</b>	Japan	<b>NL</b>	Netherlands	<b>VN</b>	Viet Nam
<b>CG</b>	Congo	<b>KE</b>	Kenya	<b>NO</b>	Norway	<b>YU</b>	Yugoslavia
<b>CH</b>	Switzerland	<b>KG</b>	Kyrgyzstan	<b>NZ</b>	New Zealand	<b>ZW</b>	Zimbabwe
<b>CI</b>	Côte d'Ivoire	<b>KP</b>	Democratic People's Republic of Korea	<b>PL</b>	Poland		
<b>CM</b>	Cameroon	<b>KR</b>	Republic of Korea	<b>PT</b>	Portugal		
<b>CN</b>	China	<b>KZ</b>	Kazakstan	<b>RO</b>	Romania		
<b>CU</b>	Cuba	<b>LC</b>	Saint Lucia	<b>RU</b>	Russian Federation		
<b>CZ</b>	Czech Republic	<b>LI</b>	Liechtenstein	<b>SD</b>	Sudan		
<b>DE</b>	Germany	<b>LK</b>	Sri Lanka	<b>SE</b>	Sweden		
<b>DK</b>	Denmark	<b>LR</b>	Liberia	<b>SG</b>	Singapore		
<b>EE</b>	Estonia						

## DATA BROADCAST SYSTEM WITH MULTIPLE-TUNER RECEIVER

## RELATED APPLICATIONS

5 This is a continuation in part of co-pending United States patent application, serial number 08/549,655, filed October 27, 1995, which is a continuation in part of co-pending United States patent application, serial number 08/425,993, filed April 20, 1995, which is a continuation in part of United States patent application, serial number 08,045,352, filed April 8, 1993, now U.S. Patent no. 5,491,838.

## BACKGROUND AND FIELD OF THE INVENTION

This invention relates generally to broadcasting systems, and specifically to a system for transmitting and receiving data using one tuner for control of a second tuner.

15 Many radio broadcast systems are known to exist in which digital data are transmitted along with audio program material. For example, the United States Radio Broadcast Data System ("RBDS") Standard, published by the National Radio Systems Committee and sponsored by the Electronics Industry Association and the National Association of Broadcasters, describes a system for broadcasting a variety of program-  
20 related information on a subcarrier of a standard FM broadcast channel. The RBDS standard teaches a system for transmitting station identification and location information, as well as time, traffic and miscellaneous other information.

U.S. patent no. 5,063,610 to Alwadish discloses a system in which advertising text, song titles, or other program-related data may be transmitted along with audio  
25 program material and stored, displayed, or printed by a listener using appropriate receiving apparatus. The Alwadish system is understood to require data corresponding to program material to be stored along with the program material source itself (*i.e.*, on compact disc or digital audio tape). Thus, the Alwadish system relies on customized audio program source hardware and software.

30 In another field of art, several systems have been taught for automatically monitoring received broadcast signals in order to log the program content of such broadcasts. For instance, U.S. patent nos. 4,450,531 and 4,843,562 to Kenyon et al.

teach schemes for automatically recognizing received program material as one of a number of "reference" library programs.

Notably absent from the known prior art, however, is a system for broadcasting program material and associated data that does not rely on customized program source material and related apparatus in which the program and the data are linked at the program source level. It would be desirable to have a system in which conventional program sources (*e.g.*, conventional phonograph records, tape cartridges, or compact discs) could be played using conventional program source apparatus (*e.g.*, conventional turntables, tape cartridge players and compact disc players), yet still provide the advantages of transmitting data pertaining to the program material.

It would also be desirable to have systems and methods for applying such broadcast data to diverse uses, and to provide such systems and methods with improvements that provide additional features and benefits.

## Summary of the Invention

In accordance with the present invention, a broadcast transmission and reception system includes a transmitter subsystem having (a) program sources, (b) a device for applying to a transmitter program material from the program sources, and (c) a device for applying to a transmitter a data stream corresponding to the program material for transmission along with the program material; and a receiver subsystem having (a) a demodulator unit for detecting the program material and data stream, and (b) a device for changing frequency for the receiver subsystem in response to the data stream.

Also in accordance with the present invention, the receiver subsystem includes a user interface device allowing user selection of an item from a menu of data options, wherein the device for changing frequency operates in response to the item.

In another aspect of the invention, a receiver includes a first tuner adapted to receive program material from a first broadcast station, a second tuner adapted to receive a data stream from a second broadcast station, and a processor operatively coupled to the first tuner and the second tuner, the processor adapted to receive as input signals from the second tuner corresponding to the data stream and to produce as output signals causing the second tuner to change operating frequency.



In still another aspect of the invention, the second tuner scans among available frequencies and collects data from a plurality of broadcast stations.

The features and advantages described in the specification are not all-inclusive, and particularly, many additional features and advantages will be apparent to one of ordinary skill in the art in view of the drawings, specification, and claims hereof. Moreover, it should be noted that the language used in the specification has been principally selected for readability and instructional purposes, and may not have been selected to delineate or circumscribe the inventive subject matter, resort to the claims being necessary to determine such inventive subject matter.

#### BRIEF DESCRIPTION OF THE DRAWINGS

Figure 1 is a block diagram of a transmission system for program material and associated data, in accordance with the present invention. Figure 1a is a block diagram detailing a data stream generator as illustrated in figure 1.

Figure 2 is a block diagram of a receiving system for program material and associated data, in accordance with the present invention.

Figure 3 is an illustration of a user interface display panel showing information about a musical composition, in accordance with the present invention.

Figure 4 is an illustration of a user interface display panel showing information about a composer, in accordance with the present invention.

Figure 5 is a flow diagram illustrating receiver operation, in accordance with the present invention.

Figure 6 illustrates memory addresses for data storage and retrieval, in accordance with the present invention.

Figure 7 illustrates the components of a data packet, in accordance with the present invention.

Figure 8 illustrates receiver screen menu hierarchy, in accordance with the present invention.

Figure 9 illustrates screen menu flow for the programmer terminal illustrated in figure 1.

Figure 10 is a block diagram for a receiver that operates in various modes to selectively receive, process and reproduce portions of transmitted program material and data, in accordance with the present invention.

5 Figure 11 is a block diagram of a receiver that includes a game-playing mode processing transmitted game-playing data, in accordance with the present invention.

Figure 12 is a block diagram of a receiver that generates signals to control connected devices based on transmitted data, in accordance with the present invention.

10 Figure 13 is a block diagram of a receiver that produces a scannable bar code based on transmitted data.

Figure 14 is a block diagram of a receiver that includes multiple tuner subsystems for selectively receiving more than one channel of program material and transmitted data, in accordance with the present invention.

15 Figure 15 is a block diagram of a system including a receiver and a connected computer system controlled responsive to transmitted data, in accordance with the present invention.

Figure 16 is a block diagram of a receiver connected to a point of sale terminal using a data link, in accordance with the present invention.

20 Figure 17 is a block diagram of a receiver module and four different liquid crystal displays connectable to the receiver module, in accordance with the present invention.

Figure 18 shows a receiver having a solar panel integrated with a liquid crystal display, in accordance with the present invention.

25 Figure 19 is a block diagram of a receiver that includes two tuner subsystems for selectively tuning stations in response to transmitted data, in accordance with the present invention.

#### DESCRIPTION OF A PREFERRED EMBODIMENT

30 The figures depict a preferred embodiment of the present invention for purposes of illustration only. One skilled in the art will readily recognize from the following discussion that alternative embodiments of the structures and methods

illustrated herein may be employed without departing from the principles of the invention described herein.

Referring now to figure 1, there is shown a transmission system 100 in accordance with the present invention. The operation of the transmission system 100 is illustrated by discussion of the component parts illustrated in figure 1.

Conventional audio sources such as microphone 102, compact disc player 103, and tape cartridge player 104 provide program source audio to mixing board 101. Mixing board 101 and audio sources 102-104 may be conventional units, such as those already present in a typical radio broadcast station. Audio output is fed from mixing board 101 to transmitter 110 in the conventional manner over an audio bus 113 for transmission from antenna 111. Transmitter 110 may be any conventional radio broadcasting transmitter with main channel and subcarrier channel input capabilities, such as that typically installed in modern FM broadcasting stations. Additional conventional audio compression, limiting, or other processing circuitry (not shown) may be installed at mixing board 101, transmitter 110, or in between, but is not pertinent for purposes herein.

The audio output of mixing board 101 is also applied to a program material recognizer 106 via audio bus 113. The purpose of the program material recognizer 106 is to compare the program material coming from mixing board 101 with a database of known program material 107. If a match is detected, program material recognizer 106 sends pertinent program data, for instance the title of the program material, the composer, and the performer, to data stream generator 105. Any suitable program recognizing system can be used to implement program material recognizer 106 and database of known program material 107, for instance the system taught by Kenyon et al. in U.S. Patent no. 4,843,562 for received broadcast audio signals. The teachings of U.S. Patent no. 4,843,562 are incorporated herein by reference. Those skilled in the art may readily apply such known systems for recognizing audio programs to implement the program material recognizer 106 and database of known program material 107 of figure 1.

The output data provided by program material recognizer 106 are converted by data stream generator 105 into a form that may be directly applied to a conventional subcarrier channel input of transmitter 110. The manner of making this conversion

will depend on the particular program material recognizer 106 employed and the desired data format for transmission, and may readily be accomplished by one skilled in the art. In a preferred embodiment, data stream generator 105 is configured to conform to the large transmission capacity multiplex data broadcast system protocol promulgated by NHK (Japan Broadcasting Corporation) known as L-MSK. This protocol permits data transmission speeds of up to 32 kbits per second.

Mixing board 101 also provides a signal, either through an existing facility on mixing board 101 or through a simple modification, representative of which program source (*i.e.*, microphone 102, compact disc player 103 or tape cartridge player 104) is currently selected by mixing board 101. Program source detector 108 converts this signal to a form usable by data stream generator 105. While the particular implementation of program source detector 108 may vary with the type of mixing board 101, those skilled in the art will readily be able to implement program source detector 108 for operation with any particular mixing board 101.

Data stream generator 105 generates different data streams depending on the program source detected by program source detector 108. For example, if program source detector 108 indicates that compact disc player 103 or tape cartridge player 104 is selected by mixing board 101, then data stream generator 105 applies to transmitter 110 the information generated by program material recognizer 106. However, if program source detector 108 indicates that microphone 102 is selected, then data stream generator 105 may generate data identifying the announcer's name, or the fact that news or traffic information is being broadcast, as appropriate for the use to which microphone 102 is put. If microphone 102 is put to multiple uses, then a general message such as the station's call sign or a random advertisement may be generated by data stream generator 105. Thus, in operation, data stream generator 105 provides a stream of data to transmitter 110 indicating, for example, details about a musical composition played on compact disc player 103, then advertiser information corresponding to a commercial played on tape cartridge machine 104, then an appropriate message corresponding to the selection of microphone 102 such as "Traffic Alert".

In one embodiment of the present invention, database of known program material 107 contains both the data needed by program material recognizer 106 to

recognize a particular program, and also the data associated with that program to be sent to transmitter 110 via data stream generator 105. The data associated with the program material can be entered, as known with regard to conventional recognition systems, by manual key entry from programmer terminal 112 or by some other  
5 common data entry method. Programmer terminal 112 may be a dedicated computer terminal or may be a personal computer connected to data stream generator 105 via a conventional local area network. Database 107 may be provided by a third party, for instance in the form of computer tapes or disks containing both the data needed for recognition and the data desired for transmission. In such an embodiment, other data  
10 associated with program material, such as data associated with commercial announcement program material, may be separately entered into database 107 using conventional data entry techniques. Furthermore, data to be transmitted when program source detector 108 indicates selection of microphone 102 may be stored either as part of database 107 or in a separate database (not shown). Those skilled in  
15 the art will recognize that any such choice that provides associated data for transmission may be used in accordance with the present invention.

As is evident from figure 1, none of the existing components of a conventional broadcast station, with the possible exception of the mixing board 101 as discussed above, needs to be replaced or altered to implement transmission system 100. An  
20 upgrade from a conventional transmission system to the transmission system 100 of figure 1 requires only the connection of the program source detector 108 to the mixing board 101, tap-off of the audio program material feed between mixing board 101 and transmitter 110 to program material recognizer 106, and connection from data stream generator 105 to a subcarrier channel input of transmitter 110.

25 Referring now to figure 1a, there is shown a detailed functional block diagram of data stream generator 105. The major components of data stream generator 105 include a data input processor 153, database manager 155, system controller 157, output spooler 154, and NHK encoder 152. Data input processor 153 receives program source data from program source detector 108 via a serial RS-232 data link 151, and  
30 receives program recognition data from program material recognizer 106, also via a serial RS-232 data link 151. Data input processor 153 uses this input data to determine which data from a screen storage database 156 should be accessed, using database

manager 155, and sent to output spooler 154. For example, if data input processor 153 receives data indicating that a compact disc player is active and that the program material being broadcast is a musical selection known as "Concertino for Piano and Chamber Ensemble", it will cause a database entry corresponding to data particular to that selection to be extracted from screen storage database 156 and applied, through database manager 155, to output spooler 154. The database entry would include all of the data required for display of information of data associated with the musical selection on a receiver, as described below in connection with figures 3 and 4.

A system controller 157 is coupled to database manager 155 and output spooler 154 for two discrete purposes. First, system controller 157 provides timing and control signals to regulate the movement of data from database manager 155 to output spooler 154. Second, system controller 157 provides, through a connection with a programmer terminal 112, a means by which data may be inserted into screen storage database 156, through database manager 155. For instance, radio station personnel may key in data to be associated with any particular entry of screen storage database, to permit such information to be transmitted over the system when the associated program material selection is played. As a specific example, if there is to be a public performance of "Concertino for Piano & Chamber Ensemble" at a local symphony hall, that fact may be entered into screen storage database 156 so that whenever this musical selection is played, this information will be transmitted for display on the user's receiver. Further discussion regarding data entry is provided below in connection with figure 9.

Output spooler 154 is a buffer that stores data to be transmitted and sends such data, via RS-232 serial data link 151, to an NHK data encoder to permit transmission of the data using transmitter 110. NHK data encoder transforms the data from output spooler 154 into a data stream meeting the specifications of the NHK high capacity multiplex data broadcast protocol L-MSK described above. One example of a commercially-available device operating in accordance with this protocol is the model 4001A FM Multiplex Signal Transmitter for Mobile Receivers available from Eiden Company Limited, Tokyo, Japan.

In the preferred embodiment, components 152-157 are implemented by using a programmed general purpose computer. Those skilled in the art may easily implement the functions of these components in such a manner.

Referring now to figure 2, there is shown a receiving system 200 in accordance with the present invention. The operation of the receiving system 200 is illustrated by discussion of the component parts illustrated in figure 2. A signal transmitted by transmission system 100 of figure 1 is received by antenna 211 and demodulated into audio and data components in a conventional manner by demodulator 201.

Demodulator 201 is of conventional design for detecting and demodulating audio and data signals transmitted over a main broadcast channel and a subcarrier of that channel, respectively. Audio program information from demodulator 201 is applied to conventional program material reproduction circuitry 202. Data associated with the program material (corresponding to that generated by data stream generator 105 of figure 1) are error corrected in a conventional manner by error correction circuitry 203, transferred to microprocessor 204, and then are stored in data memory 205, using any of the conventional techniques and devices well known to those skilled in the art.

A user interface apparatus 206 allows a user of receiving system 205 to selectively access data stored in 203. User interface apparatus 206 is implemented using a conventional microprocessor-based design well known to those skilled in the art of user interface design and implementation. User interface apparatus 206 provides both display capabilities for the transmitted data and user input capabilities to permit user selection of portions of the transmitted data.

A conventional data card recorder 207, such as that used to record information on magnetic library cards or the like, is connected to data memory 205 through microprocessor 204. The purpose of data card recorder 207 is to allow the user of receiving apparatus 200 to store selected data on portable magnetic cards. For instance, data associated with a promotion by an advertiser may be used as "electronic coupons" to allow listeners who record such data to receive a discount on merchandise. The coupon data could include standardized identifying data for a product, such as the "SKU" code for a product. A corresponding magnetic card reader of conventional design (not shown) would be used at the store where the coupon is to be redeemed.

Receiving system 200 may readily be implemented by augmenting a conventional broadcast receiver capable of providing the functions of demodulator 201, program material reproduction circuitry 202, and antenna 211, with the digital

data functions corresponding to error correction circuitry 203, microprocessor 204, data memory 205, user interface apparatus 206, and, if desired, data card recorder 207. Alternatively, the functions of elements 203 - 207 may be implemented by a general purpose digital computer, such as a conventional personal computer, notebook  
5 computer, or home entertainment computer, and antenna demodulator 201, program material reproduction circuitry 202, and antenna 211 may be implemented by an attached device or an add-in circuit card. In such a case, the general purpose digital computer may even be employed to provide the audio/video program material output of the main programming channel, as would conventionally be provided by  
10 program material reproduction circuitry 202. Those skilled in the art will readily recognize additional possible implementations in accordance with the present invention.

In some applications, it may be important for significant amounts of data corresponding to the broadcast audio material to be available as soon as the audio  
15 material is transmitted. Depending on the particular implementation of transmission system 100, complete data corresponding to a particular item of audio program material may not be available at receiver 200 until several seconds after the commencement of that item of program material. While this may be acceptable in some situations, *e.g.*, where the item of program material is a symphonic piece of a  
20 significant duration, in other instances the time delay may not be desirable. To ameliorate any problems that may be caused by this data lag, a conventional audio delay device is included in the path of the audio program material so that the broadcast of the audio material is delayed by a predetermined duration comparable to the time desired for data to be accumulated at receiver 200. In one such  
25 implementation, a time delay device is integrated into transmitter 100 so that the audio applied to program material recognizer 106 is not delayed, while the audio that is broadcast by transmitter 110 is delayed.

In an alternate embodiment in which the program material to be transmitted is known in advance, such as where a computerized "playlist," identifying each item of  
30 program material and the time that it is to be broadcast, is available to data stream generator 105, data corresponding to that program material may be scheduled to be



broadcast before the actual audio program material, thus providing the same effect as discussed above without the need for any audio delay device.

Referring now to figure 3, there is shown a display panel 300 of user interface apparatus 206. Display panel 300 includes four menu button areas 301 - 304 and a larger information window 305. In the preferred embodiment, display panel 300 is of conventional liquid crystal design, with conventional touch-screen technology being used to implement switches over the menu button areas 301 - 304. Alternatively, physically separate switches could be used in locations adjacent to menu button areas 301 - 304, but one advantage of using touch-screen technology is that button areas can dynamically change in size, location and number under software control. The information window 305 of figure 3 indicates composer, title, and performer data stored in memory 205, corresponding to program material contemporaneously being received by receiving system 200. Menu button area 301 provides the user the option of requesting another screen with further information about this composer; menu button area 302 provides the user with the option of requesting orchestra information; menu button area 303 provides the user with the option of requesting another screen with information on the running time of the current selection; and menu button area 304 provides the user with the option of requesting ordering information for this recording. It should be recognized that the information presented in information window 305 and menu button areas 301 - 304 can be of virtually infinite variety and is not limited to the type of information or layout shown in figure 3.

In an alternate embodiment some top-level menu choices may be stored in permanent memory (not shown) of user interface apparatus 206, but in general all of the information displayed on display panel 300, as well as the number, style, and labeling of the button areas (*e.g.*, 301-304) is determined by data generated by data stream generator 105, transmitted to receiving system 200, and stored in data memory 205. For convenience, data corresponding to menu button areas (*e.g.*, 301) are referred to as header data. The number of menu choices and the amount of displayable information is limited only by the bandwidth of the data transmission subcarrier channel and the capacity of data memory 205. Within these limits, each radio station may choose to include as much or as little header data as it desires, and may custom-design the menu information and layout that appear on the display panel 300.

Referring now to figure 4, there is shown display panel 300 after the user has touched menu button area 301 of figure 3 to request a screen with more information about the composer. Information window 405 now displays different information than in information window 305 of figure 3. Menu button area 301 of figure 3 is replaced with menu button 401 providing the user with the capability of returning to the first screen (*i.e.*, the screen of figure 3). Button area 302 of figure 3 is replaced with button area 402 providing the user with a further choice of viewing a screen indicating other works by the composer. There being no other options under this menu path, button areas 303, 304 of figure 3 have not been replaced with corresponding button areas in figure 4.

Referring now to figure 5, there is shown a procedure for receiving and displaying data as described in connection with figures 3 and 4. The process begins by receiving data at step 501. Next, step 502 performs error correction to validate the data received. This being accomplished, the received and validated data are stored in step 503 at a specified address for later use. A check is then made in step 504 to determine whether, based on received data, new program material, *e.g.*, a new musical selection, is currently being transmitted. If not, a check is made at step 505 to determine whether the user has requested a new screen by making a selection on one of the screen button areas, *e.g.*, 301 - 304. A new screen request is indicated by a "new screen request flag" being set. If the new screen request flag has not been set, processing returns to step 501 for the acquisition of further data.

If the check at step 504 indicates that new program material is being transmitted, processing flows to step 506, in which a new main menu screen for that new program material is displayed. In accordance with the present invention, the first data transmitted for new program material correspond to the main menu screen for that selection, so as soon as a new program is detected, main screen data for that material should already be available. Upon displaying the new main screen data in step 506, processing returns to step 501 for the acquisition and validation of further data corresponding to other screens. In a preferred embodiment, once a new program selection is detected, data from a previous program selection need not be discarded, but may be stored for later access by the user. In an alternate embodiment, users may recall data from several preceding selections, if desired. For example, if users hear a

musical selection that they like, but that they do not realize they would like to order until after the selection is complete, they may still access ordering information for that selection after the next selection begins. Conventional techniques well known to those skilled in the art may be used to store and retrieve such information from previous  
5 selections.

If the check in step 505 indicates that a user has requested a new screen, processing flows to step 507, where a determination is made as to the particular new screen requested. Next, step 508 checks to see whether data for that new screen have yet been stored for the current program selection. If not, processing returns to step  
10 501 to allow further data to be acquired. If the requisite data have been stored for that screen, step 509 resets the new screen request flag and step 510 displays the new screen. Processing then returns to step 501.

Referring now to figure 6, there is shown a memory map 600 for screen data in accordance with the present invention. Data for a main screen menu are given the  
15 highest address, in this case 1000. Data for screens corresponding to main screen menu choice numbers 1 through 4 are stored at addresses 1100-1400, respectively. Data for screens corresponding to menu selections from the screen data addressed at 1100 are stored at locations 1110 through 1130, and so on. Thus, addresses for screen data are defined such that the most significant bits of an address identify the parent  
20 screens corresponding to a screen of data. Referring now also to figure 8, this hierarchy of screens may be thought of as a pyramid, with the main menu screen of data 800 appearing at the tip of the pyramid and with the pyramid of screens broadening out as moves down through the menus of screens, *e.g.*, 801-804. The memory map 600 of figure 6 does not list addresses in numerical order, but in  
25 correspondence with this menu hierarchy. This menu hierarchy also determines which data are transmitted first once a new program material selection is broadcast. Data for the initial menu screen 800 (*e.g.*, data with address 1000) are broadcast first, then data for the menu screens 801 - 804 directly accessible from that menu screen (*e.g.*, data with addresses 1100, 1200, 1300), then data for menu screens, *e.g.*, 812, accessible  
30 from those menu screens (*e.g.*, data with addresses 1110, 1120, 1130) and so on through the hierarchy. In this manner, the user will have data that are higher in the hierarchy available more quickly than if the data were transmitted strictly in order of the

addresses. Data for the main screen 800 are sent first and repeated relatively often, while data for subsequent screens, *e.g.*, 801 - 804, are sent next and are repeated less often.

Referring now to figure 7, there is shown a data packet 700 in accordance with the present invention. To provide a flexible structure for presenting data on a receiver display, *e.g.*, the display 300 illustrated in figure 3, data are transmitted in variable-length packets, *e.g.*, 700. In a preferred embodiment, a packet 700 consists of several elements, the first of which is an eight bit pyramid address 710 identifying the data to be sent as corresponding to a particular selection of program material. Thus, if a musical selection is being broadcast, all data pertaining to that musical selection will have identical pyramid addresses. Next, an eight bit data segment is used for a screen address 720, to identify a particular screen of data. This address is used primarily for control purposes, so that when a user selects a new screen to view, an address is available to identify the data corresponding to that screen.

The following eight bit data segment serves as an identifier of packet type 730. A packet type 730 provides data indicative of whether the packet 700 is one providing screen text, one setting a parameter for such screen text (*e.g.*, the font of the text), or one providing only control information (*e.g.*, an address to jump to if a particular user selection is made from the current screen, or an action to take if no user selection is made within a particular "time-out" duration of time). In an alternate embodiment, one other packet type 730 might indicate that the data of that packet are to be used for drawing graphical images on the display 300. Following the packet type 730 is an eight bit starting address 740. In the case of packet types 730 indicative of text to be displayed on a screen, starting address 740 is used to provide a starting row and column on the display 300 for such text. In the case of packet types 730 used to control jumps to other addresses, starting address 740 is used to provide the address to be jumped to. Following the starting address is a variable length text body segment 750 containing text, if any, to be displayed on display 300. In a preferred embodiment, conventional techniques, such as a simple header, are used to indicate the length of the text body segment 750. Finally, a 16 bit error correction segment 760 is included in the packet 700 so that conventional error-checking methods may be used to validate the received data, as mentioned previously in connection with figures 2 and 5.

In a simplified alternate embodiment, a fixed hierarchical structure may be used for the data and the display 300, thereby eliminating the need for variable-length packets 700. For instance, a "block" structure may be employed, in which each program material selection has, corresponding to it, a block of data of a fixed size. As  
5 a specific example, the menu structure may be three levels deep, with menus in each level except for the last providing three choices for subsequent menus. If each menu is constrained to a given number of text characters, then fixed addresses may be used for each screen of the hierarchy. Thus, while flexibility is sacrificed, increased data  
10 throughput is possible, since addressing of data is implicit in the structure and there is no need to transmit a unique address for each portion of data. Those of ordinary skill in the art may readily apply an appropriate data structure to the particular requirements of any system in accordance with the present invention.

Referring again to figure 8, there is shown a flow diagram of a menu hierarchy in accordance with the present invention. The menu hierarchy of figure 8 corresponds  
15 to the displays illustrated in figures 3 and 4. In the diagram of figure 8, a main menu 800 provides the user with four choices for second-level screens 801-804. Screen 801 in turn provides the user with two choices for additional screens, one of which is main menu screen 800, and the second of which is a "Screen 12" 812. Screens 800 - 804 and  
20 812 are shown using larger boxes to indicate that those screens are shown directly, or are indicated as possible screen selections, in figures 3 and 4.

In the example of figure 8, other screen choices are available as well. For instance, "Screen 2" 802 provides four screen choices 822 - 824, and one of those choices, 822, provides yet another choice of a screen 825, which itself permits another choice, of screen 826. This structure may be used where information on a particular  
25 subject is so lengthy that three screens are required to present it.

Similarly, "Screen 3" 803 provides two choices 831, 832. Screen 832 also provides three choices, screens 833 - 835. "Screen 4" 804 provides three choices 841 - 843. Any configuration of screens may be employed for a given selection of program material, as suits the program material itself. The only limitations on such structure  
30 are transmission time for the data and available memory to store such data at the receiver. In an alternative embodiment, even if there is not sufficient memory to store all data in the hierarchy, a small "scratchpad" memory may be used to store user-

requested data that are low in the hierarchy the next time it is transmitted. In such a manner, a very complex hierarchy may be used, without the need for large receiver data memory, but at the added cost of a potentially slower response time.

For purposes of clarity, figure 8 only illustrates one return path to main menu 800. It should be recognized, however, that in a preferred embodiment, every screen at the bottom of the hierarchy provides the user with a choice to return to a main menu 800. In addition, other screens may provide this choice as well, and may provide the user with the possibility of jumping directly to immediately preceding screens ("parents" in the hierarchy) or even to screens elsewhere in the hierarchy. The paths for navigation through the hierarchy are not fixed in any way, and may be different for each selection of program material (*i.e.*, each musical piece).

Referring now to figure 9, there is shown a diagram of menu choices available from programmer terminal 112 of transmitting system 100 illustrated in figure 1. As previously mentioned, programmer terminal 112 permits entry of data associated with programming material. In a preferred embodiment, a menu-driven user interface provides a flexible configuration for entering various types of data. A main menu 900 permits the programmer to choose operations concerning a music database, an advertising database, a fallback database, and possibly other databases. These databases are portions of screen storage database 156, discussed previously in connection with figure 1a.

A music database menu 901 provides the programmer with three choices for further operations. An update menu 911 allows the programmer to download music database updates, for instance information provided by a third-party database service. This information may be available on magnetic disk, optical disk, magnetic tape, or may be accessed through an on-line service. This information may typically contain an identification portion identifying a particular musical selection in a manner compatible with program material recognizer 106, and title and artist information of the sort described in connection with figures 3 and 4 above. In a preferred embodiment, an existing database is merely updated by inputting new or changed information, but an entirely new database of information could also be downloaded in accordance with the present invention.

Modify menu 912 permits the programmer to change information that is currently in the music database. For instance, if there is a constraint on the amount of information that may be stored in transmitting system 100, modify menu 912 permits a programmer to delete information for musical selections for which such information is no longer required. For example, if a radio station changes the format of the music that it plays from classical to jazz, it may not be sensible to maintain classical information in the database. Programmers with greater constraints on storage space may even delete information on songs that are "stale" and will only be played rarely, if at all, in the future. Conventional techniques are used in modify menu 912 to allow a programmer to search for and select particular items for deletion.

Modify menu 912 also permits the programmer to add localized information to the database. Such information may include, for instance, the date, time and place of an upcoming local performance of a particular musical selection, or may be used to add information for selections that are not included in the general database downloaded using update menu 911. Conventional techniques are used to permit the programmer to customize any of the receiver screens, *e.g.*, those displayed in figures 3 and 4, to provide such localized information. In some circumstances, it may be desired to limit the ability of local stations to modify information for a particular selection, and conventional bit-switch techniques may be used to allow or deny such modifications. If local modifications are desired, these may supplement or replace the information downloaded using update menu 911. In cases where a programmer wishes to add information for a programming selection not included in the general database downloaded using update menu 911, the modify menu 912 also permits the programmer to record and store a "footprint" of the new programming selection so that it may be recognized by program material recognizer 106.

Print menu 913 permits the programmer to print various reports regarding the information that has previously been stored using update menu 911 and modify menu 912.

If the programmer selects the advertising database menu 902, the programmer may perform a number of operations relating to data that will be transmitted along with advertising program material. Update menu 921 provides functions similar to update menu 911 of music database 901. Update menu 921 may be used, for example,

to load an advertising database with information that is to be transmitted along with particular commercial announcements. Modify menu 922 provides capabilities for adding, deleting and changing advertising information. In addition to the functions discussed in connection with the modify menu 912 of music database menu 901, 5 modify menu 922 also permits the programmer to schedule dates for a particular advertisement to begin and end, so that the associated data may be added and deleted from a database of active advertisements as needed.

Link menu 923 provides the programmer with both internal and external linking capabilities. Exemplary of internal linking is a facility to permit advertising 10 information to selectively be broadcast during particular program selections. For instance, if an advertiser is sponsoring a local performance by a musician, any program material selections by that musician might have associated with them messages from that advertiser. Exemplary of external linking is a facility to permit a conventional "traffic" software package that keeps track of advertisement schedules, 15 rotations, and changes, to interface with the advertising database. As an example of the use of such external linking, when a traffic director deletes a completed advertising campaign, all of the information that was stored in the advertising database for that campaign will automatically be deleted.

Print menu 924 generates and prints reports concerning the advertising 20 database as desired by the programmer. For instance, the programmer may request a report of all entries corresponding to advertisers having ad information that is to be transmitted during news broadcasts on the main (*i.e.*, audio) channel.

If the programmer selects the fallback database menu 903, various operations may be performed on information that is to be transmitted when program material 25 other than music or advertising is being transmitted or when the program material being transmitted is not recognized by program material recognizer 106. For example, one fallback choice would be transmitting the station's call sign, location, and logo, or the current time. Another might be a rotating set of messages regarding upcoming programs. As a further example of use of the fallback database, if program source 30 detector 108 described in connection with figure 1 determines that a "sports microphone" is the currently selected device, current sports standings or statistics stored in the fallback database may be transmitted for display on a user's receiver



display panel 300. Update menu 931 permits the programmer to download new information for this database in a manner similar to that described in connection with update menus 911 and 921. Modify menu 932 permits the programmer to make further additions, changes, or deletions to this database, and is similar in operation to the facility described in connection with modify menus 912 and 922. Print menu 933 allows the programmer to generate and print reports concerning the contents of the fallback database, and is similar to the print menus 913 and 924 previously described.

If the programmer selects the other databases menu 904, various operations may be performed concerning any other databases supported by the transmitting system 100. One example of such other databases is a schedule for upcoming advertisements or promotions. Another database might be a horoscope database for transmission of astrological information at pre-set times regardless of what program material is being transmitted. Yet a third example of a database accessible through the other databases menu 904 is information for an automated interactive listener call-in fax service, in which a listener uses the telephone handset of a fax machine to request facsimile printouts of information corresponding to recently transmitted program material. This last database might provide listeners not having receivers with associated data capability, *e.g.*, receiver 200, with a mechanism to obtain similar information about program material selections.

In an alternative embodiment, the system illustrated in figures 1 and 2 may also be used to provide personal messages to users. A personal identification code may be stored in data memory 203 or in other available memory within receiving system 200. This identification code may be entered by the user or may be predetermined, for instance by using a serial number for receiving system 200 as the identification code. A radio station operating the transmission system 100 may include in the associated data provided by data stream generator 105 a personal message (*e.g.*, a song dedication or a promotional prize announcement) to a listener using known information as to the personal identification code stored in that listener's receiving system 200. User interface apparatus 206 performs a simple check to see whether such any such personal messages received have matching personal identification codes, and permits display (or output to card recorder 207) of only those personal messages where such a match is detected. One application of such a facility is to allow listeners

calling the radio station to request personal dedications to their loved ones who may be listening at another location. In another application, stations themselves can offer promotional prizes through electronic coupons to only those listeners who have pre-registered their identification codes and are listening when it is announced that a  
5 listener's prize coupon is available for recording on a data card.

In a second alternate embodiment, an associated data capability may be added to video programming material. For example, a menu screen might appear as an inset to a television picture, and the user might be given a choice to receive data concerning the soundtrack of a motion picture that is currently being viewed. Similarly, a  
10 conventional pointing device, or "mouse" might be available for the user to select portions of a video picture for which the user might desire additional information. Thus, if a fashion model is displaying clothes, jewelry and a particular hairstyle, the user might position the cursor on a piece of jewelry and then click the pointing device to obtain a description of the jewelry and information on how to order it.

In yet another alternate embodiment, the data associated with the  
15 programming could be data corresponding to a software computer program. For instance, a television or radio station could transmit an entire software program to the user during a particular segment of audio/video programming. That software may or may not be directly associated with the audio/video programming being sent, but  
20 would typically be of interest to one interested in that audio/video programming. As one specific example, a station might transmit, along with a children's cartoon, game software for a home entertainment computer including the same characters as in the cartoon. The software may be transmitted gradually throughout the audio/video  
25 program, or even during commercial breaks, to give the user an incentive not to change stations during the data transmission. In another aspect of this embodiment, stations may transmit software in small portions throughout the broadcast day, either to individual groups or to all listeners/viewers, thus providing a further incentive for such listeners/viewers to stay tuned to the station. This software downloading  
30 capability could also be employed to provide updated system software for use directly by receiver 200, or could alternatively be employed to download software completely unrelated to the audio/video program material being transmitted by the station.

In yet another alternate embodiment, information such as a winning lottery number may be transmitted, either along with audio/video programming relating to the lottery drawing or at other times. A simple memory configuration in the user's receiver could store such information, either for later manual review by the user or for  
5 automatic comparison against the user's previously entered lottery number selections.

Referring now to figure 10, there is shown a receiver 1000 capable of operating in multiple modes, in accordance with the present invention. Rather than having a single mode in which program material and associated data are always received and processed, receiver 1000 allows user selection of various modes of operation. By  
10 appropriate selection of a menu entry using user interface 1002, a user may select one of several modes of operation. In the example illustrated in figure 10, seven modes are available. The "Full" mode corresponds to operation as described above in connection with figure 2, in which receiver 100 provides both audio output and display of associated data. A "Sound Only" mode ignores the associated data and makes  
15 receiver 1000 operate as a conventional audio-only radio receiver. A "Data Only" mode mutes audio output from receiver 1000 so that it functions solely as a data receiver, storing and displaying data as described above in connection with figure 2.

A "Station Activate" mode similarly mutes audio output while maintaining data reception, but reactivates audio output upon receipt of predetermined associated  
20 data from a transmitting station. For example, receiver 1000 is configurable so that when it is in station activate mode, it will mute audio until such time as it receives data indicating that an emergency message is to be transmitted, at which time it will reactivate audio output for the duration of the emergency message.

A "Listener Priority" mode similarly mutes audio output while maintaining data reception, but permits listener selection of the types of data that will result in  
25 audio output reactivation. For example, in a preferred embodiment user selection of the "Listener Priority" mode results in display of a submenu listing "Weather," "Traffic," "Financial," "Sports," and "News Headlines." The user may select one or more of these categories. Before transmitting program material in any of these  
30 categories, a transmitting station transmits a corresponding data signal that, when received, causes the audio output of receiver 1000 to be reactivated. In alternative embodiments, data corresponding to each of these categories is transmitted in

addition to, or instead of, the program material. In this embodiment, receiver 1000 stores and/or displays, at the user's selection, data received in each of the selected categories. In still another embodiment, data and/or program material are categorized by their importance, *e.g.*, "5-star" (most important) to "1-star" (only moderately important. In this embodiment, the user selects a level of priority for which reactivation of audio output or storage of data is desired. For example, if the user selects "3-star," then any program material having an importance of "3-star" or higher will be provided as audio output, or alternatively all data of "3-star" or higher priority will be displayed and/or stored. Thus, the user is provided with a great deal of flexibility in determining the type and amount of information to be provided by receiver 1000.

A "Half-Sleep" mode causes the receiver 1000 to continue to receive and store data as in "Data Only" mode, but such data are not displayed. This mode may be selected when power consumption is a critical issue.

A "Game" mode is similar to the "Half-Sleep" mode, except that the only data stored is transmitted game data for use as described below in connection with figure 11.

Referring still to figure 10, user interface 1002 is coupled to data decoder 1004 so that the menu selections made via user interface 1002 may control the operation of data decoder 1004. Depending on the mode selected by the user, data decoder 1004 will either be inactive or will filter incoming data for the types of data described in connection with each of the modes discussed above. Receiver power controller 1006, coupled to data decoder 1004, receives control signals from data decoder 1004 and controls audio, data, and display circuitry of receiver 1000 in the manner discussed above for each of the selected modes. For example, if the user has selected the "Station Activate" mode of operation, data decoder 1004 examines incoming data for a predetermined data set corresponding to a transmitting station desiring to activate receivers, *e.g.*, 1000, that are in this mode. When such a data set is decoded, data decoder 1004 sends a signal to receiver power controller 1006, and receiver power controller 1006 in turn activates the audio output from receiver 1000.

In a preferred embodiment, user interface 1002 is implemented by user interface apparatus 206 of figure 2, and data decoder 1004 and receiver power controller 1006 are implemented by microprocessor 204 of figure 2.

Referring now to figure 11, there is shown a receiver 1100 that includes a game playing mode processing transmitted game-playing data, in accordance with the present invention. Data transmitted as discussed in connection with Figure 1 may include data for playing various types of games. As an example, a transmitting station may transmit data representing bingo cards and numbers, and data for card games such as poker, blackjack, and the like. As an incentive for listener loyalty, potentially "winning" data may be transmitted at various times during the day. If a receiver 1100 is tuned to the station, the winning data may be received; if not, the winning data will not be received. If a receiver 1100 is tuned in to a particular station long enough to receive winning data, a coupon may be generated, either electronically or in hard copy, that the user may remit for prizes, discounts on merchandise, or other benefits.

Specifically, receiver 1100 includes a game data decoder 1104 that filters incoming data searching for game-related data. Such data are, for example, identified by a predetermined data header. Such data are decoded by game data decoder 1104 and stored in game data storage 1106, all under the control of game data processor 1108. If game data processor 1108 determines that winning data are stored in game data storage 1106, game data processor 1108 directs coupon generator 1110 to issue a coupon that the user may redeem for a prize. User interface 1102 allows the user to interact with the game data, if desired, informs the user of the game results, and is also capable of displaying coupons, as is discussed below in connection with figure 13.

In one embodiment, a transmitting station transmits data representative of a bingo card every morning. During the day, the station transmits data representative of bingo numbers. Both the card data and the number data are stored in game data storage 1106. If, during the day, sufficient portions of the number data match the card data (as in the ordinary bingo game), the user is a winner and a coupon is issued. In one variation on this embodiment, the user selects from various cards transmitted at the beginning of the day, using user interface 1102.

In still another embodiment, the user or the transmitting station selects a particular card game by user interface selection or transmitted data, respectively. The

transmitting station periodically transmits data representative of dealt cards, which the user of receiver 1100 either accepts for storage in game data storage 1106 via user interface 1102 or ignores. If the user selects a set of cards that represents a winning hand in the selected game, as determined by game data processor 1108, then game data processor 1108 directs coupon generator 1110 to generate a prize coupon. It should be recognized that numerous other games, such as roulette and slot machine, may be implemented in this manner.

In a preferred embodiment, game data decoder 1104 and game data processor 1108 are implemented by microprocessor 204 of figure 2, game data storage is implemented by data memory 205 of figure 2, user interface 1102 is implemented by user interface apparatus 206 of figure 2, and coupon generator 1110 is implemented by microprocessor 204 and either data card recorder 207 or user interface apparatus 206 of figure 2, as described in greater detail below in connection with figure 13.

Referring now to figure 12, there is shown a receiver 1200 configured to control external equipment 1208 based on transmitted data, in accordance with the present invention. In one embodiment, receiver 1200 includes a data decoder 1204 that examines a received stream of data searching for a predetermined type of data. One such type of data corresponds to the acoustic properties of the program material being broadcast, such that lights, bells, chimes, and other annunciators may be activated in synchronism with the program material. A simple example is one in which data corresponding to the tempo and volume of the program material is transmitted, such that by use of external equipment interface 1206, external equipment 1208 comprising decorative lights may be energized in a manner corresponding with the program material. In this example, for instance, the lights of a Christmas tree could be controlled in correspondence with transmitted Christmas music program material. Similarly, specialty dance floor lighting and even "smoke" machines may be triggered by such data in correspondence with transmitted dance music program material. In yet another example, a "bouncing ball" display with or without displayed lyrics can be made to move along with the lyrics of transmitted vocal program material. In still another example, data to drive a conventional electronically-actuated piano or other instrument is transmitted along with program material, so that the listener may hear a

“live” piano performance with background music or vocals from the audio output of receiver 1200.

In a different embodiment, receiver 1200 is installed in an automobile. Data decoder 1204 is configured to examine received data for a unique data set  
5 corresponding to the serial number or other identifying number of receiver 1200 or the automobile in which it is installed. In this embodiment, if the automobile in which receiver 1200 is installed is ever stolen, the owner may request a transmitting station to broadcast the unique data set. Upon decoding the unique data set, data decoder 1204 provides a signal to equipment interface 1206 to control external equipment 1208, such  
10 as the lights, horn, electric door locks, and ignition of the automobile, in an appropriate manner. In one variation of this embodiment, receipt of the unique data set by receiver 1200 can result in the automobile’s lights flashing, the horn sounding, the doors locking, and the ignition being disabled.

Referring now to figure 13, there is shown a receiver 1300 that produces a  
15 scannable bar code 1321 based on transmitted data, in accordance with the present invention. As mentioned above, it is desirable in a variety of applications to produce coupons that the user may redeem at vendor locations for prizes, discounts, and other benefits. One way to produce such coupons is through use of a data card recorder 207, as described in connection with figure 2. Another way to produce electronic coupons  
20 is to display on user interface 1302 a bar code 1321 that may be scanned using conventional bar code reader apparatus.

In one embodiment, a data decoder 1304 examines received data searching for a predetermined type of data representing an electronic coupon. For example, while a transmitting station broadcasts program material from a particular compact disc, the  
25 station may also broadcast data representing an electronic coupon providing a discount for purchasing that disc from a particular vendor. When such data are decoded by data decoder 1304, data decoder 1304 directs coupon generator 1310 to generate a corresponding electronic coupon. In the embodiment illustrated in figure 13, coupon generator causes user interface 1302 to display a coupon 1320 including a  
30 conventional bar code 1321 and a text message 1322. User interface 1302 provides the user with the option of displaying the coupon and saving the coupon. Also, a menu selection for erasing the coupon is provided, so that the vendor can erase the coupon

after it has been scanned. In a preferred embodiment, user interface 1302 provides a liquid-crystal display on which coupon 1320 may be shown and which is of sufficient quality and contrast to permit bar code scanning. In operation, the vendor may scan not only the bar code 1321 provided by user interface 1302, but may also scan or otherwise record information identifying receiver 1300. Such information may be obtained by presentation of another bar code, carrying the serial number of receiver 1300, on user interface 1302, or may be obtained by a conventional printed bar code or serial number on the back or bottom of receiver 1300. By collecting coupon and receiver information at the same time, the vendor or third parties may compile customer profile and demographic information that may be useful for marketing or other commercial purposes.

Referring now to figure 14, there is shown a receiver 1400 that includes multiple tuners for selectively receiving more than one channel of program material and transmitted data, in accordance with the present invention. In some situations, users may prefer the program material of one station and the data of another station. Therefore, rather than requiring the user to switch between such stations, receiver 1400 includes a sound tuner 1404 and a data tuner 1406 that permit receiver 1400 to provide audio program material from a first station and data from a second station. User interface 1302 permits a user to select whether sound and data are to be received from a single station or from separate stations. In one variation of this embodiment, sound tuner 104 is used for both audio and data in this mode. In another variation, sound tuner 104 and data tuner 1406 are merely tuned to the same frequency in this mode. Conventional user interface techniques permit the user to single-station or dual-station mode, and to enter the desired frequencies. Thus, if a user prefers the music programming of a first station, but wishes to receive electronic coupons from a second station as discussed in connection with figure 13, receiver 14 permits such operation.

Referring now to figure 15, there is shown a system including a receiver 1500 and a connected computer 1510 that is to be controlled responsive to transmitted data, in accordance with the present invention. Connectors 1502 and 1512 electrically connect computer 1510 and receiver 1500. It should be recognized that other means of coupling computer 1510 and receiver 1500, such as an infrared or other wireless link,



could also be used. Connected in this manner, computer 1510 can display and process data received by receiver 1500. For example, receiver 1500 and computer 1510 may be configured so that important news, weather, or traffic information received as data by receiver 1500 flashes on the screen of computer 1510. If receiver 1500 or computer  
5 1510 is equipped with a modem, the user may enter transactions with a remote site based on received data. For example, if received data provides the name of a compact disc on which the current program material is found, computer 1510 may be configured to automatically dial to a remote location to place an order for that compact disc, which can then be sent to the user by mail.

10 In an alternate embodiment, the data received by receiver 1500 may be used directly by computer 1510. For example, the data may represent game data for use by computer 1510, computer programs for use by computer 1510 or even customized screen saver data for display by computer 1510 during periods that computer 1510 is not provided with user input. Such screen saver information may dynamically move  
15 on the display of computer 1510 with the program material being received by receiver 1500.

In still another embodiment, receiver 1500 may be configured in a foldable form, to allow ease of portability and use while still providing a form factor compatible for connection with computer 1510. It should be recognized that other  
20 convenient form factors and configurations of receiver 1500 and computer 1510 may be used, as may be desirable for any particular application.

Referring now to figure 16, there is shown a receiver 1600 connected to a remote point of sale ("POS") terminal with a data link 1602. In some applications, it may be desirable for a user of a receiver capable of receiving and storing program-related data  
25 to communicate with such a remote POS device. For example, it may be desirable for a user to have the capability for electronically redeeming coupons of the sort described above even if the user is remotely located from the establishment providing such coupon redemption. In such a situation, if receiver 1600 includes conventional interface circuitry, such as a modem for a telephone data link or an ethernet  
30 connection for a local- or wide- area network data link, a user may download such a coupon directly to a POS terminal at the coupon redemption location. In another application, the user may be provide with incentives (*e.g.*, coupons) to download other

information that may be stored in a memory of receiver 1600 using conventional techniques and apparatus. For example, market research reasons may call for information concerning the stations from which coupons were obtained, the types of information stored by the user, and the like to be provided to POS terminal 1610. As  
5 discussed above, in some embodiments each receiver 1600 is provided with a corresponding unique identifier, so through use of such a data link 1602, a POS terminal 1610 may accumulate information specific to a particular listener including the user's listening behavior (*e.g.*, tune-in and tune-out times, number of stations tuned, program identity at time of tune in or tune out) and the user's data viewing and  
10 recording behavior (*e.g.*, how often data are recorded, stations from which data are recorded, programs from which data are recorded, data recording times, which data screens are viewed but not recorded). It should be recognized that the implementation of such enhancements in the apparatus described herein, *e.g.*, receiver 200, to result in such a receiver, *e.g.*, 1600, is straightforward and well known. It  
15 should also be recognized that any of the various common data links, such as telephone modem links, local area network or wide area network links, or the like, may be readily applied to implement data link 1602.

Referring now to figure 17, there is shown an embodiment having a receiver module 1705 including a connector 1715, as well as four liquid crystal displays of  
20 various sizes 1701-1704, each having a connector 1711-1714. When receiver module 1705 is coupled to any of the displays, *e.g.*, 1701, the resulting combination provides the functionality of receiver 200 described above. By providing a display, *e.g.*, 1701 that is detachable from the remainder of the receiver electronics (receiver module 1705), a receiver module storing the user's pre-set stations, coupon information, and  
25 other data may readily be moved, for example, from a home location to automobile location to a portable device carried on the user's person. In a preferred embodiment, receiver module 1705 uses conventional techniques to automatically configure the signals it produces for driving a connected display in a manner most compatible with the size, configuration, and other characteristics of such display. For instance, when  
30 receiver module 1705 is connected to a large display, *e.g.*, 1705, menu button areas such as 301-304 illustrated in figure 3 may be provided. On a smaller display, *e.g.*, 1701, only the text corresponding to those buttons may be shown. By providing a user

with a portable receiver module 1705 that may be moved from place to place with the user, the user may collect more desired data in one place than otherwise would be possible. In addition, more complete information about the user may be collected in the manner discussed in connection, for instance, with Figure 16.

5 Referring now to figure 18, there is shown a cutaway edge view of a portion of a receiver 1820. Receiver 1820 includes a liquid crystal unit, or layer, 1801 for providing display of information as discussed herein. Underneath layer 1801, receiver 1820 further includes a solar panel unit, or layer, 1802. Solar panel layer 1802 includes a conventional solar panel array that is used in a conventional manner to power  
10 receiver 1820 and to recharge batteries for receiver 1820. In typical usage, most of the display provided by liquid crystal layer 1801 remains clear rather than opaque most of the time. Thus, virtually all of any incident light 1810 falling upon liquid crystal layer 1801 also reaches solar panel layer 1802. By integrating a conventional solar panel layer 1802 with a conventional liquid crystal layer 1801, receiver 1820 can be made  
15 physically smaller than if a solar panel unit and a liquid crystal display were disposed adjacent to one another.

In the embodiment illustrated in figure 18, a thin film transistor layer 1803 is disposed immediately below solar panel layer 1803. The remainder of the electronics comprising receiver 1820, including LSI layer 1804 and battery layer 1805, are disposed  
20 substantially underneath the thin film transistor layer 1803. It should be recognized that variations in the arrangement of these portions of receiver 1820 may readily be made while still obtaining the benefits of integrating a solar panel and a liquid crystal display. As an example, the thin film transistor layer 1803, as well as the LSI layer 1804 and battery layer 1805 may be located remotely from solar panel unit 1803 and  
25 liquid crystal layer 1801.

Alternatively, solar panel unit 1803 may be fabricated directly on one of the components of receiver 1820, for instance LSI layer 1804. Specifically, solar panel unit 1803 may be bonded to LSI layer 1804 or may even be constructed from the same substrate as used in LSI layer 1804, depending on requirements of maximum desired  
30 size and weight of receiver 1820.

It should be recognized that the readability of the display provided by liquid crystal layer 1801 may be affected by the color of solar panel unit 1803. Accordingly,

liquid crystal layer 1801 and solar panel unit 1803 should be selected in a manner that provides reasonable contrast for typical viewing conditions.

Referring now to figure 19, there is shown a receiver 1900 in accordance with the present invention. Receiver 1900 includes a tuner A 1904 and a tuner B 1906, each of which can be independently tuned to different frequencies. In normal operation, both tuner A 1904 and tuner B 1906 may be tuned to the same station, and operation as discussed above will be achieved. Typically, tuner A 1904 is coupled to audio circuit 1905 for audio reproduction of received program material, and tuner B 1906 is coupled to data decoder circuit 1907 for reception and processing of transmitted data. In certain applications where tuners 1904 and 1906 are tuned to different frequencies, it may be desirable to obtain data from the frequency to which tuner A 1904 is set, or to receive audio programming from the station to which tuner B 1906 is set, and receiver 1900 is configured to provide such operation, as indicated by the dashed lines connecting tuners 1904 and 1906 with data decoder 1907 and audio circuit 1905, respectively.

In another mode of operation, tuner A 1906 is used to provide information to receiver 1900 that is employed to change the tuning of tuner B 1904 as desired by the user. The other components of receiver 1900 making this possible are tuning processor 1910 with tuning memory 1911, and user interface 1902.

Specifically, in one particular mode of operation of receiver 1900, part of the data stream received by tuner B 1906 includes information on the types of programs being transmitted not only by the station to which tuner B 1906 is currently tuned, but by all other stations within the listening area as well. For instance, all of the broadcast stations in a particular geographic area might agree to share information on what they are broadcasting, and to transmit this information for all such stations in the data stream transmitted by each such station. As shown in figure 19, the data are applied from tuner B 1906 to tuning processor 1910 and may be displayed for the user's consideration by user interface 1902. If the user selects a particular type of program material different than that being broadcast by the currently selected station, a signal indicating the user's selection is generated by user interface 1902 to processor 1910, which in turn generates a control signal that is applied to tuner A 1404 instructing it to tune to the appropriate frequency. Typically, tuner B 1906 is directed to tune to the

new frequency, but some applications may not call for the frequency of operation of tuner B 106 to change. It should be noted that in a mode of operation where the data and sound programming are always obtained from the same frequency separate tuners are not required for sound and data, and receiver 1900 could be implemented using a single tuner for both sound and data.

In many environments, it is doubtful that broadcast stations would agree to share their programming data with competitive local stations. In these environments, each station may transmit only a description of the type of program material that it is currently transmitting. When this is the case, tuning processor 1910 instructs tuner B 1906 to scan the entire broadcast band for data transmissions indicating what type of program material is being transmitted by each station within receiving range. Tuner B 1906 and tuning processor 1910 are conventionally configured to provide interaction so that the program material description and the frequency for each such station is stored in tuning memory 1911. Then, as in the previous mode, this information is presented to the user via user interface 1902.

In still another environment, a single station in the area may be designated as the station to broadcast information as to what programming currently is being broadcast on all other stations. In this environment, tuner B 1906 tunes to that station, either by automatically scanning all stations until it finds one that identifies itself as broadcasting this information or by user command, and then provides the programming information to tuning memory 1911 and user interface 1902 as described above.

It should be noted that the description of programming provided by a station can be either generalized or extremely detailed. For instance, in one environment a station may simply indicate that it is broadcasting music, while in another the genre of music or even the particular song may be identified. Similarly, a station broadcasting sports programs may simply describe its programming as sports or may identify the particular sporting event being broadcast. Depending on uniformity of such data in a listening area, the user will be provided with greater or lesser detail by user interface 1902.

If more than one station in a broadcast area is transmitting a particular category of program material, such as "news", when the user selects that category tuning

processor 1910 may be configured either to select one of the stations automatically or to provide the user with a choice via user interface 1902. For mobile applications, automatic selection based on signal strength may be appropriate, using conventional circuitry for signal strength determination.

5 In another embodiment suited for mobile applications, receiver 1900 may be configured to scan, using tuner B 1906, for other stations broadcasting the same type of program material if the signal strength of the currently tuned station falls below a minimum threshold. For example, if someone driving in an automobile is listening to an opera program on a public radio station and begins to get too far from that station  
10 to receive a clear signal, tuner B 1906 can identify other stations, e.g., from nearby cities, that may be transmitting the same program, as indicated by the received data from that station. In one implementation, the user need merely select the "opera" choice from user interface 1902 and the opera station with the strongest signal is chosen automatically. In another implementation, if the currently tuned station is  
15 broadcasting opera, when that signal becomes weak selection of a stronger opera station is made without any user intervention at all.

Furthermore, there may be environments where the user wishes to receive certain types of data that correspond to the audio programming on a particular channel. For example, the user may seek a station that is broadcasting both an audio  
20 report of traffic conditions and data providing a textual report of those conditions. If information about both audio programming and data programming are transmitted by broadcasting stations, receiver 1900 may be configured to allow a user to request such stations where both audio and data programming relate to a particular topic, such as traffic conditions. As discussed above, additional parameters such a signal  
25 strength may also be used to prioritize or select among multiple stations that may meet the user's criteria. Certain users may not even be interested, at any given time, in the audio programming of a station, but may be solely interested in the data being broadcast by that station. In such event, receiver 1900 may be configured to allow a user to request data tuner 1406 to be tuned to a station broadcasting a particular type  
30 of data, without regard to the programming being received by tuner A 1904.

When the user is interested in selecting stations based on the type of data being broadcast, there may be instances where the user seeks multiple types of information

such as traffic, sports, and weather. To facilitate such operation, receiver 1900 is configurable to provide user interface selection of such multiple categories and to seek a station that is broadcasting all of the desired types of data.

5 If multiple such stations are found, they may be prioritized based on signal strength as described above, or based on other parameters. For example, the stations may broadcast data indicating how often they update or re-send certain types of data, such as sports scores and traffic conditions, and receiver 1900 may select among stations based on the one that provides the most frequent updates. Alternatively, tuner B 1906 may, through review of the data received from any particular station,  
10 keep track itself of how often data are changed for any particular category and thereby derive the same information.

If the user has selected multiple data types, but no single station is found that is broadcasting all such data types, receiver 1900 is configurable to selectively tune to stations broadcasting ones of those data types in order to collect all of the desired  
15 types of data. Receiver 1900 is further configurable to perform this selective tuning in a manner that maximizes the currency and retrieval speed for obtaining all of the data requested by the user. For example, if the user requests sports, weather, and traffic data types, and if station A broadcasts sports and traffic, station B broadcasts weather updated every hour and station C broadcasts weather updated every minute, receiver  
20 1900 selects data from stations A and C to satisfy the user's data requests.

Furthermore, if stations A, B, and C transmit data sufficient to determine when each such station will next broadcast data of a particular type, receiver 1900 is configurable to determine an order of reception of such data that will minimize the time the a user must wait to obtain the desired information. For example, station A  
25 may transmit, every 10 seconds, data indicating that Station A re-sends all sports information every minute at 0 seconds after the minute and re-sends traffic information every minute at 15 seconds after the minute. Station B may transmit data indicating that it re-sends weather data every 15 seconds starting at 5 seconds after every minute, even though such data are only updated (i.e., replaced with more  
30 current information). Station C may transmit data indicating that it sends weather data only every minute at 0 seconds after the minute. If a user request for sports, weather, and traffic data is entered into at 55 seconds after a minute, receiver 1900

may select stations A and B for obtaining the requested information. Assuming the transmission time for each type of data is not significant, all of the user's information will be obtained from stations A and B by receiver 1900 by 15 seconds after the minute by tuner B 1906 being set to station A by 0 seconds after the minute, station B by 5  
5 seconds after the minute, and station A again by 15 seconds after the minute. In contrast, use of stations A and C would require over one minute for the requested data to be acquired, as two portions of the information of interest to the user are broadcast by stations A and C at exactly the same time, and are only sent once per minute. Configured for operation in this manner, receiver 1900 selects which stations to use,  
10 and the order in which to tune to those stations, in a manner that minimizes the amount of time that the user needs to wait for the requested data. By decreasing response time in this manner, receiver 1900 is expected to increase user satisfaction with the data capabilities discussed herein.

In still another environment of operation, radio stations may designate a certain  
15 number of "frequent listener" points, similar to airlines' frequent flier points, for each broadcast program or for any duration of listening. In this environment, receiver 1900 receives data indicating the appropriate number of frequent listener points and stores that information in memory in a manner that can later be accumulated and remitted, for instance using a portable memory card. Related techniques to ensure that the  
20 program material is actually being listened to by the user may be used, for instance requiring the user to press a certain button or store certain data at a time announced on the main (audio) program channel. In still another variation, receiver 1900 when installed in an automobile may be coupled to the odometer of the automobile, and the miles driven while listening to the station may be accumulated as the measure of  
25 points. In any event, different stations may allocate different points at different times or for different programs, and one of the parameters that receiver 1900 may use to select among a plurality of stations that are broadcasting a selected type of program (or data) may be the value of points to be accrued by selecting a particular station. Thus, in addition to selecting a station based on signal strength or data re-send or  
30 update rate, receiver 1900 is also configurable to select a station based on such other criteria.



Numerous other variations of these embodiments will be apparent for any particular environment of use.

From the above description, it will be apparent that the invention disclosed herein provides a novel and advantageous broadcast data system with multiple tuner receiver. The foregoing discussion discloses and describes merely exemplary methods and embodiments of the present invention. As will be understood by those familiar with the art, the invention may be embodied in other specific forms without departing from the spirit or essential characteristics thereof. Accordingly, the disclosure of the present invention is intended to be illustrative, but not limiting, of the scope of the invention, which is set forth in the following claims.

What is claimed is:

1. A system for transmitting and receiving program material and data corresponding to the program material, comprising:

- 5 a transmitter subsystem, including
- (i) a transmitter unit;
  - (ii) program sources providing to the transmitter unit the program material, for transmission thereof;
  - (iii) a data stream generator providing to the transmitter unit the data
- 10 corresponding to the program material, for transmission thereof;
- a receiver subsystem, including
- (i) a first tuner detecting the program material;
  - (ii) a second tuner detecting the data stream; and
  - (ii) a processor configured to change an operating frequency of one of
- 15 said first tuner and said second tuner in response to the data stream.

2. A receiver for the reception of program material and associated data, comprising:

- a first tuner configured to detect the program material;
- 20 a second tuner configured to detect the data stream;
- a user interface operatively coupled to one of the first tuner and second tuner providing user selection of an item from a menu of data options corresponding to one of the program material and associated data; and
- a processor configured to change an operating frequency of one of the first
- 25 tuner and second tuner in response to the item.

3. A receiver for the reception of program material and associated data, comprising:

- a first tuner unit configured to detect the program material;
- 30 a second tuner unit for detect the data stream;

a user interface operatively coupled to the second tuner unit providing user selection of an item from a menu of data options corresponding to the received data; and

5 a processor coupled to the user interface and the first tuner unit, the processor configured to change an operating frequency of the first tuner unit in response to user selection of the item.

4. A receiver for the reception of program material and associated data, comprising:

10 a first tuner unit configured to detect the program material;

a second tuner unit configured to detect a data stream corresponding to the associated data, the second tuner unit also configured to scan a predetermined band of frequencies for additional data streams;

15 a user interface operatively coupled to the second tuner unit providing user selection of an item from a menu of data options corresponding to said data stream and said additional data streams; and

a processor coupled to the user interface and the first tuner unit, the processor configured to change an operating frequency of the first tuner unit in response to user selection of the item.

20

5. A receiver for the reception of program material and associated data, comprising:

a first tuner unit configured to detect the program material;

25 a second tuner unit configured to detect a data stream corresponding to the associated data, the second tuner unit also configured to scan a predetermined band of frequencies for additional data streams; and

a processor coupled to the first tuner unit and the second tuner unit, the processor configured to change an operating frequency of the first tuner unit in response to a characteristic of the associated data.

30

6. A receiver as in claim 5, wherein the characteristic includes correspondence of program-identifying data from a first station with program-identifying data from a second station.

5           7. A receiver as in claim 6, wherein the characteristic includes signal strength from the first station not exceeding a predetermined threshold and signal strength from the second station exceeding the predetermined threshold.

8. A receiver as in claim 5, further including a user interface operatively  
10 coupled to the processor, the user interface displaying available program type choices, an operating frequency of the first tuner being determined in response to user selection of one of the available program type choices.

9. A method of transmitting and receiving program material and data  
15 corresponding to the program material, comprising:  
transmitting said data, said data corresponding to program material being broadcast by a plurality of stations;  
receiving said data;  
processing said data; and  
20 selecting a frequency for reception of said program material in response to said processing.

10. A method as in claim 9, wherein said processing includes displaying  
25 information corresponding to program types on a user interface.

11. A method as in claim 9, wherein said processing includes determining  
which of a plurality of stations corresponding to a predetermined program type has a particular characteristic.

30           12. A method as in claim 11, wherein the particular characteristic is signal strength exceeding a threshold level.

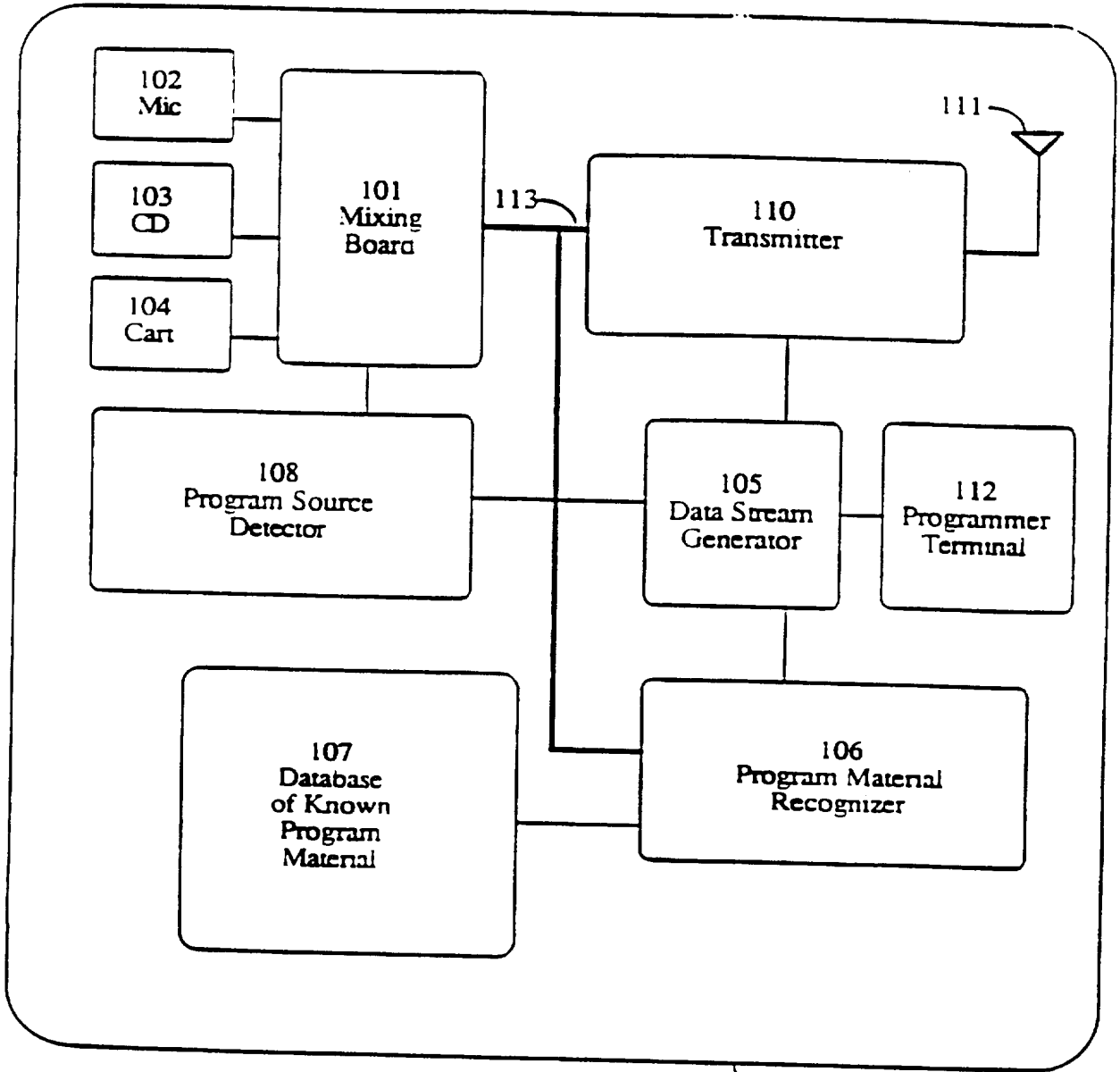


Figure 1

100

2/20

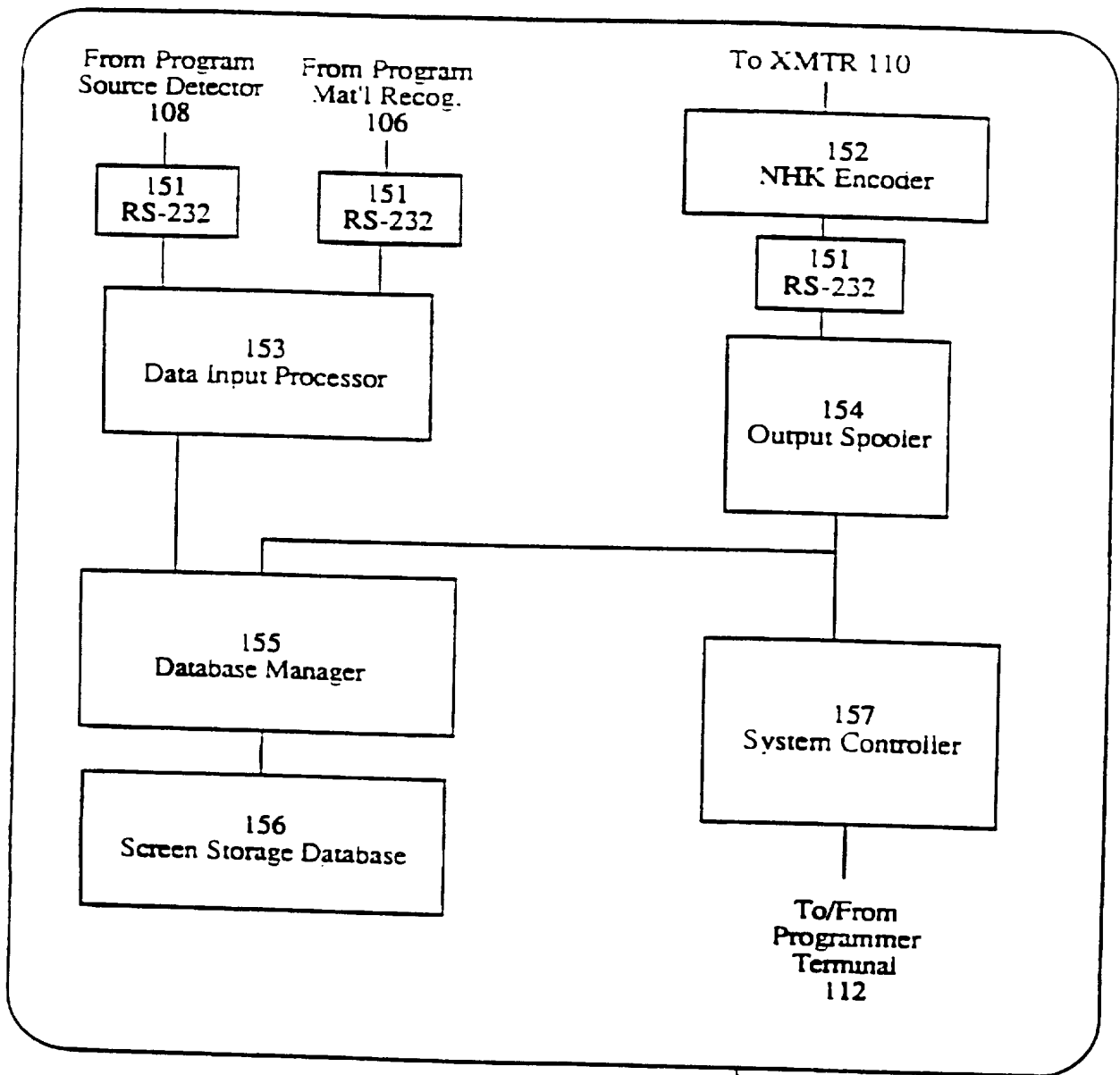


Figure 1a

105

3/20

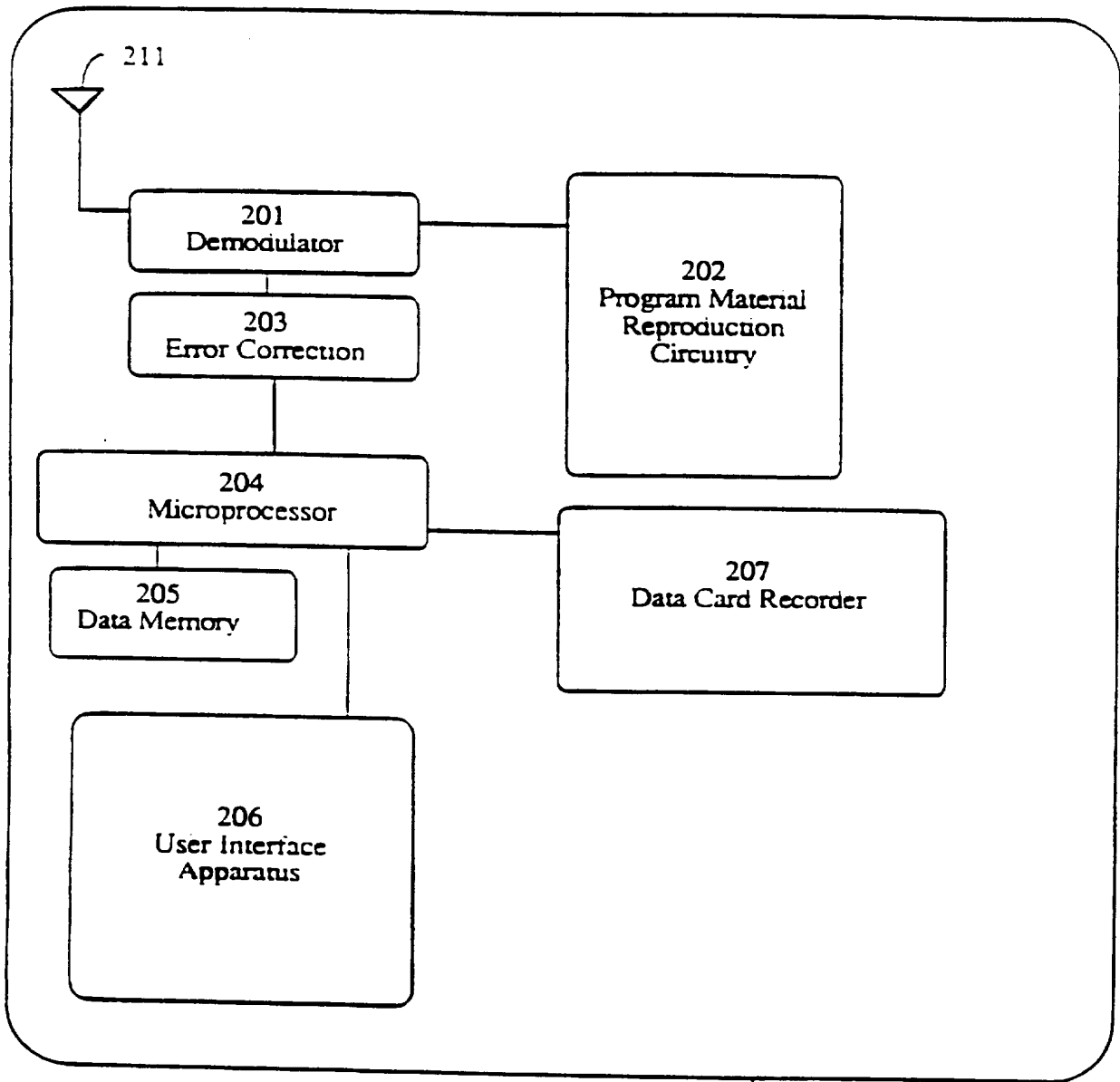


Figure 2

200

4/20

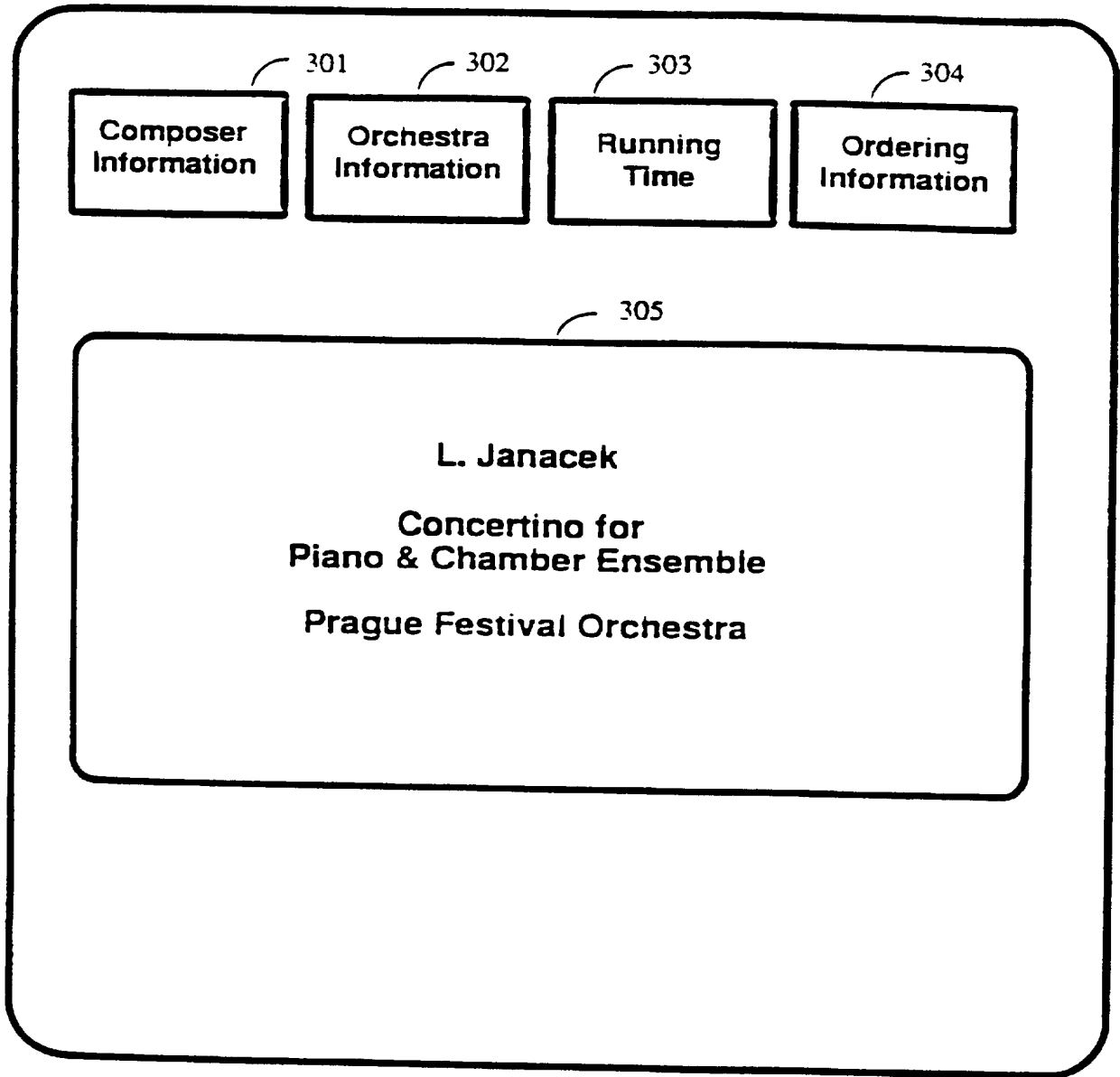


Figure 3

300



5/20

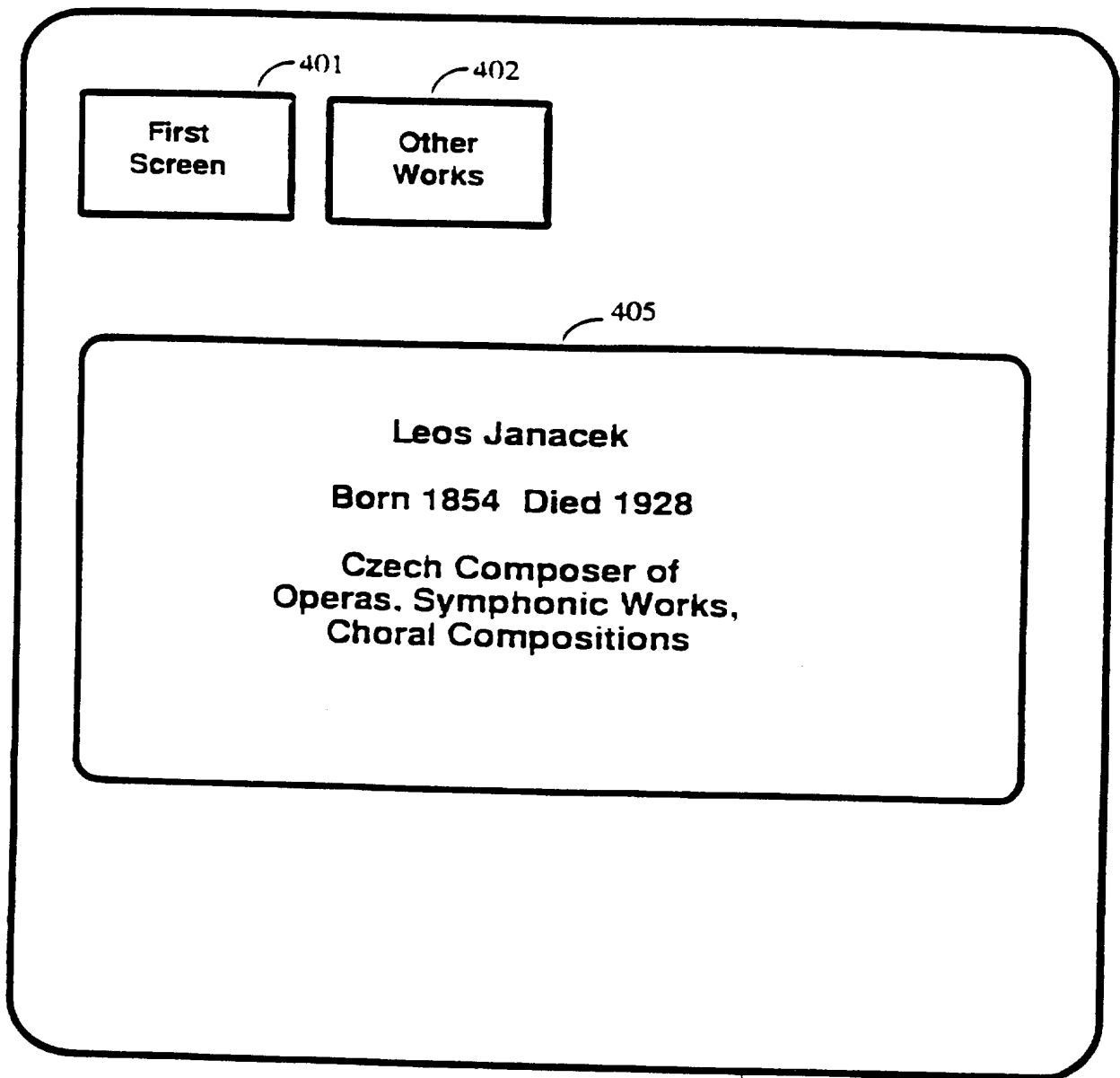


Figure 4

300

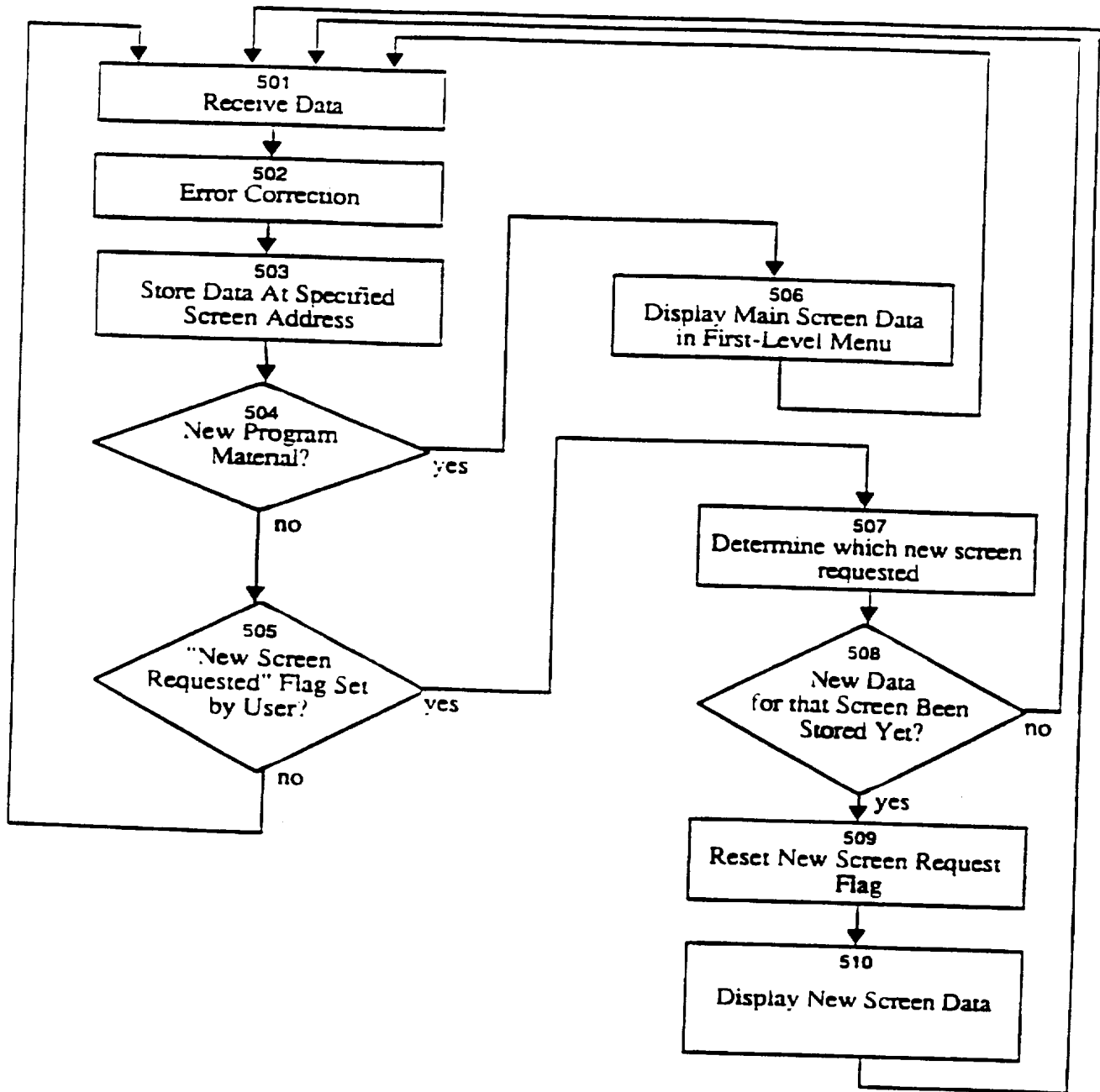


Figure 5

7/20

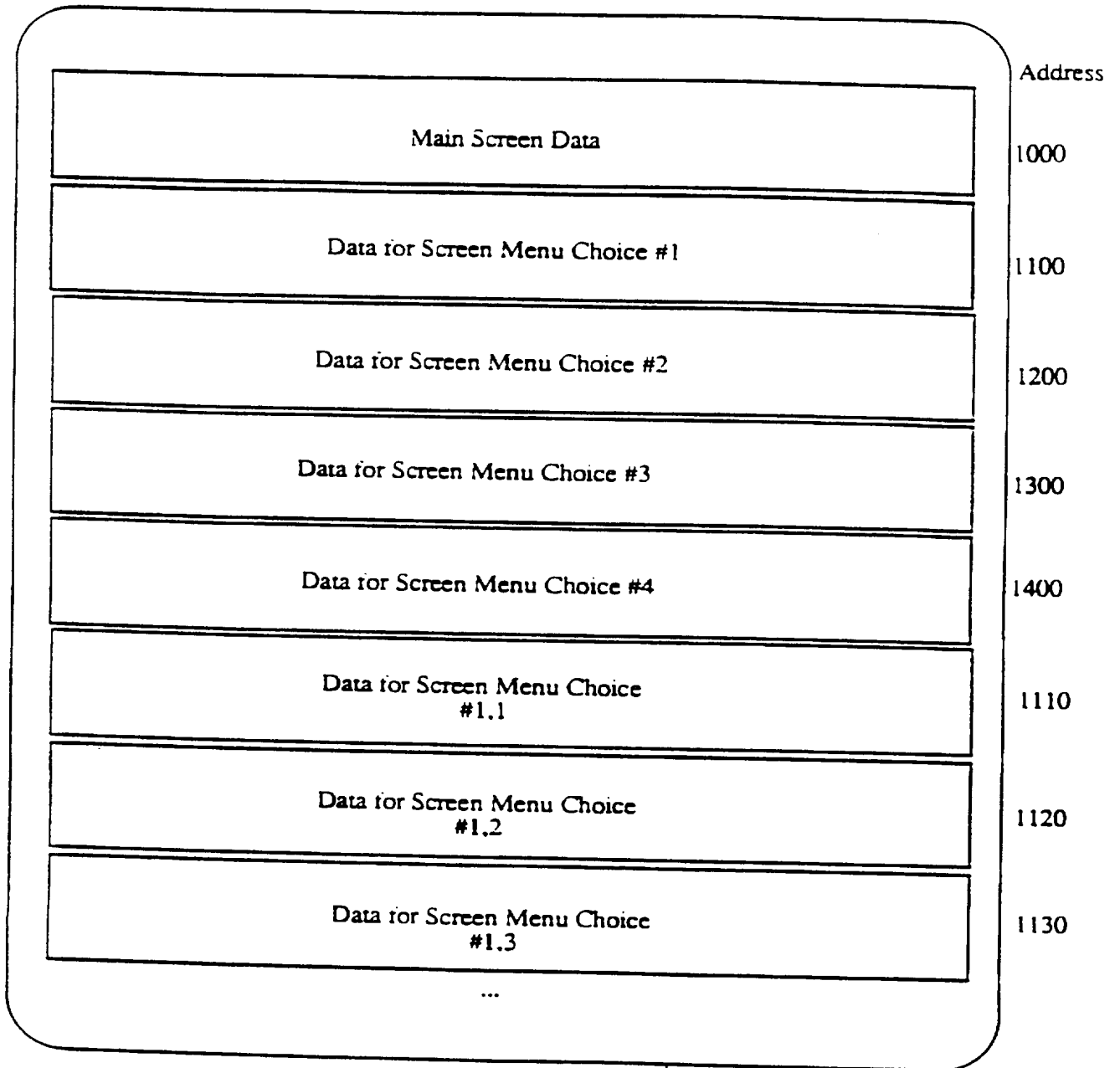


Figure 6

600

8/20

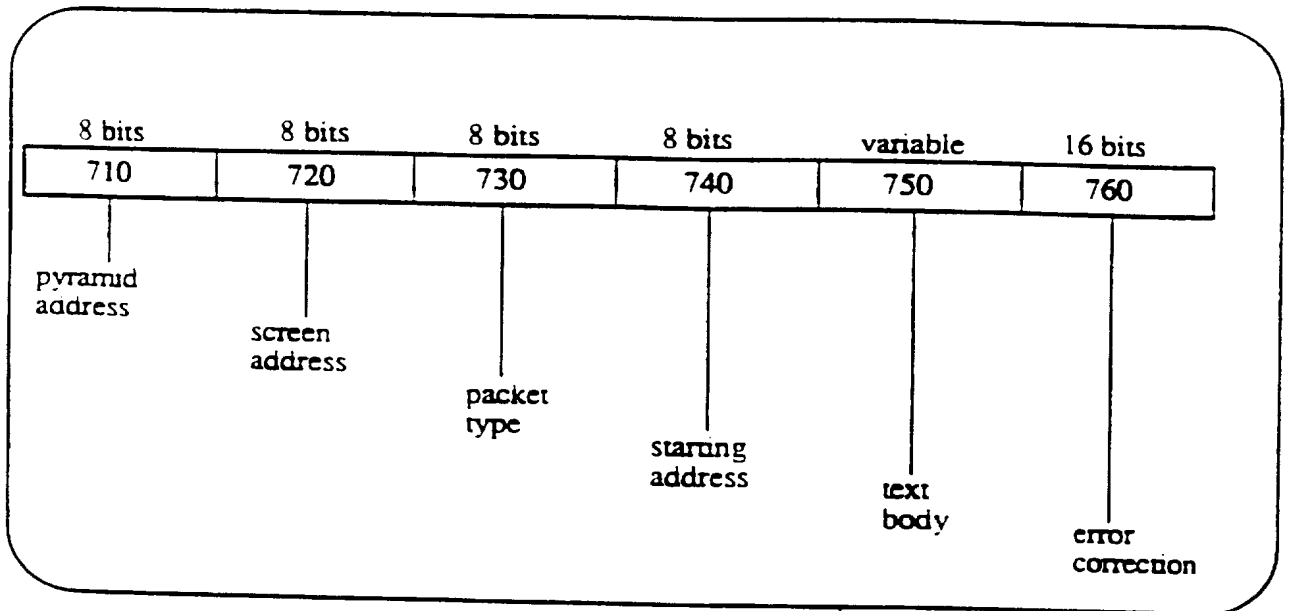


Figure 7

700

9/20

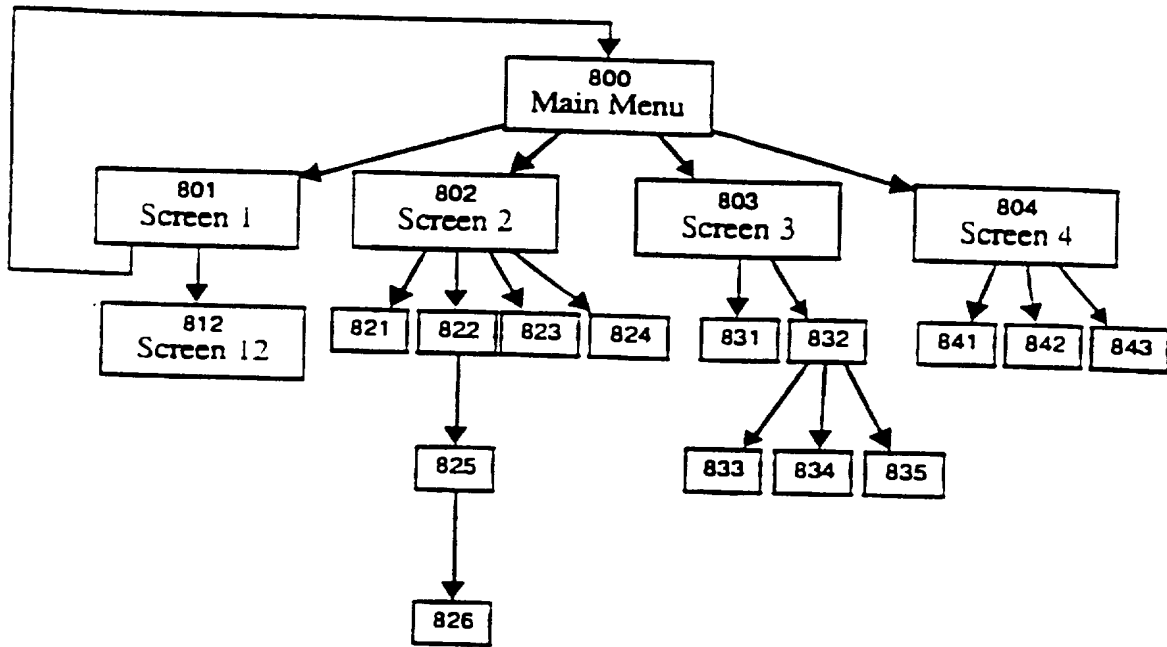


Figure 8

10/20

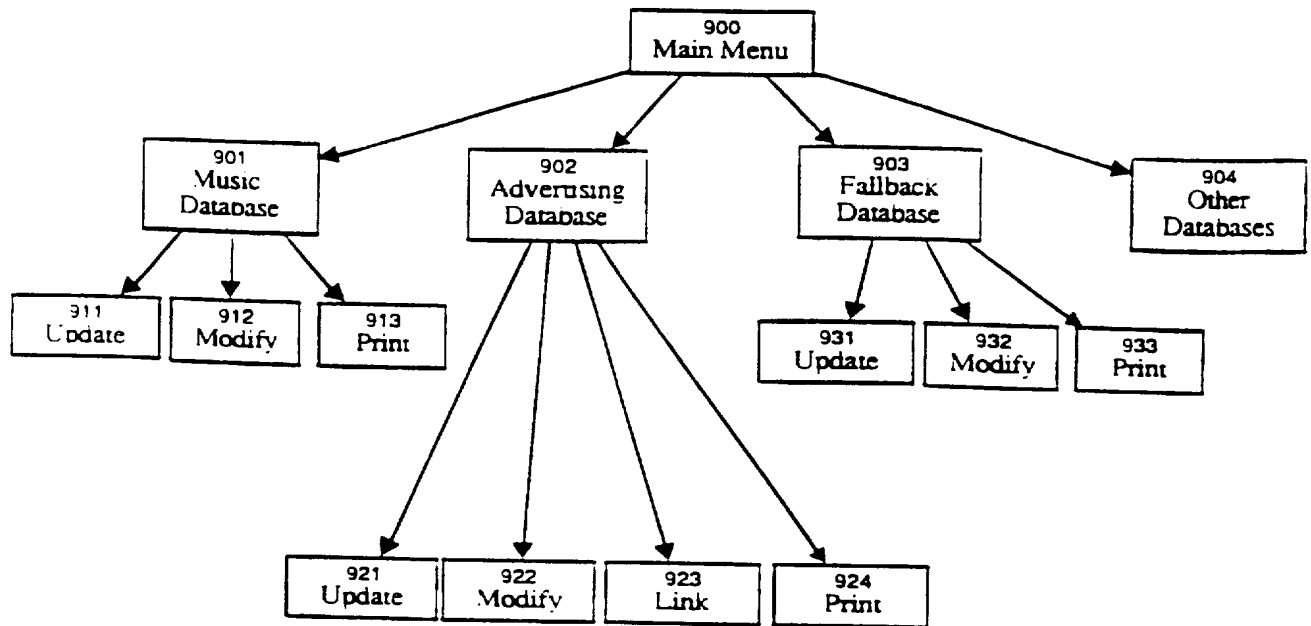


Figure 9

11/20

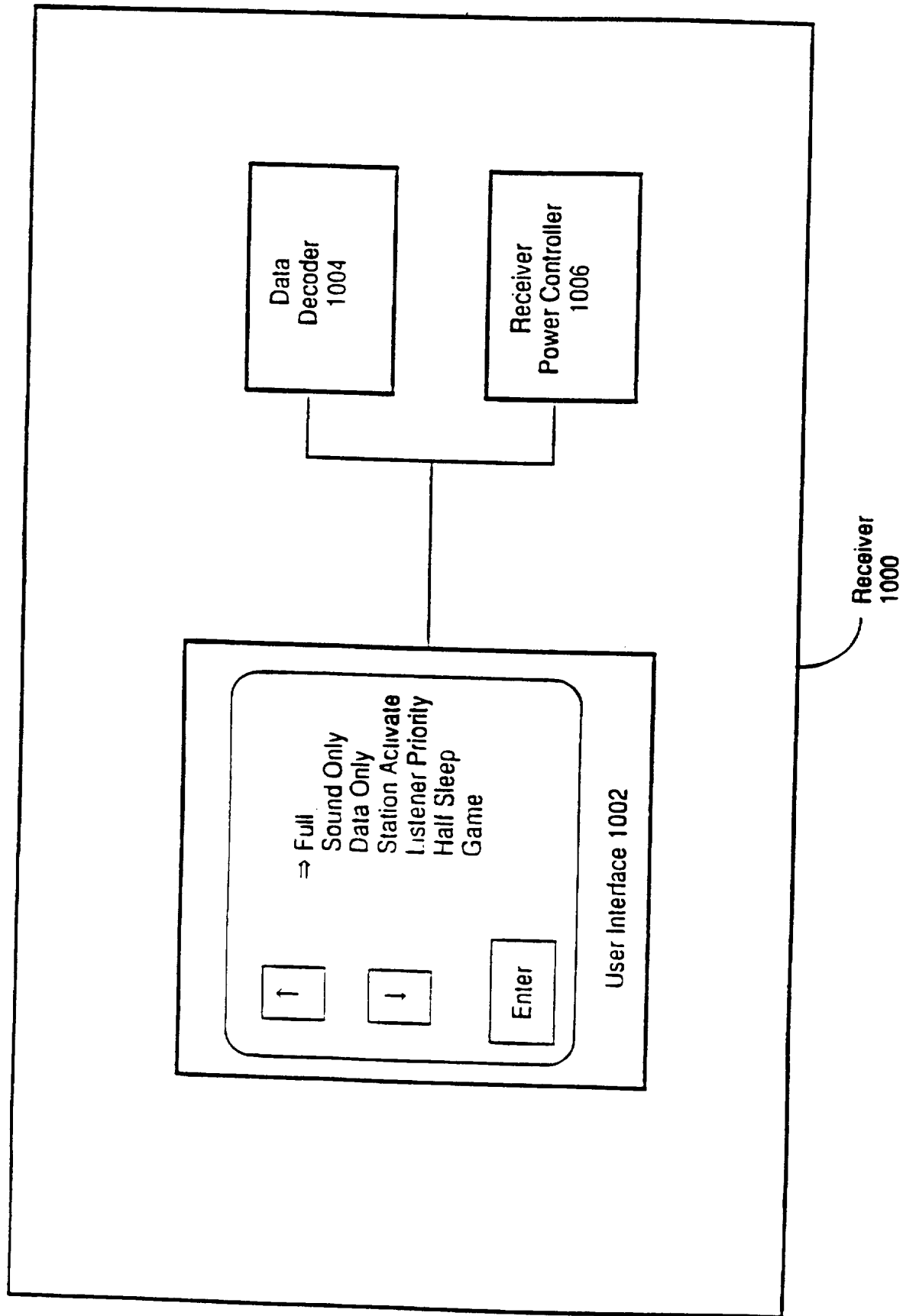


Figure 10

12/20

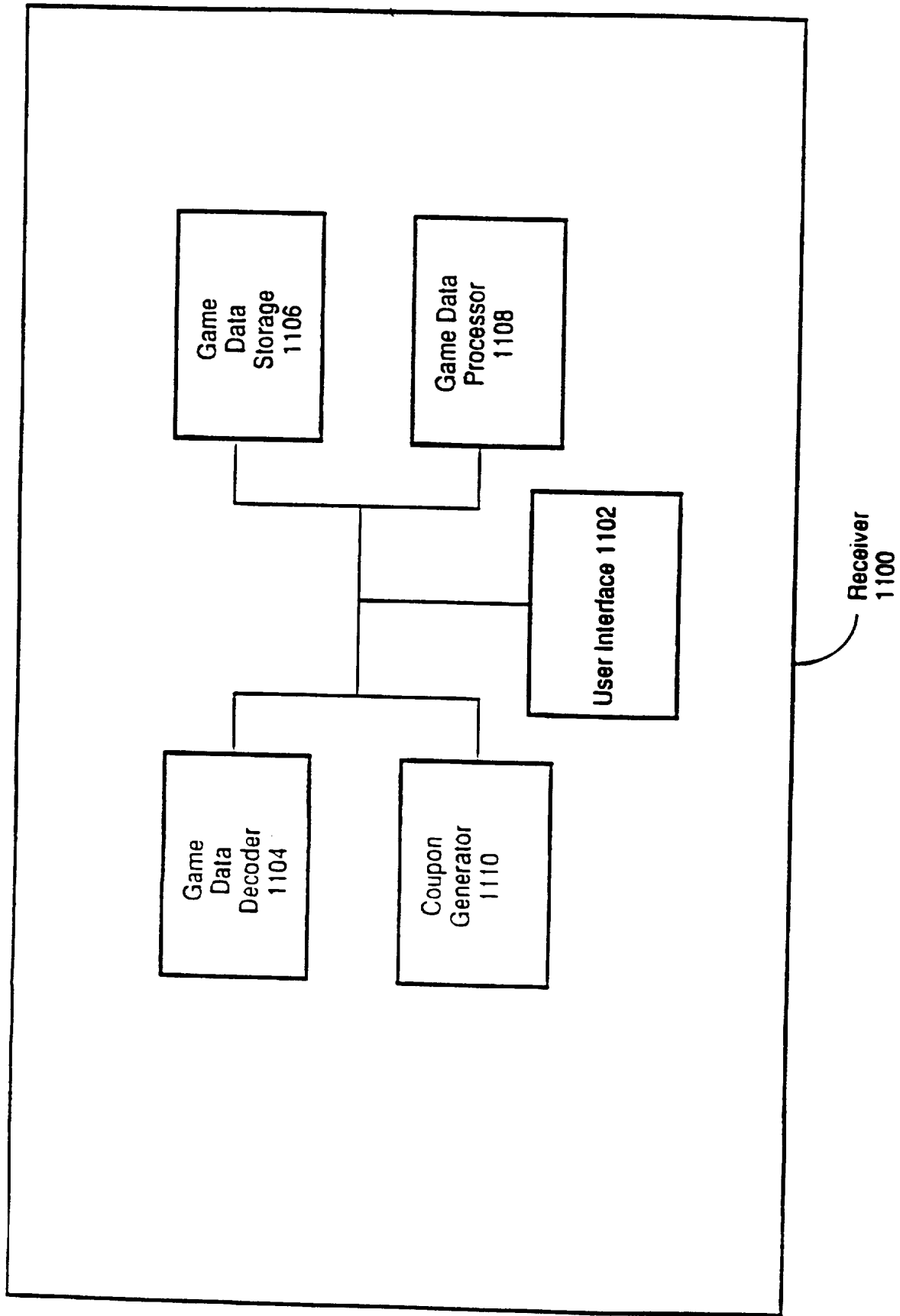


Figure 11



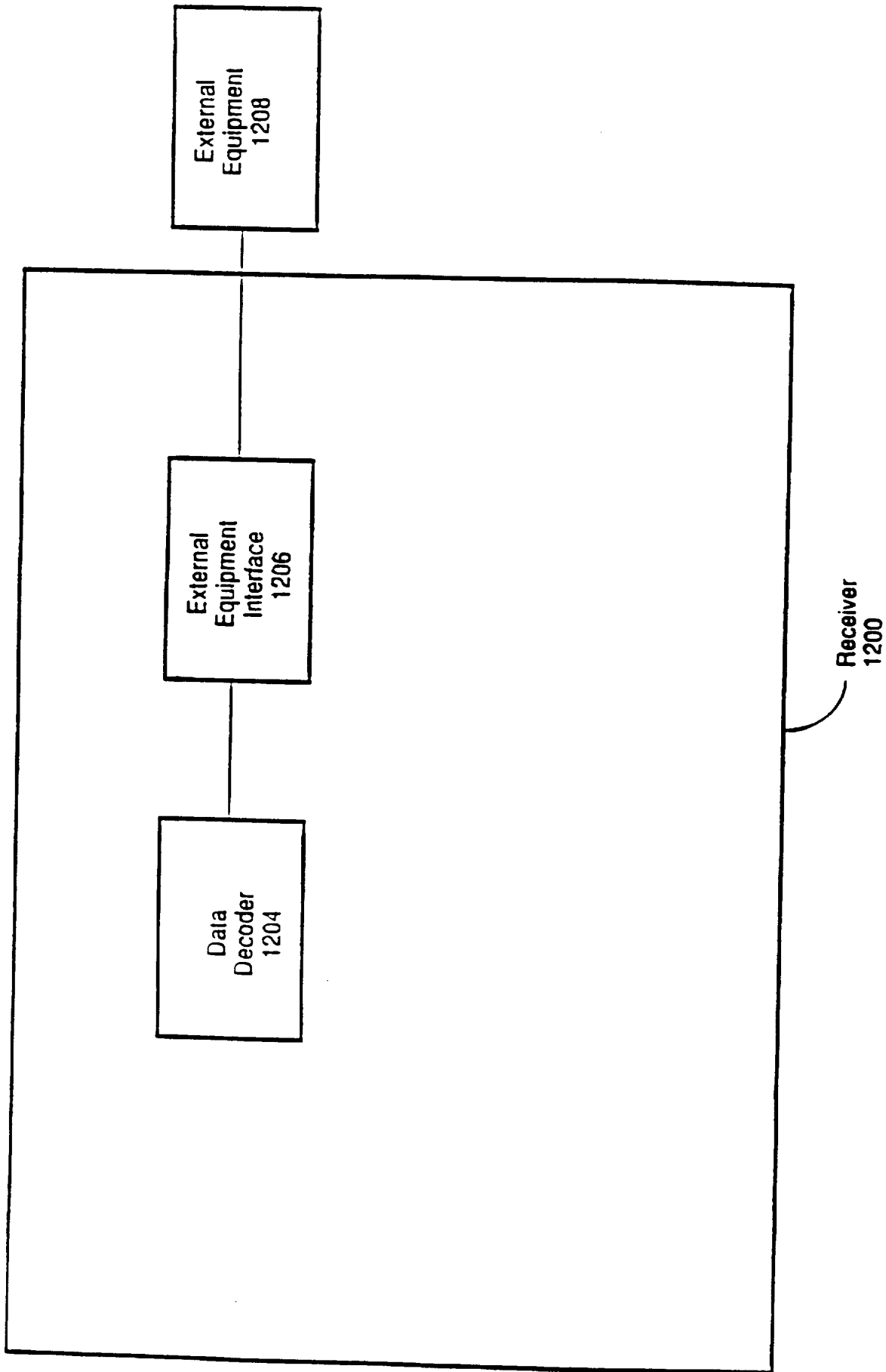


Figure 12

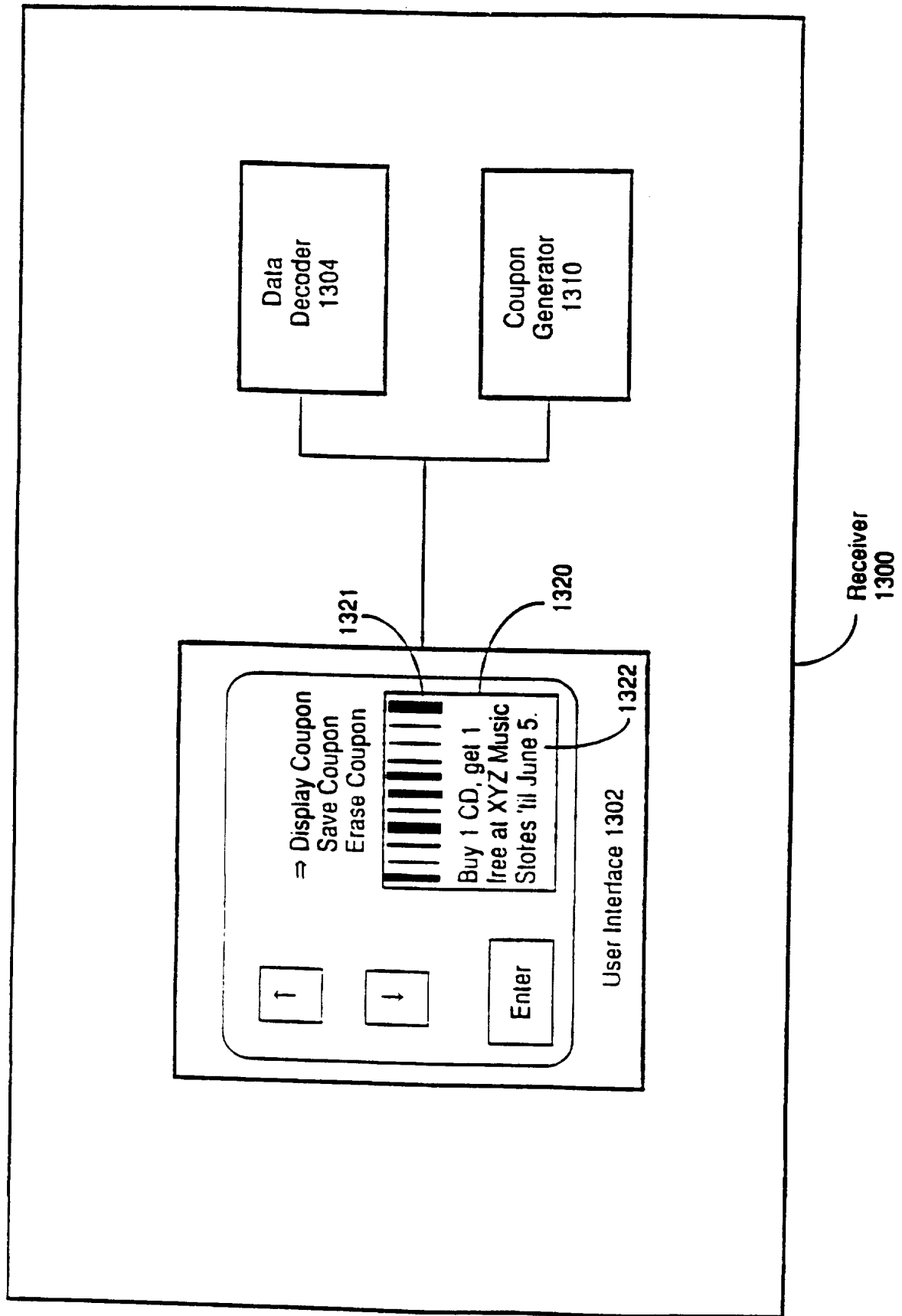


Figure 13

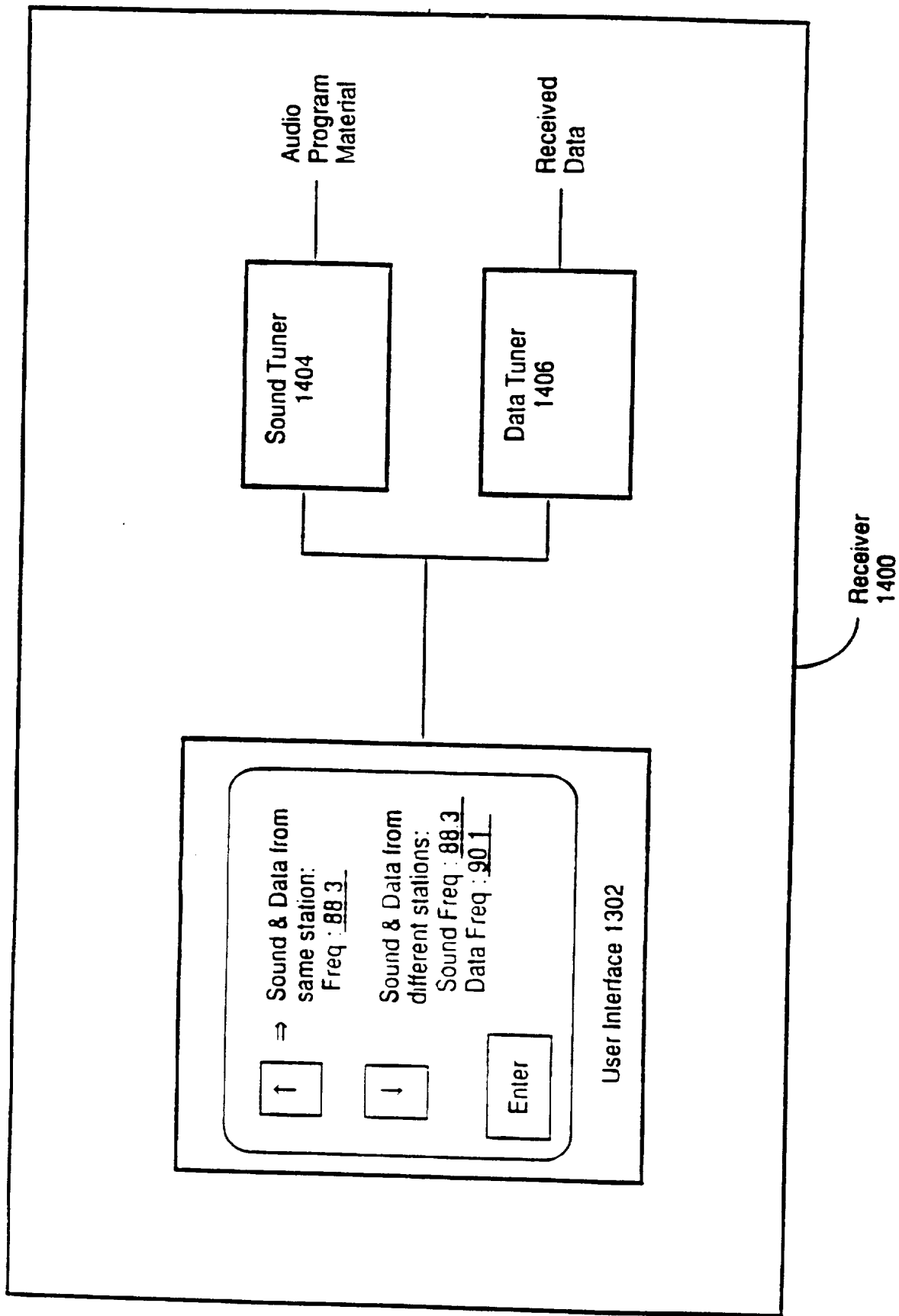


Figure 14

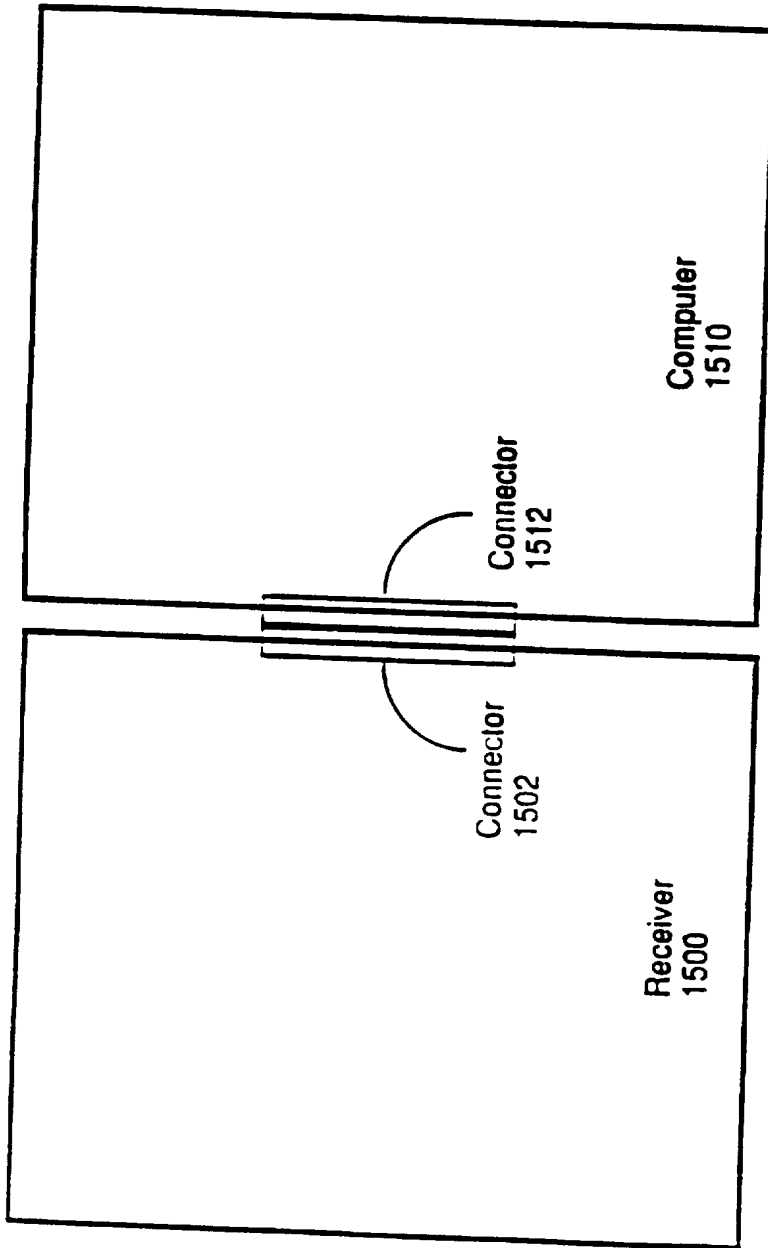
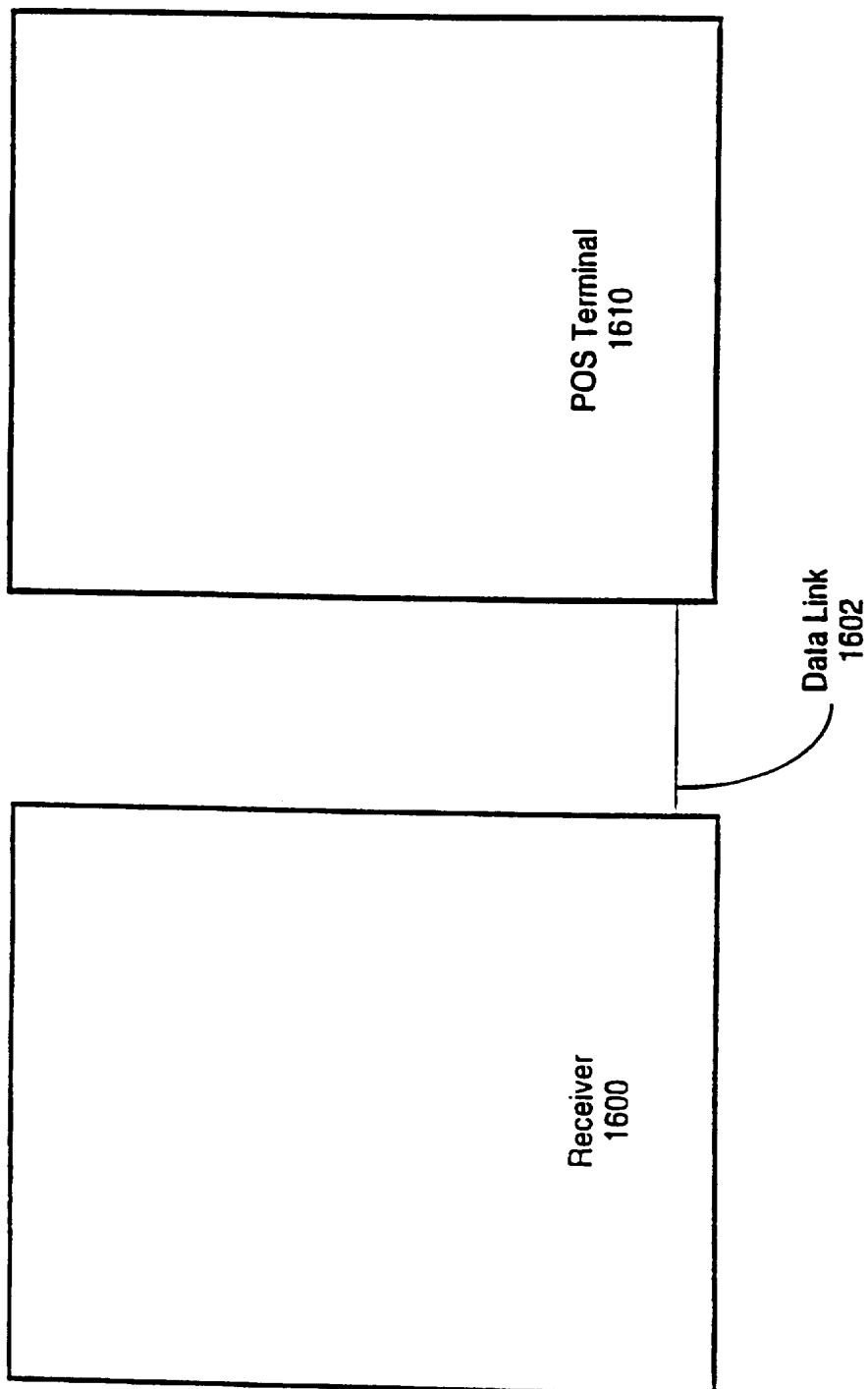


Figure 15



*Figure 16*

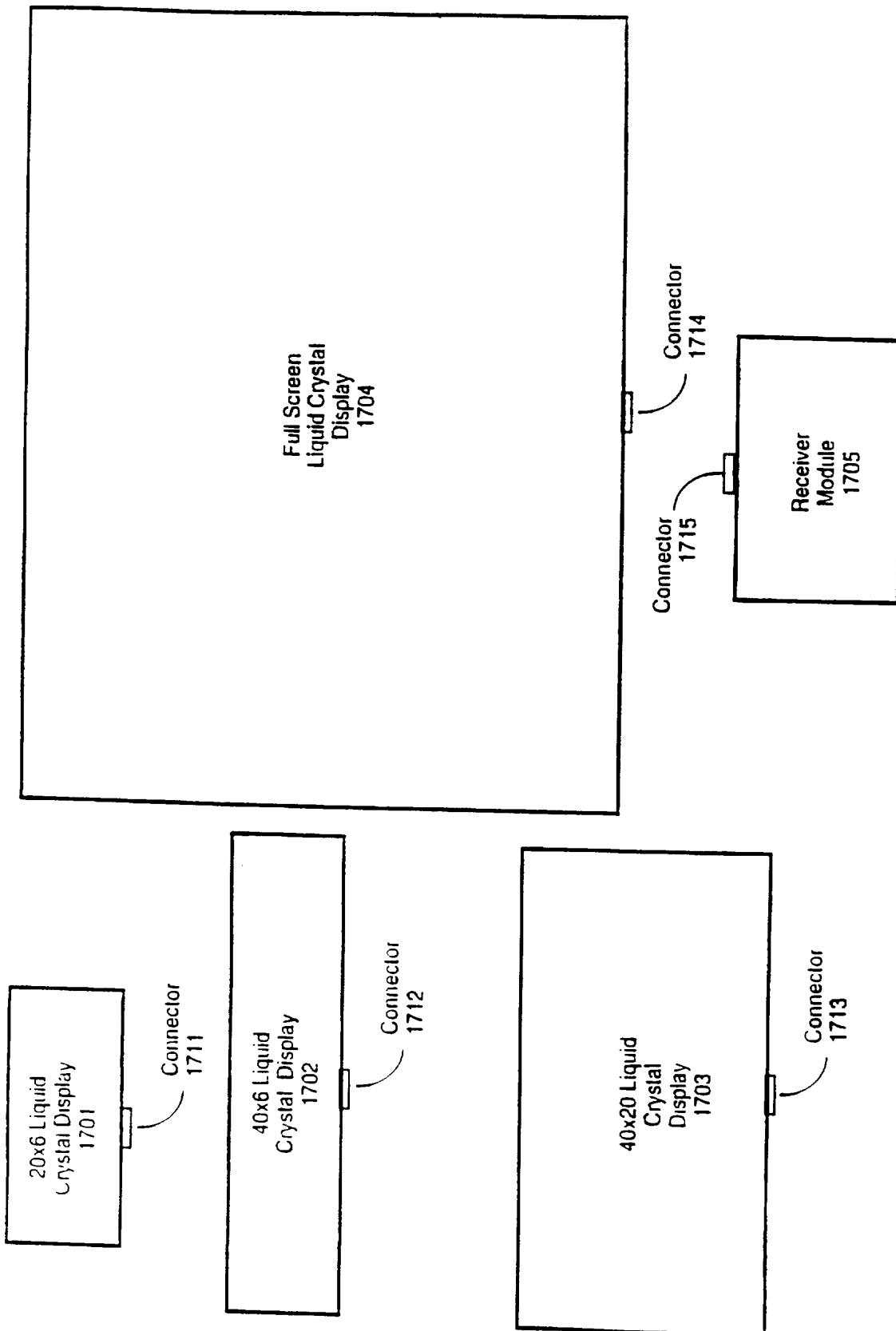


Figure 17

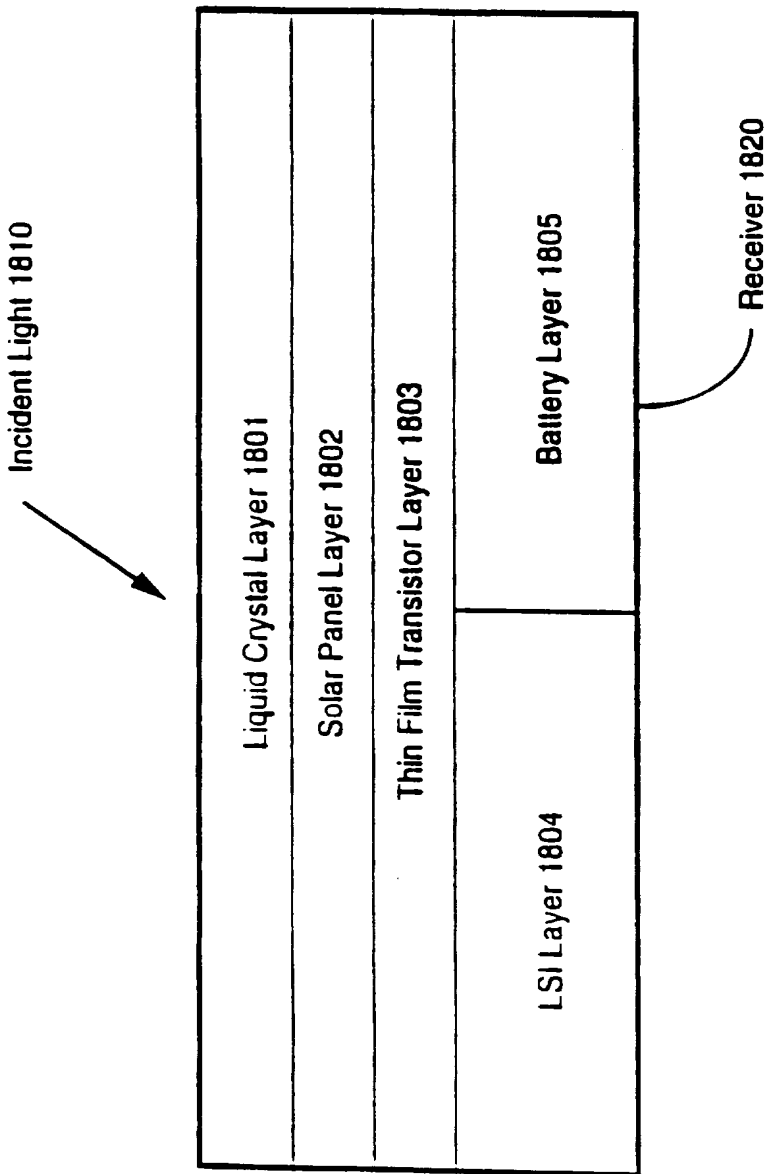


Figure 18

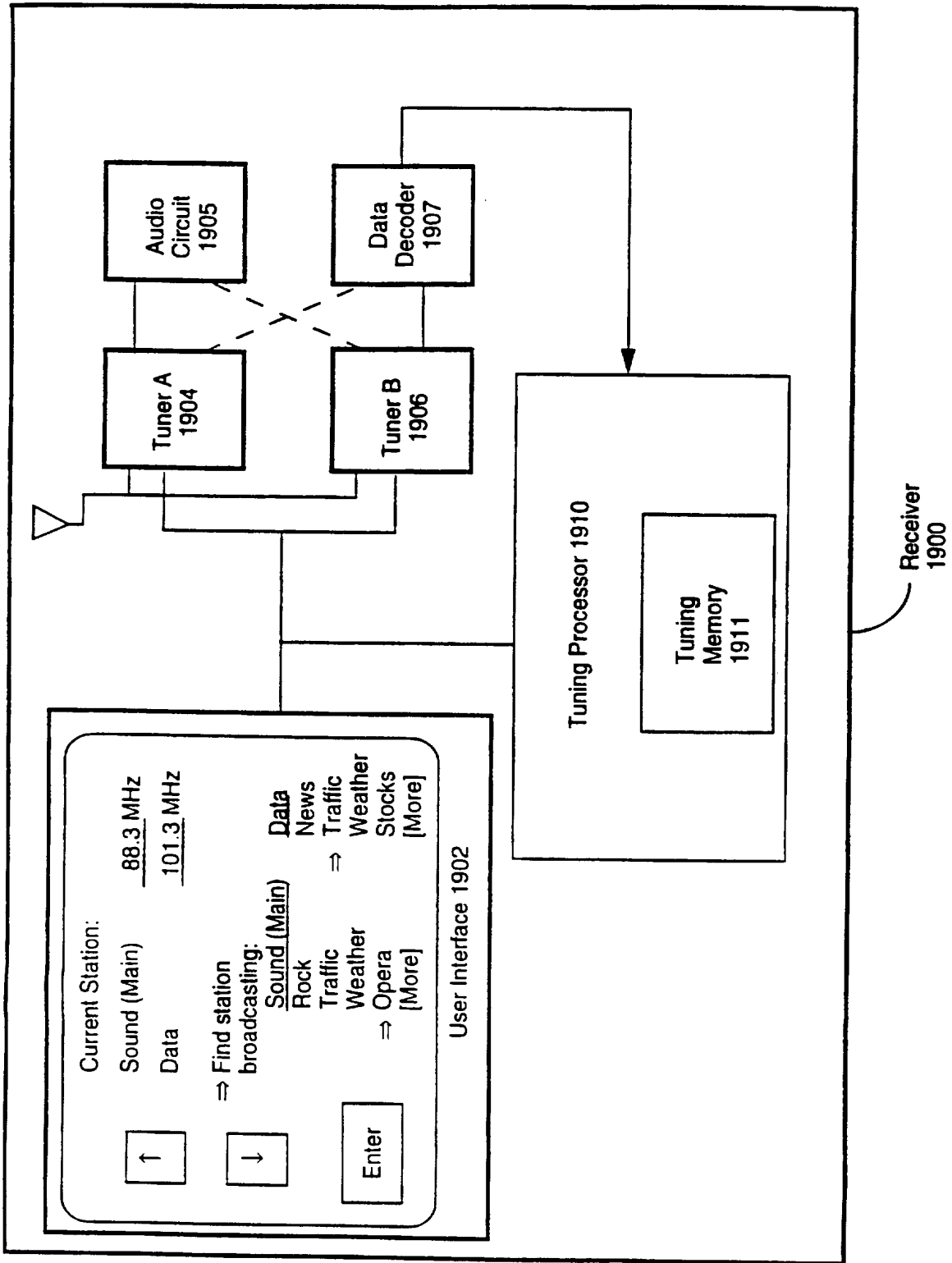


Figure 19



# INTERNATIONAL SEARCH REPORT

Internat. Application No  
PCT/US 97/07485

<b>A. CLASSIFICATION OF SUBJECT MATTER</b> IPC 6 H04H1/00		
According to International Patent Classification (IPC) or to both national classification and IPC		
<b>B. FIELDS SEARCHED</b>		
Minimum documentation searched (classification system followed by classification symbols) IPC 6 H04H		
Documentation searched other than minimum documentation to the extent that such documents are included in the fields searched		
Electronic data base consulted during the international search (name of data base and, where practical, search terms used)		
<b>C. DOCUMENTS CONSIDERED TO BE RELEVANT</b>		
Category °	Citation of document, with indication, where appropriate, of the relevant passages	Relevant to claim No.
A	EP 0 459 360 A (GRUNDIG E.M.V.) 4 December 1991 see column 1, line 1 - column 3, line 31; claims 1,2; figure 1	1-5,9
A	EP 0 333 194 A (SANYO ELECTRIC CO. LTD.) 20 September 1989 see page 2, line 1 - page 4, line 45; claims 1-3,10,21; figure 2	1,9
A	EP 0 603 792 A (KABUSHIKI KAISHA KENWOOD) 29 June 1994 see column 1, line 1 - column 2, line 30; claims 1,2; figure 1	9,13
--- -/--		
<input checked="" type="checkbox"/> Further documents are listed in the continuation of box C.		
<input checked="" type="checkbox"/> Patent family members are listed in annex.		
° Special categories of cited documents :		
*A* document defining the general state of the art which is not considered to be of particular relevance *E* earlier document but published on or after the international filing date *L* document which may throw doubts on priority claim(s) or which is cited to establish the publication date of another citation or other special reason (as specified) *O* document referring to an oral disclosure, use, exhibition or other means *P* document published prior to the international filing date but later than the priority date claimed		
*T* later document published after the international filing date or priority date and not in conflict with the application but cited to understand the principle or theory underlying the invention *X* document of particular relevance; the claimed invention cannot be considered novel or cannot be considered to involve an inventive step when the document is taken alone *Y* document of particular relevance; the claimed invention cannot be considered to involve an inventive step when the document is combined with one or more other such documents, such combination being obvious to a person skilled in the art. *&* document member of the same patent family		
Date of the actual completion of the international search  <p style="text-align: center; font-size: large;">15 October 1997</p>	Date of mailing of the international search report  <p style="text-align: center; font-size: large;">23. 10. 97</p>	
Name and mailing address of the ISA European Patent Office, P.B. 5818 Patentlaan 2 NL - 2280 HV Rijswijk Tel. (+31-70) 340-2040, Tx. 31 651 epo nl, Fax: (+31-70) 340-3016	Authorized officer  <p style="text-align: center; font-size: large;">De Haan, A.J.</p>	

2

# INTERNATIONAL SEARCH REPORT

International Application No.

PCT/US 97/07485

**C.(Continuation) DOCUMENTS CONSIDERED TO BE RELEVANT**

Category °	Citation of document, with indication, where appropriate, of the relevant passages	Relevant to claim No.
A	EP 0 595 314 A (BECKER G.M.B.H.) 4 May 1994 see column 1, line 1 - column 4, line 5; claims 1,4; figure 1 ---	1
A	US 5 457 815 A (MOREWITZ, II) 10 October 1995 see column 1, line 1 - column 2, line 32; claims 1,5,6,9,11; figure 1 -----	1,9,10

2

# INTERNATIONAL SEARCH REPORT

Information on patent family members

International Application No

PCT/US 97/07485

Patent document cited in search report	Publication date	Patent family member(s)	Publication date
EP 459360 A	04-12-91	DE 4017756 A DE 59106704 D	05-12-91 23-11-95
EP 333194 A	20-09-89	AT 154733 T DE 68928131 D JP 2124648 A KR 9608949 B	15-07-97 24-07-97 11-05-90 10-07-96
EP 603792 A	29-06-94	JP 6196972 A DE 603792 T US 5535442 A	15-07-94 29-06-95 09-07-96
EP 595314 A	04-05-94	DE 4236621 A	05-05-94
US 5457815 A	10-10-95	NONE	



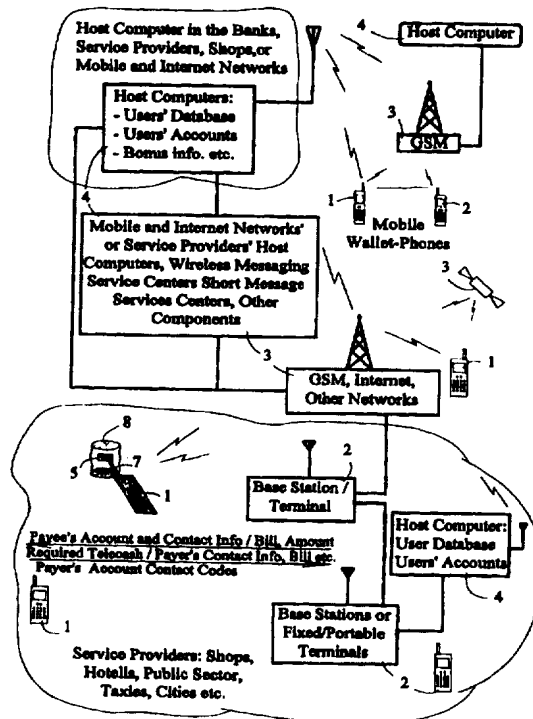
INTERNATIONAL APPLICATION PUBLISHED UNDER THE PATENT COOPERATION TREATY (PCT)

<p>(51) International Patent Classification <sup>6</sup> : G07F 7/08, 19/00, G06F 17/60 // 157:00</p>	<p>A1</p>	<p>(11) International Publication Number: <b>WO 97/45814</b> (43) International Publication Date: 4 December 1997 (04.12.97)</p>
<p>(21) International Application Number: PCT/FI97/00315 (22) International Filing Date: 26 May 1997 (26.05.97) (30) Priority Data: 962553 24 May 1996 (24.05.96) FI 971248 24 May 1996 (24.05.96) FI 970767 24 February 1997 (24.02.97) FI (71)(72) Applicant and Inventor: VAZVAN, Behruz [FI/FI]; Vuokselantie 10 B, FIN-02140 Espoo (FI).</p>	<p>(81) Designated States: US, European patent (AT, BE, CH, DE, DK, ES, FI, FR, GB, GR, IE, IT, LU, MC, NL, PT, SE).</p> <p><b>Published</b> <i>With international search report. Before the expiration of the time limit for amending the claims and to be republished in the event of the receipt of amendments.</i></p>	

(54) Title: REAL TIME SYSTEM AND METHOD FOR REMOTE PURCHASE PAYMENT AND REMOTE BILL PAYMENT TRANSACTIONS AND TRANSFERRING OF ELECTRONIC CASH AND OTHER REQUIRED DATA

(57) Abstract

A wireless/cellular terminal (1) and method is provided for allowing a user to perform remote purchase and bill payment transactions, and transferring of telecash and other required data to other terminals (2) or to the remote host computers (4) without using modem. In one embodiment, the terminal includes means for receiving and transmitting of bills and electronic cash directly to/from other terminals in a connectionless way without using the network (3). In the method of this invention, the payee's details such as account number, contact codes are sent/broadcast to the payee's terminal (e.g. mobile phone). The payer activates the payee's details upon which the bill and/or the required amount of telecash is sent to the payee's terminal or host computer. The terminal of this invention can operate as both the user's cellular/wireless electronic wallet and as his cellular/wireless telephone, thus providing a Mobile Wallet-Phone (MWP). By using MWP the user is able to send/receive payment messages and electronic cash directly to/from other terminals under a small terminal-to-terminal (1, 2) radio coverage or via the network (3). In another embodiment, the method of this invention provides a P-PIN (Payment-Personal Identification Number) process for user authentication which, when required, is used (in addition to the PIN-code which is used for mobile telephone services) to verify that the user has the right to use the terminal as his electronic wallet for paying by telecash or account transferring. In another embodiment of the method of this invention a bill inquiry is sent from other terminals or from the host computer to the user's terminal upon request of the user or automatically and/or continuously whenever the provided service requires so. In this case the user's terminal can be also a personal computer or television connected to the fixed internet or operating wirelessly.



**FOR THE PURPOSES OF INFORMATION ONLY**

Codes used to identify States party to the PCT on the front pages of pamphlets publishing international applications under the PCT.

<b>AL</b>	Albania	<b>ES</b>	Spain	<b>LS</b>	Lesotho	<b>SI</b>	Slovenia
<b>AM</b>	Armenia	<b>FI</b>	Finland	<b>LT</b>	Lithuania	<b>SK</b>	Slovakia
<b>AT</b>	Austria	<b>FR</b>	France	<b>LU</b>	Luxembourg	<b>SN</b>	Senegal
<b>AU</b>	Australia	<b>GA</b>	Gabon	<b>LV</b>	Latvia	<b>SZ</b>	Swaziland
<b>AZ</b>	Azerbaijan	<b>GB</b>	United Kingdom	<b>MC</b>	Monaco	<b>TD</b>	Chad
<b>BA</b>	Bosnia and Herzegovina	<b>GE</b>	Georgia	<b>MD</b>	Republic of Moldova	<b>TG</b>	Togo
<b>BB</b>	Barbados	<b>GH</b>	Ghana	<b>MG</b>	Madagascar	<b>TJ</b>	Tajikistan
<b>BE</b>	Belgium	<b>GN</b>	Guinea	<b>MK</b>	The former Yugoslav Republic of Macedonia	<b>TM</b>	Turkmenistan
<b>BF</b>	Burkina Faso	<b>GR</b>	Greece			<b>TR</b>	Turkey
<b>BG</b>	Bulgaria	<b>HU</b>	Hungary	<b>ML</b>	Mali	<b>TT</b>	Trinidad and Tobago
<b>BJ</b>	Benin	<b>IE</b>	Ireland	<b>MN</b>	Mongolia	<b>UA</b>	Ukraine
<b>BR</b>	Brazil	<b>IL</b>	Israel	<b>MR</b>	Mauritania	<b>UG</b>	Uganda
<b>BY</b>	Belarus	<b>IS</b>	Iceland	<b>MW</b>	Malawi	<b>US</b>	United States of America
<b>CA</b>	Canada	<b>IT</b>	Italy	<b>MX</b>	Mexico	<b>UZ</b>	Uzbekistan
<b>CF</b>	Central African Republic	<b>JP</b>	Japan	<b>NE</b>	Niger	<b>VN</b>	Viet Nam
<b>CG</b>	Congo	<b>KE</b>	Kenya	<b>NL</b>	Netherlands	<b>YU</b>	Yugoslavia
<b>CH</b>	Switzerland	<b>KG</b>	Kyrgyzstan	<b>NO</b>	Norway	<b>ZW</b>	Zimbabwe
<b>CI</b>	Côte d'Ivoire	<b>KP</b>	Democratic People's Republic of Korea	<b>NZ</b>	New Zealand		
<b>CM</b>	Cameroon	<b>KR</b>	Republic of Korea	<b>PL</b>	Poland		
<b>CN</b>	China	<b>KZ</b>	Kazakstan	<b>PT</b>	Portugal		
<b>CU</b>	Cuba	<b>LC</b>	Saint Lucia	<b>RO</b>	Romania		
<b>CZ</b>	Czech Republic	<b>LI</b>	Liechtenstein	<b>RU</b>	Russian Federation		
<b>DE</b>	Germany	<b>LK</b>	Sri Lanka	<b>SD</b>	Sudan		
<b>DK</b>	Denmark	<b>LR</b>	Liberia	<b>SE</b>	Sweden		
<b>EE</b>	Estonia			<b>SG</b>	Singapore		

**Real Time System and Method For Remote Purchase Payment and Remote Bill  
Payment Transactions and Transferring of Electronic Cash and Other Required Data**

5

**Background of the Invention**

**Field of the Invention:**

10

This invention relates to systems for purchase and bill payment transactions and transferring of electronic cash and also terminal-to-terminal wireless transmission of the required data without using modem.

15 **Description of the Related Art:**

The WO96/04618 publication has disclosed a terminal which can perform purchase payment and bill transactions via a modem coupled to or integrated into the terminal. The whole system provided in above publication is a modem-based system where the user's credit card information and the terminal's serial number are sent to a host computer for validating which after authorization by card issuing authority and a host computer the user is given the right for remote purchases. In its portable form the terminal also uses modem which is coupled through the telephone circuit to a transmitter/receiver. The portable terminal is not a wireless/cellular terminal so it does not exploit the wireless messaging for direct communication but the terminal is by means of a modem and circuit-switched call connected to a host computer and the payment procedure is performed during the established call. Moreover, in the above system transaction requests are connected to the remote host system through telephone line and the system is based only on circuit-switched communications whereby the credit card validation is performed during an established continuous call. Furthermore the above-like systems does not utilize electronic cash for purchase or bill transactions.

20  
25  
30  
35 The GB2276258 publication disclose a system for utilizing credit information to verify and accept payment for an order on site at the door of a home contemporaneously by means of credit card. The above system is also a modem-based system and is based on circuit-switched communications neither messaging means of wireless communication for purchase and payment transactions. Neither the above system uses electronic money for payment transactions. In all already known methods the user establishes a circuit-switched call for performing transaction during the established call.

In the above-like systems the communication speed is low because of using modems or data cards which also makes the terminals more expensive. The communication is also expensive for the user because of the circuit-switched calls and the user, in some cases, is also required to purchase a

separate terminal for his purchases or bill payment transactions. Furthermore the user's credit information (credit card number) communication over the open networks is not secured. In all existing systems it is the customer whose credit card number is taken by the service provider for charging the customer whereas in a secure payment system the customer is not required to give any credit information to the third parties. There continues to exist a need to further improve the efficiencies of the payment systems.

### **Summary of the Invention**

10 It is an object of this invention to provide a secure payment system wherein the payer takes the account/contact number of the payee in order to pay to the payee's terminal or account. It is another object of this invention to provide a wireless/cellular terminal which can perform purchase payment and bill payment transactions and be used as the use's electronic wallet. It is another object of this invention to provide a wireless/cellular terminal to allow users the ability to conveniently and  
15 remotely in a connectionless way perform these financial transactions and send and receive electronic money on terminal-to-terminal basis (as wallet-to-wallet) without using the network for transferring the required cash. It is another object of this invention to provide a wireless/cellular digital terminal to allow smart card holders to also remotely perform these financial transactions and also terminal-to-terminal transferring of electronic money. In this invention in order to prevent  
20 forgery the payee's account number, whereto the founds can be transferred, is delivered to the payer and not the payer's account number to the payee, which could easily be used by unauthorized users.

It is another object of this invention to provide a service as an expansion of value-added data services of currently existing mobile communications systems. It is another object of this invention to utilize the wireless or cellular terminals such as mobile phones, pagers etc. to be used as the  
25 inventive terminal (Mobile Wallet-Phone) thus creating a high value added service for mobile communication and providing the users one terminal which can be used as mobile telephone or pager when needed and as user's electronic wallet when required. Another object of this invention is to provide for wireless or cellular connectionless messaging with a remote host computer without establishing a circuit switched call.

30 It is yet another object of this invention to provide a connectionless method for terminal-to-terminal transmission of electronic money and payee's details such as contact code or number, account code or number, and bill without contacting the payee. It is another object of this invention to provide a connectionless method for broadcasting the payee's/service provider's details such as account number, contact codes, and the payable bill to the user's terminals continuously or whenever  
35 required. It is yet another object of this invention to provide a method to send a bill format to the user's terminals in a connectionless way and whenever user requests it, to be filled and sent back to the required host computer or another terminal. It is yet another object of this invention to provide a terminal which is able to communicate with another terminal directly and without using the network for transmission of the required data. It is another object of this invention to provide a terminal

which is able to configure an adjustable radio coverage area (e.g. between one millimeter to five meter) for terminal-to-terminal wireless and modemless data transmission.

According to one embodiment of this invention, a wireless terminal, such as SIM-operated (SIM: Subscriber Identification Module) portable terminals such as mobile phones or pagers, portable  
5 wireless personal computers can perform terminal-to-terminal remote purchase payment transactions, transferring of electronic money and user's details such as account number, contact code, address etc. in a connectionless way without requiring that the payee/payer contact each other or establish a circuit-switched call. The terminal includes means for receiving/transmitting of  
10 required information in a terminal-to-terminal wireless data communication without using the network for transmission the information. The terminal can produce a small and adjustable radio coverage area wherein the terminal-to-terminal sending of the user details and transferring of electronic money and other information can be done using wireless messaging and in a transparent way to other terminals/users. In another embodiment of the invention the wireless/cellular terminal or service provider's terminal (such as cash register, computer etc.) or base station broadcasts the  
15 payee's/service provider's account and bill information to all or to the required users' terminal which are under the radio coverage of the payee's/service provider's terminal/base station. Then the payer's terminal monitors the transmitted/broadcasted information which after the user activates the payee's details and sends the bill and the payee's details and when needed the required electronic money (telecash) to the payee's terminal or account at the host computer. In another embodiment of this  
20 invention the user, by sending a message, can request the host computer or the payee's terminal to send the bill or bill format to the payer's terminal, in a connectionless way (using for example internet or short massaging means of mobile networks). Then user accepts the bill or fills in the bill format (a bill inquiry) the required information (together with the required amount of telecash, when needed) and sends it back to the host computer or the payee's terminal for receiving/accepting or  
25 performing the bill.

In this invention the user's details such as account number, contact codes, numbers are sent or broadcasted to other terminal, directly or via base stations, or via network, in order to be used by payers for remote purchase transactions, bill payment, transferring of telecash and other required data from terminal-to-terminal or between the terminals and host computer.

30 Other objects and many of the attendant features of this invention will be more readily appreciated as the same becomes better understood by reference to the following detailed descriptions and considered in connection with the accompanying drawings in which like reference symbols designate like parts throughout the figures.

### 35 **Brief Description of the Drawings**

FIG. 1 illustrates a general overview of the system including cellular/wireless and internet network, host computers and Mobile Wallet-Phones utilized in the invention.

FIG. 2 is a flow chart presenting the user authentication, sending the payee's details, bills, bill  
40 inquiry, performing the transactions, sending the required amount of telecash to the payee's terminal/account in accordance to the present invention.



FIG. 3 is a terminal-to-terminal or base station-to-terminal or host computer to-terminal messaging of the payee's details, purchase and bill payment transaction messaging, and transferring of electronic money in a service provider environment in accordance with the present invention.

FIG. 4 is a flow chart between the payer's terminal, host computer and the payee's terminal.

5 FIG. 5 presents four examples wherein payee's/payer's terminal exchange contact codes, account information, required amount of electronic money, perform bill payment and transactions in a connectionless, modemless, wireless and terminal-to-terminal way, or terminal-to-base station-to-terminal way, or terminal-to-terminal-to-host computer.

FIG. 6 is a top view of the terminal in accordance with one embodiment of the present invention.

10 FIG. 7 presents an example of a connectionless method for parking payments, in accordance with the present invention.

FIG. 8 presents an example of a connectionless method for parking reservation, in accordance with the present invention.

15 FIG. 9 presents two Mobile Wallet-Phones which can send and receive information, account numbers, contact codes, required amount of telecash (i.e. electronic money) and exchange other required data directly with each other under their own adjustable radio coverage without using the network, in accordance with one embodiment of the present invention.

### **Detailed Description**

20

Referring now to the drawings, and more particularly, to FIG. 1, there is shown a block diagram of the overall system including cellular/wireless and internet networks (3), host computers (4) and user's wireless/cellular terminals "Mobile Wallet-Phones" (1, 2) or fixed terminals/base stations (2) in accordance with the invention. The terminal (1, 2) is able to send and receive the required account  
25 numbers, contact codes, telecash, bills and bill format and the products' details (such name and price) in a connectionless way either without using the network (3) or via the network. The base stations of the network (3) or service providers (2) are also arranged so that they send the required information for purchase and bill payment transactions, such as the payee's account number or codes, and bill format to the users terminal (1) continuously or whenever required. For example when the  
30 user terminal is under the coverage of base station (2) the network/base station broadcasts/sends the payee's/service provider's name and account number to the payer's terminal. Then the payer's Mobile Wallet-Phone (hereinafter MWP) monitors the payee's account number, contact code etc. (hereinafter payee's detail), then the user selects/activates the required payee's details which may be allocated for a specific service such as parking and send the bill and(or required telecash to the  
35 payee's terminal (2) or account (4) directly or via base station or via network. The payee's and payer's MWPs and fixed/portable terminals (1, 2) can exchange information, send and receive required amount of telecash directly to each other without the involvement of the network or host computer (4). The host computer (4) includes, as much as required, the users' details, data, accounts, the service provider's details etc. When the user purchases something for example in a shop by  
40 means of his/her MWP, the seller's terminal can send the bill and payment to the host computer (4)

where users have accounts. The host computer (4) takes the required bonuses into account so that the user does not require to have a different bonus card in order to give to the seller for storing the (gained) bonus in the customer's account but the required bonus can be stored in his account while shopping is done by his MWP without requiring a separate bonus card. The network (3) can be a  
5 terrestrial or satellite network. The mobile wallet-phones (1, 2) are wireless/cellular, either terrestrial or satellite or both, single mode/band, dual mode/band or multimode/multiband terminals/phones or pagers, transmitter/receivers which can also whenever required configure their own radio coverage area under which they can send and receive the required information and telecash to/from each other without using the network. Alternatively by means of terminals (1, 2) the user can request the  
10 network/host computer or other terminal to send a bill format which includes at least one question which can be answered (filled in) by user and sent back to the required host computer or other terminals. The host computer also takes into account the currency by which a bill or purchase has been performed so that when the host computer (4) receives the bills and payments from a payer's terminal, it checks the received information, the currency unit of the telecash or checks the  
15 payer's/payee's accounts in order to define by which currency the amount should be paid to the payee's account. The exchange of the money is done in a real time and then both the payee's/payer's terminals are acknowledged by a short message. In FIG 1. there is also shown that the user's terminal (1) is able to monitor (receive) the product's (8) details (such as name, price and other required information needed to perform the bill payment) from a tag/card or label (5) which is labeled or by  
20 other means connected/printed on the product package (for example a can of mushrooms). The tag or card (5) can be a microprocessor loaded with the required details and which is also able to radiate/transmit the required details over a very small area (for example 1 millimeter). The tag or card (5) can be also made from an environment-friendly radiating material and loaded with the required product's details (i.e. the information which is broadcasted/radiated with a very small radio  
25 coverage). When the tag/card (5) is (for example) touched by the antenna (7) of user's terminal (1) the terminal receives and monitors the product's details. The user can pay for the selected product (5) by sending the product's details (and when needed, the required amount of telecash to the cash register, shop keeper's terminal (2) or host computer (4) or to the host computer of the bank wherein at least the customer (payer) has an account which can be debited/charged for the purchase  
30 performed. Alternatively the user's terminal (1) can be integrated with an electronic and digital (image) camera by which the bar codes (5) of a product (8) can be read (transferred into the terminal as an image or black and white code) in order to select the product user wants to buy and pay for, without requiring to use any infrared reading devices. This application of the present invention can be seen as the best killer application for terminals having digital image processing means. Although  
35 several inventions has been made to provide mobile phones with digital camera's features or providing video telephony in mobile phones but because of the lack of good applications such products cannot have a widespread market in the near future. For example the willingness of people to participate in video telephony has been seen as a barrier for mass production of video telephony products. But shopping by means of a mobile phone integrated with an appropriate camera can be

seen as a killer application for mobile phones having digital image or mobile video telephony features. For example in FIG 1 the payer's terminal (1) can be integrated with a micro or nano digital camera in order to read the product's (8) bar codes (5) (or any other information including the product's details and price) and transfer them to the terminal (1) wherein the product details can be monitored on the screen of the user's terminal, and the terminal further arranges the product details in a shopping list on the screen. Then the user can send the bill and payment to the payee, as mentioned above, or cancel the list or an item from it, if he does not want to buy the selected product.

FIG. 2 presents a flow chart, where is shown that the MWP's user is authenticated by means of an additional code called P-PIN (Personal-Payment Identification Number) if a PIN is already used for telephone services. The user can use the same number for both PIN and P-PIN in order to remember it better. In one embodiment of this invention, first the MWP operates as the user's telephone i.e. the user has entered his/her PIN-code to the terminal for access to the network (3) for telephone services so that the MWP is in the telephone mode. According to the invention in order to provide a secure payment device and method the user is prompt to enter in addition to the PIN code another code, P-PIN, for using his mobile phone as a payment device, when required. After entering the P-PIN the mobile phone becomes a mobile wallet-phone so that it can be used both as a mobile phone and as the user wallet, thus Mobile Wallet-Phone. After that the P-PIN has been entered or spoken by user to his terminal (1, 2) an authentication procedure takes place either in the terminal (1, 2) and user's smart card (e.g. SIM) or between the terminal i.e. smart card (SIM) and network/host computer. The user can also be registered and authenticated in network's AuC (Authentication Center) HLR (Home Location Register) or other future intelligent component of the network or in the host computer. When the user is authenticated either in MWP (1) or network/host computer (3, 4), the user can perform teleshopping, bill payment and purchase transactions and exchange money with other terminals (1, 2) or host computer (4). In order to receive the payee's details (i.e. account number, contact number etc.) the user can activate a function such as "payments" or "service provider" in his terminal (1, 2) either before authentication or after or without authentication. Then the terminal (1, 2) monitors the payee's terminal's/base station's broadcasting/transmitting details or the payer by sending a message requests the payee's terminal (2) or host computer (4) to send the required information such as payee's details, bill format etc. needed to perform the purchase or bill payment. Then the payer can enter the required information, if necessary, such as transaction's amount and send the bill (either including the required telecash or without it) to the payee's account which can be in the payee's terminal/MWP (2) or in the host computer. If the bill/payment is sent to the host computer (4), the host computer either transfer the received telecash to the payee's account or debits the payee's account for the amount which should be paid to the payee's account. Then the payee's/payer's terminals are acknowledged about the completion of the payment by sending a message to both terminals. The user's account or contact numbers/codes can be a telephone number or a contact code allocated for user in order to receive and send bills and payments. The user's account or contact numbers/codes can be same a his telephone number or internet address used for sending and receiving bills and payment messages according to this invention. Alternatively, a different code or number can be used for this purpose. User can have a different user data in SIM for

registration and authentication into his terminal or host computer or network's components (e.g. HLR, AuC) for the inventive payment service, or the same user data used for telephone services can be used for user registration or authentication, if required.

When the user does not want to perform purchase transactions, bill payments, exchange or transfer telecash, the terminal (1) can be used only as a telephone i.e. the MWP operates only as a mobile phone for example by activating a required function (for example "log-out" from the wallet-mode or "close the wallet" or by activating an icon presenting a wallet shown on the corner of the terminal's display). Therefore, if the terminal is stolen, its' owner should not be worried about his money or account since only the authorized user has the required P-PIN code in order to use his mobile phone as Mobile Wallet-Phone.

FIG. 3 shows one embodiment of the present invention in a service provider's environment. The service provider's base stations or terminals (2) or host computer (4) broadcast or send whenever required the payee's/service provider's details, bill format, bill, the sum which should be paid by payer and other required information for performing the payment. Alternatively the above-mentioned information can be requested through the payer's terminal (1) by sending a message to the payee's terminal directly or through the network/base stations or they can be requested from the host computer. The payee's details can include payee's account number, contact code (such as .PizzaHut.com), the service provider's cash register's number (i.e. contact code, account number etc.). The required information is then monitored (6) by the payer's MWP (1). Then the payer activates the payee's details upon which MWP sends the required payment/bill to the payee's account kept in payee's terminal (2) (SIM card) or in the host computer (4).

FIG. 4 presents another example of the payment method according to the present invention. The payer's MWP (1) monitors the payee's/service provider's details transmitted/broadcast over the air interface in a connectionless way (payer does not need to contact the payee). After that the payer has activated the required command for example "service provider" (or a number or button) his MWP monitors the available service providers' details. Monitoring of the service provider's details depends on the radio coverage of the service providers' base stations/terminals and payer's MWP's radio coverage area. For example service provider's terminal /base station (2) can broadcast/send the required information in a 1 to 5 meter (or more or less) configured radio coverage area (which can be adjustable). When the payer's MWP is under such coverage, it can receive the service provider's/payee's details. The required coverage can be adjusted for example from 1 millimeter to few meters or more (depending on the application). In this way only the payer and payee can exchange information, payments without using the network. Furthermore a signaling protocol can take place between the terminals for precise terminal to terminal communication. According to this embodiment of the present invention the exchange of information and payments takes place terminal-to-terminal which is the most secure option. However, when the payment (telecash) is transmitted from the payer's terminal (1) to the payee's terminal (2), the payee can send the payment to the host computer to the payee's account.

On the other hand when payer's terminal (1) monitors the payee's details and the payable bill and payer activates the payee's details (6), the bill (either together with the required amount of telecash or without it) can be sent via network to the host computer (4) where the payer, payee have accounts.

Then the payer account is debited for the amount of the bill and then payer's and payee's terminals are acknowledged about the completion of the transaction or the lack of money (credit) in the payer's account. In this way payee's and payer's terminal first exchange information in order to know to which account the payment should be transferred. Then after receiving the payee's details by the  
5 payer's MWP (1) the network can be used to send the bill and/or required amount of telecash to the host computer (4), when required.

FIG. 5 presents four examples for payments in the service providers' environment. In example 1 the payee's terminal (2) broadcasts/sends the payee's details, bill (and purchase details if required) through the base stations (either payee's base station 2 or for example a GSM operator's base station  
10 3) to the payer's MWP (1). The base stations can include the required controlling systems or they can be linked to the base stations' subsystem for controlling the base stations. Then payer activates the payee's details (account number) which also includes contact codes of the required host computer (e.g. www//OKObank.PizzaHut.fi or for example 3589435634528349). Then the bill and other required information is send to the host computer (4) where the required amount is transferred to the  
15 payee's account.

In example 2 of FIG. 5 the payee's details, payable bill and other required data are directly broadcast/sent from the payee's terminal (2) to the payer's MWP (1). Both terminals (1, 2) are under each other's radio coverage so that the information broadcast/sent by payee's terminal is received by payer's MWP (1) without using the network (3). After this, the payer activates the payee's details,  
20 as explained above, and sends the bill to the host computer. In example 3 of FIG. 5 the service provider's details, for example, the gas station's or a bus company's account number, codes or other required information such as the price of petrol per litter or the price of ticket are broadcast/sent to the payer's terminals (1). For example when payer wants to pay for petrol, he activates the service provider's details received by his terminal (1) and sends it to the host computer (4), then the host  
25 computer checks the payer's account and sends a message to the petrol station's terminal (2) indicating that the payer has the right (sufficient credit) to buy the petrol. After that payer has finished tanking his car, the terminal (2) sends the bill to the host computer (4) for debiting the payer's account for the amount of the petrol he has bought. Then the host computer (4) sends an acknowledgment message to both terminals (1, 2) indicating that the payment has been completed.  
30 On the other hand if the payer pays by telecash (electronic money), he can by activating the service provider's details (account number) send the amount (for example 10 dollars) to the petrol station's terminal (2) or host computer (4) which after the payer have the right to tank his car against 10 dollars paid. The payment can be paid in different ways but according to this invention user's MWP (1) receives the payee's details (account number, contact codes) directly from the payee's terminal  
35 (2) or via the base stations/network, and then activates the payee's details, upon which, the required telecash, bill is sent to the payee's terminal (2) or his account in the host computer (4). All automatic selling machines, gas stations (and other retail registers etc.) can be integrated with a wireless/cellular transmitter and receiver to provide a wireless/cellular payment service, in accordance with this invention, so that users can pay for their purchases and required services by  
40 using the inventive Mobile Wallet-Phone in a user friendly way without any need to establish a call or to use conventional money or different credit or debit cards. For instance the example 4 of FIG. 5

shows the automatic coffee machines (coffee maker and other automatic seller machines which are equipped with the inventive terminal (transmitter- receiver 2) to send the service provider's (the coffee seller machine) details and the coffee's price, for example continuously or whenever the customer appears in front of the machine or activates a button on the machine. Then the customer  
5 (payer) activates the received payee's (the coffee seller's) details in his MWP and sends the bill (accepted price) or the required telecash to the coffee machine's terminal (2) or to the host computer (4) to be transferred to the payee's account. Then after that the payment has been completed, the coffee machine offers a cup of coffee to the payer. Any other service can be paid in a same way as above-mentioned examples or other alike procedures by using inventive method and terminals (1, 2),  
10 and when required, base stations (2, 3), host computer (4) and the network (3).

FIG. 6 shows a top view of the user's Mobile Wallet-Phone (MWP) in accordance with one embodiment of this invention. In one embodiment of this invention user activates the command "payments" which after the MWP prompts the user to enter the P-PIN code "Enter P-PIN". After that, the user's device (for example mobile telephone, pager etc.) becomes a MWP by which the user  
15 can perform purchase and bill payments and send/receive telecash. In another embodiment of this invention when the user activates a command for example "service provider" the MWP listens to the radio interface (available base stations/other terminals) or requests the network/host computer (3, 4) to send the service providers details (account number, codes etc.) and when needed the bill or bill format which after the MWP (1) monitors the details on its screen (6) for the user. The service  
20 provider also sends (whenever required) the bill which should be paid by the payer. The payer can then activate the service providers details and send a message, bill or the required amount of telecash to the host computer or the payee's terminal.

The user P-PIN code can be changed using the same method which is used in mobile phones to change the PIN code. According to the invention the user's terminal/smart card (SIM) includes the  
25 required software (or the required software can be down-loaded to the terminal whenever needed) for the process of P-PIN entering and authentication.

The user's MWP (1) can be made in different shapes and sizes. For example, the user's watch can be integrated with a wireless message receiver (pager) and transmitter which can be used for performing user's payments by using the inventive method. For example at a cash register when the  
30 customer wants to pay for his shopping, the bill (the sum to be paid) can be received by the customer's watch. Then the customer can by activating the payee's details (contact and/or account codes and number) send the bill (with the required amount of telecash, if required) to the shop's cash register (terminal 2) or host computer.

The payment method presented in this invention can be based on an open platform and can be  
35 used in different terminals (mobile phones, pagers etc.) and implemented in different scales. Furthermore, for example all products in shops can be labeled with a tag/card which transmits/radiates the product's details such as name and price, and the service provider's (for example the shop keeper's) account number continuously so that when the user's MWP's antenna is quite near to the mentioned card/label or when the tag/card is touched by said antenna then the user's  
40 MWP receives the required information, as mentioned already. In this way the user can collect all his needed goods and their information in his MWP, and then send the payment/bill to the host

computer (4) or payee's terminal (2). Therefore, there will be no need for the existing cash registers. The cashiers' work can be directed to advise the customers (for finding the needed products etc.) thus providing a better quality service rather than sitting behind the cash register desks and doing a boring job.

5 In accordance to one embodiment of this invention the transmitting/broadcasting of the payee's/service provider's details can be a location-based action. For example when the payee's and payer's terminals are in the range of each other's radio coverage, they can monitor each other's details (the user's account number, codes etc.). On the other hand the location of the payer can be located when the payer's terminal is under the radio coverage of the payee's terminal/base station, for  
10 example, when the payer is under the coverage of the base station of a petrol station, the required signaling can take place between the user MWP and the petrol station's base station system so that the base station system notices that a user is coming to get the service. Then the base station can send/broadcast the required information to the user's terminal. The location defining can be also taken place without any signaling between the terminal and base stations. The location positioning  
15 can be a cell-based or an exact location positioning option. When the user's MWP is under the service provider's terminal/base stations radio coverage, the user's MWP can monitor the service provider's terminal's/base station's transmitting/broadcasting information, including the payee's details (account or contact codes and number, charging details etc.). For example FIG. 7 and 8 presents a flow chart of a parking system where the parking service provider's base station  
20 transmits/broadcasts charging information, parking zone details and other required information based on the city's different zones/areas. The user can then activates the service provider's details under a command "parking" which is monitored by his mobile terminal (or is stored in his mobile terminal or its SIM card) and if required enters the parking zone number (if the zone number is not sent by the base stations or the host computer) into his terminal and sends the message to the host  
25 computer for getting the right to use the parking space. The charging can be an account-based or telecash-based option so that when the user collects his car from the parking space a message (including also the required amount of telecash, if needed) which can be any message is sent by his mobile terminal to the parking data base where the user's account is debited or the received telecash is transferred to the service provider's account. The parking time can be counted in the user's  
30 terminal (for example after receiving an arrival acknowledgment message from the host computer) or in the host computer, depending on either the user pays for his parking by telecash or his account must be debited.

FIG. 9 presents two Mobile Wallet-Phones which are able to configure an adjustable radio coverage within which, they can send and receive their users' details (account number, codes etc.)  
35 and the required telecash. The MWP's radio coverage for this purpose can be adjusted within a range of, for example, few millimeters to few meters or more. When for example the payer's MWP (1) is in the payment mode (which means the terminal is operating as electronic wallet and is able to send and receive the required account number and telecash) the user can send the required amount of telecash to the payee's MWP (2) or to the payee's account in the host computer. For example, when the  
40 payer's MWP (1) receive the payee's details, he can enter a number equal to the required amount of telecash (for example 10 dollars) he wants to pay to the payee then by activating the payee's details

the terminal (1) sends the required amount of telecash to the payee's MWP (2) or to the host computer. The payee can send also the bill, required to be paid by the payer, to the payer's MWP (1). In that case the payer does not need to enter anything in his MWP but just accept the bill and send it to the payee's terminal or the host computer.

5 In accordance to another embodiment of this invention the payer sends a message (any message, for example an empty short message, including a letter for example) to the payee's terminal (whenever the payer activates the contact number/codes or account number of the payee) in order to receive the bill. For example when the customer is near the cash register he can enter the cash register's contact number into his MWP or his MWP monitors the cash register's terminal's (2)  
10 broadcasting contact number. Then the message is sent to the cash register's terminal and indicates who is the message sender because the message includes the senders details (contact number). The message sender's contact number can be sent directly from the sender's MWP or from the network (for example short message center, switches or other network component) or from the host computer (for example the shop's host computer via which the message goes to the cash register's terminal, and  
15 wherein the payer can have an account). Then cashier activates the payer's contact codes (by activating "Send" button, for example) upon which the bill or the sum to be paid by the payer is sent to the payer's terminal. Then the payer activates the payee's account or contact codes or the host computer's contact codes which after the bill (sum to be paid) and/or the required telecash is sent to the payee's terminal or the required host computer (located in the service provider's service area or in  
20 the bank or in the network). Then the telecash is transferred to the payee's account (if it is not sent directly to the payee's terminal) or the payer account is debited. If the terminal-to-terminal payment is not taken place, that is, the payment is completed in the host computer, then the host computer sends the required messages to the payee's and payer's terminals to acknowledge the completion of the payment.

25 In this invention the users terminals (1, 2) can operate as the switches and base stations to each other since in one embodiment of this invention said terminals can transmit to each other any required information without using the network. Therefore, the network's capacity is not wasted when users are near to each other (as usually for example to pay in the shops the payer is near to the payee). Depending on the air interface protocol used for terminal-to-terminal communication, for  
30 (short) messaging terminals (1, 2) do not necessarily need to have any signaling or be synchronized. But when required terminals (1, 2) can have required signaling and if required be synchronized. For example payer's terminal (1) listens to the air interface and receives the signals for example from payee's terminal (2). Then the communication between the terminals can be synchronized (in case of CDMA systems, synchronization is not necessary; CDMA: Code Division Multiple Access) on  
35 terminal-to-terminal basis without using the network. Then payer's terminal (1) can transfer the information received from the payee's terminal (2) to any other terminal either directly or via network.

The users' MWPs can at the same time operate as the user's mobile phone and electronic wallet. For example the terminal can be a dual-mode or a single-mode (dual-band), for example a GSM-  
40 DECT dual-mode terminal that in accordance to this invention can operate so that when user is shopping the DECT part of the terminal operates as user's wallet for purchase payment, and the



GSM part for telephone calls. The term GSM stands for Global System for Mobile Communication, the term DECT stands for Digital European Cordless Telecommunications. The terminal (1, 2) can operate both in a wireless local loop and under the wide area wireless networks. The user's purchase payments, bills, telephone calls and all kind of payments can be paid by his MWP. By utilizing this invention there will remain no possibility to produce false money, because user does not need to use any conventional money, since the user's MWP acts as his empty wallet without any conventional money. The user's smart card can be a separate card or his SIM card which can be reloaded with the required amount of telecash. On the other hand user's money can be only kept in his account and the required bills be sent to the host computer (4) where the payer's account can be debited. In this invention the user can be both the payee and the payer. The user can reload his smart card/terminal over the air interface with the required amount of telecash. For example user can transfer the required amount of electronic money (telecash) from his account in the host computer (4) to his terminal's (1) smart card whenever required. In this invention in order to load the user's terminal's smart card with the required telecash any communication protocols (either packet switched or circuit switched means) can be used. In this invention the payee's/service provider's details (account number, codes, contact codes) can be broadcast/sent to all or a group of users (terminals 1) or to the required terminal, which are roaming under the radio coverage of the payee's/service provider's base station or terminal (2) or the network's base station (3).

In this invention the user's MWP (1) uses the wireless/cellular digital communication messaging means without using any modem for communication between the users' MWPs and host computer, network or other terminals. The terminal (2) can be also a fixed or portable terminal such as personal computer or television using both wireless and internet networks. The inventive method can be used in both wireless and internet networks.

The users' terminals (1, 2) can be used in any wireless/cellular network such as GSM, PCS, DCS, CDMA, DECT, PHS, ERMES, FLEX and internet. The user's details and payment messages can be send via messaging means of wireless networks such as short message or paging networks, and via internet or via signaling means of networks and MWPs. The user's MWP can be any standard mobile phone and pager by which the inventive method can be utilized. The host computer (2) can include the users' data and accounts or be connected to the users' bank accounts or be logically integrated into any component of the network (3). The user data, for registration and authentication in the terminal or into network or host computer can be the same as the user subscription data (if users use subscription related services, and if required). For example if the telecommunications services are subscription free then the user authentication can take place only between the user, his smart card and terminal. The user can pay for his telephone calls while he is on move (pay-as-you-go) or per each call.

The described embodiments of the invention are only considered to be preferred and illustrate of the inventive concept, the scope of the invention is not to be restricted to such embodiments. Various and numerous other arrangements may be devised by one skilled in the art without departing from the spirit and scope of this invention.

It is therefore intended by the appended claims to cover any and all such applications, modifications and embodiments within the scope of the present invention.

**What is Claimed Is:**

1. A wireless/cellular terminal, preferably a SIM operated mobile phone for operating as the user's Mobile Wallet-Phone (MWP) for allowing a user to perform remote purchase payment and remote
- 5 bill payment transactions with a remote host computer or other terminals, the terminal **comprising:**
- means for receiving, handling and transmitting the user's details, account number, contact codes and number, bill, the required amount of telecash to other terminals directly without using the network or via base stations or via any wireless/cellular and/or internet network;
- means for sending, receiving and/or broadcasting the required data to/from other terminals
- 10 directly under the coverage of said terminals without using the network;
- means for configuring an adjustable radio coverage within which said terminal can send, receive and/or broadcast data to/from other terminals or host computer without using the network;
- means integral to the terminal for operating the terminal, receiving and monitoring payee's/service providers' details, account number and codes, contact number and codes, the required
- 15 bill and bill format;
- means integral to the terminal and coupled to the terminal's control means for receiving and sending the required amount of telecash directly from said MWP to other terminals or MWP;
- means integral to the terminal for operating, when required, as a wireless/cellular terminal and when required as a cordless terminal;
- 20 means integral to the terminal for making mobile/cordless telephone calls;
- a smart card reader integral to the terminal, if user uses smart card;
- means for reloading the user's smart card with the required amount of telecash;
- a display integral to the terminal;
- a digital camera means integral to the terminal, if the user wants the purchasing product's or the
- 25 bills details to be read by a camera;
- when used for service providers, the terminal further includes interface means for connecting the terminal to the service provider's automatic machines (petrol stations, coffee machines and any other kind of automatic seller machine).
- 30 **2. The terminal of claim 1 further comprising:**
- means for prompting the user to enter a personal identification number for payments, P-PIN, which can be same as the user's PIN for mobile telephone services and can be entered after that the PIN for accessing to the telephone operating network is entered, and that after entering the P-PIN said terminal can be used as the user's electronic wallet, MWP;
- 35 means for encrypting the entered P-PIN, which can be same as the encrypting means used for encrypting the PIN code for mobile telephone services;
- means for conveniently monitoring the broadcasted/received payee's details, account number and codes, contact number and codes, bill, bill format and means for sending the received details and when required the needed amount of telecash to the remote host computer or other terminals or
- 40 MWP;

means for direct communicating with other terminals or MWP's and/or host computers without using modem in or in conjunction with said MWP, and in a connectionless way via wireless messaging means of said MWP and when required via wireless messaging means of the network without establishing any circuit-switched call.

5

**3. The terminal of claim 1 or 2 further comprising:**

means for controlling display to conveniently display the broadcasted/received payee's details, name and account number, contact codes and bill to the user;

means for the user to conveniently select and activate the broadcast/received payee's details,  
10 account number, contact codes for sending said data and when needed, the required amount of telecash to the payee's terminal or the host computer;

means for receiving the payee's details, account number, contact codes, based on the location of the payer's and payee's terminals or base stations;

means for terminal-to-terminal signaling, whenever required;

15 means for conveniently arranging the broadcasted/received payees'/service providers' details in an appropriate order to be selected and activated by payer for sending the bill and/or telecash to the payee's terminal or host computer;

means for controlling the means for reloading the smart card with the required amount of telecash and means for spending the required amount of telecash for shopping, purchasing and bill payment;

20 means for controlling the digital camera integral to the terminal, if the user wants the purchasing product's or the bill's details to be read by the camera.

**4. A method for allowing a user to perform purchase and bill payment transactions with other remote terminals or remote host computers, the method comprising the steps of receiving the**  
25 **payee's/payee's, details including account number or codes or contact codes and when required the bill or a bill format in a connectionless way without establishing a circuit-switched call, by a terminal having integral to the terminal a smart card reader, means for reloading the user's smart card with the required amount of telecash, a display, means for controlling and handling the information, each received bill format comprising fields as Amount:, Account no:, Due date:, and other required**  
30 **fields already filled in when received by the payer's terminal or to be filled in, and that by activating the payee's or the host computer's account number or contact codes the bill and, when needed, the required amount of telecash are sent to the payee's terminal or to the host computer directly without using the network or via network.**

35 **5. The method of claim 4 further comprising the following step as much as needed and when required in a different order:**

promoting the user to enter a personal identification code (P-PIN), if the user uses a smart card (as SIM) which can also be reloaded with the required amount of telecash, and if the user activates the required command (payments) in his terminal;

40 encrypting the entered personal identification number;

receiving the payee's terminal's, base station's, transmitter's, product's tag's/card's or the host

computer's transmitting/broadcasting details, or reading the product's bar codes by means of a digital camera integral to said terminal, and monitoring said details on the display of the payer's terminal as much as required, or

5 prompting the user to activate a function ("payee" or "service provider" or "payments" or any other alike command) which after activation said payer's terminal monitors the payee's terminal's/base station's or host computer's or other sources (product's tag's/card's) transmitting/broadcasting payee's (and product's) details or said payer's terminal requests said payee's terminal or a host computer to send the bill, bill format, payees details, account number, codes;

10 connectionless communicating with the remote host computer or the payee's terminal to send the bill, and when needed the required amount of telecash, to the payee's terminal or the host computer without establishing any circuit-switched call, and that the communication with the remote host computer or payee's terminal can take place both via internet or messaging means of any wireless network or directly between the payer's and payee's terminals or the host computer without using the  
15 network.

6. A method for allowing a user to perform remote purchase and bill payment transaction with other remote terminals or remote host computers, and sending and receiving data, the method **comprising** the step of controlling and configuring an adjustable radio coverage by means integral to a terminal  
20 having wireless/cellular messaging means for transmitting, receiving and handling the data without using modem, and that said radio coverage can be adjusted by means integral to said terminal in order to configure a radio coverage area within which the payee's and payer's terminals and/or host computer can exchange required information, send and receive information without using the network; and that:

25 for service providers the terminal is further connected or integrated into the automatic machines (petrol stations, coffee machines and other required automatic sellers) of the service providers so that whenever required or continuously the terminal broadcasts/sends the service provider's details, account number, contact codes, the bill, the price of the service and other required information to the payer's terminals (MWP) for performing the payment.  
30

7. A method according to claims 4-5 for sending and receiving purchase transactions and bill payment and that said method is used both in wireless/cellular terminals and also in personal computers and televisions using internet, the method **comprising** the steps of:

35 requesting, by means of the payer's terminal, the host computer or other terminals to send the bill, bill inquiry (format) and payee's details to the payer's terminal;

displaying the received bill or bill inquiry for the user;

acceptance of the bill or entering the required data into the bill inquiry by user and activating the required function to send the bill to the host computer or other terminal, or:

40 the method comprising the steps of:

broadcasting by means of payee's terminal or base station the payee's, and when required the

purchasing product's details, over the air interface for all or a group of payers' terminals;

activating the payee's and/or product's details (account code, contact number) in the payer's terminal and sending the bill, with the required amount of telecash when needed, to the payee's terminal or to the host computer.

5

8. A method for allowing a user to perform purchase and bill transactions with other remote terminals or remote host computers, the method **comprising** the steps of:

sending a (short) message to the payee's terminal, said message including the payee's contact number/codes when received by the payee's terminal;

10 sending the payable bill or a notification of the sum which must be paid by the payer to the payee to the payer's terminal using the payer's contact number/codes already received;

sending the required amount of telecash from the payer's terminal to the host computer or to the payee's terminal, or sending the bill with or without the amount of telecash to the host computer;

15 debiting the payer's account for the payee, if the required telecash has not been sent to the payee's account.

9. A system for allowing a user to perform remote purchase payment transactions with other remote terminals or remote host computer, the system **comprising**:

a wireless/cellular terminal (MWP) comprising:

20 means for receiving, handling and transmitting the users' details, account number, contact codes and number, bill, the required amount of telecash to other terminals directly without using the network or via base stations or via any wireless/cellular and /or internet network;

means for sending, receiving and/or broadcasting the required data to/from other terminals directly under the coverage of said terminals without using the network;

25 means for configuring an adjustable radio coverage within which said terminal can send, receive and/or broadcast data to/from other terminals or host computer without using the network;

means integral to the terminal for operating the terminal, receiving and monitoring the payee's/service providers' details, account number and codes, contact number and codes, the required bill or a bill inquiry;

30 means integral to the terminal and coupled to the terminal's control means for receiving and sending the required amount of telecash directly from said MWP to other terminals or MWP;

means integral to the terminal for operating, when required, as a wireless/cellular terminal and when required as a cordless terminal;

means integral to the terminal for making mobile/cordless telephone calls;

35 a smart card reader integral to the terminal, if user uses smart card;

means for reloading the user's smart card with the required amount of telecash;

a display integral to the terminal;

a digital camera means integral to the terminal, if the user wants the purchasing product's or the bill's details to be read by the camera;

40 when used for service providers, the terminal further includes interface means for connecting the terminal to the service provider's automatic machines (petrol stations, coffee machines and any other kind of automatic seller machine).

**10. The system of claim 9 further comprising:**

- means for prompting the user via the display to enter a personal identification number (P-PIN),
- means for controlling the means for encryption to encrypt the entered personal identification number, if the user uses a smart card in or in conjunction with the terminal;
- 5 means for receiving, handling and displaying a bill inquiry, bills and payee's details and sending said data in a connectionless way to other terminals, personal computers and/or host computer;
- means for wireless, modemless and connectionless communicating with other terminals or host computer to send and receive the payee's details, contact codes, numbers, account number, bills, bill inquiry, required amount of telecash, directly without using the network or via the network;
- 10 means integral to the terminal for controlling and configuring an adjustable radio coverage area for wireless/cellular terminal-to-terminal or terminal-to-host computer communications without using the network, so that the payer's and payee's terminals can exchange information securely and without interruption of other terminals;
- means integral to the terminal for controlling and configuring an adjustable radio coverage area
- 15 which can be adjusted automatically or manually to a desirable range (1 millimeter to 1 meter or more or less);
- means for controlling the display to display the received payee's details, account number, contact number, bills, bill inquiry;
- means for the user to select and activate the payee's details for sending the bill or payment to the
- 20 payee's terminal or host computer;
- means integral to the terminal and/or network and host computer for defining the location of the terminal based on which the details of all service providers/payees which are near to the payer's terminal or are under the same radio coverage can be sent/broadcast to the payer's/payers' terminals;
- means for terminal-to-terminal transmitting, broadcasting, receiving of information without using
- 25 the network;
- means for broadcasting/transmitting the service provider's/payee's details, account number, contact codes from the service provider's/payee's terminal/base station to the payer's/payers' terminals;
- means for terminal-to-terminal communicating using wireless messaging communication without
- 30 using the network;
- means for communicating between the payee's and payer's terminals and/or host computer via messaging means of wireless/cellular networks (short messaging, paging and other such networks);
- means for controlling the means for reloading the smart card with the required amount of telecash and means for spending the required amount of telecash for shopping, purchasing and bill payment;
- 35 means for controlling the digital camera integral to the terminal, if the user wants the purchasing product's or the bill's details to be read by the camera.

FIG. 1

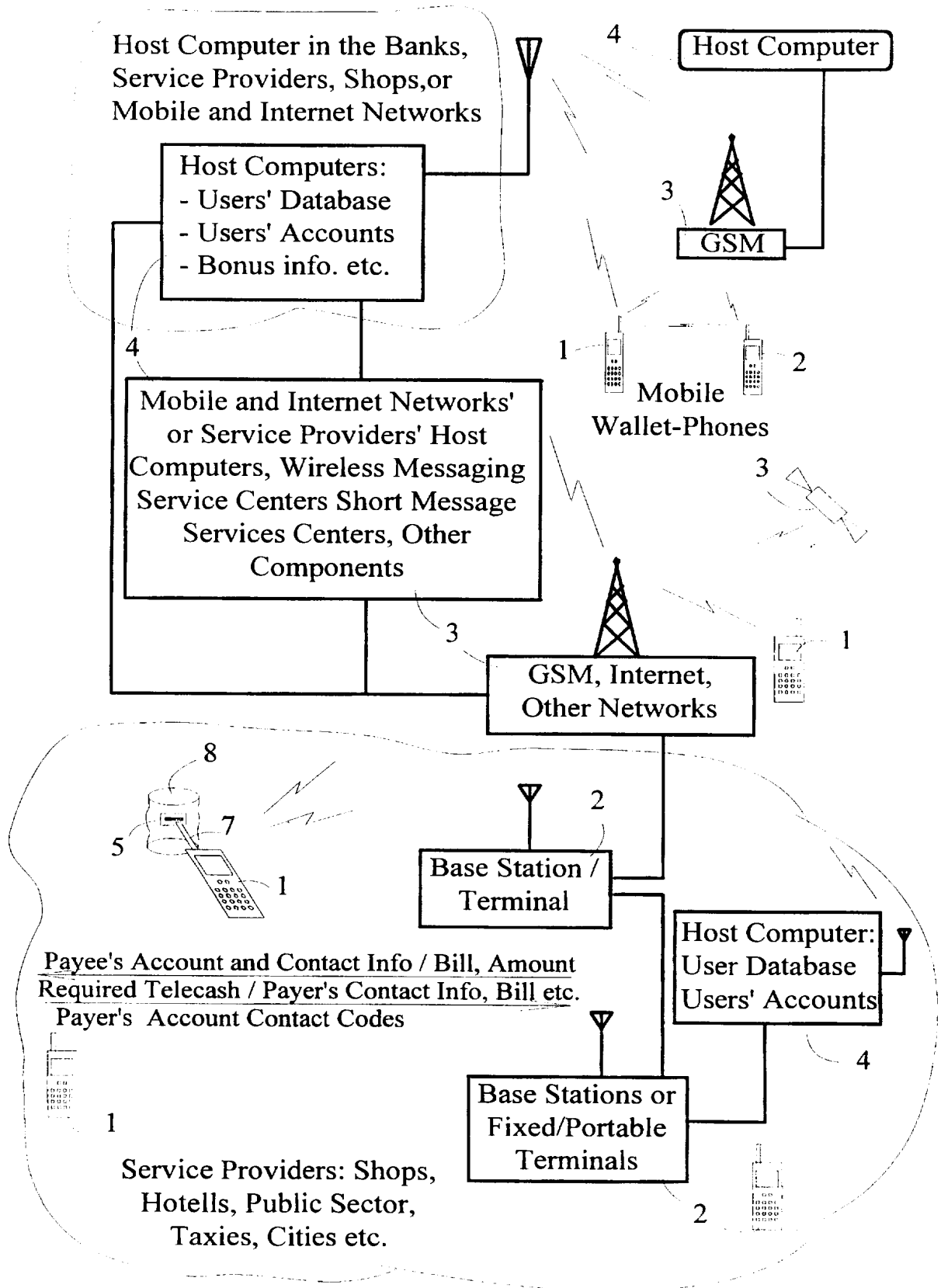


FIG. 2

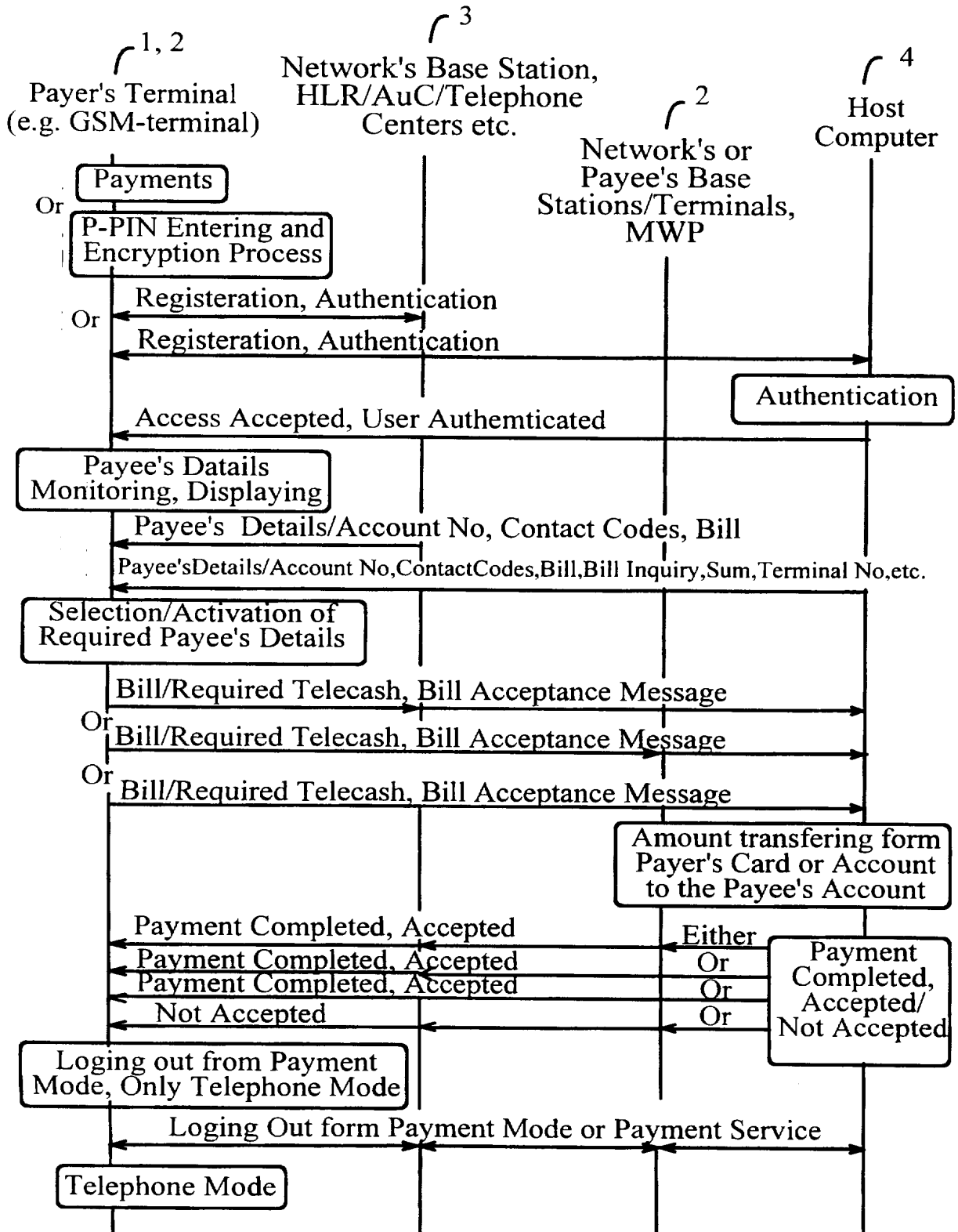




FIG. 3

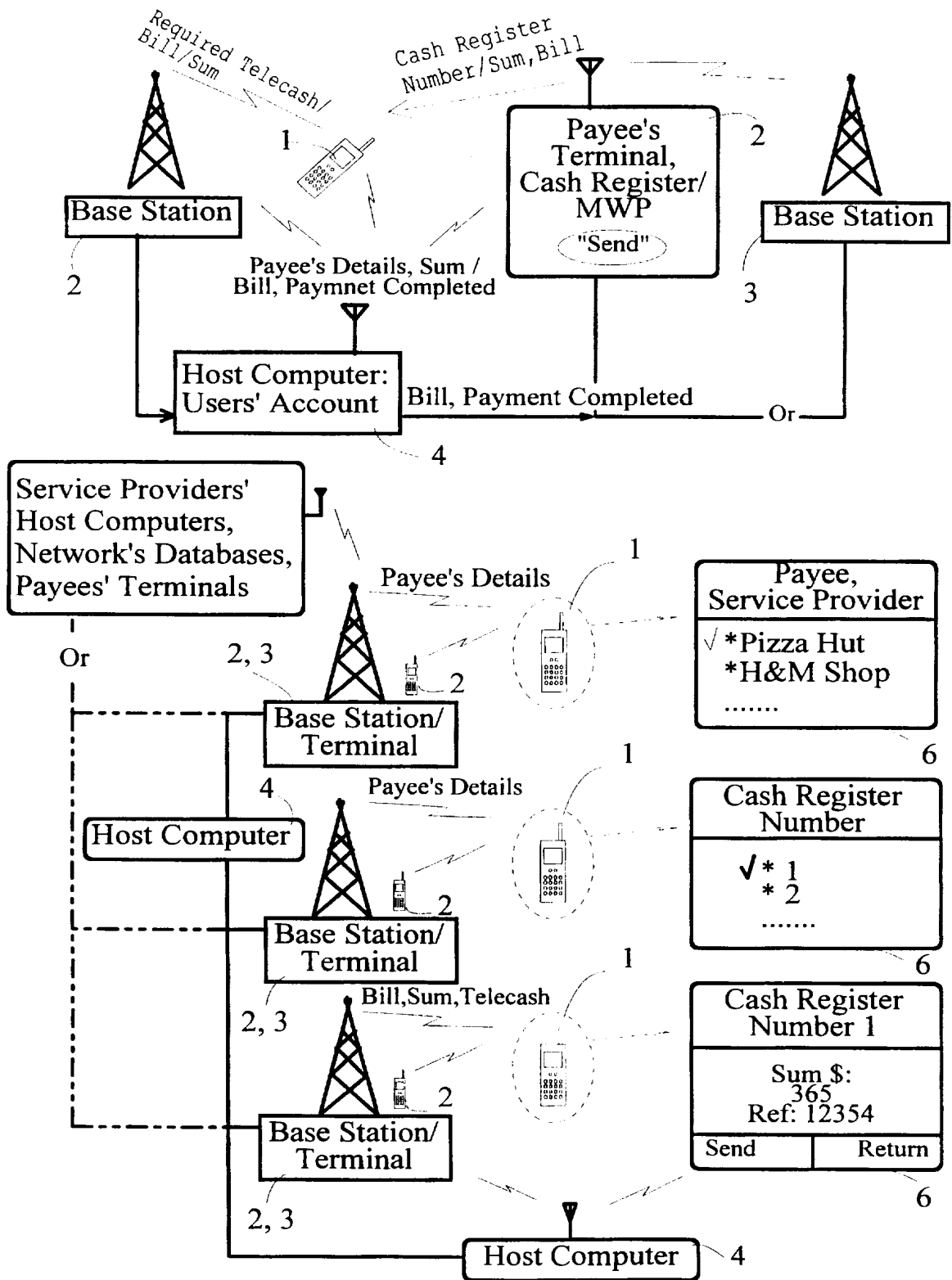


FIG. 4

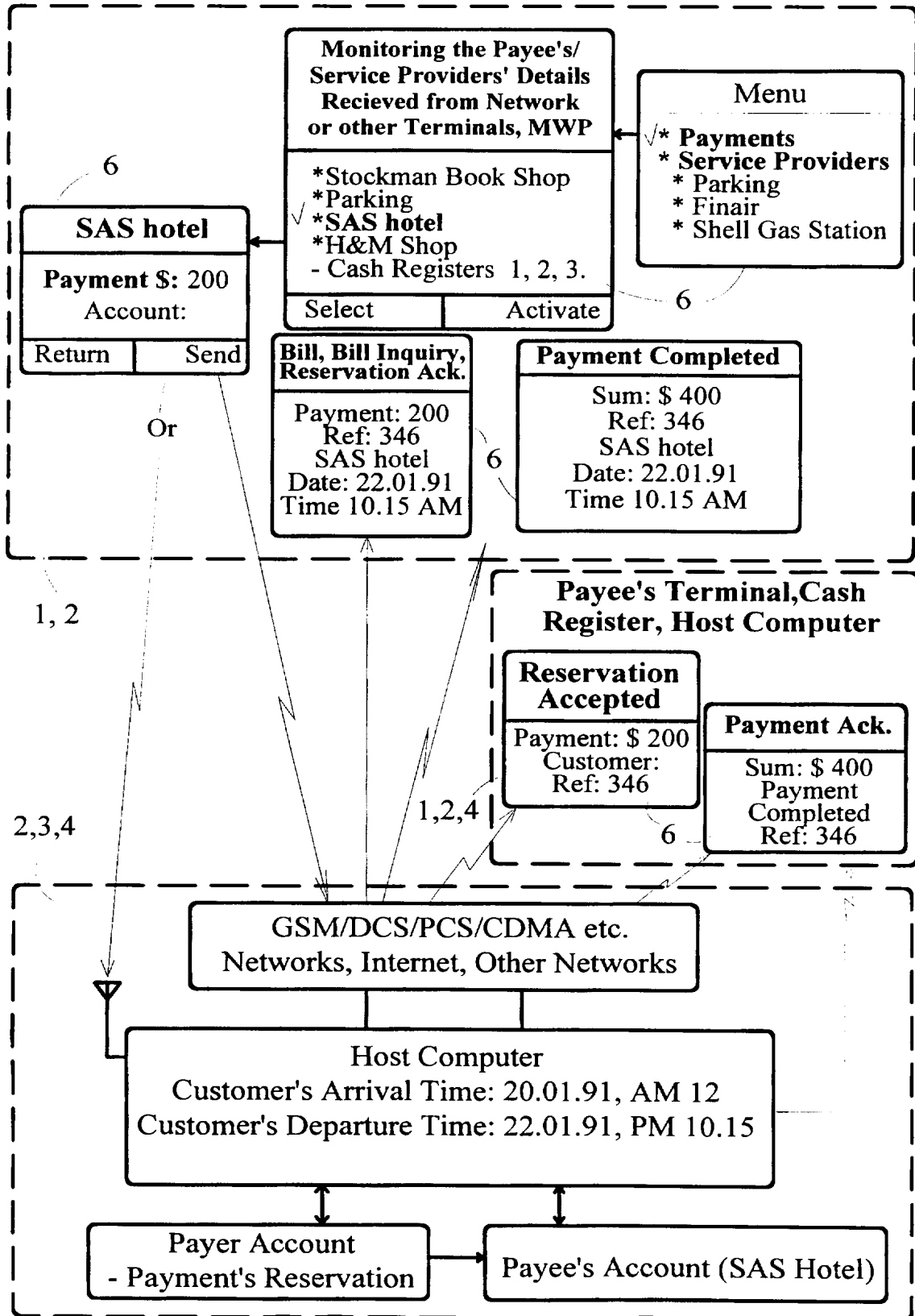
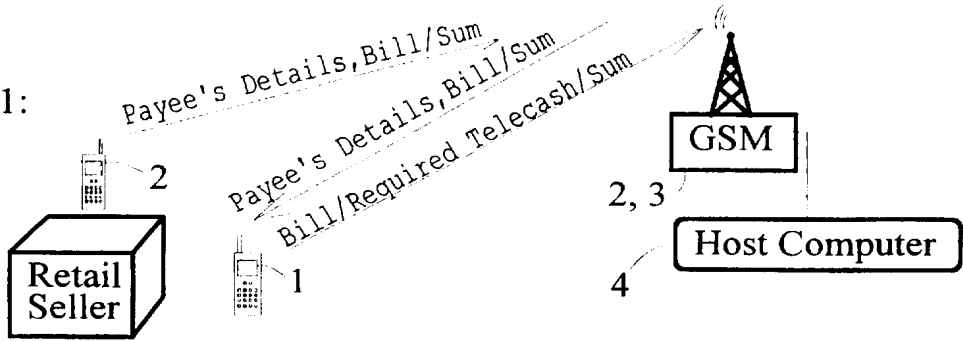
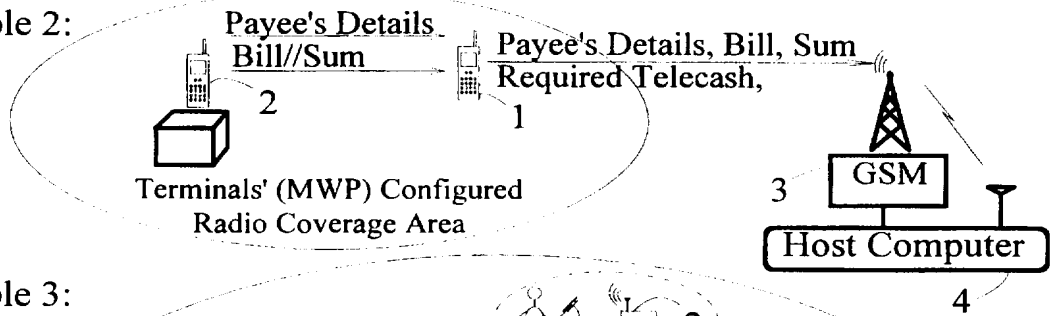


FIG. 5

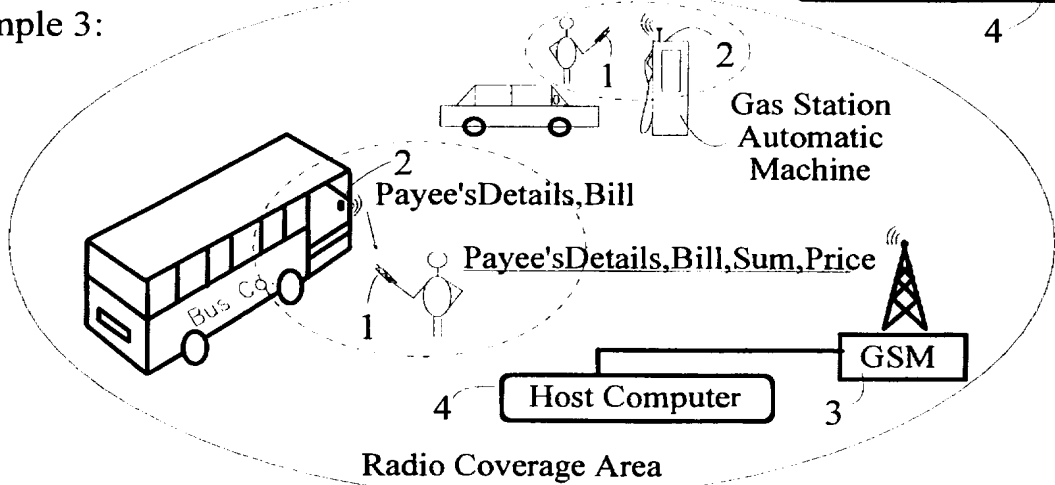
Example 1:



Example 2:



Example 3:



Example 4:

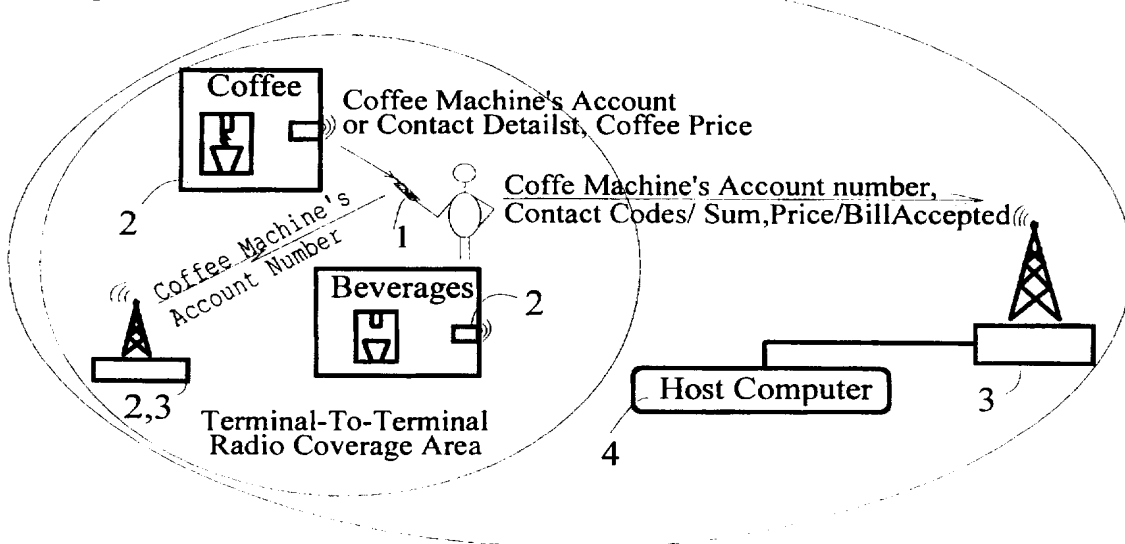


FIG. 6

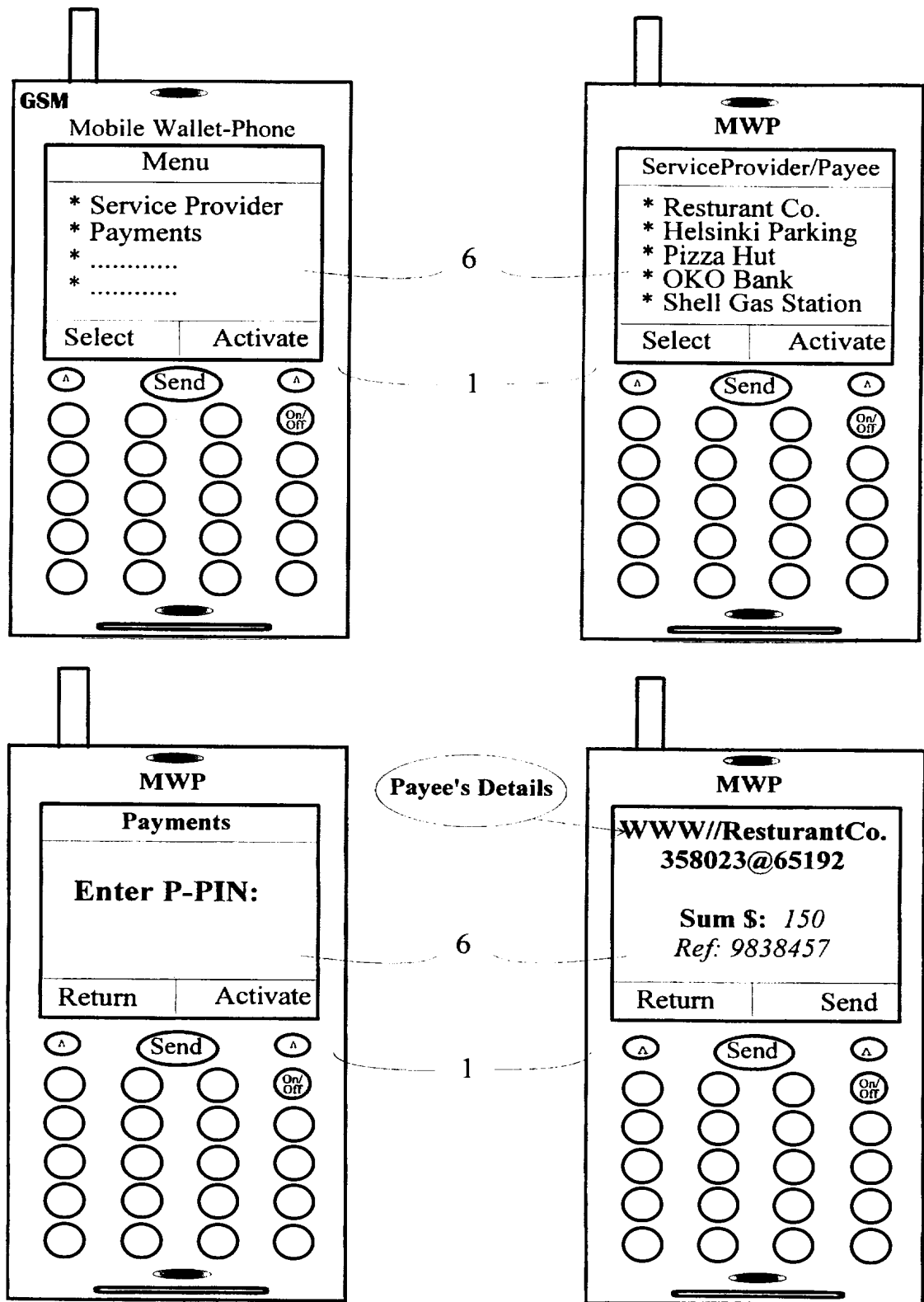


FIG. 7

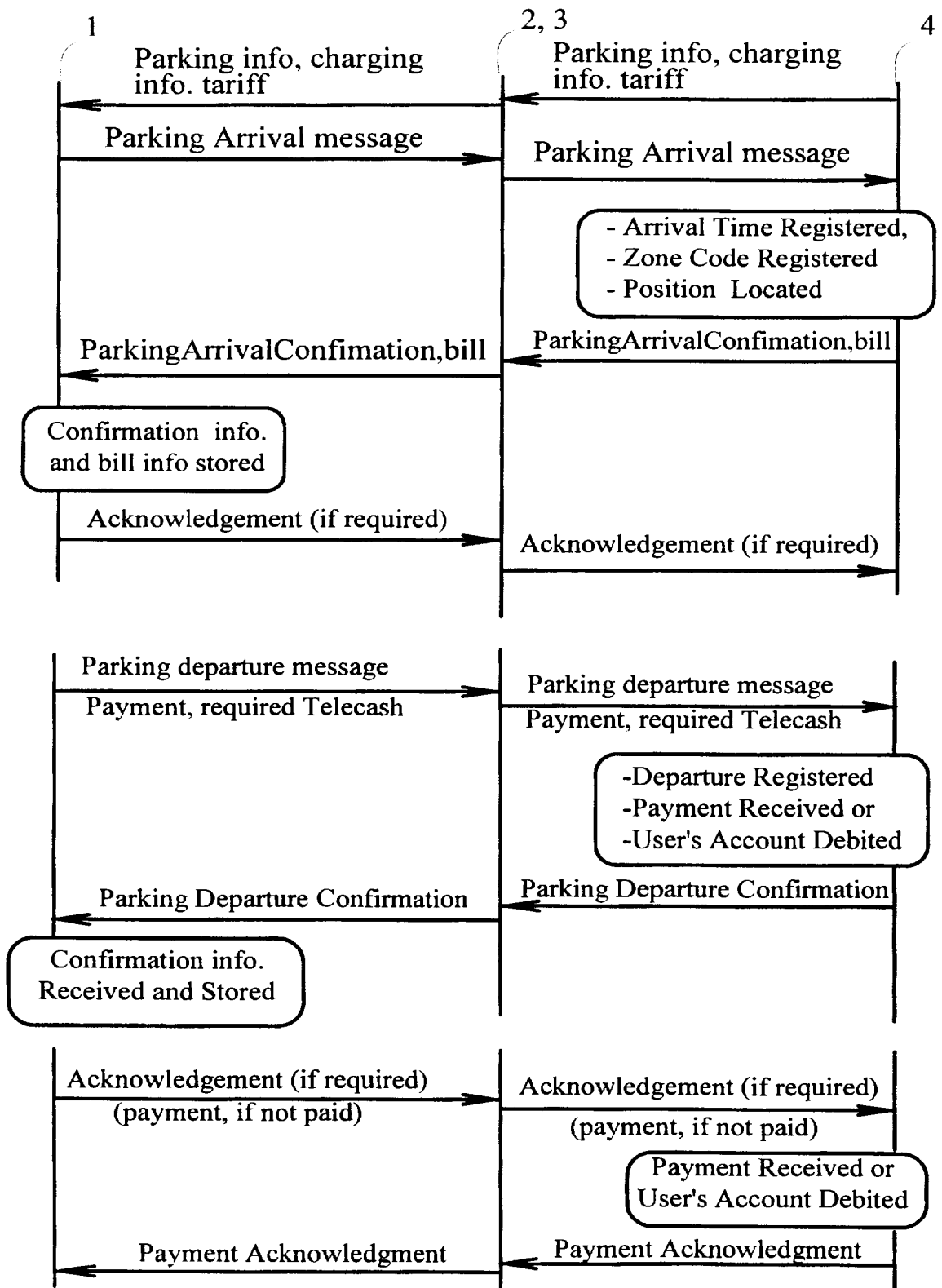
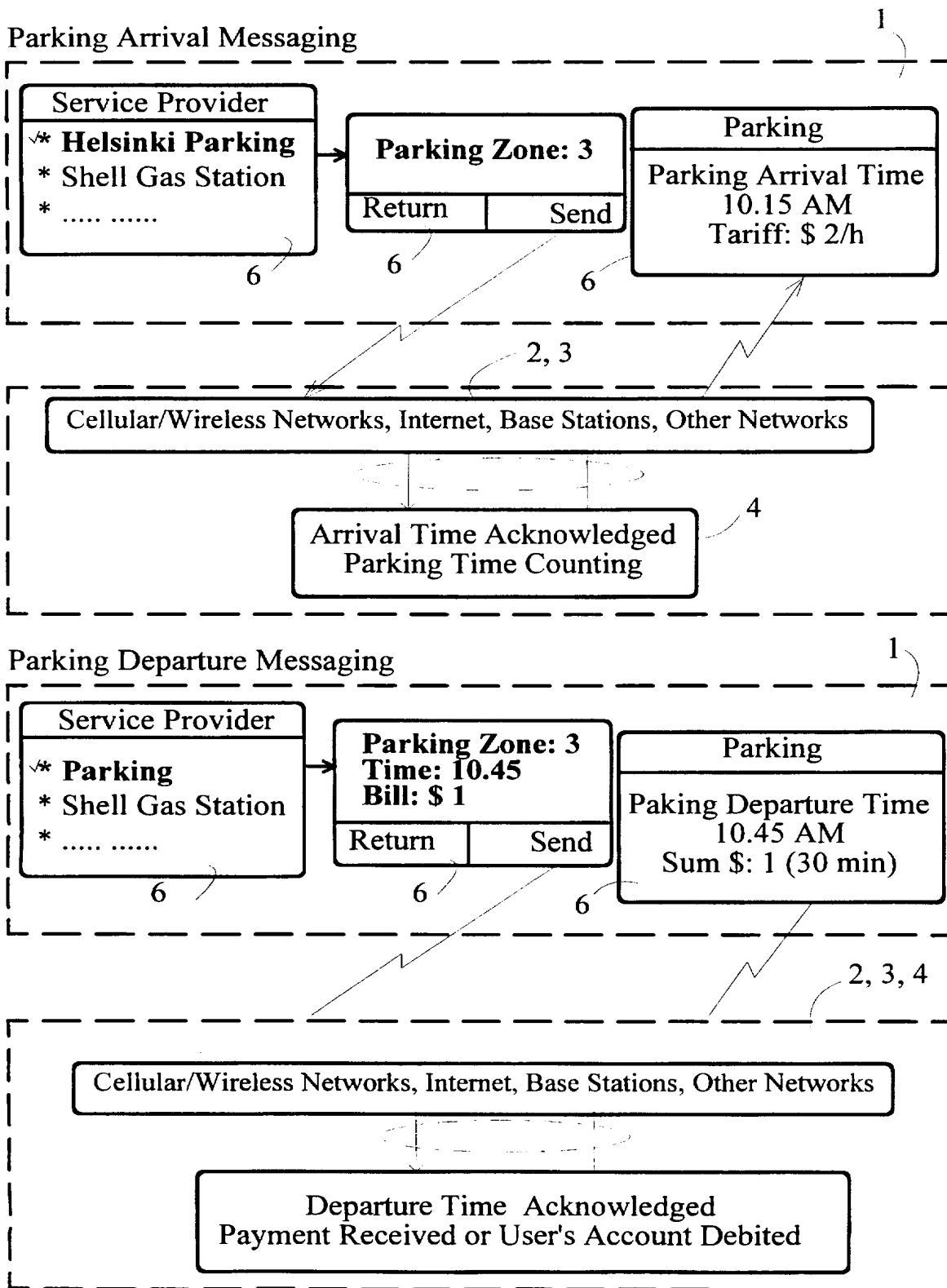
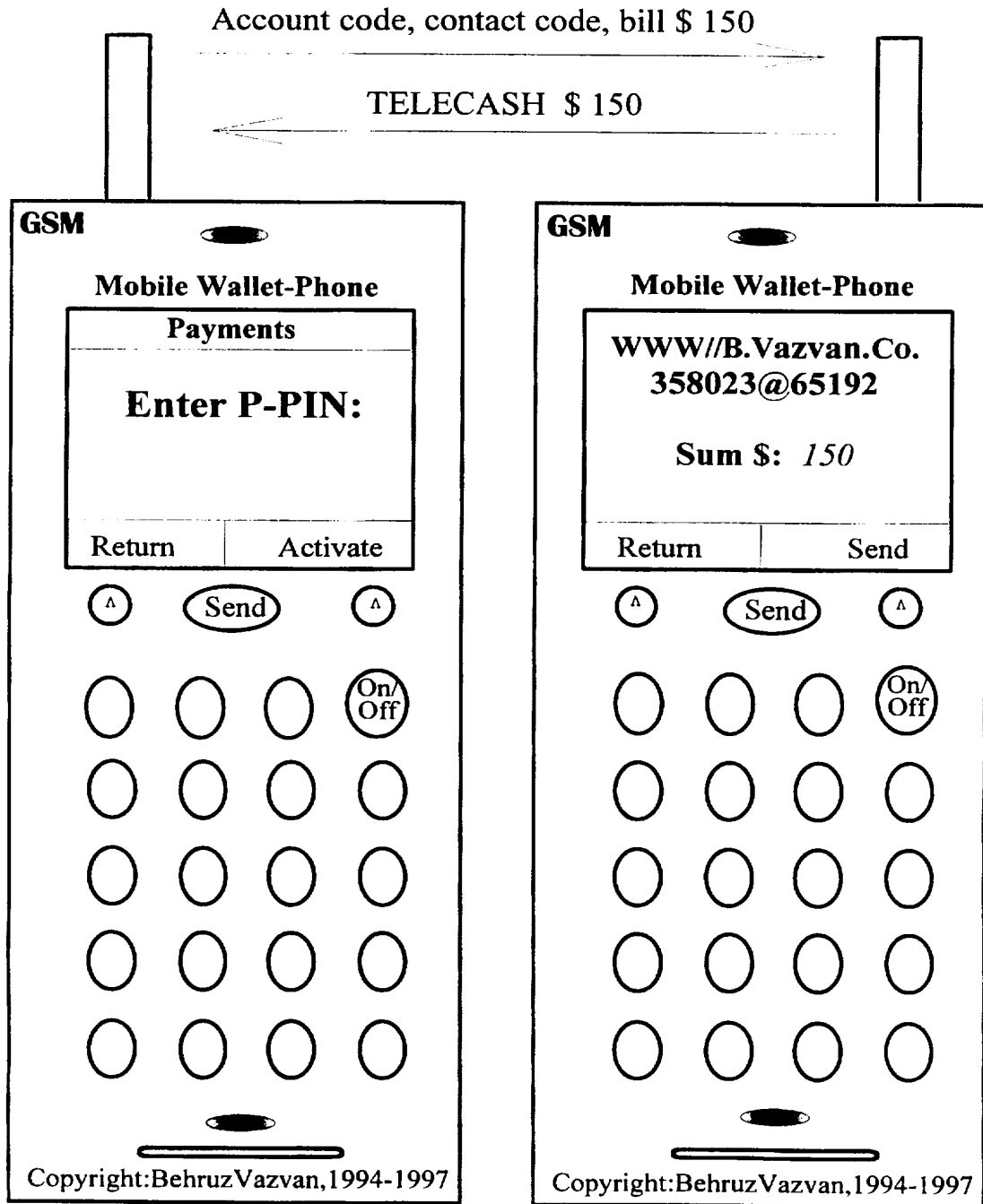


FIG. 8



**FIG. 9**



## INTERNATIONAL SEARCH REPORT

International application No.

PCT/FI 97/00315

A. CLASSIFICATION OF SUBJECT MATTER		
IPC6: G07F 7/08, G07F 19/00, G06F 17/60 // G06F 157:00 According to International Patent Classification (IPC) or to both national classification and IPC		
B. FIELDS SEARCHED		
Minimum documentation searched (classification system followed by classification symbols)		
IPC6: G07F, G06F, H04Q		
Documentation searched other than minimum documentation to the extent that such documents are included in the fields searched		
SE,DK,FI,NO classes as above		
Electronic data base consulted during the international search (name of data base and, where practicable, search terms used)		
EDOC		
C. DOCUMENTS CONSIDERED TO BE RELEVANT		
Category*	Citation of document, with indication, where appropriate, of the relevant passages	Relevant to claim No.
A	WO 9613814 A1 (VAZVAN, BEHRUZ), 9 May 1996 (09.05.96) ---	1-10
A	WO 9411849 A1 (VATANEN, HARRI), 26 May 1994 (26.05.94) ---	1-10
A	US 5030806 A (THIERRY COLLIN), 9 July 1991 (09.07.91) ---	1-10
P,A	WO 9632700 A1 (AU-SYSTEM), 17 October 1996 (17.10.96) -----	1-10
<input type="checkbox"/> Further documents are listed in the continuation of Box C. <input checked="" type="checkbox"/> See patent family annex.		
* Special categories of cited documents: "A" document defining the general state of the art which is not considered to be of particular relevance "E" earlier document but published on or after the international filing date "L" document which may throw doubts on priority claim(s) or which is cited to establish the publication date of another citation or other special reason (as specified) "O" document referring to an oral disclosure, use, exhibition or other means "P" document published prior to the international filing date but later than the priority date claimed		"T" later document published after the international filing date or priority date and not in conflict with the application but cited to understand the principle or theory underlying the invention "X" document of particular relevance: the claimed invention cannot be considered novel or cannot be considered to involve an inventive step when the document is taken alone "Y" document of particular relevance: the claimed invention cannot be considered to involve an inventive step when the document is combined with one or more other such documents, such combination being obvious to a person skilled in the art "&" document member of the same patent family
Date of the actual completion of the international search		Date of mailing of the international search report
5 November 1997		05 -11- 1997
Name and mailing address of the ISA/ Swedish Patent Office Box 5055, S-102 42 STOCKHOLM Facsimile No. +46 8 666 02 86		Authorized officer  Jan Silfverling Telephone No. +46 8 782 25 00



**INTERNATIONAL SEARCH REPORT**  
Information on patent family members

01/10/97

International application No.  
PCT/FI 97/00315

Patent document cited in search report	Publication date	Patent family member(s)	Publication date
WO 9613814 A1	09/05/96	EP 0739526 A	30/10/96
		FI 945075 A	29/04/96
		FI 962553 D	00/00/00
		FI 962961 A	28/08/96
		FI 971009 A	26/04/97
		FI 971248 D	00/00/00
		FI 971848 A	30/04/97
WO 9411849 A1	26/05/94	EP 0669031 A	30/08/95
		FI 925135 A	12/05/94
		FI 934995 A	12/05/94
		NO 951814 A	09/05/95
US 5030806 A	09/07/91	EP 0345108 A	06/12/89
		FR 2632101 A,B	01/12/89
		FR 2639742 A	01/06/90
		US 4992646 A	12/02/91
WO 9632700 A1	17/10/96	AU 3943795 A	06/06/96
		EP 0784715 A	23/07/97
		SE 9501347 A	12/10/96



INTERNATIONAL APPLICATION PUBLISHED UNDER THE PATENT COOPERATION TREATY (PCT)

<p>(51) International Patent Classification <sup>6</sup> : <b>G06F 17/00</b></p>	<p><b>A2</b></p>	<p>(11) International Publication Number: <b>WO 99/18518</b> (43) International Publication Date: 15 April 1999 (15.04.99)</p>
<p>(21) International Application Number: PCT/US98/20725 (22) International Filing Date: 2 October 1998 (02.10.98) (30) Priority Data: 60/060,963 3 October 1997 (03.10.97) US (71)(72) Applicant and Inventor: POLASH, Peter [US/US]; 20 Foxhill Road, Woodside, CA 94062 (US). (74) Agents: CELLA, Charles, H. et al.; Foley, Hoag &amp; Eliot, LLP, One Post Office Square, Boston, MA 02109 (US).</p>	<p>(81) Designated States: AL, AM, AT, AU, AZ, BA, BB, BG, BR, BY, CA, CH, CN, CU, CZ, DE, DK, EE, ES, FI, GB, GE, GH, GM, HR, HU, ID, IL, IS, JP, KE, KG, KP, KR, KZ, LC, LK, LR, LS, LT, LU, LV, MD, MG, MK, MN, MW, MX, NO, NZ, PL, PT, RO, RU, SD, SE, SG, SI, SK, SL, TJ, TM, TR, TT, UA, UG, US, UZ, VN, YU, ZW, ARIPO patent (GH, GM, KE, LS, MW, SD, SZ, UG, ZW), Eurasian patent (AM, AZ, BY, KG, KZ, MD, RU, TJ, TM), European patent (AT, BE, CH, CY, DE, DK, ES, FI, FR, GB, GR, IE, IT, LU, MC, NL, PT, SE), OAPI patent (BF, BJ, CF, CG, CI, CM, GA, GN, GW, ML, MR, NE, SN, TD, TG).</p> <p><b>Published</b> <i>Without international search report and to be republished upon receipt of that report.</i></p>	
<p>(54) Title: INTERNET BASED MUSICAL INDEXING SYSTEM FOR RADIO</p>		
<p>(57) Abstract</p> <p>The invention includes systems and methods for viewing musical selections broadcast from a radio-station. To this end the system can include a web server that generates HTML pages that contain information representative of the play list of a radio station. In one embodiment, the list is displayed in real time and the selection currently being played is highlighted on the web page. Selections that have already been played can be shown with a text field that contains the time the selection was broadcast. The web server can further comprise an interface or connection to a database that indexes music selections to a table of recordings, such as an album, CD or Video, and that further indexes the recording to an audio sample that can be downloaded over the Internet or other computer network to allow a consumer to listen and determine if the downloaded sample relates to the preferred selection of the consumer. Optionally, the web server can include a transaction server for allowing the consumer to purchase the selection or associated CD. In a further optional embodiment, the web server can allow a consumer to provide comments on the musical selections purchased broadcast.</p>		

**FOR THE PURPOSES OF INFORMATION ONLY**

Codes used to identify States party to the PCT on the front pages of pamphlets publishing international applications under the PCT.

<b>AL</b>	Albania	<b>ES</b>	Spain	<b>LS</b>	Lesotho	<b>SI</b>	Slovenia
<b>AM</b>	Armenia	<b>FI</b>	Finland	<b>LT</b>	Lithuania	<b>SK</b>	Slovakia
<b>AT</b>	Austria	<b>FR</b>	France	<b>LU</b>	Luxembourg	<b>SN</b>	Senegal
<b>AU</b>	Australia	<b>GA</b>	Gabon	<b>LV</b>	Latvia	<b>SZ</b>	Swaziland
<b>AZ</b>	Azerbaijan	<b>GB</b>	United Kingdom	<b>MC</b>	Monaco	<b>TD</b>	Chad
<b>BA</b>	Bosnia and Herzegovina	<b>GE</b>	Georgia	<b>MD</b>	Republic of Moldova	<b>TG</b>	Togo
<b>BB</b>	Barbados	<b>GH</b>	Ghana	<b>MG</b>	Madagascar	<b>TJ</b>	Tajikistan
<b>BE</b>	Belgium	<b>GN</b>	Guinea	<b>MK</b>	The former Yugoslav Republic of Macedonia	<b>TM</b>	Turkmenistan
<b>BF</b>	Burkina Faso	<b>GR</b>	Greece			<b>TR</b>	Turkey
<b>BG</b>	Bulgaria	<b>HU</b>	Hungary	<b>ML</b>	Mali	<b>TT</b>	Trinidad and Tobago
<b>BJ</b>	Benin	<b>IE</b>	Ireland	<b>MN</b>	Mongolia	<b>UA</b>	Ukraine
<b>BR</b>	Brazil	<b>IL</b>	Israel	<b>MR</b>	Mauritania	<b>UG</b>	Uganda
<b>BY</b>	Belarus	<b>IS</b>	Iceland	<b>MW</b>	Malawi	<b>US</b>	United States of America
<b>CA</b>	Canada	<b>IT</b>	Italy	<b>MX</b>	Mexico	<b>UZ</b>	Uzbekistan
<b>CF</b>	Central African Republic	<b>JP</b>	Japan	<b>NE</b>	Niger	<b>VN</b>	Viet Nam
<b>CG</b>	Congo	<b>KE</b>	Kenya	<b>NL</b>	Netherlands	<b>YU</b>	Yugoslavia
<b>CH</b>	Switzerland	<b>KG</b>	Kyrgyzstan	<b>NO</b>	Norway	<b>ZW</b>	Zimbabwe
<b>CI</b>	Côte d'Ivoire	<b>KP</b>	Democratic People's Republic of Korea	<b>NZ</b>	New Zealand		
<b>CM</b>	Cameroon	<b>KR</b>	Republic of Korea	<b>PL</b>	Poland		
<b>CN</b>	China	<b>KZ</b>	Kazakstan	<b>PT</b>	Portugal		
<b>CU</b>	Cuba	<b>LC</b>	Saint Lucia	<b>RO</b>	Romania		
<b>CZ</b>	Czech Republic	<b>LI</b>	Liechtenstein	<b>RU</b>	Russian Federation		
<b>DE</b>	Germany	<b>LK</b>	Sri Lanka	<b>SD</b>	Sudan		
<b>DK</b>	Denmark	<b>LR</b>	Liberia	<b>SE</b>	Sweden		
<b>EE</b>	Estonia			<b>SG</b>	Singapore		

## INTERNET BASED MUSICAL INDEXING SYSTEM FOR RADIO

5 **Field of the Invention**

This invention relates to a software program for viewing musical selections, and more particularly to a software program that can enable radio stations to post listings of musical selections for perusal by listeners and enable listeners to provide comments on the musical selections.

10

**Background of the Invention**

Consumers commonly get their exposure to new music from the airplay provided by radio stations. Accordingly, recording companies support radio stations with free selections of new music being produced by the recording company, incentives and advertising.

15

Although, radio stations are quite good at providing consumers with exposure to new music, the ephemeral nature of the music broadcast makes it difficult for consumers to get the information they need to purchase a preferred recording. For example, consumers are often frustrated that the title of the music they are interested in is unknown to them, and that the radio stations fails to identify the title, artist or album associated with the recording. Moreover, radio broadcasts, by their nature fail to provide any way for a consumer to communicate back to the station its interest in learning about a selection, or purchasing the selection.

20

Accordingly, there is a need in the art for a system that provides a consumer with the information necessary to identify and purchase preferred music selections.

25

**Summary of the Invention**

The invention includes systems and methods for viewing musical selections broadcast from a radio-station. To this end the system can include a web server that generated HTML pages that contain information representative of the play list of a radio station. In one embodiment, the list is displayed in real time and the selection currently

30

5 being played in highlighted on the web page. Selections that have already been played  
can be shown with a text field that contains the time the selection was broadcast. The  
web server can further comprise an interface or connection to a database that indexes  
music selections to a table of recordings, such as an album, CD or Video, and that further  
indexes the recording to an audio sample that can be downloaded over the Internet or  
10 other computer network to allow a consumer to listen and determine if the downloaded  
sample relates to the preferred selection of the consumer. Optionally, the web server can  
include a transaction server for allowing the consumer to purchase the selection or  
associated CD. In a further optional embodiment, the web server can allow a consumer  
to provide comments on the musical selections purchased or broadcast.

15 More specifically, the systems can include a host HTTP server that supports  
various HTML pages, each page being configured for an individual radio station and each  
page appearing from an external source as an independent Web site.

The host HTTP server is connected to a database that may be located on the same  
or different computer. The host HTTP server interfaces with the database using a  
20 standard interface programming language such as Common Gateway Interface (CGI).

Each HTML page contains a list of songs played by that radio station. The list  
may contain songs that have been played by the station in the past, that are currently  
being played, or that will be played in the future. The list of songs may be contained in  
the database and the database may create the HTML page and provide the HTML page  
25 or a pointer indicating the location of the HTML page to the HTTP server. By providing  
a HTML page with a list of songs played by the radio station or which will be played by  
the radio station, the radio station can easily provide access to its listeners of its set lists.

The list of songs should be scrollable and able to be sorted by date and time.  
Further, the list should indicate for each song the time and date the song was played, the  
30 title of the song, the name of the Artist who recorded the song, and the name of the  
Compact Disc on which the song is recorded. Maintaining the list of songs in the  
database facilitates sorting the songs by date and time and will also facilitate other  
functionality of the system to be described later.

The HTML page containing the list of songs may optionally contain one or more  
35 additional features enabling the viewer to search for particular songs, comment on the

5 songs played by the radio station, or actually purchase music in the form of CDs or  
Cassettes.

10 One option available to the Radio station is to enable the user to click on a  
particular selection and submit a purchase order for the underlying CD or cassette. This  
order form could be generated using a standard JAVA applet or any other type of form  
generating program which can generate the necessary form. It is currently envisioned  
that the order form would require at least basic information such as the user's name,  
address, credit card number, the expiration date of the user's credit card, and any other  
information required to process a sales order. It is possible to make this a secure order  
form by offering the user the option of encrypting communications regarding submission  
15 of an order for music.

The user of the system may wish to purchase several CDs at once, and should not  
be prompted for the same information each time the user desires to purchase a CD.  
Accordingly, the system may optionally allow the user to select multiple tracks by  
clicking once on each desired track in the song list, and then requesting the user to click  
20 on a button labeled "submit order" or in a similar fashion. This button may be, as  
described above, a JAVA applet, or a hot link to another HTML page designed to  
provide the user with a list of selected Cds, the price for each CD, the availability of the  
CD, and which is designed to receive input from the user as to the user's confidential  
information necessary to complete the sale, as described above.

25 To facilitate locating a particular song in the song list, a search function may be  
provided on the HTML page. Storing the song list in a database which creates the  
HTML page in the first instance is beneficial to facilitate this functionality since database  
programs are typically adept at searching, retrieving and organizing information from a  
large volume of data. Alternatively, other search functions could be performed on the  
content of the HTML page itself without querying the database.  
30

Another option which may be available is to enable the user to give a satisfaction  
rating of any number of tracks by simply clicking on the track as it appears in the list of  
songs. These ratings can be organized and used as concise, instantaneous feedback by  
the radio station. Additionally, the user may be allowed to enter comments for use by the  
radio station. One way of allowing the user to provide comments would be to enable the  
35

5 user to select a particular song by clicking on the song in the list of songs, and then  
clicking on a hot button labeled "comment" or in a similar manner. This button could  
cause a JAVA applet to run, or could be a link to another HTML page in which the user  
could submit comments on the selection. The type of comment entered by the user could  
10 be tailored by the radio station to a great degree by prompting the user to enter particular  
types of information and optionally requesting the user to answer particular questions  
about the selection. Optionally, the radio station could enable the user to simply provide  
narrative comments on the selection.

Other embodiments of the invention will be understood from the following  
description of certain illustrated embodiments.

#### Brief Description of the Figures

The following figures depict certain illustrative embodiments of the invention in  
which like reference numerals refer to like elements. These depicted embodiments are to  
be understood as illustrative of the invention and not as limiting in any way.

Figure 1 depicts one system according to the invention;

Figure 2 depicts one screen according to the invention that displays a play list for  
a radio station; and

Figure 3 is a flow chart diagram of one system according to the invention.

#### Detailed Description of the Illustrated Embodiments

To provide an overall understanding of the invention, certain methods, systems  
and devices of the invention will be discussed in the context of applications for providing  
30 consumers with access to radio play lists and for using the play list information to make  
purchases over the Internet. However, it will be understood by persons of ordinary skill  
in the art that the methods, systems and devices described herein are equally applicable to  
all cases in which a user accesses data from a computer network, and other applications  
35 and uses of the invention can be made without departing from the scope thereof. For

5 example, systems and methods as described herein can be employed for identifying information and purchasing movies from a television station. Other applications will, in part be described and, in part, be obvious from the following descriptions of the illustrated embodiments.

10 Figure 1 depicts a computer network that includes an server computer program running on a server 12. In this embodiment, the server 12 can be operated by a radio station and provide a user with information representative of the play list for that radio station. Figure 1 illustrates the flow of data that can incur during the operation of computer network which is allowing a user at the terminal 14 to employ the program on the server 12 to access information stored at the server site. It will be understood that  
15 Figure 1 is a logical representation of the data flow that occurs during operations of the network 10. It is not to be understood as describing or limiting the network 10 to any particular type of configuration. For example, the network 10 can be a LAN, WAN, Intranet or any other type of network. Moreover, the network 10 is not limited to any configuration or topology, nor will Figure 1 be understood to limit the network 10 to any  
20 particular type of protocol. However, for purposes of illustrating the system, the network 10 will be described as a TCP/IP network, and in particular the Internet and the World Wide Web service provided by the Internet.

The data exchanges depicted in Figure 1 illustrate generally that a user at the terminal 14 can issue a page request to the server 12, directing the server 12 to process  
25 the request and generate a page signal, such as an HTML page. In one embodiment this is done by processing information stored in the database 16 to generate a page signal for the user, and sending the page signal to the terminal 14 for viewing by the user. Typically, a browser program operating on the terminal 14 can be employed by the user for issuing the request signals and viewing the page signals.

30 In the embodiment depicted in Figure 1 the various elements, such as the terminal 14, the server 12, and the data storage devices 20 can be conventional network computer devices. For example, the terminal 14 depicted in Figure 1 can be any terminal suitable for operating a browser program for viewing information stored on the computer network, such as the Internet. For example, the terminal 14 can be an IBM PC  
35 compatible computer system running the NETSCAPE browser program. Similarly, the



5 server 12 can be any computer system capable of operating a computer program for  
accessing information stored on a data network, and for performing data processing  
functions. The memory devices 20 can be any suitable memory device for storing a  
computer readable database, and optionally can be a persistent or volatile memory device.  
10 In one example, each device 20 is one or more hard disk drive units coupled to and  
operated under the control of the server 12. The server 16 can be any computer systems  
suitable for operating as file servers for delivering information over a network system.  
Continuing with the above example, the server 16 can be an Internet file server capable of  
transferring data according to the HTTP transfer protocol. It will be understood  
15 however that any suitable transfer protocol can be practiced with the systems described  
herein, including extensions and developments to HTTP. In one example, the server can  
be a PC clone running the WINDOWS NT operating system.

The computer program operating on the server 12 will detect the page requests  
generated by the user and process the page requests to generate pages, such as HTML  
20 pages, that contain information representative of the play list of the radio station. The  
program can be written in any high level computer language, such as the C, C++, or  
JAVA program languages. Moreover, it will be understood that the invention is not  
limited to any one implementation of the program, and that the program follows from  
principles of software engineering well known in the art, including those discussed in  
25 Jamsa *et al.*, *Internet Programming*, Jamsa Press, Las Vegas, Nevada, ISBN1-884133-  
12-6 (1995); and Graham, *HTML Sourcebook*, Wiley Computer Publishing, third edition  
(1997), which are incorporated by reference herein.

In one embodiment, the program provides to a user accessing a radio stations web  
site a page, such as that depicted in Figure 2. As depicted in Figure 2, the page includes  
30 a play list 42, a playback control button 44, an order control button 46, a search button  
48, a keyword field 50 and a message board field 52.

The play back list 42 lists all the selections played by the radio-station, and in one  
embodiment, the web server updates the user's web page in real time so that the song  
currently being played is highlighted for the user. Optionally, the play list shows the title  
and the time that the selection was played or will be playing. The play list can give the  
35 schedule of radio content indicating every track played, the time/day, the CD, and the

5 artist, and put the information in a scrollable list sorted by time/date. The information can  
be available for past, present and future and playback can be available of CD samples  
played in the past and future. However, the system is not required to display schedules  
but the system can use schedules internally within the databases to help users search for  
and locate particular selections. Play lists for different days can be provided to the user  
10 on the user's request.

The display 40 can also include a playback control 44. A user can activate the  
play back button to request a sample of a selected song to be downloaded to the terminal  
14. The playback control will cause the web server 12 to access the database 16 to get  
an audio sample of the selection. The database 16 can include a set of data tables 24,  
15 such as tables 28 and 30, that are referenced to each other so that the database can select  
for a given track, such as track 1, the CD that is associated with that track. The database  
can also store for a selected CD, a set of audio samples that can be downloaded to the  
user. In one embodiment, when a user selects a track to playback, the server can  
download a set of audio samples for the CD that has the selected track. In this way, the  
20 user can hear the sample for the selected track, as well as the sample for the other tracks  
on the CD. Other database structures can be employed without departing from the scope  
of the invention. Preferably, the database is indexed on many different fields so that a  
user may quickly retrieve information based on a wide variety of criteria.

The page 40 can also include the order control 46 that allows the user to order a  
25 selection, or a CD that has the selection. In one embodiment, the order control 46 causes  
the server 12 to activate a commerce server, such as the Microsoft transaction server.  
The transaction server can operate to provide the necessary forms to the consumer and to  
implement the commercial transaction that allows the consumer to purchase the selection  
over the network 10. Optionally, the server can allow for user personalization so that a  
30 use can set up an account to store information such as credit card data, address data and  
other information, thereby allowing easier purchases. The system can be compatible with  
MS Wallet, or a similar product. The user therefore has the ability to click and buy CD's  
based on finding them from either the radios schedule displays, or clicking on the records  
found by searches related to scheduling. Optionally, users may buy individual selections

5 via download. The system also provides a service to radio stations allowing cataloging and user purchasing of promotional items.

10 Figure 2 further depicts that the display 40 can include a search button 48. The search button 48 can be associated with a keyword field 50, into which the consumer can enter a key word to be searched through the database 16 operated by server 12. By storing multiple information fields that are indexed widely, searching can be performed for particular CD by any of time, artist, track name, or CD name, “sounds like” searches; search for future play times across multiple radio stations; search for radio station within geographic areas and all above criteria. In this way, the user can search for words and a song title, the name of an artist, or any other type of information that can be searched on  
15 to collect information of interest to the consumer. The use of such search engines and their development are well known in the art of software engineering, and any suitable techniques can be employed herein.

20 Figure 2 further depicts a message board 52 wherein a user can enter information that can be stored in the database 16 by the server. For example, the user can enter information through field 52 that includes comments regarding a selection heard over the radio. These comments can be sent to the server 12 by the user and can be stored within the database to build a database of comments associated with a particular track. Other applications can be employed for the message board 52 without departing from the scope of the invention, such as allowing listeners to give satisfaction rating for any number of  
25 tracks by simply clicking on item as it appears on schedule page; comments can be left for any track; and ratings can be organized to give cohesive concise, instantaneous feedback to stations. This also allows Listener Community Development in that Users can leave comments for given tracks; Users can choose to see all messages left for a given track by clicking on schedule; Threaded messages and responses available; there is an ability to  
30 send messages to any individuals leaving messages; an ability to see more or all messages left by any author or any message and On line chat rooms associated with each radio station.

35 Figure 3 depicts one process 60 according to the invention for providing a consumer information representative of the play list, or other information on the radio station. Particularly, the process 60 depicted in Figure 3 includes a step 62 wherein the

5 Web server, such as the server 12 depicted in Figure 1, receives a request from a user,  
such as a consumer operating the terminal 14 while listening to the radio 16 depicted in  
Figure 1. The user, upon hearing a song of interest can log on through the Internet to the  
server 12 associated with the radio station. At that time the server 12 will receive a  
request from the user, and therefore the process 60 precedes step 62. Upon receiving the  
10 request the process 60 precedes the step 64 wherein the server 12 processes the request  
to generate a database access instruction. The database access instruction can be a  
standard SQL instruction for accessing a SQL database, such as the database 16 depicted  
in Figure 1. In step 66 the process causes a database access to occur and collects  
information from the database. In step 68 the process 60 employs the returned  
15 information to build an HTML page with the returned information. In one example, the  
user can click on one of the track selections shown in the play list 42. This can cause a  
page request to be sent to the server 12. Server 12 can process the page request to  
interpret it as an instruction to get information regarding the track. Such information can  
include the full title, the CD associated with the track, the artist associated with the track,  
20 the price of the CD, other CDs by the artist, Web links associated with the artist, or any  
other suitable information. With the returned information the process builds a HTML  
page that can be delivered to the user in step 70. Accordingly, in step 70 the page is  
delivered to the user who receives the information requested in step 62.

25 The invention is not to be limited to the above illustrated embodiments, but can  
include many additions and modifications, including being employed for Worldwide  
Internet Broadcasting wherein the system is available for any radio station. By hooking  
into these services to broadcast a station's air play across the Internet, stations may have  
the ability to preserve samples of every selection played automatically. This would allow  
30 sample playback associated with searches to help users identify the desired track. In  
other systems, there can be Mail Alert of future play times of favored items based on  
listener ratings of scheduled items, and of new releases of artists of favored items based  
on listener ratings of scheduled items. The system can provide Web Hosting Services for  
radio stations without web pages.

5                   Moreover, the systems and processes described herein can be formed of  
conventional components and systems include conventional database servers, such as  
Microsoft SQL server, a web server, such as Microsoft Internet Information Server, that  
can send a query to the database based on listener input from a web browser connected to  
the web server. The systems may cause additional information to be stored in the  
10                   database, in the user's cookie file, or in hidden fields in the resulting HTML page. The  
system can format the resulting information from the database into HTML that the user  
can view in their web browser. Some records in the database may be linked to other  
internal and external database, for example: Track names are matched against a table of  
song titles and CDs/CDs are matched against a table of SKUs so that they may be easily  
15                   purchased. Artist names can be matched against a list of special promotions such as  
upcoming concert tours. Based on this additional information, links are generated in the  
HTML that lead the user to other pages where they may see additional information or  
purchase related products, such as: The URL in a link for a CD encodes the CDs SKU  
and the station information so that the user can easily purchase it, and the store can assign  
20                   a commission to the referring entity or entities. Other modifications can be made.

5

I Claim:

1. A system for allowing a consumer to collect information on a portion of a broadcast, comprising  
a server program capable of receiving requests from a user representative  
of a request to identify a portion of a broadcast,  
a database for storing information representative of the play list of radio  
station associated with the broadcast, and  
a server capable of generating a page signal representative of the play list  
and for delivering the page signal to the user.
2. A system according to claim 1, wherein the page signal includes information representative of a time of day associated with the portion of the broadcast.
3. A system according to claim 1, wherein the page signal includes information representative of an author associated with the portion of the broadcast.
4. A system according to claim 1, wherein the portion of the broadcast is representative of a song.
5. A system according to claim 4, further comprising a transaction server for allowing the user to purchase a recording associated with the song.
6. A system according to claim 1, further comprising a sample database for storing audio samples associated with the broadcast.
7. A system according to claim 1, wherein said server comprises a server capable of providing an indication of the portion of the broadcast currently being provided by the radiostation.

- 5           8.     A system according to claim 1, further comprising a server capable of receiving  
            information from a user representative of input text and for string the information  
            in a database for subsequent access.
9.     A process for allowing a consumer to collect information on a portion of a  
10           broadcast, comprising the steps of  
                providing a server program capable of receiving requests from a user  
                representative of a request to identify a portion of a broadcast,  
                storing information in a database representative of the play list of radio  
                station associated with the broadcast, and  
15                  providing a server capable of generating a page signal representative of  
                the play list and for delivering the page signal to the user.
10.    A process according to claim 9, further comprising  
                providing a database having audio samples associated with said broadcast.

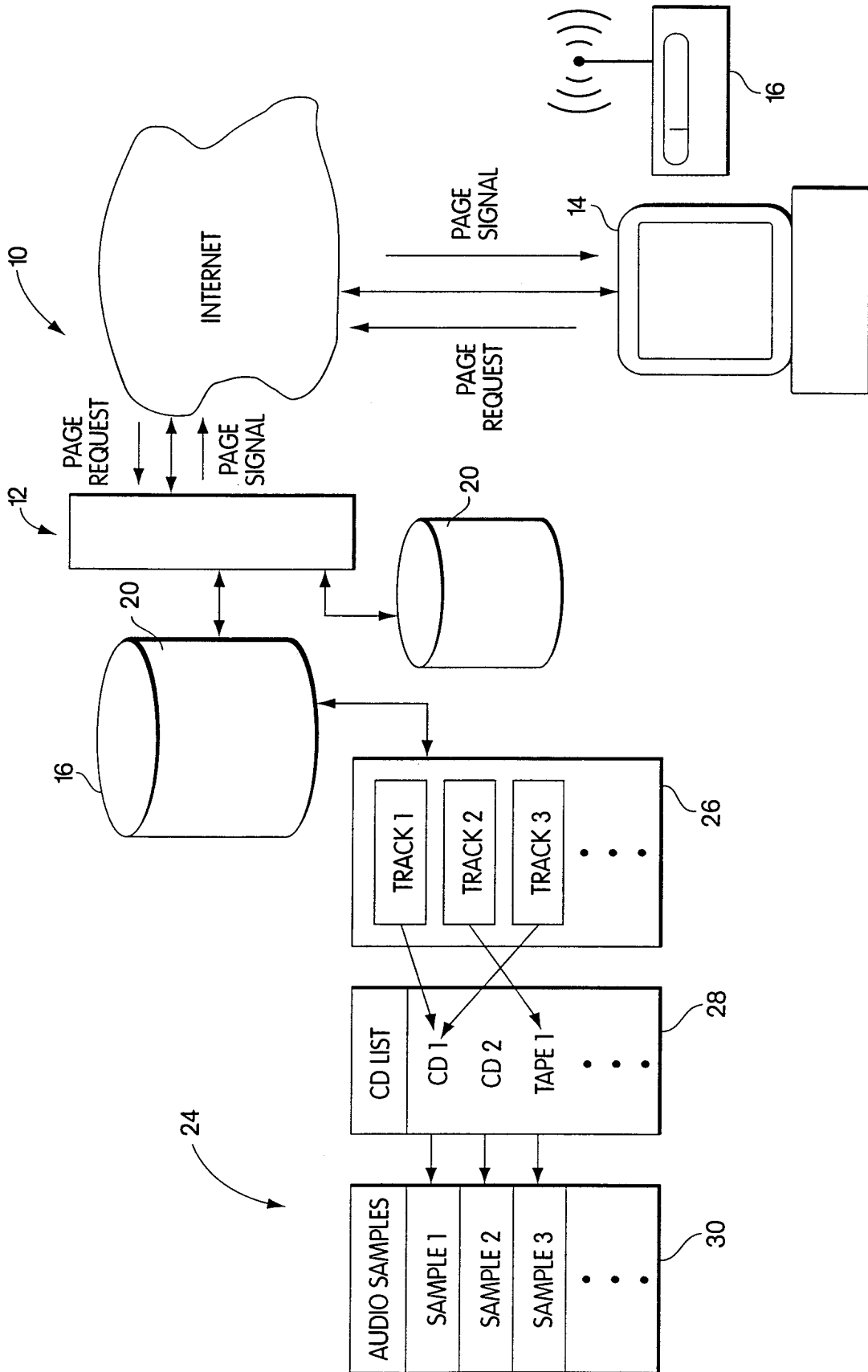


Fig. 1



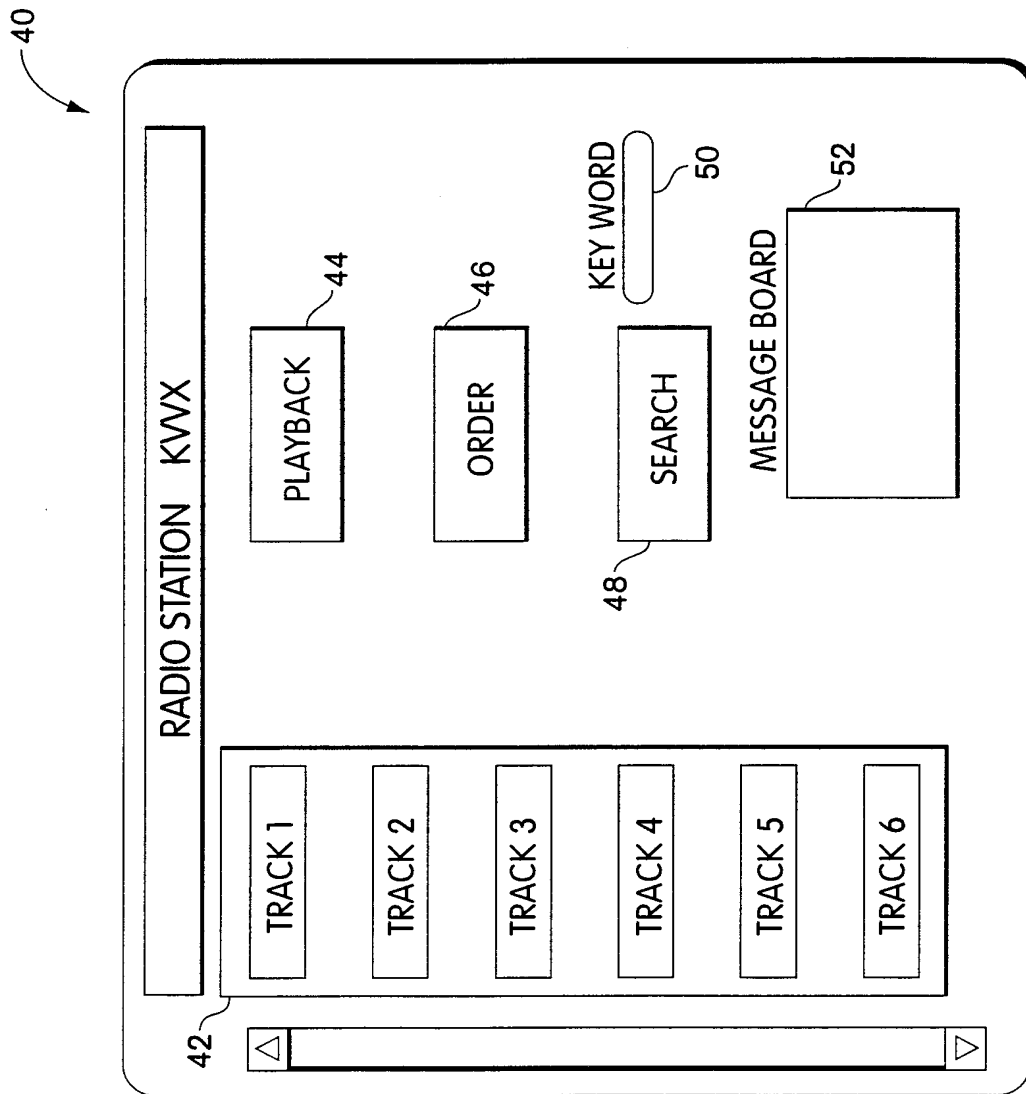


Fig. 2

3/3

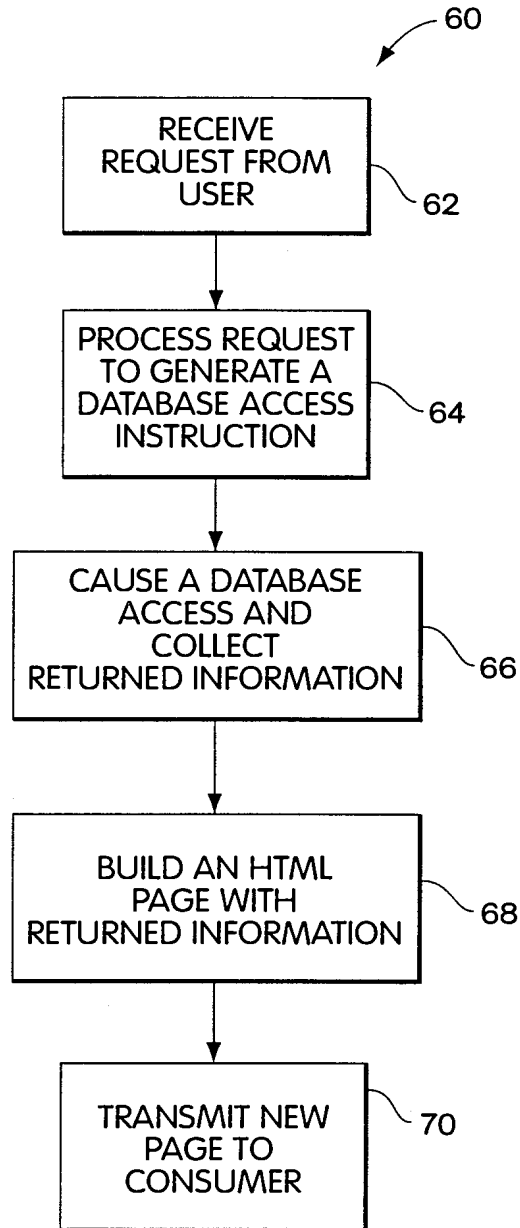


Fig. 3



**(57) Zusammenfassung**

Telekommunikationsverfahren, das folgende Schritte umfasst: Integrierung von programmbegleitenden digitalen Daten in einem TV- oder Radioprogramm, und Aussendung von diesem Programm, Empfang und Wiedergabe von diesem Programm durch ein Mobilfunkgerät, das mit einem TV- bzw. Radioempfangssystem kombiniert ist, wobei das Empfangssystem einen Chipkartenleser umfasst, in dem der Benutzer des Empfangssystems eine SIM-Karte einschieben kann, um sich zu identifizieren, Anzeige von mindestens einer den integrierten digitalen Daten entsprechenden Option auf einer Anzeige des Empfangssystems, und Auswahl einer Option durch den Benutzer des Empfangssystems, Vorbereitung einer der ausgewählten Option entsprechenden Meldung durch die SIM-Karte, wobei die vorbereitete Meldung mindestens ein Datenfeld aus den empfangenen digitalen Daten umfasst, Übermittlung der genannten Meldung durch ein bidirektionales Mobilfunknetz an einen Server, automatische Benutzererkennung durch den Server, wobei die Benutzererkennung eine in der Identifizierungskarte gespeicherte und durch das genannte bidirektionale Telekommunikationsnetz übermittelte Information benutzt, Verknüpfung von mindestens einigen empfangenen Daten mit benutzerspezifischen Daten.

**LEDIGLICH ZUR INFORMATION**

Codes zur Identifizierung von PCT-Vertragsstaaten auf den Kopfbögen der Schriften, die internationale Anmeldungen gemäss dem PCT veröffentlichen.

<b>AL</b>	Albanien	<b>ES</b>	Spanien	<b>LS</b>	Lesotho	<b>SI</b>	Slowenien
<b>AM</b>	Armenien	<b>FI</b>	Finnland	<b>LT</b>	Litauen	<b>SK</b>	Slowakei
<b>AT</b>	Österreich	<b>FR</b>	Frankreich	<b>LU</b>	Luxemburg	<b>SN</b>	Senegal
<b>AU</b>	Australien	<b>GA</b>	Gabun	<b>LV</b>	Lettland	<b>SZ</b>	Swasiland
<b>AZ</b>	Aserbaidshjan	<b>GB</b>	Vereinigtes Königreich	<b>MC</b>	Monaco	<b>TD</b>	Tschad
<b>BA</b>	Bosnien-Herzegowina	<b>GE</b>	Georgien	<b>MD</b>	Republik Moldau	<b>TG</b>	Togo
<b>BB</b>	Barbados	<b>GH</b>	Ghana	<b>MG</b>	Madagaskar	<b>TJ</b>	Tadschikistan
<b>BE</b>	Belgien	<b>GN</b>	Guinea	<b>MK</b>	Die ehemalige jugoslawische Republik Mazedonien	<b>TM</b>	Turkmenistan
<b>BF</b>	Burkina Faso	<b>GR</b>	Griechenland	<b>ML</b>	Mali	<b>TR</b>	Türkei
<b>BG</b>	Bulgarien	<b>HU</b>	Ungarn	<b>MN</b>	Mongolei	<b>TT</b>	Trinidad und Tobago
<b>BJ</b>	Benin	<b>IE</b>	Irland	<b>MR</b>	Mauretanien	<b>UA</b>	Ukraine
<b>BR</b>	Brasilien	<b>IL</b>	Israel	<b>MW</b>	Malawi	<b>UG</b>	Uganda
<b>BY</b>	Belarus	<b>IS</b>	Island	<b>MX</b>	Mexiko	<b>US</b>	Vereinigte Staaten von Amerika
<b>CA</b>	Kanada	<b>IT</b>	Italien	<b>NE</b>	Niger	<b>UZ</b>	Usbekistan
<b>CF</b>	Zentralafrikanische Republik	<b>JP</b>	Japan	<b>NL</b>	Niederlande	<b>VN</b>	Vietnam
<b>CG</b>	Kongo	<b>KE</b>	Kenia	<b>NO</b>	Norwegen	<b>YU</b>	Jugoslawien
<b>CH</b>	Schweiz	<b>KG</b>	Kirgisistan	<b>NZ</b>	Neuseeland	<b>ZW</b>	Zimbabwe
<b>CI</b>	Côte d'Ivoire	<b>KP</b>	Demokratische Volksrepublik Korea	<b>PL</b>	Polen		
<b>CM</b>	Kamerun	<b>KR</b>	Republik Korea	<b>PT</b>	Portugal		
<b>CN</b>	China	<b>KZ</b>	Kasachstan	<b>RO</b>	Rumänien		
<b>CU</b>	Kuba	<b>LC</b>	St. Lucia	<b>RU</b>	Russische Föderation		
<b>CZ</b>	Tschechische Republik	<b>LI</b>	Liechtenstein	<b>SD</b>	Sudan		
<b>DE</b>	Deutschland	<b>LK</b>	Sri Lanka	<b>SE</b>	Schweden		
<b>DK</b>	Dänemark	<b>LR</b>	Liberia	<b>SG</b>	Singapur		
<b>EE</b>	Estland						

## VERFAHREN ZUR INTERAKTIVEN TELEKOMMUNIKATION

Die vorliegende Erfindung betrifft ein Telekommunikationsverfahren und ein Empfangssystem zur Durchführung dieses Verfahrens. Die Erfindung betrifft insbesondere ein Telekommunikationsverfahren, das in einem  
5 Broadcastkanal eingesetzt werden kann.

Die verbreitetsten Broadcastsysteme sind rein monodirektional und weisen daher keinen Rückkanal auf, mit dem der Empfänger Antwortmeldungen an den Aussender senden könnte. Das ist zum Beispiel der Fall in den meisten Radio- und TV-Broadcastsystemen. Wenn der Empfänger,  
10 zum Beispiel der Radiozuhörer oder der Fernsehzuschauer, auf eine Sendung oder auf eine Werbung reagieren möchte, muss er daher auf ein anderes Telekommunikationssystem zugreifen, zum Beispiel auf sein Telefon. Wenn zum Beispiel für ein Produkt am Fernsehen geworben wird, muss sich der interessierte Kunde sofort die Adresse oder die Telefonnummer des  
15 Produktlieferanten notieren und ihn später manuell anrufen. Der Kunde muss sich dann beim Produktlieferanten selber identifizieren und das Produkt, das ihn interessiert, telefonisch angeben. Dieses Verfahren ist äusserst umständlich und fehleranfällig. Aus diesem Grund sind die meisten Broadcastsysteme nur bedingt geeignet, um den Empfänger zu  
20 Spontaneinkäufen während oder gleich nach einer Werbung zu bewegen. Ausserdem ist es schwierig, TV- oder Radioprogramme zu gestalten, in denen ein sofortiges Feedback der Empfänger benötigt wird.

Es ist ausserdem schon bekannt, programmbegleitende digitale Daten einem Radio- oder Fernsehprogramm hinzuzufügen. Bei den  
25 Fernsehsystemen können somit digitale Daten während des vertikalen Rasterintervalls übertragen werden. Eine entsprechende Hardware- und Softwarevorrichtung im Fernseher oder im PC des Empfängers ermöglicht es, diese digitalen Daten zu decodieren, sie auszuwählen und zu speichern oder auf dem Bildschirm des Empfängers anzuzeigen. In den Radiosystemen wird  
30 die Übertragung von programmbegleitenden Daten zusätzlich zu den Radioprogrammen vor allem mit den digitalen Radiosystemen DAB (Digital Audio Broadcasting) verwendet. Die DAB- Technologie ermöglicht es auf diese

Weise, sowohl Radioprogramme als auch programmbegleitende Dienste (Program Associated Data, PAD) zu übertragen. DAB-Empfänger, die einen Datendecoder und eine entsprechende Anzeige enthalten, werden schon angeboten. Dieser Kanal für programmbegleitende Daten ist leider, wie der  
5 Radio- oder TV-Programmkanal, nur monodirektional.

Broadcastkanäle, die über einen Rückkanal verfügen, bei denen digitale Daten zwischen einem Server und mehreren Empfängern zum Beispiel durch einen Push-Kanal im Internet gesandt werden, sind inzwischen auch bekannt. Je nach Wahl und Interesse des Benutzers können diese digitalen  
10 Daten dann im Empfangssystem des Benutzers gespeichert und/oder gefiltert werden. Beispielsweise kann ein komplettes Informationsprogramm an den Benutzer übertragen werden, der dann z.B. entscheidet, nur die Informationen betreffend Sportartikel oder Politik anzuzeigen oder zu speichern. Mit diesen Systemen können die Empfänger passiv ein Programm empfangen und nur  
15 dann antworten, wenn sie zum Beispiel mehr Information über ein Thema oder wenn sie ein Produkt bestellen wollen. Es ist aber bekanntlich schwierig, Benutzer zuverlässig im Internet zu identifizieren, so dass dieses Verfahren nur bedingt geeignet ist, um vertrauliche oder sicherheitskritische Daten, wie zum Beispiel Produktbestellungen oder Zahlungsaufträge, an den Sender oder an  
20 einen Lieferanten zu übermitteln. Es ist ferner ein Mindestmass an Informatik-Kenntnissen seitens des Benutzers erforderlich, um von einem durch einen Push-Kanal übertragenes Angebot im Mediaprogramm zu profitieren. Der Benutzer muss beispielsweise eine e-mail-Meldung vorbereiten, die seine eigene Identifizierung, eine Beschreibung des zu bestellenden Produktes  
25 sowie die Identifizierung des gewählten Lieferanten enthält. Dieses Verfahren ist daher ziemlich langwierig und mühsam. Ausserdem können eventuelle, durch den Benutzer eingebrachte oder durch Probleme mit der Übermittlung im Telekommunikationsnetz auftretende Fehler nicht leicht ausfindig gemacht werden. Daraus resultiert eine gewichtige Prozentzahl von Aufträgen, die nicht  
30 ausgeführt werden können, da z.B. die Angaben vom Benutzer unvollständig oder fehlerhaft eingegeben worden sind.

Es ist daher ein Ziel der vorliegenden Erfindung, ein Telekommunikationssystem anzubieten, das diese Nachteile vermeidet.

Erfindungsgemäss wird dieses Ziel mit Hilfe eines Verfahrens und eines Systems erreicht, die die Merkmale der entsprechenden unabhängigen Ansprüche aufweisen, wobei bevorzugte Ausführungsformen ferner in den Nebenansprüchen angeführt sind.

5 Mit dem erfindungsgemässen System und Verfahren kann der Empfänger Meldungen nicht nur an den Aussender, sondern auch an andere Partner, zum Beispiel an Lieferanten von angepriesenen Produkten, automatisch verfassen und übermitteln.

Die Erfindung wird mit Hilfe der als Beispiel angeführten und in den  
10 Figuren dargestellten Beschreibung besser verständlich, wobei:

die Figur 1 eine schematische Ansicht des erfindungsgemässen Systems darstellt;

die Figur 2 eine schematische Ansicht der Struktur der übertragenen Auftragskodes zeigt;

15 die Figur 3 eine Bildschirmansicht zeigt, die vom erfindungsgemässen JAVA-Applet auf der Anzeige des Empfangssystems des Benutzers erzeugt wird, und

die Figur 4 ein Flussdiagramm, mit den verschiedenen Schritten gezeigt werden, die beim Empfang eines entsprechenden Applets im  
20 Empfangssystem ausgeführt werden.

Die Figur 1 zeigt schematisch die Systemkomponenten, die für die Ausführung des erfindungsgemässen Verfahrens eingesetzt werden können. Wir werden jetzt die einzelnen Elemente näher beschreiben :

Mit 1 ist ein Marketing-Online-Studio dargestellt. Hier werden  
25 individuelle Auftragsnummern 50 vorbereitet, mit JAVA-Applets 50 (JAVA: geschützte Marken von SUN) verpackt und einem oder mehreren Sendeblocks

zugeteilt. Diese Meldungen werden später im Bezug auf Figur 2 näher erläutert.

Im Sendestudio 2 werden die Mediaprogramme vorbereitet und in Sendeblocks aufgeteilt. Ein Sendeblock kann beispielsweise einer Werbung, einem Musikstück, einem Hörspiel, einem Werbespot, einem Film, einer Webseite, usw. entsprechen. Als Sendestudio kommen beispielsweise ein Radiostudio, ein TV-Studio oder ein Internetanbieter in Frage.

Die ausgesandten Sendeblocks 4 werden in 6 mit den zugeteilten Meldungen 5 verknüpft und durch den Broadcastkanal 7 ausgesandt. Der Broadcastkanal 7 kann je nach Anwendung beispielsweise ein FM-Broadcastnetz, ein TV-Broadcastnetz oder ein Pushkanal im Internet sein. Alternativ können die Sendeblocks 4, zum Beispiel Werbemeldungen, und die entsprechenden Meldungen 5 auch durch ein konventionelles Mobilkommunikationsnetz 8 ausgesandt werden, wie mit dem Pfeil 15 angedeutet.

Das ausgesandte Mediaprogramm wird durch ein Empfangssystem 9 gemäss der Erfindung empfangen. Das Empfangssystem 9 kann zum Beispiel ein Telekommunikationsmobilgerät mit einem integrierten Radioempfänger sein. Der Benutzer kann mit diesem System ganz konventionell durch ein Mobilfunknetz 8, zum Beispiel ein GSM-Netz, telefonieren, oder es auch als klassischen FM-Empfänger benutzen, um beispielsweise Radioprogramme mit den Kopfhörern 95 zu hören. In einer Variante weist das Empfangssystem statt oder zusätzlich zum Radioempfänger einen Fernsehempfänger auf, um Fernsehprogramme auf der Anzeige 90 des Mobilgeräts anzuschauen. Mobilfunkgeräte, die mit einem ausreichenden Bildschirm versehen sind, zum Beispiel für Videotelefon-Anwendungen, sind bekannt und werden schon kommerziell angeboten; der Fachmann kann problemlos einen TV-Tuner in ein solches Mobil-Visiophongerät integrieren, damit mit diesem System auch ferngesehen werden kann. Die Mobilfunkfunktionen und die Radio- oder TV-Funktionen lassen sich einzeln oder kombiniert betreiben. Beim Einzelbetrieb kann der Radio- oder TV-Empfänger wie ein klassisches Einzelgerät betrieben werden. Im Kombibetrieb ist der Radio-FM oder der TV-Empfänger operativ



und die Mobilfunkkomponente im Stand-by oder im Kommunikations-Modus. Durch eine spezielle Taste 92 kann der Benutzer beim Empfangen einer interessanten Meldung die Ausführung des Applets 5 und die auf Figur 3 gezeigte Bildschirmdarstellung aktivieren.

5                   Das Empfangssystem 9 kann auch aus einem Radio und/oder TV-Empfänger mit im Gehäuse integrierten zusätzlichen Mobilfunkkommunikationskomponenten bestehen. Ebenso ist es möglich, die Mobilfunkkomponenten in einer Fernbedienung für einen Fernseher oder für einen anderen Broadcastempfänger zu integrieren. Ferner kann das  
10 Empfangssystem auch aus einem Rechner, zum Beispiel einem PC oder einem Palmtop, mit integriertem Radio, TV und/oder Internetempfängermittel sowie mit Kommunikationsmitteln für ein Mobilfunknetz 8 bestehen. Wie später erklärt, kann aber das erfindungsgemässe Verfahren auch mit einem  
15 konventionellen Mobilfunkgerät 9 durchgeführt werden, z.B. mit einem GSM-Endgerät.

                  Das Empfangssystem 9 enthält ausserdem vorzugsweise bekannte Mittel, um SMS- (Short Message System) und/oder USSD- (Unstructured Supplementary Service Data) Kurzmeldungen zu senden und zu empfangen, sowie bekannte Filtermittel, um spezielle Kurzmeldungen zu erkennen und  
20 zwischenzuspeichern, vorzugsweise gemäss dem SICAP-Verfahren, das unter anderem im Patent EP 0689 368 B1 beschrieben ist. Verschlüsselung und Signierungsmittel sind ausserdem vorzugsweise vorhanden, um empfangene Kurzmeldungen zu entschlüsseln und um auszusendende Kurzmeldungen zu verschlüsseln und zu signieren. Als Verschlüsselungsverfahren kann  
25 beispielsweise das TTP-Verfahren eingesetzt werden, oder auch Entschlüsselungsmittel, die nach einem Point-to-Point-Verfahren arbeiten.

                  Das Empfangssystem 9 kann eine Kurzmeldung mit einer Auftragsnummer an einen Server 13 durch das Mobilfunknetz 8 übermitteln. Der Server 13 verknüpft die empfangene Auftragsnummer mit  
30 Benutzeridentifikationsdaten aus einer Teilnehmerdatenbank 11. Diese Benutzeridentifikationsdaten enthalten mindestens die vollständige Adresse des Abonnenten. Vorzugsweise enthalten die Benutzeridentifikationsdaten

ebenfalls die Sprache des Benutzers, seine Bankverbindung bzw. sein Kreditkartenunternehmen, abonnierte Dienste, usw. Die Teilnehmerdatenbank 11 ist vorzugsweise die Datenbank des Betreibers des Telekommunikationsnetzes 8 zur Verwaltung der Abonnenten. Ihr Inhalt ist im Prinzip also äusserst zuverlässig. Sie kann auch eine temporäre Adresse des Teilnehmers enthalten. In einer Variante enthält die Teilnehmerdatenbank die Benutzeridentifikationsdaten nur von den Benutzern, die das System der Erfindung abonniert haben.

Das Empfangssystem 9 enthält Benutzeridentifizierungsmittel, vorzugsweise Chipkartenlesemittel, um den Benutzer des Empfangssystems mit einer Identifizierungskarte zu identifizieren. Solche Chipkartenlesemittel sind unter anderem in GSM-Mobilgeräten üblich, die mit SIM-Karten (Subscriber Identification Module) versehen sind. Andere Identifizierungskarten, zum Beispiel Karten, die unter dem Begriff OpenCard bekannt sind, können aber auch je nach Empfangssystem angewendet werden.

Der Server 13 verknüpft dann mindestens einige der in der vom Benutzer eingegebenen Kurzmeldung enthaltenen Informationen mit den Benutzeridentifikationen, um die nicht vollständig übermittelte Identifizierung des Benutzers zu vervollständigen.

Der Server 13 ist mit einer Produkte-/Information-Lieferanten-Datenbank 10 verbunden. Über diese Datenbank werden die Funktionen des Systems gesteuert. Vorzugsweise enthält sie neu ein Benutzerprofil. Die im Server 13 verknüpften Daten werden mittels dieser Datenbank dem Logistikzentrum 12 des entsprechenden Lieferanten zugestellt, der die bestellten Produkte oder Informationen dann an den Benutzer 16 liefert.

Ein Data-Warehouse-Server 14 analysiert die vom Benutzer 9 empfangene Meldungen und erstellt daher Benutzerprofile, die ein Marketing auf der Ebene Point-to-Point erlauben. Die Benutzer können sich dann ein Benutzerprofil oder eine Gruppe von angebotenen Profilen auf ihre Identifizierungskarte 94 laden, damit sie beim Broadcastverfahren auch direkt angesprochen werden können.

Der Benutzer kann sich ein Profil auch selber bestellen und zuteilen lassen, zum Beispiel mit einer speziellen Auftragsmeldung oder online mit einem Rechner.

Der Prozess, der in den Elementen 9 bis 14 erfolgt, ist in der  
5 Patentanmeldung PCT/CH96/00464, deren Inhalt hier übernommen wird, ausführlicher beschrieben.

Die Figur 2 zeigt die Struktur der Meldung 5. Die Auftragsnummer 52 selbst ist zusammen mit dem entsprechenden JAVA-Code 50 verpackt. Dieses Java-Applet wird von der Java-tauglichen SIM-Karte 94 im Mobilgerät 9  
10 empfangen, die folglich einen interaktiven Prozess mit dem Benutzer ausführt. Der Java-Code 50 wird nur zwischen dem Aussender 1 und dem Mobilgerät übermittelt, damit dieser interaktive Prozess zwischen der Java-tauglichen SIM-Karte 9 und dem Benutzer erfolgt, jedoch nicht zwischen dem Mobilgerät 9 und dem Server 13. Statt Java können die Applets natürlich auch in einer anderen  
15 objekt-orientierten Computersprache geschrieben werden.

Die Meldung 5 umfasst ausserdem ein im Studio 1 erfasstes Benutzerprofil 510, mit dem die für den Benutzer interessanten Daten in der SIM-Karte 94 filtriert werden. Wenn die Erfindung zum Beispiel für den Wertpapierhandel eingesetzt wird, kann zum Beispiel das Benutzerprofil einem  
20 Segment von Wertpapieren in einem automatischen Handelssystem entsprechen. Die Datenverarbeitungsmittel in der SIM-Karte 9 können dann automatisch eine Kurzmeldung für den Server 13 vorbereiten, wenn Kaufsbeziehungsweise Verkaufssignale entstehen. Der Benutzer hat dann die Wahl, einen entsprechenden Prozess durchzuführen.

25 Das Benutzerprofil kann im Data-Warehouse 14 vom Benutzer selbst oder durch Kombination erstellt werden. Mit einem persönlichen Benutzerprofil wird es möglich, einem Benutzer gezielt die Produkte anzuzeigen, für die er sich auch wirklich interessiert.

Der Benutzer kann beispielsweise durch eine Kurzmeldung eine  
30 Liste von Profilen und Detailsegmenten vom 12 anfordern, die auf seinem

Bildschirm 90 angezeigt wird. Alternativ kann auch ein Benutzerprofil online mit einem PC oder mit einem Rechner bestellt werden. Das bestellte Benutzerprofil wird zum Beispiel in einer Benutzerprofiletabelle im gesicherten Bereich der SIM-Karte 94 abgespeichert und dient der Selektion von Applets, die die  
5 interessanten Information enthalten. Die Benutzerprofiletabelle ist vorzugsweise vom Benutzer nicht direkt über das Mobilgerät veränderbar.

Das Feld 525 enthält nur einen Bezeichner F für die Auftragsnummer 52. Die Felder 526, 527 und 528 enthalten Trenner. Das Feld 521 enthält eine Produktlieferantenangabe für das angebotenen Produkt oder  
10 für die angebotene Information. Dieser Bezeichner besteht vorzugsweise aus einer vordefinierten Abkürzung des Lieferantennamens. Damit der Benutzer diese Abkürzung verstehen kann, wird vorzugsweise im Applet 50 der komplette Lieferantename als Linkfile mitübertragen (500).

Das Feld 522 enthält die Produktidentifizierung, zum Beispiel eine  
15 Produktnummer. Das angebotene Produkt entspricht vorzugsweise dem gleichzeitig ausgesandten Sendeblock 4. Wird zum Beispiel ein Musikstück im FM-Kanal gesandt, können gleichzeitig im Datenkanal oder bei DAB verschiedene dem Musikstück entsprechende Produkte als Option in einem Menü angeboten werden, zum Beispiel das Bestellen einer CD, oder von  
20 Musiknoten, oder von Eintrittskarten für ein Konzert, usw. Dieser vom Studio 1 gesteuerte Mechanismus kann auch dynamisch gestaltet werden.

Vorzugsweise wird zusätzlich zur Produktnummer 522 ein Linkfile 501 zu einer oder mehreren Produktidentifizierungen 502, 502', usw. im Klartext und in mehreren Sprachen im Applet 50 übertragen und  
25 gegebenenfalls auf dem Display 90 des Empfangssystem 9 angezeigt. Die Produktidentifizierung ist vorzugsweise mit einem Sprachflag 503, 503' usw. versehen. Damit wird ermöglicht, dass die Produktbezeichnung mit dem Sprachflag auf der benutzerspezifischen Java-SIM-Karte auf die Sprache des Benutzers gesetzt werden kann.

30 Das Feld 523 (CS) enthält eine Checksumme oder eine Paritätssumme, um allfällige Fehler im Feld 52 abzufangen. Tritt ein solcher

Fehler auf der Ebene des Servers 13 auf, wird der Benutzer aufgefordert, seine Eingabe zu wiederholen.

Die Checksumme wird festgelegt durch irgendeinen bekannten Fehlerprüfungs- oder Fehlerkorrektur-Algorithmus aus den Feldern 521 und  
5 522. Z.B. kann zum Festlegen des Wertes der Checksumme 523 ein Paritätskontrollealgorithmus verwendet werden. Die Anzahl der Zeichen der Checksumme hängt vom benützten Algorithmus und von der maximal akzeptierten Fehlerquote ab.

Das Feld 524 schliesslich enthält eine Angabe über die gewünschte  
10 Transaktion. Dieser Prozess kann interaktiv vom Benutzer gesteuert werden, um einzugeben, ob er ein Produkt bestellen möchte (Order), oder ob er beispielsweise nur Informationen anfordern möchte. Wenn das Empfangssystem auch mit dem Internet vernetzt ist, kann auch ein Code W  
15 eingegeben werden, um das Gerät direkt auf eine entsprechende WEB-Seite einzustellen. Mit einer Endgerätidentifikation IMEI im Empfangssystem kann das JAVA-Applet erkennen, ob das System Zugriff auf das Internet hat und ob der W-optioncode auch angeboten werden muss.

Ferner kann mit Optionen im Feld 524 die gewünschte Produktmenge (M) sowie die bevorzugte Zahlungsart (Z) ausgewählt werden.

20 Diese Informationsaufteilung in der Auftragskurzmeldung wird nur als Beispiel angegeben, denn andere Aufteilungen sind durchaus denkbar. Ausserdem können die verschiedenen Datenfelder vermischt, verschlüsselt und/oder signiert werden, um die Vertraulichkeit zu garantieren. Die  
25 Informationen können auch, aufgeteilt in verschiedene Kurzmeldungen, aufeinanderfolgend gesandt werden.

Die Figur 3 zeigt schematisch den Bildschirm 90 bei der Ausführung einer Meldung, welche das Filter passierte. In diesem Beispiel wird die gesamte Auftragsnummer 52 interaktiv dargestellt. Unter dem abgekürzten Lieferantenbezeichner 521 wird die vollständige Lieferantenidentifizierung 500  
30 angezeigt. Mit einem Cursor 900 kann der Benutzer eines von mehreren

Produkten 522, 522', 522'',... in einer Listbox im Bereich 901 auswählen. Die Bezeichnung des angewählten Produktes wird ständig im Klartext im Feld 502 dargestellt. Ähnlich erlaubt das JAVA-Applet eine Auswahl der Transaktionmöglichkeiten (Bestellung oder Information), der gewünschten  
5 Menge (M) und der Zahlungsart (Z) mit einem Menü, wobei die angewählte Option stets im Klartext im Textbereich 902 des Bildschirms erläutert wird.

Wir werden jetzt den Prozessablauf näher beschreiben. Im Fall eines Mobilgerätes, das mit einem Radioempfänger kombiniert wird, werden Werbesendungen, Musikdarbietung, Informationen, etc. durch den  
10 Broadcastkanal 7 ausgesandt. Gleichzeitig wird auch im verfügbaren Datenkanal die Auftragsnummer 52, vorzugsweise mit Applet 50 verpackt, ausgesandt. Ist der Benutzer von einem Angebot oder von einem Musikstück angesprochen, kann er auf die F-Taste 92 drücken, um die Ausführung des Applets und die Bildschirmanzeige von Figur 3 zu aktivieren. Mit dem Cursor  
15 kann der Benutzer dann eine Option zum Beispiel in den Listboxen auswählen und auf diese Weise einen Befehl eingeben ; je nach Lieferant kann auch nur eine einzige Option, zum Beispiel ein einziges Produkt, das man nur bestellen kann, angezeigt werden.

Wählt der Benutzer einen Transaktionscode, der nicht nur  
20 Informationen beriff, folgt vorzugsweise ein interaktiver Prozess, damit die Authentizität des Benutzers gesichert werden kann. Dieser Prozess kann direkt auf der Karte 94 erfolgen, zum Beispiel mittels TTP- (Trusted Third Party) oder PTP- (Point to Point) Ressourcen auf der Karte, oder interaktiv in einem nicht dargestellten Security Server.

25 Im Fall eines Mobilgeräts, das mit einem Fernsehempfänger oder mit einem multifunktionalen Rechner kombiniert ist, läuft der Prozess analog. In diesem Fall kann aber das Empfangssystem auch mit dem Internet vernetzt sein, und WEB-Seiten darstellen. Damit kann das System direkt auf die entsprechende Web-Seite eingestellt werden.

30 Das erfindungsgemässe Verfahren kann auch mit ganz normalen Mobilgeräten, die keinen zusätzlichen Broadcastkanalempfänger enthalten,

angewendet werden, wie schon mit dem Pfeil 15 auf Figur 1 angedeutet. In diesem Fall werden Meldungen von einer Zentrale 2 durch das normale Mobilfunknetz 8 im Broadcastverfahren an mehrere oder alle Benutzer ausgesandt. In dieser Variante ist es sinnvoll, mit Benutzerprofilen zu arbeiten, damit die Information nur an die dafür interessierten Benutzer gelangt, beziehungsweise nur an solche, die einen entsprechenden Dienst abonniert haben.

Wir werden jetzt mit Hilfe der Figur 4 das Verfahren beschreiben, das im Empfangssystem 9 beim Empfang einer Meldung 5 ausgeführt wird.

Das Empfangssystem verfügt über Empfangsmittel, um ein durch einen Broadcastkanal ausgesandtes Mediaprogramm und programmbegleitende Daten zu empfangen, und über Wiedergabemittel, um das empfangene Mediaprogramm dem Benutzer wiederzugeben. Damit kann das Empfangssystem als programmbegleitende Daten übertragene Meldungen 5 und Applets 50 empfangen (Schritt 20).

Die empfangenen Meldungen 5 werden dann ausgewertet, wobei diese Auswertung bereits erfolgt, wenn der Mobilfunkteil des Empfangssystems ausgeschaltet oder im Stand-by-Modus ist. Wird eine Meldung mit einer Auftragsnummer 52 empfangen (bezeichnet mit dem Bezeichner 525), wird das Benutzerprofil ausgewertet (Test 21). Wenn die empfangene Auftragsnummer keinem Kundenprofil entspricht, wird der Prozess beendet (Schritt 23); sonst wird dieser Code weiterbearbeitet. Ist das Mobilgerät eingeschaltet (Test 24), wird das Applet 50 direkt ausgeführt und die übermittelte Information gemäss Figur 3 direkt auf der Anzeige 90 angezeigt (Schritt 25). Der Benutzer kann dann, wie oben beschrieben, zum Beispiel Produkte bestellen oder Informationen anfordern (Schritt 29).

Ist das Mobilgerät dagegen ausgeschaltet, wird die empfangene Meldung 5 oder nur das Applet 50 in einem nicht dargestellten Buffer auf der SIM-Karte 94 oder im Empfangssystem 9 abgelegt (Schritt 26). Erst wenn das Mobilgerät später eingeschaltet wird (Schritt 27), wird das Applet 50 ausgeführt

und die Information angezeigt (Schritt 28), damit der Benutzer Produkte bestellen oder Informationen anfordern kann (Schritt 29).



## Ansprüche

1. Telekommunikationsverfahren, das folgende Schritte umfasst:

Empfang von in einem Broadcastkanal (7; 8) ausgesandten digitalen  
5 Daten (5) durch ein geeignetes Empfangssystem (9), wobei das  
Empfangssystem eine Identifizierungskarte (94) umfasst, mit der der Benutzer  
des Empfangssystems identifiziert wird,

Anzeige von Informationen, die den empfangenen digitalen Daten  
entsprechen, auf einer Anzeige (90) des Empfangssystems,

10 Eingabe eines Befehls durch den Benutzer,

Vorbereitung einer dem eingegebenen Befehl entsprechenden  
Meldung, wobei die vorbereitete Meldung mindestens ein Datenfeld (521, 522,  
524) aus den empfangenen digitalen Daten (5) sowie eine aus der  
Identifizierungskarte ermittelte Identifizierung des Benutzers umfasst,

15 Sendung der vorbereiteten Meldung durch ein bidirektionales  
Telekommunikationsnetz (8).

2. Telekommunikationsverfahren gemäss Anspruch 1, dadurch  
gekennzeichnet, dass die genannten digitalen Daten als programmbegleitende  
digitalen Daten (5) in einem Mediaprogramm (4) übertragen werden, und dass  
20 das genannte bidirektionale Telekommunikationsnetz ein Mobilfunknetz ist.

3. Telekommunikationsverfahren gemäss Anspruch 2, dadurch  
gekennzeichnet, dass das genannte Mediaprogramm (4) vom Empfangssystem  
(9) wiedergegeben wird.

4. Telekommunikationsverfahren gemäss einem der vorhergehenden Ansprüche, dadurch gekennzeichnet, dass die angezeigten Informationen mindestens ein Menü enthalten, aus dem ein Befehl ausgewählt werden kann.

5 5. Telekommunikationsverfahren gemäss einem der vorhergehenden Ansprüche, dadurch gekennzeichnet, dass die digitalen Daten Applets (50) enthalten können, die vom Empfangssystem (9) ausgeführt werden.

6. Telekommunikationsverfahren gemäss einem der vorhergehenden Ansprüche, dadurch gekennzeichnet, dass, wenn die zur Bearbeitung und Anzeige dieser Daten benötigten Komponenten ausgeschaltet sind, die  
10 empfangenen digitalen Daten in einem Buffer zwischengespeichert werden und erst beim Einschalten dieser Komponenten bearbeitet werden.

7. Telekommunikationsverfahren gemäss einem der vorhergehenden Ansprüche, dadurch gekennzeichnet, dass die empfangenen digitalen Daten in Meldungen (5) verpackt werden, die zuerst ausgewertet werden, um  
15 festzustellen, ob sie angezeigt werden müssen.

8. Telekommunikationsverfahren gemäss Anspruch 7, dadurch gekennzeichnet, dass die empfangenen Meldungen (5), die nicht dem Interesse des Benutzers entsprechen, mit Hilfe eines im Speicherbereich des Empfangssystems (9) gespeicherten Benutzerprofils aussortiert werden.

20 9. Telekommunikationsverfahren gemäss einem der vorhergehenden Ansprüche, dadurch gekennzeichnet, dass der Broadcastkanal (7) ein Radiokanal ist.

10. Telekommunikationsverfahren gemäss einem der Ansprüche 1 bis 9, dadurch gekennzeichnet, dass der Broadcastkanal (7) ein TV-Kanal ist.

25 11. Telekommunikationsverfahren gemäss einem der vorhergehenden Ansprüche, dadurch gekennzeichnet, dass die vorbereitete Meldung eine SMS-Meldung ist.

12. Telekommunikationsverfahren gemäss einem der vorhergehenden Ansprüche, dadurch gekennzeichnet, dass die vorbereitete Meldung eine USSD-Meldung ist.

5 13. Telekommunikationsverfahren gemäss einem der vorhergehenden Ansprüche, dadurch gekennzeichnet, dass die vorbereitete Meldung signiert wird.

14. Telekommunikationsverfahren gemäss einem der vorhergehenden Ansprüche, dadurch gekennzeichnet, dass die vorbereitete Meldung verschlüsselt wird.

10 15. Empfangssystem, umfassend :

Empfangsmittel, um ein durch einen Broadcastkanal (7; 8) ausgesandtes Mediaprogramm (4) und programmbegleitende Daten (5) zu empfangen,

15 Wiedergabemittel (90, 95), um das empfangene Mediaprogramm dem Benutzer wiederzugeben,

eine Identifizierungskarte (94), um den Benutzer des Empfangssystems (9) zu identifizieren,

Mobilfunkkomponenten, mit denen das Empfangssystem (9) in einem Mobilfunknetz (8) eingesetzt werden kann,

20 Meldungsvorbereitungsmittel, um Meldungen, die mindestens ein Datenfeld (521, 522, 524) aus den programmbegleitenden Daten (5) sowie eine Identifizierung des Benutzers umfassen, vorzubereiten und in das Mobilfunknetz (8) zu senden.

25 16. Empfangssystem gemäss Anspruch 15, dadurch gekennzeichnet, dass die benannten Empfangsmittel einen Radioempfänger umfassen.

17. Empfangssystem gemäss Anspruch 15, dadurch gekennzeichnet, dass die benannten Empfangsmittel einen Fernsehempfänger umfassen.

5 18. Empfangssystem gemäss einem der Ansprüche 15 bis 17, dadurch gekennzeichnet, dass die Mobilfunkkomponenten ein GSM-Mobilgerät umfassen.

10 19. Empfangssystem gemäss einem der Ansprüche 15 bis 18, dadurch gekennzeichnet, dass die Identifizierungskarte eine SIM-Karte (94) ist, die in den programmbegleitenden Daten (5) übertragene Applets (50) ausführen kann.

20. Empfangssystem gemäss einem der Ansprüche 15 bis 19, dadurch gekennzeichnet, dass die Meldungsvorbereitungsmittel SMS-Meldungen vorbereiten und senden können.

15 21. Empfangssystem gemäss einem der Ansprüche 15 bis 20, dadurch gekennzeichnet, dass die Meldungsvorbereitungsmittel USSD-Meldungen vorbereiten und senden können.

20 22. Empfangssystem gemäss einem der Ansprüche 15 bis 21, dadurch gekennzeichnet, dass es eine Taste (92) umfasst, um die Anzeige von Informationen, die den empfangenen digitalen Daten entsprechen, auf einer Anzeige (90) des Empfangssystems zu veranlassen.

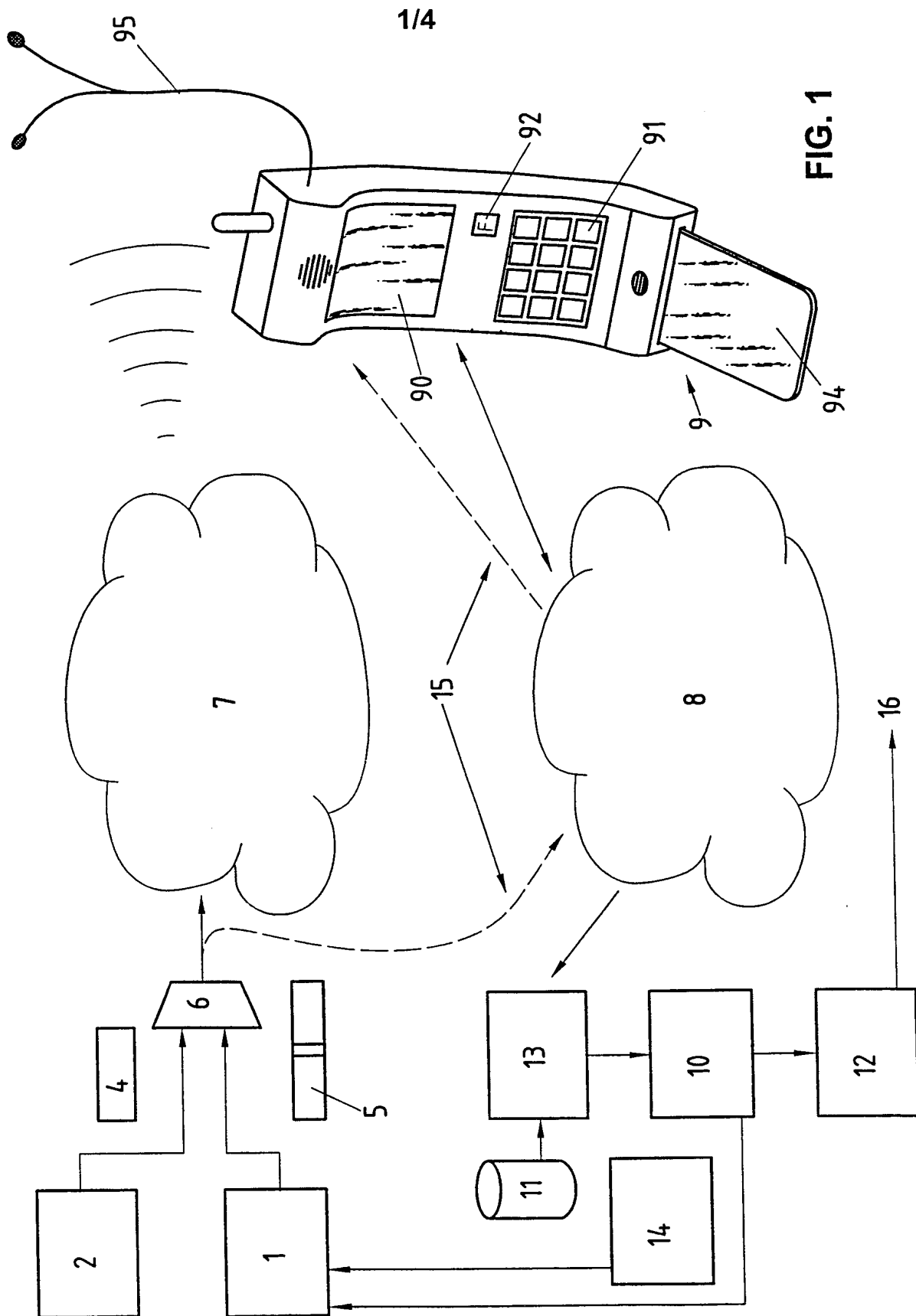
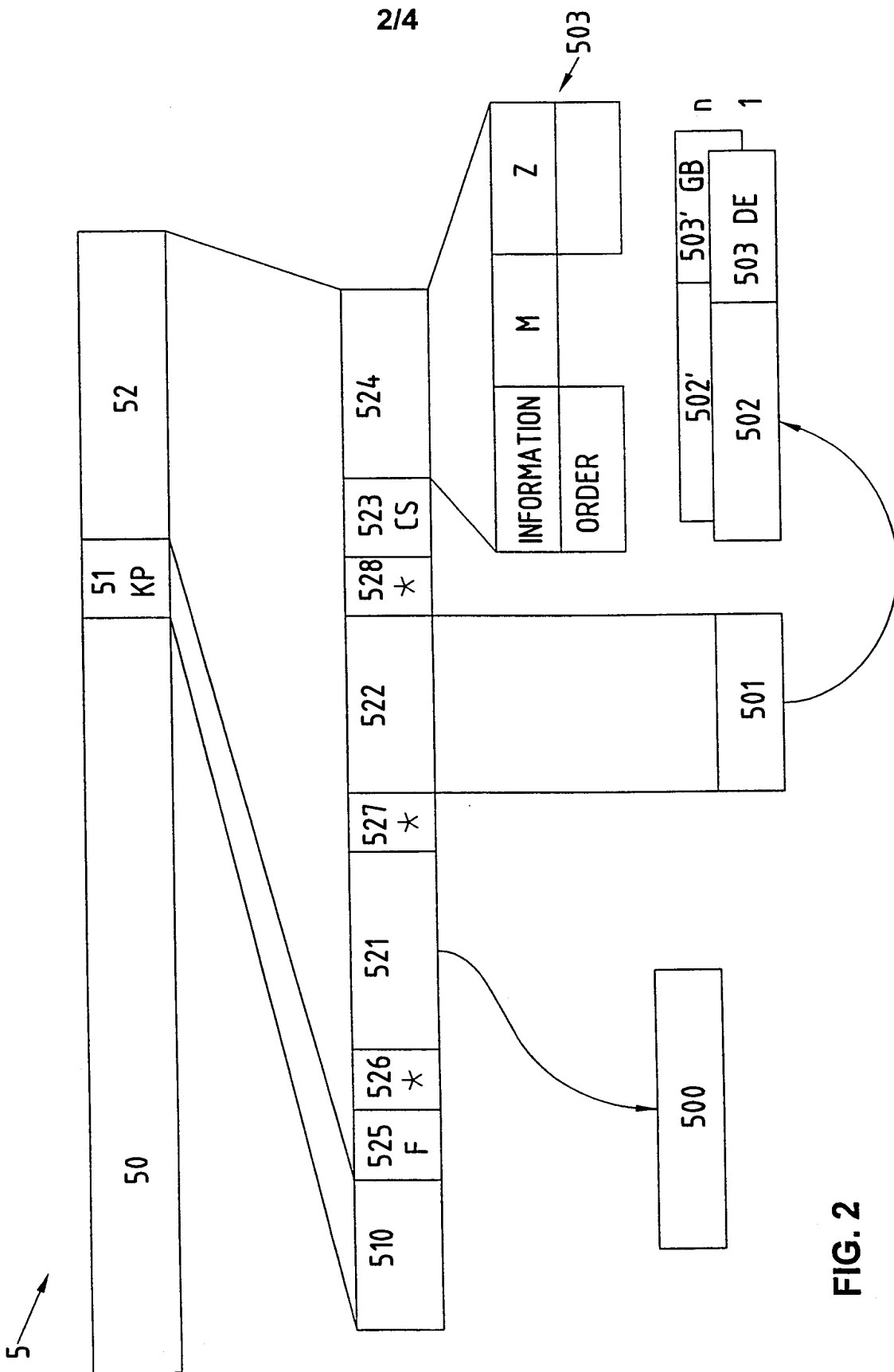


FIG. 1



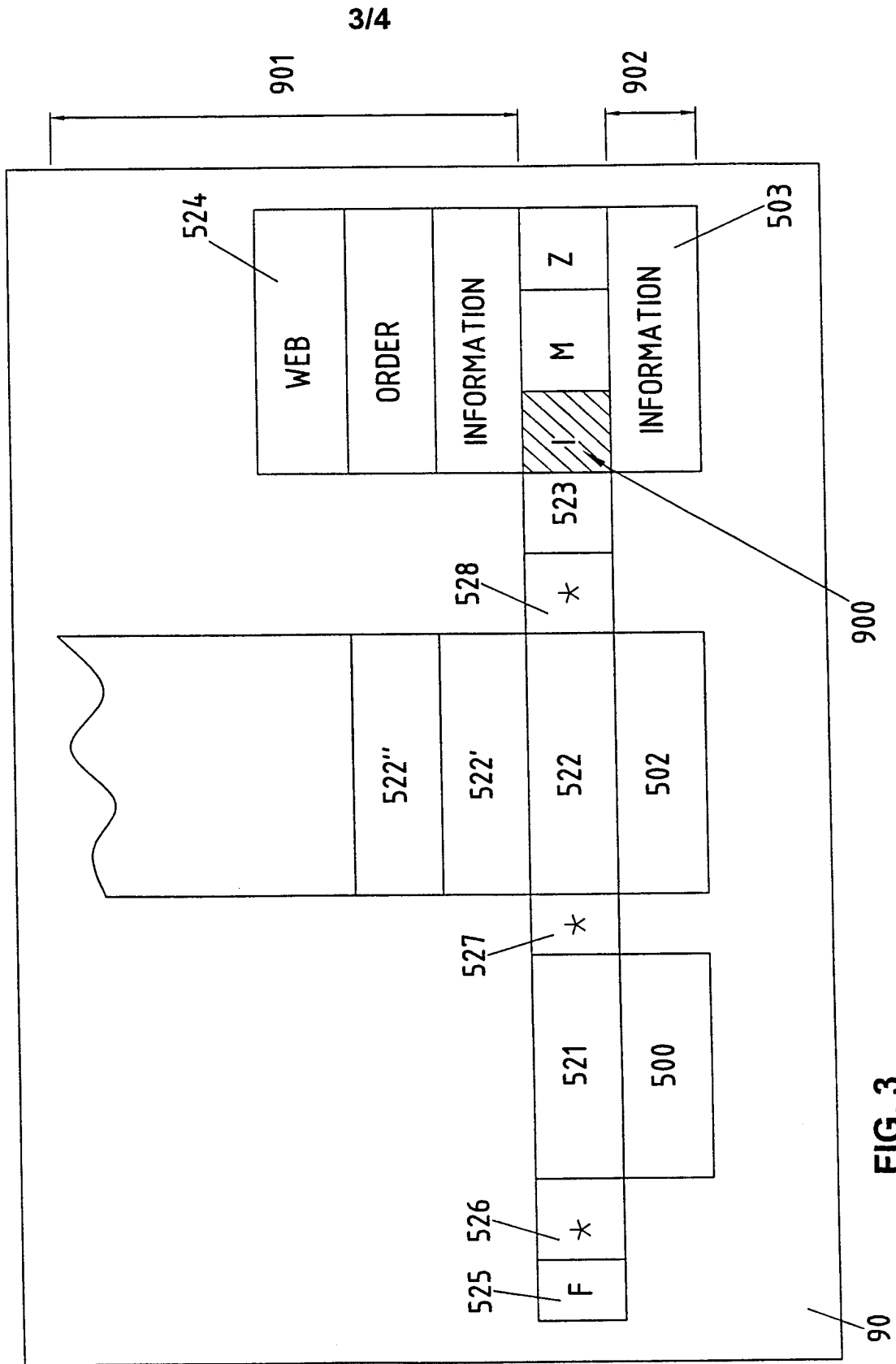


FIG. 3

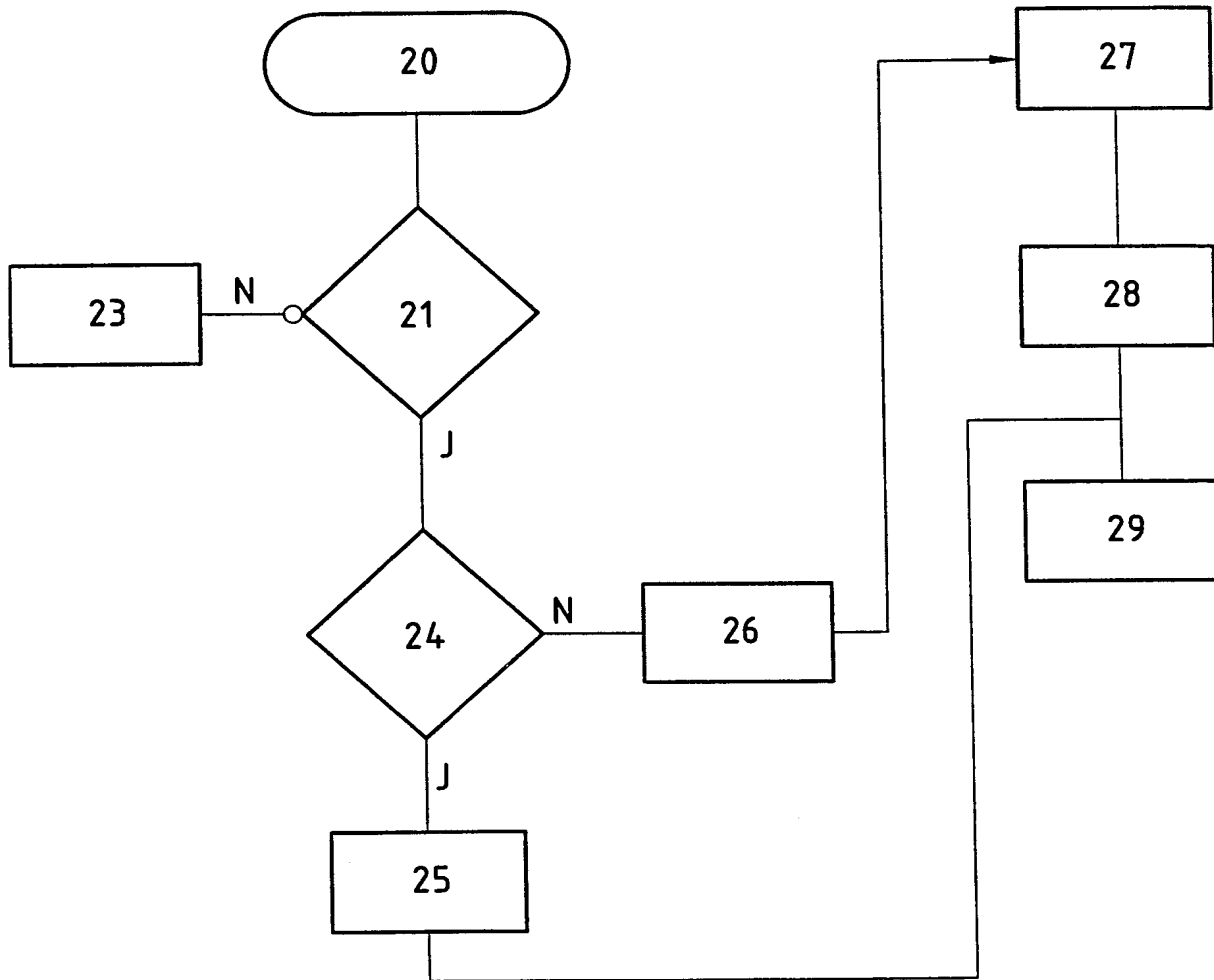


FIG. 4



# INTERNATIONAL SEARCH REPORT

International Application No

PCT/CH 99/00006

**A. CLASSIFICATION OF SUBJECT MATTER**  
IPC 6 H04H9/00

According to International Patent Classification (IPC) or to both national classification and IPC

**B. FIELDS SEARCHED**

Minimum documentation searched (classification system followed by classification symbols)

IPC 6 H04H

Documentation searched other than minimum documentation to the extent that such documents are included in the fields searched

Electronic data base consulted during the international search (name of data base and, where practical, search terms used)

**C. DOCUMENTS CONSIDERED TO BE RELEVANT**

Category	Citation of document, with indication, where appropriate, of the relevant passages	Relevant to claim No.
A	EP 0 426 542 A (EUROP RECH ELECTR LAB) 8 May 1991 see column 1, line 1 - column 4, line 19; claims 1,13; figure 1 ---	1, 15
A	W0 97 40616 A (GEMPLUS CARD INT) 30 October 1997 see page 1, line 1 - page 15, line 12; claim 1; figure 1 ---	1, 15
A	W0 95 15654 A (ZING SYSTEMS L P) 8 June 1995 see page 1, line 1 - page 10, line 26; claims 1,17,21,25,28,33,37,39; figure 1 --- -/--	1, 15

Further documents are listed in the continuation of box C.

Patent family members are listed in annex.

\* Special categories of cited documents :

- "A" document defining the general state of the art which is not considered to be of particular relevance
- "E" earlier document but published on or after the international filing date
- "L" document which may throw doubts on priority claim(s) or which is cited to establish the publication date of another citation or other special reason (as specified)
- "O" document referring to an oral disclosure, use, exhibition or other means
- "P" document published prior to the international filing date but later than the priority date claimed

- "T" later document published after the international filing date or priority date and not in conflict with the application but cited to understand the principle or theory underlying the invention
- "X" document of particular relevance; the claimed invention cannot be considered novel or cannot be considered to involve an inventive step when the document is taken alone
- "Y" document of particular relevance; the claimed invention cannot be considered to involve an inventive step when the document is combined with one or more other such documents, such combination being obvious to a person skilled in the art.
- "&" document member of the same patent family

Date of the actual completion of the international search

9 April 1999

Date of mailing of the international search report

28/04/1999

Name and mailing address of the ISA

European Patent Office, P.B. 5818 Patentlaan 2  
NL - 2280 HV Rijswijk  
Tel. (+31-70) 340-2040, Tx. 31 651 epo nl,  
Fax: (+31-70) 340-3016

Authorized officer

De Haan, A. J.

# INTERNATIONAL SEARCH REPORT

International Application No

PCT/CH 99/00006

## C.(Continuation) DOCUMENTS CONSIDERED TO BE RELEVANT

Category	Citation of document, with indication, where appropriate, of the relevant passages	Relevant to claim No.
A	US 5 444 769 A (KOEN JACOBUS P L ET AL) 22 August 1995 see column 1, line 1 - column 2, line 10; claims 1,4; figure 1 -----	1,15

# INTERNATIONAL SEARCH REPORT

Information on patent family members

International Application No

PCT/CH 99/00006

Patent document cited in search report	Publication date	Patent family member(s)	Publication date
EP 0426542 A	08-05-1991	FR 2654286 A	10-05-1991
		DE 69029835 D	13-03-1997
		DE 69029835 T	28-05-1997
		MX 171750 B	11-11-1993
		NZ 235927 A	25-03-1994
		US 5173589 A	22-12-1992
WO 9740616 A	30-10-1997	AU 2401397 A	12-11-1997
		CA 2252526 A	30-10-1997
		EP 0894397 A	03-02-1999
WO 9515654 A	08-06-1995	US 5734413 A	31-03-1998
		AU 1292895 A	19-06-1995
		EP 0740884 A	06-11-1996
		US 5638113 A	10-06-1997
US 5444769 A	22-08-1995	GB 2295746 A	05-06-1996
		ZA 9209925 A	21-09-1996

# INTERNATIONALER RECHERCHENBERICHT

ationales Aktenzeichen

PCT/CH 99/00006

**A. KLASSIFIZIERUNG DES ANMELDUNGSGEGENSTANDES**  
 IPK 6 H04H9/00

Nach der Internationalen Patentklassifikation (IPK) oder nach der nationalen Klassifikation und der IPK

**B. RECHERCHIERT GEBIETE**

Recherchierter Mindestprüfstoff (Klassifikationssystem und Klassifikationssymbole)  
 IPK 6 H04H

Recherchierte aber nicht zum Mindestprüfstoff gehörende Veröffentlichungen, soweit diese unter die recherchierten Gebiete fallen

Während der internationalen Recherche konsultierte elektronische Datenbank (Name der Datenbank und evtl. verwendete Suchbegriffe)

**C. ALS WESENTLICH ANGESEHENE UNTERLAGEN**

Kategorie*	Bezeichnung der Veröffentlichung, soweit erforderlich unter Angabe der in Betracht kommenden Teile	Betr. Anspruch Nr.
A	EP 0 426 542 A (EUROP RECH ELECTR LAB) 8. Mai 1991 siehe Spalte 1, Zeile 1 - Spalte 4, Zeile 19; Ansprüche 1,13; Abbildung 1 ----	1, 15
A	WO 97 40616 A (GEMPLUS CARD INT) 30. Oktober 1997 siehe Seite 1, Zeile 1 - Seite 15, Zeile 12; Anspruch 1; Abbildung 1 ----	1, 15
A	WO 95 15654 A (ZING SYSTEMS L P) 8. Juni 1995 siehe Seite 1, Zeile 1 - Seite 10, Zeile 26; Ansprüche 1,17,21,25,28,33,37,39; Abbildung 1 ----- -/--	1, 15

Weitere Veröffentlichungen sind der Fortsetzung von Feld C zu entnehmen

Siehe Anhang Patentfamilie

\* Besondere Kategorien von angegebenen Veröffentlichungen :

"A" Veröffentlichung, die den allgemeinen Stand der Technik definiert, aber nicht als besonders bedeutsam anzusehen ist

"E" älteres Dokument, das jedoch erst am oder nach dem internationalen Anmeldedatum veröffentlicht worden ist

"L" Veröffentlichung, die geeignet ist, einen Prioritätsanspruch zweifelhaft erscheinen zu lassen, oder durch die das Veröffentlichungsdatum einer anderen im Recherchenbericht genannten Veröffentlichung belegt werden soll oder die aus einem anderen besonderen Grund angegeben ist (wie ausgeführt)

"O" Veröffentlichung, die sich auf eine mündliche Offenbarung, eine Benutzung, eine Ausstellung oder andere Maßnahmen bezieht

"P" Veröffentlichung, die vor dem internationalen Anmeldedatum, aber nach dem beanspruchten Prioritätsdatum veröffentlicht worden ist

"T" Spätere Veröffentlichung, die nach dem internationalen Anmeldedatum oder dem Prioritätsdatum veröffentlicht worden ist und mit der Anmeldung nicht kollidiert, sondern nur zum Verständnis des der Erfindung zugrundeliegenden Prinzips oder der ihr zugrundeliegenden Theorie angegeben ist

"X" Veröffentlichung von besonderer Bedeutung; die beanspruchte Erfindung kann allein aufgrund dieser Veröffentlichung nicht als neu oder auf erfinderscher Tätigkeit beruhend betrachtet werden

"Y" Veröffentlichung von besonderer Bedeutung; die beanspruchte Erfindung kann nicht als auf erfinderscher Tätigkeit beruhend betrachtet werden, wenn die Veröffentlichung mit einer oder mehreren anderen Veröffentlichungen dieser Kategorie in Verbindung gebracht wird und diese Verbindung für einen Fachmann naheliegend ist

"&" Veröffentlichung, die Mitglied derselben Patentfamilie ist

Datum des Abschlusses der internationalen Recherche

9. April 1999

Absendedatum des internationalen Recherchenberichts

28/04/1999

Name und Postanschrift der Internationalen Recherchenbehörde  
 Europäisches Patentamt, P.B. 5818 Patentlaan 2  
 NL - 2280 HV Rijswijk  
 Tel. (+31-70) 340-2040, Tx. 31 651 epo nl,  
 Fax: (+31-70) 340-3016

Bevollmächtigter Bediensteter

De Haan, A.J.

**INTERNATIONALER RECHERCHENBERICHT**

Internationales Aktenzeichen

PCT/CH 99/00006

**C.(Fortsetzung) ALS WESENTLICH ANGESEHENE UNTERLAGEN**

Kategorie <sup>o</sup>	Bezeichnung der Veröffentlichung, soweit erforderlich unter Angabe der in Betracht kommenden Teile	Betr. Anspruch Nr.
A	US 5 444 769 A (KOEN JACOBUS P L ET AL) 22. August 1995 siehe Spalte 1, Zeile 1 - Spalte 2, Zeile 10; Ansprüche 1,4; Abbildung 1 -----	1,15

# INTERNATIONALER RECHERCHENBERICHT

Angaben zu Veröffentlichungen, die zur selben Patentfamilie gehören

Internationales Aktenzeichen

PCT/CH 99/00006

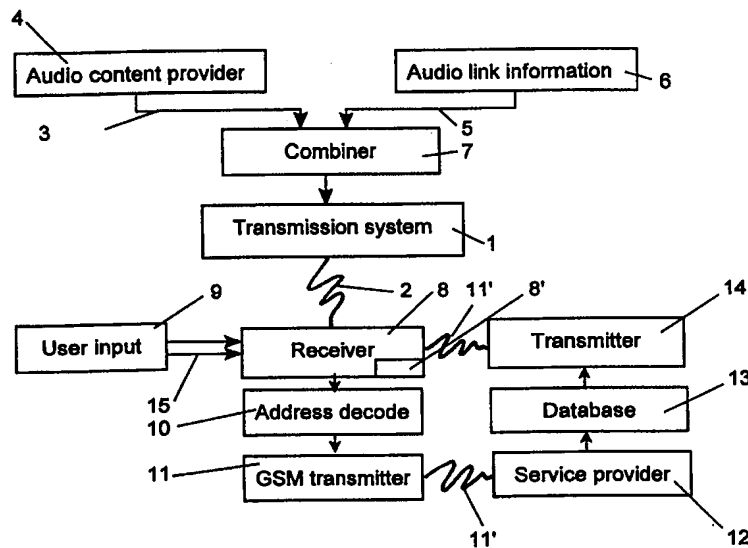
Im Recherchenbericht angeführtes Patentdokument	Datum der Veröffentlichung	Mitglied(er) der Patentfamilie	Datum der Veröffentlichung
EP 0426542 A	08-05-1991	FR 2654286 A	10-05-1991
		DE 69029835 D	13-03-1997
		DE 69029835 T	28-05-1997
		MX 171750 B	11-11-1993
		NZ 235927 A	25-03-1994
		US 5173589 A	22-12-1992
WO 9740616 A	30-10-1997	AU 2401397 A	12-11-1997
		CA 2252526 A	30-10-1997
		EP 0894397 A	03-02-1999
WO 9515654 A	08-06-1995	US 5734413 A	31-03-1998
		AU 1292895 A	19-06-1995
		EP 0740884 A	06-11-1996
		US 5638113 A	10-06-1997
US 5444769 A	22-08-1995	GB 2295746 A	05-06-1996
		ZA 9209925 A	21-09-1996



INTERNATIONAL APPLICATION PUBLISHED UNDER THE PATENT COOPERATION TREATY (PCT)

<p>(51) International Patent Classification <sup>6</sup> : <b>H04H 1/00</b></p>	<p><b>A1</b></p>	<p>(11) International Publication Number: <b>WO 99/43109</b> (43) International Publication Date: 26 August 1999 (26.08.99)</p>
<p>(21) International Application Number: PCT/GB99/00514 (22) International Filing Date: 18 February 1999 (18.02.99) (30) Priority Data: 9803623.9 20 February 1998 (20.02.98) GB (71) Applicant (for all designated States except US): TTP COMMUNICATIONS LIMITED [GB/GB]; Melbourn Science Park, Cambridge Road, Melbourn, Royston, Hertfordshire SG8 6EE (GB). (72) Inventor; and (75) Inventor/Applicant (for US only): JOHNSON, Nicholas, Dougall [GB/GB]; 24 Camp Road, St. Albans, Hertfordshire AL1 5DY (GB). (74) Agent: GILL JENNINGS &amp; EVERY; Broadgate House, 7 Eldon Street, London EC2M 7LH (GB).</p>		<p>(81) Designated States: AL, AM, AT, AU, AZ, BA, BB, BG, BR, BY, CA, CH, CN, CU, CZ, DE, DK, EE, ES, FI, GB, GD, GE, GH, GM, HR, HU, ID, IL, IN, IS, JP, KE, KG, KP, KR, KZ, LC, LK, LR, LS, LT, LU, LV, MD, MG, MK, MN, MW, MX, NO, NZ, PL, PT, RO, RU, SD, SE, SG, SI, SK, SL, TJ, TM, TR, TT, UA, UG, US, UZ, VN, YU, ZW, ARIPO patent (GH, GM, KE, LS, MW, SD, SZ, UG, ZW), Eurasian patent (AM, AZ, BY, KG, KZ, MD, RU, TJ, TM), European patent (AT, BE, CH, CY, DE, DK, ES, FI, FR, GB, GR, IE, IT, LU, MC, NL, PT, SE), OAPI patent (BF, BJ, CF, CG, CI, CM, GA, GN, GW, ML, MR, NE, SN, TD, TG).</p> <p><b>Published</b> With international search report.</p>

(54) Title: METHOD AND SYSTEM FOR TRANSMITTING AUDIO DATA TOGETHER WITH OTHER DATA, COMPRISING ADDRESSING DATA, TO A RECEIVER



(57) Abstract

The present invention concerns a method for transmitting audio information to a receiver, in which first audio information is transmitted from a first source to the receiver together with other information comprising addressing data and a data signal dependent on the addressing data is selectively transmitted from the receiver to a service provider. The data signal received at the service provider is matched with respective further audio information and the respective further audio information is then transmitted from a second source to the receiver. Thus, a web of recursively linked audio material may selectively be provided to a user of the receiver.

**FOR THE PURPOSES OF INFORMATION ONLY**

Codes used to identify States party to the PCT on the front pages of pamphlets publishing international applications under the PCT.

<b>AL</b>	Albania	<b>ES</b>	Spain	<b>LS</b>	Lesotho	<b>SI</b>	Slovenia
<b>AM</b>	Armenia	<b>FI</b>	Finland	<b>LT</b>	Lithuania	<b>SK</b>	Slovakia
<b>AT</b>	Austria	<b>FR</b>	France	<b>LU</b>	Luxembourg	<b>SN</b>	Senegal
<b>AU</b>	Australia	<b>GA</b>	Gabon	<b>LV</b>	Latvia	<b>SZ</b>	Swaziland
<b>AZ</b>	Azerbaijan	<b>GB</b>	United Kingdom	<b>MC</b>	Monaco	<b>TD</b>	Chad
<b>BA</b>	Bosnia and Herzegovina	<b>GE</b>	Georgia	<b>MD</b>	Republic of Moldova	<b>TG</b>	Togo
<b>BB</b>	Barbados	<b>GH</b>	Ghana	<b>MG</b>	Madagascar	<b>TJ</b>	Tajikistan
<b>BE</b>	Belgium	<b>GN</b>	Guinea	<b>MK</b>	The former Yugoslav Republic of Macedonia	<b>TM</b>	Turkmenistan
<b>BF</b>	Burkina Faso	<b>GR</b>	Greece	<b>ML</b>	Mali	<b>TR</b>	Turkey
<b>BG</b>	Bulgaria	<b>HU</b>	Hungary	<b>MN</b>	Mongolia	<b>TT</b>	Trinidad and Tobago
<b>BJ</b>	Benin	<b>IE</b>	Ireland	<b>MR</b>	Mauritania	<b>UA</b>	Ukraine
<b>BR</b>	Brazil	<b>IL</b>	Israel	<b>MW</b>	Malawi	<b>UG</b>	Uganda
<b>BY</b>	Belarus	<b>IS</b>	Iceland	<b>MX</b>	Mexico	<b>US</b>	United States of America
<b>CA</b>	Canada	<b>IT</b>	Italy	<b>NE</b>	Niger	<b>UZ</b>	Uzbekistan
<b>CF</b>	Central African Republic	<b>JP</b>	Japan	<b>NL</b>	Netherlands	<b>VN</b>	Viet Nam
<b>CG</b>	Congo	<b>KE</b>	Kenya	<b>NO</b>	Norway	<b>YU</b>	Yugoslavia
<b>CH</b>	Switzerland	<b>KG</b>	Kyrgyzstan	<b>NZ</b>	New Zealand	<b>ZW</b>	Zimbabwe
<b>CI</b>	Côte d'Ivoire	<b>KP</b>	Democratic People's Republic of Korea	<b>PL</b>	Poland		
<b>CM</b>	Cameroon	<b>KR</b>	Republic of Korea	<b>PT</b>	Portugal		
<b>CN</b>	China	<b>KZ</b>	Kazakstan	<b>RO</b>	Romania		
<b>CU</b>	Cuba	<b>LC</b>	Saint Lucia	<b>RU</b>	Russian Federation		
<b>CZ</b>	Czech Republic	<b>LI</b>	Liechtenstein	<b>SD</b>	Sudan		
<b>DE</b>	Germany	<b>LK</b>	Sri Lanka	<b>SE</b>	Sweden		
<b>DK</b>	Denmark	<b>LR</b>	Liberia	<b>SG</b>	Singapore		
<b>EE</b>	Estonia						



METHOD AND SYSTEM FOR TRANSMITTING AUDIO DATA TOGETHER WITH OTHER DATA,  
COMPRISING ADDRESSING DATA, TO A RECEIVER

The present invention relates to the transmission of audio information and to both a method and system for such transmission.

5 It is known to broadcast data along with audio signals in order to provide interruption of the broadcast audio signal by causing the receiver to retune automatically to a different frequency to receive alternative information such as news or traffic information. The Radio Data System (RDS) has been used for such purpose in Europe for several years. However, although the user is able  
10 to select for interruption between certain general types or categories of information, once this selection has been made by the user, the timing of interruption and the information provided are automatically determined by the service providing the information and to which the radio retunes. Whilst such a service is very valuable, it is limited in nature.

15 In order to provide a wider range of information to a radio user, a different system is necessary.

According to the present invention there is provided a method for transmitting audio information to a receiver, comprising:

20 transmitting from a first source to the receiver first audio information together with other information comprising addressing data;

selectively transmitting from the receiver to a service provider a data signal dependent on the addressing data;

matching the data signal received at the service provider with respective further audio information; and

25 transmitting the respective further audio information from a second source to the receiver.

The invention also includes a system for transmitting audio information to a receiver, comprising:

30 a first source for transmitting to the receiver first audio information together with other information comprising addressing data;

means at the receiver for converting the first audio information to an audio signal;

means at the receiver selectively operable for transmitting to a service provider a data signal dependent on the addressing data;

5 comparing means for matching the data signal received at the service provider with respective further audio information;

a second source for transmitting the respective further audio information from the service provider to the receiver; and,

10 means at the receiver for converting the further audio information to an audio signal.

By this method and system a web of recursively linked audio material may selectively be provided to a user of the receiver through the use of appropriate keys at the receiver. The system may be operated by the user to provide further audio information related to the first audio information by  
15 extracting the addressing data and transmitting a corresponding data signal, via say a digital mobile telephone network, to a service provider system at which the received addressing data is matched, using a database, with further audio information related to the first audio information, and that further audio information is then transmitted to the receiver. A further key may be used to  
20 return the listener to the original audio information transmission or to the previous one.

The system of the invention may use a conventional RDS system to provide the transmission of the further audio information, by causing a transmitter (source) related to the first transmitter (source) to interrupt the  
25 reception of the first audio information with the further audio information, but preferably, the system makes use of digital audio broadcasting (DAB) signals to provide the first audio information signal and related addressing data and the further audio information and further addressing data are transmitted by a DAB transmitter related to the transmitter providing the first audio information and  
30 addressing data, or else by the mobile telephone link used to transmit the addressing data-related signal to the service provider.

However, the invention is not limited to particular mechanisms or types of transmission of either the audio information and related addressing data nor of the addressing data-related data signal and these could be provided by wireless, wire or cable links. For example the original transmission could be an audio information signal (together with related addressing data) transmitted by an Internet web site.

In order to indicate to a user that there is further audio information related to the first (or subsequent) audio information provided to the user, the audio signal is augmented. This may be achieved in a number of ways and the augmentation may, depending on the method chosen, occur either at the source (ie. to the transmitted audio information) or else at the receiver (ie. to the received audio information before conversion). For example a beep may be inserted at the beginning and end of sections of audio information transmission to indicate to a listener that what follows is capable of being linked to to provide further information. Alternatively, audio processing may be used to give the converted audio signal a particular auditory shade or style. A further possibility is to provide a visual indication on a visual display panel associated with the receiver.

When the user has selected or linked to further audio information, the converted audio signal needs to be separated from the original audio signal to indicate that the listener is now linked to additional material. This may be done in a number of ways. For example, the transmission of audio information may be paused momentarily to indicate the change of content. Alternatively, the audio signals may be superimposed, with the further audio information being more prominent than the original. A still further possibility is to separate the original and further audio signals to left and right stereo channels, with suitable mixing down of the original signal from stereo to mono if necessary. The various type of separation may be selected by the user and they may be combined if desired, the required circuitry for the different types being provided within the receiver.

Three examples of a system according to the present invention will now be described with reference to the accompanying drawings, in which:

Figure 1 is a block diagram of the components of a generalised system;

Figure 2 is a table showing links between related audio information which  
5 might be provided by the system;

Figure 3 illustrates the components of a second system; and

Figure 4 illustrates the components of a third system.

The example illustrated in connection with the accompanying Figures 1 and 2 utilises a DAB receiver which incorporates a GSM mobile telephone.

10 A DAB transmission system 1 provides an audio information broadcast 2, the broadcast 2 comprising both audio information 3 provided from an audio content provider 4 and addressing data 5 provided by an audio link information system 6. The audio information and the addressing data are combined at 7 and fed to the DAB transmission system 1. As is well known, a DAB  
15 transmission incorporates a PAD channel and it is the PAD channel which carries the audio link information or addressing data 5.

At a receiver 8 a listener or user is able to activate a key 9 (known as the "Tell Me More" [TMM] key) which causes the addressing information received on the PAD channel to be decoded by a decoder 10 and passed to the GSM  
20 telephone 11 which, using the decoded addressing data dials, an appropriate number to a service provider 12. The service provider maintains a database of audio "clips" 13, each one corresponding to corresponding addressing data 5. On receiving the transmission from the GSM transmitter 11 the database is scanned for a match and the corresponding audio clip is transferred from the  
25 database to a transmitter 14 which transmits information to the receiver 8. The transmitter 14 may be a separate DAB transmitter or the like, but in the present example it is preferably a GSM transmitter and the information is transmitted back to the receiver through the same call initiated by the user.

The use of the system will now be described in more detail by reference  
30 to the table of figure 2.

The example shown in the table of figure 2 comprises a DAB programme 20 which carries a news item, in the example, describing an (imaginary) incident in the Gaza Strip, a portion of the text of which is shown at 21. The DAB PAD channel 30 contains addressing or link information which enables the user to  
5 find out more information about the Gaza Strip and on receipt of the PAD channel information at a receiver display 8' (see figure 1) displays the text shown at 31, inviting the listener or user to dial (a given telephone number?) on the GSM telephone 11 to find out more information. In order to avoid the listener having to actually dial the telephone number himself, the addressing  
10 data transmitted by the DAB PAD channel is decoded within the decoder 10 and the "Tell Me More button" 9 is effectively "enabled" at 9' so that if the user wishes to obtain further information all he has to do is then press (9") the TMM button.

Operation of the TMM button causes the GSM telephone 11 to establish  
15 a GSM link 11' which (11") sets up a call to the service provider 12 as described above. Addressing data within the DAB PAD channel, decoded and transmitted through the GSM link 11', is read at the service provider 12 and matched within the database 13. The corresponding further audio information or "clip" is transmitted by the transmitter 14 using the same GSM call to provide further  
20 audio information back to the listener, for example the text shown at 22. The signal transmitted back to the user and containing the audio information 22 may itself contain further links, for example, as illustrated, for further material about the state of Israel and the 6-Day war of 1967 and these are also decoded in the decoder 10 and may be used by the system and through operation of the TMM  
25 button 9, to find out further audio information from the service provider 12 or from a separate service provider if the information is held in a different database for example.

The righthand side of the table of figure 2 illustrates the audio output to the user in the textbox 40. It can be seen that at the start of the link information  
30 there is a "header" to advise the user that more information is being provided about the chosen subject (in this case the Gaza Strip) and at the end a "footer"

is provided indicating that the audio output is returning to the DAB programme material.

The first news item 21 may contain a second or further link, for example, allowing the user to operate the TMM button 9 to find out more information about the "Hammas" organisation. Again the display 8' displays relevant text 5 32 to the user. The listener may choose not to find out more information about the Gaza Strip, but may decide to find out more about Hammas instead.

A second news item 23 may contain its own separate links allowing the user to link to further material held on the service provider database 13 or on 10 the database of a separate service provider.

As described in the introduction to the specification, the presence of addressing data (which defines the presence of a link) may be highlighted in the audio stream to the user by a beep or similar and/or by text signalling in the DAB PAD channel and displayed on the display 8' of the receiver 8.

15 The linked-to material (LTM) is separated from the basic audio programme content 21 or linked-from material (LFM) so that the listener understands where the LTM starts and finishes. This may be achieved by simple replacement after a pause, a similar pause being provided at the end of the LTM, or by superposition, the LFM being mixed down and the LTM added 20 to the audio stream so that the listener hears the LFM and LTM together, with the LTM being more prominent. The listener can still "tune-in" to the LFM if desired and also unconsciously uses it as a indicator of the linked material. A third alternative is stereo separation in which case the LFM (which may already be in stereo) is mixed down to mono if necessary and placed in one direction 25 to say the left stereo channel and the LTM (which owing to GSM bandwidth limits will almost certainly be in mono) is placed in a different direction to say the right stereo channel.

All the processing necessary to implement the different styles of presentation of the LTM can be contained within the receiver 8 and may be 30 selectable by the listener as a personal preference or on an instance-by-instance basis.

The apparatus of the example of figure 1 also includes a "back" button 15 on the receiver 8, operation of which by the user can be arranged to cause the listener to be returned to the LFM.

5 The system illustrated in Figure 3 utilises a multimedia computer 80 as a receiver and an Internet connection 81 as a transport medium for passing transmitted data to and from the multimedia computer from and to audio information sources 82,83 via a server 84.

10 The system makes use of a mark-up language which is capable of catering for audio links - HAML. The current generation of mark-up languages (including HTML, HDML, TTML, etc.) although multimedia in scope are not symmetrical in the way they treat their media. They all treat text and graphical information differently to audio, in that a user can link from textual and graphical contexts into further web pages, but audio may only be listened to, ie is strictly one-way. The idea of an audio link is not catered for in these prior mark-up  
15 languages.

A mark-up language for audio has special constraints within which it must work. In particular, audio is

- non-persistent - a spoken prompt will usually be replaced quickly with following material;
- 20 • time-critical - responses to prompts must be registered and acted upon quickly;
- one-dimensional - audio material is heard in time, not seen on a page.

25 Furthermore, in terms of navigation, the normal mouse driven paradigm is no longer necessarily valid. Typical terminal equipment may only have two keys for navigation - corresponding to "Follow" and "Back", and a very limited visual display. Also, the underlying transport will not necessarily be TCP/IP. The DAB MOT protocol, GSM, SMS, GPRS or circuit-switched data, and DTMF signalling over a fixed or mobile telephone link are all possible media, either  
30 separately or in combination. Also, the link may not be full-duplex, especially in broadcast contexts.

In practical terms this means that features must be present in the language

- to latch link data and announce the link in a way that a listener may respond to at a later time if necessary.
- 5 • to announce to a server the form in which it should expect navigation commands.

The paucity of data link capacity also means that the traditional client-server model will be slightly modified. In fixed audio only link, it may be the case that the client runs within the network, and simply uses the link to the terminal for access to MMI events.

In the context of the system illustrated in Figure 3, the overall arrangement is substantially similar to a conventional Word Wide Web (WWW) situation, except that the client (receiver) and server use HAML rather than HTML to communicate. The actual transport mechanism may be conventional HTTP since the link between them is a conventional internet connection of medium to high bandwidth, but could be any file or stream transport protocol (eg. FTP, RealAudio etc.)

An HAML script is transferred from the server 84 to the client 80 and are executed in the client, just as HTML scripts are executed. Navigation is performed on the client machine which sends GET requests to the server (in HTTP anyway) for new content.

A simple HAML page might look like:

Example 1

```

25 <HAML VERSION=0.1 TIME=START_RELATIVE UNITS=MS
LINKSTYLE=INTERRUPT>
<PLAY SOURCE=LadyOfShallOt.wav>
<LINK_DESTINATION=http://www.ttpcom.com/tmm/camelot.haml
ICON=castle.bmp
START=57803
30 DURATION=5000>
<LINK DEFAULT_DESTINATION=d:\authors\tennyson.haml
ICON=d:\authors\tennyson.bmp>
</PLAY>
</HAML>
35

```



The function of this example is to play the file "Ladyofshallot.wav" to the default output device (which is set by the interpreter of the file, not by the file itself). For most of the duration of the clip, the FORWARD button is labelled with the file d:\authors\tennyson.bmp. if the listener selects FORWARD, then interpretation jumps to the locally stored file d:\authors\tennyson.haml. For the 5s after 57.803s from the beginning of the clip, the bitmap castle .bmp is used to label the FORWARD button. If the listener presses FORWARD during that time, then the internet is used to access the file /tmm/camelot.haml on the machine www.ttpcom.com, and that file is interpreted. When interpretation of either of the linked-to files ceases, then the original clip (LadyOfShallot.wav) plays again from the point at which it the link was taken.

The keywords in order, effect a behaviour as follows:

15	<HAML	introduces the file and tells the interpreter it is HAML.
	VERSION	version information for the interpreter.
	TIME=START RELATIVE	all times in the file are to be measured relative to the start of the clip.
	UNITS=MS	the units of time are milliseconds.
20	LINKSTYLE=INTERRUPT	if a link is taken, it interrupts the current audio.
	<PLAY	introduces the main audio stream.
	SOURCE=...	use this file as the source for the main audio stream.
	<LINK	introduces link information.
25	DESTINATION=...	points to an HAML file - interpretation passes to this file if FORWARD is pressed.
	ICON=...	display the named graphics file behind the FORWARD button.
30	START=...	the start time when the link becomes active (units and meaning defined by the TIME and UNITS parameters to the <HAML statement.

	DURATION=...	the length of time for which the link is active (again units and meaning defined by the <HAML statement parameters).
5	<LINK DEFAULT	introduces information for the default link. This link is used when no other link is active. Note this statement has no START or DURATION parameters.
10	<IPLAY>	tells the interpreter that the information for this particular audio stream is complete. When it reaches this it can begin playing the clip defined in the <PLAY statement.
	</HAML>	end of page

15 This example is suitable for a multimedia, internet-linked computer, where all the audio sources, links, icons, etc., are known beforehand.

20 Figure 4 illustrates a system using a convergent broadcast/telephony system employing an integrated DAB and GSM system. Again the system employs an HAML server 94 which receives audio information from sources 92,93. The receiver in this case comprises an integrated DAB/GSM terminal 90 which receives an initial stream of audio information from a broadcast DAB network 91 which, in turn communicates with the server 94 via an HAML/MOT gateway 95. The DAB/GSM terminal 90 communicates with a GSM cellular network 96 which also communicates with the server 94 via an HAML proxy client 97.

25 In operation, the HAML server 94 sends HAML scripts along with audio information down the DAB network link to the terminal 90. In this case, the transport protocol will preferably be the ETSI specified MOT protocol (ETS 301-234). The HAML scripts are executed in the HAML client sitting in the terminal 90. The HAML specification defines that new content is addressed by a similar addressing scheme to HTML, ie a protocol specifier followed by a unique address such as:

30

http://www.ttpcom.com:8080/index.html.

In HAML the addressing scheme is very similar, for example:

hatp://www.ttpcom.com:+441763266266/index.haml

The hatp: part tells the client in the terminal 90 to invoke the Hyper Audio  
 5 Transport Protocol handler (HATP) which then uses the number after the colon  
 as a telephone number, by means of which access to the file index.haml on the  
 machine www.ttpcom.com can be achieved. Note that the actual protocol is  
 HATP as distinct from the language which is HAML.

Because the telephonic link is primarily audio (together with low  
 10 bandwidth signalling like DTMF, GSM-SMS or similar), the file is not sent across  
 the link, but rather is executed in the proxy client 97. This plays the audio  
 information to the terminal across the telephonic link and indicates by means of  
 a low bandwidth signal when the 'Tell Me More' button has become active and  
 also, desirably, what text to use as a prompt on the terminals screen. The  
 15 terminal client 90 sends a signal to the proxy client 97 indicating key presses  
 ('Tell Me More' or 'Back') made by the listener as they happen. The proxy client  
 97 can then act on the requests, by accessing the new content or returning to  
 the old content appropriately.

Preferably, congestion management strategies are provided in the design  
 20 of the HATP/HAML server 94 so that, if a large number of users are calling the  
 same address, then rather than opening a full GSM voice channel to each, the  
 listeners are returned a DAB sub-channel designator and encryption key by  
 means of which their DAB receivers can be automatically retuned for receipt of  
 the requested content over the DAB channel in a broadcast manner. The  
 25 requests can be logged for billing purposes and encryption ensures that only  
 listeners who have paid for the content can decode it.

A further example illustrates the use of HATP/HAML:

Example 2

30 <HAML VERSION=0.1 TIME=ABSOLUTE LINKSTYLE=CONCURRENT  
 MIX=VOLUME>  
 <PLAY SOURCE=DAB>

```

<LINK PROXY
  DESTINATION=dialto:+441763262626:Camelot
  ICON=MOT CamelotIcon
  START=CamelotIcon.TriggerTime
5  END=CamelotIcon.ExpireTime>
<LINK DEFAULT DESTINATION=smsto:+441763261582:Tennyson
  ICON=MOT:TennysonIcon>
</PLAY>
</HAML>

```

10

The function of the new statements is as follows:

- TIME=ABSOLUTE                    all times in the file are absolute UTC.
- LINKSTYLE=CONCURRENT if a link is taken, it overlays the current audio in  
a style defined by the MIX parameter.
- 15 MIX=VOLUME                    requests that the linked-to material is mixed in  
with the linked-from audio stream, at a slightly  
higher volume to achieve separation.
- SOURCE=DAB                    the source of the main audio is the DAB station  
the listener is tuned to.
- 20 <LINK PROXY                    introduces a special kind of link. This says that  
the DESTINATION field points via a voice link to  
a proxy client, and that all navigation commands  
should therefore be sent as DTMF tones over  
that voice link.
- 25 DESTINATION=... In this case, the parameter value is a phone number,  
followed by a string. When the link is established, DTMF is  
used to signal the link reference (Camelot) to the server.
- ICON=...                    the ICON is an MOT object, with the START and  
END times referenced from this.
- 30 START=...                    the start time when the link becomes active.  
Note that this syntax uses the TriggerTime field  
of the MOT object.

DESTINATION=sms to:...

This is part of a standard link, but the sms to: prefix tells the interpreter to send a GSM short message with the designed text ("Tennyson") to the designated number.

5

**CLAIMS**

1. A method for transmitting audio information to a receiver, comprising:  
transmitting from a first source to the receiver first audio information  
5 together with other information comprising addressing data;  
selectively transmitting from the receiver to a service provider a data  
signal dependent on the addressing data;  
matching the data signal received at the service provider with respective  
further audio information; and  
10 transmitting the respective further audio information from a second source  
to the receiver.
  
2. A method according to claim 1, wherein  
further addressing information is transmitted from the second source to  
15 the receiver with the further audio information;  
selectively transmitting to the or another service provider a further data  
signal dependent on the further addressing data;  
matching the data signal received at the or another service provider with  
respective still further audio information; and,  
20 transmitting the respective still further audio information from the second  
or a further source to the receiver.
  
3. A method according to claim 1 or claim 2, wherein the first audio  
information together with other information comprising addressing data is  
25 transmitted from the first source to the receiver by a wire-less broadcast signal.
  
4. A method according to claim 3, wherein the broadcast signal is a digital  
audio broadcasting (DAB) signal.
  
- 30 5. A method according to claim 3, wherein the broadcast signal is a radio  
data service (RDS) signal.

6. A method according to claim 1 or claim 2, wherein the first audio information together with other information comprising addressing data is transmitted from the first source to the receiver by a cable or wire connection between the first source and the receiver.

5

7. A method according to claim 6, wherein the first audio information together with other information comprising addressing data is transmitted via an Internet connection.

10 8. A method according to any of claims 1 to 7, wherein the data signal dependent on the addressing data is transmitted from the receiver to the or another service provider by a mobile telephone connection.

15 9. A method according to claim 8, wherein the mobile telephone connection is a GSM or CDMA connection.

20 10. A method according to any of claims 1 to 7, wherein the data signal dependent on the addressing data is transmitted from the receiver to the or another service provider by a cable or wire connection between the receiver and the or another service provider.

25 11. A method according to any of claims 1 to 7, wherein the data signal dependent on the addressing data is transmitted from the receiver to the or another service provider by an Internet connection between the receiver and the or another service provider.

30 12. A method according to any of claims 1 to 11, wherein the data signal received at the or another service provider is matched with the respective second audio information utilising a database of audio information.

13. A method according to any of claims 1 to 12, wherein the respective further audio information is transmitted from the second or further source to the receiver by a mobile telephone connection.

5 14. A method according to claim 13, wherein the respective further audio information is transmitted from the second or further source to the receiver by a GSM or CDMA connection.

10 15. A method according to any of claims 1 to 11, wherein the respective further audio information is transmitted from the second or further source to the receiver by a cable or wire connection between the second or further source and the receiver.

15 16. A method according to any of claims 1 to 11, wherein the respective further audio information is transmitted from the second or further source to the receiver by an Internet connection between the second or further source and the receiver.

20 17. A system for transmitting audio information to a receiver, comprising:  
a first source for transmitting to the receiver first audio information together with other information comprising addressing data;  
means at the receiver for converting the first audio information to an audio signal;  
means at the receiver selectively operable for transmitting to a service  
25 provider a data signal dependent on the addressing data;  
comparing means for matching the data signal received at the service provider with respective further audio information;  
a second source for transmitting the respective further audio information from the service provider to the receiver; and,  
30 means at the receiver for converting the further audio information to an audio signal.



18. A system according to claim 17, wherein  
further addressing information is transmitted from the second source to  
the receiver with the further audio information;

5 the receiver having means selectively operable to transmit to the or  
another service provider a further data signal dependent on the further  
addressing data;

comparing means for matching the further data signal received at the or  
another service provider with respective still further audio information; and,

10 means at the second or a further source for transmitting the respective  
still further audio information to the receiver.

19. A system according to claim 17 or claim 18, wherein the first audio  
information together with other information comprising addressing data is  
transmitted from the first source to the receiver by a wire-less broadcast signal.

15

20. A system according to claim 19, wherein the broadcast signal is a digital  
audio broadcasting (DAB) signal.

21. A system according to claim 19, wherein the broadcast signal is a radio  
20 data service (RDS) signal.

22. A system according to claim 17 or claim 18, wherein the first audio  
information together with other information comprising addressing data is  
transmitted from the first source to the receiver by a cable or wire connection  
25 between the first source and the receiver.

23. A system according to claim 22, wherein the first audio information  
together with other information comprising addressing data is transmitted via an  
Internet connection.

30

24. A system according to any of claims 17 to 23, wherein the receiver includes a mobile telephone and the data signal dependent on the addressing data is transmitted from the receiver to the or another service provider by a mobile telephone connection.

5

25. A system according to claim 24, wherein the mobile telephone is a GSM or CDMA telephone.

10

26. A system according to any of claims 17 to 23, wherein the data signal dependent on the addressing data is transmitted from the receiver to the or another service provider by a cable or wire connection between the receiver and the or another service provider respectively.

15

27. A system according to claim 26, wherein the receiver includes a wire or cable-connected telephone.

20

28. A system according to any of claims 17 to 23, wherein the data signal dependent on the addressing data is transmitted from the receiver to the or another service provider by an Internet connection between the receiver and the or another service provider.

25

29. A system according to any of claims 17 to 28, further comprising a database of audio information connected to the second or further source, whereby the data signal received at the or another service provider is matched with the respective further audio information respectively.

30

30. A system according to claim 24 or claim 25, wherein the respective further audio information is transmitted from the second or further source to the receiver by a mobile telephone connection.

31. A system according to claim 26 or claim 27, wherein the respective further audio information is transmitted from the second or further source respectively to the receiver by the cable or wire connection between the second or further source respectively and the receiver.

5

32. A system according to claim 28, wherein the respective further audio information is transmitted from the second or further source to the receiver by an Internet connection between the second or further source and the receiver.

10 33. A system according to any of claims 17 to 32, wherein the receiver comprises a key operable to initiate the transmission of the respective data signal dependent on the addressing data to the or another service provider respectively.

15 34. A system according to claim 33, wherein the receiver comprises a further key operable to cancel the receipt of the respective further audio information from the second or further source respectively at the receiver and to cause the receiver to convert the audio information from the first or second source respectively to an audio signal.

1/4

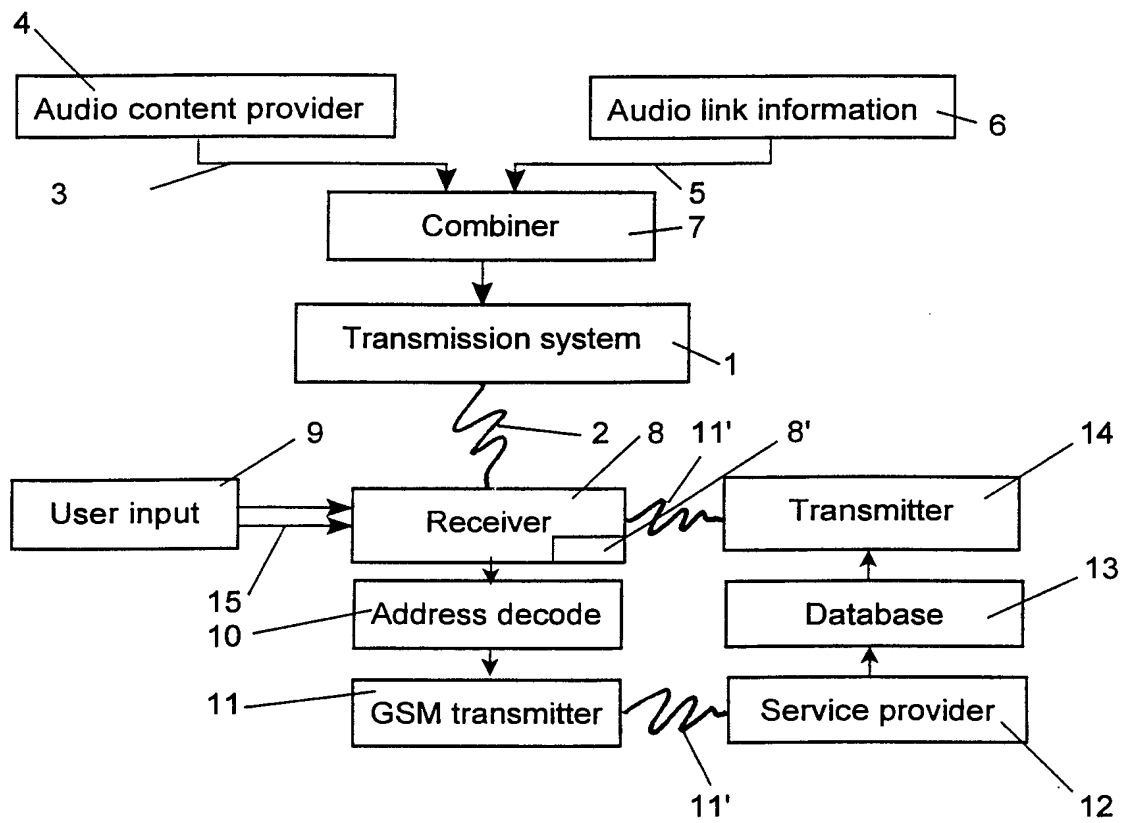
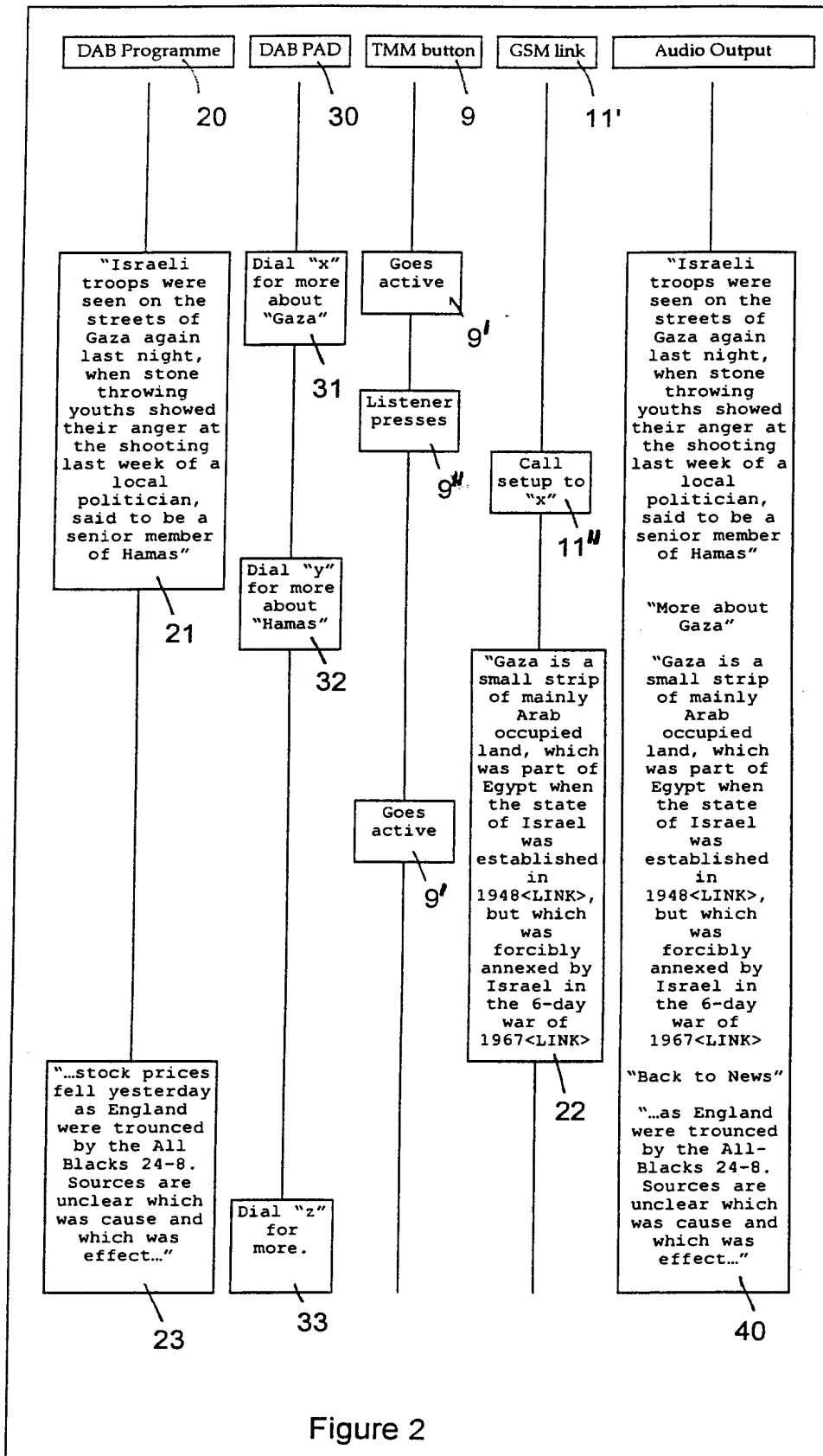


Figure 1



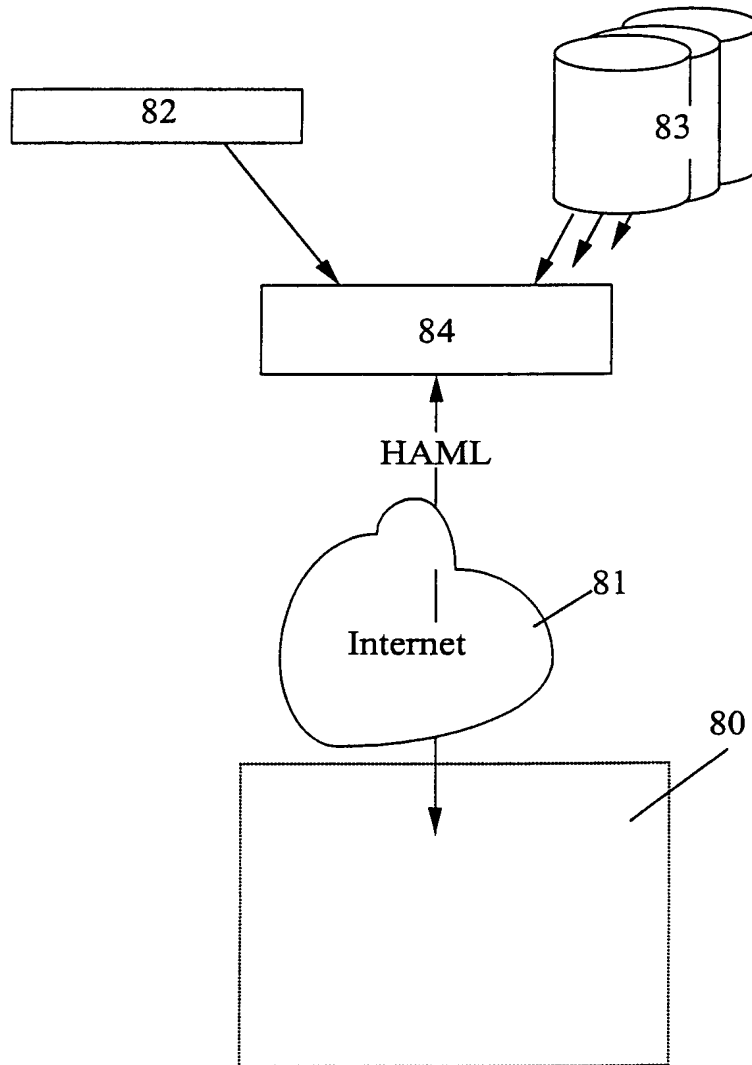


Figure 3

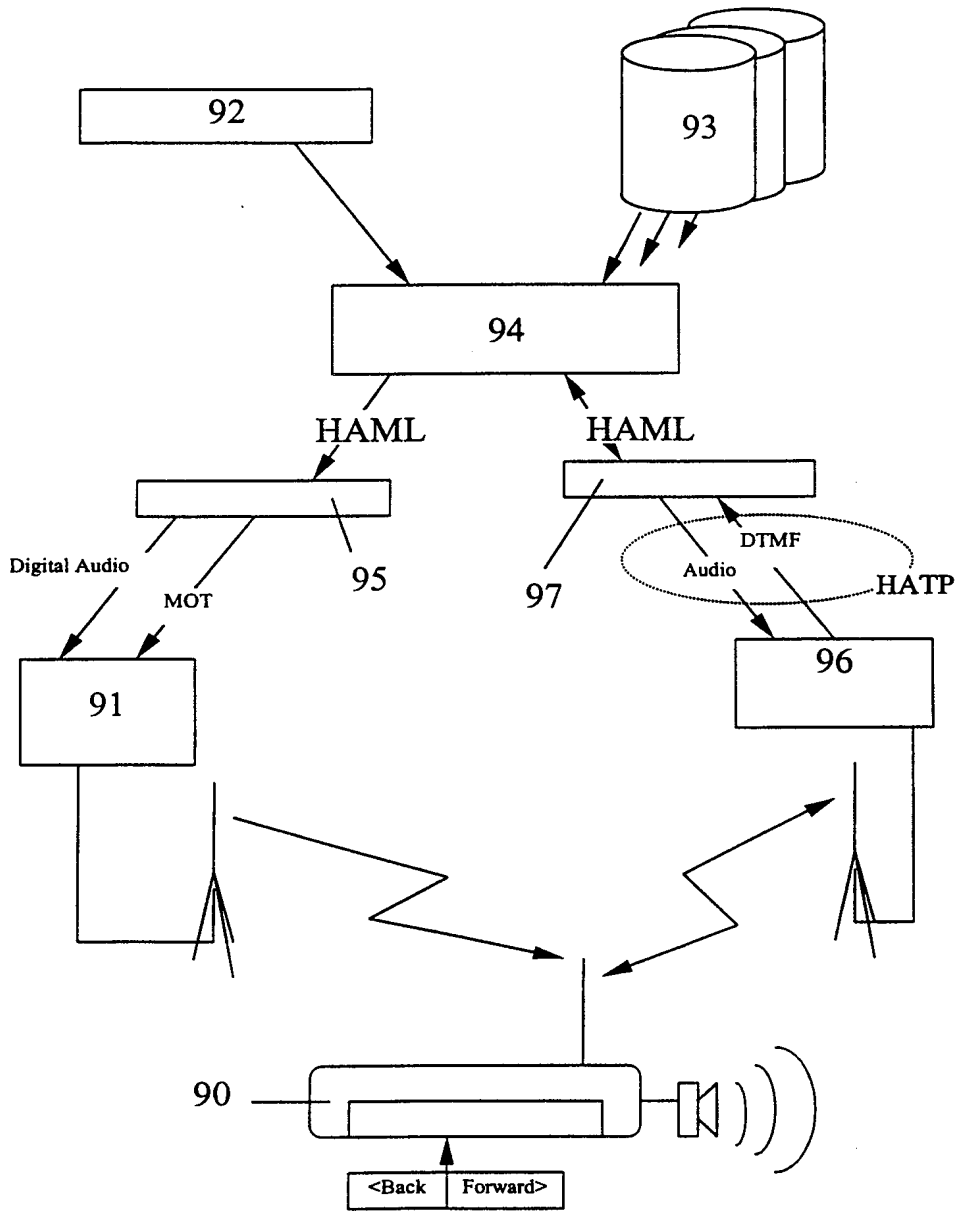


Figure 4

# INTERNATIONAL SEARCH REPORT

International Application No  
PCT/GB 99/00514

**A. CLASSIFICATION OF SUBJECT MATTER**  
IPC 6 H04H1/00

According to International Patent Classification (IPC) or to both national classification and IPC

**B. FIELDS SEARCHED**

Minimum documentation searched (classification system followed by classification symbols)  
IPC 6 H04H

Documentation searched other than minimum documentation to the extent that such documents are included in the fields searched

Electronic data base consulted during the international search (name of data base and, where practical, search terms used)

**C. DOCUMENTS CONSIDERED TO BE RELEVANT**

Category °	Citation of document, with indication, where appropriate, of the relevant passages	Relevant to claim No.
A	GB 2 313 981 A (ROKE MANOR RESEARCH) 10 December 1997  see page 1, line 1 - page 6, line 13; claims 1,10; figure 1 ---	1, 4, 9, 13, 17, 20, 25
A	EP 0 804 012 A (NOKIA MOBILE PHONES LTD) 29 October 1997  see column 1, line 1 - column 9, line 25; claim 1 ---	1, 4, 9, 13, 17, 20, 25
A	WO 95 12929 A (NSM AG ;FRANK ARMIN (DE)) 11 May 1995 see page 3, line 12 - page 6, line 2; claims 1,4,11,12; figure 1 --- -/--	1, 17

Further documents are listed in the continuation of box C.

Patent family members are listed in annex.

° Special categories of cited documents :

- "A" document defining the general state of the art which is not considered to be of particular relevance
- "E" earlier document but published on or after the international filing date
- "L" document which may throw doubts on priority claim(s) or which is cited to establish the publication date of another citation or other special reason (as specified)
- "O" document referring to an oral disclosure, use, exhibition or other means
- "P" document published prior to the international filing date but later than the priority date claimed

- "T" later document published after the international filing date or priority date and not in conflict with the application but cited to understand the principle or theory underlying the invention
- "X" document of particular relevance; the claimed invention cannot be considered novel or cannot be considered to involve an inventive step when the document is taken alone
- "Y" document of particular relevance; the claimed invention cannot be considered to involve an inventive step when the document is combined with one or more other such documents, such combination being obvious to a person skilled in the art.
- "&" document member of the same patent family

Date of the actual completion of the international search

Date of mailing of the international search report

29 April 1999

04/06/1999

Name and mailing address of the ISA  
 European Patent Office, P.B. 5818 Patentlaan 2  
 NL - 2280 HV Rijswijk  
 Tel. (+31-70) 340-2040, Tx. 31 651 epo nl,  
 Fax: (+31-70) 340-3016

Authorized officer

De Haan, A. J.



**INTERNATIONAL SEARCH REPORT**

International Application No  
PCT/GB 99/00514

C.(Continuation) DOCUMENTS CONSIDERED TO BE RELEVANT		
Category	Citation of document, with indication, where appropriate, of the relevant passages	Relevant to claim No.
A	EP 0 084 778 A (DISCOVISION ASS) 3 August 1983 see page 8, line 1 - page 9, line 25; claim 1; figure 1 ---	1,17
A	WO 93 09631 A (FINISAR CORP) 13 May 1993 see page 1, line 1 - page 5, line 7; claims 1,13; figures 1,2 ---	1,17
A	EP 0 817 139 A (SUN MICROSYSTEMS INC) 7 January 1998 see column 1, line 1 - column 2, line 47; claim 1; figures 1,5 -----	1,17

# INTERNATIONAL SEARCH REPORT

Information on patent family members

International Application No

PCT/GB 99/00514

Patent document cited in search report		Publication date	Patent family member(s)	Publication date
GB 2313981	A	10-12-1997	NONE	
EP 0804012	A	29-10-1997	FI 961750 A JP 10098706 A	24-10-1997 14-04-1998
WO 9512929	A	11-05-1995	DE 4337726 A EP 0727114 A US 5742893 A	11-05-1995 21-08-1996 21-04-1998
EP 0084778	A	03-08-1983	AT 59514 T HK 34692 A JP 2027904 C JP 7043882 B JP 58133087 A JP 2726394 B JP 7262702 A JP 2501521 B JP 7134866 A JP 2597083 B JP 8255463 A US 4757393 A	15-01-1991 22-05-1992 19-03-1996 15-05-1995 08-08-1983 11-03-1998 13-10-1995 29-05-1996 23-05-1995 02-04-1997 01-10-1996 12-07-1988
WO 9309631	A	13-05-1993	US 5404505 A AU 654885 B AU 2909092 A CA 2121592 A EP 0610367 A	04-04-1995 24-11-1994 07-06-1993 13-05-1993 17-08-1994
EP 0817139	A	07-01-1998	JP 10232690 A	02-09-1998



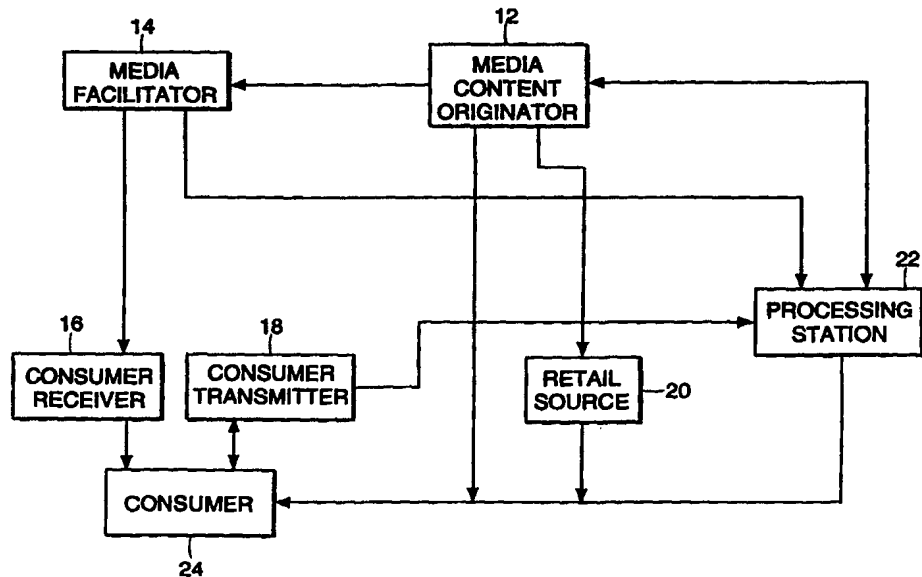
INTERNATIONAL APPLICATION PUBLISHED UNDER THE PATENT COOPERATION TREATY (PCT)

<p>(51) International Patent Classification <sup>6</sup> : <b>H04M 3/50, 11/08</b></p>	<p><b>A1</b></p>	<p>(11) International Publication Number: <b>WO 99/35809</b> (43) International Publication Date: 15 July 1999 (15.07.99)</p>
<p>(21) International Application Number: PCT/US98/00404 (22) International Filing Date: 12 January 1998 (12.01.98) (71) Applicant: CONNEXUS CORPORATION [US/US]; Suite 101, 1301 Lancaster Avenue, Berwyn, PA 19312 (US). (72) Inventor: CHEN, Humphrey, D.; 251 DeKalb Pike, King of Prussia, PA 19406 (US). (74) Agent: CAPRARO, Joseph, A.; Testa, Hurwitz &amp; Thibeault, LLP, High Street Tower, 125 High Street, Boston, MA 02110 (US).</p>		<p>(81) Designated States: JP, European patent (AT, BE, CH, DE, DK, ES, FI, FR, GB, GR, IE, IT, LU, MC, NL, PT, SE).  <b>Published</b> <i>With international search report.</i></p>

(54) Title: AUTOMATED CONSUMER RESPONSE TO PUBLICLY BROADCAST INFORMATION

(57) Abstract

An automated system for enabling consumers to respond to publicly broadcast information includes a content identification processor (34) and an order processor (36). The content identification processor (34) is configured to identify the content of publicly broadcast information in response to receipt of data specifying the publicly broadcast information. The order processor (36) receives from a consumer an order comprising data specifying information publicly broadcast over a non-interactive medium, communicates the data to the content identification processor, receives an identification of the content of the publicly broadcast information from the content identification processor, and causes action desired by the consumer to be initiated based on the content of the publicly broadcast information. A consumer transmitter device (18) is configured to transmit an order to an order processor (36) at the initiative of a consumer upon receipt by the consumer of publicly broadcast information of interest to the consumer. The consumer transmitter (18) device includes a tuning mechanism (28) and a transmitting and receiving mechanism (32). The tuning mechanism (28) selects a source of publicly broadcast information, on a waveband of sources of publicly broadcast information, that is being received by the consumer. The transmitting and receiving mechanism (32) transmits to the order processor (36) data specifying the source of the publicly broadcast information selected by the tuning mechanism and receives signals from the order processor in response to receipt by the order processor of the data.



**FOR THE PURPOSES OF INFORMATION ONLY**

Codes used to identify States party to the PCT on the front pages of pamphlets publishing international applications under the PCT.

<b>AL</b>	Albania	<b>ES</b>	Spain	<b>LS</b>	Lesotho	<b>SI</b>	Slovenia
<b>AM</b>	Armenia	<b>FI</b>	Finland	<b>LT</b>	Lithuania	<b>SK</b>	Slovakia
<b>AT</b>	Austria	<b>FR</b>	France	<b>LU</b>	Luxembourg	<b>SN</b>	Senegal
<b>AU</b>	Australia	<b>GA</b>	Gabon	<b>LV</b>	Latvia	<b>SZ</b>	Swaziland
<b>AZ</b>	Azerbaijan	<b>GB</b>	United Kingdom	<b>MC</b>	Monaco	<b>TD</b>	Chad
<b>BA</b>	Bosnia and Herzegovina	<b>GE</b>	Georgia	<b>MD</b>	Republic of Moldova	<b>TG</b>	Togo
<b>BB</b>	Barbados	<b>GH</b>	Ghana	<b>MG</b>	Madagascar	<b>TJ</b>	Tajikistan
<b>BE</b>	Belgium	<b>GN</b>	Guinea	<b>MK</b>	The former Yugoslav Republic of Macedonia	<b>TM</b>	Turkmenistan
<b>BF</b>	Burkina Faso	<b>GR</b>	Greece			<b>TR</b>	Turkey
<b>BG</b>	Bulgaria	<b>HU</b>	Hungary	<b>ML</b>	Mali	<b>TT</b>	Trinidad and Tobago
<b>BJ</b>	Benin	<b>IE</b>	Ireland	<b>MN</b>	Mongolia	<b>UA</b>	Ukraine
<b>BR</b>	Brazil	<b>IL</b>	Israel	<b>MR</b>	Mauritania	<b>UG</b>	Uganda
<b>BY</b>	Belarus	<b>IS</b>	Iceland	<b>MW</b>	Malawi	<b>US</b>	United States of America
<b>CA</b>	Canada	<b>IT</b>	Italy	<b>MX</b>	Mexico	<b>UZ</b>	Uzbekistan
<b>CF</b>	Central African Republic	<b>JP</b>	Japan	<b>NE</b>	Niger	<b>VN</b>	Viet Nam
<b>CG</b>	Congo	<b>KE</b>	Kenya	<b>NL</b>	Netherlands	<b>YU</b>	Yugoslavia
<b>CH</b>	Switzerland	<b>KG</b>	Kyrgyzstan	<b>NO</b>	Norway	<b>ZW</b>	Zimbabwe
<b>CI</b>	Côte d'Ivoire	<b>KP</b>	Democratic People's Republic of Korea	<b>NZ</b>	New Zealand		
<b>CM</b>	Cameroon			<b>PL</b>	Poland		
<b>CN</b>	China	<b>KR</b>	Republic of Korea	<b>PT</b>	Portugal		
<b>CU</b>	Cuba	<b>KZ</b>	Kazakstan	<b>RO</b>	Romania		
<b>CZ</b>	Czech Republic	<b>LC</b>	Saint Lucia	<b>RU</b>	Russian Federation		
<b>DE</b>	Germany	<b>LI</b>	Liechtenstein	<b>SD</b>	Sudan		
<b>DK</b>	Denmark	<b>LK</b>	Sri Lanka	<b>SE</b>	Sweden		
<b>EE</b>	Estonia	<b>LR</b>	Liberia	<b>SG</b>	Singapore		

AUTOMATED CONSUMER RESPONSE TO  
PUBLICLY BROADCAST INFORMATION

The present invention relates in general to a system and method that enables consumers to respond to publicly broadcast information without having to identify the content of the information, and more particularly concerns automated purchasing of recordings of songs played over the radio, automated purchasing of various products advertised on radio, television, billboards, automated responses to publicly broadcast polls, etc.

Information broadcast over public media often stimulates in a consumer of the broadcast information a desire to purchase a product or otherwise to respond in way to the broadcast information. For example, if a consumer hears a song played over the radio, the consumer might desire to purchase a compact disc containing the song, even if the consumer does not know the artist or title of the song. Similarly, a consumer might listen to or watch an advertisement on radio or television and be stimulated to purchase the advertised product. If the consumer remembers the product, the consumer might purchase the product while shopping. Likewise, a broadcast of a poll over the radio or television airwaves can stimulate a listener to call a number provided by the radio or television station in order to respond to the poll.

It is an important object of the invention to provide an improved system and method that enables consumers to respond to publicly broadcast information.

According to the invention, there is an automated system for enabling consumers to respond to publicly broadcast information, including a content identification processor and an order processor. The content identification processor is configured to identify the content of publicly broadcast information in response to receipt of data specifying the publicly broadcast information. The order processor receives from a consumer an order comprising data specifying information publicly broadcast over a non-interactive medium, communicates the data to the content identification processor, receives an identification of the content of the publicly broadcast information from the content identification processor, and causes action desired by the consumer to be initiated based on the content of the publicly broadcast information.

The communication to a content identification processor of data specifying publicly broadcast information and the receipt from the content identification processor of the content of

the publicly broadcast information makes it possible for a consumer to order the purchase of a product simply by identifying the broadcast from which the consumer learned of the product. For example, a consumer might order the purchase of a compact disc containing a song being played on FM radio station 107.9 by dialing \*CD<sup>TM</sup>1079 on a telephone while the song is being  
5 played, even if the consumer does not know the name of the song or the artist. Similarly, a consumer might dial \*TV<sup>TM</sup>NBC to order the purchase of a product corresponding to the content being delivered on national television network NBC. A consumer can respond to a broadcast poll by similarly identifying only the broadcast source and then responding to the question. All this is made possible using existing media distribution channels such as ordinary television,  
10 radio, and billboards, rather than specialized, interactive media distribution channels.

According to another aspect of the invention, there is a consumer transmitter device configured to transmit an order to an order processor at the initiative of a consumer upon receipt by the consumer of publicly broadcast information of interest to the consumer. The consumer transmitter device includes a tuning mechanism and a transmitting and receiving mechanism.  
15 The tuning mechanism selects a source of publicly broadcast information, on a waveband of sources of publicly broadcast information, that is being received by the consumer. The transmitting and receiving mechanism transmits to the order processor data specifying the source of the publicly broadcast information selected by the tuning mechanism and receives signals from the order processor in response to receipt by the order processor of the data. The  
20 transmitting and receiving mechanism is operatively connected to the tuning mechanism to enable the transmitting and receiving mechanism to specify to the order processor the source selected by the tuning mechanism.

By providing a tuning mechanism for selecting a source of publicly broadcast information that is being received by the consumer and a transmitting mechanism for  
25 transmitting an identification of the source of the publicly broadcast information to an order processor, the invention makes it possible for a consumer simply to set the tuning mechanism to a station to which the consumer is listening and to initiate placement of an order with the order processor whenever an item of interest to the consumer is broadcast over the station, without requiring the consumer to specify the same station each time an order is placed. The tuning  
30 mechanism may be synchronized with a separate consumer receiver unit that receives the publicly broadcast information, such as a radio, in which case the consumer need set the tuner of the receiver unit only.

Numerous other features, objects, and advantages of the invention will become apparent from the following detailed description when read in connection with the accompanying drawings in which:

FIG. 1 is a block diagram of an entire broadcast media system in which information is publicly broadcast to a consumer of the information over a non-interactive medium and the consumer can respond to the information without having to identify its content;

FIG. 2 is a block diagram of a processing station configured to receive orders from consumers to purchase products or other consumer responses to publicly broadcast information, and to initiate action desired by the consumer based content of the information, where the data received from the consumer does not identify the content of the information; and

FIG. 3 is a block diagram of a consumer transmitter for transmitting orders to a processing station in response to publicly broadcast information.

With reference now to the drawings and more particularly FIG. 1 thereof, broadcast media system 10 includes media content originator 12 (for example, a music manufacturer or distributor), media facilitator 14 (for example, a radio station), consumer receiver 16 (for example, a radio), a consumer transmitter 18 (for example, a cellular telephone), retail source 20 (for example, an establishment that can send a compact disc to the consumer), and a processing station 22 (described in detail below) that receives an order from a consumer 24 by means of consumer transmitter 18, pertaining to broadcast information, identifies the contents of the broadcast information, and causes an action desired by the consumer to be initiated based on the contents of the broadcast information.

Media content originator 12 is an entity who stands to gain from feedback received from consumers of broadcast information. The media content originator could be an agent representing a music artist such as a music manufacturer or a music distributor, an advertiser or a representative who stands to gain from direct interaction with the consumer, a disc jockey or master of ceremonies of a talk radio or television talk show who stands to gain from broadcasts received by the listening audience, or a news correspondent who is eager to poll consumers for their opinions on a presidential election or for traffic conditions. In summary, the media content originator can be any person or entity that creates content that is delivered across media vehicles and stands to gain from receiving feedback.

Media facilitator 14 is a media vehicle that delivers media content to consumers. Current examples include television stations, radio stations, and billboards. The media facilitator takes

the media content created by media content originator 12 and translates it into a form that is receivable by consumers.

Consumer receiver 16 is a device that receives signals transmitted by media facilitator 14. Current examples include television sets (including cable and satellite television), radios, and stereo tuners.

Consumer transmitter 18 is a device that can quickly and efficiently identify the broadcast information of interest to the consumer. The consumer transmitter can be, for example, an ordinary telephone, a cellular telephone (analog or digital), a two-way pager, a computer on a public packet switched communications network such as the Internet, or a personal communication service operating on a broad-band digital spectrum. Using a cellular telephone, the consumer can dial \*CD<sup>TM</sup>1079 (for FM radio station 107.9) to indicate the consumer's interest in purchasing a compact disc that corresponds to the music being played on the radio station. Alternatively, the consumer can dial \*TV<sup>TM</sup>NBC (national television network NBC) to indicate the consumer's interest in the content of information being broadcast on NBC at a given moment in time. Likewise, using an ordinary telephone, the consumer can dial a toll free 800 number to connect to the order processing station, and then the consumer can identify a radio station or television network. A similar scheme can be used to indicate a consumer's interest in the contents of a billboard advertisement by communicating only an ID associated with the billboard. More sophisticated examples of consumer transmitters are described below in connection with FIG. 3.

Retail source 20 is any establishment that can participate in the fulfillment of an end product or service to the consumer.

Processing station 22 is a central or distributed facility that monitors the exact scheduling of all media-related events down to the second (where appropriate) in all major geographical regions both domestically and internationally. This includes such forms of sensual stimuli as video content (shows, advertisements, news, etc.), audio content (music, advertisement, news, etc.), and physical visual billboard advertisements. In addition to the above-mentioned monitoring capability, processing station 22 can process the receipt of orders originated by a consumer by means of an automated or manual phone processing center that can provide the consumer with audio or visual confirmation regarding the actual content being ordered and then process the order by receiving customer identification in one form or another (caller ID, unique



customer-generated account numbers, social security numbers, etc.). Details of processing station 22 are described below in connection with FIG. 2.

In operation of broadcast media system 10, media content originator 12 provides media content to media facilitator 14 to be broadcast. Media facilitator 14 provides media scheduling information to processing station 22, which stores identification of the contents of the information to be broadcast. Alternatively, media facilitator 14 simply transmits radio or television broadcasts to processing station 22, in which case processing station 22 utilizes pattern recognition technology to identify the contents of the broadcast information. Media facilitator 14 also, of course, transmits broadcasts to consumer receiver 16.

Consumer 24 views, listens, feels, or experiences the media content received by consumer receiver 16, and if consumer 24 wishes to respond to the broadcast information, the consumer interacts with consumer transmitter 18 to cause an order to be transmitted to processing station 22 that includes data specifying the broadcast information (for example, specifying a particular radio or television station or the ID of a billboard), without specifying the content of the broadcast information.

Processing station 22 identifies the content of the broadcast information and responds to the consumer's order by initiating action desired by the consumer (such as the purchase of a product). This process can include feedback, an acknowledgment, or a request for additional information (such as an account number) from the processing station to consumer transmitter 18. Processing station 22 fulfills the order either by sending a product or information directly to consumer 24, or by communicating with media content originator 12, which in turn sends a product or information to consumer 24 either directly, or through retail source 20 where consumer 24 can obtain goods, services, or benefits.

Thus, processing station 22 in effect enables direct and indirect wireless or wired interaction between media content originator 12 and consumer 24. Fulfillment of an order can include a charge to a consumer account, which may be an account maintained by processing station 22 or an external account. In certain embodiments in which consumer transmitter 18 is a telephone, a charge may be applied to the consumer's phone bill.

With reference to FIG. 2, processing station 22 includes content identification processor 34, order processor 36, and fulfillment processor 38.

Content identification processor 34 tracks and identifies the content of numerous items of broadcast information on a continuous basis, and stores the content that corresponds to each item

of broadcast information. The content identification processor can receive media scheduling information from a media facilitator, or it can receive direct radio or television broadcast signals, in which case the content identification processor utilizes audio or visual pattern recognition technology to identify the content of the broadcast information. For example, the content  
5 identification processor can receive a schedule of programming or advertisements, or it can receive direct broadcasts of songs currently being played on various radio stations and, utilizing pattern recognition, identify the songs. The content identification processor stores the identification of the audio or visual contents of the broadcast information, and can respond to a request from order processor 36 that includes data specifying the broadcast information by  
10 transmitting to the order processor the identification of the contents of the broadcast information.

Order processor 36 performs either automated or manual processing of incoming orders from a consumer transmitter. The order processor can include an automated attendant voice-mail type processing system utilizing either touch tones or voice recognition as input mechanisms. In  
15 embodiments in which the consumer transmitter is a computer, the order processor can include a page on the World Wide Web having dialog boxes in which the consumer can enter the data specifying the broadcast information (such as the call letters of a radio station, the city in which the station is located, and the date and time when a certain song was played) as well as dialog boxes in which the consumer can enter account information. The order processor can also store  
20 unique customer account identification information. When the order processor receives an order from a consumer transmitter, the order processor communicates with content identification processor 34 to obtain the contents of the broadcast information specified in the order, with the consumer transmitter to provide feedback or request additional information, and with the media content originator to provide useful consumer information or as part of the process of fulfilling the consumer's order.

25 Fulfillment processor 38 is an order fulfillment mechanism that provides actual product delivery in one form or another to the consumer. In certain embodiments, this function is outsourced to an agent or entity external to processing station 22. In other embodiments, content identification processor 34 is external to processing station 22.

30 With reference to FIG. 3, sophisticated versions of consumer transmitter 18 include a transmitting and receiving mechanism 32, which can be, for example, multi-way broad-band (cellular) or multi-way narrow-band PCS (paging), digital or analog, and alpha-numeric or voice-based, combined with any number of additional features. For example, a mode selection

mechanism 26 on the transmitter can select between various modes such as television, radio, advertisements, etc., and a tuning mechanism 28 can select a specific station within a waveband. Mode selection mechanism 26 and tuning mechanism 28 may be set manually by the consumer, or may be synchronized with consumer receiver 16 so that the consumer need only select the mode and station on the receiver without having to manually select the mode and station on the transmitter as well. Once the mode and station have been selected, the consumer can place an order simply by depressing an order button 30 or any similar mechanism to automatically transmit data to an order processing station identifying the mode and the station.

In certain embodiments, consumer transmitter 18 transmits the current date and time to the order processor with each order so that the order processor need not process the order in real time, and the consumer transmitter can also request and receive from the order processor an update of the order processor's current date and time in order to automatically update the current date and time stored by the consumer transmitter. Certain embodiments of the consumer transmitter can also store and recall data corresponding to broadcast information (the data including a mode such as television, radio, advertisements, etc. combined with an identification of a station within a waveband), thereby making it easy for a consumer to recall quickly a source of broadcast information that is of frequent interest to the consumer. Also, in certain embodiments the consumer transmitter can receive RBDS/RDS signals (Radio Broadcast Data Systems / Radio Data Systems protocol) and ancillary television band signals, which can be used to cause the consumer transmitter to identify for the consumer's convenience the music being played on the radio or to identify other broadcast information (even though the consumer does not need to know this information in order to place an order in response to the broadcast). Various other features can be incorporated into the consumer transmitter, such as security capability and voice activation.

Consumer transmitter 18 and consumer receiver 16 may be combined into one integrated unit.

There has been described novel and improved apparatus and techniques for automated purchasing of products. It is evident that those skilled in the art may now make numerous uses and modifications of and departures from the specific embodiment described herein without departing from the inventive concept.

What is claimed is:

1. An automated system for enabling consumers to respond to publicly broadcast information, comprising:

5 a content identification processor configured to identify the content of publicly broadcast information in response to receipt of data specifying said publicly broadcast information; and  
an order processor configured to receive from a consumer an order comprising data specifying information publicly broadcast over a non-interactive medium, to communicate said data to said content identification processor, to receive an identification of the content of said publicly broadcast information from said content identification processor, and to cause action  
10 desired by said consumer to be initiated based on said content of said publicly broadcast information.

2. A system in accordance with claim 1, further comprising a fulfillment processor configured to receive from said order processor said identification of the content of said publicly broadcast information, and to initiate said action desired by said consumer based thereon.

15 3. A system in accordance with claim 1, wherein said content identification processor is configured to receive said publicly broadcast information and to perform a pattern recognition search to identify the content of said publicly broadcast information.

4. A system in accordance with claim 1, wherein said content identification processor is configured to receive a schedule correlating broadcast information with its content  
20 and to use said schedule to identify the content of said publicly broadcast information in response to receipt by said order processor of said order comprising said data specifying said publicly broadcast information.

5. A system in accordance with claim 1, wherein said order processor comprises a voice mail system.

25 6. A system in accordance with claim 5, wherein said voice mail system receives said data through touch tone signals.

7. A system in accordance with claim 1, further comprising a consumer transmitter unit configured to transmit said order to said order processor at the initiative of said consumer upon receipt by said consumer of publicly broadcast information of interest to said consumer.

8. A system in accordance with claim 7, wherein said consumer transmitter unit  
5 comprises a telephone.

9. A system in accordance with claim 7, wherein said consumer transmitter unit comprises a two-way pager.

10. A system in accordance with claim 7, wherein said consumer transmitter unit comprises a computer connected to a public packet switched communications network.

10 11. An automated system for enabling consumers to respond to publicly broadcast information, comprising:

an order processor configured to receive from a consumer an order comprising data specifying information publicly broadcast over a non-interactive medium, to communicate said data to a content identification processor, and to receive an identification of the content of said  
15 publicly broadcast information from said content identification processor; and

a fulfillment processor configured to receive from said order processor said identification of the content of said publicly broadcast information, and to initiate action desired by said consumer based thereon.

12. A method for enabling consumers to respond to publicly broadcast information,  
20 comprising the steps of:

receiving from a consumer an order comprising data specifying information publicly broadcast over a non-interactive medium;

communicating said data to a content identification processor;

25 identifying the content of publicly broadcast information using said content identification processor in response to receipt of data specifying said publicly broadcast information;

receiving an identification of the content of said publicly broadcast information from said content identification processor; and

causing action desired by said consumer to be initiated based on said content of said publicly broadcast information.

13. A method in accordance with claim 12, wherein said action comprises initiating delivery of a product to said consumer and initiating payment from said consumer to a provider of said product.

14. A method in accordance with claim 12, wherein said publicly broadcast information comprises music, and said identification of the content of said publicly broadcast information comprises an identification of said music.

15. A method in accordance with claim 12, wherein said publicly broadcast information comprises an advertisement, and said identification of the content of said publicly broadcast information comprises an identification of a product being advertised.

16. A method in accordance with claim 12, wherein said publicly broadcast information comprises a poll, and said identification of the content of said publicly broadcast information comprises an identification of a question being asked.

17. A method in accordance with claim 12, wherein said information is publicly broadcast by a radio station.

18. A method in accordance with claim 12, wherein said information is publicly broadcast by a television station.

19. A method in accordance with claim 12, wherein said information is publicly broadcast on a billboard.

20. A method in accordance with claim 12, further comprising the step of sending a confirmation message to said consumer confirming the content of said publicly broadcast information.

21. A method in accordance with claim 12, wherein said action desired by said consumer is dependent on the identity of said consumer, and wherein said method further comprises the steps of receiving customer identification information and causing said action to be initiated based on said customer identification information.

22. A method in accordance with claim 21, wherein said customer identification information comprises a financial account.

23. A method in accordance with claim 21, further comprising the step of identifying said customer through automated voice recognition.

24. A consumer transmitter device configured to transmit an order to an order processor at the initiative of a consumer upon receipt by said consumer of publicly broadcast information of interest to said consumer, comprising:

a tuning mechanism for selecting a source of publicly broadcast information, on a waveband of sources of publicly broadcast information, that is being received by said consumer; and

a transmitting and receiving mechanism for transmitting to said order processor data specifying said source of said publicly broadcast information selected by said tuning mechanism and for receiving signals from said order processor in response to receipt by said order processor of said data, said transmitting and receiving mechanism being operatively connected to said tuning mechanism to enable said transmitting and receiving mechanism to specify to said order processor said source selected by said tuning mechanism.

25. A device in accordance with claim 24, wherein said consumer transmitter unit determines which publicly broadcast information is being received by said consumer by direct manipulation of said tuning mechanism by said consumer.

26. A device in accordance with claim 24, wherein said consumer transmitter unit determines which publicly broadcast information is being received by said consumer through synchronization of said tuning mechanism with a consumer receiver unit that receives said publicly broadcast information.

27. A device in accordance with claim 24, wherein said consumer transmitter unit is configured to store frequently used sources of publicly broadcast information for easy retrieval by said consumer.

28. A device in accordance with claim 24, wherein said consumer transmitter unit comprises a telephone.

29. A device in accordance with claim 24, wherein said consumer transmitter unit comprises a two-way pager.

30. A device in accordance with claim 24, wherein said consumer transmitter unit is configured to receive publicly broadcast signals identifying the content of said publicly broadcast information received by said consumer.



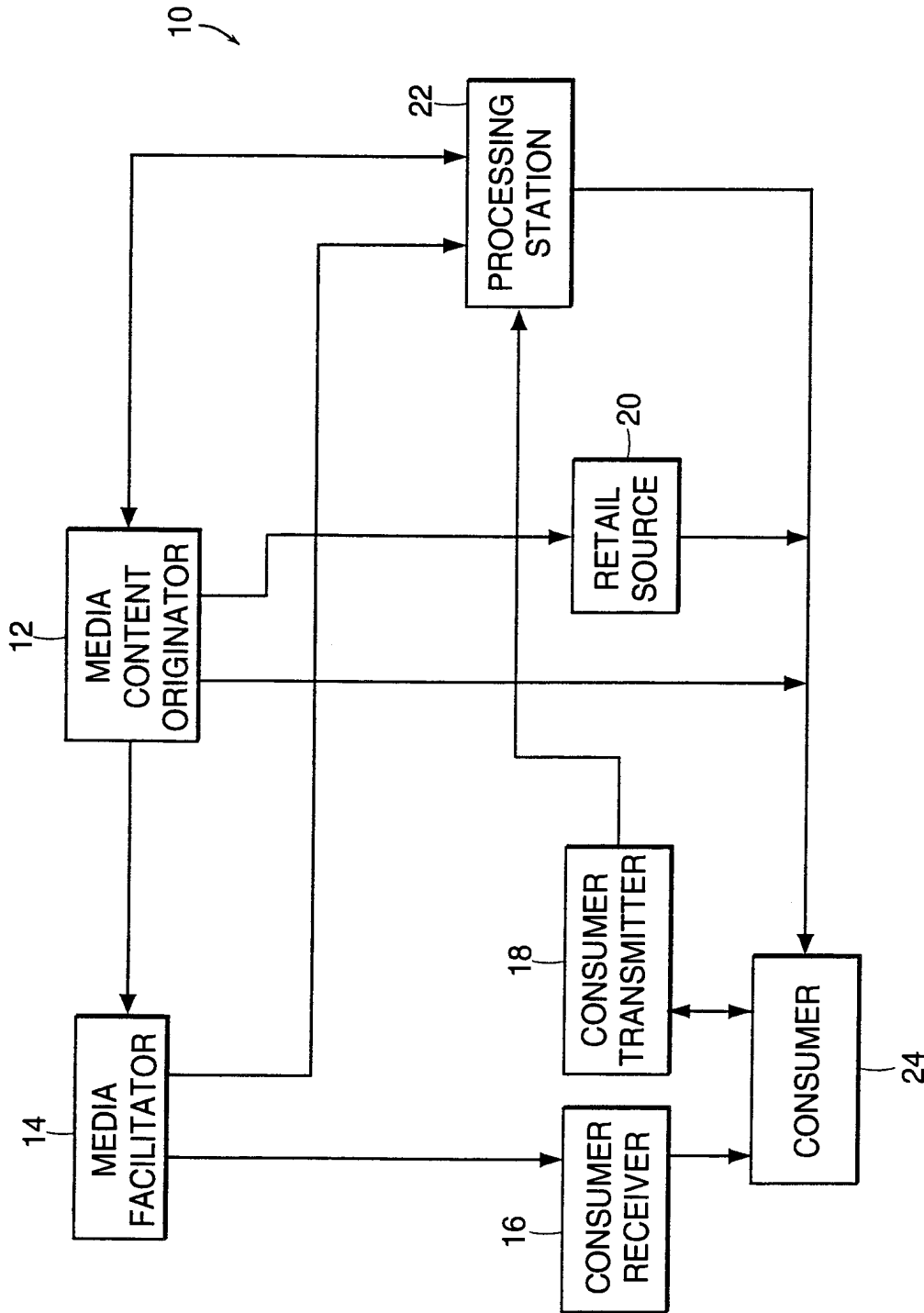


FIG. 1

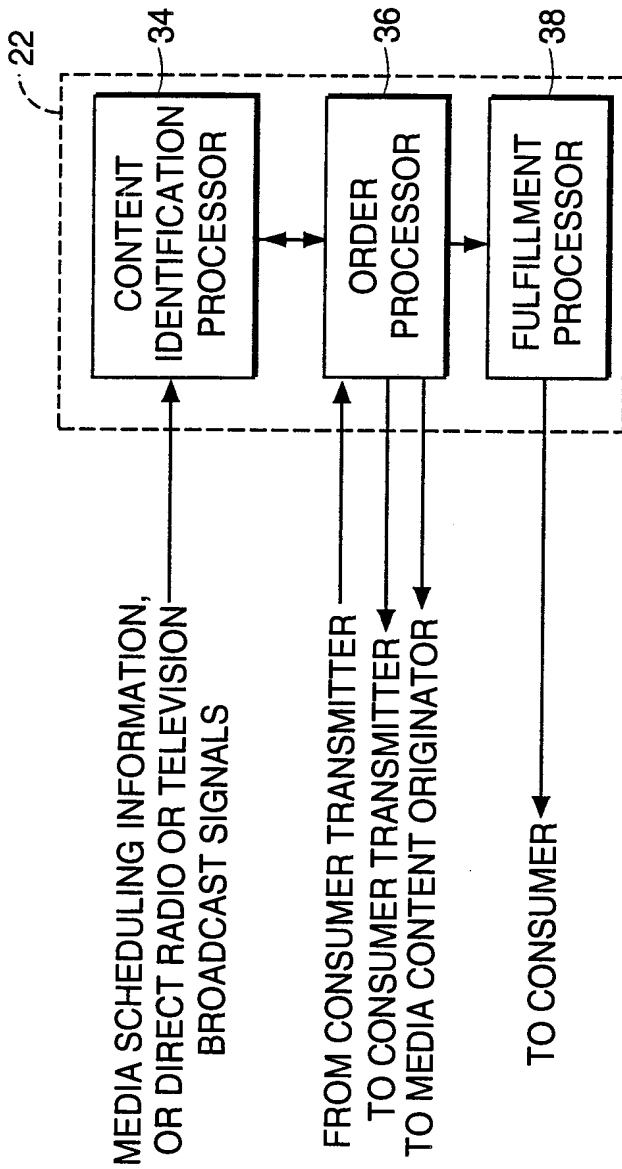


FIG. 2

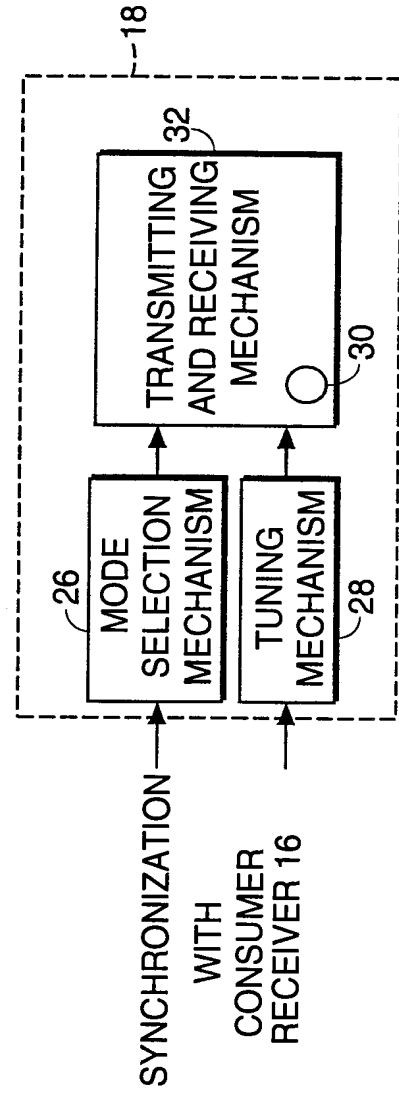


FIG. 3

# INTERNATIONAL SEARCH REPORT

International Application No <b>PCT/US 98/00404</b>
--

**A. CLASSIFICATION OF SUBJECT MATTER**  
 IPC 6 H04M3/50 H04M11/08

According to International Patent Classification (IPC) or to both national classification and IPC

**B. FIELDS SEARCHED**

Minimum documentation searched (classification system followed by classification symbols)  
 IPC 6 H04M

Documentation searched other than minimum documentation to the extent that such documents are included in the fields searched

Electronic data base consulted during the international search (name of data base and, where practical, search terms used)

**C. DOCUMENTS CONSIDERED TO BE RELEVANT**

Category °	Citation of document, with indication, where appropriate, of the relevant passages	Relevant to claim No.
X	WO 97 21291 A (POCOCK MICHAEL) 12 June 1997	1-23
A	see page 2, line 30 - page 6, line 29 see page 21, line 34 - line 41	24-30
X	US 5 539 635 A (LARSON JR ERNEST J) 23 July 1996 see column 2, line 15 - line 35	1-23

Further documents are listed in the continuation of box C.       Patent family members are listed in annex.

° Special categories of cited documents :

<p>"A" document defining the general state of the art which is not considered to be of particular relevance</p> <p>"E" earlier document but published on or after the international filing date</p> <p>"L" document which may throw doubts on priority claim(s) or which is cited to establish the publication date of another citation or other special reason (as specified)</p> <p>"O" document referring to an oral disclosure, use, exhibition or other means</p> <p>"P" document published prior to the international filing date but later than the priority date claimed</p>	<p>"T" later document published after the international filing date or priority date and not in conflict with the application but cited to understand the principle or theory underlying the invention</p> <p>"X" document of particular relevance; the claimed invention cannot be considered novel or cannot be considered to involve an inventive step when the document is taken alone</p> <p>"Y" document of particular relevance; the claimed invention cannot be considered to involve an inventive step when the document is combined with one or more other such documents, such combination being obvious to a person skilled in the art.</p> <p>"&amp;" document member of the same patent family</p>
--	--

Date of the actual completion of the international search  <b>29 July 1998</b>	Date of mailing of the international search report  <b>06/08/1998</b>
--	---

Name and mailing address of the ISA European Patent Office, P.B. 5818 Patentlaan 2 NL - 2280 HV Rijswijk Tel. (+31-70) 340-2040, Tx. 31 651 epo nl, Fax: (+31-70) 340-3016	Authorized officer  <b>Vandevenne, M</b>
--	--

# INTERNATIONAL SEARCH REPORT

Information on patent family members

International Application No

PCT/US 98/00404

Patent document cited in search report	Publication date	Patent family member(s)	Publication date
WO 9721291 A	12-06-1997	CA 2164231 A AU 7687996 A	02-06-1997 27-06-1997
US 5539635 A	23-07-1996	NONE	



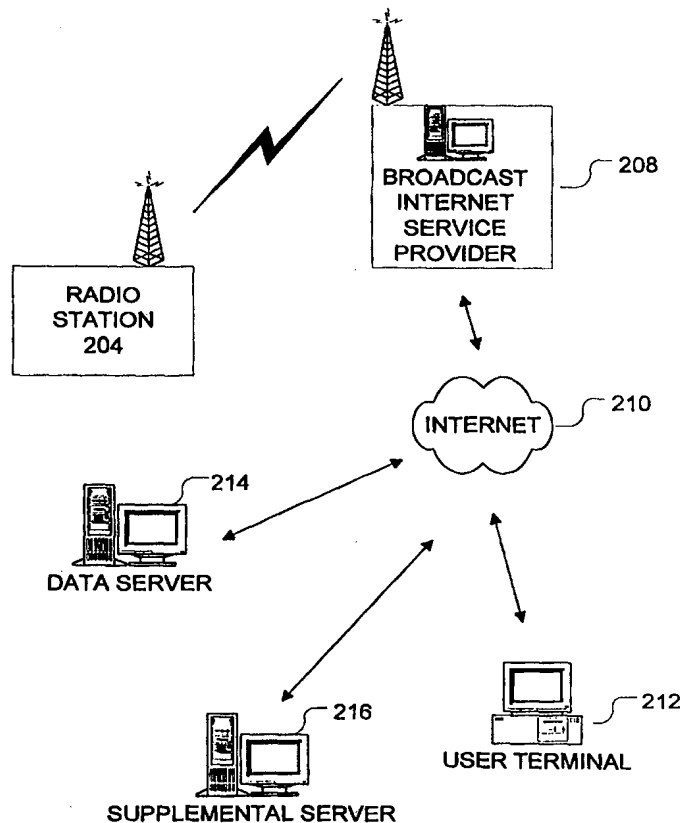
INTERNATIONAL APPLICATION PUBLISHED UNDER THE PATENT COOPERATION TREATY (PCT)

<p>(51) International Patent Classification <sup>7</sup> : <b>H04L 12/18, H04N 5/00, H04L 29/06</b></p>	<p><b>A1</b></p>	<p>(11) International Publication Number: <b>WO 00/19662</b> (43) International Publication Date: 6 April 2000 (06.04.00)</p>
<p>(21) International Application Number: PCT/US99/21232 (22) International Filing Date: 22 September 1999 (22.09.99) (30) Priority Data: 09/163,292 29 September 1998 (29.09.98) US (71) Applicant: RADIOWAVE.COM, INC. [US/US]; Suite 310 South, 1501 Woodfield Road, Schaumburg, IL 60173 (US). (72) Inventors: MACKINTOSH, Gregory, B.; 10 Meadowlark Court, Roselle, IL 60172 (US). KIM, Mike, H.; 816 Ramsgate Court, Naperville, IL 60540 (US). PRICE, Edwin, C.; 3270 N. Lake Shore Drive, #14E, Chicago, IL 60657 (US). STOJAKOVIC, Edward, C.; 2125 W. Pierce, #3c, Chicago, IL 60622 (US). (74) Agent: LAURENSEN, Robert, C.; Lyon &amp; Lyon LLP, Suite 4700, 633 West Fifth Street, Los Angeles, CA 90071-2066 (US).</p>		<p>(81) Designated States: AE, AL, AM, AT, AU, AZ, BA, BB, BG, BR, BY, CA, CH, CN, CR, CU, CZ, DE, DK, DM, EE, ES, FI, GB, GD, GE, GH, GM, HR, HU, ID, IL, IN, IS, JP, KE, KG, KP, KR, KZ, LC, LK, LR, LS, LT, LU, LV, MD, MG, MK, MN, MW, MX, NO, NZ, PL, PT, RO, RU, SD, SE, SG, SI, SK, SL, TJ, TM, TR, TT, TZ, UA, UG, UZ, VN, YU, ZA, ZW, ARIPO patent (GH, GM, KE, LS, MW, SD, SL, SZ, TZ, UG, ZW), Eurasian patent (AM, AZ, BY, KG, KZ, MD, RU, TJ, TM), European patent (AT, BE, CH, CY, DE, DK, ES, FI, FR, GB, GR, IE, IT, LU, MC, NL, PT, SE), OAPI patent (BF, BJ, CF, CG, CI, CM, GA, GN, GW, ML, MR, NE, SN, TD, TG).</p> <p><b>Published</b> <i>With international search report. Before the expiration of the time limit for amending the claims and to be republished in the event of the receipt of amendments.</i></p>

(54) Title: SYSTEM AND METHOD FOR PROVIDING BROADCAST MATERIAL HISTORY

(57) Abstract

A media player for playing broadcast material and associated supplemental information includes a receiver (212) configured to receive broadcast material from a broadcast service provider (208). The broadcast material includes program segments and program data related to one or more of said program segments. The player plays program segments of said received broadcast material on a user's terminal (212). An information retrieval module forwards an item of program data related to a given one of the program segments to a first server enabling the server (214) to retrieve parameters identifying one or more items of supplemental material for said given program segment. The information retrieval module forwards the parameters to a second server (216) to retrieve supplemental materials from said second server based on the parameters, and provides the supplemental materials to the player for playback with a given program segment of broadcast material.



**FOR THE PURPOSES OF INFORMATION ONLY**

Codes used to identify States party to the PCT on the front pages of pamphlets publishing international applications under the PCT.

<b>AL</b>	Albania	<b>ES</b>	Spain	<b>LS</b>	Lesotho	<b>SI</b>	Slovenia
<b>AM</b>	Armenia	<b>FI</b>	Finland	<b>LT</b>	Lithuania	<b>SK</b>	Slovakia
<b>AT</b>	Austria	<b>FR</b>	France	<b>LU</b>	Luxembourg	<b>SN</b>	Senegal
<b>AU</b>	Australia	<b>GA</b>	Gabon	<b>LV</b>	Latvia	<b>SZ</b>	Swaziland
<b>AZ</b>	Azerbaijan	<b>GB</b>	United Kingdom	<b>MC</b>	Monaco	<b>TD</b>	Chad
<b>BA</b>	Bosnia and Herzegovina	<b>GE</b>	Georgia	<b>MD</b>	Republic of Moldova	<b>TG</b>	Togo
<b>BB</b>	Barbados	<b>GH</b>	Ghana	<b>MG</b>	Madagascar	<b>TJ</b>	Tajikistan
<b>BE</b>	Belgium	<b>GN</b>	Guinea	<b>MK</b>	The former Yugoslav Republic of Macedonia	<b>TM</b>	Turkmenistan
<b>BF</b>	Burkina Faso	<b>GR</b>	Greece	<b>ML</b>	Mali	<b>TR</b>	Turkey
<b>BG</b>	Bulgaria	<b>HU</b>	Hungary	<b>MN</b>	Mongolia	<b>TT</b>	Trinidad and Tobago
<b>BJ</b>	Benin	<b>IE</b>	Ireland	<b>MR</b>	Mauritania	<b>UA</b>	Ukraine
<b>BR</b>	Brazil	<b>IL</b>	Israel	<b>MW</b>	Malawi	<b>UG</b>	Uganda
<b>BY</b>	Belarus	<b>IS</b>	Iceland	<b>MX</b>	Mexico	<b>US</b>	United States of America
<b>CA</b>	Canada	<b>IT</b>	Italy	<b>NE</b>	Niger	<b>UZ</b>	Uzbekistan
<b>CF</b>	Central African Republic	<b>JP</b>	Japan	<b>NL</b>	Netherlands	<b>VN</b>	Viet Nam
<b>CG</b>	Congo	<b>KE</b>	Kenya	<b>NO</b>	Norway	<b>YU</b>	Yugoslavia
<b>CH</b>	Switzerland	<b>KG</b>	Kyrgyzstan	<b>NZ</b>	New Zealand	<b>ZW</b>	Zimbabwe
<b>CI</b>	Côte d'Ivoire	<b>KP</b>	Democratic People's Republic of Korea	<b>PL</b>	Poland		
<b>CM</b>	Cameroon	<b>KR</b>	Republic of Korea	<b>PT</b>	Portugal		
<b>CN</b>	China	<b>KZ</b>	Kazakstan	<b>RO</b>	Romania		
<b>CU</b>	Cuba	<b>LC</b>	Saint Lucia	<b>RU</b>	Russian Federation		
<b>CZ</b>	Czech Republic	<b>LI</b>	Liechtenstein	<b>SD</b>	Sudan		
<b>DE</b>	Germany	<b>LK</b>	Sri Lanka	<b>SE</b>	Sweden		
<b>DK</b>	Denmark	<b>LR</b>	Liberia	<b>SG</b>	Singapore		
<b>EE</b>	Estonia						

DESCRIPTIONSystem and Method for Providing Broadcast Material History

5 The present application is related to copending United States Patent Applications  
No. To Be Assigned, docket number 237/092, titled "System and Method for Coordinating  
Supplemental Materials With Broadcast Material," No. To Be Assigned, docket number  
237/172, titled "System and Method For Playing Supplemental Materials With Broadcast  
Material," and No. To Be Assigned, docket number 237/094, titled "System and Method  
10 For Coordinating Communications Network Advertising Material," each of which are of  
common assignee and are filed concurrently herewith and each of which are incorporated  
herein by reference in their entirety.

Background Of The Invention1. Field of the Invention

15 The present invention relates generally to broadcast materials, and more  
particularly to a system and method for coordinating history information relating to  
broadcast materials.

2. Related Art

20 The proliferation of processors and processor-based systems in recent years has led  
to a tremendous increase in the ability of businesses, industry and individuals to share  
information. Most computers and workstations in today's homes and offices are  
connected in some manner to another computer or workstation, either locally or remotely.  
An early form of such inter-connection of computing systems is the local area network  
(LAN). Using LAN technology, several computers, workstations, peripherals, or other  
related devices can be connected to share data among one another and to share network  
25 resources.

The Internet can be thought of as an extension of local area network technology.  
The Internet originally began as a communication network through which government  
researchers, scientists and other personnel could exchange data or other information  
between offices and facilities throughout the world. Eventually, the Internet became  
30 accessible to the public. Initially, the public was slow to embrace the Internet, and it  
seemed as if the Internet would remain nothing more than a way for a select group of  
technologists to exchange e-mails and other data or information. Eventually, however,  
entrepreneurs who envisioned the growth of the consumer market for Internet services

were able to attract a large number of consumers into the fold. As a result, a sort of snowball effect ensued in which more and more consumers become Internet users, and in turn, more and more businesses rushed to get web pages set up on an Internet server. With more businesses offering information, products and services on the Web, more consumers were attracted to the Internet. This cycle rapidly fed on itself virtually creating an explosion on the Internet.

However, the proliferation of the Internet did not stop with the provision of web pages to the Internet users, or web surfers. In the true capitalistic spirit, providers of popular web pages found that they were able to sell advertising space on their web pages. Thus, the Internet became not only a way for businesses to advertise their own businesses on their web pages, but also a way for advertisers to include their ads on others' web pages.

Seemingly overnight, the Internet had transformed into the new advertising medium of the decade. Virtually every business and industry jumped on to the Internet bandwagon. On top of that, hundreds, if not thousands, of new businesses were created to offer Internet-related services. It seemed as if just about everyone was able to capitalize on this new medium.

However, in spite of this proliferation, there were still a few business that were left out of the Internet craze. One example of such a business is the radio industry. Although stations could offer their own web sites on the Internet, such sites typically were not popular among the web surfers, and thus were not a good source of advertising revenues. Thus, even though radio stations could participate in the Internet, their only gains from doing so were PR-related.

Eventually, enterprising web developers decided that they could offer a mechanism by which one or more radio stations or radio networks could offer their broadcast materials over the Internet. One popular Internet site offering this service is [www.broadcast.com](http://www.broadcast.com), although there are others. While many radio stations have agreed to provide their programming across the Internet by such service providers, most have found that this has not led to an increase their advertising revenues. Although these providers offer an excellent service to radio stations and their listeners, most advertisers are not willing to pay a premium for advertising slots simply because the broadcast material is additionally offered to listeners over the Internet. Thus, even though these services allowed radio stations to further participate in the Internet-related industry, their ability to fully take advantage of Internet opportunities is still somewhat limited.

Additional background information on the use of computer networks as a broadcast medium is available from "BROADCAST AND DISTRIBUTION SYSTEM AND



METHOD,” U.S. Patent Application Serial No. 08/961,314, filed October 30, 1997, and “AUDIO CONTENT PLAYER METHODS AND ARTICLES OF MANUFACTURE,” U.S. Patent Application Serial No.08/976,971, filed November 25, 1997, both of which are fully incorporated by reference herein as though set forth in full.

5 Summary Of The Invention

The present invention is directed toward systems and methods for providing enhanced features for the delivery of broadcast material to a listener, viewer or, more generally, a user. According to one aspect of the invention, supplemental materials can be provided to a user in a coordinated fashion with the broadcast materials being delivered.

10 The supplemental materials can be provided in a coordinated fashion such that they relate to the actual broadcast materials as they are being streamed or otherwise delivered to the user. For example, according to one embodiment, the broadcast material is delivered to the user in segments such as, for example, tracks of music, advertisements, and promotional materials in a radio broadcast. In this embodiment, the supplemental

15 materials can be coordinated with the individual segments (e.g., tracks) such that supplemental materials relating to the segments can be provided as the segments are being provided to the user.

Supplemental materials can include, for example, images, video clips, audio clips, data, or other materials that may be provided to the user in conjunction with the broadcast

20 materials. The supplemental materials can also include advertising information that is provided to the user during particular segments of the broadcast material. In one embodiment, this advertising information can be coordinated with the particular segments of the broadcast material such that the value of the advertising is enhanced.

One example application of this aspect of the invention is found in the broadcast of

25 radio broadcast materials over the Internet. According to this example application, the radio broadcast materials can include a plurality of tracks that can be streamed to a user via the Internet. The tracks can include, for example, music tracks, advertising tracks, DJ voice or introduction tracks, promotional tracks, and any other track that a station may wish to broadcast as part of its broadcast material. In one embodiment, the tracks are provided

30 along with program data that can indicate, for example, an identification of the track, the type of track, and other pertinent or relevant information regarding the particular track being broadcast at that time. This information can be provided to an Internet broadcast service provider that "broadcasts" the broadcast materials and the program data to the listener's Internet terminal.

The listener receives the broadcast material and the program data via the Internet connection and plays it on his or her computer, workstation or other Internet terminal. This can be a web page type player or a downloaded player that is resident on the user's terminal. When the user's terminal receives a track to be played, the user's terminal takes  
5 the program data associated with that track and uses that data to access one or more servers to retrieve the supplemental information.

In one embodiment, the data can be used to access a first server to directly retrieve the supplemental information to be coordinated with the broadcast material. In another embodiment, the program data can be used to retrieve locational or other identification  
10 information from the first server, and use this retrieved information to retrieve the supplemental information from a second server. In yet another embodiment, some or all of the supplemental information may be stored at the listener's terminal. In this case, the program data is used to retrieve the supplemental information from local storage.

According to another aspect of the invention, a history bar can be provided in  
15 conjunction with the broadcast material. The history bar can be used to display a history of the segments or tracks of the broadcast material that were broadcast to the listener or other listeners. The history bar can allow the listener or user to retrieve supplemental information about or pertaining to a previous segment that had been broadcast. Thus, if the user wishes to, for example, obtain information about a song track that was played in  
20 the recent past, or obtain additional information about a product that was advertised in the recent past, the user can select the particular item from the history bar, and retrieve this supplemental information.

In one embodiment, any information or supplemental information that was retrieved during initial playing of the subject track can be saved locally, for example in a  
25 circular type buffer or a FIFO or LIFO buffer. Thus, this information is available to the user without the need to retrieve the supplemental information again from one or more servers. Alternatively, only the program data needs to be stored and associated with each track. In this alternative, the user terminal uses the program data to retrieve the supplemental information. An advantage of the history bar is that it can allow the user to  
30 in effect go back in time to obtain information about a segment that was played in the past. In this manner, the information relating to the segment is not lost to the user once the time for the segment has past.

A method and apparatus for facilitating the coordination of visual advertisements with audio broadcast material is provided in "SYSTEM AND METHOD FOR  
35 COORDINATING COMMUNICATIONS NETWORK ADVERTISING MATERIALS," Lyon & Lyon Docket No. 237/094, filed on even date herewith and which is owned by

common assignee, and which is incorporated herein by reference as though set forth in full.

Further features and advantages of the invention as well as the structure and operation of various embodiments of the invention are described in detail below with reference to the accompanying drawings.

### Brief Description Of The Drawings

The present invention is described with reference to the accompanying drawings. In the drawings, like reference numbers indicate identical or functionally similar elements.

Figure 1 is a block diagram illustrating an example architecture for providing supplemental materials in coordination with broadcast materials according to one embodiment of the invention.

Figure 2 is an operational flow diagram illustrating a process for coordinating supplemental materials with the program provided to user equipment according to one embodiment of the invention.

Figure 3 is a block diagram illustrating an alternative embodiment to the architecture illustrated in Figure 1.

Figure 4 is an operational flow diagram describing the coordination of supplemental materials with the broadcast material according to the example embodiment illustrated in Figure 3.

Figure 5 is a block diagram illustrating the example application of the invention in which a radio station provides its broadcast materials to a listener at a user terminal according to one embodiment of the invention.

Figure 6 is a operation flow diagram illustrating an example process by which supplemental information can be coordinated with the broadcast material in the example application illustrated in Figure 5.

Figure 7 is a diagram illustrating an example user interface for an example player according to one embodiment of the invention.

Figure 8 is a diagram illustrating an example functional architecture for a player according to one embodiment of the invention.

Figure 9 is an operational flow diagram illustrating a process for implementing a history window according to one embodiment of the invention.

Figure 10 is a diagram illustrating an example implementation of an architecture for providing supplemental materials with broadcast material.

Figure 11 is a diagram illustrating an example song table and provider table according to one embodiment of the invention.

Figure 12 is a diagram illustrating an example player according to one embodiment of the invention.

Figure 13 is a diagram illustrating an example computer architecture according to one embodiment of the invention.

## 5 Detailed Description Of The Invention

The present invention is directed toward a system and method for coordinating supplemental materials with broadcast materials delivered to a viewer, listener or other program user. According to one specific implementation of the invention, the invention is directed toward a system and method for coordinating supplemental information such as  
10 advertising and promotional information with a radio station broadcast over the Internet. However, as described below, alternative embodiments can include the coordination of supplemental materials such as images, video clips, audio clips, text, data or other materials with the delivery of broadcast material.

Figure 1 is a block diagram illustrating an example architecture for providing  
15 supplemental materials in coordination with broadcast materials according to one embodiment of the invention. The example embodiment illustrated in Figure 1 includes a program provider 104 for providing broadcast materials to a user equipment 112. Program provider 104 can provide, for example, broadcast materials such as a radio program, a video program, or other broadcast materials on another program medium. For example, in  
20 one embodiment, program provider 104 can be a radio station broadcasting its radio program to a number of listeners.

Program provider 104 can provide its broadcast materials directly to a user's user equipment 112 or alternatively, via a broadcast provider 108. Broadcast provider 108 may be included to allow the broadcast material to be forwarded to the user via an alternative  
25 medium. For example, in one embodiment, an example of a broadcast provider 108 can be a service provider such as, for example, [www.broadcast.com](http://www.broadcast.com) that provides radio broadcast materials to user equipment 112 via the Internet. In this document, the term "broadcast" is used to describe the delivery of broadcast materials to one or more than one user or other destination via a hard-wired or wireless communication channel.

30 Depending on the broadcast or delivery medium, the user equipment can include, for example a processor-based system, such as a personal computer (PC) or other processor-based system, having an appropriate communication interface. In the Internet embodiment described above, user equipment 112 can include, for example, an Internet terminal having an Internet communication interface.

In the embodiment illustrated in Figure 1, program provider 104 provides information pertaining to the broadcast materials to a data server 116. For example, program provider 104 can provide to data server 116 an identification of the broadcast materials that are being broadcast or otherwise provided to user equipment 112. This data  
5 can be sent in real time as the broadcast materials are being broadcast or otherwise sent to user equipment 112. Alternatively, the data can be sent in advance of the delivery of the broadcast materials. If sent in advance, the data preferably also includes a schedule for the programming materials such that supplemental information associated with the broadcast materials can be coordinated with the broadcast materials, as discussed below.

10 In operation, data server 116 utilizes the data received from program provider 104 to retrieve supplemental materials related to the broadcast materials and to provide those supplemental materials to user equipment 112 in coordination with the broadcast materials. Thus, in one embodiment, Data server 116 uses the data from program provider 104 to retrieve the associated supplemental materials from its one or more data storage  
15 databases 118 and provide these materials to user equipment 112.

In the context of the radio station example, data from program provider 104 can include event codes identifying the item being broadcast to user equipment 112. Event codes can be codes indicating, for example, a current song being played, an advertising spot being played, or other material in the stream of broadcast materials being broadcast  
20 by program provider 104. Continuing in this example scenario, data server 116 can retrieve supplemental information pertaining to the specific item of programming being broadcast such as, for example, images, video clips, or textual data relating to the material being broadcast.

In an alternative embodiment, the supplemental materials are not necessarily stored  
25 in databases 118 of data server 116. Instead, the supplemental materials can be stored in one or more external data bases 122 associated with one or more external servers 120. Thus, also illustrated in Figure 1 is a material server 120 and its associated data base 122. In this embodiment, when data server 116 uses the data from program provider 104 to retrieve locational or other identification information about the supplemental information  
30 to be coordinated with a broadcast. Data server 116 provides this locational or identification information to user equipment 112. User equipment 112 then uses this locational or other identification information to access server 120 to retrieve the associated supplemental materials from one or more material servers 120.

Figure 2 is an operational flow diagram illustrating a process for coordinating  
35 supplemental materials with the program provided to user equipment 112 according to one embodiment of the invention. Referring now to Figure 2, in a step 132, program provider

104 delivers its broadcast materials to user equipment 112. As stated above, the broadcast materials can be audio, video or other broadcast materials including, for example, a radio broadcast, a television broadcast, an educational broadcast or other delivery of broadcast materials to a user equipment 112. As illustrated in Figure 1, delivery of the broadcast materials can also be accomplished via an intermediary broadcast provider 108. In one example, the intermediary broadcast provider 108 can be, for example, an Internet provider 108, or other intermediary provider.

In a step 134, program provider 104 delivers data pertaining to the broadcast materials to data server 116. This data can include, for example in one embodiment, data identifying the broadcast material or the particular portion of broadcast material currently being broadcast to user equipment 112. This data can be provided in real time as the broadcast material is being provided to user equipment 112, or, alternatively, in advance of delivery of the broadcast material.

As described above with reference to Figure 1, there are at least two alternative embodiments by which the supplemental materials can be provided to user equipment 112 in coordination with the broadcast materials. Each of these embodiments are described with reference to Figure 2 and are illustrated as parallel flow paths in the diagram of Figure 2. In a step 136, data server 116 uses the data from program provider 104 to retrieve the supplemental materials from data base 118. As stated, these supplemental materials can include, for example, audio, video, image, data, or other information.

In a step 138, data server 116 provides the retrieved supplemental materials to user equipment 112 such that they can be played, displayed, or otherwise provided to the user in coordination with the broadcast materials. In one embodiment the data is provided to data server 116 in real time as the broadcast material is provided to user equipment 112. In this embodiment, data server 116 can simply retrieve the supplemental materials and provide them to user equipment 112 as the server receives the data from program provider 104. Alternatively, where the data is provided by program provider 104 in advance of the broadcast material, data server 116 can build a schedule for retrieval of the supplemental materials and their delivery to user equipment 112. In these or other alternatives, the supplemental materials are provided to user equipment 112 such that they can be presented to user equipment 112 in coordination with the broadcast materials. In a step 140, the supplemental materials can be played, displayed, or otherwise provided to the user in coordination with the broadcast materials.

Referring now to the parallel path of Figure 2, in a step 142, the data server 116 uses the data from program provider 104 to retrieve supplemental material parameters from database 118. These parameters can include, for example, locational or other

identification information pertaining to the supplemental materials. In one embodiment, this information provides an identification of where user equipment 112 may locate supplemental materials on another server such as, for example, server 120. These retrieved parameters are provided to user equipment 112.

5           User equipment 112 then uses this information to retrieve the supplemental materials from another location. In one embodiment, user equipment 112 access server 120 to retrieve the supplemental materials from data base 122. This is illustrated by a step 144.

10           This data is now available to user equipment 112 in coordination with the broadcast materials. Thus, in a step 146, the supplemental materials can be played, displayed, or otherwise provided to the user in coordination with the broadcast materials. As with the previous embodiment, data from program provider 104 can be presented in real time or in advance of the broadcast materials.

15           In one embodiment, user equipment 112 can include the processing ability to either receive the supplemental materials from server 116 and provide them to the user in coordination with the broadcast materials or to retrieve the supplemental materials from material server 120 and provide them to the user in coordination with the broadcast materials. For example, in one embodiment, user equipment 112 is a computer system capable of receiving information via communication links including, for example, the  
20           Internet, and also capable of retrieving information using similar links. Where user equipment 112 is a computer system, a player may be provided to the user such that the user equipment 112 can play the broadcast material and the supplemental materials provided from program provider 104.

25           Figure 3 is a block diagram illustrating an alternative embodiment to the architecture illustrated in Figure 1. According to the alternative illustrated in Figure 3, program data relating to the broadcast material is not directly provided from program provider 104 to data server 116. Instead, in this embodiment, data pertaining to the broadcast materials is provided along with the broadcast materials to the user equipment 112. This can be done either directly, or via an interim provider such as, for example,  
30           broadcast Internet service provider 108.

35           Figure 4 is an operational flow diagram describing the coordination of supplemental materials with the broadcast material according to one or more realizations of the embodiment illustrated in Figure 3. Referring now to Figure 4, in a step 162, program provider 104 delivers the broadcast material to user equipment 112. In this step, the data relating to the broadcast material (i.e., the program data) is included in the signal provided to user equipment 112. In one embodiment, the program data and broadcast

material are multiplexed onto a single data link and provided to user equipment 112 either via a broadcast provider 108, or directly to user equipment 112.

In embodiments where the data and broadcast material delivered to user equipment 112 is ultimately in digital form, the program data can be interleaved with the broadcast materials in a digital data stream. This can be done by interleaving packets, or by  
5 interleaving the data in packet data blocks, or by interleaving the data streams together.

In a step 164, user equipment 112 delivers the program data to data server 116. Data server 116 receives the program data in real time or near real time with the associated segment of broadcast material. From this point on, the operation can continue as  
10 illustrated above in Figure 2 whereby the supplemental information is either retrieved directly from data base 118 and provided to user equipment 112 (steps 136, 138, 140) or whereby locational or other identification information is provided to user equipment 112 which then in turn receives this supplemental information from data base 122 (steps 142, 144 and 146).

Having thus generally described a system and method for coordinating supplemental information with broadcast material provided to user equipment 112, a specific application of this generalized system is now described. This specific application is described in terms of the above-mentioned example in which a radio station provides its normal broadcast material to a listener. In addition, the radio station desires that  
15 additional supplemental materials be provided to the listener through the use of one or more servers. Although the invention is now described in terms of this specific application, it will become apparent to one of ordinary skill in the art after reading this description that the invention is not limited to this specific application but can be more generally applied to other applications as well. This description is thus provided for  
20 illustration purposes only.

Figure 5 is a block diagram illustrating the example application of the invention in which a radio station 204 provides its broadcast materials to a listener at a user terminal 212 according to one embodiment of the invention. Figure 6 is a operation flow diagram illustrating an example process by which supplemental information can be coordinated  
30 with the broadcast material in the example application illustrated in Figure 5.

In a step 222, radio station 204 provides its broadcast materials to a broadcast Internet service provider 208. In one embodiment, the materials provided to broadcast Internet service provider 208 can include the actual radio broadcast from radio station 204 as well as event codes indicating current tracks in that broadcast, current advertising in  
35 that broadcast, or other data associated with the real time broadcast. In one embodiment,



these signals can be broadcast via an AM or FM radio link to broadcast Internet service provider 208.

In this embodiment, both the audio and the data can be modulated onto an AM or FM carrier signal at a desired frequency. In alternative embodiments, the broadcast materials and the data can be provided to broadcast Internet service provider 208 in a digital format, encoded, compressed or otherwise, through either a hard-wired or wireless communication link. As is well known to those in the radio industry, many radio stations pre-program their broadcast material such that it can be broadcast in an automated fashion. Thus, the broadcast material and program data can also be provided in this fashion. Systems available to facilitate such pre-programming include the DAD Pro system available from ENCO Systems, Inc., the Master Control from Radio Computer Systems, Inc. and the Audio Wizard from Prophet Systems, Inc.

These systems typically store the broadcast materials in advance on a hard drive or other data storage. As such, this data in digital form can be downloaded to broadcast Internet service provider 208 via any of a number of communication links and protocols and in any of a number of formats. Alternatively, a copy of a disc or other electronic medium on which the program is stored can be provided to broadcast Internet service provider 208 to physically provide the broadcast material and data.

In an example application of the radio station, the program data can include, for example, a cut number, a category of the cut, and a duration of the cut. In these embodiments, the cut number can include number or other alpha-numeric designation assigned by the radio station for recorded components that air on their station. These components can include, for example, songs, commercials, promotions, or other "cuts" or segments that may air on the radio. The program data can also include an identification of the broadcasting station, allowing unique codes or data sets to be maintained for different stations.

The cut number can be a numeric or alphanumeric identification (ID) that identifies the particular cut. The category of the cut can include, for example, an identification of the type of cut to which the cut number or program data refers. For example, the cut category may differentiate between music, ad traffic, DJ segments, and link promos. Other or additional categories can be included as well.

Additionally, information pertaining to the format of the cut can be included as well. Such format information can further indicate a type of music (e.g., pop, rock, jazz, classical, country and western, etc.), or a type or category of product being advertised (e.g., clothing, food and beverage, insurance, automobile services, etc.). This format

information can be used to key particular pieces or categories of supplemental material to the broadcast.

As stated, a station can include a station ID in this program data to uniquely identify that station from among a plurality of other stations that may be sending data to broadcast Internet service provider 208. In one embodiment, however, broadcast Internet service provider 208 does not need such an identification signal as it may use other means for determining the identity of the radio station 204, such as, for example, the channel on which the signal is received.

In alternative embodiments, analogous data fields can be provided with the program data. For example, other broadcast material types can include a segment ID, analogous to the cut code, or cut number, and identifying the segment; a segment category, identifying a category or class to which the segment belongs.

In a step 224, broadcast Internet service provider 208 "broadcasts" the broadcast material including the program data to user terminal 212. In the embodiment illustrated in Figure 5, this "broadcast" is via the Internet 210. Thus, broadcast Internet service provider 208 provides the broadcast materials in a digital format downloaded to user terminal 212 via the Internet 210. In the illustrated embodiment, this digital data includes the broadcast material and the program data. As stated with reference to Figure 1, in alternative embodiments, the program data can be provided directly to data server 214, which transmits the data to user terminal 212.

User terminal plays the broadcast material to the user as illustrated by a step 226. In one embodiment, user terminal 212 can access and "play" the broadcast material via a web page format. In an alternative preferred embodiment, user terminal 212 includes a player that is used to play the broadcast material downloaded via the Internet 210. This player can be a general purpose audio player or audio/video player capable of playing the broadcast material, as well as any received supplemental materials. Specific embodiments of an exemplary player are described below, although alternative players can be implemented.

In a step 228, user terminal 212 retrieves the program data from the downloaded broadcast materials and provides this program data to data server 214. Again, this program data can include data pertaining to a specific portion of the broadcast material currently being broadcast. In one embodiment as discussed above, this program data can include a cut number, a cut category, and a duration. Additionally, this can include a station ID such that cut number or other codes from different stations can be differentiated. As stated above, the station ID can be generated originally from radio station 204 and

provided to broadcast Internet service provider 208 and thus included in the downlink to user terminal 212 via the Internet 210.

Alternatively, station identification can be generated by the user terminal 212 based on a particular station that the user is currently listening to. For example, in 5 embodiments where user terminal 212 includes a player, the station selected on that player can be identified by the player and this identification included in the transmission to data server 214. In one embodiment, the data transmitted to data server 214 is also transmitted over the Internet 210. However, alternative communication means could be included. Preferably though, the Internet is used as the communication resource without requiring 10 additional communication media to be introduced. In a step 230, data server 214 uses the program data to retrieve information pertaining to supplemental materials. As described above, the supplemental materials can include, for example, images, videos, audios, text, or other data. In one embodiment, the information or parameters retrieved by data server 214 can include, for example, a URL or other location information to identify where the 15 one or more various supplemental materials may be located on additional supplemental servers 216. Data server 214 returns the information pertaining to the supplemental materials to user terminal 212. This return path can also be implemented by the Internet 210 or other communication path.

Additionally, as stated above, some or all of the supplemental materials may be 20 located on data bases directly associated with ID server 214. In this alternative, these materials can be directly returned to user terminal 212.

In a step 232, user terminal 212 uses the information provided by data server 214 to retrieve the supplemental materials from another server such as, for example, supplemental server 216. In Internet implemented embodiments, a URL provided by data 25 server 214, for example, can be used by user terminal 212 to retrieve web-based images, videos, audio clips, text files, HTML files, or other data or information from a web server via the Internet.

In a step 234, user terminal 212 provides the retrieved supplemental materials to the user while the user is listening to the broadcast materials. This provision is generally 30 referred to as "playing" the supplemental materials, regardless of whether the played materials are audio, video, still images, text or other data. Because the supplemental materials can be retrieved based on the program data associated with a current segment, the supplemental materials can be coordinated with the broadcast material.

As can be seen by the above description, there is a wealth of additional 35 supplemental information that can be provided to a user at his or her user terminal 212 to accompany the broadcast materials broadcast by radio station 204. To list just a few

examples, the user may be provided with an image of an album currently being played, album title, artist, and track number, links to purchase the album, additional materials such as promotional materials, concert schedules and materials, memorabilia, artists bios, other images or videos relating to the album or artists, or virtually any other information that may be somehow related to the current item being played by radio station 204.

Additionally, advertising information can be retrieved and provided on user terminal 212 in conjunction with the current broadcast material. For example, particular advertising spots may be keyed to particular songs or broadcast material to further enhance the user interface. Advertising can be keyed to attributes identified by the program data such as music types, products or product categories, artists, and so on.

Additionally, where the current broadcast material is an advertising spot, additional supplemental information may be coordinated with that advertising spot to allow the advertiser to offer special goods or services to the user. For example, the supplemental materials may provide electronic or virtual coupons that can be provided to the listener in conjunction with a broadcast advertisement. For example, the supplemental materials can include a coupon that is downloaded to the user and printed by user terminal 212, or a special alphanumeric code that can be written down by the user and brought to a point-of-sale outlet.

Another example of supplemental materials in the advertising or promotional capacity may include the provision of contest materials to the users. For example, the supplemental materials may include lottery numbers, electronic "puzzle" or game pieces, and the like.

Still further, banner ads or other advertisements may be pulled up, and their display can be coordinated with the broadcast material. For example, the advertisements can be directed toward products or services related to the current track, or other advertisements that may appeal to listeners of the current broadcast material. As further described below in conjunction with this and other embodiments, there is a whole host of additional supplemental material that can be provided in coordination with the broadcast material.

As stated above, in one embodiment, the interface between radio station 204 and user terminal 212 can at least in part implemented via the Internet 210. Additionally, the link by which user terminal 212 accesses data server 214 to retrieve information pertaining to the supplemental materials can also be implemented by the Internet. Although communication media such as the Internet 210 have built-in latencies that may impact different user terminals differently, it is conceivable that a large number of user terminals 212 may attempt to access data server 214 simultaneously on the receipt of new program data. As such, random delay can be inserted into the path between a broadcast Internet

service provider 208 and a one or more user terminals 212 listening to the broadcast. This random delay, which can be, for example, as much as 20 to 40 seconds, can allow the various accesses to data server 214 to be staggered among the plurality of users. As such, the load on data server 214 as well as on any supplemental servers 216 can be somewhat leveled.

Alternatively, the process can be randomized to spread out the impact to servers 214, 216. In one embodiment, the system can look ahead and use cut codes from future broadcast materials to retrieve supplemental information in advance, at randomized time intervals to level the server load. This can be accomplished, for example where cut codes are provided directly to server 214 in advance of the program.

In yet another embodiment, a look-ahead feature is provided, wherein program data for one or more upcoming tracks is used to retrieve supplemental materials prior to the actual playing of those tracks. Thus, supplemental materials can be retrieved in advance, and scheduled to occur at times when the servers are not being accessed by a large number of other users.

Additionally, the digital data provided to user terminal 212 can be compressed or encoded to allow for a more efficient communication path. In one embodiment, compression is provided using the commercially available encoders such as, for example Microsoft's NetShow or Real's Sure Stream, and others. As already stated, the example embodiment described with reference to Figures 5 and 6 can be implemented in alternative embodiments with, for example, alternative broadcast material, alternative communication interfaces, and alternative forms of supplemental materials.

As stated above, in one embodiment, a player can be downloaded to the user terminal 212 to allow the user terminal 212 to play the broadcast material broadcast from the broadcast Internet service provider 208. The player is a software application resident on user terminal 212. Although the format and features of such a player are theoretically unlimited, one example player is now described in order to illustrate the features and functionality that can be provided or included in one or more alternative embodiments of a player. Figure 7 is a diagram illustrating a screen shot of an example player according to one embodiment of the invention. Although this example player is now described in terms of the example screen shot, it will become apparent to one of ordinary skill in the art after reading this description how alternative players can be implemented and how alternative user interfaces or user screens can be provided with a player.

Referring now to Figure 7, the player illustrated in Figure 7 includes four parts: a data window 302, a player interface 304, a history window 306, and an advertising window 308. Each of these components are now described in accordance with one

example implementation. In the example illustrated in Figure 7, player interface 304 can include virtual buttons or selectors that can be selected or otherwise manipulated by the user using a mouse, track ball, keyboard, touch-screen display or other pointing or manipulation device. The controls illustrated in the example of Figure 7 include a volume control 312, a status display 314, a on-air display 316, and a station list button 318.

Although not illustrated, other controls or input devices can be provided including, for example, a tuner button or knob to allow stations to be changed or "tuned" using the player interface 304 or another interface. Also, the player interface 304 can include other controls such as, for example, balance controls, tone controls, a mute button, and other controls or features that may be desirable for an audio or audio/video player.

Data window 302 provides a place to display supplemental information or materials retrieved from other servers such as data server 116 or supplemental server 120. For the example of the radio station as provided in Figure 5, data window 302 can include an album image 322, artist or album or track information 324, a buy now button 326, and additional information selection area 328. Data window 302 can be implemented to include other or additional information or supplemental materials as well.

In embodiments where user terminal 212 is provided with URL's to retrieve supplemental materials, the URL's can be used to retrieve some or all of the information provided in the example data window 302 and display the retrieved information. In alternative embodiments, other mechanisms can be used to retrieve and display information in data window 320.

Returning now to the specific example, album image 322 is a picture or other image, preferably in a GIF format (e.g., \*.gif) that provides a graphical representation to accompany the current song being played. These GIF images can be stored locally on data server 214 and provided to user terminal 212 upon receipt of the program data, or otherwise retrieved by user terminal 212 from supplemental server 216. In one embodiment, the album image 322 is an image similar to or the same as the album cover image. Thus, for example, a listener tuning into a radio station using the player can also view the album cover of the album on which the current song can be found.

Where the current track is an advertising track, album image 322 may be an image designated by the advertiser that the advertiser would like listeners to be able to view upon hearing the advertisement being played. This for example can be pictures of the product, company logos, videos, or other images that the advertisers feel would entice the listener or provide additional information to the listener.

Track information 324 can be used to provide additional information regarding the current track. For example, where the current track is music, track information 324 can

display the artist's name, the current song being played, the album on which the current song can be found, the record label, and any other information that may be useful or pertinent regarding the current track. Similarly, when the track being played is a commercial, product information, specifications, sizes, prices, or any other pertinent material or desirable information can be displayed in track space 324. As with the other forms of supplemental information, this information can be directly retrieved from a data server 214 or alternatively via supplemental server 216.

Preferably, in one embodiment, a retrieval and display of album image 322 and track information 324 occurs automatically without user interaction upon receipt of program data. That is, these images and information are retrieved by user terminal 212 as soon as the program data is received. Playing of the track can begin immediately, or can be delayed until some or all of the supplemental materials are received.

Additional info portion 328 can be used to provide additional information to the user or to provide menu selections that the user can interact with to select or obtain additional information or supplemental materials regarding the current track. For example, additional information can include buttons to allow the user to select additional information such as, for example, artist information, concert tour information, album information, a "libretto" having words to the track being played or to other tracks on the current album, ticket information for upcoming concerts, merchandizing materials, and other information that may be of value or that a user may foreseeably desire.

Preferably, in one embodiment, these selections provide information pertaining to the current track being played, again based upon the program data that is received for the current track. This can be information relevant to a current song being played or additional information relative to an advertisement being played. In one embodiment, the specific information "behind" these buttons is not retrieved by user terminal 212 until a button is clicked. Therefore, in this embodiment, user terminal does not go through the steps of retrieving information from a server until that information is actually requested. Alternatively, of course, all of this information can be accessed and retrieved upon receipt of a program data code; however, this may result in unnecessary loading of the communication channels.

Additionally, in one embodiment, the URL's or other locational information pertaining to the information behind these buttons is also not received or retrieved from ID server 214 until requested. Alternatively, the URL's for the information are retrieved such that the response time when a button is clicked is that much faster for the user. As stated, for advertisements, this information or the buttons can provide selections pertinent or relevant to the product being advertised. For example, selections such as additional

product information, shipping or delivery information, availability information, links to a company's complete catalog or web page, product safety information, competing product information, or other information that a user may find useful or relevant can be linked to using additional information selection area 328.

5           Also illustrated in the example player of Figure 7 is a buy now button 326. In one embodiment, buy now button 326, when selected, activates a link to a source whereby the user can purchase the album title being played. For example, in one embodiment, when the user clicks buy now button 326 the URL associated with a supplier of the album is retrieved. The user terminal 212 accesses the supplier's web site, allowing the user to  
10           purchase the album on-line. One example of a supplier web site is [www.amazon.com](http://www.amazon.com). In one embodiment, buy now button 326 can bring up a list of potential suppliers such that the user can select which of a plurality of suppliers he or she wishes to access to purchase the album. Alternatively, in other embodiments, the user is not provided with the choice, but instead a single click on buy now button 326 brings the user directly to the preferred  
15           supplier. The supplier may of course vary depending upon the album title as not all suppliers carry all titles.

          In one embodiment, when program data is received at user terminal 212 and used to access the supplemental information, this supplemental information returned for the album title is a specific page within the supplier that links directly to that particular album.  
20           For example, where the supplier is [www.amazon.com](http://www.amazon.com), the URL retrieved to be associated with the buy now button 326 is the URL that maps directly to the page or pages in the Amazon.com® website that relate to the current track or album. Therefore, the user in this embodiment does not have to work his or her way through several web pages to get directly to the pages pertaining specifically to the album being played.

25           In one embodiment, when the buy now button 326 is clicked, the appropriate or related web pages can be brought up directly within data window 302. They can be configured to span the entire area of data window 302, or alternatively, to be a subset thereof. Additionally, a separate window can be opened or a separate browser launched, to allow the retrieved pages to be viewed in a windowed manner with respect to the player.  
30           Of course, the player and the window can be sized such that they both can be viewed simultaneously. The player is not limited to a single buy now button 326 and can have buy now buttons relating to the album, concert tickets, or additional materials. Also in this embodiment, it is not necessary that the buy now button 326 be on the first instance of data window 302. Buy now buttons can be interspersed within the various supplemental  
35           images that are brought up as the user navigates through the variety of supplemental information available.



Additionally, the supplier does not have to be an on-line supplier. In these alternative embodiments, buy now button 326 can execute another action to facilitate purchase of the title or advertised product by the alternative supplier. For example, the button can cause an e-mail purchase order to be generated and sent, a phone call to be placed, or some other purchase-initiating action.

In one embodiment, concert information can be provided specifically based on the geographic location of the user. Thus, a user can immediately see when the artist will be appearing next in his or her area. Again, a buy now button can be associated with this concert such that the user can access a site selling tickets to the concert or concerts, or otherwise initiate a purchase of concert tickets.

In another embodiment, a button can be provided to allow the user to obtain information regarding other artists with a similar style, feel, or sound as the current artist or track. Therefore, if a listener is particularly fond of the selection being played, that listener can search for other titles or artists who also have a similar sound, style, or feel. This embodiment can use a data base that provides relational information for the various artists based on their style, sound, or other features or characteristics of the artist. In an extension of this embodiment, the user or listener may also be provided with the ability to click to select sample sound tracks from various other artists or albums that are selected in this manner.

Therefore, if a user likes a particular sound and wants to hear a brief sample of an album by another artist, this can be accomplished with a simple selection by the listener. In one embodiment, this can be facilitated by providing the URL's of locations where the sample tracks can be found. Alternatively, a data base can be maintained within supplemental server 216 that allows sample tracks to be stored directly therein. Additionally, sample tracks can be provided for the current album such that the listener can sample other tracks of the current album before deciding whether to purchase that album.

Where the current track is an advertisement, buy now button 326 can similarly be used to provide a link to a site through which the user can purchase the product or products being advertised. Similar to the music track, this can be a direct link to the supplier's page or pages that offer their particular product for sale, or to the company's home page such that the user can browse through and obtain information about the company and all of its products.

In one embodiment, virtual coupons can be implemented whereby an "on-line" coupon is offered to the listener. In this case, a button may be provided that enables a user to select a coupon. For example, a user may click on the select coupon button causing the

coupon to be printed out on a printer associated with the listener's machine. Advertisers may use this virtual coupon as a device for offering special promotions to web-based listeners. Of course, coupons can present special deals and can have expiration dates and other features or aspects associated with conventional paper coupons.

5 A history window 306 can also be provided to display a history of tracks played by the radio station 204 or other program provider 104. In one embodiment, history window 306 is a sliding window that illustrates a predetermined or selectable number of the most recent tracks contained within the broadcast material. The history window, in one embodiment, is a chronological display of past tracks played. The display does not need  
10 to be chronological, however, this organization may represent a more user friendly interface. Where cut codes or other information pertaining to future tracks is available, the history bar may also be used to provide a look into upcoming programming.

The history window 306 can also include scroll buttons or a scroll bar such that the listener can scroll through the various selections in history window 306. History window  
15 306 does not need to be limited to displaying a history of music tracks played, but can also display a history of advertising or other tracks included in the broadcast material. History window 306 can provide a means for a listener to easily go back and retrieve information on past tracks.

In one embodiment, the user simply clicks on one of the windows in the history bar  
20 to bring up the information for that selection. For example, in the embodiment illustrated in Figure 7, history window 306 shows the five most recent tracks played. These are, in chronological order (oldest to most recent), the Beatles, a Sony advertisement, a McDonald's advertisement, a Sprint advertisement, and a Fleetwood Mac selection. In the embodiment illustrated, the Fleetwood Mac selection is the one that was most recently on  
25 air. If, for example, the listener wanted to obtain additional information about the Beatles selection that was being played, the user may simply click on the Beatles window and that information can be displayed on data window 302. In this case, live-air indicator 316 may change to show it is no longer a live selection.

However, with the history information pulled up, in one embodiment, the user can  
30 access all of the information that he or she could have accessed via the various buttons and selections when the selection was originally being played. Thus, even if the user did not take the opportunity to check on concert information or album information or to order an album when the song was originally played, the user can go back via the history bar and take the opportunity to do so at this time. In one embodiment, all that is saved is the  
35 program data for each item in the history window. Therefore, when the user makes a

selection, the process of retrieving supplemental information for the selected item begins again from scratch.

Alternatively, any or all of the information previously retrieved when that track was initially played can be stored locally such that the information does not have to be re-retrieved when a history selection is made. Of course, depending on the amount of information retrieved and the storage space available, the number of selections for which material can be stored may vary. In one embodiment, the amount of information saved can be user selected. In the case of an advertisement that included a virtual coupon, for example, the user can still go back to that advertisement and obtain the coupon.

In one embodiment, the history bar is maintained only for selections or tracks that were played while the listener terminal 212 was actively receiving broadcast material. Alternatively, program data from previous tracks prior to the time that the user terminal 212 was "listening" to the broadcast can be downloaded such that the history bar can be filled in for earlier tracks. This application is particularly suited for the embodiment in which the program data is provided from the radio station 104 directly to data server 116. In this embodiment, the server can maintain a history and schedule of the tracks played by a particular broadcaster during a given time period. However, the invention is not limited to this embodiment as this history can be maintained by keeping track of the program data codes that are received from data terminals 212 in the embodiment illustrated in Figure 5.

There are several advantages that are obtained by providing a history bar such as that illustrated in Figure 7. One advantage is that the user can go back and retrieve information pertaining to a selection that he or she may otherwise have missed. Thus, the user is afforded the opportunity to take advantage of things that can easily be missed in real time broadcasts. For example, a user may be listening to broadcast material in a car on his or her way to the office. The user may hear a song that he or she likes or perhaps may even hear an advertisement of a product that he or she is interested in purchasing. However, as the listener is currently driving down the freeway, it is not practical to write down the information provided.

Additionally, the user may wish to take advantage of the features provided by the player and cannot do so while listening in the car. Therefore, when the listener reaches his or her destination, the listener can bring up the player, access the broadcast broadcast material, and go back through the history bar 306 to find the track in which he or she was interested. For example, if the user wishes to purchase an album or obtain additional information about an album or track that was played on the radio while he or she was in the car, the user can simply select that album from the history bar and can retrieve all of the informational pertaining to that album. Additionally, the user can purchase the

product through the use of buy now button 326. Thus, simply because the listener was in the car, the listener has not missed the opportunity to obtain additional information about the track or purchase the album. In the case of advertisements, the user may wish to purchase a product that he or she heard advertised while in the car, or take advantage of a coupon that was advertised for a product while he or she was in the car. Similarly, the user can access the history bar 306, go back to the particular advertisement, and retrieve the coupon or other information that the user desires. Thus, the user has not lost the opportunity to purchase a product or obtain savings related to a product, simply because he or she was listening to the radio station in the car.

Unless the listener's user terminal 212 was on and active during the time the track of interest was broadcast, the data codes have not been provided to user terminal 212. Therefore, when the user activates his or her player, the player will retrieve the data codes for the period of time in which the player was active. In embodiments where program data is provided on server 116 from provider 104, data codes for the history prior to the time at which the player was active is also available. Additionally, server 116 may be able to obtain a history for the user based on codes or data received from other listeners of the same program. Alternatively, broadcast Internet service provider 208 may maintain a history of the data codes such that they can be provided to the user terminal to access information pertaining to past codes prior to the time at which the player was active.

An additional advantage of a history bar 306 is that the advertiser's advertising impression is provided with "air time" greater than that provided with the advertising time slot. For example, an advertiser's commercial may air for 15 to 30 seconds on the radio within the broadcast material. However, once the advertiser's logo is placed on a button in history window 306, that logo can remain on the bar for the duration of the following several slots, depending on the size of the history window. For example, in the embodiment illustrated in Figure 7, in which the history window displays 5 active buttons, an advertiser's logo would be visible to the listener during the advertiser's time slot and also during the subsequent 4 time slots. For example, if these subsequent four time slots are music tracks of approximately 3 minutes in length, the advertiser's logo is available or has "air time" for an additional 12 minutes above and beyond that which it would otherwise receive.

Also illustrated in Figure 7 is an advertising window 308. Advertising window 308 can be included to provide additional advertising slots to be displayed to the listener. In one embodiment, advertising window 308 displays banner ads or other ads of products provided by advertisers. The banner ads or other advertising materials for display in advertising window 308 can also be retrieved in a manner similar to the retrieval of the

other supplemental materials. Thus, the advertisements can be coordinated with or coded to particular tracks within the broadcast material. This has the advantage that the advertising can be geared to the particular listener expected to be listening to a track that is currently playing in the programming material. As such, the advertising material is more relevant and of greater interest to the listener which is advantageous to both the listener and the advertiser.

For example, when a Grateful Dead track is being played, banner ads related to items of interest to Grateful Dead listeners may be keyed for appearance in advertising window 308. The importance of this feature can be further illustrated by considering a typical listening scenario. Because most listeners tend to listen to broadcast material such as radio information in the background, it is anticipated that the majority of the time that the player is active, the player will be operating in the background mode on user terminal 212. For example, where the listener is at his or her office working on other applications on his or her user terminal, the player may be active in the background, providing background music to accompany the listener throughout his or her workday. However, when the listener comes upon a particular track that he or she has great interest in, that listener may bring the player window to the forefront. As such, it is during this time, that the advertising window 308 is visible to the listener. Therefore, keying the advertisements to the track in the broadcast material maximizes the benefit of the advertisement occurring in advertising window 308.

Advertising window 308 can also be coordinated with advertisement tracks being broadcast within the broadcast material. For example, advertising window 308 may advertise other related products, current specials in addition to what is being advertised on the radio, or other information or material that may be pertinent to be keyed with the advertising track. In one embodiment, it is even foreseeable that competitors' ads be placed in advertising window 308 such that competitors can have the chance to also compete in the marketplace. It should be noted however that it is foreseeable that agreements with the advertisers may restrict this practice from occurring. However, the capability exists within the system described herein.

Also provided on player interface 304 is a station list button 318. Station list button 318, when clicked, accesses a list of stations that are accessible by the player. Thus, if the listener wishes to change the station, the listener can click station list 318 and select a new station from among those listed. The list can include identifying information such as, for example, station name, frequency, format, and other information.

As the example described above with reference to Figures 5, 6 and 7 illustrates, the provision of supplemental materials coordinated with a stream of broadcast material can

provide numerous features and advantages to the user and the providers. Again, it is stressed that the invention is not limited to the specific applications or examples described herein. For example, although the player of Figure 7 was discussed in terms of the radio station example illustrated in Figures 5 and 6, such a player can be used with other architectures, including those architectures illustrated in Figures 1-4. Again, broadcast material is not limited to radio broadcast material, but can include other audio, video, or alternative format material.

One or two alternatives are briefly described such that it can be seen how they would fit within the invention described herein. For example, consider a situation where the broadcast material being delivered is television programming. Television programming can be thought of as being formatted similar to the radio broadcast in that it includes tracks of the television program as well as advertising tracks and promotional slots. Similar to the radio example, these tracks in video material can be coded such that supplemental information can be retrieved for the coded tracks. This information can be keyed to and coordinated with the tracks such that the benefit derived from the information is maximized. Information can include information such as the series or program being displayed, actors or actresses associated with the series, perhaps even products that are viewed in camera on the series that a user may wish to investigate more fully.

For example, where the broadcast material is a television show, the actors on a television show may be driving a particular automobile, using a particular brand of coffee, or otherwise using a specific consumer-related product. It is foreseeable then that supplemental information relating to this broadcast material can be coded into the program data such that this supplemental information can be retrieved in conjunction with the viewing of the broadcast material. For example, windows adjacent to the viewing window can provide the user with selections to view supplemental information pertaining to one or more products. Thus, with the click of one of these buttons, the user can obtain this additional information which again can include product specifications, ordering information, shipping and delivery information, as well as a host of other informational items that may be associated with the particular product.

As another example, consider the case in which the broadcast material is a class lecture being delivered by a professor to user equipment 112. The broadcast material may be divided into segments analogous to the tracks, and these segments can have codes associated therewith analogous to the program data. Where this format can also be useful for keying specific supplemental information to specific segments such as, for example, complete solutions to problems being solved in the class, supplemental texts or treatises

relating to the subject matter of the segment, homework assignments for the next class, class syllabus or schedule information, and any other informational materials that may be relevant to a segment or class.

As the few examples illustrate, the application of the invention is seemingly  
5 limitless in that there are numerous different types of broadcast material and associated supplemental information that can be coordinated in this manner.

A number of different architectures and configurations can be used to implement a player such as, for example, the player described above. Figure 8 is a block diagram illustrating the functionality of an example player according to one embodiment of the  
10 invention. The player, according to this embodiment, includes several modules for receiving materials, coordinating materials, and playing the materials via the player. These modules are now described according to this example embodiment. After reading this description, it will become apparent to one of ordinary skill in the art how one or more players can be implemented using this or alternative functional architectures. A received  
15 broadcast module 404 is configured to receive the broadcast from the broadcast material broadcast provider. As discussed above, in one embodiment, this broadcast is received via the Internet from an Internet broadcast provider.

A play broadcast module 408 is configured to receive the broadcast material from received module 404 and configure the broadcast material for playback via the player. In  
20 one embodiment, the broadcast material can be provided to a display screen 410, a speaker 412, as well as other peripheral devices 422. A get-data module 414 can be included to utilize the program data to retrieve information pertaining to the supplemental materials. In one embodiment, as discussed above, this information retrieved is locational or other parameters pertaining to the supplemental data that can provide an indication to the user  
25 equipment regarding where to locate the supplemental materials. In alternative embodiments, get-data module 414 can access a server to directly obtain these supplemental materials based on the program data.

A get-materials module 418 can be utilized to use the parameters retrieved by get-data module 414 to subsequently receive the broadcast materials from one or more servers.  
30 The get-materials module 418 can provide the retrieved materials to the play broadcast module 408 such that these supplemental materials can be displayed or otherwise played along with the broadcast material on the various peripheral devices.

Also illustrated in Figure 8 is a history module 420 that can be used to coordinate the archival or storage of particular pieces of information to maintain a history window, as  
35 discussed in further detail below. In one embodiment, history module 420 stores the program data received by received module 404 such that this program data can be used to

allow the user to go back and retrieve broadcast materials pertaining to a particular segment of the broadcast program. The history module 420 can be used to store program data, as well as, in one embodiment, supplemental materials that may already have been retrieved for a particular program segment.

5           Figure 9 is a block diagram illustrating one process by which a history window 306 can retrieve information pertaining to the history of the broadcast material. Referring now to Figure 9, in a step 442, the player receives the broadcast material and program data from a broadcaster. In a step 444, the broadcast material is played to the user while the program data is used to access supplemental information. In a step 446, the program data  
10 for each segment is stored in local storage such that it can be recalled by the history window for later use.

          Also stored, in a step 448, is an image associated with the program data. This image is displayed as part of the history window. Associated with the displayed image is an identification of the program data or other information that can be used to identify the  
15 particular history item. In response to a user selection of a particular item of the history window, the history module retrieves supplemental materials associated with the selected track, and plays these materials to the user. In one embodiment, only the program data is stored for each track, and the history module needs to do a retrieval of supplemental materials associated with that track.

20           In an alternative embodiment, some or all of the supplemental materials previously retrieved for that track can be stored locally and associated with the item in the history window. In this alternative, these items do not need to be retrieved, and can be more immediately played to the user.

          A more specific example implementation is now described with reference to  
25 Figures 10 – 12. As illustrated, in this example, on-air system 501 of the type typically employed by a broadcaster such as a radio station or the like broadcasts a predetermined audio stream comprising a predetermined sequence of songs interspersed with one or more audio advertisements. In one example, the on-air system is a commercially available system such as ENCO or Prophet commonly used by radio stations and the like. The on-  
30 air system transmits this audio information over the airwaves through antenna 505, and also provides it in digital form over signal line 506 to encoder 503. Concurrently, the on-air system also provides over signal line 507 data in the form of identifying indicia or codes such as cut codes. The codes are indicators of the audio information concurrently being transmitted over signal line 506. Advantageously, each song or advertisement  
35 comprising the audio information being concurrently transmitted over signal line 506 comprises a distinct segment. A cut code corresponding to and uniquely identifying a



segment from the standpoint of the radio station is transmitted over signal line 507 concurrently with the transmission of the corresponding segment over signal line 506.

Encoder 503 is configured to compress the audio information received over signal line 506. Advantageously, the encoder can be implemented using a commercially available encoding scheme such as, for example, the "Active Streaming Format" from Microsoft Netshow, or the "SureStream" G2 encoding scheme from Real. Advantageously, the encoder 503 is part of a coordinating encoder 502 configured to merge the cut codes provided over signal line 507 with the audio information provided over signal line 506 to provide a merged data stream over signal line 508. The encoder 503 under the control of the coordinating encoder 502 performs this merging procedure. Advantageously, in this procedure, a cut code is inserted into the merged stream throughout the audio segment it identifies. In one embodiment, Radowave.com, the assignee of the subject application, provides the coordinating encoder 502.

The audio information transmitted from antenna 505 is advantageously received by one or more traditional RF receivers (not shown) configured in the form of radios and the like. This process is known to those of ordinary skill in the art, and need not be described further.

Meanwhile, the merged stream is provided over signal line 508 to one or more broadcast servers 509. In one variant, the transmission of the merged data to the broadcast servers is accomplished through a wireless interface rather than a signal line. Advantageously, in one embodiment, the servers are provided by broadcast.com, of Dallas, TX, [www.broadcast.com](http://www.broadcast.com), and are configured to simply broadcast the merged stream over a communications network such as the Internet.

A player 510 is provided which executes on a client computer or other end use device within the communications network. Alternatively, the player is a web-based player resident on a server in the network, but accessible through the client machine. The player is configured to receive the merged stream over signal line 513 and play the audio component thereof through speakers or the like (not shown) configured as part of the client computer/end user device. In addition, the player is advantageously associated with the radio station or other broadcaster associated with on-air system 501, such that the identity of the radio station or other broadcaster is known to the player.

The player is also configured to detect the presence of a cut code in the merged stream, and responsive to detecting the presence of a cut code identifying a song, signal another server on the network identified with numeral 511. (The response of the player to detecting the presence of a cut code identifying an advertisement is detailed in the next section). In one embodiment, upon detecting a cut code identifying a song, the player is

configured to provide server 511 with the identity of radio station 501, as well as the cut code that has been detected.

Advantageously, in one embodiment, server 511 is provided by RadioWave.com, the assignee of the subject application. Responsive to the receipt of a station ID and a cut code identifying a song, the server 511 accesses one or more tables. With reference to  
5 Figure 11, the server 511 first accesses a song table 516, the entries of which correlate a station ID and cut code with an ID of the album containing the song, the name of the artist, the album name, and the song name. Through this step, the server 511 obtains the album ID for the album containing the song associated with the cut code and station ID that was  
10 previously sent to the server.

Next, the server 511 accesses a provider table 517. As can be seen, the entries of this table correlate the album ID with (1) a name of an image related to the cut or segment, such as but not limited to a gif image of the cover of the album or tape containing the song; (2) a provider link, i.e., a URL or other link to additional information related to the  
15 song or album, such as a link to a server 512 of a fulfillment provider; (3) the artist name; (4) album name; and ( 5) song name. In one example, by accessing this table, the server 511 obtains the name of an image file of the album or tape cover containing the song, the artist name, the album name, the song name, and the record label. In one implementation, the fulfillment provider server is that of Amazon, Inc. at [www.amazon.com](http://www.amazon.com), and the link  
20 to this server is a URL link known as an ASIN#. In one embodiment, server 511 obtains the actual image for the album cover, which is either stored locally or on another server accessible from server 511, and then provides the image, song name, artist name, and album name to player 510. In another embodiment, server 511 provides the player 510 with a link to the image stored on another server, and, responsive to this information, the  
25 player 510 obtains the actual image for the album cover, or other related image, from fulfillment provider server 512.

In the event that there is not an entry in the provider table 517 for the album ID obtained from the song table 516, the artist name, album name, and song name are obtained from the song table 516. That is the reason why entries for this information are  
30 redundantly provided in both the song table 516 and provider table 517. In this event, song name, artist name, and album name are provided to the player 510, but the provider link is omitted.

Responsive to the receipt of the artist name, album name, song name, image, and provider link (this last item of information being provided only in the case in which there  
35 is an entry for the album in the provider table) are then provided to the player 510. Upon receiving this information, the player displays it through a suitable display.

With reference to Figure 12, an example of such a display is illustrated. As can be seen, the display includes a web-based component 526 in which is displayed the image 518 of the album cover for the song that is currently being played, the name 519 of the artist of the song, the name 520 of the song, and the name 521 of the album in which the song is contained. In addition, around the web-based display component is a border 527, which is advantageously stored locally on the client machine. Displayed within or at the border 527 is an identifier 523 for the radio station 501 from which the audio information being broadcast originates, and an indicator 524 of the quality of the signal, and the elapsed listening time.

In one embodiment, a history component 525 is displayed below the web-based component. This component contains information about the audio segments that have been played by the player in the recent past. In the illustrated embodiment, the history information is displayed with the most recent information beginning at the left, and the less recent information being arranged towards the right. As can be seen, the information is displayed is the image associated with the segment. Also, images can be displayed both for songs and advertisements that have aired. Starting from the left, it can be seen that an image 525a from a Fleetwood Mac album cover is displayed, indicating that a song from this album was most recently played. This is followed by images for advertisements, which have aired, from Sprint, McDonalds, and Sony. The image for the McDonalds advertisement is identified with numeral 525b. Next, image 525c for a Beatles album cover is displayed, indicating that a song from this album was played. As audio information is played, this history information is updated.

A "buy now" button 522 is also displayed. When a user clicks on this button 522, with reference to Figure 10, a link is established to a program resident on fulfillment provider server 512 using the provider link provided by the server 511. As discussed, in one example, the fulfillment provider server 512 is [www.amazon.com](http://www.amazon.com), and the provider link is an ASIN# which is a URL link to this server. Once this link is established, in one embodiment, a browser is launched allowing a user to peruse information resident on server 511 and purchase the album containing the song being played or related albums. Alternatively, the user is allowed access to this information through a feature window displayed by the player. In one example, the link to server 512 is established simply by appending the provider link to the URL of the server 512. In this example, it is assumed that the URL of the server 512 is known to the player 510, but it should be appreciated that examples are possible in which this URL information is provided to player 510 by server 511.

It should be appreciated that examples are possible in which server 511 provides other links associated with the song being played to the player 510. One such example is a URL or other link to information describing the concert tour schedule of the artist of the song being aired, and a program allowing the user to purchase tickets to one of these concerts. With reference to Figure 512, when a user clicks on a “tours and tickets” identifier 528a, the link to this information can be established, and a browser launched or other mechanism such as a feature window initiated allowing the user to peruse this information.

Another example is a URL or other link to information describing other albums by the artist of the song currently being played. Again with reference to Figure 512, when a user clicks on an “artist archives” identifier 5028b, the link to this information can be established, and a browser launched or other mechanism initiated, such as a feature window, allowing the user to peruse this information.

A third example is a URL or other link to information about a product or service being advertised. According to this example, an advertisement regarding a product or service is displayed within web-based component 526. When a user clicks on this information, a URL or other link can be established to a server configured to provide additional information about this product or service, and a browser launched or other mechanism initiated, such as a feature window, to allow a user to peruse this information.

The above specific example is provided by way of example only, and it should be appreciated that other environments are possible allowing beneficial employment of the subject invention, including the more generic examples described above.

The various embodiments, systems and subsystems of the invention described above may be implemented using hardware, software or a combination thereof and may be implemented in one or more computer systems or other processing systems. In fact, in one embodiment, these elements are implemented using a computer system capable of carrying out the functionality described with respect thereto. An example computer system 702 is shown in and described with respect to Figure 13. The computer system 702 illustrated in Figure 10 includes one or more processors, such as processor 704. The processor 704 is connected to a communication bus 706. Various software embodiments are described in terms of this example computer system. After reading this description, it will become apparent to a person skilled in the relevant art how to implement the invention using other computer or processor systems and/or architectures. The functionality of the invention as described above is not dependent on a particular computer or processor architecture.

Computer system 702 can include a main memory 708, preferably random access memory (RAM), and can also include a secondary memory 710. The secondary memory 710 can include, for example, a hard disk drive 712 and/or a removable storage drive 714, representing a floppy disk drive, a magnetic tape drive, an optical disk drive, etc. The removable storage drive 714 reads from and/or writes to a removable storage medium 718 in a well known manner. Removable storage media 718, represents a floppy disk, magnetic tape, optical disk, etc. which is read by and written to by removable storage drive 714. As will be appreciated, the removable storage media 718 includes a computer usable storage medium having stored therein computer software and/or data.

In alternative embodiments, secondary memory 710 may include other similar means for allowing computer programs or other instructions to be loaded into computer system 702. Such means can include, for example, a removable storage unit 722 and an interface 720. Examples of such can include a program cartridge and cartridge interface (such as that found in video game devices), a removable memory chip (such as an EPROM, or PROM) and associated socket, and other removable storage units 722 and interfaces 720 which allow software and data to be transferred from the removable storage unit 718 to computer system 702.

Computer system 702 can also include a communications interface 724. Communications interface 724 allows software and data to be transferred between computer system 702 and external devices. Examples of communications interface 724 can include a modem, a network interface (such as, for example, an Ethernet card), a communications port, a PCMCIA slot and card, etc. Software and data transferred via communications interface 724 are in the form of signals which can be electronic, electromagnetic, optical or other signals capable of being received by communications interface 724. These signals are provided to communications interface via a channel 728. This channel 728 carries signals and can be implemented using a wireless medium, wire or cable, fiber optics, or other communications medium. Some examples of a channel can include a phone line, a cellular phone link, an RF link, a network interface, and other communications channels.

In this document, the terms "computer program medium" and "computer usable medium" are used to generally refer to media such as removable storage device 718, a disk capable of installation in disk drive 712, and signals on channel 728. These computer program products are means for providing software or program instructions to computer system 702.

Computer programs (also called computer control logic) are stored in main memory and/or secondary memory 710. Computer programs can also be received via

communications interface 724. Such computer programs, when executed, enable the computer system 702 to perform the features of the present invention as discussed herein. In particular, the computer programs, when executed, enable the processor 704 to perform the features of the present invention. Accordingly, such computer programs represent  
5 controllers of the computer system 702.

In an embodiment where the elements are implemented using software, the software may be stored in, or transmitted via, a computer program product and loaded into computer system 702 using removable storage drive 714, hard drive 712 or  
10 communications interface 724. The control logic (software), when executed by the processor 704, causes the processor 704 to perform the functions of the invention as described herein.

In another embodiment, the elements are implemented primarily in hardware using, for example, hardware components such as PALs, application specific integrated circuits (ASICs) or other hardware components. Implementation of a hardware state  
15 machine so as to perform the functions described herein will be apparent to persons skilled in the relevant art(s). In yet another embodiment, elements are implemented using a combination of both hardware and software.

While various embodiments of the present invention have been shown and described above, it should be understood that they have been presented by way of example  
20 only, and not limitation. It should be apparent to those of ordinary skill in the art that many other embodiments are possible without departing from the spirit and scope of the invention. Thus, the breadth and scope of the present invention should not be limited by any of the above-described exemplary embodiments, but should be defined only in accordance with the claims and their equivalents.

Claims

1. A history window associated with a media player, comprising  
a window element configured to display an item of supplemental  
information related to a previously broadcast program segment; and  
5 an identification associated with said window element identifying  
additional supplemental information related to said previously broadcast program  
segment;  
wherein said media player is configured to use said identification to retrieve  
said additional supplemental information upon selection by a user.
- 10 2. The history window of claim 1, wherein said identification is program data  
associated with said broadcast program segment.
3. The history window of claim 1, wherein said window element is one of a  
plurality of window elements arranged in chronological order on a screen of said media  
player.
- 15 4. The history window of claim 1, wherein said additional supplemental  
information is stored locally on a user terminal.
5. The history window of claim 1, wherein said additional supplemental  
information is retrieved from a data server.
6. The history window of claim 1, wherein said additional supplemental  
20 information is stored on said server.
7. The history window of claim 1, wherein said additional supplemental  
information is stored on a second server, and an identification of said supplemental  
information is stored on said data server.
8. The history window of claim 3, further comprising a scroll bar enabling  
25 scrolling through a plurality of window elements in response to user input.
9. The history window of claim 3, wherein said identification is stored in one  
of a circular buffer, a LIFO, or a FIFO.

10. The history window of claim 1, wherein said additional supplemental information includes an advertiser coupon.

11. The history window of claim 1, wherein said item of supplemental information comprises at least one of an album image or an advertiser's impression.

5 12. The history window of claim 1, wherein said additional supplemental information is provided for playback by the media player.

13. The history window of claim 1, wherein said broadcast material is a radio program.

10 14. A method for providing a history of broadcast material, comprising:  
displaying an item of supplemental information in a window element, said supplemental information related to a previously broadcast program segment; and  
providing an identification associated with said window element, said identification identifying additional supplemental information related to said previously broadcast program segment;  
15 wherein said media player is configured to use said identification to retrieve said additional supplemental information upon selection by a user.

15. The history window of claim 1, wherein said identification is program data associated with said broadcast program segment.

20 16. The history window of claim 1, wherein said window element is one of a plurality of window elements arranged in chronological order on a screen of said media player.

17. The history window of claim 1, wherein said additional supplemental information is stored locally on a user terminal.

25 18. The history window of claim 1, wherein said additional supplemental information is retrieved from a data server.

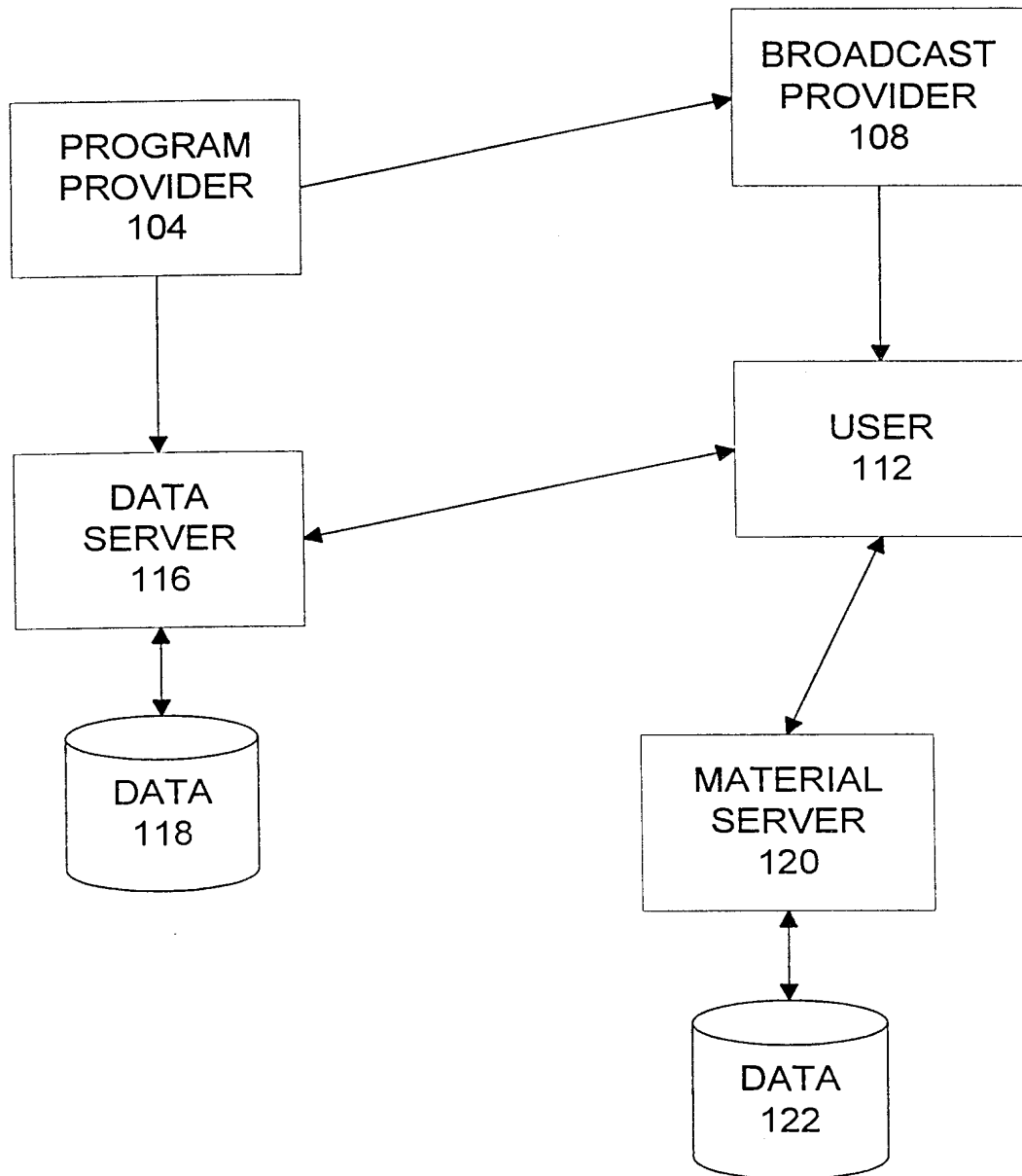
19. The history window of claim 1, wherein said additional supplemental information is stored on said server.



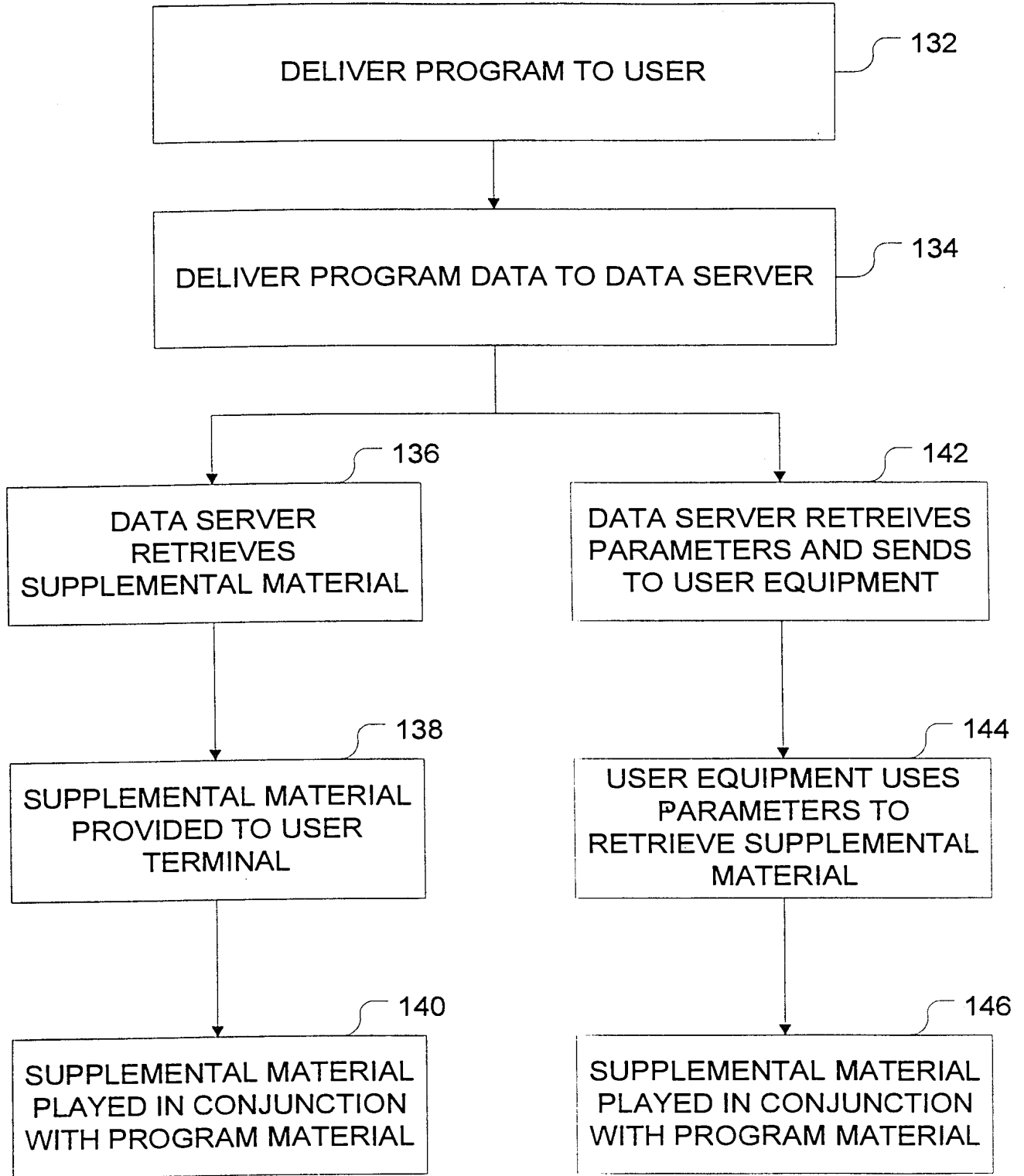
20. The history window of claim 1, wherein said additional supplemental information is stored on a second server, and an identification of said supplemental information is stored on said data server.

21. The history window of claim 1, wherein said additional supplemental  
5 information includes an advertiser coupon.

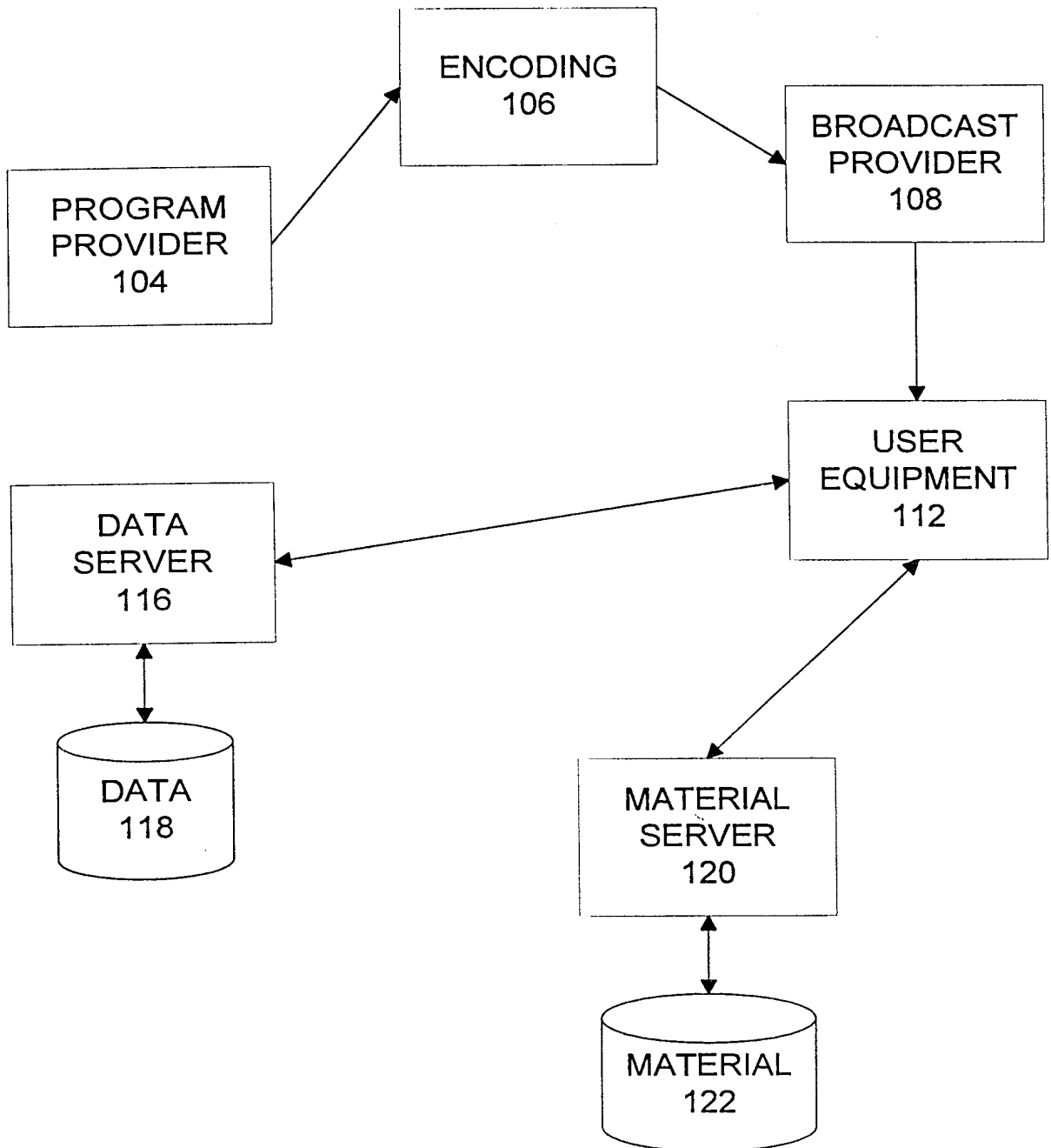
22. The history window of claim 1, wherein said item of supplemental information comprises at least one of an album image or an advertiser's impression.



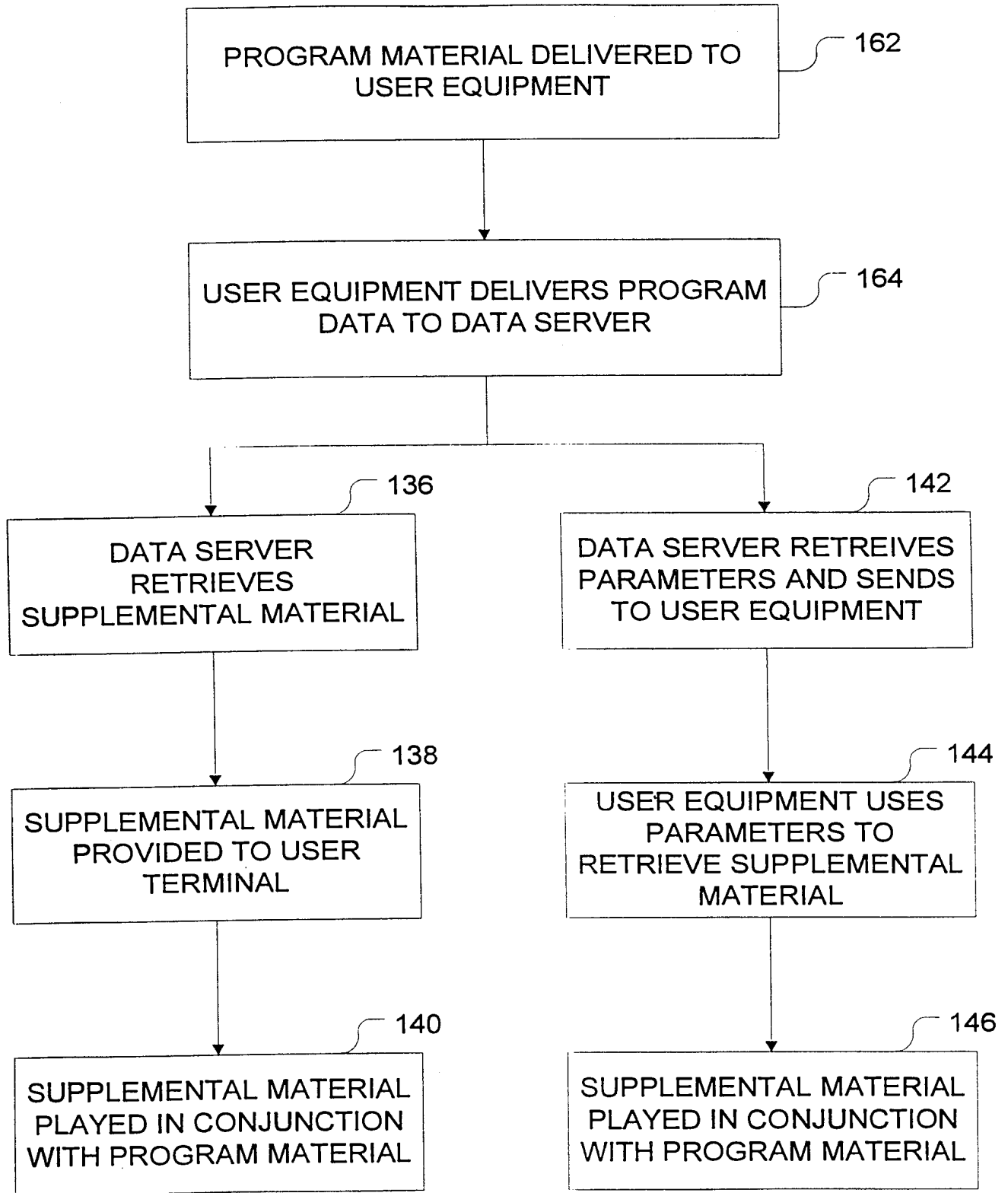
**Fig. 1**



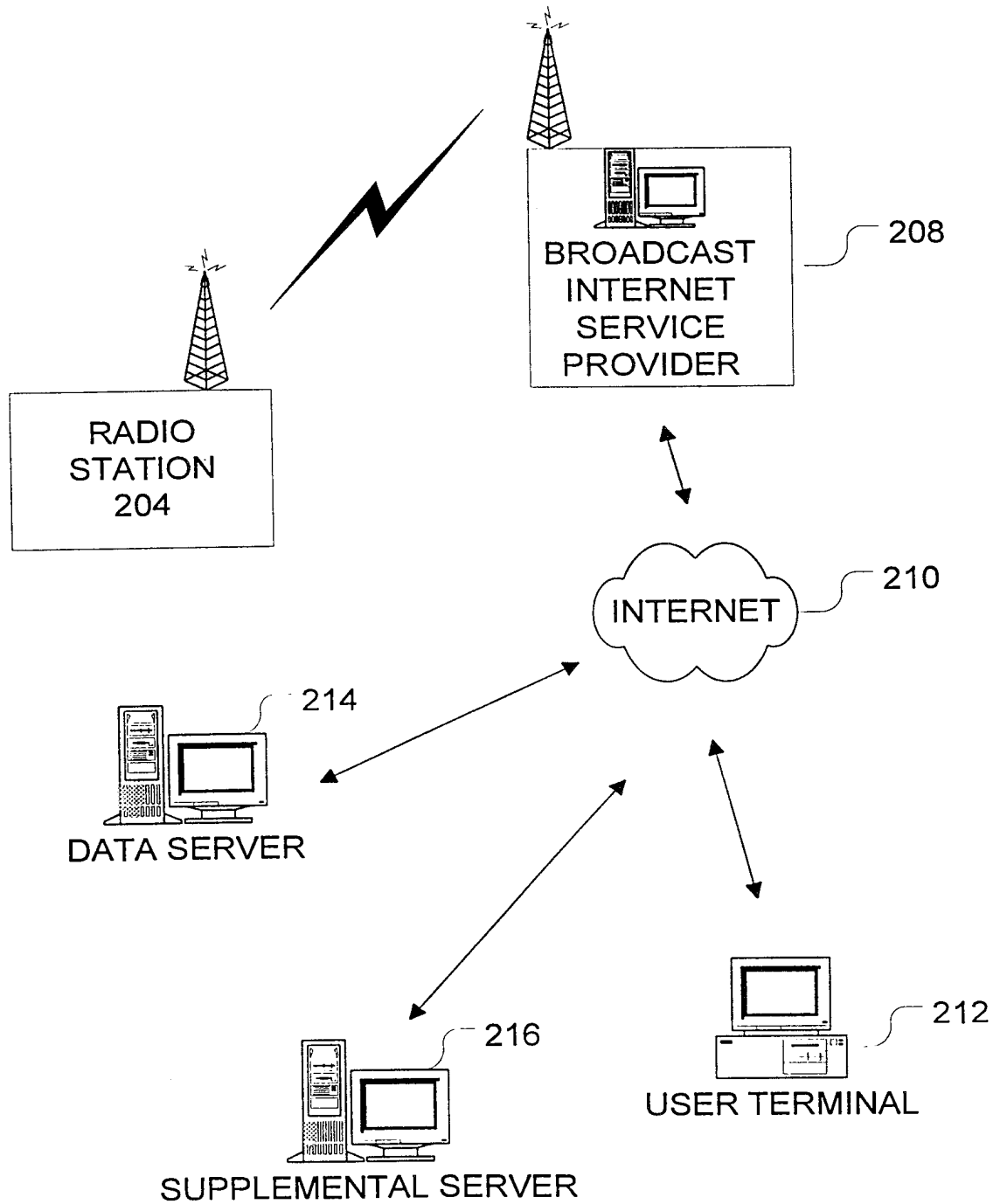
**Fig. 2**



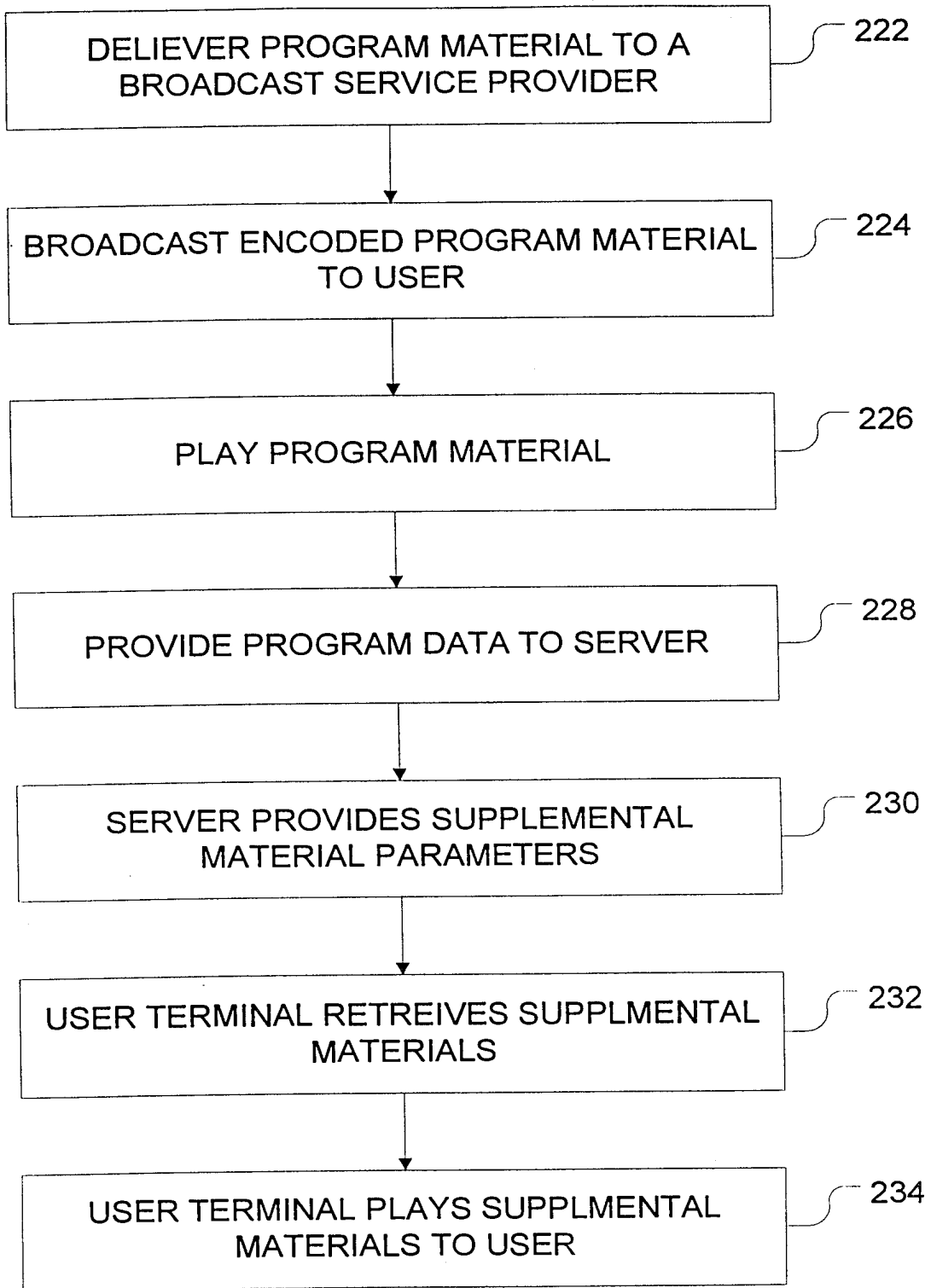
**Fig. 3**



**Fig. 4**

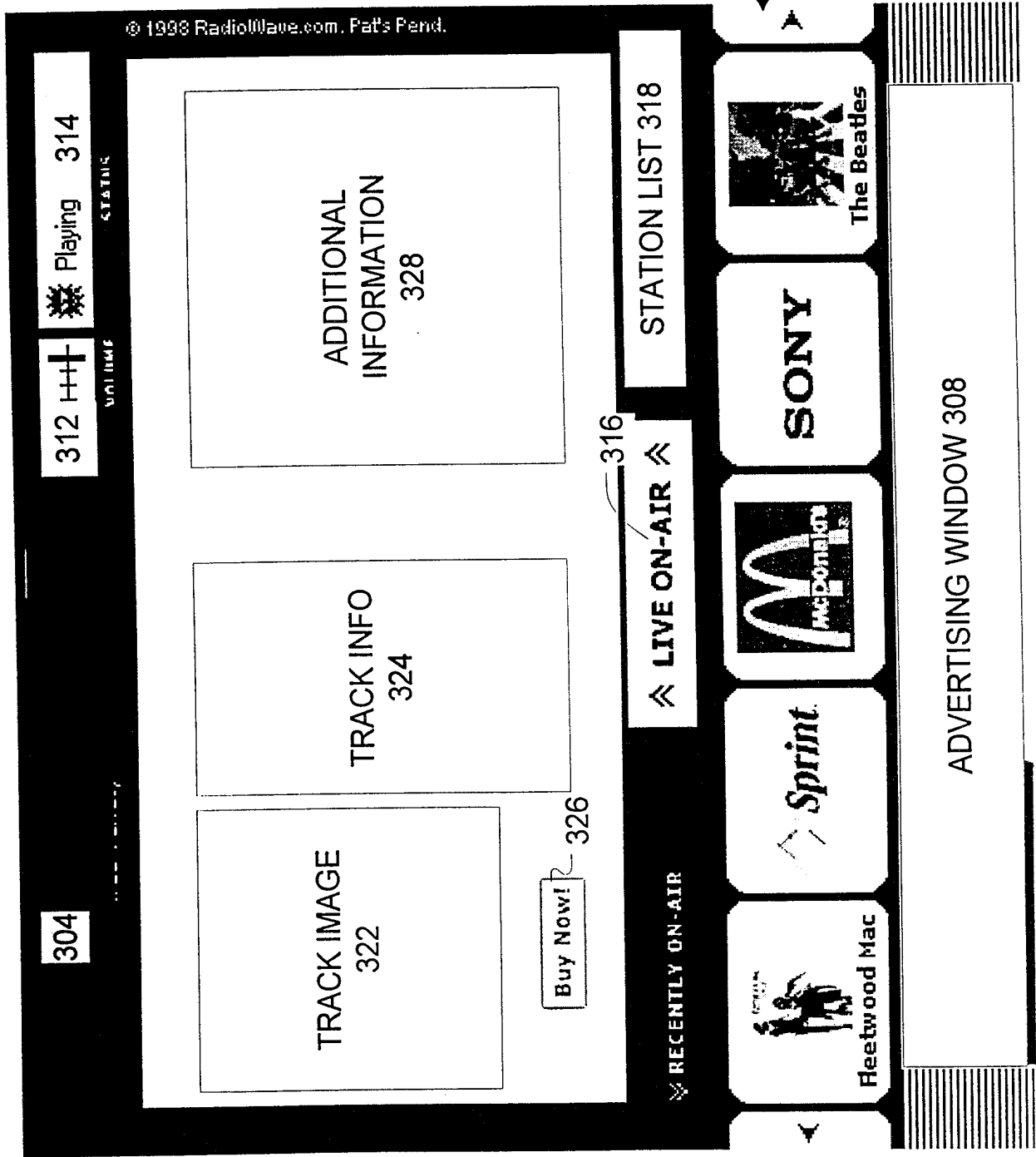


**Fig. 5**



**Fig. 6**

Fig. 7



306

RECENTLY ON-AIR

LIVE ON-AIR 316

STATION LIST 318

304

312

314

TRACK IMAGE 322

TRACK INFO 324

ADDITIONAL INFORMATION 328

Buy Now!

316

Fleetwood Mac

Sprint

McDonald's

SONY

The Beatles

ADVERTISING WINDOW 308

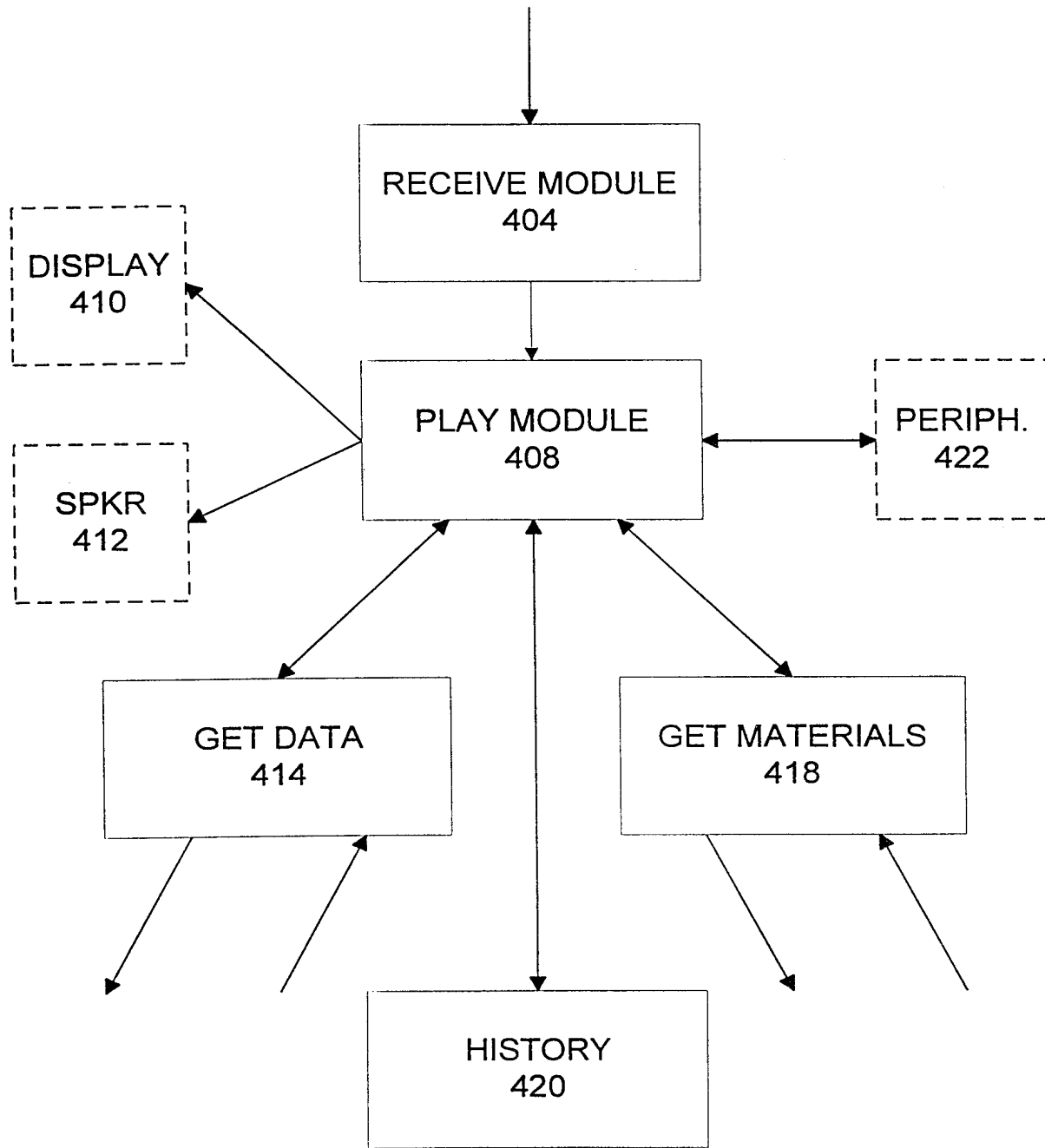
306

RECENTLY ON-AIR

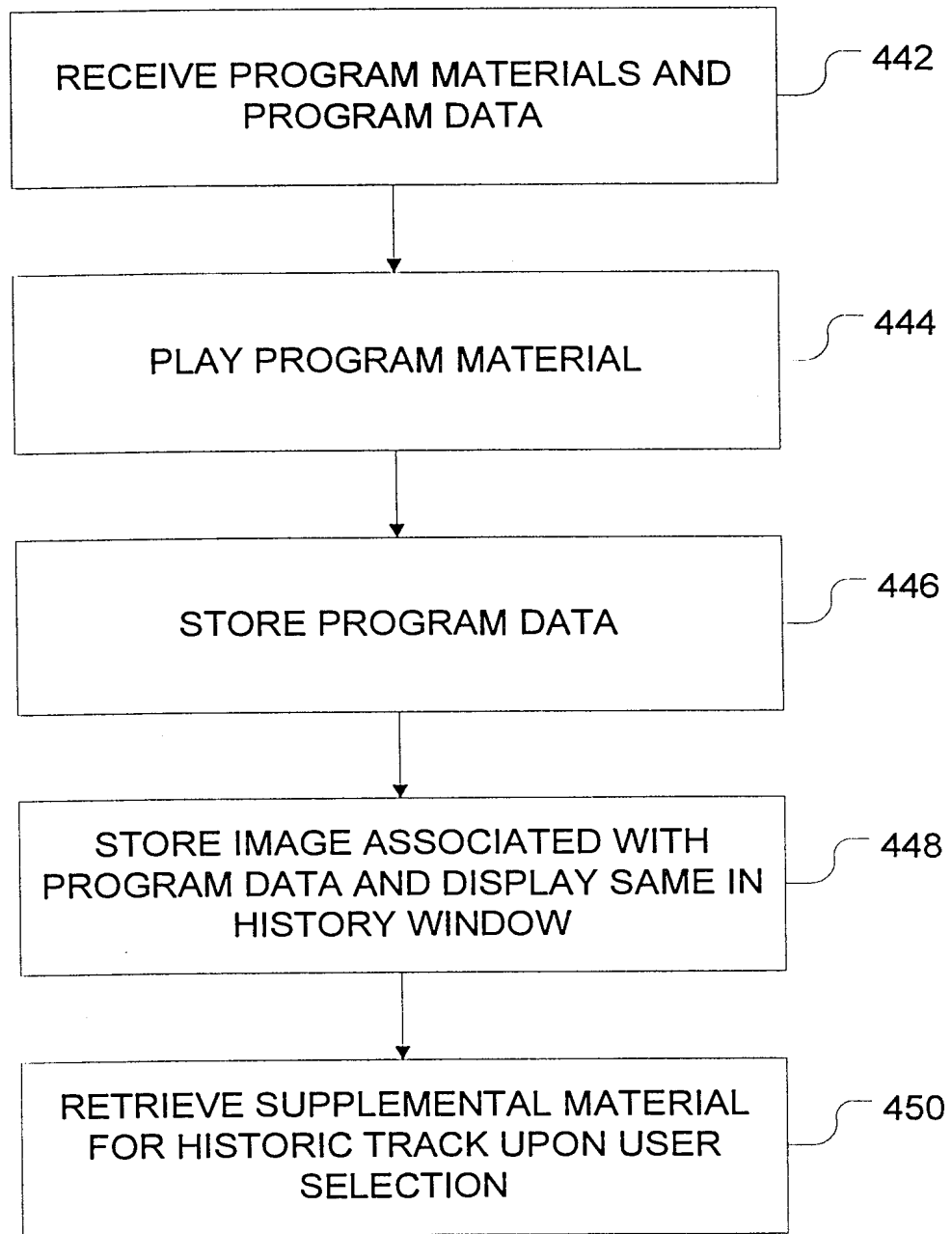
LIVE ON-AIR 316

STATION LIST 318

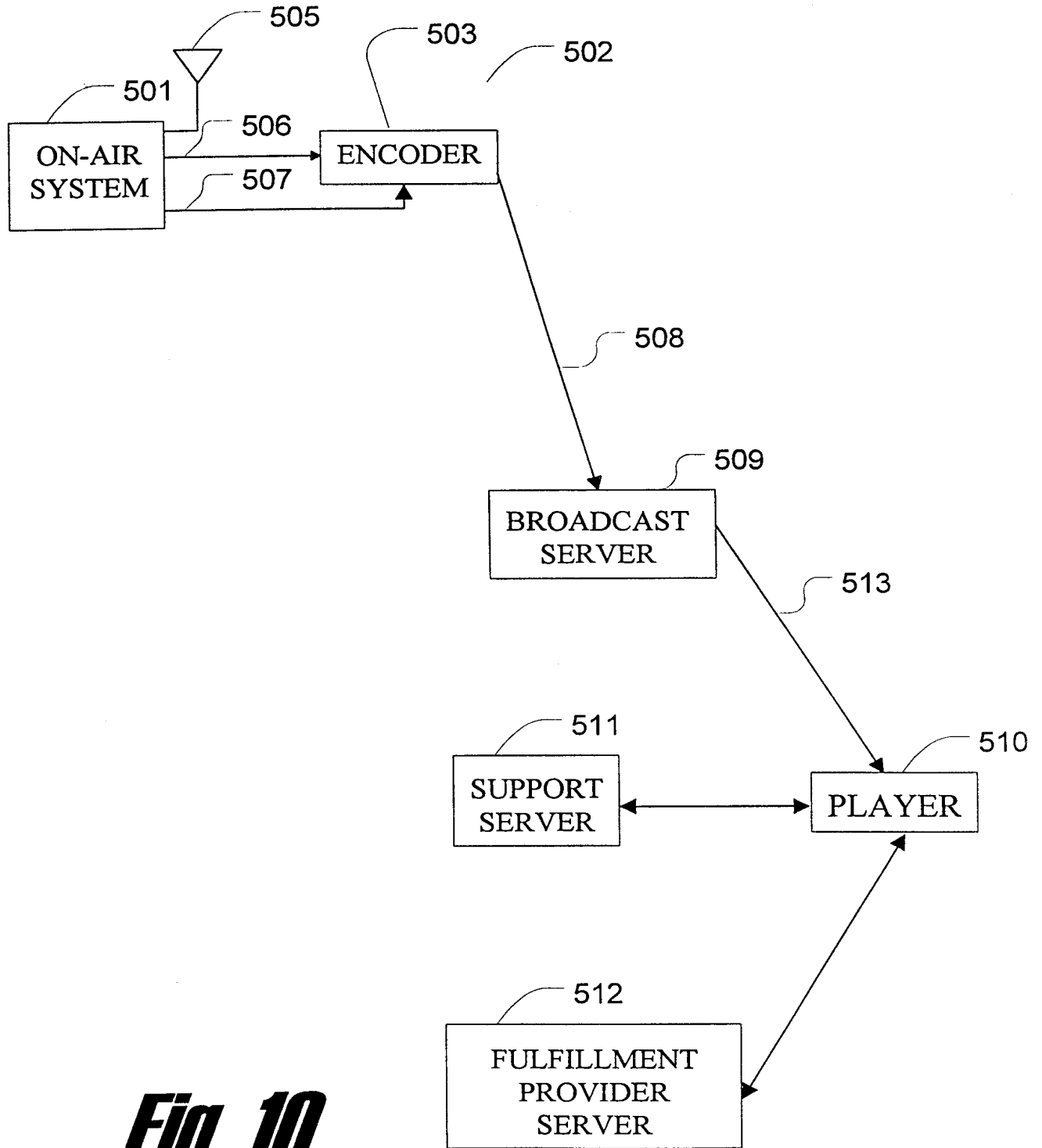




**Fig. 8**



**Fig. 9**



**Fig. 10**

517  
 ↓  
 PROVIDER TABLE

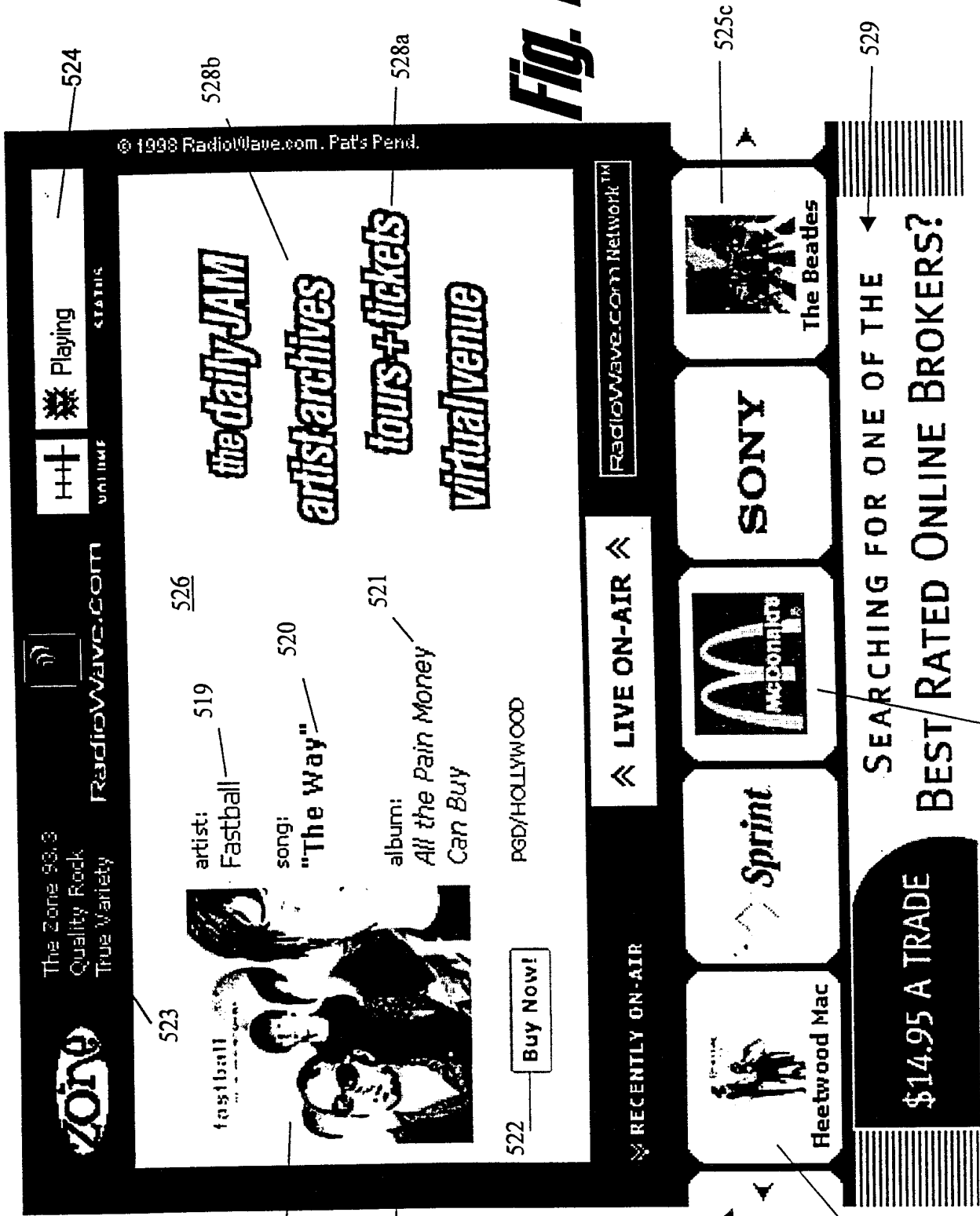
ALBUM ID	IMAGE NAME	PROVIDER LINK	ARTIST NAME	ALBUM NAME	SONG NAME
0001	#?*!!	&%#123	FASTBALL	ALL THE PAIN...	THE WAY

516  
 ↓  
 SONG TABLE

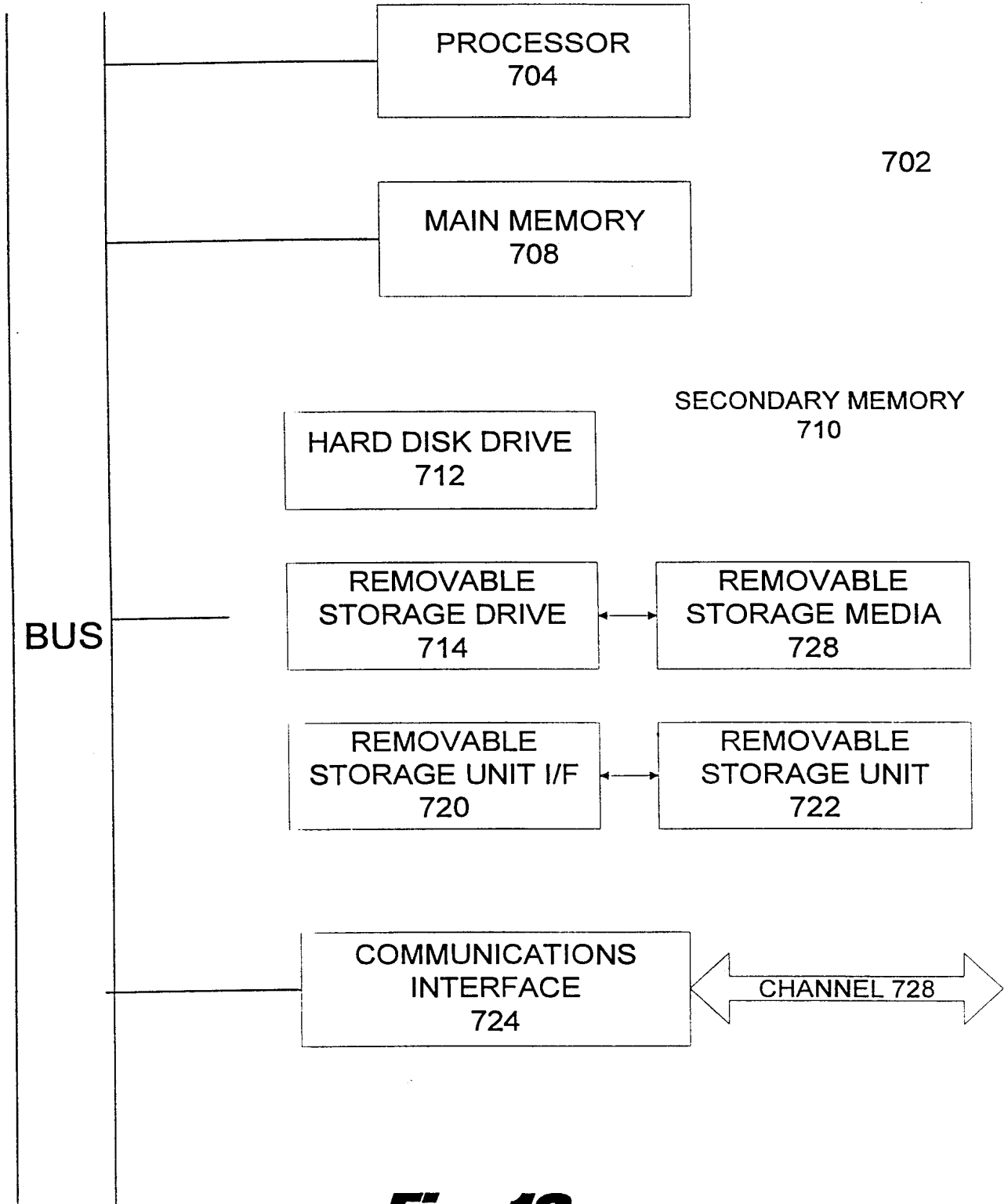
STATION ID	CUT CODE	ALBUM ID	ARTIST NAME	ALBUM NAME	SONG NAME
ZONE	Q1234	0001	FASTBALL	ALL THE PAIN..	THE WAY

**Fig. 11**

Fig. 12



12/13



**Fig. 13**

# INTERNATIONAL SEARCH REPORT

International Application No  
**PCT/US 99/21232**

<b>A. CLASSIFICATION OF SUBJECT MATTER</b> IPC 7    H04L12/18    H04N5/00    H04L29/06				
According to International Patent Classification (IPC) or to both national classification and IPC				
<b>B. FIELDS SEARCHED</b>				
Minimum documentation searched (classification system followed by classification symbols) IPC 7    H04L    H04N    G06F				
Documentation searched other than minimum documentation to the extent that such documents are included in the fields searched				
Electronic data base consulted during the international search (name of data base and, where practical, search terms used)				
<b>C. DOCUMENTS CONSIDERED TO BE RELEVANT</b>				
Category *	Citation of document, with indication, where appropriate, of the relevant passages	Relevant to claim No.		
X	WO 97 42582 A (NETCAST COMMUNICATIONS CORP) 13 November 1997 (1997-11-13) abstract page 6, line 23 -page 7, line 32 page 13, line 5 - line 19 page 30, line 33 -page 31, line 28 figures 18,19	1-6, 11-19,22		
Y	_____	7,20		
Y	US 5 557 724 A (KEMBEL JOHN ET AL) 17 September 1996 (1996-09-17) abstract column 2, line 14 - line 45 column 4, line 2 - line 23 column 5, line 14 - line 55 column 13, line 59 -column 14, line 31	7,20		
<input type="checkbox"/> Further documents are listed in the continuation of box C.				
<input checked="" type="checkbox"/> Patent family members are listed in annex.				
* Special categories of cited documents :				
<table style="width: 100%; border: none;"> <tr> <td style="width: 50%; border: none; vertical-align: top;">                     "A" document defining the general state of the art which is not considered to be of particular relevance                      "E" earlier document but published on or after the international filing date                      "L" document which may throw doubts on priority claim(s) or which is cited to establish the publication date of another citation or other special reason (as specified)                      "O" document referring to an oral disclosure, use, exhibition or other means                      "P" document published prior to the international filing date but later than the priority date claimed                 </td> <td style="width: 50%; border: none; vertical-align: top;">                     "T" later document published after the international filing date or priority date and not in conflict with the application but cited to understand the principle or theory underlying the invention                      "X" document of particular relevance; the claimed invention cannot be considered novel or cannot be considered to involve an inventive step when the document is taken alone                      "Y" document of particular relevance; the claimed invention cannot be considered to involve an inventive step when the document is combined with one or more other such documents, such combination being obvious to a person skilled in the art.                      "&amp;" document member of the same patent family                 </td> </tr> </table>			"A" document defining the general state of the art which is not considered to be of particular relevance "E" earlier document but published on or after the international filing date "L" document which may throw doubts on priority claim(s) or which is cited to establish the publication date of another citation or other special reason (as specified) "O" document referring to an oral disclosure, use, exhibition or other means "P" document published prior to the international filing date but later than the priority date claimed	"T" later document published after the international filing date or priority date and not in conflict with the application but cited to understand the principle or theory underlying the invention "X" document of particular relevance; the claimed invention cannot be considered novel or cannot be considered to involve an inventive step when the document is taken alone "Y" document of particular relevance; the claimed invention cannot be considered to involve an inventive step when the document is combined with one or more other such documents, such combination being obvious to a person skilled in the art. "&" document member of the same patent family
"A" document defining the general state of the art which is not considered to be of particular relevance "E" earlier document but published on or after the international filing date "L" document which may throw doubts on priority claim(s) or which is cited to establish the publication date of another citation or other special reason (as specified) "O" document referring to an oral disclosure, use, exhibition or other means "P" document published prior to the international filing date but later than the priority date claimed	"T" later document published after the international filing date or priority date and not in conflict with the application but cited to understand the principle or theory underlying the invention "X" document of particular relevance; the claimed invention cannot be considered novel or cannot be considered to involve an inventive step when the document is taken alone "Y" document of particular relevance; the claimed invention cannot be considered to involve an inventive step when the document is combined with one or more other such documents, such combination being obvious to a person skilled in the art. "&" document member of the same patent family			
Date of the actual completion of the international search  <p style="text-align: center; font-weight: bold;">8 February 2000</p>		Date of mailing of the international search report  <p style="text-align: center; font-weight: bold;">18/02/2000</p>		
Name and mailing address of the ISA European Patent Office, P.B. 5818 Patentlaan 2 NL - 2280 HV Rijswijk Tel. (+31-70) 340-2040, Tx. 31 651 epo nl, Fax: (+31-70) 340-3016		Authorized officer  <p style="text-align: center; font-weight: bold;">Poggio, F</p>		

# INTERNATIONAL SEARCH REPORT

Information on patent family members

Int tional Application No
PCT/US 99/21232

Patent document cited in search report		Publication date	Patent family member(s)	Publication date
WO 9742582	A	13-11-1997	US 5778187 A AU 3002097 A EP 0965087 A US 5983005 A	07-07-1998 26-11-1997 22-12-1999 09-11-1999
US 5557724	A	17-09-1996	NONE	



(19) World Intellectual Property Organization  
International Bureau



(43) International Publication Date  
21 December 2000 (21.12.2000)

PCT

(10) International Publication Number  
WO 00/78050 A1

(51) International Patent Classification<sup>7</sup>: H04N 7/173, 5/445

(21) International Application Number: PCT/US00/40148

(22) International Filing Date: 7 June 2000 (07.06.2000)

(25) Filing Language: English

(26) Publication Language: English

(30) Priority Data:  
60/138,868 11 June 1999 (11.06.1999) US  
60/164,648 10 November 1999 (10.11.1999) US

(71) Applicant: UNITED VIDEO PROPERTIES, INC.  
[US/US]; 7140 South Lewis Avenue, Tulsa, OK 74136 (US).

(72) Inventors: HERRINGTON, W., Benjamin; 725 West 20th Street, Tulsa, OK 74107 (US). THOMAS, William, L.; 11611 South 70th East Avenue, Bixby, OK 74008 (US). KELLY, Robert, L.; 163 Amsterdam Avenue, No.

191, New York, NY 10023 (US). ALLISON, Donald, W.; 3411 South 132nd East Avenue, Tulsa, OK 74134 (US). WILLIAMSON, Steven, C.; 8226 S. Toledo, Tulsa, OK 74137 (US). ANDERSON, Lyle, C.; 45 Hamilton Road, Chappaqua, NY 10514 (US). DEMERS, Timothy, B.; 7724 South Hudson Avenue, Tulsa, OK 74136 (US). DEWEESE, Toby; 4721 East 87th Street, Tulsa, OK 74137 (US). ELLIS, Michael, D.; 1300 Kingwood Place, Boulder, CO 80304 (US). BOYLAN, Peter, C., III; 6600 South Timberlane Road, Tulsa, OK 74136 (US).

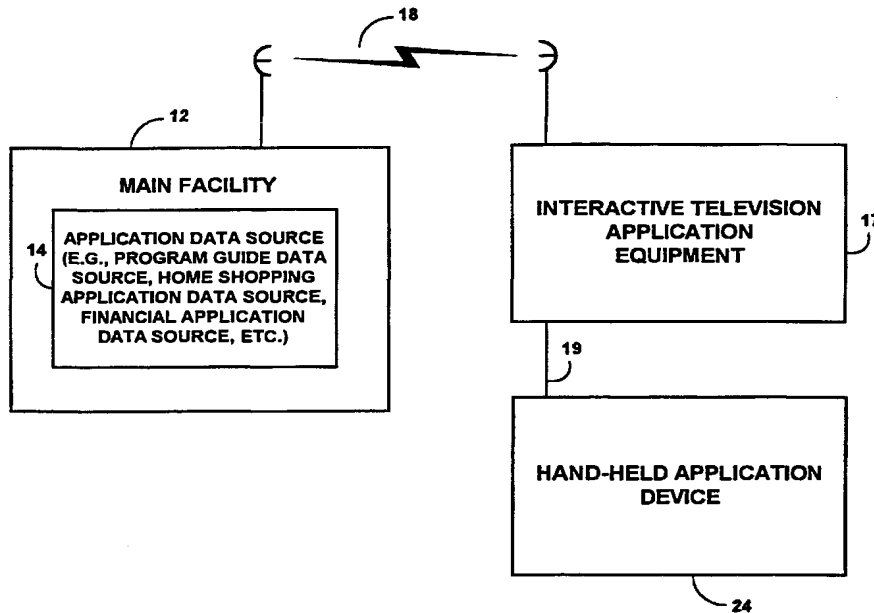
(74) Agents: GUILIANO, Joseph, M. et al.; Fish & Neave, 1251 Avenue of the Americas, New York, NY 10020 (US).

(81) Designated States (national): AE, AG, AL, AM, AT, AU, AZ, BA, BB, BG, BR, BY, CA, CH, CN, CR, CU, CZ, DE, DK, DM, DZ, EE, ES, FI, GB, GD, GE, GH, GM, HR, HU, ID, IL, IN, IS, JP, KE, KG, KP, KR, KZ, LC, LK, LR, LS, LT, LU, LV, MA, MD, MG, MK, MN, MW, MX, MZ, NO, NZ, PL, PT, RO, RU, SD, SE, SG, SI, SK, SL, TJ, TM, TR, TT, TZ, UA, UG, UZ, VN, YU, ZA, ZW.

(84) Designated States (regional): ARIPO patent (GH, GM, KE, LS, MW, MZ, SD, SL, SZ, TZ, UG, ZW), Eurasian

[Continued on next page]

(54) Title: INTERACTIVE TELEVISION APPLICATION SYSTEM WITH HAND-HELD APPLICATION DEVICE



(57) Abstract: A hand-held application device provides users with opportunities to access television-related or other applications and to control television-related applications running on user television equipment. The hand-held application device may have a touch-sensitive screen with controls that are coordinated with the features of the television-related or other applications.

WO 00/78050 A1



patent (AM, AZ, BY, KG, KZ, MD, RU, TJ, TM), European patent (AT, BE, CH, CY, DE, DK, ES, FI, FR, GB, GR, IE, IT, LU, MC, NL, PT, SE), OAPI patent (BF, BJ, CF, CG, CI, CM, GA, GN, GW, ML, MR, NE, SN, TD, TG).

— Before the expiration of the time limit for amending the claims and to be republished in the event of receipt of amendments.

**Published:**

— With international search report.

For two-letter codes and other abbreviations, refer to the "Guidance Notes on Codes and Abbreviations" appearing at the beginning of each regular issue of the PCT Gazette.

INTERACTIVE TELEVISION APPLICATION SYSTEM  
WITH HAND-HELD APPLICATION DEVICE

Background of the Invention

This invention relates to interactive  
5 television application systems, and more particularly,  
to interactive television application systems in which  
television application functionality may be provided by  
a hand-held device or coordinated between a hand-held  
device and a user's television equipment.

10 Interactive television applications typically  
run on a user's set-top box. Examples of interactive  
television applications include interactive television  
program guides, e-mail, home shopping, wagering and  
other e-commerce applications, financial applications,  
15 TV Web browsers, games, and other television based  
applications. Running these applications typically  
excludes other users from watching television other  
than the application being viewed. In addition,  
running such applications on a stationary platform on

- 2 -

the set-top box prevents users from accessing the features of such systems when away from the stationary platform.

It is therefore an object of the present invention to provide an interactive television application system having a hand-held application device with display.

It is a further object of the present invention to coordinate interactive television application functionality between an application running on the user's television equipment and an application running on a hand-held application device.

#### Summary of the Invention

These and other objects of the present invention are accomplished by providing a portable hand-held application device with display as described, for example, in Herrington et al. U.S. provisional patent application Serial No. 60/138,868, filed June 11, 1999, and Ellis U.S. provisional patent application Serial No. 60/164,648, filed November 10, 1999, which are hereby incorporated by reference herein in their entireties.

The hand-held application device may be any suitable hand-held device, such as a display remote, touch-screen remote, personal digital assistant (PDA), ebook or other hand-held device. The hand-held application device provides a user with access to interactive television application functionality remotely or while viewing a television program. In one suitable approach, the hand-held application device may run a client version of an interactive television application that requests application data from an

- 3 -

application server running on the user's television equipment. In another suitable approach, the hand-held application device acts as an independent platform running an interactive application that may run  
5 independently and may communicate with a similar interactive application running on the user's television equipment. The hand-held application device may provide, for example, a portable electronic program guide including various features of interactive program  
10 guides, Internet-based program guides, and printed program guides.

Interactive television applications may include, for example, applications that provide information related to television programming or that  
15 provide interactive features associated with television programming, such as, for example, interactive television program guides, home shopping applications, wagering applications, e-mail, and financial trading applications. Interactive television applications may  
20 also include applications provided on user television equipment.

The hand-held application device may be offered to consumers for free or for a very low cost, as it may be advertising supported. Screens or pages  
25 displayed by the device may contain passive or interactive advertisements. Providing the device at low consumer price may allow the device to be distributed in large volumes. This may increase the value of the device to advertisers. Users of the  
30 device may not have to live in a special area, subscribe to any kind of digital cable or satellite service, or have an Internet account, to use the device if desired. Once a platform like this has been

- 4 -

distributed, there will be continued opportunities for growth. New software can be downloaded. It can support future marketing opportunities, and it offers the ability to add user features at a later date, as  
5 either a free or pay upgrade.

The hand-held application device may be of a size to fit in a pocket or purse. The device may have a touch-screen LCD display, a two-way paging interface, and may run on standard batteries. The paging  
10 interface may continuously collect TV listing data and store the data in local memory. It may also download advertisements while the device is in normal use. This may be done by for example buying time from a national paging service.

15 The device may have a fold-down cover to protect the display from damage or accidental activation. Opening the cover automatically may turn the device on and activate its display. The first display may be, for example, a main menu, which may  
20 include interactive advertisements. One of the items on the menu may be a television guide. Selecting the guide feature may bring up a guide main menu, display of program listings or any other suitable guide display. When a user select a listing, the device may  
25 display a description of a program associated with the listing. Advertisements may be programming related, in which case selecting them may bring up more information about a program, allow reminders to be set, or any other suitable function. Advertisements for other  
30 products may allow a user to get more information or purchase a product.

The portable hand-held application device may include many of the features of interactive program

- 5 -

guides, such as listings by time, by channel, by category, favorite channels or any other guide feature. It may allow the user to set reminders and have them appear on the device, with both an audio alert and a display. Via a paging return, for example, the device can be used to set reminders or schedule recordings remotely. The portable device may be used for collecting data. For example, it might be used to send out surveys. It may also be used to collect audience ratings information. With an appropriate point-of-purchase device, for example, may be used to distribute electronic coupons.

The device may also include an infra-red emitter. This may allow a user to use the device as a remote control to operate an interactive television program guide on a television set and other home entertainment equipment. A paging system may be used, for example, to upload device type information and download infra-red codes. When used in this mode, keys may be displayed on the device, and the user may touch the screen to generate commands. The keys can be context sensitive, where only the keys of interest are displayed at any time.

The portable device may also offer other PDA-type functions, perhaps at an additional cost. For example, it may support e-mail, a calendar, a contact list, web browsing, a calculator, or any other suitable application. It may support data services, such as news, weather, sports, traffic, or any other suitable data service. It may be used as a pager. With suitable hardware resources, the portable program guide might include advanced communication functions. For example, it might allow a user to remotely monitor the

- 6 -

home equipment -- find out if the system is turned on,  
what channel is on, etc. It might also allow a user to  
listen to audio from a selected TV channel, or offer  
audio channels. The portable device may also serve as  
5 an ebook.

Further features of the invention, its nature  
and various advantages will be more apparent from the  
accompanying drawings, in which like reference  
characters refer to like parts throughout, and the  
10 following detailed description of the preferred  
embodiments.

#### Description of the Drawings

FIG. 1 shows a schematic view of an  
illustrative system in accordance with the present  
15 invention;

FIGS. 2a-2f show illustrative arrangements  
for the interactive television application equipment  
and hand-held application device of FIG. 1, in  
accordance with the present invention;

20 FIG. 3 shows a schematic view of the hand-  
held application device of FIG. 1, in accordance with  
the present invention;

FIG. 4 shows a schematic view of the user  
television equipment of FIGS. 2a-2f, in accordance with  
25 the present invention;

FIG. 5 shows a more generalized schematic  
view of the user television equipment of FIGS. 2a-2f,  
in accordance with the present invention;

30 FIG. 6 shows an illustrative menu screen in  
accordance with the present invention;

FIG. 7 shows an illustrative browse display  
in accordance with the present invention;



- 7 -

FIG. 8 shows an illustrative information screen in accordance with the present invention;

FIG. 9 shows an illustrative pay-per-view ordering screen in accordance with the present  
5 invention;

FIG. 10 shows an illustrative remote screen in accordance with the present invention;

FIG. 11 shows an illustrative primary guide main menu screen in accordance with the present  
10 invention;

FIG. 12 shows an illustrative display of program listings by time in accordance with the present invention;

FIG. 13 shows an illustrative premiums screen  
15 in accordance with the present invention;

FIG. 14 shows an illustrative home page in accordance with the present invention;

FIG. 15 shows an illustrative Editor's Picks page in accordance with the present invention;

FIGS. 16a and 16b show illustrative My TV Listings pages in accordance with the present  
20 invention;

FIG. 16c shows an illustrative page of program listings by criteria in accordance with the  
25 present invention;

FIG. 17 shows an illustrative about page in accordance with the present invention;

FIG. 18 is a flowchart of illustrative steps involved in providing interactive television and other  
30 application features with the hand-held application device of FIG. 1, in accordance with the present invention;

- 8 -

FIG. 19 a flowchart of illustrative steps involved in coordinating features between primary applications running within the interactive television application equipment of FIG. 1 and supplemental  
5 applications running on the hand-held access device of FIG. 1; and

FIG. 20 is a flowchart of illustrative steps involved in providing interactive television program guide functionality using the hand-held application  
10 device of FIG. 1.

#### Detailed Description of the Preferred Embodiments

An illustrative system 10 in accordance with the principles of the present invention is shown in FIG. 1. System 10 may include main facility 12. Main  
15 facility 12 provides interactive television application data from application data source 14 to interactive television application equipment 17 via communications link 18. There may be multiple main facilities 12 for providing data for a number of applications, but only  
20 one main facility 12 has been shown in FIG. 1 to avoid over-complicating the drawing. There are preferably numerous pieces or installations of interactive television application equipment 17, each linked to main facility 12 by a respective communications link 18  
25 although only one such piece or installation of interactive television application equipment 17 is shown in FIG. 1 to avoid over-complicating the drawing. Link 18 may be a satellite link, a telephone network link, a cable or fiber optic link, a microwave link, an  
30 Internet link, a digital subscriber line (DSL), a combination of such links, or any other suitable communications link. In another suitable approach,

- 9 -

interactive television application data may be generated by interactive television application equipment 17, in which case main facility 12 may be unnecessary. In still another suitable approach, main  
5 facility 12 may provide interactive television application data directly to hand-held application device 24 via a suitable link (e.g., a two-way paging - frequency link), in which case all or portions of interactive television application equipment it may be  
10 unnecessary. For the purposes of clarity, the remaining discussion will describe an approach in which main facility 12 provides interactive television application data to one or more interactive television application equipments 17.

15           The interactive television application data transmitted by main facility 12 to interactive television application equipment 17 may include any data suitable for the application supported by main facility 12. If main facility 12 provides interactive  
20 television program guide data, for example, the data may include television programming data (e.g., program identifiers, times, channels, titles, and descriptions) and other data for services other than television program listings (e.g., help text, pay-per-view  
25 information, weather information, sports information, music channel information, associated Internet Web links, associated software, etc.). Interactive television program guide data may also include unique identifiers for each showing of each program,  
30 identifiers for program groupings (e.g., series, mini-series, orderable packages of programs, network lineups, etc.), or any other suitable identifier.

- 10 -

Interactive television applications may be implemented on interactive television application equipment 17 and hand-held application device 24. As used herein, a "primary" application is intended to mean an interactive application that runs on interactive television application equipment 17. A primary application may be a server application that provides application data to hand-held application device 24 in response to one or more application communications, or may be a version of an application that works cooperatively with a version of the application that runs on hand-held application device 24. As used herein, a "secondary" application is intended to mean an interactive application that runs on hand-held application device 24. A secondary application may be a client application that obtains data from a primary application, or may be a version of an interactive application that runs cooperatively with a primary application and that obtains application data from main facility 12.

The primary and secondary applications may communicate by exchanging one or more application communications. Application communications may include any client-server or peer-to-peer communication construct suitable for exchanging interactive application data or other data (such as digital frames for display by hand-held application device 24) between the primary and secondary applications via communications link 19. Application communications may include, for example, requests, commands, messages, or remote procedure calls.

Application communications may also involve complex communications between application constructs

- 11 -

running on hand-held application device 24 and interactive television application equipment 17. Application communications may, for example, be object based. Objects running in the primary and secondary guides, for example, may communicate using an Object Request Broker (ORB). Interactive application data may, for example, be encapsulated as component object model (COM) objects and persisted to a stream that is transmitted over communications link 19. Application communications may also include, for example, HTML formatted markup language documents (e.g., Web pages), that are exchanged between hand-held application device 24 and an Internet service system.

Six illustrative arrangements for interactive television application equipment 17 and hand-held application device 24 are shown in FIGS. 2a-2f. As shown, interactive television application equipment 17 may include distribution equipment 21 located at application distribution facility 16, and user television equipment 22. The primary application may run totally on user television equipment 22 using the arrangements of FIGS. 2a and 2b, or may run partially on user television equipment 22 and partially on application server 25 or Internet service system 61 using a suitable client-server or distributed processing arrangement such as shown in FIGS. 2c, 2d, 2e, and 2f. Application distribution facility 16 may be any suitable distribution facility, and may have distribution equipment 21.

Distribution equipment 21 of FIGS. 2a, 2b, 2c, 2d, 2e, and 2f is equipment suitable for providing interactive television application data to user television equipment 22 over communications link 20.

- 12 -

Distribution equipment 21 may include, for example, suitable transmission hardware for distributing interactive television application data on a television channel sideband, in the vertical blanking interval of a television channel, using an in-band digital signal, using an out-of-band digital signal, or by any other suitable data transmission technique. Analog or digital video signals (e.g., television programs) from television distribution facility 29 may also be distributed by distribution equipment 21 to user television equipment 22 over communications link 20 on multiple television channels. Alternatively, videos may be distributed to user television equipment 22 from television distribution facility 29 to user television equipment 22 directly. Television distribution facility 29 may be any suitable distribution facility (e.g., a cable system headend, a broadcast distribution facility, a satellite television distribution facility, or any other suitable type of television distribution facility). If desired, television distribution facility 29 and application distribution facility 16 may be the same facility.

Communications link 20 may be any communications link suitable for distributing interactive television application data to user television equipment 22. Communications link 20 may include, for example, a satellite link, a telephone network link, a cable or fiber optic link, a microwave link, an Internet link, a data-over-cable service interface specification (DOCSIS) link, a digital subscriber line (DSL), a paging frequency or other radio frequency link, a combination of such links, or any other suitable communications link. There are

- 13 -

typically multiple pieces of user television equipment 22 and multiple associated communications links 20, although only one piece of user television equipment 22 and communications link 20 are shown in FIGS. 2a-2f to avoid over-complicating the drawings. If desired, television programming and interactive television application data may be provided over separate communications links.

User television equipment 22 and hand-held application device 24 may communicate over communications link 19. There may only be a single communications link 19, such as when hand-held application device 24 obtains application data exclusively from user television as shown in FIGS. 2a, 2c, and 2e. Alternatively, there may be multiple communications links 19, such as when hand-held application device 24 obtains data directly from application distribution facility 16 as shown in FIGS. 2b, 2d, and 2f. In still another suitable approach, hand-held application device 24 may run totally independently and not communicate with user television equipment 22 at all.

Communications link 19 may be any suitable wired or wireless communications link or links over which digital or analog communications may take place between hand-held application device 24 and user television equipment 22, application distribution facility 17 or main facility 12. Communications link 19 may include, for example, a serial or parallel cable, a dial-up telephone line, a computer network or Internet link (e.g., 10Base2, 10Base 5, 10BaseT, 100BaseT, 10BaseF, T1, T3, etc.), an in-home network link, an infrared link), a radio-frequency link (e.g.,

- 14 -

a 900 MHz link, a paging-frequency link, or other radio frequency link), a satellite link, or any other suitable transmission link or combination of links. Communications link 19 may include a docking station  
5 that connects hand-held device 24 to user television equipment 22 directly or via an in-home network. Any suitable transmission or access scheme may be used such as standard serial or parallel communications, Ethernet, Token Ring, Fiber Distributed Data Interface  
10 (FDDI), Circuit-Switched Cellular (CSC), Cellular Digital Packet Data (CDPD), time division multiple access (TDMA), code division multiple access (CDMA), any other suitable transmission or access scheme, or any suitable combination thereof.

15 It is envisioned that the transmission media and scheme used will be appropriate for a particular implementation and that different media and schemes may be used on different communications links 19 when there are multiple communications links 19. It may be more  
20 suitable that when in the home, for example, communications link 19 may be a RF or infrared link instead of some of the more complicated links that are more suited for data transmission over wider geographical areas. It may also be more suitable, for  
25 example, that when hand-held application device 24 communicates directly with application distribution facility 16, communications link 19 may be a link more suited for data transmission over wider geographical areas, such as an Internet link.

30 Hand-held application device 24 and user television equipment 22 may communicate using any suitable network and transport layer protocols, if desired. They may communicate, for example, using a



- 15 -

protocol stack which includes Sequenced Packet Exchange/Internetwork Packet Exchange (SPX/IPX) layers, Transmission Control Protocol/Internet Protocol (TCP/IP) layers, AppleTalk Transaction Protocol/  
5 Datagram Delivery Protocol (ATP/DDP) layers, a Wireless Access Protocol (WAP) layer, or any other suitable network or transport layer protocols. Hand-held application device 24 and user television equipment 22 may also be part of an in-home network using, for  
10 example, the Jini networking protocol by Sun Microsystems. Network and transport layer protocols may be omitted from the system if desired.

Application data may be distributed by distribution equipment 21 to user television equipment  
15 22 exclusively (such as shown in FIGS. 2a, 2c, and 2e), to user television equipment 22 and hand-held application device 24 jointly (such as shown in FIGS. 2b, 2d, and 2f), or to just hand-held application device 24, using any suitable scheme. For example,  
20 application data may be provided in a continuous stream or may be transmitted at a suitable time interval (e.g., once per hour). If transmitted continuously, it may not be necessary to store the data locally on user television equipment 22 or hand-held application device  
25 24. Rather, user television equipment 22 or hand-held application device 24 may extract data "on the fly" as it is needed. If desired, application distribution facility 16 may poll user television equipment 22 or hand-held device periodically for certain information  
30 (e.g., pay program account information or information regarding programs that have been purchased and viewed using locally-generated authorization techniques).

- 16 -

Application data may also be provided using a suitable client-server approach or the Internet.

FIG. 2a shows an illustrative arrangement for interactive television application equipment 17 and hand-held application device 24 in which a primary application runs totally on user television equipment 22. A secondary application running on hand-held application device 24 obtains application data via user television equipment 22. The secondary application may obtain application data from a primary application acting as a server via application communications sent to user television equipment 22 via communications link 19. In another suitable approach, the secondary application may obtain application data directly from user television equipment 22 without involving the primary application.

User television equipment 22 may, for example, receive application data as part of a continuous data stream, periodically, or in response to polling requests from application distribution facility 17. In such approaches, application data may be automatically provided to hand-held application device 24 without requiring the secondary application to request it from the primary application. User television equipment 22 may include, for example, a tap antenna and associated circuitry that demodulates, and if necessary decodes, the application data signal. The tap antenna may resend the data to hand-held application device 24 via communications link 19. Alternatively, user television equipment 22 may receive application data from application distribution facility 16 and transmit that data to hand-held

- 17 -

application device 24 using any other suitable transmission scheme.

In still another suitable approach, application data may be stored by user television equipment 22 and forwarded to hand-held application device 24. This approach may be desirable when, for example, the transfer rates of data between application distribution facility 16 and user television equipment 22, and between user television equipment 22 and hand-held application device 24 are unequal.

FIG. 2b shows an illustrative arrangement for interactive television application equipment 17 and hand-held application device 24 in which hand-held application device obtains application data directly from application distribution facility 16. Application distribution facility 16 may have communications device 27 for providing hand-held application device 24 with access to application data from distribution equipment 21.

Communications device 27 may be any suitable communications device for communications link 19. Communications device 27 may be, for example, a modem (e.g., any suitable analog or digital modem, cellular modem, or cable modem) such as when communications link 19 is a telephone dial-up link or an Internet link. Communications device 27 may be a network interface card (e.g., an Ethernet card, token ring card, etc.), such as when communications link 19 is a wide-area-network (WAN) link or Internet link. Communications device 27 may be a wireless transceiver (e.g., a radio-frequency or infrared transceiver or other suitable transceiver), such as when communications link 19 is a wireless analog or digital

- 18 -

link, such as a paging-frequency link. A secondary application running on hand-held application device 24 may communicate with user television equipment 22 via a separate communications link 19, or may communicate via communications device 27, distribution equipment 21, and communications link 20 if desired. Application distribution facility 16 may have multiple communications devices 27. One communications device 27 may be used to communicate with hand-held application device 24, and another may be used to communicate with user television equipment 22. Each communications device 27 may be for a different type of link 19 or 20. For example, one communications device 27 may be used to download application data or otherwise exchange access communications over a paging-frequency or 900 MHz link, and another communications device may be used to transmit application data or other information or programming to user television equipment 22 over, for example, a cable television link.

FIGS. 2c and 2d shows additional illustrative arrangements for interactive television application equipment 17 and hand-held application device 24. In FIG. 2c, the primary application runs partly on user television equipment 22 (e.g., a client application) and partly at application distribution facility 16 on application server 25. In FIG. 2d, the secondary application runs partly on hand-held application device 24 and partly at application distribution facility 16 on application server 25. If desired, a combination of the two approaches may be used. Application server 25 may use any suitable combination of hardware and software to provide a client-server based primary or

- 19 -

secondary application. Application server 25 may, for example, run a suitable database engine (e.g., SQL Server by Microsoft) and provide interactive television application data in response to queries generated by a primary application client implemented on user television equipment 22. If desired, application server 25 may be located at main facility 12, or some other location, such as television distribution facility 29.

10           The primary and secondary applications in these approaches may retrieve interactive television application data from application server 25 using any suitable client-server based approach. The application may, for example, pass SQL requests as messages to application server 25. In another suitable approach, 15 the application may invoke remote procedures that reside on application server 25 using one or more remote procedure calls. Application server 25 may execute SQL statements for such invoked remote 20 procedures. In still another suitable approach, client objects executed by the application may communicate with server objects executed by application server 25 using, for example, an object request broker (ORB). This may involve using, for example, Microsoft's 25 Distributed Component Object Model (DCOM) approach.

          The primary and secondary applications may communicate with application server 25 over communications link 20 or 19 using any suitable network and transport layer protocols, if desired. They may 30 communicate, for example, using a protocol stack which includes Sequenced Packet Exchange/Internetwork Packet Exchange (SPX/IPX) layers, Transmission Control Protocol/Internet Protocol (TCP/IP) layers, AppleTalk

- 20 -

Transaction Protocol/Datagram Delivery Protocol (ATP/DDP) layers, WAP, DOCSIS or any other suitable network and transport layer protocols.

FIGS. 2e and 2f show illustrative Internet based interactive television application systems. Application distribution facility 16 may, for example, include Internet service system 61. Internet service system 61 may use any suitable combination of hardware and software capable of providing interactive television application data to the primary or secondary application using an Internet based approach (e.g., using the HyperText Transfer Protocol (HTTP) over a Transmission Control Protocol/Internet Protocol (TCP/IP) type link). If desired, Internet service system 61 may be located at a facility that is separate from application distribution facility 16.

If the primary application is implemented on user television equipment 22 of interactive television application equipment 17 as shown in FIG. 2e, Internet service system 61 (or other suitable equipment at application distribution facility 16 that is connected to Internet service system 61) may provide interactive television application data to user television equipment 22 via the Internet, or via application distribution equipment 21 using any suitable Internet-based approach (e.g. using HTTP over a TCP/IP link). If the primary application is a client-server application as shown in FIG. 2e, or if the secondary application is a client-server application that gets data directly from application distribution facility 16, as shown in FIG. 2f, the primary or secondary application may obtain interactive television

- 21 -

application data from Internet service system 61 via an Internet connection on communications link 20 or 19.

An illustrative arrangement for hand-held application device 24 is shown in FIG. 3. Hand-held application device 24 may be any suitable display remote, personal digital assistant (PDA), ebook, or other suitable portable hand-held device. The functionality that hand-held application device 24 may provide to the user may vary depending on its processing circuitry, communications circuitry and memory. It is envisioned that hand-held application device 24 may be a Windows CE compliant or JAVA-based hand-held PDA style device, or may be enabled by any other suitable software operating system for hand-held devices. Hand-held application device 24 may have user interface 52, processing circuitry 54, storage 56, and communications device 58.

User interface 52 may be any suitable input or output device or system, and may include a liquid crystal display (LCD), touch sensitive screen, stylus, voice recognition and synthesis circuitry, microphone, speaker, manual buttons or keys, keyboard, or any other suitable user input or output hardware and software. User interface 52 preferably includes a touch sensitive screen. A touch sensitive screen may simplify navigation within various types of interactive television applications. Fixed-button remote controls of program guide systems, for example, may have as much as four dozen buttons to choose from. The remotes of these systems may be replaced by a touch sensitive screen enabled hand-held application device 24. A touch sensitive screen of hand-held application device 24 need only display those buttons or controls that

- 22 -

apply to the specific screen that the user is viewing or the specific task that the user is performing. In addition, an interface displayed on a touch sensitive screen may change to suit the type of data entry the user is going to perform in the television application. For example, a keyboard may be displayed to provide a user with an opportunity to enter one or more characters, or a number pad may be displayed to simplify numeric entries. User interface 52 may also include suitable handwriting recognition software for running on a hand-held device.

In still another suitable approach, hand-held application device 24 may have a combination of push buttons and displays. The displays may label each push button with text or graphics to indicate to the user the feature associated with a push button. When the user accesses different interactive applications, the displays may change based on the application accessed. When, for example, an interactive wagering application is accessed, two displays may read "bet" and "info." When the user changes applications to, for example, an interactive program guide, the same displays may read "channel up" and "channel down." For each application, pressing a given push button results in performing the indicated feature. Control codes may be downloaded from, for example, user television equipment 22 via a 900 MHz link, to hand-held application device 24 to indicate to hand-held application device 24 the proper labels and features for each push button.

Processing circuitry 54 may include any suitable processor, such as an Intel Pentium<sup>®</sup>, AMD, or other microprocessor. Hand-held application device 24 may also have storage 56. Storage 56 may be any



- 23 -

suitable memory or other storage device, such as RAM, ROM, flash memory, or other storage suitable for a hand-held device.

Hand-held application device 24 may also have  
5 communications device 58. Communications device 58 may  
be any device suitable for supporting communications  
between hand-held application device 24 and user  
television equipment 22 or interactive television  
application equipment 17 over link 19. Communications  
10 device 58 may be, for example, a communications port  
(e.g., a serial port, parallel port, universal serial  
bus (USB) port, etc.), modem (e.g., any suitable analog  
or digital standard modem or cellular modem), network  
interface card (e.g., an Ethernet card, token ring  
15 card, etc.), wireless transceiver (e.g., an infrared,  
radio, or other suitable analog or digital  
transceiver), or other suitable communications device  
for a hand-held device. In particular, communications  
device 58 may be a paging-frequency transceiver. If  
20 desired, hand-held application device 24 may have  
multiple communications devices 58. One communications  
device 58 may be used to communicate with application  
distribution facility 16, and another may be used to  
communicate with user television equipment 22. Each  
25 communications device 58 may be for a different type of  
link 19. For example, one communications device 58 may  
be used to download application data or otherwise  
exchange access communications over a paging-frequency  
or 900 MHz link, and another communications device,  
30 such as an infra-red emitter, may be used to control  
user television equipment 22 and other home  
entertainment equipment using infra-red controls. The  
paging-frequency emitter may be used, for example, to

- 24 -

upload device type information and download infra-red codes. When used in this mode, keys may be displayed on the device, and the user may touch the screen to generate commands. The keys can be context sensitive, where only the keys of interest are displayed at any time.

In operation, hand-held application device obtains user commands from user interface 52, processes the commands using processing circuitry 54, and outputs a suitable display screen to the user on user interface 52. When a user indicates a desire to access a function of the secondary application that requires the application to obtain application data, processing circuitry 54 may direct communications device 58 to initiate a session with user television equipment 22 or application distribution facility 16.

The hand-held application device may be of a size to fit in a pocket or purse. The device may have a touch-screen LCD display, a two-way paging interface, and may run on standard batteries. The paging interface may continuously collect TV listing data and store the data in local memory. It may also download advertisements while the device is in normal use. This may be done by for example buying time from a national paging service.

The device may have a fold-down cover to protect the display from damage or accidental activation. Opening the cover automatically may turn the device on and activate its display. The first display may be, for example, a main menu, which may include interactive advertisements. One of the items on the menu may be an interactive program guide. Selecting the guide feature may bring up a guide main

- 25 -

menu, display of program listings or any other suitable  
guide display. When a user select a listing, the  
device may display a description of a program  
associated with the listing. Advertisements may be  
5 programming related, in which case selecting them may  
bring up more information about a program, allow  
reminders to be set, or any other suitable function.  
Advertisements for other products may allow a user to  
get more information or purchase a product.

10 The hand-held application device may be  
offered to consumers for free or for a very low cost,  
as it may be advertising supported. Screens or pages  
displayed by the device may contain passive or  
interactive advertisements. Providing the device at  
15 low consumer price may allow the device to be  
distributed in large volumes. This may increase the  
value of the device to advertisers. Users of the  
device may not have to live in a special area,  
subscribe to any kind of digital cable or satellite  
20 service, or have an Internet account, to use the device  
if desired. Once a platform like this has been  
distributed, there will be continued opportunities for  
growth. New software can be downloaded. It can  
support future marketing opportunities, and it offers  
25 the ability to add user features at a later date, as  
either a free or pay upgrade.

An illustrative arrangement for user  
television equipment 22 is shown in FIG. 4. User  
television equipment 22 of FIG. 4 receives analog video  
30 or a digital video stream from a distribution facility  
at input 26. Data from application distribution  
facility 16 is also received at input 26. During  
normal television viewing, the user tunes set-top

- 26 -

box 28 to a desired television channel (analog or digital). The signal for that television channel is then provided at video output 30. The signal supplied at output 30 is typically either a radio-frequency (RF) signal on a predefined channel (e.g., channel 3 or 4), or a analog demodulated video signal, but may also be a digital signal provided to television 36 on an appropriate digital bus (e.g., a bus using the Institute of Electrical and Electronics Engineers (IEEE) 1394 standard, (not shown)). The video signal at output 30 is received by optional secondary storage device 32.

A primary application or primary application client may run on set-top box 28, on television 36, on optional digital storage device 31 (if television 36 or optional digital storage device 31 has suitable processing circuitry and memory), or on a suitable analog or digital receiver connected to television 36. The interactive television application may also run cooperatively on both television 36 and set-top box 28. Interactive television application systems in which a cooperative interactive television program guide application runs on multiple devices are described, for example, in Ellis U.S. patent application Serial No. 09/186,598, filed November 5, 1998, which is hereby incorporated by reference herein in its entirety.

Secondary storage device 32 can be any suitable type of analog or digital program storage device or player (e.g., a videocassette recorder, a digital versatile disc (DVD) player, etc.). Program recording and other features may be controlled by set-top box 28 using control link 34. If secondary storage device 32 is a videocassette recorder, for

- 27 -

example, a typical control link 34 involves the use of an infrared transmitter coupled to the infrared receiver in the videocassette recorder that normally accepts commands from a remote control such as remote control 40.

Hand-held application device 24 may be used to control set-top box 28, secondary storage device 32, and television 36. Hand-held application device 24 may, for example, have different operation modes for operating as an interface to applications and for controlling user television equipment 22 like a remote control. Hand-held application device 24 may be programmable based on, for example, the devices in user television equipment 22. The user may, for example, select device types from within a suitable setup display. In another suitable approach, hand-held application device 24 may download configuration information from an application (e.g., an interactive television program guide) running on user television equipment 22. Any other suitable approach may also be used.

If desired, the user may record programs, application data, or a suitable combination thereof in digital form on optional digital storage device 31. The user may also download software to digital storage device 31 from the Internet or some other medium. Digital storage device 31 may be a writeable optical storage device (such as a DVD player capable of handling recordable DVD discs), a magnetic storage device (such as a disk drive or digital tape), or any other digital storage device. Interactive television application systems in which program guides have digital storage devices are described, for example, in

- 28 -

Hassell et al. U.S. patent application Serial No. 09/157,256, filed September 17, 1998, which is hereby incorporated by reference herein in its entirety.

Digital storage device 31 can be contained in  
5 set-top box 28 or it can be an external device  
connected to set-top box 28 via an output port and  
appropriate interface. If necessary, processing  
circuitry in set-top box 28 formats the received video,  
audio and data signals into a digital file format.  
10 Preferably, the file format is an open file format such  
as the Moving Pictures Expert Group (MPEG) MPEG-2  
standard or the Moving Joint Photographic Experts Group  
(MJPEG) standard. The resulting data is streamed to  
digital storage device 31 via an appropriate bus (e.g.,  
15 a bus using the Institute Electrical and Electronics  
Engineers (IEEE) 1394 standard), and is stored on  
digital storage device 31. In another suitable  
approach, an MPEG-2 data stream or series of files may  
be received from distribution equipment 21 and stored  
20 in digital storage device 31. For example, files from  
programs recorded by the user using a remote media  
server at television distribution facility 29 may be  
stored. Such digital files may be played back to the  
user when desired.

25           Television 36 receives video signals from  
secondary storage device 32 via communications path 38.  
The video signals on communications path 38 may either  
be generated by secondary storage device 32 when  
playing back a prerecorded storage medium (e.g., a  
30 videocassette or a recordable digital video disc), by  
digital storage device 31 when playing back a pre-  
recorded digital video (e.g., a video for a program  
that was recorded by the user at a media server remote

- 29 -

to or within the user's home), may be passed through from set-top box 28, may be provided directly to television 36 via set-top box 28 if secondary storage device 32 is not included in user television equipment 5 22, or may be received directly by television 36. During normal television viewing, the video signals provided to television 36 correspond to the desired channel to which the user has tuned with set-top box 28. Video signals may also be provided to television 10 36 by set-top box 28 when set-top box 28 is used to play back information stored on digital storage device 31, or when set-top box 28 is used to decode a digital video stream, or digital files transmitted from television distribution facility 29.

15               Set-top box 28 may have communications device 37 for communicating directly with application server 25 or Internet service system 61 over communications link 20, or with hand-held application device 24 over communications link 19. Communications 20 device 37 may be, for example, a communications port (e.g., a serial port, parallel port, universal serial bus (USB) port, etc.), modem (e.g., any suitable analog or digital standard modem or cellular modem), network interface card (e.g., an Ethernet card, token ring 25 card, etc.), wireless transceiver (e.g., an infrared, radio, or other suitable analog or digital transceiver), or other suitable communications device. Television 36 may also have such a suitable communications device if desired. In particular, 30 communications device 37 may be a paging-frequency or 900 MHz transceiver. If desired, set-top box 28 may have multiple communications devices 37. One communications device 37 may be used to communicate

- 30 -

with application distribution facility 16, and another  
may be used to communicate with hand-held application  
device 24. Each communications device 37 may be for a  
different type of link 20. For example, one  
5 communications device 37 may be used to download  
application data or otherwise exchange access  
communications over a paging-frequency or 900 MHz link,  
and another communications device may be used to  
control user television equipment 22 using infra-red  
10 controls.

A more generalized embodiment of user  
television equipment 22 of FIG. 4 is shown in FIG. 5.  
As shown in FIG. 5, interactive application data from  
application distribution facility 16 (FIG. 1) is  
15 received by control circuitry 42 of user television  
equipment 22. The functions of control circuitry 42  
may be provided using the set-top box arrangement of  
FIG. 4. Alternatively, these functions may be  
integrated into an advanced television receiver (e.g.,  
20 a digital television receiver or high definition  
television (HDTV) receiver), personal computer  
television (PC/TV), or any other suitable arrangement.  
If desired, a combination of such arrangements may be  
used.

25 User television equipment 22 of FIG. 5 may  
have secondary storage device 47, digital storage  
device 49, or any suitable combination thereof for  
recording programming. Secondary storage device 47 and  
digital storage device 49 may be omitted if desired.  
30 Secondary storage device 47 can be any suitable type of  
analog or digital program storage device (e.g., a  
videocassette recorder, a digital versatile disc (DVD),  
etc.). Program recording and other features may be



- 31 -

controlled by control circuitry 42. Digital storage device 49 may be, for example, a writable optical storage device (such as a DVD player capable of handling recordable DVD discs), a magnetic storage device (such as a disk drive or digital tape), or any other digital storage device.

Memory 63 may be any memory or other storage device, such as a random access memory (RAM), read only memory (ROM), flash memory, a hard disk drive, a combination of such devices, etc., that is suitable for storing primary application instructions and application data for use by control circuitry 42.

User television equipment 22 of FIG. 5 may have communications device 51 for supporting communications between user television equipment 22 and application server 25 or Internet service system 61 via communications link 20, or between hand-held application device 24 via communications link 19. Communications device 51 may be, for example, a communications port (e.g., a serial port, parallel port, universal serial bus (USB) port, etc.), modem (e.g., any suitable analog or digital standard modem or cellular modem), network interface card (e.g., an Ethernet card, token ring card, etc.), wireless transceiver (e.g., an infrared, radio, or other suitable analog or digital transceiver), or other suitable communications device. In particular, communications device 51 may be a paging-frequency or 900 MHz transceiver. If desired, user television equipment 22 may have multiple communications devices 51. One communications device 51 may be used to communicate with application distribution facility 16, and another may be used to communicate with hand-held

- 32 -

application device 24. Each communications device 37 may be for a different type of link 20. For example, one communications device 51 may be used to download application data or otherwise exchange access  
5 communications over a two-way cable link, paging-frequency or 900 MHz link, and another communications device may be used to provide television programming, application data, or other information to hand-held application device 24 over an infra-red or 900 MHz  
10 link.

The primary and secondary applications may be any suitable application including, without limitation, a home shopping application, web-browser, to-do list, wagering application, or any other application. For  
15 clarity, the present invention will be illustrated in connection with a system in which an interactive television program guide application is implemented on interactive television application equipment 17 and hand-held application device 24. In one suitable  
20 arrangement for such a system, program guide data is distributed from a main facility to an interactive television program guide implemented on user television equipment via an application distribution facility. In another suitable arrangement, the interactive  
25 television program guide application may be implemented using a client-server architecture in which the primary processing power for the application is provided by a server located at, for example, application distribution facility 16 or main facility 12 (e.g.,  
30 program guide server 25), and user television equipment 22 acts as a client processor as illustrated by FIGS. 2c and 2d. In still another alternative arrangement, the program guide application may obtain

- 33 -

program guide data from the Internet, as illustrated by FIGS. 2e and 2f.

Program guides typically limit a user's ability to select interactive objects on a screen by  
5 requiring that objects be selected by positioning a highlight region or cursor over the objects. When, for example, a user is within a column of program listings, the user cannot arrow above or below the column to select an interactive object. In addition, the user  
10 may be required to perform several key strokes to navigate from one object to another. On a touch sensitive screens such as the preferred display of hand-held application device 24, however, any area can be selectable, thereby providing the user with an  
15 increased ability to access interactive objects. Hand-held application device 24 may, for example, display a menu modeled after a menu displayed on user television equipment 22 by an interactive application. The user may select a particular menu option with a single  
20 action without having to perform, as with a regular remote control, multiple keystrokes to position a highlight region.

The portable hand-held application device may include many of the features of interactive program  
25 guides, such as listings by time, by channel, by category, favorite channels or any other guide feature. It may allow the user to set reminders and have them appear on the device, with both an audio alert and a display. Via a paging return, for example, the device  
30 can be used to set reminders or schedule recordings remotely. The portable device may be used for collecting data. For example, it might be used to send out surveys. It may also be used to collect audience

- 34 -

ratings information. With an appropriate point-of-purchase device, for example, may be used to distribute electronic coupons.

A secondary program guide running on hand-held device 24 may obtain program guide data directly from application distribution facility 16 (e.g., distribution equipment 21, application server 25, or Internet service system 61), from a primary program guide application running on user television equipment 10 22, or using a combination of these approaches. Whatever the approach used, the secondary program guide application running on hand-held application device 24 may provide a user with an opportunity to coordinate the functions of the primary guide with the functions 15 of the secondary guide, thereby extending the interactivity of the primary and secondary guides.

The display of hand-held application device 24, preferably a touch sensitive screen, becomes an integrated part of the on-screen guide. Complimentary 20 interactivity between the primary and secondary guides may be provided for various program guide functions without interrupting television viewing. For example, browsing through channels and times, accessing program information, ordering pay-per-view programs, setting 25 reminders, and locking programs may all be performed by the user with hand-held application device 24. For more user-involved functions such as setting favorite channels, viewing more than one channel at a time, or setting global parental locks, the display of hand-held 30 application device 24 may seamlessly convert to a remote control that allows the user to navigate a primary guide display screen to perform the function. Hand-held applications device 24 may provide stand-

- 35 -

alone access to program guide or other interactive television application features if desired.

FIG. 6 shows an illustrative menu screen 601 that may be displayed by hand-held application device 24 when, for example, device 24 starts up. Menu screen 601 may include a number of icons 603 that indicate secondary applications that have functionality coordinated with primary applications running on user television equipment 22. Menu screen 601 may also include icons 605 that indicate other applications that run exclusively on hand-held application device 24, if desirable. A user may access a secondary program guide application by, for example, touching a TV Guide icon with his or her finger or stylus.

FIG. 7 shows an illustrative browse display screen 701 that may be displayed by the secondary program guide running on hand-held access device 24. Browse display screen 701 may be displayed, for example, on startup, or after the user selects a suitable icon from menu screen 601. Browse display screen 701 may include browse area 703 in which a program title 715 for the browsed channel 717 and time slot 719 is displayed. Browse area 703 may also include the broadcast time of the program associated with the listing, and its rating. The current time 711 and channel 713 may also be displayed.

A user may browse program listings for other time slots and channels by touching right, left, up, and down arrows 721. A user may tune to the browsed channel by, for example, touching channel 717. When a user touches channel 717, the secondary program guide may exchange one or more application communications with the primary guide via communications link 19

- 36 -

telling the primary guide that the user has indicated a desire to tune to a particular channel. The primary guide may cause user television equipment 22 to tune to the indicated channel. In another suitable approach, 5 hand-held application device 24 may be programmed to change the channel on television 36 using set-top box 28 (FIG. 4).

The controls in browse display screen 701 may also be used to perform any other suitable function. 10 The user may touch time 719 or channel 717 to, for example, enter a by-time or by-channel listings screen. In still another suitable approach, the user may touch time 719 and hand-held application device 24 may present a numeric keypad or a list of times separated 15 by, for example, one-half hour time slots, to provide the user with an opportunity to indicate a time for which the user wishes to browse listings. In response to the user touching channel 717, hand-held application device 24 may present a numeric keypad or a list of 20 channels to provide the user with an opportunity to indicate a channel for which the user wishes to browse listings.

Browse display screen 701 may include selectable advertisements 705. Selectable 25 advertisements 705 may, for example, include text and graphics advertising a program or other television or non-television products or services. When a user selects a selectable advertisement 705, the secondary guide may display information (e.g., pay-per-view 30 ordering information, program information, etc.) or take other actions related to the content of the advertisement. The secondary guide may, for example, cause user television equipment 22 to tune to a barker

- 37 -

type channel on which a trailer for an advertised pay-per-view program is displayed. Alternatively, the secondary guide may use one or more application communications to indicate to the primary guide that the user has selected an advertised for a pay-per-view program. The primary guide may then tune user television equipment 22 to the associated barker channel. While the barker channel is being played on user television equipment 22, the secondary guide may provide a user with an opportunity to order the pay-per-view program.

Browse display screen 701 may also include logo 707 for providing a user with an opportunity to access the primary program guide running on interactive television application equipment 17. The user may touch exit icon 709 to return hand-held application device 24 to its default state (e.g., power it down, return to main menu screen 601, etc.). If desired, browse display screen 701 may include other controls suitable for browsing listings. Browse display screen 701 may include, for example, next program, previous program, hour ahead, hour back, day ahead, day back, and current time controls. When selecting channels, browse display screen 701 may include, for example, next and previous favorites buttons to allow the user to indicate a desire to browse listings for favorite programs. Any other suitable control may also be used.

FIG. 8 shows an illustrative information screen 801 that the secondary program guide may display when, for example, the user touches a program title 715 from browse display screen 701 of FIG. 7, or when the user selects a selectable advertisement 705. Information screen 801 may include information 803

- 38 -

about the program indicated by the selected listing. Information screen 801 may also include selectable advertisements 705, the current time 711, the current channel 713, logo 707, and exit icon 709. When the user accesses information screen 801 by selecting a selectable advertisement 705, only the selected selectable advertisement may remain on the screen. The secondary program guide may provide a user with an opportunity to access other familiar program guide features for the indicated program from information screen 801, such as tuning to the program (by touching watch control 807).

The secondary guide may provide a user with an opportunity to set reminders. The user may set a reminder for the indicated program by, for example, touching remind control 809. When the user sets a reminder using hand-held application device 24, the secondary guide may coordinate the reminder with the primary guide. The secondary guide may, for example, indicate the program for which the reminder is set to the primary guide by exchanging one or more application communications via link 19. At an appropriate time (e.g., ten minutes before the program starts), the secondary guide may display a reminder on hand-held access device 24 and the primary guide may display a reminder on display device 45 (FIG. 5). To conserve memory on hand-held application device 24, reminders may be set by the secondary guide with the primary guide and not stored by the secondary guide. When the reminder is displayed by the primary guide, the primary guide may exchange one or more application communications with the secondary guide indicating that



- 39 -

a reminder is due for a given program. The secondary guide may display a reminder accordingly.

Hand-held application device 24 may provide the user with an opportunity to configure the time at which a reminder is displayed. The user may schedule reminders for, for example, between one and fifteen minutes before a program is available. If desired, reminders may be provided by hand-held application device 24 and user television equipment 22 at different default or user-configured times. In still another approach, reminders may be provided by only one of hand-held application device 24 and user television equipment 22.

The secondary guide may provide a user with an opportunity to parentally lock or unlock program titles, channels, ratings, or time periods. The user may indicate a desire to parentally lock an indicated program or one of its attributes (e.g., title, rating, channel, etc.) by, for example, touching lock control 811. Locking or unlocking a program title, channel, rating, or time period may be an involved function in some program guides from a user interaction standpoint. When a user indicates a desire to lock or unlock a program title, channel, rating, or time period the secondary program guide may exchange one or more application communications with the primary program guide that indicate to the primary guide that the user wishes to lock or unlock a given program title, channel, rating, or time period. The secondary guide may then convert to a remote control that allows the user to navigate within a primary guide parental control display screen. In guides where parentally controlling a program is not very involved, the

- 40 -

secondary guide may provide the user with an opportunity to lock or unlock a program by title, channel, genre, rating, or example.

The secondary guide may also provide a user with an opportunity to change a parental control code. When a user changes a parental control code, the secondary guide may indicate to the primary guide the changing of the code and the new code, using one or more application communications. The primary guide may then change the parental control code accordingly.

If desired, information screen 801 may include a more control in addition to or instead of controls 807, 809, and 811. In response to a user touching a more control, hand-held application device 24 may provide controls for additional features. Additional controls may include, for example, pay-per-view ordering controls, other air time controls, or any other suitable control.

The secondary guide running on hand-held application device 24 may provide a user with an opportunity to order pay-per-view programs. A user may indicate a desire to order a pay-per-view program by, for example, touching a selectable advertisement 705 that advertises a pay-per-view program. FIG. 9 shows an illustrative pay-per-view ordering screen. As with other display screens displayed by the secondary guide on hand-held application device 24, pay-per-view ordering screen may include brand logo 707, exit control 709, the current time 711, and current channel 713. Pay-per-view ordering screen 901 may also include ordering information 907. Ordering information 907 may include the title of the selected program, the air time 911 for the selected showing, the price, a brief

- 41 -

description, the rating of the pay-per-view program, and any other suitable information.

Pay-per-view ordering screen 901 may also include selectable advertisements 705. A single  
5 selectable advertisement 705 may be displayed when, for example, the user accesses a pay-per-view ordering screen by selecting a selectable advertisement. The single selectable advertisement may not be actionable. When the user accesses the screen by, for example,  
10 selecting a pay-per-view program title, two selectable advertisements 705 may be displayed. When a user selects one of the two selectable advertisements 705, the secondary guide may display a program information screen for an advertised program.

15 When screen 901 is initially displayed, run time 911 for the indicated pay-per-view program may start at the next available start time 913. The user may see additional air times by, for example, touching left arrow 903 or right arrow 905. When the user  
20 selects a different start time 913, the secondary guide may display ordering information 907 for the selected start time.

The secondary guide may provide a user with an opportunity to navigate within the primary guide and  
25 access features of the primary guide using hand-held application device 24. A user may indicate a desire to access the primary guide by, for example, touching logo 707. FIG. 10 shows an illustrative remote screen 1000. Remote screen 1000 may include, for example, logo 707,  
30 selectable advertisements 705, current time 711 and current channel 713. When a user selects logo 707 from within remote screen 1000, the secondary guide may instruct the primary guide to display a program

- 42 -

listings screen on display device 54 (FIG. 5). The controls of remote screen 1000 may be based on and displayed according to the screen displayed by a primary guide or other application, the option  
5 highlighted on a particular primary application screen, the content or type of information displayed in a primary application screen, or any other suitable feature, group of features, or content.

The user may navigate within a primary guide  
10 display screen by, for example, touching arrows 1003. Navigation within a program guide display screen using hand-held application device may be performed within any primary guide display screen. For the purposes of illustration, navigation within a primary guide main  
15 menu screen and within a primary guide program listings screen is discussed.

An illustrative primary guide main menu screen 100 is shown in FIG. 11. Main menu screen 100 may include menu 102 of selectable program guide  
20 features 106. If desired, program guide features 106 may be organized according to feature type. In menu 102, for example, program guide features 106 have been organized into three columns. The column labeled "TV GUIDE" is for listings related features, the column  
25 labeled "MSO SHOWCASE" is for multiple system operator (MSO) related features, and the column labeled "VIEWER SERVICES" is for viewer related features. The interactive television program guide may generate a display screen for a particular program guide feature  
30 when a user selects that feature from menu 102.

Main menu screen 100 may include one or more selectable advertisements 108. Selectable advertisements 108 may, for example, include text and

- 43 -

graphics advertising pay-per-view programs or other programs or products. When a user selects a selectable advertisement 108, the program guide may display information (e.g., pay-per-view information) or take  
5 other actions related to the content of the advertisement. Pure text advertisements may be presented, if desired, as illustrated by selectable advertisement banner 110.

Main menu screen 100 may also include other  
10 screen elements. The brand of the program guide product may be indicated, for example, using a product brand logo graphic such as product brand logo graphic 112. The identity of the television service provider may be presented, for example, using a service  
15 provider logo graphic such as service provider logo graphic 114. The current time may be displayed in clock display region 116. In addition, a suitable indicator such as indicator graphic 118 may be used to indicate to a user that mail from a cable operator is  
20 waiting for a user if the program guide supports messaging functions. Additionally a TV e-mail reminder may allow a user to know when he or she has awaiting e-mail messages from an Internet, Intranet or other computer-related e-mail account. The user may  
25 interactively correspond with his or her e-mail respondent using, for example, a virtual keyboard displayed on hand-held application device 24, voice commands that are received and processed by hand-held application device 24, or a suitable input device  
30 connected to hand-held application device 24 or user television equipment 22 (e.g., a wireless keyboard).

A user may select a feature 106 by, for example, positioning highlight region 120 over the

- 44 -

feature. The user may position highlight region 120 by, for example, touching arrows 1003. As the user touches an arrow 1003, the secondary guide may indicate the desired action (i.e., positioning highlight region 5 120) to the primary guide using one or more application communications. The primary guide may receive the application communications and position highlight region 120 on display device 45 accordingly.

When the user has positioned highlight region 10 120 over a desired feature, the user may select the feature by, for example, touching OK 1005 on hand-held application device 24. The secondary guide may indicate to the primary guide that the user has selected a feature using one or more application 15 communications. The primary guide may receive the application communications and perform the desired function.

A user may, for example, desire to view program listings using the primary guide by, for 20 example, selecting a "By Time" feature. Alternatively, the user may indicate a desire to view program listings by, for example, selecting a by-time option from within primary guide main menu screen 100. The secondary 25 guide may indicate the desired feature to the primary guide using one or more application communications, and the primary guide may display a program listings screen.

The primary guide may overlay a program listings screen over a program being viewed by a user 30 or over a portion of the program in a "browse" mode. Program listings may be displayed using any suitable list, table, grid, or other suitable display arrangement. If desired, program listings screens may

- 45 -

include selectable advertisements, product brand logo graphics, service provider brand graphics, clocks, or any other suitable indicator or graphic.

FIG. 12 illustrates the display of program listings by time. Program listings screen 130 of FIG. 12 may include highlight region 151, which highlights the current program listing 150. A user may position highlight region 151 by, for example, touching arrows 1003. A user may tune to a program by, for example, highlighting its listing and touching "OK" 1005. A user may view additional listings for the time slot indicated in time bar 111 by, for example, touching arrows 1003 to move highlight region 120 up or down past the beginning or end of the listings. A user may view program listings for other time slots by, for example, touching right and left arrows 1003. In this example, hand-held application device may include other controls appropriate for program listings screen 130, such as page up, page down, day forward, day back, or any other suitable control.

The secondary program guide may provide a user with an opportunity to navigate within the primary program guide in other ways. The secondary guide may provide a user with an opportunity to set channels as favorites on the secondary guide, the primary guide, or both. The user may, for example, navigate between listings set as favorites by touching "FAV" 1007. Alternatively, the secondary guide may re-sort program listings with the favorite channels in the most prominent or convenient position as displayed on hand-held application device 24 or user television equipment 22.

- 46 -

The user may back up one previous primary guide display screen by, for example, touching "LAST" 1009. The user may return to primary guide main menu screen 100 by, for example, touching "MENU" 1011. The user may return to watching television by, for example, touching "EXIT" 709. A user may indicate a desire to view program information for a particular listing by, for example, positioning highlight region 150 over the listing and touching "INFO" 1013. Other illustrative controls that may be displayed by the secondary guide on hand-held application device 24 when a user highlights a program listing from within a listings screen or other display screen may include controls for: setting a reminder, locking a program, ordering the program if it is a pay-per-view, seeing other air times of the program, or ordering program-related merchandise such as a CD of the soundtrack, a videotape of the program, or apparel carrying the program's brand.

The primary guide may also provide a user with an opportunity to view a listing of channels such as shown in illustrative premiums screen 231 of FIG. 13. The secondary guide may change the display on hand-held application device to display controls that are suitable for such a screen. The secondary guide may display, for example, a subscribe control for subscribing to a channel, a set favorite control to set a channel as a favorite, a lock control to lock a channel, or an info control for providing information about a channel.

The secondary guide may also provide a user with an opportunity to define what objects are always displayed on hand-held application device 24. The user



- 47 -

may choose, for example, a help control that invokes context sensitive help, a message flag that signals hand-held application device 24 or the user's television equipment has received an e-mail, a VCR  
5 button, a DVD button, or a power off button that turns off all of user television equipment 22 and devices connected to user television equipment 22.

The functionality of the primary guide may be extended to or coordinated with the secondary guide for  
10 any number of other suitable program guide related features. The secondary guide may provide a user with an opportunity to use hand-held application device 24 to, for example: send and receive e-mail (related to the guide, such as promotional messages from the cable  
15 operator, or unrelated to the guide, such as personal messages); buy merchandise; bid on a televised auction; order subscriptions services such as HBO; pay a cable bill; make a financial transaction for someone at a different household (such as renting a PPV movie for  
20 another, or making any other guide-based financial transaction); effect Internet based e-commerce (e.g., order merchandise, participate in an on-line auction or reverse auction, etc.), or surf the Internet. These and other features may be incorporated into hand-held  
25 access device 24 as a stand-alone device if desired.

Another function that may be coordinated between the primary and secondary guides using hand-held application device 24 is the control of a picture-in-picture (PIP) display. A PIP display is a small  
30 partial-screen video window of one channel's video overlaid on top of another channel's video that is displayed full-screen. Using the browse function of the secondary guide, the user could browse channels and

- 48 -

program titles on hand-held application device 24 and watch the same channels in the PIP, while other viewers can continue to watch the tuned channel on the main screen. The secondary guide may also provide a user  
5 with an opportunity to call up on-demand movie trailers, TV commercials and other downloaded video within the PIP window, using hand-held application device 24.

The secondary guide (or other software  
10 running on hand-held application device 24) may also provide a user with an opportunity to control the PIP in multi-person video conferencing. For example, in a three-way video conference the user could switch views between the two other user locations by touching  
15 suitable controls on hand-held application device 24. In a two-way video conference, for example, the user may use hand-held application device 24 to alternate between viewer locations in the PIP display.

Hand-held application device 24 may have  
20 suitable processing circuitry so as to display video. A video signal may be streamed, for example, as an MPEG-2 data stream to hand-held application device 24 for display. Video displays may also be streamed to hand-held application device 24 as a user browses  
25 through program listings using the secondary guide. In this approach, the video display may include video for a program that has its listing displayed and that is being broadcasted at the time of the browse. If system resources do not permit the streaming of video, still  
30 shots may be transmitted from interactive television application equipment 17 to hand-held application device 24 for display instead. In another suitable approach, highly compressed videos may be used to

- 49 -

account for bandwidth constraints. Using highly compressed videos may also be desirable when, for example, the resolution of the display of hand-held application device 24 would not support high-resolution video.

Other applications may be exclusively run on hand-held application device 24. Hand-held application device 24 may run, for example, an on-line program guide client. A user may indicate a desire to access an on-line program guide by, for example, touching TV Guide On-line from menu screen 601 (FIG. 6). When a user indicates a desire to access an on-line program guide, hand-held application device 24 may launch a standard Internet browser and access a suitable Web site. Alternatively, a proprietary Web browser or other remote access software may be launched in order to access a Web site or other proprietary site that provides Web access for a hand-held device.

FIG. 14 shows an illustrative home page for a hand-held access device Web site. When a user selects a HyperText link 1403 or other suitable type of anchor, hand-held access device 24 may download a HyperText Markup Language (HTML) page using the HyperText Transfer Protocol (HTTP). Any other suitable protocol may be used. In still another suitable approach, hand-held access device 24 may use suitable remote access software such as a Windows remote access software (RAS) client to download screen shots or screen shot commands, from a server (i.e., an Internet server that provides Internet access via a remote access client). FIG. 15 shows an illustrative page that hand-held access device 24 may display when, for example, a user selects a "Editor's Picks" anchor.

- 50 -

FIGS. 16a and 16b show illustrative pages that hand-held application device 24 may display when, for example, a user selects My TV listings anchor 1403. As shown, the on-line guide client, Web browser, or  
5 other access application running on hand-held application device 24 may provide a user with an opportunity to view program listings sorted according to one of a number of user selected criteria. When a user selects criteria, the on-line guide client, Web  
10 browser, or other Internet access application may retrieve program listings for the selected criteria and display the listings as shown in FIG. 16c. If desired, program listings may be downloaded based on the user's zip code, cable system, satellite service, or other  
15 suitable criteria, so that the user views program listings for programs available to the user and for the proper time zone. Users may also be provided with an opportunity to limit the listings by time, genre, favorites, or any other suitable criteria.

20 The on-line guide client, Web browser, or other access application running on hand-held application device 24 may also provide a user with an opportunity to view information about the application. FIG. 17 shows an about page that hand-held application  
25 device 24 may display when, for example, a user selects an About TVG Wireless anchor 1403, or other suitable anchor, from home page 1401 of FIG. 14.

FIGS. 18-20 are flowcharts of illustrative steps involved in providing stand-alone and coordinated  
30 application features on hand-held application device 24. The steps shown in FIGS. 18-20 are illustrative and in practice may be performed in any suitable order. FIG. 18 is a flowchart of illustrative steps involved

- 51 -

in providing interactive television and other application features with hand-held application device 24. At step 1800, application data, such as interactive television application data or data for other applications, is provided to hand-held application device 24. The data may be provided directly from main facility 12 to hand-held application device 24, from main facility 12 to hand-held application device 24 via interactive television application equipment 17, or directly from interactive television application equipment 17 (i.e., data that originates from interactive television application equipment 17). The interactive television application data may include any data suitable for interactive television or other applications. Interactive television applications may include, for example, applications that provide information related to television programming or that provide interactive features associated with television programming, such as, for example, interactive television program guides, home shopping applications, e-mail, wagering and financial trading applications. Interactive television applications may also include applications provided on user television equipment 22. As illustrative examples, home shopping applications and financial trading applications may be interactive television applications when features of such applications are provided via user television equipment. The features of these applications may be provided with television programming related to the features. A home shopping application may, for example, provide purchasing opportunities for products and services featured on a home shopping television channel.

- 52 -

Hand-held application device 24 receives the interactive television application data (step 1810) and provides a user with an opportunity to access the television related application with hand-held access device 24 (step 1820). The interactive television application may run as a stand alone application, as a client that requests data from a server (e.g., a server at main facility 12 or interactive television application equipment 17), or cooperatively with a primary application running within interactive television application equipment 17. At step 1830, hand-held application device 24 may provide the user with an opportunity to access other applications such as, for example, PDA-type functions. For example, it may support e-mail, a calendar, a contact list, web browsing, a calculator, etc. It may support data services, such as news, weather, sports, traffic, or any other suitable data service. Such applications may also be provided as stand alone or server applications running on user television equipment 22 and accessible by hand-held application device 24. Hand-held application device 24 may be used as a pager. With suitable hardware resources, the portable program guide might include advanced communication functions. For example, it might allow a user to remotely monitor the home equipment -- find out if the system is turned on, what channel is on, etc. It might also allow a user to listen to audio from a selected TV channel, or offer audio channels.

FIG. 19 is a flowchart of illustrative steps involved in coordinating features between primary applications running within interactive television application equipment 17 and supplemental applications

- 53 -

running on hand-held access device 24. At step 1900, main facility 12 or interactive television application equipment 17 provides application data to a primary application running on interactive television  
5 application equipment 17. The primary application may be an interactive television application or not related to television programming. At step 1910, the primary application provides the application data to a secondary application running on hand-held access  
10 device 24 using, for example, one or more access communications. At step 1920, the secondary application running on hand-held application device 24 provides a display of interface controls that are coordinated with the features of the primary  
15 application. For example, the interface controls may correspond with navigational features of the primary application. The illustrative remote screen 1000 of FIG. 10, for example, includes navigational arrows 1003 to correspond to navigational features of an  
20 interactive television program guide running on user television equipment 22. The user interface also includes controls for interactive guide features, such as favorites, last, more information, and menu. In a home shopping application, for example, user interface  
25 controls may include similar navigational controls, and may include other controls for home shopping features such as purchasing, information, putting items on wish lists, or any other suitable home shopping feature. In a home stock trading application for example, user  
30 interface controls may include similar navigational controls and may include other controls for features such as buying stocks, selling stocks, more information, or any other suitable feature. In a web

- 54 -

browser application, for example, similar navigational controls and other controls for, for example, back, forward, home, bookmark, or any other suitable feature may be provided. In a wagering application, for  
5 example, user interface controls may be provided for wagering, providing additional information regarding wagering opportunities, or any other suitable feature.

The interface controls may be coordinated with the features of the secondary application using  
10 the data provided by the primary application. In this way, user interface controls may be dynamically configurable based on the primary application. If desired, a library of standard controls may be stored by hand-held application device 24 so that the user is  
15 provided with a consistent interface across primary applications. Controls that are specialized for particular primary applications may be downloaded if desired.

Another example of coordinating interface  
20 controls with features of a primary application is providing primary application content on hand-held application device 24. In an interactive program guide application, for example, hand-held access device 24 may display television programming when, for example,  
25 the user browses listings while watching a program on user television equipment 22.

At step 1930, the secondary application controls the functionality of the primary application based on the user controls selected by the user as  
30 indicated on hand-held application device 24. This may be accomplished by, for example, exchanging one or more access communications with the primary application. In the example of FIG. 10, the user may select an arrow



- 55 -

1003 to position highlight region 120 or 151 of FIGS. 11 and 12. In a home shopping application, for example, the primary application may initiate a purchase sequence in response to a user selecting a purchase control on hand-held application device 24. In a stock trading application, for example, the primary application may sell stock in response to a user selecting a sell control on hand-held application device 24. In a web browser, for example, the system may go back to a previously accessed web page in response to a user selecting a back control.

FIG. 20 is a flowchart of illustrative steps involved in providing interactive television program guide functionality using hand-held application device 24. At step 2100, program guide data is provided to hand-held application device 24. The data may be provided directly from main facility 12 to hand-held application device 24, from main facility 12 to hand-held application device 24 via interactive television application equipment 17, or directly from interactive television equipment 17 (i.e., data that originates from interactive television application equipment 17). At step 2110, hand-held application device 24 provides the user with an opportunity to browse program listings. This may be accomplished independently, as a client to a primary server application running on a portion of interactive television application equipment 17, or cooperatively with a primary application running on a portion of interactive television application equipment 17. Hand-held application device 24 or user television equipment 22 may provide television programming in response to the user selecting a browsed listing (step 2115).

- 56 -

At step 2120, hand-held application device 24 may provide the user with an opportunity to set reminders. Reminders may appear on hand-held access device 24, with both an audio alert and a display 5 (step 2125). Via a paging return, for example, the device can be used to set reminders remotely with an interactive television program guide resident on user television equipment 22.

At step 2130, hand-held application device 24 10 may provide the user with an opportunity to order pay-per-view programs. A user may indicate a desire to order pay-per-view programs by, for example, selecting listings on hand-held application device 24, selecting advertisements on hand-held application device, or by 15 performing any other suitable function. Ordered pay-per-view programs may be provided on hand-held application device 24, or may be provided on user television equipment 22 (step 2135).

At step 2140, hand-held application device 24 20 may provide the user with an opportunity to view additional programming information. A user may indicate a desire to view additional programming information by, for example, selecting a program listing, selecting an advertisement (e.g., as shown in 25 FIG. 9), or by selecting any other suitable control. The additional information may be provided on hand-held application device 24, or may be provided on user television equipment 22 (step 2145).

The foregoing is merely illustrative of the 30 principles of this invention and various modifications can be made by those skilled in the art without departing from the scope and spirit of the invention.

- 57 -

What is claimed is:

1. A method for providing a user with access to an interactive television application with a hand-held application device, comprising:

    providing interactive television application data;

    receiving the interactive television application data with a hand-held application device having one or more touch-sensitive controls;

    providing the user with an opportunity to access the interactive television application data with the hand-held access device using the touch-sensitive controls.

2. The method defined in claim 1 wherein providing interactive television application data comprises providing interactive television application data from a main facility for reception by the hand-held application device.

3. The method defined in claim 1 wherein providing interactive television application data comprises providing interactive television application data from interactive television application equipment for reception by the hand-held application device.

4. The method defined in claim 1 wherein:  
    the interactive television application is an interactive television program guide;  
    the interactive television application data includes television program listings; and  
    providing the user with an opportunity to access the interactive television application data

- 58 -

with the hand-held access device using the touch-sensitive controls comprises providing the user with an opportunity to browse program listings using the touch-sensitive controls.

5. The method defined in claim 4 further comprising providing a television program associated with a browsed program listing on the hand-held application device.

6. The method defined in claim 1 wherein:  
the interactive television application is an interactive television program guide;  
the interactive television application data includes television program listings; and  
providing the user with an opportunity to access the interactive television application data with the hand-held access device using the touch-sensitive controls comprises providing the user with an opportunity to set a reminder using the touch-sensitive controls.

7. The method defined in claim 6 further comprising providing the reminder on the hand-held access device as set by the user.

8. The method defined in claim 1 wherein:  
the interactive television application is an interactive television program guide;  
the interactive television application data includes television program listings; and  
providing the user with an opportunity to access the interactive television application data

- 59 -

with the hand-held access device using the touch-sensitive controls comprises providing the user with an opportunity to order a pay-per-view program using the touch-sensitive controls.

9. The method defined in claim 1 wherein:  
the interactive television application is an interactive television program guide;  
the interactive television application data includes television program listings and additional programming information; and  
providing the user with an opportunity to access the interactive television application data with the hand-held access device using the touch-sensitive controls comprises providing the user with an opportunity to access additional programming information for a television program using the touch-sensitive controls.

10. The method defined in claim 1 further comprising:  
receiving the interactive television application data with user television equipment for use by a primary application; and  
coordinating the touch-sensitive controls with features of the primary application.

11. The method defined in claim 10 wherein coordinating the touch-sensitive controls with features of the primary application comprises exchanging one or more access communications between the hand-held application device and the user television equipment.

- 60 -

12. The method defined in claim 10 wherein the interactive television application is an interactive television program guide, a home shopping application, a home stock trading application, a home wagering application, or a television-related e-mail application.

13. The method defined in claim 10 further comprising:

providing interactive application data for a non-television application;

receiving the interactive application data with the hand-held application device; and

providing the user with an opportunity to access the interactive application data with the hand-held access device using the touch-sensitive controls.

14. The method defined in claim 13 wherein the interactive application is a calender, contact list, web browser, calculator, or to-do list.

15. The method defined in claim 10 wherein:  
the interactive television application is an interactive television program guide;

the interactive television application data includes television program listings;

coordinating the touch-sensitive controls with features of the primary application comprises coordinating the touch-sensitive controls with features of the interactive television program guide; and

- 61 -

providing the user with an opportunity to access the interactive television application data with the hand-held access device using the touch-sensitive controls comprises providing the user with an opportunity to browse program listings using the touch-sensitive controls.

16. The method defined in claim 15 further comprising providing a television program associated with a browsed program listing on the hand-held application device.

17. The method defined in claim 15 further comprising:

providing at least one access communication to the user television equipment wherein the at least one access communication indicates to the user television equipment a browsed program listing; and

providing a television program associated with a browsed program listing on the user television equipment in response to the at least one access communication.

18. The method defined in claim 10 wherein:  
the interactive television application is an interactive television program guide;

the interactive television application data includes television program listings;

coordinating the touch-sensitive controls with features of the primary application comprises coordinating the touch-sensitive controls

- 62 -

with features of the interactive television program guide; and

providing the user with an opportunity to access the interactive television application data with the hand-held access device using the touch-sensitive controls comprises providing the user with an opportunity to set a reminder using the touch-sensitive controls.

19. The method defined in claim 18 further comprising providing the reminder on the hand-held access device as set by the user.

20. The method defined in claim 10 wherein:  
the interactive television application is an interactive television program guide;

the interactive television application data includes television program listings;

coordinating the touch-sensitive controls with features of the primary application comprises coordinating the touch-sensitive controls with features of the interactive television program guide; and

providing the user with an opportunity to access the interactive television application data with the hand-held access device using the touch-sensitive controls comprises providing the user with an opportunity to order a pay-per-view program using the touch-sensitive controls.

21. The method defined in claim 20 further comprising:



- 63 -

providing at least one access communication to the user television equipment wherein the at least one access communication indicates to the user television equipment a pay-per-view program ordered by the user using the hand-held application device; and

providing the ordered pay-per-view program on the user television equipment in response to the at least one access communication.

22. The method defined in claim 10 wherein:  
the interactive television application is an interactive television program guide;

the interactive television application data includes television program listings and additional programming information;

coordinating the touch-sensitive controls with features of the primary application comprises coordinating the touch-sensitive controls with features of the interactive television program guide; and

providing the user with an opportunity to access the interactive television application data with the hand-held access device using the touch-sensitive controls comprises providing the user with an opportunity to access additional programming information for a television program using the touch-sensitive controls.

23. The method defined in claim 10 wherein providing interactive television application data comprises providing interactive television application

- 64 -

data from a main facility for reception by the hand-held application device.

24. The method defined in claim 10 wherein providing interactive television application data comprises providing interactive television application data from interactive television application equipment for reception by the hand-held application device.

25. A system for providing a user with access to an interactive television application with a hand-held application device, comprising:

means for providing interactive television application data;

means for receiving the interactive television application data with a hand-held application device having one or more touch-sensitive controls;

means for providing the user with an opportunity to access the interactive television application data with the hand-held access device using the touch-sensitive controls.

26. The system defined in claim 25 wherein the means for providing interactive television application data comprises means for providing interactive television application data from a main facility for reception by the hand-held application device.

27. The system defined in claim 25 wherein the means for providing interactive television application data comprises means for providing

- 65 -

interactive television application data from interactive television application equipment for reception by the hand-held application device.

28. The system defined in claim 25 wherein:  
the interactive television application is an interactive television program guide;  
the interactive television application data includes television program listings; and  
the means for providing the user with an opportunity to access the interactive television application data with the hand-held access device using the touch-sensitive controls comprises means for providing the user with an opportunity to browse program listings using the touch-sensitive controls.

29. The system defined in claim 28 further comprising means for providing a television program associated with a browsed program listing on the hand-held application device.

30. The system defined in claim 25 wherein:  
the interactive television application is an interactive television program guide;  
the interactive television application data includes television program listings; and  
the means for providing the user with an opportunity to access the interactive television application data with the hand-held access device using the touch-sensitive controls comprises means for providing the user with an opportunity to set a reminder using the touch-sensitive controls.

- 66 -

31. The system defined in claim 30 further comprising means for providing the reminder on the hand-held access device as set by the user.

32. The system defined in claim 25 wherein:  
the interactive television application is an interactive television program guide;  
the interactive television application data includes television program listings; and  
the means for providing the user with an opportunity to access the interactive television application data with the hand-held access device using the touch-sensitive controls comprises means for providing the user with an opportunity to order a pay-per-view program using the touch-sensitive controls.

33. The system defined in claim 25 wherein:  
the interactive television application is an interactive television program guide;  
the interactive television application data includes television program listings and additional programming information; and  
the means for providing the user with an opportunity to access the interactive television application data with the hand-held access device using the touch-sensitive controls comprises means for providing the user with an opportunity to access additional programming information for a television program using the touch-sensitive controls.

34. The system defined in claim 25 further comprising:

- 67 -

means for receiving the interactive television application data with user television equipment for use by a primary application; and  
means for coordinating the touch-sensitive controls with features of the primary application.

35. The system defined in claim 34 wherein the means for coordinating the touch-sensitive controls with features of the primary application comprises means for exchanging one or more access communications between the hand-held application device and the user television equipment.

36. The system defined in claim 34 wherein the interactive television application is an interactive television program guide, a home shopping application, a home wagering application, a home stock trading application, or a television-related e-mail application.

37. The system defined in claim 34 further comprising:

means for providing interactive application data for a non-television application;  
means for receiving the interactive application data with the hand-held application device;  
and

means for providing the user with an opportunity to access the interactive application data with the hand-held access device using the touch-sensitive controls.

- 68 -

38. The system defined in claim 37 wherein the interactive application is a calender, contact list, web browser, calculator, or to-do list.

39. The system defined in claim 34 wherein:  
the interactive television application  
is an interactive television program guide;

the interactive television application  
data includes television program listings;

the means for coordinating the touch-sensitive controls with features of the primary application comprises means for coordinating the touch-sensitive controls with features of the interactive television program guide; and

the means for providing the user with an opportunity to access the interactive television application data with the hand-held access device using the touch-sensitive controls comprises means for providing the user with an opportunity to browse program listings using the touch-sensitive controls.

40. The system defined in claim 39 further comprising means for providing a television program associated with a browsed program listing on the hand-held application device.

41. The system defined in claim 39 further comprising:

means for providing at least one access communication to the user television equipment wherein the at least one access communication indicates to the user television equipment a browsed program listing;  
and

- 69 -

means for providing a television program associated with a browsed program listing on the user television equipment in response to the at least one access communication.

42. The system defined in claim 34 wherein:  
the interactive television application is an interactive television program guide;  
the interactive television application data includes television program listings;  
the means for coordinating the touch-sensitive controls with features of the primary application comprises means for coordinating the touch-sensitive controls with features of the interactive television program guide; and  
the means for providing the user with an opportunity to access the interactive television application data with the hand-held access device using the touch-sensitive controls comprises means for providing the user with an opportunity to set a reminder using the touch-sensitive controls.

43. The system defined in claim 42 further comprising means for providing the reminder on the hand-held access device as set by the user.

44. The system defined in claim 34 wherein:  
the interactive television application is an interactive television program guide;  
the interactive television application data includes television program listings;  
the means for coordinating the touch-sensitive controls with features of the primary

- 70 -

application comprises means for coordinating the touch-sensitive controls with features of the interactive television program guide; and

the means for providing the user with an opportunity to access the interactive television application data with the hand-held access device using the touch-sensitive controls comprises means for providing the user with an opportunity to order a pay-per-view program using the touch-sensitive controls.

45. The system defined in claim 44 further comprising:

means for providing at least one access communication to the user television equipment wherein the at least one access communication indicates to the user television equipment a pay-per-view program ordered by the user using the hand-held application device; and

means for providing the ordered pay-per-view program on the user television equipment in response to the at least one access communication.

46. The system defined in claim 34 wherein:

the interactive television application is an interactive television program guide;

the interactive television application data includes television program listings and additional programming information;

the means for coordinating the touch-sensitive controls with features of the primary application comprises means for coordinating the touch-sensitive controls with features of the interactive television program guide; and



- 71 -

the means for providing the user with an opportunity to access the interactive television application data with the hand-held access device using the touch-sensitive controls comprises means for providing the user with an opportunity to access additional programming information for a television program using the touch-sensitive controls.

47. The system defined in claim 34 wherein the means for providing interactive television application data comprises means for providing interactive television application data from a main facility for reception by the hand-held application device.

48. The system defined in claim 34 wherein the means for providing interactive television application data comprises means for providing interactive television application data from interactive television application equipment for reception by the hand-held application device.

49. A system for providing a user with access to an interactive television application with a hand-held application device, comprising:

a first communications device configured to provide interactive television application data; and

a hand-held application device

comprising:

a second communications device configured to receive the interactive television application data;

- 72 -

a user interface having one or more touch-sensitive controls that provide the user with an opportunity to access the interactive television application data; and

processing circuitry configured to (i) direct the second communications device to receive the interactive television application data, and (ii) direct the user interface to display the one or more touch-sensitive controls.

50. The system defined in claim 49 wherein the first communications device is located at a main facility.

51. The system defined in claim 49 wherein the first communications device is located at interactive television application equipment.

52. The system defined in claim 49 wherein:  
the interactive television application is an interactive television program guide;  
the interactive television application data includes television program listings; and  
the touch-sensitive controls are further configured to provide the user with an opportunity to browse program listings.

53. The system defined in claim 52 wherein:  
the second communications device is further configured to receive a television program associated with a browsed program listing; and

- 73 -

the user interface is further configured to display the television program on the hand-held application device.

54. The system defined in claim 49 wherein:  
the interactive television application is an interactive television program guide;  
the interactive television application data includes television program listings; and  
the touch-sensitive controls are further configured to provide the user with an opportunity to provide the user with an opportunity to set a reminder.

55. The system defined in claim 54 wherein the hand-held access device is further configured to direct the user interface to provide the reminder as set by the user.

56. The system defined in claim 49 wherein:  
the interactive television application is an interactive television program guide;  
the interactive television application data includes television program listings; and  
the touch-sensitive controls are further configured to provide the user with an opportunity to provide the user with an opportunity to order a pay-per-view program.

57. The system defined in claim 49 wherein:  
the interactive television application is an interactive television program guide;

- 74 -

the interactive television application data includes television program listings and additional programming information; and

the touch-sensitive controls are further configured to provide the user with an opportunity to provide the user with an opportunity to access additional programming information for a television program.

58. The system defined in claim 49 wherein:

the system further comprises a primary application running at least partially on user television equipment;

the first communications device is located within the user television equipment and is further configured to receive interactive television application data for use by the primary application; and

the processing circuitry is further configured to coordinate the touch-sensitive controls with features of the primary application.

59. The system defined in claim 58 wherein the processing circuitry is further configured to direct the second communications device to exchange one or more access communications with the user television equipment.

60. The system defined in claim 58 wherein the interactive television application is an interactive television program guide, a home shopping application, a home wagering application, a home stock

- 75 -

trading application, or a television-related e-mail application.

61. The system defined in claim 58 further comprising:

the first communications device is further configured to provide interactive application data for a non-television application;

the second communications device is further configured to receive the interactive application data; and

the touch-sensitive controls are further configured to provide the user with an opportunity to access the interactive application data.

62. The system defined in claim 61 wherein the interactive application is a calender, contact list, web browser, calculator, or to-do list.

63. The system defined in claim 58 wherein:  
the interactive television application is an interactive television program guide;

the interactive television application data includes television program listings;

the processing circuitry is further configured to coordinate the touch-sensitive controls with features of the interactive television program guide; and

the touch-sensitive controls are further configured to provide the user with an opportunity to browse program listings.

64. The system defined in claim 63 wherein:

- 76 -

the second communications device is further configured to receive a television program associated with a browsed program listing; and

the user interface is further configured to display the television program on the hand-held application device.

65. The system defined in claim 64 wherein the first communications device is located in user television equipment;

the processing circuitry is further configured to direct the second communications device to provide at least one access communication to the second communication device, wherein the at least one access communication indicates to the user television equipment a browsed program listing; and

the user television equipment is further configured to provide a television program associated with a browsed program listing in response to the at least one access communication.

66. The system defined in claim 58 wherein: the interactive television application is an interactive television program guide;

the interactive television application data includes television program listings;

the processing circuitry is further configured to coordinate the touch-sensitive controls with features of the interactive television program guide; and

the touch-sensitive controls are further configured to provide the user with an opportunity to set a reminder.

- 77 -

67. The system defined in claim 66 wherein the hand-held application device is further configured to direct the user interface to provide the reminder on the hand-held access device as set by the user.

68. The system defined in claim 58 wherein:  
the interactive television application is an interactive television program guide;  
the interactive television application data includes television program listings;  
the processing circuitry is further configured to coordinate the touch-sensitive controls with features of the interactive television program guide; and  
the touch-sensitive controls are further configured to provide the user with an opportunity to order a pay-per-view program.

69. The system defined in claim 68 wherein:  
the first communications device is located in user television equipment;  
the processing circuitry is further configured to direct the second communications device to provide at least one access communication to the user television equipment, wherein the at least one access communication indicates to the user television equipment a pay-per-view program ordered by the user using the hand-held application device; and  
the user television equipment is configured to provide the ordered pay-per-view program in response to the at least one access communication.

- 78 -

70. The system defined in claim 58 wherein:  
the interactive television application  
is an interactive television program guide;

the interactive television application  
data includes television program listings and  
additional programming information;

the processing circuitry is further  
configured to coordinate the touch-sensitive controls  
with features of the interactive television program  
guide; and

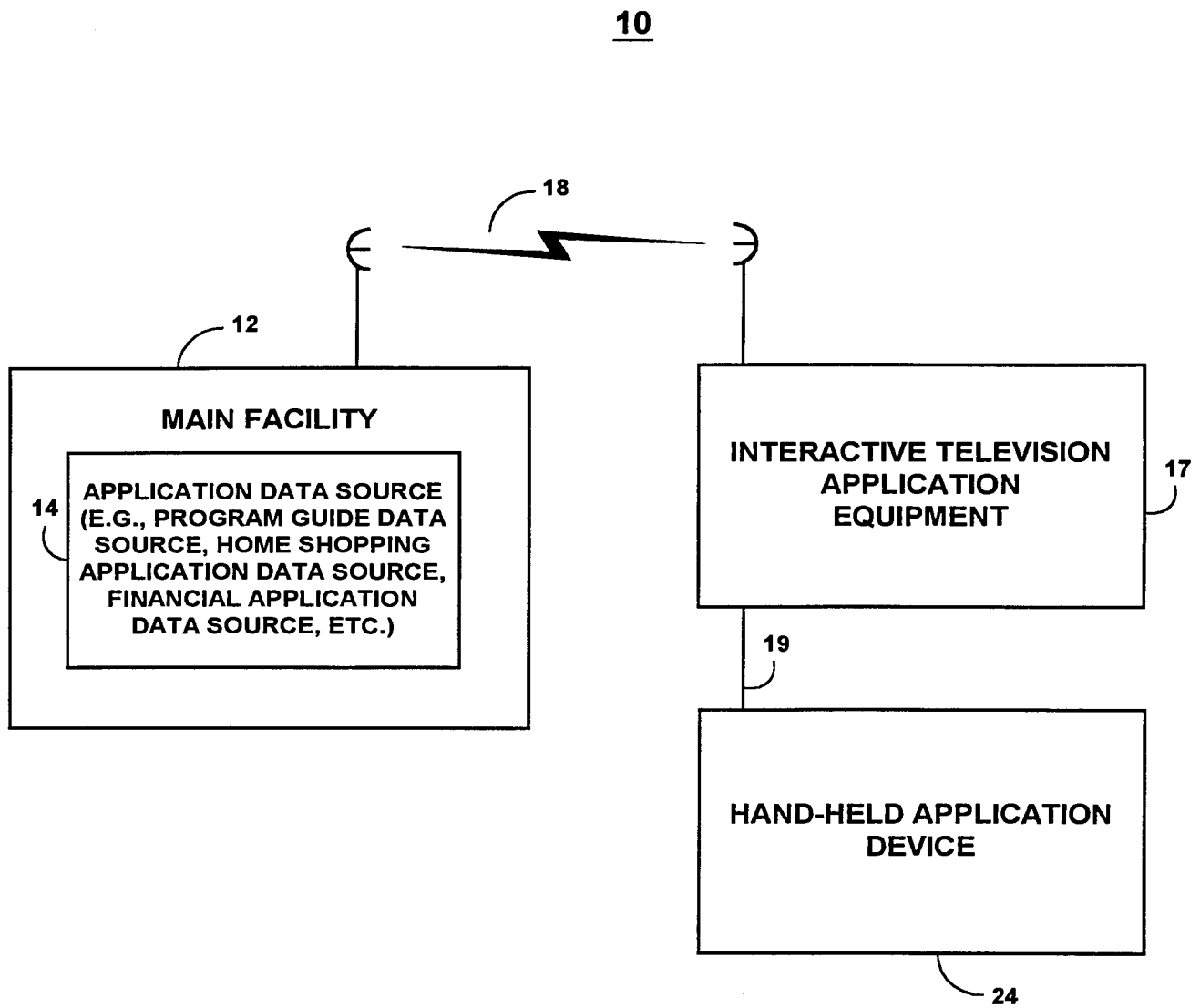
the touch-sensitive controls are further  
configured to provide the user with an opportunity to  
access additional programming information for a  
television program.

71. The system defined in claim 58 wherein  
first communications device is located at a main  
facility.

72. The system defined in claim 58 wherein  
the first communications device is located at  
interactive television application equipment.

73. The system defined in claim 49 wherein:  
the first communications device is  
further configured to provide the interactive  
television application data over a 900 MHz link; and  
the second communications device is  
further configured to receive the interactive  
television application data over the 900 MHz link.





**FIG. 1**

2/27

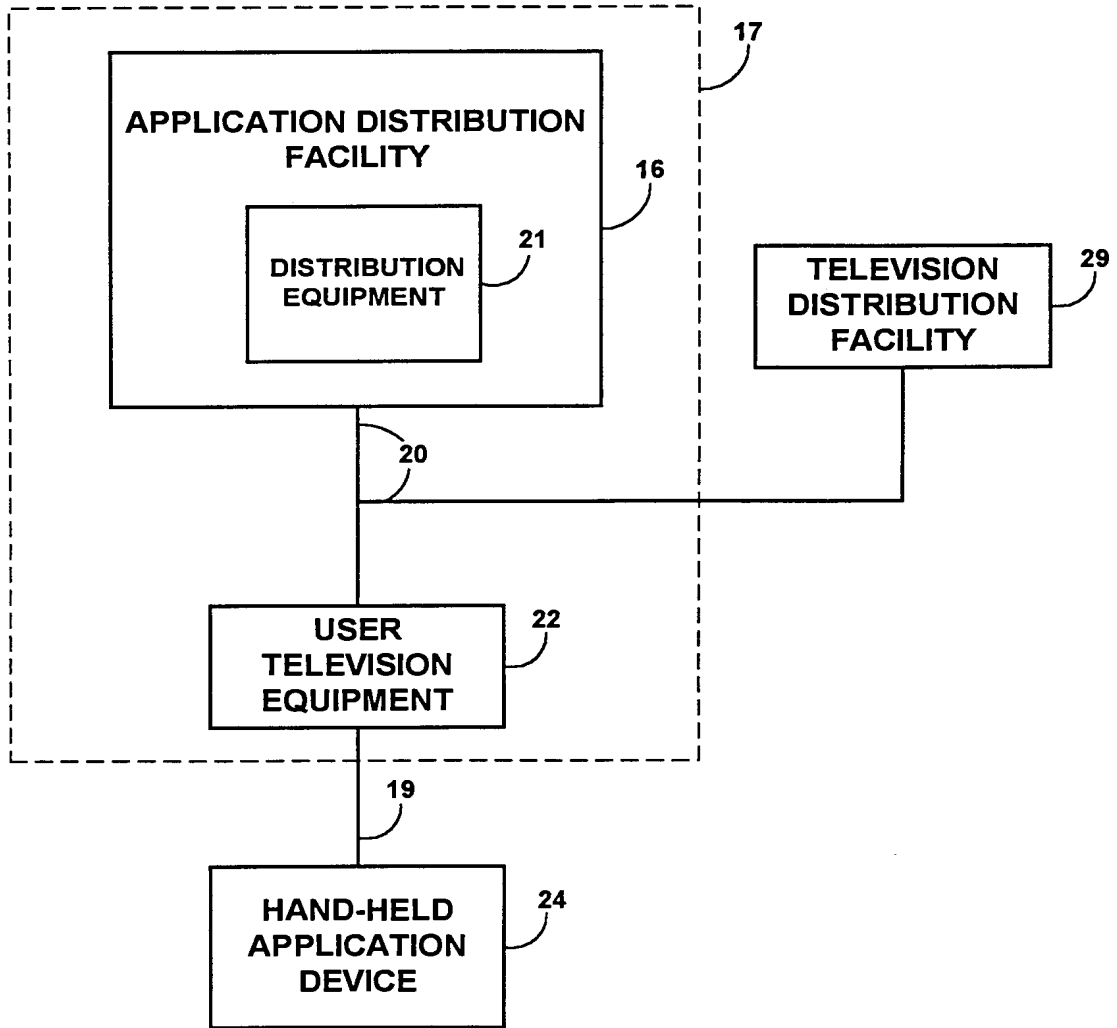


FIG. 2a

3/27

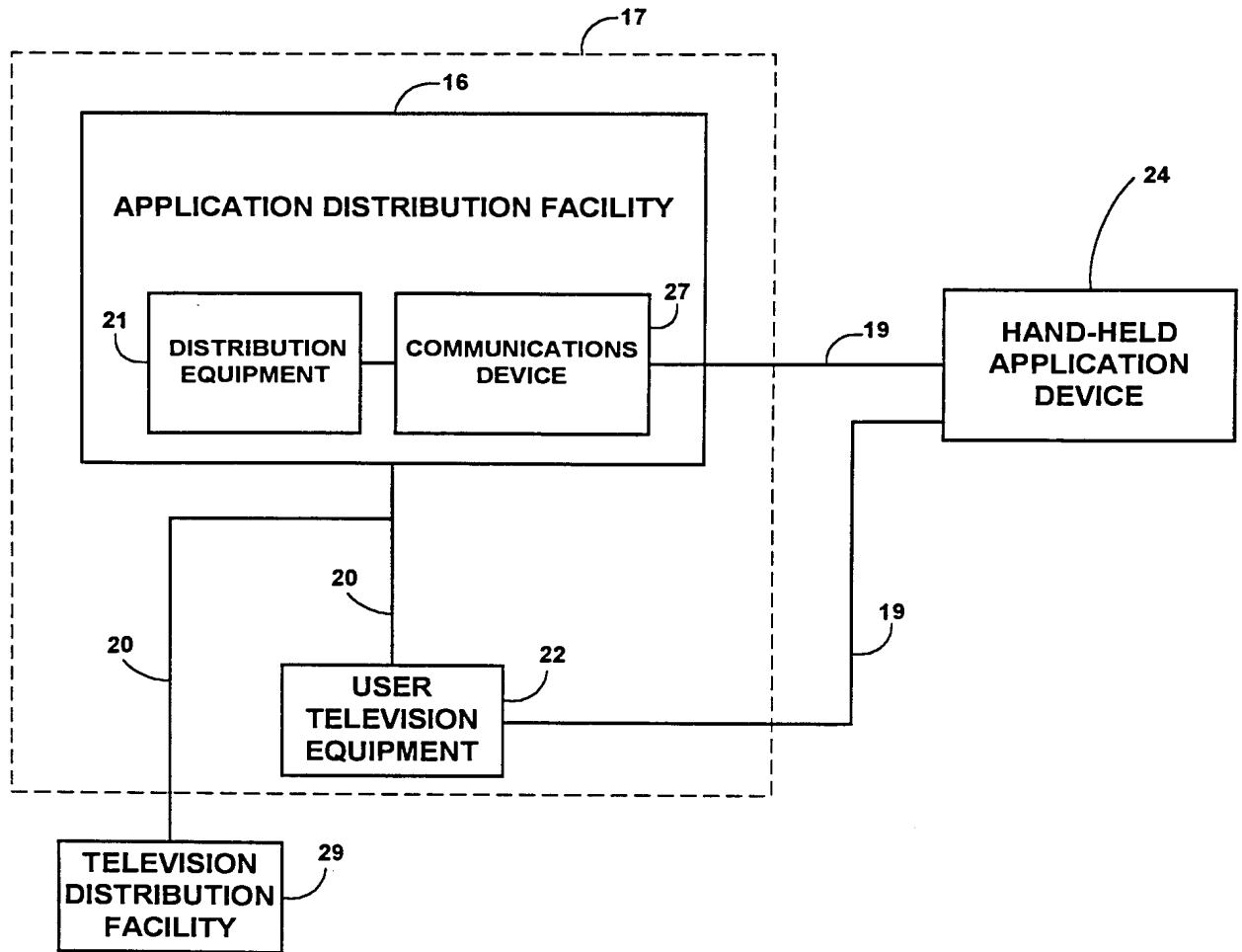


FIG. 2b

4/27

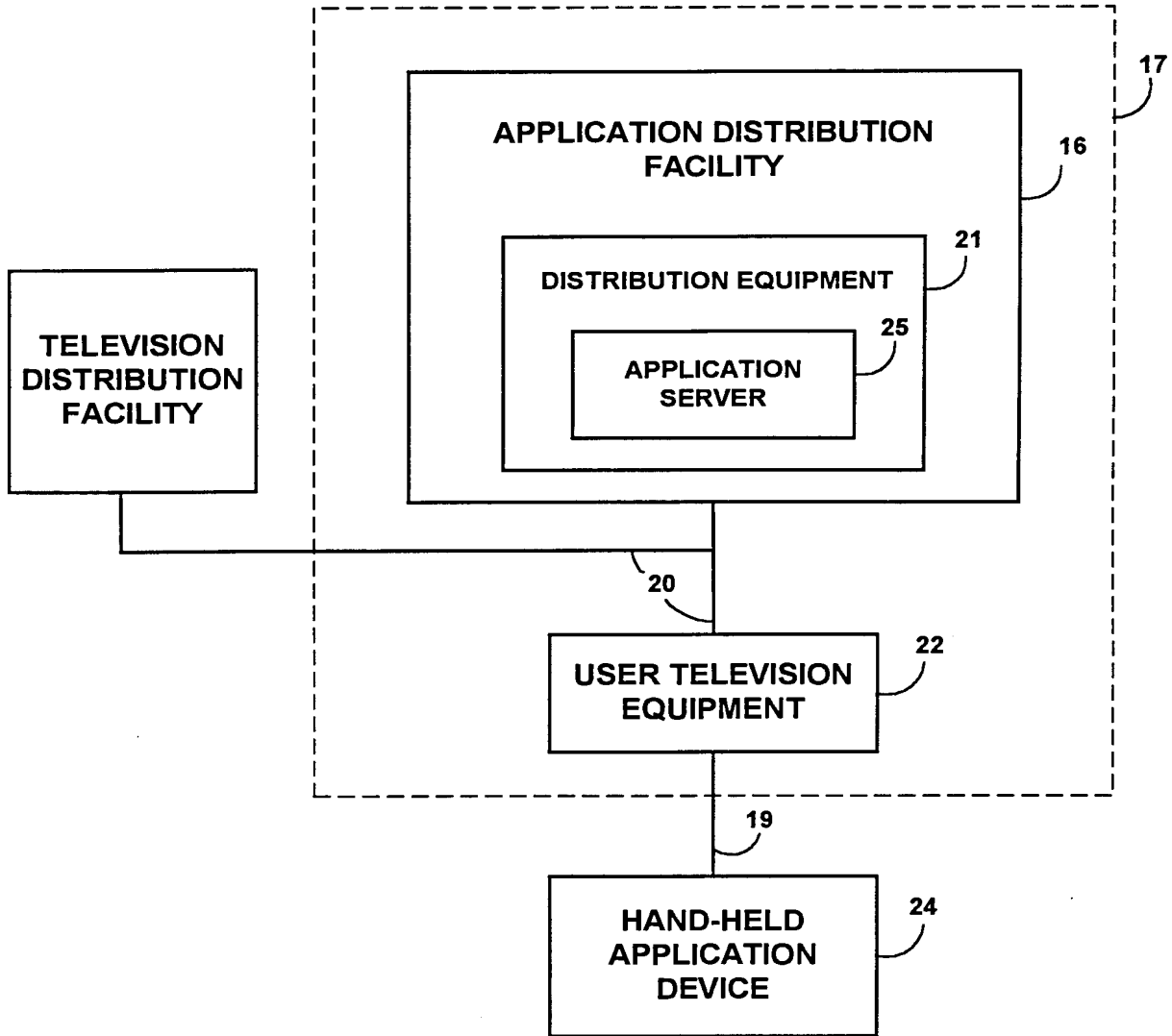


FIG. 2c

5/27

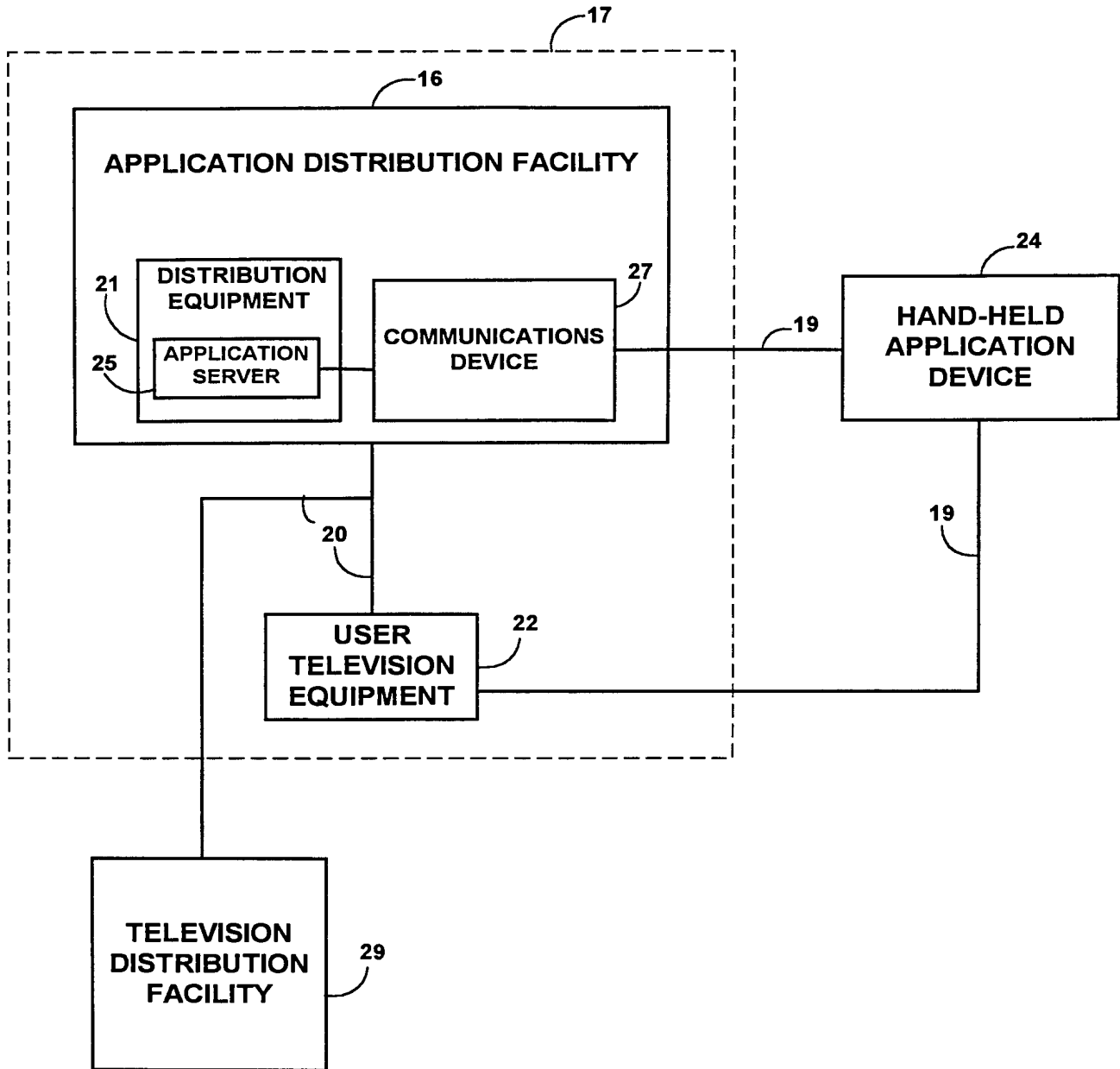


FIG. 2d

6/27

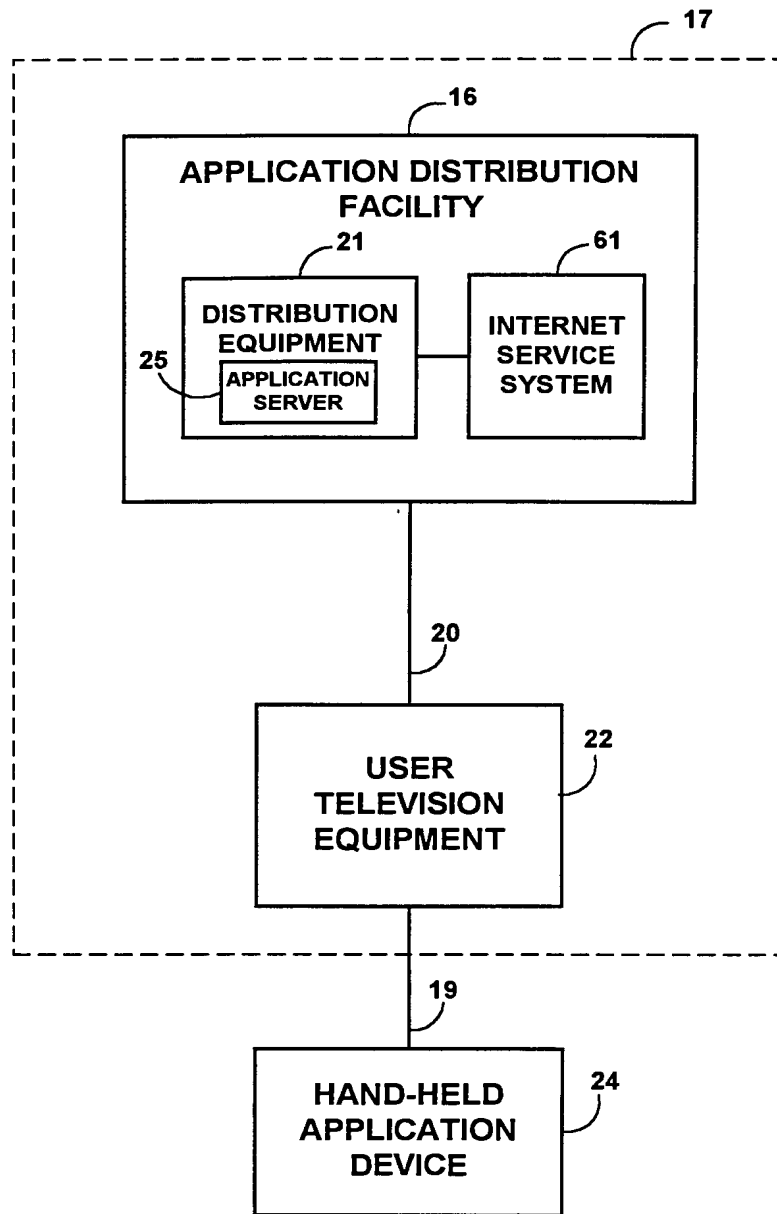


FIG. 2e

7/27

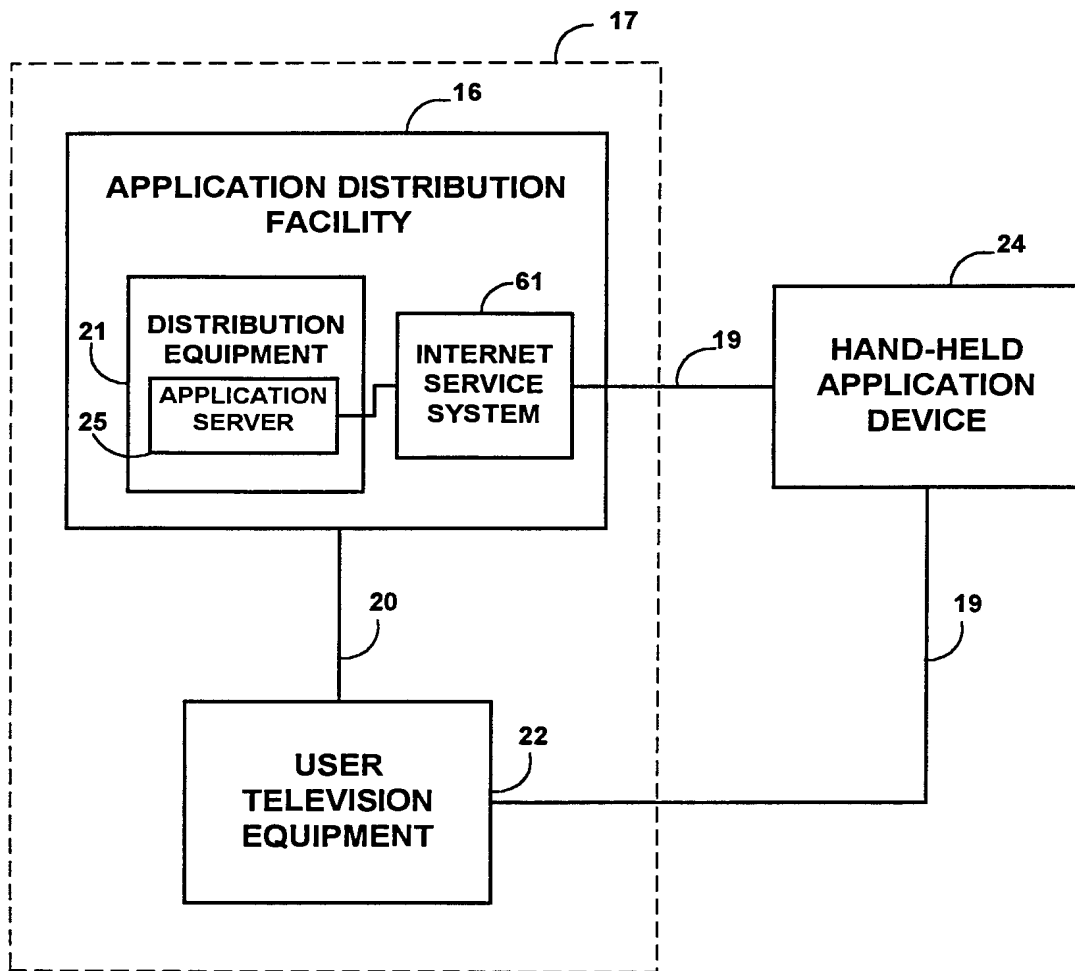


FIG. 2f

8/27

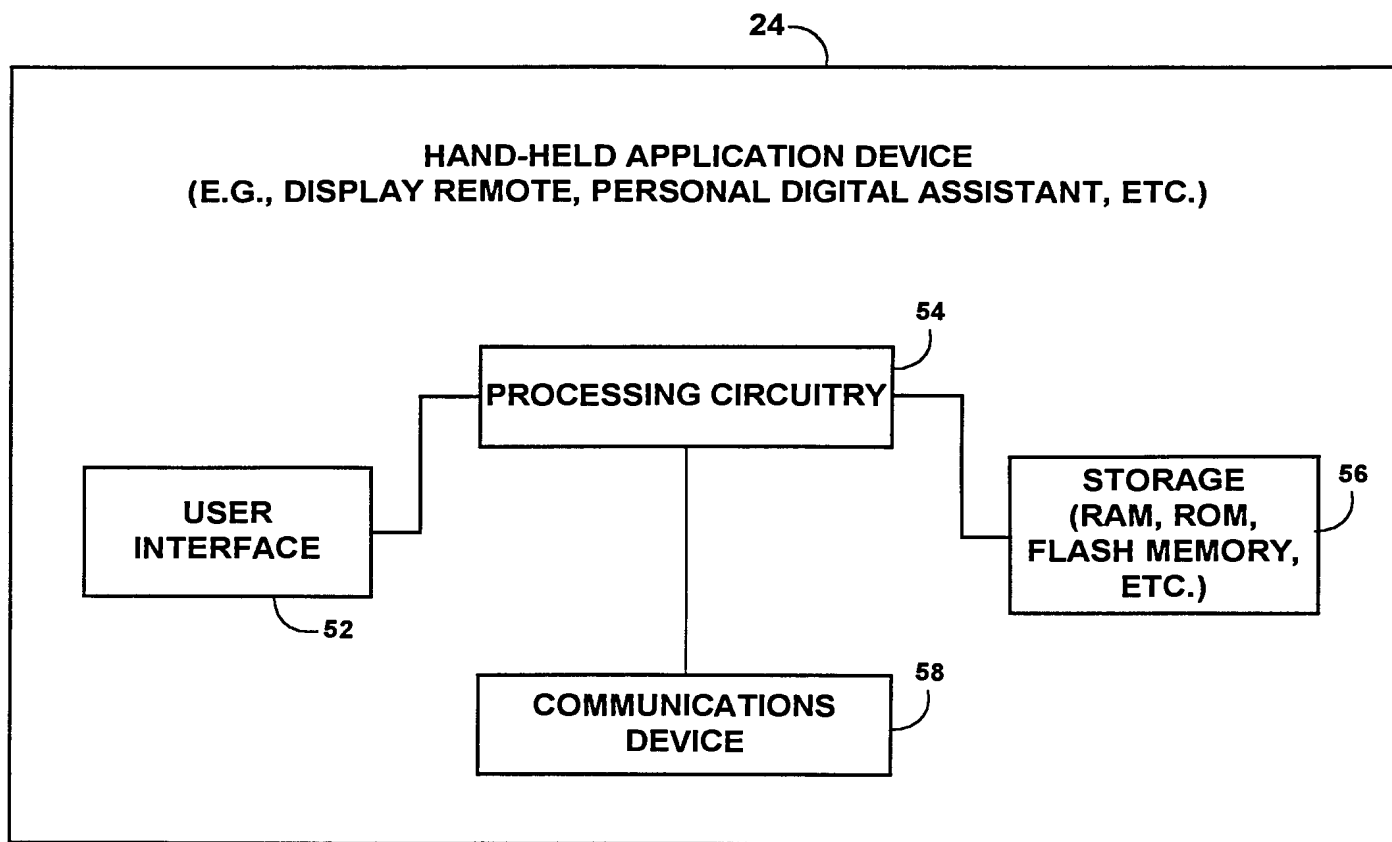


FIG. 3



9/27

22

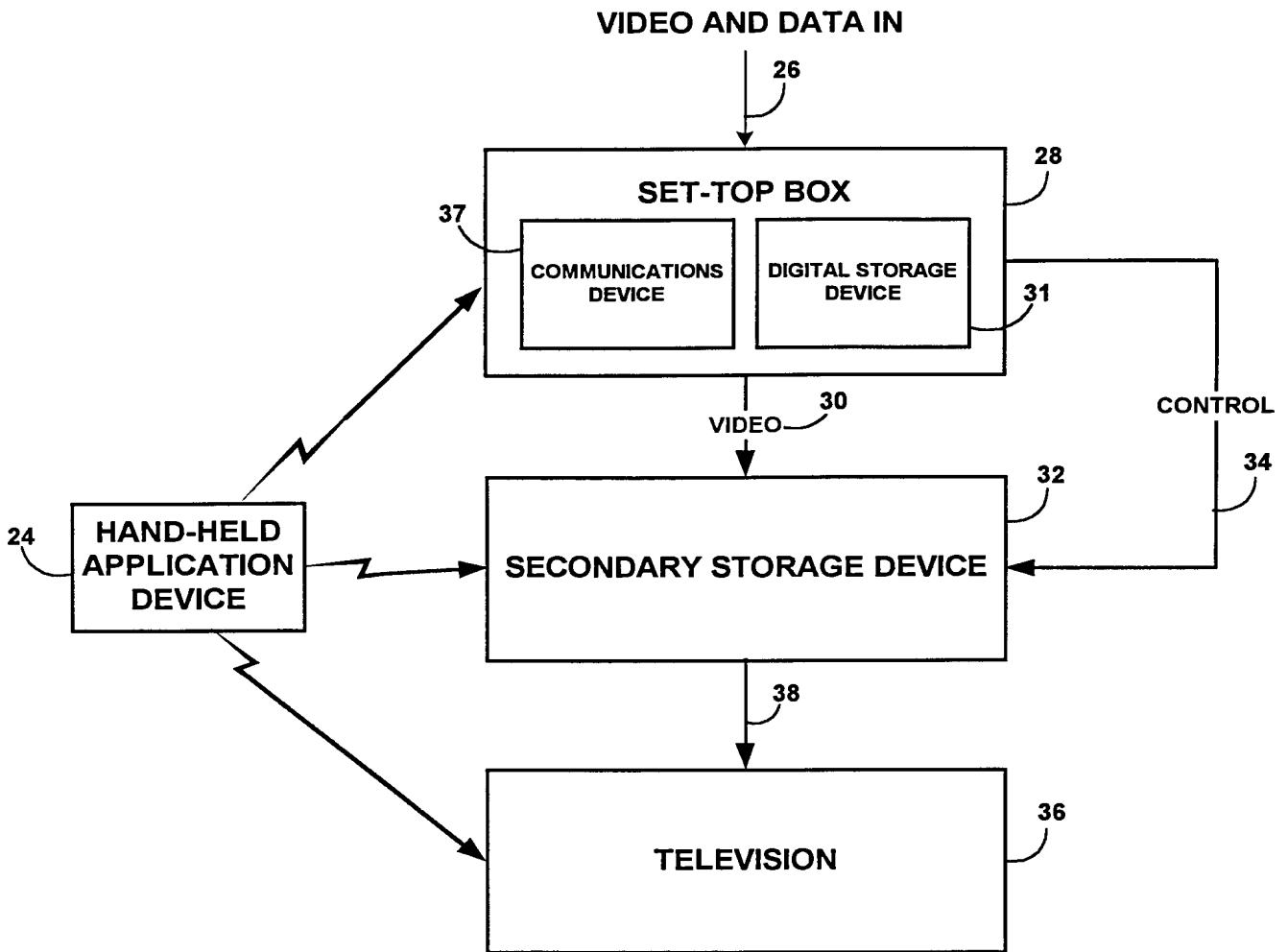


FIG. 4

10/27

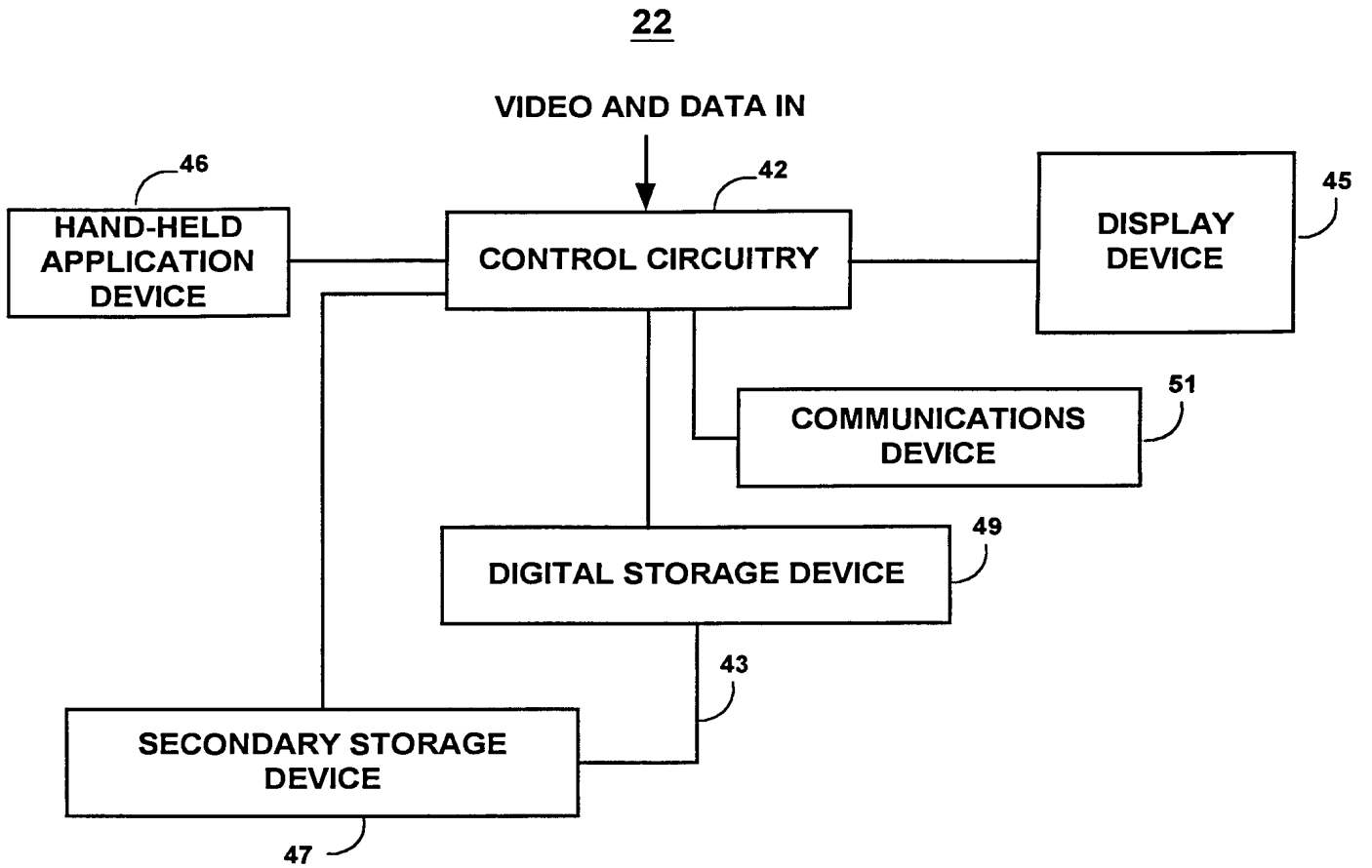
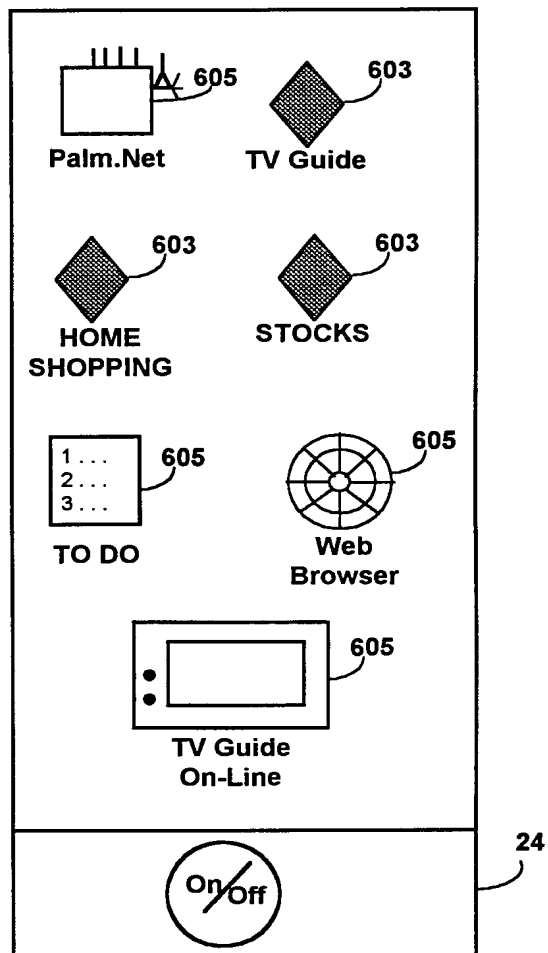


FIG. 5

11/27

**601**



**FIG. 6**

12/27

701

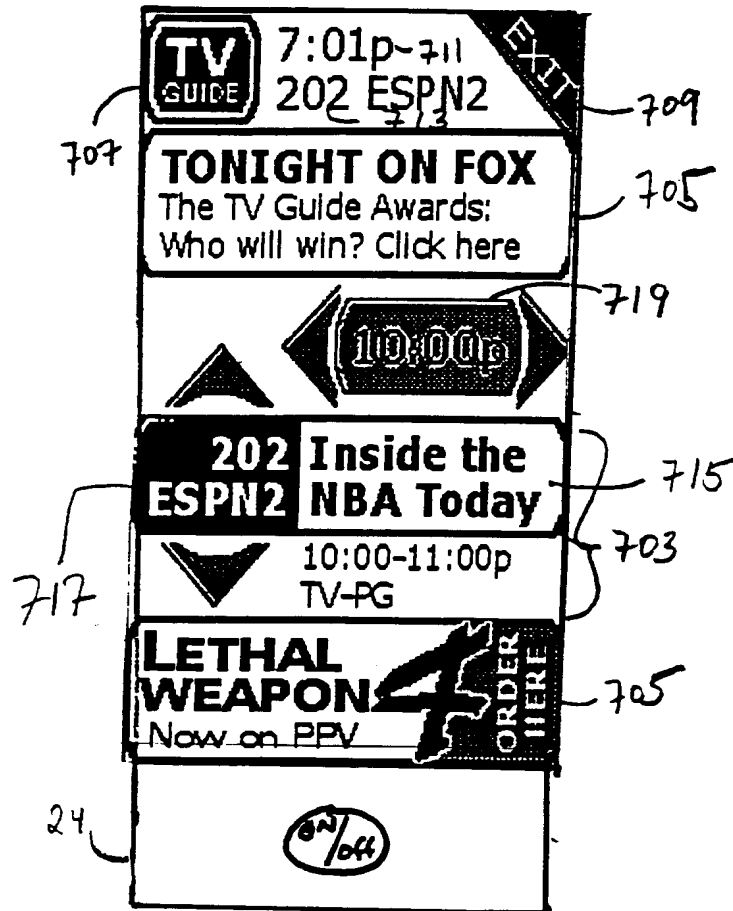


FIG. 7

13/27

801

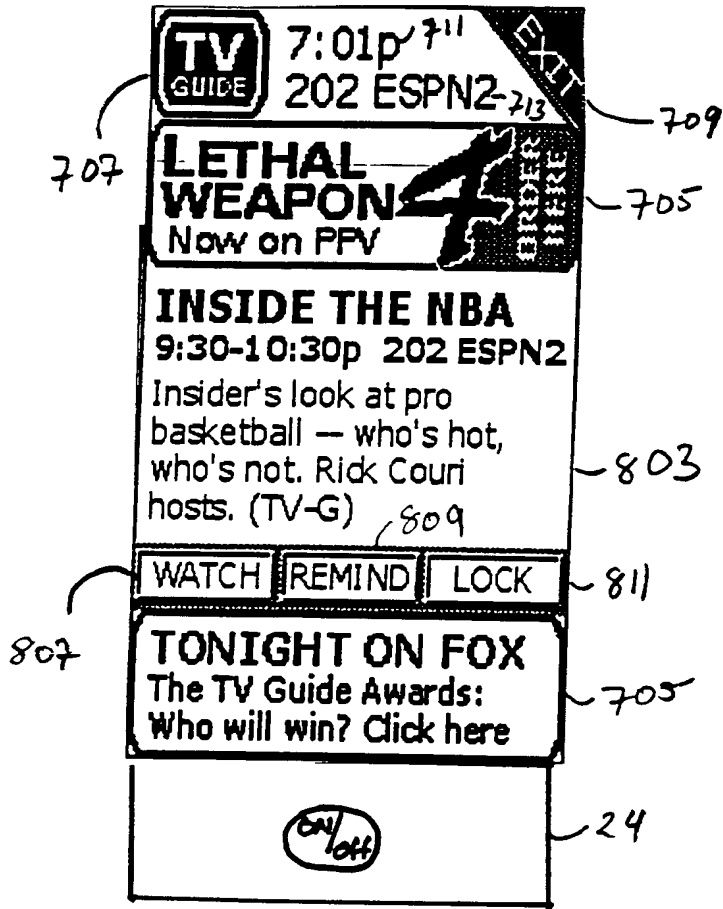


FIG. 8

14/27

901

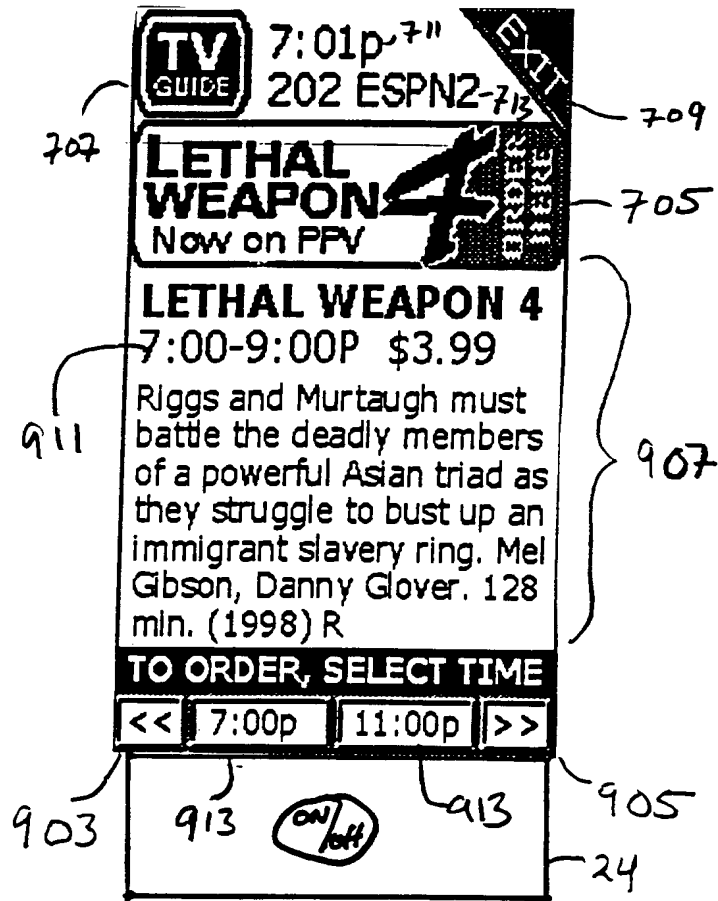


FIG. 9

15/27

1000

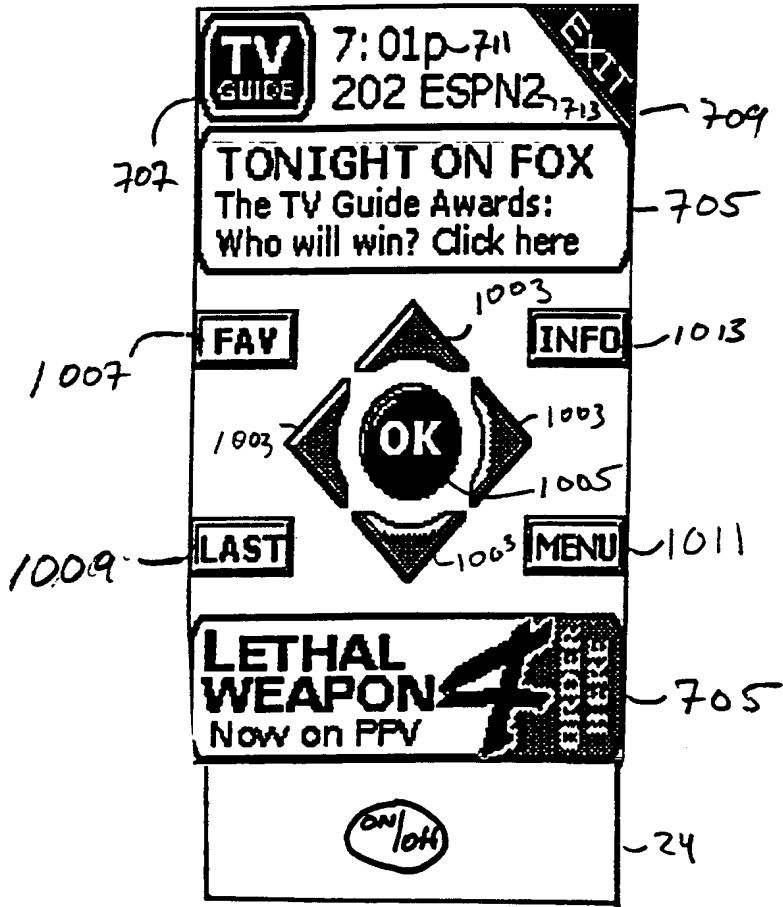
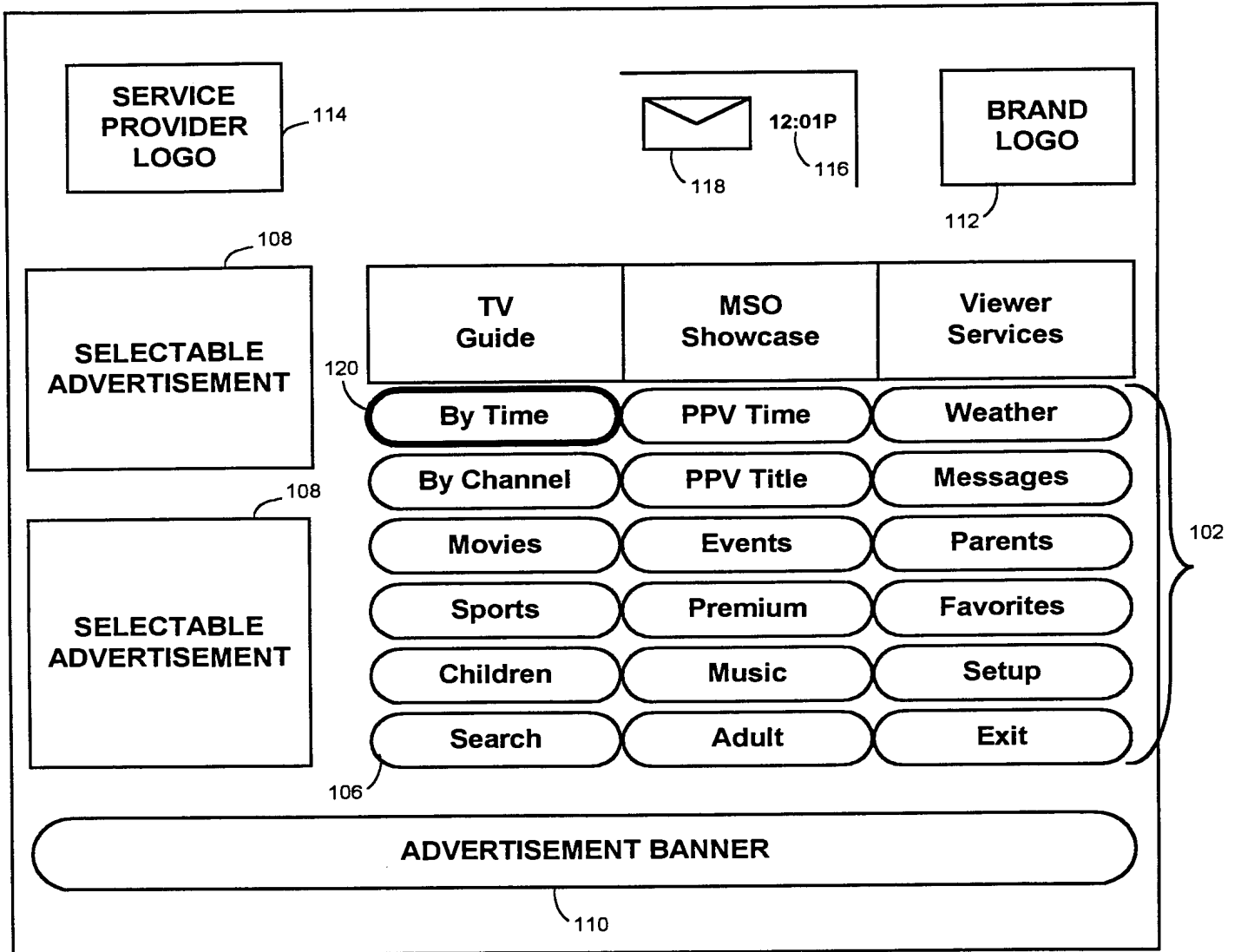


FIG. 10

16/27

**100**



**FIG. 11**



17/27

130

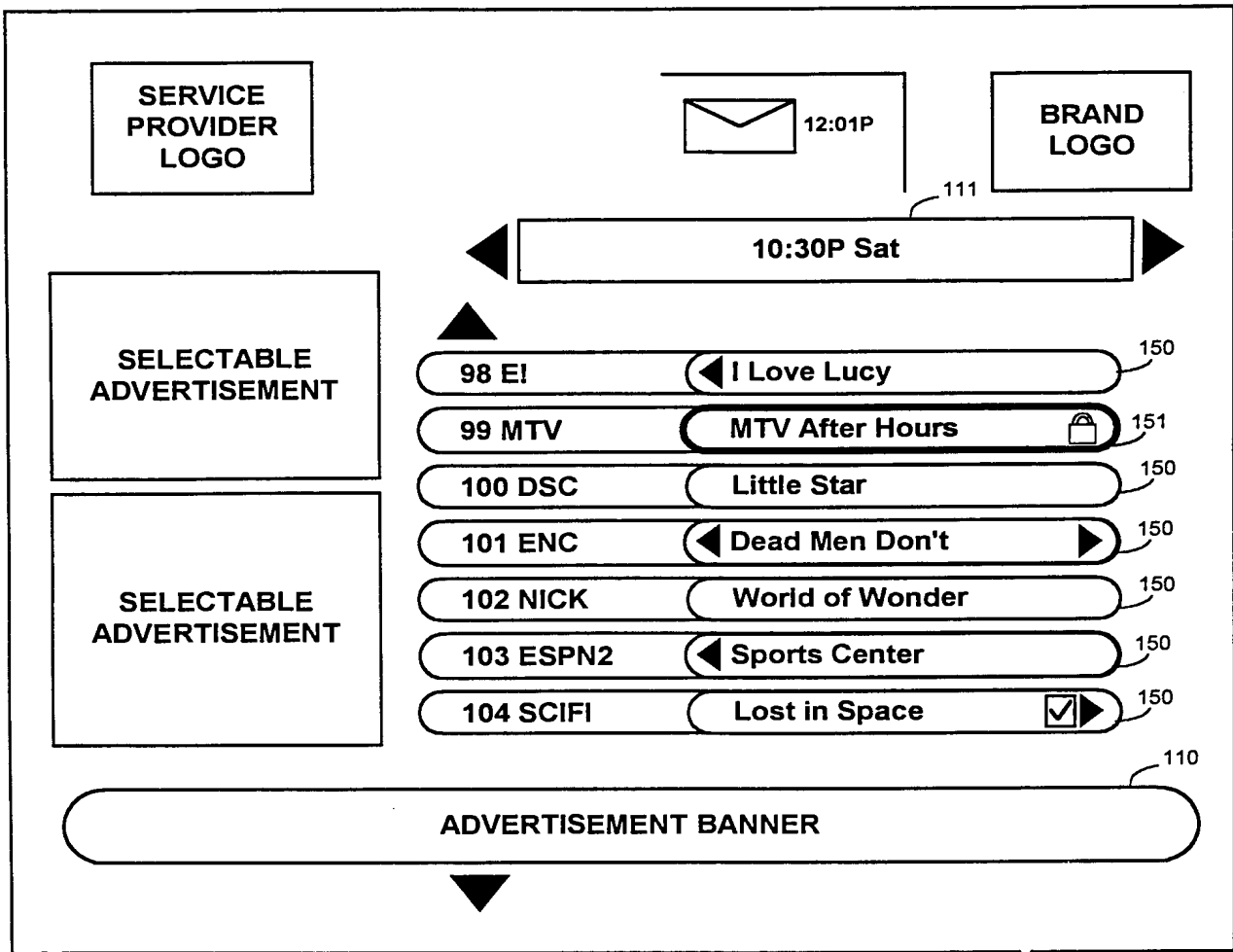


FIG. 12

18/27

231

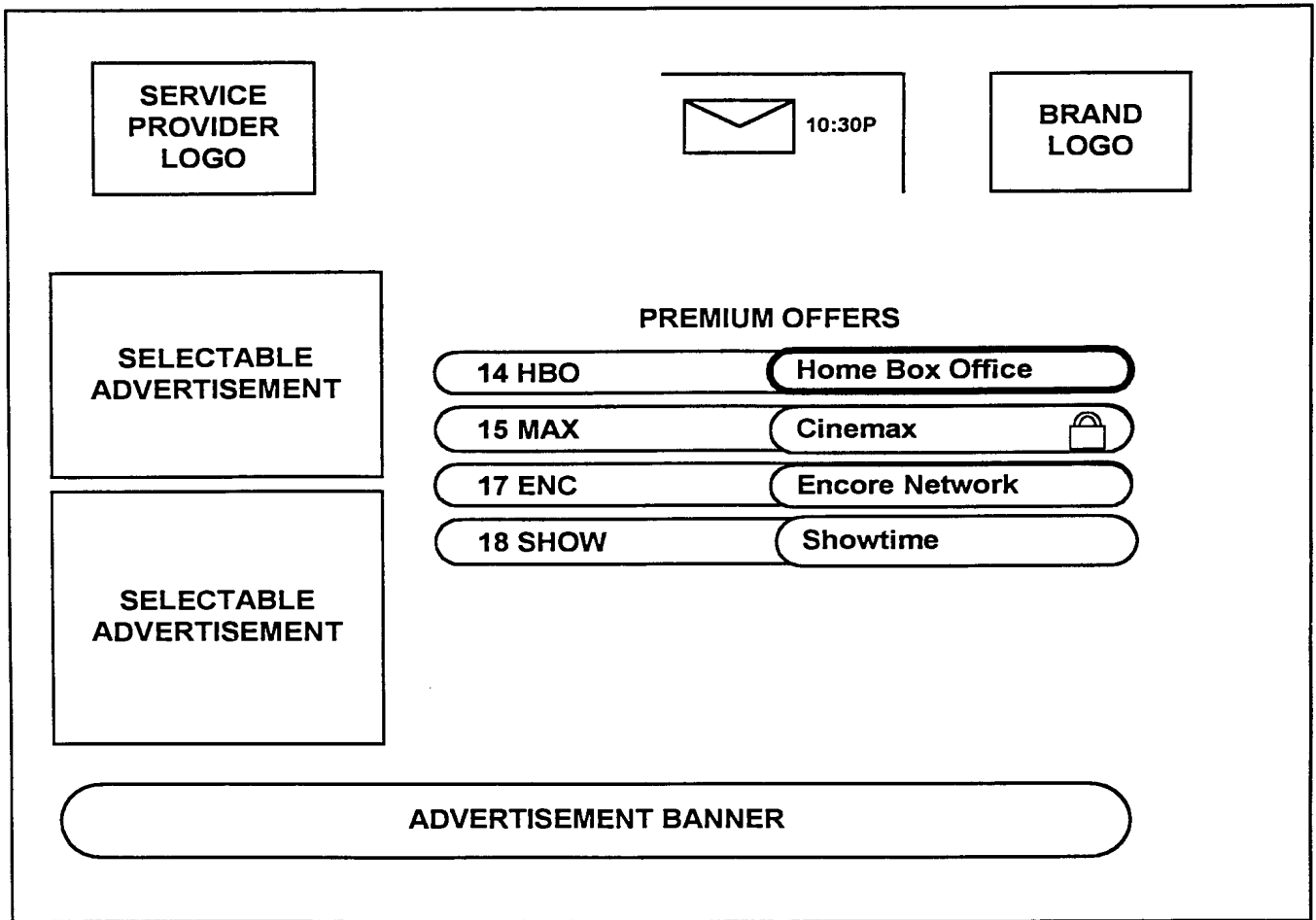


FIG. 13

19/27

1401

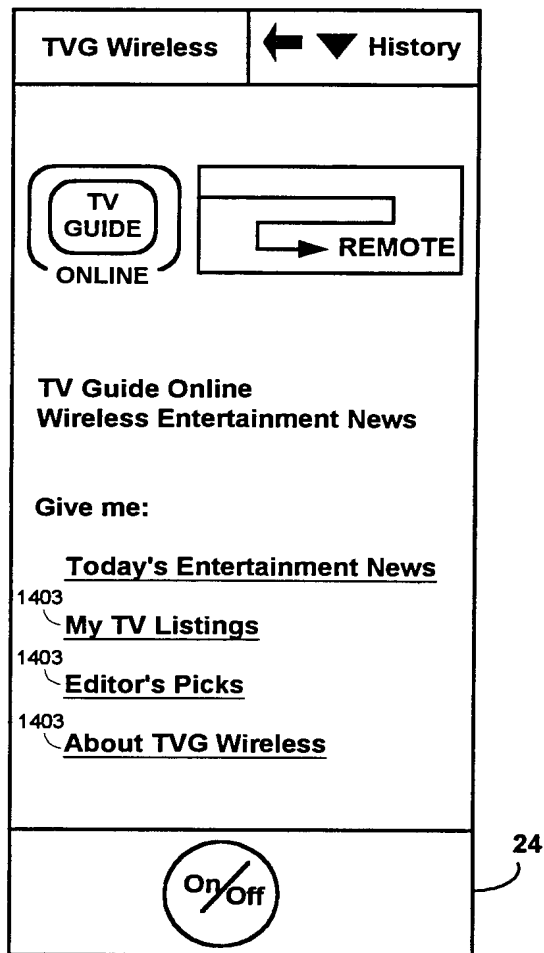


FIG. 14

20/27

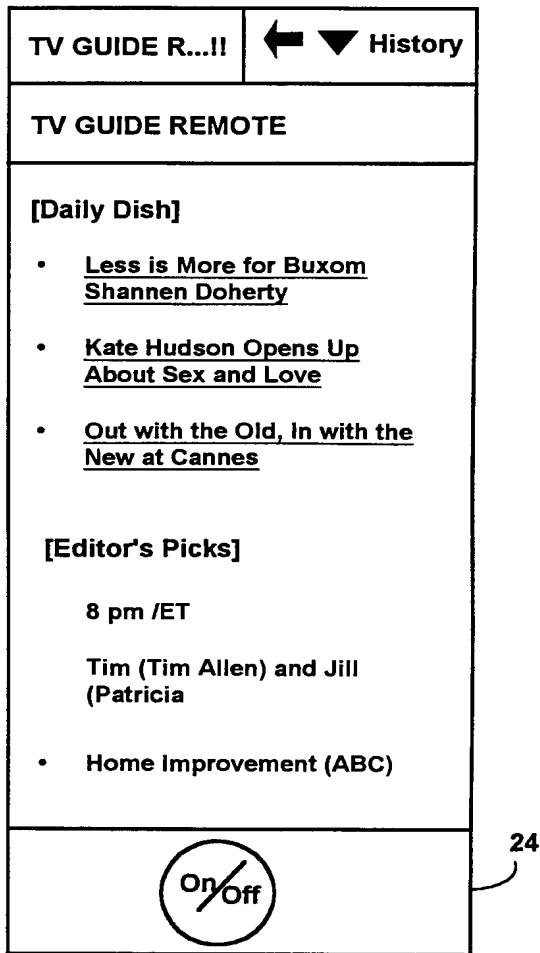


FIG. 15

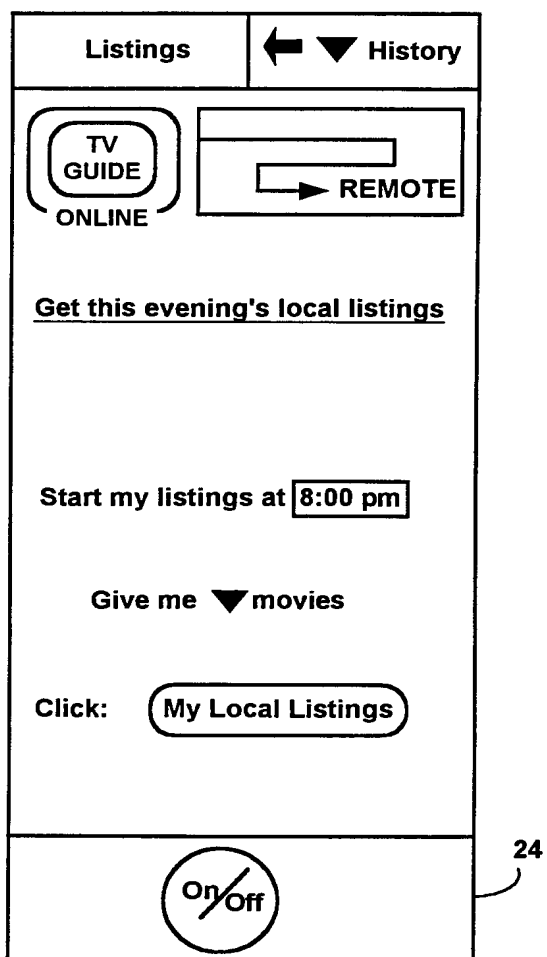


FIG. 16a

22/27

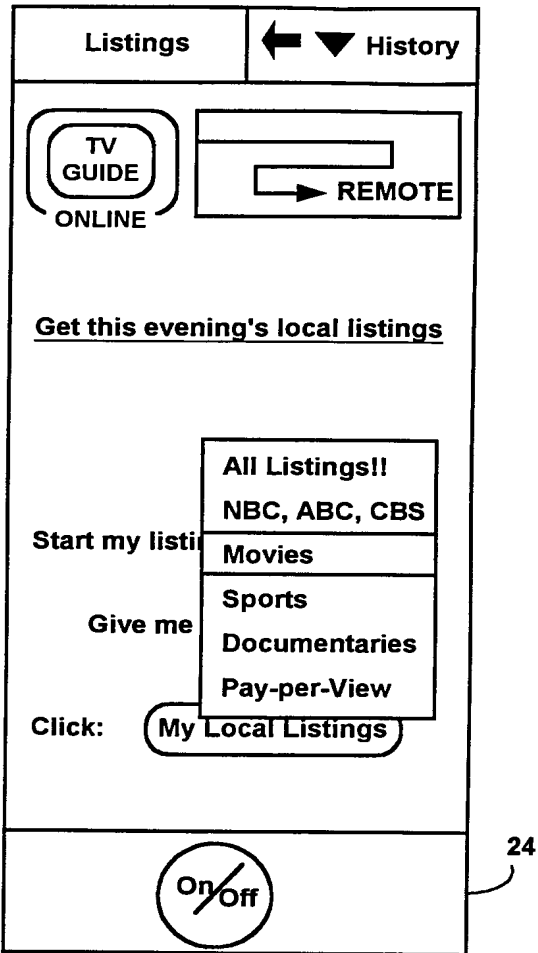


FIG. 16b

23/27

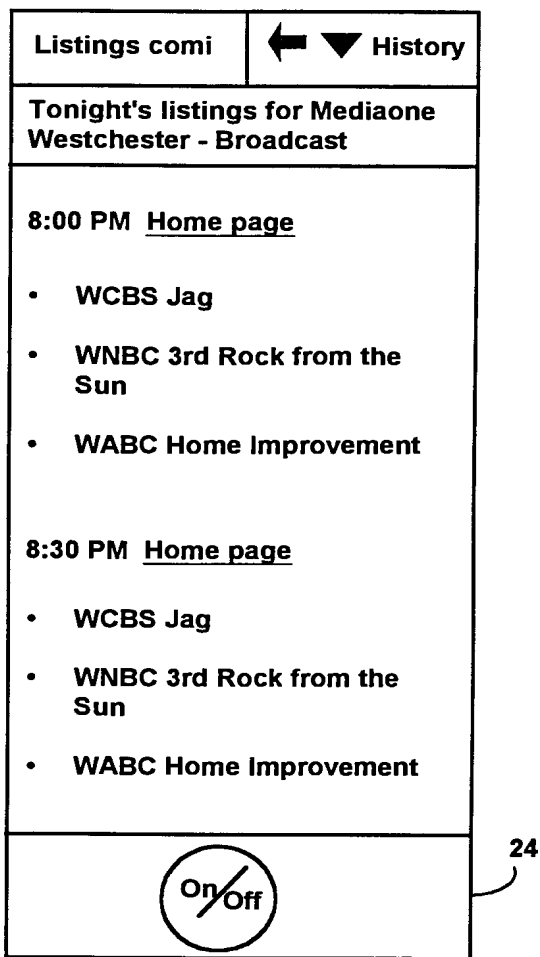


FIG. 16c

24/27

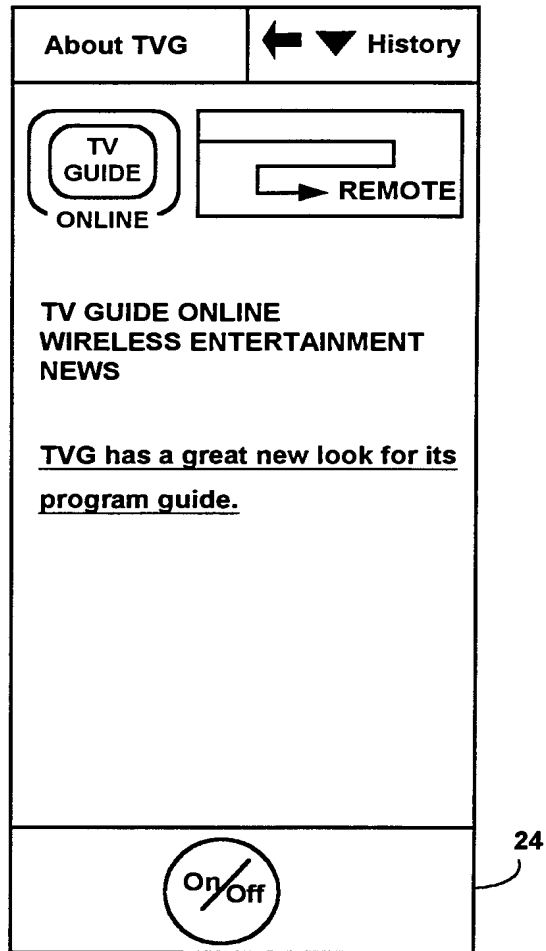


FIG. 17



25/27

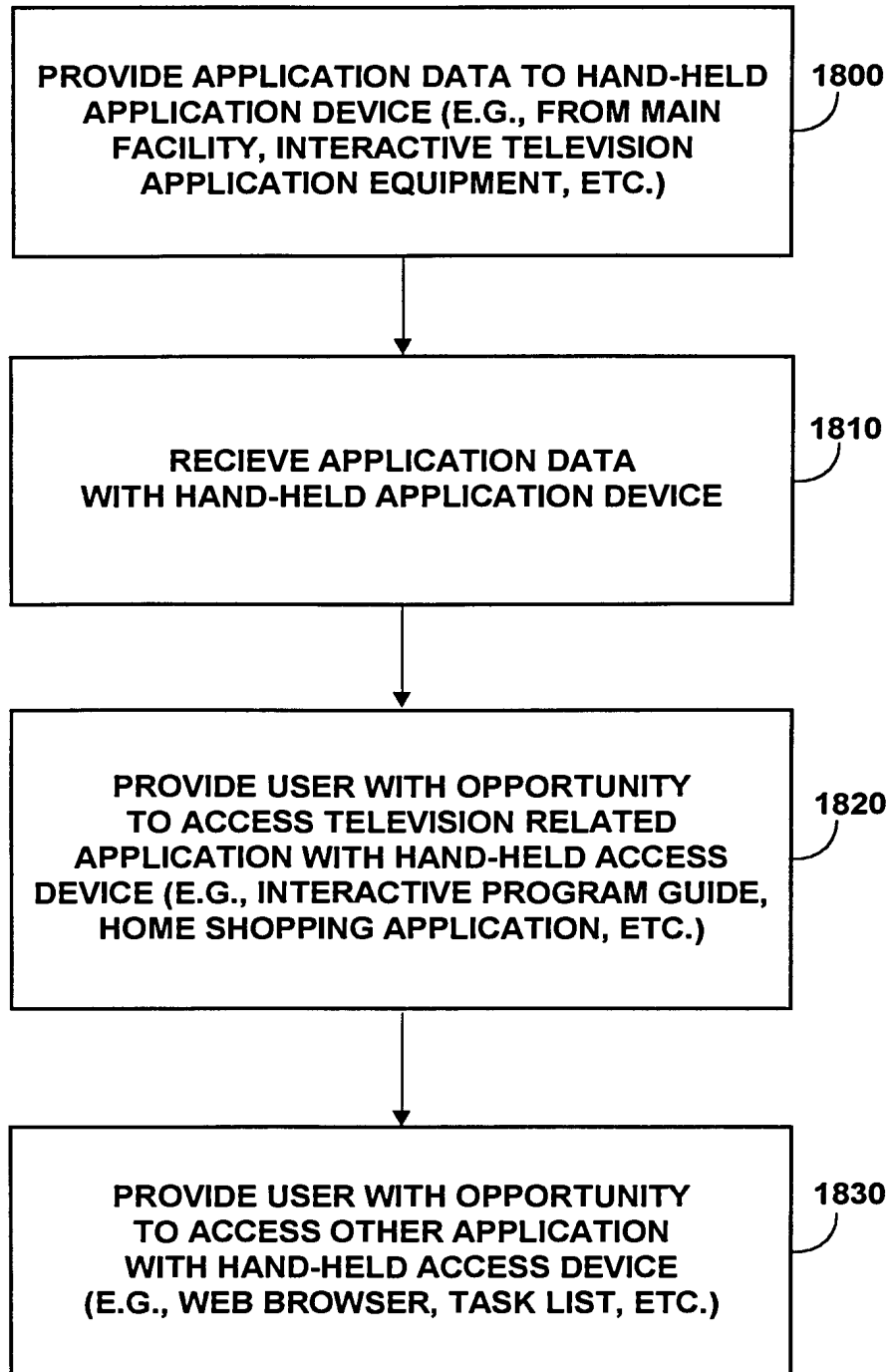


FIG. 18

26/27

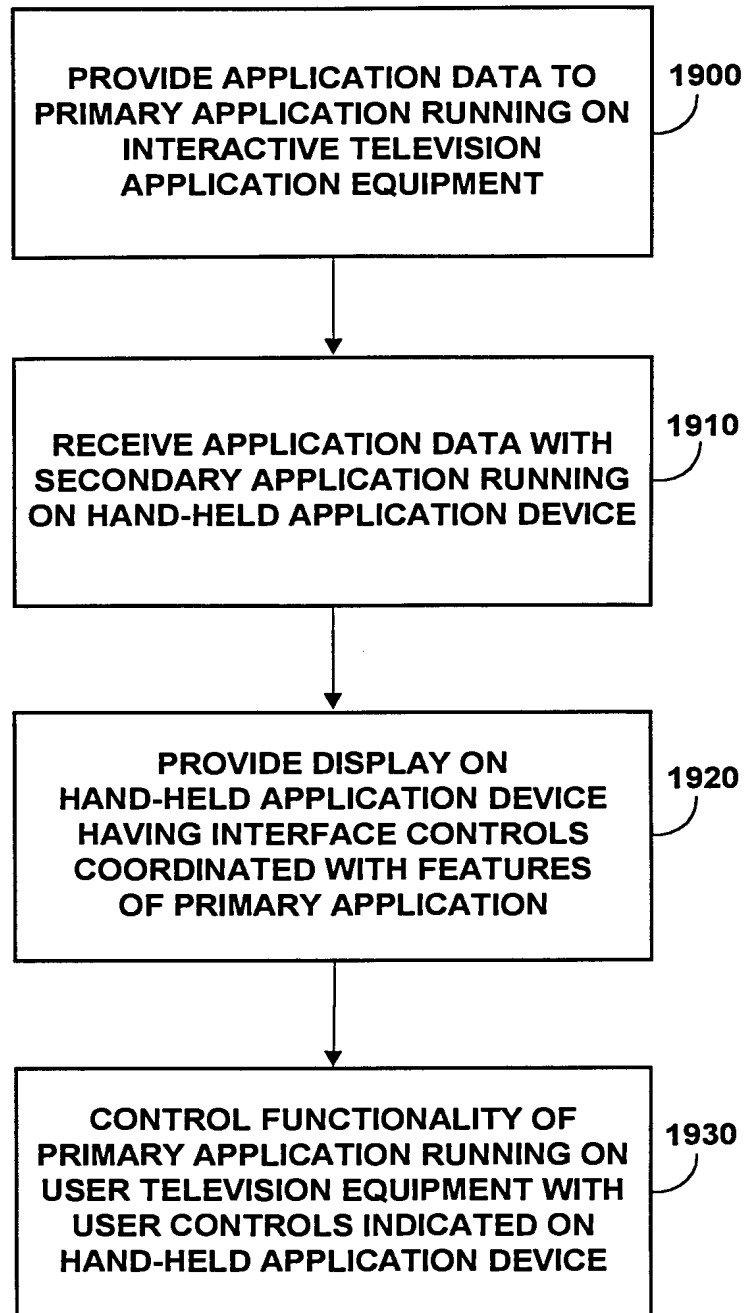


FIG. 19

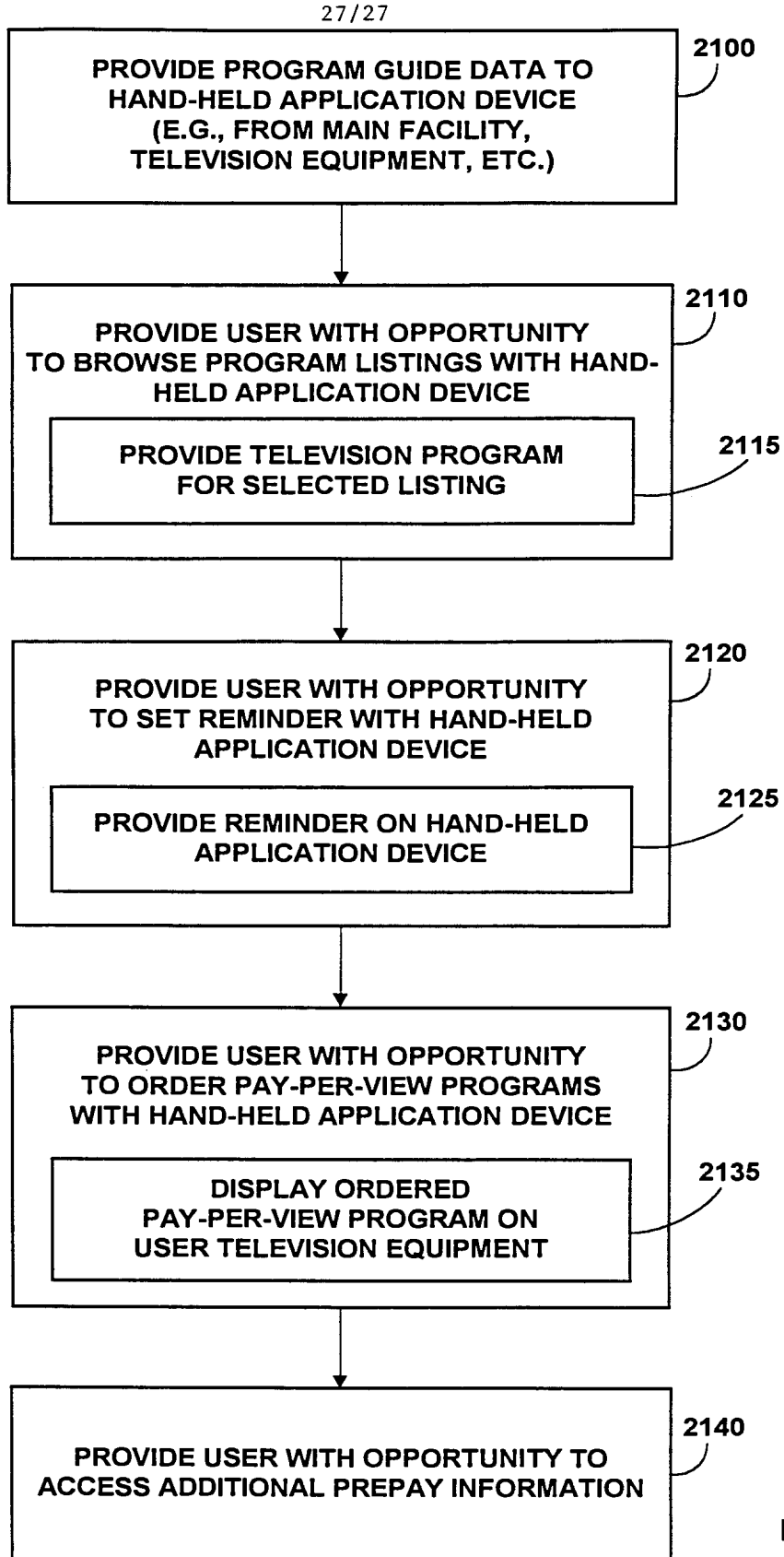


FIG. 20



# INTERNATIONAL SEARCH REPORT

Int. Patent Application No PCT/US 00/40148
---

**C.(Continuation) DOCUMENTS CONSIDERED TO BE RELEVANT**

Category *	Citation of document, with indication, where appropriate, of the relevant passages	Relevant to claim No.
X	<p>column 14, line 56 - line 65 -----</p> <p>US 5 668 591 A (SHINTANI PETER) 16 September 1997 (1997-09-16)</p>	<p>1,3, 10-12, 24,25, 27, 34-36, 48,49, 51, 58-60,72</p>
Y	<p>column 3, line 22 - line 49 column 3, line 64 -column 4, line 9 -----</p> <p>WO 98 16062 A (CHANG ALLEN) 16 April 1998 (1998-04-16)</p>	<p>4,5,9, 15,16, 22,23, 28,29, 33,39, 40,46, 47,52, 53,57, 63,64,73</p>
A	<p>page 2, line 19 - line 21 page 3, line 35 -page 4, line 25 page 6, column 15 -column 21 page 6, line 33 - line 35 -----</p> <p>US 5 898 398 A (KUMAI HISAO) 27 April 1999 (1999-04-27) column 3, line 22 - line 32 column 8, line 18 - line 26 -----</p>	<p>1,4,25, 28,49,52</p>
A	<p>WO 98 43158 A (EVOLVE PRODUCTS INC ;DARBEE PAUL (US); DONNELL FRANK O (US); THOMS) 1 October 1998 (1998-10-01) page 2, line 32 -page 3, line 1 page 3, line 32 -page 4, line 4 -----</p>	<p>1,25,49</p>

# INTERNATIONAL SEARCH REPORT

Information on patent family members

International Application No  
PCT/US 00/40148

Patent document cited in search report	A	Publication date	Patent family member(s)	Publication date
US 5410326	A	25-04-1995	NONE	
US 5668591	A	16-09-1997	JP 7271697 A GB 2288044 A, B	20-10-1995 04-10-1995
WO 9816062	A	16-04-1998	AU 4896397 A CN 1237308 A EP 0931415 A	05-05-1998 01-12-1999 28-07-1999
US 5898398	A	27-04-1999	JP 9182173 A EP 0811274 A WO 9723960 A	11-07-1997 10-12-1997 03-07-1997
WO 9843158	A	01-10-1998	US 6002450 A AU 6582298 A CN 1251182 T EP 0970418 A	14-12-1999 20-10-1998 19-04-2000 12-01-2000

(12) INTERNATIONAL APPLICATION PUBLISHED UNDER THE PATENT COOPERATION TREATY (PCT)

(19) World Intellectual Property Organization  
International Bureau



(43) International Publication Date  
4 January 2001 (04.01.2001)

PCT

(10) International Publication Number  
**WO 01/01331 A1**

(51) International Patent Classification<sup>7</sup>: **G06K 9/00**

[US/US]; 15599 Village Drive, Lake Oswego, OR 97034 (US). **RHOADS, Geoffrey, B.** [US/US]; 304 S.W. Tualatin Loop, West Linn, OR 97068 (US).

(21) International Application Number: PCT/US00/17157

(22) International Filing Date: 21 June 2000 (21.06.2000)

(74) Agent: **CONWELL, William, Y.**; Digimarc Corporation, Suite 250, 19801 SW 72nd Avenue, Tualatin, OR 97062 (US).

(25) Filing Language: English

(26) Publication Language: English

(30) Priority Data:  
60/141,538 28 June 1999 (28.06.1999) US  
60/141,763 30 June 1999 (30.06.1999) US

(81) Designated States (*national*): AE, AL, AM, AT, AU, AZ, BA, BB, BG, BR, BY, CA, CH, CN, CU, CZ, DE, DK, EE, ES, FI, GB, GD, GE, GH, GM, HR, HU, ID, IL, IN, IS, JP, KE, KG, KP, KR, KZ, LC, LK, LR, LS, LT, LU, LV, MD, MG, MK, MN, MW, MX, NO, NZ, PL, PT, RO, RU, SD, SE, SG, SI, SK, SL, TJ, TM, TR, TT, UA, UG, US, UZ, VN, YU, ZA, ZW.

(71) Applicant (*for all designated States except US*): **DIGIMARC CORPORATION** [US/US]; Suite 250, 19801 SW 72nd Avenue, Tualatin, OR 97062 (US).

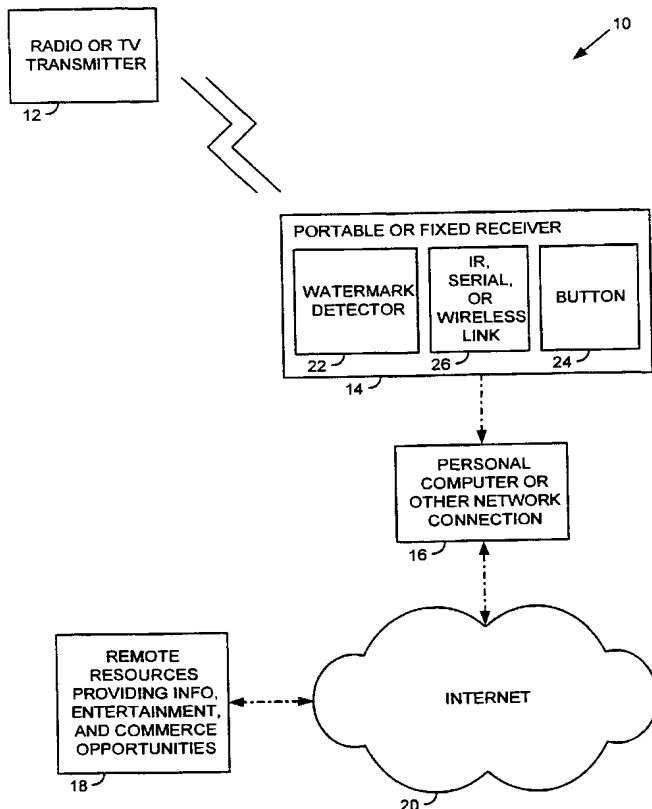
(84) Designated States (*regional*): ARIPO patent (GH, GM, KE, LS, MW, MZ, SD, SL, SZ, TZ, UG, ZW), Eurasian patent (AM, AZ, BY, KG, KZ, MD, RU, TJ, TM), European

(72) Inventors; and

(75) Inventors/Applicants (*for US only*): **DAVIS, Bruce, L.**

[Continued on next page]

(54) Title: DIGITAL WATERMARKS IN TV AND RADIO BROADCASTS



(57) Abstract: Wireless (26) and Internet (20) broadcasts can carry in-band digital information through the use of watermark technology (22). This digital information can be used to direct a user to a particular Internet site or resident application for supplemental or complimentary information, entertainment, merchandising, and commerce opportunities (18).



WO 01/01331 A1



patent (AT, BE, CH, CY, DE, DK, ES, FI, FR, GB, GR, IE, IT, LU, MC, NL, PT, SE), OAPI patent (BF, BJ, CF, CG, CI, CM, GA, GN, GW, ML, MR, NE, SN, TD, TG).

*For two-letter codes and other abbreviations, refer to the "Guidance Notes on Codes and Abbreviations" appearing at the beginning of each regular issue of the PCT Gazette.*

**Published:**

— *With international search report.*



## DIGITAL WATERMARKS IN TV AND RADIO BROADCASTS

Related Application Data

This application claims priority to provisional applications 60/141,763, filed June 30, 1999; and 60/141,468, filed June 29, 1999.

The subject matter of the present application is related to that disclosed in US Patent 5,862,260, and in copending applications 08/746,613, filed November 12, 1996 (allowed, also published as WO 9743736); 09/343,104, filed June 29, 1999; 60/164,619, filed November 10, 1999; 09/503,881, filed February 14, 2000; 09/525,865, filed March 15, 2000; and 09/547,664, filed April 12, 2000.

Background and Summary of the Invention

Broadcast signals can carry in-band digital information through use of known watermark technology (a few examples of which are detailed in the cited patents and applications). This digital information can be used to direct a user to a particular internet site or resident application for supplemental or complimentary information, entertainment, merchandising, and commerce opportunities.

Brief Description of the Drawings

Fig. 1 shows an illustrative embodiment of the present invention.

Detailed Description

Referring to Fig. 1, an illustrative embodiment 10 of the present invention includes a radio or television transmitter 12, a portable or fixed radio or television receiver 14, a personal computer or other network connection 16, and remote resources 18 available through the internet 20.

The transmitter 12 is conventional, but includes a watermark encoder to embed a digital watermark in the transmitted signal. The receiver 14 is likewise generally conventional (e.g., including an RF amplifier, a mixer, one or more

- 2 -

intermediate frequency amplifiers, and a detector), but additionally includes a watermark detector 22, a button or other user interface feature 24 (which may be on a remote control associated with the receiver), and an external interface 26 (e.g., infrared, wireless, Bluetooth, serial, USB, firewire, etc.). In some embodiments, the receiver can be a species of computer.

The watermark encoding and decoding can follow the techniques set forth in the cited patents and applications. In such arrangements, the watermark payload data is combined with a pseudo-random carrier signal (e.g., by multiplying, XORing, etc.), and combined with (e.g. added to) the audio or video content signal. The carrier signal may be shaped in various ways. For example, zeroes in the carrier signal can be omitted (e.g., leaving values of -1 and 1, or -2, -1, 1, and 2, etc.), or the frequency spectrum of the carrier can be tailored to match the frequency spectrum of the signal being encoded, etc. In some embodiments, the watermarking also encodes a calibration signal with the payload data. This calibration signal is used in decoding, as detailed in the cited patents and applications (e.g., to permit accurate detection of the payload data even from a corrupted signal).

The computer 16 can be a personal computer, an internet appliance, or other network interface device. The computer includes provision for communicating with the external link of the receiver 14, and also includes a network connection for coupling to the internet 20. The remote resources 18 include the myriad servers coupled to the internet to provide information, entertainment, and commerce opportunities to users thereof.

In the illustrated system, audio material (such as a song or an advertisement) is transmitted to the receiver in the usual manner. Encoded in the audio signal is digital information represented as a watermark. Upon decoding at the receiver, this information is transmitted to the computer 16 (or stored for later transmission if the receiver does not have a persistent network connection).

The encoded information need only comprise a unique identifier, or database key. When passed to the computer 16 (and optionally therefrom to a remote resource 18), the identifier serves to initiate from such device one or more supplemental or complimentary applications corresponding to the encoded broadcast content, such as

- 3 -

purchasing a song for download, purchasing a CD containing the song, viewing news and concert schedules for recording artists, viewing a music video, etc.

Similar arrangements and benefits can be delivered through watermarked spoken word programming, and through television (video) broadcasts. The  
5 broadcasts can be distributed through any of the conventional methods other than over-the-air, including cable and satellite.

The infrastructure through which the receiver 16 couples to the remote resources 18 can take various forms. In application 09/547,664, filed April 12, 2000, the assignee detailed one such arrangement. In that system, the user device (e.g.,  
10 receiver 14 or computer 16) dispatches the watermark ID to a router computer. That computer includes a database that stores a URL corresponding to each watermark ID. Upon receiving a watermark ID, the router computer returns the corresponding URL to the originating device (12 or 16). A browser at the originating device then establishes a link to the specified URL. That URL then provides the information,  
15 entertainment, or commerce opportunity corresponding to the encoded broadcast.

The just-detailed system is advantageous in that it permits the encoding of a short identifier in the broadcast (e.g., instead of a lengthy URL). Moreover, the corresponding URL can be changed over time, as needed. Other embodiments of the present invention, however, do not need this level of complexity; the encoded  
20 identifier can more directly trigger the desired remote resource response.

Turning to particular cases, consider a product advertisement encoded with watermark data that links to product specifications, multi-media product demonstrations, and/or purchase instructions. Alternatively, for commonplace items, the user might merely push a "buy" button 24 on the receiver and the order could be  
25 placed automatically (e.g., using one-click technology of the type detailed in Amazon's patent 5,960,411), or an order form could be invoked on the screen of the computer 16 as soon as the data was transmitted to it.

If a particular song was playing, the digital watermark transmitted with the song could cause a picture of the singer to appear on the personal computer.  
30 Alternatively, through an automatic link to the internet, users could indicate their like or dislike for the song. In still other applications the link can be used to allow the user

- 4 -

to indicate a “vote” concerning a subject being played over the audio link. (In such embodiments, the embedded ID identifies the subject matter being voted on, and likewise serves to specify the remote resource 18 that is to receive the vote. To that resource the user’s computer can dispatch a “yes” or “no” vote, a “like” or “dislike” preference, etc., by corresponding data sent over the internet.

As will be recognized, embodiments like that detailed can be used to enable interactive advertisement and promotion for local radio and TV broadcasters, generating traffic and fulfillment activities for local merchants. In one such embodiment, network broadcast content is locally customized with links corresponding to local merchants and other resources. Thus, a Ford advertisement may be customized to initiate a link to a local Ford dealership.

(Such local customization can be performed by the broadcaster or by another party. In some embodiments, nationally-distributed broadcast content can include links suitable for a national audience (e.g., to corporate web sites of advertisers). The local broadcaster may process such network feeds to identify such national links. When same are encountered, the local broadcast processor may look-up a corresponding local link. The existing national link data can then be replaced with the local link data. Or, the broadcast may have been encoded with “blank” watermark payload bits that can be filled-in by the local broadcaster without removing the national link. These supplemental payload bits can serve to indicate the locality in which the payload was received, permitting a router computer or the like to return a URL appropriate to that area.)

By employing such watermark-based content augmentation, satellite content distribution can enjoy a virtual high speed asynchronous network capability by downstreaming relatively small digital watermark payloads as segues to PCs and other devices with higher bandwidth connections. Rather than sending large payloads via the satellite link, the distributor sends “pointers” that direct receivers and recipients to certain applications on the other networks; essentially, off-loading the heavy lifting to other carriers so as to provide more value to its customers and content providers with very little bandwidth consumption. Auxiliary content that is not desired by all satellite subscribers is not sent over the satellite; those subscribers

- 5 -

employ the satellite-conveyed watermark data to obtain such auxiliary content using other connections (e.g., terrestrial internet).

Radio over the internet is increasingly popular. However, the screen of the internet terminal is poorly utilized in such radio broadcasts. In accordance with another aspect of the invention, a watermark decoded from a web broadcast is decoded, and is used to enhance the experience by supplementing the audio with accompanying visual presentations.

In one such embodiment, the display presents streaming and other media on the screen while the internet radio is playing, such ancillary content being related to the then-broadcast radio content. This ancillary visual information can include concert schedules, fan news about the musician or person being broadcast, commercial web sites offering CDs, etc. During radio advertisements the display can present associated commercial information, with accompanying visual and/or video promotional materials. In addition to eye-catching visual presentations, these displays can include the opportunity to buy the advertised product, or download a "trial" version. (The visual displays can include conventional user interface features, such as buttons that can be selected by a user to initiate a purchase transaction or other operation in known manners.)

Technically, the computer radio decodes embedded watermark data from the audio programming. In some embodiments, the watermark literally conveys the address of one or more web sites that are to be displayed. The computer can be programmed to recognize these embedded web addresses, and display the corresponding web content in one or more separate browser windows. These windows can be tiled or otherwise presented on the display screen, together with the radio user interface. (The ancillary windows may overlies the radio interface in some embodiments.) As the radio content changes, the embedded watermark information also changes. Web displays corresponding to the earlier-decoded watermark are discontinued, and new web displays corresponding to the current watermark information are presented.

As noted, the audio broadcast need not be literally encoded with web addresses. Instead, the audio can be encoded with data including an identifier (e.g., 32

- 6 -

bits). On detecting this identifier, the computer connects to a remote web server (whose address is pre-identified) and provides this identifier. The remote server responds with the web addresses of the content to be displayed. The local computer then loads and displays these web pages, as in the first embodiment. As the audio programming changes, the embedded identifier also changes, leading to changed web addresses corresponding to the current audio material.

Returning to the original example of a watermark-aware radio, consider a car radio that has a "capture" button on the front panel (or other form of user interface, e.g., a Capture icon on a GUI). If a user hears a song they want to record and keep, they press the Capture button while the song is playing. In response, the radio device decodes a watermark embedded in the music, and thereby knows the identity of the music. The radio then makes a wireless transmission identifying the user and the desired song. A local repeater network picks up the wireless signal and relays it (e.g. by wireless rebroadcast, by modem, or other communication medium) to a music clearinghouse. The clearinghouse charges the user a nominal fee (e.g. via a pre-arranged credit card), and queues the music for download to a predetermined location associated with the user.

In one embodiment, the predetermined location is the user's own computer. If a "live" IP address is known for the user's computer, the music can be transferred immediately. If the user's computer is only occasionally connected to the internet, the music can be stored at a web site (e.g. protected with a user-set password), and can be downloaded to the user's computer whenever it is convenient.

In other embodiments, the predetermined location is a personal music library maintained by the user. The library can take the form, e.g., of a hard-disk or semiconductor memory array in which the user customarily stores music. This storage device is adapted to provide music data to one or more playback units employed by the user (e.g. a personal MP3 player, a home stereo system, a car stereo system, etc.). In most installations, the library is physically located at the user's residence, but could be remotely sited, e.g. consolidated with the music libraries of many other users at a central location.

- 7 -

The personal music library can have its own internet connection. Or it can be equipped with wireless capabilities, permitting it to receive digital music from wireless broadcasts (e.g. from the clearinghouse). In either case, the library can provide music to the user's playback devices by short-range wireless broadcast.

5 By such arrangement, a user can conveniently compile an archive of favorite music – even while away from home.

Many variants of the foregoing are of course possible. The radio can be a portable unit (e.g. a boombox, a Walkman radio, etc.) or a home device, rather than an automotive unit. The UI feature employed by the user to initiate capture a musical selection need not be a button (physical or on-screen). For example, in some  
10 embodiments it can be a voice-recognition system that responds to spoken commands, such as “capture” or “record.” Or it can be a form of gesture interface.

Instead of decoding the watermark only in response to the user's “capture” command, the radio can decode watermarks from all received programs, and keep the most recent in a small FIFO memory. By such arrangement, the user need not issue  
15 the capture instruction while the song is playing, but can do so even after the song is finished.

In some embodiments, data corresponding to the watermark can be made available to the user in various forms. For example, it can be presented to the user on  
20 an LCD screen, identifying the artist and song currently playing. If a corresponding UI button is activated, the device can so-identify the last several selections. Moreover, the data need not be presented to the user in displayed form; it can be announced by known computer-speech technologies instead.

In embodiments in which the watermark does not convey ASCII text data, but  
25 instead conveys UIDs (unique identifiers), or coded abbreviations, the device must generally interpret this data before presenting it to the user. In an illustrative embodiment, the device is a pocket-sized FM radio and is equipped with a 1 megabyte semiconductor non-volatile RAM memory. The memory includes a data structure that serves as a look-up table, matching code numbers to artist names and  
30 song titles. When the user queries the device to learn the identify of a song, the memory is indexed in accordance with one or more fields from the decoded

- 8 -

watermark, and the resulting textual data from the memory (e.g. song title and artist) is annunciated or displayed to the user.

In most applications, such memory will require frequent updating. The RF receiver provides a ready mechanism for providing such updated data. In one  
5 embodiment, the radio "awakens" briefly at otherwise idle moments and tunes to a predetermined frequency at which updated data for the memory is broadcast, either in a baseband broadcast channel, or in an ancillary (e.g. SCA) channel. Or such data can be repeatedly transmitted on an SCA channel, received whenever the radio is turned  
10 on.

In variants of the foregoing, internet delivery of updated memory data can be substituted for wireless delivery. For example, the artist/song title memory in the personal player can be updated by placing the player in a "nest" every evening. The nest (which may be integrated with a battery charger for the appliance) can have an internet connection, and can exchange data with the personal device by infrared,  
15 inductive, or other proximity-coupling technologies, or through metal contacts. Each evening, the nest can receive an updated collection of artists/song titles, and can re-write the memory in the personal device accordingly. By such arrangement, the watermark data can always be properly interpreted for presentation to the user.

The "Capture" concepts noted above can be extended to other functions as  
20 well. One is akin to forwarding of email. If a consumer hears a song that another friend would enjoy, the listener can send a copy of the song to the friend. This instruction can be issued by pressing a "Send" button, or by invoking a similar function on a graphical (or voice- or gesture-responsive) user interface. In response, the appliance so-instructed can query the person as to the recipient. The person can  
25 designate the desired recipient(s) by typing in a name, or a portion thereof sufficient to uniquely identify the recipient. Or more typically, the person can speak the recipient's name. As is conventional with hands-free vehicle cell phones, a voice recognition unit can listen to the spoken instructions and identify the desired recipient. An "address book"-like feature has the requisite information for the recipient (e.g., the  
30 web site, IP address, or other data identifying the location to which music for that recipient should stored or queued, the format in which the music should be delivered,



- 9 -

etc.) stored therein. In response to such command, the appliance dispatches instructions to the clearinghouse, including an authorization to debit the sender's credit card for the music charge. Again, the clearinghouse attends to delivery of the music in a desired manner to the specified recipient.

5           Still further, a listener may query the appliance (by voice, GUI or physical button, textual, gesture, or other input) to identify CDs on which the then-playing selection is recorded. Or the listener may query the appliance for the then-playing artist's concert schedule. Again, the appliance can contact a remote database, relay the query, and forward data from the watermark payload identifying the artist and/or  
10           song title to which the query relates. The database locates the requested data, and relays same back to the appliance for presentation (via a display, by machine speech, or other output) to the user. If desired, the user can continue the dialog with a further instruction, e.g., to buy one of the CDs on which the then-playing song is included. Again, this instruction may be entered by voice, GUI, etc., and dispatched from the  
15           appliance to the clearinghouse, which can then complete the transaction in accordance with pre-stored information (e.g. credit card account number, mailing address, etc.). A confirming message is relayed to the appliance for presentation to the user.

          While the foregoing transactions require a link to a remote site or database, other watermark-based consumer services can be provided without such a link. For  
20           example, a user can query the appliance as to the artist or song-title of the selection currently playing. The appliance can consult the embedded watermark data (and optionally consult a memory to determine the textual names associated with coded watermark data), and provide the requested information to the user (e.g., by a display, annunciation, or other output).

25           The foregoing concepts (e.g. Capture, Send, etc.) can also be employed in connection with internet- rather than radio-delivery of music.

          In other embodiments of the invention, the broadcast is not encoded with different data at different times (e.g., a different payload for each song). Instead, the broadcast is constantly encoded with a single identifier, e.g., identifying the  
30           broadcaster. The encoding can be the broadcaster's FCC call sign, a binary identifier corresponding to a particular station, etc. Such encoding can be effected anywhere in

- 10 -

the audio chain, e.g., in the audio feed between the studio and the broadcast transmitter. The audio signal can be converted to digital form (if not already in such form), summed with a low level watermark signal, and converted back to analog form (if necessary).

5           In such arrangements, the user device (e.g., receiver 14) can include a real time clock. When a user hears or sees a broadcast of interest, and operates the “Capture” button (or other user interface feature), time data from the clock is written into a memory. The time data, and the decoded station identifier, can then (or later) be forwarded to a remote database to which the broadcaster writes its play log. By  
10 indexing the broadcaster’s play log with the captured time data, the audio (or video) selection being broadcast at that instant can be identified. The content identifier thereby obtained can then be utilized as above-described to augment the user’s enjoyment of the broadcast.

From the foregoing, it will be recognized that certain embodiments of the  
15 present invention allow internet and broadcast audio/video to be used to invoke the presentation of ancillary promotions, merchandizing, supplemental information, and entertainment – all keyed off watermark data.

To provide a comprehensive disclosure without unduly lengthening this  
specification, the above-detailed patents and applications are incorporated herein by  
20 reference.

Having described and illustrated the principles of the invention with reference to illustrative embodiments, it should be recognized that the invention is not so limited.

For example, while the detailed embodiment included a watermark decoder as  
25 part of the broadcast receiver, this is not essential. In other embodiments the receiver may include, for example, a memory (e.g., RAM) in which sampled excerpts of received audio can be stored under control of an associated CPU. The stored audio can thereafter be transferred to the computer 16, and the watermark decoded therefrom at the computer.

30           To save storage space in the receiver memory, the audio can be processed to reduce its size, without unduly impairing the watermark information conveyed

- 11 -

thereby. One way this can be accomplished is to high pass filter the audio (e.g., with a cutoff frequency of one-fourth the sample frequency). Then the filtered audio can be quantized into a three state signal: -1, 0, or 1, depending on the polarity of the filtered signal. (Values within a predetermined threshold of 0 can be assigned a value of 0.) It will be recognized that such processing is a form of lossless compression –  
5 lossy because the process is not reversible. The watermark payload can be decoded from the resulting three-state signal (e.g., using the techniques disclosed in the cited patents and applications), even though the underlying audio carrier signal is essentially lost. This bit sequence can be further compressed using known lossless  
10 compression techniques (e.g., LZ77 or LZ78) to further save on storage requirements.

The just-described processing technique is illustrative only. The high pass filtering can be used without the quantization, and vice versa. Still other compression techniques can naturally be used, provided same do not unduly impair the encoded watermark information.

15 In one particular embodiment in which the receiver logs snippets of audio, all audio received by the receiver is digitized, and the last 5 seconds are always available in a FIFO RAM buffer. Upon activating the button 24 or other control, those 5 seconds of audio are copied into a separate retention memory, and the five next-following seconds of audio are likewise written into that retention memory, yielding  
20 10 seconds of data from which the watermark can later be discerned. (The audio processing operation just described can be performed on-the-fly during such operation, or by post processing.) A number of such excerpts can be stored – one each time the button 24 is activated - depending on the capacity of the retention memory. Known user interface techniques can be employed to allow the user to  
25 manage this collection of data excerpts, e.g., controlling which are transmitted to the computer 16, which are invoked to obtain related internet content, which are permanently stored on-disk in the computer 16 to serve as long-term bookmarks to internet sites of particular interest, etc.

30 While receiver 14 and computer 16 are described as separate units, this need not be the case. The detailed functionality of these devices can be provided in a single unit.

- 12 -

Similarly, while the detailed embodiments employ particular watermarking techniques detailed in the cited patents and applications, the principles are equally applicable with any other digital watermarking technology, including those that transform the audio or video signal to another domain (e.g., wavelet, DCT, etc.), and alter the signal representation by changing the signal coefficients in such domain.

More generally, while the detailed embodiments have employed watermark technology, other arrangements can employ different auxiliary data-conveyal technologies, including SCA subcarriers, vertical blanking interval techniques, etc.

While the detailed embodiments focused on audio broadcast applications, the same principles can be employed with television, e.g., by encoding the picture information or the accompanying sound information. And, as noted, the techniques are likewise applicable to the internet-delivery of content, not involving over-the-air broadcast.

While the detailed embodiments contemplated that the broadcast content would correspond to a single internet destination, in other embodiments this may not be the case. In some embodiments, a song or other content may correspond to links to several alternative destinations. The user can be presented a menu of such links from which to choose. Or a link to one of several alternative destinations may be automatically chosen based on the context or environment in which the content was encountered. (E.g., if a user activates the "Capture" button on a portable radio receiver, a different link may be pursued than if the user activates the button while using a desktop computer. In such cases, context information sufficient to distinguish such settings would be relayed from the device to the remote system.)

In some of the above-described embodiments, the augmentation of the broadcast content is initiated by a user action, e.g., activating a Capture button. In others, the augmentation is automatic (e.g., presentation of streaming media corresponding to a watermark decoded from received audio). Still other arrangements are possible. For example, the augmented information can be automatically retrieved, but not presented to the user unless called for. The augmentation data can be cached, e.g., on the user's device, and presented immediately, on demand. In one such arrangement, a user listening to an internet radio broadcast can summon additional

- 13 -

information by using dropdown menus of the sort typically associated with Windows applications. A “More” menu could present options such as “About the artist,” “Order this music,” “Concert schedules,” etc. Unless requested, such information stays hidden. But when such menu is activated, the corresponding information is  
5 delivered from the cache.

The particular combinations of elements and features in the above-detailed embodiments are exemplary only; the interchanging and substitution of these teachings with other teachings in this and the incorporated-by-reference  
10 patents/applications are also contemplated.

In view of the wide variety of embodiments to which the principles and features discussed above can be applied, it should be apparent that the detailed embodiments are illustrative only and should not be taken as limiting the scope of the invention. Rather, we claim as our invention all such modifications as may come  
15 within the scope and spirit of the following claims and equivalents thereof.

- 14 -

**WE CLAIM:**

1. In a radio or television broadcasting system that conveys a content signal to an audience, an improvement comprising steganographically encoding the content signal with an in-band digital watermark prior to its broadcast, the digital watermark conveying a plural-bit identifier, the identifier serving to identify an internet-available resource to which a recipient of said content signal can refer to obtain additional information or commerce opportunities related to the broadcast.
- 5
2. The method of claim 1 in which the identifier does not convey a literal URL, but instead conveys a code that is mapped to a corresponding URL through a database.
- 10
3. The method of claim 1 in which said encoding includes processing with a shaped pseudo-random signal.
- 15
4. A broadcasting system that broadcasts beyond a single local area, according to claim 1, in which each of several local broadcast outlets to which the content is distributed encode the content with a different digital watermark, so that the internet-available resources identified thereby are customized to the outlets' respective localities.
- 20
5. The broadcasting system of claim 3 in which the local outlet encoding of said content with said watermark is performed in response to detection of a different watermark in an input content signal.
- 25
6. A broadcast receiver, the receiver having an RF amplifier, a mixer, an intermediate frequency amplifier, a detector, a speaker, and a watermark decoder, the watermark decoder serving to decode a plural-bit digital watermark steganographically encoded within a received broadcast signal, said plural-bit digital watermark serving to identify an internet-available resource to which a user of said
- 30

- 15 -

receiver can refer to obtain additional information or commerce opportunities related to the broadcast.

5 7. The receiver of claim 6 in which the watermark decoder employs a shaped pseudo-random signal to decode said watermark.

10 8. The receiver of claim 6 in which the watermark decoder refers to a calibration signal embedded as part of the digital watermark in decoding said watermark.

9. The receiver of claim 6 in which the watermark decoder has an input coupled to an output of the detector.

15 10. The receiver of claim 6 in which the watermark decoder has said input coupled to the speaker.

11. A television receiver according to claim 6.

20 12. A radio receiver according to claim 6.

13. The receiver of claim 6 further including a control by which a user can cause the receiver to act upon a watermark in said received broadcast signal.

25 14. The receiver of claim 6 further comprising a memory, the receiver serving to store decoded watermark data in said memory.

15. The receiver of claim 14 further including a control by which a user can cause the receiver to store the decoded watermark data in said memory.

30 16. The receiver of claim 6, further including an interface permitting coupling of data from said receiver to a remote device.

17. The receiver of claim 16 in which the interface includes a wireless transmitter.

5 18. The receiver of claim 17 in which the wireless transmitter comprises an infrared transmitter.

19. The receiver of claim 16 in which the interface couples to a computer device.

10

20. The receiver of claim 6, further comprising a memory, the memory having data stored therein permitting decoded watermark data to be interpreted into human-understandable form.

15 21. The receiver of claim 20, further including a display on which data from said memory can be presented to a user.

22. The receiver of claim 20, further including an annunciator for announcing data from said memory to a user.

20

23. A method of operating a receiver comprising:

listening to or viewing an output from said receiver until content of interest is presented;

25 activating a control associated with said receiver, said activation initiating the following events:

transmitting data corresponding to an in-band watermark detected in said content, from said receiver to an internet connected resource; and

receiving information or a commerce opportunity relating to said content of interest from the internet

30



- 17 -

24. The method of claim 23 in which the events initiated by activation of said control including decoding a watermark from said content of interest.

5 25. The method of claim 24 in which said decoding includes processing with a shaped pseudo-random signal.

26. The method of claim 24 in which the decoding includes detecting a calibration signal encoded as part of said watermark.

10 27. The method of claim 23 in which the events initiated by activation of said control include reading earlier-decoded watermark data from a memory in said receiver for transmission to the internet connected resource.

15 28. The method of claim 23 that includes:  
receiving the transmitted data at a first internet-connected resource;  
identifying at said first resource a URL identifying a second internet-  
connected resource that corresponds to said transmitted data; and  
providing data from said URL to a user of the receiver.

20 29. The method of claim 28 that includes relaying said URL from the first internet-connected resource to a computer associated with the user, and directing a browser on said computer to said URL.

25 30. A broadcast receiver, the receiver having an RF amplifier, a mixer, an intermediate frequency amplifier, a detector, a speaker, a sampler, a processor, and a memory, the processor serving to selectively store data corresponding to a received broadcast to the memory, said data encoding a plural-bit digital watermark that identifies an internet-available resource to which a user of said receiver can refer to obtain additional information or commerce opportunities related to the broadcast.

30

- 18 -

31. The receiver of claim 30 in which the processor stores said sampled data in response to user activation of a control.

5 32. The receiver of claim 30 in which the data stored in the memory is not simply sampled broadcast data, but has been processed by the processor to reduce storage space while still permitting the watermark to be decoded therefrom.

33. A signal processor assembly comprising:  
an input for receiving a sampled content signal having a plural-bit digital  
10 watermark steganographically encoded therein; and  
a processor for processing the sampled content signal to remove low frequency components thereof, the processed signal nonetheless including said watermark therein.

15 34. The signal processor of claim 33 in which the processor performs a high pass filtering operation on the sampled content signal.

35. The signal processor of claim 33 in which the processor performs a three-  
state quantization operation on the sampled content signal.  
20

36. A broadcast receiver according to claim 33, additionally including an RF amplifier, a mixer, an intermediate frequency amplifier, a detector, a speaker, and a sampler.

25 37. A method of signal processing, comprising:  
receiving a sampled content signal having a plural-bit digital watermark steganographically encoded therein;  
high pass filtering the sampled content signal to remove low frequency components thereof; and  
30 storing the filtered signal in a memory; and  
thereafter, providing the stored, filtered signal to a watermark decoder.

- 19 -

38. A computer device including a memory, an internet interface, and a watermark decoder, characterized in that the memory has a processed content signal stored therein that encodes a plural-bit digital watermark, the content signal  
5 corresponding to audio, video, or still image content, but being sufficiently processed that the signal is substantially unusable to render audio, video, or still image content to a user of the device, the watermark identifying an internet-available resource to which a user of said device can refer through said interface to obtain additional  
10 information or commerce opportunities related to the content.

10

1/1

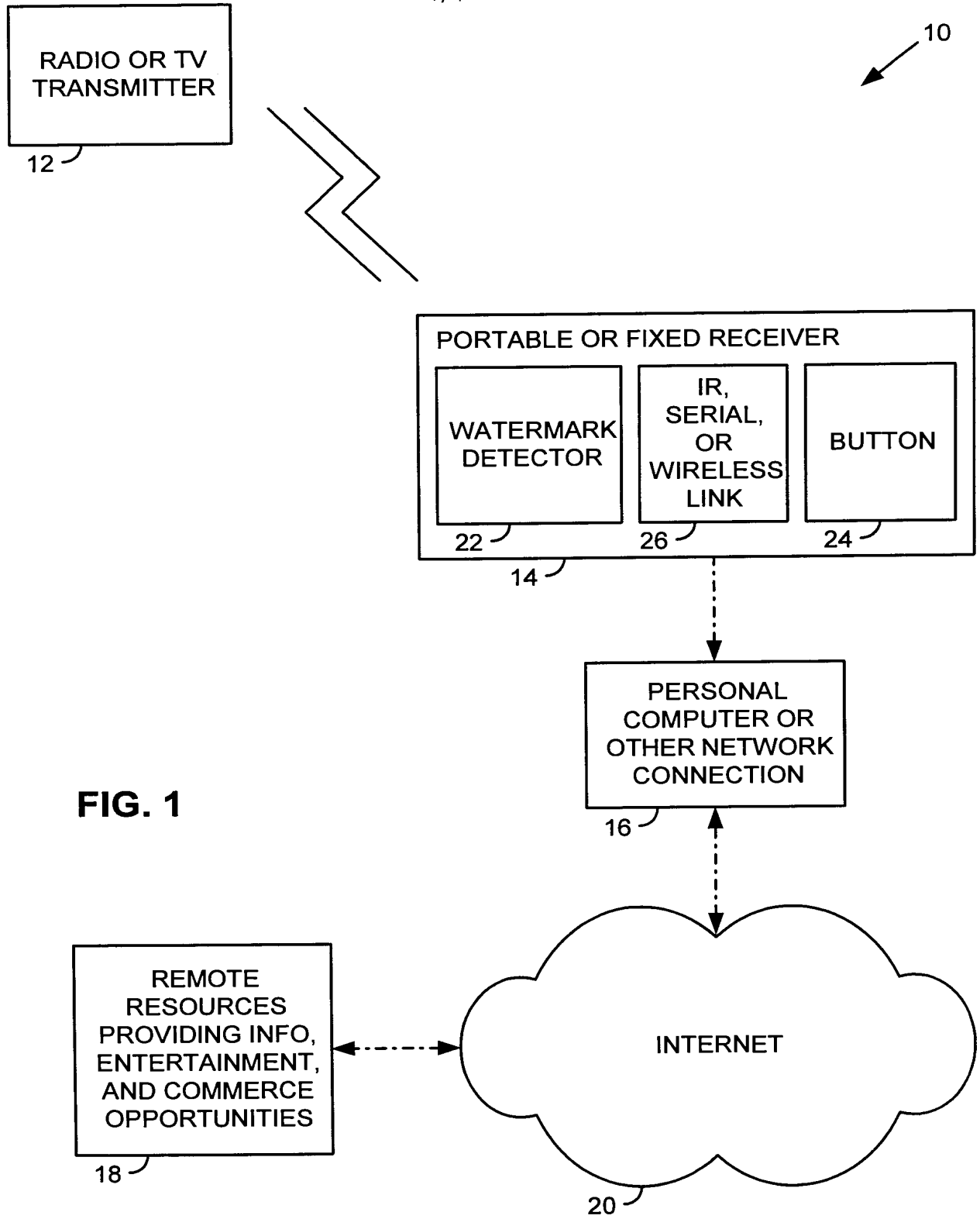


FIG. 1

INTERNATIONAL SEARCH REPORT

International application No.  
PCT/US00/17157

**A. CLASSIFICATION OF SUBJECT MATTER**  
 IPC(7) : G06K 9/00  
 US CL : 382/100, 232; 380/54  
 According to International Patent Classification (IPC) or to both national classification and IPC

**B. FIELDS SEARCHED**  
 Minimum documentation searched (classification system followed by classification symbols)  
 U.S. : 382/100, 232; 380/54

Documentation searched other than minimum documentation to the extent that such documents are included in the fields searched  
 NONE

Electronic data base consulted during the international search (name of data base and, where practicable, search terms used)  
 EAST 1.1, IEEE  
 Search terms: watermark, broadcast, video, audio, internet, amplifier, receiver

**C. DOCUMENTS CONSIDERED TO BE RELEVANT**

Category*	Citation of document, with indication, where appropriate, of the relevant passages	Relevant to claim No.
Y	US 5,892,900 A (GINTER et al.) 06 April 1999, fig. 1, elements 200, 204, 205, 208; col. 5, lines 15-45; col. 37, lines 15-50.	1-38
Y	US 5,778,102 A (SANDFORD, II et al.) 07 July 1998, fig.11, elements 11, 12; col. 13, lines 29-45; col. 15, lines 9-34.	1-38
Y	US 5,900,608 A (IIDA) 04 May 1999, fig. 1, elements 10, 20; fig. 14, element 300, 400; col. 25, lines 10-40.	1-38
Y	US 5,915,027 A ( COX et al.) 22 June 1999, col. 4, lines 15-40.	1-38
A	US 5,673,316 A (AUERBACH et al.) 30 September 1997, col. 6, lines 15-47	1-38

Further documents are listed in the continuation of Box C.  See patent family annex.

* Special categories of cited documents:	*T* later document published after the international filing date or priority date and not in conflict with the application but cited to understand the principle or theory underlying the invention
*A* document defining the general state of the art which is not considered to be of particular relevance	*X* document of particular relevance; the claimed invention cannot be considered novel or cannot be considered to involve an inventive step when the document is taken alone
*E* earlier document published on or after the international filing date	*Y* document of particular relevance; the claimed invention cannot be considered to involve an inventive step when the document is combined with one or more other such documents, such combination being obvious to a person skilled in the art
*L* document which may throw doubts on priority claim(s) or which is cited to establish the publication date of another citation or other special reason (as specified)	* & * document member of the same patent family
*O* document referring to an oral disclosure, use, exhibition or other means	
*P* document published prior to the international filing date but later than the priority date claimed	

Date of the actual completion of the international search 21 SEPTEMBER 2000	Date of mailing of the international search report <b>18 OCT 2000</b>
--	--

Name and mailing address of the ISA/US Commissioner of Patents and Trademarks Box PCT Washington, D.C. 20231 Facsimile No. (703) 305-3230	Authorized officer JAY PATEL <i>James R. Matthew</i> Telephone No. (703) 308-7728
---	---

INTERNATIONAL SEARCH REPORT

International application No.  
PCT/US00/17157

C (Continuation). DOCUMENTS CONSIDERED TO BE RELEVANT		
Category*	Citation of document, with indication, where appropriate, of the relevant passages	Relevant to claim No.
A	US 5,742,845 A (WAGNER) 21 April 1998, fig. 1, element 14; col. 7, lines 25-55.	1-38

(19) World Intellectual Property Organization  
International Bureau



(43) International Publication Date  
9 August 2001 (09.08.2001)

PCT

(10) International Publication Number  
WO 01/57759 A1

(51) International Patent Classification<sup>7</sup>: G06F 17/60

(21) International Application Number: PCT/US01/02781

(22) International Filing Date: 26 January 2001 (26.01.2001)

(25) Filing Language: English

(26) Publication Language: English

(30) Priority Data:  
09/496,224 1 February 2000 (01.02.2000) US

(71) Applicant: MINUSHKIN, Jeffrey, S. [US/US]; Apartment 25B, 875 N. Dearborn, Chicago, IL 60610 (US).

(74) Agent: SUMMERFIELD, Craig, A.; Brinks Hofer Gilson & Liono, P.O. Box 10087, Chicago, IL 60610 (US).

(81) Designated States (national): AE, AG, AL, AM, AT, AU, AZ, BA, BB, BG, BR, BY, BZ, CA, CH, CN, CR, CU, CZ,

DE, DK, DM, DZ, EE, ES, FI, GB, GD, GE, GH, GM, HR, HU, ID, IL, IN, IS, JP, KE, KG, KP, KR, KZ, LC, LK, LR, LS, LT, LU, LV, MA, MD, MG, MK, MN, MW, MX, MZ, NO, NZ, PL, PT, RO, RU, SD, SE, SG, SI, SK, SL, TJ, TM, TR, TT, TZ, UA, UG, UZ, VN, YU, ZA, ZW.

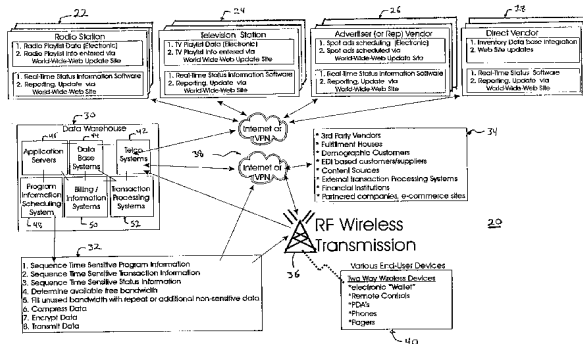
(84) Designated States (regional): ARIPO patent (GH, GM, KE, LS, MW, MZ, SD, SL, SZ, TZ, UG, ZW), Eurasian patent (AM, AZ, BY, KG, KZ, MD, RU, TJ, TM), European patent (AT, BE, CH, CY, DE, DK, ES, FI, FR, GB, GR, IE, IT, LU, MC, NL, PT, SE, TR), OAPI patent (BF, BJ, CF, CG, CI, CM, GA, GN, GW, ML, MR, NE, SN, TD, TG).

Published:

- with international search report
- before the expiration of the time limit for amending the claims and to be republished in the event of receipt of amendments

For two-letter codes and other abbreviations, refer to the "Guidance Notes on Codes and Abbreviations" appearing at the beginning of each regular issue of the PCT Gazette.

(54) Title: SYSTEM AND METHOD FOR OBTAINING IMPULSE TRANSACTION DATA



(57) Abstract: A method and system for impulse transactions is provided. Products and services advertised; included as part of radio broadcast (22), television broadcast (24), Internet content (26), or catalogs or as part of a generalized list, such as from the phone book, are provided to a user on a portable device (40). Upon hearing or seeing an advertisement or other content associated with the product or service (i.e. upon having an impulse to purchase), the user merely selects the information and creates a transaction. For example, the user requests more information about a product or service or purchases the product or service. The portable device provides two-way communication to obtain the product and services (40). Two-way device is included as part of another component, such as computer, television, or radio. The portable device may include components to assist in the impulse transaction. For example, a credit card, a smart card reader or a bar code reader may be provided. A memory for storing identification of source or finances, such as credit cards, debit cards, or bank accounts, may be provided, allowing for authorizations to pay from the identified account so that a transaction is completed without further entry by the user. The portable device may act as a universal remote or other remote controller for any or various electronic receivers. As the channel is changed, the portable device displays products or services associated with the current content of the programming provided by the television or radio receivers. Other functions that may be provided on the portable device include personal data assistant, cellular telephony service, radio frequency phones, pagers or other electronic device functionality.

WO 01/57759 A1

## SYSTEM AND METHOD FOR OBTAINING IMPULSE TRANSACTION DATA

### RELATED APPLICATIONS

5 This application claims the benefit of the filing date pursuant to 35 U.S.C.  
§119(e) of Provisional Application Serial Nos. 60/118451 (A System And Method  
For The Selection, Purchase And Transmission Of Audio, Video and Data Content  
To An Electronic Apparatus), filed February 2, 1999 and 60/121881 (A System  
And Method For The Acceptance And Transmission Of Content Description And  
Interactive Information), filed February 25, 1999, the disclosures of which are  
10 incorporated herein by reference.

### BACKGROUND

This invention relates to electronic impulse purchase and interactivity  
devices. In particular, a multi-function device and associated network is  
established to allow impulse purchases, information requests and interactivity for  
15 various media and sources of products and services.

Impulse purchases of products and services are provided through store  
displays in traditional brick and mortar retail establishments. For example, candy,  
magazines and other items are often displayed near check out lanes of grocery  
stores. These displays are designed to induce an impulse purchase of the product  
20 while a shopper waits in line to purchase other products or services. The product  
is purchased by interaction with a cashier using a bar code reader and cash register  
inventory control or other form of manual currency for product exchange. The  
transaction may be further consummated by use of a credit card. However, the  
number of products arranged for soliciting impulse purchases is limited and  
25 additional sources of information about the products are not provided.

A broad range of products is provided on the Internet by Web Page content.  
However, the immediacy of any impulse transaction is limited by requiring a user  
to turn on the computer, connect with the Internet, search for and obtain content



associated with a desired product or service and then arrange for the purchase of that product and service. The Internet provides for limited impulse transactions because the user must first seek out the content.

5 In some embodiments, the Internet's capability to provide for product information and purchasing are combined with other modalities. For example, Internet content has been provided in association with cable systems or television broadcast systems. Such systems envision providing product information from the Internet in association with television broadcasts. However, the systems typically requires Internet browsing and the associated decline in the impulse to purchase  
10 while waiting to obtain information.

Internet capabilities have also been combined with cellular telephones and personal digital assistants. Using a limited screen display on a cellular telephone or personal digital assistant, Internet information is provided to a user. The user browses through Internet content and may perform Internet transactions using the  
15 cell phone. However, like the computer at home, the user is still required to sign on and browse for product or service information, reducing the effects of an impulse to purchase a product. The Internet content is not provided in conjunction or synchronization with any other product information or sources of an impulse to purchase. Furthermore, credit card information may be required to be provided in  
20 the same communications path used to obtain content, resulting in a credit security risk.

Other systems provide analog or digital broadcast interactivity. For example, product information is transmitted with a radio broadcast. A radio receiver then indicates this information, such as the name of a song, group, or  
25 album. However, the ability for impulse transactions is still limited.

## BRIEF SUMMARY

The present invention is defined by the following claims, and nothing in this section should be taken as a limitation on those claims. By way of introduction, the preferred embodiments described below include methods and

systems for performing or consummating impulse transactions. Products and services advertised; included as part of radio broadcast, television broadcast, Internet content, or catalogs; or as part of a generalized list, such as from the phone book, are provided to a user. Upon hearing or seeing an advertisement or other content associated with the product or service (i.e., upon developing an impulse to purchase), the user merely selects the information and requests a transaction. For example, the user requests more information about a product or service or purchases the product or service.

A portable device is used to provide user selection of product and service information. The portable device provides two-way communication to obtain the product and service information associated with the broadcast or other provider of products or services. Two-way communications also allows for the transaction to occur. In some embodiments, the user device is included as part of another component, such as a computer, television, or radio.

The portable device may include components to assist in the consummation or processing of impulse transactions. For example, a credit card, a smart card or a bar code reader may be provided. A memory for storing identification of sources of finances, such as credit cards, debit cards, or bank accounts, may be provided, allowing for authorizations to pay from the identified account so that a transaction is completed without further entry by the user. For example, a restaurant bill is paid electronically using a secure transmission, avoiding credit card fraud through the handling of a card or paper receipt.

The portable device may include other multi-function features. The portable device may act as a universal remote or other remote controller for any or various electronic receivers. For example, the portable device controls a television set or radio receiver. As the channel is changed, the portable device displays products or services associated with the current content of the programming provided by the television or radio receivers. If the user is interested in a song being played, the user selects the song and depresses a purchase or request for information button on the portable device. The song is then ordered and shipped

to the user. Interactivity may also be provided with the portable device. Other functions that may be provided on the portable device include personal data assistance, cellular phones, radio frequency phones, pagers or other electronic device functionality.

5           The portable device may be used as an electronic wallet. Financial transfers are performed using secure communications. Products or services are purchased at the point of sale or in response to programming without the manual exchange of a credit card, avoiding fraud. If the electronic wallet is stolen, then all transactions using that electronic wallet are disabled. Using cellular radio  
10 frequency communications, the location of the electronic wallet may be obtained by triangulation.

Further aspects and advantages are discussed below in conjunction with the preferred embodiments.

#### BRIEF DESCRIPTION OF SEVERAL VIEWS OF THE DRAWINGS

15           FIG. 1 is a block diagram of one embodiment of a network for providing impulse transactions.

FIG. 2 is a block diagram of one embodiment of a user device for use in the network of FIG. 1.

20           FIGS. 3-5 represent various possible embodiments of the user device of FIG. 2.

FIG. 6 is a flow chart diagram showing one example embodiment of an impulse transaction process using the network of FIG. 1.

FIG. 7 is a block diagram of one embodiment of a network.

FIG. 8 is a block diagram of one embodiment of a network.

25           FIG. 9 is a block diagram of one embodiment of a content control system.

FIGS. 10 and 11 are block diagrams of embodiments of a data base table structure used by the content control system of FIG. 9.

FIG. 12 is a block diagram of one embodiment of a user device.

FIG. 13 is a block diagram of one embodiment of a radio channel content implementation.

FIG. 14 is a block diagram of one embodiment of an audio-on-demand and trial mode content implementation.

5 FIG. 15 is a graphical representation of one embodiment of a user apparatus.

#### DETAILED DESCRIPTION OF THE PREFERRED EMBODIMENTS

A personal multi-function electronic device and associated network for impulse transactions is provided. In one embodiment, the device is portable.  
10 Alternatively, the device may be part of another device. Product or service information is obtained and compiled from one or more various sources, such as television stations, radio stations, businesses with publicly accessible communications network (e.g. Internet) product or service offerings, catalogs, or other sources of products or services. Using two-way transmissions, the user  
15 device receives the compilation of product or service information and transmits impulse transaction data associated with a product or service from the compilation or entered manually regardless of the compilation. Alternatively or additionally, interactivity is provided, such as for answering questions posed in programming as part of television or radio content. The interactivity may provide for real-time  
20 communications.

A clearing house entity responsible for compiling the product and service information verifies the transaction, such as providing for payment of selected products or services, and distributes the transaction information to a source of the content, product or service. For example, a user watching a television commercial  
25 about an automobile inputs the channel information into the user device or the user device provides the channel information as a result of controlling the television. The user selects the automobile product as displayed in synchronization with the television broadcast. The user selects a request for more information option which is transmitted by the user device to the clearing house. The clearing house

forwards the request for information and the appropriate address, phone number or other contact information of the user to the manufacturer of the automobile. The manufacturer may then forward a brochure or other product information to the user. Thus, an impulse request for information transaction is satisfied.

5           **I.       NETWORK**

          FIG. 1 shows one embodiment of a network 20 for providing impulse transactions. The network 20 includes one or more sources of transaction information, such as product or service information. The sources are represented by the radio stations 22, television stations 24, advertisers 26, product or service vendors 28, and other sources 34. Other sources, include third party vendors, fulfillment houses, demographics customers, electronic data interchange (EDI) based customers or suppliers, XML based customers or suppliers, sources of programming content, external transaction processing center systems, financial institutions, Internet content providers, or other sources of information or processes associated with transactions.

          These sources communicate with a data warehouse 30 (clearinghouse) over a network 38. The data warehouse 30 interacts with a distribution control 32 to provide transaction information to and receive transaction information from a radio frequency wireless transmission network 36. The wireless transmission network 36 communicates with a plurality of end user devices 40, such as transmission using code-division multiplexing, time-division multiplexing, group speciale mobile (GSM), data total access communications, flex, bluetooth, spread-spectrum and/or other transmission techniques.

          In alternative embodiments, the radio frequency wireless transmission network 36 comprises other transmission means, such as direct connection, infrared connection, hardwire connection, hardware connection, or other communication networks. The network 38 comprises the Internet, a virtual private network (VPN) using secure socket layer (SSL software), the Intranet, direct communications, telephone system, or other system for providing information

from the sources to the data warehouse 30. Other networks including additional or fewer components may be used for the network 20.

5 The product and service information is provided by different types of media services. For example, the radio stations 22 comprise a radio broadcast media, and the television stations 24 comprise a television broadcast type of media. Other types of mass media include print media, such as company catalogs, newspapers, a list of companies such as provided by a phone book or Yellow Pages, brochures, coupons, or other printed information. Another type of mass media comprises publicly accessible communications network, such as the  
10 Internet. For example, an E-commerce Web Page host, such as Amazon.com, provides information for a plurality of products and services. Audio and/or video information may also be provided on the Internet. Other types of mass media sources include providers of data paging services, such as services that provide sports, weather and advertising information to data pagers. Likewise, other  
15 wireless communications providers, such as cell phone providers, may supply similar product and service information as another type of media. Other types of media supply may be provided, such as direct sources that provide product or service information for distribution of using infrastructures currently known or later developed. For example, the data warehouse 30 supplies product or service  
20 information for use just in the network 20.

The product or service information is provided either from the source of the product or service, such as direct vendor 28, from an advertising vendor 26 that places advertisements for other companies or from distributors of the media, such as the radio station 22 or the television station 24. In one example, brochure,  
25 coupon or catalog information is provided directly from a source of the product or service, such as direct vendor source 28. Other alternative sources may provide the information as represented by block 34.

Various product and service information is gathered from the sources. The information includes direct product or service information, such as a product or  
30 service identification, cost, description, and a relationship to any mass media

content. Other product or service information may be included. As an example, product and service information includes arrival and departure for flight services, weather information to assist travelers, lottery numbers for one or more states, special event and ticketing information, company help line phone numbers and contact information, banking information, bill payment information, electronic communications and interactivity information, and finance transfers, such as smart cart transfers. Yet other types of product and service information include address and other contact information for the nearest stores, product or service reviews, or any other related information. For example, a selection of pizzas or a menu from a local restaurant is provided with associated cost information (e.g., a Dominos Pizza menu).

Depending on the source of the product or service information, additional information may be provided with the product and service information. For example, radio stations 22 or television stations 24 also provide a schedule or guide of programming and the content information for the programming. In one example, radio, television, or Internet media sources provide a program schedule and product and services associated with the scheduled programming are provided. An advertisement is typically run in a 10, 15 or 30-second slot on television. For some advertisements, the time varies as a function of the product or service, such as on a shopping channel or infomercial (e.g. multiple minutes of advertising a product or service). The television station 24 supplies a time for the advertisement and product or service information being advertised. In another example, the radio station 22 provides a schedule of programming where the programming includes content discussing a new book for a 15 minute time slot. Product information associated with the book is also supplied and indexed to the schedule. As yet another example, the radio station 22 may provide product and service information associated with each song played as part of the programming. Product or service information is provided for various types of content, such as audio, radio, or Internet broadcast to correspond with programming from the

source of the content. In other embodiments, the program content is also supplied by the source.

In one embodiment, radio, television, data paging, print, or other time based sources of programming or content provide program guide information with the product or services. Program guide information includes identification of the source of the programming content, an identification of the content including an identification of any advertising, and identifications of the products or services associated with the content as a function of time. For example, the television station 24 provides a 24-hour schedule of programming content, including advertisements and products and services associated with either a particular program or an advertisement. This program guide information is organized as a function of time of broadcast.

The data warehouse 30 compiles the product information from the various sources. The data warehouse 30 comprises a communications or telephone systems 42, a database system 44, application servers 46, an information scheduling system 48, a billing system 50, and transaction processing systems 52. The data warehouse 30 comprises a single or multiple physical facilities operated by a single entity. In one embodiment, the single entity controls these components, but all or a sub-set of components are operated by a third party (i.e. the single entity out-sources one or more functions of the data warehouse 30). In another embodiment, the single entity owns and operates all the components of the data warehouse 30.

The telephone systems 42 comprise modems, operators, routers, servers or other devices for receiving information from the various media or product and service sources. The product or service and associated information, such as programming guide information, is provided to the data warehouse 30 over the network 38. In another embodiment, product and service information is provided electronically to the data warehouse 30. For example, the information is compiled and provided directly to the data warehouse or provided via a public source, such as a download from Internet Web Page content. The data warehouse 30 retrieves



the public product or service information. In an alternative embodiment, the data warehouse 30 provides web content and associated software for allowing a source to enter the information. In other embodiments, the sources e-mail or download using file transfer protocol or other electronic transfer the product or service information to the data warehouse 30. Electronic transfers allow for automatic processing by the data warehouse 30.

In addition to providing information ahead of schedule, the sources provide the product or service information or other information in real time. For example, the data warehouse 30 supplies software to a source so that the source may provide question information, order status information or other real-time information to the data warehouse 30. In one embodiment, the software is also operable to act as a receptor for information provided from the data warehouse 30.

The data warehouse 30 obtains information from a plurality of sources of the same and/or different types of media, such as multiple radio stations 22, multiple television stations 24, multiple advertising vendors 26, multiple direct vendors 28 and/or a plurality of other vendors 34. The various sources include local as well as distant sources of product and service information. For example, program guide and product and service information for a plurality of radio stations or television stations within the Chicagoland market is obtained as well as radio station and television station programming guide and product and service information from other markets outside of the Chicagoland area. As discussed above, product and service information from different types of media is also compiled, such as program guide, product and service information from both radio and television sources 22 and 24.

The information obtained is compiled by the data warehouse 30. The data is received by the telephone systems 42 and provided to the database system 44. The database system 44 comprises data storage devices such as RAM, hard drive, diskette or tape memory for storing data. In one embodiment, the database system 44 comprises data file servers running the Network File System (NFS) manufactured by Sun Microsystems, Inc., located in Mountain View, California.

Other database systems 44 may be used, such as structure query language (SQL) database systems. The application servers 46 control compilation and storage of the compiled data. The application servers 46 comprise a relational database management system, such as SQL (e.g. Oracle, Sybase, Microsoft SQL server or others) or an enterprise SQL server.

The information scheduling system 48 comprises one or more processors or servers for scheduling exportation of the compilation to various end user devices 40. The scheduling system 48 also schedules other network 20 bandwidth sensitive information, such as receiving transaction information from the various end-user devices 40. Time sensitive program, product or service information is scheduled with a higher priority. For example, interactive information such as questions, answers or bidding information is scheduled with the highest priority. Other high priority information includes transaction requests for time-sensitive products or services, such as ordering a pizza and status information or responses to the transactions. Other high priority information includes requests for help. For example, a request for help from an end-user device 40 is received by the data warehouse 30. The response is assigned a high priority. Alternatively, a request for help is forwarded to an operator and the operator calls either the end-user device 40 or a phone number associated with the user of the end-user device 40.

The scheduling system 48 determines the available bandwidth. The compilation, transaction information, and status information are used to fill the available bandwidth. Any unused or extra bandwidth is used to repeat or redistribute information with a high priority. This redistribution or repetition makes it more likely that the high priority data is received by the end-user device 40. Any errors in reception of high priority data due to interference are overcome through repetitive distribution.

The scheduling system 48 or the application servers 46 compress and encrypt the data for distribution or storage. Any of various compression or encryption programs may be used, such as RSA, PKI (public keys), Tripple DES

or other encryption programs or PCM, RLE, MPEG, PKZIP or other compression programs. In alternative embodiments, encryption and/or compression is not used.

Once the data is available for distribution to the user devices 40, the scheduling system 48 through the application servers 46 and the data base system 44 provides the data to the RF wireless transmission devices 36. The data may be separated by region where each region has a set of data particular to that region. The region comprises geographical regions selected arbitrarily, as a function of the extent or reach of a source of content (e.g. a cable service distribution area) or other variable. The regions may be small as a function of overlapping and non-overlapping extents for various sources of content.

The information is provided in real-time or at least at 30-second, 15-second or less intervals in one embodiment. Real-time or frequent distribution allows for continuous updating of product, service and associated programming information. Real-time or frequent update intervals also provide for less memory requirements for the end-user devices 40. In an alternative or additional embodiment, product and service information and associated programming information is provided prior to a broadcast of any programming, such as 24 hours in advance, a week in advance, or other time period in advance. For example, real-time or substantially real-time transmissions are provided for dynamic information such as interactive questions, answers, bidding, or other time-sensitive information and prior distribution is provided for product or service information that tends to be static, such as non-interactive radio or television programming, or print media information.

The RF wireless transmission system 36 comprises a data paging, telephone or other cellular two-way radio frequency wireless infrastructure. The RF wireless transmission system 36 comprises a series of base stations distributed geographically in cells. In one embodiment, the infrastructure covers at least the heavily populated areas of a region and preferably covers an entire region.

In an alternative embodiment, the RF wireless system comprises a satellite communication system. Other transmission systems may be used for

communication with the user devices 40, including direct connection through the Internet, one-way communication systems either to or from the user device 40, hardwire direct connections, or wireless infrared connections. In one embodiment, the RF wireless transmission system 36 is independent of the sources of the product or service information. In one alternative embodiment, the compilation is provided as part of the programming, such as being redistributed to the television or radio station and transmitted encoded within the programming transmission.

The RF wireless transmission system 36 distributes the compilation and schedule information in a single data stream to each user device 40. The data stream comprises one or more packets of information provided over time from the wireless system 36 directly to the user device 40. Further, the information is distributed to a plurality of users devices 40. The base stations of the RF wireless transmission system 36 distribute a single data stream to each individual user device 40. The distributed compilation includes transaction information, such as identification or other information needed for processing later received transactions.

The end-users devices 40 preferably comprise two-way wireless devices, such as portable devices. The end user devices 40 receive the compilation and make the information available to a potential purchaser or user. The user is able to select product or service information for initiating a transaction.

One or more of the end-user devices 40 generates additional transaction information. Transaction information includes purchase orders, requests for further information, requests for help, requests for status of a previous transaction, billing or financial authorization information, identification of a source of finances, product or service identification, identification of a product or service source, identification of a source of associated programming or content, identification of a source of a question or answer or other interactive information, a purchase amount, a selection of shipping options or availability information, or a review of product or service information. For example, a user device 40 receives programming guide information and an associated product identification for an

advertised knife set. The manufacturer of the knife set is identified in the information distributed to the user device 40 as well as various options associated with shipping the knife set. The user selects a purchase option. User selection of the purchase option generates a purchase order request that includes an  
5 identification of authorization to debit or withdraw from a credit account or authorization to access funds from a bank account or to authorize later billing, identification of the source of finances, identification of the selected knife set, identification of the amount of the purchase, identification of the selected shipment options, and identification of a source of the product.

10 As another example, the user sees a print ad discussing an automobile. The user selects the automobile on the user device 40 and generates a transaction as a request for additional information. Selection is performed in response to user entry of a code shown in the ad or user selection of a product or service searched for and obtained from the user device 40. The transaction includes an  
15 identification of the product, identification of the source of the product and an identification of user related information, such as a phone number or address.

The user device 40 transmits the transaction information to the RF wireless transmission system 36. The RF wireless transmission system 36 routes the information to the data warehouse 30. The telephone systems 42 of the data  
20 warehouse 30 routes the transaction request to the transaction processing systems 52.

The transaction processing systems 52 comprise servers or other processors for interacting with the data base systems 44 and the billing systems 50. Transaction processing systems 52 identify the type of transaction, such as a  
25 purchase order, a request for information, a request for help, a request for status or interactive information. For interactive formation, the transaction processing system 52 routes the transaction information to a source of a question or other interactivity, such as a radio station 22. Alternatively, interactive transaction information is routed to an application server 46 or direct vendor 28 hosting an  
30 auction or bidding.

For a request for information transaction about a product or service, the transaction processing system 52 routes the transaction information to a source of the product or service. In one embodiment, the transaction processing system 52 obtains further product or service information and provides that information to the scheduling system 48 for eventual transmission to the end-user device 40.

Alternatively or additionally, the transaction processing system 52 provides end-user contact information to a source of the product or service so that the source of the product or service may contact the end user.

For a request for status information, the transaction processing system 52 communicates with the associated source of the product, service or interactivity, such as a direct vendor of products and services 28, to obtain shipping or other status information associated with a previous transaction. Each transaction is identified with a unique code while not completed.

For a purchase order, the transaction processing system 52 interacts with the billing information system 50 and a source of the product or service. In one embodiment, the billing system 50 is used to authorize purchases and arranges for the distribution of finances to a provider of the product or service. The billing system 50 then bills an owner or user of the user device 40 (e.g., as part of a monthly statement). Alternatively, real-time billing is provided and a summary or invoice is displayed on a web site or on the user device 40. In yet another alternative embodiment, an authorization for a transfer of funds from a credit card, a smart card, a bank account or other source of finances, including an identification of a source of finances, is provided with the transaction information. The billing system 50 provides the financial information to a source of product or services so that the source of the product or service may obtain payment for the product or service. The source of the product or service then provides the product or service to the user of the user device 40.

For a request for help transaction, the transaction processing system 52 routes the transaction to a source of help, such as an operator associated with the data warehouse 30, an application server 46 available to provide responses to

frequently asked questions, or one of the sources of programming, product or service information.

The transaction processing system 52 may also provide real-time or non-real-time feedback associated with transactions. In one embodiment, the transaction processing system 52 provides a message back to the end user 40 indicating reception and processing of the transaction request.

In another or the same embodiment, the transaction processing system 52 compiles statistics associated with various sources of programming, associated with various advertisements, or associated with various products or services. The statistics are then provided to an appropriate source. For example, statistics associated with the sales of songs or albums played on the radio station 22 are provided to the radio station 22, indicating the popularity of the programming content. As another example, the number of coupons used for a product or service is provided to a source of the product or service or to a source of advertising 26 to indicate the distribution and/or popularity of the coupon. Additional statistics include demographic information associated with the users of the user devices 40 that placed orders. Demographics information is automatically provided to a source of the product or service or source of programming.

Using the network 20, impulse transactions are provided. As the user watches a program, such as a television or radio program, or reads print material, such as a newspaper or catalog, the user selects the product or service on the user device 40 and depresses a button to consummate the transaction. As another example, the user knows of a product and decides to purchase that product. The user searches for and obtains the product information on the user device 40 and selects a purchase transaction.

Another example provides for a merchant or retail transaction. A grocery store, department store, restaurant or other retail provider of services and/or products is assigned a merchant number, such as a tax identification number. The merchant number and a transaction amount (e.g. product or service amount due and any tip amount) are input into the user device 40. The wireless processes

using the network 20 is used to process the transaction without a cashier and without giving credit card or any other information. A receipt is generated and provided to the merchant, such as at a retail transaction printer connectable with the end-user device or the data warehouse 30.

5           In yet another example demonstrating the convenience of the network 20, the user finds a product on another device, such as the computer. The web content associated with the selected product is then downloaded to the user device 40 from the computer. The user device 40 is then used to select a transaction, such as a purchase. The purchase order is communicated through the network 20 without  
10 providing financial information through the computer. Since the network 20 preferably operates using encrypted and compressed data, the purchase transaction is provided in a secure environment. One such embodiment is discussed below.

## II. USER DEVICE

15           FIG. 2 shows one embodiment of the user device 40. The user device comprises a wireless radio frequency transceiver 60, a wireless infrared transceiver 62, a transceiver for wired connections 64, a memory 66, a processor 68, a component memory 69, a semi-permanent memory 70, an external bus interface 72, a user input module 74, a bar code reader 76, a credit card reader 78, a smart card reader 80, a touch screen 82, a display 84, a printer interface 86, and a power  
20 module 88. Additional components may also be provided. Fewer components may be used in the user device 40. For example, the user device 40 comprises the processor 68, the memory 66, the wireless transceiver 60, the user input 74, a display 84, and the power module 88.

25           In one embodiment, the user device 40 is portable. Alternatively, the user device 40 is non-portable, such as being included as a module in a television receiver, a radio receiver, or other electronic device.

          In one embodiment, the user device 40 comprises at least one of the components for communicating with other devices electronically. For example, the wireless radio frequency transceiver 60 (e.g. wide or local are wireless), the



wireless infrared transceiver 62, the transceiver for wired connections 64, and/or the external bus interface 72 is provided. The transceiver for wired connections 64 comprises a USB, PS2, serial, parallel, an IEEE1394, an optical or other electrical interface. The external bus interface 72 comprises a compact flash, PCMCIA,  
5 PC104, ISA, PCI, Host Bus, a proprietary interface or other interface.

The wireless radio frequency transceiver 60 comprises a transmitter and a receiver. Either or both of the transmitter and receiver comprise analog or digital transmission devices. The wireless infrared transceiver 62 comprises a transmitter and receiver for communicating with a computer. Alternatively or additionally,  
10 the wireless infrared transceiver 62 comprises a transmitter for controlling another electronic device, such as a television, radio or both. In one embodiment, a receiver is provided for receiving channel information from the electronic device. Based on feedback from the receiver or based on the time, product or service information associated with a selected channel is selected by the processor 68 for  
15 display on the user device 40. In alternative embodiments, the display 84 on the user device 40 of product or service information is independent of the control of another electronic device. The transceiver for wired connection 64 may comprise a modem, a cable system, or a digital subscriber line connector.

One or more of the communication components are used to communicate  
20 with the data warehouse 30 (FIG. 1). Product or service information, programming guide information, interactive information, or other information is transmitted to or received from the user device 40. For example, a product or service identification, associated programming guide or catalog list and a cost or amount is received by the user device 40. The processor 68 processes a purchase  
25 order transaction and transmits the product or service identification, the amount of the purchase and an identification of a source of finances for the purchase.

Communication components, such as the wireless infrared transceiver 62, also communicate with other user devices 40. For example, one user device 40 is used to authorize a transfer of funds from a smart card or other source of finances  
30 to another user device 40. In one embodiment, the funds are transferred without

communication to any other devices. Alternatively, authorization for the transfer of funds is communicated to the data warehouse 30 or another entity.

Communications components are also used to communicate with other devices, such as point of sale systems. For example, a user purchases a product at a store or a meal at a restaurant. The user uses the user device 40 to pay. The user device 40 receives information including an amount of the purchase and transmits an authorization for transfer of funds or transmits an identification of a source of finances to consummate the transaction to the point of sale system. Alternatively, the transaction information is transmitted to the data warehouse 30; the data warehouse 30 completes the financial transaction with a credit card company or the source of the product or service; and communicates a completion or receipt transaction to the user device 40 and/or the point of sale system. A virtual receipt may be provided to or from the wireless device 40 indicating completion of the transaction. Credit card or financial fraud and theft are avoided by consummating transactions without the exchange of financial information with a third party, such as a retailer or waiter. The data warehouse 30 arranges for payment to the retailer or service provider.

The communications component in combination with the processor 68 and optionally other components may provide for a multi-functional device. For example, the user device 40 also comprises a pager operable to receive data paging or other paging information with the wireless radio frequency transceiver 60. As another example, the user device 40 also comprises a cellular phone. FIGS. 3 and 4 represent portable devices that may include cellular phone capabilities. FIG. 3 shows such a device with a flip-down microphone. By using the product and service compilation download discussed above for FIG. 1, the user device 40 may operate free of the Internet. In alternative embodiments, Internet content or web pages are downloaded to the user device 40.

As yet another example, the processor 68 with the wireless infrared transceiver 62 also operates as a remote controller. A multifunction user device 40 that may include the remote control capabilities is shown in FIG. 4. The remote

controller comprises a television, radio, universal or other appliance remote controller.

As yet another example, the user device 40 also comprises a personal data assistant, electronic "checkbook" organizer and/or other personal data device. For example, in addition to the transaction processing discussed above with respect to FIG. 1, the user device 40 also stores contact information, schedule information or other data associated with the user. Once such embodiment is shown in FIG. 5. Other functions may be provided by the user device 40. The user device 40 may comprise only a single function or any combination of the multi-functions discussed above. A sub-set of functions included on the user device 40 may be made available different users.

Information obtained from the communications component, such as product or service information, is stored in the memory 66. The memory 66 comprises a RAM, RDRAM, DRAM, compact flash, smart media, hard disk, removable disc, optical storage, rambus, tape, disk, hard drive memory or other memory.

Product and service information, transaction information, or other information received by the user device 40 is stored in the memory 66 under control of the processor 68. The memory 66 stores program guide information, product or service information and transaction information. The memory 66 also stores user information, such as personal data assistant type information, and user configuration data for the user device 40. For example, the memory 66 stores an order for displaying information to a user, software programs, applications and/or other modifiable control routines.

The display 84 comprises an LCD, flat panel, monitor, or other display device for providing information to the user. For example, the display displays programming guide information. The programming guide information is synchronized with broadcast of the programming. The current programming guide information and any associated product or service is displayed. In alternative embodiments, a guide describing the current and subsequent programs

and associated product or services is displayed. The guide and product or service information is also displayed as a function of the source of the content. For example, product and service information is displayed as a function of a selected broadcasting channel or frequency. Displays of previous content schedules and or product or service information may also be provided. Likewise, product or service information associated with yet to be broadcast content may also be displayed. An alphabetical listing of vendors, products, services and/or guide information may also be provided. Other arrangements of product, service and other information may be provided for user selection.

The display of product or service information may include cost information, identification of the product or service, a source of the product or service and a cross-reference to any associated programming guide information, such as a channel and time of a scheduled broadcast associated with the product or service. In alternative embodiments, additional or fewer sources of information about a product or service is displayed or the information is sequentially displayed. For example, an estimated ship date or product reviews may be provided. For catalog information, a cross reference to related programming may or may not be provided. The display 84 is also operable to display configuration selection information of the user device 40 and/or information associated with other functions of the multi-function user device 40.

The display 84 also displays interactive information. For example a question is displayed and as the user enters the response. The response is also displayed on the display. Status information may also be displayed. For example, the user requests status information on a previous transaction. A ship date or tracking code is displayed on the display for the user.

The memory 70 comprises an EEPROM, ROM, a flash memory, or other non-volatile memory. The non-volatile memory 70 stores operating system, BIOS, set-up, update, communications and control software, applications, user configuration, security setting, financial, network setting and/or diagnostic information.

In one embodiment, the non-volatile memory 70 stores financial information for use in multiple transactions over time. For example, the non-volatile memory 70 stores one or more sources of finances for each user of the user device 40. In a virtual wallet embodiment, a plurality of sources of financial information are stored. Sources of finances include credit cards, smart cards, bank accounts, such as savings or checking accounts, debit accounts, or other sources of money, liquid resources or equity. Associated personal identification numbers (PIN) or other authorization information may also be stored in the semi-permanent memory 70. When a purchase is made using the user device 40, a source of finances is selected by the user or configured to be used automatically. The processor 68 obtains an identification and associated authorization information. The processor 68 includes the financial information with the transaction data.

The processor 68 comprises a general computer processor, an application specific integrated circuit (ASIC), a microcontroller or other digital signal processing device. In one embodiment, the processor 68 includes the secure component memory 69 for storing source of financial information, authorization information and/or encryption keys. The component memory 69, memory 66 and memory 70 may comprises a single memory. Each of the memories 69, 66 and 70 may store information described herein as being stored in another memory.

The processor 68 coordinates and controls the various functions of the user device discussed herein. For example, the processor 68 configures the user device using configuration software. The user enters a zip code, and the processor 68 configures the system to display information for broadcast sources associated with that zip code. Other configuration techniques may be used, such as using a setup program that obtains set-up data from the network 20 (e.g. time and date information is obtained). The processor 68 also controls user selectable configuration functions.

The processor 68 reformats transaction information from the data warehouse 30. For example, the processor 68 decompresses and unencrypts

information. Likewise the processor 68 compresses and encrypts information for security purposes ready to be provided to the data warehouse 30.

In one embodiment, the software used by the processor 68 is configurable by a transmission from the data warehouse 30. Likewise, the processor 68 updates  
5 and otherwise organizes the product and service information in associated programming guide information in the memory 66. The processor 68 also coordinates the dump or display of any repetitive information.

The configuration, communications and transactions are performed by the user device 40 in response to a manual user input 74. The manual user input 74  
10 comprises one or more of a keypad, dedicated command buttons, programmable (e.g. macro) buttons, software interaction with a generic button and the display, single buttons for multiple purposes or types of selections, a microphone and associated processor and software for voice input, and/or biometric devices. A touch screen 82 may also be provided for manual user input.

Biometric devices comprise retinal, finger print or other scanners for  
15 confirming an identity of a user. For example, biometrics are used to enable operation of the user device 40 or to authorize a transaction with the user device 40. Other biometric devices may be used.

FIG. 5 shows one embodiment of various user input devices. For example,  
20 a touch screen 90 is provided. A series of buttons 92 are provided that comprise either dedicated special function buttons, programmable macro buttons, or buttons associated with a function displayed on the display 90. The user device 40 also includes menu navigation and selection buttons in the form of cursor arrows and an "enter" button 94. An alphanumeric keyboard 98 is also provided with a  
25 numeric keypad 96. Additional or fewer manual user input devices may be used. Manual user input devices 74 may also perform multiple functions, such as both a display function as well as a touch screen function, or a microphone used for cellular telephone communications as well as voice recognition for control of the user device 40.

The manual user input devices 74 provide for various functions. For example, separate special command buttons are provided for each of the help function, a purchase order function, and information request function. If the user has difficulty with the user device, the user depresses the help button. The help transaction request is provided to the data warehouse 30 and a response in a form of a phone call to the user device 40 or another phone is provided. Different responses, such as help functions displayed on the display 84 or information from other sources, may be provided. If the user desires to purchase a product or service currently selected, a purchase button is depressed. As a result, a transaction is processed including automatic authorization for a transfer of funds. Likewise, if the user desires more information about a selected product or service, the user depresses the information request button. The transaction information is then automatically transmitted to the data warehouse 30. In alternative embodiments, these transaction buttons are selectable from a menu using generic or standard selection features.

The manual user input devices 74 also allow for selection of configuration information, the type of media being currently displayed, selection of a user where multiple users use the device, selection of a source of finances or other selections associated with options provided by the user device 40 and the network 20.

Product and service information for selection is organized as a function of one or more of various factors. These factors include alphabetically, by type of media, by source of product, by broadcast channel, by region, by product code, by a favorites list or by other user design arrangements. The user then scans the information by scrolling through the information, selecting products and services according to a hierarchy menu structure, or by entering a product or service code or name. Other techniques for isolating a product or service may be provided.

In one embodiment, product and/or service information associated with a broadcast outside of the region where the user device 40 is currently located is provided on the user device 40. The user device 40 may receive, through the RF wireless transmission 36 or other mechanism, a sample of programming or the

complete content being broadcast associated with any programming for that out-of-market source. Alternatively, no sampling or additional programming is provided. The user is able to make purchases for products or services or receive content associated with out-of-region broadcasting.

5           The manual user input devices 74 also allows for locking or security of the user device. For example, a personal identification number (PIN) or other lock features are provided for activation of the user device 40 or for availability of certain types of products and information on the user device 40, such as R-rated or X-rated movies (e.g., parental locks). Manual user input devices 74 may also be  
10           used for inputting a source of financial information, such as credit card numbers, bank account numbers or other financial information. Other personal information may be entered, such as identification information, medical records and/or insurance information.

          In one embodiment, the user device 40 locks out any use in response to a  
15           signal from the data warehouse 30. For example, any use of the user device 40 is prevented where the device is reported as stolen. This may increase the chances that the device is returned and prevents loss of finances from theft. The user device 40 may transmit signals in response to a lock out command allowing for triangulation to locate the user device 40.

20           The user device 40 optionally includes one or more reader devices. For example, a bar code reader 76, a credit card reader 78, and/or a smart card reader are provided. Other readers may be used. A reader obtains information from sources local to the user device, such as credit cards, smart cards, coupons or other bar coded information. For example, any of the user devices 40 shown in FIGS. 3,  
25           4, or 5 can include one or more readers. The credit card and smart card readers 78 and 80 are used to obtain transaction information for providing a source of finances. Smart cards may act as a repository of funds for transfer and allow importation and exportation (transfer) of the funds. The smart card may also store other personal information, such as identification, medical record, rewards



acquired as a function of using the user device 40, purchase history, passwords, personal user, insurance and/or other information.

Using the credit card reader, purchase transactions are authorized without storing an identification of a source of financial information and without requiring manual entry. For example, the user merely slides a credit card through the credit card reader to store the source of finances, identification or to authorize a purchase transaction.

The bar code reader 76 allows for automatic adjustment of the amount of cost of a product or service by scanning a bar code associated with a coupon. The bar coded coupon information is then provided as transaction information to the data warehouse 30 with additional transaction information for the purchase of a product. Promotional materials may also be bar coded so that an information request transaction is processed merely by scanning a bar code. Additionally or alternatively, the bar code provides reference information for a purchase or information request associated with a product. The user device 40 receives the product information in the form of a bar code identification (e.g. universal product code, ISBN book codes, data warehouse assigned codes, source assigned codes or other codes) from print media or manual user entry of an identification code. The user then requests information or indicates a purchase of that product. The purchase is arranged through the secure radio frequency wireless transmission.

The bar code reader 76 or manual user entry allows for generation of a shopping list. The product code information is entered, such as by scanning a UPC code of a soup can. For example, as a user consumes grocery items, the product code is scanned. The scanned or entered information is available for later use, such as printing or displaying a grocery list, communicating the list to a shopping service or transmitting the list to a source of products with a transaction request.

In one embodiment, the user device 40 is operated by multiple users. Individual user configuration information may be saved within the user device 40 for each user. The sources of finances specific to each user are saved independent

of other user sources so that a user has access only to their own sources of finances. For example, a PIN or biometric authorization is used for access. Information associated with favorite types of products or services may also be stored and saved as a function of the user. For example, the product or service list highlighted or provided to the user is altered as a function of the user or the user's transaction history.

For additional functionality, the external bus interface 72 is provided. The external bus interface 72 comprises a compact flash, a PCMCIA connector or other device for adding additional functionality to interact with the user device 40 and the processor 68. For example, the user device 40 may comprise only a subset of the various functions discussed above. Additional functionality is then incorporated into the user device by connection to another device.

The user device 40 interacts with an electronic programming receiver in one embodiment. The programming receiver is a separate component or a different component than the user device 40. The electronic programming receiver comprises a receiver for receiving radio, television, or computer network information. In one embodiment, the user device 40 remotely controls the programming receiver. The programming receiver receives radio broadcast, television broadcast, or network communications. The display of product or service information on the user device 40 is synchronized with the reception of programming content on the separate receiver through real time transmission of product or service information to the use device 40 or through scheduled display. By controlling the separate programming receiver, the user device 40 obtains information indicating the source of programming and the associated product or service information. Alternatively, the user inputs the source of programming being received on the separate programming receiver into the user device 40. In other embodiments, the user device 40 interacts with the global positioning system or phone systems.

In alternative devices, the user device 40 is incorporated into the programming receiver. For example, the user device 40 is provided as a module in

a CD player, a DVD player, a television, a radio, an audio expansion module (e.g. MP3) or other programming receiver device. In any one of these alternative embodiments, the user device 40 provides out of area or region programming or sampling through the RF wireless transmissions.

5           **III.    EXAMPLE EMBODIMENTS**

The capabilities of the network 20 and the user device 40 of Figures 1 and 2 are capable of use in and design for different embodiments. A few such example embodiments are disclosed below.

10           FIG. 6 is a flowchart of one embodiment using the network 20 of FIG. 1 for product or service or interactive transactions associated with a radio broadcast. In act 100, a radio station sends scheduling information, or a programming guide of content to be broadcast, to a clearing house comprising the data warehouse 30. The data warehouse 30 places the information into the data base in act 102. The scheduling system 48 applies the scheduling algorithms to the data to assign a  
15           priority for distributing the data to the user devices in act 104. In act 106, the application server 46 packages the data with appropriate header and body information for data processing and error correction. The compiled data is packaged with other compiled data. In act 108, the scheduling system 48 applies the bandwidth algorithms to add data or limit data to be within an appropriate  
20           bandwidth. The application servers 46 compress the data in act 110 and encrypts the data in act 112. In act 114, the compressed and encrypted data is sent by the application servers 46 through the telephone systems 42 to the RF wireless transmission systems 36. The RF wireless transmission systems 36 or another terrestrial or wireless system transmit the data stream to the appropriate user  
25           devices 40 in act 116.

In act 118, the compressed and encrypted packetized data is received by a plurality of user devices 40. The user devices 40 decrypt, decompress and decode the incoming data stream in act 120. The user devices 40 process the data for storage in the memory 66, and displays the appropriate data in act 122. For

example, the display of products or services provided in the radio play list (program guide) information is displayed in synchronization with the broadcast by the radio station 22 as a function of time and the selected radio channel. In act 124, the user selects a transaction option associated with the displayed product or service information, allowing an impulse purchase. For example, the user selects the purchase of a compact disc that includes a song being currently played, or the user selects the purchase of a window cleaning service displayed in synchronization with a window cleaning service advertisement. In act 126, the user device 40 prepares or processes the transaction. For example, the user device 40 compiles the data into a purchase order format including appropriate header information and product identification information. In act 128, additional information is requested by the user device 40 of the user or of the data warehouse 30 if needed. In act 130, financial information is requested by the user device 40. For example, a listing of various sources of financial information is provided to the user or the user is asked to swipe a credit card or have other information read by a reader as represented by act 132. In act 134, the processor 68 of the user device 40 formats the transaction data. The formatted data is compressed in act 136, encrypted in act 138 and transmitted to the data warehouse 30 in act 140. In one embodiment, the transmission is accomplished using the RF wireless transmission system 36. Other transmission structures may be used.

In act 142, the data warehouse 30 receives the transaction communication from the RF wireless transmission system 36. The transaction data is routed to the transaction processing system 52 in act 144. The transaction processing system 52 or application servers 58 decrypt, decompress, parse and further process the transaction data in act 146. In act 148, the transaction is processed through an application server 46 for appropriate transaction processing, such as updating billing records, updating or generating status information, generating or updating a demographics report, quality assurance checks, fraud detection, rewards or loyalty program updating, discount determination and record keeping, user confirmation, and/or other processes to provide secure services to the user and the sources. In

act 150, the transaction processing system 42 routes the purchase order or other transaction information with the product identification or other information to the appropriate source, such as a source of the product or service. In other embodiments, interactive transactions are provided to the radio station 22. In act 5 152, the billing information systems 50 process the finances associated with the transaction. For example, the billing information systems 50 record the transaction amount and identification information for later billing. As another example, the billing information systems 50 complete an authorization check with a credit card company or bank and arranges for the transfer of funds to the source 10 of the product or service. In act 154, the order status and financial status information is provided to the scheduling system 48 for sending to the appropriate user device 40.

Additional acts may be provided, such as transmitting demographic and other statistics to the radio station 22 associated with purchases of products or 15 services discussed in programming content or advertising. Another example includes receiving further question or response information from the radio station 22 or another source for transmission back to the user device 40. Some of the steps discussed above may be skipped in some of the embodiments.

From the user's perspective, the user tunes the radio to a desired radio 20 station 22 with the user device 40 or another means. The radio receiver receives programming content, such as "With or Without You" by U2. As the song is played by the radio receiver, the user device 40 displays the song title, the group title, the CD or album title, product options, such as compact disc or audio tape, and a cost associated with each product option. Alternatively, a subset of this 25 information or additional information is displayed, and the user may then be able to select various options to obtain the remaining information. The user hearing and enjoying the song impulsively decides to make the purchase. The user selects the particular product desired for purchase and selects the purchase transaction. Using either stored financial information or requiring entry through the manual

user input device 70 or reader 76 or 78 of additional financial information, the impulse purchase is completed.

In another embodiment, interactive radio is provided. For example, as a song is being played by the radio receiver or the user device 40, the user device 40 displays the question "Do you like this song?". The user responds by indicating "yes" or "no" or providing further information. This interactive transaction information is then provided through the data warehouse 30 to the radio station 22. Demographic information may also be provided. The radio station 22 may provide a further response. The further response is then routed to the particular user device 40 that provided the response. In an alternative embodiment, a radio show host or other content of the programming provided through the radio receiver includes a question such as "Should we keep playing this song?". The user indicates a response on the user device 40. The responsive transaction information is provided to the radio station 22 through the data warehouse 30. Based on statistical information, the radio station 22 may decide to continue to include that song in future programming or reduce the amount of play time of that song. Such interactive and impulse transaction systems associated with radio are disclosed in U.S. Provisional Patent Application Serial No. 60/121881, filed February 25, 1999.

In another example, the radio program guide information is provided to the data warehouse 30. The user selects a purchase or request for information transaction with the user device 40 upon hearing a song. The song is or is not displayed on the user device 40. The user device 40 provides a selection of the radio frequency or station associated with a mass media radio broadcast. The user device 40 transmits the transaction request with time information and selected channel or source information to the data warehouse 30. The time information comprises a time at which the transaction request was input to the user device 40. Based on the source and time information, the data warehouse 30 determines a product or service for the transaction request from the program guide information.

The data warehouse 30 transmits the transaction request to the source of the product or service.

In one embodiment, the radio or other receiver communicates with the user device 40, such as using a wireless infrared connection or a radio frequency signal. The receiver communicates channel or frequency information and/or time and date information. The user device 40 may provide the listening, viewing, or other information as demographics data. Other communications may be provided, such as where a transaction selection is provided on the receiver. For example, a user depresses a “buy” or “information request” button on the receiver, such as a car radio. The receiver communicates the transaction information to the user device 40, such as date, time and channel or frequency or product or service identification. The user device 40 securely transmits the transaction request to the data warehouse 30 for processing or stores the information for later selection or confirmation by the user.

In alternative or additional embodiments, the user device 40 identifies the frequency or channel of the receiver and correlates the frequency or channel information with a product or service. Identification is provided through communication with the receiver or by sensing electronic or other emissions from the receiver. The identification information is used for transactions with the user device 40, such as displaying a currently played song title and associated product information on the user device 40 and selecting a transaction in response to the display.

In yet another example embodiment, the user device 40 obtains information for later use. The information is stored in the memory 66. An impulse to later purchase, later request information or provide a later reminder or selection is satisfied by depressing a button or combination of buttons. The information is “bookmarked” for later consideration or use. The stored information comprises product or service information or frequency/channel and time information. For example, a user operating a vehicle selects radio song identification information for later consideration without jeopardizing a focus on driving. The selection is

made on the receiver with subsequent communication of the selection to the user device 40, made in response to a remote signal (e.g. from an key-chain button) or made on the user device 40. Later, the user performs any of the transactions described herein, such as purchasing or requesting further information. The user  
5 may have stored multiple products and services and selects one for purchase.

In one example use, the user device 40 connects with a computer and provides a URL or other network content identifier. The user obtains additional product or service information from the content and/or may complete a purchase or other transaction based on the content and the stored information.

10 While the examples discussed above were given for radio media, television media, data paging media, print media, or any other media may use similar processes and transactions. Likewise, song playing services on the Internet may use the network 20 for similar transactions.

In another embodiment for using the network 20, secure publicly accessible  
15 communications network (e.g. Internet) purchases are provided. The user downloads web content from the publicly accessible communications network to a computer. After selecting a product or service, such as a book, the user selects an order screen from the web content. Software such as OCX, Java, DLL or other software, is loaded into the web content to interact with the user device 40. The  
20 software includes transaction information, such as product or service identification and source information.

The product or service information is provided to the user device 40 on a first path. For example, the Internet is connected to the computer through the telephone lines and the computer is connected to the user device 40 through an  
25 infrared wireless transmission or through a wired connection. In one embodiment, the user device 40 is installed as a board within a computer. Alternatively, the user device 40 comprises a separate, preferably portable, device.

In one embodiment, the communication with the user device 40 is initiated through activation by the user device 40, such as selection of a download option.

30 The user device 40 communicates with the computer to obtain the transaction



information, such as product or service identification and associated information. In alternative embodiments, the computer initiates the communication in response to a user entry to indicate a secured purchase or information request transaction. The software content then transmits the transaction information to the user device  
5 40. In either case, the user device 40 processes the transaction as discussed above and communicates the transaction information on a second communications path.

In one embodiment, virtual wallet software or other software for storing financial information on the computer provides financial transaction information with the product and service information from the content to the user device 40.  
10 Alternatively, the user manually enters the financial transaction information or the financial information is stored on the user device 40 as discussed above.

The second communications path is free of the computer. In particular, the second communications path is free of the publicly accessible communications network (e.g. Internet) connection with the computer. The second path may  
15 include other publicly accessible communications network communications, such as the network 38. In one embodiment, the second path comprises the radio frequency wireless transmission path to the RF wireless transmission system 36. The transaction data is routed to the data warehouse 30. The data warehouse 30 processes and routes the transaction information to a source of the product or  
20 service, such as a company hosting the associated web content. Since the user device 40 reformats the transaction data through compression and encryption, the second communications path is more secure than the first communications path.

By clearing the transaction and financial information on a separate communications path, financial information piracy is more likely avoided.  
25 Transmission of personnel information on the public network is avoided. The transaction is also made simple by avoiding entry of personal information for each transaction. The source of the product or services, such as the host of the web page content, receives the order and financial information. The order and financial information may be provided electronically to speed processing.

In an alternative embodiment, the user device 40 is included as part of the computer. A transmitter is provided for the second communications path that is free of the connection between the computer and the publicly accessible network. Software on the computer performs the transaction processing. Product and service information is obtained from content from the publicly accessible computer network, manual user entry, a memory storing product or service information or other source.

In another embodiment, the network 20 is used for impulse transactions associated with print media. For example, product or service information associated with print ads or a catalog is optionally compiled by the data warehouse 30 and transmitted to the user devices 40. The user inputs product information into the user device 40 from the print media or selects the appropriate product or service from data already in the user device 40. For example, the user obtains a newspaper or catalog with a product description or advertisement. Either keying in a product identification code or reading a bar code, the user device 40 generates a transaction request, such as a purchase associated with the code. For example, the bar code reader of the user device 40 scans a bar code on an advertisement. Where product or service identification and associated source information is already stored in the user device 40, the user device 40 obtains the appropriate transaction information for the transaction and processes the order as discussed above in other embodiments. The source of the product or service then provides the product or service to the user's billing address or another address programmed into either the user device 40 or the data warehouse 30.

In alternative embodiments, the product code or bar code information entered into the user device 40 by the user includes an identification of the source of the product. The code information is included within the transaction data provided from the user device 40 to the data warehouse 30. The data warehouse 30 then uses the code information to identify a source of the product or service. The transaction is then processed as discussed above. Alternatively, the product or service information is compiled at the data warehouse 30 but is provided to the

user device 40 once a request associated with the product or service is received from the user device 40.

Additionally, the product or service code information may include a price. Alternatively, the data warehouse 30 obtains price information from the source of the product or service based on the product or service code and communicates that price information to the user device 40 or the data warehouse 30. Payment is performed by the network 20 or by billing the user.

In another embodiment of the network 20, a real time interactive bidding process is provided. Product or service identification information and description information are transmitted to the user device 40 from the data warehouse 30. A user may input a bid on the user device 40 for the product or service. The bid is sent in real time to the data warehouse 30. The data warehouse 30 transmits bids from other user devices 40 as well as from other sources, that are compiled to each user device 40 involved in the bidding process. Additionally, the bidding information may be transmitted to other user devices 40. At the end of the bidding process, a purchase transaction is generated and provided to the data warehouse 30 for the winning bidder. The product or service is then purchased as described above.

In yet another embodiment, various information services may be purchased using the user device 40. For example, the user desires to purchase news or other information services. The user selects such services and generates a purchase transaction. The news or other information purchased is then provided to the user device 40 by the data warehouse 30. For example, a weekly news service information letter is transmitted to user devices 40 that have purchased rights to that information. The news or other information is generated by the data warehouse 30 or another source.

Referring to Figure 5, another embodiment of the user device 40 for use with the network 20 is shown. The user device 40 comprises a virtual wallet or a digital electronic wallet. As discussed previously, various user input devices are provided as well as the display 90. A card reader, such as a smart card or credit

card reader, is provided as a swipe slot 91 on the user device 40. A radio frequency two-way receiver and antenna 93 are also provided. At least one digital input and output connector 95 is also provided. An infrared transceiver 97 is included. In this embodiment, the user device 40 comprises a foldable case sized to fit within a person's pocket. The virtual wallet user device comprises a personal data assistant and an impulse transaction system as discussed above. Other functionalities may be provided.

In one embodiment, the virtual wallet user device 40 is configured to communicate with point of sale systems as discussed above. The user device 40 may also communicate with other similar user devices. For example, using the infrared transceiver 97, or the digital input/output connector 95, the user device 40 arranges for the receipt or transfer of finances from one user device 40 to the other user device 40. For smart cards, the financial transfer may be direct without any further direct communication with other devices. For credit card or bank account transactions, at least one of the two user devices 40 communicates with the data warehouse 30 to arrange for the transfer transaction. Using the transaction capabilities, a transfer of funds free of Internet content (e.g. download) is provided on a portable device. While some of the transaction steps may include Internet communications, the user device is not required to download Internet content to perform the transaction.

The virtual wallet or other embodiment of the user device 40 may also display a summary or record for each source of finances. For example, a checking or savings account record is displayed in real-time on the user device 40. The summary information is either received from the bank or other source through the data warehouse 30, downloaded from another device such as a computer, or entered manually by the user. For downloading from another device or receiving the information from the data warehouse, the user device 40 and other records of the source of finances are synchronized. For example, a software program maintains an account record on a computer. Using an infrared communications, purchase or financial transfer transactions performed by the user device 40 are

communicated to the computer for synchronization with the software record or summary.

Preferably the user device 40 conforms to any appropriate government or industry standards, such as Regulation E of the Federal Reserve System, Class B Digital Devices of FCC regulations, and any ANCE banking or other financial regulations.

Any of the various embodiments discussed herein may be combined into one embodiment. Functional components may be omitted or included as needed to achieve the desired functionality.

#### **IV. OTHER EMBODIMENTS USING ASPECTS OF THE NETWORK OR USER DEVICE:**

The two general embodiments discussed below correspond to the two provisional applications referenced above. Each of these general embodiments incorporates one or more of the features or embodiments described above.

##### **A. A System and Method for the Acceptance and Transmission of Content Description and Interactive Information.**

A system and methodology for: (1) content description aggregation (gathering), (2) content recording, storage, playback and manipulation, and (3) a method for an interactive content tracking and management is provided.

A plurality of Radio Stations each have the ability to communicate information about the currently aired content, PLAYLIST information, including (1) Name of the song playing, (2) album and artist name, (3) Product Code, and other miscellaneous information. A Radio Receiver receives the content information, lets call that the Receiving Device. Finally, a system capable of receiving the PLAYLIST information and sending it to a plurality of Receiving Devices is provided, if the PLAYLIST information is not encoded in the content itself (a Tracking System).

A Listener of a Receiving Device hears the content, and receives a display of what is playing, and further, with Product Code information, it is possible for a User to Purchase, Sample, or otherwise interact with the content itself through some Impulse Buy, eCommerce, or other form of electronic transaction without much effort. A new revenue stream is made available to Radio Stations that does not exist today. Further, enhanced marketing and advertising revenue streams are similarly created based on this enhanced functionality.

In one embodiment, a unified (clearing house) system to receive and control a plurality of PLAYLIST data from a Plurality of Radio Stations is provided to supply one unified Re-transmission to a plurality of Receiving Devices. Further, it is possible for a simplified rollout of new digital Receiving Devices, that will be compatible with all Radio Stations, and further enable enhanced interactive services utilizing the content and data of a typically one-way broadcast medium.

In a non standard implementation of an embodiment, it is plausible to send real-time book, chapter, sentence information for people to follow along with an Audio-Book, or perhaps, it is able to send electronic pointer information so that a computer can follow along with a distance learning course (perhaps passing URL's for the World Wide Web, or a reference to a file on a CD-ROM, etc...). The content description information is completely modifiable, and transmittable at any time-period as set by an embodiment of a PLAYLIST.

PLAYLIST information can be generated in numerous ways, including, but not limited to, (1) Typed into a PLAYLIST computer program which is capable of sending information to a Tracking System, (2) Sent from an automated PLAYLIST generator program, (3) keyed data in real-time from personnel at a Radio Broadcast Station, (4) stored information that was created previous to a broadcast, with PLAYLIST data, and Time Stamps identifying Start and End Times.

The PLAYLIST data is transmitted. Depending on the embodiment, this can be accomplished by (1) encoded in the content stream and sent through the

broadcast, (2) as separate data sent to a Tracking System or Receiving Device directly. Such transmissions could be wireless or wired. Such PLAYLIST can go through a Tracking System (Clearing House) but does not need to. Further, an embodiment can include interactivity data, including URL, or other network address information, which could allow direct interactivity between a Receiving Device and a Radio Station, without the need for an external Clearing House Tracking System.

As can be seen from a sample embodiment as shown above, two benefits are provided to traditional Radio Broadcast Stations, (1) creating new revenue channels via interactive services, including, but not limited to (a) Pay-Per-Listen, and (b) commerce or consumer purchases, and (c) increase advertising dollars via better marketing information, and (2) keeping an informed Listener by way of supplying information about the content being played, which could include, but not be limited to, (1) Songs, (2) Commercials, (3) Talk Radio Guests, (4) Audio-Books, (5) Live events, (6) conferences, and (7) distance learning.

This functionality could be integrated into an existing control system. This functionality will include the capability to transmit PLAYIST (Content Description) information to a Tracking System located at a physically separate location, using a plurality of communications methods which could include, but not be limited to landline (phone), Satellite, and/or wireless data networks.

The Content Description information could include, but not be limited to, Station-Name or ID, Song Title, Album Title, Commercial Sponsor, Resource Locator, Phone Numbers, trigger information and linking information. In an embodiment, Resource Locators could be a Product Code for an Item (similar to unique ISBN numbers for books, or UPC codes for food products). Linking information may be a track number, spot number or some other identifier that indicates the specific content being played, if not fully defined by a Resource Locator. Further, textual information, such as a human understandable group of letters or words could be transmitted which define information related to the play of information. Further, trigger information could be included which would allow

for a Radio Station to send or Request information of a plurality of Receiving devices, for instance (how many people are listening?), (users, please vote from #1 - #10, did you like this song?), and so on.

Content Description information can be provided from the source on a Real-Time bases, wherein it is transmitted simultaneously with the content itself, or could be transmitted in a before hand time, perhaps an embodiment could send a complete PLAYLIST for a day or so, which separates content by Start and End Broadcast Times.

Once the said content description and/or trigger information has been sent to a content description Tracking System, this information will be distributed to the various listening devices based on selection information. For instance, a plurality of receiving devices “tuned” to channel “1” would receive real-time information as it relates to “channel 1”, while a plurality of receiving devices “tuned” in to channel “2” would receive real-time description information as it relates to “channel 2”. Different receiving devices may receive different versions of the said content description information, based on features and functions available in an embodiment of a receiving device.

Upon the Receiving Device receiving the said Content Description information, it is plausible that the information could be used for functions including, but not limited to, (1) displaying the information, (2) allowing the purchase of specific content, (3) survey capabilities, (4) questionnaires, (5) advertising promotions, (6) statistical information gathering, and much more.

In an example embodiment, a Radio Station may be equipped with software that allows for the entry of Play-List information. This could include a plurality of song titles, length of play time, with a plurality of commercial and promotional spots which could include Spot name, length of play time, etc... of which such a list could be arranged in a play order. Having completed such a play-list, an embodiment looks for real-time changes in this PLAYLIST of a plurality of Radio Stations (for instance a new song starting, an advertising spot



started, etc...) and instantly send that Content Description information to a Tracking System.

A program allows for this information to be transmitted via a communications link to a Tracking system capable of receiving the said content, or encoded in the content for transmission.

In an embodiment, a Windows software application could be written, which allows for data entry (or integration into an existing play-list system), which could also have the capability of sending and receiving TCP/IP packets over the Internet (assuming the computer is connected to the Internet) to an embodiment of a Tracking System, which would also be connected to the Internet. In this embodiment, a Tracking System may be capable of receiving a plurality of Content Description information from a plurality of Radio Stations, whereby said Radio Stations would have a unique ID to distinguish each from the others. In an embodiment, a simple protocol can be used whereby simple commands are used to send and receive the needed and/or requested information. This protocol need not be unique or proprietary, and could even be a version of the HTTP (World Wide Web) communications Protocol. In this embodiment, it is possible to have a Tracking System which is maintained, programmed and operational using existing Web Server and Programming techniques.

An embodiment of a Tracking System could then use the Content Description information to communicate with connected Receiving Devices, or potentially reformat, and re-broadcast over several different mediums. The Tracking System would then be responsible for Receiving Device Responses, Triggers, Requests, and Purchases. In an embodiment of a Tracking System, functions such as auditing, managing and reporting functionality could be made available to a plurality of Radio Stations. An example would be that a Radio Station is playing "With or Without You", by the Artist "U2", at which time a user of a receiving device selects "Purchase CD", whereby a Tracking System records the purchase, fulfills the order, and reports back to a Radio Station the transaction.

The components necessary and a system to implement such a transaction are provided.

As an example embodiment, it is possible that a new generation Radio Receiver is in the home of a user, tuned into a radio channel, and receiving not only the music, but information about the music, as well as the cost to purchase the current song or the Album it is on. This provides a mechanism whereby all Radio Stations would communicate with one Tracking System (instead of hundreds of Radio Receivers), whereby making the consumer purchase easier, more reliable, and much less prone to having an appliance that will become obsolete. Further, this enables not only user ease of use, but Radio Stations ease-of-deployment, and a much more open source of revenue.

In an embodiment, it is possible to enable impulse buy, whereby a listener could purchase an item being sold immediately (based on Content Description Information that is sent), which does not need to actually present the information being broadcast. Further, the system and methodology will work identically either in a traditional "over-the-air" broadcast, or in an Internet "Streaming" type application, such as a Real-Audio Stream. This embodiment describes a communication of Content Description Information, and a mechanism for Two-way interactivity utilizing said Content Description Information.

Figure 7 refers to a simple embodiment whereby the systems and methods are described as an embodiment could be used by a plurality of Radio Stations to enable interactive services with Receiving Devices capable of such activity.

Figure 7 shows an embodiment of a Content Source (1100), which could be a plurality of Content Broadcasters, which could include, but not be limited to (a) Radio Stations, (b) Television Stations, (c) Internet Web-Casters, (d) Streaming Media Providers, (e) Music and Record Studios, (f) any other source of audio, video and/or data content. In this embodiment, a plurality of Content Source (1100) each have at least one Content Description Module (1101). Note that this system can be located elsewhere, but typically each said Content Source (1100)

would have access to some form of a Content Description Module (1101), with capabilities of modifying information particular to said Content Source (1100).

A Content Description Module (1101) is a embodiment of software that is responsible for (1) the creation and transmission of Content Descriptions (Data) which will be sent to an embodiment of a Tracking System (1300), or encoded into a content stream and broadcast by a Content Source (1100), or transmitting partner on behalf of a Content Source (1100). Information gathered, created or otherwise developed could include a plurality of PLAYLIST information, which could be a plurality of data records, which can include, but not be limited to, (1) Type of content [commercial, song, guest speaker, etc], (2) name of content [song title, sponsor, etc], (3) producer [Artist, Studio, Host, etc], (4) Product Code [Album ID, Commercial Sponsor ID, URL, etc], (5) Start Time, (6) End-Time, (7) Run Length, (8) Station ID, etc...

An embodiment of a Content Description Module (1101) can be made of functional units, including but not limited to, (a) a Data management and manipulation control Module (1102), (b) a Connection API (1103), a Receiving Data Processing Module (1105), and (c) a Network Interface (1104).

A Data management and manipulation control Module (1102) in an embodiment could be responsible for the user interface, and database management system which allows for the entry, storage, manipulation, and transmission of Content Description Information. The Data management and manipulation control Module (1102) can send and receive and process any and all messages back and forth between a Data management and manipulation control Module (1102) and a plurality of Tracking Systems (1300). This system in an embodiment could be written in Microsoft Access, with ACTIVEX controls for network communications, and an interface for a DJ (if it is a Radio Station for example) to enter real-time information, and have the system updated. It is also possible that an embodiment could "Batch" the Content Descriptions (PLAYLIST) for a period of time, in hours, days, weeks, etc... a Data management and manipulation control Module (1102) could be capable of sharing data located on an embodiment of a

Tracking System (1300) which could contain information such as Album searching and sorting, Product code information, Company ID's for sponsorships, etc... An embodiment of a Data management and manipulation control Module (1102) should contain management interfaces for reporting, auditing and other manipulation of data that a Tracking System (1300) may provide. For instance, an embodiment may have the ability to send a question to all "listeners" using a trigger which asks, "IF you liked the song you heard, Press #1, otherwise Press #2", in which case any responses generated by a Receiving Device (1500) would be passed from a Tracking System (1300) to a Data management and manipulation Control Module (1102) or if available a Received Data Processing Module (1105). In this example, it is possible to see real-time results of responses from a "listening" audience. Again this example would be applicable to an embodiment designed to work with a Radio Station as an example.

A Connection API (1103) is a module that an embodiment could use to provide external connections to other management, PLAYLIST or operation support systems. An embodiment of a Connection API (1103) could be used as a gateway, or connection interface to allow legacy systems to gain new interactive functionality as described in the systems and methods. An example embodiment may use Microsoft Windows Dynamic Link Libraries (DLL), or ODBC database connectivity to read from other programs data or databases to gain access to PLAYLIST, Content Description, or any other needed data that can be used for operation or execution. In the example embodiment designed for Radio Stations, software currently exists to allow Radio Stations to prepare play-lists, prepare digital automation techniques and other management systems to control the flow and timing of content to be aired. It is an embodiment of a Connection API (1103) that could allow those systems to talk to an embodiment.

A Received Data Module (1105) could be designed in an embodiment which would allow enhanced data manipulation, storage or management of received "User Responses" from triggers, or Statistical, order or other

demographic information that may be received by an embodiment of a Tracking System (1300).

5 In an embodiment of a Content Description Module (1101) would be a Network Interface (1104). A Network Interface (1104) would be responsible for the management of a communications link between a plurality of Content Description Modules (1101) and a Plurality of Tracking Systems (1300). In general, if an embodiment was to connect a Content Description Module (1101) to a Tracking System (1300) via the Internet, then an embodiment could be made of an Ethernet Card, with TCP/IP protocol running with the proper external  
10 connections available for proper communication, of which could include hubs, routers, switches, etc... a Network Interface (1104) could use wireless mechanisms as well, including RF, PCS, Satellite, etc...

Now that a Content Source (1100) has the capabilities to create Content Description information, we must assume that communication is handled through  
15 a communication link that is formed directly, or indirectly (in the case of an embodiment using a wide area network, such as the Internet), and such communication through a link (1200) would properly connect to an embodiment of a Tracking System (1300). In an embodiment, a Content Description Module (1101) could be programmed with an Internet Address of a server it is setup to  
20 communicate with.

With a complete embodiment of a Content Description Module (1101), lets assume that data (for use as an example) is sent at a point in time to an embodiment of a Tracking System (1300) through a communications link (1200) with the following information: (STATION="WHTZ", FREQ="100.3",  
25 TIMESTART="11:35:32", TITLE="With or Without You", Artist="U2", PRODUCTCODE="1202XW1Z"). More information could be included. This data is for example purposes only.

A plurality of Tracking Systems (1300) in an embodiment could be a simple World Wide Web Server, with proper CGI or other scripts developed to  
30 interact with commands and/or responses between an embodiment of a Tracking

System (1300) and an embodiment of a Content Description Module (1100). Such communication would be made through a communications link (1200), connected to an Network Interface (1303), which in an embodiment could be an Ethernet TCP/IP connection over the Internet. Further, a Tracking System (1300) in an  
5 embodiment could also be capable of communicating with a plurality of Receiving Devices (1500).

An embodiment of a Tracking Server (1301) could be made of an embodiment of a Data Management and Manipulation Control Module (1302) in an embodiment could be database management system, capable of storing, and  
10 processing real-time and stored Content Description (PLAYLIST) type data. As referenced as sent information above for example purposes, lets follow the trace. Data is sent by a Content Description Module (1101), it is received in an embodiment by an HTTP server, which has the proper scripts to update a database with the information sent. A Data Management and Manipulation Control Module  
15 (1302) could then process the data to see if any Receiving Devices (1500) is “tuned” into the appropriate channel, in this case STATION=”WHTZ”,  
FREQ=”100.3”. For all Receiving Devices (1500) “tuned” in, an embodiment could then send a “Content changed” message, which could then send the data as received by a Content Description Module (1100). It is also a possibility that an  
20 embodiment of a Data Management and Manipulation Control Module (1302) could send information to a Content Description Module (1100) whereby such data maybe Receiving Device (1500) responses to questions, or demographic information, Receiving Device Purchase information, etc...

In an example process of an embodiment, it is clear to see that a Content  
25 Source (1100) could broadcast a song “With or without you”, by the artist “U2”, send this information to a Tracking System (1300) via a Content Description Module (1101), whereby a Tracking System (1300) could send that information to a plurality of Receiving Devices (1500), whereby a Purchase could be made by a plurality of Receiving Devices (1500), to which that transaction could be  
30 transmitted back to a Tracking System (1300) which could verify and process the

order, fulfill the order, and send audit information back to a Content Description Module (1101) that began the transaction.

5 In an embodiment of a Tracking System (1300), an Interactive Server (1304) could be put in place that takes the workload off a Tracking Server (1301), whereby additional checking, processing, monitoring of real-time and stored data and transactions can be processed. An embodiment of an Interactive Server (1304) could be responsible for communication with a plurality of Receiving Devices (1500) via a network communications link (1400).

10 In summary, Figure 7 shows an embodiment of the systems that can be put in place to complete various objectives. In general, a content source creates and provides various data to a tracking system. A tracking system is then responsible for transmitting the appropriate data to a receiving device based on various parameters. Further, a tracking system must be able to receive information and data from a Receiving Device, such as purchase information, or perhaps a request  
15 for more information inquiry, whereby the necessary data is processed, and further making it possible that information could then be passed to a content source. This full circle, communication infrastructure as described enables a system to act as a clearing house for a plurality of Content Sources, whereby enabling mass adoption, controlled rollout, and new and enhanced interactive services. This  
20 removes the traditional limitation of a one-way, unintelligent broadcast transmission as could be typically found in a Radio Broadcast Model. With the advent of Audio and Video Streaming (for instance over the internet), this further enhances that type of model by offering interactive features and services that still would not be available. Further, an embodiment would also stimulate numerous  
25 types of direct sale, direct market, and other campaigns, promotions, giveaways, or other types of marketing, or sales programs that would otherwise be impossible to implement, and further, an embodiment could also supply the two-way link, that would be needed for raffles, donations, fund raisers, surveys, polls, and all sorts of other interactive data gathering that would be impossible otherwise.

Embodiments could use any form of communication or network links, utilizing any form of network protocol, although an Internet connection using TCP/IP is preferred for simplicity. Further, any form of database management, or front end development environment can be used, although Microsoft products are referenced for its global acceptance, and vast pool for programming and development resources. Further, PLAYLIST data may be sent to Receiving Devices in Batch or real-time mode. There are times where Batch mode may make more sense due to network congestion, peak times, and other efficiency issues. Further, it is not necessary to implement an HTTP server for communication, although an example is given due to its ease of programming, and wide available base of ready-to-use resources. Further, applications or modules can be local, or distributed over a plurality of locations, without regard to features or functionality, whereby as an example a Content Description Module does not have to be a full application running at a Content Source, however, it could be any form of technology, including a Browser Plug\_in, or perhaps a Java Application. No limitation is put on an actual embodiment of any system.

**B. A System and Method for the Selection, Purchase and Transmission of streaming Audio, Video and Data content to an electronic apparatus:**

A system and methodology is provided for: (1) content aggregation management (gathering), (2) content recording, storage, playback and manipulation, (3) content distribution methods for Fixed Form Media and a plurality of real-time or other streaming formats, (4) a Content Control System (100) to handle the multimedia content, (5) a database structure to manage the functions described herein, (6) electronic sale and order fulfillment, (7) Security, (8) licensing maintenance, (9) a method for an interactive data channel for content tracking and management, (10) ability to generate User Apparatus (102) selectable "virtual" channels of audio and video content, (11) a system to implement surveys,



polls, gaming and other information gathering from a plurality of User Apparatus (102) to a Second Party connected to a Content Control System (100).

The audio, video and data content described is managed and/or controlled and/or stored and/or accessed and/or sorted and/or streamed and/or sold and/or  
5 Played and/or Recorded and/or Produced, by a plurality of Content Control System(s)(100a, 100b)(100) communicating with a plurality of User Apparatus (102a, 102b)(102). A Content Control System (100) as described above can be connected via a plurality of Communication Networks (101).

A plurality of Communication Networks (101) are made accessible to a  
10 plurality of User Apparatus (102), which can be computers and/or other electronic devices or apparatus, including set-top-boxes, consumer electronic appliances, radio receivers, home entertainment devices, modems, computers, hand-held devices, car equipment, and other gear capable of receiving electronic or optical signals.

15 Connections between a User Apparatus (102) and a Communication Network (101) can include any delivery system capable of establishing two way electronic communications, including, but not limited to a wired and/or wireless transmission system, digital and/or analog systems such as telephone, SONET, Optical, cable, satellite, PCS and cellular systems. The Communication Network  
20 (101) does not need to have intelligence, understanding and/or any other knowledge of the connection between a Content Control System (100) and a User Apparatus (102), although it can.

A Content Control System (100) as described is capable of two-way  
25 communication between a plurality of Content Control Systems (100), and/or a plurality of User Apparatus (102). All functions and needed interaction can be managed and/or manipulated through this communication connection, such as set-up, information exchange and messaging, content receipt and/or delivery, order processing, selection and/or acquisition of content, and/or any other form of digital information needed to be passed back and forth.

A Content Control System (100) as described could also be capable of connecting, and communicating database information and systems for the storage and manipulation of data, which can be combined, further broken down and defined, and/or be a subset or superset of the following:

5           (1) **security information**, which can contain smart-card ID's, Internet (IP) addresses, Ethernet controller ID numbers, user passwords, or any other information needed depending on the security scheme(s) implemented in an embodiment.

10           (2) **licensing information**, which can contain lists of users and the allowable content they have access to through either purchase or some other given right, or any other information needed depending on the licensing scheme(s) implemented in an embodiment.

15           (3) **user information**, which can contain user names, ID's, Passwords, Home/office/billing addresses, Credit/checking/debit account information, or any other information needed depending on the user information scheme(s) implemented in an embodiment.

20           (4) **demographic info**, which can contain user interactions and other user information, including, but not limited to age, sex, income, occupation, etc... It may also manage or maintain lists of content and services that individual users have played, previewed, or otherwise visited or interacted with, such as what channels a user listened or watched, and for how long, or any other information needed depending on the demographic scheme(s) implemented in an embodiment.

25           (5) **media location information**, which can contain information needed to find, retrieve or store, all forms of digital media assets available to a plurality of User Apparatus (102), such as audio files, video files, streaming ports or paths, Radio Channels, Albums, other data-paths for interactivity, routing information, and or other media connection, directory, routing or switching, etc, or any other information needed depending on the media search and/or location scheme(s) implemented in an embodiment.

(6) **Content Descriptors**, which can contain information including zones, regions, radio frequencies, television station information, virtual channel information, logos, albums, songs, audio book information, authors, writers, publishers, media location pointers, ID numbers, tracking information and/or items  
5 needed or used to display, locate, track, manipulate any form of audio or video or data content available, or any other information needed depending on the content description and pointer scheme(s) implemented in an embodiment.

(7) **Order Information**, which can include order dates, tracking and fulfillment information, money issues, and/or any and all other information related  
10 to orders, tracking, shipping, etc, or any other information needed depending on the order processing scheme(s) implemented in an embodiment.

(8) **Vendor and Merchant Interaction Systems**, which can include information related to third party affiliates, vendors or sales channels which connect to a Content Control System (100) part of this embodiment to modify  
15 customer license, receive or request user response or trigger information, or retrieve user demographic information, or any other information needed depending on the vendor and merchant scheme(s) implemented in an embodiment.

(9) **user-theme and/or sorting category information**, which can include global and user defined preferences for licensed or available audio, video and data  
20 content and materials, broken into categories, genres, classes, and or other types of groupings that might be useful for display, selection, grouping and/or Playback and retrieval, or any other information needed depending on the sorting and categorizing scheme(s) implemented in an embodiment.

(10) **Play-List and Advertising Locators**, which can contain information  
25 including a description or pointer to media locators, in or near real-time, which define or describes a currently playing audio, video or data content on each and every "radio", "television" and/or "virtual" channel available to a User Apparatus (102), such as a song or commercial on a radio station, a television show or commercial and/or current advertising spot. For instance, this information could be  
30 used to interact or engage a trigger action to a User Apparatus (102), it could be

used to set a pointer between a playing song, and a particular User Apparatus (102) requesting to be taken to the trial mode for the album of the currently playing song, or any other information needed depending on the Play-list functionality scheme(s) implemented in an embodiment.

5           (11) **Virtual Channel Control**, which can contain information needed for a Content Control System (100) to create, and produce a plurality of real-time channels, for audio, video and data content. Parameters included could be pointers to an encode system, which would take the content selected by a Content Control System (100), and then be made available as a broadcast channel to a User  
10 Apparatus (102), define an Ad-Insertion demographic scheme, Content play criteria, sorting, selecting and time criteria, and many other parameters that could be used to provide a unique, potentially individualized per User Apparatus (102), based on stored content, procedures or algorithms. An example of a virtual  
15 channel maybe a virtual "Rock" Station, where parameters are defined in the virtual channel control database to select at random a song as defined in the Themes database as ROCK, and will insert a commercial after every three songs which is requested for a rock station, maybe a beer commercial for instance. In this previous example, the information needed for the set-up of this virtual channel could be defined in the Virtual Channel Control database. Benefits to this system  
20 would be that no people are required to run the channel, and advertising can be targeted to the demographics of the users tuned in at the plurality of User Apparatus (102) at a given point in time, based on live audience demographic data that could be available, or any other information needed depending on the content or virtual content creation scheme(s) implemented in an embodiment.

25           (12) **Trigger Control**, which can contain information needed for interaction between a plurality of User Apparatus (102) with a plurality of Vendors, a plurality of Content Control System (100), or any of the available channels, or any other information needed depending on the trigger scheme(s) implemented in an embodiment. Triggers could be defined to enable User  
30 Apparatus (102) to respond in real-time to a Vendor or System survey, Vendor or

System poll, a gaming application, a lottery, or a User Apparatus (102) initiated request. For instance, a User Apparatus (102) could request a trigger for the song "with or without you" by the artist U2, in such a case, a Content Control System (100) application could continuously check the trigger database, and the Playlist database for a match in real-time, in which case, a Content Control System (100) could then send a "tune in to channel XYZ" message to the User Apparatus (102) that originally requested the trigger, which could then instantly begin playing that radio channel. Many other uses are available for User Apparatus (102), or System Control initiated triggers, one other example, could be a radio station which generates a trigger to all User Apparatus (102) which are currently "tuned in", such that they may answer a question by pressing a number on a control pad, whereby the results would be returned to the vendor (maybe a radio station for instance). As is obvious from the above description, Triggers are three-way, they can be generated from a User Apparatus (102), a Content Control System (100), or a Vendor attached to a Content Control System (100).

(13) **Content**, which can contain digital audio, video and data content, or pointers to the physical files, which contain such digital information, or any other information needed depending on the Content storage and retrieval scheme(s) implemented in an embodiment.

A system and methodology provides three functional parts, (1) a management system made of a plurality of a Content Control Systems (100) (PARTY1), (2) a network infrastructure made of a plurality of Communication Networks (101), and (3) an audio, video and/or data listening and/or transmission device, made of a plurality of User Apparatus (102) (PARTY2).

The Content Control System (100) is a system, with computer server capabilities, including, but not limited to network communication and database access and/or management.

Server functionality of a Content Control System (100) could be made by proprietary systems or by the functionality found in a simple or enhanced World Wide Web server (WWW), typically used on an Intranet, or the Internet, but does

not necessarily need to be of open standards. Further, an embodiment of this functionality can be provided on any type of network protocol available to said system, including but not limited to, (1) TCP, (2) UDP, (3) TCP-IP, (4) IPX, etc.... Server functionality must be able to listen for requests or responses, and send requests and responses. Such an embodiment could be a WWW server running on a TCP-IP protocol on a WindowsNT server. Using a combination of common standards, such as HTTP, HTML, TCP-IP and UDP, a server can be configured to receive HTTP requests from a User Apparatus (102), and/or respond to a HTTP server or client with such standard methods. It is not necessary to use common standards. For instance, a custom server application could be written using TCP-IP, and setting up a socket and port upon which the server is "listening" for requests and responses.

Requests received in these types of formats, must be processed through an application, which could be a separate application, server scripts (Active Server Pages, CGI, Perl, etc...), or custom applications and handlers.

To show the flexibility, the embodiment will show a use of the Active Server Page and/or CGI capabilities of a WWW server on a WindowsNT machine for such handling. Further, it must be recognized that not all of these approaches exist on all platforms, for instance, active server pages do not exist, or might not exist on WWW servers that run on a SUN Solaris computer or operating system. Therefore, this allows for open or proprietary message handling. The remainder of this description will assume WindowsNT, with a WWW server running and capable of Active Server Pages (ASP) for simplicity.

Database functionality of a Content Control System (100) could be available for storage management, and information management needed by a Content Control System (100) that manages a plurality of User Apparatus (102) sessions and related or needed information. One embodiment of this approach could be to use a Microsoft SQL server "connected" to the WWW server, or potentially on the same machine.

A Content Control System (100) is capable of handling User Apparatus (102) requests, and is further capable of sending or receiving information for various services, including, but not limited to, (1) log-in, (2) licensing information, (3) content requests, (4) order processing, (5) content feeds, (6) trigger communication, (7) User Apparatus (102) setup, (8) vendor integration, and any other communication needed to go back and fourth, and is further responsible for acquiring, potentially storing, and administering distribution capabilities for audio / video and data content.

A Content Control System (100) is further responsible for all database and other systems needed to store, manipulate, or communicate information with a User Apparatus (102), to handle all or some of the available functionality, which can include, but not be limited to, (1) audio playback, (2) video playback, (3) content purchase, (4) streaming playback, (5) user security and (6) connection capabilities, and other needed systems.

The second portion is made of a plurality of Communication Networks (101). A Communication Network (101) can contain any number of network connections, and/or data connections as needed to facilitate an electronic communication between a plurality of Content Control System (100) (PARTY1) and a plurality of User Apparatus (102) (PARTY2). This connection can be made by a dial-up modem, dedicated telecommunications service, cable and/or cable modems, wireless data including PCS / Satellite / other, and/or any other mechanism available for two-way electronic communication. Further a Communication Network can be a private, public, local or wide area network, or Internet network or connection, or combination thereof.

Finally, the third component, a plurality of User Apparatus (102), can be any electrical system, which could be a computer, simple consumer electronic device, or other embedded electronic device that is capable of receiving an electronic or optical signal and processing one or all of digital audio, digital video and/or data content for output into one or all of, an audible device (speakers), visual display unit (LCD, TV, Monitor, etc...), or output port or bus (1394, USB,

Audio-Out, Video-Out, or any other electrical interface), and is further capable of establishing a connection with a Content Control System (100).

A system involves a connection between PARTY1 and PARTY2, whereby one or many features could be made available, including, but not limited to, the selection, playback and/or recording of audio, video and data content.

A system of this nature can be extended by connections to EPG (electronic program guides), paper catalogs, electronic catalogs, wireless remote controls, or other manual and electronic systems for sorting, displaying, categorizing or otherwise selecting items related to audio, video or data content in a sequential, time based, random, or other organized manner.

Further, a system involves a mechanism for the communication between PARTY1 and PARTY2 to "mimic" traditional ways of content selection, including radio models (tuning in to a station), television models (changing channels), catalog product Id's (similar to UPC codes on food packaging to distinguish one product from the other), and World Wide Web (URL) models, among many other possibilities.

Functionality for audio content can include, but not be limited to, the selection of various radio stations, which can be sorted by zones (geographic regions), sub-zones which are smaller regions within a zone, theme or content or radio style or type, and/or by frequency number or station name, or virtual stations based on content theme or category. Selection of audio content can also be performed by selecting a previously licensed (purchased or otherwise) album from a menu, and/or selecting one or more previously licensed (purchased or otherwise) songs or titles from one or more previously licensed (purchased or otherwise) albums or content in a sequential, programmed or random fashion.

Audio content can also include music "trials", whereby a User Apparatus (102) would be authorized to sample (maybe 20 seconds, or some other definable plurality of time periods) of each selected title or song or content of a User Apparatus (102), or could be a randomly selected album or other form of unlicensed audio content for trail-listen-before-purchase type applications. In the



later case, this could allow a user of a User Apparatus (102) to enter a media catalog number (album, or other content code) into the User Apparatus, or by selecting a title or by some other sorting means, or by having a Content Control System (100) randomly select an unlicensed audio content asset, which could have  
5 been based on current licensed content, tastes, themes, genres, or other available demographic or other information, or other mechanism, and allow a trial preview of such audio content. A user could have the option of initiating a license purchase (which would then allow complete listening, and could also produce a shipment of some Fixed Form Media (tape, CD, DVD) to a location of choice of that licensed  
10 audio content material.

Audio trial mode could also be initiated by a "cross-link" which could be initiated by a user listening to a radio station, who likes the song that is currently playing, and decides to either manually or through some automatic mechanism, enter trial mode, which would automatically select the album of the song that is  
15 playing, and allow for Trial-before-purchase type applications.

Upon actual selection of content (radio channel, album, song, audiobook, etc...) by any of the available selection methods, and upon a message received by a Content Control System (100) of such content, a Content Control System (100) will be responsible for "finding" the content, and providing a mechanism for the  
20 retrieval of that content by a requesting User Apparatus (102). This may include Port or socket numbers, server addresses, and/or any other needed information for the content to be gathered from any location of choice by a Content Control System (100).

As with audio content above, this applies to video content in the same  
25 manner. For instance, the metaphor of a radio station could be a broadcast TV station or video feed, a cable channel, etc..., as well as an album or song could be the metaphor of a VHS tape, DVD, Beta, Hi8, etc, or any other fixed form media available to store video information.

Trial-before-purchase type applications allow a User of a User Apparatus  
30 (102) to hear, or see a small portion of content that the user is currently not

licensed to hear or see. Thus in this case, giving the user the capability to inure the selection they perhaps are going to purchase is what they are looking for. For instance, suppose a user of a User Apparatus (102) is in search for particular album of an artist with twelve albums. Instead of purchasing the wrong album, a user can "trial" each of the albums until the right one is found, then potentially initiate a purchase of the correct album.

It should further be mentioned that in trial mode, the Content Control System (100) might contain information that would force or allow alternative content to be played, other than the user-selected content. For instance, if a particular movie is selected for trial playback, then trial mode may have a movie trailer available, instead of a selected duration of actual movie viewing. Further, perhaps an audio book is selected, then trial mode may have a quick overview available for playback.

This also applies to data content in two forms, (1) streaming data and (2) interactive data. Streaming data could include Digital content, or raw data, such as Stock Tickers or quotes, news alerts, etc.... Interactive data could include protocol or control information being passed between PARTY1 and PARTY2, or other content or content information that is shared between PARTY1 and PARTY2.

Any digital content that is usable, and integrated into a Content Control System (100), can be encoded, and or decoded using a variety of off-the-shelf or proprietary CODECs, including, but not limited to, MPEG, AVI, RA, ASF, GSM, CELP, ACELP, H.323, etc.

This enables a mechanism for "virtual" content that would allow a User Apparatus (102) to potentially select media and information that is of importance or interest, and have a Content Control System (100) send "personalized" video or audio content via this content or "virtual" selection process. Similar features and functions are defined on a global scale in the "virtual" channel section, but could also be specific "virtual" channels per user, or per individual or a plurality of User Apparatus (102).

It is intended that these embodiments not be limited to digital audio music and can include digital video, digital commercials, digital images, and/or all other forms of digital information.

5 Figure 8 shows the basic overall interaction among the three core sections of the system described. A plurality of Content Control System (100a, 100b)(100) can be defined as a plurality of computers, which can be configured in any manner, with a plurality of computer systems, with a plurality of operating systems, and/or a plurality of local and/or wide area network architectures and connections.

10 A Content Control System (100) contains the necessary functionality to provide server, storage and/or interactivity with outside applications and database connectivity and functionality, of which, any and all of these functions can be provided on a plurality of computers, systems and/or processors, in any configuration available with any, including the many well known software, hardware and architectures available to the public.

15 A Content Control System (100) can connect to a plurality of Communication Networks (101a, 101b) (101), via any number of available Interfaces (103) including, but not limited to, Frame-Relay, ISDN, T1, DS3, Ethernet, ATM, SONET, DSL, Routers, Switches, Wireless, Cable, Satellite, etc....

20 A Communication Network (101) can include a plurality of local area networks (LANS), wide area networks (WANS), Intranets or even the "Internet" or an Internet. An embodiment could be to include a connection to the public "Internet", so that a User Apparatus (102) can connect via any network provider which provides access to the Internet, whereby connecting a User Apparatus (102) to a Content Control System (100). A Communication Network (101) is primarily responsible for facilitating an electronic communication connection between a plurality of Content Control System (100) and a plurality of User Apparatus (102). A Communication Network (101) could also contain various technologies, or  
30 "intelligence" to enhance data routing and switching, by way of reflectors,

multicasting, etc, to allow more efficient use of a Communication Network (101) Bandwidth, economies of scale, or some other economic or bandwidth benefit. A Communication Network (101) can connect a User Apparatus (102) via various possible interface(s) (104), which can include, but not be limited to, a dial-up  
5 modem, Ethernet, ISDN, DSL, T1, DS3, ATM, Cable, Wireless, SONET, Satellite, Frame-Relay, Router, Switch, or many other network interface or connection types that may be or become available.

In a preferred embodiment, a very high bandwidth connection to the "Internet" is made available by a Communication Network (101), with the option  
10 of supporting private networks to handle the high amount of bandwidth that could potentially be needed for digital content delivery. It is also recommended that the Communication Network (101) have the ability to use custom, or commercially available reflector or multicasting technology to reduce backbone or local bandwidth use. In this embodiment, TCP-IP would be the protocol of choice for its  
15 ability to work over the traditional "Internet"; however, it should not be limited to TCP-IP.

Another preferred embodiment could be to have a plurality of Content Control System (100) directly connected to local dial-up or other network connections, which could eliminate all "backbone" traffic and delay.

20 User Apparatus (102a, 102b) (102) are electrical devices capable of receiving an electrical or optical signal, and further processing such signal to provide audio, video and/or data processing capabilities or output. Such User Apparatus (102) can be a Computer, an embedded electrical device, a cable or other set-top-box, a consumer electronics device, a home appliance, a hand-held  
25 device, a cellular or wireless device, a phone, or any other device as described above.

A User Apparatus (102) usually will have the basic functionality to connect to a plurality of Communications Network (101) through a plurality of network interfaces, send and/or receive control and content information between a Content  
30 Control System (100), which can include, but not be limited or inclusive to, user

authentication, media selection, order processing, setting triggers, content navigation and/or information exchange. Once a Communications Network (101) connection is made, a User Apparatus (102) could also have the functionality to either playback audio content, and/or playback video content, and/or playback data content in a form suitable for each of the content types, which could be (1) a speaker system, (2) a digital or analog output(s) to a plurality of external audio device, (3) a Video Display system, (4) a digital or analog output(s) to a plurality of visual display devices, including, but not limited to, TV, computer monitor, or LCD display system, (5) a digital or analog electrical interface to other equipment. Added functionality to a User Apparatus (102) could include security or conditional access systems, such as smart-cards, or protected flash ROM systems or memory cards, a wired or wireless control panel, a display system for set-up, configuration, and/or user operation, which could have touch screen functionality, among many other options that could be created to interact with the features of this embodiment.

A User Apparatus (102) could also contain the features of a computer system, of any type with the appropriate hardware and/or software in place to handle some or all of the User Apparatus functions as described herein.

A Content Control System (100) gains its initial usefulness by having audio, video or data information, available for a User Apparatus (102). Such information can be retrieved from various internal and external systems, including a plurality of Real-Time System (103a, 103b)(103), as well as a plurality of Fixed-Store System (104a, 104b)(104).

A Real-Time System (103) can be a plurality of real-time encoded signals, such as those encoded from a Radio Station signal, or perhaps a live event, such as a concert, or presidential speech. A Real-Time System (103) is capable of audio, video and data encoding, and can be used in common or proprietary protocols or CODECS (coder - decoder), including, but not limited to, MPEG1, MPEG2 AC-3, H.323, AVI, ASF, RSTP, etc... encoded streams are provided to the Content Control System (100) which then has processes to manage and distribute upon

request the encoded information. Further, a Real-Time System (103) stream can be stored for later playback at the same time as it is streamed live, and thus could be given a Media Locator ID as will be discussed below. An embodiment of this encoder could be an implementation of a technology made available from the University of Illinois and a Company named VOSAIC, LLC. Although it is not necessary, any encoder can be used, such as those from Real-Networks, like the Real-Audio, Real-Video encoders, or Microsoft Netshow type systems.

A Fixed-Store System (104) can be a plurality of various systems that give access to CD-ROM jukeboxes, which contain audio, video or data content data files, or could be a plurality of any other mass storage device, including, but not limited to, hard-drives, Tapes, DVDs. A plurality of Fixed-Store System (104) could be used to store an unlimited amount of content, and could be connected to several type systems to expand storage capabilities as needed or at any time. Content provided to a Fixed-Store system (104) can be pre-encoded in any number of formats, or can be entered in raw form, where an encoding process will convert such content to a digital format and then stored for later retrieval.

A first step for using the system shown in Figure 8 would be to put at least one Content Control System (100) in place (to be defined in Figure 9.).

A next step would be to connect said Content Control System (100) with a Communication Network (101). Such connection could be made to the "Internet", whereby giving potential access to a Content Control System (100) by all "Internet" connected devices. Lets assume that a connection is made to a plurality of Content Control System (100) by at least one DS-3 (again, not limited or restricted).

A next step would be to create at least one User Apparatus (102) (to be defined in Figure 12, with an embodiment in Figure 15).

A next step would be to connect said User Apparatus (102) with a Communication Network (101). Such connection could be made to the "Internet", whereby giving access to a Content Control System (100). One embodiment may provide access via a dial-up connection for audio, whereby a better method for

high quality video may be a cable modem, or some other higher bandwidth connection (again, not limited or restricted).

A final step would be to add fixed-store content, or set-up steamed content to a Content Control System (100). This could be as simple a one audio streamed  
5 feed, or one digitally stored copy of a song, album or some other audio content (again, not limited to type or size of content (some embodiments are described in Figures 13 and 14).

Figure 9 shows an embodiment of a Content Control System (100). A plurality of Content Control Systems (100) can be made of a plurality of  
10 computers, workstations, mini or mainframes or any other type of computer system available. A Control Module (200) can be part of a Content Control System, and can be a plurality of computers, in multiples, it could be distributed possibly for redundancy, network load, or for any other reason. An embodiment of a Control Module (200) could be a Microsoft NT server, running a World Wide  
15 Web Server, combined with CGI, custom applications or Active Server Pages (ASP) to handle User Apparatus (102) requests, and provide responses and data, or provide the necessary information for a User Apparatus (102) to get the needed or requested information. Further, the Control Module (200) would have SQL database connection capabilities for information storage and retrieval, in this  
20 embodiment, the connection would be available with the SQL Server (205).

The Control Module (200) could be set up with Active Server Pages, that read HTML (FORM) tags and parameters (such as POST) following a HTTP protocol to communicate high level commands with a plurality of User Apparatus  
(102). An example may be a log-in process whereby a User Apparatus send a form  
25 through an HTTP protocol for a Control Module (200) to receive a User name and Password for authentication. It would then be the job of a Control Module (200) to process the appropriate ASP script, and send denial or authentication information back and fourth. This type of Question, response communication could be implemented for all aspects of User Apparatus (102) to Content Control System  
30 (100) type communications, although it is not necessary.

Such User Apparatus (102) Request/Response communication protocol could include a subset or superset, but not be limited to:

(1) Log-In, whereby the User Apparatus (102) sends [USER=username, PASS=password, IP=ip\_address, PORT=listening\_Port] information and the server responds with success or failure. Upon login, an embodiment of a server script could be to make a session, which records IP address (Internet Protocol) for use by any and all systems or sub systems within a Content Control System (100).

(2) Get-Content, whereby an embodiment of the User Apparatus (102) can send [PLAYMODE=[AM | FM | TV | AUDIO | DATA | AUDIO\_TRIAL | TV\_TRIAL | AUDIORECORD | VIDEORECORD], NAME=selection, ZONE=selection, FREQ=selection, THEME=selection, GLOBALID=catalog\_number, ML\_ID=selection], or other definable play modes, or parameters that can then be programmed with server scripts to execute commands, or provide responses. Each of these interactions will have different processing needs, but all will return one response or another for use by a User Apparatus (102). In an embodiment, [PLAYMODE=FM, ZONE=?] May ask the Control Module (200) to return all zones available for PlayMode FM. Another example may be a User Apparatus (102) sending [PLAYMODE=AUDIO, ML\_ID=1230x23], whereby this maybe a pointer to song "With or Without You" by the Artist U2, in which case the Control Module (200) could send back information needed to begin a audio stream with the selected content. In the later example, the ML\_ID would have probably been sent to the User Apparatus (102) in a previous selection command of some kind.

(3) Trigger, Whereby an embodiment of a communication protocol could sends [USER=username, PASS=password, IP=ip\_address, TRIGGER=[FIND\_SELECTION | WAIT\_SELECTION | RESPOND], PARAMETER=response\_string, ML\_ID=selection, SERVICEID=service\_id]. In this example, a command could be sent to the Control Module (200) such as [USER=username, PASS=password, IP=ip\_address, TRIGGER=FIND\_SELECTION, ML\_ID=1230x23], whereby the Control Module



(200) would update the necessary databases, so that a trigger monitor would see the request. Another example might be [USER=username, PASS=password, IP=ip\_address, TRIGGER=RESPONSE, PARAMETER=3, SERVICEID=2032], whereby maybe there was a vendor or Content Control System (100) server trigger, assigned a service ID of 2032, which requested a response from 1 through 9 for a question, whereby a user of a User Apparatus (102) entered the number 3.

(4) Setup, whereby an embodiment of a communication protocol could send [SERIALNUMBER=hardware\_sn, MAKE=equipment\_make, MODEL=equipment\_model, INTERFACE=[ MODEM | ETHERNET | DIGITAL], SERVICEID=service\_id, VERSION=software\_version, TYPE=[AUDIO | VIDEO | BOTH | DATA | ALL], BANDWIDTH=[ LOW | 144 | 288 | 336 | 56K | 64K | 128K | 256K | 1.5M | HIGH], DECODETYPE= [REAL | H323 | NETSHOW | GSM | MPEG | AVI, ASF, ALL]], or any other options that may be needed based on an embodiment.

(5) Purchase content, whereby an embodiment of a communication protocol could send [USER=username, PASS=password, BUYCODE=smart\_card\_code, ML\_ID=selection, DELIVERY=[NEXTDAY | SECONDDAY | LEASTCOST]], whereby the Control Module (200) may end back a confirmation code for display or printout by a User Apparatus (102).

(6) Send demographics, whereby an embodiment of a communication protocol could send [USER=username, PASS=password, ACTIONCODE=[CHANGECHANNEL | CHANGECONTENT | TRIALED | POWERON | POWEROFF | PURCHASE], STARTIME=start\_time, ENDTIME=end\_time, STARTDATE=start\_date, ENDDATE=end\_date], whereby a Control Module (200) could update databases, send alerts, notify customer service systems, or any other action as potentially programmed.

(7) Get information, whereby an embodiment of a communication protocol could send [USER=username, PASS=password, GETCODE=[NEWINFO | CONTENT | MESSAGE | KEYS | DESCRIPTOR | LOCATORS]], whereby a Control Module (200) could update databases, send

alerts, notify customer service systems, or any other action as potentially programmed.

In an embodiment of a communication protocol between a Control Module (200) portion of a Content Control System (100), as described above, each query to a Control Module (200) by a User Apparatus (102), would produce an action by a Control Module (200) which could be a response back to a User Apparatus (102), or some action internal or between a plurality of Content Control System (100) or modules within a Content Control System (100).

Just as an embodiment for communication by a User Apparatus (102) to a Control Module (200), as described above, can be made, a Control Module (200) could also initiate a query to a User Apparatus (102).

Such Control Module (200) Request/Response communication protocol could include a subset or superset, but not be limited to:

(1) request information, whereby an embodiment of a communication protocol could send [SERVER=server\_ip\_address, ACTION=QUESTION, QUESTION=[ HARDWAREINFO | USERINFO | ACTIONLOG | PORT | BANDWIDTHLOG | SECURITYINFO], SERVICEID=assigned\_service\_id], and a User Apparatus (102) could respond with the requested information. An example might be [SERVER=123.45.678.90, QUESTION=HARDWAREINFO], whereby a User Apparatus (200) could send back the appropriate response, which in this case would be information pertaining to the hardware configuration of a User Apparatus (102).

(2) Trigger request, whereby an embodiment of a communication protocol could send [SERVER=server\_ip\_address, ACTION=TRIGGER, TRIGGERFROM=[USER | VENDOR | SERVER], TRIGGERACTION=[FIND | REQUEST | RESPONSE], SERVICEID=assigned\_service\_id, ML\_ID=ml\_id, PARAMETER=trigger\_parameter\_string]. In this embodiment, an example might be that a User Apparatus (102) had previously issued a trigger to request a radio

station playing "With or Without You" by the Artist "U2", upon a Service Control Module (202) matching criteria, a command is sent to the proper User Apparatus (102) from a Service Control Module (202) within a Content Control System (100) a command such as [SERVER=123.45.678.90, ACTION=TRIGGER, TRIGGERACTION=RESPONSE, SERVICEID=1234, ML\_ID=130t1r, PARAMETER=PLAY], in which case, a User Apparatus (102) could select the content ML\_ID and send a play action command, perhaps in this case the ML\_ID points to a radio station playing the requested song.

As described above, the Control Module (200) should thus be able to handle request/response communication from a User Apparatus (102), and should also be able to communicate with service modules and/or applications and/or databases to accomplish the proposed processes. The Control Module (200) in this embodiment can be implemented by a developer skilled in Microsoft Active Server Pages, Microsoft World Wide Web Servers, WindowsNT, TCP-IP, CGI and other web scripting, and HTTP and HTML development.

A Content Management System (201) of an embodiment is a plurality of database management software applications, client applications, and service applications, of any kind, capable of connecting to a Database Management Module (205). Applications can be developed to handle many issues, including customer service, operational activities, database builders, or master data entry locations, management systems for adding content, or encoding and decoding content in a Content Control System (100).

A Content Management System (201) is a plurality of applications that are capable of database manipulation, management. A Content Management System (201) is in an embodiment to maintain and administer system and content information, storage and operational manipulation. An embodiment of these applications could be made by a Microsoft Access program that is connected to the databases, as managed by a Database Management Module (205). Systems could be put in place to include, but not limited to, (1) User Apparatus Management, (2) billing, (3) order processing, (4) Content management, (5)

Content configuration, (6) batch entry or content creation, (7) defining and configuring all forms of content, including "virtual" channels, etc..., (8) customer service, (9) security, and much more. Such systems would conform to the rules and criteria established in the database design scheme(s) as implemented in an embodiment. For instance, users of an application could enter media locator information into the system, making potential access of this content for all User Apparatus (102). The applications as contained in a Content Management System (201) as described in an embodiment could be developed by an application developer knowledgeable in Microsoft Access programming and Microsoft SQL Server Programming.

A Service Control Module (202) as shown in an embodiment would be used to handle various forms of processing not managed by a Control Module (200). A Service Control Module (202) is a plurality of systems with associated custom programs, or commercially available software capable of communicating with a database system, as that of a Database Management Module (205), and a Control Module (200).

A Service Control Module (202) could perform tasks, including, but not limited to, (1) Trigger detection and coordination systems, (2) software versioning, (3) order processing and fulfillment operations, (4) message and communication tasks between a plurality of Content Control Systems (100) and a plurality of User Apparatus (102) any combination thereof, (5) "virtual" channel control and "on-air" sequencing of content, ads, etc..., (6) controlling and compiling demographics, (7) interactive signaling, (8) smart alerts, (9) condition monitoring, (10) Content control, (11) initiating content transfer and coordination, and much more.

A Service Control Module (202) should have capabilities to communicate with a User Apparatus (102) through a Control Module (200), or directly, if given the proper address and port information, as would be defined in a communication protocol and data storage and management scheme of an embodiment.

An example service controlled by a Service Control Module (202) could be a trigger monitor, whereby this service would constantly analyze data in a Database Management Module (205) to look for trigger conditions being met (such as a requested song being played on a particular radio station [use playlist database]). Such a mechanism could use the information stored, match the trigger User Apparatus (102) with the content stream, and execute the procedures necessary to send the trigger message to such User Apparatus (102).

A Service Control Module (202) should be able to manage individual tasks, and potentially manage individual User Apparatus services. One embodiment could use a database to store sessions that could include service ids, user names, and functions being performed, along with other necessary information to communicate back and fourth. Additionally, functionality may be added that would allow a Control Module (200) to send information (such as a computer address) to a User Apparatus (102) so that direct communication can be handled by a Service Control Module (202).

A preferred embodiment of a Service Control Module (202) would be an implementation that was database driven, whereby one Service Control Module (202) could take over the functions of another Service Control Module (202) in real-time should failure occur, or performance decrease, or for any other reason as defined in an embodiment.

Development of the various applications which could be provided from a plurality of Service Control Module (202) as defined in an embodiment could be developed by any application developer with knowledge of WindowsNT, Microsoft Access, Microsoft SQL Server, Microsoft Active Server Pages, Microsoft WWW Server (IIS), and TCP-IP.

A Network Interconnection (203) can be any electrical device capable of interconnecting the various systems and modules as defined in an embodiment of a Content Control system (100), such that communication and networking capabilities are in place.

An embodiment of a Network Interconnection (203) could be as simple as an Ethernet hub, with enough ports available to connect the individual systems of a Content Control System (100). Further, connections could be made available for communication outside a local network, including connections to Routers or  
5 Switches, Bridges, or any other network device capable of connecting, or extending a network.

In an embodiment of a Content Control System (100), it is possible to connect all WindowsNT systems using an Ethernet 10/100 adapter to a central Hub or switch. This switch could then be connected to another switch, or to a  
10 gateway, or router for additional connections, or access to outside networks.

A Content Stream Module (204) is made of a plurality of computer systems, each capable of communication with a plurality of systems and modules of a plurality of a Content Control System (100). A Content Stream Module (204) is capable of direct communication with a plurality of User Apparatus for the  
15 purpose of providing communication to deliver or receive a plurality of Digital Audio, Digital Video, or Data content.

In an embodiment, a Service Control Module (202) service, or a Control Module (100) service could send message to a User Apparatus (102) which included a Content Stream Module (204) server address, a pointer to the content  
20 requested, security information, and additional port information. This could then initiate a content delivery to a User Apparatus from a Content Stream Module (204). For instance, a Content Stream Module (204) could take a pointer to file "album\u2\u2\u1230x23" which could point to a song "With or Without You" by the artist "U2". In such a case, an audio streaming connection is made, and the content  
25 is sent to a User Apparatus (102) for processing.

An embodiment of a Content Stream Module (204) could be an off-the-shelf server, such as a Real-Networks implementation (Real-Server), or an implementation like VOSAIC, LLC, or a custom designed streaming mechanism.

Communication between a Content Stream Module (204) and a Control  
30 Module (200) and/or a Service Control Module (202) should be implemented in an

embodiment so that various services could terminate, or otherwise manipulate a connection between a Content Stream Module (204) and a User Apparatus (102).

An embodiment of a Database Management Module (205) could be a plurality of WindowsNT computers running Microsoft SQL Server software. The responsibility of a Database Management Module (205) would be to manage all database access, and system level functions needed, including communication without external systems and/or modules.

In an embodiment of a Database Management Module (205), access would be made available to a plurality of Control Module (200), a plurality of a Content Management System (201), a plurality of Service Control Module (202), and a plurality of Content Stream Module (204).

Data contained in an embodiment of a Database Management Module (205) would be use for all the systems and modules described above to access all needed data or content to perform their individual tasks or functions. A description of an embodiment to a simple database table structure is defined in Figures 10 and 11.

Note that any and all plurality of systems and/or modules that make up a plurality of Content Control System (100), could be a plurality of "farms" of servers, or spread over a plurality of physical machines, based on design, bandwidth, or processing speed and capabilities of individual machines. Again, this embodiment is brief and simple, is not meant to limit to scope or spirit of this invention.

The network of Figure 9 operates with a first step that could be to set up a Control Module (200), which could be a WindowsNT server running the IIS (world wide web server) with Active Server Page (ASP) extensions and all other needed packs or modules to implement WWW server and ASP functionality, and with database access connectivity installed for Microsoft SQL Server, a network interface card (such as Ethernet), appropriate network drivers, and a TCP-IP stack configured properly.

Another step would be to set up a Content Management System (201), which could be a WindowsNT server with database access connectivity installed for Microsoft SQL Server, a network interface card (such as Ethernet), appropriate network drivers, and a TCP-IP stack configured properly.

5 Another step would be to set up a Service Control Module (202), which could be a WindowsNT server with database access connectivity installed for Microsoft SQL Server, a network interface card (such as Ethernet), appropriate network drivers, and a TCP-IP stack configured properly.

10 Another step would be to set up a Database Management Module (205), which could be a WindowsNT server Microsoft SQL Server installed, a network interface card (such as Ethernet), appropriate network drivers, and a TCP-IP stack configured properly.

15 Another step would be to set up a Content Stream Module, which could be a WindowsNT server with database access connectivity installed for Microsoft SQL Server, a network interface card (such as Ethernet), appropriate network drivers, and a TCP-IP stack configured properly.

Another step would be to configure a chosen media-streaming server, such as one from Real-Networks (Real-Server), or VOSAIC (mediaserver) type technology. Configure as appropriate.

20 Another step would be to develop a database scheme on the Database Management Module (205), such as an embodiment defined in Figures 10 and 11.

Another step would be to develop management applications to be used by a plurality of Content Management System (201), to interface with the table scheme(s) designed and implemented on a Database Management Module (205).  
25 Such applications should produce varied functionality, but in an embodiment described here, should produce the functionality as described above for a Content Management System (201).

Another step would be to develop the needed monitoring, tracking and management applications for the Service Control Module (202). Such applications



should produce varied functionality, but in an embodiment described here, should produce the functionality as described above for a Service Control Module (202).

Another step would be to develop the needed ASP (script) files and URL pointer MAP to produce the needed Query/Response system as described above,  
5 and further enhanced for added functionality.

Another step would be to integrate all of the functionality and systems and modules together on one network system so they can communicate.

Another step would be to connect the network created in the previous step, to an outside network, such as connection to a Communication Network (101), for  
10 access by a plurality of User Apparatus (102).

The steps provided in this section of this embodiment, with the description as outlined above and materials contained herein, should give any skilled programmer, with knowledge of open systems such as Microsoft WindowsNT, Microsoft Access, Microsoft SQL Server, and TCP-IP programming and  
15 development and Microsoft World Wide Web Server (IIS).

Figure 10 describes an embodiment of a Database Management Module (205) table Scheme. This Scheme is used by applications within a Content Control System (100), to manage, track, define, describe, manipulate, or otherwise store,  
20 modify or create information used. The tables defined in this Figure 10 should be created on a database server as defined in a Database Management Module (205).

In an embodiment, several individual tables are created to manage data, including, Content, Virtual Channels, Media Locator, Theme, Content Descriptor, Zone, Playlist, Demographics, Orders, Triggers, Users, User Apparatus, Security, License, Vendor. Although these are defined, this is not meant to limit the scope,  
25 capabilities, or spirit of this embodiment.

The relationships of the tables in this embodiment define the basic interaction between the data, and its uses. The main entry point for Digital Audio, Digital Video, or Digital Data content is the Media Locator table (303).

The Media Locator table (303) defines an entry point into every content  
30 asset available through a Content Control System (100). Records are created in

this table for each and every definable or accessible content item. For instance, every radio station, television station, album, song within an album, audio-book, virtual channel, data channel, video trailer, audio trailer, etc... has its own unique Media Locator (303) record. For instance, an album such as "The Joshua Tree", by the Artist "U2" contains the song "With or Without You". Therefore, two separate records could be found in a Media Locator (303), one for the album, and one for the individual song. As with an album, a movie (vhs,dvd), could also contain multiple records, perhaps one for a full-length version, and one for a trailer version. Another example would be for radio, where a unique record would exist for every radio station capable of broadcast through a Content Control System (100). Media Locator (303) records should contain a mechanism for other Media Locator (303) references. Such as the example above, a song should be able to point to its owner (the album), and should further point to a Media Locator (303) record of a trial version of the content (assuming this content is available).

Connected to a Media Locator table (303) record is a pointer to a Content Descriptor (304). A Content Descriptor (304) table is used to store records that define data specific to the content itself. For instance, a Content Descriptor (304) record would be connected to a Media Locator (303) for the song "With or Without You" as described above. This record could contain information related to the writers, artists, publishers, length of time, logo, and title. If a Content Descriptor (304) record pertains to a radio or television station, it may contain a Frequency number, a corporate logo, a tag name, and a region that the actual station is located and/or broadcast from.

Connected to a Content Descriptor (304) is a Zone table (314). Each record is associated with a unique zone/sub-zone descriptor. For a Radio or Television Station, it may be a geographic location, for instance, Zone could be "New York", and Sub-Zone could be "Metro", whereby indicating a Metro New York broadcast. Perhaps an audio album, could point to a zone of "Audio" and a sub-zone of "CD", of perhaps an audio book could point to a zone of "Audio" and a sub-zone of

"Book". The Zone (314) records are a dynamic list of categories to define regions, or zones of particular content.

Connected to a Media Locator table (303) is a Themes Table (302). The Theme (302) records define categories in which a Media Locator (303) record is  
5 matched with. This embodiment allows for one theme per media record, although other embodiments may associate multiple Themes (302) records with a Media Locator (303) record. Examples might be for a radio station to have a Theme (302) record of "Rock", or "Sports Talk", an album may have a Theme (302) record of "New Age", "Blues", a movie may have a Theme of "Drama", "Comedy", etc...

10 Connected to a Media Locator table (303) is a Play-List Table (305). A Play-List (305) record contains information that associates a "broadcast" channel, with a Digital Audio, Digital Video, or data item. For instance, a Play-List (305) record may have information that says there is a Media Locator (303) record that points to a radio station, which is going to play a song, which is defined by another  
15 pointer to a Media Locator (303) record. Further described, if a Media Locator (303) Record, #10, which is defined as a Radio Station (say "Z100"), and there is another Media Locator (303) record, #1230x23, which is defined as the song "With or Without You" by the Artist "U2", then a Play-List (305) record may say that: ["radio station #10 "Z100", will play the song #1230x23 "With or Without  
20 You" at 12:15pm on 1/2/99"]. A Play-List (305) record could also give the currently played radio selection by just providing the radio station Media Locator (303) record and a Media Locator (303) record for the song, without a start time or date.

25 Further, a Media Locator (303) record does not need to be a song, radio, television station, etc... It could be a Commercial that is playing. Perhaps an embodiment would give a User Apparatus (102) the ability to get more information on a currently playing advertisement on a Radio Station. This is possible because there is a Media Locator (303) record for that content to be selected. Using a Play-List (305) table, data could be provided to a User Apparatus  
30 (102), every time a Radio Station changes the content being played (from song to

song, or song to commercial, etc...) which would send a new Media Location (303) record ID pointing to the currently played selection. This is an important note, because this would allow a User Apparatus (102) to display a currently playing song on a Radio Station, or Commercial, and Further, could allow a user of a User Apparatus (102) to select trial mode, which could take the Play-List (305) record pointer, and select that content, maybe an album of the song being played. Many functions can be generated, including trigger controls from a Play-List Record (305).

Connected to a Media Locator table (303) record is a Virtual Channel (301) table. A Virtual Channel is a computer generated broadcast station for audio, video, or data content. For instance, a Virtual Radio Station can be set up to broadcast "Blues" music only, with a commercial inserted every three songs. The music can be selected randomly, or by some sort or play criteria defined elsewhere. Further, commercials could be controlled to a point where an algorithm is used that takes all the User demographics from the User Apparatus (102) that are "tuned" into the virtual channel, to give the most appropriate commercial. This is just one example of many that individual embodiments could produce.

Just as all other forms of content, (radio, etc...) contain a Media Locator (303) record, so does a Virtual Channel. A Service Control Module (202) application could use this information to maintain, and/or operate the virtual channel.

A Content (300) table is pointed to by Media Locator table (303) record. A Content (300) record contains the information needed for location of a physical media content digital file. This can be on any storage system, subsystem and the like. This embodiment simply points to a storage server (can be a URL, address, etc...) and a physical file name.

A User (309) table contains various information gathered about an actual user of a User Apparatus (102). For instance, this table can store billing and shipping address information, credit card numbers, user name and password, the type of equipment the user is using, and even the content they are currently

connected to. More information can be stored, and this embodiment is not meant to limit the scope or spirit of this embodiment.

5 Connected to a User (309) table is a User Apparatus (310) Table. A User Apparatus (310) record contains the type, make and model, software version, decode capabilities, hardware serial numbers, and other associated information with regard to an actual User Apparatus (102). Users can use more than one Apparatus, but use only one at a time in this embodiment. It will be clear to see that in this embodiment, a User (309) record could change what User Apparatus (310) record it points too as a User logs in from one device to another.

10 Connected to a User (309) table is an Orders (307) Table. An Orders (307) record can store user information, the content the user purchased, and the time and date of the transaction. As envisioned in an embodiment, a User could have selected an album, and initiated a purchase of that album in CD format. Such Orders (307) record would then contain the Media Locator (303) record pointer for the album purchased, plus date, time, price, type of shipping, and other order information. This database could be used by a Service Control Module (202) application to determine all unfulfilled orders, and execute the proper procedures to have a CD shipped to the User.

15  
20  
25 Connected to a User (309) table is a Security (311) Table. A Security (311) record is created for all User Apparatus (102) and all User (309) records. This information includes tracking of hardware, smart cards, passwords and other information needed for advanced security monitoring and control. Such information could be conditional access information, User ID, Password, Smart-Card info, Network Addresses, permissions, and other useful information for User Apparatus (102) and/or User restrictions and/or permissions.

30 Connected to a User (309) table is a Demographic (306) Table. This Demographic (306) table is capable of storing various actions that are initiated on a User Apparatus (102). For instance, a User might change from Radio Channel #1 to Radio Channel #2. This change could be stored in a Demographic (306) record for use by a statistical analysis program, or whatever other purposes could be

created. This table also points to a Media Locator (303) record, to show what content was turned on, or turned off.

5 A Vendor (313) table contains information related to authentication of Companies with rights to update the system and/or license and/or trigger databases. This functionality, for instance, would allow a record retail location to sell a Tape, or CD, then enter the information into the License Database (201), given the proper userID and password, to allow the customer's User Apparatus (102) to allow on-demand access, and other functionality associated with such license rights. Another example of this embodiment would allow a Radio Station (a vendor) DJ to ask a question, using a trigger, and allow users to respond (the first to respond wins..., statistic gathering, etc...).

10 Full audit records would be kept of all actions that vendors make. In this embodiment, it is possible for a Content Control System (100) to automatically charge a Vendor for every license entry they make in the system. For instance, a record vendor could have sold a CD and was requested by a User to enter that license into the system for use on their User Apparatus (102), thereby generating a commission for the Content Control System (100) owner or operator.

15 A License (312) table contains records that associate Users with allowable (licensed) content to hear or see. For instance, if a user were to purchase a CD, a license record would be generated to give playback rights, and would associate the appropriate Media Locator (303) pointer to the User (309) pointer. License information could also contain a start time, end time, and various other method of access and restriction controls, based on the type of license purchased, or given.

20 A Triggers (308) table contains records related to User Apparatus (102), Content Control System (100) and/or Vendor created triggers. This information relates Users, with specific content, or Play-List (305) queries, which are monitored by application in a Service Control Module (202). Trigger (308) records contain information specific to the type of Trigger it represents. Further a Trigger (308) table can be access by many application doing many different things.

For using the structure of Figure 10, a first step would be to create the needed tables using the fields defined in Figure 11.

Another step would be to insure referential integrated as defined in Figure 10, and by insuring proper keys and relationships as can be simply seen with connecting lines on the diagram, combined with the logic of the functions of each of the tables, as described above.

Figure 11 describes an embodiment of a table structure defined in a Database Management Module (205) scheme(s), this Scheme is used by applications within a Content Control System (100), to manage, track, define, describe, manipulate, or otherwise store, modify or create information used. The fields of the tables defined in this Figure should be created on a database server as defined in a Database Management Module (205).

A Media Locator (303) record is made of several fields, of which some in this embodiment include:

(1) A ML\_ID (400) is unique KEY RECORD for each record in this table. This id is used by many tables to reference a particular row (record) of this Media Locator (303) table.

(2) A Content\_type (401) [AM | FM | TV | AUDIO | VIDEO | DATA | VIRTUALAUDIO | VIRTUALVIDEO | VIRTUALDATA] this field is used to define the type of content this record defines, as seen by some of the options which can be available.

(3) A Global\_ID (402) is a reference to a universal content code if one exists. For instance, books, magazines, etc... contain ISBN numbers that are unique for every item available. Audio content can have a similar code, as well as video. These references can be used to select albums, videos or other content by entities not familiar, or without access to ML\_ID's, to allow selection.

(4) DESCRIPTOR\_ID (403) is a reference to a record within a Content Descriptor (304).

(5) Trial\_ML\_ID (404) is a pointer to another Media Locator (303) record that contains content that a user can hear or see if they are not licensed to

this Media Locator Record. If this field is not populated, then there is no content to preview, or this content can not be trialed.

(6) License\_Req (405) [YES | NO | CODE] is a field that indicates what type of license, if any, is required. If 'YES', then any license to this content will do for access.

(7) ML\_ID\_TOP (406) is a pointer to another Media Locator (303) record that contains a parent content item. For instance, a song may contain a pointer to its album. A sub-topic content may point to its topic.

(8) CONTENT\_PTR (408) is a pointer to a Content (300) record which identifies the location of a streaming file defined by the Media Locator Record (303).

(9) THEME\_Ids (409) is a pointer to a Theme (302) record.

A Content Descriptor (304) record is made of several fields, of which some in this embodiment include:

(1) DESCRIPTOR\_ID (410) is unique KEY RECORD for each record in this table. This id is used by other tables to reference a particular row (record) of this Content Descriptor (304) table.

(2) ZONE\_ID (411) is a pointer to a record within a Zone (314) table.

(3) Freq.# (412) is a field available for a Radio Station, or other content descriptor record that has a frequency associated with it.

(4) Tag Name (413) is a human understandable definition of the content described. For instance, a Radio station name, an album name, a song title, a television broadcast, etc...

(5) Info (414) can contain a complete description of content creation times, places, dates, authors, writers, producers, etc...

A Zone (314) record is made of several fields, of which some in this embodiment include:

(1) ZONE\_ID (417) is unique KEY RECORD for each record in this table. This id is used by other tables to reference a particular row (record) of this Zone (314) table.



(2) Zone1 (418) defines a Zone main topic, which could be "New York" as an example of a regional zone main topic heading.

(3) Zone2 (419) defines a Zone sub-topic, which could be "Metro" as an example of a regional zone sub-topic heading.

5 A Theme (302) record is made of several fields, of which some in this embodiment include:

(1) THEME\_ID (420) is unique KEY RECORD for each record in this table. This id is used by other tables to reference a particular row (record) of this Theme (302) table.

10 (2) Theme\_type (421) [AM | FM | TV | AUDIO | VIDEO | DATA | VIRTUALAUDIO | VIRTUALVIDEO], defines a code for a sub-category, such as "FM" for FM radio theme.

(3) Description (422) defines the theme type, such as "DRAMA", or "ROCK", or "BLUES", etc...

15 A Vendor (313) record is made of several fields, of which some in this embodiment include:

(1) VENDOR\_ID (423) is unique KEY RECORD for each record in this table. This id is used by other tables to reference a particular row (record) of this Vendor (313) table.

20 (2) Name (424) is a userid and name of the vendor.

(3) Password (425) is a password for the vendor.

A Virtual Channel (301) record is made of several fields, of which some in this embodiment include:

25 (1) VIRTUAL\_ID (426) is unique KEY RECORD for each record in this table. This id is used by other tables to reference a particular row (record) of this Virtual Channel (301) table.

(2) A Content\_type (427) [VIRTUALAUDIO | VIRTUALVIDEO | VIRTUALDATA] this field is used to define the type of content this record defines, as seen by some of the options which can be available.

(3) ML\_ID (428) is a pointer to a Media Locator (303) record that defines this virtual channel.

(4) Style\_info (429) can be a group of parameters that define the style or functionality of this virtual channel.

5 A Security (311) record is made of several fields, of which some in this embodiment include:

(1) SECURE\_ID (430) is unique KEY RECORD for each record in this table. This id is used by other tables to reference a particular row (record) of this Security (311) table.

10 (2) USER\_ID (431) this field is a pointer to a User (309) record.

(3) HARDWARE\_SN (432) is the hardware serial number returned from a User Apparatus (102) for a User.

(4) SMARTCARD\_ID (433) is the Smart-Card ID of a Smart Card inserted in a User Apparatus (102), if applicable.

15 A User Apparatus (310) record is made of several fields, of which some in this embodiment include:

(1) APPARATUS\_ID (434) is unique KEY RECORD for each record in this table. This id is used by other tables to reference a particular row (record) of this User Apparatus (310) table.

20 (2) Type (435) defines the Make of hardware.

(3) DecodeType (436) [AUDIO | VIDEO | BOTH | DATA | ALL], defines the content this device can accept.

(4) Soft\_Version (437) is the version of software running in this device.

(5) Model (438) is the model of the device.

25 A Play-List (305) record is made of several fields, of which some in this embodiment include:

(1) ML\_ID (439) is a pointer to a Media Locator (303) record, and describes the transmitting "broadcast" entity (ie. Pointer to a Radio, Virtual or television station, etc...).

(2) Content\_ML\_ID (440) is a pointer to a Media Locator (303) record, and describes the content to be, or being played currently. If a Start\_time field is empty, then it is currently playing.

5 (3) Start\_Date (441) defines the date that this play list record pertains to. This field should be left blank if the date is [Today], or is [every day]. A blank field defines the current date to the system.

(4) Start\_time (442) defines a start time, for a date given in Start\_date. If this field is empty, then it is a currently playing Play-List record.

(5) Model (438) is the model of the device.

10 A Content (300) record is made of several fields, of which some in this embodiment include:

(1) CONTENT\_PTR (480) is unique KEY RECORD for each record in this table. This id is used by other tables to reference a particular row (record) of this Content (300) table.

15 (2) Fserver (481) defines the file server that contains the content media file. This field can be in the form of IP Address, or URL.

(3) FLocation (482) defines the actual file name that contains the content media data. This field can be in the form of IP Address, or URL.

20 (4) LServer (483) defines the file server that contains the logo file. This field can be in the form of IP Address, or URL.

(5) LLocation (484) defines the actual file name that contains the Logo image data. This field can be in the form of IP Address, or URL.

A License (312) record is made of several fields, of which some in this embodiment include:

25 (1) LICENSE\_ID (448) is unique KEY RECORD for each record in this table. This id is used by other tables to reference a particular row (record) of this License (312) table.

(2) USER\_ID (449) is a pointer to a User (309) record that defines the Owner of this license Record.

(3) ML\_ID (450) is a pointer to a Media Locator (303) record that defines the content being licensed in this record.

(4) Start\_date (451) is the date upon which this license goes into effect.

5 (5) Start\_time (452) is the time upon which this license goes into effect.

(6) Expire\_Date (453) is the date upon which the license is to expire. If left empty, this license will not expire.

10 (7) Access\_type (454) [FULL | G | PG | R], is the range of content screening, or version of content based on a standard rating system.

A User (309) record is made of several fields, of which some in this embodiment include:

15 (1) USER\_ID (455) is unique KEY RECORD for each record in this table. This id is used by other tables to reference a particular row (record) of this User (309) table.

(2) Name (456) defines the name of the user this record pertains to.

(3) Password (457) defines the password as assigned by this user. This field can be encrypted.

20 (4) Address\_info (458) contains the information pertaining to mailing address, billing address, phone, etc...

(5) Billing\_info (459) contains the information pertaining to billing, including Credit Card #, expiration dates, debit accounts, etc...

25 (6) ML\_ID\_in\_use (460) contains a pointer to a currently selected Media Locator (303) Record (content) being used. This field should be populated for all users which are logged in through a User Apparatus (102), and are engaged in a stream of content. This field could be used by an application on a Service Control Module (202) as an example. For instance, a trigger application maybe looking for all users listening to radio station (Z100), as defined by a particular ML\_ID.

(7) APPARATUS\_ID (461) defines the User Apparatus (102) that is currently being, or last used by a user, and points to a record in a User Apparatus Type (310) record.

A Triggers (308) record is made of several fields, of which some in this embodiment include:

(1) TRIGGER\_ID (462) is unique KEY RECORD for each record in this table. This id is used by other tables to reference a particular row (record) of this Triggers (308) table.

(2) Type (463) [U | V | S], defines the type of trigger defined in this record as initiated by a User, Vendor or a Content Control Server.

(3) USER\_ID (464) is a pointer to a User (309) record if this trigger is of type "U".

(4) VENDOR\_ID (465) is a pointer to a Vendor (313) record if this trigger is of type "V".

(5) ML\_ID (466) is a pointer to a Media Locator (303) record that defines the content to be scanned, or communicated with as it pertains to the action of this trigger.

(6) Action (467) [FIND | REQUEST | RESPONSE] defines the type of trigger being executed. FIND could ask to find a media locator based on a particular request when available, REQUEST could send a question to a plurality of User Apparatus (102) or Content Control System (100), RESPONSE could send answers back to a REQUEST trigger.

(7) Service\_ID (468) is a Service Control Module (202) defined parameter, and should be read-only. This id allows for tracking actual logic of a trigger, and an application that is handling this particular trigger record. This field allows for an unlimited number and type of trigger applications, because a unique service\_id can be created for any and all possible interactions with a trigger, and an infinite number of ways. For instance, Service\_id could be assigned #1 for "find content playing and send to user apparatus", in which case a simple script or application monitors triggers for this, and so on. Proper service Ids would most

likely be found by a ASP script on a Control Module (200) as it reads a User Trigger and modifies this field, or could be updated by a Service Control Module (202) application that is handling a Vendor Trigger, etc...

A Orders (307) record is made of several fields, of which some in this embodiment include:

(1) ORDER\_ID (443) is unique KEY RECORD for each record in this table. This id is used by other tables to reference a particular row (record) of this Orders (307) table.

(2) USER\_ID (444) is a pointer to a User (309) record that defines the Owner of this Orders Record.

(3) Date (445) is the date of this order.

(4) Time (446) is the time of this order.

(5) ML\_ID (447) is the content being ordered in this record.

A Demographics (306) record is made of several fields, of which some in this embodiment include:

(1) DEMOGRAPHIC\_ID (472) is unique KEY RECORD for each record in this table. This id is used by other tables to reference a particular row (record) of this Demographics (306) table.

(2) USER\_ID (473) is a pointer to a User (309) record that defines the Owner of this Demographics Record.

(3) ML\_ID (474) is a pointer to a Media Locator (303) record that defines the content, if applicable used for this record.

(4) Start\_time (475) is the start time of this demographic log entry.

(5) Start\_date (476) is the start date of this demographic entry.

(6) end\_time (477) is the end time of this demographic log entry.

(7) end\_date (478) is the end date of this demographic entry.

(8) Code (479) [CHANGECHANNEL | CHANGECONTENT | TRIALED | POWERON | POWEROFF | PURCHASE], defines the demographic action being recorded in this record.

5 Figure 12 is an embodiment of a User Apparatus (102). What is described in this Figure 12 are the basic functional units for a typical User Apparatus (102) to be usable. Such functionality can exist purely in hardware, or could be a mix of hardware and software, or can be purely software.

10 In a plurality of User Apparatus (102) it is important to note that an unlimited number of embodiments are possible, and each individual embodiment can work if it communicates with a Content Control System (100).

15 In this embodiment of a User Apparatus, an electronic device would have a main processing center, in this case a Central Processor (502). A Central Processor (502) would be responsible for executing software instructions, and communicating with the various interfaces available for interfacing, processing and/or any other functions needed to become a useful User Apparatus (102). In this embodiment, a Central Processor (502) would load a stored program on a Flash memory (503) and begin execution. There is no limitation to the type of code, or processors that could be used to implement a User Apparatus, for instance, code can be written in Java, C, Basic, Assembly, or any other language that is capable of running on a particular Central Processor that is used in an embodiment. Hence, it is obvious that there is no limitation on the types of Central Processors (502) that can be implemented in an embodiment.

25 Connected to a Central Processor (502) could be a User Control (501). A User Control (501) could be a keyboard, a panel of buttons, a wireless remote control, or signals coming from other electrical or optical interfaces that may be present. In an embodiment that is not a typical computer, such as a consumer electronic device, the User Control (501) is usually a combination of a button panel on the front of the device, and a wireless remote control (similar to that of a VCR, CD player, etc).

A Central Processor (502) will need software code and "drivers" available for each type of User Control (501) connected to allow for proper communication and data handling.

5 A Network Interface (500) is used by a User Apparatus (102) to connect to a Communication Network (101). Such interfaces could be a Modem, Ethernet, USB, 1394, or any other electrical or optical bus. In an embodiment as a non-pc device, there may be a Modem, Ethernet and (Firewire) 1394 interface for communication with telephone lines, cable modems, and other consumer electronic devices that use a (1394). There is no limit to the type or number in  
10 each User Apparatus (102a) as long as there is at least one.

A Central Processor (502) will need software code and "drivers" available for each type of Network Interface (500) connected to allow for proper communication and data handling.

15 A Memory / Program Store (503) can be made of several types of local memory. This embodiment would use Flash memory (re-programmable memory) to store program code and other parameters that may be changed from time to time. This would allow for software or feature upgrades without modification to the physical User Apparatus (102a). Buffer memory could be used for Central Processor (502) temporary storage, and or temporary data storage.

20 If an embodiment of a User Apparatus (102a) is to handle video, then most likely there will be a Visual Interface (504). A Visual Interface (504) could contain a plurality of input signals and a plurality of output signals. It is not necessary for a User Apparatus (102a) to handle video.

25 Examples of Visual Interface (504) inputs could be Composite and/or S-Video and/or USB and/or 1394 and/or any other electrical or optical interface that may be available. A preferred embodiment would contain a Composite, S-Video and 1394 interface, since these are the most common for analog and digital video at this time. A Visual Interface (504) would be made of a plurality of circuitry that would convert physical inputs into data streams usable by a Central Processor  
30 (502) and its helper circuitry if it exists.



Examples of Visual Interface (504) outputs could be Composite and/or S-Video and/or SVGA and/or 1394 and/or any other electrical or optical interface that may be available. A preferred embodiment would contain a Composite, S-Video and 1394 interface, since these are the most common for analog and digital video at this time. A Central Processor (502) could be connected to a plurality of circuitry that would convert data streams into data streams and/or signals usable by a Visual Interface (504) and its helper circuitry if it exists.

If an embodiment of a User Apparatus (102a) is to handle Audio, then most likely there will be a Audio Interface (505). A Audio Interface (505) could contain a plurality of input signals and a plurality of output signals. It is not necessary for a User Apparatus (102a) to handle audio.

Examples of Audio Interface (505) inputs could be RCA style Stereo Plugs, 1/4 and 1/8 inch jacks, USB, 1394 and/or any other electrical or optical interface that may be available. A preferred embodiment would contain a RCA style Left and Right, and 1/8 inch jacks, since these are the most common for analog audio inputs at this time. A Audio Interface (505) would be made of a plurality of circuitry that would convert physical inputs into data streams usable by a Central Processor (502) and its helper circuitry if it exists.

Examples of Audio Interface (505) outputs could be RCA Style Stereo plugs, 1/4 and 1/8 inch jacks, AC-3 digital, USB, 1394 and/or any other electrical or optical interface that may be available. A preferred embodiment would contain a RCA style Plugs, 1/4 inch jack and AC-3 digital interface, since these are the most common for analog and digital audio output at this time. A Central Processor (502) could be connected to a plurality of circuitry that would convert data streams into data streams and/or signals usable by a Audio Interface (505) and its helper circuitry if it exists.

If an embodiment of a User Apparatus (102a) is to handle external data input or output, then most likely there will be a Data Interface (506). A Data Interface (506) could contain a plurality of input signals and a plurality of output

signals. It is not necessary for a User Apparatus (102a) to handle external data input and output.

5 Examples of Data Interface (506) inputs could be USB, 1394 and/or any other electrical or optical interface that may be available. A preferred embodiment would contain a USB and/or 1394, since these interfaces are becoming the most common for digital multimedia inputs at this time. A Data Interface (506) would be made of a plurality of circuitry that would convert physical inputs into data streams usable by a Central Processor (502) and its helper circuitry if it exists.

10 Examples of Data Interface (506) outputs could be USB and/or 1394 and/or any other electrical or optical interface that may be available. A preferred embodiment would contain USB and 1394 digital interface, since these are becoming the most common for digital multimedia outputs at this time. A Central Processor (502) could be connected to a plurality of circuitry that would convert data streams into data streams and/or signals usable by a Data Interface (506) and its helper circuitry if it exists.

15 It is important to note that an embodiment of a User Apparatus (102a) could be a computer with multimedia capabilities, an internet connection, and the proper code to communicate with a Content Control System (100). Such a system could have software written as native processor code, could be a part of another application (helper), such as Dynamic Link Library (DLL) in a Windows Environment, it could be a Java application running standalone, or within a browser, or any other type of application, or execution method available to computers, and any format of any kind.

20 Further it is important to note, that a User Apparatus (102a) need not be a stand-alone device. A User Apparatus (102a) functionality could be integrated, or embedded in other devices, such as a CD player, a DVD player, or any other electronic device, including all types of consumer electronic devices, such as TV, VCRs, CD Players, DVDs, etc...

30 The user device of Figure 12 is used as follows: a first step in building a simple embodiment of a User Apparatus (102a) would be to configure a Windows

98 PC, with an industry standard audio card, a modem, dial-up software for internet access or a Network card, with the proper drivers, and a connection to a network that has access to the internet.

5 A next step would be to install or create a simple HTTP server, and develop appropriate scripts or other applications that are needed to communicate with a Content Control System (100).

A next step could be to install or create a stand-alone or plug-in version of a streaming audio/video/other program, such as Real-Video, Real-Audio (such as G2) or Microsoft Netshow, or some other client software.

10 A next step would be to create a Java, C, or other program that is capable of communicating with the computer, its audio device, helper applications (if necessary, such as Netshow or G2), and communicate with a Content Control System (100).

15 To develop this simple embodiment of a User Apparatus (102a) usable would require a developer knowledgeable in TCP-IP programming, Java, C or some other programming language capable of programming for a Windows API, and internet and plug-in, DLL programming. It would be helpful to have experience in Microsoft DirectX programming, such as DirectShow.

20 Figure 13 is an embodiment of a Radio Channel Content Broadcast, utilizing a Content Control System (100), and a User Apparatus (102), connected through a Communication Network (101), as an embodiment of a method executing such a service. What is described in Figure 13 are the basic functional blocks of connection, with a description of possible execution steps needed to initiate such a service.

25 To implement an embodiment of a plurality of a Radio Station Channel (600) for availability and content delivery to a User Apparatus (102), will initially require the availability of the audio content, potentially play-list information, and proper database entries into a Content Control System (100).

30 First a traditional Radio Station (600) could maintain an Encoding System (601), which would typically be a computer on local premises which is capable of

Analog or digital input to one of the many Coder/Decoders (CODEC) available for audio, and distributeable by a Content Control System (100), which can include, but not be limited to, H323, GSM, MPEG-1 layer 3 (MP3), CELP, ACELP, etc. This device need not be a computer, and could be a simple "black box" with audio in and data out capabilities.

This embodiment of an Encoding System (601) could be connected via modem, or some other interface to gain a direct, or Internet connection via a Communication Network (101).

A Radio Station (600) may also maintain, through computer control, or manual data entry, a list of currently playing songs, commercials, or content, known as a Play-List (602) system. This system can produce real-time content play, or can be preprogrammed, based on time and data parameters and send in batch mode to a Content Control System (100). A Play-List (602) system can be connected via links through a Communication Network (101) into a Content Control System (100).

With Digital Audio data, and possibly Play-List information now sent through a Communication Network (101) to a Content Control System (100), processing can begin. As described above, a Media Locator (303) file would have been created for this radio station so that a Content Control System (100) knows the needed information about a item of Content, in this case a Radio Station (600). A Content Control System (100) would take the data sent to it by an Encoding Server (601), and route it to a Content Stream Module (204) within its control.

At this point, a Content Control System (100) at least has a few records in a various tables located on a Database Management Module (205), including, but not limited to, a Media Locator (303) record, a Content Descriptor (304) record, a Zone (314) record, a Content (300) record, and potentially a Play-List (305) record, of which an example embodiment of data entered in such tables, and used for example purposes might be:

[Media Locator:] (303)

ML\_ID = 1002

Content\_type = FM  
 Global\_ID = WHTZ  
 DESCRIPTOR\_ID = 1201  
 TRIAL\_ML\_ID = (empty)  
 5 License\_req = NO  
 ML\_ID\_top = (empty)  
 CONTENT\_PTR = 1002  
 THEME\_Ids = 1A  
 [Content Descriptor:] (304)  
 10 DESCRIPTOR\_ID = 1201  
 ZONE\_ID = 101  
 Freq. # = 100.3  
 Tag\_Name = Z-100  
 Info = (misc info)  
 15 [Zone:] (314)  
 Zone\_ID = 101  
 Zone1 = New York  
 Zone2 = Metro  
 [Theme:] (302)  
 20 THEME\_ID = 1A  
 Theme\_type = FM  
 Description = ROCK  
 [Play-List:] (305)  
 ML\_ID = 1002  
 25 Content\_ML\_ID = 1234x23  
 Start\_date = (empty)  
 Start\_time = (empty)  
 [Content:] (300)  
 30 CONTENT\_PTR = 1002  
 FServer = radio.streams

Flocation = z100.ra  
 LServer = radio.logos  
 Llocation = z100.gif

5           The basic steps for a content provider, in this case a Radio Station (600),  
 which could have been an Audio, video, or data content provider (Radio,  
 Television or other video real-time channel, live concert, etc...), to provide a form  
 of digital content into a state usable and managed by a Content Control System  
 (100) are provided. At this point, a User Apparatus (102) requests, receives, and  
 10           potentially plays this content.

          A User Apparatus (102) as defined above in an embodiment, will need to  
 be powered on, connected to a Communication Network (101), and logged into a  
 Content Control System (100). For illustrative purposes, lets assume the a User  
 Apparatus (102) as discussed is connected to an amplifier/receiver, and is capable  
 15           of sending a stereo output signal to such device, and that device is capable of  
 output to a speaker system.

          Suppose a user of a User Apparatus enters PlayMode "FM", and selects  
 'Z100' as the station he/she would like to listen to. At this point, a User Apparatus  
 (102) would send a request to a Content Control System (100), specifically a  
 20           Control Module (200), such request in an embodiment might be:

          Destination address:

          fm.stream.content\_control.com/select.asp

          Parameters might be:

          PLAYMODE =FM

25           NAME                =Z100

          At this point, a Control Module (200), would process the request, and query  
 the various database tables, potentially including, but not limited to, a Media  
 Locator (303), A Content Descriptor (304), a Content (300) table. A result will  
 supply a content pointer for a Control Module (200) to hand off the information

(perhaps (1) user ID, (2) Password, (3) IP Address, and other information), to a Service Control Module (202).

A Service Control Module (202) will then update needed databases, modify the User (309) table to indicate the ML\_ID being used, and send information to a User Apparatus (102) that made the request with needed info to begin receiving the streamed content. Further, the Service Control Module (202) will send the appropriate commands to a Content Stream Module (204) to authorize and begin a stream of the said content to a User Apparatus bearing the information given.

At this point, a User Apparatus (102), and a Content Stream Module (204) are connected through a Communication Network (101), and said Content Stream Module (204) is sending digital information streams to a User Apparatus (102).

Upon receipt of the Digital information, a User Apparatus (102) can take the steps necessary, which can include, but not be limited to, (1) data grouping, (2) data re-syncing, (3) data decoding, (4) sending data to a plurality of output ports or devices. In this embodiment, the data could be received, decoded, and sent to a D/A converter (Digital to Analog), which then provides Audio Output (603) through one RCA type plug for Left, and another for Right channels of a stereo audio signal.

Simultaneously to a stream being sent to a User Apparatus (102), a Service Control Module (202) can have an application that is monitoring Play-List changes. Assume that this application detects that an update is made to the Channel that the user is listening to, then at this point, a Service Control Module (202) could send a message to a User Apparatus (102) with the updated information, including, but not limited to, (1) ML\_ID for reference, (2) maybe the actual Name of the Artist, or Commercial owner, (3) maybe a Song Title, or Commercial Title, or any other useful information. An example of this transaction could be:

Send to address:

[(user\_Apparatus\_ip\_address):80]

Parameters:

ACTION = PLAYLISTUPDATE  
 ML\_ID = 3044  
 ARTIST = U2  
 TITLE = With or Without You

5

At this point, a User Apparatus can use this information to update a visual display, and store record pointers for potential use later (such as Trial Mode, as described above).

10

Figure 14 is an embodiment of an Audio-On-Demand and Trial Mode content selection and retrieval method, utilizing a Content Control System (100), and a User Apparatus (102), connected through a Communication Network (101).

The basic functional blocks of connection, with a description of possible execution steps needed to initiate such a service is provided.

15

To implement an embodiment of a plurality of an Audio-On-Demand service for availability and content delivery to a User Apparatus (102), will initially require the availability of the audio content, and proper database entries into a Content Control System (100).

20

In this embodiment, traditional Fixed-Form (700) media must be converted into digital data utilizing an Encoding System (701), which would typically be a computer which is capable of reading a Fixed-Form (700) media, which such Fixed-Form (700) can include but not be limited to, Tape, DVD or Compact Disc. The content read must be encoded in a plurality of Coder/Decoder (CODEC) based on an embodiment of a Content Control System 100) and the capabilities it could offer to a User Apparatus (102). A CODEC can include, but not be limited to, H.323, GSM, MPEG-1 layer 3 (MP3), CELP, ACELP, etc. This device need not be a computer, and could be a simple "black box" with audio in and data out capabilities.

25



This embodiment of an Encoding System (701) could be connected via modem, or some other interface to gain a direct, or Internet connection via a Communication Network (101).

5 A description of the encoded material (perhaps Artist, title, tracks, length, publisher, etc...) can be entered through a Content Description System (702), either through computer control, or manual data entry. Such information will be used to properly store, and connect content to individual Media Locator (303) records, Content (300), Content Descriptor (304), and others. In this embodiment, the encoded content would be stored in a Content Control System (100) storage  
 10 system, and would then be managed, tracked and maintained through the services and functions provided by a Content Control System (100), and a Content Management System (201) within a Content Control System (100). With Digital Audio data, and description and database tables updated, the process can begin.

15 As described above, a Media Locator (303) file would have been created for this audio content so that a Content Control System (100) knows the needed information about an item of Content, in this case an Audio file.

At this point, a Content Control System (100) at least has a few records in a various tables located on a Database Management Module (205), including, but not limited to, a Media Locator (303) record, a Content Descriptor (304) record, a  
 20 Zone (314) record, a Content (300) record, of which an example embodiment of data entered in such tables, and used for example purposes might be:

[Media Locator:] (303)

	ML_ID	= 1003
	Content_type	= AUDIO
25	Global_ID	= 245876
	DESCRIPTOR_ID	= 1202
	TRIAL_ML_ID	= 1004
	License_req	= YES
	ML_ID_top	= 1012
30	CONTENT_PTR	= 1003

THEME\_Ids = 1B  
 [Content Descriptor:] (304)  
 DESCRIPTOR\_ID = 1202  
 ZONE\_ID = 001  
 5 Freq. # = (empty)  
 Tag\_Name = With or Without You  
 Info = (U2, Joshua Tree)  
 [Zone:] (314)  
 Zone\_ID = 001  
 10 Zone1 = Audio  
 Zone2 = Album  
 [Theme:] (302)  
 THEME\_ID = 1B  
 Theme\_type = AUDIO  
 15 Description = ROCK  
 [Content:] (300)  
 CONTENT\_PTR = 1003  
 FServer = Audio.u.streams  
 Flocation = wwy01.ra  
 20 LServer = audio.u.logos  
 Llocation = Josh001.gif

25 The basic steps to enter a plurality of Fixed-Store (700) media into the system, to provide a form of digital content into a state usable and managed by a Content Control System (100) are provided. At this point, a User Apparatus (102) requests, receives, and potentially plays this content.

A User Apparatus (102) as defined above is powered on, connected to a Communication Network (101), and logged into a Content Control System (100). For illustrative purposes, lets assume that a User Apparatus (102) is connected to

an amplifier/receiver, and is capable of sending a stereo output signal (704) to such device, and that device is capable of output to a speaker system.

Suppose a user of a User Apparatus enters PlayMode "AUDIO", and selects 'With or Without you' (there are many ways to select content, lets assume a menu was viewed, and a ML\_ID was sent to the User Apparatus that Points to the  
5 desired content). At this point, a User Apparatus (102) would send a request to a Content Control System (100), specifically a Control Module (200), such request in an embodiment might be:

10 Destination address:

audio.stream.content\_control.com/select.asp

Parameters might be:

PLAYMODE=AUDIO

ML\_ID =1003

15 At this point, a Control Module (200), would process the request, and query the various database tables, potentially including, but not limited to, a Media Locator (303), A Content Descriptor (304), a Content (300) table. A result will supply a content pointer for a Control Module (200) to hand off the information  
20 (perhaps (1) user ID, (2) Password, (3) IP Address, and other information), to a Service Control Module (202).

Because this content is marked as "License Needed", a Control Module (200), could then check the License (312) database to insure proper authorizations.

A Service Control Module (202) will then update needed databases, modify  
25 the User (309) table to indicate the ML\_ID being used, and send information to a User Apparatus (102) that made the request with needed info to begin receiving the streamed content. Further, the Service Control Module (202) will send the appropriate commands to a Content Stream Module (204) to authorize and begin a stream of the said content to a User Apparatus bearing the information given.

At this point, a User Apparatus (102), and a Content Stream Module (204) are connected through a Communication Network (101), and said Content Stream Module (204) is sending digital information streams to a User Apparatus (102).

Upon receipt of the Digital information, a User Apparatus (102) can take the steps necessary, which can include, but not be limited to, (1) data grouping, (2) data re-syncing, (3) data decoding, (4) sending data to a plurality of output ports or devices. In this embodiment, the data could be received, decoded, and sent to a D/A converter (Digital to Analog), which then provides one RCA type plug for Left, and another for Right channels of a stereo audio signal.

Simultaneously to a stream being sent to a User Apparatus (102), a Service Control Module (202) can have an application that is monitoring Play-List changes (such as end of song). Assume that this application detects that an end-of-song is reached, then at this point, a Service Control Module (202) could send a message to a User Apparatus (102) with the updated information related to the next title (if an album, and a link between songs is established), including, but not limited to, (1) ML\_ID for reference, (2) maybe the actual Name of the Artist, or Commercial owner, (3) maybe a Song Title, or Commercial Title, or any other useful information. An example of this transaction could be:

Send to address:

[(user\_Apparatus\_ip\_address):80]

Parameters:

ACTION = TITLECHANGE

ML\_ID = 3045

ARTIST = U2

TITLE = Bullet the Blue Sky

At this point, a User Apparatus can use this information to update a visual display, and store record pointers for potential use later (such as Trial Mode, as described above), and further begin retrieving a new data stream with said content.

Figure 15 is an embodiment of a User Apparatus (102) embodiment from an interface, and/or look-and-feel. It is important to note that this is for illustrative purposes only, and may not be used to limit the scope and spirit of this invention, including but not limited to (1) features and functions, (2) content type, (3) user manipulation, (4) product and feature integration with other devices or networks or content, (5) actual design or interfaces, and any other feature, function, parameter.

Figure 15 shows an embodiment of a User Apparatus (102) front and back look-and-feel, which is in a form of a consumer electronic appliance, similar to that of a CD player, Video Cassette Recorder (VCR), etc.

Similar to the features of a Cassette or Compact Disc player, this embodiment includes Navigation Controls (801), which include, but not be limited to, Stop, Pause, Play, Back track, back, forward, forward track. A Navigation Control (801) could be used during content playback to control the playback of said content.

A LCD display (802) is included in this embodiment which allows for the display of various types of information, that I dynamic as to look and feel, with regard to different options, menus, playback modes, and information available for display. An embodiment of a LCD display (802) in this Figure 15 shows a sample display if a User Apparatus (102) was in FM Radio mode, and tuned to a particular station playing a particular song. This display need not be a LCD display (802), and need not be attached to this device, or sent through a video out signal, perhaps to a TV, whereby the display can be supper-imposed on a TV picture. The options are limitless.

A Find (803) button is found on this embodiment, which would put this device into a search mode. Here you might be able to search for an album, radio station, TV channel, audio book, or any other item of content available. Content could be searched by catalog numbers, names, or scrolling lists, which functions might be navigated through the use of a Menu (806) and/or Selection (807) dial.

Perhaps a user wants to purchase a currently selected item, lets say an album that is playing. By pressing a Buy (804) button, the system could go into a

purchase mode, that would display, price, availability, and options for shipping. The user could enter a password, answer the questions, and instantly gain access to a license to that material purchased. For instance, if a user was listening to a U2 album, The Joshua Tree, and pressed the Buy (804) button, the user then entered a password, entered next day shipping, and accepted the \$12.67 price, the following could happen through an embodiment: (1) a charge is made to a users credit card, (2) a license is granted immediately to the user for on-demand playback, (3) a CD or Tape is mailed to the user, (4) confirmation codes are send back for future reference.

5

10

A Mute (805) button could silence the audio output of this device for instant zero volume.

15

A Menu (806) dial could be made available which turns clockwise, and counterclockwise, and might also have the capability to be "pressed", which could be used to "select" menu, or volume levels, etc... This dial could be used for menu navigation and various other uses.

20

A Selection (807) dial could be made available which turns clockwise, and counterclockwise, and might also have the capability to be "pressed", which could be used to "select" selection, submenus, or other options. This dial could be used for navigation and various other uses.

25

A Smart-Card (808) could be included in an embodiment which would allow for conditional access, user preferences, security and hardware information, and more. This could also be used to allow a user to go from one User Apparatus (102) to another, without loosing any license rights, or permissions, or preferences, simply by taking the Smart-Card (808) out of one device, and placing it into another.

30

A Numeric Keypad (809) could be made available for simple numeric entry.

A Random Play (810) key can be used to allow the User Apparatus to randomly play any of the licensed content that is available to this User or this User Apparatus.

A set of buttons is made available to select a Play Mode (811). These buttons allow for filtered content review, selectability, and organization. In this embodiment, a User Apparatus can only be in one Play Mode at a time. By selecting the "TV" mode, a User Apparatus (102) will gain access, and interact only with Video content on a Content Control System (100). By selecting the "AM" mode, a User Apparatus (102) will gain access, and interact only with content defined as "AM Radio" content on a Content Control System (100). By selecting the "FM" mode, a User Apparatus (102) will gain access, and interact only with content defined as "FM Radio" on a Content Control System (100). By selecting the "TRIAL" mode, a User Apparatus (102) will gain access, and interact with Video and or audio that is not licensed, and is allowed to be "sampled" prior to purchase of a license. The Trial button could be use to sample a currently playing song on a radio station, which would switch from "AM" or "FM" mode into "TRIAL" mode under "ON DEMAND". This can be used in many ways. By selecting the "ON DEMAND" mode, a User Apparatus (102) will gain access, and interact with all licensed Video and audio content for the user on a Content Control System (100). This mode can be used to "find" an album of interest to trial as well.

The back of this embodiment of a User Apparatus (102), contains the connection needed for input, output, and power.

Audio Out (812) plugs are shown in traditional RCA style Left Channel, Right Channel configuration. These plugs usually connect to standard amplifier or receiver equipment, from manufacturers such as Sony, etc... Below Left and Right, are SR-L (surround Sound Left Channel), SR-R (surround sound Right Channel), SUB (subwoofer), and there could be mode, such as SR-C (surround sound Center channel), etc... This is not meant to be limiting.

If audio in capabilities are available, the Audio In (813) could have RCA Style Plugs for Stereo Left and Right.

Newer devices contain Digital Audio (814) output, in this case, Dolby AC-3 outputs, which could as well be fiber optic connections.

For User Apparatus with Video Out (815) capabilities, this embodiment shows a Super Video (S-Video), a Composite RCA Style Plug, and an Antenna In and Antenna Out connector.

This embodiment shows two forms of Network Interface (816), which  
5 includes one modem port to plug into a telephone jack, and an Ethernet port which could plug into any Ethernet network, including DSL, Cable Modem, Computer Networks, etc...

Digital Interfaces (819) can also be included, such as 1394 (FireWire), and  
10 USB ports among many others. These are becoming popular, so they are showed here. These ports can connect to other equipment for both input and output.

Finally, a Power Plug (817) is used to supply power, and the unit is protected from power surges through a Fuse (818).

While the invention has been described above by reference to various  
15 embodiments, it will be understood that many changes and modifications can be made without departing from the scope of the invention. For example, different sources of product and service information may be included. Different types of media may be used. Different types of communications, whether wireless or wired, may be used. Various functionalities discussed above may be implemented  
20 using any of various individual or multiple processors or other components now known or later developed. Additional functionality may be provided internal to the user device 40 or as part of an expansion connected through an expansion port.

It is therefore intended that the foregoing detailed description be  
understood as an illustration of the presently preferred embodiments of the  
25 invention, and not as a definition of the invention. It is only the following claims, including all equivalents that are intended to define the scope of the invention.



## CLAIMS

What is claimed is:

1. A method for collecting data for an electronic impulse transaction system, the method comprising the acts of:

5 (a) obtaining first programming guide information from a first broadcasting source;

(b) obtaining first transaction information associated with the programming in the first programming guide information and a first product or service;

10 (c) obtaining second programming guide information from a second broadcasting source, the first broadcasting source corresponding to a different type of media than the second broadcasting source;

(d) obtaining second transaction information associated with the programming in the second programming guide information and a second product or service; and

15 (e) transmitting a compilation of the information obtained in (a), (b), (c) and (d).

2. The method of Claim 1 wherein (e) comprises transmitting the information from (a), (b),(c) and (d) in one data stream to a plurality of electronic devices.

3. The method of Claim 2 further comprising:

(f) receiving a selected transaction from one of said plurality of electronic devices.

4. The method of Claim 3 wherein (a), (b), (c), (d), (e) and (f) are performed by a same entity.

5. The method of Claim 1 wherein the first and second transaction information comprise product or service information associated with advertisements; and

further comprising:

5 (f) storing the product or service information.

6. A method for collecting data for an electronic impulse transaction in response to radio programming, the method comprising the acts of:

(a) obtaining by a first entity first programming guide information from a first radio broadcasting source;

10 (b) obtaining by the first entity first product or service transaction information associated with programming corresponding to the first programming guide information; and

(c) providing the first product transaction information to a potential purchaser in a data path independent of the programming.

15 7. The method of Claim 6 further comprising:

(d) obtaining by the first entity second programming guide information from a second radio broadcasting source, the second radio broadcasting source different than the first radio broadcasting source; and

20 (e) obtaining by the first entity second product or service transaction information associated with programming corresponding to the second programming guide information;

wherein (c) comprises providing first and second product or service transaction information in one data stream.

8. The method of Claim 6 further comprising:

25 (d) obtaining by the first entity second programming guide information from a second broadcasting source comprising a different type of media than the first radio broadcasting source; and

(e) obtaining by the first entity second product or service transaction information associated with programming corresponding to the second programming guide information;

wherein (c) comprises providing first and second product or service transaction information in one data stream.

9. The method of Claim 6 further comprising:

(d) receiving by the first entity a product or service selection associated with the product or service transaction information; and

(e) transmitting the product or service selection to a source of the product.

10. A method for collecting data in an electronic impulse transaction system, the method comprising the acts of:

(a) receiving by a first entity transaction data including a plurality of product or service transactions corresponding to broadcast media content;

(b) transmitting from the first entity information associated with the transaction data to a broadcasting source responsible for broadcasting the media content; and

(c) transmitting from the first entity the product or service transactions to respective product or service sources.

11. The method of Claim 10 further comprising:

(d) obtaining programming guide information corresponding to the broadcast media content; and

(e) transmitting the program guide information to a plurality of portable electronic devices;

wherein (a) comprises receiving product transaction data from at least one of the plurality of portable electronic devices, the product transaction data associated with one of a purchase order, a request for information, a request for help and combinations thereof.

12. The method of Claim 10 wherein:

(b) comprises transmitting from the first entity a sub-set of the information associated with the transaction data to the broadcasting source and another sub-set of the information to another broadcasting source.

5 13. The method of Claim 12 wherein the broadcasting source and the other broadcasting source comprise different types of media sources.

14. A method for providing data to a plurality of user electronic devices, the method comprising the acts of:

10 (a) transmitting information corresponding to a plurality of products or services to the plurality of user electronic devices;

(b) determining an extra bandwidth as a function of the transmission of (a);

(c) assigning a priority to information corresponding to at least two of the plurality of products or services; and

15 (d) re-transmitting to the plurality of user electronic devices a sub-set of the information as a function of the priorities and the extra bandwidth.

15. The method of Claim 14 wherein (a) comprises transmitting program guide information.

20 16. The method of Claim 15 wherein (a) comprises transmitting advertising information.

17. The method of Claim 14 wherein (a) comprises transmitting a question; and

further comprising:

(e) receiving an answer in response to the question.

25 18. The method of Claim 14 wherein (a) comprises transmitting information corresponding to a plurality of broadcasting sources.

19. The method of Claim 14 wherein (a) comprises transmitting with a radio frequency wireless infrastructure.

20. The method of Claim 14 wherein (a) and (d) are performed prior to a broadcast of programming associated with the information.

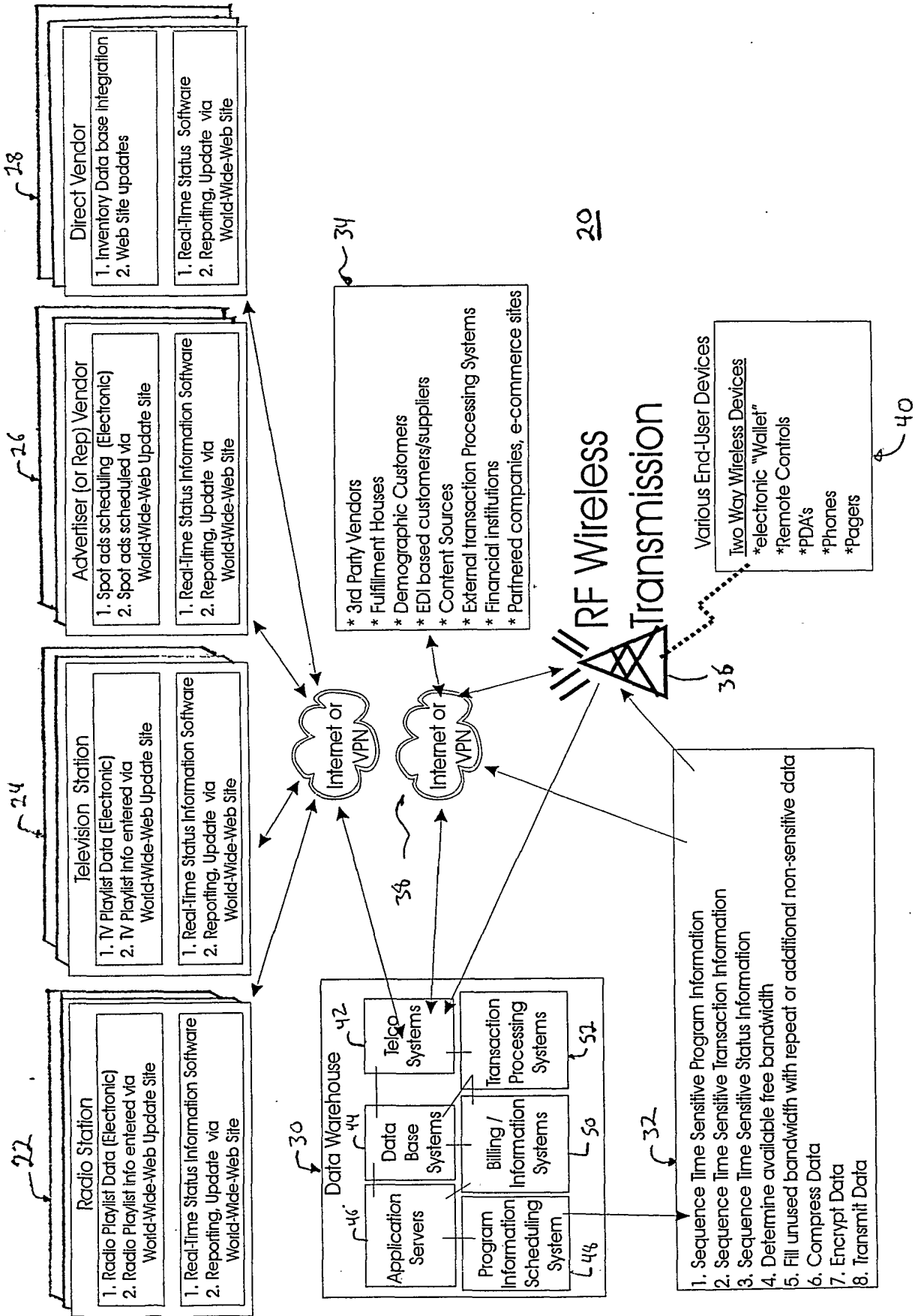


Figure 1

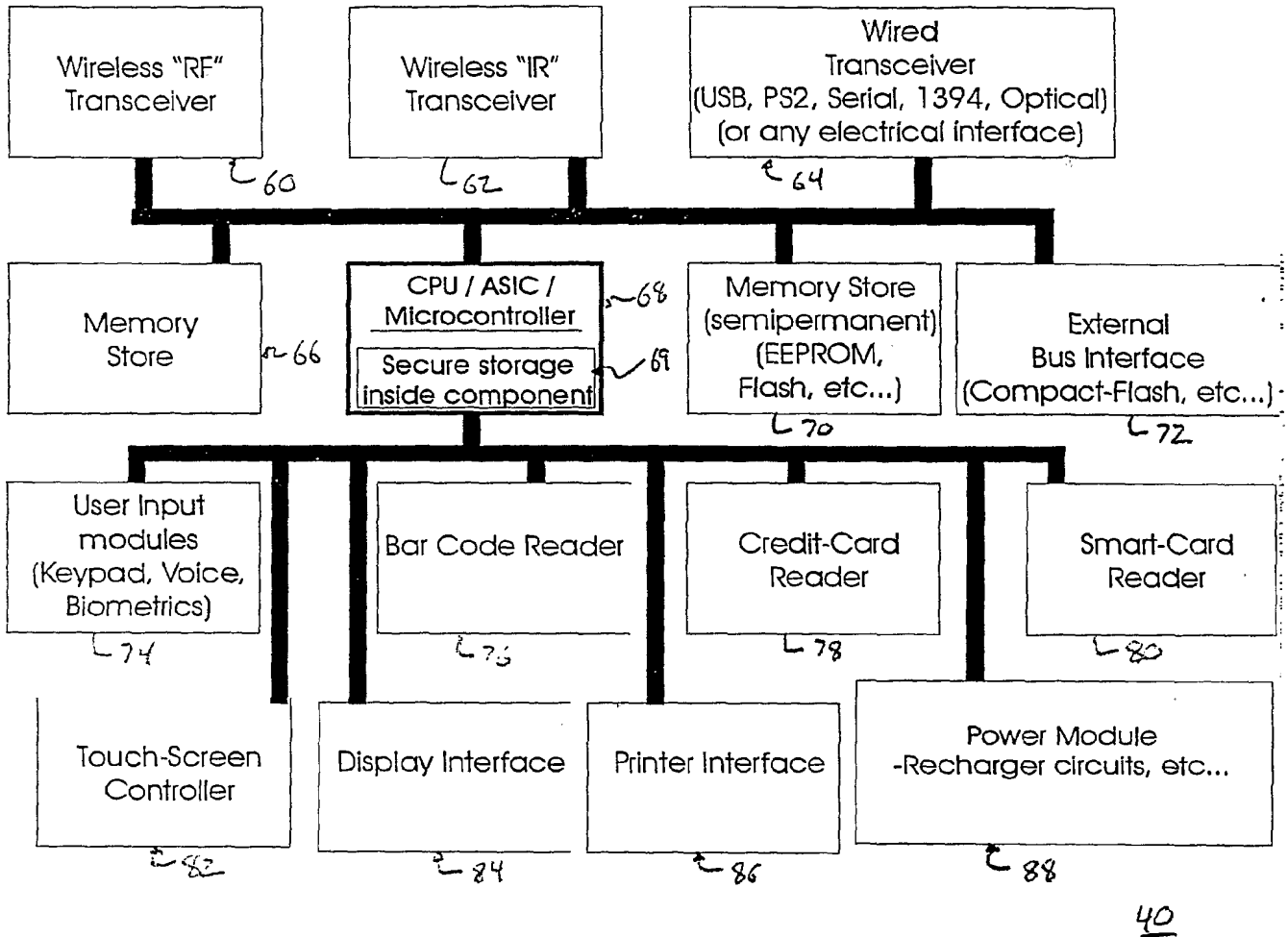


Figure 2

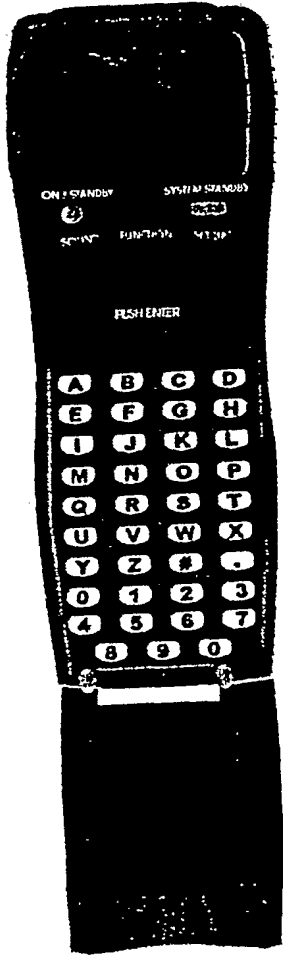


Figure 3



Figure 4



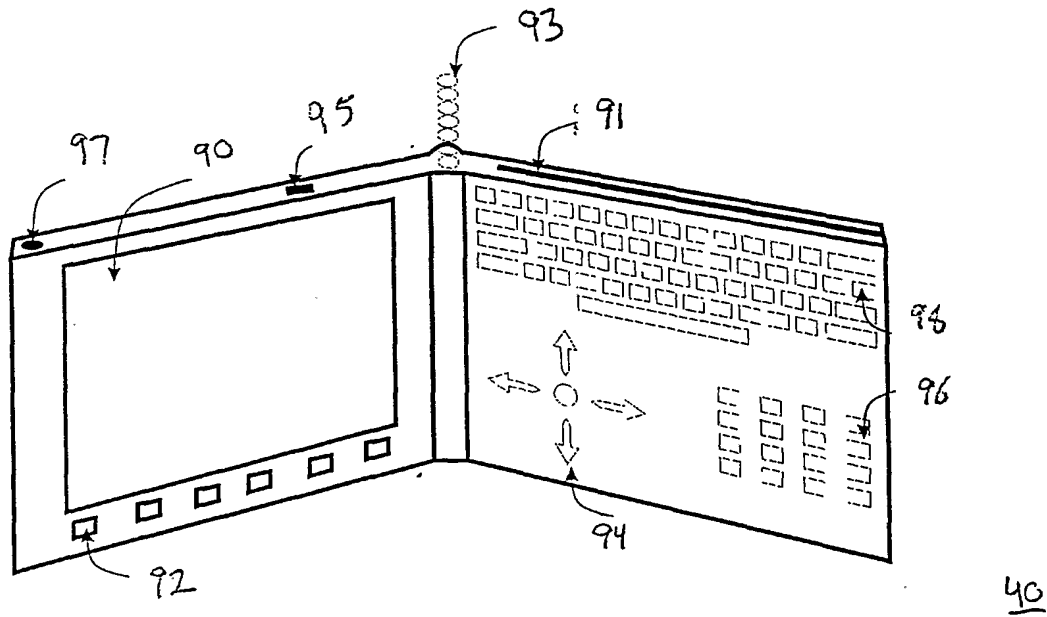


Figure 5

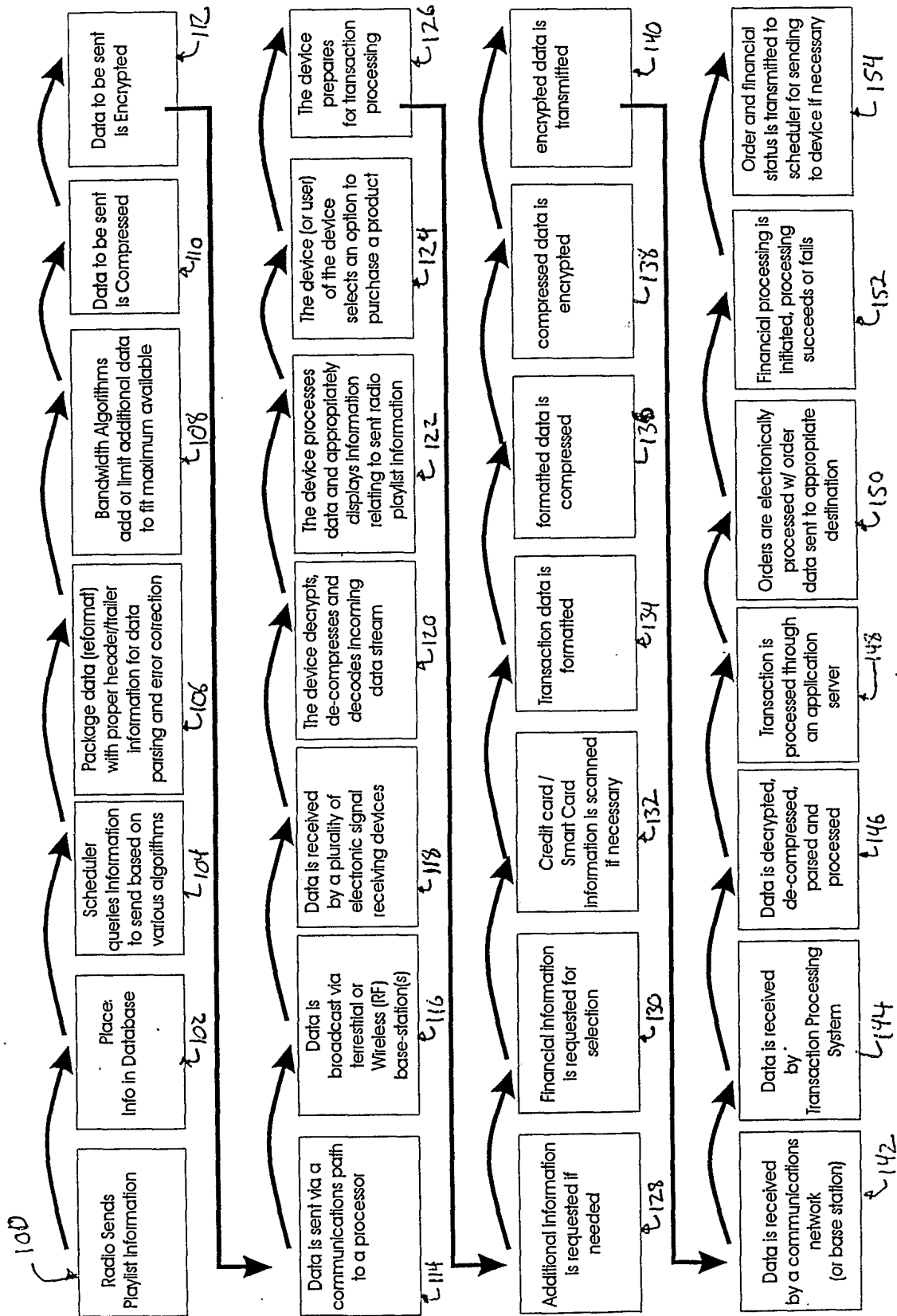


Figure 6

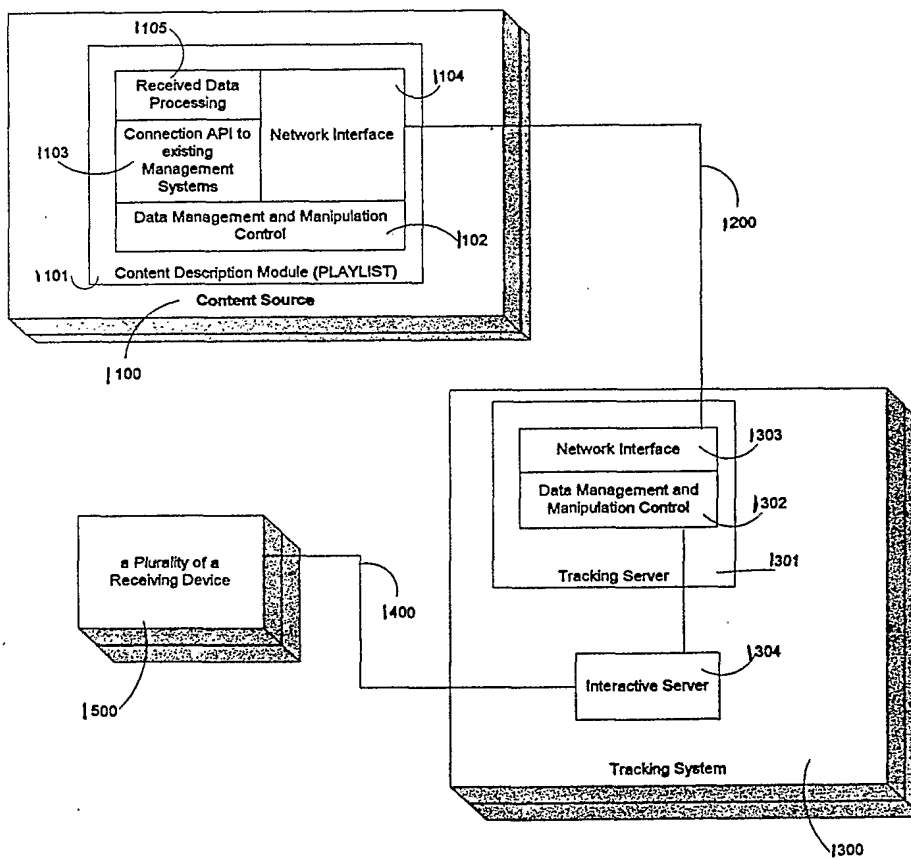


Figure 7

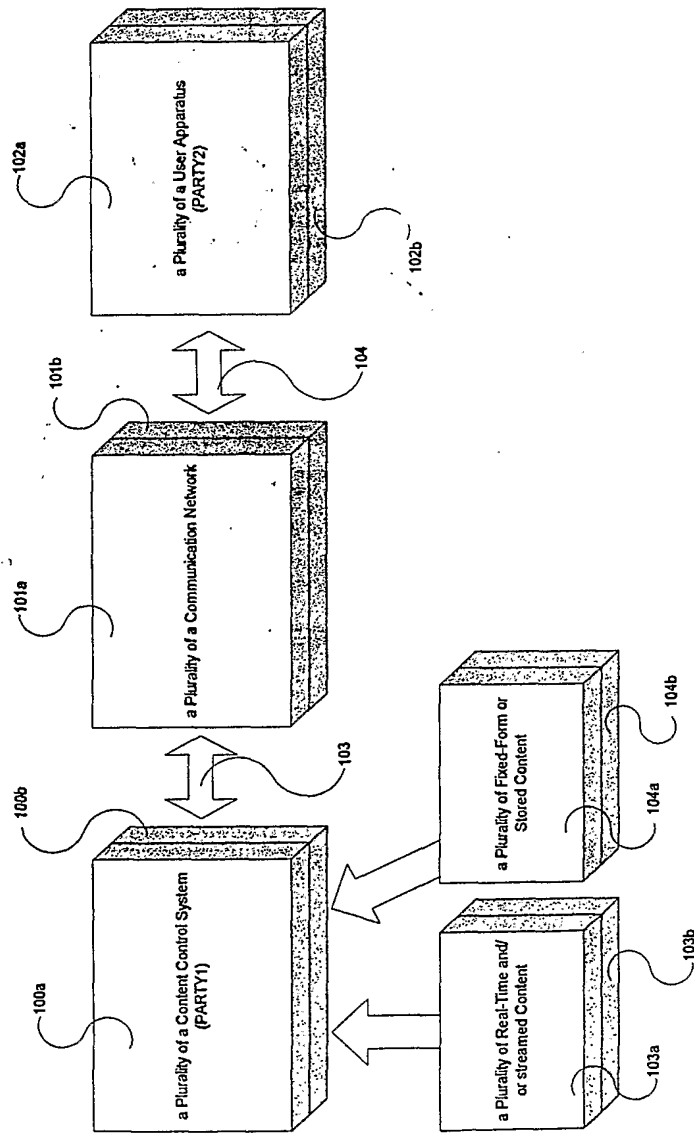


Figure 8

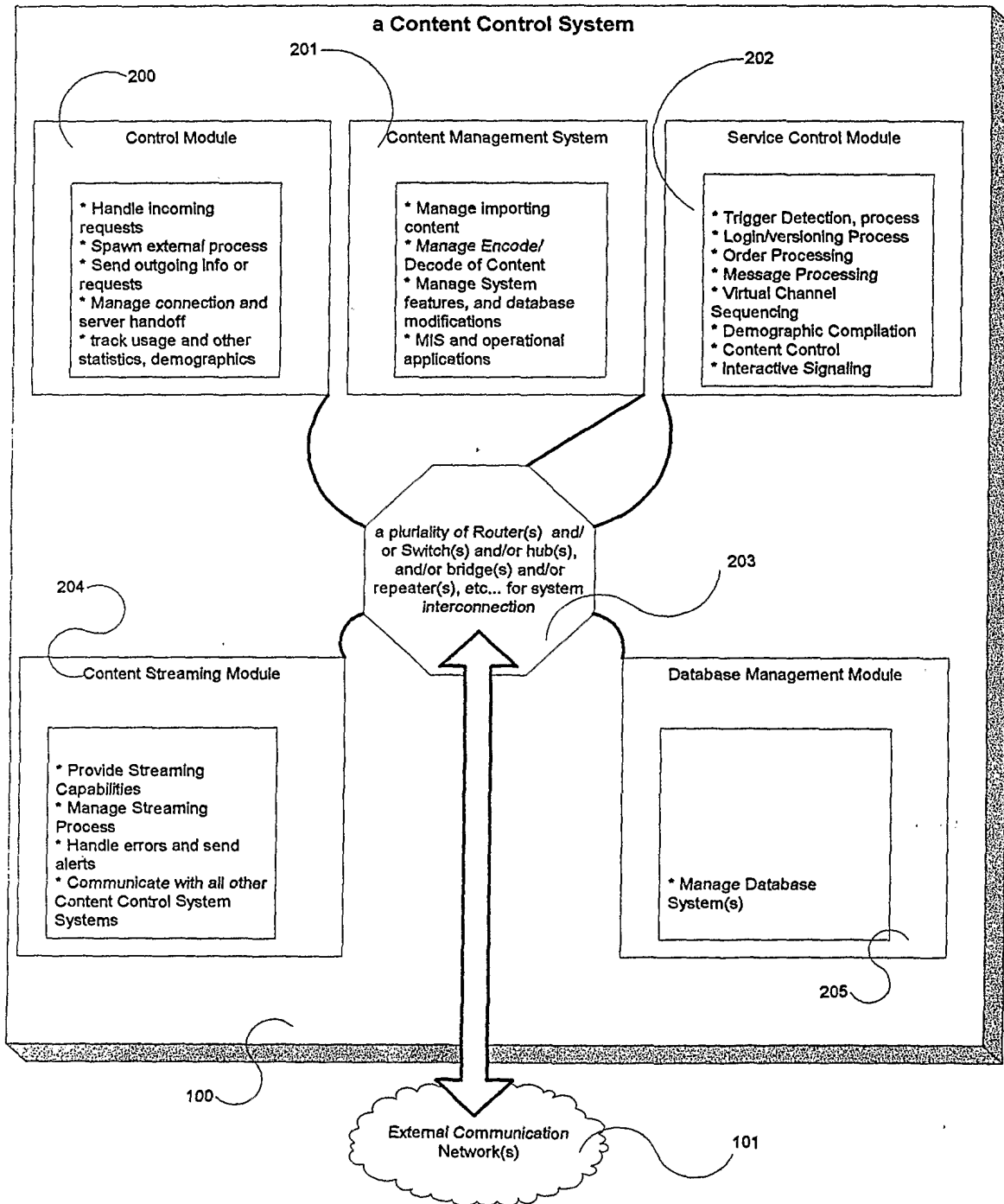


Figure 9

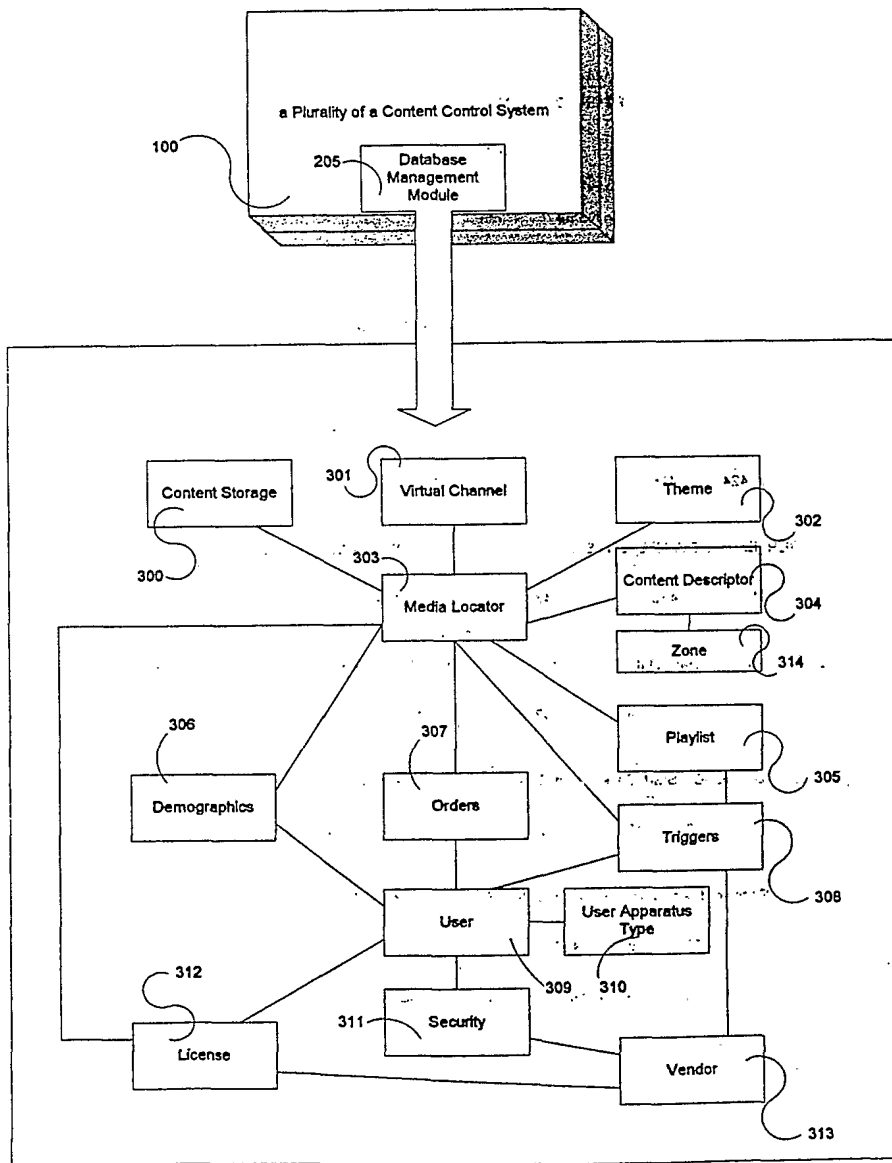


Figure 10

Media Locator

ML_ID	Content_Type	Global_ID	DESCRIPTOR_ID	Trial_ML_ID	License_Req	ML_ID_top	CONTENT_PTR	THEME_IDs
400	401	402	403	404	405	406	408	409

Content Descriptor

DESCRIPTOR_ID	ZONE_ID	Freq. #	Tag Name	Info
410	411	412	413	414

Zone

Zone_ID	Zone1	Zone2
417	418	419

Theme

THEME_ID	Theme_Type	Description
420	421	422

Vendor

VENDOR_ID	NAME	Password
423	424	425

Virtual Channel

VIRTUAL_ID	Content_Type	ML_ID	Style_Info
426	427	428	429

Security

SECURE_ID	USER_ID	HARDWARE_SN	SMARTCARD_ID
430	431	432	433

User Apparatus

APPARATUS_ID	Type	DecodeType	Soft_Version	Model
434	435	436	437	438

Play List

ML_ID	Content_ML_ID	Start_Date	Start_Time
439	440	441	442

Content

CONTENT_PTR	FServer	FLocation	LServer	LLocation
480	481	482	483	484

License

LICENSE_ID	USER_ID	ML_ID	Start_Date	Start_Time	Expire_Date	Access_Type
448	449	450	451	452	453	454

User

USER_ID	Name	Password	Address_Info	Bill_Info	ML_ID_in_use	APPARATUS_ID
455	456	457	458	459	460	461

Trigger

TRIGGER_ID	Type	USER_ID	VENDOR_ID	ML_ID	Action	Service_ID
462	463	464	465	466	467	468

Orders

ORDER_ID	USER_ID	Date	Time	ML_ID
443	444	445	446	447

Demographics

DEMOGRAPHIC_ID	USER_ID	ML_ID	Start_Time	Start_Date	End_Time	End_Date	Code
472	473	474	475	476	477	478	479

Figure 11

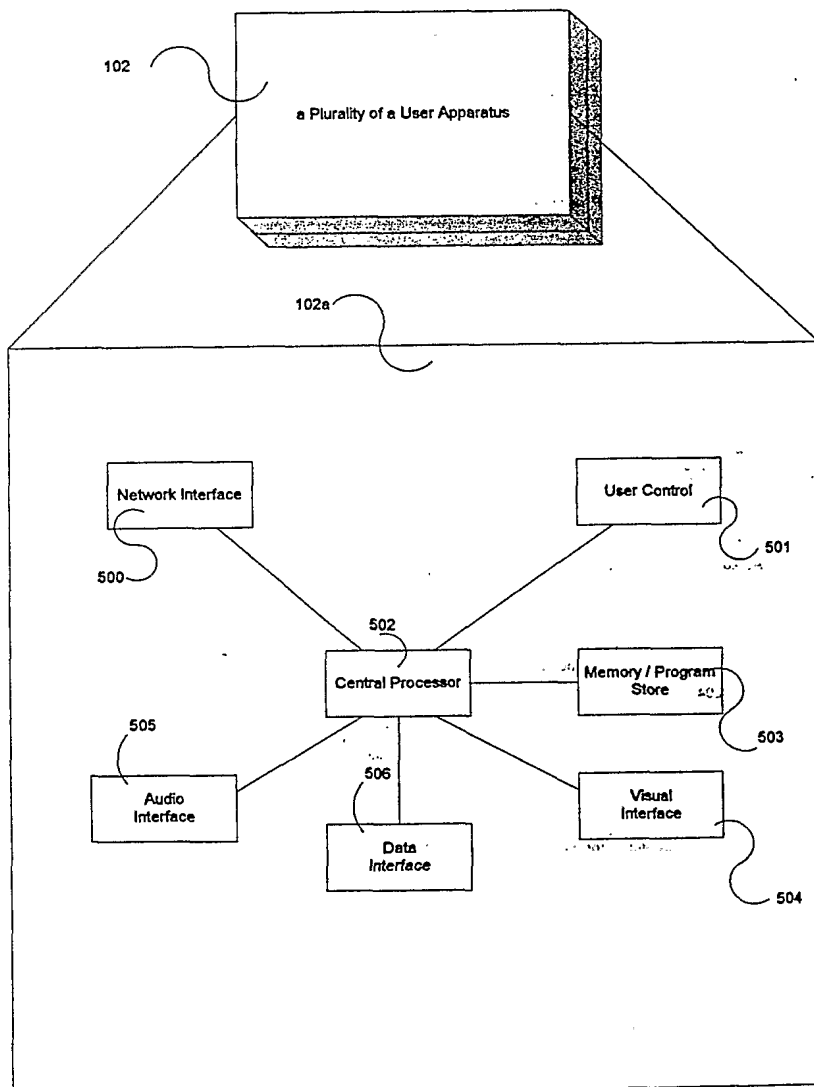


Figure 12



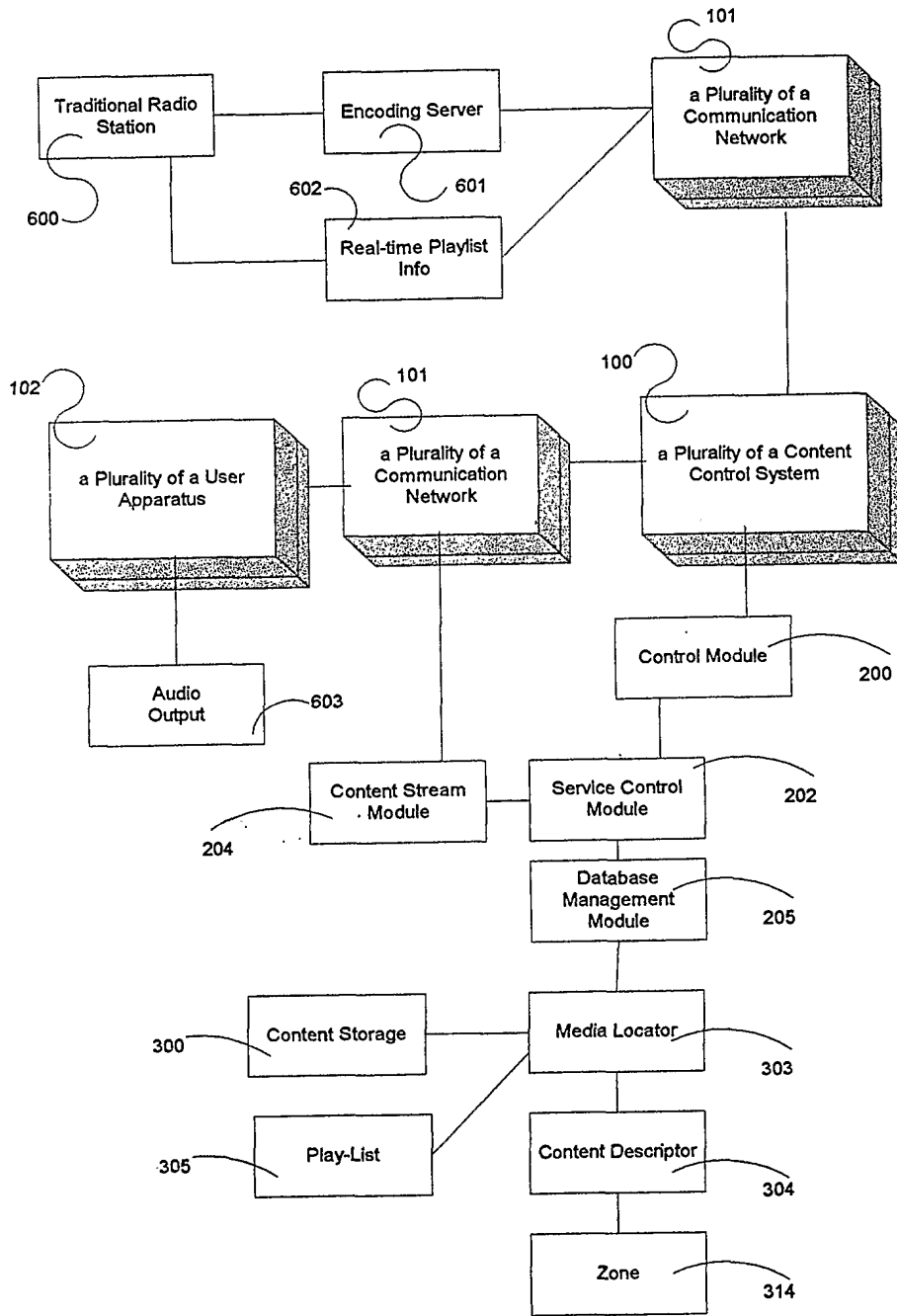


Figure 13

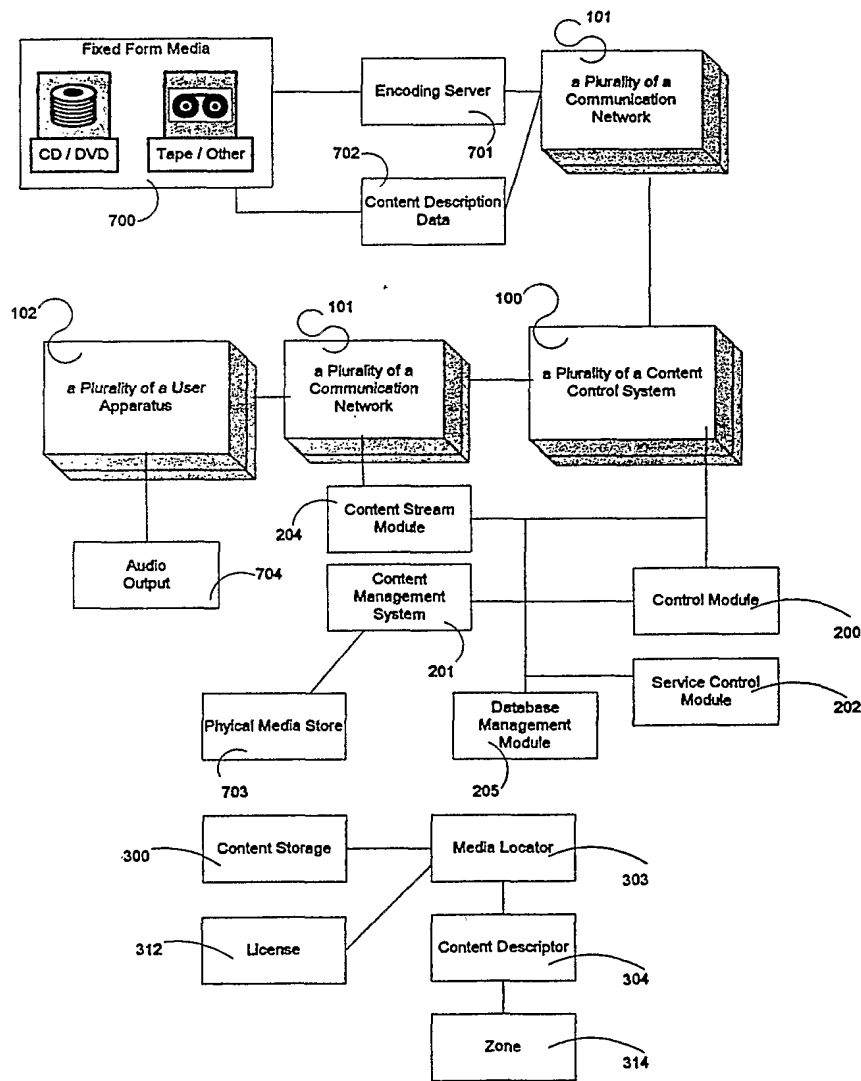


Figure 14

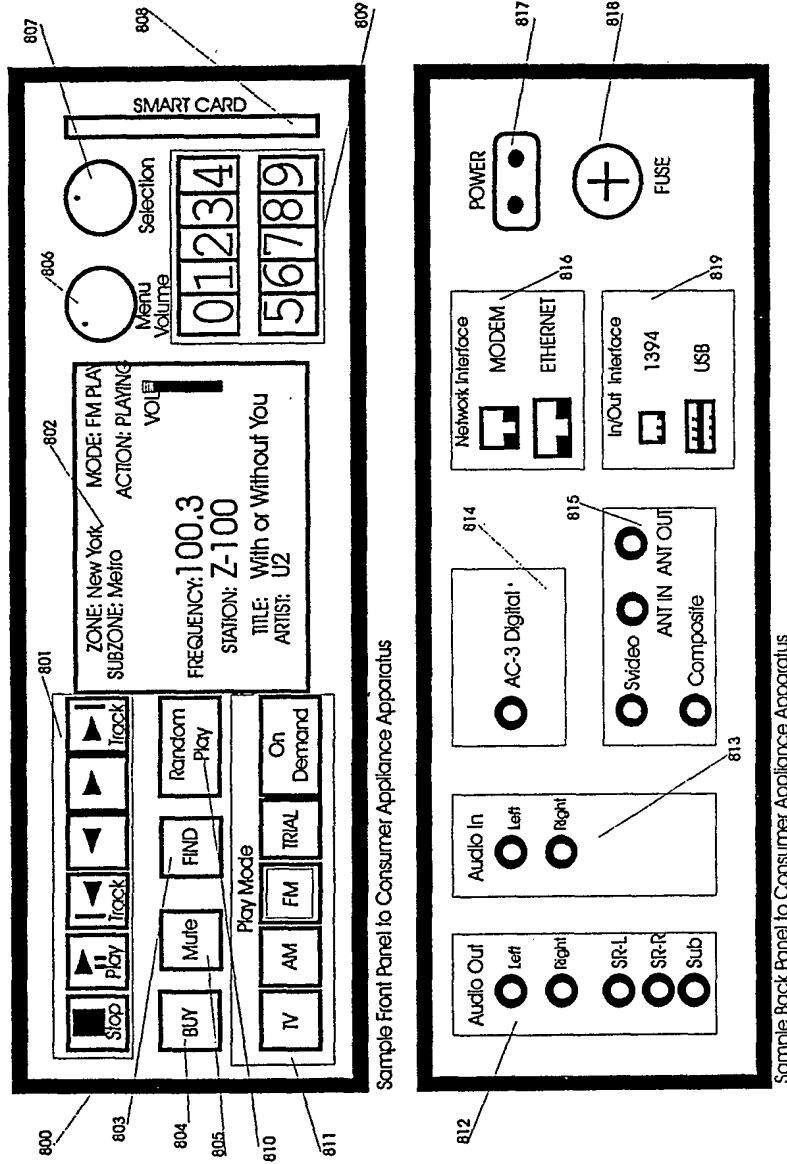


Figure 15

INTERNATIONAL SEARCH REPORT

International application No.  
PCT/US01/02781

A. CLASSIFICATION OF SUBJECT MATTER

IPC(7) :G06F 17/60  
US CL : 705/14, 26; 725/22, 39  
According to International Patent Classification (IPC) or to both national classification and IPC

B. FIELDS SEARCHED

Minimum documentation searched (classification system followed by classification symbols)

U.S. : 705/14, 26; 725/22, 39

Documentation searched other than minimum documentation to the extent that such documents are included in the fields searched

Electronic data base consulted during the international search (name of data base and, where practicable, search terms used)

EAST  
SEARCH TERMS: RADIO OR TELEVISION BROADCAST PROGRAM PORTABLE DEVICE OR TERMINAL, COMPILE

C. DOCUMENTS CONSIDERED TO BE RELEVANT

Category*	Citation of document, with indication, where appropriate, of the relevant passages	Relevant to claim No.
A	US 5898919 A (YUEN) 27 APRIL 1999, WHOLE DOCUMENT.	1-20
A	<sup>US</sup> 5,606,594 A (REGISTER ET AL.) 25 FEBRUARY 1997, WHOLE DOCUMENT.	1-20
A	US 5537314 A (KANTER) 16 JULY 1996, WHOLE DOCUMENT.	1-20
A	US 5,515,270 A (WEINBLATT) 07 MAY 1996, WHOLE DOCUMENT.	1-20
A	US 6,230,325 B1 (IINUMA ET AL.) 08 MAY 2001, WHOLE DOCUMENT.	1-20

Further documents are listed in the continuation of Box C.  See patent family annex.

* Special categories of cited documents:	"T" later document published after the international filing date or priority date and not in conflict with the application but cited to understand the principle or theory underlying the invention
"A" document defining the general state of the art which is not considered to be of particular relevance	"X" document of particular relevance; the claimed invention cannot be considered novel or cannot be considered to involve an inventive step when the document is taken alone
"E" earlier document published on or after the international filing date	"Y" document of particular relevance; the claimed invention cannot be considered to involve an inventive step when the document is combined with one or more other such documents, such combination being obvious to a person skilled in the art
"L" document which may throw doubts on priority claim(s) or which is cited to establish the publication date of another citation or other special reason (as specified)	"&" document member of the same patent family
"O" document referring to an oral disclosure, use, exhibition or other means	
"P" document published prior to the international filing date but later than the priority date claimed	

Date of the actual completion of the international search

05 JUNE 2001

Date of mailing of the international search report

15 JUN 2001

Name and mailing address of the ISA/US  
Commissioner of Patents and Trademarks  
Box PCT  
Washington, D.C. 20231

Facsimile No. (703) 305-3230

Authorized officer

ERIC STAMBER

*Peggy Harrod*

Telephone No. (703) 305-8000

INTERNATIONAL SEARCH REPORT

International application No.  
PCT/US01/02781

C (Continuation). DOCUMENTS CONSIDERED TO BE RELEVANT

Category*	Citation of document, with indication, where appropriate, of the relevant passages	Relevant to claim No.
A	US 6,101,381 A (TAJIMA ET AL.) 08 AUGUST 2000, WHOLE DOCUMENT.	1-20
A	US 5,721,827 A (LOGAN ET AL.) 24 FEBRUARY 1998, WHOLE DOCUMENT.	1-20
A	US 5,579,124 A (AIJALA ET AL.) 26 NOVEMBER 1996, WHOLE DOCUMENT.	1-20

(19) World Intellectual Property Organization  
International Bureau



(43) International Publication Date  
18 October 2001 (18.10.2001)

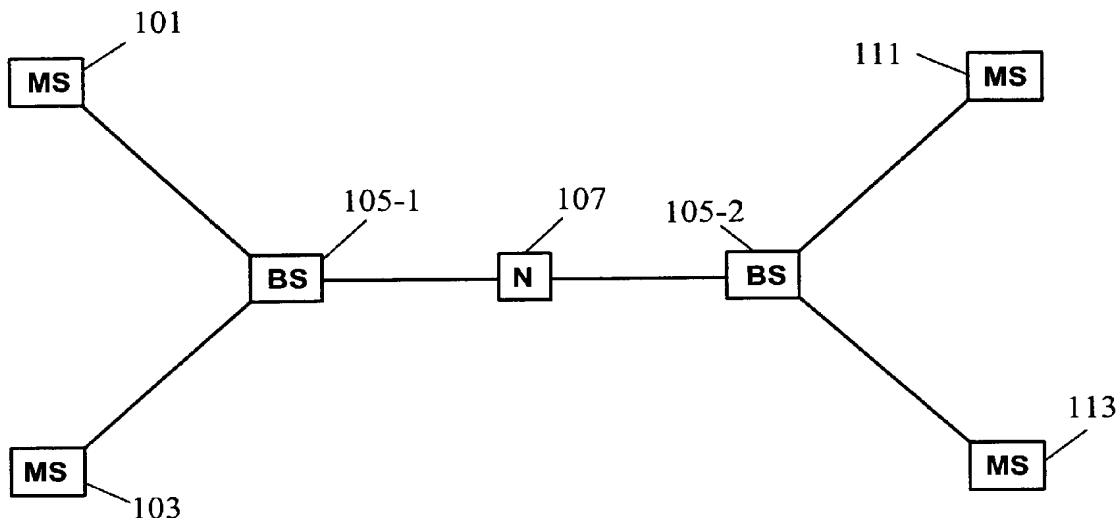
PCT

(10) International Publication Number  
WO 01/77779 A2

- (51) International Patent Classification: **G06F**
- (21) International Application Number: PCT/US01/11184
- (22) International Filing Date: 5 April 2001 (05.04.2001)
- (25) Filing Language: English
- (26) Publication Language: English
- (30) Priority Data: 60/195,096 6 April 2000 (06.04.2000) US
- (71) Applicant: **MORPHICS TECHNOLOGY, INC.** [US/US]; 675 Campbell Technology Parkway, Suite 100, Campbell, CA 95008 (US).
- (72) Inventors: **CHEN, Song**; 3052 Colonial Way, #18, San Jose, CA 95128 (US). **HESKY, Kenneth, M.**; 979-B La Mesa Terrace, Sunnyvale, CA 94086 (US). **JOAG, Raju, R.**; 3990 Hamilton Avenue, #8, San Jose, CA 95008 (US).
- (74) Agents: **MORRIS, Francis, E.** et al.; Pennie & Edmonds LLP, 1155 Avenue of the Americas, New York, NY 10036 (US).
- (81) Designated States (*national*): AE, AG, AL, AM, AT, AU, AZ, BA, BB, BG, BR, BY, BZ, CA, CH, CN, CO, CR, CU, CZ, DE, DK, DM, DZ, EE, ES, FI, GB, GD, GE, GH, GM, HR, HU, ID, IL, IN, IS, JP, KE, KG, KP, KR, KZ, LC, LK, LR, LS, LT, LU, LV, MA, MD, MG, MK, MN, MW, MX, MZ, NO, NZ, PL, PT, RO, RU, SD, SE, SG, SI, SK, SL, TJ, TM, TR, TT, TZ, UA, UG, UZ, VN, YU, ZA, ZW.
- (84) Designated States (*regional*): ARIPO patent (GH, GM, KE, LS, MW, MZ, SD, SL, SZ, TZ, UG, ZW), Eurasian patent (AM, AZ, BY, KG, KZ, MD, RU, TJ, TM), European patent (AT, BE, CH, CY, DE, DK, ES, FI, FR, GB, GR, IE, IT, LU, MC, NL, PT, SE, TR), OAPI patent (BF, BJ, CF, CG, CI, CM, GA, GN, GW, ML, MR, NE, SN, TD, TG).

[Continued on next page]

(54) Title: VIRTUAL MACHINE INTERFACE FOR HARDWARE RECONFIGURABLE AND SOFTWARE PROGRAMMABLE PROCESSORS



(57) Abstract: The present invention provides a virtual machine interface (VMI) and an application programming interface (API) usable in conjunction with a reconfigurable wireless network communication apparatus. The reconfigurable wireless network communication apparatus comprises a plurality of hardware kernels. The apparatus can be reconfigured to support different or modified communication protocols over time. The VMI comprises a library of software objects. By configuring VMI software objects, a programmer selects the communication protocol used by the reconfigurable wireless network communication apparatus. The API of the present invention provides higher level management of the communication protocol used by a reconfigurable wireless network communication apparatus. The API comprises a library of high level software objects that further abstract hardware details of the apparatus.



WO 01/77779 A2



**Published:**

— without international search report and to be republished upon receipt of that report

*For two-letter codes and other abbreviations, refer to the "Guidance Notes on Codes and Abbreviations" appearing at the beginning of each regular issue of the PCT Gazette.*

**VIRTUAL MACHINE INTERFACE FOR HARDWARE RECONFIGURABLE  
AND SOFTWARE PROGRAMMABLE PROCESSORS**

5           This application claims priority to the U.S. Provisional Patent Application  
VIRTUAL MACHINE INTERFACE AND APPLICATION PROGRAMMING  
INTERFACE FOR HARDWARE RECONFIGURABLE AND SOFTWARE  
PROGRAMMABLE PROCESSOR, Serial Number 60/195,096 that was filed April 6,  
2000.

10

**CROSS-REFERENCE TO RELATED APPLICATIONS**

Related applications incorporated herein by reference are as follows:

15

A CONFIGURABLE CODE GENERATOR SYSTEM FOR SPREAD SPECTRUM  
APPLICATIONS, U.S. Patent Application No. 09/751,782, filed 12/29/2000.

20

APPARATUS AND METHOD FOR CALCULATING AND IMPLEMENTING A  
FIBRONACCI MASK FOR A CODE GENERATOR, U.S. Patent Application No.  
09/751,776, filed 12/29/2000.

25

A FAST INITIAL ACQUISITION AND SEARCH DEVICE FOR A SPREAD  
SPECTRUM COMMUNICATION SYSTEM, U.S. Patent Application No.  
09/751,777, filed 12/29/2000.

30

A CONFIGURABLE MULTIMODE DESPREADER FOR SPREAD SPECTRUM  
APPLICATIONS, U.S. Patent Application No. 09/751,785, filed 12/29/2000.

A CONFIGURABLE ALL-DIGITAL COHERENT DEMODULATOR SYSTEM  
FOR SPREAD SPECTRUM APPLICATIONS, U.S. Patent Application No.  
09/751,783, filed 12/29/2000.



A WIRELESS SPREAD SPECTRUM COMMUNICATION PLATFORM USING DYNAMICALLY RECONFIGURABLE LOGIC, U.S. Patent Application No. 09/772,584, filed January 29, 2001.

- 5 UNIVERSAL CODE GENERATION, Serial No. 60/222,829, filed 8/3/2000.

### BRIEF DESCRIPTION OF THE INVENTION

This invention relates generally to application programming interfaces. More particularly, this invention relates to a virtual machine interface and/or application program interface.

### BACKGROUND OF THE INVENTION

A cellular communication system is a wireless communication network in which geographical areas are divided into a number of smaller areas or cells in order to provide scalability of coverage for multiple users with minimal intercell interference. A mobile cellular communication system is a cellular communication network in which the terminal devices (users, mobiles) may be in motion from one location to another relative to a basestation.

In a typical digital wireless communication system, multiple basestations are provided to perform switching and connection services between users or terminal devices. FIG. 1 illustrates typical cellular wireless communication system architecture. Basestation 105-1 provides wireless communication system to mobile stations 101 and 103. Similarly, basestation 105-2 provides wireless communication system to mobile stations 111 and 113. Basestation 105-1 is connected to the basestation 105-2 via network 107.

Referring to FIG. 1, a basestation (BS) provides basic connection service to terminal devices by terminating the radio path and connecting the terminal devices to network 107. A mobile station (MS) terminates the radio path on the user side and enables the user to gain access to services from the network. Network 107 typically comprises a mobile switching center (MSC). The MSC is an automatic system that

interfaces the user traffic from the wireless network with the wireline network or other wireless networks. The basestations exchange messages with the MSC.

A variety of communication protocols can be used to operate and control a wireless communication system such as the system shown in FIG. 1. Representative protocols include, but are not limited to, the TDMA (time division multiple access) and CDMA (code division multiple access) protocol families. Among other adoptions, TDMA protocol is used by GSM (Global System for Mobile Communication) which comprises GPRS (General Packet Radio Service), ECSD (Enhanced Circuit Switched Data), and EDGE (Enhanced Data rates for Global Evolution) systems. The CDMA protocol is adopted by cdma2000, wideband CDMA (WCDMA), IS-95 CDMA, IS-95B CDMA, CDMA TIA IS2000, TIA IS 2000A, WIMS W-CDMA, ARIB WCDMA, 1Xtrem, 3GPP-FDD, 3GPP-TDD, TD/SCDMA, as well as several other multi-carrier CDMA systems. Additional 2G and/or 3G CDMA protocols may be found in WCDMA for UMTS, Holma and Toskala eds., John Wiley & Sons. Inc., New York, (2000); and IS-95 CDMA and cdma2000, Garg ed., Prentice Hall PTR, Upper Saddle River, NJ, (2000).

Although TDMA and CDMA are the most widely used communication protocols, they each have unique system requirements. Prior art communication systems dedicated to supporting TDMA or CDMA protocols exist. However, the prior art has failed to provide a communication system that is capable of supporting several different protocols, including both TDMA and CDMA, in a satisfactory manner. This failure is in part due to the fact that the hardware necessary to support TDMA is typically not compatible with the hardware necessary to support CDMA. For example, typical TDMA systems require maximum likelihood sequence estimation (MLSE) equalization whereas CDMA systems do not. In contrast, typical CDMA systems require RAKE receivers whereas TDMA systems do not.

Even within the same protocol family, there are variations in the hardware necessary to support the protocol. For example, although both the global positioning system (GPS) and IS-95 are CDMA protocols, GPS and IS-95 have distinctly different hardware requirements. For example, an IS-95 system requires a convolutional decoder whereas GPS does not.

Because of the unique hardware requirements necessary to support each of the existing communication protocols, substantial expense is required to modify a basestation so that it supports a new communication protocol. Indeed, such a modification requires a complete or partial overhaul of a basestation. In prior art systems, the modification of a basestation to support a new communication protocol requires the installation of new equipment as well as significant modification of existing software throughout the network. In addition, new terminal devices are required in order to be compatible with the modified basestation. Thus, modification of a communication protocol used by a basestation 105 is an expensive and time-consuming task that results in service interruptions. For these reasons, conventional wireless communication systems suffer from a lack of flexibility and adaptability, and cannot provide timely and efficient adaptation to meet the ever-changing needs of the wireless communication field.

Further, in conventional wireless communication systems, preparing an application program to run a particular communication protocol requires a programmer to know or understand the complex details and specifics of the underlying communication hardware. Thus, every time there is a change in communication protocol, the programmer has to first understand what changes are to be made at the hardware level and rewrite application programs accordingly. Such dependence on specific architecture of the underlying hardware makes it even more difficult and expensive to change and maintain wireless communication systems.

In view of the foregoing, it is highly desirable to provide an adaptable and flexible wireless communication system. Also, it is desirable to provide a hardware architecture-independent communication platform on which a programmer can write application programs capable of modifying the communication protocol used by a reconfigurable wireless network communication apparatus without understanding underlying hardware requirements necessary to affect such a modification.

#### SUMMARY OF THE INVENTION

The present invention provides an object-oriented reconfigurable multi-protocol communication system comprising a virtual machine interface (VMI) and an application programming interface (API) for use in a wireless communication

network. The wireless communication network includes a reconfigurable wireless network communication apparatus having a plurality of hardware kernels and an interconnect structure. The wireless network communication apparatus is configurable in accordance with a designated communication protocol. The VMI is disposed between an application translation layer and a software virtual machine, and comprises a library of software procedures or objects.

In one embodiment, the software objects of the VMI are hierarchically related. Software objects of the VMI have static attributes and/or have dynamic attributes. The static attributes are adjustable when the reconfigurable wireless network apparatus, or components thereof, is off-line. The dynamic attributes are adjustable regardless of whether the reconfigurable wireless network apparatus is off-line or on-line.

The software objects of the VMI are associated with hardware kernels in the underlying reconfigurable wireless network communication apparatus, so that manipulation of VMI software objects regulate operations in the respective associated hardware kernels of the reconfigurable wireless network communication apparatus. Therefore, by appropriate manipulation or programming of the VMI software objects, a programmer can control essential functionality within the underlying reconfigurable wireless network communication apparatus without delving into the details and specifics of the reconfigurable wireless network communication apparatus.

A unique advantage of the present invention is that basestation conversion from one communication protocol to another is possible without expensive hardware changes. Rather, such changes are made by appropriate programming or manipulation of the VMI or API.

One embodiment of the invention is directed to CDMA (code division multiple access) applications. In this embodiment, the VMI provides the following software objects: a CDMA basestation engine, a searcher, a code generation unit (CGU), a finger, an uplink and a downlink. In turn, the reconfigurable wireless network communication apparatus provides a searcher kernel, a CGU kernel, a finger kernel, an uplink kernel and a downlink kernel. Each of these kernels are associated with corresponding software objects within the VMI. For example, a VMI finger

object is associated with a finger kernel, a VMI searcher object is associated with a searcher kernel, and so forth.

The present invention further provides an application program interface (API) to manage utilization, scheduling, and resource allocation. The API of the present invention comprises a library of higher-level software objects that further abstract the details and specifics of the VMI so that the application programmer can change the communication protocol used by a reconfigurable wireless network communication apparatus using very simple application programs. Indeed, in some embodiments, the API allows a programmer to change the communication protocol used by an apparatus by selecting an option in a simple menu of options. In one embodiment of the present invention, the API provides a standard uniform platform through which the programmer changes the wireless communication protocol used by a reconfigurable wireless network communication apparatus without having to understand the VMI, the details of the underlying hardware of the apparatus, or the requirements and specifications of the selected wireless communication protocol.

In another aspect of the present invention, the API has (i) a parsing routine for parsing an application program that designates a communication protocol and (ii) a machine instruction generation routine for producing machine readable data capable of reconfiguring a wireless network communication apparatus in accordance with a communication protocol designated by the application program. In some embodiments, in accordance with this aspect of the present invention, the machine readable data comprise VMI objects.

### BRIEF DESCRIPTION OF THE DRAWINGS

For a better understanding of the invention, reference should be made to the following detailed description taken in conjunction with the accompanying drawings, in which:

FIG. 1 illustrates a typical wireless communication system architecture;

FIG. 2 illustrates one embodiment of the invention utilizing a VMI interface between the network and mobile station hardware;

FIG. 3 illustrates one embodiment of the VMI and the API constructed in accordance with the invention;

FIG. 4 illustrates one embodiment of VMI 307 software objects in accordance with the present invention;

FIG. 5 illustrates examples of various VMI objects in accordance with one embodiment of the present invention;

5 FIG. 6 illustrates the association between VMI software objects and hardware kernels in accordance with one embodiment of the invention;

FIG. 7(A) is a flowchart illustrating the processing steps of one embodiment of a VMI software object in accordance with the invention;

10 FIG. 7(B) is a flowchart illustrating the processing steps of an alternate embodiment of a VMI software object in accordance with the invention;

FIG. 8 is a flowchart illustrating the instantiation and parameterization of various objects of the VMI to accommodate the system requirements of a communication protocol;

15 FIG. 9 is an example of an object instantiation and parameterization routine performed by steps 703-713 of FIG. 7;

FIG. 10 is an example of a searcher VMI object receiving various parameters to optimize a search pattern with controlled search throughput;

FIG. 11 is a flowchart illustrating the processing steps associated with a Finger\_new object in accordance with one embodiment of the present invention;

20 FIG. 12 is a flowchart illustrating the processing steps associated with a Searcher\_new object in accordance with one embodiment of the present invention;

FIG. 13 is a flowchart contrasting the layers used by various application programs in accordance with one embodiment of the present invention;

25 FIG. 14 is a flowchart illustrating the processing steps associated with an translation layer in accordance with one embodiment of the present invention; and

FIG. 15 is a diagram illustrating parameters that are configured in a scan chain binary.

Like reference numerals refer to corresponding parts throughout the drawings.

30

**DETAILED DESCRIPTION OF THE INVENTION**

Reference will now be made in detail to the preferred embodiments of the invention, examples of which are illustrated in the accompanying drawings. While the invention will be described in conjunction with preferred embodiments, it is understood that the description is not intended to limit the invention to these 5 embodiments. Rather, the invention is intended to cover alternatives, modifications and equivalents, which may be included within the spirit and scope of the invention, as defined by the appended claims. Additionally, in the following detailed description of the present invention, numerous specific details are set forth in order to provide a thorough understanding of the present invention. However, it will be apparent to one 10 of ordinary skill in the art that the present invention may be practiced without these specific details. In other instances, well-known methods, procedures, components, and circuits have not been described in detail so as not to obscure important aspects of the present invention. Furthermore, while the present invention may be implemented 15 in a reconfigurable wireless network communication apparatus such as a digital wireless communication system, the methods of the present invention are also well suited for other applications and devices.

Representative reconfigurable wireless network communication apparatuses include, but are not limited to, fixed wireless, unlicensed (FCC) wireless, local area 20 network (LAN), cordless telephony, cellular telephony, personal basestation, and telemetry. Other applications include navigation, encryption, and other digital data processing applications.

The present invention provides an application program interface (API) and a virtual machine interface (VMI) to abstract details of the underlying reconfigurable 25 wireless network communication apparatus so that an application programmer can prepare and modify an application program without requiring knowledge about the configuration, control or management of the underlying communication hardware. Combined with an API, the VMI gives a programmer the ability to adapt to the various communication protocols by invoking specific API and VMI software objects 30 or programs without the need to directly program the hardware of the underlying reconfigurable wireless network communication apparatus. For example, a mobile station programmer can program a mobile station so that it communicates using a new

or altered communication protocol by use of the VMI and API rather than directly accessing the registers of the mobile station hardware.

FIG. 2 illustrates one embodiment of the VMI and API of the present invention in conjunction with a reconfigurable wireless network communication apparatus. In FIG. 2, basestation 105 communicates with a multi-protocol mobile station 205 via network 203. The hardware of mobile station 205 can be configured to work with various communication protocols by changing the values of configurable parameters of table 207. The underlying hardware is controlled by API/VMI 210. Mobile station 205 has a reconfigurable hardware architecture. The VMI and API of the present invention serves as an interface between the mobile station hardware and network 203 so that application programs can be developed and prepared independently of the details and specifics of mobile station hardware 205.

In a preferred embodiment, both the VMI and API are implemented as software procedures or objects. It will be apparent to one skilled in the art that in alternate embodiments of the invention, the VMI and API can also be implemented as hardware. For instance, VMI and API implementations can be implemented as logic on a programmable chip.

In alternate embodiments of the present invention, the VMI and API may be used in conjunction with a basestation and its base transceiver station (BTS) engine. Serving as an interface between the BTS engine and network 203, the VMI and API enable the programmer to manipulate the reconfigurable BTS hardware by manipulating the VMI and API instead of directly controlling and modifying the BTS hardware. In such embodiments, the BTS hardware comprises multiple hardware kernels, which are configurable into several modes of operation, and parameterizable according to the demands of particular communication protocols such as TDMA and CDMA (code division multiple access). For example, the BTS engine may comprise one or more searchers, fingers, code generation units (CGUs), searcher dwell state machines (DSMs), combiners, uplinks, matched filters, matched filter antennas, downlinks, and transmit multicode channel kernels. Each of these kernels is interconnected by a reconfigurable interconnect structure having flexible bandwidth characteristics. Such a reconfigurable BTS engine is described in U.S. Patent Application No. 09/772,584.



While the methods of the present invention advantageously regulate the communication protocol(s) used by a base station or mobile, it will be apparent to one skilled in the art that the VMI and/or API of the present invention may also be used in conjunction with hardware units other than a mobile station or basestation as long as the underlying hardware unit has a reconfigurable architecture. Indeed, the VMI and/or API of the present invention may be used with any reconfigurable wireless network communication apparatus.

Turning to the details of the invention, FIG. 3 illustrates one embodiment of the VMI and the API constructed in accordance with the present invention. API 303 is disposed between an application translation layer 305 and an application program 301. VMI 307 is disposed between the application translation layer 305 and a virtual machine layer 309, which, in turn, is connected to a reconfigurable wireless network communication apparatus 311. The reconfigurable wireless network communication apparatus 311 may comprise basestation hardware, mobile station hardware, or any other suitable hardware.

Specifically, API 303 abstracts details and specifics of the lower level functionality and implementation of the communication system from the programmer. Such details and specifics include application translation layer 305, VMI 307, virtual machine 309 and reconfigurable wireless network communication apparatus 311. Thus, the programmer can prepare and modify a program without having to worry about the configuration, control or management of the underlying reconfigurable wireless network communication apparatus.

In one embodiment of the invention, API 303 provides an interface for writing high level programs that are translated by application translation layer 305 into programs that may include VMI commands. The translated programs, in turn, affect the communication protocol used by reconfigurable wireless network communication apparatus 311. As a result, API 303 abstracts information as to the types and numbers of VMI objects necessary to effect a given communication protocol as well as parameter values associated with VMI objects used to implement the given wireless communication protocol. Thus, in one embodiment, the programmer only has to provide application program 301 with information as to the type of communication

protocol of interest. An example of an application program in accordance with the embodiment is provided by illustrative code line 401.

---

5                   (401) Set\_Communication\_Protocol = WCDMA;

---

In illustrative code line 1, the programmer sets the communication protocol for a reconfigurable wireless network communication apparatus to WCDMA.

10                 In other embodiments in accordance with the present invention, Application programming interface 303 and application translation 305 are not used. Rather, a programmer writes a program in a language such as ANSI C that includes program calls to specific VMI objects. In this way, the programmer is able to modify or change the communication protocol or the usage of a communication protocol by  
15 reconfigurable wireless network communication apparatus 311.

                  From the perspective of the programmer, by abstracting the details and specifics as to the types and numbers of the VMI objects and relevant parameters, API 303 provides a communication protocol-independent interface through which the programmer can control and operate the underlying reconfigurable wireless network  
20 communication apparatus 311. This convenience makes it possible to standardize the wireless communication architecture because an API can be developed as a uniform, standard platform on which the user can operate and control various wireless communication protocols.

                  VMI 307, in turn, abstracts from the user details and specifics of the lower  
25 level implementation - virtual machine 309 and reconfigurable wireless network communication apparatus 311. In one embodiment of the present invention, VMI 307 provides a library of software calls for application program 301. VMI 307 contains information as to the types and numbers of objects as well as the parameter values associated with the objects necessary to implement a selected wireless communication  
30 protocol.

                  VMI 307 gives the programmer complete access to and control of reconfigurable wireless network communication apparatus 311 without the need to directly control or access the apparatus. For example, when used to implement a CDMA basestation, VMI 307 provides a hierarchical command structure including

commands that control mobile and sector allocation of resources of the underlying reconfigurable wireless network communication apparatus 311. VMI 307 also provides commands that control datapath interconnection, as well as hardware kernel parameters.

5           In operation, a particular communication protocol is selected, and the application program 301 makes the appropriate calls to software routines of API 303. Application program 301 is then translated by application translation layer 305. The software routines of application translation layer 305 have the information as to the types and numbers of the objects required to perform the particular communication  
10 protocol.

          In alternate embodiments, the methods and apparatuses of the present invention are practiced without API 303. In such embodiments, application program 301 makes calls to necessary software objects of VMI 307. For example, when the user selects a communication protocol and prepares an application program 301 to  
15 execute the communication protocol, application program 301 makes calls directly to software objects in VMI 307. The programmer can instantiate and use any object available from VMI 307 to perform necessary functions according to the selected communication protocol. After instantiating a particular object, the programmer assigns relevant parameter values to the instantiated objects in accordance with the  
20 particular communication protocols selected.

          In one embodiment, after application program 301 is translated into a program readable by virtual machine 309, virtual machine 309 issues machine readable instructions and commands to the reconfigurable wireless network communication apparatus 311 for execution. Unlike application program 301 and API 303, virtual  
25 machine 309 requires general knowledge and information associated with underlying reconfigurable wireless network communication apparatus 311. Using such knowledge, virtual machine 309 translates the application program into lower level machine code that is required to control the underlying reconfigurable wireless network communication apparatus 311. Typically, virtual machine 309 comprises a  
30 memory manager, thread scheduler, interpreter, as well as a compiler in order to control and coordinate the performance and execution of the underlying reconfigurable wireless network communication apparatus 311.

Typically, the reconfigurable wireless network communication apparatus 311 includes a resource allocator that receives and processes instructions and commands from the virtual machine 309 to allocate and reconfigure the necessary hardware resources of the reconfigurable wireless network communication apparatus 311. Thus, the scheduling and resource allocation of the underlying hardware 311 are transparent to the user. The resource allocation and hardware reconfiguration of the reconfigurable wireless network communication apparatus 311 is described in U.S. Patent Application No. 09/772,584.

One advantage of including VMI 307 between virtual machine 309 and any user program is to use the VMI to abstract details and specifics of the underlying hardware, such as registry values. The specifics and details of the underlying reconfigurable wireless network communication apparatus 311 are handled by virtual machine 309. Thus, regardless of the type of communication protocol used, the programmer can instantiate and use the Cellular Basestation Modem Engine (CBME), searcher, CGU, uplink, and matched filter objects available within VMI 307. In one embodiment of the present invention, the programmer does not have to handle any level lower than VMI 307 in order to program a particular reconfigurable wireless network communication apparatus. Specifically, the user can control the underlying reconfigurable wireless network communication apparatus 311 by manipulating the objects in VMI 307 instead of directly controlling and accessing the underlying hardware of the reconfigurable wireless network communication apparatus 311.

In one embodiment of the present invention, there is at least one hardware kernel assigned to reconfigurable wireless network communication apparatus 311 for each instantiated software object of VMI 307. For example, if CBME, searcher, CGU, uplink, and matched filter objects are instantiated from VMI 307, there is at least one CBME engine, searcher, CGU, uplink, and matched filter kernel assigned in the reconfigurable wireless network communication apparatus 311. This relationship between the VMI and the underlying hardware makes it easier for a user to prepare and analyze an application program, and shortens the time for the user to convert from one communication protocol to another. For example, in order to convert from W-CDMA protocol to IS-2000, the user instantiates additional objects as necessary, deletes unnecessary objects, and assigns parameter values as appropriate for the new

protocol, thereby effectively modifying the underlying reconfigurable wireless network communication apparatus 311.

FIG. 4 illustrates one embodiment of VMI 307 constructed in accordance with the present invention. Typically, objects in VMI 307 have a hierarchical relationship. The exemplary embodiment of FIG. 4 uses an object-oriented programming technique and provides various objects at different levels of the hierarchy: CDMA basestation modem engine (CBME) 401, uplink 403, searchers 413-1 and 413-2, searcher DSM 421-1 and 421-2, preamble detection engine (PDE) 533, "finger1" 417-1, "finger2" 417-2, combiner 411, and Downlink 567 with one or more Tx multicode channels 571. In FIG. 4, CBME 401 is the highest level object and other objects lower in the hierarchy are associated, directly or indirectly, with CBME 401.

Although certain software objects have been described with respect to FIG. 4 for the purpose of illustration, one of skill in the art will appreciate that other suitable software objects may be created and utilized as the system requires. For example, an encoder/decoder object may be added.

Turning attention to FIG. 5, each object within VMI 307 may comprise one or more associated functions or objects. Each of the objects within VMI 307 is associated with one or more hardware kernels so that changes in the object affect the state of the associate hardware kernel. In some embodiments, each object within VMI 307 is assigned to a unique or different hardware kernel. However, one of skill in the art will appreciate that many other configurations are possible, including configurations where one or more VMI objects are assigned to the same hardware kernel, or the inverse configuration, in which one or more hardware kernels are assigned to the same VMI object. Each of the software objects illustrated in FIG. 5 will now be described. In this description, both the purpose of the software object and the function of the underlying hardware to which the software object is associated are provided.

#### *Cellular Basestation Modem Engine 401*

A cellular basestation modem engine (CBME) kernel is a reconfigurable wireless network communication apparatus which itself is composed of a plurality of kernels to facilitate wireless communication. In one embodiment, CBME is a

Morphics cellular base transceiver system (BTS). CBME object 401 is a software object within VMI 307 that regulates various aspects of the underlying CBME hardware. CBME object 401 includes associated functions CBME\_new 503 and CBME\_set\_user-data 505. CBME\_new 503 is invoked to allocate a new CBME  
5 object. CBME\_set\_user\_data 505 is used to write user data to a CBME object.

#### *Code Generation Unit 507*

The CBME kernel includes one or more code generation unit (CGU) kernels. The on-chip CGU kernels are object-specific in that each on-chip CGU kernel only  
10 works with one type of VMI object. In one embodiment of the present invention, a particular CGU kernel only works with an Uplink 403, Searcher 413, a preamble detection engine antenna object, or a downlink object 567. Illustrative CGU kernels in accordance with various embodiments of the present invention are disclosed in "A configurable code generator system for spread spectrum applications," U.S. Patent  
15 Application No. 09/751,782, filed 12/29/2000; "Apparatus and method for calculating and implementing a Fibonacci mask for a code generator," U.S. Patent Application No. 09/751,776, filed 12/29/2000; "Universal code generation," U.S. Serial No. 60/222,829, filed 8/3/2000; and "A Wireless Spread Spectrum Communication Platform Using Dynamically Reconfigurable Logic," U.S. Patent Application No.  
20 09/772,584, filed January 29, 2001.

In some embodiments of the present invention, the CGU unit kernel provides all required codes among a set of standards, including but not limited to IS-95, cdma2000, IS2000, ARIB, and 3GPP. Various codes are generated for both uplink and downlink requirements. In some embodiments of the present invention, CGU  
25 kernels contain timing information for a modem and for each individual finger of a RAKE receiver. In additional embodiments of the present invention, the CGU contains a mask generation unit, which is used to transform a given code offset into a set of code dependent parameters. Such parameters are used in the reassignment of a code's phase. The output of a CGU kernel is a pseudo-random noise code sequence  
30 for the downlink and each RAKE finger.

Code generation unit (CGU) object 507 includes functions such as CGU\_new 509 and CGU\_set\_user\_data 511. CGU\_new 509 is invoked to allocate a new CGU

object 507 and object CGU\_set\_user\_data 511 is used to write user data to a CGU object 507.

*Searcher 413*

5 In a spread spectrum system, basestations as well as some handsets transmit a standardized pilot signal having a known sequence of binary digits to aid in communication of data signals. These pilot signals can have a wide variety of codes, as determined by a specific communication protocol. For example, in one protocol a pilot signal has a length of  $2^{15}$  (32,768) bits (or chips). This known sequence is  
10 referred to as a short pseudonoise (PN) sequence in IS-95 CDMA.

A searcher kernel is designed to search for new multi-paths by correlating a received code sequence such as a short PN sequence having an unknown phase with a second code sequence that is a locally generated PN sequence with a known phase. Once a searcher kernel finds a multi-path, a finger kernel is assigned to the multipath.  
15 Searcher kernels in accordance with the present invention are disclosed in "A Fast Initial Acquisition and Search Device for a Spread Spectrum Communication System," U.S. Patent Application No. 09/751,777, filed 12/29/2000; "A Configurable Multimode Despreader for Spread Spectrum Applications," U.S. Patent Application No. 09/751,785, filed 12/29/2000; "A Configurable All-Digital Coherent Demodulator  
20 System For Spread Spectrum Applications," U.S. Patent Application No. 09/751,783, filed 12/29/2000.

Referring to FIG. 5, a Searcher object 413 provides a software object for controlling a searcher kernel. In a typical embodiment, a Searcher object 413 is associated with a searcher kernel and thereby processes correlation results, performs  
25 peak detection, threshold comparison, and controls a multi-standard multi-dwell search engine.

Searcher object class 413 includes Searcher\_new 515. When Searcher\_new 515 is called by VMI 307, a number of processing steps are automatically performed for the user programmer in order to look for conflicts and to properly initialize  
30 resources for the underlying searcher kernel. Use of an object such as Searcher\_new 515 is advantageous because it allows the programmer to request a Searcher kernel without painstaking hardware level programming, such as board and chip

programming, and conflict management. The processing steps that are performed for the programmer by Searcher\_new 515 in one embodiment in accordance with the present invention are illustrated in FIG. 12.

Turning attention to FIG. 12, the processing steps performed by one embodiment of Searcher\_new 515 begin with processing step 1202. In processing step 1202, a particular searcher object 413 is identified. All subsequent processing steps either check to determine whether attributes of the searcher 413 identified in step 1202 are in the appropriate state and/or set particular attributes of the searcher 413 identified in processing step 1202.

In processing step 1204, a check is made to see if error checking is enabled. If error checking is enabled (1204-Yes) then a number of checks are performed. It will be appreciated that the order of many of the checks that are performed is not important. Additionally, one of skill in the art will appreciate that several additional checks that are not disclosed in FIG. 12 could be performed and all such checks are within the scope of the preset invention.

In a first check, a determination is made as to whether the searcher 413 that has been obtained by a call to Searcher\_new 515 is of the right type. In some embodiments of the present invention, there are two types of searchers, those that are dedicated to finding new mobiles and those that are dedicated to existing mobiles. If the searcher 413 that has been obtained by a call to Searcher\_new 515 is not dedicated to finding new mobiles (1240-No) the process ends with return error 1240. If the searcher 413 is dedicated to finding new mobiles (1206-Yes) then check 1208 is performed. In processing step 1208, a check is performed to see whether a function call has been made to a routine that sets cellular basestation modem engine (CBME) mobile resources. If the routine has not been called (1208-No), CBME 401 (FIG. 4) is not in the appropriate state and the process ends with return error 1240. If the routine has been called (1208-Yes) check 1210 is performed. In check 1210, a determination is made as to whether the time period for the searcher 413 identified in processing step 1202 has been set. Check 1210 returns an error if the time period for the searcher 413 has not been set (1210-No) and the process ends with error condition 1240. If a time period has been set for the searcher 413, the process continues with check 1212.



In processing step 1212, a check is made to determine whether the function CGU\_new has been called. CGU\_new 509 allocates a new CGU kernel. Illustrative CGU kernels in accordance with one embodiment of the present invention are disclosed in "A Configurable Code Generator System for spread spectrum applications," U.S. Patent Application No. 09/751,782, filed 12/29/2000. If CGU\_new 509 has not called (1212-No), the process ends with return error 1240. If a CGU\_new 509 has been called (1212-Yes), a determination 1214 is made as to whether the CGU kernel fetched by CGU\_new 509 is the right type. In one embodiment of the present invention there are four types of CGU kernels, a searcher CGU, an uplink CGU, a Preamble Detection Engine (PDE) Antenna CGU, and a downlink CGU. Check 1214 will return an error (1214-No; 1240) if the CGU type for Searcher 413 is any type other than a Searcher CGU.

If the CGU kernel called by CGU\_new 509 is a valid type (1214-Yes), check 1216 is performed to determine whether the CGU fetched by CGU\_new 509 and the Searcher are assigned to the same CBME 401 (FIG. 4). If the CGU and the searcher are not assigned to the same CBME 401 (1240-No) the process ends with error 1240. If the CGU and the searcher are assigned to the same CBME (1240-Yes), the process continues with check 1218. In check 1218, a determination is made as to whether the maximum number of Searchers have already been committed to CBME 401. If the maximum number of Searchers have already been committed to CBME 401 (1218-Yes), then Searcher\_new 515 will fail and the process ends with error code 1240. If the maximum number of Searchers have not already been committed to CBME 401 (1218-No) the process continues with processing steps 1220 through 1238, which are designed to initialize Searcher 413 and the associated Searcher kernel to the proper state. Although FIG. 12 refers to each error code as error 1240, one of skill in the art will appreciate that each error code 1240 could in fact be a unique error code. For example, a different return value for Searcher\_new 515 could be assigned for each different type of error encountered during processing steps 1206 through 1218.

Attention now turns to processing steps 1220 through 1238 in FIG. 12. Processing step 1220 is reached if all error checks are performed satisfactorily (1218-No) or if error checking is disabled (1204-No). In processing step 1220, the

searcher type of the searcher is designated as "NEW." In one embodiment of the present invention, VMI 307 flags Searcher 413 as new using illustrative code line 101.

---

5 (101) p\_searcher->searcher\_type = M\_New\_Mobile\_Searcher;

---

In illustrative code line 101, "p\_searcher" is a pointer to the Searcher 413 identified in processing step 1202 (FIG. 12). "Searcher\_type" is the attribute of "p\_searcher" that  
10 tracks the type of "p\_searcher." By assigning the attribute "searcher\_type" to "M\_New\_Mobile\_Searcher," "p\_searcher" is committed to type NEW.

In processing step 1222, a CGU is attached to Searcher 413. In processing step 1224 an attribute that tracks the number of CGUs that have been attached to the searcher is incremented by "1". In one embodiment in accordance with the present invention, this  
15 attribute is associated with the pointer to the CGU that has been associated with p\_searcher and the increment is performed using illustrative code line 102.

---

20 (102) ++p\_cgu->attach\_count;

---

In illustrative code line 102, p\_cgu is a pointer to the CGU 507 that has been attached to p\_searcher, p\_searcher is the Searcher 413 identified in processing step 1202. In processing step 1226, a mobile RAM index is assigned to Searcher 413. In processing  
25 step 1228, a searcher finger context memory (SFCM) element is assigned to Searcher 413. The SFCM element controls the scheduling and attributes of Searcher 413 such as the search window size of the code offset, dwell state number, a phase count for searches greater than ½ chip resolution, and a control flag that is used to start and stop Searcher 413. One of skill in the art will appreciate that any number of SFCM  
30 element data structures and schemes are possible for controlling Searcher 413 and the associated Searcher kernel and all such data structures and schemes are within the scope of the present invention.

In processing step 1230, the mobile random access memory (RAM) linear feedback shift register (LFSR) associated with Searcher 413 is zeroed out. In  
35 processing step 1232, the mobile RAM DSP memory is zeroed. In processing step 1234, the attribute that tracks the number of searchers assigned to CBME 401 is

incremented by “1”. In processing step 1236, Searcher 413 is added to the searcher list of CBME 401 using the SFCM element assigned to Searcher 413 as an index. In one embodiment, processing step 1236 is performed using illustrative code line 103.

5

---

```
(103) p_cbme->p_searcher_list[p_searcher->p_sfc_m_data->sfc_m_index] =
      p_searcher;
```

---

- 10 In illustrative code line 103, “p\_cbme” represents the CBME 401 (FIG. 4) to which p\_searcher is associated. Further, “p\_searcher\_list” is the list of searchers that are associated with CBME 401. This list is indexed by the SFCM element assigned to Searcher 413 by querying the value of “p\_searcher->p\_sfc\_m\_data->sfc\_m\_index.” In processing step 1238 various searcher attributes are initialized. In one embodiment,
- 15 processing step 1238 is performed using illustrative code lines 104 through 109.

---

```
(104) p_searcher->p_sfc_m_data->p_searcher = p_searcher;
```

```
(105) p_searcher->p_sfc_m_data->active = M_FALSE;
```

- 20 (106) p\_searcher->pdp\_read = M\_TRUE;

```
(107) p_searcher->new_searcher_called = M_TRUE;
```

```
(108) p_searcher->p_cbme = p_cbme;
```

```
(109) p_searcher->state = M_SEARCHER_STOPPED;
```

---

25

- In illustrative code line 104, the SFCM element that tracks the identity of Searcher 413 is assigned the value of pointer “p\_searcher.” “P\_searcher” is the pointer to Searcher 413 that was identified in processing step 1202 (FIG. 12). In illustrative code line 105, the attribute “active” is set to M\_FALSE. When attribute “active” is set to
- 30 M\_FALSE, virtual machine 309 (FIG. 3) is directed not to search or store data for “p\_searcher.” In illustrative code line 106, the attribute “pdp\_read” is set to M\_TRUE. The power delay profile (PDP) is a data structure that stores the search results of “p\_searcher.” Setting “pdp\_read” to M\_TRUE indicates that the most recent searcher results have been read by an application program 301 (FIG. 3). This is
- 35 appropriate during searcher initialization because “p\_searcher” has in fact never stored search results to the PDP. When “p\_searcher” performs a search at a later time, VMI

307 will set the attribute `pdp_read` to "M\_FALSE" until application program 301 reads the PDP associated with "p\_searcher."

In illustrative code line 107, the attribute "new\_searcher\_called" is set to "M\_TRUE." This attribute is used to indicate that Searcher\_new 515 has been properly called for "p\_searcher." In illustrative code line 108, "p\_searcher" is associated with CBME 401. Finally, in illustrative code line 109, the attribute "state" is set to "M\_SEARCHER\_STOPPED" to indicate that the searcher kernel associated with "p\_searcher" is not currently in search mode. In processing step 1260, Searcher\_New ends with an error free return to the calling program.

Review of the flowchart in FIG. 12 reveals a number of advantages of VMI 307. The VMI 307 programmer can use VMI 307 to request a Searcher 413 and associated Searcher kernels without need, for instance, to resolve complex hardware conflicts and board level programming.

Returning attention to FIG. 5, Searcher 413 further includes functions such as Set\_searcher\_static\_attributes 517, Set\_searcher\_dynamic\_attributes 519, Searcher\_start 521, Searcher\_stop 523, and Assign\_DSM\_to\_searcher 525. Set\_searcher\_static\_attributes 517 is used to set searcher static attributes such as system parameters, antenna data port, and despread mode. The function Set\_searcher\_dynamic\_attributes 519 is used to set searcher dynamic attributes such as channel type and number. Searcher\_start 521 is used to start a Searcher 413. Searcher\_stop 523 is used to stop a Searcher 413. Assign\_DSM\_to\_searcher 525 is used to assign a searcher DSM to a Searcher 413.

#### *Searcher Dwell State Machine 421*

Each Searcher 413 must be assigned to a dwell state machine (DSM). A DSM is used to configure the Searcher algorithm. Searcher\_DSM 421 includes Searcher\_DSM\_new 529 and Set\_DSM\_state\_attributes 531. Searcher\_DSM\_new 529 is invoked to allocate a new DSM and Set\_DSM\_state\_attributes 531 is used to set the integration length and threshold for a specific state of a searcher\_DSM. Functionally, a searcher VMI object 413 is used to control the corresponding searcher kernel hardware for mobile channels, and a searcher\_DSM 421 is used to configure

the searcher algorithms. Further details of the searcher hardware kernel are found in U.S. Patent Application No. 09/751,777, filed December 29, 2000.

A searcher PDP (power delay profile) is a data type used to store results returned from the searcher. In one embodiment of the invention, each searcher has  
5 one DSM and one PDP.

#### *Preamble Detection Engine 533*

A Preamble Detection Engine (PDE) kernel detects the presence of access bursts from new mobiles. A PDE is associated with one or more antennas. An access  
10 burst signal is used by a mobile to attempt access to a basestation, its time of transmission is random. In the methods of the present invention, a PDE object 533 is associated with a PDE kernel. The PDE object class 533 includes PDE\_new 535, for allocating a new PDE, as well as PDE\_add\_antenna 537, for adding an antenna to a PDE 533.

15

#### *Finger 417*

A finger kernel is a component of a RAKE receiver kernel. Each finger kernel of the RAKE receiver kernel is used to track an individual multipath signal over time. Multipath signals are caused when the signal emitted from a transmitter "bounces" off  
20 an object and arrives at the receiver through an alternate, delayed path. In a typical environment, multipaths are very dynamic in nature since a mobile is moving relative to reflecting objects. A RAKE receiver kernel is used to collect echos (multipath signals), align them in time, then accumulate the energy to produce the best possible signal strength. Each finger locks onto and tracks a particular multipath signal and  
25 demodulates the data associated with the signal for later combining with other multipaths. In addition to the fundamental demodulation of the incoming multipath, each finger kernel is required to continually update an estimate of channel quality in order to test for a minimum level of quality across the channel. Further details of finger kernels that are associated with the finger object class 417 of the present  
30 invention may be found in U.S. Patent Application No. 09/772,584.

A finger object 417 is used to control the corresponding finger kernel. In one embodiment of the present invention, each finger kernel used is associated with a

different Finger object 417 using an association process such as the one described below in conjunction with FIG. 11. The fingers can be combined using combiner object 411, or can remain independent. Finger object class 417 includes Finger\_new 541. Finger\_new 541 is invoked to allocate a new finger.

5           When Finger\_new 541 is called by a VMI application, a number of processing steps are performed by VMI 307. FIG. 11 is a flowchart that illustrates one embodiment of Finger\_new 541 in accordance with the present invention. The process begins at start 1102. In processing step 1104 a query is made as to whether error checking is to be performed. If error checking is to be performed (1104-Yes), a  
10          number of checks are performed before associating a new finger with a CBME.

          In check 1106, VMI 307 determines whether an instance of CBME\_new 503 has been called. The purpose of CBME\_new 503 is to create a CDMA basestation modem engine object 401. Thus, by barring allocation of a finger unless CBME\_new has been called (1106-No; 1140), check 1106 insures that fingers are not allocated to a  
15          nonexistent CDMA basestation modem engine object 401.

          In check 1108, VMI 307 determines whether CBME\_set\_mobile\_resources has been called. CBME\_set\_mobile\_resources configures the CDMA basestation modem engine object 401 for (a) the number of mobiles that can be supported and (b) the tracking finger block size for each mobile. CBME\_set\_mobile\_resources is called  
20          by VMI 307 after calling CBME\_get\_resource\_attributes, which returns the maximum number of fingers (max\_fingers) that may be associated with the CBME as well as the maximum number of tracking fingers supported by the CBME at its input clock rate. Using max\_fingers, a determination can be made, based on system requirements, on how many mobiles to support, and for each mobile, what will be the initial number of  
25          tracking fingers available to it. By barring allocation of a finger unless CBME\_set\_mobile\_resources been called (1108-No; 1140), check 1108 insures that fingers are not allocated to a CDMA basestation modem engine object that has not been properly initialized.

          Once CBME\_set\_mobile\_resources and CBME\_get\_resource\_attributes have  
30          been called, the CBME is properly initialized. Therefore, the maximum number of fingers that may be associated with the CBME is determined. Check 1110 insures that this maximum is not exceeded. If a request is made to associate a finger to a CBME

that already has the maximum number of fingers associated with it (1110-Yes), an error code 1140 is returned.

If error checking is disabled (1104-No) or all error checks are satisfied (1106-Yes; 1108-Yes; 1110-No), then normal processing steps 1120 through 1126 are performed by Finger\_new 541. In processing step 1120, the CBME finger count is incremented. The CBME finger count tracks the number of fingers that have been associated with the CBME. In processing step 1122, the finger that is to be associated with the CBME ("parent CBME") is set a known default state. In one embodiment, processing step 1122 resets the state of the finger in accordance with lines (201) through (206) of the following exemplary code.

---

```
(201) memset(p_finger, 0x00, sizeof(FINGER));
(202) p_finger->legal_static_attrib = M_FALSE;
15 (203) p_finger->toa_delay_valid = M_FALSE;
(204) p_finger->state = M_FINGER_STOPPED;
(205) p_finger->p_comb = NULL;
(206) p_finger->new_finger_called = M_FALSE;
```

---

20

In lines (201) through (206) of the exemplary code, p\_finger represents the finger that will ultimately be associated with the parent CBME in processing step 1126 (FIG. 11). In line (201) of the exemplary code, the entire finger kernel is zeroed. In line (202) of the exemplary code, the attribute "legal\_static\_attrib" is set to indicate that the finger kernel does not yet have a legal set of static or dynamic attribute data. In line (203) of the exemplary code, the attribute "toa\_delay\_valid" is set to "M\_FALSE" to indicate that the finger kernel does not have a valid time of arrival delay. In line (204) of the exemplary code, the attribute "state" is set to "M\_FINGER\_STOPPED" to indicate that the finger kernel is not running. In line (205) of the exemplary code, the attribute "p\_comb" is set to "NULL" to indicate that the finger object 417 has not been added to a combiner. Finally, in line (206) of the exemplary code, the attribute "new\_finger\_called" is set to "M\_FALSE" to indicate that a new finger has not been called.

In processing step 1124, the attribute "new\_finger\_called" is set to "M\_TRUE" to indicate that a new finger has been called. Finally, in processing step 1126, the finger object 417 is associated with a parent CBME. In one embodiment, processing step 1126 is performed by setting an attribute termed "p\_cbme" to the address of the parent p\_cbme. Such a command could be performed using line (207) of the exemplary code.

---

10 (207) p\_finger->p\_cbme = p\_cbme;

---

Exemplary code line (207) causes finger object 417 to become associated with CBME object 401. At the hardware level, exemplary code line 207 causes the finger kernel associated with p\_finger (Finger 417) to become associated with the combiner kernel associated with p\_cbme (CBME 401).

Returning attention to FIG 5, the Finger object class 417 further includes Finger\_set\_static\_attributes 543, Finger\_set\_dynamic attributes 545, Finger\_start 547, and Finger\_stop 549. Set\_finger\_static\_attributes 543 as well as the VMI object Set\_finger\_dynamic\_attributes 545 are used to set static and dynamic attributes for a finger, respectively. Finger\_start 547 and Finger\_stop 549 are used to start and stop a finger object 417, respectively.

#### *Combiner 411*

A combiner kernel combines the outputs of one or more finger kernels and sums them in accordance with a combining rule. In some embodiments, a combiner kernel is associated with one to sixteen finger kernels. In one embodiment of the present invention, each finger kernel is assumed to track a single multi-path and a set of finger kernels are set up for combining using VMI 307 (Fig. 3).

After time alignment of each stream, the outputs of the set of finger kernels are combined by arithmetically summing the outputs. In non-coherent IS-95 mode, for example, a combination operation such as a Hadamard Transform results in arithmetic summation of the outputs before entry into a soft decision device. In coherent-mode, each finger kernel provides an estimate of instantaneous channel energy and each is selected for combining based on a sufficiently large SIR. In one embodiment, the



largest and smallest instantaneous estimate is recorded for each finger kernel over a window of size K. The finger kernel is selected for combining if the following condition is true:

$$5 \quad \bar{S}_l(k) \geq \max\{S_{\min}(k) \cdot 10^{0.1\Delta_{noise}}, S_{\max}(k) \cdot 10^{-0.1\Delta_{rake}}\}$$

where,

"S over-bar" is the energy estimate and

$\Delta_{noise}$  and  $\Delta_{rake}$  are design parameters.

10

Combiner objects 411 are used to combine the outputs of one or more fingers based on a combining rule. Thus, a combiner object can be associated with 1 to N fingers. The Combiner object class 411 includes Combiner\_new 553, which is used to allocate a new combiner for a CBME 401. The Combiner object class 411 also includes  
 15 Add\_finger\_to\_combiner 555 and Remove\_finger\_from\_combiner 557 which are respectively used to add a finger 417 to or remove a finger 417 from a Combiner object 411. The Combiner object class 411 also includes Combiner\_start 559 and Combiner\_stop 561, which are respectively used to start and stop a Combiner object 411.

20

#### *Uplink 403 and Downlink 567*

In CDMA, logical channels include the control and traffic channels. The traffic channels are used to carry user information, along with signaling traffic, between the basestation and the mobile station. The control channels comprise  
 25 downlink channels and uplink channels. Accordingly, VMI 307 provides an uplink object 403 and a downlink object 567.

Uplink object 403 is used to group Combiners 411 along with their respective attached Fingers 417 as well as Searchers 413 that are common to a mobile uplink. Typically, Combiners 411 and Searchers 413 are added to an Uplink. In some  
 30 embodiments of VMI 307, there is no limit to the number of Uplink objects 403 that can be declared. Uplink object class 403 includes Uplink\_new 565, which is used to

allocate a new uplink. Downlink object class 567 includes Downlink\_new 569, which is used to allocate a new downlink.

*Tx Multicode Channel 571*

5 Transmit multicode channel object 571 includes MTX\_new 573. MTX\_new 573 is used to allocate a Transmitter channel.

*Static versus Dynamic Attributes*

In some embodiments, objects Set\_searcher\_static\_attributes 517 and  
10 Set\_finger\_static\_attributes 543 are called to set static attributes when the underlying hardware is not running or is off-line. For example, static attributes of a searcher object may be set by calling Set\_searcher\_static\_attributes 517 upon a power-up or reboot of the system or if the pertinent objects are not running. On the other hand,  
objects Set\_finger\_dynamic\_attributes 545 and Set\_searcher\_dynamic\_attributes 519  
15 are called regardless of whether the underlying hardware is running or not, allowing the dynamic attributes to be set "on the fly."

*Additional VMI 307 objects*

In addition to the VMI objects illustrated in FIG. 5, VMI 307 includes  
20 additional software objects such as a matched filter. The matched filter VMI object is used to control the corresponding matched filter kernel. The matched filter is a faster version of a searcher kernel, but the matched filter kernel is not as configurable as the searcher kernel. In one embodiment of the invention, the matched filter is used when the underlying reconfigurable wireless network communication apparatus 311 (FIG. 3)  
25 is configured for 3GPP mode. In another embodiment of the present invention, a matched filter may be used in either a multi-standard CDMA traffic channel receiver or a RACH-type receiver (3GPP) and both coherent and noncoherent accumulation modes are allowed.

Although certain methods and objects have been described with respect to FIG.  
30 5, it will be apparent to one skilled in the art that other objects and methods may be defined and used as appropriate in conjunction with the invention. Further, some objects may be combined or divided. For example, the searcher and finger objects

may be combined to form a single object. In another embodiment, the searcher and finger may be further divided into multiple objects.

The VMI of the present invention is designed to synchronize respective hardware kernels with corresponding software objects so that a manipulation of VMI objects within the VMI causes an analogous change in the hardware. To this end, each software object has one or more corresponding hardware components in the underlying hardware CBME. For example, CBME 401 corresponds to and controls a CBME (CDMA BTS engine). Uplink 403 corresponds to and controls the uplink hardware components and searcher 413 corresponds to and controls a hardware searcher in the CBME. Thus, in one embodiment, there is at least one hardware module for each VMI software object. In alternate embodiments of the invention, there may be a many-to-one correspondence between software objects and the counterpart hardware kernel. This is possible when one hardware kernel is configured to support multiple counterpart software objects in a time-sliced fashion. For example, one hardware searcher kernel may support many software searcher objects if the latter can be serviced by the hardware kernel in a time multiplexed fashion. In still other embodiments, there may be a many-to-one correspondence between hardware kernels and a VMI software object.

FIG. 6 illustrates the relationship between software objects and counterpart hardware kernels in accordance with one aspect of the present invention. In the example shown in FIG. 6, the programmer instantiates the following objects from the VMI library: searcher1 601, searcher2 603, CGU 605, combiner 607, matched filter 609, "finger1" 611, and "finger2" 613 in order to enable a particular communication protocol. In response to the user's instantiation of the objects, the hardware configures the following kernels: searcher 615, CGU 617, combiner 619, matched filter 621, and finger 623. Once the software objects are instantiated and the hardware kernels are configured, the user can manipulate the software objects through various functions in order to control and coordinate the functions of the corresponding hardware kernels.

As FIG. 6 illustrates, there is a hierarchical relationship among VMI objects in one embodiment of the present invention. On the hardware side, hardware kernels, 615, 617, 619, 621 and 623 are coupled to each other via a reconfigurable interconnect

625. As FIG. 6 illustrates, there is at least one hardware kernel for each instantiated object in the VMI in some embodiments of the present invention. For example, the CGU 605, combiner 607, and matched filter 609 are each supported by hardware counterparts: CGU 617, combiner 619 and matched filter 621. However, it is also possible for one hardware kernel to support a plurality of VMI objects. For example, in FIG. 6, searcher objects 601 and 603 are supported by a single searcher kernel 615. Such single-kernel-to-multiple-object correspondence is possible if searcher objects 601 and 603 can be serviced by the single searcher kernel 615 in a time multiplexed fashion.

As discussed above, the VMI objects illustrated in FIG. 6 are designed to synchronize the corresponding hardware kernels so that a manipulation of the VMI objects causes an analogous change in the hardware components. For example, if the user changes a parameter in a searcher object 601, for instance the sub-chip resolution value of the searcher object 601, that change will be reflected in the corresponding hardware kernel 615 within the appropriate time interval.

Although a searcher, finger, combiner, code generation unit and matched filter are shown in FIG. 6, it will be appreciated by one skilled in the art that as many hardware kernels and corresponding software objects may be created and utilized according to the needs and requirements of a particular communication system as may be permitted by the available resources. Various VMI objects can be instantiated, parameterized and reconfigured to accommodate and adapt to the unique requirements of various communication protocols. For example, when a CDMA protocol is used, a MPSK (multiple phase shift keying) demodulator object, a convolutional decoder object, and a rake receiver object are instantiated and parameterized to configure the corresponding hardware modules. On the other hand, when a TDMA protocol is used, an MPSK demodulator object, a convolutional decoder object, and an MLSE equalization object are instantiated and parameterized according to TDMA system specifications.

FIG. 7(A) is a flowchart illustrating one embodiment of a VMI software object in accordance with the invention. In step 701, an object, for example a searcher object, allocates hardware resources of the reconfigurable wireless network communication apparatus 311 for implementing a searcher hardware kernel(s). In step

701, hardware memory resources and processing resources are secured and allocated to implement a searcher. In step 703, the object configures hardware resources allocated in step 701 to perform a function such as a searcher function. In step 705, the VMI software object generates and communicates messages to virtual machine 5 309 that incorporate information regarding allocation and configuration of the hardware resources performed in steps 701 and 703. The information regarding the allocation and configuration can be translated by the virtual machine 309 into machine-readable instructions and relayed to the reconfigurable wireless network communication apparatus 311.

10 After the resource allocation and configuration are performed in steps 701 and 703, the actual allocation and configuration of the hardware resources are performed by the resource allocator of the reconfigurable wireless network communication apparatus 311, based on the machine-readable instructions provided by the virtual machine 309.

15 FIG. 7(B) is a flowchart illustrating an alternate embodiment of a VMI software object in accordance with the invention. The flowchart in FIG. 7(B) represents a VMI software object that is protocol-dependent, i.e., one that requires protocol-specific information. The steps performed in FIG. 7(B) are similar to the steps in FIG. 7(A) except for step 707. In step 707, the software object obtains 20 protocol-specific information downloaded via a scan chain. The protocol-specific information is used to initialize the state of the reconfigurable wireless network communication apparatus 311. For example, a transmitter VMI object needs information as to what type of communication protocol is desired. In one case, if a CDMA protocol is used, the transmitter VMI object obtains relevant information in 25 step 707 in order to allocate and configure hardware resources in steps 709 and 711. In step 713, the VMI object generates and communicates messages to virtual machine 309 that incorporate information regarding allocation and configuration of the hardware resources performed in steps 709 and 711. The information regarding the allocation and configuration can then be translated by the virtual machine 309 into 30 machine-readable instructions and relayed to the reconfigurable wireless network communication apparatus 311.

FIG. 8 is a flowchart illustrating the instantiation and parameterization of various objects of the VMI to accommodate the system requirements of a communication protocol. In step 801, a program selects a communication protocol. Alternatively, an initialization of the system may be performed prior to step 801.

5 Different embodiments may be used to initialize the system. In a preferred embodiment, a scan chain technique is used to download initialization information into the reconfigurable wireless network communication apparatus. For example, if a CDMA communication protocol is used, CDMA-related data and parameters are downloaded into the memory of the reconfigurable wireless network communication  
10 apparatus 311 or into any memory device that the software virtual machine interface 307 can access. The scan chain technique is well-known in the art, and not described in detail so as not to obscure important aspects of the present invention.

In step 803, the programmer determines what objects to instantiate and use for the protocol determined in step 801. In step 805, the programmer instantiates an  
15 object, and continues until all necessary objects have been instantiated. In step 809, the programmer parameterizes each object instantiated according to the system specification of the protocol. When the parameterization is complete in step 811, the programmer continues to the next task.

Alternatively, the programmer may combine instantiation and parameterization  
20 in step 805. In other words, the programmer may instantiate and parameterize each object in step 805, instead of performing a separate parameterization step in 809. Thus, the present invention provides the ability to instantiate different VMI objects in steps 805 through 807 and to give different parameters to the instantiated objects in steps 809 through 811 in order to accommodate different protocols. Once instantiated,  
25 VMI objects control and coordinate functions of the corresponding hardware kernels in order to perform a given task. Reconfiguration and parameterization of corresponding hardware kernels are described in U.S. Patent Application No. 09/772,584.

FIG. 9 is an example of an object instantiation and parameterization routine  
30 performed by steps 803-811. One or more CBME objects can be instantiated, provided there is one physical CBME hardware counterpart for every software CBME object. A CBME object is created in step 901 by calling object CBME\_new 503.

Then a new searcher object is created in step 903 by object Searcher\_new 515. In step 905, the new searcher is parameterized by setting its static and dynamic attributes with object Set\_searcher\_static\_attributes 517 as well as Set\_searcher\_dynamic\_attributes 519. In step 907, an uplink object is created by calling object Uplink\_new 565. It will  
 5 be apparent to one skilled in the art that other objects may be instantiated and parameterized in a similar fashion.

FIG. 10 is an example of a VMI searcher object 413 receiving various parameters to optimize a search pattern with controlled search throughput. In FIG. 10, the programmer specifies the following parameters: the number of searchers, window  
 10 size of searchers, sub-chip resolution for searchers, starting offset for searchers, and code generation parameters (1001). The system may construct a single fast searcher, many slower searchers, or any combination thereof. Block 1003 illustrates an abstraction of a searcher object.

In one embodiment of the invention, a searcher can be optimized in different  
 15 ways. For example, in order to minimize dropped phone calls in a wireless terminal application, a programmer may decide to allocate the majority of search resources to detecting new multi-paths for existing calls at the expense of detecting new calls. The present invention allows such dynamic reallocation of search resources and parameterization at 1005 and 1007, performed by a searcher VMI object. For  
 20 example, at a peak number of callers, the searchers can be prioritized for minimum dropped calls whereas at a lower number of callers, the searchers can be prioritized to minimize the detection time of new callers.

In the embodiment shown in FIG. 10, blocks 1003 through 1009 are implemented by a VMI searcher object 413. Hardware/software interface 1009  
 25 provides an interface between the VMI searcher object 413 and BTS modem 1011.

Now that the basic operation of various VMI 307 objects has been described, a detailed example of an Application program 301 will be described to further illustrate the advantages of the present invention. In this example, a CBME 401 is created, a searcher 413 is created and associated with the CBME and then the searcher is started.

30

---

```
(301) void DFS_Pre_Simulation_Hook(void)
(302) {
```

```

(303) UINT16 i;
(304) UINT16 fcount, scount;
(305) UINT16 cgu_index = -1;
(306) UINT16 stat = 0;
5 (307) UINT16 delay = 0;
(308) UINT16 fractional_delay = 0;
(309) UINT16 cgu_counter = 0;

(310) /* open the PDP output file */
10 (311) p_pdp_file = fopen(pdp_filename, "w");

(312) /* first set up a CBME */
(313) p_cbme = malloc(sizeof(CBME));
(314) stat |= CBME_new(p_cbme, DEFAULT_CBME_ADDR, M_MERGE_INT);
15 (315) stat |= CBME_Set_Mobile_Resources(p_cbme, VMI_FOUR_FING_BLK,
(316) VMI_SIXTY_FOUR_MOBS);

(317) /* perform CBME self test 0, not effect for now... */
20 (318) stat |= CBME_Perform_Self_Tests(p_cbme, VMI_TEST0); /** VMI call **/

(319) /* set up a CGU for the uplink */
(320) stat |= CBME_Get_CGU_List(p_cbme, &cgu_list);
(321) for (i=0; i<cgu_list.num_on_chip_cgus; i++)
25 (322) {
(323) if (cgu_list.cgu_attributes[i].cgu_object_type == M_UPLINK_CGU)
(324) {
(325) cgu_index = cgu_list.cgu_attributes[i].cgu_index;
(326) }
30 (327) }
(328) if (cgu_index == -1)
(329) {
(330) fprintf(stderr, "error: Unable to find CGU type in CGU list\n.");
(331) }
35 (332) p_ul_cgu = malloc(sizeof(CGU));
(333) stat |= CGU_new(p_cbme, p_ul_cgu,
(334) cgu_index, VMI_CGU_CODE_NUMBER);

(335) /* set up an uplink */
40 (336) p_ul = malloc(sizeof(UPLINK));
(337) stat |= Uplink_New(p_cbme, p_ul, p_ul_cgu);

(338) /* set up a combiner */
(339) p_comb = malloc(sizeof(COMBINER));
45 (340) stat |= Combiner_New(p_cbme, p_comb);

(341) /* add combiner to the uplink */

```



```

(342) stat |= Uplink_Add_Combiner(p_ul, p_comb);

(343) /* set up 1 finger */
(344) for (fcount = 0; fcount < num_fingers; fcount++)
5 (345) {
(346)   p_fing = malloc(sizeof(FINGER));
(347)   stat |= Finger_New(p_cbme, p_fing);
(348)   /* set up the finger in the combiner */
(349)   stat |= Finger_Set_Static_Attributes(p_fing, &fing_stat_attrib);
10 (350)   stat |= Finger_Set_Dynamic_Attributes(p_fing, &fing_dynamic_attrib);
(351)   stat |= Add_Finger_To_Combiner(p_comb, p_fing);
(352)   /* set finger position */
(353)   stat |= Finger_Set_Offset(p_fing,
(354)     fing_offset[fcount], fing_frac_offset[fcount]);
15 (355) }

(356) stat |= Combiner_Start(p_comb);
(357) assert(stat == 0);

20 (358) /* set up a searcher */
(359) stat |= CBME_Set_Searcher_Energy_Scaling(p_cbme,
(360)     M_SEARCHER_SCALE_19_8);
(361) stat |= CBME_Set_Search_Time_Period(p_cbme, TIMER_CONSTANT);
(362) p_searcher = malloc(sizeof(SEARCHER));
25 (363) stat |= Searcher_New(p_cbme, p_searcher,
(364)     M_EXISTING_MOBILE_SEARCHER, NULL);
(365) stat |= Searcher_Set_Existing_Mobile_Static_Attributes(p_searcher,
(366)     &searcher_static_attrib);
(367) assert(stat == 0);

30 (368) /* set up a searcher DSM */
(369) stat |= CBME_Set_DSM_Subchip_Phase(p_cbme, VMI_DSM_HP_LOW,
(370)     VMI_DSM_HP_HIGH,
(371)     VMI_DSM_1QP_LOW,
35 (372)     VMI_DSM_1QP_HIGH,
(373)     VMI_DSM_2QP_LOW,
(374)     VMI_DSM_2QP_HIGH);
(375) p_dsm = malloc(sizeof(SEARCHER_DSM));
(376) stat |= Searcher_DSM_New(p_cbme, p_dsm,
40 (377)     M_DSM_HALF_CHIP, num_dsm_states);
(378) assert(stat == 0);

(379) /* set up each state of the DSM */
(380) for (scount = 0; scount < num_dsm_states; scount++)
45 (381) {
(382)   stat |= Searcher_DSM_Set_State_Attributes(p_dsm,
(383)     scount, VMI_DSM_INT_LEN,

```

```

(384)          VMI_DSM_PDI_LEN,
(385)          VMI_DSM_THRESHOLD);
(386)          assert(stat == 0);
(387) }
5
(388) /* assign the DSM to the searcher */
(389) stat |= Searcher_Assign_DSM(p_searcher, p_dsm);
(390) assert(stat == 0);

10 (391) /* add searcher to the uplink */
(392) stat |= Uplink_Add_Searcher(p_ul, p_searcher); assert(stat == 0);

(393) /* start the searcher */
(394) stat |= Searcher_Start(p_searcher);
15 (395) assert(stat == 0);

(396)} /* end DFS_Pre_Simulation */

```

---

20 Lines 301 through 396 will now be described in detail.

Step 1: (lines 301 - 311) In Step 1, the procedure "DFS\_Pre\_Simulation\_Hook" is defined. This procedure will create a CBME 401 and start a searcher 413. Further, in lines 301 through 311, various variables that are used  
25 by the procedure are defined. Finally, a file for writing out a power delay profile (PDP) is opened.

Step 2: (lines 313 - 316) VMI 307 object CBME\_new 503 is used create a CBME 401. The mobile resources for the newly created CBME 401 are defined using  
30 the VMI 307 object CBME\_set\_mobile\_resources.

Step 3: (lines 317 - 318) The VMI 307 object CBME\_Perform\_Self\_Tests is executed to test the newly created CBME 401.

35 Step 4: (lines 319 - 334) VMI 307 objects are used to obtain a code generation unit 507 for an uplink. First, the list of possible CGUs available is obtained. For each available CGU, a check is performed to insure that the CGU has the object type

"M\_UPLINK\_CGU." When a CGU having this attribute is found, it is initialized and assigned to the newly created CBME 401 using the VMI 307 object CGU\_new 509.

Step 5: (lines 335 - 337) An uplink 403 is associated with the newly created  
5 CBME 401 using VMI 307 object Uplink\_new 565.

Step 6: (lines 338 - 342) A Combiner 411 is assigned to the newly created  
CBME 401 using the VMI 307 objects Combiner\_new 553 and  
Uplink\_Add\_Combiner.

10

Step 7: (lines 343 - 357) VMI 307 objects Finger\_New 541,  
Add\_Finger\_To\_Combiner 555, and Finger\_Set\_Offset are buried in a loop so that  
"num\_finger" fingers can be created, added to the newly created CBME 401 and set to  
an appropriate position. In one embodiment, the value of num\_finger is set to "1" so  
15 that only one finger is added during step 7. Once the combiner has been appropriately  
populated with one or more fingers, the Combiner 411 is started with the VMI 307  
command Combiner\_start 559.

Step 8: (lines 358 - 367) A searcher is defined. First, the VMI 307 object  
20 CBME\_Set\_searcher\_energy\_scaling is run. Internally, CBME 401 generates a 32-bit  
search result value. However, in some embodiments of the present invention, only 12  
bits are reported to the microprocessor. CBME\_set\_searcher\_energy\_scaling sets the  
range of energy bits to report to the microprocessor. Next, the VMI 307 object  
CBME\_Set\_Search\_Time\_Period is executed. This function sets the search period for  
25 all searchers under a CBME 401. The search period is nominally 50 milliseconds and  
is defined by the following formula:

$$\text{timer\_constant} = (\text{input\_chipping\_rate} * \text{search\_period}) / 256$$

30 As an example, presume that the desired search period is 50 milliseconds and that the  
input chipping rate is 3.84 Mcps. Then:

$$\text{timer\_constant} = (3.84\text{E}6 * 50\text{E}-3) / 256 = 750$$

The minimum duration for the timer setting should be such that it does not restart a new search before the completion of the previous search.

5           Once the time period has been set, the VMI 307 command Searcher\_New 515 is used to assign a Searcher to the newly created CBME 401 and the static attributes of the searcher are defined using VMI 307 object Searcher\_set\_existing\_mobile\_static\_attributes. In one embodiment, because the Searcher is set up as an 'existing mobile' searcher the following conditions must be satisfied before a Searcher is started: (i) 10 Searcher\_set\_existing\_mobile\_static\_attributes must be called, (ii) the Searcher 413 must be added to an uplink 403, and (iii) a Combiner 411, with at least one Finger 417 must have been added to uplink 403 and the Combiner 411 must have been started.

Step 9: (lines 368 - 392) Once a Searcher 413 has been defined, a Searcher 15 DSM 421 is created and assigned to the Searcher. Using VMI 307 objects, a Searcher DSM 421 is created and assigned to a Searcher in three stages (i) setting up the Searcher DSM 421 (lines 368 - 378), (ii) setting up the state of Searcher DSM 421 (lines 379 - 387), and (iii) assigning the Searcher DSM 421 to the Searcher 413 (lines 388-390). More specifically, in order to set up a Searcher DSM 421, the VMI 307 20 object CBME\_set\_DSM\_subchip\_phase is used to configure the DSM subchip phase. Then, the VMI 307 object Searcher\_DSM\_new is used to obtain a searcher DSM 421 on lines 376 and 377 of the illustrative code. Each state of the Searcher DSM 421 is then set up using the VMI 307 object Searcher\_DSM\_set\_state\_attributes on lines 382 through 386 of the illustrative code. Once each state of the Searcher DSM 421 has 25 been set, the Searcher DSM is assigned to the searcher 413 that was defined in step 8. Further, in lined 392 of the illustrative code, the Searcher 413 is added to the Uplink 403 that was associated in step 5 with the newly created CBME 401.

Step 10: (lines 393-396) In the final step of this illustrative example, Searcher 30 413 is started with VMI 307 object Searcher\_start 521. The process ends on line 396 of the illustrative code with a return to the calling function.

### Application Translation

A sophisticated virtual machine interface (VMI) has been described. Further, the function of several VMI objects or procedures in accordance with one embodiment of the present invention have been introduced. In addition, the detailed processing  
5 steps performed by two such VMI objects, Finger\_new 541 (FIG. 11) and Searcher\_new 515 (FIG. 12) have been described in detail. From these examples, one of skill in the art will appreciate that the VMI 307 of the present invention facilitates the rapid adaptation of a reconfigurable wireless network communication apparatus from supporting one communication protocol, such as CDMA, to supporting another  
10 communication protocol, such as a different form of CDMA or, indeed, even TDMA.

The VMI 307 of the present invention is an example of an approach to providing high level programming support for a reconfigurable wireless network communication apparatus. Such high level programming frees a programmer from the intricacies of setting the appropriate state for each of the hardware kernels as  
15 otherwise necessary to support a given communication protocol. Referring to FIG. 13, a programmer uses VMI 307 by writing Application programs 1304 which include VMI function calls.

As shown in FIG. 13, the methods of the present invention provide an even higher level of programming control over an apparatus 311. For instance, Application  
20 programs 1302 are in general higher level programs for configuring an apparatus 311 than Application programs 1304. Application translation mechanism 1306 translates Application program 1302 into a language recognize by virtual machine 309. In some embodiments, Application Translation 1306 translates Application program 1302 into instructions that are recognized directly by reconfigurable wireless network  
25 communication apparatus 311 and a virtual machine 309 is not used. In other embodiments, Application Translation translates Application program 1032 into instructions that include VMI instructions. Exemplary codes lines 301 through 396, above, detail an exemplary Application program 1304 whereas Exemplary code line 401, below, illustrates an exemplary Application program 1302.

30 In FIG. 13, the relationship between an Application program 1302 and an underlying object-oriented, reconfigurable wireless network communication apparatus 311, in accordance with one embodiment of the present invention, is detailed. One

characteristic of Application program 1302 is that it uses a limited instruction set to reconfigure the communication protocol used by the associated reconfigurable wireless network communication apparatus 311. For example, in one embodiment, a representative Application program 1302 that requests a mobile to communicate using  
5 wideband CDMA (WCDMA) protocol has the form of illustrative code line 401:

---

```
(401) Set_Communication_Protocol = WCDMA;
```

---

10

A comparison of illustrative code lines 301 through 396, which represents a program of format 1304 (FIG. 13), to the program represented by illustrative code line 401, which represents a program of format 1302, provides one example of how usage of an application translation 1306 layer can be used to simplify the task of a  
15 programmer who is reconfiguring a reconfigurable wireless network communication apparatus 311 to support a different communication protocol.

While FIG. 13 distinguishes between an Application program 1302 and 1304, the present invention contemplates any number of variants of Application program 1302 and 1304. For example, in some embodiments, Application translation 1306  
20 uses VMI objects 307 as well as a scan chain binary to support an Application program 1302. In other embodiments, Application translation 1306 uses VMI objects 307 and does not use a scan chain binary.

Reference will now be made to FIGS. 14 and 15 in order to illustrate the advantage of one embodiment of the present invention in which an Application  
25 program 1302 (FIG. 13) is used to set the communication protocol for a basestation. In particular, FIG. 14 details the processing steps that are performed in response to the execution of an Application program 1302 such as the one provided by illustrative code line 401 above.

In processing step 1402, application translation 1306 allocates a CBME object  
30 401 using a software routine such as CBME\_new 503. In processing step 1404 the RAM scan chain is sent to the basestation using a VMI 307 software routine such as CBME\_scan\_chain\_write. Processing step 1404 is used to initialize a number of on-board CBME RAMs within the basestation. Each of these RAMs can be of a different bit width and word depth. In the embodiment shown in FIG. 14, the RAM

CBME scan chain is separated from writing from other scan chains because writing from the RAM scan chain corrupts the data from other scan chains. In processing step 1406, all other scan chains are written to the CBME.

The scan chains that are written to the basestation are summarized in FIG. 15.

5 In FIG. 15, CBME Config Tools 1514 are used to write a scan chain binary 1516 based on appropriate parameterization of  $\mu$ DSP parameters 1502, DLL early/late settings 1504,  $\mu$ DSP code 1506, types of code generation 1508, slot formats 1510, and antenna modes 1512. Scan chain binary 1516 therefore consists of microcode for CBME processor elements and parameters for CBME RAM which set items such as  
10 decimator taps, interpolator taps, DLL taps, DLL microcode, rate selection, PDE vs. FHT, bypass decimator mode selection, enable/disable TFCI input, PDEs antenna selection, CGU polynomials, and CGU microcode as well as many other hardware settings.

In processing step 1408, the resources available within reconfigurable wireless  
15 network apparatus are determined using a querying routine such as VMI 307 object CBME\_Get\_Resource\_Attributes. Processing step 1408 will return the maximum number of fingers available to CBME 401 at the input clock rate supplied by the basestation. In processing step 1410 a determination is made on how many mobiles to support. This decision is based on the number of fingers available to CBME 401 that  
20 was calculated in processing step 1408. Further, in processing step 1410, for each mobile that will be supported by CBME 401, a decision is made on the initial number of tracking fingers available to the mobile. In one embodiment, processing step 1410 is executed using VMI 307 object CBME\_set\_mobile\_resources.

In processing step 1412, the search periodicity of each searcher that will  
25 support CBME 401 is set using a routine such as VMI 307 object CBME\_set\_search\_periodicity. Further, in processing step 1414, the energy range limits that each searcher will be allowed to report is defined using a routine such as VMI 307 object CBME\_set\_searcher\_energy\_scaling. In processing step 1416 the subchip phase of the searcher DSM associated with each searcher that will support the  
30 CBME is set using a routine such as VMI 307 object CBME\_set\_DSM\_subchip\_phase.

In processing step 1418, Preamble Detection Engine (PDE) parameters are defined. Each PDE is assigned a specific mode of operation and an access slot within the basestation. In some basestations in accordance with the present invention, a PDE can be associated with one to eight antennas depending on its mode. In some  
5 embodiments, the VMI 307 function CBME\_Set\_PDE\_Num\_Slots configures the total number of access slots for the specific communication standard requested by application program 1302 (FIG. 13) as well as the number of PDE time slots.

In processing step 1420, the number of CGUs that are available in the basestation is obtained using a command such as VMI 307 object  
10 CBME\_get\_CGU\_list. Then, in processing step 1422, the list of downlink slot formats that are available on the CBME is retrieved. In processing step 1424, the list of multiplexed transmission fields available within the basestation is retrieved using a routine such as VMI 307 object CBME\_get\_downlink\_field\_list. Finally, in  
15 processing step 1426, the uplink slot formats that are available are retrieved using a routine such as VMI 307 object CBME\_get\_uplink\_slot\_format\_list.

The VMI of the present invention may be implemented in conjunction with any suitable operating system: real time operating system (RTOS) or non-RTOS. For example, in one embodiment of the invention, the VMI is integrated with a real time operating system (RTOS). In RTOS environment, any preemptive, multi-tasking  
20 operating system that supports counting semaphores may be used to support the VMI. A typical example of non-RTOS integrated with the VMI of the present invention is a round robin based operating system.

### ALTERNATIVE EMBODIMENTS

25 While reference was made to a Cellular Basestation Modem Engine (CBME) object 401 when describing VMI 307, it will be appreciated that VMI 307 may be used not only for changing or modifying the attributes of one or more communication protocols used by a basestations, but in fact, the communication protocol used by any reconfigurable wireless network communication apparatus including a mobile.  
30 Accordingly, in such alternative embodiments, parameters within the CBME object 401 may be modified, added or deleted in order to adopt to the specific hardware attributes of a particular reconfigurable wireless network communication apparatus.



While VMI 307 objects were typically referred to as objects such as those found in an object oriented language, it will be appreciated that this representation serves merely as an example. In various embodiments of the present invention, the VMI 307 software objects (objects) of the present invention are objects, object classes, sets of objects, sets of object classes, procedures, sets of procedures, functions, or sets of functions. What is common to all VMI 307 software objects of the present invention is that they run to a completed state when called. This feature is advantageous because it allow the software VMI 307 objects of the present invention to be operated in an operation system free environment. As used herein, a completed state is includes both a successful operation, such as the acquisition of a finger kernel by Finger\_new 541, or an error code upon failure to achieve a task.

### CONCLUSION

A VMI and API have been described in conjunction with a reconfigurable wireless network communication apparatus. Unlike conventional wireless communication apparatuses, the present invention provides a flexible and efficient platform that can easily adapt to various wireless communication protocols. Also, the VMI and API of the present invention abstract the details and specifics of the underlying communication hardware so that a programmer can prepare an application program without having to change or know the specific configuration requirements of the underlying hardware.

As described above, the VMI of the present invention provides a programmer interface to the underlying CBME hardware kernel, providing reconfigurability and flexibility necessary to take advantage of the reconfigurability and flexibility of the underlying CBME kernel. The VMI of the present invention synchronizes the hardware kernels, which comprise the CBME, with corresponding software objects so that a manipulation of the VMI objects causes an analogous change in the hardware. In one embodiment, each software object has one or more corresponding hardware components in the underlying hardware CBME.

The foregoing description, for purposes of explanation, used specific nomenclature to provide a thorough understanding of the invention. However, it will be apparent to one skilled in the art that the specific details are not required in order to

practice the invention. In other instances, well known components and devices are shown in block diagram form in order to avoid unnecessary distraction from the underlying invention. Thus, the foregoing descriptions of specific embodiments of the present invention are presented for purposes of illustration and description. They are not intended to be exhaustive or to limit the invention to the precise forms disclosed, obviously many modifications and variations are possible in view of the above teachings. Obviously, the embodiments were chosen and described in order to best explain the principles of the invention and its practical applications, to thereby enable others skilled in the art to best utilize the invention and various embodiments with various modifications as are suited to the particular use contemplated. It is intended that the scope of the invention be defined by the following claims and their equivalents.

WHAT IS CLAIMED IS:

1. An object-oriented virtual machine interface for a reconfigurable wireless  
5 network communication apparatus;  
said reconfigurable wireless network communication apparatus comprising a plurality of kernels; and  
said object-oriented virtual machine interface comprising a plurality of software objects including a first subset of said software objects, each software object  
10 in said first subset of said software objects associated with a different kernel in said plurality of kernels so that a change to a software object in said first subset of said software objects results in a change in said kernel associated with said software object.
2. The object-oriented virtual machine interface of claim 1 wherein said plurality  
15 of software objects includes a second subset of said software objects, each software object in said second subset of said software objects having at least one adjustable attribute.
3. The object-oriented virtual machine interface of claim 2 wherein said as least  
20 one adjustable attribute is a static or dynamic attribute.
4. The object-oriented virtual machine interface of claim 1 wherein a kernel in  
said plurality of kernels is configurable in accordance with a communication protocol.
- 25 5. The object-oriented virtual machine interface of claim 4 wherein said selected communication protocol is a CDMA (code division multiple access) protocol.
6. The object-oriented virtual machine interface of claim 4 wherein said  
communication protocol is selected from the group consisting of IS-95 CDMA,  
30 IS-95B CDMA, CDMA TIA IS2000, TIA IS 2000A, wideband CDMA (WCDMA), cdma2000, and ARIB WCDMA.

7. The object-oriented virtual machine interface of claim 4 wherein said selected communication protocol is a time division multiple access (TDMA) protocol.

35

8. The object-oriented virtual machine interface of claim 7 wherein said communication protocol is IS-136 TDMA.

9. The object-oriented virtual machine interface of claim 1 wherein a software object in said plurality of software objects is a searcher object, a code generation unit object or a finger object.

40

10. The object-oriented virtual machine interface of claim 1 wherein a software object in said plurality of software objects is a matched filter object or a combiner object.

45

11. The object-oriented virtual machine interface of claim 1 wherein a software object in said plurality of software objects is an uplink object or a downlink object.

12. The object-oriented virtual machine interface of claim 1, said plurality of software objects comprising a searcher object, a code generation unit object, a finger object, a matched filter object, a combiner object, an uplink object and a downlink object; and

50

said plurality of kernels comprising a searcher kernel, a code generation unit kernel, a finger kernel, a matched filter kernel, a combiner kernel, an uplink kernel and a downlink kernel; wherein:

55

said searcher object is associated with said searcher kernel;

said code generation unit object is associated with said code generation unit kernel;

60

said finger object is associated with said finger kernel;

said matched filter object is associated with said matched filter kernel;

said combiner object is associated with said combiner kernel;

said uplink object is associated with said uplink kernel; and

and said downlink object is associated with said downlink kernel.

65 13. An object-oriented reconfigurable system comprising an object-oriented virtual machine interface, a virtual machine and a reconfigurable apparatus,  
said reconfigurable apparatus coupled to said virtual machine and comprising a plurality of kernels; and

70 said object-oriented virtual machine interface coupled to said virtual machine and comprising a plurality of software objects including a first subset of said software objects, each software object in said first subset of said software objects associated with a different kernel in said plurality of kernels such that a change to a software object in said first subset of said software objects results in a change in said kernel associated with said software object.

75

14. The object-oriented reconfigurable system of claim 13 wherein said plurality of software objects includes a second subset of said software objects, each software object in said second subset of said software objects having at least one adjustable attribute.

80

15. The object-oriented reconfigurable system of claim 14 wherein said at least one adjustable attribute is a static or dynamic attribute.

85 16. The object-oriented reconfigurable system of claim 13 further comprising:  
an application program interface comprising a plurality of software routines, each software routine in said plurality of software routines representing a different communication protocol, wherein said plurality of software routines comprise software calls to said plurality of software objects; and

90 an application program comprising software calls to said plurality of software routines.

17. The object-oriented reconfigurable system of claim 16 further comprising:  
a compiler within said virtual machine to translate said application program into machine-readable instructions executable on said object-oriented reconfigurable  
95 system.

18. The object-oriented reconfigurable system of claim 17 further comprising:  
a resource allocator within said object-oriented reconfigurable system, said  
5 resource allocator configured to receive said machine-readable instructions and issue a  
signal to configure a kernel in said plurality of kernels.
19. The object-oriented reconfigurable system of claim 13 further comprising:  
an application program for utilizing said plurality of software objects.
- 10 20. The object-oriented reconfigurable system of claim 19 further comprising:  
a compiler within said virtual machine to translate said application program  
into machine-readable instructions executable on said object-oriented reconfigurable  
system.
- 15 21. The object-oriented reconfigurable system of claim 20 further comprising:  
a resource allocator configured to receive said machine-readable instructions,  
and issue a command signal to control a kernel in said plurality of kernels.
- 20 22. The object-oriented reconfigurable system of claim 13 wherein a software  
object in said plurality of software objects is a searcher object, a code generation unit  
object a finger object, an uplink object or a downlink object.
- 25 23. The object-oriented reconfigurable system of claim 13,  
said plurality of software objects in said first subset of said software objects  
comprising a searcher object, a code generation unit object, a finger object, a matched  
filter object, a combiner object, an uplink object and a downlink object; and  
said plurality of kernels comprising a searcher kernel, a code generation unit  
kernel, a finger kernel, a matched filter kernel, a combiner kernel, an uplink kernel and  
30 a downlink kernel; wherein:  
said searcher object is associated with said searcher kernel;  
said code generation unit object is associated with said code generation unit  
kernel;  
said finger object is associated with said finger kernel;

- said matched filter object is associated with said matched filter kernel;  
said combiner object is associated with said combiner kernel;  
5 said uplink object is associated with said uplink kernel; and  
and said downlink object is associated with said downlink kernel.
24. The object-oriented reconfigurable system of claim 13 wherein said plurality  
of kernels comprise a searcher kernel, a code generation unit kernel, a finger kernel, an  
10 uplink kernel and a downlink kernel.
25. The object-oriented reconfigurable system of claim 13 wherein a kernel in said  
plurality of kernels is configured to operate under a CDMA protocol.
- 15 26. The object-oriented reconfigurable system of claim 25 wherein said CDMA  
protocol is selected from the group consisting of IS-95 CDMA, IS-95B CDMA,  
CDMA TIA IS2000, TIA IS 2000A, wideband CDMA (WCDMA), cdma2000, and  
ARIB WCDMA.
- 20 27. The object-oriented reconfigurable system of claim 13 wherein a kernel in said  
plurality of kernels is configured to operate under a TDMA protocol.
28. The object-oriented reconfigurable system of claim 27 wherein said TDMA  
25 protocol is IS-136 TDMA.
29. A method of communication using an object oriented virtual machine interface  
and a reconfigurable multi-protocol communication apparatus, said reconfigurable  
multi-protocol communication apparatus including a plurality of kernels and an  
interconnect structure for interconnecting said plurality of kernels, said method  
30 comprising:  
creating a plurality of software objects, each software object in said plurality of  
software objects corresponding to a different kernel in said plurality of kernels;  
assigning an attribute value to a software object in said plurality of software  
objects in accordance with a communication protocol; and

configuring the kernel associated with said software object in accordance with said attribute value.

5

30. The method of claim 29 wherein at least two software objects in said plurality of software objects have a hierarchical relationship.

31. The method of claim 29 further comprising developing an application program  
10 that includes software calls to said plurality of software objects.

32. The method of claim 31 further comprising developing a software virtual machine to process said application program.

15 33. The method of claim 32 further comprising translating said application program into a program executable on said software virtual machine.

34. The method of claim 33 further comprising issuing, from said software virtual machine, an instruction for controlling a kernel in said plurality of kernels.

20

35. The method of claim 29 further comprising:  
forming an application program interface comprising a plurality of software routines, said plurality of software routines representing a plurality of communication protocols, wherein said plurality of software routines comprise software calls to said  
25 plurality of software objects.

36. The method of claim 29 further comprising developing an application program comprising software calls to said plurality of software routines.

30 37. A computer program product for a reconfigurable object-oriented apparatus comprising a plurality of kernels and an interconnect structure for interconnecting said plurality of kernels, the computer program product comprising a computer readable storage medium and a computer program mechanism embedded therein, the computer program mechanism comprising:



instructions for instantiating a plurality of software objects, each software object in said plurality of software objects corresponding to a different kernel in said plurality of kernels such that a change to said software object results in a change in a state of said corresponding different kernel;

instructions for assigning an attribute value to a first software object in said plurality of objects according to a communication protocol; and

issuing machine-readable instructions to configure the kernel associated with said first software object in accordance with said attribute value.

38. The computer program product of claim 37, wherein the computer program mechanism further comprising instructions for:

instantiating a plurality of software routines from an application program interface, said plurality of software routines representing a plurality of standards, wherein said plurality of software routines comprise software calls to said plurality of software objects.

39. The computer program product of claim 37 wherein said plurality of software objects comprise:

a searcher object;  
a code generation unit object;  
a finger object;  
an uplink object; and  
a downlink object.

40. The computer program product of claim 39 wherein said plurality of kernels comprise:

a searcher kernel, a code generation unit kernel, a finger kernel, an uplink kernel and a downlink kernel respectively corresponding to said searcher object, said code generation unit object, said finger object, said uplink object and said downlink object, respectively.

41. A computer program product of claim 39 wherein said communication protocol is CDMA.
- 5
42. An apparatus to facilitate wireless communication, comprising a hardware reconfigurable and software programmable processor responsive to a predetermined virtual machine interface.
- 10 43. A method for reconfiguring a wireless network communication apparatus; said reconfigurable wireless network communication apparatus comprising a plurality of kernels;
- the method comprising:
- parsing an application program that designates a communication protocol; and
- 15 producing machine readable data capable of reconfiguring said reconfigurable wireless network communication apparatus in accordance with said communication protocol.
44. The method of claim 43 wherein an object-oriented virtual machine interface
- 20 comprises a plurality of software objects, each software object in said plurality of software objects associated with a different kernel in said plurality of kernels so that a change to a software object in said plurality of software objects results in a change in said kernel associated with said software object;
- said machine readable data including a first software object selected from said
- 25 plurality of software objects.
45. The method of claim 44 wherein said first software object is a function or procedure.
- 30 46. A computer program product for use in conjunction with a reconfigurable wireless network communication apparatus, said reconfigurable apparatus comprising a plurality of kernels, the computer program product comprising a computer readable storage medium and a computer program mechanism embedded therein, the computer program mechanism comprising:

a program module for reconfiguring said reconfigurable wireless network communication apparatus comprising:

5                   instructions for parsing an application program that designates a communication protocol; and

                  instructions for producing machine readable data capable of reconfiguring said reconfigurable network communication apparatus in accordance with said communication protocol.

10

47.    The computer program product of claim 46, further including:

                  an object-oriented virtual machine module comprising a plurality of software objects, each software object in said plurality of software objects associated with a different kernel in said plurality of kernels so that a change to a software object in said plurality of software objects results in a change in said kernel associated with said software object; wherein

                  said machine readable data include a first software object selected from said plurality of software objects.

20    48.    The computer program product of claim 47 wherein said first software object is a function or procedure.

49.    The method of claim 1 wherein a software object in said plurality of software objects is associated with at least two kernels in said plurality of kernels.

25

50.    The method of claim 1 wherein at least two kernels in said plurality of kernels is associated with the same software object in said plurality of software objects.

51.    The object-oriented reconfigurable system of claim 13 wherein a software object in said plurality of software objects is associated with at least two kernels in said plurality of kernels.

30

52. The object-oriented reconfigurable system of claim 13 wherein at least two  
kernels in said plurality of kernels is associated with the same software object in said  
5 plurality of software objects.

1/14

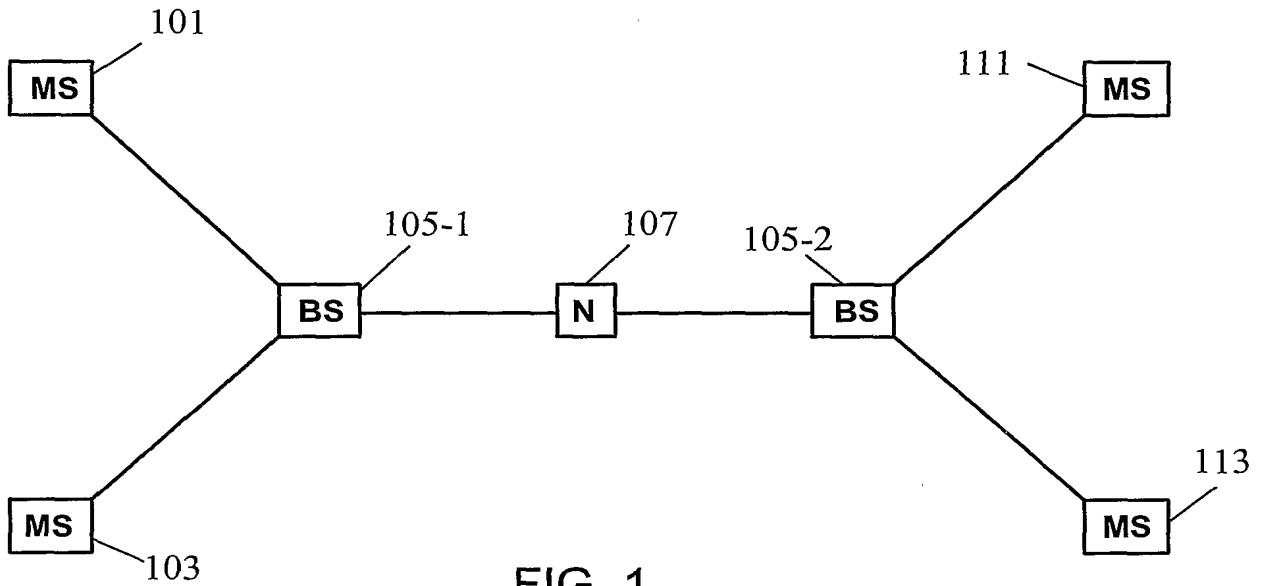


FIG. 1

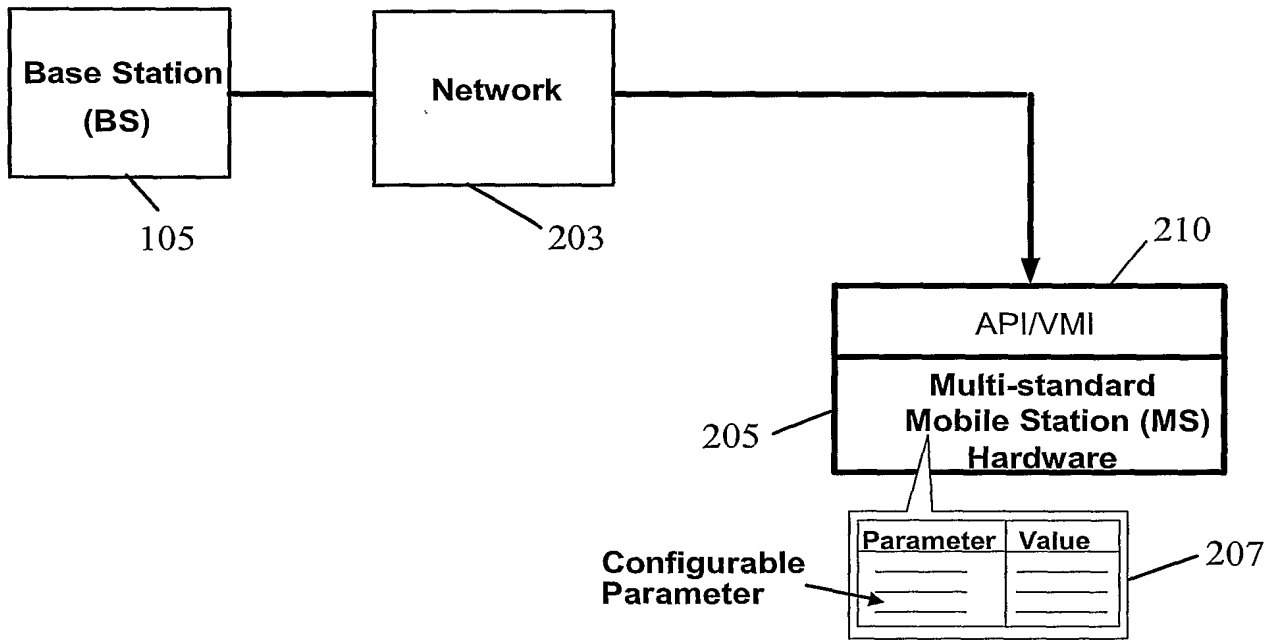


FIG. 2

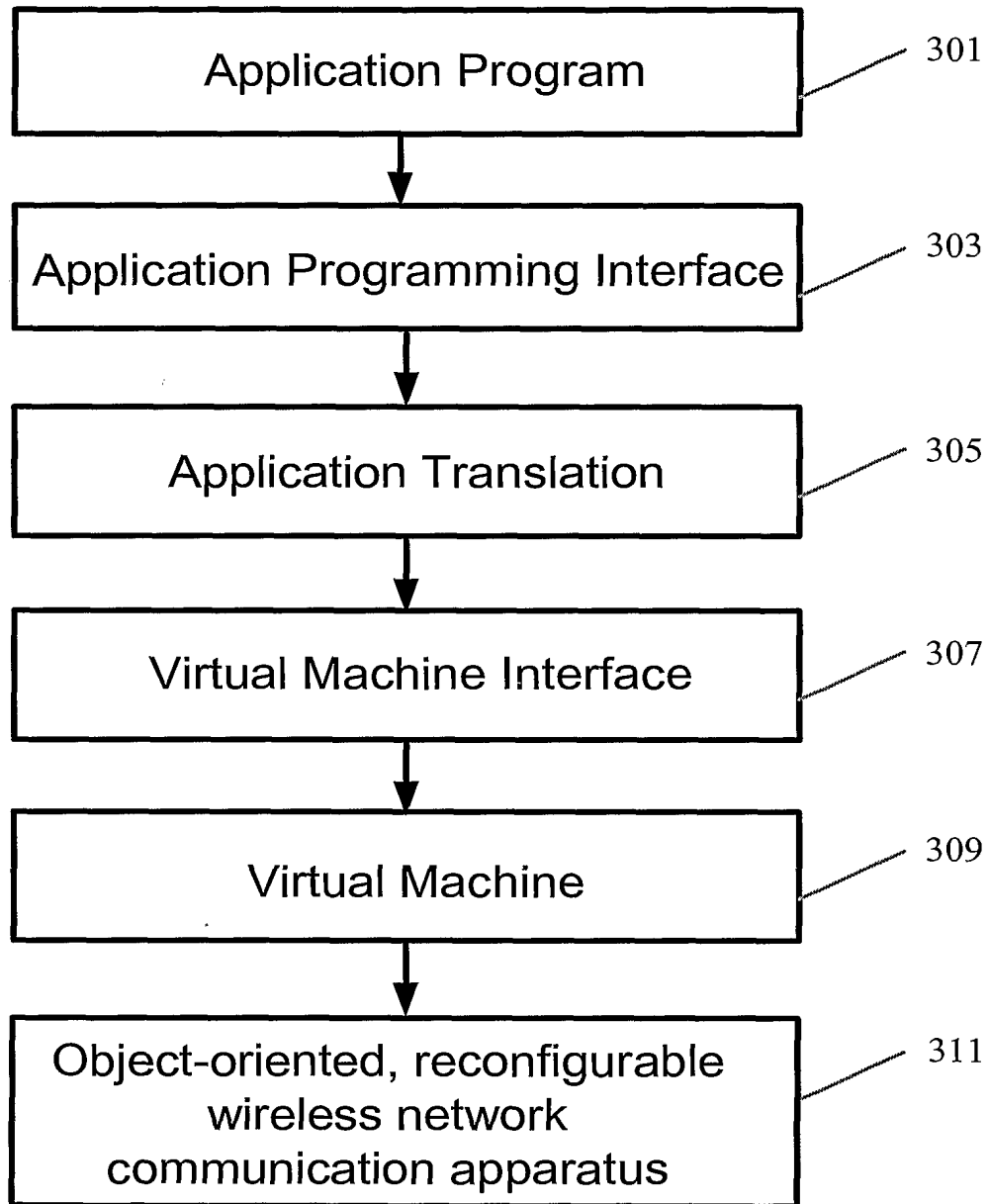


FIG. 3

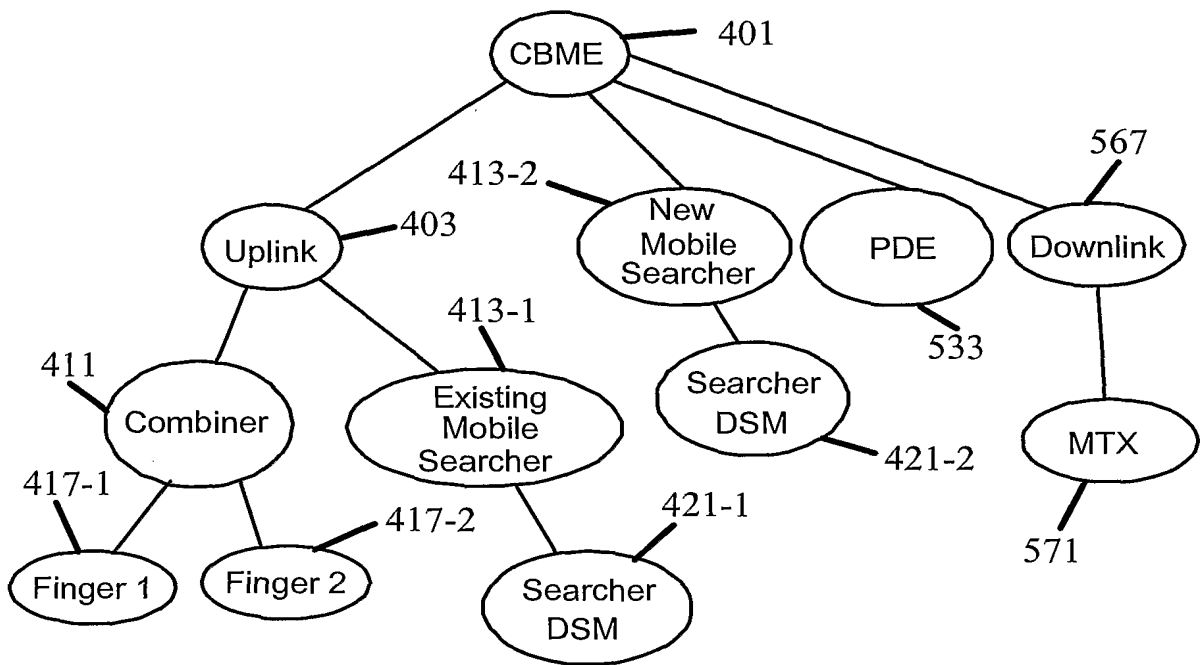


FIG. 4

<b>CBME</b>	401
CBME_New	503
CBME_Set_User-Data	505
<b>CGU</b>	507
CGU_New	509
CGU_Set_User_Data	511
<b>Searcher</b>	413
Searcher_New	515
Set_Searcher_Static_Attributes	517
Set_Searcher_Dynamic_Attributes	519
Searcher_Start	521
Searcher_Stop	523
Assign_DSM_To_Searcher	525
<b>Searcher DSM</b>	421
Searcher_DSM_New	529
Set_DSM_State_Attributes	531
<b>Preamble Detection Engine (PDE)</b>	533
PDE_New	535
PDE_Add_Antenna	537
<b>Finger</b>	417
Finger_New	541
Set_Finger_Static_Attributes	543
Set_Finger_Dynamic_Attributes	545
Finger_Start	547
Finger_Stop	549
<b>Combiner</b>	411
Combiner_New	553
Add_Finger_To_Combiner	555
Remove_Finger_From_Combiner	557
Combiner_Start	559
Combiner_Stop	561
<b>Uplink</b>	403
Uplink_New	565
<b>Downlink</b>	567
Downlink_New	569
<b>Tx Multicode Channel (MTX)</b>	571
MTX_New	573

FIG. 5



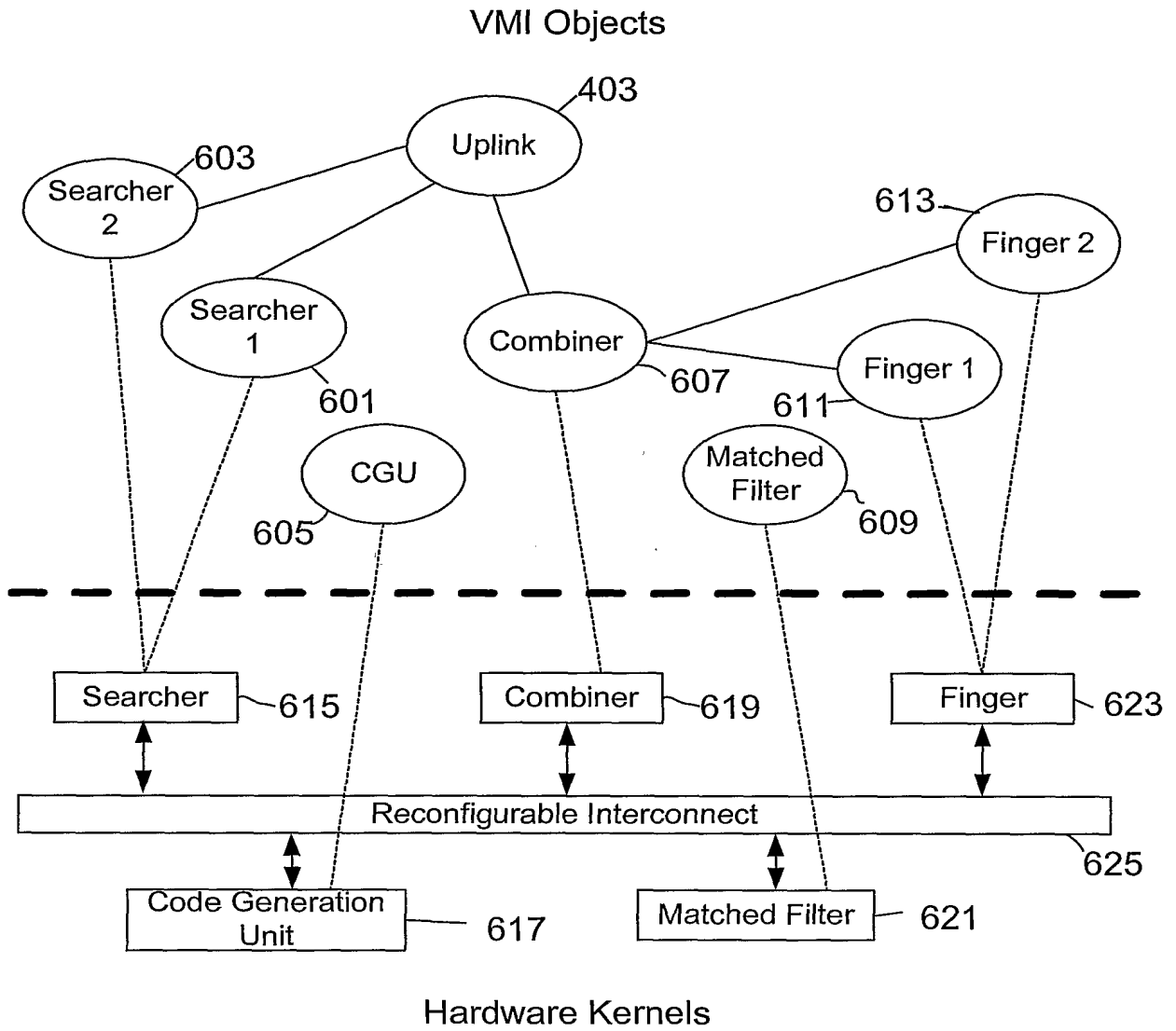


FIG. 6

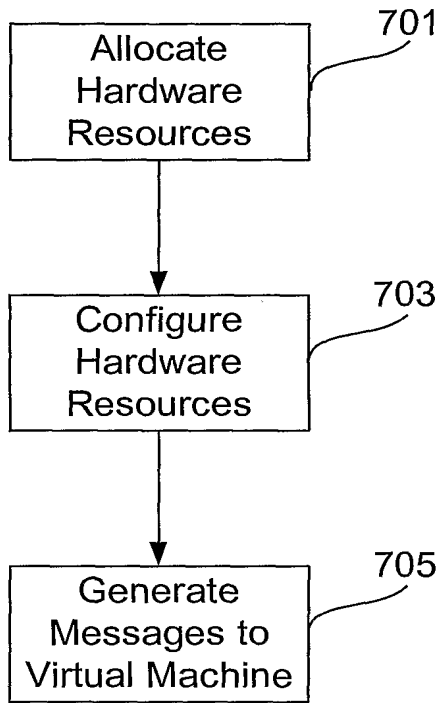


FIG. 7(A)

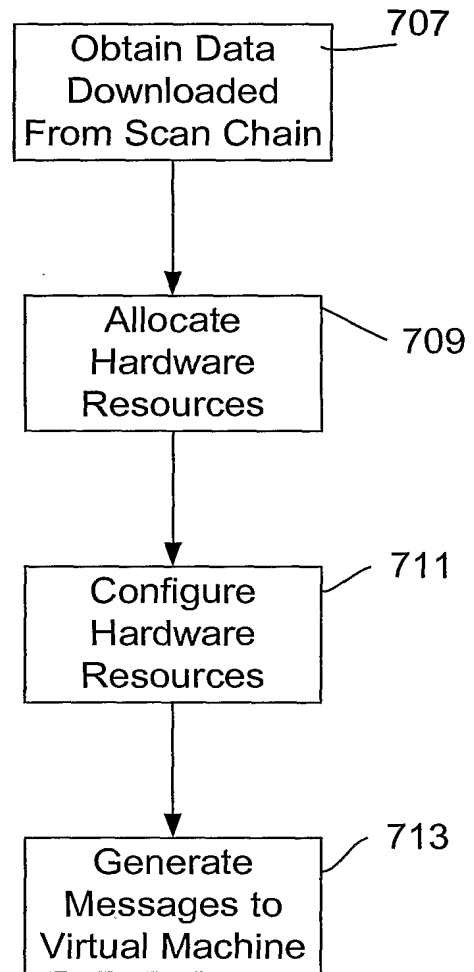


FIG. 7(B)

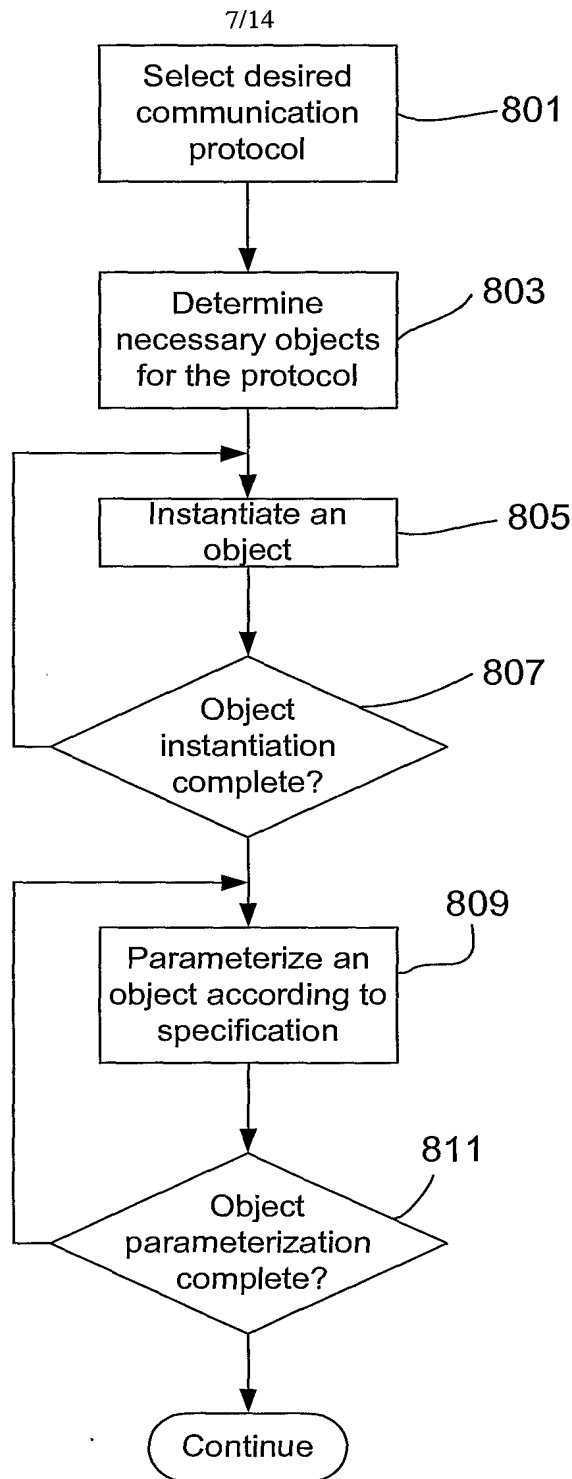


FIG. 8

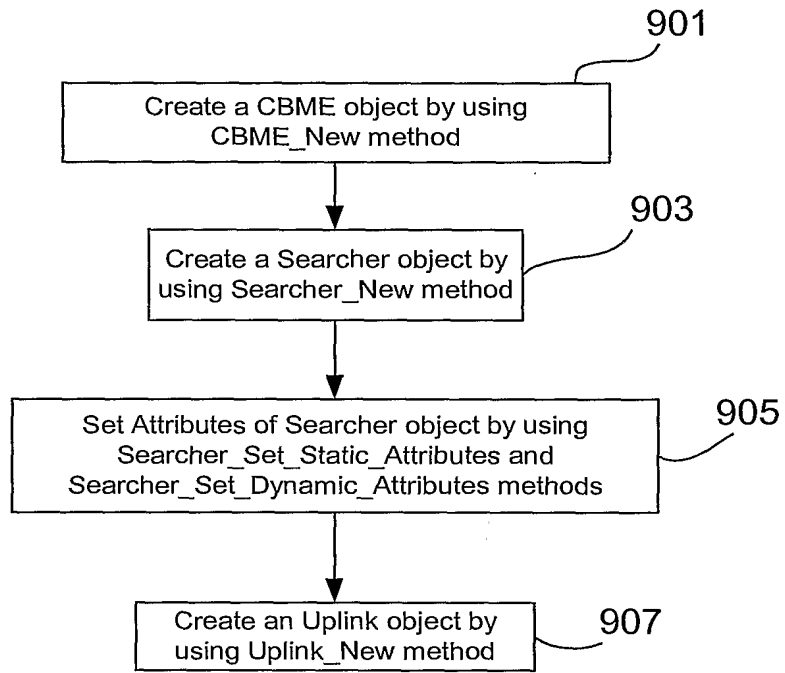


FIG. 9

9/14

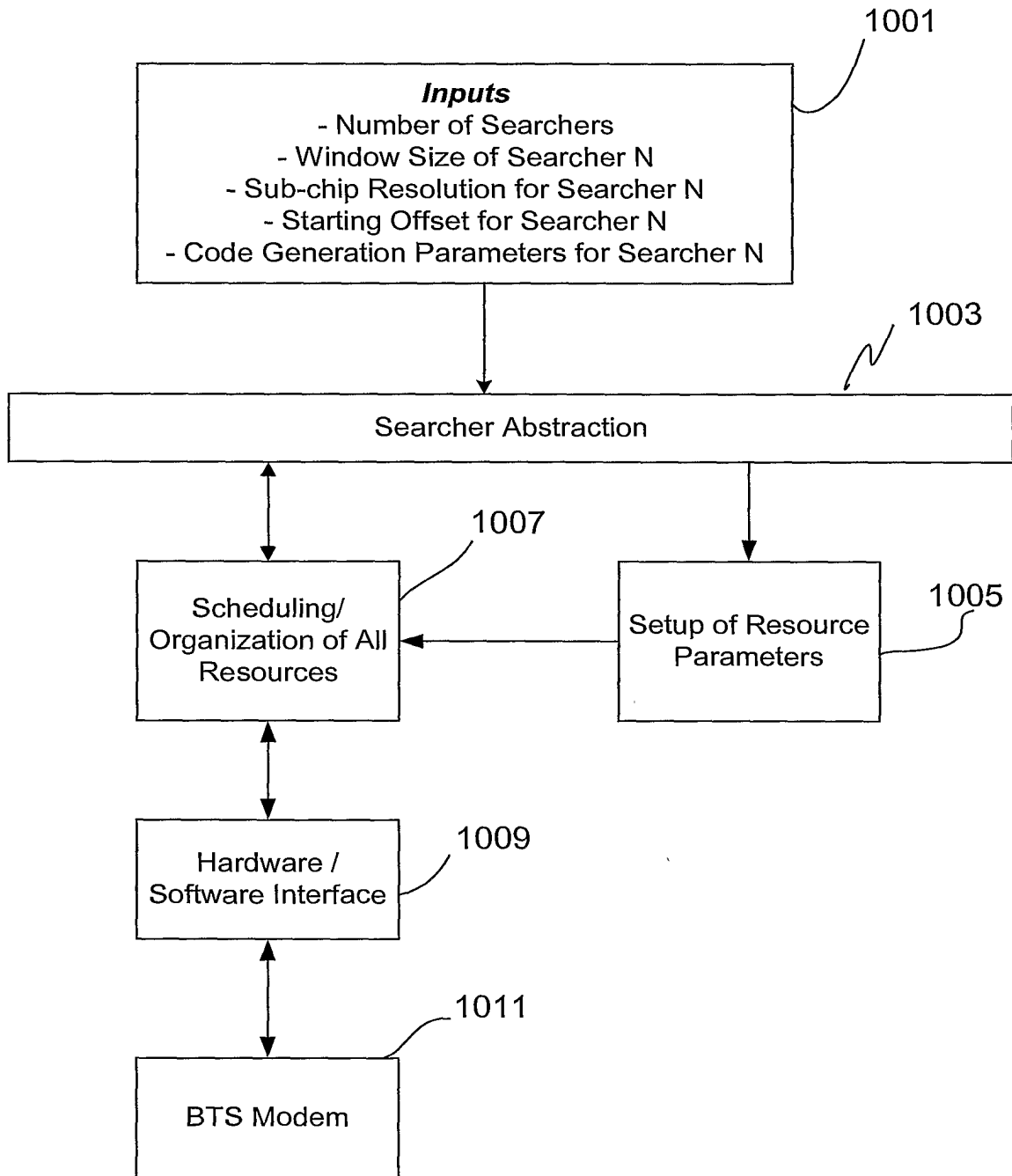


FIG. 10

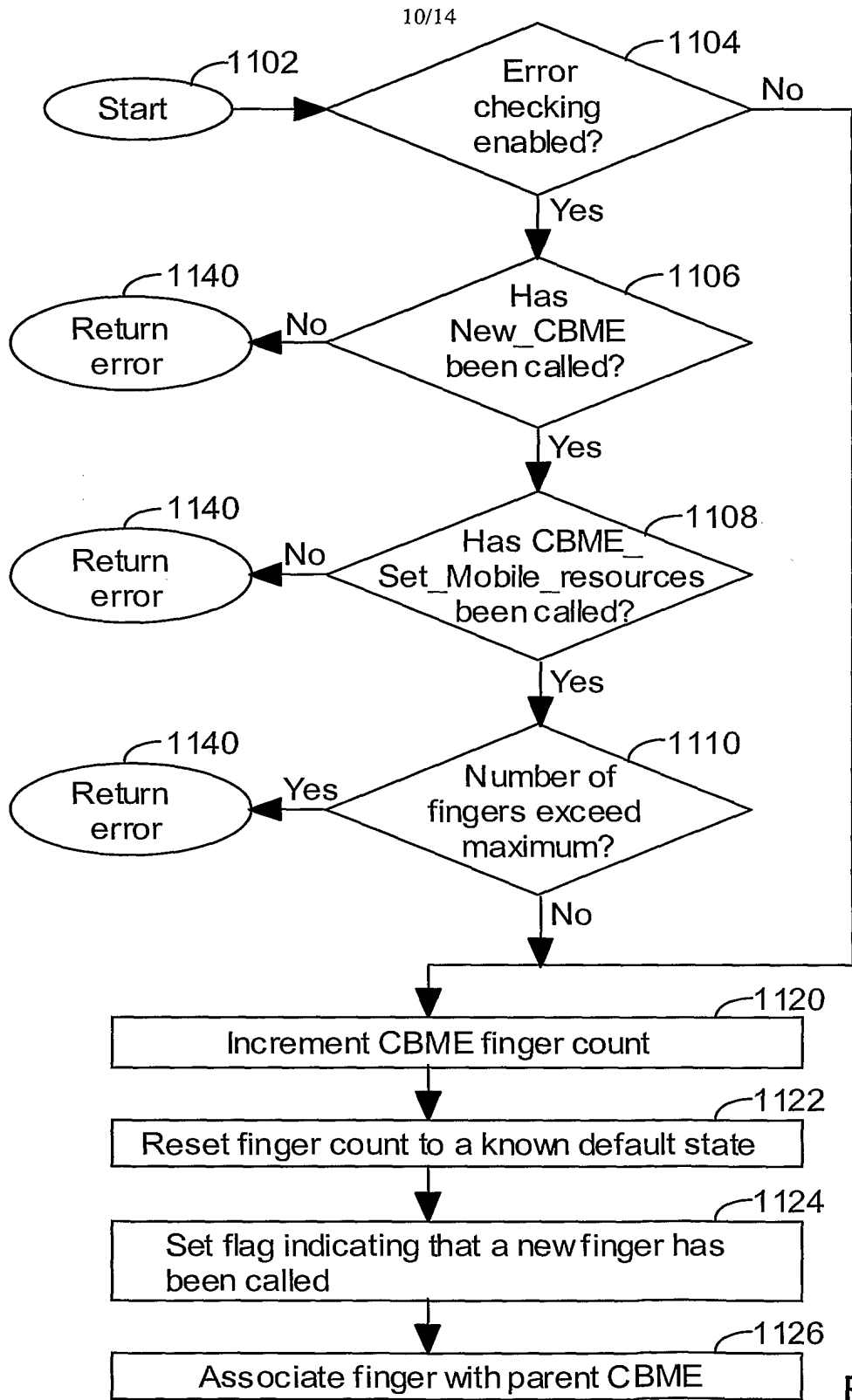


FIG. 11

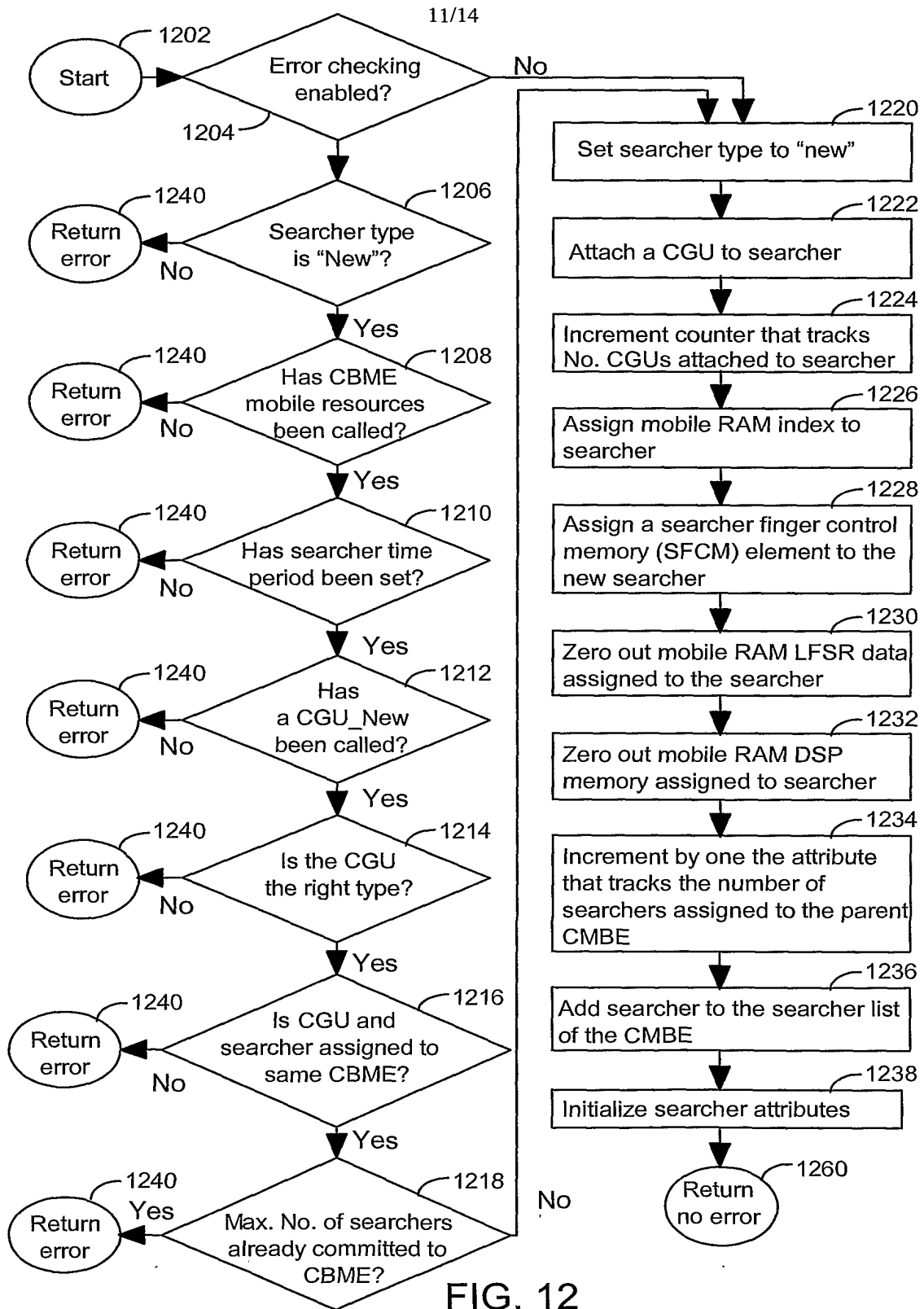


FIG. 12

12/14

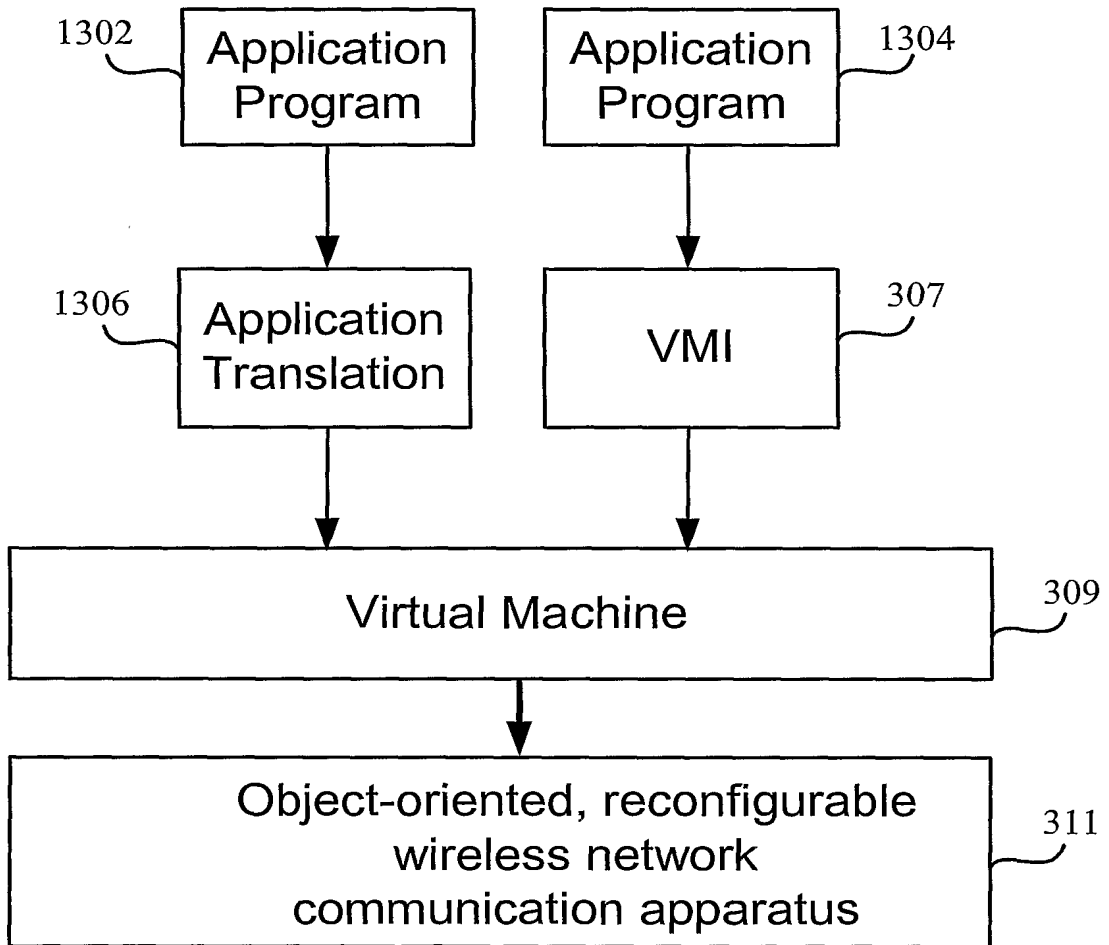


FIG. 13



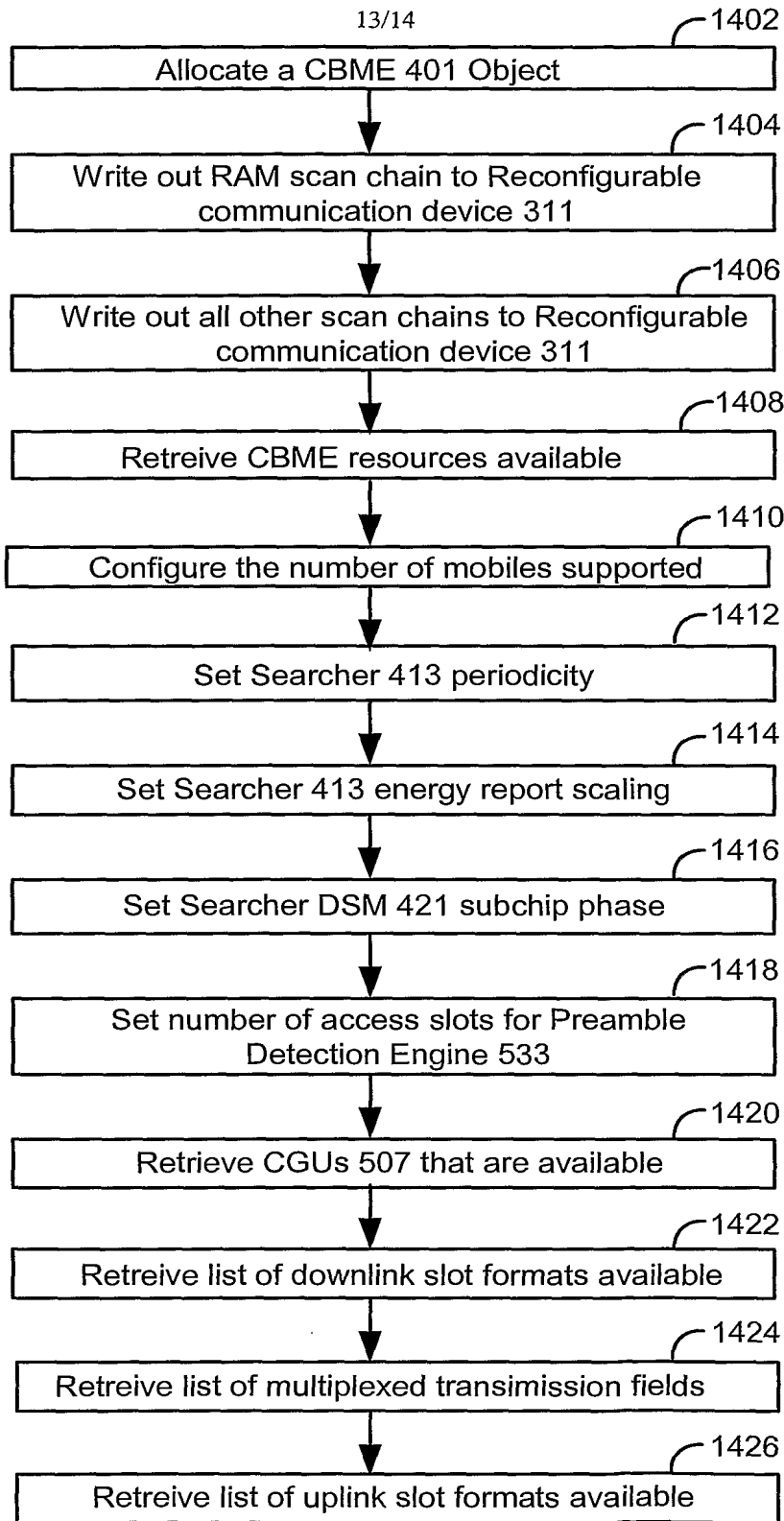


FIG. 14

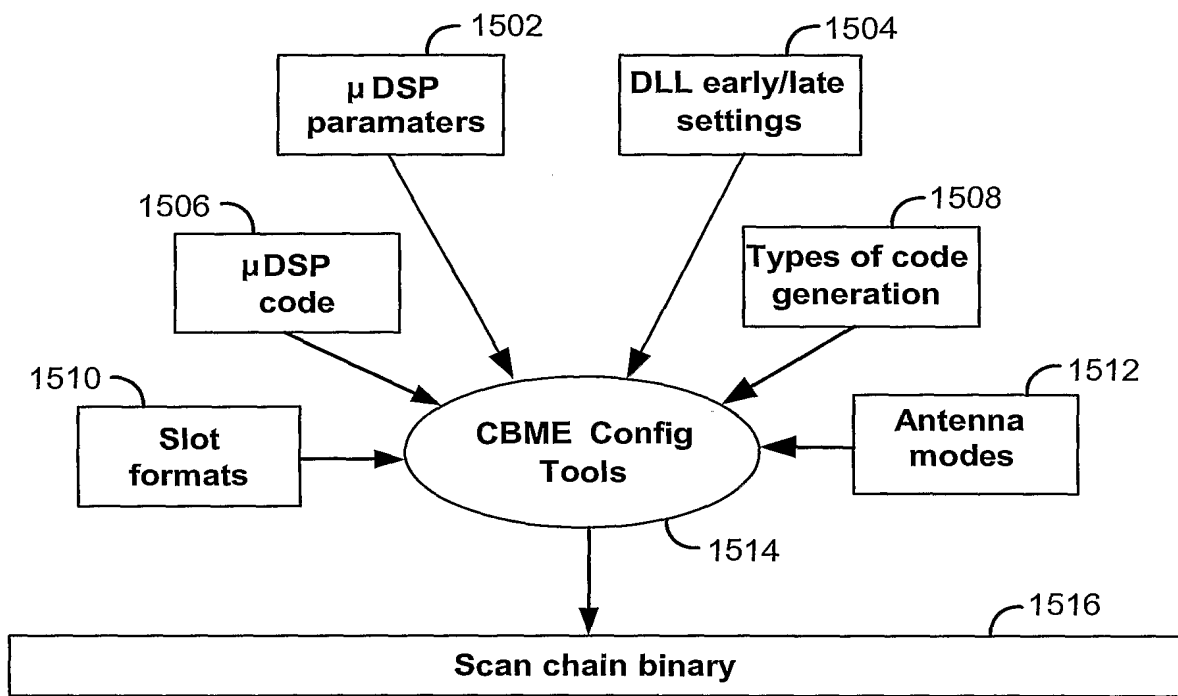


FIG. 15

(19) World Intellectual Property Organization  
International Bureau



(43) International Publication Date  
21 March 2002 (21.03.2002)

PCT

(10) International Publication Number  
WO 02/23773 A2

(51) International Patent Classification<sup>7</sup>: H04H 1/00

(21) International Application Number: PCT/US01/28831

(22) International Filing Date:  
13 September 2001 (13.09.2001)

(25) Filing Language: English

(26) Publication Language: English

(30) Priority Data:  
60/232,333 13 September 2000 (13.09.2000) US

(71) Applicant: STRATOS AUDIO [US/US]; 935 North Dos Robles Avenue, Alhambra, CA 91801 (US).

(72) Inventors: CHRISTENSEN, Kelly, M.; 935 North Dos Robles Avenue, Alhambra, CA 91801 (US). THOMAS, Barry, D.; 1710 North Fairfax, Los Angeles, CA 90046-2136 (US). SMYTH, Thomas, J.; 10723 Valley Spring Lane, North Hollywood, CA 91602 (US).

(74) Agent: ALTMAN, Daniel, E.; Knobbe, Martens, Olson & Bear, LLP, 620 Newport Center Drive, 16th Floor, Newport Beach, CA 92660 (US).

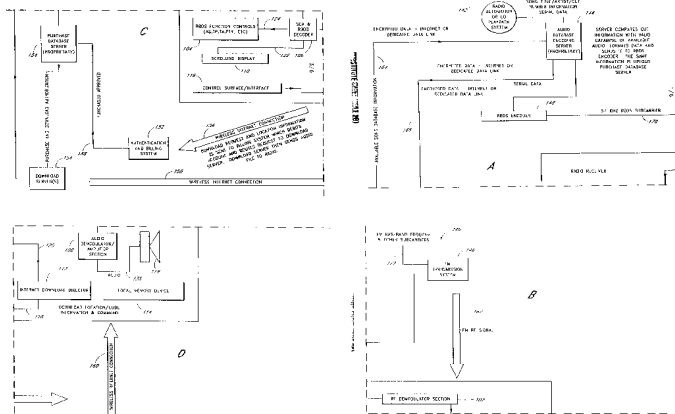
(81) Designated States (national): AE, AG, AL, AM, AT, AU, AZ, BA, BB, BG, BR, BY, BZ, CA, CH, CN, CO, CR, CU, CZ, CZ (utility model), DE, DE (utility model), DK, DK (utility model), DM, DZ, EC, EE, EE (utility model), ES, FI, FI (utility model), GB, GD, GE, GH, GM, HR, HU, ID, IL, IN, IS, JP, KE, KG, KP, KR, KZ, LC, LK, LR, LS, LT, LU, LV, MA, MD, MG, MK, MN, MW, MX, MZ, NO, NZ, PH, PL, PT, RO, RU, SD, SE, SG, SI, SK, SK (utility model), SL, TJ, TM, TR, TT, TZ, UA, UG, UZ, VN, YU, ZA, ZW.

(84) Designated States (regional): ARIPO patent (GH, GM, KE, LS, MW, MZ, SD, SL, SZ, TZ, UG, ZW), Eurasian patent (AM, AZ, BY, KG, KZ, MD, RU, TJ, TM), European patent (AT, BE, CH, CY, DE, DK, ES, FI, FR, GB, GR, IE, IT, LU, MC, NL, PT, SE, TR), OAPI patent (BF, BJ, CF, CG, CI, CM, GA, GN, GQ, GW, ML, MR, NE, SN, TD, TG).

Published:  
— without international search report and to be republished upon receipt of that report

For two-letter codes and other abbreviations, refer to the "Guidance Notes on Codes and Abbreviations" appearing at the beginning of each regular issue of the PCT Gazette.

(54) Title: SYSTEM AND METHOD FOR ORDERING AND DELIVERING MEDIA CONTENT



(57) Abstract: An Automatic Purchase System (APS) provides a radio broadcast listener with the ability to conveniently purchase media content such as music or speech while listening to the radio. The user can respond to items in the radio broadcast such as advertisements, fund raising drives such as those conducted by public radio, or interactive listener polls during the broadcast. Data such as song title and artist, author or publisher and the IP address for the location where the digital version of the content is stored, can be transmitted using the RBDS/RDS data stream. A reference number representing song title and artist, author or publisher and the IP address for the location where the digital version of the content is stored can also be employed for ease of implementation. This reference number can reside in a lookup table to be accessed by the APS server software on a Data Server located at the broadcast site, a remote site or both for purposes of redundancy. Transmission of purchase requests from a Technology Enabled Radio (TER) is provided via wireless transmission, or by accessing the Internet using a personal computer or through a cellular or wireless phone.



WO 02/23773 A2

**SYSTEM AND METHOD FOR ORDERING AND DELIVERING MEDIA CONTENT**Background of the InventionField of the Invention

5 This invention relates to electronic purchasing systems, and more particularly to providing electronic purchasing in response to AM/FM radio broadcast.

Description of the Related Art

10 From the early days of FM broadcast transmission, stations have included ancillary signals such as background music or reading services for the blind along with a main carrier signal. The idea of transmitting data along with the main carrier signal caught on, and now many broadcast radio services either transmit an ancillary data signal or are developing a method to do so. The most current and widely used data transmission standard is the United States Radio Broadcast Data Systems ("RBDS") standard.

15 The RBDS standard, published by the National Radio Systems Committee and sponsored by the Electronics Industry Association and the National Association of Broadcasters, describes a system for broadcasting a variety of program-related information on a subcarrier of a standard FM broadcast channel. The RBDS standard teaches a system for transmitting station identification and location information, as well as time, traffic and miscellaneous other information.

The RBDS standard was designed to allow stations to send information such as call letters, station format, traffic alerts and scrolling text messages to compatible radios.

20 Many stations installed RBDS encoders through a program encouraged by the FCC in the early 1990's that provided encoders at no charge. Radio stations that did not participate in this "RBDS Roll-Out" can still obtain encoders at competitive prices.

25 RBDS encoders generate what is known as a "subcarrier" that modulates along with an FM station broadcast signal and can be demodulated by special decoders. The RBDS uses a subcarrier frequency of 57khz. Commercially available RBDS encoders usually accept information via either serial or parallel data ports and format the information into the appropriate RBDS block type.

The RBDS data signal is a specially encoded text stream containing up to 32 repeating data "groups" transmitting at 1187.5 bits/second. The RBDS data signal does not require inclusion of all potential data group blocks of both repeating and unique data. One embodiment includes using one of several groups that are designed for data transmission functions.

30 An RBDS data group is composed of 4 blocks, each divided by checkwords used for error correction. Block 1 is a 4-digit Program Identification code (PI) which is derived from the transmitting station's call letters. Block 2 includes a 4-bit type code and a 1-bit group version code which identifies the type of information the data group contains. This block also contains a 1-bit code that identifies the transmitting station as one that broadcasts traffic information, followed by a 5-bit Program Type (PTY) code which describes the current program or format being broadcast by the station (Rock, Oldies, Talk, News, etc.). Information contained in

35

Blocks 3 and 4 are dependent on the codes included in Block 2. Blocks 3 and 4 provide two 16-bit data slots where specific information can be sent to the special receiver.

For example, RBDS Group types 2A, use blocks 3 and 4 to transmit a 64-character text message known as RadioText (RT). This appears on RBDS-enabled radios as a scrolling message which some stations use to identify the song or program being broadcasted. Other group types use these blocks to identify alternate frequencies where the same programming can be available, in-house station text messages, or Emergency Alert System (EAS) communication messages. An extensive description of the RBDS standard is available through the National Association of Broadcasters and the National Radio Systems Committee.

A similar standard used in Europe is the European Radio Data Service (RDS).

Broadcasters using the RBDS standard can distribute information to a large number of users. However, the standard does not allow individual users to respond to the broadcast information.

Currently, users listening to the radio or watching television may particularly like a song or program that they would like to purchase. While stations using RBDS/RDS may provide a user with the station call letters or the name of the song currently being broadcast, the user has no way to purchase the media at that point. Instead, the user must write down or remember the identifying information and then go to a store or online retailer to purchase the media. Not only is this inconvenient, but the user may forget the name of the song or not be able to find a store that sells the song. Additionally, the information provided by the radio station may not be enough to sufficiently identify the song. For example, the user may have the song title, but not the artist name, album name, or other necessary identifying information. Some material, such as editorial news broadcasts or live events, may not be available for purchase or may be difficult to find. Radio stations often have fund raising drives or listener surveys that require a listener to call the station or respond within a limited time. These same problems also apply to television and other forms of broadcast media.

#### Summary of the Invention

The present invention solves these and other problems by providing a system that allows an individual user to respond to a data broadcast. In one embodiment, an Automatic Purchase System (APS) provides a radio broadcast listener with the ability to conveniently purchase media content such as music or speech while listening to the radio. Additionally, the user can respond to items in the radio broadcast such as advertisements, fund raising drives such as those conducted by public radio, or interactive listener polls during the broadcast.

In one embodiment, the user establishes a "Creative content" purchasing account with a wireless carrier. In one embodiment, a personal URL (web address) is assigned to the user to allow the user, for example, to monitor account activity, enable or disable APS software downloads, display premiums offered by sponsors, and manage and track content or APS purchases using a Technology Enabled Radio (TER) or a personal computer.

In one embodiment, the user makes routing choices between the TER or the web account for content. In one embodiment, the user selects the compression type, such as MP3, RA, Liquid Audio etc.

5 In one embodiment, each broadcaster has an RBDS/RDS or similar technology enabled server onsite to, for example, generate RBDS/RDS or equivalent code for inclusion in the broadcast, validate and route purchase information to the user's wireless carrier for billing, monitor online sales transactions for data mining, or route validated purchases to licensed creative content providers.

10 In one embodiment, radio hardware can include, for example, RBDS/RDS or equivalent decoder capability (e.g., in an internal chip with APS code); flash card slot and recording ability; or storage of multiple items such as artist name, song title, IP address of creative content provider, and time stamp for delayed purchase (e.g., in an internal chip with APS code).

15 In one embodiment, the system uses the RBDS/RDS to send a data stream in combination with a broadcast signal for identifying music or speech content available for purchase. A broadcast organization participating in the APS system is able to respond to requests for purchases placed by users who either click a button or issue a voice command to the radio at the time of the content was broadcast, at a later time by scrolling through the playlist stored in the APS module in the radio then selecting one or more items for purchase from the list stored in the radio, or by accessing a private web account via the Internet and downloading content to the personal computer. In one embodiment, purchases are made by saving requests for selected items for purchase on a flash card or storage technology and transferring that data to a personal computer for purchase through the Internet at a later time.

20 Data such as song title and artist, author or publisher and the IP address for the location where the digital version of the content is stored, can be transmitted using the RBDS/RDS data stream. A reference number representing song title and artist, author or publisher and the IP address for the location where the digital version of the content is stored can also be employed for ease of implementation. This reference number can reside in a lookup table to be accessed by the APS server software on a Data Server located at the broadcast site, a remote site or both for purposes of redundancy. Transmission of purchase requests from a Technology Enabled Radio (TER) is provided via wireless transmission, or by accessing the Internet using a personal computer or through a cellular or wireless phone. In one embodiment, activity of each sale using the above system is tracked for the purposes of aggregating data or "Data Mining" for sale to interested parties such as trade publications and record companies.

30 Portable radios can come equipped with a voice interface or a purchase button, a flash card or storage device and a port for connecting the radio to the personal computer such as a 9 pin serial, USB or wireless networking technology.

#### Brief Description of the Drawings

35 Figure 1 illustrates an electronic purchasing system with a radio station that broadcasts information to individual radio receivers.

Figure 2 illustrates a radio receiver that includes an automatic purchasing system module.

Figure 3 illustrates a television adapter that includes an automatic purchasing system module.

#### Detailed Description of the Preferred Embodiment

5 The present invention solves various problems in the prior art by providing a system that allows an individual user to respond to a data broadcast. In one embodiment, an Automatic Purchase System (APS) provides a radio broadcast listener with the ability to conveniently purchase media content such as music or speech while listening to the radio. Additionally, the user can respond to items in the radio broadcast such as advertisements, fund raising drives such as those conducted by public radio, or interactive listener polls during the broadcast.

10 One of ordinary skill in the art will recognize that there are various forms of media that can be broadcast. Where a specific type of media is used in the following examples, it is for demonstration purposes only and the examples should not be limited in that regard. Some examples of the various types of media can include music, songs, speech, text, video, etc.

15 Fig. 1 illustrates one embodiment of a system that allows a user to respond to a data broadcast. Fig. 1 shows a radio station 140 that broadcasts information to a radio receiver 100. The radio receiver 100 has a control interface 116 that allows a user to initiate a purchase of music or products based on the radio station broadcast.

20 The terms RBDS/RDS are used throughout this document, but it should be understood other data standards can also be used. In one embodiment, the radio receiver 100 comprises a Radio Frequency (RF) Demodulator Section 102, a RBDS/RDS Decoder 106, a RBDS/RDS function control interpreter 104, an audio demodulator amplifier section 108, a scrolling display 110, an Internet Download Director 112, a local memory device 114 and the control interface 116. Additionally, the receiver 100 provides for audio output by transmitting an audio signal 128 from an audio demodulator amplifier section 108 to the speaker 118.

25 In one embodiment, the RF Demodulator Section 102 splits the signal into an audio signal and a data signal, with the data signal provided to the RBDS/RDS decoder 106 and the audio signal provided to the audio demodulator amplifier section 108. The RBDS/RDS decoder 106 parses the data signal from the RF Demodulator Section 102 and transmits the data to the RBDS/RDS Function Controller 104, the Scrolling Display 110, and the Internet Download Director 112.

30 The RBDS/RDS Function Controller 104 handles codes 124 sent using the RBDS/RDS standard. The codes 124 can, for example, include a Program Service name (PS), a Program Type (PTY), a Program Identification (PI), a Traffic Program (TP), a Traffic Announcement (TA), etc.

In one embodiment, the data is converted to an audio signal played on one or more speakers for the user to hear. A 64 character radio text message can be transmitted in five seconds under the RBDS standard, where a Type 2A group with 4 characters is transmitted 3.2 times a second.

In one embodiment, a pointer to an Open Application Data (OAD) group is transmitted in a Type 3A group. The pointer, 16 message bits and 16 bit identifier (AID) are transmitted once a second.

In one embodiment, an OAD group with 37 usable bits is transmitted once a second during the broadcast of a "tagged" program. The OAD group can contain, for example, a song or commercial campaign  
5 identification.

In one embodiment, the scrolling display 110 receives display data 122 from the RBDS/RDS Decoder 106. The display data 122 can include information such as the program service name and program type, or it can include radio text information or messages displaying purchase options.

10 Additionally, the RBDS/RDS Decoder 106 provides data to the Internet Download Director 112 that includes instructions for the location of downloadable audio. For example, a radio station 140 can broadcast data regarding the current song that is playing, such as the song name, artist, album name, and year the song was recorded. The radio station 140 can also broadcast information providing a location where the song, editorial news broadcast, collection of songs, or other program material can be downloaded or purchased, and the purchase price for the song.

15 In one embodiment, a user can place an order to download a song using the control interface 116. The control interface 116 provides a download command signal 126 to the Internet Download Director 112. The Internet Download Director 112 can then provide download instructions such as, for example, the location of the file for download and the security procedures required for access. The download information is then transmitted over, for example, a wireless internet connection 156 to the authentication and billing system 152.  
20 The authentication and billing system 152 verifies the customer information and determines whether the customer account can be debited for the cost of the order. The authentication and billing system 152 then provides an approval signal 168 indicating whether the purchase was approved. The approval signal 168 is transmitted to the purchase database server 150.

25 Once the purchase is approved, the purchase database server 150 provides purchase and download authorization to the download server 154. The download server 154 can then transmit the requested material over a network connection 158. In one embodiment, the material is transmitted using a wireless internet connection directly to the radio receiver 100. In another embodiment, the material is made available to a personal computer. In one embodiment, the material is sent using traditional mail or parcel services. The download server 154 also communicates with the audio database and encoding server 144 to provide  
30 available sound database information 164.

The radio station 140 includes a radio automation or CD playback system 142, an audio database/encoding server 144, an FM transmission system 146 and a RBDS/RDS encoder 148. The radio automation or CD playback system 142 can extract information about songs or a radio program from the station playlist or by extracting information encoded on a CD or a CD-ROM. The playlist information is  
35 provided to the audio database and coding server 144. The playlist information can include the song title,



artist, cut or other information. The audio database/encoding server 144 matches the information sent from the radio automation system 142 with information in the database. If there is an audio file available for download, the database/encoding server 144 formats the download information and sends it to the RBDS/RDS encoder 148. Corresponding information is uploaded to the purchase database server 150.

5           The RBDS/RDS encoder 148 transmits the RBDS/RDS information using the 57khz RBDS/RDS subcarrier 170 to the FM transmission system 146. The RBDS/RDS subcarrier signal 170 is mixed by the FM transmission system 146 with the FM baseband program signal 172 and any other subcarriers. The FM transmission system 146 then transmits an FM RF signal 162 which is received by the radio receiver 100.

10           As shown in Fig. 1, a radio station 140, using either a standard radio automation system for tracking of music content which is being broadcast, or a data-enabled audio player, broadcasts audio material and synchronously sends RBDS/RDS or similar data to an APS server 144 that assigns a unique identifier to each specific broadcast segment or song.

15           The APS server 144 compares the broadcast segment identifier with a database 150 of audio available for purchase. If the broadcasted audio is available, the APS server 144 incorporates station call letter information, and an audio download location such as IP address and a file name into a data stream that is inserted into a radio station's broadcast using RBDS/RDS or similar technology. The information identifying the audio selected by the listener or user is routed to the APS Data Server and passed on to the location where a digital version of the audio content is stored and available for transfer to the end user. The user's radio receiver 100 receives and recognizes the encoded RBDS/RDS or other data and presents it on the radio display 110 notifying the user that the audio is available for purchase.

20           If the user elects to purchase the audio content or responds to an ad or "pledge" drive, a request including the station's data and the user's cell phone or wireless Electronic Serial Number (ESN) or other identifier, such as a credit card number, combined with the audio content information is issued by the radio and passed via the cellular or wireless phone transmission to the APS Data Server and finally routed to the source server at the record company, publisher or licensed content provider. If a "good" connection is not available using the wireless connection, or the user does not have a wireless account, the information can be stored on the internal flash card or other storage device 114 in the radio for transfer to a personal computer at a time of the user's choosing.

25           Each server typically records the purchase or response information. The storage server 154 at a source location then uploads the requested audio to the routing address associated with the user's cell phone account identifier. The user's receiver 100 then saves the audio on internal memory or a removable memory device or holds the audio content until the user chooses to download it using the Internet.

30           One embodiment includes the use of several group types reserved for "open data applications" by the RBDS/RDS standard. These groups were designed for use with data applications and are readily available for use.

35

Fig. 2 shows one example of a technology enabled radio 200. The radio 200 includes a module 202 for the Automatic Purchase System. In one embodiment, the APS provides relatively quick delivery of the purchased material. In one embodiment, quick delivery is provided by wireless transmission such that the user can receive the purchased material while traveling. In one embodiment, the system also provides  
5 delayed delivery, when, for example: the user so chooses; the user does not have a wireless account; or the user cannot obtain a good signal with a wireless connection for transmission.

In one embodiment, the radio 200 contains an APS module 202 configured to store identifier data 204, to provide security functions, and to assist in routing selections made by the user (using either a voice command issued to voice recognition technology 214 contained in the radio or by the press of a button 212 on  
10 the radio interface). In one embodiment, the APS module 202 is a proprietary microchip (or portion of a microchip) that implements the radio receiver-side functions of the APS. In one embodiment, the APS module 202 is a software module that runs on a processor in the radio 200.

The audio content can also be "tagged" for delayed purchase at a later time by scrolling through the playlist 208 stored in the APS module 202 on the radio 200 and presented on the external display 210 of the  
15 radio 200. The user can then select one or more items for purchase from the list presented on the display 210 (stored in the APS module 202 in the radio). In one embodiment, the selected items are transmitted using a wireless transmitter 218 such as a wireless telephone. In another embodiment, a user can store the playlist 208 on removable memory 220 that is readable by a personal computer 240. The user can then access a private web account via the Internet for downloading the content to the personal computer 240. At  
20 this point, the user can transfer the downloaded content to a storage device 242 such as, for example, a flash card or CD-ROM.

Non-automotive or portable radios containing the APS module 202 can also include either a voice interface 214, an interactive button 212, or both, to enable listener-selection of broadcast material (or for responding to advertisements, fund raising drives, or any other interactive event). A port 216 such as a 9-pin  
25 serial port, a USB port, or any other port designed to provide connectivity between the radio 200 and a personal computer 240 can also be integrated into the radio 200 for the purposes of transferring the selection list from the APS module 202 to software in a personal computer 240 or other device. APS software running on the personal computer 240 is configured to recognize an embedded security code enabling purchase of the selected material via the Internet, or respond to an advertisement or fund raising drive. Wireless  
30 technology, such as, for example, BlueTooth and the like, can also be used for the purposes of transferring the selection data between devices.

Automotive radios equipped with the APS module 202 and associated technologies can use a wireless interface 218 to send a purchase request (or interactive response) complete with a user Electronic Serial Number (ESN), WIN identifiers, and routing information such as artist and song title derived from the  
35 RBDS/RDS data string accompanying the associated broadcast. The purchase request and routing

information can then be directed to an APS server 260 for processing, billing approval, and delivery of the content to a particular location (such as the user's flash card or storage technology in the radio 200 or a personal account web URL), as requested by the user.

The flash card or storage technology 220 in the automotive radio offers the user a second option.  
5 The user can select content for purchase using the interactive voice technologies 214 or the button interface 212 to select broadcast content for purchase. If that user does not have a wireless phone, or does not have a good connection with a wireless phone connected to the radio, then the content selections can be stored on the flash card or storage technology 220 for later use.

In one embodiment, the APS polls the wireless network until a good connection is obtained, at which  
10 point the selection data is transferred for completion of the transaction. In cases where the user cannot obtain a good connection or the user does not have a wireless account, the flash card or storage technology 220 can later be removed by the user and inserted into a personal computer 240. The routing information for each selection stored on the flash card or storage technology 220 is passed to the APS download software running on the user's personal computer 240. Once the user has an active connection to the Internet, the APS  
15 download software allows the user to purchase the selected content and download it to a personal computer 240 as long as the content was tagged with the proper security codes obtained from the APS module 202 in the radio 200.

Using this system, the user can respond to a live broadcast radio advertisement to qualify for coupons, premiums or other sponsor-offered rewards. This system can also be applied to pledge drives  
20 employed by public radio stations, allowing listeners to pledge money while driving or listening to a portable radio. The system can also be used for listener polls where the broadcaster can obtain quick responses from listeners to new music, speech content or general questions such as a talk show format. In each case, the user/listener can respond by pressing a "Respond" button 212 on the radio 200. On a voice-enabled radio 200, the user/listener can order content or provide responses by voice commands.

The user can also receive offers or hyperlinks posted on a personal web site presenting premiums such as discounted tickets (to events for the artists or writers for which they purchased content), suggestions of purchase for related artists or music genres, record company club offerings, or other premiums. Associated books, magazine articles, merchandise and event information can also be posted for the user to purchase using the APS. Hyperlinks can also be present for content not available on the radio but provided  
30 either through partnerships with existing digital content providers or content owners who have made direct arrangements for digital distribution through the APS web site.

Billing for the purchase of content and user-identification can be managed through the user's wireless phone account or the user can establish an account at an APS web site. Content purchased can be directed to Technology-Enabled Radios (TERs), or receivers using a wireless-telephone transmission, and  
35 stored on a flash card. Purchase content can also be directed to a personal web page assigned to the user

upon creation of a specific account. The user can access the account over the Internet, and the user can download purchased content to a personal computer.

In order to protect the purchased content from piracy, various access-rights controls and copy-protections can be provided. In one embodiment, the user is allowed to copy purchased content to a CD or flash card one time only (unless additional licenses are purchased). Additional licenses can be purchased within the APS download software or in the user's web account by the click of a button or through using a third-party software package enabled with the APS security keys such as the ESN and WIN numbers from a wireless account.

Each sales transaction can be monitored by an APS server located at each participating radio station, by an Internet-based APS server, or both. The data collected through "data mining" of sales transactions can be sold to companies interested in tracking demographic information and music sales such as record companies and trade publications. In one embodiment, personal information regarding the users is not disclosed.

In one embodiment, the system includes one or more of the following features:

1. The user establishes a "Creative content" purchasing account with a wireless carrier.
2. A personal URL (web address) is assigned to the user to:
  - Monitor account activity
  - Enable or disable APS software downloads
  - Display premiums offered by sponsors
  - Manage & track content or APS purchases using a TER or a personal computer.
  - User makes routing choice between the TER or the web account for content
  - User makes selection of compression type: MP3, RA, Liquid Audio etc.
3. Each broadcaster has an RBDS/RDS or similar technology enabled server onsite to:
  - Generate RBDS/RDS or equivalent code for inclusion in the broadcast
  - Validate and route purchase information to the user's wireless carrier for billing
  - Monitor online sales transactions for data mining
  - Route validated purchase to licensed creative content providers
4. Radio hardware can include:
  - RBDS/RDS or equivalent decoder capability (e.g., in an internal chip with APS code)
  - Flash card slot and recording ability (Optional)
  - Storage of multiple items including: artist name, song title, IP address of creative content provider, and time stamp for delayed purchase (e.g., in an internal chip with APS code)

In one embodiment, the system uses the RBDS/RDS to send a data stream in combination with a broadcast signal for identifying music or speech content available for purchase. A broadcast organization participating in the APS system is able to respond to requests for purchase placed by users who either click a

button or issue a voice command to the radio at the time of the content was broadcast, at a later time by scrolling through the playlist stored in the APS module in the radio then selecting one or more items for purchase from the list stored in the radio, or by accessing a private web account via the Internet and downloading content to the personal computer. In one embodiment, purchases are made by saving requests  
5 for selected items for purchase on a flash card or storage technology and transferring that data to a personal computer for purchase through the Internet at a later time.

Data such as song title and artist, author or publisher and the IP address for the location where the digital version of the content is stored, can be transmitted using the RBDS/RDS data stream. A reference number representing song title and artist, author or publisher and the IP address for the location where the  
10 digital version of the content is stored can also be employed for ease of implementation. This reference number can reside in a lookup table to be accessed by the APS server software on a Data Server located at the broadcast site, a remote site or both for purposes of redundancy. Transmission of purchase requests from a Technology Enabled Radio (TER) is provided via wireless transmission, or by accessing the Internet using a personal computer or through a cellular or wireless phone. In one embodiment, activity of each sale using the  
15 above system is tracked for the purposes of aggregating data or "Data Mining" for sale to interested parties such as trade publications and record companies.

Portable radios can come equipped with a voice interface or a purchase button, a flash card or storage device and a port for connecting the radio to the personal computer such as a 9 pin serial, USB or wireless networking technology.

20 Music radio stations often depend on computer-programmed and optimized playlists to ensure consistency and success of the format. Many stations use computer-based playback systems that play from hard disc libraries or control CD changers. At the start of the day, a playlist is loaded into these computers that include information. These "automation" systems provide continual logging of functions and activities and can output the "as played" information in a variety of ways, such as serial data. Data can be taken as an  
25 event occurs or can be read from a text file. Most automated systems can be programmed to send information out of the serial port.

Some stations have used this data to use RBDS/RDS and display song information in the RadioText group. More recently stations are using this information to feed a "now playing" message on Internet web sites.

30 Even stations that play CD's manually from a paper playlist can provide the information needed. Professional CD players usually have serial ports (i.e. RS232, RS485) that can be programmed to transmit CD code information. This code information is similar to the song codes used by internet-enabled computers to automatically download song information from the website known as CDDDB.com for a CD inserted into a CD-ROM player. Every RIAA-registered CD has a unique registered code with the RIAA. Thus, on an RIAA  
35 registered CD, a song can be identified by the registered code number in combination with the track number.

For content that is not registered with the RIAA, a registration code is provided by APS. In one embodiment, the broadcaster providing the APS service to its listeners assigns an identifier code to the content. In one embodiment, an identifier code for non-RIAA registered content is provided by an APS registering organization or service.

5           In one embodiment, the system operates by acquiring playlist data or a reference number that identifies the broadcast content. The playlist data is included in the RBDS/RDS data sub-carrier by either the APS server software or a combination of the APS server software in conjunction with a compatible RDS/RBDS encoder.

10           Once the data source is identified, a connection pathway is established between the broadcaster and the APS Data Server. APS software residing on the APS Data Server stores that information in a "look up" table. The codes representing "cut numbers", or text song information such as artist and song title, are referenced against the internal look up table to determine if the song is available for download from the content owner such as a music publisher or record company. Once determination has been made regarding availability of the requested content, the APS software residing on the APS Data Server builds the data  
15 stream that can include the group 3 and group 4 data of the RBDS/RDS standard containing download location and/or file name. The APS software then transmits the information to a compatible RDS/RBDS encoder residing at the participating broadcaster.

20           For example: the 64-character text space contained in the RBDS standard is long enough to include an Internet IP address and directory location or reference code contained in a look up table capable of enabling the APS software to route the request for purchase from a user to the appropriate download site such as a publisher, record company or news organization.

25           The APS software residing on the APS Data Server can be employed to create the complete RBDS/RDS data signal and feed a slave encoder located at each broadcast location. The APS software also tracks each inquiry and purchase for billing verification and crediting the broadcaster for payment for their part in the sale. The APS software also conducts data mining tracking for purposes of the future sale of transaction data.

30           In one embodiment, the RBDS/RDS encoder formats and encodes the non-APS elements of the data stream (such as station identification (Call Letters), date and time, etc.) and the APS software on the APS Data Server inserts content-specific data such as song title and artist information or author and news service, into the continual RBDS/RDS data stream through the RBDS/RDS encoder's standard interfaces. The APS Data Server software can be well suited to provide content specific information but the other RBDS/RDS group applications can be better managed by broadcast equipment designed for those applications.

RBDS/RDS is an FM-only transmission system but one of ordinary skill in the art will recognize that APS data can be included with other radio services (e.g. AM, etc.).

Digital Audio Broadcasting (DAB), which includes flexible, open-source, data transmission functions along with the audio signal. Systems for adapting digital audio and data transmission to the current allocation of AM and FM stations using a technique known as In Band On Channel (IBOC) are known. IBOC includes an ancillary data stream in the broadcast signal to be used by the station for whatever purposes they see fit.

5 The ancillary data stream signal can be used to carry APS information.

Other developing radio systems also include a data path that can be used to send the information used by the APS system to successfully allow the acquisition of music or other material being broadcast. Satellite DAB providers, such as XM Satellite and Sirius Satellite Radio, have access to the audio and ancillary data signals being sent to compatible receivers.

10 As other audio services develop, the capability to transmit complimentary, simultaneous data can be used as a component of the APS. The APS can be simply adapted to each new transmission form with no significant change in the overall system.

Wireless technology and the related developments in high-speed Internet access using systems such as BlueTooth or other wireless network technology allows faster downloads of the desired material by taking advantage of the newer, faster technology.

15 NTSC, PAL and other technologies employed to transmit television signals around the world allow for similar capabilities in transmitting subcarrier data within the carrier signal.

Fig. 3 shows one example of a Technology Enabled Television (TET) adapter 300. The television adapter 300 includes a module 302 for the Automatic Purchase System. In one embodiment, the television adapter 300 is incorporated into the television. In one embodiment, the television adapter 300 is a settop box. In one embodiment, the APS provides relatively quick delivery of the purchased material. The material available for purchase can cover a wide range of products, such as music, video, print, pledges of money, or consumer goods related to displayed advertisements. In one embodiment, quick delivery is provided by using a cable modem. In one embodiment, the television adapter 300 uses a modem and a telephone connection to download the data. In one embodiment, the television adapter 300 uses a network connection to download the data. In one embodiment, the system provides delayed delivery, when, for example: the user so chooses; the user does not have a cable modem; the user does not have a network account at that location; or the user cannot obtain a good signal with a wireless connection for transmission.

In one embodiment, a television adapter 300 contains an APS module 302 configured to store identifier data 304, to provide security functions, and to assist in routing selections made by the user (using either a voice command issued to voice recognition technology 314 contained in the television adapter or by the press of a button 312 on the television adapter interface). In one embodiment, the APS module 302 is a proprietary microchip (or portion of a microchip) that implements the television adapter-side functions of the APS. In one embodiment, the APS module 302 is a software module that runs on a processor in the television adapter 300.

35

The material can also be "tagged" for delayed purchase at a later time by scrolling through the selection list 308 stored in the APS module 302 on the television adapter 300 and presented on the external television display 380. The user can then select one or more items for purchase from the list presented on the display 380 (stored in the APS module 302 in the television adapter). In one embodiment, the selected items are transmitted using a cable modem. In one embodiment, the selected items are transmitted using a wireless transmitter 318 such as a wireless telephone. In another embodiment, a user can store the selection list 308 on removable memory 320 that is readable by a personal computer 340. The user can then access a private web account via the Internet for downloading the content to the personal computer 340. At this point, the user can transfer the downloaded content to a storage device 342 such as, for example, a flash card or CD-ROM.

A port 316 such as a 9-pin serial port, a USB port, or any other port designed to provide connectivity between the television adapter 300 and a personal computer 340 can also be integrated into the television adapter 300 for the purposes of transferring the selection list from the APS module 302 to software in a personal computer 340 or other device. APS software running on the personal computer 340 is configured to recognize an embedded security code enabling purchase of the selected material via the Internet, or respond to an advertisement or fund raising drive. Wireless technology, such as, for example, BlueTooth and the like, can also be used for the purposes of transferring the selection data between devices.

In one embodiment, television adapters equipped with the APS module 302 and associated technologies can use a wireless interface 318 to send a purchase request (or interactive response) complete with a user Electronic Serial Number (ESN), WIN identifiers, and routing information such as artist and song title derived from the RBDS/RDS data string accompanying the associated broadcast. In one embodiment, television adapters can use a modem (e.g. a telephone modem, cable modem, etc.) or other network connection to send a purchase request. The purchase request and routing information can then be directed to an APS server 360 for processing, billing approval, and delivery of the content to a particular location (such as the user's flash card or storage technology in the television adapter 300 or a personal account web URL), as requested by the user. In one embodiment, the purchased material is delivered with traditional mail or parcel services.

The flash card or storage technology 320 in the television adapter offers the user a second option. The user can select content for purchase using the interactive voice technologies 314 or the button interface 312 to select broadcast content for purchase. If that user does not have a network connection, then the content selections can be stored on the flash card or storage technology 320 for later use.

User access to the APS is provided by the remote control, voice interaction or buttons on the actual TV. As a user views broadcast content, the user can respond to the television broadcast to make purchases, respond to an advertisement, to qualify for premiums, or the user can respond to pledge drives on public television or an interactive event such as a talk or game show.



In one embodiment, the user responses are provided to a computing device such as a personal computer, set-top box, and the like (e.g., via flash card or other removable storage medium, via a network connection between the computer and the TET, via a wireless connection such as BlueTooth, etc.). The computing device is then used to transfer the content in a manner similar to that described in the radio  
5 embodiment above.

In one embodiment, a cable connection from the TET to the computing device is used for immediate transfer of the user response. In one embodiment, data is transferred between the TET and the computing device using a communication port such as, for example, a serial port, a USB port, infrared port, a parallel port, and Ethernet port, or other port technology.

10 In one embodiment, the APS module also provides web-enabled cable or satellite television interactive services. In one embodiment, a modem (such as ,for example, a cable modem) is included in the TET thereby allowing the TET to send a user response request directly to a content provider (such as a cable company). In one embodiment, the APS module is provided in a cable set-top box to allow the APS system to be used with a conventional television.

15 The mechanisms for routing, customer identification, security, tracking, and purchase used with the radio embodiments described above can also be used with the TET.

It is understood that the download server, purchase database server, audio database server and encoding server can reside on one or more computers, and that the shown organization of the servers is for clarification. One or more programs can be used to perform part or all of the functions described in this  
20 description.

The foregoing description of a preferred implementation has been presented by way of example only, and should not be read in a limiting sense. Although this invention has been described in terms of certain preferred embodiments, other embodiments that are apparent to those of ordinary skill in the art, including embodiments which do not provide all of the benefits and features set forth herein, are also within the scope of  
25 this invention. Accordingly, the scope of the present invention is defined only by reference to the appended claims.

WHAT IS CLAIMED IS:

1. A system for performing a transaction based on data provided as part of a broadcast signal, comprising:
- 5 a broadcast receiver circuit that extracts a RBDS data signal from a broadcast channel, said broadcast channel comprising an audio stream and a RBDS data stream that identifies program material in the audio stream;
- a display capable of displaying information corresponding to the data signal;
- a user input control that allows a user to select a transaction from the displayed information;
- and
- 10 an output device that provides a transaction request comprising an identity of a user and an identification of the selected transaction, said transaction request being provided to a response authentication system.
2. The system as in Claim 1, wherein the displayed information identifies a media file available for purchase.
- 15 3. The system as in Claim 2, further comprising an input to receive the purchased audio.
4. The system as in Claim 3, wherein the input is a wireless network connection.
5. The system as in Claim 1, wherein the output device is a removable memory device.
6. The system as in Claim 1, wherein the output device is a serial data port.
7. The system as in Claim 1, wherein the output device is a parallel data port.
- 20 8. The system as in Claim 1, wherein the output device is a wireless transmitter.
9. A system for responding to a data stream sent in combination with a media stream on a radio broadcast signal, comprising:
- a broadcast receiver circuit that detects the radio broadcast signal and extracts a data signal from the data stream, at least a portion of the data signal configured to identify program
- 25 content in said media stream;
- memory for storing the data signal;
- a display for displaying information corresponding to the data signal;
- a user input control that allows a user to initiate a purchase request corresponding to the data signal;
- 30 a transmitter that transmits the purchase request to a response authentication system; and
- a media download device for receiving media corresponding to said purchase request over a communications network.
10. The system as in Claim 9, wherein said user input control is a button.
11. The system as in Claim 9, wherein said user input control is a voice command device.

12. The system as in Claim 9, wherein the data stream conforms to the Radio Broadcast Data System Standard.

13. The system as in Claim 9, wherein the data stream conforms to the Radio Data Service Standard.

5 14. The system as in Claim 9, wherein the transmitter uses a wireless connection.

15. The system as in Claim 9, wherein the transmitter uses an interface with a computer.

16. A response authentication system for processing requests sent in response to a data stream embedded within a broadcast radio signal, comprising:

a database that contains customer information;

10 a database that correlates a data stream identifier code with a location of the data stream on a communications network;

a server that correlates the receipt of a request for a specified data stream with information contained in the data stream location database, the request generated by user response to the broadcast radio signal having a program portion and a data portion, said data portion identifying said program portion; and

15 an order fulfillment server that receives communication of customer information.

17. The system as in Claim 16, wherein a completed order results in a download of a file corresponding to the specified data stream.

20 18. The system of Claim 16, wherein the data stream identifier code is extracted from identification information stored on a compact disc.

19. A method of providing a response to a data stream embedded within a broadcast channel, comprising the steps of:

extracting a digital data signal from a radio broadcast signal that comprises a modulated digital signal stream and a modulated analog signal stream;

25 demodulating the modulated analog signal stream and playing the demodulated analog signal stream;

displaying the digital data in a format that allows a user to identify and scroll through the contents of the digital data signal; and

transmitting a selection chosen from the displayed digital data by the user.

30 20. A method of receiving responses to an audio broadcast, comprising:

broadcasting a signal comprising an audio signal and an accompanying identifying data signal, where the data signal identifies the audio signal, wherein the data signal is broadcast in a format that allows a receiver to display to a user information about the audio signal;

35 receiving a response from a user that identifies the user and the audio signal that the user is responding to;

verifying the user identification and the availability of the audio signal; and  
acting on the user response.

21. The method of Claim 20, wherein said acting on the user response comprises sending a media  
file.

5 22. The method of Claim 20, wherein said acting on the user response comprises transacting a  
donation.

23. The method of Claim 20, wherein said acting on the user response comprises sending a plurality  
of media files

10 24. A system for performing a transaction based on data provided as part of a broadcast signal,  
comprising:

a broadcast receiver circuit that extracts a data signal from a broadcast signal, said  
broadcast signal comprising an audio stream, a video stream and a data stream;

a display driver capable of displaying on a television screen information corresponding to  
the data signal;

15 a user input control that allows a user to select a transaction from the displayed information;

an output device that provides a transaction request comprising an identity of a user and an  
identification of the selected transaction, said transaction request being provided to a response  
authentication system.

20 25. A system for performing a transaction based on data provided as part of a broadcast signal,  
comprising:

a broadcast receiver circuit that extracts a data signal from a broadcast radio-frequency  
signal, said broadcast signal comprising an audio stream and a data stream;

a user input control that allows a user to initiate a transaction based on the audio stream  
content;

25 an output device that provides a transaction request comprising an identity of a user and an  
identification of the selected transaction, said transaction request being provided to a response  
authentication system.

26. A system for performing a transaction based on data provided as part of a broadcast radio-  
frequency signal, comprising:

30 a means for extracting a data signal from a broadcast channel, said broadcast channel  
comprising an audio stream and a data stream that identifies program material in the audio stream;

a means for displaying information corresponding to the data signal;

a means for allowing a user to select a transaction from the displayed information;

a means for requesting a transaction, said transaction request comprising an identity of a user and an identification of the selected transaction, said transaction request being provided to a response authentication system.

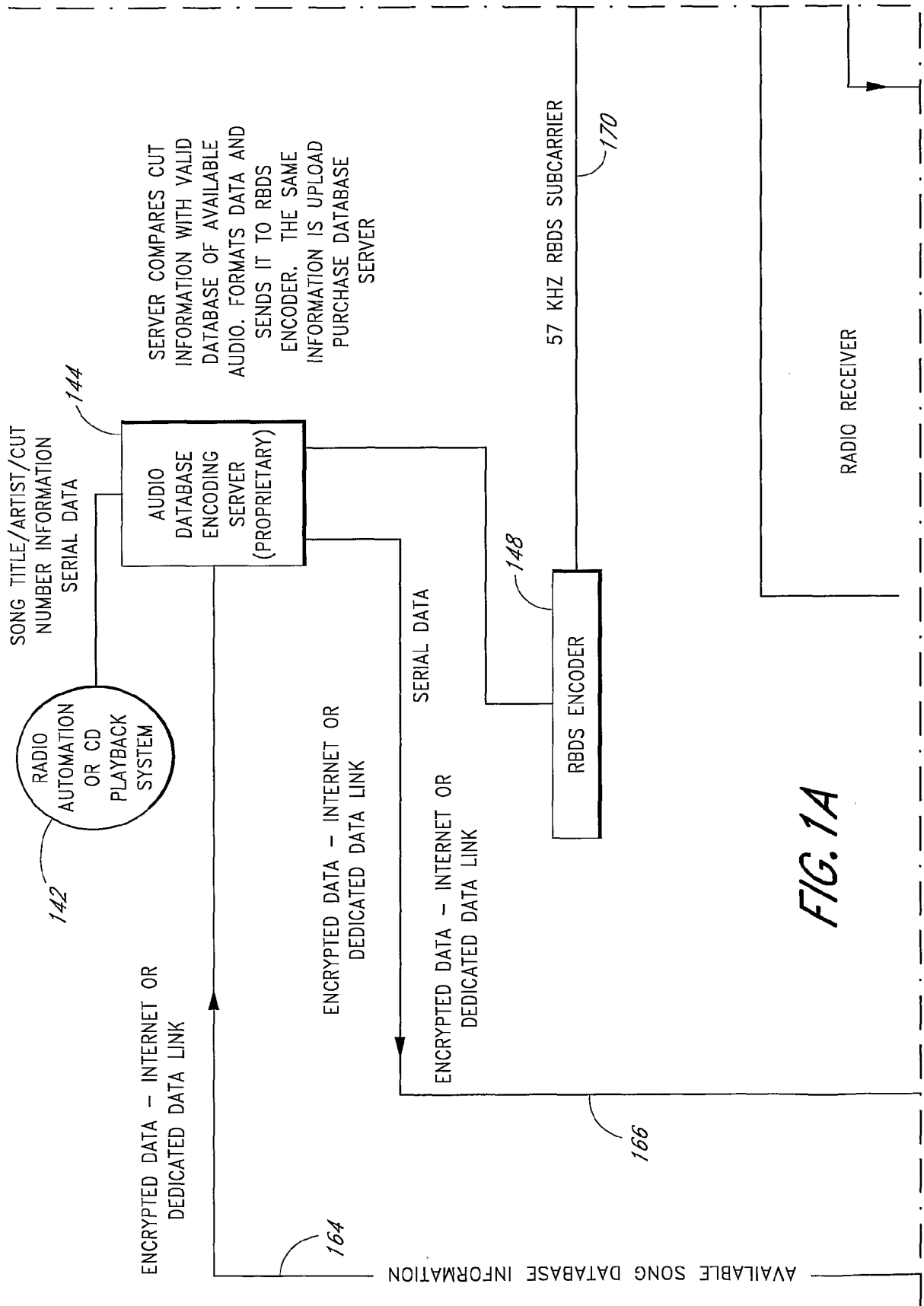
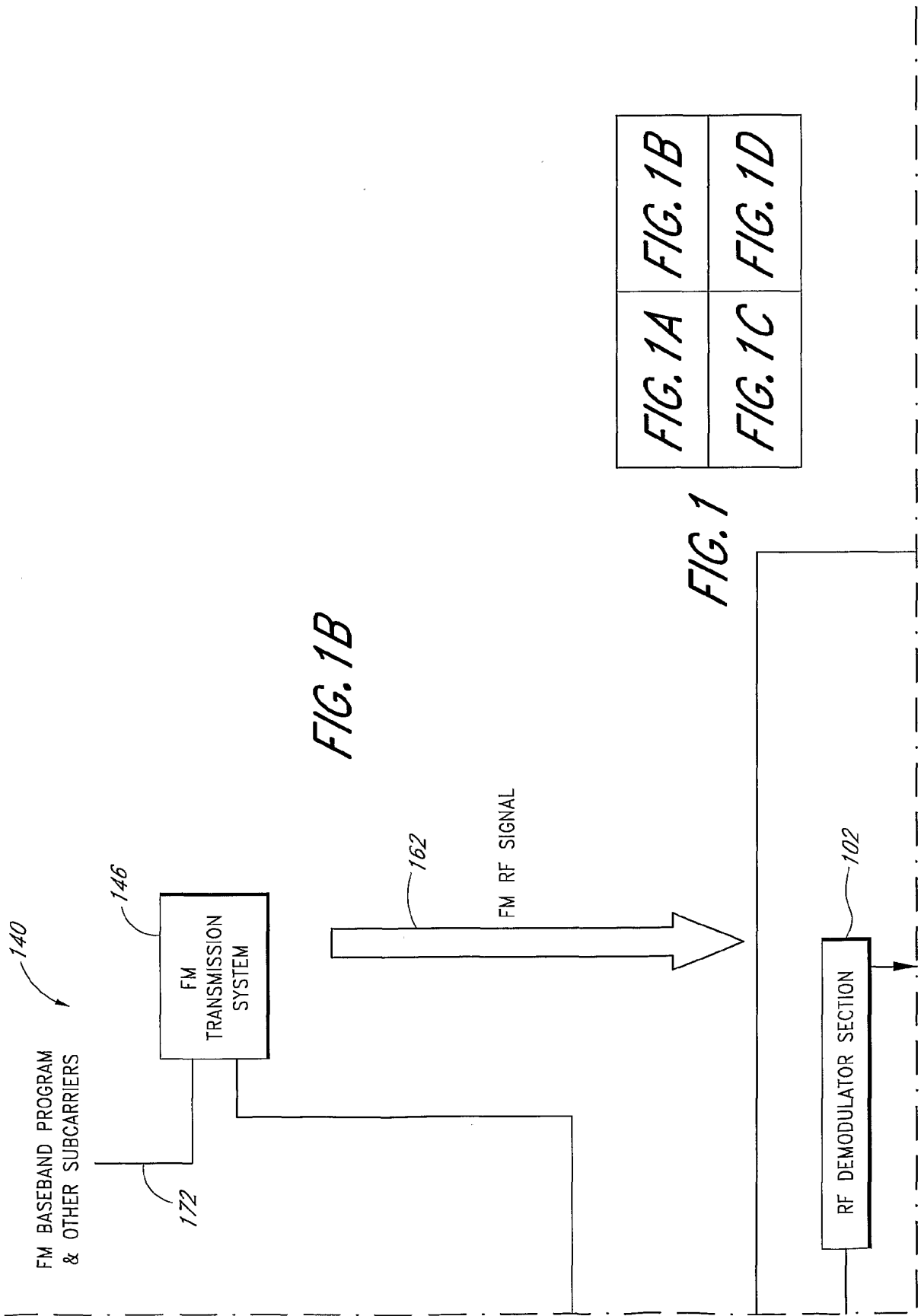
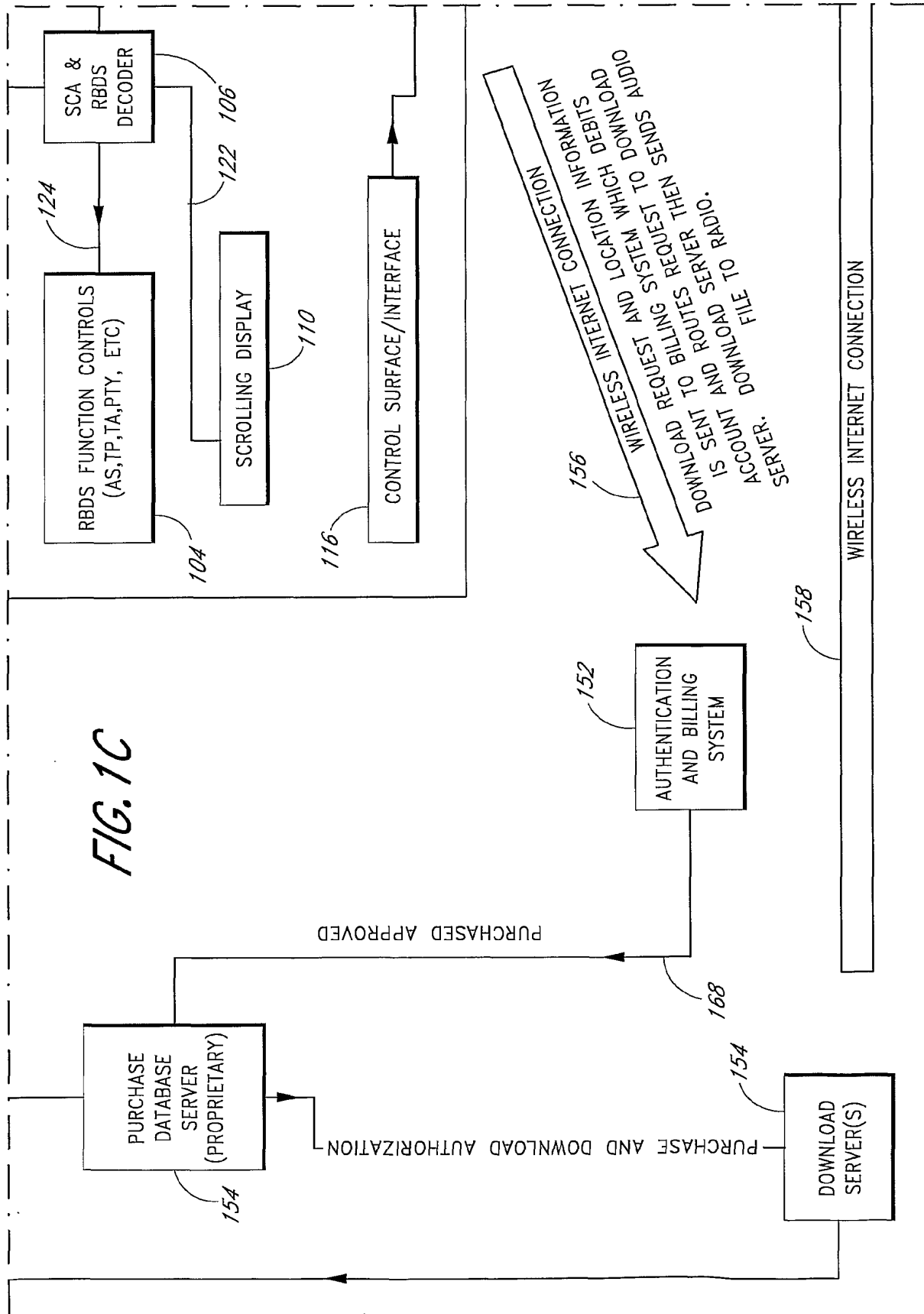


FIG. 1A







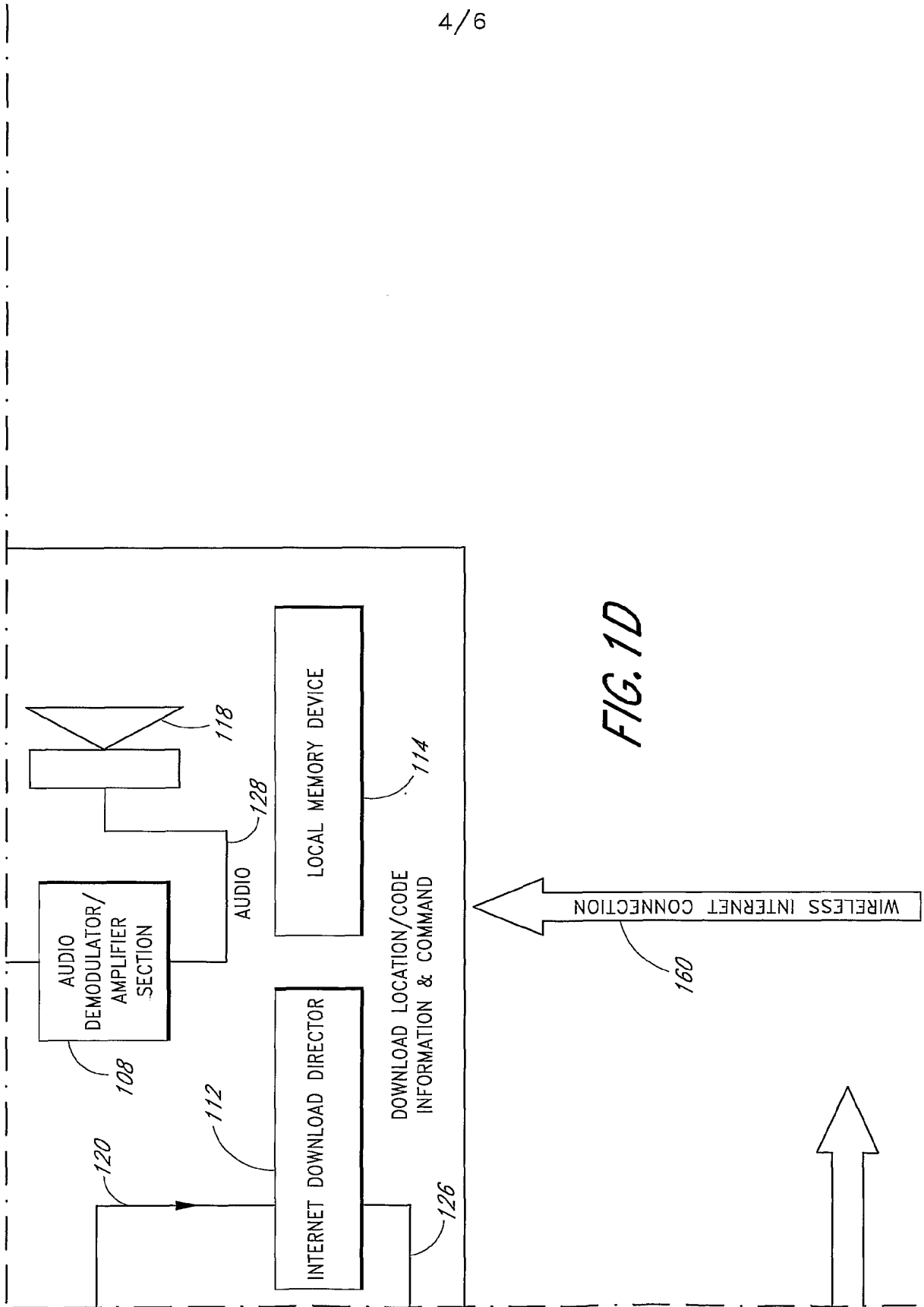


FIG. 1D

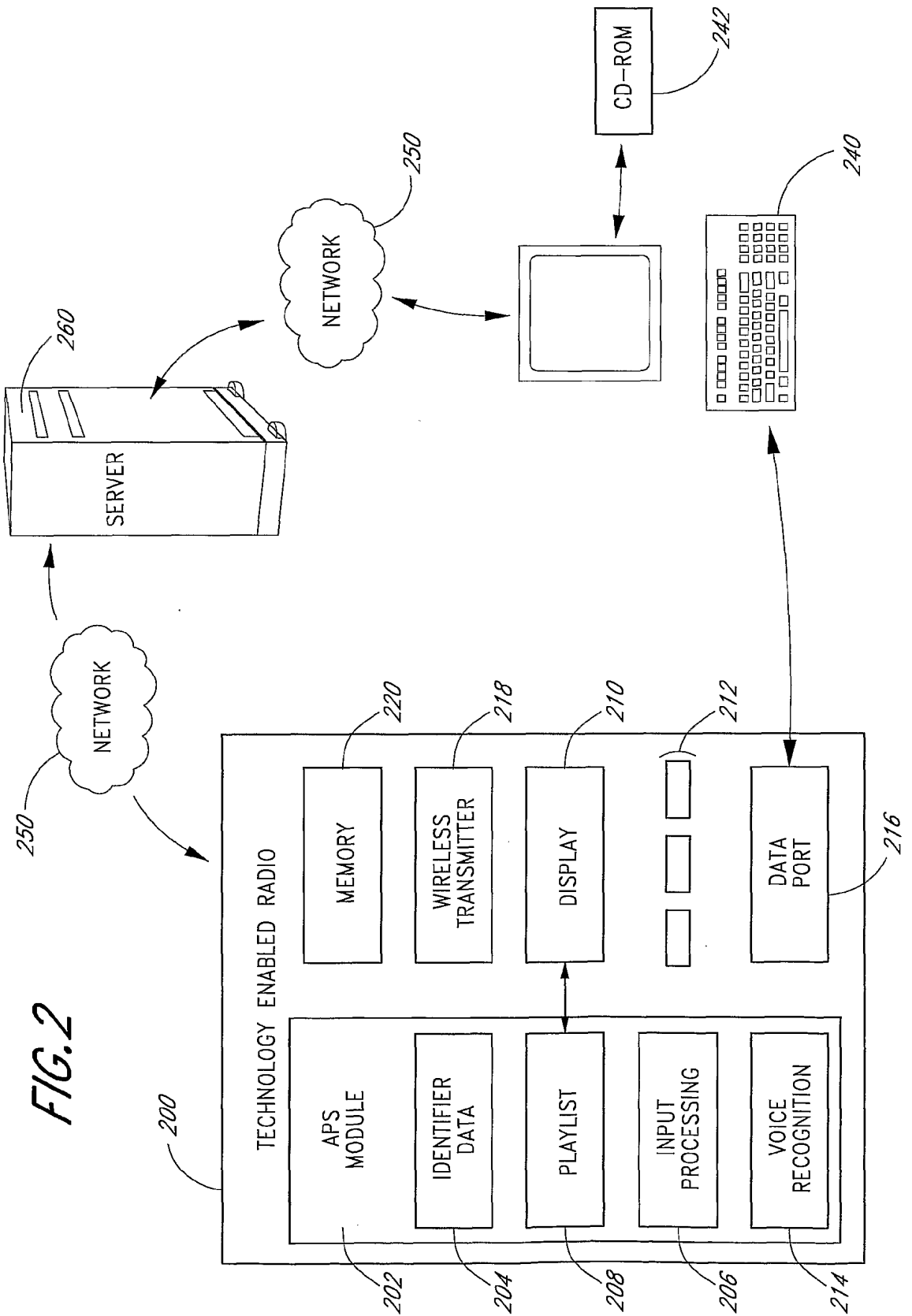
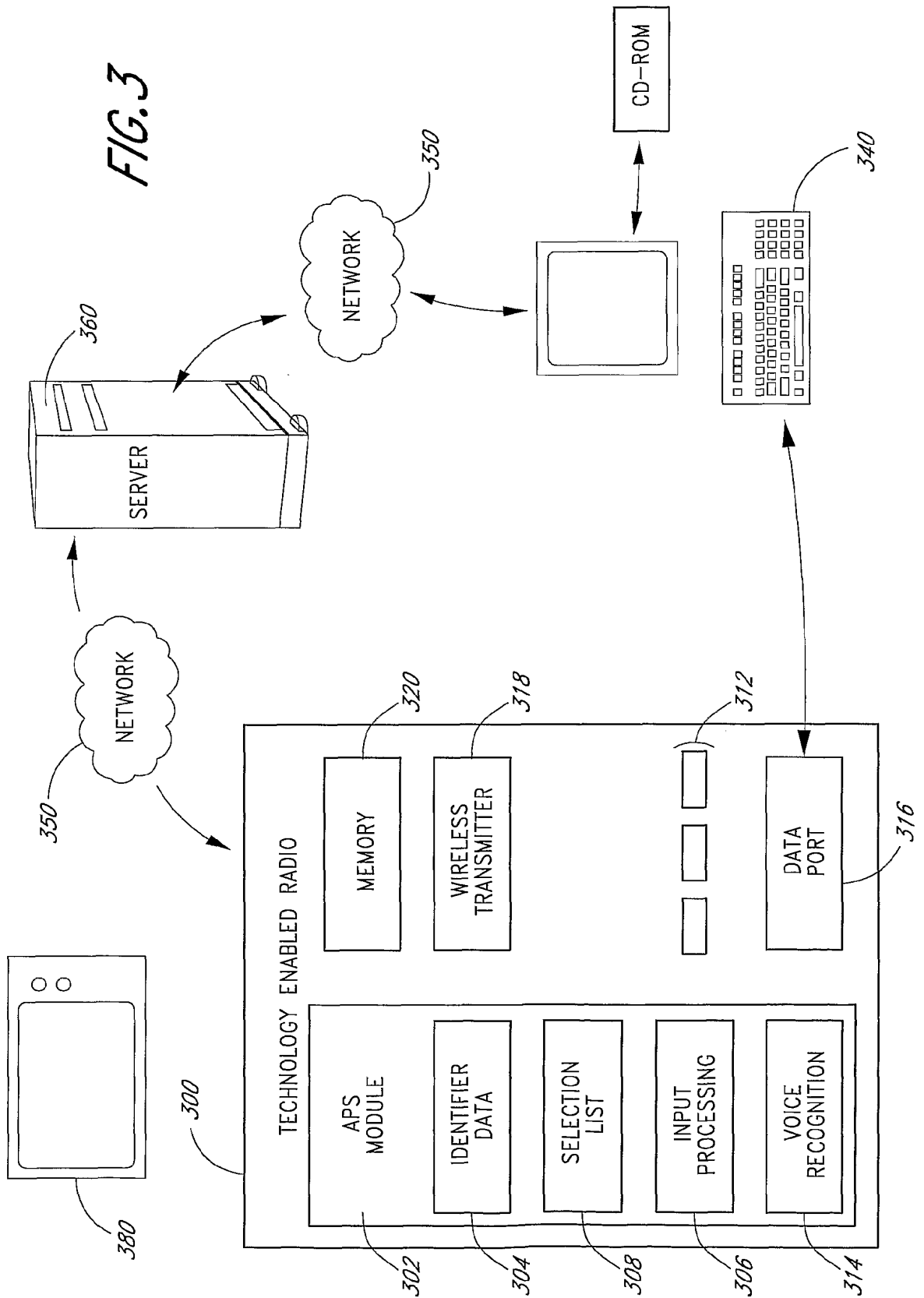


FIG. 2



(19) World Intellectual Property Organization  
International Bureau



(43) International Publication Date  
16 November 2006 (16.11.2006)

PCT

(10) International Publication Number  
WO 2006/122028 A2

(51) International Patent Classification:  
G06Q 40/00 (2006.01)

(21) International Application Number:  
PCT/US2006/017726

(22) International Filing Date: 8 May 2006 (08.05.2006)

(25) Filing Language: English

(26) Publication Language: English

(30) Priority Data:  
11/125,512 10 May 2005 (10.05.2005) US

(71) Applicant (for all designated States except US): **ROOT MARKETS INC.** [US/US]; 601 West 26th Street, 15th Floor, New York, New York 10001 (US).

(72) Inventors; and

(75) Inventors/Applicants (for US only): **GOLDSTEIN, Seth** [US/US]; 115 Central Park West, Suite 7a, New York, New York 10023 (US). **HERSHBERG, Peter** [US/US]; 134 West 23rd Street, 3rd Floor, New York, New York 10011 (US). **STYLMAN, Joshua** [US/US]; 80 Montague Street, #2, Brooklyn, New York 11201 (US).

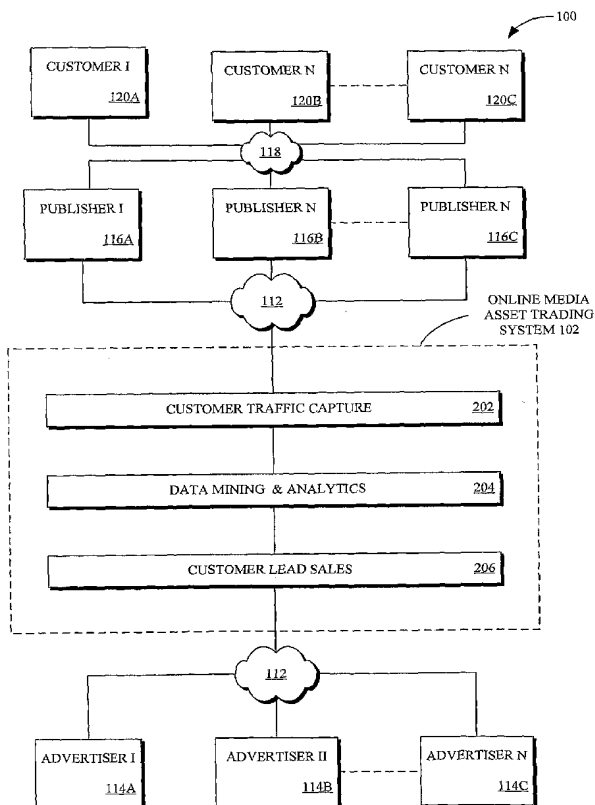
(74) Agent: **BRANDT, Jeffrey L.**; JLB Consulting, Inc., c/o Intellevate, P.O. Box 52050, Minneapolis, MN 55402 (US).

(81) Designated States (unless otherwise indicated, for every kind of national protection available): AE, AG, AL, AM, AT, AU, AZ, BA, BB, BG, BR, BW, BY, BZ, CA, CH, CN, CO, CR, CU, CZ, DE, DK, DM, DZ, EC, EE, EG, ES, FI, GB, GD, GE, GH, GM, HR, HU, ID, IL, IN, IS, JP, KE, KG, KM, KN, KP, KR, KZ, LC, LK, LR, LS, LT, LU, LV, LY, MA, MD, MG, MK, MN, MW, MX, MZ, NA, NG, NI, NO, NZ, OM, PG, PH, PL, PT, RO, RU, SC, SD, SE, SG, SK, SL, SM, SY, TJ, TM, TN, TR, TT, TZ, UA, UG, US, UZ, VC, VN, YU, ZA, ZM, ZW.

(84) Designated States (unless otherwise indicated, for every kind of regional protection available): ARIPO (BW, GH, GM, KE, LS, MW, MZ, NA, SD, SL, SZ, TZ, UG, ZM, ZW), Eurasian (AM, AZ, BY, KG, KZ, MD, RU, TJ, TM), European (AT, BE, BG, CH, CY, CZ, DE, DK, EE, ES, FI, FR, GB, GR, HU, IE, IS, IT, LT, LU, LV, MC, NL, PL, PT, RO, SE, SI, SK, TR), OAPI (BF, BJ, CF, CG, CI, CM, GA, GN, GQ, GW, ML, MR, NE, SN, TD, TG).

[Continued on next page]

(54) Title: METHODS AND SYSTEMS FOR FACILITATING INVESTMENT IN CONSUMER INTEREST IN ONLINE MEDIA



(57) Abstract: There is provided herein methods and systems for facilitating the trading, i.e. purchase and sale, of consumer interest arising from online media assets. A particular online media asset trading platform 102 is described, including various traffic capture 202, data mining, analytic 204 and customer lead sales 206 functions. Further provided is an investment structure 400 that facilitates private investment in the consumer interest arising from the online media assets traded by the trading system. The investment structure brings the discipline of the financial market directly to the management of online media assets, providing relative efficiency and predictability to online advertisers and publishers, and creating new opportunities for investors.

WO 2006/122028 A2



**Published:**

— without international search report and to be republished upon receipt of that report

*For two-letter codes and other abbreviations, refer to the "Guidance Notes on Codes and Abbreviations" appearing at the beginning of each regular issue of the PCT Gazette.*

METHODS AND SYSTEMS FOR FACILITATING INVESTMENT IN  
CONSUMER INTEREST IN ONLINE MEDIA

Field of the Invention

[0001] The present invention relates generally to online media and more particularly to methods and systems for investing in the buying and selling of value generated through consumer interest in online media.

Background of the Invention

[0002] According to some estimates consumers spent over \$100 billion making online purchases in 2004, buying products and services over the Internet. It has been further estimated that advertisers spend almost \$10 billion per year in placing online advertisements. Indeed, many online retail business models rely heavily on paid advertising and/or commissions for sales made through online advertisements. The reader will thus appreciate that online markets, such as those supported by the Internet, represent a substantial source of heavily advertised retail opportunities.

[0003] Online media assets comprise electronic indicia used on electronic networks, for example the Internet, as advertisements for attracting customers. Online media assets can take many forms, including keywords, banners, traditional advertisements, graphical inserts, e-mail, domain names and others as are known to the reader. Online media assets are purchased by media buyers on behalf of online retailers and, as described above, used in Internet advertising to attract customers for the purpose of initiating online sales. Owning the appropriate online media assets can be critical to attracting online customers and consummating sales. By their nature, however, online media assets are limited in availability. A single banner ad, for example, can only be purchased at any given time by a single user. Similarly, advertising opportunities and graphical space within web pages are by their nature limited in availability.

[0004] Commercial online search engines Yahoo™ and Google™ both operate online keyword auction services. The Yahoo® Search Marketing service and the Google™ online auction service are well known to online media buyers.

Google™ alone is estimated to have generated over \$1 billion in advertising revenue in 2004. Valuable keywords and advertising media assets may sell for upwards of \$150 per customer click-through.

[0005] The sale and purchase of online media assets, while necessary to a successful e-commerce market, poses many challenges to both buyers and sellers. Volatile demand for online media assets makes the management of inventory difficult for publishers, often generating uneven or unpredictable cash flow and resulting financial difficulties. Similarly, advertisers find the online media asset market to be complicated and inefficient.

[0006] One reason that online media assets are difficult to value is because the online media asset marketplace is fractured and inefficient. There is no central price discovery mechanism for comparing prices of ad impressions, paid search clicks, and direct response leads across multiple networks and marketplaces. A number of direct response agencies are beginning to acquire online media assets on a principal basis in an attempt to take advantage of the spread between the purchase costs and sales value of online media assets, as well as to provide some discipline. Most such agencies have been launched within the past 3 - 5 years. The reader is directed, for example, to Adteractive™, Azoogleads™, LeadClick™, NetBlue™ and Quin Street™ for examples of companies purchasing and reselling online media assets. The reader may consider right media™ as an example of a company that auctions advertising impressions and bluelithlum™ as an example of a company that helps advertisers and publishers optimize their advertising opportunities.

[0007] These agencies act as intermediaries between online publishers and online advertisers. In operation, they purchase online media assets from publishers, for example click - through advertisements and keywords, and resell them to advertisers. The agencies may purchase online media assets from publishers, for example, on an impression basis, while resale to advertisers may be priced, for example, on a CPA, or cost per action, basis. These agencies are currently generating substantial returns on their media costs by converting online traffic into customers more effectively than advertisers themselves. Publishers thus benefit through more

efficient and cost-effective sales of online media assets, while advertisers benefit through the more cost-effective purchase of the same assets.

[0008] It will be appreciated by those skilled in the art that the operation of the above described online media resellers constitutes arbitrage. That is, these resellers purchase and sell inventory at substantially the same time, profiting from the margins between the buying price and the selling price.

[0009] Because of the structure of these online media asset resellers, it will be further appreciated by the reader that any efficiencies provided by the online media asset resellers are limited to those efficiencies that can be generated through the conventional supply and demand dynamics of the online media asset market. That is, the efficiencies are generally limited by conventional retail dynamics as determined by the profitability of privately and publicly traded online media asset resellers. In their current form these online media asset resellers fail to provide to investors the ability to invest directly in online media assets, limiting investment opportunities to those that may be available in the operating companies.

[0010] While online media asset resellers provide some efficiency and improvements to the online media asset market, the market still suffers from much significant inefficiency. Volatility of buyer/advertiser demand for online media assets makes the efficient sale of online advertising difficult for sellers/publishers, while an inefficient, fractured market makes appropriate valuation difficult for advertisers.

#### Summary of the Invention

[0011] The present inventors have determined that it would be desirable and beneficial for both the online media asset market and investors to provide the ability for investors to participate directly in the function of the online media market. This is accomplished by providing methods and systems for securitizing online media assets, the media assets in the form generally of consumer interest, for financial investment by investors. It is believed that the efficiencies generated by investor-driven dynamics would improve the online media asset market, resulting in a more efficient market for both publishers and advertisers, and creates new opportunities for investors.



[0012] In accordance with one embodiment of the present invention, there are shown methods and systems for facilitating investment in consumer interest in online media assets, a system comprising: a trading system for buying and selling online media assets, the online media assets used to generate consumer interest; means for securitizing the consumer interest; and means for enabling investments in the securitized consumer interest.

[0013] In accordance with another embodiment of the present invention, there are shown methods and systems for facilitating investment in consumer interest in online media assets, a method comprising: establishing a trading system for buying and selling online media assets; generating consumer interest from consumer selections of the online media assets; the trading system further operative to buy and sell the consumer interest; establishing a management company to operate the trading system; establishing a limited partnership to invest funds for management by the management company in the operation of the trading system; and receiving investor funds into the limited partnership; whereby investors in the limited partnership own a financial interest in the consumer interest.

[0014] In accordance with another embodiment of the present invention, there are shown methods and systems for enabling investors to invest in consumer interest in online media assets, a method comprising: means for arbitraging real-time online consumer leads to generate an arbitrage value; means for securitizing the arbitrage value of the real-time online consumer leads; and means for using investor funds to purchase an interest in the arbitrage value of the real-time online consumer leads.

[0015] Through the securitization of Internet customer preferences and 'intent to purchase' using a Wall Street-like trading discipline, the present invention brings significant efficiencies to the online media asset and market, while providing investors the ability to recognize investments and return in this same market.

Description of the Drawing Figures

[0016] These and other objects, features and advantages of the present invention will be apparent from a consideration of the following Detailed Description of the Invention, when considered in cooperation with the drawing Figures, in which:

[0017] Figure 1 is a block diagram of an online media asset trading system in accordance with the present invention;

[0018] Figure 2 is a block diagram of the online media asset trading system of Figure 1, showing functional aspects of the system;

[0019] Figure 3 is a block diagram showing more detailed functional aspects of the online media asset trading system in accordance with the present invention;

[0020] Figure 4 is a block diagram illustrating a corporate and investment structure in accordance with the present invention;

[0021] Figure 5 is a flow chart showing at a high level a process for managing online media assets in accordance with the present invention;

[0022] Figure 6 is a flow chart showing the details of the media asset processing step of Figure 5; and

[0023] Figure 7 is a flow chart showing a more detailed process for trading online media assets in accordance with the present invention.

#### Detailed Description of the Invention

[0024] The present invention shows an online media trading system wherein the online media assets are securitized for investment by investors. In the described embodiments of the invention, the online media assets are in the form of consumer interest, also described as consumer leads, for example as indicated by a consumer selection or 'click-through' of an advertising impression. The invention enables direct investment in the relative performance of online advertising, directly relating the return in an investment securitized by media assets to the to the generation of

consumer interest in those assets, thereby bringing the disciplines and benefits of a Wall Street - type investment structure to the field of online media buying and selling.

[0025] As used herein, the term "securitization" and variants thereof is meant in the conventional sense as a process of creating a financial instrument by combining financial assets for marketing to investors. The reader will appreciate that the underlying financial assets described and securitized herein comprises the value associated with consumer interest in the online media asset inventory managed by the online media trading system.

[0026] Further as used herein, the term "media assets" and variants thereof means keywords, banners, traditional advertisements, graphical inserts, e-mail, domain names and others as are known to the reader.

[0027] Further as used herein, the terms "consumer interest," "consumer leads," and variants thereof mean demonstrated consumer response to an online media asset, for example the selection or "click - through" of an online media asset. As described in further detail below the present invention recognizes that there is real, securitizable value associated with consumer interest in online media assets.

[0028] With reference now to Figure 1, there is shown a system 100 including an online media asset trading platform 102. Online media asset trading platform 102 is seen to include a processor 104 connected to a user terminal 106, a landing page 108 and a database 110. The processor 104 is connected through conventional network connections, for example the Internet as shown at 112, to communicate with a variety of external parties.

[0029] Continuing with reference to Figure 1, processor 104 is seen to be connected to communicate with a plurality of advertisers 114, three of which are indicated at 114A, 114B and 114C. Similarly, processor 104 is seen to be connected to communicate with a plurality of publishers 116, three of which are indicated at 116A, 116B and 116C. The publishers are connected so as to serve advertisements through a network 118, such as the Internet, to a plurality of customers 120, three of

which are indicated at 120A, 120B and 120C. The interactions of advertisers 114, publishers 116 and customers 120 are described in further detail herein below.

[0030] It will be appreciated that media trading platform 102 can comprise conventional system components situated and programmed to perform the described elements of the present invention. Processor 104 can comprise, for example, a conventional network server with a conventional microprocessor and operating system. User terminal 106 can comprise a conventional keyboard and display device. Database 110 can comprise a conventional arrangement of memory, for example an appropriate combination of semiconductor, magnetic and optical storage. As is further described below, landing page 108 is seen to comprise a specialized, customer - accessible web page, for example assembled and stored in database 110 and managed appropriately by processor 104. It will be understood by the reader that while online media asset trading platform 102 has been shown in simplified form, in actual construction it can comprise one of many known configurations, for example a centralized system and/or a decentralized system comprising the described components in multiple and/or decentralized configurations.

[0031] Publishers 116 comprise online content publishers, many of which are known to the reader. Advertisers 114 comprise online advertisers, for example retail advertisers, who desire to purchase online media for the purpose of placing advertisements through publishers 116 for display to customers 120. It will be understood by the reader that in many instances a single entity can comprise both a publisher and an advertiser. Amazon.com™, for example, is a well-known online retailer who both publishes content pages including advertising as well as purchases advertising from others.

[0032] Like elements throughout the Figures are indicated by like reference numbers.

[0033] With reference now to Figures 2 and 3 functional aspects of platform 102 are shown. Firstly, with respect to Figure 2, platform 102 is seen to include customer traffic capture means 202, data mining and analytic evaluation means 204 and customer lead sales means 206.

[0034] With reference to Figure 3, customer traffic capture function 202 is seen to include a click – through gateway 302, landing page 108, and a plurality of landing page lead information forms 304, three of which are indicated at 304A, 304B and 304C, the click – through gateway, landing page and information forms all connected to database 110. (Database 110 is of course connected to processor 104 as shown in Figure 1.)

[0035] Continuing with reference to Figure 3, data mining & analytic means 204 is seen to include a price tracker 312, a behavioral analyzer 314 and a traffic optimizer 316, each connected to database 110 and an internal trading application 317. Price tracker 312 is seen to be connected to an ad publisher 116, while the components of data mining analytic means 204 are connected to an advertiser enrollment interface 318. Customer lead sales means 206 comprises advertiser enrollment interface 318 as well as components of internal trading application 317 that enable the sale of customer leads to advertisers as described herein.

[0036] Considering now the operation of the functional elements of Figures 2 and 3, it will be understood that online media asset trading platform 102 operates to purchase online media assets from publishers 116, and collect customer 120 click – through traffic, resulting from customer selection of the online media assets, for sale to advertisers 114. Click – through gateway 302 functions to serve cookies and track referrals and other foot-printing information relevant to customers 120 who select online media assets owned by trading platform 102. Almost instantaneously, the click – through traffic received onto gateway 302 is redirected to landing page 108. The operation of click – through gateway 302 is substantially imperceptible to a customer 120.

[0037] Landing page 108 functions as a dynamic web site to present a customer 120 with relevant information. The landing page further functions as a point to collect possible lead information. Lead information forms 304, in the described embodiment contained within the landing page 108, provide forms for collecting customer information. Exemplary forms and information collected include: contact details, customer demographics and other lead – specific information.

Numerous other customer information and appropriate forms for collecting same will now be apparent to the reader.

[0038] Considering now the operation of data mining and analytic means 204, price tracker 312 functions to gather current inventory price information, for example through public and private data sharing facilities provided by the Yahoo® and Google® keyword auction sites described above. The current inventory price information is integrated with observed conversion rates, as observed by behavior analyzer 314, to optimize online media trades. Behavior analyzer 314 functions to analyze click – stream data as observed through the consumer traffic passing through click-through gateway 302 to landing page 108, whereby to process post-landing page behavior to determine the conversion rate of consumer traffic to lead sales. The analysis is used to optimize offers displayed to landing page customers, thus optimizing the overall success and profitability of the system.

[0039] Additionally, the data developed by behavior analyzer 314 is used to match possible leads with lead purchase requests. Traffic optimizer 316 functions to reconfigure landing pages 108 to optimize conversion and lead acquisition. Internal trading application 312 presents human traders/operators of asset trading system 100 with the data developed by the tracking, analyzing and optimizing functions described above, for use in selling media to advertisers 114.

[0040] Continuing with reference to Figure 3, advertiser enrollment interface 318 comprises a web site where advertisers 114 interested in purchasing consumer leads developed from online media assets can register their demand for such consumer interest. The interface further provides for the ability to collect useful information from the advertisers, such as desired consumer demographics and preferences, etc., of potential customer information supplied to the advertisers. This information is used by the operators of trading application 317 to buy and sell online media assets in the processes described herein.

[0041] With reference now to Figure 4, in accordance with one key aspect of the invention there is shown a new and unique business structure 400 including an operating management company 402 established in the form of a limited liability

corporation (LLC). Management company 402 owns and operates the trading platform 102 and its assets, including the consumer interest assets described above and indicated at 408 in Figure 4. Management company 402 further receives and directs the use of investment funds from a limited partnership 404. Limited partnership 404 includes, in a conventional sense, general partners who direct the operation of the limited partnership and limited partners liable only to the extent of their investments in the limited partnership.

[0042] Limited partnership 404 receives and invests the limited partner's investment funds. Limited partnership 404 further functions to allocate, reinvest and distribute investment profits and losses recognized by the limited partnership, among the limited partners and general partners of the limited partnership, through the investment in the assets of management company 402 and other investments as may be made by the limited partnership. As noted above, management company 402 owns the assets and resources of the trading platform and operates the trading platform, in exchange for compensation paid by the limited partnership, typically as a fee calculated as a percentage of the limited partnership assets invested under the direction of the management company.

[0043] From a consideration of the above it will be apparent to the reader that the present invention enables the direct investment by investors in the consumer interest owned and managed by asset trading system 102. It will be understood that, while limited partnership 404 is described as owning an interest in only a single management company 402, in practice it may own ownership interests in a portfolio comprising multiple operating companies or funds.

[0044] With reference now to Figure 5, there is shown a process 500 for enabling investors to invest in online media assets in accordance with one embodiment of the present invention. Initially, there is established and operated online media asset trading platform 102 in accordance with the above described embodiments (step 502). Subsequent to the establishment of the trading platform, online media assets are purchased by the trader/operators of management system 102 and used to develop consumer interest (step 504).

[0045] With the establishment and operation of trading platform 102, there is performed a process enabling investments in the consumer interest by investors (step 506).

[0046] With reference now to Figure 6, there is shown a process 600 whereby purchased online media assets are managed by online media trading system 102 (Figure 1) to develop consumer interest. It will be understood that by the reader that process 600 comprises details of the above – described steps 500, 502 (Figure 5).

[0047] Initially, research is performed regarding existing online media advertising prices (step 602), for example using the price tracking mechanism 312 from Figure 3. The research may be based, for example, on observed changes in media asset prices coupled with observed changes in their lead generation capability, such changes indicating direction to media asset traders working within media trading platform 102.

[0048] Online consumer behavior is researched (step 604), for example using behavior analyzer 314 of Figure 3. The purpose of this behavior research is to identify the relationships between user responses to advertising generated from media assets, thereby determining the optimal processes to cost-effectively convert consumer interest to valuable consumer lead sales.

[0049] Online media assets are then purchased from publishers 116 (step 606), for example through the keyword auction sites described herein. Consumer leads are processed from the purchased online media (step 608) for example using the customer traffic capture function 202 described with respect to Figures 2 and 3 above.

[0050] Continuing with respect to Figure 6, the collected and processed consumer leads are sold to direct response advertisers 114 (step 610), for example using the internal trading application 312 described with respect to Figure 3 above. The purchase and sale of online media are analyzed in an iterative process (step 612) in order to optimize the profits associated there-with. This optimization can be performed by different methods, for example: i) adjusting buy and sell prices of media assets, ii) adjust buy and sell of media assets based on recognized risk associated with



those assets, iii) fine-tuning consumer experiences through the adjustment of landing pages, and iv) numerous other methods as will now be apparent to the reader.

[0051] It will be understood by the reader that the above-described operation of online media asset trading system 102 is exemplary in nature. Many alternative embodiments will now be apparent to the reader. It will be understood the processing of such online media assets whereby to generate salable, securitizable consumer interest is pertinent to the ability of investors to invest in the online media as described herein above. The invention is not limited to any particular embodiment of processing online media.

[0052] With reference now to Figure 7, there is shown a process 700 for facilitating an investor investment in media assets as described with respect to Figure 5 above. Initially, financial investments are received from investors through limited partnership 404 (Figure 4) (step 702). Investor financial investments are invested by limited partnership 400 into management company 402, whereby they are managed by the management company in the operation of the operating company, including the purchase and sale of media assets (step 704). Management company 402 manages and processes the media assets in accordance with the above – described processes to generate and sell consumer interest (step 706) to advertisers 114, recognizing profits and losses.

[0053] Conventional profit and loss determinations are made with respect to management company 402 based upon the purchase and sale of online media assets and consumer interest in accordance with the above-described processes (steps 708). Based on such profits and losses, the evaluation of the limited partnership investment in the management company is periodically recalculated (step 710). Through this process, and further in consideration of the fees paid to the management company, the capital account value of the partners in limited partnership 404 is periodically re-assessed (step 712).

[0054] There have thus been provided methods and systems for facilitating private investment in online media assets, particularly in the form of consumer interest as represented by consumer leads. The present invention enables investors,

for the first time, to directly own interests in the value of the consumer interest. This brings investment – type structure and uniformity to the business of online media asset trading. The invention thus provides for relative efficiency and predictability in the business of online media asset trading, providing business predictability and security to publishers and advertisers, and creates new opportunities for investors. The invention has application in the field of online advertising, and particularly in the field of Internet e-commerce.

What is Claimed is:

1. A system for facilitating investment in consumer interest in online media assets, comprising:
  - a trading system for buying and selling online media assets, the online media assets used to generate consumer interest;
  - means for securitizing the consumer interest; and
  - means for enabling investments in the securitized consumer interest.
2. The system of claim 1 wherein the consumer interest comprises a real-time consumer lead generated through a consumer selection of an online media asset.
3. The system of claim 2 wherein the online media assets are selected from the group comprising keywords, banners, traditional advertisements, graphical inserts, e-mail and domain names.
4. The system of claim 1 wherein the means for securitizing the consumer interest includes a management company for owning the consumer interest.
5. The system of claim 4 wherein the means for means for enabling investments in the securitized consumer interest includes a limited partnership for providing investment funds managed by the management company in the operation of the trading system.
6. A process for facilitating investment in consumer interest in online media assets, comprising:
  - establishing an electronic trading system for buying and selling online media assets on a network;
  - using the online media assets to generate consumer interest;
  - securitizing the consumer interest for financial investment; and
  - enabling investments in the securitized consumer interest.
7. A system for facilitating investment in consumer interest in online media assets, comprising:

a network;  
a processor connected to the network;  
a memory connected to the processor storing instructions to control the operation of the processor to perform the steps of:  
establishing an electronic trading system for buying and selling online media assets on a network;  
using the online media assets to generate consumer interest;  
securitizing the consumer interest for financial investment; and  
enabling investments in the securitized consumer interest.

8. A method for facilitating investment in consumer interest in online media assets, comprising:  
establishing a trading system for buying and selling online media assets;  
generating consumer interest from consumer selections of the online media assets;  
the trading system further operative to buy and sell the consumer interest;  
establishing a management company to operate the trading system;  
establishing a limited partnership to invest funds for management by the management company in the operation of the trading system; and  
receiving investor funds into the limited partnership;  
whereby investors in the limited partnership own a financial interest in the consumer interest.

9. The method of claim 8 wherein the online media assets are selected from the group comprising keywords, banners, traditional advertisements, graphical inserts, e-mail and domain names.

10. The method of claim 8 wherein the consumer interest comprises the selection by a consumer of a link in a graphical user interface.

11. The method of claim 8 and further comprising the step of periodically determining a profit on the investor funds in the limited partnership based on the financial performance of the management company resulting from the operation of the trading system.

12. The method of claim 11 and further comprising the step of operating the trading system, by the management company, to recognize a profit on the buying and selling of the consumer interest.

13. A system for facilitating investment in consumer interest in online media assets, comprising:

means for establishing a trading system for buying and selling online media assets;

means for generating consumer interest from consumer selections of the online media assets;

the means for establishing a trading system further including means for buying and selling the consumer interest;

means for establishing a management company to operate the trading system;

means for establishing a limited partnership to invest funds for management by the management company in the operation of the trading system; and

means for receiving investor funds into the limited partnership;

whereby investors in the limited partnership own a financial interest in the consumer interest.

14. A system for enabling investors to invest in consumer interest in online media assets, comprising:

means for arbitraging real-time online consumer leads to generate an arbitrage value;

means for securitizing the arbitrage value of the real-time online consumer leads; and

means for using investor funds to purchase an interest in the arbitrage value of the real-time online consumer leads.

15. The system of claim 14 wherein the arbitraging means includes:

a trading system for trading online media assets; and

the trading system including means for selling consumer interest in the online media assets.

16. The system of claim 15 wherein the securitizing means includes a management company for owning the trading system.
17. The system of claim 16 wherein the using means includes a corporate structure for investing investor funds in the management company.
18. The system of claim 14 wherein the online media assets are selected from the group comprising keywords, banners, traditional advertisements, graphical inserts, e-mail and domain names.
19. The system of claim 18 wherein the online consumer leads result from consumer selection of the online media assets.
20. A method for enabling investors to invest in consumer interest in online media assets, comprising:
  - establishing an electronic management system to arbitrage real-time online consumer leads to generate an arbitrage value;
  - securitizing the arbitrage value of the real-time online consumer leads; and
  - using investor funds to purchase an interest in the arbitrage value of the real-time online consumer leads.

1/6

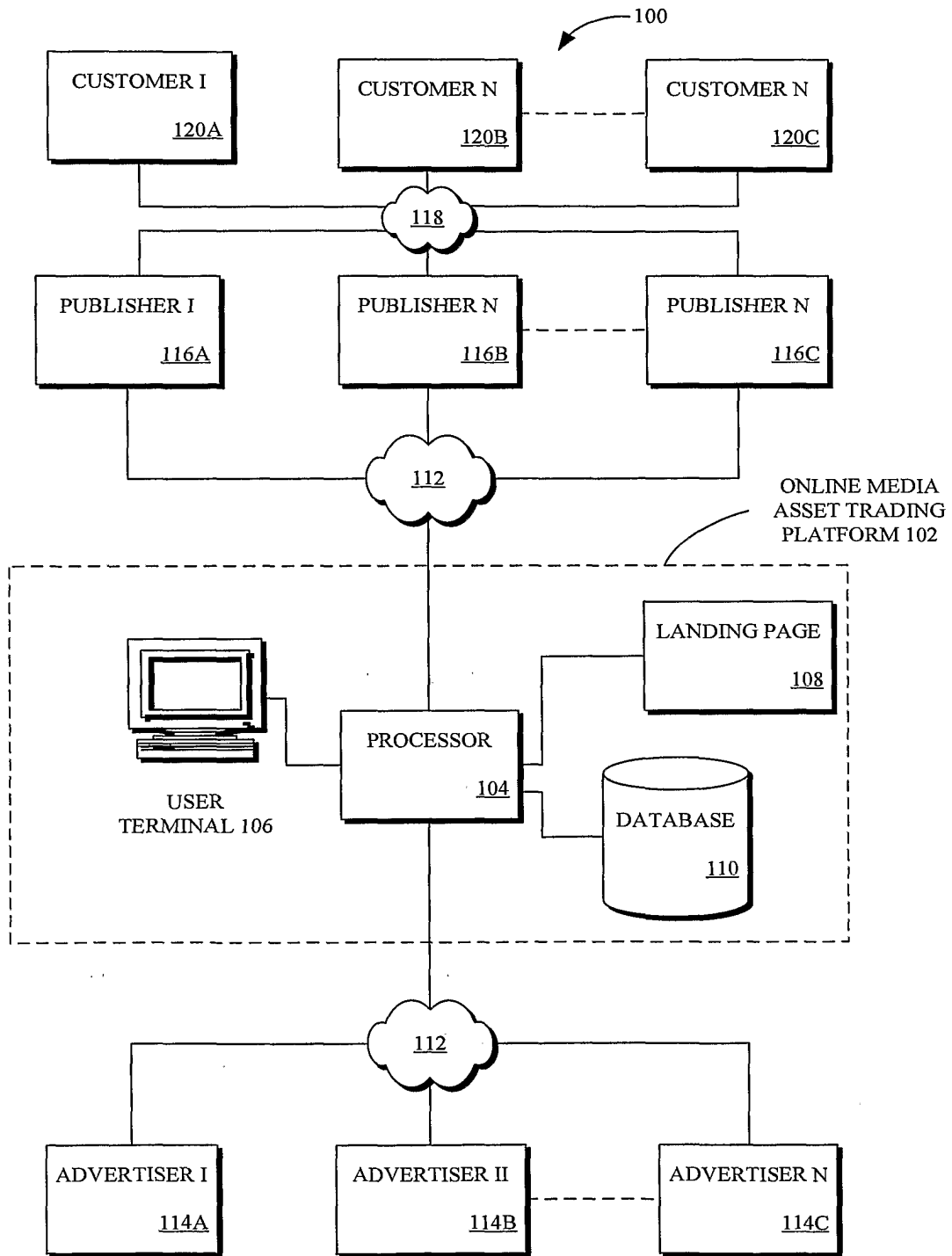


FIG. 1

2/6

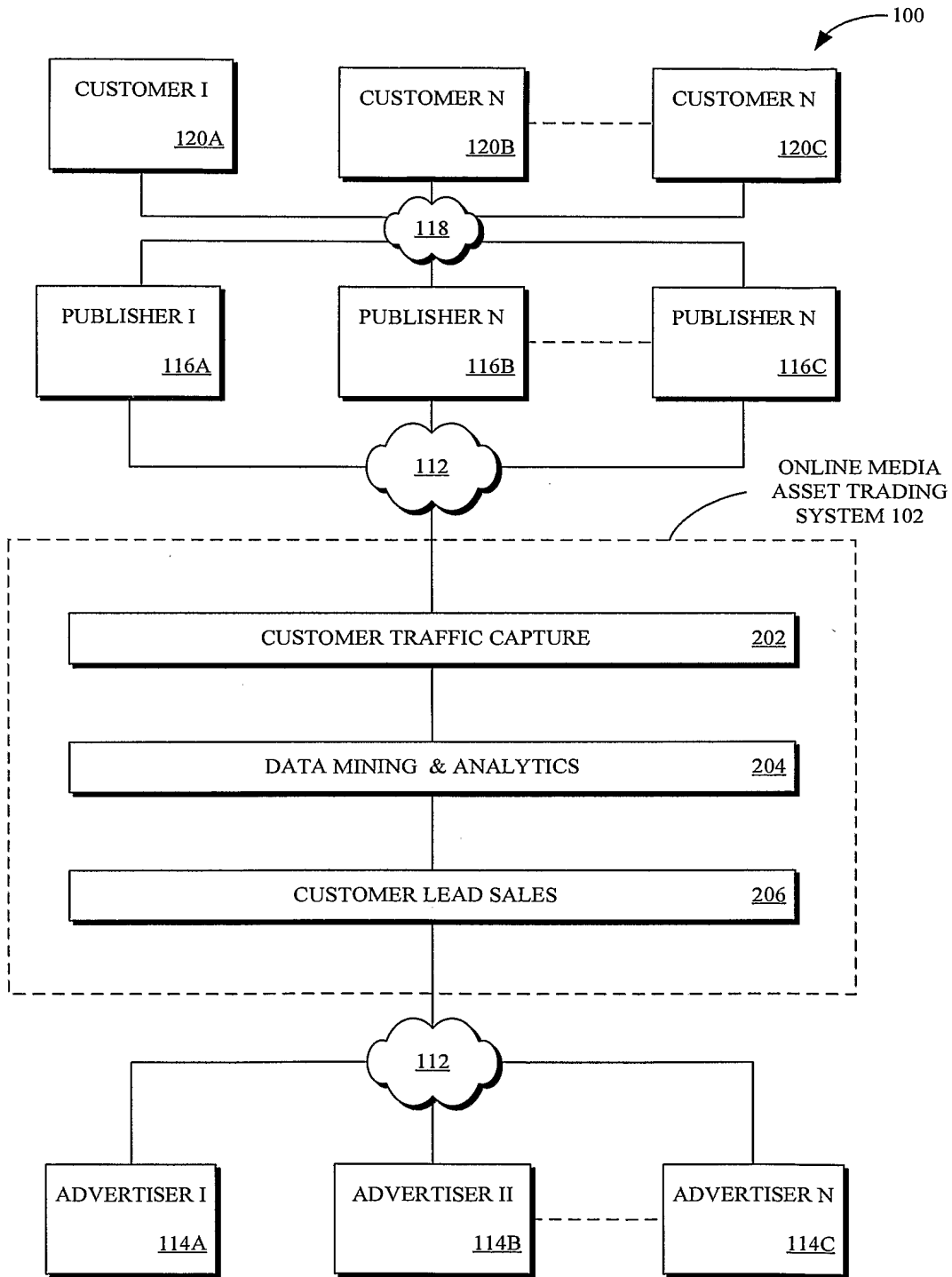


FIG. 2



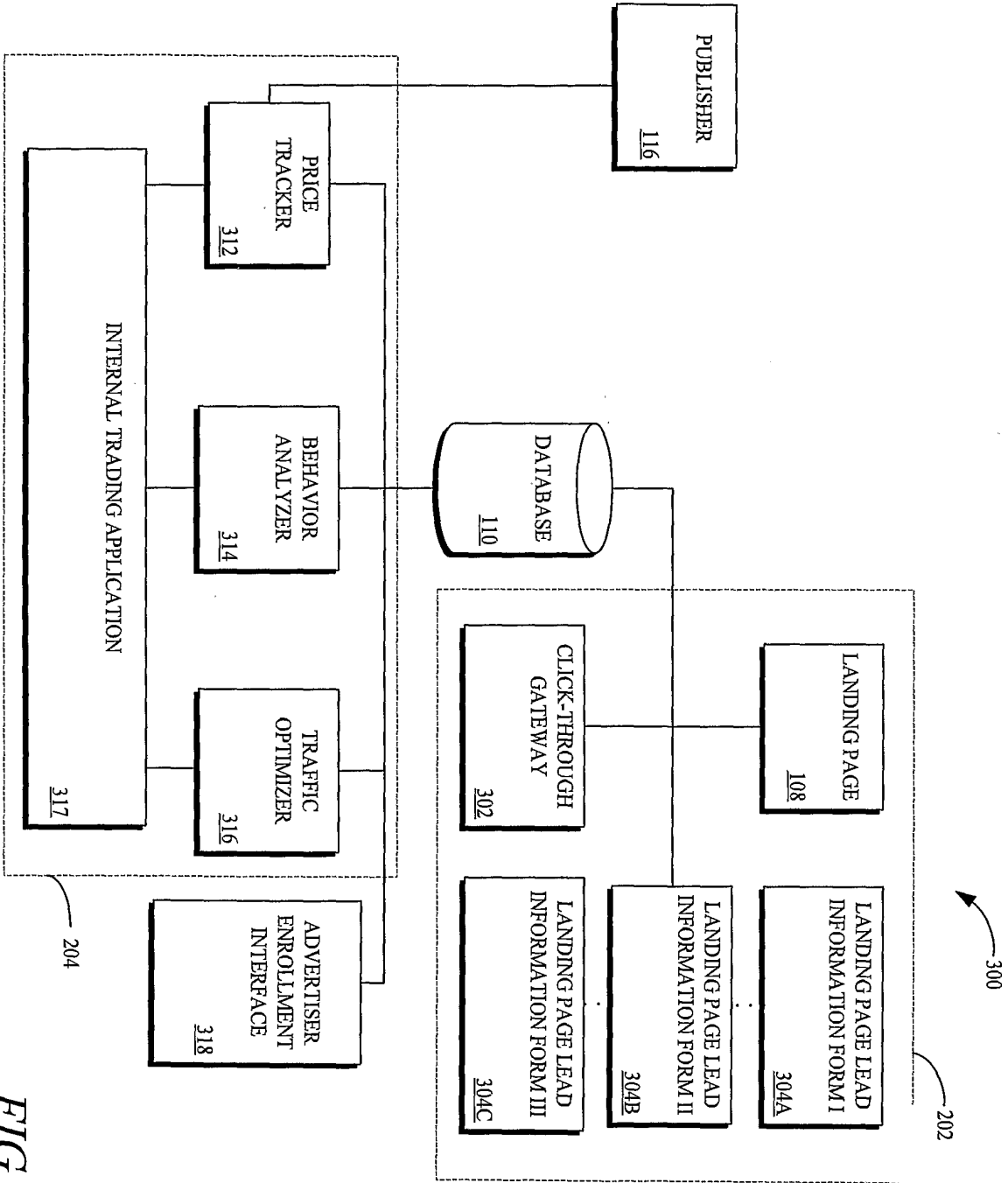


FIG. 3

4/6

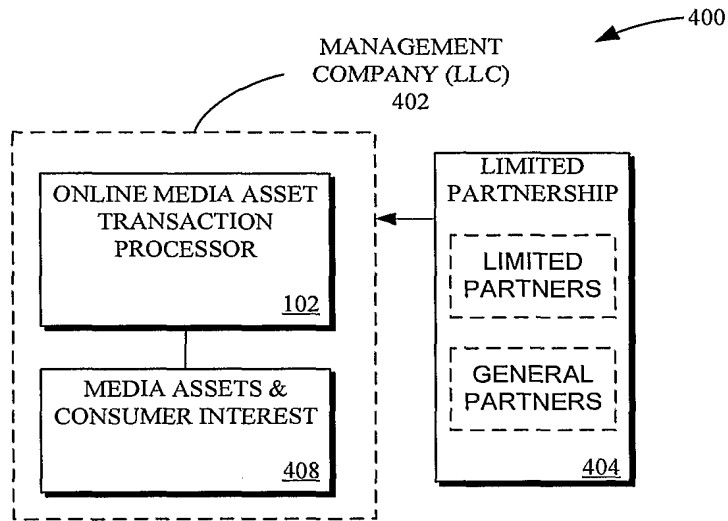


FIG. 4

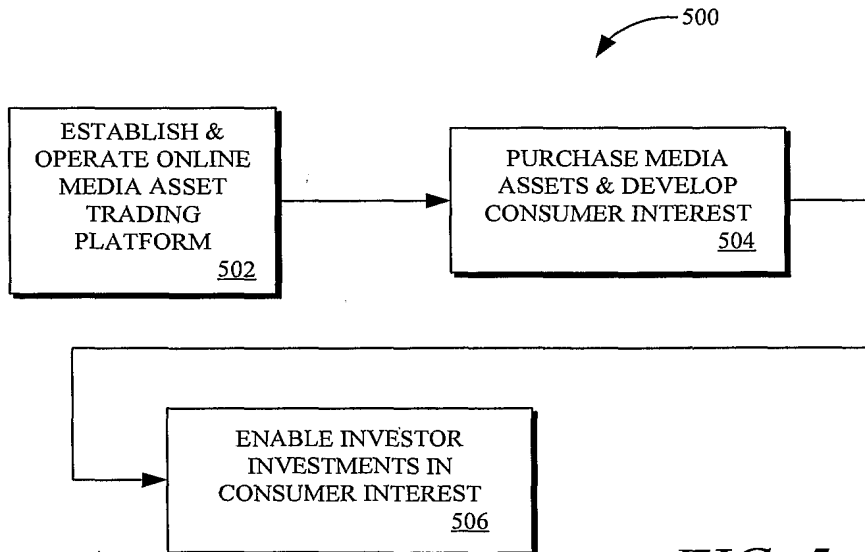


FIG. 5

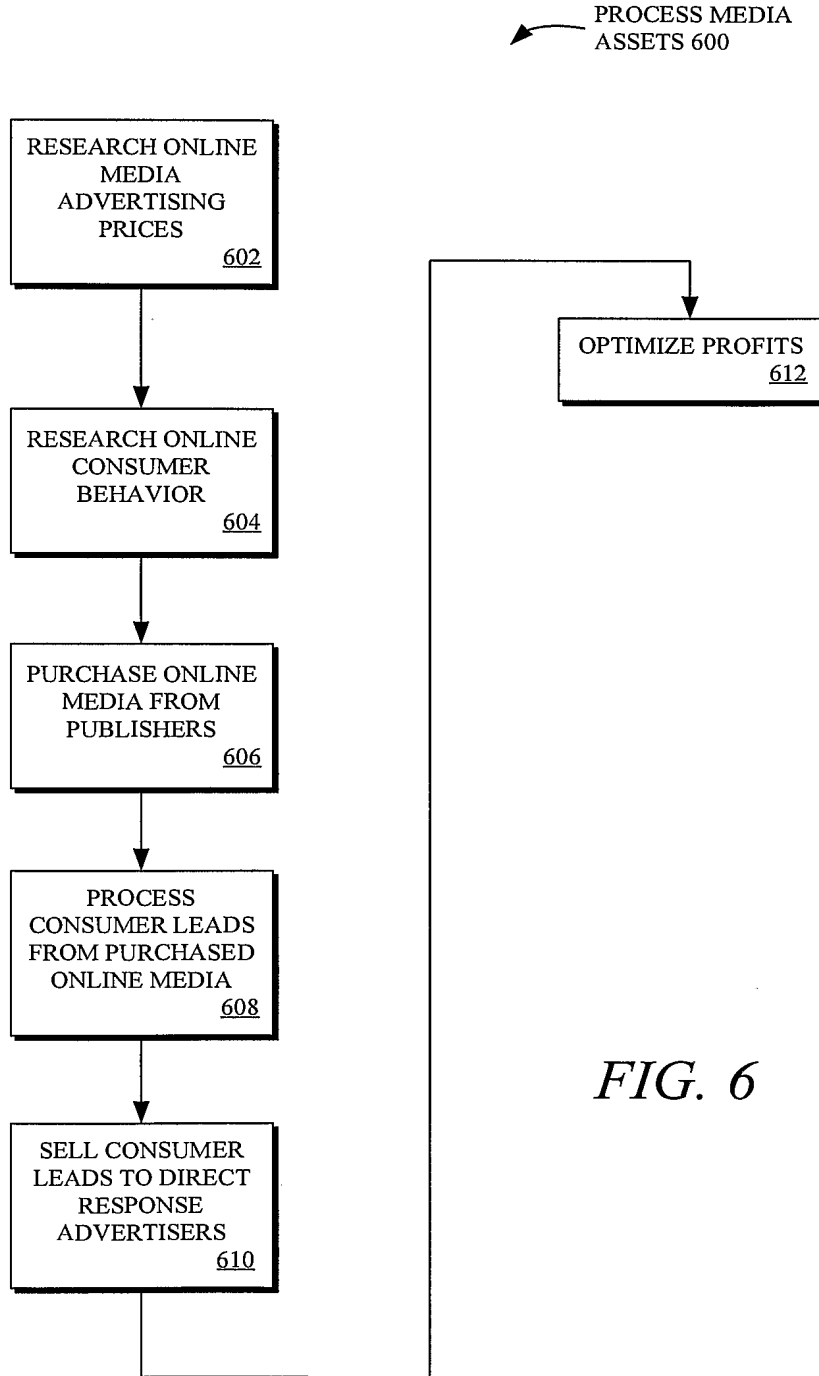


FIG. 6

6/6

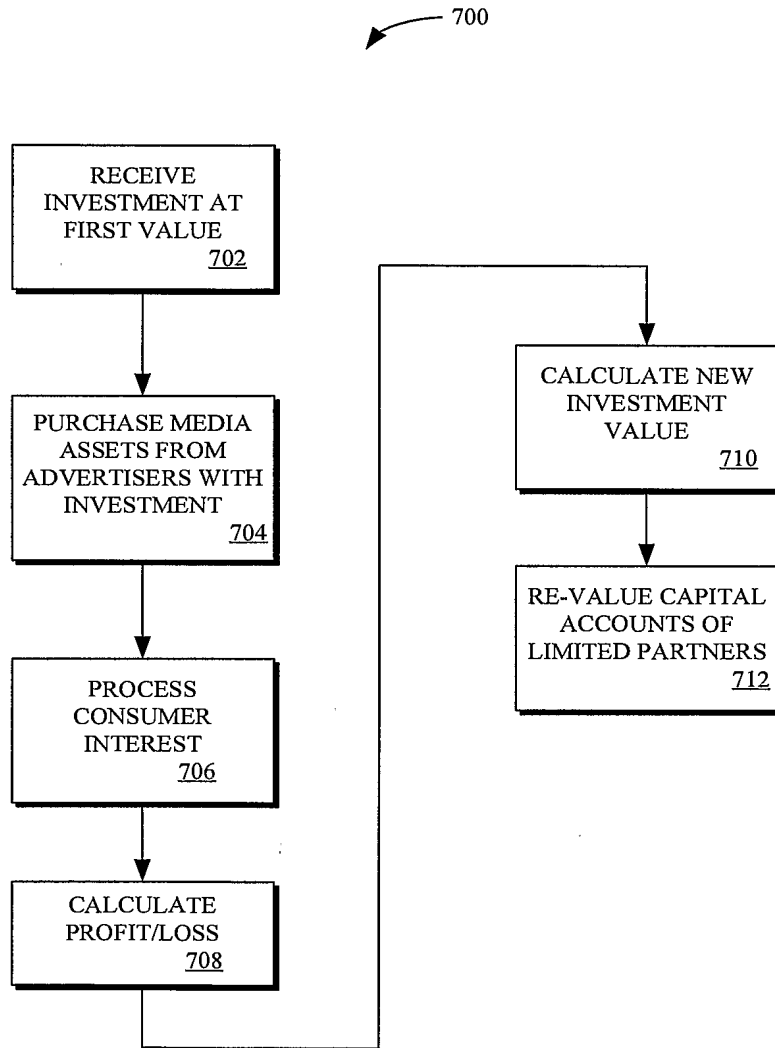


FIG. 7

(19) World Intellectual Property Organization  
International Bureau



(43) International Publication Date  
3 January 2008 (03.01.2008)

PCT

(10) International Publication Number  
WO 2008/002000 A1

(51) International Patent Classification:  
H04N 7/12 (2006.01)

Soo-In [KR/KR]; #106-606 Clover Apt., Dunsan-dong, Seo-gu, Daejeon 302-120 (KR).

(21) International Application Number:  
PCT/KR2007/000494

(74) Agent: SHINSUNG INTERNATIONAL PATENT & LAW FIRM; ID Tower #601, Jungdaero 105, (99-7 Garak-dong), Songpa-gu, Seoul 138-805 (KR).

(22) International Filing Date: 29 January 2007 (29.01.2007)

(81) Designated States (unless otherwise indicated, for every kind of national protection available): AE, AG, AL, AM, AT, AU, AZ, BA, BB, BG, BR, BW, BY, BZ, CA, CH, CN, CO, CR, CU, CZ, DE, DK, DM, DZ, EC, EE, EG, ES, FI, GB, GD, GE, GH, GM, GT, HN, HR, HU, ID, IL, IN, IS, JP, KE, KG, KM, KN, KP, KZ, LA, LC, LK, LR, LS, LT, LU, LV, LY, MA, MD, MG, MK, MN, MW, MX, MY, MZ, NA, NG, NI, NO, NZ, OM, PG, PH, PL, PT, RO, RS, RU, SC, SD, SE, SG, SK, SL, SM, SV, SY, TJ, TM, TN, TR, TT, TZ, UA, UG, US, UZ, VC, VN, ZA, ZM, ZW.

(25) Filing Language: English

(26) Publication Language: English

(30) Priority Data:  
10-2006-0061225 30 June 2006 (30.06.2006) KR  
10-2006-0094380  
27 September 2006 (27.09.2006) KR

(71) Applicant (for all designated States except US): ELECTRONICS AND TELECOMMUNICATIONS RESEARCH INSTITUTE [KR/KR]; 161, Gajeong-dong, Yuseong-gu, Daejeon 305-350 (KR).

(84) Designated States (unless otherwise indicated, for every kind of regional protection available): ARIPO (BW, GH, GM, KE, LS, MW, MZ, NA, SD, SL, SZ, TZ, UG, ZM, ZW), Eurasian (AM, AZ, BY, KG, KZ, MD, RU, TJ, TM), European (AT, BE, BG, CH, CY, CZ, DE, DK, EE, ES, FI, FR, GB, GR, HU, IE, IS, IT, LT, LU, LV, MC, NL, PL, PT, RO, SE, SI, SK, TR), OAPI (BF, BJ, CF, CG, CI, CM, GA, GN, GQ, GW, ML, MR, NE, SN, TD, TG).

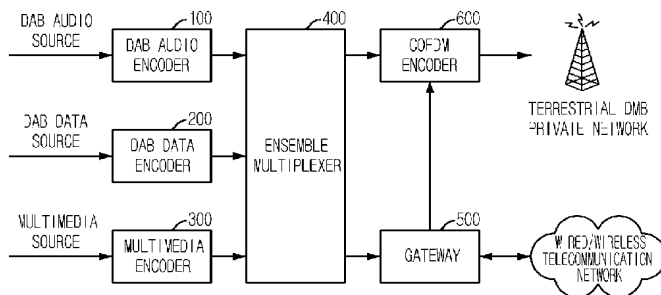
(72) Inventors; and

(75) Inventors/Applicants (for US only): BAE, Byung-Jun [KR/KR]; #212-405 Saemmeori Apt., Dunsan 2-dong, Seo-gu, Daejeon 302-777 (KR). YUN, Joung-II [KR/KR]; #401 Hwangje Villa, 329-16, Jangdae-dong, Yuseong-gu, Daejeon 305-308 (KR). KIM, Woo-Suk [KR/KR]; #1521 Yuseong Hanjin Resort Officetel, 535-5, Bongmyeong-dong, Yuseong-gu, Daejeon 305-301 (KR). AHN, Chung-Hyun [KR/KR]; #103-306 Hyundai Apt., Doryong-dong, Yuseong-gu, Daejeon 305-340 (KR). LEE,

Published:  
— with international search report

For two-letter codes and other abbreviations, refer to the "Guidance Notes on Codes and Abbreviations" appearing at the beginning of each regular issue of the PCT Gazette.

(54) Title: METHOD FOR TRANSFORMING TERRESTRIAL DMB CONTENTS AND GATEWAY EMPLOYING THE SAME



(57) Abstract: The present invention provides a gateway for transforming a terrestrial digital multimedia broadcasting (DMB) contents. A gateway for transforming a terrestrial DMB contents includes an ensemble transport interface (ETI) demultiplexing unit for dividing the terrestrial DMB contents having ETI frame format into a fast information channel (FIC) and a main service channel (MSC); a session description protocol (SDP) packet processing unit for converting the FIC into a SDP packet; a transmission control protocol/Internet protocol (TCP/IP) packet generating unit for generating a TCP/IP packet based on the SDP packet; a real-time transport protocol (RTP) packet processing unit for converting the MSC into a first RTP packet; a user datagram protocol/Internet protocol (UDP/IP) packet generating unit for generating a UDP/IP packet based on the RTP packet; and an IP output unit for transmitting the TCP/IP packet and the UDP/IP packet through an IP network.

WO 2008/002000 A1

## Description

### METHOD FOR TRANSFORMING TERRESTRIAL DMB CONTENTS AND GATEWAY EMPLOYING THE SAME

#### Technical Field

- [1] The present invention relates to a terrestrial digital multimedia broadcasting (DMB); more particularly, to a method for transforming terrestrial DMB contents, and a gateway employing the same which provides the DMB services through not only a terrestrial DMB private network but also various telecommunication networks efficiently by considering characteristics of various telecommunication networks and formation of the terrestrial DMB contents.

[2]

#### Background Art

- [3] Generally, a terrestrial digital multimedia broadcasting (DMB) is a digital multimedia broadcasting service providing terrestrial DMB contents, e.g., an audio, a data and multimedia through a terrestrial DMB network when a subscriber is in motion. The terrestrial DMB network is a private network having a low transmission rate implemented by private interface technology, e.g., a service transport interface (STI), an ensemble transport interface (ETI) and EN 300-401 coded orthogonal frequency division multiplexing (COFDM). Herein, a network supporting for the terrestrial DMB is defined as a terrestrial DMB private network.
- [4] In the terrestrial DMB private network, high-compression coded contents are generated for the terrestrial DMB service, the terrestrial DMB contents can be provided through a channel having low transmission rate. Herein, the high-compression coded contents provided through the terrestrial DMB private network is defined as terrestrial DMB contents.
- [5] In the past, the terrestrial DMB contents are provided through the terrestrial DMB private network. However, as the terrestrial DMB service is activated, the terrestrial DMB contents are various. Therefore, request of user who wants to receive the terrestrial DMB contents through the various telecommunication networks as well as the terrestrial DMB private network is increased.
- [6] There was a conventional transportation method of the terrestrial DMB contents through an Internet protocol (IP) network. The conventional transportation method presents IP packetization of the terrestrial DMB contents and transportation of the IP packet through the IP network, abstractly. The conventional transportation method has several problems. First, it does not consider characteristics of various IP networks. In addition, features of multimedia transportation technology through the IP network in

which media information and control information separately transported and formation of the terrestrial DMB contents based on a terrestrial DMB standard are overlooked. That is, it is uncertain whether or not transportation of the terrestrial DMB contents through the IP network is possible. Therefore, a system for providing the terrestrial DMB service through the IP network, which considers characteristics of the various telecommunication networks and the formation of the terrestrial DMB contents, is needed.

[7]

## **Disclosure of Invention**

### **Technical Problem**

[8]

It is, therefore, an object of the present invention to provide a method for transforming terrestrial DMB contents which offers the DMB services through not only a terrestrial DMB private network but also various telecommunication networks efficiently by considering characteristics of various telecommunication networks and formation of the terrestrial DMB contents, and a gateway employing the same.

[9]

Other objects and advantages of the present invention will be clearly understood by the following description and embodiments. Also, it is obvious to those skilled in the art that the objects and advantages of the present invention can be realized by the means as claimed and combinations thereof.

[10]

### **Technical Solution**

[11]

In accordance with one aspect of the present invention, there is provided A gateway for transforming a terrestrial digital multimedia broadcasting (DMB) contents, including: an ensemble transport interface (ETI) demultiplexing unit for dividing the terrestrial DMB contents having ETI frame format into a fast information channel (FIC) and a main service channel (MSC); a session description protocol (SDP) packet processing unit for converting the FIC into a SDP packet; a transmission control protocol/Internet protocol (TCP/IP) packet generating unit for generating a TCP/IP packet based on the SDP packet; a real-time transport protocol (RTP) packet processing unit for converting the MSC into a first RTP packet; a user datagram protocol/Internet protocol (UDP/IP) packet generating unit for generating a UDP/IP packet based on the RTP packet; and an IP output unit for transmitting the TCP/IP packet and the UDP/IP packet through an IP network.

[12]

In accordance with another aspect of the present invention, there is provided A method for transforming a terrestrial digital multimedia broadcasting (DMB) contents, including the steps of: a) demultiplexing the terrestrial DMB contents having ensemble transport interface (ETI) frame format into a fast information channel (FIC) and a main

service channel (MSC); b) converting the FIC into a session description protocol (SDP) packet and generating a transmission control protocol/Internet protocol (TCP/IP) packet based on the SDP packet; c) converting the MSC into an RTP packet and generating a UDP/IP packet based on the RTP packet; and d) transmitting the TCP/IP packet and the UDP/IP packet through an IP network.

- [13] In accordance with another aspect of the present invention, there is provided A terrestrial digital multimedia broadcasting (DMB) contents service system, including: an encoding means for encoding a DAB audio source, a DAB data source and a multimedia source; an ensemble multiplexing means for multiplexing the encoded DAB audio, the encoded DAB data and the encoded multimedia into a terrestrial DMB contents based on a ETI standard; a gateway for transforming the terrestrial DMB contents into packets having a IP format to access IP networks or transporting the terrestrial DMB contents to a coded orthogonal frequency division multiplexing (COFDM) encoding means to access a terrestrial DMB private network; and the COFDM encoding means for encoding the terrestrial DMB contents based on a COFDM and transmitting the encoded terrestrial DMB contents, wherein the gateway demultiplexes the terrestrial DMB contents based on the ETI frame format into a FIC and a MSC, converts the FIC into a packet having the IP format based on a SDP and a TCP/IP, and converts the MSC into a packet having the IP format based on an RTP and a UDP/IP.

[14]

### **Advantageous Effects**

- [15] The present invention can provide a terrestrial DMB services to a user through not only a terrestrial DMB private network but also various telecommunication networks efficiently by considering characteristics of various telecommunication networks and formation of the terrestrial DMB contents.

[16]

### **Brief Description of the Drawings**

- [17] The above and other objects and features of the present invention will become apparent from the following description of the preferred embodiments given in conjunction with the accompanying drawings, in which:

[18] Fig. 1 is a block diagram illustrating a conventional terrestrial digital multimedia broadcasting (DMB) service system;

[19] Fig. 2 is a block diagram illustrating a gateway in accordance with an embodiment of the present invention;

[20] Fig. 3 is a detailed block diagram illustrating a first contents transformer of Fig. 2;

[21] Fig. 4 is a detailed block diagram illustrating a second contents transformer of Fig.



2;

[22] Fig. 5 is a detailed block diagram illustrating a third contents transformer of Fig. 2;

[23] Fig. 6 is a flowchart illustrating a method for transforming the terrestrial DMB contents in accordance with an embodiment of the present invention;

[24] Fig. 7 is a detailed flowchart illustrating a method for transforming a fast information channel (FIC) of Fig. 6;

[25] Fig. 8 is a detailed flowchart illustrating a method for transforming a main service channel (MSC) of Fig. 6 in accordance with a first embodiment of the present invention;

[26] Fig. 9 is a detailed flowchart illustrating a method for transforming the MSC in accordance with a second embodiment of the present invention; and

[27] Fig. 10 is a detailed flowchart illustrating a method for transforming the MSC in accordance with a third embodiment of the present invention.

[28]

### **Best Mode for Carrying Out the Invention**

[29] Other objects and aspects of the invention will become apparent from the following description of the embodiments with reference to the accompanying drawings, which is set forth hereinafter.

[30] Fig. 1 is a block diagram illustrating a conventional terrestrial digital multimedia broadcasting (DMB) service system.

[31] As shown, the terrestrial DMB service system of the present invention includes a digital audio broadcasting (DAB) audio encoder 100, a DAB data encoder 200, a multimedia encoder 300, an ensemble multiplexer 400, a gateway 500 and a coded orthogonal frequency division multiplexing (COFDM) encoder 600.

[32] The DAB audio encoder 100, the DAB data encoder 200 and the multimedia encoder 300 encode a DAB audio source, a DAB data source and a multimedia source, respectively, based on a digital multimedia broadcasting (DMB) standard to thereby generate coded DAB audio, coded DAB data and coded multimedia.

[33] The ensemble multiplexer 400 multiplexes the coded DAB audio encoded in the DAB audio encoder 100, the coded DAB data encoded in the DAB data encoder 200 and the coded multimedia encoded in the multimedia encoder 300 into ensemble transport interface (ETI) frames and outputs the ETI frame to the gateway 500. The ETI frame includes a main service channel (MSC), a fast information channel (FIC) and an ETI header. The MSC includes terrestrial DMB contents information, i.e. DAB audio information, DAB data information and multimedia information. The FIC includes control information, i.e. construction information and service information of the terrestrial DMB contents, for controlling the terrestrial DMB contents. The ETI

header includes general construction information of the ETI frame. That is, the terrestrial DMB contents are generated based on a format of the ETI frame including the MSC, the FIC and the ETI header based on the terrestrial DMB standard.

[34] The gateway 500 transmits the terrestrial DMB contents generated by a format of the ETI frame to the COFDM encoder 600 or transforms the terrestrial DMB contents into packets having an Internet protocol (IP) format based on a network accessed by the terrestrial DMB service system. In DMB private network, the gateway 500 bypasses the terrestrial DMB contents to the COFDM encoder 600. Then, the COFDM encoder 600 encodes the terrestrial DMB contents based on a COFDM format and transmits the encoded terrestrial DMB contents through the DMB private network. Otherwise, in various telecommunication networks based on IP except the DMB private network, the gateway 500 transforms the terrestrial DMB contents generated based on a format of the ETI frame into a format of IP in the various telecommunication networks. Particular diagram of the gateway will be described in detail referring to Figs. 2 to 5.

[35] That is, the terrestrial DMB service system provides the terrestrial DMB contents through the terrestrial DMB private network and various telecommunication networks by adding the terrestrial DMB contents transforming gateway 500.

[36] Fig. 2 is a block diagram illustrating the gateway in accordance with an embodiment of the present invention.

[37] As shown, when the terrestrial DMB service system accesses the terrestrial DMB private network, the gateway 500 bypasses the terrestrial DMB contents generated by the ETI frame format. Therefore, a user terminal, i.e., a terrestrial DMB private terminal, accessing the terrestrial DMB private network can be served by a conventional terrestrial DMB service system without the added gateway 500.

[38] Herein, since the terrestrial DMB service system in accordance with the present invention may access not only the terrestrial DMB private network but also the various telecommunication networks, the gateway 500 includes a plurality of contents transformers, in order to transform the terrestrial DMB contents based on characteristics of the various telecommunication networks. For example, the various telecommunication networks may be a wired Internet, a wireless Internet, e.g., a wireless LAN, a wibro, a mobile telecommunication network, e.g., a code division multiple access (CDMA) and a global system for mobile communications (GSM). The wired Internet is the most stable and has high transmission bandwidth, and the mobile telecommunication network is the most unstable and has low transmission bandwidth. That is, the gateway 500 must be designed to support each telecommunication network for transforming the terrestrial DMB contents efficiently considering the characteristics of telecommunication networks described above.

- [39] For example, the gateway 500 includes three contents transformers, i.e., a first contents transformer 210, second contents transformer 220 and third contents transformer 230. Hereinafter, the first contents transformer 210, second contents transformer 220 and the third contents transformer 230 are described corresponding to the wired Internet, the wireless Internet and the mobile telecommunication network, respectively.
- [40] Fig. 3 is a detailed block diagram illustrating a first contents transformer of the Fig. 2.
- [41] As shown in Fig. 3, the first contents transformer 210 include a ETI demultiplexing unit 301, a session description protocol (SDP) packet processing unit 302, a transmission control protocol/Internet protocol (TCP/IP) generating unit 303, a real-time transport protocol (RTP) packet processing unit 304, a user datagram protocol/Internet protocol (UDP/IP) generating unit 305, and an IP output unit 306. As described above, the first contents transformer is designed for supporting the wired Internet.
- [42] When the telecommunication network is decided as the wired Internet, the terrestrial DMB contents having an ETI frame format are inputted to the first contents transformer 210.
- [43] The ETI frame includes a MSC having information of the terrestrial DMB contents, a FIC having control information of the terrestrial DMB contents and an ETI header having construction information of the ETI frame.
- [44] The ETI demultiplexing unit 301 analyzes the ETI header of the inputted ETI frame, demultiplexes the ETI frame into the MSC and the FIC, and outputs the FIC into the SDP packet processing unit 302 and the MSC into the RTP packet processing unit 304, respectively.
- [45] The SDP packet processing unit 302 forms a SDP packet based on the inputted FIC. Herein, the SDP packet is generated based on the SDP which is a protocol describing session in Internet multimedia transmission technology. The SDP packet includes session information of the terrestrial DMB contents, e.g., a name and a purpose of a session, creator information of the session, media information for the session and information needed to transmit media e.g., address, port, format. That is, the SDP packet includes the session information as well as the control information of the terrestrial DMB contents which is included in the FIC. The session information for the SDP packet is inputted by a user terminal and saved in a predetermined database. Therefore, the SDP packet is generated based on the session information and the control information of the FIC.
- [46] The TCP/IP generating unit 303 receives the SDP packet inputted from the SDP packet processing unit 302, generates the TCP/IP packet and outputs the TCP/IP

packet into the IP output unit 306 for transmitting the SDP packet by IP format. Then, the IP output unit 306 transmits the TCP/IP packet through the wired Internet. That is, the SDP and the TCP/IP are used for transforming the FIC into the packet having the IP format.

[47] Meanwhile, the RTP packet processing unit 304 receives the MSC and forms the RTP packet. Herein, the RTP packet is generated based on the RTP which is a protocol transmitting media in Internet multimedia transmission technology. The RTP packet includes information of the terrestrial DMB contents, e.g., DAB audio information, DAB data information, multimedia information. In the present invention, the RTP packet is generated by considering transmission characteristics of the terrestrial DMB contents. That is, size and payload type information of the RTP packet are setup for transmission of the terrestrial DMB contents. For example, the size of the RTP packet is defined by on the basis of 8 bytes as the same as the terrestrial DMB contents, and a payload type of the RTP packet may be decided as the terrestrial DMB contents.

[48] The UDP/IP generating unit 305 receives the RTP packet inputted from the RTP packet processing unit 304, generates the UDP/IP packet and outputs the UDP/IP packet into the IP output unit 306 for transmitting the RTP packet by IP format. Then, the IP output unit 306 transmits the UDP/IP packet through the wired Internet. That is, the RTP and the UDP/IP are used for transforming the MSC into the packet having the IP format.

[49] As described above, the terrestrial DMB contents are divided by media information and the control information of the terrestrial DMB contents. The media information of the terrestrial DMB contents is transformed by the RTP which is a protocol for transmitting media in the Internet multimedia transmission technology, and the control information of the terrestrial DMB contents is transformed by the SDP which is a protocol describing session in the Internet multimedia transmission technology. Therefore, the terrestrial DMB service system can be realized suitable for the characteristics of the Internet multimedia transmission technology, the media information and the control information of the terrestrial DMB contents are separately transmitted.

[50] Fig. 4 is a detailed block diagram illustrating a second contents transformer of Fig. 2.

[51] As shown, the second contents transformer 220 includes an ETI demultiplexing unit 401, a SDP packet processing unit 402, a TCP/IP generating unit 403, a MSC demultiplexing unit 404, an outer coding unit 405, an RTP packet processing unit 406, a UDP/IP generating unit 407, and an IP output unit 408. As described above, the second contents transformer is designed for supporting wireless Internet.

[52] Herein, the ETI demultiplexing unit 401, the SDP packet processing unit 402, the TCP/IP generating unit 403, the RTP packet processing unit 406, the UDP/IP

generating unit 407, and the IP output unit 408 perform the same functions as the ETI demultiplexing unit 301, the SDP packet processing unit 302, the TCP/IP generating unit 303, the RTP packet processing unit 304, the UDP/IP generating unit 305, and the IP output unit 306 of Fig. 3, respectively.

[53] Since the second contents transformer 220 is corresponding to the wireless Internet which is unstable and has narrower bandwidth than the wired Internet, an additional decoding procedure of the MSC is needed for improving transmission efficiency. The second contents transformer 220 divides the MSC into sub channels, i.e., a DAB audio stream, a DAB data stream and a multimedia stream and transforms each of the sub channels.

[54] The MSC demultiplexing unit 404 receives the MSC from the ETI demultiplexing unit 401 and demultiplexes the MSC into the DAB audio stream, the DAB data stream and the multimedia stream. The RTP packet processing unit 406 generates an RTP packet based on the DAB audio stream and the DAB data stream. Then, the UDP/IP generating unit 407 generates a UDP/IP packet based on the RTP packet and output the UDP/IP packet to the IP output unit 408.

[55] On the other hand, the multimedia stream is outer-decoded in the outer decoding unit 405. Herein, the outer-decoding is the deletion procedure of unnecessary bytes in the multimedia stream. Since the multimedia stream includes additional bytes by an outer-coding, the additional bytes do not necessary for IP transmission. For example, when the multimedia stream is a MPEG-2 transport stream (TS), the outer decoding unit 405 receives the MPEG-2 multimedia TS of which size is increased into 204 bytes by the outer-coding and generates a 188-byte MPEG-2 multimedia TS by the outer-decoding.

[56] The RTP packet processing unit 406 generates the RTP packet based on the outer-decoded multimedia stream. The UDP/IP generating unit 407 generates the UDP/IP packet based on the RTP packet, and output the UDP/IP packet into the IP output unit 408.

[57] As described above, the second contents transformer 220 divides the MSC into sub channels, converts and transmits each of the sub channels. Especially, the second contents transformer 220 decreases the size of the multimedia TS by using additional outer-decoding. Therefore, the second contents transformer 220 is needed for wireless Internet which is unstable and has narrower bandwidth than the wired Internet.

[58] Fig. 5 is a detailed block diagram illustrating a third contents transformer of Fig. 2.

[59] As shown, the third contents transformer 220 include a ETI demultiplexing unit 501, a SDP packet processing unit 502, a TCP/IP generating unit 503, a MSC demultiplexing unit 504, an outer coding unit 505, a multimedia stream analyzing/demultiplexing unit 506, a video elementary stream (ES) generating unit 507, an audio

ES generating unit 508, an RTP packet processing unit 509, a UDP/IP generating unit 510, and an IP output unit 511. As described above, the third contents transformer is designed for supporting a mobile telecommunication network.

[60] Herein, the ETI demultiplexing unit 501, the SDP packet processing unit 502, the TCP/IP generating unit 503, the RTP packet processing unit 509, the UDP/IP generating unit 510, and the IP output unit 511 perform the same functions as the ETI demultiplexing units 301 and 401, the SDP packet processing units 302 and 402, the TCP/IP generating units 303 and 403, the RTP packet processing units 304 and 406, the UDP/IP generating units 305 and 407, and the IP output units 306 and 408 shown in Figs. 3 and 4, respectively. Moreover, the MSC demultiplexing unit 504 and the outer coding unit 505 perform the same functions as the MSC demultiplexing unit 404 and the outer coding unit 405 of Fig. 4, respectively.

[61] Since the third contents transformer 230 is corresponding to the mobile telecommunication network which is unstable and has narrower bandwidth than the wired Internet and the wireless Internet, an additional decoding procedure of the multimedia outputted from the outer decoding unit 505 is needed. The third contents transformer 230 divides the multimedia stream into an audio stream and a video stream and transforms them.

[62] The multimedia stream analyzing/demultiplexing unit 506 receives the multimedia transport stream from the outer decoding unit 505, analyzes the multimedia stream and demultiplexes the multimedia stream into a video transport stream (TS) and an audio TS.

[63] The video ES generating unit 507 receives the video TS from the multimedia stream analyzing/demultiplexing unit 506 and generates a video ES by demultiplexing and depacketization of the video TS. The RTP packet processing unit 509 receives the video ES and generates an RTP packet based on the video ES. Then, the UDP/IP generating unit 510 receives the RTP packet, generates the UDP/IP packet based on the RTP packet and outputs the UDP/IP packet into the IP output unit 511.

[64] Meanwhile, the audio ES generating unit 508 receives the audio TS from the multimedia stream analyzing/demultiplexing unit 506 and generates an audio ES by demultiplexing and depacketization of the audio TS. The RTP packet processing unit 509 receives the audio ES and generates an RTP packet based on the audio ES. Then, the UDP/IP generating unit 510 receives the RTP packet, generates the UDP/IP packet based on the RTP packet and outputs the UDP/IP packet into the IP output unit 511.

[65] As described above, the third contents transformer 230 divides the multimedia stream into the video TS and the audio TS, and generates the video ES and the audio ES by performing additional decoding of the video TS and the audio TS to thereby decrease data size. Therefore, the third contents transformer 230 is suitable to support

themobile telecommunication network which is unstable and has narrower bandwidth than the wireless Internet.

[66] Fig. 6 is a flowchart illustrating a method for transforming the terrestrial DMB contents in accordance with an embodiment of the present invention.

[67] First, the terrestrial DMB contents having an ETI frame format are demultiplexed into a FIC and a MSC at step S601. Herein, the step S601 is performed identically in transforming the terrestrial DMB contents for all types of networks. That is, the terrestrial DMB contents are divided into the FIC (control information) and the MSC (media information) according to the characteristics of the Internet multimedia transportation technology.

[68] At step S602, the FIC is converted into a packet of IP format to access telecommunication network based on the IP. Herein, the step S602 is performed identically in transforming the terrestrial DMB contents for all types of networks. Below, the FIC conversion procedure is described in detail referring to Fig. 7.

[69] At step S603, the MSC is converted into a packet of IP format to access telecommunication network based on the IP. Herein, the MSC conversion procedure is performed differently in transforming the terrestrial DMB contents for each type of networks. In the present invention, three MSC conversion procedures are described corresponding to the wired Internet, the wireless Internet and the mobile telecommunication network. Below, the three MSC conversion procedures are described in detail referring to Figs. 8 to 10.

[70] At step S604, the packet of the IP format converted at the steps S602 and S603 is transmitted into the IP network. Then, transformation of the terrestrial DMB contents is terminated.

[71] Fig. 7 is a detailed flowchart illustrating a method for transforming a fast information channel (FIC) of Fig. 6.

[72] First, control information of the terrestrial DMB contents is extracted in the FIC at step S701.

[73] At step S702, a SDP packet is generated based on the extracted control information and predetermined session information from a user terminal, because session information needed for the SDP packet includes not only the FIC but also additional information.

[74] Next, a TCP/IP packet is generated by using the SDP packet at step S703. That is, the FIC conversion procedure S602 of Fig. 6 is terminated.

[75] Fig. 8 is a detailed flowchart illustrating a method for transforming a main service channel (MSC) of Fig. 6 in accordance with a first embodiment of the present invention.

[76] First, the RTP packet is produced based on the MSC at step S801. As described

above, the size of the RTP packet is defined on the basis of 8 bytes as the same as the terrestrial DMB contents, and the payload type of the RTP packet may be decided by a type of the terrestrial DMB contents.

[77] At step S802, the UDP/IP packet is generated based on the RTP packet. That is, the MSC conversion procedure S603 of Fig. 6 needed to access the wired Internet is terminated.

[78] Fig. 9 is a detailed flowchart illustrating a method for transforming the MSC in accordance with a second embodiment of the present invention.

[79] First, the MSC is demultiplexed into a DAB audio stream, a DAB data stream and a multimedia stream at step S803. Then, the multimedia stream is outer-decoded at step S804.

[80] At step S805, the RTP packet is produced based on the demultiplexed DAB audio stream and the demultiplexed DAB video stream at step S803 and the outer-decoded multimedia stream at step S804. Herein, the RTP packet is generated by considering the characteristics of the terrestrial DMB contents transportation technology.

[81] At step S806, the UDP/IP packet is generated based on the RTP packet. That is, the MSC conversion procedure S603 needed to access the wireless Internet is terminated.

[82] Fig. 10 is a detailed flowchart illustrating a method for transforming the MSC in accordance with a third embodiment of the present invention.

[83] First, the MSC is demultiplexed into a DAB audio stream, a DAB data stream and a multimedia stream at step S807 as the same as step S803. Then, the multimedia stream is outer-decoded at step S808 as the same as step S804.

[84] At step S809, the outer-decoded multimedia stream is demultiplexed into a video transport stream (TS) and an audio transport stream (TS). Then, a video elementary stream (ES) and an audio elementary stream (ES) are generated based on the video TS and the audio TS at step S810.

[85] At step S811, the RTP packet is produced based on the demultiplexed DAB audio stream and the demultiplexed DAB video stream demultiplexed at step S807, the video ES and the audio ES generated at step S810. At step S812, the UDP/IP packet is generated based on the RTP packet. That is, the MSC conversion procedure S603 needed to access the mobile telecommunication network is terminated.

[86] Referring to Figs. 8 to 10, the MSC including the media information is decoded in accordance with the characteristics of network, i.e., stability and transportation bandwidth, differently. Therefore, the terrestrial DMB contents can be transported to a variety of IP networks efficiently.

[87] The above described method according to the present invention can be embodied as a program and be stored on a computer readable recording medium. The computer readable recording medium is any data storage device that can store data which can be



read by the computer system. The computer readable recording medium includes a read-only memory (ROM), a random-access memory (RAM), a CD-ROM, a floppy disk, a hard disk and an optical magnetic disk.

[88] The present application contains subject matter related to Korean patent application Nos. 2006-0061225 and 2006-0094380, filed with the Korean Intellectual Property Office on June 30, 2006, and September 27, 2006, respectively, the entire contents of which is incorporated herein by reference.

[89] While the present invention has been described with respect to certain preferred embodiments, it will be apparent to those skilled in the art that various changes and modifications may be made without departing from the scope of the invention as defined in the following claims.

## Claims

- [1] A gateway for transforming a terrestrial digital multimedia broadcasting (DMB) contents, comprising:  
an ensemble transport interface (ETI) demultiplexing means for dividing the terrestrial DMB contents having ETI frame format into a fast information channel (FIC) and a main service channel (MSC);  
a session description protocol (SDP) packet processing means for converting the FIC into a SDP packet;  
a transmission control protocol/Internet protocol (TCP/IP) packet generating means for generating a TCP/IP packet based on the SDP packet;  
a real-time transport protocol (RTP) packet processing means for converting the MSC into a first RTP packet;  
a user datagram protocol/Internet protocol (UDP/IP) packet generating means for generating a UDP/IP packet based on the RTP packet; and  
an IP output means for transmitting the TCP/IP packet and the UDP/IP packet through an IP network.
- [2] The gateway as recited in the claim 1, wherein the RTP packet processing means includes:  
an MSC demultiplexing block for demultiplexing the MSC into a digital audio broadcasting (DAB) audio stream, a DAB data stream and a multimedia stream;  
an outer decoding block for performing outer decoding of the multimedia stream to thereby generate outer-decoded multimedia stream; and  
an RTP packet processing block for forming a second RTP packet based on the DAB audio stream, the DAB data stream and the outer-decoded multimedia stream.
- [3] The gateway as recited in the claim 2, wherein the RTP packet processing block includes:  
a multimedia stream analyzing and demultiplexing unit for demultiplexing the outer-decoded multimedia stream into a video transport stream (TS) and an audio TS by analyzing the outer-decoded multimedia stream;  
an elementary stream (ES) generating unit for receiving the video TS and the audio TS, and generating a video ES and an audio ES, respectively; and  
an RTP packet processing unit for forming a third RTP packet based on the DAB audio stream and the DAB data stream from the MSC demultiplexing block and the video ES and the audio ES from the ES generating unit.
- [4] The gateway as recited in the claim 1, wherein the SDP packet processing means forms the SDP packet based on information included in the FIC and additional

- session information.
- [5] The gateway as recited in the claim 1, wherein the RTP packet processing means forms an RTP packet having the same size as the terrestrial DMB contents, and decides a payload type of the RTP packet as the terrestrial DMB contents.
- [6] A method for transforming a terrestrial digital multimedia broadcasting (DMB) contents, comprising the steps of:
- a) demultiplexing the terrestrial DMB contents having ensemble transport interface (ETI) frame format into a fast information channel (FIC) and a main service channel (MSC);
  - b) converting the FIC into a session description protocol (SDP) packet and generating a transmission control protocol/Internet protocol (TCP/IP) packet based on the SDP packet;
  - c) converting the MSC into an RTP packet and generating a UDP/IP packet based on the RTP packet; and
  - d) transmitting the TCP/IP packet and the UDP/IP packet through an IP network.
- [7] The method as recited in the claim 6, wherein the SDP packet is formed based on information included in the FIC and additional session information.
- [8] The method as recited in the claim 6, wherein the step c) includes the steps of:
- c1) demultiplexing the MSC into a DAB audio stream, a DAB data stream and a multimedia stream;
  - c2) performing outer decoding of the multimedia stream;
  - c3) forming a first RTP packet based on the DAB audio stream, the DAB data stream and the outer-decoded multimedia stream; and
  - c4) generating an UDP/IP packet based on the RTP packet.
- [9] The method as recited in the claim 8, wherein the step c3) includes the steps of:
- c3-1) demultiplexing the outer-decoded multimedia stream into a video TS and an audio TS by analyzing the outer-decoded multimedia stream;
  - c3-2) generating a video ES and the audio ES by using the video TS and the audio TS, respectively; and
  - c3-3) forming a second RTP packet based on the DAB audio stream, the DAB data stream, the video ES and the audio ES.
- [10] The method as recited in the claim 6, wherein the RTP packet has the same size as the terrestrial DMB contents, and a payload type of the RTP packet is the terrestrial DMB contents type.
- [11] A terrestrial digital multimedia broadcasting (DMB) contents service system, comprising:
- an encoding means for encoding a DAB audio source, a DAB data source and a multimedia source;

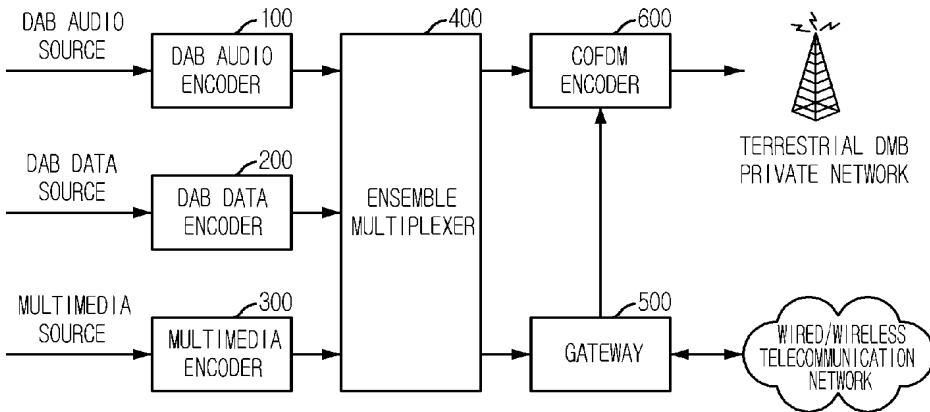
an ensemble multiplexing means for multiplexing the encoded DAB audio, the encoded DAB data and the encoded multimedia into a terrestrial DMB contents based on a ETI standard;

a gateway for transforming the terrestrial DMB contents into packets having a IP format to access IP networks or transporting the terrestrial DMB contents to a coded orthogonal frequency division multiplexing (COFDM) encoding means to access a terrestrial DMB private network; and

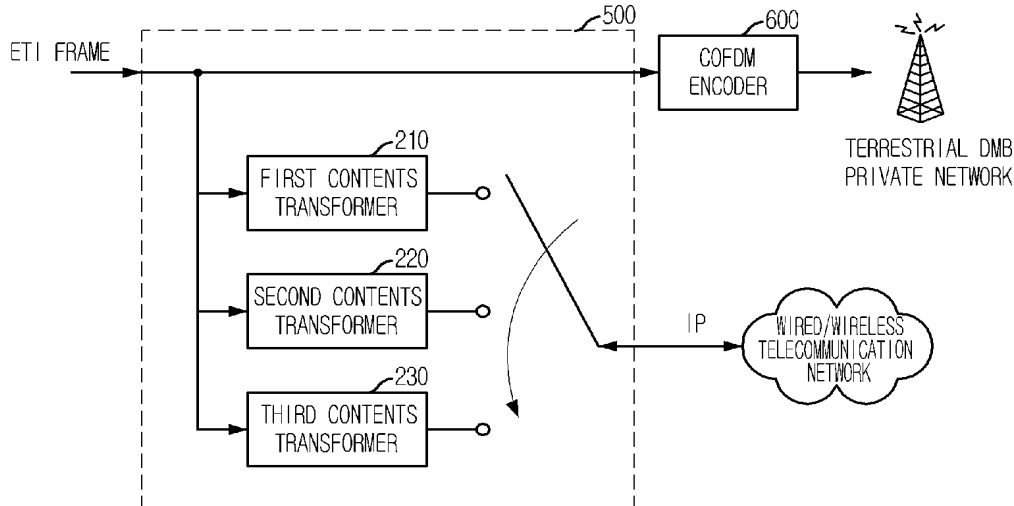
the COFDM encoding means for encoding the terrestrial DMB contents based on a COFDM and transmitting the encoded terrestrial DMB contents,

wherein the gateway demultiplexes the terrestrial DMB contents based on the ETI frame format into a FIC and a MSC, converts the FIC into a packet having the IP format based on a SDP and a TCP/IP, and converts the MSC into a packet having the IP format based on an RTP and a UDP/IP.

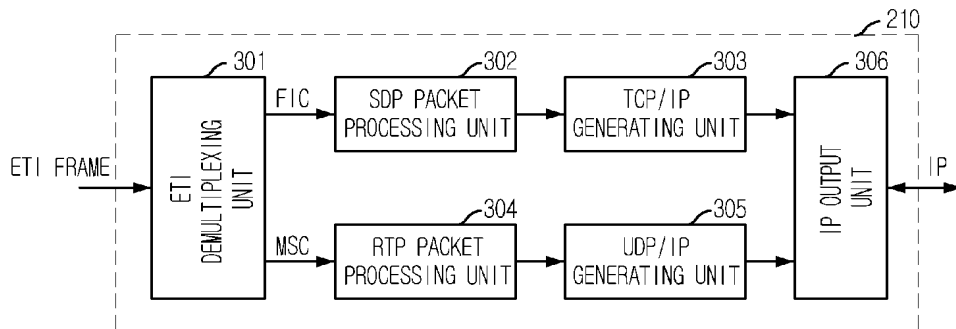
[Fig. 1]



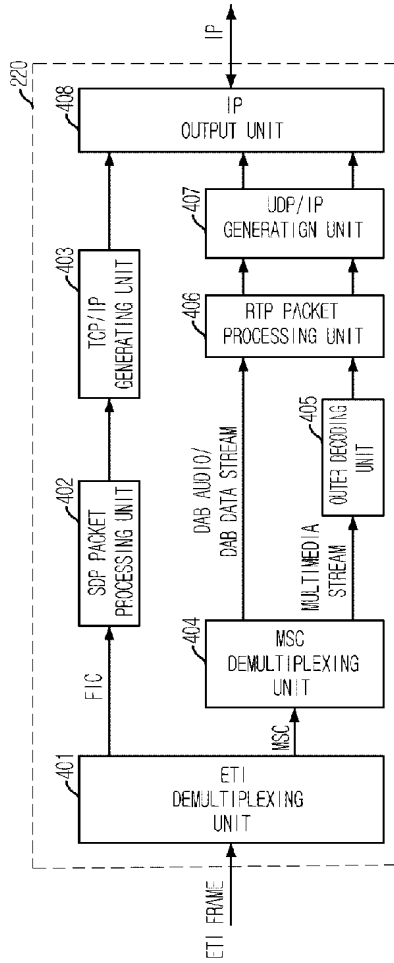
[Fig. 2]



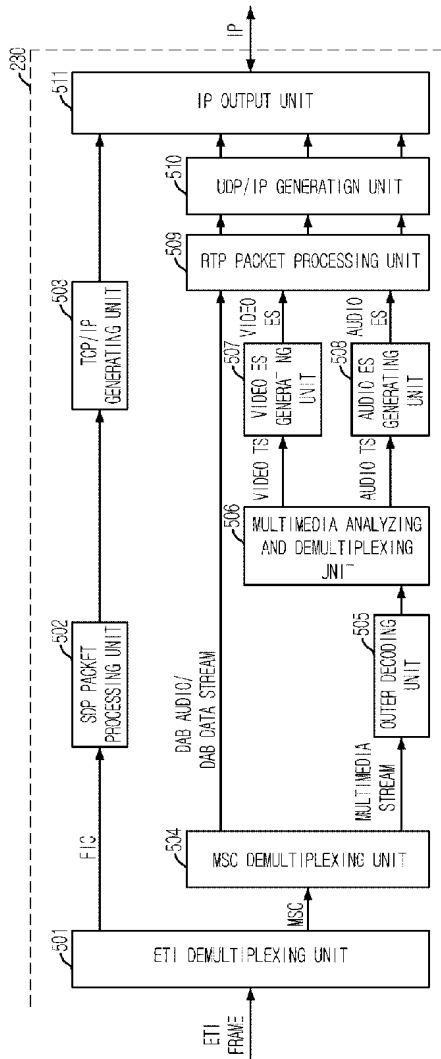
[Fig. 3]



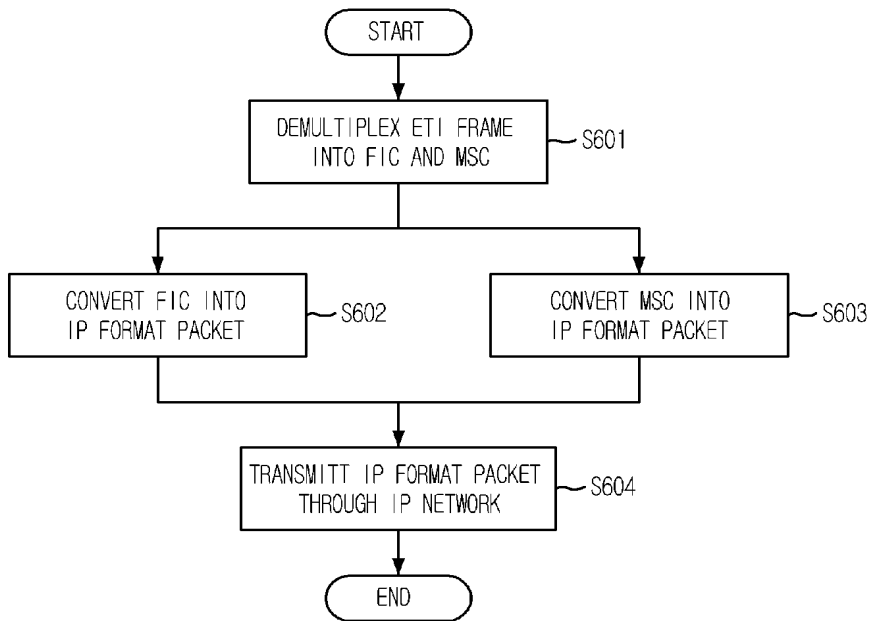
[Fig. 4]



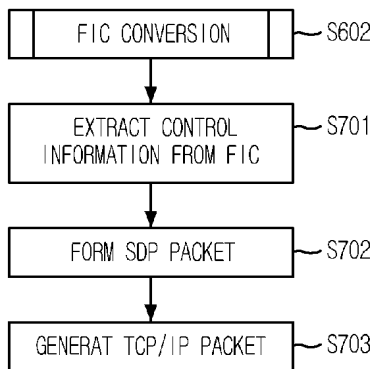
[Fig. 5]



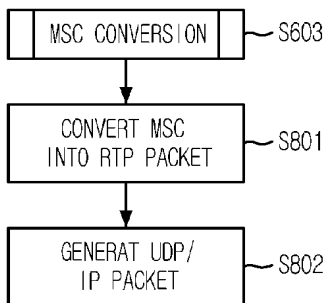
[Fig. 6]



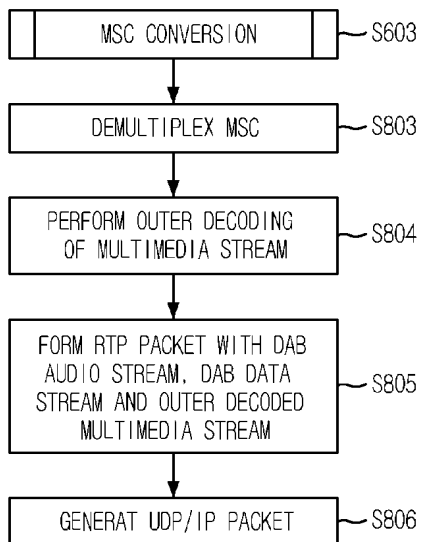
[Fig. 7]



[Fig. 8]

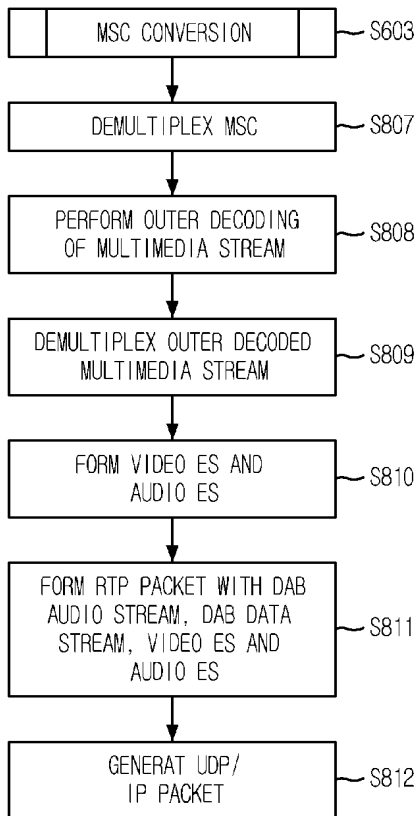


[Fig. 9]





[Fig. 10]



**A. CLASSIFICATION OF SUBJECT MATTER****H04N 7/12(2006.01)i**

According to International Patent Classification (IPC) or to both national classification and IPC

**B. FIELDS SEARCHED**

Minimum documentation searched (classification system followed by classification symbols)

IPC 8 H04N

Documentation searched other than minimum documentation to the extent that such documents are included in the fields searched

Korean Utility models and applications for Utility Models : IPC as above

Electronic data base consulted during the international search (name of data base and, where practicable, search terms used)

eKIPASS(KIPO Internal): "DMB, ensemble, FIC, MSC"

**C. DOCUMENTS CONSIDERED TO BE RELEVANT**

Category*	Citation of document, with indication, where appropriate, of the relevant passages	Relevant to claim No.
A	WO 2006-001600 A1 (ELECTRONICS AND TELECOMMUNICATIONS RESEARCH INSTITUTE) 05 Jan. 2006 See abstract; claim 1; figure 2	1-11
A	WO 03-045064 A1 (NOKIA CORPORATION) 30 May 2003 See abstract; claim 1,16; figure 1	1-11
A	EP 1009114 A2 (ENSIGMA LIMITED) 14 June 2000 See abstract; claim 1; figure 3	1-11

 Further documents are listed in the continuation of Box C. See patent family annex.

\* Special categories of cited documents:

"A" document defining the general state of the art which is not considered to be of particular relevance

"E" earlier application or patent but published on or after the international filing date

"L" document which may throw doubts on priority claim(s) or which is cited to establish the publication date of citation or other special reason (as specified)

"O" document referring to an oral disclosure, use, exhibition or other means

"P" document published prior to the international filing date but later than the priority date claimed

"T" later document published after the international filing date or priority date and not in conflict with the application but cited to understand the principle or theory underlying the invention

"X" document of particular relevance; the claimed invention cannot be considered novel or cannot be considered to involve an inventive step when the document is taken alone

"Y" document of particular relevance; the claimed invention cannot be considered to involve an inventive step when the document is combined with one or more other such documents, such combination being obvious to a person skilled in the art

"&amp;" document member of the same patent family

Date of the actual completion of the international search

02 MAY 2007 (02.05.2007)

Date of mailing of the international search report

**02 MAY 2007 (02.05.2007)**

Name and mailing address of the ISA/KR

Korean Intellectual Property Office  
920 Dunsan-dong, Seo-gu, Daejeon 302-701,  
Republic of Korea

Facsimile No. 82-42-472-7140

Authorized officer

CHOI, Seong Jin

Telephone No. 82-42-481-8366



**INTERNATIONAL SEARCH REPORT**

Information on patent family members

International application No.

PCT/KR2007/000494

Patent document cited in search report	Publication date	Patent family member(s)	Publication date
W02006001600A1	05.01.2006	EP1774778A1 KR2006045403A	18.04.2007 17.05.2006
W02003045064A1	30.05.2003	AU2002339006A1 CN1589574A EP01457051A1 FI20012256A0 KR1020040066829 US20050043020A1	10.06.2003 02.03.2005 15.09.2004 20.11.2001 27.07.2004 24.02.2005
EP01009114A3	19.07.2000	None	

PATENT COOPERATION TREATY

From the INTERNATIONAL SEARCHING AUTHORITY

PCT

NOTIFICATION OF TRANSMITTAL OF  
THE INTERNATIONAL SEARCH REPORT AND  
THE WRITTEN OPINION OF THE INTERNATIONAL  
SEARCHING AUTHORITY, OR THE DECLARATION

To:  
KNOBBE, MARTENS, OLSON & BEAR, LLP  
Attn. Altman, Daniel, E.  
2040 Main Street 14th Floor  
Irvine, CA 92614  
ETATS-UNIS D'AMERIQUE

(PCT Rule 44.1)

Date of mailing  
(day/month/year) 23/06/2009

Applicant's or agent's file reference  
STRATOS: 029V

**FOR FURTHER ACTION** See paragraphs 1 and 4 below

International application No.  
PCT/US2009/033249

International filing date  
(day/month/year) 05/02/2009

Applicant  
STRATOSAUDIO, INC.

1.  The applicant is hereby notified that the international search report and the written opinion of the International Searching Authority have been established and are transmitted herewith.

**Filing of amendments and statement under Article 19:**

The applicant is entitled, if he so wishes, to amend the claims of the International Application (see Rule 46):

**When?** The time limit for filing such amendments is normally two months from the date of transmittal of the International Search Report.

**Where?** Directly to the International Bureau of WIPO, 34 chemin des Colombettes  
1211 Geneva 20, Switzerland, Facsimile No.: (41-22) 338.82.70

**For more detailed instructions,** see the notes on the accompanying sheet.

2.  The applicant is hereby notified that no International search report will be established and that the declaration under Article 17(2)(a) to that effect and the written opinion of the International Searching Authority are transmitted herewith.

3.  **With regard to the protest** against payment of (an) additional fee(s) under Rule 40.2, the applicant is notified that:

the protest together with the decision thereon has been transmitted to the International Bureau together with the applicant's request to forward the texts of both the protest and the decision thereon to the designated Offices.

no decision has been made yet on the protest; the applicant will be notified as soon as a decision is made.

**4. Reminders**

Shortly after the expiration of **18 months** from the priority date, the international application will be published by the International Bureau. If the applicant wishes to avoid or postpone publication, a notice of withdrawal of the international application, or of the priority claim, must reach the International Bureau as provided in Rules 90bis.1 and 90bis.3, respectively, before the completion of the technical preparations for international publication.

The applicant may submit comments on an informal basis on the written opinion of the International Searching Authority to the International Bureau. The International Bureau will send a copy of such comments to all designated Offices unless an international preliminary examination report has been or is to be established. These comments would also be made available to the public but not before the expiration of 30 months from the priority date.

Within **19 months** from the priority date, but only in respect of some designated Offices, a demand for international preliminary examination must be filed if the applicant wishes to postpone the entry into the national phase **until 30 months** from the priority date (in some Offices even later); otherwise, the applicant must, **within 20 months** from the priority date, perform the prescribed acts for entry into the national phase before those designated Offices.

In respect of other designated Offices, the time limit of **30 months** (or later) will apply even if no demand is filed within 19 months.

See the Annex to Form PCT/IB/301 and, for details about the applicable time limits, Office by Office, see the *PCT Applicant's Guide*, Volume II, National Chapters and the WIPO Internet site.

Name and mailing address of the International Searching Authority



European Patent Office, P.B. 5818 Patentlaan 2  
NL-2280 HV Rijswijk  
Tel. (+31-70) 340-2040, Tx. 31 651 epo nl,  
Fax: (+31-70) 340-3016

Authorized officer

Anita Rothenbücher

## NOTES TO FORM PCT/ISA/220

These Notes are intended to give the basic instructions concerning the filing of amendments under article 19. The Notes are based on the requirements of the Patent Cooperation Treaty, the Regulations and the Administrative Instructions under that Treaty. In case of discrepancy between these Notes and those requirements, the latter are applicable. For more detailed information, see also the *PCT Applicant's Guide*, a publication of WIPO.

In these Notes, "Article", "Rule", and "Section" refer to the provisions of the PCT, the PCT Regulations and the PCT Administrative Instructions, respectively.

### INSTRUCTIONS CONCERNING AMENDMENTS UNDER ARTICLE 19

The applicant has, after having received the international search report and the written opinion of the International Searching Authority, one opportunity to amend the claims of the international application. It should however be emphasized that, since all parts of the international application (claims, description and drawings) may be amended during the international preliminary examination procedure, there is usually no need to file amendments of the claims under Article 19 except where, e.g. the applicant wants the latter to be published for the purposes of provisional protection or has another reason for amending the claims before international publication. Furthermore, it should be emphasized that provisional protection is available in some States only (see *PCT Applicant's Guide*, Volume I/A, Annexes B1 and B2).

The attention of the applicant is drawn to the fact that amendments to the claims under Article 19 are not allowed where the International Searching Authority has declared, under Article 17(2), that no international search report would be established (see *PCT Applicant's Guide*, Volume I/A, paragraph 296).

#### What parts of the international application may be amended?

Under Article 19, only the claims may be amended.

During the international phase, the claims may also be amended (or further amended) under Article 34 before the International Preliminary Examining Authority. The description and drawings may only be amended under Article 34 before the International Examining Authority.

Upon entry into the national phase, all parts of the international application may be amended under Article 28 or, where applicable, Article 41.

#### When?

Within 2 months from the date of transmittal of the international search report or 16 months from the priority date, whichever time limit expires later. It should be noted, however, that the amendments will be considered as having been received on time if they are received by the International Bureau after the expiration of the applicable time limit but before the completion of the technical preparations for international publication (Rule 46.1).

#### Where not to file the amendments?

The amendments may only be filed with the International Bureau and not with the receiving Office or the International Searching Authority (Rule 46.2).

Where a demand for international preliminary examination has been/is filed, see below.

#### How?

Either by cancelling one or more entire claims, by adding one or more new claims or by amending the text of one or more of the claims as filed.

A replacement sheet must be submitted for each sheet of the claims which, on account of an amendment or amendments, differs from the sheet originally filed.

All the claims appearing on a replacement sheet must be numbered in Arabic numerals. Where a claim is cancelled, no renumbering of the other claims is required. In all cases where claims are renumbered, they must be renumbered consecutively (Section 205(b)).

**The amendments must be made in the language in which the international application is to be published.**

#### What documents must/may accompany the amendments?

##### Letter (Section 205(b)):

The amendments must be submitted with a letter.

The letter will not be published with the international application and the amended claims. It should not be confused with the "Statement under Article 19(1)" (see below, under "Statement under Article 19(1)").

**The letter must be in English or French, at the choice of the applicant. However, if the language of the international application is English, the letter must be in English; if the language of the international application is French, the letter must be in French.**

## NOTES TO FORM PCT/ISA/220 (continued)

The letter must indicate the differences between the claims as filed and the claims as amended. It must, in particular, indicate, in connection with each claim appearing in the international application (it being understood that identical indications concerning several claims may be grouped), whether

- (i) the claim is unchanged;
- (ii) the claim is cancelled;
- (iii) the claim is new;
- (iv) the claim replaces one or more claims as filed;
- (v) the claim is the result of the division of a claim as filed.

**The following examples illustrate the manner in which amendments must be explained in the accompanying letter:**

1. [Where originally there were 48 claims and after amendment of some claims there are 51]:  
"Claims 1 to 29, 31, 32, 34, 35, 37 to 48 replaced by amended claims bearing the same numbers; claims 30, 33 and 36 unchanged; new claims 49 to 51 added."
2. [Where originally there were 15 claims and after amendment of all claims there are 11]:  
"Claims 1 to 15 replaced by amended claims 1 to 11."
3. [Where originally there were 14 claims and the amendments consist in cancelling some claims and in adding new claims]:  
"Claims 1 to 6 and 14 unchanged; claims 7 to 13 cancelled; new claims 15, 16 and 17 added."  
"Claims 7 to 13 cancelled; new claims 15, 16 and 17 added; all other claims unchanged."
4. [Where various kinds of amendments are made]:  
"Claims 1-10 unchanged; claims 11 to 13, 18 and 19 cancelled; claims 14, 15 and 16 replaced by amended claim 14; claim 17 subdivided into amended claims 15, 16 and 17; new claims 20 and 21 added."

### "Statement under article 19(1)" (Rule 46.4)

The amendments may be accompanied by a statement explaining the amendments and indicating any impact that such amendments might have on the description and the drawings (which cannot be amended under Article 19(1)).

The statement will be published with the international application and the amended claims.

**It must be in the language in which the international application is to be published.**

It must be brief, not exceeding 500 words if in English or if translated into English.

It should not be confused with and does not replace the letter indicating the differences between the claims as filed and as amended. It must be filed on a separate sheet and must be identified as such by a heading, preferably by using the words "Statement under Article 19(1)."

It may not contain any disparaging comments on the international search report or the relevance of citations contained in that report. Reference to citations, relevant to a given claim, contained in the international search report may be made only in connection with an amendment of that claim.

### **Consequence if a demand for international preliminary examination has already been filed**

If, at the time of filing any amendments and any accompanying statement, under Article 19, a demand for international preliminary examination has already been submitted, the applicant must preferably, at the time of filing the amendments (and any statement) with the International Bureau, also file with the International Preliminary Examining Authority a copy of such amendments (and of any statement) and, where required, a translation of such amendments for the procedure before that Authority (see Rules 55.3(a) and 62.2, first sentence). For further information, see the Notes to the demand form (PCT/PEA/401).

If a demand for international preliminary examination is made, the written opinion of the International Searching Authority will, except in certain cases where the International Preliminary Examining Authority did not act as International Searching Authority and where it has notified the International Bureau under Rule 66.1 bis(b), be considered to be a written opinion of the International Preliminary Examining Authority. If a demand is made, the applicant may submit to the International Preliminary Examining Authority a reply to the written opinion together, where appropriate, with amendments before the expiration of 3 months from the date of mailing of Form PCT/ISA/220 or before the expiration of 22 months from the priority date, whichever expires later (Rule 43 bis.1(c)).

### **Consequence with regard to translation of the international application for entry into the national phase**

The applicant's attention is drawn to the fact that, upon entry into the national phase, a translation of the claims as amended under Article 19 may have to be furnished to the designated/elected Offices, instead of, or in addition to, the translation of the claims as filed.

For further details on the requirements of each designated/elected Office, see the *PCT Applicant's Guide*, Volume II.

PATENT COOPERATION TREATY

PCT

INTERNATIONAL SEARCH REPORT

(PCT Article 18 and Rules 43 and 44)

Applicant's or agent's file reference <b>STRATOS.029V</b>	<b>FOR FURTHER ACTION</b>		see Form PCT/ISA/220 as well as, where applicable, item 5 below.
International application No. <b>PCT/US2009/033249</b>	International filing date (day/month/year) <b>05/02/2009</b>	(Earliest) Priority Date (day/month/year) <b>05/02/2008</b>	
Applicant  <b>STRATOSAUDIO, INC.</b>			

This international search report has been prepared by this International Searching Authority and is transmitted to the applicant according to Article 18. A copy is being transmitted to the International Bureau.

This international search report consists of a total of 3 sheets.

It is also accompanied by a copy of each prior art document cited in this report.

1. **Basis of the report**

a. With regard to the **language**, the international search was carried out on the basis of:

the international application in the language in which it was filed

a translation of the international application into \_\_\_\_\_, which is the language of a translation furnished for the purposes of international search (Rules 12.3(a) and 23.1(b))

b.  This international search report has been established taking into account the **rectification of an obvious mistake** authorized by or notified to this Authority under Rule 91 (Rule 43.6bis(a)).

c.  With regard to any **nucleotide and/or amino acid sequence** disclosed in the international application, see Box No. I.

2.  **Certain claims were found unsearchable** (See Box No. II)

3.  **Unity of invention is lacking** (see Box No III)

4. With regard to the **title**,

the text is approved as submitted by the applicant

the text has been established by this Authority to read as follows:

5. With regard to the **abstract**,

the text is approved as submitted by the applicant

the text has been established, according to Rule 38.2(b), by this Authority as it appears in Box No. IV. The applicant may, within one month from the date of mailing of this international search report, submit comments to this Authority

6. With regard to the **drawings**,

a. the figure of the **drawings** to be published with the abstract is Figure No. 5

as suggested by the applicant

as selected by this Authority, because the applicant failed to suggest a figure

as selected by this Authority, because this figure better characterizes the invention

b.  none of the figures is to be published with the abstract

INTERNATIONAL SEARCH REPORT

International application No  
PCT/US2009/033249

**A. CLASSIFICATION OF SUBJECT MATTER**  
INV. H04L29/06

According to International Patent Classification (IPC) or to both national classification and IPC

**B. FIELDS SEARCHED**

Minimum documentation searched (classification system followed by classification symbols)  
H04L G06Q

Documentation searched other than minimum documentation to the extent that such documents are included in the fields searched

Electronic data base consulted during the international search (name of data base and, where practical, search terms used)  
EPO-Internal, WPI Data, PAJ

**C. DOCUMENTS CONSIDERED TO BE RELEVANT**

Category*	Citation of document, with indication, where appropriate, of the relevant passages	Relevant to claim No.
X	US 7 299 194 B1 (MANGANARIS STEFANOS [US] ET AL) 20 November 2007 (2007-11-20) abstract figures 1-3 column 3, line 30 - column 3, line 67 column 4, line 63 - column 5, line 41 column 5, line 63 - column 6, line 9	1-19
A	WO 2006/122028 A (ROOT MARKETS INC [US]; GOLDSTEIN SETH [US]; HERSHBERG PETER [US]; STYL) 16 November 2006 (2006-11-16) the whole document	1-19

Further documents are listed in the continuation of Box C.  See patent family annex.

\* Special categories of cited documents :

\*A\* document defining the general state of the art which is not considered to be of particular relevance

\*E\* earlier document but published on or after the International filing date

\*L\* document which may throw doubts on priority claim(s) or which is cited to establish the publication date of another citation or other special reason (as specified)

\*O\* document referring to an oral disclosure, use, exhibition or other means

\*P\* document published prior to the international filing date but later than the priority date claimed

\*T\* later document published after the international filing date or priority date and not in conflict with the application but cited to understand the principle or theory underlying the invention

\*X\* document of particular relevance; the claimed invention cannot be considered novel or cannot be considered to involve an inventive step when the document is taken alone

\*Y\* document of particular relevance; the claimed invention cannot be considered to involve an inventive step when the document is combined with one or more other such documents, such combination being obvious to a person skilled in the art.

\*Z\* document member of the same patent family

Date of the actual completion of the international search <b>16 June 2009</b>	Date of mailing of the international search report <b>23/06/2009</b>
--	---

Name and mailing address of the ISA/ European Patent Office, P.B. 5818 Patentlaan 2 NL - 2280 HV Rijswijk Tel. (+31-70) 340-2040, Fax: (+31-70) 340-3016	Authorized officer <b>Pereira, Mafalda</b>
--	---



# INTERNATIONAL SEARCH REPORT

Information on patent family members

International application No

PCT/US2009/033249

Patent document cited in search report	Publication date	Patent family member(s)	Publication date
US 7299194	B1	20-11-2007	AU 782052 B2 30-06-2005
			AU 7196900 A 23-08-2001
			CA 2334300 A1 22-08-2001
			CN 1310414 A 29-08-2001
			JP 2001243334 A 07-09-2001
			US 2008154701 A1 26-06-2008
WO 2006122028	A	16-11-2006	US 2007219896 A1 20-09-2007

# PATENT COOPERATION TREATY

From the  
INTERNATIONAL SEARCHING AUTHORITY

## PCT

To:

see form PCT/ISA/220

WRITTEN OPINION OF THE  
INTERNATIONAL SEARCHING AUTHORITY  
(PCT Rule 43bis.1)

Date of mailing  
(day/month/year) see form PCT/ISA/210 (second sheet)

Applicant's or agent's file reference  
see form PCT/ISA/220

**FOR FURTHER ACTION**  
See paragraph 2 below

International application No.  
PCT/US2009/033249

International filing date (day/month/year)  
05.02.2009

Priority date (day/month/year)  
05.02.2008

International Patent Classification (IPC) or both national classification and IPC  
INV. H04L29/06

Applicant  
STRATOSAUDIO, INC.

1. This opinion contains indications relating to the following items:
  - Box No. I Basis of the opinion
  - Box No. II Priority
  - Box No. III Non-establishment of opinion with regard to novelty, inventive step and industrial applicability
  - Box No. IV Lack of unity of invention
  - Box No. V Reasoned statement under Rule 43bis.1(a)(i) with regard to novelty, inventive step or industrial applicability; citations and explanations supporting such statement
  - Box No. VI Certain documents cited
  - Box No. VII Certain defects in the international application
  - Box No. VIII Certain observations on the international application
  
2. **FURTHER ACTION**

If a demand for international preliminary examination is made, this opinion will usually be considered to be a written opinion of the International Preliminary Examining Authority ("IPEA") except that this does not apply where the applicant chooses an Authority other than this one to be the IPEA and the chosen IPEA has notified the International Bureau under Rule 66.1bis(b) that written opinions of this International Searching Authority will not be so considered.

If this opinion is, as provided above, considered to be a written opinion of the IPEA, the applicant is invited to submit to the IPEA a written reply together, where appropriate, with amendments, before the expiration of 3 months from the date of mailing of Form PCT/ISA/220 or before the expiration of 22 months from the priority date, whichever expires later.

For further options, see Form PCT/ISA/220.
  
3. For further details, see notes to Form PCT/ISA/220.

Name and mailing address of the ISA:



European Patent Office  
P.B. 5818 Patentlaan 2  
NL-2280 HV Rijswijk - Pays Bas  
Tel. +31 70 340 - 2040  
Fax: +31 70 340 - 3016


Date of completion of this opinion

see form  
PCT/ISA/210

Authorized Officer:

Pereira, Mafalda

Telephone No. +31 70 340-4322



---

**Box No. I Basis of the opinion**

---

1. With regard to the **language**, this opinion has been established on the basis of:
  - the international application in the language in which it was filed
  - a translation of the international application into , which is the language of a translation furnished for the purposes of international search (Rules 12.3(a) and 23.1 (b)).
2.  This opinion has been established taking into account the **rectification of an obvious mistake** authorized by or notified to this Authority under Rule 91 (Rule 43bis.1(a))
3. With regard to any **nucleotide and/or amino acid sequence** disclosed in the international application and necessary to the claimed invention, this opinion has been established on the basis of:
  - a. type of material:
    - a sequence listing
    - table(s) related to the sequence listing
  - b. format of material:
    - on paper
    - in electronic form
  - c. time of filing/furnishing:
    - contained in the international application as filed.
    - filed together with the international application in electronic form.
    - furnished subsequently to this Authority for the purposes of search.
4.  In addition, in the case that more than one version or copy of a sequence listing and/or table relating thereto has been filed or furnished, the required statements that the information in the subsequent or additional copies is identical to that in the application as filed or does not go beyond the application as filed, as appropriate, were furnished.
5. Additional comments:

---

**Box No. V Reasoned statement under Rule 43bis.1(a)(i) with regard to novelty, inventive step or industrial applicability; citations and explanations supporting such statement**

---

1. Statement

Novelty (N)	Yes: Claims	
	No: Claims	<u>1-19</u>
Inventive step (IS)	Yes: Claims	
	No: Claims	<u>1-19</u>
Industrial applicability (IA)	Yes: Claims	<u>1-19</u>
	No: Claims	

2. Citations and explanations

see separate sheet

**Re Item V.**

1 The present application does not meet the criteria of Article 33(1) PCT, because the subject-matter of each of the independent claims 1, 12, 16 and 19 is not new in the sense of Article 33(2) PCT.

1.1 Reference is made to the following document:

D1 : US 7 299 194 B1 (MANGANARIS STEFANOS [US] ET AL) 20 November 2007 (2007-11-20)

1.2 Document D1 discloses, in terms of the wording of claim 1, a method for associating multiple media signals, comprising:  
obtaining information about a first media signal (D1: column 3 line 30 to 67 in particular "sales data concerning items sold in retails");  
analysing the information about the first media signal (D1: column 3 line 30 to 67 and column 5 lines 10 to 18);  
selecting at least one second media signal to be correlated with the first media signal based on at least one criteria (D1 column 4 line 63 to column 5 line 18);  
assigning a unique identifier that is specific to the transmission of the selected second media signal, wherein at least the unique identifier is stored in a database (D1: column 5 line lines 19 to 23 and column 5 line 63 to column 6 line 9);  
transmitting at least the second media signal and the unique identifier to a user device, wherein the user device outputs the first media signal and the second media signal to a user (column 5 line 63 to column 6 line 9);  
receiving a user response from the user in relation to the second media signal wherein the user response includes at least the unique identifier; and correlating at least the unique identifier in the database(D1: column 5 line lines 19 to 23 and column 5 line 63 to column 6 line 9).

Therefore the subject-matter of claim 1 is not new in the sense of Article 33(2) PCT.

1.3 Analogously to claim 1, the subject-matter of each of the independent claims 12, 16 and 19 is also not new in the sense of Article 33(2) PCT.

2 Dependent claims 2-11, 13-15, 17, 18 do not contain any features which, in

combination with the features of any claim to which they refer, meet the requirements of the PCT in respect of novelty or inventive step. See passages cited on the Search Report.

Possible steps after receipt of the international search report (ISR) and written opinion of the International Searching Authority (WO-ISA)

---

**General information** For all international applications filed on or after 01/01/2004 the competent ISA will establish an ISR. It is accompanied by the WO-ISA. Unlike the former written opinion of the IPEA (Rule 66.2 PCT), the WO-ISA is not meant to be responded to, but to be taken into consideration for further procedural steps. This document explains about the possibilities.

---

**Amending claims under Art. 19 PCT** Within 2 months after the date of mailing of the ISR and the WO-ISA the applicant may file amended claims under Art. 19 PCT directly with the International Bureau of WIPO. The PCT reform of 2004 did not change this procedure. For further information please see Rule 46 PCT as well as form PCT/ISA/220 and the corresponding Notes to form PCT/ISA/220.

---

**Filing a demand for international preliminary examination** In principle, the WO-ISA will be considered as the written opinion of the IPEA. This should, in many cases, make it unnecessary to file a demand for international preliminary examination. If the applicant nevertheless wishes to file a demand this must be done before expiry of 3 months after the date of mailing of the ISR/ WO-ISA or 22 months after priority date, whichever expires later (Rule 54bis PCT). Amendments under Art. 34 PCT can be filed with the IPEA as before, normally at the same time as filing the demand (Rule 66.1 (b) PCT).

If a demand for international preliminary examination is filed and no comments/amendments have been received the WO-ISA will be transformed by the IPEA into an IPRP (International Preliminary Report on Patentability) which would merely reflect the content of the WO-ISA. The demand can still be withdrawn (Art. 37 PCT).

---

**Filing informal comments** After receipt of the ISR/WO-ISA the applicant may file informal comments on the WO-ISA directly with the International Bureau of WIPO. These will be communicated to the designated Offices together with the IPRP (International Preliminary Report on Patentability) at 30 months from the priority date. Please also refer to the next box.

---

**End of the international phase** At the end of the international phase the International Bureau of WIPO will transform the WO-ISA or, if a demand was filed, the written opinion of the IPEA into the IPRP, which will then be transmitted together with possible informal comments to the designated Offices. The IPRP replaces the former IPER (international preliminary examination report).

---

**Relevant PCT Rules and more information** Rule 43 PCT, Rule 43bis PCT, Rule 44 PCT, Rule 44bis PCT, PCT Newsletter 12/2003, OJ 11/2003, OJ 12/2003

## Electronic Acknowledgement Receipt

<b>EFS ID:</b>	8881322
<b>Application Number:</b>	12366535
<b>International Application Number:</b>	
<b>Confirmation Number:</b>	7989
<b>Title of Invention:</b>	SYSTEM AND METHOD FOR ADVERTISEMENT TRANSMISSION AND DISPLAY
<b>First Named Inventor/Applicant Name:</b>	Kelly M. Christensen
<b>Customer Number:</b>	20995
<b>Filer:</b>	Don Neil Caceres Pua/Valerie Jones
<b>Filer Authorized By:</b>	Don Neil Caceres Pua
<b>Attorney Docket Number:</b>	STRATOS.029A
<b>Receipt Date:</b>	19-NOV-2010
<b>Filing Date:</b>	05-FEB-2009
<b>Time Stamp:</b>	19:38:55
<b>Application Type:</b>	Utility under 35 USC 111(a)

### Payment information:

Submitted with Payment	no
------------------------	----

### File Listing:

Document Number	Document Description	File Name	File Size(Bytes)/ Message Digest	Multi Part /.zip	Pages (if appl.)
1		STRATOS-029A_IDS.pdf	345021 <small>57b64b147101d6ed34400b347b863705591a8e15</small>	yes	7



Multipart Description/PDF files in .zip description					
Document Description			Start	End	
Transmittal Letter			1	2	
Information Disclosure Statement (IDS) Filed (SB/08)			3	7	
<b>Warnings:</b>					
<b>Information:</b>					
2	Foreign Reference	CA2316925.pdf	972404	no	23
			b4af1f209195a2a33d838e049383898a2c0b25e9		
<b>Warnings:</b>					
<b>Information:</b>					
3	Foreign Reference	DE19627308.pdf	297418	no	6
			b40ababab2fde6465f8467b49d1de2d5d87a3b4b		
<b>Warnings:</b>					
<b>Information:</b>					
4	Foreign Reference	DE4427046.pdf	369990	no	6
			efeda1f6e843a04af73c23295115e0cc9fbdcba2		
<b>Warnings:</b>					
<b>Information:</b>					
5	Foreign Reference	EP0713335.pdf	809752	no	12
			996236f8fd9e36b4af9b00a869ac345ce0491b86		
<b>Warnings:</b>					
<b>Information:</b>					
6	Foreign Reference	JP08-139624.pdf	1313852	no	27
			a9a2c2f57a28ad5924932f881e75f06d74b534a0		
<b>Warnings:</b>					
<b>Information:</b>					
7	Foreign Reference	JP10-135855.pdf	271204	no	6
			7309fa152ad39923cc4cd87fe9f18bef9264a339		
<b>Warnings:</b>					
<b>Information:</b>					
8	Foreign Reference	JP2000292182.pdf	36266	no	1
			97c0e49762b3f9b03567cd5559dadaa7fd6628b20		
<b>Warnings:</b>					
<b>Information:</b>					

9	Foreign Reference	KR1998-0078248.pdf	765920	no	9
			6533f39cb4d2d0435ea91f3608b87fd064d be8b8		
<b>Warnings:</b>					
<b>Information:</b>					
10	Foreign Reference	KR1996-0033096.pdf	311701	no	4
			e74a7193de009a53459d22c342a182fd07a ab2ed		
<b>Warnings:</b>					
<b>Information:</b>					
11	Foreign Reference	WO1990000847.pdf	976210	no	24
			0922b74f556004eb88c93eb284988678645 cfbb6		
<b>Warnings:</b>					
<b>Information:</b>					
12	Foreign Reference	WO1992014222.pdf	1090480	no	33
			40fd268beb3a26dd210fb8cd273e0ba4253 b02a6		
<b>Warnings:</b>					
<b>Information:</b>					
13	Foreign Reference	WO1994002909.pdf	897878	no	32
			bde5ed9ac9e665bfb2041c92af324cc8172d 6d7c		
<b>Warnings:</b>					
<b>Information:</b>					
14	Foreign Reference	WO1997021291.pdf	2269819	no	46
			7db8888ee18a500c3198c0ace513277dbdb 9a066		
<b>Warnings:</b>					
<b>Information:</b>					
15	Foreign Reference	WO1997042724.pdf	2543539	no	63
			9f127bf7ac7c7cf86443f7cff7ce2bf21d3844 c6		
<b>Warnings:</b>					
<b>Information:</b>					
16	Foreign Reference	WO1997045814.pdf	1639874	no	30
			c79fe645c007f44c58dd6c9647681450fce0 1a09		
<b>Warnings:</b>					
<b>Information:</b>					
17	Foreign Reference	WO1999018518.pdf	685216	no	17
			ef1988d576ac6583ec78170dff0e1d92c56b ed75		
<b>Warnings:</b>					
<b>Information:</b>					

18	Foreign Reference	WO1999035771.pdf	1081386	no	28
			e7efbfb831c44e2815614f699b87782cad0b6234		
<b>Warnings:</b>					
<b>Information:</b>					
19	Foreign Reference	WO1999043109.pdf	982508	no	28
			48b22b2c6a6e22e8affa8f8d744977344b4e5387		
<b>Warnings:</b>					
<b>Information:</b>					
20	Foreign Reference	WO1999035809.pdf	829039	no	18
			e3aa0a273d0c8b64e98f37c6dde9afb1839e47f2		
<b>Warnings:</b>					
<b>Information:</b>					
21	Foreign Reference	WO2000019662.pdf	2623482	no	52
			6e5d4b017e598b515bf6d03df5a71598212641d2		
<b>Warnings:</b>					
<b>Information:</b>					
22	Foreign Reference	WO2000078050.pdf	3495921	no	110
			563f36cc2ffab05ea65a51a0870ce704282315c		
<b>Warnings:</b>					
<b>Information:</b>					
23	Foreign Reference	WO2001001331.pdf	991465	no	24
			b7ad3716871bace24c172f620829c4e7fbd02953		
<b>Warnings:</b>					
<b>Information:</b>					
24	Foreign Reference	WO2001057759.pdf	6408472	no	127
			4511d21cd302995d1940492ead9b0af33230e8f8		
<b>Warnings:</b>					
<b>Information:</b>					
25	Foreign Reference	WO2001077779.pdf	3040870	no	69
			c79aea49060e4a560d4dbeb97b6006ffa423dc48a		
<b>Warnings:</b>					
<b>Information:</b>					
26	Foreign Reference	WO2002023773.pdf	1279792	no	25
			e3fc977cfa071d7367a114919135f05df99bf0a7		
<b>Warnings:</b>					
<b>Information:</b>					

27	Foreign Reference	WO2006122028.pdf	1019244	no	25
			a2497d95fa233eb1ed3c349bbeac53d1e8e2bfc		
<b>Warnings:</b>					
<b>Information:</b>					
28	Foreign Reference	WO2008002000.pdf	1043303	no	23
			b0c0cbf3007494229a954fca53ab1cd68ccef		
<b>Warnings:</b>					
<b>Information:</b>					
29	NPL Documents	Bookmarkyourworld.pdf	106368	no	4
			b3c553060ba62535a75df8063cdde77c46d40920		
<b>Warnings:</b>					
<b>Information:</b>					
30	NPL Documents	Sirusinstantbuy.pdf	74431	no	2
			c8334e44ee8631c4e4eecf3ddb9ee70cb04b68c		
<b>Warnings:</b>					
<b>Information:</b>					
31	NPL Documents	Jan25XenoteShowcase.pdf	165171	no	4
			45fb9697abcfb54ec456ec399d2abd1098e3194c		
<b>Warnings:</b>					
<b>Information:</b>					
32	NPL Documents	ISR29VPC.pdf	2604879	no	59
			935f9299e33df4f8ded0a0704e2f6ad4e65e27ff		
<b>Warnings:</b>					
<b>Information:</b>					
<b>Total Files Size (in bytes):</b>			41342875		

**This Acknowledgement Receipt evidences receipt on the noted date by the USPTO of the indicated documents, characterized by the applicant, and including page counts, where applicable. It serves as evidence of receipt similar to a Post Card, as described in MPEP 503.**

**New Applications Under 35 U.S.C. 111**

**If a new application is being filed and the application includes the necessary components for a filing date (see 37 CFR 1.53(b)-(d) and MPEP 506), a Filing Receipt (37 CFR 1.54) will be issued in due course and the date shown on this Acknowledgement Receipt will establish the filing date of the application.**

**National Stage of an International Application under 35 U.S.C. 371**

**If a timely submission to enter the national stage of an international application is compliant with the conditions of 35 U.S.C. 371 and other applicable requirements a Form PCT/DO/EO/903 indicating acceptance of the application as a national stage submission under 35 U.S.C. 371 will be issued in addition to the Filing Receipt, in due course.**

**New International Application Filed with the USPTO as a Receiving Office**

**If a new international application is being filed and the international application includes the necessary components for an international filing date (see PCT Article 11 and MPEP 1810), a Notification of the International Application Number and of the International Filing Date (Form PCT/RO/105) will be issued in due course, subject to prescriptions concerning national security, and the date shown on this Acknowledgement Receipt will establish the international filing date of the application.**

### INFORMATION DISCLOSURE STATEMENT

Applicant	: Christensen et al.
App. No	: 12/366,535
Filed	: February 5, 2009
For	: SYSTEM AND METHOD FOR ADVERTISEMENT TRANSMISSION AND DISPLAY
Examiner	: Belix M. Ortiz
Art Unit	: 2164
Conf No.	: 7989

Mail Stop Amendment  
 Commissioner for Patents  
 P.O. Box 1450  
 Alexandria, VA 22313-1450

Dear Sir:

Enclosed for filing in the above-identified application is a PTO/SB/08 Equivalent listing 107 references, of which 31 are enclosed/submitted.

The following is a list of co-pending applications assigned to the assignee of this application.

Cite No.	Application No.
66	11/562,300 STRATOS.001C2
70	12/343,434 STRATOS.001C1C1
71	12/343,413 STRATOS.001C1C2
72	12/334,411 STRATOS.022A
73	12/334,400 STRATOS.030A
74	12/366,483 STRATOS.028A
75	10/806,084 STRATOS.006A

**Application No.:** 12/366,535  
**Filing Date:** February 5, 2009

76	12/2897,509 STRATOS.006C1
----	------------------------------

The Applicants believe that the Examiner has access to the applications and associated file histories through the Patent Office (e.g., the IFW system). Accordingly, the Applicants have not provided copies of these applications or their associated file histories. The Applicants would be happy to provide copies of these applications or their associated file histories, now or in the future, should the Examiner so request. The Applicants have listed all of the corresponding publication numbers that they are presently aware of.

This Information Disclosure Statement is being filed before the receipt of a first Office Action on the merits, and presumably no fee is required. If a first Office Action on the merits was mailed before the mailing date of this Statement, the Commissioner is authorized to charge the fee set forth in 37 C.F.R. § 1.17(p) to Deposit Account No. 11-1410.

Respectfully submitted,

KNOBBE, MARTENS, OLSON & BEAR, LLP

Dated: 11/19/10

By: 

Don C. Pua  
Registration No. 67,028  
Attorney of Record  
Customer No. 20995  
(949) 760-0404

10034923



UNITED STATES PATENT AND TRADEMARK OFFICE

UNITED STATES DEPARTMENT OF COMMERCE
United States Patent and Trademark Office
Address: COMMISSIONER FOR PATENTS
P.O. Box 1450
Alexandria, Virginia 22313-1450
www.uspto.gov

Table with 5 columns: APPLICATION NO., FILING DATE, FIRST NAMED INVENTOR, ATTORNEY DOCKET NO., CONFIRMATION NO.
12/366,535 02/05/2009 Kelly M. Christensen STRATOS.029A 7989

20995 7590 04/01/2011
KNOBBE MARTENS OLSON & BEAR LLP
2040 MAIN STREET
FOURTEENTH FLOOR
IRVINE, CA 92614

EXAMINER

ORTIZ, BELIX M

Table with 2 columns: ART UNIT, PAPER NUMBER

2164

Table with 2 columns: NOTIFICATION DATE, DELIVERY MODE

04/01/2011

ELECTRONIC

Please find below and/or attached an Office communication concerning this application or proceeding.

The time period for reply, if any, is set in the attached communication.

Notice of the Office communication was sent electronically on above-indicated "Notification Date" to the following e-mail address(es):

jcartee@kmob.com
efiling@kmob.com
eOAPilot@kmob.com



<b>Office Action Summary</b>	<b>Application No.</b> 12/366,535	<b>Applicant(s)</b> CHRISTENSEN ET AL.	
	<b>Examiner</b> BELIX M. ORTIZ	<b>Art Unit</b> 2164	

-- The MAILING DATE of this communication appears on the cover sheet with the correspondence address --

**Period for Reply**

A SHORTENED STATUTORY PERIOD FOR REPLY IS SET TO EXPIRE 3 MONTH(S) OR THIRTY (30) DAYS, WHICHEVER IS LONGER, FROM THE MAILING DATE OF THIS COMMUNICATION.

- Extensions of time may be available under the provisions of 37 CFR 1.136(a). In no event, however, may a reply be timely filed after SIX (6) MONTHS from the mailing date of this communication.
- If NO period for reply is specified above, the maximum statutory period will apply and will expire SIX (6) MONTHS from the mailing date of this communication.
- Failure to reply within the set or extended period for reply will, by statute, cause the application to become ABANDONED (35 U.S.C. § 133). Any reply received by the Office later than three months after the mailing date of this communication, even if timely filed, may reduce any earned patent term adjustment. See 37 CFR 1.704(b).

**Status**

- 1)  Responsive to communication(s) filed on 05 February 2009.
- 2a)  This action is **FINAL**.
- 2b)  This action is non-final.
- 3)  Since this application is in condition for allowance except for formal matters, prosecution as to the merits is closed in accordance with the practice under *Ex parte Quayle*, 1935 C.D. 11, 453 O.G. 213.

**Disposition of Claims**

- 4)  Claim(s) 1-19 is/are pending in the application.
  - 4a) Of the above claim(s) \_\_\_\_\_ is/are withdrawn from consideration.
- 5)  Claim(s) \_\_\_\_\_ is/are allowed.
- 6)  Claim(s) 1-19 is/are rejected.
- 7)  Claim(s) \_\_\_\_\_ is/are objected to.
- 8)  Claim(s) \_\_\_\_\_ are subject to restriction and/or election requirement.

**Application Papers**

- 9)  The specification is objected to by the Examiner.
- 10)  The drawing(s) filed on 23 April 2009 is/are: a)  accepted or b)  objected to by the Examiner.
  - Applicant may not request that any objection to the drawing(s) be held in abeyance. See 37 CFR 1.85(a).
  - Replacement drawing sheet(s) including the correction is required if the drawing(s) is objected to. See 37 CFR 1.121(d).
- 11)  The oath or declaration is objected to by the Examiner. Note the attached Office Action or form PTO-152.

**Priority under 35 U.S.C. § 119**

- 12)  Acknowledgment is made of a claim for foreign priority under 35 U.S.C. § 119(a)-(d) or (f).
  - a)  All    b)  Some \*    c)  None of:
    - 1.  Certified copies of the priority documents have been received.
    - 2.  Certified copies of the priority documents have been received in Application No. \_\_\_\_\_.
    - 3.  Copies of the certified copies of the priority documents have been received in this National Stage application from the International Bureau (PCT Rule 17.2(a)).

\* See the attached detailed Office action for a list of the certified copies not received.

**Attachment(s)**

- |   |   |
|---|---|
| 1) <input checked="" type="checkbox"/> Notice of References Cited (PTO-892)   | 4) <input type="checkbox"/> Interview Summary (PTO-413)<br>Paper No(s)/Mail Date: _____ |
| 2) <input type="checkbox"/> Notice of Draftsperson's Patent Drawing Review (PTO-948)  | 5) <input type="checkbox"/> Notice of Informal Patent Application                       |
| 3) <input checked="" type="checkbox"/> Information Disclosure Statement(s) (PTO/SB/08)<br>Paper No(s)/Mail Date <u>11/19/2010</u> . | 6) <input type="checkbox"/> Other: _____  |

Art Unit: 2164

**DETAILED ACTION**  
**Information Disclosure Statement**

The information disclosure statement (IDS) submitted on 11/19/2010 has been received and considered by the examiner. See attached form PTO-1449.

**Claim Objections**

Claims 16-18 are objected to because of the following informalities:

In claim 16, the recitation of "capable of" constitute intended use, never actually takes place, therefore renders any recitation claimed after not be given patentable weight. The functionality claim may or may not occur. Appropriate correction is required.

**35 USC § 101 (Remarks)**

Independent claim 16 recites a user device system capable of combining multiple media. In view of the specification paragraphs 6, 9, 15-16, and 30, where the user device is define as a hardware "storage device that could be connected via a network to at least a computational device and/or the user device/cell phone" And fig. 3 define the user device as a Cell phone. Therefore, examiner interprets the user device system as hardware (e.g. cell phone) making these claims statutory.

**Claim Rejections - 35 USC § 102**

The following is a quotation of the appropriate paragraphs of 35 U.S.C. 102 that form the basis for the rejections under this section made in this Office action:

Art Unit: 2164

A person shall be entitled to a patent unless –

(a) the invention was known or used by others in this country, or patented or described in a printed publication in this or a foreign country, before the invention thereof by the applicant for a patent.

Claims 1-19 are rejected under 35 U.S.C. 102(e) (Eff. filing date of benefit application: 2/5/2008) as being anticipated by Manganaris et al. (US Pat. 7,299,194) (Eff. filing date of application: 2/22/2000) (Hereinafter Manganaris).

As to claim 1, 16, and 19, Manganaris teaches a method for associating multiple media signals, comprising in no particular order:

obtaining information about a first media signal (see col. 3, lines 30-67);

analyzing the information about the first media signal (see col. 3, lines 30-67 and col. 5, lines 10-18);

selecting at least one second media signal to be correlated with the first media signal based on at least one criteria (see col. 4, line 66 - col. 5, line 18);

assigning a unique identifier that is specific to the transmission of the selected second media signal, wherein at least the unique identifier is stored in a database (see col. 5, lines 19-23 and col. 5, line 63 – col. 6, line 9);

transmitting at least the second media signal and the unique identifier to a user device, wherein the user device outputs the first media signal and the second media signal to a user (see col. 5, line 63 – col. 6, line 9);

Art Unit: 2164

receiving a user response from the user in relation to the second media signal wherein the user response includes at least the unique identifier; and correlating at least the unique identifier in the database (see col. 5, lines 19-23 and col. 5, line 63 – col. 6, line 9).

As to claim 2, Manganaris teaches wherein the obtaining the first media signal and the transmitting the second media signal are performed using different communications methods (see col. 5, lines 24-36).

As to claim 3, Manganaris teaches wherein at least one additional media signal beyond the second media signal is transmitted to the device (see col. 8, lines 9-13).

As to claim 4, Manganaris teaches wherein the first media signal is disseminated through a second device (see fig. 1).

As to claim 5, Manganaris teaches wherein the first media signal and the second media signal are outputted to the user on the same device (see fig. 1, character 102).

As to claim 6, Manganaris teaches wherein the first media signal comprises a radio broadcast and the second media signal comprises a graphic image.

As to claim 7, Manganaris teaches the method further comprising generating a report wherein at least a portion of the report generation uses at least the unique identifier

Art Unit: 2164

and the database (see fig. 2 and col. 5, line 63 – col. 6, line 9).

As to claim 8, Manganaris teaches wherein the first media signal is publicly available and the second media signal is transmitted to a specific user device.

As to claim 9, Manganaris teaches the method further comprising transmitting to the user device a third media signal, wherein the second media signal is at the request of the user device and the third media signal is at the request of an advertisement entity (see col. 4, line 66 - col. 5, line 18).

As to claim 10, Manganaris teaches wherein the at least one criteria is modified according to the return user response (see col. 4, line 66 – col. 5, line 9).

As to claim 11, Manganaris teaches wherein the at least one association criteria is modified continuously (see col. 6, lines 35-46).

As to claim 12, Manganaris teaches a method for combining multiple media signals in a device, comprising in no particular order:

obtaining a first media signal by the device (see fig. 1);

outputting a first media content comprised in the first media signal to a user of the device (see fig. 1 and col. 3, lines 30-67);

obtaining a second media signal by the device (see col. 4, line 66 – col. 5, line 18);

Art Unit: 2164

obtaining a criteria correlated to the second media signal (see col. 4, line 63 – col. 5, line 18);

evaluating the criteria in reference to the user of the device (see col. 4, line 66 – col. 5, line 23); and

outputting at least a second media content comprised in the second media signal to the user of the device, wherein in the second media content outputted is determined at least in part based on the evaluation of the criteria (see col. 5, lines 19-23 and col. 5, line 63 – col. 6, line 9).

As to claim 13, Manganaris teaches The method further comprising communicating the obtainment of the first media signal to a media signal association system (see col. 4, line 63 – col. 5, line 18).

As to claim 14, Manganaris teaches the method further comprising communicating the status of the device to a media signal association system (see claim 4).

As to claim 15, Manganaris teaches the method further comprising obtaining a unique identifier specific to the instance of the outputting of the second media signal; detecting a user response to the second media content and transmitting at least the unique identifier to a computer server, wherein the computer server has access to a database containing at least the unique identifier (see col. 5, lines 19-23 and col. 5, line 63 – col. 6, line 9).

Art Unit: 2164

As to claim 17, Manganaris teaches the user device further comprising an output selection module capable of limiting the output of the primary and secondary media content based on a criteria (see col. 4, line 66 - col. 5, line 18).

As to claim 18, Manganaris teaches the user device further comprising a mass storage device capable of storing at least one of one the media content (see fig. 1, character 110).

### **Conclusion**

Any inquiry concerning this communication or earlier communications from the examiner should be directed to BELIX M. ORTIZ whose telephone number is (571)272-4081. The examiner can normally be reached on moday-friday 9am-5pm.

The fax phone number for the organization where this application or proceeding is assigned is 571-273-8300.

Information regarding the status of an application may be obtained from the Patent Application Information Retrieval (PAIR) system. Status information for published applications may be obtained from either Private PAIR or Public PAIR. Status information for unpublished applications is available through Private PAIR only. For more information about the PAIR system, see <http://pair-direct.uspto.gov>. Should you have questions on access to the Private PAIR system, contact the Electronic Business Center (EBC) at 866-217-9197 (toll-free). If you would like assistance from a USPTO Customer Service Representative or access to the automated information system, call 800-786-9199 (IN USA OR CANADA) or 571-272-1000.

Belix M Ortiz

Application/Control Number: 12/366,535

Page 8

Art Unit: 2164

Patent Examiner  
Art Unit 2164  
March 26, 2011

/Belix M. Ortiz/  
Examiner, Art Unit 2164



<b>Notice of References Cited</b>	Application/Control No. 12/366,535	Applicant(s)/Patent Under Reexamination CHRISTENSEN ET AL.	
	Examiner BELIX M. ORTIZ	Art Unit 2164	Page 1 of 1

**U.S. PATENT DOCUMENTS**

*	Document Number Country Code-Number-Kind Code	Date MM-YYYY	Name	Classification
*	A US-7,299,194	11-2007	Manganaris et al.	705/7.29
	B US-			
	C US-			
	D US-			
	E US-			
	F US-			
	G US-			
	H US-			
	I US-			
	J US-			
	K US-			
	L US-			
	M US-			


**FOREIGN PATENT DOCUMENTS**

*	Document Number Country Code-Number-Kind Code	Date MM-YYYY	Country	Name	Classification
	N				
	O				
	P				
	Q				
	R				
	S				
	T				

**NON-PATENT DOCUMENTS**

*	Document Number Country Code-Number-Kind Code	Date MM-YYYY	Country	Name	Classification
	Include as applicable: Author, Title Date, Publisher, Edition or Volume, Pertinent Pages)				
	U				
	V				
	W				
	X				

\*A copy of this reference is not being furnished with this Office action. (See MPEP § 707.05(a).)  
Dates in MM-YYYY format are publication dates. Classifications may be US or foreign.


<b>Search Notes</b>  	<b>Application/Control No.</b>  12366535	<b>Applicant(s)/Patent Under Reexamination</b>  CHRISTENSEN ET AL.
	<b>Examiner</b>  BELIX M ORTIZ	<b>Art Unit</b>  2164

SEARCHED			
Class	Subclass	Date	Examiner
707	737, 812, using keyword search	3/26/11	bmo
455	using keyword search	3/26/11	bmo

SEARCH NOTES		
Search Notes	Date	Examiner
Searched: East, JPO, EPO, USPAT, USPG-PUB, DERWENT, IBM_TDB	3/26/11	bmo
Inventors search on East and Edan	3/26/11	bmo
Keyword and Class search	3/26/11	bmo
Search strategies are enclosed	3/26/11	bmo

INTERFERENCE SEARCH			
Class	Subclass	Date	Examiner

--	--

<b>Index of Claims</b>  	<b>Application/Control No.</b> 12366535	<b>Applicant(s)/Patent Under Reexamination</b> CHRISTENSEN ET AL.
	<b>Examiner</b> BELIX M ORTIZ	<b>Art Unit</b> 2164

✓	<b>Rejected</b>
=	<b>Allowed</b>

-	<b>Cancelled</b>
÷	<b>Restricted</b>

N	<b>Non-Elected</b>
I	<b>Interference</b>

A	<b>Appeal</b>
O	<b>Objected</b>

Claims renumbered in the same order as presented by applicant
  CPA
  T.D.
  R.1.47

CLAIM		DATE							
Final	Original	03/26/2011							
	1	✓							
	2	✓							
	3	✓							
	4	✓							
	5	✓							
	6	✓							
	7	✓							
	8	✓							
	9	✓							
	10	✓							
	11	✓							
	12	✓							
	13	✓							
	14	✓							
	15	✓							
	16	✓							
	17	✓							
	18	✓							
	19	✓							

## EAST Search History

## EAST Search History (Prior Art)

Ref #	Hits	Search Query	DBs	Default Operator	Plurals	Time Stamp
L1	2	"20090204640".pn.	US-PGPUB; USPAT; EPO; JPO; DERWENT; IBM_TDB	OR	ON	2011/03/26 16:33
L2	15	christensen-kelly-m.in.	US-PGPUB; USPAT; EPO; JPO; DERWENT; IBM_TDB	OR	ON	2011/03/26 16:36
L3	3	christensen-kelly-m.in. "707"/\$.ccls.	US-PGPUB; USPAT; EPO; JPO; DERWENT; IBM_TDB	AND	ON	2011/03/26 16:36
L4	13	christensen-kelly-m.in. advertisement	US-PGPUB; USPAT; EPO; JPO; DERWENT; IBM_TDB	AND	ON	2011/03/26 16:36
L5	13	christensen-kelly-m.in. transmission	US-PGPUB; USPAT; EPO; JPO; DERWENT; IBM_TDB	AND	ON	2011/03/26 16:37
L6	13	christensen-kelly-m.in. transmission advertisement	US-PGPUB; USPAT; EPO; JPO; DERWENT; IBM_TDB	AND	ON	2011/03/26 16:37
L7	13	christensen-kelly-m.in. radio broadcast	US-PGPUB; USPAT; EPO; JPO; DERWENT; IBM_TDB	AND	ON	2011/03/26 16:38
L8	13	christensen-kelly-m.in. radio broadcast unique identifier	US-PGPUB; USPAT; EPO; JPO; DERWENT; IBM_TDB	AND	ON	2011/03/26 16:39
L9	13	christensen-kelly-m.in. radio broadcast unique identifier second media signal	US-PGPUB; USPAT; EPO; JPO; DERWENT; IBM_TDB	AND	ON	2011/03/26 16:39
L10	3024	"455"/\$.ccls. radio broadcast unique identifier second media signal	US-PGPUB; USPAT; EPO; JPO; DERWENT; IBM_TDB	AND	ON	2011/03/26 17:02

L11	58	("4,926,255" "5,134,719" "5,303,393" "5,438,355" "5,444,769" "5,539,635" "5,548,828" "5,557,541" "5,579,537" "5,661,787" "5,708,478" "5,752,159" "5,857,156" "5,872,589" "5,905,865" "5,907,793" "5,991,601" "5,991,737" "6,036,086" "6,098,106" "6,202,210" "6,286,140" "6,446,262" "6,463,469" "6,473,792" "6,507,727" "6,578,047" "6,611,201" "6,658,232").pn.	US-PGPUB; USPAT; EPO; JPO; DERWENT; IBM_TDB	OR	ON	2011/03/26 17:03
L12	59	("6,725,022" "6,829,486" "6,888,457" "6,928,423" "6,941,154" "6,957,041" "6,987,734" "6,990,312" "7,054,653" "7,088,950" "7,110,714" "7,149,541" "7,158,753" "7,190,971" "7,194,235" "7,260,842" "7,266,343" "7,299,194" "7,313,359" "7,313,360" "7,415,430" "7,500,256" "7,647,609" "7,773,939" 2001/0031013 2002/0026474 2002/0046407 2002/0133824	US-PGPUB; USPAT; EPO; JPO; DERWENT; IBM_TDB	OR	ON	2011/03/26 17:04

		2002/0178441).pn.				
L13	2	"20070088852".pn.	US-PGPUB; USPAT; EPO; JPO; DERWENT; IBM_TDB	OR	ON	2011/03/26 17:07
L14	2	"20080263673".pn.	US-PGPUB; USPAT; EPO; JPO; DERWENT; IBM_TDB	OR	ON	2011/03/26 17:07
L15	2	"6725022".pn.	US-PGPUB; USPAT; EPO; JPO; DERWENT; IBM_TDB	OR	ON	2011/03/26 17:07
L16	2	"20020046407".pn.	US-PGPUB; USPAT; EPO; JPO; DERWENT; IBM_TDB	OR	ON	2011/03/26 17:07
L17	186	"455"/\$.ccls. radio near broadcast unique near identifier second media signal	US-PGPUB; USPAT; EPO; JPO; DERWENT; IBM_TDB	AND	ON	2011/03/26 17:08
L18	141	"707"/\$.ccls. radio near broadcast unique near identifier second media signal	US-PGPUB; USPAT; EPO; JPO; DERWENT; IBM_TDB	AND	ON	2011/03/26 17:09
L19	10044	"707"/\$.ccls. advertisement	US-PGPUB; USPAT; EPO; JPO; DERWENT; IBM_TDB	AND	ON	2011/03/26 17:09
L20	5116	"707"/\$.ccls. advertisement transmission	US-PGPUB; USPAT; EPO; JPO; DERWENT; IBM_TDB	AND	ON	2011/03/26 17:10
L21	647	"707"/\$.ccls. advertisement same transmission	US-PGPUB; USPAT; EPO; JPO; DERWENT; IBM_TDB	AND	ON	2011/03/26 17:10
L22	1	"707"/737.ccls. radio near broadcast unique near identifier second media signal	US-PGPUB; USPAT; EPO; JPO; DERWENT; IBM_TDB	AND	ON	2011/03/26 17:11
L23	3	"707"/812.ccls. radio near broadcast unique near identifier second media signal	US-PGPUB; USPAT; EPO; JPO; DERWENT; IBM_TDB	AND	ON	2011/03/26 17:11
L24	1085	advertisement transmission	US-PGPUB; USPAT; EPO; JPO; DERWENT; IBM_TDB	NEAR	ON	2011/03/26 17:12

L25	0	first near media second near media criteria	US-PGPUB; USPAT; EPO; JPO; DERWENT; IBM_TDB	NEAR	ON	2011/03/26 17:13
L26	34	first near media second near media criteria	US-PGPUB; USPAT; EPO; JPO; DERWENT; IBM_TDB	WITH	ON	2011/03/26 17:13
L27	74	first near media second near media criteria	US-PGPUB; USPAT; EPO; JPO; DERWENT; IBM_TDB	SAME	ON	2011/03/26 17:13
L28	2404	first near media second near media criteria	US-PGPUB; USPAT; EPO; JPO; DERWENT; IBM_TDB	AND	ON	2011/03/26 17:13
L29	236	first near media second near media criteria unique near identifier	US-PGPUB; USPAT; EPO; JPO; DERWENT; IBM_TDB	AND	ON	2011/03/26 17:13
L30	3	first near media second near media criteria unique near identifier	US-PGPUB; USPAT; EPO; JPO; DERWENT; IBM_TDB	SAME	ON	2011/03/26 17:13
L31	1	first near media second near media criteria unique near identifier	US-PGPUB; USPAT; EPO; JPO; DERWENT; IBM_TDB	WITH	ON	2011/03/26 17:13
L32	0	first near media second near media criteria unique near identifier	US-PGPUB; USPAT; EPO; JPO; DERWENT; IBM_TDB	NEAR	ON	2011/03/26 17:13
L33	2	"7299194".pn.	US-PGPUB; USPAT; EPO; JPO; DERWENT; IBM_TDB	SAME	ON	2011/03/26 17:14
L34	830	advertisement radio near broadcast	US-PGPUB; USPAT; EPO; JPO; DERWENT; IBM_TDB	SAME	ON	2011/03/26 17:19
L35	496	advertisement radio near broadcast	US-PGPUB; USPAT; EPO; JPO; DERWENT; IBM_TDB	WITH	ON	2011/03/26 17:19
L36	73	advertisement radio near broadcast	US-PGPUB; USPAT; EPO; JPO; DERWENT; IBM_TDB	NEAR	ON	2011/03/26 17:19

L37	158	transmission advertisement radio near broadcast	US-PGPUB; USPAT; EPO; JPO; DERWENT; IBM_TDB	SAME	ON	2011/03/26 17:19
L38	24	transmission advertisement radio near broadcast	US-PGPUB; USPAT; EPO; JPO; DERWENT; IBM_TDB	WITH	ON	2011/03/26 17:19
L39	0	transmission advertisement radio near broadcast	US-PGPUB; USPAT; EPO; JPO; DERWENT; IBM_TDB	NEAR	ON	2011/03/26 17:20
L42	10	"705"/\$.ccls. and transmission advertisement radio near broadcast	US-PGPUB; USPAT; EPO; JPO; DERWENT; IBM_TDB	WITH	ON	2011/03/26 17:21
L43	0	L38 identifier	US-PGPUB; USPAT; EPO; JPO; DERWENT; IBM_TDB	WITH	ON	2011/03/26 17:22
L44	10	L38 identifier	US-PGPUB; USPAT; EPO; JPO; DERWENT; IBM_TDB	AND	ON	2011/03/26 17:22
L45	87	L37 identifier	US-PGPUB; USPAT; EPO; JPO; DERWENT; IBM_TDB	AND	ON	2011/03/26 17:22
L46	13	L37 identifier	US-PGPUB; USPAT; EPO; JPO; DERWENT; IBM_TDB	SAME	ON	2011/03/26 17:22

**EAST Search History (Interference)**

&lt;This search history is empty&gt;

**3/26/11 8:06:01 PM**



<b>INFORMATION DISCLOSURE STATEMENT BY APPLICANT</b>	Application No.	12/366,535
	Filing Date	February 5, 2009
	First Named Inventor	Kelly M. Christensen
	Art Unit	2164
<i>(Multiple sheets used when necessary)</i>	Examiner	Belix M. Ortiz
SHEET 1 OF 5	Attorney Docket No.	STRATOS.029A

U.S. PATENT DOCUMENTS					
Examiner Initials	Cite No.	Document Number Number - Kind Code (if known) Example: 1,234,567 B1	Publication Date MM-DD-YYYY	Name of Patentee or Applicant	Pages, Columns, Lines Where Relevant Passages or Relevant Figures Appear
	1	4,926,255	05-15-1990	Von Kohorn	
	2	5,134,719	07-28-1992	Mankovitz	
	3	5,303,393	04-12-1994	Noreen et al.	
	4	5,438,355	08-01-1995	Palmer	
	5	5,444,769	08-22-1995	Koen et al.	
	6	5,539,635	07-23-1996	Larson, Jr.	
	7	5,548,828	02-20-1996	Kozaki, et al.	
	8	5,557,541	09-17-1996	Schulhof et al.	
	9	5,579,537	11-26-1996	Takahisa	
	10	5,661,787	08-26-1997	Pocock	
	11	5,708,478	01-13-1998	Tognazzini	
	12	5,752,159	05-12-1998	Faust et al.	
	13	5,857,156	01-05-1999	Anderson	
	14	5,872,589	02-16-1999	Morales	
	15	5,905,865	05-18-1999	Palmer et al.	
	16	5,907,793	05-25-1999	Reams	
	17	5,991,601	11-23-1999	Anderson	
	18	5,991,737	11-23-1999	Chen	
	19	6,036,086	03-14-2000	Sizer, II et al.	
	20	6,098,106	08-01-2000	Philyaw et al.	
	21	6,202,210	03-13-2001	Ludtke	
	22	6,286,140	09-04-2001	Ivanyi	
	23	6,446,262	09-03-2002	Malaure et al.	
	24	6,463,469	10-08-2002	Yavitz	
	25	6,473,792	10-29-2002	Yavitz et al	
	26	6,507,727	01-14-2003	Henrick	
	27	6,578,047	06-10-2003	Deguchi	
	28	6,611,201	08-26-2003	Bishop et al.	
	29	6,658,232	12-02-2003	Johnson	

Examiner Signature <i>/Belix M Ortiz/</i>	Date Considered <i>03/26/2011</i>
---	-----------------------------------

\*Examiner: Initial if reference considered, whether or not citation is in conformance with MPEP 609. Draw line through citation if not in conformance and not considered. Include copy of this form with next communication to applicant.

<b>INFORMATION DISCLOSURE STATEMENT BY APPLICANT</b>	Application No.	12/366,535	
	Filing Date	February 5, 2009	
	First Named Inventor	Kelly M. Christensen	
	Art Unit	2164	
<i>(Multiple sheets used when necessary)</i>		Examiner	Belix M. Ortiz
SHEET 2 OF 5		Attorney Docket No.	STRATOS.029A

U.S. PATENT DOCUMENTS					
Examiner Initials	Cite No.	Document Number Number - Kind Code (if known) Example: 1,234,567 B1	Publication Date MM-DD-YYYY	Name of Patentee or Applicant	Pages, Columns, Lines Where Relevant Passages or Relevant Figures Appear
	30	6,725,022	04-20-2004	Clayton et al.	
	31	6,829,486	12-07-2004	McKenna et al.	
	32	6,888,457	03-03-2005	Wilkinson et al.	
	33	6,928,423	08-09-2005	Yamanaka	
	34	6,941,154	09-06-2005	Ritter	
	35	6,957,041	10-18-2005	Christensen et al.	
	36	6,987,734	01-17-2006	Hundemer	
	37	6,990,312	01-24-2006	Gioscia et al.	
	38	7,054,653	05-30-2006	Järvi et al.	
	39	7,088,950	08-08-2006	Tassberg et al.	
	40	7,110,714	09-19-2006	Kay et al.	
	41	7,149,541	12-12-2006	Rautila	
	42	7,158,753	01-02-2007	Kagan et al.	
	43	7,190,971	03-13-2007	Kagan et al.	
	44	7,194,235	03-20-2007	Nykanen et al.	
	45	7,260,842	08-21-2007	Hirayama	
	46	7,266,343	09-04-2007	Yli-juuti et al.	
	47	7,299,194	11-20-2007	Manganaris et al.	
	48	7,313,359	12-25-2007	Steelberg et al.	
	49	7,313,360	12-25-2007	Steelberg et al.	
	50	7,415,430	08-19-2008	Christensen et al.	
	51	7,500,256	03-03-2009	Ohmae et al.	
	52	7,647,609	01-12-2010	Wachtfogel et al.	
	53	7,773,939	08-10-2010	Christensen et al.	
	54	2001/0031013	10-18-2001	Stetzler et al.	
	55	2002/0026474	02-28-2002	Wang et al.	
	56	2002/0046407	04-18-2002	Franco	
	57	2002/0133824	09-19-2002	Mensch	
	58	2002/0178441	11-28-2002	Hashimoto	

Examiner Signature /Belix M Ortiz/	Date Considered 03/26/2011
------------------------------------	----------------------------

\*Examiner: Initial if reference considered, whether or not citation is in conformance with MPEP 609. Draw line through citation if not in conformance and not considered. Include copy of this form with next communication to applicant.

<b>INFORMATION DISCLOSURE STATEMENT BY APPLICANT</b>	Application No.	12/366,535	
	Filing Date	February 5, 2009	
	First Named Inventor	Kelly M. Christensen	
	Art Unit	2164	
<i>(Multiple sheets used when necessary)</i>		Examiner	Belix M. Ortiz
SHEET 3 OF 5		Attorney Docket No.	STRATOS.029A

U.S. PATENT DOCUMENTS					
Examiner Initials	Cite No.	Document Number <i>Number - Kind Code (if known)</i> Example: 1,234,567 B1	Publication Date MM-DD-YYYY	Name of Patentee or Applicant	Pages, Columns, Lines Where Relevant Passages or Relevant Figures Appear
	59	2003/0086694	05-08-2003	Davidsson	
	60	2003/0097338	05-22-2003	Mankovich et al.	
	61	2003/0200543	10-23-2003	Burns	
	62	2004/0205810	10-14-2004	Matheny et al.	
	63	2005/0021744	01-27-2005	Haitsuka	
	64	2006/0174261	08-03-2006	Cline Jr. et al.	
	65	2006/0184960	08-17-2006	Horton et al.	
	66	2007/0155311 (STRATOS.001C2)	07-05-2007	Christensen et al.	
	67	2007/0198353	08-23-2007	Behringer et al.	
	68	2007/0226146	09-27-2007	Ruul	
	69	2008/0049704	02-28-2008	Witteman et al.	
	70	2009/0104870 (STRATOS.001C1C1)	04-23-2009	Christensen et al.	
	71	2009/0104872 (STRATOS.001C1C2)	04-23-2009	Christensen et al.	
	72	2009/0177736 (STRATOS.022A)	07-09-2009	Christensen et al.	
	73	2009/0183208 (STRATOS.030A)	12-12-2008	Christensen et al.	
	74	2009/0205000 (STRATOS.028A)	08-13-2009	Christensen et al.	
	75	U.S. App. No. 10/806,084 (Our reference STRATOS.006A)	Filing Date 03-22-2004	Christensen et al.	
	76	U.S. App. No. 12/897,509 (Our reference STRATOS.006C1)	Filing Date 10-04-2010	Christensen et al.	

FOREIGN PATENT DOCUMENTS						
Examiner Initials	Cite No.	Foreign Patent Document <i>Country Code-Number-Kind Code</i> Example: JP 1234567 A1	Publication Date MM-DD-YYYY	Name of Patentee or Applicant	Pages, Columns, Lines Where Relevant Passages or Relevant Figures Appear	T <sup>1</sup>
	77	CA 2 316 925	07-15-1999	Swisscom AG		
	78	DE 196 27 308	01-02-1998	Mihatsch		
	79	DE 44 27 046	02-01-1996	Goldscheider et al.		
	80	EP 0713335	05-22-1996	AT&T Corp.		
	81	JP 08-139624	05-31-1996	Yoshio et al.		X
	82	JP 10-135855	05-22-1998	Tetsujiro et al.		

Examiner Signature /Belix M Ortiz/	Date Considered 03/26/2011
------------------------------------	----------------------------

\*Examiner: Initial if reference considered, whether or not citation is in conformance with MPEP 609. Draw line through citation if not in conformance and not considered. Include copy of this form with next communication to applicant.

<b>INFORMATION DISCLOSURE STATEMENT BY APPLICANT</b>	Application No.	12/366,535	
	Filing Date	February 5, 2009	
	First Named Inventor	Kelly M. Christensen	
	Art Unit	2164	
<i>(Multiple sheets used when necessary)</i>		Examiner	Belix M. Ortiz
SHEET 4 OF 5		Attorney Docket No.	STRATOS.029A

FOREIGN PATENT DOCUMENTS						
Examiner Initials	Cite No.	Foreign Patent Document Country Code-Number-Kind Code Example: JP 1234567 A1	Publication Date MM-DD-YYYY	Name of Patentee or Applicant	Pages, Columns, Lines Where Relevant Passages or Relevant Figures Appear	T <sup>1</sup>
	83	JP 2000292182	10-20-2000	Akio		
	84	Korean Patent Publication No. 10-1996-0033096	09-17-1996			
	85	Korean Patent Publication No. 10-1998-0078248	11-16-1998			
	86	WO 1990/000847	01-25-1990	Insight Telecast, Inc.		
	87	WO 1992/014222	08-20-1992	Tait et al.		
	88	WO 1994/002909	02-03-1994	Whinhall Limited		
	89	WO 1997/021291	06-12-1997	Pocock		
	90	WO 1997/042724	11-13-1997	Digital D.J. Inc.		
	91	WO 1997/045814	12-04-1997	Vazvan		
	92	WO 1999/018518	04-15-1999	Polash		
	93	WO 1999/035771	07-15-1999	Swisscom AG		
	94	WO 1999/043109	08-26-1999	TTP Communications Ltd		
	95	WO 1999/035809	07-15-1999	Connexus Corporation		
	96	WO 2000/019662	04-06-2000	Radiowave.com, Inc.		
	97	WO 2000/078050	12-21-2000	United Video Properties, Inc.		
	98	WO 2001/001331	01-04-2001	Digimarc Corporation		
	99	WO 2001/057759	08-09-2001	Minushkin		
	100	WO 2001/077779	10-18-2001	Morphics Technology, Inc.		
	101	WO 2002/023773	03-21-2002	Stratos Audio		
	102	WO 2006/122028	11-16-2006	Root Markets Inc.		
	103	WO 2008/002000	01-03-2008	Electronics and Telecommunications Research Institute		

NON PATENT LITERATURE DOCUMENTS			
Examiner Initials	Cite No.	Include name of the author (in CAPITAL LETTERS), title of the article (when appropriate), title of the item (book, magazine, journal, serial, symposium, catalog, etc.), date, page(s), volume-issue number(s), publisher, city and/or country where published.	T <sup>1</sup>
	104	"Bookmark Your World", 1999-2000 Xenote, www.xenote.com	
	105	"Sirus to Add 'Instant Buy' Button," March 13, 2000, Twice, V 15, n 7, p. 28.	

Examiner Signature	/Belix M Ortiz/	Date Considered	03/26/2011
--------------------	-----------------	-----------------	------------

\*Examiner: Initial if reference considered, whether or not citation is in conformance with MPEP 609. Draw line through citation if not in conformance and not considered. Include copy of this form with next communication to applicant.

Receipt date: 11/19/2010

PTO/SB/08 Equivalent

<b>INFORMATION DISCLOSURE STATEMENT BY APPLICANT</b>	Application No.	12/366,535
	Filing Date	February 5, 2009
	First Named Inventor	Kelly M. Christensen
	Art Unit	2164
<i>(Multiple sheets used when necessary)</i>	Examiner	Belix M. Ortiz
SHEET 5 OF 5	Attorney Docket No.	STRATOS.029A

<b>NON PATENT LITERATURE DOCUMENTS</b>			
Examiner Initials	Cite No.	Include name of the author (in CAPITAL LETTERS), title of the article (when appropriate), title of the item (book, magazine, journal, serial, symposium, catalog, etc.), date, page(s), volume-issue number(s), publisher, city and/or country where published.	T <sup>1</sup>
	106	Jan. 25, 2000, Showcase 2000 - Xenote Press Release re Xenote iTag, www.xenote.com/html/press/releases.html	
	107	International Search Report and Written Opinion for International Application No. PCT/US2009/03349, Notification mailed June 23, 2009. (STRATOS.029VPC)	

9798042

Examiner Signature	/Belix M Ortiz/	Date Considered	03/26/2011
--------------------	-----------------	-----------------	------------

\*Examiner: Initial if reference considered, whether or not citation is in conformance with MPEP 609. Draw line through citation if not in conformance and not considered. Include copy of this form with next communication to applicant.

T<sup>1</sup> - Place a check mark in this area when an English language Translation is attached

## IN THE UNITED STATES PATENT AND TRADEMARK OFFICE

Applicant : Christensen et al.  
 App. No. : 12/366,535  
 Filed : February 5, 2009  
 For : SYSTEM AND METHOD FOR  
 ADVERTISEMENT TRANSMISSION  
 AND DISPLAY  
 Examiner : Ortiz, Belix M  
 Art Unit : 2164  
 Conf No. : 7989

CERTIFICATE OF EFS WEB  
TRANSMISSION

I hereby certify that this correspondence, and any other attachment noted on the automated Acknowledgement Receipt, is being transmitted from within the Pacific Time zone to the Commissioner for Patents via the EFS Web server on:

September 30, 2011

(Date)



Don C. Pua, Reg. No. 67,028

RESPONSE TO OFFICE ACTION MAILED APRIL 1, 2011

**Mail Stop Amendment**

Commissioner for Patents  
 P.O. Box 1450  
 Alexandria, VA 22313-1450

Dear Sir:

In response to the Office Action mailed April 1, 2011, please consider the following:

**Amendments to the Claims** are reflected in the listing of claims which begins on page 2 of this paper.

**Remarks** begin on page 8 of this paper.

### AMENDMENTS TO THE CLAIMS

1. (**Currently amended**) A method for associating ~~multiple a secondary media content~~ with a primary broadcast segment signals, comprising in no particular order:

obtaining information about a first media broadcast communications medium received by a plurality of user devices signal;

analyzing obtaining the information about the first media signal broadcast communications medium to determine at least data enabling the identification of a specific instance of a primary broadcast segment conveyed on the broadcast communications medium;

selecting at least one a secondary media content signal to be correlated with the first media signal based on at least one criteria criterion;

assigning determining a uniquely identifying data specific to the secondary media content unique identifier that is specific to the transmission of the selected second media signal, wherein at least the uniquely identifying data unique identifier is stored in a database;

transmitting at least the secondary media content second media signal and the uniquely identifying data unique identifier to a user device of the plurality of user devices on a secondary communications medium discrete from the broadcast communications medium, wherein the secondary media content is configured to be presented substantially concurrently with the primary broadcast segment received by the user device on the broadcast communications medium wherein the user device outputs the first media signal and the second media signal to a user;

monitoring response messages received from the user device in response to a presentation of the secondary media content, wherein at least one response message receiving a user response from the user in relation to the second media signal wherein the user response includes at least the uniquely identifying data specific to the secondary media content unique identifier; and

obtaining a report on user activity, the report correlating user activity with the secondary media content using the uniquely identifying data specific to the secondary media content.

~~correlating at least the unique identifier in the database.~~

2. **(Currently amended)** The method of claim 1, wherein the broadcast communications medium ~~obtaining the first media signal and the electronic communications medium~~ ~~the transmitting the second media signal~~ are performed using different types of communications methods ~~medium~~.

3. **(Canceled)**

4. **(Canceled)**

5. **(Canceled)**

6. **(Canceled)**

7. **(Canceled)**

8. **(Canceled)**

9. **(Canceled)**

10. **(Currently amended)** The method of claim 1, wherein the at least one criteria criterion is modified ~~according based at least partly on the report on user activity to the return~~ ~~user response~~.

11. **(Currently amended)** The method of claim 10, wherein the at least one ~~association~~ criteria-criterion is modified continuously.

12. **(Currently amended)** A method for combining multiple media ~~signals~~ content in a receiving system device, ~~comprising in no particular order:~~

obtaining a first media ~~signal~~ broadcast by the receiving system device;

outputting a first media content comprised in the first media ~~signal~~ broadcast to a user of the ~~device~~ receiving system;

obtaining a second media content and uniquely identifying data specific to the secondary media content ~~signal~~ by the receiving system via a secondary media content transmission discrete from the first media content broadcast ~~device~~;

obtaining a ~~criteria~~ at least one criterion correlated to the second media content ~~signal~~;

evaluating the ~~criteria~~ at least one criterion in reference to the usage data for user ~~of the device~~;

~~and~~



~~outputting, based at least partly on the evaluation, at least a the second media content comprised in the second media signal to the user of on the device receiving system, wherein the second media content is configured to be concurrently presented in association with the first media content;~~ ~~wherein in the second media content outputted is determined at least in part based on the evaluation of the criteria and~~

~~sending a response containing at least uniquely identifying data associated with the second media content.~~

13. **(Currently amended)** The method of claim 12, further comprising communicating the obtainment of the first media ~~signal broadcast~~ to a media signal association system.

14. **(Original)** The method of claim 12, further comprising communicating the status of the device to a media signal association system.

15. **(Currently amended)** The method of claim 12, further comprising:

~~obtaining data a unique identifier specific to the instance of the outputting of the second media signal content;~~

~~detecting a user response to the second media content; and~~

~~transmitting at least the data specific to the instance of the outputting unique identifier to a computer server, wherein the computer server has access to a database containing at least the unique identifier.~~

16. **(Currently amended)** A user device system ~~capable of for~~ combining multiple media signals comprising:

~~a first receiver module configured to receive at least a first media signal content and data enabling the identification of a specific instance of the first media content from a first transmitter broadcast medium;~~

~~a second receiver module configured to receive at least a second media signal content and uniquely identifying data specific to at least the second media content, the second media content received discretely from the first media content a unique identifier correlated to the second media signal;~~

~~an output module system configured to output present concurrently a primary the first media content from the first media signal and output a the secondary media content~~

~~on an output of the first receiver module or the second receiver module from the second media signal;~~

~~an input module capable of configured to receive receiving at least a user input response input responsive to the second media content; and~~

~~a transmitting module configured to transmit a response message having capable of transmitting at least the user input and the uniquely identifying data specific to the second media content unique identifier to a computer server, wherein the computer server has access to a database containing at least the unique identifier.~~

17. **(Currently amended)** The ~~user device system~~ of claim 16 further comprising an output selection module ~~capable of configured to~~ limiting the output of the ~~primary first and secondary second~~ media content based on a ~~criteria criterion~~.

18. **(Currently amended)** The ~~user device system~~ of claim 16 further comprising a mass storage device ~~capable configured to store of storing~~ at least one of one the first and second media content.

19. **(Canceled)**

20. **(New)** A method for associating a secondary media content presentation to a primary broadcast segment:

obtaining information about a first media content broadcast received by a plurality of user devices;

organizing the information about the first media content broadcast to determine at least data enabling the identification of a specific instance of a primary broadcast segment conveyed by the first media content broadcast;

selecting at least a secondary media content based on at least one criterion;

determining uniquely identifying data specific to the secondary media content, wherein at least the uniquely identifying data is stored in a database;

enabling access of at least the secondary media content and the uniquely identifying data to a user device of the plurality of user devices via at least a secondary media content transmission discrete from the first media content broadcast, wherein the secondary media content is configured to be concurrently presented in association with the primary broadcast segment accessible to the user device using the first media content broadcast;

enabling access to one or more response messages received from the user device in relation to the contextual presentation of the secondary media content, the one or more response messages including at least the uniquely identifying data specific to the secondary media content; and

obtaining a report on user activity, the report correlating user activity with at least the secondary media content broadcast and the uniquely identifying data specific to the secondary media content broadcast.

21. (New) The method of claim 2, wherein the broadcast communications medium comprises a radio broadcast and the electronic communications medium comprises a mobile wireless transmission.

22. (New) The method of claim 1, wherein the report further correlates the user activity with the specific instance of the primary broadcast segment.

23. (New) The system of claim 16, wherein, in response to receiving the response message, the computer server is configured to correlate the response message to the second media content with the specific instance of the first media content.

24. (New) The method of claim 20, whereby the data enabling the identification of a specific instance of a primary broadcast segment conveyed by the first media content broadcast and the uniquely identifying data specific to the secondary media content are cross referenced in the database.

25. (New) The method of claim 20, whereby the report obtained corollary to user activity includes secondary media content presentation activity obtained from the user device.

26. (New) The method of claim 20, whereby the secondary media content transmission is conveyed substantially synchronously with the first media content broadcast being discretely separated by time multiplexing.

27. (New) The method of claim 20, whereby the secondary media content transmission is conveyed substantially synchronously with the first media content broadcast being discretely separate by frequency multiplexing.

28. (New) The method of claim 20, whereby the secondary media content transmission is conveyed by means of at least one of the following: discrete multi-tone modulation, in-band on-

**Application No.:** 12/366,535  
**Filing Date:** February 5, 2009

channel (IBOC) radio, Digital Radio Mondial, CDMA, HSDPA, WiFi, RDS, RBDS, GPRS, mobile wireless network, satellite communication, Ethernet.

**Application No.:** 12/366,535  
**Filing Date:** February 5, 2009

### **REMARKS**

The remarks herein are responsive to the Office Action, mailed on April 1, 2011. By way of summary, Claims 1-19 are pending and these pending claims stand rejected. Applicants have amended Claims 1-2, 10-13 and 15-18. Applicants have canceled Claims 3-9 and 19. Applicants have added Claims 20-28. Accordingly, Claims 1-2, 10-18 and 20-28 remain pending for consideration.

Applicants respectfully request that the Examiner reconsider the rejections in the above Office Action in light of the amendments and the following comments.

#### **Objections To Claims 16-18**

The Office Action objected to Claims 16-18 for minor informalities. In particular, the Office Action objected to the recitation of “capable of.” In response, the Applicants have replaced instances of “capable of.” Accordingly, the Applicants respectfully request withdrawal of the objection to the claims.

#### **New Claims**

New Claims 20-28 have been added to more fully define the Applicant’s invention and are believed to be fully distinguished over the prior art of record.

#### **Rejection Of Claims 1-19 Under 35 U.S.C. § 102 (e)**

The Office Action rejected Claims 1-19 under 35 U.S.C. § 102(e) as being anticipated by U.S. Patent No. 7,299,194, issued to Manganaris et al, (“*Manganaris*”). The Applicants respectfully traverse this rejection because *Manganaris* fails to identically teach every element of the claim. See M.P.E.P. § 2131 (stating that in order to anticipate a claim, a prior art reference must identically teach every element of the claim).

The Applicants respectfully submit that the claims as previously pending are patentably distinguished over *Manganaris*. Claims 1-2 and 10-18, however, have been amended in order to clarify the features of the Applicants’ inventions.

With reference to amended Claim 1, *Manganaris* discloses receiving retailer information from input/output devices 102. “Retailer information input devices 102 provide means for

inputting to the system information regarding the needs and desires of a particular Retailer. The Retailer information can be **manually input by the user of the system via, for example, a standard keyboard,**” (Manganaris, Col. 4:65 – 5:3). Applicants respectfully submit that *Manganaris* does not teach or disclose, among other things “obtaining the information about the first electronic communications medium to determine at least **data enabling the identification of a specific instance of a primary broadcast segment conveyed on the broadcast communications medium,**” and “**transmitting at least the secondary media content and the uniquely identifying data to a user device of the plurality of user devices on a secondary communications medium discrete from the broadcast communications medium,** wherein the secondary media content is configured to be presented substantially concurrently with the **primary broadcast segment** received by the user device on the broadcast communications medium.” In certain examples,

[0024] For example, in one embodiment, a radio station transmits a song that is received by a user enabled-device, such as a cellular phone with a radio. The transmitted song is transmitted in a first media signal. The song is analyzed by a media association system to determine what prospective media elements can be associated with the song. The user enabled-device obtains and/or receives from the media association system a secondary media signal that is separate and/or discrete from the first media signal. For example, the secondary media signal could be an advertisement for a particular truck. As the user enabled-device is playing a song obtained from the first media signal, the user enabled-device displays the media content in the second media signal, wherein the media content can be a still or moving picture of the advertised truck. In another embodiment, as the user enabled-device is playing a song obtained from the first media signal, the user enabled-device displays the media content obtained from the second media signal, wherein the media content can be a still or moving picture with user selectable audio of the advertised truck wherein the first audio track could be paused upon selection.

(par. [0024] of this application)

Therefore, Applicants respectfully submit that Claim 1 is allowable at least for the reasons set forth above as well as for the additional unique combination of features disclosed therein. The dependant claims of Claim 1 are allowable for at least the same reasons as discussed above for Claim 1 as well as for the additional unique combination of features disclosed therein.

With reference to amended Claim 12, Applicants respectfully submit that *Manganaris* does not teach or disclose, among other things “obtaining a first media broadcast by the receiving

**Application No.:** 12/366,535  
**Filing Date:** February 5, 2009

system” and “obtaining a second media content and uniquely identifying data specific to the secondary media content by the receiving system via a secondary media content transmission discrete from the first media content broadcast” and “outputting, based at least partly on the evaluation, at least the second media content on the receiving system, wherein the second media content is configured to be concurrently presented in association with the first media content.”

With reference to amended Claim 16, Applicants respectfully submit that *Manganaris* does not teach or disclose, among other things “a first receiver module configured to receive at least a first media content and data enabling the identification of a specific instance of the first media content from a first broadcast medium,” “a second receiver module configured to receive at least a second media content and uniquely identifying data specific to at least the second media content, the second media content received discretely from the first media content,” and “an output system configured to present concurrently the first media content and the second media content on an output of the first receiver module or the second receiver module.”

With reference to new Claim 20, Applicants respectfully submit that *Manganaris* does not teach or disclose, among other things “obtaining information about a first media content broadcast received by a plurality of user devices,” and “enabling access of at least the secondary media content and the uniquely identifying data to a user device of the plurality of user devices via at least a secondary media content transmission discrete from the first media content broadcast, wherein the secondary media content is configured to be concurrently presented in association with the primary broadcast segment accessible to the user device using the first media content broadcast.”

Therefore, Applicants respectfully submit that Claims 12, 16, and 20 are allowable at least for the reasons set forth above as well as for the additional unique combination of features disclosed therein. The dependant claims of Claim 12, 16, and 20 are allowable for at least the same reasons as discussed above their respective independent claims as well as for the additional unique combination of features disclosed therein.

### **Conclusion**

Applicants respectfully submit that the claims are in condition for allowance. Furthermore, any remarks in support of patentability of one claim should not be imputed to any

**Application No.:** 12/366,535  
**Filing Date:** February 5, 2009

other claim, even if similar terminology is used. Any remarks referring to only a portion of a claim should not be understood to base patentability on that portion or that the limitation discussed is essential or critical; rather, patentability must rest on each claim taken as a whole. Applicants respectfully traverse each of the Examiner's rejections and each of the Examiner's assertions regarding what the prior art shows or teaches, even if not expressly discussed herein.

No Disclaimers or Disavowals

Although the present communication may include alterations to the application or claims, or characterizations of claim scope or referenced art, Applicant is not conceding in this application that previously pending claims are not patentable over the cited references. Rather, any alterations or characterizations are being made to facilitate expeditious prosecution of this application. Applicant reserves the right to pursue at a later date any previously pending or other broader or narrower claims that capture any subject matter supported by the present disclosure, including subject matter found to be specifically disclaimed herein or by any prior prosecution. Accordingly, reviewers of this or any parent, child or related prosecution history shall not reasonably infer that Applicant has made any disclaimers or disavowals of any subject matter supported by the present application.

Please charge any additional fees, including any fees for additional extension of time, or credit overpayment to Deposit Account No. 11-1410.

Respectfully submitted,

KNOBBE, MARTENS, OLSON & BEAR, LLP

Dated: September 30, 2011

By: 

Don C. Pua  
Registration No. 67,028  
Attorney of Record  
Customer No. 20995  
(949) 760-0404



## Electronic Patent Application Fee Transmittal

<b>Application Number:</b>	12366535
<b>Filing Date:</b>	05-Feb-2009
<b>Title of Invention:</b>	SYSTEM AND METHOD FOR ADVERTISEMENT TRANSMISSION AND DISPLAY
<b>First Named Inventor/Applicant Name:</b>	Kelly M. Christensen
<b>Filer:</b>	Don Neil Caceres Pua/Will Nguyen
<b>Attorney Docket Number:</b>	STRATOS.029A

Filed as Small Entity

### Utility under 35 USC 111(a) Filing Fees

Description	Fee Code	Quantity	Amount	Sub-Total in USD(\$)
<b>Basic Filing:</b>				
<b>Pages:</b>				
<b>Claims:</b>				
<b>Miscellaneous-Filing:</b>				
<b>Petition:</b>				
<b>Patent-Appeals-and-Interference:</b>				
<b>Post-Allowance-and-Post-Issuance:</b>				
<b>Extension-of-Time:</b>				
Extension - 3 months with \$0 paid	2253	1		635

Volkswagen Exhibit 1002<sup>635</sup>

Description	Fee Code	Quantity	Amount	Sub-Total in USD(\$)
<b>Miscellaneous:</b>				
<b>Total in USD (\$)</b>				<b>635</b>

## Electronic Acknowledgement Receipt

<b>EFS ID:</b>	11093557
<b>Application Number:</b>	12366535
<b>International Application Number:</b>	
<b>Confirmation Number:</b>	7989
<b>Title of Invention:</b>	SYSTEM AND METHOD FOR ADVERTISEMENT TRANSMISSION AND DISPLAY
<b>First Named Inventor/Applicant Name:</b>	Kelly M. Christensen
<b>Customer Number:</b>	20995
<b>Filer:</b>	Don Neil Caceres Pua/Erica Van Sciver
<b>Filer Authorized By:</b>	Don Neil Caceres Pua
<b>Attorney Docket Number:</b>	STRATOS.029A
<b>Receipt Date:</b>	30-SEP-2011
<b>Filing Date:</b>	05-FEB-2009
<b>Time Stamp:</b>	21:13:49
<b>Application Type:</b>	Utility under 35 USC 111(a)

### Payment information:

Submitted with Payment	yes
Payment Type	Credit Card
Payment was successfully received in RAM	\$635
RAM confirmation Number	9665
Deposit Account	111410
Authorized User	KNOBBE MARTENS OLSON AND BEAR

The Director of the USPTO is hereby authorized to charge indicated fees and credit any overpayment as follows:

Charge any Additional Fees required under 37 C.F.R. Section 1.16 (National application filing, search, and examination fees)

Charge any Additional Fees required under 37 C.F.R. Section 1.17 (Patent application and reexamination processing fees)

Volkswagen Exhibit 1002

<b>File Listing:</b>					
<b>Document Number</b>	<b>Document Description</b>	<b>File Name</b>	<b>File Size(Bytes)/ Message Digest</b>	<b>Multi Part /.zip</b>	<b>Pages (if appl.)</b>
1		STRATOS-029A_RESPONSE.pdf	525065 6d13fc6ad50ec43a5e441fdb62b0c4edd40003d	yes	11
<b>Multipart Description/PDF files in .zip description</b>					
<b>Document Description</b>			<b>Start</b>	<b>End</b>	
Amendment/Req. Reconsideration-After Non-Final Reject			1	1	
Claims			2	7	
Applicant Arguments/Remarks Made in an Amendment			8	11	
<b>Warnings:</b>					
<b>Information:</b>					
2	Fee Worksheet (SB06)	fee-info.pdf	30409 281b6801399a79aefd8b4c4afcb208aa8f3b4456	no	2
<b>Warnings:</b>					
<b>Information:</b>					
<b>Total Files Size (in bytes):</b>			555474		
<p><b>This Acknowledgement Receipt evidences receipt on the noted date by the USPTO of the indicated documents, characterized by the applicant, and including page counts, where applicable. It serves as evidence of receipt similar to a Post Card, as described in MPEP 503.</b></p> <p><b><u>New Applications Under 35 U.S.C. 111</u></b>  If a new application is being filed and the application includes the necessary components for a filing date (see 37 CFR 1.53(b)-(d) and MPEP 506), a Filing Receipt (37 CFR 1.54) will be issued in due course and the date shown on this Acknowledgement Receipt will establish the filing date of the application.</p> <p><b><u>National Stage of an International Application under 35 U.S.C. 371</u></b>  If a timely submission to enter the national stage of an international application is compliant with the conditions of 35 U.S.C. 371 and other applicable requirements a Form PCT/DO/EO/903 indicating acceptance of the application as a national stage submission under 35 U.S.C. 371 will be issued in addition to the Filing Receipt, in due course.</p> <p><b><u>New International Application Filed with the USPTO as a Receiving Office</u></b>  If a new international application is being filed and the international application includes the necessary components for an international filing date (see PCT Article 11 and MPEP 1810), a Notification of the International Application Number and of the International Filing Date (Form PCT/RO/105) will be issued in due course, subject to prescriptions concerning national security, and the date shown on this Acknowledgement Receipt will establish the international filing date of the application.</p>					

Under the Paperwork Reduction Act of 1995, no persons are required to respond to a collection of information unless it displays a valid OMB control number.

<b>PATENT APPLICATION FEE DETERMINATION RECORD</b> Substitute for Form PTO-875	Application or Docket Number <b>12/366,535</b>	Filing Date <b>02/05/2009</b>	<input type="checkbox"/> To be Mailed
---	---	----------------------------------	---------------------------------------

APPLICATION AS FILED – PART I			OTHER THAN SMALL ENTITY				
	(Column 1)	(Column 2)	SMALL ENTITY <input checked="" type="checkbox"/>	OR			
FOR	NUMBER FILED	NUMBER EXTRA	RATE (\$)	FEE (\$)	OR	RATE (\$)	FEE (\$)
<input type="checkbox"/> BASIC FEE <small>(37 CFR 1.16(a), (b), or (c))</small>	N/A	N/A	N/A			N/A	
<input type="checkbox"/> SEARCH FEE <small>(37 CFR 1.16(k), (j), or (m))</small>	N/A	N/A	N/A			N/A	
<input type="checkbox"/> EXAMINATION FEE <small>(37 CFR 1.16(o), (p), or (q))</small>	N/A	N/A	N/A			N/A	
TOTAL CLAIMS <small>(37 CFR 1.16(j))</small>	minus 20 =	*	X \$ =		OR	X \$ =	
INDEPENDENT CLAIMS <small>(37 CFR 1.16(h))</small>	minus 3 =	*	X \$ =			X \$ =	
<input type="checkbox"/> APPLICATION SIZE FEE <small>(37 CFR 1.16(s))</small>	If the specification and drawings exceed 100 sheets of paper, the application size fee due is \$250 (\$125 for small entity) for each additional 50 sheets or fraction thereof. See 35 U.S.C. 41(a)(1)(G) and 37 CFR 1.16(s).						
<input type="checkbox"/> MULTIPLE DEPENDENT CLAIM PRESENT <small>(37 CFR 1.16(j))</small>							
* If the difference in column 1 is less than zero, enter "0" in column 2.			TOTAL			TOTAL	

APPLICATION AS AMENDED – PART II					OTHER THAN SMALL ENTITY				
	(Column 1)	(Column 2)	(Column 3)						
AMENDMENT	<b>09/30/2011</b>	CLAIMS REMAINING AFTER AMENDMENT	HIGHEST NUMBER PREVIOUSLY PAID FOR	PRESENT EXTRA	RATE (\$)	ADDITIONAL FEE (\$)	OR	RATE (\$)	ADDITIONAL FEE (\$)
	Total <small>(37 CFR 1.16(i))</small>	* 20	Minus ** 20	= 0	X \$30 =	0	OR	X \$ =	
	Independent <small>(37 CFR 1.16(h))</small>	* 4	Minus *** 4	= 0	X \$125 =	0	OR	X \$ =	
	<input type="checkbox"/> Application Size Fee <small>(37 CFR 1.16(s))</small>								
	<input type="checkbox"/> FIRST PRESENTATION OF MULTIPLE DEPENDENT CLAIM <small>(37 CFR 1.16(j))</small>						OR		
					TOTAL ADD'L FEE	<b>0</b>	OR	TOTAL ADD'L FEE	

	(Column 1)	(Column 2)	(Column 3)						
AMENDMENT		CLAIMS REMAINING AFTER AMENDMENT	HIGHEST NUMBER PREVIOUSLY PAID FOR	PRESENT EXTRA	RATE (\$)	ADDITIONAL FEE (\$)	OR	RATE (\$)	ADDITIONAL FEE (\$)
	Total <small>(37 CFR 1.16(i))</small>	*	Minus **	=	X \$ =		OR	X \$ =	
	Independent <small>(37 CFR 1.16(h))</small>	*	Minus ***	=	X \$ =		OR	X \$ =	
	<input type="checkbox"/> Application Size Fee <small>(37 CFR 1.16(s))</small>								
	<input type="checkbox"/> FIRST PRESENTATION OF MULTIPLE DEPENDENT CLAIM <small>(37 CFR 1.16(j))</small>						OR		
					TOTAL ADD'L FEE		OR	TOTAL ADD'L FEE	

\* If the entry in column 1 is less than the entry in column 2, write "0" in column 3.  
 \*\* If the "Highest Number Previously Paid For" IN THIS SPACE is less than 20, enter "20".  
 \*\*\* If the "Highest Number Previously Paid For" IN THIS SPACE is less than 3, enter "3".  
 The "Highest Number Previously Paid For" (Total or Independent) is the highest number found in the appropriate box in column 1.

Legal Instrument Examiner:  
/EFREM WARREN/

This collection of information is required by 37 CFR 1.16. The information is required to obtain or retain a benefit by the public which is to file (and by the USPTO to process) an application. Confidentiality is governed by 35 U.S.C. 122 and 37 CFR 1.14. This collection is estimated to take 12 minutes to complete, including gathering, preparing, and submitting the completed application form to the USPTO. Time will vary depending upon the individual case. Any comments on the amount of time you require to complete this form and/or suggestions for reducing this burden, should be sent to the Chief Information Officer, U.S. Patent and Trademark Office, U.S. Department of Commerce, P.O. Box 1450, Alexandria, VA 22313-1450. DO NOT SEND FEES OR COMPLETED FORMS TO THIS ADDRESS. **SEND TO: Commissioner for Patents, P.O. Box 1450, Alexandria, VA 22313-1450.**

If you need assistance in completing the form, call 1-800-PTO-9199 and select option 2.



NOTICE OF ALLOWANCE AND FEE(S) DUE

20995 7590 12/12/2011
KNOBBE MARTENS OLSON & BEAR LLP
2040 MAIN STREET
FOURTEENTH FLOOR
IRVINE, CA 92614

Table with 2 columns: EXAMINER (ORTIZ, BELIX M), ART UNIT (2164), PAPER NUMBER

DATE MAILED: 12/12/2011

Table with 5 columns: APPLICATION NO., FILING DATE, FIRST NAMED INVENTOR, ATTORNEY DOCKET NO., CONFIRMATION NO.

TITLE OF INVENTION: SYSTEM AND METHOD FOR ADVERTISEMENT TRANSMISSION AND DISPLAY

Table with 7 columns: APPLN. TYPE, SMALL ENTITY, ISSUE FEE DUE, PUBLICATION FEE DUE, PREV. PAID ISSUE FEE, TOTAL FEE(S) DUE, DATE DUE

THE APPLICATION IDENTIFIED ABOVE HAS BEEN EXAMINED AND IS ALLOWED FOR ISSUANCE AS A PATENT. PROSECUTION ON THE MERITS IS CLOSED. THIS NOTICE OF ALLOWANCE IS NOT A GRANT OF PATENT RIGHTS. THIS APPLICATION IS SUBJECT TO WITHDRAWAL FROM ISSUE AT THE INITIATIVE OF THE OFFICE OR UPON PETITION BY THE APPLICANT. SEE 37 CFR 1.313 AND MPEP 1308.

THE ISSUE FEE AND PUBLICATION FEE (IF REQUIRED) MUST BE PAID WITHIN THREE MONTHS FROM THE MAILING DATE OF THIS NOTICE OR THIS APPLICATION SHALL BE REGARDED AS ABANDONED. THIS STATUTORY PERIOD CANNOT BE EXTENDED. SEE 35 U.S.C. 151. THE ISSUE FEE DUE INDICATED ABOVE DOES NOT REFLECT A CREDIT FOR ANY PREVIOUSLY PAID ISSUE FEE IN THIS APPLICATION. IF AN ISSUE FEE HAS PREVIOUSLY BEEN PAID IN THIS APPLICATION (AS SHOWN ABOVE), THE RETURN OF PART B OF THIS FORM WILL BE CONSIDERED A REQUEST TO REAPPLY THE PREVIOUSLY PAID ISSUE FEE TOWARD THE ISSUE FEE NOW DUE.

HOW TO REPLY TO THIS NOTICE:

I. Review the SMALL ENTITY status shown above.

If the SMALL ENTITY is shown as YES, verify your current SMALL ENTITY status:

A. If the status is the same, pay the TOTAL FEE(S) DUE shown above.

B. If the status above is to be removed, check box 5b on Part B - Fee(s) Transmittal and pay the PUBLICATION FEE (if required) and twice the amount of the ISSUE FEE shown above, or

If the SMALL ENTITY is shown as NO:

A. Pay TOTAL FEE(S) DUE shown above, or

B. If applicant claimed SMALL ENTITY status before, or is now claiming SMALL ENTITY status, check box 5a on Part B - Fee(s) Transmittal and pay the PUBLICATION FEE (if required) and 1/2 the ISSUE FEE shown above.

II. PART B - FEE(S) TRANSMITTAL, or its equivalent, must be completed and returned to the United States Patent and Trademark Office (USPTO) with your ISSUE FEE and PUBLICATION FEE (if required). If you are charging the fee(s) to your deposit account, section "4b" of Part B - Fee(s) Transmittal should be completed and an extra copy of the form should be submitted. If an equivalent of Part B is filed, a request to reapply a previously paid issue fee must be clearly made, and delays in processing may occur due to the difficulty in recognizing the paper as an equivalent of Part B.

III. All communications regarding this application must give the application number. Please direct all communications prior to issuance to Mail Stop ISSUE FEE unless advised to the contrary.

IMPORTANT REMINDER: Utility patents issuing on applications filed on or after Dec. 12, 1980 may require payment of maintenance fees. It is patentee's responsibility to ensure timely payment of maintenance fees when due.

**PART B - FEE(S) TRANSMITTAL**

**Complete and send this form, together with applicable fee(s), to: Mail Mail Stop ISSUE FEE  
 Commissioner for Patents  
 P.O. Box 1450  
 Alexandria, Virginia 22313-1450  
 or Fax (571)-273-2885**

**INSTRUCTIONS:** This form should be used for transmitting the ISSUE FEE and PUBLICATION FEE (if required). Blocks 1 through 5 should be completed where appropriate. All further correspondence including the Patent, advance orders and notification of maintenance fees will be mailed to the current correspondence address as indicated unless corrected below or directed otherwise in Block 1, by (a) specifying a new correspondence address; and/or (b) indicating a separate "FEE ADDRESS" for maintenance fee notifications.

CURRENT CORRESPONDENCE ADDRESS (Note: Use Block 1 for any change of address)

Note: A certificate of mailing can only be used for domestic mailings of the Fee(s) Transmittal. This certificate cannot be used for any other accompanying papers. Each additional paper, such as an assignment or formal drawing, must have its own certificate of mailing or transmission.

20995                      7590                      12/12/2011  
**KNOBBE MARTENS OLSON & BEAR LLP**  
 2040 MAIN STREET  
 FOURTEENTH FLOOR  
 IRVINE, CA 92614

**Certificate of Mailing or Transmission**

I hereby certify that this Fee(s) Transmittal is being deposited with the United States Postal Service with sufficient postage for first class mail in an envelope addressed to the Mail Stop ISSUE FEE address above, or being facsimile transmitted to the USPTO (571) 273-2885, on the date indicated below.

(Depositor's name)
(Signature)
(Date)

APPLICATION NO.	FILING DATE	FIRST NAMED INVENTOR	ATTORNEY DOCKET NO.	CONFIRMATION NO.
12/366,535	02/05/2009	Kelly M. Christensen	STRATOS.029A	7989

TITLE OF INVENTION: SYSTEM AND METHOD FOR ADVERTISEMENT TRANSMISSION AND DISPLAY

APPLN. TYPE	SMALL ENTITY	ISSUE FEE DUE	PUBLICATION FEE DUE	PREV. PAID ISSUE FEE	TOTAL FEE(S) DUE	DATE DUE
nonprovisional	YES	\$870	\$300	\$0	\$1170	03/12/2012

EXAMINER	ART UNIT	CLASS-SUBCLASS
ORTIZ, BELIX M	2164	707-812000

<p>1. Change of correspondence address or indication of "Fee Address" (37 CFR 1.363).</p> <p><input type="checkbox"/> Change of correspondence address (or Change of Correspondence Address form PTO/SB/122) attached.</p> <p><input type="checkbox"/> "Fee Address" indication (or "Fee Address" Indication form PTO/SB/47; Rev 03-02 or more recent) attached. <b>Use of a Customer Number is required.</b></p>	<p>2. For printing on the patent front page, list</p> <p>(1) the names of up to 3 registered patent attorneys or agents OR, alternatively, 1 _____</p> <p>(2) the name of a single firm (having as a member a registered attorney or agent) and the names of up to 2 registered patent attorneys or agents. If no name is listed, no name will be printed. 2 _____</p> <p>3 _____</p>
---	---

3. ASSIGNEE NAME AND RESIDENCE DATA TO BE PRINTED ON THE PATENT (print or type)

PLEASE NOTE: Unless an assignee is identified below, no assignee data will appear on the patent. If an assignee is identified below, the document has been filed for recordation as set forth in 37 CFR 3.11. Completion of this form is NOT a substitute for filing an assignment.

(A) NAME OF ASSIGNEE \_\_\_\_\_ (B) RESIDENCE: (CITY and STATE OR COUNTRY) \_\_\_\_\_

Please check the appropriate assignee category or categories (will not be printed on the patent) :  Individual  Corporation or other private group entity  Government

<p>4a. The following fee(s) are submitted:</p> <p><input type="checkbox"/> Issue Fee</p> <p><input type="checkbox"/> Publication Fee (No small entity discount permitted)</p> <p><input type="checkbox"/> Advance Order - # of Copies _____</p>	<p>4b. Payment of Fee(s); (Please first reapply any previously paid issue fee shown above)</p> <p><input type="checkbox"/> A check is enclosed.</p> <p><input type="checkbox"/> Payment by credit card. Form PTO-2038 is attached.</p> <p><input type="checkbox"/> The Director is hereby authorized to charge the required fee(s), any deficiency, or credit any overpayment, to Deposit Account Number _____ (enclose an extra copy of this form).</p>
---	--

5. Change in Entity Status (from status indicated above)

a. Applicant claims SMALL ENTITY status. See 37 CFR 1.27.       b. Applicant is no longer claiming SMALL ENTITY status. See 37 CFR 1.27(g)(2).

NOTE: The Issue Fee and Publication Fee (if required) will not be accepted from anyone other than the applicant; a registered attorney or agent; or the assignee or other party in interest as shown by the records of the United States Patent and Trademark Office.

Authorized Signature \_\_\_\_\_ Date \_\_\_\_\_

Typed or printed name \_\_\_\_\_ Registration No. \_\_\_\_\_

This collection of information is required by 37 CFR 1.311. The information is required to obtain or retain a benefit by the public which is to file (and by the USPTO to process) an application. Confidentiality is governed by 35 U.S.C. 122 and 37 CFR 1.14. This collection is estimated to take 12 minutes to complete, including gathering, preparing, and submitting the completed application form to the USPTO. Time will vary depending upon the individual case. Any comments on the amount of time you require to complete this form and/or suggestions for reducing this burden, should be sent to the Chief Information Officer, U.S. Patent and Trademark Office, U.S. Department of Commerce, P.O. Box 1450, Alexandria, Virginia 22313-1450. DO NOT SEND FEES OR COMPLETED FORMS TO THIS ADDRESS. SEND TO: Commissioner for Patents, P.O. Box 1450, Alexandria, Virginia 22313-1450.

Under the Paperwork Reduction Act of 1995, no persons are required to respond to a collection of information unless it displays a valid OMB control number.



UNITED STATES PATENT AND TRADEMARK OFFICE

UNITED STATES DEPARTMENT OF COMMERCE
United States Patent and Trademark Office
Address: COMMISSIONER FOR PATENTS
P.O. Box 1450
Alexandria, Virginia 22313-1450
www.uspto.gov

Table with 5 columns: APPLICATION NO., FILING DATE, FIRST NAMED INVENTOR, ATTORNEY DOCKET NO., CONFIRMATION NO.
12/366,535 02/05/2009 Kelly M. Christensen STRATOS.029A 7989

20995 7590 12/12/2011
KNOBBE MARTENS OLSON & BEAR LLP
2040 MAIN STREET
FOURTEENTH FLOOR
IRVINE, CA 92614

Table with 2 columns: EXAMINER, ART UNIT, PAPER NUMBER
EXAMINER: ORTIZ, BELIX M
ART UNIT: 2164
PAPER NUMBER: (empty)

DATE MAILED: 12/12/2011

Determination of Patent Term Adjustment under 35 U.S.C. 154 (b)
(application filed on or after May 29, 2000)

The Patent Term Adjustment to date is 270 day(s). If the issue fee is paid on the date that is three months after the mailing date of this notice and the patent issues on the Tuesday before the date that is 28 weeks (six and a half months) after the mailing date of this notice, the Patent Term Adjustment will be 270 day(s).

If a Continued Prosecution Application (CPA) was filed in the above-identified application, the filing date that determines Patent Term Adjustment is the filing date of the most recent CPA.

Applicant will be able to obtain more detailed information by accessing the Patent Application Information Retrieval (PAIR) WEB site (http://pair.uspto.gov).

Any questions regarding the Patent Term Extension or Adjustment determination should be directed to the Office of Patent Legal Administration at (571)-272-7702. Questions relating to issue and publication fee payments should be directed to the Customer Service Center of the Office of Patent Publication at 1-(888)-786-0101 or (571)-272-4200.



## Privacy Act Statement

**The Privacy Act of 1974 (P.L. 93-579)** requires that you be given certain information in connection with your submission of the attached form related to a patent application or patent. Accordingly, pursuant to the requirements of the Act, please be advised that: (1) the general authority for the collection of this information is 35 U.S.C. 2(b)(2); (2) furnishing of the information solicited is voluntary; and (3) the principal purpose for which the information is used by the U.S. Patent and Trademark Office is to process and/or examine your submission related to a patent application or patent. If you do not furnish the requested information, the U.S. Patent and Trademark Office may not be able to process and/or examine your submission, which may result in termination of proceedings or abandonment of the application or expiration of the patent.

The information provided by you in this form will be subject to the following routine uses:

1. The information on this form will be treated confidentially to the extent allowed under the Freedom of Information Act (5 U.S.C. 552) and the Privacy Act (5 U.S.C. 552a). Records from this system of records may be disclosed to the Department of Justice to determine whether disclosure of these records is required by the Freedom of Information Act.
2. A record from this system of records may be disclosed, as a routine use, in the course of presenting evidence to a court, magistrate, or administrative tribunal, including disclosures to opposing counsel in the course of settlement negotiations.
3. A record in this system of records may be disclosed, as a routine use, to a Member of Congress submitting a request involving an individual, to whom the record pertains, when the individual has requested assistance from the Member with respect to the subject matter of the record.
4. A record in this system of records may be disclosed, as a routine use, to a contractor of the Agency having need for the information in order to perform a contract. Recipients of information shall be required to comply with the requirements of the Privacy Act of 1974, as amended, pursuant to 5 U.S.C. 552a(m).
5. A record related to an International Application filed under the Patent Cooperation Treaty in this system of records may be disclosed, as a routine use, to the International Bureau of the World Intellectual Property Organization, pursuant to the Patent Cooperation Treaty.
6. A record in this system of records may be disclosed, as a routine use, to another federal agency for purposes of National Security review (35 U.S.C. 181) and for review pursuant to the Atomic Energy Act (42 U.S.C. 218(c)).
7. A record from this system of records may be disclosed, as a routine use, to the Administrator, General Services, or his/her designee, during an inspection of records conducted by GSA as part of that agency's responsibility to recommend improvements in records management practices and programs, under authority of 44 U.S.C. 2904 and 2906. Such disclosure shall be made in accordance with the GSA regulations governing inspection of records for this purpose, and any other relevant (i.e., GSA or Commerce) directive. Such disclosure shall not be used to make determinations about individuals.
8. A record from this system of records may be disclosed, as a routine use, to the public after either publication of the application pursuant to 35 U.S.C. 122(b) or issuance of a patent pursuant to 35 U.S.C. 151. Further, a record may be disclosed, subject to the limitations of 37 CFR 1.14, as a routine use, to the public if the record was filed in an application which became abandoned or in which the proceedings were terminated and which application is referenced by either a published application, an application open to public inspection or an issued patent.
9. A record from this system of records may be disclosed, as a routine use, to a Federal, State, or local law enforcement agency, if the USPTO becomes aware of a violation or potential violation of law or regulation.

**Notice of Allowability**

**Application No.**

12/366,535

**Examiner**

BELIX M. ORTIZ

**Applicant(s)**

CHRISTENSEN ET AL.

**Art Unit**

2164

**-- The MAILING DATE of this communication appears on the cover sheet with the correspondence address--**

All claims being allowable, PROSECUTION ON THE MERITS IS (OR REMAINS) CLOSED in this application. If not included herewith (or previously mailed), a Notice of Allowance (PTOL-85) or other appropriate communication will be mailed in due course. **THIS NOTICE OF ALLOWABILITY IS NOT A GRANT OF PATENT RIGHTS.** This application is subject to withdrawal from issue at the initiative of the Office or upon petition by the applicant. See 37 CFR 1.313 and MPEP 1308.

- 1.  This communication is responsive to 9/30/2011.
- 2.  An election was made by the applicant in response to a restriction requirement set forth during the interview on \_\_\_\_\_; the restriction requirement and election have been incorporated into this action.
- 3.  The allowed claim(s) is/are 1,2,10-18 and 20-28.
- 4.  Acknowledgment is made of a claim for foreign priority under 35 U.S.C. § 119(a)-(d) or (f).
  - a)  All    b)  Some\*    c)  None    of the:
    - 1.  Certified copies of the priority documents have been received.
    - 2.  Certified copies of the priority documents have been received in Application No. \_\_\_\_\_ .
    - 3.  Copies of the certified copies of the priority documents have been received in this national stage application from the International Bureau (PCT Rule 17.2(a)).

\* Certified copies not received: \_\_\_\_\_.

Applicant has THREE MONTHS FROM THE "MAILING DATE" of this communication to file a reply complying with the requirements noted below. Failure to timely comply will result in ABANDONMENT of this application.  
**THIS THREE-MONTH PERIOD IS NOT EXTENDABLE.**

- 5.  A SUBSTITUTE OATH OR DECLARATION must be submitted. Note the attached EXAMINER'S AMENDMENT or NOTICE OF INFORMAL PATENT APPLICATION (PTO-152) which gives reason(s) why the oath or declaration is deficient.
  - 6.  CORRECTED DRAWINGS ( as "replacement sheets") must be submitted.
    - (a)  including changes required by the Notice of Draftsperson's Patent Drawing Review ( PTO-948) attached
      - 1)  hereto or 2)  to Paper No./Mail Date \_\_\_\_\_.
    - (b)  including changes required by the attached Examiner's Amendment / Comment or in the Office action of Paper No./Mail Date \_\_\_\_\_.
- Identifying indicia such as the application number (see 37 CFR 1.84(c)) should be written on the drawings in the front (not the back) of each sheet. Replacement sheet(s) should be labeled as such in the header according to 37 CFR 1.121(d).**
- 7.  DEPOSIT OF and/or INFORMATION about the deposit of BIOLOGICAL MATERIAL must be submitted. Note the attached Examiner's comment regarding REQUIREMENT FOR THE DEPOSIT OF BIOLOGICAL MATERIAL.

**Attachment(s)**

- 1.  Notice of References Cited (PTO-892)
- 2.  Notice of Draftsperson's Patent Drawing Review (PTO-948)
- 3.  Information Disclosure Statements (PTO/SB/08), Paper No./Mail Date \_\_\_\_\_
- 4.  Examiner's Comment Regarding Requirement for Deposit of Biological Material
- 5.  Notice of Informal Patent Application
- 6.  Interview Summary (PTO-413), Paper No./Mail Date \_\_\_\_\_ .
- 7.  Examiner's Amendment/Comment
- 8.  Examiner's Statement of Reasons for Allowance
- 9.  Other \_\_\_\_\_.

## DETAILED ACTION

### EXAMINER'S AMENDMENT

An examiner's amendment to the record appears below. Should the changes and/or additions be unacceptable to applicant, an amendment may be filed as provided by 37 CFR 1.312. To ensure consideration of such an amendment, it MUST be submitted no later than the payment of the issue fee.

The application has been amended as follows:

16. (Currently amended) A system for combining multiple media ~~signals~~ comprising:

a first receiver module configured to receive at least a first media content and data enabling the identification of a specific instance of the first media content from a first broadcast medium;

a second receiver module configured to receive at least a second media signal content and uniquely identifying data specific to at least the second media content, the second media content received discretely from the first media content;

an output system configured to present concurrently the first media content and the second media content on an output of the first receiver module or the second receiver module;

an input module configured to receive at least a response input responsive to the second media content; and

a transmitting module configured to transmit a response message having at least the uniquely identifying data specific to the second media content to a computer server.

***Allowable Subject Matter***

In response to communications files on September 30, 2011, Claims 1-2, 10-13, and 15-18 are amended; claims 3-9 and 19 are cancelled; and claims 20-28 are added per applicant's request. Therefore, claims 1-8 are presently pending in the application.

Claims 1-2, 10-18, and 20-28 are allowed based on Applicant's amended claims filed 9/30/2011.

***Conclusion***

Any inquiry concerning this communication or earlier communications from the examiner should be directed to Belix M. Ortiz whose telephone number is 571-272-4081. The examiner can normally be reached on Monday-Friday 9am-5pm. The fax phone number for the organization where this application or proceeding is assigned is 571-273-8300.

Information regarding the status of an application may be obtained from the Patent Application Information Retrieval (PAIR) system. Status information for published applications may be obtained from either Private PAIR or Public PAIR. Status information for unpublished applications is available through Private PAIR only. For more information about the PAIR system, see <http://pair-direct.uspto.gov>. Should you have questions on access to the Private PAIR system, contact the Electronic Business Center (EBC) at 866-217-9197 (toll-free).

Belix M Ortiz  
Primary Examiner

Application/Control Number: 12/366,535

Page 4


Art Unit: 2164

Art Unit 2164

December 5, 2011

/Belix M. Ortiz/

Examiner, Art Unit 2164

<b>Search Notes</b>  	<b>Application/Control No.</b>  12366535	<b>Applicant(s)/Patent Under Reexamination</b>  CHRISTENSEN ET AL.
	<b>Examiner</b>  BELIX M ORTIZ	<b>Art Unit</b>  2164

SEARCHED			
Class	Subclass	Date	Examiner
707	737, 812, using keyword search	3/26/11	bmo
455	using keyword search	3/26/11	bmo

SEARCH NOTES		
Search Notes	Date	Examiner
Searched: East, JPO, EPO, USPAT, USPG-PUB, DERWENT, IBM_TDB	3/26/11	bmo
Inventors search on East and Edan	3/26/11	bmo
Keyword and Class search	3/26/11	bmo
Search strategies are enclosed	3/26/11	bmo
Updated search on East and edan	12/5/2011	bmo

INTERFERENCE SEARCH			
Class	Subclass	Date	Examiner
707	737, 812	12/5/2011	bmo
455	3.06	12/5/2011	bmo


--	--


**UNITED STATES PATENT AND TRADEMARK OFFICE**

UNITED STATES DEPARTMENT OF COMMERCE  
**United States Patent and Trademark Office**  
 Address: COMMISSIONER FOR PATENTS  
 P.O. Box 1450  
 Alexandria, Virginia 22313-1450  
 www.uspto.gov

**BIB DATA SHEET**
**CONFIRMATION NO. 7989**

SERIAL NUMBER	FILING or 371(c) DATE	CLASS	GROUP ART UNIT	ATTORNEY DOCKET NO.		
12/366,535	02/05/2009	707	2164	STRATOS.029A		
<b>APPLICANTS</b> Kelly M. Christensen, Marina Del Rey, CA; John Phillip Hansen, Austin, TX; Thomas Daniel Mock, Sheffield, PA;						
** CONTINUING DATA ***** This appln claims benefit of 61/026,449 02/05/2008						
** FOREIGN APPLICATIONS *****						
** IF REQUIRED, FOREIGN FILING LICENSE GRANTED ** ** SMALL ENTITY ** 02/17/2009						
Foreign Priority claimed 35 USC 119(a-d) conditions met Verified and Acknowledged	<input type="checkbox"/> Yes <input checked="" type="checkbox"/> No  <input type="checkbox"/> Yes <input checked="" type="checkbox"/> No  /BELIX M ORTIZ/ Examiner's Signature	<input type="checkbox"/> Met after Allowance bmo Initials	<b>STATE OR COUNTRY</b>  CA	<b>SHEETS DRAWINGS</b>  14	<b>TOTAL CLAIMS</b>  19	<b>INDEPENDENT CLAIMS</b>  4
<b>ADDRESS</b>  KNOBBE MARTENS OLSON & BEAR LLP 2040 MAIN STREET FOURTEENTH FLOOR IRVINE, CA 92614 UNITED STATES						
<b>TITLE</b>  SYSTEM AND METHOD FOR ADVERTISEMENT TRANSMISSION AND DISPLAY						
<b>FILING FEE RECEIVED</b>  637	FEES: Authority has been given in Paper No. _____ to charge/credit DEPOSIT ACCOUNT No. _____ for following:		<input type="checkbox"/> All Fees <input type="checkbox"/> 1.16 Fees (Filing) <input type="checkbox"/> 1.17 Fees (Processing Ext. of time) <input type="checkbox"/> 1.18 Fees (Issue) <input type="checkbox"/> Other _____ <input type="checkbox"/> Credit			

<b>Index of Claims</b>  	<b>Application/Control No.</b>  12366535	<b>Applicant(s)/Patent Under Reexamination</b>  CHRISTENSEN ET AL.
	<b>Examiner</b>  BELIX M ORTIZ	<b>Art Unit</b>  2164

✓	<b>Rejected</b>
=	<b>Allowed</b>

-	<b>Cancelled</b>
÷	<b>Restricted</b>


N	<b>Non-Elected</b>
I	<b>Interference</b>

A	<b>Appeal</b>
O	<b>Objected</b>

Claims renumbered in the same order as presented by applicant
  CPA
  T.D.
  R.1.47

CLAIM		DATE							
Final	Original	03/26/2011	12/05/2011						
1	1	✓	=						
2	2	✓	=						
	3	✓	-						
	4	✓	-						
	5	✓	-						
	6	✓	-						
	7	✓	-						
	8	✓	-						
	9	✓	-						
3	10	✓	=						
4	11	✓	=						
5	12	✓	=						
6	13	✓	=						
7	14	✓	=						
8	15	✓	=						
9	16	✓	=						
10	17	✓	=						
11	18	✓	=						
	19	✓	-						
12	20		=						
13	21		=						
14	22		=						
15	23		=						
16	24		=						
17	25		=						
18	26		=						
19	27		=						
20	28		=						



<b>Issue Classification</b> 	<b>Application/Control No.</b> 12366535	<b>Applicant(s)/Patent Under Reexamination</b> CHRISTENSEN ET AL.
	<b>Examiner</b> BELIX M ORTIZ	<b>Art Unit</b> 2164

ORIGINAL					INTERNATIONAL CLASSIFICATION														
CLASS		SUBCLASS			CLAIMED					NON-CLAIMED									
707		812			G	0	6	F	17 / 00 (2006.01.01)										
<b>CROSS REFERENCE(S)</b>																			
CLASS	SUBCLASS (ONE SUBCLASS PER BLOCK)																		
707	737																		
455	3.06																		

<input type="checkbox"/> Claims renumbered in the same order as presented by applicant																<input type="checkbox"/> CPA		<input type="checkbox"/> T.D.		<input type="checkbox"/> R.1.47	
Final	Original	Final	Original	Final	Original	Final	Original	Final	Original	Final	Original	Final	Original	Final	Original						
1	1	10	17																		
2	2	11	18																		
	3		19																		
	4	12	20																		
	5	13	21																		
	6	14	22																		
	7	15	23																		
	8	16	24																		
	9	17	25																		
3	10	18	26																		
4	11	19	27																		
5	12	20	28																		
6	13																				
7	14																				
8	15																				
9	16																				

NONE		<b>Total Claims Allowed:</b>	
		20	
(Assistant Examiner)	(Date)	O.G. Print Claim(s)	O.G. Print Figure
/BELIX M ORTIZ/ Primary Examiner. Art Unit 2164	12/5/2011	1	7
(Primary Examiner)	(Date)		

<b>INFORMATION DISCLOSURE STATEMENT BY APPLICANT</b>	Application No.	12/366535
	Filing Date	February 5, 2009
	First Named Inventor	Kelly M. Christensen
	Art Unit	2164
<i>(Multiple sheets used when necessary)</i>	Examiner	Ortiz, Belix M *
SHEET 1 OF 1	Attorney Docket No.	STRATOS.029A

<b>U.S. PATENT DOCUMENTS</b>					
Examiner Initials	Cite No.	Document Number Number - Kind Code (if known) Example: 1,234,567 B1	Publication Date MM-DD-YYYY	Name of Patentee or Applicant	Pages, Columns, Lines Where Relevant Passages or Relevant Figures Appear
	1	5,903,617	05-11-1999	Kamalski	
	2	6,701,355	03-02-2004	Brandt et al.	
	3	7,917,130	03-29-2011	Christensen et al.	
	4	2003/0208756	11-06-2003	Macrae et al.	
	5	2005/0071223	03-31-2005	Jain et al.	
	6	2007/0088852	04-19-2007	Levkovitz	
	7	2007/0156457	07-05-2007	Brown	
	8	2008/0263673	10-23-2008	Brun et al.	
	9	2009/0192916	07-30-2009	Casper	

<b>NON PATENT LITERATURE DOCUMENTS</b>			
Examiner Initials	Cite No.	Include name of the author (in CAPITAL LETTERS), title of the article (when appropriate), title of the item (book, magazine, journal, serial, symposium, catalog, etc.), date, page(s), volume-issue number(s), publisher, city and/or country where published.	T <sup>1</sup>
	10	International Search Report and Written Opinion for Application No. PCT/US2009/033249 mailed June 23, 2009.	

12475364

Examiner Signature	Date Considered
*Examiner: Initial if reference considered, whether or not citation is in conformance with MPEP 609. Draw line through citation if not in conformance and not considered. Include copy of this form with next communication to applicant.	

T<sup>1</sup> - Place a check mark in this area when an English language Translation is attached.

Volkswagen Exhibit 1002

PATENT COOPERATION TREATY

From the INTERNATIONAL SEARCHING AUTHORITY

PCT

To:  
 KNOBBE, MARTENS, OLSON & BEAR, LLP  
 Attn. Altman, Daniel, E.  
 2040 Main Street 14th Floor  
 Irvine, CA 92614  
 ETATS-UNIS D'AMERIQUE

NOTIFICATION OF TRANSMITTAL OF  
 THE INTERNATIONAL SEARCH REPORT AND  
 THE WRITTEN OPINION OF THE INTERNATIONAL  
 SEARCHING AUTHORITY, OR THE DECLARATION

(PCT Rule 44.1)

Date of mailing  
 (day/month/year) 23/06/2009

Applicant's or agent's file reference  
 STRATOS.029V

**FOR FURTHER ACTION** See paragraphs 1 and 4 below

International application No.  
 PCT/US2009/033249

International filing date  
 (day/month/year) 05/02/2009

Applicant  
 STRATOSAUDIO, INC.

1.  The applicant is hereby notified that the international search report and the written opinion of the International Searching Authority have been established and are transmitted herewith.

**Filing of amendments and statement under Article 19:**

The applicant is entitled, if he so wishes, to amend the claims of the International Application (see Rule 46):

**When?** The time limit for filing such amendments is normally two months from the date of transmittal of the International Search Report.

**Where?** Directly to the International Bureau of WIPO, 34 chemin des Colombettes  
 1211 Geneva 20, Switzerland, Facsimile No.: (41-22) 338.82.70

**For more detailed instructions,** see the notes on the accompanying sheet.

2.  The applicant is hereby notified that no International search report will be established and that the declaration under Article 17(2)(a) to that effect and the written opinion of the International Searching Authority are transmitted herewith.

3.  **With regard to the protest** against payment of (an) additional fee(s) under Rule 40.2, the applicant is notified that:

the protest together with the decision thereon has been transmitted to the International Bureau together with the applicant's request to forward the texts of both the protest and the decision thereon to the designated Offices.

no decision has been made yet on the protest; the applicant will be notified as soon as a decision is made.

**4. Reminders**

Shortly after the expiration of **18 months** from the priority date, the international application will be published by the International Bureau. If the applicant wishes to avoid or postpone publication, a notice of withdrawal of the international application, or of the priority claim, must reach the International Bureau as provided in Rules 90bis.1 and 90bis.3, respectively, before the completion of the technical preparations for international publication.

The applicant may submit comments on an informal basis on the written opinion of the International Searching Authority to the International Bureau. The International Bureau will send a copy of such comments to all designated Offices unless an international preliminary examination report has been or is to be established. These comments would also be made available to the public but not before the expiration of 30 months from the priority date.

Within **19 months** from the priority date, but only in respect of some designated Offices, a demand for international preliminary examination must be filed if the applicant wishes to postpone the entry into the national phase **until 30 months** from the priority date (in some Offices even later); otherwise, the applicant must, **within 20 months** from the priority date, perform the prescribed acts for entry into the national phase before those designated Offices.

In respect of other designated Offices, the time limit of **30 months** (or later) will apply even if no demand is filed within 19 months.

See the Annex to Form PCT/IB/301 and, for details about the applicable time limits, Office by Office, see the *PCT Applicant's Guide*, Volume II, National Chapters and the WIPO Internet site.

Name and mailing address of the International Searching Authority



European Patent Office, P.B. 5818 Patentlaan 2  
 NL-2280 HV Rijswijk  
 Tel. (+31-70) 340-2040, Tx. 31 651 epo nl,  
 Fax: (+31-70) 340-3016

Authorized officer

Anita Rothenbücher

## NOTES TO FORM PCT/ISA/220

These Notes are intended to give the basic instructions concerning the filing of amendments under article 19. The Notes are based on the requirements of the Patent Cooperation Treaty, the Regulations and the Administrative Instructions under that Treaty. In case of discrepancy between these Notes and those requirements, the latter are applicable. For more detailed information, see also the *PCT Applicant's Guide*, a publication of WIPO.

In these Notes, "Article", "Rule", and "Section" refer to the provisions of the PCT, the PCT Regulations and the PCT Administrative Instructions, respectively.

### INSTRUCTIONS CONCERNING AMENDMENTS UNDER ARTICLE 19

The applicant has, after having received the international search report and the written opinion of the International Searching Authority, one opportunity to amend the claims of the international application. It should however be emphasized that, since all parts of the international application (claims, description and drawings) may be amended during the international preliminary examination procedure, there is usually no need to file amendments of the claims under Article 19 except where, e.g. the applicant wants the latter to be published for the purposes of provisional protection or has another reason for amending the claims before international publication. Furthermore, it should be emphasized that provisional protection is available in some States only (see *PCT Applicant's Guide*, Volume I/A, Annexes B1 and B2).

The attention of the applicant is drawn to the fact that amendments to the claims under Article 19 are not allowed where the International Searching Authority has declared, under Article 17(2), that no international search report would be established (see *PCT Applicant's Guide*, Volume I/A, paragraph 296).

#### What parts of the international application may be amended?

Under Article 19, only the claims may be amended.

During the international phase, the claims may also be amended (or further amended) under Article 34 before the International Preliminary Examining Authority. The description and drawings may only be amended under Article 34 before the International Examining Authority.

Upon entry into the national phase, all parts of the international application may be amended under Article 28 or, where applicable, Article 41.

#### When?

Within 2 months from the date of transmittal of the international search report or 16 months from the priority date, whichever time limit expires later. It should be noted, however, that the amendments will be considered as having been received on time if they are received by the International Bureau after the expiration of the applicable time limit but before the completion of the technical preparations for international publication (Rule 46.1).

#### Where not to file the amendments?

The amendments may only be filed with the International Bureau and not with the receiving Office or the International Searching Authority (Rule 46.2).

Where a demand for international preliminary examination has been/is filed, see below.

#### How?

Either by cancelling one or more entire claims, by adding one or more new claims or by amending the text of one or more of the claims as filed.

A replacement sheet must be submitted for each sheet of the claims which, on account of an amendment or amendments, differs from the sheet originally filed.

All the claims appearing on a replacement sheet must be numbered in Arabic numerals. Where a claim is cancelled, no renumbering of the other claims is required. In all cases where claims are renumbered, they must be renumbered consecutively (Section 205(b)).

**The amendments must be made in the language in which the international application is to be published.**

#### What documents must/may accompany the amendments?

##### Letter (Section 205(b)):

The amendments must be submitted with a letter.

The letter will not be published with the international application and the amended claims. It should not be confused with the "Statement under Article 19(1)" (see below, under "Statement under Article 19(1)").

**The letter must be in English or French, at the choice of the applicant. However, if the language of the international application is English, the letter must be in English; if the language of the international application is French, the letter must be in French.**

## NOTES TO FORM PCT/ISA/220 (continued)

The letter must indicate the differences between the claims as filed and the claims as amended. It must, in particular, indicate, in connection with each claim appearing in the international application (it being understood that identical indications concerning several claims may be grouped), whether

- (i) the claim is unchanged;
- (ii) the claim is cancelled;
- (iii) the claim is new;
- (iv) the claim replaces one or more claims as filed;
- (v) the claim is the result of the division of a claim as filed.

**The following examples illustrate the manner in which amendments must be explained in the accompanying letter:**

1. [Where originally there were 48 claims and after amendment of some claims there are 51]:  
"Claims 1 to 29, 31, 32, 34, 35, 37 to 48 replaced by amended claims bearing the same numbers; claims 30, 33 and 36 unchanged; new claims 49 to 51 added."
2. [Where originally there were 15 claims and after amendment of all claims there are 11]:  
"Claims 1 to 15 replaced by amended claims 1 to 11."
3. [Where originally there were 14 claims and the amendments consist in cancelling some claims and in adding new claims]:  
"Claims 1 to 6 and 14 unchanged; claims 7 to 13 cancelled; new claims 15, 16 and 17 added." or  
"Claims 7 to 13 cancelled; new claims 15, 16 and 17 added; all other claims unchanged."
4. [Where various kinds of amendments are made]:  
"Claims 1-10 unchanged; claims 11 to 13, 18 and 19 cancelled; claims 14, 15 and 16 replaced by amended claim 14; claim 17 subdivided into amended claims 15, 16 and 17; new claims 20 and 21 added."

### "Statement under article 19(1)" (Rule 46.4)

The amendments may be accompanied by a statement explaining the amendments and indicating any impact that such amendments might have on the description and the drawings (which cannot be amended under Article 19(1)).

The statement will be published with the international application and the amended claims.

**It must be in the language in which the international application is to be published.**

It must be brief, not exceeding 500 words if in English or if translated into English.

It should not be confused with and does not replace the letter indicating the differences between the claims as filed and as amended. It must be filed on a separate sheet and must be identified as such by a heading, preferably by using the words "Statement under Article 19(1)."

It may not contain any disparaging comments on the international search report or the relevance of citations contained in that report. Reference to citations, relevant to a given claim, contained in the international search report may be made only in connection with an amendment of that claim.

### **Consequence if a demand for international preliminary examination has already been filed**

If, at the time of filing any amendments and any accompanying statement, under Article 19, a demand for international preliminary examination has already been submitted, the applicant must preferably, at the time of filing the amendments (and any statement) with the International Bureau, also file with the International Preliminary Examining Authority a copy of such amendments (and of any statement) and, where required, a translation of such amendments for the procedure before that Authority (see Rules 55.3(a) and 62.2, first sentence). For further information, see the Notes to the demand form (PCT/PEA/401).

If a demand for international preliminary examination is made, the written opinion of the International Searching Authority will, except in certain cases where the International Preliminary Examining Authority did not act as International Searching Authority and where it has notified the International Bureau under Rule 66.1 bis(b), be considered to be a written opinion of the International Preliminary Examining Authority. If a demand is made, the applicant may submit to the International Preliminary Examining Authority a reply to the written opinion together, where appropriate, with amendments before the expiration of 3 months from the date of mailing of Form PCT/ISA/220 or before the expiration of 22 months from the priority date, whichever expires later (Rule 43 bis(c)).

### **Consequence with regard to translation of the international application for entry into the national phase**

The applicant's attention is drawn to the fact that, upon entry into the national phase, a translation of the claims as amended under Article 19 may have to be furnished to the designated/elected Offices, instead of, or in addition to, the translation of the claims as filed.

For further details on the requirements of each designated/elected Office, see the *PCT Applicant's Guide*, Volume II.

PATENT COOPERATION TREATY

PCT

INTERNATIONAL SEARCH REPORT

(PCT Article 18 and Rules 43 and 44)

Applicant's or agent's file reference <b>STRATOS.029V</b>	<b>FOR FURTHER ACTION</b> see Form PCT/ISA/220 as well as, where applicable, item 5 below.	
International application No. <b>PCT/US2009/033249</b>	International filing date (day/month/year) <b>05/02/2009</b>	(Earliest) Priority Date (day/month/year) <b>05/02/2008</b>
Applicant <b>STRATOSAUDIO, INC.</b>		

This international search report has been prepared by this International Searching Authority and is transmitted to the applicant according to Article 18. A copy is being transmitted to the International Bureau.

This international search report consists of a total of 3 sheets.

It is also accompanied by a copy of each prior art document cited in this report.

1. **Basis of the report**

a. With regard to the **language**, the international search was carried out on the basis of:

the international application in the language in which it was filed

a translation of the international application into \_\_\_\_\_, which is the language of a translation furnished for the purposes of international search (Rules 12.3(a) and 23.1(b))

b.  This international search report has been established taking into account the **rectification of an obvious mistake** authorized by or notified to this Authority under Rule 91 (Rule 43.6bis(a)).

c.  With regard to any **nucleotide and/or amino acid sequence** disclosed in the international application, see Box No. I.

2.  **Certain claims were found unsearchable** (See Box No. II)

3.  **Unity of invention is lacking** (see Box No III)

4. With regard to the **title**,

the text is approved as submitted by the applicant

the text has been established by this Authority to read as follows:

5. With regard to the **abstract**,

the text is approved as submitted by the applicant

the text has been established, according to Rule 38.2(b), by this Authority as it appears in Box No. IV. The applicant may, within one month from the date of mailing of this international search report, submit comments to this Authority

6. With regard to the **drawings**,

a. the figure of the **drawings** to be published with the abstract is Figure No. 5

as suggested by the applicant

as selected by this Authority, because the applicant failed to suggest a figure

as selected by this Authority, because this figure better characterizes the invention

b.  none of the figures is to be published with the abstract

INTERNATIONAL SEARCH REPORT

International application No  
PCT/US2009/033249

<b>A. CLASSIFICATION OF SUBJECT MATTER</b> INV. H04L29/06		
According to International Patent Classification (IPC) or to both national classification and IPC		
<b>B. FIELDS SEARCHED</b>		
Minimum documentation searched (classification system followed by classification symbols) H04L G06Q		
Documentation searched other than minimum documentation to the extent that such documents are included in the fields searched		
Electronic data base consulted during the international search (name of data base and, where practical, search terms used) EPO-Internal, WPI Data, PAJ		
<b>C. DOCUMENTS CONSIDERED TO BE RELEVANT</b>		
Category*	Citation of document, with indication, where appropriate, of the relevant passages	Relevant to claim No.
X	US 7 299 194 B1 (MANGANARIS STEFANOS [US] ET AL) 20 November 2007 (2007-11-20) abstract figures 1-3 column 3, line 30 - column 3, line 67 column 4, line 63 - column 5, line 41 column 5, line 63 - column 6, line 9	1-19
A	WO 2006/122028 A (ROOT MARKETS INC [US]; GOLDSTEIN SETH [US]; HERSHBERG PETER [US]; STYL) 16 November 2006 (2006-11-16) the whole document	1-19
<input type="checkbox"/> Further documents are listed in the continuation of Box C. <input checked="" type="checkbox"/> See patent family annex.		
* Special categories of cited documents :		
*A* document defining the general state of the art which is not considered to be of particular relevance *E* earlier document but published on or after the international filing date *L* document which may throw doubts on priority claim(s) or which is cited to establish the publication date of another citation or other special reason (as specified) *O* document referring to an oral disclosure, use, exhibition or other means *P* document published prior to the international filing date but later than the priority date claimed *T* later document published after the international filing date or priority date and not in conflict with the application but cited to understand the principle or theory underlying the invention *X* document of particular relevance; the claimed invention cannot be considered novel or cannot be considered to involve an inventive step when the document is taken alone *Y* document of particular relevance; the claimed invention cannot be considered to involve an inventive step when the document is combined with one or more other such documents, such combination being obvious to a person skilled in the art. *&* document member of the same patent family		
Date of the actual completion of the international search  16 June 2009		Date of mailing of the international search report  23/06/2009
Name and mailing address of the ISA/ European Patent Office, P.B. 5818 Patentlaan 2 NL - 2280 HV Rijswijk Tel. (+31-70) 340-2040, Fax: (+31-70) 340-3016		Authorized officer  Pereira, Mafalda

# INTERNATIONAL SEARCH REPORT

Information on patent family members

International application No

PCT/US2009/033249

Patent document cited in search report	Publication date	Patent family member(s)	Publication date
US 7299194	B1	20-11-2007	AU 782052 B2 30-06-2005
			AU 7196900 A 23-08-2001
			CA 2334300 A1 22-08-2001
			CN 1310414 A 29-08-2001
			JP 2001243334 A 07-09-2001
			US 2008154701 A1 26-06-2008
WO 2006122028	A	16-11-2006	US 2007219896 A1 20-09-2007



# PATENT COOPERATION TREATY

From the  
INTERNATIONAL SEARCHING AUTHORITY

## PCT

To:

see form PCT/ISA/220

**WRITTEN OPINION OF THE  
INTERNATIONAL SEARCHING AUTHORITY  
(PCT Rule 43bis.1)**

Date of mailing  
(day/month/year) see form PCT/ISA/210 (second sheet)

Applicant's or agent's file reference  
see form PCT/ISA/220

**FOR FURTHER ACTION**  
See paragraph 2 below

International application No.  
PCT/US2009/033249

International filing date (day/month/year)  
05.02.2009

Priority date (day/month/year)  
05.02.2008

International Patent Classification (IPC) or both national classification and IPC  
INV. H04L29/06

Applicant  
STRATOSAUDIO, INC.


1. This opinion contains indications relating to the following items:
  - Box No. I Basis of the opinion
  - Box No. II Priority
  - Box No. III Non-establishment of opinion with regard to novelty, inventive step and industrial applicability
  - Box No. IV Lack of unity of invention
  - Box No. V Reasoned statement under Rule 43bis.1(a)(i) with regard to novelty, inventive step or industrial applicability; citations and explanations supporting such statement
  - Box No. VI Certain documents cited
  - Box No. VII Certain defects in the international application
  - Box No. VIII Certain observations on the international application
  
2. **FURTHER ACTION**

If a demand for international preliminary examination is made, this opinion will usually be considered to be a written opinion of the International Preliminary Examining Authority ("IPEA") except that this does not apply where the applicant chooses an Authority other than this one to be the IPEA and the chosen IPEA has notified the International Bureau under Rule 66.1bis(b) that written opinions of this International Searching Authority will not be so considered.

If this opinion is, as provided above, considered to be a written opinion of the IPEA, the applicant is invited to submit to the IPEA a written reply together, where appropriate, with amendments, before the expiration of 3 months from the date of mailing of Form PCT/ISA/220 or before the expiration of 22 months from the priority date, whichever expires later.

For further options, see Form PCT/ISA/220.
  
3. For further details, see notes to Form PCT/ISA/220.

Name and mailing address of the ISA:



European Patent Office  
P.B. 5818 Patentlaan 2  
NL-2280 HV Rijswijk - Pays Bas  
Tel. +31 70 340 - 2040  
Fax: +31 70 340 - 3016


Date of completion of this opinion

see form  
PCT/ISA/210

Authorized Officer

Pereira, Mafalda

Telephone No. +31 70 340-4322



---

**Box No. 1 Basis of the opinion**

---

1. With regard to the **language**, this opinion has been established on the basis of:
  - the international application in the language in which it was filed
  - a translation of the international application into , which is the language of a translation furnished for the purposes of international search (Rules 12.3(a) and 23.1 (b)).
2.  This opinion has been established taking into account the **rectification of an obvious mistake** authorized by or notified to this Authority under Rule 91 (Rule 43bis.1(a))
3. With regard to any **nucleotide and/or amino acid sequence** disclosed in the international application and necessary to the claimed invention, this opinion has been established on the basis of:
  - a. type of material:
    - a sequence listing
    - table(s) related to the sequence listing
  - b. format of material:
    - on paper
    - in electronic form
  - c. time of filing/furnishing:
    - contained in the international application as filed.
    - filed together with the international application in electronic form.
    - furnished subsequently to this Authority for the purposes of search.
4.  In addition, in the case that more than one version or copy of a sequence listing and/or table relating thereto has been filed or furnished, the required statements that the information in the subsequent or additional copies is identical to that in the application as filed or does not go beyond the application as filed, as appropriate, were furnished.
5. Additional comments:

---

**Box No. V Reasoned statement under Rule 43bis.1(a)(i) with regard to novelty, inventive step or industrial applicability; citations and explanations supporting such statement**

---

1. Statement

Novelty (N)	Yes: Claims	
	No: Claims	<u>1-19</u>
Inventive step (IS)	Yes: Claims	
	No: Claims	<u>1-19</u>
Industrial applicability (IA)	Yes: Claims	<u>1-19</u>
	No: Claims	

2. Citations and explanations

see separate sheet

**Re Item V.**

1 The present application does not meet the criteria of Article 33(1) PCT, because the subject-matter of each of the independent claims 1, 12, 16 and 19 is not new in the sense of Article 33(2) PCT.

1.1 Reference is made to the following document:

D1 : US 7 299 194 B1 (MANGANARIS STEFANOS [US] ET AL) 20 November 2007 (2007-11-20)

1.2 Document D1 discloses, in terms of the wording of claim 1, a method for associating multiple media signals, comprising:  
obtaining information about a first media signal (D1: column 3 line 30 to 67 in particular "sales data concerning items sold in retails");  
analysing the information about the first media signal (D1: column 3 line 30 to 67 and column 5 lines 10 to 18);  
selecting at least one second media signal to be correlated with the first media signal based on at least one criteria (D1 column 4 line 63 to column 5 line 18);  
assigning a unique identifier that is specific to the transmission of the selected second media signal, wherein at least the unique identifier is stored in a database (D1: column 5 line lines 19 to 23 and column 5 line 63 to column 6 line 9);  
transmitting at least the second media signal and the unique identifier to a user device, wherein the user device outputs the first media signal and the second media signal to a user (column 5 line 63 to column 6 line 9);  
receiving a user response from the user in relation to the second media signal wherein the user response includes at least the unique identifier; and correlating at least the unique identifier in the database (D1: column 5 line lines 19 to 23 and column 5 line 63 to column 6 line 9).

Therefore the subject-matter of claim 1 is not new in the sense of Article 33(2) PCT.

1.3 Analogously to claim 1, the subject-matter of each of the independent claims 12, 16 and 19 is also not new in the sense of Article 33(2) PCT.

2 Dependent claims 2-11, 13-15, 17, 18 do not contain any features which, in

combination with the features of any claim to which they refer, meet the requirements of the PCT in respect of novelty or inventive step. See passages cited on the Search Report.

## Electronic Patent Application Fee Transmittal

<b>Application Number:</b>	12366535
<b>Filing Date:</b>	05-Feb-2009
<b>Title of Invention:</b>	SYSTEM AND METHOD FOR ADVERTISEMENT TRANSMISSION AND DISPLAY
<b>First Named Inventor/Applicant Name:</b>	Kelly M. Christensen
<b>Filer:</b>	Don Neil Caceres Pua/Will Nguyen
<b>Attorney Docket Number:</b>	STRATOS.029A

Filed as Small Entity

### Utility under 35 USC 111(a) Filing Fees

Description	Fee Code	Quantity	Amount	Sub-Total in USD(\$)
<b>Basic Filing:</b>				
<b>Pages:</b>				
<b>Claims:</b>				
<b>Miscellaneous-Filing:</b>				
<b>Petition:</b>				
<b>Patent-Appeals-and-Interference:</b>				
<b>Post-Allowance-and-Post-Issuance:</b>				
<b>Extension-of-Time:</b>				

Description	Fee Code	Quantity	Amount	Sub-Total in USD(\$)
<b>Miscellaneous:</b>				
Submission- Information Disclosure Stmt	1806	1	180	180
<b>Total in USD (\$)</b>				<b>180</b>

## Electronic Acknowledgement Receipt

<b>EFS ID:</b>	11682374
<b>Application Number:</b>	12366535
<b>International Application Number:</b>	
<b>Confirmation Number:</b>	7989
<b>Title of Invention:</b>	SYSTEM AND METHOD FOR ADVERTISEMENT TRANSMISSION AND DISPLAY
<b>First Named Inventor/Applicant Name:</b>	Kelly M. Christensen
<b>Customer Number:</b>	20995
<b>Filer:</b>	Don Neil Caceres Pua/Jessica Egigian
<b>Filer Authorized By:</b>	Don Neil Caceres Pua
<b>Attorney Docket Number:</b>	STRATOS.029A
<b>Receipt Date:</b>	21-DEC-2011
<b>Filing Date:</b>	05-FEB-2009
<b>Time Stamp:</b>	19:02:41
<b>Application Type:</b>	Utility under 35 USC 111(a)

### Payment information:

Submitted with Payment	yes
Payment Type	Credit Card
Payment was successfully received in RAM	\$180
RAM confirmation Number	8592
Deposit Account	111410
Authorized User	KNOBBE MARTENS OLSON AND BEAR

The Director of the USPTO is hereby authorized to charge indicated fees and credit any overpayment as follows:

Charge any Additional Fees required under 37 C.F.R. Section 1.16 (National application filing, search, and examination fees)

Charge any Additional Fees required under 37 C.F.R. Section 1.17 (Patent application and reexamination processing fees)

Volkswagen Exhibit 1002



<b>File Listing:</b>					
<b>Document Number</b>	<b>Document Description</b>	<b>File Name</b>	<b>File Size(Bytes)/ Message Digest</b>	<b>Multi Part /.zip</b>	<b>Pages (if appl.)</b>
1		STRATOS-029A_IDS.pdf	88484 02cfc5042b9bdb990a8688e32fe01ff36f1cda8	yes	3
<b>Multipart Description/PDF files in .zip description</b>					
<b>Document Description</b>			<b>Start</b>	<b>End</b>	
Transmittal Letter			1	2	
Information Disclosure Statement (IDS) Form (SB08)			3	3	
<b>Warnings:</b>					
<b>Information:</b>					
2	Non Patent Literature	ISR29A.pdf	787784 0d2029ed3ec0726487c8171469a3220156e82dda	no	11
<b>Warnings:</b>					
<b>Information:</b>					
3	Fee Worksheet (SB06)	fee-info.pdf	30306 d8525f4ab18d77913bea280bab2457c4f39185aa	no	2
<b>Warnings:</b>					
<b>Information:</b>					
<b>Total Files Size (in bytes):</b>			906574		
<p><b>This Acknowledgement Receipt evidences receipt on the noted date by the USPTO of the indicated documents, characterized by the applicant, and including page counts, where applicable. It serves as evidence of receipt similar to a Post Card, as described in MPEP 503.</b></p> <p><b><u>New Applications Under 35 U.S.C. 111</u></b>  <b>If a new application is being filed and the application includes the necessary components for a filing date (see 37 CFR 1.53(b)-(d) and MPEP 506), a Filing Receipt (37 CFR 1.54) will be issued in due course and the date shown on this Acknowledgement Receipt will establish the filing date of the application.</b></p> <p><b><u>National Stage of an International Application under 35 U.S.C. 371</u></b>  <b>If a timely submission to enter the national stage of an international application is compliant with the conditions of 35 U.S.C. 371 and other applicable requirements a Form PCT/DO/EO/903 indicating acceptance of the application as a national stage submission under 35 U.S.C. 371 will be issued in addition to the Filing Receipt, in due course.</b></p> <p><b><u>New International Application Filed with the USPTO as a Receiving Office</u></b>  <b>If a new international application is being filed and the international application includes the necessary components for an international filing date (see PCT Article 11 and MPEP 1810), a Notification of the International Application Number and of the International Filing Date (Form PCT/RO/105) will be issued in due course, subject to prescriptions concerning national security, and the date shown on this Acknowledgement Receipt will establish the international filing date of the application.</b></p>					

**INFORMATION DISCLOSURE STATEMENT**

Applicant	:	Christensen et al.
App. No	:	12/366,535
Filed	:	February 5, 2009
For	:	SYSTEM AND METHOD FOR ADVERTISEMENT TRANSMISSION AND DISPLAY
Examiner	:	Ortiz, Belix M
Art Unit	:	2164
Conf No.	:	7989

Mail Stop Amendment  
Commissioner for Patents  
P.O. Box 1450  
Alexandria, VA 22313-1450

Dear Sir:

Enclosed for filing in the above-identified application is a PTO/SB/08 Equivalent listing 10 references, of which 1 is enclosed/submitted. Please note that we are re-submitting Cite No. 10, a copy of which was submitted in an earlier IDS on November 19, 2010 but listed with an incorrect application number on the IDS form.

The Commissioner is hereby authorized to charge any additional fees which may be required or to credit any overpayment to Account No. 11-1410.

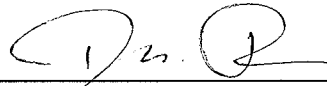
Pursuant to 37 C.F.R § 1.97(g) and (h), Applicant makes no representation that the information is considered to be material to patentability. Additionally, inclusion on this list is

**Application No.:** 12/366,535  
**Filing Date:** February 5, 2009

not an admission that any of the cited documents are prior art in this application. Further, Applicant makes no representation regarding the completeness of this list, or that better art does not exist.

Respectfully submitted,  
KNOBBE, MARTÈNS, OLSON & BEAR, LLP

Dated: 12/21/11

By:  \_\_\_\_\_

Don C. Pua  
Registration No. 67,028  
Attorney of Record  
Customer No. 20995  
(949) 760-0404

12475468



UNITED STATES PATENT AND TRADEMARK OFFICE

UNITED STATES DEPARTMENT OF COMMERCE
United States Patent and Trademark Office
Address: COMMISSIONER FOR PATENTS
P.O. Box 1450
Alexandria, Virginia 22313-1450
www.uspto.gov

Table with 5 columns: APPLICATION NO., FILING DATE, FIRST NAMED INVENTOR, ATTORNEY DOCKET NO., CONFIRMATION NO.
12/366,535 02/05/2009 Kelly M. Christensen STRATOS.029A 7989
7590 12/30/2011
KNOBBE MARTENS OLSON & BEAR LLP
2040 MAIN STREET
FOURTEENTH FLOOR
IRVINE, CA 92614
EXAMINER
ORTIZ, BELIX M
ART UNIT PAPER NUMBER
2164
NOTIFICATION DATE DELIVERY MODE
12/30/2011 ELECTRONIC

NOTICE OF NON-COMPLIANT INFORMATION DISCLOSURE STATEMENT

An Information Disclosure Statement (IDS) filed 12-21-11 in the above-identified application fails to meet the requirements of 37 CFR 1.97(d) for the reason(s) specified below. Accordingly, the IDS will be placed in the file, but the information referred to therein has not been considered.

The IDS is not compliant with 37 CFR 1.97(d) because:

- [X] The IDS lacks a statement as specified in 37 CFR 1.97(e).
[ ] The IDS lacks the fee set forth in 37 CFR 1.17(p).
[ ] The IDS was filed after the issue fee was paid. Applicant may wish to consider filing a petition to withdraw the application from issue under 37 CFR 1.313(c) to have the IDS considered. See MPEP 1308.

Handwritten signature of Amy Carahan

571-272-4200 or 1-888-786-0101
Application Assistance Unit
Office of Data Management

<b>INFORMATION DISCLOSURE STATEMENT BY APPLICANT</b>	Application No.	12/366,535
	Filing Date	February 5, 2009
	First Named Inventor	Kelly M. Christensen
	Art Unit	2164
<i>(Multiple sheets used when necessary)</i>	Examiner	Ortiz, Belix M
SHEET 1 OF 1	Attorney Docket No.	STRATOS.029A

<b>U.S. PATENT DOCUMENTS</b>					
Examiner Initials	Cite No.	Document Number Number - Kind Code (if known) Example: 1,234,567 B1	Publication Date MM-DD-YYYY	Name of Patentee or Applicant	Pages, Columns, Lines Where Relevant Passages or Relevant Figures Appear
	1	5,903,617	05-11-1999	Kamalski	
	2	6,701,355	03-02-2004	Brandt et al.	
	3	7,917,130	03-29-2011	Christensen et al.	
	4	2003/0208756	11-06-2003	Macrae et al.	
	5	2005/0071223	03-31-2005	Jain et al.	
	6	2007/0088852	04-19-2007	Levkovitz	
	7	2007/0156457	07-05-2007	Brown	
	8	2008/0263673	10-23-2008	Brun et al.	
	9	2009/0192916	07-30-2009	Casper	

<b>NON PATENT LITERATURE DOCUMENTS</b>			
Examiner Initials	Cite No.	Include name of the author (in CAPITAL LETTERS), title of the article (when appropriate), title of the item (book, magazine, journal, serial, symposium, catalog, etc.), date, page(s), volume-issue number(s), publisher, city and/or country where published.	T <sup>1</sup>
	10	International Search Report and Written Opinion for Application No. PCT/US2009/033249 mailed June 23, 2009.	

12898976

Examiner Signature	Date Considered
*Examiner: Initial if reference considered, whether or not citation is in conformance with MPEP 609. Draw line through citation if not in conformance and not considered. Include copy of this form with next communication to applicant.	

T<sup>1</sup> - Place a check mark in this area when an English language Translation is attached Volkswagen Exhibit 1002

PATENT COOPERATION TREATY

From the INTERNATIONAL SEARCHING AUTHORITY

PCT

NOTIFICATION OF TRANSMITTAL OF  
THE INTERNATIONAL SEARCH REPORT AND  
THE WRITTEN OPINION OF THE INTERNATIONAL  
SEARCHING AUTHORITY, OR THE DECLARATION

To:  
KNOBBE, MARTENS, OLSON & BEAR, LLP  
Attn. Altman, Daniel, E.  
2040 Main Street 14th Floor  
Irvine, CA 92614  
ETATS-UNIS D'AMERIQUE

(PCT Rule 44.1)

Date of mailing  
(day/month/year) 23/06/2009

Applicant's or agent's file reference  
STRATOS.029V

**FOR FURTHER ACTION** See paragraphs 1 and 4 below

International application No.  
PCT/US2009/033249

International filing date  
(day/month/year) 05/02/2009

Applicant  
STRATOSAUDIO, INC.

1.  The applicant is hereby notified that the international search report and the written opinion of the International Searching Authority have been established and are transmitted herewith.

**Filing of amendments and statement under Article 19:**

The applicant is entitled, if he so wishes, to amend the claims of the International Application (see Rule 46):

**When?** The time limit for filing such amendments is normally two months from the date of transmittal of the International Search Report.

**Where?** Directly to the International Bureau of WIPO, 34 chemin des Colombettes  
1211 Geneva 20, Switzerland, Facsimile No.: (41-22) 338.82.70

**For more detailed instructions,** see the notes on the accompanying sheet.

2.  The applicant is hereby notified that no International search report will be established and that the declaration under Article 17(2)(a) to that effect and the written opinion of the International Searching Authority are transmitted herewith.

3.  **With regard to the protest** against payment of (an) additional fee(s) under Rule 40.2, the applicant is notified that:

the protest together with the decision thereon has been transmitted to the International Bureau together with the applicant's request to forward the texts of both the protest and the decision thereon to the designated Offices.

no decision has been made yet on the protest; the applicant will be notified as soon as a decision is made.

**4. Reminders**

Shortly after the expiration of **18 months** from the priority date, the international application will be published by the International Bureau. If the applicant wishes to avoid or postpone publication, a notice of withdrawal of the international application, or of the priority claim, must reach the International Bureau as provided in Rules 90bis.1 and 90bis.3, respectively, before the completion of the technical preparations for international publication.

The applicant may submit comments on an informal basis on the written opinion of the International Searching Authority to the International Bureau. The International Bureau will send a copy of such comments to all designated Offices unless an international preliminary examination report has been or is to be established. These comments would also be made available to the public but not before the expiration of 30 months from the priority date.

Within **19 months** from the priority date, but only in respect of some designated Offices, a demand for international preliminary examination must be filed if the applicant wishes to postpone the entry into the national phase **until 30 months** from the priority date (in some Offices even later); otherwise, the applicant must, **within 20 months** from the priority date, perform the prescribed acts for entry into the national phase before those designated Offices.

In respect of other designated Offices, the time limit of **30 months** (or later) will apply even if no demand is filed within 19 months.

See the Annex to Form PCT/IB/301 and, for details about the applicable time limits, Office by Office, see the *PCT Applicant's Guide*, Volume II, National Chapters and the WIPO Internet site.

Name and mailing address of the International Searching Authority



European Patent Office, P.B. 5818 Patentlaan 2  
NL-2280 HV Rijswijk  
Tel. (+31-70) 340-2040, Tx. 31 651 epo nl,  
Fax: (+31-70) 340-3016

Authorized officer

Anita Rothenbücher

## NOTES TO FORM PCT/ISA/220

These Notes are intended to give the basic instructions concerning the filing of amendments under article 19. The Notes are based on the requirements of the Patent Cooperation Treaty, the Regulations and the Administrative Instructions under that Treaty. In case of discrepancy between these Notes and those requirements, the latter are applicable. For more detailed information, see also the *PCT Applicant's Guide*, a publication of WIPO.

In these Notes, "Article", "Rule", and "Section" refer to the provisions of the PCT, the PCT Regulations and the PCT Administrative Instructions, respectively.

### INSTRUCTIONS CONCERNING AMENDMENTS UNDER ARTICLE 19

The applicant has, after having received the international search report and the written opinion of the International Searching Authority, one opportunity to amend the claims of the international application. It should however be emphasized that, since all parts of the international application (claims, description and drawings) may be amended during the international preliminary examination procedure, there is usually no need to file amendments of the claims under Article 19 except where, e.g. the applicant wants the latter to be published for the purposes of provisional protection or has another reason for amending the claims before international publication. Furthermore, it should be emphasized that provisional protection is available in some States only (see *PCT Applicant's Guide*, Volume I/A, Annexes B1 and B2).

The attention of the applicant is drawn to the fact that amendments to the claims under Article 19 are not allowed where the International Searching Authority has declared, under Article 17(2), that no international search report would be established (see *PCT Applicant's Guide*, Volume I/A, paragraph 296).

#### What parts of the international application may be amended?

Under Article 19, only the claims may be amended.

During the international phase, the claims may also be amended (or further amended) under Article 34 before the International Preliminary Examining Authority. The description and drawings may only be amended under Article 34 before the International Examining Authority.

Upon entry into the national phase, all parts of the international application may be amended under Article 28 or, where applicable, Article 41.

#### When?

Within 2 months from the date of transmittal of the international search report or 16 months from the priority date, whichever time limit expires later. It should be noted, however, that the amendments will be considered as having been received on time if they are received by the International Bureau after the expiration of the applicable time limit but before the completion of the technical preparations for international publication (Rule 46.1).

#### Where not to file the amendments?

The amendments may only be filed with the International Bureau and not with the receiving Office or the International Searching Authority (Rule 46.2).

Where a demand for international preliminary examination has been/is filed, see below.

#### How?

Either by cancelling one or more entire claims, by adding one or more new claims or by amending the text of one or more of the claims as filed.

A replacement sheet must be submitted for each sheet of the claims which, on account of an amendment or amendments, differs from the sheet originally filed.

All the claims appearing on a replacement sheet must be numbered in Arabic numerals. Where a claim is cancelled, no renumbering of the other claims is required. In all cases where claims are renumbered, they must be renumbered consecutively (Section 205(b)).

**The amendments must be made in the language in which the international application is to be published.**

#### What documents must/may accompany the amendments?

##### Letter (Section 205(b)):

The amendments must be submitted with a letter.

The letter will not be published with the international application and the amended claims. It should not be confused with the "Statement under Article 19(1)" (see below, under "Statement under Article 19(1)").

**The letter must be in English or French, at the choice of the applicant. However, if the language of the international application is English, the letter must be in English; if the language of the international application is French, the letter must be in French.**

## NOTES TO FORM PCT/ISA/220 (continued)

The letter must indicate the differences between the claims as filed and the claims as amended. It must, in particular, indicate, in connection with each claim appearing in the international application (it being understood that identical indications concerning several claims may be grouped), whether

- (i) the claim is unchanged;
- (ii) the claim is cancelled;
- (iii) the claim is new;
- (iv) the claim replaces one or more claims as filed;
- (v) the claim is the result of the division of a claim as filed.

**The following examples illustrate the manner in which amendments must be explained in the accompanying letter:**

1. [Where originally there were 48 claims and after amendment of some claims there are 51]:  
"Claims 1 to 29, 31, 32, 34, 35, 37 to 48 replaced by amended claims bearing the same numbers; claims 30, 33 and 36 unchanged; new claims 49 to 51 added."
2. [Where originally there were 15 claims and after amendment of all claims there are 11]:  
"Claims 1 to 15 replaced by amended claims 1 to 11."
3. [Where originally there were 14 claims and the amendments consist in cancelling some claims and in adding new claims]:  
"Claims 1 to 6 and 14 unchanged; claims 7 to 13 cancelled; new claims 15, 16 and 17 added." or  
"Claims 7 to 13 cancelled; new claims 15, 16 and 17 added; all other claims unchanged."
4. [Where various kinds of amendments are made]:  
"Claims 1-10 unchanged; claims 11 to 13, 18 and 19 cancelled; claims 14, 15 and 16 replaced by amended claim 14; claim 17 subdivided into amended claims 15, 16 and 17; new claims 20 and 21 added."

### "Statement under article 19(1)" (Rule 46.4)

The amendments may be accompanied by a statement explaining the amendments and indicating any impact that such amendments might have on the description and the drawings (which cannot be amended under Article 19(1)).

The statement will be published with the international application and the amended claims.

**It must be in the language in which the international application is to be published.**

It must be brief, not exceeding 500 words if in English or if translated into English.

It should not be confused with and does not replace the letter indicating the differences between the claims as filed and as amended. It must be filed on a separate sheet and must be identified as such by a heading, preferably by using the words "Statement under Article 19(1)."

It may not contain any disparaging comments on the international search report or the relevance of citations contained in that report. Reference to citations, relevant to a given claim, contained in the international search report may be made only in connection with an amendment of that claim.

### **Consequence if a demand for international preliminary examination has already been filed**

If, at the time of filing any amendments and any accompanying statement, under Article 19, a demand for international preliminary examination has already been submitted, the applicant must preferably, at the time of filing the amendments (and any statement) with the International Bureau, also file with the International Preliminary Examining Authority a copy of such amendments (and of any statement) and, where required, a translation of such amendments for the procedure before that Authority (see Rules 55.3(a) and 62.2, first sentence). For further information, see the Notes to the demand form (PCT/PEA/401).

If a demand for international preliminary examination is made, the written opinion of the International Searching Authority will, except in certain cases where the International Preliminary Examining Authority did not act as International Searching Authority and where it has notified the International Bureau under Rule 66.1 bis(b), be considered to be a written opinion of the International Preliminary Examining Authority. If a demand is made, the applicant may submit to the International Preliminary Examining Authority a reply to the written opinion together, where appropriate, with amendments before the expiration of 3 months from the date of mailing of Form PCT/ISA/220 or before the expiration of 22 months from the priority date, whichever expires later (Rule 43 bis(c)).

### **Consequence with regard to translation of the international application for entry into the national phase**

The applicant's attention is drawn to the fact that, upon entry into the national phase, a translation of the claims as amended under Article 19 may have to be furnished to the designated/elected Offices, instead of, or in addition to, the translation of the claims as filed.

For further details on the requirements of each designated/elected Office, see the *PCT Applicant's Guide*, Volume II.



PATENT COOPERATION TREATY

PCT

INTERNATIONAL SEARCH REPORT

(PCT Article 18 and Rules 43 and 44)

Applicant's or agent's file reference <b>STRATOS.029V</b>	<b>FOR FURTHER ACTION</b> see Form PCT/ISA/220 as well as, where applicable, item 5 below.	
International application No. <b>PCT/US2009/033249</b>	International filing date (day/month/year) <b>05/02/2009</b>	(Earliest) Priority Date (day/month/year) <b>05/02/2008</b>
Applicant <b>STRATOSAUDIO, INC.</b>		

This international search report has been prepared by this International Searching Authority and is transmitted to the applicant according to Article 18. A copy is being transmitted to the International Bureau.

This international search report consists of a total of 3 sheets.

It is also accompanied by a copy of each prior art document cited in this report.

1. **Basis of the report**

a. With regard to the **language**, the international search was carried out on the basis of:

the international application in the language in which it was filed

a translation of the international application into \_\_\_\_\_, which is the language of a translation furnished for the purposes of international search (Rules 12.3(a) and 23.1(b))

b.  This international search report has been established taking into account the **rectification of an obvious mistake** authorized by or notified to this Authority under Rule 91 (Rule 43.6bis(a)).

c.  With regard to any **nucleotide and/or amino acid sequence** disclosed in the international application, see Box No. I.

2.  **Certain claims were found unsearchable** (See Box No. II)

3.  **Unity of invention is lacking** (see Box No III)

4. With regard to the **title**,

the text is approved as submitted by the applicant

the text has been established by this Authority to read as follows:

5. With regard to the **abstract**,

the text is approved as submitted by the applicant

the text has been established, according to Rule 38.2(b), by this Authority as it appears in Box No. IV. The applicant may, within one month from the date of mailing of this international search report, submit comments to this Authority

6. With regard to the **drawings**,

a. the figure of the **drawings** to be published with the abstract is Figure No. 5

as suggested by the applicant

as selected by this Authority, because the applicant failed to suggest a figure

as selected by this Authority, because this figure better characterizes the invention

b.  none of the figures is to be published with the abstract

INTERNATIONAL SEARCH REPORT

International application No  
PCT/US2009/033249

**A. CLASSIFICATION OF SUBJECT MATTER**  
INV. H04L29/06

According to International Patent Classification (IPC) or to both national classification and IPC

**B. FIELDS SEARCHED**

Minimum documentation searched (classification system followed by classification symbols)  
H04L G06Q

Documentation searched other than minimum documentation to the extent that such documents are included in the fields searched

Electronic data base consulted during the international search (name of data base and, where practical, search terms used)  
EPO-Internal, WPI Data, PAJ

**C. DOCUMENTS CONSIDERED TO BE RELEVANT**

Category*	Citation of document, with indication, where appropriate, of the relevant passages	Relevant to claim No.
X	US 7 299 194 B1 (MANGANARIS STEFANOS [US] ET AL) 20 November 2007 (2007-11-20) abstract figures 1-3 column 3, line 30 - column 3, line 67 column 4, line 63 - column 5, line 41 column 5, line 63 - column 6, line 9	1-19
A	WO 2006/122028 A (ROOT MARKETS INC [US]; GOLDSTEIN SETH [US]; HERSHBERG PETER [US]; STYL) 16 November 2006 (2006-11-16) the whole document	1-19

Further documents are listed in the continuation of Box C.  See patent family annex.

\* Special categories of cited documents :

\*A\* document defining the general state of the art which is not considered to be of particular relevance

\*E\* earlier document but published on or after the international filing date

\*L\* document which may throw doubts on priority claim(s) or which is cited to establish the publication date of another citation or other special reason (as specified)

\*O\* document referring to an oral disclosure, use, exhibition or other means

\*P\* document published prior to the international filing date but later than the priority date claimed

\*T\* later document published after the international filing date or priority date and not in conflict with the application but cited to understand the principle or theory underlying the invention

\*X\* document of particular relevance; the claimed invention cannot be considered novel or cannot be considered to involve an inventive step when the document is taken alone

\*Y\* document of particular relevance; the claimed invention cannot be considered to involve an inventive step when the document is combined with one or more other such documents, such combination being obvious to a person skilled in the art.

\*Z\* document member of the same patent family

Date of the actual completion of the international search <b>16 June 2009</b>	Date of mailing of the international search report <b>23/06/2009</b>
--	---

Name and mailing address of the ISA/ European Patent Office, P.B. 5818 Patentlaan 2 NL - 2280 HV Rijswijk Tel. (+31-70) 340-2040, Fax: (+31-70) 340-3016	Authorized officer <b>Pereira, Mafalda</b>
--	---

# INTERNATIONAL SEARCH REPORT

Information on patent family members

International application No

PCT/US2009/033249

Patent document cited in search report	Publication date	Patent family member(s)	Publication date
US 7299194	B1	20-11-2007	AU 782052 B2 30-06-2005
			AU 7196900 A 23-08-2001
			CA 2334300 A1 22-08-2001
			CN 1310414 A 29-08-2001
			JP 2001243334 A 07-09-2001
			US 2008154701 A1 26-06-2008
WO 2006122028	A	16-11-2006	US 2007219896 A1 20-09-2007

# PATENT COOPERATION TREATY

From the  
INTERNATIONAL SEARCHING AUTHORITY

## PCT

**WRITTEN OPINION OF THE  
INTERNATIONAL SEARCHING AUTHORITY  
(PCT Rule 43bis.1)**

To:

see form PCT/ISA/220

Date of mailing  
(day/month/year) see form PCT/ISA/210 (second sheet)

Applicant's or agent's file reference  
see form PCT/ISA/220

**FOR FURTHER ACTION**  
See paragraph 2 below

International application No.  
PCT/US2009/033249

International filing date (day/month/year)  
05.02.2009

Priority date (day/month/year)  
05.02.2008

International Patent Classification (IPC) or both national classification and IPC  
INV. H04L29/06

Applicant  
STRATOSAUDIO, INC.

1. This opinion contains indications relating to the following items:

- Box No. I Basis of the opinion
- Box No. II Priority
- Box No. III Non-establishment of opinion with regard to novelty, inventive step and industrial applicability
- Box No. IV Lack of unity of invention
- Box No. V Reasoned statement under Rule 43bis.1(a)(i) with regard to novelty, inventive step or industrial applicability; citations and explanations supporting such statement
- Box No. VI Certain documents cited
- Box No. VII Certain defects in the international application
- Box No. VIII Certain observations on the international application

2. **FURTHER ACTION**


If a demand for international preliminary examination is made, this opinion will usually be considered to be a written opinion of the International Preliminary Examining Authority ("IPEA") except that this does not apply where the applicant chooses an Authority other than this one to be the IPEA and the chosen IPEA has notified the International Bureau under Rule 66.1bis(b) that written opinions of this International Searching Authority will not be so considered.

If this opinion is, as provided above, considered to be a written opinion of the IPEA, the applicant is invited to submit to the IPEA a written reply together, where appropriate, with amendments, before the expiration of 3 months from the date of mailing of Form PCT/ISA/220 or before the expiration of 22 months from the priority date, whichever expires later.

For further options, see Form PCT/ISA/220.

3. For further details, see notes to Form PCT/ISA/220.

Name and mailing address of the ISA:



European Patent Office  
P.B. 5818 Patentlaan 2  
NL-2280 HV Rijswijk - Pays Bas  
Tel. +31 70 340 - 2040  
Fax: +31 70 340 - 3016


Date of completion of this opinion

see form  
PCT/ISA/210

Authorized Officer

Pereira, Mafalda

Telephone No. +31 70 340-4322



---

**Box No. 1 Basis of the opinion**

---

1. With regard to the **language**, this opinion has been established on the basis of:
  - the international application in the language in which it was filed
  - a translation of the international application into , which is the language of a translation furnished for the purposes of international search (Rules 12.3(a) and 23.1 (b)).
2.  This opinion has been established taking into account the **rectification of an obvious mistake** authorized by or notified to this Authority under Rule 91 (Rule 43bis.1(a))
3. With regard to any **nucleotide and/or amino acid sequence** disclosed in the international application and necessary to the claimed invention, this opinion has been established on the basis of:
  - a. type of material:
    - a sequence listing
    - table(s) related to the sequence listing
  - b. format of material:
    - on paper
    - in electronic form
  - c. time of filing/furnishing:
    - contained in the international application as filed.
    - filed together with the international application in electronic form.
    - furnished subsequently to this Authority for the purposes of search.
4.  In addition, in the case that more than one version or copy of a sequence listing and/or table relating thereto has been filed or furnished, the required statements that the information in the subsequent or additional copies is identical to that in the application as filed or does not go beyond the application as filed, as appropriate, were furnished.
5. Additional comments:

---

**Box No. V Reasoned statement under Rule 43bis.1(a)(i) with regard to novelty, inventive step or industrial applicability; citations and explanations supporting such statement**

---

1. Statement

Novelty (N)	Yes: Claims	
	No: Claims	<u>1-19</u>
Inventive step (IS)	Yes: Claims	
	No: Claims	<u>1-19</u>
Industrial applicability (IA)	Yes: Claims	<u>1-19</u>
	No: Claims	

2. Citations and explanations

see separate sheet

**Re Item V.**

1 The present application does not meet the criteria of Article 33(1) PCT, because the subject-matter of each of the independent claims 1, 12, 16 and 19 is not new in the sense of Article 33(2) PCT.

1.1 Reference is made to the following document:

D1 : US 7 299 194 B1 (MANGANARIS STEFANOS [US] ET AL) 20 November 2007 (2007-11-20)

1.2 Document D1 discloses, in terms of the wording of claim 1, a method for associating multiple media signals, comprising:  
obtaining information about a first media signal (D1: column 3 line 30 to 67 in particular "sales data concerning items sold in retails");  
analysing the information about the first media signal (D1: column 3 line 30 to 67 and column 5 lines 10 to 18);  
selecting at least one second media signal to be correlated with the first media signal based on at least one criteria (D1 column 4 line 63 to column 5 line 18);  
assigning a unique identifier that is specific to the transmission of the selected second media signal, wherein at least the unique identifier is stored in a database (D1: column 5 line lines 19 to 23 and column 5 line 63 to column 6 line 9);  
transmitting at least the second media signal and the unique identifier to a user device, wherein the user device outputs the first media signal and the second media signal to a user (column 5 line 63 to column 6 line 9);  
receiving a user response from the user in relation to the second media signal wherein the user response includes at least the unique identifier; and correlating at least the unique identifier in the database (D1: column 5 line lines 19 to 23 and column 5 line 63 to column 6 line 9).

Therefore the subject-matter of claim 1 is not new in the sense of Article 33(2) PCT.

1.3 Analogously to claim 1, the subject-matter of each of the independent claims 12, 16 and 19 is also not new in the sense of Article 33(2) PCT.

2 Dependent claims 2-11, 13-15, 17, 18 do not contain any features which, in

combination with the features of any claim to which they refer, meet the requirements of the PCT in respect of novelty or inventive step. See passages cited on the Search Report.





## Electronic Patent Application Fee Transmittal

<b>Application Number:</b>	12366535
<b>Filing Date:</b>	05-Feb-2009
<b>Title of Invention:</b>	SYSTEM AND METHOD FOR ADVERTISEMENT TRANSMISSION AND DISPLAY
<b>First Named Inventor/Applicant Name:</b>	Kelly M. Christensen
<b>Filer:</b>	Don Neil Caceres Pua/Will Nguyen
<b>Attorney Docket Number:</b>	STRATOS.029A

Filed as Small Entity

### Utility under 35 USC 111(a) Filing Fees

Description	Fee Code	Quantity	Amount	Sub-Total in USD(\$)
<b>Basic Filing:</b>				
<b>Pages:</b>				
<b>Claims:</b>				
<b>Miscellaneous-Filing:</b>				
<b>Petition:</b>				
<b>Patent-Appeals-and-Interference:</b>				
<b>Post-Allowance-and-Post-Issuance:</b>				
Utility Appl issue fee	2501	1	870	870
Publ. Fee- early, voluntary, or normal	1504	1	300	300

Description	Fee Code	Quantity	Amount	Sub-Total in USD(\$)
<b>Extension-of-Time:</b>				
<b>Miscellaneous:</b>				
<b>Total in USD (\$)</b>				<b>1170</b>

## Electronic Acknowledgement Receipt

<b>EFS ID:</b>	12261435
<b>Application Number:</b>	12366535
<b>International Application Number:</b>	
<b>Confirmation Number:</b>	7989
<b>Title of Invention:</b>	SYSTEM AND METHOD FOR ADVERTISEMENT TRANSMISSION AND DISPLAY
<b>First Named Inventor/Applicant Name:</b>	Kelly M. Christensen
<b>Customer Number:</b>	20995
<b>Filer:</b>	Don Neil Caceres Pua/Heide Young
<b>Filer Authorized By:</b>	Don Neil Caceres Pua
<b>Attorney Docket Number:</b>	STRATOS.029A
<b>Receipt Date:</b>	08-MAR-2012
<b>Filing Date:</b>	05-FEB-2009
<b>Time Stamp:</b>	19:23:34
<b>Application Type:</b>	Utility under 35 USC 111(a)

### Payment information:

Submitted with Payment	yes
Payment Type	Credit Card
Payment was successfully received in RAM	\$1170
RAM confirmation Number	6324
Deposit Account	111410
Authorized User	KNOBBE MARTENS OLSON AND BEAR

The Director of the USPTO is hereby authorized to charge indicated fees and credit any overpayment as follows:

Charge any Additional Fees required under 37 C.F.R. Section 1.16 (National application filing, search, and examination fees)

Charge any Additional Fees required under 37 C.F.R. Section 1.17 (Patent application and reexamination processing fees)

Volkswagen Exhibit 1002

<b>File Listing:</b>					
<b>Document Number</b>	<b>Document Description</b>	<b>File Name</b>	<b>File Size(Bytes)/ Message Digest</b>	<b>Multi Part /.zip</b>	<b>Pages (if appl.)</b>
1		STRATOS-029A_312AMEND.pdf	377593 2f3a7961dac7748bb92cd01c7ffe83843902e6a0	yes	9
<b>Multipart Description/PDF files in .zip description</b>					
		<b>Document Description</b>	<b>Start</b>	<b>End</b>	
		Amendment after Notice of Allowance (Rule 312)	1	1	
		Claims	2	6	
		Applicant Arguments/Remarks Made in an Amendment	7	9	
<b>Warnings:</b>					
<b>Information:</b>					
2		STRATOS-029A_IDS.pdf	87924 ecc3f41449e38d8a97cc592c7b0fd2fc0ca8e9f	yes	3
<b>Multipart Description/PDF files in .zip description</b>					
		<b>Document Description</b>	<b>Start</b>	<b>End</b>	
		Transmittal Letter	1	2	
		Information Disclosure Statement (IDS) Form (SB08)	3	3	
<b>Warnings:</b>					
<b>Information:</b>					
3	Non Patent Literature	STRATOS-029A_NPL.pdf	462751 86564886d035cf61b2721916b33a1eab9f53562e	no	11
<b>Warnings:</b>					
<b>Information:</b>					
4	Issue Fee Payment (PTO-85B)	STRATOS-029A_IFEE.pdf	97291 938b8528ee18ae202d94c893d2551ee9a0dc5e3d	no	1
<b>Warnings:</b>					
<b>Information:</b>					
5	Fee Worksheet (SB06)	fee-info.pdf	31998 67a78b2045c40903b56e1d79869f7467cc5ed7fa	no	2
<b>Warnings:</b>					
<b>Information:</b>					
<b>Total Files Size (in bytes):</b>			1057557		

**This Acknowledgement Receipt evidences receipt on the noted date by the USPTO of the indicated documents, characterized by the applicant, and including page counts, where applicable. It serves as evidence of receipt similar to a Post Card, as described in MPEP 503.**

**New Applications Under 35 U.S.C. 111**

**If a new application is being filed and the application includes the necessary components for a filing date (see 37 CFR 1.53(b)-(d) and MPEP 506), a Filing Receipt (37 CFR 1.54) will be issued in due course and the date shown on this Acknowledgement Receipt will establish the filing date of the application.**

**National Stage of an International Application under 35 U.S.C. 371**

**If a timely submission to enter the national stage of an international application is compliant with the conditions of 35 U.S.C. 371 and other applicable requirements a Form PCT/DO/EO/903 indicating acceptance of the application as a national stage submission under 35 U.S.C. 371 will be issued in addition to the Filing Receipt, in due course.**

**New International Application Filed with the USPTO as a Receiving Office**

**If a new international application is being filed and the international application includes the necessary components for an international filing date (see PCT Article 11 and MPEP 1810), a Notification of the International Application Number and of the International Filing Date (Form PCT/RO/105) will be issued in due course, subject to prescriptions concerning national security, and the date shown on this Acknowledgement Receipt will establish the international filing date of the application.**

## IN THE UNITED STATES PATENT AND TRADEMARK OFFICE

Applicant	:	Christensen et al.
App. No.	:	12/366,535
Filed	:	February 5, 2009
For	:	SYSTEM AND METHOD FOR ADVERTISEMENT TRANSMISSION AND DISPLAY
Examiner	:	Ortiz, Belix M
Art Unit	:	2164
Conf No.	:	7989

37 C.F.R. §1.312 AMENDMENT AFTER ALLOWANCE AND COMMENT ON  
EXAMINER'S REASONS FOR ALLOWANCE**Mail Stop AF**

Commissioner for Patents  
P.O. Box 14508  
Alexandria, VA 22313-1450

Dear Sir:

In response to the Notice of Allowability mailed December 12, 2011, please consider the following:

**Amendments to the Claims** are reflected in the listing of claims which begins on page 2 of this paper.

**Remarks** begin on page 7 of this paper.

**AMENDMENTS TO THE CLAIMS**

1. **(Previously presented)** A method for associating a secondary media content with a primary broadcast segment:

obtaining information about a broadcast communications medium received by a plurality of user devices;

obtaining the information about the broadcast communications medium to determine at least data enabling the identification of a specific instance of a primary broadcast segment conveyed on the broadcast communications medium;

selecting at least a secondary media content based on at least one criterion;

determining uniquely identifying data specific to the secondary media content, wherein at least the uniquely identifying data is stored in a database;

transmitting at least the secondary media content and the uniquely identifying data to a user device of the plurality of user devices on a secondary communications medium discrete from the broadcast communications medium, wherein the secondary media content is configured to be presented substantially concurrently with the primary broadcast segment received by the user device on the broadcast communications medium;

monitoring response messages received from the user device in response to a presentation of the secondary media content, wherein at least one response message includes at least the uniquely identifying data specific to the secondary media content; and

obtaining a report on user activity, the report correlating user activity with the secondary media content using the uniquely identifying data specific to the secondary media content.

2. **(Currently amended)** The method of claim 1, wherein the broadcast communications medium and the secondary electronic ~~electronic~~ communications medium are different types of communications medium.

3. **(Canceled)**

4. **(Canceled)**

5. **(Canceled)**

6. **(Canceled)**



7. (Canceled)

8. (Canceled)

9. (Canceled)

10. (Previously presented) The method of claim 1, wherein the at least one criterion is modified based at least partly on the report on user activity.

11. (Previously presented) The method of claim 10, wherein the at least one criterion is modified continuously.

12. (Currently amended) A method for combining multiple media content in a receiving system:

obtaining, by the receiving system, a first media broadcast~~by the receiving system;~~

outputting on the receiving system a first media content comprised in the first media broadcast~~to a user of the receiving system;~~

obtaining, by the receiving system, a second media content and uniquely identifying data specific to the secondary media content~~by the receiving system~~via a secondary media content transmission discrete from the first media content broadcast;

obtaining at least one criterion correlated to the second media content;

evaluating the at least one criterion in reference to usage data for the receiving system~~device;~~

and

outputting, based at least partly on the evaluation, at least the second media content on the receiving system, wherein the second media content is configured to be concurrently presented in association with the first media content; and

sending a response containing at least uniquely identifying data associated with the second media content.

13. (Currently amended) The method of claim 12, further comprising communicating ~~the~~ obtainment of the first media broadcast to a media signal association system.

14. (Currently amended) The method of claim 12, further comprising communicating ~~a~~ the status of the receiving system ~~device~~ to a media signal association system.

15. (Currently amended) The method of claim 12, further comprising:

obtaining data specific to ~~the~~an instance of ~~the~~ outputting of the second media content;

detecting a user response to the second media content; and

transmitting at least the data specific to the instance of the outputting to a computer server.

**16. (Previously presented)** A system for combining multiple media comprising:

a first receiver module configured to receive at least a first media content and data enabling the identification of a specific instance of the first media content from a first broadcast medium;

a second receiver module configured to receive at least a second media content and uniquely identifying data specific to at least the second media content, the second media content received discretely from the first media content;

an output system configured to present concurrently the first media content and the second media content on an output of the first receiver module or the second receiver module;

an input module configured to receive at least a response input responsive to the second media content; and

a transmitting module configured to transmit a response message having at least the uniquely identifying data specific to the second media content to a computer server.

**17. (Previously presented)** The system of claim 16 further comprising an output selection module configured to limit the output of the first and second media content based on a criterion.

**18. (Currently amended)** The system of claim 16 further comprising a ~~mass-computer~~ storage device configured to store at least one of one the first and second media content.

**19. (Canceled)**

**20. (Currently amended)** A method for associating a secondary media content presentation to a primary broadcast segment:

obtaining information about a first media content broadcast received by a plurality of user devices;

organizing the information about the first media content broadcast to determine at least data enabling the identification of a specific instance of a primary broadcast segment conveyed by the first media content broadcast;

selecting at least a secondary media content based on at least one criterion;

determining uniquely identifying data specific to the secondary media content, wherein at least the uniquely identifying data is stored in a database;

enabling access of at least the secondary media content and the uniquely identifying data to a user device of the plurality of user devices via at least a secondary media content transmission discrete from the first media content broadcast, wherein the secondary media content is configured to be concurrently presented in association with the primary broadcast segment, wherein the primary broadcast segment is accessible to the user device using via the first media content broadcast;

enabling access to one or more response messages received from the user device in relation to ~~the~~ a contextual presentation of the secondary media content, the one or more response messages including at least the uniquely identifying data specific to the secondary media content; and

obtaining a report on user activity, the report correlating user activity with at least the secondary media content broadcast and the uniquely identifying data specific to the secondary media content broadcast.

21. **(Currently amended)** The method of claim 2, wherein the broadcast communications medium comprises a radio broadcast and the secondary electronic communications medium comprises a mobile wireless transmission.

22. **(Previously presented)** The method of claim 1, wherein the report further correlates the user activity with the specific instance of the primary broadcast segment.

23. **(Previously presented)** The system of claim 16, wherein, in response to receiving the response message, the computer server is configured to correlate the response message to the second media content with the specific instance of the first media content.

24. **(Previously presented)** The method of claim 20, whereby the data enabling the identification of a specific instance of a primary broadcast segment conveyed by the first media

content broadcast and the uniquely identifying data specific to the secondary media content are cross referenced in the database.

25. **(Currently amended)** The method of claim 20, whereby the report ~~obtained corollary to correlating~~ user activity includes secondary media content presentation activity obtained from the user device.

26. **(Currently amended)** The method of claim 20, whereby the secondary media content transmission is conveyed substantially synchronously with the first media content broadcast, ~~being~~ discretely separated by time multiplexing.

27. **(Currently amended)** The method of claim 20, whereby the secondary media content transmission is conveyed substantially synchronously with the first media content broadcast, ~~being~~ discretely separated by frequency multiplexing.

28. **(Previously presented)** The method of claim 20, whereby the secondary media content transmission is conveyed by means of at least one of the following: discrete multi-tone modulation, in-band on-channel (IBOC) radio, Digital Radio Mondial, CDMA, HSDPA, WiFi, RDS, RBDS, GPRS, mobile wireless network, satellite communication, Ethernet.

29. **(New)** The method of claim 1, wherein the at least one response message includes data that enables identification of a responder.

30. **(New)** The method of claim 12, wherein the response further includes data that data that enables identification of a responder.

31. **(New)** The system of claim 16, wherein the response message includes data that enables identification of a responder.

32. **(New)** The method of claim 20, wherein at least one of the response messages includes data that enables identification of a responder.

**Application No.:** 12/366,535  
**Filing Date:** February 5, 2009

### **REMARKS**

The claims are amended under C.F.R. § 1.312. Claims 2, 12-15, 18, 20-21, and 25-27 are currently amended to clarify features of those claims.

#### **New Claims**

New dependant Claims 29-32 have been added to more fully define the Applicant's invention and are believed to be fully distinguished over the prior art of record. Support for the claims can be found at least in the following paragraph:

[0053] As illustrated in FIG. 1, the primary device 4 and/or ancillary device 5 can also send signals back to the media association system 2 and/or to the control management system 100. For example, if the related media signal 114 sent by the media association system 2 to the devices 4, 5 comprises purchasing information for a song present in the first media signal 111, the primary and/or ancillary devices 4, 5 can provide a purchase request to the media association system 2. The media association system 2 can then transmit the purchase request to the first transmitter 3, to a third party for fulfillment, and/or to the control management system 100. The response transmission sent back to the media association system 2 and/or the control management system 100 can comprise: the response to a first media signal 111 and/or a unique identifier 115 obtained from first media signal 111, a response to an advertisement media signal 113, and/or a unique identifier 115 obtained from advertisement media signal 113, (**and/or a user identifier, a device identifier etc**), a user selection from a list of options and/or the status of the device (including but not limited to the presentation of the first media signal, presentation of the advertisement signal, changing which first transmitter 3 is being received, the device turning on or off).

#### **Comments On The Examiner's Statement Of Reasons For Allowance**

Applicant respectfully submits the following comments on the Examiner's Statement of Reasons for Allowance. Applicant acknowledges Examiner's statements of Reasons for Allowance of the above-referenced patent application and agrees that the claimed subject matter is patentable. However, Applicant takes no position regarding the Reasons for Allowance

**Application No.:** 12/366,535  
**Filing Date:** February 5, 2009

presented by the Examiner other than the positions Applicant may have previously taken during prosecution. Therefore, the Examiner's Reasons for Allowance should not be attributed to Applicant as an indication of the basis for Applicant's belief that the claims are patentable. Furthermore, Applicant respectfully asserts that there may also be additional reasons for patentability of the claimed subject matter not explicitly stated in this record and Applicant does not waive its rights to such arguments by not further addressing such reasons herein.

Applicant also respectfully reserves the right to traverse the characterizations of what any particular reference shows or teaches, of what any combination of references shows or teaches, or the appropriateness of combining references. Further, by making certain amendments to the claims, Applicant is not conceding that previously pending claims are not patentable. Rather, the amendments are being made to facilitate expeditious prosecution of this application. Applicant reserves the right to pursue at a later date any previously pending or other broader or narrower claims that capture any subject matter supported by the application's disclosure. Accordingly, reviewers of this or any child or related prosecution history shall not reasonably infer that the Applicant has made any disclaimers or disavowals of any subject matter.

*No Disclaimers or Disavowals*

Although the present communication may include alterations to the application or claims, or characterizations of claim scope or referenced art, Applicant is not conceding in this application that previously pending claims are not patentable over the cited references. Rather, any alterations or characterizations are being made to facilitate expeditious prosecution of this application. Applicant reserves the right to pursue at a later date any previously pending or other broader or narrower claims that capture any subject matter supported by the present disclosure, including subject matter found to be specifically disclaimed herein or by any prior prosecution. Accordingly, reviewers of this or any parent, child or related prosecution history shall not reasonably infer that Applicant has made any disclaimers or disavowals of any subject matter supported by the present application.

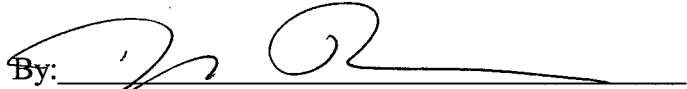
**Application No.:** 12/366,535  
**Filing Date:** February 5, 2009

Please charge any additional fees, including any fees for additional extension of time, or credit overpayment to Deposit Account No. 11-1410.

Respectfully submitted,

KNOBBE, MARTENS, OLSON & BEAR, LLP

Dated: March 8, 2012

By: 

Don C. Pua  
Registration No. 67,028  
Attorney of Record  
Customer No. 20995  
(949) 760-0404

12548134

**INFORMATION DISCLOSURE STATEMENT**

Applicant	:	Christensen et al.
App. No	:	12/366,535
Filed	:	February 5, 2009
For	:	SYSTEM AND METHOD FOR ADVERTISEMENT TRANSMISSION AND DISPLAY
Examiner	:	Ortiz, Belix M
Art Unit	:	2164
Conf No.	:	7989

Mail Stop Amendment  
Commissioner for Patents  
P.O. Box 1450  
Alexandria, VA 22313-1450

**References and Listing**

Enclosed for filing in the above-identified application is a PTO/SB/08 Equivalent listing 10 references, of which 1 is enclosed/submitted. Please note that we are re-submitting Cite No. 10, a copy of which was submitted in an earlier IDS on November 19, 2010 but listed with an incorrect application number on the IDS form.

The Commissioner is hereby authorized to charge any additional fees which may be required or to credit any overpayment to Account No. 11-1410.

Pursuant to 37 C.F.R. § 1.97(g) and (h), Applicant makes no representation that the information is considered to be material to patentability. Additionally, inclusion on this list is

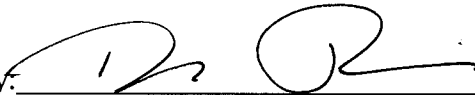


**Application No.:** 12/366,535  
**Filing Date:** February 5, 2009

not an admission that any of the cited documents are prior art in this application. Further, Applicant makes no representation regarding the completeness of this list, or that better art does not exist.

Respectfully submitted,  
KNOBBE, MARTENS, OLSON & BEAR, LLP

Dated: March 8, 2012

By:   
\_\_\_\_\_  
Don C. Pua  
Registration No. 67,028  
Attorney of Record  
Customer No. 20995  
(949) 760-0404

12899226



UNITED STATES PATENT AND TRADEMARK OFFICE

UNITED STATES DEPARTMENT OF COMMERCE
United States Patent and Trademark Office
Address: COMMISSIONER FOR PATENTS
P.O. Box 1450
Alexandria, Virginia 22313-1450
www.uspto.gov

Table with 5 columns: APPLICATION NO., FILING DATE, FIRST NAMED INVENTOR, ATTORNEY DOCKET NO., CONFIRMATION NO.
Values: 12/366,535, 02/05/2009, Kelly M. Christensen, STRATOS.029A, 7989

7590 03/16/2012
KNOBBE MARTENS OLSON & BEAR LLP
2040 MAIN STREET
FOURTEENTH FLOOR
IRVINE, CA 92614

EXAMINER
ORTIZ DITREN, BELIX M

ART UNIT PAPER NUMBER

2164

NOTIFICATION DATE DELIVERY MODE

03/16/2012

ELECTRONIC

NOTICE OF NON-COMPLIANT INFORMATION DISCLOSURE STATEMENT

An Information Disclosure Statement (IDS) filed 3-8-12 in the above-identified application fails to meet the requirements of 37 CFR 1.97(d) for the reason(s) specified below. Accordingly, the IDS will be placed in the file, but the information referred to therein has not been considered.

The IDS is not compliant with 37 CFR 1.97(d) because:

- [X] The IDS lacks a statement as specified in 37 CFR 1.97(e).
[ ] The IDS lacks the fee set forth in 37 CFR 1.17(p).
[ ] The IDS was filed after the issue fee was paid. Applicant may wish to consider filing a petition to withdraw the application from issue under 37 CFR 1.313(c) to have the IDS considered. See MPEP 1308.

A. Marty Willis

571-272-4200 or 1-888-786-0101
Application Assistance Unit
Office of Data Management



UNITED STATES PATENT AND TRADEMARK OFFICE

UNITED STATES DEPARTMENT OF COMMERCE
United States Patent and Trademark Office
Address: COMMISSIONER FOR PATENTS
P.O. Box 1450
Alexandria, Virginia 22313-1450
www.uspto.gov

Table with 5 columns: APPLICATION NO., FILING DATE, FIRST NAMED INVENTOR, ATTORNEY DOCKET NO., CONFIRMATION NO.
12/366,535 02/05/2009 Kelly M. Christensen STRATOS.029A 7989

20995 7590 04/02/2012
KNOBBE MARTENS OLSON & BEAR LLP
2040 MAIN STREET
FOURTEENTH FLOOR
IRVINE, CA 92614

EXAMINER

ORTIZ DITREN, BELIX M

Table with 2 columns: ART UNIT, PAPER NUMBER

2164

Table with 2 columns: NOTIFICATION DATE, DELIVERY MODE

04/02/2012

ELECTRONIC

Please find below and/or attached an Office communication concerning this application or proceeding.

The time period for reply, if any, is set in the attached communication.

Notice of the Office communication was sent electronically on above-indicated "Notification Date" to the following e-mail address(es):

jcartee@kmob.com
efiling@kmob.com
eOAPilot@kmob.com

<b>Response to Rule 312 Communication</b>	<b>Application No.</b> 12/366,535	<b>Applicant(s)</b> CHRISTENSEN ET AL.
	<b>Examiner</b> BELIX M. ORTIZ	<b>Art Unit</b> 2164

*-- The MAILING DATE of this communication appears on the cover sheet with the correspondence address --*

1.  The amendment filed on 08 March 2012 under 37 CFR 1.312 has been considered, and has been:
- a)  entered.
  - b)  entered as directed to matters of form not affecting the scope of the invention.
  - c)  disapproved because the amendment was filed after the payment of the issue fee.  
Any amendment filed after the date the issue fee is paid must be accompanied by a petition under 37 CFR 1.313(c)(1) and the required fee to withdraw the application from issue.
  - d)  disapproved. See explanation below.
  - e)  entered in part. See explanation below.

	/BELIX M. ORTIZ/ Primary Examiner, Art Unit 2164
--	---



APPLICATION NO.	ISSUE DATE	PATENT NO.	ATTORNEY DOCKET NO.	CONFIRMATION NO.
12/366,535	04/24/2012	8166081	STRATOS.029A	7989

20995 7590 04/04/2012  
KNOBBE MARTENS OLSON & BEAR LLP  
2040 MAIN STREET  
FOURTEENTH FLOOR  
IRVINE, CA 92614

### ISSUE NOTIFICATION

The projected patent number and issue date are specified above.

#### **Determination of Patent Term Adjustment under 35 U.S.C. 154 (b)** (application filed on or after May 29, 2000)

The Patent Term Adjustment is 323 day(s). Any patent to issue from the above-identified application will include an indication of the adjustment on the front page.

If a Continued Prosecution Application (CPA) was filed in the above-identified application, the filing date that determines Patent Term Adjustment is the filing date of the most recent CPA.

Applicant will be able to obtain more detailed information by accessing the Patent Application Information Retrieval (PAIR) WEB site (<http://pair.uspto.gov>).

Any questions regarding the Patent Term Extension or Adjustment determination should be directed to the Office of Patent Legal Administration at (571)-272-7702. Questions relating to issue and publication fee payments should be directed to the Application Assistance Unit (AAU) of the Office of Data Management (ODM) at (571)-272-4200.

APPLICANT(s) (Please see PAIR WEB site <http://pair.uspto.gov> for additional applicants):

Kelly M. Christensen, Marina Del Rey, CA;  
John Phillip Hansen, Austin, TX;  
Thomas Daniel Mock, Sheffield, PA;



UNITED STATES PATENT AND TRADEMARK OFFICE

UNITED STATES DEPARTMENT OF COMMERCE
United States Patent and Trademark Office
Address: COMMISSIONER FOR PATENTS
P.O. Box 1450
Alexandria, Virginia 22313-1450
www.uspto.gov

Table with 5 columns: APPLICATION NO., FILING DATE, FIRST NAMED INVENTOR, ATTORNEY DOCKET NO., CONFIRMATION NO.
12/366,535 02/05/2009 Kelly M. Christensen STRATOS.029A 7989

20995 7590 04/11/2012
KNOBBE MARTENS OLSON & BEAR LLP
2040 MAIN STREET
FOURTEENTH FLOOR
IRVINE, CA 92614

EXAMINER

ORTIZ DITREN, BELIX M

Table with 2 columns: ART UNIT, PAPER NUMBER

2164

Table with 2 columns: NOTIFICATION DATE, DELIVERY MODE

04/11/2012

ELECTRONIC

Please find below and/or attached an Office communication concerning this application or proceeding.

The time period for reply, if any, is set in the attached communication.

Notice of the Office communication was sent electronically on above-indicated "Notification Date" to the following e-mail address(es):

jcartee@kmob.com
efiling@kmob.com
eOAPilot@kmob.com

Art Unit: 2164

### DETAILED ACTION

#### EXAMINER'S AMENDMENT

An examiner's amendment to the record appears below. Should the changes and/or additions be unacceptable to applicant, an amendment may be filed as provided by 37 CFR 1.312. To ensure consideration of such an amendment, it **MUST** be submitted no later than the payment of the issue fee.

Authorization for this examiner's amendment was given in a telephone interview with Don C Pua on 4/4/2012.

Amendment after notice of allowance filed on 3/8/2012 are accepted and approved on 4/2/2012. Additional typo need to be fixed on claim 12.

#### AMENDMENT TO THE CLAIMS:

Claim 12 is amended. Claims 1-2, 10-18, and 20-32 remain pending in the application.

#### WHAT IS CLAIMED IS:

12. (**Currently amended**) A method for combining multiple media content in a receiving system:

obtaining, by the receiving system, a first media broadcast;

outputting on the receiving system a first media content comprised in the first

media broadcast ~~of~~;

Art Unit: 2164

obtaining, by the receiving system, a second media content and uniquely identifying data specific to the secondary media content via a secondary media content transmission discrete from the first media content broadcast;

obtaining at least one criterion correlated to the second media content;

evaluating the at least one criterion in reference to usage data for the receiving system;

outputting, based at least partly on the evaluation, at least the second media content on the receiving system, wherein the second media content is configured to be concurrently presented in association with the first media content; and

sending a response containing at least uniquely identifying data associated with the second media content.

### *Allowable Subject Matter*

In response to communications files on September 30, 2011, Claims 1-2, 10-13, and 15-18 are amended; claims 3-9 and 19 are cancelled; and claims 20-32 are added per applicant's request. Therefore, claims 1-2, 10-18, and 20-32 are presently pending in the application.

Claims 1-2, 10-18, and 20-32 are allowed based on Applicant's amended claims filed 9/30/2011.

### *Conclusion*



Art Unit: 2164

Any inquiry concerning this communication or earlier communications from the examiner should be directed to Belix M. Ortiz whose telephone number is 571-272-4081. The examiner can normally be reached on Monday-Friday 9am-5pm. The fax phone number for the organization where this application or proceeding is assigned is 571-273-8300.

Information regarding the status of an application may be obtained from the Patent Application Information Retrieval (PAIR) system. Status information for published applications may be obtained from either Private PAIR or Public PAIR. Status information for unpublished applications is available through Private PAIR only. For more information about the PAIR system, see <http://pair-direct.uspto.gov>. Should you have questions on access to the Private PAIR system, contact the Electronic Business Center (EBC) at 866-217-9197 (toll-free).

Belix M Ortiz  
Primary Examiner  
Art Unit 2164  
April 5, 2012

/Belix M. Ortiz/  
Examiner, Art Unit 2164

# UNITED STATES PATENT AND TRADEMARK OFFICE CERTIFICATE OF CORRECTION

**PATENT NO.** : 8,166,081  
**APPLICATION NO.** : 12/366,535  
**ISSUE DATE** : April 24, 2012  
**INVENTOR(S)** : Kelly M. Christensen, et al.

Page 1 of 1

It is certified that error appears in the above-identified patent and that said Letters Patent is hereby corrected as shown below:

Issued Patent		Description of Discrepancy
Column	Line	
(Item 56) Page 2 Col. 2	41	Under Other Publications, change ""Sirus" to --"Sirius--.
6	45	Change "WIFI," to --WiFi--.
10	40	Change "information." to --information--.
28	50	Change "on going," to --ongoing--.
32	28	Change "farther" to --further--.
34	52	In Claim 2, after "medium" insert --are--.
34	61	In Claim 5, change "broadcast of;" to --broadcast;--.
35	11	In Claim 6, after "media" delete "signal-".
35	20	In Claim 8, before "instance" change "an" to --the--.
35	21	In Claim 8, before "outputting" insert --the--.
35	28	In Claim 9, after "media" delete "signal".
35	46	In Claim 11, change "one of one the" to --one of the--.
36	47	In Claim 20, change "Mondial," to --Mondiale,--.
36	54	In Claim 22, change "data that data that" to --data that--.

15206701

**MAILING ADDRESS OF SENDER:**

Morgan R. Coates  
 KNOBBE, MARTENS, OLSON & BEAR, LLP  
 2040 Main Street, 14<sup>th</sup> Floor  
 Irvine, California 92614

DOCKET NO. STRATOS.029A

## Electronic Patent Application Fee Transmittal

<b>Application Number:</b>	12366535
<b>Filing Date:</b>	05-Feb-2009
<b>Title of Invention:</b>	SYSTEM AND METHOD FOR ADVERTISEMENT TRANSMISSION AND DISPLAY
<b>First Named Inventor/Applicant Name:</b>	Kelly M. Christensen
<b>Filer:</b>	Morgan Ross Coates/Millie Lein
<b>Attorney Docket Number:</b>	STRATOS.029A

Filed as Small Entity

### Utility under 35 USC 111(a) Filing Fees

Description	Fee Code	Quantity	Amount	Sub-Total in USD(\$)
<b>Basic Filing:</b>				
<b>Pages:</b>				
<b>Claims:</b>				
<b>Miscellaneous-Filing:</b>				
<b>Petition:</b>				
<b>Patent-Appeals-and-Interference:</b>				
<b>Post-Allowance-and-Post-Issuance:</b>				
Certificate of Correction	1811	1	100	100

**Extension-of-Time:**

Volkswagen Exhibit 1002

Description	Fee Code	Quantity	Amount	Sub-Total in USD(\$)
<b>Miscellaneous:</b>				
<b>Total in USD (\$)</b>				<b>100</b>

## Electronic Acknowledgement Receipt

<b>EFS ID:</b>	15667442
<b>Application Number:</b>	12366535
<b>International Application Number:</b>	
<b>Confirmation Number:</b>	7989
<b>Title of Invention:</b>	SYSTEM AND METHOD FOR ADVERTISEMENT TRANSMISSION AND DISPLAY
<b>First Named Inventor/Applicant Name:</b>	Kelly M. Christensen
<b>Customer Number:</b>	20995
<b>Filer:</b>	Morgan Ross Coates/Daniela Lopez
<b>Filer Authorized By:</b>	Morgan Ross Coates
<b>Attorney Docket Number:</b>	STRATOS.029A
<b>Receipt Date:</b>	01-MAY-2013
<b>Filing Date:</b>	05-FEB-2009
<b>Time Stamp:</b>	17:38:01
<b>Application Type:</b>	Utility under 35 USC 111(a)

### Payment information:

Submitted with Payment	yes
Payment Type	Credit Card
Payment was successfully received in RAM	\$100
RAM confirmation Number	4747
Deposit Account	111410
Authorized User	KNOBBE MARTENS OLSON AND BEAR

The Director of the USPTO is hereby authorized to charge indicated fees and credit any overpayment as follows:

Charge any Additional Fees required under 37 C.F.R. Section 1.16 (National application filing, search, and examination fees)

Charge any Additional Fees required under 37 C.F.R. Section 1.17 (Patent application and reexamination processing fees)

Volkswagen Exhibit 1002

<b>File Listing:</b>					
<b>Document Number</b>	<b>Document Description</b>	<b>File Name</b>	<b>File Size(Bytes)/ Message Digest</b>	<b>Multi Part /.zip</b>	<b>Pages (if appl.)</b>
1	Transmittal Letter	cert_transmittal_stratos_029a.pdf	34410 <small>c7e244e1af3e2678c782778f9696416a78745c8b</small>	no	1
<b>Warnings:</b>					
<b>Information:</b>					
2	Request for Certificate of Correction	request_cert_correction_stratos_029a.pdf	35344 <small>bcd548a096f91bdb06b9ef9e8b8489ba7546cfe</small>	no	1
<b>Warnings:</b>					
<b>Information:</b>					
3	Fee Worksheet (SB06)	fee-info.pdf	29991 <small>dadfcf10173ab856dc6faade6ca9b90f1ca3f3d5</small>	no	2
<b>Warnings:</b>					
<b>Information:</b>					
<b>Total Files Size (in bytes):</b>			99745		

This Acknowledgement Receipt evidences receipt on the noted date by the USPTO of the indicated documents, characterized by the applicant, and including page counts, where applicable. It serves as evidence of receipt similar to a Post Card, as described in MPEP 503.

**New Applications Under 35 U.S.C. 111**

If a new application is being filed and the application includes the necessary components for a filing date (see 37 CFR 1.53(b)-(d) and MPEP 506), a Filing Receipt (37 CFR 1.54) will be issued in due course and the date shown on this Acknowledgement Receipt will establish the filing date of the application.

**National Stage of an International Application under 35 U.S.C. 371**

If a timely submission to enter the national stage of an international application is compliant with the conditions of 35 U.S.C. 371 and other applicable requirements a Form PCT/DO/EO/903 indicating acceptance of the application as a national stage submission under 35 U.S.C. 371 will be issued in addition to the Filing Receipt, in due course.

**New International Application Filed with the USPTO as a Receiving Office**

If a new international application is being filed and the international application includes the necessary components for an international filing date (see PCT Article 11 and MPEP 1810), a Notification of the International Application Number and of the International Filing Date (Form PCT/RO/105) will be issued in due course, subject to prescriptions concerning national security, and the date shown on this Acknowledgement Receipt will establish the international filing date of the application.

Please Direct All Correspondence to Customer Number 20995

**REQUEST FOR CERTIFICATE OF CORRECTION**

Inventor	:	Kelly M. Christensen, et al.
App. No.	:	12/366535
Filed	:	February 5, 2009
Patent No.	:	8,166,081
Issue Date	:	April 24, 2012
Title	:	SYSTEM AND METHOD FOR ADVERTISEMENT TRANSMISSION AND DISPLAY
Conf No.	:	7989

Commissioner for Patents  
Office of Data Management Attention: Certificates of Correction Branch  
P.O. Box 1450  
Alexandria, VA 22313-1450

Dear Sir:

Enclosed for filing is a Certificate of Correction in connection with the above-identified patent.

Some of the errors cited in the Certificate of Correction appear to have been incurred through the fault of the PTO (see 35 USC § 254, 37 CFR § 1.322, and MPEP § 1480). However, because this may not apply to each item in the Certificate of Correction, the \$100 fee under 37 CFR §§ 1.20(a) is submitted herewith. Please charge any additional fees to our Deposit Account No. 11-1410.

Respectfully submitted,

KNOBBE, MARTENS, OLSON & BEAR, LLP

Dated: 5/1/2013

By: 

Morgan R. Coates  
Registration No. 64,970  
Attorney of Record  
Customer No. 20995  
(949) 760-0404

UNITED STATES PATENT AND TRADEMARK OFFICE  
**CERTIFICATE OF CORRECTION**

PATENT NO. : 8,166,081 B2  
APPLICATION NO. : 12/366535  
DATED : April 24, 2012  
INVENTOR(S) : Kelly M. Christensen et al.

Page 1 of 1

It is certified that error appears in the above-identified patent and that said Letters Patent is hereby corrected as shown below:

<b>Issued Patent</b>		
<b>Column</b>	<b>Line</b>	<b>Description of Discrepancy</b>
(Item 56) Title Page 2 Col. 2	41	Under Other Publications, change ““Sirus” to --“Sirius--.
In the Specifications:		
6	45	Change “WIFI,” to --WiFi--.
10	40	Change “information.” to --information--.
28	50	Change “on going.” to --ongoing--.
32	28	Change “farther” to --further--.
In the Claims:		
34	52	In Claim 2, after “medium” insert --are--.
34	61	In Claim 5, change “broadcast of;” to --broadcast;--.
35	11	In Claim 6, after “media” delete “signal-”.
35	20	In Claim 8, before “instance” change “an” to --the--.
35	21	In Claim 8, before “outputting” insert --the--.
35	28	In Claim 9, after “media” delete “signal”.
35	46	In Claim 11, change “one of one the” to --one of the--.
36	47	In Claim 20, change “Mondial,” to --Mondiale,--.
36	54	In Claim 22, change “data that data that” to --data that--.

Signed and Sealed this  
Fourth Day of June, 2013



Teresa Stanek Rea  
*Acting Director of the United States Patent and Trademark Office*





UNITED STATES PATENT AND TRADEMARK OFFICE

UNITED STATES DEPARTMENT OF COMMERCE
United States Patent and Trademark Office
Address: COMMISSIONER FOR PATENTS
P.O. Box 1450
Alexandria, Virginia 22313-1450
www.uspto.gov

Table with 4 columns: APPLICATION NUMBER (12/366,535), PATENT NUMBER (8166081), GROUP ART UNIT (2164), REQUEST ID (23768)

PAIR Correspondence Address/Fee Address Change

The following fields have been changed to Customer Number 197 on 08/23/2016 via Private PAIR in view of the certification copied below that authorized the change.

- Maintenance Fee Address

The address for Customer Number 197 is:

197
CPA GLOBAL LIMITED
2318 Mill Road 12th Floor
ALEXANDRIA, VA 22314

I certify, in accordance with 37 CFR 1.4(d)(4) that I am:

An attorney or Agent of Record registered to practice before the Patent and Trademark Office who has been given power of attorney in this application

Table with 2 columns: Signature ( /Morgan Coates/ ), Name ( Morgan Coates ), Registration Number ( 64970 )

AO 120 (Rev. 08/10)

<b>TO: Mail Stop 8</b> <b>Director of the U.S. Patent and Trademark Office</b> <b>P.O. Box 1450</b> <b>Alexandria, VA 22313-1450</b>	<b>REPORT ON THE</b> <b>FILING OR DETERMINATION OF AN</b> <b>ACTION REGARDING A PATENT OR</b> <b>TRADEMARK</b>
---	---

In Compliance with 35 U.S.C. § 290 and/or 15 U.S.C. § 1116 you are hereby advised that a court action has been filed in the U.S. District Court Western District of Texas on the following

Trademarks or  Patents. (  the patent action involves 35 U.S.C. § 292.):

DOCKET NO.	DATE FILED	U.S. DISTRICT COURT <u>Western District of Texas</u>
PLAINTIFF <b>STRATOSAUDIO, INC.</b>		DEFENDANT <b>VOLVO CARS OF NORTH AMERICA, LLC and VOLVO CAR USA, LLC</b>

PATENT OR TRADEMARK NO.	DATE OF PATENT OR TRADEMARK	HOLDER OF PATENT OR TRADEMARK
1 8166081	4/24/2012	StratosAudio, Inc.
2 8688028	4/1/2014	StratosAudio, Inc.
3 8903307	12/2/2014	StratosAudio, Inc.
4 9584843	2/28/2017	StratosAudio, Inc.
5 8200203	6/12/2012	StratosAudio, Inc.
6 9294806	3/22/2016	StratosAudio, Inc.
7 9355405	5/31/2016	StratosAudio, Inc.

In the above—entitled case, the following patent(s)/ trademark(s) have been included:

DATE INCLUDED	INCLUDED BY
	<input type="checkbox"/> Amendment <input type="checkbox"/> Answer <input type="checkbox"/> Cross Bill <input type="checkbox"/> Other Pleading
PATENT OR TRADEMARK NO.	DATE OF PATENT OR TRADEMARK
1	
2	
3	
4	
5	

In the above—entitled case, the following decision has been rendered or judgement issued:

DECISION/JUDGEMENT
--------------------

CLERK	(BY) DEPUTY CLERK	DATE
-------	-------------------	------

Copy 1—Upon initiation of action, mail this copy to Director    Copy 3—Upon termination of action, mail this copy to Director  
 Copy 2—Upon filing document adding patent(s), mail this copy to Director    Copy 4—Case file copy

AO 120 (Rev. 08/10)

Case No.: 6:20-cv-1126

<b>TO: Mail Stop 8</b> <b>Director of the U.S. Patent and Trademark Office</b> <b>P.O. Box 1450</b> <b>Alexandria, VA 22313-1450</b>	<b>REPORT ON THE</b> <b>FILING OR DETERMINATION OF AN</b> <b>ACTION REGARDING A PATENT OR</b> <b>TRADEMARK</b>
---	---

In Compliance with 35 U.S.C. § 290 and/or 15 U.S.C. § 1116 you are hereby advised that a court action has been filed in the U.S. District Court Western District of Texas on the following

Trademarks or  Patents. (  the patent action involves 35 U.S.C. § 292.):

DOCKET NO.	DATE FILED	U.S. DISTRICT COURT Western District of Texas
PLAINTIFF STRATOSAUDIO, INC.		DEFENDANT MAZDA MOTOR OF AMERICA, INC.

PATENT OR TRADEMARK NO.	DATE OF PATENT OR TRADEMARK	HOLDER OF PATENT OR TRADEMARK
1 8166081	4/24/2012	StratosAudio, Inc.
2 8688028	4/1/2014	StratosAudio, Inc.
3 8903307	12/2/2014	StratosAudio, Inc.
4 9584843	2/28/2017	StratosAudio, Inc.
5 8200203	6/12/2012	StratosAudio, Inc.
6 9294806	3/22/2016	StratosAudio, Inc.
7 9355405	5/31/2016	StratosAudio, Inc.

In the above—entitled case, the following patent(s)/ trademark(s) have been included:

DATE INCLUDED	INCLUDED BY
	<input type="checkbox"/> Amendment <input type="checkbox"/> Answer <input type="checkbox"/> Cross Bill <input type="checkbox"/> Other Pleading
PATENT OR TRADEMARK NO.	DATE OF PATENT OR TRADEMARK
1	
2	
3	
4	
5	

In the above—entitled case, the following decision has been rendered or judgement issued:

DECISION/JUDGEMENT
--------------------

CLERK	(BY) DEPUTY CLERK	DATE
-------	-------------------	------

Copy 1—Upon initiation of action, mail this copy to Director    Copy 3—Upon termination of action, mail this copy to Director  
 Copy 2—Upon filing document adding patent(s), mail this copy to Director    Copy 4—Case file copy

AO 120 (Rev. 08/10)

<b>TO: Mail Stop 8</b> <b>Director of the U.S. Patent and Trademark Office</b> <b>P.O. Box 1450</b> <b>Alexandria, VA 22313-1450</b>	<b>REPORT ON THE</b> <b>FILING OR DETERMINATION OF AN</b> <b>ACTION REGARDING A PATENT OR</b> <b>TRADEMARK</b>
---	---

In Compliance with 35 U.S.C. § 290 and/or 15 U.S.C. § 1116 you are hereby advised that a court action has been filed in the U.S. District Court Western District of Texas on the following

Trademarks or  Patents. (  the patent action involves 35 U.S.C. § 292.):

DOCKET NO.	DATE FILED	U.S. DISTRICT COURT Western District of Texas
PLAINTIFF STRATOSAUDIO, INC.		DEFENDANT VOLKSWAGEN GROUP OF AMERICA, INC.

PATENT OR TRADEMARK NO.	DATE OF PATENT OR TRADEMARK	HOLDER OF PATENT OR TRADEMARK
1 8166081	4/24/2012	StratosAudio, Inc.
2 8688028	4/1/2014	StratosAudio, Inc.
3 8903307	12/2/2014	StratosAudio, Inc.
4 9584843	2/28/2017	StratosAudio, Inc.
5 8200203	6/12/2012	StratosAudio, Inc.
6 9294806	3/22/2016	StratosAudio, Inc.
7 9355405	5/31/2016	StratosAudio, Inc.

In the above—entitled case, the following patent(s)/ trademark(s) have been included:

DATE INCLUDED	INCLUDED BY
	<input type="checkbox"/> Amendment <input type="checkbox"/> Answer <input type="checkbox"/> Cross Bill <input type="checkbox"/> Other Pleading
PATENT OR TRADEMARK NO.	DATE OF PATENT OR TRADEMARK
1	
2	
3	
4	
5	

In the above—entitled case, the following decision has been rendered or judgement issued:

DECISION/JUDGEMENT
--------------------

CLERK	(BY) DEPUTY CLERK	DATE
-------	-------------------	------

Copy 1—Upon initiation of action, mail this copy to Director    Copy 3—Upon termination of action, mail this copy to Director  
 Copy 2—Upon filing document adding patent(s), mail this copy to Director    Copy 4—Case file copy

AO 120 (Rev. 08/10)

<b>TO: Mail Stop 8</b> <b>Director of the U.S. Patent and Trademark Office</b> <b>P.O. Box 1450</b> <b>Alexandria, VA 22313-1450</b>	<b>REPORT ON THE</b> <b>FILING OR DETERMINATION OF AN</b> <b>ACTION REGARDING A PATENT OR</b> <b>TRADEMARK</b>
---	---

In Compliance with 35 U.S.C. § 290 and/or 15 U.S.C. § 1116 you are hereby advised that a court action has been filed in the U.S. District Court Western District of Texas on the following

Trademarks or  Patents. (  the patent action involves 35 U.S.C. § 292.):

DOCKET NO.	DATE FILED	U.S. DISTRICT COURT <u>Western District of Texas</u>
PLAINTIFF <b>STRATOSAUDIO, INC.</b>		DEFENDANT <b>HYUNDAI MOTOR AMERICA</b>

PATENT OR TRADEMARK NO.	DATE OF PATENT OR TRADEMARK	HOLDER OF PATENT OR TRADEMARK
1 8166081	4/24/2012	StratosAudio, Inc.
2 8688028	4/1/2014	StratosAudio, Inc.
3 8903307	12/2/2014	StratosAudio, Inc.
4 9584843	2/28/2017	StratosAudio, Inc.
5 8200203	6/12/2012	StratosAudio, Inc.
6 9294806	3/22/2016	StratosAudio, Inc.
7 9355405	5/31/2016	StratosAudio, Inc.

In the above—entitled case, the following patent(s)/ trademark(s) have been included:

DATE INCLUDED	INCLUDED BY
	<input type="checkbox"/> Amendment <input type="checkbox"/> Answer <input type="checkbox"/> Cross Bill <input type="checkbox"/> Other Pleading
PATENT OR TRADEMARK NO.	DATE OF PATENT OR TRADEMARK
1	
2	
3	
4	
5	

In the above—entitled case, the following decision has been rendered or judgement issued:

DECISION/JUDGEMENT
--------------------

CLERK	(BY) DEPUTY CLERK	DATE
-------	-------------------	------

Copy 1—Upon initiation of action, mail this copy to Director    Copy 3—Upon termination of action, mail this copy to Director  
 Copy 2—Upon filing document adding patent(s), mail this copy to Director    Copy 4—Case file copy