



[54] TWO PIECE ASSEMBLY FOR THE SELECTION OF PINOUTS AND BOND OPTIONS ON A SEMICONDUCTOR DEVICE

[75] Inventors: Tyler A. Lowrey, Boise, Id.; Alan R. Reinberg, Westport, Conn.; Kevin D. Martin, Boise, Id.

[73] Assignee: Micron Technology, Inc., Boise, Id.

[21] Appl. No.: 221,974

[22] Filed: Apr. 1, 1994

Related U.S. Application Data

[63] Continuation of Ser. No. 811,768, Dec. 20, 1991, abandoned.

[51] Int. Cl.<sup>5</sup> ..... H01L 23/48; H01L 29/44; H01L 29/52; H01L 29/60

[52] U.S. Cl. .... 257/666; 257/698; 257/692

[58] Field of Search ..... 257/691, 698, 692, 693, 257/690, 666

[56] References Cited

U.S. PATENT DOCUMENTS

3,663,868	5/1972	Noguchi et al. ....	257/698
4,901,136	2/1990	Neugebauer et al. ....	257/691
4,922,324	5/1990	Sudo .....	257/698
5,045,921	9/1991	Lin et al. ....	257/698
5,302,849	4/1994	Covasin .....	257/676

OTHER PUBLICATIONS

"Z-Axis Conductive Adhesive" Zymet Inc., 7 Great Meadow Lane, E. Hanover, N.J. 07936.

Primary Examiner—Andrew J. James

Assistant Examiner—S. V. Clark

Attorney, Agent, or Firm—Kevin D. Martin

[57] ABSTRACT

The invention comprises a semiconductor package which allows pinouts and bond options to be customized after the encasement of a die in plastic, ceramic, or other suitable materials. A first embodiment of the invention has a first assembly comprising an encapsulated die having bond pads connected to bond wires which terminate in exterior pad portions on the exterior of the encapsulant. Conductive paths which are part of a second assembly electrically connect with the exterior pad portions of the first assembly and pass signals to device pinouts, which can be leads or other connecting means, to an electronic device into which the module is installed. By selectively connecting the exterior pad portions of the first assembly to the connection points of the conductive paths of the second assembly, the device pinouts and bond options can be selected. To manufacture a device having different pinouts or bond options, a bottom section having a different design is used.

20 Claims, 7 Drawing Sheets

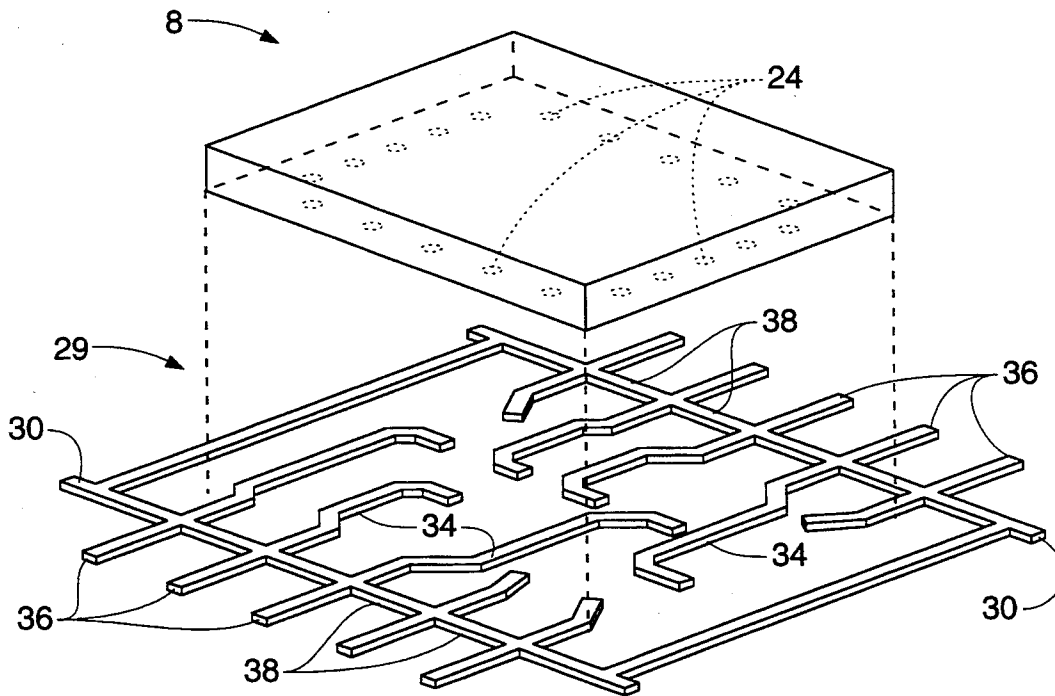

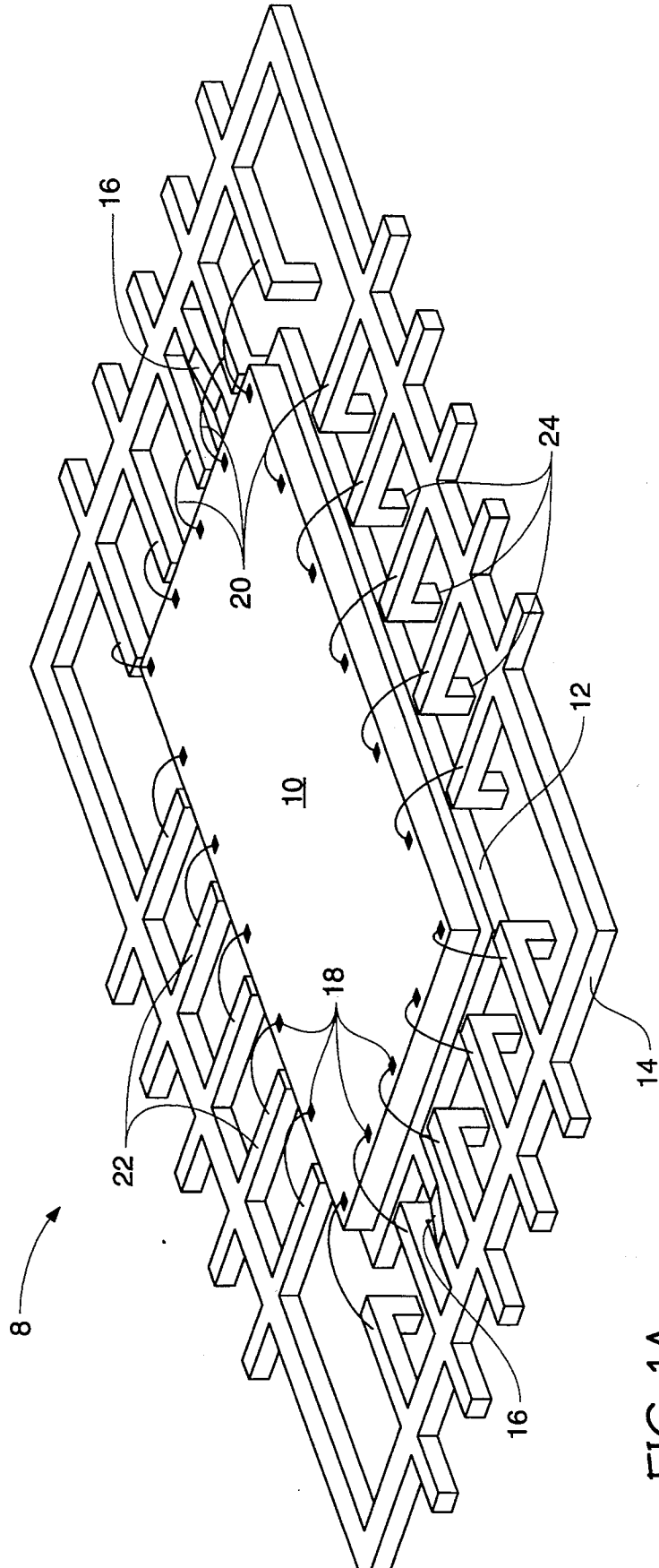

FIG. 1A

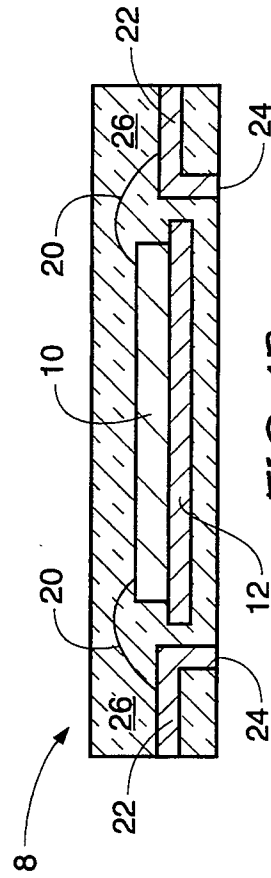

FIG. 1B

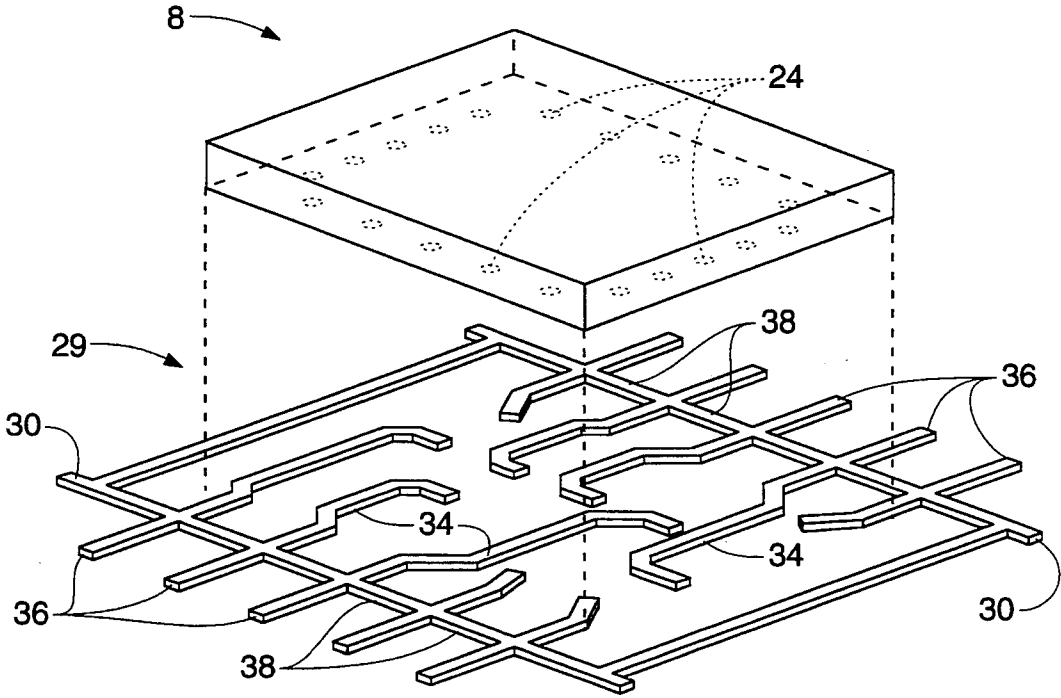

FIG. 2A

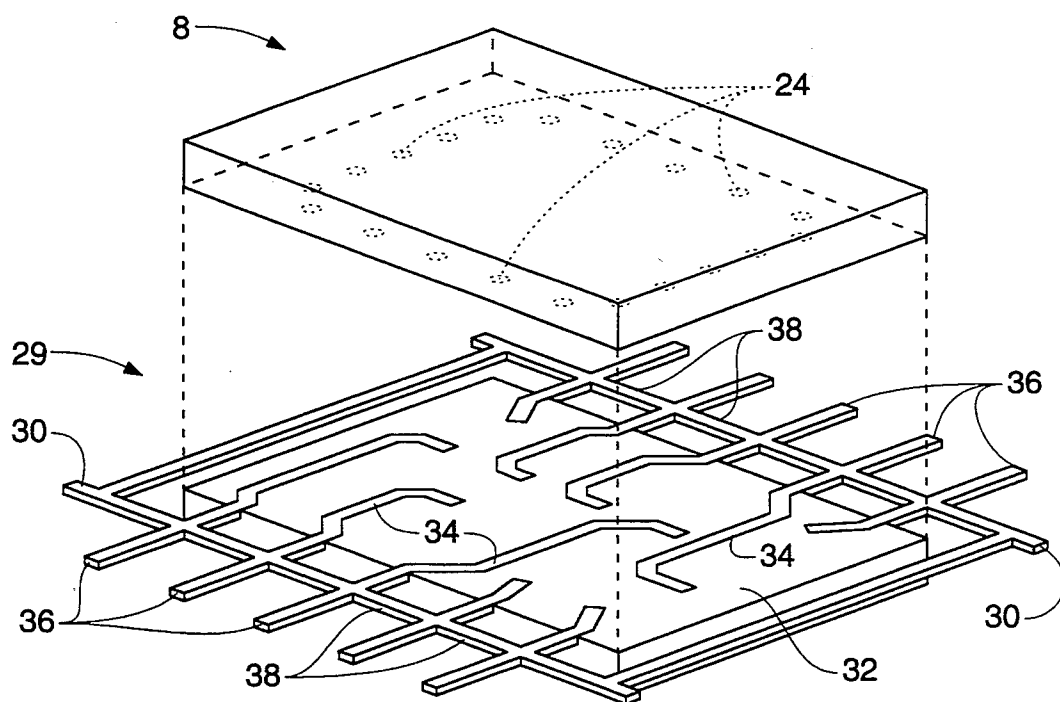

FIG. 2B

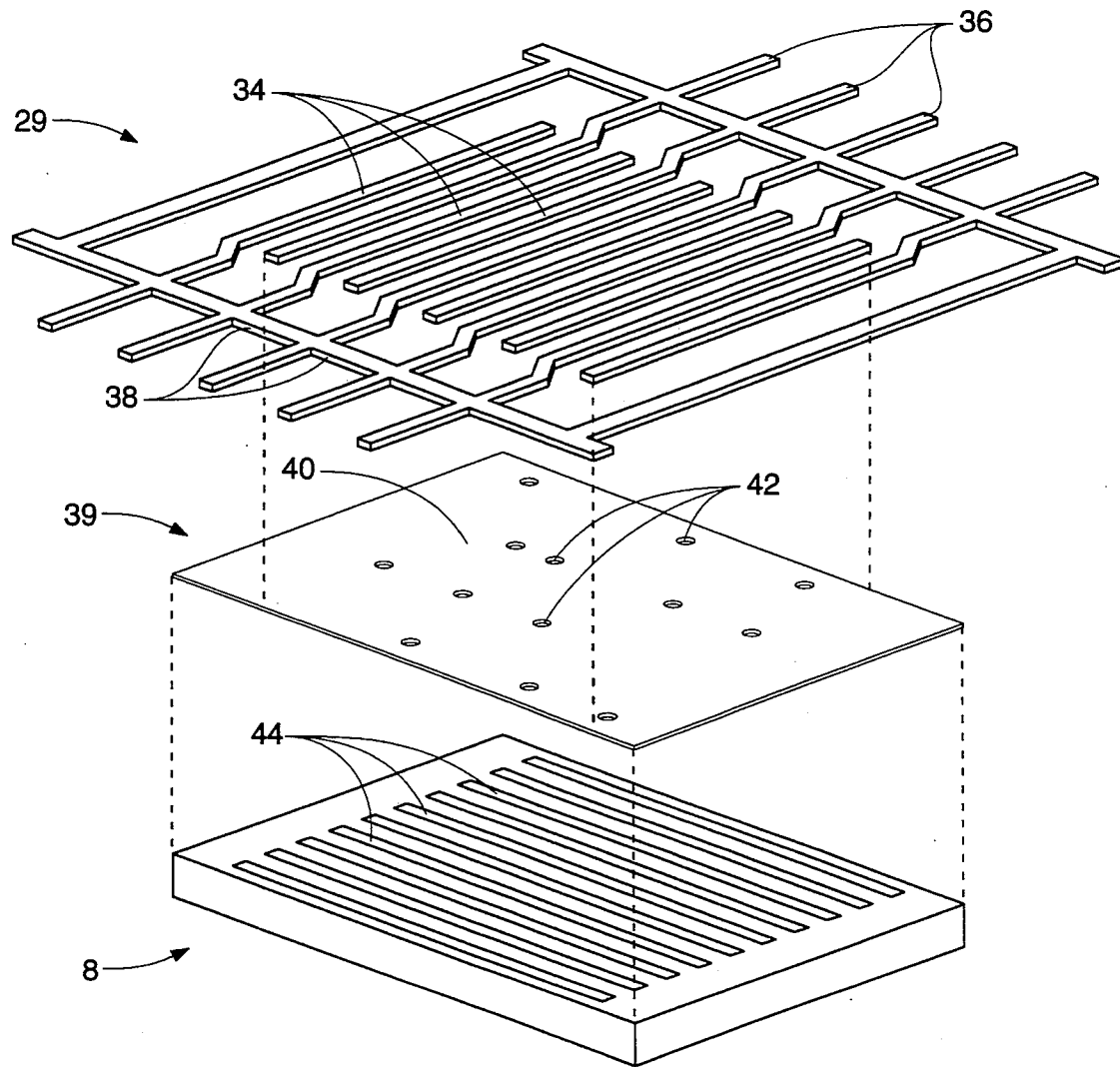

FIG. 3

# Explore Litigation Insights

Docket Alarm provides insights to develop a more informed litigation strategy and the peace of mind of knowing you're on top of things.

## Real-Time Litigation Alerts



Keep your litigation team up-to-date with **real-time alerts** and advanced team management tools built for the enterprise, all while greatly reducing PACER spend.

Our comprehensive service means we can handle Federal, State, and Administrative courts across the country.

## Advanced Docket Research



With over 230 million records, Docket Alarm's cloud-native docket research platform finds what other services can't. Coverage includes Federal, State, plus PTAB, TTAB, ITC and NLRB decisions, all in one place.

Identify arguments that have been successful in the past with full text, pinpoint searching. Link to case law cited within any court document via Fastcase.

## Analytics At Your Fingertips



Learn what happened the last time a particular judge, opposing counsel or company faced cases similar to yours.

Advanced out-of-the-box PTAB and TTAB analytics are always at your fingertips.

## API

Docket Alarm offers a powerful API (application programming interface) to developers that want to integrate case filings into their apps.

## LAW FIRMS

Build custom dashboards for your attorneys and clients with live data direct from the court.

Automate many repetitive legal tasks like conflict checks, document management, and marketing.

## FINANCIAL INSTITUTIONS

Litigation and bankruptcy checks for companies and debtors.

## E-DISCOVERY AND LEGAL VENDORS

Sync your system to PACER to automate legal marketing.