

(12) **United States Patent**  
**Pelland et al.**

(10) **Patent No.:** **US 8,571,544 B2**  
(45) **Date of Patent:** **Oct. 29, 2013**

(54) **SYSTEM WITH WIRELESS EARPHONES**  
(75) Inventors: **Michael J. Pelland**, Princeton, WI (US);  
**Michael J. Koss**, Milwaukee, WI (US);  
**Michael Sagan**, Marshall, WI (US);  
**Steven Reckamp**, Brooklyn, NY (US);  
**Gregory J. Hallingstad**, Madison, WI (US);  
**Jeffrey K. Bovee**, Lake Geneva, WI (US);  
**Morgan J. Lowery**, DeForest, WI (US)

(73) Assignee: **Koss Corporation**, Milwaukee, WI (US)

(\* ) Notice: Subject to any disclaimer, the term of this patent is extended or adjusted under 35 U.S.C. 154(b) by 0 days.

(21) Appl. No.: **13/459,291**

(22) Filed: **Apr. 30, 2012**

(65) **Prior Publication Data**  
US 2012/0213381 A1 Aug. 23, 2012

**Related U.S. Application Data**

(63) Continuation of application No. 12/936,488, filed as application No. PCT/US2009/039754 on Apr. 7, 2009, now Pat. No. 8,190,203.

(60) Provisional application No. 61/123,265, filed on Apr. 7, 2008.

(51) **Int. Cl.**  
**H04W 40/00** (2009.01)

(52) **U.S. Cl.**  
USPC ..... **455/425**

(58) **Field of Classification Search**  
USPC ..... 455/569.1, 462, 466, 556.1, 66.1,  
455/343.2, 575.2, 553.1; 381/74, 57, 401,  
381/17, 103, 309

See application file for complete search history.

(56) **References Cited**

U.S. PATENT DOCUMENTS

5,784,685 A 7/1998 Stanford et al.  
6,792,091 B2 9/2004 Lemchen et al.

(Continued)

FOREIGN PATENT DOCUMENTS

JP 2004-320597 A 11/2004  
WO WO 2006/047724 A2 5/2006

(Continued)

OTHER PUBLICATIONS

Supplementary European Search Report for European Application No. 09731146.8 mailed Jun. 10, 2011, 7 pages.

(Continued)

*Primary Examiner* — Kiet Doan

(74) *Attorney, Agent, or Firm* — K&L Gates LLP

(57) **ABSTRACT**

A system comprising a wireless network adapter and a pair of earphone. The wireless network adapter is external to a digital audio player and configured to connect to the digital audio player via an audio jack of the digital audio player. The wireless network adapter is for encoding analog audio received from the digital audio player into digital format and wirelessly transmitting the digitally-formatted audio. The pair of earphones is in direct wireless communication with the wireless network adapter and are configured to be worn simultaneously by a user. Each earphone in the pair of earphones comprises: (i) a transceiver that is for receiving the digitally-formatted audio from the wireless network adapter via the wireless network, and converting the digitally-formatted audio received via the wireless network to analog audio signals; and (ii) at least one acoustic transducer connected to the transceiver, wherein the at least one acoustic transducer is for outputting the analog audio signals.

**7 Claims, 16 Drawing Sheets**

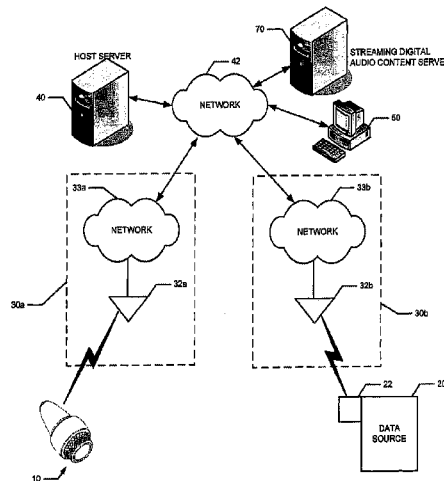

(56)

**References Cited**

U.S. PATENT DOCUMENTS

6,937,712 B2 8/2005 Lemchen et al.  
 7,003,515 B1 2/2006 Glaser  
 7,027,311 B2 4/2006 Vanderelli  
 7,099,370 B2 8/2006 Takahashi  
 7,120,388 B2 10/2006 Hall  
 7,139,585 B2 11/2006 Hachimura et al.  
 7,599,679 B2 10/2009 Awiszus  
 7,697,899 B2 4/2010 Rofougaran  
 7,764,775 B2 7/2010 Tarkoff et al.  
 7,805,210 B2 9/2010 Cucos  
 2004/0157649 A1\* 8/2004 Jannard et al. .... 455/569.1  
 2005/0064853 A1 3/2005 Radpour  
 2005/0198233 A1 9/2005 Manchester  
 2005/0240296 A1\* 10/2005 Nishiguchi et al. .... 700/94  
 2006/0206487 A1 9/2006 Harada  
 2006/0212442 A1 9/2006 Conrad  
 2006/0212444 A1 9/2006 Handman  
 2007/0008984 A1 1/2007 Philips  
 2007/0037615 A1 2/2007 Glezerman  
 2007/0049198 A1 3/2007 Walsh et al.  
 2007/0116316 A1 5/2007 Goldberg  
 2007/0147630 A1 6/2007 Chiloyan  
 2007/0150963 A1\* 6/2007 Lee et al. .... 726/27  
 2007/0165875 A1 7/2007 Rezvani  
 2007/0230727 A1 10/2007 Sanguino

2008/0004052 A1\* 1/2008 Bloebaum et al. .... 455/466  
 2008/0062939 A1 3/2008 Van Horn  
 2008/0076489 A1\* 3/2008 Rosener et al. .... 455/575.2  
 2008/0101279 A1 5/2008 Russell  
 2008/0291891 A1 11/2008 Jerlhagen  
 2009/0063703 A1\* 3/2009 Finkelstein et al. .... 709/240  
 2010/0246788 A1 9/2010 Menard et al.

FOREIGN PATENT DOCUMENTS

WO WO 2007/136620 A2 11/2007  
 WO WO 2007/139578 A1 12/2007  
 WO WO 2008/054985 A2 5/2008  
 WO WO 2009/086555 A1 7/2009

OTHER PUBLICATIONS

International Search Report for International Application No. PCT/US09/39754 mailed Jun. 11, 2009, 2 pages.  
 International Preliminary Examination Report for International Application No. PCT/US09/39754 mailed Oct. 28, 2010, 8 pages.  
 Written Opinion of the International Searching Authority for International Application No. PCT/US09/39754 mailed Jun. 11, 2009, 5 pages.  
 IT Review, "LTB 802.11 WiFi Headphones", <http://itreview.belproject.com/item/1536> accessed on Mar. 13, 2008 (4 pages).

\* cited by examiner

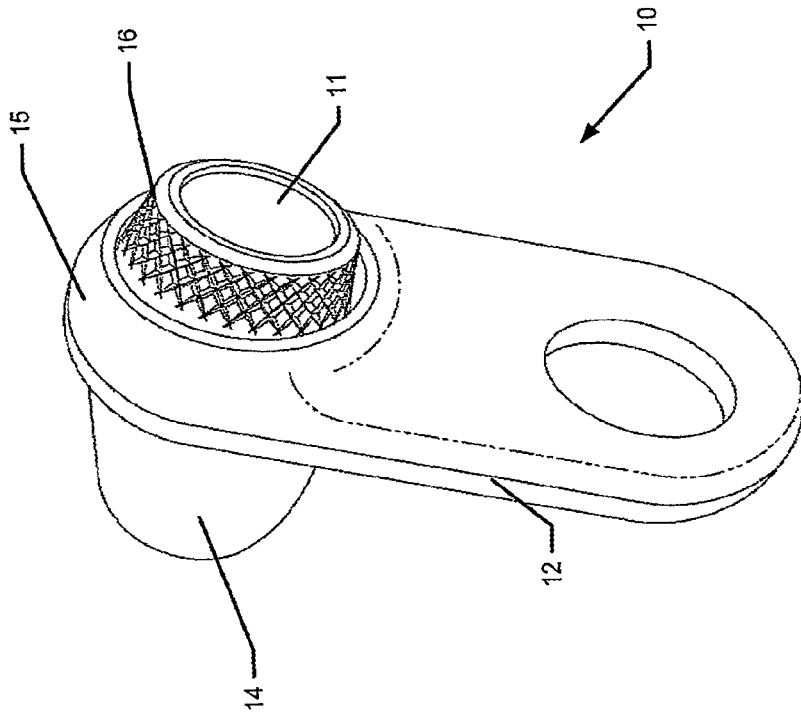

**Fig. 1B**

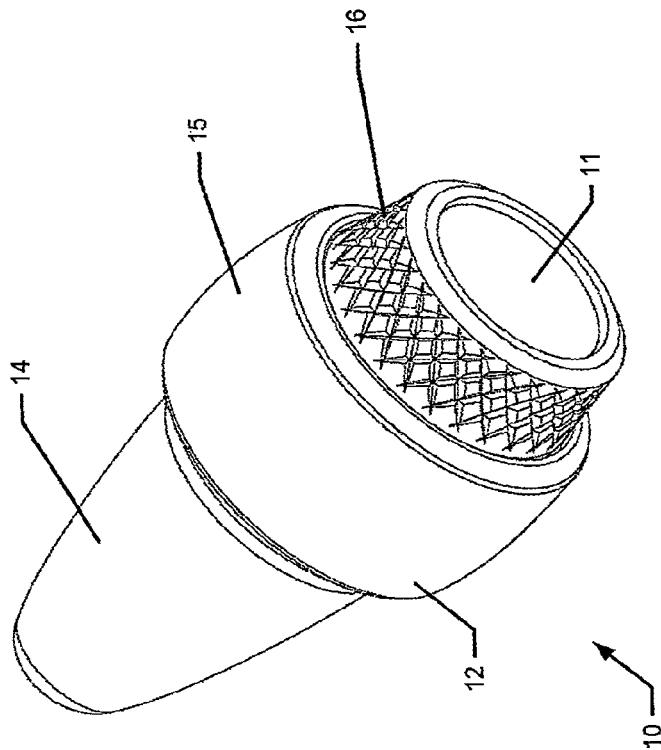

**Fig. 1A**

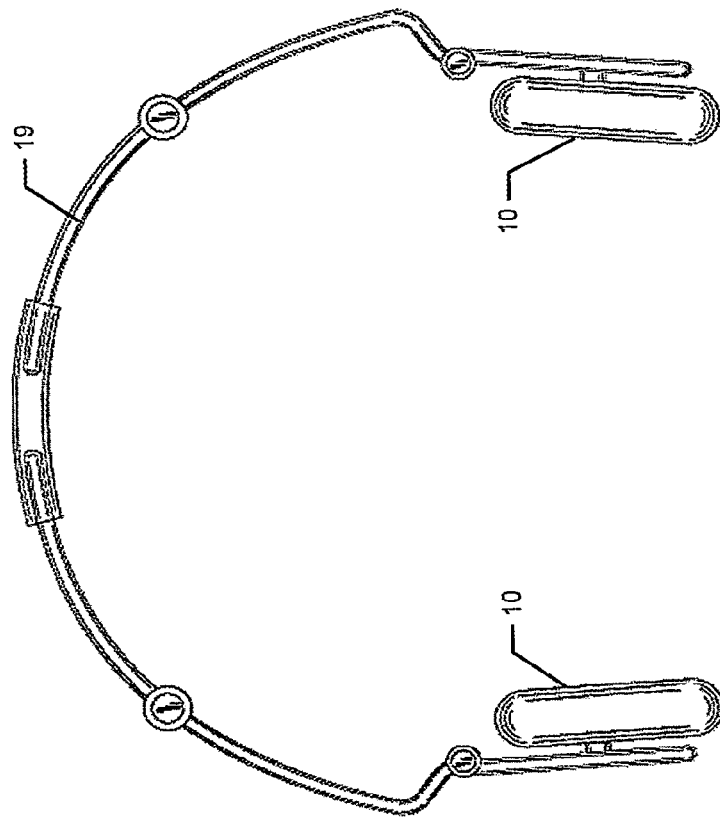

**Fig. 1C**

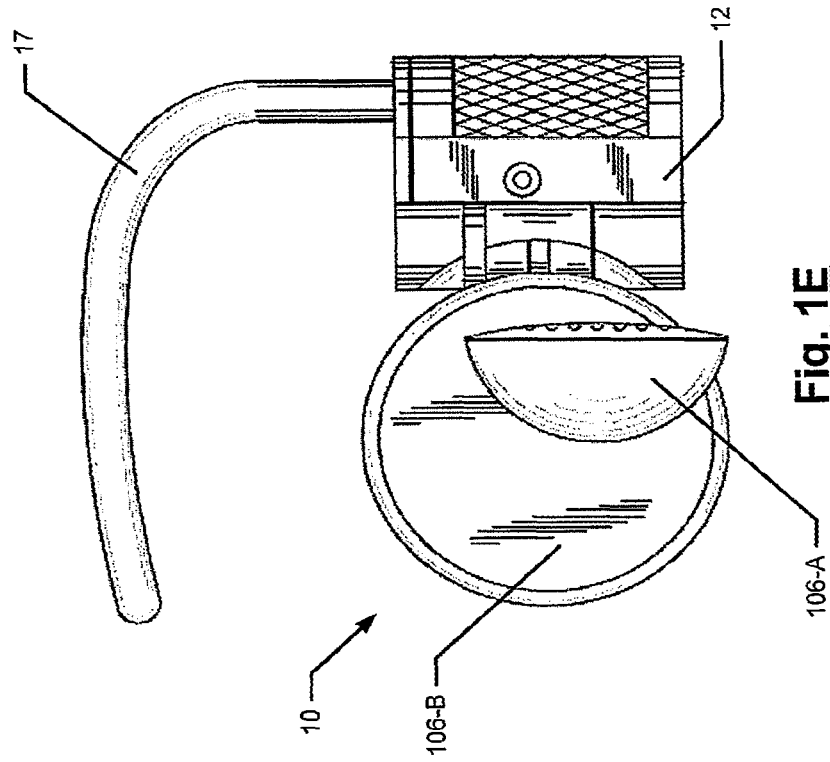

**Fig. 1E**

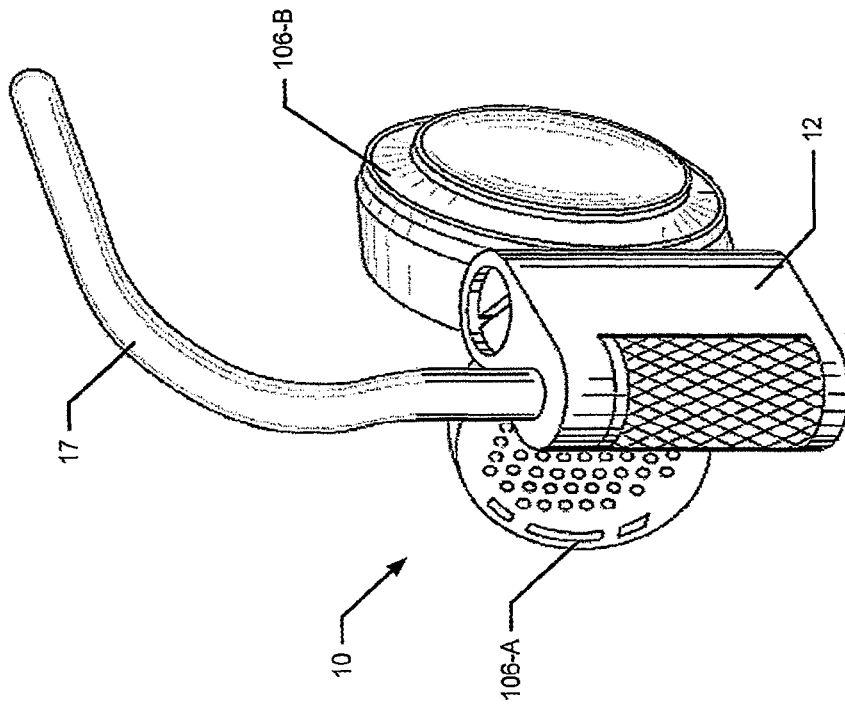

**Fig. 1D**

# Explore Litigation Insights

Docket Alarm provides insights to develop a more informed litigation strategy and the peace of mind of knowing you're on top of things.

## Real-Time Litigation Alerts



Keep your litigation team up-to-date with **real-time alerts** and advanced team management tools built for the enterprise, all while greatly reducing PACER spend.

Our comprehensive service means we can handle Federal, State, and Administrative courts across the country.

## Advanced Docket Research



With over 230 million records, Docket Alarm's cloud-native docket research platform finds what other services can't. Coverage includes Federal, State, plus PTAB, TTAB, ITC and NLRB decisions, all in one place.

Identify arguments that have been successful in the past with full text, pinpoint searching. Link to case law cited within any court document via Fastcase.

## Analytics At Your Fingertips



Learn what happened the last time a particular judge, opposing counsel or company faced cases similar to yours.

Advanced out-of-the-box PTAB and TTAB analytics are always at your fingertips.

## API

Docket Alarm offers a powerful API (application programming interface) to developers that want to integrate case filings into their apps.

## LAW FIRMS

Build custom dashboards for your attorneys and clients with live data direct from the court.

Automate many repetitive legal tasks like conflict checks, document management, and marketing.

## FINANCIAL INSTITUTIONS

Litigation and bankruptcy checks for companies and debtors.

## E-DISCOVERY AND LEGAL VENDORS

Sync your system to PACER to automate legal marketing.