

CERTIFICATE OF TRANSLATION ACCURACY

I, Dwaine Palmer, declare:

1. I am a professional translator specializing in translating Japanese to English.
2. I have over 18 years of experience translating thousands of technical documents and patents from Japanese to English.
3. I certify that the Japanese to English translation of the laid-open patent application publication document identified below is true and correct to the best of my knowledge and ability.

JP2001-210122A

Title:

Lighting Device, Video Display Device, Method of Driving Video Display Device, Liquid Crystal Display Panel, Method of Manufacturing Liquid Crystal Display Panel, Method of Driving Liquid Crystal Display Panel, Array Substrate, display device, Viewfinder, and Video Camera

I hereby certify under penalty of perjury that the foregoing is true and correct. Executed this 17th day of February, 2021 in the Utah County of the state of Utah.

By: 

Dwaine Palmer

(19) Japanese Patent Office (JP)

(12) Laid-Open Patent Application Gazette (A)

(11) Laid-Open Patent Application No.

2001-210122

A(P2001-210122A)

(43) Laid-Open Disclosure Date: August 3, 2001

(51) Int. Cl ⁷	ID Number	FI	Theme code (ref.)
F 21 V	8/00 601	F 21 V 8/00	601D 601E
G 02 F	1/133 535	G 02 F 1/133	535
	1/13357	G 09 F 9/00	336J
G 09 F	9/00 336	9/30	338

Request for Examination: No

Number of Claims: 51 Total pages: 118

Continued on last page

(21) Application No.: 2000-20831	(71) Applicant	000005821 Matsushita Electric Industrial Co., Ltd. 1006 Oaza Kadoma, Kadoma-shi Osaka-fu
(22) Application Date: January 28, 2000	(72) Inventor	TAKAHARA, Hiroshi c/o Matsushita Electric Industrial Co., Ltd. 1006 Oaza Kadoma, Kadoma-shi Osaka-fu
	(74) Agent	100092794 Patent Attorney: MATSUDA, Tadamichi

(54) [Title of the Invention]

Lighting Device, Video Display Device, Method of Driving Video Display Device, Liquid Crystal Display Panel, Method of Manufacturing Liquid Crystal Display Panel, Method of Driving Liquid Crystal Display Panel, Array Substrate, display device, Viewfinder, and Video Camera

(57) ABSTRACT

PROBLEM

To provide a video display device and related equipment where video blurring does not occur.

MEANS TO SOLVE THE PROBLEM

A backlight 16 is provided on a rear surface of a display panel 21, and a light guiding plate 14 configuring the backlight is configured from a plurality of blocks. White LEDs 11 or R, G, and B LEDs are provided on an end of the light guiding plate 14. The white LEDs are turned on individually or in plurality in pairs. The lighting position is scanned in synchronization with an image writing position of the display panel 21. Each pixel row of the display panel 21 is rewritten. Thereafter, the white LEDs 11 positioned in the rewritten pixel rows are turned on after a prescribed period of time, and an image is displayed.

11: (White) LED (light emitting element) 14: Light guiding plate (light guiding member) 16: Backlight
12: LED array 15: Reflective plate (reflective member, reflective film) 18: Light beam (light)

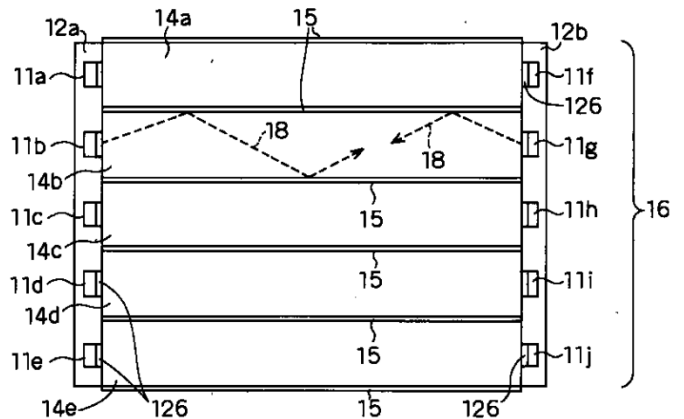

What is claimed is:

[Claim 1]

A lighting device, comprising:
linear light generating means;
light shielding means that emits light in a slit shape from the light generating means;
rotating means that rotates the light generating means or light shielding means around a center of rotation; and
a light guiding plate that guides light emitted from the slit.

[Claim 2]

A lighting device, comprising:
a light guiding plate;
light generating means provided in a matrix shape on the light guiding plate; and
light diffusing means formed or provided on a light emitting surface of the light guiding plate; wherein
the light generating means is configured from light emitting elements generating monochromatic lighting device
provided in close proximity to each other.

[Claim 3]

A lighting device, comprising:
a light guiding plate configured by dividing a plurality of light shielding bodies or reflective bodies;
light generating means formed or provided in each of the divided light guiding plates; and
light diffusing means formed or provided on a light emitting surface of the light guiding plate; wherein
the light generating means is configured from light emitting elements generating monochromatic lighting device
provided in close proximity to each other.

[Claim 4]

A video display device, comprising:
the lighting device according to any one of claims 1 to 3; and
a liquid crystal display panel that modulates light emitted from the lighting device.

[Claim 5]

A liquid crystal display panel, comprising:
a first substrate where a recessed part is formed into a matrix shape;
a black matrix formed in the recessed part;
a second substrate where pixels are formed into a matrix shape; and
a liquid crystal layer interposed between the first substrate and second substrate; wherein
a surface where the recessed part of the first substrate is formed and a surface where the pixel of the second
substrate is formed are opposite each other.

[Claim 6]

A liquid crystal display panel, comprising:
a first substrate where a matrix shaped recessed part is formed;
a black matrix formed in the recessed part;
a second substrate where pixels are formed into a matrix shape; and
a liquid crystal layer interposed between the first substrate and second substrate; wherein
a surface where the recessed part of the first substrate is formed and a surface where the pixel of the second
substrate is formed are opposite each other,
a smoothing film is formed on the black matrix; and
a counter electrode is formed on the smoothing film.

[Claim 7]

A method of manufacturing a liquid crystal display panel containing a light permeable first substrate and a second substrate where pixel electrodes are formed into a matrix shape, comprising:
a first step of forming a recessed part into a matrix shape in the first substrate;
a second step of forming a thin metal film having silver or aluminum in the recessed part;
a third step of forming a smoothing film having light permeability on the thin film; and
a fourth step of sandwiching liquid crystal between the first substrate and second substrate.

[Claim 8]

A liquid crystal display panel, comprising:
a first substrate where a matrix shaped recessed part is formed;
a black matrix formed in the recessed part;
an additional capacitor formed on the first substrate;
a second substrate where pixels are formed into a matrix shape;
a connecting part that connects the additional capacitor and the pixel electrodes; and
a liquid crystal layer interposed between the first substrate and second substrate; wherein
a surface where the recessed part of the first substrate is formed and a surface where the pixel of the second substrate is formed are opposite each other.

[Claim 9]

A lighting device, comprising:
a first light guiding plate;
first light emitting means that inputs a luminous flux into the first light guiding plate;
a second light guiding plate;
second light emitting means that inputs a luminous flux into the second light guiding plate; and
controlling means that controls turning the first light emitting means and second light emitting means ON/OFF.

[Claim 10]

A video display device, comprising:
a first light guiding plate;
first light emitting means that inputs a luminous flux into the first light guiding plate;
a second light guiding plate;
second light emitting means that inputs a luminous flux into the second light guiding plate;
controlling means that controls turning the first light emitting means and second light emitting means ON/OFF;
light diffusing means provided on light emitting surfaces of the first light guiding plate and second light guiding plate; and
a liquid crystal display panel provided on a light emitting side of the light diffusing means.

[Claim 11]

A method of driving a video display device using the video display device according to claim 10, comprising:
a step of turning on the first light emitting means at a first time when pixels in an upper half of a screen is rewritten; and
a step of turning on the second light emitting means at a second time when pixels in a lower half of the screen is rewritten.

[Claim 12]

A video display device, comprising:
a light guiding plate;
first light emitting means provided or formed on an upper end part of the light guiding plate;
second light emitting means provided or formed on a lower end part of the light guiding plate;
controlling means that controls turning the first light emitting means and second light emitting means ON/OFF;
light diffusing means provided on a light emitting surface of the light guiding plate; and
a liquid crystal display panel provided on a light emitting side of the light diffusing means.

[Claim 13]

A method of driving a video display device using the video display device according to claim 12, comprising:
an OFF step of turning the first and second light emitting means OFF at a first time when a screen of a liquid crystal display panel is rewritten; and
an ON step of turning the first or second light emitting means ON at a second time when the screen of the liquid crystal display panel is not rewritten; wherein
the first light emitting means and second light emitting means are alternately turned ON in the ON step.

[Claim 14]

A video display device, comprising:
a first liquid crystal display panel having a stripe shaped electrode;
a second liquid crystal display panel that displays a video; and
light diffusing means provided between the first liquid crystal display panel and second liquid crystal display panel.

[Claim 15]

A liquid crystal display panel, comprising:
a first substrate having a striped electrode;
a second substrate having a pixel electrode;
a third electrode having a counter electrode function;
a first liquid crystal layer having a polymer and liquid crystal molecules interposed between the striped electrode and the third electrode; and
a second liquid crystal layer interposed between the pixel electrode and third electrode.

[Claim 16]

A video display device, comprising:
a first substrate having a striped electrode;
a second substrate having a pixel electrode;
a third electrode having a counter electrode function;
a first liquid crystal layer having a polymer and liquid crystal molecules interposed between the striped electrode and the third electrode;
a second liquid crystal layer interposed between the pixel electrode and the third electrode;
a backlight provided on the first substrate side;
a first driver circuit that applies a video signal to the pixel electrode; and
a second driver circuit that applies a drive voltage to the striped electrode.

[Claim 17]

A method of driving a video display device using the video display device according to claim 16, comprising:
a step of rewriting the pixels in the second liquid crystal layer, applying a voltage to the first liquid crystal layer corresponding to the point, and then irradiating light of the backlight onto the first liquid crystal layer.

Explore Litigation Insights

Docket Alarm provides insights to develop a more informed litigation strategy and the peace of mind of knowing you're on top of things.

Real-Time Litigation Alerts



Keep your litigation team up-to-date with **real-time alerts** and advanced team management tools built for the enterprise, all while greatly reducing PACER spend.

Our comprehensive service means we can handle Federal, State, and Administrative courts across the country.

Advanced Docket Research



With over 230 million records, Docket Alarm's cloud-native docket research platform finds what other services can't. Coverage includes Federal, State, plus PTAB, TTAB, ITC and NLRB decisions, all in one place.

Identify arguments that have been successful in the past with full text, pinpoint searching. Link to case law cited within any court document via Fastcase.

Analytics At Your Fingertips



Learn what happened the last time a particular judge, opposing counsel or company faced cases similar to yours.

Advanced out-of-the-box PTAB and TTAB analytics are always at your fingertips.

API

Docket Alarm offers a powerful API (application programming interface) to developers that want to integrate case filings into their apps.

LAW FIRMS

Build custom dashboards for your attorneys and clients with live data direct from the court.

Automate many repetitive legal tasks like conflict checks, document management, and marketing.

FINANCIAL INSTITUTIONS

Litigation and bankruptcy checks for companies and debtors.

E-DISCOVERY AND LEGAL VENDORS

Sync your system to PACER to automate legal marketing.