

[54] **SOFTWARE DISTRIBUTION SYSTEM**

[76] **Inventor:** Martin E. Hellman, 730 Alvarado Ct., Stanford, Calif. 94305

[21] **Appl. No.:** 512,685

[22] **Filed:** Jul. 11, 1983

[51] **Int. Cl.⁴** H04L 9/00

[52] **U.S. Cl.** 380/25; 380/4; 380/30

[58] **Field of Search** 178/22.08, 22.11, 22.09; 358/86

[56] **References Cited**

U.S. PATENT DOCUMENTS

3,798,605	3/1974	Feistel	178/22.08
4,200,770	4/1980	Hellman et al.	178/22.11
4,218,582	8/1980	Hellman et al.	178/22.11
4,264,782	4/1981	Konheim	178/22.08
4,405,829	9/1983	Rivest et al.	178/22.11
4,424,414	1/1984	Hellman et al.	178/22.11
4,446,519	5/1984	Thomas	178/22.08
4,458,315	7/1984	Uchenick	178/22.08
4,465,901	8/1984	Best	178/22.08
4,567,512	1/1986	Abraham	358/86

OTHER PUBLICATIONS

"New Directions in Cryptography", by Diffie and Hell-

man IEEE Transaction on Information Theory, vol. 22 #6, 11/76.

"Multiuser Cryptographic Techniques", by Diffie and Hellman AFIPS-Conference Proceedings, vol. 45, pp. 109-112, 6/8/76.

Primary Examiner—Salvatore Cangialosi

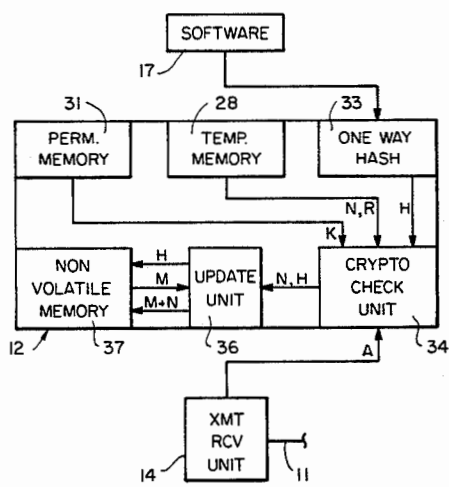
Assistant Examiner—Aaron J. Lewis

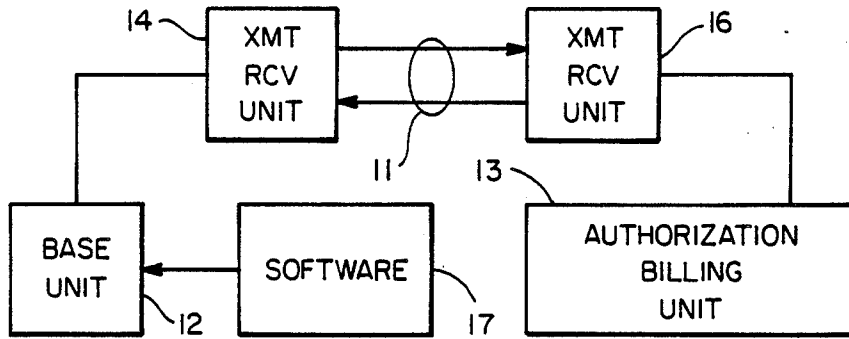
Attorney, Agent, or Firm—Flehr, Hohbach, Test, Albritton & Herbert

[57] **ABSTRACT**

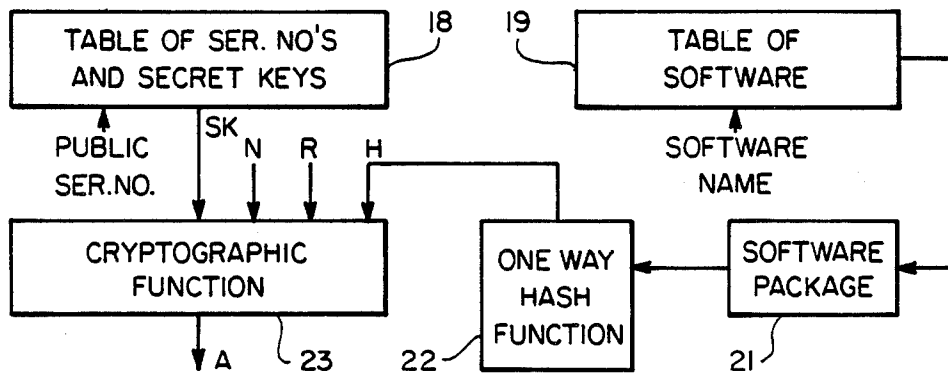
Software (programs, videogames, music, movies, etc.) can be authorized for use a given number of times by a base unit after which the base unit (computer, videogame base unit, record player, videorecorder or video-disk player) cannot use that software until the manufacturer sends an authorization for additional uses to the user's base unit. Authorizations may be sent via telephone line, mail, or whatever form of communication is most suited to the application. Authorizations cannot be reused, for example by recording the telephone authorization signal and replaying it to the base unit. Similarly, authorizations can be made base unit specific, so that an authorization for one base unit cannot be transferred to another base unit. This invention also solves the "software piracy problem" and allows telephone sales of software as additional benefits.

10 Claims, 11 Drawing Figures

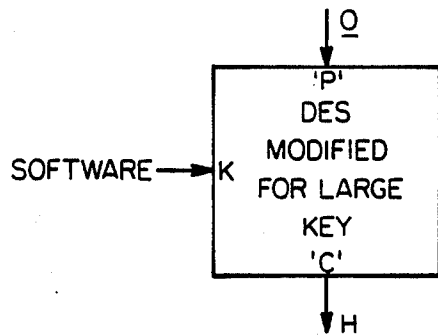




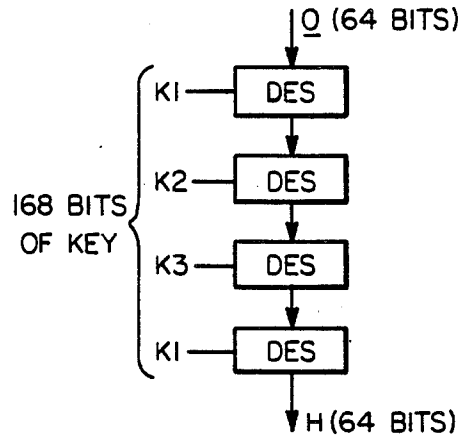
FIG_1



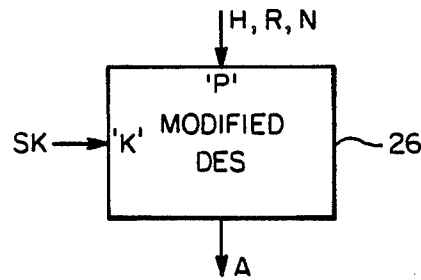
FIG_2



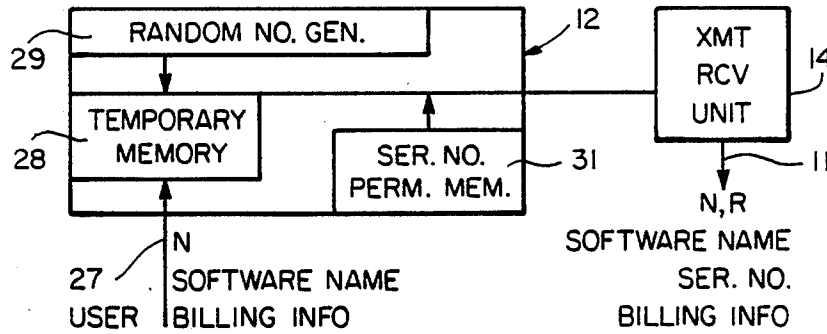
FIG_3



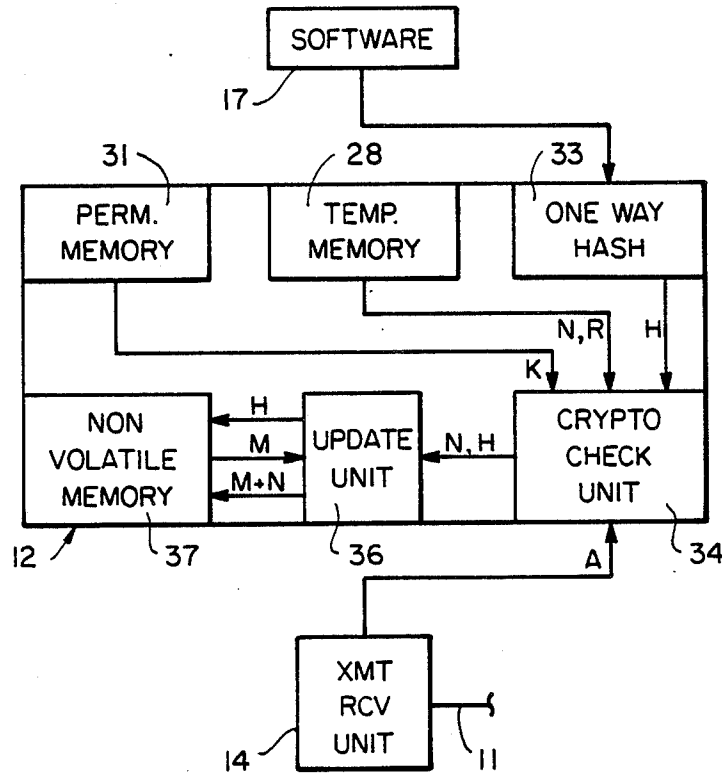
FIG_3A



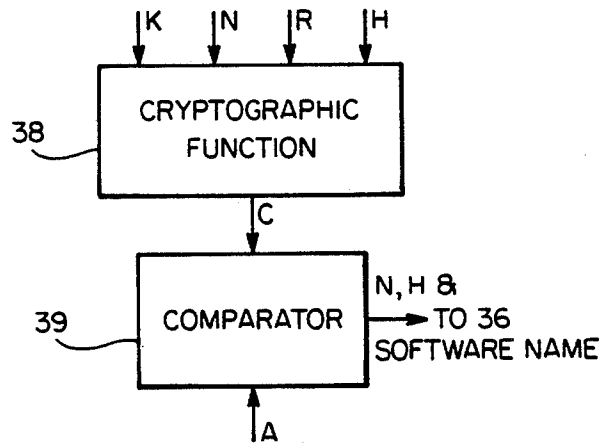
FIG_4



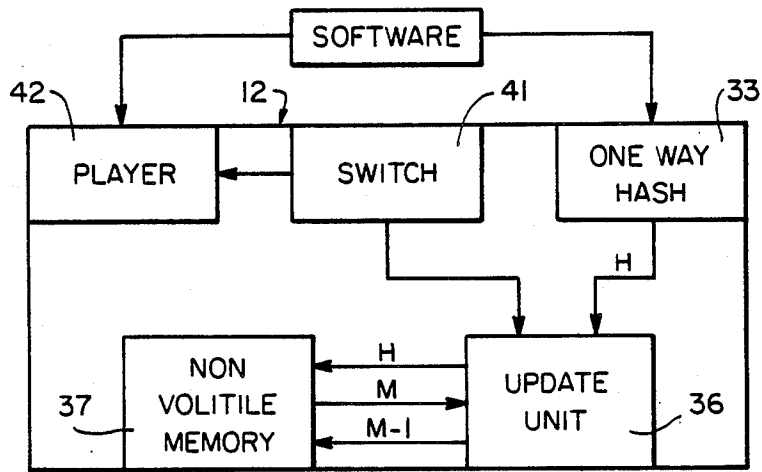
FIG_5



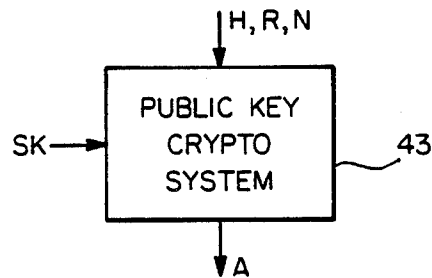
FIG_6



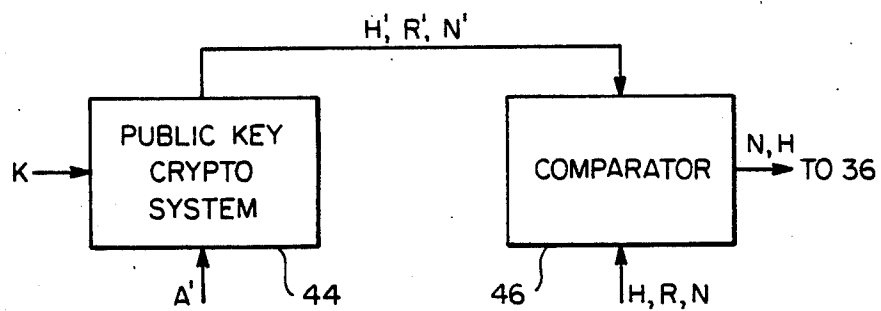
FIG_7



FIG_8



FIG_9



FIG_10

Explore Litigation Insights

Docket Alarm provides insights to develop a more informed litigation strategy and the peace of mind of knowing you're on top of things.

Real-Time Litigation Alerts



Keep your litigation team up-to-date with **real-time alerts** and advanced team management tools built for the enterprise, all while greatly reducing PACER spend.

Our comprehensive service means we can handle Federal, State, and Administrative courts across the country.

Advanced Docket Research



With over 230 million records, Docket Alarm's cloud-native docket research platform finds what other services can't. Coverage includes Federal, State, plus PTAB, TTAB, ITC and NLRB decisions, all in one place.

Identify arguments that have been successful in the past with full text, pinpoint searching. Link to case law cited within any court document via Fastcase.

Analytics At Your Fingertips



Learn what happened the last time a particular judge, opposing counsel or company faced cases similar to yours.

Advanced out-of-the-box PTAB and TTAB analytics are always at your fingertips.

API

Docket Alarm offers a powerful API (application programming interface) to developers that want to integrate case filings into their apps.

LAW FIRMS

Build custom dashboards for your attorneys and clients with live data direct from the court.

Automate many repetitive legal tasks like conflict checks, document management, and marketing.

FINANCIAL INSTITUTIONS

Litigation and bankruptcy checks for companies and debtors.

E-DISCOVERY AND LEGAL VENDORS

Sync your system to PACER to automate legal marketing.