



UNITED STATES PATENT AND TRADEMARK OFFICE

UNITED STATES DEPARTMENT OF COMMERCE
United States Patent and Trademark Office
Address: COMMISSIONER FOR PATENTS
P.O. Box 1450
Alexandria, Virginia 22313-1450
www.uspto.gov

Table with 5 columns: APPLICATION NO., ISSUE DATE, PATENT NO., ATTORNEY DOCKET NO., CONFIRMATION NO.
Row 1: 16/380,844, 12/24/2019, 10517133, P74267 US2, 8653

27045 7590 12/04/2019
ERICSSON INC.
6300 LEGACY DRIVE
M/S EVR 1-C-11
PLANO, TX 75024

ISSUE NOTIFICATION

The projected patent number and issue date are specified above.

Determination of Patent Term Adjustment under 35 U.S.C. 154 (b)
(application filed on or after May 29, 2000)

The Patent Term Adjustment is 0 day(s). Any patent to issue from the above-identified application will include an indication of the adjustment on the front page.

If a Continued Prosecution Application (CPA) was filed in the above-identified application, the filing date that determines Patent Term Adjustment is the filing date of the most recent CPA.

Applicant will be able to obtain more detailed information by accessing the Patent Application Information Retrieval (PAIR) WEB site (http://pair.uspto.gov).

Any questions regarding the Patent Term Extension or Adjustment determination should be directed to the Office of Patent Legal Administration at (571)-272-7702. Questions relating to issue and publication fee payments should be directed to the Application Assistance Unit (AAU) of the Office of Data Management (ODM) at (571)-272-4200.

APPLICANT(s) (Please see PAIR WEB site http://pair.uspto.gov for additional applicants):

Oumer TEYEB, SOLNA, SWEDEN;
TELEFONAKTIEBOLAGET LM ERICSSON (PUBL), Stockholm, SWEDEN;
Gunnar MILDH, SOLLENTUNA, SWEDEN;

The United States represents the largest, most dynamic marketplace in the world and is an unparalleled location for business investment, innovation, and commercialization of new technologies. The USA offers tremendous resources and advantages for those who invest and manufacture goods here. Through SelectUSA, our nation works to encourage and facilitate business investment. To learn more about why the USA is the best country in the world to develop technology, manufacture products, and grow your business, visit SelectUSA.gov.

**PART B - FEE(S) TRANSMITTAL**

Complete and send this form, together with applicable fee(s), by mail or fax, or via EFS-Web.

By mail, send to: Mail Stop ISSUE FEE  
 Commissioner for Patents  
 P.O. Box 1450  
 Alexandria, Virginia 22313-1450

By fax, send to: (571)-273-2885

**INSTRUCTIONS:** This form should be used for transmitting the ISSUE FEE and PUBLICATION FEE (if required). Blocks 1 through 5 should be completed where appropriate. All further correspondence including the Patent, advance orders and notification of maintenance fees will be mailed to the current correspondence address as indicated unless corrected below or directed otherwise in Block 1, by (a) specifying a new correspondence address; and/or (b) indicating a separate "FEE ADDRESS" for maintenance fee notifications.

CURRENT CORRESPONDENCE ADDRESS (Note: Use Block 1 for any change of address)

27045 7590 11/08/2019  
 ERICSSON INC.  
 6300 LEGACY DRIVE  
 M/S EVR 1-C-11  
 PLANO, TX 75024

Note: A certificate of mailing can only be used for domestic mailings of the Fee(s) Transmittal. This certificate cannot be used for any other accompanying papers. Each additional paper, such as an assignment or formal drawing, must have its own certificate of mailing or transmission.

**Certificate of Mailing or Transmission**

I hereby certify that this Fee(s) Transmittal is being deposited with the United States Postal Service with sufficient postage for first class mail in an envelope addressed to the Mail Stop ISSUE FEE address above, or being transmitted to the USPTO via EFS-Web or by facsimile to (571) 273-2885, on the date below.

|               |                         |
|---------------|-------------------------|
| Lala Deleon   | (Typed or printed name) |
| /Lala Deleon/ | (Signature)             |
| 2019/11/15    | (Date)                  |

| APPLICATION NO. | FILING DATE | FIRST NAMED INVENTOR | ATTORNEY DOCKET NO. | CONFIRMATION NO. |
|-----------------|-------------|----------------------|---------------------|------------------|
| 16/380,844      | 04/10/2019  | Oumer TEYEB          | P74267 US2          | 8653             |

TITLE OF INVENTION: METHODS AND UE FOR RESUMING A CONNECTION WITH FULL CONFIGURATION

| APPLN. TYPE    | ENTITY STATUS | ISSUE FEE DUE | PUBLICATION FEE DUE | PREV. PAID ISSUE FEE | TOTAL FEE(S) DUE | DATE DUE   |
|----------------|---------------|---------------|---------------------|----------------------|------------------|------------|
| nonprovisional | UNDISCOUNTED  | \$1000        | \$0.00              | \$0.00               | \$1000           | 02/10/2020 |

| EXAMINER             | ART UNIT | CLASS-SUBCLASS |
|----------------------|----------|----------------|
| THOMPSON, JR, OTIS L | 2477     | 370-328000     |

1. Change of correspondence address or indication of "Fee Address" (37 CFR 1.363).

- Change of correspondence address (or Change of Correspondence Address form PTO/SB/122) attached.
- "Fee Address" indication (or "Fee Address" Indication form PTO/SB/47; Rev 03-09 or more recent) attached. **Use of a Customer Number is required.**

2. For printing on the patent front page, list

- (1) The names of up to 3 registered patent attorneys or agents OR, alternatively, 1 \_\_\_\_\_
- (2) The name of a single firm (having as a member a registered attorney or agent) and the names of up to 2 registered patent attorneys or agents. If no name is listed, no name will be printed. 2 \_\_\_\_\_
- 3 \_\_\_\_\_

3. ASSIGNEE NAME AND RESIDENCE DATA TO BE PRINTED ON THE PATENT (print or type)

PLEASE NOTE: Unless an assignee is identified below, no assignee data will appear on the patent. If an assignee is identified below, the document must have been previously recorded, or filed for recordation, as set forth in 37 CFR 3.11 and 37 CFR 3.81(a). Completion of this form is NOT a substitute for filing an assignment.

(A) NAME OF ASSIGNEE

(B) RESIDENCE: (CITY and STATE OR COUNTRY)

Telefonaktiebolaget LM Ericsson (publ)

Stockholm, Sweden

Please check the appropriate assignee category or categories (will not be printed on the patent):  Individual  Corporation or other private group entity  Government

4a. Fees submitted:  Issue Fee  Publication Fee (if required)  Advance Order - # of Copies \_\_\_\_\_

4b. Method of Payment: (Please first reapply any previously paid fee shown above)

Electronic Payment via EFS-Web  Enclosed check  Non-electronic payment by credit card (Attach form PTO-2038)

The Director is hereby authorized to charge the required fee(s), any deficiency, or credit any overpayment to Deposit Account No. 50-1379

5. Change in Entity Status (from status indicated above)

- Applicant certifying micro entity status. See 37 CFR 1.29
- Applicant asserting small entity status. See 37 CFR 1.27
- Applicant changing to regular undiscounted fee status.

**NOTE:** Absent a valid certification of Micro Entity Status (see forms PTO/SB/15A and 15B), issue fee payment in the micro entity amount will not be accepted at the risk of application abandonment.

**NOTE:** If the application was previously under micro entity status, checking this box will be taken to be a notification of loss of entitlement to micro entity status.

**NOTE:** Checking this box will be taken to be a notification of loss of entitlement to small or micro entity status, as applicable.

**NOTE:** This form must be signed in accordance with 37 CFR 1.31 and 1.33. See 37 CFR 1.4 for signature requirements and certifications.

Authorized Signature /BrentCapehart/ Date 2019-11-15

Typed or printed name Brent Capehart Registration No. 39620

## Electronic Patent Application Fee Transmittal

|                                                    |                                                                  |                 |               |                             |
|----------------------------------------------------|------------------------------------------------------------------|-----------------|---------------|-----------------------------|
| <b>Application Number:</b>                         | 16380844                                                         |                 |               |                             |
| <b>Filing Date:</b>                                | 10-Apr-2019                                                      |                 |               |                             |
| <b>Title of Invention:</b>                         | METHODS AND UE FOR RESUMING A CONNECTION WITH FULL CONFIGURATION |                 |               |                             |
| <b>First Named Inventor/Applicant Name:</b>        | Oumer TEYEB                                                      |                 |               |                             |
| <b>Filer:</b>                                      | Brian Michael Kearns/Lala Deleon                                 |                 |               |                             |
| <b>Attorney Docket Number:</b>                     | P74267 US2                                                       |                 |               |                             |
| Filed as Large Entity                              |                                                                  |                 |               |                             |
| <b>Filing Fees for Utility under 35 USC 111(a)</b> |                                                                  |                 |               |                             |
| <b>Description</b>                                 | <b>Fee Code</b>                                                  | <b>Quantity</b> | <b>Amount</b> | <b>Sub-Total in USD(\$)</b> |
| <b>Basic Filing:</b>                               |                                                                  |                 |               |                             |
| <b>Pages:</b>                                      |                                                                  |                 |               |                             |
| <b>Claims:</b>                                     |                                                                  |                 |               |                             |
| <b>Miscellaneous-Filing:</b>                       |                                                                  |                 |               |                             |
| <b>Petition:</b>                                   |                                                                  |                 |               |                             |
| <b>Patent-Appeals-and-Interference:</b>            |                                                                  |                 |               |                             |
| <b>Post-Allowance-and-Post-Issuance:</b>           |                                                                  |                 |               |                             |
| UTILITY APPL ISSUE FEE                             | 1501                                                             | 1               | 1000          | 1000                        |

| Description               | Fee Code | Quantity | Amount | Sub-Total in USD(\$) |
|---------------------------|----------|----------|--------|----------------------|
| <b>Extension-of-Time:</b> |          |          |        |                      |
| <b>Miscellaneous:</b>     |          |          |        |                      |
| <b>Total in USD (\$)</b>  |          |          |        | <b>1000</b>          |

## Electronic Acknowledgement Receipt

|                                             |                                                                  |
|---------------------------------------------|------------------------------------------------------------------|
| <b>EFS ID:</b>                              | 37765897                                                         |
| <b>Application Number:</b>                  | 16380844                                                         |
| <b>International Application Number:</b>    |                                                                  |
| <b>Confirmation Number:</b>                 | 8653                                                             |
| <b>Title of Invention:</b>                  | METHODS AND UE FOR RESUMING A CONNECTION WITH FULL CONFIGURATION |
| <b>First Named Inventor/Applicant Name:</b> | Oumer TEYEB                                                      |
| <b>Customer Number:</b>                     | 27045                                                            |
| <b>Filer:</b>                               | Brian Michael Kearns/Lala Deleon                                 |
| <b>Filer Authorized By:</b>                 | Brian Michael Kearns                                             |
| <b>Attorney Docket Number:</b>              | P74267 US2                                                       |
| <b>Receipt Date:</b>                        | 15-NOV-2019                                                      |
| <b>Filing Date:</b>                         | 10-APR-2019                                                      |
| <b>Time Stamp:</b>                          | 14:32:22                                                         |
| <b>Application Type:</b>                    | Utility under 35 USC 111(a)                                      |

### Payment information:

|                                          |                  |
|------------------------------------------|------------------|
| Submitted with Payment                   | yes              |
| Payment Type                             | DA               |
| Payment was successfully received in RAM | \$1000           |
| RAM confirmation Number                  | E2019AEE33101924 |
| Deposit Account                          | 501379           |
| Authorized User                          | Lala Deleon      |

The Director of the USPTO is hereby authorized to charge indicated fees and credit any overpayment as follows:

37 CFR 1.20 (Post Issuance fees)

|  |
|--|
|  |
|--|

**File Listing:**

| Document Number | Document Description        | File Name                                   | File Size(Bytes)/ Message Digest                   | Multi Part /.zip | Pages (if appl.) |
|-----------------|-----------------------------|---------------------------------------------|----------------------------------------------------|------------------|------------------|
| 1               | Issue Fee Payment (PTO-85B) | P74267_US2_2019-11-15_Issue_fee_payment.pdf | 135385<br>f34d6c768d45e2f2608db73d4a8b3a7050c0b9eb | no               | 1                |

**Warnings:**

**Information:**

|   |                      |              |                                                   |    |   |
|---|----------------------|--------------|---------------------------------------------------|----|---|
| 2 | Fee Worksheet (SB06) | fee-info.pdf | 30633<br>b7115a8862a2a9f6f6c3f49b2df8197616da2fdd | no | 2 |
|---|----------------------|--------------|---------------------------------------------------|----|---|

**Warnings:**

**Information:**

|                                     |        |
|-------------------------------------|--------|
| <b>Total Files Size (in bytes):</b> | 166018 |
|-------------------------------------|--------|

**This Acknowledgement Receipt evidences receipt on the noted date by the USPTO of the indicated documents, characterized by the applicant, and including page counts, where applicable. It serves as evidence of receipt similar to a Post Card, as described in MPEP 503.**

**New Applications Under 35 U.S.C. 111**

**If a new application is being filed and the application includes the necessary components for a filing date (see 37 CFR 1.53(b)-(d) and MPEP 506), a Filing Receipt (37 CFR 1.54) will be issued in due course and the date shown on this Acknowledgement Receipt will establish the filing date of the application.**

**National Stage of an International Application under 35 U.S.C. 371**

**If a timely submission to enter the national stage of an international application is compliant with the conditions of 35 U.S.C. 371 and other applicable requirements a Form PCT/DO/EO/903 indicating acceptance of the application as a national stage submission under 35 U.S.C. 371 will be issued in addition to the Filing Receipt, in due course.**

**New International Application Filed with the USPTO as a Receiving Office**

**If a new international application is being filed and the international application includes the necessary components for an international filing date (see PCT Article 11 and MPEP 1810), a Notification of the International Application Number and of the International Filing Date (Form PCT/RO/105) will be issued in due course, subject to prescriptions concerning national security, and the date shown on this Acknowledgement Receipt will establish the international filing date of the application.**



UNITED STATES PATENT AND TRADEMARK OFFICE

UNITED STATES DEPARTMENT OF COMMERCE
United States Patent and Trademark Office
Address: COMMISSIONER FOR PATENTS
P.O. Box 1450
Alexandria, Virginia 22313-1450
www.uspto.gov

NOTICE OF ALLOWANCE AND FEE(S) DUE

27045 7590 11/08/2019
ERICSSON INC.
6300 LEGACY DRIVE
M/S EVR 1-C-11
PLANO, TX 75024

EXAMINER

THOMPSON, JR, OTIS L

ART UNIT PAPER NUMBER

2477

DATE MAILED: 11/08/2019

Table with 5 columns: APPLICATION NO., FILING DATE, FIRST NAMED INVENTOR, ATTORNEY DOCKET NO., CONFIRMATION NO. Values: 16/380,844, 04/10/2019, Oumer TEYEB, P74267 US2, 8653

TITLE OF INVENTION: METHODS AND UE FOR RESUMING A CONNECTION WITH FULL CONFIGURATION

Table with 7 columns: APPLN. TYPE, ENTITY STATUS, ISSUE FEE DUE, PUBLICATION FEE DUE, PREV. PAID ISSUE FEE, TOTAL FEE(S) DUE, DATE DUE. Values: nonprovisional, UNDISCOUNTED, \$1000, \$0.00, \$0.00, \$1000, 02/10/2020

THE APPLICATION IDENTIFIED ABOVE HAS BEEN EXAMINED AND IS ALLOWED FOR ISSUANCE AS A PATENT. PROSECUTION ON THE MERITS IS CLOSED. THIS NOTICE OF ALLOWANCE IS NOT A GRANT OF PATENT RIGHTS. THIS APPLICATION IS SUBJECT TO WITHDRAWAL FROM ISSUE AT THE INITIATIVE OF THE OFFICE OR UPON PETITION BY THE APPLICANT. SEE 37 CFR 1.313 AND MPEP 1308.

THE ISSUE FEE AND PUBLICATION FEE (IF REQUIRED) MUST BE PAID WITHIN THREE MONTHS FROM THE MAILING DATE OF THIS NOTICE OR THIS APPLICATION SHALL BE REGARDED AS ABANDONED. THIS STATUTORY PERIOD CANNOT BE EXTENDED. SEE 35 U.S.C. 151. THE ISSUE FEE DUE INDICATED ABOVE DOES NOT REFLECT A CREDIT FOR ANY PREVIOUSLY PAID ISSUE FEE IN THIS APPLICATION. IF AN ISSUE FEE HAS PREVIOUSLY BEEN PAID IN THIS APPLICATION (AS SHOWN ABOVE), THE RETURN OF PART B OF THIS FORM WILL BE CONSIDERED A REQUEST TO REAPPLY THE PREVIOUSLY PAID ISSUE FEE TOWARD THE ISSUE FEE NOW DUE.

HOW TO REPLY TO THIS NOTICE:

I. Review the ENTITY STATUS shown above. If the ENTITY STATUS is shown as SMALL or MICRO, verify whether entitlement to that entity status still applies.

If the ENTITY STATUS is the same as shown above, pay the TOTAL FEE(S) DUE shown above.

If the ENTITY STATUS is changed from that shown above, on PART B - FEE(S) TRANSMITTAL, complete section number 5 titled "Change in Entity Status (from status indicated above)".

For purposes of this notice, small entity fees are 1/2 the amount of undiscounted fees, and micro entity fees are 1/2 the amount of small entity fees.

II. PART B - FEE(S) TRANSMITTAL, or its equivalent, must be completed and returned to the United States Patent and Trademark Office (USPTO) with your ISSUE FEE and PUBLICATION FEE (if required). If you are charging the fee(s) to your deposit account, section "4b" of Part B - Fee(s) Transmittal should be completed and an extra copy of the form should be submitted. If an equivalent of Part B is filed, a request to reapply a previously paid issue fee must be clearly made, and delays in processing may occur due to the difficulty in recognizing the paper as an equivalent of Part B.

III. All communications regarding this application must give the application number. Please direct all communications prior to issuance to Mail Stop ISSUE FEE unless advised to the contrary.

IMPORTANT REMINDER: Maintenance fees are due in utility patents issuing on applications filed on or after Dec. 12, 1980. It is patentee's responsibility to ensure timely payment of maintenance fees when due. More information is available at www.uspto.gov/PatentMaintenanceFees.

**PART B - FEE(S) TRANSMITTAL**

Complete and send this form, together with applicable fee(s), by mail or fax, or via EFS-Web.

By mail, send to: Mail Stop ISSUE FEE  
 Commissioner for Patents  
 P.O. Box 1450  
 Alexandria, Virginia 22313-1450

By fax, send to: (571)-273-2885

**INSTRUCTIONS:** This form should be used for transmitting the ISSUE FEE and PUBLICATION FEE (if required). Blocks 1 through 5 should be completed where appropriate. All further correspondence including the Patent, advance orders and notification of maintenance fees will be mailed to the current correspondence address as indicated unless corrected below or directed otherwise in Block 1, by (a) specifying a new correspondence address; and/or (b) indicating a separate "FEE ADDRESS" for maintenance fee notifications.

CURRENT CORRESPONDENCE ADDRESS (Note: Use Block 1 for any change of address)

27045 7590 11/08/2019  
 ERICSSON INC.  
 6300 LEGACY DRIVE  
 M/S EVR 1-C-11  
 PLANO, TX 75024

Note: A certificate of mailing can only be used for domestic mailings of the Fee(s) Transmittal. This certificate cannot be used for any other accompanying papers. Each additional paper, such as an assignment or formal drawing, must have its own certificate of mailing or transmission.

**Certificate of Mailing or Transmission**

I hereby certify that this Fee(s) Transmittal is being deposited with the United States Postal Service with sufficient postage for first class mail in an envelope addressed to the Mail Stop ISSUE FEE address above, or being transmitted to the USPTO via EFS-Web or by facsimile to (571) 273-2885, on the date below.

|                                  |
|----------------------------------|
| _____<br>(Typed or printed name) |
| _____<br>(Signature)             |
| _____<br>(Date)                  |

| APPLICATION NO. | FILING DATE | FIRST NAMED INVENTOR | ATTORNEY DOCKET NO. | CONFIRMATION NO. |
|-----------------|-------------|----------------------|---------------------|------------------|
| 16/380,844      | 04/10/2019  | Oumer TEYEB          | P74267 US2          | 8653             |

TITLE OF INVENTION: METHODS AND UE FOR RESUMING A CONNECTION WITH FULL CONFIGURATION

| APPLN. TYPE    | ENTITY STATUS | ISSUE FEE DUE | PUBLICATION FEE DUE | PREV. PAID ISSUE FEE | TOTAL FEE(S) DUE | DATE DUE   |
|----------------|---------------|---------------|---------------------|----------------------|------------------|------------|
| nonprovisional | UNDISCOUNTED  | \$1000        | \$0.00              | \$0.00               | \$1000           | 02/10/2020 |

| EXAMINER             | ART UNIT | CLASS-SUBCLASS |
|----------------------|----------|----------------|
| THOMPSON, JR, OTIS L | 2477     | 370-328000     |

|                                                                                                                                                                                                                                                                                                                                                                                                                   |                                                                                                                                                                                                                                                                                                                                                                                       |
|-------------------------------------------------------------------------------------------------------------------------------------------------------------------------------------------------------------------------------------------------------------------------------------------------------------------------------------------------------------------------------------------------------------------|---------------------------------------------------------------------------------------------------------------------------------------------------------------------------------------------------------------------------------------------------------------------------------------------------------------------------------------------------------------------------------------|
| <p>1. Change of correspondence address or indication of "Fee Address" (37 CFR 1.363).</p> <p><input type="checkbox"/> Change of correspondence address (or Change of Correspondence Address form PTO/SB/122) attached.</p> <p><input type="checkbox"/> "Fee Address" indication (or "Fee Address" Indication form PTO/SB/47; Rev 03-09 or more recent) attached. <b>Use of a Customer Number is required.</b></p> | <p>2. For printing on the patent front page, list</p> <p>(1) The names of up to 3 registered patent attorneys or agents OR, alternatively, 1 _____</p> <p>(2) The name of a single firm (having as a member a registered attorney or agent) and the names of up to 2 registered patent attorneys or agents. If no name is listed, no name will be printed. 2 _____</p> <p>3 _____</p> |
|-------------------------------------------------------------------------------------------------------------------------------------------------------------------------------------------------------------------------------------------------------------------------------------------------------------------------------------------------------------------------------------------------------------------|---------------------------------------------------------------------------------------------------------------------------------------------------------------------------------------------------------------------------------------------------------------------------------------------------------------------------------------------------------------------------------------|

3. ASSIGNEE NAME AND RESIDENCE DATA TO BE PRINTED ON THE PATENT (print or type)

PLEASE NOTE: Unless an assignee is identified below, no assignee data will appear on the patent. If an assignee is identified below, the document must have been previously recorded, or filed for recordation, as set forth in 37 CFR 3.11 and 37 CFR 3.81(a). Completion of this form is NOT a substitute for filing an assignment.

(A) NAME OF ASSIGNEE \_\_\_\_\_ (B) RESIDENCE: (CITY and STATE OR COUNTRY) \_\_\_\_\_

Please check the appropriate assignee category or categories (will not be printed on the patent):  Individual  Corporation or other private group entity  Government

4a. Fees submitted:  Issue Fee  Publication Fee (if required)  Advance Order - # of Copies \_\_\_\_\_

4b. Method of Payment: (Please first reapply any previously paid fee shown above)

Electronic Payment via EFS-Web  Enclosed check  Non-electronic payment by credit card (Attach form PTO-2038)

The Director is hereby authorized to charge the required fee(s), any deficiency, or credit any overpayment to Deposit Account No. \_\_\_\_\_

5. Change in Entity Status (from status indicated above)

Applicant certifying micro entity status. See 37 CFR 1.29

Applicant asserting small entity status. See 37 CFR 1.27

Applicant changing to regular undiscounted fee status.

**NOTE:** Absent a valid certification of Micro Entity Status (see forms PTO/SB/15A and 15B), issue fee payment in the micro entity amount will not be accepted at the risk of application abandonment.

**NOTE:** If the application was previously under micro entity status, checking this box will be taken to be a notification of loss of entitlement to micro entity status.

**NOTE:** Checking this box will be taken to be a notification of loss of entitlement to small or micro entity status, as applicable.

**NOTE:** This form must be signed in accordance with 37 CFR 1.31 and 1.33. See 37 CFR 1.4 for signature requirements and certifications.

Authorized Signature \_\_\_\_\_ Date \_\_\_\_\_

Typed or printed name \_\_\_\_\_ Registration No. \_\_\_\_\_





UNITED STATES PATENT AND TRADEMARK OFFICE

UNITED STATES DEPARTMENT OF COMMERCE
United States Patent and Trademark Office
Address: COMMISSIONER FOR PATENTS
P.O. Box 1450
Alexandria, Virginia 22313-1450
www.uspto.gov

Table with 5 columns: APPLICATION NO., FILING DATE, FIRST NAMED INVENTOR, ATTORNEY DOCKET NO., CONFIRMATION NO.
Row 1: 16/380,844, 04/10/2019, Oumer TEYEB, P74267 US2, 8653
Row 2: 27045, 7590, 11/08/2019, EXAMINER THOMPSON, JR. OTIS L
Row 3: ERICSSON INC., 6300 LEGACY DRIVE, M/S EVR 1-C-11, PLANO, TX 75024, ART UNIT 2477, PAPER NUMBER

DATE MAILED: 11/08/2019

Determination of Patent Term Adjustment under 35 U.S.C. 154 (b)
(Applications filed on or after May 29, 2000)

The Office has discontinued providing a Patent Term Adjustment (PTA) calculation with the Notice of Allowance.

Section 1(h)(2) of the AIA Technical Corrections Act amended 35 U.S.C. 154(b)(3)(B)(i) to eliminate the requirement that the Office provide a patent term adjustment determination with the notice of allowance. See Revisions to Patent Term Adjustment, 78 Fed. Reg. 19416, 19417 (Apr. 1, 2013). Therefore, the Office is no longer providing an initial patent term adjustment determination with the notice of allowance. The Office will continue to provide a patent term adjustment determination with the Issue Notification Letter that is mailed to applicant approximately three weeks prior to the issue date of the patent, and will include the patent term adjustment on the patent. Any request for reconsideration of the patent term adjustment determination (or reinstatement of patent term adjustment) should follow the process outlined in 37 CFR 1.705.

Any questions regarding the Patent Term Extension or Adjustment determination should be directed to the Office of Patent Legal Administration at (571)-272-7702. Questions relating to issue and publication fee payments should be directed to the Customer Service Center of the Office of Patent Publication at 1-(888)-786-0101 or (571)-272-4200.

## OMB Clearance and PRA Burden Statement for PTOL-85 Part B

The Paperwork Reduction Act (PRA) of 1995 requires Federal agencies to obtain Office of Management and Budget approval before requesting most types of information from the public. When OMB approves an agency request to collect information from the public, OMB (i) provides a valid OMB Control Number and expiration date for the agency to display on the instrument that will be used to collect the information and (ii) requires the agency to inform the public about the OMB Control Number's legal significance in accordance with 5 CFR 1320.5(b).

The information collected by PTOL-85 Part B is required by 37 CFR 1.311. The information is required to obtain or retain a benefit by the public which is to file (and by the USPTO to process) an application. Confidentiality is governed by 35 U.S.C. 122 and 37 CFR 1.14. This collection is estimated to take 30 minutes to complete, including gathering, preparing, and submitting the completed application form to the USPTO. Time will vary depending upon the individual case. Any comments on the amount of time you require to complete this form and/or suggestions for reducing this burden, should be sent to the Chief Information Officer, U.S. Patent and Trademark Office, U.S. Department of Commerce, P.O. Box 1450, Alexandria, Virginia 22313-1450. DO NOT SEND FEES OR COMPLETED FORMS TO THIS ADDRESS. SEND TO: Commissioner for Patents, P.O. Box 1450, Alexandria, Virginia 22313-1450. Under the Paperwork Reduction Act of 1995, no persons are required to respond to a collection of information unless it displays a valid OMB control number.

### Privacy Act Statement

**The Privacy Act of 1974 (P.L. 93-579)** requires that you be given certain information in connection with your submission of the attached form related to a patent application or patent. Accordingly, pursuant to the requirements of the Act, please be advised that: (1) the general authority for the collection of this information is 35 U.S.C. 2(b)(2); (2) furnishing of the information solicited is voluntary; and (3) the principal purpose for which the information is used by the U.S. Patent and Trademark Office is to process and/or examine your submission related to a patent application or patent. If you do not furnish the requested information, the U.S. Patent and Trademark Office may not be able to process and/or examine your submission, which may result in termination of proceedings or abandonment of the application or expiration of the patent.

The information provided by you in this form will be subject to the following routine uses:

1. The information on this form will be treated confidentially to the extent allowed under the Freedom of Information Act (5 U.S.C. 552) and the Privacy Act (5 U.S.C. 552a). Records from this system of records may be disclosed to the Department of Justice to determine whether disclosure of these records is required by the Freedom of Information Act.
2. A record from this system of records may be disclosed, as a routine use, in the course of presenting evidence to a court, magistrate, or administrative tribunal, including disclosures to opposing counsel in the course of settlement negotiations.
3. A record in this system of records may be disclosed, as a routine use, to a Member of Congress submitting a request involving an individual, to whom the record pertains, when the individual has requested assistance from the Member with respect to the subject matter of the record.
4. A record in this system of records may be disclosed, as a routine use, to a contractor of the Agency having need for the information in order to perform a contract. Recipients of information shall be required to comply with the requirements of the Privacy Act of 1974, as amended, pursuant to 5 U.S.C. 552a(m).
5. A record related to an International Application filed under the Patent Cooperation Treaty in this system of records may be disclosed, as a routine use, to the International Bureau of the World Intellectual Property Organization, pursuant to the Patent Cooperation Treaty.
6. A record in this system of records may be disclosed, as a routine use, to another federal agency for purposes of National Security review (35 U.S.C. 181) and for review pursuant to the Atomic Energy Act (42 U.S.C. 218(c)).
7. A record from this system of records may be disclosed, as a routine use, to the Administrator, General Services, or his/her designee, during an inspection of records conducted by GSA as part of that agency's responsibility to recommend improvements in records management practices and programs, under authority of 44 U.S.C. 2904 and 2906. Such disclosure shall be made in accordance with the GSA regulations governing inspection of records for this purpose, and any other relevant (i.e., GSA or Commerce) directive. Such disclosure shall not be used to make determinations about individuals.
8. A record from this system of records may be disclosed, as a routine use, to the public after either publication of the application pursuant to 35 U.S.C. 122(b) or issuance of a patent pursuant to 35 U.S.C. 151. Further, a record may be disclosed, subject to the limitations of 37 CFR 1.14, as a routine use, to the public if the record was filed in an application which became abandoned or in which the proceedings were terminated and which application is referenced by either a published application, an application open to public inspection or an issued patent.
9. A record from this system of records may be disclosed, as a routine use, to a Federal, State, or local law enforcement agency, if the USPTO becomes aware of a violation or potential violation of law or regulation.

|                               |                                        |                                     |                                 |
|-------------------------------|----------------------------------------|-------------------------------------|---------------------------------|
| <b>Notice of Allowability</b> | <b>Application No.</b><br>16/380,844   | <b>Applicant(s)</b><br>TEYEB et al. |                                 |
|                               | <b>Examiner</b><br>OTIS L THOMPSON, JR | <b>Art Unit</b><br>2477             | <b>AIA (FITF) Status</b><br>Yes |

**-- The MAILING DATE of this communication appears on the cover sheet with the correspondence address--**

All claims being allowable, PROSECUTION ON THE MERITS IS (OR REMAINS) CLOSED in this application. If not included herewith (or previously mailed), a Notice of Allowance (PTOL-85) or other appropriate communication will be mailed in due course. **THIS NOTICE OF ALLOWABILITY IS NOT A GRANT OF PATENT RIGHTS.** This application is subject to withdrawal from issue at the initiative of the Office or upon petition by the applicant. See 37 CFR 1.313 and MPEP 1308.

1.  This communication is responsive to communications filed 17 October 2019.  
 A declaration(s)/affidavit(s) under **37 CFR 1.130(b)** was/were filed on \_\_\_\_\_.
2.  An election was made by the applicant in response to a restriction requirement set forth during the interview on \_\_\_\_\_; the restriction requirement and election have been incorporated into this action.
3.  The allowed claim(s) is/are 1-20 (Renumbering: claims 1-16, 18-20 and 17 are now 1-20 respectively). As a result of the allowed claim(s), you may be eligible to benefit from the **Patent Prosecution Highway** program at a participating intellectual property office for the corresponding application. For more information, please see [http://www.uspto.gov/patents/init\\_events/pph/index.jsp](http://www.uspto.gov/patents/init_events/pph/index.jsp) or send an inquiry to [PPHfeedback@uspto.gov](mailto:PPHfeedback@uspto.gov).
4.  Acknowledgment is made of a claim for foreign priority under 35 U.S.C. § 119(a)-(d) or (f).

**Certified copies:**

- a)  All      b)  Some      \*c)  None of the:
1.  Certified copies of the priority documents have been received.
  2.  Certified copies of the priority documents have been received in Application No. \_\_\_\_\_.
  3.  Copies of the certified copies of the priority documents have been received in this national stage application from the International Bureau (PCT Rule 17.2(a)).

\* Certified copies not received: \_\_\_\_\_.

Applicant has THREE MONTHS FROM THE "MAILING DATE" of this communication to file a reply complying with the requirements noted below. Failure to timely comply will result in ABANDONMENT of this application.  
**THIS THREE-MONTH PERIOD IS NOT EXTENDABLE.**

5.  CORRECTED DRAWINGS (as "replacement sheets") must be submitted.  
 including changes required by the attached Examiner's Amendment / Comment or in the Office action of Paper No./Mail Date \_\_\_\_\_.
- Identifying indicia such as the application number (see 37 CFR 1.84(c)) should be written on the drawings in the front (not the back) of each sheet. Replacement sheet(s) should be labeled as such in the header according to 37 CFR 1.121(d).**
6.  DEPOSIT OF and/or INFORMATION about the deposit of BIOLOGICAL MATERIAL must be submitted. Note the attached Examiner's comment regarding REQUIREMENT FOR THE DEPOSIT OF BIOLOGICAL MATERIAL.

**Attachment(s)**

- |                                                                                                                   |                                                                                      |
|-------------------------------------------------------------------------------------------------------------------|--------------------------------------------------------------------------------------|
| 1. <input type="checkbox"/> Notice of References Cited (PTO-892)                                                  | 5. <input type="checkbox"/> Examiner's Amendment/Comment                             |
| 2. <input type="checkbox"/> Information Disclosure Statements (PTO/SB/08),<br>Paper No./Mail Date _____.          | 6. <input checked="" type="checkbox"/> Examiner's Statement of Reasons for Allowance |
| 3. <input type="checkbox"/> Examiner's Comment Regarding Requirement for Deposit<br>of Biological Material _____. | 7. <input type="checkbox"/> Other _____.                                             |
| 4. <input type="checkbox"/> Interview Summary (PTO-413),<br>Paper No./Mail Date _____.                            |                                                                                      |

/OTIS L THOMPSON, JR/  
Primary Examiner, Art Unit 2477

## **DETAILED ACTION**

### ***Notice of Pre-AIA or AIA Status***

1. The present application, filed on or after March 16, 2013, is being examined under the first inventor to file provisions of the AIA.

### ***Allowable Subject Matter***

2. Claims 1-20 (Renumbering: claims 1-16, 18-20 and 17 are now 1-20 respectively) are allowed.

3. The following is an examiner's statement of reasons for allowance: the prior art does not teach or adequately suggest a full configuration being indicated by a network node and applied by wireless *without receiving a reconfiguration message*.

Any comments considered necessary by applicant must be submitted no later than the payment of the issue fee and, to avoid processing delays, should preferably accompany the issue fee. Such submissions should be clearly labeled "Comments on Statement of Reasons for Allowance."

### ***Conclusion***

4. Any inquiry concerning this communication or earlier communications from the examiner should be directed to OTIS L THOMPSON, JR whose telephone number is (571)270-1953. The examiner can normally be reached on Monday - Friday, 6:30am - 7:00pm.

Examiner interviews are available via telephone, in-person, and video conferencing using a USPTO supplied web-based collaboration tool. To schedule an interview, applicant is

encouraged to use the USPTO Automated Interview Request (AIR) at  
<http://www.uspto.gov/interviewpractice>.

If attempts to reach the examiner by telephone are unsuccessful, the examiner's supervisor, Chirag G Shah can be reached on 571-272-3144. The fax phone number for the organization where this application or proceeding is assigned is 571-273-8300.

Information regarding the status of an application may be obtained from the Patent Application Information Retrieval (PAIR) system. Status information for published applications may be obtained from either Private PAIR or Public PAIR. Status information for unpublished applications is available through Private PAIR only. For more information about the PAIR system, see <http://pair-direct.uspto.gov>. Should you have questions on access to the Private PAIR system, contact the Electronic Business Center (EBC) at 866-217-9197 (toll-free). If you would like assistance from a USPTO Customer Service Representative or access to the automated information system, call 800-786-9199 (IN USA OR CANADA) or 571-272-1000.

/OTIS L THOMPSON, JR/  
Primary Examiner, Art Unit 2477

November 5, 2019

|                                                                                                                 |                                              |                                                                |
|-----------------------------------------------------------------------------------------------------------------|----------------------------------------------|----------------------------------------------------------------|
| <b><i>Search Notes</i></b><br> | <b>Application/Control No.</b><br>16/380,844 | <b>Applicant(s)/Patent Under Reexamination</b><br>TEYEB et al. |
|                                                                                                                 | <b>Examiner</b><br>OTIS L THOMPSON, JR       | <b>Art Unit</b><br>2477                                        |

| CPC - Searched* |      |          |
|-----------------|------|----------|
| Symbol          | Date | Examiner |
|                 |      |          |

| CPC Combination Sets - Searched* |            |          |
|----------------------------------|------------|----------|
| Symbol                           | Date       | Examiner |
| H04W76 with text in EAST         | 05/28/2019 | OT       |

| US Classification - Searched* |          |      |          |
|-------------------------------|----------|------|----------|
| Class                         | Subclass | Date | Examiner |
|                               |          |      |          |

\* See search history printout included with this form or the SEARCH NOTES box below to determine the scope of the search.

| Search Notes                                                           |            |          |
|------------------------------------------------------------------------|------------|----------|
| Search Notes                                                           | Date       | Examiner |
| EAST Text Search                                                       | 05/24/2019 | OT       |
| EAST Text Search                                                       | 05/25/2019 | OT       |
| EAST Text Search                                                       | 05/28/2019 | OT       |
| Double patenting search                                                | 05/28/2019 | OT       |
| NPL search (Google: rrcconnectionresume/rrcresume, full configuration) | 05/28/2019 | OT       |
| EAST text search                                                       | 09/06/2019 | OT       |
| EAST Text Search                                                       | 11/05/2019 | OT       |
| Double patenting search                                                | 11/05/2019 | OT       |
| Interference text search                                               | 11/05/2019 | OT       |

|                                                          |  |
|----------------------------------------------------------|--|
| /OTIS L THOMPSON, JR/<br>Primary Examiner, Art Unit 2477 |  |
|----------------------------------------------------------|--|

|                                                                                                                 |                                              |                                                                |
|-----------------------------------------------------------------------------------------------------------------|----------------------------------------------|----------------------------------------------------------------|
| <b><i>Search Notes</i></b><br> | <b>Application/Control No.</b><br>16/380,844 | <b>Applicant(s)/Patent Under Reexamination</b><br>TEYEB et al. |
|                                                                                                                 | <b>Examiner</b><br>OTIS L THOMPSON, JR       | <b>Art Unit</b><br>2477                                        |

| Interference Search |                       |            |          |
|---------------------|-----------------------|------------|----------|
| US Class/CPC Symbol | US Subclass/CPC Group | Date       | Examiner |
| H04W76              | 19 with text in EAST  | 11/05/2019 | OT       |

|                                                          |  |
|----------------------------------------------------------|--|
| /OTIS L THOMPSON, JR/<br>Primary Examiner, Art Unit 2477 |  |
|----------------------------------------------------------|--|

|                                                                                                                  |                                              |                                                                |
|------------------------------------------------------------------------------------------------------------------|----------------------------------------------|----------------------------------------------------------------|
| <b>Issue Classification</b><br> | <b>Application/Control No.</b><br>16/380,844 | <b>Applicant(s)/Patent Under Reexamination</b><br>TEYEB et al. |
|                                                                                                                  | <b>Examiner</b><br>OTIS L THOMPSON, JR       | <b>Art Unit</b><br>2477                                        |

|               |    |    |             |                |
|---------------|----|----|-------------|----------------|
| <b>CPC</b>    |    |    |             |                |
| <b>Symbol</b> |    |    | <b>Type</b> | <b>Version</b> |
| H04W          | 76 | 19 | F           | 2018-02-01     |

|                             |             |            |                |                |
|-----------------------------|-------------|------------|----------------|----------------|
| <b>CPC Combination Sets</b> |             |            |                |                |
| <b>Symbol</b>               | <b>Type</b> | <b>Set</b> | <b>Ranking</b> | <b>Version</b> |
|                             |             |            |                |                |

|                                                          |                              |                     |                   |
|----------------------------------------------------------|------------------------------|---------------------|-------------------|
| NONE                                                     | <b>Total Claims Allowed:</b> |                     |                   |
| (Assistant Examiner)                                     | (Date)                       | 20                  |                   |
| /OTIS L THOMPSON, JR/<br>Primary Examiner, Art Unit 2477 | 05 November 2019             | O.G. Print Claim(s) |                   |
| (Primary Examiner)                                       | (Date)                       | 1                   | O.G. Print Figure |
|                                                          |                              | 1                   | 1                 |



|                                                                                                                  |                                              |                                                                |
|------------------------------------------------------------------------------------------------------------------|----------------------------------------------|----------------------------------------------------------------|
| <b>Issue Classification</b><br> | <b>Application/Control No.</b><br>16/380,844 | <b>Applicant(s)/Patent Under Reexamination</b><br>TEYEB et al. |
|                                                                                                                  | <b>Examiner</b><br>OTIS L THOMPSON, JR       | <b>Art Unit</b><br>2477                                        |

|                                     |  |    |    |
|-------------------------------------|--|----|----|
| <b>INTERNATIONAL CLASSIFICATION</b> |  |    |    |
| <b>CLAIMED</b>                      |  |    |    |
| H04W                                |  | 76 | 19 |
| <b>NON-CLAIMED</b>                  |  |    |    |
|                                     |  |    |    |

|                                   |                 |
|-----------------------------------|-----------------|
| <b>US ORIGINAL CLASSIFICATION</b> |                 |
| <b>CLASS</b>                      | <b>SUBCLASS</b> |
|                                   |                 |

|                            |                                          |  |  |  |  |
|----------------------------|------------------------------------------|--|--|--|--|
| <b>CROSS REFERENCES(S)</b> |                                          |  |  |  |  |
| <b>CLASS</b>               | <b>SUBCLASS (ONE SUBCLASS PER BLOCK)</b> |  |  |  |  |
|                            |                                          |  |  |  |  |

|                                                          |                  |                     |                              |  |
|----------------------------------------------------------|------------------|---------------------|------------------------------|--|
| NONE                                                     |                  |                     | <b>Total Claims Allowed:</b> |  |
| (Assistant Examiner)                                     | (Date)           | 20                  |                              |  |
| /OTIS L THOMPSON, JR/<br>Primary Examiner, Art Unit 2477 | 05 November 2019 | O.G. Print Claim(s) | O.G. Print Figure            |  |
| (Primary Examiner)                                       | (Date)           | 1                   | 1                            |  |

|                                                                                                                  |                                              |                                                                |
|------------------------------------------------------------------------------------------------------------------|----------------------------------------------|----------------------------------------------------------------|
| <b>Issue Classification</b><br> | <b>Application/Control No.</b><br>16/380,844 | <b>Applicant(s)/Patent Under Reexamination</b><br>TEYEB et al. |
|                                                                                                                  | <b>Examiner</b><br>OTIS L THOMPSON, JR       | <b>Art Unit</b><br>2477                                        |

Claims renumbered in the same order as presented by applicant  
  CPA  
  T.D.  
  R.1.47

| CLAIMS |          |       |          |       |          |       |          |       |          |       |          |       |          |       |          |
|--------|----------|-------|----------|-------|----------|-------|----------|-------|----------|-------|----------|-------|----------|-------|----------|
| Final  | Original | Final | Original | Final | Original | Final | Original | Final | Original | Final | Original | Final | Original | Final | Original |
| 1      | 1        | 10    | 10       | 18    | 19       |       |          |       |          |       |          |       |          |       |          |
| 2      | 2        | 11    | 11       | 19    | 20       |       |          |       |          |       |          |       |          |       |          |
| 3      | 3        | 12    | 12       |       |          |       |          |       |          |       |          |       |          |       |          |
| 4      | 4        | 13    | 13       |       |          |       |          |       |          |       |          |       |          |       |          |
| 5      | 5        | 14    | 14       |       |          |       |          |       |          |       |          |       |          |       |          |
| 6      | 6        | 15    | 15       |       |          |       |          |       |          |       |          |       |          |       |          |
| 7      | 7        | 16    | 16       |       |          |       |          |       |          |       |          |       |          |       |          |
| 8      | 8        | 20    | 17       |       |          |       |          |       |          |       |          |       |          |       |          |
| 9      | 9        | 17    | 18       |       |          |       |          |       |          |       |          |       |          |       |          |

|                                                          |                              |                     |
|----------------------------------------------------------|------------------------------|---------------------|
| NONE                                                     | <b>Total Claims Allowed:</b> |                     |
| (Assistant Examiner)                                     | (Date)                       | 20                  |
| /OTIS L THOMPSON, JR/<br>Primary Examiner, Art Unit 2477 | 05 November 2019             | O.G. Print Claim(s) |
| (Primary Examiner)                                       | (Date)                       | 1                   |
|                                                          |                              | O.G. Print Figure   |
|                                                          |                              | 1                   |



OK TO ENTER: /O.L.T/

**IN THE UNITED STATES PATENT AND TRADEMARK OFFICE**

|                        |                                                                  |
|------------------------|------------------------------------------------------------------|
| In re: Application of: | TEYEB Oumer et al.                                               |
| Serial No.:            | 16/380,844                                                       |
| Application Filed:     | April 10, 2019                                                   |
| Title                  | METHODS AND UE FOR RESUMING A CONNECTION WITH FULL CONFIGURATION |
| Examiner:              | Thompson JR. Otis L.                                             |
| Attorney Ref:          | P74267 US2                                                       |

Commissioner for Patents  
 United States Patent and Trade Mark Office  
 Customer Service Window  
**MAILSTOP AF**  
 P.O. Box 1450  
 Alexandria, VA 22313-1450  
 USA

|                                                                                                                                                                                                                                                                                                                         |
|-------------------------------------------------------------------------------------------------------------------------------------------------------------------------------------------------------------------------------------------------------------------------------------------------------------------------|
| <p>CERTIFICATE OF MAILING OR TRANSMISSION [37 CFR 1.8(A)]</p> <p>I hereby certify that this correspondence is being electronically transmitted via EFS Web to the United States Patent and Trademark Office</p> <p>On: ...2019-10-17.....by:...Lala Deleon.....</p> <p>.../Lala Deleon/.....<br/>         Signature</p> |
|-------------------------------------------------------------------------------------------------------------------------------------------------------------------------------------------------------------------------------------------------------------------------------------------------------------------------|

Dear Sir:

**AMENDMENTS AND RESPONSE TO OFFICE ACTION**

This is in response to the Office Action dated September 12, 2019. Please amend the above-identified application as follows:

**Amendments to the Claims** begin on page 2 of this paper.

**Remarks and arguments** begin on page 5 of this paper.

The Commissioner is hereby authorized to charge any additional fee to Deposit Account No. 501379.

## EAST Search History

## EAST Search History (Prior Art)

| Ref # | Hits  | Search Query                                                                                                                                                     | DBs                                                                  | Default Operator | Plurals | Time Stamp          |
|-------|-------|------------------------------------------------------------------------------------------------------------------------------------------------------------------|----------------------------------------------------------------------|------------------|---------|---------------------|
| S55   | 4     | (rrcconnectionreconfig\$7 or rrc connect\$3 reconfig\$7 or reconfig\$7) same (fullconfig or full config or full config\$7) near2 without                         | US-PGPUB;<br>USPAT; USOCR;<br>FPRS; EPO;<br>JPO; DERWENT;<br>IBM_TDB | ADJ              | ON      | 2019/11/05<br>12:59 |
| S56   | 5     | (rrcconnectionreconfig\$7 or rrc connect\$3 reconfig\$7 or reconfig\$7) near2 without same (fullconfig or full config or full config\$7)                         | US-PGPUB;<br>USPAT; USOCR;<br>FPRS; EPO;<br>JPO; DERWENT;<br>IBM_TDB | ADJ              | ON      | 2019/11/05<br>13:01 |
| S57   | 16123 | (rrcconnectionreconfig\$7 or rrc connect\$3 reconfig\$7 or reconfig\$7) near2 (without or omit\$4 or omission)                                                   | US-PGPUB;<br>USPAT; USOCR;<br>FPRS; EPO;<br>JPO; DERWENT;<br>IBM_TDB | ADJ              | ON      | 2019/11/05<br>14:34 |
| S58   | 124   | (rrcconnectionreconfig\$7 or rrc connect\$3 reconfig\$7 or reconfig\$7) near2 (without or omit\$4 or omission) and (fullconfig or full config or full config\$7) | US-PGPUB;<br>USPAT; USOCR;<br>FPRS; EPO;<br>JPO; DERWENT;<br>IBM_TDB | ADJ              | ON      | 2019/11/05<br>14:35 |
| L1    | 2     | ("20190254102").PN.                                                                                                                                              | US-PGPUB;<br>USPAT; USOCR;<br>DERWENT                                | ADJ              | ON      | 2019/11/05<br>19:09 |
| L3    | 1     | l2 and full configuration.clm. and resum\$5.clm.                                                                                                                 | US-PGPUB;<br>USPAT; USOCR;<br>FPRS; EPO;<br>JPO; DERWENT;<br>IBM_TDB | ADJ              | ON      | 2019/11/05<br>19:25 |
| L2    | 550   | ((("TEYEB") near3 ("Oumer")) OR ((("MILDH") near3 ("Gunnar"))).INV.                                                                                              | US-PGPUB;<br>USPAT; USOCR;<br>EPO; JPO;<br>DERWENT                   | ADJ              | ON      | 2019/11/05<br>19:25 |
| L4    | 1     | l2 and full configuration.clm. and reconfig\$7.clm.                                                                                                              | US-PGPUB;<br>USPAT; USOCR;<br>FPRS; EPO;<br>JPO; DERWENT;<br>IBM_TDB | ADJ              | ON      | 2019/11/05<br>19:26 |

## EAST Search History (Interference)

| Ref # | Hits | Search Query                                                 | DBs   | Default Operator | Plurals | Time Stamp          |
|-------|------|--------------------------------------------------------------|-------|------------------|---------|---------------------|
| L8    | 11   | full configuration.clm. and reconfig\$7.clm.                 | USPAT | ADJ              | ON      | 2019/11/05<br>19:27 |
| L7    | 0    | full configuration.clm. and resum\$5.clm.                    | USPAT | ADJ              | ON      | 2019/11/05<br>19:27 |
| L6    | 0    | h04w76/19.cpc. and full configuration.clm. and resum\$5.clm. | USPAT | ADJ              | ON      | 2019/11/05<br>19:27 |

EAST Search History

|    |   |                                                                    |       |     |    |                     |
|----|---|--------------------------------------------------------------------|-------|-----|----|---------------------|
| L5 | 0 | h04w76/19.cpc. and full configuration.clm.<br>and reconfig\$7.clm. | USPAT | ADJ | ON | 2019/11/05<br>19:27 |
|----|---|--------------------------------------------------------------------|-------|-----|----|---------------------|

**11/ 5/ 2019 7:28:48 PM**

**C:\Users\othompson1\Documents\EAST\Workspaces\16-380844.wsp**

**IN THE UNITED STATES PATENT AND TRADEMARK OFFICE**

In re: Application of: TEYEB Oumer et al.  
Serial No.: 16/380,844  
Application Filed: April 10, 2019  
Title: METHODS AND UE FOR RESUMING A CONNECTION WITH FULL CONFIGURATION  
Examiner: Thompson JR. Otis L.  
Attorney Ref: P74267 US2

Commissioner for Patents  
United States Patent and Trade Mark Office  
Customer Service Window  
**MAILSTOP AF**  
P.O. Box 1450  
Alexandria, VA 22313-1450  
USA

|                                                                                                                                                                                                                                                                                                        |
|--------------------------------------------------------------------------------------------------------------------------------------------------------------------------------------------------------------------------------------------------------------------------------------------------------|
| CERTIFICATE OF MAILING OR TRANSMISSION [37 CFR 1.8(A)]<br><br>I hereby certify that this correspondence is being electronically transmitted via EFS Web to the United States Patent and Trademark Office<br><br>On: ...2019-10-17.....by:...Lala Deleon.....<br><br>.../Lala Deleon/.....<br>Signature |
|--------------------------------------------------------------------------------------------------------------------------------------------------------------------------------------------------------------------------------------------------------------------------------------------------------|

Dear Sir:

**AMENDMENTS AND RESPONSE TO OFFICE ACTION**

This is in response to the Office Action dated September 12, 2019. Please amend the above-identified application as follows:

**Amendments to the Claims** begin on page 2 of this paper.

**Remarks and arguments** begin on page 5 of this paper.

The Commissioner is hereby authorized to charge any additional fee to Deposit Account No. 501379.

UNITED STATES PROVISIONAL APPLICATION

For

**NEW RADIO (NR) RADIO RESOURCE CONTROL (RRC) CONNECTION SETUP  
OPTIMIZATION**

Inventors:

Sudeep Palat

Richard Burbidge

Yi Guo

Seau S. Lim

Prepared by:

Ryan N. Strauss

Reg. No. 68,392



## **NEW RADIO (NR) RADIO RESOURCE CONTROL (RRC) CONNECTION SETUP OPTIMIZATION**

### **BACKGROUND**

Various embodiments generally may relate to the field of wireless communications.

### **DETAILED DESCRIPTION**

The following detailed description refers to the accompanying drawings. The same reference numbers may be used in different drawings to identify the same or similar elements. In the following description, for purposes of explanation and not limitation, specific details are set forth such as particular structures, architectures, interfaces, techniques, etc. in order to provide a thorough understanding of the various aspects of various embodiments. However, it will be apparent to those skilled in the art having the benefit of the present disclosure that the various aspects of the various embodiments may be practiced in other examples that depart from these specific details. In certain instances, descriptions of well-known devices, circuits, and methods are omitted so as not to obscure the description of the various embodiments with unnecessary detail. For the purposes of the present document, the phrase “A or B” means (A), (B), or (A and B).

Embodiments herein provide optimizations to radio resource control (RRC) connection setup procedure for new radio (NR) systems as compared to Long Term Evolution (LTE) in terms of number of signaling messages and bits and connection set up delay.

In various embodiments, the RRC Connection set up may be combined with the subsequent Short Message Control (SMC) and RRC reconfiguration message to eliminate the messages and delay associated with Setup procedure. This saves delay if initial Non-Access Stratum (NAS) message(s) is/are sent to the network either as part of Random Access Channel (RACH) message 3 (msg 3) or immediately after msg 3. The procedures of the embodiments may reduce idle to active transition delay and may save the number of bits conveyed over the radio, which may reduce signaling overhead.

LTE connection request is designed and optimized around the worst case msg 3 size of 48bits. Service request is the most time critical procedure for Idle Active transition and LTE has taken extra care to optimize this procedure. Msg 3 carries the NAS UE id (unique within the TA list) that is also used for contention resolution guaranteeing no further collision after msg 4 contention resolution.

RACH message 4 (msg 4) includes the Contention Resolution control element (CE) and also RRC connection setup message that sets up Signaling Radio Bearer 1 (SRB1). UE sends RRC Setup complete with the initial direct transfer NAS message in RACH msg 5. Further efficiency is achieved by removing duplication of information between msg 3 and msg 5 by using the UE id provided in msg 3 to send to Mobility Management Entity (MME) over S1-AP.

On receipt of UE context containing the Security and UE capability information, eNB sends RRC SMC and RRC reconfiguration message to the UE. These messages are concatenated to further reduce delay.

Figure B.1 provides an example C-plane flow for the IDLE to CONNECTED transition for Rel-8.

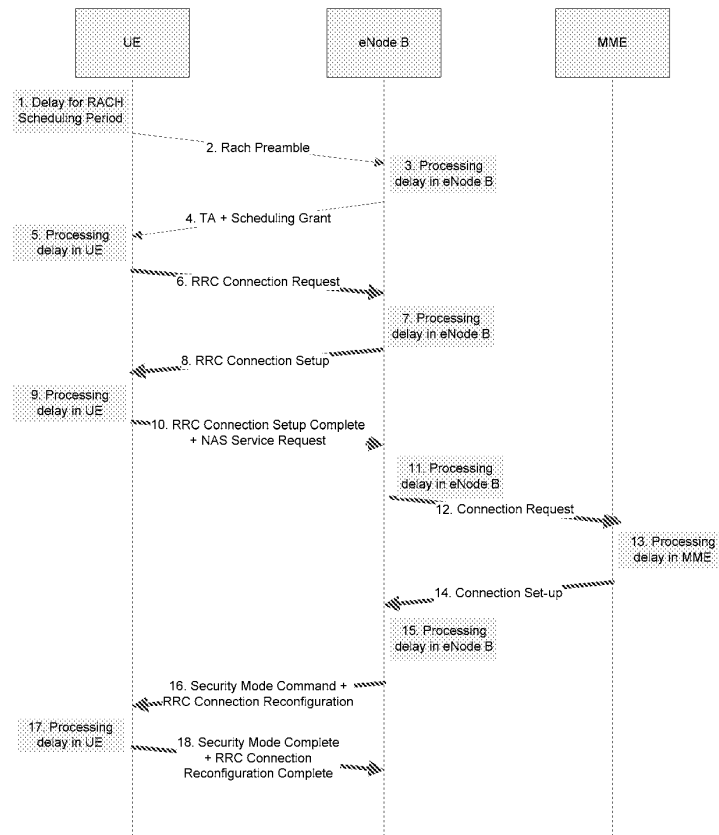

Figure B.1.1-1: C-plane activation procedure (example for Rel-8)

**1.1.1 Limitations of LTE**

As shown by Figure B.1, it is still not possible to contact the CN until after reception of msg 5 because the information needed for NAS is only available in msg 5. This procedure is associated with the following delay as captured in Table B.1.1.1-1.

**Table B.1.1.1-1**

|    |                                                                                |    |    |
|----|--------------------------------------------------------------------------------|----|----|
| 7  | Processing delay in eNB (L2 and RRC)                                           | 4  | 4  |
| 8  | Transmission of RRC Connection Set-up (and UL grant)                           | 1  | 1  |
| 9  | Processing delay in the UE (L2 and RRC)                                        | 15 | 15 |
| 10 | Transmission of RRC Connection Set-up complete (including NAS Service Request) | 1  | 1  |
| 11 | Processing delay in eNB (Uu → S1-C)                                            | 4  | 4  |

While Msg 5 is also optimised to reduce message size for Service Request. However, over several releases, msg 5 size has crept up increasing delay for transmission of msg 5 and hence leading to increased delay in contacting the CN. Much of this new information is not really needed to contact the CN for Service request procedure.

It is not possible to further reduce the Idle Active transition delay even if larger msg 3 size was possible because only message size is defined for RRC connection request (note that Resume request already defines multiple message sizes).

The multi-step set up procedures for SRB1 (using RRC Connection setup), followed by SMC and another RRC reconfiguration to setup SRB2 and DRBs also add delay to the Idle Active transition in LTE.

Reducing the signaling procedures and messages discussed above can reduce the signaling and Idle/Active transition delay.

Observation 1: LTE Idle Active transition, while fairly optimal, can be further optimised in terms of signaling and Idle/Active transition delay.

**1.2 Optimization Embodiments for NR**

As discussed above about 20ms of Idle Active transition can be reduced by avoiding msg 3 to msg 5 delay for initiating the connection to the CN. It would also be useful to include other information early.

**1.2.1 Sending Msg 5 contents early**

|                       |                             |           |
|-----------------------|-----------------------------|-----------|
| selectedPLMN-Identity | INTEGER (1..maxPLMN-r11),   |           |
| registeredMME         | RegisteredMME               | OPTIONAL, |
| dedicatedInfoNAS      | DedicatedInfoNAS,           |           |
| gummei-Type-r10       | ENUMERATED {native, mapped} | OPTIONAL, |
| r1f-InfoAvailable-r10 | ENUMERATED {true}           | OPTIONAL, |

|                                   |                                          |           |
|-----------------------------------|------------------------------------------|-----------|
| logMeasAvailable-r10              | ENUMERATED {true}                        | OPTIONAL, |
| rn-SubframeConfigReq-r10          | ENUMERATED {required, notRequired}       | OPTIONAL, |
| connEstFailInfoAvailable-r11      | ENUMERATED {true}                        | OPTIONAL, |
| mobilityState-r12                 | ENUMERATED {normal, medium, high, spare} | OPTIONAL, |
| mobilityHistoryAvail-r12          | ENUMERATED {true}                        | OPTIONAL, |
| logMeasAvailableMBSFN-r12         | ENUMERATED {true}                        | OPTIONAL, |
| ce-ModeB-r13                      | ENUMERATED {supported}                   | OPTIONAL, |
| s-TMSI-r13                        | S-TMSI                                   | OPTIONAL, |
| attachWithoutPDN-Connectivity-r13 | ENUMERATED {true}                        | OPTIONAL, |
| up-CIoT-EPS-Optimisation-r13      | ENUMERATED {true}                        | OPTIONAL, |
| cp-CIoT-EPS-Optimisation-r13      | ENUMERATED {true}                        | OPTIONAL, |
| ue-CE-NeedULGaps-r13              | ENUMERATED {true}                        | OPTIONAL, |
| dcn-ID-r14                        | INTEGER {0..65535}                       | OPTIONAL, |

Of the above, only the dedicatedInfoNAS is essential to contact the CN. For Service Request, the NAS message size is 32bits (see Annex). If this is of variable size (as in LTE), size information is also needed.

CT1 has also defined an Extended Service Request to be used for CSFB and other services that is of larger size where normal Service request cannot be used.

It would be useful for RAN2 to know the NAS message sizes for NR to design the connection establishment optimally.

For other initial transfer messages such as NAS TAU which are not time critical, the current procedure can be re-used.

While transfer of the rest of the information in msg 5 can happen while the UE context is being retrieved from the CN, it would be helpful for the network to receive some of the information if available early. For example:

- Some parts of UE capability
- Coverage extension status
- Mobility state
- Number of Cause values could also be dependent on the size available, making it possible to directly use the Access barring call types as cause values without the need for further mapping.

Considering the size of NAS message and other critical information, both together could come to about 40bits.

### 1.2.2 Embodiments

Using LTE as an example, it could be useful to send about 40 bits early as discussed above. Some possible solutions to early transfer of critical information from message 5 are discussed below.

### **1.2.2.1 Increasing RACH msg 3 Size**

Increasing msg 3 size may be possible without significantly increasing delay from HARQ retransmissions. If increasing it by about 40bits is possible, it would be the simplest solution by simply defining RRC connection request to optionally include NAS Service Request and other critical information.

Increasing msg 3 size may increase number of HARQ re-tx. However, even with increased number of HARQ re-tx, it may still be faster overall for Idle/Active transmission than sending information in msg 5. A trade-off between msg 3 size and overall delay for connection setup could to be considered.

As there is no possibility for segmentation, RRC connection request message size has to be defined for the worst case msg 3 size. Possible RACH message 3 size information should come from RAN1.

### **1.2.2.2 Variable Size msg 3**

MSg 3 size may depend on various factors like cell size, UE path loss, delay tolerance etc. While LTE allows indication of path loss using RACH partition, it defines only one msg 3 size for Connection request. Hence even if large msg 3 size was possible, UE may not include additional RRC fields in msg 3 to reduce call setup time (though two message sizes are already defined for Resume Request).

Different sizes for RRC connection Request can be considered – one for worst case, and one or more for a larger msg 3 size. The larger message definition can include additional information from msg 5 as discussed above. The number of message sizes allowed should be limited to very few discrete sizes to minimise complexity and it is proposed to define two sizes based on RAN1 feedback on msg 3 size.

Define two different for RRC connection request message sizes including additional critical information for connection set up in the larger message. Actual message size and fields to be included should be based on RAN1 feedback on message size.

### **1.2.2.3 Use “msg 3.5”**

Another option is to use so called “Msg 3.5” If msg 3 size cannot be increased sufficiently. This can be seen as an RRC level segmentation of a larger msg 3 including the additional relevant fields from msg 5. It can be sent before network sends a Setup request. This saves delay compared

to LTE by eliminating the delay associated with the processing of RRC connection request in the network and Connection Setup in the UE.

There are a few different ways this can be realised. Network provides additional grant for “msg 3.5”, either always in RAR. Alternatively, network can provide an additional grant after receipt of some indication in msg 3 or RACH. “Msg 3.5” can also be sent after contention resolution, possibly after contention resolution (though this would be after RACH msg 4 but before RRC connection).

**1.2.2.4 Reducing Downlink Signaling**

Another optimization that can be considered if NAS Service request is sent early is to eliminate the step of RRC connection setup. It would be possible and useful to go directly to SMC+RRC connection reconfiguration by using default SRB1 configuration to send these messages.

The default SRB1 configuration could be specified in standards. This could set up RLC-AM configuration for SRB1. This allows the transfer of SMC+RRC connection reconfiguration using RLC-acknowledged mode, thereby providing reliability and possibility to segment the messages.

Further reconfiguration of SRB1 can be done in the RRC reconfiguration message. This message can also set up additional SRBs and DRBs. Since it is sent after SMC, it is a secure message and can provide also sensitive configuration information.

The combined procedure could look as shown in Figure B.2 below.

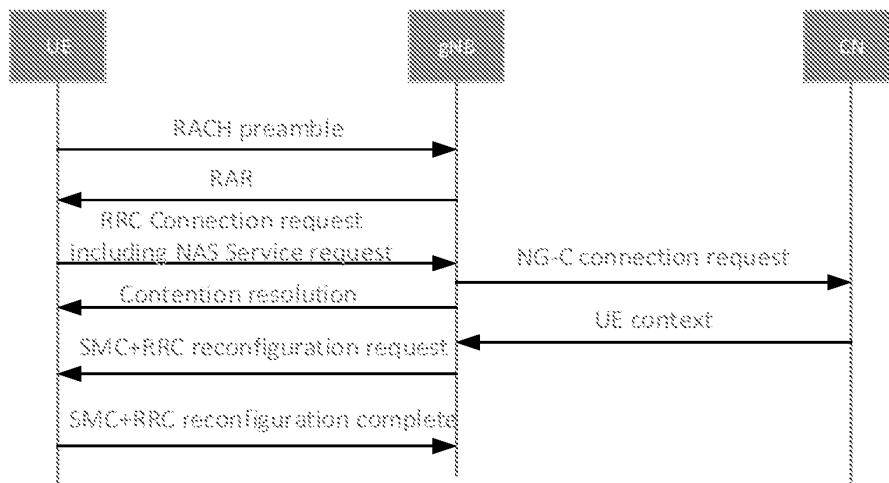

**Figure B.1: example of an optimized RRC connection setup procedure**

It is proposed to consider eliminating two setup procedure of RRC connection setup following by SMC/Reconfiguration and use a single step setup procedure.

**Figures XQ-XZ**

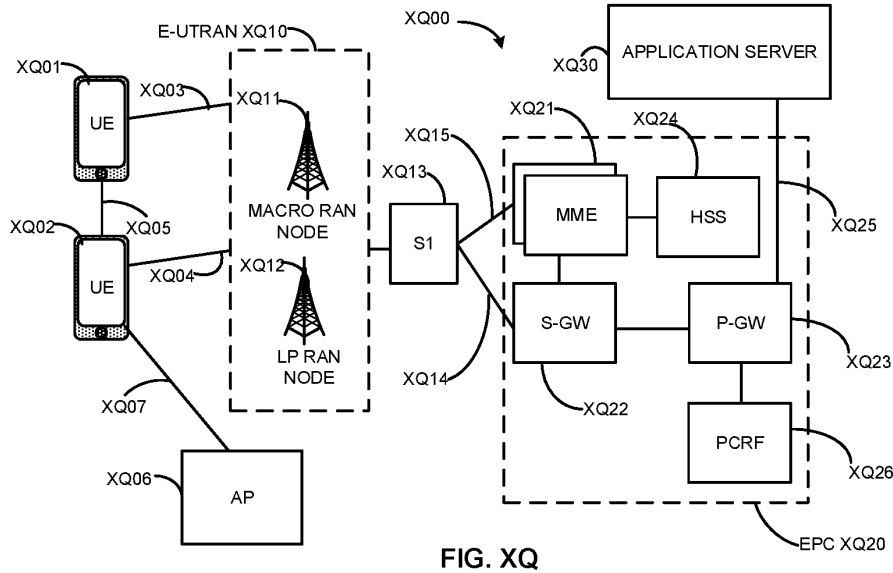

FIG. XQ

FIG. XQ illustrates an architecture of a system XQ00 of a network in accordance with some embodiments. The system XQ00 is shown to include a user equipment (UE) XQ01 and a UE XQ02. The UEs XQ01 and XQ02 are illustrated as smartphones (e.g., handheld touchscreen mobile computing devices connectable to one or more cellular networks), but may also comprise any mobile or non-mobile computing device, such as Personal Data Assistants (PDAs), pagers, laptop computers, desktop computers, wireless handsets, or any computing device including a wireless communications interface.

In some embodiments, any of the UEs XQ01 and XQ02 can comprise an Internet of Things (IoT) UE, which can comprise a network access layer designed for low-power IoT applications utilizing short-lived UE connections. An IoT UE can utilize technologies such as machine-to-machine (M2M) or machine-type communications (MTC) for exchanging data with an MTC server or device via a public land mobile network (PLMN), Proximity-Based Service (ProSe) or device-to-device (D2D) communication, sensor networks, or IoT networks. The M2M or MTC exchange of data may be a machine-initiated exchange of data. An IoT network describes interconnecting IoT UEs, which may include uniquely identifiable embedded computing devices (within the Internet infrastructure), with short-lived connections. The IoT UEs may execute

background applications (e.g., keep-alive messages, status updates, etc.) to facilitate the connections of the IoT network.

The UEs XQ01 and XQ02 may be configured to connect, e.g., communicatively couple, with a radio access network (RAN) XQ10 — the RAN XQ10 may be, for example, an Evolved Universal Mobile Telecommunications System (UMTS) Terrestrial Radio Access Network (E-UTRAN), a NextGen RAN (NG RAN), or some other type of RAN. The UEs XQ01 and XQ02 utilize connections XQ03 and XQ04, respectively, each of which comprises a physical communications interface or layer (discussed in further detail infra); in this example, the connections XQ03 and XQ04 are illustrated as an air interface to enable communicative coupling, and can be consistent with cellular communications protocols, such as a Global System for Mobile Communications (GSM) protocol, a code-division multiple access (CDMA) network protocol, a Push-to-Talk (PTT) protocol, a PTT over Cellular (POC) protocol, a Universal Mobile Telecommunications System (UMTS) protocol, a 3GPP Long Term Evolution (LTE) protocol, a fifth generation (5G) protocol, a New Radio (NR) protocol, and the like.

In this embodiment, the UEs XQ01 and XQ02 may further directly exchange communication data via a ProSe interface XQ05. The ProSe interface XQ05 may alternatively be referred to as a sidelink interface comprising one or more logical channels, including but not limited to a Physical Sidelink Control Channel (PSCCH), a Physical Sidelink Shared Channel (PSSCH), a Physical Sidelink Discovery Channel (PSDCH), and a Physical Sidelink Broadcast Channel (PSBCH). In various implementations, the SL interface XQ05 may be used in vehicular applications and communications technologies, which are often referred to as V2X systems. V2X is a mode of communication where UEs (for example, UEs XQ01, XQ02) communicate with each other directly over the PC5/SL interface 105 and can take place when the UEs XQ01, XQ02 are served by RAN nodes XQ11, XQ12 or when one or more UEs are outside a coverage area of the RAN XS10. V2X may be classified into four different types: vehicle-to-vehicle (V2V), vehicle-to-infrastructure (V2I), vehicle-to-network (V2N), and vehicle-to-pedestrian (V2P). These V2X applications can use “co-operative awareness” to provide more intelligent services for end-users. For example, vUEs XQ01, XQ02, RAN nodes XQ11, XQ12, application servers XQ30, and pedestrian UEs XQ01, XQ02 may collect knowledge of their local environment (for example, information received from other vehicles or sensor equipment in proximity) to process and share that knowledge in order to provide more intelligent services, such as cooperative collision warning,



autonomous driving, and the like. In these implementations, the UEs XQ01, XQ02 may be implemented/employed as Vehicle Embedded Communications Systems (VECS) or vUEs.

The UE XQ02 is shown to be configured to access an access point (AP) XQ06 (also referred to as also referred to as “WLAN node XQ06”, “WLAN XQ06”, “WLAN Termination XQ06” or “WT XQ06” or the like) via connection XQ07. The connection XQ07 can comprise a local wireless connection, such as a connection consistent with any IEEE 802.11 protocol, wherein the AP XQ06 would comprise a wireless fidelity (WiFi®) router. In this example, the AP XQ06 is shown to be connected to the Internet without connecting to the core network of the wireless system (described in further detail below). In various embodiments, the UE XQ02, RAN XQ10, and AP XQ06 may be configured to utilize LTE-WLAN aggregation (LWA) operation and/or WLAN LTE/WLAN Radio Level Integration with IPsec Tunnel (LWIP) operation. The LWA operation may involve the UE XQ02 in RRC\_CONNECTED being configured by a RAN node XQ11, XQ12 to utilize radio resources of LTE and WLAN. LWIP operation may involve the UE XQ02 using WLAN radio resources (e.g., connection XQ07) via Internet Protocol Security (IPsec) protocol tunneling to authenticate and encrypt packets (e.g., internet protocol (IP) packets) sent over the connection XQ07. IPsec tunneling may include encapsulating entirety of original IP packets and adding a new packet header thereby protecting the original header of the IP packets.

The RAN XQ10 can include one or more access nodes that enable the connections XQ03 and XQ04. These access nodes (ANs) can be referred to as base stations (BSs), NodeBs, evolved NodeBs (eNBs), next Generation NodeBs (gNB), RAN nodes, Road Side Units (RSUs), and so forth, and can comprise ground stations (e.g., terrestrial access points) or satellite stations providing coverage within a geographic area (e.g., a cell). The term “Road Side Unit” or “RSU” may refer to any transportation infrastructure entity implemented in or by an gNB/eNB/RAN node or a stationary (or relatively stationary) UE, where an RSU implemented in or by a UE may be referred to as a “UE-type RSU”, an RSU implemented in or by an eNB may be referred to as an “eNB-type RSU.” The RAN XQ10 may include one or more RAN nodes for providing macrocells, e.g., macro RAN node XQ11, and one or more RAN nodes for providing femtocells or picocells (e.g., cells having smaller coverage areas, smaller user capacity, or higher bandwidth compared to macrocells), e.g., low power (LP) RAN node XQ12.

Any of the RAN nodes XQ11 and XQ12 can terminate the air interface protocol and can be the first point of contact for the UEs XQ01 and XQ02. In some embodiments, any of the RAN

nodes XQ11 and XQ12 can fulfill various logical functions for the RAN XQ10 including, but not limited to, radio network controller (RNC) functions such as radio bearer management, uplink and downlink dynamic radio resource management and data packet scheduling, and mobility management.

In accordance with some embodiments, the UEs XQ01 and XQ02 can be configured to communicate using Orthogonal Frequency-Division Multiplexing (OFDM) communication signals with each other or with any of the RAN nodes XQ11 and XQ12 over a multicarrier communication channel in accordance various communication techniques, such as, but not limited to, an Orthogonal Frequency-Division Multiple Access (OFDMA) communication technique (e.g., for downlink communications) or a Single Carrier Frequency Division Multiple Access (SC-FDMA) communication technique (e.g., for uplink and ProSe or sidelink communications), although the scope of the embodiments is not limited in this respect. The OFDM signals can comprise a plurality of orthogonal subcarriers.

In some embodiments, a downlink resource grid can be used for downlink transmissions from any of the RAN nodes XQ11 and XQ12 to the UEs XQ01 and XQ02, while uplink transmissions can utilize similar techniques. The grid can be a time-frequency grid, called a resource grid or time-frequency resource grid, which is the physical resource in the downlink in each slot. Such a time-frequency plane representation is a common practice for OFDM systems, which makes it intuitive for radio resource allocation. Each column and each row of the resource grid corresponds to one OFDM symbol and one OFDM subcarrier, respectively. The duration of the resource grid in the time domain corresponds to one slot in a radio frame. The smallest time-frequency unit in a resource grid is denoted as a resource element. Each resource grid comprises a number of resource blocks, which describe the mapping of certain physical channels to resource elements. Each resource block comprises a collection of resource elements; in the frequency domain, this may represent the smallest quantity of resources that currently can be allocated. There are several different physical downlink channels that are conveyed using such resource blocks.

The physical downlink shared channel (PDSCH) may carry user data and higher-layer signaling to the UEs XQ01 and XQ02. The physical downlink control channel (PDCCH) may carry information about the transport format and resource allocations related to the PDSCH channel, among other things. It may also inform the UEs XQ01 and XQ02 about the transport format, resource allocation, and H-ARQ (Hybrid Automatic Repeat Request) information related

to the uplink shared channel. Typically, downlink scheduling (assigning control and shared channel resource blocks to the UE 102 within a cell) may be performed at any of the RAN nodes XQ11 and XQ12 based on channel quality information fed back from any of the UEs XQ01 and XQ02. The downlink resource assignment information may be sent on the PDCCH used for (e.g., assigned to) each of the UEs XQ01 and XQ02.

The PDCCH may use control channel elements (CCEs) to convey the control information. Before being mapped to resource elements, the PDCCH complex-valued symbols may first be organized into quadruplets, which may then be permuted using a sub-block interleaver for rate matching. Each PDCCH may be transmitted using one or more of these CCEs, where each CCE may correspond to nine sets of four physical resource elements known as resource element groups (REGs). Four Quadrature Phase Shift Keying (QPSK) symbols may be mapped to each REG. The PDCCH can be transmitted using one or more CCEs, depending on the size of the downlink control information (DCI) and the channel condition. There can be four or more different PDCCH formats defined in LTE with different numbers of CCEs (e.g., aggregation level,  $L=1, 2, 4, \text{ or } 8$ ).

Some embodiments may use concepts for resource allocation for control channel information that are an extension of the above-described concepts. For example, some embodiments may utilize an enhanced physical downlink control channel (EPDCCH) that uses PDSCH resources for control information transmission. The EPDCCH may be transmitted using one or more enhanced the control channel elements (ECCEs). Similar to above, each ECCE may correspond to nine sets of four physical resource elements known as an enhanced resource element groups (EREGs). An ECCE may have other numbers of EREGs in some situations.

The RAN XQ10 is shown to be communicatively coupled to a core network (CN) XQ20—via an S1 interface XQ13. In embodiments, the CN XQ20 may be an evolved packet core (EPC) network, a NextGen Packet Core (NPC) network, or some other type of CN. In this embodiment the S1 interface XQ13 is split into two parts: the S1-U interface XQ14, which carries traffic data between the RAN nodes XQ11 and XQ12 and the serving gateway (S-GW) XQ22, and the S1-mobility management entity (MME) interface XQ15, which is a signaling interface between the RAN nodes XQ11 and XQ12 and MMEs XQ21.

In this embodiment, the CN XQ20 comprises the MMEs XQ21, the S-GW XQ22, the Packet Data Network (PDN) Gateway (P-GW) XQ23, and a home subscriber server (HSS) XQ24. The MMEs XQ21 may be similar in function to the control plane of legacy Serving General Packet

Radio Service (GPRS) Support Nodes (SGSN). The MMEs XQ21 may manage mobility aspects in access such as gateway selection and tracking area list management. The HSS XQ24 may comprise a database for network users, including subscription-related information to support the network entities' handling of communication sessions. The CN XQ20 may comprise one or several HSSs XQ24, depending on the number of mobile subscribers, on the capacity of the equipment, on the organization of the network, etc. For example, the HSS XQ24 can provide support for routing/roaming, authentication, authorization, naming/addressing resolution, location dependencies, etc.

The S-GW XQ22 may terminate the S1 interface XQ13 towards the RAN XQ10, and routes data packets between the RAN XQ10 and the CN XQ20. In addition, the S-GW XQ22 may be a local mobility anchor point for inter-RAN node handovers and also may provide an anchor for inter-3GPP mobility. Other responsibilities may include lawful intercept, charging, and some policy enforcement.

The P-GW XQ23 may terminate an SGi interface toward a PDN. The P-GW XQ23 may route data packets between the EPC network XQ23 and external networks such as a network including the application server XQ30 (alternatively referred to as application function (AF)) via an Internet Protocol (IP) interface XQ25. Generally, the application server XQ30 may be an element offering applications that use IP bearer resources with the core network (e.g., UMTS Packet Services (PS) domain, LTE PS data services, etc.). In this embodiment, the P-GW XQ23 is shown to be communicatively coupled to an application server XQ30 via an IP communications interface XQ25. The application server XQ30 can also be configured to support one or more communication services (e.g., Voice-over-Internet Protocol (VoIP) sessions, PTT sessions, group communication sessions, social networking services, etc.) for the UEs XQ01 and XQ02 via the CN XQ20.

The P-GW XQ23 may further be a node for policy enforcement and charging data collection. Policy and Charging Enforcement Function (PCRF) XQ26 is the policy and charging control element of the CN XQ20. In a non-roaming scenario, there may be a single PCRF in the Home Public Land Mobile Network (HPLMN) associated with a UE's Internet Protocol Connectivity Access Network (IP-CAN) session. In a roaming scenario with local breakout of traffic, there may be two PCRFs associated with a UE's IP-CAN session: a Home PCRF (H-PCRF) within a HPLMN and a Visited PCRF (V-PCRF) within a Visited Public Land Mobile Network

(VPLMN). The PCRF XQ26 may be communicatively coupled to the application server XQ30 via the P-GW XQ23. The application server XQ30 may signal the PCRF XQ26 to indicate a new service flow and select the appropriate Quality of Service (QoS) and charging parameters. The PCRF XQ26 may provision this rule into a Policy and Charging Enforcement Function (PCEF) (not shown) with the appropriate traffic flow template (TFT) and QoS class of identifier (QCI), which commences the QoS and charging as specified by the application server XQ30.

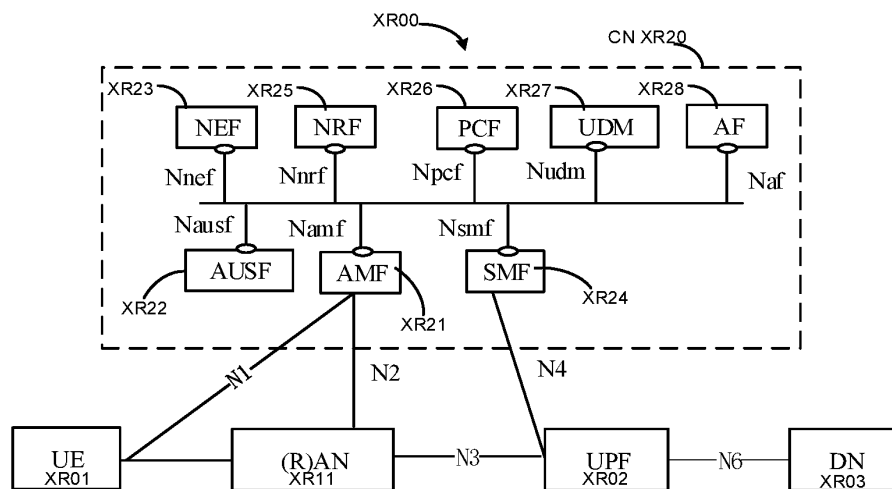

**FIG. XR**

FIG. XR illustrates an architecture of a system XR00 of a network in accordance with some embodiments. The system XR00 is shown to include a UE XR01, which may be the same or similar to UEs XQ01 and XQ02 discussed previously; a RAN node XR11, which may be the same or similar to RAN nodes XQ11 and XQ12 discussed previously; a User Plane Function (UPF) XR02; a Data network (DN) XR03, which may be, for example, operator services, Internet access or 3rd party services; and a 5G Core Network (5GC or CN) XR20.

The CN XR20 may include an Authentication Server Function (AUSF) XR22; a Core Access and Mobility Management Function (AMF) XR21; a Session Management Function (SMF) XR24; a Network Exposure Function (NEF) XR23; a Policy Control function (PCF) XR26; a Network Function (NF) Repository Function (NRF) XR25; a Unified Data Management (UDM) XR27; and an Application Function (AF) XR28. The CN XR20 may also include other elements that are not shown, such as a Structured Data Storage network function (SDSF), an Unstructured Data Storage network function (UDSF), and the like.

The UPF XR02 may act as an anchor point for intra-RAT and inter-RAT mobility, an external PDU session point of interconnect to DN XR03, and a branching point to support multi-homed PDU session. The UPF XR02 may also perform packet routing and forwarding, packet inspection, enforce user plane part of policy rules, lawfully intercept packets (UP collection); traffic usage reporting, perform QoS handling for user plane (e.g. packet filtering, gating, UL/DL rate enforcement), perform Uplink Traffic verification (e.g., SDF to QoS flow mapping), transport level packet marking in the uplink and downlink, and downlink packet buffering and downlink data notification triggering. UPF XR02 may include an uplink classifier to support routing traffic flows to a data network. The DN XR03 may represent various network operator services, Internet access, or third party services. NY XR03 may include, or be similar to application server XQ30 discussed previously.

The AUSF XR22 may store data for authentication of UE XR01 and handle authentication related functionality. The AUSF XR22 may facilitate a common authentication framework for various access types.

The AMF XR21 may be responsible for registration management (e.g., for registering UE XR01, etc.), connection management, reachability management, mobility management, and lawful interception of AMF-related events, and access authentication and authorization. AMF XR21 may provide transport for SM messages between and SMF XR24, and act as a transparent proxy for routing SM messages. AMF XR21 may also provide transport for short message service (SMS) messages between UE XR01 and an SMS function (SMSF) (not shown by FIG. XR). AMF XR21 may act as Security Anchor Function (SEA), which may include interaction with the AUSF XR22 and the UE XR01, receipt of an intermediate key that was established as a result of the UE XR01 authentication process. Where USIM based authentication is used, the AMF XR21 may retrieve the security material from the AUSF XR22. AMF XR21 may also include a Security Context Management (SCM) function, which receives a key from the SEA that it uses to derive access-network specific keys. Furthermore, AMF XR21 may be a termination point of RAN CP interface (N2 reference point), a termination point of NAS (N1) signalling, and perform NAS ciphering and integrity protection.

AMF XR21 may also support NAS signalling with a UE XR01 over an N3 interworking-function (IWF) interface. The N3IWF may be used to provide access to untrusted entities. N3IWF may be a termination point for the N2 and N3 interfaces for control plane and user plane,

respectively, and as such, may handle N2 signalling from SMF and AMF for PDU sessions and QoS, encapsulate/de-encapsulate packets for IPsec and N3 tunnelling, mark N3 user-plane packets in the uplink, and enforce QoS corresponding to N3 packet marking taking into account QoS requirements associated to such marking received over N2. N3IWF may also relay uplink and downlink control-plane NAS (N1) signalling between the UE XR01 and AMF XR21, and relay uplink and downlink user-plane packets between the UE XR01 and UPF XR02. The N3IWF also provides mechanisms for IPsec tunnel establishment with the UE XR01.

The SMF XR24 may be responsible for session management (e.g., session establishment, modify and release, including tunnel maintain between UPF and AN node); UE IP address allocation & management (including optional Authorization); Selection and control of UP function; Configures traffic steering at UPF to route traffic to proper destination; termination of interfaces towards Policy control functions; control part of policy enforcement and QoS; lawful intercept (for SM events and interface to LI System); termination of SM parts of NAS messages; downlink Data Notification; initiator of AN specific SM information, sent via AMF over N2 to AN; determine SSC mode of a session. The SMF XR24 may include the following roaming functionality: handle local enforcement to apply QoS SLAs (VPLMN); charging data collection and charging interface (VPLMN); lawful intercept (in VPLMN for SM events and interface to LI System); support for interaction with external DN for transport of signalling for PDU session authorization/authentication by external DN.

The NEF XR23 may provide means for securely exposing the services and capabilities provided by 3GPP network functions for third party, internal exposure/re-exposure, Application Functions (e.g., AF XR28), edge computing or fog computing systems, etc. In such embodiments, the NEF XR23 may authenticate, authorize, and/or throttle the AFs. NEF XR23 may also translate information exchanged with the AF XR28 and information exchanged with internal network functions. For example, the NEF XR23 may translate between an AF-Service-Identifier and an internal 5GC information. NEF XR23 may also receive information from other network functions (NFs) based on exposed capabilities of other network functions. This information may be stored at the NEF XR23 as structured data, or at a data storage NF using a standardized interfaces. The stored information can then be re-exposed by the NEF XR23 to other NFs and AFs, and/or used for other purposes such as analytics.

The NRF XR25 may support service discovery functions, receive NF Discovery Requests from NF instances, and provide the information of the discovered NF instances to the NF instances. NRF XR25 also maintains information of available NF instances and their supported services.

The PCF XR26 may provide policy rules to control plane function(s) to enforce them, and may also support unified policy framework to govern network behaviour. The PCF XR26 may also implement a front end (FE) to access subscription information relevant for policy decisions in a UDR of UDM XR27.

The UDM XR27 may handle subscription-related information to support the network entities' handling of communication sessions, and may store subscription data of UE XR01. The UDM XR27 may include two parts, an application FE and a User Data Repository (UDR). The UDM may include a UDM FE, which is in charge of processing of credentials, location management, subscription management and so on. Several different front ends may serve the same user in different transactions. The UDM-FE accesses subscription information stored in the UDR and performs authentication credential processing; user identification handling; access authorization; registration/mobility management; and subscription management. The UDR may interact with PCF XR26. UDM XR27 may also support SMS management, wherein an SMS-FE implements the similar application logic as discussed previously.

The AF XR28 may provide application influence on traffic routing, access to the Network Capability Exposure (NCE), and interact with the policy framework for policy control. The NCE may be a mechanism that allows the 5GC and AF XR28 to provide information to each other via NEF XR23, which may be used for edge computing implementations. In such implementations, the network operator and third party services may be hosted close to the UE XR01 access point of attachment to achieve an efficient service delivery through the reduced end-to-end latency and load on the transport network. For edge computing implementations, the 5GC may select a UPF XR02 close to the UE XR01 and execute traffic steering from the UPF XR02 to DN XR03 via the N6 interface. This may be based on the UE subscription data, UE location, and information provided by the AF XR28. In this way, the AF XR28 may influence UPF (re)selection and traffic routing. Based on operator deployment, when AF XR28 is considered to be a trusted entity, the network operator may permit AF XR28 to interact directly with relevant NFs.

As discussed previously, the CN XR20 may include an SMSF, which may be responsible for SMS subscription checking and verification, and relaying SM messages to/from the UE XR01



to/from other entities, such as an SMS-GMSC/IWMSC/SMS-router. The SMS may also interact with AMF XR21 and UDM XR27 for notification procedure that the UE XR01 is available for SMS transfer (e.g., set a UE not reachable flag, and notifying UDM XR27 when UE XR01 is available for SMS).

The system XR00 may include the following service-based interfaces: Namf: Service-based interface exhibited by AMF; Nsmf: Service-based interface exhibited by SMF; Nnef: Service-based interface exhibited by NEF; Npcf: Service-based interface exhibited by PCF; Nudm: Service-based interface exhibited by UDM; Naf: Service-based interface exhibited by AF; Nnrf: Service-based interface exhibited by NRF; and Nausf: Service-based interface exhibited by AUSF.

The system XR00 may include the following reference points: N1: Reference point between the UE and the AMF; N2: Reference point between the (R)AN and the AMF; N3: Reference point between the (R)AN and the UPF; N4: Reference point between the SMF and the UPF; and N6: Reference point between the UPF and a Data Network. There may be many more reference points and/or service-based interfaces between the NF services in the NFs, however, these interfaces and reference points have been omitted for clarity. For example, an N5 reference point may be between the PCF and the AF; an N7 reference point may be between the PCF and the SMF; an N11 reference point between the AMF and SMF; etc. In some embodiments, the CN XR20 may include an Nx interface, which is an inter-CN interface between the MME (e.g., MME XQ21) and the AMF XR21 in order to enable interworking between CN XR20 and CN XQ20.

Although not shown by FIG. XR, system XR00 may include multiple RAN nodes XR11 wherein an Xn interface is defined between two or more RAN nodes XR11 (e.g., gNBs and the like) that connecting to 5GC XR20, between a RAN node XR11 (e.g., gNB) connecting to 5GC XR20 and an eNB (e.g., a RAN node XQ11 of FIG. XQ), and/or between two eNBs connecting to 5GC XR20.

In some implementations, the Xn interface may include an Xn user plane (Xn-U) interface and an Xn control plane (Xn-C) interface. The Xn-U may provide non-guaranteed delivery of user plane PDUs and support/provide data forwarding and flow control functionality. The Xn-C may provide management and error handling functionality, functionality to manage the Xn-C interface; mobility support for UE XR01 in a connected mode (e.g., CM-CONNECTED) including functionality to manage the UE mobility for connected mode between one or more RAN nodes XR11. The mobility support may include context transfer from an old (source) serving RAN node

XR11 to new (target) serving RAN node XR11; and control of user plane tunnels between old (source) serving RAN node XR11 to new (target) serving RAN node XR11.

A protocol stack of the Xn-U may include a transport network layer built on Internet Protocol (IP) transport layer, and a GTP-U layer on top of a UDP and/or IP layer(s) to carry user plane PDUs. The Xn-C protocol stack may include an application layer signaling protocol (referred to as Xn Application Protocol (Xn-AP)) and a transport network layer that is built on an SCTP layer. The SCTP layer may be on top of an IP layer. The SCTP layer provides the guaranteed delivery of application layer messages. In the transport IP layer point-to-point transmission is used to deliver the signaling PDUs. In other implementations, the Xn-U protocol stack and/or the Xn-C protocol stack may be same or similar to the user plane and/or control plane protocol stack(s) shown and described herein.

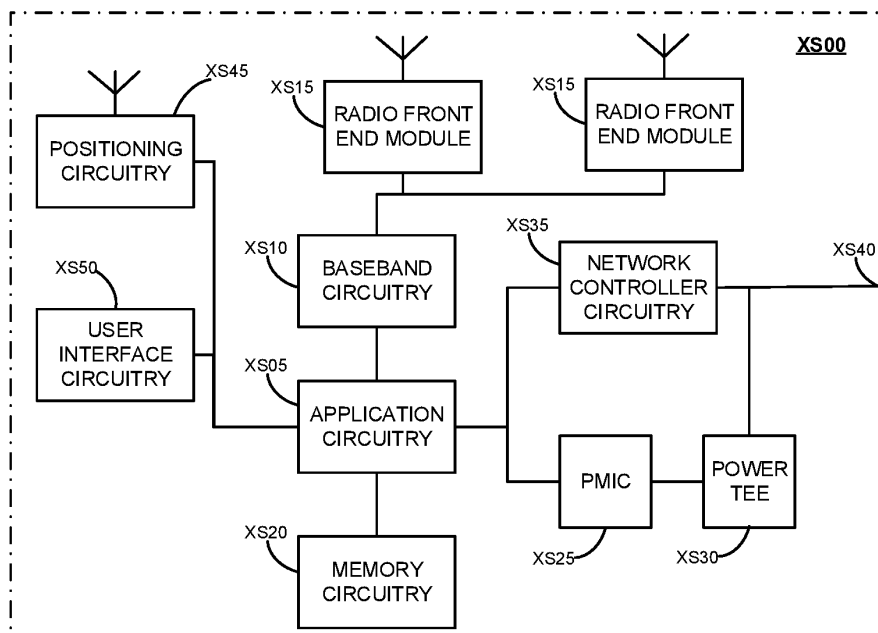

FIG. XS

FIG. XS illustrates an example of infrastructure equipment XS00 in accordance with various embodiments. The infrastructure equipment XS00 (or “system XS00”) may be implemented as a base station, radio head, RAN node, etc., such as the RAN nodes XQ11 and XQ12, and/or AP XQ06 shown and described previously. In other examples, the system XS00 could be implemented in or by a UE. The system XS00 may include one or more of application circuitry XS05, baseband circuitry XS10, one or more radio front end modules XS15, memory

XS20, power management integrated circuitry (PMIC) XS25, power tee circuitry XS30, network controller XS35, network interface connector XS40, satellite positioning circuitry XS45, and user interface XS50. In some embodiments, the device XT00 may include additional elements such as, for example, memory/storage, display, camera, sensor, or input/output (I/O) interface. In other embodiments, the components described below may be included in more than one device (e.g., said circuitries may be separately included in more than one device for Cloud-RAN (C-RAN) implementations).

As used herein, the term “circuitry” may refer to, is part of, or includes hardware components such as an electronic circuit, a logic circuit, a processor (shared, dedicated, or group) and/or memory (shared, dedicated, or group), an Application Specific Integrated Circuit (ASIC), a field-programmable device (FPD), (for example, a field-programmable gate array (FPGA), a programmable logic device (PLD), a complex PLD (CPLD), a high-capacity PLD (HCPLD), a structured ASIC, or a programmable System on Chip (SoC)), digital signal processors (DSPs), etc., that are configured to provide the described functionality. In some embodiments, the circuitry may execute one or more software or firmware programs to provide at least some of the described functionality. In addition, the term “circuitry” may also refer to a combination of one or more hardware elements (or a combination of circuits used in an electrical or electronic system) with the program code used to carry out the functionality of that program code. In these embodiments, the combination of hardware elements and program code may be referred to as a particular type of circuitry.

Application circuitry XS05 may include one or more central processing unit (CPU) cores and one or more of cache memory, low drop-out voltage regulators (LDOs), interrupt controllers, serial interfaces such as SPI, I<sup>2</sup>C or universal programmable serial interface module, real time clock (RTC), timer-counters including interval and watchdog timers, general purpose input/output (I/O or IO), memory card controllers such as Secure Digital (SD)/MultiMediaCard (MMC) or similar, Universal Serial Bus (USB) interfaces, Mobile Industry Processor Interface (MIPI) interfaces and Joint Test Access Group (JTAG) test access ports. As examples, the application circuitry XS05 may include one or more Intel Pentium®, Core®, or Xeon® processor(s); Advanced Micro Devices (AMD) Ryzen® processor(s), Accelerated Processing Units (APUs), or Epyc® processors; and/or the like. In some embodiments, the system XS00 may not utilize

application circuitry XS05, and instead may include a special-purpose processor/controller to process IP data received from an EPC or 5GC, for example.

User interface circuitry XS50 may include one or more user interfaces designed to enable user interaction with the system XS00 or peripheral component interfaces designed to enable peripheral component interaction with the system XS00. User interfaces may include, but are not limited to one or more physical or virtual buttons (e.g., a reset button), one or more indicators (e.g., light emitting diodes (LEDs)), a physical keyboard or keypad, a mouse, a touchpad, a touchscreen, speakers or other audio emitting devices, microphones, a printer, a scanner, a headset, a display screen or display device, etc. Peripheral component interfaces may include, but are not limited to, a non-volatile memory port, a universal serial bus (USB) port, an audio jack, a power supply interface, etc.

Additionally or alternatively, application circuitry XS05 may include circuitry such as, but not limited to, one or more a field-programmable devices (FPDs) such as field-programmable gate arrays (FPGAs) and the like; programmable logic devices (PLDs) such as complex PLDs (CPLDs), high-capacity PLDs (HCPLDs), and the like; ASICs such as structured ASICs and the like; programmable SoCs (PSoCs); and the like. In such embodiments, the circuitry of application circuitry XS05 may comprise logic blocks or logic fabric including and other interconnected resources that may be programmed to perform various functions, such as the procedures, methods, functions, etc. of the various embodiments discussed herein. In such embodiments, the circuitry of application circuitry XS05 may include memory cells (e.g., erasable programmable read-only memory (EPROM), electrically erasable programmable read-only memory (EEPROM), flash memory, static memory (e.g., static random access memory (SRAM), anti-fuses, etc.) used to store logic blocks, logic fabric, data, etc. in lookup-tables (LUTs) and the like.

The baseband circuitry XS10 may be implemented, for example, as a solder-down substrate including one or more integrated circuits, a single packaged integrated circuit soldered to a main circuit board or a multi-chip module containing two or more integrated circuits. Although not shown, baseband circuitry XS10 may comprise one or more digital baseband systems, which may be coupled via an interconnect subsystem to a CPU subsystem, an audio subsystem, and an interface subsystem. The digital baseband subsystems may also be coupled to a digital baseband interface and a mixed-signal baseband sub-system via another interconnect subsystem. Each of the interconnect subsystems may include a bus system, point-to-point connections, network-on-chip

(NOC) structures, and/or some other suitable bus or interconnect technology, such as those discussed herein. The audio sub-system may include digital signal processing circuitry, buffer memory, program memory, speech processing accelerator circuitry, data converter circuitry such as analog-to-digital and digital-to-analog converter circuitry, analog circuitry including one or more of amplifiers and filters, and/or other like components. In an aspect of the present disclosure, baseband circuitry XS10 may include protocol processing circuitry with one or more instances of control circuitry (not shown) to provide control functions for the digital baseband circuitry and/or radio frequency circuitry (for example, the radio front end modules XS15).

The radio front end modules (RFEMs) XS15 may comprise a millimeter wave RFEM and one or more sub-millimeter wave radio frequency integrated circuits (RFICs). In some implementations, the one or more sub-millimeter wave RFICs may be physically separated from the millimeter wave RFEM. The RFICs may include connections to one or more antennas or antenna arrays, and the RFEM may be connected to multiple antennas. In alternative implementations, both millimeter wave and sub-millimeter wave radio functions may be implemented in the same physical radio front end module XS15. The RFEMs XS15 may incorporate both millimeter wave antennas and sub-millimeter wave antennas.

The memory circuitry XS20 may include one or more of volatile memory including dynamic random access memory (DRAM) and/or synchronous dynamic random access memory (SDRAM), and nonvolatile memory (NVM) including high-speed electrically erasable memory (commonly referred to as Flash memory), phase change random access memory (PRAM), magnetoresistive random access memory (MRAM), etc., and may incorporate the three-dimensional (3D) cross-point (XPOINT) memories from Intel® and Micron®. Memory circuitry XS20 may be implemented as one or more of solder down packaged integrated circuits, socketed memory modules and plug-in memory cards.

The PMIC XS25 may include voltage regulators, surge protectors, power alarm detection circuitry, and one or more backup power sources such as a battery or capacitor. The power alarm detection circuitry may detect one or more of brown out (under-voltage) and surge (over-voltage) conditions. The power tee circuitry XS30 may provide for electrical power drawn from a network cable to provide both power supply and data connectivity to the infrastructure equipment XS00 using a single cable.

The network controller circuitry XS35 may provide connectivity to a network using a standard network interface protocol such as Ethernet, Ethernet over GRE Tunnels, Ethernet over Multiprotocol Label Switching (MPLS), or some other suitable protocol. Network connectivity may be provided to/from the infrastructure equipment XS00 using a physical connection, which may be electrical (commonly referred to as a “copper interconnect”), optical, or wireless. The network controller circuitry XS35 may include one or more dedicated processors and/or FPGAs to communicate using one or more of the aforementioned protocol. In some implementations, the network controller circuitry XS35 may include multiple controllers to provide connectivity to other networks using the same or different protocols.

The positioning circuitry XS45, which may include circuitry to receive and decode signals transmitted by one or more navigation satellite constellations of a global navigation satellite system (GNSS). Examples of navigation satellite constellations (or GNSS) may include United States’ Global Positioning System (GPS), Russia’s Global Navigation System (GLONASS), the European Union’s Galileo system, China’s BeiDou Navigation Satellite System, a regional navigation system or GNSS augmentation system (e.g., Navigation with Indian Constellation (NAVIC), Japan’s Quasi-Zenith Satellite System (QZSS), France’s Doppler Orbitography and Radio-positioning Integrated by Satellite (DORIS), etc.), or the like. The positioning circuitry XS45 may comprise various hardware elements (e.g., including hardware devices such as switches, filters, amplifiers, antenna elements, and the like to facilitate the communications over-the-air (OTA) communications) to communicate with components of a positioning network, such as navigation satellite constellation nodes.

Nodes or satellites of the navigation satellite constellation(s) (“GNSS nodes”) may provide positioning services by continuously transmitting or broadcasting GNSS signals along a line of sight, which may be used by GNSS receivers (e.g., positioning circuitry XS45 and/or positioning circuitry implemented by UEs XQ01, XQ02, or the like) to determine their GNSS position. The GNSS signals may include a pseudorandom code (e.g., a sequence of ones and zeros) that is known to the GNSS receiver and a message that includes a time of transmission (ToT) of a code epoch (e.g., a defined point in the pseudorandom code sequence) and the GNSS node position at the ToT. The GNSS receivers may monitor/measure the GNSS signals transmitted/broadcasted by a plurality of GNSS nodes (e.g., four or more satellites) and solve various equations to determine a corresponding GNSS position (e.g., a spatial coordinate). The GNSS receivers also implement

clocks that are typically less stable and less precise than the atomic clocks of the GNSS nodes, and the GNSS receivers may use the measured GNSS signals to determine the GNSS receivers' deviation from true time (e.g., an offset of the GNSS receiver clock relative to the GNSS node time). In some embodiments, the positioning circuitry XS45 may include a Micro-Technology for Positioning, Navigation, and Timing (Micro-PNT) IC that uses a master timing clock to perform position tracking/estimation without GNSS assistance.

The GNSS receivers may measure the time of arrivals (ToAs) of the GNSS signals from the plurality of GNSS nodes according to its own clock. The GNSS receivers may determine ToF values for each received GNSS signal from the ToAs and the ToTs, and then may determine, from the ToFs, a three-dimensional (3D) position and clock deviation. The 3D position may then be converted into a latitude, longitude and altitude. The positioning circuitry XS45 may provide data to application circuitry XS05 which may include one or more of position data or time data. Application circuitry XS05 may use the time data to synchronize operations with other radio base stations (e.g., RAN nodes XQ11, XQ12, XR11 or the like).

The components shown by FIG. XS may communicate with one another using a suitable bus technology, which may include any number of technologies, including industry standard architecture (ISA), extended ISA (EISA), peripheral component interconnect (PCI), peripheral component interconnect extended (PCIx), PCI express (PCIe), or any number of other technologies. The bus may be a proprietary bus, for example, used in a SoC based system. Other bus systems may be included, such as an I<sup>2</sup>C interface, an SPI interface, point to point interfaces, and a power bus, among others.

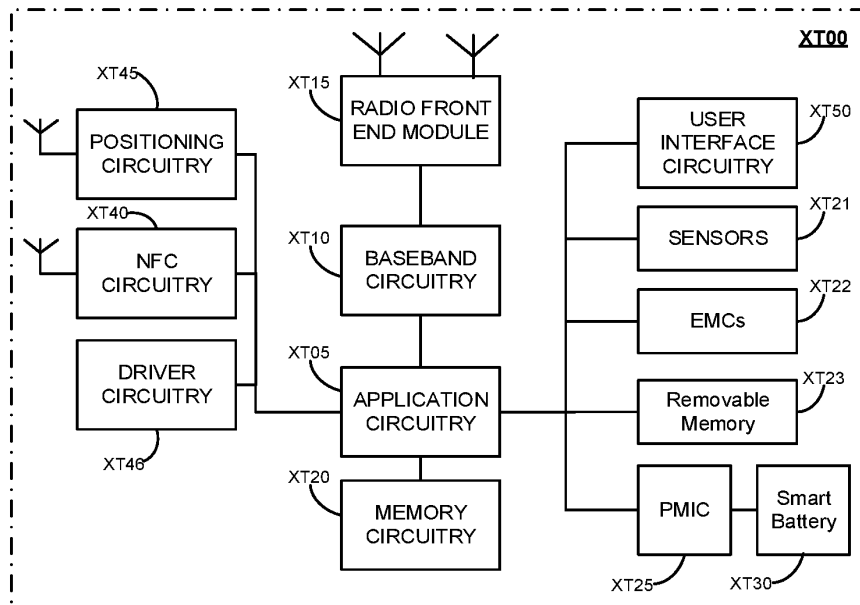

FIG. XT1

FIG. XT1 illustrates an example of a platform XT00 (or "device XT00") in accordance with various embodiments. In embodiments, the computer platform XT01 may be suitable for use as UEs XQ01, XQ02, XR01, application servers XQ30, and/or any other element/device discussed herein. The platform XT00 may include any combinations of the components shown in the example. The components of platform XT00 may be implemented as integrated circuits (ICs), portions thereof, discrete electronic devices, or other modules, logic, hardware, software, firmware, or a combination thereof adapted in the computer platform XT00, or as components otherwise incorporated within a chassis of a larger system. The block diagram of FIG. XT1 is intended to show a high level view of components of the computer platform XT00. However, some of the components shown may be omitted, additional components may be present, and different arrangement of the components shown may occur in other implementations.

The application circuitry XT05 may include circuitry such as, but not limited to single-core or multi-core processors and one or more of cache memory, low drop-out voltage regulators (LDOs), interrupt controllers, serial interfaces such as serial peripheral interface (SPI), inter-integrated circuit (I<sup>2</sup>C) or universal programmable serial interface circuit, real time clock (RTC), timer-counters including interval and watchdog timers, general purpose input-output (IO), memory card controllers such as secure digital / multi-media card (SD/MMC) or similar, universal serial bus (USB) interfaces, mobile industry processor interface (MIPI) interfaces and Joint Test Access



Group (JTAG) test access ports. The processor(s) may include any combination of general-purpose processors and/or dedicated processors (e.g., graphics processors, application processors, etc.). The processors (or cores) may be coupled with or may include memory/storage and may be configured to execute instructions stored in the memory/storage to enable various applications or operating systems to run on the platform XT00. In some embodiments, processors of application circuitry XS05/XT05 may process IP data packets received from an EPC or 5GC.

Application circuitry XT05 be or include a microprocessor, a multi-core processor, a multithreaded processor, an ultra-low voltage processor, an embedded processor, or other known processing element. In one example, the application circuitry XT05 may include an Intel® Architecture Core™ based processor, such as a Quark™, an Atom™, an i3, an i5, an i7, or an MCU-class processor, or another such processor available from Intel® Corporation, Santa Clara, CA. The processors of the application circuitry XT05 may also be one or more of Advanced Micro Devices (AMD) Ryzen® processor(s) or Accelerated Processing Units (APUs); A5-A9 processor(s) from Apple® Inc., Snapdragon™ processor(s) from Qualcomm® Technologies, Inc., Texas Instruments, Inc.® Open Multimedia Applications Platform (OMAP)™ processor(s); a MIPS-based design from MIPS Technologies, Inc; an ARM-based design licensed from ARM Holdings, Ltd.; or the like. In some implementations, the application circuitry XT05 may be a part of a system on a chip (SoC) in which the application circuitry XT05 and other components are formed into a single integrated circuit, or a single package, such as the Edison™ or Galileo™ SoC boards from Intel® Corporation.

Additionally or alternatively, application circuitry XT05 may include circuitry such as, but not limited to, one or more a field-programmable devices (FPDs) such as FPGAs and the like; programmable logic devices (PLDs) such as complex PLDs (CPLDs), high-capacity PLDs (HCPLDs), and the like; ASICs such as structured ASICs and the like; programmable SoCs (PSoCs); and the like. In such embodiments, the circuitry of application circuitry XT05 may comprise logic blocks or logic fabric including and other interconnected resources that may be programmed to perform various functions, such as the procedures, methods, functions, etc. of the various embodiments discussed herein. In such embodiments, the circuitry of application circuitry XT05 may include memory cells (e.g., erasable programmable read-only memory (EPROM), electrically erasable programmable read-only memory (EEPROM), flash memory, static memory

(e.g., static random access memory (SRAM), anti-fuses, etc.) used to store logic blocks, logic fabric, data, etc. in lookup-tables (LUTs) and the like.

The baseband circuitry XT10 may be implemented, for example, as a solder-down substrate including one or more integrated circuits, a single packaged integrated circuit soldered to a main circuit board or a multi-chip module containing two or more integrated circuits. Although not shown, baseband circuitry XT10 may comprise one or more digital baseband systems, which may be coupled via an interconnect subsystem to a CPU subsystem, an audio subsystem, and an interface subsystem. The digital baseband subsystems may also be coupled to a digital baseband interface and a mixed-signal baseband sub-system via another interconnect subsystem. Each of the interconnect subsystems may include a bus system, point-to-point connections, network-on-chip (NOC) structures, and/or some other suitable bus or interconnect technology, such as those discussed herein. The audio sub-system may include digital signal processing circuitry, buffer memory, program memory, speech processing accelerator circuitry, data converter circuitry such as analog-to-digital and digital-to-analog converter circuitry, analog circuitry including one or more of amplifiers and filters, and/or other like components. In an aspect of the present disclosure, baseband circuitry XT10 may include protocol processing circuitry with one or more instances of control circuitry (not shown) to provide control functions for the digital baseband circuitry and/or radio frequency circuitry (for example, the radio front end modules XT15).

The radio front end modules (RFEMs) XS15 may comprise a millimeter wave RFEM and one or more sub-millimeter wave radio frequency integrated circuits (RFICs). In some implementations, the one or more sub-millimeter wave RFICs may be physically separated from the millimeter wave RFEM. The RFICs may include connections to one or more antennas or antenna arrays, and the RFEM may be connected to multiple antennas. In alternative implementations, both millimeter wave and sub-millimeter wave radio functions may be implemented in the same physical radio front end module XS15. The RFEMs XS15 may incorporate both millimeter wave antennas and sub-millimeter wave antennas.

The memory circuitry XT20 may include any number and type of memory devices used to provide for a given amount of system memory. As examples, the memory circuitry XT20 may include one or more of volatile memory including be random access memory (RAM), dynamic RAM (DRAM) and/or synchronous dynamic RAM (SDRAM), and nonvolatile memory (NVM) including high-speed electrically erasable memory (commonly referred to as Flash memory),

phase change random access memory (PRAM), magnetoresistive random access memory (MRAM), etc. The memory circuitry XT20 may be developed in accordance with a Joint Electron Devices Engineering Council (JEDEC) low power double data rate (LPDDR)-based design, such as LPDDR2, LPDDR3, LPDDR4, or the like. Memory circuitry XS20 may be implemented as one or more of solder down packaged integrated circuits, single die package (SDP), dual die package (DDP) or quad die package (Q17P), socketed memory modules, dual inline memory modules (DIMMs) including microDIMMs or MiniDIMMs, and/or soldered onto a motherboard via a ball grid array (BGA). In low power implementations, the mass storage XQ08 may be on-die memory or registers associated with the application circuitry XT05. To provide for persistent storage of information such as data, applications, operating systems and so forth, memory circuitry XT20 may include one or more mass storage devices, which may include, inter alia, a solid state disk drive (SSDD), hard disk drive (HDD), a micro HDD, resistance change memories, phase change memories, holographic memories, or chemical memories, among others. For example, the computer platform XT00 may incorporate the three-dimensional (3D) cross-point (XPOINT) memories from Intel® and Micron®.

Removable memory circuitry XT23 may include devices, circuitry, enclosures/housings, ports or receptacles, etc. used to couple portable data storage devices with the platform XT00. These portable data storage devices may be used for mass storage purposes, and may include, for example, flash memory cards (e.g., Secure Digital (SD) cards, microSD cards, xD picture cards, and the like), and USB flash drives, optical discs, external HDDs, and the like.

The platform XT00 may also include interface circuitry (not shown) that is used to connect external devices with the platform XT00. The external devices may include sensors XT21, such as accelerometers, level sensors, flow sensors, temperature sensors, pressure sensors, barometric pressure sensors, and the like. The interface circuitry may be used to connect the platform XT00 to electro-mechanical components (EMCs) XT22, which may allow platform XT00 to change its state, position, and/or orientation, or move or control a mechanism or system. The EMCs XT22 may include one or more power switches, relays including electromechanical relays (EMRs) and/or solid state relays (SSRs), actuators (e.g., valve actuators, etc.), an audible sound generator, a visual warning device, motors (e.g., DC motors, stepper motors, etc.), wheels, thrusters, propellers, claws, clamps, hooks, and/or other like electro-mechanical components. In embodiments, platform XT00 may be configured to operate one or more EMCs XT22 based on

one or more captured events and/or instructions or control signals received from a service provider and/or various clients.

In some implementations, the interface circuitry may connect the platform XT00 with positioning circuitry XT45, which may be the same or similar as the positioning circuitry XT45 discussed with regard to FIG. XS.

In some implementations, the interface circuitry may connect the platform XT00 with near-field communication (NFC) circuitry XT40, which may include an NFC controller coupled with an antenna element and a processing device. The NFC circuitry XT40 may be configured to read electronic tags and/or connect with another NFC-enabled device.

The driver circuitry XT46 may include software and hardware elements that operate to control particular devices that are embedded in the platform XT00, attached to the platform XT00, or otherwise communicatively coupled with the platform XT00. The driver circuitry XT46 may include individual drivers allowing other components of the platform XT00 to interact or control various input/output (I/O) devices that may be present within, or connected to, the platform XT00. For example, driver circuitry XT46 may include a display driver to control and allow access to a display device, a touchscreen driver to control and allow access to a touchscreen interface of the platform XT00, sensor drivers to obtain sensor readings of sensors XT21 and control and allow access to sensors XT21, EMC drivers to obtain actuator positions of the EMCs XT22 and/or control and allow access to the EMCs XT22, a camera driver to control and allow access to an embedded image capture device, audio drivers to control and allow access to one or more audio devices.

The power management integrated circuitry (PMIC) XT25 (also referred to as “power management circuitry XT25”) may manage power provided to various components of the platform XT00. In particular, with respect to the baseband circuitry XT10, the PMIC XT25 may control power-source selection, voltage scaling, battery charging, or DC-to-DC conversion. The PMIC XT25 may often be included when the platform XT00 is capable of being powered by a battery XT30, for example, when the device is included in a UE XS01, XS02, XR01.

In some embodiments, the PMIC XT25 may control, or otherwise be part of, various power saving mechanisms of the platform XT00. For example, if the platform XT00 is in an RRC\_Connected state, where it is still connected to the RAN node as it expects to receive traffic shortly, then it may enter a state known as Discontinuous Reception Mode (DRX) after a period

of inactivity. During this state, the platform XT00 may power down for brief intervals of time and thus save power. If there is no data traffic activity for an extended period of time, then the platform XT00 may transition off to an RRC\_Idle state, where it disconnects from the network and does not perform operations such as channel quality feedback, handover, etc. The platform XT00 goes into a very low power state and it performs paging where again it periodically wakes up to listen to the network and then powers down again. The platform XT00 may not receive data in this state, in order to receive data, it must transition back to RRC\_Connected state. An additional power saving mode may allow a device to be unavailable to the network for periods longer than a paging interval (ranging from seconds to a few hours). During this time, the device is totally unreachable to the network and may power down completely. Any data sent during this time incurs a large delay and it is assumed the delay is acceptable.

A battery XT30 may power the platform XT00, although in some examples the platform XT00 may be mounted deployed in a fixed location, and may have a power supply coupled to an electrical grid. The battery XT30 may be a lithium ion battery, a metal-air battery, such as a zinc-air battery, an aluminum-air battery, a lithium-air battery, and the like. In some implementations, such as in V2X applications, the battery XT30 may be a typical lead-acid automotive battery.

In some implementations, the battery XT30 may be a “smart battery,” which includes or is coupled with a Battery Management System (BMS) or battery monitoring integrated circuitry. The BMS may be included in the platform XT00 to track the state of charge (SoCh) of the battery XT30. The BMS may be used to monitor other parameters of the battery XT30 to provide failure predictions, such as the state of health (SoH) and the state of function (SoF) of the battery XT30. The BMS may communicate the information of the battery XT30 to the application circuitry XT05 or other components of the platform XT00. The BMS may also include an analog-to-digital (ADC) convertor that allows the application circuitry XT05 to directly monitor the voltage of the battery XT30 or the current flow from the battery XT30. The battery parameters may be used to determine actions that the platform XT00 may perform, such as transmission frequency, network operation, sensing frequency, and the like.

A power block, or other power supply coupled to an electrical grid may be coupled with the BMS to charge the battery XT30. In some examples, the power block XQ28 may be replaced with a wireless power receiver to obtain the power wirelessly, for example, through a loop antenna in the computer platform XT00. In these examples, a wireless battery charging circuit may be

included in the BMS. The specific charging circuits chosen may depend on the size of the battery XT30, and thus, the current required. The charging may be performed using the Airfuel standard promulgated by the Airfuel Alliance, the Qi wireless charging standard promulgated by the Wireless Power Consortium, or the Rezence charging standard, promulgated by the Alliance for Wireless Power, among others.

Although not shown, the components of platform XT00 may communicate with one another using a suitable bus technology, which may include any number of technologies, including industry standard architecture (ISA), extended ISA (EISA), peripheral component interconnect (PCI), peripheral component interconnect extended (PCIx), PCI express (PCIe), a Time-Trigger Protocol (TTP) system, or a FlexRay system, or any number of other technologies. The bus may be a proprietary bus, for example, used in a SoC based system. Other bus systems may be included, such as an I<sup>2</sup>C interface, an SPI interface, point to point interfaces, and a power bus, among others.

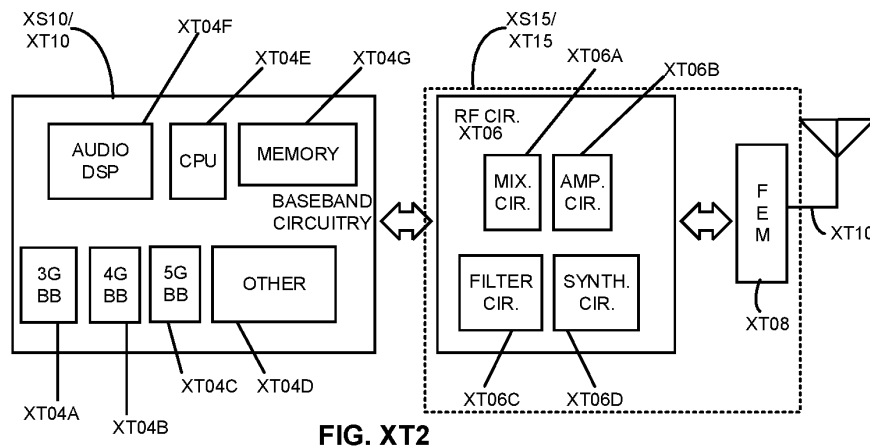

FIG. XT2 illustrates example components of baseband circuitry XS10/XT10 and radio front end modules (RFEM) XS15/XT15 in accordance with some embodiments. As shown, the RFEM XS15/XT15 may include Radio Frequency (RF) circuitry XT06, front-end module (FEM) circuitry XT08, one or more antennas XT10 coupled together at least as shown.

The baseband circuitry XS10/XT10 may include circuitry such as, but not limited to, one or more single-core or multi-core processors. The baseband circuitry XS10/XT10 may include one or more baseband processors or control logic to process baseband signals received from a receive signal path of the RF circuitry XT06 and to generate baseband signals for a transmit signal path of the RF circuitry XT06. Baseband processing circuitry XS10/XT10 may interface with the

application circuitry XS05/XT05 for generation and processing of the baseband signals and for controlling operations of the RF circuitry XT06. For example, in some embodiments, the baseband circuitry XS10/XT10 may include a third generation (3G) baseband processor XT04A, a fourth generation (4G) baseband processor XT04B, a fifth generation (5G) baseband processor XT04C, or other baseband processor(s) XT04D for other existing generations, generations in development or to be developed in the future (e.g., second generation (2G), sixth generation (6G), etc.). The baseband circuitry XS10/XT10 (e.g., one or more of baseband processors XT04A-D) may handle various radio control functions that enable communication with one or more radio networks via the RF circuitry XT06. In other embodiments, some or all of the functionality of baseband processors XT04A-D may be included in modules stored in the memory XT04G and executed via a Central Processing Unit (CPU) XT04E. The radio control functions may include, but are not limited to, signal modulation/demodulation, encoding/decoding, radio frequency shifting, etc. In some embodiments, modulation/demodulation circuitry of the baseband circuitry XS10/XT10 may include Fast-Fourier Transform (FFT), precoding, or constellation mapping/demapping functionality. In some embodiments, encoding/decoding circuitry of the baseband circuitry XS10/XT10 may include convolution, tail-biting convolution, turbo, Viterbi, or Low Density Parity Check (LDPC) encoder/decoder functionality. Embodiments of modulation/demodulation and encoder/decoder functionality are not limited to these examples and may include other suitable functionality in other embodiments.

In some embodiments, the baseband circuitry XS10/XT10 may include one or more audio digital signal processor(s) (DSP) XT04F. The audio DSP(s) XT04F may include elements for compression/decompression and echo cancellation and may include other suitable processing elements in other embodiments. Components of the baseband circuitry may be suitably combined in a single chip, a single chipset, or disposed on a same circuit board in some embodiments. In some embodiments, some or all of the constituent components of the baseband circuitry XS10/XT10 and the application circuitry XS05/XT05 may be implemented together such as, for example, on a system on a chip (SOC).

In some embodiments, the baseband circuitry XS10/XT10 may provide for communication compatible with one or more radio technologies. For example, in some embodiments, the baseband circuitry XS10/XT10 may support communication with an evolved universal terrestrial radio access network (EUTRAN) or other wireless metropolitan area networks (WMAN), a wireless

local area network (WLAN), a wireless personal area network (WPAN). Embodiments in which the baseband circuitry XS10/XT10 is configured to support radio communications of more than one wireless protocol may be referred to as multi-mode baseband circuitry.

RF circuitry XT06 may enable communication with wireless networks using modulated electromagnetic radiation through a non-solid medium. In various embodiments, the RF circuitry XT06 may include switches, filters, amplifiers, etc. to facilitate the communication with the wireless network. RF circuitry XT06 may include a receive signal path which may include circuitry to down-convert RF signals received from the FEM circuitry XT08 and provide baseband signals to the baseband circuitry XS10/XT10. RF circuitry XT06 may also include a transmit signal path which may include circuitry to up-convert baseband signals provided by the baseband circuitry XS10/XT10 and provide RF output signals to the FEM circuitry XT08 for transmission.

In some embodiments, the receive signal path of the RF circuitry XT06 may include mixer circuitry XT06a, amplifier circuitry XT06b and filter circuitry XT06c. In some embodiments, the transmit signal path of the RF circuitry XT06 may include filter circuitry XT06c and mixer circuitry XT06a. RF circuitry XT06 may also include synthesizer circuitry XT06d for synthesizing a frequency for use by the mixer circuitry XT06a of the receive signal path and the transmit signal path. In some embodiments, the mixer circuitry XT06a of the receive signal path may be configured to down-convert RF signals received from the FEM circuitry XT08 based on the synthesized frequency provided by synthesizer circuitry XT06d. The amplifier circuitry XT06b may be configured to amplify the down-converted signals and the filter circuitry XT06c may be a low-pass filter (LPF) or band-pass filter (BPF) configured to remove unwanted signals from the down-converted signals to generate output baseband signals. Output baseband signals may be provided to the baseband circuitry XS10/XT10 for further processing. In some embodiments, the output baseband signals may be zero-frequency baseband signals, although this is not a requirement. In some embodiments, mixer circuitry XT06a of the receive signal path may comprise passive mixers, although the scope of the embodiments is not limited in this respect.

In some embodiments, the mixer circuitry XT06a of the transmit signal path may be configured to up-convert input baseband signals based on the synthesized frequency provided by the synthesizer circuitry XT06d to generate RF output signals for the FEM circuitry XT08. The baseband signals may be provided by the baseband circuitry XS10/XT10 and may be filtered by filter circuitry XT06c.



In some embodiments, the mixer circuitry XT06a of the receive signal path and the mixer circuitry XT06a of the transmit signal path may include two or more mixers and may be arranged for quadrature downconversion and upconversion, respectively. In some embodiments, the mixer circuitry XT06a of the receive signal path and the mixer circuitry XT06a of the transmit signal path may include two or more mixers and may be arranged for image rejection (e.g., Hartley image rejection). In some embodiments, the mixer circuitry XT06a of the receive signal path and the mixer circuitry XT06a may be arranged for direct downconversion and direct upconversion, respectively. In some embodiments, the mixer circuitry XT06a of the receive signal path and the mixer circuitry XT06a of the transmit signal path may be configured for super-heterodyne operation.

In some embodiments, the output baseband signals and the input baseband signals may be analog baseband signals, although the scope of the embodiments is not limited in this respect. In some alternate embodiments, the output baseband signals and the input baseband signals may be digital baseband signals. In these alternate embodiments, the RF circuitry XT06 may include analog-to-digital converter (ADC) and digital-to-analog converter (DAC) circuitry and the baseband circuitry XS10/XT10 may include a digital baseband interface to communicate with the RF circuitry XT06.

In some dual-mode embodiments, a separate radio IC circuitry may be provided for processing signals for each spectrum, although the scope of the embodiments is not limited in this respect.

In some embodiments, the synthesizer circuitry XT06d may be a fractional-N synthesizer or a fractional N/N+1 synthesizer, although the scope of the embodiments is not limited in this respect as other types of frequency synthesizers may be suitable. For example, synthesizer circuitry XT06d may be a delta-sigma synthesizer, a frequency multiplier, or a synthesizer comprising a phase-locked loop with a frequency divider.

The synthesizer circuitry XT06d may be configured to synthesize an output frequency for use by the mixer circuitry XT06a of the RF circuitry XT06 based on a frequency input and a divider control input. In some embodiments, the synthesizer circuitry XT06d may be a fractional N/N+1 synthesizer.

In some embodiments, frequency input may be provided by a voltage controlled oscillator (VCO), although that is not a requirement. Divider control input may be provided by either the

baseband circuitry XS10/XT10 or the applications processor XS05/XT05 depending on the desired output frequency. In some embodiments, a divider control input (e.g., N) may be determined from a look-up table based on a channel indicated by the applications processor XS05/XT05.

Synthesizer circuitry XT06d of the RF circuitry XT06 may include a divider, a delay-locked loop (DLL), a multiplexer and a phase accumulator. In some embodiments, the divider may be a dual modulus divider (DMD) and the phase accumulator may be a digital phase accumulator (DPA). In some embodiments, the DMD may be configured to divide the input signal by either N or N+1 (e.g., based on a carry out) to provide a fractional division ratio. In some example embodiments, the DLL may include a set of cascaded, tunable, delay elements, a phase detector, a charge pump and a D-type flip-flop. In these embodiments, the delay elements may be configured to break a VCO period up into  $N_d$  equal packets of phase, where  $N_d$  is the number of delay elements in the delay line. In this way, the DLL provides negative feedback to help ensure that the total delay through the delay line is one VCO cycle.

In some embodiments, synthesizer circuitry XT06d may be configured to generate a carrier frequency as the output frequency, while in other embodiments, the output frequency may be a multiple of the carrier frequency (e.g., twice the carrier frequency, four times the carrier frequency) and used in conjunction with quadrature generator and divider circuitry to generate multiple signals at the carrier frequency with multiple different phases with respect to each other. In some embodiments, the output frequency may be a LO frequency ( $f_{LO}$ ). In some embodiments, the RF circuitry XT06 may include an IQ/polar converter.

FEM circuitry XT08 may include a receive signal path which may include circuitry configured to operate on RF signals received from one or more antennas XT10, amplify the received signals and provide the amplified versions of the received signals to the RF circuitry XT06 for further processing. FEM circuitry XT08 may also include a transmit signal path which may include circuitry configured to amplify signals for transmission provided by the RF circuitry XT06 for transmission by one or more of the one or more antennas XT10. In various embodiments, the amplification through the transmit or receive signal paths may be done solely in the RF circuitry XT06, solely in the FEM XT08, or in both the RF circuitry XT06 and the FEM XT08.

In some embodiments, the FEM circuitry XT08 may include a TX/RX switch to switch between transmit mode and receive mode operation. The FEM circuitry may include a receive signal path and a transmit signal path. The receive signal path of the FEM circuitry may include

an LNA to amplify received RF signals and provide the amplified received RF signals as an output (e.g., to the RF circuitry XT06). The transmit signal path of the FEM circuitry XT08 may include a power amplifier (PA) to amplify input RF signals (e.g., provided by RF circuitry XT06), and one or more filters to generate RF signals for subsequent transmission (e.g., by one or more of the one or more antennas XT10).

Processors of the application circuitry XS05/XT05 and processors of the baseband circuitry XS10/XT10 may be used to execute elements of one or more instances of a protocol stack. For example, processors of the baseband circuitry XS10/XT10, alone or in combination, may be used execute Layer 3, Layer 2, or Layer 1 functionality, while processors of the baseband circuitry XS10/XT10 may utilize data (e.g., packet data) received from these layers and further execute Layer 4 functionality (e.g., transmission communication protocol (TCP) and user datagram protocol (UDP) layers). As referred to herein, Layer 3 may comprise a radio resource control (RRC) layer, described in further detail below. As referred to herein, Layer 2 may comprise a medium access control (MAC) layer, a radio link control (RLC) layer, and a packet data convergence protocol (PDCP) layer, described in further detail below. As referred to herein, Layer 1 may comprise a physical (PHY) layer of a UE/RAN node, described in further detail below.

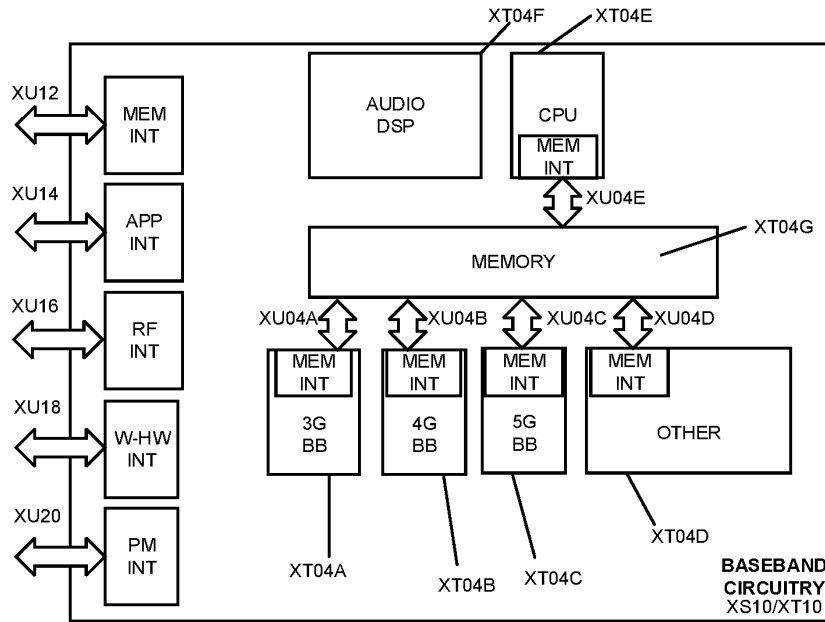
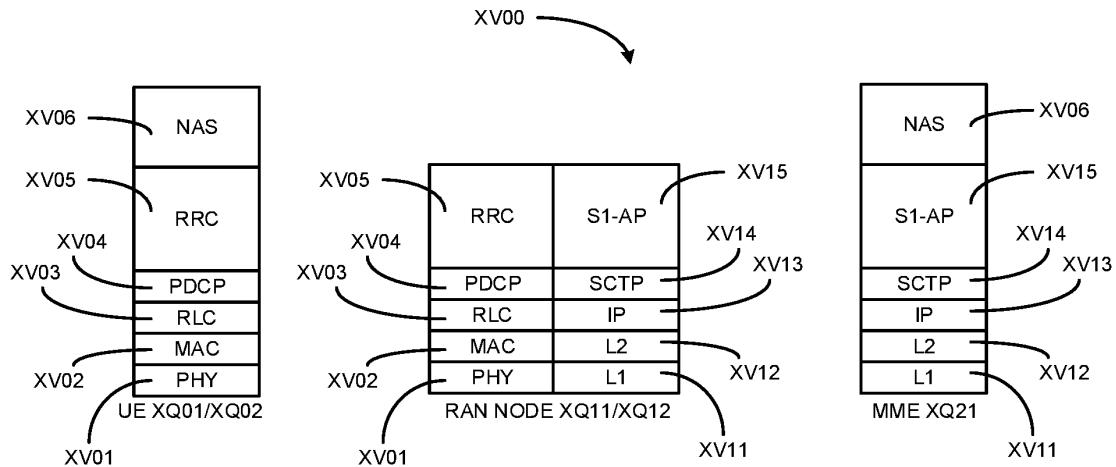

FIG. XU

FIG. XU illustrates example interfaces of baseband circuitry in accordance with some embodiments. As discussed above, the baseband circuitry XS10/XT10 of FIG. XT may comprise

processors XT04A-XT04E and a memory XT04G utilized by said processors. Each of the processors XT04A-XT04E may include a memory interface, XU04A-XU04E, respectively, to send/receive data to/from the memory XT04G.

The baseband circuitry XS10/XT10 may further include one or more interfaces to communicatively couple to other circuitries/devices, such as a memory interface XU12 (e.g., an interface to send/receive data to/from memory external to the baseband circuitry XS10/XT10), an application circuitry interface XU14 (e.g., an interface to send/receive data to/from the application circuitry XS05/XT05 of FIG. XT), an RF circuitry interface XU16 (e.g., an interface to send/receive data to/from RF circuitry XT06 of FIG. XT), a wireless hardware connectivity interface XU18 (e.g., an interface to send/receive data to/from Near Field Communication (NFC) components, Bluetooth® components (e.g., Bluetooth® Low Energy), Wi-Fi® components, and other communication components), and a power management interface XU20 (e.g., an interface to send/receive power or control signals to/from the PMIC XT25).



**FIG. XV**

FIG. XV is an illustration of a control plane protocol stack in accordance with some embodiments. In this embodiment, a control plane XV00 is shown as a communications protocol stack between the UE XQ01 (or alternatively, the UE XQ02), the RAN node XQ11 (or alternatively, the RAN node XQ12), and the MME XQ21.

The PHY layer XV01 may transmit or receive information used by the MAC layer XV02 over one or more air interfaces. The PHY layer XV01 may further perform link adaptation or adaptive modulation and coding (AMC), power control, cell search (e.g., for initial synchronization and handover purposes), and other measurements used by higher layers, such as

the RRC layer XV05. The PHY layer XV01 may still further perform error detection on the transport channels, forward error correction (FEC) coding/decoding of the transport channels, modulation/demodulation of physical channels, interleaving, rate matching, mapping onto physical channels, and Multiple Input Multiple Output (MIMO) antenna processing.

The MAC layer XV02 may perform mapping between logical channels and transport channels, multiplexing of MAC service data units (SDUs) from one or more logical channels onto transport blocks (TB) to be delivered to PHY via transport channels, de-multiplexing MAC SDUs to one or more logical channels from transport blocks (TB) delivered from the PHY via transport channels, multiplexing MAC SDUs onto TBs, scheduling information reporting, error correction through hybrid automatic repeat request (HARQ), and logical channel prioritization.

The RLC layer XV03 may operate in a plurality of modes of operation, including: Transparent Mode (TM), Unacknowledged Mode (UM), and Acknowledged Mode (AM). The RLC layer XV03 may execute transfer of upper layer protocol data units (PDUs), error correction through automatic repeat request (ARQ) for AM data transfers, and concatenation, segmentation and reassembly of RLC SDUs for UM and AM data transfers. The RLC layer XV03 may also execute re-segmentation of RLC data PDUs for AM data transfers, reorder RLC data PDUs for UM and AM data transfers, detect duplicate data for UM and AM data transfers, discard RLC SDUs for UM and AM data transfers, detect protocol errors for AM data transfers, and perform RLC re-establishment.

The PDCP layer XV04 may execute header compression and decompression of IP data, maintain PDCP Sequence Numbers (SNs), perform in-sequence delivery of upper layer PDUs at re-establishment of lower layers, eliminate duplicates of lower layer SDUs at re-establishment of lower layers for radio bearers mapped on RLC AM, cipher and decipher control plane data, perform integrity protection and integrity verification of control plane data, control timer-based discard of data, and perform security operations (e.g., ciphering, deciphering, integrity protection, integrity verification, etc.).

The main services and functions of the RRC layer XV05 may include broadcast of system information (e.g., included in Master Information Blocks (MIBs) or System Information Blocks (SIBs) related to the non-access stratum (NAS)), broadcast of system information related to the access stratum (AS), paging, establishment, maintenance and release of an RRC connection between the UE and E-UTRAN (e.g., RRC connection paging, RRC connection establishment,

RRC connection modification, and RRC connection release), establishment, configuration, maintenance and release of point to point Radio Bearers, security functions including key management, inter radio access technology (RAT) mobility, and measurement configuration for UE measurement reporting. Said MIBs and SIBs may comprise one or more information elements (IEs), which may each comprise individual data fields or data structures.

The UE XQ01 and the RAN node XQ11 may utilize a Uu interface (e.g., an LTE-Uu interface) to exchange control plane data via a protocol stack comprising the PHY layer XV01, the MAC layer XV02, the RLC layer XV03, the PDCP layer XV04, and the RRC layer XV05.

The non-access stratum (NAS) protocols XV06 form the highest stratum of the control plane between the UE XQ01 and the MME XQ21. The NAS protocols XV06 support the mobility of the UE XQ01 and the session management procedures to establish and maintain IP connectivity between the UE XQ01 and the P-GW XQ23.

The S1 Application Protocol (S1-AP) layer XV15 may support the functions of the S1 interface and comprise Elementary Procedures (EPs). An EP is a unit of interaction between the RAN node XQ11 and the CN XQ20. The S1-AP layer services may comprise two groups: UE-associated services and non UE-associated services. These services perform functions including, but not limited to: E-UTRAN Radio Access Bearer (E-RAB) management, UE capability indication, mobility, NAS signaling transport, RAN Information Management (RIM), and configuration transfer.

The Stream Control Transmission Protocol (SCTP) layer (alternatively referred to as the SCTP/IP layer) XV14 may ensure reliable delivery of signaling messages between the RAN node XQ11 and the MME XQ21 based, in part, on the IP protocol, supported by the IP layer XV13. The L2 layer XV12 and the L1 layer XV11 may refer to communication links (e.g., wired or wireless) used by the RAN node and the MME to exchange information.

The RAN node XQ11 and the MME XQ21 may utilize an S1-MME interface to exchange control plane data via a protocol stack comprising the L1 layer XV11, the L2 layer XV12, the IP layer XV13, the SCTP layer XV14, and the S1-AP layer XV15.

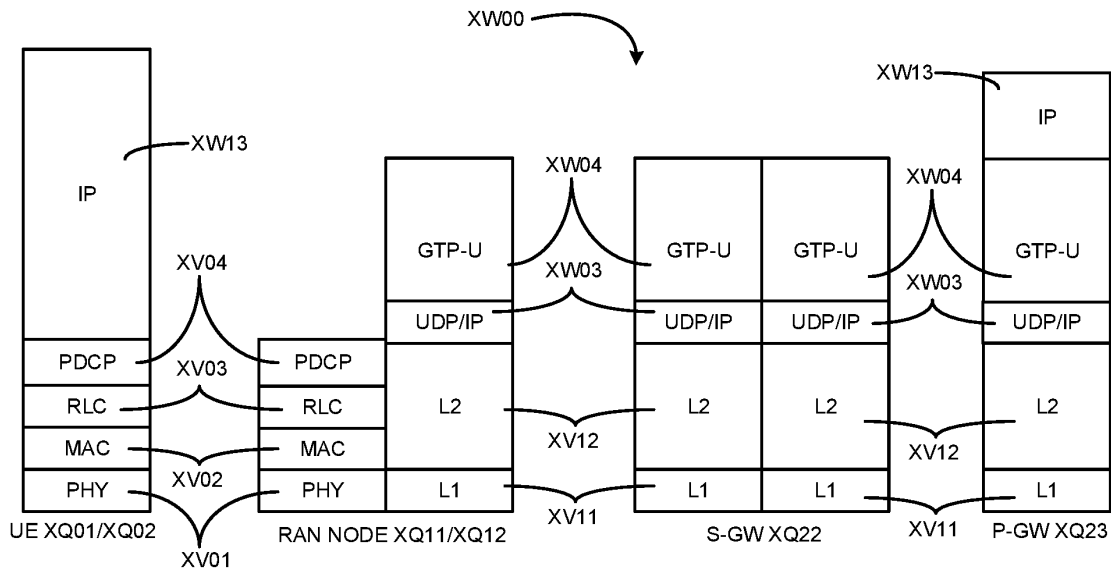

**FIG. XW**

FIG. XW is an illustration of a user plane protocol stack in accordance with some embodiments. In this embodiment, a user plane XW00 is shown as a communications protocol stack between the UE XQ01 (or alternatively, the UE XQ02), the RAN node XQ11 (or alternatively, the RAN node XQ12), the S-GW XQ22, and the P-GW XQ23. The user plane XW00 may utilize at least some of the same protocol layers as the control plane XV00. For example, the UE XQ01 and the RAN node XQ11 may utilize a Uu interface (e.g., an LTE-Uu interface) to exchange user plane data via a protocol stack comprising the PHY layer XV01, the MAC layer XV02, the RLC layer XV03, the PDCP layer XV04.

The General Packet Radio Service (GPRS) Tunneling Protocol for the user plane (GTP-U) layer XW04 may be used for carrying user data within the GPRS core network and between the radio access network and the core network. The user data transported can be packets in any of IPv4, IPv6, or PPP formats, for example. The UDP and IP security (UDP/IP) layer XW03 may provide checksums for data integrity, port numbers for addressing different functions at the source and destination, and encryption and authentication on the selected data flows. The RAN node XQ11 and the S-GW XQ22 may utilize an S1-U interface to exchange user plane data via a protocol stack comprising the L1 layer XV11, the L2 layer XV12, the UDP/IP layer XW03, and the GTP-U layer XW04. The S-GW XQ22 and the P-GW XQ23 may utilize an S5/S8a interface to exchange user plane data via a protocol stack comprising the L1 layer XV11, the L2 layer XV12,

the UDP/IP layer XW03, and the GTP-U layer XW04. As discussed above with respect to FIG. XV, NAS protocols support the mobility of the UE XQ01 and the session management procedures to establish and maintain IP connectivity between the UE XQ01 and the P-GW XQ23.

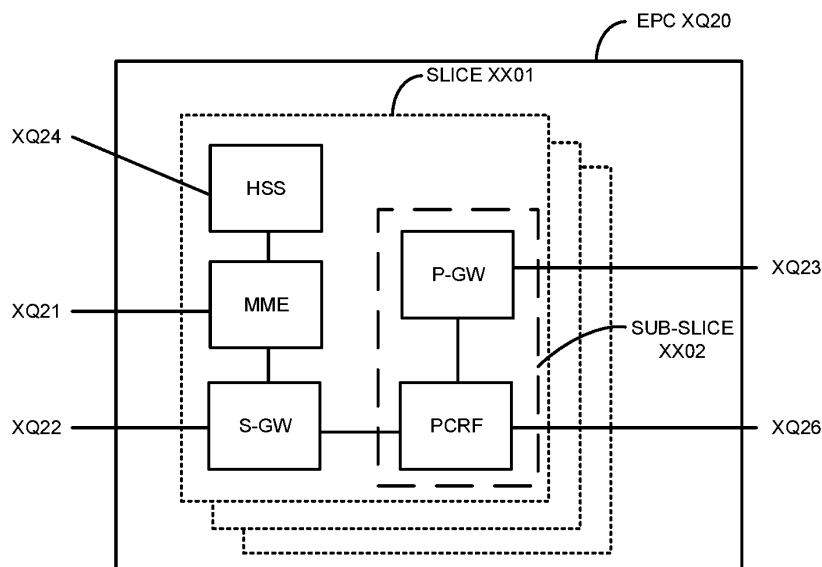

FIG. XX

FIG. XX illustrates components of a core network in accordance with some embodiments. The components of the CN XQ20 may be implemented in one physical node or separate physical nodes including components to read and execute instructions from a machine-readable or computer-readable medium (e.g., a non-transitory machine-readable storage medium). In embodiments, the components of CN XR20 may be implemented in a same or similar manner as discussed herein with regard to the components of CN XQ20. In some embodiments, Network Functions Virtualization (NFV) is utilized to virtualize any or all of the above described network node functions via executable instructions stored in one or more computer readable storage mediums (described in further detail below). A logical instantiation of the CN XQ20 may be referred to as a network slice XX01. A logical instantiation of a portion of the CN XQ20 may be referred to as a network sub-slice XX02 (e.g., the network sub-slice XX02 is shown to include the PGW XQ23 and the PCRF XQ26).

NFV architectures and infrastructures may be used to virtualize one or more network functions, alternatively performed by proprietary hardware, onto physical resources comprising a combination of industry-standard server hardware, storage hardware, or switches. In other words,



NFV systems can be used to execute virtual or reconfigurable implementations of one or more EPC components/functions.

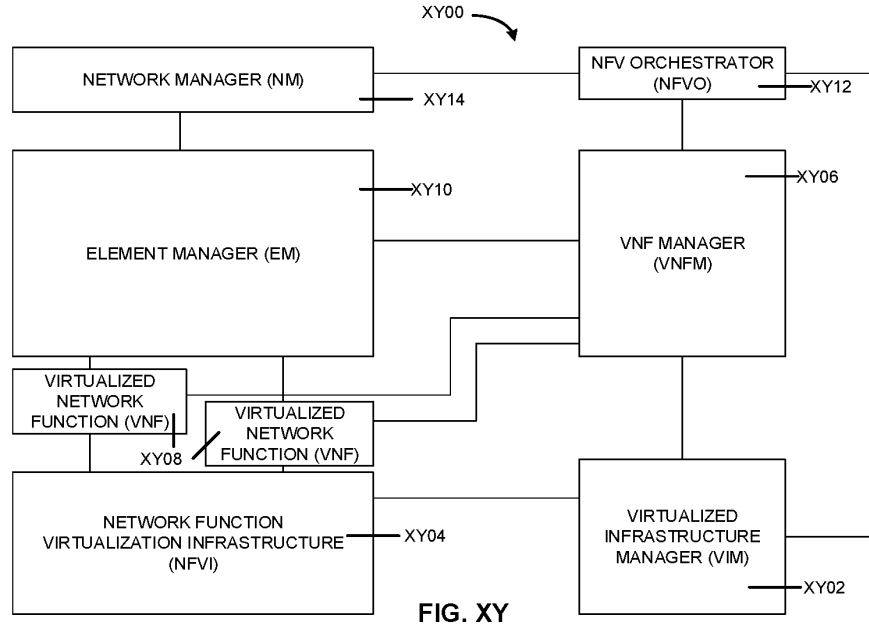

FIG. XY

FIG. XY is a block diagram illustrating components, according to some example embodiments, of a system XY00 to support NFV. The system XY00 is illustrated as including a virtualized infrastructure manager (VIM) XY02, a network function virtualization infrastructure (NFVI) XY04, a VNF manager (VNFM) XY06, virtualized network functions (VNFs) XY08, an element manager (EM) XY10, an NFV Orchestrator (NFVO) XY12, and a network manager (NM) XY14.

The VIM XY02 manages the resources of the NFVI XY04. The NFVI XY04 can include physical or virtual resources and applications (including hypervisors) used to execute the system XY00. The VIM XY02 may manage the life cycle of virtual resources with the NFVI XY04 (e.g., creation, maintenance, and tear down of virtual machines (VMs) associated with one or more physical resources), track VM instances, track performance, fault and security of VM instances and associated physical resources, and expose VM instances and associated physical resources to other management systems.

The VNFM XY06 may manage the VNFs XY08. The VNFs XY08 may be used to execute EPC components/functions. The VNFM XY06 may manage the life cycle of the VNFs XY08 and track performance, fault and security of the virtual aspects of VNFs XY08. The EM XY10 may

track the performance, fault and security of the functional aspects of VNFs XY08. The tracking data from the VNFM XY06 and the EM XY10 may comprise, for example, performance measurement (PM) data used by the VIM XY02 or the NFVI XY04. Both the VNFM XY06 and the EM XY10 can scale up/down the quantity of VNFs of the system XY00.

The NFVO XY12 may coordinate, authorize, release and engage resources of the NFVI XY04 in order to provide the requested service (e.g., to execute an EPC function, component, or slice). The NM XY14 may provide a package of end-user functions with the responsibility for the management of a network, which may include network elements with VNFs, non-virtualized network functions, or both (management of the VNFs may occur via the EM XY10).

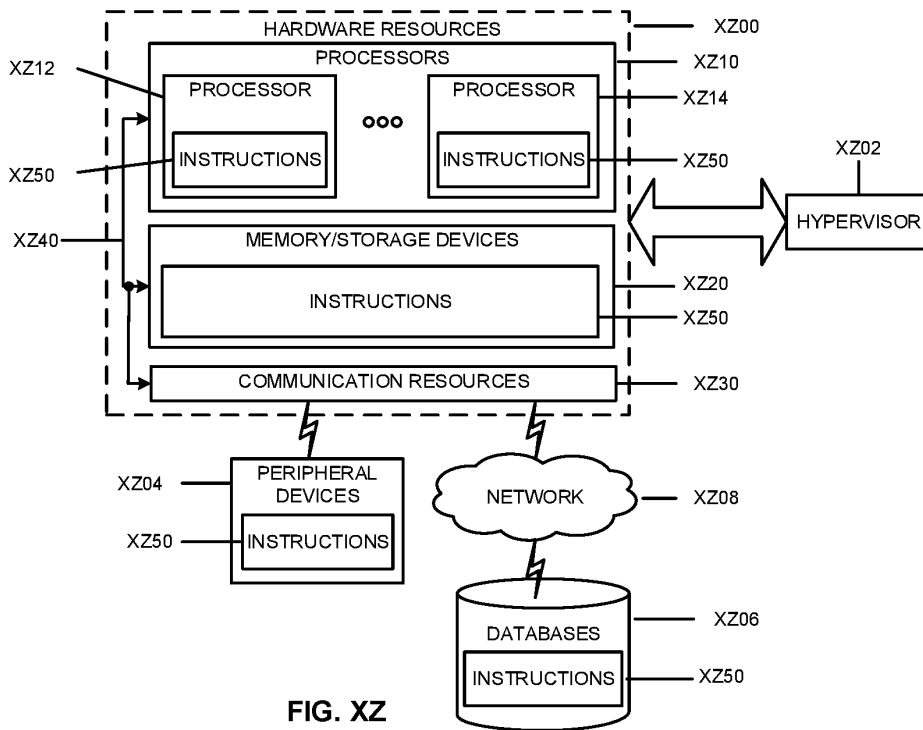

FIG. XZ

FIG. XZ is a block diagram illustrating components, according to some example embodiments, able to read instructions from a machine-readable or computer-readable medium (e.g., a non-transitory machine-readable storage medium) and perform any one or more of the methodologies discussed herein. Specifically, FIG. XZ shows a diagrammatic representation of hardware resources XZ00 including one or more processors (or processor cores) XZ10, one or more memory/storage devices XZ20, and one or more communication resources XZ30, each of which may be communicatively coupled via a bus XZ40. For embodiments where node

virtualization (e.g., NFV) is utilized, a hypervisor XZ02 may be executed to provide an execution environment for one or more network slices/sub-slices to utilize the hardware resources XZ00

The processors XZ10 (e.g., a central processing unit (CPU), a reduced instruction set computing (RISC) processor, a complex instruction set computing (CISC) processor, a graphics processing unit (GPU), a digital signal processor (DSP) such as a baseband processor, an application specific integrated circuit (ASIC), a radio-frequency integrated circuit (RFIC), another processor, or any suitable combination thereof) may include, for example, a processor XZ12 and a processor XZ14.

The memory/storage devices XZ20 may include main memory, disk storage, or any suitable combination thereof. The memory/storage devices XZ20 may include, but are not limited to any type of volatile or non-volatile memory such as dynamic random access memory (DRAM), static random-access memory (SRAM), erasable programmable read-only memory (EPROM), electrically erasable programmable read-only memory (EEPROM), Flash memory, solid-state storage, etc.

The communication resources XZ30 may include interconnection or network interface components or other suitable devices to communicate with one or more peripheral devices XZ04 or one or more databases XZ06 via a network XZ08. For example, the communication resources XZ30 may include wired communication components (e.g., for coupling via a Universal Serial Bus (USB)), cellular communication components, NFC components, Bluetooth® components (e.g., Bluetooth® Low Energy), Wi-Fi® components, and other communication components.

Instructions XZ50 may comprise software, a program, an application, an applet, an app, or other executable code for causing at least any of the processors XZ10 to perform any one or more of the methodologies discussed herein. The instructions XZ50 may reside, completely or partially, within at least one of the processors XZ10 (e.g., within the processor's cache memory), the memory/storage devices XZ20, or any suitable combination thereof. Furthermore, any portion of the instructions XZ50 may be transferred to the hardware resources XZ00 from any combination of the peripheral devices XZ04 or the databases XZ06. Accordingly, the memory of processors XZ10, the memory/storage devices XZ20, the peripheral devices XZ04, and the databases XZ06 are examples of computer-readable and machine-readable media.

In some embodiments, the electronic device(s), network(s), system(s), chip(s) or component(s), or portions or implementations thereof, of any figure herein may be configured to perform one or more processes, techniques, or methods as described herein, or portions thereof.

### **EXAMPLES**

Example 1 may include an NR UE attempting to set up an RRC connection with an NR network, performing a set up procedure, involving setting up of radio bearers for transfer of signalling, providing information needed by RAN (gNB) to contact the Core network immediately after the RACH procedure.

Example 2 may include the subject matter of example 1 and/or some other examples herein, wherein gNB using this information contacting the CN and getting necessary information from CN to establish the connection configuration to the UE including DRBs and security.

Example 3 may include the subject matter of examples 1-2 and/or some other examples herein, wherein gNB immediately sending the SMC and rest of the configuration to the UE without first setting up SRB1.

Example 4 may include the subject matter of examples 1-3 and/or some other examples herein, wherein UE setting up SRB1 autonomously immediately after sending RRC connection request and capable of receiving the SMC and RRC reconfiguration without network setting up SRB1 first by explicit signaling.

Example 5 may include the subject matter of examples 1-4 and/or some other examples herein, wherein UE and network using configuration in SMC and reconfiguration message for subsequent communication.

Example 6 may include the subject matter of examples 1-5 and/or some other examples herein, wherein Network providing a contention resolution message immediately after receiving the RRC connection request without including any RRC setup message or configuration to the UE.

Example 7 may include the subject matter of examples 1-6 and/or some other examples herein, wherein Network providing additional resources to the UE to provide information to contact the CN either as part of RRC connection request or as immediately after the RRC connection request or immediately after contention resolution

Example 8 may include an apparatus comprising means to perform one or more elements of a method described in or related to any of examples 1-7, or any other method or process described herein.

Example 9 may include one or more non-transitory computer-readable media comprising instructions to cause an electronic device, upon execution of the instructions by one or more processors of the electronic device, to perform one or more elements of a method described in or related to any of examples 1-7, or any other method or process described herein.

Example 10 may include an apparatus comprising logic, modules, or circuitry to perform one or more elements of a method described in or related to any of examples 1-7, or any other method or process described herein.

Example 11 may include a method, technique, or process as described in or related to any of examples 1-7, or portions or parts thereof.

Example 12 may include an apparatus comprising: one or more processors and one or more computer readable media comprising instructions that, when executed by the one or more processors, cause the one or more processors to perform the method, techniques, or process as described in or related to any of examples 1-7, or portions thereof.

Example 13 may include a signal as described in or related to any of examples 1-7, or portions or parts thereof.

Example 14 may include a signal in a wireless network as shown and described herein.

Example 15 may include a method of communicating in a wireless network as shown and described herein.

Example 16 may include a system for providing wireless communication as shown and described herein.

Example 17 may include a device for providing wireless communication as shown and described herein.

Any of the above described examples may be combined with any other example (or combination of examples), unless explicitly stated otherwise. The foregoing description of one or more implementations provides illustration and description, but is not intended to be exhaustive or to limit the scope of embodiments to the precise form disclosed. Modifications and variations are possible in light of the above teachings or may be acquired from practice of various embodiments.

## Electronic Acknowledgement Receipt

|                                             |                                                                  |
|---------------------------------------------|------------------------------------------------------------------|
| <b>EFS ID:</b>                              | 37488811                                                         |
| <b>Application Number:</b>                  | 16380844                                                         |
| <b>International Application Number:</b>    |                                                                  |
| <b>Confirmation Number:</b>                 | 8653                                                             |
| <b>Title of Invention:</b>                  | METHODS AND UE FOR RESUMING A CONNECTION WITH FULL CONFIGURATION |
| <b>First Named Inventor/Applicant Name:</b> | Oumer TEYEB                                                      |
| <b>Customer Number:</b>                     | 27045                                                            |
| <b>Filer:</b>                               | Brian Michael Kearns/Lala Deleon                                 |
| <b>Filer Authorized By:</b>                 | Brian Michael Kearns                                             |
| <b>Attorney Docket Number:</b>              | P74267 US2                                                       |
| <b>Receipt Date:</b>                        | 17-OCT-2019                                                      |
| <b>Filing Date:</b>                         | 10-APR-2019                                                      |
| <b>Time Stamp:</b>                          | 16:15:41                                                         |
| <b>Application Type:</b>                    | Utility under 35 USC 111(a)                                      |

### Payment information:

|                        |    |
|------------------------|----|
| Submitted with Payment | no |
|------------------------|----|

### File Listing:

| Document Number | Document Description | File Name                                     | File Size(Bytes)/<br>Message Digest                        | Multi Part /.zip | Pages (if appl.) |
|-----------------|----------------------|-----------------------------------------------|------------------------------------------------------------|------------------|------------------|
| 1               |                      | P74267_US2_2019-10-17_Resp<br>onse_to_FOA.pdf | 157200<br><br>60c8800aca9fab68da4f270fdc5a2b00fda47<br>bcd | yes              | 8                |

| Multipart Description/PDF files in .zip description |       |     |  |
|-----------------------------------------------------|-------|-----|--|
| Document Description                                | Start | End |  |
| Applicant Arguments/Remarks Made in an Amendment    | 5     | 8   |  |
| Claims                                              | 2     | 4   |  |
| Response After Final Action                         | 1     | 1   |  |

**Warnings:**

**Information:**

|   |                                                  |                                                                                          |                                                               |    |    |
|---|--------------------------------------------------|------------------------------------------------------------------------------------------|---------------------------------------------------------------|----|----|
| 2 | Applicant Arguments/Remarks Made in an Amendment | P74267_US2_2019-10-17_Anne<br>x_to_response_cited_prior_art<br>_provisional_62616141.pdf | 2544766<br><br>64cccf055ebcd8ba5a33557241508d779de3<br>0cfile | no | 46 |
|---|--------------------------------------------------|------------------------------------------------------------------------------------------|---------------------------------------------------------------|----|----|

**Warnings:**

**Information:**

|                                     |         |
|-------------------------------------|---------|
| <b>Total Files Size (in bytes):</b> | 2701966 |
|-------------------------------------|---------|

**This Acknowledgement Receipt evidences receipt on the noted date by the USPTO of the indicated documents, characterized by the applicant, and including page counts, where applicable. It serves as evidence of receipt similar to a Post Card, as described in MPEP 503.**

**New Applications Under 35 U.S.C. 111**

**If a new application is being filed and the application includes the necessary components for a filing date (see 37 CFR 1.53(b)-(d) and MPEP 506), a Filing Receipt (37 CFR 1.54) will be issued in due course and the date shown on this Acknowledgement Receipt will establish the filing date of the application.**

**National Stage of an International Application under 35 U.S.C. 371**

**If a timely submission to enter the national stage of an international application is compliant with the conditions of 35 U.S.C. 371 and other applicable requirements a Form PCT/DO/EO/903 indicating acceptance of the application as a national stage submission under 35 U.S.C. 371 will be issued in addition to the Filing Receipt, in due course.**

**New International Application Filed with the USPTO as a Receiving Office**

**If a new international application is being filed and the international application includes the necessary components for an international filing date (see PCT Article 11 and MPEP 1810), a Notification of the International Application Number and of the International Filing Date (Form PCT/RO/105) will be issued in due course, subject to prescriptions concerning national security, and the date shown on this Acknowledgement Receipt will establish the international filing date of the application.**

## Remarks

### *Claims Status*

Claims 1-20 are currently pending. Claim 11 is currently amended. Claims 2- 5, 7-9, and 12-20 are original. Claims 1 and 6 are as previously presented.

### *Claim Rejections – 35 USC § 102*

Claims 1, 2, 4-7, 9 and 10 are rejected under 35 U.S.C. 102(a)(2) as being anticipated by Burbidge et al. (US 2019/0215887).

The Applicant respectfully submits that Burbidge et al. cannot be cited as a prior art against claims 1 and 6 of the present application.

Burbidge et al.'s application was filed on **January 8, 2019**, claiming priority from a provisional application (62/616,141) filed on **January 11, 2018**.

The present application was filed on **February 1, 2019**, claiming priority on a provisional application filed on **February 15, 2018**.

The Applicant checked the provisional application (62/616,141) to see if the passages cited by the Examiner were present in the provisional application. It is submitted that the passages cited by the Final Office Action (FOA), such as Figure 5 and paragraphs [0060]-[0070], were not in the provisional application. The applicant has attached the provisional application for the Examiner, in case the Examiner is interested in seeing the provisional application as well.

Therefore, it is submitted that the subject matter of the passages cited by the FOA is not supported by the provisional application and as such the effective filing date of the subject matter of these passages is **January 8, 2019**.

Since the effective filing date of the present application is **February 15, 2018** (which is before January 8, 2019), it is respectfully submitted that the passages cited by the FOA do not constitute proper prior art. Therefore, the rejection under 35 U.S.C. 102(a)(2) is moot.



Accordingly, it is submitted that claims 1, 2, 4-7, 9 and 10 are patentable.

Claims 11-16, 18 and 20 are rejected under 35 U.S.C. 102 (a)(1) as being anticipated by Rayavarapy (US 2013/0260811).

Claim 11 has been amended in a similar way as claim 1. As such, amended claim 11 now contains similar limitations as amended claim 1. Therefore, the discussion with regards to claim 1, as presented in the response to the Office Action, filed on August 27, 2019, equally applies to amended claim 11. Therefore, claim 11 is submitted to be also patentable over Rayavarapy et al.

Claims 12-16, 18 and 20 are submitted to be also patentable over Rayavarapy et al., at least by virtue of their dependency from amended claim 11.

The Applicant kindly refers the Examiner to the response to the Office Action, filed on August 27, 2019 for the details of the discussion with regards to claim 1.

#### ***Claim Rejections – 35 USC § 103***

Claims 3 and 8 are rejected under 35 U.S.C. 103 as being unpatentable over Burbidge et al. as applied to claims 1 and 6 and further in view of Guo et al. (US 2019/0037635).

Guo et al. disclose methods and apparatuses for recovering a Radio Resource Control (RRC) connection in a wireless communication system. In one method, a user equipment (UE) performs a procedure used to re-establish a RRC connection between the UE and a network node. The UE enters a RRC\_INACTIVE state when the procedure is failed and if the UE has at least one parameter of the RRC\_INACTIVE state. The UE enters a RRC\_IDLE state when the procedure is failed and if the UE does not have the at least one parameter of the RRC\_INACTIVE state. (see the abstract of Guo et al.)

It is respectfully submitted that Guo et al. fail to disclose the features of claims 1 and 6. Since Burbidge et al. cannot be considered as citable prior art, claims 1 and 6 are submitted to be patentable over Guo et al.

Claims 3 and 8 are submitted to be also patentable over of Guo et al., at least by virtue of their dependency from claims 1 and 6 respectively.

Claims 17 and 19 are rejected under 35 U.S.C. 103 as being unpatentable over Rayavarapy et al. as applied to claim 11 and further in view of Kim et al. (US 2018/0213452).

Kim relates to a communication method and system for converging a 5<sup>th</sup>-Generation (5G) communication system for supporting higher data rates beyond a 4<sup>th</sup>-Generation (4G) system with a technology for IoT, which may be applied to intelligent services based on the 5G communication technology and the IoT-related technology, e.g., smart home, smart building, smart city, smart car, connected car, health care, digital education, smart retail, security and safety services. A method by a terminal in a wireless communication system is provided, and includes receiving, from a base station, a paging message for switching a mode of the terminal in an RRC inactive mode to an RRC idle mode, transmitting an RRC message to the base station based on the paging message, receiving an RRC-connection release message (CRR) from the base station, and transitioning from the RRC inactive mode to the RRC idle mode based on the RRC-CRR (see the abstract of Kim et al.).

It is respectfully submitted that Kim et al. fail to disclose the features of claim 11, as Kim et al. are not concerned at all with the full configuration. As such, when combined with Rayavarapy et al., the combination still fails to cure the deficiencies left by Rayavarapy et al. Therefore, Rayavarapy et al. and Kim et al., either separately or in combination, fail to disclose the features of claim 11. Accordingly, claim 11 is submitted to be patentable over Rayavarapy et al. in view of Kim et al.

Claims 17 and 19 are submitted to be also patentable over Rayavarapy et al. in view of Kim et al., at least by virtue of their dependency from claim 11.

***Conclusion***

Applicant submits that the within application is now in condition for allowance and accordingly, earnestly solicits reconsideration and action to that end, and requests that a timely Notice of Allowance be issued in this case.

Should the Examiner believe, however, that additional amendments to the claim may be required to secure allowance of the within application, the Examiner is invited to telephone or email the undersigned at the below-noted coordinates to facilitate further prosecution of the within application.

Respectfully submitted,

/BrentCapehart/

Brent Capehart

Registration No. 39620

Brent.Capehart@ericsson.com

Phone: +16134079700

Dated: 2019-10-17

## **Amendments to the Claims**

This listing of claims will replace all prior version, and listings, of claims in the application:

### **Listing of Claims:**

1. (Previously presented) A method in a wireless device, the method comprising:
  - sending to a network node a request to resume a connection in a communication network;
  - receiving a resume message from the network node, the message comprising an indication to perform a full configuration; and
  - applying the full configuration, without receiving a reconfiguration message.
2. (Original) The method of claim 1, further comprising discarding an old bearer configuration and old radio parameters.
3. (Original) The method of claim 1, further comprising keeping security keys.
4. (Original) The method of claim 1, further comprising receiving a configuration.
5. (Original) The method of claim 4, further comprising applying the received configuration.
6. (Previously presented) A wireless device, comprising a communication interface; and one or more processing circuits communicatively connected to the communication interface, the one or more processing circuits comprising at least one processor and memory, the memory containing instructions that, when executed, cause the at least one processor to:
  - send to a network node a request to resume a connection in a communication network;
  - receive a resume response message from the network node, the message comprising an indication to perform a full configuration; and
  - apply the full configuration, without receiving a reconfiguration message.
7. (Original) The wireless device of claim 6, wherein the at least one processor is configured to discard an old bearer configuration and old radio parameters.

8. (Original) The wireless device of claim 6, wherein the at least one processor is configured to keep security keys.
9. (Original) The wireless device of claim 6, wherein the at least one processor is configured to receive a configuration.
10. (Original) The wireless device of claim 9, wherein the at least one processor is configured to apply the received configuration.
11. (Currently amended) A network node comprising:
  - a communication interface; and
  - one or more processing circuits communicatively connected to the communication interface, the one or more processing circuits comprising at least one processors and memory, the memory containing instructions that, when executed, cause the at least one processor to:
    - receive, from a wireless device, a request to resume a connection in a communication network;
    - send a resume response message to the wireless device, the message comprising an indication to perform a full configuration, without sending a reconfiguration message.
12. (Original) The network node of claim 11, wherein the indication comprises a flag.
13. (Original) The network node of claim 11, wherein the network node has a different radio access technology than a previous network node which suspended a previous connection for the wireless device.
14. (Original) The network node of claim 11, wherein the at least one processor is configured to retrieve configuration information for the wireless device.
15. (Original) The network node of claim 11, wherein the message further comprises configuration parameters.
16. (Original) The network node of claim 15, wherein the indication comprises an indication to perform a full configuration using the configuration parameters.
17. (Original) The network node of claim 11, wherein the resume response message is one of a *RRCConnectionResume and a RRCResume*.

18. (Original) The network node of claim 15, wherein the at least one processor is configured to generate the configuration parameters by generating a new User Equipment (UE) Access Stratum (AS) context.
19. (Original) The network node of claim 15, wherein the at least one processor is configured to generate the configuration parameters based on S1 and Next Generation (NG) context which contains bearer information used during an initial context setup.
20. (Original) The network node of claim 15, wherein the configuration parameters comprise one or more of bearer configuration, Packet Data Convergence Protocol (PDCP) configuration and Radio Link Control (RLC) configuration.

|                                                                                                                                 |                                                                                                                                                                                                                               |                                            |                                    |                           |                                       |                     |
|---------------------------------------------------------------------------------------------------------------------------------|-------------------------------------------------------------------------------------------------------------------------------------------------------------------------------------------------------------------------------|--------------------------------------------|------------------------------------|---------------------------|---------------------------------------|---------------------|
| <b>PATENT APPLICATION FEE DETERMINATION RECORD</b><br>Substitute for Form PTO-875                                               |                                                                                                                                                                                                                               | Application or Docket Number<br>16/380,844 |                                    | Filing Date<br>04/10/2019 | <input type="checkbox"/> To be Mailed |                     |
| ENTITY: <input checked="" type="checkbox"/> LARGE <input type="checkbox"/> SMALL <input type="checkbox"/> MICRO                 |                                                                                                                                                                                                                               |                                            |                                    |                           |                                       |                     |
| <b>APPLICATION AS FILED - PART I</b>                                                                                            |                                                                                                                                                                                                                               |                                            |                                    |                           |                                       |                     |
|                                                                                                                                 | (Column 1)                                                                                                                                                                                                                    | (Column 2)                                 |                                    |                           |                                       |                     |
| FOR                                                                                                                             | NUMBER FILED                                                                                                                                                                                                                  | NUMBER EXTRA                               | RATE (\$)                          | FEE (\$)                  |                                       |                     |
| <input type="checkbox"/> BASIC FEE<br><small>(37 CFR 1.16(a), (b), or (c))</small>                                              | N/A                                                                                                                                                                                                                           | N/A                                        | N/A                                |                           |                                       |                     |
| <input type="checkbox"/> SEARCH FEE<br><small>(37 CFR 1.16(k), (l), or (m))</small>                                             | N/A                                                                                                                                                                                                                           | N/A                                        | N/A                                |                           |                                       |                     |
| <input type="checkbox"/> EXAMINATION FEE<br><small>(37 CFR 1.16(o), (p), or (q))</small>                                        | N/A                                                                                                                                                                                                                           | N/A                                        | N/A                                |                           |                                       |                     |
| TOTAL CLAIMS<br><small>(37 CFR 1.16(j))</small>                                                                                 | minus 20 =                                                                                                                                                                                                                    | *                                          | x \$100 =                          |                           |                                       |                     |
| INDEPENDENT CLAIMS<br><small>(37 CFR 1.16(h))</small>                                                                           | minus 3 =                                                                                                                                                                                                                     | *                                          | x \$460 =                          |                           |                                       |                     |
| <input type="checkbox"/> APPLICATION SIZE FEE (37 CFR 1.16(s))                                                                  | If the specification and drawings exceed 100 sheets of paper, the application size fee due is \$310 (\$155 for small entity) for each additional 50 sheets or fraction thereof. See 35 U.S.C. 41(a)(1)(G) and 37 CFR 1.16(s). |                                            |                                    |                           |                                       |                     |
| <input type="checkbox"/> MULTIPLE DEPENDENT CLAIM PRESENT (37 CFR 1.16(j))                                                      |                                                                                                                                                                                                                               |                                            |                                    |                           |                                       |                     |
| * If the difference in column 1 is less than zero, enter "0" in column 2.                                                       |                                                                                                                                                                                                                               |                                            |                                    | TOTAL                     |                                       |                     |
| <b>APPLICATION AS AMENDED - PART II</b>                                                                                         |                                                                                                                                                                                                                               |                                            |                                    |                           |                                       |                     |
|                                                                                                                                 | (Column 1)                                                                                                                                                                                                                    | (Column 2)                                 | (Column 3)                         |                           |                                       |                     |
| AMENDMENT                                                                                                                       | 10/17/2019                                                                                                                                                                                                                    | CLAIMS REMAINING AFTER AMENDMENT           | HIGHEST NUMBER PREVIOUSLY PAID FOR | PRESENT EXTRA             | RATE (\$)                             | ADDITIONAL FEE (\$) |
|                                                                                                                                 | Total<br><small>(37 CFR 1.16(i))</small>                                                                                                                                                                                      | * 20                                       | Minus                              | ** 20                     | = 0                                   | x \$100 = 0         |
|                                                                                                                                 | Independent<br><small>(37 CFR 1.16(h))</small>                                                                                                                                                                                | * 3                                        | Minus                              | *** 3                     | = 0                                   | x \$460 = 0         |
|                                                                                                                                 | <input type="checkbox"/> Application Size Fee (37 CFR 1.16(s))                                                                                                                                                                |                                            |                                    |                           |                                       |                     |
|                                                                                                                                 | <input type="checkbox"/> FIRST PRESENTATION OF MULTIPLE DEPENDENT CLAIM (37 CFR 1.16(j))                                                                                                                                      |                                            |                                    |                           |                                       |                     |
|                                                                                                                                 |                                                                                                                                                                                                                               |                                            |                                    |                           | TOTAL ADD'L FEE                       | 0                   |
| AMENDMENT                                                                                                                       | (Column 1)                                                                                                                                                                                                                    | (Column 2)                                 | (Column 3)                         | RATE (\$)                 | ADDITIONAL FEE (\$)                   |                     |
|                                                                                                                                 | Total<br><small>(37 CFR 1.16(i))</small>                                                                                                                                                                                      | *                                          | Minus                              | **                        | =                                     | x \$0 =             |
|                                                                                                                                 | Independent<br><small>(37 CFR 1.16(h))</small>                                                                                                                                                                                | *                                          | Minus                              | ***                       | =                                     | x \$0 =             |
|                                                                                                                                 | <input type="checkbox"/> Application Size Fee (37 CFR 1.16(s))                                                                                                                                                                |                                            |                                    |                           |                                       |                     |
|                                                                                                                                 | <input type="checkbox"/> FIRST PRESENTATION OF MULTIPLE DEPENDENT CLAIM (37 CFR 1.16(j))                                                                                                                                      |                                            |                                    |                           |                                       |                     |
|                                                                                                                                 |                                                                                                                                                                                                                               |                                            |                                    |                           | TOTAL ADD'L FEE                       |                     |
| * If the entry in column 1 is less than the entry in column 2, write "0" in column 3.                                           |                                                                                                                                                                                                                               |                                            |                                    |                           | LIE                                   |                     |
| ** If the "Highest Number Previously Paid For" IN THIS SPACE is less than 20, enter "20".                                       |                                                                                                                                                                                                                               |                                            |                                    |                           | /PEGGY S YARBOROUGH/                  |                     |
| *** If the "Highest Number Previously Paid For" IN THIS SPACE is less than 3, enter "3".                                        |                                                                                                                                                                                                                               |                                            |                                    |                           |                                       |                     |
| The "Highest Number Previously Paid For" (Total or Independent) is the highest number found in the appropriate box in column 1. |                                                                                                                                                                                                                               |                                            |                                    |                           |                                       |                     |

This collection of information is required by 37 CFR 1.16. The information is required to obtain or retain a benefit by the public which is to file (and by the USPTO to process) an application. Confidentiality is governed by 35 U.S.C. 122 and 37 CFR 1.14. This collection is estimated to take 12 minutes to complete, including gathering, preparing, and submitting the completed application form to the USPTO. Time will vary depending upon the individual case. Any comments on the amount of time you require to complete this form and/or suggestions for reducing this burden, should be sent to the Chief Information Officer, U.S. Patent and Trademark Office, U.S. Department of Commerce, P.O. Box 1450, Alexandria, VA 22313-1450. DO NOT SEND FEES OR COMPLETED FORMS TO THIS ADDRESS. **SEND TO: Commissioner for Patents, P.O. Box 1450, Alexandria, VA 22313-1450.**

*If you need assistance in completing the form, call 1-800-PTO-9199 and select option 2.*



UNITED STATES PATENT AND TRADEMARK OFFICE

UNITED STATES DEPARTMENT OF COMMERCE
United States Patent and Trademark Office
Address: COMMISSIONER FOR PATENTS
P.O. Box 1450
Alexandria, Virginia 22313-1450
www.uspto.gov

Table with columns: APPLICATION NO., FILING DATE, FIRST NAMED INVENTOR, ATTORNEY DOCKET NO., CONFIRMATION NO.
Row 1: 16/380,844, 04/10/2019, Oumer TEYEB, P74267 US2, 8653
Row 2: 27045, 7590, 09/12/2019, ERICSSON INC., 6300 LEGACY DRIVE, M/S EVR 1-C-11, PLANO, TX 75024, EXAMINER THOMPSON, JR, OTIS L, ART UNIT 2477, PAPER NUMBER, NOTIFICATION DATE 09/12/2019, DELIVERY MODE ELECTRONIC

Please find below and/or attached an Office communication concerning this application or proceeding.

The time period for reply, if any, is set in the attached communication.

Notice of the Office communication was sent electronically on above-indicated "Notification Date" to the following e-mail address(es):

- amber.rogers@ericsson.com
michelle.sanderson@ericsson.com
pam.ewing@ericsson.com





**DETAILED ACTION**

***Notice of Pre-AIA or AIA Status***

1. The present application, filed on or after March 16, 2013, is being examined under the first inventor to file provisions of the AIA.

***Response to Arguments***

2. Applicant's arguments filed August 27, 2019 with respect to claims 1 and 6 (and their dependent claims) have been considered but are moot because the arguments do not apply to any of the new references, necessitated by the amendments, being used in the current rejection.

3. Applicant's arguments filed August 27, 2019 with respect to claim 11 have been fully considered but they are not persuasive. Applicant contends that claim 11 has similar limitations to amended claim 1, and that arguments with respect claim 1 equally apply to claim 11. Although other limitations of claim 11 are substantially similar to limitations of claim 1, claim 1 has been amended to further recite "*without receiving a reconfiguration message*", and arguments with respect to claim 1 are directed toward this amended limitation. Claim 11 does not include this limitation. Thus, the arguments with respect to claim 11 are not persuasive, and rejections of claim 11 and its dependent claims are maintained as indicated in the non-final rejection.

***Claim Rejections - 35 USC § 102***

4. The following is a quotation of the appropriate paragraphs of 35 U.S.C. 102 that form the basis for the rejections under this section made in this Office action:

A person shall be entitled to a patent unless –

(a)(2) the claimed invention was described in a patent issued under section 151, or in an application for patent published or deemed published under section 122(b), in which the patent or application, as the case may be, names another inventor and was effectively filed before the effective filing date of the claimed invention.

5. Claim(s) 1, 2, 4-7, 9 and 10 is/are rejected under 35 U.S.C. 102(a)(2) as being anticipated by Burbidge et al. (US 2019/0215887).

6. **Regarding claims 1 and 6**, Burbidge et al. disclose *a method in a wireless device and a wireless device, the method and wireless device comprising:*

- a. *A communication interface* (Figure 2, network interface device 220); *and*
- b. *One or more processing circuits communicatively connected to the communication interface* (Figure 2, processor 202 connected to network interface device 220 via bus link 208), *the one or more processing circuits comprising at least one processor and memory* (Figure 2 processor 202 and memory 204 and 206), *the memory containing instructions that, when executed, cause the at least one processor* (Figure 2, memories and processor store software executed by the processor) *to:*
- c. *Sending to a network node a request to resume a connection in a communication network* (Figure 5 and paragraph 0071, UE 502 sends RRC Reestablish/Resume Request to the eNB/gNB 504);
- d. *Receiving a resume message from the network node* (Figure 5 and paragraph 0071, UE receives RRC Reestablish/Resume/Reconfiguration message from eNB/gNB 504), *the message comprising an indication to perform a full configuration* (Paragraph 0068 and corresponding table indicating fullConfig option applicable for the RRCResume message; Paragraphs 0069-0070 and corresponding tables indicating fullConfig option applicable for the RRCReestablishment message); *and*

- e. *Applying the full configuration, without receiving a reconfiguration message* (Paragraph 0071, UE 502 receives RRCReestablishment/RRCResume/RRCSetup message containing new SRB1 configuration and uses the new SRB1 configuration for transmission).
7. **Regarding claims 2 and 7**, Burbidge et al. disclose *discarding an old bearer configuration and old radio parameters* (Paragraph 0071, UE 502 uses new SRB1 configuration for transmission after initially using a default configuration, the default configuration being the discarded configuration).
8. **Regarding claims 4 and 9**, Burbidge et al. disclose *receiving a configuration* (Figure 5 and paragraph 0071, UE 502 receives and uses SRB1 configuration for transmission).
9. **Regarding claims 5 and 10**, Burbidge et al. disclose *applying the received configuration* (Figure 5 and paragraph 0071, UE 502 receives and uses SRB1 configuration for transmission).

***Claim Rejections - 35 USC § 102***

10. The following is a quotation of the appropriate paragraphs of 35 U.S.C. 102 that form the basis for the rejections under this section made in this Office action:

A person shall be entitled to a patent unless –

(a)(1) the claimed invention was patented, described in a printed publication, or in public use, on sale or otherwise available to the public before the effective filing date of the claimed invention.

11. Claim(s) 11-16, 18 and 20 is/are rejected under 35 U.S.C. 102(a)(1) as being anticipated by Rayavarapu (US 2013/0260811).
12. **Regarding claim 11**, Rayavarapu discloses *a network node (eNB 102b) comprising:*

- a. *a communications interface* (Figure 29, eNB 102b's communications interface is inherent for communication with the UE 101; eNB 102b has communications interface similar to that of UE 200 in figure 2); *and*
- b. *one or more processing circuits communicatively connected to the communication interface* (Paragraph 0295, eNB comprising processing circuit including one or more processors executing software stored on a computer readable medium; eNB 102b has processing circuit similar to that of UE 200 in figure 2 connected to its communications interface), *the one or more processing circuits comprising at least one processors and memory, the memory containing instructions that, when executed, cause the at least one processor to* (Paragraph 0295, eNB comprising processing circuit including one or more processors executing software stored on a computer readable medium):
  - i. *receive, from a wireless device, a request to resume a connection in a communication network* (Paragraph 0590, 0594 and figure 29 step 3, UE 101 sends RRC reestablishment request to eNB 102b [network node] to reactivate a suspended RRC connection; Step 7, UE 101 transmits RRC connection request message to eNB 102b, the message identifying the setup cause as resume); *and*
  - ii. *send a resume response message to the wireless device, the message comprising an indication to perform a full configuration* (Paragraph 0602-0603 and figure 29 step 17, eNB 102b sends RRC connection reconfiguration message [resume message] to UE 101. eNB 102b may also instruct the UE to throw away the suspended configuration and adopt a new configuration by setting the 'full config' IE).

13. **Regarding claim 12**, Rayavarapu discloses *wherein the indication comprises a flag* (Paragraph 0602, ‘full config’ IE [flag] set in the message from the eNB to the UE).

14. **Regarding claim 13**, Rayavarapu discloses *wherein the network node has a different radio access technology than a previous network node which suspended a previous connection for the wireless device* (Paragraph 0602, eNB 102b derives a configuration that needs to be signaled to the UE by comparing the current configuration at the UE with the configuration desired by eNB 102b, or eNB 102b instructs UE to throw away suspended configuration [radio access technology] and adopt a new configuration by setting the ‘full config’ IE. This indicates that suspended/current configuration of the UE with old eNB 102a is different from the new configuration of UE with new eNB).

15. **Regarding claim 14**, Rayavarapu discloses *wherein the at least one processor is configured to retrieve configuration information for the wireless device* (Paragraph 0602, new eNB 102b derives a new configuration to be signaled to the UE).

16. **Regarding claim 15**, Rayavarapu discloses *wherein the message further comprises configuration parameters* (Paragraphs 0602-0603, RRC connection reconfiguration message comprises new configuration set by the new eNB 102b).

17. **Regarding claim 16**, Rayavarapu discloses *wherein the indication comprises an indication to perform a full configuration using the configuration parameters* (Paragraph 602, ‘full config’ IE, delta configuration derived by eNB 102b and signaled to UE).

18. **Regarding claim 18**, Rayavarapu discloses *wherein the at least one processor is configured to generate the configuration parameters by generating a new UE AS context* (Paragraph 0512, new AS security context or modified AS security context to resume connection with another eNB).

19. **Regarding claim 20**, Rayavarapu discloses *wherein the configuration parameters comprise one or more of bearer configuration, PDCP configuration and RLC configuration* (Paragraph 0603, bearer configuration for SRB2 and other DRBs).

***Claim Rejections - 35 USC § 103***

20. The following is a quotation of 35 U.S.C. 103 which forms the basis for all obviousness rejections set forth in this Office action:

A patent for a claimed invention may not be obtained, notwithstanding that the claimed invention is not identically disclosed as set forth in section 102, if the differences between the claimed invention and the prior art are such that the claimed invention as a whole would have been obvious before the effective filing date of the claimed invention to a person having ordinary skill in the art to which the claimed invention pertains. Patentability shall not be negated by the manner in which the invention was made.

21. The factual inquiries set forth in *Graham v. John Deere Co.*, 383 U.S. 1, 148 USPQ 459 (1966), that are applied for establishing a background for determining obviousness under 35 U.S.C. 103 are summarized as follows:

1. Determining the scope and contents of the prior art.
2. Ascertaining the differences between the prior art and the claims at issue.
3. Resolving the level of ordinary skill in the pertinent art.
4. Considering objective evidence present in the application indicating obviousness or nonobviousness.

22. Claims 3 and 8 is/are rejected under 35 U.S.C. 103 as being unpatentable over Burbidge et al. as applied to claims 1 and 6 above, and further in view of Guo et al. (US 2019/0037635).

23. **Regarding claims 3 and 8**, Burbidge et al. disclose the claimed invention above but does not specifically disclose the following limitations found in Guo et al.: *keeping security keys* (Guo et al., Paragraph 0116, re-establishment with or without a security key change).

Therefore, it would have been obvious to one of ordinary skill in the art before the effective filing date of the claimed invention to modify the teachings of Burbidge et al. with the teachings of Guo et al. in order to perform secure connection re-establishment (Guo et al., paragraph 0116).

24. Claims 17 and 19 is/are rejected under 35 U.S.C. 103 as being unpatentable over Rayavarapu as applied to claim 11 and 15 above, and further in view of Kim et al. (US 2018/0213452).

25. **Regarding claim 17**, Rayavarapu discloses the claimed invention above but does not specifically disclose the following limitations found in Kim et al.: *wherein the resume response message is one of a RRCConnectionResume or a RRCResume* (Kim et al., Paragraph 0336, UE receives RRCConnectionResume message from eNB, the message including SRB setup information which the UE applies when resuming connection).

Therefore, it would have been obvious to one of ordinary skill in the art before the effective filing date of the claimed invention to modify the teachings of Rayavarapu with the teachings of Kim et al. in order to implement higher data rate communication (Kim et al., Abstract).

26. **Regarding claim 19**, Rayavarapu discloses the claimed invention above but does not specifically disclose the following limitations found in Kim et al.: *wherein the at least one processor is configured to generate the configuration parameters based on S1 and NG context which contains bearer information used during an initial context setup* (Kim et al., Paragraph 0337, reconfigured S1 bearer to new eNB; Paragraph 0326, next-generation mobile



communication system in which S1 bearer can be maintained in order to make the access more occur more rapidly with a small number of signaling procedures).

Therefore, it would have been obvious to one of ordinary skill in the art before the effective filing date of the claimed invention to modify the teachings of Rayavarapu with the teachings of Kim et al. in order to make the access more occur more rapidly with a small number of signaling procedures (Kim et al., Paragraph 0326).

### *Conclusion*

Applicant's amendment necessitated the new ground(s) of rejection presented in this Office action. Accordingly, **THIS ACTION IS MADE FINAL**. See MPEP § 706.07(a). Applicant is reminded of the extension of time policy as set forth in 37 CFR 1.136(a).

A shortened statutory period for reply to this final action is set to expire **THREE MONTHS** from the mailing date of this action. In the event a first reply is filed within **TWO MONTHS** of the mailing date of this final action and the advisory action is not mailed until after the end of the **THREE-MONTH** shortened statutory period, then the shortened statutory period will expire on the date the advisory action is mailed, and any extension fee pursuant to 37 CFR 1.136(a) will be calculated from the mailing date of the advisory action. In no event, however, will the statutory period for reply expire later than **SIX MONTHS** from the date of this final action.

Any inquiry concerning this communication or earlier communications from the examiner should be directed to OTIS L THOMPSON, JR whose telephone number is (571)270-1953. The examiner can normally be reached on Monday - Friday, 6:30am - 7:00pm.

Examiner interviews are available via telephone, in-person, and video conferencing using a USPTO supplied web-based collaboration tool. To schedule an interview, applicant is encouraged to use the USPTO Automated Interview Request (AIR) at <http://www.uspto.gov/interviewpractice>.

If attempts to reach the examiner by telephone are unsuccessful, the examiner's supervisor, Chirag G Shah can be reached on 571-272-3144. The fax phone number for the organization where this application or proceeding is assigned is 571-273-8300.

Information regarding the status of an application may be obtained from the Patent Application Information Retrieval (PAIR) system. Status information for published applications may be obtained from either Private PAIR or Public PAIR. Status information for unpublished applications is available through Private PAIR only. For more information about the PAIR system, see <http://pair-direct.uspto.gov>. Should you have questions on access to the Private PAIR system, contact the Electronic Business Center (EBC) at 866-217-9197 (toll-free). If you would like assistance from a USPTO Customer Service Representative or access to the automated information system, call 800-786-9199 (IN USA OR CANADA) or 571-272-1000.

/OTIS L THOMPSON, JR/  
Primary Examiner, Art Unit 2477

September 6, 2019

|                                   |                                       |                                                            |             |
|-----------------------------------|---------------------------------------|------------------------------------------------------------|-------------|
| <b>Notice of References Cited</b> | Application/Control No.<br>16/380,844 | Applicant(s)/Patent Under<br>Reexamination<br>TEYEB et al. |             |
|                                   | Examiner<br>OTIS L THOMPSON, JR       | Art Unit<br>2477                                           | Page 1 of 1 |

**U.S. PATENT DOCUMENTS**

| * |   | Document Number<br>Country Code-Number-Kind Code | Date<br>MM-YYYY | Name                 | CPC Classification | US Classification |
|---|---|--------------------------------------------------|-----------------|----------------------|--------------------|-------------------|
| * | A | US-20170311206-A1                                | 10-2017         | Ryoo; Sunheui        | H04W24/08          | 1/1               |
| * | B | US-20190053199-A1                                | 02-2019         | FUJISHIRO; Masato    | H04W72/04          | 1/1               |
| * | C | US-20190053102-A1                                | 02-2019         | OOHIRA; Mayo         | H04W8/06           | 1/1               |
| * | D | US-20180091968-A1                                | 03-2018         | LY; Hung             | H04L43/16          | 1/1               |
| * | E | US-20180270741-A1                                | 09-2018         | ENOMOTO; Masayuki    | H04W36/12          | 1/1               |
| * | F | US-20190215800-A1                                | 07-2019         | FUJISHIRO; Masato    | H04W8/08           | 1/1               |
| * | G | US-20190215887-A1                                | 07-2019         | Burbidge; Richard C. | H04W48/14          | 1/1               |
| * | H | US-20190254074-A1                                | 08-2019         | Jeon; Hyongsuk       | H04W36/0069        | 1/1               |
| * | I | US-20190124572-A1                                | 04-2019         | Park; Kyungmin       | H04W76/27          | 1/1               |
|   | J |                                                  |                 |                      |                    |                   |
|   | K |                                                  |                 |                      |                    |                   |
|   | L |                                                  |                 |                      |                    |                   |
|   | M |                                                  |                 |                      |                    |                   |

**FOREIGN PATENT DOCUMENTS**

| * |   | Document Number<br>Country Code-Number-Kind Code | Date<br>MM-YYYY | Country | Name | CPC Classification |
|---|---|--------------------------------------------------|-----------------|---------|------|--------------------|
|   | N |                                                  |                 |         |      |                    |
|   | O |                                                  |                 |         |      |                    |
|   | P |                                                  |                 |         |      |                    |
|   | Q |                                                  |                 |         |      |                    |
|   | R |                                                  |                 |         |      |                    |
|   | S |                                                  |                 |         |      |                    |
|   | T |                                                  |                 |         |      |                    |

**NON-PATENT DOCUMENTS**

| * |   | Include as applicable: Author, Title Date, Publisher, Edition or Volume, Pertinent Pages) |
|---|---|-------------------------------------------------------------------------------------------|
|   | U |                                                                                           |
|   | V |                                                                                           |
|   | W |                                                                                           |
|   | X |                                                                                           |

\*A copy of this reference is not being furnished with this Office action. (See MPEP § 707.05(a).)  
Dates in MM-YYYY format are publication dates. Classifications may be US or foreign.



|                                                                                                                 |                                              |                                                                |
|-----------------------------------------------------------------------------------------------------------------|----------------------------------------------|----------------------------------------------------------------|
| <b><i>Search Notes</i></b><br> | <b>Application/Control No.</b><br>16/380,844 | <b>Applicant(s)/Patent Under Reexamination</b><br>TEYEB et al. |
|                                                                                                                 | <b>Examiner</b><br>OTIS L THOMPSON, JR       | <b>Art Unit</b><br>2477                                        |

|                        |             |                 |
|------------------------|-------------|-----------------|
| <b>CPC - Searched*</b> |             |                 |
| <b>Symbol</b>          | <b>Date</b> | <b>Examiner</b> |
|                        |             |                 |

|                                         |             |                 |
|-----------------------------------------|-------------|-----------------|
| <b>CPC Combination Sets - Searched*</b> |             |                 |
| <b>Symbol</b>                           | <b>Date</b> | <b>Examiner</b> |
| H04W76 with text in EAST                | 05/28/2019  | OT              |

|                                      |                 |             |                 |
|--------------------------------------|-----------------|-------------|-----------------|
| <b>US Classification - Searched*</b> |                 |             |                 |
| <b>Class</b>                         | <b>Subclass</b> | <b>Date</b> | <b>Examiner</b> |
|                                      |                 |             |                 |

\* See search history printout included with this form or the SEARCH NOTES box below to determine the scope of the search.

|                                                                        |             |                 |
|------------------------------------------------------------------------|-------------|-----------------|
| <b>Search Notes</b>                                                    |             |                 |
| <b>Search Notes</b>                                                    | <b>Date</b> | <b>Examiner</b> |
| EAST Text Search                                                       | 05/24/2019  | OT              |
| EAST Text Search                                                       | 05/25/2019  | OT              |
| EAST Text Search                                                       | 05/28/2019  | OT              |
| Double patenting search                                                | 05/28/2019  | OT              |
| NPL search (Google: rrcconnectionresume/rrcresume, full configuration) | 05/28/2019  | OT              |
| EAST text search                                                       | 09/06/2019  | OT              |

|                            |                              |             |                 |
|----------------------------|------------------------------|-------------|-----------------|
| <b>Interference Search</b> |                              |             |                 |
| <b>US Class/CPC Symbol</b> | <b>US Subclass/CPC Group</b> | <b>Date</b> | <b>Examiner</b> |
|                            |                              |             |                 |

|                                                          |  |
|----------------------------------------------------------|--|
| /OTIS L THOMPSON, JR/<br>Primary Examiner, Art Unit 2477 |  |
|----------------------------------------------------------|--|

## EAST Search History

## EAST Search History (Prior Art)

| Ref # | Hits | Search Query                                                                                                                          | DBs                                                                  | Default Operator | Plurals | Time Stamp          |
|-------|------|---------------------------------------------------------------------------------------------------------------------------------------|----------------------------------------------------------------------|------------------|---------|---------------------|
| S42   | 427  | RRCConnectionReconfiguration with (without or necessary or need\$3)                                                                   | US-PGPUB;<br>USPAT; USOCR;<br>FPRS; EPO; JPO;<br>DERWENT;<br>IBM_TDB | ADJ              | ON      | 2019/09/05<br>14:48 |
| S45   | 35   | RRCConnectionReconfiguration near2 (without or necessary or need\$3) same (fullconfig or full config or full config\$7)               | US-PGPUB;<br>USPAT; USOCR;<br>FPRS; EPO; JPO;<br>DERWENT;<br>IBM_TDB | ADJ              | ON      | 2019/09/05<br>14:49 |
| S44   | 0    | RRCConnectionReconfiguration near2 (without or necessary or need\$3) same (fullconfig or full config or full config\$7)               | US-PGPUB;<br>USPAT; USOCR;<br>FPRS; EPO; JPO;<br>DERWENT;<br>IBM_TDB | ADJ              | ON      | 2019/09/05<br>14:49 |
| S43   | 178  | RRCConnectionReconfiguration near2 (without or necessary or need\$3)                                                                  | US-PGPUB;<br>USPAT; USOCR;<br>FPRS; EPO; JPO;<br>DERWENT;<br>IBM_TDB | ADJ              | ON      | 2019/09/05<br>14:49 |
| L1    | 28   | reconfig\$7 near2 (without or necessary or need\$3) same (fullconfig or full config or full config\$7)                                | US-PGPUB;<br>USPAT; USOCR;<br>FPRS; EPO; JPO;<br>DERWENT;<br>IBM_TDB | ADJ              | ON      | 2019/09/06<br>13:20 |
| L2    | 352  | (rrcconnectionreconfig\$7 or rrc connect\$3 reconfig\$7) near2 (without or necessary or need\$3)                                      | US-PGPUB;<br>USPAT; USOCR;<br>FPRS; EPO; JPO;<br>DERWENT;<br>IBM_TDB | ADJ              | ON      | 2019/09/06<br>13:25 |
| L3    | 6    | (rrcconnectionreconfig\$7 or rrc connect\$3 reconfig\$7) near2 (without or necessary or need\$3) same resum\$5                        | US-PGPUB;<br>USPAT; USOCR;<br>FPRS; EPO; JPO;<br>DERWENT;<br>IBM_TDB | ADJ              | ON      | 2019/09/06<br>13:39 |
| L4    | 19   | (rrcconnectionreconfig\$7 or rrc connect\$3 reconfig\$7) same (fullconfig or full config or full config\$7) same resum\$5             | US-PGPUB;<br>USPAT; USOCR;<br>FPRS; EPO; JPO;<br>DERWENT;<br>IBM_TDB | ADJ              | ON      | 2019/09/06<br>13:44 |
| L5    | 4    | (rrcconnectionresume or rrcresume or rrcconnectionresume or rrc connection resume) same (fullconfig or full config or full config\$7) | US-PGPUB;<br>USPAT; USOCR;<br>FPRS; EPO; JPO;<br>DERWENT;<br>IBM_TDB | ADJ              | ON      | 2019/09/06<br>13:47 |
| L6    | 6768 | rrc near2 (reestablish\$4 or re establish\$4)                                                                                         | US-PGPUB;<br>USPAT; USOCR;<br>FPRS; EPO; JPO;<br>DERWENT;<br>IBM_TDB | ADJ              | ON      | 2019/09/06<br>14:09 |

EAST Search History

|    |      |                                                                                             |                                                                      |     |    |                     |
|----|------|---------------------------------------------------------------------------------------------|----------------------------------------------------------------------|-----|----|---------------------|
| L8 | 6986 | l6 or 7 or (rrconnectionresume or rrcresume or rrconnectionresume or rrc connection resume) | US-PGPUB;<br>USPAT; USOCR;<br>FPRS; EPO; JPO;<br>DERWENT;<br>IBM_TDB | ADJ | ON | 2019/09/06<br>14:10 |
| L7 | 4    | rrcreestablish\$4                                                                           | US-PGPUB;<br>USPAT; USOCR;<br>FPRS; EPO; JPO;<br>DERWENT;<br>IBM_TDB | ADJ | ON | 2019/09/06<br>14:10 |
| L9 | 95   | l8 same (full config\$7 or fullconfig\$7)                                                   | US-PGPUB;<br>USPAT; USOCR;<br>FPRS; EPO; JPO;<br>DERWENT;<br>IBM_TDB | ADJ | ON | 2019/09/06<br>14:11 |

**EAST Search History (Interference)**

< This search history is empty >

**9/ 6/ 2019 3:33:05 PM**

**C:\Users\othompson1\Documents\EAST\Workspaces\16-380844.wsp**

**IN THE UNITED STATES PATENT AND TRADEMARK OFFICE**

In re: Application of: TEYEB Oumer et al.  
Serial No.: 16/380,844  
Application Filed: April 10, 2019  
Title: METHODS AND UE FOR RESUMING A CONNECTION WITH FULL CONFIGURATION  
Examiner: Thompson JR. Otis L.  
Attorney Ref: P74267 US2

Commissioner for Patents  
United States Patent and Trade Mark Office  
Customer Service Window  
**MAILSTOP AMENDMENT**  
P.O. Box 1450  
Alexandria, VA 22313-1450  
USA

|                                                                                                                                                                                                                                                                                                        |
|--------------------------------------------------------------------------------------------------------------------------------------------------------------------------------------------------------------------------------------------------------------------------------------------------------|
| CERTIFICATE OF MAILING OR TRANSMISSION [37 CFR 1.8(A)]<br><br>I hereby certify that this correspondence is being electronically transmitted via EFS Web to the United States Patent and Trademark Office<br><br>On: ...2019-08-27.....by:...Lala Deleon.....<br><br>.../Lala Deleon/.....<br>Signature |
|--------------------------------------------------------------------------------------------------------------------------------------------------------------------------------------------------------------------------------------------------------------------------------------------------------|

Dear Sir:

**AMENDMENTS AND RESPONSE TO OFFICE ACTION**

This is in response to the Office Action dated May 31, 2019. Please amend the above-identified application as follows:

**Amendments to the Claims** begin on page 2 of this paper.

**Remarks and arguments** begin on page 5 of this paper.

The Commissioner is hereby authorized to charge any additional fee to Deposit Account No. 501379.



## **Amendments to the Claims**

This listing of claims will replace all prior version, and listings, of claims in the application:

### **Listing of Claims:**

1. (Currently amended) A method in a wireless device, the method comprising:
  - sending to a network node a request to resume a connection in a communication network;
  - receiving a resume message from the network node, the message comprising an indication to perform a full configuration; and
  - applying the full configuration, without receiving a reconfiguration message.
2. (Original) The method of claim 1, further comprising discarding an old bearer configuration and old radio parameters.
3. (Original) The method of claim 1, further comprising keeping security keys.
4. (Original) The method of claim 1, further comprising receiving a configuration.
5. (Original) The method of claim 4, further comprising applying the received configuration.
6. (Currently amended) A wireless device, comprising a communication interface; and one or more processing circuits communicatively connected to the communication interface, the one or more processing circuits comprising at least one processor and memory, the memory containing instructions that, when executed, cause the at least one processor to:
  - send to a network node a request to resume a connection in a communication network;
  - receive a resume response message from the network node, the message comprising an indication to perform a full configuration; and
  - apply the full configuration, without receiving a reconfiguration message.
7. (Original) The wireless device of claim 6, wherein the at least one processor is configured to discard an old bearer configuration and old radio parameters.

8. (Original) The wireless device of claim 6, wherein the at least one processor is configured to keep security keys.
9. (Original) The wireless device of claim 6, wherein the at least one processor is configured to receive a configuration.
10. (Original) The wireless device of claim 9, wherein the at least one processor is configured to apply the received configuration.
11. (Original) A network node comprising:
  - a communication interface; and
  - one or more processing circuits communicatively connected to the communication interface, the one or more processing circuits comprising at least one processors and memory, the memory containing instructions that, when executed, cause the at least one processor to:
    - receive, from a wireless device, a request to resume a connection in a communication network;
    - send a resume response message to the wireless device, the message comprising an indication to perform a full configuration.
12. (Original) The network node of claim 11, wherein the indication comprises a flag.
13. (Original) The network node of claim 11, wherein the network node has a different radio access technology than a previous network node which suspended a previous connection for the wireless device.
14. (Original) The network node of claim 11, wherein the at least one processor is configured to retrieve configuration information for the wireless device.
15. (Original) The network node of claim 11, wherein the message further comprises configuration parameters.
16. (Original) The network node of claim 15, wherein the indication comprises an indication to perform a full configuration using the configuration parameters.
17. (Original) The network node of claim 11, wherein the resume response message is one of a *RRCConnectionResume* and a *RRCResume*.

18. (Original) The network node of claim 15, wherein the at least one processor is configured to generate the configuration parameters by generating a new User Equipment (UE) Access Stratum (AS) context.
19. (Original) The network node of claim 15, wherein the at least one processor is configured to generate the configuration parameters based on S1 and Next Generation (NG) context which contains bearer information used during an initial context setup.
20. (Original) The network node of claim 15, wherein the configuration parameters comprise one or more of bearer configuration, Packet Data Convergence Protocol (PDCP) configuration and Radio Link Control (RLC) configuration.

## **Remarks**

### *Claims Status*

Claims 1-20 are currently pending.

Claims 1 and 6 are currently amended.

Claims 2- 5, 7-20 are original.

### *Claim Rejections – 35 USC § 102*

Claims 1, 2, 4-7, 9-16, 18 and 20 are rejected under 35 U.S.C. 102(a)(1) as being anticipated by Rayavarapy et al. (US 2013/0260811).

The Applicant respectfully disagrees.

Claim 1 has been amended in order to clarify that there is no need for the wireless device to receive a reconfiguration message for performing a full configuration.

First, the Applicant would like to explain the full configuration procedure in the current systems. In the current systems, including the embodiments in Rayavarapy et al., the full configuration is available only in the *RRCConnectionReconfiguration* message with the *fullConfig* flag set. The full configuration it is not available for other radio messages such as re-establishment and resume. In the case of the re-establishment procedure, the re-establishment procedure is always followed by an *RRCConnectionReconfiguration* procedure, and as such the full configuration is performed by the *RRCConnectionReconfiguration* procedure.

One of the main aims of the resume procedure is to transit the User Equipment (UE) to the connected mode as fast as possible (with as little signaling as possible), reusing the saved configuration of the UE when it got suspended, for example. Therefore, an additional *RRCConnectionReconfiguration* procedure is not desired (see paragraph [0089] of the application as filed).

Furthermore, in order to be able to perform a full reconfiguration, the UE needs (new) security keys in order to receive encrypted configuration information.

It can be seen that what is described in Rayavarapy et al. is basically applying the same principle that is used in the legacy/current re-establishment procedure for the resume case as explained above (i.e. resume the connection and then send an RRC reconfiguration message with a full config flag to do the full configuration).

For example, in Figure 28 of Rayavarapy et al., paragraphs [0576-0577] describe that a new security key is communicated in the re-establishment command sent to the UE, and then the UE uses that key to derive new security key (see steps 7 and 8). As such, it is only in the first reconfiguration message after that (i.e. message 10) that the full configuration can be indicated, since it is only at this point that the RRC message can be encrypted.

In Figure 29, even though they mention “full config” when describing step 15, the security mode command is sent in step 16 and then a reconfiguration message is sent in step 17. Therefore, the full configuration cannot be sent before the UE has received the security mode command and has derived the new keys. The difference between Figures 28 and 29 is that in Figure 28, the UE receives a re-establishment message that directly resumes the connection, while in Figure 29, even though the name “RRC re-establishment request” is used to initiate the procedure, most of the actions taken are very similar to the setting up of a new connection from IDLE (i.e. as if the UE is coming from the IDLE mode using the RRC connection setup request, followed by a security mode command, followed by a RRC reconfiguration message).

It is only in Release 15 (in 2017) that it was agreed to send the Next Hop Chaining Count (NCC) parameter on suspending a connection, so that the UE is able to derive the new security keys during the resume procedure and as such the UE can receive an encrypted RRC Resume message (see paragraph [0065] of the application as filed). Thus, at the time the application of Rayavarapy et al. was filed, the only way the full configuration could be achieved was via an RRC reconfiguration after the connection was resumed.

In contrast, claim 1 recites receiving a resume message that comprises an indication to perform a full configuration. Since the UE has already the NCC, the UE can receive an encrypted resume message comprising an indication to perform a full configuration. As such, there is no need for the UE to wait to receive a RRC reconfiguration message, after resuming the connection.

Therefore, at least for the above reasons, Rayavarapy et al. fail to disclose the features of claim 1. Indeed, Rayavarapy et al. fail to disclose a resume message and at least the steps of “*receiving a resume message from the network node, the message comprising an indication to perform a full configuration*” and “*applying the full configuration, without receiving a reconfiguration message*”.

Accordingly, it is respectfully submitted that claim 1 is patentable over Rayavarapy et al.

Claim 6 has been amended in a similar was as in claim 1. As such, amended claim 6 contains similar limitations as amended claim 1. Claim 11 has also similar limitations as claim 1. As such, the above discussion with regards to amended claim 1 equally applies to amended claim 6 and claim 11. Therefore, claims 6 and 11 are submitted to be also patentable over Rayavarapy et al.

Claims 2, 4-5 and 7, 9-10 and 12-16, 18 and 20 are submitted to be patentable over Rayavarapy et al., at least by virtue of their dependency from claims 1, 6 and 11 respectively (which are submitted to be patentable over over Rayavarapy et al.).

### ***Claim Rejections – 35 USC § 103***

Claims 3 and 8 are rejected under 35 U.S.C. 103 as being unpatentable over Rayavarapy et al. as applied to claims 1 and 6 and further in view of Guo et al. (US 2019/0037635).

Guo et al. disclose methods and apparatuses for recovering a Radio Resource Control (RRC) connection in a wireless communication system. In one method, a user equipment (UE) performs a procedure used to re-establish a RRC connection between the UE and a network node. The UE enters a RRC\_INACTIVE state when the procedure is failed and if the UE has at least one parameter of the RRC\_INACTIVE state. The UE enters a RRC\_IDLE state when the procedure is failed and if the UE does not have the at least one parameter of the RRC\_INACTIVE state. (see the abstract of Guo et al.)

It is respectfully submitted that Guo et al. fail to disclose the features of claims 1 and 6. As such, when combined with Rayavarapy et al., the combination still fails to cure the deficiencies left by Rayavarapy et al. Therefore, Rayavarapy et al. and Guo et al., either separately or in

combination, fail to disclose the features of claims 1 and 6. Accordingly, claims 1 and 6 are submitted to be patentable over Rayavarapy et al. in view of Guo et al.

Claims 3 and 8 are submitted to be also patentable over Rayavarapy et al. in view of Guo et al., at least by virtue of their dependency from claims 1 and 6 respectively.

Claims 17 and 19 are rejected under 35 U.S.C. 103 as being unpatentable over Rayavarapy et al. as applied to claim 11 and further in view of Kim et al. (US 2018/0213452).

Kim relates to a communication method and system for converging a 5<sup>th</sup>-Generation (5G) communication system for supporting higher data rates beyond a 4<sup>th</sup>-Generation (4G) system with a technology for IoT, which may be applied to intelligent services based on the 5G communication technology and the IoT-related technology, e.g., smart home, smart building, smart city, smart car, connected car, health care, digital education, smart retail, security and safety services. A method by a terminal in a wireless communication system is provided, and includes receiving, from a base station, a paging message for switching a mode of the terminal in an RRC inactive mode to an RRC idle mode, transmitting an RRC message to the base station based on the paging message, receiving an RRC-connection release message (CRR) from the base station, and transitioning from the RRC inactive mode to the RRC idle mode based on the RRC-CRR (see the abstract of Kim et al.).

It is respectfully submitted that Kim et al. fail to disclose the features of claim 11, as Kim et al. are not concerned at all with the full configuration. As such, when combined with Rayavarapy et al., the combination still fails to cure the deficiencies left by Rayavarapy et al. Therefore, Rayavarapy et al. and Kim et al., either separately or in combination, fail to disclose the features of claim 11. Accordingly, claim 11 is submitted to be patentable over Rayavarapy et al. in view of Kim et al.

Claims 17 and 19 are submitted to be also patentable over Rayavarapy et al. in view of Kim et al., at least by virtue of their dependency from claim 11.

***Conclusion***

Applicant submits that the within application is now in condition for allowance and accordingly, earnestly solicits reconsideration and action to that end, and requests that a timely Notice of Allowance be issued in this case.

Should the Examiner believe, however, that additional amendments to the claim may be required to secure allowance of the within application, the Examiner is invited to telephone or email the undersigned at the below-noted coordinates to facilitate further prosecution of the within application.

Respectfully submitted,

/BrentCapehart/

Brent Capehart

Registration No. 39620

Brent.Capehart@ericsson.com

Phone: +16134079700

Dated: 2019-08-27



## Electronic Acknowledgement Receipt

|                                             |                                                                  |
|---------------------------------------------|------------------------------------------------------------------|
| <b>EFS ID:</b>                              | 36994751                                                         |
| <b>Application Number:</b>                  | 16380844                                                         |
| <b>International Application Number:</b>    |                                                                  |
| <b>Confirmation Number:</b>                 | 8653                                                             |
| <b>Title of Invention:</b>                  | METHODS AND UE FOR RESUMING A CONNECTION WITH FULL CONFIGURATION |
| <b>First Named Inventor/Applicant Name:</b> | Oumer TEYEB                                                      |
| <b>Customer Number:</b>                     | 27045                                                            |
| <b>Filer:</b>                               | Brian Michael Kearns/Lala Deleon                                 |
| <b>Filer Authorized By:</b>                 | Brian Michael Kearns                                             |
| <b>Attorney Docket Number:</b>              | P74267 US2                                                       |
| <b>Receipt Date:</b>                        | 27-AUG-2019                                                      |
| <b>Filing Date:</b>                         | 10-APR-2019                                                      |
| <b>Time Stamp:</b>                          | 16:52:10                                                         |
| <b>Application Type:</b>                    | Utility under 35 USC 111(a)                                      |

### Payment information:

|                        |    |
|------------------------|----|
| Submitted with Payment | no |
|------------------------|----|

### File Listing:

| Document Number | Document Description | File Name                                   | File Size(Bytes)/<br>Message Digest                        | Multi Part /.zip | Pages (if appl.) |
|-----------------|----------------------|---------------------------------------------|------------------------------------------------------------|------------------|------------------|
| 1               |                      | P74267US2_2019-08-27_Resp<br>onse_to_OA.pdf | 162208<br><br>9ca55fcc5d6e736045f4ff84084688cff26ab4<br>93 | yes              | 9                |

| <b>Multipart Description/PDF files in .zip description</b> |              |            |
|------------------------------------------------------------|--------------|------------|
| <b>Document Description</b>                                | <b>Start</b> | <b>End</b> |
| Amendment/Req. Reconsideration-After Non-Final Reject      | 1            | 1          |
| Claims                                                     | 2            | 4          |
| Applicant Arguments/Remarks Made in an Amendment           | 5            | 9          |

**Warnings:**

**Information:**

|                                     |        |
|-------------------------------------|--------|
| <b>Total Files Size (in bytes):</b> | 162208 |
|-------------------------------------|--------|

This Acknowledgement Receipt evidences receipt on the noted date by the USPTO of the indicated documents, characterized by the applicant, and including page counts, where applicable. It serves as evidence of receipt similar to a Post Card, as described in MPEP 503.

**New Applications Under 35 U.S.C. 111**

If a new application is being filed and the application includes the necessary components for a filing date (see 37 CFR 1.53(b)-(d) and MPEP 506), a Filing Receipt (37 CFR 1.54) will be issued in due course and the date shown on this Acknowledgement Receipt will establish the filing date of the application.

**National Stage of an International Application under 35 U.S.C. 371**

If a timely submission to enter the national stage of an international application is compliant with the conditions of 35 U.S.C. 371 and other applicable requirements a Form PCT/DO/EO/903 indicating acceptance of the application as a national stage submission under 35 U.S.C. 371 will be issued in addition to the Filing Receipt, in due course.

**New International Application Filed with the USPTO as a Receiving Office**

If a new international application is being filed and the international application includes the necessary components for an international filing date (see PCT Article 11 and MPEP 1810), a Notification of the International Application Number and of the International Filing Date (Form PCT/RO/105) will be issued in due course, subject to prescriptions concerning national security, and the date shown on this Acknowledgement Receipt will establish the international filing date of the application.

|                                                                                                                                 |                                                                                                                                                                                                                               |                                            |                                    |                           |                                       |                     |
|---------------------------------------------------------------------------------------------------------------------------------|-------------------------------------------------------------------------------------------------------------------------------------------------------------------------------------------------------------------------------|--------------------------------------------|------------------------------------|---------------------------|---------------------------------------|---------------------|
| <b>PATENT APPLICATION FEE DETERMINATION RECORD</b><br>Substitute for Form PTO-875                                               |                                                                                                                                                                                                                               | Application or Docket Number<br>16/380,844 |                                    | Filing Date<br>04/10/2019 | <input type="checkbox"/> To be Mailed |                     |
| ENTITY: <input checked="" type="checkbox"/> LARGE <input type="checkbox"/> SMALL <input type="checkbox"/> MICRO                 |                                                                                                                                                                                                                               |                                            |                                    |                           |                                       |                     |
| <b>APPLICATION AS FILED - PART I</b>                                                                                            |                                                                                                                                                                                                                               |                                            |                                    |                           |                                       |                     |
|                                                                                                                                 | (Column 1)                                                                                                                                                                                                                    | (Column 2)                                 |                                    |                           |                                       |                     |
| FOR                                                                                                                             | NUMBER FILED                                                                                                                                                                                                                  | NUMBER EXTRA                               | RATE (\$)                          | FEE (\$)                  |                                       |                     |
| <input type="checkbox"/> BASIC FEE<br><small>(37 CFR 1.16(a), (b), or (c))</small>                                              | N/A                                                                                                                                                                                                                           | N/A                                        | N/A                                |                           |                                       |                     |
| <input type="checkbox"/> SEARCH FEE<br><small>(37 CFR 1.16(k), (l), or (m))</small>                                             | N/A                                                                                                                                                                                                                           | N/A                                        | N/A                                |                           |                                       |                     |
| <input type="checkbox"/> EXAMINATION FEE<br><small>(37 CFR 1.16(o), (p), or (q))</small>                                        | N/A                                                                                                                                                                                                                           | N/A                                        | N/A                                |                           |                                       |                     |
| TOTAL CLAIMS<br><small>(37 CFR 1.16(j))</small>                                                                                 | minus 20 =                                                                                                                                                                                                                    | *                                          | x \$100 =                          |                           |                                       |                     |
| INDEPENDENT CLAIMS<br><small>(37 CFR 1.16(h))</small>                                                                           | minus 3 =                                                                                                                                                                                                                     | *                                          | x \$460 =                          |                           |                                       |                     |
| <input type="checkbox"/> APPLICATION SIZE FEE (37 CFR 1.16(s))                                                                  | If the specification and drawings exceed 100 sheets of paper, the application size fee due is \$310 (\$155 for small entity) for each additional 50 sheets or fraction thereof. See 35 U.S.C. 41(a)(1)(G) and 37 CFR 1.16(s). |                                            |                                    |                           |                                       |                     |
| <input type="checkbox"/> MULTIPLE DEPENDENT CLAIM PRESENT (37 CFR 1.16(j))                                                      |                                                                                                                                                                                                                               |                                            |                                    |                           |                                       |                     |
| * If the difference in column 1 is less than zero, enter "0" in column 2.                                                       |                                                                                                                                                                                                                               |                                            |                                    | TOTAL                     |                                       |                     |
| <b>APPLICATION AS AMENDED - PART II</b>                                                                                         |                                                                                                                                                                                                                               |                                            |                                    |                           |                                       |                     |
|                                                                                                                                 | (Column 1)                                                                                                                                                                                                                    | (Column 2)                                 | (Column 3)                         |                           |                                       |                     |
| AMENDMENT                                                                                                                       | 08/27/2019                                                                                                                                                                                                                    | CLAIMS REMAINING AFTER AMENDMENT           | HIGHEST NUMBER PREVIOUSLY PAID FOR | PRESENT EXTRA             | RATE (\$)                             | ADDITIONAL FEE (\$) |
|                                                                                                                                 | Total<br><small>(37 CFR 1.16(i))</small>                                                                                                                                                                                      | * 20                                       | Minus                              | ** 20                     | = 0                                   | x \$100 = 0         |
|                                                                                                                                 | Independent<br><small>(37 CFR 1.16(h))</small>                                                                                                                                                                                | * 3                                        | Minus                              | *** 3                     | = 0                                   | x \$460 = 0         |
|                                                                                                                                 | <input type="checkbox"/> Application Size Fee (37 CFR 1.16(s))                                                                                                                                                                |                                            |                                    |                           |                                       |                     |
|                                                                                                                                 | <input type="checkbox"/> FIRST PRESENTATION OF MULTIPLE DEPENDENT CLAIM (37 CFR 1.16(j))                                                                                                                                      |                                            |                                    |                           |                                       |                     |
|                                                                                                                                 |                                                                                                                                                                                                                               |                                            |                                    |                           | TOTAL ADD'L FEE                       | 0                   |
| AMENDMENT                                                                                                                       |                                                                                                                                                                                                                               | CLAIMS REMAINING AFTER AMENDMENT           | HIGHEST NUMBER PREVIOUSLY PAID FOR | PRESENT EXTRA             | RATE (\$)                             | ADDITIONAL FEE (\$) |
|                                                                                                                                 | Total<br><small>(37 CFR 1.16(i))</small>                                                                                                                                                                                      | *                                          | Minus                              | **                        | =                                     | x \$0 =             |
|                                                                                                                                 | Independent<br><small>(37 CFR 1.16(h))</small>                                                                                                                                                                                | *                                          | Minus                              | ***                       | =                                     | x \$0 =             |
|                                                                                                                                 | <input type="checkbox"/> Application Size Fee (37 CFR 1.16(s))                                                                                                                                                                |                                            |                                    |                           |                                       |                     |
|                                                                                                                                 | <input type="checkbox"/> FIRST PRESENTATION OF MULTIPLE DEPENDENT CLAIM (37 CFR 1.16(j))                                                                                                                                      |                                            |                                    |                           |                                       |                     |
|                                                                                                                                 |                                                                                                                                                                                                                               |                                            |                                    |                           | TOTAL ADD'L FEE                       | 0                   |
| * If the entry in column 1 is less than the entry in column 2, write "0" in column 3.                                           |                                                                                                                                                                                                                               |                                            |                                    |                           | LIE                                   |                     |
| ** If the "Highest Number Previously Paid For" IN THIS SPACE is less than 20, enter "20".                                       |                                                                                                                                                                                                                               |                                            |                                    |                           | /STEFANIE A BRYCE/                    |                     |
| *** If the "Highest Number Previously Paid For" IN THIS SPACE is less than 3, enter "3".                                        |                                                                                                                                                                                                                               |                                            |                                    |                           |                                       |                     |
| The "Highest Number Previously Paid For" (Total or Independent) is the highest number found in the appropriate box in column 1. |                                                                                                                                                                                                                               |                                            |                                    |                           |                                       |                     |

This collection of information is required by 37 CFR 1.16. The information is required to obtain or retain a benefit by the public which is to file (and by the USPTO to process) an application. Confidentiality is governed by 35 U.S.C. 122 and 37 CFR 1.14. This collection is estimated to take 12 minutes to complete, including gathering, preparing, and submitting the completed application form to the USPTO. Time will vary depending upon the individual case. Any comments on the amount of time you require to complete this form and/or suggestions for reducing this burden, should be sent to the Chief Information Officer, U.S. Patent and Trademark Office, U.S. Department of Commerce, P.O. Box 1450, Alexandria, VA 22313-1450. DO NOT SEND FEES OR COMPLETED FORMS TO THIS ADDRESS. **SEND TO: Commissioner for Patents, P.O. Box 1450, Alexandria, VA 22313-1450.**

*If you need assistance in completing the form, call 1-800-PTO-9199 and select option 2.*



UNITED STATES PATENT AND TRADEMARK OFFICE

UNITED STATES DEPARTMENT OF COMMERCE
United States Patent and Trademark Office
Address: COMMISSIONER FOR PATENTS
P.O. Box 1450
Alexandria, Virginia 22313-1450
www.uspto.gov

Table with 4 columns: APPLICATION NUMBER (16/380,844), FILING OR 371(C) DATE (04/10/2019), FIRST NAMED APPLICANT (Oumer TEYEB), ATTY. DOCKET NO./TITLE (P74267 US2)

CONFIRMATION NO. 8653

27045
ERICSSON INC.
6300 LEGACY DRIVE
M/S EVR 1-C-11
PLANO, TX 75024

PUBLICATION NOTICE



Title:METHODS AND UE FOR RESUMING A CONNECTION WITH FULL CONFIGURATION

Publication No.US-2019-0254102-A1

Publication Date:08/15/2019

NOTICE OF PUBLICATION OF APPLICATION

The above-identified application will be electronically published as a patent application publication pursuant to 37 CFR 1.211, et seq. The patent application publication number and publication date are set forth above.

The publication may be accessed through the USPTO's publically available Searchable Databases via the Internet at www.uspto.gov. The direct link to access the publication is currently http://www.uspto.gov/patft/.

The publication process established by the Office does not provide for mailing a copy of the publication to applicant. A copy of the publication may be obtained from the Office upon payment of the appropriate fee set forth in 37 CFR 1.19(a)(1). Orders for copies of patent application publications are handled by the USPTO's Public Records Division. The Public Records Division can be reached by telephone at (571) 272-3150 or (800) 972-6382, by facsimile at (571) 273-3250, by mail addressed to the United States Patent and Trademark Office, Public Records Division, Alexandria, VA 22313-1450 or via the Internet.

In addition, information on the status of the application, including the mailing date of Office actions and the dates of receipt of correspondence filed in the Office, may also be accessed via the Internet through the Patent Electronic Business Center at www.uspto.gov using the public side of the Patent Application Information and Retrieval (PAIR) system. The direct link to access this status information is currently https://portal.uspto.gov/pair/PublicPair. Prior to publication, such status information is confidential and may only be obtained by applicant using the private side of PAIR.

Further assistance in electronically accessing the publication, or about PAIR, is available by calling the Patent Electronic Business Center at 1-866-217-9197.

Office of Data Management, Application Assistance Unit (571) 272-4000, or (571) 272-4200, or 1-888-786-0101



UNITED STATES PATENT AND TRADEMARK OFFICE

UNITED STATES DEPARTMENT OF COMMERCE
United States Patent and Trademark Office
Address: COMMISSIONER FOR PATENTS
P.O. Box 1450
Alexandria, Virginia 22313-1450
www.uspto.gov

Table with columns: APPLICATION NO., FILING DATE, FIRST NAMED INVENTOR, ATTORNEY DOCKET NO., CONFIRMATION NO.
Row 1: 16/380,844, 04/10/2019, Oumer TEYEB, P74267 US2, 8653
Row 2: 27045, 7590, 05/31/2019, ERICSSON INC., 6300 LEGACY DRIVE, M/S EVR 1-C-11, PLANO, TX 75024, EXAMINER THOMPSON, JR, OTIS L, ART UNIT 2477, PAPER NUMBER, NOTIFICATION DATE 05/31/2019, DELIVERY MODE ELECTRONIC

Please find below and/or attached an Office communication concerning this application or proceeding.

The time period for reply, if any, is set in the attached communication.

Notice of the Office communication was sent electronically on above-indicated "Notification Date" to the following e-mail address(es):

michelle.sanderson@ericsson.com
pam.ewing@ericsson.com



## DETAILED ACTION

### *Notice of Pre-AIA or AIA Status*

1. The present application, filed on or after March 16, 2013, is being examined under the first inventor to file provisions of the AIA.

### *Claim Rejections - 35 USC § 102*

2. The following is a quotation of the appropriate paragraphs of 35 U.S.C. 102 that form the basis for the rejections under this section made in this Office action:

A person shall be entitled to a patent unless –

(a)(1) the claimed invention was patented, described in a printed publication, or in public use, on sale or otherwise available to the public before the effective filing date of the claimed invention.

3. Claim(s) 1, 2, 4-7, 9-16, 18 and 20 is/are rejected under 35 U.S.C. 102(a)(1) as being anticipated by Rayavarapu (US 2013/0260811).
4. **Regarding claim 1**, Rayavarapu discloses *a method in a wireless device* (Figure 29, UE 101), *the method comprising*:
  - a. *Sending to a network node a request to resume a connection in a communication network* (Paragraphs 0590, 0594 and figure 29 step 3, UE 101 sends RRC reestablishment request to eNB 102b [network node] to reactivate a suspended RRC connection; Step 7, UE 101 transmits RRC connection request message to eNB 102b, the message identifying the setup cause as resume);
  - b. *Receiving a resume message from the network node, the message comprising an indication to perform a full configuration* (Paragraph 0602-0603 and figure 29 step 17, eNB 102b sends RRC connection reconfiguration message [resume message] to UE 101.

- eNB 102b may also instruct the UE to throw away the suspended configuration and adopt a new configuration by setting the ‘full config’ IE); *and*
- c. *Applying the full configuration* (Paragraph 0602-0603, UE 101 adopts new configuration indicated by ‘full config’ IE from eNB 102b by reactivating SRB2 and other DRBs).
5. **Regarding claim 2**, Rayavarapu discloses *discarding an old bearer configuration and old parameters* (Paragraph 0602, UE 101 throws away suspended configuration, which comprises bearers such as SRB2 and other DRBs, at eNB 102b’s instruction to do so).
6. **Regarding claim 4**, Rayavarapu discloses *receiving a configuration* (Paragraph 0587-0602-0603, UE 101 receives ‘full config’ IE from eNB 102b).
7. **Regarding claim 5**, Rayavarapu discloses *applying the received configuration* (Paragraph 0602, UE 101 adopts new configuration indicated by ‘full config’ IE from eNB 102b by reactivating SRB2 and other DRBs).
8. **Regarding claims 6, 7, 9 and 10, the functional limitations are rejected for reasons set forth in rejecting claims 1, 2, 4 and 5 above.** Rayavarapu additionally discloses *a wireless device* (Figure 29 UE 101; Figure 2, UE 200), *comprising a communication interface* (Figure 2, communications subsystem 204), *and one or more processing circuits communicatively connected to the communication interface* (Figure 2, processor 202 connected to communications subsystem 205 via bus 201), *the one or more processing circuits comprising at least one processor and memory* (Figure 2, processor 202 and storage 212, ROM 214, RAM 210), *the memory containing instructions that, when executed, cause at least one processor to perform the functional limitations* (Paragraph 0235, processor 202 executes instructions, code, software or



computer programs it may access from communications subsystem 204, RAM 210, storage 212 or ROM 214).

9. **Regarding claim 11**, Rayavarapu discloses *a network node (eNB 102b) comprising:*

d. *a communications interface (Figure 29, eNB 102b's communications interface is inherent for communication with the UE 101; eNB 102b has communications interface similar to that of UE 200 in figure 2); and*

e. *one or more processing circuits communicatively connected to the communication interface (Paragraph 0295, eNB comprising processing circuit including one or more processors executing software stored on a computer readable medium; eNB 102b has processing circuit similar to that of UE 200 in figure 2 connected to its communications interface), the one or more processing circuits comprising at least one processors and memory, the memory containing instructions that, when executed, cause the at least one processor to (Paragraph 0295, eNB comprising processing circuit including one or more processors executing software stored on a computer readable medium):*

i. *receive, from a wireless device, a request to resume a connection in a communication network (Paragraph 0590, 0594 and figure 29 step 3, UE 101 sends RRC reestablishment request to eNB 102b [network node] to reactivate a suspended RRC connection; Step 7, UE 101 transmits RRC connection request message to eNB 102b, the message identifying the setup cause as resume); and*

ii. *send a resume response message to the wireless device, the message comprising an indication to perform a full configuration (Paragraph 0602-0603 and figure 29 step 17, eNB 102b sends RRC connection reconfiguration message [resume message] to UE 101. eNB 102b may also instruct the UE to throw away*

the suspended configuration and adopt a new configuration by setting the ‘full config’ IE).

10. **Regarding claim 12**, Rayavarapu discloses *wherein the indication comprises a flag* (Paragraph 0602, ‘full config’ IE [flag] set in the message from the eNB to the UE).
11. **Regarding claim 13**, Rayavarapu discloses *wherein the network node has a different radio access technology than a previous network node which suspended a previous connection for the wireless device* (Paragraph 0602, eNB 102b derives a configuration that needs to be signaled to the UE by comparing the current configuration at the UE with the configuration desired by eNB 102b, or eNB 102b instructs UE to throw away suspended configuration [radio access technology] and adopt a new configuration by setting the ‘full config’ IE. This indicates that suspended/current configuration of the UE with old eNB 102a is different from the new configuration of UE with new eNB).
12. **Regarding claim 14**, Rayavarapu discloses *wherein the at least one processor is configured to retrieve configuration information for the wireless device* (Paragraph 0602, new eNB 102b derives a new configuration to be signaled to the UE).
13. **Regarding claim 15**, Rayavarapu discloses *wherein the message further comprises configuration parameters* (Paragraphs 0602-0603, RRC connection reconfiguration message comprises new configuration set by the new eNB 102b).
14. **Regarding claim 16**, Rayavarapu discloses *wherein the indication comprises an indication to perform a full configuration using the configuration parameters* (Paragraph 602, ‘full config’ IE, delta configuration derived by eNB 102b and signaled to UE).
15. **Regarding claim 18**, Rayavarapu discloses *wherein the at least one processor is configured to generate the configuration parameters by generating a new UE AS context*

(Paragraph 0512, new AS security context or modified AS security context to resume connection with another eNB).

16. **Regarding claim 20**, Rayavarapu discloses *wherein the configuration parameters comprise one or more of bearer configuration, PDCP configuration and RLC configuration* (Paragraph 0603, bearer configuration for SRB2 and other DRBs).

### ***Claim Rejections - 35 USC § 103***

17. The following is a quotation of 35 U.S.C. 103 which forms the basis for all obviousness rejections set forth in this Office action:

A patent for a claimed invention may not be obtained, notwithstanding that the claimed invention is not identically disclosed as set forth in section 102, if the differences between the claimed invention and the prior art are such that the claimed invention as a whole would have been obvious before the effective filing date of the claimed invention to a person having ordinary skill in the art to which the claimed invention pertains. Patentability shall not be negated by the manner in which the invention was made.

18. The factual inquiries set forth in *Graham v. John Deere Co.*, 383 U.S. 1, 148 USPQ 459 (1966), that are applied for establishing a background for determining obviousness under 35 U.S.C. 103 are summarized as follows:

1. Determining the scope and contents of the prior art.
2. Ascertaining the differences between the prior art and the claims at issue.
3. Resolving the level of ordinary skill in the pertinent art.
4. Considering objective evidence present in the application indicating obviousness or nonobviousness.

19. Claims 3 and 8 is/are rejected under 35 U.S.C. 103 as being unpatentable over Rayavarapu as applied to claims 1 and 6 above, and further in view of Guo et al. (US 2019/0037635).

20. **Regarding claims 3 and 8**, Rayavarapu discloses the claimed invention above but does not specifically disclose the following limitations found in Guo et al.: *keeping security keys* (Guo et al., Paragraph 0116, re-establishment with or without a security key change).

Therefore, it would have been obvious to one of ordinary skill in the art before the effective filing date of the claimed invention to modify the teachings of Rayavarapu with the teachings of Guo et al. in order to connection re-establishment (Guo et al., paragraph 0116).

21. Claims 17 and 19 is/are rejected under 35 U.S.C. 103 as being unpatentable over Rayavarapu as applied to claim 11 and 15 above, and further in view of Kim et al. (US 2018/0213452).

22. **Regarding claim 17**, Rayavarapu discloses the claimed invention above but does not specifically disclose the following limitations found in Kim et al.: *wherein the resume response message is one of a RRCConnectionResume or a RRCResume* (Kim et al., Paragraph 0336, UE receives RRCConnectionResume message from eNB, the message including SRB setup information which the UE applies when resuming connection).

Therefore, it would have been obvious to one of ordinary skill in the art before the effective filing date of the claimed invention to modify the teachings of Rayavarapu with the teachings of Kim et al. in order to implement higher data rate communication (Kim et al., Abstract).

23. **Regarding claim 19**, Rayavarapu discloses the claimed invention above but does not specifically disclose the following limitations found in Kim et al.: *wherein the at least one processor is configured to generate the configuration parameters based on S1 and NG context*

*which contains bearer information used during an initial context setup* (Kim et al., Paragraph 0337, reconfigured S1 bearer to new eNB; Paragraph 0326, next-generation mobile communication system in which S1 bearer can be maintained in order to make the access more occur more rapidly with a small number of signaling procedures).

Therefore, it would have been obvious to one of ordinary skill in the art before the effective filing date of the claimed invention to modify the teachings of Rayavarapu with the teachings of Kim et al. in order to make the access more occur more rapidly with a small number of signaling procedures (Kim et al., Paragraph 0326).

### ***Conclusion***

Any inquiry concerning this communication or earlier communications from the examiner should be directed to OTIS L THOMPSON, JR whose telephone number is (571)270-1953. The examiner can normally be reached on Monday - Friday, 6:30am - 7:00pm.

Examiner interviews are available via telephone, in-person, and video conferencing using a USPTO supplied web-based collaboration tool. To schedule an interview, applicant is encouraged to use the USPTO Automated Interview Request (AIR) at <http://www.uspto.gov/interviewpractice>.

If attempts to reach the examiner by telephone are unsuccessful, the examiner's supervisor, Chirag G Shah can be reached on 571-272-3144. The fax phone number for the organization where this application or proceeding is assigned is 571-273-8300.

Information regarding the status of an application may be obtained from the Patent Application Information Retrieval (PAIR) system. Status information for published applications may be obtained from either Private PAIR or Public PAIR. Status information for unpublished

Application/Control Number: 16/380,844  
Art Unit: 2477

Page 9

applications is available through Private PAIR only. For more information about the PAIR system, see <http://pair-direct.uspto.gov>. Should you have questions on access to the Private PAIR system, contact the Electronic Business Center (EBC) at 866-217-9197 (toll-free). If you would like assistance from a USPTO Customer Service Representative or access to the automated information system, call 800-786-9199 (IN USA OR CANADA) or 571-272-1000.

/OTIS L THOMPSON, JR/  
Primary Examiner, Art Unit 2477

May 28, 2019

|                                   |                                       |                                                            |             |
|-----------------------------------|---------------------------------------|------------------------------------------------------------|-------------|
| <b>Notice of References Cited</b> | Application/Control No.<br>16/380,844 | Applicant(s)/Patent Under<br>Reexamination<br>TEYEB et al. |             |
|                                   | Examiner<br>OTIS L THOMPSON, JR       | Art Unit<br>2477                                           | Page 1 of 2 |

**U.S. PATENT DOCUMENTS**

| * |   | Document Number<br>Country Code-Number-Kind Code | Date<br>MM-YYYY | Name                             | CPC Classification | US Classification |
|---|---|--------------------------------------------------|-----------------|----------------------------------|--------------------|-------------------|
| * | A | US-20150117286-A1                                | 04-2015         | Kim; Soeng Hun                   | H04W52/0216        | 370/311           |
| * | B | US-20150131540-A1                                | 05-2015         | KOO; Changhoi                    | H04W76/14          | 370/329           |
| * | C | US-20150181461-A1                                | 06-2015         | Kim; Soeng Hun                   | H04W74/08          | 370/236           |
| * | D | US-20180049255-A1                                | 02-2018         | Chen; Te-Ming                    | H04W76/12          | 1/1               |
| * | E | US-20130039339-A1                                | 02-2013         | Rayavarapu; Venkata Ratnakar Rao | H04W76/19          | 370/331           |
| * | F | US-20130260740-A1                                | 10-2013         | Rayavarapu; Venkata Ratnakar Rao | H04W76/27          | 455/422.1         |
| * | G | US-20180359149-A1                                | 12-2018         | Shaheen; Kamel M.                | H04L5/0092         | 1/1               |
| * | H | US-20130260810-A1                                | 10-2013         | Rayavarapu; Venkata Ratnakar Rao | H04W76/19          | 455/509           |
| * | I | US-20170188269-A1                                | 06-2017         | SUNEL; Kai-Erik                  | H04W8/22           | 1/1               |
| * | J | US-20190037635-A1                                | 01-2019         | Guo; Yu-Hsuan                    | H04W76/27          | 1/1               |
| * | K | US-20130260811-A1                                | 10-2013         | Rayavarapu; Venkata Ratnakar Rao | H04W76/19          | 455/509           |
| * | L | US-20180213452-A1                                | 07-2018         | Kim; Donggun                     | H04W36/0033        | 1/1               |
| * | M | US-20180234941-A1                                | 08-2018         | KIM; Soenghun                    | H04W68/005         | 1/1               |

**FOREIGN PATENT DOCUMENTS**

| * |   | Document Number<br>Country Code-Number-Kind Code | Date<br>MM-YYYY | Country | Name | CPC Classification |
|---|---|--------------------------------------------------|-----------------|---------|------|--------------------|
|   | N |                                                  |                 |         |      |                    |
|   | O |                                                  |                 |         |      |                    |
|   | P |                                                  |                 |         |      |                    |
|   | Q |                                                  |                 |         |      |                    |
|   | R |                                                  |                 |         |      |                    |
|   | S |                                                  |                 |         |      |                    |
|   | T |                                                  |                 |         |      |                    |

**NON-PATENT DOCUMENTS**

| * |   | Include as applicable: Author, Title Date, Publisher, Edition or Volume, Pertinent Pages) |
|---|---|-------------------------------------------------------------------------------------------|
|   | U |                                                                                           |
|   | V |                                                                                           |
|   | W |                                                                                           |
|   | X |                                                                                           |

\*A copy of this reference is not being furnished with this Office action. (See MPEP § 707.05(a).)  
Dates in MM-YYYY format are publication dates. Classifications may be US or foreign.

|                                   |                                       |                                                            |             |
|-----------------------------------|---------------------------------------|------------------------------------------------------------|-------------|
| <b>Notice of References Cited</b> | Application/Control No.<br>16/380,844 | Applicant(s)/Patent Under<br>Reexamination<br>TEYEB et al. |             |
|                                   | Examiner<br>OTIS L THOMPSON, JR       | Art Unit<br>2477                                           | Page 2 of 2 |

**U.S. PATENT DOCUMENTS**

| * | Document Number<br>Country Code-Number-Kind Code | Date<br>MM-YYYY | Name         | CPC Classification | US Classification |
|---|--------------------------------------------------|-----------------|--------------|--------------------|-------------------|
| * | A US-20180279204-A1                              | 09-2018         | KIM; Sangbum | H04W48/02          | 1/1               |
| B |                                                  |                 |              |                    |                   |
| C |                                                  |                 |              |                    |                   |
| D |                                                  |                 |              |                    |                   |
| E |                                                  |                 |              |                    |                   |
| F |                                                  |                 |              |                    |                   |
| G |                                                  |                 |              |                    |                   |
| H |                                                  |                 |              |                    |                   |
| I |                                                  |                 |              |                    |                   |
| J |                                                  |                 |              |                    |                   |
| K |                                                  |                 |              |                    |                   |
| L |                                                  |                 |              |                    |                   |
| M |                                                  |                 |              |                    |                   |

**FOREIGN PATENT DOCUMENTS**

| * | Document Number<br>Country Code-Number-Kind Code | Date<br>MM-YYYY | Country | Name | CPC Classification |
|---|--------------------------------------------------|-----------------|---------|------|--------------------|
| N |                                                  |                 |         |      |                    |
| O |                                                  |                 |         |      |                    |
| P |                                                  |                 |         |      |                    |
| Q |                                                  |                 |         |      |                    |
| R |                                                  |                 |         |      |                    |
| S |                                                  |                 |         |      |                    |
| T |                                                  |                 |         |      |                    |

**NON-PATENT DOCUMENTS**

| * | U                                                                                         | V | W | X |
|---|-------------------------------------------------------------------------------------------|---|---|---|
|   | Include as applicable: Author, Title Date, Publisher, Edition or Volume, Pertinent Pages) |   |   |   |
|   |                                                                                           |   |   |   |
|   |                                                                                           |   |   |   |
|   |                                                                                           |   |   |   |
|   |                                                                                           |   |   |   |

\*A copy of this reference is not being furnished with this Office action. (See MPEP § 707.05(a).)  
Dates in MM-YYYY format are publication dates. Classifications may be US or foreign.





|                                                                                                                 |                                              |                                                                |
|-----------------------------------------------------------------------------------------------------------------|----------------------------------------------|----------------------------------------------------------------|
| <b><i>Search Notes</i></b><br> | <b>Application/Control No.</b><br>16/380,844 | <b>Applicant(s)/Patent Under Reexamination</b><br>TEYEB et al. |
|                                                                                                                 | <b>Examiner</b><br>OTIS L THOMPSON, JR       | <b>Art Unit</b><br>2477                                        |

| CPC - Searched* |      |          |
|-----------------|------|----------|
| Symbol          | Date | Examiner |
|                 |      |          |

| CPC Combination Sets - Searched* |            |          |
|----------------------------------|------------|----------|
| Symbol                           | Date       | Examiner |
| H04W76 with text in EAST         | 05/28/2019 | OT       |

| US Classification - Searched* |          |      |          |
|-------------------------------|----------|------|----------|
| Class                         | Subclass | Date | Examiner |
|                               |          |      |          |

\* See search history printout included with this form or the SEARCH NOTES box below to determine the scope of the search.

| Search Notes                                                           |            |          |
|------------------------------------------------------------------------|------------|----------|
| Search Notes                                                           | Date       | Examiner |
| EAST Text Search                                                       | 05/24/2019 | OT       |
| EAST Text Search                                                       | 05/25/2019 | OT       |
| EAST Text Search                                                       | 05/28/2019 | OT       |
| Double patenting search                                                | 05/28/2019 | OT       |
| NPL search (Google: rrcconnectionresume/rrcresume, full configuration) | 05/28/2019 | OT       |

| Interference Search |                       |      |          |
|---------------------|-----------------------|------|----------|
| US Class/CPC Symbol | US Subclass/CPC Group | Date | Examiner |
|                     |                       |      |          |

|                                                          |  |
|----------------------------------------------------------|--|
| /OTIS L THOMPSON, JR/<br>Primary Examiner, Art Unit 2477 |  |
|----------------------------------------------------------|--|

## EAST Search History

## EAST Search History (Prior Art)

| Ref # | Hits | Search Query                                                               | DBs                                                                        | Default Operator | Plurals | Time Stamp          |
|-------|------|----------------------------------------------------------------------------|----------------------------------------------------------------------------|------------------|---------|---------------------|
| S1    | 32   | fullconfig same rrc with reconfigur\$5                                     | US-PGPUB;<br>USPAT;<br>USOCR;<br>FPRS; EPO;<br>JPO;<br>DERWENT;<br>IBM_TDB | ADJ              | ON      | 2019/05/24<br>14:21 |
| S2    | 17   | (full config or fullconfig) same rrc same request\$3                       | US-PGPUB;<br>USPAT;<br>USOCR;<br>FPRS; EPO;<br>JPO;<br>DERWENT;<br>IBM_TDB | ADJ              | ON      | 2019/05/24<br>14:35 |
| S3    | 276  | rrconnectionreestablishmentrequest                                         | US-PGPUB;<br>USPAT;<br>USOCR;<br>FPRS; EPO;<br>JPO;<br>DERWENT;<br>IBM_TDB | ADJ              | ON      | 2019/05/24<br>14:54 |
| S4    | 0    | S3 same (fullconfig or full config or full configuration)                  | US-PGPUB;<br>USPAT;<br>USOCR;<br>FPRS; EPO;<br>JPO;<br>DERWENT;<br>IBM_TDB | ADJ              | ON      | 2019/05/24<br>14:55 |
| S5    | 35   | (full config or fullconfig or full configuration) same rrc same request\$3 | US-PGPUB;<br>USPAT;<br>USOCR;<br>FPRS; EPO;<br>JPO;<br>DERWENT;<br>IBM_TDB | ADJ              | ON      | 2019/05/24<br>14:56 |
| S8    | 2    | S7 and (fullconfig or full config or full configuration)                   | US-PGPUB;<br>USPAT;<br>USOCR;<br>FPRS; EPO;<br>JPO;<br>DERWENT;<br>IBM_TDB | ADJ              | ON      | 2019/05/24<br>15:04 |
| S7    | 70   | rrconnectionresume or rrcresume                                            | US-PGPUB;<br>USPAT;<br>USOCR;<br>FPRS; EPO;<br>JPO;<br>DERWENT;<br>IBM_TDB | ADJ              | ON      | 2019/05/24<br>15:04 |
| S6    | 68   | rrconnectionresume                                                         | US-PGPUB;                                                                  | ADJ              | ON      | 2019/05/24          |

|     |     |                                                                                                                                                                       |                                                                            |     |    |                     |
|-----|-----|-----------------------------------------------------------------------------------------------------------------------------------------------------------------------|----------------------------------------------------------------------------|-----|----|---------------------|
|     |     |                                                                                                                                                                       | USPAT;<br>USOCR;<br>FPRS; EPO;<br>JPO;<br>DERWENT;<br>IBM_TDB              |     |    | 15:04               |
| S9  | 303 | (resum\$5 or reconfig\$7 or re config\$7 or reestablish\$4 or re establish\$4) same (fullconfig or full config or full configuration)                                 | US-PGPUB;<br>USPAT;<br>USOCR;<br>FPRS; EPO;<br>JPO;<br>DERWENT;<br>IBM_TDB | ADJ | ON | 2019/05/24<br>15:48 |
| S10 | 151 | (resum\$5 or reconfig\$7 or re config\$7 or reestablish\$4 or re establish\$4) same (fullconfig or full config or full configuration) same rrc                        | US-PGPUB;<br>USPAT;<br>USOCR;<br>FPRS; EPO;<br>JPO;<br>DERWENT;<br>IBM_TDB | ADJ | ON | 2019/05/24<br>16:38 |
| S11 | 135 | (resum\$5 or reconfig\$7 or re config\$7 or reestablish\$4 or re establish\$4) with (fullconfig or full config or full configuration) same rrc                        | US-PGPUB;<br>USPAT;<br>USOCR;<br>FPRS; EPO;<br>JPO;<br>DERWENT;<br>IBM_TDB | ADJ | ON | 2019/05/24<br>16:39 |
| S12 | 42  | ue near2 (request\$3 or resum\$5 or reconfig\$7 or re config\$7 or reestablish\$4 or re establish\$4) with (fullconfig or full config or full configuration) same rrc | US-PGPUB;<br>USPAT;<br>USOCR;<br>FPRS; EPO;<br>JPO;<br>DERWENT;<br>IBM_TDB | ADJ | ON | 2019/05/24<br>17:36 |
| S15 | 0   | (rrconnectionresume or rrcresume or rrc resum\$5 or rrc connect\$3 resum\$5) same (fullconfig or full config or full config\$7)                                       | US-PGPUB;<br>USPAT;<br>USOCR;<br>FPRS; EPO;<br>JPO;<br>DERWENT;<br>IBM_TDB | ADJ | ON | 2019/05/24<br>17:55 |
| S14 | 0   | (rrconnectionresume or rrcresume) same (fullconfig or full config or full config\$7)                                                                                  | US-PGPUB;<br>USPAT;<br>USOCR;<br>FPRS; EPO;<br>JPO;<br>DERWENT;<br>IBM_TDB | ADJ | ON | 2019/05/24<br>17:55 |
| S13 | 68  | rrconnectionresume or rrcresume same (fullconfig or full config or full config\$7)                                                                                    | US-PGPUB;<br>USPAT;<br>USOCR;<br>FPRS; EPO;<br>JPO;<br>DERWENT;<br>IBM_TDB | ADJ | ON | 2019/05/24<br>17:55 |
| S16 | 2   | (rrconnectionresume or rrcresume or rrcconnectionresume) same (fullconfig or full config or full config\$7)                                                           | US-PGPUB;<br>USPAT;<br>USOCR;<br>FPRS; EPO;<br>JPO;<br>DERWENT;            | ADJ | ON | 2019/05/24<br>17:56 |

|     |     |                                                                                                                                            | IBM_TDB                                                                    |     |    |                     |
|-----|-----|--------------------------------------------------------------------------------------------------------------------------------------------|----------------------------------------------------------------------------|-----|----|---------------------|
| S17 | 3   | (rrcconnectionresume or rrcresume or rrcconnectionresume) and (fullconfig or full config or full config\$7)                                | US-PGPUB;<br>USPAT;<br>USOCR;<br>FPRS; EPO;<br>JPO;<br>DERWENT;<br>IBM_TDB | ADJ | ON | 2019/05/24<br>17:57 |
| S18 | 53  | rrc same (continu\$3 or resum\$5) same (fullconfig or full config or full config\$7)                                                       | US-PGPUB;<br>USPAT;<br>USOCR;<br>FPRS; EPO;<br>JPO;<br>DERWENT;<br>IBM_TDB | ADJ | ON | 2019/05/24<br>18:08 |
| S19 | 35  | resum\$5 same (fullconfig or full config or full config\$7)                                                                                | US-PGPUB;<br>USPAT;<br>USOCR;<br>FPRS; EPO;<br>JPO;<br>DERWENT;<br>IBM_TDB | ADJ | ON | 2019/05/24<br>18:31 |
| S20 | 47  | (resum\$5 or suspend\$3 or suspension) same (fullconfig or full config or full config\$7)                                                  | US-PGPUB;<br>USPAT;<br>USOCR;<br>FPRS; EPO;<br>JPO;<br>DERWENT;<br>IBM_TDB | ADJ | ON | 2019/05/24<br>18:33 |
| S21 | 30  | (resum\$5 or suspend\$3 or suspension) same (fullconfig or full config or full config\$7) same (UE or lte or user equipment)               | US-PGPUB;<br>USPAT;<br>USOCR;<br>FPRS; EPO;<br>JPO;<br>DERWENT;<br>IBM_TDB | ADJ | ON | 2019/05/24<br>18:34 |
| S22 | 80  | (resum\$5 or suspend\$3 or suspension or continu\$3) same (fullconfig or full config or full config\$7) same (UE or lte or user equipment) | US-PGPUB;<br>USPAT;<br>USOCR;<br>FPRS; EPO;<br>JPO;<br>DERWENT;<br>IBM_TDB | ADJ | ON | 2019/05/25<br>12:34 |
| S23 | 13  | (resum\$5 or continu\$3) with (fullconfig or full config or full config\$7) with (UE or lte or user equipment)                             | US-PGPUB;<br>USPAT;<br>USOCR;<br>FPRS; EPO;<br>JPO;<br>DERWENT;<br>IBM_TDB | ADJ | ON | 2019/05/25<br>13:07 |
| S24 | 1   | (fullconfig or full config or full config\$7) with (UE or wtru or user equipment) near2 request\$3                                         | US-PGPUB;<br>USPAT;<br>USOCR;<br>FPRS; EPO;<br>JPO;<br>DERWENT;<br>IBM_TDB | ADJ | ON | 2019/05/25<br>13:09 |
| S25 | 228 | (fullconfig or full config or full config\$7) with (UE or wtru or user equipment)                                                          | US-PGPUB;<br>USPAT;<br>USOCR;<br>FPRS; EPO;                                | ADJ | ON | 2019/05/25<br>13:12 |

|     |     |                                                                                                                                                             |                                                                            |     |    |                     |
|-----|-----|-------------------------------------------------------------------------------------------------------------------------------------------------------------|----------------------------------------------------------------------------|-----|----|---------------------|
|     |     |                                                                                                                                                             | JPO;<br>DERWENT;<br>IBM_TDB                                                |     |    |                     |
| S26 | 29  | (fullconfig or full config or full config\$7) and (UE or wtru or user equipment) near2 resum\$5                                                             | US-PGPUB;<br>USPAT;<br>USOCR;<br>FPRS; EPO;<br>JPO;<br>DERWENT;<br>IBM_TDB | ADJ | ON | 2019/05/25<br>13:31 |
| S28 | 9   | (fullconfig or full config or full config\$7) with resum\$5                                                                                                 | US-PGPUB;<br>USPAT;<br>USOCR;<br>FPRS; EPO;<br>JPO;<br>DERWENT;<br>IBM_TDB | ADJ | ON | 2019/05/25<br>13:38 |
| S27 | 9   | (fullconfig or full config or full config\$7) with resum\$4                                                                                                 | US-PGPUB;<br>USPAT;<br>USOCR;<br>FPRS; EPO;<br>JPO;<br>DERWENT;<br>IBM_TDB | ADJ | ON | 2019/05/25<br>13:38 |
| S29 | 71  | (fullconfig or full config or full config\$7) same (UE or wtru or user equipment) with (reestablish\$4 or re establish\$4)                                  | US-PGPUB;<br>USPAT;<br>USOCR;<br>FPRS; EPO;<br>JPO;<br>DERWENT;<br>IBM_TDB | ADJ | ON | 2019/05/25<br>13:44 |
| S30 | 73  | (fullconfig or full config or full config\$7) same (UE or wtru or user equipment) with (reestablish\$4 or re establish\$4 or reconnect\$3 or re connect\$3) | US-PGPUB;<br>USPAT;<br>USOCR;<br>FPRS; EPO;<br>JPO;<br>DERWENT;<br>IBM_TDB | ADJ | ON | 2019/05/25<br>13:45 |
| S31 | 221 | H04w76/\$.cpc. and (fullconfig or full config or full configur\$5)                                                                                          | US-PGPUB;<br>USPAT;<br>USOCR;<br>FPRS; EPO;<br>JPO;<br>DERWENT;<br>IBM_TDB | ADJ | ON | 2019/05/28<br>09:00 |
| S32 | 2   | H04w76/\$.cpc. and (fullconfig or full config or full configur\$5) same (rrconnectionresume or rrconnectionresume or rrcresume)                             | US-PGPUB;<br>USPAT;<br>USOCR;<br>FPRS; EPO;<br>JPO;<br>DERWENT;<br>IBM_TDB | ADJ | ON | 2019/05/28<br>09:01 |
| S33 | 54  | H04w76/\$.cpc. and (rrconnectionresume or rrconnectionresume or rrcresume)                                                                                  | US-PGPUB;<br>USPAT;<br>USOCR;<br>FPRS; EPO;<br>JPO;<br>DERWENT;<br>IBM_TDB | ADJ | ON | 2019/05/28<br>09:02 |
| S35 | 2   | H04w76/\$.cpc. and (rrconnectionresume or                                                                                                                   | US-PGPUB;<br>USPAT;                                                        | ADJ | ON | 2019/05/28<br>09:03 |

|     |     |                                                                                                                              |                                                                            |     |    |                     |
|-----|-----|------------------------------------------------------------------------------------------------------------------------------|----------------------------------------------------------------------------|-----|----|---------------------|
|     |     | rrconnectionresume or rrcresume or rrc connection resume or rrc resume) same (fullconfig or full config or full configur\$5) | USOCR;<br>FPRS; EPO;<br>JPO;<br>DERWENT;<br>IBM_TDB                        |     |    |                     |
| S34 | 277 | H04w76/\$.cpc. and (rrconnectionresume or rrcconnectionresume or rrcresume or rrc connection resume or rrc resume)           | US-PGPUB;<br>USPAT;<br>USOCR;<br>FPRS; EPO;<br>JPO;<br>DERWENT;<br>IBM_TDB | ADJ | ON | 2019/05/28<br>09:03 |
| S36 | 20  | H04w76/\$.cpc. and (rrconnectionresume or rrcconnectionresume or rrcresume) same (config or configur\$5)                     | US-PGPUB;<br>USPAT;<br>USOCR;<br>FPRS; EPO;<br>JPO;<br>DERWENT;<br>IBM_TDB | ADJ | ON | 2019/05/28<br>09:04 |
| S37 | 35  | H04w76/\$.cpc. and (keep\$3 or old) near2 security key                                                                       | US-PGPUB;<br>USPAT;<br>USOCR;<br>FPRS; EPO;<br>JPO;<br>DERWENT;<br>IBM_TDB | ADJ | ON | 2019/05/28<br>09:23 |
| S38 | 6   | H04w76/\$.cpc. and (keep\$3 or old) near2 security key and 5g                                                                | US-PGPUB;<br>USPAT;<br>USOCR;<br>FPRS; EPO;<br>JPO;<br>DERWENT;<br>IBM_TDB | ADJ | ON | 2019/05/28<br>09:24 |
| L1  | 0   | keep\$3 near2 security key same resum\$5 same (suspend\$3 or suspension)                                                     | US-PGPUB;<br>USPAT;<br>USOCR;<br>FPRS; EPO;<br>JPO;<br>DERWENT;<br>IBM_TDB | ADJ | ON | 2019/05/28<br>09:32 |
| L8  | 505 | ((("TEYEB" near3 ("Oumer")) OR ((("MILDH" near3 ("Gunnar")))).INV.                                                           | US-PGPUB;<br>USPAT;<br>USOCR; EPO;<br>JPO;<br>DERWENT                      | ADJ | ON | 2019/05/28<br>09:55 |
| L9  | 15  | l8 and resum\$5.clm. and (config or configur\$5).clm.                                                                        | US-PGPUB;<br>USPAT;<br>USOCR;<br>FPRS; EPO;<br>JPO;<br>DERWENT;<br>IBM_TDB | ADJ | ON | 2019/05/28<br>09:56 |

**EAST Search History (Interference)**

&lt; This search history is empty &gt;

**5/ 28/ 2019 9:57:31 AM****C:\Users\othompson1\Documents\EAST\Workspaces\16-380844.wsp**





Doc code: IDS

Doc description: Information Disclosure Statement (IDS) Filed

PTO/SB/08a (01-10)  
 Approved for use through 07/31/2012. OMB 0651-0031  
 U.S. Patent and Trademark Office; U.S. DEPARTMENT OF COMMERCE

Under the Paperwork Reduction Act of 1995, no persons are required to respond to a collection of information unless it contains a valid OMB control number.

|                                                                                                 |                        |            |
|-------------------------------------------------------------------------------------------------|------------------------|------------|
| <b>INFORMATION DISCLOSURE STATEMENT BY APPLICANT</b><br>( Not for submission under 37 CFR 1.99) | Application Number     | 16380844   |
|                                                                                                 | Filing Date            | 2019-04-10 |
|                                                                                                 | First Named Inventor   | Teyeb      |
|                                                                                                 | Art Unit               |            |
|                                                                                                 | Examiner Name          |            |
|                                                                                                 | Attorney Docket Number | P74267 US2 |

| U.S. PATENTS                                                                                               |         |                                                                                                                                                                                                                                                                 |                            |                        |                                                 |                                                                          | Remove                                                                   |                |
|------------------------------------------------------------------------------------------------------------|---------|-----------------------------------------------------------------------------------------------------------------------------------------------------------------------------------------------------------------------------------------------------------------|----------------------------|------------------------|-------------------------------------------------|--------------------------------------------------------------------------|--------------------------------------------------------------------------|----------------|
| Examiner Initial*                                                                                          | Cite No | Patent Number                                                                                                                                                                                                                                                   | Kind Code <sup>1</sup>     | Issue Date             | Name of Patentee or Applicant of cited Document | Pages, Columns, Lines where Relevant Passages or Relevant Figures Appear |                                                                          |                |
|                                                                                                            | 1       |                                                                                                                                                                                                                                                                 |                            |                        |                                                 |                                                                          |                                                                          |                |
| If you wish to add additional U.S. Patent citation information please click the Add button.                |         |                                                                                                                                                                                                                                                                 |                            |                        |                                                 |                                                                          | Add                                                                      |                |
| U.S. PATENT APPLICATION PUBLICATIONS                                                                       |         |                                                                                                                                                                                                                                                                 |                            |                        |                                                 |                                                                          | Remove                                                                   |                |
| Examiner Initial*                                                                                          | Cite No | Publication Number                                                                                                                                                                                                                                              | Kind Code <sup>1</sup>     | Publication Date       | Name of Patentee or Applicant of cited Document | Pages, Columns, Lines where Relevant Passages or Relevant Figures Appear |                                                                          |                |
|                                                                                                            | 1       |                                                                                                                                                                                                                                                                 |                            |                        |                                                 |                                                                          |                                                                          |                |
| If you wish to add additional U.S. Published Application citation information please click the Add button. |         |                                                                                                                                                                                                                                                                 |                            |                        |                                                 |                                                                          | Add                                                                      |                |
| FOREIGN PATENT DOCUMENTS                                                                                   |         |                                                                                                                                                                                                                                                                 |                            |                        |                                                 |                                                                          | Remove                                                                   |                |
| Examiner Initial*                                                                                          | Cite No | Foreign Document Number <sup>3</sup>                                                                                                                                                                                                                            | Country Code <sup>2i</sup> | Kind Code <sup>4</sup> | Publication Date                                | Name of Patentee or Applicant of cited Document                          | Pages, Columns, Lines where Relevant Passages or Relevant Figures Appear | T <sup>5</sup> |
|                                                                                                            | 1       |                                                                                                                                                                                                                                                                 |                            |                        |                                                 |                                                                          |                                                                          |                |
| If you wish to add additional Foreign Patent Document citation information please click the Add button.    |         |                                                                                                                                                                                                                                                                 |                            |                        |                                                 |                                                                          | Add                                                                      |                |
| NON-PATENT LITERATURE DOCUMENTS                                                                            |         |                                                                                                                                                                                                                                                                 |                            |                        |                                                 |                                                                          | Remove                                                                   |                |
| Examiner Initials*                                                                                         | Cite No | Include name of the author (in CAPITAL LETTERS), title of the article (when appropriate), title of the item (book, magazine, journal, serial, symposium, catalog, etc), date, pages(s), volume-issue number(s), publisher, city and/or country where published. |                            |                        |                                                 |                                                                          | T <sup>5</sup>                                                           |                |

|                                                                                                     |                        |            |
|-----------------------------------------------------------------------------------------------------|------------------------|------------|
| <b>INFORMATION DISCLOSURE<br/>STATEMENT BY APPLICANT</b><br>( Not for submission under 37 CFR 1.99) | Application Number     | 16380844   |
|                                                                                                     | Filing Date            | 2019-04-10 |
|                                                                                                     | First Named Inventor   | Teyeb      |
|                                                                                                     | Art Unit               |            |
|                                                                                                     | Examiner Name          |            |
|                                                                                                     | Attorney Docket Number | P74267 US2 |

|   |                                                                                                                                                                                                                                                              |
|---|--------------------------------------------------------------------------------------------------------------------------------------------------------------------------------------------------------------------------------------------------------------|
| 1 | 3GPP TS 36.331 V15.0.1 (2018-01), 3rd Generation Partnership Project; Technical Specification Group Radio Access Network; Evolved Universal Terrestrial Radio Access (E-UTRA); Radio Resource Control (RRC); Protocol specification (Release 15), pp. 1-776. |
| 2 | Ericsson, OFFLINE#22 LTE re-establishment and resume while using NR PDCP, 3GPP TSG-RAN WG2 Meeting #100, Reno, US, 27 Nov-1 Dec, 2017, pp. 1-12.                                                                                                             |

If you wish to add additional non-patent literature document citation information please click the Add button

**EXAMINER SIGNATURE**

|                    |                       |                 |            |
|--------------------|-----------------------|-----------------|------------|
| Examiner Signature | /OTIS L THOMPSON, JR/ | Date Considered | 05/28/2019 |
|--------------------|-----------------------|-----------------|------------|

\*EXAMINER: Initial if reference considered, whether or not citation is in conformance with MPEP 609. Draw line through a citation if not in conformance and not considered. Include copy of this form with next communication to applicant.

<sup>1</sup> See Kind Codes of USPTO Patent Documents at [www.USPTO.GOV](http://www.USPTO.GOV) or MPEP 901.04. <sup>2</sup> Enter office that issued the document, by the two-letter code (WIPO Standard ST.3). <sup>3</sup> For Japanese patent documents, the indication of the year of the reign of the Emperor must precede the serial number of the patent document. <sup>4</sup> Kind of document by the appropriate symbols as indicated on the document under WIPO Standard ST.16 if possible. <sup>5</sup> Applicant is to place a check mark here if English language translation is attached.

|                                                                                                 |                        |       |            |
|-------------------------------------------------------------------------------------------------|------------------------|-------|------------|
| <b>INFORMATION DISCLOSURE STATEMENT BY APPLICANT</b><br>( Not for submission under 37 CFR 1.99) | Application Number     |       | 16380844   |
|                                                                                                 | Filing Date            |       | 2019-04-10 |
|                                                                                                 | First Named Inventor   | Teyeb |            |
|                                                                                                 | Art Unit               |       |            |
|                                                                                                 | Examiner Name          |       |            |
|                                                                                                 | Attorney Docket Number |       | P74267 US2 |

**CERTIFICATION STATEMENT**

Please see 37 CFR 1.97 and 1.98 to make the appropriate selection(s):

That each item of information contained in the information disclosure statement was first cited in any communication from a foreign patent office in a counterpart foreign application not more than three months prior to the filing of the information disclosure statement. See 37 CFR 1.97(e)(1).

**OR**

That no item of information contained in the information disclosure statement was cited in a communication from a foreign patent office in a counterpart foreign application, and, to the knowledge of the person signing the certification after making reasonable inquiry, no item of information contained in the information disclosure statement was known to any individual designated in 37 CFR 1.56(c) more than three months prior to the filing of the information disclosure statement. See 37 CFR 1.97(e)(2).

See attached certification statement.

The fee set forth in 37 CFR 1.17 (p) has been submitted herewith.

A certification statement is not submitted herewith.

**SIGNATURE**

A signature of the applicant or representative is required in accordance with CFR 1.33, 10.18. Please see CFR 1.4(d) for the form of the signature.

|            |                 |                     |            |
|------------|-----------------|---------------------|------------|
| Signature  | /BrentCapehart/ | Date (YYYY-MM-DD)   | 2019-05-10 |
| Name/Print | Brent Capehart  | Registration Number | 39620      |

This collection of information is required by 37 CFR 1.97 and 1.98. The information is required to obtain or retain a benefit by the public which is to file (and by the USPTO to process) an application. Confidentiality is governed by 35 U.S.C. 122 and 37 CFR 1.14. This collection is estimated to take 1 hour to complete, including gathering, preparing and submitting the completed application form to the USPTO. Time will vary depending upon the individual case. Any comments on the amount of time you require to complete this form and/or suggestions for reducing this burden, should be sent to the Chief Information Officer, U.S. Patent and Trademark Office, U.S. Department of Commerce, P.O. Box 1450, Alexandria, VA 22313-1450. **DO NOT SEND FEES OR COMPLETED FORMS TO THIS ADDRESS. SEND TO: Commissioner for Patents, P.O. Box 1450, Alexandria, VA 22313-1450.**

## Privacy Act Statement

The Privacy Act of 1974 (P.L. 93-579) requires that you be given certain information in connection with your submission of the attached form related to a patent application or patent. Accordingly, pursuant to the requirements of the Act, please be advised that: (1) the general authority for the collection of this information is 35 U.S.C. 2(b)(2); (2) furnishing of the information solicited is voluntary; and (3) the principal purpose for which the information is used by the U.S. Patent and Trademark Office is to process and/or examine your submission related to a patent application or patent. If you do not furnish the requested information, the U.S. Patent and Trademark Office may not be able to process and/or examine your submission, which may result in termination of proceedings or abandonment of the application or expiration of the patent.

The information provided by you in this form will be subject to the following routine uses:

1. The information on this form will be treated confidentially to the extent allowed under the Freedom of Information Act (5 U.S.C. 552) and the Privacy Act (5 U.S.C. 552a). Records from this system of records may be disclosed to the Department of Justice to determine whether the Freedom of Information Act requires disclosure of these records.
2. A record from this system of records may be disclosed, as a routine use, in the course of presenting evidence to a court, magistrate, or administrative tribunal, including disclosures to opposing counsel in the course of settlement negotiations.
3. A record in this system of records may be disclosed, as a routine use, to a Member of Congress submitting a request involving an individual, to whom the record pertains, when the individual has requested assistance from the Member with respect to the subject matter of the record.
4. A record in this system of records may be disclosed, as a routine use, to a contractor of the Agency having need for the information in order to perform a contract. Recipients of information shall be required to comply with the requirements of the Privacy Act of 1974, as amended, pursuant to 5 U.S.C. 552a(m).
5. A record related to an International Application filed under the Patent Cooperation Treaty in this system of records may be disclosed, as a routine use, to the International Bureau of the World Intellectual Property Organization, pursuant to the Patent Cooperation Treaty.
6. A record in this system of records may be disclosed, as a routine use, to another federal agency for purposes of National Security review (35 U.S.C. 181) and for review pursuant to the Atomic Energy Act (42 U.S.C. 218(c)).
7. A record from this system of records may be disclosed, as a routine use, to the Administrator, General Services, or his/her designee, during an inspection of records conducted by GSA as part of that agency's responsibility to recommend improvements in records management practices and programs, under authority of 44 U.S.C. 2904 and 2906. Such disclosure shall be made in accordance with the GSA regulations governing inspection of records for this purpose, and any other relevant (i.e., GSA or Commerce) directive. Such disclosure shall not be used to make determinations about individuals.
8. A record from this system of records may be disclosed, as a routine use, to the public after either publication of the application pursuant to 35 U.S.C. 122(b) or issuance of a patent pursuant to 35 U.S.C. 151. Further, a record may be disclosed, subject to the limitations of 37 CFR 1.14, as a routine use, to the public if the record was filed in an application which became abandoned or in which the proceedings were terminated and which application is referenced by either a published application, an application open to public inspections or an issued patent.
9. A record from this system of records may be disclosed, as a routine use, to a Federal, State, or local law enforcement agency, if the USPTO becomes aware of a violation or potential violation of law or regulation.

~~ALL REFERENCES CONSIDERED EXCEPT WHERE LINED THROUGH. /O.L.T/~~

|                                                                                                 |                        |            |
|-------------------------------------------------------------------------------------------------|------------------------|------------|
| <b>INFORMATION DISCLOSURE STATEMENT BY APPLICANT</b><br>( Not for submission under 37 CFR 1.99) | Application Number     | 16380844   |
|                                                                                                 | Filing Date            | 2019-04-10 |
|                                                                                                 | First Named Inventor   | Teyeb      |
|                                                                                                 | Art Unit               |            |
|                                                                                                 | Examiner Name          |            |
|                                                                                                 | Attorney Docket Number | P74267 US2 |

| U.S.PATENTS       |         |               |                        |            |                                                 |                                                                        | Remove |
|-------------------|---------|---------------|------------------------|------------|-------------------------------------------------|------------------------------------------------------------------------|--------|
| Examiner Initial* | Cite No | Patent Number | Kind Code <sup>1</sup> | Issue Date | Name of Patentee or Applicant of cited Document | Pages,Columns,Lines where Relevant Passages or Relevant Figures Appear |        |
|                   | 1       |               |                        |            |                                                 |                                                                        |        |

If you wish to add additional U.S. Patent citation information please click the Add button.

| U.S.PATENT APPLICATION PUBLICATIONS |         |                    |                        |                  |                                                 |                                                                        | Remove |
|-------------------------------------|---------|--------------------|------------------------|------------------|-------------------------------------------------|------------------------------------------------------------------------|--------|
| Examiner Initial*                   | Cite No | Publication Number | Kind Code <sup>1</sup> | Publication Date | Name of Patentee or Applicant of cited Document | Pages,Columns,Lines where Relevant Passages or Relevant Figures Appear |        |
|                                     | 1       |                    |                        |                  |                                                 |                                                                        |        |

If you wish to add additional U.S. Published Application citation information please click the Add button.

| FOREIGN PATENT DOCUMENTS |         |                                      |                             |                        |                  |                                                 |                                                                        | Remove         |
|--------------------------|---------|--------------------------------------|-----------------------------|------------------------|------------------|-------------------------------------------------|------------------------------------------------------------------------|----------------|
| Examiner Initial*        | Cite No | Foreign Document Number <sup>3</sup> | Country Code <sup>2</sup> i | Kind Code <sup>4</sup> | Publication Date | Name of Patentee or Applicant of cited Document | Pages,Columns,Lines where Relevant Passages or Relevant Figures Appear | T <sup>5</sup> |
|                          | 1       |                                      |                             |                        |                  |                                                 |                                                                        |                |

If you wish to add additional Foreign Patent Document citation information please click the Add button.

| NON-PATENT LITERATURE DOCUMENTS |         |                                                                                                                                                                                                                                                                 |  |  |  |  |  | Remove         |
|---------------------------------|---------|-----------------------------------------------------------------------------------------------------------------------------------------------------------------------------------------------------------------------------------------------------------------|--|--|--|--|--|----------------|
| Examiner Initials*              | Cite No | Include name of the author (in CAPITAL LETTERS), title of the article (when appropriate), title of the item (book, magazine, journal, serial, symposium, catalog, etc), date, pages(s), volume-issue number(s), publisher, city and/or country where published. |  |  |  |  |  | T <sup>5</sup> |
|                                 |         |                                                                                                                                                                                                                                                                 |  |  |  |  |  |                |

|                                                                                                     |                        |            |
|-----------------------------------------------------------------------------------------------------|------------------------|------------|
| <b>INFORMATION DISCLOSURE<br/>STATEMENT BY APPLICANT</b><br>( Not for submission under 37 CFR 1.99) | Application Number     | 16380844   |
|                                                                                                     | Filing Date            | 2019-04-10 |
|                                                                                                     | First Named Inventor   | Teyeb      |
|                                                                                                     | Art Unit               |            |
|                                                                                                     | Examiner Name          |            |
|                                                                                                     | Attorney Docket Number | P74267 US2 |

|   |                                                                                                                                                                                                                                                              |
|---|--------------------------------------------------------------------------------------------------------------------------------------------------------------------------------------------------------------------------------------------------------------|
| 1 | 3GPP TS 36.331 V15.0.1 (2018-01), 3rd Generation Partnership Project; Technical Specification Group Radio Access Network; Evolved Universal Terrestrial Radio Access (E-UTRA); Radio Resource Control (RRC); Protocol specification (Release 15), pp. 1-776. |
| 2 | Ericsson, OFFLINE#22 LTE re-establishment and resume while using NR PDCP, 3GPP TSG-RAN WG2 Meeting #100, Reno, US, 27 Nov-1 Dec, 2017, pp. 1-12.                                                                                                             |

If you wish to add additional non-patent literature document citation information please click the Add button

**EXAMINER SIGNATURE**

|                    |  |                 |  |
|--------------------|--|-----------------|--|
| Examiner Signature |  | Date Considered |  |
|--------------------|--|-----------------|--|

\*EXAMINER: Initial if reference considered, whether or not citation is in conformance with MPEP 609. Draw line through a citation if not in conformance and not considered. Include copy of this form with next communication to applicant.

<sup>1</sup> See Kind Codes of USPTO Patent Documents at [www.USPTO.GOV](http://www.USPTO.GOV) or MPEP 901.04. <sup>2</sup> Enter office that issued the document, by the two-letter code (WIPO Standard ST.3). <sup>3</sup> For Japanese patent documents, the indication of the year of the reign of the Emperor must precede the serial number of the patent document. <sup>4</sup> Kind of document by the appropriate symbols as indicated on the document under WIPO Standard ST.16 if possible. <sup>5</sup> Applicant is to place a check mark here if English language translation is attached.

|                                                                                                 |                        |            |
|-------------------------------------------------------------------------------------------------|------------------------|------------|
| <b>INFORMATION DISCLOSURE STATEMENT BY APPLICANT</b><br>( Not for submission under 37 CFR 1.99) | Application Number     | 16380844   |
|                                                                                                 | Filing Date            | 2019-04-10 |
|                                                                                                 | First Named Inventor   | Teyeb      |
|                                                                                                 | Art Unit               |            |
|                                                                                                 | Examiner Name          |            |
|                                                                                                 | Attorney Docket Number | P74267 US2 |

**CERTIFICATION STATEMENT**

Please see 37 CFR 1.97 and 1.98 to make the appropriate selection(s):

That each item of information contained in the information disclosure statement was first cited in any communication from a foreign patent office in a counterpart foreign application not more than three months prior to the filing of the information disclosure statement. See 37 CFR 1.97(e)(1).

**OR**

That no item of information contained in the information disclosure statement was cited in a communication from a foreign patent office in a counterpart foreign application, and, to the knowledge of the person signing the certification after making reasonable inquiry, no item of information contained in the information disclosure statement was known to any individual designated in 37 CFR 1.56(c) more than three months prior to the filing of the information disclosure statement. See 37 CFR 1.97(e)(2).

See attached certification statement.

The fee set forth in 37 CFR 1.17 (p) has been submitted herewith.

A certification statement is not submitted herewith.

**SIGNATURE**

A signature of the applicant or representative is required in accordance with CFR 1.33, 10.18. Please see CFR 1.4(d) for the form of the signature.

|            |                 |                     |            |
|------------|-----------------|---------------------|------------|
| Signature  | /BrentCapehart/ | Date (YYYY-MM-DD)   | 2019-05-10 |
| Name/Print | Brent Capehart  | Registration Number | 39620      |

This collection of information is required by 37 CFR 1.97 and 1.98. The information is required to obtain or retain a benefit by the public which is to file (and by the USPTO to process) an application. Confidentiality is governed by 35 U.S.C. 122 and 37 CFR 1.14. This collection is estimated to take 1 hour to complete, including gathering, preparing and submitting the completed application form to the USPTO. Time will vary depending upon the individual case. Any comments on the amount of time you require to complete this form and/or suggestions for reducing this burden, should be sent to the Chief Information Officer, U.S. Patent and Trademark Office, U.S. Department of Commerce, P.O. Box 1450, Alexandria, VA 22313-1450. **DO NOT SEND FEES OR COMPLETED FORMS TO THIS ADDRESS. SEND TO: Commissioner for Patents, P.O. Box 1450, Alexandria, VA 22313-1450.**

## Privacy Act Statement

The Privacy Act of 1974 (P.L. 93-579) requires that you be given certain information in connection with your submission of the attached form related to a patent application or patent. Accordingly, pursuant to the requirements of the Act, please be advised that: (1) the general authority for the collection of this information is 35 U.S.C. 2(b)(2); (2) furnishing of the information solicited is voluntary; and (3) the principal purpose for which the information is used by the U.S. Patent and Trademark Office is to process and/or examine your submission related to a patent application or patent. If you do not furnish the requested information, the U.S. Patent and Trademark Office may not be able to process and/or examine your submission, which may result in termination of proceedings or abandonment of the application or expiration of the patent.

The information provided by you in this form will be subject to the following routine uses:

1. The information on this form will be treated confidentially to the extent allowed under the Freedom of Information Act (5 U.S.C. 552) and the Privacy Act (5 U.S.C. 552a). Records from this system of records may be disclosed to the Department of Justice to determine whether the Freedom of Information Act requires disclosure of these records.
2. A record from this system of records may be disclosed, as a routine use, in the course of presenting evidence to a court, magistrate, or administrative tribunal, including disclosures to opposing counsel in the course of settlement negotiations.
3. A record in this system of records may be disclosed, as a routine use, to a Member of Congress submitting a request involving an individual, to whom the record pertains, when the individual has requested assistance from the Member with respect to the subject matter of the record.
4. A record in this system of records may be disclosed, as a routine use, to a contractor of the Agency having need for the information in order to perform a contract. Recipients of information shall be required to comply with the requirements of the Privacy Act of 1974, as amended, pursuant to 5 U.S.C. 552a(m).
5. A record related to an International Application filed under the Patent Cooperation Treaty in this system of records may be disclosed, as a routine use, to the International Bureau of the World Intellectual Property Organization, pursuant to the Patent Cooperation Treaty.
6. A record in this system of records may be disclosed, as a routine use, to another federal agency for purposes of National Security review (35 U.S.C. 181) and for review pursuant to the Atomic Energy Act (42 U.S.C. 218(c)).
7. A record from this system of records may be disclosed, as a routine use, to the Administrator, General Services, or his/her designee, during an inspection of records conducted by GSA as part of that agency's responsibility to recommend improvements in records management practices and programs, under authority of 44 U.S.C. 2904 and 2906. Such disclosure shall be made in accordance with the GSA regulations governing inspection of records for this purpose, and any other relevant (i.e., GSA or Commerce) directive. Such disclosure shall not be used to make determinations about individuals.
8. A record from this system of records may be disclosed, as a routine use, to the public after either publication of the application pursuant to 35 U.S.C. 122(b) or issuance of a patent pursuant to 35 U.S.C. 151. Further, a record may be disclosed, subject to the limitations of 37 CFR 1.14, as a routine use, to the public if the record was filed in an application which became abandoned or in which the proceedings were terminated and which application is referenced by either a published application, an application open to public inspections or an issued patent.
9. A record from this system of records may be disclosed, as a routine use, to a Federal, State, or local law enforcement agency, if the USPTO becomes aware of a violation or potential violation of law or regulation.



## Electronic Acknowledgement Receipt

|                                             |                                                                  |
|---------------------------------------------|------------------------------------------------------------------|
| <b>EFS ID:</b>                              | 35974537                                                         |
| <b>Application Number:</b>                  | 16380844                                                         |
| <b>International Application Number:</b>    |                                                                  |
| <b>Confirmation Number:</b>                 | 8653                                                             |
| <b>Title of Invention:</b>                  | METHODS AND UE FOR RESUMING A CONNECTION WITH FULL CONFIGURATION |
| <b>First Named Inventor/Applicant Name:</b> | Oumer TEYEB                                                      |
| <b>Customer Number:</b>                     | 27045                                                            |
| <b>Filer:</b>                               | Brian Michael Kearns/Lala Deleon                                 |
| <b>Filer Authorized By:</b>                 | Brian Michael Kearns                                             |
| <b>Attorney Docket Number:</b>              | P74267 US2                                                       |
| <b>Receipt Date:</b>                        | 10-MAY-2019                                                      |
| <b>Filing Date:</b>                         | 10-APR-2019                                                      |
| <b>Time Stamp:</b>                          | 10:47:51                                                         |
| <b>Application Type:</b>                    | Utility under 35 USC 111(a)                                      |

### Payment information:

|                        |    |
|------------------------|----|
| Submitted with Payment | no |
|------------------------|----|

### File Listing:

| Document Number | Document Description | File Name                                           | File Size(Bytes)/<br>Message Digest              | Multi Part /.zip | Pages (if appl.) |
|-----------------|----------------------|-----------------------------------------------------|--------------------------------------------------|------------------|------------------|
| 1               | Transmittal Letter   | P74267US2_2019-05-10_Transmittal_letter_for_IDS.pdf | 92423<br>8f941f606cc9a7fba18001ae1b516a77b16bb38 | no               | 2                |

### Warnings:

|                                                                                                                                                                                                                                                                                                                                                                                                                                                                                                                                                                                                                                                                                                                                                                                                                                                                                                                                                                                                                                                                                                                                                                                                                                                                                                                                                                                                                                                                                                                                                                                                                                                                                                                                                                             |                                                    |                                              |                                                      |         |     |
|-----------------------------------------------------------------------------------------------------------------------------------------------------------------------------------------------------------------------------------------------------------------------------------------------------------------------------------------------------------------------------------------------------------------------------------------------------------------------------------------------------------------------------------------------------------------------------------------------------------------------------------------------------------------------------------------------------------------------------------------------------------------------------------------------------------------------------------------------------------------------------------------------------------------------------------------------------------------------------------------------------------------------------------------------------------------------------------------------------------------------------------------------------------------------------------------------------------------------------------------------------------------------------------------------------------------------------------------------------------------------------------------------------------------------------------------------------------------------------------------------------------------------------------------------------------------------------------------------------------------------------------------------------------------------------------------------------------------------------------------------------------------------------|----------------------------------------------------|----------------------------------------------|------------------------------------------------------|---------|-----|
| <b>Information:</b>                                                                                                                                                                                                                                                                                                                                                                                                                                                                                                                                                                                                                                                                                                                                                                                                                                                                                                                                                                                                                                                                                                                                                                                                                                                                                                                                                                                                                                                                                                                                                                                                                                                                                                                                                         |                                                    |                                              |                                                      |         |     |
| 2                                                                                                                                                                                                                                                                                                                                                                                                                                                                                                                                                                                                                                                                                                                                                                                                                                                                                                                                                                                                                                                                                                                                                                                                                                                                                                                                                                                                                                                                                                                                                                                                                                                                                                                                                                           | Information Disclosure Statement (IDS) Form (SB08) | P74267US2_2019-05-10_US_ID_S_Form_SB_08a.pdf | 612169<br>a53657a7e5d8ab923b7891deb42bbbf39745294    | no      | 4   |
| <b>Warnings:</b>                                                                                                                                                                                                                                                                                                                                                                                                                                                                                                                                                                                                                                                                                                                                                                                                                                                                                                                                                                                                                                                                                                                                                                                                                                                                                                                                                                                                                                                                                                                                                                                                                                                                                                                                                            |                                                    |                                              |                                                      |         |     |
| <b>Information:</b>                                                                                                                                                                                                                                                                                                                                                                                                                                                                                                                                                                                                                                                                                                                                                                                                                                                                                                                                                                                                                                                                                                                                                                                                                                                                                                                                                                                                                                                                                                                                                                                                                                                                                                                                                         |                                                    |                                              |                                                      |         |     |
| A U.S. Patent Number Citation or a U.S. Publication Number Citation is required in the Information Disclosure Statement (IDS) form for autoloading of data into USPTO systems. You may remove the form to add the required data in order to correct the Informational Message if you are citing U.S. References. If you chose not to include U.S. References, the image of the form will be processed and be made available within the Image File Wrapper (IFW) system. However, no data will be extracted from this form. Any additional data such as Foreign Patent Documents or Non Patent Literature will be manually reviewed and keyed into USPTO systems.                                                                                                                                                                                                                                                                                                                                                                                                                                                                                                                                                                                                                                                                                                                                                                                                                                                                                                                                                                                                                                                                                                            |                                                    |                                              |                                                      |         |     |
| 3                                                                                                                                                                                                                                                                                                                                                                                                                                                                                                                                                                                                                                                                                                                                                                                                                                                                                                                                                                                                                                                                                                                                                                                                                                                                                                                                                                                                                                                                                                                                                                                                                                                                                                                                                                           | Non Patent Literature                              | P74267_2019-05-08_36331f01_WO.pdf            | 4193753<br>ec01dc032d3760b76f4ad16d752b0add9b6f9710  | no      | 776 |
| <b>Warnings:</b>                                                                                                                                                                                                                                                                                                                                                                                                                                                                                                                                                                                                                                                                                                                                                                                                                                                                                                                                                                                                                                                                                                                                                                                                                                                                                                                                                                                                                                                                                                                                                                                                                                                                                                                                                            |                                                    |                                              |                                                      |         |     |
| <b>Information:</b>                                                                                                                                                                                                                                                                                                                                                                                                                                                                                                                                                                                                                                                                                                                                                                                                                                                                                                                                                                                                                                                                                                                                                                                                                                                                                                                                                                                                                                                                                                                                                                                                                                                                                                                                                         |                                                    |                                              |                                                      |         |     |
| 4                                                                                                                                                                                                                                                                                                                                                                                                                                                                                                                                                                                                                                                                                                                                                                                                                                                                                                                                                                                                                                                                                                                                                                                                                                                                                                                                                                                                                                                                                                                                                                                                                                                                                                                                                                           | Non Patent Literature                              | P74267_2019-05-08_R21714208_WO.pdf           | 5041838<br>c826a468b7ddaa84799478cd1bbcb2e76434025ba | no      | 12  |
| <b>Warnings:</b>                                                                                                                                                                                                                                                                                                                                                                                                                                                                                                                                                                                                                                                                                                                                                                                                                                                                                                                                                                                                                                                                                                                                                                                                                                                                                                                                                                                                                                                                                                                                                                                                                                                                                                                                                            |                                                    |                                              |                                                      |         |     |
| <b>Information:</b>                                                                                                                                                                                                                                                                                                                                                                                                                                                                                                                                                                                                                                                                                                                                                                                                                                                                                                                                                                                                                                                                                                                                                                                                                                                                                                                                                                                                                                                                                                                                                                                                                                                                                                                                                         |                                                    |                                              |                                                      |         |     |
| <b>Total Files Size (in bytes):</b>                                                                                                                                                                                                                                                                                                                                                                                                                                                                                                                                                                                                                                                                                                                                                                                                                                                                                                                                                                                                                                                                                                                                                                                                                                                                                                                                                                                                                                                                                                                                                                                                                                                                                                                                         |                                                    |                                              |                                                      | 9940183 |     |
| <p><b>This Acknowledgement Receipt evidences receipt on the noted date by the USPTO of the indicated documents, characterized by the applicant, and including page counts, where applicable. It serves as evidence of receipt similar to a Post Card, as described in MPEP 503.</b></p> <p><b><u>New Applications Under 35 U.S.C. 111</u></b><br/> <b>If a new application is being filed and the application includes the necessary components for a filing date (see 37 CFR 1.53(b)-(d) and MPEP 506), a Filing Receipt (37 CFR 1.54) will be issued in due course and the date shown on this Acknowledgement Receipt will establish the filing date of the application.</b></p> <p><b><u>National Stage of an International Application under 35 U.S.C. 371</u></b><br/> <b>If a timely submission to enter the national stage of an international application is compliant with the conditions of 35 U.S.C. 371 and other applicable requirements a Form PCT/DO/EO/903 indicating acceptance of the application as a national stage submission under 35 U.S.C. 371 will be issued in addition to the Filing Receipt, in due course.</b></p> <p><b><u>New International Application Filed with the USPTO as a Receiving Office</u></b><br/> <b>If a new international application is being filed and the international application includes the necessary components for an international filing date (see PCT Article 11 and MPEP 1810), a Notification of the International Application Number and of the International Filing Date (Form PCT/RO/105) will be issued in due course, subject to prescriptions concerning national security, and the date shown on this Acknowledgement Receipt will establish the international filing date of the application.</b></p> |                                                    |                                              |                                                      |         |     |



Furthermore, any markings, underlines, notations or the like present in any reference are not to be construed as drawing the Examiner's attention to or away from other parts or portions of the reference.

Applicants hereby expressly reserve the right to swear behind the effective dates of any of the references. Applicants further reserve the right to question the relevance and materiality of the references in whole, in part or in combination subsequent to the filing of this statement.

The Commissioner is hereby authorized to charge any fees that may be required or credit any overpayment to Deposit Account 501379.

Respectfully submitted,

/BrentCapehart/

Brent Capehart

Registration No. 39620

Date: May 10, 2019

|                                                                                   |                                            |
|-----------------------------------------------------------------------------------|--------------------------------------------|
| <b>PATENT APPLICATION FEE DETERMINATION RECORD</b><br>Substitute for Form PTO-875 | Application or Docket Number<br>16/380,844 |
|-----------------------------------------------------------------------------------|--------------------------------------------|

| APPLICATION AS FILED - PART I                                             |                                                                                                                                                                                                                               |              | SMALL ENTITY |         | OR | OTHER THAN SMALL ENTITY |         |
|---------------------------------------------------------------------------|-------------------------------------------------------------------------------------------------------------------------------------------------------------------------------------------------------------------------------|--------------|--------------|---------|----|-------------------------|---------|
|                                                                           | (Column 1)                                                                                                                                                                                                                    | (Column 2)   |              |         |    |                         |         |
| FOR                                                                       | NUMBER FILED                                                                                                                                                                                                                  | NUMBER EXTRA | RATE(\$)     | FEE(\$) |    | RATE(\$)                | FEE(\$) |
| BASIC FEE<br>(37 CFR 1.16(a), (b), or (c))                                | N/A                                                                                                                                                                                                                           | N/A          | N/A          |         |    | N/A                     | 300     |
| SEARCH FEE<br>(37 CFR 1.16(k), (j), or (m))                               | N/A                                                                                                                                                                                                                           | N/A          | N/A          |         |    | N/A                     | 660     |
| EXAMINATION FEE<br>(37 CFR 1.16(o), (p), or (q))                          | N/A                                                                                                                                                                                                                           | N/A          | N/A          |         |    | N/A                     | 760     |
| TOTAL CLAIMS<br>(37 CFR 1.16(i))                                          | 20                                                                                                                                                                                                                            | minus 20 = * |              |         | OR | x 100 =                 | 0.00    |
| INDEPENDENT CLAIMS<br>(37 CFR 1.16(h))                                    | 3                                                                                                                                                                                                                             | minus 3 = *  |              |         |    | x 460 =                 | 0.00    |
| APPLICATION SIZE FEE<br>(37 CFR 1.16(s))                                  | If the specification and drawings exceed 100 sheets of paper, the application size fee due is \$310 (\$155 for small entity) for each additional 50 sheets or fraction thereof. See 35 U.S.C. 41(a)(1)(G) and 37 CFR 1.16(s). |              |              |         |    |                         | 0.00    |
| MULTIPLE DEPENDENT CLAIM PRESENT (37 CFR 1.16(j))                         |                                                                                                                                                                                                                               |              |              |         |    |                         | 0.00    |
| * If the difference in column 1 is less than zero, enter "0" in column 2. |                                                                                                                                                                                                                               |              | TOTAL        |         |    | TOTAL                   | 1720    |

| APPLICATION AS AMENDED - PART II                                                                                                                                                                                                                                                                                                                                                                                              |                                                                 |            |                                    |               | SMALL ENTITY       |                    | OR | OTHER THAN SMALL ENTITY |                    |  |
|-------------------------------------------------------------------------------------------------------------------------------------------------------------------------------------------------------------------------------------------------------------------------------------------------------------------------------------------------------------------------------------------------------------------------------|-----------------------------------------------------------------|------------|------------------------------------|---------------|--------------------|--------------------|----|-------------------------|--------------------|--|
|                                                                                                                                                                                                                                                                                                                                                                                                                               | (Column 1)                                                      | (Column 2) | (Column 3)                         |               |                    |                    |    |                         |                    |  |
| AMENDMENT A                                                                                                                                                                                                                                                                                                                                                                                                                   | CLAIMS REMAINING AFTER AMENDMENT                                | MINUS      | HIGHEST NUMBER PREVIOUSLY PAID FOR | PRESENT EXTRA | RATE(\$)           | ADDITIONAL FEE(\$) |    | RATE(\$)                | ADDITIONAL FEE(\$) |  |
|                                                                                                                                                                                                                                                                                                                                                                                                                               | Total<br>(37 CFR 1.16(i))                                       | *          | Minus                              | **            | =                  |                    | OR | x                       | =                  |  |
|                                                                                                                                                                                                                                                                                                                                                                                                                               | Independent<br>(37 CFR 1.16(h))                                 | *          | Minus                              | ***           | =                  |                    | OR | x                       | =                  |  |
|                                                                                                                                                                                                                                                                                                                                                                                                                               | Application Size Fee (37 CFR 1.16(s))                           |            |                                    |               |                    |                    |    | OR                      |                    |  |
|                                                                                                                                                                                                                                                                                                                                                                                                                               | FIRST PRESENTATION OF MULTIPLE DEPENDENT CLAIM (37 CFR 1.16(j)) |            |                                    |               |                    |                    |    | OR                      |                    |  |
|                                                                                                                                                                                                                                                                                                                                                                                                                               |                                                                 |            |                                    |               | TOTAL<br>ADD'L FEE |                    | OR | TOTAL<br>ADD'L FEE      |                    |  |
| AMENDMENT B                                                                                                                                                                                                                                                                                                                                                                                                                   | CLAIMS REMAINING AFTER AMENDMENT                                | MINUS      | HIGHEST NUMBER PREVIOUSLY PAID FOR | PRESENT EXTRA | RATE(\$)           | ADDITIONAL FEE(\$) |    | RATE(\$)                | ADDITIONAL FEE(\$) |  |
|                                                                                                                                                                                                                                                                                                                                                                                                                               | Total<br>(37 CFR 1.16(i))                                       | *          | Minus                              | **            | =                  |                    | OR | x                       | =                  |  |
|                                                                                                                                                                                                                                                                                                                                                                                                                               | Independent<br>(37 CFR 1.16(h))                                 | *          | Minus                              | ***           | =                  |                    | OR | x                       | =                  |  |
|                                                                                                                                                                                                                                                                                                                                                                                                                               | Application Size Fee (37 CFR 1.16(s))                           |            |                                    |               |                    |                    |    | OR                      |                    |  |
|                                                                                                                                                                                                                                                                                                                                                                                                                               | FIRST PRESENTATION OF MULTIPLE DEPENDENT CLAIM (37 CFR 1.16(j)) |            |                                    |               |                    |                    |    | OR                      |                    |  |
|                                                                                                                                                                                                                                                                                                                                                                                                                               |                                                                 |            |                                    |               | TOTAL<br>ADD'L FEE |                    | OR | TOTAL<br>ADD'L FEE      |                    |  |
| <p>* If the entry in column 1 is less than the entry in column 2, write "0" in column 3.</p> <p>** If the "Highest Number Previously Paid For" IN THIS SPACE is less than 20, enter "20".</p> <p>*** If the "Highest Number Previously Paid For" IN THIS SPACE is less than 3, enter "3".</p> <p>The "Highest Number Previously Paid For" (Total or Independent) is the highest found in the appropriate box in column 1.</p> |                                                                 |            |                                    |               |                    |                    |    |                         |                    |  |



UNITED STATES PATENT AND TRADEMARK OFFICE

UNITED STATES DEPARTMENT OF COMMERCE
United States Patent and Trademark Office
Address: COMMISSIONER FOR PATENTS
P.O. Box 1450
Alexandria, Virginia 22313-1450
www.uspto.gov

Table with 7 columns: APPLICATION NUMBER, FILING or 371(c) DATE, GRP ART UNIT, FIL FEE REC'D, ATTY DOCKET NO, TOT CLAIMS, IND CLAIMS. Row 1: 16/380,844, 04/10/2019, 1720, P74267 US2, 20, 3

CONFIRMATION NO. 8653

FILING RECEIPT

27045
ERICSSON INC.
6300 LEGACY DRIVE
M/S EVR 1-C-11
PLANO, TX 75024



Date Mailed: 04/25/2019

Receipt is acknowledged of this non-provisional utility patent application. The application will be taken up for examination in due course. Applicant will be notified as to the results of the examination. Any correspondence concerning the application must include the following identification information: the U.S. APPLICATION NUMBER, FILING DATE, NAME OF FIRST INVENTOR, and TITLE OF INVENTION. Fees transmitted by check or draft are subject to collection.

Please verify the accuracy of the data presented on this receipt. If an error is noted on this Filing Receipt, please submit a written request for a corrected Filing Receipt, including a properly marked-up ADS showing the changes with strike-through for deletions and underlining for additions. If you received a "Notice to File Missing Parts" or other Notice requiring a response for this application, please submit any request for correction to this Filing Receipt with your reply to the Notice. When the USPTO processes the reply to the Notice, the USPTO will generate another Filing Receipt incorporating the requested corrections provided that the request is grantable.

Inventor(s)

Oumer TEYEB, SOLNA, SWEDEN;
Gunnar MILDH, SOLLENTUNA, SWEDEN;

Applicant(s)

TELEFONAKTIEBOLAGET LM ERICSSON (PUBL), Stockholm, SWEDEN;

Power of Attorney: The patent practitioners associated with Customer Number 27045

Domestic Priority data as claimed by applicant

This application is a CON of PCT/IB2019/050836 02/01/2019
which claims benefit of 62/631,467 02/15/2018

Foreign Applications for which priority is claimed (You may be eligible to benefit from the Patent Prosecution Highway program at the USPTO. Please see http://www.uspto.gov for more information.) - None.

Foreign application information must be provided in an Application Data Sheet in order to constitute a claim to foreign priority. See 37 CFR 1.55 and 1.76.

Permission to Access Application via Priority Document Exchange: Yes

Permission to Access Search Results: Yes

Applicant may provide or rescind an authorization for access using Form PTO/SB/39 or Form PTO/SB/69 as appropriate.

**If Required, Foreign Filing License Granted:** 04/24/2019

The country code and number of your priority application, to be used for filing abroad under the Paris Convention, is **US 16/380,844**

**Projected Publication Date:** 08/15/2019

**Non-Publication Request:** No

**Early Publication Request:** No  
**Title**

METHODS AND UE FOR RESUMING A CONNECTION WITH FULL CONFIGURATION

**Preliminary Class**

**Statement under 37 CFR 1.55 or 1.78 for AIA (First Inventor to File) Transition Applications:** No

### **PROTECTING YOUR INVENTION OUTSIDE THE UNITED STATES**

Since the rights granted by a U.S. patent extend only throughout the territory of the United States and have no effect in a foreign country, an inventor who wishes patent protection in another country must apply for a patent in a specific country or in regional patent offices. Applicants may wish to consider the filing of an international application under the Patent Cooperation Treaty (PCT). An international (PCT) application generally has the same effect as a regular national patent application in each PCT-member country. The PCT process **simplifies** the filing of patent applications on the same invention in member countries, but **does not result** in a grant of "an international patent" and does not eliminate the need of applicants to file additional documents and fees in countries where patent protection is desired.

Almost every country has its own patent law, and a person desiring a patent in a particular country must make an application for patent in that country in accordance with its particular laws. Since the laws of many countries differ in various respects from the patent law of the United States, applicants are advised to seek guidance from specific foreign countries to ensure that patent rights are not lost prematurely.

Applicants also are advised that in the case of inventions made in the United States, the Director of the USPTO must issue a license before applicants can apply for a patent in a foreign country. The filing of a U.S. patent application serves as a request for a foreign filing license. The application's filing receipt contains further information and guidance as to the status of applicant's license for foreign filing.

Applicants may wish to consult the USPTO booklet, "General Information Concerning Patents" (specifically, the section entitled "Treaties and Foreign Patents") for more information on timeframes and deadlines for filing foreign patent applications. The guide is available either by contacting the USPTO Contact Center at 800-786-9199, or it can be viewed on the USPTO website at <http://www.uspto.gov/web/offices/pac/doc/general/index.html>.

For information on preventing theft of your intellectual property (patents, trademarks and copyrights), you may wish to consult the U.S. Government website, <http://www.stopfakes.gov>. Part of a Department of Commerce initiative, this website includes self-help "toolkits" giving innovators guidance on how to protect intellectual property in specific countries such as China, Korea and Mexico. For questions regarding patent enforcement issues, applicants may call the U.S. Government hotline at 1-866-999-HALT (1-866-999-4258).

**LICENSE FOR FOREIGN FILING UNDER**  
**Title 35, United States Code, Section 184**  
**Title 37, Code of Federal Regulations, 5.11 & 5.15**

**GRANTED**

The applicant has been granted a license under 35 U.S.C. 184, if the phrase "IF REQUIRED, FOREIGN FILING LICENSE GRANTED" followed by a date appears on this form. Such licenses are issued in all applications where the conditions for issuance of a license have been met, regardless of whether or not a license may be required as set forth in 37 CFR 5.15. The scope and limitations of this license are set forth in 37 CFR 5.15(a) unless an earlier license has been issued under 37 CFR 5.15(b). The license is subject to revocation upon written notification. The date indicated is the effective date of the license, unless an earlier license of similar scope has been granted under 37 CFR 5.13 or 5.14.

This license is to be retained by the licensee and may be used at any time on or after the effective date thereof unless it is revoked. This license is automatically transferred to any related applications(s) filed under 37 CFR 1.53(d). This license is not retroactive.

The grant of a license does not in any way lessen the responsibility of a licensee for the security of the subject matter as imposed by any Government contract or the provisions of existing laws relating to espionage and the national security or the export of technical data. Licensees should apprise themselves of current regulations especially with respect to certain countries, of other agencies, particularly the Office of Defense Trade Controls, Department of State (with respect to Arms, Munitions and Implements of War (22 CFR 121-128)); the Bureau of Industry and Security, Department of Commerce (15 CFR parts 730-774); the Office of Foreign Assets Control, Department of Treasury (31 CFR Parts 500+) and the Department of Energy.

**NOT GRANTED**

No license under 35 U.S.C. 184 has been granted at this time, if the phrase "IF REQUIRED, FOREIGN FILING LICENSE GRANTED" DOES NOT appear on this form. Applicant may still petition for a license under 37 CFR 5.12, if a license is desired before the expiration of 6 months from the filing date of the application. If 6 months has lapsed from the filing date of this application and the licensee has not received any indication of a secrecy order under 35 U.S.C. 181, the licensee may foreign file the application pursuant to 37 CFR 5.15(b).

---

***SelectUSA***

The United States represents the largest, most dynamic marketplace in the world and is an unparalleled location for business investment, innovation, and commercialization of new technologies. The U.S. offers tremendous resources and advantages for those who invest and manufacture goods here. Through SelectUSA, our nation works to promote and facilitate business investment. SelectUSA provides information assistance to the international investor community; serves as an ombudsman for existing and potential investors; advocates on behalf of U.S. cities, states, and regions competing for global investment; and counsels U.S. economic development organizations on investment attraction best practices. To learn more about why the United States is the best country in the world to develop technology, manufacture products, deliver services, and grow your business, visit <http://www.SelectUSA.gov> or call +1-202-482-6800.





UNITED STATES PATENT AND TRADEMARK OFFICE

UNITED STATES DEPARTMENT OF COMMERCE  
United States Patent and Trademark Office  
Address: COMMISSIONER FOR PATENTS  
P.O. Box 1450  
Alexandria, Virginia 22313-1450  
www.uspto.gov

| APPLICATION NO.                                                         | FILING DATE | FIRST NAMED INVENTOR | ATTORNEY DOCKET NO. | CONFIRMATION NO. |
|-------------------------------------------------------------------------|-------------|----------------------|---------------------|------------------|
| 16/380,844                                                              | 04/10/2019  | Oumer TEYEB          | P74267 US2          | 8653             |
| 27045                                                                   | 7590        | 04/25/2019           | EXAMINER            |                  |
| ERICSSON INC.<br>6300 LEGACY DRIVE<br>M/S EVR 1-C-11<br>PLANO, TX 75024 |             |                      | ART UNIT            | PAPER NUMBER     |
|                                                                         |             |                      | NOTIFICATION DATE   | DELIVERY MODE    |
|                                                                         |             |                      | 04/25/2019          | ELECTRONIC       |

**Please find below and/or attached an Office communication concerning this application or proceeding.**

The time period for reply, if any, is set in the attached communication.

Notice of the Office communication was sent electronically on above-indicated "Notification Date" to the following e-mail address(es):

michelle.sanderson@ericsson.com  
pam.ewing@ericsson.com

|                                                                                                                                                                                                                                                                                                                                                                                                                                                                                                                                                                                                                                                                                                                                                                                                                                                                                                                                                                                                                                                                                                                                                                                                                                                                                                                                                                                                                                                               |                                      |                                     |                                 |
|---------------------------------------------------------------------------------------------------------------------------------------------------------------------------------------------------------------------------------------------------------------------------------------------------------------------------------------------------------------------------------------------------------------------------------------------------------------------------------------------------------------------------------------------------------------------------------------------------------------------------------------------------------------------------------------------------------------------------------------------------------------------------------------------------------------------------------------------------------------------------------------------------------------------------------------------------------------------------------------------------------------------------------------------------------------------------------------------------------------------------------------------------------------------------------------------------------------------------------------------------------------------------------------------------------------------------------------------------------------------------------------------------------------------------------------------------------------|--------------------------------------|-------------------------------------|---------------------------------|
| <b><i>Decision Granting Request for Prioritized Examination (Track I)</i></b>                                                                                                                                                                                                                                                                                                                                                                                                                                                                                                                                                                                                                                                                                                                                                                                                                                                                                                                                                                                                                                                                                                                                                                                                                                                                                                                                                                                 | <b>Application No.</b><br>16/380,844 | <b>Applicant(s)</b><br>TEYEB et al. |                                 |
|                                                                                                                                                                                                                                                                                                                                                                                                                                                                                                                                                                                                                                                                                                                                                                                                                                                                                                                                                                                                                                                                                                                                                                                                                                                                                                                                                                                                                                                               | <b>Examiner</b><br>BRIAN W BROWN     | <b>Art Unit</b><br>OPET             | <b>AIA (FITF) Status</b><br>Yes |
| <p>1. THE REQUEST FILED <u>10 April 2019</u> IS <b>GRANTED</b> .</p> <p>The above-identified application has met the requirements for prioritized examination</p> <p>A. <input checked="" type="checkbox"/> for an original nonprovisional application (Track I).</p> <p>B. <input type="checkbox"/> for an application undergoing continued examination (RCE).</p> <p>2. <b>The above-identified application will undergo prioritized examination.</b> The application will be accorded special status throughout its entire course of prosecution until one of the following occurs:</p> <p>A. filing a <b><u>petition for extension of time</u></b> to extend the time period for filing a reply;</p> <p>B. filing an <b><u>amendment to amend the application to contain more than four independent claims, more than thirty total claims</u></b>, or a multiple dependent claim;</p> <p>C. filing a <b><u>request for continued examination</u></b> ;</p> <p>D. filing a notice of appeal;</p> <p>E. filing a request for suspension of action;</p> <p>F. mailing of a notice of allowance;</p> <p>G. mailing of a final Office action;</p> <p>H. completion of examination as defined in 37 CFR 41.102; or</p> <p>I. abandonment of the application.</p> <p>Telephone inquiries with regard to this decision should be directed to BRIAN BROWN at (571)272-5338. In his/her absence, calls may be directed to Petition Help Desk at (571) 272-3282.</p> |                                      |                                     |                                 |
| /BRIAN W BROWN/<br>Petitions Examiner, OPET                                                                                                                                                                                                                                                                                                                                                                                                                                                                                                                                                                                                                                                                                                                                                                                                                                                                                                                                                                                                                                                                                                                                                                                                                                                                                                                                                                                                                   |                                      |                                     |                                 |

**CERTIFICATION AND REQUEST FOR PRIORITIZED EXAMINATION  
 UNDER 37 CFR 1.102(e) (Page 1 of 1)**

|                       |                                                                  |                                               |  |
|-----------------------|------------------------------------------------------------------|-----------------------------------------------|--|
| First Named Inventor: | Oumer TEYEB                                                      | Nonprovisional Application Number (if known): |  |
| Title of Invention:   | METHODS AND UE FOR RESUMING A CONNECTION WITH FULL CONFIGURATION |                                               |  |

**APPLICANT HEREBY CERTIFIES THE FOLLOWING AND REQUESTS PRIORITIZED EXAMINATION FOR THE ABOVE-IDENTIFIED APPLICATION.**

1. The processing fee set forth in 37 CFR 1.17(i)(1) and the prioritized examination fee set forth in 37 CFR 1.17(c) have been filed with the request. The publication fee requirement is met because that fee, set forth in 37 CFR 1.18(d), is currently \$0. The basic filing fee, search fee, and examination fee are filed with the request or have been already been paid. I understand that any required excess claims fees or application size fee must be paid for the application.
2. I understand that the application may not contain, or be amended to contain, more than four independent claims, more than thirty total claims, or any multiple dependent claims, and that any request for an extension of time will cause an outstanding Track I request to be dismissed.
3. The applicable box is checked below:
  - I.  **Original Application (Track One) - Prioritized Examination under § 1.102(e)(1)**
    - i. (a) The application is an original nonprovisional utility application filed under 35 U.S.C. 111(a). This certification and request is being filed with the utility application via EFS-Web.  
 ---OR---
      - (b) The application is an original nonprovisional plant application filed under 35 U.S.C. 111(a). This certification and request is being filed with the plant application in paper.
    - ii. An executed inventor's oath or declaration under 37 CFR 1.63 or 37 CFR 1.64 for each inventor, **or** the application data sheet meeting the conditions specified in 37 CFR 1.53(f)(3)(i) is filed with the application.
  - II.  **Request for Continued Examination - Prioritized Examination under § 1.102(e)(2)**
    - i. A request for continued examination has been filed with, or prior to, this form.
    - ii. If the application is a utility application, this certification and request is being filed via EFS-Web.
    - iii. The application is an original nonprovisional utility application filed under 35 U.S.C. 111(a), or is a national stage entry under 35 U.S.C. 371.
    - iv. This certification and request is being filed prior to the mailing of a first Office action responsive to the request for continued examination.
    - v. No prior request for continued examination has been granted prioritized examination status under 37 CFR 1.102(e)(2).

|                                    |                                        |
|------------------------------------|----------------------------------------|
| Signature /Michael Cameron/        | Date 2019-04-10                        |
| Name (Print/Typed) Michael Cameron | Practitioner Registration Number 50298 |

**Note:** This form must be signed in accordance with 37 CFR 1.33. See 37 CFR 1.4(d) for signature requirements and certifications. Submit multiple forms if more than one signature is required.\*

\*Total of 1 forms are submitted.

## Privacy Act Statement

The **Privacy Act of 1974 (P.L. 93-579)** requires that you be given certain information in connection with your submission of the attached form related to a patent application or patent. Accordingly, pursuant to the requirements of the Act, please be advised that: (1) the general authority for the collection of this information is 35 U.S.C. 2(b)(2); (2) furnishing of the information solicited is voluntary; and (3) the principal purpose for which the information is used by the U.S. Patent and Trademark Office is to process and/or examine your submission related to a patent application or patent. If you do not furnish the requested information, the U.S. Patent and Trademark Office may not be able to process and/or examine your submission, which may result in termination of proceedings or abandonment of the application or expiration of the patent.

The information provided by you in this form will be subject to the following routine uses:

1. The information on this form will be treated confidentially to the extent allowed under the Freedom of Information Act (5 U.S.C. 552) and the Privacy Act (5 U.S.C. 552a). Records from this system of records may be disclosed to the Department of Justice to determine whether disclosure of these records is required by the Freedom of Information Act.
2. A record from this system of records may be disclosed, as a routine use, in the course of presenting evidence to a court, magistrate, or administrative tribunal, including disclosures to opposing counsel in the course of settlement negotiations.
3. A record in this system of records may be disclosed, as a routine use, to a Member of Congress submitting a request involving an individual, to whom the record pertains, when the individual has requested assistance from the Member with respect to the subject matter of the record.
4. A record in this system of records may be disclosed, as a routine use, to a contractor of the Agency having need for the information in order to perform a contract. Recipients of information shall be required to comply with the requirements of the Privacy Act of 1974, as amended, pursuant to 5 U.S.C. 552a(m).
5. A record related to an International Application filed under the Patent Cooperation Treaty in this system of records may be disclosed, as a routine use, to the International Bureau of the World Intellectual Property Organization, pursuant to the Patent Cooperation Treaty.
6. A record in this system of records may be disclosed, as a routine use, to another federal agency for purposes of National Security review (35 U.S.C. 181) and for review pursuant to the Atomic Energy Act (42 U.S.C. 218(c)).
7. A record from this system of records may be disclosed, as a routine use, to the Administrator, General Services, or his/her designee, during an inspection of records conducted by GSA as part of that agency's responsibility to recommend improvements in records management practices and programs, under authority of 44 U.S.C. 2904 and 2906. Such disclosure shall be made in accordance with the GSA regulations governing inspection of records for this purpose, and any other relevant (*i.e.*, GSA or Commerce) directive. Such disclosure shall not be used to make determinations about individuals.
8. A record from this system of records may be disclosed, as a routine use, to the public after publication of the application pursuant to 35 U.S.C. 122(b) or issuance of a patent pursuant to 35 U.S.C. 151. Further, a record may be disclosed, subject to the limitations of 37 CFR 1.14, as a routine use, to the public if the record was filed in an application which became abandoned or in which the proceedings were terminated and which application is referenced by either a published application, an application open to public inspection or an issued patent.
9. A record from this system of records may be disclosed, as a routine use, to a Federal, State, or local law enforcement agency, if the USPTO becomes aware of a violation or potential violation of law or regulation.

Under the Paperwork Reduction Act of 1995, no persons are required to respond to a collection of information unless it contains a valid OMB control number.

|                                                                                                                                                                                                                                                                                                                                                                                                                                                                                                       |                                                                  |                        |            |
|-------------------------------------------------------------------------------------------------------------------------------------------------------------------------------------------------------------------------------------------------------------------------------------------------------------------------------------------------------------------------------------------------------------------------------------------------------------------------------------------------------|------------------------------------------------------------------|------------------------|------------|
| <b>Application Data Sheet 37 CFR 1.76</b>                                                                                                                                                                                                                                                                                                                                                                                                                                                             |                                                                  | Attorney Docket Number | P74267 US2 |
|                                                                                                                                                                                                                                                                                                                                                                                                                                                                                                       |                                                                  | Application Number     |            |
| Title of Invention                                                                                                                                                                                                                                                                                                                                                                                                                                                                                    | METHODS AND UE FOR RESUMING A CONNECTION WITH FULL CONFIGURATION |                        |            |
| The application data sheet is part of the provisional or nonprovisional application for which it is being submitted. The following form contains the bibliographic data arranged in a format specified by the United States Patent and Trademark Office as outlined in 37 CFR 1.76. This document may be completed electronically and submitted to the Office in electronic format using the Electronic Filing System (EFS) or the document may be printed and included in a paper filed application. |                                                                  |                        |            |

**Secrecy Order 37 CFR 5.2:**

Portions or all of the application associated with this Application Data Sheet may fall under a Secrecy Order pursuant to 37 CFR 5.2 (Paper filers only. Applications that fall under Secrecy Order may not be filed electronically.)

**Inventor Information:**

|                                                                                                                                      |                   |                                   |             |        |        |
|--------------------------------------------------------------------------------------------------------------------------------------|-------------------|-----------------------------------|-------------|--------|--------|
| Inventor                                                                                                                             | 1                 |                                   |             |        | Remove |
| Legal Name                                                                                                                           |                   |                                   |             |        |        |
| Prefix                                                                                                                               | Given Name        | Middle Name                       | Family Name | Suffix |        |
|                                                                                                                                      | Oumer             |                                   | TEYEB       |        |        |
| Residence Information (Select One)    US Residency <input type="radio"/> Non US Residency    Active US Military Service              |                   |                                   |             |        |        |
| City                                                                                                                                 | SOLNA             | Country of Residence <sup>i</sup> | SE          |        |        |
| Mailing Address of Inventor:                                                                                                         |                   |                                   |             |        |        |
| Address 1                                                                                                                            | Huvudstagatan 3 D |                                   |             |        |        |
| Address 2                                                                                                                            |                   |                                   |             |        |        |
| City                                                                                                                                 | SOLNA             | State/Province                    |             |        |        |
| Postal Code                                                                                                                          | SE-171 44         | Country <sup>i</sup>              | SE          |        |        |
| Inventor                                                                                                                             | 2                 |                                   |             |        | Remove |
| Legal Name                                                                                                                           |                   |                                   |             |        |        |
| Prefix                                                                                                                               | Given Name        | Middle Name                       | Family Name | Suffix |        |
|                                                                                                                                      | Gunnar            |                                   | MILDH       |        |        |
| Residence Information (Select One)    US Residency <input checked="" type="radio"/> Non US Residency    Active US Military Service   |                   |                                   |             |        |        |
| City                                                                                                                                 | SOLLENTUNA        | Country of Residence <sup>i</sup> | SE          |        |        |
| Mailing Address of Inventor:                                                                                                         |                   |                                   |             |        |        |
| Address 1                                                                                                                            | Koltrastvägen 28  |                                   |             |        |        |
| Address 2                                                                                                                            |                   |                                   |             |        |        |
| City                                                                                                                                 | SOLLENTUNA        | State/Province                    |             |        |        |
| Postal Code                                                                                                                          | SE-192 55         | Country <sup>i</sup>              | SE          |        |        |
| All Inventors Must Be Listed - Additional Inventor Information blocks may be generated within this form by selecting the Add button. |                   |                                   |             |        |        |
|                                                                                                                                      |                   |                                   |             |        | Add    |

**Correspondence Information:**

Under the Paperwork Reduction Act of 1995, no persons are required to respond to a collection of information unless it contains a valid OMB control number.

|                                           |                                                                  |                        |            |
|-------------------------------------------|------------------------------------------------------------------|------------------------|------------|
| <b>Application Data Sheet 37 CFR 1.76</b> |                                                                  | Attorney Docket Number | P74267 US2 |
|                                           |                                                                  | Application Number     |            |
| Title of Invention                        | METHODS AND UE FOR RESUMING A CONNECTION WITH FULL CONFIGURATION |                        |            |

Enter either Customer Number or complete the Correspondence Information section below.  
For further information see 37 CFR 1.33(a).

An Address is being provided for the correspondence information of this application.

|                 |                                 |                                          |                                             |
|-----------------|---------------------------------|------------------------------------------|---------------------------------------------|
| Customer Number | 27045                           |                                          |                                             |
| Email Address   | Patent.development@ericsson.com | <input type="button" value="Add Email"/> | <input type="button" value="Remove Email"/> |

### Application Information:

|                                         |                                                                  |                                           |                          |
|-----------------------------------------|------------------------------------------------------------------|-------------------------------------------|--------------------------|
| Title of the Invention                  | METHODS AND UE FOR RESUMING A CONNECTION WITH FULL CONFIGURATION |                                           |                          |
| Attorney Docket Number                  | P74267 US2                                                       | Small Entity Status Claimed               | <input type="checkbox"/> |
| Application Type                        | Nonprovisional                                                   |                                           |                          |
| Subject Matter                          | Utility                                                          |                                           |                          |
| Total Number of Drawing Sheets (if any) | 17                                                               | Suggested Figure for Publication (if any) | 17                       |

### Filing By Reference:

Only complete this section when filing an application by reference under 35 U.S.C. 111(c) and 37 CFR 1.57(a). Do not complete this section if application papers including a specification and any drawings are being filed. Any domestic benefit or foreign priority information must be provided in the appropriate section(s) below (i.e., "Domestic Benefit/National Stage Information" and "Foreign Priority Information").

For the purposes of a filing date under 37 CFR 1.53(b), the description and any drawings of the present application are replaced by this reference to the previously filed application, subject to conditions and requirements of 37 CFR 1.57(a).

| Application number of the previously filed application | Filing date (YYYY-MM-DD) | Intellectual Property Authority or Country |
|--------------------------------------------------------|--------------------------|--------------------------------------------|
|                                                        |                          |                                            |

### Publication Information:

Request Early Publication (Fee required at time of Request 37 CFR 1.219)

**Request Not to Publish.** I hereby request that the attached application not be published under 35 U.S.C. 122(b) and certify that the invention disclosed in the attached application **has not and will not** be the subject of an application filed in another country, or under a multilateral international agreement, that requires publication at eighteen months after filing.

### Representative Information:

Representative information should be provided for all practitioners having a power of attorney in the application. Providing this information in the Application Data Sheet does not constitute a power of attorney in the application (see 37 CFR 1.32). Either enter Customer Number or complete the Representative Name section below. If both sections are completed the customer number will be used for the Representative Information during processing.

|                    |                                                  |                                              |                                                         |
|--------------------|--------------------------------------------------|----------------------------------------------|---------------------------------------------------------|
| Please Select One: | <input checked="" type="radio"/> Customer Number | <input type="radio"/> US Patent Practitioner | <input type="radio"/> Limited Recognition (37 CFR 11.9) |
| Customer Number    | 27045                                            |                                              |                                                         |

Under the Paperwork Reduction Act of 1995, no persons are required to respond to a collection of information unless it contains a valid OMB control number.

|                                           |                                                                  |                        |            |
|-------------------------------------------|------------------------------------------------------------------|------------------------|------------|
| <b>Application Data Sheet 37 CFR 1.76</b> |                                                                  | Attorney Docket Number | P74267 US2 |
|                                           |                                                                  | Application Number     |            |
| Title of Invention                        | METHODS AND UE FOR RESUMING A CONNECTION WITH FULL CONFIGURATION |                        |            |

### Domestic Benefit/National Stage Information:

This section allows for the applicant to either claim benefit under 35 U.S.C. 119(e), 120, 121, 365(c), or 386(c) or indicate National Stage entry from a PCT application. Providing benefit claim information in the Application Data Sheet constitutes the specific reference required by 35 U.S.C. 119(e) or 120, and 37 CFR 1.78.

When referring to the current application, please leave the "Application Number" field blank.

|                                                                                                                       |                               |                          |                                       |
|-----------------------------------------------------------------------------------------------------------------------|-------------------------------|--------------------------|---------------------------------------|
| Prior Application Status                                                                                              | Pending                       |                          | <input type="button" value="Remove"/> |
| Application Number                                                                                                    | Continuity Type               | Prior Application Number | Filing or 371(c) Date (YYYY-MM-DD)    |
|                                                                                                                       | Continuation of               | PCT/IB2019/050836        | 2019-02-01                            |
| Prior Application Status                                                                                              | Expired                       |                          | <input type="button" value="Remove"/> |
| Application Number                                                                                                    | Continuity Type               | Prior Application Number | Filing or 371(c) Date (YYYY-MM-DD)    |
| PCT/IB2019/050836                                                                                                     | Claims benefit of provisional | 62631467                 | 2018-02-15                            |
| Additional Domestic Benefit/National Stage Data may be generated within this form by selecting the <b>Add</b> button. |                               |                          | <input type="button" value="Add"/>    |

### Foreign Priority Information:

This section allows for the applicant to claim priority to a foreign application. Providing this information in the application data sheet constitutes the claim for priority as required by 35 U.S.C. 119(b) and 37 CFR 1.55. When priority is claimed to a foreign application that is eligible for retrieval under the priority document exchange program (PDX)<sup>i</sup> the information will be used by the Office to automatically attempt retrieval pursuant to 37 CFR 1.55(i)(1) and (2). Under the PDX program, applicant bears the ultimate responsibility for ensuring that a copy of the foreign application is received by the Office from the participating foreign intellectual property office, or a certified copy of the foreign priority application is filed, within the time period specified in 37 CFR 1.55(g)(1).

|                                                                                                        |                      |                          |                                          |                                       |
|--------------------------------------------------------------------------------------------------------|----------------------|--------------------------|------------------------------------------|---------------------------------------|
| Application Number                                                                                     | Country <sup>i</sup> | Filing Date (YYYY-MM-DD) | Access Code <sup>i</sup> (if applicable) | <input type="button" value="Remove"/> |
|                                                                                                        |                      |                          |                                          |                                       |
| Additional Foreign Priority Data may be generated within this form by selecting the <b>Add</b> button. |                      |                          |                                          | <input type="button" value="Add"/>    |

### Statement under 37 CFR 1.55 or 1.78 for AIA (First Inventor to File) Transition Applications

- This application (1) claims priority to or the benefit of an application filed before March 16, 2013 and (2) also contains, or contained at any time, a claim to a claimed invention that has an effective filing date on or after March 16, 2013.
- NOTE: By providing this statement under 37 CFR 1.55 or 1.78, this application, with a filing date on or after March 16, 2013, will be examined under the first inventor to file provisions of the AIA.

|                                           |                                                                  |                        |            |
|-------------------------------------------|------------------------------------------------------------------|------------------------|------------|
| <b>Application Data Sheet 37 CFR 1.76</b> |                                                                  | Attorney Docket Number | P74267 US2 |
|                                           |                                                                  | Application Number     |            |
| Title of Invention                        | METHODS AND UE FOR RESUMING A CONNECTION WITH FULL CONFIGURATION |                        |            |

## Authorization or Opt-Out of Authorization to Permit Access:

When this Application Data Sheet is properly signed and filed with the application, applicant has provided written authority to permit a participating foreign intellectual property (IP) office access to the instant application-as-filed (see paragraph A in subsection 1 below) and the European Patent Office (EPO) access to any search results from the instant application (see paragraph B in subsection 1 below).

Should applicant choose not to provide an authorization identified in subsection 1 below, applicant **must opt-out** of the authorization by checking the corresponding box A or B or both in subsection 2 below.

**NOTE:** This section of the Application Data Sheet is **ONLY** reviewed and processed with the **INITIAL** filing of an application. After the initial filing of an application, an Application Data Sheet cannot be used to provide or rescind authorization for access by a foreign IP office(s). Instead, Form PTO/SB/39 or PTO/SB/69 must be used as appropriate.

### 1. Authorization to Permit Access by a Foreign Intellectual Property Office(s)

**A. Priority Document Exchange (PDX)** - Unless box A in subsection 2 (opt-out of authorization) is checked, the undersigned hereby **grants the USPTO authority** to provide the European Patent Office (EPO), the Japan Patent Office (JPO), the Korean Intellectual Property Office (KIPO), the State Intellectual Property Office of the People's Republic of China (SIPO), the World Intellectual Property Organization (WIPO), and any other foreign intellectual property office participating with the USPTO in a bilateral or multilateral priority document exchange agreement in which a foreign application claiming priority to the instant patent application is filed, access to: (1) the instant patent application-as-filed and its related bibliographic data, (2) any foreign or domestic application to which priority or benefit is claimed by the instant application and its related bibliographic data, and (3) the date of filing of this Authorization. See 37 CFR 1.14(h)(1).

**B. Search Results from U.S. Application to EPO** - Unless box B in subsection 2 (opt-out of authorization) is checked, the undersigned hereby **grants the USPTO authority** to provide the EPO access to the bibliographic data and search results from the instant patent application when a European patent application claiming priority to the instant patent application is filed. See 37 CFR 1.14(h)(2).

The applicant is reminded that the EPO's Rule 141(1) EPC (European Patent Convention) requires applicants to submit a copy of search results from the instant application without delay in a European patent application that claims priority to the instant application.

### 2. Opt-Out of Authorizations to Permit Access by a Foreign Intellectual Property Office(s)

A. Applicant **DOES NOT** authorize the USPTO to permit a participating foreign IP office access to the instant application-as-filed. If this box is checked, the USPTO will not be providing a participating foreign IP office with any documents and information identified in subsection 1A above.

B. Applicant **DOES NOT** authorize the USPTO to transmit to the EPO any search results from the instant patent application. If this box is checked, the USPTO will not be providing the EPO with search results from the instant application.

**NOTE:** Once the application has published or is otherwise publicly available, the USPTO may provide access to the application in accordance with 37 CFR 1.14.



Under the Paperwork Reduction Act of 1995, no persons are required to respond to a collection of information unless it contains a valid OMB control number.

|                                           |                                                                  |                        |            |
|-------------------------------------------|------------------------------------------------------------------|------------------------|------------|
| <b>Application Data Sheet 37 CFR 1.76</b> |                                                                  | Attorney Docket Number | P74267 US2 |
|                                           |                                                                  | Application Number     |            |
| Title of Invention                        | METHODS AND UE FOR RESUMING A CONNECTION WITH FULL CONFIGURATION |                        |            |

## Applicant Information:

Providing assignment information in this section does not substitute for compliance with any requirement of part 3 of Title 37 of CFR to have an assignment recorded by the Office.

|                                                                                                                                                                                                                                                                                                                                                                                                                                                                                                                                                                                                                                                                                                                                                                                                                                                                       |                                          |                                                  |
|-----------------------------------------------------------------------------------------------------------------------------------------------------------------------------------------------------------------------------------------------------------------------------------------------------------------------------------------------------------------------------------------------------------------------------------------------------------------------------------------------------------------------------------------------------------------------------------------------------------------------------------------------------------------------------------------------------------------------------------------------------------------------------------------------------------------------------------------------------------------------|------------------------------------------|--------------------------------------------------|
| <b>Applicant</b>                                                                                                                                                                                                                                                                                                                                                                                                                                                                                                                                                                                                                                                                                                                                                                                                                                                      | 1                                        | <input type="button" value="Remove"/>            |
| <p>If the applicant is the inventor (or the remaining joint inventor or inventors under 37 CFR 1.45), this section should not be completed. The information to be provided in this section is the name and address of the legal representative who is the applicant under 37 CFR 1.43; or the name and address of the assignee, person to whom the inventor is under an obligation to assign the invention, or person who otherwise shows sufficient proprietary interest in the matter who is the applicant under 37 CFR 1.46. If the applicant is an applicant under 37 CFR 1.46 (assignee, person to whom the inventor is obligated to assign, or person who otherwise shows sufficient proprietary interest) together with one or more joint inventors, then the joint inventor or inventors who are also the applicant should be identified in this section.</p> |                                          |                                                  |
| <input type="button" value="Clear"/>                                                                                                                                                                                                                                                                                                                                                                                                                                                                                                                                                                                                                                                                                                                                                                                                                                  |                                          |                                                  |
| <input checked="" type="radio"/> Assignee                                                                                                                                                                                                                                                                                                                                                                                                                                                                                                                                                                                                                                                                                                                                                                                                                             | Legal Representative under 35 U.S.C. 117 | Joint Inventor                                   |
| Person to whom the inventor is obligated to assign.                                                                                                                                                                                                                                                                                                                                                                                                                                                                                                                                                                                                                                                                                                                                                                                                                   |                                          | Person who shows sufficient proprietary interest |
| If applicant is the legal representative, indicate the authority to file the patent application, the inventor is:                                                                                                                                                                                                                                                                                                                                                                                                                                                                                                                                                                                                                                                                                                                                                     |                                          |                                                  |
| <div style="border: 1px solid black; height: 20px; width: 100%;"></div>                                                                                                                                                                                                                                                                                                                                                                                                                                                                                                                                                                                                                                                                                                                                                                                               |                                          |                                                  |
| Name of the Deceased or Legally Incapacitated Inventor: <input type="text"/>                                                                                                                                                                                                                                                                                                                                                                                                                                                                                                                                                                                                                                                                                                                                                                                          |                                          |                                                  |
| If the Applicant is an Organization check here. <input checked="" type="checkbox"/>                                                                                                                                                                                                                                                                                                                                                                                                                                                                                                                                                                                                                                                                                                                                                                                   |                                          |                                                  |
| Organization Name                                                                                                                                                                                                                                                                                                                                                                                                                                                                                                                                                                                                                                                                                                                                                                                                                                                     | TELEFONAKTIEBOLAGET LM ERICSSON (PUBL)   |                                                  |
| <b>Mailing Address Information For Applicant:</b>                                                                                                                                                                                                                                                                                                                                                                                                                                                                                                                                                                                                                                                                                                                                                                                                                     |                                          |                                                  |
| Address 1                                                                                                                                                                                                                                                                                                                                                                                                                                                                                                                                                                                                                                                                                                                                                                                                                                                             | <input type="text"/>                     |                                                  |
| Address 2                                                                                                                                                                                                                                                                                                                                                                                                                                                                                                                                                                                                                                                                                                                                                                                                                                                             | <input type="text"/>                     |                                                  |
| City                                                                                                                                                                                                                                                                                                                                                                                                                                                                                                                                                                                                                                                                                                                                                                                                                                                                  | Stockholm                                | State/Province                                   |
| Country                                                                                                                                                                                                                                                                                                                                                                                                                                                                                                                                                                                                                                                                                                                                                                                                                                                               | SE                                       | Postal Code                                      |
| Phone Number                                                                                                                                                                                                                                                                                                                                                                                                                                                                                                                                                                                                                                                                                                                                                                                                                                                          |                                          | Fax Number                                       |
| Email Address                                                                                                                                                                                                                                                                                                                                                                                                                                                                                                                                                                                                                                                                                                                                                                                                                                                         | <input type="text"/>                     |                                                  |
| Additional Applicant Data may be generated within this form by selecting the Add button. <input type="button" value="Add"/>                                                                                                                                                                                                                                                                                                                                                                                                                                                                                                                                                                                                                                                                                                                                           |                                          |                                                  |

## Assignee Information including Non-Applicant Assignee Information:

Providing assignment information in this section does not substitute for compliance with any requirement of part 3 of Title 37 of CFR to have an assignment recorded by the Office.

Under the Paperwork Reduction Act of 1995, no persons are required to respond to a collection of information unless it contains a valid OMB control number.

|                                           |                                                                  |                        |            |
|-------------------------------------------|------------------------------------------------------------------|------------------------|------------|
| <b>Application Data Sheet 37 CFR 1.76</b> |                                                                  | Attorney Docket Number | P74267 US2 |
|                                           |                                                                  | Application Number     |            |
| Title of Invention                        | METHODS AND UE FOR RESUMING A CONNECTION WITH FULL CONFIGURATION |                        |            |

|                                                                                                                                                                                                                                                                                                                                                                                                                                                        |                      |                      |                      |                      |
|--------------------------------------------------------------------------------------------------------------------------------------------------------------------------------------------------------------------------------------------------------------------------------------------------------------------------------------------------------------------------------------------------------------------------------------------------------|----------------------|----------------------|----------------------|----------------------|
| <b>Assignee</b>   1                                                                                                                                                                                                                                                                                                                                                                                                                                    |                      |                      |                      |                      |
| Complete this section if assignee information, including non-applicant assignee information, is desired to be included on the patent application publication. An assignee-applicant identified in the "Applicant Information" section will appear on the patent application publication as an applicant. For an assignee-applicant, complete this section only if identification as an assignee is also desired on the patent application publication. |                      |                      |                      |                      |
| <input type="button" value="Remove"/>                                                                                                                                                                                                                                                                                                                                                                                                                  |                      |                      |                      |                      |
| If the Assignee or Non-Applicant Assignee is an Organization check here. <input type="checkbox"/>                                                                                                                                                                                                                                                                                                                                                      |                      |                      |                      |                      |
| Prefix                                                                                                                                                                                                                                                                                                                                                                                                                                                 | Given Name           | Middle Name          | Family Name          | Suffix               |
| <input type="text"/>                                                                                                                                                                                                                                                                                                                                                                                                                                   | <input type="text"/> | <input type="text"/> | <input type="text"/> | <input type="text"/> |
| <b>Mailing Address Information For Assignee including Non-Applicant Assignee:</b>                                                                                                                                                                                                                                                                                                                                                                      |                      |                      |                      |                      |
| Address 1                                                                                                                                                                                                                                                                                                                                                                                                                                              | <input type="text"/> |                      |                      |                      |
| Address 2                                                                                                                                                                                                                                                                                                                                                                                                                                              | <input type="text"/> |                      |                      |                      |
| City                                                                                                                                                                                                                                                                                                                                                                                                                                                   | <input type="text"/> | State/Province       | <input type="text"/> |                      |
| Country i                                                                                                                                                                                                                                                                                                                                                                                                                                              | <input type="text"/> | Postal Code          | <input type="text"/> |                      |
| Phone Number                                                                                                                                                                                                                                                                                                                                                                                                                                           | <input type="text"/> | Fax Number           | <input type="text"/> |                      |
| Email Address                                                                                                                                                                                                                                                                                                                                                                                                                                          | <input type="text"/> |                      |                      |                      |
| Additional Assignee or Non-Applicant Assignee Data may be generated within this form by selecting the Add button. <input type="button" value="Add"/>                                                                                                                                                                                                                                                                                                   |                      |                      |                      |                      |

**Signature:**

**NOTE:** This Application Data Sheet must be signed in accordance with 37 CFR 1.33(b). **However, if this Application Data Sheet is submitted with the INITIAL filing of the application and either box A or B is not checked in subsection 2 of the "Authorization or Opt-Out of Authorization to Permit Access" section, then this form must also be signed in accordance with 37 CFR 1.14(c).**

This Application Data Sheet **must** be signed by a patent practitioner if one or more of the applicants is a **juristic entity** (e.g., corporation or association). If the applicant is two or more joint inventors, this form must be signed by a patent practitioner, **all** joint inventors who are the applicant, or one or more joint inventor-applicants who have been given power of attorney (e.g., see USPTO Form PTO/AIA/81) on behalf of **all** joint inventor-applicants.

See 37 CFR 1.4(d) for the manner of making signatures and certifications.

|                                                                                                                        |                   |           |                   |                     |       |
|------------------------------------------------------------------------------------------------------------------------|-------------------|-----------|-------------------|---------------------|-------|
| <b>Signature</b>                                                                                                       | /Michael Cameron/ |           | Date (YYYY-MM-DD) | 2019-04-10          |       |
| First Name                                                                                                             | Michael           | Last Name | Cameron           | Registration Number | 50298 |
| Additional Signature may be generated within this form by selecting the Add button. <input type="button" value="Add"/> |                   |           |                   |                     |       |

Under the Paperwork Reduction Act of 1995, no persons are required to respond to a collection of information unless it contains a valid OMB control number.

|                                           |                                                                  |                        |            |
|-------------------------------------------|------------------------------------------------------------------|------------------------|------------|
| <b>Application Data Sheet 37 CFR 1.76</b> |                                                                  | Attorney Docket Number | P74267 US2 |
|                                           |                                                                  | Application Number     |            |
| Title of Invention                        | METHODS AND UE FOR RESUMING A CONNECTION WITH FULL CONFIGURATION |                        |            |

This collection of information is required by 37 CFR 1.76. The information is required to obtain or retain a benefit by the public which is to file (and by the USPTO to process) an application. Confidentiality is governed by 35 U.S.C. 122 and 37 CFR 1.14. This collection is estimated to take 23 minutes to complete, including gathering, preparing, and submitting the completed application data sheet form to the USPTO. Time will vary depending upon the individual case. Any comments on the amount of time you require to complete this form and/or suggestions for reducing this burden, should be sent to the Chief Information Officer, U.S. Patent and Trademark Office, U.S. Department of Commerce, P.O. Box 1450, Alexandria, VA 22313-1450. DO NOT SEND FEES OR COMPLETED FORMS TO THIS ADDRESS. **SEND TO: Commissioner for Patents, P.O. Box 1450, Alexandria, VA 22313-1450.**

## Privacy Act Statement

The Privacy Act of 1974 (P.L. 93-579) requires that you be given certain information in connection with your submission of the attached form related to a patent application or patent. Accordingly, pursuant to the requirements of the Act, please be advised that: (1) the general authority for the collection of this information is 35 U.S.C. 2(b)(2); (2) furnishing of the information solicited is voluntary; and (3) the principal purpose for which the information is used by the U.S. Patent and Trademark Office is to process and/or examine your submission related to a patent application or patent. If you do not furnish the requested information, the U.S. Patent and Trademark Office may not be able to process and/or examine your submission, which may result in termination of proceedings or abandonment of the application or expiration of the patent.

The information provided by you in this form will be subject to the following routine uses:

1. The information on this form will be treated confidentially to the extent allowed under the Freedom of Information Act (5 U.S.C. 552) and the Privacy Act (5 U.S.C. 552a). Records from this system of records may be disclosed to the Department of Justice to determine whether the Freedom of Information Act requires disclosure of these records.
2. A record from this system of records may be disclosed, as a routine use, in the course of presenting evidence to a court, magistrate, or administrative tribunal, including disclosures to opposing counsel in the course of settlement negotiations.
3. A record in this system of records may be disclosed, as a routine use, to a Member of Congress submitting a request involving an individual, to whom the record pertains, when the individual has requested assistance from the Member with respect to the subject matter of the record.
4. A record in this system of records may be disclosed, as a routine use, to a contractor of the Agency having need for the information in order to perform a contract. Recipients of information shall be required to comply with the requirements of the Privacy Act of 1974, as amended, pursuant to 5 U.S.C. 552a(m).
5. A record related to an International Application filed under the Patent Cooperation Treaty in this system of records may be disclosed, as a routine use, to the International Bureau of the World Intellectual Property Organization, pursuant to the Patent Cooperation Treaty.
6. A record in this system of records may be disclosed, as a routine use, to another federal agency for purposes of National Security review (35 U.S.C. 181) and for review pursuant to the Atomic Energy Act (42 U.S.C. 218(c)).
7. A record from this system of records may be disclosed, as a routine use, to the Administrator, General Services, or his/her designee, during an inspection of records conducted by GSA as part of that agency's responsibility to recommend improvements in records management practices and programs, under authority of 44 U.S.C. 2904 and 2906. Such disclosure shall be made in accordance with the GSA regulations governing inspection of records for this purpose, and any other relevant (i.e., GSA or Commerce) directive. Such disclosure shall not be used to make determinations about individuals.
8. A record from this system of records may be disclosed, as a routine use, to the public after either publication of the application pursuant to 35 U.S.C. 122(b) or issuance of a patent pursuant to 35 U.S.C. 151. Further, a record may be disclosed, subject to the limitations of 37 CFR 1.14, as a routine use, to the public if the record was filed in an application which became abandoned or in which the proceedings were terminated and which application is referenced by either a published application, an application open to public inspections or an issued patent.
9. A record from this system of records may be disclosed, as a routine use, to a Federal, State, or local law enforcement agency, if the USPTO becomes aware of a violation or potential violation of law or regulation.

**METHODS AND UE FOR RESUMING A CONNECTION WITH FULL  
CONFIGURATION**

**RELATED APPLICATIONS**

5 [0001] The present application is a continuation of International Application No. PCT/IB2019/050836, filed February 1, 2019, entitled “Methods and UE for resuming a connection with full configuration” which claims priority to and the benefit of the filing of U.S. Provisional Patent Application No. 62/631467, entitled “ RRC Resume with Full Configuration”, and filed at the United States Patent and Trademark Office on February 15, 2018, all of which are incorporated herein by reference in their entireties.

10 **TECHNICAL FIELD**

[0002] The present description generally relates to wireless communications and, more particularly, to resume a connection for a wireless device.

**BACKGROUND**

15 [0003] Radio Resource Control (RRC) Protocol

[0004] As in Long Term Evolution (LTE), the Radio Resource Control (RRC) protocol is used to configure/setup and maintain the radio connection between the User Equipment (UE) and the network node (e.g. eNB). When the UE receives an RRC message from the eNB, it will apply the configuration (the term “compile” can be also used to refer to the application of the configuration).  
20 And if this succeeds, the UE generates an RRC complete message that indicates the transaction identity (ID) of the message that triggered this response.

[0005] Since LTE-release (rel.) 8, three Signaling Radio Bearers (SRBs), namely SRB0, SRB1 and SRB2 have been available for the transport of RRC and Non Access Stratum (NAS) messages between the User Equipment (UE) and eNB. A new SRB, known as SRB1bis, was also introduced  
25 in rel-13 for supporting DoNAS (Data Over NAS) in Narrowband Internet of Things (NB-IoT).

[0006] SRB0 is used for RRC messages using the Common Control Channel (CCCH) logical channel, and it is used for handling RRC connection setup, RRC connection resume and RRC connection re-establishment. Once the UE is connected to the eNB (i.e. RRC connection setup or RRC connection reestablishment/resume has succeeded), SRB1 is used for handling RRC  
30 messages (which may include a piggybacked NAS message) as well as for NAS messages prior to the establishment of SRB2, all using Dedicated Control Channel (DCCH) logical channel.

**[0007]** SRB2 is used for RRC messages which include logged measurement information and for NAS messages, all using DCCH logical channel. SRB2 has a lower priority than SRB1, because logged measurement information and NAS messages can be lengthy and could cause the blocking of more urgent and smaller SRB1 messages. SRB2 is always configured by Evolved-Universal  
 5 Mobile Telecommunications Service (UMTS) Terrestrial Radio Access Network (E-UTRAN) after security activation.

**[0008]** Dual Connectivity (DC) in LTE

**[0009]** Evolved-UMTS Terrestrial Radio Access Network (E-UTRAN) supports Dual  
 10 Connectivity (DC) operation whereby a multiple Receive/Transmit (Rx/Tx) UE in RRC\_CONNECTED is configured to utilize radio resources provided by two distinct schedulers, located in two eNBs connected via a non-ideal backhaul over the X2 interface (see 3GPP 36.300). eNBs involved in DC for a certain UE may assume two different roles: an eNB may either act as an Master node (MN) or as an Secondary node (SN). In DC, a UE is connected to one MN and one SN.

15 **[0010]** In LTE DC, the radio protocol architecture that a particular bearer uses depends on how the bearer is setup. Three bearer types exist: Master Cell Group (MCG) bearer, Secondary Cell Group (SCG) bearer and split bearers. RRC is located in MN and SRBs are always configured as a MCG bearer type and therefore only use the radio resources of the MN. Figure 1 illustrates the LTE DC User Plane (UP), with the 3 types of bearers in a UE.

20 **[0011]** LTE-NR Dual Connectivity

**[0012]** LTE-NR (LTE-New Radio) DC (also referred to as LTE-NR tight interworking) is currently being discussed for rel-15. In this context, the major changes from LTE DC are:

**[0013]** The introduction of split bearer from the SN (known as SCG split bearer);

**[0014]** The introduction of split bearer for RRC;

25 **[0015]** The introduction of a direct RRC from the SN (also referred to as SCG SRB).

**[0016]** Figures 2 and 3 show the UP and Control Plane (CP) architectures respectively for LTE-NR tight interworking.

**[0017]** The SN is sometimes referred to as SgNB (where gNB is an NR base station), and the MN as MeNB in case the LTE is the master node and NR is the secondary node. In the other case  
 30 where NR is the master and LTE is the secondary node, the corresponding terms are SeNB and MgNB.

**[0018]** Split RRC messages are mainly used for creating diversity, and the sender can decide to either choose one of the links for scheduling the RRC messages, or it can duplicate the message

over both links. In the downlink, the path switching between the MCG or SCG legs or duplication on both is left to network implementation. On the other hand, for the UL, the network configures the UE to use the MCG, SCG or both legs. The terms “leg” and “path” are used interchangeably throughout this document.

5 **[0019]** The following terminologies are used throughout this disclosure to differentiate different dual connectivity scenarios:

**[0020]** DC: LTE DC (i.e. both MN and SN employ LTE);

**[0021]** EN-DC: LTE-NR dual connectivity where LTE is the master and NR is the secondary;

**[0022]** NE-DC: LTE-NR dual connectivity where NR is the master and LTE is the secondary;

10 **[0023]** NR-DC (or NR-NR DC): both MN and SN employ NR;

**[0024]** MR-DC (multi-RAT DC): a generic term to describe where the MN and SN employ different Radio Access Technologies (RATs), EN-DC and NE-DC are two different example cases of MR-DC.

**[0025]** Bearer harmonization in EN-DC

15 **[0026]** In Radio Access Network 2 (RAN2), it has been agreed to harmonize what was former called MCG bearers, MCG split bearers, SCG bearers and SCG split bearers in the following way:

**[0027]** a) It is possible to configure the UE to use NR Packet Data Convergence Protocol (PDCP) for all the bearers (even when the UE is operating in standalone LTE mode and EN-DC is not setup);

20 **[0028]** b) For all bearers configured with NR PDCP, it is possible to configure the UE to either use KeNB or S-KeNB as security key;

**[0029]** c) The configuration of the PDCP layers is separated from the configuration of the lower layers of the MCG and SCG leg.

25 **[0030]** From a UE point of view, this means that there are only 3 different bearers (as can be seen in Figure 4) namely the:

**[0031]** d) MCG bearer which uses the radio link towards the MN node only;

**[0032]** e) SCG bearer which uses the radio of the SN node only;

**[0033]** f) And the split bearer which uses the radio of both the MN and SN.

30 **[0034]** Where these bearers are terminated in the network is not important from the UE’s perspective anymore, i.e. the UE will just use the key that is being configured from each bearer. From a RAN2 point of view it is fully supported to setup MCG bearers being terminated in the SN node using S-KeNB and SCG bearers being terminated in the MN node. Similarly, it is

possible to support both SN and MN terminated bearers at the same time i.e. both SN terminated split bearers and MN terminated split bearers.

**[0035]** LTE re-establishment procedure

5 **[0036]** The purpose of the LTE re-establishment procedure is to re-establish the RRC connection upon detecting radio link failure, handover failure, mobility from E-UTRA failure, integrity check failure on SRBs or RRC connection reconfiguration failure. Re-establishment involves the resumption of SRB1, the re-activation of security and the configuration of only the Primary cell (PCell), i.e. Carrier Aggregation (CA) or DC operations are not re-established.

10 **[0037]** When the target eNB gets a re-establishment request, it identifies the source eNB/cell from the *ReestabUE-Identity* included in the request and can send a Radio Link Failure (*RLF Indication X2*) message to the source eNB. The source eNB may respond with a Handover Request message that includes the UE context (RRC context and S1 context). If the target eNB is able to understand the UE context, re-establishment succeeds and the target eNB sends an *RRCCConnectionReestablishment* message to the UE. If the target eNB does not receive the UE  
15 context or it doesn't understand the context, it may reject the re-establishment and the UE has to go to RRC\_IDLE to re-connect. If the target eNB doesn't understand the RRC context but can understand the S1 context, it doesn't necessarily reject the re-establishment and can still respond with *RRCCConnectionReestablishment* and later use full reconfiguration to reconfigure the bearers based on the S1 context.

20 **[0038]** In case of a re-establishment success, SRB1 operation resumes while the operation of other radio bearers (SRB2 and DRBs) remains suspended. If Access Stratum (AS) security has not been activated, the UE does not initiate the procedure but instead moves to RRC\_IDLE directly.

**[0039]** E-UTRAN applies the re-establishment procedure as follows:

**[0040]** When AS security has been activated:

25 **[0041]** - reconfigure SRB1 and resume data transfer only for this Radio Bearer;

**[0042]** - re-activate AS security without changing algorithms.

**[0043]** After this, the UE sends the *RRCCConnectionReestablishmentComplete* message, and the target eNB responds by sending an *RRCCConnectionReconfiguration* message to reconfigure SRB2 and the DRBs.

30 **[0044]** The RRC connection re-establishment procedure flow is shown in Figures 5 (success case) and Figure 6 (failure case). SRB0 is used for sending the *RRCCConnectionReestablishmentRequest*, *RRCCConnectionReestablishment* and



*RRCConnectionReestablishmentReject* messages, while  
*RRCConnectionReestablishmentComplete* uses SRB1.

**[0045]** LTE Suspend/Resume procedure

**[0046]** The RRC suspend/resume functionality has been introduced in LTE rel-13. A suspended  
 5 UE can be considered to be in an intermediate state between IDLE and CONNECTED, where the  
 UE AS context is kept both at the UE and RAN, and the UE can be seen as if it is in connected  
 mode but suspended from the Core Network (CN) point of view and in IDLE mode from the RAN  
 point of view. The advantage of operating in this mode is reduced signaling and faster transition  
 to CONNECTED mode as compared to legacy IDLE-CONNECTED mode transitions, while  
 10 maintaining the UE power saving advantages of IDLE mode.

**[0047]** When a decision is made by the network to move the UE to suspended state, the eNB sends  
 the UE an *RRCConnectionRelease* message with the release cause value of *rrc-suspend*. The  
*RRCConnectionRelease* message also contains a *Resume ID*. The UE stores the *Resume ID* and  
 UE AS context (including the current RRC configuration, the current security context, the PDCP  
 15 state including Robust Header Compression (ROHC) state, Cell-Radio Network Temporary  
 Identifier (C-RNTI) used in the source PCell, the cell Identity (cellID) and the physical cell  
 identity of the source PCell); re-establishes all Radio Link Control (RLC) entities (both for SRBs  
 and DRBs); and suspends all DRBs and SRBs except SRB0.

**[0048]** When the UE later on wants to resume the connection (in response to UL data to be sent  
 20 or a paging request for DL data), it sends an *RRCConnectionResumeRequest* message with the  
 saved *Resume ID*. If the resume operation is performed in an eNB other than the eNB that was  
 serving the UE when the UE was suspended, the new eNB can perform a context fetch by using  
 the *Retrieve UE Context X2* procedure from the old eNB (as the Resume ID includes information  
 about the old eNB/cell). Upon getting the context (if resuming on a new eNB) or if the resumption  
 25 was in the same eNB, the target eNB responds with an *RRCConnectionResume* message, and both  
 the UE and eNB restore the saved UE context, and data transmission/reception from/to the UE  
 can be resumed.

**[0049]** The RRC connection resume procedure flow is shown in Figure 7 (success case) and  
 Figure 8 (fallback to RRC connection establishment). Figure 9 (network reject or release) shows  
 30 the resume procedure in LTE. SRB0 is used for sending the *RRCConnectionResumeRequest*,  
*RRCConnectionSetup* and *RRCConnectionReestablishmentReject*, while  
*RRCConnectionResume* and *RRCConnectionResume Complete* messages use SRB1.

- [0050]** The main difference between resume and re-establishment is (from a procedural perspective): SRB1 is used for the *RRCCConnectionResume* message, while SRB0 is used for the *RRCCConnectionReestablishment* message.
- [0051]** The *RRCCConnectionResume* message, unlike the *RRCCConnectionReestablishment* message, can contain the SRB2/DRB configuration, and thus *RRCCConnectionReconfiguration* is not needed after resume (while it is necessary in the re-establishment case to reconfigure SRB2/DRBs).
- [0052]** The detailed RRC connection suspend procedure 1000 is illustrated in Figure 10.
- [0053]** More specifically, in step 1010 of Figure 10, due to some triggers, e.g. the expiry of a UE inactivity timer, the eNB decides to suspend the RRC connection.
- [0054]** In step 1020, the eNB initiates the S1-Application Protocol (AP) UE Context Suspend procedure to inform the Mobility Management Entity (MME) that the RRC connection is being suspended. To do so, the eNB sends a UE context Suspend Request. As a note, S1 refers to the interface between the eNB and the core network.
- [0055]** In step 1030, the MME requests the Serving- Gateway (S-GW) to release all S1-U bearers for the UE. The S1-U refers to the S1 user plane and the S1-U bearers are the bearers that carry user data between the eNB and the core network.
- [0056]** In step 1040, the MME Acknowledges step 1020. For example, the MME sends a response to the request of step 1020.
- [0057]** In step 1050, the eNB suspends the RRC connection by sending an *RRCCConnectionRelease* message with the *releaseCause* set to *rrc-Suspend*, to the UE. The message includes the *resumeIdentity* which is stored by the UE.
- [0058]** In step 1060, the UE stores the AS context, suspends all SRBs and DRBs. The UE enters the RRC\_IDLE light connected state.
- [0059]** When the UE later on wants to resume the connection (in response to UL data to be sent or a paging request for DL data), it sends an *RRCCConnectionResumeRequest* message with the saved *resumeIdentity*. The eNB responds with an *RRCCConnectionResume* message, and both the UE and eNB restore the saved UE context, and data transmission/reception from/to the UE can be resumed. Note that the resume operation can be performed in an eNB other than the eNB that was serving the UE when the UE was suspended. In that case, the new eNB can perform a context fetch e.g. by using the Retrieve UE Context procedure from the old eNB (as the *resumeIdentity* includes information about the old eNB/cell).

- [0060] The RRC connection resume procedure in the same eNB and new eNB are illustrated in Figures 11 and 12, respectively.
- [0061] Figure 11 illustrates a RRC connection resume procedure 1100 in the same eNB.
- 5 [0062] In step 1110, the UE sends a Random Access Preamble to the eNB, in order to access the network.
- [0063] In step 1120, the eNB replies by sending a Random Access Response, to confirm that the UE is connected to the network node (eNB).
- [0064] In step 1130 of Figure 11, at some later point in time (e.g. when the UE is being paged or when new data arrive in the uplink buffer) the UE resumes the connection by sending an  
10 *RRCCConnectionResumeRequest* to the eNB. The UE may include its Resume ID, the establishment cause, and authentication token. The authentication token is calculated in the same way as the short Message Authentication Code-Integrity (MAC-I) used in RRC connection re-establishment and allows the eNB to verify the UE identity.
- [0065] In step 1140, provided that the Resume ID exists and the authentication token is  
15 successfully validated, the eNB responds with an *RRCCConnectionResume*. The message includes the Next Hop Chaining Count (NCC) value which is required in order to re-establish the AS security.
- [0066] In step 1150, the UE resumes all SRBs and DRBs and re-establishes the AS security. The UE is now in RRC\_CONNECTED.
- 20 [0067] In step 1160, the UE responds with an *RRCCConnectionResumeComplete* confirming that the RRC connection was resumed successfully.
- [0068] In step 1170, the eNB initiates the S1-AP Context Resume procedure to notify the MME about the UE state change.
- [0069] In step 1180, the MME requests the S-GW to activate the S1-U bearers for the UE.
- 25 [0070] In step 1190, the MME acknowledges step 1170.
- [0071] Figure 12 illustrates the RRC resume procedure 1200 in an eNB different from the source eNB where the UE got suspended.
- [0072] Steps 1205 to 1215 are the same as steps 1110 to 1130 in Figure 11.
- [0073] In step 1220 (X2-AP: Retrieve UE Context Request), the new eNB locates the old eNB  
30 using the Resume ID and retrieves the UE context by means of the X2-AP Retrieve UE Context procedure.
- [0074] In step 1225 (X2-AP: Retrieve UE Context Response), the old eNB responds to the new eNB with the UE context associated with the Resume ID.

- [0075]** In step 1230, it is the same step as step 1140 of Figure 11 (in the intra eNB connection resumption).
- [0076]** In step 1235, it is the same step as step 1150 of Figure 11 (in the intra eNB connection resumption).
- 5 **[0077]** In step 1240, it is the same as step 1160 of Figure 11 (in the intra eNB connection resumption).
- [0078]** In step 1245, the new eNB initiates the S1-AP Path Switch procedure to establish a S1 UE associated signalling connection to the serving MME and to request the MME to resume the UE context.
- 10 **[0079]** In step 1250, the MME requests the S-GW to activate the S1-U bearers for the UE and updates the downlink path.
- [0080]** In step 1255, the MME acknowledges step 1245.
- [0081]** In step 1260 (X2-AP: UE Context Release), after the S1-AP Path Switch procedure, the new eNB triggers release of the UE context at the old eNB by means of the X2-AP UE Context
- 15 Release procedure.
- [0082]** The resume procedure is an opportunistic procedure in that there may be cases where the RAN node does not have the stored UE context. In this case, it has been specified a solution enabling the RAN to recover the UE context by using the RRC connection setup procedure which involves UE signalling to the CN and then the CN rebuilding the UE context in the RAN. The
- 20 RRC procedure for this is shown in Figure 8. In figure 13, a more detailed procedure is shown for this case. This case could also be referred to as using NAS recovery or transitioning via IDLE (since the UE AS context is removed). Figure 13 is known in the art, as such, it will not be described further.
- [0083]** Full RRC configurations in LTE
- 25 **[0084]** In LTE, during a Handover (HO) or re-establishment, the UE context is passed from the source to the target eNB. If the target eNB does not understand any part of the UE configuration, then it triggers full configuration. The full configuration procedure is specified in Third Generation Partnership Project Technical Specification (3GPP TS) 36.331 section 5.3.5.8 as below.
- 30 **[0085]** The UE shall:
- 1> release/ clear all current dedicated radio configurations except the MCG C-RNTI, the MCG security configuration and the PDCP, RLC, logical channel configurations for the RBs and the logged measurement configuration;

NOTE 1: Radio configuration is not just the resource configuration but includes other configurations like *MeasConfig* and *OtherConfig*.

- 1> if the *RRCConnectionReconfiguration* message includes the *mobilityControlInfo*:
- 5 2> release/ clear all current common radio configurations;
- 2> use the default values specified in 9.2.5 for timer T310, T311 and constant N310, N311;
- 1> else:
  - 2>use values for timers T301, T310, T311 and constants N310, N311, as included in *ue-TimersAndConstants* received in *SystemInformationBlockType2* (or
  - 10 *SystemInformationBlockType2-NB* in NB-IoT);
  - 1>apply the default physical channel configuration as specified in 9.2.4;
  - 1>apply the default semi-persistent scheduling configuration as specified in 9.2.3;
  - 1>apply the default MAC main configuration as specified in 9.2.2;
  - 1>if the UE is a NB-IoT UE; or
  - 15 1>for each *srb-Identity* value included in the *srb-ToAddModList* (SRB reconfiguration):
    - 2>apply the specified configuration defined in 9.1.2 for the corresponding SRB;
    - 2>apply the corresponding default RLC configuration for the SRB specified in 9.2.1.1 for SRB1 or in 9.2.1.2 for SRB2;
    - 2>apply the corresponding default logical channel configuration for the SRB as specified
    - 20 in 9.2.1.1 for SRB1 or in 9.2.1.2 for SRB2;

NOTE 2: This is to get the SRBs (SRB1 and SRB2 for handover and SRB2 for reconfiguration after reestablishment) to a known state from which the reconfiguration message can do further configuration.

- 1> for each *eps-BearerIdentity* value included in the *drb-ToAddModList* that is part of the
- 25 current UE configuration:
  - 2>release the PDCP entity;
  - 2>release the RLC entity or entities;
  - 2>release the DTCH logical channel;
  - 2>release the *drb-identity*;

- 30 NOTE 3: This will retain the *eps-bearerIdentity* but remove the DRBs including *drb-identity* of these bearers from the current UE configuration and trigger the setup of the DRBs within the AS in Section 5.3.10.3 using the new configuration. The *eps-bearerIdentity* acts as the anchor for

associating the released and re-setup DRB. In the AS the DRB re-setup is equivalent with a new DRB setup (including new PDCP and logical channel configurations).

1> for each *eps-BearerIdentity* value that is part of the current UE configuration but not part of the *drb-ToAddModList*:

5 2> perform DRB release as specified in 5.3.10.2;

[0086] As can be seen from above, the full configuration option includes an initialization of the radio configuration, which makes the procedure independent of the configuration used in the source cell(s) with the exception that the security algorithms are continued for the RRC re-establishment. If a DRB is not included in the *drb-ToAddModList*, the DRB will be released, and hence a message to upper layers is sent indicating the release of the bearer (i.e. a full-fledged bearer setup from scratch is required to continue data service(s) associated with the released bearer(s)). For those bearers included in the *drb-toAddModList*, the PDCP/RLC/Logical Channel (LCH) entities are released and established again.

[0087] The advantages with using full configuration is that the target node (of the handover) does not need to understand the UE configuration in the source node. This makes it then possible to support mobility between different nodes which support different protocol versions of the RRC and other protocols. It also makes it possible to handle cases when the source and target nodes support different solutions for UE handling and configuration (e.g. using different algorithms).

[0088] The disadvantage of using full configuration (i.e. the advantage of using delta signaling) is that full configuration may lead to larger messages sent over the radio compared to delta signaling where only relevant parts of the UE context is reconfigured.

Note that even though full configuration is normally employed during HO or re-establishment, the network may decide to perform a full reconfiguration of the UE at any time.

## SUMMARY

[0089] The full configuration procedure described above is performed by sending an *RRCCConnectionReconfiguration* message with the *fullConfig* flag set and it is not available for other radio reconfiguration messages such as re-establishment and resume. In the case of re-establishment, the procedure is always followed by an *RRCCConnectionReconfiguration* procedure, and as such full configuration can be performed during this stage. On the other hand, one of the main aims of the resume procedure is to transit the UE to connected mode as fast as possible (with as little signaling as possible), reusing the saved configuration of the UE when it got suspended, and thus an additional *RRCCConnectionReconfiguration* is not needed.

[0090] However, there are scenarios where, during resuming after suspending, the target node doesn't understand the radio configuration of the UE, and since full configuration is not supported, the only viable option for the UE to resume will be via IDLE mode (as illustrated in Figure 8 and 12), which incurs further delays in the service continuity at the UE.

5 [0091] In the context of rel-15 and EN-DC, such situations can easily happen. For example, a UE may be configured to use NR PDCP for some of the radio bearers (SRBs or DRBs), even when it is not in EN-DC mode, it can be resumed in an eNB that doesn't support NR PDCP.

[0092] In order to resolve this problem to some extent, a solution was proposed in the provisional patent application number 62/565,067, filed with the USPTO on September 28/2017 (the content of which is herein incorporated), and later captured in an agreement that was made in RAN2 #100 meeting [ftp://ftp.3gpp.org/tsg\_ran/WG2\_RL2/TSGR2\_100/Report/RAN2-100-Reno-Chair-Notes-2017-12-01-eom.docx].

15  
20  
25

|                                                                                                                                         |
|-----------------------------------------------------------------------------------------------------------------------------------------|
| Agreements                                                                                                                              |
| 1 On re-establishment,                                                                                                                  |
| • UE reverts to using LTE PDCP for SRB1                                                                                                 |
| • If target eNB supports NR-PDCP, it can use RRCConnectionReconfiguration to revert the PDCP version of SRB1 or any other bearers to NR |
| • If target eNB doesn't support NR-PDCP, it can perform full configuration to revert the PDCP version of all bearers to LTE PDCP.       |
| 2 On resume,                                                                                                                            |
| • UE reverts to using LTE PDCP for SRB1                                                                                                 |
| 3 The RRCResume message extend to enable configuration of bearers with NR PDCP                                                          |

[0093] This solution ensures that the eNB will be able to send the *RRCConnectionResume* command in SRB1 that uses LTE PDCP, and the UE will be able to understand it. However, the solution still requires that the eNB understands the UE context (or configuration) in the source cell to know how it should be able to configure the UE in the target cell. If the target cell (or network node) does not understand the UE context it will have no choice to let the UE perform NAS recovery by sending an RRC connection setup message to the UE (as illustrated in Figures 8 and 12).

[0094] Certain aspects and their embodiments of the present disclosure may provide solutions to the above mentioned problems.

35 [0095] According to a first aspect, a method in a network node (e.g., base station, gNB, eNB) is provided. The method includes: receiving, from a wireless device, a request to resume a connection in a communication network; in response to the request, sending a resume message to the wireless device, the message comprising an indication to perform a full configuration.

**[0096]** According to a second aspect, a network node comprising circuitry is provided. The circuitry may include one or more processors and memory. The network node is operable to perform steps according to embodiments of the method disclosed herein, according to the various aspects.

5 **[0097]** According to a third aspect, some embodiments include a network node configured, or operable, to perform one or more network node functionalities (e.g. actions, operations, steps, etc.) as described herein.

**[0098]** In some embodiments, the network node may comprise one or more communication interfaces configured to communicate with one or more other radio nodes and/or with one or more network nodes, and processing circuitry operatively connected to the communication interface,  
10 the processing circuitry being configured to perform one or more network node functionalities as described herein. In some embodiments, the processing circuitry may comprise at least one processor and at least one memory storing instructions which, upon being executed by the processor, configure the at least one processor to perform one or more network node  
15 functionalities as described herein.

**[0099]** In some embodiments, the network node may comprise one or more functional modules configured to perform one or more network node functionalities as described herein.

**[0100]** According to a fourth aspect, some embodiments include a non-transitory computer-readable medium storing a computer program product comprising instructions which, upon being  
20 executed by processing circuitry (e.g., at least one processor) of the network node, configure the processing circuitry to perform one or more network node functionalities as described herein.

**[0101]** According to fifth aspect, computer programs, computer readable media configured to process and/or store instructions for steps according to embodiments of the method disclosed herein, according to the various aspects, are also provided.

25 **[0102]** According to sixth aspect, a method in a wireless device is provided. The method includes: sending to a network node a request to resume a connection in a communication network; receiving a resume message from the network node, the message comprising an indication to perform a full configuration; and applying the full configuration.

**[0103]** According to a seventh aspect, a wireless device comprising circuitry is provided. The  
30 circuitry may include one or more processors and memory. The wireless device is operable to perform steps according to embodiments of the method disclosed herein, according to the various aspects.



**[0104]** According to an eighth aspect, some embodiments include a network node configured, or operable, to perform one or more network node functionalities (e.g. actions, operations, steps, etc.) as described herein.

**[0105]** In some embodiments, the wireless device may comprise one or more communication interfaces configured to communicate with one or more other radio nodes and/or with one or more network nodes, and processing circuitry operatively connected to the communication interface, the processing circuitry being configured to perform one or more wireless device functionalities as described herein. In some embodiments, the processing circuitry may comprise at least one processor and at least one memory storing instructions which, upon being executed by the processor, configure the at least one processor to perform one or more wireless device functionalities as described herein.

**[0106]** Certain embodiments of aspects of the present disclosure may provide one or more technical advantages, including:

**[0107]** - It will be possible to resume a suspended UE in an e/gNB that is employing an earlier version of the RAT (or the same version of the RAT but with limited functionality) than that is being used by the source eNB where the UE got suspended (or was sent to inactive mode).

**[0108]** - Uniform UE behavior as the UE roams within the network (i.e. UE can be resumed with the same latency regardless of the version of RAT being used by the source and target).

**[0109]** - Operators get some leeway in terms of when to upgrade their network nodes (i.e. they are not required to upgrade all their network nodes to support resume functionality whenever they deploy new network nodes employing the latest version of the RAT or upgrade some parts of their already deployed nodes).

**[0110]** Certain embodiments may have some, or none of the above advantages. Other advantages will be apparent to persons of ordinary skill in the art.

**[0111]** This summary is not an extensive overview of all contemplated embodiments, and is not intended to identify key or critical aspects or features of any or all embodiments or to delineate the scope of any or all embodiments. In that sense, other aspects and features will become apparent to those ordinarily skilled in the art upon review of the following description of specific embodiments in conjunction with the accompanying figures.

### 30 **BRIEF DESCRIPTION OF THE DRAWINGS**

**[0112]** Exemplary embodiments will be described in more detail with reference to the following figures, in which:

**[0113]** Figure 1 illustrates a schematic block diagram of a LTE DC User Plane (UP).

- [0114] Figure 2 is a schematic block diagram of a LTE-NR tight interworking for the UP.
- [0115] Figure 3 is a schematic block diagram of a LTE-NR tight interworking for the Control Plane (CP).
- [0116] Figure 4 illustrates a schematic block diagram of the configuration of 3 bearers in a communication network.
- 5 [0117] Figure 5 illustrates a signal diagram of a successful RRC connection re-establishment procedure.
- [0118] Figure 6 illustrates a signal diagram of a failed RRC connection re-establishment procedure.
- 10 [0119] Figure 7 illustrates a signal diagram of a successful RRC connection resume procedure.
- [0120] Figure 8 illustrates a signal diagram of a successful RRC connection resume fallback to RRC connection establishment procedure.
- [0121] Figure 9 illustrates a signal diagram of a RRC connection resume procedure, with a network reject or release.
- 15 [0122] Figure 10 is a signal diagram of a RRC connection suspend.
- [0123] Figure 11 is another signal diagram of a RRC connection resume procedure.
- [0124] Figure 12 is a signal diagram of a RRC connection resume procedure in a target network node that is different from the source network node where the UE got suspended.
- [0125] Figure 13 illustrates a signal diagram for handling the case when a UE context cannot be
- 20 retrieved.
- [0126] Figure 14 illustrates a schematic block diagram of a communication network.
- [0127] Figure 15 illustrates a flow chart of a method in a network node, according to an embodiment.
- [0128] Figure 16 illustrates a flow chart of another method in a network node, according to an
- 25 embodiment.
- [0129] Figure 17 illustrates a flow chart of a method in a wireless device, according to an embodiment.
- [0130] Figure 18 illustrates a flow chart of yet another method in a network node, according to an embodiment.
- 30 [0131] Figures 19 and 20 illustrate schematic block diagrams of a network node, according to some embodiments.
- [0132] Figures 21 and 22 illustrate schematic block diagrams of a wireless device according to some embodiments.

[0133] Figure 23 illustrates a schematic block diagram illustrating a virtualization environment in which functions implemented by some embodiments may be virtualized.

#### DETAILED DESCRIPTION

5 [0134] The embodiments set forth below represent information to enable those skilled in the art to practice the embodiments. Upon reading the following description in light of the accompanying figures, those skilled in the art will understand the concepts of the description and will recognize applications of these concepts not particularly addressed herein. It should be understood that these concepts and applications fall within the scope of the description.

10 [0135] In the following description, numerous specific details are set forth. However, it is understood that embodiments may be practiced without these specific details. In other instances, well-known circuits, structures, and techniques have not been shown in detail in order not to obscure the understanding of the description. Those of ordinary skill in the art, with the included description, will be able to implement appropriate functionality without undue experimentation.

15 [0136] References in the specification to “one embodiment,” “an embodiment,” “an example embodiment,” etc., indicate that the embodiment described may include a particular feature, structure, or characteristic, but every embodiment may not necessarily include the particular feature, structure, or characteristic. Moreover, such phrases are not necessarily referring to the same embodiment. Further, when a particular feature, structure, or characteristic is described in connection with an embodiment, it is submitted that it is within the knowledge of one skilled in  
20 the art to implement such feature, structure, or characteristic in connection with other embodiments whether or not explicitly described.

[0137] As used herein, the singular forms “a,” “an” and “the” are intended to include the plural forms as well, unless the context clearly indicates otherwise. It will be further understood that the terms “comprises,” “comprising,” “includes,” and/or “including” when used herein, specify the  
25 presence of stated features, integers, steps, operations, elements, and/or components, but do not preclude the presence or addition of one or more other features, integers, steps, operations, elements, components, and/or groups thereof.

[0138] Figure 14 illustrates a wireless communication network 200 for wireless communications. Wireless communication network 200 includes wireless devices 210 (e.g., user equipments, UEs)  
30 and a plurality of network nodes 220 (e.g., eNBs, gNBs, base stations, etc.) connected to one or more core network nodes 240 via an interconnecting network 230. Wireless devices 210 within a coverage area may each be capable of communicating directly with network nodes 220 over a wireless interface. The UEs 210 are massive MIMO (M-MIMO) capable UEs, for example. The

network node can be the serving network node of the M-MIMO UE or any network node with which the M-MIMO UE can establish or maintain a communication link and/or receive information (e.g. via broadcast channel). As such, the network node may comprise multiple antennas, distributed over a plurality of RRHs.

5 **[0139]** In certain embodiments, wireless devices 210 may also be capable of communicating with each other via device-to-device (D2D) communication. In certain embodiments, network nodes 220 may also be capable of communicating with each other, e.g. via an interface (e.g. X2 in LTE or other suitable interface).

10 **[0140]** As an example, wireless device 210 may communicate with network node 220 over a wireless interface. That is, wireless device 210 may transmit wireless signals and/or receive wireless signals from network node 220. The wireless signals may contain voice traffic, data traffic, control signals, and/or any other suitable information. In some embodiments, an area of wireless signal coverage associated with a network node 220 may be referred to as a cell.

15 **[0141]** In some embodiments wireless device 210 may be interchangeably referred to by the non-limiting term user equipment (UE). Wireless device 210 can be any type of wireless device capable of at least M-MIMO communications with a network node or another UE over radio signals. Examples of such M-MIMO UEs are a sensor, modem, smart phone, machine type (MTC) device aka machine to machine (M2M) device, PDA, iPad, Tablet, smart phone, laptop embedded equipped (LEE), laptop mounted equipment (LME), USB dongles etc.

20 **[0142]** In some embodiments, the “network node” can be any kind of network nodes. Examples of network nodes are eNodeB, Node B, Base Station, wireless access point (AP), base station controller, radio network controller, relay, donor node controlling relay, base transceiver station (BTS), transmission points, transmission nodes, Remote Radio Unit (RRU), Remote Radio Head (RRH), nodes in distributed antenna system (DAS), core network node, Mobility Management Entity (MME) etc.

25 **[0143]** In certain embodiments, network nodes 220 may interface with a radio network controller (not shown). The radio network controller may control network nodes 220 and may provide certain radio resource management functions, mobility management functions, and/or other suitable functions. In certain embodiments, the functions of the radio network controller may be included  
30 in the network node 220. The radio network controller may interface with the core network node 240. In certain embodiments, the radio network controller may interface with the core network node 240 via the interconnecting network 230.

5 [0144] The interconnecting network 230 may refer to any interconnecting system capable of transmitting audio, video, signals, data, messages, or any combination of the preceding. The interconnecting network 230 may include all or a portion of a public switched telephone network (PSTN), a public or private data network, a local area network (LAN), a metropolitan area network (MAN), a wide area network (WAN), a local, regional, or global communication or computer network such as the Internet, a wireline or wireless network, an enterprise intranet, or any other suitable communication link, including combinations thereof.

10 [0145] In some embodiments, the core network node 240 may manage the establishment of communication sessions and various other functionalities for wireless devices 210. Examples of core network node 340 may include MSC, MME, SGW, PGW, O&M, OSS, SON, positioning node (e.g. E-SMLC), MDT node, etc. Wireless devices 210 may exchange certain signals with the core network node 240 using the non-access stratum layer. In non-access stratum signaling, signals between wireless devices 310 and the core network node 240 may be transparently passed through the radio access network. In certain embodiments, network nodes 220 may interface with one or more other network nodes over an internode interface. For example, network nodes 220 may interface each other over an X2 interface.

15 [0146] Although Figure 14 illustrates a particular arrangement of network 200, the present disclosure contemplates that the various embodiments described herein may be applied to a variety of networks having any suitable configuration. For example, network 200 may include any suitable number of wireless devices 210 and network nodes 220, as well as any additional elements suitable to support communication between wireless devices or between a wireless device and another communication device (such as a landline telephone). The embodiments may be implemented in any appropriate type of telecommunication system supporting any suitable communication standards and using any suitable components, and are applicable to any radio access technology (RAT) or multi-RAT systems in which the wireless device receives and/or transmits signals (e.g., data).

20 [0147] Although terminology from 3GPP LTE (or E-UTRAN) has been used in this disclosure to exemplify the embodiments and describe both the serving and victim network nodes, this should not be seen as limiting the scope of the disclosure to only the aforementioned system. Other wireless systems, including WCDMA, UTRA FDD, UTRA TDD, and GSM/GERAN/EDGE, may also benefit from exploiting the ideas covered within this disclosure. Furthermore, embodiments of this disclosure can apply to scenarios in which the serving and victim nodes employ differing radio access technologies (RATs).

**[0148]** As mentioned above, the full reconfiguration (or configuration) procedure is not available for radio control procedures such as the re-establishment and resume procedures.

**[0149]** Embodiments of this disclosure can address the drawbacks of the current LTE and NR Resume procedures, for the case where an UE resumes in an eNB/gNB that does not support all the functionalities of the source eNB. In such a case, the target eNB/gNB may not be able to read the information contained in the UE AS context, thereby making it impossible to resume the UE connection without going back to the IDLE mode (also known as NAS recovery). Using the NAS recovery may generate additional delays and signaling. Some embodiments mitigate this problem, by introducing the possibility to perform a full reconfiguration during the resume procedure, for example.

**[0150]** Embodiment A

**[0151]** Embodiment A proposes to utilize a full configuration towards the UE in the resume procedure, as shown in Figure 12, but where the new eNB is not compatible with the old eNB, meaning that the new eNB cannot read, identify, understand, access some files, such as the configuration information (e.g. UE AS context).

**[0152]** More specifically, the resume procedure is enhanced to support a full configuration (or reconfiguration). When a target/new eNB (gNB) gets a resume request from a UE (see for example step 1215 of Figure 12), it retrieves a UE AS context from the source/old eNB (see steps 1220 and 1225 of Figure 12). In case the target/new eNB and the source/old eNB are different (using different radio access technologies, or different releases of the technology), the target eNB may not be able to fully access or read the UE AS context.

**[0153]** Figure 15 illustrates a method 300 for resuming a connection in a network node, such as the new eNB. In such a case, the target eNB (gNB) performs the following steps or operations of:

**[0154]** Step 305: receiving, from a wireless device, a request to resume a connection in the communication network.

**[0155]** Step 310: based on the request, retrieving configuration information (e.g. UE AS context) for the wireless device.

**[0156]** Step 315: in response to determining that the retrieved configuration information is unidentifiable, generating new configuration parameters.

**[0157]** Step 320: sending a resume response message to the wireless device, the message comprising an indication to perform a full configuration using the new configuration parameters.

**[0158]** In step 305, the request to resume can be a RRC Connection Resume Request.

**[0159]** In step 315: after determining that the retrieved configuration information is unidentifiable, the new eNB can just ignore the retrieved UE AS context information. Then, it can prepare (or generate) a new UE AS context information from the S1 or NG context information that is provided during the retrieval of the UE AS context. The S1 and NG context contains information that the core network has sent down to the RAN during the initial UE context setup or at a subsequent signaling. This information could comprise radio parameters for configuration and information regarding the different bearers. This information should be sufficient for the target eNB to rebuild the UE AS context.

**[0160]** In step 320: the new eNB prepares the RRC Resume message that includes the new UE AS context information for sending to the wireless device. To do so, the new eNB sets a flag to the full configuration in the RRC Resume message. Once the flag is set, it could be referred to as the *fullConfig* flag. In the current systems, there is no such flag in the Resume message. Then, the new eNB sends the RRC Resume message to the UE with the flag.

**[0161]** In response to receiving the RRC resume message that contains the *fullConfig* flag, the UE will discard the old bearer configuration and other old radio parameters, for example. Then, it will only apply the (new) configuration it received in the RRC Resume message. In this way, the UE could switch to a new configuration from a network node which cannot understand the old configuration. It should be noted that some parameters, such as the security keys, will be kept in the UE even after receiving the *fullConfig* flag since the encryption and integrity protection is already up and running when the network node (gNB) sends the RRC Resume message.

**[0162]** It should be noted that modifications, additions, or omissions may be made to method 300 of Figure 15. Additionally, one or more steps in method 300 may be performed in parallel or in any suitable order. As such, Figure 16 illustrates another method 300 for resuming a connection with a network node. This method is referred to as method 330 and can be performed in a network node 220 of Figure 14. This network node may be referred to as the new network node or a target eNB or gNB. Method 330 includes the following steps:

**[0163]** Step 335: receiving, from a wireless device, a request to resume a connection in the communication network.

**[0164]** Step 340: in response to the request, sending a resume response message to the wireless device, the message comprising an indication to perform a full configuration.

**[0165]** In some examples, the network node 220 (e.g. new eNB) can retrieve configuration information (e.g. UE AS context) from the source/old eNB upon receipt of the resume request. Furthermore, in case the target/new eNB and the source/old eNB are different (using different

radio access technologies, or different releases of the technology), the target eNB may not be able to fully access or read the UE AS context. In this case, the new eNB can generate configuration parameters (which are new compared to the current configuration parameters) for the full configuration.

5 **[0166]** In some embodiments, the new network node may determine that the retrieved configuration information is unidentifiable/unreadable, the new eNB can just ignore the retrieved UE AS context information. Then, it can prepare (or generate) configuration parameters, e.g. new UE AS context information from the S1 or NG context information that is provided during the retrieval of the UE AS context. The S1 and NG contexts contain information that the core network  
10 has sent down to the RAN during the initial UE context setup or at a subsequent signaling. This information could comprise radio parameters for configuration and information regarding the different bearers. This information should be sufficient for the target eNB to rebuild the UE AS context. As a note, S1 is the interface between the eNB and the core network, when the core network is Enhanced Packet Core (EPC). NG is the interface between an eNB/gNB and the core  
15 network, when the core network is 5GC.

**[0167]** In some embodiments, the new eNB prepares the RRC Resume message that includes the new UE AS context information (or configuration parameters) to be sent to the wireless device. The new eNB sets a flag to the full configuration in the RRC Resume message. Once the flag is set, it could be referred to as the *fullConfig* flag. Then, the new eNB sends the RRC Resume  
20 message to the UE with the flag.

**[0168]** In response to receiving the RRC resume message that contains the *fullConfig* flag, the UE will discard the old bearer configuration and other old radio parameters, for example. Then, it will only apply the (new) configuration it received in the RRC Resume message. In this way, the UE could switch to a new configuration from a network node which cannot understand the old  
25 configuration. It should be noted that some parameters, such as the security keys, will be kept in the UE even after receiving the *fullConfig* flag since the encryption and integrity protection is already up and running when the network node (gNB) sends the RRC Resume message.

**[0169]** In some embodiments, the configuration parameters comprise one or more of bearer configuration, Packet Data Convergence Protocol (PDCP) configuration, Radio Link Control  
30 (RLC) configuration.

**[0170]** Now turning to Figure 17, a method 350 in a wireless device/UE for resuming a connection will be described. The wireless device could be the UE 210 of Figure 14.

**[0171]** Method 350 comprises the following steps:



**[0172]** Step 355: Sending to a network node a request to resume a connection in the communication network.

**[0173]** Step 360: Receiving a resume response message from the network node, the message comprising an indication to perform a full configuration.

5 **[0174]** Step 365: Applying (or performing) the full configuration.

**[0175]** In some embodiments, the method 350 may further comprise discarding an old bearer configuration and old radio parameters.

**[0176]** In some embodiments, the method 350 may further comprise keeping security keys.

10 **[0177]** In some embodiments, the method 350 may further comprise receiving a new configuration.

**[0178]** In some embodiments, the method 350 may further comprise applying the new configuration.

**[0179]** Embodiment B

15 **[0180]** Embodiment B addresses the incompatibility between the target and source network nodes (e.g. eNBs) by considering the UE context mismatch from the point of view of the network.

**[0181]** For example, the following network enhancements could be considered to solve the incompatibility problem of the network nodes:

20 **[0182]** 1) The UE AS context information that is passed from the source network node can be coded in such a way that the target network node is able to understand the legacy information elements (IEs) (e.g. LTE PDCP configurations), even though some new IEs might have been introduced in later releases of the standard than the version of the legacy eNB.

**[0183]** 2) When the source network node knows that the target network node is a legacy eNB, it can convert the UE AS context information to a format that the legacy eNB is able to understand (e.g. convert NR PDCP configurations to LTE PDCP configurations).

25 **[0184]** In the first case, the target network node can get the relevant bearer information that it can understand (e.g. the DRB-id and RLC and lower layer configurations) through proper coding. It can get the rest of the information for that particular bearer from the S1 bearer context (i.e. so that it can re-configure the UE with the proper LTE PDCP version). The problem with this solution is that it assumes that a legacy eNB performs something new (combine S1 or NG context with other  
30 UE context received from the source network node) to handle this case (i.e. it is not actually a legacy eNB) but at least it should be possible to add new parameters in the future which do not need to be understood by the existing eNBs, since these eNBs would get all the relevant information from the parts they understand of the UE context and the S1 context. Those parts are

the parts that have been properly coded so as to be understood by all the network nodes (legacy and new generations of network nodes).

**[0185]** In the second case, the target eNB will understand the UE context from the source eNB. It needs however to signal all DRBs to the UE to trigger the UE to change those DRBs from the old configuration (not understood by the target eNB). Normally, the eNB does not need to signal DRB configuration for DRBs that it does not want to change (since delta signaling is used). So, an added impact of this solution would be to add a function to the target eNB to trigger the DRB signaling for all DRBs. This would require the target eNB to be upgraded, but at least it should be possible to add new parameters in the future which do not need to be understood by the existing/legacy eNBs since the eNB will understand all the parameters forwarded from the source eNB and always send the DRB configuration to the UE.

**[0186]** As can be seen above, the first and second solutions rely on new functionalities in both the target and source nodes, but the advantage is that once those nodes have been upgraded it should be possible in the future to add new features to the standard and only upgrade the network nodes supporting the features.

**[0187]** Here is a summary of some exemplary new functionalities that need to be supported for the embodiments B:

**[0188]** [Case 1] The source node should forward a UE context coded in such a way that the target node can understand all needed legacy parameters and ignore new parameters. The coding could for instance utilize non-critical extensions, which could be ignored by legacy target eNBs.

**[0189]** [Case 1] The target node should rebuild the UE context using a combination of S1 or NG context information and parameters it understands of the UE context forwarded from the source node.

**[0190]** [Case 2] The source node should obtain information from the target node about which release of the specification of the standard it understands or which features it supports. This could be signaled in a message from the target to the source node during X2 or Xn setup.

**[0191]** [Case 2] The source node should code the UE context information in a way understood by the target node. In case the target node support later releases than the source node, it is assumed that the source node's code according to its own release should be understood by the target node. The context is then sent over X2, Xn or via the Core Network to the target node.

**[0192]** [Case 2] The target node should trigger a re-configuration of all bearers or other relevant configuration parameters even in case it would use the same configuration as before. The purpose

of this is to inform the UE, which supports later releases, that the configuration is reverted back to the legacy configuration.

5 **[0193]** Now turning to Figure 18, a flow chart of a method 370 for resuming a connection for a wireless device in a communication network will be described. The communication network node can be the network 200. The wireless device can be the UE 210.

**[0194]** Method 370 can be implemented in a network node, such as the network 220 of Figure 14.

**[0195]** Method 370 includes:

**[0196]** Step 375: receiving, from a wireless device, a request to resume a connection in a communication network;

10 **[0197]** Step 380: based on the request, retrieving configuration information for the wireless device; wherein the configuration information is adapted from a source network node to the network node so as to be usable by the network node; and

**[0198]** Step 385: sending a resume response message to the wireless device to resume the connection based on the adapted configuration information.

15 **[0199]** For example, the configuration information can be adapted by coding at least parts of the configuration information to be readable by both the network node and the source network node.

**[0200]** In some embodiments, the configuration information is adapted by converting the format of the configuration information from the source network node to a format of the network node.

20 **[0201]** Figure 19 is a block diagram of an exemplary radio network node 220, in accordance with certain embodiments. Radio network node 220 may include one or transceivers 420 with multiple antennas, processor 440, memory 450, and network interface 430. In some embodiments, the transceiver facilitates transmitting wireless signals to and receiving wireless signals from wireless device 210 (e.g., via transmitter(s) (Tx), receiver(s) (Rx), and antennas). The processor 440 executes instructions to provide some or all of the functionalities described above as being  
25 provided by a radio network node 220, the memory stores the instructions executed by the processor. In some embodiments, the processor 440 and the memory 450 form processing circuitry 410. The network interface communicates signals to backend network components, such as a gateway, switch, router, Internet, Public Switched Telephone Network (PSTN), core network nodes or radio network controllers, etc.

30 **[0202]** The processor 440 may include any suitable combination of hardware to execute instructions and manipulate data to perform some or all of the described functions of radio network node 220, such as those described above, e.g. methods 300 of Figure 15, 330 of Figure 16 and 370 of Figure 18 and their related embodiments. In some embodiments, the processor may include, for

example, one or more computers, one or more central processing units (CPUs), one or more microprocessors, one or more application specific integrated circuits (ASICs), one or more field programmable gate arrays (FPGAs) and/or other logic.

5 **[0203]** The memory is generally operable to store instructions, such as a computer program, software, an application including one or more of logic, rules, algorithms, code, tables, etc. and/or other instructions capable of being executed by a processor. Examples of memory include computer memory (for example, Random Access Memory (RAM) or Read Only Memory (ROM)), mass storage media (for example, a hard disk), removable storage media (for example, a Compact Disk (CD) or a Digital Video Disk (DVD)), and/or or any other volatile or non-volatile,  
10 non-transitory computer-readable and/or computer-executable memory devices that store information.

**[0204]** In some embodiments, the network interface is communicatively coupled to the processor and may refer to any suitable device operable to receive input for radio network node 220, send output from radio network node 220, perform suitable processing of the input or output or both,  
15 communicate to other devices, or any combination of the preceding. The network interface may include appropriate hardware (e.g., port, modem, network interface card, etc.) and software, including protocol conversion and data processing capabilities, to communicate through a network.

**[0205]** Other embodiments of radio network node 220 may include additional components beyond  
20 those shown in Figure 19 that may be responsible for providing certain aspects of the radio network node's functionalities, including any of the functionalities described above and/or any additional functionalities (including any functionality necessary to support the solutions described above). The various different types of network nodes may include components having the same physical hardware but configured (e.g., via programming) to support different radio access  
25 technologies, or may represent partly or entirely different physical components.

**[0206]** Processors, interfaces, and memory similar to those described with respect to Figure 19 may be included in other network nodes (such as core network node 230). Other network nodes may optionally include or not include a wireless interface (such as the transceiver described in Figure 19).

30 **[0207]** In some embodiments, the network node 220 may comprise a series of modules 510 (see Figure 20) configured to implement the functionalities of the network node 220 described above. Referring to Figure 20, in some embodiments, the network node 220 may comprise a receiving module configured to receive, from a wireless device, a request to resume a connection. The

network 220 may comprise, for example, a sending module configured to send a resume response message to the wireless device, the message comprising an indication to perform a full configuration. The network node 220 may also comprise a receiving module configured to receive a request to resume a connection from a wireless device. The network node may comprise other  
5 modules configured to perform the functionalities of method 300 of Figure 15 and method 370 of Figure 18, for example.

**[0208]** It will be appreciated that the various modules may be implemented as combination of hardware and/or software, for instance, the processor, memory and transceiver(s) of radio network node 220 shown in Figure 19. Some embodiments may also include additional modules to support  
10 additional and/or optional functionalities.

**[0209]** In some embodiments, the retrieving module may also be configured to retrieve configuration information for the wireless device; wherein the configuration information is adapted from a source network node to the network node so as to be usable by the network node. In some embodiments, the sending module may also be configured to send a resume response  
15 message to the wireless device to resume the connection based on the adapted configuration information.

**[0210]** Figure 21 illustrates a schematic block diagram of a wireless device 210 according to some embodiments of the present disclosure. As illustrated, the wireless device 210 includes circuitry/circuit 610 comprising one or more processors 620 (e.g., Central Processing Units (CPUs), Application Specific Integrated Circuits (ASICs), Field Programmable Gate Arrays (FPGAs), and/or the like) and memory 630. The wireless device 210 also includes one or more transceivers 640 each including one or more transmitter 650 and one or more receivers 660 coupled to one or more antennas 670. In some embodiments, the functionality of the wireless device 210 described above may be fully or partially implemented in software that is, e.g., stored  
20 in the memory 630 and executed by the processor(s) 620. For example, the processor 620 is configured to perform any operations related to the UE, e.g. method 350 of Figure 17.

**[0211]** In some embodiments, a computer program including instructions which, when executed by the at least one processor 620, causes the at least one processor 620 to carry out the functionality of the wireless device 210 according to any of the embodiments described herein is provided (e.g.  
30 any operations related to the UE, e.g. method 350 of Figure 17). In some embodiments, a carrier containing the aforementioned computer program product is provided. The carrier is one of an electronic signal, an optical signal, a radio signal, or a computer readable storage medium (e.g., a non-transitory computer readable medium such as memory).

**[0212]** Figure 22 is a schematic block diagram of the wireless device 210 according to some other embodiments of the present disclosure. The wireless device 210 includes one or more modules 700, each of which is implemented in software. The module(s) 700 provide the functionality of the wireless device 210 described herein. For example, the modules 700 may comprise a sending module operable to perform at least step 355 of Figure 17, a receiving module operable to perform at least step 360 of Figure 17 and an applying module operable to perform at least step 365 of Figure 17.

**[0213]** Embodiments may also be practiced in distributed computing environments where tasks are performed by remote-processing devices that are linked through a communications network.

**[0214]** For example, Figure 23 is a schematic block diagram illustrating a virtualization environment 800 in which functions implemented by some embodiments may be virtualized. In the present context, virtualizing means creating virtual versions of apparatuses or devices which may include virtualizing hardware platforms, storage devices and networking resources. As used herein, virtualization can be applied to a network node 220 (e.g., a virtualized base station or a virtualized radio access node) or to a device 210 (e.g., a UE, a wireless device or any other type of communication device) or components thereof and relates to an implementation in which at least a portion of the functionality is implemented as one or more virtual components (e.g., via one or more applications, components, functions, virtual machines or containers executing on one or more physical processing nodes in one or more networks).

**[0215]** In some embodiments, some or all of the functions described herein may be implemented as virtual components executed by one or more virtual machines implemented in one or more virtual environments 800 hosted by one or more of hardware nodes QQ330. Further, in embodiments in which the virtual node is not a radio access node or does not require radio connectivity (e.g., a core network node), then the network node may be entirely virtualized.

**[0216]** The functions may be implemented by one or more applications QQ320 (which may alternatively be called software instances, virtual appliances, network functions, virtual nodes, virtual network functions, etc.) operative to implement some of the features, functions, and/or benefits of some of the embodiments disclosed herein. Applications QQ320 are run in virtualization environment 800 which provides hardware QQ330 comprising processing circuitry QQ360 and memory QQ390. Memory QQ390 contains instructions QQ395 executable by processing circuitry QQ360 whereby application QQ320 is operative to provide one or more of the features, benefits, and/or functions disclosed herein.

**[0217]** Virtualization environment 800, comprises general-purpose or special-purpose network hardware devices QQ330 comprising a set of one or more processors or processing circuitry QQ360, which may be commercial off-the-shelf (COTS) processors, dedicated Application Specific Integrated Circuits (ASICs), or any other type of processing circuitry including digital or analog hardware components or special purpose processors. Each hardware device may comprise memory QQ390-1 which may be non-persistent memory for temporarily storing instructions QQ395 or software executed by processing circuitry QQ360. Each hardware device may comprise one or more network interface controllers (NICs) QQ370, also known as network interface cards, which include physical network interface QQ380. Each hardware device may also include non-transitory, persistent, machine-readable storage media QQ390-2 having stored therein software QQ395 and/or instructions executable by processing circuitry QQ360. Software QQ395 may include any type of software including software for instantiating one or more virtualization layers QQ350 (also referred to as hypervisors), software to execute virtual machines QQ340 as well as software allowing it to execute functions, features and/or benefits described in relation with some embodiments described herein.

**[0218]** Virtual machines QQ340, comprise virtual processing, virtual memory, virtual networking or interface and virtual storage, and may be run by a corresponding virtualization layer QQ350 or hypervisor. Different embodiments of the instance of virtual appliance QQ320 may be implemented on one or more of virtual machines QQ340, and the implementations may be made in different ways.

**[0219]** During operation, processing circuitry QQ360 executes software QQ395 to instantiate the hypervisor or virtualization layer QQ350, which may sometimes be referred to as a virtual machine monitor (VMM). Virtualization layer QQ350 may present a virtual operating platform that appears like networking hardware to virtual machine QQ340.

**[0220]** As shown in Figure QQ3, hardware QQ330 may be a standalone network node with generic or specific components. Hardware QQ330 may comprise antenna QQ3225 and may implement some functions via virtualization. Alternatively, hardware QQ330 may be part of a larger cluster of hardware (e.g. such as in a data center or customer premise equipment (CPE)) where many hardware nodes work together and are managed via management and orchestration (MANO) QQ3100, which, among others, oversees lifecycle management of applications QQ320.

**[0221]** Virtualization of the hardware is in some contexts referred to as network function virtualization (NFV). NFV may be used to consolidate many network equipment types onto

industry standard high volume server hardware, physical switches, and physical storage, which can be located in data centers, and customer premise equipment.

5 **[0222]** In the context of NFV, virtual machine QQ340 may be a software implementation of a physical machine that runs programs as if they were executing on a physical, non-virtualized machine. Each of virtual machines QQ340, and that part of hardware QQ330 that executes that virtual machine, be it hardware dedicated to that virtual machine and/or hardware shared by that virtual machine with others of the virtual machines QQ340, forms a separate virtual network elements (VNE).

10 **[0223]** Still in the context of NFV, Virtual Network Function (VNF) is responsible for handling specific network functions that run in one or more virtual machines QQ340 on top of hardware networking infrastructure QQ330 and corresponds to application QQ320 in Figure QQ3.

15 **[0224]** In some embodiments, one or more radio units QQ3200 that each include one or more transmitters QQ3220 and one or more receivers QQ3210 may be coupled to one or more antennas QQ3225. Radio units QQ3200 may communicate directly with hardware nodes QQ330 via one or more appropriate network interfaces and may be used in combination with the virtual components to provide a virtual node with radio capabilities, such as a radio access node or a base station.

20 **[0225]** In some embodiments, some signalling can be effected with the use of control system QQ3230 which may alternatively be used for communication between the hardware nodes QQ330 and radio units QQ3200.

25 **[0226]** Some embodiments may be represented as a non-transitory software product stored in a machine-readable medium (also referred to as a computer-readable medium, a processor-readable medium, or a computer usable medium having a computer readable program code embodied therein). The machine-readable medium may be any suitable tangible medium including a magnetic, optical, or electrical storage medium including a diskette, compact disk read only memory (CD-ROM), digital versatile disc read only memory (DVD-ROM) memory device (volatile or non-volatile), or similar storage mechanism. The machine-readable medium may contain various sets of instructions, code sequences, configuration information, or other data, which, when executed, cause a processor to perform steps in a method according to one or more of the described embodiments. Those of ordinary skill in the art will appreciate that other instructions and operations necessary to implement the described embodiments may also be stored on the machine-readable medium. Software running from the machine-readable medium may interface with circuitry to perform the described tasks.

30



**[0227]** The above-described embodiments are intended to be examples only. Alterations, modifications and variations may be effected to the particular embodiments by those of skill in the art without departing from the scope of the description.

**CLAIMS**

What is claimed is:

1. A method in a wireless device, the method comprising:
  - sending to a network node a request to resume a connection in a communication network;
  - receiving a resume message from the network node, the message comprising an indication to perform a full configuration; and
  - applying the full configuration.
2. The method of claim 1, further comprising discarding an old bearer configuration and old radio parameters.
3. The method of claim 1, further comprising keeping security keys.
4. The method of claim 1, further comprising receiving a configuration.
5. The method of claim 4, further comprising applying the received configuration.
6. A wireless device, comprising a communication interface; and one or more processing circuits communicatively connected to the communication interface, the one or more processing circuits comprising at least one processor and memory, the memory containing instructions that, when executed, cause the at least one processor to:
  - send to a network node a request to resume a connection in a communication network;
  - receive a resume response message from the network node, the message comprising an indication to perform a full configuration; and
  - apply the full configuration.
7. The wireless device of claim 6, wherein the at least one processor is configured to discard an old bearer configuration and old radio parameters.
8. The wireless device of claim 6, wherein the at least one processor is configured to keep security keys.
9. The wireless device of claim 6, wherein the at least one processor is configured to receive a configuration.
10. The wireless device of claim 9, wherein the at least one processor is configured to apply the received configuration.

11. A network node comprising:
- a communication interface; and
  - one or more processing circuits communicatively connected to the communication interface, the one or more processing circuits comprising at least one processors and memory, the memory containing instructions that, when executed, cause the at least one processor to:
    - receive, from a wireless device, a request to resume a connection in a communication network;
    - send a resume response message to the wireless device, the message comprising an indication to perform a full configuration.
12. The network node of claim 11, wherein the indication comprises a flag.
13. The network node of claim 11, wherein the network node has a different radio access technology than a previous network node which suspended a previous connection for the wireless device.
14. The network node of claim 11, wherein the at least one processor is configured to retrieve configuration information for the wireless device.
15. The network node of claim 11, wherein the message further comprises configuration parameters.
16. The network node of claim 15, wherein the indication comprises an indication to perform a full configuration using the configuration parameters.
17. The network node of claim 11, wherein the resume response message is one of a *RRCConnectionResume* and a *RRCResume*.
18. The network node of claim 15, wherein the at least one processor is configured to generate the configuration parameters by generating a new User Equipment (UE) Access Stratum (AS) context.
19. The network node of claim 15, wherein the at least one processor is configured to generate the configuration parameters based on S1 and Next Generation (NG) context which contains bearer information used during an initial context setup.

20. The network node of claim 15, wherein the configuration parameters comprise one or more of bearer configuration, Packet Data Convergence Protocol (PDCP) configuration and Radio Link Control (RLC) configuration.

## ABSTRACT

A wireless device for resuming a connection in a communication network. The wireless device comprises a communication interface; and one or more processing circuits communicatively connected to the communication interface, the one or more processing circuits comprising at least one processor and memory, the memory containing instructions that, when executed, cause the at least one processor to: send to a network node a request to resume a connection in a communication network; receive a resume response message from the network node, the message comprising an indication to perform a full configuration; and apply the full configuration.

**IN THE UNITED STATES PATENT AND TRADEMARK OFFICE**

In re Application of: Teyeb et al. )  
)  
)  
Serial No.: New application ) Examiner: Unknown  
)  
Filed: 2019-02-01 ) Group Art Unit: Unknown  
)  
For: METHODS AND UE FOR RESUMING A CONNECTION WITH FULL  
CONFIGURATION

VIA EFS-Web

Commissioner for Patents  
P.O. Box 1450  
Alexandria, VA 22313-1450

CERTIFICATE OF MAILING OR TRANSMISSION [37 CFR 1.8(A)]  
  
I hereby certify that this correspondence is being electronically transmitted via EFS Web to the United States Patent and Trademark Office  
  
On: ...2019-04-10.....by: ...Lala Deleon.....  
  
.../Lala Deleon/.....  
Signature

Dear Sir:

**REQUEST TO RETRIEVE PRIORITY DOCUMENT**

Applicant hereby requests the Commissioner to retrieve a certified copy of the priority document PCT/IB2019/050836 filed on February 1, 2019.

The PCT application is available to participating offices in the DAS system using access control code CB05, as shown in attached Form PCT/RO/132.

The Commissioner is hereby authorized to charge any fees that may be required or credit any overpayment to Deposit Account 501379.

Respectfully submitted,

/Michael Cameron/

Michael Cameron

Registration No. 50298

Date: April 10, 2019

Ericsson Inc.  
6300 Legacy Drive, M/S EVR 1-C-11  
Plano, Texas 75024  
(408) 662-7009  
michael.cameron@ericsson.com

**PATENT COOPERATION TREATY**

From the RECEIVING OFFICE

**PCT**

COMMUNICATION IN CASES FOR  
WHICH NO OTHER FORM IS APPLICABLE

To:

**CARTIER, Francois  
Ericsson Canada Inc.  
8275 Route Transcanadienne  
Saint-Laurent, Québec H4S 0B6  
CANADA**

Facsimile No.: +1 514 315-0718

|                                                                          |                                                                                    |
|--------------------------------------------------------------------------|------------------------------------------------------------------------------------|
| Date of mailing<br>(day/month/year) <b>13 February 2019 (13.02.2019)</b> |                                                                                    |
| Applicant's or agent's file reference<br><b>P74267WO1</b>                | <b>REPLY DUE</b> See paragraph 1 below                                             |
| International application No.<br><b>PCT/IB2019/050836</b>                | International filing date<br>(day/month/year) <b>01 February 2019 (01.02.2019)</b> |
| Applicant<br><b>TELEFONAKTIEBOLAGET LM ERICSSON (PUBL)</b>               |                                                                                    |

1.  REPLY DUE within \_\_\_\_\_ months/days from the above date of mailing

NO REPLY DUE, however, see below \_\_\_\_\_

IMPORTANT COMMUNICATION

INFORMATION ONLY

2. COMMUNICATION:

WIPO DAS Notification: Confirmation of Access Control Code

As requested, the receiving Office of the International Bureau confirms that this international application can now be made available to participating Offices using the following access control code: CB05.

|                                                                                                                                                                                    |                                                                     |
|------------------------------------------------------------------------------------------------------------------------------------------------------------------------------------|---------------------------------------------------------------------|
| Name and mailing address of the receiving Office<br><br><b>The International Bureau of WIPO<br/>PCT RO/IB Team<br/>34, chemin des Colombettes,<br/>1211 Geneva 20, Switzerland</b> | Authorized officer<br><br><b>DELBARD, Sabine</b>                    |
| Facsimile No. <b>+41 22 910 06 10</b>                                                                                                                                              | Telephone No. <b>+4122 338 9484</b><br>Email: <b>ro.ib@wipo.int</b> |



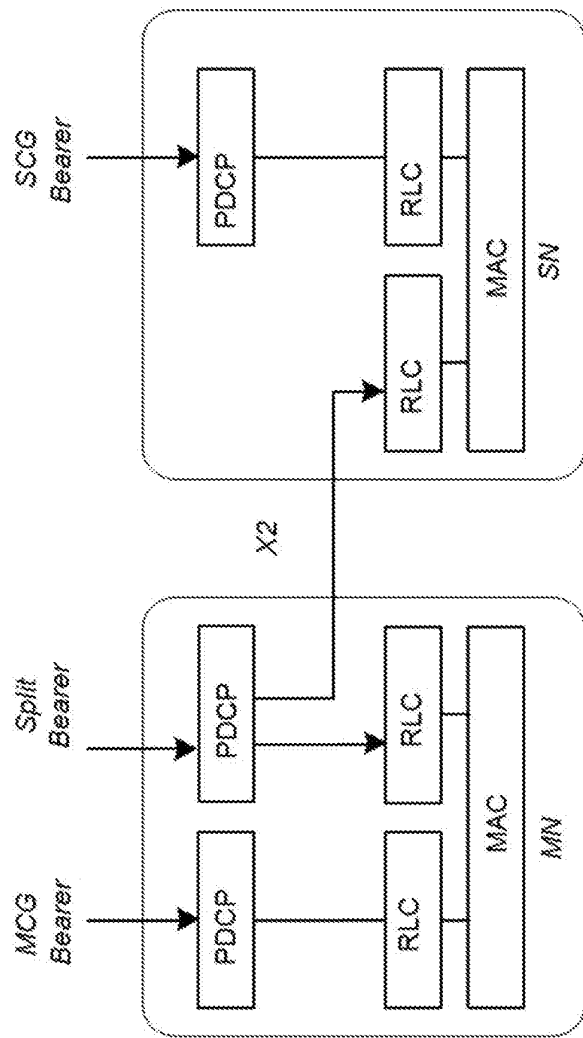

**Figure 1**

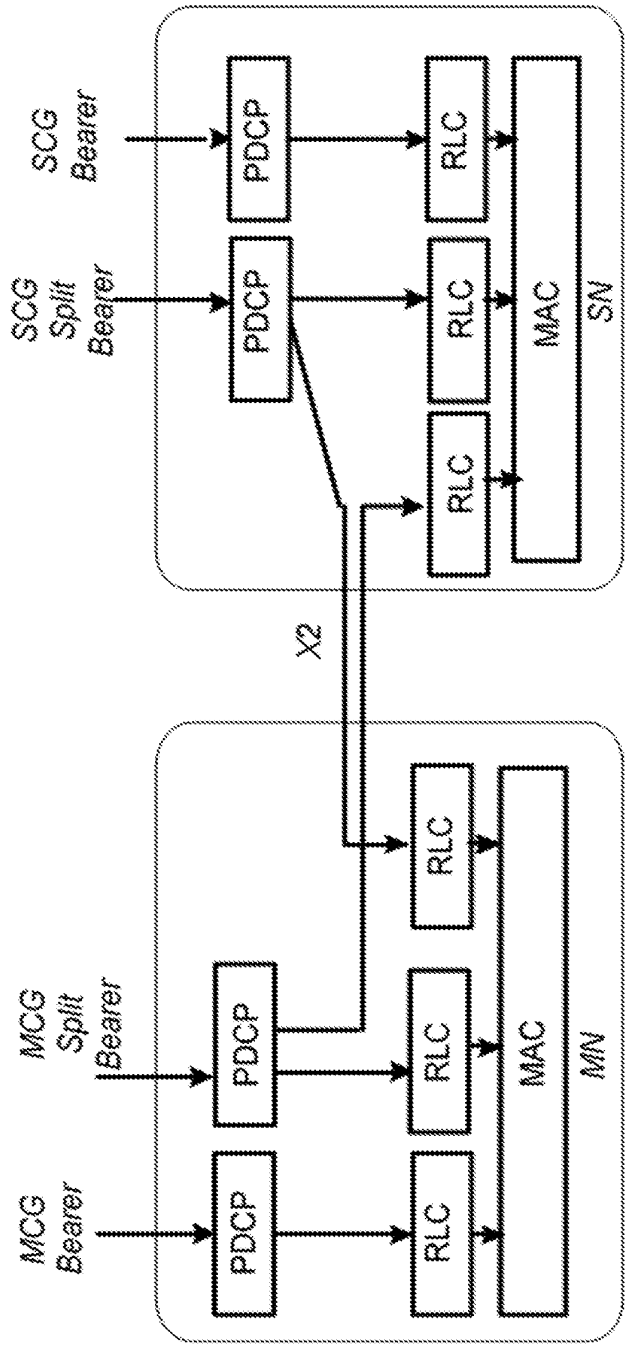

**Figure 2**

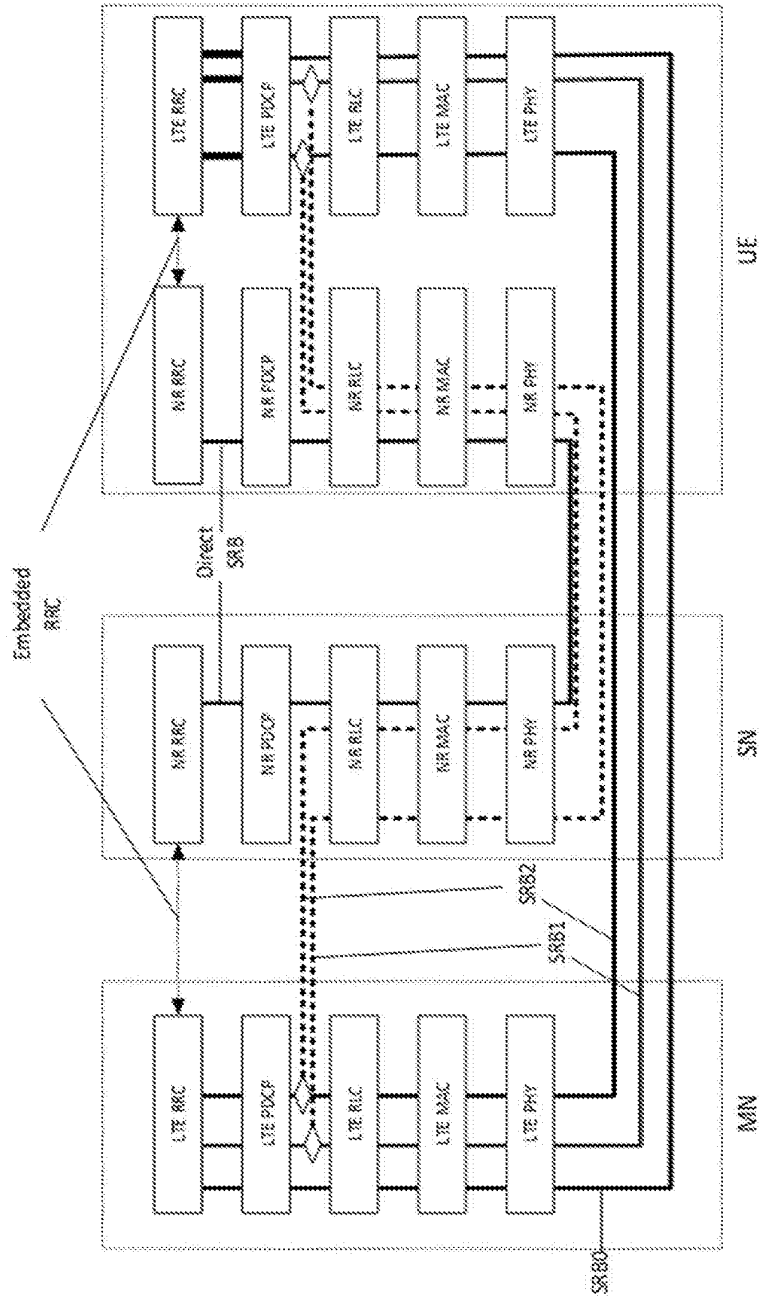
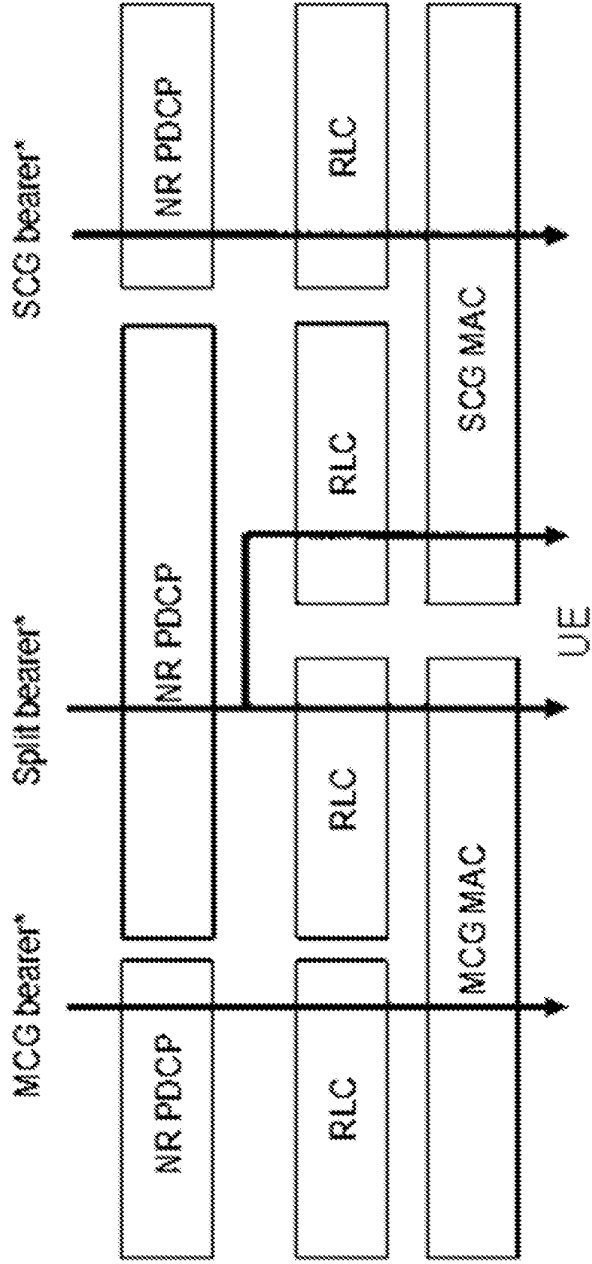
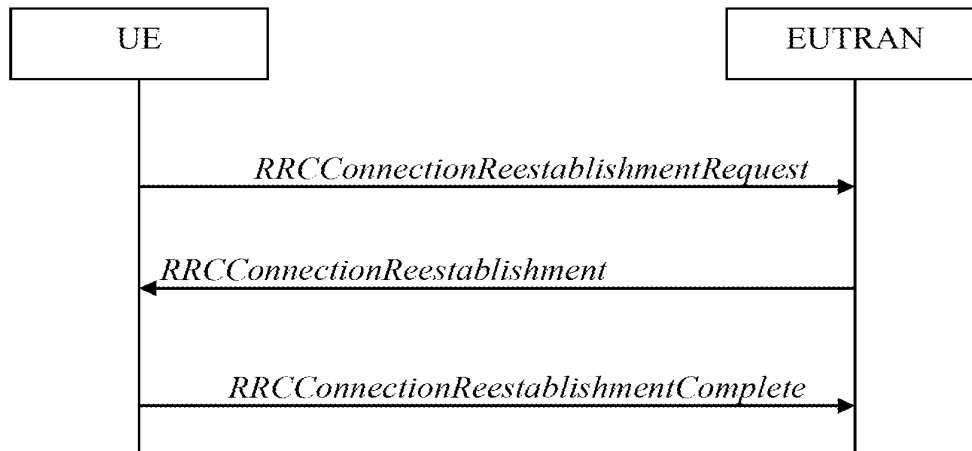

Figure 3



\* Security key (KeNB or S-KeNB) is configurable per bearer

Figure 4



**Figure 5**

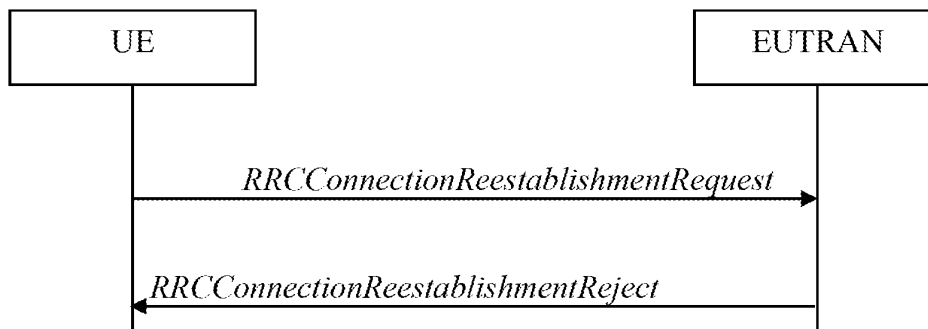

**Figure 6**

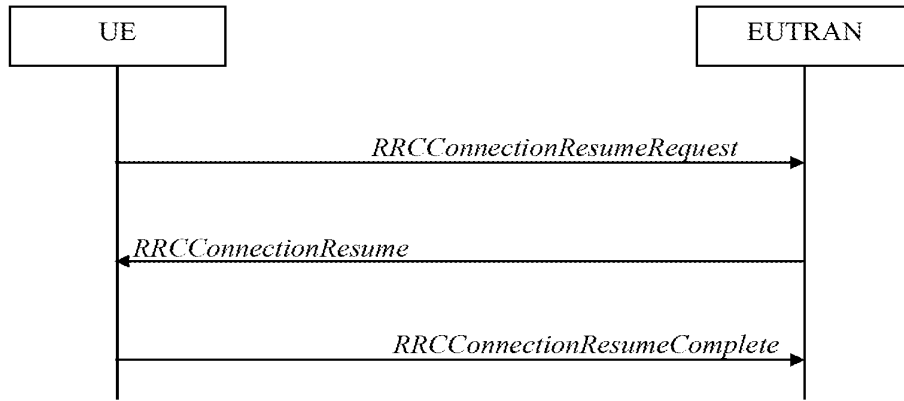

**Figure 7**

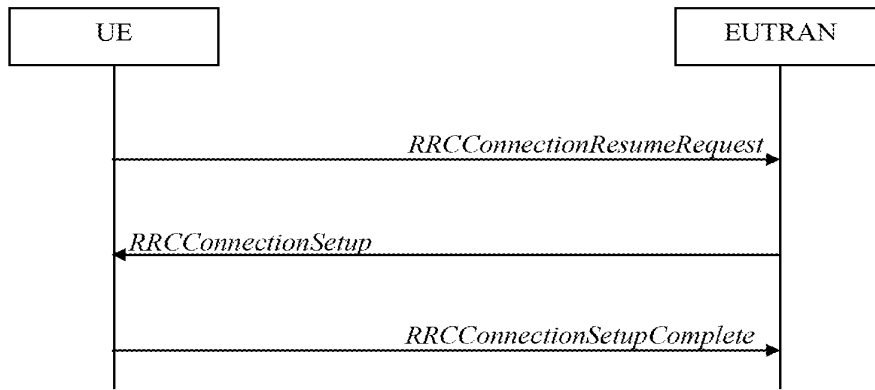

**Figure 8**

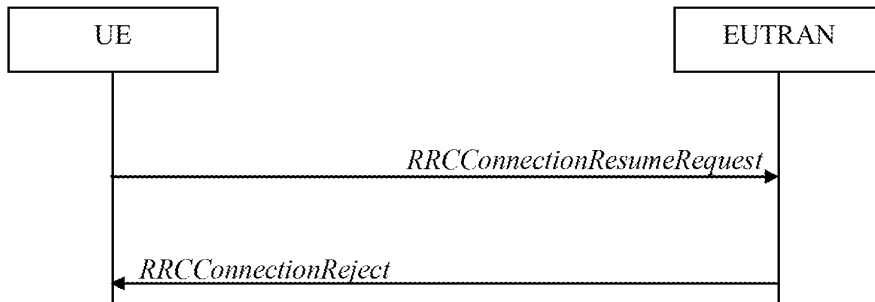

**Figure 9**

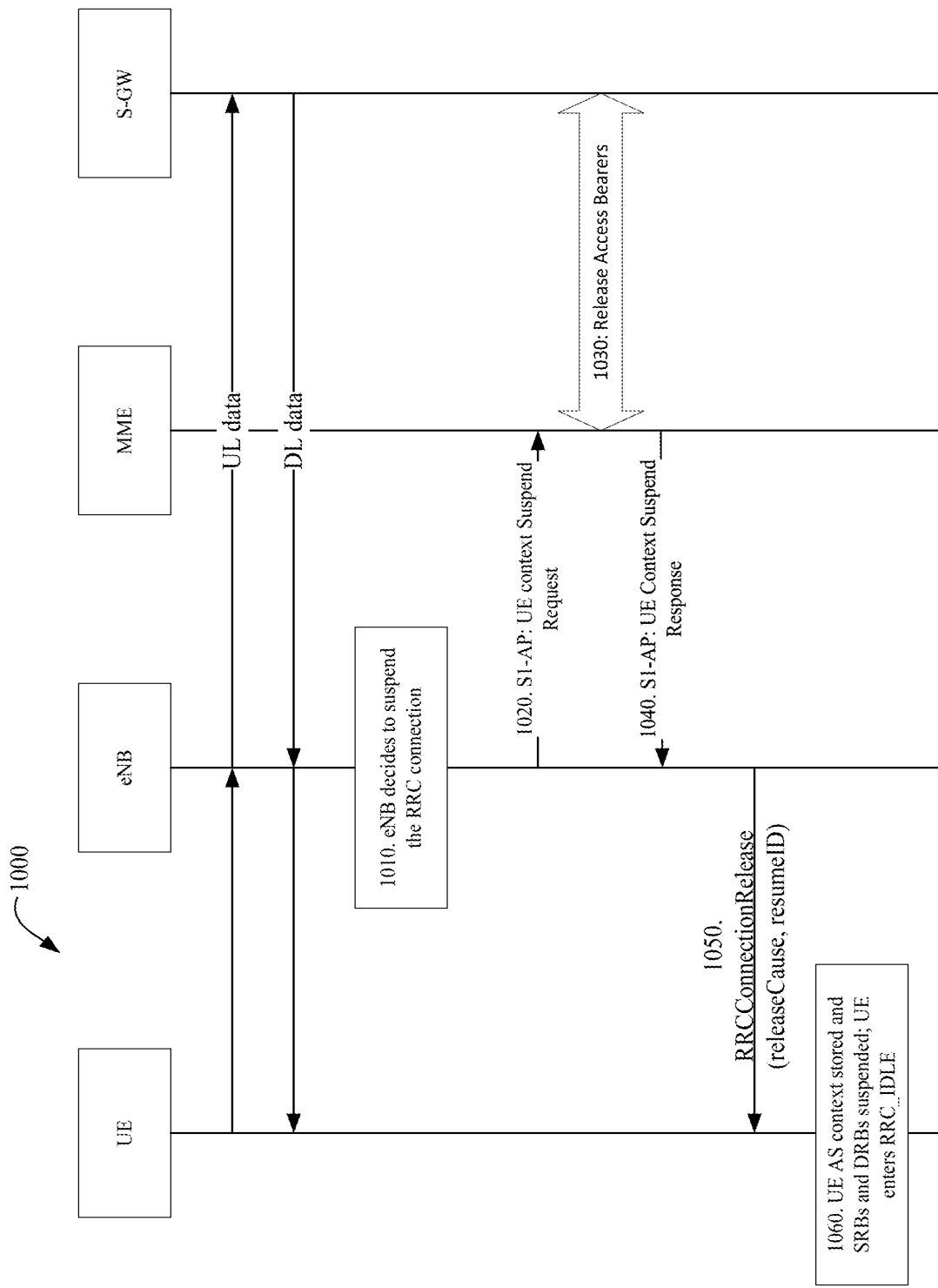

Figure 10

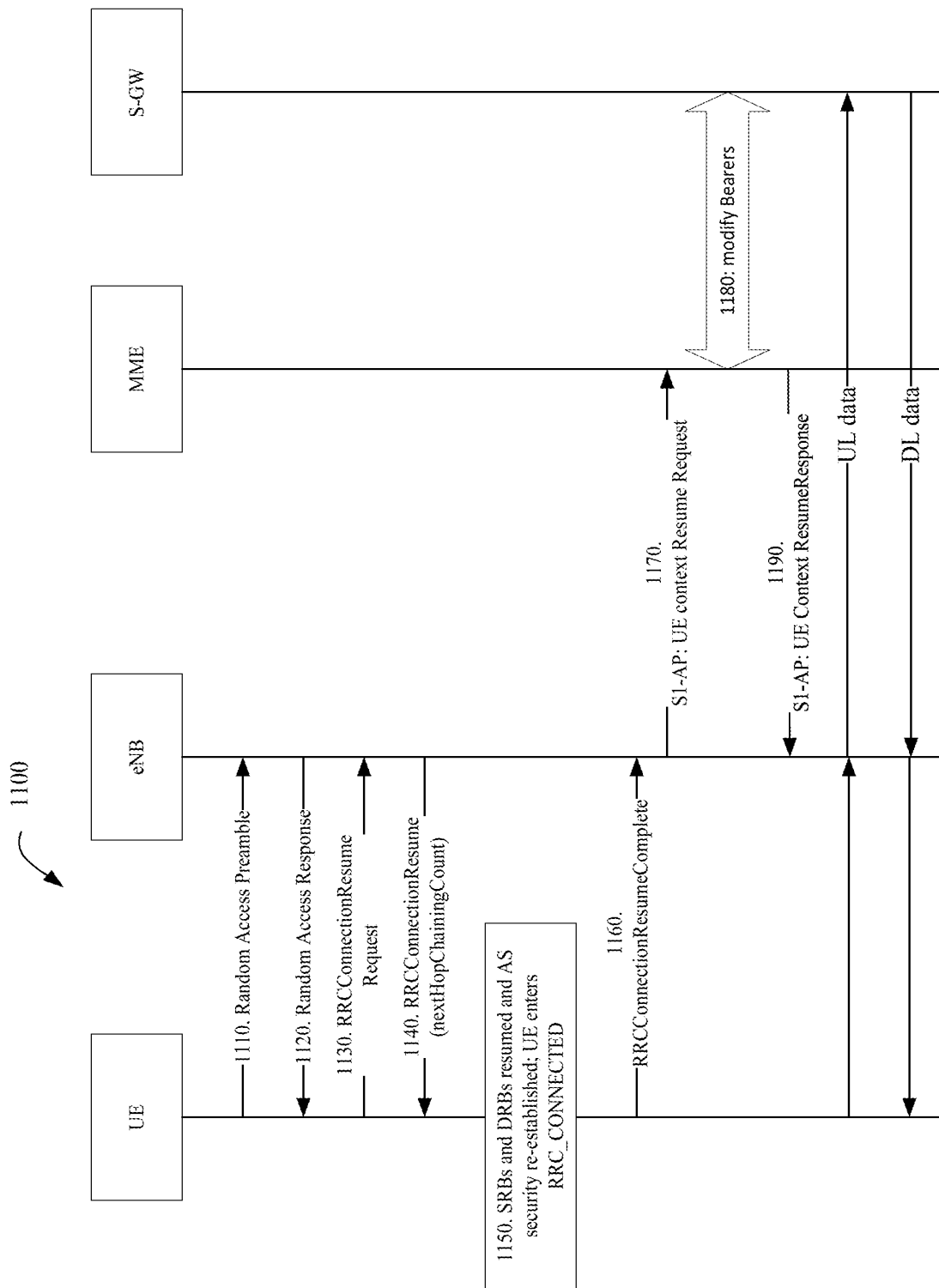

Figure 11



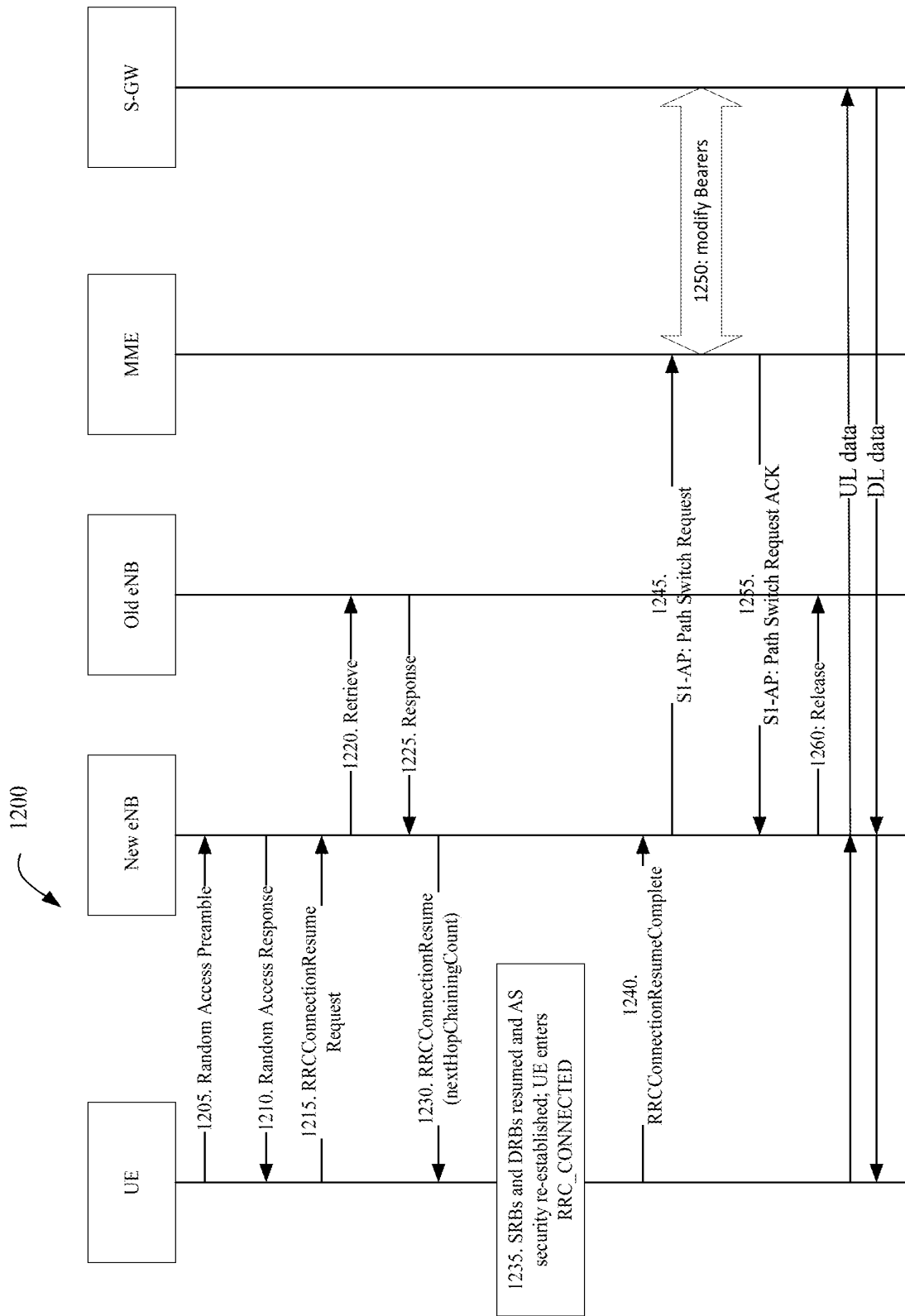
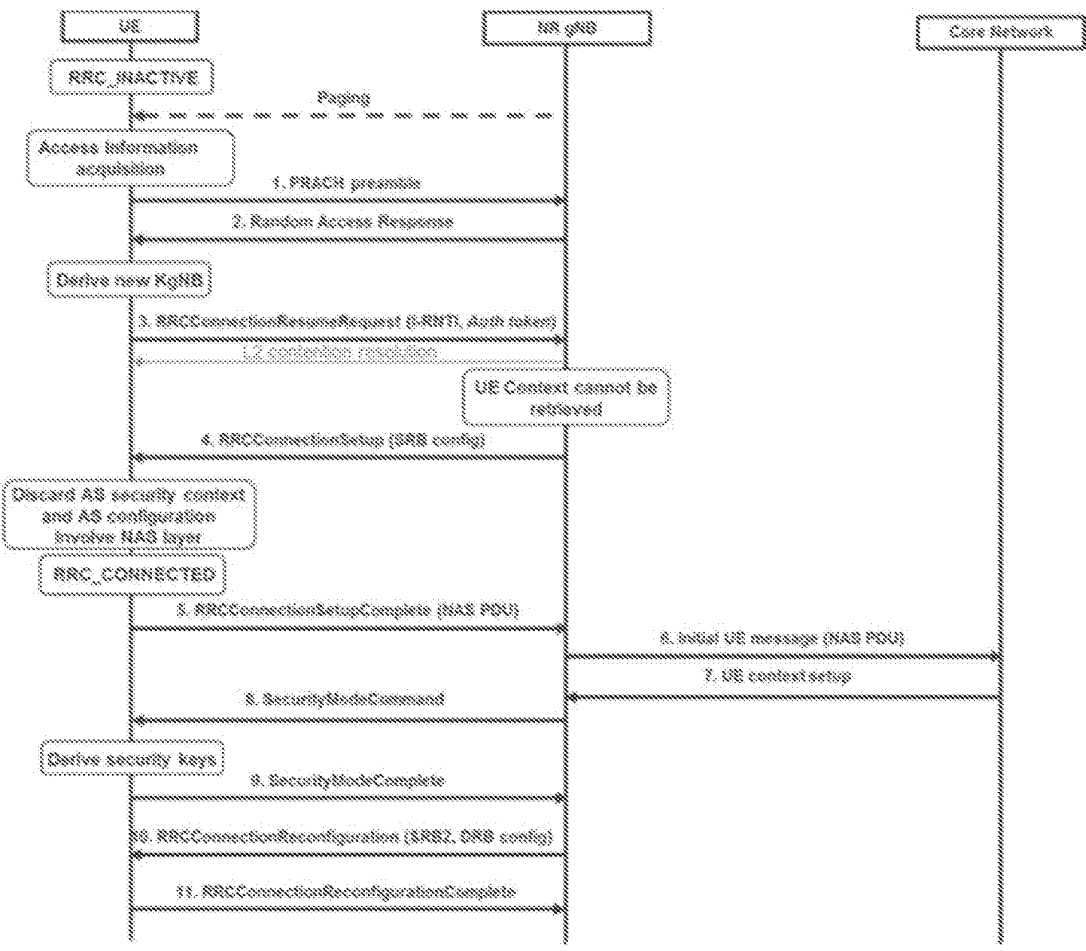
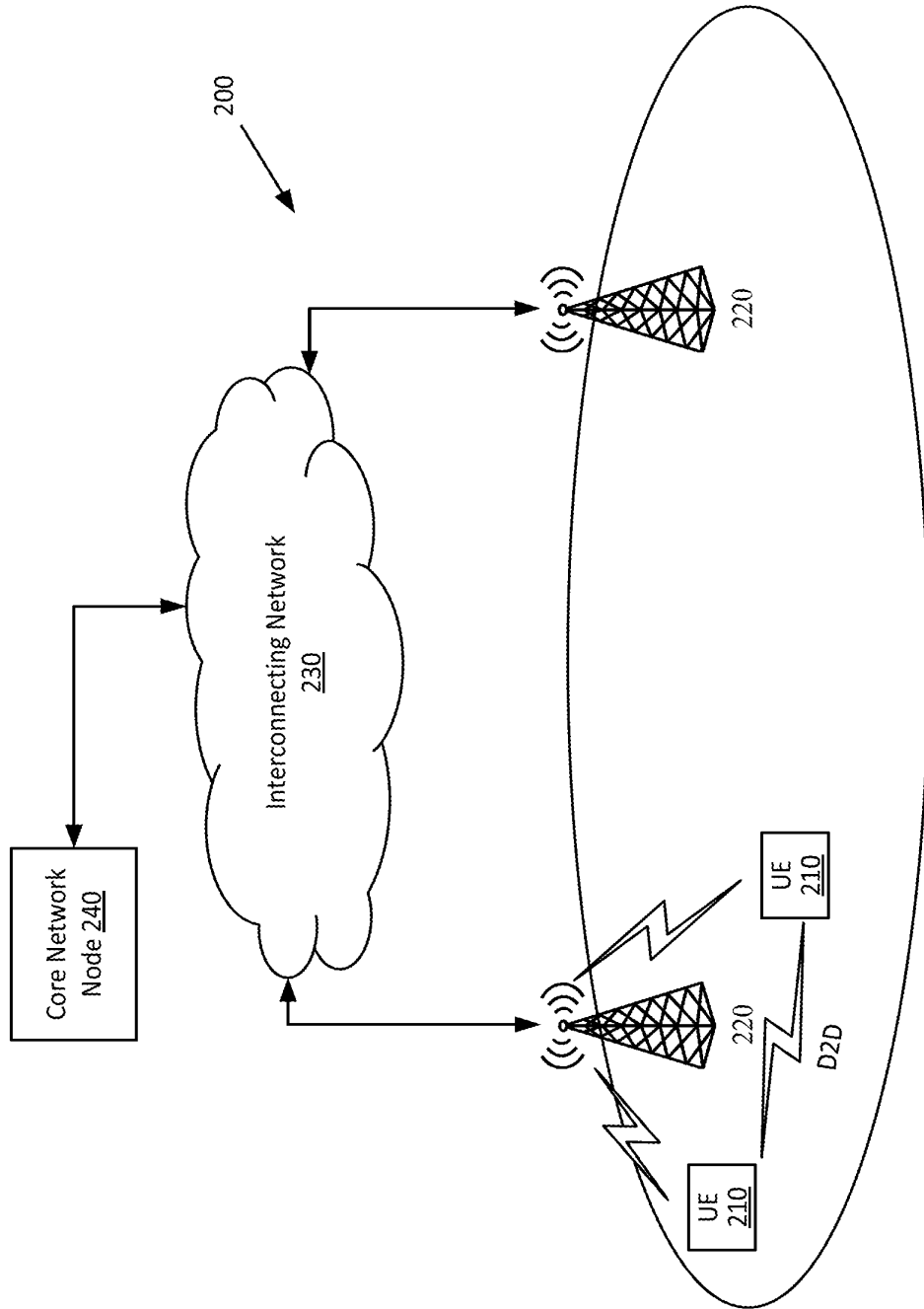

Figure 12



**Figure 13**



**Figure 14**

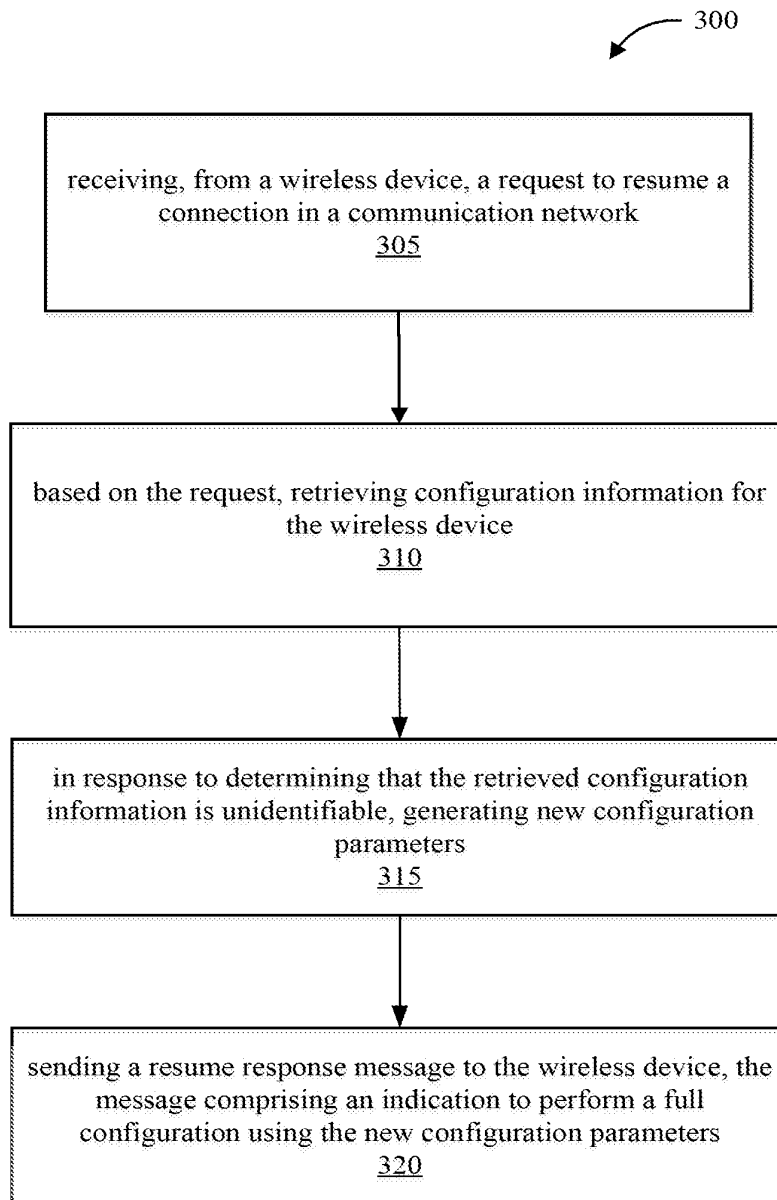

**Figure 15**

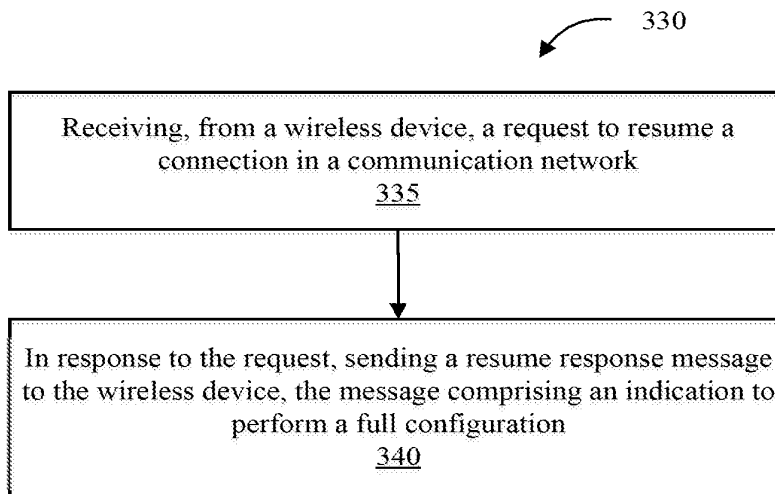

**Figure 16**

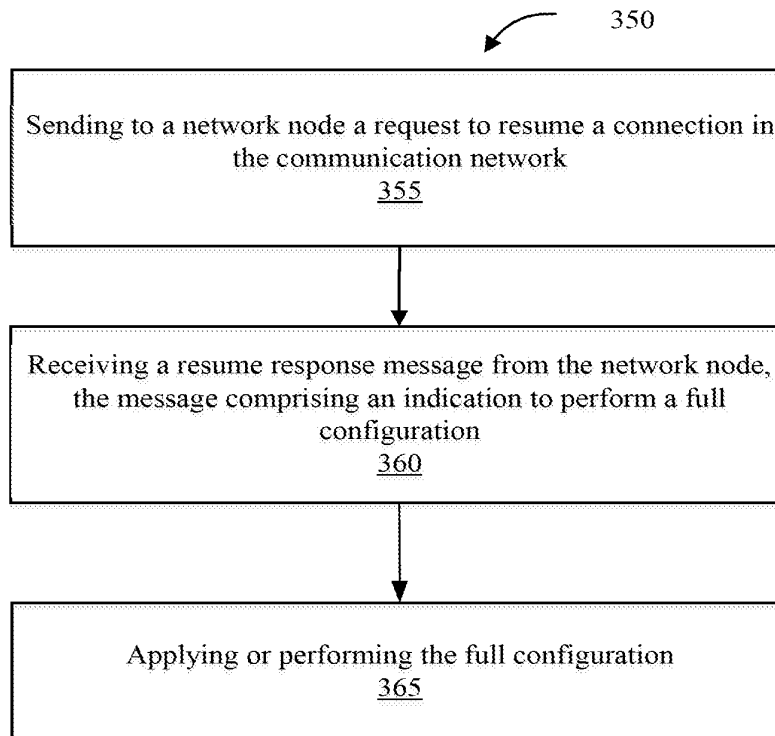

**Figure 17**

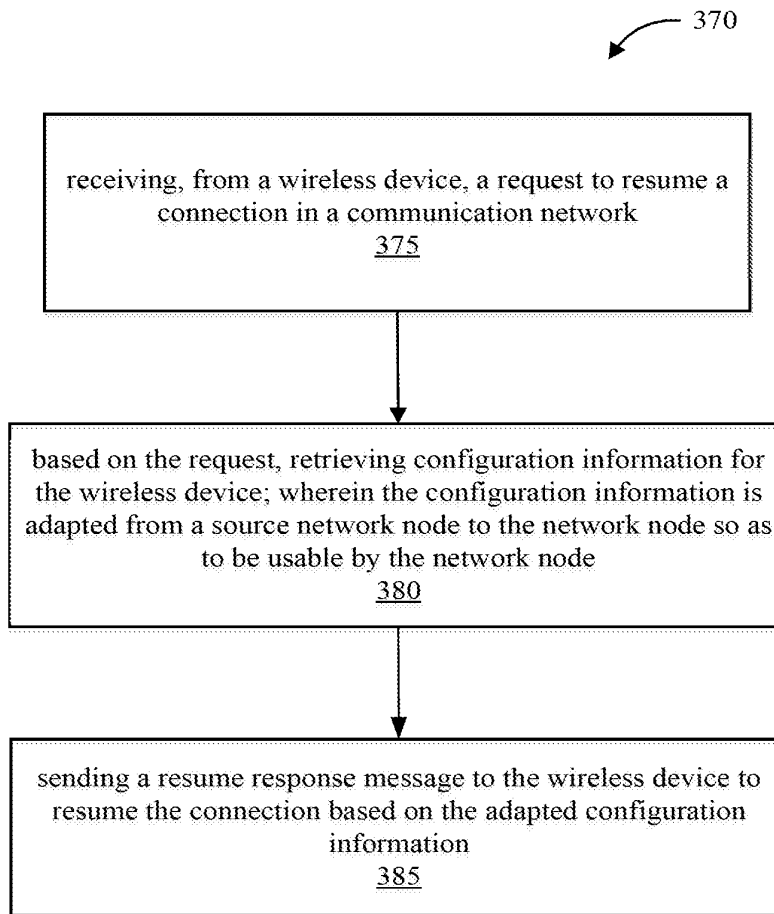

**Figure 18**

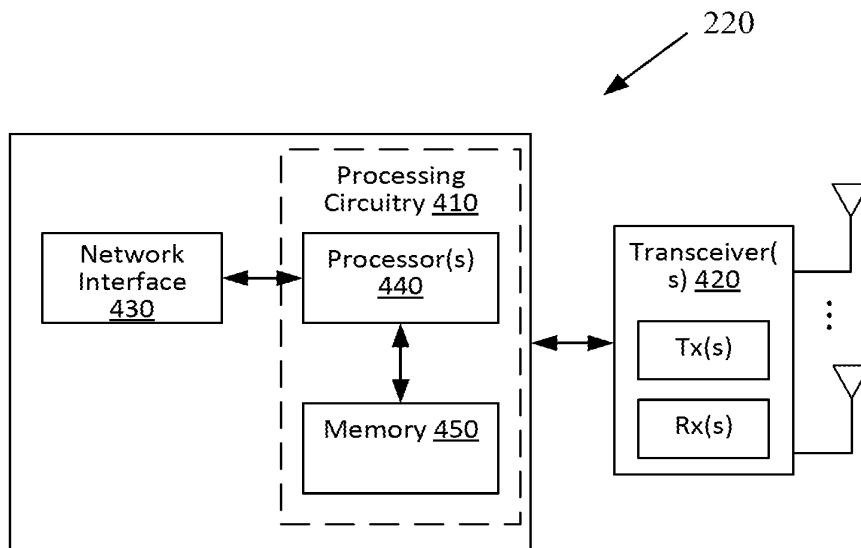

**Figure 19**

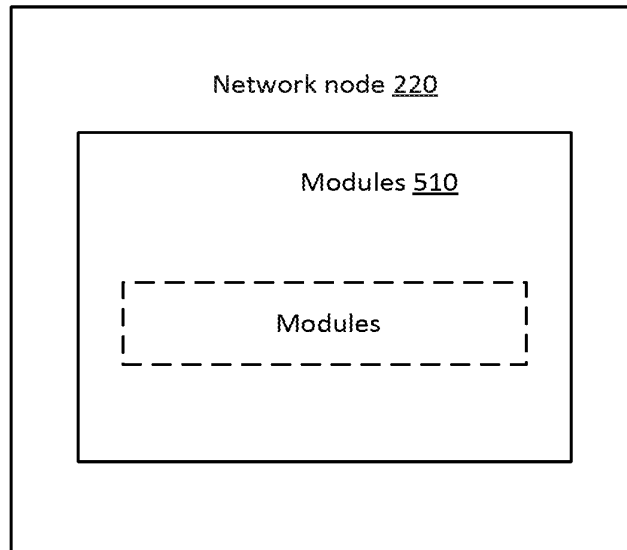

**Figure 20**

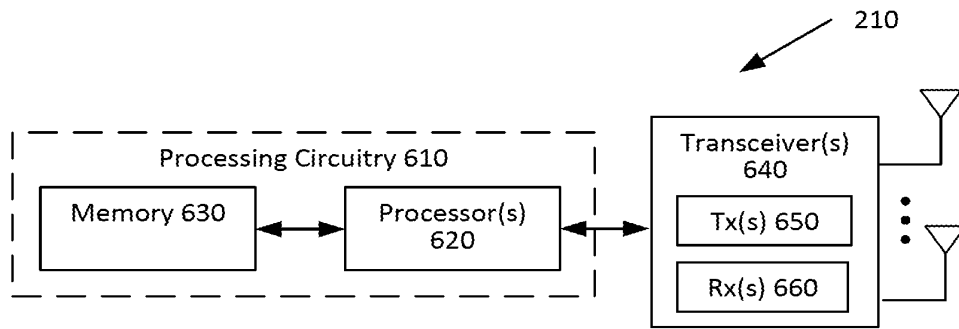

**Figure 21**

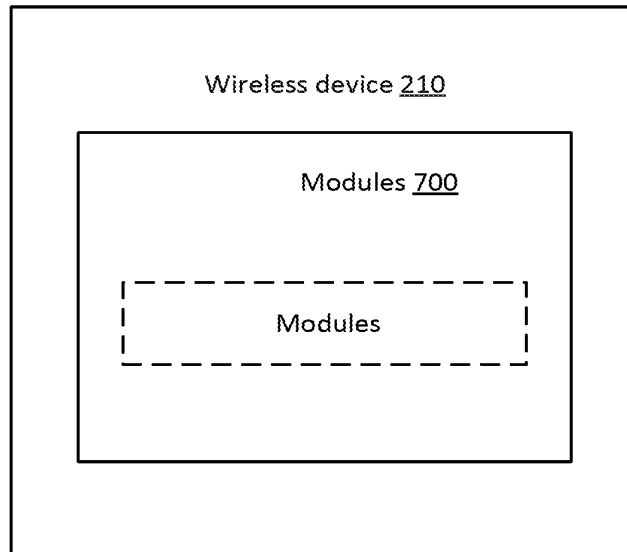

**Figure 22**



800

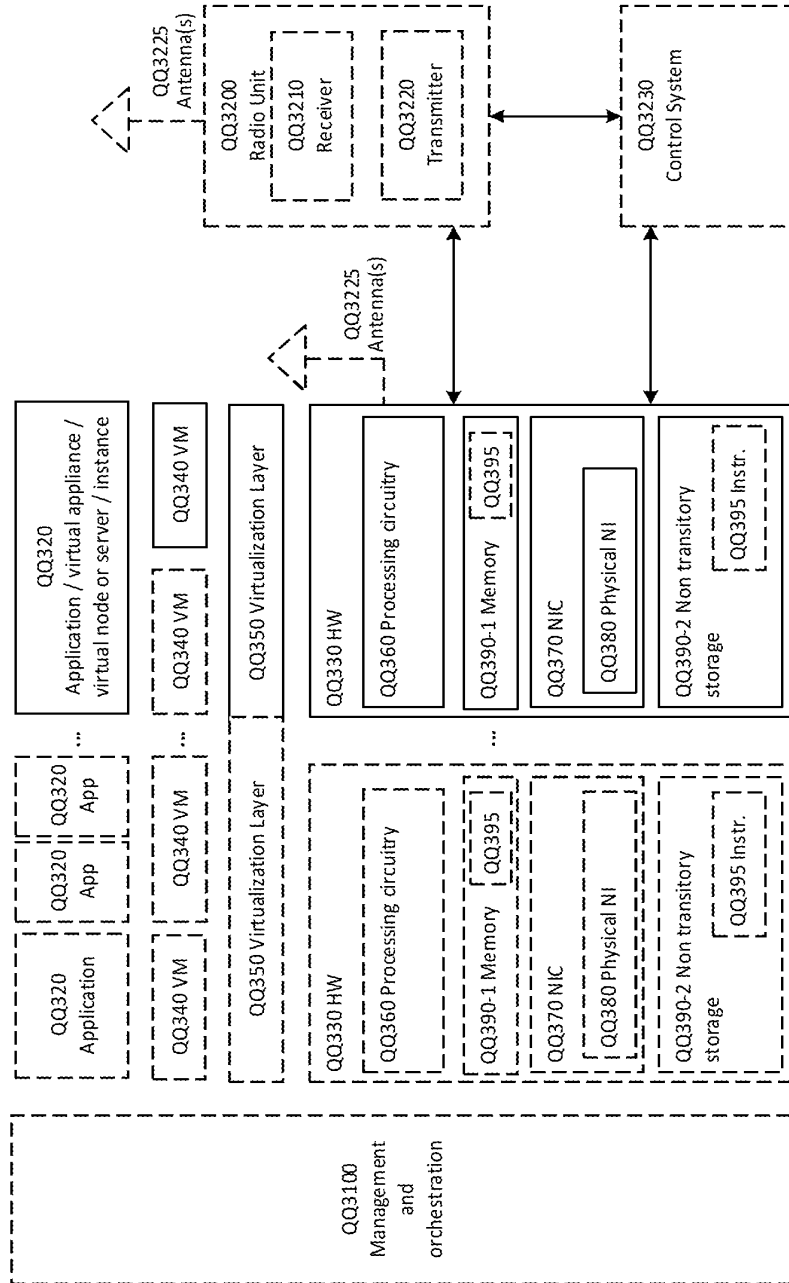

Figure 23

## TRANSMITTAL FOR POWER OF ATTORNEY TO ONE OR MORE REGISTERED PRACTITIONERS

NOTE: This form is to be submitted with the Power of Attorney by Applicant form (PTO/AIA/82B) to identify the application to which the Power of Attorney is directed, in accordance with 37 CFR 1.5, unless the application number and filing date are identified in the Power of Attorney by Applicant form. If neither form PTO/AIA/82A nor form PTO/AIA/82B identifies the application to which the Power of Attorney is directed, the Power of Attorney will not be recognized in the application.

|                        |                                                                  |
|------------------------|------------------------------------------------------------------|
| Application Number     |                                                                  |
| Filing Date            |                                                                  |
| First Named Inventor   | Oumer TEYEB                                                      |
| Title                  | METHODS AND UE FOR RESUMING A CONNECTION WITH FULL CONFIGURATION |
| Art Unit               |                                                                  |
| Examiner Name          |                                                                  |
| Attorney Docket Number | P74267 US2                                                       |

| SIGNATURE of Applicant or Patent Practitioner      |                                        |                     |            |
|----------------------------------------------------|----------------------------------------|---------------------|------------|
| Signature                                          | /Michael Cameron/                      | Date (Optional)     | 2019-04-10 |
| Name                                               | Michael Cameron                        | Registration Number | 50298      |
| Title (if Applicant is a juristic entity)          |                                        |                     |            |
| Applicant Name (if Applicant is a juristic entity) | TELEFONAKTIEBOLAGET LM ERICSSON (PUBL) |                     |            |

**NOTE:** This form must be signed in accordance with 37 CFR 1.33. See 37 CFR 1.4(d) for signature requirements and certifications. If more than one applicant, use multiple forms.

\*Total of 1 forms are submitted.

This collection of information is required by 37 CFR 1.131, 1.32, and 1.33. The information is required to obtain or retain a benefit by the public which is to file (and by the USPTO to process) an application. Confidentiality is governed by 35 U.S.C. 122 and 37 CFR 1.11 and 1.14. This collection is estimated to take 3 minutes to complete, including gathering, preparing, and submitting the completed application form to the USPTO. Time will vary depending upon the individual case. Any comments on the amount of time you require to complete this form and/or suggestions for reducing this burden, should be sent to the Chief Information Officer, U.S. Patent and Trademark Office, U.S. Department of Commerce, P.O. Box 1450, Alexandria, VA 22313-1450. DO NOT SEND FEES OR COMPLETED FORMS TO THIS ADDRESS. **SEND TO: Commissioner for Patents, P.O. Box 1450, Alexandria, VA 22313-1450.**

*If you need assistance in completing the form, call 1-800-PTO-9199 and select option 2.*

Under the Paperwork Reduction Act of 1995, no persons are required to respond to a collection of information unless it displays a valid OMB control number

## POWER OF ATTORNEY BY APPLICANT

I hereby revoke all previous powers of attorney given in the application identified in either the attached transmittal letter or the boxes below.

|                    |             |
|--------------------|-------------|
| Application Number | Filing Date |
|                    |             |

(Note: The boxes above may be left blank if information is provided on form PTO/AIA/82A.)

- I hereby appoint the Patent Practitioner(s) associated with the following Customer Number as my/our attorney(s) or agent(s), and to transact all business in the United States Patent and Trademark Office connected therewith for the application referenced in the attached transmittal letter (form PTO/AIA/82A) or identified above: 27045
- OR**
- I hereby appoint Practitioner(s) named in the attached list (form PTO/AIA/82C) as my/our attorney(s) or agent(s), and to transact all business in the United States Patent and Trademark Office connected therewith for the patent application referenced in the attached transmittal letter (form PTO/AIA/82A) or identified above. (Note: Complete form PTO/AIA/82C.)

**Please recognize or change the correspondence address for the application identified in the attached transmittal letter or the boxes above to:**

- The address associated with the above-mentioned Customer Number
- OR**
- The address associated with Customer Number: 27045
- OR**

|                          |                         |     |  |  |
|--------------------------|-------------------------|-----|--|--|
| <input type="checkbox"/> | Firm or Individual Name |     |  |  |
| Address                  |                         |     |  |  |
| City                     | State                   | Zip |  |  |
| Country                  |                         |     |  |  |
| Telephone                | Email                   |     |  |  |

I am the Applicant (if the Applicant is a juristic entity, list the Applicant name in the box):

TELEFONAKTIEBOLAGET L M ERICSSON (PUBL)

- Inventor or Joint Inventor (title not required below)
- Legal Representative of a Deceased or Legally Incapacitated Inventor (title not required below)
- Assignee or Person to Whom the Inventor is Under an Obligation to Assign (provide signer's title if applicant is a juristic entity)
- Person Who Otherwise Shows Sufficient Proprietary Interest (e.g., a petition under 37 CFR 1.46(b)(2) was granted in the application or is concurrently being filed with this document) (provide signer's title if applicant is a juristic entity)

**SIGNATURE of Applicant for Patent**

|                                                                                                                                                   |                           |                 |
|---------------------------------------------------------------------------------------------------------------------------------------------------|---------------------------|-----------------|
| The undersigned (whose title is supplied below) is authorized to act on behalf of the applicant (e.g., where the applicant is a juristic entity). |                           |                 |
| Signature                                                                                                                                         |                           | Date (Optional) |
| Name                                                                                                                                              | Brian Kearns              |                 |
| Title                                                                                                                                             | Director, Patent Unit USA |                 |

**NOTE:** Signature - This form must be signed by the applicant in accordance with 37 CFR 1.33. See 37 CFR 1.4 for signature requirements and certifications. If more than one applicant, use multiple forms.

Total of \_\_\_\_\_ forms are submitted.

This collection of information is required by 37 CFR 1.131, 1.32, and 1.33. The information is required to obtain or retain a benefit by the public which is to file (and by the USPTO to process) an application. Confidentiality is governed by 35 U.S.C. 122 and 37 CFR 1.11 and 1.14. This collection is estimated to take 3 minutes to complete, including gathering, preparing, and submitting the completed application form to the USPTO. Time will vary depending upon the individual case. Any comments on the amount of time you require to complete this form and/or suggestions for reducing this burden, should be sent to the Chief Information Officer, U.S. Patent and Trademark Office, U.S. Department of Commerce, P.O. Box 1450, Alexandria, VA 22313-1450. DO NOT SEND FEES OR COMPLETED FORMS TO THIS ADDRESS. SEND TO: Commissioner for Patents, P.O. Box 1450, Alexandria, VA 22313-1450.

If you need assistance in completing the form, call 1-800-PTO-9199 and select option 2.

|                                                                                                                          |                           |            |
|--------------------------------------------------------------------------------------------------------------------------|---------------------------|------------|
| <b>DECLARATION (37 CFR 1.63) FOR UTILITY OR DESIGN<br/>APPLICATION USING AN<br/>APPLICATION DATA SHEET (37 CFR 1.76)</b> | Attorney Docket<br>Number | P74267 US2 |
|--------------------------------------------------------------------------------------------------------------------------|---------------------------|------------|

|                               |                                                                         |
|-------------------------------|-------------------------------------------------------------------------|
| <b>Title of<br/>Invention</b> | <b>METHODS AND UE FOR RESUMING A CONNECTION WITH FULL CONFIGURATION</b> |
|-------------------------------|-------------------------------------------------------------------------|

As the below named inventor, I hereby declare that:

This declaration is directed to:

The attached application, or  
 United States application or PCT international application number PCT/IB2019/050836, filed on February 01, 2019

The above-identified application was made or authorized to be made by me.

I believe that I am the original inventor or an original joint inventor of a claimed invention in the application.

I have reviewed and understand the contents of the above identified application, including the claims, as amended by any amendment specifically referred to above.

I am aware of the duty to disclose information which is material to patentability as defined in 37 CFR 1.56, including for continuation-in-part applications, material information which became available between the filing date of the prior application and the national or PCT international filing date of the continuation-in-part application.

I hereby acknowledge that any willful false statement made in this declaration is punishable under 18 U.S.C. 1001 by fine or imprisonment of not more than five (5) years, or both.

**LEGAL NAME OF INVENTOR**

Inventor: Oumer Tayeb

Date (Optional):

Signature:

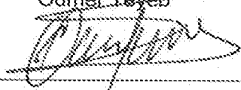

2019-04-01

|                                                                                                                  |                        |            |
|------------------------------------------------------------------------------------------------------------------|------------------------|------------|
| <b>DECLARATION (37 CFR 1.63) FOR UTILITY OR DESIGN APPLICATION USING AN APPLICATION DATA SHEET (37 CFR 1.76)</b> | Attorney Docket Number | P74267 US2 |
|------------------------------------------------------------------------------------------------------------------|------------------------|------------|

|                                                                                                                                                                                                                                                                                                                                                                                                                                                                                                                                                                                                                                                                                                                                                                                                                                                                                                                                                                                                                                                                                                                                                                                                                                                                         |                                                                                     |                  |
|-------------------------------------------------------------------------------------------------------------------------------------------------------------------------------------------------------------------------------------------------------------------------------------------------------------------------------------------------------------------------------------------------------------------------------------------------------------------------------------------------------------------------------------------------------------------------------------------------------------------------------------------------------------------------------------------------------------------------------------------------------------------------------------------------------------------------------------------------------------------------------------------------------------------------------------------------------------------------------------------------------------------------------------------------------------------------------------------------------------------------------------------------------------------------------------------------------------------------------------------------------------------------|-------------------------------------------------------------------------------------|------------------|
| <b>Title of Invention</b>                                                                                                                                                                                                                                                                                                                                                                                                                                                                                                                                                                                                                                                                                                                                                                                                                                                                                                                                                                                                                                                                                                                                                                                                                                               | METHODS AND UE FOR RESUMING A CONNECTION WITH FULL CONFIGURATION                    |                  |
| <p>As the below named inventor, I hereby declare that:</p> <p>This declaration is directed to:</p> <p><input type="checkbox"/> The attached application, or</p> <p><input checked="" type="checkbox"/> United States application or PCT international application number PCT/IB2019/050836, filed on February 01, 2019</p> <p>The above-identified application was made or authorized to be made by me.</p> <p>I believe that I am the original inventor or an original joint inventor of a claimed invention in the application.</p> <p>I have reviewed and understand the contents of the above identified application, including the claims, as amended by any amendment specifically referred to above.</p> <p>I am aware of the duty to disclose information which is material to patentability as defined in 37 CFR 1.56, including for continuation-in-part applications, material information which became available between the filing date of the prior application and the national or PCT international filing date of the continuation-in-part application.</p> <p>I hereby acknowledge that any willful false statement made in this declaration is punishable under 18 U.S.C. 1001 by fine or imprisonment of not more than five (5) years, or both.</p> |                                                                                     |                  |
| <b>LEGAL NAME OF INVENTOR</b>                                                                                                                                                                                                                                                                                                                                                                                                                                                                                                                                                                                                                                                                                                                                                                                                                                                                                                                                                                                                                                                                                                                                                                                                                                           |                                                                                     |                  |
| Inventor:                                                                                                                                                                                                                                                                                                                                                                                                                                                                                                                                                                                                                                                                                                                                                                                                                                                                                                                                                                                                                                                                                                                                                                                                                                                               | Gunnar Mildh                                                                        | Date (Optional): |
| Signature:                                                                                                                                                                                                                                                                                                                                                                                                                                                                                                                                                                                                                                                                                                                                                                                                                                                                                                                                                                                                                                                                                                                                                                                                                                                              |  |                  |

## Electronic Patent Application Fee Transmittal

|                                                                                                         |                                                                  |                 |               |                             |  |
|---------------------------------------------------------------------------------------------------------|------------------------------------------------------------------|-----------------|---------------|-----------------------------|--|
| <b>Application Number:</b>                                                                              |                                                                  |                 |               |                             |  |
| <b>Filing Date:</b>                                                                                     |                                                                  |                 |               |                             |  |
| <b>Title of Invention:</b>                                                                              | METHODS AND UE FOR RESUMING A CONNECTION WITH FULL CONFIGURATION |                 |               |                             |  |
| <b>First Named Inventor/Applicant Name:</b>                                                             | Oumer TEYEB                                                      |                 |               |                             |  |
| <b>Filer:</b>                                                                                           | Taylor Merritt Meacham/Lala Deleon                               |                 |               |                             |  |
| <b>Attorney Docket Number:</b>                                                                          | P74267 US2                                                       |                 |               |                             |  |
| Filed as Large Entity                                                                                   |                                                                  |                 |               |                             |  |
| <b>Filing Fees for Track I Prioritized Examination - Nonprovisional Application under 35 USC 111(a)</b> |                                                                  |                 |               |                             |  |
| <b>Description</b>                                                                                      | <b>Fee Code</b>                                                  | <b>Quantity</b> | <b>Amount</b> | <b>Sub-Total in USD(\$)</b> |  |
| <b>Basic Filing:</b>                                                                                    |                                                                  |                 |               |                             |  |
| UTILITY APPLICATION FILING                                                                              | 1011                                                             | 1               | 300           | 300                         |  |
| UTILITY SEARCH FEE                                                                                      | 1111                                                             | 1               | 660           | 660                         |  |
| UTILITY EXAMINATION FEE                                                                                 | 1311                                                             | 1               | 760           | 760                         |  |
| REQUEST FOR PRIORITIZED EXAMINATION                                                                     | 1817                                                             | 1               | 4000          | 4000                        |  |
| <b>Pages:</b>                                                                                           |                                                                  |                 |               |                             |  |
| <b>Claims:</b>                                                                                          |                                                                  |                 |               |                             |  |
| <b>Miscellaneous-Filing:</b>                                                                            |                                                                  |                 |               |                             |  |

| Description                              | Fee Code | Quantity | Amount | Sub-Total in USD(\$) |
|------------------------------------------|----------|----------|--------|----------------------|
| PUBL. FEE- EARLY, VOLUNTARY, OR NORMAL   | 1504     | 1        | 0      | 0                    |
| PROCESSING FEE, EXCEPT PROV. APPLS.      | 1830     | 1        | 140    | 140                  |
| <b>Petition:</b>                         |          |          |        |                      |
| <b>Patent-Appeals-and-Interference:</b>  |          |          |        |                      |
| <b>Post-Allowance-and-Post-Issuance:</b> |          |          |        |                      |
| <b>Extension-of-Time:</b>                |          |          |        |                      |
| <b>Miscellaneous:</b>                    |          |          |        |                      |
| <b>Total in USD (\$)</b>                 |          |          |        | <b>5860</b>          |

## Electronic Acknowledgement Receipt

|                                             |                                                                  |
|---------------------------------------------|------------------------------------------------------------------|
| <b>EFS ID:</b>                              | 35690733                                                         |
| <b>Application Number:</b>                  | 16380844                                                         |
| <b>International Application Number:</b>    |                                                                  |
| <b>Confirmation Number:</b>                 | 8653                                                             |
| <b>Title of Invention:</b>                  | METHODS AND UE FOR RESUMING A CONNECTION WITH FULL CONFIGURATION |
| <b>First Named Inventor/Applicant Name:</b> | Oumer TEYEB                                                      |
| <b>Customer Number:</b>                     | 27045                                                            |
| <b>Filer:</b>                               | Taylor Merritt Meacham/Lala Deleon                               |
| <b>Filer Authorized By:</b>                 | Taylor Merritt Meacham                                           |
| <b>Attorney Docket Number:</b>              | P74267 US2                                                       |
| <b>Receipt Date:</b>                        | 10-APR-2019                                                      |
| <b>Filing Date:</b>                         |                                                                  |
| <b>Time Stamp:</b>                          | 19:00:00                                                         |
| <b>Application Type:</b>                    | Utility under 35 USC 111(a)                                      |

### Payment information:

|                                          |                             |
|------------------------------------------|-----------------------------|
| Submitted with Payment                   | yes                         |
| Payment Type                             | DA                          |
| Payment was successfully received in RAM | \$5860                      |
| RAM confirmation Number                  | 041119INTEFSW00005803501379 |
| Deposit Account                          | 501379                      |
| Authorized User                          | Lala Deleon                 |

The Director of the USPTO is hereby authorized to charge indicated fees and credit any overpayment as follows:

37 CFR 1.16 (National application filing, search, and examination fees)



| <b>File Listing:</b>                                       |                                             |                                                                                  |                                                     |                         |                         |  |
|------------------------------------------------------------|---------------------------------------------|----------------------------------------------------------------------------------|-----------------------------------------------------|-------------------------|-------------------------|--|
| <b>Document Number</b>                                     | <b>Document Description</b>                 | <b>File Name</b>                                                                 | <b>File Size(Bytes)/ Message Digest</b>             | <b>Multi Part /.zip</b> | <b>Pages (if appl.)</b> |  |
| 1                                                          | TrackOne Request                            | P74267US2_2019-04-10_Track-1-Request_for_prioritized_exam-<br>aia0424.pdf        | 129205<br>7d06bdd205a9bacb2142720089bd50f56cfd0cc   | no                      | 2                       |  |
| <b>Warnings:</b>                                           |                                             |                                                                                  |                                                     |                         |                         |  |
| <b>Information:</b>                                        |                                             |                                                                                  |                                                     |                         |                         |  |
| 2                                                          | Application Data Sheet                      | P74267US2_2019-04-10_Application_Data_Sheet.pdf                                  | 1256122<br>d7a9d62bd2ff850cd308f1609aed52e0a70466   | no                      | 8                       |  |
| <b>Warnings:</b>                                           |                                             |                                                                                  |                                                     |                         |                         |  |
| <b>Information:</b>                                        |                                             |                                                                                  |                                                     |                         |                         |  |
| 3                                                          |                                             | P74267US2_2019-04-10_Application.pdf                                             | 270449<br>aaa8b0e957a5adf515b04fdff0c72e0780b49b66b | yes                     | 33                      |  |
| <b>Multipart Description/PDF files in .zip description</b> |                                             |                                                                                  |                                                     |                         |                         |  |
|                                                            |                                             | <b>Document Description</b>                                                      | <b>Start</b>                                        | <b>End</b>              |                         |  |
|                                                            |                                             | Specification                                                                    | 1                                                   | 29                      |                         |  |
|                                                            |                                             | Claims                                                                           | 30                                                  | 32                      |                         |  |
|                                                            |                                             | Abstract                                                                         | 33                                                  | 33                      |                         |  |
| <b>Warnings:</b>                                           |                                             |                                                                                  |                                                     |                         |                         |  |
| <b>Information:</b>                                        |                                             |                                                                                  |                                                     |                         |                         |  |
| 4                                                          | Request for USPTO to retrieve priority docs | P74267US2_2019-04-10_Request_to_USPTO_to_retrieve_priority_document_as_filed.pdf | 112297<br>9acabd47e8ad9e3b675429f755bcd1cc50ed58ca  | no                      | 3                       |  |
| <b>Warnings:</b>                                           |                                             |                                                                                  |                                                     |                         |                         |  |
| <b>Information:</b>                                        |                                             |                                                                                  |                                                     |                         |                         |  |
| 5                                                          | Drawings-only black and white line drawings | P74267US2_2019-04-10_Drawings.pdf                                                | 4110137<br>3e80554aed9392b50096ba5e5edcd46deb0a3b8c | no                      | 17                      |  |

|                                                                                                                                                                                                                                                                                                                                                                                                                                                                                                                                                                                                                                                                                                                                                                                                                                                                                                                                                                                                                                                                                                                                                                                                                                                                                                                                                                                                                                                                                                                                                                                                                                                                                                                                                                             |                           |                                            |                                                     |          |   |
|-----------------------------------------------------------------------------------------------------------------------------------------------------------------------------------------------------------------------------------------------------------------------------------------------------------------------------------------------------------------------------------------------------------------------------------------------------------------------------------------------------------------------------------------------------------------------------------------------------------------------------------------------------------------------------------------------------------------------------------------------------------------------------------------------------------------------------------------------------------------------------------------------------------------------------------------------------------------------------------------------------------------------------------------------------------------------------------------------------------------------------------------------------------------------------------------------------------------------------------------------------------------------------------------------------------------------------------------------------------------------------------------------------------------------------------------------------------------------------------------------------------------------------------------------------------------------------------------------------------------------------------------------------------------------------------------------------------------------------------------------------------------------------|---------------------------|--------------------------------------------|-----------------------------------------------------|----------|---|
| <b>Warnings:</b>                                                                                                                                                                                                                                                                                                                                                                                                                                                                                                                                                                                                                                                                                                                                                                                                                                                                                                                                                                                                                                                                                                                                                                                                                                                                                                                                                                                                                                                                                                                                                                                                                                                                                                                                                            |                           |                                            |                                                     |          |   |
| <b>Information:</b>                                                                                                                                                                                                                                                                                                                                                                                                                                                                                                                                                                                                                                                                                                                                                                                                                                                                                                                                                                                                                                                                                                                                                                                                                                                                                                                                                                                                                                                                                                                                                                                                                                                                                                                                                         |                           |                                            |                                                     |          |   |
| 6                                                                                                                                                                                                                                                                                                                                                                                                                                                                                                                                                                                                                                                                                                                                                                                                                                                                                                                                                                                                                                                                                                                                                                                                                                                                                                                                                                                                                                                                                                                                                                                                                                                                                                                                                                           | Power of Attorney         | P74267US2_2019-04-10_POA.pdf               | 2966171<br>dc1333770459bb7cb646b618ab118a70329bcf1e | no       | 2 |
| <b>Warnings:</b>                                                                                                                                                                                                                                                                                                                                                                                                                                                                                                                                                                                                                                                                                                                                                                                                                                                                                                                                                                                                                                                                                                                                                                                                                                                                                                                                                                                                                                                                                                                                                                                                                                                                                                                                                            |                           |                                            |                                                     |          |   |
| <b>Information:</b>                                                                                                                                                                                                                                                                                                                                                                                                                                                                                                                                                                                                                                                                                                                                                                                                                                                                                                                                                                                                                                                                                                                                                                                                                                                                                                                                                                                                                                                                                                                                                                                                                                                                                                                                                         |                           |                                            |                                                     |          |   |
| 7                                                                                                                                                                                                                                                                                                                                                                                                                                                                                                                                                                                                                                                                                                                                                                                                                                                                                                                                                                                                                                                                                                                                                                                                                                                                                                                                                                                                                                                                                                                                                                                                                                                                                                                                                                           | Oath or Declaration filed | P74267_2019-04-08_US_Declaration_Teyeb.pdf | 1136655<br>ef10e65738062f1076231087507d140c0a3355dc | no       | 1 |
| <b>Warnings:</b>                                                                                                                                                                                                                                                                                                                                                                                                                                                                                                                                                                                                                                                                                                                                                                                                                                                                                                                                                                                                                                                                                                                                                                                                                                                                                                                                                                                                                                                                                                                                                                                                                                                                                                                                                            |                           |                                            |                                                     |          |   |
| <b>Information:</b>                                                                                                                                                                                                                                                                                                                                                                                                                                                                                                                                                                                                                                                                                                                                                                                                                                                                                                                                                                                                                                                                                                                                                                                                                                                                                                                                                                                                                                                                                                                                                                                                                                                                                                                                                         |                           |                                            |                                                     |          |   |
| 8                                                                                                                                                                                                                                                                                                                                                                                                                                                                                                                                                                                                                                                                                                                                                                                                                                                                                                                                                                                                                                                                                                                                                                                                                                                                                                                                                                                                                                                                                                                                                                                                                                                                                                                                                                           | Oath or Declaration filed | P74267_2019-04-08_US_Declaration_Mildh.pdf | 1192638<br>e8c64c4291b1c01809f5411a58043699f5c95662 | no       | 1 |
| <b>Warnings:</b>                                                                                                                                                                                                                                                                                                                                                                                                                                                                                                                                                                                                                                                                                                                                                                                                                                                                                                                                                                                                                                                                                                                                                                                                                                                                                                                                                                                                                                                                                                                                                                                                                                                                                                                                                            |                           |                                            |                                                     |          |   |
| <b>Information:</b>                                                                                                                                                                                                                                                                                                                                                                                                                                                                                                                                                                                                                                                                                                                                                                                                                                                                                                                                                                                                                                                                                                                                                                                                                                                                                                                                                                                                                                                                                                                                                                                                                                                                                                                                                         |                           |                                            |                                                     |          |   |
| 9                                                                                                                                                                                                                                                                                                                                                                                                                                                                                                                                                                                                                                                                                                                                                                                                                                                                                                                                                                                                                                                                                                                                                                                                                                                                                                                                                                                                                                                                                                                                                                                                                                                                                                                                                                           | Fee Worksheet (SB06)      | fee-info.pdf                               | 40269<br>6dd15932e94eaf8dad167470ed5147d4f8b37a2f   | no       | 2 |
| <b>Warnings:</b>                                                                                                                                                                                                                                                                                                                                                                                                                                                                                                                                                                                                                                                                                                                                                                                                                                                                                                                                                                                                                                                                                                                                                                                                                                                                                                                                                                                                                                                                                                                                                                                                                                                                                                                                                            |                           |                                            |                                                     |          |   |
| <b>Information:</b>                                                                                                                                                                                                                                                                                                                                                                                                                                                                                                                                                                                                                                                                                                                                                                                                                                                                                                                                                                                                                                                                                                                                                                                                                                                                                                                                                                                                                                                                                                                                                                                                                                                                                                                                                         |                           |                                            |                                                     |          |   |
| <b>Total Files Size (in bytes):</b>                                                                                                                                                                                                                                                                                                                                                                                                                                                                                                                                                                                                                                                                                                                                                                                                                                                                                                                                                                                                                                                                                                                                                                                                                                                                                                                                                                                                                                                                                                                                                                                                                                                                                                                                         |                           |                                            |                                                     | 11213943 |   |
| <p><b>This Acknowledgement Receipt evidences receipt on the noted date by the USPTO of the indicated documents, characterized by the applicant, and including page counts, where applicable. It serves as evidence of receipt similar to a Post Card, as described in MPEP 503.</b></p> <p><b><u>New Applications Under 35 U.S.C. 111</u></b><br/> <b>If a new application is being filed and the application includes the necessary components for a filing date (see 37 CFR 1.53(b)-(d) and MPEP 506), a Filing Receipt (37 CFR 1.54) will be issued in due course and the date shown on this Acknowledgement Receipt will establish the filing date of the application.</b></p> <p><b><u>National Stage of an International Application under 35 U.S.C. 371</u></b><br/> <b>If a timely submission to enter the national stage of an international application is compliant with the conditions of 35 U.S.C. 371 and other applicable requirements a Form PCT/DO/EO/903 indicating acceptance of the application as a national stage submission under 35 U.S.C. 371 will be issued in addition to the Filing Receipt, in due course.</b></p> <p><b><u>New International Application Filed with the USPTO as a Receiving Office</u></b><br/> <b>If a new international application is being filed and the international application includes the necessary components for an international filing date (see PCT Article 11 and MPEP 1810), a Notification of the International Application Number and of the International Filing Date (Form PCT/RO/105) will be issued in due course, subject to prescriptions concerning national security, and the date shown on this Acknowledgement Receipt will establish the international filing date of the application.</b></p> |                           |                                            |                                                     |          |   |