



US 20120147249A1

(19) **United States**

(12) **Patent Application Publication**

Okano

(10) **Pub. No.: US 2012/0147249 A1**

(43) **Pub. Date: Jun. 14, 2012**

(54) **IMAGING LENS AND IMAGING APPARATUS**

(52) **U.S. Cl. 348/340; 359/773; 348/E05.024**

(75) **Inventor: Hideaki Okano, Aichi (JP)**

(57) **ABSTRACT**

(73) **Assignee: Sony Corporation, Tokyo (JP)**

(21) **Appl. No.: 13/302,655**

(22) **Filed: Nov. 22, 2011**

An imaging lens includes: an aperture stop; a first lens having a positive refractive power; a second lens having a negative refractive power which is formed in a concave shape on both sides thereof; a third lens having a positive refractive power which is formed in a meniscus shape in which a concave surface is directed toward the side of an object; and a fourth lens having a negative refractive power in which a convex surface is directed toward the object side, which are sequentially disposed from the object side to the image side, wherein the imaging lens satisfies the following conditional expressions (1), (2), (3), (4) and (5):

(30) **Foreign Application Priority Data**

Dec. 14, 2010 (JP) 2010-278528

$0.40 < f1/f2 < 0.80$ (1)

$0.80 < f2/f3 < 1.50$ (2)

$0.90 < f1/f4 < 2.00$ (3)

$2.60 < |(R2-R3)/f1| < 4.00$ (4)

$vd1 - vd2 > 25$ (5)

Publication Classification

(51) **Int. Cl.**

H04N 5/225 (2006.01)

G02B 9/34 (2006.01)

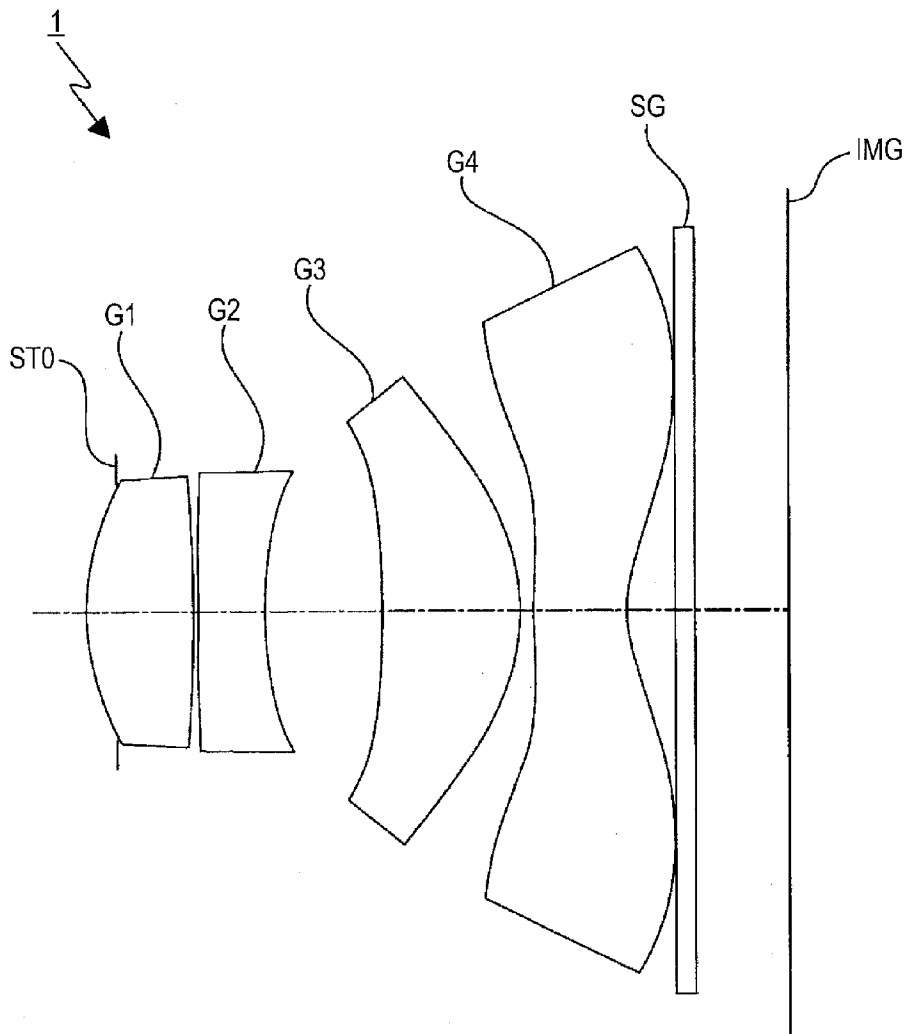

FIG. 1

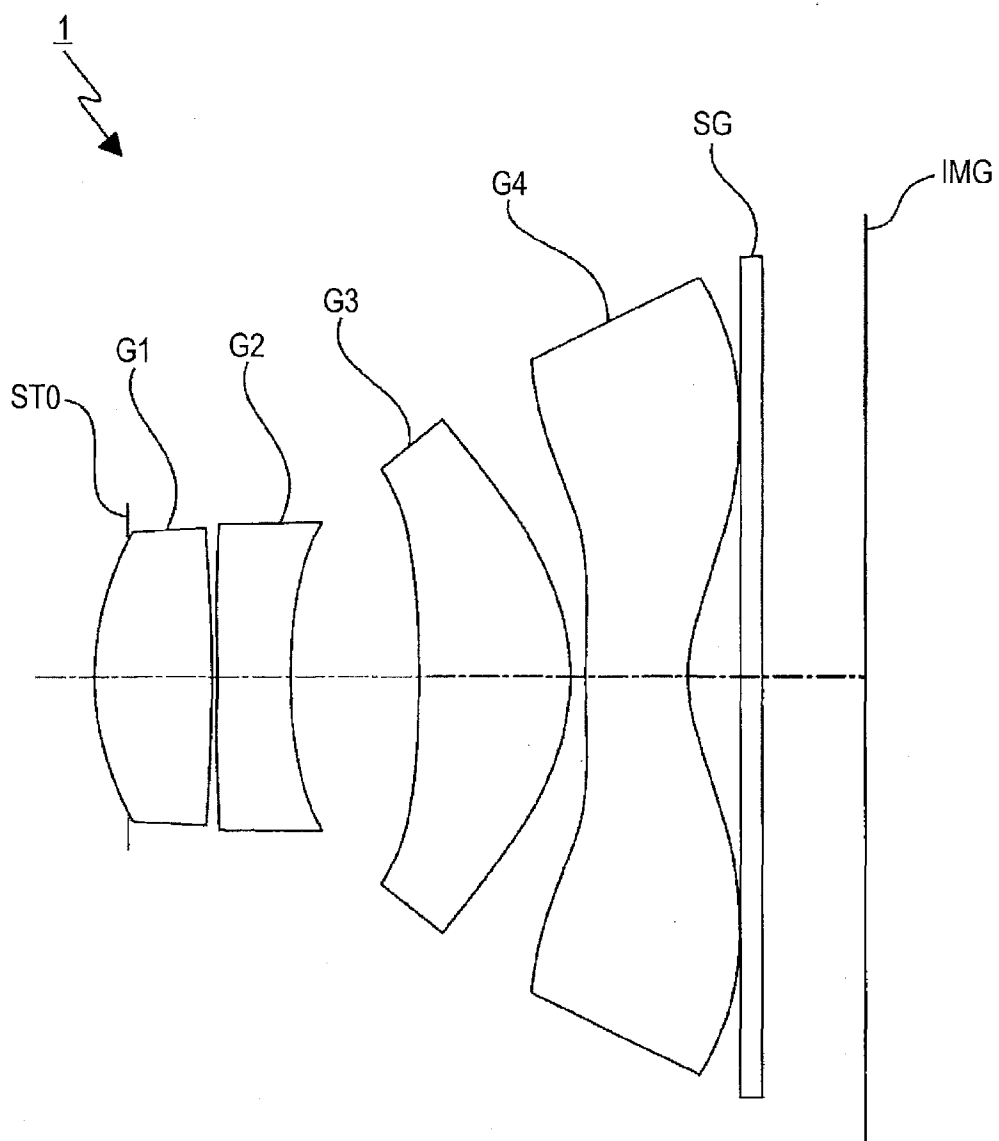

FIG.2

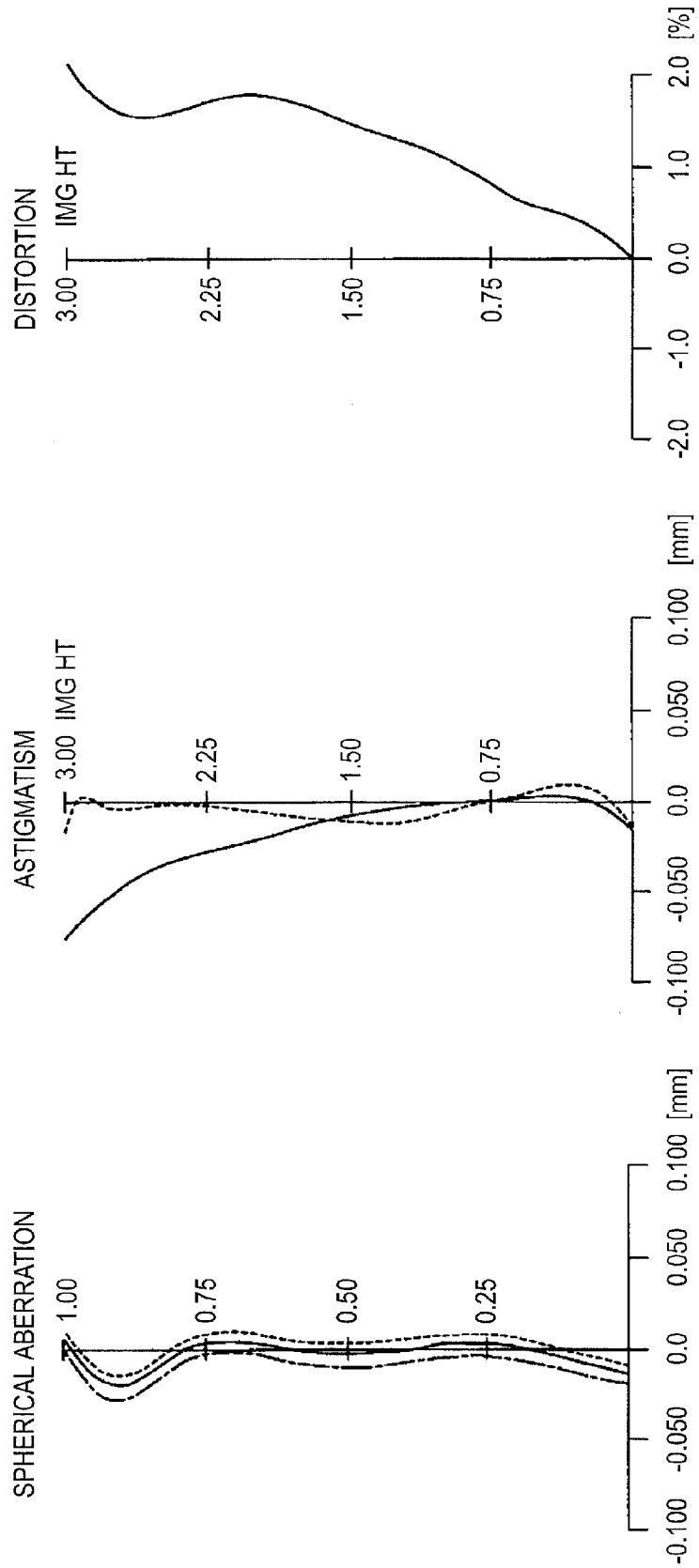

FIG.3

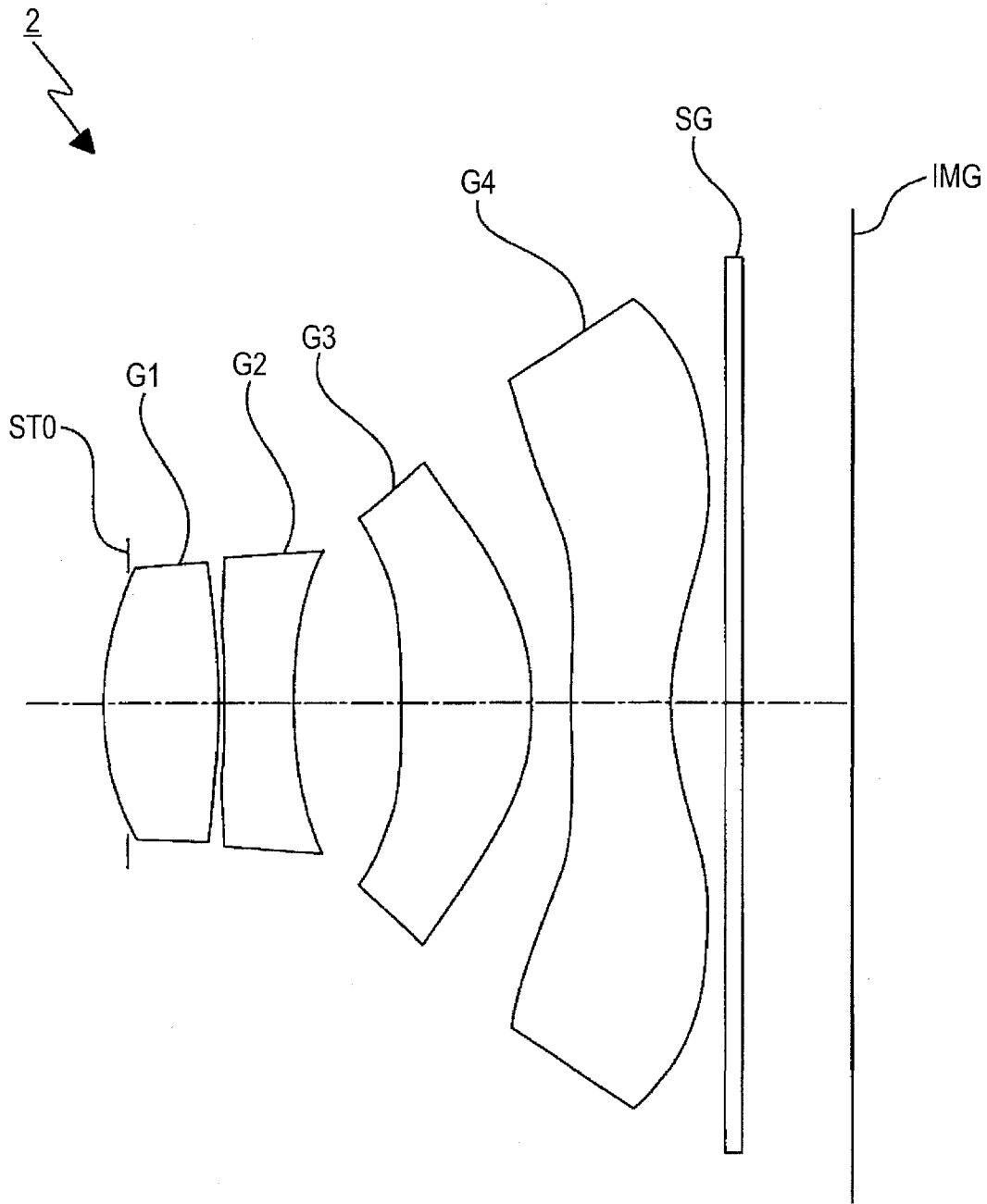
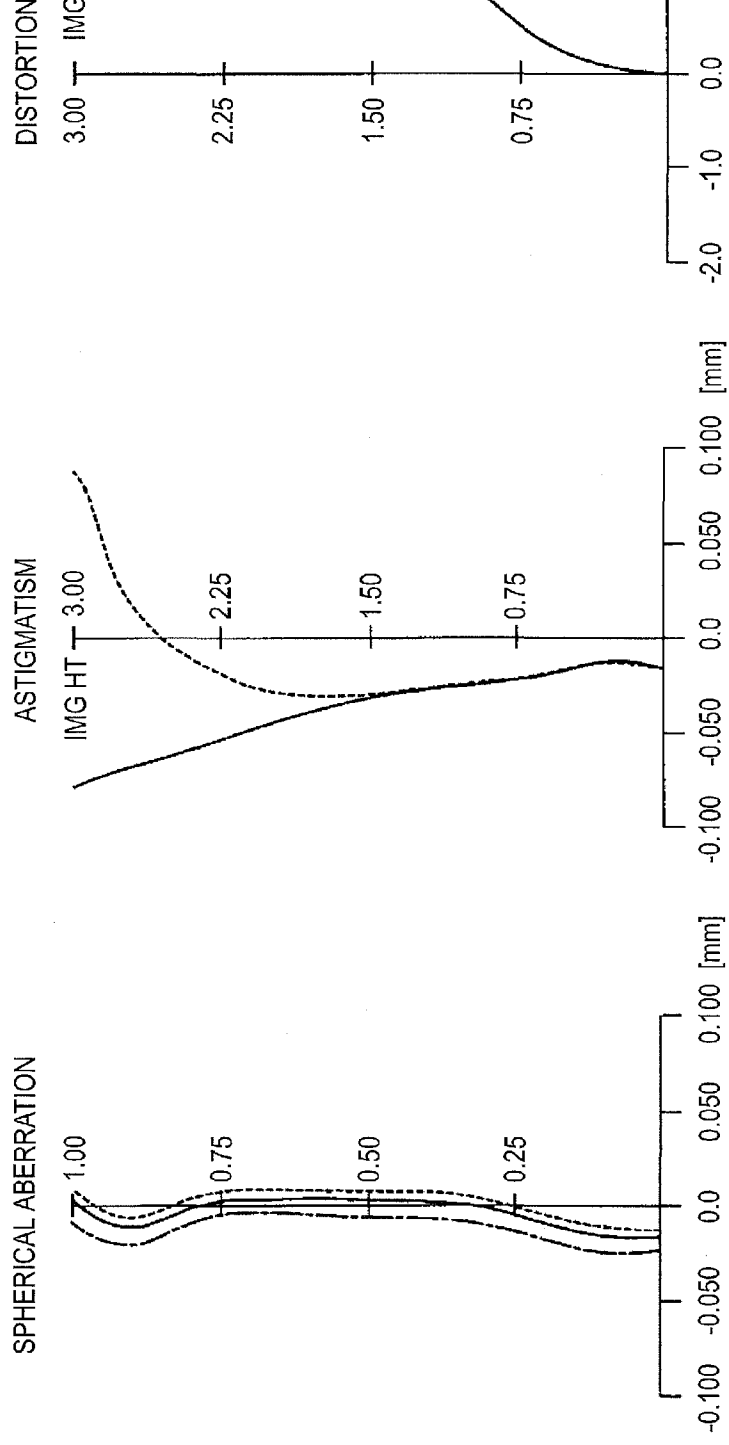

FIG.4



Explore Litigation Insights

Docket Alarm provides insights to develop a more informed litigation strategy and the peace of mind of knowing you're on top of things.

Real-Time Litigation Alerts



Keep your litigation team up-to-date with **real-time alerts** and advanced team management tools built for the enterprise, all while greatly reducing PACER spend.

Our comprehensive service means we can handle Federal, State, and Administrative courts across the country.

Advanced Docket Research



With over 230 million records, Docket Alarm's cloud-native docket research platform finds what other services can't. Coverage includes Federal, State, plus PTAB, TTAB, ITC and NLRB decisions, all in one place.

Identify arguments that have been successful in the past with full text, pinpoint searching. Link to case law cited within any court document via Fastcase.

Analytics At Your Fingertips



Learn what happened the last time a particular judge, opposing counsel or company faced cases similar to yours.

Advanced out-of-the-box PTAB and TTAB analytics are always at your fingertips.

API

Docket Alarm offers a powerful API (application programming interface) to developers that want to integrate case filings into their apps.

LAW FIRMS

Build custom dashboards for your attorneys and clients with live data direct from the court.

Automate many repetitive legal tasks like conflict checks, document management, and marketing.

FINANCIAL INSTITUTIONS

Litigation and bankruptcy checks for companies and debtors.

E-DISCOVERY AND LEGAL VENDORS

Sync your system to PACER to automate legal marketing.