

**IN THE UNITED STATES DISTRICT COURT
FOR THE DISTRICT OF MINNESOTA**

OXYGENATOR WATER
TECHNOLOGIES, INC.

Plaintiff,

v.

TENNANT COMPANY

Defendant.

Civil Action No. 0:20-cv-00358

Jury Trial Demanded

Complaint

This is a complaint for patent infringement. Plaintiff Oxygenator Water Technologies, Inc. (“OWT”) brings this action against Tennant Company (“Tennant”) and states as follows.

Parties

1. OWT is a Minnesota corporation having a principal place of business at 8170 Carriage Court North, Suite 200, Shakopee MN 55379.
2. Tennant is a Minnesota corporation having a principal place of business at 701 North Lilac Drive, Minneapolis MN 55422.

Jurisdiction

3. This action arises under the Patent Act, 35 U.S.C. § 271 *et seq.*
4. This court has subject matter jurisdiction under 28 U.S.C. §§ 1331 and 1338(a).

5. This Court has personal jurisdiction over Tennant. Tennant is a resident of Minnesota and maintains offices and transacts business within Minnesota.

6. Venue is proper in this district under 28 U.S.C. §§ 1391 and 1400(b). Tennant resides in this district. Tennant has committed acts of infringement in this district and has a regular and established place of business in this district.

OWT's Patented Technology

7. OWT is the owner of U.S. Patent Nos. RE45,415, RE47,092, and RE47,665 (respectively “the ’415 patent”, “the ’092 patent”, and “the ’665 patent”, collectively, “the patents-in-suit”). These patents are included herewith as Exhibit A, B, and C, respectively. These patents arose from research and development into products for the generation of micro and nanobubbles of oxygen in water that was performed by Aqua Innovations, Inc. (“Aqua Innovations”). Aqua Innovations was looking for a way to increase the amount of oxygen present in a quantity of water. Aqua Innovations realized that by creating tiny micro and nanobubbles of oxygen, the oxygen remained in the water rather than breaking the surface and being discharged into the atmosphere. With this revelation, it set out to learn more about how to effectively create these tiny bubbles.

8. A known manner of creating oxygen from water is via electrolysis. In electrolysis oppositely charged electrodes (anode and cathode) are placed in water in order to induce an electric current therebetween. The electric current breaks apart the water molecule into hydrogen and oxygen gas, thereby creating oxygen and hydrogen bubbles within the water. Aqua Innovations discovered that the electrolysis parameters, including the distance between electrodes, could be used to control the size of the bubble

generated. Aqua Innovations determined that electrodes that were from 0.005 inches to 0.140 inches apart created micro and nanobubbles at an effective rate.

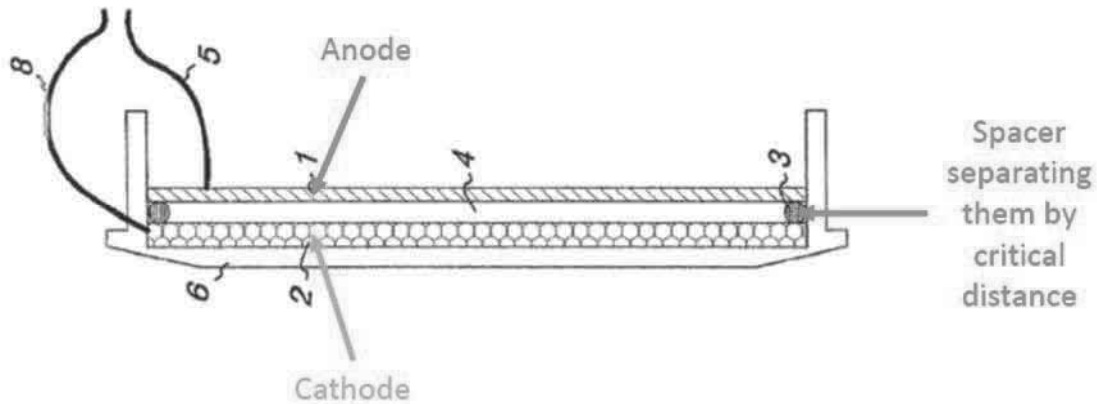

9. Aqua Innovations also focused on how to efficiently create micro and nanobubbles in flowing water. Creating such micro and nanobubbles in flowing water opened up the technology to a wider variety of applications. In 2003, Aqua Innovations applied for a patent on its flow-through oxygenators and methods of oxygenating flowing water. This patent application ultimately resulted in the '415, '092, and '665 patents involved here. One example flow-through oxygenator from the patent is shown below (annotations added).

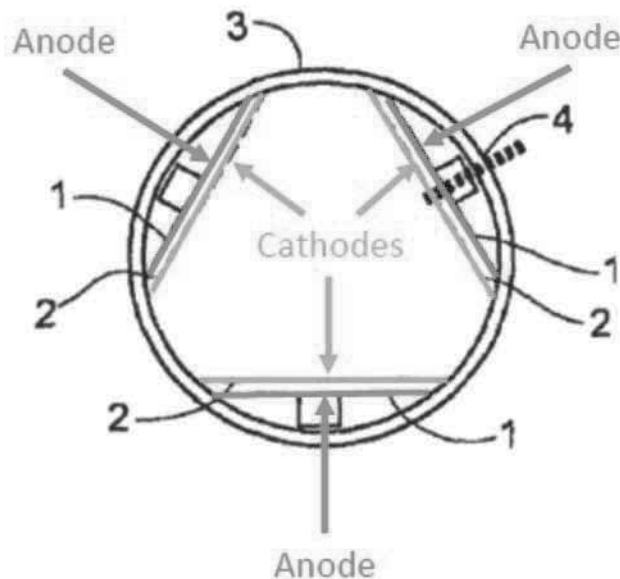

10. OWT was formed to commercialize this flow-through technology. The rights to the patents-in-suit were assigned to OWT on August 8, 2008.

Tennant’s Infringing Products

11. Tennant is a global organization with its world headquarters, engineering, and manufacturing center located in Minnesota. Tennant’s largest and most important product area is commercial floor scrubbers. These floor scrubbers can put water down onto a floor, scrub the floor while the water is on it and draw the water back up by suction. One example floor scrubber from Tennant’s website is shown here.



12. The global floor cleaning market is lucrative and growing. It is predicted to surpass \$6 billion by 2025 and Tennant is one of three major floor scrubber manufacturers in that market.

13. In 2008 Tennant introduced ec-H2OTM electrolysis modules to its scrubbers. The ec-H2OTM electrolysis modules use electrolysis to generate millions of tiny microscopic bubbles in the water that flows through the scrubber on its way to the floor. Tennant advertises that these tiny bubbles provide huge benefits. Tennant states that the ec-H2OTM electrolysis modules enable the floor scrubber to clean without the use of daily floor cleaning chemicals. Tennant states that the ec-H2OTM equipped scrubbers “transform tap water into a safe, effective cleaning solution”. Because there are no floor cleaning chemicals used, Tennant markets the technology as a cheaper and greener alternative to “conventional scrubbers” since no purchase of cleaning chemicals is required and there is no chemical residue left behind.

Explore Litigation Insights

Docket Alarm provides insights to develop a more informed litigation strategy and the peace of mind of knowing you're on top of things.

Real-Time Litigation Alerts



Keep your litigation team up-to-date with **real-time alerts** and advanced team management tools built for the enterprise, all while greatly reducing PACER spend.

Our comprehensive service means we can handle Federal, State, and Administrative courts across the country.

Advanced Docket Research



With over 230 million records, Docket Alarm's cloud-native docket research platform finds what other services can't. Coverage includes Federal, State, plus PTAB, TTAB, ITC and NLRB decisions, all in one place.

Identify arguments that have been successful in the past with full text, pinpoint searching. Link to case law cited within any court document via Fastcase.

Analytics At Your Fingertips



Learn what happened the last time a particular judge, opposing counsel or company faced cases similar to yours.

Advanced out-of-the-box PTAB and TTAB analytics are always at your fingertips.

API

Docket Alarm offers a powerful API (application programming interface) to developers that want to integrate case filings into their apps.

LAW FIRMS

Build custom dashboards for your attorneys and clients with live data direct from the court.

Automate many repetitive legal tasks like conflict checks, document management, and marketing.

FINANCIAL INSTITUTIONS

Litigation and bankruptcy checks for companies and debtors.

E-DISCOVERY AND LEGAL VENDORS

Sync your system to PACER to automate legal marketing.