

(12) **United States Patent**
Taylor et al.

(10) **Patent No.:** **US 6,728,885 B1**
 (45) **Date of Patent:** **Apr. 27, 2004**

(54) **SYSTEM AND METHOD FOR NETWORK ACCESS CONTROL USING ADAPTIVE PROXIES**

Networks, T. Ramteke, Prentice Hall, 1994, Chapter 19, pp. 430–436.

(75) Inventors: **Kevin R. Taylor**, Ellicott City, MD (US); **Ganesh Murugesan**, Reston, VA (US); **Homayoon Tajalli**, Ellicott City, MD (US)

Computer Network, A. Tanenbaum, Prentice Hall, 1981, pp. 15–21.

* cited by examiner

(73) Assignee: **Networks Associates Technology, Inc.**, Santa Clara, CA (US)

Primary Examiner—Gilberto Barron

Assistant Examiner—A. Nobahar

(*) Notice: Subject to any disclaimer, the term of this patent is extended or adjusted under 35 U.S.C. 154(b) by 0 days.

(74) *Attorney, Agent, or Firm*—Silicon Valley IP Group, PC; Kevin J. Zilka; Christopher J. Hamaty

(57) **ABSTRACT**

A method, system and computer program for providing multilevel security to a computer network. The method comprises the step of receiving a first communication packet on at least one network interface port from an outside network. The method further includes the steps of filtering the first packet in one of at least two levels of security comprising a first level of security which examines the content information of the packet and a second level of security which examines the first packet excluding the content information of the packet. The system includes a first packet filter configured to filter its input packets by examining content information of its packets and a second packet filter configured to filter its input packets by examining the header information without examining the content information of its packets. The system further includes a third filter which is configured to forward a number of packets to one of the first and second filters, thereby providing security to the computer network. The computer program includes a first module located in an application layer, a second module located in a network layer, and a third module located in a kernel space and configured to examine a number of packets received by the computer network from at least one outside network and to forward the number of packets to one of the first and second modules after examining the number of packets.

(21) Appl. No.: **09/414,711**

(22) Filed: **Oct. 8, 1999**

Related U.S. Application Data

(60) Provisional application No. 60/103,837, filed on Oct. 9, 1998.

(51) **Int. Cl.**⁷ **H04L 9/32**; G06F 11/30; G06F 12/14

(52) **U.S. Cl.** **713/201**; 709/238; 709/249

(58) **Field of Search** 713/201, 200; 709/238, 249

(56) **References Cited**

U.S. PATENT DOCUMENTS

5,606,668 A	2/1997	Shwed	395/200.11
5,884,025 A *	3/1999	Baehr et al.	713/201
5,898,830 A *	4/1999	Wesinger et al.	713/201
5,968,176 A *	10/1999	Nessett et al.	713/201
6,128,298 A *	10/2000	Wootton et al.	370/392

OTHER PUBLICATIONS

Firewall Software for NT and Unix, D. Seachrist et al., Byte, Jun. 1997, pp. 130–134.
 Applied Cryptography, Second Edition, Protocols, Algorithms, and Source Code in C, B. Schneier, John Wiley & Sons, 1996, Chapters 8 and 24, pp. 185–187 and 574–579.

29 Claims, 7 Drawing Sheets

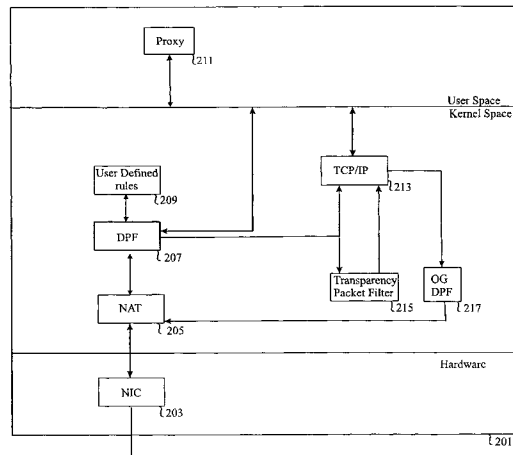

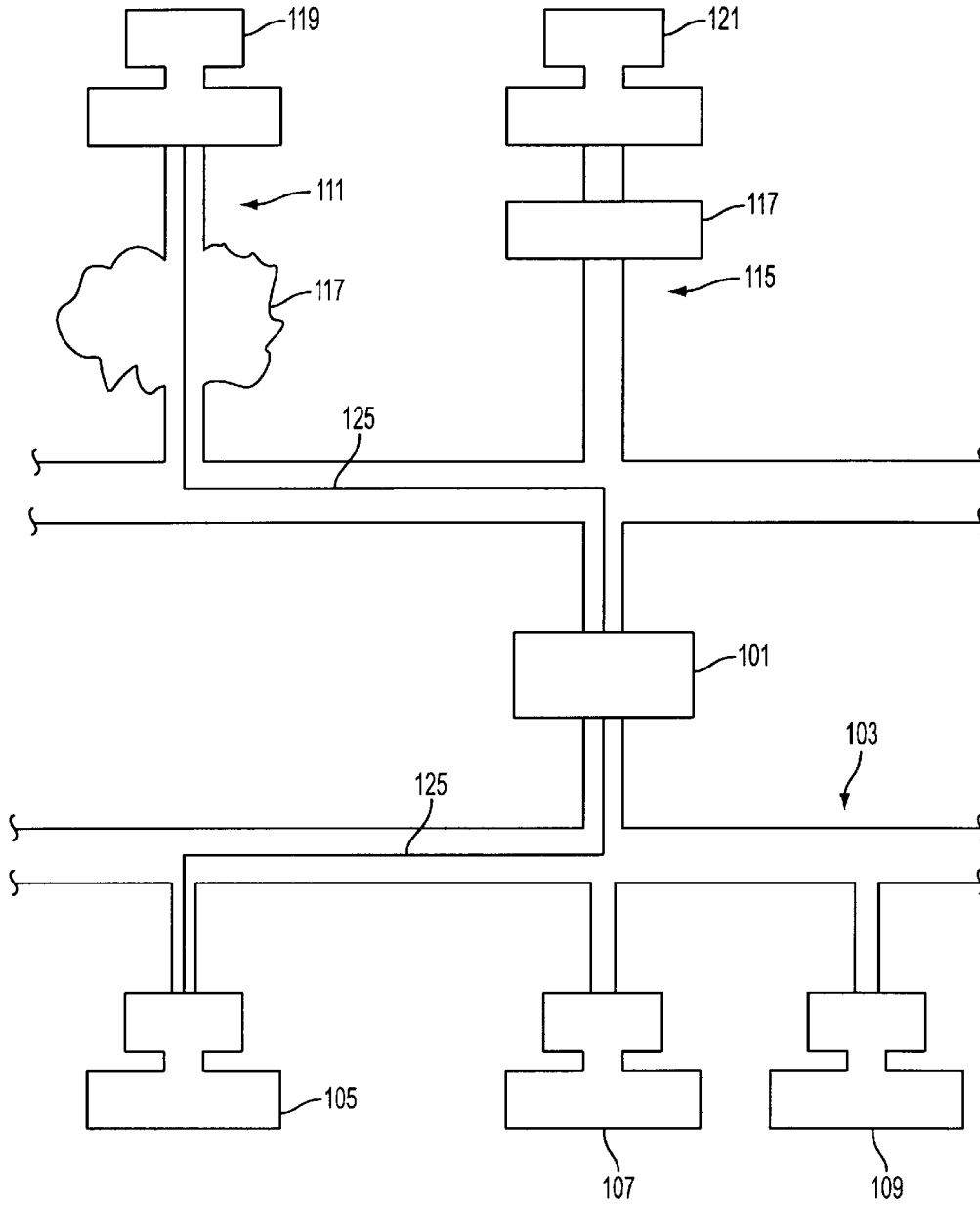

FIG. 1
(PRIOR ART)

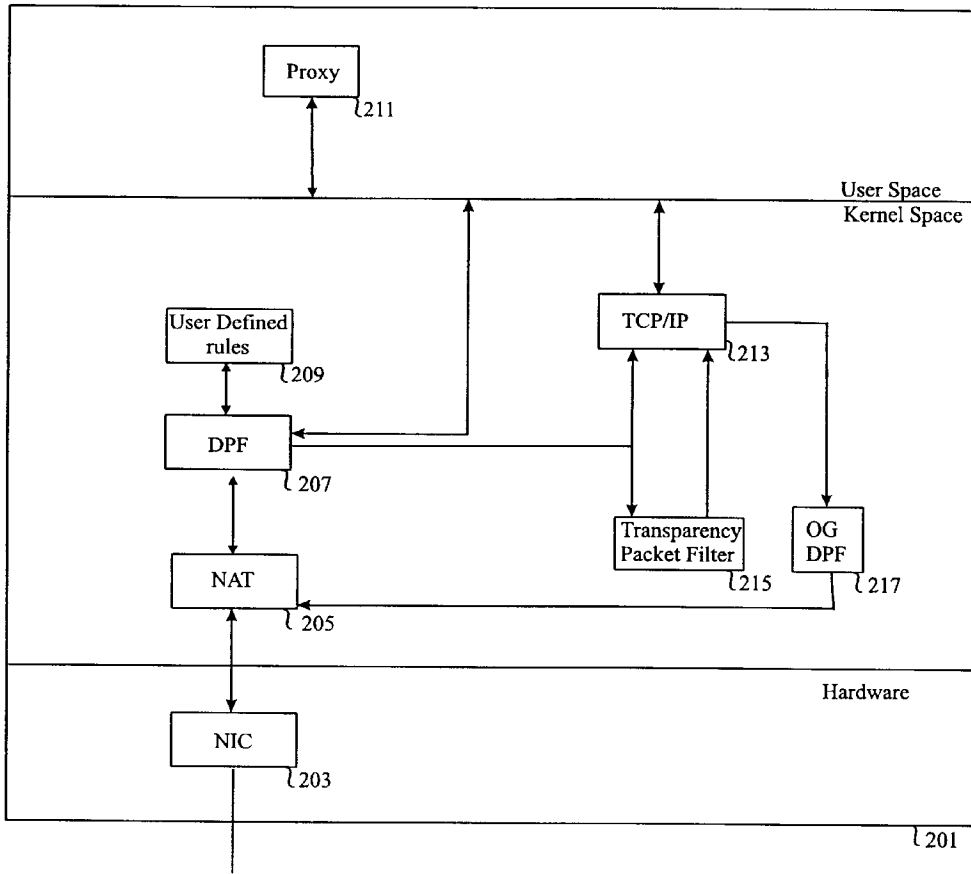

FIG. 2

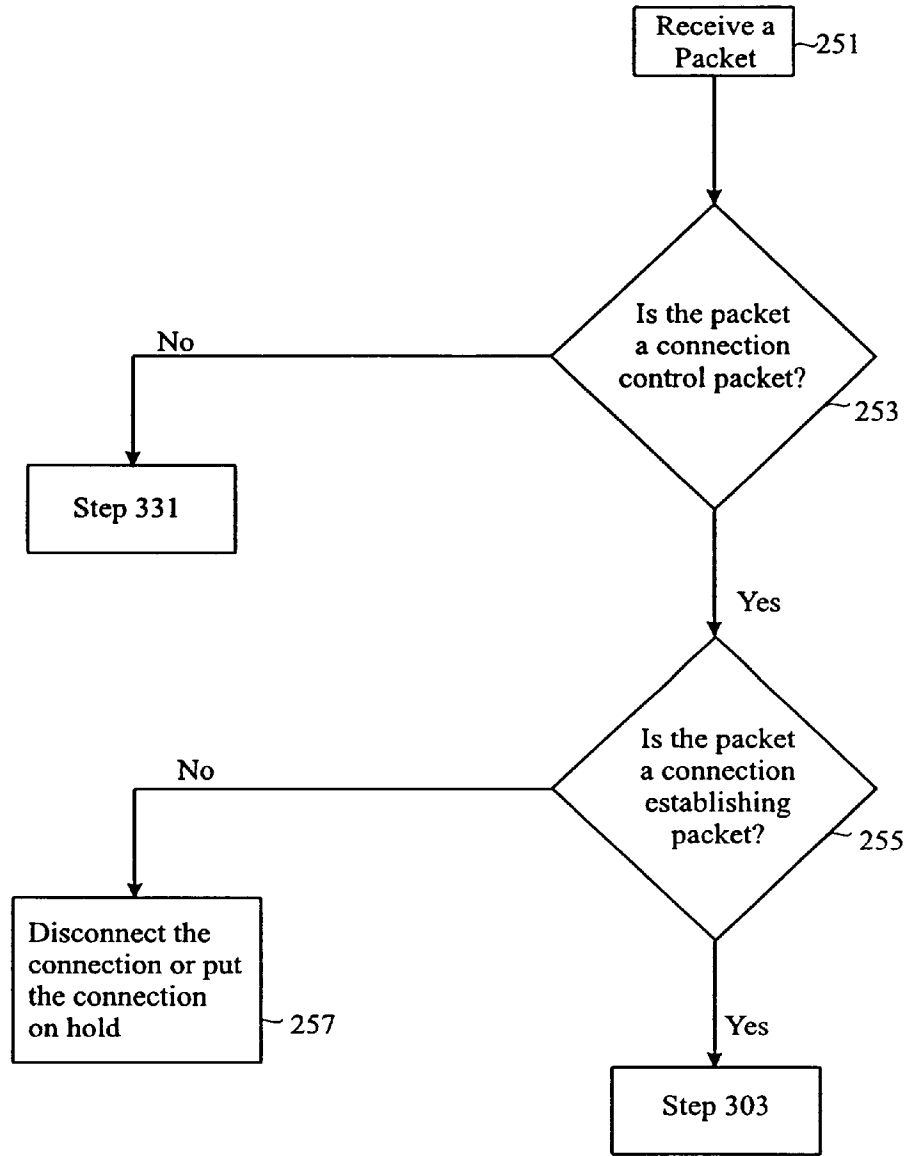

FIG 3

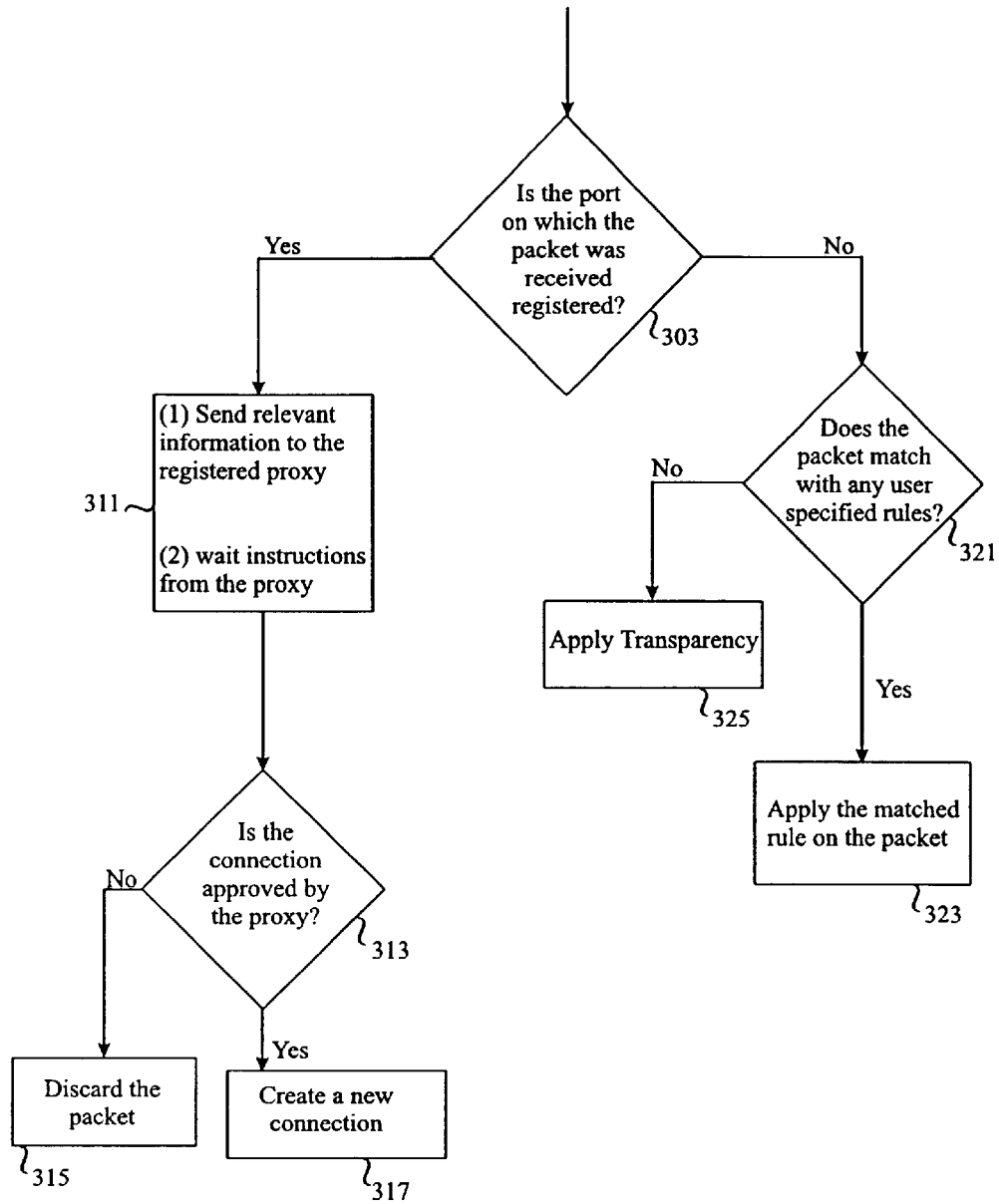

FIG. 4

Explore Litigation Insights

Docket Alarm provides insights to develop a more informed litigation strategy and the peace of mind of knowing you're on top of things.

Real-Time Litigation Alerts



Keep your litigation team up-to-date with **real-time alerts** and advanced team management tools built for the enterprise, all while greatly reducing PACER spend.

Our comprehensive service means we can handle Federal, State, and Administrative courts across the country.

Advanced Docket Research



With over 230 million records, Docket Alarm's cloud-native docket research platform finds what other services can't. Coverage includes Federal, State, plus PTAB, TTAB, ITC and NLRB decisions, all in one place.

Identify arguments that have been successful in the past with full text, pinpoint searching. Link to case law cited within any court document via Fastcase.

Analytics At Your Fingertips



Learn what happened the last time a particular judge, opposing counsel or company faced cases similar to yours.

Advanced out-of-the-box PTAB and TTAB analytics are always at your fingertips.

API

Docket Alarm offers a powerful API (application programming interface) to developers that want to integrate case filings into their apps.

LAW FIRMS

Build custom dashboards for your attorneys and clients with live data direct from the court.

Automate many repetitive legal tasks like conflict checks, document management, and marketing.

FINANCIAL INSTITUTIONS

Litigation and bankruptcy checks for companies and debtors.

E-DISCOVERY AND LEGAL VENDORS

Sync your system to PACER to automate legal marketing.