

Docket No.: 11574US05
Preliminary Amendment

REMARKS/ARGUMENTS

This Preliminary Amendment is filed to correct a minor informality in the Preliminary Amendment filed with the application on November 6, 2018.

Favorable consideration of this application as presently amended and in light of the following discussion is respectfully requested.

In view of the foregoing discussion and present amendment, it is respectfully submitted that this application is in condition for examination. An early and favorable action is therefore respectfully requested.

Respectfully Submitted,

XSENSUS, L.L.P.

/Andrew T. Harry/

Andrew T. Harry
Attorney of Record
Registration No. 56,959

CUSTOMER NO. 154930

Phone No. 571-376-6333
Fax. 571-376-6334

Under the Paperwork Reduction Act of 1995, no persons are required to respond to a collection of information unless it contains a valid OMB control number.

Application Data Sheet 37 CFR 1.76		Attorney Docket Number	11574US05
		Application Number	16/099,390
Title of Invention	DISTRIBUTED CONTROL IN WIRELESS SYSTEMS		
The application data sheet is part of the provisional or nonprovisional application for which it is being submitted. The following form contains the bibliographic data arranged in a format specified by the United States Patent and Trademark Office as outlined in 37 CFR 1.76. This document may be completed electronically and submitted to the Office in electronic format using the Electronic Filing System (EFS) or the document may be printed and included in a paper filed application.			

Secrecy Order 37 CFR 5.2:

- Portions or all of the application associated with this Application Data Sheet may fall under a Secrecy Order pursuant to 37 CFR 5.2 (Paper filers only. Applications that fall under Secrecy Order may not be filed electronically.)

Inventor Information:

Inventor 1					Remove
Legal Name					
Prefix	Given Name	Middle Name	Family Name	Suffix	
	Yugeswar		DEENOO		
Residence Information (Select One) <input checked="" type="radio"/> US Residency <input type="radio"/> Non US Residency <input type="radio"/> Active US Military Service					
City	Conshohocken	State/Province	PA	Country of Residence	US
Mailing Address of Inventor:					
Address 1	c/o Sony Corporation				
Address 2	1-7-1 Konan, Minato-ku				
City	Tokyo	State/Province			
Postal Code	108-0075	Country	JP		
Inventor 2					Remove
Legal Name					
Prefix	Given Name	Middle Name	Family Name	Suffix	
	Ghyslain		PELLETIER		
Residence Information (Select One) <input type="radio"/> US Residency <input checked="" type="radio"/> Non US Residency <input type="radio"/> Active US Military Service					
City	Montreal, QC	Country of Residence	CA		
Mailing Address of Inventor:					
Address 1	c/o Sony Corporation				
Address 2	1-7-1 Konan, Minato-ku				
City	Tokyo	State/Province			
Postal Code	108-0075	Country	JP		
Inventor 3					Remove
Legal Name					
Prefix	Given Name	Middle Name	Family Name	Suffix	
	Ping	Hsuan	TAN		

Under the Paperwork Reduction Act of 1995, no persons are required to respond to a collection of information unless it contains a valid OMB control number.

Application Data Sheet 37 CFR 1.76		Attorney Docket Number	11574USD5	
		Application Number	16/099,390	
Title of Invention	DISTRIBUTED CONTROL IN WIRELESS SYSTEMS			
Residence Information (Select One) <input type="radio"/> US Residency <input checked="" type="radio"/> Non US Residency <input type="radio"/> Active US Military Service				
City	Montreal, QC	Country of Residence ¹	CA	
Mailing Address of Inventor:				
Address 1	c/o Sony Corporation			
Address 2	1-7-1 Konan, Minato-ku			
City	Tokyo	State/Province		
Postal Code	108-0075	Country ¹	JP	
Inventor 4				<input type="button" value="Remove"/>
Legal Name				
Prefix	Given Name	Middle Name	Family Name	Suffix
	Martino	M	FREDA	
Residence Information (Select One) <input type="radio"/> US Residency <input checked="" type="radio"/> Non US Residency <input type="radio"/> Active US Military Service				
City	Montreal, QC	Country of Residence ¹	CA	
Mailing Address of Inventor:				
Address 1	c/o Sony Corporation			
Address 2	1-7-1 Konan, Minato-ku			
City	Tokyo	State/Province		
Postal Code	108-0075	Country ¹	JP	
All Inventors Must Be Listed - Additional Inventor Information blocks may be generated within this form by selecting the Add button. <input type="button" value="Add"/>				

Correspondence Information:

Enter either Customer Number or complete the Correspondence Information section below. For further information see 37 CFR 1.33(a).	
<input type="checkbox"/> An Address is being provided for the correspondence information of this application.	
Customer Number	154930
Email Address	xsensuspat@xsensus.com <input type="button" value="Add Email"/> <input type="button" value="Remove Email"/>

Application Data Sheet 37 CFR 1.76	Attorney Docket Number	11574US05
	Application Number	16/099,390
Title of Invention	DISTRIBUTED CONTROL IN WIRELESS SYSTEMS	

Application Information:

Title of the Invention	DISTRIBUTED CONTROL IN WIRELESS SYSTEMS		
Attorney Docket Number	11574US05	Small Entity Status Claimed	<input type="checkbox"/>
Application Type	Nonprovisional		
Subject Matter	Utility		
Total Number of Drawing Sheets (if any)	13	Suggested Figure for Publication (if any)	

Filing By Reference:

Only complete this section when filing an application by reference under 35 U.S.C. 111(c) and 37 CFR 1.57(a). Do not complete this section if application papers including a specification and any drawings are being filed. Any domestic benefit or foreign priority information must be provided in the appropriate section(s) below (i.e., "Domestic Benefit/National Stage Information" and "Foreign Priority Information").

For the purposes of a filing date under 37 CFR 1.53(b), the description and any drawings of the present application are replaced by this reference to the previously filed application, subject to conditions and requirements of 37 CFR 1.57(a).

Application number of the previously filed application	Filing date (YYYY-MM-DD)	Intellectual Property Authority or Country

Publication Information:

Request Early Publication (Fee required at time of Request 37 CFR 1.219)

Request Not to Publish. I hereby request that the attached application not be published under 35 U.S.C. 122(b) and certify that the invention disclosed in the attached application **has not and will not** be the subject of an application filed in another country, or under a multilateral international agreement, that requires publication at eighteen months after filing.

Representative Information:

Representative information should be provided for all practitioners having a power of attorney in the application. Providing this information in the Application Data Sheet does not constitute a power of attorney in the application (see 37 CFR 1.32).

Either enter Customer Number or complete the Representative Name section below. If both sections are completed the customer number will be used for the Representative Information during processing.

Please Select One:	<input checked="" type="radio"/> Customer Number	<input type="radio"/> US Patent Practitioner	<input type="radio"/> Limited Recognition (37 CFR 11.9)
Customer Number	154930		

Under the Paperwork Reduction Act of 1995, no persons are required to respond to a collection of information unless it contains a valid OMB control number.

Application Data Sheet 37 CFR 1.76		Attorney Docket Number	11574US05
		Application Number	16/099,390
Title of Invention	DISTRIBUTED CONTROL IN WIRELESS SYSTEMS		

Domestic Benefit/National Stage Information:

This section allows for the applicant to either claim benefit under 35 U.S.C. 119(e), 120, 121, 365(c), or 386(c) or indicate National Stage entry from a PCT application. Providing benefit claim information in the Application Data Sheet constitutes the specific reference required by 35 U.S.C. 119(e) or 120, and 37 CFR 1.76.

When referring to the current application, please leave the "Application Number" field blank.

Prior Application Status	Pending	Remove	
Application Number	Continuity Type	Prior Application Number	Filing or 371(c) Date (YYYY-MM-DD)
	a 371 of International	PCT/US2017/032069	2017-11-05 2017-05-11
Prior Application Status	Expired	Remove	
Application Number	Continuity Type	Prior Application Number	Filing or 371(c) Date (YYYY-MM-DD)
PCT/US2017/032069	Claims benefit of provisional	62334704	2016-05-11
Prior Application Status	Expired	Remove	
Application Number	Continuity Type	Prior Application Number	Filing or 371(c) Date (YYYY-MM-DD)
PCT/US2017/032069	Claims benefit of provisional	62400810	2016-09-28
Prior Application Status	Expired	Remove	
Application Number	Continuity Type	Prior Application Number	Filing or 371(c) Date (YYYY-MM-DD)
PCT/US2017/032069	Claims benefit of provisional	62416499	2016-11-02
Prior Application Status	Expired	Remove	
Application Number	Continuity Type	Prior Application Number	Filing or 371(c) Date (YYYY-MM-DD)
PCT/US2017/032069	Claims benefit of provisional	62442317	2017-01-04
Additional Domestic Benefit/National Stage Data may be generated within this form by selecting the Add button.			

Foreign Priority Information:

This section allows for the applicant to claim priority to a foreign application. Providing this information in the application data sheet constitutes the claim for priority as required by 35 U.S.C. 119(b) and 37 CFR 1.55. When priority is claimed to a foreign application that is eligible for retrieval under the priority document exchange program (PDX)¹ the information will be used by the Office to automatically attempt retrieval pursuant to 37 CFR 1.55(i)(1) and (2). Under the PDX program, applicant bears the ultimate responsibility for ensuring that a copy of the foreign application is received by the Office from the participating foreign intellectual property office, or a certified copy of the foreign priority application is filed, within the time period specified in 37 CFR 1.55(g)(1).

Under the Paperwork Reduction Act of 1995, no persons are required to respond to a collection of information unless it contains a valid OMB control number.

Application Data Sheet 37 CFR 1.76		Attorney Docket Number	11574US05
		Application Number	16/099,390
Title of Invention	DISTRIBUTED CONTROL IN WIRELESS SYSTEMS		
Application Number	Country ¹	Filing Date (YYYY-MM-DD)	Access Code ¹ (if applicable)
Additional Foreign Priority Data may be generated within this form by selecting the Add button.			

Statement under 37 CFR 1.55 or 1.78 for AIA (First Inventor to File) Transition Applications

- This application (1) claims priority to or the benefit of an application filed before March 16, 2013 and (2) also contains, or contained at any time, a claim to a claimed invention that has an effective filing date on or after March 16, 2013.
- NOTE: By providing this statement under 37 CFR 1.55 or 1.78, this application, with a filing date on or after March 16, 2013, will be examined under the first inventor to file provisions of the AIA.

Application Data Sheet 37 CFR 1.76		Attorney Docket Number	11574US05
		Application Number	16/099,390
Title of Invention	DISTRIBUTED CONTROL IN WIRELESS SYSTEMS		

Authorization or Opt-Out of Authorization to Permit Access:

When this Application Data Sheet is properly signed and filed with the application, applicant has provided written authority to permit a participating foreign intellectual property (IP) office access to the instant application-as-filed (see paragraph A in subsection 1 below) and the European Patent Office (EPO) access to any search results from the instant application (see paragraph B in subsection 1 below).

Should applicant choose not to provide an authorization identified in subsection 1 below, applicant **must opt-out** of the authorization by checking the corresponding box A or B or both in subsection 2 below.

NOTE: This section of the Application Data Sheet is **ONLY** reviewed and processed with the **INITIAL** filing of an application. After the initial filing of an application, an Application Data Sheet cannot be used to provide or rescind authorization for access by a foreign IP office(s). Instead, Form PTO/SB/39 or PTO/SB/69 must be used as appropriate.

1. Authorization to Permit Access by a Foreign Intellectual Property Office(s)

A. Priority Document Exchange (PDX) - Unless box A in subsection 2 (opt-out of authorization) is checked, the undersigned hereby **grants the USPTO authority** to provide the European Patent Office (EPO), the Japan Patent Office (JPO), the Korean Intellectual Property Office (KIPO), the State Intellectual Property Office of the People's Republic of China (SIPO), the World Intellectual Property Organization (WIPO), and any other foreign intellectual property office participating with the USPTO in a bilateral or multilateral priority document exchange agreement in which a foreign application claiming priority to the instant patent application is filed, access to: (1) the instant patent application-as-filed and its related bibliographic data, (2) any foreign or domestic application to which priority or benefit is claimed by the instant application and its related bibliographic data, and (3) the date of filing of this Authorization. See 37 CFR 1.14(h)(1).

B. Search Results from U.S. Application to EPO - Unless box B in subsection 2 (opt-out of authorization) is checked, the undersigned hereby **grants the USPTO authority** to provide the EPO access to the bibliographic data and search results from the instant patent application when a European patent application claiming priority to the instant patent application is filed. See 37 CFR 1.14(h)(2).

The applicant is reminded that the EPO's Rule 141(1) EPC (European Patent Convention) requires applicants to submit a copy of search results from the instant application without delay in a European patent application that claims priority to the instant application.

2. Opt-Out of Authorizations to Permit Access by a Foreign Intellectual Property Office(s)

A. Applicant **DOES NOT** authorize the USPTO to permit a participating foreign IP office access to the instant application-as-filed. If this box is checked, the USPTO will not be providing a participating foreign IP office with any documents and information identified in subsection 1A above.

B. Applicant **DOES NOT** authorize the USPTO to transmit to the EPO any search results from the instant patent application. If this box is checked, the USPTO will not be providing the EPO with search results from the instant application.

NOTE: Once the application has published or is otherwise publicly available, the USPTO may provide access to the application in accordance with 37 CFR 1.14.

Under the Paperwork Reduction Act of 1995, no persons are required to respond to a collection of information unless it contains a valid OMB control number.

Application Data Sheet 37 CFR 1.76	Attorney Docket Number	11574USD5
	Application Number	16/099,390
Title of Invention	DISTRIBUTED CONTROL IN WIRELESS SYSTEMS	

Applicant Information:

Providing assignment information in this section does not substitute for compliance with any requirement of part 3 of Title 37 of CFR to have an assignment recorded by the Office.

Applicant 1

If the applicant is the inventor (or the remaining joint inventor or inventors under 37 CFR 1.45), this section should not be completed. The information to be provided in this section is the name and address of the legal representative who is the applicant under 37 CFR 1.43; or the name and address of the assignee, person to whom the inventor is under an obligation to assign the invention, or person who otherwise shows sufficient proprietary interest in the matter who is the applicant under 37 CFR 1.46. If the applicant is an applicant under 37 CFR 1.46 (assignee, person to whom the inventor is obligated to assign, or person who otherwise shows sufficient proprietary interest) together with one or more joint inventors, then the joint inventor or inventors who are also the applicant should be identified in this section.

Assignee Legal Representative under 35 U.S.C. 117 Joint Inventor

Person to whom the inventor is obligated to assign. Person who shows sufficient proprietary interest

If applicant is the legal representative, indicate the authority to file the patent application, the inventor is:

Name of the Deceased or Legally Incapacitated Inventor:

If the Applicant is an Organization check here.

Organization Name Sony Corporation

Mailing Address Information For Applicant:

Address 1	1-7-1 Konan, Minato-ku		
Address 2			
City	Tokyo	State/Province	
Country	JP	Postal Code	108-0075
Phone Number		Fax Number	
Email Address			

Additional Applicant Data may be generated within this form by selecting the Add button.

Assignee Information including Non-Applicant Assignee Information:

Providing assignment information in this section does not substitute for compliance with any requirement of part 3 of Title 37 of CFR to have an assignment recorded by the Office.

Under the Paperwork Reduction Act of 1995, no persons are required to respond to a collection of information unless it contains a valid OMB control number.

Application Data Sheet 37 CFR 1.76	Attorney Docket Number	11574US05
	Application Number	16/099,390
Title of Invention	DISTRIBUTED CONTROL IN WIRELESS SYSTEMS	

Assignee 1

Complete this section if assignee information, including non-applicant assignee information, is desired to be included on the patent application publication. An assignee-applicant identified in the "Applicant Information" section will appear on the patent application publication as an applicant. For an assignee-applicant, complete this section only if identification as an assignee is also desired on the patent application publication.

If the Assignee or Non-Applicant Assignee is an Organization check here.

Organization Name Sony Corporation

Mailing Address Information For Assignee including Non-Applicant Assignee:

Address 1	1-7-1 Konan, Minato-ku		
Address 2			
City	Tokyo	State/Province	
Country ⁱ	JP	Postal Code	108-0075
Phone Number		Fax Number	
Email Address			

Additional Assignee or Non-Applicant Assignee Data may be generated within this form by selecting the Add button.

Signature:

NOTE: This Application Data Sheet must be signed in accordance with 37 CFR 1.33(b). However, if this Application Data Sheet is submitted with the INITIAL filing of the application and either box A or B is not checked in subsection 2 of the "Authorization or Opt-Out of Authorization to Permit Access" section, then this form must also be signed in accordance with 37 CFR 1.14(c).

This Application Data Sheet **must** be signed by a patent practitioner if one or more of the applicants is a **juristic entity** (e.g., corporation or association). If the applicant is two or more joint inventors, this form must be signed by a patent practitioner, **all** joint inventors who are the applicant, or one or more joint inventor-applicants who have been given power of attorney (e.g., see USPTO Form PTO/AIA/81) on behalf of **all** joint inventor-applicants.

See 37 CFR 1.4(d) for the manner of making signatures and certifications.

Signature	/Andrew T. Harry/		Date (YYYY-MM-DD)	12/06/2018	
First Name	Andrew T.	Last Name	Harry	Registration Number	56,959
Additional Signature may be generated within this form by selecting the Add button.					

Under the Paperwork Reduction Act of 1995, no persons are required to respond to a collection of information unless it contains a valid OMB control number.

Application Data Sheet 37 CFR 1.76	Attorney Docket Number	11574USD5
	Application Number	16/099,390
Title of Invention	DISTRIBUTED CONTROL IN WIRELESS SYSTEMS	

This collection of information is required by 37 CFR 1.76. The information is required to obtain or retain a benefit by the public which is to file (and by the USPTO to process) an application. Confidentiality is governed by 35 U.S.C. 122 and 37 CFR 1.14. This collection is estimated to take 23 minutes to complete, including gathering, preparing, and submitting the completed application data sheet form to the USPTO. Time will vary depending upon the individual case. Any comments on the amount of time you require to complete this form and/or suggestions for reducing this burden, should be sent to the Chief Information Officer, U.S. Patent and Trademark Office, U.S. Department of Commerce, P.O. Box 1450, Alexandria, VA 22313-1450. **DO NOT SEND FEES OR COMPLETED FORMS TO THIS ADDRESS. SEND TO: Commissioner for Patents, P.O. Box 1450, Alexandria, VA 22313-1450.**

Privacy Act Statement

The Privacy Act of 1974 (P.L. 93-579) requires that you be given certain information in connection with your submission of the attached form related to a patent application or patent. Accordingly, pursuant to the requirements of the Act, please be advised that: (1) the general authority for the collection of this information is 35 U.S.C. 21b(2); (2) furnishing of the information solicited is voluntary; and (3) the principal purpose for which the information is used by the U.S. Patent and Trademark Office is to process and/or examine your submission related to a patent application or patent. If you do not furnish the requested information, the U.S. Patent and Trademark Office may not be able to process and/or examine your submission, which may result in termination of proceedings or abandonment of the application or expiration of the patent.

The information provided by you in this form will be subject to the following routine uses:

1. The information on this form will be treated confidentially to the extent allowed under the Freedom of Information Act (5 U.S.C. 552) and the Privacy Act (5 U.S.C. 552a). Records from this system of records may be disclosed to the Department of Justice to determine whether the Freedom of Information Act requires disclosure of these records.
2. A record from this system of records may be disclosed, as a routine use, in the course of presenting evidence to a court, magistrate, or administrative tribunal, including disclosures to opposing counsel in the course of settlement negotiations.
3. A record in this system of records may be disclosed, as a routine use, to a Member of Congress submitting a request involving an individual, to whom the record pertains, when the individual has requested assistance from the Member with respect to the subject matter of the record.
4. A record in this system of records may be disclosed, as a routine use, to a contractor of the Agency having need for the information in order to perform a contract. Recipients of information shall be required to comply with the requirements of the Privacy Act of 1974, as amended, pursuant to 5 U.S.C. 552a(m).
5. A record related to an International Application filed under the Patent Cooperation Treaty in this system of records may be disclosed, as a routine use, to the International Bureau of the World Intellectual Property Organization, pursuant to the Patent Cooperation Treaty.
6. A record in this system of records may be disclosed, as a routine use, to another federal agency for purposes of National Security review (35 U.S.C. 181) and for review pursuant to the Atomic Energy Act (42 U.S.C. 218(C)).
7. A record from this system of records may be disclosed, as a routine use, to the Administrator, General Services, or his/her designee, during an inspection of records conducted by GSA as part of that agency's responsibility to recommend improvements in records management practices and programs, under authority of 44 U.S.C. 2904 and 2906. Such disclosure shall be made in accordance with the GSA regulations governing inspection of records for this purpose, and any other relevant (i.e., GSA or Commerce) directive. Such disclosure shall not be used to make determinations about individuals.
8. A record from this system of records may be disclosed, as a routine use, to the public after either publication of the application pursuant to 35 U.S.C. 122(b) or issuance of a patent pursuant to 35 U.S.C. 151. Further, a record may be disclosed, subject to the limitations of 37 CFR 1.14, as a routine use, to the public if the record was filed in an application which became abandoned or in which the proceedings were terminated and which application is referenced by either a published application, an application open to public inspections or an issued patent.
9. A record from this system of records may be disclosed, as a routine use, to a Federal, State, or local law enforcement agency, if the USPTO becomes aware of a violation or potential violation of law or regulation.

Electronic Acknowledgement Receipt

EFS ID:	34509524
Application Number:	16099390
International Application Number:	
Confirmation Number:	4717
Title of Invention:	DISTRIBUTED CONTROL IN WIRELESS SYSTEMS
First Named Inventor/Applicant Name:	Yugeswar DEENOO
Customer Number:	154930
Filer:	Andrew T. Harry/Christine Grimes
Filer Authorized By:	Andrew T. Harry
Attorney Docket Number:	11574US05
Receipt Date:	06-DEC-2018
Filing Date:	
Time Stamp:	16:20:46
Application Type:	U.S. National Stage under 35 USC 371

Payment information:

Submitted with Payment	no
------------------------	----

File Listing:

Document Number	Document Description	File Name	File Size(Bytes)/ Message Digest	Multi Part /.zip	Pages (if appl.)
1		11574US05_PreliminaryAmendment_12062018.pdf	331987 4bc21cfe42a75147bb6fe85558cbb318a712c03	yes	3

Multipart Description/PDF files in .zip description			
Document Description	Start	End	
Preliminary Amendment	1	1	
Specification	2	2	
Applicant Arguments/Remarks Made in an Amendment	3	3	

Warnings:

Information:

2	Application Data Sheet	11574US05_Supplemental_AD S_12062018.pdf	2742192	no	10
			e76872f94b26a45f492c26762032a7e79868 b8f5		

Warnings:

Information:

This is not an USPTO supplied ADS fillable form

Total Files Size (in bytes): 3074179

This Acknowledgement Receipt evidences receipt on the noted date by the USPTO of the indicated documents, characterized by the applicant, and including page counts, where applicable. It serves as evidence of receipt similar to a Post Card, as described in MPEP 503.

New Applications Under 35 U.S.C. 111

If a new application is being filed and the application includes the necessary components for a filing date (see 37 CFR 1.53(b)-(d) and MPEP 506), a Filing Receipt (37 CFR 1.54) will be issued in due course and the date shown on this Acknowledgement Receipt will establish the filing date of the application.

National Stage of an International Application under 35 U.S.C. 371

If a timely submission to enter the national stage of an international application is compliant with the conditions of 35 U.S.C. 371 and other applicable requirements a Form PCT/DO/EO/903 indicating acceptance of the application as a national stage submission under 35 U.S.C. 371 will be issued in addition to the Filing Receipt, in due course.

New International Application Filed with the USPTO as a Receiving Office

If a new international application is being filed and the international application includes the necessary components for an international filing date (see PCT Article 11 and MPEP 1810), a Notification of the International Application Number and of the International Filing Date (Form PCT/RO/105) will be issued in due course, subject to prescriptions concerning national security, and the date shown on this Acknowledgement Receipt will establish the international filing date of the application.

TRANSMITTAL LETTER TO THE UNITED STATES DESIGNATED/ELECTED OFFICE (DO/EO/US) CONCERNING A SUBMISSION UNDER 35 U.S.C. 371		Attorney Docket No. 11574US05
		U.S. Application No. (if known, see 37 CFR 1.5)
International Application No. PCT/US2017/032069	International Filing Date May 11, 2017	Priority Date Claimed May 11, 2016
Title of Invention DISTRIBUTED CONTROL IN WIRELESS SYSTEMS		
First Named Inventor Yugeswar DEENOO et al.		
<p>Applicant herewith submits to the United States Designated/Elected Office (DO/EO/US) the following items and other information.</p> <p>1. <input checked="" type="checkbox"/> This is an express request to begin national examination procedures (35 U.S.C. 371(f)). NOTE: The express request under 35 U.S.C. 371(f) will not be effective unless the requirements under 35 U.S.C. 371(c)(1), (2), and (4) for payment of the basic national fee, copy of the International Application and English translation thereof (if required), and the oath or declaration of the inventor(s) have been received.</p> <p>2. <input checked="" type="checkbox"/> A copy of the International Application (35 U.S.C. 371(c)(2)) is attached hereto (not required if the International Application was previously communicated by the International Bureau or was filed in the United States Receiving Office (RO/US)).</p> <p>3. An English language translation of the International Application (35 U.S.C. 371(c)(2))</p> <p>a. <input checked="" type="checkbox"/> is attached hereto.</p> <p>b. <input type="checkbox"/> has been previously submitted under 35 U.S.C. 154(d)(4).</p> <p>4. An oath or declaration of the inventor(s) (35 U.S.C. 371(c)(4))</p> <p>a. <input type="checkbox"/> is attached.</p> <p>b. <input type="checkbox"/> was previously filed in the international phase under PCT Rule 4.17(iv)</p> <p>Items 5 to 8 below concern amendments made in the international phase.</p> <p><u>PCT Article 19 and 34 amendments</u></p> <p>5. <input type="checkbox"/> Amendments to the claims under PCT Article 19 are attached (not required if communicated by the International Bureau) (35 U.S.C. 371(c)(3)).</p> <p>6. <input type="checkbox"/> English translation of the PCT Article 19 amendment is attached (35 U.S.C. 371(c)(3)).</p> <p>7. <input type="checkbox"/> English translation of annexes (Article 19 and/or 34 amendments only) of the international Preliminary Examination Report is attached (35 U.S.C. 371(c)(5)).</p> <p><u>Cancellation of amendments made in the international phase</u></p> <p>8a. <input type="checkbox"/> Do not enter the amendment made in the international phase under PCT Article 19.</p> <p>8b. <input type="checkbox"/> Do not enter the amendment made in the international phase under PCT Article 34.</p> <p>NOTE: A proper amendment made in English under Article 19 or 34 will be entered in the U.S. national phase application absent a clear instruction from applicant not to enter the amendment(s).</p> <p>The following items 9 to 17 concern a document(s) or information included.</p> <p>9. <input checked="" type="checkbox"/> An Information Disclosure Statement under 37 CFR 1.97 and 1.98.</p> <p>10. <input checked="" type="checkbox"/> A preliminary amendment.</p> <p>11. <input checked="" type="checkbox"/> An Application Data Sheet under 37 CFR 1.76.</p> <p>12. <input type="checkbox"/> A substitute specification. NOTE: A substitute specification cannot include claims. See 37 CFR 1.125(b).</p> <p>13. <input checked="" type="checkbox"/> A power of attorney and/or change of address letter.</p> <p>14. <input type="checkbox"/> A computer-readable form of the sequence listing in accordance with PCT Rule 13ter.3 and 37 CFR 1.821-1.825 (not required if sequence listing in text format was indicated on the PCT Request as part of the International Application and the sequence listing was published as part of the international application).</p> <p>15. <input type="checkbox"/> Assignment papers (cover sheet and document(s)). Name of Assignee: <u>Sony Corporation</u></p> <p>16. <input type="checkbox"/> 37 CFR 3.73(c) Statement (when there is an Assignee).</p>		

This collection of information is required by 37 CFR 1.414 and 1.491-1.492. The information is required to obtain or retain a benefit by the public, which is to file (and by the USPTO to process) an application. Confidentiality is governed by 35 U.S.C. 122 and 37 CFR 1.11 and 1.14. This collection is estimated to take 15 minutes to complete, including gathering, preparing, and submitting the completed application form to the USPTO. Time will vary depending upon the individual case. Any comments on the amount of time you require to complete this form and/or suggestions for reducing this burden should be sent to the Chief Information Officer, U.S. Patent and Trademark Office, U.S. Department of Commerce, P.O. Box 1450, Alexandria, VA 22313-1450. DO NOT SEND FEES OR COMPLETED FORMS TO THIS ADDRESS. SEND TO: Mail Stop PCT, Commissioner for Patents, P.O. Box 1450, Alexandria, VA 22313-1450.

U.S. APPLN. No. (if known – see 37 CFR 1.5)		INTERNATIONAL APPLICATION No.		ATTORNEY DOCKET No.	
		PCT/US2017/032069		11574US05	
17. <input type="checkbox"/> Other items or information:					
The following fees have been submitted.					CALCULATIONS
18. <input checked="" type="checkbox"/> Basic national fee (37 CFR 1.492(a))					\$300
19. <input checked="" type="checkbox"/> Examination fee (37 CFR 1.492(c))					\$760.00
• If the written opinion prepared by ISA/US or the international preliminary examination report prepared by IPEA/US indicates all claims satisfy provisions of PCT Article 33(1)-(4)					\$0
• All other situations					\$760
20. <input checked="" type="checkbox"/> Search fee (37 CFR 1.492(b))					\$520.00
• If the written opinion prepared by ISA/US or the international preliminary examination report prepared by IPEA/US indicates all claims satisfy provisions of PCT Article 33(1)-(4)					\$0
• Search fee (37 CFR 1.445(a)(2)) has been paid on the international application to the USPTO as an International Searching Authority					\$140
• International Search Report prepared by an ISA other than the US and provided to the Office or previously communicated to the US by the IB					\$520
• All other situations					\$660
TOTAL OF 18, 19, and 20 =					\$1580.00
<input checked="" type="checkbox"/> Additional fee for specification and drawings filed in paper over 100 sheets (excluding sequence listing in compliance with 37 CFR 1.821(c) or (e) in an electronic medium or computer program listing in an electronic medium) (37 CFR 1.492(j)).					
Fee for each additional 50 sheets of paper or fraction thereof					\$400
Total Sheets	Extra Sheets	Number of each additional 50 or fraction thereof (round up to a whole number)		RATE	
125 - 100 =	25 / 50 =	25		x \$400	
					\$400.00
Surcharge for furnishing any of the search fee, examination fee, or the oath or declaration after the date of commencement of the national stage (37 CFR 1.492(h))					\$140
CLAIMS		NUMBER FILED	NUMBER EXTRA	RATE	
Total claims		40 - 20 =	20	x \$100	
Independent claims		4 - 3 =	1	x \$460	
				+ \$820	
					\$2000.00
					\$460.00
MULTIPLE DEPENDENT CLAIM(S) (if applicable)					\$0.00
Fee for submission of Sequence Listing text file of 300 MB to 800 MB (37 CFR 1.21(o)(1))					\$1,000
Fee for submission of Sequence Listing text file of more than 800 MB (37 CFR 1.21(o)(2))					\$10,000
Processing fee for furnishing the English translation later than 30 months from the earliest claimed priority date (37 CFR 1.492(i))					\$140 +
TOTAL OF ABOVE CALCULATIONS =					\$4580.00
<input type="checkbox"/> Applicant asserts small entity status. See 37 CFR 1.27. Fees above are reduced by ½.					
<input type="checkbox"/> Applicant certifies micro entity status. See 37 CFR 1.29. Fees above are reduced by ¾. Applicant must attach form PTO/SB/15A or B or equivalent.					
TOTAL NATIONAL FEE =					\$4580.00
Fee for recording the enclosed assignment (37 CFR 1.21(h)). The assignment must be accompanied by an appropriate cover sheet (37 CFR 3.28, 3.31)					\$50.00 per property +
TOTAL FEES ENCLOSED =					\$4580.00

Under the Paperwork Reduction Act of 1995, no persons are required to respond to a collection of information unless it displays a valid OMB control number.

a. A check in the amount of \$ _____ to cover the above fees is enclosed.

b. Please charge my Deposit Account No. _____ in the amount of \$ _____ to cover the above fees.

c. The Director is hereby authorized to charge additional fees which may be required, or credit any overpayment, to Deposit Account No. 602325 as follows:

i. any required fee.

ii. any required fee except for excess claims fees required under 37 CFR 1.492(d) and (e) and multiple dependent claim fee required under 37 CFR 1.492(f).

d. Fees are to be charged to a credit card. **WARNING:** Information on this form may become public. Credit card information should not be included on this form. Provide credit card information and authorization on PTO-2038. The PTO-2038 should only be mailed or faxed to the USPTO. However, when paying the basic national fee, the PTO-2038 may NOT be faxed to the USPTO.

ADVISORY: If filing by EFS-Web, do NOT attach the PTO-2038 form as a PDF along with your EFS-Web submission. Please be advised that this is not recommended and by doing so your credit card information may be displayed via PAIR. To protect your information, it is recommended to pay fees online by using the electronic payment method.

NOTE: Where an appropriate time limit under 37 CFR 1.495 has not been met, a petition to revive (37 CFR 1.137(a) or (b)) must be filed and granted to restore the International Application to pending status.

Statement under 37 CFR 1.55 or 1.78 for AIA (First Inventor to File) Transition Applications

This application (1) claims priority to or the benefit of an application filed before March 16, 2013, and (2) also contains, or contained at any time, a claim to a claimed invention that has an effective filing date on or after March 16, 2013.

NOTE 1: By providing this statement under 37 CFR 1.55 or 1.78, this application, with a filing date on or after March 16, 2013, will be examined under the first inventor to file provisions of the AIA.

NOTE 2: A U.S. national stage application may not claim priority to the international application of which it is the national phase. The filing date of a U.S. national stage application is the international filing date. See 35 U.S.C. 363.

Correspondence Address

The address associated with Customer Number: 154930 OR Correspondence address below

Name					
Address					
City		State		Zip Code	
Country				Telephone	
Email					

Signature	/Bradley D. Lytle/	Date	11/06/2018
Name (Print/Type)	Bradley D. Lytle	Registration No. (Attorney/Agent)	40,073

DISTRIBUTED CONTROL IN WIRELESS SYSTEMS

CROSS-REFERENCE TO RELATED APPLICATIONS

[0001] This application claims the benefit of U.S. Provisional Patent Application No. 62/442,317 filed on January 4, 2017; U.S. Provisional Patent Application No. 62/416,499, filed on November 2, 2016; U.S. Provisional Patent Application No. 62/400,810, filed on September 28, 2016; and U.S. Provisional Patent Application No. 62/334,704, filed on May 11, 2016, the contents of all of which being hereby incorporated by reference as if fully set-forth herein in their respective entirety, for all purposes.

BACKGROUND

[0002] Mobile communications continue to evolve. A fifth generation may be referred to as 5G. A previous (legacy) generation of mobile communication may be, for example, fourth generation (4G) long term evolution (LTE).

SUMMARY

[0003] Systems, procedures, and instrumentalities (e.g., aspects of entities, interfaces and/or procedures in a wireless transmit/receive unit (WTRU) and/or network layers L1, L2, L3) are disclosed for distributed control in wireless systems, such as 5G flexible radio access technology (RAT) (5gFLEX). Example procedures are provided for WTRU and network operation associated with a distributed control plane architecture, connectionless data transfer and/or dedicated system information acquisition. Distributed control may be provided, for example, by replicating a plurality of access control functions (ACFs) using a plurality of instances in a plurality of different transmission/reception points (TRPs) with multi-connectivity. The plurality of TRPs may concurrently provide control services to a WTRU. Centralized control functions may manage core network connectivity and/or a plurality of user plane instances for the WTRU and/or may facilitate coordination between the plurality of ACF instances for the WTRU in the plurality of different TRPs of the WTRU's configuration. For example, there may be a first

access plane between the WTRU and a first TRP that provides a first ACF for the WTRU, a second access plane between the WTRU and a second TRP that provides a second ACF for the WTRU, a RAN central control plane between the WTRU and a first RAN central control function (RCCF) and/or a RAN central user plane between the WTRU and a RAN central user function (RCUF).

[0004] A WTRU may use assistance information for beamformed system information delivery. Assistance information may be determined and/or transmitted.

[0005] A WTRU may determine when to apply and/or activate on-demand system information. A WTRU may determine when to delete and/or deactivate on-demand system information.

[0006] A WTRU may have saved instructions in memory executable by a processor and/or received from a wireless network via a message (e.g., rules) for triggering a system information ("SI") request procedure. A WTRU may also have saved instructions in memory executable by a processor and/or received from a wireless network via a message for performing an SI request, (e.g., using a random access channel "RACH"), and/or msg3 and/or handling of networks.

[0007] A wireless transmit/receive unit (WTRU) may be in communication with a communication network. The WTRU may comprise a memory. The WTRU may comprise a processor. The processor may be configured to determine to request one or more system information (SI) messages from the communication network. The processor may be configured to determine if a transmission of the one or more SI message from the communication network will utilize at least one beamformed communication based on one or more communication parameters. The WTRU may comprise a transceiver. The transceiver may be configured to receive at least one of the one or more SI messages from the communication network via the at least one beamformed communication.

[0008] A wireless transmit/receive unit (WTRU) may be in communication with a communication network. The WTRU may comprise a memory. The WTRU may comprise a processor. The processor may be configured to determine to request one or more system information (SI) messages from the communication network. The processor may be configured to conduct a beam sweep operation of one or more downlink (DL) beams transmitted from the communication network. The processor may be configured to identify at least one DL beam of the one or more DL beams via which to receive the one or more on-demand SI messages based at least in part on the beam sweep operation. The processor may be configured to determine one or more uplink (UL) resources with which to communicate information for the WTRU reception of the one or more on-demand SI messages. The information for the WTRU reception may include

the at least one DL beam. The processor may be configured to initiate the request for the one or more on-demand SI messages from the communication network. The WTRU may comprise a transceiver. The transceiver may be configured to send the request for the one or more on-demand SI messages to the communication network using the one or more UL resources. The request may include the information for the WTRU reception of the one or more on-demand SI messages. The transceiver may be configured to receive at least one of the one or more on-demand SI messages from the communication network via the at least one DL beam.

[0009] A wireless transmit/receive unit (WTRU) may be in communication with a communication network. The WTRU may comprise a memory. The WTRU may comprise a transceiver. The transceiver may be configured to receive system information (SI) from the communication network at a first-time instance. The WTRU may comprise a processor. The processor may be configured to determine a first-reference identifier (ID) that corresponds to at least some of the SI of the first-time instance. The processor may be configured to determine a first-value identifier (ID) that corresponds to the at least some of the SI of the first-time instance. The processor may be configured to associate the first-reference ID and/or the first-value ID with the at least some of the SI of the first-time instance. The processor may be configured to utilize the at least some of the SI of the first-time instance in communication with the communication network. The processor may be configured to search the memory for stored SI of a previous-time instance that is associated with the same first-reference ID of the at least some of the SI of the first-time instance. The processor may be configured to store the at least some of the SI of the first-time instance upon no stored SI of the previous-time instance associated with the same first-reference ID being found. The processor may be configured to replace stored SI of the previous-time instance associated with the same first-reference ID with the at least some of the SI of the first-time instance upon a value ID associated with the stored SI of the previous-time instance associated with the same first-reference ID being different from the first-value ID.

[0010] A wireless transmit/receive unit (WTRU) may be in communication with a communication network. The WTRU may comprise a memory. The WTRU may comprise a processor. The processor may be configured to determine to request other system information (other-SI) from the communication network. The WTRU may be configured to initiate the request for the other-SI from the communication network as part of a Random Access Channel (RACH) procedure. The WTRU may comprise a transceiver. The transceiver may be configured to transmit a RACH signal. The RACH signal may include the request for the other-SI in a random access preamble of the RACH signal. The processor may be configured to monitor for a message that includes a minimum SI from the communication network for a

predetermined period of time following the transmission of the RACH signal. The processor may be configured to determine if the requested other-SI is included in the message that includes the minimum SI upon a detection of the message that includes the minimum SI. The processor may initiate one or more retransmissions of the RACH signal the message that includes the minimum SI not being detected, and/or the other-SI is determined to not be included in a detected message that includes the minimum SI.

BRIEF DESCRIPTION OF THE DRAWINGS

[0011] FIG. 1A is a system diagram of an example communications system in which one or more disclosed embodiments may be implemented.

[0012] FIG. 1B is a system diagram of an example WTRU that may be used within the communications system illustrated in FIG. 1A.

[0013] FIG. 1C is a system diagram of an example radio access network and an example core network that may be used within the communications system illustrated in FIG. 1A.

[0014] FIG. 1D is a system diagram of another example radio access network and another example core network that may be used within the communications system illustrated in FIG. 1A.

[0015] FIG. 1E is a system diagram of another example radio access network and another example core network that may be used within the communications system illustrated in FIG. 1A.

[0016] FIG. 2 is an example of transmission bandwidths.

[0017] FIG. 3 is an example of flexible spectrum allocation.

[0018] FIG. 4 is an example of types of assistance modes.

[0019] FIG. 5 is an example of tri-plane architecture.

[0020] FIG. 6 is an example of non-overlapping windows for minimum-system information (SI) and other-SI.

[0021] FIG. 7 is an example of overlapping windows for other-SI and minimum-SI.

[0022] FIG. 8A and 8B together illustrate an example of an on-demand SI request in a beamformed context.

DETAILED DESCRIPTION

[0023] A detailed description of illustrative embodiments will now be described with reference to the various Figures. Although this description provides a detailed example of

possible implementations, it should be noted that the details are intended to be examples and in no way limit the scope of the application.

[0024] FIG. 1A is a diagram of an example communications system 100 in which one or more disclosed embodiments may be implemented. The communications system 100 may be a multiple access system that provides content, such as voice, data, video, messaging, broadcast, etc., to multiple wireless users. The communications system 100 may enable multiple wireless users to access such content through the sharing of system resources, including wireless bandwidth. For example, the communications system 100 may employ one or more channel access methods, such as code division multiple access (CDMA), time division multiple access (TDMA), frequency division multiple access (FDMA), orthogonal FDMA (OFDMA), single-carrier FDMA (SC-FDMA), and the like.

[0025] As shown in FIG. 1A, the communications system 100 may include wireless transmit/receive units (WTRUs), e.g., WTRUs, 102a, 102b, 102c, and/or 102d (which generally or collectively may be referred to as WTRU 102), a radio access network (RAN) 103/104/105, a core network 106/107/109, a public switched telephone network (PSTN) 108, the Internet 110, and other networks 112, though it will be appreciated that the disclosed embodiments contemplate any number of WTRUs, base stations, networks, and/or network elements. Each of the WTRUs 102a, 102b, 102c, 102d may be any type of device configured to operate and/or communicate in a wireless environment. By way of example, the WTRUs 102a, 102b, 102c, 102d may be configured to transmit and/or receive wireless signals and may include user equipment (UE), a mobile station, a fixed or mobile subscriber unit, a pager, a cellular telephone, a personal digital assistant (PDA), a smartphone, a laptop, a netbook, a personal computer, a wireless sensor, consumer electronics, and the like.

[0026] The communications system 100 may also include a base station 114a and a base station 114b. Each of the base stations 114a, 114b may be any type of device configured to wirelessly interface with at least one of the WTRUs 102a, 102b, 102c, 102d to facilitate access to one or more communication networks, such as the core network 106/107/109, the Internet 110, and/or the networks 112. By way of example, the base stations 114a, 114b may be a base transceiver station (BTS), a Node-B, an eNode B, a Home Node B, a Home eNode B, a site controller, an access point (AP), a wireless router, and the like. While the base stations 114a, 114b are each depicted as a single element, it will be appreciated that the base stations 114a, 114b may include any number of interconnected base stations and/or network elements.

[0027] The base station 114a may be part of the RAN 103/104/105, which may also include other base stations and/or network elements (not shown), such as a base station controller (BSC),

a radio network controller (RNC), relay nodes, etc. The base station 114a and/or the base station 114b may be configured to transmit and/or receive wireless signals within a particular geographic region, which may be referred to as a cell (not shown). The cell may further be divided into cell sectors. For example, the cell associated with the base station 114a may be divided into three sectors. Thus, in some embodiments, the base station 114a may include three transceivers, e.g., one for each sector of the cell. In another embodiment, the base station 114a may employ multiple-input multiple output (MIMO) technology and, therefore, may utilize multiple transceivers for each sector of the cell.

[0028] The base stations 114a, 114b may communicate with one or more of the WTRUs 102a, 102b, 102c, 102d over an air interface 115/116/117, which may be any suitable wireless communication link (e.g., radio frequency (RF), microwave, infrared (IR), ultraviolet (UV), visible light, etc.). The air interface 115/116/117 may be established using any suitable radio access technology (RAT).

[0029] More specifically, as noted above, the communications system 100 may be a multiple access system and may employ one or more channel access schemes, such as CDMA, TDMA, FDMA, OFDMA, SC-FDMA, and the like. For example, the base station 114a in the RAN 103/104/105 and the WTRUs 102a, 102b, 102c may implement a radio technology such as Universal Mobile Telecommunications System (UMTS) Terrestrial Radio Access (UTRA), which may establish the air interface 115/116/117 using wideband CDMA (WCDMA). WCDMA may include communication protocols such as High-Speed Packet Access (HSPA) and/or Evolved HSPA (HSPA+). HSPA may include High-Speed Downlink Packet Access (HSDPA) and/or High-Speed Uplink Packet Access (HSUPA).

[0030] In another embodiment, the base station 114a and the WTRUs 102a, 102b, 102c may implement a radio technology such as Evolved UMTS Terrestrial Radio Access (E-UTRA), which may establish the air interface 115/116/117 using Long Term Evolution (LTE) and/or LTE-Advanced (LTE-A).

[0031] In other embodiments, the base station 114a and the WTRUs 102a, 102b, 102c may implement radio technologies such as IEEE 802.16 (e.g., Worldwide Interoperability for Microwave Access (WiMAX)), CDMA2000, CDMA2000 1X, CDMA2000 EV-DO, Interim Standard 2000 (IS-2000), Interim Standard 95 (IS-95), Interim Standard 856 (IS-856), Global System for Mobile communications (GSM), Enhanced Data rates for GSM Evolution (EDGE), GSM EDGE (GERAN), and the like.

[0032] The base station 114b in FIG. 1A may be a wireless router, Home Node B, Home eNode B, or access point, for example, and may utilize any suitable RAT for facilitating wireless

connectivity in a localized area, such as a place of business, a home, a vehicle, a campus, and the like. In some embodiments, the base station 114b and the WTRUs 102c, 102d may implement a radio technology such as IEEE 802.11 to establish a wireless local area network (WLAN). In another embodiment, the base station 114b and the WTRUs 102c, 102d may implement a radio technology such as IEEE 802.15 to establish a wireless personal area network (WPAN). In yet another embodiment, the base station 114b and the WTRUs 102c, 102d may utilize a cellular-based RAT (e.g., WCDMA, CDMA2000, GSM, LTE, LTE-A, etc.) to establish a picocell or femtocell. As shown in FIG. 1A, the base station 114b may have a direct connection to the Internet 110. Thus, the base station 114b may not be required to access the Internet 110 via the core network 106/107/109.

[0033] The RAN 103/104/105 may be in communication with the core network 106/107/109, which may be any type of network configured to provide voice, data, applications, and/or voice over internet protocol (VoIP) services to one or more of the WTRUs 102a, 102b, 102c, 102d. For example, the core network 106/107/109 may provide call control, billing services, mobile location-based services, pre-paid calling, Internet connectivity, video distribution, etc., and/or perform high-level security functions, such as user authentication. Although not shown in FIG. 1A, it will be appreciated that the RAN 103/104/105 and/or the core network 106/107/109 may be in direct or indirect communication with other RANs that employ the same RAT as the RAN 103/104/105 or a different RAT. For example, in addition to being connected to the RAN 103/104/105, which may be utilizing an E-UTRA radio technology, the core network 106/107/109 may also be in communication with another RAN (not shown) employing a GSM radio technology.

[0034] The core network 106/107/109 may also serve as a gateway for the WTRUs 102a, 102b, 102c, 102d to access the PSTN 108, the Internet 110, and/or other networks 112. The PSTN 108 may include circuit-switched telephone networks that provide plain old telephone service (POTS). The Internet 110 may include a global system of interconnected computer networks and devices that use common communication protocols, such as the transmission control protocol (TCP), user datagram protocol (UDP) and the internet protocol (IP) in the TCP/IP internet protocol suite. The networks 112 may include wired or wireless communications networks owned and/or operated by other service providers. For example, the networks 112 may include another core network connected to one or more RANs, which may employ the same RAT as the RAN 103/104/105 or a different RAT.

[0035] Some or all of the WTRUs 102a, 102b, 102c, 102d in the communications system 100 may include multi-mode capabilities, e.g., the WTRUs 102a, 102b, 102c, 102d may include

multiple transceivers for communicating with different wireless networks over different wireless links. For example, the WTRU 102c shown in FIG. 1A may be configured to communicate with the base station 114a, which may employ a cellular-based radio technology, and with the base station 114b, which may employ an IEEE 802 radio technology.

[0036] FIG. 1B is a system diagram of an example WTRU 102. As shown in FIG. 1B, the WTRU 102 may include a processor 118, a transceiver 120, a transmit/receive element 122, a speaker/microphone 124, a keypad 126, a display/touchpad 128, non-removable memory 130, removable memory 132, a power source 134, a global positioning system (GPS) chipset 136, and other peripherals 138. It will be appreciated that the WTRU 102 may include any sub-combination of the foregoing elements while remaining consistent with an embodiment. Also, embodiments contemplate that the base stations 114a and 114b, and/or the nodes that base stations 114a and 114b may represent, such as but not limited to transceiver station (BTS), a Node-B, a site controller, an access point (AP), a home node-B, an evolved home node-B (eNodeB), a home evolved node-B (HeNB or HeNodeB), a home evolved node-B gateway, and proxy nodes, among others, may include some or all of the elements depicted in FIG. 1B and described herein.

[0037] The processor 118 may be a general purpose processor, a special purpose processor, a conventional processor, a digital signal processor (DSP), a plurality of microprocessors, one or more microprocessors in association with a DSP core, a controller, a microcontroller, Application Specific Integrated Circuits (ASICs), Field Programmable Gate Array (FPGAs) circuits, any other type of integrated circuit (IC), a state machine, and the like. The processor 118 may perform signal coding, data processing, power control, input/output processing, and/or any other functionality that enables the WTRU 102 to operate in a wireless environment. The processor 118 may be coupled to the transceiver 120, which may be coupled to the transmit/receive element 122. While FIG. 1B depicts the processor 118 and the transceiver 120 as separate components, it will be appreciated that the processor 118 and the transceiver 120 may be integrated together in an electronic package or chip.

[0038] The transmit/receive element 122 may be configured to transmit signals to, or receive signals from, a base station (e.g., the base station 114a) over the air interface 115/116/117. For example, in some embodiments, the transmit/receive element 122 may be an antenna configured to transmit and/or receive RF signals. In another embodiment, the transmit/receive element 122 may be an emitter/detector configured to transmit and/or receive IR, UV, or visible light signals, for example. In yet another embodiment, the transmit/receive element 122 may be configured to

transmit and receive RF and/or light signals. It will be appreciated that the transmit/receive element 122 may be configured to transmit and/or receive any combination of wireless signals.

[0039] In addition, although the transmit/receive element 122 is depicted in FIG. 1B as a single element, the WTRU 102 may include any number of transmit/receive elements 122. More specifically, the WTRU 102 may employ MIMO technology. Thus, in some embodiments, the WTRU 102 may include two or more transmit/receive elements 122 (e.g., multiple antennas) for transmitting and receiving wireless signals over the air interface 115/116/117.

[0040] The transceiver 120 may be configured to modulate the signals that are to be transmitted by the transmit/receive element 122 and to demodulate the signals that are received by the transmit/receive element 122. As noted above, the WTRU 102 may have multi-mode capabilities. Thus, the transceiver 120 may include multiple transceivers for enabling the WTRU 102 to communicate via multiple RATs, such as UTRA and IEEE 802.11, for example.

[0041] The processor 118 of the WTRU 102 may be coupled to, and may receive user input data from, the speaker/microphone 124, the keypad 126, and/or the display/touchpad 128 (e.g., a liquid crystal display (LCD) display unit or organic light-emitting diode (OLED) display unit). The processor 118 may also output user data to the speaker/microphone 124, the keypad 126, and/or the display/touchpad 128. In addition, the processor 118 may access information from, and store data in, any type of suitable memory, such as the non-removable memory 130 and/or the removable memory 132. The non-removable memory 130 may include random-access memory (RAM), read-only memory (ROM), a hard disk, or any other type of memory storage device. The removable memory 132 may include a subscriber identity module (SIM) card, a memory stick, a secure digital (SD) memory card, and the like. In other embodiments, the processor 118 may access information from, and store data in, memory that is not physically located on the WTRU 102, such as on a server or a home computer (not shown).

[0042] The processor 118 may receive power from the power source 134, and may be configured to distribute and/or control the power to the other components in the WTRU 102. The power source 134 may be any suitable device for powering the WTRU 102. For example, the power source 134 may include one or more dry cell batteries (e.g., nickel-cadmium (NiCd), nickel-zinc (NiZn), nickel metal hydride (NiMH), lithium-ion (Li-ion), etc.), solar cells, fuel cells, and the like.

[0043] The processor 118 may also be coupled to the GPS chipset 136, which may be configured to provide location information (e.g., longitude and latitude) regarding the current location of the WTRU 102. In addition to, or in lieu of, the information from the GPS chipset 136, the WTRU 102 may receive location information over the air interface 115/116/117 from a

base station (e.g., base stations 114a, 114b) and/or determine its location based on the timing of the signals being received from two or more nearby base stations. It will be appreciated that the WTRU 102 may acquire location information by way of any suitable location-determination implementation while remaining consistent with an embodiment.

[0044] The processor 118 may further be coupled to other peripherals 138, which may include one or more software and/or hardware modules that provide additional features, functionality and/or wired or wireless connectivity. For example, the peripherals 138 may include an accelerometer, an e-compass, a satellite transceiver, a digital camera (for photographs or video), a universal serial bus (USB) port, a vibration device, a television transceiver, a hands free headset, a Bluetooth® module, a frequency modulated (FM) radio unit, a digital music player, a media player, a video game player module, an Internet browser, and the like.

[0045] FIG. 1C is a system diagram of the RAN 103 and the core network 106 according to an embodiment. As noted above, the RAN 103 may employ a UTRA radio technology to communicate with the WTRUs 102a, 102b, 102c over the air interface 115. The RAN 103 may also be in communication with the core network 106. As shown in FIG. 1C, the RAN 103 may include Node-Bs 140a, 140b, 140c, which may each include one or more transceivers for communicating with the WTRUs 102a, 102b, 102c over the air interface 115. The Node-Bs 140a, 140b, 140c may each be associated with a particular cell (not shown) within the RAN 103. The RAN 103 may also include RNCs 142a, 142b. It will be appreciated that the RAN 103 may include any number of Node-Bs and RNCs while remaining consistent with an embodiment.

[0046] As shown in FIG. 1C, the Node-Bs 140a, 140b may be in communication with the RNC 142a. Additionally, the Node-B 140c may be in communication with the RNC 142b. The Node-Bs 140a, 140b, 140c may communicate with the respective RNCs 142a, 142b via an Iub interface. The RNCs 142a, 142b may be in communication with one another via an Iur interface. Each of the RNCs 142a, 142b may be configured to control the respective Node-Bs 140a, 140b, 140c to which it is connected. In addition, each of the RNCs 142a, 142b may be configured to carry out or support other functionality, such as outer loop power control, load control, admission control, packet scheduling, handover control, macrodiversity, security functions, data encryption, and the like.

[0047] The core network 106 shown in FIG. 1C may include a media gateway (MGW) 144, a mobile switching center (MSC) 146, a serving GPRS support node (SGSN) 148, and/or a gateway GPRS support node (GGSN) 150. While each of the foregoing elements are depicted as part of the core network 106, it will be appreciated that any one of these elements may be owned and/or operated by an entity other than the core network operator.

[0048] The RNC 142a in the RAN 103 may be connected to the MSC 146 in the core network 106 via an IuCS interface. The MSC 146 may be connected to the MGW 144. The MSC 146 and the MGW 144 may provide the WTRUs 102a, 102b, 102c with access to circuit-switched networks, such as the PSTN 108, to facilitate communications between the WTRUs 102a, 102b, 102c and traditional land-line communications devices.

[0049] The RNC 142a in the RAN 103 may also be connected to the SGSN 148 in the core network 106 via an IuPS interface. The SGSN 148 may be connected to the GGSN 150. The SGSN 148 and the GGSN 150 may provide the WTRUs 102a, 102b, 102c with access to packet-switched networks, such as the Internet 110, to facilitate communications between and the WTRUs 102a, 102b, 102c and IP-enabled devices.

[0050] As noted above, the core network 106 may also be connected to the networks 112, which may include other wired or wireless networks that are owned and/or operated by other service providers.

[0051] FIG. 1D is a system diagram of the RAN 104 and the core network 107 according to an embodiment. As noted above, the RAN 104 may employ an E-UTRA radio technology to communicate with the WTRUs 102a, 102b, 102c over the air interface 116. The RAN 104 may also be in communication with the core network 107.

[0052] The RAN 104 may include eNode-Bs 160a, 160b, 160c, though it will be appreciated that the RAN 104 may include any number of eNode-Bs while remaining consistent with an embodiment. The eNode-Bs 160a, 160b, 160c may each include one or more transceivers for communicating with the WTRUs 102a, 102b, 102c over the air interface 116. In some embodiments, the eNode-Bs 160a, 160b, 160c may implement MIMO technology. Thus, the eNode-B 160a, for example, may use multiple antennas to transmit wireless signals to, and receive wireless signals from, the WTRU 102a.

[0053] Each of the eNode-Bs 160a, 160b, 160c may be associated with a particular cell (not shown) and may be configured to handle radio resource management decisions, handover decisions, scheduling of users in the uplink (UL) and/or downlink (DL), and the like. As shown in FIG. 1D, the eNode-Bs 160a, 160b, 160c may communicate with one another over an X2 interface.

[0054] The core network 107 shown in FIG. 1D may include a mobility management gateway (MME) 162, a serving gateway 164, and a packet data network (PDN) gateway 166. While each of the foregoing elements are depicted as part of the core network 107, it will be appreciated that any one of these elements may be owned and/or operated by an entity other than the core network operator.

[0055] The MME 162 may be connected to each of the eNode-Bs 160a, 160b, 160c in the RAN 104 via an S1 interface and may serve as a control node. For example, the MME 162 may be responsible for authenticating users of the WTRUs 102a, 102b, 102c, bearer activation/deactivation, selecting a particular serving gateway during an initial attach of the WTRUs 102a, 102b, 102c, and the like. The MME 162 may also provide a control plane function for switching between the RAN 104 and other RANs (not shown) that employ other radio technologies, such as GSM or WCDMA.

[0056] The serving gateway 164 may be connected to each of the eNode-Bs 160a, 160b, 160c in the RAN 104 via the S1 interface. The serving gateway 164 may generally route and forward user data packets to/from the WTRUs 102a, 102b, 102c. The serving gateway 164 may also perform other functions, such as anchoring user planes during inter-eNode B handovers, triggering paging when downlink data is available for the WTRUs 102a, 102b, 102c, managing and storing contexts of the WTRUs 102a, 102b, 102c, and the like.

[0057] The serving gateway 164 may also be connected to the PDN gateway 166, which may provide the WTRUs 102a, 102b, 102c with access to packet-switched networks, such as the Internet 110, to facilitate communications between the WTRUs 102a, 102b, 102c and IP-enabled devices.

[0058] The core network 107 may facilitate communications with other networks. For example, the core network 107 may provide the WTRUs 102a, 102b, 102c with access to circuit-switched networks, such as the PSTN 108, to facilitate communications between the WTRUs 102a, 102b, 102c and traditional land-line communications devices. For example, the core network 107 may include, or may communicate with, an IP gateway (e.g., an IP multimedia subsystem (IMS) server) that serves as an interface between the core network 107 and the PSTN 108. In addition, the core network 107 may provide the WTRUs 102a, 102b, 102c with access to the networks 112, which may include other wired or wireless networks that are owned and/or operated by other service providers.

[0059] FIG. 1E is a system diagram of the RAN 105 and the core network 109 according to an embodiment. The RAN 105 may be an access service network (ASN) that employs IEEE 802.16 radio technology to communicate with the WTRUs 102a, 102b, 102c over the air interface 117. As will be further discussed below, the communication links between the different functional entities of the WTRUs 102a, 102b, 102c, the RAN 105, and the core network 109 may be defined as reference points.

[0060] As shown in FIG. 1E, the RAN 105 may include base stations 180a, 180b, 180c, and an ASN gateway 182, though it will be appreciated that the RAN 105 may include any number

of base stations and ASN gateways while remaining consistent with an embodiment. The base stations 180a, 180b, 180c may each be associated with a particular cell (not shown) in the RAN 105 and may each include one or more transceivers for communicating with the WTRUs 102a, 102b, 102c over the air interface 117. In some embodiments, the base stations 180a, 180b, 180c may implement MIMO technology. Thus, the base station 180a, for example, may use multiple antennas to transmit wireless signals to, and receive wireless signals from, the WTRU 102a. The base stations 180a, 180b, 180c may also provide mobility management functions, such as handoff triggering, tunnel establishment, radio resource management, traffic classification, quality of service (QoS) policy enforcement, and the like. The ASN gateway 182 may serve as a traffic aggregation point and may be responsible for paging, caching of subscriber profiles, routing to the core network 109, and the like.

[0061] The air interface 117 between the WTRUs 102a, 102b, 102c and the RAN 105 may be defined as an R1 reference point that implements the IEEE 802.16 specification. In addition, each of the WTRUs 102a, 102b, 102c may establish a logical interface (not shown) with the core network 109. The logical interface between the WTRUs 102a, 102b, 102c and the core network 109 may be defined as an R2 reference point, which may be used for authentication, authorization, IP host configuration management, and/or mobility management.

[0062] The communication link between each of the base stations 180a, 180b, 180c may be defined as an R8 reference point that includes protocols for facilitating WTRU handovers and the transfer of data between base stations. The communication link between the base stations 180a, 180b, 180c and the ASN gateway 182 may be defined as an R6 reference point. The R6 reference point may include protocols for facilitating mobility management based on mobility events associated with each of the WTRUs 102a, 102b, 102c.

[0063] As shown in FIG. 1E, the RAN 105 may be connected to the core network 109. The communication link between the RAN 105 and the core network 109 may be defined as an R3 reference point that includes protocols for facilitating data transfer and mobility management capabilities, for example. The core network 109 may include a mobile IP home agent (MIP-HA) 184, an authentication, authorization, accounting (AAA) server 186, and a gateway 188. While each of the foregoing elements are depicted as part of the core network 109, it will be appreciated that any one of these elements may be owned and/or operated by an entity other than the core network operator.

[0064] The MIP-HA may be responsible for IP address management, and may enable the WTRUs 102a, 102b, 102c to roam between different ASNs and/or different core networks. The MIP-HA 184 may provide the WTRUs 102a, 102b, 102c with access to packet-switched

networks, such as the Internet 110, to facilitate communications between the WTRUs 102a, 102b, 102c and IP-enabled devices. The AAA server 186 may be responsible for user authentication and for supporting user services. The gateway 188 may facilitate interworking with other networks. For example, the gateway 188 may provide the WTRUs 102a, 102b, 102c with access to circuit-switched networks, such as the PSTN 108, to facilitate communications between the WTRUs 102a, 102b, 102c and traditional land-line communications devices. In addition, the gateway 188 may provide the WTRUs 102a, 102b, 102c with access to the networks 112, which may include other wired or wireless networks that are owned and/or operated by other service providers.

[0065] Although not shown in FIG. 1E, RAN 105 may be connected to other ASNs and the core network 109 may be connected to other core networks. The communication link between the RAN 105 the other ASNs may be defined as an R4 reference point, which may include protocols for coordinating the mobility of the WTRUs 102a, 102b, 102c between the RAN 105 and the other ASNs. The communication link between the core network 109 and the other core networks may be defined as an R5 reference, which may include protocols for facilitating interworking between home core networks and visited core networks.

[0066] In view of Figures 1A-1E, and the corresponding description of Figures 1A-1E, one or more, or all, of the functions described herein with regard to one or more of: WTRU 102a-d, Base Station 114a-b, Node B 140a-c, RNC 142a-b, MSC 146, SGSN 148, MGW 144, CGSN 150, eNode-B 160a-c, MME 162, Serving Gateway 164, PDN Gateway 166, Base Station 180a-c, ASN Gateway 182, AAA 186, MIP-HA 184, and/or Gateway 188, or the like, may be performed by one or more emulation devices (not shown) (e.g., one or more devices configured to emulate one or more, or all, of the functions described herein).

[0067] The one or more emulation devices may be configured to perform the one or more, or all, functions in one or more modalities. For example, the one or more emulation devices may perform the one or more, or all, functions while being fully or partially implemented/deployed as part of a wired and/or wireless communication network. The one or more emulation devices may perform the one or more, or all, functions while being temporarily implemented/deployed as part of a wired and/or wireless communication network. The one or more emulation devices may perform the one or more, or all, functions while not being implemented/deployed as part of a wired and/or wireless communication network (e.g., such as in a testing scenario in a testing laboratory and/or a non-deployed (e.g. testing) wired and/or wireless communication network, and/or testing performed on one or more deployed components of a wired and/or wireless communication network). The one or more emulation devices may be test equipment.

[0068] Below is a list of abbreviations and acronyms that may be used herein, by way of example and not limitation.

Δf	Sub-carrier spacing
5gFlex	5G Flexible Radio Access Technology
5gNB	5G Flex NodeB
ACK	Acknowledgement
BLER	Block Error Rate
BTI	Basic TI (in integer multiple of one or more symbol duration)
CB	Contention-Based (e.g. access, channel, resource)
CoMP	Coordinated Multi-Point transmission/reception
CP	Cyclic Prefix
CP-OFDM	Conventional OFDM (relying on cyclic prefix)
CQI	Channel Quality Indicator
CN	Core Network (e.g. LTE packet core)
CRC	Cyclic Redundancy Check
CSG	Closed Subscriber Group
CSI	Channel State Information
D2D	Device to Device transmissions (e.g. LTE Sidelink)
DCI	Downlink Control Information
DL	Downlink
DM-RS	Demodulation Reference Signal
DRB	Data Radio Bearer
EPC	Evolved Packet Core
FBMC	Filtered Band Multi-Carrier
FBMC/OQAM	A FBMC technique using Offset Quadrature Amplitude Modulation
FDD	Frequency Division Duplexing
FDM	Frequency Division Multiplexing
ICC	Industrial Control and Communications
ICIC	Inter-Cell Interference Cancellation
IP	Internet Protocol
LAA	License Assisted Access
LBT	Listen-Before-Talk
LCH	Logical Channel
LCP	Logical Channel Prioritization
LLC	Low Latency Communications
LTE	Long Term Evolution e.g. from 3GPP LTE R8 and up
MAC	Medium Access Control
NACK	Negative ACK
MC	MultiCarrier
MCS	Modulation and Coding Scheme
MIMO	Multiple Input Multiple Output
MTC	Machine-Type Communications
NAS	Non-Access Stratum
NR	New Radio access technology
NR-eNB	A network node that may e.g. schedule NR resources
OFDM	Orthogonal Frequency-Division Multiplexing
OOB	Out-Of-Band (emissions)
P_{cmax}	Total available UE power in a given TI
PHY	Physical Layer
PRACH	Physical Random Access Channel

PDU	Protocol Data Unit
PER	Packet Error Rate
PLMN	Public Land Mobile Network
PLR	Packet Loss Rate
PSS	Primary Synchronization Signal
QoS	Quality of Service (from the physical layer perspective)
RAB	Radio Access Bearer
RACH	Random Access Channel (or procedure)
RAR	Random Access Response
RCU	Radio access network Central Unit
RF	Radio Front end
RNTI	Radio Network Temporary Identifier
RRC	Radio Resource Control
RRM	Radio Resource Management
RS	Reference Signal
RTT	Round-Trip Time
SCMA	Single Carrier Multiple Access
SDU	Service Data Unit
SI	System Information
SL	Sidelink
SOM	Spectrum Operation Mode
SS	Synchronization Signal
SSS	Secondary Synchronization Signal
SRB	Signaling Radio Bearer
SWG	Switching Gap (in a self-contained subframe)
TB	Transport Block
TBS	Transport Block Size
TDD	Time-Division Duplexing
TDM	Time-Division Multiplexing
TI	Time Interval (in integer multiple of one or more BTI)
TTI	Transmission Time Interval (in integer multiple of one or more TI)
TRP	Transmission / Reception Point
TRPG	Transmission / Reception Point Group
TRx	Transceiver
UFMC	Universal Filtered MultiCarrier
UF-OFDM	Universal Filtered OFDM
UL	Uplink
URC	Ultra-Reliable Communications
URLLC	Ultra-Reliable and Low Latency Communications
Uu	Interface between a NR-eNB/TRP (or equivalent) and a UE
V2V	Vehicle to vehicle communications
V2X	Vehicular communications
WLAN	Wireless Local Area Networks and related technologies (IEEE 802.xx domain)

[0069] Systems may manage (e.g., attempt to minimize) the impact of on-demand other-SI broadcast on an uninterested WTRU. Multi-stage RACH may be used for other-SI request. A WTRU may handle stored SI and/or may operate in a reduced MSI cell.

[0070] Terms New Radio (NR), 5gFLEX and 5G may be used interchangeably. While examples may refer to 3GPP protocols, subject matter described herein is applicable to other

wireless systems (e.g., other wireless technologies, communication and/or control procedures). Terms and definitions do not limit the applicability of disclosed subject matter to other definitions, types of signals, configuration procedures and/or logical associations, e.g., between different user data units.

[0071] An air interface, e.g., for a new radio (NR) access technology in a 5G system, may support a variety of use cases, such as improved broadband performance (IBB), Industrial control and communications (ICC) and/or vehicular applications (V2X) and/or Massive Machine-Type Communications (mMTC). Use cases may have associated support in an air interface (e.g., 5G air interface).

[0072] An air interface may support, for example, ultra-low transmission latency (LLC), ultra-reliable transmission (URC) and/or machine-type communications (MTC) operation (including narrowband operation).

[0073] Support for ultra-low transmission latency (LLC) may comprise, for example, air interface latency such as 1ms RTT and/or TTIs between 100us to 250us. Support may be provided for ultra-low access latency (e.g., time from initial system access until the completion of the transmission of the first user plane data unit). End-to-end (e2e) latency less than 10ms may be supported, for example, for IC and/or V2X.

[0074] Support for ultra-reliable transmission (URC) may comprise, for example, improved transmission reliability, such as 99.999% transmission success and/or service availability. Support may be provided for mobility speed in the range of 0-500km/h. Packet Loss Ratio of less than $10e^{-6}$ may be supported, for example, for IC and/or V2X.

[0075] Support for MTC operation may comprise, for example, air interface support for narrowband operation (e.g. using less than 200 KHz), extended battery life (e.g., up to 15 years of autonomy) and/or minimal communication overhead for small and/or infrequent data transmissions (e.g., low data rate in the range of 1-100kbps with access latency of seconds to hours).

[0076] A 5gFLEX system may be implemented with OFDM and/or other waveforms for uplink and/or downlink. Description of examples herein is non-limiting. Examples are applicable and/or adaptable to other waveforms and wireless technologies.

[0077] OFDM may be used as a signal format for data transmissions, e.g., in LTE and IEEE 802.11. OFDM may efficiently divide spectrum into multiple parallel orthogonal subbands. A (e.g., one or more, or each) subcarrier may be shaped using a rectangular window in the time domain, which may lead to sinc-shaped subcarriers in the frequency domain. OFDMA may rely on (e.g., perfect) frequency synchronization and/or tight management of uplink timing alignment

within the duration of the cyclic prefix, for example, to maintain orthogonality between signals and/or to minimize intercarrier interference. Tight synchronization may be difficult, for example, in a system where a WTRU may be simultaneously connected to one or more, or multiple access points. Additional power reduction may be applied to uplink transmissions, for example, to comply with spectral emission requirements for adjacent bands. Fragmented spectrum may be aggregated for WTRU transmissions.

[0078] OFDM (CP-OFDM) performance may be improved, for example, by more stringent RF requirements for implementations, such as operation using a large amount of contiguous spectrum that might not require aggregation. A CP-based OFDM transmission scheme may provide a downlink physical layer for 5G similar to a 4G system with modifications to pilot signal density and/or location.

[0079] 5gFLEX radio access may be characterized by a very high degree of spectrum flexibility that enables deployment in different frequency bands with different characteristics, which may include different duplex arrangements, different and/or variable sizes of available spectrum, such as contiguous and/or non-contiguous spectrum allocations in the same or different bands. 5gFLEX radio access may support variable timing aspects, such as support for one or more, or multiple TTI lengths and/or asynchronous transmissions.

[0080] Multiple duplexing schemes (e.g., TDD, FDD) may be supported. Supplemental downlink operation may be supported, e.g., for FDD operation, for example, using spectrum aggregation. FDD operation may support full-duplex FDD and/or half-duplex FDD operation. DL/UL allocation may be dynamic (e.g., might not be based on a fixed DL/UL frame configuration), e.g., for TDD operation. The length of a DL and/or a UL transmission interval may be set per transmission opportunity.

[0081] A 5G air interface characteristic and/or capability may enable different transmission bandwidths on uplink and/or downlink ranging, e.g., varying between a nominal system bandwidth to a maximum value corresponding to the system bandwidth.

[0082] Single carrier operation may support a variety and/or range of system bandwidths, such as 5, 10, 20, 40, and/or 80 MHz, and/or 160MHz. Nominal bandwidths may have one or more fixed values. Narrowband transmissions (e.g., 0 to 200 KHz) may be supported within the operating bandwidth for MTC devices.

[0083] System bandwidth may refer to the largest portion of spectrum that may be managed by a network for a given carrier. The spectral portion of a carrier that a WTRU minimally supports for cell acquisition, measurements and/or initial access to the network may correspond to the nominal system bandwidth. A WTRU may be configured with a channel bandwidth that

may be within the range of the entire system bandwidth. A WTRU's configured channel bandwidth may or might not include a nominal part of system bandwidth, e.g., as shown in the example in FIG. 2.

[0084] FIG. 2 is an example of transmission bandwidths. Bandwidth flexibility may be achieved, for example, because (e.g., all) applicable sets of RF requirements for a given maximum operating bandwidth in a band may be met without the introduction of additional allowed channel bandwidths for that operating band, e.g., due to the efficient support of baseband filtering of the frequency domain waveform.

[0085] A WTRU's channel bandwidth for single carrier operation may be configured, reconfigured and/or dynamically changed. Spectrum for narrowband transmissions within the nominal system, system and/or configured channel bandwidth may be allocated.

[0086] A 5G air interface physical layer may be band-agnostic and/or may support operation in licensed bands (e.g., below 5 GHz) and/or unlicensed bands (e.g., in the range 5-6 GHz). Listen before talk (LBT) Cat 4 based channel access framework similar to LTE LAA may be supported, e.g., for operation in unlicensed bands.

[0087] Cell-specific and/or WTRU-specific channel bandwidths for arbitrary spectrum block sizes may be scaled and/or managed (e.g., scheduling, addressing of resources, broadcasted signals, measurements, etc.).

[0088] Downlink control channels and signals may support FDM operation. A WTRU may acquire a downlink carrier, for example, by receiving transmissions using (e.g., only) the nominal part of the system bandwidth. For example, a WTRU might not initially receive transmissions covering the entire bandwidth being managed by the network for the concerned carrier.

[0089] Downlink data channels may be allocated over a bandwidth that may or might not correspond to nominal system bandwidth, e.g., without restrictions other than being within a WTRU's configured channel bandwidth. For example, a network may operate a carrier with a 12 MHz system bandwidth using a 5MHz nominal bandwidth allowing devices supporting 5 MHz maximum RF bandwidth to acquire and/or access the system while potentially allocating +10 to -10 MHz of the carrier frequency to other WTRU's supporting up to 20 MHz worth of channel bandwidth.

[0090] FIG. 3 is an example of flexible spectrum allocation. FIG. 3 shows an example of spectrum allocation where different subcarriers may be (e.g., at least conceptually) assigned to different modes of operation (hereafter Spectrum Operation Mode or SOM). Different SOM may be used to fulfill different requirements for different transmissions. A SOM may include

and/or be defined based on one or more of a subcarrier spacing, a TTI length and/or one or more reliability aspects (e.g., HARQ processing aspects, secondary control channel). A SOM may be used to refer to a (e.g., specific) waveform and/or may be related to a processing aspect (e.g., in support of co-existence of different waveforms in the same carrier using FDM and/or TDM and/or coexistence of FDD operation in a TDD band (e.g. with support in a TDM manner or similar)).

[0091] A WTRU may be configured to perform transmissions according to one or more SOMs. For example, a SOM may correspond to transmissions that use at least one of the following: a specific TTI duration, a specific initial power level, a specific HARQ processing type, a specific upper bound for successful HARQ reception/transmission, a specific transmission mode, a specific physical channel (uplink and/or downlink), a specific waveform type and/or even a transmission according to a specific RAT (e.g., LTE and/or according to a 5G transmission technique). A SOM may correspond to a QoS level and/or a related aspect (e.g., maximum/target latency, maximum/target BLER or similar). A SOM may correspond to a spectrum area and/or to a specific control channel and/or aspect thereof (e.g., search space and/or DCI type). For example, a WTRU may be configured with a SOM for a URC type of service, a LLC type of service and/or an MBB type of service. A WTRU may have a configuration for a SOM for system access and/or for transmission/reception of L3 control signaling (e.g., RRC), for example, in a portion of a spectrum associated with a system, such as in a nominal system bandwidth.

[0092] Spectrum aggregation may be supported (e.g., for single carrier operation). A WTRU may support transmission and/or reception of one or more, or multiple transport blocks over contiguous and/or non-contiguous sets of physical resource blocks (PRBs), e.g., within the same operating band. Mapping of a single transport block to separate sets of PRBs may be supported. Support may be provided for simultaneous transmissions associated with different SOM requirements.

[0093] Multicarrier operation may be supported, for example, using contiguous and/or non-contiguous spectrum blocks within the same operating band and/or across two or more operating bands. Support may be provided for aggregation of spectrum blocks using different modes (e.g., FDD and/or TDD) and/or different channel access procedures (e.g., licensed and/or unlicensed band operation below 6 GHz). Support may be provided for procedures that configure, reconfigure and/or dynamically change a WTRU's multicarrier aggregation.

[0094] A scheduling function may be supported in the MAC layer. Support may be provided for one or more, or multiple (e.g., two) scheduling modes, e.g., network-based scheduling (e.g.,

for tight scheduling in terms of resources, timing and/or transmission parameters of downlink transmissions, and/or uplink transmissions) and/or WTRU-based scheduling (e.g., for more flexibility in terms of timing and/or transmission parameters). Scheduling information for modes may be valid for one or more TTIs.

[0095] Network-based scheduling may enable a network to tightly manage available radio resources assigned to different WTRUs, which may permit optimal sharing of resources.

Dynamic scheduling may be supported.

[0096] WTRU-based scheduling may enable a WTRU to opportunistically access uplink resources with minimal latency on a per-use basis, for example, within a set of shared and/or dedicated uplink resources assigned (e.g., statically and/or dynamically) by the network. Support may be provided for synchronized and/or unsynchronized opportunistic transmissions. Support may be provided for contention-based transmissions and/or contention-free transmissions.

[0097] Support for opportunistic transmissions (scheduled and/or unscheduled) may be provided, for example, to meet ultra-low latency requirements for 5G and/or power saving requirements for mMTC.

[0098] A WTRU may be configured to receive and/or detect one or more system signatures. A system signature may consist of a signal structure using a sequence. A signal may be similar to a synchronization signal, e.g., similar to LTE PSS and/or SSS. A signature may be specific to (e.g., may uniquely identify) a particular node (and/or transmission/reception point (TRP)) within a given area and/or it may be common to a plurality of nodes (and/or TRPs) within an area, which aspect might not be known and/or relevant to a WTRU. A WTRU may determine and/or detect a system signature sequence. A WTRU may determine one or more parameters associated with the system. For example, a WTRU may further derive an index therefrom and/or may use the index to retrieve associated parameters, e.g., within a table, such as an access table. For example, a WTRU may use received power associated with a signature for open-loop power control, e.g., to set an initial transmission power when a WTRU determines that it may access (and/or transmit) using applicable resources of the system. For example, a WTRU may use the timing of a received signature sequence, e.g., to set the timing of a transmission (e.g., a preamble on a PRACH resource) when the WTRU determines that it may access (and/or transmit) using applicable resources of the system.

[0099] A system signature may consist of any type of signal received by a WTRU for one or more purposes described herein.

[0100] A WTRU may be configured with a list of one or more entries. A list may be referred to as an access table. A list may be indexed, e.g., where an (e.g., one or more, or each) entry

may be associated with a system signature and/or to a sequence thereof. An access table may provide initial access parameters for one or more areas. An (e.g., one or more, or each) entry may provide one or more parameters necessary for performing an initial access to the system. Parameters may include one or more of a set of one or more random access parameters (e.g., including applicable physical layer resources, such as PRACH resources) in time and/or frequency, initial power level and/or physical layer resources for reception of a response. Parameters may (e.g., further) include access restrictions (e.g., PLMN identity and/or CSG information). Parameters may (e.g., further) include routing-related information, such as one or more applicable routing areas. An entry may be associated with (and/or indexed by) a system signature. Such entry may be common to a plurality of nodes (and/or TRPs), for example. A WTRU may receive an access table, for example, via a transmission using dedicated resources (e.g., by RRC configuration) and/or by a transmission using broadcast resources. In the latter case, the periodicity of the transmission of an access table may be relatively long (e.g., up to 10240ms), which may be longer than the periodicity of the transmission of a signature (e.g., in the range of 100ms).

[0101] An access table may consist of any type of system information received by a WTRU for one or more purposes described herein.

[0102] 5gFLEX may support one or more forms of association between data available for transmission and/or available resources for uplink transmissions. Multiplexing of data with different QoS requirements within the same transport block may be supported, for example, when multiplexing does not introduce a negative impact to the service with the most stringent QoS requirement and/or does not introduce an unnecessary waste of system resources.

[0103] A Logical Channel (LCH) may represent a logical association between data packets and/or PDUs. An association may be based on data units being associated with the same bearer (similar to legacy), and/or being associated with the same SOM and/or slice (e.g., a processing path using a set of physical resources). For example, an association may be characterized by one or more of a chaining of processing functions, an applicable physical data (and/or control) channel (and/or instance thereof) and/or an instantiation of a protocol stack with one or more of: a specific portion being centralized (e.g., PDCP and/or anything beyond portions of the physical layer processing such as Radio Front (RF) end); and/or another portion being closer to the edge (e.g. MAC/PHY in the TRP and/or RF) potentially separated by a fronthauling interface. The term LCH as used herein may have a different and/or broader meaning than a similar term for LTE systems.

[0104] A WTRU may be configured to determine a relationship between different data units. A relationship may be based on a matching function (e.g., based on the configuration of one or more field values common to data units that are part of the same logical association). Fields may correspond to fields in a protocol header associated with the data unit(s). For example, a matching function may use a tuple of parameters for fields of the IP headers of a data unit, such as IP source/destination address(es), transport protocol source/destination port(s) and/or transport protocol type, IP protocol version (e.g., IPv4 and/or IPv6), etc.

[0105] For example, data units that are part of the same logical association may share a common radio bearer, processing function, SOM and/or may (e.g., at least conceptually) correspond to the same LCH and/or LCG.

[0106] A Logical Channel Group (LCG) may consist of a group of LCH(s) (and/or equivalent as per the definition above), e.g., where a grouping may be based on one or more criteria. Criteria may be, for example, that one or more LCH(s) may have a similar priority level applicable to one or more, or all LCHs of the same LCG and/or may be associated with the same SOM (and/or type thereof), the same slice (and/or type thereof). For example, an association may be characterized by one or more of a chaining of processing functions, an applicable physical data (and/or control) channel (and/or instance thereof) and/or instantiation of a protocol stack, which may include one or more of: a specific portion being centralized (e.g., PDCP and/or anything except RF); and/or another portion being closer to the edge (e.g., MAC/PHY in the TRP and/or RF) that may be separated by a fronthauling interface. The term LCG as used herein may have a different and/or broader meaning than a similar term for LTE systems.

[0107] A radio access network (RAN) slice may include (e.g. one or more, or all) radio access network functions and/or transport network functions and/or resources, e.g., radio resources and/or backhaul/fronthaul resources along with core network functions/resources that may be used and/or required to provide end-to-end services to a user. Network functions may, for example, be virtualized on a general purpose processor, run as network functions on specialized hardware and/or split between specialized hardware and general purpose hardware. A PLMN may consist of one or more network slices. A slice may be equivalent to an operator's single, common and/or general purpose network. A RAN slice may consist of one or more SOMs that may be optimized to support various services that the RAN slice may have to offer.

[0108] For example, WTRUs served within a slice may have, for example, one or more of the following aspects in common: services and/or QoE requirements (e.g. ULLRC, eMBB, MMTc); WTRU categories (e.g., CAT 0 to M and beyond, additional categories may be defined for >6GHz to differentiate beamforming capability); coverage requirements (e.g., normal

coverage, enhanced coverage); PLMN/Operators; support for specific Uu interface (e.g., LTE, LTE-Evo, 5G below 6Ghz, 5G above 6Ghz, Unlicensed); and/or served by same core network slice. The terms “RAN slice” and “slice” may be used interchangeably.

[0109] A Transport Channel (TrCH) may include one or more sets (e.g., a specific set) of processing steps and/or a specific set of functions applied to data information that may affect one or more transmission characteristics over a radio interface.

[0110] LTE may define one or more, or multiple types of TrCH, such as the Broadcast Channel (BCH), the Paging Channel (PCH), the Downlink Shared Channel (DL-SCH), the Multicast Channel (MCH), the Uplink Shared Channel (UL-SCH) and/or the Random Access Channel (which might not carry user plane data). Transport channels for carrying user plane data may include the DL-SCH and/or the UL-SCH for the downlink and for the uplink, respectively.

[0111] An augmented set of requirements may be supported by an air interface for a 5G system. Support may be provided for one or more, or multiple transport channels, e.g., for user and/or control plane data, for one or more WTRU devices. The term TrCH as used herein may have a different and/or broader meaning than a similar term for LTE systems. For example, a transport channel for URLLC (e.g., URLLCH), for mobile broadband (MBBCH) and/or for machine type communications (MTCCH) may be defined for downlink transmission (e.g., DL-URLLCH, DL-MBBCH and/or DL-MTCCH) and/or for uplink transmissions (e.g., UL-URLLCH, UL-MBBCH and/or UL-MTCCH).

[0112] For example, one or more, or multiple TrCH may be mapped to a different set of physical resources (e.g., PhCH) belonging to the same SOM. This may be advantageous, for example, to support simultaneous transmission of traffic with different requirements over the same SOM. An example of this may be transmitting a URLLCH along MTCCH simultaneously when a WTRU is configured with a single SOM.

[0113] A WTRU may be configured with one or more parameters associated with a characterization of how data should be transmitted. A characterization may represent constraints and/or requirements that a WTRU may be expected to meet and/or enforce. A WTRU may perform different operations and/or adjust its behavior as a function of the state associated with the data based on a characterization. Parameters may include, for example, time-related aspects (e.g., Time to Live (TTL) - for a packet, which represents the time before which the packet should be transmitted to meet, acknowledged, etc. to meet latency requirements), rate-related aspects and/or configuration related aspects (e.g., absolute priority). Parameters may (e.g., also) be changed with time while a packet and/or data may be pending for transmission.

[0114] A WTRU may be connected to TRPs, e.g., in standalone mode and/or assisted mode. A group of cells that requires assistance may be referred to as an assisted layer. A group of cells that provides the assistance may be referred to as an assistance layer.

[0115] FIG. 4 is an example of different types of assistance layers, using example WTRUs 401-408. Examples of assistance modes may include, for example one or more of: a WTRU 401 connected to 5Gflex small cell in below-6Ghz band assisted by 5Gflex macro cell in sub-6Ghz band; a WTRU 402 connected to 5Gflex small cell in below-6Ghz band assisted by LTE-Evo macro cell; a WTRU 403 connected to 5Gflex small cell in above-6Ghz band assisted by 5Gflex macro cell in sub-6Ghz band; a WTRU 404 connected to 5Gflex small cell in above-6Ghz band assisted by LTE-Evo macro cell; a WTRU 405 connected to 5Gflex small cell in above-6Ghz band assisted by 5Gflex small cell in below-6Ghz band; a WTRU 407 connected to 5Gflex small cell in below-6Ghz band in standalone mode; a WTRU 406 connected to 5Gflex macro cell in above-6Ghz band in standalone mode and/or a WTRU 408 connected to 5Gflex small cell in above-6Ghz band in standalone mode.

[0116] Deployment scenarios may be supported by one or more procedures described herein. For example, a deployment scenario may be LTE-assisted 5gFLEX Aggregation (DC/CA/Offload). A WTRU may be configured, for example, using an LTE Control Plane (e.g., with an LTE RRC connection) using an LTE User Plane (e.g., with one or more LTE Uu interfaces). A WTRU may be (e.g., further) configured (e.g., by reception of access table(s) from broadcast and/or dedicated signaling) to operate with one or more additional 5gFLEX Uu(s), for example, using the principles of LTE DC, LTE CA and/or LTE-WLAN offload.

[0117] An example of a deployment scenario may be LTE-assisted 5gFLEX Transport Channel(s) (LTE CP, LTE UP, LTE Uu with one or more 5gFLEX TrCH/Physical channels plugged into LTE Uu). A WTRU may be configured for LTE Uu operation (e.g., using LTE procedure(s)). A WTRU may be (e.g., further) configured with one or more physical layer (e.g. control and/or data) channels for a 5gFLEX Uu of the WTRU's configuration. Downlink (DL) physical channels may co-exist in the DL carrier and/or frequency band. An uplink (UL) carrier may (e.g., also) be common or separate. Cell-specific LTE signals/channels may be viewed as "holes" in the 5gFLEX map of physical layer resources, for example, from the perspective of a WTRU configured with one or more 5gFLEX physical channels.

[0118] An example of a deployment scenario may be LTE-based Stand-alone 5gFLEX operation (LTE CP, LTE L2 at least in part, 5gFLEX PHY). A WTRU may be configured with one or more (e.g., many, most or one or more, or all) of the components of an LTE control plane (e.g., RRC connection, security, etc.) and/or the LTE user plane (e.g., EPS RABs, PDCP, RLC).

A WTRU may be (e.g., further) configured with one or more 5G MAC instance(s). An (e.g., one or more, or each) instance may have one or more 5gFLEX Uu(s). Stated somewhat differently, for example, a WTRU might not be configured with an LTE PCell.

[0119] For example, a deployment scenario may be Stand-alone 5gFLEX operation. A WTRU may be configured with a 5G control plane and/or a 5G user plane. 5gFLEX Uu operation may be supported.

[0120] WTRU states may be modeled. The terms “state” and “mode” may be used interchangeably. Aspects of this disclosure may be applicable independent of state. Some aspects may be applicable for more than one state. Some aspects described herein may be applicable whether or not such states are actually defined.

[0121] A WTRU may operate according to at least one of the following states and/or similar: idle mode, light connected/loosely connected/inactive mode, and/or connected, fully connected/active mode.

[0122] In WTRU idle mode, from the network's perspective, the WTRU might not have a context with the radio access network (“RAN”). For example, in a distributed architecture, a WTRU might not have context at the edge control function and/or the central control function. From the WTRU's perspective in idle mode, the WTRU may monitor paging from the core network (e.g., at a well-defined DRX cycle). The WTRU may perform measurements and/or autonomous mobility. The WTRU may acquire, store, and/or apply system information valid for at least idle mode operations.

[0123] In WTRU light connected/loosely connected/inactive mode, from the network's perspective, there may exist a WTRU context stored in the RAN. There may also exist a RAN-core connection for the WTRU. For example, in a distributed architecture, a WTRU may have context established at the central control function with limited and/or no context at the edge control function. The WTRU may be tracked (e.g., at a granularity of a logical area greater than or equal to a cell). The WTRU may be reached by the RAN via paging messages that originates in the RAN (e.g., at DRX cycles specific to the light connected state). From the WTRU's perspective, a WTRU might not have an active and/or established connection to the RAN. Mobility in light connected state may be WTRU controlled. A WTRU may move within a logical area without notifying the network. A WTRU may notify the network when the WTRU determines that the WTRU has moved outside a logical area (e.g., the WTRU would fail to detect the signature/reference signal and/or another property that identifies the concerned area) and/or across a boundary between two different logical areas (e.g., the WTRU would detect a

different identity for the current area). Mobility in light connected state may also be network controlled (e.g., to enable handover when data transfer is allowed and/or ongoing).

[0124] In the connected/fully connected/active mode, from the network's perspective, the WTRU may have connectivity with the network (e.g., the WTRU context may be established at the radio access network, and/or WTRU specific connection may be established between RAN and core network). For example, in a distributed architecture, a WTRU may have context established at a central control function and/or one or more edge control functions. A WTRU may have at least one user plane function/component established. WTRU mobility may be tracked at the cell level and/or may be WTRU assisted, network controlled mobility. Network configured WTRU controlled mobility may be used.

[0125] The states described may represent a standalone/independent state, with transition logic in between. Some of the states may have relationships to each other. For example, some states may be functional elements of another state (e.g., where transition between sub-states might not imply significantly different RRC function and/or trigger RRC behavior). For example, a connectionless transfer may be a sub-state and/or an access method for a WTRU in idle or light connected state. In another example, the light connected state may be a RAN controlled state.

[0126] WTRU control aspects may include procedures enabling configuration and/or coherent operation for one or more of the following aspects: a plurality of radio "layers"; a plurality of radio access technologies (e.g., NR, LTE, Wifi, etc.); a plurality of L2 transport and/or user plane components, which may be realized using different network slices and/or sets of physical resources; and/or enhanced connectivity principles such as loosely connected state.

[0127] In the broadcast transmission of on-demand other-SI, the notification of presence of other-SI and/or scheduling indication of other-SI may trigger a reception procedure (e.g., unnecessary) for the WTRUs that are uninterested in the other-SI. Trigger reception procedures in uninterested WTRU's may be energy inefficient.

[0128] Although examples describe procedures, features and elements in particular combinations, the disclosed subject matter encompasses implementation of one or more, or each procedure, feature and/or element in whole or in part, individually or in any combination with and without other procedures, features and/or elements disclosed herein or known.

[0129] A transmission/reception point (TRP) may support, for example, one or more of the following access procedures: LTE/LTE-A/LTE-Evo air interface, an NR access (e.g. based on a flexible 5G air interface and/or similar), a beamformed interface for higher frequencies, a non-3GPP access (e.g. 802.11 family such as WiFi), License Assisted Access (LAA), a narrow band

air interface and/or similar. TRP, eNB/NR-eNB, access point, base station and/or the like may be used interchangeably.

[0130] A WTRU may be connected in a number of different manners with a radio system. For example, a WTRU may be configured for transmission to/from one or more TRPs. One or more, or multiple transmissions may be transmitted and/or received concurrently. A WTRU may (e.g. further) be configured for transmissions that may be characterized by varying levels of diversity/reliability, mobility robustness, differentiation in terms of services, etc. Higher level services may involve, for example, the configuration of a plurality of TRPs to achieve service levels. For example, one or more TRPs may support (e.g. only) narrow band transmissions, one or more TRPs may provide best effort offload, one or more TRPs may provide less overhead (e.g. specific signatures, preconfigured bearer), etc. A WTRU may be agnostic to the identity of a TRP and/or the number of TRPs, for example, even when configured with one or more, or multiple TRPs. For example, transmissions to/from different TRPs may be differentiated, for example, based on applicable reference signals (RS), control channels, timing and/or operating carrier/frequencies.

[0131] A distributed approach may be implemented for control plane modeling. A control plane in previous generations of wireless systems (e.g. LTE) may have a suite of protocols (e.g. RRC and/or NAS) use a very centralized and/or monolithic approach, e.g., from a WTRU perspective. A centralized approach may be difficult to scale for next generation systems that may require support for and/or coordination between differentiated services (e.g. very low latency services), multi-connectivity, a larger number of small cells for a given WTRU.

[0132] Distribution of (e.g. certain) functions, for example, towards the edge of a RAN (e.g. in or close to a TRP) may provide a more scalable approach for an NR system. Furthermore, increased isolation between different user plane processing paths (e.g. similar to bearers in EPC/LTE) may facilitate differentiated QoS, management of multi-path bearers (and/or similar) as well as differentiated allocation of network resources in a system and/or (e.g. potentially) sharing of network resources between operators.

[0133] Example procedures disclosed herein may enable a WTRU to be configured with plurality of user plane functions and/or processing paths according to diverse service requirements with support for diverse device types, deployment scenarios and/or other requirements in an NR system. For example, procedures disclosed herein may enable a control plane entity to establish, maintain and/or tear down service specific user plane components as useful, e.g., using a distributed model.

[0134] A separation and protocol/functional split may be provided. A distributed control plane may be modeled, for example, to enable a number of control functions to operate close to the edge of the system. The functions may be replicated, for example, using a number of instances (e.g. in different TRPs with multi-connectivity). Some functions may be centralized (e.g. to manage core network connectivity and/or user plane instances). Consequently, there may be one or more, or multiple different termination points in the access network that concurrently provide control services for a given WTRU. A WTRU may support a multiplexing/demultiplexing function (e.g. different sets of one or more SRBs) associated with one or more (e.g. specific) control plane contexts/instances/functions and/or a set thereof. A control plane model may (e.g. also) support one or more control plane functions to operate concurrently and/or in parallel, e.g., for functions logically closer to the edge. Centralizing one or more control plane functions may enable and/or facilitate coordination between different control plane instances of the same WTRUs, e.g., coordination between different TRPs of a WTRU's configuration.

[0135] Control plane/user plane (CP/UP) separation may be modeled in a variety of different ways. There may be a variety of potential axes for separation of the different components of a control plane.

[0136] For example, vertical isolation may be provided in a protocol stack (CP and/or UP). Different options may be based on depth of separation. For example, in a partial separation and/or split approach, CP/UP specific higher layers may be followed by one or more common lower layers. For example, in a complete separation, an independent protocol stack may be provided, e.g., all the way down to L1/PHY. For example, an optimized PHY channel design and/or different DCI/grant level may be provided. A different Spectral Operating Mode/signal structure may be provided.

[0137] For example, horizontal separation may be provided between instances of a (e.g. potentially different) protocol stack. A control plane instance may operate on a user plane instance. A protocol stack may be separated, e.g., by an interface between a central unit (CU) and a remote unit (RU). Functional splits may be based on one or more of the following, for example: transport network profile (e.g. fronthaul and/or backhaul bandwidth, latency, jitter, etc.); specific deployment scenarios; type of service (e.g. eMBB services may utilize centralized processing for cost savings and/or URLLC services may utilize distributed processing to minimize latency); resource availability (e.g. processing resource, specialized hardware); vendor interoperability; and/or dynamic changes to transport network capacity (e.g. when the transport network is shared with one or more, or multiple TRPs and/or operators).

[0138] For example, physical and/or access separation may be provided. Uu termination may be provided for control and/or user plane at different nodes in the RAN (e.g. assisted layer and/or different TRP). For example, CP termination may be at LTE-Evo eNB and/or UP termination may be at NG TRP/RCU, e.g., in assisted mode. For example, an L2 transport and/or termination point for CP may be different from UP, e.g., in standalone mode. For example, an L2 transport and/or termination point for CP may be any TRP while for UP it may be using a restricted set of TRPs, e.g., in standalone mode.

[0139] Modeling described herein may support any of the foregoing separation models and/or other models, alone or in combination. For example, modeling may facilitate having a control plane component and its associated user plane in different RAN slices. Slices may be realized, for example, by physical and/or vertical separation. For example, a multi-plane architecture may support a combination of horizontal separation and/or vertical isolation.

[0140] Examples of elements and/or characteristics may be provided for a distributed control plane architecture.

[0141] A high level generalization (e.g. a conceptual view) of a control plane may be as a set of one or more control function(s). A control function may include processing actions and/or related parameters. Examples of control functions are described herein. A control function may apply to one or more component(s) of a WTRU.

[0142] Components may include, for example, a protocol (e.g. NAS, RRC, PDCP, RLC, MAC, PHY, etc.) and/or a corresponding entity, an implementation aspect (e.g. a power control function, a state of a WTRU, etc.), a set of resources (e.g. a data transport path, a bearer, etc.) and/or a combination thereof (e.g. a set of physical/processing resources, a slice, etc.). Examples of component combinations are described herein.

[0143] A control functions may be characterized as being applicable, for example, according to one or more of the following: a WTRU-specific function; a component-specific function; and/or a plural-component function.

[0144] A WTRU-specific function, for example, such as a control function may be applicable to any aspect(s) and/or component(s) of a WTRU. For example, a function that controls a WTRU's connectivity to a core network (e.g. in terms of access credentials) may be WTRU-specific. A function may (e.g. from a network perspective) be centralized in a node that supports connectivity to a plurality of TRPs/NR-eNBs. For example, a function may be logically part of a RAN Central Control Function (RCCF), e.g., described below.

[0145] A component-specific function, for example, such as a control function may be applicable to one or more aspects of a WTRU. An aspect may be, for example: a MAC instance;

a signature-specific aspect (e.g. a configuration corresponding to a signature); a TRP-specific aspect (e.g. a configuration corresponding to a TRP); a TRPG-specific aspect (e.g. a configuration corresponding to a TRPG); an LCH (and/or equivalent)-specific aspect (e.g. a configuration corresponding to an LCH); an instance of a component combination (e.g. a bearer, a flow such as a sequence of packets identified by a matching rule (e.g. a tuple, etc.), for example, as described herein; a slice specific aspect (e.g. a configuration) corresponding to a RAN slice and/or a core network slice and/or to an end-to-end network slice (e.g. a core network slice, a slice selection function and/or one or more RAN functions); a spectral operating mode (e.g. a configuration) corresponding to a spectral operating mode, and/or other examples. For example, a WTRU may apply a received configuration to a specific time/frequency resource while using a different configuration for other time/frequency resources in the system.

[0146] For example, a function may be logically part of an Access Control Function (ACF), e.g., for a function dedicated to connectivity to a single TRP/NR-eNB, which may include configuration for a MAC instance and/or physical layer parameters (e.g. single or multiple cells/carriers) for a given WTRU.

[0147] In a plural-component function, for example a control function may be applicable to a plurality of components of a WTRU. For example, a function may be logically part of an Access Control Function (ACF) for a function that may control connectivity for a TRPG and/or for one or more NR-eNB(s), which may include configuration for a single MAC instance (e.g. COMP) and/or for one or more, or multiple MAC instances (e.g. for multi-connectivity) and/or (e.g. required) physical layer parameters for a given WTRU. This may, for example, further include coordination and/or configuration aspects for a WTRU to handle, e.g., with reception of one or more, or multiple responses to a random access within a TRPG, if applicable, for single TRP selection and/or for multiple TRP selection (e.g. for aggregation and/or multiple connectivity).

[0148] Examples may be provided for some (e.g. most) applicable control plane functions, e.g., individually. A function may be described with reference to its applicability to these non-limiting characterizations.

[0149] High-level modeling of a control plane for NR may be provided. Functions and/or components may, for example, be logically grouped.

[0150] A multi-plane architecture may be provided. For example, functions and/or components supporting an NR system may be logically grouped, for example, in terms of an Access Plane (AP), a Central Control Plane (CCP) and/or a Central User Plane (CUP). A description of example realizations of user plane components is described herein.

[0151] Logical grouping of functions may enable different components and/or functions of a system to be isolated from each other. Isolation may (e.g. further) enable components and/or functions to be controlled, configured, modified and/or operated separately from each other. Separation may be applied for components and/or functions associated with a specific WTRU, per TRP/NR-eNB, per TRPG, per TRPGs, per group of NR-eNBs, per LCH (and/or equivalent), per slice, etc. Separation between centralized and access-related grouping may enable coordination between different instances of a function (e.g. system information provisioning, bearer configuration and/or equivalent) and/or between different instances of different functions (e.g. core network connectivity and/or user plane/bearer instances).

[0152] FIG. 5 is an example of logical grouping. There may be an architectural aspect and/or approach to a functional split. For example, FIG. 5 shows an example of a tri-plane architecture.

[0153] Different principles for a functional split between an access control plane and a central control plane may be considered.

[0154] For example, there may be a single access plane per RAT and/or central control per one or more, or multiple RATs. For example, an access control plane may include control functions specific to the access technology (e.g. beamforming control function, control function specific to LTE, non-3GPP control function, etc.). A central control plane may include control functions that are agonistic to an air interface. A common central control plane may be associated with one or more, or multiple TRPs with diverse access technologies, for example, for LTE/LTE-A/LTE-Evo air interface, a flexible 5G air interface, a beamformed air interface for higher frequencies, a non-3GPP access (e.g. 802.11 family such as WiFi), License assisted access (LAA), a narrow band air interface, etc.

[0155] For example, there may be one access plane per TRP/cell and/or central control per one or more, or multiple TRPs. For example, an access control plane may include control functions specific to a TRP/cell. A central control plane may include control functions applicable to more than one TRP. This approach may simplify inter-TRP coordination for efficient radio resource management, RAN mobility management and/or self-organizing functions, etc. A central control plane may (e.g. in one or more cases) lead to cost effective deployments, for example, as it might not require additional interface between TRPs.

[0156] For example, an access control plane may be responsible for establishment, maintenance and/or release of a layer 1/layer 2 (L1/2) connection, allocation of a temporary identifier to identify a WTRU uniquely within a TRP, common and/or dedicated L1 and/or L2 resource configuration specific to a TRP, etc. A central control plane may be responsible for

configuring L3 signaling flows and/or abstraction thereof (e.g. signaling radio bearers), configuration of higher layer data flows and/or abstraction thereof (e.g. data radio bearers), security functions (e.g. may include key management), radio resource configuration (e.g. may be common across two or more TRPs), mobility functions (e.g. may include WTRU measurement control), handover control, context transfer, paging, etc.

[0157] QoS management functions may be controlled by a central control plane and/or may be enforced by an access control plane. QoS management functions may be part of a user plane control function, if applicable.

[0158] A system information broadcast function may be shared between an access control plane and a central control plane. For example, an access control plane may be responsible for scheduling and/or transmission of TRP specific system information related to accessibility, physical channel configuration, SC-PTM configuration, etc. An access control plane may be responsible for transmission of MIB and/or for handling dedicated system information procedure.

[0159] A central control plane may, for example, determine the contents of system information for cell (re)-selection information, intra-frequency, inter-frequency and/or inter-RAT neighbor information, MBMS information, side link information etc. Common and/or shared channel related configuration may be coordinated between the access control plane and central control plane. For example, a configuration for layer 2 RAN functions located in TRPs may be configured and/or controlled by the access control plane (e.g. for MAC, physical layer) while layer 2 RAN functions placed in the central user plane entity may be configured and/or controlled by the central control plane (e.g. for PDCP, RLC, bearers and/or similar and/or accessible for a TRPG, if applicable).

[0160] A service/QoS-based functional location may be provided for a function in an access plane and/or a control plane. For example, control functions that may be time sensitive with a strict deadline may be placed in TRPs while other control functions may be placed in the central control plane. This approach may relax latency requirements on the fronthaul interface between the central unit and the TRPs and/or may enable cost efficient deployments.

[0161] Another example of a functional split may be applied, for example, when RAN level slicing is supported. For example, control functions that are common across two or more slices may be placed in the central control plane while control functions that are specific to a slice may be placed in the access control plane. In this approach, mobility control, WTRU context handling, etc. may be a part of a central control plane while the access control plane may include

slice specific system information broadcast, slice specific authentication and/or security management, and/or slice specific QoS enforcement, etc.

[0162] A WTRU may be able to determine how to exchange signaling with different endpoints and/or with specific instances of a function, for example, based on these modeling examples. Such may be realized using different multiplexing procedures such as those described herein.

[0163] Access control functions (e.g. from the perspective of an overall RAN architecture) may be (e.g. conceptually) defined as set of logical functions, parameters and/or procedures that enable a WTRU to be uniquely addressed and/or identified by one or more TRPs. A WTRU may (e.g. further) generate and/or exchange data and/or signaling with those TRPs. Access control functions may provide distributed/edge control and/or user plane functions that may be specific to a TRP and WTRU pair. An (e.g. one or more, or each) access control function may be associated with a scheduler instance controlling one or more TRPs (e.g. over ideal backhaul). Such function may be part of a radio resource control protocol (e.g. RRC). Such function may be performed by a RRC entity e.g. located in a TRP. A WTRU may (e.g. from the WTRU perspective) be configured to associate a specific signaling bearer and/or equivalent (e.g. a transport path/procedure) for control of a MAC entity with the concerned MAC entity. The function may be part of a Medium Access Control (e.g. MAC) protocol. This function may be performed by a MAC entity. The Access Plane function may use transport services of MAC protocols (e.g. as MAC Control Elements, as MAC Control PDUs, and/or similar), for example, when the MAC entity perform the functions associated to the Access Plane.

[0164] An access plane may be considered to be established, for example, when a WTRU may be uniquely identified by access control functions. An access plane may be established, for example, when a WTRU can start transmission of user plane data. An access plane may be established, for example, when a WTRU receives a response that configures a capability for the WTRU to start performing (receiving and/or transmitting) dedicated transmissions, which may include when security is activated (if applicable) for the concerned configuration.

[0165] High level scoping of an access plane may be performed. For example, a WTRU may be configured to access resources associated with one or more radio access network nodes (e.g. TRP(s), TRPG(s) and/or NR-eNB(s)) using one or more of a set of functions, parameters and/or procedures.

[0166] For example, such procedures may include capabilities for a WTRU to perform an initial access (e.g. to establish access plane connectivity), perform a random access procedure and/or similar, for example, to obtain uplink timing alignment and/or further resources for uplink

transmission, to select a suitable network node (e.g. based on measurements of downlink signals and/or based on reception of one or more responses to the initial request such as one or more RARs), to obtain a unique identifier (e.g. a dedicated RNTI), to obtain a configuration (e.g. for physical layer operation), to enable transmission of control signaling (e.g. a signaling radio bearer and/or equivalent) and/or to establish a Uu interface and/or equivalent with a corresponding network node.

[0167] An access plane may terminate a control signaling protocol. An access plane may be provided for component-specific applicability. For example, an access plane may control aspects related to (e.g. at most) an (e.g. one) access network node. For example, an access plane may provide services for control and/or configuration of a physical layer and/or configuration of a MAC instance associated with a (e.g. one) TRP/NR-eNB. Coordination between one or more, or multiple access nodes might not be assumed and/or useful, for example, in this case.

[0168] An access plane may be provided for plural-component applicability. For example, an access plane may control aspects related to one or more access nodes. For example, an access plane may provide services for control and/or configuration for a physical layer for one or more cells and/or configuration of a MAC instance, where (e.g. potentially) one or more, or each may be associated with applicable TRPs/NR-eNBs. For example, an access plane may support coordination of one or more aspects between different network nodes. Coordination may be per TRPG, per area, per signature and/or per set of access parameters. Coordination may be provided, for example, using a (e.g. single) MAC entity (e.g. with a coordinated scheduling function such as carrier aggregation-like assuming ideal interfaces) and/or by a control function that may interface with a WTRU for the configuration of one or more, or multiple MAC instances, e.g., when applicable (e.g. a multi-connectivity approach).

[0169] A central control plane (e.g. a RAN control plane) may be provided. RAN Central Control Functions (RCCF) may include control functions, protocols and/or context that may be WTRU specific and/or applicable to one or more TRPs/ACFs. A central control plane may be considered as an anchor control function that may terminate a control interface towards the core network (e.g. through configuration/setup of routing paths and transport paths, for example, based on tuples configured for a WTRU). An RCCF may (e.g. additionally) include control functions related to selection of a core network slice, CN-RAN interfaces, QoS management, security (e.g. master key management and/or key derivation, which may be per group of TRPs/NR-eNBs), WTRU capability management and/or WTRU reachability within RAN.

[0170] WTRU context may be setup at RCCF (e.g. after CORE/NAS interaction). From RCCF point of view: a WTRU (e.g. from RCCF perspective) may have a known TRP(G) granularity (e.g. when access plane is active).

[0171] Central User Plane control functions may be (e.g. conceptually) defined as set of logical functions, parameters and/or procedures that may enable a WTRU to transfer user plane data with a network. Functions may be applicable to one or more user plane components (e.g. bearers, L2 transport path, flow-based routing entry, slice instance managing such, etc.). One or more functions may be part of the set of central control plane functions and/or may be logically separated therefrom.

[0172] Signaling may be generated and/or exchanged with one or more TRPs that may be part of a concerned user plane component. Central user plane functions may provide control for aspects that may be specific to a service, a slice, a bearer and/or a set of processing steps configured for the transport of one or more (e.g. specific) flows, which may be determined by configured tuples. A (e.g. one or more, or each) control function may be associated with a scheduler instance controlling one or more TRPs (e.g. over ideal backhaul). A WTRU (e.g. from its own perspective) may be configured to associate a specific central user plane instance with a signaling bearer and/or equivalent (e.g. a transport path/procedure) for control of a user plane component with one (e.g. single path/Uu) or more (e.g. multi-path/Uu) applicable MAC entities. A function may use transport services of corresponding MAC protocols, for example, as MAC Control Elements and/or similar.

[0173] An efficient data path may be setup between a TRP and a RAN Central User Function (RCUF) and/or between different RCUFs, e.g., when applicable. Connection oriented and/or connection-less user plane (e.g. WTRU assisted packet-based routing) may be supported.

[0174] RAN central user plane functions may comprise, for example, functions, protocols and/or parameters that may be service and/or data traffic specific.

[0175] There may be interactions between different control functions and components. A timing relation between access plane establishment and central control plane establishment may, for example, depend on a WTRU state. For example, a WTRU in a passive or IDLE state may transition to connected state by (e.g. first) establishing an access plane, e.g., using control signaling interaction with one or more access control functions (ACFs). For example, an access plane may be established as a result of an association procedure between a WTRU and a network. A WTRU may (e.g. then) trigger central control plane establishment, for example, using control signaling interaction with one or more central control functions. For example, a WTRU may establish a central control plane (e.g. only) and/or may establish a central control

plane and a central user plane, for example, based on whether the WTRU has signaling traffic and/or data traffic. In an (e.g. another) example, a WTRU may (e.g. directly) transmit data without access plane establishment, for example, when the WTRU (e.g. in a loosely connected state) may have a central control context without an access plane established.

[0176] A WTRU may store a Central control plane context, for example, even after an access plane may be deactivated. Central control functions may (e.g. similarly) retain a WTRU context, for example, even after the access control functions release WTRU context and/or WTRU specific connectivity between access control functions and central control functions. Central control functions may (e.g. additionally) retain WTRU context, for example, even after central user functions release WTRU context and/or WTRU specific connectivity between central user plane functions and core network user plane functions. In other words, for example, a RAN control plane (e.g. SRBs) may exist without an active user plane (e.g. DRBs). For example, a WTRU may attach to a network without a corresponding data bearer establishment. A WTRU may (e.g. be required to) maintain central user plane context, for example, (e.g. only) when the central control plane context is active.

[0177] An access plane may be dynamically activated/deactivated, e.g., by access control functions and/or by central control functions, for example, when a control plane context is active.

[0178] WTRU connectivity may have one or more supported states. For example, a WTRU may operate according to one or more of the following states: idle mode; idle mode with connectionless transfers; and/or connected mode and/or loosely connected mode.

[0179] In an IDLE mode, for example, a WTRU might not have established connectivity with a network (e.g. a WTRU might not have ACF/ACP, RCCF/RCCP and/or RCUF/RCUP established).

[0180] In an IDLE mode with Connectionless Transfers, for example, a WTRU may have some connectivity with a network (e.g. it may have at least one ACF/ACP established with at least one user plane component, e.g., with a default configuration, e.g., for routing and/or security). A WTRU may have RCCF/RCCP established (e.g. a security context, access tables).

[0181] In a connected mode, for example, a WTRU may have complete connectivity with a network (e.g. it may have at least one ACF/ACP, RCCF/RCCP and/or RCUF/RCUP (e.g. when applicable) established with at least one user plane component).

[0182] In a loosely connected mode, for example, a WTRU may have some connectivity with a network (e.g. it may have at least one RCCF/RCCP established, e.g., a security context, access tables).

[0183] Connectionless data transfer may be provided. A WTRU may establish an L3/RRC connection to transmit data PDUs irrespective of the size of the data packet. Establishing a connection may be difficult relative to one or more of: overheads associated with signaling to establish a connection at the RAN and/or Core network before the start of a small packet transfer; overhead associated with tearing down a connection after periods of inactivity; and/or WTRU battery drain to stay in connected mode for extended periods of time.

[0184] A WTRU may (e.g. directly) perform connectionless data transfer in a loosely connected state, for example, using a pre-existing context with a central control plane function. A pre-existing context may include (e.g. at least) a security context, WTRU subscription and/or WTRU capability configuration. A WTRU may (e.g. also) perform connectionless data transfer from an idle connectionless state, e.g., using a pre-existing context with the core network control function. A WTRU may (e.g. in this example) not have a RAN central context established. For example, a WTRU may be associated with (e.g. only) a default slice and/or a core network control function and may still transmit connectionless data. A WTRU may (e.g. in this example) include additional session information with a data PDU.

[0185] Connectionless data transfer may allow a WTRU to transmit data, for example, with one or more following characteristics/properties: without requiring access plane establishment; using modified msg1 (e.g. modified RACH preamble + data, multi-user non-orthogonal data channel, etc.); without receiving an explicit grant (e.g. contention based UL shared data channel); after UL synch (e.g. using piggybacked data with and/or as msg3); before UL synch to the network (e.g. using asynchronous access channel); and/or transmitting additional context information associated with the data PDU.

[0186] A WTRU may use a simplified security procedure that may, for example, involve one or more of: using stored context, which may be result of previous network interaction and/or hard coded security context in SIM; and/or explicit indication of security algorithm used.

[0187] A connectionless data transfer mode may allow a WTRU to transmit data PDUs earlier than connection oriented data transmission. Such data PDUs may be referred to as early data PDUs.

[0188] For example, a connectionless data transfer mode may (e.g. also) be used for downlink transmissions. For example, a WTRU may receive data PDUs in the same TTI with a paging message and/or along with the paging message itself. A network may trigger such connectionless downlink transfer, for example, when a WTRU location is known at a fine granularity and/or the size of the data packet is small.

[0189] A WTRU may trigger connectionless data transfer, for example, based on one or more of the following criteria: a service (e.g. low overhead service and/or a low latency service, etc.); a size of a packet (e.g. when the size of the packet is less than a predefined number of bytes); WTRU buffer occupancy (e.g. when a WTRU buffer size is less than a predefined number of bytes); latency experienced by the packet (e.g. when the packet exceeds latency budget); packet filtering (e.g. WTRU may be configured with a packet filter/TFT to identify packets matching specific criteria, such as IP address, protocol, port number, type of service, flow label and/or a preconfigured session ID); absence of valid/configured logical connection (e.g. EPS bearer/Radio bearer); type of PDUs (e.g. initial signaling messages may use connectionless); WTRU mobility state (e.g. when WTRU speed and/or number of reselections/HO per second exceeds a threshold, which may be used to limit the number of handovers for medium/fast moving WTRU); a WTRU category; and/or an access class.

[0190] For example, a WTRU may (e.g. always) trigger a connectionless transfer, e.g., by default and/or as configured by an access table. A WTRU may (e.g. subsequently) transition to connection oriented transfer, for example, based on WTRU and/or network procedures described herein.

[0191] A WTRU may determine L1 and/or L2 configuration for connectionless transfer, for example, using one or more of the following procedures: a WTRU may apply a default configuration; a WTRU may apply a predefined configuration acquired via system broadcast (e.g. access table and/or system signature based) that may be specific to a access control function, to a central control function and/or to a TRP or a group of TRPs; a WTRU may apply a stored configuration (e.g. received upon establishing central control plane context) that may be dedicated for a WTRU or a group of WTRUs where the same configuration may be used across one or more, or multiple TRPs; and/or a WTRU may (e.g. explicitly) request connectionless transfer and/or may obtain specific configuration that may include transmission resources (e.g. contention based/non-orthogonal resources, layer2 configuration, etc.).

[0192] A layer 2 configuration may (e.g. in addition to a physical layer time/frequency resource configuration) include a max data rate restriction, bucket size, RLC mode, PDPC discard timer, security algorithm, etc. For example, specific MAC instances may be configured for connectionless transfer.

[0193] One or more connectionless configuration parameters may be associated with a validity timer. A WTRU may start a validity timer, for example, upon receiving configuration parameters. A WTRU may consider configurations, for example, (e.g. only) when the timer is

running. A WTRU may delete/release configurations, for example, upon the expiration of a validity timer.

[0194] A WTRU may include additional context information with a data PDU, for example, to assist a network with processing and/or routing a data packet to an appropriate destination. Additional context information may be included, for example, in a layer 3 message and/or as a part of a layer 2 header field. For example, a layer3 message type may be defined to identify connectionless data. An IE (e.g. connectionless-data-IE) may be introduced in a layer 3 message (e.g. UL information transfer).

[0195] A WTRU may include one or more types of information as context information in an early data PDU.

[0196] For example, context information may comprise WTRU Identity information, which may comprise, for example, one or more of the following: an L3 identity that may have been allocated by a central control function during a previous interaction; an associated Identity of the central control function and/or an NAS level identity; an implicit indication of a portion of and/or a whole identity, e.g., using the selection of time/frequency resource; and/or a demodulation reference signal and/or unique word that may be a function of WTRU ID.

[0197] For example, context information may comprise a more data left indication and/or last PDU indication, which may indicate whether there are additional PDUs in WTRU buffer along with the early data PDU.

[0198] For example, context information may comprise one or more of: QoS related information, e.g., an indication to treat the early data PDU as a default QoS and/or as a non-default bearer data PDU; a low latency indicator, e.g., to allow a network to use low latency and/or an efficient data path; and/or a low overhead indicator, e.g., to allow a network to use a low overhead mechanism for transfer (e.g. a connectionless transport).

[0199] For example, context information may comprise application description and/or session related information, such as a predefined session ID, e.g., so a network knows which session a data PDU is associated with.

[0200] For example, context information may comprise forwarding/routing/transport layer information (e.g. a general packet radio service tunneling protocol (GTP) tunnel and/or a flow table entry and/or an index to flow table entry).

[0201] For example, context information may comprise security context information.

[0202] For example, context information may comprise destination ID, such as a control plane ID and/or a user plane entity ID, e.g., perhaps depending whether a PDU is a signaling PDU or data PDU.

[0203] For example, context information may comprise user plane entity ID (e.g. when one already exists to avoid signaling towards RAN control plane entity), for example, for a RAN and/or Core user plane entity.

[0204] For example, context information may comprise control plane entity ID (e.g. entity with a valid WTRU context including subscription, security, etc.), for example, for a RAN Control entity and/or a core (e.g. MME ID + WTRU ID within the MME service area).

[0205] For example, context information may comprise slice identity, e.g., when a WTRU is already configured with a specific slice for connectionless transfer.

[0206] A WTRU may receive and/or may process feedback for a connectionless data transfer, where processing may be different from a connection oriented data transfer. A WTRU may (e.g. implicitly) determine the resources for feedback, for example, as a function of UL time/frequency resources used for early data PDU transmission and/or as a function of WTRU ID included in the data PDU.

[0207] Feedback (e.g. for data transmitted using connectionless/early data transfer based mode) may be associated with additional information, including, one or more types of additional information.

[0208] For example, additional information may comprise a WTRU ID for which feedback is sent (e.g., copied from UL Data PDU), e.g., where WTRU may verify the WTRU ID present in the feedback before processing the feedback message.

[0209] For example, additional information may comprise a timing advance (e.g. for async/contention based UL).

[0210] For example, additional information may comprise a power control command.

[0211] For example, additional information may comprise an ACK/NACK, e.g., where additional resources may be granted for retransmission for NACK.

[0212] For example, additional information may comprise a collision/contention indication, e.g., when WTRU action is based on a contention indicator, such as one or more of: when WTRUs can be distinguished at eNB (e.g., by orthogonal DMRS) and/or when WTRU receives other WTRU IDs in the feedback, a WTRU may transmit at next opportunity; and/or when WTRU receives a contention indication, the WTRU may perform, for example, a random back off and/or fallback to connection based data transfer.

[0213] For example, additional information may comprise an indication to trigger access plane establishment and/or fallback to connection oriented mode.

[0214] For example, additional information may comprise additional UL resource grants and/or an Indication to go back to idle mode (and/or implicitly an ACK may be used to go back to idle mode), for example, depending on last PDU indication.

[0215] For example, additional information may comprise a request for WTRU identity and/or additional authentication procedure, e.g., when WTRU context might not be fetched and/or when WTRU may be unknown at the RCCF and/or the security check failure, etc., where a WTRU may respond to the authentication procedure and/or provide additional context information.

[0216] A WTRU may (e.g., in connectionless transfer mode) trigger a transition to connected oriented mode, for example, based on one or more of the following criteria and/or events: when a WTRU spends more than a predefined time in connectionless mode; when a WTRU receives a data packet with more than predefined number of bytes; when a WTRU transmits more than a predefined number of bytes in connectionless mode; when a WTRU buffer size exceeds a threshold; when a latency of buffered data exceeds a threshold; when a number of NACKs/retransmissions for an early data PDU exceeds a threshold; when a data rate over a predefined time window exceeds threshold; and/or when an activity timer exceeds a threshold, e.g., when an activity timer that may be (e.g. always) running when a WTRU enters connectionless transfer mode, where the activity timer may be reset to zero and started again, perhaps for example when the time between two consecutive packets exceeds a threshold.

[0217] For example, a WTRU may be configured to report one or more events. A network may determine whether to transition the WTRU to connection oriented mode. A WTRU may report events, for example, using a control message and/or signal and/or piggyback indication in a connectionless data PDU. A network may (e.g., also) trigger a transition to connection oriented mode, for example, based on policies, type of services, WTRU subscription, WTRU mobility, etc. For example, a WTRU may transition from connection oriented mode to connectionless mode, for example, based on a network command (e.g., based on inactivity).

[0218] A user plane component may be (e.g., conceptually) represented as a transport path. A transport path may include, for example, one or more of the following: one or more Uu (which may be associated with a specific SOM and/or physical layer QoS) and/or a configuration thereof; a QoS profile (e.g., in terms of maximum latency, jitter, packet loss rate and/or the likes) and/or a configuration thereof; an association with one or more data flows and/or service (e.g., as indicated by a multiplexing function that may be based on logical radio bearer, tuples and/or a configuration thereof); routing table entries (e.g., in the network); a list and/or set of one or more

matching rules; and/or a list and/or set of one or more tuples (e.g., to determine what logical path a packet may be directed to).

[0219] A distributed control plane for NR may have functions and/or components, which may be discussed from the perspective of their different applicability.

[0220] For example, a WTRU-specific function may be associated with an anchor control function. An RCCF may manage connectivity of a WTRU with a core network (e.g., PDN connectivity, reachability, etc.).

[0221] For example, a component-specific function may operate on one or more aspects of a single instance of a component for a given WTRU.

[0222] For example, a plural-component function may operate on one or more aspects of one or more, or multiple instances of a component for a given WTRU.

[0223] For example, control functions may be associated with MAC instances that may (e.g. also) map to a set of access control functions.

[0224] For example, control functions may be associated with a single MAC instance.

[0225] System information may be acquired, for example, as a WTRU-specific function, as a component-specific function and/or as a plural-component function.

[0226] A component of System information acquired as a WTRU-specific function, for example may include, a cell, TRP, and/or TRPG and/or groups thereof (e.g. everything a WTRU may find useful). On-Demand procedures, including requests and/or combination with already known SysInfo (pre-provisioning and/or acquired) may be described. SysInfo split may be supported. Out-of-band SysInfo may be supported.

[0227] A component of system information acquired as a Component-specific function may be, for example, a cell and/or a TRP. SysInfo split may be supported. Out-of-band SysInfo may be supported.

[0228] A component of system information acquired as a Plural-component function may be, for example, one or more, or multiple cells, one or more, or multiple TRPs, one or more, or multiple TRPGs, and/or one or more, or multiple NR-eNBs, etc. SysInfo split may be supported. Out-of-band SysInfo may be supported.

[0229] System information may be acquired, for example, using one or more approaches and/or procedures.

[0230] For example, system information may be acquired by broadcast, e.g., similar to LTE.

[0231] For example, system information may be acquired by splitting information in a first set of information and in a second set of information. Such information may comprise one or more system parameters. Such split of information may be based on one or more characteristics

of the concerned information. Such characteristic may include whether or not the information is essential for accessing the concerned network resources, whether or not the information relates to a feature and/or function available using the concerned network resources, whether or not the information relates to a feature and/or function for low-latency access (e.g. URLLC), whether or not the information may enable specific UE procedures such as camping, measurements, and/or the like. Such first set may be further referred to as “Essential” information and/or such second set may be further referred to as “Non-essential” information. In some solutions, “Essential” information may be referred as Minimum-SI and/or “Non-essential” information may be referred as Other-SI. Such split may be network-controlled and/or vary from one area to another, where essential system information (if any) may be broadcast (e.g. to enable a WTRU to access the system and/or obtain further system information through dedicated resources. Broadcast information may comprise MIB, SIB1 (access-related information e.g. PLMN, TAC, CellID, p-Max, frequency band indicator), SIB2 (access barring information, RACH parameters, UL power control). The amount of broadcasted system information may vary (e.g., depending on the split between “Essential” and “Non-essential” information). For example, the amount of system information included in the broadcast may be one or more of the following: no broadcasted system information (e.g., pre-provisioning, acquired, and/or on-demand); MIB; MIB + SIB1; MIB + SIB1 + SIB2; (v) MIB + SIB1 + SIB2 + combination of remaining SIBs (e.g., SIB3 may be broadcasted to support cell reselection, etc.); and/or other combinations of “Essential” and “Non-essential” information. In some examples, there may be no “Essential” system information broadcasts. On-demand (dedicated) information may comprise obtaining remaining system information through dedicated resources (e.g. triggered through PRACH), where, on-demand acquisition may be based on a service (e.g. camping/paging etc.), WTRU capability, slice, etc.

[0232] For example, system information may be acquired by splitting information across broadcast and dedicated transmissions. A split may be network-controlled and/or may vary from one area to another. A flexible mechanism may be provided to support variable split between broadcast and dedicated information.

[0233] For example, system information may be acquired by system information modification, which may provide one or more mechanisms, for example: to update the delta, whether pushed and/or on-demand (e.g. WTRU-initiated and/or NW-initiated by control signaling ordering WTRU to start the procedure); and/or to request a specific element of system information (e.g. SIB).

[0234] For example, system information may be acquired by variable acquisition, for example, based on location and/or frequency band (e.g. system information applicable in one location and/or for one carrier may be received in different locations and/or carrier).

[0235] Broadcast information may include specific information components related to specific services, such as a configuration for low latency access and/or for connectionless data transfers.

[0236] Essential information may be broadcast. Essential information may include, for example, MIB, SIB1 (access-related information e.g. PLMN, TAC, CellID, p-Max, frequency band indicator), SIB2 (access barring information, RACH parameters, UL power control). A WTRU may acquire broadcast system information and/or may request further system information, e.g., using an on-demand procedure.

[0237] More information (e.g. beyond essential information) may be broadcast, for example, based on capacity/load. For example, more system information may be broadcast, for example, perhaps when the system has the capacity and broadcast capacity is limited. A WTRU may acquire broadcast system information and/or may request further system information, e.g., using an on-demand procedure.

[0238] System information may be modified (e.g. changed and/or updated). For example, system information modification may be triggered by paging for WTRUs in RRC_IDLE and/or WTRUs in RRC_CONNECTED. A WTRU (e.g. when WTRU receives notification of system information modification) may identify a delta and/or may acquire modified/new system information, for example, by one or more procedures, such as broadcast (e.g. when a delta is broadcast) and/or on-demand (e.g. when a delta is not broadcast).

[0239] Variable acquisition may be based on location and/or frequency band. For example, deployment scenario may include macro and/or micro, wherein system information (e.g. for the macro and/or micro) may be broadcast over the macro. A WTRU may (e.g. when not in coverage of a macro) acquire system information from a micro.

[0240] System information may be variable portioned. Essential system information (if any) may be broadcast, for example, to enable a WTRU to access the system. A WTRU may acquire further system information through dedicated resources.

[0241] For example, more than essential system information (if any) may be broadcast, for example, when the system has significant excess capacity, when many WTRUs are acquiring system information and/or when a use arises to broadcast new system information that is essential for system access. It may be beneficial to support acquisition procedures allowing a variable/dynamic split between broadcast and on-demand information acquisition.

[0242] System information may be grouped and/or may be controlled, for example, by different logical functions, e.g., based on periodicity, latency, feature, etc.

[0243] In one or more groupings, a default set may comprise, for example, information that may be essential for system access, camping, mobility, etc. Essential information may comprise, for example, common and shared channel information (e.g., similar to MIB, SIB1, SIB2 in LTE). Essential information may comprise, for example, cell selection/re-selection information (e.g. similar to SIB3, SIB4, SIB5(E-UTRA), SIB6(UTRA), SIB7(GERAN), SIB8(CDMA2000) in LTE).

[0244] In one or more groupings, a common set may comprise, for example, information that may be required by most devices, such as one or more of the following: HNB name (e.g. similar to SIB9 in LTE); ETWS (Earthquake and Tsunami Warning System) primary notification (e.g. similar to SIB10 in LTE); ETWS secondary notification (e.g. similar to SIB11 in LTE); and/or Commercial Mobile Alert System (CMAS) warning notification (e.g. similar to SIB12 in LTE).

[0245] In one or more groupings, a feature set may comprise, for example, information that may be required for particular features/device categories, such as one or more of the following: MBMS (e.g. similar to SIB13 in LTE); extended access barring for access control (e.g. similar to SIB14 in LTE); mobility procedures for MBMS reception (e.g. similar to SIB15 in LTE); GPS time and UTC time (e.g. similar to SIB16 in LTE); for traffic steering between E-UTRAN and/or WLAN (e.g. similar to SIB17 in LTE); sidelink communication (e.g. similar to SIB18 in LTE); sidelink discovery (e.g. similar to SIB19 in LTE); and/or SC-PTM e.g. similar to SIB20 in LTE.

[0246] For example, a WTRU may receive System Information (SI) applicable to a cell/TRP (and/or similar) and/or to a plurality thereof. A WTRU may receive SI, for example, by broadcast transmissions and/or by dedicated transmissions. For example, a WTRU may receive SI applicable to a cell/TRP on a transmission, for example, using resources associated with a different cell/TRP. SI applicable to a cell/TRP may include a (e.g. first) portion that may correspond to a (e.g. first) set of functions (e.g. access parameters, location tracking, WTRU-autonomous mobility related parameters, signature detection/measurement) and/or a (e.g. second) portion that may correspond to a (e.g. second) set of functions (e.g. supported features, supported services, etc.). The set of functions included in a (e.g. one or more, or each) portion may be a configuration aspect of the system and/or may be explicitly indicated in the corresponding transmission. Additional information may be included, for example, to indicate whether there is further SI (e.g. a second portion) applicable and/or the identity/type of further available SI (e.g. a bitmap representing the different SIBs). Additional information may, for example, include an indication whether a WTRU is required to acquire remaining information

(e.g. one or more, or all remaining SIBs) and/or a subset thereof (e.g. SIB-based indication), which may be accompanied by an indication of an applicable procedure (e.g. DL broadcast and/or using an on-demand mechanism). Additional information may include a validity criteria for the SI.

[0247] For example, a WTRU may acquire SI for a cell, for example, using a broadcasting channel. A WTRU may (e.g. further) perform an initial access, e.g., to establish connectivity with the access network (e.g. ACP and/or RCCP). A WTRU may (e.g. subsequently) receive SI for one or more cell(s), TRP(s), etc. (e.g. similar and/or the like), for example, using a (e.g. dedicated) transmission such as a reconfiguration procedure. SI may be indexed, for example, using a characteristic associated with a reference signal (e.g. a signature, a positioning signal, etc.) that may be applicable. SI may be indexed, for example, for one or more, or each of the concerned cell(s)/TRP(s) and/or TRPGs. An SI may include (e.g. only) a portion of the information associated with a cell/TRP, such as access parameters. A WTRU may (e.g. subsequently) detect a reference signal associated with a configured SI. A WTRU may perform acquisition of further SI, for example, from a downlink broadcast channel (e.g. when applicable) and/or by initiating an access using the access parameters that are part of the configured SI for the concerned cell/TRP and/or detected reference signal / signature.

[0248] Additional SI may be acquired immediately. For example, a WTRU may initiate reception of broadcast system information, for example, when it determines that a broadcast channel may be available. A WTRU may initiate a procedure to request activation of a broadcast channel. A WTRU may (e.g. when it cannot receive broadcast SI using resources associated with the cell/TRP) initiate an access, for example, using access parameters that may be part of a configured SI for a concerned cell/TRP and/or detected reference signal/signature. A WTRU may initiate a procedure to request remaining SI for the concerned cell/TRP using dedicated resources thereof.

[0249] Additional SI may be acquired immediately, for example, when instructed and/or configured to do so. For example, a WTRU may initiate reception of broadcast system information, for example, when the WTRU determines that it is required (e.g. based on information in a first portion of the configured SI) to initiate such a procedure upon detection of a suitable reference signal (e.g. corresponding to a “known”/configured signature and/or received with sufficient power). A WTRU may use an applicable SI acquisition procedure, e.g., when configured.

[0250] Additional SI may be acquired on demand. A WTRU may acquire system information, for example, through dedicated resources (e.g. triggered through PRACH). On-demand acquisition may be based on service, WTRU capability, slice, etc.

[0251] A WTRU may initiate on-demand acquisition of additional SI, for example, after initial access. A WTRU may request a default set of SI messages, for example, based on WTRU capability and/or based on previously used services.

[0252] A WTRU may initiate on-demand acquisition of additional SI, for example, when a WTRU initiates new services. A WTRU may request additional SI messages, for example, when the associated SI messages have not already been acquired.

[0253] A WTRU may initiate on-demand acquisition of additional SI (e.g. specific SI messages), for example, when a WTRU determines that stored SI messages are no longer valid, e.g. upon receiving a modification indication for one or more SI messages and/or upon receiving an unknown system signature.

[0254] A WTRU may initiate on-demand acquisition of additional SI, for example, based on expiration of a timer. A timer may be associated with the validity of stored system information.

[0255] In a WTRU terminated example, a WTRU may (e.g. at reception of service requests) request additional SI messages, for example, when associated SI messages have not already been acquired.

[0256] In a WTRU terminated example, a WTRU may receive control signaling (e.g. paging/PDCCH-order) that may trigger an acquisition/update. The procedure may be included in the signaling/order. Signaling may provide an indication of an applicable information component (e.g. one or more components to be updated).

[0257] For example, a WTRU may activate transmission of system information, for example, by transmitting an uplink signal. An uplink signal may be transmitted in resources that may be reserved for system information activation. For example, a specific time/frequency resource and/or a UL physical channel may be reserved for system information activation. In an (e.g. another) example, a WTRU may transmit a reserved RACH preamble, for example, to indicate a system information activation request. In an (e.g. another) example, a WTRU may transmit a UL signal on an asynchronous resource that may be reserved for system information activation. UL resources for system information activation may be specific to a TRP, a group of TRPs and/or a MAC instance. A WTRU may use a system information activation procedure, for example, to indicate interest in acquiring system information. WTRU identification by the network may be optional during a system information activation procedure.

[0258] A WTRU may receive configuration for system information activation at different levels of granularity. For example, a WTRU may trigger different system information transmission behavior from a network based on UL signal type, UL resource selection, UL preamble selection, etc. Transmission behavior may include transmitting (e.g. only mandatory) system information, transmitting system information belonging to a specific slice, transmitting specific group of system information, etc. Transmission behavior may be, for example, one shot (e.g. for one or more, or each activation request one instance of the associated system information may be transmitted) and/or multi-shot (e.g. for one or more, or each activation request one or more, or multiple instances and/or repetition of the associated system information may be transmitted). For example, UL resources may be, for example, specific to a TRP and/or common to a group of TRPs. A WTRU may trigger TRP specific system information and/or TRP group specific system information, for example, based on the corresponding selection of UL resource.

[0259] The terms system information request and Other-SI request may be used interchangeably. For example, a WTRU may transmit a (e.g. an explicit) request message to trigger system information transmission. For example, a request message may include WTRU identity and/or type of system information requested. For example, a network may trigger security procedures, e.g. authentication as a response to a system information request procedure. A procedure may enable secure delivery of system information message. For example, a WTRU may acquire common system information via broadcast and/or activation procedure. A WTRU may (e.g. for slice specific system information) trigger a system information request procedure. A WTRU may (e.g. be required to) establish an access control plane, for example, to trigger a system information request message. For example, a WTRU may transmit its capability information (e.g. along with a system information request), for example, so a network may provide (e.g. only) the system information applicable for a WTRU capability.

[0260] For example, a WTRU may piggyback an SIB request together with a control signaling procedure. A WTRU may (e.g., implicitly) indicate a desire and/or usefulness for system information, for example, by transmitting additional indication with the control signaling procedure. For example, a WTRU may transmit a system information request bit/bitmap (e.g., along with a service request procedure), for example, to indicate a desire and/or usefulness for system information for that procedure. For example, a WTRU may include a value tag (and/or value identifier) associated with stored system information (e.g., along with a control procedure), for example, so a network may provide additional system information, e.g., when the value tag

doesn't reflect the latest system information. A WTRU may trigger a control procedure, for example, by requesting system information associated with a control procedure.

[0261] A WTRU may trigger an other-SI request (e.g., towards a serving cell) to obtain other-SI associated with a neighbor cell. A WTRU may include identity and/or information associated with the neighbor cell (e.g., physical cell ID, EARFCN, global cell ID, and/or parts of MIB etc.) in the other-SI request. A WTRU may include a reference ID and/or a value tag of the neighbor cell in the other-SI request. A WTRU may include more than one neighbor cell identity in a single other-SI request message (e.g., to obtain other-SI for one or more, or multiple neighbor cells in a single procedure). Neighbor cell SI acquisition may be useful for the WTRU to perform autonomous mobility decisions towards that neighbor cell.

[0262] A WTRU may trigger an other-SI request to obtain other-SI associated with one or more beams. A WTRU may include identity and/or information associated with the beam, (e.g., beam ID, a reference signal associated with the beam, and/or parts of MIB in the beam etc.), in the other-SI request. A WTRU may include more than one beam identity in an other-SI request message to obtain other-SI for one or more, or multiple beams (e.g., in a single procedure).

[0263] A WTRU may include information about the stored SI in the other-SI request. For example, a WTRU may indicate the version and/or validity tag of SI stored in the WTRU memory during the transmission of other-SI request. The network may transmit (e.g., only) the delta and/or updated portion of the other-SI. Signaling overhead and/or acquisition time associated other-SI may be reduced.

[0264] A WTRU may include additional information in the other-SI request to request characteristics of other-SI broadcast. For example, a WTRU may indicate one or more aspects related to downlink signal quality in the other-SI request. Such indications may be used by the network to adapt the periodicity, for beamforming, for repetition, and/or MCS for the other-SI broadcast transmission. For example, a WTRU may indicate the desire and/or usefulness for more repetition and/or robust MCS when in a poor condition (e.g., cell edge and/or high path loss conditions). Also, as an example, a WTRU may indicate such a request based on a preamble selection, RACH resource selection, in the message portion of an enhanced RACH format, and/or in a field in a msg3 carrying other-SI request.

[0265] A WTRU may trigger a system information request procedure in any state (e.g., idle, inactive, and/or connected). A WTRU may or might not transition to a connected state to acquire the other-SI. A WTRU may perform a system information request by for example using a dedicated resource and/or a contention based resource.

[0266] A WTRU may be configured with one or more rules for transmission of on-demand system information request that may be saved in memory as instructions executable by a processor. A WTRU may trigger (e.g., only) if one or more of the following conditions are satisfied. An example condition for triggering an on-demand system information request may be the status of essential SI. For example, a WTRU may request for other-SI (e.g. only) when the WTRU has up to date essential system information. A WTRU may abort any ongoing other-SI request if it determines a change in essential SI. A WTRU may acquire the essential SI and/or reacquire the other-SI according to the updated essential SI.

[0267] An example condition for triggering an on-demand system information request may be the absence of required information. For example, a WTRU may determine that the system information transmitted in the essential SI is not sufficient (e.g., for a specific procedure and/or operation in a WTRU state). A WTRU may determine that system information stored in the WTRU (e.g., based on previous other-SI request procedure and/or based on network assistance) is not sufficient (e.g., for a specific procedure and/or operation in a WTRU state). A WTRU may trigger other-SI request when a new procedure is triggered/started (e.g., for which the WTRU does not have a valid and/or stored SI associated with such procedure). For example, a WTRU may start a procedure, which may require operation in a numerology/SOM different from the current numerology/SOM. A WTRU may trigger an other-SI request to obtain system information relevant for the new numerology/SOM and/or may request system information for a specific numerology/SOM. For example, a WTRU may implicitly indicate request for a specific numerology/SOM based on the choice of resources (e.g. time/frequency or preambles) for other-SI request.

[0268] A WTRU may be preconfigured (e.g., saved in memory) with the list of SIs required for the supported procedures and/or operation in a WTRU state.

[0269] An example condition for triggering an on-demand system information request may be the absence of broadcast Other-SI; a WTRU may determine that the other-SI is not broadcasted. For example, a WTRU may determine the presence of other-SI based on scheduling information in the essential SI. For example, a WTRU may trigger other-SI request if a WTRU may determine that the broadcast of other-SI is stopped before the WTRU can acquire the required other-SI and/or if a WTRU determines that one or more specific other-SI required by the WTRU is not present in the current schedule of other-SI broadcast.

[0270] An example condition for triggering an on-demand system information request may be the support/presence of the other SI. For example, a WTRU may trigger the request for other-

SI if (e.g., only if) transmission of such other SI is supported by the network. For example, a WTRU may determine the support of specific type of other-SI from the essential SI.

[0271] An example condition for triggering an on-demand system information request may be the WTRU not being prevented by access control from making such a request. For example, a WTRU may belong to one or more of many access classes. A WTRU may determine (e.g., may be required to determine) if requesting other-SI is not forbidden for its access class. For example, such forbidden access class for other-SI request may be broadcasted as a part of essential SI.

[0272] An example condition for triggering an on-demand system information request may be the presence of UL resources for other-SI request(s). For example, a WTRU may determine and/or receive the configuration of UL resources for system information request procedure. The configuration may include, e.g. UL RACH resources, RACH formats (e.g. including enhanced RACH formats).

[0273] An example condition for triggering an on-demand system information request may be the WTRU detecting change/update of other-SI and/or when WTRU determines the stored other-SI is invalid: a WTRU may monitor for the change in other-SI via signaling in broadcast message (e.g., MIB and/or essential SI and/or a paging message). A WTRU may monitor a change only for other-SI that are acquired and/or stored by the WTRU. A WTRU may receive the signaling indicating whether the modified other-SI is broadcasted and/or whether a system information request procedure is desired and/or useful. A WTRU UE may trigger other-SI request (e.g., only) if so indicated by the network. For example, a WTRU may apply stored other-SI instead of request for other-SI, upon determining the validity tag and/or similar matches (e.g., substantially corresponds) with the stored SI.

[0274] An example condition for triggering an on-demand system information request may be the discovery of a neighbor cell. For example, a WTRU may trigger other-SI request upon discovery of a neighbor cell for which the WTRU does not have a valid and/or stored system information. The WTRU may trigger an other-SI request based on quality of neighbor cells being above (or below) a predefined threshold.

[0275] A WTRU may start a timer A and/or a timer B (e.g., where timer A time > timer B time), when the first other-SI request message is transmitted. A WTRU may stop timer A and/or timer B when the WTRU completes the acquisition of other-SI. Upon expiry of timer B, a WTRU may retransmit the other-SI request message and/or restart timer B. A WTRU may be configured with a predefined number of retransmissions to acquire the other-SI until expiry of timer A. Upon expiry of timer A, a WTRU may consider the cell to be barred for a predefined

duration (e.g., not use that cell). While timer B is running, a WTRU may monitor for the presence and/or scheduling of other-SI via a broadcast signaling (e.g., minimum SI, paging message, and/or via unicast signaling via downlink control channel).

[0276] As a step (in msg1), a WTRU may transmit a reserved RACH preamble to request system information. For example, such reserved RACH preambles may be used to indicate a specific system information block and/or group thereof, indicate the WTRU state (e.g., RACH preambles are associated to a WTRU state), indicate the system information for a type of service and/or group thereof, indicate aspect related to timing/latency for acquiring system information, and/or indicate that WTRU may perform data transmission following acquisition of system information.

[0277] A WTRU may be configured (e.g., programmed with executable instructions by a processor) to transmit an enhanced first message and/or msg1 for requesting other-SI. A WTRU may, in addition to a preamble portion in the enhanced first message, may include additional bits in a message portion. A WTRU may be configured (e.g., programmed with executable instructions by a processor) with predefined relations (e.g., in time and/or frequency between the preamble portion and message portion). A WTRU may indicate a request for other SI (e.g., based on a selection of a preamble sequence). A WTRU may indicate a specific type/group of other-SI requested (e.g., based on the reserved identity in the message portion). For example, a WTRU may transmit a preamble from a common pool and/or indicate the request for other-SI and/or specific type of other-SI (e.g., using the reserved identity in the message portion). A WTRU may be preconfigured (e.g., programmed with executable instructions by a processor) with the mapping of reserved identities to the types of other-SI. One or more WTRU identities may be reserved for such purpose. A WTRU may receive the configuration of reserved identity usage from minimum SI. The preamble may indicate the request for other-SI and/or the message portion may indicate connection establishment cause. A WTRU may be configured (e.g., programmed with executable instructions by a processor) to receive other-SI associated with a specific connection establishment cause, save such information and/or execute such received instructions. A WTRU may fallback to a normal msg1 (e.g., without message portion) if the retransmission of enhanced msg1 exceeds a threshold.

[0278] A WTRU may be configured to monitor for the MSG2 containing a response to the other-SI request. For example, a WTRU may be configured to monitor for a temporary identifier (e.g. a RNTI) specific to the other-SI request. For example, the temporary identifier may include a component specific to the other-SI request and/or the time/frequency and/or the preamble resource used for the other-SI request. For example, a WTRU may be configured to monitor a

(e.g., single) temporary identifier that may be predefined for one or more, or all, other-SI requests, perhaps irrespective of the time/frequency/preamble resources used for the other-SI request transmission.

[0279] A WTRU may be configured to process the received MSG2, perhaps for example in response to an other-SI request. For example, the MSG2 format may be specific to the other-SI request, perhaps indicated by a separate type field. For example, the MSG2 response to the other-SI request may include the identity of the preamble associated with the other-SI request and/or may directly include an indication of the other-SI type. For example, the MSG2 might not include the timing advance, UL grant, and/or temporary identity. The MSG2 may include a bitmap of one or more, or all, the other-SI types that may be transmitted in an upcoming other-SI window.

[0280] A WTRU may be configured to process one or more MSG2 within a predefined time window, perhaps for example to determine the transmission status of one or more other-SI types. This may occur irrespective of whether the MSG2 corresponds to the MSG1 transmitted by the WTRU. The predefined time window may be configured, for example, in the minimum SI. The predefined time window may be related to the SI window of the SI being requested (e.g. a number of frames/subframes prior to the start of the SI window). This may be useful for the WTRU to determine one or more other-SI windows that may contain other-SIs of interest to the WTRU. This may include one or more other-SIs of interest for which the WTRU might not have been able to transmit the other-SI request. For example, a WTRU may be configured to monitor and/or process MSG2, perhaps until the WTRU receives the MSG2 including the response to requested other-SI and/or interested other-SI, and/or until the end of a predefined time window.

[0281] A WTRU may be configured to receive a MSG2 that may include a response to normal access by other WTRUs and/or a response to other SI request(s). The WTRU may distinguish the different responses in the same MSG2, perhaps for example based on the RAPID (ID of the RACH preamble). The WTRU, perhaps for example depending on whether it has performed access and/or SI request, may read the RAR (e.g., only the RAR) associated with the RAPID for which it transmitted a MSG1 (e.g., preamble).

[0282] A WTRU may be configured (e.g., programmed with executable instructions by a processor) with one or more actions/behaviors based on reception on a second message as follows. If no response is received by the WTRU (e.g., msg2 was not received), and/or the requested system information has not been received either through broadcast and/or through dedicated signaling within a certain period, the WTRU may re-transmit the system information request in msg1. If a WTRU receives the response in msg2, with indication that the requested

system information is not available, and/or no further system information is available, the WTRU may perform no further actions for this procedure. The WTRU may receive a response in msg2. The response in the msg2 may indicate whether the WTRU should request in msg3 the specific SI the WTRU wants. For example, the WTRU may receive an indication that some or all other SI will be broadcast by the network, in which case the WTRU will not transmit msg3, and/or an indication that may instruct the WTRU to transmit msg3 with the specific other-SI to be requested.

[0283] If a WTRU receives the response in msg2, with indication that the requested system information will be broadcasted, the WTRU may obtain the scheduling information from the "Essential" system information and/or may acquire the applicable system information from the broadcast. These approaches may provide power savings and/or signaling overhead reduction (e.g., WTRUs in Idle mode or Inactive mode can acquire the system information while remaining within the respective state).

[0284] If a WTRU receives the response in msg2, with scheduling information of the requested system information, the WTRU may acquire the broadcasted system information using the scheduling information included in msg2. The WTRU may acquire the system information faster instead of obtaining the scheduling information from the next broadcasted "Essential" system information and then acquire the application system information.

[0285] If a WTRU receives the response in msg2, with an entry/index to the access table, the WTRU may retrieve the applicable system information from the access table. The WTRU may have low latency and/or resource efficiency since the WTRU had previously already acquired the access table.

[0286] If a WTRU receives the response in msg2, with timing advance, grant and/or indication to transition to the connected state in order to acquire the system information, the WTRU may transition to the connected state and acquire the system information using dedicated resources. The WTRU may have resource efficiency (e.g., when few WTRUs are requesting system information/accessing the system). The WTRU may have indicated (e.g., based on the selection of the reserved RACH preamble) that data transfer may occur after acquisition of system information.

[0287] A WTRU may receive the response in msg2 (e.g., the msg2 may carry complete and/or parts of other-SI). For example, a msg2 may schedule DL time/frequency resources that carry other-SI. DL resources may be either multiplexed in the same TTI as the msg2 and/or at an offset from the TTI carrying msg2.

[0288] A WTRU may be configured to monitor the minimum-SI after transmission of other-SI request (e.g., for a pre-defined time interval). A WTRU may determine the scheduling configuration for broadcast of other-SI transmission based on the received minimum-SI.

[0289] A WTRU may be configured to monitor a paging message after transmission of other-SI request (e.g., for a pre-defined time interval). A WTRU may determine the scheduling configuration for broadcasting an other-SI transmission based on the received paging message.

[0290] A WTRU may transmit the Other-SI request in a MSG3. For example, a WTRU may be configured to transmit an other-SI request in MSG3, perhaps for example if no RACH resources are configured for the specific other-SI and/or combinations of other-SIs desired by the WTRU. A WTRU may be configured to use a specific RACH resource to transmit an other-SI in MSG3. A WTRU may be configured to utilize one or more, or any, RACH resource to initiate the procedure for other-SI in MSG3. The WTRU may select a RACH resource which has a specific timing relation (e.g., configured and/or specified/static) in relation to the SI window of the other-SI that may be requested. For example, the WTRU may perform an other-SI request by utilizing one or more, or any, RACH resource associated to a subframe/frame which may occur a certain time, and/or within a certain window, prior to the start of the SI window associated with the other-SI being requested. This can also be applicable for other-SI requests made using the techniques that use the MSG1.

[0291] A WTRU may indicate the reason for message3 transmission in msg1 (e.g., using either RACH resource/preamble resource selection and/or using an indication in the message portion of enhanced msg1). A WTRU might not provide any indication in msg1. A WTRU may utilize the grant received in msg2 for the transmission of other-SI request in msg3. The other-SI request may be an RRC message. A WTRU may receive msg4 as a response. The msg4 may be a RRC message carrying other-SI. The msg4 may carry an indication of whether the WTRU wishes, desires, and/or may find useful, to transition to a connected state or stay in the current state (e.g., idle, inactive etc.). Using RRC message for other-SI request may support Other-SIs (e.g., that could be introduced).

[0292] The WTRU may transmit the other-SI request in a msg3 and/or receive in msg4 information (e.g., information for obtaining other-SI). The information could include, for example, an RNTI to be used to receive the other-SI, time/frequency information about where to look for the other-SI (e.g., a specific subband of the control and/or data channel), validity information and/or validity tag associated with other-SI, and/or other parameters required to allow the WTRU to decode and/or receive the other-SI once it is transmitted. The WTRU may receive other-SI following reception of msg4 using the received information.

[0293] A WTRU may use multi-stage RACH for an other-SI request.

[0294] A WTRU may transmit a request for other-SI with one or more, or multiple RACH transmissions and/or transmissions on contention-based resources.

[0295] For example, a WTRU may transmit a first RACH preamble to indicate the desire for other-SI, and/or the WTRU may use a subsequent RACH preamble to request the other-SI that should be transmitted. In the transmission of the preamble (e.g., first preamble and/or in the transmission of the subsequent preamble), a WTRU may use the selected preamble and/or the resources on which the preamble is transmitted (e.g., to indicate the desire for other-SI and/or the specific other-SI being requested).

[0296] The potential collision of msg3 transmissions by one or more, or multiple WTRUs transmitting other-SI requests simultaneously when a WTRU requests specific SI to be transmitted using msg3 may be avoided. The network broadcast of some or all the other-SI (e.g., if only a single preamble was used to request some or all other-SI in msg1) may be avoided.

[0297] A WTRU may use an initial RACH transmission.

[0298] A (e.g., first) RACH transmission may be performed using a preamble and/or on a PRACH resource (e.g., which is dedicated for initiating a multi-stage RACH procedure for other-SI request). This may be determined by the WTRU from broadcast signaling (such as in the Minimum SI) and/or preconfigured in the WTRU. The WTRU may initiate a multi-stage MACH transmission for other-SI request by selecting the dedicated preamble and/or RACH resource configured for such purpose and/or performing the RACH transmission (e.g., first RACH transmission).

[0299] A WTRU may be programmed with a processor with instructions for responding to a response to a RACH transmission (e.g., initial RACH transmission).

[0300] A WTRU may receive, in msg2, following a RACH transmission (e.g., initial RACH transmission), an indication of the presence of additional RACH resources and/or contention-based resources for transmitting request for other-SI. An indication may also include configuration information of the RACH resources, such as a preamble and/or resources to be used; mapping between preamble and/or resources and the other-SI to be requested; timing information related to the validity of the RACH resources and/or contention-based resources; timing information related to the reception of the other-SI; and/or C-RNTI and/or other identifier to be used for monitoring transmission of the other-SI.

[0301] A WTRU may receive an indication of whether to request other-SI using a second stage of RACH transmission and/or a transmission on contention-based resources and/or whether the WTRU should expect to receive other-SI (e.g., some or all other-SI) following the

transmission of the RACH transmission (e.g. initial RACH transmission). For example, an msg2 message may indicate that additional RACH resources for indication of the other-SI requested will not be provided and/or the WTRU should receive some or all other-SI based on scheduling information of the other-SI, which the WTRU may have determined in the minimum SI.

[0302] A WTRU may have a processor programmed with instructions for determining RACH resources for second stage RACH transmission.

[0303] The WTRU may be configured (e.g., following transmission of the first RACH) with additional RACH resources and/or with contention-based resources (e.g., for indicating the specific other-SI being requested by the WTRU). The configuration of the additional RACH resources and/or contention-based resources used for requesting other-SI may be determined by the WTRU based on one or more of: msg2, preconfigurations and/or configurations of minimum SI, function of identity, and/or function of timing.

[0304] For received in msg2 configurations, the WTRU may receive a configuration of resources and/or preambles from the network in msg2 following transmission of a RACH transmission (e.g., initial RACH transmission). The configuration may be provided as an index into a table of specific RACH resources and/or preamble configurations known to the WTRU. The WTRU may receive several such indices representing one or more, or multiple configurations. The WTRU may receive the resources to use for the subsequent RACH transmission through an explicit grant. The grant may be accompanied by an indication that the grant is for transmission of a preamble identifying the other-SI being requested.

[0305] For preconfigurations and/or configurations of minimum SI, the WTRU may be pre-configured and/or configured by minimum SI to use defined RACH resources and/or RACH preambles for the other-SI. The WTRU may assume such resources are enabled/validated upon reception of an indication (e.g., RACH resources/RACH preambles activated). The indication may be received by the WTRU in msg2 and/or in a message in a separate PHY control channel.

[0306] For function of identity, the WTRU may determine the configuration of resources (time/frequency) for the second stage RACH resources based on an identity. The identity may be the cell identity, WTRU identity (e.g., temporary and/or provided in msg2), and/or network identity.

[0307] For function of timing, the WTRU may determine the configuration of resources (time/frequency) from the timing of msg2 reception and/or msg1 transmission. For example, the time location of the activated RACH resources may be configured as a predefined pattern of resources, which is offset from msg2 reception time by a specific amount.

[0308] The WTRU may map preamble/resources in second stage to other-SI.

[0309] The WTRU may indicate the other-SI it is requesting (e.g., through the selection of the preamble) including the preamble sequence and/or other transmission characteristics of the preamble such as preamble length, numerology, and/or power. The WTRU may select a preamble based on the other-SI that the WTRU requires. The WTRU may randomly select a time/frequency resource for transmitting the selected preamble.

[0310] The WTRU may indicate the other-SI being requested through the selection of the resources used for transmission of the preamble from the set of RACH resources available for transmission of the second stage RACH. For example, the WTRU may determine the other-SI it requires to request and/or may select a resource from the set of configured time/frequency resources, which corresponds to the specific other-SI being requested. The WTRU may (e.g., randomly) select a preamble to transmit on that specific resource.

[0311] The WTRU may indicate the other-SI requested through a combination of the selection of preamble and resources. For example, a combination of a specific preamble and a distinct resource on which that preamble is transmitted may indicate the request for a specific SI.

[0312] Specific combinations of preamble and resources may be reserved for the WTRU to request one or more, or multiple other-SI and/or a set of SIBs (e.g., a set of SIBs and/or SI related to a specific feature).

[0313] The mapping between resources/preamble and specific other-SI (e.g., SIB and/or SI message) may be determined by the WTRU based on one or more of: reception of the mapped information in the minimum SI (e.g., the information related to the other-SI which is provided in minimum SI may provide such mapping); a preconfiguration and/or a fixed definition; a WTRU category (e.g., a WTRU of one category may have a different mapping compared to a WTRU of a different category); stored information (e.g., the WTRU may have stored mapped information from the same or a different cell's broadcast and/or may determine that such information is still valid); and/or specific ordering (e.g., the WTRU may assume one or more, or each other-SI (e.g., SIB number) corresponds to a preamble and/or a resource in increasing order). For specific ordering, the WTRU may associate a specific starting preamble and/or resource to the first SIB, which may be requested as other-SI, and/or the next SIB may use the next preamble and/or resource, etc. based on some ordered numbering. The SIB numbering may further be based on the SIBs that the cell has available. Availability information can be determined by the WTRU in the minimum SI.

[0314] The mapping of resource/preambles and other-SI requested by the WTRU may depend on information provided by the WTRU in the RACH transmission (e.g. initial RACH transmission). For example, the WTRU may have provided, (e.g., in the initial RACH

transmission), some information pertaining to the other-SI that the WTRU would request in the second RACH transmission. The WTRU may provide a subset or a group of the other-SI in the initial RACH transmission. The WTRU may have provided this information through the specific preamble, resource selected in the initial RACH transmission, and/or using a RACH procedure (e.g., 2-step RACH procedure whereby additional data was transmitted along with the preamble). The WTRU may determine the mapping of the preamble and/or data to use and/or the other-SI requested using the second stage RACH transmission based on the subset or group which was selected in the first stage. For example, in case the preambles and/or resources are based on a specific ordering, the ordering may be applied (e.g., only) to the subset or group indicated by the WTRU in the first RACH transmission.

[0315] A WTRU may have a processor configured with executable instructions for the validity of second-stage RACH resources.

[0316] The resources for transmission of the second-stage RACH for request of other-SI may have a specific validity time. For instance, the WTRU may assume such resources are available upon reception of msg2 and/or upon transmission of msg1. Such resources may then be valid for a finite period of time following message receipt. A WTRU may assume the validity of received and/or enabled/validated resources based on a timer. For example, a WTRU may set a timer upon reception of msg2 with RACH resource activation indication and/or may (re)transmit other-SI requests using the configured RACH resources until expiry of a timer.

[0317] A WTRU may perform requests for other-SI using transmission of one or more, or multiple preambles in different RACH resources (e.g., in order to request different (e.g., possible sets of) other-SI). For example, a WTRU may transmit a specific preamble for one or more, or each, of the other-SI (e.g., SIB and/or SI message) used (e.g., required) by the WTRU and/or may continue to perform one or more, or all, preamble transmissions until the expiry of validity of the second-stage RACH preambles and/or until it may have received some or all of the required other-SI.

[0318] Distinct WTRUs may be programmed to transmit one or multiple requests for other-SI through regularly-occurring RACH resources, which may be temporarily reserved and/or configured for such by the network. Upon expiry of the timer, the network may then re-use such resources for normal scheduling. The configuration of RACH resources for the purposes of other-SI request will be provided (e.g., only) during the periods of time where the network knows there will be WTRUs using them (as a result of transmission of the first RACH by one or more WTRUs).

[0319] A WTRU processor may be programmed for retransmission of other-SI requests.

[0320] A WTRU may be configured with one or more retransmissions upon transmitting/attempting to transmit other-SI request via a random access preamble, which implicitly and/or explicitly indicates other-SI request a during single, a multi-stage RACH transmission, and/or requests resources for other-SI transmission in msg3. A WTRU may retransmit other-SI request in a contention based and/or grant-free channel.

[0321] Upon transmission of other-SI request, a WTRU may be configured to monitor a minimum-SI for a predefined time interval to determine the presence of scheduling information associated with the requested other-SI. For example, the predefined time interval may correspond to a random access response window. A WTRU may retransmit the random access preamble (e.g., with power ramping) when one or more of the following conditions may be true: if no random access response is received within a response window; if the received random access response does not correspond to the requested other-SI, which may or might not correspond to the transmitted other-SI request preamble/message; if the minimum-SI does not indicate a schedule for requested other-SI during the predefined time interval; and/or if the maximum preamble counter associated with an other-SI request transmission is not reached.

[0322] A WTRU may consider the other-SI procedure to be successful and/or stop retransmissions of other-SI request, when one or more of the following may be true: if a received random access response corresponds to the requested other-SI, wherein the random access response may or might not correspond to the transmitted other-SI request preamble/message; and/or if a received minimum-SI indicates the presence of scheduling information for requested other-SI.

[0323] A WTRU processor may be programmed for actions related to reception of broadcast other-SI. A minimum-SI may refer to transmissions in one or more logical broadcast channels mapped to one or more physical channels providing system information (e.g., essential) directly and/or indirectly (e.g., via indexes to stored/pre-acquired information) for the WTRUs to utilize services (e.g., to camp, reselect, perform initial access, and/or request further system information) from a cell. For example, realization minimum-SI may include Master System Information Block (MIB) and/or one or more SI messages carrying one or more SIBs and/or downlink signals indicating one or more aspects related to a minimum-SI transmission. The SIBs not carried in the minimum-SI may be called other-SI. A WTRU may be configured to receive other-SI transmitted via broadcast, multi-cast (e.g., to a group of relevant WTRUs), simulcast (e.g., from two or more transmission points using SFN) and/or unicast (e.g., to a specific WTRU). Depending on the transmission protocol, a WTRU may be configured to receive other-SI on the same physical channels as minimum-SI and/or a different physical

channel(s). WTRUs may be classified into the following different groups based on status of system information available at one or more, or each, of: WTRU: NULL WTRU; MSI WTRU; OSI UE; and/or FULL UE.

[0324] A NULL WTRU may be a WTRU without a valid minimum-SI and/or other-SI associated with the serving cell. For example, a NULL WTRU may have acquired and/or stored incomplete minimum SI and/or other-SI associated with the serving cell.

[0325] An MSI WTRU may be a WTRU with a valid minimum-SI but without other-SI associated with the serving cell. For example, an MSI may have acquired and/or stored minimum-SI, but not required other-SI for the ongoing procedures at the WTRU.

[0326] An OSI WTRU may be a WTRU with a valid minimum-SI and/or in the process of acquiring (e.g., re-acquiring) other-SI associated with the serving cell. For example, an OSI WTRU may or might not have triggered an other-SI request.

[0327] A FULL WTRU may be a WTRU with a valid minimum-SI and/or valid other-SI associated with the serving cell. For example, a FULL WTRU may have acquired and/or stored some or all the other-SI associated with serving cell and/or other-SI relevant for ongoing procedures at the WTRU.

[0328] An OSI WTRU may be configured to acquire other-SI transmitted as a response to an other-SI request. An OSI WTRU and/or a FULL WTRU may be configured to acquire other-SI transmitted as a result of update/changes to the other-SI. A NULL WTRU may be configured to pre-acquire other-SI before completion of minimum-SI acquisition.

[0329] A WTRU may determine the presence of other-SI scheduling information upon receiving an indication in a paging message. A WTRU may determine a change in value-tag associated with other-SI upon receiving an indication in a paging message. A WTRU may be configured with a timing relation between the other-SI request in the uplink and possible presence of other-SI schedule in the downlink. A WTRU may use the timing relation to determine the starting point for monitoring the presence of an other-SI schedule in a minimum-SI. For example, the timing relation may be expressed via a modification period. The timing relation may be expressed in relation to a paging occasion (e.g., the timing relation may be expressed as an offset in terms of timing units like a subframe and/or a radio frame). A WTRU may be configured with a timing relation in a paging message and/or in a response message to other-SI request.

[0330] A WTRU may be configured to suppress transmission of other-SI request based on reception of one or more downlink signals. For example, a WTRU may suppress the transmission of an other-SI request if a minimum-SI carries scheduling information for

corresponding other-SI. A WTRU may suppress transmission of other-SI request if a minimum-SI indicates that the corresponding other-SI may be scheduled in the future. Suppression may be used to prevent duplicate transmissions of other-SI request (e.g., when a network is preparing for transmission of broadcast other-SI based on a previous other-SI request possibly from a same and/or different WTRU).

[0331] A WTRU may be configured to acquire the broadcasted other-SI using one or more signaling aspects common to minimum-SI transmission. For example, a WTRU may be configured to receive the scheduling information for an other-SI broadcast and/or a minimum-SI broadcast (e.g., from a common minimum-SI). A WTRU may be configured to determine the presence of an other-SI schedule in the minimum-SI (e.g., via a change in the value tag associated with the minimum-SI). A WTRU may be configured to receive the dynamic time/frequency resources for minimum-SI and/or other-SI broadcast using the common control channel characteristic (e.g., search spaces, RNTI and/or the like). A WTRU may be configured to receive the other-SI broadcast transmission in time windows overlapping with the minimum-SI transmissions. WTRUs not interested in the other-SI broadcast may be triggered not to perform unnecessary receptions.

[0332] A WTRU may be configured to acquire the broadcasted other-SI using one or more signaling aspects decoupled from the minimum-SI broadcast.

[0333] A WTRU may be configured to determine the presence of other-SI broadcast (e.g., via the presence of scheduling information in a minimum-SI message). For example, a minimum-SI may carry scheduling information for minimum-SI and other-SI. A WTRU might not assume a change in the value-tag associated with the minimum-SI due to the addition and/or removal of other-SI scheduling information in the minimum-SI. In another example, the minimum-SI (e.g., MSI-M) carrying scheduling information for minimum-SI may be different from minimum-SI (e.g., MSI-O) carrying scheduling information for other-SI. A WTRU may be configured with separate value tags associated with one or more, or each, of MSI-M and/or MSI-O.

[0334] A WTRU may be configured with non-overlapping time windows for a minimum-SI broadcast and/or an other-SI broadcast. For example, a WTRU may be configured with the first other-SI time window after the last minimum-SI time window (e.g., a WTRU may be configured with one or more other-SI time windows with one or more unused minimum-SI time windows). For a specific other-SI message, a WTRU may determine a number "n+m" where "n" may correspond to the order of entry in the list of SI messages scheduled by a scheduling information list associated in MSI-O. "M" may correspond to the highest index associated with the list of

minimum-SI messages in MSI-M. For example, a WTRU may be configured with the same RNTI for minimum-SI reception and/or other-SI reception (e.g., a WTRU may be configured with the same control channel search space in time and/or frequency associated with minimum-SI and/or other-SI scheduling). An example of non-overlapping windows for minimum-SI and other-SI is shown in FIG 6.

[0335] A WTRU may be configured with one or more other-SI broadcast time windows partially and/or wholly overlapping with one or more time windows for a minimum-SI broadcast. A WTRU may be further configured with one or more aspects to avoid unnecessary reception of other-SI (e.g., when monitoring for minimum-SI). For example, a WTRU may be configured with an aspect of control channel monitoring that is different for minimum-SI as compared to other-SI acquisition (e.g., a WTRU may be configured with a separate RNTI associated with other-SI scheduling different from RNTI associated with minimum-SI scheduling). A WTRU may be configured with a control channel search space in time and/or frequency associated with other-SI scheduling different from control channel search space associated with minimum-SI scheduling. A WTRU may be configured with the other-SI transmission window length to be different than the transmission window length associated with minimum-SI. For example, overlapping windows for minimum-SI and other-SI is shown in FIG. 7.

[0336] A WTRU may determine beamforming applicability to system information delivery. A WTRU may be configured to determine whether beamforming is applicable for transmission of one or more system information messages. A WTRU may determine that system information delivery is beamformed (e.g., based on the carrier frequency). A WTRU may be configured with a predefined relationship between the frequency band and the nature of transmission. For example, a WTRU may consider system information to be beamformed for frequency bands higher than 6 GHz.

[0337] A WTRU may determine that system information delivery is beamformed (e.g., based on the characteristic of a downlink signal). The downlink signal may include a synchronization signal and/or any other reference signal. For example, characteristics of the downlink signal may include a type of the synchronization signal (e.g., a ZC sequence and/or a binary sequence), system signature, a root and/or basis sequence, and/or one or more predefined sequence numbers.

[0338] A WTRU may determine the nature of a system information transmission based on a relation between two or more synchronization signals in time and/or frequency. A WTRU may determine that system information delivery is beamformed (e.g., based on the information carried in a broadcast message). For example, a master system information block, a first system information message, and/or an essential system information (if any) may contain an indication

that one or more system information may be beamformed. A WTRU may apply receive beamforming for system information reception (e.g., based on the measurements made on downlink signal quality). For example, a WTRU may apply receive beamforming for system information reception when the received power of a reference signal, a synchronization signal, a master system information block, and/or an essential system information (if any) is below (or above) a predefined threshold.

[0339] A WTRU may use uplink assistance to beamforming for system information delivery. A WTRU may provide uplink assistance information to a network element to assist the network element in performing system information delivery. A WTRU may transmit assistance information in an UL signal and/or an UL message (e.g., a transmission for system information activation, system information request, and/or a measurement report). A WTRU may provide transmit assistance information in a deployment applying beamformed transmissions for system information messages. A WTRU may be configured to acquire system information (e.g. using beamformed transmissions). WTRU assistance may help reduce on-demand system information overhead (e.g., reduce required number of beamformed transmissions) and/or reduce the time required for beamformed on-demand system information acquisition. A beam sweep may refer to transmission and/or reception of system information in a plurality of TX and/or RX beams associated with a transmission point and/or reception point (e.g., multiplexed in time, frequency and/or space). A WTRU may receive synchronization signal, master system information, and/or essential system information (if any) in a beam sweep operation. A WTRU may receive on-demand system information in a subset of beams used for transmission of synchronization signal, master system information, and/or essential system information.

[0340] A WTRU may determine assistance information (e.g., based on the measurement of one or more aspects related to downlink transmission). For example, the downlink beamformed transmission may include one or more of: a reference signal transmission (such as a reference signal specific to a beam, antenna port, cell and/or sector etc.), a synchronization signal transmission, a transmission of a master system information block, and/or a transmission of one or more essential system information, any other periodic system information transmission associated with the DL beams, and/or an initial transmission of on-demand system information. A WTRU may measure a received energy metric based associated with the downlink transmission (e.g., RSSI (Received Signal Strength Indication)). A WTRU may measure a quality metric associated with the downlink beamformed transmission. For example, the quality metric may be based on received reference signal power (such as RSRP, RSRQ), signal to noise ratio (such as SNR), and/or a channel quality indication (e.g., CQI) etc. A WTRU may measure

one or more spatial metric associated with the downlink beamformed transmission (e.g., angle of arrival of a downlink transmission). A WTRU may average the measurement results over a predefined time window. A WTRU may use the result to determine the assistance information. A WTRU may consider/favor the measurement samples that are most recent based on freshness/age criteria to determine the assistance information.

[0341] A WTRU may indicate (e.g., via the assistance information) the quality of the serving cell based on one or more measurement metrics described herein. A WTRU may indicate (e.g., via the assistance information) whether to beamform the on-demand system information transmissions (e.g., based on one or more measurement metrics described herein). For example, a WTRU may provide the indication in cell edge and/or in a poor link condition where beamforming may overcome the increased path loss. A WTRU may determine whether to beamform the on-demand system information transmission (e.g., based on the received quality of the downlink transmission). For example, a WTRU may request a beamformed transmission of on-demand system information when the quality of the serving cell is below (or above) a predefined threshold. A WTRU may determine the usefulness for beamformed on-demand system information transmission based on the WTRU's capability. For example, a WTRU may consider the receive beamforming capability and/or the antenna gain achievable with receive beamforming. For example, a WTRU may request a beamformed on-demand system information transmission, when the quality of the serving cell is below a threshold in the presence of receive beamforming. A WTRU may indicate (e.g., via the assistance information) the reception status/quality of one or more downlink beams based on one or more measurement metrics described herein. A WTRU may indicate (e.g., via the assistance information) one or more downlink beams to receive the on-demand system information (e.g., based on one or more measurement metrics described herein).

[0342] FIG. 8A and 8B illustrate an example of an on-demand SI request in a beamformed context. At 802, a WTRU may determine one or more UL resources, perhaps for example based on one or more of: at least one (e.g., preferred) DL beam on which Sync and/or MIB and/or MSI and/or ESI may be received, an UL resource mapping to that DL beam, and/or one or more on-demand SI messages to be requested. At 804, the WTRU may transmit (TX) information for reception of the one or more on-demand SI messages using the one or more determined UL resources. At 806, the WTRU may receive a message (e.g., MSG2) that may be associated with the requested on-demand SI. At 808 the WTRU may monitor an on-demand SI window on Beam3 (e.g. a selected DL beam of one or more beams transmitted from the communication network) for the one or more on-demand SI messages.

[0343] A WTRU may transmit assistance information. A WTRU may organize the measurement results and/or send a measurement report to the network. A WTRU may include a list (e.g., of one or more, or all) the downlink beams above a predefined quality metric and/or energy metric in the measurement report. A WTRU may be configured to transmit a list of N beams (e.g., best beams) in a measurement report. A WTRU may determine the number of beams to be reported based on the size of measurement report resource.

[0344] A WTRU may request for on-demand system information to be transmitted (e.g., in one or more specific beams). For example, a WTRU may request for on-demand system information in a DL beam (e.g., from which the WTRU received a synchronization signal, a master system information block, and/or essential system information). A WTRU may transmit the request (e.g., in a layer 3 message and/or a layer 2 control element).

[0345] A WTRU may indicate one or more DL beams to receive on-demand system information (e.g., based on a choice of an UL resource and/or a transmission on that UL resource). For example, the UL resource may be a sounding reference signal and/or a random access resource. One or more, or each preconfigured UL resource may be associated with one or more DL beams. A WTRU may obtain the mapping between a DL beam and an UL resource in a broadcast message (e.g., an essential system information (if any) and/or a time/frequency relation based on identity associated with the DL beam).

[0346] The assistance information may be piggybacked with an on-demand system information request and/or system information activation procedure.

[0347] The WTRU may indicate the identity of DL beams in the assistance information. A WTRU may determine the identity of a DL beam based on one or more of the following: based on reference signal sequence associated with the DL beam; based on antenna port associated with the DL beam; based on time/frequency resources associated with the DL beam; based on synchronization signal associated with the DL beam; and/or based on an (e.g., explicit) identity carried in a known downlink transmission on the DL beam (e.g., a master information block and/or an essential system information (if any)).

[0348] A WTRU may transmit assistance information in a layer 3 message. For example, the assistance information may be transmitted on a default signaling radio bearer.

[0349] A WTRU may transmit assistance information in a MAC control element. For example, a new field in the MAC header (such as a predefined LCID) may indicate the presence of assistance information.

[0350] A WTRU may transmit assistance information in a physical channel reserved for layer 1 control signaling.

[0351] A WTRU may transmit assistance information on a contention based channel. Use of a contention based channel may be resource efficient. In case of collision of assistance information, at least the usefulness for on-demand system information may be conveyed by the presence of transmissions/signal energy in the contention based channel.

[0352] A WTRU may transmit assistance information before entering a connected state. For example, a WTRU may transmit assistance information on a common control logical channel.

[0353] A WTRU may transmit the assistance information in a message during connection establishment procedure. For example, a WTRU may include assistance information as a response to connection setup message.

[0354] A WTRU may transmit assistance information when an on-demand system information request and/or system information activation procedure is triggered.

[0355] A WTRU may transmit assistance information based on availability of measurement results. For example, a WTRU may start a timer upon achieving downlink synchronization to the cell. A WTRU may trigger on-demand system information with assistance information (e.g., if the measurement results are available before timer expiry). A WTRU may trigger on-demand system information without assistance information when the timer expires before the measurement results are available.

[0356] A WTRU may transmit assistance information when the acquisition of essential system information (if any) is complete.

[0357] A WTRU may transmit assistance information when explicitly requested by the network.

[0358] A WTRU may transmit assistance information based on an initial transmission of on-demand system information. Such assistance information may be included along with the feedback for such initial transmission.

[0359] A WTRU may determine DL resources for on-demand system information, for example, by using one or more of the following: a predefined timing relation between the system information request and start of control channel monitoring (e.g. a control channel may carry a scheduling grant for on-demand system information); and/or a predefined relation between time/frequency resources used for an SI request and start of data channel carrying on-demand system information.

[0360] For example, an identity (e.g. an RNTI) for an on-demand system information schedule may, for example, be specific to a WTRU that transmitted the request (e.g. a function of time/frequency resources used for UL SIB request). For example, an identity (e.g. an RNTI) for on-demand system information schedule may, for example, be specific to a cell and/or a

predefined constant, which may allow opportunistic reception for WTRUs that did not transmit the SIB request. For example, an RNTI for periodic system information may be different from on-demand system information.

[0361] A WTRU may be configured with a temporary periodic resource and/or a semi-persistent resource for on-demand system information reception. For example, a WTRU may receive such a resource as a response to system information activation and/or an on-demand system information request. A WTRU may determine the end of an on-demand system information procedure.

[0362] For example, a WTRU may enter connected mode, e.g., to receive on-demand system information messages. A WTRU may be in a loosely connected state or idle connectionless state to trigger an on-demand system information procedure. A WTRU may determine the end of on-demand system information transmission using one or more criteria.

[0363] For example, a WTRU may determine the end of an on-demand system information transmission based on a predefined time-window. For example, a WTRU may consider the start of the time window as a start of a first DL transmission corresponding to on-demand system information and/or an end of the TTI containing the system information request. For example, a WTRU may consider end of on-demand system information upon the end of time-window.

[0364] For example, a WTRU may determine the end of an on-demand system information transmission, for example, based on explicit indication. For example, a WTRU may receive a special end-marker in the last TTI carrying on-demand system information.

[0365] For example, a WTRU may determine the end of an on-demand system information transmission based on a counter. For example, a WTRU may receive a countdown value in a (e.g. one or more, or each) on-demand system information. A WTRU may consider the system information carrying the countdown value as the last on-demand system information.

[0366] For example, a WTRU may determine the end of an on-demand system information transmission based on a candidate system information list. For example, a WTRU may be pre-configured with and/or may be signaled a candidate system information list to be acquired and/or associated with an on-demand system information procedure. A WTRU may consider end of on-demand system information transmission, for example, when (e.g. some or all) the system information in the list is received successfully.

[0367] For example, a WTRU may determine the end of an on-demand system information transmission based on an explicit release command. For example, a WTRU may (e.g. when the WTRU entered connected mode to receive the on-demand system information) consider an end

of on-demand system information upon receiving a connection release command from the network.

[0368] A WTRU may process received on-demand system information. A WTRU may trigger a control procedure and/or transition back to idle mode at the end of on-demand system information reception.

[0369] A WTRU may consider a cell/TRP to be barred, for example, when a WTRU fails to acquire essential system information (if any) before the end of on-demand system information procedure.

[0370] A WTRU may start (e.g., first start) to apply received/acquired system information or parts thereof. A WTRU may apply/activate the received on-demand system information (e.g., at a specific reference point in time determined by the WTRU).

[0371] A WTRU may apply system information received via an on-demand procedure (e.g., at a specific time offset from the TTI corresponding to end of on-demand system information procedure as described herein). Such time offset may be predefined and/or transmitted along with the system information.

[0372] A WTRU may apply the on-demand system information (e.g., at the modification boundary after the completion of on-demand system information procedure). For example, a WTRU may reuse the modification boundary defined for essential system information.

[0373] A WTRU may apply the on-demand system information upon receiving an explicit activation message. A WTRU may receive such activation message via layer 3 signaling and/or MAC/Layer 1 control signaling.

[0374] A WTRU may apply the on-demand system information upon entering a specific state. For example, a WTRU may apply on-demand system information relevant to connected mode operation upon entering connected state. A WTRU may apply on-demand system information relevant to light connected operation upon entering light connected state.

[0375] A WTRU may apply the on-demand system information upon transmitting an indication to the network. For example, a WTRU may indicate completion of on-demand system information acquisition to the network and/or may apply (e.g., subsequently) the stored on-demand system information.

[0376] The WTRU may invalidate configured system information or parts thereof. A WTRU may receive, apply, and/or store the on-demand system information. A WTRU may monitor the validity of stored on-demand system information. A WTRU may stop using, deactivate, invalidate, overwrite, replace, and/or delete the on-demand system information based on one or more of the following criteria: validity of on-demand system information may be

associated with WTRU state; validity of on-demand system information that may be associated with WTRU location; validity of on-demand system information that may be associated with validity of essential system information; validity of on-demand system information that may be associated with a timer; and/or an explicit indication of on-demand system information validity.

[0377] For validity of on-demand system information that may be associated with a WTRU state, a WTRU may receive on-demand system information after transition to connected mode. Such on-demand system information may be used (e.g., required) for operation in connected mode. A WTRU may consider the on-demand system information to be invalid upon exiting connected state.

[0378] For validity of on-demand system information that may be associated with a WTRU state, a WTRU may acquire on-demand system information while in light connected state. Such on-demand system information may be used (e.g., required) for operation in connected mode. A WTRU may consider the on-demand system information to be invalid upon exiting to light connected state.

[0379] For validity of on-demand system information that may be associated with a WTRU state, on-demand system information may be applicable for light connected and/or connected state. A WTRU may consider the on-demand system information to be valid across transition between light connected and connected state. A WTRU may consider the on-demand system information to be invalid upon transition to IDLE state.

[0380] For validity of the on-demand system information that may be associated with WTRU location, a WTRU may consider the on-demand system information received in a DL beam to be valid (e.g., only) within that DL beam. Such an approach may be extended for a group of DL beams. For example a WTRU may consider a received on-demand system information to be valid in a group of DL beams.

[0381] For validity of the on-demand system information that may be associated with WTRU location, the group of DL beams may be associated with the same control channel. A WTRU may consider the on-demand associated with the group of DL beams valid as long as the WTRU can reliably receive the control channel.

[0382] For validity of the on-demand system information that may be associated with WTRU location, a WTRU may consider the on-demand system information to be valid (e.g., only) within the cell from which the WTRU received the on-demand system information. A WTRU may consider the on-demand system information to be invalid when the measured quality of the cell is below (or above) a predefined threshold.

[0383] For validity of the on-demand system information that may be associated with WTRU location, a WTRU may consider the on-demand system information to be valid in a geographical area, e.g. a RAN paging area and/or a list of preconfigured cells.

[0384] For validity of an on-demand system information that may be associated with validity of an essential system information, a WTRU may consider the on-demand system information associated with a transmission point, beam, cell, and/or region to be invalid if the validity of essential system information (if any) associated with the same transmission point/beam/cell/region becomes invalid.

[0385] For validity of an on-demand system information that may be associated with validity of an essential system information, a WTRU may be explicitly configured with the linkage between validity of one or more essential system information (if any) and validity of one or more on-demand system information.

[0386] For validity of on-demand system information that may be associated with a timer, a WTRU may consider the on-demand system information to be valid until expiry of a validity timer. For example, the value of validity timer may be specific to a valuetag (e.g. validity timer may be implicit based on ranges of valuetags and/or explicitly configured per valuetag). The value of validity timer may and/or specific to the type of system information (e.g. different timer values for MSI compared to OSI, and/or different validity for different types of SI within MSI and/or OSI). The value of validity timer may be specific to logical area, perhaps for example where the SI was acquired (e.g. a different longer value for SIs acquired in the current cell and/or current RAN area and/or shorter values for SIs acquired from non-serving cell and/or different RAN area).

[0387] For an explicit indication of on-demand system information validity, the on-demand system information may be associated with a validity tag and/or version. A WTRU may monitor the validity of stored on-demand system information using a validity tag in a broadcast message (e.g. MIB and/or SIB), paging message, and/or the like.

[0388] For an explicit indication of on-demand system information validity, the value tag may be specific to a single on-demand system information message, common to a group of on-demand system information messages, and/or common to some or all the on-demand system information messages from a transmission point/beam/cell/region.

[0389] A WTRU may use any combination of the above to stop using, deactivate, invalidate, and/or delete the on-demand system information.

[0390] A WTRU may re-acquire the specific SI that is changed (e.g., upon determining that an SI is invalid using one or more methods described herein). For example, the WTRU may re-

acquire changed SI and/or refrain from re-acquiring unchanged SI. A WTRU may monitor minimum-SI for the schedule and/or trigger other-SI request for a specific SI to acquire (e.g., only) the required SI.

[0391] A WTRU may store different versions of SI in memory. A WTRU may determine validity in a specific cell of essential and/or on-demand system information obtained from a different cell and/or stored at the WTRU.

[0392] A WTRU may maintain and/or store in memory one or more, or multiple versions of SI from the network. Such different versions of SI may be received from the current serving cell, from a different cell, and/or from a different frequency layer. Stored SI may enable the WTRU to avoid acquiring SI after every cell change. A WTRU may determine a specific stored version of an SI applicable for a cell based on one or more aspects related to the DL transmission in that cell. A WTRU may consider spatial applicability and/or temporal applicability of a stored system information to avoid unambiguity and/or configuration mismatch between WTRU and the network.

[0393] A WTRU may use spatial applicability with SI. SI may be associated with an area for which it applies (e.g., where the area may correspond to a beam, group of beams, a cell, one or more, or each cell in an eNB, group of cells (within a RAN area, tracking area and/or similar), and/or a PLMN etc.). For example, a WTRU may be configured with a version of SI to apply in a geographical area covered by a group of cells. For example, a version of SI may be associated with the SI to be applied by the WTRU in different conditions (e.g., at different times of the day within the same cell).

[0394] A WTRU may use temporal applicability with SI. A WTRU may store one or more, or each instance of a received SI for a maximum of a timer ("T") (e.g., started when the WTRU first receives that SI). On expiry of the timer, a WTRU may delete the stored SI. The WTRU may have one or more, or multiple timers active (e.g., one or more, or each associated with a different SI instance).

[0395] A WTRU may use application of stored SI for cells transmitting a reference ID.

[0396] The term reference ID may refer to unique identity for a specific instance of an SI and/or a group of SIs. The reference ID may be unique over a predefined area and/or for a predefined time interval.

[0397] A WTRU may acquire SI from a transmission point that is not applicable to that transmission point (e.g., the SI may be applicable to a different transmission point). Thus, the WTRU may be configured to not assume an SI received from a transmission point that is applicable to that transmission point. A WTRU may be configured to associate an SI to a

transmission point based on a reference ID associated to that SI. A WTRU may receive an SI from a transmission point and/or may apply the received/stored SI in a different transmission point, which may or might not transmit the corresponding SI. A WTRU may be configured to apply one or more SIs to a subset of beams from a transmission point. For example, a WTRU may activate one or more stored SIs based on the reference ID carried in a beam (e.g., implicitly based on reference signals in the beam and/or explicitly carried in a MIB associated with a beam).

[0398] A WTRU may determine to store a version of SI based on one or more reference IDs associated with one or more, or each version of SI and/or portions thereof. The reference ID for a version of SI may be broadcast by the network as part of the essential system information and/or along with the on-demand SI. For example, the reference ID may be implicitly determined by the WTRU by aspects related to the transmission by the network of the essential SI. For example, the WTRU may determine the reference ID for an SI based on the timing/frequency of the transmission of that SI relative to a reference time/frequency. In addition to the reference ID, and/or as part of the reference ID, the WTRU may also receive a value tag associated with the system information. The value tag may be used as in legacy LTE systems.

[0399] The reference ID and value tag may be independent identifiers received by the WTRU. For example, a single reference ID may be received by the WTRU, which may include a value tag. For example, a set of bits in the reference ID may indicate the specific version of the SI, while another set of bits in the reference ID may indicate the value tag associated with the version of the SI.

[0400] The reference ID may be applicable to all or part of the system information. For example, a WTRU may receive a reference ID (e.g., which may be applicable to some or all the SI transmitted by a cell (e.g., essential SI and/or on-demand SI)). A WTRU may receive a reference ID which is associated with the essential SI, and/or one or more different reference IDs associated with distinct portions of the on-demand SI. A WTRU may receive the reference ID and/or value tag associated with an SI or a portion of an SI via broadcast and/or dedicated signaling. A WTRU may be configured with the association of one or more sets of reference IDs and/or value tags with one or more sets of SI.

[0401] A WTRU may derive an implicit reference ID based on one or more aspects/characteristics associated with DL transmissions. A WTRU may associate the derived reference ID with one or more SI(s) based on predefined rules. For example, a WTRU may derive a reference ID based on a broadcasted area ID (e.g., a RAN area and/or a tracking area

ID). A WTRU may be configured to apply the stored SI linked to a reference ID (e.g., while the WTRU can determine that the WTRU is within an area associated with that reference ID). For example, a WTRU may derive a reference ID based on the frequency layer and/or frequency band indication. A WTRU may be configured to apply the stored SI linked to a reference ID (e.g., while the WTRU can determine that a cell belongs to a frequency layer and/or frequency band). For example, a WTRU may derive a reference ID based on a geographical location (e.g., a WTRU may derive a reference ID based on part of global cell identity transmitted in a broadcast signaling). A WTRU may derive a reference ID based on characteristics of DL signals (e.g., logical sequence carried in a synchronization signal). A WTRU may associate the derived reference ID to one or a subset of received SIs. For example, a WTRU may determine the subset based on SI type (e.g., a WTRU may associate the derived reference ID to minimum-SI and/or other-SI). A WTRU may determine the subset based nature of physical channel carrying the SI (e.g., a WTRU may associate the derived reference ID to the SI carried in a physical channel dedicated for a SI transmission, a physical channel defined for single frequency network transmission, a SI transmitted on a physical shared downlink channel, and/or a SI transmitted on a beamformed physical channel. For example, a WTRU may be configured explicitly for the subset of SIs for which the derived implicit reference ID is applicable.

[0402] A WTRU may determine to apply a stored version of SI (e.g., upon detecting a cell which transmits a reference ID which matches (e.g., substantially corresponds with) at least one of the WTRU's stored SI versions). The match may also include, without loss of generality, some relational equivalence (e.g., greater than, less than, etc.). A WTRU may be allowed to perform cell operations with stored SI based on equivalence of the reference ID transmitted by a cell with a stored version of SI at the WTRU. A WTRU may be able to camp on a cell and/or perform INACTIVE/CONNECTED mode operations on that cell without acquiring SI from the cell (e.g., despite the cell transmitting a limited amount of SI and/or complete minimum-SI, one or more of which may include a reference ID). For example, a WTRU may camp on a cell which transmits (e.g., only) a portion of the essential SI (and including the reference ID) if the WTRU detects the reference ID matches (e.g., substantially corresponds with) the reference ID of a version of SI stored by the WTRU. A WTRU may consider a neighbor cell transmitting reduced minimum-SI as a candidate for reselection if the WTRU can determine that the reference ID of the neighbor cell (e.g., by receiving reduced minimum-SI from the neighbor cell and/or querying the serving cell) matches (e.g., substantially corresponds with) the reference ID of a version of SI stored by the WTRU.

[0403] A cell may transmit the reference ID (e.g., to identify the SI version) and/or a value tag associated with that SI version. One or more reference ID and/or value tags may be transmitted by network cells. A cell may transmit the essential SI, which may be the SI for a WTRU to access the cell. A cell may transmit less than the essential SI while still transmitting the one or more sets of reference IDs and/or a value tag.

[0404] The reference ID and/or value tag may be assumed to be associated with the essential SI. A reference ID and value tag pair may be associated with the on-demand SI and/or a subset of the on-demand SI.

[0405] A WTRU may have a processor programmed with conditions for storing a version of SI in memory.

[0406] A WTRU may store in memory newly acquired SI associated with a reference ID for which the WTRU does not currently have any stored information. A WTRU may also maintain and/or store in memory the SI for a particular amount of time, for a specific area (e.g., as long as the WTRU does not move beyond an area or by more than a certain amount), and/or as long as the value tag associated with the reference ID has not changed. For example, a WTRU may invalidate/delete stored SI associated with a reference ID when it detects a change in the value tag transmitted by the network for SI with the same reference ID.

[0407] A WTRU may replace stored SI associated with a reference ID when it detects and/or determines transmission by a cell of SI with the same reference ID as a version of SI stored by the WTRU, but where the value tag has changed. The newly acquired SI may also be stored in memory by the WTRU as stored SI.

[0408] A WTRU may have a processor programmed with conditions for applying a stored SI version.

[0409] A WTRU may determine that the WTRU may change from a current version of SI to applying a stored version of SI upon reselection to a new cell, moving from an out of coverage condition to in coverage condition, upon detection of a change of the essential SI and/or parts of the essential SI transmitted by the network, upon detecting a change of the reference ID and/or value tag, associated with the SI and/or a different subset of the SI, upon leaving connected state, and/or upon receiving a handover command; for example a WTRU may receive a handover command with a reference ID and/or value tag (or value identifier). A WTRU may apply the stored SI associated with the received reference ID and/or value tag for operation in the target cell. This approach may reduce the size of the handover command and/or allow compressed signaling of target cell parameters. A WTRU may further determine, following the above events, that it may apply a specific version of stored SI based on one or more of the following

scenarios: the reference ID of a version of the stored SI matches (e.g., substantially corresponds with) the reference ID currently broadcast by the cell (e.g., in the essential SI); the reference ID and value tag of a version of stored SI matches the reference ID and value tag currently being broadcast by the cell (for example in the essential SI) and/or provided by the cell in dedicated signaling; the implicit reference ID derived by the WTRU for the cell matches with the implicit reference ID stored for the essential SI; the time elapsed since the version of stored SI was acquired by the WTRU does not exceed a predefined and/or configured threshold; and/or the distance travelled by the WTRU since it acquired the specific version of stored SI is below a predefined and/or configured threshold. Upon applying the stored SI(s) associated with the matching reference ID(s), a WTRU may perform one or more actions as if those SIs are acquired in the current cell (e.g., monitoring possible updates to the applied SI, requesting for one or more other-SIs if missing, forwarding relevant information to upper layers (e.g., cell identity, tracking area code, supported features) etc.).

[0410] A WTRU may have a processor programmed with instructions for actions upon having no valid stored SI.

[0411] A WTRU may determine that the WTRU does not have a valid stored SI for a cell if the reference ID received from a cell does not match any of the reference IDs of stored SI versions at the WTRU. A WTRU may determine that the WTRU does not have valid stored SI if the value tag for a transmitted reference ID which matches (e.g., substantially corresponds with) the reference ID of a stored version of SI does not match the value tag of the stored SI having that reference ID.

[0412] A WTRU may, under such conditions, perform and/or determine to perform one or more of the following actions: the WTRU may acquire the SI from the cell and/or store in memory the SI with the associated reference ID and value tag (e.g., if the cell transmits the SI in question (essential SI and/or other-SI)); the WTRU may determine the cell to be barred and/or inaccessible; the WTRU may perform a cell (re)selection and/or attempt to camp on a recent cell and/or another detectable cell for which the above conditions do not occur (e.g., if the cell does not transmit the essential SI); and/or the WTRU may initiate a request for SI, such as some or all other-SI, and/or possibly for the other-SI for which the associated reference ID and value tag meet the conditions described herein.

[0413] A WTRU may have a processor programmed with instructions for requesting a reference ID and/or value tag of SI. The network might not broadcast the reference ID and/or value tag of an SI. For example, the network may transmit the reference ID and/or value tag of the on-demand SI with the SI itself, and/or may currently not be broadcasting any other-SI. A

WTRU may perform a request for the reference ID and/or value tag for some or all or a specific subset of SI. The request may be triggered as a result of one or more of the following triggers: a WTRU reselects to a different cell; a WTRU, in reselecting to a different cell, has one or more versions of stored SI for the SI and/or subset of SI for which the WTRU is requesting a reference ID/value tag; a WTRU detects a change in another (potentially related and/or linked) reference ID and/or value tag broadcast by the network; a WTRU initiates a service requiring access to a certain SIB and/or subset of SI, for which the WTRU may potentially have stored SI which may be validated; a WTRU reselects and/or connects to a cell where the current reference ID and/or value tag associated with a required part of the SI is not being broadcast by the cell; a WTRU has moved by a certain amount; and/or the validity timer associated with a subset of SI (potentially related to the specific SI in question) has expired.

[0414] A WTRU may perform a request for reference ID and/or value tag for a subset of SI through RRC signaling. A WTRU may make the request in IDLE/INACTIVE states and/or in a CONNECTED state. A WTRU may utilize a RACH procedure (e.g., 2-step and/or 4-step RACH) to make the request. A WTRU may use PHY layer signaling on an UL control channel and/or dedicated resources using RRC signaling to make the request.

[0415] The WTRU may include in the request of one or more of the following information: one or more reference IDs and/or value tag of any stored SI at the WTRU; a WTRU ID (e.g., C-RNTI, S-TMSI, resume ID, etc.); and/or a specific SIB, SI subset, and/or SI type for which the WTRU is interested in obtaining a reference ID and/or value tag.

[0416] Following a request, a WTRU may perform one or more of the following actions: acquire essential SI that may contain at least a reference ID and/or a value tag; apply a specific version of SI that may be associated with a reference ID and/or a value tag transmitted by the network in response to the request; perform reselection to a different cell, which may be a cell utilizing an SI for which the WTRU has a stored valid version; perform a request for other-SI that may be a result of the WTRU determining that the WTRU does not have a valid stored version of the SI; determine the scheduling information associated with on-demand SI, potentially transmitted by the network in the essential SI; and/or acquire SI, potentially based on previously acquired and/or configured scheduling information. Examples include a reference ID applicable to essential and on-demand SI; a reference ID applicable to essential SI (e.g., only essential SI); non-broadcast reference ID for on-demand SI; broadcast reference ID for on-demand SI; and reference ID applicable for a subset of minimum-SI and/or other-SI.

[0417] For a reference ID applicable to essential and/or on-demand SI, a WTRU may reselect to a cell (e.g., new cell) which transmits all or part of the essential SI, but includes a

reference ID (indicating the version) and/or a value tag. A WTRU may apply a stored version of the essential SI for the cell if the WTRU possesses a version of SI having the same reference ID and/or value tag. A WTRU may apply the stored essential SI and/or on-demand SI. The WTRU may determine that the reference ID and/or value tag transmitted by the network is applicable to essential SI and/or on-demand SI.

[0418] For a reference ID applicable to essential SI (e.g., only to essential SI), a WTRU may reselect to a cell (e.g., new cell) and/or may determine that the reference ID and/or value tag transmitted by the network is applicable to the essential SI (e.g., only the essential SI). A WTRU may apply a valid stored SI for essential SI. A WTRU may initiate a request for on-demand SI in the new cell and/or acquire the on-demand SI (e.g., if it is already being transmitted by the cell).

[0419] For non-broadcast reference ID for on-demand SI, a WTRU may receive a reference ID and/or a value tag for essential SI and/or one or more sets of reference IDs/value tags for the on-demand SI. For example, the on-demand SI may be divided into one or more, or multiple, subsets and/or types of on-demand SI. One or more, or each set may have its own reference ID and/or value tag. A WTRU may be configured with the subset information. A WTRU may receive the reference ID and/or value tag sets for the on-demand SI during the transmission of the on-demand SI itself (either through dedicated and/or broadcast signaling). A WTRU may reselect to a cell (e.g., new cell) and/or may detect transmission of the essential SI (e.g., essential SI only) and/or part of the essential SI which may include the reference ID and/or the value tag for the essential SI. For example, a WTRU may receive the reference ID and/or value tag of the essential SI, may determine that the WTRU has a valid version of stored essential SI, and/or may apply the stored essential SI.

[0420] The WTRU may determine that the WTRU does not have a valid version of stored essential SI and/or may acquire the essential SI from the cell. The WTRU may perform a request for on-demand SI if the WTRU does not determine that the cell is transmitting the on-demand SI. The WTRU may include, in the request for the on-demand SI, the reference IDs and/or value tag(s) of any on-demand SI. This information may be useful to the network to determine whether to broadcast on-demand SI.

[0421] The WTRU may receive, from the network, an indication to use the stored on-demand SI associated with a reference ID; an indication that the on-demand SI will be broadcast by the network; and/or the WTRU may start to receive the on-demand SI from the network as an indication that it should acquire the on-demand SI. The WTRU may perform a request to have the network transmit the reference ID and/or value tag associated with the on-demand SI. The

WTRU may receive the reference ID and/or value tag pairs associated with one or more, or each set of on-demand SI, may determine the validity of any stored on-demand SI, and/or may determine whether to perform a request for on-demand SI.

[0422] For broadcast reference ID for on-demand SI, a WTRU may reselect a cell (e.g., a new cell) and/or may receive in the essential SI, and/or as part of the essential SI, an independent reference ID and/or value tag pairs for essential SI and/or on-demand SI. The WTRU may determine whether it has a valid version of the essential SI and/or may apply the determined valid version of the essential SI. If the WTRU determines that the WTRU does not have a valid version of the essential SI, the WTRU may acquire the essential SI and the cell may broadcast the essential SI. The WTRU may reselect to a different cell (e.g., if the WTRU determines that the WTRU does not have a valid version and/or the WTRU cannot acquire the essential SI). The WTRU may determine whether the WTRU has a valid version of one or more, or each set of on-demand SI. The WTRU may perform a request for on-demand SI for any set of SI for which the reference ID and/or value tag does not match a stored version of SI at the WTRU.

[0423] For a reference ID applicable for a subset of minimum-SI and/or other-SI, a WTRU may apply a combination of stored SI and the SI received from a cell. For example, a WTRU may determine that the reference ID broadcasted for a subset of minimum-SI and/or other-SI, remaining minimum-SI, and/or other-SI should be acquired from the cell. A WTRU may have stored only a subset of minimum-SI and/or other-SI associated with a broadcasted reference ID and/or may determine that the remaining minimum-SI and/or other-SI should be acquired from a cell. A WTRU may implement a subset of SI that is area specific. The remaining SI may be cell specific. A WTRU may be configured with semi-static system information common to an area that may be associated with the area specific reference ID, whereas more dynamic system information may be configured as cell specific SI. A WTRU may be configured with an overlapping subset of area specific SI and cell specific SI. A WTRU may apply precedence for SI transmitted from the cell over the area specific SI (e.g., applied via reference ID+ stored SI). A WTRU may apply two or more subsets of stored SIs based on two or more reference IDs to obtain a complete minimum SI in a cell. For example, a WTRU may receive and/or store different parts of minimum SI. One or more, or each part may be associated with a reference ID. A WTRU may determine the complete minimum SI by a union of different parts of the stored minimum SI.

[0424] A WTRU may determine a reception of a list of valid cells. A WTRU may receive (e.g., as part of the SI of a cell) a list of other cells for which the SI can be used for the cell. The WTRU may apply the same rules described above for a reference ID in relation to storage and/or

may apply the SI. The WTRU may determine based on whether a cell is within the list of other cells (e.g., based on, for example, the PSS/SSS, and/or cell ID), whether the WTRU can apply acquired/stored SI in the cell, and/or whether the WTRU wishes, desires, and/or finds useful to acquire new (e.g., fresh) SI for a cell.

[0425] A WTRU may have a processor programmed to determine conditions (e.g., dependent conditions) for applying SI.

[0426] A WTRU may store different instances of SI (associated with the same or different reference IDs) and/or may apply (e.g., selectively apply) an instance of the SI based on certain conditions in the WTRU. The conditions may be configured in the WTRU and/or provided to the WTRU as part of the SI instances. The conditions may include one or more of: the time of day; the geographical location, speed, and/or heading of the WTRU; beam configuration; active service(s) and/or service type(s); and/or an active numerology.

[0427] A WTRU may have a processor programmed for actions related to reception of minimum-SI, reduced minimum-SI, and/or other-SI. A WTRU may be configured to receive "reduced minimum-SI" if transmitted. Reduced minimum-SI refers to a transmission of minimum-SI with a reduced size, whose contents are a subset of a complete minimum-SI, and may have one or more information elements not present in complete minimum-SI. A WTRU may be configured to receive reduced minimum-SI in one or more of the following ways: a DL signal as reduced minimum-SI (e.g., a WTRU may derive a reference ID based on one DL signal or a combination of two or more DL signals (e.g. synchronization signals, reference signals)); an MIB as a reduced minimum-SI (e.g., a WTRU may receive from a Master Information Block, one or more reference ID(s) and/or value-tag(s) associated with pre-provisioned SI(s)); a MIB and most frequent minimum-SI as reduced minimum-SI (e.g., a WTRU may determine one or more aspects related to a more frequent minimum-SI from a master information block and the frequent (e.g., most) minimum-SI may carry one or more reference ID(s) and/or value-tag(s) associated with pre-provisioned SI(s)); an MIB, most frequent minimum-SI, and one or more minimum-SI with configurable periodicity; and/or the WTRU may receive and/or apply a minimum-SI with configurable periodicity (e.g., configured in a most frequent minimum-SI) to obtain the complete minimum-SI.

[0428] A WTRU may be configured to receive one or more of the following information in a (e.g., complete) minimum-SI; a minimum-SI (e.g., most frequent SI) may include a reference ID(s) and/or validity tag(s) common to some or all minimum-SIs and/or specific to a subset of minimum-SI; and/or a reference ID(s) and/or validity tag(s) common to some or all other-SIs and/or specific to a subset of other-SI.

[0429] A WTRU may be configured to determine a support for an SI based on the presence of a reference ID(s) and/or validity tag(s) for that SI. A minimum-SI may include the scheduling configuration for minimum-SI broadcast (e.g., MSI type, periodicity, window length) and/or one (e.g., only one) of the following for one or more, or each, supported other-SI: scheduling configuration for other-SI broadcast (e.g., other-SI type, periodicity, and/or window length) and/or RACH configuration to request other-SI.

[0430] Additional minimum SIs may include cell accessibility information (e.g., barring status, access control parameters, PLMN ID, cell ID, area ID etc.), initial access information (e.g., RACH configuration to enter connected state and/or data transfer in inactive state etc.), cell selection info (e.g., Qrxlevmin/offset, Qquallevemin/offset), and/or information for idle mode operation (cell reselection info for intra, inter neighbors, mobility scaling, common radio resource configuration (e.g., paging) etc.). A WTRU may be configured to request and/or receive one or more of the following information in other-SI: SI that might not be a part of complete minimum-SI and/or a reduced minimum-SI; SI that may be a part of minimum-SI (e.g., this may be useful for WTRUs that are coverage limited and/or may allow a less conservative design for broadcast minimum-SI); minimum-SI applicable for non-serving cells; and/or other-SI applicable for non-serving cells.

[0431] A WTRU may perform one or more of the following actions, perhaps for example when a system information acquisition procedure for a cell is triggered. If the cell transmits reduced minimum-SI, a WTRU may attempt to receive reduced minimum-SI. If reduced minimum-SI is received successfully by the WTRU, the WTRU may determine/derive one or more reference ID(s) associated with the cell. If the WTRU can determine a complete minimum-SI based on a received reduced-minimum-SI, derived reference ID(s), value-tag(s) and/or matching stored SI(s), the WTRU may perform one or more actions as if acquisition of minimum-SI was completed. If the WTRU receives configuration for resources for other-SI request from the reduced minimum-SI, a WTRU may trigger an other-SI request procedure to acquire one or more on-demand SI and/or perform one or more actions as if acquisition of minimum-SI is completed. A WTRU may assume that the cell is barred.

[0432] If the cell transmits complete minimum-SI, a WTRU may attempt to receive/determine a reference ID from the minimum-SI transmitted in the cell. If the WTRU can determine a complete minimum-SI based on reference ID(s), value-tag(s) and/or matching stored SI(s), a WTRU may perform one or more actions as if acquisition of minimum-SI is completed. A WTRU may attempt to receive complete minimum-SI transmitted in the cell. A WTRU may

perform actions (e.g., subsequent actions) depending on the contents/status of received minimum-SI (e.g., whether WTRU is allowed to camp on the cell or if the cell is barred).

[0433] A WTRU may be configured to reclaim the random access resources (e.g., time/frequency and/or preambles) which may be configured for other-SI request(s), perhaps based on one or more factors. For example, a WTRU may reclaim the random access resources configured with the other-SI request(s), perhaps when the WTRU determines that the other-SI is broadcasted. For example, a WTRU may determine that the other-SI is broadcasted from an indication in the minimum-SI. For example, a WTRU may reclaim (e.g., only) the resources associated with a subset of other-SIs that may be broadcasted.

[0434] A WTRU may be configured to perform random access procedures for purposes other than other-SI request(s) on the reclaimed random access resources. For example, the WTRU may be configured to utilize the reclaimed random access resources configured for other-SI request(s) to perform an initial access and/or scheduling request and/or respond to a PDCCH order and/or to initiate UL synchronization and/or to initiate UL beam management and/or access target cell during handover, etc. For example, a WTRU may be configured to use reclaimed resources perhaps when the random access procedure fails on the resources configured for such procedure and/or on dedicated random access resources. For example, a WTRU may consider one or more, or a combination, of resources configured for access and/or reclaimed resources for random access resource selection.

[0435] A paging control function may be applied, for example, per TRP, per TRP group, per service, per configured MAC instance, per channel per instance, per central control function, etc.

[0436] A central control function may store a WTRU context and/or track a WTRU mobility within the coverage of RCCF, for example, for a WTRU in a light connected state. A WTRU may receive a paging message originated at the RCCF and/or transmitted by the RCCF triggered, for example, upon arrival of downlink data. A paging message may be transmitted, for example, at ACF granularity and/or RCCF granularity. A WTRU in a light connected state, e.g., upon receiving the paging message, may perform one or more actions.

[0437] For example, a WTRU action may resume a WTRU user plane path towards the central user plane function, e.g., without having to invoke any additional central control functions.

[0438] For example, a WTRU may perform control plane actions and/or user plane actions, e.g., based on the received paging message.

[0439] For example, a WTRU may receive additional indication(s) in the paging message that determine WTRU actions. For example, a WTRU may receive a type of service in the

paging message. A WTRU may (e.g. based on the indication) transition to fully connected state or light connected state. For example, a WTRU may determine a type of initial access procedure (e.g. contention based, beamformed, initial access on a specific ACF), for example, based on a received paging message.

[0440] For example, a WTRU may receive an indication for the resources used for data transmission. A WTRU may (e.g. directly) receive the data without having to establish any connection. A WTRU may (e.g. upon completing data reception) transition back to idle or a light connected state.

[0441] For example, a paging message may trigger establishment of ACF. For example, a paging message may trigger RCCF establishment while another paging message may trigger resumption of RCUF.

[0442] WTRU identification may be provided, for example, by a layer 3 (L3)/central control plane connection/WTRU context identifier. Singular connectivity may have a one to one relation between WTRU identity on the radio (e.g. RNTI) and an RRC connection. A WTRU's RRC connection for dual connectivity may be associated with a WTRU specific RNTI in the MeNB (Master eNB). A WTRU may be assigned one or more, or multiple RNTIs during multi-connectivity (e.g. different RNTI per TRP), for example, in a tri-plane architecture. A WTRU context may be identified in the centralized control function, for example, by assigning an L3 identity to a WTRU. A WTRU may receive an L3 identity, for example, upon central control plane establishment. An L3 identity may be used, for example, to uniquely identify an RRC connection and/or RRC context associated with a WTRU.

[0443] An RCCF connection may be managed. There may be one or more triggers for re-association with RCCF. For example, a WTRU may trigger an association and/or re-association procedure with the RCCF when one or more of criteria are satisfied.

[0444] An example criteria may be when no valid L3 context exists in a WTRU, for example, due to a power up scenario where a WTRU may be unknown at the network, and/or an L3 context expired (e.g. due to extended periods of inactivity).

[0445] An example criteria may be when a WTRU enters a coverage of an anchor control function different than a serving anchor control function. A WTRU may determine presence and/or identity of an anchor control function using one or more procedures. An example procedure may comprise using a shared system signature. For example, TRPs associated with the same anchor control function may share at least one system signature. An example procedure may comprise using explicit identification in MIB. For example, TRPs associated with an anchor control function may transmit some form identity associated with the anchor

control function. A WTRU may obtain the anchor control function identity during a previous association. An example procedure may comprise using logical area transmitted in broadcast channels. For example, an (e.g. one or more, or each) anchor control function may provide anchoring services to a logical area including one or more TRPs. A WTRU may consider TRPs belonging to a specific logical area as associated with the same anchor control function. An example of a procedure may be using a pre-configured system signature group. For example, two or more system signatures may be preconfigured to be associated with the same anchor control function. A WTRU may consider TRPs transmitting at least one of the system signatures within a particular system signature group to be associated with the same anchor control function.

[0446] An example criteria may be when an access control function associated with macro eNB experiences failure and/or a WTRU might (e.g. does) not have a valid access table entry.

[0447] An example criteria may be when (e.g. one or more, or all, of) the configured/activated access control functions may be terminated/released.

[0448] An example of a criteria may be upon arrival of a paging message indicating arrival of DL data and/or DL signaling from the core network.

[0449] An example of a criteria may be unreachability of a serving anchor control function, which may be determined, for example, based on an absence of response to signaling message towards the anchor control function and/or absence of keep alive/heart beat with the serving anchor control function.

[0450] An example of a criteria may be upon receiving a last RAR message. A WTRU may (e.g. during initial access to a network) perform a multi-point random access procedure. A WTRU may wait for a last RAR message to trigger an RCCF association procedure. A WTRU may determine the last RAR message in one or more ways. For example a (e.g. one or more, or each) RAR message may include a countdown value. For example, a WTRU may consider the RAR message with countdown value of zero as the last RAR message. For example, a WTRU may wait until the end of an RAR window to receive an (e.g. every possible) RAR message before triggering an RCCF association procedure.

[0451] A WTRU may initiate association towards an anchor control function, for example, any time after acquiring UL resources to transmit, e.g., after access plane establishment. A WTRU may transmit a higher layer signaling message that may include a WTRU identity, an identity of an anchor control function, a reason for association, a number of RAR messages, a list of TRPs and/or a selected list of TRPs.

[0452] A WTRU identity may be, for example, one or more of the following: an identity allocated by a previous anchor control function, a temporary identity allocated by a core network and/or a sufficiently long random number (e.g. ≥ 40 bits).

[0453] An identity of anchor control function may be, for example, optionally present, e.g., when a WTRU had a previous association with an anchor control function.

[0454] A reason for association may be, for example, one or more of the following: a request for anchoring control service, a request for paging service, a request for access to specific core network slice, an initial association for subsequent core network signaling, an association due to change in anchor control function, a failure of a previous anchor control function, a response to paging, UL data arrival and/or type of service requested (e.g. high throughput service, low latency service and/or low overhead and energy efficient service), etc.

[0455] A number of RAR messages may be, for example, a number of RAR messages received in response to a random access procedure.

[0456] A list of TRPs may be, for example, a list of TRPs that transmitted the RAR messages and/or quality metric for a (e.g. one or more, or each) received RAR.

[0457] A selected List of TRPs may be, for example, a list of TRPs selected by a WTRU using a predefined selection criteria.

[0458] A WTRU may transmit an RCCF association request on available resources. A request may be transmitted in an order. An example of an order may be, for example one or more of: time/frequency resources associated with a macro ACF whose suitability metric is highest among available macro ACFs; time/frequency resources associated with a macro ACF whose suitability metric is above a certain threshold; time/frequency resources associated with a TRP ACF whose suitability metric is highest among configured/active/available TRP ACFs; and/or time/frequency resources associated with a TRP ACF whose suitability metric is above a certain threshold.

[0459] A suitability metric may be, for example, received power measured from a reference signal and/or system signature averaged over a time window.

[0460] A WTRU may prefer ACFs associated with one or more licensed bands over ACFs associated with unlicensed bands.

[0461] A WTRU may prefer non-beamformed ACFs over beamformed ACFs.

[0462] A WTRU may (e.g. in response to an RCCF association request) receive and/or process an association response. The contents of a response may include, for example, one or more of an identity of an RCCF, an identity of a WTRU, access table parameters, a measurement

configuration, an SRB configuration, a DRB configuration, dedicated ACF parameters/resources and/or user plane RCUF status and/or parameters.

[0463] An identity of an RCCF may be stored and/or used (e.g. by a WTRU), for example, to address subsequent control signaling towards the RCCF.

[0464] An identity of a WTRU may be stored and/or used (e.g. by a WTRU), for example, to identify itself for subsequent interaction with the RCCF.

[0465] Access table parameters may be received in a response. A WTRU may (e.g. directly) receive access table contents within the association response message and/or parameters that may help a WTRU to obtain the access table parameters (e.g. ACFs and/or time/frequency resources that carry access table transmission, and/or an RNTI to decode the schedule for access table transmission, etc.).

[0466] A measurement configuration may comprise configuration of measurement resources, measurement objects, measurement quantity and/or measurement id, triggers, etc. A measurement configuration may be specific to an ACF or group of TRPs.

[0467] An SRB configuration may indicate mapping rules for SRB. For example, an SRB to ACF mapping (e.g. for SRBs terminating at ACFs) may provide (e.g. an explicit) mapping between SRBs and an ACF. A mapping may map an SRB to transport/physical channels associated with a specific ACF. For example, an SRB to ACF mapping restriction may be provided. A WTRU may be configured with restricted ACFs that might not be used for SRB transmission. WTRU may flexibly split the SRBs among available/allowed ACFs. For example, an SRB prioritization via ACF mapping may be provided. High priority SRBs may be mapped and/or low priority SRBs may be mapped, e.g., to a different ACF/ACF group. For example, Dynamic SRB mapping based on ACF quality may be provided. A mapping may transmit high priority SRBs over ACFs whose quality metric is above certain threshold. For example, a DRB configuration may include, for example, DRB tagging information. A WTRU may attach to a (e.g. one or more, or each) PDU belonging to a DRB associated tagging information provided by the central control function. Tagging information may be used, for example, by the RCUF to map the PDUs to the right core network flow. Dedicated ACF parameters/resources may be provided in a response to an RCCF association request. User plane RCUF status and/or parameters may be provided in a response to an RCCF association request.

[0468] An ACF connection may be managed. Triggers may be provided for access plane management. A WTRU may trigger access plane establishment, for example, when one or more criteria is satisfied.

[0469] An example of trigger criteria may be, for example, when a WTRU receives an unknown signal (e.g. without a valid entry in the access table), which may occur when an SIB might not be broadcast in the cell, UL resource for SIB interest notification and/or on-demand access table and/or when a WTRU may request an access table entry from another TRP (e.g. send the signature).

[0470] An example of a trigger criteria may be, for example, upon arrival of user plane data (e.g. IP packet), which may occur, for example, when a WTRU already has an access plane established or does not have an access plane established, such as when higher layer data may allow for early data transfer and/or a valid entry in the access table is available that indicates UL resources timing (e.g. w.r.t to another signal and/or control channel, etc.).

[0471] An example of a trigger criteria may be, for example, upon arrival of control plane signaling (e.g. L3/RRC message and/or NAS message).

[0472] An example of a trigger criteria may be, for example, change in RAN tracking area, proximity to non-serving anchor control function, change in anchor control function, etc.

[0473] An example of a trigger criteria may be, for example, re-establishment of an access plane on a same or better TRP, for example, when a WTRU loses uplink synchronization (TAT expiration) and/or when a WTRU goes out of sync at lower layers.

[0474] An example of a trigger criteria may be, for example, WTRU mobility based on, for example, one or more of: a discovery of a new TRP associated with a serving anchor control function, a measurement events at (L1/L2/L3) above a predefined threshold; and/or a reception of a new system signature above (or below) a predefined threshold.

[0475] A TRP/network may trigger access plane establishment, for example, when one or more of the following criteria is satisfied: upon command from central control plane entity; upon receiving user plane data, e.g. paging; and/or upon an addition of a new TRP and/or cell group.

[0476] Access plane establishment may involve, for example, one or more of the following: a WTRU may trigger a random access on a predefined UL resource determined by system signature; and/or a WTRU may trigger a random access procedure on a multi-point random access resource.

[0477] A WTRU may consider an access plane established, for example, when it receives one or more RAR messages that pass a suitability criteria.

[0478] A WTRU may take one or more actions after establishing an access plane. For example, a WTRU may be uplink synchronized and/or may (e.g. be required to) maintain the synchronization.

[0479] WTRU may be assigned an identifier, e.g., to uniquely identify a WTRU with a single TRP or a group of TRPs. For example, a WTRU may monitor downlink control channels for possible scheduling grants and/or feedback. For example, a WTRU transmit periodic and/or event triggered feedback and/or reference signals on the uplink control channels.

[0480] Access plane establishment may enable one or more of the following: a WTRU may be reachable at TRP level granularity; and/or a WTRU may be assigned dedicated physical resources (e.g. UL control channel resources, semi-persistent resources, etc.).

[0481] A WTRU may transmit higher layer data and/or signaling terminated at a TRP and/or signaling messages terminated at the RRC to setup control plane. A WTRU may (e.g. additionally) transmit L3 control/signaling, measurement report, NAS signaling messages, etc., for example, when the control plane may be set up. A WTRU may (e.g. additionally) transmit application/user data, for example, when the user plane is set up.

[0482] A radio link monitoring (RLM) function may be provided, for example, as a WTRU-specific function, a component-specific function and/or a plural-component function.

[0483] A WTRU-specific function, for example such as an RLM function may be configured per WTRU.

[0484] A component-specific function, for example such as an RLM function may be configured per WTRU-TRP pair and/or a WTRU-ACF pair.

[0485] A plural-component function, for example such as an RLM function may be configured per group of components, such as one or more, or multiple cells, one or more, or multiple TRPs, one or more, or multiple TRPGs, and/or one or more, or multiple NR-eNBs, etc. For example, a WTRU may perform radio link monitoring on one or more (e.g. a subset of TRPs per group of TRPs). A WTRU may consider the measurements on a TRP as indicative of radio link status for a group of TRPs. For example, a WTRU may consider measurements on a (e.g. any) TRP as indicative of radio link status for a group of TRPs.

[0486] A WTRU may be configured with a different monitoring procedure, for example, based on one or more of the characteristics/property of Uu with a TRP, a nature of a service and/or a WTRU state.

[0487] One or more characteristics/property of Uu with a TRP, for example such as an RLM procedure for a beamformed Uu may be different from a narrow band Uu. For example, an RLM may be optional in some scenarios, e.g., in an unlicensed Uu.

[0488] In an example of a nature of a service, one or more aspects of an RLM procedure may be tied to the type of services active in a WTRU. For example, a WTRU may perform RLM with (e.g. strict) thresholds while using a URLLC service.

[0489] For example one or more aspects of an RLM procedure may be tied to one or more WTRU states. For example, a WTRU may perform a relaxed monitoring procedure in a light connected state, e.g., compared to fully connected state.

[0490] A radio link failure handling function may be, for example, a WTRU-specific function, component-specific function and/or a plural-component function.

[0491] A WTRU may support multi-connectivity to increase reliability, mobility robustness, throughput etc. For example, a relation between configured cells for a WTRU may be flexible. A (e.g. one or more, or each) cell configured for a WTRU may be dynamically assigned different roles. For example, a cell may be a Pcell, PScell and/or Scell, where roles may vary with time, e.g., based on predefined criteria and/or measurements.

[0492] A WTRU may (e.g. be required to) determine and/or may react to different types of failure. A WTRU may (e.g. with a distributed control plane architecture) distinguish between aspects related to connectivity to a TRP, reachability to different control functions, etc.

[0493] For example, a WTRU may determine different types of failure, such as a TRP level failure, an ACF level failure and/or an RCCF failure.

[0494] For example, a TRP level failure may be related to status of lower layer functions, e.g., loss of timing, unsuitability based on measurements below threshold, etc.

[0495] For example, an ACF level failure may be related to unreachability of a specific ACF. A WTRU may trigger a report to a central control function, which may include which ACF failed and/or a reason for failure.

[0496] For example, an RCCF failure may be related to unreachability of a central control function, for example, based on a timer expiring from the last interaction with RCCF.

[0497] A WTRU may decouple a capability to transmit data from different levels of failure on a control plane. For example, a TRP level failure might not trigger a WTRU to suspend the data transmissions. For example, a WTRU may continue data transmissions, for example, even while a control plane is being re-established. For example, a WTRU may perform connectionless transfer, for example, while trying to recover from partial control plane failure.

[0498] A mobility control function may be a WTRU-specific function, component-specific function and/or a Plural-component function.

[0499] WTRU mobility may be (e.g. closely) tracked at the RAN for WTRUs, e.g., in light connected states and/or IDLE connectionless states. Tracking may be at a granularity of a TRP group and/or a central control function. Different levels of mobility control functions may be defined, such as one or more of the following: Intra-TRP (e.g. may include beam level mobility); Inter-TRP (e.g. may include mobility handling at ACF level without involving a central anchor

function); Inter-ACF (e.g. may be controlled by central anchor function and/or may be defined between LTE ACF and NR ACF in example of a tightly coordinated mobility function); Inter-RCCF (e.g. may be applicable for WTRUs in connected state and/or light connected state and/or a WTRU may support a control anchor change without a change to the user plane functions and/or user plane anchor); and/or Inter-RAT (e.g. may include mobility between NR to legacy RATs like GSM/UMTS, etc.).

[0500] Mobility control functions may be WTRU autonomous, network controlled, network assisted WTRU controlled and/or WTRU assisted network controlled.

[0501] Different parts of WTRU context and/or L2 state may persist after a mobility event. A WTRU may reset different parts of context and/or L2 state, for example, based on a type of mobility event. For example, a WTRU may use a specific set of rules to 'convert' a configuration/context upon handover to a different TRP/ACF. For example, a WTRU may retain parts of configuration and/or L2 context that are compatible while applying equivalent configurations and/or mapped configurations and/or while converting certain aspects during a mobility event between LTE and NR.

[0502] A WTRU may be configured with mobility restrictions. For example, a WTRU might not perform autonomous mobility to a LTE TRP.

[0503] A measurement configuration and reporting function may be a WTRU-specific function, component-specific function and/or a plural-component function.

[0504] A WTRU may transmit a measurement report to plurality of TRPs. A WTRU may, for example, based on a configuration, report beam related measurements (e.g. intra-cell beam level RRM measurements) to the associated TRP. A WTRU may report measurements of a plurality of TRPs to an associated ACF. For example, a WTRU may report measurements on LTE TRPs to an LTE ACF.

[0505] For example, a WTRU may differentiate measurements on TRPs associated with a serving central control function from the measurements on TRPs associated with a different central control function. For example, a WTRU may be configured to measure (e.g. only) the TRPs associated with a serving control function.

[0506] The placement of a measurement processing control function may be flexible. For example, a measurement processing control function may be placed closer to a WTRU, e.g., for URLLC service.

[0507] A security and authentication control function may be a WTRU-specific function, component-specific function and/or a plural-component function.

[0508] A WTRU may treat security aspects associated with an ACF independently from other ACFs. For example, a security failure in ACF may be localized to that ACF and/or might not affect WTRU connectivity to other ACFs.

[0509] For example, a WTRU may perform independent integrity protection for control plane messages, such as control plane signaling towards an ACF and/or control plane signaling towards an RCCF.

[0510] For example, WTRU control signaling towards an RCCF may be placed in a container within ACF messages. A WTRU may apply (e.g. only) ACF integrity protection to the RCCF messages.

[0511] For example, a WTRU may obtain integrity protection keys for a (e.g. one or more, or each) ACF, for example, based on interaction with those ACFs. A WTRU may obtain integrity protection keys for an (e.g. one or more, or each) ACF from the RCCF.

[0512] Configuration failure handling may be a WTRU-specific function, component-specific function and/or a plural-component function.

[0513] A WTRU may trigger failure handling, for example, based on a control function that triggered the configuration. For example, configuration failure for an access control function might not affect WTRU association with other access control functions. A WTRU may report a failure to the RCCF indicating the specific ACF that triggered the configuration and/or the reason for failure, for example, when a WTRU is unable to comply with one or more aspects of a configuration. For example, a WTRU may perform connectionless signaling transfer, e.g., to report a configuration failure. For example, configuration failure towards a central control function might not affect WTRU capability to transmit data over the user plane. For example, configuration failure may trigger release of an access plane towards (e.g. one or more, or all) the access control functions.

[0514] A Logical association may be defined between PDU carrying control signaling. An association may, for example, be based on data units being associated with an access control function or an instance thereof, with a central control function or instance thereof and/or with the same SOM and/or slice. For example, an association may be characterized, for example, by at least one of a chaining of processing functions, an applicable physical data (and/or control) channel (or instance thereof) and/or an instantiation of a protocol stack, which may include a specific portion being centralized (e.g. anchor control function) and another portion being closer to the edge (e.g. access control function).

[0515] An example of logical association may be a signaling radio bearer (SRB). A WTRU may have one or more, or multiple termination points for control signaling. A WTRU may a

have signaling association towards an access control function, e.g., access signaling radio bearer (ASRB). A WTRU may (e.g. in case of multi-connectivity) have more than one ASRB. An (e.g. one or more, or each) ASRB may terminate at a different access control function. A WTRU may have a signaling association towards an anchor control function (e.g. a central SRB (CSRB)) that may terminate at the anchor control function.

[0516] A WTRU may transmit a control message on the same SRB that carried an original message, for example, when the control message is a response to a control message from a network (e.g. setup and/or reconfiguration message). For example, a WTRU may address a response to an access control function that transmitted the control message. In an (e.g. another) example, a WTRU may transmit a response to a control message received from a downlink cell group, e.g., in an uplink cell group associated with the same MAC instance.

[0517] An (e.g. one or more, or each) ASRB may be associated with a MAC instance. Mapping ASRB to physical channels may be specific to one or more, or each ACF instance. For example, the characteristics of physical channels that carry ASRB may be different from physical channels carrying data packets. For example, an ASRB may be mapped to physical channels with wider spatial coverage, for example, when a MAC instance utilizes beamformed channels.

[0518] A WTRU may use data transmission services provided, for example, by the access plane, e.g., to transmit a control signaling message towards an anchor control function.

[0519] A WTRU may be preconfigured with a (e.g. exactly one) MAC instance to transmit control signaling (e.g. a message) towards an anchor control function. For example, a MAC instance may be associated with a macro TRP.

[0520] For example, a WTRU may be configured with one or more MAC instances for CSRB transmission. A WTRU may shortlist candidate MAC instances, for example, based on one or more criteria, such as one or more of access plane status, UL TAT, prohibited MAC instances, coverage of a TRP, security status and/or activation status.

[0521] For example of an access plane status, a WTRU may choose MAC instances for which an access plane is already established.

[0522] For example of UL TAT, a WTRU may choose MAC instances with valid UL timing (e.g. TAT timer is running).

[0523] For example of prohibited MAC instances, a WTRU may consider one or more MAC instances that are not prohibited for CSRB transmission. For example, a WTRU may be configured with blacklisted MAC instances that might not carry CSRB transmission and/or (e.g.

equivalently) a WTRU may be configured with whitelisted MAC instances for CSRB transmission.

[0524] For example of coverage of a TRP, a WTRU may choose MAC instances that are associated with a larger coverage, e.g., belonging to a macro TRP.

[0525] For example of security status, a WTRU may choose MAC instances associated with ACFs for which security context may be (e.g. already) established. For example, a WTRU might not consider MAC instances for which an authentication/security mode procedure is ongoing or not yet started. For example, a WTRU may wait for security activation for the access control function to complete before transmission of control message towards the anchor control function.

[0526] In an example of activation status, a WTRU may choose MAC instances that may be configured and/or activated by a network.

[0527] For example, a WTRU may have one or more, or multiple candidate MAC instances available for CSRB transmission. A WTRU may select a MAC instance for a CSRB transmission in one or more ways, such as based on signal quality, transmission opportunity, explicit priority, reliability, outcome of previous transmission and/or linked MAC status.

[0528] In an example of signal quality, a WTRU may choose a MAC instance with a better signal quality metric (e.g. RSRP/RSRQ/Hypothetical PDCCH error rate) for one or more cells in the cell group associated with that MAC instance.

[0529] In an example of transmission opportunity, a WTRU may choose a MAC instance with the earliest transmission opportunity. A WTRU may prefer a MAC instance with an available scheduling grant over a MAC instance that may find a resource request procedure useful and/or may have (e.g. only) contention based resources. A WTRU may (e.g., temporarily) suspend transmissions on MAC instances that may have an outstanding reconfiguration procedure that reconfigures one or more characteristics associated with that MAC instance.

[0530] In an example of explicit priority, a (e.g. one or more, or each) MAC instance may be associated with a priority. A WTRU may choose the MAC instance with highest priority for transmission of CSRB messages.

[0531] In an example of reliability, a WTRU may choose to transmit the same control message over plurality of MAC instances, for example, for control messages that may require high reliability (e.g. those associated with ultrareliable services).

[0532] In an example of outcome of previous transmission, a WTRU may choose a different MAC instance (e.g. for retransmission) than the MAC instance used for a (e.g. an original) failed transmission.

[0533] In an example of a linked MAC instance – WTRU may (e.g. for a response control message) choose the same MAC instance on which the corresponding request/setup control message was received.

[0534] For example, a WTRU may perform MAC instance selection (e.g. only) during initial registration and/or association towards a new anchor control function. A WTRU may use the same MAC instance for a (e.g. any) subsequent control message exchange with that anchor control function.

[0535] For example, a WTRU may perform MAC instance selection (e.g. once) for a (e.g. one or more, or each) control signaling procedure with the anchor control function. A control signaling procedure may involve one or more control signaling message transactions. For example, a (e.g. one or more, or all) control messages belonging to the same procedure may be transmitted over a (e.g. single) MAC instance.

[0536] For example, a WTRU may perform MAC instance selection for a (e.g. one or more, or each) control message transmission. For example, control messages belonging to the same procedure may be transmitted over different MAC instances. A WTRU may switch to a different MAC instance, for example, for a retransmission of the control message.

[0537] A WTRU may prioritize transmission signaling messages mapped to ASRB over control signaling mapped to CSRB. A WTRU may have an access control message and/or an anchor control message ready for transmission. For example, a WTRU may (e.g. first) transmit an access control message in the earliest transmission opportunity and/or may (e.g. subsequently) transmit the anchor control message in the same subframe/TTI from the same MAC instance or a different MAC instance, for example, when resources are available and/or in the next available resource from the same MAC instance or a different MAC instance. For example, a WTRU may wait for the completion of the ongoing procedure with the access control function and then transmit the anchor control message at the first available transmission opportunity. For example, a WTRU may be configured with two more ASRBs mapped to the same MAC instance. One or more, or each of the ASRBs may be identified by a different logical channel identity and/or ASRB identity. A WTRU may be preconfigured with rules to prioritize between two or more ASRBs mapped to the same MAC instance. For example, a prioritization may be implicit, e.g., based on the type of control message and/or based on explicit SRB identity/logical channel identity.

[0538] A WTRU may provide an (e.g. additional) indication in a PDU, for example, to differentiate a control message addressed to access a control function from a control message addressed to an anchor control function. For example, an indication may include one or more of

the following: a logical channel identity, an explicit indication of a type of message and/or an explicit identity of an anchor control function.

[0539] In an example of a logical channel identity, a different logical channel identifier may be used to differentiate different ASRB within the same MAC instance. Logical channel identifiers may be reserved, for example, to indicate that the control message belongs to CSRB.

[0540] In an example of an explicit indication of a type of message, a (e.g. one or more, or each) control message may carry an indication for a type of the message. For example, a first type may indicate that it may be an access control message and/or a second type may indicate an anchor control message.

[0541] In an example of an explicit identity of anchor control function, a WTRU may (e.g. additionally) provide an explicit identity of a destination anchor control function, for example, when the access control function may be associated with more than one instance of the anchor control function. A WTRU may transmit a special/reserved identity, for example, to indicate lack of previous interaction with an anchor control function (e.g. a network may select a new anchor control function to deliver the control message).

[0542] A WTRU may receive a control message with configuration. A configuration may be applicable, for example, to a specific cell within a cell group associated with a MAC instance, to multiple (e.g. one or more, or all) cells within a cell group associated with a MAC instance, to a group of MAC instances or to one or more, or all MAC instances. For example, configuration parameters may include one or more of the following: slicing configuration, supported services configuration, addition/removal/modification of cells, QoS configuration, DRX configuration, security configuration, measurement configuration, dedicated radio resource configuration like SRB configuration, DRB configuration including PDCP and/or RLC and/or MAC configuration, physical channel configuration, SPS-configuration, etc.

[0543] A WTRU may determine the applicability of a configuration, for example, based on one or more criteria, such as a type of SRB, a linked MAC instance and/or an explicit access control identity.

[0544] In an example of a type of SRB, a WTRU may apply configuration parameters received in the ASRB applicable (e.g. only) to a MAC instance associated with the ASRB. A WTRU may consider the configuration parameters received in CSRB applicable to (e.g. one or more, or all) the MAC instances, e.g., unless explicitly indicated within the configuration message.

[0545] In an example of a linked MAC instance, a WTRU may apply configuration parameters received from a cell/cell group to a MAC instance associated with that cell/cell group.

[0546] In an example of an explicit Access control function identity, a WTRU may receive configuration parameters with an explicit indication of a MAC instance to which the configuration is applicable. For example, a WTRU may receive a MAC identity and/or access control function identity, e.g., along with the configuration parameters.

[0547] For example, a WTRU may be configured with a linked-SRB. A linked-SRB may be an ASRB that may be associated with one or more DRBs. For example, linkage may be many-to-many association. A (e.g. one or more, or each) DRB may be linked to one or more ASRBs. A WTRU may apply configurations received in a ASRB to (e.g. only) the DRBs linked with the ASRB.

[0548] For example, a WTRU may (de)multiplex control signaling (e.g. RRC PDUs and/or the like) using different logical connections, bearers (e.g. SRB0, 1, 2, 3, etc. and/or using different sets thereof), flow-based treatment (e.g. based on configured tuples applicable to L3 protocols), for example, as a function of the logical grouping of the function that generated the RRC SDU.

[0549] For example, a WTRU RRC function for access plane establishment may generate an RRC SDU that may be mapped to a specific SRB. An SRB may correspond to a set thereof. A set may be associated with the Access Plane connection being established. For example, a procedure may use a first SRB corresponding to the set of SRBs available for establishment of such connection, for example, for initial access to the system (e.g. while security is not yet activated). A (e.g. the) procedure may use a second SRB otherwise, for example, when at least part of the security may be activated, e.g., for the RRC. A WTRU may (e.g. in the latter case) include authentication (and/or encryption), for example, for at least part of the RRC SDU, e.g. the part of the SDU that may be used to determine the identity of a WTRU and/or may provide capability for the network to fetch a WTRU's context.

[0550] A WTRU RRC function for central control plane may (e.g. similarly) generate an RRC SDU that may be mapped to a different specific SRB (e.g. an SRB that may correspond to a different set of SRBs).

[0551] For example, different logical grouping of functions may have different sets of SRBs from each other.

[0552] For example, when a single set of logical paths may be configured, and/or when a WTRU may be configured with a (e.g. one) set of logical paths for one or more, or each type of

logical grouping), an RRC SDU may include an identifier (e.g. the identity of the instance of the logical group of functions that generated the SDU), for example, when a WTRU may be configured with one or more, or multiple user plane “slices” and/or equivalent.

[0553] For example, procedures may be (e.g. further) applied, for example, (e.g. similarly) as a function of the physical transport paths. Grouping of functions and/or association of transport paths may be a configurable aspect, e.g., from a WTRU’s perspective.

[0554] Systems, procedures, and instrumentalities (e.g. aspects of entities, interfaces and procedures in a wireless transmit/receive unit (WTRU) and/or network layers L1, L2, L3) have been disclosed for distributed control in wireless systems, such as 5G flexible radio access technology (RAT) (5gFLEX). Example procedures are provided for WTRU and network operation associated with a distributed control plane architecture, connectionless data transfer and dedicated system information acquisition. Distributed control may be provided, for example, by replicating a plurality of access control functions (ACFs) using a plurality of instances in a plurality of different transmission/reception points (TRPs) with multi-connectivity. The plurality of TRPs may concurrently provide control services to a WTRU. Centralized control functions may manage core network connectivity and/or a plurality of user plane instances for the WTRU and/or may facilitate coordination between the plurality of ACF instances for the WTRU in the plurality of different TRPs of the WTRU’s configuration. For example, there may be a first access plane between the WTRU and a first TRP that provides a first ACF for the WTRU, a second access plane between the WTRU and a second TRP that provides a second ACF for the WTRU, a RAN central control plane between the WTRU and a first RAN central control function (RCCF) and a RAN central user plane between the WTRU and a RAN central user function (RCUF).

[0555] The processes and instrumentalities described herein may apply in any combination, may apply to other wireless technologies, and/or for other services.

[0556] A WTRU may refer to an identity of the physical device, and/or to the user’s identity such as subscription related identities, e.g., MSISDN, SIP URI, etc. WTRU may refer to application-based identities, e.g., user names that may be used per application.

[0557] One or more, or each of the computing systems (e.g., WTRU) described herein may have one or more computer processors having memory that are configured with executable instructions and/or hardware for accomplishing the functions described herein including determining the parameters described herein and/or sending and receiving messages between entities (e.g., WTRU and network) to accomplish the described functions. The processes described above may be implemented in a computer program, software, and/or firmware

incorporated in a computer-readable medium for execution by a computer and/or processor. Except as explicitly noted, determinations in reference to a computer generally refers to a processor programmed with instructions for determining. Likewise, the term store in reference to a computer generally means a processor programmed with instructions for storing in computer memory.

[0558] The processes described above may be implemented in a computer program, software, and/or firmware incorporated in a computer-readable medium for execution by a computer and/or processor. Examples of computer-readable media include, but are not limited to, electronic signals (transmitted over wired and/or wireless connections) and/or computer-readable storage media. Examples of computer-readable storage media include, but are not limited to, a read only memory (ROM), a random access memory (RAM), a register, cache memory, semiconductor memory devices, magnetic media such as, but not limited to, internal hard disks and removable disks, magneto-optical media, and/or optical media such as CD-ROM disks, and/or digital versatile disks (DVDs). A processor in association with software may be used to implement a radio frequency transceiver for use in a WTRU, terminal, base station, RNC, and/or any host computer.

CLAIMS

What is Claimed is:

1. A wireless transmit/receive unit (WTRU) in communication with a communication network, the WTRU comprising:
 - a memory;
 - a processor, the processor configured at least to:
 - determine to request one or more system information (SI) messages from the communication network; and
 - determine if a transmission of the one or more SI message from the communication network will utilize at least one beamformed communication based on one or more communication parameters; and
 - a transceiver, the transceiver configured at least to:
 - receive at least one of the one or more SI messages from the communication network via the at least one beamformed communication.
2. The WTRU of claim 1, wherein the one or more communication parameters include a frequency band of the transmission, the processor being further configured to:
 - compare the frequency band of the transmission to a predetermined threshold; and
 - determine that the transmission of the one or more SI messages from the communication network utilizes at least one beamformed communication based on the frequency band of the transmission exceeding the predetermined threshold.
3. The WTRU of claim 1, wherein the one or more communication parameters include a characteristic of a downlink signal, the transceiver being further configured to:
 - receive the downlink signal, the processor being further configured to:
 - identify the characteristic of the downlink signal; and
 - determine that the transmission of the one or more SI messages from the communication network utilizes at least one beamformed communication based on the identified characteristic of the downlink signal.
4. The WTRU of claim 3, wherein the downlink signal includes a reference signal.

5. The WTRU of claim 4, wherein the characteristic of the downlink signal includes one or more of: a type of the reference signal, a system signature, a root signature, a basis sequence, or one or more predefined sequence numbers.
6. The WTRU of claim 5, wherein the type of the reference signal is a synchronization signal.
7. The WTRU of claim 1, wherein the one or more communication parameters include information provided in a broadcast message, the transceiver being further configured to:
 - receive the broadcast message, the processor being further configured to:
 - identify the information in the broadcast message; and
 - determine that the transmission of the one or more SI messages from the communication network utilizes at least one beamformed communication based on the information in the broadcast message.
8. The WTRU of claim 7, wherein the information provided in the broadcast message is included in at least one of: a master system information block (MIB), or a system information block (SIB), or a system information message.
9. The WTRU of claim 1, wherein the one or more communication parameters include a quality of a downlink signal, the transceiver being further configured to:
 - receive the downlink signal, the processor being further configured to:
 - measure a quality of the downlink signal; and
 - determine that the transmission of the one or more SI messages from the communication network utilizes at least one beamformed communication based on the quality of the downlink signal being below a predetermined threshold.
10. The WTRU of claim 9, wherein the downlink signal includes a reference signal, and the quality of the downlink signal includes a received power of a reference signal.
11. The WTRU of claim 1, wherein the processor is further configured to initiate an uplink (UL) request to the communication network for the one or more SI messages.

12. A wireless transmit/receive unit (WTRU) in communication with a communication network, the WTRU comprising:
 - a memory;
 - a processor, the processor configured at least to:
 - determine to request one or more system information (SI) messages from the communication network;
 - conduct a beam sweep operation of one or more downlink (DL) beams transmitted from the communication network;
 - identify at least one DL beam of the one or more DL beams via which to receive the one or more on-demand SI messages based at least in part on the beam sweep operation;
 - determine one or more uplink (UL) resources with which to communicate information for a WTRU reception of the one or more on-demand SI messages, the information for the WTRU reception including the at least one DL beam; and
 - initiate the request for the one or more on-demand SI messages from the communication network; and
 - a transceiver, the transceiver configured at least to:
 - send the request for the one or more on-demand SI messages to the communication network using the one or more UL resources, the request including the information for the WTRU reception of the one or more on-demand SI messages; and
 - receive at least one of the one or more on-demand SI messages from the communication network via the at least one DL beam.
13. The WTRU of claim 12, wherein the one or more UL resources are mapped to the at least one DL beam.
14. The WTRU of claim 12, wherein the processor is further configured such that the one or more UL resources are determined based on at least one of: the at least one DL beam of the one or more DL beams, a mapping between the one or more UL resources and the at least one DL beam of the one or more DL beams, or the requested one or more on-demand SI messages

15. The WTRU of claim 12, wherein the processor is further configured such that the request for the one or more on-demand SI messages is sent as part of a Random Access Channel (RACH) transmission.

16. The WTRU of claim 12, wherein the processor is further configured such that the at least one DL beam of the one or more DL beams is identified based on which of the one or more DL beams at least one of: a synchronization signal, a master system information block (MIB), or essential system information is received in the beam sweep operation.

17. A wireless transmit/receive unit (WTRU) in communication with a communication network, the WTRU comprising:
 - a memory;
 - a transceiver, the transceiver configured at least to:
 - receive system information (SI) from the communication network at a first-time instance; and
 - a processor, the processor configured at least to:
 - determine a first-reference identifier (ID) that corresponds to at least some of the SI of the first-time instance;
 - determine a first-value identifier (ID) that corresponds to the at least some of the SI of the first-time instance;
 - associate at least one of: the first-reference ID, or the first-value ID with the at least some of the SI of the first-time instance;
 - utilize the at least some of the SI of the first-time instance in communication with the communication network;
 - search the memory for stored SI of a previous-time instance that is associated with the same first-reference ID of the at least some of the SI of the first-time instance;
 - store the at least some of the SI of the first-time instance upon no stored SI of the previous-time instance associated with the same first-reference ID being found; and
 - replace stored SI of the previous-time instance associated with the same first-reference ID with the at least some of the SI of the first-time instance upon a value ID associated with the stored SI of the previous-time instance associated with the same first-reference ID being different from the first-value ID.

18. The WTRU of claim 17, wherein the processor is further configured to interpret that the value ID associated with the stored SI of the previous-time instance associated with the same first-reference ID being different from the first-value ID corresponds the at least some of the SI of the first-time instance being more current than the stored SI of the previous-time instance.
19. The WTRU of claim 17, wherein the processor is further configured to recognize that the first-reference ID corresponds to at least one of: a first-spatial area, or a first-temporal interval.
20. The WTRU of claim 17, wherein the processor is further configured to determine the first-reference ID by identifying the first-reference ID as communicated from the communication network via at least one of: a broadcast message, or dedicated signaling.
21. The WTRU of claim 20, wherein the processor is further configured to determine the first-value ID by identifying a part of the first-reference ID that represents the first-value ID.
22. The WTRU of claim 20, wherein the processor is further configured to determine the first-value ID by identifying the first-value ID as communicated from the communication network via at least one of: a broadcast message, or dedicated signaling.
23. The WTRU of claim 17, wherein the processor is further configured to determine the first-reference ID by deriving the first-reference ID based on one or more characteristics associated with one or more downlink (DL) transmissions.
24. The WTRU of claim 23, wherein the processor is further configured to determine the first-value ID by identifying the first-value ID as expressly communicated from the communication network via at least one of: a broadcast message, or dedicated signaling.
25. The WTRU of claim 17, wherein the at least some of the SI of the first-time instance is at least one of: essential SI, minimum SI message, or on-demand SI.
26. The WTRU of claim 17, wherein the processor is further configured such that to replace the stored SI of the previous-time instance associated with the same first-reference ID

with the at least some of the SI of the first-time instance includes the processor being configured to:

- delete from the memory the stored SI of the previous-time instance associated with the same first-reference ID; and
- store in the memory the at least some of the SI of the first-time instance.

27. The WTRU of claim 17, wherein the processor is further configured such that to replace the stored SI of the previous-time instance associated with the same first-reference ID with the at least some of the SI of the first-time instance includes the processor being configured to:

- overwrite in the memory the stored SI of the previous-time instance associated with the same first-reference ID with the at least some of the SI of the first-time instance.

28. The WTRU of claim 20, wherein the processor is further configured to:

- detect that a second-reference ID is being communicated by the communication network in lieu of the first-reference ID;
- search the memory for stored SI of a previous-time instance that is associated with the second-reference ID;
- utilize the SI of the previous-time instance that is associated with the second-reference ID upon the SI of the previous-time instance that is associated with the second-reference ID being found; and
- obtain updated SI from the communication network upon the SI of the previous-time instance that is associated with the second-reference ID not being found.

29. The WTRU of claim 22, wherein the processor is further configured to:

- detect that a second-reference ID is being communicated by the communication network in lieu of the first-reference ID;
- detect that a second-value ID is being communicated by the communication network in lieu of the first-value ID;
- search the memory for stored SI of a previous-time instance that is associated with the second-reference ID and the second-value ID;

utilize the SI of the previous-time instance that is associated with the second-reference ID and the second-value ID upon the SI of the previous-time instance that is associated with the second-reference ID and second-value ID being found; and

obtain updated SI from the communication network upon the SI of the previous-time instance that is associated with the second-reference ID and the second-value ID not being found.

30. A wireless transmit/receive unit (WTRU) in communication with a communication network, the WTRU comprising:

a memory;

a processor, the processor configured at least to:

determine to request other system information (other-SI) from the communication network;

initiate the request for the other-SI from the communication network as part of a Random Access Channel (RACH) procedure; and

a transceiver, the transceiver configured at least to:

transmit a RACH signal, the RACH signal including the request for the other-SI in a random access preamble of the RACH signal, the processor being further configured to:

monitor for a message that includes a minimum SI from the communication network for a predetermined period of time following the transmission of the RACH signal;

determine if the requested other-SI is included in the message that includes the minimum SI upon a detection of the message that includes the minimum SI; and

initiate one or more retransmissions of the RACH signal upon at least one of: the message that includes the minimum SI not being detected, or the other-SI is determined to not be included in a detected message that includes the minimum SI.

31. The WTRU of claim 30, wherein the processor is further configured such that the predetermined period of time occurs within a random access response time window.

32. The WTRU of claim 31, wherein the processor is further configured to monitor for a predefined identifier in a control channel within the random access response time window.
33. The WTRU of claim 32, wherein the processor is further configured such that the predefined identifier is specific to the request of the other-SI.
34. The WTRU of claim 32, wherein the processor is further configured such that the predefined identifier is a Radio Network Temporary Identifier (RNTI).
35. The WTRU of claim 31, wherein the processor is further configured such that the message that includes the minimum SI is at least one of: one or more random access response messages, the processor being further configured to process the at least one of the one or more random access response messages within the random access response time window.
36. The WTRU of claim 35, wherein a format of the at least one of the one or more random access response messages is specific to the request for the other-SI.
37. The WTRU of claim 30, wherein the processor is further configured to initiate a power ramping of the random access preamble in the one or more retransmissions.
38. The WTRU of claim 30, wherein the processor is further configured to initiate the one or more retransmissions of the RACH signal upon at least one of: no response to the RACH signal being detected in the predetermined period of time; or a limit of a preamble counter associated with the RACH signal not being reached.
39. The WTRU of claim 30, wherein the processor is further configured such that the message that includes the minimum SI is at least one of: a random access response message that corresponds to the random access preamble of the RACH signal, or a random access response message that does not correspond to the random access preamble of the RACH signal.
40. The WTRU of claim 30, wherein at least one of the one or more retransmissions have been initiated by the processor, the processor being further configured to:

I5GSYS_13091WO01

cease an initiation of any further retransmissions of the one or more retransmissions upon:

a detection of the message that includes the minimum SI; and
a determination that the requested other-SI is included in the detected message that includes the minimum SI.

ABSTRACT

Systems, procedures, and instrumentalities are disclosed for distributed control in wireless systems, such as 5G flexible radio access technology (RAT) (5gFLEX). Example procedures are provided for WTRU and network operation associated with a distributed control plane architecture, connectionless data transfer and dedicated system information acquisition. Distributed control may be provided, for example, by replicating a plurality of access control functions (ACFs) using a plurality of instances in a plurality of different transmission/reception points (TRPs) with multi-connectivity. The plurality of TRPs may concurrently provide control services to a WTRU. Centralized control functions may manage core network connectivity and/or a plurality of user plane instances for the WTRU and/or may facilitate coordination between the plurality of ACF instances for the WTRU in the plurality of different TRPs of the WTRU's configuration.

100

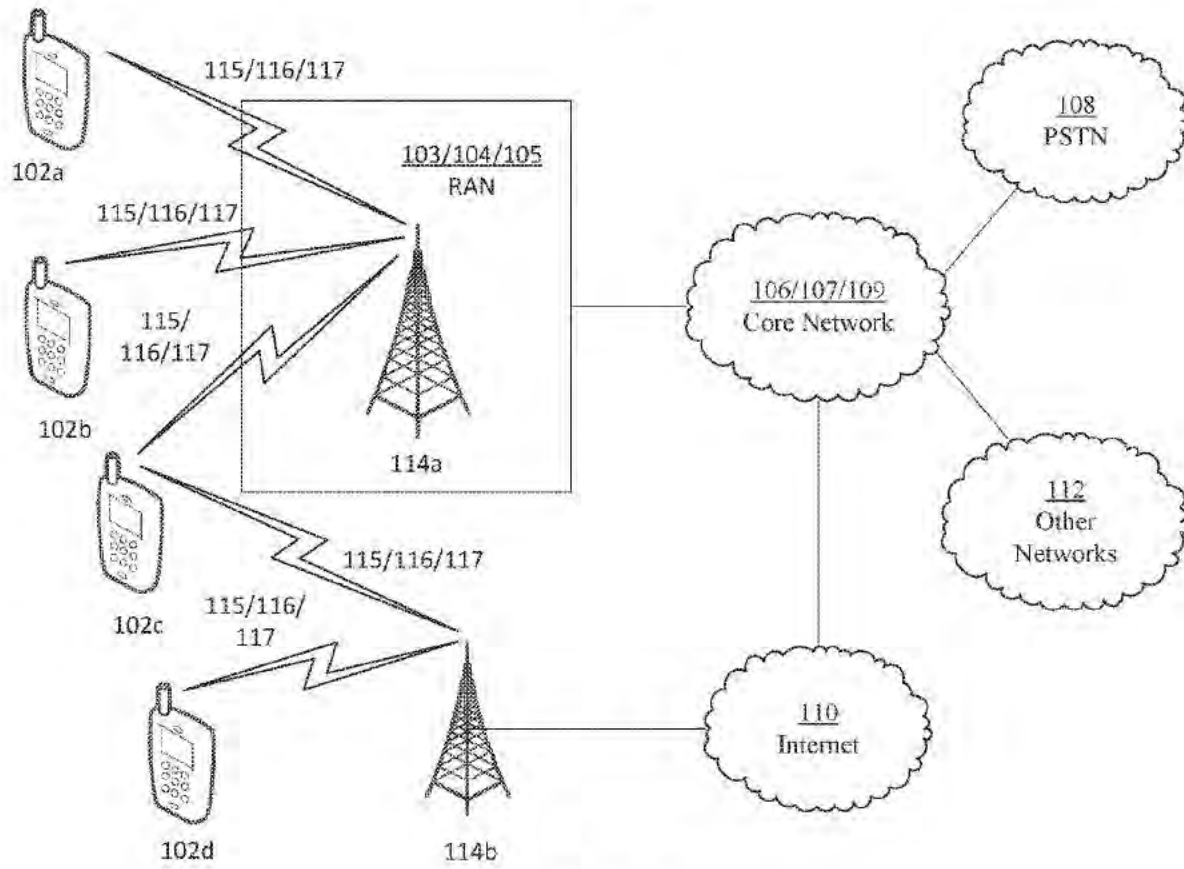

FIG. 1A

1/13

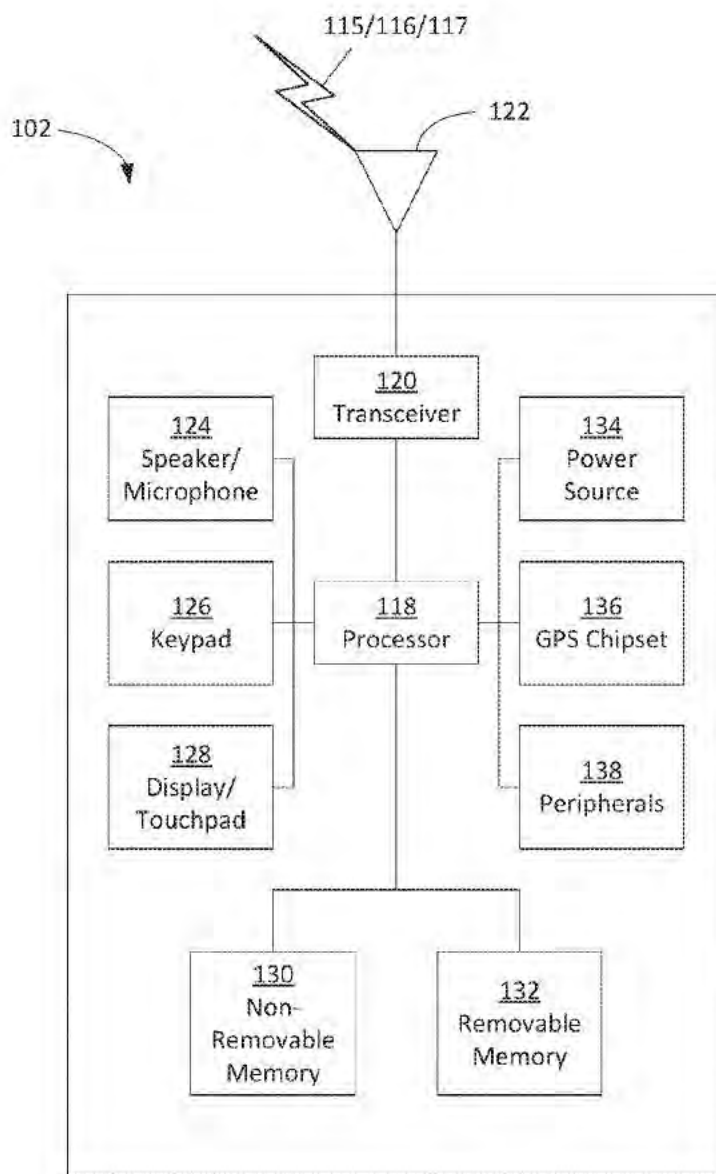

FIG. 1B

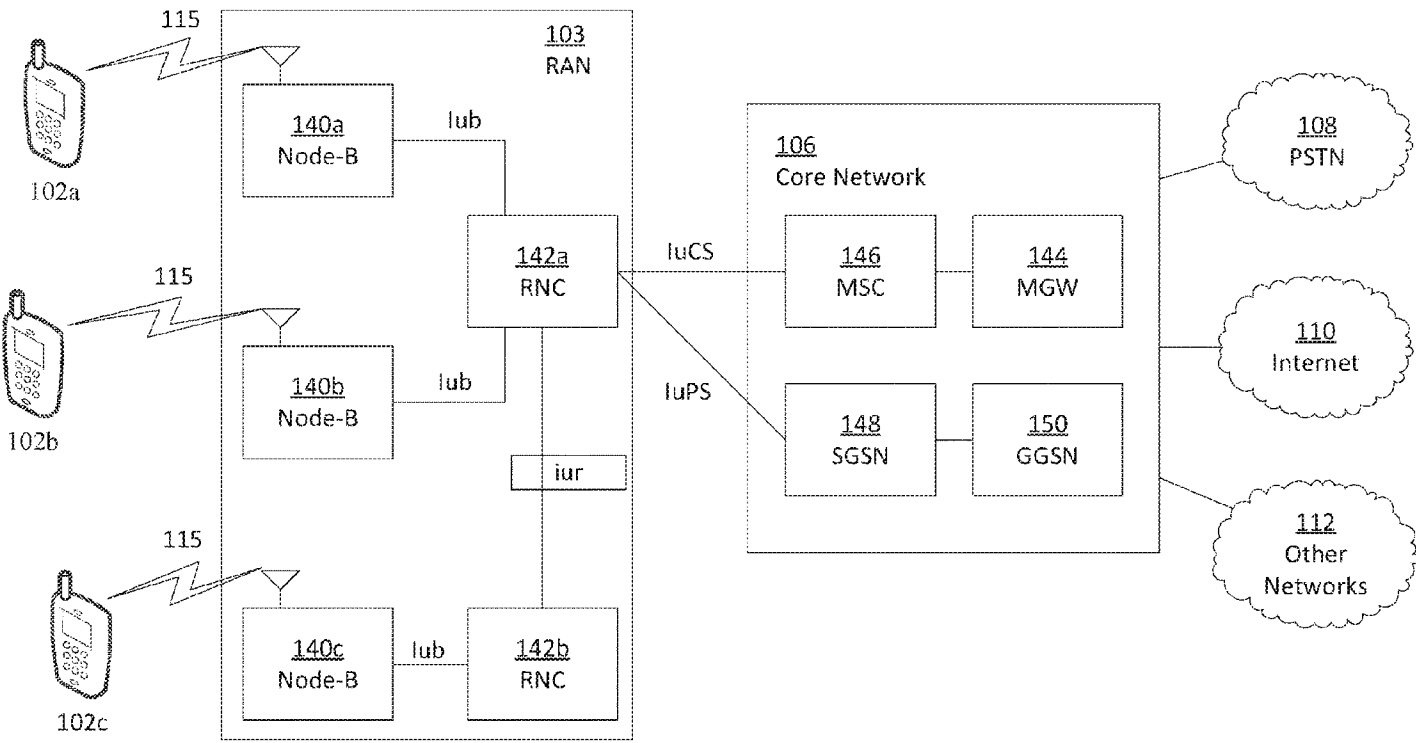
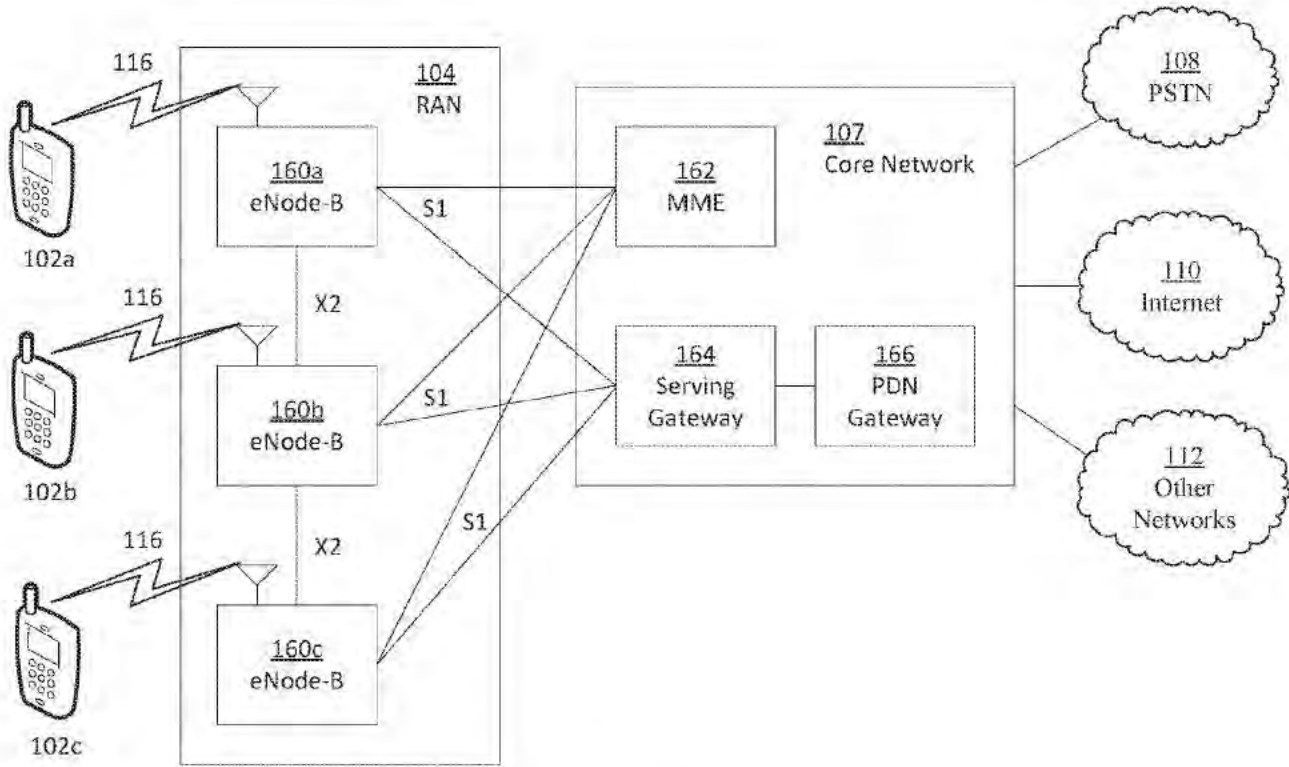

FIG. 1C

3/13



4/13

FIG. 1D

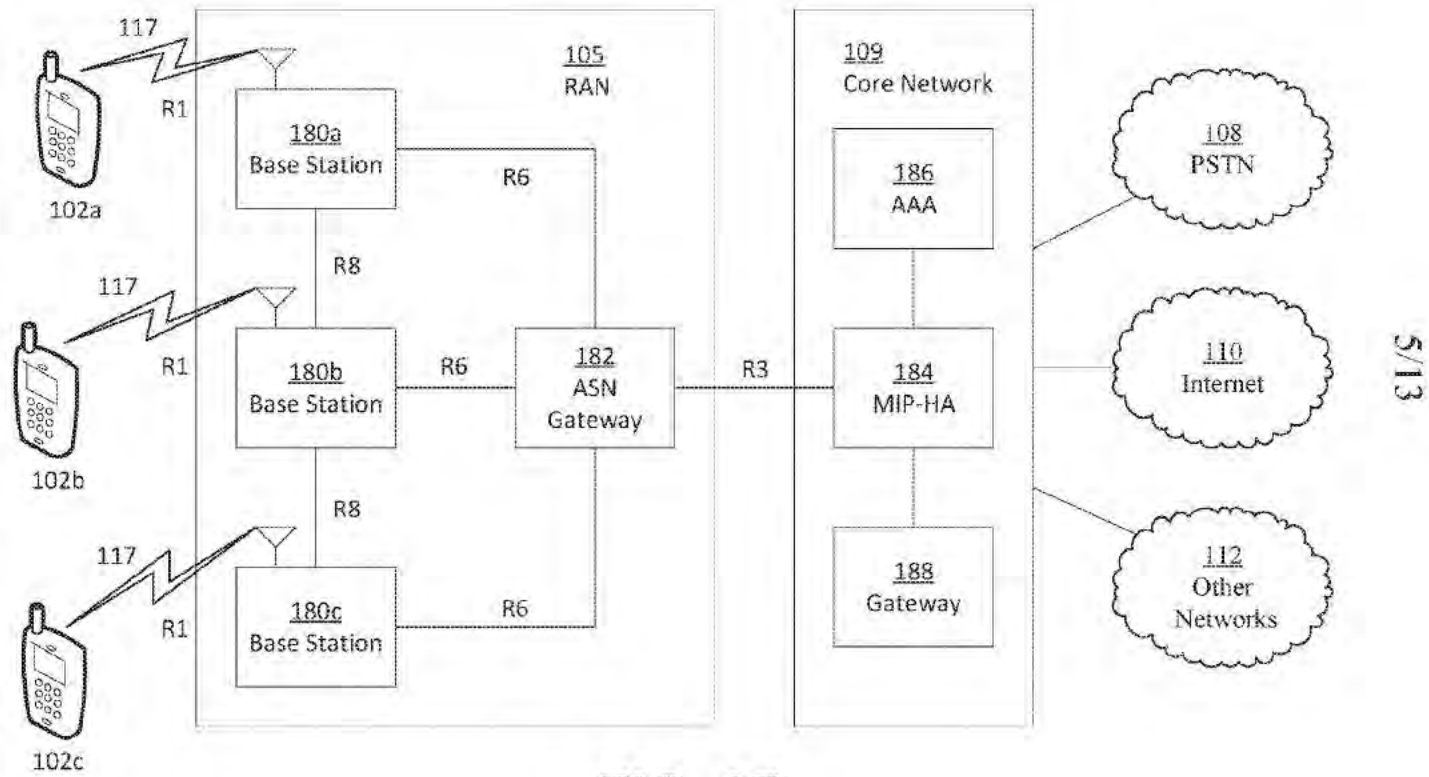
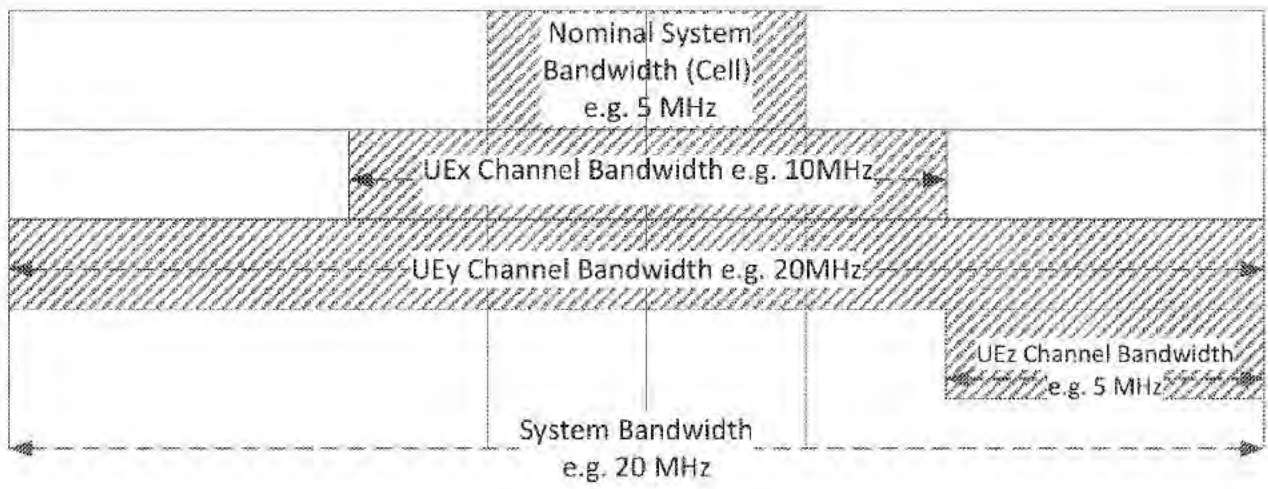

FIG. 1E

S/13



6/13

FIG. 2

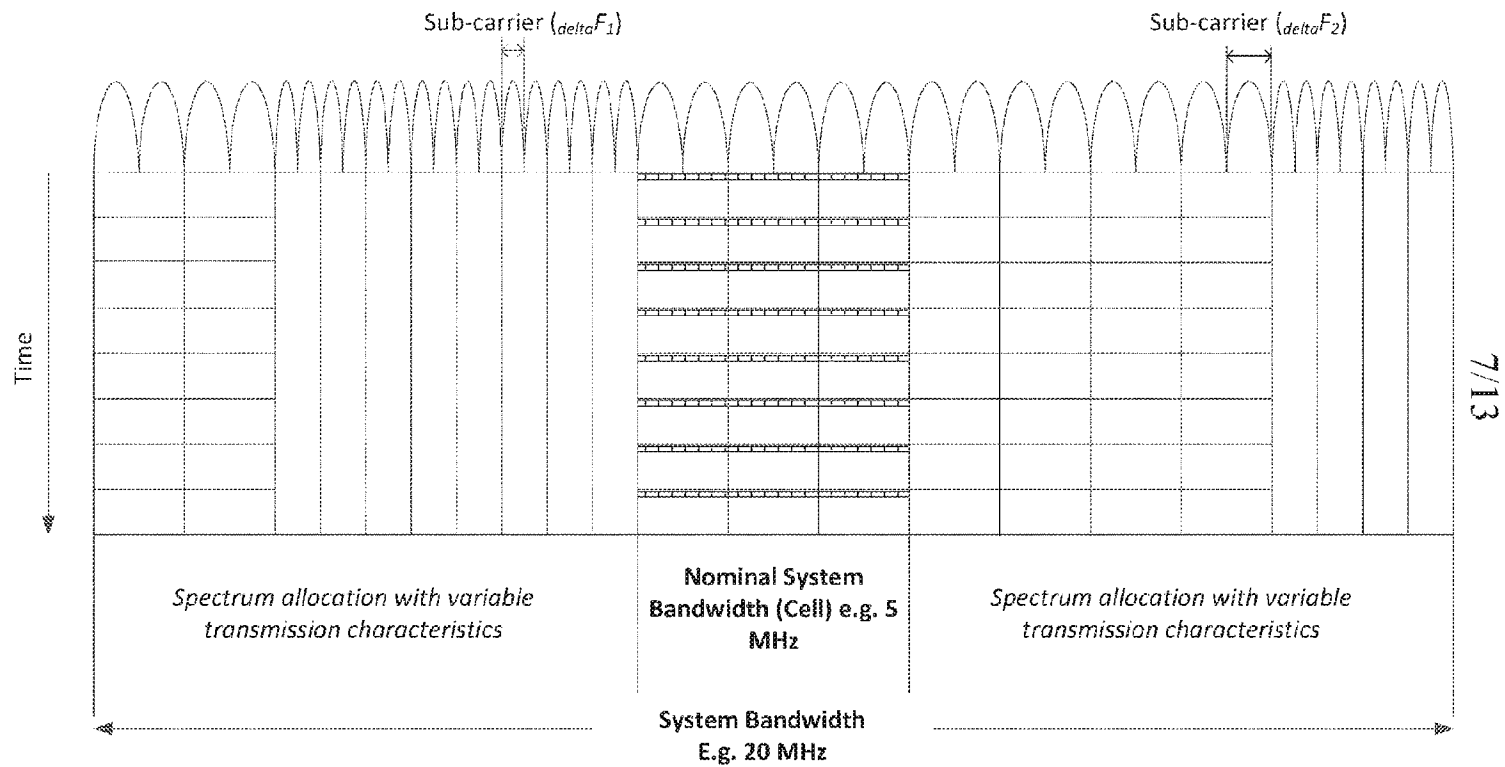

FIG. 3

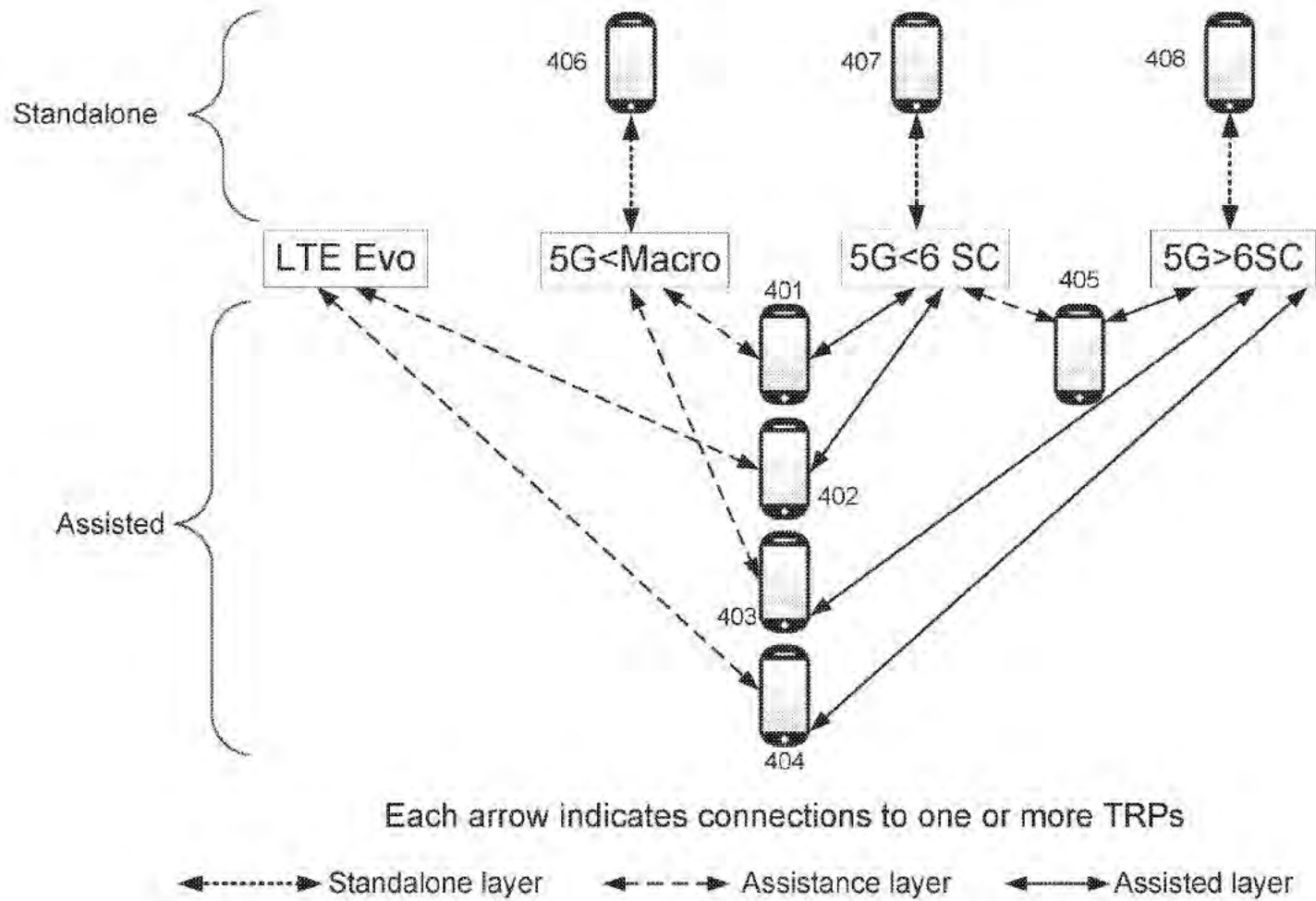

FIG. 4

8/13

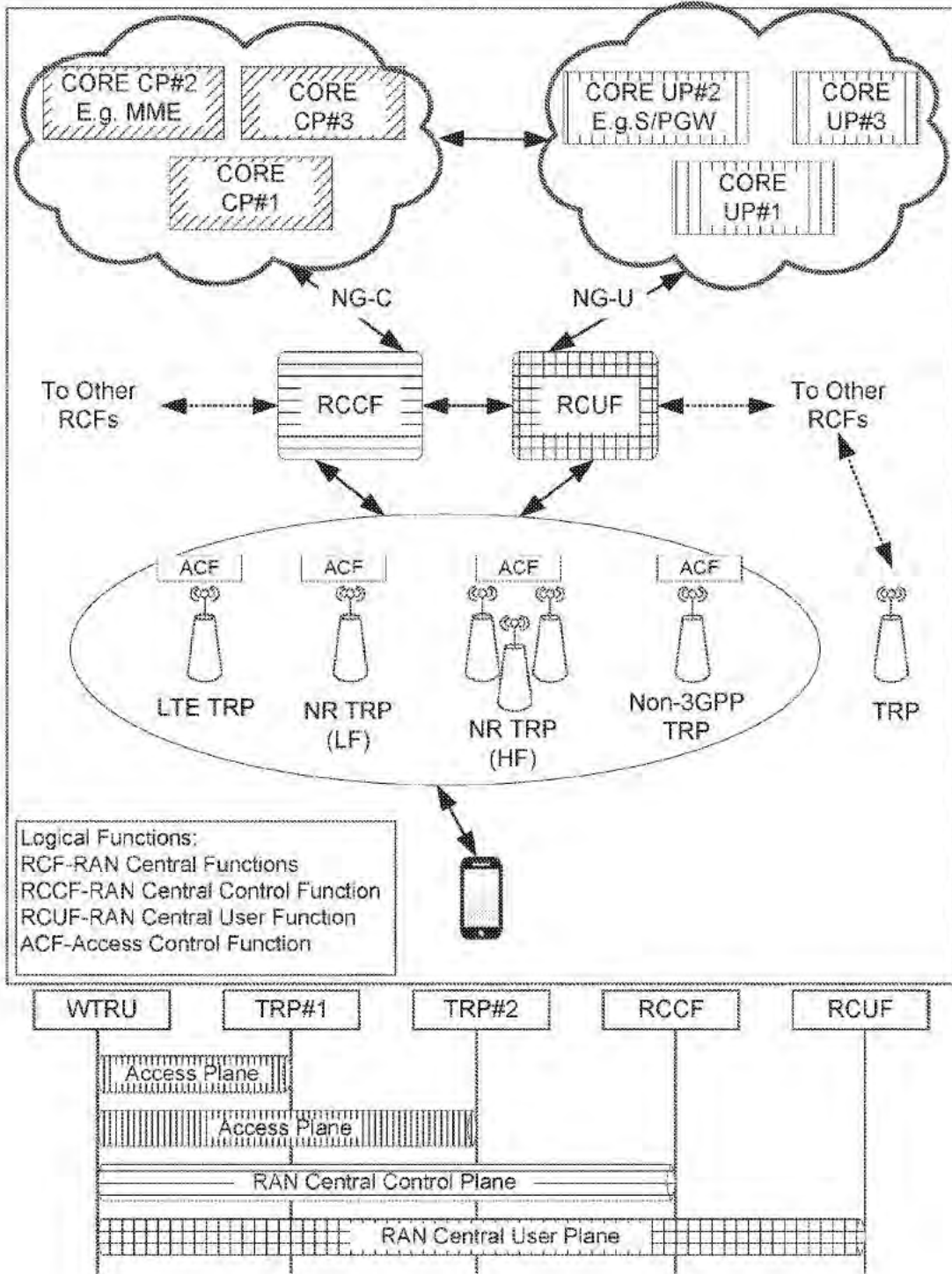

FIG. 5

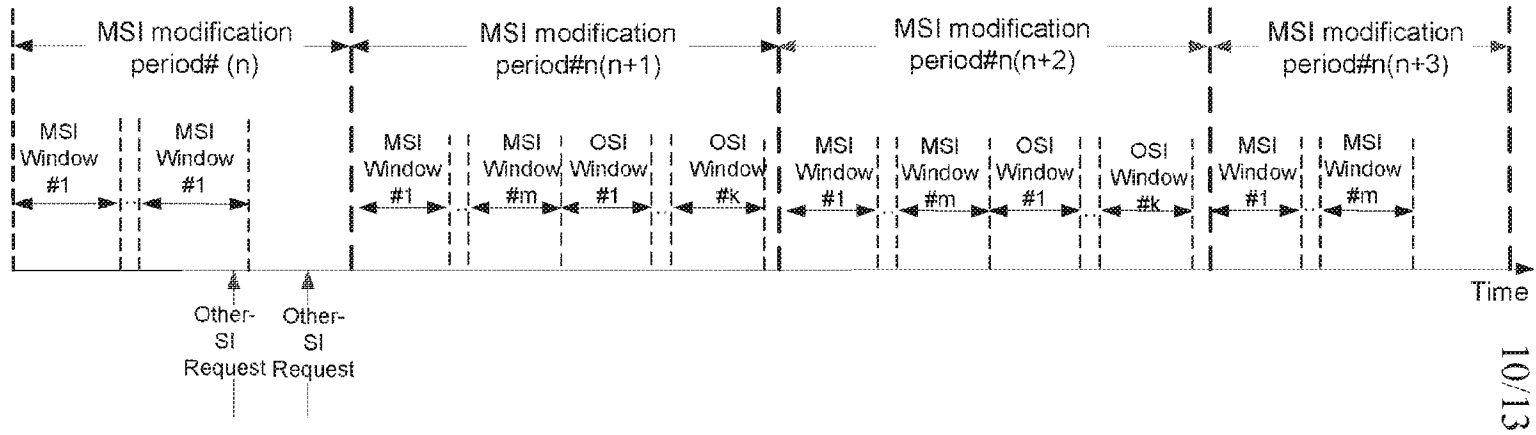
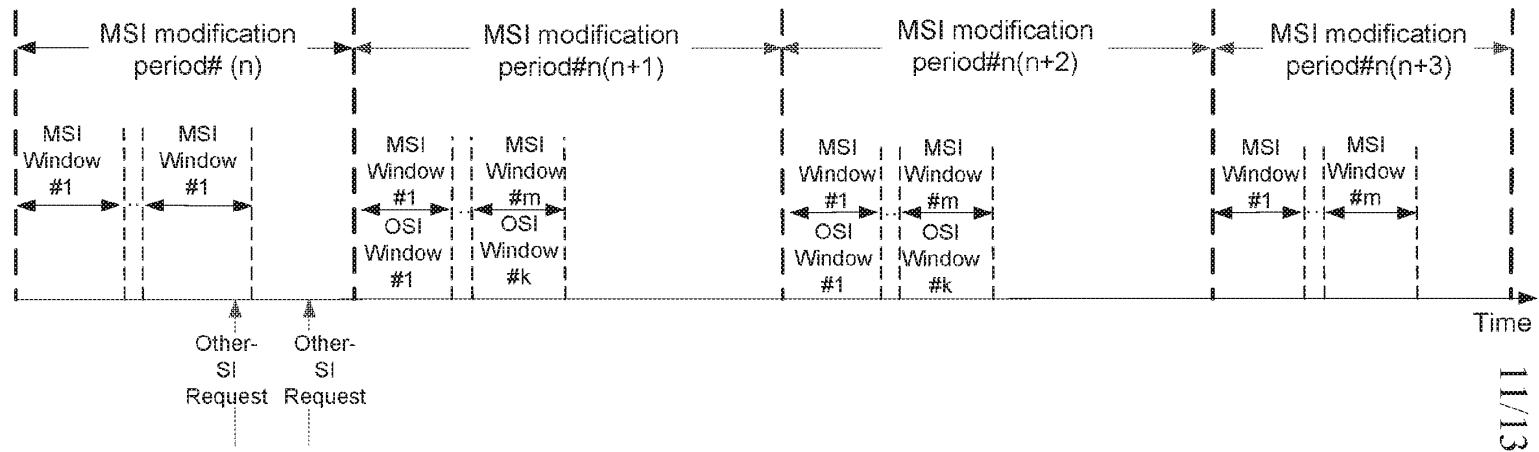
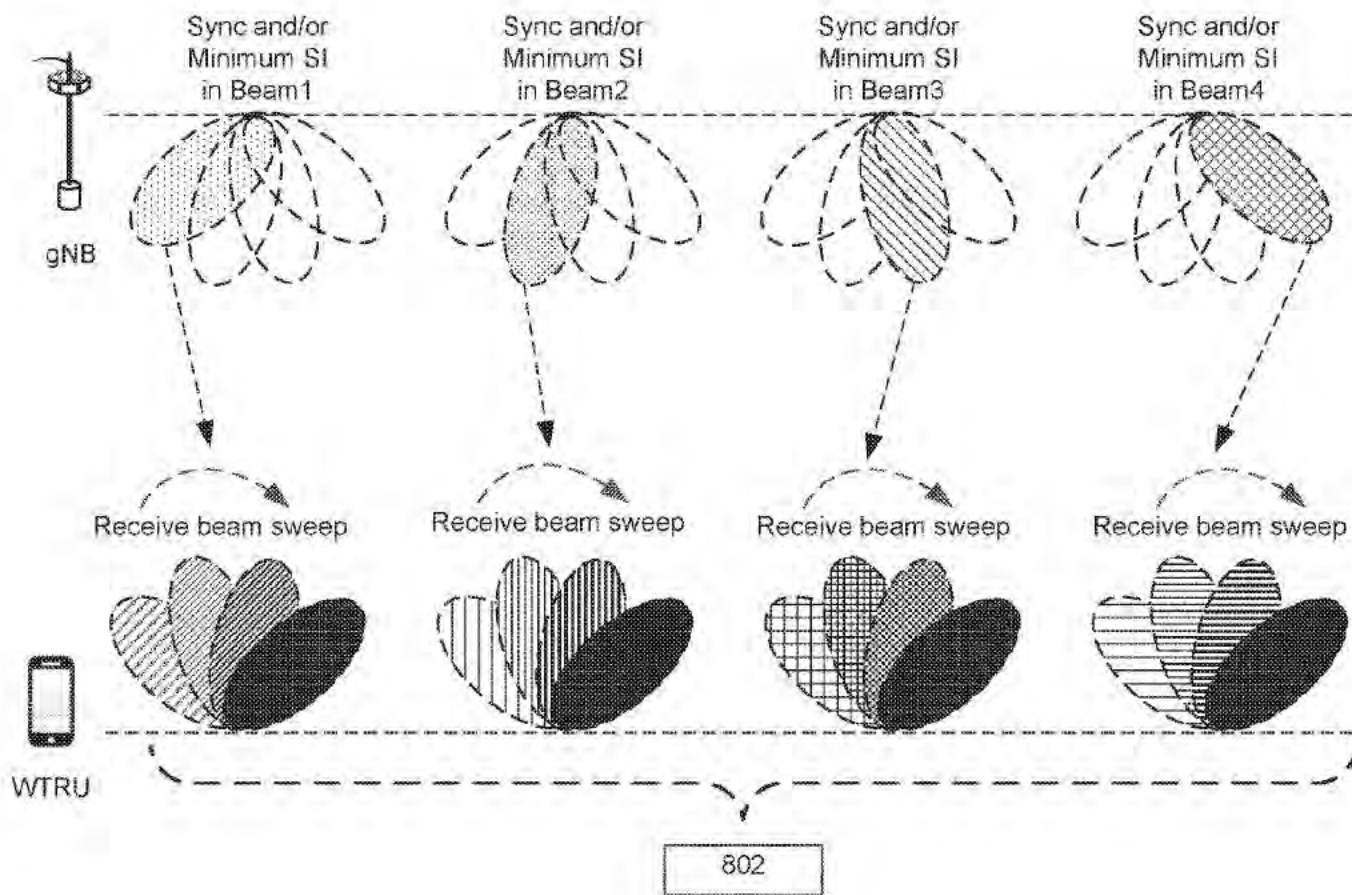

FIG. 6



11/13

FIG. 7



12/13

FIG. 8A

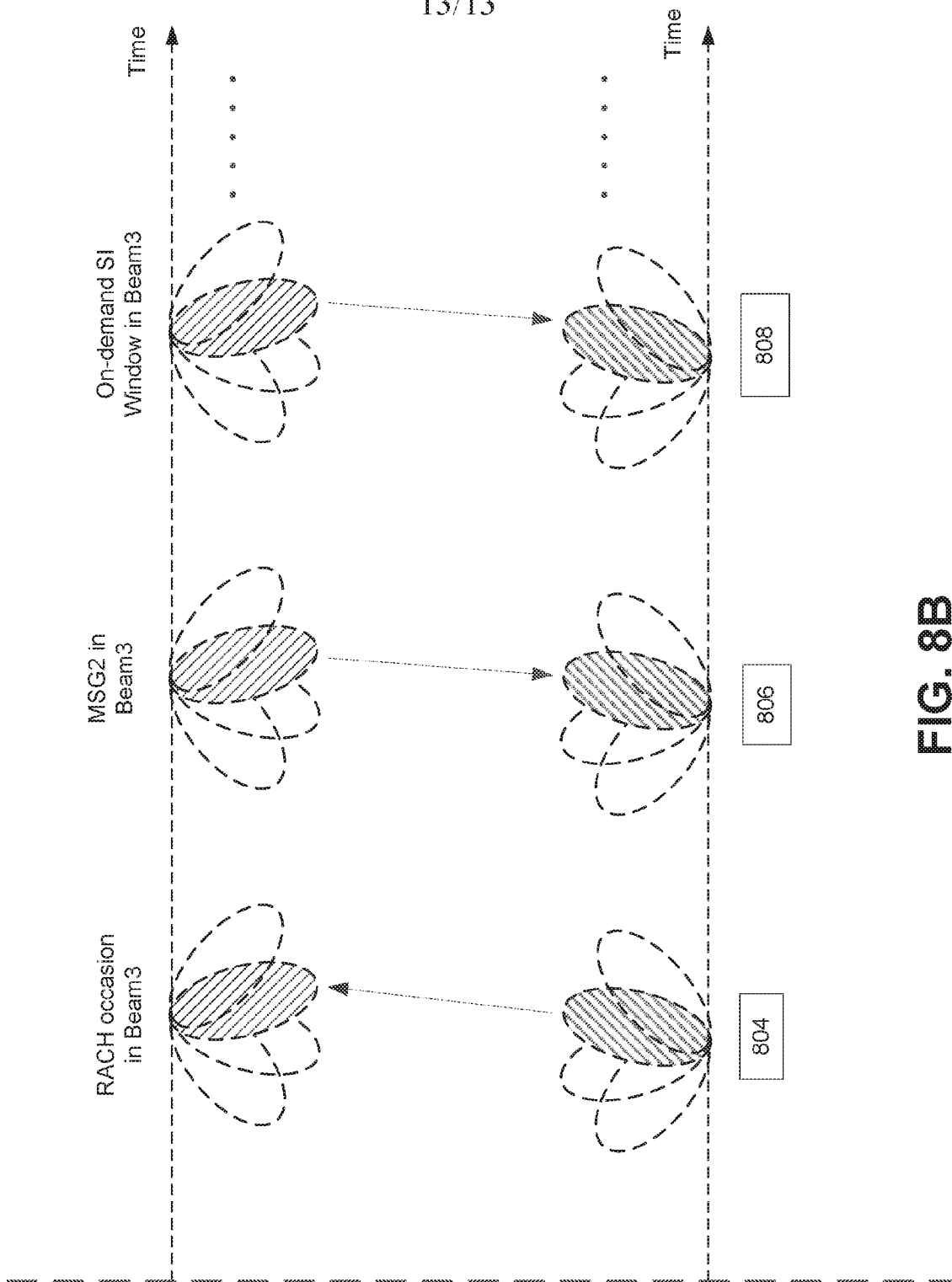

FIG. 8B

ADVANCE E-MAIL

From the INTERNATIONAL BUREAU

PCT

**NOTIFICATION OF THE RECORDING
OF A CHANGE**

(PCT Rule 92bis.1 and
Administrative Instructions, Section 422)

To:

LYTLE, BRADLEY D.
200 Daingerfield Road, Suite 201
Alexandria, VA 22314
ÉTATS-UNIS D'AMÉRIQUE

Date of mailing (<i>day/month/year</i>) 01 November 2018 (01.11.2018)	IMPORTANT NOTIFICATION
Applicant's or agent's file reference IG5SYS_13091WC01	
International application No. PCT/US2017/032069	International filing date (<i>day/month/year</i>) 11 May 2017 (11.05.2017)

1. The following indications appeared on record concerning:

the applicant the inventor the agent the common representative

Name and Address IDAC HOLDINGS, INC. 200 Bellevue Parkway, Suite 300 Wilmington, DE 19809 United States of America	State of Nationality US	State of Residence US
	Telephone No.	
	Facsimile No.	
	E-mail address	

2. The International Bureau hereby notifies the applicant that the following change has been recorded concerning:

the person the name the address the nationality the residence

Name and Address SONY CORPORATION 1-7-1 Konan, Minato-Ku Tokyo, 108-0075 Japan	State of Nationality JP	State of Residence JP
	Telephone No.	
	Facsimile No.	
	E-mail address <input type="checkbox"/> Notifications by e-mail authorized	

3. Further observations, if necessary:

4. A copy of this notification has been sent to:

<input checked="" type="checkbox"/> the receiving Office	<input type="checkbox"/> the International Preliminary Examining Authority
<input checked="" type="checkbox"/> the International Searching Authority	<input checked="" type="checkbox"/> the designated Offices concerned
<input type="checkbox"/> the Authority(ies) specified for supplementary search	<input type="checkbox"/> the elected Offices concerned
	<input type="checkbox"/> other:

The International Bureau of WIPO 34, chemin des Colombettes 1211 Geneva 20, Switzerland	Authorized officer Safi Horiya e-mail pct.team4@wipo.int Telephone No. +41 22 338 74 09
Facsimile No. +41 22 338 89 95	

Under the Paperwork Reduction Act of 1995, no persons are required to respond to a collection of information unless it displays a valid OMB control number.

TRANSMITTAL FOR POWER OF ATTORNEY TO ONE OR MORE REGISTERED PRACTITIONERS

NOTE: This form is to be submitted with the Power of Attorney by Applicant form (PTO/AIA/82B) to identify the application to which the Power of Attorney is directed, in accordance with 37 CFR 1.5, unless the application number and filing date are identified in the Power of Attorney by Applicant form. If neither form PTO/AIA/82A nor form PTO/AIA/82B identifies the application to which the Power of Attorney is directed, the Power of Attorney will not be recognized in the application.

Application Number	NEW APPLICATION
Filing Date	HEREWITH
First Named Inventor	Yugeswar DEENOO
Title	DISTRIBUTED CONTROL IN WIRELESS SYSTEMS
Art Unit	UNASSIGNED
Examiner Name	UNASSIGNED
Attorney Docket Number	11574US05

SIGNATURE of Applicant or Patent Practitioner

Signature	/Bradley D. Lytle/	Date (Optional)	11/06/2018
Name	Bradley D. Lytle	Registration Number	40,073
Title (if Applicant is a juristic entity)			
Applicant Name (if Applicant is a juristic entity)	Sony Corporation		

NOTE: This form must be signed in accordance with 37 CFR 1.33. See 37 CFR 1.4(d) for signature requirements and certifications. If more than one applicant, use multiple forms.

*Total of _____ forms are submitted.

This collection of information is required by 37 CFR 1.131, 1.32, and 1.33. The information is required to obtain or retain a benefit by the public which is to file (and by the USPTO to process) an application. Confidentiality is governed by 35 U.S.C. 122 and 37 CFR 1.11 and 1.14. This collection is estimated to take 3 minutes to complete, including gathering, preparing, and submitting the completed application form to the USPTO. Time will vary depending upon the individual case. Any comments on the amount of time you require to complete this form and/or suggestions for reducing this burden, should be sent to the Chief Information Officer, U.S. Patent and Trademark Office, U.S. Department of Commerce, P.O. Box 1450, Alexandria, VA 22313-1450. DO NOT SEND FEES OR COMPLETED FORMS TO THIS ADDRESS. SEND TO: Commissioner for Patents, P.O. Box 1450, Alexandria, VA 22313-1450.

If you need assistance in completing the form, call 1-800-PTO-9199 and select option 2.

POWER OF ATTORNEY BY APPLICANT

I hereby revoke all previous powers of attorney given in the application identified in either the attached transmittal letter or the boxes below.

Application Number	Filing Date

(Note: The boxes above may be left blank if information is provided on form PTO/AIA/82A.)

- I hereby appoint the Patent Practitioner(s) associated with the following Customer Number as my/our attorney(s) or agent(s), and to transact all business in the United States Patent and Trademark Office connected therewith for the application referenced in the attached transmittal letter (form PTO/AIA/82A) or identified above: 154930
- OR
- I hereby appoint Practitioner(s) named in the attached list (form PTO/AIA/82C) as my/our attorney(s) or agent(s), and to transact all business in the United States Patent and Trademark Office connected therewith for the patent application referenced in the attached transmittal letter (form PTO/AIA/82A) or identified above. (Note: Complete form PTO/AIA/82C.)

Please recognize or change the correspondence address for the application identified in the attached transmittal letter or the boxes above to:

- The address associated with the above-mentioned Customer Number
- OR
- The address associated with Customer Number:
- OR

<input type="checkbox"/> Firm or Individual Name			
Address			
City	State	Zip	
Country			
Telephone	Email		

I am the Applicant (if the Applicant is a juristic entity, list the Applicant name in the box):

Sony Corporation

- Inventor or Joint Inventor (title not required below)
- Legal Representative of a Deceased or Legally Incapacitated Inventor (title not required below)
- Assignee or Person to Whom the Inventor is Under an Obligation to Assign (provide signer's title if applicant is a juristic entity)
- Person Who Otherwise Shows Sufficient Proprietary Interest (e.g., a petition under 37 CFR 1.46(b)(2) was granted in the application or is concurrently being filed with this document) (provide signer's title if applicant is a juristic entity)

SIGNATURE of Applicant for Patent

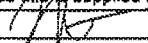
The undersigned (whose title is supplied below) is authorized to act on behalf of the applicant (e.g., where the applicant is a juristic entity).			
Signature		Date (Optional)	June 28, 2018
Name	Hifoshi Kamitani		
Title	General Manager, Planning & Control Department, Intellectual Property Division		

NOTE: Signature - This form must be signed by the applicant in accordance with 37 CFR 1.33. See 37 CFR 1.4 for signature requirements and certifications. If more than one applicant, use multiple forms.

Total of 1 forms are submitted.

This collection of information is required by 37 CFR 1.131, 1.32, and 1.33. The information is required to obtain or retain a benefit by the public which is to file (and by the USPTO to process) an application. Confidentiality is governed by 35 U.S.C. 122 and 37 CFR 1.11 and 1.14. This collection is estimated to take 3 minutes to complete, including gathering, preparing, and submitting the completed application form to the USPTO. Time will vary depending upon the individual case. Any comments on the amount of time you require to complete this form and/or suggestions for reducing this burden, should be sent to the Chief Information Officer, U.S. Patent and Trademark Office, U.S. Department of Commerce, P.O. Box 1450, Alexandria, VA 22313-1450. DO NOT SEND FEES OR COMPLETED FORMS TO THIS ADDRESS. SEND TO: Commissioner for Patents, P.O. Box 1450, Alexandria, VA 22313-1450.

If you need assistance in completing the form, call 1-800-PTO-9199 and select option 2.

DOCKET NO: 11574US05

IN THE UNITED STATES PATENT & TRADEMARK OFFICE

IN RE APPLICATION OF :
YUGESWAR DEENOO ET AL. : ATTN: APPLICATION DIVISION
SERIAL NO: NEW APPLICATION :
FILED: HEREWITH :
FOR: DISTRIBUTED CONTROL IN :
WIRELESS SYSTEMS :

PRELIMINARY AMENDMENT

COMMISSIONER FOR PATENTS
ALEXANDRIA, VIRGINIA 22313

Commissioner:

Prior to examination on the merits, please amend the above-identified application as follows:

Amendments to the Specification begin on page 2 of this paper.

Remarks/Arguments begin on page 3 of this paper.

Docket No.: 11574US05
Preliminary Amendment

IN THE SPECIFICATION

Please amend the Specification by amending paragraph [0001] on page 1 as follows:

This application is a national stage (under 35 U.S.C. 371) of International Patent Application No. PCT/US2017/032069, filed November 5, 2017 and claims the benefit of U.S. Provisional Patent Application No. 62/442,317 filed on January 4, 2017; U.S. Provisional Patent Application No. 62/416,499, filed on November 2, 2016; U.S. Provisional Patent Application No. 62/400,810, filed on September 28, 2016; and U.S. Provisional Patent Application No. 62/334,704, filed on May 11, 2016, the contents of all of which being hereby incorporated by reference as if fully set-forth herein in their respective entirety, for all purposes.

Docket No.: 11574US05
Preliminary Amendment

REMARKS/ARGUMENTS

Favorable consideration of this application as presently amended and in light of the following discussion is respectfully requested.

In view of the foregoing discussion and present amendment, it is respectfully submitted that this application is in condition for examination. An early and favorable action is therefore respectfully requested.

Respectfully Submitted,

XSENSUS, L.L.P.



Bradley D. Lytle
Attorney of Record
Registration No. 40,073

CUSTOMER NO. 154930

Phone No. 571-376-6333
Fax: 571-376-6334

Under the Paperwork Reduction Act of 1995, no persons are required to respond to a collection of information unless it contains a valid OMB control number.

Application Data Sheet 37 CFR 1.76		Attorney Docket Number	11574US05
		Application Number	
Title of Invention	DISTRIBUTED CONTROL IN WIRELESS SYSTEMS		
<p>The application data sheet is part of the provisional or nonprovisional application for which it is being submitted. The following form contains the bibliographic data arranged in a format specified by the United States Patent and Trademark Office as outlined in 37 CFR 1.76. This document may be completed electronically and submitted to the Office in electronic format using the Electronic Filing System (EFS) or the document may be printed and included in a paper filed application.</p>			

Secrecy Order 37 CFR 5.2:

Portions or all of the application associated with this Application Data Sheet may fall under a Secrecy Order pursuant to 37 CFR 5.2 (Paper filers only. Applications that fall under Secrecy Order may not be filed electronically.)

Inventor Information:

Inventor	1				Remove
Legal Name					
Prefix	Given Name	Middle Name	Family Name	Suffix	
	Yugeswar		DEENOO		
Residence Information (Select One) <input checked="" type="radio"/> US Residency <input type="radio"/> Non US Residency <input type="radio"/> Active US Military Service					
City	Conshohocken	State/Province	PA	Country of Residence	US
Mailing Address of Inventor:					
Address 1	c/o Sony Corporation				
Address 2	1-7-1 Konan, Minato-ku				
City	Tokyo	State/Province			
Postal Code	108-0075	Country i	JP		
Inventor	2				Remove
Legal Name					
Prefix	Given Name	Middle Name	Family Name	Suffix	
	Ghyslain		PELLETIER		
Residence Information (Select One) <input type="radio"/> US Residency <input checked="" type="radio"/> Non US Residency <input type="radio"/> Active US Military Service					
City	Montreal, QC	Country of Residence i	CA		
Mailing Address of Inventor:					
Address 1	c/o Sony Corporation				
Address 2	1-7-1 Konan, Minato-ku				
City	Tokyo	State/Province			
Postal Code	108-0075	Country i	JP		
Inventor	3				Remove
Legal Name					
Prefix	Given Name	Middle Name	Family Name	Suffix	
	Ping	Hsuan	TAN		

Under the Paperwork Reduction Act of 1995, no persons are required to respond to a collection of information unless it contains a valid OMB control number.

Application Data Sheet 37 CFR 1.76		Attorney Docket Number	11574US05
		Application Number	
Title of Invention	DISTRIBUTED CONTROL IN WIRELESS SYSTEMS		

Residence Information (Select One) <input type="radio"/> US Residency <input checked="" type="radio"/> Non US Residency <input type="radio"/> Active US Military Service			
City	Montreal, QC	Country of Residence ⁱ	CA

Mailing Address of Inventor:			
Address 1	c/o Sony Corporation		
Address 2	1-7-1 Konan, Minato-ku		
City	Tokyo	State/Province	
Postal Code	108-0075	Country ⁱ	JP
Inventor	4	<input type="button" value="Remove"/>	

Legal Name				
Prefix	Given Name	Middle Name	Family Name	Suffix
	Martino	M	FREDA	

Residence Information (Select One) <input type="radio"/> US Residency <input checked="" type="radio"/> Non US Residency <input type="radio"/> Active US Military Service			
City	Montreal, QC	Country of Residence ⁱ	CA

Mailing Address of Inventor:			
Address 1	c/o Sony Corporation		
Address 2	1-7-1 Konan, Minato-ku		
City	Tokyo	State/Province	
Postal Code	108-0075	Country ⁱ	JP
All Inventors Must Be Listed - Additional Inventor Information blocks may be generated within this form by selecting the Add button. <input type="button" value="Add"/>			

Correspondence Information:

Enter either Customer Number or complete the Correspondence Information section below. For further information see 37 CFR 1.33(a).	
<input type="checkbox"/> An Address is being provided for the correspondence information of this application.	
Customer Number	154930
Email Address	xsensuspat@xsensus.com <input type="button" value="Add Email"/> <input type="button" value="Remove Email"/>

Under the Paperwork Reduction Act of 1995, no persons are required to respond to a collection of information unless it contains a valid OMB control number.

Application Data Sheet 37 CFR 1.76		Attorney Docket Number	11574US05
		Application Number	
Title of Invention	DISTRIBUTED CONTROL IN WIRELESS SYSTEMS		

Application Information:

Title of the Invention	DISTRIBUTED CONTROL IN WIRELESS SYSTEMS		
Attorney Docket Number	11574US05	Small Entity Status Claimed	<input type="checkbox"/>
Application Type	Nonprovisional		
Subject Matter	Utility		
Total Number of Drawing Sheets (if any)	13	Suggested Figure for Publication (if any)	

Filing By Reference:

Only complete this section when filing an application by reference under 35 U.S.C. 111(c) and 37 CFR 1.57(a). Do not complete this section if application papers including a specification and any drawings are being filed. Any domestic benefit or foreign priority information must be provided in the appropriate section(s) below (i.e., "Domestic Benefit/National Stage Information" and "Foreign Priority Information").

For the purposes of a filing date under 37 CFR 1.53(b), the description and any drawings of the present application are replaced by this reference to the previously filed application, subject to conditions and requirements of 37 CFR 1.57(a).

Application number of the previously filed application	Filing date (YYYY-MM-DD)	Intellectual Property Authority or Country

Publication Information:

Request Early Publication (Fee required at time of Request 37 CFR 1.219)

Request Not to Publish. I hereby request that the attached application not be published under 35 U.S.C. 122(b) and certify that the invention disclosed in the attached application **has not and will not be** the subject of an application filed in another country, or under a multilateral international agreement, that requires publication at eighteen months after filing.

Representative Information:

Representative information should be provided for all practitioners having a power of attorney in the application. Providing this information in the Application Data Sheet does not constitute a power of attorney in the application (see 37 CFR 1.32).

Either enter Customer Number or complete the Representative Name section below. If both sections are completed the customer number will be used for the Representative Information during processing.

Please Select One:	<input checked="" type="radio"/> Customer Number	<input type="radio"/> US Patent Practitioner	<input type="radio"/> Limited Recognition (37 CFR 11.9)
Customer Number	154930		

Under the Paperwork Reduction Act of 1995, no persons are required to respond to a collection of information unless it contains a valid OMB control number.

Application Data Sheet 37 CFR 1.76		Attorney Docket Number	11574US05
		Application Number	
Title of Invention	DISTRIBUTED CONTROL IN WIRELESS SYSTEMS		

Domestic Benefit/National Stage Information:

This section allows for the applicant to either claim benefit under 35 U.S.C. 119(e), 120, 121, 365(c), or 386(c) or indicate National Stage entry from a PCT application. Providing benefit claim information in the Application Data Sheet constitutes the specific reference required by 35 U.S.C. 119(e) or 120, and 37 CFR 1.78.

When referring to the current application, please leave the "Application Number" field blank.

Prior Application Status	Pending		<input type="button" value="Remove"/>
Application Number	Continuity Type	Prior Application Number	Filing or 371(c) Date (YYYY-MM-DD)
	a 371 of international	PCT/US2017/032069	2017-11-05
Prior Application Status	Expired		<input type="button" value="Remove"/>
Application Number	Continuity Type	Prior Application Number	Filing or 371(c) Date (YYYY-MM-DD)
PCT/US2017/032069	Claims benefit of provisional	62334704	2016-05-11
Prior Application Status	Expired		<input type="button" value="Remove"/>
Application Number	Continuity Type	Prior Application Number	Filing or 371(c) Date (YYYY-MM-DD)
PCT/US2017/032069	Claims benefit of provisional	62400810	2016-09-28
Prior Application Status	Expired		<input type="button" value="Remove"/>
Application Number	Continuity Type	Prior Application Number	Filing or 371(c) Date (YYYY-MM-DD)
PCT/US2017/032069	Claims benefit of provisional	62416499	2016-11-02
Prior Application Status	Expired		<input type="button" value="Remove"/>
Application Number	Continuity Type	Prior Application Number	Filing or 371(c) Date (YYYY-MM-DD)
PCT/US2017/032069	Claims benefit of provisional	62442317	2017-01-04
Additional Domestic Benefit/National Stage Data may be generated within this form by selecting the Add button.			<input type="button" value="Add"/>

Foreign Priority Information:

This section allows for the applicant to claim priority to a foreign application. Providing this information in the application data sheet constitutes the claim for priority as required by 35 U.S.C. 119(b) and 37 CFR 1.55. When priority is claimed to a foreign application that is eligible for retrieval under the priority document exchange program (PDX)¹ the information will be used by the Office to automatically attempt retrieval pursuant to 37 CFR 1.55(i)(1) and (2). Under the PDX program, applicant bears the ultimate responsibility for ensuring that a copy of the foreign application is received by the Office from the participating foreign intellectual property office, or a certified copy of the foreign priority application is filed, within the time period specified in 37 CFR 1.55(g)(1).

Under the Paperwork Reduction Act of 1995, no persons are required to respond to a collection of information unless it contains a valid OMB control number.

Application Data Sheet 37 CFR 1.76		Attorney Docket Number	11574US05
		Application Number	
Title of Invention	DISTRIBUTED CONTROL IN WIRELESS SYSTEMS		
Application Number	Country ⁱ	Filing Date (YYYY-MM-DD)	Access Code ⁱ (if applicable)
Additional Foreign Priority Data may be generated within this form by selecting the Add button.			<input type="button" value="Add"/>

Statement under 37 CFR 1.55 or 1.78 for AIA (First Inventor to File) Transition Applications

- This application (1) claims priority to or the benefit of an application filed before March 16, 2013 and (2) also contains, or contained at any time, a claim to a claimed invention that has an effective filing date on or after March 16, 2013.
- NOTE: By providing this statement under 37 CFR 1.55 or 1.78, this application, with a filing date on or after March 16, 2013, will be examined under the first inventor to file provisions of the AIA.

Application Data Sheet 37 CFR 1.76		Attorney Docket Number	11574US05
		Application Number	
Title of Invention	DISTRIBUTED CONTROL IN WIRELESS SYSTEMS		

Authorization or Opt-Out of Authorization to Permit Access:

When this Application Data Sheet is properly signed and filed with the application, applicant has provided written authority to permit a participating foreign intellectual property (IP) office access to the instant application-as-filed (see paragraph A in subsection 1 below) and the European Patent Office (EPO) access to any search results from the instant application (see paragraph B in subsection 1 below).

Should applicant choose not to provide an authorization identified in subsection 1 below, applicant **must opt-out** of the authorization by checking the corresponding box A or B or both in subsection 2 below.

NOTE: This section of the Application Data Sheet is **ONLY** reviewed and processed with the **INITIAL** filing of an application. After the initial filing of an application, an Application Data Sheet cannot be used to provide or rescind authorization for access by a foreign IP office(s). Instead, Form PTO/SB/39 or PTO/SB/69 must be used as appropriate.

1. Authorization to Permit Access by a Foreign Intellectual Property Office(s)

A. Priority Document Exchange (PDX) - Unless box A in subsection 2 (opt-out of authorization) is checked, the undersigned hereby **grants the USPTO authority** to provide the European Patent Office (EPO), the Japan Patent Office (JPO), the Korean Intellectual Property Office (KIPO), the State Intellectual Property Office of the People's Republic of China (SIPO), the World Intellectual Property Organization (WIPO), and any other foreign intellectual property office participating with the USPTO in a bilateral or multilateral priority document exchange agreement in which a foreign application claiming priority to the instant patent application is filed, access to: (1) the instant patent application-as-filed and its related bibliographic data, (2) any foreign or domestic application to which priority or benefit is claimed by the instant application and its related bibliographic data, and (3) the date of filing of this Authorization. See 37 CFR 1.14(h)(1).

B. Search Results from U.S. Application to EPO - Unless box B in subsection 2 (opt-out of authorization) is checked, the undersigned hereby **grants the USPTO authority** to provide the EPO access to the bibliographic data and search results from the instant patent application when a European patent application claiming priority to the instant patent application is filed. See 37 CFR 1.14(h)(2).

The applicant is reminded that the EPO's Rule 141(1) EPC (European Patent Convention) requires applicants to submit a copy of search results from the instant application without delay in a European patent application that claims priority to the instant application.

2. Opt-Out of Authorizations to Permit Access by a Foreign Intellectual Property Office(s)

A. Applicant **DOES NOT** authorize the USPTO to permit a participating foreign IP office access to the instant application-as-filed. If this box is checked, the USPTO will not be providing a participating foreign IP office with any documents and information identified in subsection 1A above.

B. Applicant **DOES NOT** authorize the USPTO to transmit to the EPO any search results from the instant patent application. If this box is checked, the USPTO will not be providing the EPO with search results from the instant application.

NOTE: Once the application has published or is otherwise publicly available, the USPTO may provide access to the application in accordance with 37 CFR 1.14.

Under the Paperwork Reduction Act of 1995, no persons are required to respond to a collection of information unless it contains a valid OMB control number.

Application Data Sheet 37 CFR 1.76		Attorney Docket Number	11574US05
		Application Number	
Title of Invention	DISTRIBUTED CONTROL IN WIRELESS SYSTEMS		

Applicant Information:

Providing assignment information in this section does not substitute for compliance with any requirement of part 3 of Title 37 of CFR to have an assignment recorded by the Office.

Applicant 1	<input type="button" value="Remove"/>		
<p>If the applicant is the inventor (or the remaining joint inventor or inventors under 37 CFR 1.45), this section should not be completed. The information to be provided in this section is the name and address of the legal representative who is the applicant under 37 CFR 1.43; or the name and address of the assignee, person to whom the inventor is under an obligation to assign the invention, or person who otherwise shows sufficient proprietary interest in the matter who is the applicant under 37 CFR 1.46. If the applicant is an applicant under 37 CFR 1.46 (assignee, person to whom the inventor is obligated to assign, or person who otherwise shows sufficient proprietary interest) together with one or more joint inventors, then the joint inventor or inventors who are also the applicant should be identified in this section.</p>			
<input type="button" value="Clear"/>			
<input checked="" type="radio"/> Assignee	Legal Representative under 35 U.S.C. 117	Joint Inventor	
Person to whom the inventor is obligated to assign.		Person who shows sufficient proprietary interest	
If applicant is the legal representative, indicate the authority to file the patent application, the inventor is:			
-			
Name of the Deceased or Legally Incapacitated Inventor: <input type="text"/>			
If the Applicant is an Organization check here. <input checked="" type="checkbox"/>			
Organization Name	Sony Corporation		
Mailing Address Information For Applicant:			
Address 1	1-7-1 Konan, Minato-ku		
Address 2			
City	Tokyo	State/Province	
Country	JP	Postal Code	108-0075
Phone Number		Fax Number	
Email Address			
Additional Applicant Data may be generated within this form by selecting the Add button.			
<input type="button" value="Add"/>			

Assignee Information including Non-Applicant Assignee Information:

Providing assignment information in this section does not substitute for compliance with any requirement of part 3 of Title 37 of CFR to have an assignment recorded by the Office.

Under the Paperwork Reduction Act of 1995, no persons are required to respond to a collection of information unless it contains a valid OMB control number.

Application Data Sheet 37 CFR 1.76	Attorney Docket Number	11574US05
	Application Number	
Title of Invention	DISTRIBUTED CONTROL IN WIRELESS SYSTEMS	

Assignee	1		
Complete this section if assignee information, including non-applicant assignee information, is desired to be included on the patent application publication. An assignee-applicant identified in the "Applicant Information" section will appear on the patent application publication as an applicant. For an assignee-applicant, complete this section only if identification as an assignee is also desired on the patent application publication.			
<input type="button" value="Remove"/>			
If the Assignee or Non-Applicant Assignee is an Organization check here. <input checked="" type="checkbox"/>			
Organization Name	Sony Corporation		
Mailing Address Information For Assignee including Non-Applicant Assignee:			
Address 1	1-7-1 Konan, Minato-ku		
Address 2			
City	Tokyo	State/Province	
Country	JP	Postal Code	108-0075
Phone Number		Fax Number	
Email Address			
Additional Assignee or Non-Applicant Assignee Data may be generated within this form by selecting the Add button. <input type="button" value="Add"/>			

Signature:	<input type="button" value="Remove"/>		
NOTE: This Application Data Sheet must be signed in accordance with 37 CFR 1.33(b). However, if this Application Data Sheet is submitted with the INITIAL filing of the application and either box A or B is not checked in subsection 2 of the "Authorization or Opt-Out of Authorization to Permit Access" section, then this form must also be signed in accordance with 37 CFR 1.14(c).			
This Application Data Sheet must be signed by a patent practitioner if one or more of the applicants is a juristic entity (e.g., corporation or association). If the applicant is two or more joint inventors, this form must be signed by a patent practitioner, all joint inventors who are the applicant, or one or more joint inventor-applicants who have been given power of attorney (e.g., see USPTO Form PTO/AIA/81) on behalf of all joint inventor-applicants.			
See 37 CFR 1.4(d) for the manner of making signatures and certifications.			
Signature	/Bradley D. Lytle/	Date (YYYY-MM-DD)	2018-11-06
First Name	Bradley D.	Last Name	Lytle
		Registration Number	40,073
Additional Signature may be generated within this form by selecting the Add button. <input type="button" value="Add"/>			

Under the Paperwork Reduction Act of 1995, no persons are required to respond to a collection of information unless it contains a valid OMB control number.

Application Data Sheet 37 CFR 1.76		Attorney Docket Number	11574US05
		Application Number	
Title of Invention	DISTRIBUTED CONTROL IN WIRELESS SYSTEMS		

This collection of information is required by 37 CFR 1.76. The information is required to obtain or retain a benefit by the public which is to file (and by the USPTO to process) an application. Confidentiality is governed by 35 U.S.C. 122 and 37 CFR 1.14. This collection is estimated to take 23 minutes to complete, including gathering, preparing, and submitting the completed application data sheet form to the USPTO. Time will vary depending upon the individual case. Any comments on the amount of time you require to complete this form and/or suggestions for reducing this burden, should be sent to the Chief Information Officer, U.S. Patent and Trademark Office, U.S. Department of Commerce, P.O. Box 1450, Alexandria, VA 22313-1450. DO NOT SEND FEES OR COMPLETED FORMS TO THIS ADDRESS. **SEND TO: Commissioner for Patents, P.O. Box 1450, Alexandria, VA 22313-1450.**

Privacy Act Statement

The Privacy Act of 1974 (P.L. 93-579) requires that you be given certain information in connection with your submission of the attached form related to a patent application or patent. Accordingly, pursuant to the requirements of the Act, please be advised that: (1) the general authority for the collection of this information is 35 U.S.C. 2(b)(2); (2) furnishing of the information solicited is voluntary; and (3) the principal purpose for which the information is used by the U.S. Patent and Trademark Office is to process and/or examine your submission related to a patent application or patent. If you do not furnish the requested information, the U.S. Patent and Trademark Office may not be able to process and/or examine your submission, which may result in termination of proceedings or abandonment of the application or expiration of the patent.

The information provided by you in this form will be subject to the following routine uses:

1. The information on this form will be treated confidentially to the extent allowed under the Freedom of Information Act (5 U.S.C. 552) and the Privacy Act (5 U.S.C. 552a). Records from this system of records may be disclosed to the Department of Justice to determine whether the Freedom of Information Act requires disclosure of these records.
2. A record from this system of records may be disclosed, as a routine use, in the course of presenting evidence to a court, magistrate, or administrative tribunal, including disclosures to opposing counsel in the course of settlement negotiations.
3. A record in this system of records may be disclosed, as a routine use, to a Member of Congress submitting a request involving an individual, to whom the record pertains, when the individual has requested assistance from the Member with respect to the subject matter of the record.
4. A record in this system of records may be disclosed, as a routine use, to a contractor of the Agency having need for the information in order to perform a contract. Recipients of information shall be required to comply with the requirements of the Privacy Act of 1974, as amended, pursuant to 5 U.S.C. 552a(m).
5. A record related to an International Application filed under the Patent Cooperation Treaty in this system of records may be disclosed, as a routine use, to the International Bureau of the World Intellectual Property Organization, pursuant to the Patent Cooperation Treaty.
6. A record in this system of records may be disclosed, as a routine use, to another federal agency for purposes of National Security review (35 U.S.C. 181) and for review pursuant to the Atomic Energy Act (42 U.S.C. 218(c)).
7. A record from this system of records may be disclosed, as a routine use, to the Administrator, General Services, or his/her designee, during an inspection of records conducted by GSA as part of that agency's responsibility to recommend improvements in records management practices and programs, under authority of 44 U.S.C. 2904 and 2906. Such disclosure shall be made in accordance with the GSA regulations governing inspection of records for this purpose, and any other relevant (i.e., GSA or Commerce) directive. Such disclosure shall not be used to make determinations about individuals.
8. A record from this system of records may be disclosed, as a routine use, to the public after either publication of the application pursuant to 35 U.S.C. 122(b) or issuance of a patent pursuant to 35 U.S.C. 151. Further, a record may be disclosed, subject to the limitations of 37 CFR 1.14, as a routine use, to the public if the record was filed in an application which became abandoned or in which the proceedings were terminated and which application is referenced by either a published application, an application open to public inspections or an issued patent.
9. A record from this system of records may be disclosed, as a routine use, to a Federal, State, or local law enforcement agency, if the USPTO becomes aware of a violation or potential violation of law or regulation.

INFORMATION DISCLOSURE STATEMENT BY APPLICANT (Not for submission under 37 CFR 1.99)	Application Number	
	Filing Date	2018-11-06
	First Named Inventor	Yugeswar DEENOO
	Art Unit	
	Examiner Name	
	Attorney Docket Number	11574US05

U.S. PATENTS							Remove
Examiner Initial*	Cite No	Patent Number	Kind Code ¹	Issue Date	Name of Patentee or Applicant of cited Document	Pages, Columns, Lines where Relevant Passages or Relevant Figures Appear	
	1						

If you wish to add additional U.S. Patent citation information please click the Add button. Add

U.S. PATENT APPLICATION PUBLICATIONS							Remove
Examiner Initial*	Cite No	Publication Number	Kind Code ¹	Publication Date	Name of Patentee or Applicant of cited Document	Pages, Columns, Lines where Relevant Passages or Relevant Figures Appear	
	1	20140112220	A1	2014-04-24	Kwak et al.		
	2	20150201368	A1	2015-07-16	Cudak et al.		

If you wish to add additional U.S. Published Application citation information please click the Add button. Add

FOREIGN PATENT DOCUMENTS								Remove
Examiner Initial*	Cite No	Foreign Document Number ³	Country Code ²ⁱ	Kind Code ⁴	Publication Date	Name of Patentee or Applicant of cited Document	Pages, Columns, Lines where Relevant Passages or Relevant Figures Appear	T ⁵
	1	2013141541	WO	A1	2013-09-26	LG ELECTRONICS INC.		

If you wish to add additional Foreign Patent Document citation information please click the Add button. Add

NON-PATENT LITERATURE DOCUMENTS								Remove
---------------------------------	--	--	--	--	--	--	--	--------

INFORMATION DISCLOSURE STATEMENT BY APPLICANT (Not for submission under 37 CFR 1.99)	Application Number	
	Filing Date	2018-11-06
	First Named Inventor	Yugeswar DEENOO
	Art Unit	
	Examiner Name	
	Attorney Docket Number	11574US05

Examiner Initials*	Cite No	Include name of the author (in CAPITAL LETTERS), title of the article (when appropriate), title of the item (book, magazine, journal, serial, symposium, catalog, etc), date, pages(s), volume-issue number(s), publisher, city and/or country where published.	T ⁵
	1	International Search Report and Written Opinion dated September 11, 2017, issued in International Application No. PCT/US2017/032069	
	2		

If you wish to add additional non-patent literature document citation information please click the Add button

EXAMINER SIGNATURE

Examiner Signature		Date Considered	
--------------------	--	-----------------	--

*EXAMINER: Initial if reference considered, whether or not citation is in conformance with MPEP 609. Draw line through a citation if not in conformance and not considered. Include copy of this form with next communication to applicant.

¹ See Kind Codes of USPTO Patent Documents at www.USPTO.GOV or MPEP 901.04. ² Enter office that issued the document, by the two-letter code (WIPO Standard ST.3). ³ For Japanese patent documents, the indication of the year of the reign of the Emperor must precede the serial number of the patent document. ⁴ Kind of document by the appropriate symbols as indicated on the document under WIPO Standard ST.16 if possible. ⁵ Applicant is to place a check mark here if English language translation is attached.

INFORMATION DISCLOSURE STATEMENT BY APPLICANT (Not for submission under 37 CFR 1.99)	Application Number		
	Filing Date		2018-11-06
	First Named Inventor	Yugeswar DEENOO	
	Art Unit		
	Examiner Name		
	Attorney Docket Number		11574US05

CERTIFICATION STATEMENT

Please see 37 CFR 1.97 and 1.98 to make the appropriate selection(s):

That each item of information contained in the information disclosure statement was first cited in any communication from a foreign patent office in a counterpart foreign application not more than three months prior to the filing of the information disclosure statement. See 37 CFR 1.97(e)(1).

OR

That no item of information contained in the information disclosure statement was cited in a communication from a foreign patent office in a counterpart foreign application, and, to the knowledge of the person signing the certification after making reasonable inquiry, no item of information contained in the information disclosure statement was known to any individual designated in 37 CFR 1.56(c) more than three months prior to the filing of the information disclosure statement. See 37 CFR 1.97(e)(2).

See attached certification statement.

The fee set forth in 37 CFR 1.17 (p) has been submitted herewith.

A certification statement is not submitted herewith.

SIGNATURE

A signature of the applicant or representative is required in accordance with CFR 1.33, 10.18. Please see CFR 1.4(d) for the form of the signature.

Signature	/Bradley D. Lytle/	Date (YYYY-MM-DD)	2018-11-06
Name/Print	Bradley D. Lytle	Registration Number	40,073

This collection of information is required by 37 CFR 1.97 and 1.98. The information is required to obtain or retain a benefit by the public which is to file (and by the USPTO to process) an application. Confidentiality is governed by 35 U.S.C. 122 and 37 CFR 1.14. This collection is estimated to take 1 hour to complete, including gathering, preparing and submitting the completed application form to the USPTO. Time will vary depending upon the individual case. Any comments on the amount of time you require to complete this form and/or suggestions for reducing this burden, should be sent to the Chief Information Officer, U.S. Patent and Trademark Office, U.S. Department of Commerce, P.O. Box 1450, Alexandria, VA 22313-1450. **DO NOT SEND FEES OR COMPLETED FORMS TO THIS ADDRESS. SEND TO: Commissioner for Patents, P.O. Box 1450, Alexandria, VA 22313-1450.**

Privacy Act Statement

The Privacy Act of 1974 (P.L. 93-579) requires that you be given certain information in connection with your submission of the attached form related to a patent application or patent. Accordingly, pursuant to the requirements of the Act, please be advised that: (1) the general authority for the collection of this information is 35 U.S.C. 2(b)(2); (2) furnishing of the information solicited is voluntary; and (3) the principal purpose for which the information is used by the U.S. Patent and Trademark Office is to process and/or examine your submission related to a patent application or patent. If you do not furnish the requested information, the U.S. Patent and Trademark Office may not be able to process and/or examine your submission, which may result in termination of proceedings or abandonment of the application or expiration of the patent.

The information provided by you in this form will be subject to the following routine uses:

1. The information on this form will be treated confidentially to the extent allowed under the Freedom of Information Act (5 U.S.C. 552) and the Privacy Act (5 U.S.C. 552a). Records from this system of records may be disclosed to the Department of Justice to determine whether the Freedom of Information Act requires disclosure of these records.
2. A record from this system of records may be disclosed, as a routine use, in the course of presenting evidence to a court, magistrate, or administrative tribunal, including disclosures to opposing counsel in the course of settlement negotiations.
3. A record in this system of records may be disclosed, as a routine use, to a Member of Congress submitting a request involving an individual, to whom the record pertains, when the individual has requested assistance from the Member with respect to the subject matter of the record.
4. A record in this system of records may be disclosed, as a routine use, to a contractor of the Agency having need for the information in order to perform a contract. Recipients of information shall be required to comply with the requirements of the Privacy Act of 1974, as amended, pursuant to 5 U.S.C. 552a(m).
5. A record related to an International Application filed under the Patent Cooperation Treaty in this system of records may be disclosed, as a routine use, to the International Bureau of the World Intellectual Property Organization, pursuant to the Patent Cooperation Treaty.
6. A record in this system of records may be disclosed, as a routine use, to another federal agency for purposes of National Security review (35 U.S.C. 181) and for review pursuant to the Atomic Energy Act (42 U.S.C. 218(c)).
7. A record from this system of records may be disclosed, as a routine use, to the Administrator, General Services, or his/her designee, during an inspection of records conducted by GSA as part of that agency's responsibility to recommend improvements in records management practices and programs, under authority of 44 U.S.C. 2904 and 2906. Such disclosure shall be made in accordance with the GSA regulations governing inspection of records for this purpose, and any other relevant (i.e., GSA or Commerce) directive. Such disclosure shall not be used to make determinations about individuals.
8. A record from this system of records may be disclosed, as a routine use, to the public after either publication of the application pursuant to 35 U.S.C. 122(b) or issuance of a patent pursuant to 35 U.S.C. 151. Further, a record may be disclosed, subject to the limitations of 37 CFR 1.14, as a routine use, to the public if the record was filed in an application which became abandoned or in which the proceedings were terminated and which application is referenced by either a published application, an application open to public inspections or an issued patent.
9. A record from this system of records may be disclosed, as a routine use, to a Federal, State, or local law enforcement agency, if the USPTO becomes aware of a violation or potential violation of law or regulation.

(12) INTERNATIONAL APPLICATION PUBLISHED UNDER THE PATENT COOPERATION TREATY (PCT)

(19) World Intellectual Property Organization
International Bureau



(10) International Publication Number
WO 2013/141541 A1

(43) International Publication Date
26 September 2013 (26.09.2013)

- (51) International Patent Classification:
H04W 36/04 (2009.01) *H04W 48/14* (2009.01)
- (21) International Application Number:
PCT/KR2013/002178
- (22) International Filing Date:
18 March 2013 (18.03.2013)
- (25) Filing Language: English
- (26) Publication Language: English
- (30) Priority Data:

61/612,388	18 March 2012 (18.03.2012)	US
61/646,232	11 May 2012 (11.05.2012)	US
61/666,931	2 July 2012 (02.07.2012)	US
61/673,238	18 July 2012 (18.07.2012)	US
- (71) Applicant: LG ELECTRONICS INC. [KR/KR]; 20 Yeouido-dong, Yeongdeungpo-gu, Seoul 150-721 (KR).

- (72) Inventors: **KIM, Eansun**; LG Institute, #533 Hoge 1(il)-dong, Dongan-gu, Anyang-si, Gyeonggi-do 431-080 (KR). **SEO, Hanbyul**; LG Institute, #533 Hoge 1(il)-dong, Dongan-gu, Anyang-si, Gyeonggi-do 431-080 (KR). **KIM, Byoungsoon**; LG Institute, #533 Hoge 1(il)-dong, Dongan-gu, Anyang-si, Gyeonggi-do 431-080 (KR). **KIM, Kijun**; LG Institute, #533 Hoge 1(il)-dong, Dongan-gu, Anyang-si, Gyeonggi-do 431-080 (KR).
- (74) Agents: **KIM, Yong In** et al.; KBK & Associates, 7th Floor, Hyundai Building, 175-9 Jamsil-dong, Songpa-ku, Seoul 138-861 (KR).
- (81) Designated States (unless otherwise indicated, for every kind of national protection available): AE, AG, AL, AM, AO, AT, AU, AZ, BA, BB, BG, BH, BN, BR, BW, BY, BZ, CA, CH, CL, CN, CO, CR, CU, CZ, DE, DK, DM, DO, DZ, EC, EE, EG, ES, FI, GB, GD, GE, GH, GM, GT, HN, HR, HU, ID, IL, IN, IS, JP, KE, KG, KM, KN, KP, KR, KZ, LA, LC, LK, LR, LS, LT, LU, LY, MA, MD, ME, MG, MK, MN, MW, MX, MY, MZ, NA, NG, NI, NO, NZ, OM, PA, PE, PG, PH, PL, PT, QA, RO, RS, RU, RW, SC, SD, SE, SG, SK, SL, SM, ST, SV, SY, TH, TJ, TM, TN, TR, TT, TZ, UA, UG, US, UZ, VC, VN, ZA, ZM, ZW.

(84) Designated States (unless otherwise indicated, for every kind of regional protection available): ARIPO (BW, GH,

[Continued on next page]

(54) Title: METHOD AND APPARATUS FOR ACQUIRING SYSTEM INFORMATION IN WIRELESS COMMUNICATION SYSTEM

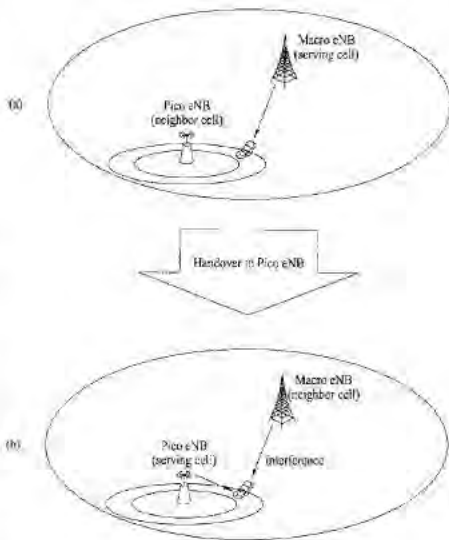

(57) Abstract: A method and apparatus for acquiring system information in a wireless communication system are disclosed. The method for acquiring system information by a user equipment (UE) in a wireless communication system includes: performing a handover from a first cell to a second cell; and acquiring system information of the second cell, wherein a method for acquiring the system information of the second cell is determined according to CRE (Cell Range Extension) -related capability of the UE.

WO 2013/141541 A1



GM, KE, LR, LS, MW, MZ, NA, RW, SD, SL, SZ, TZ,
UG, ZM, ZW), Eurasian (AM, AZ, BY, KG, KZ, RU, TJ,
TM), European (AL, AT, BE, BG, CH, CY, CZ, DE, DK,
EE, ES, FI, FR, GB, GR, HR, HU, IE, IS, IT, LT, LU,
LV, MC, MK, MT, NL, NO, PL, PT, RO, RS, SE, SI, SK,

SM, TR), OAPI (BF, BJ, CF, CG, CI, CM, GA, GN, GQ,
GW, ML, MR, NE, SN, TD, TG).

Published:

— with international search report (Art. 21(3))

【DESCRIPTION】**【Invention Title】**

METHOD AND APPARATUS FOR ACQUIRING SYSTEM INFORMATION IN WIRELESS COMMUNICATION SYSTEM

5 **【Technical Field】**

[1] The present invention relates to a wireless communication system, and more particularly to a method and apparatus for acquiring system information in a wireless communication system.

【Background Art】

10 [2] Wireless communication systems have been widely used to provide various kinds of communication services such as voice or data services. Generally, a wireless communication system is a multiple access system that can communicate with multiple users by sharing available system resources (bandwidth, transmission (Tx) power, and the like). A variety of multiple access systems can be used. For example, a Code Division
15 Multiple Access (CDMA) system, a Frequency Division Multiple Access (FDMA) system, a Time Division Multiple Access (TDMA) system, an Orthogonal Frequency Division Multiple Access (OFDMA) system, a Single Carrier Frequency-Division Multiple Access (SC-FDMA) system, a Multi-Carrier Frequency Division Multiple Access (MC-FDMA) system, and the like.

20 **【Disclosure】****【Technical Problem】**

[3] Accordingly, the present invention is directed to a method and apparatus for acquiring system information in a wireless communication system that substantially obviates one or more problems due to limitations and disadvantages of the related art.

25 [4] An object of the present invention is to provide technologies related to system information acquisition in a serious interference situation.

[5] It is to be understood that technical objects to be achieved by the present invention are not limited to the aforementioned technical objects and other technical objects which are not mentioned herein will be apparent from the following description to one of
30 ordinary skill in the art to which the present invention pertains.

【Technical Solution】

[6] The object of the present invention can be achieved by providing a method for acquiring system information by a user equipment (UE) in a wireless communication

system including: performing a handover from a first cell to a second cell; and acquiring system information of the second cell, wherein a method for acquiring the system information of the second cell is determined according to CRE (Cell Range Extension) – related capability of the UE.

5 [7] In another aspect of the present invention, a user equipment (UE) apparatus for use in a wireless communication system includes: a reception (Rx) module, and a processor, wherein the processor performs a handover from a first cell to a second cell and acquires system information of the second cell, wherein a method for acquiring the system information of the second cell is determined according to CRE (Cell Range Extension) –
10 related capability of the UE.

 [8] If the UE has PBCH (Physical Broadcast Channel) cancellation capability, the UE may acquire system information of the second cell through a PBCH of the second cell.

 [9] The UE may perform PBCH cancellation of the first cell when acquiring the
15 PBCH of the second cell.

 [10] If the UE does not have the PBCH cancellation capability, the UE may acquire system information of the second cell from the first cell.

 [11] The system information of the second cell may be transferred to the UE in a step of performing the handover.

20 [12] The method may further include: if a predetermined condition is satisfied after completion of the handover, transmitting an error report to the second cell.

 [13] The predetermined condition may that the UE fail to successively receive signals from the second cell.

 [14] The method may further include: receiving at least one of changed system
25 information and specific information indicating no change of the system information, as a response to the error report.

 [15] The method may further include: if the UE is located within a predetermined distance of the second cell after completion of the handover, transmitting a request of system information to the second cell.

30 [16] The method may further include: receiving system information masked with C-RNTI of the UE, as a response to the system information request.

 [17] The system information request may be any one of an MIB (Master Information Block) request, an SIB (System Information Block) request, and a paging request, which are updated information of the second cell.

[18] The first cell may be a macro eNB, and a second cell may be a pico eNB.

[19] The CRE-related capability information may include at least one of reference signal (RS) cancellation capability and synchronization signal cancellation capability.

5 **【Advantageous Effects】**

[20] As is apparent from the above description, exemplary embodiments of the present invention can stably receive system information even in a serious interference situation.

10 [21] It will be appreciated by persons skilled in the art that the effects that can be achieved with the present invention are not limited to what has been particularly described hereinabove and other advantages of the present invention will be more clearly understood from the following detailed description taken in conjunction with the accompanying drawings.

【Description of Drawings】

15 [22] The accompanying drawings, which are included to provide a further understanding of the invention, illustrate embodiments of the invention and together with the description serve to explain the principle of the invention.

[23] FIG. 1 exemplarily shows a radio frame structure.

[24] FIG. 2 exemplarily shows a resource grid of a downlink slot.

20 [25] FIG. 3 exemplarily shows a downlink subframe structure.

[26] FIG. 4 exemplarily shows an uplink subframe structure.

[27] FIG. 5 is a conceptual diagram illustrating a reference signal (RS).

[28] FIG. 6 is a conceptual diagram illustrating a cooperative transmission cluster.

25 [29] FIG. 7 is a conceptual diagram illustrating CoMP(Coordinated Multi Point) cluster.

[30] FIG. 8 is a conceptual diagram illustrating restricted measurement.

[31] FIG. 9 is a conceptual diagram illustrating Cell Ranging Expansion (CRE).

[32] FIG. 10 is a conceptual diagram illustrating summaries of embodiments of the present invention.

30 [33] FIGS. 11 to 13 are flowcharts illustrating methods for measuring a neighbor cell according to embodiments of the present invention.

[34] FIG. 14 is a flowchart illustrating a method for measuring a serving cell according to embodiments of the present invention.

[35] FIG. 15 is a block diagram illustrating a transceiver apparatus applicable to embodiments of the present invention.

【Best Mode】

[36] The following embodiments are proposed by combining constituent
5 components and characteristics of the present invention according to a predetermined format. The individual constituent components or characteristics should be considered optional factors on the condition that there is no additional remark. If required, the individual constituent components or characteristics may not be combined with other
10 components or characteristics. Also, some constituent components and/or characteristics may be combined to implement the embodiments of the present invention. The order of operations to be disclosed in the embodiments of the present invention may be changed. Some components or characteristics of any embodiment may also be included in other embodiments, or may be replaced with those of the other embodiments as necessary.

[37] The embodiments of the present invention are disclosed on the basis of a
15 data communication relationship between a base station and a terminal. In this case, the base station is used as a terminal node of a network via which the base station can directly communicate with the terminal. Specific operations to be conducted by the base station in the present invention may also be conducted by an upper node of the base station as necessary.

[38] In other words, it will be obvious to those skilled in the art that various
20 operations for enabling the base station to communicate with the terminal in a network composed of several network nodes including the base station will be conducted by the base station or other network nodes other than the base station. The term “Base Station (BS)” may be replaced with a fixed station, Node-B, eNode-B (eNB), or an access point as
25 necessary. The term “relay” may be replaced with the terms Relay Node (RN) or Relay Station (RS). The term “terminal” may also be replaced with a User Equipment (UE), a Mobile Station (MS), a Mobile Subscriber Station (MSS) or a Subscriber Station (SS) as necessary.

[39] It should be noted that specific terms disclosed in the present invention are
30 proposed for convenience of description and better understanding of the present invention, and the use of these specific terms may be changed to other formats within the technical scope or spirit of the present invention.

[40] In some instances, well-known structures and devices are omitted in order to avoid obscuring the concepts of the present invention and important functions of the structures and devices are shown in block diagram form. The same reference numbers will be used throughout the drawings to refer to the same or like parts.

5 [41] Exemplary embodiments of the present invention are supported by standard documents disclosed for at least one of wireless access systems including an Institute of Electrical and Electronics Engineers (IEEE) 802 system, a 3rd Generation Partnership Project (3GPP) system, a 3GPP Long Term Evolution (LTE) system, an LTE-Advanced (LTE-A) system, and a 3GPP2 system. In particular, steps or parts, which are not described
10 to clearly reveal the technical idea of the present invention, in the embodiments of the present invention may be supported by the above documents. All terminology used herein may be supported by at least one of the above-mentioned documents.

[42] The following embodiments of the present invention can be applied to a variety of wireless access technologies, for example, CDMA (Code Division Multiple
15 Access), FDMA (Frequency Division Multiple Access), TDMA (Time Division Multiple Access), OFDMA (Orthogonal Frequency Division Multiple Access), SC-FDMA (Single Carrier Frequency Division Multiple Access), and the like. CDMA may be embodied through wireless (or radio) technology such as UTRA (Universal Terrestrial Radio Access) or CDMA2000. TDMA may be embodied through wireless (or radio) technology such as
20 GSM (Global System for Mobile communication)/GPRS (General Packet Radio Service)/EDGE (Enhanced Data Rates for GSM Evolution). OFDMA may be embodied through wireless (or radio) technology such as Institute of Electrical and Electronics Engineers (IEEE) 802.11 (Wi-Fi), IEEE 802.16 (WiMAX), IEEE 802-20, and E-UTRA (Evolved UTRA). UTRA is a part of UMTS (Universal Mobile Telecommunications
25 System). 3GPP (3rd Generation Partnership Project) LTE (long term evolution) is a part of E-UMTS (Evolved UMTS), which uses E-UTRA. 3GPP LTE employs OFDMA in downlink and employs SC-FDMA in uplink. LTE-Advanced (LTE-A) is an evolved version of 3GPP LTE. WiMAX can be explained by IEEE 802.16e (WirelessMAN-OFDMA Reference System) and advanced IEEE 802.16m (WirelessMAN-OFDMA
30 Advanced System). For clarity, the following description focuses on IEEE 802.11 systems. However, technical features of the present invention are not limited thereto.

[43] **LTE/LTE-A resource structure/channel**

[44] FIG. 1 exemplarily shows a radio frame structure.

[45] The structure of a radio frame in 3GPP LTE system will be described with reference to FIG. 1. In a cellular Orthogonal Frequency Division Multiplexing (OFDM) radio packet communication system, uplink/downlink data packet transmission is performed in subframe units. One subframe is defined as a predetermined time interval including a plurality of OFDM symbols. The 3GPP LTE standard supports a type 1 radio frame structure applicable to Frequency Division Duplex (FDD) and a type 2 radio frame structure applicable to Time Division Duplex (TDD).

[46] FIG. 1(a) is a diagram showing the structure of the type 1 radio frame. A radio frame includes 10 subframes, and one subframe includes two slots in the time domain. A time required for transmitting one subframe is defined in a Transmission Time Interval (TTI). For example, one subframe may have a length of 1 ms and one slot may have a length of 0.5 ms. One slot may include a plurality of OFDM symbols in time domain and include a plurality of Resource Blocks (RBs) in frequency domain. Since the 3GPP LTE system uses OFDMA in downlink, the OFDM symbol indicates one symbol duration. The OFDM symbol may be called an SC-FDMA symbol or a symbol duration. An RB is a resource allocation unit and includes a plurality of contiguous subcarriers in one slot.

[47] The number of OFDM symbols included in one slot may be changed according to the configuration of a Cyclic Prefix (CP). The CP includes an extended CP and a normal CP. For example, if the OFDM symbols are configured by the normal CP, the number of OFDM symbols included in one slot may be seven. If the OFDM symbols are configured by the extended CP, the length of one OFDM symbol is increased, the number of OFDM symbols included in one slot is less than that of the case of the normal CP. In case of the extended CP, for example, the number of OFDM symbols included in one slot may be six. If a channel state is unstable, for example, if a User Equipment (UE) moves at a high speed, the extended CP may be used in order to further reduce interference between symbols.

[48] In case of using the normal CP, since one slot includes seven OFDM symbols, one subframe includes 14 OFDM symbols. At this time, the first two or three OFDM symbols of each subframe may be allocated to a Physical Downlink Control Channel (PDCCH) and the remaining OFDM symbols may be allocated to a Physical Downlink Shared Channel (PDSCH).

[49] The structure of a type 2 radio frame is shown in FIG. 1(b). The type 2 radio frame includes two half-frames, each of which is made up of five subframes, a downlink pilot time slot (DwPTS), a guard period (GP), and an uplink pilot time slot

(UpPTS), in which one subframe consists of two slots. That is, one subframe is composed of two slots irrespective of the radio frame type. DwPTS is used to perform initial cell search, synchronization, or channel estimation. UpPTS is used to perform channel estimation of a base station and uplink transmission synchronization of a user equipment (UE). The guard interval (GP) is located between an uplink and a downlink so as to remove interference generated in the uplink due to multi-path delay of a downlink signal. That is, one subframe is composed of two slots irrespective of the radio frame type.

[50] The structure of the radio frame is only exemplary. Accordingly, the number of subframes included in the radio frame, the number of slots included in the subframe or the number of symbols included in the slot may be changed in various manners.

[51] FIG. 2 is a diagram showing a resource grid in a downlink slot. Although one downlink slot includes seven OFDM symbols in a time domain and one RB includes 12 subcarriers in a frequency domain in the figure, the scope or spirit of the present invention is not limited thereto. For example, in case of a normal Cyclic Prefix (CP), one slot includes 7 OFDM symbols. However, in case of an extended CP, one slot may include 6 OFDM symbols. Each element on the resource grid is referred to as a resource element. One RB includes 12×7 resource elements. The number N^{DL} of RBs included in the downlink slot is determined based on downlink transmission bandwidth. The structure of the uplink slot may be equal to the structure of the downlink slot.

[52] FIG. 3 is a diagram showing the structure of a downlink subframe. A maximum of three OFDM symbols of a front portion of a first slot within one subframe corresponds to a control region to which a control channel is allocated. The remaining OFDM symbols correspond to a data region to which a Physical Downlink Shared Channel (PDSCH) is allocated. The basic unit of transmission becomes one subframe. Examples of the downlink control channels used in the 3GPP LTE system include, for example, a Physical Control Format Indicator Channel (PCFICH), a Physical Downlink Control Channel (PDCCH), a Physical Hybrid automatic repeat request Indicator Channel (PHICH), etc. The PCFICH is transmitted at a first OFDM symbol of a subframe, and includes information about the number of OFDM symbols used to transmit the control channel in the subframe. The PHICH includes a HARQ ACK/NACK signal as a response to uplink transmission. The control information transmitted through the PDCCH is referred to as Downlink Control Information (DCI). The DCI includes uplink or downlink scheduling information or an uplink transmit power control command for a certain UE group. The PDCCH may include resource allocation and transmission format of a Downlink Shared

Channel (DL-SCH), resource allocation information of an Uplink Shared Channel (UL-SCH), paging information of a Paging Channel (PCH), system information on the DL-SCH, resource allocation of a higher layer control message such as a Random Access Response (RAR) transmitted on the PDSCH, a set of transmit power control commands for individual
5 UEs in a certain UE group, transmit power control information, activation of Voice over IP (VoIP), etc. A plurality of PDCCHs may be transmitted within the control region. The UE may monitor the plurality of PDCCHs. The PDCCHs are transmitted as an aggregate of one or several contiguous control channel elements (CCEs). The CCE is a logical allocation unit used to provide the PDCCHs at a coding rate based on the state of a radio channel. The
10 CCE corresponds to a plurality of resource element groups. The format of the PDCCH and the number of available bits are determined based on a correlation between the number of CCEs and the coding rate provided by the CCEs. The eNB (or base station) determines a PDCCH format according to a DCI to be transmitted to the UE, and attaches a Cyclic Redundancy Check (CRC) to control information. The CRC is masked with a Radio
15 Network Temporary Identifier (RNTI) according to an owner or usage of the PDCCH. If the PDCCH is for a specific UE, a cell-RNTI (C-RNTI) of the UE may be masked to the CRC. Alternatively, if the PDCCH is for a paging message, a paging indicator identifier P-RNTI) may be masked to the CRC. If the PDCCH is for system information (more specifically, a system information block (SIB)), a system information identifier and a
20 system information RNTI (SI-RNTI) may be masked to the CRC. To indicate a random access response that is a response for transmission of a random access preamble of the UE, a random access-RNTI (RA-RNTI) may be masked to the CRC.

[53] FIG. 4 is a diagram showing the structure of an uplink frame. The uplink subframe may be divided into a control region and a data region in a frequency domain. A
25 Physical Uplink Control Channel (PUCCH) including uplink control information is allocated to the control region. A Physical Uplink Shared Channel (PUSCH) including user data is allocated to the data region. In order to maintain single carrier characteristics, one UE does not simultaneously transmit the PUCCH and the PUSCH. The PUCCH for one UE is allocated to an RB pair in a subframe. RBs belonging to the RB pair occupy different
30 subcarriers with respect to two slots. Thus, the RB pair allocated to the PUCCH is “frequency-hopped” at a slot edge.

[54] **Reference Signal (RS)**

[55] In a wireless communication system, since packets are transmitted through a radio channel, a signal may be distorted during transmission. In order to enable a reception

side to correctly receive the distorted signal, distortion of the received signal should be corrected using channel information. In order to detect the channel information, a method of transmitting a signal, of which both the transmission side and the reception side are aware, and detecting channel information using a distortion degree when the signal is received through a channel is mainly used. The above signal is referred to as a pilot signal or a reference signal (RS).

[56] When transmitting and receiving data using multiple antennas, the channel states between the transmission antennas and the reception antennas should be detected in order to correctly receive the signal. Accordingly, each transmission antenna has an individual RS. In more detail, an independent RS should be transmitted through each Tx port.

[57] RS may be divided into downlink RS and uplink RS. In the current LTE system, the uplink RS include:

[58] i) DeModulation-Reference Signal (DM-RS) used for channel estimation for coherent demodulation of information delivered on a PUSCH and a PUCCH; and

[59] ii) Sounding Reference Signal (SRS) used for a BS (eNB) or a network to measure the quality of an uplink channel in a different frequency.

[60] The downlink RS are categorized into:

[61] i) Cell-specific Reference Signal (CRS) shared among all UEs of a cell;

[62] ii) UE-specific RS dedicated to a specific UE;

[63] iii) DM-RS used for coherent demodulation of a PDSCH, when the PDSCH is transmitted;

[64] iv) Channel State Information-Reference Signal (CSI-RS) carrying CSI, when downlink DM-RS are transmitted;

[65] v) Multimedia Broadcast Single Frequency Network (MBSFN) RS used for coherent demodulation of a signal transmitted in MBSFN mode; and

[66] vi) positioning RS used to estimate geographical position information about a UE.

[67] RS may also be divided into two types according to their purposes: RS for channel information acquisition and RS for data demodulation. Since its purpose lies in that a UE acquires downlink channel information, the former should be transmitted in a broad band and received even by a UE that does not receive downlink data in a specific subframe. This RS is also used in a situation like handover. The latter is an RS that a BS (eNB) transmits along with downlink data in specific resources. A UE can demodulate the data by

measuring a channel using the RS. This RS should be transmitted in a data transmission area.

[68] CRS serve two purposes, that is, channel information acquisition and data demodulation. A UE-specific RS is used only for data demodulation. CRS are transmitted in every subframe in a broad band and CRS for up to four antenna ports are transmitted according to the number of Tx antennas in an eNB.

[69] For example, if the BS (eNB) has two Tx antennas, CRS for antenna ports 0 and 1 are transmitted. In the case of four Tx antennas, CRS for antenna ports 0 to 3 are respectively transmitted.

[70] FIG. 5 illustrates patterns in which CRS and DRS are mapped to a downlink RB pair, as defined in a legacy 3GPP LTE system (e.g. Release-8). An RS mapping unit, i.e. a downlink RB pair may include one subframe in time by 12 subcarriers in frequency. That is, an RB pair includes 14 OFDM symbols in time in the case of the normal CP (see FIG. 5(a)) and 12 OFDM symbols in time in the case of the extended CP (see FIG. 5(b)).

[71] In FIG. 5, the positions of RS in an RB pair for a system where a BS (eNB) supports four Tx antennas are illustrated. Reference numerals 0, 1, 2 and 3 denote the REs of CRS for first to fourth antenna ports, antenna port 0 to antenna port 3, respectively, and reference character 'D' denotes the positions of DRS.

[72] **CSI (Channel Status Information) Feedback**

[73] MIMO schemes are classified into an open-loop MIMO scheme and a closed-loop MIMO scheme. The open-loop MIMO scheme means that a transmitter performs MIMO transmission without receiving CSI feedback information from a MIMO receiver. The closed-loop MIMO scheme means that a transmitter receives CSI feedback information from the MIMO receiver and performs MIMO transmission. In accordance with the closed-loop MIMO scheme, each of a transmitter and a receiver can perform beamforming on the basis of CSI so as to obtain a multiplexing gain of a MIMO transmission antenna. The transmitter (for example, BS) can allocate an uplink control channel or an uplink shared channel to a receiver (for example, a user equipment) in such a manner that the receiver can feed back the CSI.

[74] The feedback CSI may include a rank indicator (RI), a precoding matrix index (PMI), and a channel quality indicator (CQI).

[75] RI is information of a channel rank. The channel rank means a maximum number of layers (or streams) via which different information can be transmitted through the same time-frequency resources. Since a rank value is determined depending on long-

term fading of a channel, the rank value is generally fed back for a longer period than PMI and CQI. That is, the rank value can be fed back less frequently than PMI and CQI.

[76] PMI is information regarding a precoding matrix used for data transmission from the transmitter, and includes spatial characteristics of a channel. Precoding means that a transmit layer is mapped to a transmit antenna, and the layer-antenna mapping relationship can be determined by precoding matrices. PMI corresponds to a UE-preferred precoding matrix index of a BS on the basis of metric data such as Signal-to-Interference plus Noise Ratio (SINR). In order to reduce feedback overhead of the precoding information, a transmitter and a receiver may share a variety of precoding matrices in advance, and only indices indicating a specific precoding matrix from among the corresponding codebook can be fed back.

[77] Acquisition of an additional multi-user diversity using Multi-User MIMO (MU-MIMO) is under consideration in a system supporting an extended antenna configuration (e.g. an LTE-A system). In MU-MIMO, an interference channel exists between UEs multiplexed in an antenna domain. Therefore, when the eNB transmits a downlink signal based on CSI feedback received from one UE, it needs to perform the downlink transmission in a manner that avoids interference with other UEs. Hence, for a reliable MU-MIMO operation, CSI should be fed back with more accuracy than for a Single-User MIMO (SU-MIMO) operation.

[78] To enable more accurate CSI measurement and reporting, a new CSI feedback scheme may be used by improving conventional CSI including an RI, a PMI, and a CQI. For example, precoding information fed back by a receiver may be indicated by a combination of two PMIs. One of the two PMIs (a first PMI) may be referred to as W1 having a long term and/or wideband property and the other PMI (a second PMI) may be referred to as W2 having a short term and/or subband property. A final PMI may be determined by a function of W1 and W2. For example, let the final PMI be denoted by W. Then it may be defined that $W=W1*W2$ or $W=W2*W1$.

[79] CQI is information indicating channel quality or channel strength. CQI may be represented by a combination of predetermined MCSs. That is, a feedback CQI index may indicate a modulation scheme and a code rate. Generally, a reception SINR capable of being obtained when the BS constructs a spatial channel using a PMI is applied to CQI.

[80] The current LTE/LTE-A system defines 'CSI reference resource' related to channel measurement for the above-described CSI feedback/reporting. The CSI reference resource is defined by a group of physical RBs corresponding to a frequency band for which

a CQI is calculated in the frequency domain. From a time perspective, for CSI transmission/reporting in subframe n , the CSI reference resource is defined by a single downlink subframe, $n-n_{CQI_ref}$. i) For periodic CSI reporting, $n-n_{CQI_ref}$ is the smallest value greater than or equal to 4, which is a valid downlink subframe. ii) For aperiodic CSI reporting, $n-n_{CQI_ref}$ is typically the reference resource in the same valid downlink subframe as a corresponding CSI request in a DCI format for uplink transmissions. iii) For aperiodic CSI reporting triggered by a Random Access Response Grant carrying a CSI request, $n-n_{CQI_ref}$ equals 4. A downlink subframe is considered valid when it is configured as a downlink subframe for a particular UE, it is not an MBSFN subframe except for Mode 9, it contains a DwPTS with a predetermined size or larger, it does not fall within a configured measurement gap for that UE, and for periodic CSI reporting, it should be an element of a CSI subframe set when that UE is configured with CSI subframe sets. A higher layer may configure CSI subframe sets $(C_{CSI,0}, C_{CSI,1})$ for the UE. The current standard defines that the CSI reference resource is included in one of the two CSI subframe sets $(C_{CSI,0}, C_{CSI,1})$, not in both.

[81] Heterogeneous Deployments

[82] FIG. 6 is a heterogeneous network wireless communication system including a macro eNB (MeNB) and a micro eNB (PeNB or FeNB). The term “heterogeneous network” refers to a network in which a macro eNB (MeNB) and a micro eNB (PeNB or FeNB) coexist even though the same Radio Access Technology (RAT) is used.

[83] The macro eNB (MeNB) is a normal eNB having wide coverage and high transmission power in a wireless communication system. The macro eNB (MeNB) may also be referred to as a macro cell.

[84] The micro eNB (PeNB or FeNB) may also be referred to as a micro cell, a pico cell, a femto cell, a home eNB (HeNB), a relay, etc. (MeNB, PeNB and FeNB may also be generically named a transmission point as necessary). The micro eNB (PeNB or FeNB) is a small-sized version of the macro eNB (MeNB), such that the micro eNB (PeNB or FeNB) may independently perform most of the functions of the macro eNB (MeNB). The micro eNB (PeNB or FeNB) may be installed (in an overlay manner) in an area covered by the macro eNB (MeNB) or may be installed (in a non-overlay manner) in a shadow area that cannot be covered by the macro eNB (MeNB). The micro eNB (PeNB or FeNB) has a

narrower coverage and lower transmission power and may accommodate a smaller number of user equipments (UEs), compared to the micro eNB (MeNB).

[85] UE, which is hereinafter referred to as a macro UE (MUE), may be directly served by the macro eNB (MeNB). UE, which is hereinafter referred to as a micro UE
5 (MUE), may be served by the micro eNB (PeNB or FeNB). In some cases, the UE present within the coverage of the micro eNB (MeNB) may be served by the macro eNB (MeNB).

[86] The micro eNB (eNB) may be classified into two types according to access limitations of the UE.

[87] The first type is a Closed Subscriber Group (CSG) or non-Closed Access
10 Subscriber Group (non-CSG) eNB serving as a cell that allows either a legacy macro UE or another micro eNB to access a micro UE. The legacy macro UE (MUE) or the like may be handed over to an OSG-type eNB.

[88] The second type is a CSG eNB that prevents the legacy macro UE or
15 another micro eNB from accessing the micro UE, such that it is impossible to be handed over to the CSG eNB.

[89] **Coordinated Multi-Point (CoMP)**

[90] According to the improved system performance requirements of the 3GPP
20 LTE-A system, CoMP transmission/reception technology (may be referred to as co-MIMO, collaborative MIMO or network MIMO) is proposed. The CoMP technology can increase the performance of the UE located on a cell edge and increase average sector throughput.

[91] In general, in a multi-cell environment in which a frequency reuse factor is 1,
the performance of the UE located on the cell edge and average sector throughput may be reduced due to Inter-Cell Interference (ICI). In order to reduce the ICI, in the existing LTE system, a method of enabling the UE located on the cell edge to have appropriate
25 throughput and performance using a simple passive method such as Fractional Frequency Reuse (FFR) through the UE-specific power control in the environment restricted by interference is applied. However, rather than decreasing the use of frequency resources per cell, it is preferable that the ICI is reduced or the UE reuses the ICI as a desired signal. In order to accomplish the above object, a CoMP transmission scheme may be applied.

[92] The CoMP scheme applicable to the downlink may be largely classified into
30 a Joint Processing (JP) scheme and a Coordinated Scheduling/Beamforming (CS/CB) scheme.

[93] In the JP scheme, each point (eNodeB) of a CoMP unit may use data. The CoMP unit refers to a set of eNodeBs used in the CoMP scheme. The JP scheme may be classified into a joint transmission scheme and a dynamic cell selection scheme.

[94] The joint transmission scheme refers to a scheme for transmitting a PDSCH from a plurality of points (a part or the whole of the CoMP unit). That is, data transmitted to a single UE may be simultaneously transmitted from a plurality of transmission points. According to the joint transmission scheme, it is possible to coherently or non-coherently improve the quality of the received signals and to actively eliminate interference with another UE.

[95] The dynamic cell selection scheme refers to a scheme for transmitting a PDSCH from one point (of the CoMP unit). That is, data transmitted to a single UE at a specific time is transmitted from one point and the other points in the cooperative unit at that time do not transmit data to the UE. The point for transmitting the data to the UE may be dynamically selected.

[96] According to the CS/CB scheme, the CoMP units may cooperatively perform beamforming of data transmission to a single UE. Although only a serving cell transmits the data, user scheduling/beamforming may be determined by the coordination of the cells of the CoMP unit.

[97] In uplink, coordinated multi-point reception refers to reception of a signal transmitted by coordination of a plurality of geographically separated points. The CoMP scheme applicable to the uplink may be classified into Joint Reception (JR) and Coordinated Scheduling/Beamforming (CS/CB).

[98] The JR scheme indicates that a plurality of reception points receives a signal transmitted through a PUSCH, the CS/CB scheme indicates that only one point receives a PUSCH, and user scheduling/beamforming is determined by the coordination of the cells of the CoMP unit.

[99] In this CoMP system, multi-cell BSs (eNBs) can support data for a UE. In addition, the BSs (eNBs) support one or more UEs simultaneously in the same radio frequency resources, thereby increasing system performance. The BSs (eNBs) may also operate in Space Division Multiple Access (SDMA) based on CSI between a UE and the eNBs.

[100] A serving BS (eNB) and one or more cooperative BSs (eNBs) are connected to a scheduler through a backbone network in the CoMP system. The scheduler may receive channel information about the channel states between a UE and the cooperative

eNBs, measured by each cooperative BS (eNB) and operate based on the channel information. For example, the scheduler may schedule information for cooperative MIMO for the serving BS (eNB) and the one or more cooperative BSs (eNBs). That is, the scheduler may transmit a command directly to each eNB in regard to the cooperative
5 MIMO operation.

[101] As can be seen from the above description, it can be recognized that a CoMP system operates as a virtual MIMO system by grouping a plurality of cells into one group. Basically, the CoMP system adopts a MIMO communication scheme using multiple
10 antennas.

[102] A CoMP cluster is a set of cells that are capable of performing the CoMP operations (i.e., cooperative scheduling and cooperative data transmission/reception). For example, cells of a single cluster may be assigned different physical cell IDs (PCIDs) as shown in FIG. 7(a), and cells of a single cluster may share the same PCIDs such that the cells may be configured in the form of a distributed antenna or RRH of a single BS. In
15 modified examples of FIG. 7, some cells from among cells of the single cluster may share the same PCIDs.

[103] Generally, cells of the same CoMP cluster are interconnected through a backhaul link, such as an optical fiber having high capacity and low latency, so as to implement cooperative scheduling and cooperative data transmission/reception, such that
20 the cooperative scheduling is possible and maintained at a correct time synchronization state, resulting in implementation of cooperative data transmission. In addition, when receiving signals from cells of the CoMP cluster participating in the cooperative transmission, the size of CoMP cluster must be determined in a manner that a reception time difference between signals transmitted from respective cells can enter the scope of a cyclic prefix (CP) length
25 on the basis of a propagation delay difference between respective cells. In contrast, cells belonging to different clusters may be interconnected through a lower-capacity backhaul link, and may not maintain time synchronization.

[104] A UE configured to perform CoMP can perform cooperative scheduling and cooperative data transmission/reception by some or all of cells contained in the CoMP
30 cluster, and the UE measures a reference signal that is transmitted from some or all cells of the CoMP cluster according to a UE reception signal quality (i.e., QoS of a UE reception signal). In order to measure link performances of UE and each cell, the UE may measure a reference signal of each cell and may report a QoS of the measured reference signal. Specifically, cells to be measured by the UE may be defined as a CoMP measurement set.

[105] For CoMP, there is a need to define the reference resource set through which UE channel measurement and UE channel measurement reporting must be performed, because the CoMP scheme and downlink scheduling, etc. of the corresponding UE are determined according to per-cell channel information to be reported by the UE on uplink.

5 Information (i.e., the CoMP measurement set) indicating that the UE must measure/report signals from a certain cell should be transferred through higher layer signaling, and associated information can be signaled as CSI-RS resources.

[106] **Inter-Cell Interference Coordination (ICIC)**

10 [107] In the above-mentioned heterogeneous network environment (heterogeneous deployment) or CoMP environment, inter-cell interference (ICI) may occur. In order to solve the inter-cell interference (ICI) problem, an inter-cell interference coordination (ICIC) may be used.

[108] As an exemplary ICIC of the frequency resource, the 3GPP LTE Release-8 system is designed to divide an overall frequency region (for example, a system bandwidth) into one or more sub-regions (for example, a physical resource block (PRB) unit), and a predetermined scheme for exchanging ICIC messages of individual frequency sub-regions between cells is defined in the 3GPP LTE Release-8 system. A variety of parameters may be contained in an ICIC message for frequency resources. For example, a Relative Narrowband Transmission Power (RNTP) related to downlink transmission power, uplink (UL) Interference Overhead Indication (IOI) related to uplink interference, UL High Interference Indication (HII), etc. may be defined in the ICIC message for frequency resources.

[109] RNTP is information indicating downlink transmission power used in a specific frequency sub-region by a cell transmitting an ICIC message. For example, if an RNTP field for a specific frequency sub-region is set to a first value (for example, 0), this means that downlink transmission power of the corresponding cell does not exceed a predetermined threshold value in the corresponding frequency sub-region. Alternatively, if the RNTP field for the specific frequency sub-region is set to a second value (for example, 1), this means that the corresponding cell cannot promise downlink transmission power in the corresponding frequency sub-region. In other words, if the RNTP field is set to zero '0', this means that downlink transmission power of the corresponding cell is low in the corresponding frequency sub-region. Otherwise, if the RNTP field is set to 1, this means that downlink transmission power of the corresponding cell is not low in the corresponding frequency sub-region.

[110] UL IOI is information indicating the amount of uplink interference experienced (or generated) in a specific frequency sub-region including a cell configured to transmit an ICIC message. For example, if an IOI field for a specific frequency sub-region has a high-interference amount, this means that the corresponding cell experiences high uplink interference in the corresponding frequency sub-region. In the frequency sub-region corresponding to an IOI indicating high uplink interference, the cell having received the ICIC message can schedule a UE that uses low uplink transmission power from among serving UEs of the cell. Therefore, since UEs perform uplink transmission at low transmission power in the frequency sub-region corresponding to an IOI indicating high uplink interference, uplink interference experienced by a neighbor cell (that is, a cell having transmitted the ICIC message) may be reduced.

[111] UL HII indicates the degree of interference (or uplink interference sensitivity) that may be encountered in the corresponding frequency sub-region because of uplink transmission within a cell configured to transmit the ICIC message. For example, if the HII field is set to a first value (for example, 1) in a specific frequency sub-region, there is a high possibility of scheduling a high uplink transmission power UE by a cell for transmission of the ICIC message in the corresponding frequency sub-region. On the other hand, if the HII field is set to a second value (for example, 0) in a specific frequency sub-region, there is a possibility of scheduling a low uplink transmission power UE by the cell for transmission of the ICI message in the corresponding frequency sub-region. Meanwhile, if a UE is first scheduled in a frequency sub-region in which an HII is set to a second value (for example, 0) and some UEs capable of properly operating even under high interference are scheduled in another frequency sub-region in which an HII is set to a first value (for example, 1), one cell having received the ICIC message can avoid interference from another cell having transmitted the ICIC message.

[112] Meanwhile, as an exemplary ICIC of the time resource, the 3GPP LTE-A system (or 3GPP LTE Release-10) system is designed to divide an overall time region into one or more sub-regions (for example, a subframe unit) in a frequency domain, and a predetermined scheme for exchanging specific information indicating silencing or non-silencing of individual frequency sub-regions between cells is defined in the 3GPP LTE-A system. The cell having transmitted the ICIC message may transmit specific information indicating the presence of silencing in a specific subframe to neighbor cells, and does not schedule a PDSCH and a PUSCH in the corresponding subframe. On the other hand, the cell having received the ICIC message can schedule uplink transmission and/or downlink

transmission for a UE on a subframe in which silencing is performed in another cell having transmitted the ICIC message.

[113] Silencing may refer to an operation of a specific cell within a specific subframe. That is, the silencing operation indicates that a specific cell does not perform most of signal transmission on uplink or downlink of a specific subframe. If necessary, the silencing operation may also indicate that a specific cell can transmit signals at no power or low power on uplink and downlink of a specific subframe. As an example of the silencing operation, a specific cell may configure a specific subframe as a Multicast-Broadcast Single Frequency Network (MBSFN) subframe. In a downlink subframe configured as the MBSFN subframe, a signal is transmitted only in a control region and is not transmitted in a data region. As another example of the silencing operation, a cell causing interference may configure a specific frame as a specific Almost Blank Subframe (ABS) or an ABS-with-MBSFN. The ABS refers to a subframe in which only a CRS is transmitted in a control region and a data region of a downlink subframe and the remaining control information and data other than the CRS are not transmitted in the control and data regions of the downlink subframe. If necessary, signals are transmitted at no power or low power in the subframe corresponding to the ABS. Nonetheless, downlink channels and downlink signals such as a Physical Broadcast Channel (PBCH), a Primary Synchronization Signal (PSS), and a Secondary Synchronization Signal (SSS) may be transmitted even in the ABS. The ABS-with-MBSFN may mean a subframe in which even the CRS is not transmitted in the data region of the above-described ABS. As described above, silencing may be performed in units of a specific subframe, and information indicating whether silencing is performed is referred to as a silent subframe pattern.

[114] In association with ABS, ABS signaling defined in 3GPP LTE-A is largely classified into ABS information and an ABS status. The ABS information indicates a subframe to be used as ABS using bitmap. The ABS information is composed of 40 bits in case of FDD, and is composed of a maximum of 70 bits in case of TDD. The number of bits used for ABS information in TDD may be changed according to UL-DL configuration. In case of FDD, 40 bits indicate 40 subframes. If the value of a bit is set to 1, the bit indicates ABS. If the value of a bit is set to zero, the bit indicates non-ABS. When restricted measurement is configured in a UE, the number of CRS antenna ports of the corresponding cell is notified for CRS measurement. A measurement subset is a subset of ABS pattern information. The measurement subset is a bitmap composed of 40 bits in case of FDD, and is a bitmap composed of a maximum of 70 bits in case of TDD. The above

information can be understood as a restricted measurement for configuring restricted measurement. Table 1 indicates ABS information defined in the legacy LTE/LTE-A system.

[115] [Table 1]

IE/Group Name	Presence	Range	IE type and reference	Semantics description
CHOICE <i>ABS Information</i>	M		–	–
> <i>FDD</i>			–	–
>>ABS Pattern Info	M		BIT STRING (SIZE(40))	Each position in the bitmap represents a DL subframe, for which value "1" indicates 'ABS' and value "0" indicates 'non ABS'. The first position of the ABS pattern corresponds to subframe 0 in a radio frame where $SFN = 0$. The ABS pattern is continuously repeated in all radio frames. The maximum number of subframes is 40.
>>Number Of Cell-specific Antenna Ports	M		ENUMERATED (1, 2, 4, ...)	P (number of antenna ports for cell-specific reference signals) defined in TS 36.211 [10]
>>Measurement Subset	M		BIT STRING (SIZE(40))	Indicates a subset of the ABS Pattern Info above, and is used to configure specific measurements towards the UE.
> <i>TDD</i>			–	–
>>ABS Pattern Info	M		BIT STRING (1..70, ...)	Each position in the bitmap represents a DL subframe for which value "1" indicates 'ABS' and value "0" indicates 'non ABS'. The maximum number of subframes depends on UL/DL subframe configuration. The maximum number of subframes is 20 for UL/DL subframe configuration 1~5; 60 for UL/DL subframe configuration 6; 70 for UL/DL subframe configuration 0. UL/DL subframe configuration defined in TS 36.211 [10]. The first position of the ABS pattern corresponds to subframe 0 in a radio frame where $SFN = 0$. The ABS pattern is continuously repeated in all radio frames, and restarted each time $SFN = 0$.
>>Number Of Cell-specific Antenna Ports	M		ENUMERATED (1, 2, 4, ...)	P (number of antenna ports for cell-specific reference signals) defined in TS 36.211 [10]
>>Measurement	M		BIT	Indicates a subset of the ABS Pattern Info above,

Subset			STRING (1..70, ...)	and is used to configure specific measurements towards the UE
>ABS Inactive	M		NULL	Indicates that interference coordination by means of almost blank sub frames is not active

[116] Table 2 shows ABS status information elements (IEs) defined in the legacy LTE/LTE-A system. The ABS status information elements are used to enable the eNB to determine whether the ABS pattern must be changed. In Table 2, 'Usable ABS Pattern Info' is bitmap information of a subset of ABS pattern information, and indicates whether a subframe designated as ABS has been correctly used for interference reduction. 'DL ABS status' indicates the ratio of the number of DL RBs scheduled in a subframe indicated by 'Usable ABS Pattern Info' to the number of RBs allocated for a UE to be protected through ABS. 'DL ABS status' may also indicate whether ABS has been efficiently used in a victim cell according to its own purpose.

10 [117] [Table 2]

IE/Group Name	Presence	Range	IE type and reference	Semantics description
DL ABS status	M		INTEGER (0..100)	Percentage of used ABS resources. The numerator of the percentage calculation consists of resource blocks within the ABS indicated in the <i>Usable ABS Pattern Info</i> IE allocated by the eNB ₂ for UEs needing protection by ABS from inter-cell interference for DL scheduling, or allocated by the eNB ₂ for other reasons (e.g. some control channels). The denominator of the percentage calculation is the total quantity of resource blocks within the ABS indicated in the <i>Usable ABS Pattern Info</i> IE.
CHOICE <i>Usable ABS Information</i>	M		–	–
>FDD			–	–
>>Usable ABS Pattern Info	M		BIT STRING (SIZE(40))	Each position in the bitmap represents a subframe, for which value "1" indicates 'ABS that has been designated as protected from inter-cell interference by the eNB ₁ , and available to serve this purpose for DL scheduling in the eNB ₂ ' and value "0" is used for all other subframes. The pattern represented by the bitmap is a subset of, or the same as, the corresponding <i>ABS Pattern Info</i> IE conveyed in the LOAD INFORMATION message from the eNB ₁ .
>TDD			–	–

>>Usable ABS Pattern Info	M		BIT STRING (1..70)	Each position in the bitmap represents a subframe, for which value "1" indicates 'ABS that has been designated as protected from inter-cell interference by the eNB ₁ , and available to serve this purpose for DL scheduling in the eNB ₂ ' and value "0" is used for all other subframes. The pattern represented by the bitmap is a subset of, or the same as, the corresponding <i>ABS Pattern Info</i> IE conveyed in the LOAD INFORMATION message from the eNB ₁ .
------------------------------	---	--	--------------------------	--

[118] A measurement subset composed of a subset of an ABS pattern is a subframe statically used as ABS, and the remaining subframes contained in the ABS pattern may determine whether a transmission point will be used as the ABS according to traffic load.

5 [119] Measurement/Measurement Report

[120] A measurement report is used for many techniques designed to ensure the mobility of UEs (handover, random access, cell search, etc.) or for one of the techniques. Since the measurement report needs a certain degree of coherent demodulation, a UE may perform measurement after acquiring synchronization and physical layer parameters, except
10 for measurement of a received signal strength. The measurement report conceptually covers Radio Resource Management (RRM) measurement of measuring the signal strengths or signal strengths to total reception power of a serving cell and neighbor cells, including Reference Signal Received Power (RSRP), Received Signal Strength Indicator (RSSI), and Reference Signal Received Quality (RSRQ), and Radio Link Monitoring (RLM)
15 measurement of measuring link quality with respect to the serving cell to thereby determine whether a radio link has been failed.

[121] In association with Radio Resource Management (RRM), RSRP is defined as the linear average over the power contributions of REs that carry downlink CRS. RSSI is defined as the linear average of the total received power of a UE. The RSSI is measured
20 from OFDM symbols carrying RS for antenna port 0, including interference and noise power from neighbor cells. If a specific subframe is indicated for RSRQ measurement by higher-layer signaling, the RSSI is measured over all OFDM symbols of the indicated subframe. RSRQ is defined as (N_xRSRP/RSSI), where N is the number of RBs over the measurement bandwidth of RSSI.

25 [122] The purpose of RLM execution is to enable a UE to monitor a downlink quality of its own serving cell, such that the UE can determine 'in-sync' or 'out-of-sync' of

the corresponding cell. In this case, RLM is based on CRS. A downlink quality estimated by the UE is compared with each of 'in-sync threshold(Q_{in})' and 'out-of-sync threshold(Q_{out})'. Each threshold value may be denoted by a PDCCH BLER (Block Error Rate) of a serving cell. Specifically, Q_{out} may correspond to a BLER of 10%, and Q_{in} may correspond to a BLER of 2%. Actually, Q_{in} and Q_{out} correspond to SINR of the received CRS. If CRS reception SINR is equal to or higher than a predetermined level (Q_{in}), the UE decides to attach the corresponding cell. If CRS reception SINR is less than a predetermined level (Q_{out}), the UE declares a radio link failure (RLF).

[123] As can be seen from the above-mentioned RSRP definition, it should be premised that measurement reporting is performed using CRS. However, assuming that cells share the same PCID as shown in FIG. 7(b), the cells are unable to discriminate between the cells having the same PCID on the basis of the CRS, such that it is impossible to perform RRM of each cell using only measurement reporting including RSRP/RSRQ based on CRS. Therefore, assuming that cells have the same PCID, it is possible to perform additional RSRP/RSRQ measurement reporting on the basis of CSI-RS being independently transmitted. In order to increase reception accuracy during CSI-RS reception of a specific cell, neighbor cells do not transmit signals to a resource element (RE) to which the corresponding CSI-RS is transmitted, such that the neighbor cells can perform higher-accuracy measurement although a frequency of CRS-RS transmission is less than a frequency of CRS transmission. Therefore, although cells have different PCIDs, CRS-based RSRP/RSRQ measurement reporting and CSI-RS RSRP/RSRQ measurement reporting are simultaneously performed, resulting in increased accuracy of a network RRM.

[124] Another purpose of CSI-RS transmission in each cell is to perform CSI feedback to be performed by a UE to aid scheduling of a BS (eNB) that determines a rank, precoding matrix, a modulation and coding scheme (MCS) or CQI to be used for DL data transmission between the corresponding cell and the UE. In accordance with the CoMP transmission scheme, the UE must feed back a CSI to a downlink related to a cooperative cell other than the serving cell. An excessive amount of overhead occurs when CSIs of all cells contained in the CoMP cluster including the serving cell are fed back, such that CSIs of some cells (i.e., CoMP measurement set) contained in the CoMP cluster that is valuable in cooperative scheduling and cooperative data transmission. Deciding of the CoMP measurement set of a specific UE may be configured by selecting cells each having an RSRP of a predetermined level or higher. To achieve the above-mentioned operation, the UE performs RSRP measurement reporting of cells contained in the CoMP cluster including

the UE. Alternatively, the BS sets configurations of CSI_RS each of which will perform RSPR or RSRQ measurement to a CoMP measurement set, and informs the UE of the resultant configurations. The UE may perform RSRP or RSRQ measurement of CSI-RS transmitted from cells contained in the CoMP management set. If the measurement result
5 satisfies a specific condition, the UE may perform reporting.

[125] In order to implement ICIC between CoMP clusters, a UE performs RSRP measurement and reporting of cells contained in a contiguous CoMP cluster, such that a network and a UE can recognize which one of cells of the contiguous CoMP cluster gives strong interference to the corresponding UE and can also recognize which one of cells
10 receives strong UL interference from the corresponding UE.

[126] In addition to CRS based RSRP/RSRQ measurement reporting for mobility management of UE handover, the CoMP measurement set configuration and the CSI-RS based RSRP/RSRQ measurement reporting for ICIC are simultaneously performed, such that accuracy and flexibility of network RRM can be increased.

15 [127] **Restricted Measurement**

[128] If a cell reduces a transmission (Tx) power of a specific resource region, a variation width of a per-resource-region interference signal received by a contiguous cell is increased. If averaging of the interference signals is achieved irrespective of a resource region, it is difficult to correctly obtain CoMP and ICIC effects. A detailed description
20 thereof will hereinafter be described with reference to FIG. 8.

[129] Referring to FIG. 8, in case of a normal situation, a macro cell (macro eNB) is used as an aggressor cell of a pico cell (pico eNB). The macro cell (macro eNB) can guarantee/protect performance of the pico cell (pico eNB) using the aforementioned ABS for the pico cell or pico UE. In more detail, the macro cell can deboost a maximum of 9dB
25 transmission power in specific subframe(s), or may not transmit signals in the specific subframe(s), resulting in the cell range extension (CRE) effect of the pico cell. In other words, if a macro cell reduces a downlink transmission power in the ABS, a UE located in the vicinity of a cell edge of cells can recognize that performance of a picocell signal having
30 been received with a noise level or lower in a normal subframe is increased in a manner that data can be stably received in the ABS, such that cell coverage of a pico cell can be actually extended.

[130] Under this situation, restricted measurement may be used for measurement reporting. In other words, if the macro cell reduces a transmission power in a specific subframe through the ABS, signals and/or interference level of the pico cell seen by the UE

is greatly changed per subframe, and it is prevented that signals are simply averaged due to introduction of the restricted measurement.

[131] For such restricted measurement, if several CSI subframe sets (e.g., C0, C1) for channel measurement are used as a higher layer signal, the UE can perform channel measurement and reporting dedicated for the CSI subframe set. In addition, it is desirable that the UE may perform ABS measurement of the macro cell for RLM/RRM.

[132] **Cell Range Extension (CRE)**

[133] Several small-sized pico eNBs (BSs) are installed in a coverage of the macro BS, such that UEs covered by the macro BS are handed over to the pico BS, resulting in traffic dispersion of the macro BS. Handover from a serving BS to a target BS is achieved when target-BS measurement result obtained from the UE is identical to or higher than a predetermined threshold value (S_{th_conv}). In this case, the network improves UE capability using arbitrary means, such that handover can be performed even though signal strength (e.g., SNR) of the target BS is less than a predetermined threshold. The above-mentioned operation may be referred to as a cell range expansion (CRE). A CRE enable region is referred to as a CRE region/area, and the CRE region may be represented by a specific region in which a reception performance ($S_{received}$) of a reference signal of the corresponding BS is higher than a new threshold value (S_{th_CRE}) for CRE. That is, the CRE region configures the following equation 1.

[134] [Equation 1]

$$[135] \quad S_{th_conv} \geq S_{received} \geq S_{th_CRE}$$

[136] For better understanding of the present invention, a CRE region configured to satisfy Equation 1 may correspond to a shaded part.

[137] In FIG. 9, a macro eNB enables a PUE located in the CRE region to be handed over to a pico eNB (PeNB), resulting in implementation of traffic offloading. As a result, overall system performance is improved. The CRE can extend a cell range or a cell radius of the corresponding eNB. In the legacy LTE/LTE-A system, a reference signal reception intensity of the PeNB may be denoted by RSRP/RSRQ, a reference for enabling the UE to attach a specific cell satisfies a specific condition in which a difference between the best RSRP and a specific cell RSRP is 6dB or less on the basis of per-cell RSRP. However, in order to increase the traffic dispersion effect to the PeNB, the reference may be adjusted to 6dB (e.g., 9dB) or higher. In this case, the operation (i.e., CRE) for enabling the UE to measure the PeNB, when the UE performs handover to the PeNB and then measures the PeNB acting as a serving cell, influence of interference caused by the macro eNB (that

is located close to the PeNB and includes other BSs not shown in drawings may be further increased unavoidably. Therefore, the following description discloses a variety of methods for solving various interference problems encountered when a reference is higher than the CRE reference.

5 [138] FIG. 10 is a conceptual diagram illustrating summaries of detailed proposals according to embodiments of the present invention.

 [139] In FIG. 10, it is premised that a UE configured to use a macro eNB as a serving cell is located in the CRE region of 6dB or higher contained in the pico eNB (PeNB). It is also premised that timing points (e.g., radio frame boundary or subframe
10 boundary, etc.) of the macro eNB and the pico eNB are synchronized within the range of a predetermined degree (e.g., 3 μ s), or timing points of two cells are identical to each other.

 [140] In addition, the UE may have Further enhanced ICIC (FeICIC) capability capable of supporting FeICIC. In this case, FeICIC means that a pico eNB performs CRE of at least 6dB and at the same time the macro eNB and the pico eNB perform
15 time/frequency ICIC. There are a variety of UE capabilities related to FeICIC capability, for example, CRS interference cancellation (CRS IC) capability (including the number of CRS to cancel, the number of CRS capable of being cancelled in one subframe, and information indicating how many cells can be CRS-cancelled) capable of performing
20 cancellation of CRS interference, PSS/SSS IC capability (including the number of PSSs/SSSs to cancel, the number of PSSs/SSSs capable of being cancelled in one subframe, and information indicating how many cells can be PSS/SSS-cancelled) capable of
cancelling PSS/SSS interference of a contiguous cell, PBCH IC capability (including the number of PBCHs to cancel, the number of PBCHs capable of being cancelled in one
25 subframe, and information indicating how many cells can be PBCH-cancelled) capable of
cancelling PBCH interference of a contiguous cell. Hereinafter, the UE capability related to FeICIC capability will be referred to as CRE-related capability. UE capability information
related to CRE may be transferred from a UE to a core network after RRC connection. In more detail, after the UE performs RRC connection, the core network transmits
UECapabilityEnquiry information to the UE through NAS (Non-Access Stratum) signaling,
30 and the UE transmits UE capability information in response to the received
UECapabilityEnquiry information. If necessary, the core network may transmit the
UECapabilityEnquiry information.

[141] Referring to FIG. 10(a), a macro eNB acting as a serving cell may transmit a command for measuring neighbor cell(s) and a pico eNB to the UE including FeICIC capability. Therefore, if the UE measures the pico eNB, it may be impossible for the UE to measure the pico eNB without receiving the help of a network because interference transmitted from the macro eNB occurs. Furthermore, the UE may fail to obtain picocell synchronization (PSS/SSS reception) needed for measurement due to the occurrence of interference from the macro eNB. Although the UE has CRE-related capability (specifically, CRS IC capability), assuming that the UE does not recognize which cell of the pico eNB is a main interference causing cell or does not recognize which one of CRS configurations must be cancelled, the UE may have difficulty in achieving synchronization acquisition/measurement.

[142] In relation to the above-mentioned problem, the embodiment of the present invention will disclose signaling, process, etc. needed for the UE having obtained synchronization of a neighbor cell including high interference under the above-mentioned situation.

[143] If the UE measures a neighbor cell under high interference and receives a handover command of a serving cell for a high-level (6dB or higher) CRE, the UE needs to receive a PBCH of the neighbor cell when being handed over to the neighbor cell (i.e., state transition from FIG. 10a to FIG. 10b). However, the UE may have difficulty in receiving a PBCH of the neighbor cell due to a PBCH of a cell acting as an interference source (macro eNB of FIG. 10b). The above-mentioned operation may also be applied to the case of receiving other system information without change. In association with the above-mentioned description, signaling, process, etc., needed for correctly transferring system information including a PBCH to the UE will hereinafter be described in detail.

[144] Continuously, according to the embodiment of the present invention, the UE may have difficulty in measuring the serving cell even when handover to the neighbor cell (e.g., pico eNB of FIG. 10a) under high interference. In other words, there is a high possibility that a UE configured to use a high-interference cell (e.g., pico eNB of FIG. 10b) as a serving cell has difficulty in correctly measuring its own serving cell due to a neighbor cell (e.g., a macro eNB of FIG. 10b) causing high interference. Therefore, the embodiment of the present invention will disclose signaling, process, etc. related to the serving cell measurement to solve the above-mentioned problems.

[145] In summary, the following description will sequentially disclose: i) acquisition of synchronization of a neighbor cell under high interference; ii) measurement

of a neighbor cell under high interference; iii) acquisition of system information of a neighbor cell under high interference; and iv) measurement of a serving cell under high interference.

[146] In the following description, the term 'measurement' refers to measurement of at least one of RRM/RLM/CSI unless specially noted, and each of the neighbor cell receiving interference and the serving cell receiving interference may be referred to as a weak cell or a victim cell, and a cell causing interference may be referred to as an aggressor cell.

[147] **Synchronization Acquisition of Neighbor Cell under high interference**

[148] In accordance with a method for synchronization acquisition of a neighbor cell (i.e., a weak cell) receiving high interference from neighbor cells, if the UE has FeICIC capability and PSS/SSS IC capability, the eNB (BS) may allow the UE to directly receive PSS/SSS of the weak cell such that the UE can acquire necessary information. In more detail, the eNB gives the list of weak cells (i.e., the list of neighbor cells to be described later) to the UE, and may command the UE to perform cell acquisition of the corresponding cell using the PSS/SSS IC. In this case, information indicating who an aggressor cell for weak cells is may be omitted as necessary, and the UE can detect PSS/SSS of the weak cell without using information of the aggressor cell.

[149] In accordance with another method, a serving cell may inform a UE having FeICIC capability of specific information indicating which aggressor cell is synchronized with a specific weak cell, and the serving cell may command the UE having received such information to perform CRS measurement without detecting PSS/SS of the corresponding cell. That is, in order to measure a neighbor cell of a UE by the eNB, the list of weak cells to be measured by the UE should be transferred, and RSRP/RSRQ of these cells can be measured only in a specific subframe. In addition, information indicating which macro eNB has been synchronized in these cells is provided. In this case, provision of the information regarding synchronization with a certain macro eNB may enable the UE to measure RSRP/RSRQ without detecting PSS/SSS of a weak cell, because a signal intensity is high in a manner that the UE can perform PSS/SSS detection and specific weak cells inform the UE of the same radio frame boundary/subframe boundary as those of the corresponding macro eNB .

[150] In this case, it is impossible to recognize TDD/FDD information, CP type information, etc. capable of being recognized in PSS/SSS detection. For this purpose, information regarding the macro eNB having an aggressor relationship per weak cell is

transferred to the UE. In this case, the macro eNB may have the same duplex (TDD/FDD) scheme as those of the corresponding weak cell, and may have the same CP type as in the corresponding weak cell. In association with the CP type, a network (macro eNBs configured to use the ABS and the pico eNBs configured to receive the help) in which the ABS is configured may have the same CP type. The UE may operate on the assumption that the macro eNB and the pico eNB have the same CP type. Alternatively, the multiplexing schemes of individual weak cells, the CP type, and other system information may be further notified as necessary.

[151] Measurement of Neighbor Cell under high interference

[152] A UE having received a command for measuring a neighbor cell (weak cell) serving has to measure a reference signal of the corresponding cell after synchronization acquisition of weak cells. From the viewpoint of CRS, the UE measures intensity of CRS reception signals of neighbor cells and must report the measurement result to the eNB. The CRS reception intensity may be represented by RSRP/RSRQ. In order to correctly measure the CRS of each weak cell, it is necessary for the UE to properly process CRS interference of eNBs.

[153] Provided that FeICIC capability is set and CRS IC capability is set, the eNB can transmit the list of weak cells to be measured to the corresponding UE. When the eNB transmits a measurement execution command to the UE, the eNB can transmit reference signal information (e.g., CRS information) of a neighbor cell (aggressor cell, for example, a macro eNB adjacent to a pico cell) causing interference to cell(s) contained in the weak-cell list. In this case, CRS information of contiguous macro eNBs may include a cell ID, a CRS port number, and information of time/frequency domains to which CRS is transmitted. Detailed information related to RS information will be disclosed later. When the UE having received the above information measures a specific cell contained in the weak-cell list, RS cancellation is performed using CRS information of the specific cell, such that the UE may report the measurement result from which influence of interference is removed. If the eNB performs PDSCH mapping through CRS rate-matching and transmits CRS information to inform the UE of the mapped result, the eNB may transmit CRS information of a neighbor cell irrespective of the CRS IC capability of a UE, differently from the above-mentioned explanation.

[154] FIGS. 11 and 12 are flowcharts illustrating a method for enabling the eNB to transmit a measurement command. Referring to FIG. 11, the eNB confirms UE capability information in step S1111. In this case, the UE capability information relates to CRE

related capability, such as FeICIC capability, CRS IC capability, etc. If the eNB does not have the UE capability information, the eNB may perform the UE capability information exchange procedure. If the UE has FeICIC capability in step S1113, it is determined whether the UE has CRS IC capability in step S1115. Assuming that the UE has CRS IC capability, when the eNB commands the UE to measure a weak cell, the eNB may include i) the list of weak cells to be measured, ii) a subframe pattern which will measure a weak cell, iii) relationship between an aggressor cell and a victim cell for each weak cell, iv) system information of a weak cell (e.g., duplex type, CP length, etc.), and v) CRS information of an aggressor cell for weak-cell measurement.

5
10 [155] FIG. 12 is a flowchart illustrating a method for signaling CRS information of a neighbor cell on the basis of UE capability information. Referring to FIG. 12, steps other than step S1217 are replaced with those of FIG. 11. If the UE has FeICIC capability and CRS IC capability, the UE certainly provides CRS information of aggressor cells of weak cells, and requires measurement of each weak cell. In this case, since there is a high possibility that UE battery power can be excessively consumed, the eNB may command the corresponding UE to measure a weak cell as necessary. For example, if the corresponding UE may be located in the CRE region of a neighbor pico eNB, the eNB may command the UE to measure the weak cell. Under the condition that the eNB has difficulty in correctly recognizing whether the UE is located in the CRE region, if specific events i), ii) and iii) occur (where i) a CQI level reported by a UE is continuously equal to or less than a predetermined CQI level, ii) successive errors occur in DL data for the corresponding UE or UL data, iii) a UE average throughput is equal to or less than a predetermined throughput) , the eNB can estimate that the corresponding UE has been located in the CRE region.

15
20
25 [156] Therefore, the eNB may command the corresponding UE to measure a weak cell to perform handover to a neighbor pico eNB, and may transmit necessary signaling information and CRS information of a neighbor cell. FIG. 13 is a flowchart of a process from among processes in which the eNB can recognize that the corresponding UE is located in the CRE region under the condition that a CQI level reported by the UE is continuously equal to or less than a predetermined CQI level. In S1311 to S1315, if a CQI level reported by the UE is equal to or less than a threshold value and reaches a predetermined value (N) or higher, the eNB determines the UE capability in step S1317. If the UE has FeICIC capability and CRS IC capability, the UE may transmit a weak cell measurement command in step S1317. Detailed description of information that is capable of being contained in the

weak cell measurement command or being simultaneously transmitted is based on step S1117 of FIG. 11.

[157] The above-mentioned measurement command will hereinafter be described in detail.

5 [158] If the FeICIC capability is set in the UE-EUTRA-Capability information element (if the corresponding UE can perform FeICIC), the eNB may command the corresponding UE to measure a reference signal of each neighbor pico eNB having low intensity of a reception signal of the corresponding UE. In the network in which ABS is configured, the eNB may command the UE to perform restricted measurement. In this case, 10 in order to perform the restricted measurement in view of a subframe, different subframe sets for serving cell CQI reporting are configured, and the list of cell IDs and the measurement subframe pattern for the cell ID list may be designated for restricted RRM/RLM measurement of a neighbor cell.

[159] For example, the eNB may indicate restricted RRM/RLM measurement 15 through MeasObjectEUTRA information element (IE) including subfields shown in the following Table 3.

[160] [Table 3]

MeasSubframePatternConfigNeigh ::=	CHOICE {
release	NULL,
setup	SEQUENCE {
measSubframePatternNeigh	MeasSubframePattern-r10,
measSubframeCellList	MeasSubframeCellList-r10
OPTIONAL -- Cond measSubframe	
aggressorCellCRSInformation {	
Cell ID, Number of CRS ports, CRS transmission BW, center frequency, subframes containing CRS in the data region }	
}	
}	
}	

[161] In Table 3, 'measSubframePatternNeig' may denote a subframe pattern that must perform neighbor cell RSRP/RSRQ measurement, and 'measSubframeCellList-r10' 20 may denote the list of cells to which 'measSubframePatternNeig' is applied. That is, the eNB may allocate a subframe pattern to be used for RSRP/RSRQ measurement of a specific cell list to the UE through a sub-element shown in Table 3. Preferably, the subframe pattern must be designated as a subframe pattern, that is set to ABS by the macro eNBs, to increase RSRP/RSRQ performance of the pico eNB. The cell contained in

'measSubframeCellList' information may be a weak cell under high interference, and 'aggressorCellCRSinformation' information may be RS information causing high interference to a cell contained in the measSubframeCellList information.

[162] Configuration of restricted measurement for neighbor cell RRM measurement may indicate that 'MeassubframePatternNeigh' information for a neighbor cell RRM has been configured. In this case, assuming that additional aggressor cell CRS information is not present, the UE performs RRM only in a subframe designated in the 'MeassubframePatternNeigh' information of cells contained in the 'meassubframeCellList' information. However, upon receiving the additional aggressor cell list and CRS information (aggressorCellCRSinformation) of the corresponding cells, the UE performs RRM only in a subframe designated in 'MeassubframePatternNeigh' information in association with the cells contained in the measSubframeCellList information, and then reports a value (e.g., measured RSRQ/RSRP) obtained after CRS interference of aggressor cells is reduced to a serving cell of the UE.

[163] In more detail, the RRM operations are as follows. If the restricted measurement for RRM is configured and CRS information of aggressor cells is received, and if the CRS transmission position of a target cell which will attempt to perform RRM in a non-MBSFN subframe overlaps and collides with a CRS transmission position of a specific cell contained in 'aggressorCellCRSinformation' (i.e., Colliding CRS case), CRS of the specific cell is cancelled to measure RSRP of the target cell to be measured, and the RSRP value is then calculated and reported. That is, the CRS quality obtained after interference of the colliding CRS is reduced is defined as RSRP and the defined RSRP is then reported.

[164] However, for RSSI measurement, CRS IC of the aggressor cells is not always requested for RSSI measurement. In other words, CRS IC of the aggressor cells may be omitted as necessary. If the restricted measurement is configured, RSSI has been defined to perform electric field strength measurement and averaging within all symbols of a specific subframe in which RRM measurement is needed, such that CRS IC need not be performed. Therefore, in the case of calculating RSRQ (where $RSRQ = N * RSRP / RSSI$), CRS cancellation of a specific cell is performed in a numerator of RSRQ such that CRS influence of the aggressor cell is excluded. In the case of calculating RSSI, influence of CRS of aggressor cells remains unchanged.

[165] The above-mentioned RSRP and RSRQ measurement can be applied to the case in which RRM of the corresponding target cell is performed under the condition that

restricted measurement is established for RRM of a specific target cell and CRS information of aggressor cells of the corresponding target cell is signaled.

[166] In addition, 'aggressorCellCRSinformation' may include serving cell information. That is, a serving cell of a specific neighbor cell may be used as an aggressor.
5 In this case, when the UE performs weak cell RRM, the UE must report the value obtained after CRS IC of the serving cell is executed to the serving cell. However, if the UE has already received serving cell information as another container, the UE need not perform additional signaling of the serving cell CRS information, such that it can report a value
10 obtained after CRS IC of the serving cell requiring restricted RRM measurement is performed, through a serving cell ID or simple signaling information.

[167] For example, if the remaining information other than a cell ID is missed (lost) in 'aggressorCellCRSinformation' and the corresponding cell ID is identical to the serving cell ID, the UE may reduce interference of the serving cell CRS for neighbor cell RRM on the basis of the serving cell information already known to the UE. In addition, if
15 information of a cell ID corresponding to the serving cell ID in the 'aggressorCellCRSinformation' information is different from serving cell information received through another higher layer signaling (e.g., dedicated RRC configuration or common RRC configuration), the information received through another higher layer signaling may have priority.

[168] In another example, if restricted measurement for neighbor cell RRM is
20 configured, the operation for reporting RSRP/RSRQ values obtained after execution of IC of the serving cell CRS may be established as a default. This reporting operation is requisite for the case in which a CRS of a specific neighbor cell requiring RRM measurement overlaps and collides with a CRS of the serving cell in time/frequency
25 domains. Specifically, for RSRP, the value obtained after execution of IC of the serving cell CRS must be reported/calculated.

[169] If restricted measurement for the neighbor cell RRM is not configured, 'aggressorCellCRSinformation' information (i.e., 'MeassubframePatternNeigh' information) may not be signaled to a UE. In other words, 'aggressorCellCRSinformation'
30 information can be signaled only when 'MeassubframePatternNeigh' information is configured.

[170] In order to deliver 'aggressorCellCRSinformation' information when the serving cell commands the UE to perform neighbor cell RRM, it is necessary for a plurality of eNBs to first exchange information of the aggressor cell or information the victim cell

with one another. For this operation, the eNB acting as each victim cell can transmit the list of its own aggressor cells to neighbor eNBs through a communication interface between eNBs. When the eNBs having received the aggressor cell list commands the UE to measure each weak cell, the eNBs perform signaling of the aggressor cell list of the corresponding
5 weak cells to the UE, such that the UE can report an RSRQ value obtained after reduction of CRS interference of cells acting as aggressors, i.e., an RSRQ value obtained after cancellation of CRS of aggressor cells. In another scheme, individual eNBs may exchange the list of victim cells, each of which receives serious interference from the eNBs, through an X2 interface, such that the eNBs may share information indicating whether which cell is
10 operated as an aggressor of each victim cell.

[171] Acquisition of System Information of Neighbor Cell under high Interference

[172] The eNB may enable the UE to be handed over to a specific pico eNB. For handover to the pico eNB, the macro eNB may further transmit a variety of information to
15 the UE. For example, system information of the corresponding pico eNB, master information block (MIB) information of the LTE system, SFN of the corresponding cell, and an SFN difference between the macro eNB and the current serving macro eNB can be additionally transmitted from the macro eNB to the UE. (Since SFN may be different from SFN obtained through a PBCH of a pico cell, the UE may transmit not only SFN subframe
20 offset/radio frame offset but also OFDM symbol offset/sample offset information between two cells so as to indicate a correct timing offset between two cells) It may be impossible to decode a PBCH of the pico eNB due to interference caused by a PBCH of the macro eNB, and the macro eNB previously transmits system information of a target cell, MIB and SFN/SFN offset transmitted through a PBCH to the UE either in case of handover or prior
25 to execution of such handover, such that the corresponding UE can be handed over to the pico eNB without decoding a PBCH of the pico eNB.

[173] Meanwhile, assuming that a UE to be handed over to a specific pico eNB by the macro eNB has PBCH IC capability, the macro eNB need not pre-deliver at least information transmitted through a PBCH from among system information of the pico eNB
30 to the UE. If the UE has PBCH IC capability, the UE can be handed over to the pico eNB such that it can directly decode a PBCH of the pico eNB.

[174] That is, a method for acquiring system information of a target cell by a UE performing handover may be determined according to UE CRE related capability (specifically, PBCH IC capability).

[175] However, in this case, the ratio of PBCH power to CRS power of the corresponding pico eNB (i.e., the ratio of CRS transmission power to PBCH transmission power of the corresponding pico BS) and the ratio of PBCH power of a neighbor cell to PBCH power of a serving cell must be recognized by the UE. The above-mentioned PBCH to CRS power ratio may be contained in a handover command and then transmitted. However, the scope or spirit of the present invention is not limited thereto, and the PBCH to CRS power ratio may be signaled separately.

[176] In accordance with another embodiment, instead of using signaling of the PSS/SSS/PBCH -to- CRS power ratio of its own cell and a neighbor cell, the UE may assume the PSS/SSS -to- PBCH transmission power ratios of its own cell and a neighbor cell in a manner that the UE can recognize the degree of interference of the neighbor cell. For example, the UE must assume that corresponding channels are transmitted with either the same transmission power or a difference of a predetermined level (Δ_{power}) compared with CRS, and such information may be promised as a higher layer signal. Signaling of more detailed power ratio will be described later.

[177] Meanwhile, after the UE is successfully handed over to the pico eNB, if MIB contained in a PBCH of the pico eNB is changed and there is no PBCH IC capability, it is very difficult for the UE to recognize the changed MIB. Assuming that the UE does not recognize the changed MIB, the corresponding UE may experience continuous errors in transmission/reception of data and control information. For example, although PHICH configuration contained in MIB is changed, the UE fails in successful reception of PBCH. Thus, if the UE does not recognize the changed MIB, the corresponding UE may experience continuous errors. In this case, the UE must carry out a specific procedure for querying the pico eNB whether MIB was changed. Therefore, the UE transmits an error report to the pico eNB, such that this information may be used as an indicator for indicating the problems generated when the corresponding UE receives services. The error report may be used as a signal indicating that a problem unknown to the UE is associated with the UE itself. As a result, the error report may be used as a signal for querying the eNB whether system information is changed. Upon receiving the error report, the eNB transmits the changed system information to the UE only when system information is changed. If system information is not changed, the eNB may indicate no change of system information or may also indicate no change of system information using an acknowledgement (ACK) message. A valid time is present per system information. In this case, the UE may request specific information indicating whether system information has been changed for a specific time

duration from the eNB. In this case, information regarding the specific time duration must be transmitted to the eNB.

[178] In another example related to change of system information, a UE may separately request each system information from the eNB. In case of a UE located in the
5 CRE region (i.e., a UE which uses a pico eNB as a serving cell and is located at a specific position having high CRE bias of the pico eNB), the UE may have difficulty in correctly receiving system information of the pico eNB. However, if the UE is located within a predetermined range from a pico cell, namely, if the UE is located close to the pico eNB, the UE may receive some system information. The UE may request specific system
10 information from the eNB. If the UE transmits the MIB request to the eNB, the eNB must transmit the MIB to the corresponding UE over a PDSCH. In this case, MIB is CRC-masked with UE's C-RNTI but not SI-RNTI, such that the CRC-masked result is sent to the corresponding UE through dedicated transmission.

[179] In addition, a transmission start time of the paging and SIB 1 (System
15 Information Block 1) information to be transmitted by the macro eNB may be identical to that of the pico eNB in so far as coordination of separate subframe number arrangement between the macro eNB and the pico eNB is not performed through a channel assigned a decided subframe number. In this case, paging and SIB 1 transmitted from the pico eNB may receive serious interference in the same manner as in a PBCH. Therefore, the UE may
20 transmit the paging and SIB 1 request to the eNB. The above-mentioned system information request may not be limited to MIB, paging, and SIB 1.

[180] In another embodiment, the UE may request only information changed within a specific time interval (i.e., only newly updated system information) from the eNB. Likewise, the eNB having received the above information transmits only updated system
25 information, performs CRC masking with a C-RNIT of a UE requesting system information, and transmits the CRC masking result to the corresponding UE over a PDSCH. If an aggregate of UEs requesting such information is present, the eNB may perform multicasting of a group of specific UEs.

[181] From among the above-mentioned information, if the macro eNB (source
30 eNB) before handover transmits system information of the pico eNB (target eNB) to the UE, the UE may assume that two cells maintain synchronization within a predetermined range (e.g., within the CP length, or within a specific time (within 3 μ s)). Alternatively, the UE may explicitly indicate that two cells maintain synchronization within a predetermined range. In this case, the UE may perform synchronization and time/frequency tracking

through CRS of a pico cell or another cell maintaining synchronization with the corresponding pico cell. However, if a timing jitter or low time accuracy are decided, the timing jitter must be tracked on the basis of a CRS of the pico cell.

5 [182] If timing points of two cells always collide with each other, i.e., if PSS/SSS and/or CRS of the two cells are always transmitted in the same time-frequency resource region, the BS informs the UE that PSS/SSS and/or CRS always maintain synchronization. Specifically, the above-mentioned case is more important in the case in which the UE has to perform tracking using a CRS of the macro eNB.

10 [183] Although assumption of synchronization and synchronization signaling related to only two cells have been disclosed for convenience of description and better understanding of the present invention, it should be noted that the above-mentioned assumption and signaling can also be equally or similarly applied to a plurality of cells as necessary.

[184] **Execution of Measurement of Serving Cell under high interference**

15 [185] If FeICIC capability is set in UE-EUTRA-Capability information element (if the corresponding UE is configured to perform FeICIC), and if CRS IC capability is set, the serving cell can inform the UE of not only the list of aggressor causing serious interference to the serving cell cells, but also CRS information of each cell. However, information as to whether the UE will perform CRS IC on certain measurement (i.e., information as to whether CRE-related capability of a UE was used) may be determined in different ways
20 according to a measurement target, the presence or absence of UE capability, restricted measurement configuration, etc. Hereinafter, the case (i) for RRM measurement, the case (ii) for RLM measurement, and the case (iii) for restricted measurement will be sequentially described.

25 [186] In case of RRM measurement, in the legacy LTE/LTE0A system, RRM/RLM of the serving cell is performed only in a given subframe (MeassubframePattern) when 'MeassubframePatternPCell(-r10)' is received in 'RadioResourceconfigDedicated IE'. If restricted measurement for the serving cell RRM/RLM is configured as described above, and if the UE FeICIC capability is set, the
30 serving cell informs the UE of CRS information of each cell operated as an aggressor, resulting in increased RRM/RLM performance. The UE having received the above CRS information performs CRS IC of these cells, and then performs RRM/RLM. In this case, detailed information of the above CRS information may refer to the signaling part of RS information to be described later.

[187] Meanwhile, although the UE receives CRS information of aggressor cells from the eNB, if restricted measurement for RRM/RLM is not configured, i.e., if the UE does not receive a separate measurement pattern for RRM/RLM, the UE does not perform any other IC operations related to CRS interference of a neighbor cell when performing
5 RRM/RLM of the serving cell.

[188] A more detailed description of the RRM operation is as follows. Assuming that restricted measurement for RRM is configured and CRS information of aggressor cells is received, if the CRS transmission position of a target cell that attempts to perform RRM in a non-MBSFN subframe overlaps and collides with (i.e., Colliding CRS case) the CRS
10 transmission position of a specific cell contained in 'aggressorCellCRSInformation', CRS of the specific cell is cancelled to measure RSRP of the target cell to be measured, and the RSRP value is then calculated and reported. That is, the CRS quality obtained after interference of the colliding CRS is reduced is defined as RSRP and the defined RSRP is then reported.

[189] However, for RSSI measurement, CRS IC of the aggressor cells is not
15 always requested for RSSI measurement. In other words, CRS IC of the aggressor cells may be omitted as necessary. If the restricted measurement is configured, RSSI has been defined to perform electric field strength measurement and averaging within all symbols of a specific subframe in which RRM measurement is needed, such that CRS IC need not be
20 performed. Therefore, in the case of calculating RSRQ (where $RSRQ = N * RSRP / RSSI$), CRS cancellation of a specific cell is performed in a numerator of RSRQ such that CRS influence of the aggressor cell is excluded. In the case of calculating RSSI, influence of CRS of aggressor cells remains unchanged.

[190] If a specific UE has interference cancellation capability, RLM of the
25 corresponding UE must be carried out on the basis of SINR obtained after completion of cancellation of CRS interference. Although interference is higher than a predetermined interference level, data and control information received by the corresponding UE can be stably demodulated and decoded because the corresponding UE performs cancellation of interference.

[191] Specifically, if the CRS of several cells collide with each other because CRS
30 positions are transmitted from the same REs as those of the neighbor cells, the UE first performs cancellation of a neighbor cell CRS used as dominant interference. Thereafter, the UE determines how much SINR of a CRS received from its own serving cell is good, such that it may determine whether to continuously maintain synchronization with the

corresponding cell, or may decide to declare Radio Link Failure (RLF). However, CRS SINR obtained after all CRS of neighbor cells are cancelled are unable to reflect realistic SINR in an RE other than CRS. Interference may be removed from the RE mapped to CRS, such that SINR of the RE can be improved. However, in fact, interference from neighbor
5 cells may still remain in an RE mapped to a PDCCH, such that it is impossible for the CRS SINR to reflect realistic SINR in the RE. thereafter, after completion of CRS interference cancellation, the degree of neighbor-cell interference applied to the RE mapped to a PDCCH needs to be recognized by the UE, such that the UE can recognize a substantial interference level and can perform more accurate RLM.

10 [192] In conclusion, for reliable RLM, the PDCCH-to-CRS power ratio of a neighbor cell must be signaled to the UE. The UE cancels CRS using such information, and then performs RLM by referring to the resultant value. That is, when measuring/calculating CRS SINR for RLM, the remaining information amount obtained after completion CRS interference cancellation of a neighbor cell is calculated in consideration of the PDCCH-to-
15 CRS power ratio of a neighbor or contiguous cell.

[193] The PDCCH-to-CRS power ratio of the neighbor cell can be transmitted as a higher layer signal. Specifically, if the eNB transmission power is divided into a plurality of subframe sets having different transmission powers in the same manner as in ABS, the PDCCH-to-CRS power ratio of the eNB per set must be signaled.

20 [194] If restricted measurement for CSI measurement is configured, i.e., if a subframe pattern for CSI reporting is configured, the UE measures a CSI per subframe pattern and reports the measured CSI. In the following description, it is assumed that 'csi-MeassubframeSet1' related to restricted measurement is a subframe set obtained when neighbor macro eNBs reduce interference through ABS operations or the like, and 'csi-
25 MeassubframeSet2' is a subframe set obtained when interference from neighbor macro eNBs is not reduced. Restricted CSI measurement is configured in the UE, and the serving cell can inform the UE of CRS information of neighbor aggressor cells. The UE having received the above information performs CRS IC of neighbor aggressor eNBs in the subframe set (csi-MeassubframeSet1) corresponding to a subframe in which the neighbor
30 aggressor eNBs can reduce interference using ABS operations or the like, such that the UE may report more improved CSI. However, although the UE has CRS IC capability in the other subframe set (csi-MeassubframeSet2) used as a normal subframe in which the operation for reducing transmission power of neighbor aggressor cells is not performed, CRS IC is not performed in the corresponding subframe set. In more detail, although CRS

interference is cancelled, interference generated in data REs other than CRS is not reduced, so that the UE does not perform the CRS IC in the corresponding subframe set.

[195] Although CRS information of neighbor aggressor cells is received, if 'csi-subframePattern' information is not configured in the UE, i.e., if the UE does not receive a plurality of CSI measurement subframe patterns (e.g., csi-MeassubframeSet1 and csi-MeassubframeSet2), the UE may not perform CRS IC for CSI measurement.

[196] Alternatively, although 'csi-subframePattern' information is configured in the UE, i.e., although the UE receives a plurality of CSI measurement subframe patterns (e.g., csi-MeassubframeSet1 and csi-MeassubframeSet2) and does not receive CRS information of each neighbor aggressor cell, the UE may not perform the CRS IC operation for CSI measurement even at a certain CSI measurement subframe set. Provided that the UE performs the CRS IC operation at a specific subframe set for CSI measurement, the UE informs the eNB of CRS IC execution when calculating the CSI value, and can inform the eNB of information indicating which one of subframe sets has been used to carry out the above operation.

[197] In order to configure, by the UE, 'csi-subframePatternconfig' information and to receive the CSI report after execution of CRS IC at a specific subframe set by providing CRS information of the aggressor cells, the eNB may inform the UE of information indicating which subframe sets is a subframe set that must be CRS-IC-processed by the UE. Alternatively, the above-mentioned information may be promised in the order of subframes signaled between the eNB and the UE. For example, if CRS information is given in 'csi-MeassubframeSet1', the csi-MeassubframeSet1 may be promised to be a subframe set, CRS IC of which is needed. In case of csi-MeassubframeSet2, the csi-MeassubframeSet2 may be promised to be a subframe set, CRS IC of which is no longer required.

[198] FIG. 14 is a flowchart illustrating measurement of the serving cell. Referring to FIG. 14(a), if the eNB acting as the serving cell recognizes UE capability information (CRE related capability information), the eNB confirms the UE capability information. If there is no UE capability information, a procedure for exchanging the UE capability information may be performed. If the UE has FeICIC capability in step S1413, it is determined whether the UE has CRS IC capability in step S1415. If the UE has CRS IC capability, RS information of aggressor cells may be transferred to the UE. FIG. 14(b) is basically similar to FIG. 14(a). However, if restricted RRM/RLM configuration or

restricted CSI measurement configuration is further considered and satisfied in step S1427, RS information of the aggressor cells may be signaled.

[199] Signaling of Power Ratio

[200] If the UE has a interference cancellation receiver, the eNB may inform the
5 UE of the PSS-to-CRS power ratio of its own cell and neighbor cell, the SSS-to-CRS power ratio, and the PBCH-to-CRS power ratio, the UE may remove interference such as PSS/SSS/PBCH of the cell causing such interference, such that handover to a weak cell can be smoothly carried out. In this case, estimation of channels (such as PSS/SSS and PBCH) is achieved on the basis of CRS, the PSS/SSS to CRS power ratio and the PBCH to CRS
10 power ratio must be signaled to the UE. Specifically, if a dominant interference source of the target cell for handover is a cell currently attached to the UE, the eNB can transmit the PSS/SSS/PBCH to CRS power ratio of its own cell.

[201] In accordance with another embodiment, instead of using signaling of the PSS/SSS/PBCH -to- CRS power ratio of its own cell and a neighbor cell, the UE may
15 assume the PSS/SSS -to- PBCH transmission power ratios of its own cell and a neighbor cell in a manner that the UE can recognize the degree of interference of the neighbor cell. For example, the UE must assume that corresponding channels are transmitted with either the same transmission power or a difference of a predetermined level (Δ_{power}) compared with CRS, and such information may be promised as a higher layer signal.
20 Preferably, in order to perform not only performance improvement of a channel reception signal from the UE serving cell but also interference cancellation of the reception signal, the BS may perform signaling of per-channel CRS power ratios of its own cell and a neighbor cell as necessary.

[202] As an example for reliably receiving/demodulating PSS/SSS/PBCH in a
25 serious interference environment, the UE may detect a cell only in a subframe established as ABS by macro eNBs. That is, when ABS patterns are exchanged between the macro eNB and the pico eNB, subframe offset information between individual eNBs is also exchanged, such that a subframe for PSS/SSS/PBCH transmission of the macro eNB may not collide with a subframe for PSS/SSS/PBCH of the pico eNB. In addition, the macro eNBs
30 exchange the ABS patterns with one another in consideration of the above information, and each macro eNB may certainly set the subframe requisite for the pico eNB configured to transmit PSS/SSS/PBCH to the ABS as necessary. The UE may attempt to detect PSS/SSS/PBCH only in a subframe established as ABS by the macro eNBs.

[203] Signaling of RS (Reference Signal) information

[204] For CRS interference handling of a UE, RS information signaled by the eNB may include a cell ID of a neighbor cell, the number of CRS ports, and time/frequency information requisite for CRS transmission. Time-related information may be denoted by a subframe in which CRS is transmitted, and its associated signaling may be MBSFN subframe setting. Frequency-related information requires a center frequency and bandwidth of each neighbor cell, the number of PRBs for CRS transmission, and the PRB position information. A message 'NeighborCellCRSInformation' requisite for transmission of such information may be defined as the following table 4.

[205] [Table 4]

NeighborCellCRSInformation ::= CHOICE { Cell ID { number of CRS ports, frequency information of CRS transmission, time information of CRS transmission } }

[206] Multiple cell IDs may be transmitted in 'NeighborCellCRSInformation', the number of CRS ports per cell ID, transmission of frequency CRS information, and time information of CRS transmission may be transmitted. Whereas the number of CRS ports per specific cell ID must be transmitted, frequency CRS information transmission and CRS transmission time information may be transmitted as necessary. In this case, the frequency CRS information transmission may be frequency information related to CRS transmission, and may be denoted by a center frequency and bandwidth of a specific cell, or the number of PRBs for CRS transmission and the PRB position information. The term 'time information' for CRS transmission may be time information related to CRS transmission, and may be denoted by a subframe in which CRS is transmitted. For example, the time information may be set to MBSFN subframe configuration.

[207] FIG. 15 is a block diagram illustrating a transmission point apparatus and a UE apparatus according to embodiments of the present invention.

[208] Referring to FIG. 15, the transmission point apparatus 1510 according to the present invention may include a reception (Rx) module 1511, a transmission (Tx) module 1512, a processor 1513, a memory 1514, and a plurality of antennas 1515. The plurality of antennas 1515 indicates a transmission point apparatus for supporting MIMO transmission and reception. The reception (Rx) module 1511 may receive a variety of signals, data and information on an uplink starting from the UE. The Tx module 1512 may transmit a variety

of signals, data and information on a downlink for the UE. The processor 1513 may provide overall control to the transmission point apparatus 1510.

[209] The processor 1513 of the transmission point apparatus 1510 according to one embodiment of the present invention can process the above-mentioned embodiments.

5 [210] The processor 1513 of the transmission point apparatus 1510 processes information received at the transmission point apparatus 1510 and transmission information to be transmitted externally. The memory 1514 may store the processed information for a predetermined time. The memory 1514 may be replaced with a component such as a buffer (not shown).

10 [211] Referring to FIG. 15, the UE apparatus 1520 may include an Rx module 1521, a Tx module 1522, a processor 1523, a memory 1524, and a plurality of antennas 1525. The plurality of antennas 1525 indicates a UE apparatus for supporting MIMO transmission and reception. The Rx module 1521 may receive downlink signals, data and information from the BS (eNB). The Tx module 1522 may transmit uplink signals, data and
15 information to the BS (eNB). The processor 1523 may provide overall control to the UE apparatus 1520.

[212] The processor 1523 of the UE apparatus 1520 according to one embodiment of the present invention can process the above-mentioned embodiments.

[213] The processor 1523 of the UE apparatus 1520 processes information
20 received at the UE apparatus 1520 and transmission information to be transmitted externally. The memory 1524 may store the processed information for a predetermined time. The memory 1524 may be replaced with a component such as a buffer (not shown).

[214] The specific configurations of the transmission point apparatus and the UE
25 apparatus may be implemented such that the various embodiments of the present invention are performed independently or two or more embodiments of the present invention are performed simultaneously. Redundant matters will not be described herein for clarity.

[215] The description of the transmission point apparatus 1510 shown in FIG. 15
30 may be applied to the eNB (BS), or may also be applied to a relay node (RN) acting as a DL transmission entity or UL reception entity without departing from the scope or spirit of the present invention. In addition, the description of the UE apparatus 1520 may be applied to the UE, or may also be applied to a relay node (RN) acting as a UL transmission entity or DL reception entity without departing from the scope or spirit of the present invention.

[216] The above-described embodiments of the present invention can be implemented by a variety of means, for example, hardware, firmware, software, or a combination thereof.

[217] In the case of implementing the present invention by hardware, the present invention can be implemented with application specific integrated circuits (ASICs), Digital signal processors (DSPs), digital signal processing devices (DSPDs), programmable logic devices (PLDs), field programmable gate arrays (FPGAs), a processor, a controller, a microcontroller, a microprocessor, etc.

[218] If operations or functions of the present invention are implemented by firmware or software, the present invention can be implemented in the form of a variety of formats, for example, modules, procedures, functions, etc. The software codes may be stored in a memory to be driven by a processor. The memory is located inside or outside of the processor, so that it can communicate with the aforementioned processor via a variety of well-known parts.

[219] The detailed description of the exemplary embodiments of the present invention has been given to enable those skilled in the art to implement and practice the invention. Although the invention has been described with reference to the exemplary embodiments, those skilled in the art will appreciate that various modifications and variations can be made in the present invention without departing from the spirit or scope of the invention described in the appended claims. For example, those skilled in the art may use each construction described in the above embodiments in combination with each other. Accordingly, the invention should not be limited to the specific embodiments described herein, but should be accorded the broadest scope consistent with the principles and novel features disclosed herein.

[220] Those skilled in the art will appreciate that the present invention may be carried out in other specific ways than those set forth herein without departing from the spirit and essential characteristics of the present invention. The above exemplary embodiments are therefore to be construed in all aspects as illustrative and not restrictive. The scope of the invention should be determined by the appended claims and their legal equivalents, not by the above description, and all changes coming within the meaning and equivalency range of the appended claims are intended to be embraced therein. Also, it will be obvious to those skilled in the art that claims that are not explicitly cited in the appended claims may be presented in combination as an exemplary embodiment of the

present invention or included as a new claim by subsequent amendment after the application is filed.

【Mode for Invention】

5 **[221]** Various embodiments have been described in the best mode for carrying out the invention.

【Industrial Applicability】

The embodiments of the present invention can be applied to a variety of mobile communication systems..

【CLAIMS】

【Claim 1】 A method for acquiring system information by a user equipment (UE) in a wireless communication system, the method comprising:

- 5 performing a handover from a first cell to a second cell; and
acquiring system information of the second cell,
wherein a method for acquiring the system information of the second cell is determined according to CRE (Cell Range Extension) – related capability of the UE.

【Claim 2】 The method according to claim 1, wherein:

- 10 if the UE has PBCH (Physical Broadcast Channel) cancellation capability, the UE acquires system information of the second cell through a PBCH of the second cell.

【Claim 3】 The method according to claim 2, wherein the UE performs PBCH cancellation of the first cell when acquiring the PBCH of the second cell.

15

【Claim 4】 The method according to claim 1, wherein:

if the UE does not have the PBCH cancellation capability, the UE acquires system information of the second cell from the first cell.

- 20 【Claim 5】 The method according to claim 4, wherein the system information of the second cell is transferred to the UE in a step of performing the handover.

【Claim 6】 The method according to claim 1, further comprising:

- 25 if a predetermined condition is satisfied after completion of the handover, transmitting an error report to the second cell.

【Claim 7】 The method according to claim 6, wherein the predetermined condition is that the UE fails to successively receive signals from the second cell.

- 30 【Claim 8】 The method according to claim 6, further comprising:

receiving at least one of changed system information and specific information indicating no change of the system information, as a response to the error report.

【Claim 9】 The method according to claim 1, further comprising:

if the UE is located within a predetermined distance of the second cell after completion of the handover, transmitting a request of system information to the second cell.

5

【Claim 10】 The method according to claim 1, further comprising:

receiving system information masked with C-RNTI of the UE, as a response to the system information request.

10 【Claim 11】 The method according to claim 9, wherein the system information request is any one of an MIB (Master Information Block) request, an SIB (System Information Block) request, and a paging request, which are updated information of the second cell.

15 【Claim 12】 The method according to claim 1, wherein the first cell is a macro eNB, and a second cell is a pico eNB.

【Claim 13】 The method according to claim 1, wherein the CRE-related capability information includes at least one of reference signal (RS) cancellation capability and synchronization signal cancellation capability.

20

【Claim 14】 A user equipment (UE) apparatus for use in a wireless communication system comprising:

a reception (Rx) module; and

a processor,

25 wherein the processor performs a handover from a first cell to a second cell and acquires system information of the second cell, wherein a method for acquiring the system information of the second cell is determined according to CRE (Cell Range Extension) – related capability of the UE.

30

FIG. 1

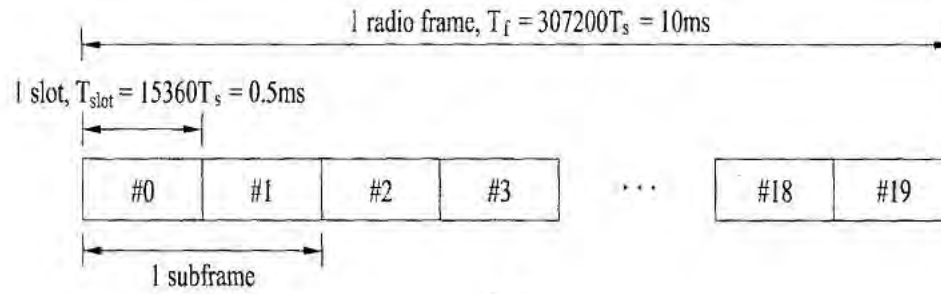

(a)

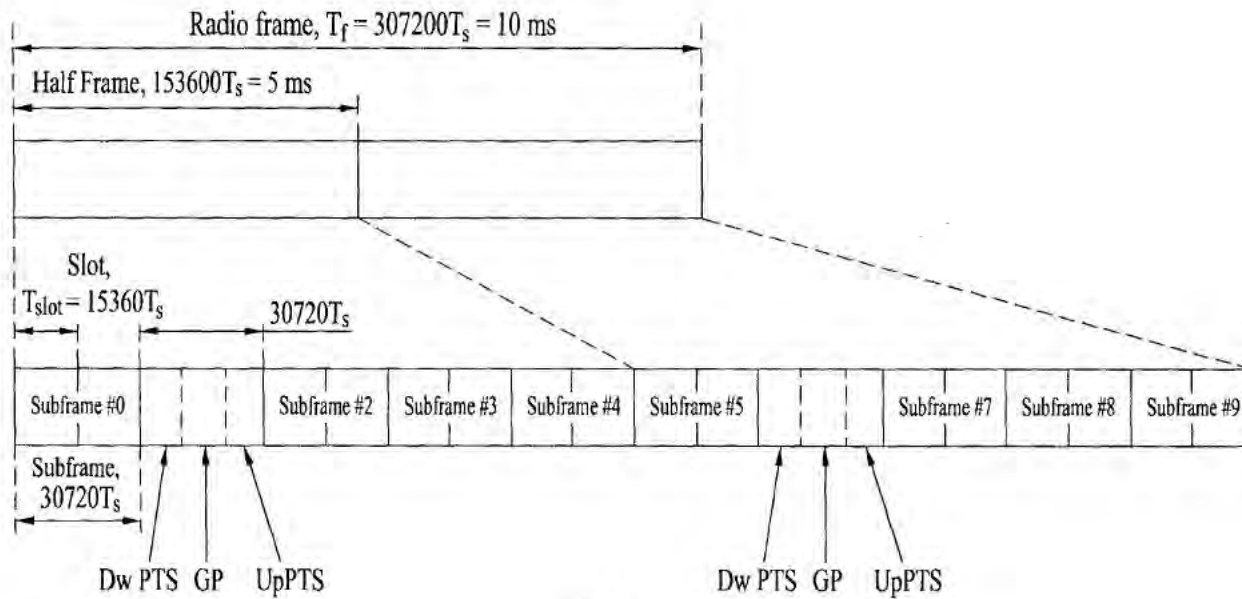

(b)

FIG. 2

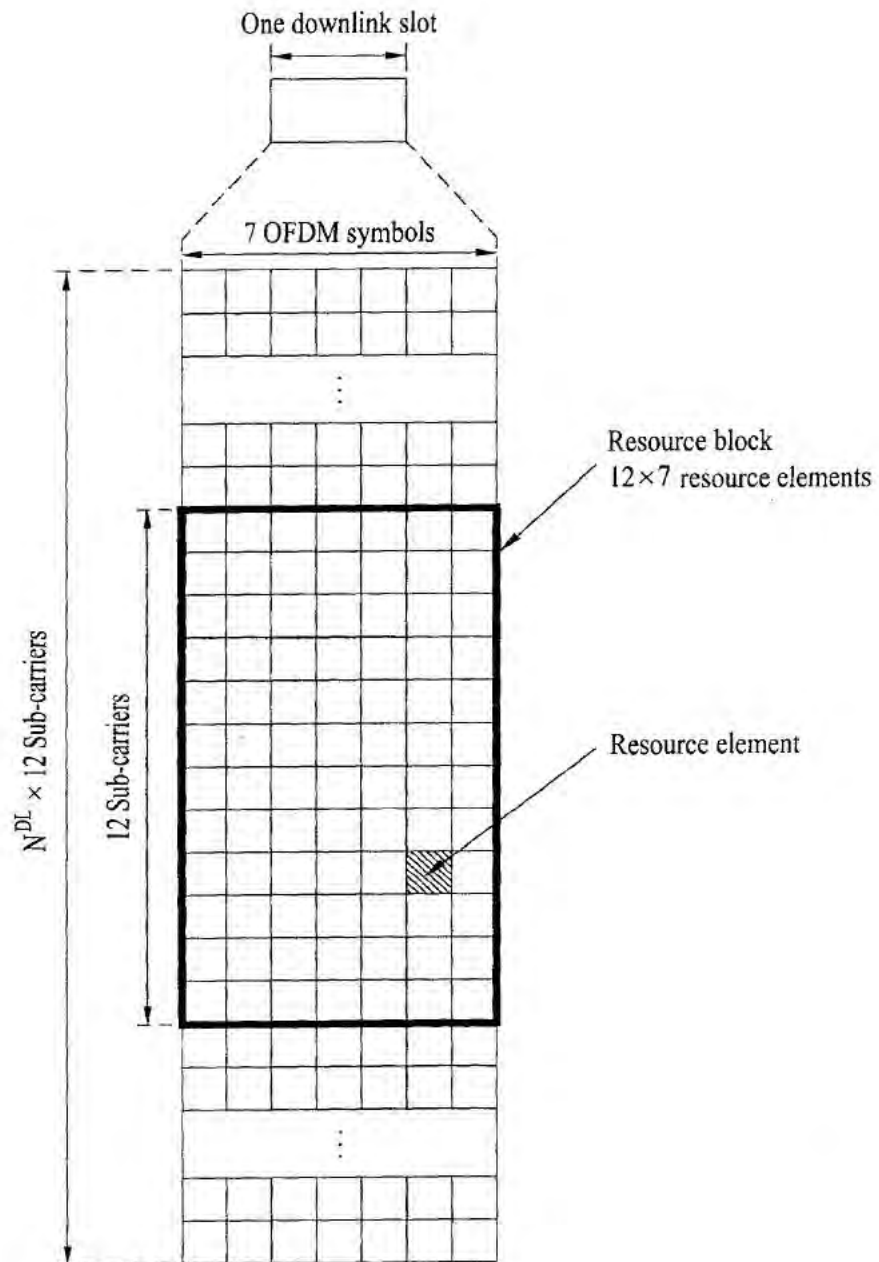

FIG. 3

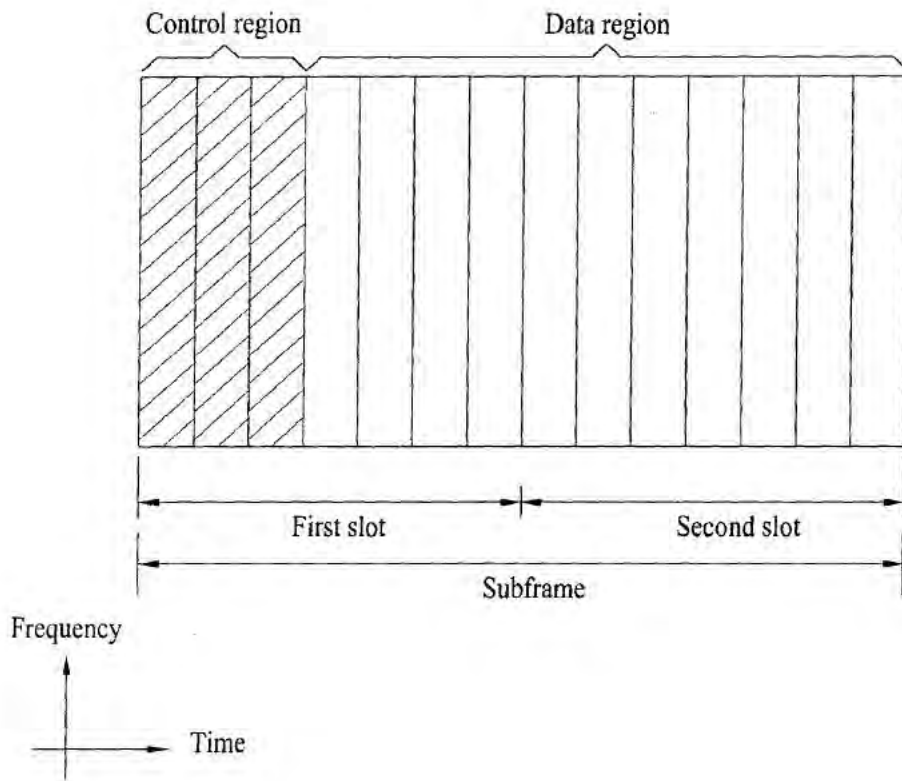
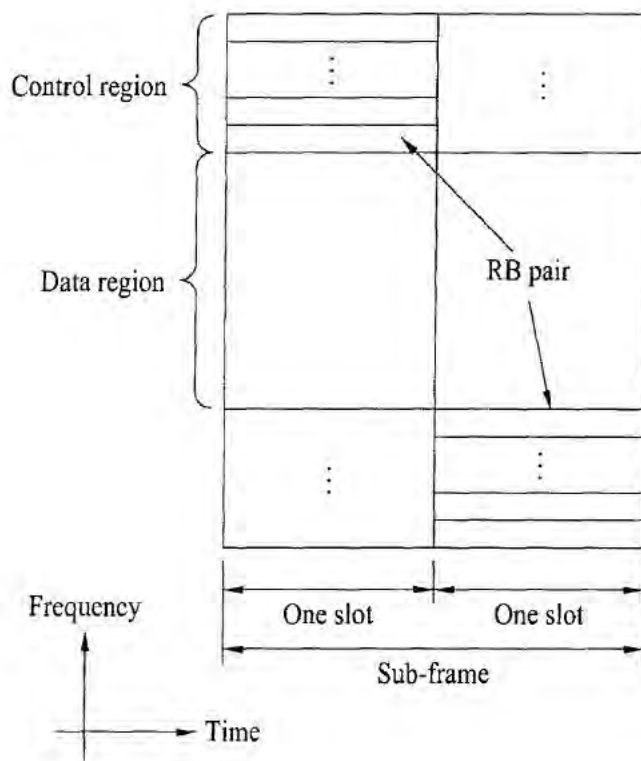

FIG. 4



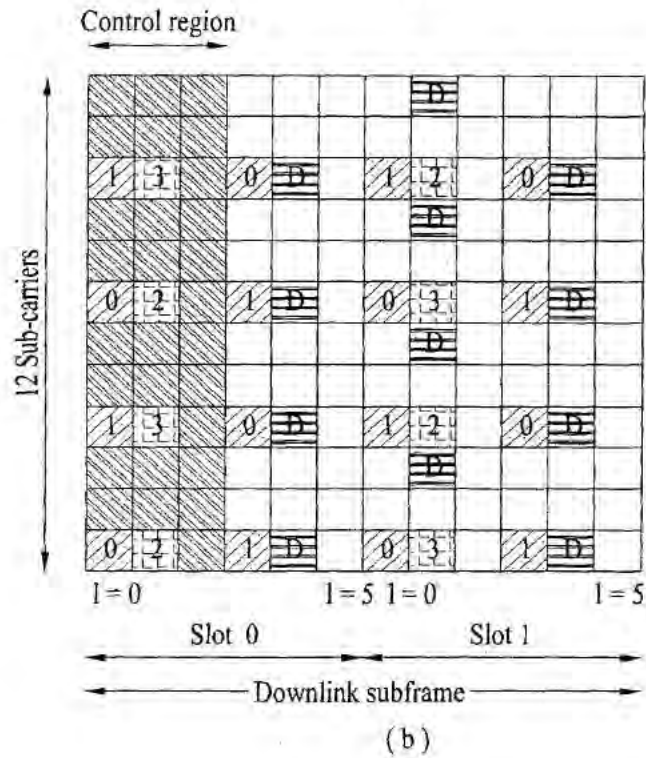
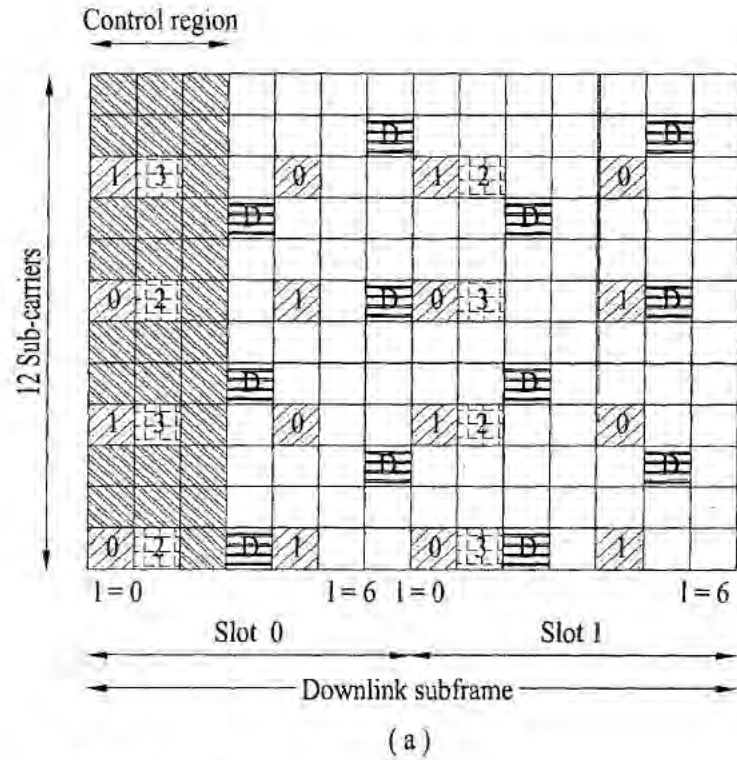
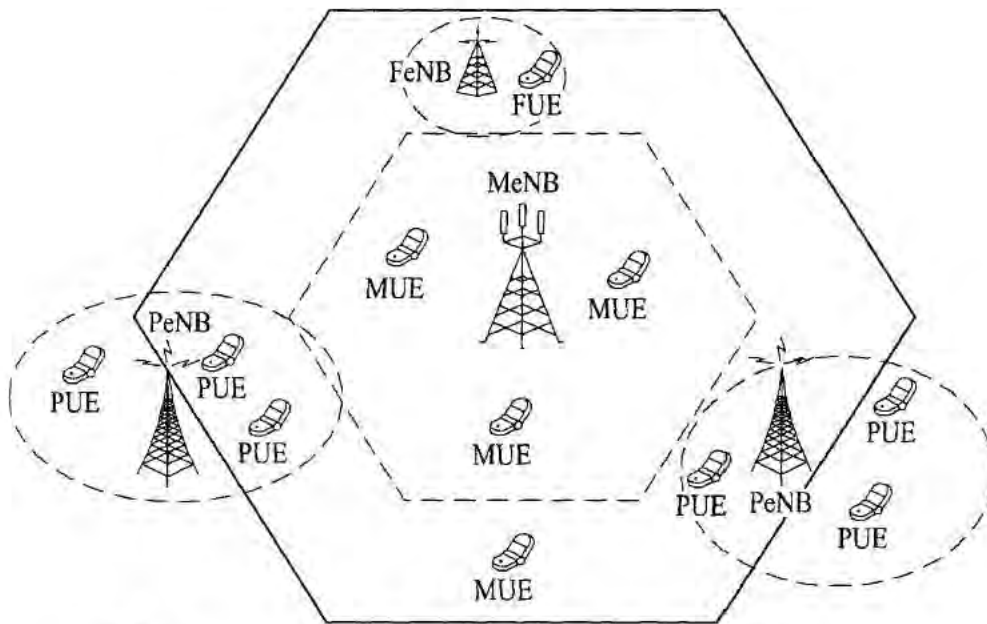

FIG. 6



MeNB : macro eNodeB
PeNB : pico eNodeB
FeNB : femto eNodeB

MUE : macro UE
PUE : pico UE
FUE : femto eNodeB

FIG. 7

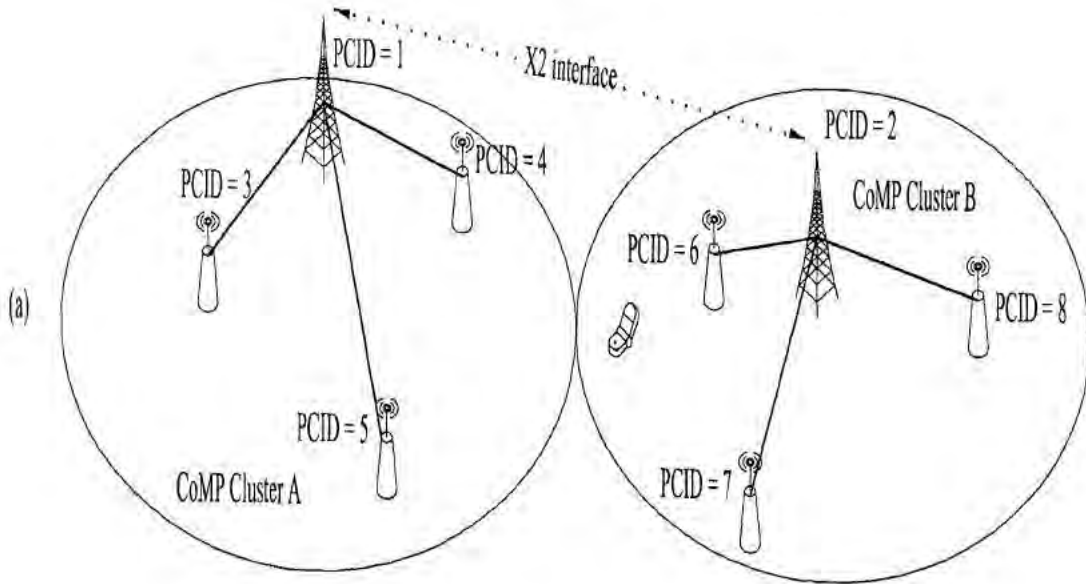

— Optical fiber link

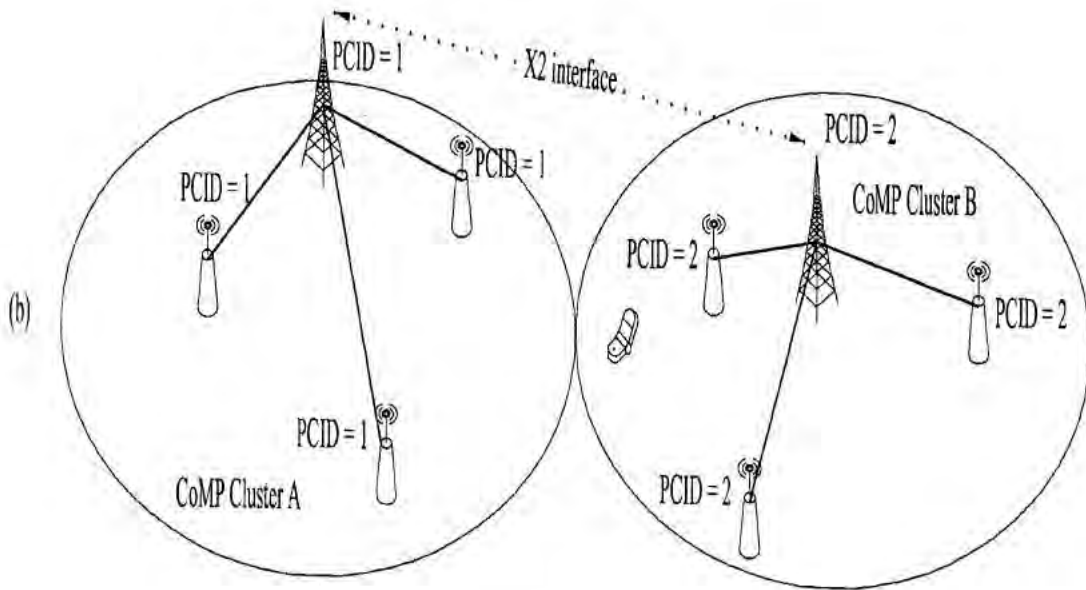

— Optical fiber link

FIG. 8

Marco-pico
(With pathloss-based cell selection)

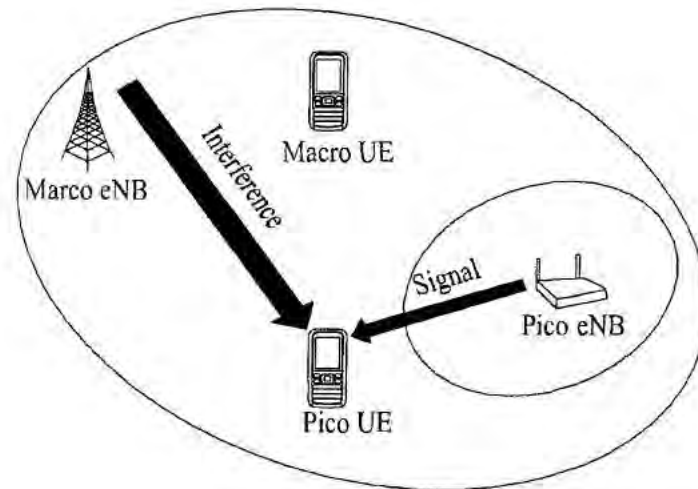

FIG. 9

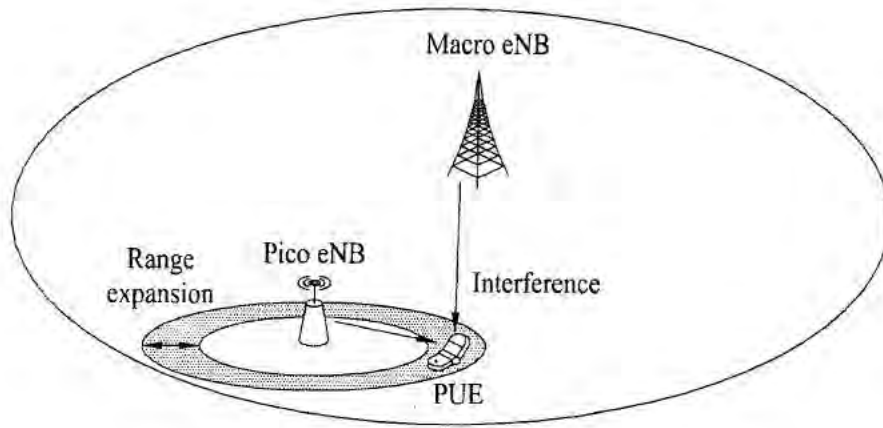

FIG. 10

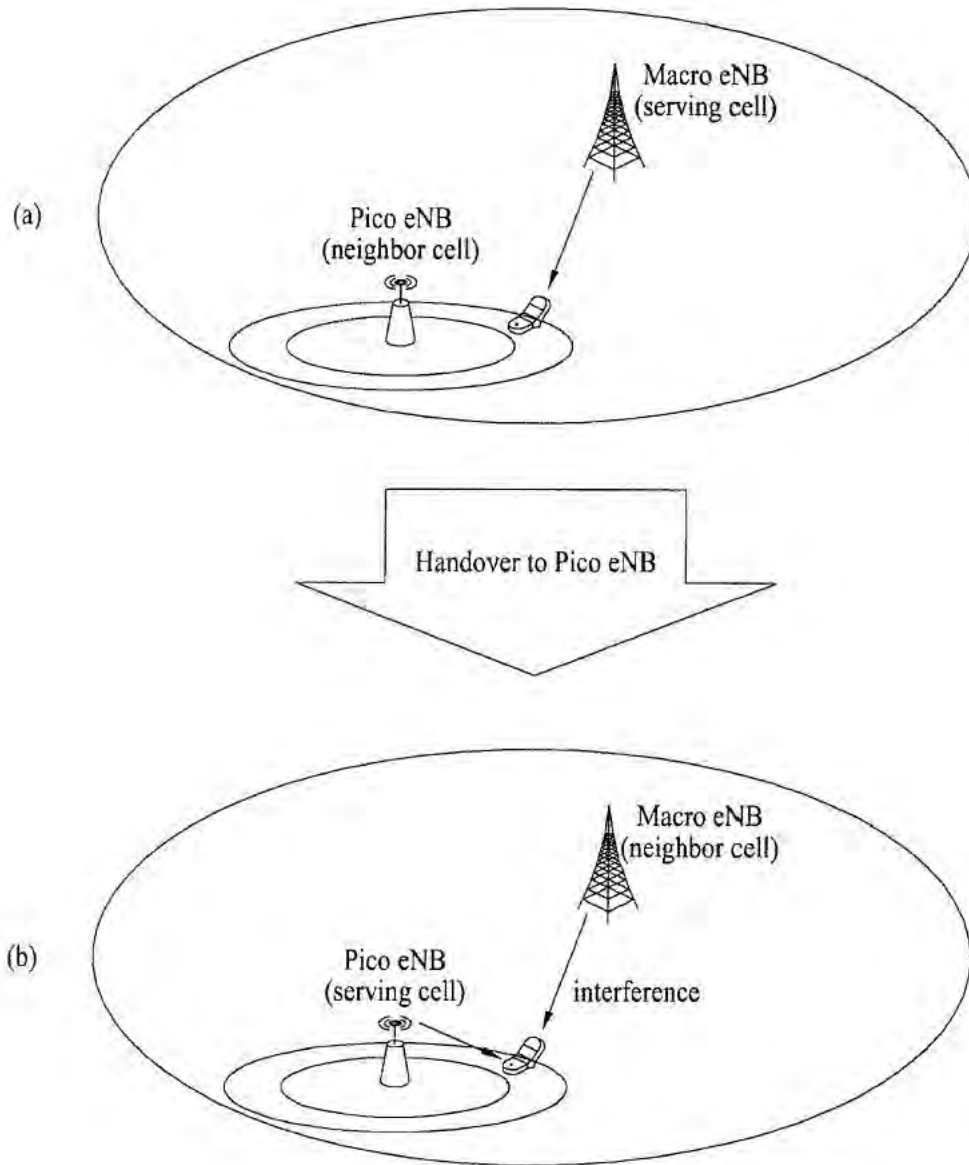

FIG. 11

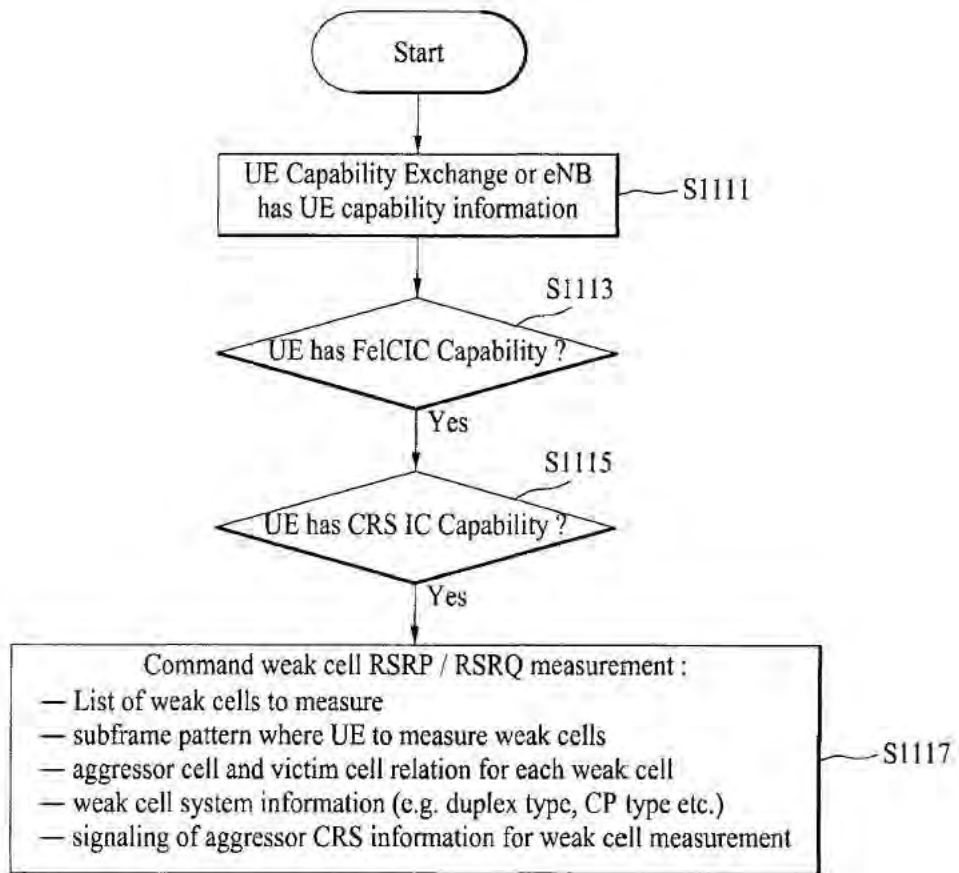

FIG. 12

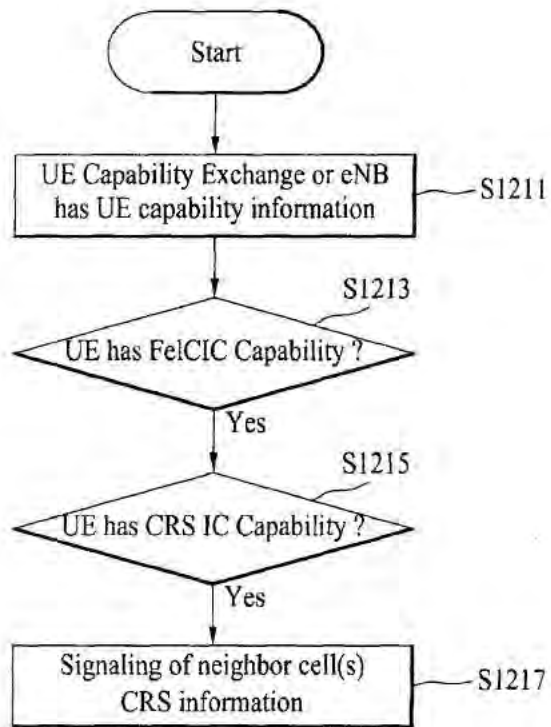

FIG. 13

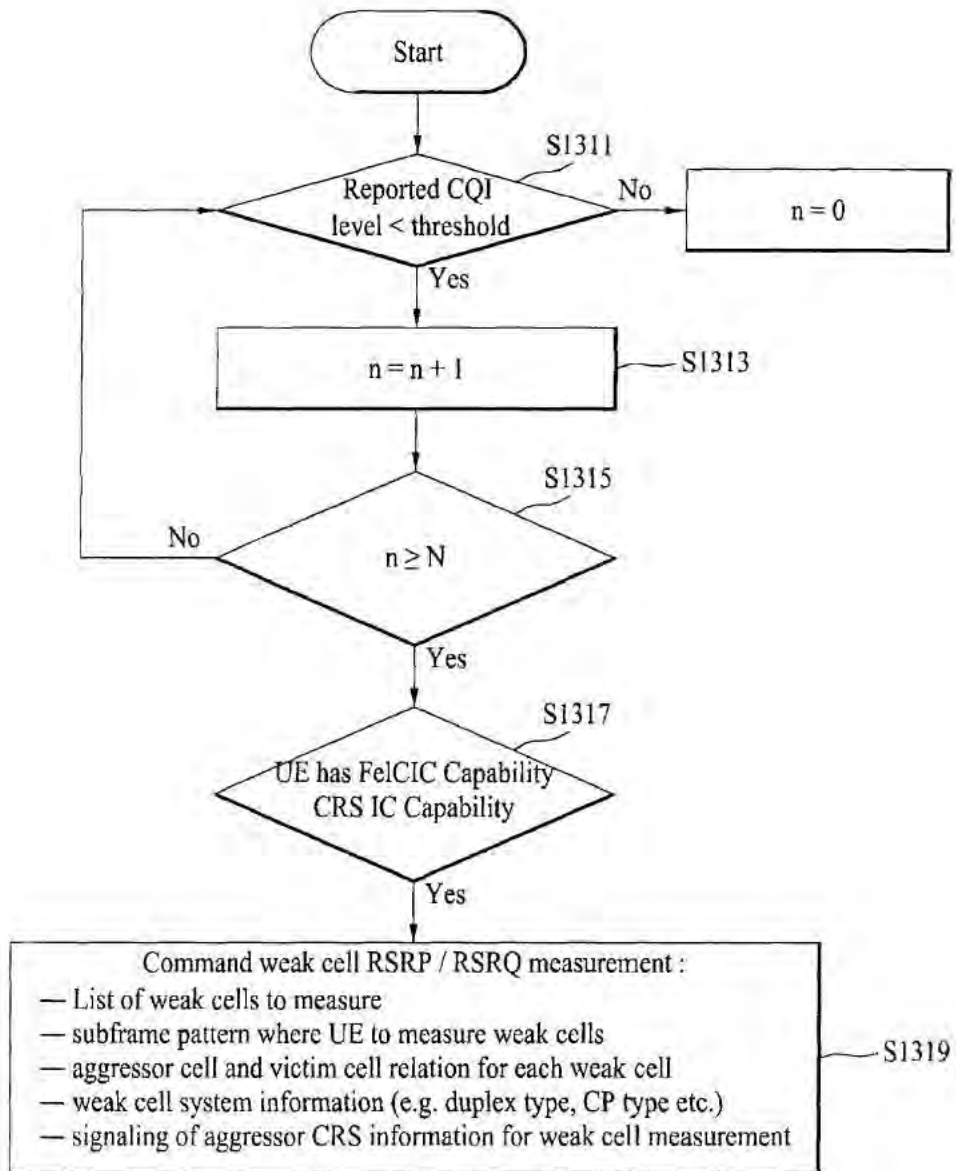

FIG. 14

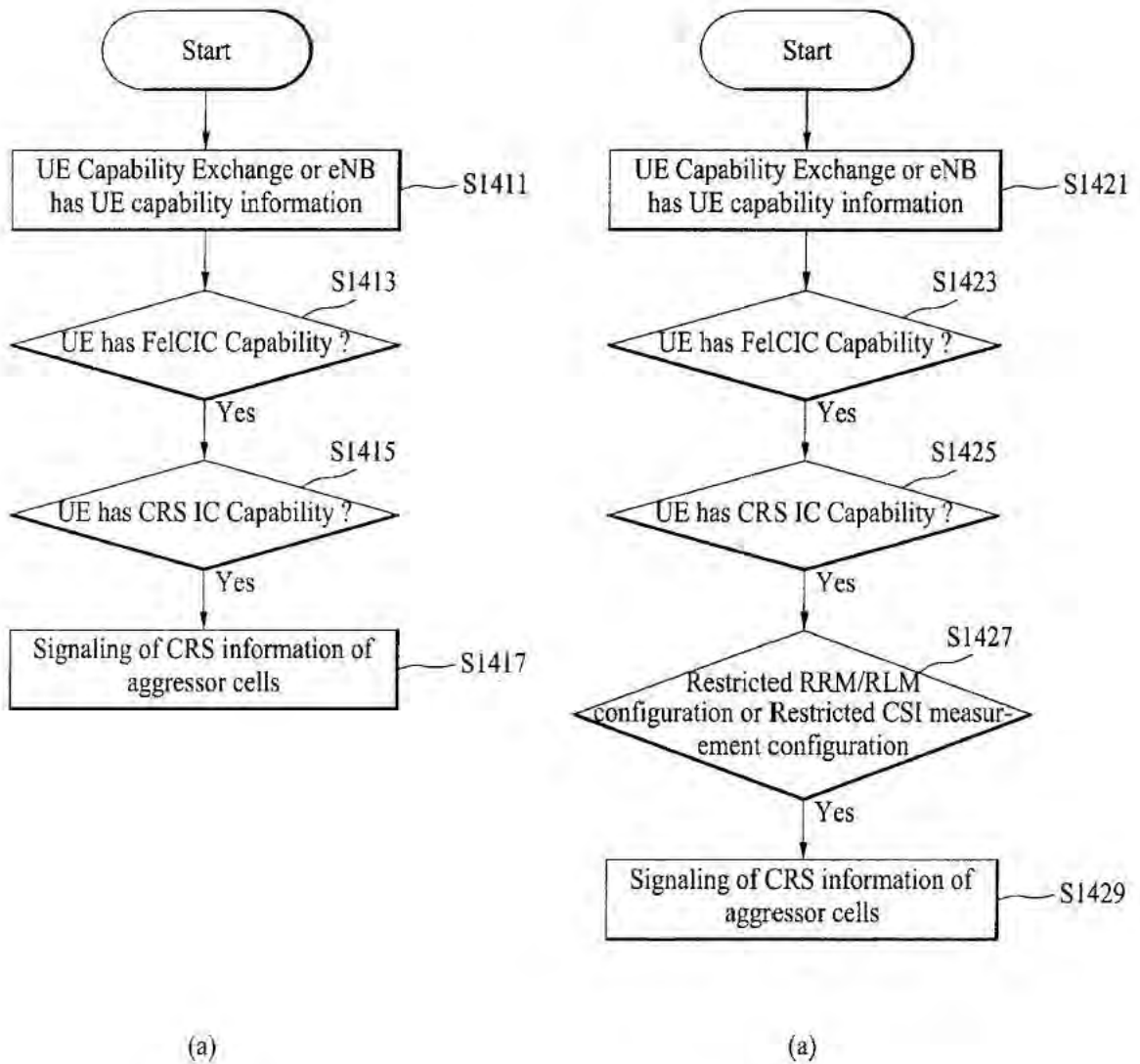
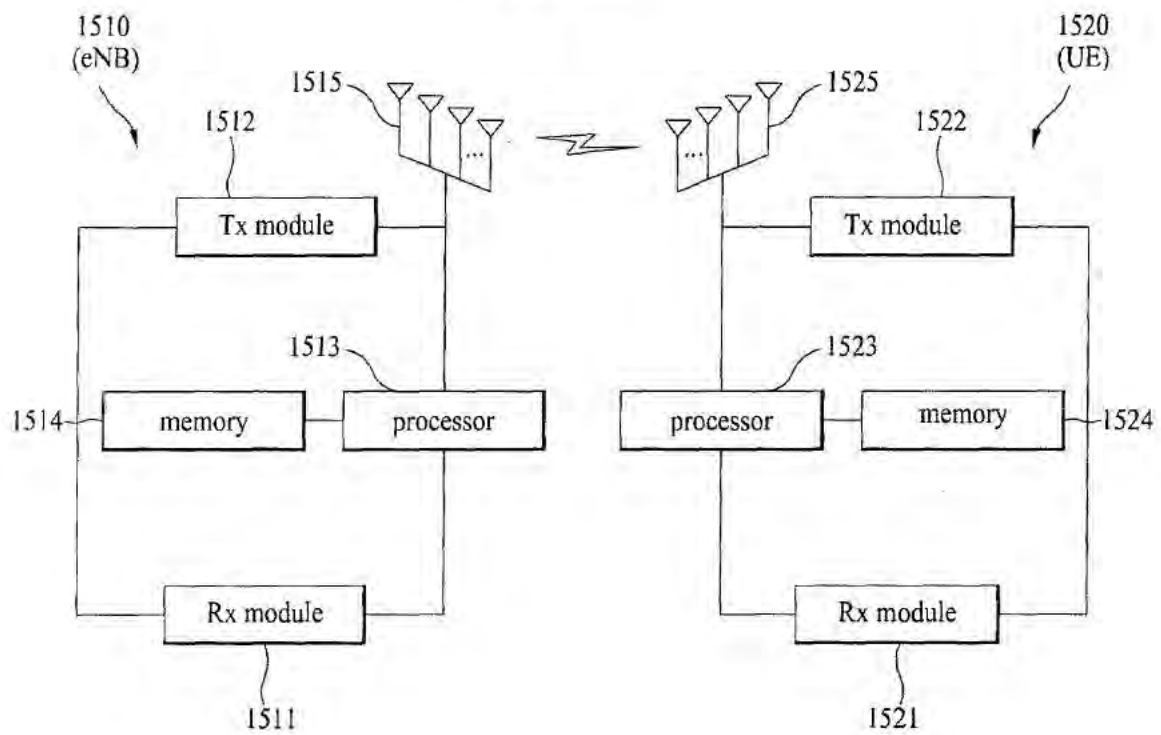

FIG. 15



INTERNATIONAL SEARCH REPORT

International application No.
PCT/KR2013/002178

A. CLASSIFICATION OF SUBJECT MATTER		
<i>H04W 36/04(2009.01)i, H04W 48/14(2009.01)i</i>		
According to International Patent Classification (IPC) or to both national classification and IPC		
B. FIELDS SEARCHED		
Minimum documentation searched (classification system followed by classification symbols) H04W 36/04		
Documentation searched other than minimum documentation to the extent that such documents are included in the fields searched Korean utility models and applications for utility models Japanese utility models and applications for utility models		
Electronic data base consulted during the international search (name of data base and, where practicable, search terms used) eKOMPASS(KIPO internal) & Keywords: hand off, cell extension, system information		
C. DOCUMENTS CONSIDERED TO BE RELEVANT		
Category*	Citation of document, with indication, where appropriate, of the relevant passages	Relevant to claim No.
Y	VICTOR O. K. LI et al., "Personal Communication Systems (PCS)," IEEE, Sept 1995 See abstract; page 1225, right col, line 45 – page 1233, right col, line 9; table 4; figs 15-20. See whole document.	1,4,5,10,12-14
A		2-3,5,7-9,11
Y	US 6363261 B1 (RAGHAVAN; RAMABADRAN S.) 26 March 2002	1,4,5,10,12-14
A	See abstract; col 3, line 33 – col 4, line 6. See whole document	2-3,5,7-9,11
<input type="checkbox"/> Further documents are listed in the continuation of Box C. <input checked="" type="checkbox"/> See patent family annex.		
<p>* Special categories of cited documents:</p> <p>"A" document defining the general state of the art which is not considered to be of particular relevance</p> <p>"E" earlier application or patent but published on or after the international filing date</p> <p>"L" document which may throw doubts on priority claim(s) or which is cited to establish the publication date of citation or other special reason (as specified)</p> <p>"O" document referring to an oral disclosure, use, exhibition or other means</p> <p>"P" document published prior to the international filing date but later than the priority date claimed</p> <p>"T" later document published after the international filing date or priority date and not in conflict with the application but cited to understand the principle or theory underlying the invention</p> <p>"X" document of particular relevance; the claimed invention cannot be considered novel or cannot be considered to involve an inventive step when the document is taken alone</p> <p>"Y" document of particular relevance; the claimed invention cannot be considered to involve an inventive step when the document is combined with one or more other such documents, such combination being obvious to a person skilled in the art</p> <p>"&" document member of the same patent family</p>		
Date of the actual completion of the international search 08 May 2013 (08.05.2013)		Date of mailing of the international search report 15 May 2013 (15.05.2013)
Name and mailing address of the ISA/KR  Korean Intellectual Property Office 189 Cheongsa-ro, Seo-gu, Daejeon Metropolitan City, 302-701, Republic of Korea Facsimile No. 82-42-472-7140		Authorized officer LEE, Seoung Young Telephone No. 82-42-481-8591 

Form PCT/ISA/210 (second sheet) (July 2009)

INTERNATIONAL SEARCH REPORT
Information on patent family members

International application No.
PCT/KR2013/002178

Patent document cited in search report	Publication date	Patent family member(s)	Publication date
US 6363261 B1	26.03.2002	AU 1999-44749 A1	16.03.2000
		AU 1999-44749 B2	29.08.2002
		AU 4474999 A	16.03.2000
		AU 751791 B2	29.08.2002
		BR 9902843 A	28.03.2000
		CA 2278377 A1	29.02.2000
		CN 1248832 A0	29.03.2000
		EP 0984643 A2	08.03.2000
		EP 0984643 A3	05.07.2000
		JP 2000-092564 A	31.03.2000
		KR 10-2000-0017658 A	25.03.2000
		TW 457822 B	01.10.2001

PATENT COOPERATION TREATY

PCT

INTERNATIONAL SEARCH REPORT

(PCT Article 18 and Rules 43 and 44)

Applicant's or agent's file reference IG5SYS_13091WO01	FOR FURTHER ACTION		see Form PCT/ISA/220 as well as, where applicable, item 5 below.
International application No. PCT/US2017/032069	International filing date (<i>day/month/year</i>) 11 May 2017 (11-05-2017)	(Earliest) Priority Date (<i>day/month/year</i>) 11 May 2016 (11-05-2016)	
Applicant IDAC HOLDINGS, INC			

This international search report has been prepared by this International Searching Authority and is transmitted to the applicant according to Article 18. A copy is being transmitted to the International Bureau.

This international search report consists of a total of 7 sheets.

It is also accompanied by a copy of each prior art document cited in this report.

1. Basis of the report

a. With regard to the **language**, the international search was carried out on the basis of:

- the international application in the language in which it was filed
- a translation of the international application into _____, which is the language of a translation furnished for the purposes of international search (Rules 12.3(a) and 23.1(b))

b. This international search report has been established taking into account the **rectification of an obvious mistake** authorized by or notified to this Authority under Rule 91 (Rule 43.6**bis**(a)).

c. With regard to any **nucleotide and/or amino acid sequence** disclosed in the international application, see Box No. I.

2. **Certain claims were found unsearchable** (See Box No. II)

3. **Unity of invention is lacking** (see Box No III)

4. With regard to the **title**,

- the text is approved as submitted by the applicant
- the text has been established by this Authority to read as follows:

5. With regard to the **abstract**,

- the text is approved as submitted by the applicant
- the text has been established, according to Rule 38.2, by this Authority as it appears in Box No. IV. The applicant may, within one month from the date of mailing of this international search report, submit comments to this Authority

6. With regard to the **drawings**,

- a. the figure of the **drawings** to be published with the abstract is Figure No. _____
 - as suggested by the applicant
 - as selected by this Authority, because the applicant failed to suggest a figure
 - as selected by this Authority, because this figure better characterizes the invention
- b. none of the figures is to be published with the abstract

INTERNATIONAL SEARCH REPORT

International application No.
PCT/US2017/032069

Box No. II Observations where certain claims were found unsearchable (Continuation of item 2 of first sheet)

This international search report has not been established in respect of certain claims under Article 17(2)(a) for the following reasons:

1. Claims Nos.:
because they relate to subject matter not required to be searched by this Authority, namely:

2. Claims Nos.:
because they relate to parts of the international application that do not comply with the prescribed requirements to such an extent that no meaningful international search can be carried out, specifically:

3. Claims Nos.:
because they are dependent claims and are not drafted in accordance with the second and third sentences of Rule 6.4(a).

Box No. III Observations where unity of invention is lacking (Continuation of item 3 of first sheet)

This International Searching Authority found multiple inventions in this international application, as follows:

see additional sheet

1. As all required additional search fees were timely paid by the applicant, this international search report covers all searchable claims.
2. As all searchable claims could be searched without effort justifying an additional fees, this Authority did not invite payment of additional fees.
3. As only some of the required additional search fees were timely paid by the applicant, this international search report covers only those claims for which fees were paid, specifically claims Nos.:
4. No required additional search fees were timely paid by the applicant. Consequently, this international search report is restricted to the invention first mentioned in the claims; it is covered by claims Nos.:

1-11

Remark on Protest

- The additional search fees were accompanied by the applicant's protest and, where applicable, the payment of a protest fee.
- The additional search fees were accompanied by the applicant's protest but the applicable protest fee was not paid within the time limit specified in the invitation.
- No protest accompanied the payment of additional search fees.

INTERNATIONAL SEARCH REPORT

International application No
PCT/US2017/032069

A. CLASSIFICATION OF SUBJECT MATTER
 INV. H04B7/0408 H04B7/06
 ADD.
 According to International Patent Classification (IPC) or to both national classification and IPC

B. FIELDS SEARCHED
 Minimum documentation searched (classification system followed by classification symbols)
 H04B
 Documentation searched other than minimum documentation to the extent that such documents are included in the fields searched

Electronic data base consulted during the international search (name of data base and, where practicable, search terms used)
 EPO-Internal, WPI Data, INSPEC

C. DOCUMENTS CONSIDERED TO BE RELEVANT		
Category*	Citation of document, with indication, where appropriate, of the relevant passages	Relevant to claim No.
Y	US 2015/201368 A1 (CUDAK MARK [US] ET AL) 16 July 2015 (2015-07-16) paragraphs [0046], [0151]; figure 3A -----	1-11
Y	US 2014/112220 A1 (KWAK YONGJUN [KR] ET AL) 24 April 2014 (2014-04-24) paragraphs [0068], [0069] -----	1-11
A	WO 2013/141541 A1 (LG ELECTRONICS INC [KR]) 26 September 2013 (2013-09-26) the whole document -----	1-11

Further documents are listed in the continuation of Box C. See patent family annex.

* Special categories of cited documents :

"A" document defining the general state of the art which is not considered to be of particular relevance	"T" later document published after the international filing date or priority date and not in conflict with the application but cited to understand the principle or theory underlying the invention
"E" earlier application or patent but published on or after the international filing date	"X" document of particular relevance; the claimed invention cannot be considered novel or cannot be considered to involve an inventive step when the document is taken alone
"L" document which may throw doubts on priority claim(s) or which is cited to establish the publication date of another citation or other special reason (as specified)	"Y" document of particular relevance; the claimed invention cannot be considered to involve an inventive step when the document is combined with one or more other such documents, such combination being obvious to a person skilled in the art
"O" document referring to an oral disclosure, use, exhibition or other means	"&" document member of the same patent family
"P" document published prior to the international filing date but later than the priority date claimed	

Date of the actual completion of the international search 10 July 2017	Date of mailing of the international search report 11/09/2017
---	--

Name and mailing address of the ISA/ European Patent Office, P.B. 5818 Patentlaan 2 NL - 2280 HV Rijswijk Tel. (+31-70) 340-2040, Fax: (+31-70) 340-3016	Authorized officer Akbudak, Tarik
--	--

INTERNATIONAL SEARCH REPORT

Information on patent family members

International application No
PCT/US2017/032069

Patent document cited in search report	Publication date	Patent family member(s)	Publication date
US 2015201368 A1	16-07-2015	CN 104604300 A	06-05-2015
		EP 2870802 A1	13-05-2015
		US 2015201368 A1	16-07-2015
		WO 2014009250 A1	16-01-2014

US 2014112220 A1	24-04-2014	US 2014112220 A1	24-04-2014
		WO 2014065600 A1	01-05-2014

WO 2013141541 A1	26-09-2013	US 2015016419 A1	15-01-2015
		US 2015043367 A1	12-02-2015
		US 2015055495 A1	26-02-2015
		WO 2013141541 A1	26-09-2013
		WO 2013141542 A1	26-09-2013
		WO 2013141543 A1	26-09-2013

FURTHER INFORMATION CONTINUED FROM PCT/ISA/ 210

This International Searching Authority found multiple (groups of) inventions in this international application, as follows:

1. claims: 1-11

Independent claim 1 refers to a wireless transmit/receive unit (WTRU) in communication with a communication network, the WTRU comprising:

- a memory;
- a processor, the processor configured at least to:
 - a) determine to request one or more system information (SI) messages from the communication network; and
 - b) determine if a transmission of the one or more SI message from the communication network will utilize at least one beamformed communication based on one or more communication parameters; and
- a transceiver, the transceiver configured at least to:
 - c) receive at least one of the one or more SI messages from the communication network via the at least one beamformed communication.

2. claims: 12-16

Independent claim 12 refers to a wireless transmit/receive unit (WTRU) in communication with a communication network, the WTRU comprising:

- a memory;
- a processor, the processor configured at least to:
 - a) determine to request one or more system information (SI) messages from the communication network;
 - b) conduct a beam sweep operation of one or more downlink (DL) beams transmitted from the communication network;
 - c) identify at least one DL beam of the one or more DL beams via which to receive the one or more on-demand SI messages based at least in part on the beam sweep operation;
 - d) determine one or more uplink (UL) resources with which to communicate information for a WTRU reception of the one or more on-demand SI messages, the information for the WTRU reception including the at least one DL beam; and
 - e) initiate the request for the one or more on-demand SI messages from the communication network; and
- a transceiver, the transceiver configured at least to:
 - f) send the request for the one or more on-demand SI messages to the communication network using the one or more UL resources, the request including the information for the WTRU reception of the one or more on-demand SI messages; and
 - g) receive at least one of the one or more on-demand SI messages from the communication network via the at least one DL beam.

3. claims: 17-29

FURTHER INFORMATION CONTINUED FROM PCT/ISA/ 210

Independent claim 17 refers to a wireless transmit/receive unit (WTRU) in communication with a communication network, the WTRU comprising:

- a memory;
- a transceiver, the transceiver configured at least to:
 - a) receive system information (SI) from the communication network at a first-time instance; and
 - a processor, the processor configured at least to:
 - b) determine a first-reference identifier (ID) that corresponds to at least some of the SI of the first-time instance;
 - c) determine a first-value identifier (ID) that corresponds to the at least some of the SI of the first-time instance;
 - d) associate at least one of: the first-reference ID, or the first-value ID with the at least some of the SI of the first-time instance;
 - e) utilize the at least some of the SI of the first-time instance in communication with the communication network;
 - f) search the memory for stored SI of a previous-time instance that is associated with the same first-reference ID of the at least some of the SI of the first-time instance;
 - g) store the at least some of the SI of the first-time instance upon no stored SI of the previous-time instance associated with the same first-reference ID being found; and
 - h) replace stored SI of the previous-time instance associated with the same first-reference ID with the at least some of the SI of the first-time instance upon a value ID associated with the stored SI of the previous-time instance associated with the same first-reference ID being different from the first-value ID.

4. claims: 30-40

Independent claim 30 refers to a wireless transmit/receive unit (WTRU) in communication with a communication network, the WTRU comprising:

- a memory;
- a processor, the processor configured at least to:
 - a) determine to request other system information (other-SI) from the communication network;
 - b) initiate the request for the other-SI from the communication network as part of a Random Access Channel (RACH) procedure; and
- a transceiver, the transceiver configured at least to:
 - c) transmit a RACH signal, the RACH signal including the request for the other-SI in a random access preamble of the RACH signal, the processor being further configured to:
 - d) monitor for a message that includes a minimum SI from the communication network for a predetermined period of time following the transmission of the RACH signal;
 - e) determine if the requested other-SI is included in the message that includes the minimum SI upon a detection of

FURTHER INFORMATION CONTINUED FROM PCT/ISA/ 210

the message that includes the minimum SI; and
- f) initiate one or more retransmissions of the RACH signal upon at least one of: the message that includes the minimum SI not being detected, or the other-SI is determined to not be included in a detected message that includes the minimum SI.

PATENT COOPERATION TREATY

From the
INTERNATIONAL SEARCHING AUTHORITY

PCT

WRITTEN OPINION OF THE
INTERNATIONAL SEARCHING AUTHORITY
(PCT Rule 43*bis*.1)

To:

see form PCT/ISA/220

Date of mailing
(*day/month/year*) see form PCT/ISA/210 (second sheet)

Applicant's or agent's file reference
see form PCT/ISA/220

FOR FURTHER ACTION
See paragraph 2 below

International application No.
PCT/US2017/032069

International filing date (*day/month/year*)
11.05.2017

Priority date (*day/month/year*)
11.05.2016

International Patent Classification (IPC) or both national classification and IPC
INV. H04B7/0408 H04B7/06

Applicant
IDAC HOLDINGS, INC

1. This opinion contains indications relating to the following items:

- Box No. I Basis of the opinion
- Box No. II Priority
- Box No. III Non-establishment of opinion with regard to novelty, inventive step and industrial applicability
- Box No. IV Lack of unity of invention
- Box No. V Reasoned statement under Rule 43*bis*.1(a)(i) with regard to novelty, inventive step and industrial applicability; citations and explanations supporting such statement
- Box No. VI Certain documents cited
- Box No. VII Certain defects in the international application
- Box No. VIII Certain observations on the international application

2. FURTHER ACTION

If a demand for international preliminary examination is made, this opinion will usually be considered to be a written opinion of the International Preliminary Examining Authority ("IPEA") except that this does not apply where the applicant chooses an Authority other than this one to be the IPEA and the chosen IPEA has notified the International Bureau under Rule 66.1*bis*(b) that written opinions of this International Searching Authority will not be so considered.

If this opinion is, as provided above, considered to be a written opinion of the IPEA, the applicant is invited to submit to the IPEA a written reply together, where appropriate, with amendments, before the expiration of 3 months from the date of mailing of Form PCT/ISA/220 or before the expiration of 22 months from the priority date, whichever expires later.

For further options, see Form PCT/ISA/220.

Name and mailing address of the ISA:



European Patent Office
D-80298 Munich
Tel. +49 89 2399 - 0
Fax: +49 89 2399 - 4465

Date of completion of
this opinion

see form
PCT/ISA/210

Authorized Officer

Telephone No. +49 89 2399-0



**WRITTEN OPINION OF THE
INTERNATIONAL SEARCHING AUTHORITY**

International application No.
PCT/US2017/032069

Box No. I Basis of the opinion

1. With regard to the **language**, this opinion has been established on the basis of:
 - the international application in the language in which it was filed.
 - a translation of the international application into , which is the language of a translation furnished for the purposes of international search (Rules 12.3(a) and 23.1 (b)).
2. This opinion has been established taking into account the **rectification of an obvious mistake** authorized by or notified to this Authority under Rule 91 (Rule 43*bis*.1(a))
3. With regard to any **nucleotide and/or amino acid sequence** disclosed in the international application, this opinion has been established on the basis of a sequence listing:
 - a. forming part of the international application as filed:
 - in the form of an Annex C/ST.25 text file.
 - on paper or in the form of an image file.
 - b. furnished together with the international application under PCT Rule 13*ter*.1(a) for the purposes of international search only in the form of an Annex C/ST.25 text file.
 - c. furnished subsequent to the international filing date for the purposes of international search only:
 - in the form of an Annex C/ST.25 text file (Rule 13*ter*.1(a)).
 - on paper or in the form of an image file (Rule 13*ter*.1(b) and Administrative Instructions, Section 713).
4. In addition, in the case that more than one version or copy of a sequence listing has been filed or furnished, the required statements that the information in the subsequent or additional copies is identical to that forming part of the application as filed or does not go beyond the application as filed, as appropriate, were furnished.
5. Additional comments:

Box No. III Non-establishment of opinion with regard to novelty, inventive step and industrial applicability

The questions whether the claimed invention appears to be novel, to involve an inventive step (to be non obvious), or to be industrially applicable have not been examined in respect of

the entire international application

claims Nos. 12-40

because:

the said international application, or the said claims Nos. relate to the following subject matter which does not require an international search (*specify*):

the description, claims or drawings (*indicate particular elements below*) or said claims Nos. are so unclear that no meaningful opinion could be formed (*specify*):

the claims, or said claims Nos. are so inadequately supported by the description that no meaningful opinion could be formed (*specify*):

no international search report has been established for the whole application or for said claims Nos. 12-40

a meaningful opinion could not be formed without the sequence listing; the applicant did not, within the prescribed time limit:

furnish a sequence listing in the form of an Annex C/ST.25 text file, and such listing was not available to the International Searching Authority in the form and manner acceptable to it; or the sequence listing furnished did not comply with the standard provided for in Annex C of the Administrative Instructions.

furnish a sequence listing on paper or in the form of an image file complying with the standard provided for in Annex C of the Administrative Instructions, and such listing was not available to the International Searching Authority in the form and manner acceptable to it; or the sequence listing furnished did not comply with the standard provided for in Annex C of the Administrative Instructions.

pay the required late furnishing fee for the furnishing of a sequence listing in response to an invitation under Rule 13ter.1(a) or (b).

See Supplemental Box for further details

Box No. IV Lack of unity of invention

1. In response to the invitation (Form PCT/ISA/206) to pay additional fees, the applicant has, within the applicable time limit:
- paid additional fees
 - paid additional fees under protest and, where applicable, the protest fee
 - paid additional fees under protest but the applicable protest fee was not paid
 - not paid additional fees
2. This Authority found that the requirement of unity of invention is not complied with and chose not to invite the applicant to pay additional fees.
3. This Authority considers that the requirement of unity of invention in accordance with Rule 13.1, 13.2 and 13.3 is
- complied with
 - not complied with for the following reasons:
see separate sheet
4. Consequently, this report has been established in respect of the following parts of the international application:
- all parts.
 - the parts relating to claims Nos. 1-11

Box No. V Reasoned statement under Rule 43bis.1(a)(i) with regard to novelty, inventive step or industrial applicability; citations and explanations supporting such statement

1. Statement

Novelty (N)	Yes: Claims	<u>1-11</u>
	No: Claims	
Inventive step (IS)	Yes: Claims	
	No: Claims	<u>1-11</u>
Industrial applicability (IA)	Yes: Claims	<u>1-11</u>
	No: Claims	

2. Citations and explanations

see separate sheet

Box No. VII Certain defects in the international application

The following defects in the form or contents of the international application have been noted:

see separate sheet

Re Item IV

1 This Authority considers that the application does not meet the requirements of unity of invention under Rule 13.1 PCT.

1.1 The application comprises following groups of inventions:

1.1.1 Group 1: Claims 1-11

Independent claim 1 refers to a wireless transmit/receive unit (WTRU) in communication with a communication network, the WTRU comprising:

- a memory;
- a processor, the processor configured at least to:
 - a) determine to request one or more system information (SI) messages from the communication network; and
 - b) determine if a transmission of the one or more SI message from the communication network will utilize at least one beamformed communication based on one or more communication parameters; and
- a transceiver, the transceiver configured at least to:
 - c) receive at least one of the one or more SI messages from the communication network via the at least one beamformed communication.

1.1.2 Group 2: Claims 12-16

Independent claim 12 refers to a wireless transmit/receive unit (WTRU) in communication with a communication network, the WTRU comprising:

- a memory;
- a processor, the processor configured at least to:
 - a) determine to request one or more system information (SI) messages from the communication network;
 - b) conduct a beam sweep operation of one or more downlink (DL) beams transmitted from the communication network;
 - c) identify at least one DL beam of the one or more DL beams via which to receive the one or more on-demand SI messages based at least in part on the beam sweep operation;

- d) determine one or more uplink (UL) resources with which to communicate information for a WTRU reception of the one or more on-demand SI messages, the information for the WTRU reception including the at least one DL beam; and
- e) initiate the request for the one or more on-demand SI messages from the communication network; and
- a transceiver, the transceiver configured at least to:
 - f) send the request for the one or more on-demand SI messages to the communication network using the one or more UL resources, the request including the information for the WTRU reception of the one or more on-demand SI messages; and
 - g) receive at least one of the one or more on-demand SI messages from the communication network via the at least one DL beam.

1.1.3 Group 3: Claims 17-29

Independent claim 17 refers to a wireless transmit/receive unit (WTRU) in communication with a communication network, the WTRU comprising:

- a memory;
- a transceiver, the transceiver configured at least to:
 - a) receive system information (SI) from the communication network at a first-time instance; and
- a processor, the processor configured at least to:
 - b) determine a first-reference identifier (ID) that corresponds to at least some of the SI of the first-time instance;
 - c) determine a first-value identifier (ID) that corresponds to the at least some of the SI of the first-time instance;
 - d) associate at least one of: the first-reference ID, or the first-value ID with the at least some of the SI of the first-time instance;
 - e) utilize the at least some of the SI of the first-time instance in communication with the communication network;
 - f) search the memory for stored SI of a previous-time instance that is associated with the same first-reference ID of the at least some of the SI of the first-time instance;

- g) store the at least some of the SI of the first-time instance upon no stored SI of the previous-time instance associated with the same first-reference ID being found; and
- h) replace stored SI of the previous-time instance associated with the same first-reference ID with the at least some of the SI of the first-time instance upon a value ID associated with the stored SI of the previous-time instance associated with the same first-reference ID being different from the first-value ID.

1.1.4 Group 4: Claims 30-40

Independent claim 30 refers to a wireless transmit/receive unit (WTRU) in communication with a communication network, the WTRU comprising:

- a memory;
- a processor, the processor configured at least to:
 - a) determine to request other system information (other-SI) from the communication network;
 - b) initiate the request for the other-SI from the communication network as part of a Random Access Channel (RACH) procedure; and
- a transceiver, the transceiver configured at least to:
 - c) transmit a RACH signal, the RACH signal including the request for the other-SI in a random access preamble of the RACH signal, the processor being further configured to:
 - d) monitor for a message that includes a minimum SI from the communication network for a predetermined period of time following the transmission of the RACH signal;
 - e) determine if the requested other-SI is included in the message that includes the minimum SI upon a detection of the message that includes the minimum SI; and
 - f) initiate one or more retransmissions of the RACH signal upon at least one of: the message that includes the minimum SI not being detected, or the other-SI is determined to not be included in a detected message that includes the minimum SI.

1.2 These groups do not meet the requirements of unity for the following reasons:

1.2.1 Group 1 has the following common technical features with group 2:

- a WTRU comprising:
 - a processor, the processor configured at least to:
 - determine to request one or more system information (SI) messages from the communication network; and
 - a transceiver, the transceiver configured at least to:
 - receive at least one of the one or more SI messages from the communication network.

1.2.2 Group 1 has no further common technical features with groups 3 and 4.

1.2.3 Group 2 has no further common technical features with groups 3 and 4.

1.2.4 Group 3 has no further common technical features with group 4.

1.2.5 These technical features cannot bear the label "inventive" as required by Rule 13.1 PCT.

In this respect, document D1 (US 2015/201368 A1) discloses a WTRU comprising:

- a memory (par. 46:"computer-readable memory");
- a processor (par. 46:"data processor") configured at least to:
 - determine to request one or more system information (SI) messages from the communication network (par. 151:"the subscriber station transmits a system information request message to the cluster"); and
- a transceiver (par. 46:"... may also comprise communicating means such as a transmitter TX and a receiver RX"), the transceiver configured at least to:
 - receive at least one of the one or more SI messages from the communication network (par. 151: "... the cluster would send the system information to the subscriber station with the beamforming weights; ... ").

Thus, the above-mentioned technical features are not novel.

As a consequence, groups 1-4 do not have any special technical feature in common.

1.2.6 Groups 1-4 relate to different technical problems:

- Group 1 solves the problem of increasing reliability by the following special technical features:
 - determining if a transmission of the one or more SI message from the communication network will utilize at least one beamformed communication based on one or more communication parameters; and
 - receiving the SI messages via the one beamformed communication.
- Group 2 solves the problem of uplink resource allocation by the following special technical features:
 - determining one or more uplink (UL) resources with which to communicate information for a WTRU reception of the one or more on-demand SI messages, the information for the WTRU reception including the at least one DL beam; and
 - sending the request for the one or more on-demand SI messages to the communication network using the one or more UL resources, the request including the information for the WTRU reception of the one or more on-demand SI messages.
- Group 3 solves the problem of updating system information by the (special) technical features a)-h) of claim 17 as listed above.
- Group 4 solves the problem of random access by the (special) technical features b)-f) of claim 30 as listed above.

1.2.7 In conclusion therefore, the four groups of inventions are not linked by common or corresponding special technical features nor do they solve the same or corresponding objective problems. Therefore, they define four different inventions not linked by a single general inventive concept. Hence, the application does not meet the requirements of unity of invention as defined by Rule 13.1 PCT.

Re Item V

Reasoned statement with regard to novelty, inventive step or industrial applicability; citations and explanations supporting such statement

1 Cited documents

Reference is made to the following document(s):

- D1 US 2015/201368 A1 (CUDAK MARK [US] ET AL) 16 July 2015
(2015-07-16)
- D2 US 2014/112220 A1 (KWAK YONGJUN [KR] ET AL) 24 April 2014
(2014-04-24)

2 Novelty and inventive step

The present application does not meet the criteria of Article 33(1) PCT, because the subject-matter of claims 1-11 does not involve an inventive step in the sense of Article 33(3) PCT.

2.1 Claim 1

Document D1, which is considered to represent the most relevant state of the art, discloses a wireless transmit/receive unit (WTRU) in communication with a communication network (Fig. 3A:300), the WTRU comprising:

- a memory (par. 46:"computer-readable memory");
- a processor (par. 46:"data processor") configured at least to:
 - determine to request one or more system information (SI) messages from the communication network (par. 151:"the subscriber station transmits a system information request message to the cluster"); and
- a transceiver (par. 46:"... may also comprise communicating means such as a transmitter TX and a receiver RX"), the transceiver configured at least to:
 - receive at least one of the one or more SI messages from the communication network (par. 151: "... the cluster would send the system information to the subscriber station with the beamforming weights; ... ").

The subject-matter of claim 1 differs from that of document D1 in that:

- the processor is further configured to determine if a transmission of the one or more SI message from the communication network will utilize at least one beamformed communication based on one or more communication parameters;
- the transceiver is configured to receive the one or more SI messages from the communication network via the at least one beamformed communication.

The technical effect due to these differences is that the SI messages are received using beamforming. Therefore, as the SI messages can be more reliably received due to the beamforming, the reliability of the system is increased.

Thus, the objective problem to be solved by the current invention is to be regarded as how to increase the reliability.

When confronted with the above mentioned problem, the person skilled in the art would certainly look for documents comprising solutions for increasing reliability.

Document D2 discloses a WTRU being configured to determine if a transmission of SI messages from a communication network will utilize at least one beamformed communication based on one or more communication parameters, and to receive SI messages from the communication network via the at least one beamformed communication (par. 68).

Thus, the person skilled in the art, having the device known from document D1 as a starting point, aiming to solve the identified objective problem, could with the knowledge of document D2 arrive at the invention according to claim 1.

Since documents D1 and D2 both relate to similar technical fields and no unexpected effect is obtained, the person skilled in the art would obviously combine what is known from D1 and D2, thereby arriving at the definition of claim 1 without any inventive activity.

Thus, the subject-matter of claim 1 is novel but is not considered to involve an inventive step.

2.2 Claims 2, 9, 10

The supplementary features of claims 2, 9, 10 relate to obvious design variations that form part of the common general knowledge of the person skilled in the art.

Consequently, the subject-matter of said claim does not involve an inventive step.

2.3 Claims 3-6

Document D2 discloses the feature of analyzing the characteristics of a synchronisation signal as a reference signal to determine that the transmission of SI messages utilizes beamforming communication based on the identified characteristics (par. 68).

Consequently, the subject-matter of said claims does not involve an inventive step.

2.4 Claims 7, 8

Document D2 discloses the feature of identifying a master information block in a broadcast message to determine that the transmission of SI messages utilizes beamforming communication based on the identified information (par. 68, 69).

Consequently, the subject-matter of said claims does not involve an inventive step.

2.5 Claim 11

Document D1 discloses the feature of initiating an UL request (par. 151).

Consequently, the subject-matter of said claim does not involve an inventive step.

Re Item VII

Certain defects in the international application

- The features of the claims are not provided with reference signs placed in parentheses (Rule 6.2(b) PCT).
- Contrary to the requirements of Rule 5.1(a)(ii) PCT, the relevant background art disclosed in documents D1 and D2 is not mentioned in the description, nor are these documents identified therein.

Electronic Patent Application Fee Transmittal

Application Number:					
Filing Date:					
Title of Invention:	DISTRIBUTED CONTROL IN WIRELESS SYSTEMS				
First Named Inventor/Applicant Name:	Yugeswar DEENOO				
Filer:	Bradley Davis Lytle/Christine Grimes				
Attorney Docket Number:	11574US05				
Filed as Large Entity					
Filing Fees for U.S. National Stage under 35 USC 371					
Description	Fee Code	Quantity	Amount	Sub-Total in USD(\$)	
Basic Filing:					
NATIONAL STAGE FEE	1631	1	300	300	
NATL STAGE SEARCH FEE - REPORT PROVIDED	1642	1	520	520	
NATIONAL STAGE EXAM - ALL OTHER CASES	1633	1	760	760	
Pages:					
NATL STAGE APPL SZ FEE PER 50 PGS >100	1681	1	400	400	
Claims:					
CLAIMS IN EXCESS OF 20	1615	20	100	2000	
INDEPENDENT CLAIMS IN EXCESS OF 3	1614	1	460	460	

Description	Fee Code	Quantity	Amount	Sub-Total in USD(\$)
Miscellaneous-Filing:				
OATH/DECL > 30 MOS FROM 371 COMMENCEMENT	1617	1	140	140
Petition:				
Patent-Appeals-and-Interference:				
Post-Allowance-and-Post-Issuance:				
Extension-of-Time:				
Miscellaneous:				
Total in USD (\$)				4580

Electronic Acknowledgement Receipt

EFS ID:	34229551
Application Number:	16099390
International Application Number:	PCT/US2017/032069
Confirmation Number:	4717
Title of Invention:	DISTRIBUTED CONTROL IN WIRELESS SYSTEMS
First Named Inventor/Applicant Name:	Yugeswar DEENOO
Customer Number:	154930
Filer:	Bradley Davis Lytle/Christine Grimes
Filer Authorized By:	Bradley Davis Lytle
Attorney Docket Number:	11574US05
Receipt Date:	06-NOV-2018
Filing Date:	
Time Stamp:	17:21:59
Application Type:	U.S. National Stage under 35 USC 371

Payment information:

Submitted with Payment	yes
Payment Type	CARD
Payment was successfully received in RAM	\$4580
RAM confirmation Number	110718INTEFSW17225600
Deposit Account	
Authorized User	

The Director of the USPTO is hereby authorized to charge indicated fees and credit any overpayment as follows:

File Listing:					
Document Number	Document Description	File Name	File Size(Bytes)/ Message Digest	Multi Part /.zip	Pages (if appl.)
1		371Application_.pdf	2042238 140c486becf3f1b356fd4bea22389a5cc452f89b	yes	131
Multipart Description/PDF files in .zip description					
	Document Description		Start		End
	Transmittal of New Application		1		3
	Specification		4		102
	Claims		103		111
	Abstract		112		112
	Drawings-only black and white line drawings		113		125
	Documents submitted with 371 Applications		126		126
	Power of Attorney		127		128
	Preliminary Amendment		129		129
	Specification		130		130
	Applicant Arguments/Remarks Made in an Amendment		131		131
Warnings:					
Information:					
2	Application Data Sheet	ADS.pdf	1256547 c83d331862b5017e55ddce7ea51e384778ea852b	no	10
Warnings:					
Information:					

3	Information Disclosure Statement (IDS) Form (SB08)	IDSTransmittal.pdf	1034504	no	4
			cb4beeb09240aa3fea0fecfd177203c74c4e3a1e		
Warnings:					
Information:					
4	Foreign Reference	WO2013141541A1.pdf	3109424	no	65
			28b8026dcae1a7dd5bc94d5f3ffa05f418f3b57		
Warnings:					
Information:					
5	Non Patent Literature	ISR_WO.pdf	726598	no	21
			f308e2fddadb2fd6848ce0b45a8c609dccc57021b4		
Warnings:					
Information:					
6	Fee Worksheet (SB06)	fee-info.pdf	41707	no	2
			6d3eb9d8f6147b3809c21280de784217e0111845		
Warnings:					
Information:					
Total Files Size (in bytes):			8211018		
<p>This Acknowledgement Receipt evidences receipt on the noted date by the USPTO of the indicated documents, characterized by the applicant, and including page counts, where applicable. It serves as evidence of receipt similar to a Post Card, as described in MPEP 503.</p> <p><u>New Applications Under 35 U.S.C. 111</u> If a new application is being filed and the application includes the necessary components for a filing date (see 37 CFR 1.53(b)-(d) and MPEP 506), a Filing Receipt (37 CFR 1.54) will be issued in due course and the date shown on this Acknowledgement Receipt will establish the filing date of the application.</p> <p><u>National Stage of an International Application under 35 U.S.C. 371</u> If a timely submission to enter the national stage of an international application is compliant with the conditions of 35 U.S.C. 371 and other applicable requirements a Form PCT/DO/EO/903 indicating acceptance of the application as a national stage submission under 35 U.S.C. 371 will be issued in addition to the Filing Receipt, in due course.</p> <p><u>New International Application Filed with the USPTO as a Receiving Office</u> If a new international application is being filed and the international application includes the necessary components for an international filing date (see PCT Article 11 and MPEP 1810), a Notification of the International Application Number and of the International Filing Date (Form PCT/RO/105) will be issued in due course, subject to prescriptions concerning national security, and the date shown on this Acknowledgement Receipt will establish the international filing date of the application.</p>					

ADVANCE E-MAIL

From the INTERNATIONAL BUREAU

PCT

NOTIFICATION OF THE RECORDING
OF A CHANGE

(PCT Rule 92bis.1 and
Administrative Instructions, Section 422)

To:

LYTLE, BRADLEY D.
200 Daingerfield Road, Suite 201
Alexandria, VA 22314
ÉTATS-UNIS D'AMÉRIQUE

Date of mailing (day/month/year) 01 November 2018 (01.11.2018)	IMPORTANT NOTIFICATION
Applicant's or agent's file reference IG5SYS_13091WO01	
International application No. PCT/US2017/032069	International filing date (day/month/year) 11 May 2017 (11.05.2017)

1. The following indications appeared on record concerning:

the applicant the inventor the agent the common representative

Name and Address SANTOS, Julian F. 200 Bellevue Parkway, Suite 300 Wilmington, Delaware 19809 (US) United States of America	State of Nationality	State of Residence
	Telephone No. 302-281 -3600	
	Facsimile No. 302-281 -3766	
	E-mail address docketing@interdigital.com	

2. The International Bureau hereby notifies the applicant that the following change has been recorded concerning:

the person the name the address the nationality the residence

Name and Address LYTLE, BRADLEY D. 200 Daingerfield Road, Suite 201 Alexandria, VA 22314 United States of America	State of Nationality	State of Residence
	Telephone No. 571-376-6333	
	Facsimile No. 571-376-6334	
	E-mail address xsensuspat@xsensus.com <input checked="" type="checkbox"/> Notifications by e-mail authorized	

3. Further observations, if necessary:

4. A copy of this notification has been sent to:

the receiving Office the International Preliminary Examining Authority
 the International Searching Authority the designated Offices concerned
 the Authority(ies) specified for supplementary search other:

The International Bureau of WIPO 34, chemin des Colombettes 1211 Geneva 20, Switzerland	Authorized officer Safi Horiya e-mail pct.team4@wipo.int Telephone No. +41 22 338 74 09
---	---

Facsimile No. +41 22 338 89 95

Form PCT/IB/306 (January 2009)

1/TNQYHHFHN72JD0

TITLE:

APPLICANT: IDAC HOLDINGS, INC

IPC CLASSIFICATION: H04B7/0408, H04B7/06

EXAMINER: Akbudak, Tarik

CONSULTED DATABASES: WPI, DOSYS, NPL, XPI3E, XP3GPP, INSPEC

CLASSIFICATION SYMBOLS DEFINING EXTENT OF THE SEARCH:

IPC:

CPC: H04B7/0408, H04B7/0617

FI/F-TERMS:

KEYWORDS OR OTHER ELEMENTS FEATURING THE INVENTION:

A UE method comprising requesting system information from a network and receiving the system information using beamforming

85022



THE UNITED STATES OF AMERICA

TO ALL TO WHOM THESE PRESENTS SHALL COME

UNITED STATES DEPARTMENT OF COMMERCE

United States Patent and Trademark Office

May 20, 2017

THIS IS TO CERTIFY THAT ANNEXED HERETO IS A TRUE COPY FROM THE RECORDS OF THE UNITED STATES PATENT AND TRADEMARK OFFICE OF THOSE PAPERS OF THE BELOW IDENTIFIED PATENT APPLICATION THAT MET THE REQUIREMENTS TO BE GRANTED A FILING DATE.

APPLICATION NUMBER: 62/334,704

FILING DATE: *May 11, 2016*

RELATED PCT APPLICATION NUMBER: *PCT/US17/32069*

THE COUNTRY CODE AND NUMBER OF YOUR PRIORITY APPLICATION, TO BE USED FOR FILING ABROAD UNDER THE PARIS CONVENTION, IS *US62/334,704*



Certified by

Under Secretary of Commerce
for Intellectual Property
and Director of the United States
Patent and Trademark Office

Under the Paperwork Reduction Act of 1995, no persons are required to respond to a collection of information unless it contains a valid OMB control number.

Application Data Sheet 37 CFR 1.76	Attorney Docket Number	ILTE_13091US01
	Application Number	
Title of Invention	Distributed Control in Wireless Systems	
<p>The application data sheet is part of the provisional or nonprovisional application for which it is being submitted. The following form contains the bibliographic data arranged in a format specified by the United States Patent and Trademark Office as outlined in 37 CFR 1.76. This document may be completed electronically and submitted to the Office in electronic format using the Electronic Filing System (EFS) or the document may be printed and included in a paper filed application.</p>		

Secrecy Order 37 CFR 5.2:

<input type="checkbox"/>	Portions or all of the application associated with this Application Data Sheet may fall under a Secrecy Order pursuant to 37 CFR 5.2 (Paper filers only. Applications that fall under Secrecy Order may not be filed electronically.)
--------------------------	---

Inventor Information:

Inventor 1					<input type="button" value="Remove"/>
Legal Name					
Prefix	Given Name	Middle Name	Family Name	Suffix	
	Yugeswar		Deenoo		
Residence Information (Select One) <input checked="" type="radio"/> US Residency <input type="radio"/> Non US Residency <input type="radio"/> Active US Military Service					
City	King of Prussia	State/Province	PA	Country of Residence	US
Mailing Address of Inventor:					
Address 1	1001 E. Hector St.				
Address 2	Suite 300				
City	Conshohocken	State/Province	PA		
Postal Code	19428	Country	US		
Inventor 2					<input type="button" value="Remove"/>
Legal Name					
Prefix	Given Name	Middle Name	Family Name	Suffix	
	Ghyslain		Pelletier		
Residence Information (Select One) <input type="radio"/> US Residency <input checked="" type="radio"/> Non US Residency <input type="radio"/> Active US Military Service					
City	Montreal	Country of Residence	CA		
Mailing Address of Inventor:					
Address 1	1000 Sherbrooke Street West				
Address 2	10th Floor				
City	Montreal	State/Province	QC		
Postal Code	H3A 3G4	Country	CA		
Inventor 3					<input type="button" value="Remove"/>
Legal Name					
Prefix	Given Name	Middle Name	Family Name	Suffix	
	Ping Hsuan		Tan		

Under the Paperwork Reduction Act of 1995, no persons are required to respond to a collection of information unless it contains a valid OMB control number.

Application Data Sheet 37 CFR 1.76	Attorney Docket Number	ILTE_13091US01
	Application Number	
Title of Invention	Distributed Control in Wireless Systems	

Residence Information (Select One) US Residency Non US Residency Active US Military Service

City Country of Residenceⁱ

Mailing Address of Inventor:

Address 1	1000 Sherbrooke Street West		
Address 2	10th Floor		
City	<input type="text" value="Montreal"/>	State/Province	<input type="text" value="QC"/>
Postal Code	<input type="text" value="H3A 3G4"/>	Country ⁱ	<input type="text" value="CA"/>

All Inventors Must Be Listed - Additional Inventor Information blocks may be generated within this form by selecting the Add button.

Correspondence Information:

Enter either Customer Number or complete the Correspondence Information section below.
For further information see 37 CFR 1.33(a).

An Address is being provided for the correspondence information of this application.

Customer Number	<input type="text" value="15800"/>
Email Address	<input type="text"/> <input type="button" value="Add Email"/> <input type="button" value="Remove Email"/>

Application Information:

Title of the Invention	Distributed Control in Wireless Systems		
Attorney Docket Number	ILTE_13091US01	Small Entity Status Claimed	<input type="checkbox"/>
Application Type	Provisional		
Subject Matter	Utility		
Total Number of Drawing Sheets (if any)	<input type="text" value="9"/>	Suggested Figure for Publication (if any)	<input type="text"/>

Filing By Reference:

Only complete this section when filing an application by reference under 35 U.S.C. 111(c) and 37 CFR 1.57(a). Do not complete this section if application papers including a specification and any drawings are being filed. Any domestic benefit or foreign priority information must be provided in the appropriate section(s) below (i.e., "Domestic Benefit/National Stage Information" and "Foreign Priority Information").

For the purposes of a filing date under 37 CFR 1.53(b), the description and any drawings of the present application are replaced by this reference to the previously filed application, subject to conditions and requirements of 37 CFR 1.57(a).

Application number of the previously filed application	Filing date (YYYY-MM-DD)	Intellectual Property Authority or Country
<input type="text"/>	<input type="text"/>	<input type="text"/>

Under the Paperwork Reduction Act of 1995, no persons are required to respond to a collection of information unless it contains a valid OMB control number.

Application Data Sheet 37 CFR 1.76	Attorney Docket Number	ILTE_13091US01
	Application Number	
Title of Invention	Distributed Control in Wireless Systems	

Publication Information:
 Request Early Publication (Fee required at time of Request 37 CFR 1.219)

 Request Not to Publish. I hereby request that the attached application not be published under 35 U.S.C. 122(b) and certify that the invention disclosed in the attached application **has not and will not** be the subject of an application filed in another country, or under a multilateral international agreement, that requires publication at eighteen months after filing.
Representative Information:

Representative information should be provided for all practitioners having a power of attorney in the application. Providing this information in the Application Data Sheet does not constitute a power of attorney in the application (see 37 CFR 1.32). Either enter Customer Number or complete the Representative Name section below. If both sections are completed the customer number will be used for the Representative Information during processing.

Please Select One:	<input checked="" type="radio"/> Customer Number	US Patent Practitioner	<input type="radio"/> Limited Recognition (37 CFR 11.9)
Customer Number	15800		

Domestic Benefit/National Stage Information:

This section allows for the applicant to either claim benefit under 35 U.S.C. 119(e), 120, 121, 365(c), or 386(c) or indicate National Stage entry from a PCT application. Providing benefit claim information in the Application Data Sheet constitutes the specific reference required by 35 U.S.C. 119(e) or 120, and 37 CFR 1.78.

When referring to the current application, please leave the "Application Number" field blank.

Prior Application Status	<input type="text"/>	<input type="button" value="Remove"/>
Application Number	Continuity Type	Prior Application Number
<input type="text"/>	<input type="text"/>	Filing or 371(c) Date (YYYY-MM-DD)
Additional Domestic Benefit/National Stage Data may be generated within this form by selecting the Add button.		<input type="button" value="Add"/>

Foreign Priority Information:

This section allows for the applicant to claim priority to a foreign application. Providing this information in the application data sheet constitutes the claim for priority as required by 35 U.S.C. 119(b) and 37 CFR 1.55. When priority is claimed to a foreign application that is eligible for retrieval under the priority document exchange program (PDX),¹ the information will be used by the Office to automatically attempt retrieval pursuant to 37 CFR 1.55(i)(1) and (2). Under the PDX program, applicant bears the ultimate responsibility for ensuring that a copy of the foreign application is received by the Office from the participating foreign intellectual property office, or a certified copy of the foreign priority application is filed, within the time period specified in 37 CFR 1.55(g)(1).

Under the Paperwork Reduction Act of 1995, no persons are required to respond to a collection of information unless it contains a valid OMB control number.

Application Data Sheet 37 CFR 1.76		Attorney Docket Number	ILTE_13091US01
		Application Number	
Title of Invention	Distributed Control in Wireless Systems		

Application Number	Country ⁱ	Filing Date (YYYY-MM-DD)	Access Code ⁱ (if applicable)	Remove
Additional Foreign Priority Data may be generated within this form by selecting the Add button.				Add

Statement under 37 CFR 1.55 or 1.78 for AIA (First Inventor to File) Transition Applications

- This application (1) claims priority to or the benefit of an application filed before March 16, 2013 and (2) also contains, or contained at any time, a claim to a claimed invention that has an effective filing date on or after March 16, 2013.
- NOTE: By providing this statement under 37 CFR 1.55 or 1.78, this application, with a filing date on or after March 16, 2013, will be examined under the first inventor to file provisions of the AIA.

Application Data Sheet 37 CFR 1.76		Attorney Docket Number	ILTE_13091US01
		Application Number	
Title of Invention	Distributed Control in Wireless Systems		

Authorization or Opt-Out of Authorization to Permit Access:

When this Application Data Sheet is properly signed and filed with the application, applicant has provided written authority to permit a participating foreign intellectual property (IP) office access to the instant application-as-filed (see paragraph A in subsection 1 below) and the European Patent Office (EPO) access to any search results from the instant application (see paragraph B in subsection 1 below).

Should applicant choose not to provide an authorization identified in subsection 1 below, applicant **must opt-out** of the authorization by checking the corresponding box A or B or both in subsection 2 below.

NOTE: This section of the Application Data Sheet is **ONLY** reviewed and processed with the **INITIAL** filing of an application. After the initial filing of an application, an Application Data Sheet cannot be used to provide or rescind authorization for access by a foreign IP office(s). Instead, Form PTO/SB/39 or PTO/SB/69 must be used as appropriate.

1. Authorization to Permit Access by a Foreign Intellectual Property Office(s)

A. Priority Document Exchange (PDX) - Unless box A in subsection 2 (opt-out of authorization) is checked, the undersigned hereby **grants the USPTO authority** to provide the European Patent Office (EPO), the Japan Patent Office (JPO), the Korean Intellectual Property Office (KIPO), the State Intellectual Property Office of the People's Republic of China (SIPO), the World Intellectual Property Organization (WIPO), and any other foreign intellectual property office participating with the USPTO in a bilateral or multilateral priority document exchange agreement in which a foreign application claiming priority to the instant patent application is filed, access to: (1) the instant patent application-as-filed and its related bibliographic data, (2) any foreign or domestic application to which priority or benefit is claimed by the instant application and its related bibliographic data, and (3) the date of filing of this Authorization. See 37 CFR 1.14(h) (1).

B. Search Results from U.S. Application to EPO - Unless box B in subsection 2 (opt-out of authorization) is checked, the undersigned hereby **grants the USPTO authority** to provide the EPO access to the bibliographic data and search results from the instant patent application when a European patent application claiming priority to the instant patent application is filed. See 37 CFR 1.14(h)(2).

The applicant is reminded that the EPO's Rule 141(1) EPC (European Patent Convention) requires applicants to submit a copy of search results from the instant application without delay in a European patent application that claims priority to the instant application.

2. Opt-Out of Authorizations to Permit Access by a Foreign Intellectual Property Office(s)

A. Applicant **DOES NOT** authorize the USPTO to permit a participating foreign IP office access to the instant application-as-filed. If this box is checked, the USPTO will not be providing a participating foreign IP office with any documents and information identified in subsection 1A above.

B. Applicant **DOES NOT** authorize the USPTO to transmit to the EPO any search results from the instant patent application. If this box is checked, the USPTO will not be providing the EPO with search results from the instant application.

NOTE: Once the application has published or is otherwise publicly available, the USPTO may provide access to the application in accordance with 37 CFR 1.14.

Under the Paperwork Reduction Act of 1995, no persons are required to respond to a collection of information unless it contains a valid OMB control number.

Application Data Sheet 37 CFR 1.76		Attorney Docket Number	ILTE_13091US01
		Application Number	
Title of Invention	Distributed Control in Wireless Systems		

Applicant Information:

Providing assignment information in this section does not substitute for compliance with any requirement of part 3 of Title 37 of CFR to have an assignment recorded by the Office.			
Applicant 1		<input type="button" value="Remove"/>	
If the applicant is the inventor (or the remaining joint inventor or inventors under 37 CFR 1.45), this section should not be completed. The information to be provided in this section is the name and address of the legal representative who is the applicant under 37 CFR 1.43; or the name and address of the assignee, person to whom the inventor is under an obligation to assign the invention, or person who otherwise shows sufficient proprietary interest in the matter who is the applicant under 37 CFR 1.46. If the applicant is an applicant under 37 CFR 1.46 (assignee, person to whom the inventor is obligated to assign, or person who otherwise shows sufficient proprietary interest) together with one or more joint inventors, then the joint inventor or inventors who are also the applicant should be identified in this section.			
		<input type="button" value="Clear"/>	
Assignee	Legal Representative under 35 U.S.C. 117	Joint Inventor	
<input type="radio"/> Person to whom the inventor is obligated to assign.		<input type="radio"/> Person who shows sufficient proprietary interest	
If applicant is the legal representative, indicate the authority to file the patent application, the inventor is:			
<input type="text"/>			
Name of the Deceased or Legally Incapacitated Inventor: <input type="text"/>			
If the Applicant is an Organization check here. <input checked="" type="checkbox"/>			
Organization Name	DAC HOLDINGS, INC.		
Mailing Address Information For Applicant:			
Address 1	200 Bellevue Parkway		
Address 2	Suite 300		
City	Wilmington	State/Province	DE
Country	US	Postal Code	19809
Phone Number		Fax Number	
Email Address			
Additional Applicant Data may be generated within this form by selecting the Add button.			<input type="button" value="Add"/>

Assignee Information including Non-Applicant Assignee Information:

Providing assignment information in this section does not substitute for compliance with any requirement of part 3 of Title 37 of CFR to have an assignment recorded by the Office.

Under the Paperwork Reduction Act of 1995, no persons are required to respond to a collection of information unless it contains a valid OMB control number.

Application Data Sheet 37 CFR 1.76	Attorney Docket Number	ILTE_13091US01
	Application Number	
Title of Invention	Distributed Control in Wireless Systems	

Assignee 1			
Complete this section if assignee information, including non-applicant assignee information, is desired to be included on the patent application publication. An assignee-applicant identified in the "Applicant Information" section will appear on the patent application publication as an applicant. For an assignee-applicant, complete this section only if identification as an assignee is also desired on the patent application publication.			
			<input type="button" value="Remove"/>
If the Assignee or Non-Applicant Assignee is an Organization check here. <input checked="" type="checkbox"/>			
Organization Name	DAC HOLDINGS, INC.		
Mailing Address Information For Assignee including Non-Applicant Assignee:			
Address 1	200 Bellevue Parkway		
Address 2	Suite 300		
City	Wilmington	State/Province	DE
Country ⁱ	US	Postal Code	19809
Phone Number		Fax Number	
Email Address			
Additional Assignee or Non-Applicant Assignee Data may be generated within this form by selecting the Add button.			<input type="button" value="Add"/>

Signature:

NOTE: This Application Data Sheet must be signed in accordance with 37 CFR 1.33(b). However, if this Application Data Sheet is submitted with the INITIAL filing of the application and either box A or B is not checked in subsection 2 of the "Authorization or Opt-Out of Authorization to Permit Access" section, then this form must also be signed in accordance with 37 CFR 1.14(c).

This Application Data Sheet **must** be signed by a patent practitioner if one or more of the applicants is a **juristic entity** (e.g., corporation or association). If the applicant is two or more joint inventors, this form must be signed by a patent practitioner, **all** joint inventors who are the applicant, or one or more joint inventor-applicants who have been given power of attorney (e.g., see USPTO Form PTO/AIA/81) on behalf of **all** joint inventor-applicants.

See 37 CFR 1.4(d) for the manner of making signatures and certifications.

Signature	/Mu Yang/		Date (YYYY-MM-DD)	2016-05-11	
First Name	Mu	Last Name	Yang	Registration Number	73,103
Additional Signature may be generated within this form by selecting the Add button.				<input type="button" value="Add"/>	

Under the Paperwork Reduction Act of 1995, no persons are required to respond to a collection of information unless it contains a valid OMB control number.

Application Data Sheet 37 CFR 1.76		Attorney Docket Number	ILTE_13091US01
		Application Number	
Title of Invention	Distributed Control in Wireless Systems		

This collection of information is required by 37 CFR 1.76. The information is required to obtain or retain a benefit by the public which is to file (and by the USPTO to process) an application. Confidentiality is governed by 35 U.S.C. 122 and 37 CFR 1.14. This collection is estimated to take 23 minutes to complete, including gathering, preparing, and submitting the completed application data sheet form to the USPTO. Time will vary depending upon the individual case. Any comments on the amount of time you require to complete this form and/or suggestions for reducing this burden, should be sent to the Chief Information Officer, U.S. Patent and Trademark Office, U.S. Department of Commerce, P.O. Box 1450, Alexandria, VA 22313-1450. DO NOT SEND FEES OR COMPLETED FORMS TO THIS ADDRESS. **SEND TO: Commissioner for Patents, P.O. Box 1450, Alexandria, VA 22313-1450.**

Privacy Act Statement

The Privacy Act of 1974 (P.L. 93-579) requires that you be given certain information in connection with your submission of the attached form related to a patent application or patent. Accordingly, pursuant to the requirements of the Act, please be advised that: (1) the general authority for the collection of this information is 35 U.S.C. 2(b)(2); (2) furnishing of the information solicited is voluntary; and (3) the principal purpose for which the information is used by the U.S. Patent and Trademark Office is to process and/or examine your submission related to a patent application or patent. If you do not furnish the requested information, the U.S. Patent and Trademark Office may not be able to process and/or examine your submission, which may result in termination of proceedings or abandonment of the application or expiration of the patent.

The information provided by you in this form will be subject to the following routine uses:

1. The information on this form will be treated confidentially to the extent allowed under the Freedom of Information Act (5 U.S.C. 552) and the Privacy Act (5 U.S.C. 552a). Records from this system of records may be disclosed to the Department of Justice to determine whether the Freedom of Information Act requires disclosure of these records.
2. A record from this system of records may be disclosed, as a routine use, in the course of presenting evidence to a court, magistrate, or administrative tribunal, including disclosures to opposing counsel in the course of settlement negotiations.
3. A record in this system of records may be disclosed, as a routine use, to a Member of Congress submitting a request involving an individual, to whom the record pertains, when the individual has requested assistance from the Member with respect to the subject matter of the record.
4. A record in this system of records may be disclosed, as a routine use, to a contractor of the Agency having need for the information in order to perform a contract. Recipients of information shall be required to comply with the requirements of the Privacy Act of 1974, as amended, pursuant to 5 U.S.C. 552a(m).
5. A record related to an International Application filed under the Patent Cooperation Treaty in this system of records may be disclosed, as a routine use, to the International Bureau of the World Intellectual Property Organization, pursuant to the Patent Cooperation Treaty.
6. A record in this system of records may be disclosed, as a routine use, to another federal agency for purposes of National Security review (35 U.S.C. 181) and for review pursuant to the Atomic Energy Act (42 U.S.C. 218(c)).
7. A record from this system of records may be disclosed, as a routine use, to the Administrator, General Services, or his/her designee, during an inspection of records conducted by GSA as part of that agency's responsibility to recommend improvements in records management practices and programs, under authority of 44 U.S.C. 2904 and 2906. Such disclosure shall be made in accordance with the GSA regulations governing inspection of records for this purpose, and any other relevant (i.e., GSA or Commerce) directive. Such disclosure shall not be used to make determinations about individuals.
8. A record from this system of records may be disclosed, as a routine use, to the public after either publication of the application pursuant to 35 U.S.C. 122(b) or issuance of a patent pursuant to 35 U.S.C. 151. Further, a record may be disclosed, subject to the limitations of 37 CFR 1.14, as a routine use, to the public if the record was filed in an application which became abandoned or in which the proceedings were terminated and which application is referenced by either a published application, an application open to public inspections or an issued patent.
9. A record from this system of records may be disclosed, as a routine use, to a Federal, State, or local law enforcement agency, if the USPTO becomes aware of a violation or potential violation of law or regulation.

DISTRIBUTED CONTROL IN WIRELESS SYSTEMS

BACKGROUND

[0001] Mobile communications continue to evolve. A fifth generation may be referred to as 5G. A previous (legacy) generation of mobile communication may be, for example, fourth generation (4G) long term evolution (LTE).

SUMMARY

[0002] Systems, procedures, and instrumentalities (e.g. aspects of entities, interfaces and procedures in a wireless transmit/receive unit (WTRU) and/or network layers L1, L2, L3) are disclosed for distributed control in wireless systems, such as 5G flexible radio access technology (RAT) (5gFLEX). Example procedures are provided for WTRU and network operation associated with a distributed control plane architecture, connectionless data transfer and dedicated system information acquisition. Distributed control may be provided, for example, by replicating a plurality of access control functions (ACFs) using a plurality of instances in a plurality of different transmission/reception points (TRPs) with multi-connectivity. The plurality of TRPs may concurrently provide control services to a WTRU. Centralized control functions may manage core network connectivity and a plurality of user plane instances for the WTRU and may facilitate coordination between the plurality of ACF instances for the WTRU in the plurality of different TRPs of the WTRU's configuration. For example, there may be a first access plane between the WTRU and a first TRP that provides a first ACF for the WTRU, a second access plane between the WTRU and a second TRP that provides a second ACF for the WTRU, a RAN central control plane between the WTRU and a first RAN central control function (RCCF) and a RAN central user plane between the WTRU and a RAN central user function (RCUF).

BRIEF DESCRIPTION OF THE DRAWINGS

ILTE_13091US01

[0003] FIG. 1A is a system diagram of an example communications system in which one or more disclosed embodiments may be implemented.

[0004] FIG. 1B is a system diagram of an example WTRU that may be used within the communications system illustrated in FIG. 1A.

[0005] FIG. 1C is a system diagram of an example radio access network and an example core network that may be used within the communications system illustrated in FIG. 1A.

[0006] FIG. 1D is a system diagram of another example radio access network and another example core network that may be used within the communications system illustrated in FIG. 1A.

[0007] FIG. 1E is a system diagram of another example radio access network and another example core network that may be used within the communications system illustrated in FIG. 1A.

[0008] FIG. 2 is an example of transmission bandwidths.

[0009] FIG. 3 is an example of flexible spectrum allocation.

[0010] FIG. 4 is an example of types of assistance modes.

[0011] FIG. 5 is an example of tri-plane architecture.

DETAILED DESCRIPTION

[0012] A detailed description of illustrative embodiments will now be described with reference to the various Figures. Although this description provides a detailed example of possible implementations, it should be noted that the details are intended to be exemplary and in no way limit the scope of the application.

[0013] FIG. 1A is a diagram of an example communications system 100 in which one or more disclosed embodiments may be implemented. The communications system 100 may be a multiple access system that provides content, such as voice, data, video, messaging, broadcast, etc., to multiple wireless users. The communications system 100 may enable multiple wireless users to access such content through the sharing of system resources, including wireless bandwidth. For example, the communications system 100 may employ one or more channel access methods, such as code division multiple access (CDMA), time division multiple access (TDMA), frequency division multiple access (FDMA), orthogonal FDMA (OFDMA), single-carrier FDMA (SC-FDMA), and the like.

[0014] As shown in FIG. 1A, the communications system 100 may include wireless transmit/receive units (WTRUs), e.g., WTRUs, 102a, 102b, 102c, and/or 102d (which generally or collectively may be referred to as WTRU 102), a radio access network (RAN) 103/104/105, a core network 106/107/109, a public switched telephone network (PSTN) 108, the Internet 110,

ILTE_13091US01

and other networks 112, though it will be appreciated that the disclosed embodiments contemplate any number of WTRUs, base stations, networks, and/or network elements. Each of the WTRUs 102a, 102b, 102c, 102d may be any type of device configured to operate and/or communicate in a wireless environment. By way of example, the WTRUs 102a, 102b, 102c, 102d may be configured to transmit and/or receive wireless signals and may include user equipment (UE), a mobile station, a fixed or mobile subscriber unit, a pager, a cellular telephone, a personal digital assistant (PDA), a smartphone, a laptop, a netbook, a personal computer, a wireless sensor, consumer electronics, and the like.

[0015] The communications system 100 may also include a base station 114a and a base station 114b. Each of the base stations 114a, 114b may be any type of device configured to wirelessly interface with at least one of the WTRUs 102a, 102b, 102c, 102d to facilitate access to one or more communication networks, such as the core network 106/107/109, the Internet 110, and/or the networks 112. By way of example, the base stations 114a, 114b may be a base transceiver station (BTS), a Node-B, an eNode B, a Home Node B, a Home eNode B, a site controller, an access point (AP), a wireless router, and the like. While the base stations 114a, 114b are each depicted as a single element, it will be appreciated that the base stations 114a, 114b may include any number of interconnected base stations and/or network elements.

[0016] The base station 114a may be part of the RAN 103/104/105, which may also include other base stations and/or network elements (not shown), such as a base station controller (BSC), a radio network controller (RNC), relay nodes, etc. The base station 114a and/or the base station 114b may be configured to transmit and/or receive wireless signals within a particular geographic region, which may be referred to as a cell (not shown). The cell may further be divided into cell sectors. For example, the cell associated with the base station 114a may be divided into three sectors. Thus, in some embodiments, the base station 114a may include three transceivers, e.g., one for each sector of the cell. In another embodiment, the base station 114a may employ multiple-input multiple output (MIMO) technology and, therefore, may utilize multiple transceivers for each sector of the cell.

[0017] The base stations 114a, 114b may communicate with one or more of the WTRUs 102a, 102b, 102c, 102d over an air interface 115/116/117, which may be any suitable wireless communication link (e.g., radio frequency (RF), microwave, infrared (IR), ultraviolet (UV), visible light, etc.). The air interface 115/116/117 may be established using any suitable radio access technology (RAT).

[0018] More specifically, as noted above, the communications system 100 may be a multiple access system and may employ one or more channel access schemes, such as CDMA, TDMA,

ILTE_13091US01

FDMA, OFDMA, SC-FDMA, and the like. For example, the base station 114a in the RAN 103/104/105 and the WTRUs 102a, 102b, 102c may implement a radio technology such as Universal Mobile Telecommunications System (UMTS) Terrestrial Radio Access (UTRA), which may establish the air interface 115/116/117 using wideband CDMA (WCDMA). WCDMA may include communication protocols such as High-Speed Packet Access (HSPA) and/or Evolved HSPA (HSPA+). HSPA may include High-Speed Downlink Packet Access (HSDPA) and/or High-Speed Uplink Packet Access (HSUPA).

[0019] In another embodiment, the base station 114a and the WTRUs 102a, 102b, 102c may implement a radio technology such as Evolved UMTS Terrestrial Radio Access (E-UTRA), which may establish the air interface 115/116/117 using Long Term Evolution (LTE) and/or LTE-Advanced (LTE-A).

[0020] In other embodiments, the base station 114a and the WTRUs 102a, 102b, 102c may implement radio technologies such as IEEE 802.16 (e.g., Worldwide Interoperability for Microwave Access (WiMAX)), CDMA2000, CDMA2000 1X, CDMA2000 EV-DO, Interim Standard 2000 (IS-2000), Interim Standard 95 (IS-95), Interim Standard 856 (IS-856), Global System for Mobile communications (GSM), Enhanced Data rates for GSM Evolution (EDGE), GSM EDGE (GERAN), and the like.

[0021] The base station 114b in FIG. 1A may be a wireless router, Home Node B, Home eNode B, or access point, for example, and may utilize any suitable RAT for facilitating wireless connectivity in a localized area, such as a place of business, a home, a vehicle, a campus, and the like. In some embodiments, the base station 114b and the WTRUs 102c, 102d may implement a radio technology such as IEEE 802.11 to establish a wireless local area network (WLAN). In another embodiment, the base station 114b and the WTRUs 102c, 102d may implement a radio technology such as IEEE 802.15 to establish a wireless personal area network (WPAN). In yet another embodiment, the base station 114b and the WTRUs 102c, 102d may utilize a cellular-based RAT (e.g., WCDMA, CDMA2000, GSM, LTE, LTE-A, etc.) to establish a picocell or femtocell. As shown in FIG. 1A, the base station 114b may have a direct connection to the Internet 110. Thus, the base station 114b may not be required to access the Internet 110 via the core network 106/107/109.

[0022] The RAN 103/104/105 may be in communication with the core network 106/107/109, which may be any type of network configured to provide voice, data, applications, and/or voice over internet protocol (VoIP) services to one or more of the WTRUs 102a, 102b, 102c, 102d. For example, the core network 106/107/109 may provide call control, billing services, mobile location-based services, pre-paid calling, Internet connectivity, video distribution, etc., and/or

ILTE_13091US01

perform high-level security functions, such as user authentication. Although not shown in FIG. 1A, it will be appreciated that the RAN 103/104/105 and/or the core network 106/107/109 may be in direct or indirect communication with other RANs that employ the same RAT as the RAN 103/104/105 or a different RAT. For example, in addition to being connected to the RAN 103/104/105, which may be utilizing an E-UTRA radio technology, the core network 106/107/109 may also be in communication with another RAN (not shown) employing a GSM radio technology.

[0023] The core network 106/107/109 may also serve as a gateway for the WTRUs 102a, 102b, 102c, 102d to access the PSTN 108, the Internet 110, and/or other networks 112. The PSTN 108 may include circuit-switched telephone networks that provide plain old telephone service (POTS). The Internet 110 may include a global system of interconnected computer networks and devices that use common communication protocols, such as the transmission control protocol (TCP), user datagram protocol (UDP) and the internet protocol (IP) in the TCP/IP internet protocol suite. The networks 112 may include wired or wireless communications networks owned and/or operated by other service providers. For example, the networks 112 may include another core network connected to one or more RANs, which may employ the same RAT as the RAN 103/104/105 or a different RAT.

[0024] Some or all of the WTRUs 102a, 102b, 102c, 102d in the communications system 100 may include multi-mode capabilities, e.g., the WTRUs 102a, 102b, 102c, 102d may include multiple transceivers for communicating with different wireless networks over different wireless links. For example, the WTRU 102c shown in FIG. 1A may be configured to communicate with the base station 114a, which may employ a cellular-based radio technology, and with the base station 114b, which may employ an IEEE 802 radio technology.

[0025] FIG. 1B is a system diagram of an example WTRU 102. As shown in FIG. 1B, the WTRU 102 may include a processor 118, a transceiver 120, a transmit/receive element 122, a speaker/microphone 124, a keypad 126, a display/touchpad 128, non-removable memory 130, removable memory 132, a power source 134, a global positioning system (GPS) chipset 136, and other peripherals 138. It will be appreciated that the WTRU 102 may include any sub-combination of the foregoing elements while remaining consistent with an embodiment. Also, embodiments contemplate that the base stations 114a and 114b, and/or the nodes that base stations 114a and 114b may represent, such as but not limited to transceiver station (BTS), a Node-B, a site controller, an access point (AP), a home node-B, an evolved home node-B (eNodeB), a home evolved node-B (HeNB or HeNodeB), a home evolved node-B gateway, and

ILTE_13091US01

proxy nodes, among others, may include some or all of the elements depicted in FIG. 1B and described herein.

[0026] The processor 118 may be a general purpose processor, a special purpose processor, a conventional processor, a digital signal processor (DSP), a plurality of microprocessors, one or more microprocessors in association with a DSP core, a controller, a microcontroller, Application Specific Integrated Circuits (ASICs), Field Programmable Gate Array (FPGAs) circuits, any other type of integrated circuit (IC), a state machine, and the like. The processor 118 may perform signal coding, data processing, power control, input/output processing, and/or any other functionality that enables the WTRU 102 to operate in a wireless environment. The processor 118 may be coupled to the transceiver 120, which may be coupled to the transmit/receive element 122. While FIG. 1B depicts the processor 118 and the transceiver 120 as separate components, it will be appreciated that the processor 118 and the transceiver 120 may be integrated together in an electronic package or chip.

[0027] The transmit/receive element 122 may be configured to transmit signals to, or receive signals from, a base station (e.g., the base station 114a) over the air interface 115/116/117. For example, in some embodiments, the transmit/receive element 122 may be an antenna configured to transmit and/or receive RF signals. In another embodiment, the transmit/receive element 122 may be an emitter/detector configured to transmit and/or receive IR, UV, or visible light signals, for example. In yet another embodiment, the transmit/receive element 122 may be configured to transmit and receive both RF and light signals. It will be appreciated that the transmit/receive element 122 may be configured to transmit and/or receive any combination of wireless signals.

[0028] In addition, although the transmit/receive element 122 is depicted in FIG. 1B as a single element, the WTRU 102 may include any number of transmit/receive elements 122. More specifically, the WTRU 102 may employ MIMO technology. Thus, in some embodiments, the WTRU 102 may include two or more transmit/receive elements 122 (e.g., multiple antennas) for transmitting and receiving wireless signals over the air interface 115/116/117.

[0029] The transceiver 120 may be configured to modulate the signals that are to be transmitted by the transmit/receive element 122 and to demodulate the signals that are received by the transmit/receive element 122. As noted above, the WTRU 102 may have multi-mode capabilities. Thus, the transceiver 120 may include multiple transceivers for enabling the WTRU 102 to communicate via multiple RATs, such as UTRA and IEEE 802.11, for example.

[0030] The processor 118 of the WTRU 102 may be coupled to, and may receive user input data from, the speaker/microphone 124, the keypad 126, and/or the display/touchpad 128 (e.g., a liquid crystal display (LCD) display unit or organic light-emitting diode (OLED) display unit).

ILTE_13091US01

The processor 118 may also output user data to the speaker/microphone 124, the keypad 126, and/or the display/touchpad 128. In addition, the processor 118 may access information from, and store data in, any type of suitable memory, such as the non-removable memory 130 and/or the removable memory 132. The non-removable memory 130 may include random-access memory (RAM), read-only memory (ROM), a hard disk, or any other type of memory storage device. The removable memory 132 may include a subscriber identity module (SIM) card, a memory stick, a secure digital (SD) memory card, and the like. In other embodiments, the processor 118 may access information from, and store data in, memory that is not physically located on the WTRU 102, such as on a server or a home computer (not shown).

[0031] The processor 118 may receive power from the power source 134, and may be configured to distribute and/or control the power to the other components in the WTRU 102. The power source 134 may be any suitable device for powering the WTRU 102. For example, the power source 134 may include one or more dry cell batteries (e.g., nickel-cadmium (NiCd), nickel-zinc (NiZn), nickel metal hydride (NiMH), lithium-ion (Li-ion), etc.), solar cells, fuel cells, and the like.

[0032] The processor 118 may also be coupled to the GPS chipset 136, which may be configured to provide location information (e.g., longitude and latitude) regarding the current location of the WTRU 102. In addition to, or in lieu of, the information from the GPS chipset 136, the WTRU 102 may receive location information over the air interface 115/116/117 from a base station (e.g., base stations 114a, 114b) and/or determine its location based on the timing of the signals being received from two or more nearby base stations. It will be appreciated that the WTRU 102 may acquire location information by way of any suitable location-determination implementation while remaining consistent with an embodiment.

[0033] The processor 118 may further be coupled to other peripherals 138, which may include one or more software and/or hardware modules that provide additional features, functionality and/or wired or wireless connectivity. For example, the peripherals 138 may include an accelerometer, an e-compass, a satellite transceiver, a digital camera (for photographs or video), a universal serial bus (USB) port, a vibration device, a television transceiver, a hands free headset, a Bluetooth® module, a frequency modulated (FM) radio unit, a digital music player, a media player, a video game player module, an Internet browser, and the like.

[0034] FIG. 1C is a system diagram of the RAN 103 and the core network 106 according to an embodiment. As noted above, the RAN 103 may employ a UTRA radio technology to communicate with the WTRUs 102a, 102b, 102c over the air interface 115. The RAN 103 may also be in communication with the core network 106. As shown in FIG. 1C, the RAN 103 may

ILTE_13091US01

include Node-Bs 140a, 140b, 140c, which may each include one or more transceivers for communicating with the WTRUs 102a, 102b, 102c over the air interface 115. The Node-Bs 140a, 140b, 140c may each be associated with a particular cell (not shown) within the RAN 103. The RAN 103 may also include RNCs 142a, 142b. It will be appreciated that the RAN 103 may include any number of Node-Bs and RNCs while remaining consistent with an embodiment.

[0035] As shown in FIG. 1C, the Node-Bs 140a, 140b may be in communication with the RNC 142a. Additionally, the Node-B 140c may be in communication with the RNC 142b. The Node-Bs 140a, 140b, 140c may communicate with the respective RNCs 142a, 142b via an Iub interface. The RNCs 142a, 142b may be in communication with one another via an Iur interface. Each of the RNCs 142a, 142b may be configured to control the respective Node-Bs 140a, 140b, 140c to which it is connected. In addition, each of the RNCs 142a, 142b may be configured to carry out or support other functionality, such as outer loop power control, load control, admission control, packet scheduling, handover control, macrodiversity, security functions, data encryption, and the like.

[0036] The core network 106 shown in FIG. 1C may include a media gateway (MGW) 144, a mobile switching center (MSC) 146, a serving GPRS support node (SGSN) 148, and/or a gateway GPRS support node (GGSN) 150. While each of the foregoing elements are depicted as part of the core network 106, it will be appreciated that any one of these elements may be owned and/or operated by an entity other than the core network operator.

[0037] The RNC 142a in the RAN 103 may be connected to the MSC 146 in the core network 106 via an IuCS interface. The MSC 146 may be connected to the MGW 144. The MSC 146 and the MGW 144 may provide the WTRUs 102a, 102b, 102c with access to circuit-switched networks, such as the PSTN 108, to facilitate communications between the WTRUs 102a, 102b, 102c and traditional land-line communications devices.

[0038] The RNC 142a in the RAN 103 may also be connected to the SGSN 148 in the core network 106 via an IuPS interface. The SGSN 148 may be connected to the GGSN 150. The SGSN 148 and the GGSN 150 may provide the WTRUs 102a, 102b, 102c with access to packet-switched networks, such as the Internet 110, to facilitate communications between and the WTRUs 102a, 102b, 102c and IP-enabled devices.

[0039] As noted above, the core network 106 may also be connected to the networks 112, which may include other wired or wireless networks that are owned and/or operated by other service providers.

[0040] FIG. 1D is a system diagram of the RAN 104 and the core network 107 according to an embodiment. As noted above, the RAN 104 may employ an E-UTRA radio technology to

ILTE_13091US01

communicate with the WTRUs 102a, 102b, 102c over the air interface 116. The RAN 104 may also be in communication with the core network 107.

[0041] The RAN 104 may include eNode-Bs 160a, 160b, 160c, though it will be appreciated that the RAN 104 may include any number of eNode-Bs while remaining consistent with an embodiment. The eNode-Bs 160a, 160b, 160c may each include one or more transceivers for communicating with the WTRUs 102a, 102b, 102c over the air interface 116. In some embodiments, the eNode-Bs 160a, 160b, 160c may implement MIMO technology. Thus, the eNode-B 160a, for example, may use multiple antennas to transmit wireless signals to, and receive wireless signals from, the WTRU 102a.

[0042] Each of the eNode-Bs 160a, 160b, 160c may be associated with a particular cell (not shown) and may be configured to handle radio resource management decisions, handover decisions, scheduling of users in the uplink (UL) and/or downlink (DL), and the like. As shown in FIG. 1D, the eNode-Bs 160a, 160b, 160c may communicate with one another over an X2 interface.

[0043] The core network 107 shown in FIG. 1D may include a mobility management gateway (MME) 162, a serving gateway 164, and a packet data network (PDN) gateway 166. While each of the foregoing elements are depicted as part of the core network 107, it will be appreciated that any one of these elements may be owned and/or operated by an entity other than the core network operator.

[0044] The MME 162 may be connected to each of the eNode-Bs 160a, 160b, 160c in the RAN 104 via an S1 interface and may serve as a control node. For example, the MME 162 may be responsible for authenticating users of the WTRUs 102a, 102b, 102c, bearer activation/deactivation, selecting a particular serving gateway during an initial attach of the WTRUs 102a, 102b, 102c, and the like. The MME 162 may also provide a control plane function for switching between the RAN 104 and other RANs (not shown) that employ other radio technologies, such as GSM or WCDMA.

[0045] The serving gateway 164 may be connected to each of the eNode-Bs 160a, 160b, 160c in the RAN 104 via the S1 interface. The serving gateway 164 may generally route and forward user data packets to/from the WTRUs 102a, 102b, 102c. The serving gateway 164 may also perform other functions, such as anchoring user planes during inter-eNode B handovers, triggering paging when downlink data is available for the WTRUs 102a, 102b, 102c, managing and storing contexts of the WTRUs 102a, 102b, 102c, and the like.

[0046] The serving gateway 164 may also be connected to the PDN gateway 166, which may provide the WTRUs 102a, 102b, 102c with access to packet-switched networks, such as the

Internet 110, to facilitate communications between the WTRUs 102a, 102b, 102c and IP-enabled devices.

[0047] The core network 107 may facilitate communications with other networks. For example, the core network 107 may provide the WTRUs 102a, 102b, 102c with access to circuit-switched networks, such as the PSTN 108, to facilitate communications between the WTRUs 102a, 102b, 102c and traditional land-line communications devices. For example, the core network 107 may include, or may communicate with, an IP gateway (e.g., an IP multimedia subsystem (IMS) server) that serves as an interface between the core network 107 and the PSTN 108. In addition, the core network 107 may provide the WTRUs 102a, 102b, 102c with access to the networks 112, which may include other wired or wireless networks that are owned and/or operated by other service providers.

[0048] FIG. 1E is a system diagram of the RAN 105 and the core network 109 according to an embodiment. The RAN 105 may be an access service network (ASN) that employs IEEE 802.16 radio technology to communicate with the WTRUs 102a, 102b, 102c over the air interface 117. As will be further discussed below, the communication links between the different functional entities of the WTRUs 102a, 102b, 102c, the RAN 105, and the core network 109 may be defined as reference points.

[0049] As shown in FIG. 1E, the RAN 105 may include base stations 180a, 180b, 180c, and an ASN gateway 182, though it will be appreciated that the RAN 105 may include any number of base stations and ASN gateways while remaining consistent with an embodiment. The base stations 180a, 180b, 180c may each be associated with a particular cell (not shown) in the RAN 105 and may each include one or more transceivers for communicating with the WTRUs 102a, 102b, 102c over the air interface 117. In some embodiments, the base stations 180a, 180b, 180c may implement MIMO technology. Thus, the base station 180a, for example, may use multiple antennas to transmit wireless signals to, and receive wireless signals from, the WTRU 102a. The base stations 180a, 180b, 180c may also provide mobility management functions, such as handoff triggering, tunnel establishment, radio resource management, traffic classification, quality of service (QoS) policy enforcement, and the like. The ASN gateway 182 may serve as a traffic aggregation point and may be responsible for paging, caching of subscriber profiles, routing to the core network 109, and the like.

[0050] The air interface 117 between the WTRUs 102a, 102b, 102c and the RAN 105 may be defined as an R1 reference point that implements the IEEE 802.16 specification. In addition, each of the WTRUs 102a, 102b, 102c may establish a logical interface (not shown) with the core network 109. The logical interface between the WTRUs 102a, 102b, 102c and the core network

ILTE_13091US01

109 may be defined as an R2 reference point, which may be used for authentication, authorization, IP host configuration management, and/or mobility management.

[0051] The communication link between each of the base stations 180a, 180b, 180c may be defined as an R8 reference point that includes protocols for facilitating WTRU handovers and the transfer of data between base stations. The communication link between the base stations 180a, 180b, 180c and the ASN gateway 182 may be defined as an R6 reference point. The R6 reference point may include protocols for facilitating mobility management based on mobility events associated with each of the WTRUs 102a, 102b, 102c.

[0052] As shown in FIG. 1E, the RAN 105 may be connected to the core network 109. The communication link between the RAN 105 and the core network 109 may be defined as an R3 reference point that includes protocols for facilitating data transfer and mobility management capabilities, for example. The core network 109 may include a mobile IP home agent (MIP-HA) 184, an authentication, authorization, accounting (AAA) server 186, and a gateway 188. While each of the foregoing elements are depicted as part of the core network 109, it will be appreciated that any one of these elements may be owned and/or operated by an entity other than the core network operator.

[0053] The MIP-HA may be responsible for IP address management, and may enable the WTRUs 102a, 102b, 102c to roam between different ASNs and/or different core networks. The MIP-HA 184 may provide the WTRUs 102a, 102b, 102c with access to packet-switched networks, such as the Internet 110, to facilitate communications between the WTRUs 102a, 102b, 102c and IP-enabled devices. The AAA server 186 may be responsible for user authentication and for supporting user services. The gateway 188 may facilitate interworking with other networks. For example, the gateway 188 may provide the WTRUs 102a, 102b, 102c with access to circuit-switched networks, such as the PSTN 108, to facilitate communications between the WTRUs 102a, 102b, 102c and traditional land-line communications devices. In addition, the gateway 188 may provide the WTRUs 102a, 102b, 102c with access to the networks 112, which may include other wired or wireless networks that are owned and/or operated by other service providers.

[0054] Although not shown in FIG. 1E, RAN 105 may be connected to other ASNs and the core network 109 may be connected to other core networks. The communication link between the RAN 105 and the other ASNs may be defined as an R4 reference point, which may include protocols for coordinating the mobility of the WTRUs 102a, 102b, 102c between the RAN 105 and the other ASNs. The communication link between the core network 109 and the other core

networks may be defined as an R5 reference, which may include protocols for facilitating interworking between home core networks and visited core networks.

[0055] Below is a list of abbreviations and acronyms that may be used herein.

Af	Sub-carrier spacing
5gFlex	5G Flexible Radio Access Technology
5gNB	5GFlex NodeB
ACK	Acknowledgement
BLER	Block Error Rate
BTI	Basic TI (in integer multiple of one or more symbol duration)
CB	Contention-Based (e.g. access, channel, resource)
CoMP	Coordinated Multi-Point transmission/reception
CP	Cyclic Prefix
CP-OFDM	Conventional OFDM (relying on cyclic prefix)
CQI	Channel Quality Indicator
CN	Core Network (e.g. LTE packet core)
CRC	Cyclic Redundancy Check
CSG	Closed Subscriber Group
CSI	Channel State Information
D2D	Device to Device transmissions (e.g. LTE Sidelink)
DCI	Downlink Control Information
DL	Downlink
DM-RS	Demodulation Reference Signal
DRB	Data Radio Bearer
EPC	Evolved Packet Core
FBMC	Filtered Band Multi-Carrier
FBMC/OQAM	A FBMC technique using Offset Quadrature Amplitude Modulation
FDD	Frequency Division Duplexing
FDM	Frequency Division Multiplexing
ICC	Industrial Control and Communications
ICIC	Inter-Cell Interference Cancellation
IP	Internet Protocol
LAA	License Assisted Access
LBT	Listen-Before-Talk
LCH	Logical Channel
LCP	Logical Channel Prioritization
LLC	Low Latency Communications
LTE	Long Term Evolution e.g. from 3GPP LTE R8 and up
MAC	Medium Access Control
NACK	Negative ACK
MC	MultiCarrier
MCS	Modulation and Coding Scheme
MIMO	Multiple Input Multiple Output
MTC	Machine-Type Communications
NAS	Non-Access Stratum
NR	New Radio access technology
NR-eNB	A network node that may e.g. schedule NR resources
OFDM	Orthogonal Frequency-Division Multiplexing
OOB	Out-Of-Band (emissions)
P_{max}	Total available UE power in a given TI
PHY	Physical Layer

ILTE_13091US01

PRACH	Physical Random Access Channel
PDU	Protocol Data Unit
PER	Packet Error Rate
PLMN	Public Land Mobile Network
PLR	Packet Loss Rate
PSS	Primary Synchronization Signal
QoS	Quality of Service (from the physical layer perspective)
RAB	Radio Access Bearer
RACH	Random Access Channel (or procedure)
RAR	Random Access Response
RCU	Raadio access network Central Unit
RF	Radio Front end
RNTI	Radio Network Identifier
RRC	Radio Resource Control
RRM	Radio Resource Management
RS	Reference Signal
RTT	Round-Trip Time
SCMA	Single Carrier Multiple Access
SDU	Service Data Unit
SL	Sidelink
SOM	Spectrum Operation Mode
SS	Synchronization Signal
SSS	Secondary Synchronization Signal
SRB	Signalling Radio Bearer
SWG	Switching Gap (in a self-contained subframe)
TB	Transport Block
TBS	Transport Block Size
TDD	Time-Division Duplexing
TDM	Time-Division Multiplexing
TI	Time Interval (in integer multiple of one or more BTI)
TTI	Transmission Time Interval (in integer multiple of one or more TI)
TRP	Transmission / Reception Point
TRPG	Transmission / Reception Point Group
TRx	Transceiver
UFMC	Universal Filtered MultiCarrier
UF-OFDM	Universal Filtered OFDM
UL	Uplink
URC	Ultra-Reliable Communications
URLLC	Ultra-Reliable and Low Latency Communications
Uu	Interface between a NR-eNB/TRP (or equivalent) and a UE
V2V	Vehicle to vehicle communications
V2X	Vehicular communications
WLAN	Wireless Local Area Networks and related technologies (IEEE 802.xx domain)

[0056] Terms New Radio (NR), 5gFLEX and 5G may be used interchangeably. While examples may refer to 3GPP protocols, subject matter described herein is applicable to other wireless systems (e.g. other wireless technologies, communication and/or control procedures). Terms and definitions do not limit the applicability of disclosed subject matter to other

ILTE_13091US01

definitions, types of signals, configuration procedures and logical associations, e.g., between different user data units.

[0057] An air interface, e.g., for a new radio (NR) access technology in a 5G system, may support a variety of use cases, such as improved broadband performance (IBB), Industrial control and communications (ICC) and vehicular applications (V2X) and Massive Machine-Type Communications (mMTC). Use cases may have associated support in an air interface (e.g. 5G air interface).

[0058] An air interface may support, for example, ultra-low transmission latency (LLC), ultra-reliable transmission (URC) and machine-type communications (MTC) operation (including narrowband operation).

[0059] Support for ultra-low transmission latency (LLC) may comprise, for example, air interface latency such as 1ms RTT and TTIs between 100us to 250us. Support may be provided for ultra-low access latency (e.g. time from initial system access until the completion of the transmission of the first user plane data unit). End-to-end (e2e) latency less than 10ms may be supported, for example, for IC and V2X.

[0060] Support for ultra-reliable transmission (URC) may comprise, for example, improved transmission reliability, such as 99.999% transmission success and service availability. Support may be provided for mobility speed in the range of 0-500km/h. Packet Loss Ratio of less than $10e^{-6}$ may be supported, for example, for IC and V2X.

[0061] Support for MTC operation may comprise, for example, air interface support for narrowband operation (e.g. using less than 200 KHz), extended battery life (e.g. up to 15 years of autonomy) and minimal communication overhead for small and infrequent data transmissions (e.g. low data rate in the range of 1-100kbps with access latency of seconds to hours).

[0062] A 5gFLEX system may be implemented with OFDM and/or other waveforms for uplink and/or downlink. Description of examples herein is non-limiting. Examples are applicable and adaptable to other waveforms and wireless technologies.

[0063] OFDM may be used as a signal format for data transmissions, e.g., in LTE and IEEE 802.11. OFDM may efficiently divide spectrum into multiple parallel orthogonal subbands. A (e.g. each) subcarrier may be shaped using a rectangular window in the time domain, which may lead to sinc-shaped subcarriers in the frequency domain. OFDMA may rely on (e.g. perfect) frequency synchronization and tight management of uplink timing alignment within the duration of the cyclic prefix, for example, to maintain orthogonality between signals and to minimize intercarrier interference. Tight synchronization may be difficult, for example, in a system where a WTRU may be simultaneously connected to multiple access points. Additional power

ILTE_13091US01

reduction may be applied to uplink transmissions, for example, to comply with spectral emission requirements for adjacent bands. Fragmented spectrum may be aggregated for WTRU transmissions.

[0064] OFDM (CP-OFDM) performance may be improved, for example, by more stringent RF requirements for implementations, such as operation using a large amount of contiguous spectrum that may not require aggregation. A CP-based OFDM transmission scheme may provide a downlink physical layer for 5G similar to a 4G system with modifications to pilot signal density and location.

[0065] 5gFLEX radio access may be characterized by a very high degree of spectrum flexibility that enables deployment in different frequency bands with different characteristics, which may include different duplex arrangements, different and/or variable sizes of available spectrum, such as contiguous and non-contiguous spectrum allocations in the same or different bands. 5gFLEX radio access may support variable timing aspects, such as support for multiple TTI lengths and asynchronous transmissions.

[0066] Multiple duplexing schemes (e.g. TDD, FDD) may be supported. Supplemental downlink operation may be supported, e.g., for FDD operation, for example, using spectrum aggregation. FDD operation may support full-duplex FDD and half-duplex FDD operation. DL/UL allocation may be dynamic (e.g. may not be based on a fixed DL/UL frame configuration), e.g., for TDD operation. The length of a DL or a UL transmission interval may be set per transmission opportunity.

[0067] A 5G air interface characteristic or capability may enable different transmission bandwidths on uplink and downlink ranging, e.g., varying between a nominal system bandwidth to a maximum value corresponding to the system bandwidth.

[0068] Single carrier operation may support a variety or range of system bandwidths, such as 5, 10, 20, 40 and 80 MHz, 160MHz. Nominal bandwidths may have one or more fixed values. Narrowband transmissions (e.g. 0 to 200 KHz) may be supported within the operating bandwidth for MTC devices.

[0069] System bandwidth may refer to the largest portion of spectrum that may be managed by a network for a given carrier. The spectral portion of a carrier that a WTRU minimally supports for cell acquisition, measurements and initial access to the network may correspond to the nominal system bandwidth. A WTRU may be configured with a channel bandwidth that may be within the range of the entire system bandwidth. A WTRU's configured channel bandwidth may or may not include a nominal part of system bandwidth, e.g., as shown in an example in FIG. 2.

ILTE_13091US01

[0070] FIG. 2 is an example of transmission bandwidths. Bandwidth flexibility may be achieved, for example, because (e.g. all) applicable sets of RF requirements for a given maximum operating bandwidth in a band may be met without the introduction of additional allowed channel bandwidths for that operating band, e.g., due to the efficient support of baseband filtering of the frequency domain waveform.

[0071] A WTRU's channel bandwidth for single carrier operation may be configured, reconfigured and/or dynamically changed. Spectrum for narrowband transmissions within the nominal system, system or configured channel bandwidth may be allocated.

[0072] A 5G air interface physical layer may be band-agnostic and may support operation in licensed bands (e.g. below 5 GHz) and unlicensed bands (e.g. in the range 5-6 GHz). Listen before talk (LBT) Cat 4 based channel access framework similar to LTE LAA may be supported, e.g., for operation in unlicensed bands.

[0073] Cell-specific and/or WTRU-specific channel bandwidths for arbitrary spectrum block sizes may be scaled and managed (e.g. scheduling, addressing of resources, broadcasted signals, measurements, etc.).

[0074] Downlink control channels and signals may support FDM operation. A WTRU may acquire a downlink carrier, for example, by receiving transmissions using (e.g. only) the nominal part of the system bandwidth. For example, a WTRU may not initially receive transmissions covering the entire bandwidth being managed by the network for the concerned carrier.

[0075] Downlink data channels may be allocated over a bandwidth that may or may not correspond to nominal system bandwidth, e.g., without restrictions other than being within a WTRU's configured channel bandwidth. For example, a network may operate a carrier with a 12 MHz system bandwidth using a 5MHz nominal bandwidth allowing devices supporting 5 MHz maximum RF bandwidth to acquire and access the system while potentially allocating +10 to -10 MHz of the carrier frequency to other WTRU's supporting up to 20 MHz worth of channel bandwidth.

[0076] FIG. 3 is an example of flexible spectrum allocation. FIG. 3 shows an example of spectrum allocation where different subcarriers may be (e.g. at least conceptually) assigned to different modes of operation (hereafter Spectrum Operation Mode or SOM). Different SOM may be used to fulfill different requirements for different transmissions. A SOM may consist of a subcarrier spacing, a TTI length and/or one or more reliability aspects (e.g. HARQ processing aspects, secondary control channel). A SOM may be used to refer to a (e.g. specific) waveform or may be related to a processing aspect (e.g. in support of co-existence of different waveforms

ILTE_13091US01

in the same carrier using FDM and/or TDM or coexistence of FDD operation in a TDD band (e.g. with support in a TDM manner or similar)).

[0077] A WTRU may be configured to perform transmissions according to one or more SOMs. For example, a SOM may correspond to transmissions that use at least one of the following: a specific TTI duration, a specific initial power level, a specific HARQ processing type, a specific upper bound for successful HARQ reception/transmission, a specific transmission mode, a specific physical channel (uplink or downlink), a specific waveform type or even a transmission according to a specific RAT (e.g. LTE or according to a 5G transmission technique). A SOM may correspond to a QoS level and/or a related aspect (e.g. maximum/target latency, maximum/target BLER or similar). A SOM may correspond to a spectrum area and/or to a specific control channel or aspect thereof (e.g. search space or DCI type). For example, a WTRU may be configured with a SOM for a URC type of service, a LLC type of service and/or an MBB type of service. A WTRU may have a configuration for a SOM for system access and/or for transmission/reception of L3 control signaling (e.g. RRC), for example, in a portion of a spectrum associated with a system, such as in a nominal system bandwidth.

[0078] Spectrum aggregation may be supported (e.g. for single carrier operation). A WTRU may support transmission and reception of multiple transport blocks over contiguous or non-contiguous sets of physical resource blocks (PRBs), e.g., within the same operating band. Mapping of a single transport block to separate sets of PRBs may be supported. Support may be provided for simultaneous transmissions associated with different SOM requirements.

[0079] Multicarrier operation may be supported, for example, using contiguous or non-contiguous spectrum blocks within the same operating band or across two or more operating bands. Support may be provided for aggregation of spectrum blocks using different modes (e.g. FDD and TDD) and/or different channel access procedures (e.g. licensed and unlicensed band operation below 6 GHz). Support may be provided for procedures that configure, reconfigure and/or dynamically change a WTRU's multicarrier aggregation.

[0080] A scheduling function may be supported in the MAC layer. Support may be provided for multiple (e.g. two) scheduling modes, e.g., network-based scheduling (e.g. for tight scheduling in terms of resources, timing and transmission parameters of downlink transmissions and/or uplink transmissions) and WTRU-based scheduling (e.g. for more flexibility in terms of timing and transmission parameters). Scheduling information for modes may be valid for one or more TTIs.

ILTE_13091US01

[0081] Network-based scheduling may enable a network to tightly manage available radio resources assigned to different WTRUs, which may permit optimal sharing of resources. Dynamic scheduling may be supported.

[0082] WTRU-based scheduling may enable a WTRU to opportunistically access uplink resources with minimal latency on a per-need basis, for example, within a set of shared or dedicated uplink resources assigned (e.g. statically or dynamically) by the network. Support may be provided for synchronized and unsynchronized opportunistic transmissions. Support may be provided for contention-based transmissions and contention-free transmissions.

[0083] Support for opportunistic transmissions (scheduled or unscheduled) may be provided, for example, to meet ultra-low latency requirements for 5G and power saving requirements for mMTC.

[0084] A WTRU may be configured to receive and/or detect one or more system signatures. A system signature may consist of a signal structure using a sequence. A signal may be similar to a synchronization signal, e.g., similar to LTE PSS and/or SSS. A signature may be specific to (e.g. may uniquely identify) a particular node (or transmission/reception point (TRP)) within a given area or it may be common to a plurality of nodes (or TRPs) within an area, which aspect may not be known and/or relevant to a WTRU. A WTRU may determine and/or detect a system signature sequence and may further determine one or more parameters associated with the system. For example, a WTRU may further derive an index therefrom and may use the index to retrieve associated parameters, e.g., within a table, such as an access table. For example, a WTRU may use received power associated with a signature for open-loop power control, e.g., to set an initial transmission power when a WTRU determines that it may access (and/or transmit) using applicable resources of the system. For example, a WTRU may use the timing of a received signature sequence, e.g., to set the timing of a transmission (e.g. a preamble on a PRACH resource) when the WTRU determines that it may access (and/or transmit) using applicable resources of the system.

[0085] A system signature may consist of any type of signal received by a WTRU for one or more purposes described herein.

[0086] A WTRU may be configured with a list of one or more entries. A list may be referred to as an access table. A list may be indexed, e.g., where an (e.g. each) entry may be associated with a system signature and/or to a sequence thereof. An access table may provide initial access parameters for one or more areas. An (e.g. each) entry may provide one or more parameters necessary for performing an initial access to the system. Parameters may include at least one of a set of one or more random access parameters (e.g. including applicable physical layer

ILTE_13091US01

resources, such as PRACH resources) in time and/or frequency, initial power level and/or physical layer resources for reception of a response. Parameters may (e.g. further) include access restrictions (e.g. PLMN identity and/or CSG information). Parameters may (e.g. further) include routing-related information, such as one or more applicable routing areas. An entry may be associated with (and/or indexed by) a system signature. An such entry may be common to a plurality of nodes (or TRPs). A WTRU may receive an access table, for example, via a transmission using dedicated resources (e.g. by RRC configuration) and/or by a transmission using broadcast resources. In the latter case, the periodicity of the transmission of an access table may be relatively long (e.g. up to 10240ms), which may be longer than the periodicity of the transmission of a signature (e.g. in the range of 100ms).

[0087] An access table may consist of any type of system information received by a WTRU for one or more purposes described herein.

[0088] 5gFLEX may support one or more forms of association between data available for transmission and available resources for uplink transmissions. Multiplexing of data with different QoS requirements within the same transport block may be supported, for example, when multiplexing does not introduce a negative impact to the service with the most stringent QoS requirement and does not introduce an unnecessary waste of system resources.

[0089] A Logical Channel (LCH) may represent a logical association between data packets and/or PDUs. An association may be based on data units being associated with the same bearer (similar to legacy), and/or being associated with the same SOM and/or slice (e.g. a processing path using a set of physical resources). For example, an association may be characterized by at least one of a chaining of processing functions, an applicable physical data (and/or control) channel (or instance thereof) or an instantiation of a protocol stack with (i) a specific portion being centralized (e.g. PDCP or anything beyond portions of the physical layer processing such as Radio Front (RF) end) and (ii) another portion being closer to the edge (e.g. MAC/PHY in the TRP or RF) potentially separated by a fronthauling interface. The term LCH as used herein may have a different and/or broader meaning than a similar term for LTE systems.

[0090] A WTRU may be configured to determine a relationship between different data units. A relationship may be based on a matching function (e.g. based on the configuration of one or more field values common to data units that are part of the same logical association). Fields may correspond to fields in a protocol header associated with the data unit(s). For example, a matching function may use a tuple of parameters for fields of the IP headers of a data unit, such as IP source/destination address(es), transport protocol source/destination port(s) and transport protocol type, IP protocol version (e.g. IPv4 or IPv6), etc.

ILTE_13091US01

[0091] For example, data units that are part of the same logical association may share a common radio bearer, processing function, SOM and/or may (e.g. at least conceptually) correspond to the same LCH and/or LCG.

[0092] A Logical Channel Group (LCG) may consist of a group of LCH(s) (or equivalent as per the definition above), e.g., where a grouping may be based on one or more criteria. Criteria may be, for example, that one or more LCH(s) may have a similar priority level applicable to all LCHs of the same LCG or may be associated with the same SOM (or type thereof), the same slice (or type thereof). For example, an association may be characterized by at least one of a chaining of processing functions, an applicable physical data (and/or control) channel (or instance thereof) or instantiation of a protocol stack, which may include (i) a specific portion being centralized (e.g. PDCP or anything except RF) and (ii) another portion being closer to the edge (e.g. MAC/PHY in the TRP or RF) potentially separated by a fronthauling interface. The term LCG as used herein may have a different and/or broader meaning than a similar term for LTE systems.

[0093] A radio access network (RAN) slice may consist of (e.g. all) radio access network functions and transport network functions and resources, e.g., radio resources and backhaul/fronthaul resources along with core network functions/resources that may be used or required to provide end-to-end services to a user. Network functions may, for example, be virtualized on a general purpose processor, run as network functions on specialized hardware or split between specialized hardware and general purpose hardware. A PLMN may consist of one or more network slices. A slice may be equivalent to an operator's single, common or general purpose network. A RAN slice may consist of one or more SOMs that may be optimized to support various services that the RAN slice may have to offer.

[0094] In an example, WTRUs served within a slice may have, for example, one or more of the following aspects in common: (i) services and/or QoE requirements (e.g. ULLRC, eMBB, MMTc); (ii) WTRU categories (e.g. CAT 0 to M and beyond, additional categories may be defined for >6GHz to differentiate beamforming capability); (iii) coverage requirements (e.g. normal coverage, enhanced coverage); (iv) PLMN/Operators; (v) support for specific Uu interface (e.g. LTE, LTE-Evo, 5G below 6Ghz, 5G above 6Ghz, Unlicensed) and/or (vi) served by same core network slice. The terms "RAN slice" and "slice" may be used interchangeably.

[0095] A Transport Channel (TrCH) may consist of a specific set of processing steps and/or a specific set of functions applied to data information that may affect one or more transmission characteristics over a radio interface.

ILTE_13091US01

[0096] LTE may define multiple types of TrCH, such as the Broadcast Channel (BCH), the Paging Channel (PCH), the Downlink Shared Channel (DL-SCH), the Multicast Channel (MCH), the Uplink Shared Channel (UL-SCH) and the Random Access Channel (which may not carry user plane data). Transport channels for carrying user plane data may include the DL-SCH and the UL-SCH for the downlink and for the uplink, respectively.

[0097] An augmented set of requirements may be supported by an air interface for a 5G system. Support may be provided for multiple transport channels, e.g., for user and/or control plane data, for one or more WTRU devices. The term TrCH as used herein may have a different and/or broader meaning than a similar term for LTE systems. For example, a transport channel for URLLC (e.g. URLLCH), for mobile broadband (MBBCH) and/or for machine type communications (MTCCH) may be defined for downlink transmission (e.g. DL-URLLCH, DL-MBBCH and DL-MTCCH) and for uplink transmissions (e.g. UL-URLLCH, UL-MBBCH and UL-MTCCH).

[0098] In an example, multiple TrCH may be mapped to a different set of physical resources (e.g. PhCH) belonging to the same SOM. This may be advantageous, for example, to support simultaneous transmission of traffic with different requirements over the same SOM. An example of this may be transmitting a URLLCH along MTCCH simultaneously when a WTRU is configured with a single SOM.

[0099] A WTRU may be configured with one or more parameters associated with a characterization of how data should be transmitted. A characterization may represent constraints and/or requirements that a WTRU may be expected to meet and/or enforce. A WTRU may perform different operations and/or adjust its behavior as a function of the state associated with the data based on a characterization. Parameters may include, for example, time-related aspects (e.g. Time to Live (TTL) - for a packet, which represents the time before which the packet should be transmitted to meet, acknowledged, etc. to meet latency requirements), rate-related aspects and configuration related aspects (e.g. absolute priority). Parameters may (e.g. also) be changed with time while a packet or data may be pending for transmission.

[0100] A WTRU may be connected to TRPs, e.g., in standalone mode or assisted mode. A group of cells that requires assistance may be referred to as an assisted layer. A group of cells that provides the assistance may be referred to as an assistance layer.

[0101] FIG. 4 is an example of different types of assistance layers. Examples of assistance modes may include, for example: (i) WTRU connected to 5Gflex small cell in sub-6Ghz band assisted by 5Gflex macro cell in sub-6Ghz band; (ii) WTRU connected to 5Gflex small cell in sub-6Ghz band assisted by LTE-Evo macro cell; (iii) WTRU connected to 5Gflex small cell in

ILTE_13091US01

above-6Ghz band assisted by 5Gflex macro cell in sub-6Ghz band; (iv) WTRU connected to 5Gflex small cell in above-6Ghz band assisted by LTE-Evo macro cell; (v) WTRU connected to 5Gflex small cell in above-6Ghz band assisted by 5Gflex small cell in above-6Ghz band; (vi) WTRU connected to 5Gflex small cell in below-6Ghz band in standalone mode; (vii) WTRU connected to 5Gflex macro cell in above-6Ghz band in standalone mode and (viii) WTRU connected to 5Gflex small cell in above-6Ghz band in standalone mode.

[0102] Deployment scenarios may be supported by one or more procedures described herein.

[0103] An example of a deployment scenario may be LTE-assisted 5gFLEX Aggregation (DC/CA/Offload). A WTRU may be configured, for example, using an LTE Control Plane (e.g. with an LTE RRC connection) using an LTE User Plane (e.g. with one or more LTE Uu interfaces). A WTRU may be (e.g. further) configured (e.g. by reception of access table(s) from broadcast or dedicated signaling) to operate with one or more additional 5gFLEX Uu(s), for example, using the principles of LTE DC, LTE CA or LTE-WLAN offload.

[0104] An example of a deployment scenario may be LTE-assisted 5gFLEX Transport Channel(s) (LTE CP, LTE UP, LTE Uu with one or more 5gFLEX TrCH/Physical channels plugged into LTE Uu). A WTRU may be configured for LTE Uu operation (e.g. using LTE procedure(s)). A WTRU may be (e.g. further) configured with one or more physical layer (e.g. control and/or data) channels for a 5gFLEX Uu of the WTRU's configuration. Downlink (DL) physical channels may co-exist in the DL carrier and/or frequency band. An uplink (UL) carrier may (e.g. also) be common or separate. Cell-specific LTE signals/channels may be viewed as "holes" in the 5gFLEX map of physical layer resources, for example, from the perspective of a WTRU configured with one or more 5gFLEX physical channels.

[0105] An example of a deployment scenario may be LTE-based Stand-alone 5gFLEX operation (LTE CP, LTE L2 at least in part, 5gFLEX PHY). A WTRU may be configured with one or more (e.g. many, most or all) of the components of an LTE control plane (e.g. RRC connection, security, etc.) and the LTE user plane (e.g. EPS RABs, PDCP, RLC). A WTRU may be (e.g. further) configured with one or more 5G MAC instance(s). An (e.g. each) instance may have one or more 5gFLEX Uu(s). Stated differently, in an example, a WTRU may not be configured with an LTE PCell.

[0106] An example of a deployment scenario may be Stand-alone 5gFLEX operation. A WTRU may be configured with a 5G control plane and a 5G user plane. 5gFLEX Uu operation may be supported.

[0107] WTRU control aspects may include procedures enabling configuration and coherent operation for one or more of the following aspects: (i) a plurality of radio "layers"; (ii) a plurality

ILTE_13091US01

of radio access technologies (e.g. NR, LTE, Wifi, etc.); (iii) a plurality of L2 transport and/or user plane components, which may be realized using different network slices and/or sets of physical resources; and/or (iv) enhanced connectivity principles such as loosely connected state.

[0108] Although examples describe procedures, features and elements in particular combinations, the disclosed subject matter encompasses implementation of each procedure, feature and/or element in whole or in part, individually or in any combination with and without other procedures, features and/or elements disclosed herein or known.

[0109] A transmission/reception point (TRP) may support, for example, one or more of the following access procedures: LTE/LTE-A/LTE-Evo air interface, an NR access (e.g. based on a flexible 5G air interface or similar), a beamformed interface for higher frequencies, a non-3GPP access (e.g. 802.11 family such as WiFi), License Assisted Access (LAA), a narrow band air interface or similar. TRP, eNB/NR-eNB, access point, base station and the like may be used interchangeably.

[0110] A WTRU may be connected in a number of different manners with a radio system. For example, a WTRU may be configured for transmission to/from one or more TRPs. Multiple transmissions may be transmitted and/or received concurrently. A WTRU may (e.g. further) be configured for transmissions that may be characterized by varying levels of diversity/reliability, mobility robustness, differentiation in terms of services, etc. Higher level services may involve, for example, the configuration of a plurality of TRPs to achieve service levels. For example, one or more TRPs may support (e.g. only) narrow band transmissions, one or more TRPs may provide best effort offload, one or more TRPs may provide less overhead (e.g. specific signatures, preconfigured bearer), etc. A WTRU may be agnostic to the identity of a TRP and/or the number of TRPs, for example, even when configured with multiple TRPs. In an example, transmissions to/from different TRPs may be differentiated, for example, based on applicable reference signals (RS), control channels, timing and/or operating carrier/frequencies.

[0111] A distributed approach may be implemented for control plane modeling. A control plane in previous generations of wireless systems (e.g. LTE) may have a suite of protocols (e.g. RRC and NAS) use a very centralized and monolithic approach, e.g., from a WTRU perspective. A centralized approach may be difficult to scale for next generation systems that may require support for and/or coordination between differentiated services (e.g. very low latency services), multi-connectivity, a larger number of small cells for a given WTRU.

[0112] Distribution of (e.g. certain) functions, for example, towards the edge of a RAN (e.g. in or close to a TRP) may provide a more scalable approach for an NR system. Furthermore, increased isolation between different user plane processing paths (e.g. similar to bearers in

ILTE_13091US01

EPC/LTE) may facilitate differentiated QoS, management of multi-path bearers (or similar) as well as differentiated allocation of network resources in a system and (e.g. potentially) sharing of network resources between operators.

[0113] Example procedures disclosed herein may enable a WTRU to be configured with plurality of user plane functions and/or processing paths according to diverse service requirements with support for diverse device types, deployment scenarios and other requirements in an NR system. For example, procedures disclosed herein may enable a control plane entity to establish, maintain and/or tear down service specific user plane components as needed, e.g., using a distributed model.

[0114] A separation and protocol/functional split may be provided. A distributed control plane may be modeled, for example, to enable a number of control functions to operate close to the edge of the system. The functions may be replicated, for example, using a number of instances (e.g. in different TRPs with multi-connectivity). Some functions may be centralized (e.g. to manage core network connectivity and user plane instances). Consequently, there may be multiple different termination points in the access network that concurrently provide control services for a given WTRU. A WTRU may support a multiplexing/demultiplexing function (e.g. different sets of one or more SRBs) associated with one or more (e.g. specific) control plane contexts/instances/functions or a set thereof. A control plane model may (e.g. also) support one or more control plane functions to operate concurrently and/or in parallel, e.g., for functions logically closer to the edge. Centralizing one or more control plane functions may enable or facilitate coordination between different control plane instances of the same WTRUs, e.g., coordination between different TRPs of a WTRU's configuration.

[0115] Control plane/user plane (CP/UP) separation may be modeled in a variety of different ways. There may be a variety of potential axes for separation of the different components of a control plane.

[0116] In an example, vertical isolation may be provided in a protocol stack (CP and/or UP). Different options may be based on *depth* of separation. In an example of a *partial separation or split approach*, CP/UP specific higher layers may be followed by one or more common lower layers. In an example of a *complete separation*, an independent protocol stack may be provided, e.g., all the way down to L1/PHY. For example, an optimized PHY channel design and/or different DCI/grant level may be provided. A different Spectral Operating Mode/signal structure may be provided.

[0117] In an example, horizontal separation may be provided between instances of a (e.g. potentially different) protocol stack. A control plane instance may operate on a user plane

instance. A protocol stack may be separated, e.g., by an interface between a central unit (CU) and a remote unit (RU). Functional splits may be based on or more of the following, for example: (i) transport network profile (e.g. fronthaul and/or backhaul bandwidth, latency, jitter, etc.); (ii) specific deployment scenarios; (iii) type of service (e.g. eMBB services may utilize centralized processing for cost savings and URLLC services may utilize distributed processing to minimize latency); (iv) resource availability (e.g. processing resource, specialized hardware); (v) vendor interoperability and/or (vi) dynamic changes to transport network capacity (e.g. when the transport network is shared with multiple TRPs and/or operators).

[0118] In an example, physical or access separation may be provided. Uu termination may be provided for control and user plane at different nodes in the RAN (e.g. assisted layer or different TRP). For example, CP termination may be at LTE-Evo eNB and UP termination may be at NG TRP/RCU, e.g., in assisted mode. In an example, an L2 transport and/or termination point for CP may be different from UP, e.g., in standalone mode. In an example, an L2 transport and/or termination point for CP may be any TRP while for UP it may be using a restricted set of TRPs, e.g., in standalone mode.

[0119] Modeling described herein may support any of the foregoing separation models and/or other models, alone or in combination. For example, modeling may facilitate having a control plane component and its associated user plane in different RAN slices. Slices may be realized, for example, by physical and/or vertical separation. For example, a multi-plane architecture may support a combination of horizontal separation and vertical isolation.

[0120] Examples of elements and characteristics may be provided for a distributed control plane architecture.

[0121] A high level generalization (e.g. a conceptual view) of a control plane may be as a set of one or more control function(s). A control function may include processing steps and related parameters. Examples of control functions are described herein. A control function may apply to one or more component(s) of a WTRU.

[0122] Components may include, for example, a protocol (e.g. NAS, RRC, PDCP, RLC, MAC, PHY, etc.) and/or a corresponding entity, an implementation aspect (e.g. a power control function, a state of a WTRU, etc.), a set of resources (e.g. a data transport path, a bearer, etc.) or a combination thereof (e.g. a set of physical/processing resources, a slice, etc.). Examples of component combinations are described herein.

[0123] A control functions may be characterized as being applicable, for example, according to one or more of the following: (i) a WTRU-specific function; (ii) a component-specific function and/or (iii) a plural-component function.

ILTE_13091US01

[0124] In an example of a WTRU-specific function, a control function may be applicable to any aspect(s) and/or component(s) of a WTRU. For example, a function that controls a WTRU's connectivity to a core network (e.g. in terms of access credentials) may be WTRU-specific. A function may (e.g. from a network perspective) be centralized in a node that supports connectivity to a plurality of TRPs/NR-eNBs. For example, a function may be logically part of a RAN Central Control Function (RCCF), e.g., described below.

[0125] In an example of a component-specific function, a control function may be applicable to one or more aspects of a WTRU. An aspect may be, for example: (i) a MAC instance; (ii) a signature-specific aspect (e.g. a configuration corresponding to a signature); (iii) a TRP-specific aspect (e.g. a configuration corresponding to a TRP); (iv) a TRPG-specific aspect (e.g. a configuration corresponding to a TRPG); (v) an LCH (or equivalent)-specific aspect (e.g. a configuration corresponding to an LCH); (vi) an instance of a component combination (e.g. a bearer, a flow such as a sequence of packets identified by a matching rule (e.g. a tuple, etc.), for example, as described herein; (vii) a slice specific aspect (e.g. a configuration) corresponding to a RAN slice and/or a core network slice or (e.g. alternatively) to an end-to-end network slice (e.g. a core network slice, a slice selection function and one or more RAN functions); (viii) a spectral operating mode (e.g. a configuration) corresponding to a spectral operating mode and/or (ix) other FFS. In an example, a WTRU may apply a received configuration to a specific time/frequency resource while using a different configuration for other time/frequency resources in the system.

[0126] For example, a function may be logically part of an Access Control Function (ACF), e.g., for a function dedicated to connectivity to a single TRP/NR-eNB, which may include configuration for a MAC instance and physical layer parameters (e.g. single or multiple cells/carriers) for a given WTRU.

[0127] In an example of a plural-component function, a control function may be applicable to a plurality of components of a WTRU. For example, a function may be logically part of an Access Control Function (ACF) for a function that may control connectivity for a TRPG and/or for one or more NR-eNB(s), which may include configuration for a single MAC instance (e.g. COMP) or for multiple MAC instances (e.g. for multi-connectivity) and (e.g. required) physical layer parameters for a given WTRU. This may, for example, further include coordination and/or configuration aspects for a WTRU to handle, e.g., with reception of multiple responses to a random access within a TRPG, if applicable, for single TRP selection or for multiple TRP selection (e.g. for aggregation and/or multiple connectivity).

ILTE_13091US01

[0128] Examples may be provided for some (e.g. most) applicable control plane functions, e.g., individually. A function may be described with reference to its applicability to these non-limiting characterizations.

[0129] High-level modeling of a control plane for NR may be provided. Functions and components may, for example, be logically grouped.

[0130] A multi-plane architecture may be provided. In an example procedure, functions and components supporting an NR system may be logically grouped, for example, in terms of an Access Plane (AP), a Central Control Plane (CCP) and/or a Central User Plane (CUP). A description of example realizations of user plane components is described herein.

[0131] Logical grouping of functions may enable different components and functions of a system to be isolated from each other. Isolation may (e.g. further) enable components and functions to be controlled, configured, modified and/or operated separately from each other. Separation may be applied for components and functions associated with a specific WTRU, per TRP/NR-eNB, per TRPG, per TRPGs, per group of NR-eNBs, per LCH (or equivalent), per slice, etc. Separation between centralized and access-related grouping may enable coordination between different instances of a function (e.g. system information provisioning, bearer configuration or equivalent) or between different instances of different functions (e.g. core network connectivity and user plane / bearer instances).

[0132] FIG. 5 is an example of logical grouping. There may be an architectural aspect or approach to a functional split. For example, FIG. 5 shows an example of a tri-plane architecture.

[0133] Different principles for a functional split between an access control plane and a central control plane may be considered.

[0134] In an example, there may be a single access plane per RAT and central control per multiple RATs. For example, an access control plane may include control functions specific to the access technology (e.g. beamforming control function, control function specific to LTE, non-3GPP control function, etc.). A central control plane may include control functions that are agonistic to an air interface. A common central control plane may be associated with multiple TRPs with diverse access technologies, for example, for LTE/LTE-A/LTE-Evo air interface, a flexible 5G air interface, a beamformed air interface for higher frequencies, a non-3GPP access (e.g. 802.11 family such as WiFi), License assisted access (LAA), a narrow band air interface, etc.

[0135] In an example, there may be one access plane per TRP/cell and central control per multiple TRPs. For example, an access control plane may include control functions specific to a TRP/cell. A central control plane may include control functions applicable to more than one

TRP. This approach may simplify inter-TRP coordination for efficient radio resource management, RAN mobility management and self-organizing functions, etc. A central control plane may (e.g. in one or more cases) lead to cost effective deployments, for example, as it may not require additional interface between TRPs.

[0136] For example, an access control plane may be responsible for establishment, maintenance and release of a layer 1/layer 2 (L1/2) connection, allocation of a temporary identifier to identify a WTRU uniquely within a TRP, common and dedicated L1 and L2 resource configuration specific to a TRP, etc. A central control plane may be responsible for configuring L3 signaling flows or abstraction thereof (e.g. signaling radio bearers), configuration of higher layer data flows or abstraction thereof (e.g. data radio bearers), security functions (e.g. may include key management), radio resource configuration (e.g. may be common across two or more TRPs), mobility functions (e.g. may include WTRU measurement control), handover control, context transfer, paging, etc.

[0137] QoS management functions may be controlled by a central control plane and may be enforced by an access control plane. QoS management functions may (e.g. alternatively) be part of a user plane control function, if applicable.

[0138] A system information broadcast function may be shared between an access control plane and a central control plane. For example, an access control plane may be responsible for scheduling and transmission of TRP specific system information related to accessibility, physical channel configuration, SC-PTM configuration, etc. An access control plane may be responsible for transmission of MIB and/or for handling dedicated system information procedure.

[0139] A central control plane may, for example, determine the contents of system information for cell (re)-selection information, intra-frequency, inter-frequency and inter-RAT neighbor information, MBMS information, side link information etc. Common and shared channel related configuration may be coordinated between the access control plane and central control plane. For example, a configuration for layer 2 RAN functions located in TRPs may be configured and controlled by the access control plane (e.g. for MAC, physical layer) while layer 2 RAN functions placed in the central user plane entity may be configured and controlled by the central control plane (e.g. for PDCP, RLC, bearers or similar and/or access table for a TRPG, if applicable).

[0140] A service/QoS-based functional location may be provided for a function in an access plane or a control plane. In an example, control functions that may be time sensitive with a strict deadline may be placed in TRPs while other control functions may be placed in the central

ILTE_13091US01

control plane. This approach may relax latency requirements on the fronthaul interface between the central unit and the TRPs and may enable cost efficient deployments.

[0141] Another example of a functional split may be applied, for example, when RAN level slicing is supported. For example, control functions that are common across two or more slices may be placed in the central control plane while control functions that are specific to a slice may be placed in the access control plane. In this approach, mobility control, WTRU context handling, etc. may be a part of a central control plane while the access control plane may include slice specific system information broadcast, slice specific authentication and security management, slice specific QoS enforcement, etc.

[0142] A WTRU may be able to determine how to exchange signaling with different endpoints and/or with specific instances of a function, for example, based on these modeling examples. Such may be realized using different multiplexing procedures such as those described herein.

[0143] Access control functions (e.g. from the perspective of an overall RAN architecture) may be (e.g. conceptually) defined as set of logical functions, parameters and procedures that enable a WTRU to be uniquely addressed and/or identified by one or more TRPs. A WTRU may (e.g. further) generate and/or exchange data and/or signaling with those TRPs. Access control functions may provide distributed/edge control and user plane functions that may be specific to a TRP and WTRU pair. An (e.g. each) Access control function may be associated with a scheduler instance controlling one or more TRPs (e.g. over ideal backhaul). Such function may be part of a radio resource control protocol (e.g. RRC). Such function may be performed by a RRC entity e.g. located in a TRP. A WTRU may (e.g. from the WTRU perspective) be configured to associate a specific signaling bearer or equivalent (e.g. a transport path/procedure) for control of a MAC entity with the concerned MAC entity. The function may be part of a Medium Access Control (e.g. MAC) protocol. This function may be performed by a MAC entity. The Access Plane function may use transport services of MAC protocols (e.g. as MAC Control Elements, as MAC Control PDUs, or similar), for example, when the MAC entity perform the functions associated to the Access Plane.

[0144] An access plane may be considered to be established, for example, when a WTRU may be uniquely identified by access control functions. An access plane may (e.g. alternatively) be established, for example, when a WTRU can start transmission of user plane data. An access plane may (e.g. alternatively) be established, for example, when a WTRU receives a response that configures a capability for the WTRU to start performing (receiving or transmitting)

ILTE_13091US01

dedicated transmissions, which may include when security is activated (if applicable) for the concerned configuration.

[0145] High level scoping of an access plane may be performed. For example, a WTRU may be configured to access resources associated with one or more radio access network nodes (e.g. TRP(s), TRPG(s) or NR-eNB(s)) using one or more of a set of functions, parameters and/or procedures.

[0146] In an example, such procedures may include capabilities for a WTRU to perform an initial access (e.g. to establish access plane connectivity), perform a random access procedure or similar, for example, to obtain uplink timing alignment and/or further resources for uplink transmission, to select a suitable network node (e.g. based on measurements of downlink signals and/or based on reception of one or more responses to the initial request such as one or more RARs), to obtain a unique identifier (e.g. a dedicated RNTI), to obtain a configuration (e.g. for physical layer operation), to enable transmission of control signaling (e.g. a signaling radio bearer or equivalent) and/or to establish a Uu interface or equivalent with a corresponding network node.

[0147] An access plane may terminate a control signaling protocol.

[0148] An access plane may be provided for component-specific applicability. In an example procedure, an access plane may control aspects related to (e.g. at most) an (e.g. one) access network node. For example, an access plane may provide services for control and configuration of a physical layer and/or configuration of a MAC instance associated with a (e.g. one) TRP/NR-eNB. Coordination between multiple access nodes may not be assumed or necessary, for example, in this case.

[0149] An access plane may be provided for plural-component applicability. In an example procedure, an access plane may control aspects related to one or more access nodes. For example, an access plane may provide services for control and configuration for a physical layer for one or more cells and/or configuration of a MAC instance, where (e.g. potentially) each may be associated with applicable TRPs/NR-eNBs. For example, an access plane may support coordination of one or more aspects between different network nodes. Coordination may be per TRPG, per area, per signature and/or per set of access parameters. Coordination may be provided, for example, using a (e.g. single) MAC entity (e.g. with a coordinated scheduling function such as carrier aggregation-like assuming ideal interfaces) or by a control function that may interface with a WTRU for the configuration of multiple MAC instances, e.g., when applicable (e.g. a multi-connectivity approach).

[0150] A central control plane (e.g. a RAN control plane) may be provided. RAN Central Control Functions (RCCF) may include control functions, protocols and/or context that may be WTRU specific and/or applicable to one or more TRPs/ACFs. A central control plane may be considered as an anchor control function that may terminate a control interface towards the core network (e.g. through configuration/setup of routing paths and transport paths, for example, based on tuples configured for a WTRU). An RCCF may (e.g. additionally) include control functions related to selection of a core network slice, CN-RAN interfaces, QoS management, security (e.g. master key management and key derivation, which may be per group of TRPs/NR-eNBs), WTRU capability management and WTRU reachability within RAN.

[0151] WTRU context may be setup at RCCF (e.g. after CORE/NAS interaction). From RCCF point of view: a WTRU (e.g. from RCCF perspective) may have a known TRP(G) granularity (e.g. when access plane is active).

[0152] Central User Plane control functions may be (e.g. conceptually) defined as set of logical functions, parameters and procedures that may enable a WTRU to transfer user plane data with a network. Functions may be applicable to one of more user plane components (e.g. bearers, L2 transport path, flow-based routing entry, slice instance managing such, etc.). One or more functions may be part of the set of central control plane functions or may be logically separated therefrom.

[0153] Signaling may be generated and/or exchanged with one more or TRPs that may be part of a concerned user plane component. Central user plane functions may provide control for aspects that may be specific to a service, a slice, a bearer and/or a set of processing steps configured for the transport of one or more (e.g. specific) flows, which may be determined by configured tuples. A (e.g. each) control function may be associated with a scheduler instance controlling one or more TRPs (e.g. over ideal backhaul). A WTRU (e.g. from its own perspective) may be configured to associate a specific central user plane instance with a signaling bearer or equivalent (e.g. a transport path/procedure) for control of a user plane component with one (e.g. single path/Uu) or more (e.g. multi-path/Uu) applicable MAC entities. A function may (e.g. alternatively) use transport services of corresponding MAC protocols, for example, as MAC Control Elements or similar.

[0154] An efficient data path may be setup between a TRP and a RAN Central User Function (RCUF) and/or between different RCUFs, e.g., when applicable. Connection oriented or connection-less user plane (e.g. WTRU assisted packet-based routing) may be supported.

[0155] RAN central user plane functions may comprise, for example, functions, protocols and/or parameters that may be service or data traffic specific.

ILTE_13091US01

[0156] There may be interactions between different control functions and components. A timing relation between access plane establishment and central control plane establishment may, for example, depend on a WTRU state. For example, a WTRU in a passive or IDLE state may transition to connected state by (e.g. first) establishing an access plane, e.g., using control signaling interaction with one or more access control functions (ACFs). In an example, an access plane may be established as a result of an association procedure between a WTRU and a network. A WTRU may (e.g. then) trigger central control plane establishment, for example, using control signaling interaction with one or more central control functions. In an example, a WTRU may establish a central control plane (e.g. only) or may establish a central control plane and a central user plane, for example, based on whether the WTRU has signaling traffic and/or data traffic. In an (e.g. another) example, a WTRU may (e.g. directly) transmit data without access plane establishment, for example, when the WTRU (e.g. in a loosely connected state) may have a central control context without an access plane established.

[0157] A WTRU may store a Central control plane context, for example, even after an access plane may be deactivated. Central control functions may (e.g. similarly) retain a WTRU context, for example, even after the access control functions release WTRU context and/or WTRU specific connectivity between access control functions and central control functions. Central control functions may (e.g. additionally) retain WTRU context, for example, even after central user functions release WTRU context and/or WTRU specific connectivity between central user plane functions and core network user plane functions. In other words, for example, a RAN control plane (e.g. SRBs) may exist without an active user plane (e.g. DRBs). In an example, a WTRU may attach to a network without a corresponding data bearer establishment. A WTRU may (e.g. be required to) maintain central user plane context, for example, (e.g. only) when the central control plane context is active.

[0158] An access plane may be dynamically activated/deactivated, e.g., by access control functions or by central control functions, for example, when a control plane context is active.

[0159] WTRU connectivity may have one or more supported states. For example, a WTRU may operate according to one or more of the following states: (i) idle mode; (ii) idle mode with connectionless transfers; (iii) connected mode and/or (iv) loosely connected mode.

[0160] In an example of an IDLE mode, a WTRU may not have established connectivity with a network (e.g. a WTRU may not have ACF/ACP, RCCF/RCCP or RCUF/RCUP established).

[0161] In an example of an IDLE mode with Connectionless Transfers, a WTRU may have some connectivity with a network (e.g. it may have at least one ACF/ACP established with at

ILTE_13091US01

least one user plane component, e.g., with a default configuration, e.g., for routing and/or security). A WTRU may have RCCF/RCCP established (e.g. a security context, access tables).

[0162] In an example of a connected mode, a WTRU may have complete connectivity with a network (e.g. it may have at least one ACF/ACP, RCCF/RCCP and RCUF/RCUP (e.g. when applicable) established with at least one user plane component).

[0163] In an example of a loosely connected mode, a WTRU may have some connectivity with a network (e.g. it may have at least one RCCF/RCCP established, e.g., a security context, access tables).

[0164] Connectionless data transfer may be provided. A WTRU may establish an L3/RRC connection to transmit data PDUs irrespective of the size of the data packet. However, establishing a connection may be difficult relative to (i) overheads associated with signaling to establish a connection at the RAN and Core network before the start of a small packet transfer; (ii) overhead associated with tearing down a connection after periods of inactivity and (iii) WTRU battery drain to stay in connected mode for extended periods of time.

[0165] A WTRU may (e.g. directly) perform connectionless data transfer in a loosely connected state, for example, using a pre-existing context with a central control plane function. A pre-existing context may include (e.g. at least) a security context, WTRU subscription and WTRU capability configuration. A WTRU may (e.g. also) perform connectionless data transfer from an idle connectionless state, e.g., using a pre-existing context with the core network control function. A WTRU may (e.g. in this example) not have a RAN central context established. In an example, a WTRU may be associated with (e.g. only) a default slice or a core network control function and may still transmit connectionless data. A WTRU may (e.g. in this example) include additional session information with a data PDU.

[0166] Connectionless data transfer may allow a WTRU to transmit data, for example, with one or more following characteristics/properties: (i) without requiring access plane establishment, (ii) using modified msg1 (e.g. modified RACH preamble + data, multi-user non-orthogonal data channel, etc.); (iii) without receiving an explicit grant (e.g. contention based UL shared data channel); (iv) after UL synch (e.g. using piggybacked data with or as msg3); (v) before UL synch to the network (e.g. using asynchronous access channel) and/or (vi) transmitting additional context information associated with the data PDU.

[0167] A WTRU may use a simplified security procedure that may, for example, involve one or more of following: (i) using stored context, which may be result of previous network interaction or hard coded security context in SIM and/or (ii) explicit indication of security algorithm used.

ILTE_13091US01

[0168] A connectionless data transfer mode may allow a WTRU to transmit data PDUs earlier than connection oriented data transmission. Such data PDUs may be referred to as early data PDUs.

[0169] In an example, a connectionless data transfer mode may (e.g. also) be used for downlink transmissions. For example, a WTRU may receive data PDUs in the same TTI with a paging message or along with the paging message itself. A network may trigger such connectionless downlink transfer, for example, when a WTRU location is known at a fine granularity and the size of the data packet is small.

[0170] A WTRU may trigger connectionless data transfer, for example, based on one or more of the following criteria: (i) a service (e.g. low overhead service or a low latency service, etc.); (ii) a size of a packet (e.g. when the size of the packet is less than a predefined number of bytes); (iii) WTRU buffer occupancy (e.g. when a WTRU buffer size is less than a predefined number of bytes); (iv) latency experienced by the packet (e.g. when the packet exceeds latency budget); (v) packet filtering (e.g. WTRU may be configured with a packet filter/TFT to identify packets matching specific criteria, such as IP address, protocol, port number, type of service, flow label or a preconfigured session ID); (vi) absence of valid/configured logical connection (e.g. EPS bearer/Radio bearer); (vii) type of PDUs (e.g. initial signaling messages may use connectionless); (viii) WTRU mobility state (e.g. when WTRU speed or number of reselections/HO per second exceeds a threshold, which may be used to limit the number of handovers for medium/fast moving WTRU); (ix) a WTRU category; and/or (x) access class.

[0171] In an example, a WTRU may (e.g. always) trigger a connectionless transfer, e.g., by default or as configured by an access table. A WTRU may (e.g. subsequently) transition to connection oriented transfer, for example, based on WTRU and/or network procedures described herein.

[0172] A WTRU may determine L1 and L2 configuration for connectionless transfer, for example, using one or more of the following procedures: (i) WTRU may apply a default configuration; (ii) WTRU may apply a predefined configuration acquired via system broadcast (e.g. access table and/or system signature based) that may be specific to a access control function, to a central control function and/or to a TRP or a group of TRPs; (iii) WTRU may apply a stored configuration (e.g. received upon establishing central control plane context) that may be dedicated for a WTRU or a group of WTRUs where the same configuration may be used across multiple TRPs and/or (iv) WTRU may (e.g. explicitly) request connectionless transfer and may obtain specific configuration that may include transmission resources (e.g. contention based/non-orthogonal resources, layer2 configuration, etc.).

ILTE_13091US01

[0173] A layer 2 configuration may (e.g. in addition to a physical layer time/frequency resource configuration) include a max data rate restriction, bucket size, RLC mode, PDPC discard timer, security algorithm, etc. In an example, specific MAC instances may be configured for connectionless transfer.

[0174] One or more connectionless configuration parameters may be associated with a validity timer. A WTRU may start a validity timer, for example, upon receiving configuration parameters. A WTRU may consider configurations, for example, (e.g. only) when the timer is running. A WTRU may delete/release configurations, for example, upon the expiration of a validity timer.

[0175] A WTRU may include additional context information with a data PDU, for example, to assist a network with processing and routing a data packet to an appropriate destination. Additional context information may be included, for example, in a layer 3 message and/or as a part of a layer 2 header field. In an example, a layer3 message type may be defined to identify connectionless data. An IE (e.g. connectionless-data-IE) may (e.g. alternatively) be introduced in a layer 3 message (e.g. UL information transfer).

[0176] A WTRU may include one or more types of information as context information in an early data PDU.

[0177] For example, context information may comprise WTRU Identity information, which may comprise, for example, one or more of the following: (i) an L3 identity that may have been allocated by a central control function during a previous interaction; an associated Identity of the central control function and/or an NAS level identity; (ii) an implicit indication of a portion of or a or whole identity, e.g., using the selection of time/frequency resource; and/or (iii) a demodulation reference signal or unique word that may be a function of WTRU ID.

[0178] For example, context information may comprise a more data left indication or last PDU indication, which may indicate whether there are additional PDUs in WTRU buffer along with the early data PDU.

[0179] For example, context information may comprise one or more of: (i) QoS related information, e.g., an indication to treat the early data PDU as a default QoS or as a non-default bearer data PDU; (ii) a low latency indicator, e.g., to allow a network to use low latency and an efficient data path; (iii) a low overhead indicator, e.g., to allow a network to use a low overhead mechanism for transfer (e.g. a connectionless transport).

[0180] For example, context information may comprise application description or session related information, such as a predefined session ID, e.g., so a network knows which session a data PDU is associated with.

ILTE_13091US01

[0181] For example, context information may comprise forwarding/routing/transport layer information (e.g. a general packet radio service tunneling protocol (GTP) tunnel or a flow table entry or an index to flow table entry).

[0182] For example, context information may comprise security context information.

[0183] For example, context information may comprise destination ID, such as a control plane ID or a user plane entity ID, e.g., depending whether a PDU is a signaling PDU or data PDU.

[0184] For example, context information may comprise user plane entity ID (e.g. when one already exists to avoid signaling towards RAN control plane entity), for example, for a RAN and/or Core user plane entity.

[0185] For example, context information may comprise control plane entity ID (e.g. entity with a valid WTRU context including subscription, security, etc.), for example, for a RAN Control entity and/or a core (e.g. MME ID + WTRU ID within the MME service area).

[0186] For example, context information may comprise slice identity, e.g., when a WTRU is already configured with a specific slice for connectionless transfer.

[0187] A WTRU may receive and may process feedback for a connectionless data transfer, where processing may be different from a connection oriented data transfer. A WTRU may (e.g. implicitly) determine the resources for feedback, for example, as a function of UL time/frequency resources used for early data PDU transmission and/or as a function of WTRU ID included in the data PDU.

[0188] Feedback (e.g. for data transmitted using connectionless/early data transfer based mode) may be associated with additional information, including, one or more types of additional information.

[0189] For example, additional information may comprise a WTRU ID for which feedback is sent (e.g. copied from UL Data PDU), e.g., where WTRU may verify the WTRU ID present in the feedback before processing the feedback message.

[0190] For example, additional information may comprise a timing advance (e.g. for async/contention based UL).

[0191] For example, additional information may comprise a power control command.

[0192] For example, additional information may comprise an ACK/NACK, e.g., where additional resources may be granted for retransmission for NACK.

[0193] For example, additional information may comprise a collision/contention indication, e.g., when WTRU action is based on contention indicator, such as: (i) when WTRUs can be distinguished at eNB (e.g. by orthogonal DMRS) and/or when WTRU receives other WTRU IDs

ILTE_13091US01

in the feedback, a WTRU may transmit at next opportunity; and/or (ii) when WTRU receives a contention indication, the WTRU may perform, for example, a random back off or fallback to connection based data transfer.

[0194] For example, additional information may comprise an indication to trigger access plane establishment or fallback to connection oriented mode.

[0195] For example, additional information may comprise additional UL resource grants and/or an Indication to go back to idle mode (or implicitly an ACK may be used to go back to idle mode), for example, depending on last PDU indication.

[0196] For example, additional information may comprise a request for WTRU identity or additional authentication procedure, e.g., when WTRU context may not be fetched or when WTRU may be unknown at the RCCF or the security check failure, etc, where a WTRU may respond to the authentication procedure and/or provide additional context information.

[0197] A WTRU may (e.g. in connectionless transfer mode) trigger a transition to connected oriented mode, for example, based on one or more of the following criteria or events: (i) when a WTRU spends more than a predefined time in connectionless mode; (ii) when a WTRU receives a data packet with more than predefined number of bytes; (iii) when a WTRU transmits more than a predefined number of bytes in connectionless mode; (iv) when a WTRU buffer size exceeds a threshold; (v) when a latency of buffered data exceeds a threshold; (vi) when a number of NACKs/retransmissions for an early data PDU exceeds a threshold; (vii) when a data rate over a predefined time window exceeds threshold and/or (viii) when an activity timer exceeds a threshold, e.g., when an activity timer that may be (e.g. always) running when a WTRU enters connectionless transfer mode, where the activity timer may be reset to zero and started again when the time between two consecutive packets exceeds a threshold.

[0198] In an example, a WTRU may be configured to report one or more events. A network may determine whether to transition the WTRU to connection oriented mode. A WTRU may report events, for example, using a control message or signal or piggyback indication in a connectionless data PDU. A network may (e.g. also) trigger a transition to connection oriented mode, for example, based on policies, type of services, WTRU subscription, WTRU mobility, etc. In an example, a WTRU may transition from connection oriented mode to connectionless mode, for example, based on a network command (e.g. based on inactivity).

[0199] A user plane component may be (e.g. conceptually) represented as a transport path. A transport path may include, for example, one or more of the following: (i) one or more Uu (which may be associated with a specific SOM and/or physical layer QoS) and/or a configuration thereof; (ii) a QoS profile (e.g. in terms of maximum latency, jitter, packet loss rate or the likes)

ILTE_13091US01

or a configuration thereof; (iii) an association with one or more data flows and/or service (e.g. as indicated by a multiplexing function that may be based on logical radio bearer, tuples or a configuration thereof); (iv) routing table entries (e.g. in the network); (v) a list or set of one or more matching rules; (vi) a list or set of one or more tuples (e.g. to determine what logical path a packet may or should be directed to) and/or (vii) other FFS.

[0200] A distributed control plane for NR may have functions and components, which may be discussed from the perspective of their different applicability.

[0201] In an example, a WTRU-specific function may be associated with an anchor control function. An RCCF may manage connectivity of a WTRU with a core network (e.g. PDN connectivity, reachability, etc).

[0202] In an example, a component-specific function may operate on one or more aspects of a single instance of a component for a given WTRU.

[0203] In an example, a plural-component function may operate on one or more aspects of multiple instances of a component for a given WTRU.

[0204] In an example, control functions may be associated with MAC instances that may (e.g. also) map to a set of access control functions.

[0205] In an example, control functions may be associated with a single MAC instance.

[0206] System information may be acquired, for example, as a WTRU-specific function, as a component-specific function and/or as a plural-component function.

[0207] In an example of system information acquired as a WTRU-specific function, a component may include, for example, a cell, TRP, TRPG or groups thereof (e.g. everything a WTRU may need). On-Demand procedures, including requests and combination with already known SysInfo (pre-provisioning or acquired) may be described. SysInfo split may be supported. Out-of-band SysInfo may be supported.

[0208] In an example of system information acquired as a Component-specific function, a component may be, for example, a cell and/or a TRP. SysInfo split may be supported. Out-of-band SysInfo may be supported.

[0209] In an example of system information acquired as a Plural-component function, a component may be, for example, multiple cells, multiple TRPs, multiple TRPGs, multiple NR-eNBs, etc. SysInfo split may be supported. Out-of-band SysInfo may be supported.

[0210] System information may be acquired, for example, using one or more approaches or procedures.

[0211] For example, system information may be acquired by broadcast, e.g., similar to LTE.

ILTE_13091US01

[0212] For example, system information may be acquired by splitting information in a first set of information and in a second set of information. Such information may comprise one or more system parameters. Such split of information may be based on one or more characteristics of the concerned information. Such characteristic may include whether or not the information is essential for accessing the concerned network resources, whether or not the information relates to a feature and/or function available using the concerned network resources, whether or not the information relates to a feature and/or function for low-latency access (e.g. URLLC), whether or not the information may enable specific UE procedures such as camping, measurements, and/or the likes. Such first set may be further referred to as “Essential” information and such second set may be further referred to as “Non-essential” information. Such split may be network-controlled and vary from one area to another, where essential system information may be broadcast (e.g. to enable a WTRU to access the system and obtain further system information through dedicated resources. Broadcast information may comprise MIB, SIB1 (access-related information e.g. PLMN, TAC, CellID, p-Max, frequency band indicator), SIB2 (access barring information, RACH parameters, UL power control). On-demand (dedicated) information may comprise obtaining remaining system information through dedicated resources (e.g. triggered through PRACH), where, on-demand acquisition may be based on a service (e.g. camping/paging etc.), WTRU capability, slice, etc.

[0213] For example, system information may be acquired by splitting information across broadcast and dedicated transmissions. A split may be network-controlled and may vary from one area to another. A flexible mechanism may be provided to support variable split between broadcast and dedicated information.

[0214] For example, system information may be acquired by system information modification, which may provide one or more mechanisms, for example: (i) to update the delta, whether pushed or on-demand (e.g. WTRU-initiated or NW-initiated by control signaling ordering WTRU to start the procedure) and/or (ii) to request a specific element of system information (e.g. SIB).

[0215] For example, system information may be acquired by variable acquisition, for example, based on location and/or frequency band (e.g. system information applicable in one location and/or for one carrier may be received in different locations and/or carrier).

[0216] Broadcast information may include specific information components related to specific services, such as a configuration for low latency access and/or for connectionless data transfers.

ILTE_13091US01

[0217] Essential information may be broadcast. Essential information may include, for example, MIB, SIB1 (access-related information e.g. PLMN, TAC, CellID, p-Max, frequency band indicator), SIB2 (access barring information, RACH parameters, UL power control). A WTRU may acquire broadcast system information and may request further system information, e.g., using an on-demand procedure.

[0218] More information (e.g. beyond essential information) may be broadcast, for example, based on capacity/load. In an example, more system information may be broadcast, for example, when the system has the capacity and broadcast capacity is limited. A WTRU may acquire broadcast system information and may request further system information, e.g., using an on-demand procedure.

[0219] System information may be modified (e.g. changed or updated). For example, system information modification may be triggered by paging for WTRUs in RRC_IDLE and WTRUs in RRC_CONNECTED. A WTRU (e.g. when WTRU receives notification of system information modification) may identify a delta and may acquire modified/new system information, for example, by one or more procedures, such as broadcast (e.g. when a delta is broadcast) and/or on-demand (e.g. when a delta is not broadcast).

[0220] Variable acquisition may be based on location and/or frequency band. In an example deployment scenario consisting of macro and micro, system information (e.g. for both the macro and micro) may be broadcast over the macro. A WTRU may (e.g. when not in coverage of a macro) acquire system information from a micro.

[0221] System information may be variable portioned. Essential system information may be broadcast, for example, to enable a WTRU to access the system. A WTRU may acquire further system information through dedicated resources.

[0222] In an example, more than essential system information may be broadcast, for example, when the system has significant excess capacity, when many WTRUs are acquiring system information and/or when a need arises to broadcast new system information that is essential for system access. It may be beneficial to support acquisition procedures allowing a variable/dynamic split between broadcast and on-demand information acquisition.

[0223] System information may be grouped and/or may be controlled, for example, by different logical functions, e.g., based on periodicity, latency, feature, etc.

[0224] In an example of groupings, a default set may comprise, for example, information that may be essential for system access, camping, mobility, etc. Essential information may comprise, for example, common and shared channel information (e.g., similar to MIB, SIB1, SIB2 in LTE). Essential information may comprise, for example, cell selection/re-selection information (e.g.

ILTE_13091US01

similar to SIB3, SIB4, SIB5(E-UTRA), SIB6(UTRA), SIB7(GERAN), SIB8(CDMA2000) in LTE).

[0225] In an example of groupings, a common set may comprise, for example, information that may be required by most devices, such as one or more of the following: (i) HNB name (e.g. similar to SIB9 in LTE); (ii) ETWS (Earthquake and Tsunami Warning System) primary notification (e.g. similar to SIB10 in LTE); (iii) ETWS secondary notification (e.g. similar to SIB11 in LTE) and/or (iv) Commercial Mobile Alert System (CMAS) warning notification (e.g. similar to SIB12 in LTE).

[0226] In an example of groupings, a feature set may comprise, for example, information that may be required for particular features/device categories, such as one or more of the following: (i) MBMS (e.g. similar to SIB13 in LTE); (ii) extended access barring for access control (e.g. similar to SIB14 in LTE); (iii) mobility procedures for MBMS reception (e.g. similar to SIB15 in LTE); (iv) GPS time and UTC time (e.g. similar to SIB16 in LTE); (v) for traffic steering between E-UTRAN and WLAN (e.g. similar to SIB17 in LTE); (vi) sidelink communication (e.g. similar to SIB18 in LTE); (vii) sidelink discovery (e.g. similar to SIB19 in LTE) and/or (viii) SC-PTM e.g. similar to SIB20 in LTE.

[0227] In an example, a WTRU may receive System Information (SI) applicable to a cell/TRP (or similar) or to a plurality thereof. A WTRU may receive SI, for example, by broadcast transmissions and/or by dedicated transmissions. In an example, a WTRU may receive SI applicable to a cell/TRP on a transmission, for example, using resources associated with a different cell/TRP. SI applicable to a cell/TRP may consist of a (e.g. first) portion that may correspond to a (e.g. first) set of functions (e.g. access parameters, location tracking, WTRU-autonomous mobility related parameters, signature detection/measurement) and a (e.g. second) portion that may correspond to a (e.g. second) set of functions (e.g. supported features, supported services, etc.). The set of functions included in a (e.g. each) portion may be a configuration aspect of the system or may be explicitly indicated in the corresponding transmission. Additional information may be included, for example, to indicate whether there is further SI (e.g. a second portion) applicable and/or the identity/type of further available SI (e.g. a bitmap representing the different SIBs). Additional information may, for example, include an indication whether a WTRU is required to acquire remaining information (e.g. all remaining SIBs) or a subset thereof (e.g. SIB-based indication), which may be accompanied by an indication of an applicable procedure (e.g. DL broadcast or using an on-demand mechanism). Additional information may include a validity criteria for the SI.

[0228] In an example, a WTRU may acquire SI for a cell, for example, using a broadcasting channel. A WTRU may (e.g. further) perform an initial access, e.g., to establish connectivity with the access network (e.g. ACP and RCCP). A WTRU may (e.g. subsequently) receive SI for one or more cell(s), TRP(s), etc. (e.g. similar or the like), for example, using a (e.g. dedicated) transmission such as a reconfiguration procedure. SI may be indexed, for example, using a characteristic associated with a reference signal (e.g. a signature, a positioning signal, etc.) that may be applicable. SI may be indexed, for example, for each of the concerned cell(s)/TRP(s) or TRPGs. An SI may include (e.g. only) a portion of the information associated with a cell/TRP, such as access parameters. A WTRU may (e.g. subsequently) detect a reference signal associated with a configured SI. A WTRU may perform acquisition of further SI, for example, from a downlink broadcast channel (e.g. when applicable) and/or by initiating an access using the access parameters that are part of the configured SI for the concerned cell/TRP and/or detected reference signal / signature.

[0229] Additional SI may be acquired immediately. In an example procedure, a WTRU may initiate reception of broadcast system information, for example, when it determines that a broadcast channel may be available. A WTRU may initiate a procedure to request activation of a broadcast channel. A WTRU may (e.g. when it cannot receive broadcast SI using resources associated with the cell/TRP) initiate an access, for example, using access parameters that may be part of a configured SI for a concerned cell/TRP and/or detected reference signal/signature. A WTRU may initiate a procedure to request remaining SI for the concerned cell/TRP using dedicated resources thereof.

[0230] Additional SI may be acquired immediately, for example, when instructed or configured to do so. In an example procedure, a WTRU may initiate reception of broadcast system information, for example, when the WTRU determines that it is required (e.g. based on information in a first portion of the configured SI) to initiate such a procedure upon detection of a suitable reference signal (e.g. corresponding to a “known”/configured signature and/or received with sufficient power). A WTRU may use an applicable SI acquisition procedure, e.g., when configured.

[0231] Additional SI may be acquired on demand. A WTRU may acquire system information, for example, through dedicated resources (e.g. triggered through PRACH). On-demand acquisition may be based on service, WTRU capability, slice, etc.

[0232] A WTRU may initiate on-demand acquisition of additional SI, for example, after initial access. A WTRU may request a default set of SI messages, for example, based on WTRU capability and/or based on previously used services.

ILTE_13091US01

[0233] A WTRU may initiate on-demand acquisition of additional SI, for example, when a WTRU initiates new services. A WTRU may request additional SI messages, for example, when the associated SI messages have not already been acquired.

[0234] A WTRU may initiate on-demand acquisition of additional SI (e.g. specific SI messages), for example, when a WTRU determines that stored SI messages are no longer valid, e.g. upon receiving a modification indication for one or more SI messages or upon receiving a unknown system signature.

[0235] A WTRU may initiate on-demand acquisition of additional SI, for example, based on expiration of a timer. A timer may be associated with the validity of stored system information.

[0236] In a WTRU terminated example, a WTRU may (e.g. at reception of service requests) request additional SI messages, for example, when associated SI messages have not already been acquired.

[0237] In a WTRU terminated example, a WTRU may receive control signalling (e.g. paging/PDCCH-order) that may trigger an acquisition/update. The procedure may be included in the signaling/order. Signaling may provide an indication of an applicable information component (e.g. one or more components to be updated).

[0238] In an example, a WTRU may activate transmission of system information, for example, by transmitting an uplink signal. An uplink signal may be transmitted in resources that may be reserved for system information activation. In an example, a specific time/frequency resource or a UL physical channel may be reserved for system information activation. In an (e.g. another) example, a WTRU may transmit a reserved RACH preamble, for example, to indicate a system information activation request. In an (e.g. another) example, a WTRU may transmit a UL signal on an asynchronous resource that may be reserved for system information activation. UL resources for system information activation may be specific to a TRP, a group of TRPs and/or a MAC instance. A WTRU may use a system information activation procedure, for example, to indicate interest in acquiring system information. WTRU identification by the network may be optional during a system information activation procedure.

[0239] A WTRU may receive configuration for system information activation at different levels of granularity. For example, a WTRU may trigger different system information transmission behavior from a network based on UL signal type, UL resource selection, UL preamble selection, etc. Transmission behavior may include transmitting (e.g. only mandatory) system information, transmitting system information belonging to a specific slice, transmitting specific group of system information, etc. Transmission behavior may be, for example, one shot (e.g. for each activation request one instance of the associated system information may be

ILTE_13091US01

transmitted) or multi-shot (e.g. for each activation request multiple instances and/or repetition of the associated system information may be transmitted). In an example, UL resources may be, for example, specific to a TRP or common to a group of TRPs. A WTRU may trigger TRP specific system information or TRP group specific system information, for example, based on the corresponding selection of UL resource.

[0240] In an example, a WTRU may transmit a (e.g. an explicit) request message to trigger system information transmission. For example, a request message may include WTRU identity and type of system information requested. In an example, a network may trigger security procedures, e.g. authentication as a response to a system information request procedure. A procedure may enable secure delivery of system information message. In an example, a WTRU may acquire common system information via broadcast and/or activation procedure. A WTRU may (e.g. for slice specific system information) trigger a system information request procedure. A WTRU may (e.g. be required to) establish an access control plane, for example, to trigger a system information request message. In an example, a WTRU may transmit its capability information (e.g. along with a system information request), for example, so a network may provide (e.g. only) the system information applicable for a WTRU capability.

[0241] In an example, a WTRU may piggyback an SIB request together with a control signaling procedure. A WTRU may (e.g. implicitly) indicate a need for system information, for example, by transmitting additional indication with the control signaling procedure. For example, a WTRU may transmit a system information request bit/bitmap (e.g. along with a service request procedure), for example, to indicate a need for system information for that procedure. In an example, a WTRU may include a valuetag associated with stored system information (e.g. along with a control procedure), for example, so a network may provide additional system information, e.g., when the valuetag doesn't reflect the latest system information. A WTRU may (e.g. alternatively) trigger a control procedure, for example, by requesting system information associated with a control procedure.

[0242] A WTRU may determine DL resources for on-demand system information, for example, by using one or more of the following: (i) a predefined timing relation between the system information request and start of control channel monitoring (e.g. a control channel may carry a scheduling grant for on-demand system information) and/or (ii) a predefined relation between time/frequency resources used for an SI request and start of data channel carrying on-demand system information.

[0243] In an example, an identity (e.g. an RNTI) for an on-demand system information schedule may, for example, be specific to a WTRU that transmitted the request (e.g. a function of

ILTE_13091US01

time/frequency resources used for UL SIB request). In an example, an identity (e.g. an RNTI) for on-demand system information schedule may, for example, be specific to a cell or predefined constant, which may allow opportunistic reception for WTRUs that did not transmit the SIB request. In an example, an RNTI for periodic system information may be different from on-demand system information.

[0244] A WTRU may apply system information received via an on-demand procedure, for example, at a specific time offset from the TTI corresponding to the DL transmission. A time offset may be predefined or transmitted (e.g. along with the system information).

[0245] In an example, a WTRU may enter connected mode, e.g., to receive on-demand system information messages. A WTRU may (e.g. alternatively) be in a loosely connected state or idle connectionless state to trigger an on-demand system information procedure. A WTRU may determine the end of on-demand system information transmission using one or more criteria.

[0246] In an example, a WTRU may determine the end of an on-demand system information transmission based on a predefined time-window. For example, a WTRU may consider the start of the time window as a start of a first DL transmission corresponding to on-demand system information or an end of the TTI containing the system information request. For example, a WTRU may consider end of on-demand system information upon the end of time-window.

[0247] In an example, a WTRU may determine the end of an on-demand system information transmission, for example, based on explicit indication. For example, a WTRU may receive a special end-marker in the last TTI carrying on-demand system information.

[0248] In an example, a WTRU may determine the end of an on-demand system information transmission based on a counter. For example, a WTRU may receive a countdown value in a (e.g. each) on-demand system information. A WTRU may consider the system information carrying the countdown value as the last on-demand system information.

[0249] In an example, a WTRU may determine the end of an on-demand system information transmission based on a candidate system information list. For example, a WTRU may be pre-configured with or may be signaled a candidate system information list to be acquired or associated with an on-demand system information procedure. A WTRU may consider end of on-demand system information transmission, for example, when (e.g. all) the system information in the list is received successfully.

[0250] In an example, a WTRU may determine the end of an on-demand system information transmission based on an explicit release command. For example, a WTRU may (e.g. when the WTRU entered connected mode to receive the on-demand system information) consider an end

ILTE_13091US01

of on-demand system information upon receiving a connection release command from the network.

[0251] A WTRU may process received on-demand system information. A WTRU may trigger a control procedure or transition back to idle mode at the end of on-demand system information reception.

[0252] A WTRU may consider a cell/TRP to be barred, for example, when a WTRU fails to acquire essential system information before the end of on-demand system information procedure.

[0253] A paging control function may be applied, for example, per TRP, per TRP group, per service, per configured MAC instance, per channel per instance, per central control function, etc.

[0254] A central control function may store a WTRU context and track a WTRU mobility within the coverage of RCCF, for example, for a WTRU in a light connected state. A WTRU may receive a paging message originated at the RCCF or transmitted by the RCCF triggered, for example, upon arrival of downlink data. A paging message may be transmitted, for example, at ACF granularity or RCCF granularity. A WTRU in a light connected state, e.g., upon receiving the paging message, may perform one or more actions.

[0255] For example, a WTRU action may resume a WTRU user plane path towards the central user plane function, e.g., without having to invoke any additional central control functions.

[0256] For example, a WTRU may perform control plane actions and/or user plane actions, e.g., based on the received paging message.

[0257] For example, a WTRU may receive additional indication(s) in the paging message that determine WTRU actions. For example, a WTRU may receive a type of service in the paging message. A WTRU may (e.g. based on the indication) transition to fully connected state or light connected state. In an example, a WTRU may determine a type of initial access procedure (e.g. contention based, beamformed, initial access on a specific ACF), for example, based on a received paging message.

[0258] For example, a WTRU may receive an indication for the resources used for data transmission. A WTRU may (e.g. directly) receive the data without having to establish any connection. A WTRU may (e.g. upon completing data reception) transition back to idle or a light connected state.

[0259] In an example, a paging message may trigger establishment of ACF. In an example, a paging message may trigger RCCF establishment while another paging message may trigger resumption of RCUF.

[0260] WTRU identification may be provided, for example, by a layer 3 (L3)/central control plane connection/WTRU context identifier. Singular connectivity may have a one to one relation between WTRU identity on the radio (e.g. RNTI) and an RRC connection. A WTRU's RRC connection for dual connectivity may be associated with a WTRU specific RNTI in the MeNB (Master eNB). A WTRU may be assigned multiple RNTIs during multi-connectivity (e.g. different RNTI per TRP), for example, in a tri-plane architecture. A WTRU context may be identified in the centralized control function, for example, by assigning an L3 identity to a WTRU. A WTRU may receive an L3 identity, for example, upon central control plane establishment. An L3 identity may be used, for example, to uniquely identify an RRC connection or RRC context associated with a WTRU.

[0261] An RCCF connection may be managed. There may be one or more triggers for re-association with RCCF. For example, a WTRU may trigger an association or re-association procedure with the RCCF when one or more of criteria are satisfied.

[0262] An example criteria may be when no valid L3 context exists in a WTRU, for example, due to (i) a power up scenario where a WTRU may be unknown at the network and/or (ii) an L3 context expired (e.g. due to extended periods of inactivity).

[0263] An example criteria may be when a WTRU enters a coverage of an anchor control function different than a serving anchor control function. A WTRU may determine presence and identity of an anchor control function using one or more procedures. An example procedure may comprise using a shared system signature. For example, TRPs associated with the same anchor control function may share at least one system signature. An example procedure may comprise using explicit identification in MIB. For example, TRPs associated with an anchor control function may transmit some form identity associated with the anchor control function. A WTRU may obtain the anchor control function identity during a previous association. An example procedure may comprise using logical area transmitted in broadcast channels. For example, an (e.g. each) anchor control function may provide anchoring services to a logical area consisting of one or more TRPs. A WTRU may consider TRPs belonging to a specific logical area as associated with the same anchor control function. An example of a procedure may be using a pre-configured system signature group. For example, two or more system signatures may be preconfigured to be associated with the same anchor control function. A WTRU may consider TRPs transmitting at least one of the system signatures within a particular system signature group to be associated with the same anchor control function.

[0264] An example criteria may be when an access control function associated with macro eNB experiences failure and a WTRU may (e.g. does) not have a valid access table entry.

ILTE_13091US01

[0265] An example criteria may be when (e.g. all of) the configured/activated access control functions may be terminated/released.

[0266] An example of a criteria may be upon arrival of a paging message indicating arrival of DL data or DL signaling from the core network.

[0267] An example of a criteria may be unreachability of a serving anchor control function, which may be determined, for example, based on an absence of response to signaling message towards the anchor control function or absence of keep alive/heart beat with the serving anchor control function.

[0268] An example of a criteria may be upon receiving a last RAR message. A WTRU may (e.g. during initial access to a network) perform a multi-point random access procedure. A WTRU may wait for a last RAR message to trigger an RCCF association procedure. A WTRU may determine the last RAR message in one or more ways. In an example a (e.g. each) RAR message may include a countdown value. For example, a WTRU may consider the RAR message with countdown value of zero as the last RAR message. In an example, a WTRU may wait until the end of an RAR window to receive an (e.g. every possible) RAR message before triggering an RCCF association procedure.

[0269] A WTRU may initiate association towards an anchor control function, for example, any time after acquiring UL resources to transmit, e.g., after access plane establishment. A WTRU may transmit a higher layer signaling message that may include a WTRU identity, an identity of an anchor control function, a reason for association, a number of RAR messages, a list of TRPs and/or a selected list of TRPs.

[0270] A WTRU identity may be, for example, one or more of the following: an identity allocated by a previous anchor control function, a temporary identity allocated by a core network and/or a sufficiently long random number (e.g. ≥ 40 bits).

[0271] An identity of anchor control function may be, for example, optionally present, e.g., when a WTRU had a previous association with an anchor control function.

[0272] A reason for association may be, for example, one or more of the following: a request for anchoring control service, a request for paging service, a request for access to specific core network slice, an initial association for subsequent core network signaling, an association due to change in anchor control function, a failure of a previous anchor control function, a response to paging, UL data arrival and/or type of service requested (e.g. high throughput service, low latency service or low overhead and energy efficient service), etc.

[0273] A number of RAR messages may be, for example, a number of RAR messages received in response to a random access procedure.

ILTE_13091US01

[0274] A list of TRPs may be, for example, a list of TRPs that transmitted the RAR messages and quality metric for a (e.g. each) received RAR.

[0275] A selected List of TRPs may be, for example, a list of TRPs selected by a WTRU using a predefined selection criteria.

[0276] A WTRU may transmit an RCCF association request on available resources. A request may be transmitted in an order. An example of an order may be, for example: (1) time/frequency resources associated with a macro ACF whose suitability metric is highest among available macro ACFs; (2) time/frequency resources associated with a macro ACF whose suitability metric is above a certain threshold; (3) time/frequency resources associated with a TRP ACF whose suitability metric is highest among configured/active/available TRP ACFs and (4) time/frequency resources associated with a TRP ACF whose suitability metric is above a certain threshold.

[0277] A suitability metric may be, for example, received power measured from a reference signal or system signature averaged over a time window.

[0278] A WTRU may prefer ACFs associated with one or more licensed bands over ACFs associated with unlicensed bands.

[0279] A WTRU may prefer non-beamformed ACFs over beamformed ACFs.

[0280] A WTRU may (e.g. in response to an RCCF association request) receive and process an association response. The contents of a response may include, for example, one or more of an identity of an RCCF, an identity of a WTRU, access table parameters, a measurement configuration, an SRB configuration, a DRB configuration, dedicated ACF parameters/resources and/or user plane RCUF status and parameters.

[0281] An identity of an RCCF may be stored and used (e.g. by a WTRU), for example, to address subsequent control signaling towards the RCCF.

[0282] An identity of a WTRU may be stored and used (e.g. by a WTRU), for example, to identify itself for subsequent interaction with the RCCF.

[0283] Access table parameters may be received in a response. A WTRU may (e.g. directly) receive access table contents within the association response message and/or parameters that may help a WTRU to obtain the access table parameters (e.g. ACFs and time/frequency resources that carry access table transmission, an RNTI to decode the schedule for access table transmission, etc.).

[0284] A measurement configuration may comprise configuration of measurement resources, measurement objects, measurement quantity and measurement id, triggers, etc. A measurement configuration may be specific to an ACF or group of TRPs.

ILTE_13091US01

[0285] An SRB configuration may indicate mapping rules for SRB. For example, an SRB to ACF mapping (e.g. for SRBs terminating at ACFs) may provide (e.g. an explicit) mapping between SRBs and an ACF. A mapping may map an SRB to transport/physical channels associated with a specific ACF. For example, an SRB to ACF mapping restriction may be provided. A WTRU may be configured with restricted ACFs that may not be used for SRB transmission. WTRU may flexibly split the SRBs among available/allowed ACFs. For example, an SRB prioritization via ACF mapping may be provided. High priority SRBs may be mapped and/or low priority SRBs may be mapped, e.g., to a different ACF/ACF group. For example, Dynamic SRB mapping based on ACF quality may be provided. A mapping may transmit high priority SRBs over ACFs whose quality metric is above certain threshold. For example, a DRB configuration may include, for example, DRB tagging information. A WTRU may attach to a (e.g. each) PDU belonging to a DRB associated tagging information provided by the central control function. Tagging information may be used, for example, by the RCUF to map the PDUs to the right core network flow. Dedicated ACF parameters/resources may be provided in a response to an RCCF association request. User plane RCUF status and parameters may be provided in a response to an RCCF association request.

[0286] An ACF connection may be managed. Triggers may be provided for access plane management. A WTRU may trigger access plane establishment, for example, when one or more criteria is satisfied.

[0287] An example of trigger criteria may be, for example, when a WTRU receives an unknown signal (e.g. without a valid entry in the access table), which may occur when an SIB may not be broadcast in the cell, UL resource for SIB interest notification and on-demand access table or when a WTRU may request an access table entry from another TRP (e.g. send the signature).

[0288] An example of a trigger criteria may be, for example, upon arrival of user plane data (e.g. IP packet), which may occur, for example, when a WTRU already has an access plane established or does not have an access plane established, such as when higher layer data may allow for early data transfer and a valid entry in the access table is available that indicates UL resources timing (e.g. w.r.t to another signal or control channel, etc.).

[0289] An example of a trigger criteria may be, for example, upon arrival of control plane signalling (e.g. L3/RRC message or NAS message).

[0290] An example of a trigger criteria may be, for example, change in RAN tracking area, proximity to non-serving anchor control function, change in anchor control function, etc.

ILTE_13091US01

[0291] An example of a trigger criteria may be, for example, re-establishment of an access plane on a same or better TRP, for example, when a WTRU loses uplink synchronization (TAT expiration) or when a WTRU goes out of sync at lower layers.

[0292] An example of a trigger criteria may be, for example, WTRU mobility based on, for example, (i) discovery of a new TRP associated with a serving anchor control function, (ii) measurement events at (L1/L2/L3) above a predefined threshold and/or (iii) reception of a new system signature above a predefined threshold.

[0293] A TRP/network may trigger access plane establishment, for example, when one or more of the following criteria is satisfied: (i) upon command from central control plane entity, (ii) upon receiving user plane data, e.g. paging and/or (iii) upon addition of a new TRP or cell group.

[0294] Access plane establishment may involve, for example, one or more of the following: (i) a WTRU may trigger a random access on a predefined UL resource determined by system signature and/or (ii) a WTRU may trigger a random access procedure on a multi-point random access resource.

[0295] A WTRU may consider an access plane established, for example, when it receives one or more RAR messages that pass a suitability criteria.

[0296] A WTRU may take one or more actions after establishing an access plane. For example, a WTRU may be uplink synchronized and may (e.g. be required to) maintain the synchronization.

[0297] WTRU may be assigned an identifier, e.g., to uniquely identify a WTRU with a single TRP or a group of TRPs. For example, a WTRU may monitor downlink control channels for possible scheduling grants and/or feedback. For example, a WTRU transmit periodic and/or event triggered feedback and/or reference signals on the uplink control channels.

[0298] Access plane establishment may enable one or more of the following: (i) a WTRU may be reachable at TRP level granularity; and/or (ii) a WTRU may be assigned dedicated physical resources (e.g. UL control channel resources, semi-persistent resources, etc.).

[0299] A WTRU may transmit higher layer data and/or signaling terminated at a TRP and/or signaling messages terminated at the RCCRF to setup control plane. A WTRU may (e.g. additionally) transmit L3 control/signalling, measurement report, NAS signalling messages, etc., for example, when the control plane may be set up. A WTRU may (e.g. additionally) transmit application/user data, for example, when the user plane is set up.

[0300] A radio link monitoring (RLM) function may be provided, for example, as a WTRU-specific function, a component-specific function and/or a plural-component function.

ILTE_13091US01

[0301] In an example of a WTRU-specific function, an RLM function may be configured per WTRU.

[0302] In an example of a component-specific function, an RLM function may be configured per WTRU-TRP pair or a WTRU-ACF pair.

[0303] In an example of a plural-component function, an RLM function may be configured per group of components, such as multiple cells, multiple TRPs, multiple TRPGs, multiple NR-eNBs, etc. In an example, a WTRU may perform radio link monitoring on one or more (e.g. a subset of TRPs per group of TRPs). A WTRU may consider the measurements on a TRP as indicative of radio link status for a group of TRPs. In an (e.g. another) example, a WTRU may consider measurements on a (e.g. any) TRP as indicative of radio link status for a group of TRPs.

[0304] A WTRU may be configured with a different monitoring procedure, for example, based on one or more of the characteristics/property of Uu with a TRP, a nature of a service and/or a WTRU state.

[0305] In an example of the characteristics/property of Uu with a TRP, an RLM procedure for a beamformed Uu may be different from a narrow band Uu. In another example, an RLM may be optional in some scenarios, e.g., in an unlicensed Uu.

[0306] In an example of a nature of a service, one or more aspects of an RLM procedure may be tied to the type of services active in a WTRU. For example, a WTRU may perform RLM with (e.g. strict) thresholds while using a URLLC service.

[0307] In an example of a WTRU state, one or more aspects of an RLM procedure may be tied to a WTRU state. For example, a WTRU may perform a relaxed monitoring procedure in a light connected state, e.g., compared to fully connected state.

[0308] A radio link failure handling function may be, for example, a WTRU-specific function, component-specific function and/or a plural-component function.

[0309] A WTRU may support multi-connectivity to increase reliability, mobility robustness, throughput etc. In an example, a relation between configured cells for a WTRU may be flexible. A (e.g. each) cell configured for a WTRU may be dynamically assigned different roles. For example, a cell may be a Pcell, PScell or Scell, where roles may vary with time, e.g., based on predefined criteria and/or measurements.

[0310] A WTRU may (e.g. be required to) determine and may react to different types of failure. A WTRU may (e.g. with a distributed control plane architecture) distinguish between aspects related to connectivity to a TRP, reachability to different control functions, etc.

[0311] In an example, a WTRU may determine different types of failure, such as a TRP level failure, an ACF level failure and/or an RCCF failure.

ILTE_13091US01

[0312] In an example, a TRP level failure may be related to status of lower layer functions, e.g., loss of timing, unsuitability based on measurements below threshold, etc.

[0313] In an example, an ACF level failure may be related to unreachability of a specific ACF. A WTRU may trigger a report to a central control function, which may include which ACF failed and a reason for failure.

[0314] In an example, an RCCF failure may be related to unreachability of a central control function, for example, based on a timer expiring from the last interaction with RCCF.

[0315] A WTRU may decouple a capability to transmit data from different levels of failure on a control plane. For example, a TRP level failure may not trigger a WTRU to suspend the data transmissions. In an example, a WTRU may continue data transmissions, for example, even while a control plane is being re-established. In an example, a WTRU may perform connectionless transfer, for example, while trying to recover from partial control plane failure.

[0316] A mobility control function may be a WTRU-specific function, component-specific function and/or a Plural-component function.

[0317] WTRU mobility may be (e.g. closely) tracked at the RAN for WTRUs, e.g., in light connected states and/or IDLE connectionless states. Tracking may be at a granularity of a TRP group or a central control function. Different levels of mobility control functions may be defined, such as one or more of the following: (i) Intra-TRP (e.g. may include beam level mobility); (ii) Inter-TRP (e.g. may include mobility handling at ACF level without involving a central anchor function); (iii) Inter-ACF (e.g. may be controlled by central anchor function and/or may be defined between LTE ACF and NR ACF in example of a tightly coordinated mobility function); (iv) Inter-RCCF (e.g. may be applicable for WTRUs in connected state and/or light connected state and/or a WTRU may support a control anchor change without a change to the user plane functions or user plane anchor) and/or (v) Inter-RAT (e.g. may include mobility between NR to legacy RATs like GSM/UMTS, etc.).

[0318] Mobility control functions may be WTRU autonomous, network controlled, network assisted WTRU controlled and/or WTRU assisted network controlled.

[0319] Different parts of WTRU context and L2 state may persist after a mobility event. A WTRU may reset different parts of context and/or L2 state, for example, based on a type of mobility event. In an example, a WTRU may use a specific set of rules to 'convert' a configuration/context upon handover to a different TRP/ACF. In an example, a WTRU may retain parts of configuration and/or L2 context that are compatible while applying equivalent configurations or mapped configurations and/or while converting certain aspects during a mobility event between LTE and NR.

[0320] A WTRU may be configured with mobility restrictions. In an example, a WTRU may not perform autonomous mobility to a LTE TRP.

[0321] A measurement configuration and reporting function may be a WTRU-specific function, component-specific function and/or a plural-component function.

[0322] A WTRU may transmit a measurement report to plurality of TRPs. A WTRU may, for example, based on a configuration, report beam related measurements (e.g. intra-cell beam level RRM measurements) to the associated TRP. A WTRU may report measurements of a plurality of TRPs to an associated ACF. In an example, a WTRU may report measurements on LTE TRPs to an LTE ACF.

[0323] In an example, a WTRU may differentiate measurements on TRPs associated with a serving central control function from the measurements on TRPs associated with a different central control function. In an example, a WTRU may be configured to measure (e.g. only) the TRPs associated with a serving control function.

[0324] The placement of a measurement processing control function may be flexible. For example, a measurement processing control function may be placed closer to a WTRU, e.g., for URLLC service.

[0325] A security and authentication control function may be a WTRU-specific function, component-specific function and/or a plural-component function.

[0326] A WTRU may treat security aspects associated with an ACF independently from other ACFs. For example, a security failure in ACF may be localized to that ACF and may not affect WTRU connectivity to other ACFs.

[0327] In an example, a WTRU may perform independent integrity protection for control plane messages, such as control plane signaling towards an ACF and/or control plane signaling towards an RCCF.

[0328] In an example, WTRU control signaling towards an RCCF may be placed in a container within ACF messages. A WTRU may apply (e.g. only) ACF integrity protection to the RCCF messages.

[0329] In an example, a WTRU may obtain integrity protection keys for a (e.g. each) ACF, for example, based on interaction with those ACFs. A WTRU may (e.g. alternatively) obtain integrity protection keys for an (e.g. each) ACF from the RCCF.

[0330] Configuration failure handling may be a WTRU-specific function, component-specific function and/or a plural-component function.

[0331] A WTRU may trigger failure handling, for example, based on a control function that triggered the configuration. In an example, configuration failure for an access control function

may not affect WTRU association with other access control functions. A WTRU may report a failure to the RCCF indicating the specific ACF that triggered the configuration and the reason for failure, for example, when a WTRU is unable to comply with one or more aspects of a configuration. In an example, a WTRU may perform connectionless signaling transfer, e.g., to report a configuration failure. In an example, configuration failure towards a central control function may not affect WTRU capability to transmit data over the user plane. In an example, configuration failure may trigger release of an access plane towards (e.g. all) the access control functions.

[0332] A Logical association may be defined between PDU carrying control signaling. An association may, for example, be based on data units being associated with an access control function or an instance thereof, with a central control function or instance thereof or with the same SOM and/or slice. In an example, an association may be characterized, for example, by at least one of a chaining of processing functions, an applicable physical data (and/or control) channel (or instance thereof) or an instantiation of a protocol stack, which may include a specific portion being centralized (e.g. anchor control function) and another portion being closer to the edge (e.g. access control function).

[0333] An example of logical association may be a signaling radio bearer (SRB). A WTRU may have multiple termination points for control signaling. A WTRU may have a signaling association towards an access control function, e.g., access signaling radio bearer (ASRB). A WTRU may (e.g. in case of multi-connectivity) have more than one ASRB. An (e.g. each) ASRB may terminate at a different access control function. A WTRU may have a signaling association towards an anchor control function (e.g. a central SRB (CSR)) that may terminate at the anchor control function.

[0334] A WTRU may transmit a control message on the same SRB that carried an original message, for example, when the control message is a response to a control message from a network (e.g. setup or reconfiguration message). For example, a WTRU may address a response to an access control function that transmitted the control message. In an (e.g. another) example, a WTRU may transmit a response to a control message received from a downlink cell group, e.g., in an uplink cell group associated with the same MAC instance.

[0335] An (e.g. each) ASRB may be associated with a MAC instance. Mapping ASRB to physical channels may be specific to each ACF instance. In an example, the characteristics of physical channels that carry ASRB may be different from physical channels carrying data packets. For example, an ASRB may be mapped to physical channels with wider spatial coverage, for example, when a MAC instance utilizes beamformed channels.

ILTE_13091US01

[0336] A WTRU may use data transmission services provided, for example, by the access plane, e.g., to transmit a control signaling message towards an anchor control function.

[0337] A WTRU may be preconfigured with a (e.g. exactly one) MAC instance to transmit control signaling (e.g. a message) towards an anchor control function. In an example, a MAC instance may be associated with a macro TRP.

[0338] In an example, a WTRU may be configured with one or more MAC instances for CSRB transmission. A WTRU may shortlist candidate MAC instances, for example, based on one or more criteria, such as one or more of access plane status, UL TAT, prohibited MAC instances, coverage of a TRP, security status and/or activation status.

[0339] In an example of access plane status, a WTRU may choose MAC instances for which an access plane is already established.

[0340] In an example of UL TAT, a WTRU may choose MAC instances with valid UL timing (e.g. TAT timer is running).

[0341] In an example of prohibited MAC instances, a WTRU may consider one or more MAC instances that are not prohibited for CSRB transmission. For example, a WTRU may be configured with blacklisted MAC instances that may not carry CSRB transmission or (e.g. equivalently) a WTRU may be configured with whitelisted MAC instances for CSRB transmission.

[0342] In an example of coverage of a TRP, a WTRU may choose MAC instances that are associated with a larger coverage, e.g., belonging to a macro TRP.

[0343] In an example of security status, a WTRU may choose MAC instances associated with ACFs for which security context may be (e.g. already) established. In an example, a WTRU may not consider MAC instances for which an authentication/security mode procedure is ongoing or not yet started. In an example, a WTRU may wait for security activation for the access control function to complete before transmission of control message towards the anchor control function.

[0344] In an example of activation status, a WTRU may choose MAC instances that may be configured and/or activated by a network.

[0345] In an example, a WTRU may have multiple candidate MAC instances available for CSRB transmission. A WTRU may select a MAC instance for a CSRB transmission in one or more ways, such a based on signal quality, transmission opportunity, explicit priority, reliability, outcome of previous transmission and/or linked MAC status.

ILTE_13091US01

[0346] In an example of signal quality, a WTRU may choose a MAC instance with a better signal quality metric (e.g. RSRP/RSRQ/Hypothetical PDCCH error rate) for one or more cells in the cell group associated with that MAC instance.

[0347] In an example of transmission opportunity, a WTRU may choose a MAC instance with the earliest transmission opportunity. A WTRU may prefer a MAC instance with an available scheduling grant over a MAC instance that may need a resource request procedure or may have (e.g. only) contention based resources. A WTRU may (e.g. additionally) temporarily suspend transmissions on MAC instances that may have an outstanding reconfiguration procedure that reconfigures one or more characteristics associated with that MAC instance.

[0348] In an example of explicit priority, a (e.g. each) MAC instance may be associated with a priority. A WTRU may choose the MAC instance with highest priority for transmission of CSRB messages.

[0349] In an example of reliability, a WTRU may choose to transmit the same control message over plurality of MAC instances, for example, for control messages that may require high reliability (e.g. those associated with ultra reliable services).

[0350] In an example of outcome of previous transmission, a WTRU may choose a different MAC instance (e.g. for retransmission) than the MAC instance used for a (e.g. an original) failed transmission.

[0351] In an example of a linked MAC instance – WTRU may (e.g. for a response control message) choose the same MAC instance on which the corresponding request/setup control message was received.

[0352] In an example, a WTRU may perform MAC instance selection (e.g. only) during initial registration or association towards a new anchor control function. A WTRU may use the same MAC instance for a (e.g. any) subsequent control message exchange with that anchor control function.

[0353] In an example, a WTRU may perform MAC instance selection (e.g. once) for a (e.g. each) control signaling procedure with the anchor control function. A control signaling procedure may involve one or more control signaling message transactions. For example, a (e.g. all) control messages belonging to the same procedure may be transmitted over a (e.g. single) MAC instance.

[0354] In an example, a WTRU may perform MAC instance selection for a (e.g. each) control message transmission. For example, control messages belonging to the same procedure may be transmitted over different MAC instances. A WTRU may switch to a different MAC instance, for example, for a retransmission of the control message.

ILTE_13091US01

[0355] A WTRU may prioritize transmission signaling messages mapped to ASRB over control signaling mapped to CSRB. A WTRU may have an access control message and an anchor control message ready for transmission. For example, a WTRU may (e.g. first) transmit an access control message in the earliest transmission opportunity and may (e.g. subsequently) transmit the anchor control message in the same subframe/TTI from the same MAC instance or a different MAC instance, for example, when resources are available or in the next available resource from the same MAC instance or a different MAC instance. In an (e.g. another) example, a WTRU may wait for the completion of the ongoing procedure with the access control function and then transmit the anchor control message at the first available transmission opportunity. In an example, a WTRU may be configured with two more ASRBs mapped to the same MAC instance. A (e.g. each) of the ASRBs may be identified by a different logical channel identity and/or ASRB identity. A WTRU may be preconfigured with rules to prioritize between two or more ASRBs mapped to the same MAC instance. For example, a prioritization may be implicit, e.g., based on the type of control message or based on explicit SRB identity/logical channel identity.

[0356] A WTRU may provide an (e.g. additional) indication in a PDU, for example, to differentiate a control message addressed to access a control function from a control message addressed to an anchor control function. For example, an indication may include one or more of the following: a logical channel identity, an explicit indication of a type of message and an explicit identity of an anchor control function.

[0357] In an example of a logical channel identity, a different logical channel identifier may be used to differentiate different ASRB within the same MAC instance. Logical channel identifiers may be reserved, for example, to indicate that the control message belongs to CSRB.

[0358] In an example of an explicit indication of a type of message, a (e.g. each) control message may carry an indication for a type of the message. For example, a first type may indicate that it may be an access control message and a second type may indicate an anchor control message.

[0359] In an example of an explicit identity of anchor control function, a WTRU may (e.g. additionally) provide an explicit identity of a destination anchor control function, for example, when the access control function may be associated with more than one instance of the anchor control function. A WTRU may transmit a special/reserved identity, for example, to indicate lack of previous interaction with an anchor control function (e.g. a network may select a new anchor control function to deliver the control message).

[0360] A WTRU may receive a control message with configuration. A configuration may be applicable, for example, to a specific cell within a cell group associated with a MAC instance, to multiple (e.g. all) cells within a cell group associated with a MAC instance, to a group of MAC instances or to all MAC instances. In an example, configuration parameters may include one or more of the following: slicing configuration, supported services configuration, addition/removal/modification of cells, QoS configuration, DRX configuration, security configuration, measurement configuration, dedicated radio resource configuration like SRB configuration, DRB configuration including PDCP and/or RLC and/or MAC configuration, physical channel configuration, SPS-configuration, etc.

[0361] A WTRU may determine the applicability of a configuration, for example, based on one or more criteria, such as a type of SRB, a linked MAC instance and/or an explicit access control identity.

[0362] In an example of a type of SRB, a WTRU may apply configuration parameters received in the ASRB applicable (e.g. only) to a MAC instance associated with the ASRB. A WTRU may consider the configuration parameters received in CSRB applicable to (e.g. all) the MAC instances, e.g., unless explicitly indicated within the configuration message.

[0363] In an example of a linked MAC instance, a WTRU may apply configuration parameters received from a cell/cell group to a MAC instance associated with that cell/cell group.

[0364] In an example of an explicit Access control function identity, a WTRU may receive configuration parameters with an explicit indication of a MAC instance to which the configuration is applicable. For example, a WTRU may receive a MAC identity or access control function identity, e.g., along with the configuration parameters.

[0365] In an example, a WTRU may be configured with a linked-SRB. A linked-SRB may be an ASRB that may be associated with one or more DRBs. In an example, linkage may be many-to-many association. A (e.g. each) DRB may be linked to one or more ASRBs. A WTRU may apply configurations received in a ASRB to (e.g. only) the DRBs linked with the ASRB.

[0366] In an example, a WTRU may (de)multiplex control signaling (e.g. RRC PDUs or the like) using different logical connections, bearers (e.g. SRB0, 1, 2, 3, etc. or using different sets thereof), flow-based treatment (e.g. based on configured tuples applicable to L3 protocols), for example, as a function of the logical grouping of the function that generated the RRC SDU.

[0367] For example, a WTRU RRC function for access plane establishment may generate an RRC SDU that may be mapped to a specific SRB. An SRB may correspond to a set thereof. A set may be associated with the Access Plane connection being established. In an example, a

ILTE_13091US01

procedure may use a first SRB corresponding to the set of SRBs available for establishment of such connection, for example, for initial access to the system (e.g. while security is not yet activated). A (e.g. the) procedure may use a second SRB otherwise, for example, when at least part of the security may be activated, e.g., for the RCCF. A WTRU may (e.g. in the latter case) include authentication (and/or encryption), for example, for at least part of the RRC SDU, e.g. the part of the SDU that may be used to determine the identity of a WTRU and/or may provide capability for the network to fetch a WTRU's context.

[0368] A WTRU RRC function for central control plane may (e.g. similarly) generate an RRC SDU that may be mapped to a different specific SRB (e.g. an SRB that may correspond to a different set of SRBs).

[0369] For example, different logical grouping of functions may have different sets of SRBs from each other.

[0370] Alternatively (e.g. when a single set of logical paths may be configured) or in addition (e.g. when a WTRU may be configured with a (e.g. one) set of logical paths for each type of logical grouping), an RRC SDU may include an identifier (e.g. the identity of the instance of the logical group of functions that generated the SDU), for example, when a WTRU may be configured with multiple user plane "slices" or equivalent.

[0371] In an example, procedures may be (e.g. further) applied, for example, (e.g. similarly) as a function of the physical transport paths. Grouping of functions and association of transport paths may be a configurable aspect, e.g., from a WTRU's perspective.

[0372] Systems, procedures, and instrumentalities (e.g. aspects of entities, interfaces and procedures in a wireless transmit/receive unit (WTRU) and/or network layers L1, L2, L3) have been disclosed for distributed control in wireless systems, such as 5G flexible radio access technology (RAT) (5gFLEX). Example procedures are provided for WTRU and network operation associated with a distributed control plane architecture, connectionless data transfer and dedicated system information acquisition. Distributed control may be provided, for example, by replicating a plurality of access control functions (ACFs) using a plurality of instances in a plurality of different transmission/reception points (TRPs) with multi-connectivity. The plurality of TRPs may concurrently provide control services to a WTRU. Centralized control functions may manage core network connectivity and a plurality of user plane instances for the WTRU and may facilitate coordination between the plurality of ACF instances for the WTRU in the plurality of different TRPs of the WTRU's configuration. For example, there may be a first access plane between the WTRU and a first TRP that provides a first ACF for the WTRU, a second access plane between the WTRU and a second TRP that provides a second

ILTE_13091US01

ACF for the WTRU, a RAN central control plane between the WTRU and a first RAN central control function (RCCF) and a RAN central user plane between the WTRU and a RAN central user function (RCUF).

[0373] The processes and instrumentalities described herein may apply in any combination, may apply to other wireless technologies, and for other services.

[0374] A WTRU may refer to an identity of the physical device, or to the user's identity such as subscription related identities, *e.g.*, MSISDN, SIP URI, *etc.* WTRU may refer to application-based identities, *e.g.*, user names that may be used per application.

[0375] The processes described above may be implemented in a computer program, software, and/or firmware incorporated in a computer-readable medium for execution by a computer and/or processor. Examples of computer-readable media include, but are not limited to, electronic signals (transmitted over wired and/or wireless connections) and/or computer-readable storage media. Examples of computer-readable storage media include, but are not limited to, a read only memory (ROM), a random access memory (RAM), a register, cache memory, semiconductor memory devices, magnetic media such as, but not limited to, internal hard disks and removable disks, magneto-optical media, and/or optical media such as CD-ROM disks, and/or digital versatile disks (DVDs). A processor in association with software may be used to implement a radio frequency transceiver for use in a WTRU, terminal, base station, RNC, and/or any host computer.

CLAIMS

What is Claimed:

1. A method comprising:
 - providing distributed control for a wireless transmit/receive unit (WTRU) in a radio access network (RAN) of a wireless system by:
 - replicating a plurality of access control functions (ACFs) using a plurality of instances in a plurality of different transmission/reception points (TRPs) with multi-connectivity, the plurality of TRPs concurrently providing control services for the WTRU; and
 - centralizing a plurality of control functions to manage core network connectivity and a plurality of user plane instances for the WTRU and to facilitate coordination between the plurality of ACF instances for the WTRU in the plurality of different TRPs of the WTRU's configuration.

2. The method of claim 1, further comprising:
 - supporting, by the WTRU, a multiplexing/demultiplexing function with a plurality of different sets of one or more signaling radio bearers (SRBs) associated with one or more control plane contexts, instances or functions.

3. A method comprising:
 - providing distributed control of a wireless transmit/receive unit (WTRU) in a wireless system by concurrently providing:
 - a first access plane between the WTRU and a first transmission/reception point (TRP), the first TRP providing a first access control function (ACF) for the WTRU;
 - a second access plane between the WTRU and a second TRP, the second TRP providing a second ACF for the WTRU;
 - a radio access network (RAN) central control plane between the WTRU and a first RAN central control function (RCCF); and
 - a RAN central user plane between the WTRU and a RAN central user function (RCUF).

4. A device or system configured to perform the method recited in any one or more of claims 1-3.

ILTE_13091US01

5. A computer readable storage medium having stored thereon a plurality of computer-executable instructions for performing the method recited in any one or more claims 1-3.

ABSTRACT

Systems, procedures, and instrumentalities (e.g. aspects of entities, interfaces and procedures in a wireless transmit/receive unit (WTRU) and/or network layers L1, L2, 13) are disclosed for distributed control in wireless systems, such as 5G flexible radio access technology (RAT) (5gFLEX). Example procedures are provided for WTRU and network operation associated with a distributed control plane architecture, connectionless data transfer and dedicated system information acquisition. Distributed control may be provided, for example, by replicating a plurality of access control functions (ACFs) using a plurality of instances in a plurality of different transmission/reception points (TRPs) with multi-connectivity. The plurality of TRPs may concurrently provide control services to a WTRU. Centralized control functions may manage core network connectivity and a plurality of user plane instances for the WTRU and may facilitate coordination between the plurality of ACF instances for the WTRU in the plurality of different TRPs of the WTRU's configuration. For example, there may be a first access plane between the WTRU and a first TRP that provides a first ACF for the WTRU, a second access plane between the WTRU and a second TRP that provides a second ACF for the WTRU, a RAN central control plane between the WTRU and a first RAN central control function (RCCF) and a RAN central user plane between the WTRU and a RAN central user function (RCUF).

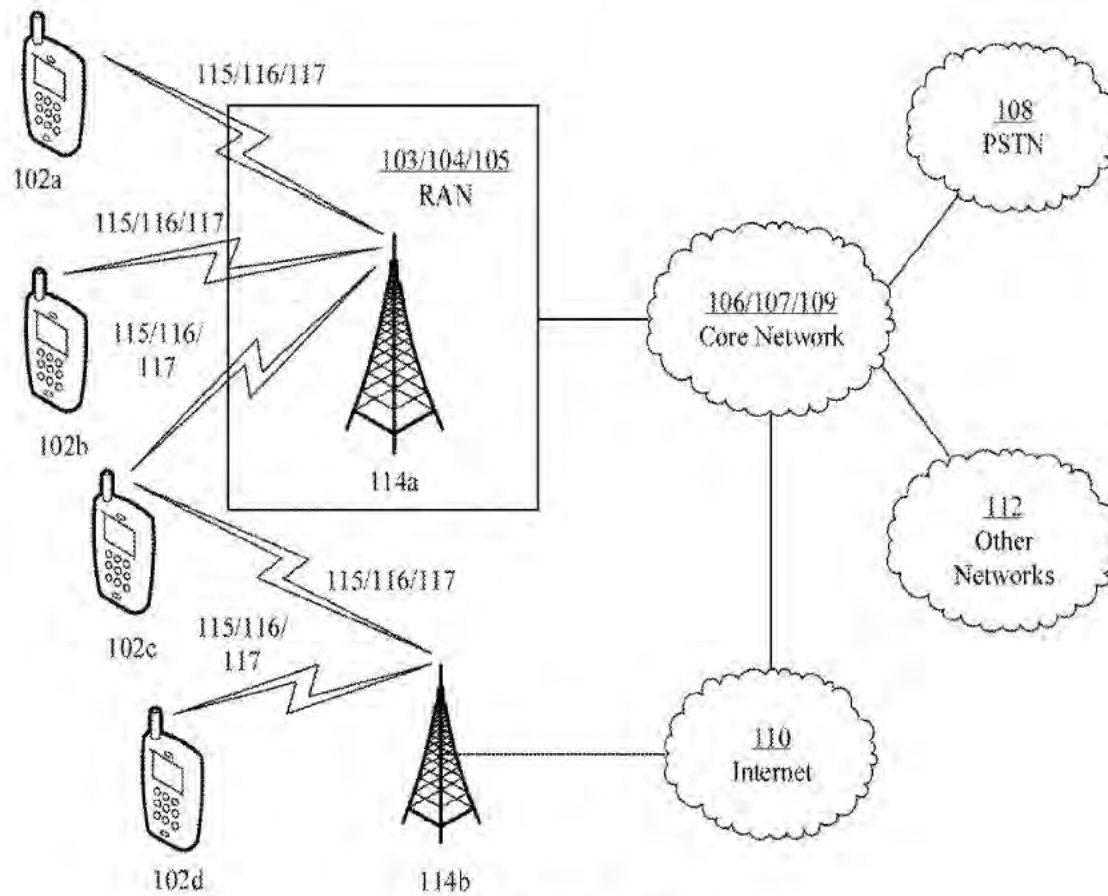

FIG. 1A

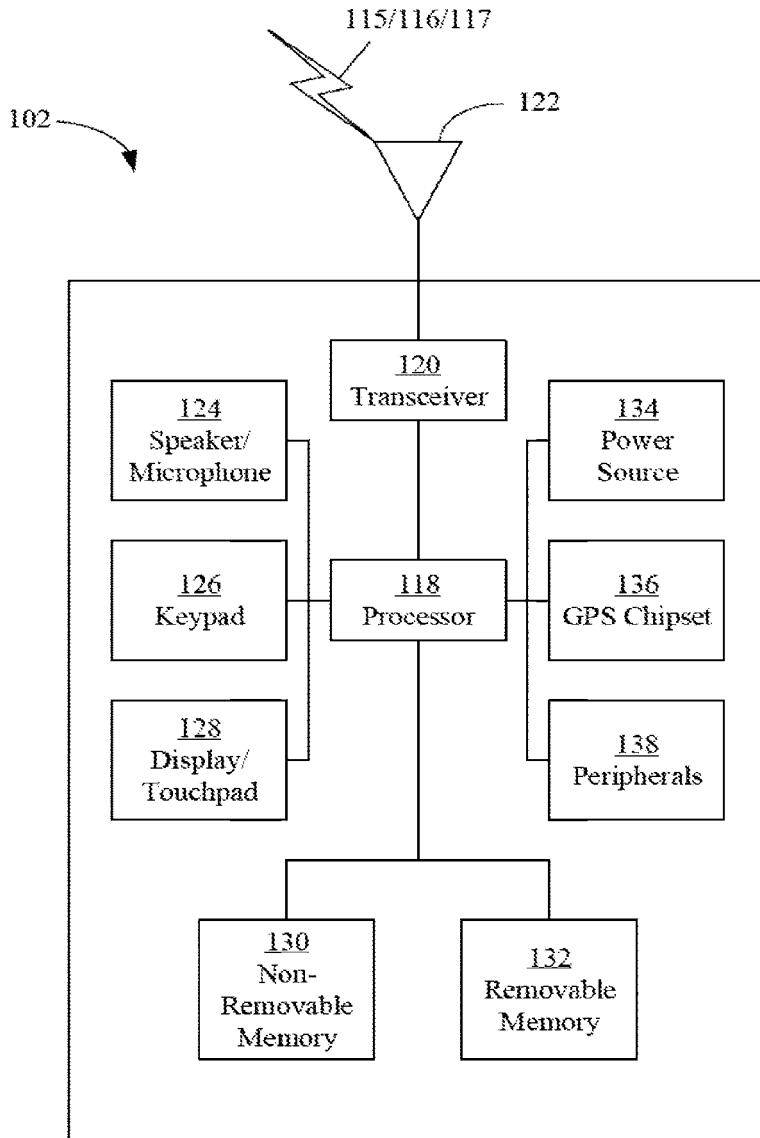

FIG. 1B

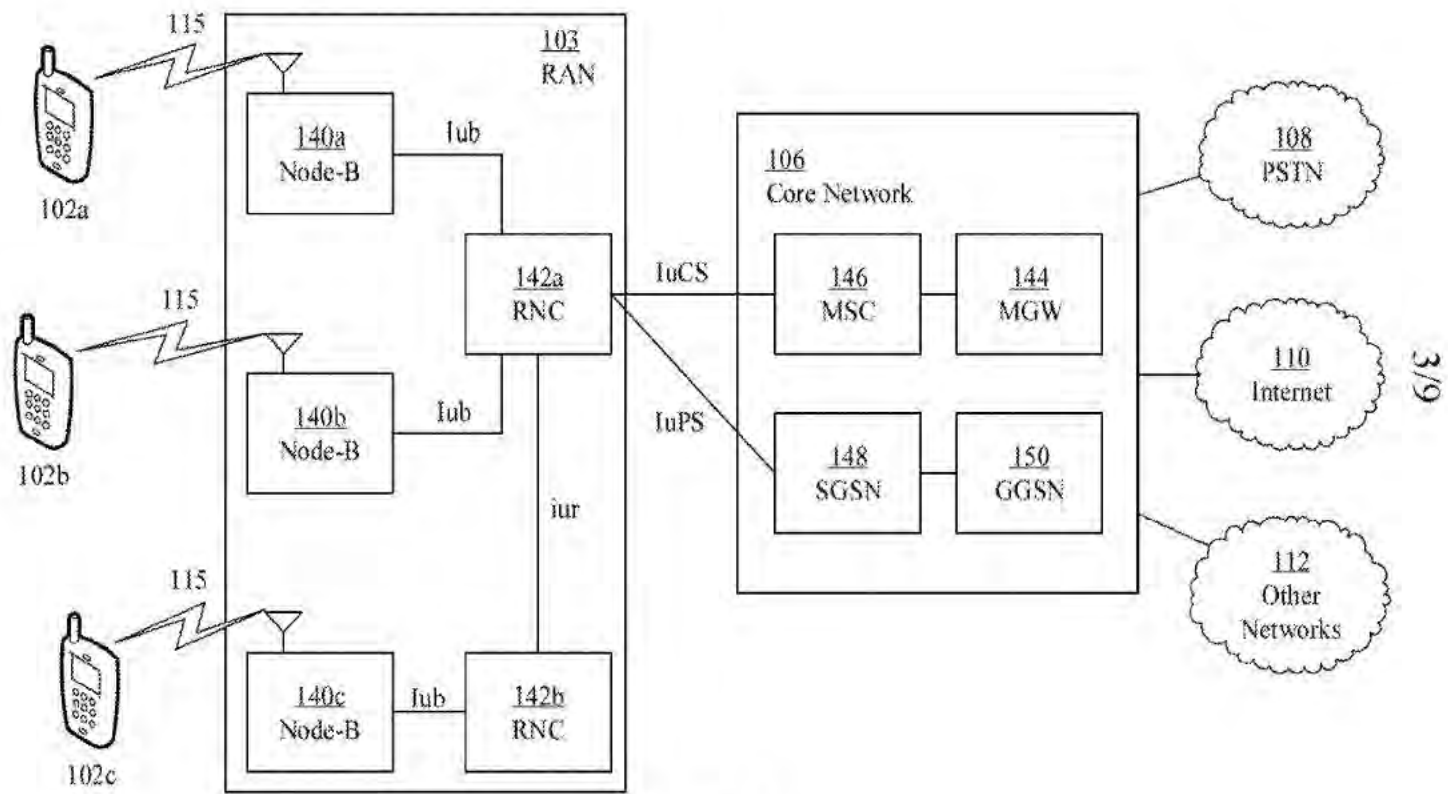
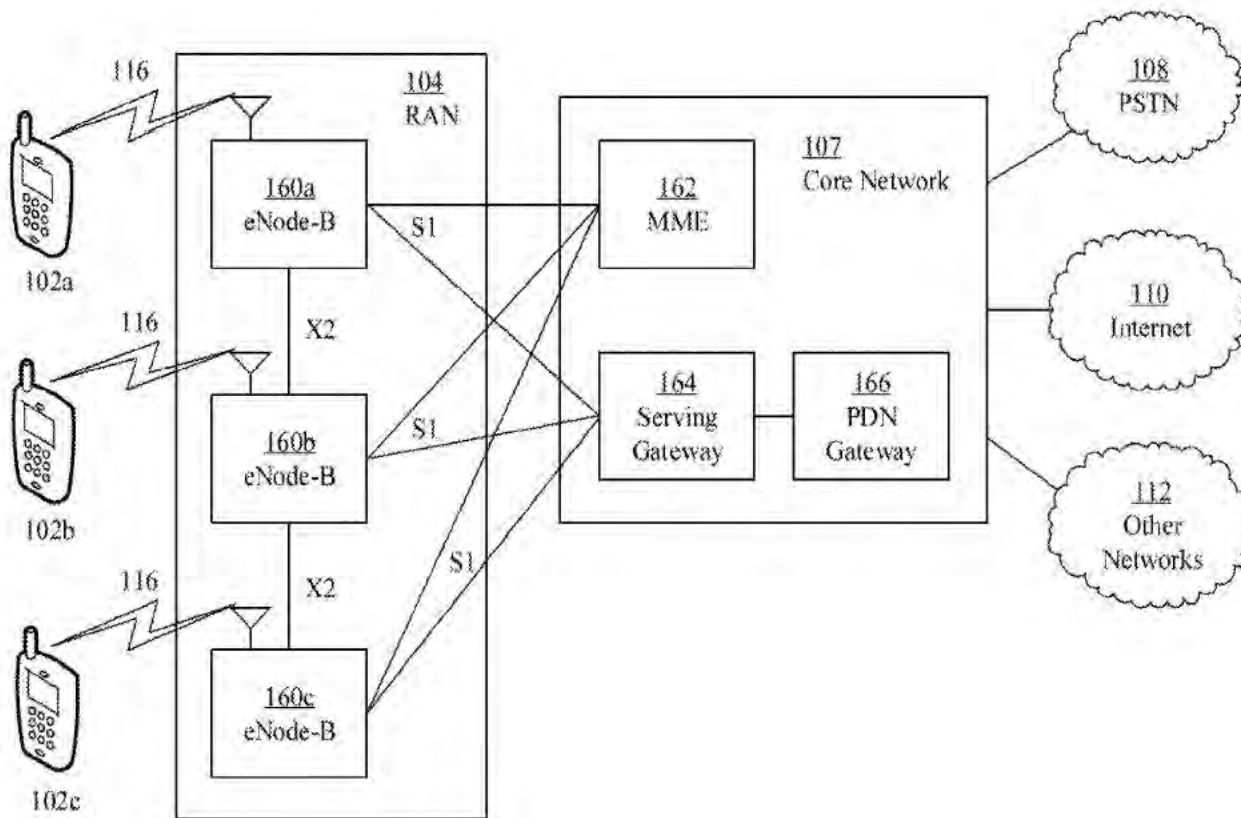

FIG. 1C

3/9



4/9

FIG. 1D

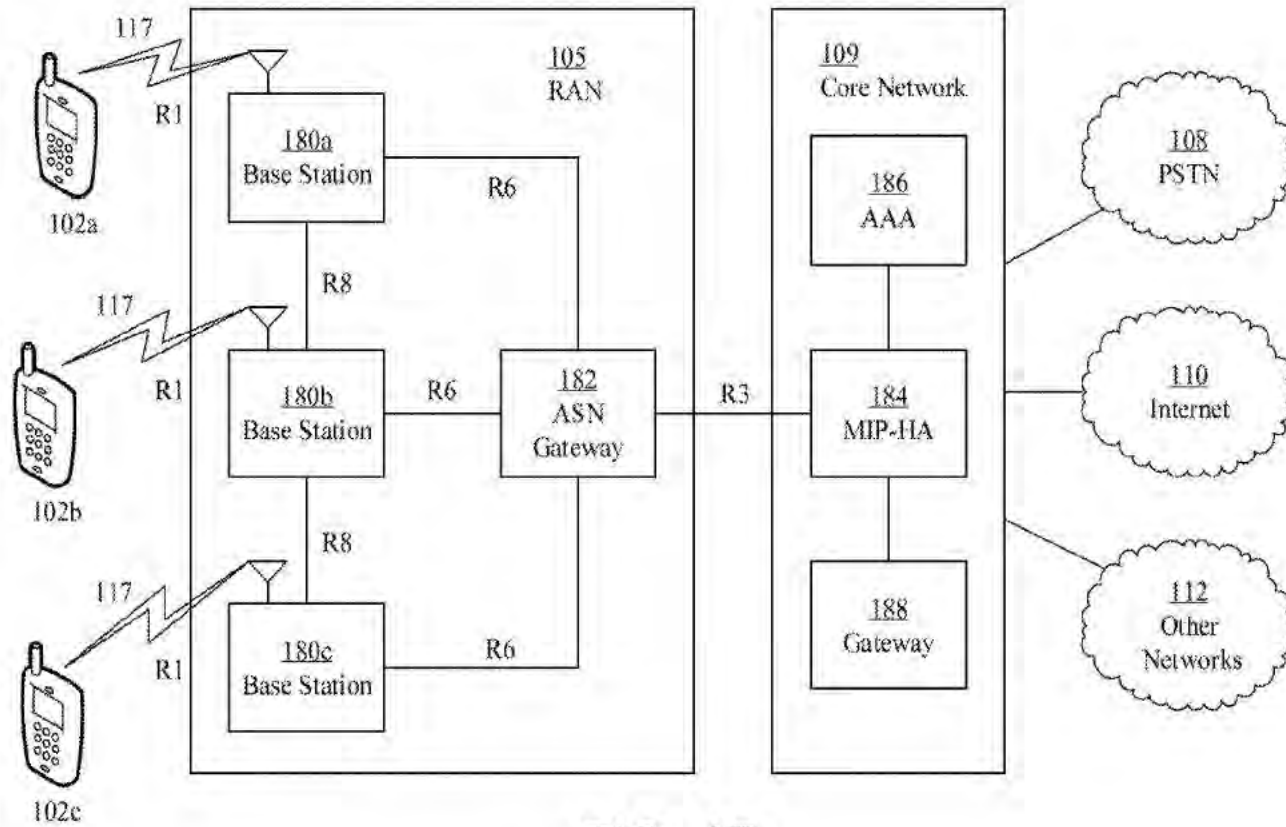

FIG. 1E

5/9

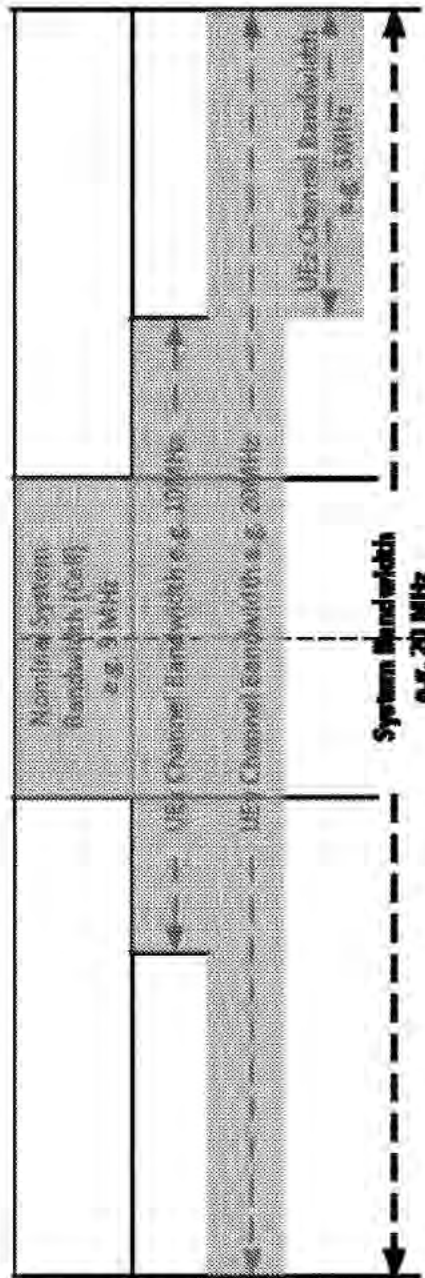
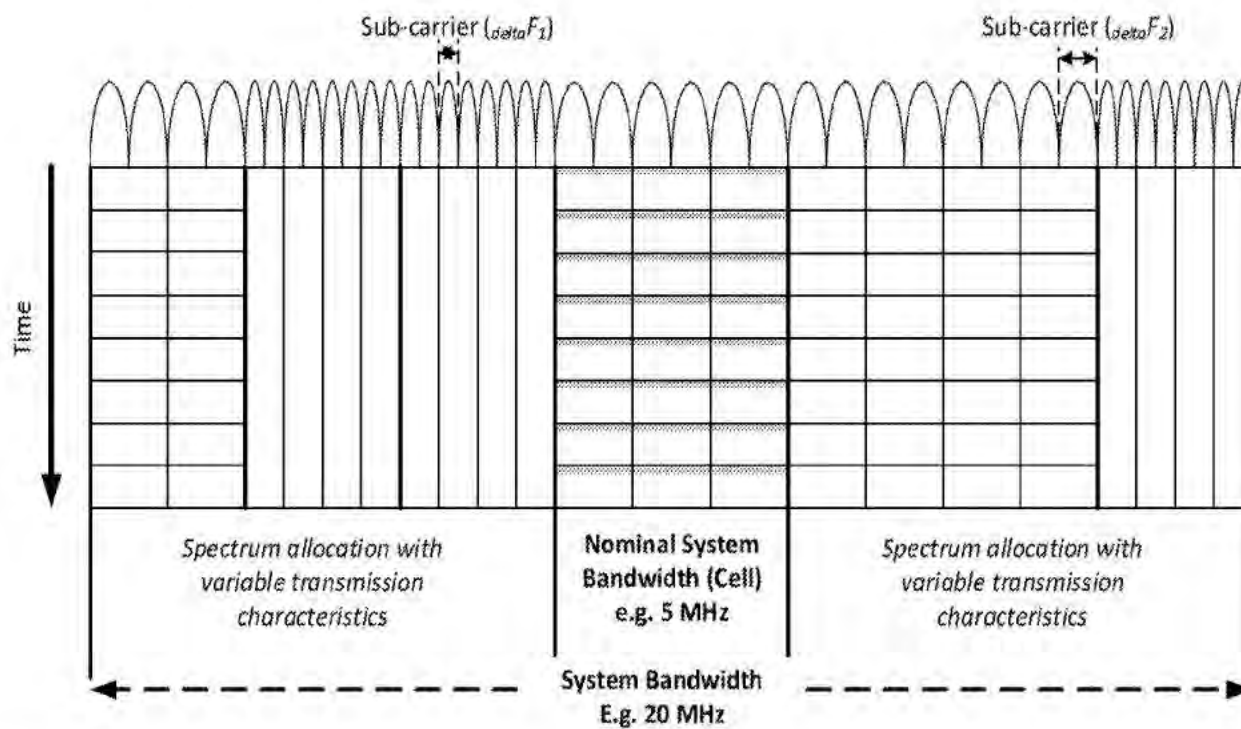

FIG. 2



7/9

FIG. 3

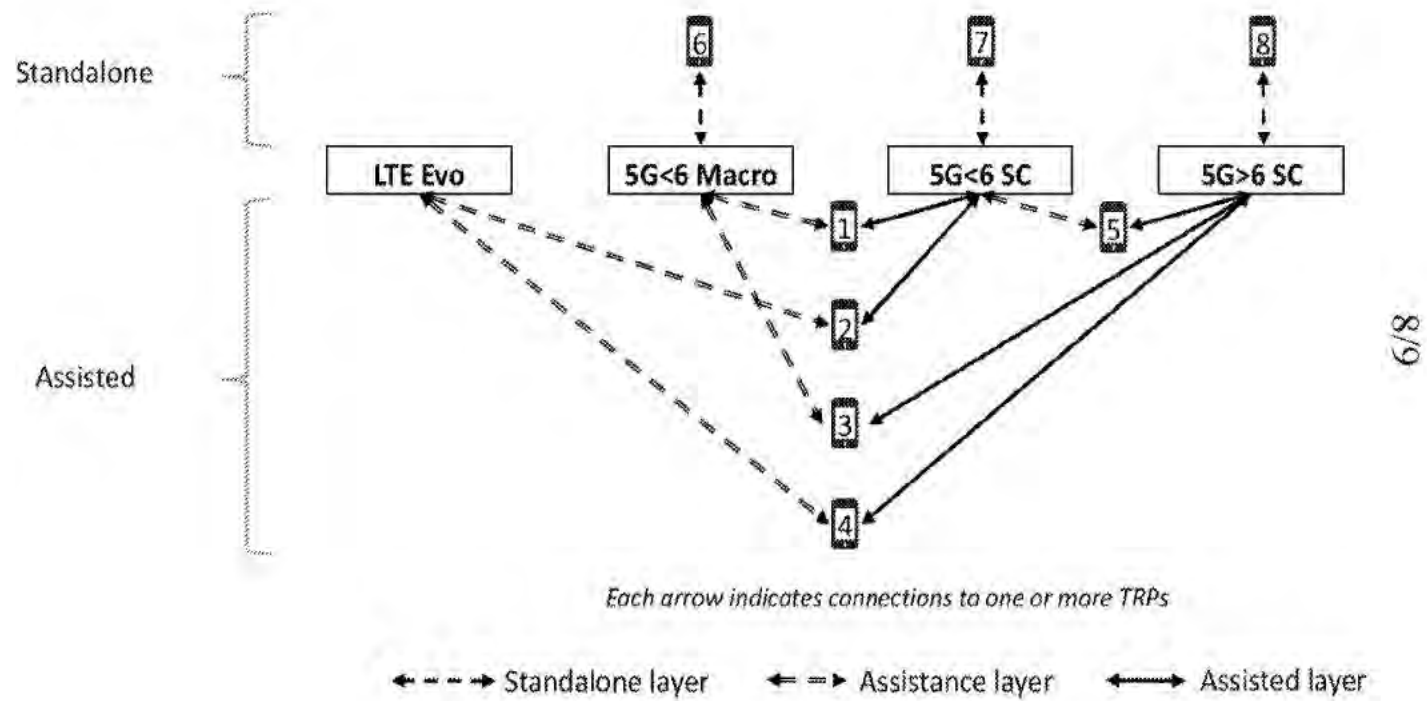

FIG. 4

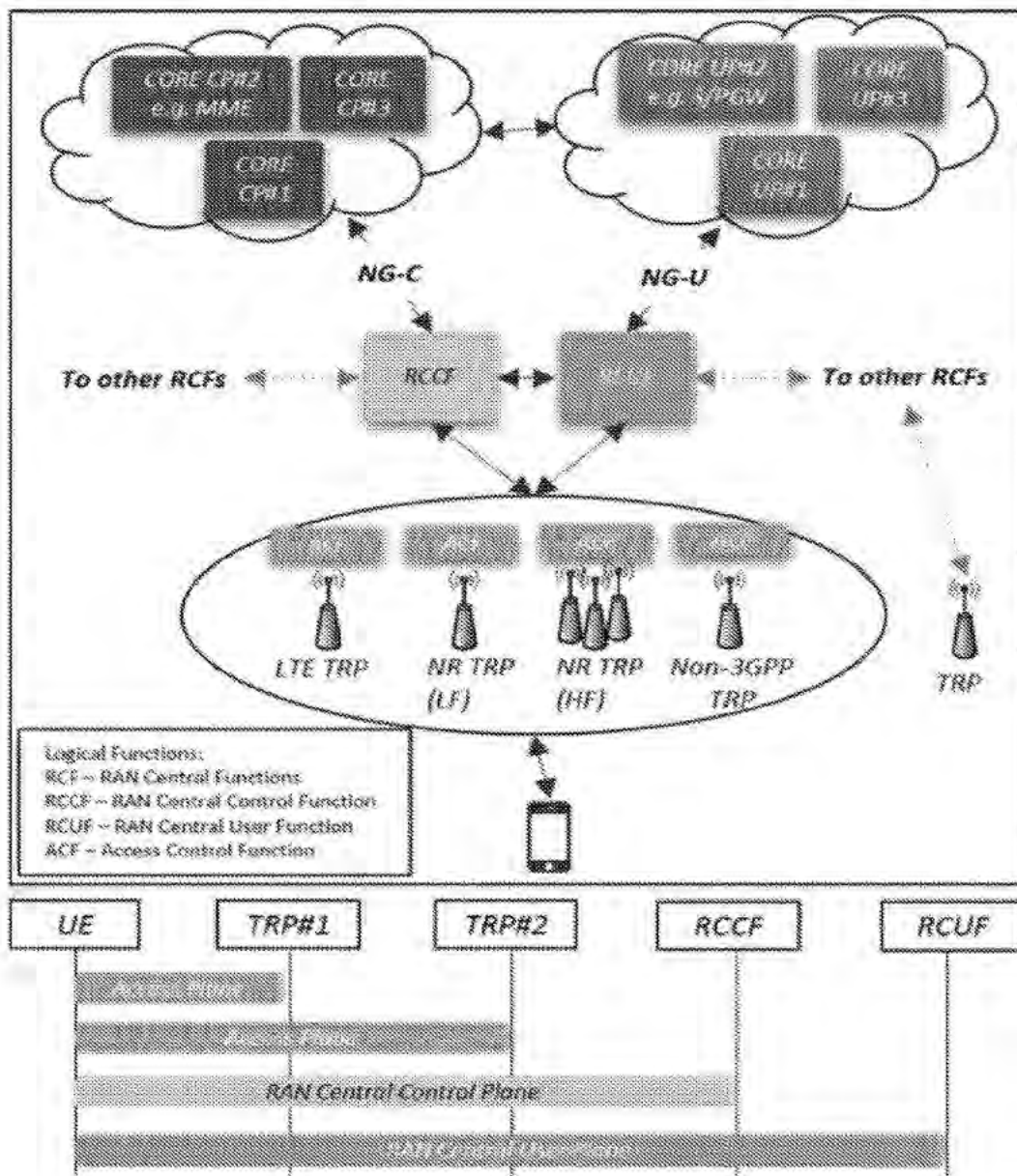

FIG. 5

Electronic Acknowledgement Receipt

EFS ID:	25748815
Application Number:	62334704
International Application Number:	
Confirmation Number:	2879
Title of Invention:	Distributed Control in Wireless Systems
First Named Inventor/Applicant Name:	Yugeswar Deenoo
Customer Number:	15800
Filer:	Mu Yang/Deidre Medina
Filer Authorized By:	Mu Yang
Attorney Docket Number:	ILTE_13091US01
Receipt Date:	11-MAY-2016
Filing Date:	
Time Stamp:	15:40:43
Application Type:	Provisional

Payment information:

Submitted with Payment	yes
Payment Type	Deposit Account
Payment was successfully received in RAM	\$260
RAM confirmation Number	2386
Deposit Account	090435
Authorized User	YANG, MU

The Director of the USPTO is hereby authorized to charge indicated fees and credit any overpayment as follows:

Charge any Additional Fees required under 37 CFR 1.16 (National application filing, search, and examination fees)

Charge any Additional Fees required under 37 CFR 1.17 (Patent application and reexamination processing fees)

Charge any Additional Fees required under 37 CFR 1.19 (Document supply fees)
 Charge any Additional Fees required under 37 CFR 1.20 (Post Issuance fees)
 Charge any Additional Fees required under 37 CFR 1.21 (Miscellaneous fees and charges)

File Listing:

Document Number	Document Description	File Name	File Size(Bytes)/ Message Digest	Multi Part /.zip	Pages (if appl.)
1	Application Data Sheet	ILTE_13091US01_Application_Data_Sheet.pdf	1823189 d3b7128f099619322cb05cf609ff35aa00c4994	no	9
Warnings:					
Information:					
2		ILTE_13091US01_Specification_FINAL.pdf	357698 6cccb9eac7e9a96b2101e6223bc61c16867c91d	yes	64
Multipart Description/PDF files in .zip description					
		Document Description	Start	End	
		Specification	1	61	
		Claims	62	63	
		Abstract	64	64	
Warnings:					
Information:					
3	Drawings-only black and white line drawings	ILTE_13091US01_Drawings_FINAL.pdf	1039801 3f358cd441d447a2fd563b7c2f61767bee492e9	no	9
Warnings:					
Information:					
4	Fee Worksheet (SB06)	fee-info.pdf	29752 a59b97bdea825b4ca3f50aad7bc35d7a0f99cd35	no	2
Warnings:					
Information:					
Total Files Size (in bytes):			3250440		

This Acknowledgement Receipt evidences receipt on the noted date by the USPTO of the indicated documents, characterized by the applicant, and including page counts, where applicable. It serves as evidence of receipt similar to a Post Card, as described in MPEP 503.

New Applications Under 35 U.S.C. 111

If a new application is being filed and the application includes the necessary components for a filing date (see 37 CFR 1.53(b)-(d) and MPEP 506), a Filing Receipt (37 CFR 1.54) will be issued in due course and the date shown on this Acknowledgement Receipt will establish the filing date of the application.

National Stage of an International Application under 35 U.S.C. 371

If a timely submission to enter the national stage of an international application is compliant with the conditions of 35 U.S.C. 371 and other applicable requirements a Form PCT/DO/EO/903 indicating acceptance of the application as a national stage submission under 35 U.S.C. 371 will be issued in addition to the Filing Receipt, in due course.

New International Application Filed with the USPTO as a Receiving Office

If a new international application is being filed and the international application includes the necessary components for an international filing date (see PCT Article 11 and MPEP 1810), a Notification of the International Application Number and of the International Filing Date (Form PCT/RO/105) will be issued in due course, subject to prescriptions concerning national security, and the date shown on this Acknowledgement Receipt will establish the international filing date of the application.

**DOCUMENT MADE AVAILABLE UNDER THE
PATENT COOPERATION TREATY (PCT)**

International application number:	PCT/US2017/032069
International filing date:	11 May 2017 (11.05.2017)
Document type:	Certified copy of priority document
Document details:	Country/Office: US
	Number: 62/334,704
	Filing date: 11 May 2016 (11.05.2016)
Date of receipt at the International Bureau:	21 May 2017 (21.05.2017)

Remark: Priority document submitted or transmitted to the International Bureau in compliance with Rule 17.1(a),(b) or (b-bis)

PCT

REQUEST

The undersigned requests that the present international application be processed according to the Patent Cooperation Treaty.

For receiving Office use only

PCT/US17/32069

International Application No.

11 MAY 2017 (11.05.17)

International Filing Date

PCT INTERNATIONAL APPLICATION
RO/US

Name of receiving Office and "PCT International Application"

Applicant's or agent's file reference
(if desired) (12 characters maximum) IG5SYS_13091WO01

Box No. I TITLE OF INVENTION	
DISTRIBUTED CONTROL IN WIRELESS SYSTEMS	
Box No. II APPLICANT <input type="checkbox"/> This person is also inventor	
Name and address: (Family name followed by given name; for a legal entity, full official designation. The address must include postal code and name of country. The country of the address indicated in this Box is the applicant's State (that is, country) of residence if no State of residence is indicated below.) IDAC Holdings, Inc. 200 Bellevue Parkway, Suite 300 Wilmington, Delaware 19809 United States of America	Telephone No. Facsimile No. Applicant's registration No. with the Office
E-mail authorization: Marking one of the check-boxes below authorizes the receiving Office, the International Searching Authority, the International Bureau and the International Preliminary Examining Authority to use the e-mail address indicated in this Box to send notifications issued in respect of this international application to that e-mail address if those offices are willing to do so. <input type="checkbox"/> as advance copies followed by paper notifications; or <input type="checkbox"/> exclusively in electronic form (no paper notifications will be sent). E-mail address:	
State (that is, country) of nationality: US	State (that is, country) of residence: US
This person is applicant for the purposes of: <input checked="" type="checkbox"/> all designated States <input type="checkbox"/> the States indicated in the Supplemental Box	
Box No. III FURTHER APPLICANT(S) AND/OR (FURTHER) INVENTOR(S)	
<input checked="" type="checkbox"/> Further applicants and/or (further) inventors are indicated on a continuation sheet.	
Box No. IV AGENT OR COMMON REPRESENTATIVE; OR ADDRESS FOR CORRESPONDENCE	
The person identified below is hereby/has been appointed to act on behalf of the applicant(s) before the competent International Authorities as: <input checked="" type="checkbox"/> agent <input type="checkbox"/> common representative	
Name and address: (Family name followed by given name; for a legal entity, full official designation. The address must include postal code and name of country.) ROCCIA, Vincent, JORDAN, Michael Condo Roccia Koptiw LLP 1800 JFK Blvd., Suite 1700 Philadelphia, Pennsylvania 19103 United States of America	Telephone No. 215-558-5740 Facsimile No. 215-558-5676 Agent's registration No. with the Office 43,887; 61,698
E-mail authorization: Marking one of the check-boxes below authorizes the receiving Office, the International Searching Authority, the International Bureau and the International Preliminary Examining Authority to use the e-mail address indicated in this Box to send notifications issued in respect of this international application to that e-mail address if those offices are willing to do so. <input type="checkbox"/> as advance copies followed by paper notifications; or <input checked="" type="checkbox"/> exclusively in electronic form (no paper notifications will be sent). E-mail address: docketing@condoroccia.com	
<input type="checkbox"/> Address for correspondence: Mark this check-box where no agent or common representative is/has been appointed and the space above is used instead to indicate a special address to which correspondence should be sent.	

Box No. III FURTHER APPLICANT(S) AND/OR (FURTHER) INVENTOR(S)	
<i>If none of the following sub-boxes is used, this sheet should not be included in the request.</i>	
<p>Name and address: <i>(Family name followed by given name; for a legal entity, full official designation. The address must include postal code and name of country. The country of the address indicated in this Box is the applicant's State (that is, country) of residence if no State of residence is indicated below.)</i></p> <p>DEENOO, Yugeswar 412 Monroe Blvd King of Prussia, Pennsylvania, 19406 United States of America</p>	<p>This person is:</p> <p><input type="checkbox"/> applicant only</p> <p><input type="checkbox"/> applicant and inventor</p> <p><input checked="" type="checkbox"/> inventor only <i>(If this check-box is marked, do not fill in below.)</i></p> <p>Applicant's registration No. with the Office</p>
State <i>(that is, country)</i> of nationality:	State <i>(that is, country)</i> of residence:
This person is applicant for the purposes of: <input type="checkbox"/> all designated States <input type="checkbox"/> the States indicated in the Supplemental Box	
<p>Name and address: <i>(Family name followed by given name; for a legal entity, full official designation. The address must include postal code and name of country. The country of the address indicated in this Box is the applicant's State (that is, country) of residence if no State of residence is indicated below.)</i></p> <p>PELLETIER, Ghyslain 4650 Charlemagne Montréal, Québec, H1X 3P2 Canada</p>	<p>This person is:</p> <p><input type="checkbox"/> applicant only</p> <p><input type="checkbox"/> applicant and inventor</p> <p><input checked="" type="checkbox"/> inventor only <i>(If this check-box is marked, do not fill in below.)</i></p> <p>Applicant's registration No. with the Office</p>
State <i>(that is, country)</i> of nationality:	State <i>(that is, country)</i> of residence:
This person is applicant for the purposes of: <input type="checkbox"/> all designated States <input type="checkbox"/> the States indicated in the Supplemental Box	
<p>Name and address: <i>(Family name followed by given name; for a legal entity, full official designation. The address must include postal code and name of country. The country of the address indicated in this Box is the applicant's State (that is, country) of residence if no State of residence is indicated below.)</i></p> <p>TAN, Ping Hsuan 115 De La Gauchetiere West, Apt.608 Montreal, Quebec, H2Z 1Y2 Canada</p>	<p>This person is:</p> <p><input type="checkbox"/> applicant only</p> <p><input type="checkbox"/> applicant and inventor</p> <p><input checked="" type="checkbox"/> inventor only <i>(If this check-box is marked, do not fill in below.)</i></p> <p>Applicant's registration No. with the Office</p>
State <i>(that is, country)</i> of nationality:	State <i>(that is, country)</i> of residence:
This person is applicant for the purposes of: <input type="checkbox"/> all designated States <input type="checkbox"/> the States indicated in the Supplemental Box	
<p>Name and address: <i>(Family name followed by given name; for a legal entity, full official designation. The address must include postal code and name of country. The country of the address indicated in this Box is the applicant's State (that is, country) of residence if no State of residence is indicated below.)</i></p> <p>FREDA, Martino M. 7131 du Cabernet Laval, Quebec, H7A 0A8 Canada</p>	<p>This person is:</p> <p><input type="checkbox"/> applicant only</p> <p><input type="checkbox"/> applicant and inventor</p> <p><input checked="" type="checkbox"/> inventor only <i>(If this check-box is marked, do not fill in below.)</i></p> <p>Applicant's registration No. with the Office</p>
State <i>(that is, country)</i> of nationality:	State <i>(that is, country)</i> of residence:
This person is applicant for the purposes of: <input type="checkbox"/> all designated States <input type="checkbox"/> the States indicated in the Supplemental Box	
<input type="checkbox"/> Further applicants and/or (further) inventors are indicated on another continuation sheet.	

Supplemental Box

If the Supplemental Box is not used, this sheet should not be included in the request.

1. *If, in any of the Boxes, except Boxes Nos. VIII(i) to (v) for which a special continuation box is provided, **the space is insufficient** to furnish all the information: in such case, write "Continuation of Box No. ..." (indicate the number of the Box) and furnish the information in the same manner as required according to the captions of the Box in which the space was insufficient, in particular:

 - (i) **if more than one person is to be indicated as applicant and/or inventor** and no "continuation sheet" is available: in such case, write "Continuation of Box No. III" and indicate for each additional person the same type of information as required in Box No. III. The country of the address indicated in this Box is the applicant's State (that is, country) of residence if no State of residence is indicated below;
 - (ii) if, in Box No. II or in any of the sub-boxes of Box No. III, the indication **"the States indicated in the Supplemental Box"** is checked: in such case, write "Continuation of Box No. II" or "Continuation of Box No. III" or "Continuation of Boxes No. II and No. III" (as the case may be), indicate the name of the applicant(s) involved and, next to (each) such name, the State(s) (and/or, where applicable, ARIPO, Eurasian, European or OAPI patent) for the purposes of which the named person is applicant;
 - (iii) if, in Box No. II or in any of the sub-boxes of Box No. III, **the inventor or the inventor/applicant is not inventor for the purposes of all designated States**: in such case, write "Continuation of Box No. II" or "Continuation of Box No. III" or "Continuation of Boxes No. II and No. III" (as the case may be), indicate the name of the inventor(s) and, next to (each) such name, the State(s) (and/or, where applicable, ARIPO, Eurasian, European or OAPI patent) for the purposes of which the named person is inventor;
 - (iv) if, in addition to the agent(s) indicated in Box No. IV, there are **further agents**: in such case, write "Continuation of Box No. IV" and indicate for each further agent the same type of information as required in Box No. IV;
 - (v) if, in Box No. VI, there are **more than three earlier applications whose priority is claimed**: in such case, write "Continuation of Box No. VI" and indicate for each additional earlier application the same type of information as required in Box No. VI.*
2. *If the applicant intends to make an indication of the wish that the international application be treated, in certain designated States, as an application for a patent of addition, certificate of addition, inventor's certificate of addition or utility certificate of addition: in such case, write the name or two-letter code of each designated State concerned and the indication "patent of addition," "certificate of addition," "inventor's certificate of addition" or "utility certificate of addition," the number of the parent application or parent patent or other parent grant and the date of grant of the parent patent or other parent grant or the date of filing of the parent application (Rules 4.11(a)(i) and 49bis.1(a) or (b)).*
3. *If the applicant intends to make an indication of the wish that the international application be treated, in the United States of America, as a continuation or continuation-in-part of an earlier application: in such case, write "United States of America" or "US" and the indication "continuation" or "continuation-in-part" and the number and the filing date of the parent application (Rules 4.11(a)(ii) and 49bis.1(d)).*

US Provisional Patent Application No. 62/442,317
Filed: 04 January 2017 (04.01.2017)

Box No. V DESIGNATIONS				
<p>The filing of this request constitutes under Rule 4.9(a) the designation of all Contracting States bound by the PCT on the international filing date, for the grant of every kind of protection available and, where applicable, for the grant of both regional and national patents. However,</p> <p><input type="checkbox"/> DE Germany is not designated for any kind of national protection</p> <p><input type="checkbox"/> JP Japan is not designated for any kind of national protection</p> <p><input type="checkbox"/> KR Republic of Korea is not designated for any kind of national protection</p> <p><i>(The check-boxes above may only be used to exclude (irrevocably) the designations concerned if, at the time of filing or subsequently under Rule 26bis.1, the international application contains in Box No. VI a priority claim to an earlier national application filed in the particular State concerned, in order to avoid the ceasing of the effect, under the national law, of this earlier national application.)</i></p>				
Box No. VI PRIORITY CLAIM AND DOCUMENT				
The priority of the following earlier application(s) is hereby claimed:				
Filing date of earlier application <i>(day/month/year)</i>	Number of earlier application	Where earlier application is:		
		national application: country or Member of WTO	regional application: regional Office	international application: receiving Office
item (1) 11 MAY 2016 (11.05.2016)	62/334,704	US		
item (2) 28 SEPTEMBER 2016 (28.09.2016)	62/400,810	US		
item (3) 02 NOVEMBER 2016 (02.11.2016)	62/416,499	US		
<input checked="" type="checkbox"/> Further priority claims are indicated in the Supplemental Box.				
Furnishing the priority document(s):				
<input checked="" type="checkbox"/> The receiving Office is requested to prepare and transmit to the International Bureau a certified copy of the earlier application(s) <i>(only if the earlier application(s) was filed with the receiving Office which, for the purposes of this international application, is the receiving Office)</i> identified above as: <p><input checked="" type="checkbox"/> all items <input checked="" type="checkbox"/> item (1) <input checked="" type="checkbox"/> item (2) <input checked="" type="checkbox"/> item (3) <input checked="" type="checkbox"/> other, see Supplemental Box</p>				
<input type="checkbox"/> The International Bureau is requested to obtain from a digital library a certified copy of the earlier application(s) identified above, using, where applicable, the access code(s) indicated below <i>(if the earlier application(s) is available to it from a digital library)</i> : <p><input type="checkbox"/> item (1) <input type="checkbox"/> item (2) <input type="checkbox"/> item (3) <input type="checkbox"/> other, see Supplemental Box</p> <p>access code _____ access code _____ access code _____</p>				
Restore the right of priority: the receiving Office is requested to restore the right of priority for the earlier application(s) identified above or in the Supplemental Box as item(s) (_____). <i>(See also the Notes to Box No. VI; further information must be provided to support a request to restore the right of priority.)</i>				
Incorporation by reference: where an element of the international application referred to in Article 11(1)(iii)(d) or (e) or a part of the description, claims or drawings referred to in Rule 20.5(a) is not otherwise contained in this international application but is completely contained in an earlier application whose priority is claimed on the date on which one or more elements referred to in Article 11(1)(iii) were first received by the receiving Office, that element or part is, subject to confirmation under Rule 20.6, incorporated by reference in this international application for the purposes of Rule 20.6.				
Box No. VII INTERNATIONAL SEARCHING AUTHORITY				
Choice of International Searching Authority (ISA) <i>(if more than one International Searching Authority is competent to carry out the international search, indicate the Authority chosen; the two-letter code may be used):</i> ISA/ EP _____				

Box No. IX CHECKLIST for EFS-Web filings - this sheet is only to be used when filing an international application with RO/US via EFS-Web			
This international application contains the following:	Number of sheets	This international application is accompanied by the following item(s) (mark the applicable check-boxes below and indicate in right column the number of each item):	Number of items
(a) request form PCT/RO/101 (including any declarations and supplemental sheets)	5	1. <input checked="" type="checkbox"/> fee calculation sheet	1
(b) description (excluding any sequence listing part of the description, see (f), below)	99	2. <input type="checkbox"/> original separate power of attorney	
(c) claims	9	3. <input type="checkbox"/> original general power of attorney	
(d) abstract	1	4. <input type="checkbox"/> copy of general power of attorney; reference number	
(e) drawings (if any)	13	5. <input type="checkbox"/> priority document(s) identified in Box No. VI as item(s)	
(f) sequence listing part of the description in the form of an image file (e.g. PDF)		6. <input type="checkbox"/> Translation of international application into (language):	
Total number of sheets (including the sequence listing part of the description if filed as an image file)	127	7. <input type="checkbox"/> separate indications concerning deposited microorganism or other biological material	
(g) sequence listing part of the description		8. <input type="checkbox"/> (only where item (f) is marked in the left column) copy of the sequence listing in electronic form (Annex C/ST.25 text file) not forming part of the international application but furnished only for the purposes of international search under Rule 13ter	
<input type="checkbox"/> filed in the form of an Annex C/ST.25 text file		9. <input type="checkbox"/> (only where item (f) in the left column and item 8 (above) are marked) a statement confirming that "the information recorded in electronic form submitted under Rule 13ter is identical to the sequence listing as contained in the international application" as filed via EFS-Web:	
<input type="checkbox"/> WILL BE filed separately on physical data carrier(s), on the same day and in the form of an Annex C/ST.25 text file		10. <input type="checkbox"/> copy of results of earlier search(es) (Rule 12bis.1(a))	
Indicate type and number of physical data carrier(s)		11. <input checked="" type="checkbox"/> other (specify): PCT Transmittal	1
Figure of the drawings which should accompany the abstract: 8A		Language of filing of the international application: English	

Box No. X SIGNATURE OF APPLICANT, AGENT OR COMMON REPRESENTATIVE
Next to each signature, indicate the name of the person signing and the capacity in which the person signs (if such capacity is not obvious from reading the request).

/Michael Jordan/
 Michael Jordan
 Agent for Applicant
 US Reg. No. 61,698

For receiving Office use only	
1. Date of actual receipt of the purported international application: 11 MAY 2017 (11.05.17)	2. Drawings <input type="checkbox"/> received; <input type="checkbox"/> not received.
3. Corrected date of actual receipt due to later but timely received papers or drawings completing the purported international application:	
4. Date of timely receipt of the required corrections under PCT Article 11(2):	
5. International Searching Authority (if two or more are competent): ISA /EP	6. <input type="checkbox"/> Transmittal of search copy delayed until search fee is paid

For International Bureau use only

Date of receipt of the record copy by the International Bureau:

(12) INTERNATIONAL APPLICATION PUBLISHED UNDER THE PATENT COOPERATION TREATY (PCT)

(19) World Intellectual Property
Organization
International Bureau



(10) International Publication Number
WO 2017/197063 A1

(43) International Publication Date
16 November 2017 (16.11.2017)

WIPO | PCT

- (51) International Patent Classification:
H04B 7/0408 (2017.01) **H04B 7/06** (2006.01)
- (21) International Application Number:
PCT/US2017/032069
- (22) International Filing Date:
11 May 2017 (11.05.2017)
- (25) Filing Language: English
- (26) Publication Language: English
- (30) Priority Data:
62/334,704 11 May 2016 (11.05.2016) US
62/400,810 28 September 2016 (28.09.2016) US
62/416,499 02 November 2016 (02.11.2016) US
62/442,317 04 January 2017 (04.01.2017) US

EE, ES, FI, FR, GB, GR, HR, HU, IE, IS, IT, LT, LU, LV, MC, MK, MT, NL, NO, PL, PT, RO, RS, SE, SI, SK, SM, TR), OAPI (BF, BJ, CF, CG, CI, CM, GA, GN, GQ, GW, KM, ML, MR, NE, SN, TD, TG).

Published:

- with international search report (Art. 21(3))
- before the expiration of the time limit for amending the claims and to be republished in the event of receipt of amendments (Rule 48.2(h))

(71) Applicant: **IDAC HOLDINGS, INC.** [US/US]; 200 Bellevue Parkway, Suite 300, Wilmington, DE 19809 (US).

(72) Inventors: **DEENOO, Yugeswar**; 412 Monroe Blvd, King Of Prussia, PA 19406 (US). **PELLETIER, Ghyslain**; 4650 Charlemagne, Montréal, Québec, H1X 3P2 (CA). **TAN, Ping, Hsuan**; 115 De La Gauchetiere West, Apt. 608, Montréal, Québec, H2Z 1Y2 (CA). **FREDA, Martino, M.**; 7131 Du Cabernet, Laval, Québec, H7A 0A8 (CA).

(74) Agent: **ROCCIA, Vincent** et al.; Condo Roccia Koptiw LLP, 1800 JFK Blvd., Suite 1700, Philadelphia, PA 19103 (US).

(81) Designated States (unless otherwise indicated, for every kind of national protection available): AE, AG, AL, AM, AO, AT, AU, AZ, BA, BB, BG, BH, BN, BR, BW, BY, BZ, CA, CH, CL, CN, CO, CR, CU, CZ, DE, DJ, DK, DM, DO, DZ, EC, EE, EG, ES, FI, GB, GD, GE, GH, GM, GT, HN, HR, HU, ID, IL, IN, IR, IS, JP, KE, KG, KH, KN, KP, KR, KW, KZ, LA, LC, LK, LR, LS, LU, LY, MA, MD, ME, MG, MK, MN, MW, MX, MY, MZ, NA, NG, NI, NO, NZ, OM, PA, PE, PG, PH, PL, PT, QA, RO, RS, RU, RW, SA, SC, SD, SE, SG, SK, SL, SM, ST, SV, SY, TH, TJ, TM, TN, TR, TT, TZ, UA, UG, US, UZ, VC, VN, ZA, ZM, ZW.

(84) Designated States (unless otherwise indicated, for every kind of regional protection available): ARIPO (BW, GH, GM, KE, LR, LS, MW, MZ, NA, RW, SD, SL, ST, SZ, TZ, UG, ZM, ZW), Eurasian (AM, AZ, BY, KG, KZ, RU, TJ, TM), European (AL, AT, BE, BG, CH, CY, CZ, DE, DK,



WO 2017/197063 A1

(54) Title: DISTRIBUTED CONTROL IN WIRELESS SYSTEMS

(57) Abstract: Systems, procedures, and instrumentalities are disclosed for distributed control in wireless systems, such as 5G flexible radio access technology (RAT) (5gFLEX). Example procedures are provided for WTRU and network operation associated with a distributed control plane architecture, connectionless data transfer and dedicated system information acquisition. Distributed control may be provided, for example, by replicating a plurality of access control functions (ACFs) using a plurality of instances in a plurality of different transmission/reception points (TRPs) with multi-connectivity. The plurality of TRPs may concurrently provide control services to a WTRU. Centralized control functions may manage core network connectivity and/or a plurality of user plane instances for the WTRU and/or may facilitate coordination between the plurality of ACF instances for the WTRU in the plurality of different TRPs of the WTRU's configuration.

CLAIMS**What is Claimed is:**

1. A wireless transmit/receive unit (WTRU) in communication with a communication network, the WTRU comprising:
 - a memory;
 - a processor, the processor configured at least to:
 - determine to request one or more system information (SI) messages from the communication network; and
 - determine if a transmission of the one or more SI message from the communication network will utilize at least one beamformed communication based on one or more communication parameters; and
 - a transceiver, the transceiver configured at least to:
 - receive at least one of the one or more SI messages from the communication network via the at least one beamformed communication.
2. The WTRU of claim 1, wherein the one or more communication parameters include a frequency band of the transmission, the processor being further configured to:
 - compare the frequency band of the transmission to a predetermined threshold; and
 - determine that the transmission of the one or more SI messages from the communication network utilizes at least one beamformed communication based on the frequency band of the transmission exceeding the predetermined threshold.
3. The WTRU of claim 1, wherein the one or more communication parameters include a characteristic of a downlink signal, the transceiver being further configured to:
 - receive the downlink signal, the processor being further configured to:
 - identify the characteristic of the downlink signal; and
 - determine that the transmission of the one or more SI messages from the communication network utilizes at least one beamformed communication based on the identified characteristic of the downlink signal.
4. The WTRU of claim 3, wherein the downlink signal includes a reference signal.

5. The WTRU of claim 4, wherein the characteristic of the downlink signal includes one or more of: a type of the reference signal, a system signature, a root signature, a basis sequence, or one or more predefined sequence numbers.
6. The WTRU of claim 5, wherein the type of the reference signal is a synchronization signal.
7. The WTRU of claim 1, wherein the one or more communication parameters include information provided in a broadcast message, the transceiver being further configured to:
 - receive the broadcast message, the processor being further configured to:
 - identify the information in the broadcast message; and
 - determine that the transmission of the one or more SI messages from the communication network utilizes at least one beamformed communication based on the information in the broadcast message.
8. The WTRU of claim 7, wherein the information provided in the broadcast message is included in at least one of: a master system information block (MIB), or a system information block (SIB), or a system information message.
9. The WTRU of claim 1, wherein the one or more communication parameters include a quality of a downlink signal, the transceiver being further configured to:
 - receive the downlink signal, the processor being further configured to:
 - measure a quality of the downlink signal; and
 - determine that the transmission of the one or more SI messages from the communication network utilizes at least one beamformed communication based on the quality of the downlink signal being below a predetermined threshold.
10. The WTRU of claim 9, wherein the downlink signal includes a reference signal, and the quality of the downlink signal includes a received power of a reference signal.
11. The WTRU of claim 1, wherein the processor is further configured to initiate an uplink (UL) request to the communication network for the one or more SI messages.

12. A wireless transmit/receive unit (WTRU) in communication with a communication network, the WTRU comprising:
- a memory;
 - a processor, the processor configured at least to:
 - determine to request one or more system information (SI) messages from the communication network;
 - conduct a beam sweep operation of one or more downlink (DL) beams transmitted from the communication network;
 - identify at least one DL beam of the one or more DL beams via which to receive the one or more on-demand SI messages based at least in part on the beam sweep operation;
 - determine one or more uplink (UL) resources with which to communicate information for a WTRU reception of the one or more on-demand SI messages, the information for the WTRU reception including the at least one DL beam; and
 - initiate the request for the one or more on-demand SI messages from the communication network; and
 - a transceiver, the transceiver configured at least to:
 - send the request for the one or more on-demand SI messages to the communication network using the one or more UL resources, the request including the information for the WTRU reception of the one or more on-demand SI messages; and
 - receive at least one of the one or more on-demand SI messages from the communication network via the at least one DL beam.
13. The WTRU of claim 12, wherein the one or more UL resources are mapped to the at least one DL beam.
14. The WTRU of claim 12, wherein the processor is further configured such that the one or more UL resources are determined based on at least one of: the at least one DL beam of the one or more DL beams, a mapping between the one or more UL resources and the at least one DL beam of the one or more DL beams, or the requested one or more on-demand SI messages

15. The WTRU of claim 12, wherein the processor is further configured such that the request for the one or more on-demand SI messages is sent as part of a Random Access Channel (RACH) transmission.
16. The WTRU of claim 12, wherein the processor is further configured such that the at least one DL beam of the one or more DL beams is identified based on which of the one or more DL beams at least one of: a synchronization signal, a master system information block (MIB), or essential system information is received in the beam sweep operation.
17. A wireless transmit/receive unit (WTRU) in communication with a communication network, the WTRU comprising:
 - a memory;
 - a transceiver, the transceiver configured at least to:
 - receive system information (SI) from the communication network at a first-time instance; and
 - a processor, the processor configured at least to:
 - determine a first-reference identifier (ID) that corresponds to at least some of the SI of the first-time instance;
 - determine a first-value identifier (ID) that corresponds to the at least some of the SI of the first-time instance;
 - associate at least one of: the first-reference ID, or the first-value ID with the at least some of the SI of the first-time instance;
 - utilize the at least some of the SI of the first-time instance in communication with the communication network;
 - search the memory for stored SI of a previous-time instance that is associated with the same first-reference ID of the at least some of the SI of the first-time instance;
 - store the at least some of the SI of the first-time instance upon no stored SI of the previous-time instance associated with the same first-reference ID being found; and
 - replace stored SI of the previous-time instance associated with the same first-reference ID with the at least some of the SI of the first-time instance upon a value ID associated with the stored SI of the previous-time instance associated with the same first-reference ID being different from the first-value ID.

18. The WTRU of claim 17, wherein the processor is further configured to interpret that the value ID associated with the stored SI of the previous-time instance associated with the same first-reference ID being different from the first-value ID corresponds to at least some of the SI of the first-time instance being more current than the stored SI of the previous-time instance.
19. The WTRU of claim 17, wherein the processor is further configured to recognize that the first-reference ID corresponds to at least one of: a first-spatial area, or a first-temporal interval.
20. The WTRU of claim 17, wherein the processor is further configured to determine the first-reference ID by identifying the first-reference ID as communicated from the communication network via at least one of: a broadcast message, or dedicated signaling.
21. The WTRU of claim 20, wherein the processor is further configured to determine the first-value ID by identifying a part of the first-reference ID that represents the first-value ID.
22. The WTRU of claim 20, wherein the processor is further configured to determine the first-value ID by identifying the first-value ID as communicated from the communication network via at least one of: a broadcast message, or dedicated signaling.
23. The WTRU of claim 17, wherein the processor is further configured to determine the first-reference ID by deriving the first-reference ID based on one or more characteristics associated with one or more downlink (DL) transmissions.
24. The WTRU of claim 23, wherein the processor is further configured to determine the first-value ID by identifying the first-value ID as expressly communicated from the communication network via at least one of: a broadcast message, or dedicated signaling.
25. The WTRU of claim 17, wherein the at least some of the SI of the first-time instance is at least one of: essential SI, minimum SI message, or on-demand SI.
26. The WTRU of claim 17, wherein the processor is further configured such that to replace the stored SI of the previous-time instance associated with the same first-reference ID

with the at least some of the SI of the first-time instance includes the processor being configured to:

delete from the memory the stored SI of the previous-time instance associated with the same first-reference ID; and
store in the memory the at least some of the SI of the first-time instance.

27. The WTRU of claim 17, wherein the processor is further configured such that to replace the stored SI of the previous-time instance associated with the same first-reference ID with the at least some of the SI of the first-time instance includes the processor being configured to:

overwrite in the memory the stored SI of the previous-time instance associated with the same first-reference ID with the at least some of the SI of the first-time instance.

28. The WTRU of claim 20, wherein the processor is further configured to:

detect that a second-reference ID is being communicated by the communication network in lieu of the first-reference ID;
search the memory for stored SI of a previous-time instance that is associated with the second-reference ID;
utilize the SI of the previous-time instance that is associated with the second-reference ID upon the SI of the previous-time instance that is associated with the second-reference ID being found; and
obtain updated SI from the communication network upon the SI of the previous-time instance that is associated with the second-reference ID not being found.

29. The WTRU of claim 22, wherein the processor is further configured to:

detect that a second-reference ID is being communicated by the communication network in lieu of the first-reference ID;
detect that a second-value ID is being communicated by the communication network in lieu of the first-value ID;
search the memory for stored SI of a previous-time instance that is associated with the second-reference ID and the second-value ID;

utilize the SI of the previous-time instance that is associated with the second-reference ID and the second-value ID upon the SI of the previous-time instance that is associated with the second-reference ID and second-value ID being found; and

obtain updated SI from the communication network upon the SI of the previous-time instance that is associated with the second-reference ID and the second-value ID not being found.

30. A wireless transmit/receive unit (WTRU) in communication with a communication network, the WTRU comprising:

a memory;

a processor, the processor configured at least to:

determine to request other system information (other-SI) from the communication network;

initiate the request for the other-SI from the communication network as part of a Random Access Channel (RACH) procedure; and

a transceiver, the transceiver configured at least to:

transmit a RACH signal, the RACH signal including the request for the other-SI in a random access preamble of the RACH signal, the processor being further configured to:

monitor for a message that includes a minimum SI from the communication network for a predetermined period of time following the transmission of the RACH signal;

determine if the requested other-SI is included in the message that includes the minimum SI upon a detection of the message that includes the minimum SI; and

initiate one or more retransmissions of the RACH signal upon at least one of: the message that includes the minimum SI not being detected, or the other-SI is determined to not be included in a detected message that includes the minimum SI.

31. The WTRU of claim 30, wherein the processor is further configured such that the predetermined period of time occurs within a random access response time window.

32. The WTRU of claim 31, wherein the processor is further configured to monitor for a predefined identifier in a control channel within the random access response time window.
33. The WTRU of claim 32, wherein the processor is further configured such that the predefined identifier is specific to the request of the other-SI.
34. The WTRU of claim 32, wherein the processor is further configured such that the predefined identifier is a Radio Network Temporary Identifier (RNTI).
35. The WTRU of claim 31, wherein the processor is further configured such that the message that includes the minimum SI is at least one of: one or more random access response messages, the processor being further configured to process the at least one of the one or more random access response messages within the random access response time window.
36. The WTRU of claim 35, wherein a format of the at least one of the one or more random access response messages is specific to the request for the other-SI.
37. The WTRU of claim 30, wherein the processor is further configured to initiate a power ramping of the random access preamble in the one or more retransmissions.
38. The WTRU of claim 30, wherein the processor is further configured to initiate the one or more retransmissions of the RACH signal upon at least one of: no response to the RACH signal being detected in the predetermined period of time; or a limit of a preamble counter associated with the RACH signal not being reached.
39. The WTRU of claim 30, wherein the processor is further configured such that the message that includes the minimum SI is at least one of: a random access response message that corresponds to the random access preamble of the RACH signal, or a random access response message that does not correspond to the random access preamble of the RACH signal.
40. The WTRU of claim 30, wherein at least one of the one or more retransmissions have been initiated by the processor, the processor being further configured to:

cease an initiation of any further retransmissions of the one or more retransmissions upon:

a detection of the message that includes the minimum SI; and
a determination that the requested other-SI is included in the detected message that includes the minimum SI.

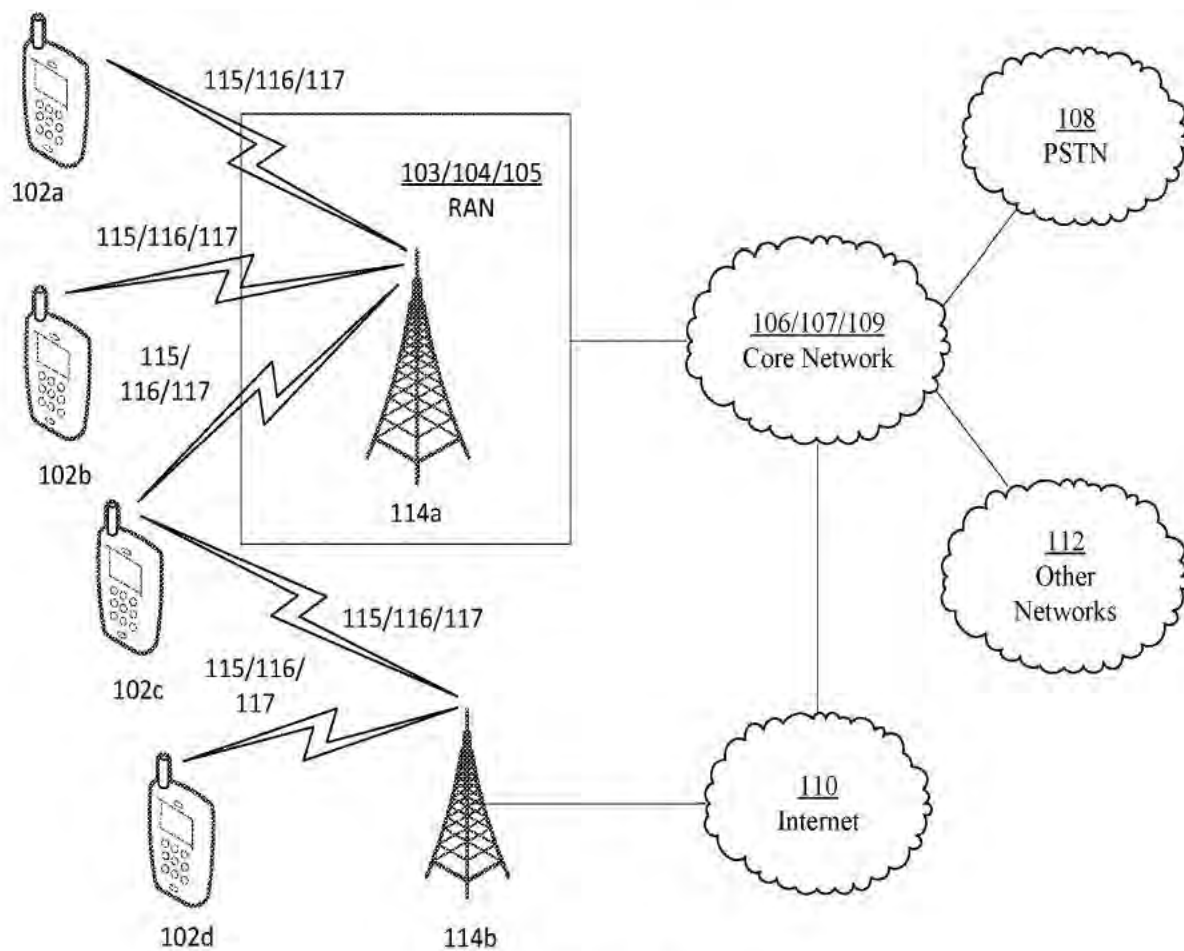

FIG. 1A

2/13

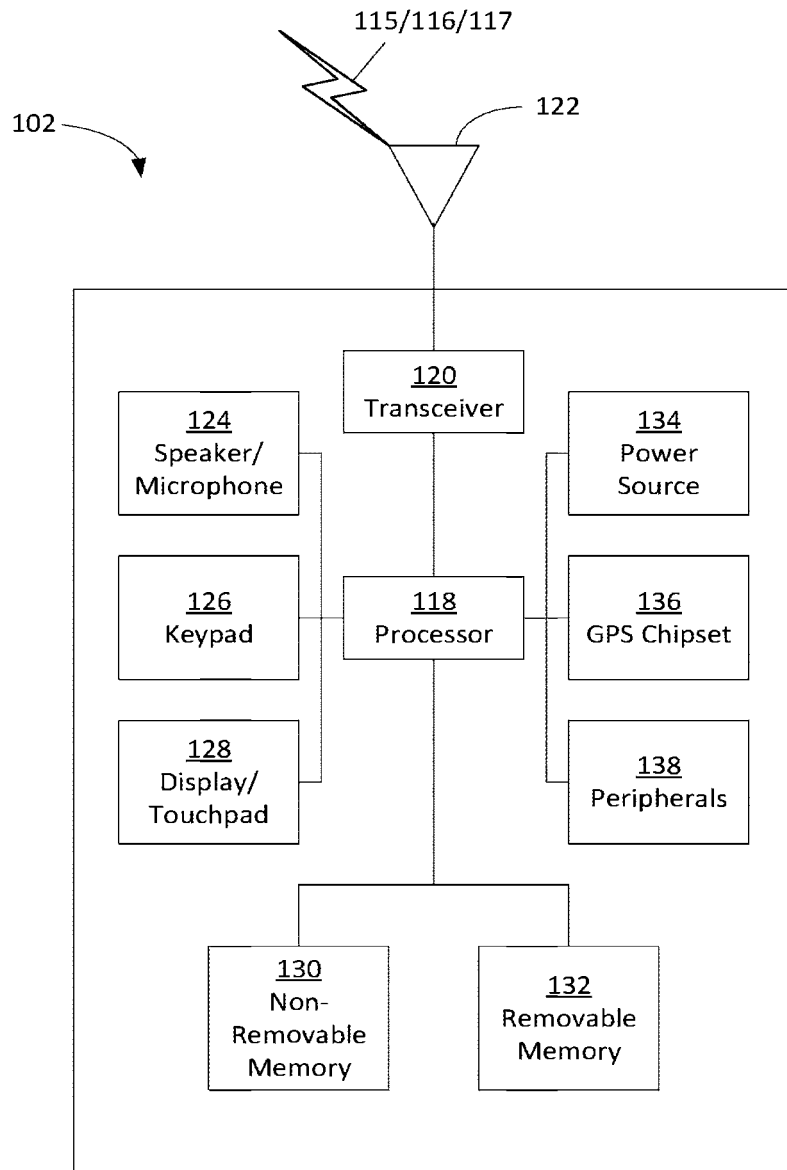

FIG. 1B

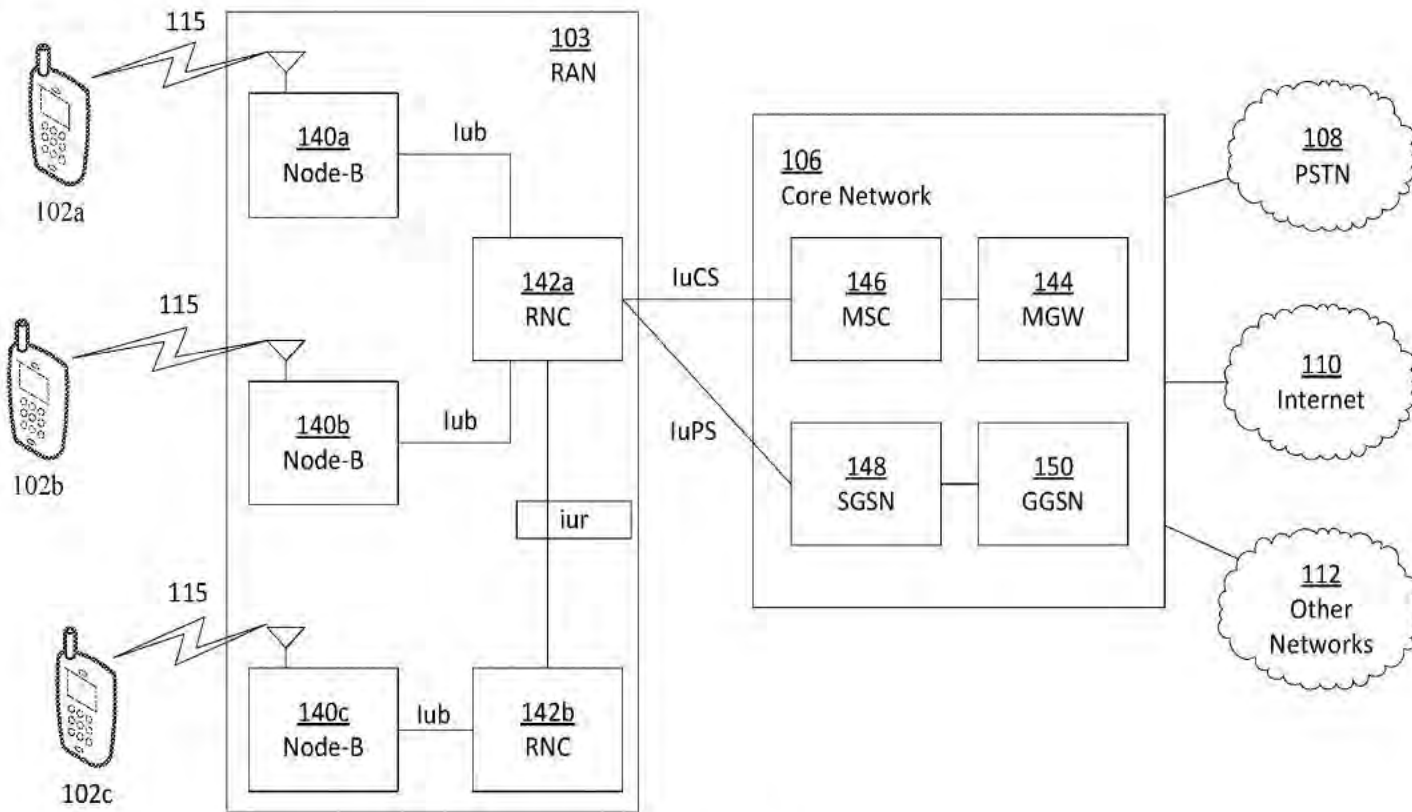

FIG. 1C

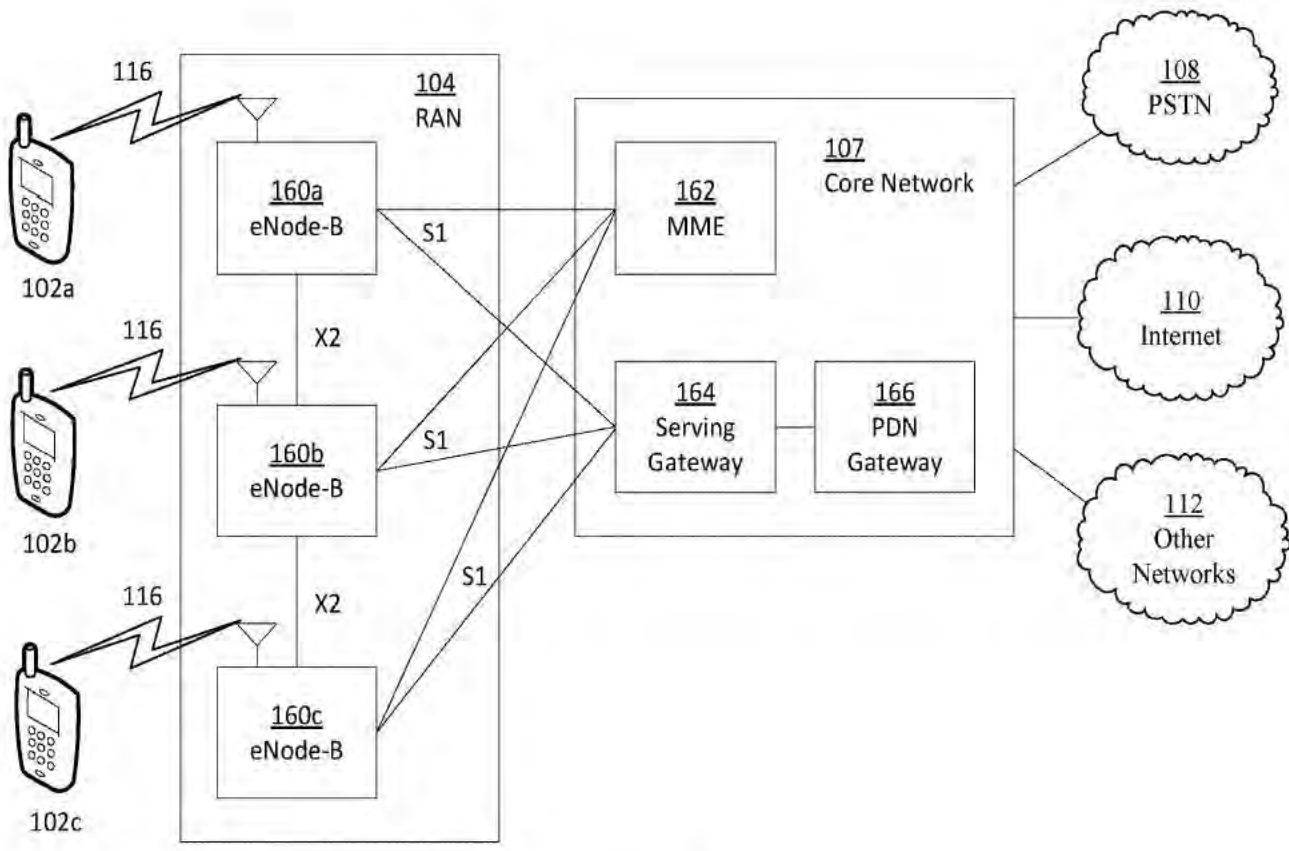

FIG. 1D

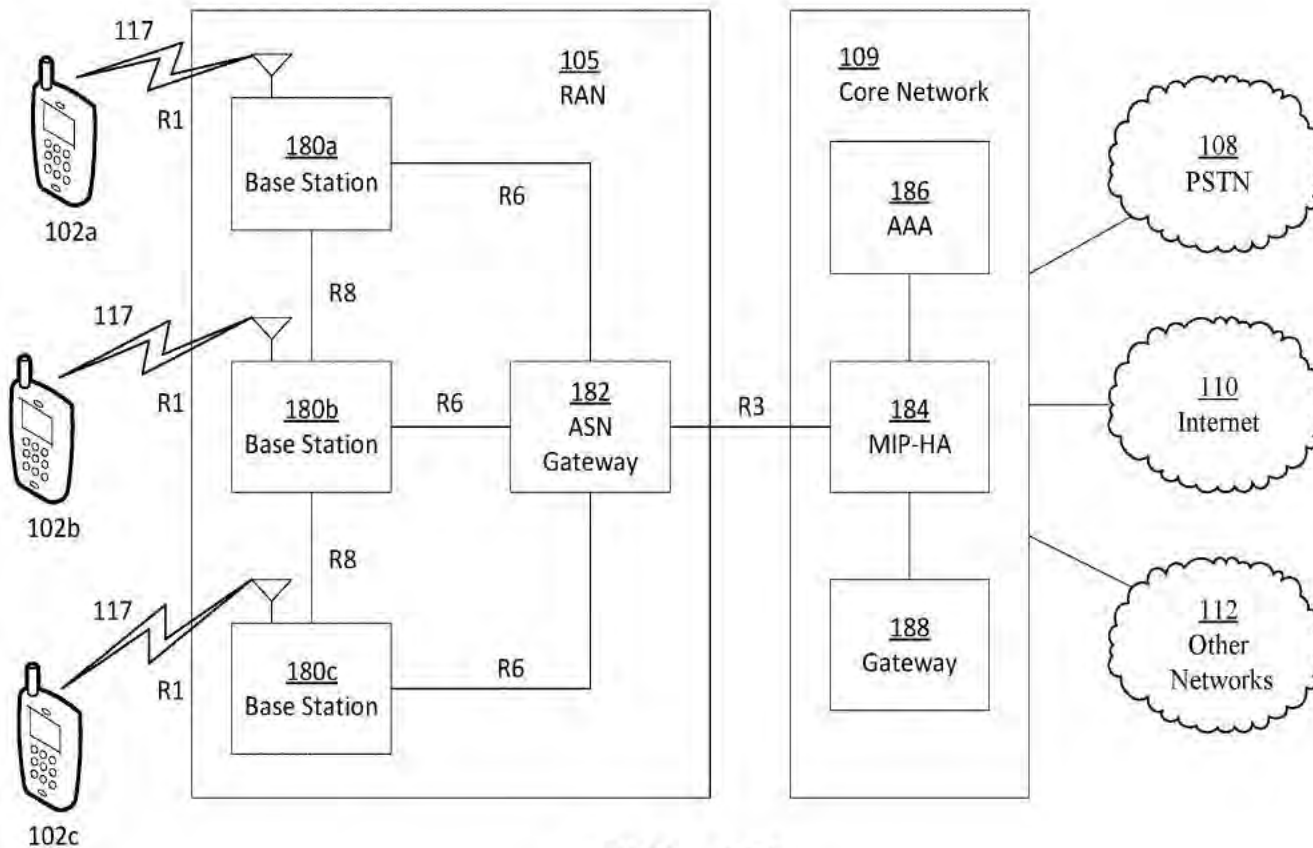

FIG. 1E

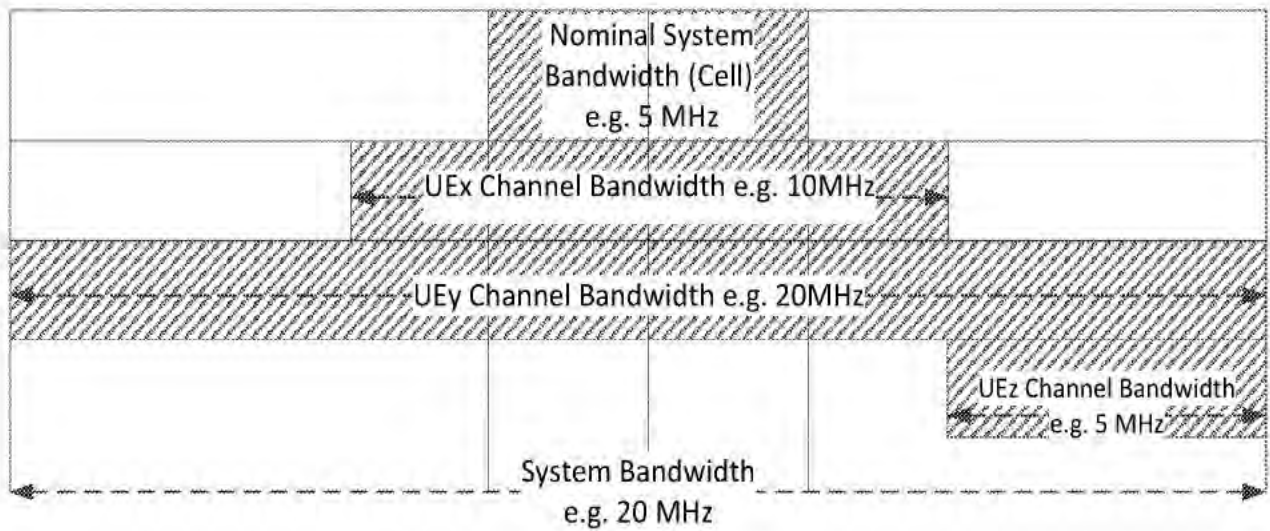

FIG. 2

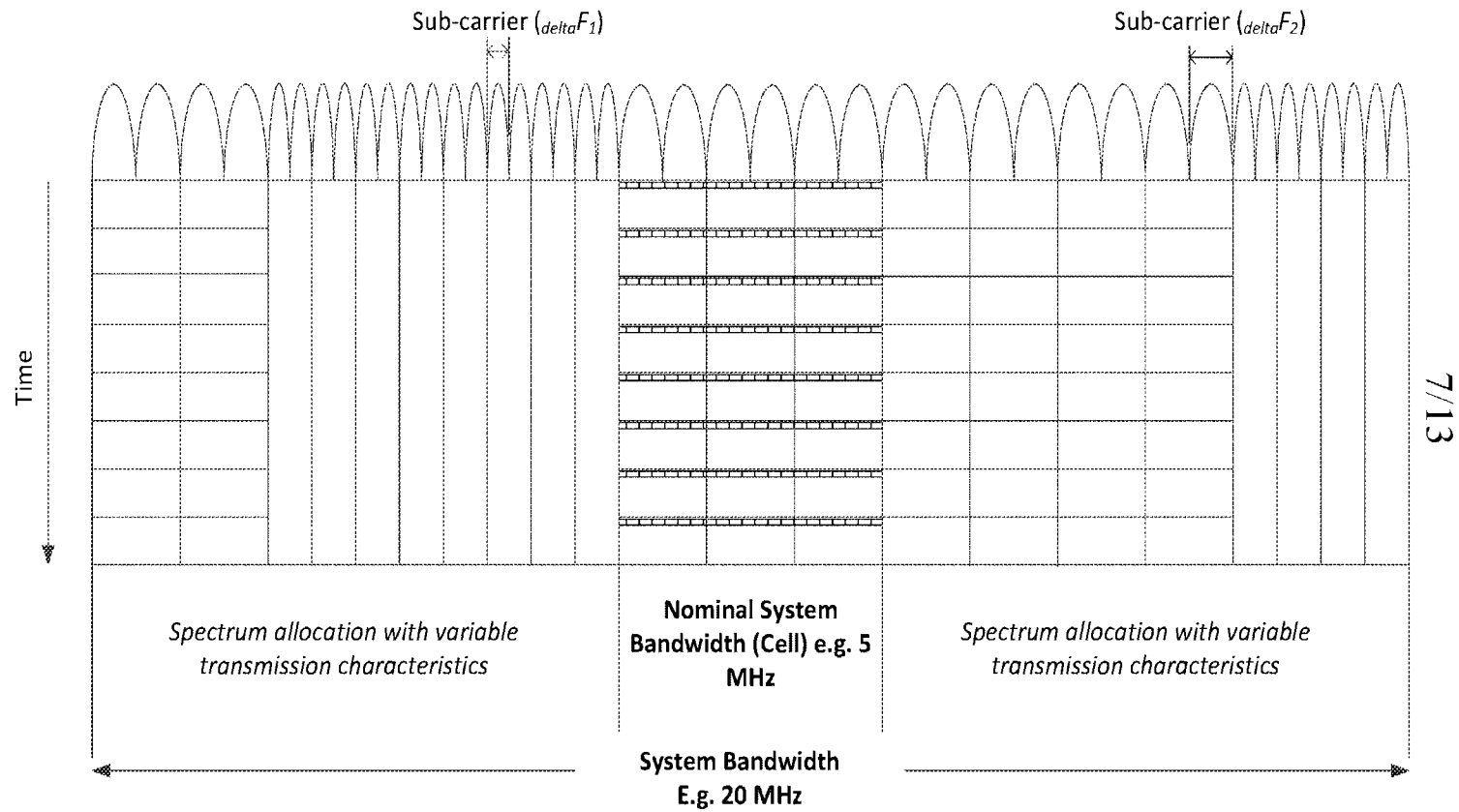

FIG. 3

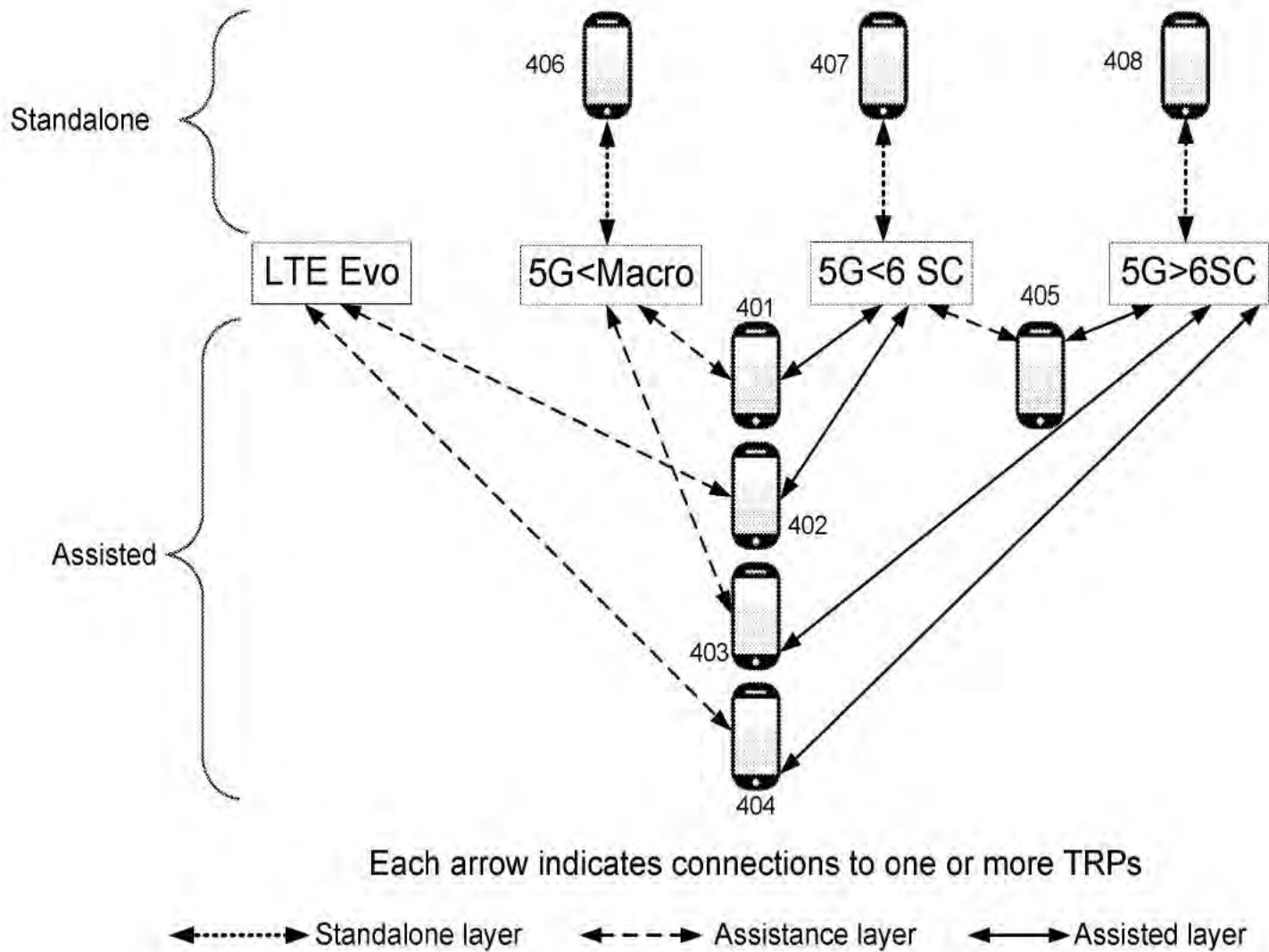

FIG. 4

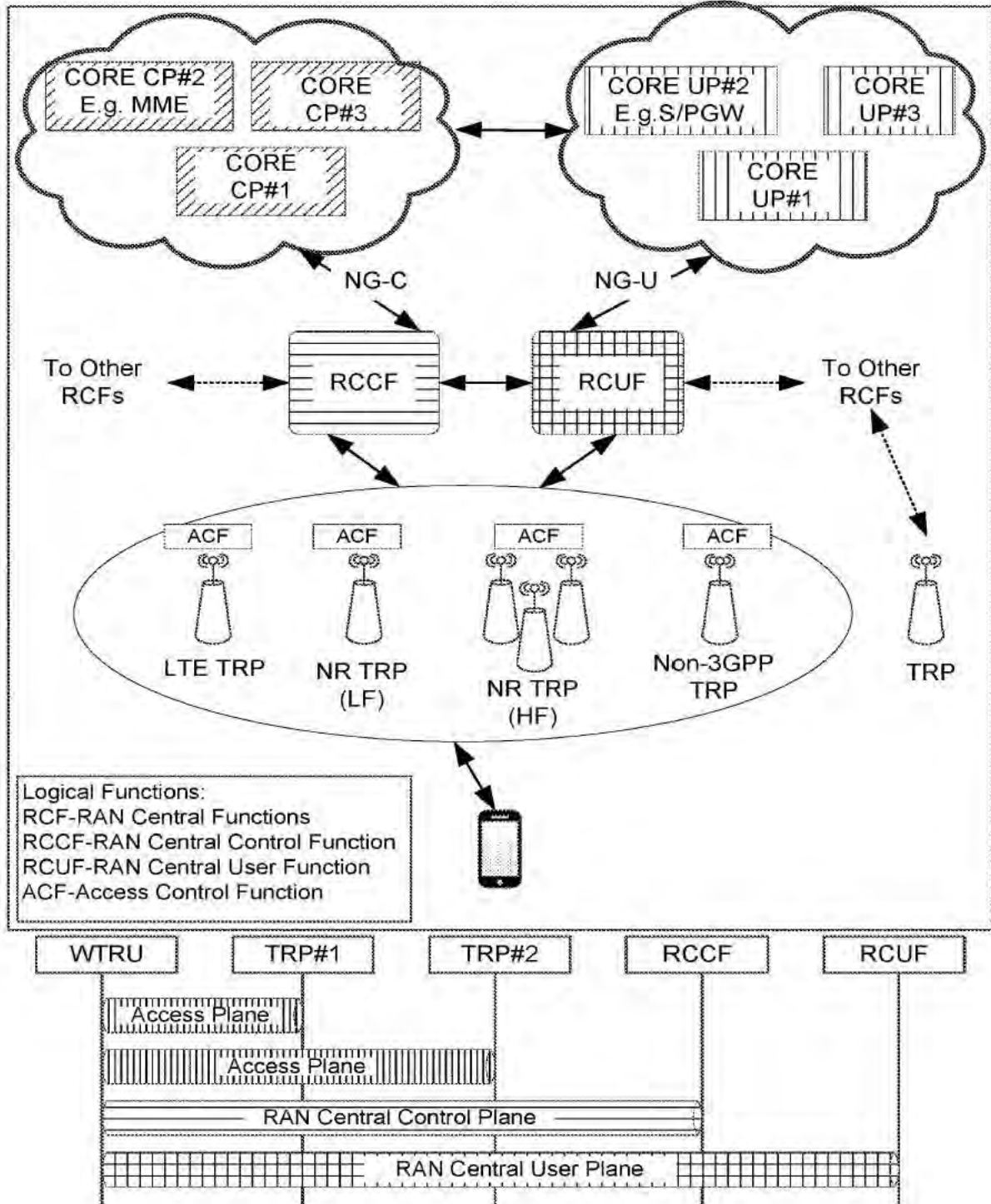

FIG. 5

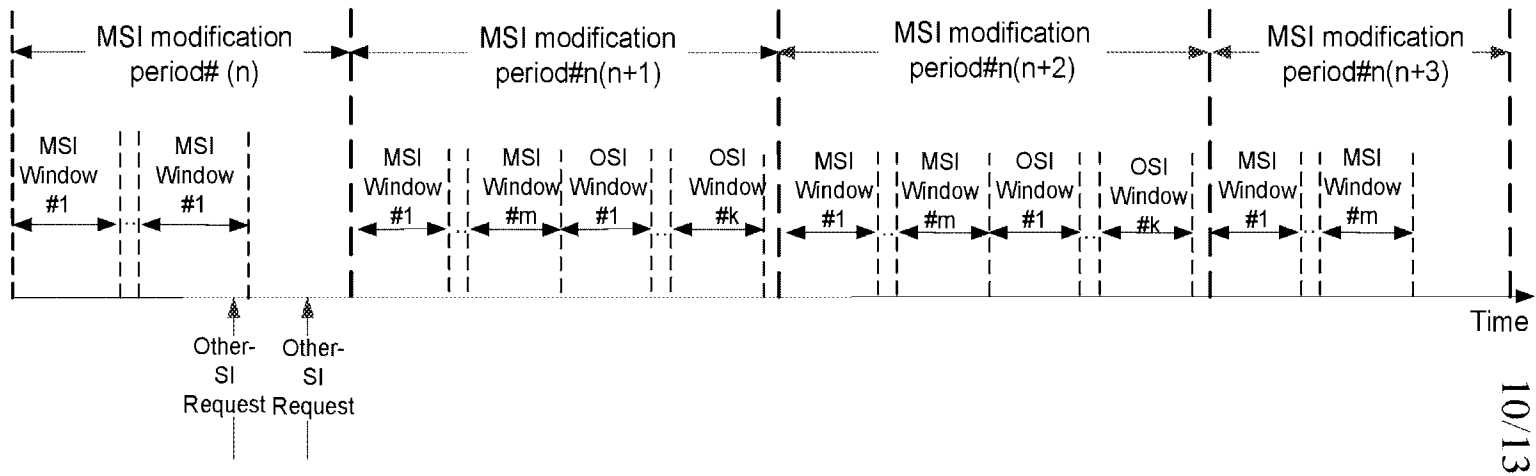
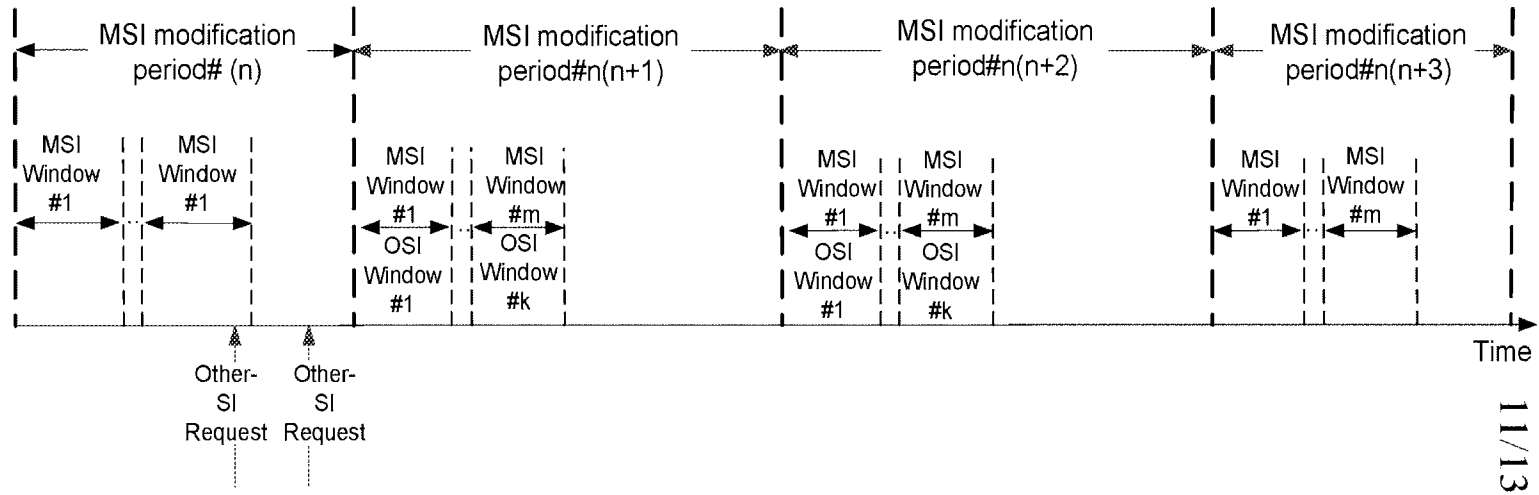

FIG. 6



11/13

FIG. 7

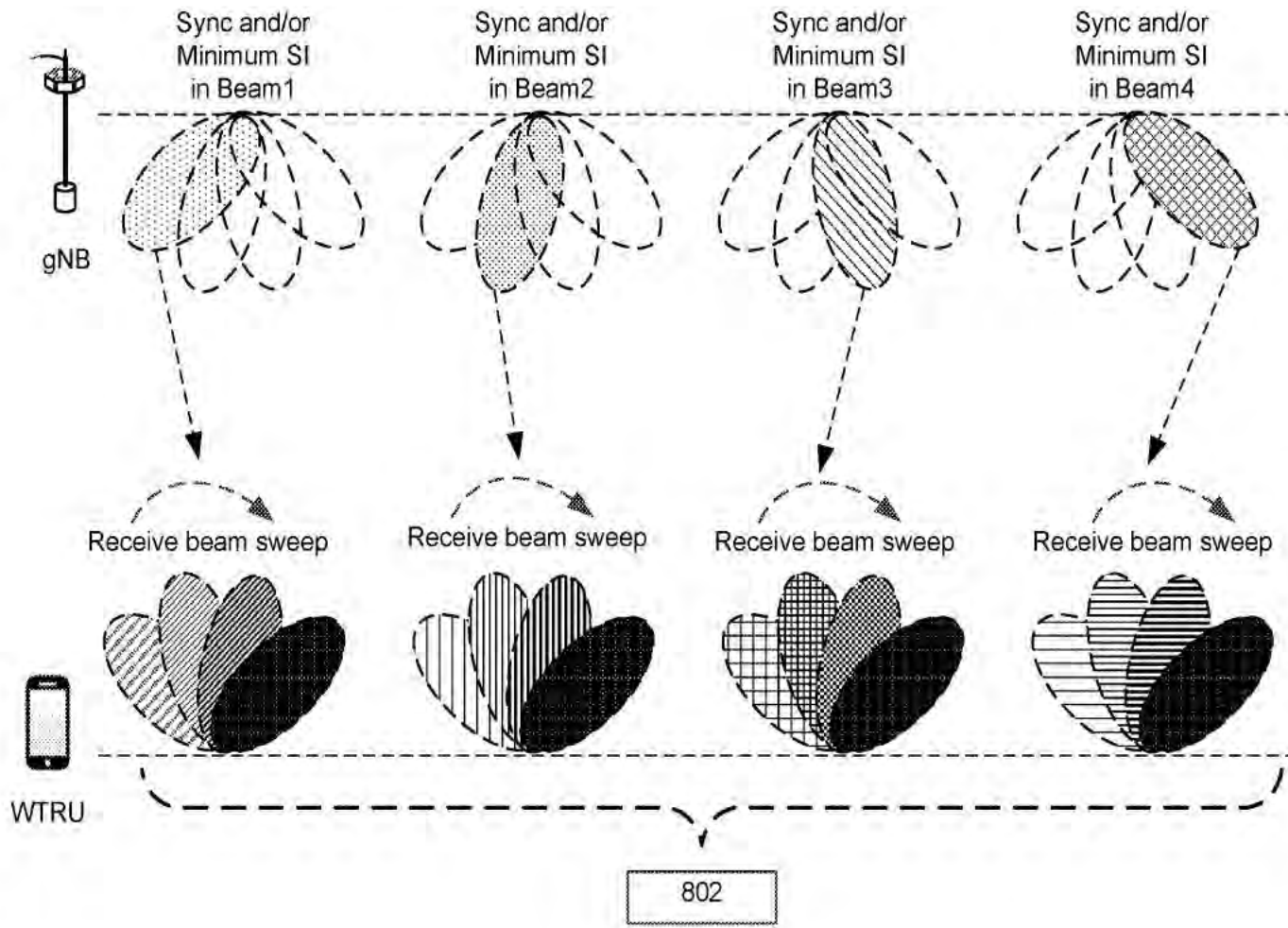

FIG. 8A

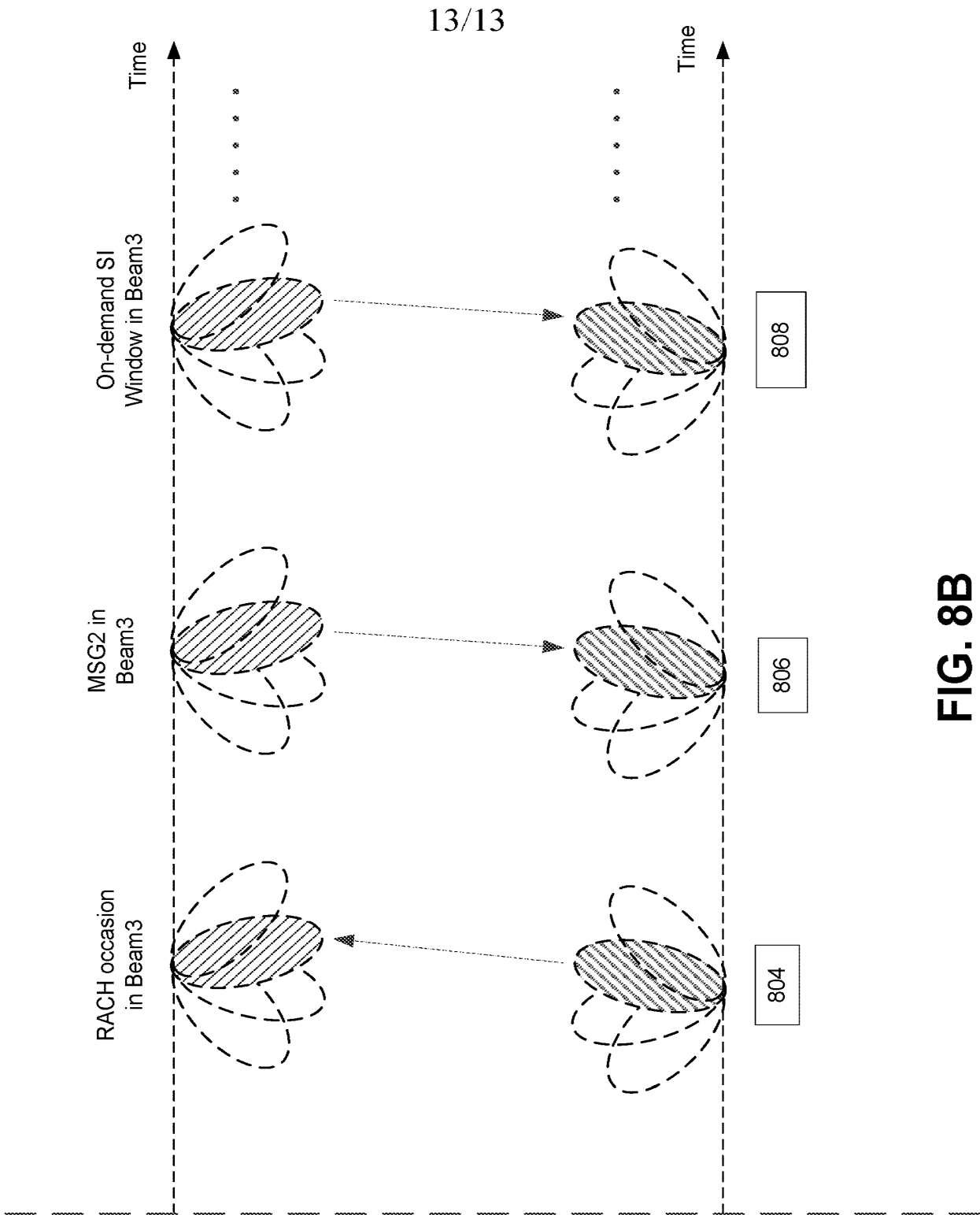

FIG. 8B

DISTRIBUTED CONTROL IN WIRELESS SYSTEMS

CROSS-REFERENCE TO RELATED APPLICATIONS

[0001] This application claims the benefit of U.S. Provisional Patent Application No. 62/442,317 filed on January 4, 2017; U.S. Provisional Patent Application No. 62/416,499, filed on November 2, 2016; U.S. Provisional Patent Application No. 62/400,810, filed on September 28, 2016; and U.S. Provisional Patent Application No. 62/334,704, filed on May 11, 2016, the contents of all of which being hereby incorporated by reference as if fully set-forth herein in their respective entirety, for all purposes.

BACKGROUND

[0002] Mobile communications continue to evolve. A fifth generation may be referred to as 5G. A previous (legacy) generation of mobile communication may be, for example, fourth generation (4G) long term evolution (LTE).

SUMMARY

[0003] Systems, procedures, and instrumentalities (e.g., aspects of entities, interfaces and/or procedures in a wireless transmit/receive unit (WTRU) and/or network layers L1, L2, L3) are disclosed for distributed control in wireless systems, such as 5G flexible radio access technology (RAT) (5gFLEX). Example procedures are provided for WTRU and network operation associated with a distributed control plane architecture, connectionless data transfer and/or dedicated system information acquisition. Distributed control may be provided, for example, by replicating a plurality of access control functions (ACFs) using a plurality of instances in a plurality of different transmission/reception points (TRPs) with multi-connectivity. The plurality of TRPs may concurrently provide control services to a WTRU. Centralized control functions may manage core network connectivity and/or a plurality of user plane instances for the WTRU and/or may facilitate coordination between the plurality of ACF instances for the WTRU in the plurality of different TRPs of the WTRU's configuration. For example, there may be a first

access plane between the WTRU and a first TRP that provides a first ACF for the WTRU, a second access plane between the WTRU and a second TRP that provides a second ACF for the WTRU, a RAN central control plane between the WTRU and a first RAN central control function (RCCF) and/or a RAN central user plane between the WTRU and a RAN central user function (RCUF).

[0004] A WTRU may use assistance information for beamformed system information delivery. Assistance information may be determined and/or transmitted.

[0005] A WTRU may determine when to apply and/or activate on-demand system information. A WTRU may determine when to delete and/or deactivate on-demand system information.

[0006] A WTRU may have saved instructions in memory executable by a processor and/or received from a wireless network via a message (e.g., rules) for triggering a system information (“SI”) request procedure. A WTRU may also have saved instructions in memory executable by a processor and/or received from a wireless network via a message for performing an SI request, (e.g., using a random access channel “RACH”), and/or msg3 and/or handling of networks.

[0007] A wireless transmit/receive unit (WTRU) may be in communication with a communication network. The WTRU may comprise a memory. The WTRU may comprise a processor. The processor may be configured to determine to request one or more system information (SI) messages from the communication network. The processor may be configured to determine if a transmission of the one or more SI message from the communication network will utilize at least one beamformed communication based on one or more communication parameters. The WTRU may comprise a transceiver. The transceiver may be configured to receive at least one of the one or more SI messages from the communication network via the at least one beamformed communication.

[0008] A wireless transmit/receive unit (WTRU) may be in communication with a communication network. The WTRU may comprise a memory. The WTRU may comprise a processor. The processor may be configured to determine to request one or more system information (SI) messages from the communication network. The processor may be configured to conduct a beam sweep operation of one or more downlink (DL) beams transmitted from the communication network. The processor may be configured to identify at least one DL beam of the one or more DL beams via which to receive the one or more on-demand SI messages based at least in part on the beam sweep operation. The processor may be configured to determine one or more uplink (UL) resources with which to communicate information for the WTRU reception of the one or more on-demand SI messages. The information for the WTRU reception may include

the at least one DL beam. The processor may be configured to initiate the request for the one or more on-demand SI messages from the communication network. The WTRU may comprise a transceiver. The transceiver may be configured to send the request for the one or more on-demand SI messages to the communication network using the one or more UL resources. The request may include the information for the WTRU reception of the one or more on-demand SI messages. The transceiver may be configured to receive at least one of the one or more on-demand SI messages from the communication network via the at least one DL beam.

[0009] A wireless transmit/receive unit (WTRU) may be in communication with a communication network. The WTRU may comprise a memory. The WTRU may comprise a transceiver. The transceiver may be configured to receive system information (SI) from the communication network at a first-time instance. The WTRU may comprise a processor. The processor may be configured to determine a first-reference identifier (ID) that corresponds to at least some of the SI of the first-time instance. The processor may be configured to determine a first-value identifier (ID) that corresponds to the at least some of the SI of the first-time instance. The processor may be configured to associate the first-reference ID and/or the first-value ID with the at least some of the SI of the first-time instance. The processor may be configured to utilize the at least some of the SI of the first-time instance in communication with the communication network. The processor may be configured to search the memory for stored SI of a previous-time instance that is associated with the same first-reference ID of the at least some of the SI of the first-time instance. The processor may be configured to store the at least some of the SI of the first-time instance upon no stored SI of the previous-time instance associated with the same first-reference ID being found. The processor may be configured to replace stored SI of the previous-time instance associated with the same first-reference ID with the at least some of the SI of the first-time instance upon a value ID associated with the stored SI of the previous-time instance associated with the same first-reference ID being different from the first-value ID.

[0010] A wireless transmit/receive unit (WTRU) may be in communication with a communication network. The WTRU may comprise a memory. The WTRU may comprise a processor. The processor may be configured to determine to request other system information (other-SI) from the communication network. The WTRU may be configured to initiate the request for the other-SI from the communication network as part of a Random Access Channel (RACH) procedure. The WTRU may comprise a transceiver. The transceiver may be configured to transmit a RACH signal. The RACH signal may include the request for the other-SI in a random access preamble of the RACH signal. The processor may be configured to monitor for a message that includes a minimum SI from the communication network for a

predetermined period of time following the transmission of the RACH signal. The processor may be configured to determine if the requested other-SI is included in the message that includes the minimum SI upon a detection of the message that includes the minimum SI. The processor may initiate one or more retransmissions of the RACH signal the message that includes the minimum SI not being detected, and/or the other-SI is determined to not be included in a detected message that includes the minimum SI.

BRIEF DESCRIPTION OF THE DRAWINGS

[0011] FIG. 1A is a system diagram of an example communications system in which one or more disclosed embodiments may be implemented.

[0012] FIG. 1B is a system diagram of an example WTRU that may be used within the communications system illustrated in FIG. 1A.

[0013] FIG. 1C is a system diagram of an example radio access network and an example core network that may be used within the communications system illustrated in FIG. 1A.

[0014] FIG. 1D is a system diagram of another example radio access network and another example core network that may be used within the communications system illustrated in FIG. 1A.

[0015] FIG. 1E is a system diagram of another example radio access network and another example core network that may be used within the communications system illustrated in FIG. 1A.

[0016] FIG. 2 is an example of transmission bandwidths.

[0017] FIG. 3 is an example of flexible spectrum allocation.

[0018] FIG. 4 is an example of types of assistance modes.

[0019] FIG. 5 is an example of tri-plane architecture.

[0020] FIG. 6 is an example of non-overlapping windows for minimum-system information (SI) and other-SI.

[0021] FIG. 7 is an example of overlapping windows for other-SI and minimum-SI.

[0022] FIG. 8A and 8B together illustrate an example of an on-demand SI request in a beamformed context.

DETAILED DESCRIPTION

[0023] A detailed description of illustrative embodiments will now be described with reference to the various Figures. Although this description provides a detailed example of

possible implementations, it should be noted that the details are intended to be examples and in no way limit the scope of the application.

[0024] FIG. 1A is a diagram of an example communications system 100 in which one or more disclosed embodiments may be implemented. The communications system 100 may be a multiple access system that provides content, such as voice, data, video, messaging, broadcast, etc., to multiple wireless users. The communications system 100 may enable multiple wireless users to access such content through the sharing of system resources, including wireless bandwidth. For example, the communications system 100 may employ one or more channel access methods, such as code division multiple access (CDMA), time division multiple access (TDMA), frequency division multiple access (FDMA), orthogonal FDMA (OFDMA), single-carrier FDMA (SC-FDMA), and the like.

[0025] As shown in FIG. 1A, the communications system 100 may include wireless transmit/receive units (WTRUs), e.g., WTRUs, 102a, 102b, 102c, and/or 102d (which generally or collectively may be referred to as WTRU 102), a radio access network (RAN) 103/104/105, a core network 106/107/109, a public switched telephone network (PSTN) 108, the Internet 110, and other networks 112, though it will be appreciated that the disclosed embodiments contemplate any number of WTRUs, base stations, networks, and/or network elements. Each of the WTRUs 102a, 102b, 102c, 102d may be any type of device configured to operate and/or communicate in a wireless environment. By way of example, the WTRUs 102a, 102b, 102c, 102d may be configured to transmit and/or receive wireless signals and may include user equipment (UE), a mobile station, a fixed or mobile subscriber unit, a pager, a cellular telephone, a personal digital assistant (PDA), a smartphone, a laptop, a netbook, a personal computer, a wireless sensor, consumer electronics, and the like.

[0026] The communications system 100 may also include a base station 114a and a base station 114b. Each of the base stations 114a, 114b may be any type of device configured to wirelessly interface with at least one of the WTRUs 102a, 102b, 102c, 102d to facilitate access to one or more communication networks, such as the core network 106/107/109, the Internet 110, and/or the networks 112. By way of example, the base stations 114a, 114b may be a base transceiver station (BTS), a Node-B, an eNode B, a Home Node B, a Home eNode B, a site controller, an access point (AP), a wireless router, and the like. While the base stations 114a, 114b are each depicted as a single element, it will be appreciated that the base stations 114a, 114b may include any number of interconnected base stations and/or network elements.

[0027] The base station 114a may be part of the RAN 103/104/105, which may also include other base stations and/or network elements (not shown), such as a base station controller (BSC),

a radio network controller (RNC), relay nodes, etc. The base station 114a and/or the base station 114b may be configured to transmit and/or receive wireless signals within a particular geographic region, which may be referred to as a cell (not shown). The cell may further be divided into cell sectors. For example, the cell associated with the base station 114a may be divided into three sectors. Thus, in some embodiments, the base station 114a may include three transceivers, e.g., one for each sector of the cell. In another embodiment, the base station 114a may employ multiple-input multiple output (MIMO) technology and, therefore, may utilize multiple transceivers for each sector of the cell.

[0028] The base stations 114a, 114b may communicate with one or more of the WTRUs 102a, 102b, 102c, 102d over an air interface 115/116/117, which may be any suitable wireless communication link (e.g., radio frequency (RF), microwave, infrared (IR), ultraviolet (UV), visible light, etc.). The air interface 115/116/117 may be established using any suitable radio access technology (RAT).

[0029] More specifically, as noted above, the communications system 100 may be a multiple access system and may employ one or more channel access schemes, such as CDMA, TDMA, FDMA, OFDMA, SC-FDMA, and the like. For example, the base station 114a in the RAN 103/104/105 and the WTRUs 102a, 102b, 102c may implement a radio technology such as Universal Mobile Telecommunications System (UMTS) Terrestrial Radio Access (UTRA), which may establish the air interface 115/116/117 using wideband CDMA (WCDMA). WCDMA may include communication protocols such as High-Speed Packet Access (HSPA) and/or Evolved HSPA (HSPA+). HSPA may include High-Speed Downlink Packet Access (HSDPA) and/or High-Speed Uplink Packet Access (HSUPA).

[0030] In another embodiment, the base station 114a and the WTRUs 102a, 102b, 102c may implement a radio technology such as Evolved UMTS Terrestrial Radio Access (E-UTRA), which may establish the air interface 115/116/117 using Long Term Evolution (LTE) and/or LTE-Advanced (LTE-A).

[0031] In other embodiments, the base station 114a and the WTRUs 102a, 102b, 102c may implement radio technologies such as IEEE 802.16 (e.g., Worldwide Interoperability for Microwave Access (WiMAX)), CDMA2000, CDMA2000 1X, CDMA2000 EV-DO, Interim Standard 2000 (IS-2000), Interim Standard 95 (IS-95), Interim Standard 856 (IS-856), Global System for Mobile communications (GSM), Enhanced Data rates for GSM Evolution (EDGE), GSM EDGE (GERAN), and the like.

[0032] The base station 114b in FIG. 1A may be a wireless router, Home Node B, Home eNode B, or access point, for example, and may utilize any suitable RAT for facilitating wireless

connectivity in a localized area, such as a place of business, a home, a vehicle, a campus, and the like. In some embodiments, the base station 114b and the WTRUs 102c, 102d may implement a radio technology such as IEEE 802.11 to establish a wireless local area network (WLAN). In another embodiment, the base station 114b and the WTRUs 102c, 102d may implement a radio technology such as IEEE 802.15 to establish a wireless personal area network (WPAN). In yet another embodiment, the base station 114b and the WTRUs 102c, 102d may utilize a cellular-based RAT (e.g., WCDMA, CDMA2000, GSM, LTE, LTE-A, etc.) to establish a picocell or femtocell. As shown in FIG. 1A, the base station 114b may have a direct connection to the Internet 110. Thus, the base station 114b may not be required to access the Internet 110 via the core network 106/107/109.

[0033] The RAN 103/104/105 may be in communication with the core network 106/107/109, which may be any type of network configured to provide voice, data, applications, and/or voice over internet protocol (VoIP) services to one or more of the WTRUs 102a, 102b, 102c, 102d. For example, the core network 106/107/109 may provide call control, billing services, mobile location-based services, pre-paid calling, Internet connectivity, video distribution, etc., and/or perform high-level security functions, such as user authentication. Although not shown in FIG. 1A, it will be appreciated that the RAN 103/104/105 and/or the core network 106/107/109 may be in direct or indirect communication with other RANs that employ the same RAT as the RAN 103/104/105 or a different RAT. For example, in addition to being connected to the RAN 103/104/105, which may be utilizing an E-UTRA radio technology, the core network 106/107/109 may also be in communication with another RAN (not shown) employing a GSM radio technology.

[0034] The core network 106/107/109 may also serve as a gateway for the WTRUs 102a, 102b, 102c, 102d to access the PSTN 108, the Internet 110, and/or other networks 112. The PSTN 108 may include circuit-switched telephone networks that provide plain old telephone service (POTS). The Internet 110 may include a global system of interconnected computer networks and devices that use common communication protocols, such as the transmission control protocol (TCP), user datagram protocol (UDP) and the internet protocol (IP) in the TCP/IP internet protocol suite. The networks 112 may include wired or wireless communications networks owned and/or operated by other service providers. For example, the networks 112 may include another core network connected to one or more RANs, which may employ the same RAT as the RAN 103/104/105 or a different RAT.

[0035] Some or all of the WTRUs 102a, 102b, 102c, 102d in the communications system 100 may include multi-mode capabilities, e.g., the WTRUs 102a, 102b, 102c, 102d may include

multiple transceivers for communicating with different wireless networks over different wireless links. For example, the WTRU 102c shown in FIG. 1A may be configured to communicate with the base station 114a, which may employ a cellular-based radio technology, and with the base station 114b, which may employ an IEEE 802 radio technology.

[0036] FIG. 1B is a system diagram of an example WTRU 102. As shown in FIG. 1B, the WTRU 102 may include a processor 118, a transceiver 120, a transmit/receive element 122, a speaker/microphone 124, a keypad 126, a display/touchpad 128, non-removable memory 130, removable memory 132, a power source 134, a global positioning system (GPS) chipset 136, and other peripherals 138. It will be appreciated that the WTRU 102 may include any sub-combination of the foregoing elements while remaining consistent with an embodiment. Also, embodiments contemplate that the base stations 114a and 114b, and/or the nodes that base stations 114a and 114b may represent, such as but not limited to transceiver station (BTS), a Node-B, a site controller, an access point (AP), a home node-B, an evolved home node-B (eNodeB), a home evolved node-B (HeNB or HeNodeB), a home evolved node-B gateway, and proxy nodes, among others, may include some or all of the elements depicted in FIG. 1B and described herein.

[0037] The processor 118 may be a general purpose processor, a special purpose processor, a conventional processor, a digital signal processor (DSP), a plurality of microprocessors, one or more microprocessors in association with a DSP core, a controller, a microcontroller, Application Specific Integrated Circuits (ASICs), Field Programmable Gate Array (FPGAs) circuits, any other type of integrated circuit (IC), a state machine, and the like. The processor 118 may perform signal coding, data processing, power control, input/output processing, and/or any other functionality that enables the WTRU 102 to operate in a wireless environment. The processor 118 may be coupled to the transceiver 120, which may be coupled to the transmit/receive element 122. While FIG. 1B depicts the processor 118 and the transceiver 120 as separate components, it will be appreciated that the processor 118 and the transceiver 120 may be integrated together in an electronic package or chip.

[0038] The transmit/receive element 122 may be configured to transmit signals to, or receive signals from, a base station (e.g., the base station 114a) over the air interface 115/116/117. For example, in some embodiments, the transmit/receive element 122 may be an antenna configured to transmit and/or receive RF signals. In another embodiment, the transmit/receive element 122 may be an emitter/detector configured to transmit and/or receive IR, UV, or visible light signals, for example. In yet another embodiment, the transmit/receive element 122 may be configured to

transmit and receive RF and/or light signals. It will be appreciated that the transmit/receive element 122 may be configured to transmit and/or receive any combination of wireless signals.

[0039] In addition, although the transmit/receive element 122 is depicted in FIG. 1B as a single element, the WTRU 102 may include any number of transmit/receive elements 122. More specifically, the WTRU 102 may employ MIMO technology. Thus, in some embodiments, the WTRU 102 may include two or more transmit/receive elements 122 (e.g., multiple antennas) for transmitting and receiving wireless signals over the air interface 115/116/117.

[0040] The transceiver 120 may be configured to modulate the signals that are to be transmitted by the transmit/receive element 122 and to demodulate the signals that are received by the transmit/receive element 122. As noted above, the WTRU 102 may have multi-mode capabilities. Thus, the transceiver 120 may include multiple transceivers for enabling the WTRU 102 to communicate via multiple RATs, such as UTRA and IEEE 802.11, for example.

[0041] The processor 118 of the WTRU 102 may be coupled to, and may receive user input data from, the speaker/microphone 124, the keypad 126, and/or the display/touchpad 128 (e.g., a liquid crystal display (LCD) display unit or organic light-emitting diode (OLED) display unit). The processor 118 may also output user data to the speaker/microphone 124, the keypad 126, and/or the display/touchpad 128. In addition, the processor 118 may access information from, and store data in, any type of suitable memory, such as the non-removable memory 130 and/or the removable memory 132. The non-removable memory 130 may include random-access memory (RAM), read-only memory (ROM), a hard disk, or any other type of memory storage device. The removable memory 132 may include a subscriber identity module (SIM) card, a memory stick, a secure digital (SD) memory card, and the like. In other embodiments, the processor 118 may access information from, and store data in, memory that is not physically located on the WTRU 102, such as on a server or a home computer (not shown).

[0042] The processor 118 may receive power from the power source 134, and may be configured to distribute and/or control the power to the other components in the WTRU 102. The power source 134 may be any suitable device for powering the WTRU 102. For example, the power source 134 may include one or more dry cell batteries (e.g., nickel-cadmium (NiCd), nickel-zinc (NiZn), nickel metal hydride (NiMH), lithium-ion (Li-ion), etc.), solar cells, fuel cells, and the like.

[0043] The processor 118 may also be coupled to the GPS chipset 136, which may be configured to provide location information (e.g., longitude and latitude) regarding the current location of the WTRU 102. In addition to, or in lieu of, the information from the GPS chipset 136, the WTRU 102 may receive location information over the air interface 115/116/117 from a

base station (e.g., base stations 114a, 114b) and/or determine its location based on the timing of the signals being received from two or more nearby base stations. It will be appreciated that the WTRU 102 may acquire location information by way of any suitable location-determination implementation while remaining consistent with an embodiment.

[0044] The processor 118 may further be coupled to other peripherals 138, which may include one or more software and/or hardware modules that provide additional features, functionality and/or wired or wireless connectivity. For example, the peripherals 138 may include an accelerometer, an e-compass, a satellite transceiver, a digital camera (for photographs or video), a universal serial bus (USB) port, a vibration device, a television transceiver, a hands free headset, a Bluetooth® module, a frequency modulated (FM) radio unit, a digital music player, a media player, a video game player module, an Internet browser, and the like.

[0045] FIG. 1C is a system diagram of the RAN 103 and the core network 106 according to an embodiment. As noted above, the RAN 103 may employ a UTRA radio technology to communicate with the WTRUs 102a, 102b, 102c over the air interface 115. The RAN 103 may also be in communication with the core network 106. As shown in FIG. 1C, the RAN 103 may include Node-Bs 140a, 140b, 140c, which may each include one or more transceivers for communicating with the WTRUs 102a, 102b, 102c over the air interface 115. The Node-Bs 140a, 140b, 140c may each be associated with a particular cell (not shown) within the RAN 103. The RAN 103 may also include RNCs 142a, 142b. It will be appreciated that the RAN 103 may include any number of Node-Bs and RNCs while remaining consistent with an embodiment.

[0046] As shown in FIG. 1C, the Node-Bs 140a, 140b may be in communication with the RNC 142a. Additionally, the Node-B 140c may be in communication with the RNC 142b. The Node-Bs 140a, 140b, 140c may communicate with the respective RNCs 142a, 142b via an Iub interface. The RNCs 142a, 142b may be in communication with one another via an Iur interface. Each of the RNCs 142a, 142b may be configured to control the respective Node-Bs 140a, 140b, 140c to which it is connected. In addition, each of the RNCs 142a, 142b may be configured to carry out or support other functionality, such as outer loop power control, load control, admission control, packet scheduling, handover control, macrodiversity, security functions, data encryption, and the like.

[0047] The core network 106 shown in FIG. 1C may include a media gateway (MGW) 144, a mobile switching center (MSC) 146, a serving GPRS support node (SGSN) 148, and/or a gateway GPRS support node (GGSN) 150. While each of the foregoing elements are depicted as part of the core network 106, it will be appreciated that any one of these elements may be owned and/or operated by an entity other than the core network operator.

[0048] The RNC 142a in the RAN 103 may be connected to the MSC 146 in the core network 106 via an IuCS interface. The MSC 146 may be connected to the MGW 144. The MSC 146 and the MGW 144 may provide the WTRUs 102a, 102b, 102c with access to circuit-switched networks, such as the PSTN 108, to facilitate communications between the WTRUs 102a, 102b, 102c and traditional land-line communications devices.

[0049] The RNC 142a in the RAN 103 may also be connected to the SGSN 148 in the core network 106 via an IuPS interface. The SGSN 148 may be connected to the GGSN 150. The SGSN 148 and the GGSN 150 may provide the WTRUs 102a, 102b, 102c with access to packet-switched networks, such as the Internet 110, to facilitate communications between and the WTRUs 102a, 102b, 102c and IP-enabled devices.

[0050] As noted above, the core network 106 may also be connected to the networks 112, which may include other wired or wireless networks that are owned and/or operated by other service providers.

[0051] FIG. 1D is a system diagram of the RAN 104 and the core network 107 according to an embodiment. As noted above, the RAN 104 may employ an E-UTRA radio technology to communicate with the WTRUs 102a, 102b, 102c over the air interface 116. The RAN 104 may also be in communication with the core network 107.

[0052] The RAN 104 may include eNode-Bs 160a, 160b, 160c, though it will be appreciated that the RAN 104 may include any number of eNode-Bs while remaining consistent with an embodiment. The eNode-Bs 160a, 160b, 160c may each include one or more transceivers for communicating with the WTRUs 102a, 102b, 102c over the air interface 116. In some embodiments, the eNode-Bs 160a, 160b, 160c may implement MIMO technology. Thus, the eNode-B 160a, for example, may use multiple antennas to transmit wireless signals to, and receive wireless signals from, the WTRU 102a.

[0053] Each of the eNode-Bs 160a, 160b, 160c may be associated with a particular cell (not shown) and may be configured to handle radio resource management decisions, handover decisions, scheduling of users in the uplink (UL) and/or downlink (DL), and the like. As shown in FIG. 1D, the eNode-Bs 160a, 160b, 160c may communicate with one another over an X2 interface.

[0054] The core network 107 shown in FIG. 1D may include a mobility management gateway (MME) 162, a serving gateway 164, and a packet data network (PDN) gateway 166. While each of the foregoing elements are depicted as part of the core network 107, it will be appreciated that any one of these elements may be owned and/or operated by an entity other than the core network operator.

[0055] The MME 162 may be connected to each of the eNode-Bs 160a, 160b, 160c in the RAN 104 via an S1 interface and may serve as a control node. For example, the MME 162 may be responsible for authenticating users of the WTRUs 102a, 102b, 102c, bearer activation/deactivation, selecting a particular serving gateway during an initial attach of the WTRUs 102a, 102b, 102c, and the like. The MME 162 may also provide a control plane function for switching between the RAN 104 and other RANs (not shown) that employ other radio technologies, such as GSM or WCDMA.

[0056] The serving gateway 164 may be connected to each of the eNode-Bs 160a, 160b, 160c in the RAN 104 via the S1 interface. The serving gateway 164 may generally route and forward user data packets to/from the WTRUs 102a, 102b, 102c. The serving gateway 164 may also perform other functions, such as anchoring user planes during inter-eNode B handovers, triggering paging when downlink data is available for the WTRUs 102a, 102b, 102c, managing and storing contexts of the WTRUs 102a, 102b, 102c, and the like.

[0057] The serving gateway 164 may also be connected to the PDN gateway 166, which may provide the WTRUs 102a, 102b, 102c with access to packet-switched networks, such as the Internet 110, to facilitate communications between the WTRUs 102a, 102b, 102c and IP-enabled devices.

[0058] The core network 107 may facilitate communications with other networks. For example, the core network 107 may provide the WTRUs 102a, 102b, 102c with access to circuit-switched networks, such as the PSTN 108, to facilitate communications between the WTRUs 102a, 102b, 102c and traditional land-line communications devices. For example, the core network 107 may include, or may communicate with, an IP gateway (e.g., an IP multimedia subsystem (IMS) server) that serves as an interface between the core network 107 and the PSTN 108. In addition, the core network 107 may provide the WTRUs 102a, 102b, 102c with access to the networks 112, which may include other wired or wireless networks that are owned and/or operated by other service providers.

[0059] FIG. 1E is a system diagram of the RAN 105 and the core network 109 according to an embodiment. The RAN 105 may be an access service network (ASN) that employs IEEE 802.16 radio technology to communicate with the WTRUs 102a, 102b, 102c over the air interface 117. As will be further discussed below, the communication links between the different functional entities of the WTRUs 102a, 102b, 102c, the RAN 105, and the core network 109 may be defined as reference points.

[0060] As shown in FIG. 1E, the RAN 105 may include base stations 180a, 180b, 180c, and an ASN gateway 182, though it will be appreciated that the RAN 105 may include any number

of base stations and ASN gateways while remaining consistent with an embodiment. The base stations 180a, 180b, 180c may each be associated with a particular cell (not shown) in the RAN 105 and may each include one or more transceivers for communicating with the WTRUs 102a, 102b, 102c over the air interface 117. In some embodiments, the base stations 180a, 180b, 180c may implement MIMO technology. Thus, the base station 180a, for example, may use multiple antennas to transmit wireless signals to, and receive wireless signals from, the WTRU 102a. The base stations 180a, 180b, 180c may also provide mobility management functions, such as handoff triggering, tunnel establishment, radio resource management, traffic classification, quality of service (QoS) policy enforcement, and the like. The ASN gateway 182 may serve as a traffic aggregation point and may be responsible for paging, caching of subscriber profiles, routing to the core network 109, and the like.

[0061] The air interface 117 between the WTRUs 102a, 102b, 102c and the RAN 105 may be defined as an R1 reference point that implements the IEEE 802.16 specification. In addition, each of the WTRUs 102a, 102b, 102c may establish a logical interface (not shown) with the core network 109. The logical interface between the WTRUs 102a, 102b, 102c and the core network 109 may be defined as an R2 reference point, which may be used for authentication, authorization, IP host configuration management, and/or mobility management.

[0062] The communication link between each of the base stations 180a, 180b, 180c may be defined as an R8 reference point that includes protocols for facilitating WTRU handovers and the transfer of data between base stations. The communication link between the base stations 180a, 180b, 180c and the ASN gateway 182 may be defined as an R6 reference point. The R6 reference point may include protocols for facilitating mobility management based on mobility events associated with each of the WTRUs 102a, 102b, 102c.

[0063] As shown in FIG. 1E, the RAN 105 may be connected to the core network 109. The communication link between the RAN 105 and the core network 109 may be defined as an R3 reference point that includes protocols for facilitating data transfer and mobility management capabilities, for example. The core network 109 may include a mobile IP home agent (MIP-HA) 184, an authentication, authorization, accounting (AAA) server 186, and a gateway 188. While each of the foregoing elements are depicted as part of the core network 109, it will be appreciated that any one of these elements may be owned and/or operated by an entity other than the core network operator.

[0064] The MIP-HA may be responsible for IP address management, and may enable the WTRUs 102a, 102b, 102c to roam between different ASNs and/or different core networks. The MIP-HA 184 may provide the WTRUs 102a, 102b, 102c with access to packet-switched

networks, such as the Internet 110, to facilitate communications between the WTRUs 102a, 102b, 102c and IP-enabled devices. The AAA server 186 may be responsible for user authentication and for supporting user services. The gateway 188 may facilitate interworking with other networks. For example, the gateway 188 may provide the WTRUs 102a, 102b, 102c with access to circuit-switched networks, such as the PSTN 108, to facilitate communications between the WTRUs 102a, 102b, 102c and traditional land-line communications devices. In addition, the gateway 188 may provide the WTRUs 102a, 102b, 102c with access to the networks 112, which may include other wired or wireless networks that are owned and/or operated by other service providers.

[0065] Although not shown in FIG. 1E, RAN 105 may be connected to other ASNs and the core network 109 may be connected to other core networks. The communication link between the RAN 105 the other ASNs may be defined as an R4 reference point, which may include protocols for coordinating the mobility of the WTRUs 102a, 102b, 102c between the RAN 105 and the other ASNs. The communication link between the core network 109 and the other core networks may be defined as an R5 reference, which may include protocols for facilitating interworking between home core networks and visited core networks.

[0066] In view of Figures 1A-1E, and the corresponding description of Figures 1A-1E, one or more, or all, of the functions described herein with regard to one or more of: WTRU 102a-d, Base Station 114a-b, Node B 140a-c, RNC 142a-b, MSC 146, SGSN 148, MGW 144, CGSN 150, eNode-B 160a-c, MME 162, Serving Gateway 164, PDN Gateway 166, Base Station 180a-c, ASN Gateway 182, AAA 186, MIP-HA 184, and/or Gateway 188, or the like, may be performed by one or more emulation devices (not shown) (e.g., one or more devices configured to emulate one or more, or all, of the functions described herein).

[0067] The one or more emulation devices may be configured to perform the one or more, or all, functions in one or more modalities. For example, the one or more emulation devices may perform the one or more, or all, functions while being fully or partially implemented/deployed as part of a wired and/or wireless communication network. The one or more emulation devices may perform the one or more, or all, functions while being temporarily implemented/deployed as part of a wired and/or wireless communication network. The one or more emulation devices may perform the one or more, or all, functions while not being implemented/deployed as part of a wired and/or wireless communication network (e.g., such as in a testing scenario in a testing laboratory and/or a non-deployed (e.g. testing) wired and/or wireless communication network, and/or testing performed on one or more deployed components of a wired and/or wireless communication network). The one or more emulation devices may be test equipment.

[0068] Below is a list of abbreviations and acronyms that may be used herein, by way of example and not limitation.

Δf	Sub-carrier spacing
5gFlex	5G Flexible Radio Access Technology
5gNB	5G Flex NodeB
ACK	Acknowledgement
BLER	Block Error Rate
BTI	Basic TI (in integer multiple of one or more symbol duration)
CB	Contention-Based (e.g. access, channel, resource)
CoMP	Coordinated Multi-Point transmission/reception
CP	Cyclic Prefix
CP-OFDM	Conventional OFDM (relying on cyclic prefix)
CQI	Channel Quality Indicator
CN	Core Network (e.g. LTE packet core)
CRC	Cyclic Redundancy Check
CSG	Closed Subscriber Group
CSI	Channel State Information
D2D	Device to Device transmissions (e.g. LTE Sidelink)
DCI	Downlink Control Information
DL	Downlink
DM-RS	Demodulation Reference Signal
DRB	Data Radio Bearer
EPC	Evolved Packet Core
FBMC	Filtered Band Multi-Carrier
FBMC/OQAM	A FBMC technique using Offset Quadrature Amplitude Modulation
FDD	Frequency Division Duplexing
FDM	Frequency Division Multiplexing
ICC	Industrial Control and Communications
ICIC	Inter-Cell Interference Cancellation
IP	Internet Protocol
LAA	License Assisted Access
LBT	Listen-Before-Talk
LCH	Logical Channel
LCP	Logical Channel Prioritization
LLC	Low Latency Communications
LTE	Long Term Evolution e.g. from 3GPP LTE R8 and up
MAC	Medium Access Control
NACK	Negative ACK
MC	MultiCarrier
MCS	Modulation and Coding Scheme
MIMO	Multiple Input Multiple Output
MTC	Machine-Type Communications
NAS	Non-Access Stratum
NR	New Radio access technology
NR-eNB	A network node that may e.g. schedule NR resources
OFDM	Orthogonal Frequency-Division Multiplexing
OOB	Out-Of-Band (emissions)
P_{cmax}	Total available UE power in a given TI
PHY	Physical Layer
PRACH	Physical Random Access Channel

PDU	Protocol Data Unit
PER	Packet Error Rate
PLMN	Public Land Mobile Network
PLR	Packet Loss Rate
PSS	Primary Synchronization Signal
QoS	Quality of Service (from the physical layer perspective)
RAB	Radio Access Bearer
RACH	Random Access Channel (or procedure)
RAR	Random Access Response
RCU	Radio access network Central Unit
RF	Radio Front end
RNTI	Radio Network Temporary Identifier
RRC	Radio Resource Control
RRM	Radio Resource Management
RS	Reference Signal
RTT	Round-Trip Time
SCMA	Single Carrier Multiple Access
SDU	Service Data Unit
SI	System Information
SL	Sidelink
SOM	Spectrum Operation Mode
SS	Synchronization Signal
SSS	Secondary Synchronization Signal
SRB	Signaling Radio Bearer
SWG	Switching Gap (in a self-contained subframe)
TB	Transport Block
TBS	Transport Block Size
TDD	Time-Division Duplexing
TDM	Time-Division Multiplexing
TI	Time Interval (in integer multiple of one or more BTI)
TTI	Transmission Time Interval (in integer multiple of one or more TI)
TRP	Transmission / Reception Point
TRPG	Transmission / Reception Point Group
TRx	Transceiver
UFMC	Universal Filtered MultiCarrier
UF-OFDM	Universal Filtered OFDM
UL	Uplink
URC	Ultra-Reliable Communications
URLLC	Ultra-Reliable and Low Latency Communications
Uu	Interface between a NR-eNB/TRP (or equivalent) and a UE
V2V	Vehicle to vehicle communications
V2X	Vehicular communications
WLAN	Wireless Local Area Networks and related technologies (IEEE 802.xx domain)

[0069] Systems may manage (e.g., attempt to minimize) the impact of on-demand other-SI broadcast on an uninterested WTRU. Multi-stage RACH may be used for other-SI request. A WTRU may handle stored SI and/or may operate in a reduced MSI cell.

[0070] Terms New Radio (NR), 5gFLEX and 5G may be used interchangeably. While examples may refer to 3GPP protocols, subject matter described herein is applicable to other

wireless systems (e.g., other wireless technologies, communication and/or control procedures). Terms and definitions do not limit the applicability of disclosed subject matter to other definitions, types of signals, configuration procedures and/or logical associations, e.g., between different user data units.

[0071] An air interface, e.g., for a new radio (NR) access technology in a 5G system, may support a variety of use cases, such as improved broadband performance (IBB), Industrial control and communications (ICC) and/or vehicular applications (V2X) and/or Massive Machine-Type Communications (mMTC). Use cases may have associated support in an air interface (e.g., 5G air interface).

[0072] An air interface may support, for example, ultra-low transmission latency (LLC), ultra-reliable transmission (URC) and/or machine-type communications (MTC) operation (including narrowband operation).

[0073] Support for ultra-low transmission latency (LLC) may comprise, for example, air interface latency such as 1ms RTT and/or TTIs between 100us to 250us. Support may be provided for ultra-low access latency (e.g., time from initial system access until the completion of the transmission of the first user plane data unit). End-to-end (e2e) latency less than 10ms may be supported, for example, for IC and/or V2X.

[0074] Support for ultra-reliable transmission (URC) may comprise, for example, improved transmission reliability, such as 99.999% transmission success and/or service availability. Support may be provided for mobility speed in the range of 0-500km/h. Packet Loss Ratio of less than $10e^{-6}$ may be supported, for example, for IC and/or V2X.

[0075] Support for MTC operation may comprise, for example, air interface support for narrowband operation (e.g. using less than 200 KHz), extended battery life (e.g., up to 15 years of autonomy) and/or minimal communication overhead for small and/or infrequent data transmissions (e.g., low data rate in the range of 1-100kbps with access latency of seconds to hours).

[0076] A 5gFLEX system may be implemented with OFDM and/or other waveforms for uplink and/or downlink. Description of examples herein is non-limiting. Examples are applicable and/or adaptable to other waveforms and wireless technologies.

[0077] OFDM may be used as a signal format for data transmissions, e.g., in LTE and IEEE 802.11. OFDM may efficiently divide spectrum into multiple parallel orthogonal subbands. A (e.g., one or more, or each) subcarrier may be shaped using a rectangular window in the time domain, which may lead to sinc-shaped subcarriers in the frequency domain. OFDMA may rely on (e.g., perfect) frequency synchronization and/or tight management of uplink timing alignment

within the duration of the cyclic prefix, for example, to maintain orthogonality between signals and/or to minimize intercarrier interference. Tight synchronization may be difficult, for example, in a system where a WTRU may be simultaneously connected to one or more, or multiple access points. Additional power reduction may be applied to uplink transmissions, for example, to comply with spectral emission requirements for adjacent bands. Fragmented spectrum may be aggregated for WTRU transmissions.

[0078] OFDM (CP-OFDM) performance may be improved, for example, by more stringent RF requirements for implementations, such as operation using a large amount of contiguous spectrum that might not require aggregation. A CP-based OFDM transmission scheme may provide a downlink physical layer for 5G similar to a 4G system with modifications to pilot signal density and/or location.

[0079] 5gFLEX radio access may be characterized by a very high degree of spectrum flexibility that enables deployment in different frequency bands with different characteristics, which may include different duplex arrangements, different and/or variable sizes of available spectrum, such as contiguous and/or non-contiguous spectrum allocations in the same or different bands. 5gFLEX radio access may support variable timing aspects, such as support for one or more, or multiple TTI lengths and/or asynchronous transmissions.

[0080] Multiple duplexing schemes (e.g., TDD, FDD) may be supported. Supplemental downlink operation may be supported, e.g., for FDD operation, for example, using spectrum aggregation. FDD operation may support full-duplex FDD and/or half-duplex FDD operation. DL/UL allocation may be dynamic (e.g., might not be based on a fixed DL/UL frame configuration), e.g., for TDD operation. The length of a DL and/or a UL transmission interval may be set per transmission opportunity.

[0081] A 5G air interface characteristic and/or capability may enable different transmission bandwidths on uplink and/or downlink ranging, e.g., varying between a nominal system bandwidth to a maximum value corresponding to the system bandwidth.

[0082] Single carrier operation may support a variety and/or range of system bandwidths, such as 5, 10, 20, 40, and/or 80 MHz, and/or 160MHz. Nominal bandwidths may have one or more fixed values. Narrowband transmissions (e.g., 0 to 200 KHz) may be supported within the operating bandwidth for MTC devices.

[0083] System bandwidth may refer to the largest portion of spectrum that may be managed by a network for a given carrier. The spectral portion of a carrier that a WTRU minimally supports for cell acquisition, measurements and/or initial access to the network may correspond to the nominal system bandwidth. A WTRU may be configured with a channel bandwidth that

may be within the range of the entire system bandwidth. A WTRU's configured channel bandwidth may or might not include a nominal part of system bandwidth, e.g., as shown in the example in FIG. 2.

[0084] FIG. 2 is an example of transmission bandwidths. Bandwidth flexibility may be achieved, for example, because (e.g., all) applicable sets of RF requirements for a given maximum operating bandwidth in a band may be met without the introduction of additional allowed channel bandwidths for that operating band, e.g., due to the efficient support of baseband filtering of the frequency domain waveform.

[0085] A WTRU's channel bandwidth for single carrier operation may be configured, reconfigured and/or dynamically changed. Spectrum for narrowband transmissions within the nominal system, system and/or configured channel bandwidth may be allocated.

[0086] A 5G air interface physical layer may be band-agnostic and/or may support operation in licensed bands (e.g., below 5 GHz) and/or unlicensed bands (e.g., in the range 5-6 GHz). Listen before talk (LBT) Cat 4 based channel access framework similar to LTE LAA may be supported, e.g., for operation in unlicensed bands.

[0087] Cell-specific and/or WTRU-specific channel bandwidths for arbitrary spectrum block sizes may be scaled and/or managed (e.g., scheduling, addressing of resources, broadcasted signals, measurements, etc.).

[0088] Downlink control channels and signals may support FDM operation. A WTRU may acquire a downlink carrier, for example, by receiving transmissions using (e.g., only) the nominal part of the system bandwidth. For example, a WTRU might not initially receive transmissions covering the entire bandwidth being managed by the network for the concerned carrier.

[0089] Downlink data channels may be allocated over a bandwidth that may or might not correspond to nominal system bandwidth, e.g., without restrictions other than being within a WTRU's configured channel bandwidth. For example, a network may operate a carrier with a 12 MHz system bandwidth using a 5MHz nominal bandwidth allowing devices supporting 5 MHz maximum RF bandwidth to acquire and/or access the system while potentially allocating +10 to -10 MHz of the carrier frequency to other WTRU's supporting up to 20 MHz worth of channel bandwidth.

[0090] FIG. 3 is an example of flexible spectrum allocation. FIG. 3 shows an example of spectrum allocation where different subcarriers may be (e.g., at least conceptually) assigned to different modes of operation (hereafter Spectrum Operation Mode or SOM). Different SOM may be used to fulfill different requirements for different transmissions. A SOM may include

and/or be defined based on one or more of a subcarrier spacing, a TTI length and/or one or more reliability aspects (e.g., HARQ processing aspects, secondary control channel). A SOM may be used to refer to a (e.g., specific) waveform and/or may be related to a processing aspect (e.g., in support of co-existence of different waveforms in the same carrier using FDM and/or TDM and/or coexistence of FDD operation in a TDD band (e.g. with support in a TDM manner or similar)).

[0091] A WTRU may be configured to perform transmissions according to one or more SOMs. For example, a SOM may correspond to transmissions that use at least one of the following: a specific TTI duration, a specific initial power level, a specific HARQ processing type, a specific upper bound for successful HARQ reception/transmission, a specific transmission mode, a specific physical channel (uplink and/or downlink), a specific waveform type and/or even a transmission according to a specific RAT (e.g., LTE and/or according to a 5G transmission technique). A SOM may correspond to a QoS level and/or a related aspect (e.g., maximum/target latency, maximum/target BLER or similar). A SOM may correspond to a spectrum area and/or to a specific control channel and/or aspect thereof (e.g., search space and/or DCI type). For example, a WTRU may be configured with a SOM for a URC type of service, a LLC type of service and/or an MBB type of service. A WTRU may have a configuration for a SOM for system access and/or for transmission/reception of L3 control signaling (e.g., RRC), for example, in a portion of a spectrum associated with a system, such as in a nominal system bandwidth.

[0092] Spectrum aggregation may be supported (e.g., for single carrier operation). A WTRU may support transmission and/or reception of one or more, or multiple transport blocks over contiguous and/or non-contiguous sets of physical resource blocks (PRBs), e.g., within the same operating band. Mapping of a single transport block to separate sets of PRBs may be supported. Support may be provided for simultaneous transmissions associated with different SOM requirements.

[0093] Multicarrier operation may be supported, for example, using contiguous and/or non-contiguous spectrum blocks within the same operating band and/or across two or more operating bands. Support may be provided for aggregation of spectrum blocks using different modes (e.g., FDD and/or TDD) and/or different channel access procedures (e.g., licensed and/or unlicensed band operation below 6 GHz). Support may be provided for procedures that configure, reconfigure and/or dynamically change a WTRU's multicarrier aggregation.

[0094] A scheduling function may be supported in the MAC layer. Support may be provided for one or more, or multiple (e.g., two) scheduling modes, e.g., network-based scheduling (e.g.,

for tight scheduling in terms of resources, timing and/or transmission parameters of downlink transmissions, and/or uplink transmissions) and/or WTRU-based scheduling (e.g., for more flexibility in terms of timing and/or transmission parameters). Scheduling information for modes may be valid for one or more TTIs.

[0095] Network-based scheduling may enable a network to tightly manage available radio resources assigned to different WTRUs, which may permit optimal sharing of resources.

Dynamic scheduling may be supported.

[0096] WTRU-based scheduling may enable a WTRU to opportunistically access uplink resources with minimal latency on a per-use basis, for example, within a set of shared and/or dedicated uplink resources assigned (e.g., statically and/or dynamically) by the network. Support may be provided for synchronized and/or unsynchronized opportunistic transmissions. Support may be provided for contention-based transmissions and/or contention-free transmissions.

[0097] Support for opportunistic transmissions (scheduled and/or unscheduled) may be provided, for example, to meet ultra-low latency requirements for 5G and/or power saving requirements for mMTC.

[0098] A WTRU may be configured to receive and/or detect one or more system signatures. A system signature may consist of a signal structure using a sequence. A signal may be similar to a synchronization signal, e.g., similar to LTE PSS and/or SSS. A signature may be specific to (e.g., may uniquely identify) a particular node (and/or transmission/reception point (TRP)) within a given area and/or it may be common to a plurality of nodes (and/or TRPs) within an area, which aspect might not be known and/or relevant to a WTRU. A WTRU may determine and/or detect a system signature sequence. A WTRU may determine one or more parameters associated with the system. For example, a WTRU may further derive an index therefrom and/or may use the index to retrieve associated parameters, e.g., within a table, such as an access table. For example, a WTRU may use received power associated with a signature for open-loop power control, e.g., to set an initial transmission power when a WTRU determines that it may access (and/or transmit) using applicable resources of the system. For example, a WTRU may use the timing of a received signature sequence, e.g., to set the timing of a transmission (e.g., a preamble on a PRACH resource) when the WTRU determines that it may access (and/or transmit) using applicable resources of the system.

[0099] A system signature may consist of any type of signal received by a WTRU for one or more purposes described herein.

[0100] A WTRU may be configured with a list of one or more entries. A list may be referred to as an access table. A list may be indexed, e.g., where an (e.g., one or more, or each) entry

may be associated with a system signature and/or to a sequence thereof. An access table may provide initial access parameters for one or more areas. An (e.g., one or more, or each) entry may provide one or more parameters necessary for performing an initial access to the system. Parameters may include one or more of a set of one or more random access parameters (e.g., including applicable physical layer resources, such as PRACH resources) in time and/or frequency, initial power level and/or physical layer resources for reception of a response. Parameters may (e.g., further) include access restrictions (e.g., PLMN identity and/or CSG information). Parameters may (e.g., further) include routing-related information, such as one or more applicable routing areas. An entry may be associated with (and/or indexed by) a system signature. Such entry may be common to a plurality of nodes (and/or TRPs), for example. A WTRU may receive an access table, for example, via a transmission using dedicated resources (e.g., by RRC configuration) and/or by a transmission using broadcast resources. In the latter case, the periodicity of the transmission of an access table may be relatively long (e.g., up to 10240ms), which may be longer than the periodicity of the transmission of a signature (e.g., in the range of 100ms).

[0101] An access table may consist of any type of system information received by a WTRU for one or more purposes described herein.

[0102] 5gFLEX may support one or more forms of association between data available for transmission and/or available resources for uplink transmissions. Multiplexing of data with different QoS requirements within the same transport block may be supported, for example, when multiplexing does not introduce a negative impact to the service with the most stringent QoS requirement and/or does not introduce an unnecessary waste of system resources.

[0103] A Logical Channel (LCH) may represent a logical association between data packets and/or PDUs. An association may be based on data units being associated with the same bearer (similar to legacy), and/or being associated with the same SOM and/or slice (e.g., a processing path using a set of physical resources). For example, an association may be characterized by one or more of a chaining of processing functions, an applicable physical data (and/or control) channel (and/or instance thereof) and/or an instantiation of a protocol stack with one or more of: a specific portion being centralized (e.g., PDCP and/or anything beyond portions of the physical layer processing such as Radio Front (RF) end); and/or another portion being closer to the edge (e.g. MAC/PHY in the TRP and/or RF) potentially separated by a fronthauling interface. The term LCH as used herein may have a different and/or broader meaning than a similar term for LTE systems.

[0104] A WTRU may be configured to determine a relationship between different data units. A relationship may be based on a matching function (e.g., based on the configuration of one or more field values common to data units that are part of the same logical association). Fields may correspond to fields in a protocol header associated with the data unit(s). For example, a matching function may use a tuple of parameters for fields of the IP headers of a data unit, such as IP source/destination address(es), transport protocol source/destination port(s) and/or transport protocol type, IP protocol version (e.g., IPv4 and/or IPv6), etc.

[0105] For example, data units that are part of the same logical association may share a common radio bearer, processing function, SOM and/or may (e.g., at least conceptually) correspond to the same LCH and/or LCG.

[0106] A Logical Channel Group (LCG) may consist of a group of LCH(s) (and/or equivalent as per the definition above), e.g., where a grouping may be based on one or more criteria. Criteria may be, for example, that one or more LCH(s) may have a similar priority level applicable to one or more, or all LCHs of the same LCG and/or may be associated with the same SOM (and/or type thereof), the same slice (and/or type thereof). For example, an association may be characterized by one or more of a chaining of processing functions, an applicable physical data (and/or control) channel (and/or instance thereof) and/or instantiation of a protocol stack, which may include one or more of: a specific portion being centralized (e.g., PDCP and/or anything except RF); and/or another portion being closer to the edge (e.g., MAC/PHY in the TRP and/or RF) that may be separated by a fronthauling interface. The term LCG as used herein may have a different and/or broader meaning than a similar term for LTE systems.

[0107] A radio access network (RAN) slice may include (e.g. one or more, or all) radio access network functions and/or transport network functions and/or resources, e.g., radio resources and/or backhaul/fronthaul resources along with core network functions/resources that may be used and/or required to provide end-to-end services to a user. Network functions may, for example, be virtualized on a general purpose processor, run as network functions on specialized hardware and/or split between specialized hardware and general purpose hardware. A PLMN may consist of one or more network slices. A slice may be equivalent to an operator's single, common and/or general purpose network. A RAN slice may consist of one or more SOMs that may be optimized to support various services that the RAN slice may have to offer.

[0108] For example, WTRUs served within a slice may have, for example, one or more of the following aspects in common: services and/or QoE requirements (e.g. ULLRC, eMBB, MMTc); WTRU categories (e.g., CAT 0 to M and beyond, additional categories may be defined for >6GHz to differentiate beamforming capability); coverage requirements (e.g., normal

coverage, enhanced coverage); PLMN/Operators; support for specific Uu interface (e.g., LTE, LTE-Evo, 5G below 6Ghz, 5G above 6Ghz, Unlicensed); and/or served by same core network slice. The terms “RAN slice” and “slice” may be used interchangeably.

[0109] A Transport Channel (TrCH) may include one or more sets (e.g., a specific set) of processing steps and/or a specific set of functions applied to data information that may affect one or more transmission characteristics over a radio interface.

[0110] LTE may define one or more, or multiple types of TrCH, such as the Broadcast Channel (BCH), the Paging Channel (PCH), the Downlink Shared Channel (DL-SCH), the Multicast Channel (MCH), the Uplink Shared Channel (UL-SCH) and/or the Random Access Channel (which might not carry user plane data). Transport channels for carrying user plane data may include the DL-SCH and/or the UL-SCH for the downlink and for the uplink, respectively.

[0111] An augmented set of requirements may be supported by an air interface for a 5G system. Support may be provided for one or more, or multiple transport channels, e.g., for user and/or control plane data, for one or more WTRU devices. The term TrCH as used herein may have a different and/or broader meaning than a similar term for LTE systems. For example, a transport channel for URLLC (e.g., URLLCH), for mobile broadband (MBBCH) and/or for machine type communications (MTCCH) may be defined for downlink transmission (e.g., DL-URLLCH, DL-MBBCH and/or DL-MTCCH) and/or for uplink transmissions (e.g., UL-URLLCH, UL-MBBCH and/or UL-MTCCH).

[0112] For example, one or more, or multiple TrCH may be mapped to a different set of physical resources (e.g., PhCH) belonging to the same SOM. This may be advantageous, for example, to support simultaneous transmission of traffic with different requirements over the same SOM. An example of this may be transmitting a URLLCH along MTCCH simultaneously when a WTRU is configured with a single SOM.

[0113] A WTRU may be configured with one or more parameters associated with a characterization of how data should be transmitted. A characterization may represent constraints and/or requirements that a WTRU may be expected to meet and/or enforce. A WTRU may perform different operations and/or adjust its behavior as a function of the state associated with the data based on a characterization. Parameters may include, for example, time-related aspects (e.g., Time to Live (TTL) - for a packet, which represents the time before which the packet should be transmitted to meet, acknowledged, etc. to meet latency requirements), rate-related aspects and/or configuration related aspects (e.g., absolute priority). Parameters may (e.g., also) be changed with time while a packet and/or data may be pending for transmission.

[0114] A WTRU may be connected to TRPs, e.g., in standalone mode and/or assisted mode. A group of cells that requires assistance may be referred to as an assisted layer. A group of cells that provides the assistance may be referred to as an assistance layer.

[0115] FIG. 4 is an example of different types of assistance layers, using example WTRUs 401-408. Examples of assistance modes may include, for example one or more of: a WTRU 401 connected to 5Gflex small cell in below-6Ghz band assisted by 5Gflex macro cell in sub-6Ghz band; a WTRU 402 connected to 5Gflex small cell in below-6Ghz band assisted by LTE-Evo macro cell; a WTRU 403 connected to 5Gflex small cell in above-6Ghz band assisted by 5Gflex macro cell in sub-6Ghz band; a WTRU 404 connected to 5Gflex small cell in above-6Ghz band assisted by LTE-Evo macro cell; a WTRU 405 connected to 5Gflex small cell in above-6Ghz band assisted by 5Gflex small cell in below-6Ghz band; a WTRU 407 connected to 5Gflex small cell in below-6Ghz band in standalone mode; a WTRU 406 connected to 5Gflex macro cell in above-6Ghz band in standalone mode and/or a WTRU 408 connected to 5Gflex small cell in above-6Ghz band in standalone mode.

[0116] Deployment scenarios may be supported by one or more procedures described herein. For example, a deployment scenario may be LTE-assisted 5gFLEX Aggregation (DC/CA/Offload). A WTRU may be configured, for example, using an LTE Control Plane (e.g., with an LTE RRC connection) using an LTE User Plane (e.g., with one or more LTE Uu interfaces). A WTRU may be (e.g., further) configured (e.g., by reception of access table(s) from broadcast and/or dedicated signaling) to operate with one or more additional 5gFLEX Uu(s), for example, using the principles of LTE DC, LTE CA and/or LTE-WLAN offload.

[0117] An example of a deployment scenario may be LTE-assisted 5gFLEX Transport Channel(s) (LTE CP, LTE UP, LTE Uu with one or more 5gFLEX TrCH/Physical channels plugged into LTE Uu). A WTRU may be configured for LTE Uu operation (e.g., using LTE procedure(s)). A WTRU may be (e.g., further) configured with one or more physical layer (e.g. control and/or data) channels for a 5gFLEX Uu of the WTRU's configuration. Downlink (DL) physical channels may co-exist in the DL carrier and/or frequency band. An uplink (UL) carrier may (e.g., also) be common or separate. Cell-specific LTE signals/channels may be viewed as "holes" in the 5gFLEX map of physical layer resources, for example, from the perspective of a WTRU configured with one or more 5gFLEX physical channels.

[0118] An example of a deployment scenario may be LTE-based Stand-alone 5gFLEX operation (LTE CP, LTE L2 at least in part, 5gFLEX PHY). A WTRU may be configured with one or more (e.g., many, most or one or more, or all) of the components of an LTE control plane (e.g., RRC connection, security, etc.) and/or the LTE user plane (e.g., EPS RABs, PDCP, RLC).

A WTRU may be (e.g., further) configured with one or more 5G MAC instance(s). An (e.g., one or more, or each) instance may have one or more 5gFLEX Uu(s). Stated somewhat differently, for example, a WTRU might not be configured with an LTE PCell.

[0119] For example, a deployment scenario may be Stand-alone 5gFLEX operation. A WTRU may be configured with a 5G control plane and/or a 5G user plane. 5gFLEX Uu operation may be supported.

[0120] WTRU states may be modeled. The terms “state” and “mode” may be used interchangeably. Aspects of this disclosure may be applicable independent of state. Some aspects may be applicable for more than one state. Some aspects described herein may be applicable whether or not such states are actually defined.

[0121] A WTRU may operate according to at least one of the following states and/or similar: idle mode, light connected/loosely connected/inactive mode, and/or connected, fully connected/active mode.

[0122] In WTRU idle mode, from the network's perspective, the WTRU might not have a context with the radio access network (“RAN”). For example, in a distributed architecture, a WTRU might not have context at the edge control function and/or the central control function. From the WTRU's perspective in idle mode, the WTRU may monitor paging from the core network (e.g., at a well-defined DRX cycle). The WTRU may perform measurements and/or autonomous mobility. The WTRU may acquire, store, and/or apply system information valid for at least idle mode operations.

[0123] In WTRU light connected/loosely connected/inactive mode, from the network's perspective, there may exist a WTRU context stored in the RAN. There may also exist a RAN-core connection for the WTRU. For example, in a distributed architecture, a WTRU may have context established at the central control function with limited and/or no context at the edge control function. The WTRU may be tracked (e.g., at a granularity of a logical area greater than or equal to a cell). The WTRU may be reached by the RAN via paging messages that originates in the RAN (e.g., at DRX cycles specific to the light connected state). From the WTRU's perspective, a WTRU might not have an active and/or established connection to the RAN. Mobility in light connected state may be WTRU controlled. A WTRU may move within a logical area without notifying the network. A WTRU may notify the network when the WTRU determines that the WTRU has moved outside a logical area (e.g., the WTRU would fail to detect the signature/reference signal and/or another property that identifies the concerned area) and/or across a boundary between two different logical areas (e.g., the WTRU would detect a

different identity for the current area). Mobility in light connected state may also be network controlled (e.g., to enable handover when data transfer is allowed and/or ongoing).

[0124] In the connected/fully connected/active mode, from the network's perspective, the WTRU may have connectivity with the network (e.g., the WTRU context may be established at the radio access network, and/or WTRU specific connection may be established between RAN and core network). For example, in a distributed architecture, a WTRU may have context established at a central control function and/or one or more edge control functions. A WTRU may have at least one user plane function/component established. WTRU mobility may be tracked at the cell level and/or may be WTRU assisted, network controlled mobility. Network configured WTRU controlled mobility may be used.

[0125] The states described may represent a standalone/independent state, with transition logic in between. Some of the states may have relationships to each other. For example, some states may be functional elements of another state (e.g., where transition between sub-states might not imply significantly different RRC function and/or trigger RRC behavior). For example, a connectionless transfer may be a sub-state and/or an access method for a WTRU in idle or light connected state. In another example, the light connected state may be a RAN controlled state.

[0126] WTRU control aspects may include procedures enabling configuration and/or coherent operation for one or more of the following aspects: a plurality of radio "layers"; a plurality of radio access technologies (e.g., NR, LTE, Wifi, etc.); a plurality of L2 transport and/or user plane components, which may be realized using different network slices and/or sets of physical resources; and/or enhanced connectivity principles such as loosely connected state.

[0127] In the broadcast transmission of on-demand other-SI, the notification of presence of other-SI and/or scheduling indication of other-SI may trigger a reception procedure (e.g., unnecessary) for the WTRUs that are uninterested in the other-SI. Trigger reception procedures in uninterested WTRU's may be energy inefficient.

[0128] Although examples describe procedures, features and elements in particular combinations, the disclosed subject matter encompasses implementation of one or more, or each procedure, feature and/or element in whole or in part, individually or in any combination with and without other procedures, features and/or elements disclosed herein or known.

[0129] A transmission/reception point (TRP) may support, for example, one or more of the following access procedures: LTE/LTE-A/LTE-Evo air interface, an NR access (e.g. based on a flexible 5G air interface and/or similar), a beamformed interface for higher frequencies, a non-3GPP access (e.g. 802.11 family such as WiFi), License Assisted Access (LAA), a narrow band

air interface and/or similar. TRP, eNB/NR-eNB, access point, base station and/or the like may be used interchangeably.

[0130] A WTRU may be connected in a number of different manners with a radio system. For example, a WTRU may be configured for transmission to/from one or more TRPs. One or more, or multiple transmissions may be transmitted and/or received concurrently. A WTRU may (e.g. further) be configured for transmissions that may be characterized by varying levels of diversity/reliability, mobility robustness, differentiation in terms of services, etc. Higher level services may involve, for example, the configuration of a plurality of TRPs to achieve service levels. For example, one or more TRPs may support (e.g. only) narrow band transmissions, one or more TRPs may provide best effort offload, one or more TRPs may provide less overhead (e.g. specific signatures, preconfigured bearer), etc. A WTRU may be agnostic to the identity of a TRP and/or the number of TRPs, for example, even when configured with one or more, or multiple TRPs. For example, transmissions to/from different TRPs may be differentiated, for example, based on applicable reference signals (RS), control channels, timing and/or operating carrier/frequencies.

[0131] A distributed approach may be implemented for control plane modeling. A control plane in previous generations of wireless systems (e.g. LTE) may have a suite of protocols (e.g. RRC and/or NAS) use a very centralized and/or monolithic approach, e.g., from a WTRU perspective. A centralized approach may be difficult to scale for next generation systems that may require support for and/or coordination between differentiated services (e.g. very low latency services), multi-connectivity, a larger number of small cells for a given WTRU.

[0132] Distribution of (e.g. certain) functions, for example, towards the edge of a RAN (e.g. in or close to a TRP) may provide a more scalable approach for an NR system. Furthermore, increased isolation between different user plane processing paths (e.g. similar to bearers in EPC/LTE) may facilitate differentiated QoS, management of multi-path bearers (and/or similar) as well as differentiated allocation of network resources in a system and/or (e.g. potentially) sharing of network resources between operators.

[0133] Example procedures disclosed herein may enable a WTRU to be configured with plurality of user plane functions and/or processing paths according to diverse service requirements with support for diverse device types, deployment scenarios and/or other requirements in an NR system. For example, procedures disclosed herein may enable a control plane entity to establish, maintain and/or tear down service specific user plane components as useful, e.g., using a distributed model.

[0134] A separation and protocol/functional split may be provided. A distributed control plane may be modeled, for example, to enable a number of control functions to operate close to the edge of the system. The functions may be replicated, for example, using a number of instances (e.g. in different TRPs with multi-connectivity). Some functions may be centralized (e.g. to manage core network connectivity and/or user plane instances). Consequently, there may be one or more, or multiple different termination points in the access network that concurrently provide control services for a given WTRU. A WTRU may support a multiplexing/demultiplexing function (e.g. different sets of one or more SRBs) associated with one or more (e.g. specific) control plane contexts/instances/functions and/or a set thereof. A control plane model may (e.g. also) support one or more control plane functions to operate concurrently and/or in parallel, e.g., for functions logically closer to the edge. Centralizing one or more control plane functions may enable and/or facilitate coordination between different control plane instances of the same WTRUs, e.g., coordination between different TRPs of a WTRU's configuration.

[0135] Control plane/user plane (CP/UP) separation may be modeled in a variety of different ways. There may be a variety of potential axes for separation of the different components of a control plane.

[0136] For example, vertical isolation may be provided in a protocol stack (CP and/or UP). Different options may be based on depth of separation. For example, in a partial separation and/or split approach, CP/UP specific higher layers may be followed by one or more common lower layers. For example, in a complete separation, an independent protocol stack may be provided, e.g., all the way down to L1/PHY. For example, an optimized PHY channel design and/or different DCI/grant level may be provided. A different Spectral Operating Mode/signal structure may be provided.

[0137] For example, horizontal separation may be provided between instances of a (e.g. potentially different) protocol stack. A control plane instance may operate on a user plane instance. A protocol stack may be separated, e.g., by an interface between a central unit (CU) and a remote unit (RU). Functional splits may be based on one or more of the following, for example: transport network profile (e.g. fronthaul and/or backhaul bandwidth, latency, jitter, etc.); specific deployment scenarios; type of service (e.g. eMBB services may utilize centralized processing for cost savings and/or URLLC services may utilize distributed processing to minimize latency); resource availability (e.g. processing resource, specialized hardware); vendor interoperability; and/or dynamic changes to transport network capacity (e.g. when the transport network is shared with one or more, or multiple TRPs and/or operators).

[0138] For example, physical and/or access separation may be provided. Uu termination may be provided for control and/or user plane at different nodes in the RAN (e.g. assisted layer and/or different TRP). For example, CP termination may be at LTE-Evo eNB and/or UP termination may be at NG TRP/RCU, e.g., in assisted mode. For example, an L2 transport and/or termination point for CP may be different from UP, e.g., in standalone mode. For example, an L2 transport and/or termination point for CP may be any TRP while for UP it may be using a restricted set of TRPs, e.g., in standalone mode.

[0139] Modeling described herein may support any of the foregoing separation models and/or other models, alone or in combination. For example, modeling may facilitate having a control plane component and its associated user plane in different RAN slices. Slices may be realized, for example, by physical and/or vertical separation. For example, a multi-plane architecture may support a combination of horizontal separation and/or vertical isolation.

[0140] Examples of elements and/or characteristics may be provided for a distributed control plane architecture.

[0141] A high level generalization (e.g. a conceptual view) of a control plane may be as a set of one or more control function(s). A control function may include processing actions and/or related parameters. Examples of control functions are described herein. A control function may apply to one or more component(s) of a WTRU.

[0142] Components may include, for example, a protocol (e.g. NAS, RRC, PDCP, RLC, MAC, PHY, etc.) and/or a corresponding entity, an implementation aspect (e.g. a power control function, a state of a WTRU, etc.), a set of resources (e.g. a data transport path, a bearer, etc.) and/or a combination thereof (e.g. a set of physical/processing resources, a slice, etc.). Examples of component combinations are described herein.

[0143] A control functions may be characterized as being applicable, for example, according to one or more of the following: a WTRU-specific function; a component-specific function; and/or a plural-component function.

[0144] A WTRU-specific function, for example, such as a control function may be applicable to any aspect(s) and/or component(s) of a WTRU. For example, a function that controls a WTRU's connectivity to a core network (e.g. in terms of access credentials) may be WTRU-specific. A function may (e.g. from a network perspective) be centralized in a node that supports connectivity to a plurality of TRPs/NR-eNBs. For example, a function may be logically part of a RAN Central Control Function (RCCF), e.g., described below.

[0145] A component-specific function, for example, such as a control function may be applicable to one or more aspects of a WTRU. An aspect may be, for example: a MAC instance;

a signature-specific aspect (e.g. a configuration corresponding to a signature); a TRP-specific aspect (e.g. a configuration corresponding to a TRP); a TRPG-specific aspect (e.g. a configuration corresponding to a TRPG); an LCH (and/or equivalent)-specific aspect (e.g. a configuration corresponding to an LCH); an instance of a component combination (e.g. a bearer, a flow such as a sequence of packets identified by a matching rule (e.g. a tuple, etc.), for example, as described herein; a slice specific aspect (e.g. a configuration) corresponding to a RAN slice and/or a core network slice and/or to an end-to-end network slice (e.g. a core network slice, a slice selection function and/or one or more RAN functions); a spectral operating mode (e.g. a configuration) corresponding to a spectral operating mode, and/or other examples. For example, a WTRU may apply a received configuration to a specific time/frequency resource while using a different configuration for other time/frequency resources in the system.

[0146] For example, a function may be logically part of an Access Control Function (ACF), e.g., for a function dedicated to connectivity to a single TRP/NR-eNB, which may include configuration for a MAC instance and/or physical layer parameters (e.g. single or multiple cells/carriers) for a given WTRU.

[0147] In a plural-component function, for example a control function may be applicable to a plurality of components of a WTRU. For example, a function may be logically part of an Access Control Function (ACF) for a function that may control connectivity for a TRPG and/or for one or more NR-eNB(s), which may include configuration for a single MAC instance (e.g. COMP) and/or for one or more, or multiple MAC instances (e.g. for multi-connectivity) and/or (e.g. required) physical layer parameters for a given WTRU. This may, for example, further include coordination and/or configuration aspects for a WTRU to handle, e.g., with reception of one or more, or multiple responses to a random access within a TRPG, if applicable, for single TRP selection and/or for multiple TRP selection (e.g. for aggregation and/or multiple connectivity).

[0148] Examples may be provided for some (e.g. most) applicable control plane functions, e.g., individually. A function may be described with reference to its applicability to these non-limiting characterizations.

[0149] High-level modeling of a control plane for NR may be provided. Functions and/or components may, for example, be logically grouped.

[0150] A multi-plane architecture may be provided. For example, functions and/or components supporting an NR system may be logically grouped, for example, in terms of an Access Plane (AP), a Central Control Plane (CCP) and/or a Central User Plane (CUP). A description of example realizations of user plane components is described herein.

[0151] Logical grouping of functions may enable different components and/or functions of a system to be isolated from each other. Isolation may (e.g. further) enable components and/or functions to be controlled, configured, modified and/or operated separately from each other. Separation may be applied for components and/or functions associated with a specific WTRU, per TRP/NR-eNB, per TRPG, per TRPGs, per group of NR-eNBs, per LCH (and/or equivalent), per slice, etc. Separation between centralized and access-related grouping may enable coordination between different instances of a function (e.g. system information provisioning, bearer configuration and/or equivalent) and/or between different instances of different functions (e.g. core network connectivity and/or user plane/bearer instances).

[0152] FIG. 5 is an example of logical grouping. There may be an architectural aspect and/or approach to a functional split. For example, FIG. 5 shows an example of a tri-plane architecture.

[0153] Different principles for a functional split between an access control plane and a central control plane may be considered.

[0154] For example, there may be a single access plane per RAT and/or central control per one or more, or multiple RATs. For example, an access control plane may include control functions specific to the access technology (e.g. beamforming control function, control function specific to LTE, non-3GPP control function, etc.). A central control plane may include control functions that are agonistic to an air interface. A common central control plane may be associated with one or more, or multiple TRPs with diverse access technologies, for example, for LTE/LTE-A/LTE-Evo air interface, a flexible 5G air interface, a beamformed air interface for higher frequencies, a non-3GPP access (e.g. 802.11 family such as WiFi), License assisted access (LAA), a narrow band air interface, etc.

[0155] For example, there may be one access plane per TRP/cell and/or central control per one or more, or multiple TRPs. For example, an access control plane may include control functions specific to a TRP/cell. A central control plane may include control functions applicable to more than one TRP. This approach may simplify inter-TRP coordination for efficient radio resource management, RAN mobility management and/or self-organizing functions, etc. A central control plane may (e.g. in one or more cases) lead to cost effective deployments, for example, as it might not require additional interface between TRPs.

[0156] For example, an access control plane may be responsible for establishment, maintenance and/or release of a layer 1/layer 2 (L1/2) connection, allocation of a temporary identifier to identify a WTRU uniquely within a TRP, common and/or dedicated L1 and/or L2 resource configuration specific to a TRP, etc. A central control plane may be responsible for

configuring L3 signaling flows and/or abstraction thereof (e.g. signaling radio bearers), configuration of higher layer data flows and/or abstraction thereof (e.g. data radio bearers), security functions (e.g. may include key management), radio resource configuration (e.g. may be common across two or more TRPs), mobility functions (e.g. may include WTRU measurement control), handover control, context transfer, paging, etc.

[0157] QoS management functions may be controlled by a central control plane and/or may be enforced by an access control plane. QoS management functions may be part of a user plane control function, if applicable.

[0158] A system information broadcast function may be shared between an access control plane and a central control plane. For example, an access control plane may be responsible for scheduling and/or transmission of TRP specific system information related to accessibility, physical channel configuration, SC-PTM configuration, etc. An access control plane may be responsible for transmission of MIB and/or for handling dedicated system information procedure.

[0159] A central control plane may, for example, determine the contents of system information for cell (re)-selection information, intra-frequency, inter-frequency and/or inter-RAT neighbor information, MBMS information, side link information etc. Common and/or shared channel related configuration may be coordinated between the access control plane and central control plane. For example, a configuration for layer 2 RAN functions located in TRPs may be configured and/or controlled by the access control plane (e.g. for MAC, physical layer) while layer 2 RAN functions placed in the central user plane entity may be configured and/or controlled by the central control plane (e.g. for PDCP, RLC, bearers and/or similar and/or access table for a TRPG, if applicable).

[0160] A service/QoS-based functional location may be provided for a function in an access plane and/or a control plane. For example, control functions that may be time sensitive with a strict deadline may be placed in TRPs while other control functions may be placed in the central control plane. This approach may relax latency requirements on the fronthaul interface between the central unit and the TRPs and/or may enable cost efficient deployments.

[0161] Another example of a functional split may be applied, for example, when RAN level slicing is supported. For example, control functions that are common across two or more slices may be placed in the central control plane while control functions that are specific to a slice may be placed in the access control plane. In this approach, mobility control, WTRU context handling, etc. may be a part of a central control plane while the access control plane may include

slice specific system information broadcast, slice specific authentication and/or security management, and/or slice specific QoS enforcement, etc.

[0162] A WTRU may be able to determine how to exchange signaling with different endpoints and/or with specific instances of a function, for example, based on these modeling examples. Such may be realized using different multiplexing procedures such as those described herein.

[0163] Access control functions (e.g. from the perspective of an overall RAN architecture) may be (e.g. conceptually) defined as set of logical functions, parameters and/or procedures that enable a WTRU to be uniquely addressed and/or identified by one or more TRPs. A WTRU may (e.g. further) generate and/or exchange data and/or signaling with those TRPs. Access control functions may provide distributed/edge control and/or user plane functions that may be specific to a TRP and WTRU pair. An (e.g. one or more, or each) access control function may be associated with a scheduler instance controlling one or more TRPs (e.g. over ideal backhaul). Such function may be part of a radio resource control protocol (e.g. RRC). Such function may be performed by a RRC entity e.g. located in a TRP. A WTRU may (e.g. from the WTRU perspective) be configured to associate a specific signaling bearer and/or equivalent (e.g. a transport path/procedure) for control of a MAC entity with the concerned MAC entity. The function may be part of a Medium Access Control (e.g. MAC) protocol. This function may be performed by a MAC entity. The Access Plane function may use transport services of MAC protocols (e.g. as MAC Control Elements, as MAC Control PDUs, and/or similar), for example, when the MAC entity perform the functions associated to the Access Plane.

[0164] An access plane may be considered to be established, for example, when a WTRU may be uniquely identified by access control functions. An access plane may be established, for example, when a WTRU can start transmission of user plane data. An access plane may be established, for example, when a WTRU receives a response that configures a capability for the WTRU to start performing (receiving and/or transmitting) dedicated transmissions, which may include when security is activated (if applicable) for the concerned configuration.

[0165] High level scoping of an access plane may be performed. For example, a WTRU may be configured to access resources associated with one or more radio access network nodes (e.g. TRP(s), TRPG(s) and/or NR-eNB(s)) using one or more of a set of functions, parameters and/or procedures.

[0166] For example, such procedures may include capabilities for a WTRU to perform an initial access (e.g. to establish access plane connectivity), perform a random access procedure and/or similar, for example, to obtain uplink timing alignment and/or further resources for uplink

transmission, to select a suitable network node (e.g. based on measurements of downlink signals and/or based on reception of one or more responses to the initial request such as one or more RARs), to obtain a unique identifier (e.g. a dedicated RNTI), to obtain a configuration (e.g. for physical layer operation), to enable transmission of control signaling (e.g. a signaling radio bearer and/or equivalent) and/or to establish a Uu interface and/or equivalent with a corresponding network node.

[0167] An access plane may terminate a control signaling protocol. An access plane may be provided for component-specific applicability. For example, an access plane may control aspects related to (e.g. at most) an (e.g. one) access network node. For example, an access plane may provide services for control and/or configuration of a physical layer and/or configuration of a MAC instance associated with a (e.g. one) TRP/NR-eNB. Coordination between one or more, or multiple access nodes might not be assumed and/or useful, for example, in this case.

[0168] An access plane may be provided for plural-component applicability. For example, an access plane may control aspects related to one or more access nodes. For example, an access plane may provide services for control and/or configuration for a physical layer for one or more cells and/or configuration of a MAC instance, where (e.g. potentially) one or more, or each may be associated with applicable TRPs/NR-eNBs. For example, an access plane may support coordination of one or more aspects between different network nodes. Coordination may be per TRPG, per area, per signature and/or per set of access parameters. Coordination may be provided, for example, using a (e.g. single) MAC entity (e.g. with a coordinated scheduling function such as carrier aggregation-like assuming ideal interfaces) and/or by a control function that may interface with a WTRU for the configuration of one or more, or multiple MAC instances, e.g., when applicable (e.g. a multi-connectivity approach).

[0169] A central control plane (e.g. a RAN control plane) may be provided. RAN Central Control Functions (RCCF) may include control functions, protocols and/or context that may be WTRU specific and/or applicable to one or more TRPs/ACFs. A central control plane may be considered as an anchor control function that may terminate a control interface towards the core network (e.g. through configuration/setup of routing paths and transport paths, for example, based on tuples configured for a WTRU). An RCCF may (e.g. additionally) include control functions related to selection of a core network slice, CN-RAN interfaces, QoS management, security (e.g. master key management and/or key derivation, which may be per group of TRPs/NR-eNBs), WTRU capability management and/or WTRU reachability within RAN.

[0170] WTRU context may be setup at RCCF (e.g. after CORE/NAS interaction). From RCCF point of view: a WTRU (e.g. from RCCF perspective) may have a known TRP(G) granularity (e.g. when access plane is active).

[0171] Central User Plane control functions may be (e.g. conceptually) defined as set of logical functions, parameters and/or procedures that may enable a WTRU to transfer user plane data with a network. Functions may be applicable to one of more user plane components (e.g. bearers, L2 transport path, flow-based routing entry, slice instance managing such, etc.). One or more functions may be part of the set of central control plane functions and/or may be logically separated therefrom.

[0172] Signaling may be generated and/or exchanged with one or more TRPs that may be part of a concerned user plane component. Central user plane functions may provide control for aspects that may be specific to a service, a slice, a bearer and/or a set of processing steps configured for the transport of one or more (e.g. specific) flows, which may be determined by configured tuples. A (e.g. one or more, or each) control function may be associated with a scheduler instance controlling one or more TRPs (e.g. over ideal backhaul). A WTRU (e.g. from its own perspective) may be configured to associate a specific central user plane instance with a signaling bearer and/or equivalent (e.g. a transport path/procedure) for control of a user plane component with one (e.g. single path/Uu) or more (e.g. multi-path/Uu) applicable MAC entities. A function may use transport services of corresponding MAC protocols, for example, as MAC Control Elements and/or similar.

[0173] An efficient data path may be setup between a TRP and a RAN Central User Function (RCUF) and/or between different RCUFs, e.g., when applicable. Connection oriented and/or connection-less user plane (e.g. WTRU assisted packet-based routing) may be supported.

[0174] RAN central user plane functions may comprise, for example, functions, protocols and/or parameters that may be service and/or data traffic specific.

[0175] There may be interactions between different control functions and components. A timing relation between access plane establishment and central control plane establishment may, for example, depend on a WTRU state. For example, a WTRU in a passive or IDLE state may transition to connected state by (e.g. first) establishing an access plane, e.g., using control signaling interaction with one or more access control functions (ACFs). For example, an access plane may be established as a result of an association procedure between a WTRU and a network. A WTRU may (e.g. then) trigger central control plane establishment, for example, using control signaling interaction with one or more central control functions. For example, a WTRU may establish a central control plane (e.g. only) and/or may establish a central control

plane and a central user plane, for example, based on whether the WTRU has signaling traffic and/or data traffic. In an (e.g. another) example, a WTRU may (e.g. directly) transmit data without access plane establishment, for example, when the WTRU (e.g. in a loosely connected state) may have a central control context without an access plane established.

[0176] A WTRU may store a Central control plane context, for example, even after an access plane may be deactivated. Central control functions may (e.g. similarly) retain a WTRU context, for example, even after the access control functions release WTRU context and/or WTRU specific connectivity between access control functions and central control functions. Central control functions may (e.g. additionally) retain WTRU context, for example, even after central user functions release WTRU context and/or WTRU specific connectivity between central user plane functions and core network user plane functions. In other words, for example, a RAN control plane (e.g. SRBs) may exist without an active user plane (e.g. DRBs). For example, a WTRU may attach to a network without a corresponding data bearer establishment. A WTRU may (e.g. be required to) maintain central user plane context, for example, (e.g. only) when the central control plane context is active.

[0177] An access plane may be dynamically activated/deactivated, e.g., by access control functions and/or by central control functions, for example, when a control plane context is active.

[0178] WTRU connectivity may have one or more supported states. For example, a WTRU may operate according to one or more of the following states: idle mode; idle mode with connectionless transfers; and/or connected mode and/or loosely connected mode.

[0179] In an IDLE mode, for example, a WTRU might not have established connectivity with a network (e.g. a WTRU might not have ACF/ACP, RCCF/RCCP and/or RCUF/RCUP established).

[0180] In an IDLE mode with Connectionless Transfers, for example, a WTRU may have some connectivity with a network (e.g. it may have at least one ACF/ACP established with at least one user plane component, e.g., with a default configuration, e.g., for routing and/or security). A WTRU may have RCCF/RCCP established (e.g. a security context, access tables).

[0181] In a connected mode, for example, a WTRU may have complete connectivity with a network (e.g. it may have at least one ACF/ACP, RCCF/RCCP and/or RCUF/RCUP (e.g. when applicable) established with at least one user plane component).

[0182] In a loosely connected mode, for example, a WTRU may have some connectivity with a network (e.g. it may have at least one RCCF/RCCP established, e.g., a security context, access tables).

[0183] Connectionless data transfer may be provided. A WTRU may establish an L3/RRC connection to transmit data PDUs irrespective of the size of the data packet. Establishing a connection may be difficult relative to one or more of: overheads associated with signaling to establish a connection at the RAN and/or Core network before the start of a small packet transfer; overhead associated with tearing down a connection after periods of inactivity; and/or WTRU battery drain to stay in connected mode for extended periods of time.

[0184] A WTRU may (e.g. directly) perform connectionless data transfer in a loosely connected state, for example, using a pre-existing context with a central control plane function. A pre-existing context may include (e.g. at least) a security context, WTRU subscription and/or WTRU capability configuration. A WTRU may (e.g. also) perform connectionless data transfer from an idle connectionless state, e.g., using a pre-existing context with the core network control function. A WTRU may (e.g. in this example) not have a RAN central context established. For example, a WTRU may be associated with (e.g. only) a default slice and/or a core network control function and may still transmit connectionless data. A WTRU may (e.g. in this example) include additional session information with a data PDU.

[0185] Connectionless data transfer may allow a WTRU to transmit data, for example, with one or more following characteristics/properties: without requiring access plane establishment; using modified msg1 (e.g. modified RACH preamble + data, multi-user non-orthogonal data channel, etc.); without receiving an explicit grant (e.g. contention based UL shared data channel); after UL synch (e.g. using piggybacked data with and/or as msg3); before UL synch to the network (e.g. using asynchronous access channel); and/or transmitting additional context information associated with the data PDU.

[0186] A WTRU may use a simplified security procedure that may, for example, involve one or more of: using stored context, which may be result of previous network interaction and/or hard coded security context in SIM; and/or explicit indication of security algorithm used.

[0187] A connectionless data transfer mode may allow a WTRU to transmit data PDUs earlier than connection oriented data transmission. Such data PDUs may be referred to as early data PDUs.

[0188] For example, a connectionless data transfer mode may (e.g. also) be used for downlink transmissions. For example, a WTRU may receive data PDUs in the same TTI with a paging message and/or along with the paging message itself. A network may trigger such connectionless downlink transfer, for example, when a WTRU location is known at a fine granularity and/or the size of the data packet is small.

[0189] A WTRU may trigger connectionless data transfer, for example, based on one or more of the following criteria: a service (e.g. low overhead service and/or a low latency service, etc.); a size of a packet (e.g. when the size of the packet is less than a predefined number of bytes); WTRU buffer occupancy (e.g. when a WTRU buffer size is less than a predefined number of bytes); latency experienced by the packet (e.g. when the packet exceeds latency budget); packet filtering (e.g. WTRU may be configured with a packet filter/TFT to identify packets matching specific criteria, such as IP address, protocol, port number, type of service, flow label and/or a preconfigured session ID); absence of valid/configured logical connection (e.g. EPS bearer/Radio bearer); type of PDUs (e.g. initial signaling messages may use connectionless); WTRU mobility state (e.g. when WTRU speed and/or number of reselections/HO per second exceeds a threshold, which may be used to limit the number of handovers for medium/fast moving WTRU); a WTRU category; and/or an access class.

[0190] For example, a WTRU may (e.g. always) trigger a connectionless transfer, e.g., by default and/or as configured by an access table. A WTRU may (e.g. subsequently) transition to connection oriented transfer, for example, based on WTRU and/or network procedures described herein.

[0191] A WTRU may determine L1 and/or L2 configuration for connectionless transfer, for example, using one or more of the following procedures: a WTRU may apply a default configuration; a WTRU may apply a predefined configuration acquired via system broadcast (e.g. access table and/or system signature based) that may be specific to a access control function, to a central control function and/or to a TRP or a group of TRPs; a WTRU may apply a stored configuration (e.g. received upon establishing central control plane context) that may be dedicated for a WTRU or a group of WTRUs where the same configuration may be used across one or more, or multiple TRPs; and/or a WTRU may (e.g. explicitly) request connectionless transfer and/or may obtain specific configuration that may include transmission resources (e.g. contention based/non-orthogonal resources, layer2 configuration, etc.).

[0192] A layer 2 configuration may (e.g. in addition to a physical layer time/frequency resource configuration) include a max data rate restriction, bucket size, RLC mode, PDPC discard timer, security algorithm, etc. For example, specific MAC instances may be configured for connectionless transfer.

[0193] One or more connectionless configuration parameters may be associated with a validity timer. A WTRU may start a validity timer, for example, upon receiving configuration parameters. A WTRU may consider configurations, for example, (e.g. only) when the timer is

running. A WTRU may delete/release configurations, for example, upon the expiration of a validity timer.

[0194] A WTRU may include additional context information with a data PDU, for example, to assist a network with processing and/or routing a data packet to an appropriate destination. Additional context information may be included, for example, in a layer 3 message and/or as a part of a layer 2 header field. For example, a layer3 message type may be defined to identify connectionless data. An IE (e.g. connectionless-data-IE) may be introduced in a layer 3 message (e.g. UL information transfer).

[0195] A WTRU may include one or more types of information as context information in an early data PDU.

[0196] For example, context information may comprise WTRU Identity information, which may comprise, for example, one or more of the following: an L3 identity that may have been allocated by a central control function during a previous interaction; an associated Identity of the central control function and/or an NAS level identity; an implicit indication of a portion of and/or a whole identity, e.g., using the selection of time/frequency resource; and/or a demodulation reference signal and/or unique word that may be a function of WTRU ID.

[0197] For example, context information may comprise a more data left indication and/or last PDU indication, which may indicate whether there are additional PDUs in WTRU buffer along with the early data PDU.

[0198] For example, context information may comprise one or more of: QoS related information, e.g., an indication to treat the early data PDU as a default QoS and/or as a non-default bearer data PDU; a low latency indicator, e.g., to allow a network to use low latency and/or an efficient data path; and/or a low overhead indicator, e.g., to allow a network to use a low overhead mechanism for transfer (e.g. a connectionless transport).

[0199] For example, context information may comprise application description and/or session related information, such as a predefined session ID, e.g., so a network knows which session a data PDU is associated with.

[0200] For example, context information may comprise forwarding/routing/transport layer information (e.g. a general packet radio service tunneling protocol (GTP) tunnel and/or a flow table entry and/or an index to flow table entry).

[0201] For example, context information may comprise security context information.

[0202] For example, context information may comprise destination ID, such as a control plane ID and/or a user plane entity ID, e.g., perhaps depending whether a PDU is a signaling PDU or data PDU.

[0203] For example, context information may comprise user plane entity ID (e.g. when one already exists to avoid signaling towards RAN control plane entity), for example, for a RAN and/or Core user plane entity.

[0204] For example, context information may comprise control plane entity ID (e.g. entity with a valid WTRU context including subscription, security, etc.), for example, for a RAN Control entity and/or a core (e.g. MME ID + WTRU ID within the MME service area).

[0205] For example, context information may comprise slice identity, e.g., when a WTRU is already configured with a specific slice for connectionless transfer.

[0206] A WTRU may receive and/or may process feedback for a connectionless data transfer, where processing may be different from a connection oriented data transfer. A WTRU may (e.g. implicitly) determine the resources for feedback, for example, as a function of UL time/frequency resources used for early data PDU transmission and/or as a function of WTRU ID included in the data PDU.

[0207] Feedback (e.g. for data transmitted using connectionless/early data transfer based mode) may be associated with additional information, including, one or more types of additional information.

[0208] For example, additional information may comprise a WTRU ID for which feedback is sent (e.g., copied from UL Data PDU), e.g., where WTRU may verify the WTRU ID present in the feedback before processing the feedback message.

[0209] For example, additional information may comprise a timing advance (e.g. for async/contention based UL).

[0210] For example, additional information may comprise a power control command.

[0211] For example, additional information may comprise an ACK/NACK, e.g., where additional resources may be granted for retransmission for NACK.

[0212] For example, additional information may comprise a collision/contention indication, e.g., when WTRU action is based on a contention indicator, such as one or more of: when WTRUs can be distinguished at eNB (e.g., by orthogonal DMRS) and/or when WTRU receives other WTRU IDs in the feedback, a WTRU may transmit at next opportunity; and/or when WTRU receives a contention indication, the WTRU may perform, for example, a random back off and/or fallback to connection based data transfer.

[0213] For example, additional information may comprise an indication to trigger access plane establishment and/or fallback to connection oriented mode.

[0214] For example, additional information may comprise additional UL resource grants and/or an Indication to go back to idle mode (and/or implicitly an ACK may be used to go back to idle mode), for example, depending on last PDU indication.

[0215] For example, additional information may comprise a request for WTRU identity and/or additional authentication procedure, e.g., when WTRU context might not be fetched and/or when WTRU may be unknown at the RCCF and/or the security check failure, etc., where a WTRU may respond to the authentication procedure and/or provide additional context information.

[0216] A WTRU may (e.g., in connectionless transfer mode) trigger a transition to connected oriented mode, for example, based on one or more of the following criteria and/or events: when a WTRU spends more than a predefined time in connectionless mode; when a WTRU receives a data packet with more than predefined number of bytes; when a WTRU transmits more than a predefined number of bytes in connectionless mode; when a WTRU buffer size exceeds a threshold; when a latency of buffered data exceeds a threshold; when a number of NACKs/retransmissions for an early data PDU exceeds a threshold; when a data rate over a predefined time window exceeds threshold; and/or when an activity timer exceeds a threshold, e.g., when an activity timer that may be (e.g. always) running when a WTRU enters connectionless transfer mode, where the activity timer may be reset to zero and started again, perhaps for example when the time between two consecutive packets exceeds a threshold.

[0217] For example, a WTRU may be configured to report one or more events. A network may determine whether to transition the WTRU to connection oriented mode. A WTRU may events, for example, using a control message and/or signal and/or piggyback indication in a connectionless data PDU. A network may (e.g., also) trigger a transition to connection oriented mode, for example, based on policies, type of services, WTRU subscription, WTRU mobility, etc. For example, a WTRU may transition from connection oriented mode to connectionless mode, for example, based on a network command (e.g., based on inactivity).

[0218] A user plane component may be (e.g., conceptually) represented as a transport path. A transport path may include, for example, one or more of the following: one or more Uu (which may be associated with a specific SOM and/or physical layer QoS) and/or a configuration thereof; a QoS profile (e.g., in terms of maximum latency, jitter, packet loss rate and/or the likes) and/or a configuration thereof; an association with one or more data flows and/or service (e.g., as indicated by a multiplexing function that may be based on logical radio bearer, tuples and/or a configuration thereof); routing table entries (e.g., in the network); a list and/or set of one or more

matching rules; and/or a list and/or set of one or more tuples (e.g., to determine what logical path a packet may be directed to).

[0219] A distributed control plane for NR may have functions and/or components, which may be discussed from the perspective of their different applicability.

[0220] For example, a WTRU-specific function may be associated with an anchor control function. An RCCF may manage connectivity of a WTRU with a core network (e.g., PDN connectivity, reachability, etc.).

[0221] For example, a component-specific function may operate on one or more aspects of a single instance of a component for a given WTRU.

[0222] For example, a plural-component function may operate on one or more aspects of one or more, or multiple instances of a component for a given WTRU.

[0223] For example, control functions may be associated with MAC instances that may (e.g. also) map to a set of access control functions.

[0224] For example, control functions may be associated with a single MAC instance.

[0225] System information may be acquired, for example, as a WTRU-specific function, as a component-specific function and/or as a plural-component function.

[0226] A component of System information acquired as a WTRU-specific function, for example may include, a cell, TRP, and/or TRPG and/or groups thereof (e.g. everything a WTRU may find useful). On-Demand procedures, including requests and/or combination with already known SysInfo (pre-provisioning and/or acquired) may be described. SysInfo split may be supported. Out-of-band SysInfo may be supported.

[0227] A component of system information acquired as a Component-specific function may be, for example, a cell and/or a TRP. SysInfo split may be supported. Out-of-band SysInfo may be supported.

[0228] A component of system information acquired as a Plural-component function may be, for example, one or more, or multiple cells, one or more, or multiple TRPs, one or more, or multiple TRPGs, and/or one or more, or multiple NR-eNBs, etc. SysInfo split may be supported. Out-of-band SysInfo may be supported.

[0229] System information may be acquired, for example, using one or more approaches and/or procedures.

[0230] For example, system information may be acquired by broadcast, e.g., similar to LTE.

[0231] For example, system information may be acquired by splitting information in a first set of information and in a second set of information. Such information may comprise one or more system parameters. Such split of information may be based on one or more characteristics

of the concerned information. Such characteristic may include whether or not the information is essential for accessing the concerned network resources, whether or not the information relates to a feature and/or function available using the concerned network resources, whether or not the information relates to a feature and/or function for low-latency access (e.g. URLLC), whether or not the information may enable specific UE procedures such as camping, measurements, and/or the like. Such first set may be further referred to as “Essential” information and/or such second set may be further referred to as “Non-essential” information. In some solutions, “Essential” information may be referred as Minimum-SI and/or “Non-essential” information may be referred as Other-SI. Such split may be network-controlled and/or vary from one area to another, where essential system information (if any) may be broadcast (e.g. to enable a WTRU to access the system and/or obtain further system information through dedicated resources. Broadcast information may comprise MIB, SIB1 (access-related information e.g. PLMN, TAC, CellID, p-Max, frequency band indicator), SIB2 (access barring information, RACH parameters, UL power control). The amount of broadcasted system information may vary (e.g., depending on the split between “Essential” and “Non-essential” information). For example, the amount of system information included in the broadcast may be one or more of the following: no broadcasted system information (e.g., pre-provisioning, acquired, and/or on-demand); MIB; MIB + SIB1; MIB + SIB1 + SIB2; (v) MIB + SIB1 + SIB2 + combination of remaining SIBs (e.g., SIB3 may be broadcasted to support cell reselection, etc.); and/or other combinations of “Essential” and “Non-essential” information. In some examples, there may be no “Essential” system information broadcasts. On-demand (dedicated) information may comprise obtaining remaining system information through dedicated resources (e.g. triggered through PRACH), where, on-demand acquisition may be based on a service (e.g. camping/paging etc.), WTRU capability, slice, etc.

[0232] For example, system information may be acquired by splitting information across broadcast and dedicated transmissions. A split may be network-controlled and/or may vary from one area to another. A flexible mechanism may be provided to support variable split between broadcast and dedicated information.

[0233] For example, system information may be acquired by system information modification, which may provide one or more mechanisms, for example: to update the delta, whether pushed and/or on-demand (e.g. WTRU-initiated and/or NW-initiated by control signaling ordering WTRU to start the procedure); and/or to request a specific element of system information (e.g. SIB).

[0234] For example, system information may be acquired by variable acquisition, for example, based on location and/or frequency band (e.g. system information applicable in one location and/or for one carrier may be received in different locations and/or carrier).

[0235] Broadcast information may include specific information components related to specific services, such as a configuration for low latency access and/or for connectionless data transfers.

[0236] Essential information may be broadcast. Essential information may include, for example, MIB, SIB1 (access-related information e.g. PLMN, TAC, CellID, p-Max, frequency band indicator), SIB2 (access barring information, RACH parameters, UL power control). A WTRU may acquire broadcast system information and/or may request further system information, e.g., using an on-demand procedure.

[0237] More information (e.g. beyond essential information) may be broadcast, for example, based on capacity/load. For example, more system information may be broadcast, for example, perhaps when the system has the capacity and broadcast capacity is limited. A WTRU may acquire broadcast system information and/or may request further system information, e.g., using an on-demand procedure.

[0238] System information may be modified (e.g. changed and/or updated). For example, system information modification may be triggered by paging for WTRUs in RRC_IDLE and/or WTRUs in RRC_CONNECTED. A WTRU (e.g. when WTRU receives notification of system information modification) may identify a delta and/or may acquire modified/new system information, for example, by one or more procedures, such as broadcast (e.g. when a delta is broadcast) and/or on-demand (e.g. when a delta is not broadcast).

[0239] Variable acquisition may be based on location and/or frequency band. For example, deployment scenario may include macro and/or micro, wherein system information (e.g. for the macro and/or micro) may be broadcast over the macro. A WTRU may (e.g. when not in coverage of a macro) acquire system information from a micro.

[0240] System information may be variable portioned. Essential system information (if any) may be broadcast, for example, to enable a WTRU to access the system. A WTRU may acquire further system information through dedicated resources.

[0241] For example, more than essential system information (if any) may be broadcast, for example, when the system has significant excess capacity, when many WTRUs are acquiring system information and/or when a use arises to broadcast new system information that is essential for system access. It may be beneficial to support acquisition procedures allowing a variable/dynamic split between broadcast and on-demand information acquisition.

[0242] System information may be grouped and/or may be controlled, for example, by different logical functions, e.g., based on periodicity, latency, feature, etc.

[0243] In one or more groupings, a default set may comprise, for example, information that may be essential for system access, camping, mobility, etc. Essential information may comprise, for example, common and shared channel information (e.g., similar to MIB, SIB1, SIB2 in LTE). Essential information may comprise, for example, cell selection/re-selection information (e.g. similar to SIB3, SIB4, SIB5(E-UTRA), SIB6(UTRA), SIB7(GERAN), SIB8(CDMA2000) in LTE).

[0244] In one or more groupings, a common set may comprise, for example, information that may be required by most devices, such as one or more of the following: HNB name (e.g. similar to SIB9 in LTE); ETWS (Earthquake and Tsunami Warning System) primary notification (e.g. similar to SIB10 in LTE); ETWS secondary notification (e.g. similar to SIB11 in LTE); and/or Commercial Mobile Alert System (CMAS) warning notification (e.g. similar to SIB12 in LTE).

[0245] In one or more groupings, a feature set may comprise, for example, information that may be required for particular features/device categories, such as one or more of the following: MBMS (e.g. similar to SIB13 in LTE); extended access barring for access control (e.g. similar to SIB14 in LTE); mobility procedures for MBMS reception (e.g. similar to SIB15 in LTE); GPS time and UTC time (e.g. similar to SIB16 in LTE); for traffic steering between E-UTRAN and/or WLAN (e.g. similar to SIB17 in LTE); sidelink communication (e.g. similar to SIB18 in LTE); sidelink discovery (e.g. similar to SIB19 in LTE); and/or SC-PTM e.g. similar to SIB20 in LTE.

[0246] For example, a WTRU may receive System Information (SI) applicable to a cell/TRP (and/or similar) and/or to a plurality thereof. A WTRU may receive SI, for example, by broadcast transmissions and/or by dedicated transmissions. For example, a WTRU may receive SI applicable to a cell/TRP on a transmission, for example, using resources associated with a different cell/TRP. SI applicable to a cell/TRP may include a (e.g. first) portion that may correspond to a (e.g. first) set of functions (e.g. access parameters, location tracking, WTRU-autonomous mobility related parameters, signature detection/measurement) and/or a (e.g. second) portion that may correspond to a (e.g. second) set of functions (e.g. supported features, supported services, etc.). The set of functions included in a (e.g. one or more, or each) portion may be a configuration aspect of the system and/or may be explicitly indicated in the corresponding transmission. Additional information may be included, for example, to indicate whether there is further SI (e.g. a second portion) applicable and/or the identity/type of further available SI (e.g. a bitmap representing the different SIBs). Additional information may, for example, include an indication whether a WTRU is required to acquire remaining information

(e.g. one or more, or all remaining SIBs) and/or a subset thereof (e.g. SIB-based indication), which may be accompanied by an indication of an applicable procedure (e.g. DL broadcast and/or using an on-demand mechanism). Additional information may include a validity criteria for the SI.

[0247] For example, a WTRU may acquire SI for a cell, for example, using a broadcasting channel. A WTRU may (e.g. further) perform an initial access, e.g., to establish connectivity with the access network (e.g. ACP and/or RCCP). A WTRU may (e.g. subsequently) receive SI for one or more cell(s), TRP(s), etc. (e.g. similar and/or the like), for example, using a (e.g. dedicated) transmission such as a reconfiguration procedure. SI may be indexed, for example, using a characteristic associated with a reference signal (e.g. a signature, a positioning signal, etc.) that may be applicable. SI may be indexed, for example, for one or more, or each of the concerned cell(s)/TRP(s) and/or TRPGs. An SI may include (e.g. only) a portion of the information associated with a cell/TRP, such as access parameters. A WTRU may (e.g. subsequently) detect a reference signal associated with a configured SI. A WTRU may perform acquisition of further SI, for example, from a downlink broadcast channel (e.g. when applicable) and/or by initiating an access using the access parameters that are part of the configured SI for the concerned cell/TRP and/or detected reference signal / signature.

[0248] Additional SI may be acquired immediately. For example, a WTRU may initiate reception of broadcast system information, for example, when it determines that a broadcast channel may be available. A WTRU may initiate a procedure to request activation of a broadcast channel. A WTRU may (e.g. when it cannot receive broadcast SI using resources associated with the cell/TRP) initiate an access, for example, using access parameters that may be part of a configured SI for a concerned cell/TRP and/or detected reference signal/signature. A WTRU may initiate a procedure to request remaining SI for the concerned cell/TRP using dedicated resources thereof.

[0249] Additional SI may be acquired immediately, for example, when instructed and/or configured to do so. For example, a WTRU may initiate reception of broadcast system information, for example, when the WTRU determines that it is required (e.g. based on information in a first portion of the configured SI) to initiate such a procedure upon detection of a suitable reference signal (e.g. corresponding to a “known”/configured signature and/or received with sufficient power). A WTRU may use an applicable SI acquisition procedure, e.g., when configured.

[0250] Additional SI may be acquired on demand. A WTRU may acquire system information, for example, through dedicated resources (e.g. triggered through PRACH). On-demand acquisition may be based on service, WTRU capability, slice, etc.

[0251] A WTRU may initiate on-demand acquisition of additional SI, for example, after initial access. A WTRU may request a default set of SI messages, for example, based on WTRU capability and/or based on previously used services.

[0252] A WTRU may initiate on-demand acquisition of additional SI, for example, when a WTRU initiates new services. A WTRU may request additional SI messages, for example, when the associated SI messages have not already been acquired.

[0253] A WTRU may initiate on-demand acquisition of additional SI (e.g. specific SI messages), for example, when a WTRU determines that stored SI messages are no longer valid, e.g. upon receiving a modification indication for one or more SI messages and/or upon receiving an unknown system signature.

[0254] A WTRU may initiate on-demand acquisition of additional SI, for example, based on expiration of a timer. A timer may be associated with the validity of stored system information.

[0255] In a WTRU terminated example, a WTRU may (e.g. at reception of service requests) request additional SI messages, for example, when associated SI messages have not already been acquired.

[0256] In a WTRU terminated example, a WTRU may receive control signaling (e.g. paging/PDCCH-order) that may trigger an acquisition/update. The procedure may be included in the signaling/order. Signaling may provide an indication of an applicable information component (e.g. one or more components to be updated).

[0257] For example, a WTRU may activate transmission of system information, for example, by transmitting an uplink signal. An uplink signal may be transmitted in resources that may be reserved for system information activation. For example, a specific time/frequency resource and/or a UL physical channel may be reserved for system information activation. In an (e.g. another) example, a WTRU may transmit a reserved RACH preamble, for example, to indicate a system information activation request. In an (e.g. another) example, a WTRU may transmit a UL signal on an asynchronous resource that may be reserved for system information activation. UL resources for system information activation may be specific to a TRP, a group of TRPs and/or a MAC instance. A WTRU may use a system information activation procedure, for example, to indicate interest in acquiring system information. WTRU identification by the network may be optional during a system information activation procedure.

[0258] A WTRU may receive configuration for system information activation at different levels of granularity. For example, a WTRU may trigger different system information transmission behavior from a network based on UL signal type, UL resource selection, UL preamble selection, etc. Transmission behavior may include transmitting (e.g. only mandatory) system information, transmitting system information belonging to a specific slice, transmitting specific group of system information, etc. Transmission behavior may be, for example, one shot (e.g. for one or more, or each activation request one instance of the associated system information may be transmitted) and/or multi-shot (e.g. for one or more, or each activation request one or more, or multiple instances and/or repetition of the associated system information may be transmitted). For example, UL resources may be, for example, specific to a TRP and/or common to a group of TRPs. A WTRU may trigger TRP specific system information and/or TRP group specific system information, for example, based on the corresponding selection of UL resource.

[0259] The terms system information request and Other-SI request may be used interchangeably. For example, a WTRU may transmit a (e.g. an explicit) request message to trigger system information transmission. For example, a request message may include WTRU identity and/or type of system information requested. For example, a network may trigger security procedures, e.g. authentication as a response to a system information request procedure. A procedure may enable secure delivery of system information message. For example, a WTRU may acquire common system information via broadcast and/or activation procedure. A WTRU may (e.g. for slice specific system information) trigger a system information request procedure. A WTRU may (e.g. be required to) establish an access control plane, for example, to trigger a system information request message. For example, a WTRU may transmit its capability information (e.g. along with a system information request), for example, so a network may provide (e.g. only) the system information applicable for a WTRU capability.

[0260] For example, a WTRU may piggyback an SIB request together with a control signaling procedure. A WTRU may (e.g., implicitly) indicate a desire and/or usefulness for system information, for example, by transmitting additional indication with the control signaling procedure. For example, a WTRU may transmit a system information request bit/bitmap (e.g., along with a service request procedure), for example, to indicate a desire and/or usefulness for system information for that procedure. For example, a WTRU may include a value tag (and/or value identifier) associated with stored system information (e.g., along with a control procedure), for example, so a network may provide additional system information, e.g., when the value tag

doesn't reflect the latest system information. A WTRU may trigger a control procedure, for example, by requesting system information associated with a control procedure.

[0261] A WTRU may trigger an other-SI request (e.g., towards a serving cell) to obtain other-SI associated with a neighbor cell. A WTRU may include identity and/or information associated with the neighbor cell (e.g., physical cell ID, EARFCN, global cell ID, and/or parts of MIB etc.) in the other-SI request. A WTRU may include a reference ID and/or a value tag of the neighbor cell in the other-SI request. A WTRU may include more than one neighbor cell identity in a single other-SI request message (e.g., to obtain other-SI for one or more, or multiple neighbor cells in a single procedure). Neighbor cell SI acquisition may be useful for the WTRU to perform autonomous mobility decisions towards that neighbor cell.

[0262] A WTRU may trigger an other-SI request to obtain other-SI associated with one or more beams. A WTRU may include identity and/or information associated with the beam, (e.g., beam ID, a reference signal associated with the beam, and/or parts of MIB in the beam etc.), in the other-SI request. A WTRU may include more than one beam identity in an other-SI request message to obtain other-SI for one or more, or multiple beams (e.g., in a single procedure).

[0263] A WTRU may include information about the stored SI in the other-SI request. For example, a WTRU may indicate the version and/or validity tag of SI stored in the WTRU memory during the transmission of other-SI request. The network may transmit (e.g., only) the delta and/or updated portion of the other-SI. Signaling overhead and/or acquisition time associated other-SI may be reduced.

[0264] A WTRU may include additional information in the other-SI request to request characteristics of other-SI broadcast. For example, a WTRU may indicate one or more aspects related to downlink signal quality in the other-SI request. Such indications may be used by the network to adapt the periodicity, for beamforming, for repetition, and/or MCS for the other-SI broadcast transmission. For example, a WTRU may indicate the desire and/or usefulness for more repetition and/or robust MCS when in a poor condition (e.g., cell edge and/or high path loss conditions). Also, as an example, a WTRU may indicate such a request based on a preamble selection, RACH resource selection, in the message portion of an enhanced RACH format, and/or in a field in a msg3 carrying other-SI request.

[0265] A WTRU may trigger a system information request procedure in any state (e.g., idle, inactive, and/or connected). A WTRU may or might not transition to a connected state to acquire the other-SI. A WTRU may perform a system information request by for example using a dedicated resource and/or a contention based resource.

[0266] A WTRU may be configured with one or more rules for transmission of on-demand system information request that may be saved in memory as instructions executable by a processor. A WTRU may trigger (e.g., only) if one or more of the following conditions are satisfied. An example condition for triggering an on-demand system information request may be the status of essential SI. For example, a WTRU may request for other-SI (e.g. only) when the WTRU has up to date essential system information. A WTRU may abort any ongoing other-SI request if it determines a change in essential SI. A WTRU may acquire the essential SI and/or reacquire the other-SI according to the updated essential SI.

[0267] An example condition for triggering an on-demand system information request may be the absence of required information. For example, a WTRU may determine that the system information transmitted in the essential SI is not sufficient (e.g., for a specific procedure and/or operation in a WTRU state). A WTRU may determine that system information stored in the WTRU (e.g., based on previous other-SI request procedure and/or based on network assistance) is not sufficient (e.g., for a specific procedure and/or operation in a WTRU state). A WTRU may trigger other-SI request when a new procedure is triggered/started (e.g., for which the WTRU does not have a valid and/or stored SI associated with such procedure). For example, a WTRU may start a procedure, which may require operation in a numerology/SOM different from the current numerology/SOM. A WTRU may trigger an other-SI request to obtain system information relevant for the new numerology/SOM and/or may request system information for a specific numerology/SOM. For example, a WTRU may implicitly indicate request for a specific numerology/SOM based on the choice of resources (e.g. time/frequency or preambles) for other-SI request.

[0268] A WTRU may be preconfigured (e.g., saved in memory) with the list of SIs required for the supported procedures and/or operation in a WTRU state.

[0269] An example condition for triggering an on-demand system information request may be the absence of broadcast Other-SI; a WTRU may determine that the other-SI is not broadcasted. For example, a WTRU may determine the presence of other-SI based on scheduling information in the essential SI. For example, a WTRU may trigger other-SI request if a WTRU may determine that the broadcast of other-SI is stopped before the WTRU can acquire the required other-SI and/or if a WTRU determines that one or more specific other-SI required by the WTRU is not present in the current schedule of other-SI broadcast.

[0270] An example condition for triggering an on-demand system information request may be the support/presence of the other SI. For example, a WTRU may trigger the request for other-

SI if (e.g., only if) transmission of such other SI is supported by the network. For example, a WTRU may determine the support of specific type of other-SI from the essential SI.

[0271] An example condition for triggering an on-demand system information request may be the WTRU not being prevented by access control from making such a request. For example, a WTRU may belong to one or more of many access classes. A WTRU may determine (e.g., may be required to determine) if requesting other-SI is not forbidden for its access class. For example, such forbidden access class for other-SI request may be broadcasted as a part of essential SI.

[0272] An example condition for triggering an on-demand system information request may be the presence of UL resources for other-SI request(s). For example, a WTRU may determine and/or receive the configuration of UL resources for system information request procedure. The configuration may include, e.g. UL RACH resources, RACH formats (e.g. including enhanced RACH formats).

[0273] An example condition for triggering an on-demand system information request may be the WTRU detecting change/update of other-SI and/or when WTRU determines the stored other-SI is invalid: a WTRU may monitor for the change in other-SI via signaling in broadcast message (e.g., MIB and/or essential SI and/or a paging message). A WTRU may monitor a change only for other-SI that are acquired and/or stored by the WTRU. A WTRU may receive the signaling indicating whether the modified other-SI is broadcasted and/or whether a system information request procedure is desired and/or useful. A WTRU UE may trigger other-SI request (e.g., only) if so indicated by the network. For example, a WTRU may apply stored other-SI instead of request for other-SI, upon determining the validity tag and/or similar matches (e.g., substantially corresponds) with the stored SI.

[0274] An example condition for triggering an on-demand system information request may be the discovery of a neighbor cell. For example, a WTRU may trigger other-SI request upon discovery of a neighbor cell for which the WTRU does not have a valid and/or stored system information. The WTRU may trigger an other-SI request based on quality of neighbor cells being above (or below) a predefined threshold.

[0275] A WTRU may start a timer A and/or a timer B (e.g., where timer A time > timer B time), when the first other-SI request message is transmitted. A WTRU may stop timer A and/or timer B when the WTRU completes the acquisition of other-SI. Upon expiry of timer B, a WTRU may retransmit the other-SI request message and/or restart timer B. A WTRU may be configured with a predefined number of retransmissions to acquire the other-SI until expiry of timer A. Upon expiry of timer A, a WTRU may consider the cell to be barred for a predefined

duration (e.g., not use that cell). While timer B is running, a WTRU may monitor for the presence and/or scheduling of other-SI via a broadcast signaling (e.g., minimum SI, paging message, and/or via unicast signaling via downlink control channel).

[0276] As a step (in msg1), a WTRU may transmit a reserved RACH preamble to request system information. For example, such reserved RACH preambles may be used to indicate a specific system information block and/or group thereof, indicate the WTRU state (e.g., RACH preambles are associated to a WTRU state), indicate the system information for a type of service and/or group thereof, indicate aspect related to timing/latency for acquiring system information, and/or indicate that WTRU may perform data transmission following acquisition of system information.

[0277] A WTRU may be configured (e.g., programmed with executable instructions by a processor) to transmit an enhanced first message and/or msg1 for requesting other-SI. A WTRU may, in addition to a preamble portion in the enhanced first message, may include additional bits in a message portion. A WTRU may be configured (e.g., programmed with executable instructions by a processor) with predefined relations (e.g., in time and/or frequency between the preamble portion and message portion). A WTRU may indicate a request for other SI (e.g., based on a selection of a preamble sequence). A WTRU may indicate a specific type/group of other-SI requested (e.g., based on the reserved identity in the message portion). For example, a WTRU may transmit a preamble from a common pool and/or indicate the request for other-SI and/or specific type of other-SI (e.g., using the reserved identity in the message portion). A WTRU may be preconfigured (e.g., programmed with executable instructions by a processor) with the mapping of reserved identities to the types of other-SI. One or more WTRU identities may be reserved for such purpose. A WTRU may receive the configuration of reserved identity usage from minimum SI. The preamble may indicate the request for other-SI and/or the message portion may indicate connection establishment cause. A WTRU may be configured (e.g., programmed with executable instructions by a processor) to receive other-SI associated with a specific connection establishment cause, save such information and/or execute such received instructions. A WTRU may fallback to a normal msg1 (e.g., without message portion) if the retransmission of enhanced msg1 exceeds a threshold.

[0278] A WTRU may be configured to monitor for the MSG2 containing a response to the other-SI request. For example, a WTRU may be configured to monitor for a temporary identifier (e.g. a RNTI) specific to the other-SI request. For example, the temporary identifier may include a component specific to the other-SI request and/or the time/frequency and/or the preamble resource used for the other-SI request. For example, a WTRU may be configured to monitor a

(e.g., single) temporary identifier that may be predefined for one or more, or all, other-SI requests, perhaps irrespective of the time/frequency/preamble resources used for the other-SI request transmission.

[0279] A WTRU may be configured to process the received MSG2, perhaps for example in response to an other-SI request. For example, the MSG2 format may be specific to the other-SI request, perhaps indicated by a separate type field. For example, the MSG2 response to the other-SI request may include the identity of the preamble associated with the other-SI request and/or may directly include an indication of the other-SI type. For example, the MSG2 might not include the timing advance, UL grant, and/or temporary identity. The MSG2 may include a bitmap of one or more, or all, the other-SI types that may be transmitted in an upcoming other-SI window.

[0280] A WTRU may be configured to process one or more MSG2 within a predefined time window, perhaps for example to determine the transmission status of one or more other-SI types. This may occur irrespective of whether the MSG2 corresponds to the MSG1 transmitted by the WTRU. The predefined time window may be configured, for example, in the minimum SI. The predefined time window may be related to the SI window of the SI being requested (e.g. a number of frames/subframes prior to the start of the SI window). This may be useful for the WTRU to determine one or more other-SI windows that may contain other-SIs of interest to the WTRU. This may include one or more other-SIs of interest for which the WTRU might not have been able to transmit the other-SI request. For example, a WTRU may be configured to monitor and/or process MSG2, perhaps until the WTRU receives the MSG2 including the response to requested other-SI and/or interested other-SI, and/or until the end of a predefined time window.

[0281] A WTRU may be configured to receive a MSG2 that may include a response to normal access by other WTRUs and/or a response to other SI request(s). The WTRU may distinguish the different responses in the same MSG2, perhaps for example based on the RAPID (ID of the RACH preamble). The WTRU, perhaps for example depending on whether it has performed access and/or SI request, may read the RAR (e.g., only the RAR) associated with the RAPID for which it transmitted a MSG1 (e.g., preamble).

[0282] A WTRU may be configured (e.g., programmed with executable instructions by a processor) with one or more actions/behaviors based on reception on a second message as follows. If no response is received by the WTRU (e.g., msg2 was not received), and/or the requested system information has not been received either through broadcast and/or through dedicated signaling within a certain period, the WTRU may re-transmit the system information request in msg1. If a WTRU receives the response in msg2, with indication that the requested

system information is not available, and/or no further system information is available, the WTRU may perform no further actions for this procedure. The WTRU may receive a response in msg2. The response in the msg2 may indicate whether the WTRU should request in msg3 the specific SI the WTRU wants. For example, the WTRU may receive an indication that some or all other SI will be broadcast by the network, in which case the WTRU will not transmit msg3, and/or an indication that may instruct the WTRU to transmit msg3 with the specific other-SI to be requested.

[0283] If a WTRU receives the response in msg2, with indication that the requested system information will be broadcast, the WTRU may obtain the scheduling information from the "Essential" system information and/or may acquire the applicable system information from the broadcast. These approaches may provide power savings and/or signaling overhead reduction (e.g., WTRUs in Idle mode or Inactive mode can acquire the system information while remaining within the respective state).

[0284] If a WTRU receives the response in msg2, with scheduling information of the requested system information, the WTRU may acquire the broadcasted system information using the scheduling information included in msg2. The WTRU may acquire the system information faster instead of obtaining the scheduling information from the next broadcasted "Essential" system information and then acquire the application system information.

[0285] If a WTRU receives the response in msg2, with an entry/index to the access table, the WTRU may retrieve the applicable system information from the access table. The WTRU may have low latency and/or resource efficiency since the WTRU had previously already acquired the access table.

[0286] If a WTRU receives the response in msg2, with timing advance, grant and/or indication to transition to the connected state in order to acquire the system information, the WTRU may transition to the connected state and acquire the system information using dedicated resources. The WTRU may have resource efficiency (e.g., when few WTRUs are requesting system information/accessing the system). The WTRU may have indicated (e.g., based on the selection of the reserved RACH preamble) that data transfer may occur after acquisition of system information.

[0287] A WTRU may receive the response in msg2 (e.g., the msg2 may carry complete and/or parts of other-SI). For example, a msg2 may schedule DL time/frequency resources that carry other-SI. DL resources may be either multiplexed in the same TTI as the msg2 and/or at an offset from the TTI carrying msg2.

[0288] A WTRU may be configured to monitor the minimum-SI after transmission of other-SI request (e.g., for a pre-defined time interval). A WTRU may determine the scheduling configuration for broadcast of other-SI transmission based on the received minimum-SI.

[0289] A WTRU may be configured to monitor a paging message after transmission of other-SI request (e.g., for a pre-defined time interval). A WTRU may determine the scheduling configuration for broadcasting an other-SI transmission based on the received paging message.

[0290] A WTRU may transmit the Other-SI request in a MSG3. For example, a WTRU may be configured to transmit an other-SI request in MSG3, perhaps for example if no RACH resources are configured for the specific other-SI and/or combinations of other-SIs desired by the WTRU. A WTRU may be configured to use a specific RACH resource to transmit an other-SI in MSG3. A WTRU may be configured to utilize one or more, or any, RACH resource to initiate the procedure for other-SI in MSG3. The WTRU may select a RACH resource which has a specific timing relation (e.g., configured and/or specified/static) in relation to the SI window of the other-SI that may be requested. For example, the WTRU may perform an other-SI request by utilizing one or more, or any, RACH resource associated to a subframe/frame which may occur a certain time, and/or within a certain window, prior to the start of the SI window associated with the other-SI being requested. This can also be applicable for other-SI requests made using the techniques that use the MSG1.

[0291] A WTRU may indicate the reason for message3 transmission in msg1 (e.g., using either RACH resource/preamble resource selection and/or using an indication in the message portion of enhanced msg1). A WTRU might not provide any indication in msg1. A WTRU may utilize the grant received in msg2 for the transmission of other-SI request in msg3. The other-SI request may be an RRC message. A WTRU may receive msg4 as a response. The msg4 may be a RRC message carrying other-SI. The msg4 may carry an indication of whether the WTRU wishes, desires, and/or may find useful, to transition to a connected state or stay in the current state (e.g., idle, inactive etc.). Using RRC message for other-SI request may support Other-SIs (e.g., that could be introduced).

[0292] The WTRU may transmit the other-SI request in a msg3 and/or receive in msg4 information (e.g., information for obtaining other-SI). The information could include, for example, an RNTI to be used to receive the other-SI, time/frequency information about where to look for the other-SI (e.g., a specific subband of the control and/or data channel), validity information and/or validity tag associated with other-SI, and/or other parameters required to allow the WTRU to decode and/or receive the other-SI once it is transmitted. The WTRU may receive other-SI following reception of msg4 using the received information.

- [0293] A WTRU may use multi-stage RACH for an other-SI request.
- [0294] A WTRU may transmit a request for other-SI with one or more, or multiple RACH transmissions and/or transmissions on contention-based resources.
- [0295] For example, a WTRU may transmit a first RACH preamble to indicate the desire for other-SI, and/or the WTRU may use a subsequent RACH preamble to request the other-SI that should be transmitted. In the transmission of the preamble (e.g., first preamble and/or in the transmission of the subsequent preamble), a WTRU may use the selected preamble and/or the resources on which the preamble is transmitted (e.g., to indicate the desire for other-SI and/or the specific other-SI being requested).
- [0296] The potential collision of msg3 transmissions by one or more, or multiple WTRUs transmitting other-SI requests simultaneously when a WTRU requests specific SI to be transmitted using msg3 may be avoided. The network broadcast of some or all the other-SI (e.g., if only a single preamble was used to request some or all other-SI in msg1) may be avoided.
- [0297] A WTRU may use an initial RACH transmission.
- [0298] A (e.g., first) RACH transmission may be performed using a preamble and/or on a PRACH resource (e.g., which is dedicated for initiating a multi-stage RACH procedure for other-SI request). This may be determined by the WTRU from broadcast signaling (such as in the Minimum SI) and/or preconfigured in the WTRU. The WTRU may initiate a multi-stage MACH transmission for other-SI request by selecting the dedicated preamble and/or RACH resource configured for such purpose and/or performing the RACH transmission (e.g., first RACH transmission).
- [0299] A WTRU may be programmed with a processor with instructions for responding to a response to a RACH transmission (e.g., initial RACH transmission).
- [0300] A WTRU may receive, in msg2, following a RACH transmission (e.g., initial RACH transmission), an indication of the presence of additional RACH resources and/or contention-based resources for transmitting request for other-SI. An indication may also include configuration information of the RACH resources, such as a preamble and/or resources to be used; mapping between preamble and/or resources and the other-SI to be requested; timing information related to the validity of the RACH resources and/or contention-based resources; timing information related to the reception of the other-SI; and/or C-RNTI and/or other identifier to be used for monitoring transmission of the other-SI.
- [0301] A WTRU may receive an indication of whether to request other-SI using a second stage of RACH transmission and/or a transmission on contention-based resources and/or whether the WTRU should expect to receive other-SI (e.g., some or all other-SI) following the

transmission of the RACH transmission (e.g. initial RACH transmission). For example, an msg2 message may indicate that additional RACH resources for indication of the other-SI requested will not be provided and/or the WTRU should receive some or all other-SI based on scheduling information of the other-SI, which the WTRU may have determined in the minimum SI.

[0302] A WTRU may have a processor programmed with instructions for determining RACH resources for second stage RACH transmission.

[0303] The WTRU may be configured (e.g., following transmission of the first RACH) with additional RACH resources and/or with contention-based resources (e.g., for indicating the specific other-SI being requested by the WTRU). The configuration of the additional RACH resources and/or contention-based resources used for requesting other-SI may be determined by the WTRU based on one or more of: msg2, preconfigurations and/or configurations of minimum SI, function of identity, and/or function of timing.

[0304] For received in msg2 configurations, the WTRU may receive a configuration of resources and/or preambles from the network in msg2 following transmission of a RACH transmission (e.g., initial RACH transmission). The configuration may be provided as an index into a table of specific RACH resources and/or preamble configurations known to the WTRU. The WTRU may receive several such indices representing one or more, or multiple configurations. The WTRU may receive the resources to use for the subsequent RACH transmission through an explicit grant. The grant may be accompanied by an indication that the grant is for transmission of a preamble identifying the other-SI being requested.

[0305] For preconfigurations and/or configurations of minimum SI, the WTRU may be pre-configured and/or configured by minimum SI to use defined RACH resources and/or RACH preambles for the other-SI. The WTRU may assume such resources are enabled/validated upon reception of an indication (e.g., RACH resources/RACH preambles activated). The indication may be received by the WTRU in msg2 and/or in a message in a separate PHY control channel.

[0306] For function of identity, the WTRU may determine the configuration of resources (time/frequency) for the second stage RACH resources based on an identity. The identity may be the cell identity, WTRU identity (e.g., temporary and/or provided in msg2), and/or network identity.

[0307] For function of timing, the WTRU may determine the configuration of resources (time/frequency) from the timing of msg2 reception and/or msg1 transmission. For example, the time location of the activated RACH resources may be configured as a predefined pattern of resources, which is offset from msg2 reception time by a specific amount.

[0308] The WTRU may map preamble/resources in second stage to other-SI.

[0309] The WTRU may indicate the other-SI it is requesting (e.g., through the selection of the preamble) including the preamble sequence and/or other transmission characteristics of the preamble such as preamble length, numerology, and/or power. The WTRU may select a preamble based on the other-SI that the WTRU requires. The WTRU may randomly select a time/frequency resource for transmitting the selected preamble.

[0310] The WTRU may indicate the other-SI being requested through the selection of the resources used for transmission of the preamble from the set of RACH resources available for transmission of the second stage RACH. For example, the WTRU may determine the other-SI it requires to request and/or may select a resource from the set of configured time/frequency resources, which corresponds to the specific other-SI being requested. The WTRU may (e.g., randomly) select a preamble to transmit on that specific resource.

[0311] The WTRU may indicate the other-SI requested through a combination of the selection of preamble and resources. For example, a combination of a specific preamble and a distinct resource on which that preamble is transmitted may indicate the request for a specific SI.

[0312] Specific combinations of preamble and resources may be reserved for the WTRU to request one or more, or multiple other-SI and/or a set of SIBs (e.g., a set of SIBs and/or SI related to a specific feature).

[0313] The mapping between resources/preamble and specific other-SI (e.g., SIB and/or SI message) may be determined by the WTRU based on one or more of: reception of the mapped information in the minimum SI (e.g., the information related to the other-SI which is provided in minimum SI may provide such mapping); a preconfiguration and/or a fixed definition; a WTRU category (e.g., a WTRU of one category may have a different mapping compared to a WTRU of a different category); stored information (e.g., the WTRU may have stored mapped information from the same or a different cell's broadcast and/or may determine that such information is still valid); and/or specific ordering (e.g., the WTRU may assume one or more, or each other-SI (e.g., SIB number) corresponds to a preamble and/or a resource in increasing order). For specific ordering, the WTRU may associate a specific starting preamble and/or resource to the first SIB, which may be requested as other-SI, and/or the next SIB may use the next preamble and/or resource, etc. based on some ordered numbering. The SIB numbering may further be based on the SIBs that the cell has available. Availability information can be determined by the WTRU in the minimum SI.

[0314] The mapping of resource/preambles and other-SI requested by the WTRU may depend on information provided by the WTRU in the RACH transmission (e.g. initial RACH transmission). For example, the WTRU may have provided, (e.g., in the initial RACH

transmission), some information pertaining to the other-SI that the WTRU would request in the second RACH transmission. The WTRU may provide a subset or a group of the other-SI in the initial RACH transmission. The WTRU may have provided this information through the specific preamble, resource selected in the initial RACH transmission, and/or using a RACH procedure (e.g., 2-step RACH procedure whereby additional data was transmitted along with the preamble). The WTRU may determine the mapping of the preamble and/or data to use and/or the other-SI requested using the second stage RACH transmission based on the subset or group which was selected in the first stage. For example, in case the preambles and/or resources are based on a specific ordering, the ordering may be applied (e.g., only) to the subset or group indicated by the WTRU in the first RACH transmission.

[0315] A WTRU may have a processor configured with executable instructions for the validity of second-stage RACH resources.

[0316] The resources for transmission of the second-stage RACH for request of other-SI may have a specific validity time. For instance, the WTRU may assume such resources are available upon reception of msg2 and/or upon transmission of msg1. Such resources may then be valid for a finite period of time following message receipt. A WTRU may assume the validity of received and/or enabled/validated resources based on a timer. For example, a WTRU may set a timer upon reception of msg2 with RACH resource activation indication and/or may (re)transmit other-SI requests using the configured RACH resources until expiry of a timer.

[0317] A WTRU may perform requests for other-SI using transmission of one or more, or multiple preambles in different RACH resources (e.g., in order to request different (e.g., possible sets of) other-SI). For example, a WTRU may transmit a specific preamble for one or more, or each, of the other-SI (e.g., SIB and/or SI message) used (e.g., required) by the WTRU and/or may continue to perform one or more, or all, preamble transmissions until the expiry of validity of the second-stage RACH preambles and/or until it may have received some or all of the required other-SI.

[0318] Distinct WTRUs may be programmed to transmit one or multiple requests for other-SI through regularly-occurring RACH resources, which may be temporarily reserved and/or configured for such by the network. Upon expiry of the timer, the network may then re-use such resources for normal scheduling. The configuration of RACH resources for the purposes of other-SI request will be provided (e.g., only) during the periods of time where the network knows there will be WTRUs using them (as a result of transmission of the first RACH by one or more WTRUs).

[0319] A WTRU processor may be programmed for retransmission of other-SI requests.

[0320] A WTRU may be configured with one or more retransmissions upon transmitting/attempting to transmit other-SI request via a random access preamble, which implicitly and/or explicitly indicates other-SI request a during single, a multi-stage RACH transmission, and/or requests resources for other-SI transmission in msg3. A WTRU may retransmit other-SI request in a contention based and/or grant-free channel.

[0321] Upon transmission of other-SI request, a WTRU may be configured to monitor a minimum-SI for a predefined time interval to determine the presence of scheduling information associated with the requested other-SI. For example, the predefined time interval may correspond to a random access response window. A WTRU may retransmit the random access preamble (e.g., with power ramping) when one or more of the following conditions may be true: if no random access response is received within a response window; if the received random access response does not correspond to the requested other-SI, which may or might not correspond to the transmitted other-SI request preamble/message; if the minimum-SI does not indicate a schedule for requested other-SI during the predefined time interval; and/or if the maximum preamble counter associated with an other-SI request transmission is not reached.

[0322] A WTRU may consider the other-SI procedure to be successful and/or stop retransmissions of other-SI request, when one or more of the following may be true: if a received random access response corresponds to the requested other-SI, wherein the random access response may or might not correspond to the transmitted other-SI request preamble/message; and/or if a received minimum-SI indicates the presence of scheduling information for requested other-SI.

[0323] A WTRU processor may be programmed for actions related to reception of broadcast other-SI. A minimum-SI may refer to transmissions in one or more logical broadcast channels mapped to one or more physical channels providing system information (e.g., essential) directly and/or indirectly (e.g., via indexes to stored/pre-acquired information) for the WTRUs to utilize services (e.g., to camp, reselect, perform initial access, and/or request further system information) from a cell. For example, realization minimum-SI may include Master System Information Block (MIB) and/or one or more SI messages carrying one or more SIBs and/or downlink signals indicating one or more aspects related to a minimum-SI transmission. The SIBs not carried in the minimum-SI may be called other-SI. A WTRU may be configured to receive other-SI transmitted via broadcast, multi-cast (e.g., to a group of relevant WTRUs), simulcast (e.g., from two or more transmission points using SFN) and/or unicast (e.g., to a specific WTRU). Depending on the transmission protocol, a WTRU may be configured to receive other-SI on the same physical channels as minimum-SI and/or a different physical

channel(s). WTRUs may be classified into the following different groups based on status of system information available at one or more, or each, of: WTRU: NULL WTRU; MSI WTRU; OSI UE; and/or FULL UE.

[0324] A NULL WTRU may be a WTRU without a valid minimum-SI and/or other-SI associated with the serving cell. For example, a NULL WTRU may have acquired and/or stored incomplete minimum SI and/or other-SI associated with the serving cell.

[0325] An MSI WTRU may be a WTRU with a valid minimum-SI but without other-SI associated with the serving cell. For example, an MSI may have acquired and/or stored minimum-SI, but not required other-SI for the ongoing procedures at the WTRU.

[0326] An OSI WTRU may be a WTRU with a valid minimum-SI and/or in the process of acquiring (e.g., re-acquiring) other-SI associated with the serving cell. For example, an OSI WTRU may or might not have triggered an other-SI request.

[0327] A FULL WTRU may be a WTRU with a valid minimum-SI and/or valid other-SI associated with the serving cell. For example, a FULL WTRU may have acquired and/or stored some or all the other-SI associated with serving cell and/or other-SI relevant for ongoing procedures at the WTRU.

[0328] An OSI WTRU may be configured to acquire other-SI transmitted as a response to an other-SI request. An OSI WTRU and/or a FULL WTRU may be configured to acquire other-SI transmitted as a result of update/changes to the other-SI. A NULL WTRU may be configured to pre-acquire other-SI before completion of minimum-SI acquisition.

[0329] A WTRU may determine the presence of other-SI scheduling information upon receiving an indication in a paging message. A WTRU may determine a change in value-tag associated with other-SI upon receiving an indication in a paging message. A WTRU may be configured with a timing relation between the other-SI request in the uplink and possible presence of other-SI schedule in the downlink. A WTRU may use the timing relation to determine the starting point for monitoring the presence of an other-SI schedule in a minimum-SI. For example, the timing relation may be expressed via a modification period. The timing relation may be expressed in relation to a paging occasion (e.g., the timing relation may be expressed as an offset in terms of timing units like a subframe and/or a radio frame). A WTRU may be configured with a timing relation in a paging message and/or in a response message to other-SI request.

[0330] A WTRU may be configured to suppress transmission of other-SI request based on reception of one or more downlink signals. For example, a WTRU may suppress the transmission of an other-SI request if a minimum-SI carries scheduling information for

corresponding other-SI. A WTRU may suppress transmission of other-SI request if a minimum-SI indicates that the corresponding other-SI may be scheduled in the future. Suppression may be used to prevent duplicate transmissions of other-SI request (e.g., when a network is preparing for transmission of broadcast other-SI based on a previous other-SI request possibly from a same and/or different WTRU).

[0331] A WTRU may be configured to acquire the broadcasted other-SI using one or more signaling aspects common to minimum-SI transmission. For example, a WTRU may be configured to receive the scheduling information for an other-SI broadcast and/or a minimum-SI broadcast (e.g., from a common minimum-SI). A WTRU may be configured to determine the presence of an other-SI schedule in the minimum-SI (e.g., via a change in the value tag associated with the minimum-SI). A WTRU may be configured to receive the dynamic time/frequency resources for minimum-SI and/or other-SI broadcast using the common control channel characteristic (e.g., search spaces, RNTI and/or the like). A WTRU may be configured to receive the other-SI broadcast transmission in time windows overlapping with the minimum-SI transmissions. WTRUs not interested in the other-SI broadcast may be triggered not to perform unnecessary receptions.

[0332] A WTRU may be configured to acquire the broadcasted other-SI using one or more signaling aspects decoupled from the minimum-SI broadcast.

[0333] A WTRU may be configured to determine the presence of other-SI broadcast (e.g., via the presence of scheduling information in a minimum-SI message). For example, a minimum-SI may carry scheduling information for minimum-SI and other-SI. A WTRU might not assume a change in the value-tag associated with the minimum-SI due to the addition and/or removal of other-SI scheduling information in the minimum-SI. In another example, the minimum-SI (e.g., MSI-M) carrying scheduling information for minimum-SI may be different from minimum-SI (e.g., MSI-O) carrying scheduling information for other-SI. A WTRU may be configured with separate value tags associated with one or more, or each, of MSI-M and/or MSI-O.

[0334] A WTRU may be configured with non-overlapping time windows for a minimum-SI broadcast and/or an other-SI broadcast. For example, a WTRU may be configured with the first other-SI time window after the last minimum-SI time window (e.g., a WTRU may be configured with one or more other-SI time windows with one or more unused minimum-SI time windows). For a specific other-SI message, a WTRU may determine a number "n+m" where "n" may correspond to the order of entry in the list of SI messages scheduled by a scheduling information list associated in MSI-O. "M" may correspond to the highest index associated with the list of

minimum-SI messages in MSI-M. For example, a WTRU may be configured with the same RNTI for minimum-SI reception and/or other-SI reception (e.g., a WTRU may be configured with the same control channel search space in time and/or frequency associated with minimum-SI and/or other-SI scheduling). An example of non-overlapping windows for minimum-SI and other-SI is shown in FIG 6.

[0335] A WTRU may be configured with one or more other-SI broadcast time windows partially and/or wholly overlapping with one or more time windows for a minimum-SI broadcast. A WTRU may be further configured with one or more aspects to avoid unnecessary reception of other-SI (e.g., when monitoring for minimum-SI). For example, a WTRU may be configured with an aspect of control channel monitoring that is different for minimum-SI as compared to other-SI acquisition (e.g., a WTRU may be configured with a separate RNTI associated with other-SI scheduling different from RNTI associated with minimum-SI scheduling). A WTRU may be configured with a control channel search space in time and/or frequency associated with other-SI scheduling different from control channel search space associated with minimum-SI scheduling. A WTRU may be configured with the other-SI transmission window length to be different than the transmission window length associated with minimum-SI. For example, overlapping windows for minimum-SI and other-SI is shown in FIG. 7.

[0336] A WTRU may determine beamforming applicability to system information delivery. A WTRU may be configured to determine whether beamforming is applicable for transmission of one or more system information messages. A WTRU may determine that system information delivery is beamformed (e.g., based on the carrier frequency). A WTRU may be configured with a predefined relationship between the frequency band and the nature of transmission. For example, a WTRU may consider system information to be beamformed for frequency bands higher than 6 GHz.

[0337] A WTRU may determine that system information delivery is beamformed (e.g., based on the characteristic of a downlink signal). The downlink signal may include a synchronization signal and/or any other reference signal. For example, characteristics of the downlink signal may include a type of the synchronization signal (e.g., a ZC sequence and/or a binary sequence), system signature, a root and/or basis sequence, and/or one or more predefined sequence numbers.

[0338] A WTRU may determine the nature of a system information transmission based on a relation between two or more synchronization signals in time and/or frequency. A WTRU may determine that system information delivery is beamformed (e.g., based on the information carried in a broadcast message). For example, a master system information block, a first system information message, and/or an essential system information (if any) may contain an indication

that one or more system information may be beamformed. A WTRU may apply receive beamforming for system information reception (e.g., based on the measurements made on downlink signal quality). For example, a WTRU may apply receive beamforming for system information reception when the received power of a reference signal, a synchronization signal, a master system information block, and/or an essential system information (if any) is below (or above) a predefined threshold.

[0339] A WTRU may use uplink assistance to beamforming for system information delivery. A WTRU may provide uplink assistance information to a network element to assist the network element in performing system information delivery. A WTRU may transmit assistance information in an UL signal and/or an UL message (e.g., a transmission for system information activation, system information request, and/or a measurement report). A WTRU may provide transmit assistance information in a deployment applying beamformed transmissions for system information messages. A WTRU may be configured to acquire system information (e.g. using beamformed transmissions). WTRU assistance may help reduce on-demand system information overhead (e.g., reduce required number of beamformed transmissions) and/or reduce the time required for beamformed on-demand system information acquisition. A beam sweep may refer to transmission and/or reception of system information in a plurality of TX and/or RX beams associated with a transmission point and/or reception point (e.g., multiplexed in time, frequency and/or space). A WTRU may receive synchronization signal, master system information, and/or essential system information (if any) in a beam sweep operation. A WTRU may receive on-demand system information in a subset of beams used for transmission of synchronization signal, master system information, and/or essential system information.

[0340] A WTRU may determine assistance information (e.g., based on the measurement of one or more aspects related to downlink transmission). For example, the downlink beamformed transmission may include one or more of: a reference signal transmission (such as a reference signal specific to a beam, antenna port, cell and/or sector etc.), a synchronization signal transmission, a transmission of a master system information block, and/or a transmission of one or more essential system information, any other periodic system information transmission associated with the DL beams, and/or an initial transmission of on-demand system information. A WTRU may measure a received energy metric based associated with the downlink transmission (e.g., RSSI (Received Signal Strength Indication)). A WTRU may measure a quality metric associated with the downlink beamformed transmission. For example, the quality metric may be based on received reference signal power (such as RSRP, RSRQ), signal to noise ratio (such as SNR), and/or a channel quality indication (e.g., CQI) etc. A WTRU may measure

one or more spatial metric associated with the downlink beamformed transmission (e.g., angle of arrival of a downlink transmission). A WTRU may average the measurement results over a predefined time window. A WTRU may use the result to determine the assistance information. A WTRU may consider/favor the measurement samples that are most recent based on freshness/age criteria to determine the assistance information.

[0341] A WTRU may indicate (e.g., via the assistance information) the quality of the serving cell based on one or more measurement metrics described herein. A WTRU may indicate (e.g., via the assistance information) whether to beamform the on-demand system information transmissions (e.g., based on one or more measurement metrics described herein). For example, a WTRU may provide the indication in cell edge and/or in a poor link condition where beamforming may overcome the increased path loss. A WTRU may determine whether to beamform the on-demand system information transmission (e.g., based on the received quality of the downlink transmission). For example, a WTRU may request a beamformed transmission of on-demand system information when the quality of the serving cell is below (or above) a predefined threshold. A WTRU may determine the usefulness for beamformed on-demand system information transmission based on the WTRU's capability. For example, a WTRU may consider the receive beamforming capability and/or the antenna gain achievable with receive beamforming. For example, a WTRU may request a beamformed on-demand system information transmission, when the quality of the serving cell is below a threshold in the presence of receive beamforming. A WTRU may indicate (e.g., via the assistance information) the reception status/quality of one or more downlink beams based on one or more measurement metrics described herein. A WTRU may indicate (e.g., via the assistance information) one or more downlink beams to receive the on-demand system information (e.g., based on one or more measurement metrics described herein).

[0342] FIG. 8A and 8B illustrate an example of an on-demand SI request in a beamformed context. At 802, a WTRU may determine one or more UL resources, perhaps for example based on one or more of: at least one (e.g., preferred) DL beam on which Sync and/or MIB and/or MSI and/or ESI may be received, an UL resource mapping to that DL beam, and/or one or more on-demand SI messages to be requested. At 804, the WTRU may transmit (TX) information for reception of the one or more on-demand SI messages using the one or more determined UL resources. At 806, the WTRU may receive a message (e.g., MSG2) that may be associated with the requested on-demand SI. At 808 the WTRU may monitor an on-demand SI window on Beam3 (e.g. a selected DL beam of one or more beams transmitted from the communication network) for the one or more on-demand SI messages.

[0343] A WTRU may transmit assistance information. A WTRU may organize the measurement results and/or send a measurement report to the network. A WTRU may include a list (e.g., of one or more, or all) the downlink beams above a predefined quality metric and/or energy metric in the measurement report. A WTRU may be configured to transmit a list of N beams (e.g., best beams) in a measurement report. A WTRU may determine the number of beams to be reported based on the size of measurement report resource.

[0344] A WTRU may request for on-demand system information to be transmitted (e.g., in one or more specific beams). For example, a WTRU may request for on-demand system information in a DL beam (e.g., from which the WTRU received a synchronization signal, a master system information block, and/or essential system information). A WTRU may transmit the request (e.g., in a layer 3 message and/or a layer 2 control element).

[0345] A WTRU may indicate one or more DL beams to receive on-demand system information (e.g., based on a choice of an UL resource and/or a transmission on that UL resource). For example, the UL resource may be a sounding reference signal and/or a random access resource. One or more, or each preconfigured UL resource may be associated with one or more DL beams. A WTRU may obtain the mapping between a DL beam and an UL resource in a broadcast message (e.g., an essential system information (if any) and/or a time/frequency relation based on identity associated with the DL beam).

[0346] The assistance information may be piggybacked with an on-demand system information request and/or system information activation procedure.

[0347] The WTRU may indicate the identity of DL beams in the assistance information. A WTRU may determine the identity of a DL beam based on one or more of the following: based on reference signal sequence associated with the DL beam; based on antenna port associated with the DL beam; based on time/frequency resources associated with the DL beam; based on synchronization signal associated with the DL beam; and/or based on an (e.g., explicit) identity carried in a known downlink transmission on the DL beam (e.g., a master information block and/or an essential system information (if any)).

[0348] A WTRU may transmit assistance information in a layer 3 message. For example, the assistance information may be transmitted on a default signaling radio bearer.

[0349] A WTRU may transmit assistance information in a MAC control element. For example, a new field in the MAC header (such as a predefined LCID) may indicate the presence of assistance information.

[0350] A WTRU may transmit assistance information in a physical channel reserved for layer 1 control signaling.

[0351] A WTRU may transmit assistance information on a contention based channel. Use of a contention based channel may be resource efficient. In case of collision of assistance information, at least the usefulness for on-demand system information may be conveyed by the presence of transmissions/signal energy in the contention based channel.

[0352] A WTRU may transmit assistance information before entering a connected state. For example, a WTRU may transmit assistance information on a common control logical channel.

[0353] A WTRU may transmit the assistance information in a message during connection establishment procedure. For example, a WTRU may include assistance information as a response to connection setup message.

[0354] A WTRU may transmit assistance information when an on-demand system information request and/or system information activation procedure is triggered.

[0355] A WTRU may transmit assistance information based on availability of measurement results. For example, a WTRU may start a timer upon achieving downlink synchronization to the cell. A WTRU may trigger on-demand system information with assistance information (e.g., if the measurement results are available before timer expiry). A WTRU may trigger on-demand system information without assistance information when the timer expires before the measurement results are available.

[0356] A WTRU may transmit assistance information when the acquisition of essential system information (if any) is complete.

[0357] A WTRU may transmit assistance information when explicitly requested by the network.

[0358] A WTRU may transmit assistance information based on an initial transmission of on-demand system information. Such assistance information may be included along with the feedback for such initial transmission.

[0359] A WTRU may determine DL resources for on-demand system information, for example, by using one or more of the following: a predefined timing relation between the system information request and start of control channel monitoring (e.g. a control channel may carry a scheduling grant for on-demand system information); and/or a predefined relation between time/frequency resources used for an SI request and start of data channel carrying on-demand system information.

[0360] For example, an identity (e.g. an RNTI) for an on-demand system information schedule may, for example, be specific to a WTRU that transmitted the request (e.g. a function of time/frequency resources used for UL SIB request). For example, an identity (e.g. an RNTI) for on-demand system information schedule may, for example, be specific to a cell and/or a

predefined constant, which may allow opportunistic reception for WTRUs that did not transmit the SIB request. For example, an RNTI for periodic system information may be different from on-demand system information.

[0361] A WTRU may be configured with a temporary periodic resource and/or a semi-persistent resource for on-demand system information reception. For example, a WTRU may receive such a resource as a response to system information activation and/or an on-demand system information request. A WTRU may determine the end of an on-demand system information procedure.

[0362] For example, a WTRU may enter connected mode, e.g., to receive on-demand system information messages. A WTRU may be in a loosely connected state or idle connectionless state to trigger an on-demand system information procedure. A WTRU may determine the end of on-demand system information transmission using one or more criteria.

[0363] For example, a WTRU may determine the end of an on-demand system information transmission based on a predefined time-window. For example, a WTRU may consider the start of the time window as a start of a first DL transmission corresponding to on-demand system information and/or an end of the TTI containing the system information request. For example, a WTRU may consider end of on-demand system information upon the end of time-window.

[0364] For example, a WTRU may determine the end of an on-demand system information transmission, for example, based on explicit indication. For example, a WTRU may receive a special end-marker in the last TTI carrying on-demand system information.

[0365] For example, a WTRU may determine the end of an on-demand system information transmission based on a counter. For example, a WTRU may receive a countdown value in a (e.g. one or more, or each) on-demand system information. A WTRU may consider the system information carrying the countdown value as the last on-demand system information.

[0366] For example, a WTRU may determine the end of an on-demand system information transmission based on a candidate system information list. For example, a WTRU may be pre-configured with and/or may be signaled a candidate system information list to be acquired and/or associated with an on-demand system information procedure. A WTRU may consider end of on-demand system information transmission, for example, when (e.g. some or all) the system information in the list is received successfully.

[0367] For example, a WTRU may determine the end of an on-demand system information transmission based on an explicit release command. For example, a WTRU may (e.g. when the WTRU entered connected mode to receive the on-demand system information) consider an end

of on-demand system information upon receiving a connection release command from the network.

[0368] A WTRU may process received on-demand system information. A WTRU may trigger a control procedure and/or transition back to idle mode at the end of on-demand system information reception.

[0369] A WTRU may consider a cell/TRP to be barred, for example, when a WTRU fails to acquire essential system information (if any) before the end of on-demand system information procedure.

[0370] A WTRU may start (e.g., first start) to apply received/acquired system information or parts thereof. A WTRU may apply/activate the received on-demand system information (e.g., at a specific reference point in time determined by the WTRU).

[0371] A WTRU may apply system information received via an on-demand procedure (e.g., at a specific time offset from the TTI corresponding to end of on-demand system information procedure as described herein). Such time offset may be predefined and/or transmitted along with the system information.

[0372] A WTRU may apply the on-demand system information (e.g., at the modification boundary after the completion of on-demand system information procedure). For example, a WTRU may reuse the modification boundary defined for essential system information.

[0373] A WTRU may apply the on-demand system information upon receiving an explicit activation message. A WTRU may receive such activation message via layer 3 signaling and/or MAC/Layer 1 control signaling.

[0374] A WTRU may apply the on-demand system information upon entering a specific state. For example, a WTRU may apply on-demand system information relevant to connected mode operation upon entering connected state. A WTRU may apply on-demand system information relevant to light connected operation upon entering light connected state.

[0375] A WTRU may apply the on-demand system information upon transmitting an indication to the network. For example, a WTRU may indicate completion of on-demand system information acquisition to the network and/or may apply (e.g., subsequently) the stored on-demand system information.

[0376] The WTRU may invalidate configured system information or parts thereof. A WTRU may receive, apply, and/or store the on-demand system information. A WTRU may monitor the validity of stored on-demand system information. A WTRU may stop using, deactivate, invalidate, overwrite, replace, and/or delete the on-demand system information based on one or more of the following criteria: validity of on-demand system information may be

associated with WTRU state; validity of on-demand system information that may be associated with WTRU location; validity of on-demand system information that may be associated with validity of essential system information; validity of on-demand system information that may be associated with a timer; and/or an explicit indication of on-demand system information validity.

[0377] For validity of on-demand system information that may be associated with a WTRU state, a WTRU may receive on-demand system information after transition to connected mode. Such on-demand system information may be used (e.g., required) for operation in connected mode. A WTRU may consider the on-demand system information to be invalid upon exiting connected state.

[0378] For validity of on-demand system information that may be associated with a WTRU state, a WTRU may acquire on-demand system information while in light connected state. Such on-demand system information may be used (e.g., required) for operation in connected mode. A WTRU may consider the on-demand system information to be invalid upon exiting to light connected state.

[0379] For validity of on-demand system information that may be associated with a WTRU state, on-demand system information may be applicable for light connected and/or connected state. A WTRU may consider the on-demand system information to be valid across transition between light connected and connected state. A WTRU may consider the on-demand system information to be invalid upon transition to IDLE state.

[0380] For validity of the on-demand system information that may be associated with WTRU location, a WTRU may consider the on-demand system information received in a DL beam to be valid (e.g., only) within that DL beam. Such an approach may be extended for a group of DL beams. For example a WTRU may consider a received on-demand system information to be valid in a group of DL beams.

[0381] For validity of the on-demand system information that may be associated with WTRU location, the group of DL beams may be associated with the same control channel. A WTRU may consider the on-demand associated with the group of DL beams valid as long as the WTRU can reliably receive the control channel.

[0382] For validity of the on-demand system information that may be associated with WTRU location, a WTRU may consider the on-demand system information to be valid (e.g., only) within the cell from which the WTRU received the on-demand system information. A WTRU may consider the on-demand system information to be invalid when the measured quality of the cell is below (or above) a predefined threshold.

[0383] For validity of the on-demand system information that may be associated with WTRU location, a WTRU may consider the on-demand system information to be valid in a geographical area, e.g. a RAN paging area and/or a list of preconfigured cells.

[0384] For validity of an on-demand system information that may be associated with validity of an essential system information, a WTRU may consider the on-demand system information associated with a transmission point, beam, cell, and/or region to be invalid if the validity of essential system information (if any) associated with the same transmission point/beam/cell/region becomes invalid.

[0385] For validity of an on-demand system information that may be associated with validity of an essential system information, a WTRU may be explicitly configured with the linkage between validity of one or more essential system information (if any) and validity of one or more on-demand system information.

[0386] For validity of on-demand system information that may be associated with a timer, a WTRU may consider the on-demand system information to be valid until expiry of a validity timer. For example, the value of validity timer may be specific to a valuetag (e.g. validity timer may be implicit based on ranges of valuetags and/or explicitly configured per valuetag). The value of validity timer may and/or specific to the type of system information (e.g. different timer values for MSI compared to OSI, and/or different validity for different types of SI within MSI and/or OSI). The value of validity timer may be specific to logical area, perhaps for example where the SI was acquired (e.g. a different longer value for SIs acquired in the current cell and/or current RAN area and/or shorter values for SIs acquired from non-serving cell and/or different RAN area).

[0387] For an explicit indication of on-demand system information validity, the on-demand system information may be associated with a validity tag and/or version. A WTRU may monitor the validity of stored on-demand system information using a validity tag in a broadcast message (e.g. MIB and/or SIB), paging message, and/or the like.

[0388] For an explicit indication of on-demand system information validity, the value tag may be specific to a single on-demand system information message, common to a group of on-demand system information messages, and/or common to some or all the on-demand system information messages from a transmission point/beam/cell/region.

[0389] A WTRU may use any combination of the above to stop using, deactivate, invalidate, and/or delete the on-demand system information.

[0390] A WTRU may re-acquire the specific SI that is changed (e.g., upon determining that an SI is invalid using one or more methods described herein). For example, the WTRU may re-

acquire changed SI and/or refrain from re-acquiring unchanged SI. A WTRU may monitor minimum-SI for the schedule and/or trigger other-SI request for a specific SI to acquire (e.g., only) the required SI.

[0391] A WTRU may store different versions of SI in memory. A WTRU may determine validity in a specific cell of essential and/or on-demand system information obtained from a different cell and/or stored at the WTRU.

[0392] A WTRU may maintain and/or store in memory one or more, or multiple versions of SI from the network. Such different versions of SI may be received from the current serving cell, from a different cell, and/or from a different frequency layer. Stored SI may enable the WTRU to avoid acquiring SI after every cell change. A WTRU may determine a specific stored version of an SI applicable for a cell based on one or more aspects related to the DL transmission in that cell. A WTRU may consider spatial applicability and/or temporal applicability of a stored system information to avoid unambiguity and/or configuration mismatch between WTRU and the network.

[0393] A WTRU may use spatial applicability with SI. SI may be associated with an area for which it applies (e.g., where the area may correspond to a beam, group of beams, a cell, one or more, or each cell in an eNB, group of cells (within a RAN area, tracking area and/or similar), and/or a PLMN etc.). For example, a WTRU may be configured with a version of SI to apply in a geographical area covered by a group of cells. For example, a version of SI may be associated with the SI to be applied by the WTRU in different conditions (e.g., at different times of the day within the same cell).

[0394] A WTRU may use temporal applicability with SI. A WTRU may store one or more, or each instance of a received SI for a maximum of a timer ("T") (e.g., started when the WTRU first receives that SI). On expiry of the timer, a WTRU may delete the stored SI. The WTRU may have one or more, or multiple timers active (e.g., one or more, or each associated with a different SI instance).

[0395] A WTRU may use application of stored SI for cells transmitting a reference ID.

[0396] The term reference ID may refer to unique identity for a specific instance of an SI and/or a group of SIs. The reference ID may be unique over a predefined area and/or for a predefined time interval.

[0397] A WTRU may acquire SI from a transmission point that is not applicable to that transmission point (e.g., the SI may be applicable to a different transmission point). Thus, the WTRU may be configured to not assume an SI received from a transmission point that is applicable to that transmission point. A WTRU may be configured to associate an SI to a

transmission point based on a reference ID associated to that SI. A WTRU may receive an SI from a transmission point and/or may apply the received/stored SI in a different transmission point, which may or might not transmit the corresponding SI. A WTRU may be configured to apply one or more SIs to a subset of beams from a transmission point. For example, a WTRU may activate one or more stored SIs based on the reference ID carried in a beam (e.g., implicitly based on reference signals in the beam and/or explicitly carried in a MIB associated with a beam).

[0398] A WTRU may determine to store a version of SI based on one or more reference IDs associated with one or more, or each version of SI and/or portions thereof. The reference ID for a version of SI may be broadcast by the network as part of the essential system information and/or along with the on-demand SI. For example, the reference ID may be implicitly determined by the WTRU by aspects related to the transmission by the network of the essential SI. For example, the WTRU may determine the reference ID for an SI based on the timing/frequency of the transmission of that SI relative to a reference time/frequency. In addition to the reference ID, and/or as part of the reference ID, the WTRU may also receive a value tag associated with the system information. The value tag may be used as in legacy LTE systems.

[0399] The reference ID and value tag may be independent identifiers received by the WTRU. For example, a single reference ID may be received by the WTRU, which may include a value tag. For example, a set of bits in the reference ID may indicate the specific version of the SI, while another set of bits in the reference ID may indicate the value tag associated with the version of the SI.

[0400] The reference ID may be applicable to all or part of the system information. For example, a WTRU may receive a reference ID (e.g., which may be applicable to some or all the SI transmitted by a cell (e.g., essential SI and/or on-demand SI)). A WTRU may receive a reference ID which is associated with the essential SI, and/or one or more different reference IDs associated with distinct portions of the on-demand SI. A WTRU may receive the reference ID and/or value tag associated with an SI or a portion of an SI via broadcast and/or dedicated signaling. A WTRU may be configured with the association of one or more sets of reference IDs and/or value tags with one or more sets of SI.

[0401] A WTRU may derive an implicit reference ID based on one or more aspects/characteristics associated with DL transmissions. A WTRU may associate the derived reference ID with one or more SI(s) based on predefined rules. For example, a WTRU may derive a reference ID based on a broadcasted area ID (e.g., a RAN area and/or a tracking area

ID). A WTRU may be configured to apply the stored SI linked to a reference ID (e.g., while the WTRU can determine that the WTRU is within an area associated with that reference ID). For example, a WTRU may derive a reference ID based on the frequency layer and/or frequency band indication. A WTRU may be configured to apply the stored SI linked to a reference ID (e.g., while the WTRU can determine that a cell belongs to a frequency layer and/or frequency band). For example, a WTRU may derive a reference ID based on a geographical location (e.g., a WTRU may derive a reference ID based on part of global cell identity transmitted in a broadcast signaling). A WTRU may derive a reference ID based on characteristics of DL signals (e.g., logical sequence carried in a synchronization signal). A WTRU may associate the derived reference ID to one or a subset of received SIs. For example, a WTRU may determine the subset based on SI type (e.g., a WTRU may associate the derived reference ID to minimum-SI and/or other-SI). A WTRU may determine the subset based nature of physical channel carrying the SI (e.g., a WTRU may associate the derived reference ID to the SI carried in a physical channel dedicated for a SI transmission, a physical channel defined for single frequency network transmission, a SI transmitted on a physical shared downlink channel, and/or a SI transmitted on a beamformed physical channel. For example, a WTRU may be configured explicitly for the subset of SIs for which the derived implicit reference ID is applicable.

[0402] A WTRU may determine to apply a stored version of SI (e.g., upon detecting a cell which transmits a reference ID which matches (e.g., substantially corresponds with) at least one of the WTRU's stored SI versions). The match may also include, without loss of generality, some relational equivalence (e.g., greater than, less than, etc.). A WTRU may be allowed to perform cell operations with stored SI based on equivalence of the reference ID transmitted by a cell with a stored version of SI at the WTRU. A WTRU may be able to camp on a cell and/or perform INACTIVE/CONNECTED mode operations on that cell without acquiring SI from the cell (e.g., despite the cell transmitting a limited amount of SI and/or complete minimum-SI, one or more of which may include a reference ID). For example, a WTRU may camp on a cell which transmits (e.g., only) a portion of the essential SI (and including the reference ID) if the WTRU detects the reference ID matches (e.g., substantially corresponds with) the reference ID of a version of SI stored by the WTRU. A WTRU may consider a neighbor cell transmitting reduced minimum-SI as a candidate for reselection if the WTRU can determine that the reference ID of the neighbor cell (e.g., by receiving reduced minimum-SI from the neighbor cell and/or querying the serving cell) matches (e.g., substantially corresponds with) the reference ID of a version of SI stored by the WTRU.

[0403] A cell may transmit the reference ID (e.g., to identify the SI version) and/or a value tag associated with that SI version. One or more reference ID and/or value tags may be transmitted by network cells. A cell may transmit the essential SI, which may be the SI for a WTRU to access the cell. A cell may transmit less than the essential SI while still transmitting the one or more sets of reference IDs and/or a value tag.

[0404] The reference ID and/or value tag may be assumed to be associated with the essential SI. A reference ID and value tag pair may be associated with the on-demand SI and/or a subset of the on-demand SI.

[0405] A WTRU may have a processor programmed with conditions for storing a version of SI in memory.

[0406] A WTRU may store in memory newly acquired SI associated with a reference ID for which the WTRU does not currently have any stored information. A WTRU may also maintain and/or store in memory the SI for a particular amount of time, for a specific area (e.g., as long as the WTRU does not move beyond an area or by more than a certain amount), and/or as long as the value tag associated with the reference ID has not changed. For example, a WTRU may invalidate/delete stored SI associated with a reference ID when it detects a change in the value tag transmitted by the network for SI with the same reference ID.

[0407] A WTRU may replace stored SI associated with a reference ID when it detects and/or determines transmission by a cell of SI with the same reference ID as a version of SI stored by the WTRU, but where the value tag has changed. The newly acquired SI may also be stored in memory by the WTRU as stored SI.

[0408] A WTRU may have a processor programmed with conditions for applying a stored SI version.

[0409] A WTRU may determine that the WTRU may change from a current version of SI to applying a stored version of SI upon reselection to a new cell, moving from an out of coverage condition to in coverage condition, upon detection of a change of the essential SI and/or parts of the essential SI transmitted by the network, upon detecting a change of the reference ID and/or value tag, associated with the SI and/or a different subset of the SI, upon leaving connected state, and/or upon receiving a handover command; for example a WTRU may receive a handover command with a reference ID and/or value tag (or value identifier). A WTRU may apply the stored SI associated with the received reference ID and/or value tag for operation in the target cell. This approach may reduce the size of the handover command and/or allow compressed signaling of target cell parameters. A WTRU may further determine, following the above events, that it may apply a specific version of stored SI based on one or more of the following

scenarios: the reference ID of a version of the stored SI matches (e.g., substantially corresponds with) the reference ID currently broadcast by the cell (e.g., in the essential SI); the reference ID and value tag of a version of stored SI matches the reference ID and value tag currently being broadcast by the cell (for example in the essential SI) and/or provided by the cell in dedicated signaling; the implicit reference ID derived by the WTRU for the cell matches with the implicit reference ID stored for the essential SI; the time elapsed since the version of stored SI was acquired by the WTRU does not exceed a predefined and/or configured threshold; and/or the distance travelled by the WTRU since it acquired the specific version of stored SI is below a predefined and/or configured threshold. Upon applying the stored SI(s) associated with the matching reference ID(s), a WTRU may perform one or more actions as if those SIs are acquired in the current cell (e.g., monitoring possible updates to the applied SI, requesting for one or more other-SIs if missing, forwarding relevant information to upper layers (e.g., cell identity, tracking area code, supported features) etc.).

[0410] A WTRU may have a processor programmed with instructions for actions upon having no valid stored SI.

[0411] A WTRU may determine that the WTRU does not have a valid stored SI for a cell if the reference ID received from a cell does not match any of the reference IDs of stored SI versions at the WTRU. A WTRU may determine that the WTRU does not have valid stored SI if the value tag for a transmitted reference ID which matches (e.g., substantially corresponds with) the reference ID of a stored version of SI does not match the value tag of the stored SI having that reference ID.

[0412] A WTRU may, under such conditions, perform and/or determine to perform one or more of the following actions: the WTRU may acquire the SI from the cell and/or store in memory the SI with the associated reference ID and value tag (e.g., if the cell transmits the SI in question (essential SI and/or other-SI)); the WTRU may determine the cell to be barred and/or inaccessible; the WTRU may perform a cell (re)selection and/or attempt to camp on a recent cell and/or another detectable cell for which the above conditions do not occur (e.g., if the cell does not transmit the essential SI); and/or the WTRU may initiate a request for SI, such as some or all other-SI, and/or possibly for the other-SI for which the associated reference ID and value tag meet the conditions described herein.

[0413] A WTRU may have a processor programmed with instructions for requesting a reference ID and/or value tag of SI. The network might not broadcast the reference ID and/or value tag of an SI. For example, the network may transmit the reference ID and/or value tag of the on-demand SI with the SI itself, and/or may currently not be broadcasting any other-SI. A

WTRU may perform a request for the reference ID and/or value tag for some or all or a specific subset of SI. The request may be triggered as a result of one or more of the following triggers: a WTRU reselects to a different cell; a WTRU, in reselecting to a different cell, has one or more versions of stored SI for the SI and/or subset of SI for which the WTRU is requesting a reference ID/value tag; a WTRU detects a change in another (potentially related and/or linked) reference ID and/or value tag broadcast by the network; a WTRU initiates a service requiring access to a certain SIB and/or subset of SI, for which the WTRU may potentially have stored SI which may be validated; a WTRU reselects and/or connects to a cell where the current reference ID and/or value tag associated with a required part of the SI is not being broadcast by the cell; a WTRU has moved by a certain amount; and/or the validity timer associated with a subset of SI (potentially related to the specific SI in question) has expired.

[0414] A WTRU may perform a request for reference ID and/or value tag for a subset of SI through RRC signaling. A WTRU may make the request in IDLE/INACTIVE states and/or in a CONNECTED state. A WTRU may utilize a RACH procedure (e.g., 2-step and/or 4-step RACH) to make the request. A WTRU may use PHY layer signaling on an UL control channel and/or dedicated resources using RRC signaling to make the request.

[0415] The WTRU may include in the request of one or more of the following information: one or more reference IDs and/or value tag of any stored SI at the WTRU; a WTRU ID (e.g., C-RNTI, S-TMSI, resume ID, etc.); and/or a specific SIB, SI subset, and/or SI type for which the WTRU is interested in obtaining a reference ID and/or value tag.

[0416] Following a request, a WTRU may perform one or more of the following actions: acquire essential SI that may contain at least a reference ID and/or a value tag; apply a specific version of SI that may be associated with a reference ID and/or a value tag transmitted by the network in response to the request; perform reselection to a different cell, which may be a cell utilizing an SI for which the WTRU has a stored valid version; perform a request for other-SI that may be a result of the WTRU determining that the WTRU does not have a valid stored version of the SI; determine the scheduling information associated with on-demand SI, potentially transmitted by the network in the essential SI; and/or acquire SI, potentially based on previously acquired and/or configured scheduling information. Examples include a reference ID applicable to essential and on-demand SI; a reference ID applicable to essential SI (e.g., only essential SI); non-broadcast reference ID for on-demand SI; broadcast reference ID for on-demand SI; and reference ID applicable for a subset of minimum-SI and/or other-SI.

[0417] For a reference ID applicable to essential and/or on-demand SI, a WTRU may reselect to a cell (e.g., new cell) which transmits all or part of the essential SI, but includes a

reference ID (indicating the version) and/or a value tag. A WTRU may apply a stored version of the essential SI for the cell if the WTRU possesses a version of SI having the same reference ID and/or value tag. A WTRU may apply the stored essential SI and/or on-demand SI. The WTRU may determine that the reference ID and/or value tag transmitted by the network is applicable to essential SI and/or on-demand SI.

[0418] For a reference ID applicable to essential SI (e.g., only to essential SI), a WTRU may reselect to a cell (e.g., new cell) and/or may determine that the reference ID and/or value tag transmitted by the network is applicable to the essential SI (e.g., only the essential SI). A WTRU may apply a valid stored SI for essential SI. A WTRU may initiate a request for on-demand SI in the new cell and/or acquire the on-demand SI (e.g., if it is already being transmitted by the cell).

[0419] For non-broadcast reference ID for on-demand SI, a WTRU may receive a reference ID and/or a value tag for essential SI and/or one or more sets of reference IDs/value tags for the on-demand SI. For example, the on-demand SI may be divided into one or more, or multiple, subsets and/or types of on-demand SI. One or more, or each set may have its own reference ID and/or value tag. A WTRU may be configured with the subset information. A WTRU may receive the reference ID and/or value tag sets for the on-demand SI during the transmission of the on-demand SI itself (either through dedicated and/or broadcast signaling). A WTRU may reselect to a cell (e.g., new cell) and/or may detect transmission of the essential SI (e.g., essential SI only) and/or part of the essential SI which may include the reference ID and/or the value tag for the essential SI. For example, a WTRU may receive the reference ID and/or value tag of the essential SI, may determine that the WTRU has a valid version of stored essential SI, and/or may apply the stored essential SI.

[0420] The WTRU may determine that the WTRU does not have a valid version of stored essential SI and/or may acquire the essential SI from the cell. The WTRU may perform a request for on-demand SI if the WTRU does not determine that the cell is transmitting the on-demand SI. The WTRU may include, in the request for the on-demand SI, the reference IDs and/or value tag(s) of any on-demand SI. This information may be useful to the network to determine whether to broadcast on-demand SI.

[0421] The WTRU may receive, from the network, an indication to use the stored on-demand SI associated with a reference ID; an indication that the on-demand SI will be broadcast by the network; and/or the WTRU may start to receive the on-demand SI from the network as an indication that it should acquire the on-demand SI. The WTRU may perform a request to have the network transmit the reference ID and/or value tag associated with the on-demand SI. The

WTRU may receive the reference ID and/or value tag pairs associated with one or more, or each set of on-demand SI, may determine the validity of any stored on-demand SI, and/or may determine whether to perform a request for on-demand SI.

[0422] For broadcast reference ID for on-demand SI, a WTRU may reselect a cell (e.g., a new cell) and/or may receive in the essential SI, and/or as part of the essential SI, an independent reference ID and/or value tag pairs for essential SI and/or on-demand SI. The WTRU may determine whether it has a valid version of the essential SI and/or may apply the determined valid version of the essential SI. If the WTRU determines that the WTRU does not have a valid version of the essential SI, the WTRU may acquire the essential SI and the cell may broadcast the essential SI. The WTRU may reselect to a different cell (e.g., if the WTRU determines that the WTRU does not have a valid version and/or the WTRU cannot acquire the essential SI). The WTRU may determine whether the WTRU has a valid version of one or more, or each set of on-demand SI. The WTRU may perform a request for on-demand SI for any set of SI for which the reference ID and/or value tag does not match a stored version of SI at the WTRU.

[0423] For a reference ID applicable for a subset of minimum-SI and/or other-SI, a WTRU may apply a combination of stored SI and the SI received from a cell. For example, a WTRU may determine that the reference ID broadcasted for a subset of minimum-SI and/or other-SI, remaining minimum-SI, and/or other-SI should be acquired from the cell. A WTRU may have stored only a subset of minimum-SI and/or other-SI associated with a broadcasted reference ID and/or may determine that the remaining minimum-SI and/or other-SI should be acquired from a cell. A WTRU may implement a subset of SI that is area specific. The remaining SI may be cell specific. A WTRU may be configured with semi-static system information common to an area that may be associated with the area specific reference ID, whereas more dynamic system information may be configured as cell specific SI. A WTRU may be configured with an overlapping subset of area specific SI and cell specific SI. A WTRU may apply precedence for SI transmitted from the cell over the area specific SI (e.g., applied via reference ID+ stored SI). A WTRU may apply two or more subsets of stored SIs based on two or more reference IDs to obtain a complete minimum SI in a cell. For example, a WTRU may receive and/or store different parts of minimum SI. One or more, or each part may be associated with a reference ID. A WTRU may determine the complete minimum SI by a union of different parts of the stored minimum SI.

[0424] A WTRU may determine a reception of a list of valid cells. A WTRU may receive (e.g., as part of the SI of a cell) a list of other cells for which the SI can be used for the cell. The WTRU may apply the same rules described above for a reference ID in relation to storage and/or

may apply the SI. The WTRU may determine based on whether a cell is within the list of other cells (e.g., based on, for example, the PSS/SSS, and/or cell ID), whether the WTRU can apply acquired/stored SI in the cell, and/or whether the WTRU wishes, desires, and/or finds useful to acquire new (e.g., fresh) SI for a cell.

[0425] A WTRU may have a processor programmed to determine conditions (e.g., dependent conditions) for applying SI.

[0426] A WTRU may store different instances of SI (associated with the same or different reference IDs) and/or may apply (e.g., selectively apply) an instance of the SI based on certain conditions in the WTRU. The conditions may be configured in the WTRU and/or provided to the WTRU as part of the SI instances. The conditions may include one or more of: the time of day; the geographical location, speed, and/or heading of the WTRU; beam configuration; active service(s) and/or service type(s); and/or an active numerology.

[0427] A WTRU may have a processor programmed for actions related to reception of minimum-SI, reduced minimum-SI, and/or other-SI. A WTRU may be configured to receive “reduced minimum-SI” if transmitted. Reduced minimum-SI refers to a transmission of minimum-SI with a reduced size, whose contents are a subset of a complete minimum-SI, and may have one or more information elements not present in complete minimum-SI. A WTRU may be configured to receive reduced minimum-SI in one or more of the following ways: a DL signal as reduced minimum-SI (e.g., a WTRU may derive a reference ID based on one DL signal or a combination of two or more DL signals (e.g. synchronization signals, reference signals)); an MIB as a reduced minimum-SI (e.g., a WTRU may receive from a Master Information Block, one or more reference ID(s) and/or value-tag(s) associated with pre-provisioned SI(s)); a MIB and most frequent minimum-SI as reduced minimum-SI (e.g., a WTRU may determine one or more aspects related to a more frequent minimum-SI from a master information block and the frequent (e.g., most) minimum-SI may carry one or more reference ID(s) and/or value-tag(s) associated with pre-provisioned SI(s)); an MIB, most frequent minimum-SI, and one or more minimum-SI with configurable periodicity; and/or the WTRU may receive and/or apply a minimum-SI with configurable periodicity (e.g., configured in a most frequent minimum-SI) to obtain the complete minimum-SI.

[0428] A WTRU may be configured to receive one or more of the following information in a (e.g., complete) minimum-SI; a minimum-SI (e.g., most frequent SI) may include a reference ID(s) and/or validity tag(s) common to some or all minimum-SIs and/or specific to a subset of minimum-SI; and/or a reference ID(s) and/or validity tag(s) common to some or all other-SIs and/or specific to a subset of other-SI.

[0429] A WTRU may be configured to determine a support for an SI based on the presence of a reference ID(s) and/or validity tag(s) for that SI. A minimum-SI may include the scheduling configuration for minimum-SI broadcast (e.g., MSI type, periodicity, window length) and/or one (e.g., only one) of the following for one or more, or each, supported other-SI: scheduling configuration for other-SI broadcast (e.g., other-SI type, periodicity, and/or window length) and/or RACH configuration to request other-SI.

[0430] Additional minimum SIs may include cell accessibility information (e.g., barring status, access control parameters, PLMN ID, cell ID, area ID etc.), initial access information (e.g., RACH configuration to enter connected state and/or data transfer in inactive state etc.), cell selection info (e.g., Qrxlevmin/offset, Qquallevmin/offset), and/or information for idle mode operation (cell reselection info for intra, inter neighbors, mobility scaling, common radio resource configuration (e.g., paging) etc.). A WTRU may be configured to request and/or receive one or more of the following information in other-SI: SI that might not be a part of complete minimum-SI and/or a reduced minimum-SI; SI that may be a part of minimum-SI (e.g., this may be useful for WTRUs that are coverage limited and/or may allow a less conservative design for broadcast minimum-SI); minimum-SI applicable for non-serving cells; and/or other-SI applicable for non-serving cells.

[0431] A WTRU may perform one or more of the following actions, perhaps for example when a system information acquisition procedure for a cell is triggered. If the cell transmits reduced minimum-SI, a WTRU may attempt to receive reduced minimum-SI. If reduced minimum-SI is received successfully by the WTRU, the WTRU may determine/derive one or more reference ID(s) associated with the cell. If the WTRU can determine a complete minimum-SI based on a received reduced-minimum-SI, derived reference ID(s), value-tag(s) and/or matching stored SI(s), the WTRU may perform one or more actions as if acquisition of minimum-SI was completed. If the WTRU receives configuration for resources for other-SI request from the reduced minimum-SI, a WTRU may trigger an other-SI request procedure to acquire one or more on-demand SI and/or perform one or more actions as if acquisition of minimum-SI is completed. A WTRU may assume that the cell is barred.

[0432] If the cell transmits complete minimum-SI, a WTRU may attempt to receive/determine a reference ID from the minimum-SI transmitted in the cell. If the WTRU can determine a complete minimum-SI based on reference ID(s), value-tag(s) and/or matching stored SI(s), a WTRU may perform one or more actions as if acquisition of minimum-SI is completed. A WTRU may attempt to receive complete minimum-SI transmitted in the cell. A WTRU may

perform actions (e.g., subsequent actions) depending on the contents/status of received minimum-SI (e.g., whether WTRU is allowed to camp on the cell or if the cell is barred).

[0433] A WTRU may be configured to reclaim the random access resources (e.g., time/frequency and/or preambles) which may be configured for other-SI request(s), perhaps based on one or more factors. For example, a WTRU may reclaim the random access resources configured with the other-SI request(s), perhaps when the WTRU determines that the other-SI is broadcasted. For example, a WTRU may determine that the other-SI is broadcasted from an indication in the minimum-SI. For example, a WTRU may reclaim (e.g., only) the resources associated with a subset of other-SIs that may be broadcasted.

[0434] A WTRU may be configured to perform random access procedures for purposes other than other-SI request(s) on the reclaimed random access resources. For example, the WTRU may be configured to utilize the reclaimed random access resources configured for other-SI request(s) to perform an initial access and/or scheduling request and/or respond to a PDCCH order and/or to initiate UL synchronization and/or to initiate UL beam management and/or access target cell during handover, etc. For example, a WTRU may be configured to use reclaimed resources perhaps when the random access procedure fails on the resources configured for such procedure and/or on dedicated random access resources. For example, a WTRU may consider one or more, or a combination, of resources configured for access and/or reclaimed resources for random access resource selection.

[0435] A paging control function may be applied, for example, per TRP, per TRP group, per service, per configured MAC instance, per channel per instance, per central control function, etc.

[0436] A central control function may store a WTRU context and/or track a WTRU mobility within the coverage of RCCF, for example, for a WTRU in a light connected state. A WTRU may receive a paging message originated at the RCCF and/or transmitted by the RCCF triggered, for example, upon arrival of downlink data. A paging message may be transmitted, for example, at ACF granularity and/or RCCF granularity. A WTRU in a light connected state, e.g., upon receiving the paging message, may perform one or more actions.

[0437] For example, a WTRU action may resume a WTRU user plane path towards the central user plane function, e.g., without having to invoke any additional central control functions.

[0438] For example, a WTRU may perform control plane actions and/or user plane actions, e.g., based on the received paging message.

[0439] For example, a WTRU may receive additional indication(s) in the paging message that determine WTRU actions. For example, a WTRU may receive a type of service in the

paging message. A WTRU may (e.g. based on the indication) transition to fully connected state or light connected state. For example, a WTRU may determine a type of initial access procedure (e.g. contention based, beamformed, initial access on a specific ACF), for example, based on a received paging message.

[0440] For example, a WTRU may receive an indication for the resources used for data transmission. A WTRU may (e.g. directly) receive the data without having to establish any connection. A WTRU may (e.g. upon completing data reception) transition back to idle or a light connected state.

[0441] For example, a paging message may trigger establishment of ACF. For example, a paging message may trigger RCCF establishment while another paging message may trigger resumption of RCUF.

[0442] WTRU identification may be provided, for example, by a layer 3 (L3)/central control plane connection/WTRU context identifier. Singular connectivity may have a one to one relation between WTRU identity on the radio (e.g. RNTI) and an RRC connection. A WTRU's RRC connection for dual connectivity may be associated with a WTRU specific RNTI in the MeNB (Master eNB). A WTRU may be assigned one or more, or multiple RNTIs during multi-connectivity (e.g. different RNTI per TRP), for example, in a tri-plane architecture. A WTRU context may be identified in the centralized control function, for example, by assigning an L3 identity to a WTRU. A WTRU may receive an L3 identity, for example, upon central control plane establishment. An L3 identity may be used, for example, to uniquely identify an RRC connection and/or RRC context associated with a WTRU.

[0443] An RCCF connection may be managed. There may be one or more triggers for re-association with RCCF. For example, a WTRU may trigger an association and/or re-association procedure with the RCCF when one or more of criteria are satisfied.

[0444] An example criteria may be when no valid L3 context exists in a WTRU, for example, due to a power up scenario where a WTRU may be unknown at the network, and/or an L3 context expired (e.g. due to extended periods of inactivity).

[0445] An example criteria may be when a WTRU enters a coverage of an anchor control function different than a serving anchor control function. A WTRU may determine presence and/or identity of an anchor control function using one or more procedures. An example procedure may comprise using a shared system signature. For example, TRPs associated with the same anchor control function may share at least one system signature. An example procedure may comprise using explicit identification in MIB. For example, TRPs associated with an anchor control function may transmit some form identity associated with the anchor

control function. A WTRU may obtain the anchor control function identity during a previous association. An example procedure may comprise using logical area transmitted in broadcast channels. For example, an (e.g. one or more, or each) anchor control function may provide anchoring services to a logical area including one or more TRPs. A WTRU may consider TRPs belonging to a specific logical area as associated with the same anchor control function. An example of a procedure may be using a pre-configured system signature group. For example, two or more system signatures may be preconfigured to be associated with the same anchor control function. A WTRU may consider TRPs transmitting at least one of the system signatures within a particular system signature group to be associated with the same anchor control function.

[0446] An example criteria may be when an access control function associated with macro eNB experiences failure and/or a WTRU might (e.g. does) not have a valid access table entry.

[0447] An example criteria may be when (e.g. one or more, or all, of) the configured/activated access control functions may be terminated/released.

[0448] An example of a criteria may be upon arrival of a paging message indicating arrival of DL data and/or DL signaling from the core network.

[0449] An example of a criteria may be unreachability of a serving anchor control function, which may be determined, for example, based on an absence of response to signaling message towards the anchor control function and/or absence of keep alive/heart beat with the serving anchor control function.

[0450] An example of a criteria may be upon receiving a last RAR message. A WTRU may (e.g. during initial access to a network) perform a multi-point random access procedure. A WTRU may wait for a last RAR message to trigger an RCCF association procedure. A WTRU may determine the last RAR message in one or more ways. For example a (e.g. one or more, or each) RAR message may include a countdown value. For example, a WTRU may consider the RAR message with countdown value of zero as the last RAR message. For example, a WTRU may wait until the end of an RAR window to receive an (e.g. every possible) RAR message before triggering an RCCF association procedure.

[0451] A WTRU may initiate association towards an anchor control function, for example, any time after acquiring UL resources to transmit, e.g., after access plane establishment. A WTRU may transmit a higher layer signaling message that may include a WTRU identity, an identity of an anchor control function, a reason for association, a number of RAR messages, a list of TRPs and/or a selected list of TRPs.

[0452] A WTRU identity may be, for example, one or more of the following: an identity allocated by a previous anchor control function, a temporary identity allocated by a core network and/or a sufficiently long random number (e.g. ≥ 40 bits).

[0453] An identity of anchor control function may be, for example, optionally present, e.g., when a WTRU had a previous association with an anchor control function.

[0454] A reason for association may be, for example, one or more of the following: a request for anchoring control service, a request for paging service, a request for access to specific core network slice, an initial association for subsequent core network signaling, an association due to change in anchor control function, a failure of a previous anchor control function, a response to paging, UL data arrival and/or type of service requested (e.g. high throughput service, low latency service and/or low overhead and energy efficient service), etc.

[0455] A number of RAR messages may be, for example, a number of RAR messages received in response to a random access procedure.

[0456] A list of TRPs may be, for example, a list of TRPs that transmitted the RAR messages and/or quality metric for a (e.g. one or more, or each) received RAR.

[0457] A selected List of TRPs may be, for example, a list of TRPs selected by a WTRU using a predefined selection criteria.

[0458] A WTRU may transmit an RCCF association request on available resources. A request may be transmitted in an order. An example of an order may be, for example one or more of: time/frequency resources associated with a macro ACF whose suitability metric is highest among available macro ACFs; time/frequency resources associated with a macro ACF whose suitability metric is above a certain threshold; time/frequency resources associated with a TRP ACF whose suitability metric is highest among configured/active/available TRP ACFs; and/or time/frequency resources associated with a TRP ACF whose suitability metric is above a certain threshold.

[0459] A suitability metric may be, for example, received power measured from a reference signal and/or system signature averaged over a time window.

[0460] A WTRU may prefer ACFs associated with one or more licensed bands over ACFs associated with unlicensed bands.

[0461] A WTRU may prefer non-beamformed ACFs over beamformed ACFs.

[0462] A WTRU may (e.g. in response to an RCCF association request) receive and/or process an association response. The contents of a response may include, for example, one or more of an identity of an RCCF, an identity of a WTRU, access table parameters, a measurement

configuration, an SRB configuration, a DRB configuration, dedicated ACF parameters/resources and/or user plane RCUF status and/or parameters.

[0463] An identity of an RCCF may be stored and/or used (e.g. by a WTRU), for example, to address subsequent control signaling towards the RCCF.

[0464] An identity of a WTRU may be stored and/or used (e.g. by a WTRU), for example, to identify itself for subsequent interaction with the RCCF.

[0465] Access table parameters may be received in a response. A WTRU may (e.g. directly) receive access table contents within the association response message and/or parameters that may help a WTRU to obtain the access table parameters (e.g. ACFs and/or time/frequency resources that carry access table transmission, and/or an RNTI to decode the schedule for access table transmission, etc.).

[0466] A measurement configuration may comprise configuration of measurement resources, measurement objects, measurement quantity and/or measurement id, triggers, etc. A measurement configuration may be specific to an ACF or group of TRPs.

[0467] An SRB configuration may indicate mapping rules for SRB. For example, an SRB to ACF mapping (e.g. for SRBs terminating at ACFs) may provide (e.g. an explicit) mapping between SRBs and an ACF. A mapping may map an SRB to transport/physical channels associated with a specific ACF. For example, an SRB to ACF mapping restriction may be provided. A WTRU may be configured with restricted ACFs that might not be used for SRB transmission. WTRU may flexibly split the SRBs among available/allowed ACFs. For example, an SRB prioritization via ACF mapping may be provided. High priority SRBs may be mapped and/or low priority SRBs may be mapped, e.g., to a different ACF/ACF group. For example, Dynamic SRB mapping based on ACF quality may be provided. A mapping may transmit high priority SRBs over ACFs whose quality metric is above certain threshold. For example, a DRB configuration may include, for example, DRB tagging information. A WTRU may attach to a (e.g. one or more, or each) PDU belonging to a DRB associated tagging information provided by the central control function. Tagging information may be used, for example, by the RCUF to map the PDUs to the right core network flow. Dedicated ACF parameters/resources may be provided in a response to an RCCF association request. User plane RCUF status and/or parameters may be provided in a response to an RCCF association request.

[0468] An ACF connection may be managed. Triggers may be provided for access plane management. A WTRU may trigger access plane establishment, for example, when one or more criteria is satisfied.

[0469] An example of trigger criteria may be, for example, when a WTRU receives an unknown signal (e.g. without a valid entry in the access table), which may occur when an SIB might not be broadcast in the cell, UL resource for SIB interest notification and/or on-demand access table and/or when a WTRU may request an access table entry from another TRP (e.g. send the signature).

[0470] An example of a trigger criteria may be, for example, upon arrival of user plane data (e.g. IP packet), which may occur, for example, when a WTRU already has an access plane established or does not have an access plane established, such as when higher layer data may allow for early data transfer and/or a valid entry in the access table is available that indicates UL resources timing (e.g. w.r.t to another signal and/or control channel, etc.).

[0471] An example of a trigger criteria may be, for example, upon arrival of control plane signaling (e.g. L3/RRC message and/or NAS message).

[0472] An example of a trigger criteria may be, for example, change in RAN tracking area, proximity to non-serving anchor control function, change in anchor control function, etc.

[0473] An example of a trigger criteria may be, for example, re-establishment of an access plane on a same or better TRP, for example, when a WTRU loses uplink synchronization (TAT expiration) and/or when a WTRU goes out of sync at lower layers.

[0474] An example of a trigger criteria may be, for example, WTRU mobility based on, for example, one or more of: a discovery of a new TRP associated with a serving anchor control function, a measurement events at (L1/L2/L3) above a predefined threshold; and/or a reception of a new system signature above (or below) a predefined threshold.

[0475] A TRP/network may trigger access plane establishment, for example, when one or more of the following criteria is satisfied: upon command from central control plane entity; upon receiving user plane data, e.g. paging; and/or upon an addition of a new TRP and/or cell group.

[0476] Access plane establishment may involve, for example, one or more of the following: a WTRU may trigger a random access on a predefined UL resource determined by system signature; and/or a WTRU may trigger a random access procedure on a multi-point random access resource.

[0477] A WTRU may consider an access plane established, for example, when it receives one or more RAR messages that pass a suitability criteria.

[0478] A WTRU may take one or more actions after establishing an access plane. For example, a WTRU may be uplink synchronized and/or may (e.g. be required to) maintain the synchronization.

[0479] WTRU may be assigned an identifier, e.g., to uniquely identify a WTRU with a single TRP or a group of TRPs. For example, a WTRU may monitor downlink control channels for possible scheduling grants and/or feedback. For example, a WTRU transmit periodic and/or event triggered feedback and/or reference signals on the uplink control channels.

[0480] Access plane establishment may enable one or more of the following: a WTRU may be reachable at TRP level granularity; and/or a WTRU may be assigned dedicated physical resources (e.g. UL control channel resources, semi-persistent resources, etc.).

[0481] A WTRU may transmit higher layer data and/or signaling terminated at a TRP and/or signaling messages terminated at the RCCRF to setup control plane. A WTRU may (e.g. additionally) transmit L3 control/signaling, measurement report, NAS signaling messages, etc., for example, when the control plane may be set up. A WTRU may (e.g. additionally) transmit application/user data, for example, when the user plane is set up.

[0482] A radio link monitoring (RLM) function may be provided, for example, as a WTRU-specific function, a component-specific function and/or a plural-component function.

[0483] A WTRU-specific function, for example such as an RLM function may be configured per WTRU.

[0484] A component-specific function, for example such as an RLM function may be configured per WTRU-TRP pair and/or a WTRU-ACF pair.

[0485] A plural-component function, for example such as an RLM function may be configured per group of components, such as one or more, or multiple cells, one or more, or multiple TRPs, one or more, or multiple TRPGs, and/or one or more, or multiple NR-eNBs, etc. For example, a WTRU may perform radio link monitoring on one or more (e.g. a subset of TRPs per group of TRPs). A WTRU may consider the measurements on a TRP as indicative of radio link status for a group of TRPs. For example, a WTRU may consider measurements on a (e.g. any) TRP as indicative of radio link status for a group of TRPs.

[0486] A WTRU may be configured with a different monitoring procedure, for example, based on one or more of the characteristics/property of Uu with a TRP, a nature of a service and/or a WTRU state.

[0487] One or more characteristics/property of Uu with a TRP, for example such as an RLM procedure for a beamformed Uu may be different from a narrow band Uu. For example, an RLM may be optional in some scenarios, e.g., in an unlicensed Uu.

[0488] In an example of a nature of a service, one or more aspects of an RLM procedure may be tied to the type of services active in a WTRU. For example, a WTRU may perform RLM with (e.g. strict) thresholds while using a URLLC service.

[0489] For example one or more aspects of an RLM procedure may be tied to one or more WTRU states. For example, a WTRU may perform a relaxed monitoring procedure in a light connected state, e.g., compared to fully connected state.

[0490] A radio link failure handling function may be, for example, a WTRU-specific function, component-specific function and/or a plural-component function.

[0491] A WTRU may support multi-connectivity to increase reliability, mobility robustness, throughput etc. For example, a relation between configured cells for a WTRU may be flexible. A (e.g. one or more, or each) cell configured for a WTRU may be dynamically assigned different roles. For example, a cell may be a Pcell, PScell and/or Scell, where roles may vary with time, e.g., based on predefined criteria and/or measurements.

[0492] A WTRU may (e.g. be required to) determine and/or may react to different types of failure. A WTRU may (e.g. with a distributed control plane architecture) distinguish between aspects related to connectivity to a TRP, reachability to different control functions, etc.

[0493] For example, a WTRU may determine different types of failure, such as a TRP level failure, an ACF level failure and/or an RCCF failure.

[0494] For example, a TRP level failure may be related to status of lower layer functions, e.g., loss of timing, unsuitability based on measurements below threshold, etc.

[0495] For example, an ACF level failure may be related to unreachability of a specific ACF. A WTRU may trigger a report to a central control function, which may include which ACF failed and/or a reason for failure.

[0496] For example, an RCCF failure may be related to unreachability of a central control function, for example, based on a timer expiring from the last interaction with RCCF.

[0497] A WTRU may decouple a capability to transmit data from different levels of failure on a control plane. For example, a TRP level failure might not trigger a WTRU to suspend the data transmissions. For example, a WTRU may continue data transmissions, for example, even while a control plane is being re-established. For example, a WTRU may perform connectionless transfer, for example, while trying to recover from partial control plane failure.

[0498] A mobility control function may be a WTRU-specific function, component-specific function and/or a Plural-component function.

[0499] WTRU mobility may be (e.g. closely) tracked at the RAN for WTRUs, e.g., in light connected states and/or IDLE connectionless states. Tracking may be at a granularity of a TRP group and/or a central control function. Different levels of mobility control functions may be defined, such as one or more of the following: Intra-TRP (e.g. may include beam level mobility); Inter-TRP (e.g. may include mobility handling at ACF level without involving a central anchor

function); Inter-ACF (e.g. may be controlled by central anchor function and/or may be defined between LTE ACF and NR ACF in example of a tightly coordinated mobility function); Inter-RCCF (e.g. may be applicable for WTRUs in connected state and/or light connected state and/or a WTRU may support a control anchor change without a change to the user plane functions and/or user plane anchor); and/or Inter-RAT (e.g. may include mobility between NR to legacy RATs like GSM/UMTS, etc.).

[0500] Mobility control functions may be WTRU autonomous, network controlled, network assisted WTRU controlled and/or WTRU assisted network controlled.

[0501] Different parts of WTRU context and/or L2 state may persist after a mobility event. A WTRU may reset different parts of context and/or L2 state, for example, based on a type of mobility event. For example, a WTRU may use a specific set of rules to ‘convert’ a configuration/context upon handover to a different TRP/ACF. For example, a WTRU may retain parts of configuration and/or L2 context that are compatible while applying equivalent configurations and/or mapped configurations and/or while converting certain aspects during a mobility event between LTE and NR.

[0502] A WTRU may be configured with mobility restrictions. For example, a WTRU might not perform autonomous mobility to a LTE TRP.

[0503] A measurement configuration and reporting function may be a WTRU-specific function, component-specific function and/or a plural-component function.

[0504] A WTRU may transmit a measurement report to plurality of TRPs. A WTRU may, for example, based on a configuration, report beam related measurements (e.g. intra-cell beam level RRM measurements) to the associated TRP. A WTRU may report measurements of a plurality of TRPs to an associated ACF. For example, a WTRU may report measurements on LTE TRPs to an LTE ACF.

[0505] For example, a WTRU may differentiate measurements on TRPs associated with a serving central control function from the measurements on TRPs associated with a different central control function. For example, a WTRU may be configured to measure (e.g. only) the TRPs associated with a serving control function.

[0506] The placement of a measurement processing control function may be flexible. For example, a measurement processing control function may be placed closer to a WTRU, e.g., for URLLC service.

[0507] A security and authentication control function may be a WTRU-specific function, component-specific function and/or a plural-component function.

[0508] A WTRU may treat security aspects associated with an ACF independently from other ACFs. For example, a security failure in ACF may be localized to that ACF and/or might not affect WTRU connectivity to other ACFs.

[0509] For example, a WTRU may perform independent integrity protection for control plane messages, such as control plane signaling towards an ACF and/or control plane signaling towards an RCCF.

[0510] For example, WTRU control signaling towards an RCCF may be placed in a container within ACF messages. A WTRU may apply (e.g. only) ACF integrity protection to the RCCF messages.

[0511] For example, a WTRU may obtain integrity protection keys for a (e.g. one or more, or each) ACF, for example, based on interaction with those ACFs. A WTRU may obtain integrity protection keys for an (e.g. one or more, or each) ACF from the RCCF.

[0512] Configuration failure handling may be a WTRU-specific function, component-specific function and/or a plural-component function.

[0513] A WTRU may trigger failure handling, for example, based on a control function that triggered the configuration. For example, configuration failure for an access control function might not affect WTRU association with other access control functions. A WTRU may report a failure to the RCCF indicating the specific ACF that triggered the configuration and/or the reason for failure, for example, when a WTRU is unable to comply with one or more aspects of a configuration. For example, a WTRU may perform connectionless signaling transfer, e.g., to report a configuration failure. For example, configuration failure towards a central control function might not affect WTRU capability to transmit data over the user plane. For example, configuration failure may trigger release of an access plane towards (e.g. one or more, or all) the access control functions.

[0514] A Logical association may be defined between PDU carrying control signaling. An association may, for example, be based on data units being associated with an access control function or an instance thereof, with a central control function or instance thereof and/or with the same SOM and/or slice. For example, an association may be characterized, for example, by at least one of a chaining of processing functions, an applicable physical data (and/or control) channel (or instance thereof) and/or an instantiation of a protocol stack, which may include a specific portion being centralized (e.g. anchor control function) and another portion being closer to the edge (e.g. access control function).

[0515] An example of logical association may be a signaling radio bearer (SRB). A WTRU may have one or more, or multiple termination points for control signaling. A WTRU may a

have signaling association towards an access control function, e.g., access signaling radio bearer (ASRB). A WTRU may (e.g. in case of multi-connectivity) have more than one ASRB. An (e.g. one or more, or each) ASRB may terminate at a different access control function. A WTRU may have a signaling association towards an anchor control function (e.g. a central SRB (CSRB)) that may terminate at the anchor control function.

[0516] A WTRU may transmit a control message on the same SRB that carried an original message, for example, when the control message is a response to a control message from a network (e.g. setup and/or reconfiguration message). For example, a WTRU may address a response to an access control function that transmitted the control message. In an (e.g. another) example, a WTRU may transmit a response to a control message received from a downlink cell group, e.g., in an uplink cell group associated with the same MAC instance.

[0517] An (e.g. one or more, or each) ASRB may be associated with a MAC instance. Mapping ASRB to physical channels may be specific to one or more, or each ACF instance. For example, the characteristics of physical channels that carry ASRB may be different from physical channels carrying data packets. For example, an ASRB may be mapped to physical channels with wider spatial coverage, for example, when a MAC instance utilizes beamformed channels.

[0518] A WTRU may use data transmission services provided, for example, by the access plane, e.g., to transmit a control signaling message towards an anchor control function.

[0519] A WTRU may be preconfigured with a (e.g. exactly one) MAC instance to transmit control signaling (e.g. a message) towards an anchor control function. For example, a MAC instance may be associated with a macro TRP.

[0520] For example, a WTRU may be configured with one or more MAC instances for CSRB transmission. A WTRU may shortlist candidate MAC instances, for example, based on one or more criteria, such as one or more of access plane status, UL TAT, prohibited MAC instances, coverage of a TRP, security status and/or activation status.

[0521] For example of an access plane status, a WTRU may choose MAC instances for which an access plane is already established.

[0522] For example of UL TAT, a WTRU may choose MAC instances with valid UL timing (e.g. TAT timer is running).

[0523] For example of prohibited MAC instances, a WTRU may consider one or more MAC instances that are not prohibited for CSRB transmission. For example, a WTRU may be configured with blacklisted MAC instances that might not carry CSRB transmission and/or (e.g.

equivalently) a WTRU may be configured with whitelisted MAC instances for CSRB transmission.

[0524] For example of coverage of a TRP, a WTRU may choose MAC instances that are associated with a larger coverage, e.g., belonging to a macro TRP.

[0525] For example of security status, a WTRU may choose MAC instances associated with ACFs for which security context may be (e.g. already) established. For example, a WTRU might not consider MAC instances for which an authentication/security mode procedure is ongoing or not yet started. For example, a WTRU may wait for security activation for the access control function to complete before transmission of control message towards the anchor control function.

[0526] In an example of activation status, a WTRU may choose MAC instances that may be configured and/or activated by a network.

[0527] For example, a WTRU may have one or more, or multiple candidate MAC instances available for CSRB transmission. A WTRU may select a MAC instance for a CSRB transmission in one or more ways, such as based on signal quality, transmission opportunity, explicit priority, reliability, outcome of previous transmission and/or linked MAC status.

[0528] In an example of signal quality, a WTRU may choose a MAC instance with a better signal quality metric (e.g. RSRP/RSRQ/Hypothetical PDCCH error rate) for one or more cells in the cell group associated with that MAC instance.

[0529] In an example of transmission opportunity, a WTRU may choose a MAC instance with the earliest transmission opportunity. A WTRU may prefer a MAC instance with an available scheduling grant over a MAC instance that may find a resource request procedure useful and/or may have (e.g. only) contention based resources. A WTRU may (e.g., temporarily) suspend transmissions on MAC instances that may have an outstanding reconfiguration procedure that reconfigures one or more characteristics associated with that MAC instance.

[0530] In an example of explicit priority, a (e.g. one or more, or each) MAC instance may be associated with a priority. A WTRU may choose the MAC instance with highest priority for transmission of CSRB messages.

[0531] In an example of reliability, a WTRU may choose to transmit the same control message over plurality of MAC instances, for example, for control messages that may require high reliability (e.g. those associated with ultrareliable services).

[0532] In an example of outcome of previous transmission, a WTRU may choose a different MAC instance (e.g. for retransmission) than the MAC instance used for a (e.g. an original) failed transmission.

[0533] In an example of a linked MAC instance – WTRU may (e.g. for a response control message) choose the same MAC instance on which the corresponding request/setup control message was received.

[0534] For example, a WTRU may perform MAC instance selection (e.g. only) during initial registration and/or association towards a new anchor control function. A WTRU may use the same MAC instance for a (e.g. any) subsequent control message exchange with that anchor control function.

[0535] For example, a WTRU may perform MAC instance selection (e.g. once) for a (e.g. one or more, or each) control signaling procedure with the anchor control function. A control signaling procedure may involve one or more control signaling message transactions. For example, a (e.g. one or more, or all) control messages belonging to the same procedure may be transmitted over a (e.g. single) MAC instance.

[0536] For example, a WTRU may perform MAC instance selection for a (e.g. one or more, or each) control message transmission. For example, control messages belonging to the same procedure may be transmitted over different MAC instances. A WTRU may switch to a different MAC instance, for example, for a retransmission of the control message.

[0537] A WTRU may prioritize transmission signaling messages mapped to ASRB over control signaling mapped to CSRB. A WTRU may have an access control message and/or an anchor control message ready for transmission. For example, a WTRU may (e.g. first) transmit an access control message in the earliest transmission opportunity and/or may (e.g. subsequently) transmit the anchor control message in the same subframe/TTI from the same MAC instance or a different MAC instance, for example, when resources are available and/or in the next available resource from the same MAC instance or a different MAC instance. For example, a WTRU may wait for the completion of the ongoing procedure with the access control function and then transmit the anchor control message at the first available transmission opportunity. For example, a WTRU may be configured with two more ASRBs mapped to the same MAC instance. One or more, or each of the ASRBs may be identified by a different logical channel identity and/or ASRB identity. A WTRU may be preconfigured with rules to prioritize between two or more ASRBs mapped to the same MAC instance. For example, a prioritization may be implicit, e.g., based on the type of control message and/or based on explicit SRB identity/logical channel identity.

[0538] A WTRU may provide an (e.g. additional) indication in a PDU, for example, to differentiate a control message addressed to access a control function from a control message addressed to an anchor control function. For example, an indication may include one or more of

the following: a logical channel identity, an explicit indication of a type of message and/or an explicit identity of an anchor control function.

[0539] In an example of a logical channel identity, a different logical channel identifier may be used to differentiate different ASRB within the same MAC instance. Logical channel identifiers may be reserved, for example, to indicate that the control message belongs to CSRB.

[0540] In an example of an explicit indication of a type of message, a (e.g. one or more, or each) control message may carry an indication for a type of the message. For example, a first type may indicate that it may be an access control message and/or a second type may indicate an anchor control message.

[0541] In an example of an explicit identity of anchor control function, a WTRU may (e.g. additionally) provide an explicit identity of a destination anchor control function, for example, when the access control function may be associated with more than one instance of the anchor control function. A WTRU may transmit a special/reserved identity, for example, to indicate lack of previous interaction with an anchor control function (e.g. a network may select a new anchor control function to deliver the control message).

[0542] A WTRU may receive a control message with configuration. A configuration may be applicable, for example, to a specific cell within a cell group associated with a MAC instance, to multiple (e.g. one or more, or all) cells within a cell group associated with a MAC instance, to a group of MAC instances or to one or more, or all MAC instances. For example, configuration parameters may include one or more of the following: slicing configuration, supported services configuration, addition/removal/modification of cells, QoS configuration, DRX configuration, security configuration, measurement configuration, dedicated radio resource configuration like SRB configuration, DRB configuration including PDCP and/or RLC and/or MAC configuration, physical channel configuration, SPS-configuration, etc.

[0543] A WTRU may determine the applicability of a configuration, for example, based on one or more criteria, such as a type of SRB, a linked MAC instance and/or an explicit access control identity.

[0544] In an example of a type of SRB, a WTRU may apply configuration parameters received in the ASRB applicable (e.g. only) to a MAC instance associated with the ASRB. A WTRU may consider the configuration parameters received in CSRB applicable to (e.g. one or more, or all) the MAC instances, e.g., unless explicitly indicated within the configuration message.

[0545] In an example of a linked MAC instance, a WTRU may apply configuration parameters received from a cell/cell group to a MAC instance associated with that cell/cell group.

[0546] In an example of an explicit Access control function identity, a WTRU may receive configuration parameters with an explicit indication of a MAC instance to which the configuration is applicable. For example, a WTRU may receive a MAC identity and/or access control function identity, e.g., along with the configuration parameters.

[0547] For example, a WTRU may be configured with a linked-SRB. A linked-SRB may be an ASRB that may be associated with one or more DRBs. For example, linkage may be many-to-many association. A (e.g. one or more, or each) DRB may be linked to one or more ASRBs. A WTRU may apply configurations received in a ASRB to (e.g. only) the DRBs linked with the ASRB.

[0548] For example, a WTRU may (de)multiplex control signaling (e.g. RRC PDUs and/or the like) using different logical connections, bearers (e.g. SRB0, 1, 2, 3, etc. and/or using different sets thereof), flow-based treatment (e.g. based on configured tuples applicable to L3 protocols), for example, as a function of the logical grouping of the function that generated the RRC SDU.

[0549] For example, a WTRU RRC function for access plane establishment may generate an RRC SDU that may be mapped to a specific SRB. An SRB may correspond to a set thereof. A set may be associated with the Access Plane connection being established. For example, a procedure may use a first SRB corresponding to the set of SRBs available for establishment of such connection, for example, for initial access to the system (e.g. while security is not yet activated). A (e.g. the) procedure may use a second SRB otherwise, for example, when at least part of the security may be activated, e.g., for the RCCF. A WTRU may (e.g. in the latter case) include authentication (and/or encryption), for example, for at least part of the RRC SDU, e.g. the part of the SDU that may be used to determine the identity of a WTRU and/or may provide capability for the network to fetch a WTRU's context.

[0550] A WTRU RRC function for central control plane may (e.g. similarly) generate an RRC SDU that may be mapped to a different specific SRB (e.g. an SRB that may correspond to a different set of SRBs).

[0551] For example, different logical grouping of functions may have different sets of SRBs from each other.

[0552] For example, when a single set of logical paths may be configured, and/or when a WTRU may be configured with a (e.g. one) set of logical paths for one or more, or each type of

logical grouping), an RRC SDU may include an identifier (e.g. the identity of the instance of the logical group of functions that generated the SDU), for example, when a WTRU may be configured with one or more, or multiple user plane “slices” and/or equivalent.

[0553] For example, procedures may be (e.g. further) applied, for example, (e.g. similarly) as a function of the physical transport paths. Grouping of functions and/or association of transport paths may be a configurable aspect, e.g., from a WTRU’s perspective.

[0554] Systems, procedures, and instrumentalities (e.g. aspects of entities, interfaces and procedures in a wireless transmit/receive unit (WTRU) and/or network layers L1, L2, L3) have been disclosed for distributed control in wireless systems, such as 5G flexible radio access technology (RAT) (5gFLEX). Example procedures are provided for WTRU and network operation associated with a distributed control plane architecture, connectionless data transfer and dedicated system information acquisition. Distributed control may be provided, for example, by replicating a plurality of access control functions (ACFs) using a plurality of instances in a plurality of different transmission/reception points (TRPs) with multi-connectivity. The plurality of TRPs may concurrently provide control services to a WTRU. Centralized control functions may manage core network connectivity and/or a plurality of user plane instances for the WTRU and/or may facilitate coordination between the plurality of ACF instances for the WTRU in the plurality of different TRPs of the WTRU’s configuration. For example, there may be a first access plane between the WTRU and a first TRP that provides a first ACF for the WTRU, a second access plane between the WTRU and a second TRP that provides a second ACF for the WTRU, a RAN central control plane between the WTRU and a first RAN central control function (RCCF) and a RAN central user plane between the WTRU and a RAN central user function (RCUF).

[0555] The processes and instrumentalities described herein may apply in any combination, may apply to other wireless technologies, and/or for other services.

[0556] A WTRU may refer to an identity of the physical device, and/or to the user’s identity such as subscription related identities, e.g., MSISDN, SIP URI, etc. WTRU may refer to application-based identities, e.g., user names that may be used per application.

[0557] One or more, or each of the computing systems (e.g., WTRU) described herein may have one or more computer processors having memory that are configured with executable instructions and/or hardware for accomplishing the functions described herein including determining the parameters described herein and/or sending and receiving messages between entities (e.g., WTRU and network) to accomplish the described functions. The processes described above may be implemented in a computer program, software, and/or firmware

incorporated in a computer-readable medium for execution by a computer and/or processor. Except as explicitly noted, determinations in reference to a computer generally refers to a processor programmed with instructions for determining. Likewise, the term store in reference to a computer generally means a processor programmed with instructions for storing in computer memory.

[0558] The processes described above may be implemented in a computer program, software, and/or firmware incorporated in a computer-readable medium for execution by a computer and/or processor. Examples of computer-readable media include, but are not limited to, electronic signals (transmitted over wired and/or wireless connections) and/or computer-readable storage media. Examples of computer-readable storage media include, but are not limited to, a read only memory (ROM), a random access memory (RAM), a register, cache memory, semiconductor memory devices, magnetic media such as, but not limited to, internal hard disks and removable disks, magneto-optical media, and/or optical media such as CD-ROM disks, and/or digital versatile disks (DVDs). A processor in association with software may be used to implement a radio frequency transceiver for use in a WTRU, terminal, base station, RNC, and/or any host computer.

Under the Paperwork Reduction Act of 1995, no persons are required to respond to a collection of information unless it displays a valid OMB control number.

PATENT APPLICATION FEE DETERMINATION RECORD Substitute for Form PTO-875		Application or Docket Number 16/099,390	Filing Date 11/06/2018	<input type="checkbox"/> To be Mailed		
ENTITY: <input checked="" type="checkbox"/> LARGE <input type="checkbox"/> SMALL <input type="checkbox"/> MICRO						
APPLICATION AS FILED - PART I						
	(Column 1)	(Column 2)				
FOR	NUMBER FILED	NUMBER EXTRA	RATE (\$)	FEE (\$)		
<input type="checkbox"/> BASIC FEE <small>(37 CFR 1.16(a), (b), or (c))</small>	N/A	N/A	N/A			
<input type="checkbox"/> SEARCH FEE <small>(37 CFR 1.16(k), (l), or (m))</small>	N/A	N/A	N/A			
<input type="checkbox"/> EXAMINATION FEE <small>(37 CFR 1.16(o), (p), or (q))</small>	N/A	N/A	N/A			
TOTAL CLAIMS <small>(37 CFR 1.16(j))</small>	minus 20 =	*	x \$100 =			
INDEPENDENT CLAIMS <small>(37 CFR 1.16(h))</small>	minus 3 =	*	x \$460 =			
<input type="checkbox"/> APPLICATION SIZE FEE (37 CFR 1.16(s))	If the specification and drawings exceed 100 sheets of paper, the application size fee due is \$310 (\$155 for small entity) for each additional 50 sheets or fraction thereof. See 35 U.S.C. 41(a)(1)(G) and 37 CFR 1.16(s).					
<input type="checkbox"/> MULTIPLE DEPENDENT CLAIM PRESENT (37 CFR 1.16(j))						
* If the difference in column 1 is less than zero, enter "0" in column 2.			TOTAL			
APPLICATION AS AMENDED - PART II						
	(Column 1)	(Column 2)	(Column 3)			
AMENDMENT	11/06/2018	CLAIMS REMAINING AFTER AMENDMENT	HIGHEST NUMBER PREVIOUSLY PAID FOR	PRESENT EXTRA	RATE (\$)	ADDITIONAL FEE (\$)
Total <small>(37 CFR 1.16(i))</small>	* 40	Minus	** 20	= 20	x \$100 =	2000
Independent <small>(37 CFR 1.16(m))</small>	* 4	Minus	*** 3	= 1	x \$460 =	460
<input type="checkbox"/> Application Size Fee (37 CFR 1.16(s))						
<input type="checkbox"/> FIRST PRESENTATION OF MULTIPLE DEPENDENT CLAIM (37 CFR 1.16(j))						
					TOTAL ADD'L FEE	2460
AMENDMENT		CLAIMS REMAINING AFTER AMENDMENT	HIGHEST NUMBER PREVIOUSLY PAID FOR	PRESENT EXTRA	RATE (\$)	ADDITIONAL FEE (\$)
Total <small>(37 CFR 1.16(i))</small>	*	Minus	**	=	x \$0 =	
Independent <small>(37 CFR 1.16(m))</small>	*	Minus	***	=	x \$0 =	
<input type="checkbox"/> Application Size Fee (37 CFR 1.16(s))						
<input type="checkbox"/> FIRST PRESENTATION OF MULTIPLE DEPENDENT CLAIM (37 CFR 1.16(j))						
					TOTAL ADD'L FEE	
* If the entry in column 1 is less than the entry in column 2, write "0" in column 3.					LIE	
** If the "Highest Number Previously Paid For" IN THIS SPACE is less than 20, enter "20".					/SHERRY A DAVIS/	
*** If the "Highest Number Previously Paid For" IN THIS SPACE is less than 3, enter "3".						
The "Highest Number Previously Paid For" (Total or Independent) is the highest number found in the appropriate box in column 1.						

This collection of information is required by 37 CFR 1.16. The information is required to obtain or retain a benefit by the public which is to file (and by the USPTO to process) an application. Confidentiality is governed by 35 U.S.C. 122 and 37 CFR 1.14. This collection is estimated to take 12 minutes to complete, including gathering, preparing, and submitting the completed application form to the USPTO. Time will vary depending upon the individual case. Any comments on the amount of time you require to complete this form and/or suggestions for reducing this burden, should be sent to the Chief Information Officer, U.S. Patent and Trademark Office, U.S. Department of Commerce, P.O. Box 1450, Alexandria, VA 22313-1450. DO NOT SEND FEES OR COMPLETED FORMS TO THIS ADDRESS. **SEND TO: Commissioner for Patents, P.O. Box 1450, Alexandria, VA 22313-1450.**

If you need assistance in completing the form, call 1-800-PTO-9199 and select option 2.