

By Nicholas Smith, Manager Wireless Power Product Applications Engineering, Integrated Device Technology, Inc.

**Abstract:** Wireless power transfer is accomplished using two isolated halves of an air-core transformer (a transmitter pad and a mobile receiver device, such as a cell phone). Due to the lack of a continuous core, accurate mathematical models that can predict the performance of a wireless power transfer system are challenging to create. The magnetic losses are substantially increased due to the low coupling caused by the lack of continuous core material. This article will discuss the challenges of simulation and the methods that can develop a sufficiently close approximation in order to generate inductor samples. The standard method to determine the resonance point in order to improve the efficacy of the system is described. A demonstration is provided for the best practice methods for optimally tuning the resonance circuits to achieve peak efficiency while charging a mobile device with a Qi® and/or PMA® inductive resonance circuit.

## Introduction

Wireless power transfer is accomplished using two isolated halves of an air-core transformer (a transmitter pad and a mobile receiver device, such as a cell phone). Due to the lack of a continuous core, accurate mathematical models that can predict the performance of wireless power transfer systems are challenging to create, and it is difficult to represent all real-use cases. Rough estimates are possible using standard mutual inductance calculations, but often due to limited resources or time, these estimates do not account for physical geometries of the actual coils that will be used. Other challenges that are difficult to account for are the magnetic losses and energy that will be consumed by ferrous materials necessary for the final system transmitter and receiver designs. This article will discuss the challenges of simulation and focus on the methods that can develop an adequate approximation in order to generate inductor samples. Finally with consideration for the Qi® and AirFuel® inductive resonance standards, a demonstration is provided for the best practice methods for empirically determining the resonance point of the system and for tuning the receiver resonance tank to maximize the efficiency based on the efficacy of the system.

As the market leader supplying integrated circuits for wireless power transfer, Integrated Device Technology, Inc. (IDT®) has accumulated a great deal of experience in tuning such circuits to optimize efficiency. A quick introduction is in order for the two most prominent inductive resonance standards that wireless power designs can follow, the Wireless Power Consortium's Qi ("Chi") and AirFuel (a merger of two prior standards groups: PMA and A4WP). Qi and PMA both call for designs that operate within the frequency range of 110kHz to 300kHz. Typical systems are based on input voltages of 5VDC, 12VDC, and 18 to 19 VDC. In general, the higher the input voltage, the higher the Tx coil inductance, and the Tx side of the system is typically designed to resonate at 100kHz. In order to control the amount of power being transferred, the operating frequency is adjusted and is always kept above the resonance frequency of the Tx LC tank. A frequency change toward resonance (lower frequency than the current set point) results in more power delivered, and a change away from resonance (increase in frequency) results in less power delivered to the receiver.

In these systems, the Rx demand (which is typically, but not exclusively, the amount of charge required to fully charge the battery plus any system needs while charging) is used to control the Tx by communication from the Rx to the Tx. Systems currently available in the market are designed to provide 5W up to 15W and are designed to charge one device per charging pad. An in-depth analysis of the system should quickly produce a large matrix of dependent variables inclusive of second and third order derivatives and nonlinear circuits, which can lead to confusion and distraction. For example, the Tx side is composed of active semiconductors that control a DC-to-AC inverter that drives the Tx series LC resonance tank, which is composed of a coil with a given area, inductance, and number of turns, which is firmly attached to a ferrite shield with some permeability, connected in series with a resonance capacitor bank. It is designed to operate below the saturation point of the ferrite material.

Then there is the space inherent to the Tx design above the surface of the coil and some ferrous materials plus a stylish case, which is then coupled to an Rx device, such as a cell phone. When it is placed in close proximity to the center of the Tx coil, a magnetic coupling is created and used to transfer energy from the Tx to the Rx device. The Rx device is composed of a ferrous lithium-ion battery, any other permeable materials necessary to the device (such as copper PCBs and metallic cases), a secondary Rx coil with a given area and number of turns, and a second ferrite shield in series with another resonance capacitor. The Rx resonance tank feeds active semiconductor devices that convert the AC energy into DC in order to charge the Rx device. The mutual inductance is a function of the coupling, which depends on the distance between coils; the angle of the magnetic flux intersection with the Rx coil; remaining battery life (output load); and even the temperature of the system. To control the transmitted power, the receiver communicates with the transmitter by modulating the incoming AC magnetic field, which results in Rx impedance changes that are reflected across the mutual inductance and are detectable by the Tx. The Rx sends a series of digital communication messages that are used to adjust power levels or terminate power transfer as well as to authenticate valid devices.

## Application Design Methodology

It is the simple break-down of first-order variables during steady-state operation that influences the system, and if properly investigated, it should be determined that there are many other variables that can influence the performance at higher orders in addition to the necessary inclusion of non-steady-state variables, such as transients, temperature, spatial positioning, and rapid coupling changes in addition to the non-linear effects of the semiconductors themselves. While the analysis can be conducted and is always encouraged, under the influence of time to market, it is often productive to simply build a prototype based on educated first-order assumptions and test the performance to advance the system design toward release. In Figure 1, some of the key items associated with the magnetic system are shown and will be discussed in further detail.

**Figure 1. Cross Section of a Typical Wireless Power Transmitter (Tx) and Receiver (Rx)**

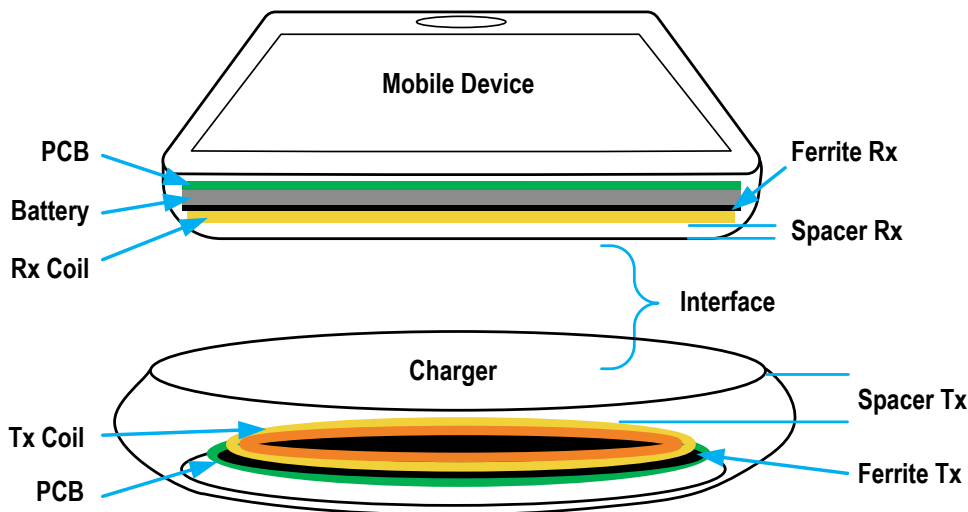

### Tx and Rx Coil Design

The most important parts of the system are the Tx and Rx coils, and these are positioned such that they are facing the interface. In order to maximize the efficacy of the system, the Tx and Rx devices need a spacer consisting of the cases (i.e. back cover of the phone and the plastic casing of the charger) that is 2 to 4 mm in thickness so that the system coupling is adequate for power transfer, but the devices are not so close to each other as to transfer too much energy to the Rx for proper conversion to DC.

In general, the Tx coil designs are well defined by the WPC and PMA specifications, which should be consulted when starting a design to determine the appropriate Tx coil and resonance capacitors. Standard coils are readily available. A common system is operated using a 5VDC input voltage with a 6.3μH Tx coil and 400nF resonance capacitors. If powered by IDT's P9239A Tx IC, a mobile device designed to comply with WPC or PMA standards can be wirelessly charged with this system. Each coil must have a ferrite sheet with high permeability in order to shield the device from magnetic fields and to concentrate the flux behind the respective coil during operation, which boosts system efficiency. Typically on the Tx, the ferrite is placed adjacent to and immediately above the main circuit board (PCB) with the Tx coil above the ferrite facing up toward the interface. Typically, the Rx device is stacked in the opposite order with the Rx coil facing down under the ferrite, which is typically next to the battery.

## Wireless Tx and Rx Controller IC Design

The primary components of the wireless power system are the integrated circuits (ICs) used to convert a DC power source to AC that energizes the Tx resonance tank, an Rx resonance tank that collects the AC power, and another set of ICs used to convert the AC power back to DC to be used to charge the battery or provide power to the receiver. Since different IC manufacturers will have different characteristics, they will not be specifically considered based on performance characteristics, but will be generalized so that the main power transfer elements, i.e., the Tx and Rx resonance tanks, can be considered in isolation.

In Figure 2, the wireless Tx and Rx controllers have been reduced to basic blocks. The TX controller is a DC-to-AC inverter and communication demodulator. The Rx controller is an AC-to-DC rectifier and communication generator.

**Figure 2. Basics of a Wireless Power System – Example using the P9235A Wireless Tx and the P9221 Wireless Rx**

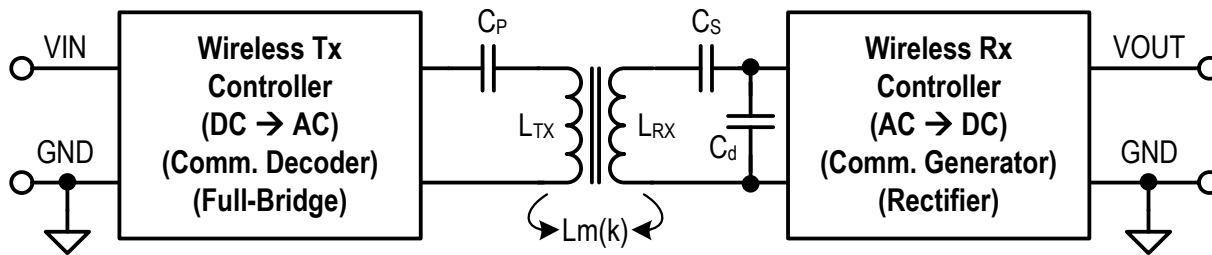

## Designing the Inductive Resonance Circuit

The components under discussion shown in Figure 2 are the Tx resonance tank comprised of  $C_P$  and  $L_{TX}$ , the mutual inductance based on the spacing (total of Tx and Rx spacers when the device to be charged is placed on the charger), and the resonance tank of the Rx composed of  $C_S$ ,  $L_{RX}$ , and  $C_d$ . Additional attributes of significance are the inner diameters of the Tx and Rx coils and the number of turns for each. As stated earlier, most Tx resonance tanks are well defined and designed to resonate at a certain frequency (100kHz typically). The Tx will always operate above 110kHz (or above resonance) to guarantee that the Tx does not stimulate the resonance tank at its resonant frequency and so that any frequency change can have a predictable effect on transmitted power (when operated at frequencies greater than the resonance frequency, additional increases in operating frequency will result in less transferred power and frequency decreases will result in more transmitted power).

In most Tx designs, there is a spacer above the Tx resonance coil that is 1.5 to 2 mm thick composed of non-ferrous material (Tx spacer) between the uppermost surface of the windings; below the Rx coil, there is commonly 0.75 to 1.5 mm of non-ferrous material between the bottom of the Rx coil windings and the interface. These two dimensions are critical to the performance of the system since the total thickness of the two spacers determines the effective  $k$  (coupling factor) that will govern the amount of energy transmitted at any given frequency based on the Tx coil attributes (inductance, Tx spacer, ferrite permeability, and number of turns) and the same features for the Rx coil.

For common Rx coil designs with 5W to 15W power levels, the most effective coils tend to have 7 to 10 turns and are  $7\mu\text{H}$  to  $11\mu\text{H}$ . An important attribute of the Rx coil design is to keep the windings tightly coupled and close together and to ensure that the inner diameter (ID, area in center of coil windings) is in the range of 75% to 125% of the size of the ID of the Tx coil most likely to be used with the Rx under development. It is fairly easy to narrow down the expected Tx types based on the power level that the Rx will demand by following the standard specifications. The Rx coil allows design flexibility, and the optimal component values are not always easily calculated depending on the constraints. Figure 3 and Figure 4 demonstrate a typical A11 Tx coil and Rx coil, respectively, that can be used with IDT controller ICs.

**Figure 3. Example: Würth 760308100111 WPC A11 Tx Coil (6.3µH) Used for 5W Wireless Power Systems**

Note: All dimensions are in mm.

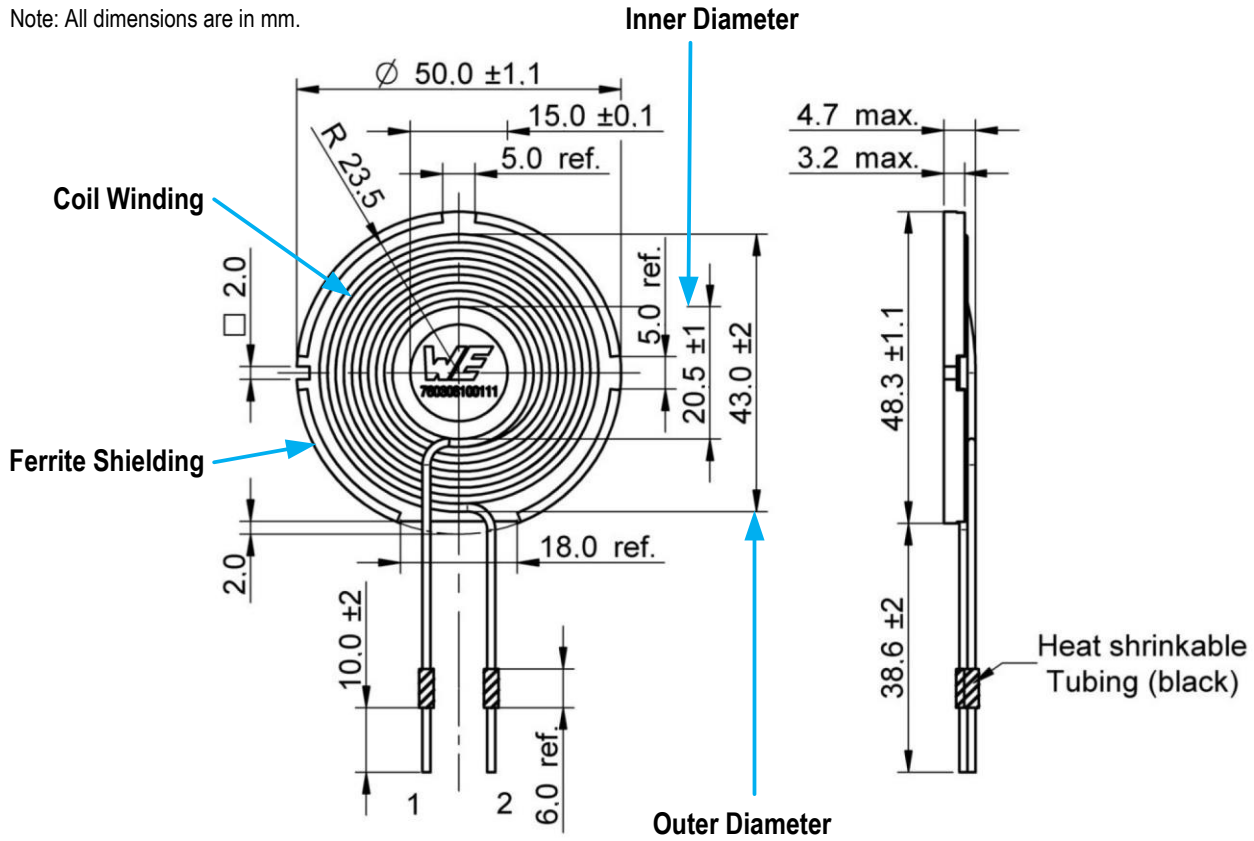

Image used with permission from Würth Elektronik GmbH.

**Figure 4. Example: Amotech ASC-504060M22-S00 Rx Coil (8.2μH) Used for 5W Wireless Power Systems**

Note: All dimensions are in mm.

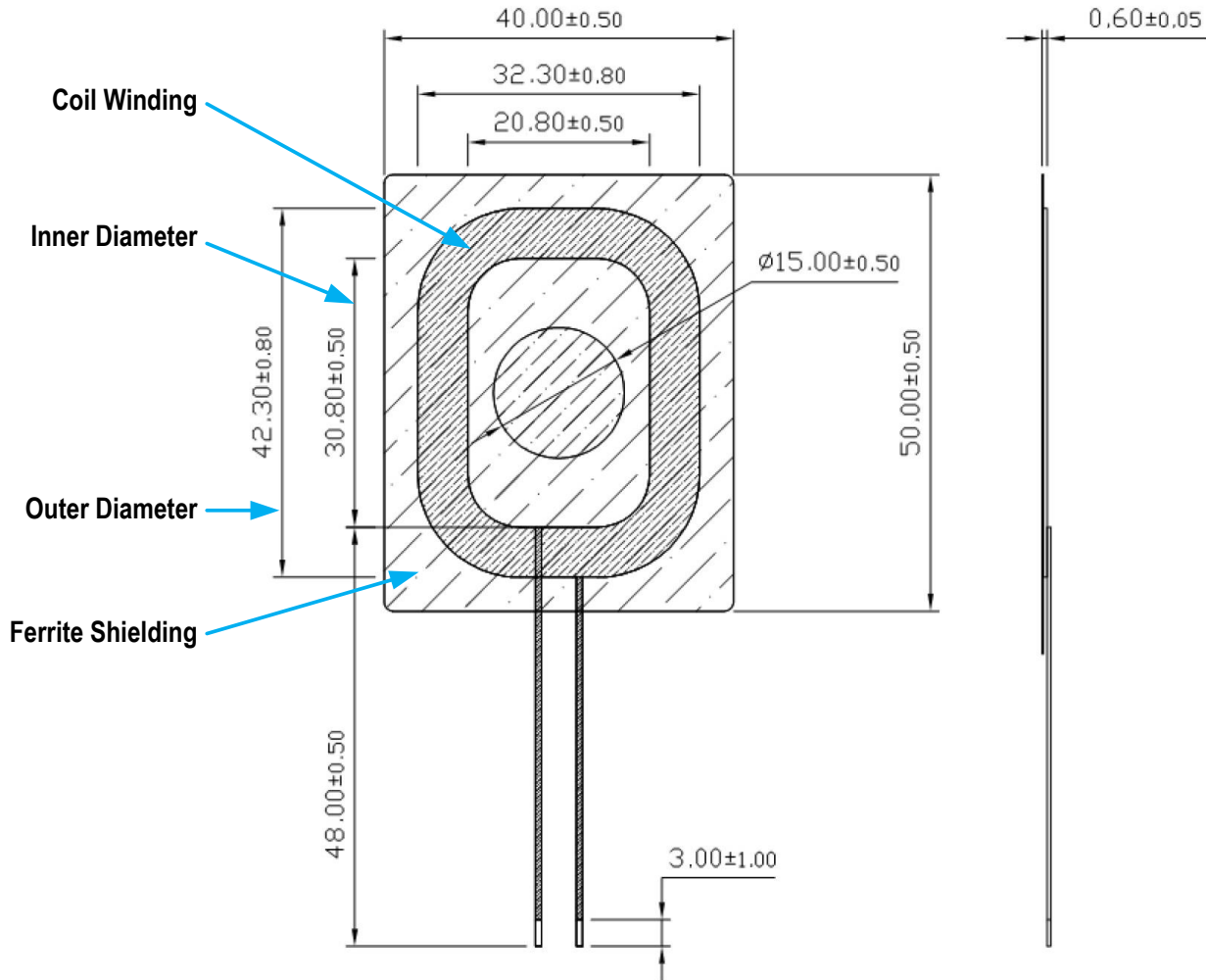

Image used with permission from AMOTECH Corp., Ltd.

## Tuning the Inductive Resonance Circuit

Most wireless power systems have the majority of the geometric limitation placed on the receiver design. As such, it is the receiver that plays the most critical role in fine-tuning the system. Normally the mechanical engineers for the Rx device will assign the physical dimensions that the Rx coil can occupy; once the available space is known, the Rx coil design should be undertaken. For very thin designs (< 0.7mm), flex PCB circuit types are the main solution due to the thin copper thickness in order to keep the ferrite as thick as possible. In general, thicker ferrites in the Rx will provide a more stable response across the power delivery range and thin ferrites tend to allow more flux to pass through their volume at higher power levels, which can result in degraded system performance at higher loads, such as diminished communication strength and poor transient step-load performance. In choosing the copper material, it should be considered that the copper wire types are thicker than the flex PCB type but have the advantage of having lower DC losses and thus offer higher efficiencies.

# Explore Litigation Insights

Docket Alarm provides insights to develop a more informed litigation strategy and the peace of mind of knowing you're on top of things.

## Real-Time Litigation Alerts



Keep your litigation team up-to-date with **real-time alerts** and advanced team management tools built for the enterprise, all while greatly reducing PACER spend.

Our comprehensive service means we can handle Federal, State, and Administrative courts across the country.

## Advanced Docket Research



With over 230 million records, Docket Alarm's cloud-native docket research platform finds what other services can't. Coverage includes Federal, State, plus PTAB, TTAB, ITC and NLRB decisions, all in one place.

Identify arguments that have been successful in the past with full text, pinpoint searching. Link to case law cited within any court document via Fastcase.

## Analytics At Your Fingertips



Learn what happened the last time a particular judge, opposing counsel or company faced cases similar to yours.

Advanced out-of-the-box PTAB and TTAB analytics are always at your fingertips.

## API

Docket Alarm offers a powerful API (application programming interface) to developers that want to integrate case filings into their apps.

## LAW FIRMS

Build custom dashboards for your attorneys and clients with live data direct from the court.

Automate many repetitive legal tasks like conflict checks, document management, and marketing.

## FINANCIAL INSTITUTIONS

Litigation and bankruptcy checks for companies and debtors.

## E-DISCOVERY AND LEGAL VENDORS

Sync your system to PACER to automate legal marketing.