



US 20070145255A1

(19) **United States**

(12) **Patent Application Publication**
Nishikawa et al.

(10) **Pub. No.: US 2007/0145255 A1**
(43) **Pub. Date: Jun. 28, 2007**

(54) **LENS-EQUIPPED LIGHT-EMITTING DIODE
DEVICE AND METHOD OF
MANUFACTURING THE SAME**

Publication Classification

(76) Inventors: **Shouichi Nishikawa**, Yokohama-shi
(JP); **Tetsuro Komatsu**, Yokohama-shi
(JP); **Hatsuo Takezawa**, Yokohama-shi
(JP); **Yukinori Aoki**, Yokohama-shi (JP)

(51) **Int. Cl.**
H01J 5/02 (2006.01)
H01J 40/14 (2006.01)
(52) **U.S. Cl.** **250/239**

(57) **ABSTRACT**

Correspondence Address:
**OBLON, SPIVAK, MCCLELLAND, MAIER &
NEUSTADT, P.C.**
1940 DUKE STREET
ALEXANDRIA, VA 22314 (US)

A lens-equipped light-emitting diode device of the present invention includes a lead frame in which an electrode is formed, a light-emitting diode which is mounted on the electrode of the lead frame, an outer peripheral unit which is made of a first resin, which is provided on the lead frame, and in which a hollow portion is formed while an area including at least the light-emitting diode is exposed in the outer peripheral unit, a sealing portion which is made of a second resin filled in the lead frame of the hollow portion of the outer peripheral unit, and which seals the light-emitting diode, and a lens unit made of a third resin laminated and filled in the sealing portion.

(21) Appl. No.: **11/613,503**

(22) Filed: **Dec. 20, 2006**

(30) **Foreign Application Priority Data**

Dec. 26, 2005 (JP) 2005-373498

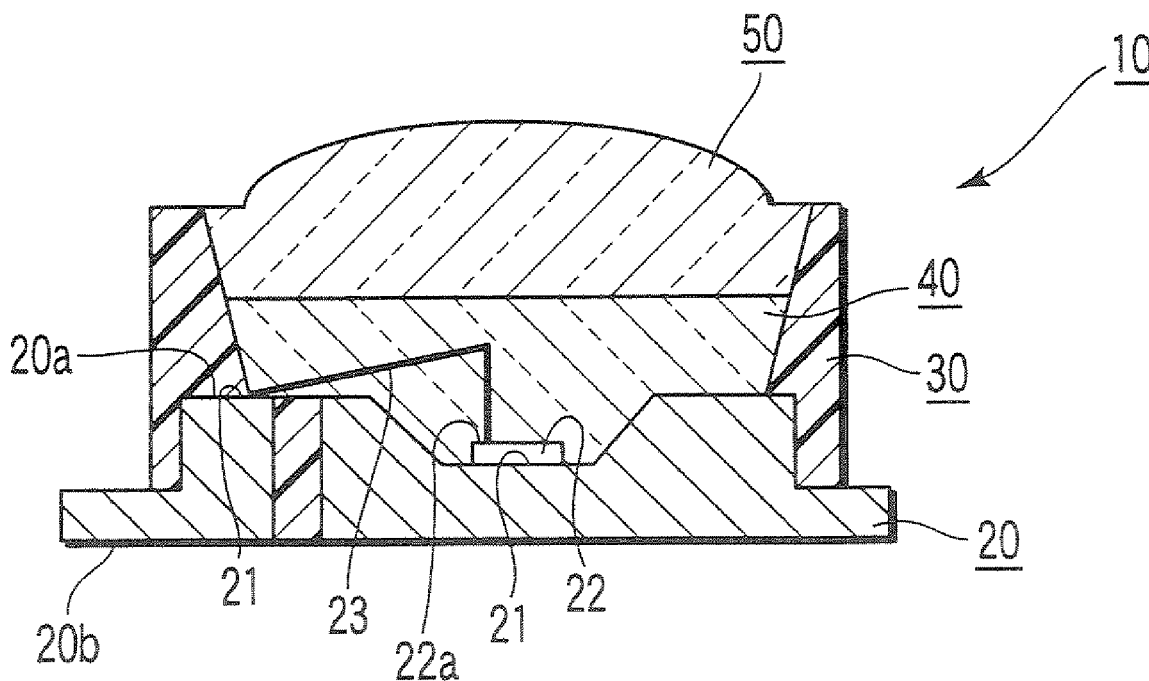

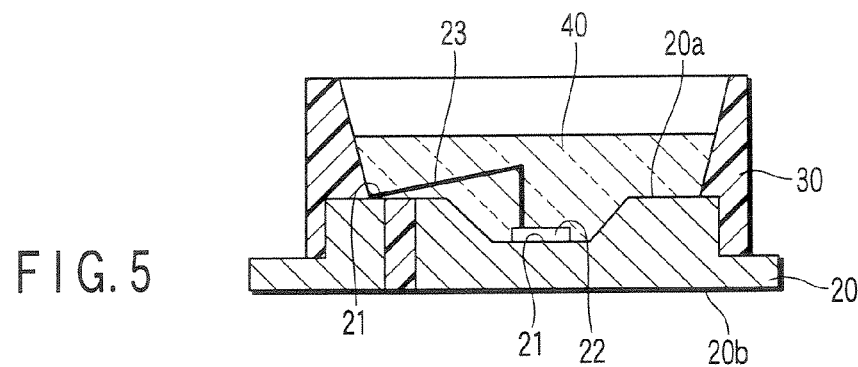
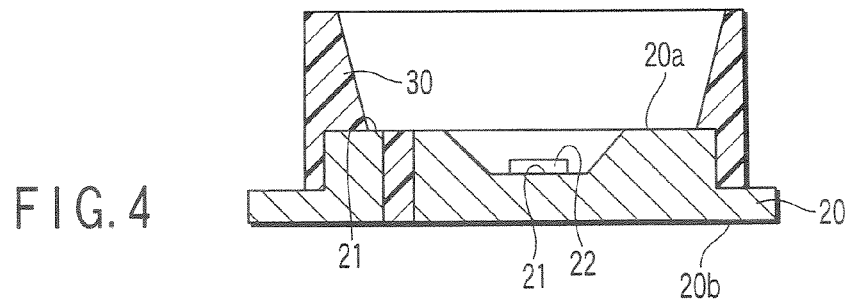
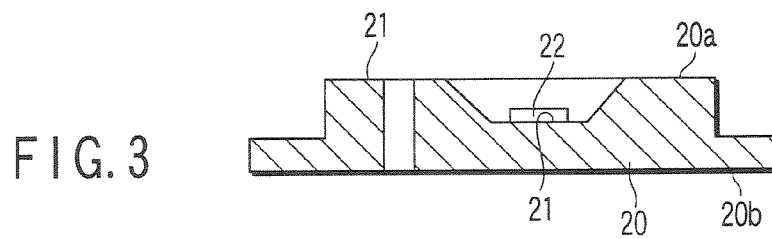
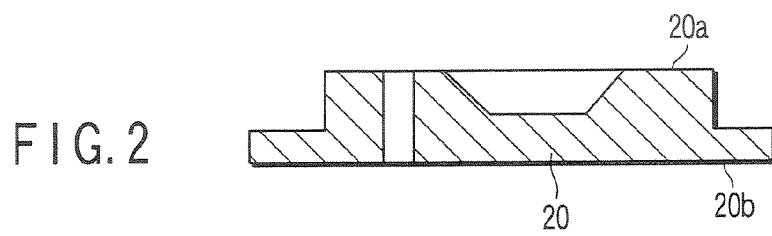
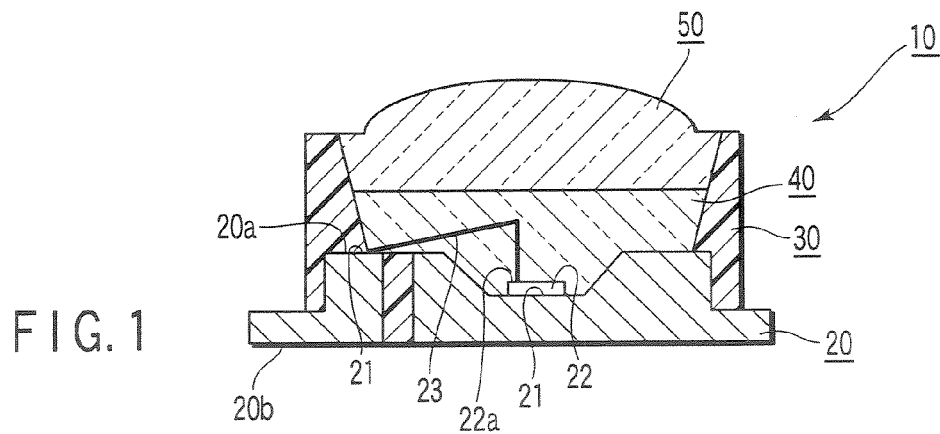

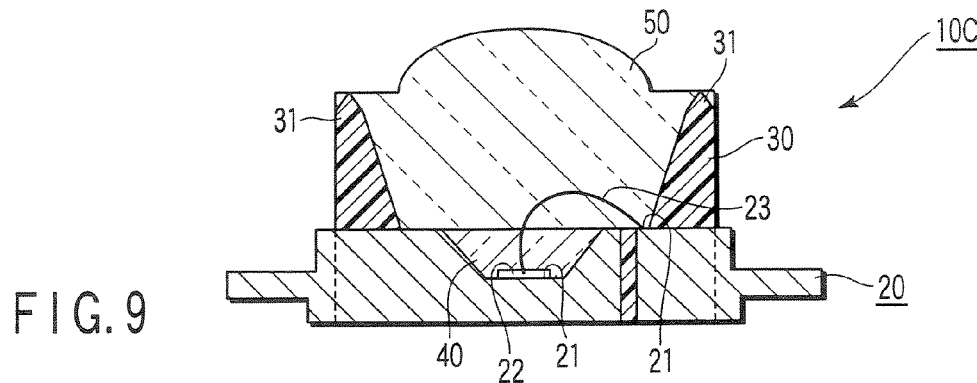
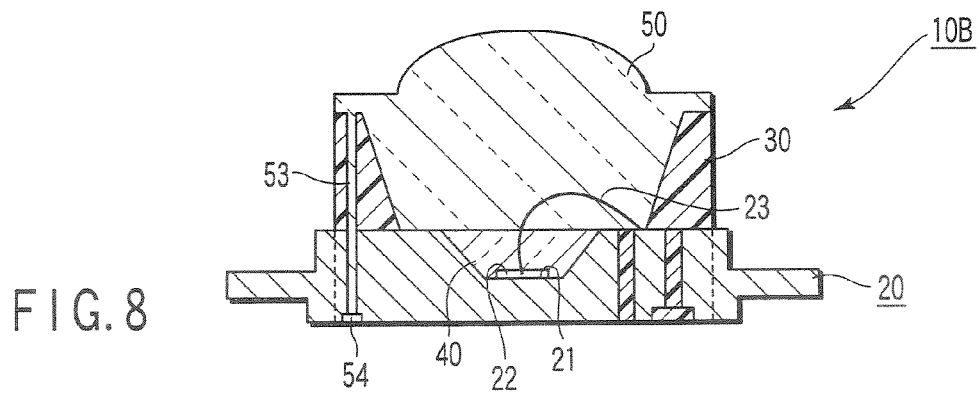
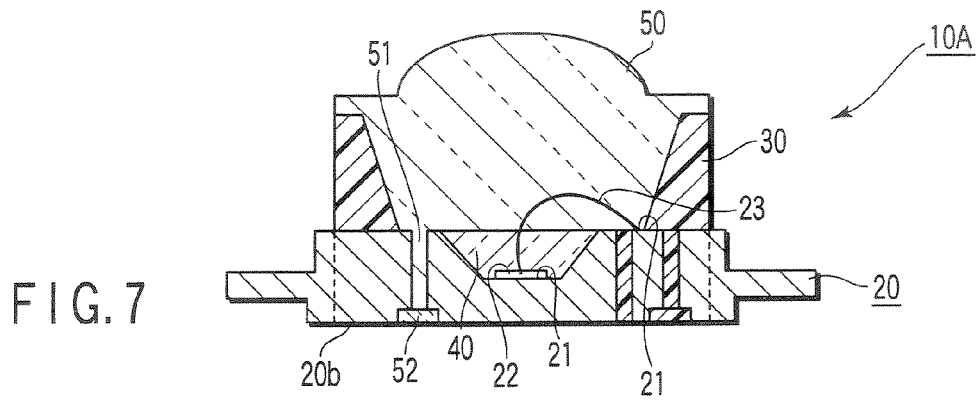
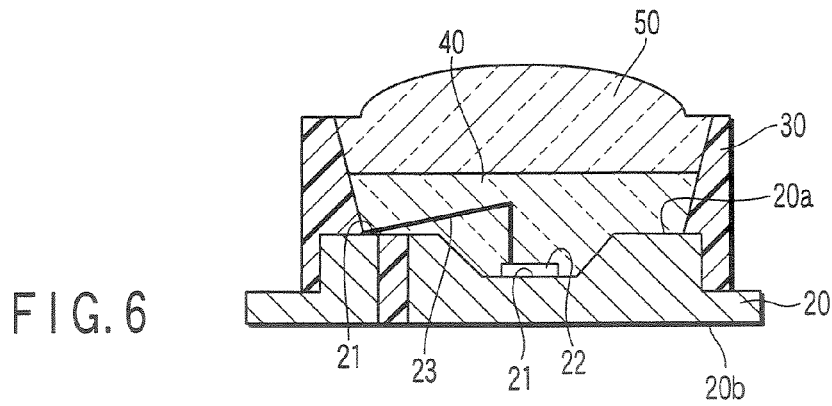

FIG. 10

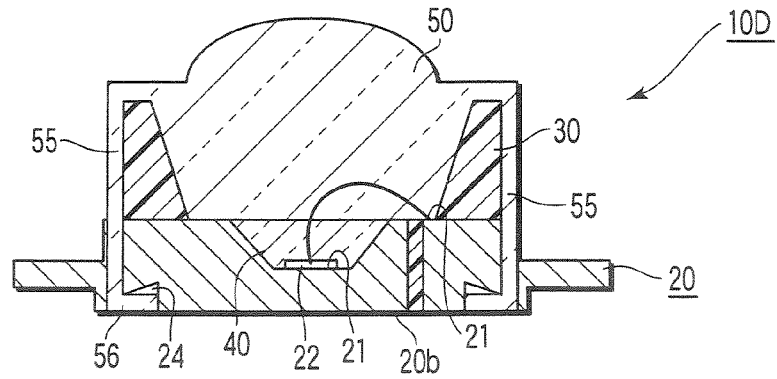

FIG. 11

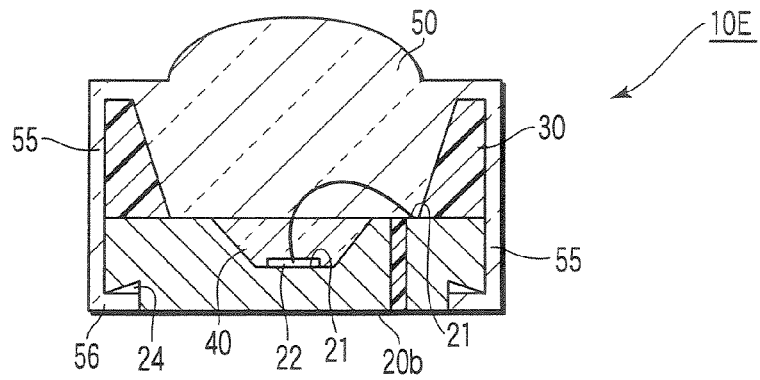

FIG. 12

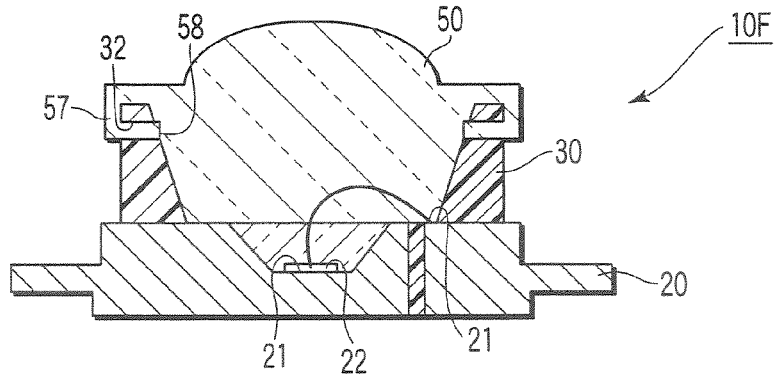
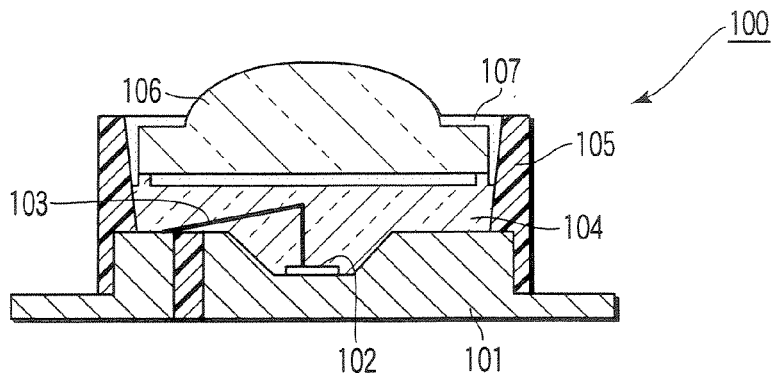

FIG. 13
(PRIOR ART)



**LENS-EQUIPPED LIGHT-EMITTING DIODE
DEVICE AND METHOD OF MANUFACTURING
THE SAME**

CROSS-REFERENCE TO RELATED
APPLICATIONS

[0001] This application is based upon and claims the benefit of priority from prior Japanese Patent Application No. 2005-373498, filed Dec. 26, 2005, the entire contents of which are incorporated herein by reference.

BACKGROUND OF THE INVENTION

[0002] 1. Field of the Invention

[0003] The present invention relates to a lens-equipped light-emitting diode device which extracts light from a light-emitting diode through a lens and a method of manufacturing the same, and particularly to a lens-equipped light-emitting diode device which is excellent for light extraction efficiency and reliability and whose production cost can be reduced.

[0004] 2. Description of the Related Art

[0005] FIG. 13 is a longitudinal sectional view showing a conventional lens-equipped light-emitting diode device 100. In the lens-equipped light-emitting diode device 100, a light-emitting diode element 102 is mounted through a die mounting material (not shown) on a lead frame 101 in which an electrode is formed, and an electrode of the light-emitting diode element 102 and an electrode exposed outside the lead frame are connected by a bonding wire 103.

[0006] A sealing portion 104 made of resin is formed around the light-emitting diode element 102, and an outer peripheral unit 105 is formed outside the lead frame 101 and light-emitting diode element 102 using a white thermoplastic resin. A lens 106 is attached to upwardly collect light emitted from the light-emitting diode element, and the lens 106 is made of a transparent resin produced in a different process. In FIG. 13, the number 107 designates a bonding agent.

[0007] Generally a transparent resin is used as the sealing portion 104. Recently, a white light-emitting diode device is proceeding toward the practical use in illumination. In this case, frequently a fluorescent material for converting blue or UV light emitted from the light-emitting diode element is mixed into the transparent resin.

[0008] In the conventional lens-equipped light-emitting diode device, the lens 106 produced in the different process is attached to the outer peripheral unit 105 by bonding or fitting. A method of casting a thermosetting resin into the outer peripheral unit 105 is also adopted (for example, see Jpn. Pat. Appln. KOKAI Publication No. 2004-343059).

[0009] In the conventional lens-equipped light-emitting diode device, there are the following problems. In the case where the lens 106 is attached to the outer peripheral unit 105 by bonding or fitting, sometimes a micro-gap is generated between the sealing portion 104 and lens 106, which decreases light extraction efficiency. There is also generated the problem that mechanical strength or a heat-resistant

[0010] On the other hand, in a production process, the following factors become an obstacle for reducing assembly cost. That is, an assembly process of attaching the lens 106 to the outer peripheral unit 105 is required, and an optical axis adjustment process is required to accurately attaching the lens 106 to the outer peripheral unit 105. In the case where the lens 106 is formed by casting, only the thermo-setting resin is used. However, generally a long-time curing process is required for the casting, so that the cost reduction also becomes the problem in the casting.

BRIEF SUMMARY OF THE INVENTION

[0011] In view of the foregoing, an object of the invention is to provide a lens-equipped light-emitting diode which is excellent in light extraction efficiency and reliability while production cost can be reduced, and a production method thereof.

[0012] In order to achieve the object, the lens-equipped light-emitting diode device according to the invention and the production method thereof have the following configurations.

[0013] A lens-equipped light-emitting diode device comprises: a support member in which an electrode is formed; a light-emitting diode which is mounted on the electrode of the support member; an outer peripheral unit which is provided on the support member, a hollow portion being formed while an area including at least the light-emitting diode is exposed in the outer peripheral unit made of a first resin; a sealing portion which is made of a second resin, the support member side of the hollow portion of the outer peripheral unit being filled with the second resin to seal the light-emitting diode; and a lens unit which is made of a third resin, the lens unit being laminated on the sealing portion by integral molding.

[0014] A method of producing a lens-equipped light-emitting diode device comprises: a process of mounting a light-emitting diode element on a support member; a first positioning process of positioning the support member in a first die; an outer peripheral unit forming process of supplying a resin into the first die to form an outer peripheral unit; a sealing process of sealing the light-emitting diode element; a second positioning process of positioning the support member in a second die; and a lens unit forming process of supplying a resin into the second die to form a lens unit.

[0015] Additional objects and advantages of the invention will be set forth in the description which follows, and in part will be obvious from the description, or may be learned by practice of the invention. The objects and advantages of the invention may be realized and obtained by means of the instrumentalities and combinations particularly pointed out hereinafter.

BRIEF DESCRIPTION OF THE SEVERAL
VIEWS OF THE DRAWING

[0016] The accompanying drawings, which are incorporated in and constitute a part of the specification, illustrate embodiments of the invention, and together with the general description given above and detailed description of the

Explore Litigation Insights

Docket Alarm provides insights to develop a more informed litigation strategy and the peace of mind of knowing you're on top of things.

Real-Time Litigation Alerts



Keep your litigation team up-to-date with **real-time alerts** and advanced team management tools built for the enterprise, all while greatly reducing PACER spend.

Our comprehensive service means we can handle Federal, State, and Administrative courts across the country.

Advanced Docket Research



With over 230 million records, Docket Alarm's cloud-native docket research platform finds what other services can't. Coverage includes Federal, State, plus PTAB, TTAB, ITC and NLRB decisions, all in one place.

Identify arguments that have been successful in the past with full text, pinpoint searching. Link to case law cited within any court document via Fastcase.

Analytics At Your Fingertips



Learn what happened the last time a particular judge, opposing counsel or company faced cases similar to yours.

Advanced out-of-the-box PTAB and TTAB analytics are always at your fingertips.

API

Docket Alarm offers a powerful API (application programming interface) to developers that want to integrate case filings into their apps.

LAW FIRMS

Build custom dashboards for your attorneys and clients with live data direct from the court.

Automate many repetitive legal tasks like conflict checks, document management, and marketing.

FINANCIAL INSTITUTIONS

Litigation and bankruptcy checks for companies and debtors.

E-DISCOVERY AND LEGAL VENDORS

Sync your system to PACER to automate legal marketing.