

Wireless Power Transfer for Electric Vehicle Applications

Siqi Li, *Member, IEEE*, and Chunting Chris Mi, *Fellow, IEEE*

Abstract—Wireless power transfer (WPT) using magnetic resonance is the technology which could set human free from the annoying wires. In fact, the WPT adopts the same basic theory which has already been developed for at least 30 years with the term inductive power transfer. WPT technology is developing rapidly in recent years. At kilowatts power level, the transfer distance increases from several millimeters to several hundred millimeters with a grid to load efficiency above 90%. The advances make the WPT very attractive to the electric vehicle (EV) charging applications in both stationary and dynamic charging scenarios. This paper reviewed the technologies in the WPT area applicable to EV wireless charging. By introducing WPT in EVs, the obstacles of charging time, range, and cost can be easily mitigated. Battery technology is no longer relevant in the mass market penetration of EVs. It is hoped that researchers could be encouraged by the state-of-the-art achievements, and push forward the further development of WPT as well as the expansion of EV.

Index Terms—Dynamic charging, electric vehicle (EV), inductive power transfer (IPT), safety guidelines, stationary charging, wireless power transfer (WPT).

I. INTRODUCTION

FOR energy, environment, and many other reasons, the electrification for transportation has been carrying out for many years. In railway systems, the electric locomotives have already been well developed for many years. A train runs on a fixed track. It is easy to get electric power from a conductor rail using pantograph sliders. However, for electric vehicles (EVs), the high flexibility makes it not easy to get power in a similar way. Instead, a high power and large capacity battery pack is usually equipped as an energy storage unit to make an EV to operate for a satisfactory distance.

Until now, the EVs are not so attractive to consumers even with many government incentive programs. Government subsidy and tax incentives are one key to increase the market share of EV today. The problem for an electric vehicle is nothing else but the electricity storage technology, which requires a battery which is the bottleneck today due to its unsatisfactory energy density, limited life time and high cost.

Manuscript received February 2, 2014; revised April 6, 2014; accepted April 18, 2014. Date of publication April 23, 2014; date of current version January 29, 2015. Recommended for publication by Associate Editor J. M. Miller.

S. Li is with the Department of Electrical Engineering, Kunming University of Science and Technology, Kunming 650500, China (e-mail: lisiqi@kmust.edu.cn).

C. C. Mi is with the Department of Electrical and Computer Engineering, University of Michigan, Dearborn, MI 48128 USA (e-mail: chrismi@umich.edu).

Color versions of one or more of the figures in this paper are available online at <http://ieeexplore.ieee.org>.

Digital Object Identifier 10.1109/JESTPE.2014.2319453

In an EV, the battery is not so easy to design because of the following requirements: high energy density, high power density, affordable cost, long cycle life time, good safety, and reliability, should be met simultaneously. Lithium-ion batteries are recognized as the most competitive solution to be used in electric vehicles [1]. However, the energy density of the commercialized lithium-ion battery in EVs is only 90–100 Wh/kg for a finished pack [2].¹ This number is so poor compared with gasoline, which has an energy density about 12 000 Wh/kg. To challenge the 300-mile range of an internal combustion engine power vehicle, a pure EV needs a large amount of batteries which are too heavy and too expensive. The lithium-ion battery cost is about 500\$/kWh at the present time. Considering the vehicle initial investment, maintenance, and energy cost, the owning of a battery electric vehicle will make the consumer spend an extra 1000\$/year on average compared with a gasoline-powered vehicle [1]. Besides the cost issue, the long charging time of EV batteries also makes the EV not acceptable to many drivers. For a single charge, it takes about one half-hour to several hours depending on the power level of the attached charger, which is many times longer than the gasoline refueling process. The EVs cannot get ready immediately if they have run out of battery energy. To overcome this, what the owners would most likely do is to find any possible opportunity to plug-in and charge the battery. It really brings some trouble as people may forget to plug-in and find themselves out of battery energy later on. The charging cables on the floor may bring tripping hazards. Leakage from cracked old cable, in particular in cold zones, can bring additional hazardous conditions to the owner. Also, people may have to brave the wind, rain, ice, or snow to plug-in with the risk of an electric shock.

The wireless power transfer (WPT) technology, which can eliminate all the charging troublesome, is desirable by the EV owners. By wirelessly transferring energy to the EV, the charging becomes the easiest task. For a stationary WPT system, the drivers just need to park their car and leave. For a dynamic WPT system, which means the EV could be powered while driving; the EV is possible to run forever without a stop. Also, the battery capacity of EVs with wireless charging could be reduced to 20% or less compared to EVs with conductive charging.

Although the market demand is huge, people were just wondering whether the WPT could be realized efficiently at

¹Although lithium ion battery can achieve up to 200 Wh/kg for individual cells, the battery pack requires structure design, cooling, and battery management systems. The over energy density of a battery pack is much lower than the cell density.

a reasonable cost. The research team from MIT published a paper in Science [3], in which 60 W power is transferred at a 2-m distance with the so called strongly coupled magnetic resonance theory. The result surprised the academia and the WPT quickly became a hot research area. A lot of interesting works were accomplished with different kinds of innovative circuit, as well as the system analysis and control [4]–[9]. The power transfer path can even be guided using the domino-form repeaters [10], [11]. In order to transfer power more efficiently and further, the resonant frequency is usually selected at MHz level, and air-core coils are adopted.

When the WPT is used in the EV charging, the MHz frequency operation is hard to meet the power and efficiency criteria. It is inefficient to convert a few to a few hundred kilowatts power at MHz frequency level using state-of-the-art power electronics devices. Moreover, air-core coils are too sensitive to the surrounding ferromagnetic objects. When an air-core coil is attached to a car, the magnetic flux will go inside the chassis causing high eddy current loss as well as a significant change in the coil parameters. To make it more practical in the EV charging, ferrite as a magnetic flux guide and aluminum plate as a shield are usually adopted in the coil design [12]. With the lowered frequency to less than 100 kHz, and the use of ferrite, the WPT system is no different from the inductive power transfer (IPT) technology which has been developed for many years [13]–[39]. In fact, since the WPT is based on the nonradiative and near-field electromagnetic, there is no difference with the traditional IPT which is based on magnetic field coupling between the transmitting and receiving coils. The IPT system has already been proposed and applied to various applications, such as underwater vehicles [32]–[34], mining systems [16], cordless robots in automation production lines [36]–[39], as well as the charging of electric vehicles [13], [14], [25]–[27].

Recently, as the need of EV charging and also the progress in technology, the power transfer distance increases from several millimeters to a few hundred millimeters at kilowatts power level [12], [14], [40]–[60]. As a proof-of-concept of a roadway inductively powered EV, the Partners for Advance Transit and Highways (PATH) program was conducted at the UC Berkeley in the late 1970s [14], [54]. A 60 kW, 35-passenger bus was tested along a 213 m long track with two powered sections. The bipolar primary track was supplied with 1200 A, 400 Hz ac current. The distance of the pickup from the primary track was 7.6 cm. The attained efficiency was around 60% due to limited semiconductor technology. During the last 15 years, researchers at Auckland University have focused on the inductive power supply of movable objects. Their recent achievement in designing pads for the stationary charging of EV is worth noting. A 766 mm × 578 mm pad that delivers 5 kW of power with over 90% efficiency for distances about 200 mm was reported [48], [55]. The achieved lateral and longitudinal misalignment tolerance is 250 and 150 mm, respectively. The knowledge gained from the on-line electric vehicle (OLEV) project conducted at the Korea Advanced Institute of Science and Technology (KAIST) also contributes to the WPT design. Three generations of OLEV systems have been built: a light golf cart as the first

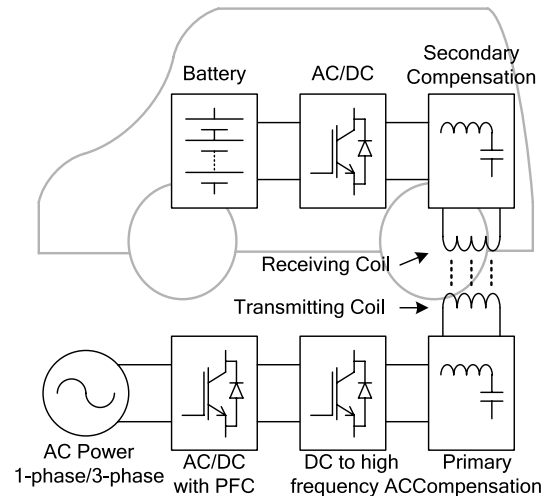

Fig. 1. Typical wireless EV charging system.

generation, a bus for the second, and an SUV for the third. The accomplishment of the second and the third is noteworthy: 60 kW power transfer for the buses and 20 kW for the SUVs with efficiency of 70% and 83%, respectively; allowable vertical distance and lateral misalignment up to 160 mm and up to 200 mm, respectively [56], [57]. In the United States, more and more public attention was drawn to the WPT since the publication of the 2007 Science paper [3]. The WiTricity Corporation with technology from MIT released their WiT-3300 development kit, which achieves 90% efficiency over a 180 mm gap at 3.3 kW output. Recently, a wireless charging system prototype for EV was developed at Oak Ridge National Laboratory (ORNL) in the United States. The tested efficiency is nearly 90% for 3 kW power delivery [53]. The research at the University of Michigan–Dearborn achieved a 200 mm distance, 8 kW WPT system with dc to dc efficiency as high as 95.7% [61]. From the functional aspects, it could be seen that the WPT for EV is ready in both stationary and dynamic applications. However, to make it available for large-scale commercialization, there is still abundant work to be done on the performance optimization, setup of the industrial standards, making it more cost effective, and so on.

This paper starts with the basic WPT theory, and then gives a brief overview of the main parts in a WPT system, including the magnetic coupler, compensation network, power electronics converter, study methodology, and its control, and some other issues like the safety considerations. By introducing the latest achievements in the WPT area, we hope the WPT in EV applications could gain a widespread acceptance in both theoretical and practical terms. Also, we hope more researchers could have an interest and make more brilliant contributions in the developing of WPT technology.

II. FUNDAMENTAL THEORY

A typical wireless EV charging system is shown in Fig. 1. It includes several stages to charge an EV wirelessly. First, the utility ac power is converted to a dc power source by an ac to dc converter with power factor correction.

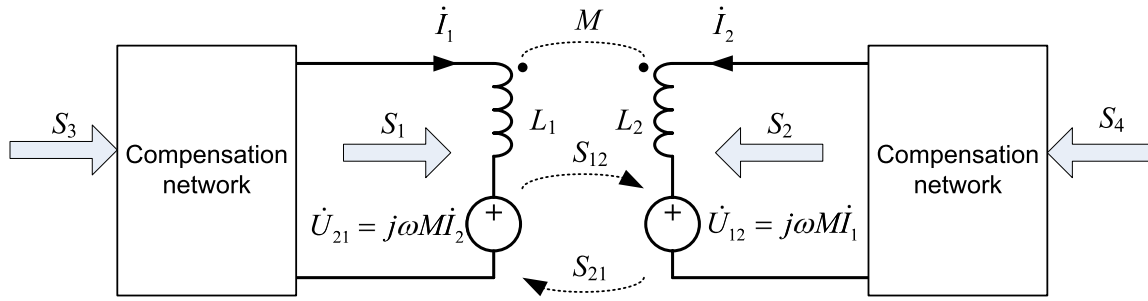

Fig. 2. General two-coil WPT system.

Then, the dc power is converted to a high-frequency ac to drive the transmitting coil through a compensation network. Considering the insulation failure of the primary side coil, a high-frequency isolated transformer may be inserted between the dc-ac inverter and primary side coil for extra safety and protection. The high-frequency current in the transmitting coil generates an alternating magnetic field, which induces an ac voltage on the receiving coil. By resonating with the secondary compensation network, the transferred power and efficiency are significantly improved. At last, the ac power is rectified to charge the battery. Fig. 1 shows that a wireless EV charger consists of the following main parts:

- 1) the detached (or separated, loosely coupled) transmitting and receiving coils. Usually, the coils are built with ferrite and shielding structure, in the later sections, the term magnetic coupler is used to represent the entirety, including coil, ferrite, and shielding;
- 2) the compensation network;
- 3) the power electronics converters.

The main difference between a wireless charger and a conventional conductive or wired charger is that a transformer is replaced by a set of loosely couple coils. To give a quick idea of the WPT principle, the coil and the compensation network are pulled out separately, as shown in Fig. 2, where L_1 represents the self-inductance of the primary side transmitting coil and L_2 represents the self-inductance of the receiving coil; I_1 and I_2 are the current in the two coils; \dot{U}_{12} is the voltage in the secondary coil that is induced by the current in the primary side coil. \dot{U}_{21} is the voltage in the primary coil that is induced by the current in secondary side coil due to coupling, or mutual inductance between the primary and secondary coils. S_1 and S_2 are the apparent power goes into L_1 and L_2 , respectively. S_3 and S_4 are the apparent power provided by the power converter. S_{12} and S_{21} represent the apparent power exchange between the two coils. The form of the compensation network is not specified. The characteristics of the compensation network will be discussed later.

As shown in Fig. 2, neglecting the coil resistance and magnetic losses, we can calculate the simplified form of exchanged complex power from L_1 to L_2

$$\begin{aligned} \dot{S}_{12} &= -\dot{U}_{12}\dot{I}_2^* = -j\omega M\dot{I}_1\dot{I}_2^* \\ &= \omega MI_1I_2 \sin \varphi_{12} - j\omega MI_1I_2 \cos \varphi_{12} \end{aligned} \quad (1)$$

$$\begin{aligned} \dot{S}_{21} &= -\dot{U}_{21}\dot{I}_1^* = -j\omega M\dot{I}_2\dot{I}_1^* \\ &= -\omega MI_1I_2 \sin \varphi_{12} - j\omega MI_1I_2 \cos \varphi_{12} \end{aligned} \quad (2)$$

where I_1 and I_2 are the root mean square value and φ_{12} is the phase difference between \dot{I}_1 and \dot{I}_2 . The active power transfer from the primary side to the secondary side can be expressed as

$$P_{12} = \omega MI_1I_2 \sin \varphi_{12}. \quad (3)$$

The system shown in Fig. 2 can transfer active power in both directions. In the analysis below, we assume the power is transferred from L_1 to L_2 . When $\varphi_{12} = \pi/2$, which means \dot{I}_1 leads \dot{I}_2 by a quarter cycle, the maximum power can be transferred from L_1 to L_2 .

The total complex power goes into the two-coil system is

$$\begin{aligned} \dot{S} &= \dot{S}_1 + \dot{S}_2 \\ &= j(\omega L_1\dot{I}_1 + \omega M\dot{I}_2)\dot{I}_1^* + j(\omega L_2\dot{I}_2 + \omega M\dot{I}_1)\dot{I}_2^* \\ &= j\omega(L_1I_1^2 + L_2I_2^2 + 2MI_1I_2 \cos \varphi_{12}). \end{aligned} \quad (4)$$

Therefore, the total reactive power goes into the two-coil system is

$$Q = \omega(L_1I_1^2 + L_2I_2^2 + 2MI_1I_2 \cos \varphi_{12}). \quad (5)$$

For a traditional transformer, the reactive power represents the magnetizing power. Higher magnetizing power brings higher copper and core loss. To increase the transformer efficiency, the ratio between the active power and reactive power should be maximized. The ratio is defined by

$$\begin{aligned} f(\varphi_{12}) &= \frac{|P_{12}|}{|Q|} = \left| \frac{\omega MI_1I_2 \sin \varphi_{12}}{\omega L_1I_1^2 + \omega L_2I_2^2 + 2\omega MI_1I_2 \cos \varphi_{12}} \right| \\ &= \frac{k\sqrt{1-\cos^2 \varphi_{12}}}{\sqrt{\frac{L_1}{L_2}\frac{I_1}{I_2} + \sqrt{\frac{L_2}{L_1}\frac{I_2}{I_1}} + 2k \cos \varphi_{12}}} = \frac{k\sqrt{1-\cos^2 \varphi_{12}}}{x + \frac{1}{x} + 2k \cos \varphi_{12}} \end{aligned} \quad (6)$$

where $\pi/2 < \varphi_{12} < \pi$

$$x = \sqrt{\frac{L_1}{L_2}\frac{I_1}{I_2}} > 0$$

k is the coupling coefficient between L_1 and L_2 .

To achieve the maximum value of $f(\varphi_{12})$, we solve the following equations:

$$\frac{\partial}{\partial \varphi_{12}} f(\varphi_{12}) = 0, \quad \frac{\partial^2}{\partial^2 \varphi_{12}} f(\varphi_{12}) < 0 \quad (7)$$

and the solutions are

$$\cos \varphi_{12} = -\frac{2k}{x + \frac{1}{x}}, \quad \sin \varphi_{12} = \sqrt{1 - \frac{4k^2}{(x + \frac{1}{x})^2}}. \quad (8)$$

When k is close to 1, it is a traditional transformer. In this case, if \dot{I}_2 is an induced current by \dot{I}_1 , x will be close to 1. Thus, $\cos \varphi_{12} \approx -1$. The phase difference between \dot{I}_1 and \dot{I}_2 is nearly 180° . While for WPT, k is close to 0. $f(\varphi_{12})$ is maximized at $\sin \varphi_{12} = 1$, at which point the transferred power is also maximized. The phase between \dot{I}_1 and \dot{I}_2 is around 90° instead of 180° . Hence we can see the difference between the tightly and the loosely coupled coils.

The degree of coupling affects the design of the compensation network. Taking the series-series topology as an example, there are two ways to design the resonant capacitor. One way is design the capacitor to resonate with the leakage inductance [46], [62] which could achieve a higher $f(\varphi_{12})$. Another way is to resonate with the coil self-inductance [27], [41], [63] which could maximum the transferred power at a certain coil current. When the coupling is tight with a ferrite, like $k > 0.5$, it is important to increase $f(\varphi_{12})$ to achieve better efficiency. In this case, resonate with the coil self inductance, which makes $\varphi_{12} = \pi/2$ and lowers $f(\varphi_{12})$, is not recommended. Otherwise the magnetizing loss may significantly increase. When the capacitor resonates with the leakage inductance, it is like the leakage inductance is compensated. This makes the transformer perform as a traditional one and increases $f(\varphi_{12})$. However, the overall system does not work at a resonant mode. When the coupling is loose, like $k < 0.5$, which is the case for the EV wireless charging, usually the capacitor is tuned with the self inductance to make the system working at a resonate mode to achieve maximum transferred power at a certain coil current. In this case, most of the magnetic field energy is stored in the large air gap between the two coils. The hysteresis loss in the ferrite is not so relative to the magnetizing power. However, the loss in the copper wire is proportional to the square of the conducting current. To efficiently transfer more power at a certain coil current, the induced current \dot{I}_2 should lag \dot{I}_1 by 90° . Since the induced voltage \dot{U}_{12} on the receiving coil lags \dot{I}_1 by 90° , \dot{U}_{12} and \dot{I}_2 should be in phase. The secondary side should have a pure resistive characteristic seen from \dot{U}_{12} at the frequency of \dot{I}_1 . At the meanwhile, the primary side input apparent power S_3 should be minimized. At $\cos \varphi_{12} = 0$, the complex power \dot{S}_1 is

$$\dot{S}_1 = j\omega L_1 I_1^2 + \omega M I_1 I_2. \quad (9)$$

Ideally, the primary side compensation network should cancel the reactive power and make $S_3 = \omega_0 M I_1 I_2$, where ω_0 is the resonant frequency. From the above analysis, we see for a certain transferred power, it is necessary to make the secondary side resonant to reduce the coil volt-ampere (VA) rating, which reduces the loss in the coils; and to make the primary side resonant to reduce the power electronics converter VA rating, which reduces the loss in the power converter. Therefore, we transfer power at the magnetic resonance.

With the above analysis, we can calculate the power transfer efficiency between the two coils at the resonant frequency.

We have

$$U_{12} = I_2(R_2 + R_{Le}) = \omega M I_1 = \omega k \sqrt{L_1 L_2} I_1 \quad (10)$$

where R_2 is the secondary winding resistance and R_{Le} is the equivalent load resistance.

By defining the quality factor of the two coils, $Q_1 = \omega L_1 / R_1$, $Q_2 = \omega L_2 / R_2$, the transferred efficiency can be expressed as

$$\eta = \frac{I_2^2 R_{Le}}{I_1^2 R_1 + I_2^2 R_2 + I_2^2 R_{Le}} = \frac{R_{Le}}{\frac{(R_2 + R_{Le})^2}{k^2 Q_1 Q_2 R_2} + R_2 + R_{Le}} \quad (11)$$

By defining $a = R_{Le} / R_2$, we obtain the expression of efficiency as a function of a

$$\eta(a) = \frac{1}{\frac{a + \frac{1}{a} + 2}{k^2 Q_1 Q_2} + \frac{1}{a} + 1}. \quad (12)$$

The maximum efficiency is obtained by solving the following equations:

$$\frac{\partial}{\partial a} \eta(a) = 0, \quad \frac{\partial^2}{\partial a^2} \eta(a) < 0. \quad (13)$$

The maximum efficiency

$$\eta_{\max} = \frac{k^2 Q_1 Q_2}{(1 + \sqrt{1 + k^2 Q_1 Q_2})^2}$$

is achieved at $a_{\eta_{\max}} = (1 + k^2 Q_1 Q_2)^{1/2}$.

In [64], the maximum efficiency is also derived based on several different kinds of compensation network. The results are identical and accord with the above results. The analysis here does not specify a particular compensation form. It can be regarded as a general formula to evaluate the coil performance and estimate the highest possible power transfer efficiency.

In EV wireless charging applications, the battery is usually connected to the coil through a diode-bridge rectifier. Most of the time, there is some reactive power required. The reactive power can be provide by either the coil or the compensation network like a unit-power-factor pickup. The battery could be equivalent to a resistance $R_b = U_b / I_b$, where U_b and I_b is the battery voltage and current, respectively. If the battery is connected to the rectifier directly in a series-series compensation form, the equivalent ac side resistance could be calculated by $R_{ac} = 8/\pi^2 \cdot R_b$. Thus, a battery load could be converted to a resistive load. The R_{ac} equation is different for different battery connection style, like with or without dc/dc converter, parallel or series compensation. Most of the time, the equivalent R_{ac} could be derived. Some typical equivalent impedance at the primary side is given in paper [42]. By calculating the equivalent ac resistances, the above equations could also be applied to a battery load with rectifier.

For stationary EV wireless charging, the coupling between the two coils is usually around 0.2. If both the sending and receiving coils have a quality factor of 300, the theoretical maximum power transfer efficiency is about 96.7%. More efficiency calculations under different coupling and quality factors are shown in Fig. 3.

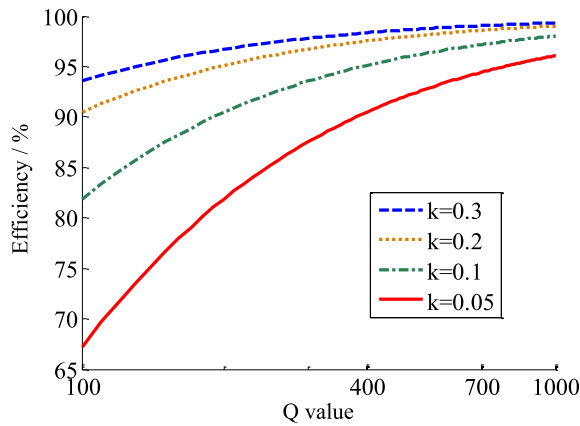

Fig. 3. Theoretical maximum transfer efficiency between two coils.

III. MAGNETIC COUPLER DESIGN

To transfer power wirelessly, there are at least two magnetic couplers in a WPT system. One is at the sending side, named primary coupler. The other is at the receiving side, named pickup coupler. Depending on the application scenarios, the magnetic coupler in a WPT for an EV could be either a pad or a track form. For higher efficiency, it is important to have high coupling coefficient k and quality factor Q . Generally, for a given structure, the larger the size to gap ratio of the coupler is, the higher the k is; the thicker the wire and the larger the ferrite section area is, the higher the Q is. By increasing the dimensions and materials, higher efficiency can be achieved. But this is not a good engineering approach. It is preferred to have higher k and Q with the minimum dimensions and cost. Since Q equals $\omega L/R$, high frequency is usually adopted to increase the value of Q . The researchers at Massachusetts Institute of Technology (MIT) used a frequency at around 10 MHz and the coil Q value reached nearly 1000 [3]. In high power EV WPT applications, the frequency is also increased to have these benefits. In Bolger's early design, the frequency is only 180 Hz [13]. A few years later, a 400 Hz frequency EV WPT system was designed by System Control Technology [14]. Neither 180 Hz nor 400 Hz is high enough for a loosely coupled system. Huge couplers were employed in the two designs. Modern WPT system uses at least 10 kHz frequency [15]. As the technical progress of power electronics, 100 kHz could be achieved [65] at high power level. The WiTricity Company with the technology from MIT adopts 145 kHz in their design. In the recent researches and applications, the frequency adopted in an EV WPT system is between 20 and 150 kHz to balance the efficiency and cost. At this frequency, to reduce the ac loss of copper coils, Litz wire is usually adopted.

Besides the frequency, the coupling coefficient k is significantly affected by the design of the magnetic couplers, which is considered one of the most important factors in a WPT system. With similar dimensions and materials, different coupler geometry and configuration will have a significant difference of coupling coefficient. A better coupler design may lead to a 50%–100% improvement compared with some nonoptimal designs [48].

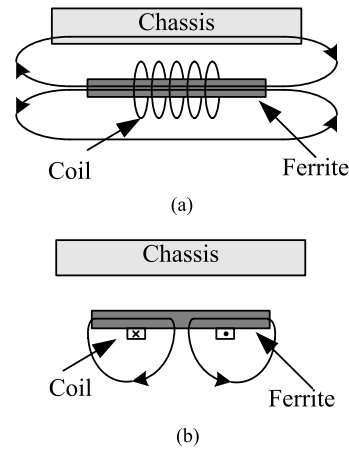

Fig. 4. Main flux path of double-sided and single-sided coupler. (a) Double-sided type. (b) Single-sided type.

A. Coupler in the Stationary Charging

In a stationary charging, the coupler is usually designed in a pad form. The very early couplers are just like a simple split core transformer [19], [38], [56]. Usually this kind of design could only transfer power through a very small gap. To meet the requirements for EV charging, the deformations from split core transformers and new magnetic coupler forms are presented for large gap power transfer [12], [31], [37], [42], [47]–[50], [66]–[71]. According to the magnetic flux distribution area, the coupler could be classified as the double-sided and single-sided types. For the double-sided type, the flux goes to both sides of the coupler [12], [31], [67]. A flattened solenoid inductor form is proposed in [12] and [67]. Because the flux goes through the ferrite like through a pipe, it is also called a flux-pipe coupler. To prevent the eddy current loss in the EV chassis, an aluminum shielding is usually added which bring a loss of 1%–2% [12]. When the shielding is added, the quality factor of a flux-pipe coupler reduces from 260 to 86 [48]. The high shielding loss makes the double-sided coupler not the optimal choice. For the single-sided coupler, most of the flux exists at only one side of the coupler. As shown in Fig. 4, the main flux path flows through the ferrite in a single-sided coupler. Unlike the double-sided coupler having half of the main flux at the back, the single-sided coupler only has a leakage flux in the back. This makes the shielding effort of a single-sided type much less.

Two typical single-sided flux type pads are shown in Fig. 5. One is a circular unipolar pad [47]. Another one is a rectangular bipolar pad proposed by University of Auckland, which is also named DD pad [48]. Besides the mechanical support material, a single-sided pad is composed of three layers. The top layer is the coil. Below the coil, a ferrite layer is inserted for the purpose of enhancing and guiding the flux. At the bottom is a shielding layer. To transfer power, the two pads are put closed with coil to coil. With the shielding layer, most of the high-frequency alternating magnetic flux can be confined in the space between the two pads. A fundamental flux path concept was proposed in the flux pipe paper [67].

Explore Litigation Insights

Docket Alarm provides insights to develop a more informed litigation strategy and the peace of mind of knowing you're on top of things.

Real-Time Litigation Alerts



Keep your litigation team up-to-date with **real-time alerts** and advanced team management tools built for the enterprise, all while greatly reducing PACER spend.

Our comprehensive service means we can handle Federal, State, and Administrative courts across the country.

Advanced Docket Research



With over 230 million records, Docket Alarm's cloud-native docket research platform finds what other services can't. Coverage includes Federal, State, plus PTAB, TTAB, ITC and NLRB decisions, all in one place.

Identify arguments that have been successful in the past with full text, pinpoint searching. Link to case law cited within any court document via Fastcase.

Analytics At Your Fingertips



Learn what happened the last time a particular judge, opposing counsel or company faced cases similar to yours.

Advanced out-of-the-box PTAB and TTAB analytics are always at your fingertips.

API

Docket Alarm offers a powerful API (application programming interface) to developers that want to integrate case filings into their apps.

LAW FIRMS

Build custom dashboards for your attorneys and clients with live data direct from the court.

Automate many repetitive legal tasks like conflict checks, document management, and marketing.

FINANCIAL INSTITUTIONS

Litigation and bankruptcy checks for companies and debtors.

E-DISCOVERY AND LEGAL VENDORS

Sync your system to PACER to automate legal marketing.