



US 20070135185A1

(19) **United States**

(12) **Patent Application Publication** (10) **Pub. No.: US 2007/0135185 A1**

Dvorak et al.

(43) **Pub. Date: Jun. 14, 2007**

(54) **MODULAR MULTIFUNCTION SPEAKER AND HEADSET**

(52) **U.S. Cl. 455/575.2; 455/569.1**

(75) Inventors: **Joseph L. Dvorak**, Boca Raton, FL (US); **Ryan M. Nilsen**, Pompano, FL (US)

(57) **ABSTRACT**

Correspondence Address:
MOTOROLA, INC
INTELLECTUAL PROPERTY SECTION
LAW DEPT
8000 WEST SUNRISE BLVD
FT LAUDERDAL, FL 33322 (US)

A wireless communication product (10) can include an electronic host device (12) having a transceiver (13) for wide area communications and a modular peripheral device (30) having a speaker (31), a microphone (33) and a display (37) serving at least as a speaker and a display for the wireless communication product when attached to the electronic host device and the speaker and the microphone serving as a wireless headset and the display serving as an activation button when detached from the electronic host device. The display can serve as a push-to-connect activation when the modular peripheral device is undocked from the electronic host device. The modular peripheral device can include a hook shaped portion (39) formed between the display and the speaker enabling the modular peripheral device to grasp the electronic host device when serving as the speaker or the user's ear when serving as the wireless headset.

(73) Assignee: **Motorola, Inc.**, Schaumburg, IL

(21) Appl. No.: **11/285,274**

(22) Filed: **Nov. 22, 2005**

Publication Classification

(51) **Int. Cl.**
H04M 1/00 (2006.01)

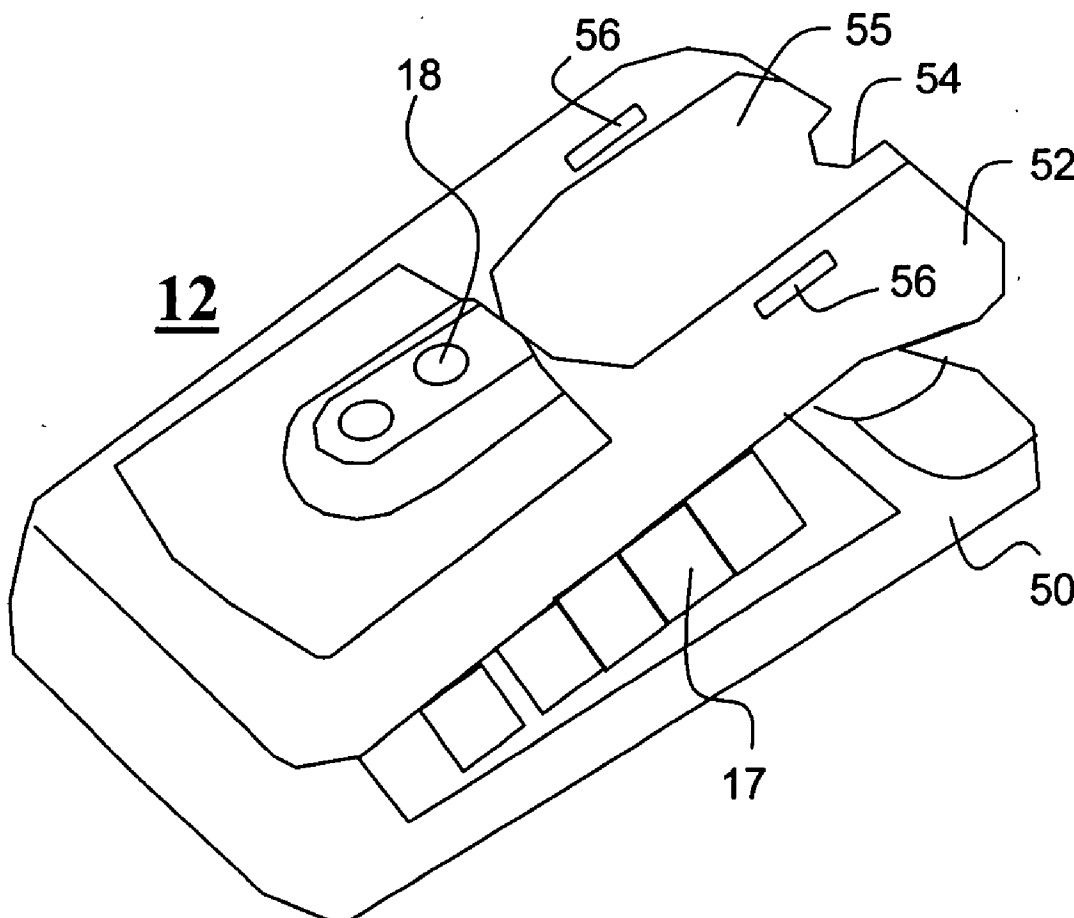

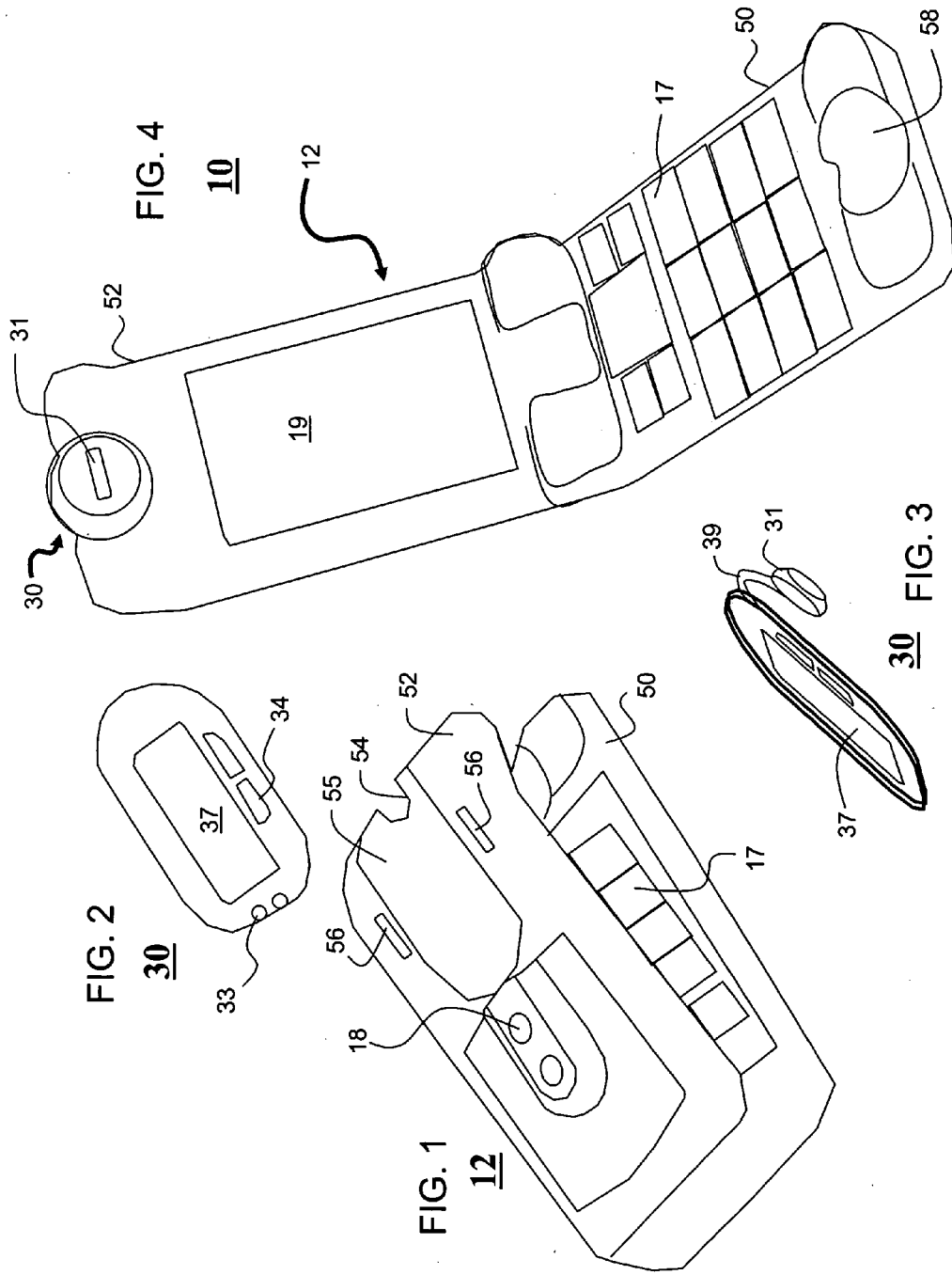

FIG. 5

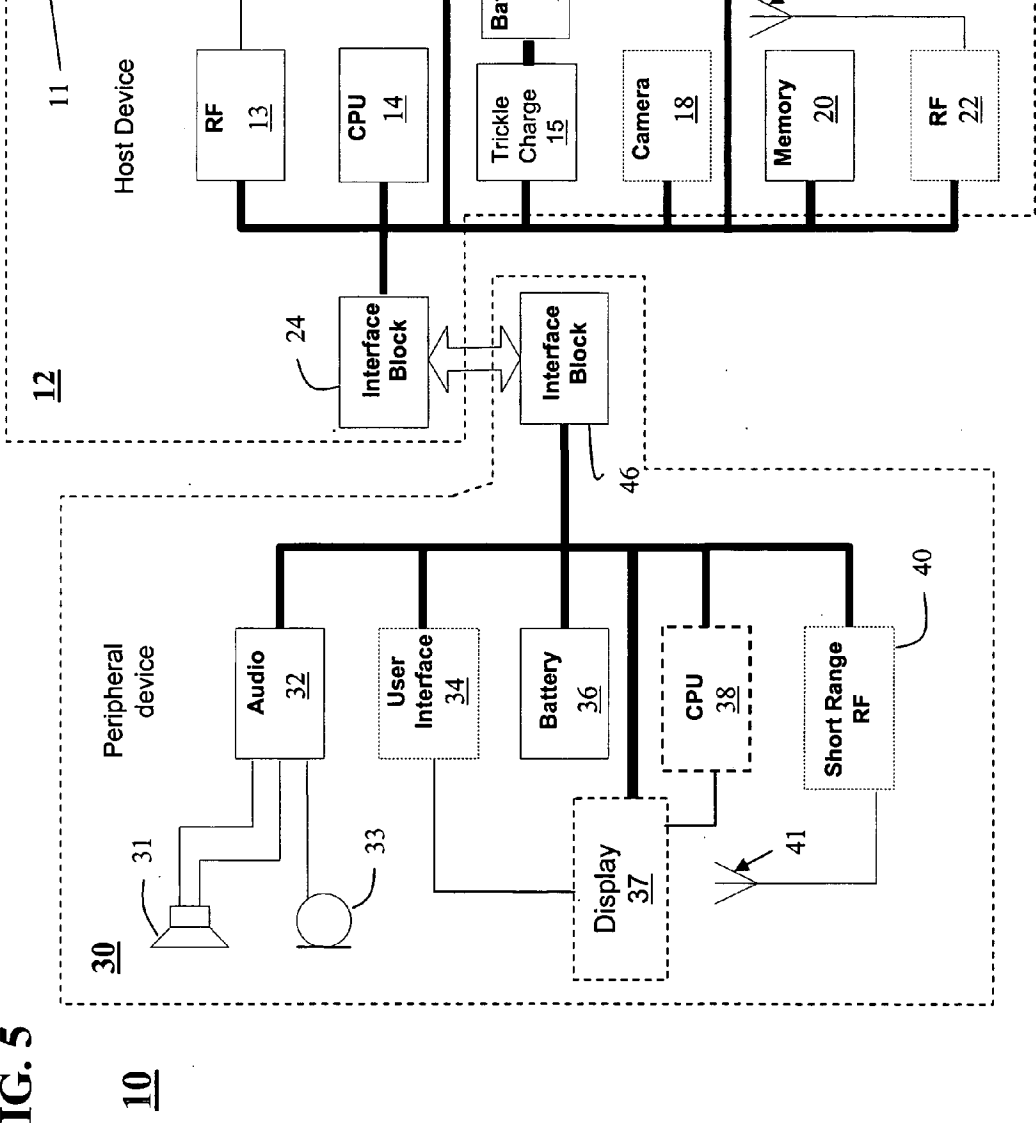
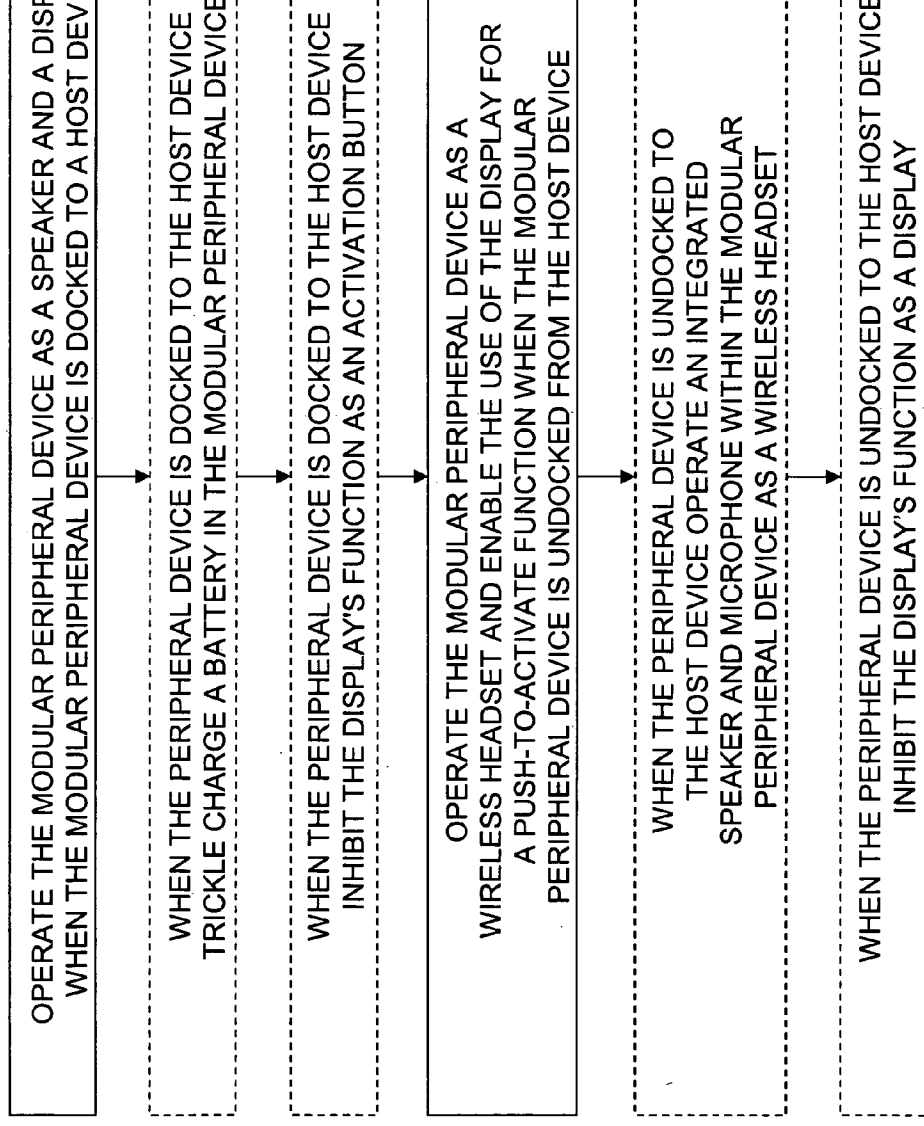

FIG. 6 100



MODULAR MULTIFUNCTION SPEAKER AND HEADSET

FIELD

[0001] This invention relates generally to electronic devices, and more particularly to a modular peripheral device that operates as a speaker or headset based on a docked status to host device.

BACKGROUND

[0002] Wireless headsets such as Bluetooth headsets are very convenient. However, when they are not in use, there is generally no place to put the headset that is unobtrusive. Other modular wireless headsets might include a wearable earpiece and a physically separate microphone. Although these existing devices are modular, they have dedicated functions and become obtrusive when not in use.

SUMMARY

[0003] Embodiments in accordance with the present invention can provide a convenient arrangement or mechanism where a modular multipurpose peripheral can serve as a wireless headset or earpiece as well as a device's own speaker in a manner enabling unobtrusive storage capability of the headset. Such embodiments can also minimize the combined size of the electronic device and earpiece or headset.

[0004] In a first embodiment of the present invention, an electronic product can include an electronic host device and at least one modular peripheral device serving as a speaker and a display when docked to the electronic host device and as a headset or as an earpiece when undocked from the electronic host device. The electronic product can be any number of devices

[0005] including, but not limit to a cellular phone, a camera phone, a smart phone, a dictation device, or a videophone. The display can further serve as a push-to-connect activation when the modular peripheral device is undocked electronic host device. The modular peripheral device can have a hook shape formed between the display and the speaker enabling the modular peripheral device to grasp the electronic host device when serving as a speaker or grasp the user's ear when serving as a headset. The electronic product can further include magnets for aligning the docking of the modular peripheral device with the electronic host device. The magnets can also serve to provide electrical contact between the at least one modular peripheral device and the electronic host device. The modular peripheral device can be charged (such as trickle charged) from a power source for the electronic host device when the modular peripheral device is docked to the electronic host device. The display can further serve as a send button or end call button when the at least one modular peripheral device is undocked from the electronic host device. A camera can also be integrated with the modular peripheral device or the electronic host device.

[0006] In a second embodiment of the present invention, a wireless communication product can include an electronic host device having a transceiver for wide area communica-

a display for the wireless communication product when attached to the electronic host device and the speaker and the microphone serving as a wireless headset and the display serving as an activation button when detached from the electronic host device. The wireless communication product can be a cellular phone, a camera phone, a smart phone, a dictation device, or a videophone for example. The display can serve as a push-to-connect connect activation when the modular peripheral device is undocked from the electronic host device. The modular peripheral device can include a hook shape formed between the display and the speaker enabling the modular peripheral device to grasp the electronic host device when serving as the speaker or the user's ear when serving as the wireless headset. The wireless communication product can further include magnets for aligning the docking of the at least one modular peripheral device with the electronic host device and the magnets can further serve to provide electrical contact between the at least one modular peripheral device and the electronic host device. The modular peripheral device can be charged (such as trickle charged) from a power source for the electronic host device when the at least one modular peripheral device is docked to the electronic host device. Note, function of the electronic host device can be conditioned on a modular peripheral device status as being docked to the electronic host device and function of the modular peripheral device can be conditioned on the modular peripheral device status as being docked to the electronic host device. In one configuration, the wireless communication product can be a cellular phone having a clam shell housing with a flip portion that holds the modular peripheral device.

[0007] In a third embodiment of the present invention, a method of changing the functionality of a modular peripheral device and a host device forming a wireless communication product can include the steps of operating the modular peripheral device as a speaker and a display when the modular peripheral device is docked to the host device and operating the modular peripheral device as a wireless headset and enabling the use of the display as a push-to-activate function when the modular peripheral device is undocked from the host device. When the peripheral device is docked to the host device, the method can include the steps of charging a battery in the modular peripheral device or inhibiting the display's function as an activation button. When the peripheral device is undocked to the host device, the method can also include the steps of inhibiting the display's function as a display or operating an integrated speaker and microphone within the modular peripheral device as a wireless headset.

[0008] The terms "a" or "an," as used herein, are defined as one or more than one. The term "plurality," as used herein, is defined as two or more than two. The term "another," as used herein, is defined as at least a second or more. The terms "including" and/or "having," as used herein, are defined as comprising (i.e., open language). The term "coupled," as used herein, is defined as connected, although not necessarily directly, and not necessarily mechanically. The term "suppressing" or "inhibiting" can be defined as reducing or removing, either partially or completely.

[0009] The terms "program," "software application," and

Explore Litigation Insights

Docket Alarm provides insights to develop a more informed litigation strategy and the peace of mind of knowing you're on top of things.

Real-Time Litigation Alerts



Keep your litigation team up-to-date with **real-time alerts** and advanced team management tools built for the enterprise, all while greatly reducing PACER spend.

Our comprehensive service means we can handle Federal, State, and Administrative courts across the country.

Advanced Docket Research



With over 230 million records, Docket Alarm's cloud-native docket research platform finds what other services can't. Coverage includes Federal, State, plus PTAB, TTAB, ITC and NLRB decisions, all in one place.

Identify arguments that have been successful in the past with full text, pinpoint searching. Link to case law cited within any court document via Fastcase.

Analytics At Your Fingertips



Learn what happened the last time a particular judge, opposing counsel or company faced cases similar to yours.

Advanced out-of-the-box PTAB and TTAB analytics are always at your fingertips.

API

Docket Alarm offers a powerful API (application programming interface) to developers that want to integrate case filings into their apps.

LAW FIRMS

Build custom dashboards for your attorneys and clients with live data direct from the court.

Automate many repetitive legal tasks like conflict checks, document management, and marketing.

FINANCIAL INSTITUTIONS

Litigation and bankruptcy checks for companies and debtors.

E-DISCOVERY AND LEGAL VENDORS

Sync your system to PACER to automate legal marketing.