

Under the Paperwork Reduction Act of 1995, no persons are required to respond to a collection of information unless it displays a valid OMB control number.

UTILITY PATENT APPLICATION TRANSMITTAL

(Only for new nonprovisional applications under 37 CFR 1.53(b))

Attorney Docket No.	11298.0188-08000
First Inventor	Daniel M. Fischer
Title	MULTIFUNCTIONAL CHARGER SYSTEM
Express Mail Label No.	

APPLICATION ELEMENTS

See MPEP chapter 600 concerning utility patent application contents.

1. Fee Transmittal Form (e.g., PTO/SB/17)
2. Applicant claims small entity status.
See 37 CFR 1.27.
3. Specification [Total Pages 28]
Both the claims and abstract must start on a new page
(For information on the preferred arrangement, see MPEP 608.01(a))
4. Drawing(s) (35 U.S.C. 113) [Total Sheets 4]
5. Oath or Declaration [Total Sheets 8]
a. Newly executed (original or copy)
b. A copy from a prior application (37 CFR 1.63(d))
(for continuation/divisional with Box 18 completed)
i. DELETION OF INVENTOR(S)
Signed statement attached deleting inventor(s)
name in the prior application, see 37 CFR
1.63(d)(2) and 1.33(b).
6. Application Data Sheet. See 37 CFR 1.76
7. CD-ROM or CD-R in duplicate, large table or
Computer Program (Appendix)
 Landscape Table on CD
8. Nucleotide and/or Amino Acid Sequence Submission
(if applicable, items a. - c. are required)
a. Computer Readable Form (CRF)
b. Specification Sequence Listing on:
i. CD-ROM or CD-R (2 copies); or
ii. Paper
c. Statements verifying identity of above copies

ADDRESS TO:
Commissioner for Patents
P.O. Box 1450
Alexandria VA 22313-1450

ACCOMPANYING APPLICATION PARTS

9. Assignment Papers (cover sheet & document(s))
Name of Assignee Research In Motion Limited
10. 37 CFR 3.73(b) Statement (when there is an assignee) Power of Attorney
11. English Translation Document (if applicable)
12. Information Disclosure Statement (PTO/SB/08 or PTO-1449)
 Copies of citations attached
13. Preliminary Amendment
14. Return Receipt Postcard (MPEP 503)
(Should be specifically itemized)
15. Certified Copy of Priority Document(s)
(if foreign priority is claimed)
16. Nonpublication Request under 35 U.S.C. 122(b)(2)(B)(i).
Applicant must attach form PTO/SB/35 or equivalent.
17. Other: _____

18. If a CONTINUING APPLICATION, check appropriate box, and supply the requisite information below and in the first sentence of the specification following the title, or in an Application Data Sheet under 37 CFR 1.76:

Continuation Divisional Continuation-in-part (CIP) of prior application No.: 13/175,509.....

Prior application information: Examiner Edward H. Tso Art Unit: 2858

19. CORRESPONDENCE ADDRESS

The address associated with Customer Number: 93377 OR Correspondence address below

Name			
Address			
City	State	Zip Code	
Country	Telephone	Email	

Signature	<u>/Yi Yu/</u>	Date	<u>June 28, 2012</u>
Name (Print/Type)	<u>Yi Yu</u>	Registration No. (Attorney/Agent)	<u>69,397</u>

This collection of information is required by 37 CFR 1.53(b). The information is required to obtain or retain a benefit by the public which is to file (and by the USPTO to process) an application. Confidentiality is governed by 35 U.S.C. 122 and 37 CFR 1.11 and 1.14. This collection is estimated to take 12 minutes to complete, including gathering, preparing, and submitting the completed application form to the USPTO. Time will vary depending upon the individual case. Any comments on the amount of time you require to complete this form and/or suggestions for reducing this burden, should be sent to the Chief Information Officer, U.S. Patent and Trademark Office, U.S. Department of Commerce, P.O. Box 1450, Alexandria, VA 22313-1450. DO NOT SEND FEES OR COMPLETED FORMS TO THIS ADDRESS. SEND TO: Commissioner for Patents, P.O. Box 1450, Alexandria, VA 22313-1450.

If you need assistance in completing the form, call 1-800-PTO-9199 and select option 2.

Petitioners Ex. 1002

IPR USP 8,624,550

Page 1 of 174

Under the Paperwork Reduction Act of 1995, no persons are required to respond to a collection of information unless it contains a valid OMB control number.

Application Data Sheet 37 CFR 1.76		Attorney Docket Number	11298.0188-08000
		Application Number	
Title of Invention	MULTIFUNCTIONAL CHARGER SYSTEM AND METHOD		
<p>The application data sheet is part of the provisional or nonprovisional application for which it is being submitted. The following form contains the bibliographic data arranged in a format specified by the United States Patent and Trademark Office as outlined in 37 CFR 1.76. This document may be completed electronically and submitted to the Office in electronic format using the Electronic Filing System (EFS) or the document may be printed and included in a paper filed application.</p>			

Secrecy Order 37 CFR 5.2

Portions or all of the application associated with this Application Data Sheet may fall under a Secrecy Order pursuant to 37 CFR 5.2 (Paper filers only. Applications that fall under Secrecy Order may not be filed electronically.)

Applicant Information:

Applicant 1				
Applicant Authority		<input checked="" type="radio"/> Inventor		<input type="radio"/> Legal Representative under 35 U.S.C. 117
				<input type="radio"/> Party of Interest under 35 U.S.C. 118
Prefix	Given Name	Middle Name	Family Name	Suffix
	Daniel	M.	FISCHER	
Residence Information (Select One)				
		<input type="radio"/> US Residency		<input checked="" type="radio"/> Non US Residency
				<input type="radio"/> Active US Military Service
City	Waterloo	Country Of Residence i	CA	
Citizenship under 37 CFR 1.41(b)		CA		
Mailing Address of Applicant:				
Address 1	295 Phillip Street			
Address 2				
City	Waterloo	State/Province	ON	
Postal Code	N2L 3W8	Country	CA	
Applicant 2				
Applicant Authority		<input checked="" type="radio"/> Inventor		<input type="radio"/> Legal Representative under 35 U.S.C. 117
				<input type="radio"/> Party of Interest under 35 U.S.C. 118
Prefix	Given Name	Middle Name	Family Name	Suffix
	Dan	G.	RADUT	
Residence Information (Select One)				
		<input type="radio"/> US Residency		<input checked="" type="radio"/> Non US Residency
				<input type="radio"/> Active US Military Service
City	Waterloo	Country Of Residence i	CA	
Citizenship under 37 CFR 1.41(b)		CA		
Mailing Address of Applicant:				
Address 1	300 Regina Street, North			
Address 2				
City	Waterloo	State/Province	ON	
Postal Code	N2J 3B8	Country	CA	
Applicant 3				
Applicant Authority		<input checked="" type="radio"/> Inventor		<input type="radio"/> Legal Representative under 35 U.S.C. 117
				<input type="radio"/> Party of Interest under 35 U.S.C. 118
Prefix	Given Name	Middle Name	Family Name	Suffix
	Michael	F.	HABICHER	
Residence Information (Select One)				
		<input type="radio"/> US Residency		<input checked="" type="radio"/> Non US Residency
				<input type="radio"/> Active US Military Service
City	Toronto	Country Of Residence i	CA	

Petitioners Ex. 1002

IPR USP 8,624,550

Under the Paperwork Reduction Act of 1995, no persons are required to respond to a collection of information unless it contains a valid OMB control number.

Application Data Sheet 37 CFR 1.76		Attorney Docket Number	11298.0188-08000
		Application Number	
Title of Invention	MULTIFUNCTIONAL CHARGER SYSTEM AND METHOD		

Citizenship under 37 CFR 1.41(b)	CA
Mailing Address of Applicant:	
Address 1	12 Sudbury Street
Address 2	
City	Toronto
State/Province	ON
Postal Code	M6J 3W7
Country	CA

Applicant 4				
Applicant Authority	<input checked="" type="radio"/> Inventor	<input type="radio"/> Legal Representative under 35 U.S.C. 117	<input type="radio"/> Party of Interest under 35 U.S.C. 118	
Prefix	Given Name	Middle Name	Family Name	Suffix
	Quang	A.	LUONG	
Residence Information (Select One) <input type="radio"/> US Residency <input checked="" type="radio"/> Non US Residency <input type="radio"/> Active US Military Service				
City	Mississauga	Country Of Residence	CA	
Citizenship under 37 CFR 1.41(b)	CA			

Mailing Address of Applicant:				
Address 1	5847 Mersey Street			
Address 2				
City	Mississauga	State/Province	ON	
Postal Code	L5V 1V9	Country	CA	

Applicant 5				
Applicant Authority	<input checked="" type="radio"/> Inventor	<input type="radio"/> Legal Representative under 35 U.S.C. 117	<input type="radio"/> Party of Interest under 35 U.S.C. 118	
Prefix	Given Name	Middle Name	Family Name	Suffix
	Jonathan	T.	MALTON	
Residence Information (Select One) <input type="radio"/> US Residency <input checked="" type="radio"/> Non US Residency <input type="radio"/> Active US Military Service				
City	Kitchener	Country Of Residence	CA	
Citizenship under 37 CFR 1.41(b)	CA			

Mailing Address of Applicant:				
Address 1	100 Highland Crescent			
Address 2				
City	Kitchener	State/Province	ON	
Postal Code	N2M 5C1	Country	CA	

All Inventors Must Be Listed - Additional Inventor Information blocks may be generated within this form by selecting the **Add** button.

Add

Correspondence Information:

Enter either Customer Number or complete the Correspondence Information section below. For further information see 37 CFR 1.33(a).	
<input type="checkbox"/> An Address is being provided for the correspondence information of this application.	
Customer Number	93377
IPR USP 8,624,550	

Petitioners Ex. 1002

Under the Paperwork Reduction Act of 1995, no persons are required to respond to a collection of information unless it contains a valid OMB control number.

Application Data Sheet 37 CFR 1.76		Attorney Docket Number	11298.0188-08000
		Application Number	
Title of Invention	MULTIFUNCTIONAL CHARGER SYSTEM AND METHOD		

Email Address		Add Email	Remove Email
---------------	--	-----------	--------------

Application Information:

Title of the Invention	MULTIFUNCTIONAL CHARGER SYSTEM AND METHOD		
Attorney Docket Number	11298.0188-08000	Small Entity Status Claimed	<input type="checkbox"/>
Application Type	Nonprovisional		
Subject Matter	Utility		
Suggested Class (if any)		Sub Class (if any)	
Suggested Technology Center (if any)			
Total Number of Drawing Sheets (if any)	4	Suggested Figure for Publication (if any)	

Publication Information:

Request Early Publication (Fee required at time of Request 37 CFR 1.219)

Request Not to Publish. I hereby request that the attached application not be published under 35 U.S.C. 122(b) and certify that the invention disclosed in the attached application **has not and will not** be the subject of an application filed in another country, or under a multilateral international agreement, that requires publication at eighteen months after filing.

Representative Information:

Representative information should be provided for all practitioners having a power of attorney in the application. Providing this information in the Application Data Sheet does not constitute a power of attorney in the application (see 37 CFR 1.32). Enter either Customer Number or complete the Representative Name section below. If both sections are completed the Customer Number will be used for the Representative Information during processing.

Please Select One:	<input checked="" type="radio"/> Customer Number	<input type="radio"/> US Patent Practitioner	<input type="radio"/> Limited Recognition (37 CFR 11.9)
Customer Number	93377		

Domestic Benefit/National Stage Information:

This section allows for the applicant to either claim benefit under 35 U.S.C. 119(e), 120, 121, or 365(c) or indicate National Stage entry from a PCT application. Providing this information in the application data sheet constitutes the specific reference required by 35 U.S.C. 119(e) or 120, and 37 CFR 1.78(a)(2) or CFR 1.78(a)(4), and need not otherwise be made part of the specification.

Prior Application Status	Pending	Remove	
Application Number	Continuity Type	Prior Application Number	Filing Date (YYYY-MM-DD)
	Continuation of	13175509	2011-07-01
Prior Application Status	Pending	Remove	
Application Number	Continuity Type	Prior Application Number	Filing Date (YYYY-MM-DD)
13175509	Continuation of	12905934	2010-10-15
Prior Application Status	Patented	Remove	

Petitioners Ex. 1002
IPR USP 8,624,550

Under the Paperwork Reduction Act of 1995, no persons are required to respond to a collection of information unless it contains a valid OMB control number.

Application Data Sheet 37 CFR 1.76		Attorney Docket Number	11298.0188-08000
		Application Number	
Title of Invention	MULTIFUNCTIONAL CHARGER SYSTEM AND METHOD		

Application Number	Continuity Type	Prior Application Number	Filing Date (YYYY-MM-DD)	Patent Number	Issue Date (YYYY-MM-DD)
12905934	Continuation of	12714204	2010-02-26	8169187	2012-05-01
Prior Application Status		Patented		Remove	
Application Number	Continuity Type	Prior Application Number	Filing Date (YYYY-MM-DD)	Patent Number	Issue Date (YYYY-MM-DD)
12714204	Continuation of	12268297	2008-11-10	7737657	2010-06-15
Prior Application Status		Patented		Remove	
Application Number	Continuity Type	Prior Application Number	Filing Date (YYYY-MM-DD)	Patent Number	Issue Date (YYYY-MM-DD)
12268297	Continuation of	11749680	2007-05-16	7453233	2008-11-18
Prior Application Status		Patented		Remove	
Application Number	Continuity Type	Prior Application Number	Filing Date (YYYY-MM-DD)	Patent Number	Issue Date (YYYY-MM-DD)
11749680	Continuation of	11175885	2005-07-06	7239111	2007-07-03
Prior Application Status		Patented		Remove	
Application Number	Continuity Type	Prior Application Number	Filing Date (YYYY-MM-DD)	Patent Number	Issue Date (YYYY-MM-DD)
11175885	Continuation of	10087629	2002-03-01	6936936	2006-08-30
Prior Application Status		Expired		Remove	
Application Number	Continuity Type	Prior Application Number	Filing Date (YYYY-MM-DD)	Patent Number	Issue Date (YYYY-MM-DD)
10087629	non provisional of	60273021	2001-03-01		
Prior Application Status		Expired		Remove	
Application Number	Continuity Type	Prior Application Number	Filing Date (YYYY-MM-DD)	Patent Number	Issue Date (YYYY-MM-DD)
60273021		60330486	2001-10-23		
Additional Domestic Benefit/National Stage Data may be generated within this form by selecting the Add button.					

Foreign Priority Information:

This section allows for the applicant to claim benefit of foreign priority and to identify any prior foreign application for which priority is not claimed. Providing this information in the application data sheet constitutes the claim for priority as required by 35 U.S.C. 119(b) and 37 CFR 1.55(a).

[Remove](#)

Application Number	Country ¹	Parent Filing Date (YYYY-MM-DD)	Priority Claimed
			<input checked="" type="radio"/> Yes <input type="radio"/> No

Additional Foreign Priority Data may be generated within this form by selecting the **Add** button.

Assignee Information:

Providing this information in the application data sheet does not substitute for compliance with any requirement of part 3 of Title 37 of the CFR to have an assignment recorded in the Office.

Assignee 1	Petitioners Ex. 1002
	IPR USP 8,624,550

Under the Paperwork Reduction Act of 1995, no persons are required to respond to a collection of information unless it contains a valid OMB control number.

Application Data Sheet 37 CFR 1.76	Attorney Docket Number	11298.0188-08000
	Application Number	
Title of Invention	MULTIFUNCTIONAL CHARGER SYSTEM AND METHOD	

If the Assignee is an Organization check here. <input checked="" type="checkbox"/>			
Organization Name	Research In Motion Limited		
Mailing Address Information:			
Address 1	295 Phillip Street		
Address 2			
City	Waterloo	State/Province	ON
Country	CA	Postal Code	N2L 3W8
Phone Number		Fax Number	
Email Address			
Additional Assignee Data may be generated within this form by selecting the Add button.			

Signature:

A signature of the applicant or representative is required in accordance with 37 CFR 1.33 and 10.18. Please see 37 CFR 1.4(d) for the form of the signature.			
Signature	/Yi Yu/	Date (YYYY-MM-DD)	2012-06-28
First Name	Yi	Last Name	Yu
		Registration Number	69397

This collection of information is required by 37 CFR 1.76. The information is required to obtain or retain a benefit by the public which is to file (and by the USPTO to process) an application. Confidentiality is governed by 35 U.S.C. 122 and 37 CFR 1.14. This collection is estimated to take 23 minutes to complete, including gathering, preparing, and submitting the completed application data sheet form to the USPTO. Time will vary depending upon the individual case. Any comments on the amount of time you require to complete this form and/or suggestions for reducing this burden, should be sent to the Chief Information Officer, U.S. Patent and Trademark Office, U.S. Department of Commerce, P.O. Box 1450, Alexandria, VA 22313-1450. DO NOT SEND FEES OR COMPLETED FORMS TO THIS ADDRESS. **SEND TO: Commissioner for Patents, P.O. Box 1450, Alexandria, VA 22313-1450.**

Under the Paperwork Reduction Act of 1995, no persons are required to respond to a collection of information unless it displays a valid OMB control number.

STATEMENT UNDER 37 CFR 3.73(b)

Applicant/Patent Owner: RESEARCH IN MOTION LIMITED

Application No./Patent No.: 12/905,934 Filed/Issue Date: October 15, 2010

Titled:

RESEARCH IN MOTION LIMITED, a Corporation

(Name of Assignee)

(Type of Assignee, e.g., corporation, partnership, university, government agency, etc.)

states that it is:

- 1. the assignee of the entire right, title, and interest in;
- 2. an assignee of less than the entire right, title, and interest in
(The extent (by percentage) of its ownership interest is _____ %); or
- 3. the assignee of an undivided interest in the entirety of (a complete assignment from one of the joint inventors was made)

the patent application/patent identified above, by virtue of either:

A. An assignment from the inventor(s) of the patent application/patent identified above. The assignment was recorded in the United States Patent and Trademark Office at Reel 013155, Frame 0301, or for which a copy therefore is attached.

OR

B. A chain of title from the inventor(s), of the patent application/patent identified above, to the current assignee as follows:

1. From: _____ To: _____

The document was recorded in the United States Patent and Trademark Office at
Reel _____, Frame _____, or for which a copy thereof is attached.

2. From: _____ To: _____

The document was recorded in the United States Patent and Trademark Office at
Reel _____, Frame _____, or for which a copy thereof is attached.

3. From: _____ To: _____

The document was recorded in the United States Patent and Trademark Office at
Reel _____, Frame _____, or for which a copy thereof is attached.

Additional documents in the chain of title are listed on a supplemental sheet(s).

As required by 37 CFR 3.73(b)(1)(i), the documentary evidence of the chain of title from the original owner to the assignee was, or concurrently is being, submitted for recordation pursuant to 37 CFR 3.11.

[NOTE: A separate copy (*i.e.*, a true copy of the original assignment document(s)) must be submitted to Assignment Division in accordance with 37 CFR Part 3, to record the assignment in the records of the USPTO. See MPEP 302.08]

The undersigned (whose title is supplied below) is authorized to act on behalf of the assignee.

/BRYAN C. DINER/
Signature

November 10, 2010
Date

BRYAN C. DINER
Printed or Typed Name

Reg. No. 32,409
Title

This collection of information is required by 37 CFR 3.73(b). The information is required to obtain or retain a benefit by the public which is to file (and by the USPTO to process) an application. Confidentiality is governed by 35 U.S.C. 122 and 37 CFR 1.11 and 1.14. This collection is estimated to take 12 minutes to complete, including gathering, preparing, and submitting the completed application form to the USPTO. Time will vary depending upon the individual case. Any comments on the amount of time you require to complete this form and/or suggestions for reducing this burden, should be sent to the Chief Information Officer, U.S. Patent and Trademark Office, U.S. Department of Commerce, P.O. Box 1450, Alexandria, VA 22313-1450. DO NOT SEND FEES OR COMPLETED FORMS TO THIS ADDRESS. SEND TO: Commissioner for Patents, P.O. Box 1450, Alexandria, VA 22313-1450.

If you need assistance in completing the form, call 1-800-PTO-9199 and select option 2.

Petitioners Ex. 1002

IPR USP 8,624,550

Page 7 of 174

Under the Paperwork Reduction Act of 1995, no persons are required to respond to a collection of information unless it displays a valid OMB control number.

POWER OF ATTORNEY TO PROSECUTE APPLICATIONS BEFORE THE USPTO

I hereby revoke all previous powers of attorney given in the application identified in the attached statement under 37 CFR 3.73(b).

I hereby appoint:

Practitioners associated with the Customer Number: 93377

OR

Practitioner(s) named below (if more than ten patent practitioners are to be named, then a customer number must be used):

Name	Registration Number		Name	Registration Number

as attorney(s) or agent(s) to represent the undersigned before the United States Patent and Trademark Office (USPTO) in connection with any and all patent applications assigned only to the undersigned according to the USPTO assignment records or assignment documents attached to this form in accordance with 37 CFR 3.73(b).

Please change the correspondence address for the application identified in the attached statement under 37 CFR 3.73(b) to:

The address associated with Customer Number: 93377

OR

<input type="checkbox"/> Firm or Individual Name			
Address			
City	State	Zip	
Country			
Telephone	Email		

Assignee Name and Address:
 Research In Motion Limited
 295 Phillip Street
 Waterloo, Ontario, Canada N2L 3W8

A copy of this form, together with a statement under 37 CFR 3.73(b) (Form PTO/SB/96 or equivalent) is required to be filed in each application in which this form is used. The statement under 37 CFR 3.73(b) may be completed by one of the practitioners appointed in this form if the appointed practitioner is authorized to act on behalf of the assignee, and must identify the application in which this Power of Attorney is to be filed.

SIGNATURE of Assignee of Record

The individual whose signature and title is supplied below is authorized to act on behalf of the assignee

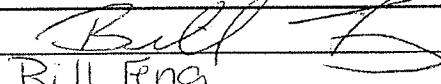
Signature		Date	(59) 888-7465
Name	Bill Peng	Telephone	Dec. 23/09
Title	Vice President, Shared Services		

This collection of information is required by 37 CFR 1.31, 1.32 and 1.33. The information is required to obtain or retain a benefit by the public which is to file (and by the USPTO to process) an application. Confidentiality is governed by 35 U.S.C. 122 and 37 CFR 1.11 and 1.14. This collection is estimated to take 3 minutes to complete, including gathering, preparing, and submitting the completed application form to the USPTO. Time will vary depending upon the individual case. Any comments on the amount of time you require to complete this form and/or suggestions for reducing this burden, should be sent to the Chief Information Officer, U.S. Patent and Trademark Office, U.S. Department of Commerce, P.O. Box 1450, Alexandria, VA 22313-1450. DO NOT SEND FEES OR COMPLETED FORMS TO THIS ADDRESS. SEND TO: Commissioner for Patents, P.O. Box 1450, Alexandria, VA 22313-1450.

If you need assistance in completing the form, call 1-800-PTO-9199 and select option 2.

Legal OK

Petitioners Ex. 1002

IPR USP 8,624,550

Page 8 of 174

RIM 01

IN THE UNITED STATES PATENT AND TRADEMARK OFFICE

In re Application of:)
)
Daniel M. FISCHER et al.) Parent Group Art Unit: 2858
)
Application No.: Unknown) Parent Examiner: Edward H. Tso
(Continuation of Appln. No. 13/175,509))
)
Filed: June 28, 2012)
) Confirmation No.: Unknown
For: MULTIFUNCTIONAL CHARGER)
SYSTEM AND METHOD)

Commissioner for Patents
P.O. Box 1450
Alexandria, VA 22313-1450

Sir:

INFORMATION DISCLOSURE STATEMENT UNDER 37 C.F.R. § 1.97(b)

Pursuant to 37 C.F.R. §§ 1.56 and 1.97(b), Applicants bring to the attention of the Examiner the listed documents on the attached listing. This Information Disclosure Statement is being filed concurrently with the continuation application.

Copies of the listed documents are not attached since they were submitted in the parent case (Application No. 13/175,509).

Applicants respectfully request that the Examiner consider the listed documents and indicate that they were considered by making appropriate notations on the attached form.

This submission does not represent that a search has been made or that no better art exists and does not constitute an admission that each or all of the listed documents are material or constitute "prior art." If the Examiner applies any of the

documents as prior art against any claim in the application and Applicants determine that the cited documents do not constitute "prior art" under United States law, Applicants reserve the right to present to the U.S. Patent and Trademark Office the relevant facts and law regarding the appropriate status of such documents.

Applicants further reserve the right to take appropriate action to establish the patentability of the disclosed invention over the listed documents, should one or more of the documents be applied against the claims of the present application.

If there is any fee due in connection with the filing of this Statement, please charge the fee to Deposit Account No. 06-0916.

Respectfully submitted,

FINNEGAN, HENDERSON, FARABOW,
GARRETT & DUNNER, L.L.P.

Dated: June 28, 2012

By: Yi Yu
Yi Yu
Reg. No. 69,397
(571) 203-2700

INFORMATION DISCLOSURE STATEMENT BY APPLICANT (Not for submission under 37 CFR 1.99)	Application Number	Unknown
	Filing Date	June 28, 2012
	First Named Inventor	Daniel M. Fischer
	Art Unit	Unknown
	Examiner Name	Unknown
	Attorney Docket Number	11298.0188-08000

U.S. PATENTS						
Examiner Initial*	Cite No	Patent Number	Kind Code ¹	Issue Date	Name of Patentee or Applicant of cited Document	Pages, Columns, Lines where Relevant Passages or Relevant Figures Appear
	1	3775659		1973-11-27	Carlsen, II	
	2	4433251		1984-02-21	Banks et al.	
	3	4510431		1985-04-09	Winkler	
	4	5173855		1992-12-22	Nielsen et al.	
	5	5229649		1993-07-20	Nielsen et al.	
	6	5272475		1993-12-21	Eaton et al.	
	7	5444378		1995-08-22	Rogers	
	8	5631503		1997-05-20	Cioffi	
	9	5638540		1997-06-10	Aldous	
	10	5651057		1997-07-22	Blood et al.	
	11	5769877		1998-06-23	Barreras, Sr.	
	12	5850113		1998-12-15	Weimer et al.	
	13	5939860		1999-08-17	William	
	14	6006088		1999-12-21	Couse	
	15	6104162		2000-08-15	Sanisbury et al.	
	16	6104759		2000-08-15	Carkner et al.	
	17	6130518		2000-10-10	Gabehart et al.	
	18	6138242		2000-10-24	Massman et al.	
	19	6184652		2001-02-06	Yang	
	20	6211649		2001-04-03	Matsuda	
	21	6252375		2001-06-26	Richter et al.	
	22	6255800		2001-07-03	Bork	
	23	6283789		2001-09-04	Tsai	
	24	6357011		2002-03-12	Gilbert	
	25	6397696		2002-06-04	Ogami	
	26	6663420		2003-12-16	Xiao	
	27	6668296		2003-12-23	Dougherty et al.	

**INFORMATION DISCLOSURE
STATEMENT BY APPLICANT**
(Not for submission under 37 CFR 1.99)

Application Number	Unknown
Filing Date	June 28, 2012
First Named Inventor	Daniel M. Fischer
Art Unit	Unknown
Examiner Name	Unknown
Attorney Docket Number	11298.0188-08000

28	6738856		2004-05-18	Milley et al.	
29	7159132		2007-01-02	Takahashi et al.	
30	7170259		2007-01-30	Veselic	
31	7340627		2008-03-04	Harvey	
32	7629767		2009-12-08	Kang	
33	7631111		2009-12-08	Monks et al.	
34	7698490		2010-04-13	Terrell, II	
35	7737657		2010-06-15	Fischer, et al.	
36	7812565		2010-10-12	Bayne et al.	
37	7884570		2011-02-08	Purdy et al.	
38	7986127		2011-07-26	Fischer et al.	
39	7834586		2010-02-26	Fischer et al.	

U.S. PATENT APPLICATION PUBLICATIONS

Examiner Initial*	Cite No	Publication Number	Kind Code ¹	Publication Date	Name of Patentee or Applicant of cited Document	Pages, Columns, Lines where Relevant Passages or Relevant Figures Appear
	1	2001/0003205		2001-06-07	Gilbert	
	2	2003/0034898		2003-02-20	Shamoon et al.	
	3	2004/0063464		2004-04-01	Akam et al.	
	4	2004/0251878		2004-12-16	Veselic	
	5	2005/0269883		2005-12-08	Drader et al.	
	6	2006/0181241		2006-08-17	Veselic	
	7	2007/0108938		2007-05-17	Veselic	
	8	2009/0128091		2009-05-21	Purdy et al.	
	9	2009/0130874		2009-05-21	Englund	
	10	2010/0052620		2010-03-04	Wong	
	11	2010/0060233		2010-03-11	Kung et al.	
	12	2010/0201308		2010-08-12	Lindholm	
	13	2004/0251878		2004-12-16	Veselic	

**INFORMATION DISCLOSURE
STATEMENT BY APPLICANT**
(Not for submission under 37 CFR 1.99)

Application Number	Unknown
Filing Date	June 28, 2012
First Named Inventor	Daniel M. Fischer
Art Unit	Unknown
Examiner Name	Unknown
Attorney Docket Number	11298.0188-08000

FOREIGN PATENT DOCUMENTS

Examiner Initial*	Cite No	Foreign Document Number	Country Code ²ⁱ	Kind Code ¹	Publication Date	Name of Patentee or Applicant of cited Document	Pages, Columns, Lines where Relevant Passages or Relevant Figures Appear	T ⁵
	1	0684680	EP		1995-11-29	Nokia Mobile Phones Ltd.		<input type="checkbox"/>
	2	1198049	EP		2002-04-17	Sony International (Eur.)		
	3	2001/01330	WO		2001-01-04	Cross Match Technologies, Inc.		
	4	2005063355	JP		2005-03-10	Matsushita Electric Inc. Co. Ltd.		
	5	2517333	CA		2002-09-01	Research in Motion Ltd.		

NON-PATENT LITERATURE DOCUMENTS

Examiner Initial*	Cite No	Include the name of the author (in CAPITAL LETTERS), title of the article (when appropriate), title of the item (book, magazine, journal, serial, symposium, catalog, etc.), date, page(s), volume-issue number(s), publisher, city and/or country where published.	T ⁵
	1	Canadian Office Action for Canadian Application No. 2,374,344 dated March 12, 2004 (3 pages)	<input type="checkbox"/>
	2	Charging Big Supercaps, Portable Design, p. 26, March 1997	
	3	Electric Double-Layer Capacitors, Vol. 2, October 25, 1996, (Japan, Tokin Corp., Cat. No. EC-200E)	
	4	Supercapacitor: User's Manual, Vol. 2, Japan, Tokin Corporation, January 1997 (47 pages)	
	5	U.S. Office Action for U.S. Application 10/087,629 dated September 7, 2004 (6 pages)	
	6	U.S. Office Action for U.S. Application 11/175,885 dated April 4, 2006 (5 pages)	
	7	U.S. Office Action for U.S. Application 11/175,885 dated October 20, 2005 (8 pages)	
	8	U.S. Office Action for U.S. Application 11/749,680 dated September 25, 2007 (9 pages)	
	9	U.S. Office Action for U.S. Application 12/174,204 dated August 5, 2010 (11 pages)	
	10	U.S. Office Action for U.S. Application 12/268,297 dated August 18, 2009 (9 pages)	
	11	U.S. Office Action for U.S. Application 12/905,934 dated November 29, 2010 (11 pages)	
	12	U.S. Office Action for U.S. Application No. 11/175,885 dated August 24, 2006 (6 pages)	
	13	U.S. Office Action for U.S. Application No. 12/714,204 dated August 5, 2010 (11 pages)	

INFORMATION DISCLOSURE STATEMENT BY APPLICANT (Not for submission under 37 CFR 1.99)	Application Number		Unknown
	Filing Date		June 28, 2012
	First Named Inventor	Daniel M. Fischer	
	Art Unit		Unknown
	Examiner Name	Unknown	
	Attorney Docket Number		11298.0188-08000

	14	U.S. Office Action for US. Application 11/175,885 dated August 24, 2006 (6 pages)	
	15	U.S. Office Action for US. Application 13/175,487 dated December 12, 2011 (10 pages)	

EXAMINER SIGNATURE

Examiner Signature		Date Considered	
--------------------	--	-----------------	--

*EXAMINER: Initial if reference considered, whether or not citation is in conformance with MPEP 609. Draw line through a citation if not in conformance and not considered. Include copy of this form with next communication to applicant.,

¹ See Kind Codes of USPTO Patent Document at www.USPTO.GOV or MPEP 901.04. ² Enter office that issued the document, by the two letter code (WIPO Standard ST.3). ³ For Japanese patent documents, the indication of the year of the reign of the Emperor must precede the serial number of the patent document. ⁴ Kind of document by the appropriate symbols as indicated on the document under WIPO Standard ST.16 if possible. ⁵ Applicant to place a check mark here if English language translation is attached.

IN THE UNITED STATES PATENT AND TRADEMARK OFFICE

In re Application of:)
)
Daniel M. FISCHER et al.) Parent Group Art Unit: 2858
)
Application No.: To be Assigned) Parent Examiner: Edward H. Tso
(Continuation of Appln. No. 13/175,509))
)
Filed: June 28, 2012)
) Confirmation No.: To be Assigned
For: MULTIFUNCTIONAL CHARGER)
SYSTEM AND METHOD)

Commissioner for Patents
P.O. Box 1450
Alexandria, VA 22313-1450

Sir:

PRELIMINARY AMENDMENT

Prior to the examination of the above application, please amend this application as follows:

Amendments to the Specification begin on page 2 of this paper.

Amendments to the Claims are reflected in the listing of claims and begins on page 13 of this paper.

Remarks follow the amendment sections of this paper.

AMENDMENTS TO THE SPECIFICATION:

Please amend the specification as follows:

Please amend Page 1, paragraph [0001] as follows:

[0001] This is a continuation application of U.S. Patent Application No. 13/175,509, filed July 1, 2011, by Daniel M. Fischer, et al. and entitled "Multifunctional Charger System and Method," which is a continuation of U.S. Patent Application No. 12/905,934, filed October 15, 2010, now U.S. Patent No. 7,986,127, issued on July 26, 2011, by Daniel M. Fischer, et al. and entitled "Multifunctional Charger System and Method," which is a continuation of U.S. Patent Application No. 12/714,204, filed February 26, 2010, now U.S. Patent No. 7,834,586 issued on November 16, 2010, by Daniel M. Fischer, et al. and entitled "Multifunctional Charger System and Method," which is a continuation of U.S. Patent Application No. 12/268,297, filed November 10, 2008, now U.S. Patent No. 7,737,657 issued on June 15, 2010, by Daniel M. Fischer, et al. and entitled "System and Method for Charging a Battery in a Mobile Device," which is a continuation of U.S. Patent Application No. 11/749,680, filed May 16, 2007, now U.S. Patent No. 7,453,233 issued on November 18, 2008, by Daniel M. Fischer, et al. and entitled "Adapter System and Method for Powering a Device," which is a continuation of U.S. Patent Application No. 11/175,885, filed on July 6, 2005, now U.S. Patent No. 7,239,111 issued on July 3, 2007, by Daniel M. Fischer, et al. and entitled "Universal Serial Bus Adapter for a Mobile Device," which is a continuation of U.S. Patent Application No. 10/087,629, filed March 1, 2002, now U.S. Patent No. 6,936,936 issued on August 30, 2006, by Daniel M. Fischer, et al. and entitled "Multifunctional Charger

System and Method,” which claims priority from U.S. Provisional Application no. 60/273,021, filed March 1, 2001, by Daniel M. Fischer, et al. and entitled “System and Method for Adapting a USB to Provide Power for Charging a Mobile Device” and U.S. Provisional Application No. 60/330,486, filed October 23, 2001, by Daniel M. Fischer, et al. and entitled “multifunctional Charger System and Method.” Each of the above patent applications is hereby incorporated herein by reference in its entirety for all purposes.

Please amend Page 2, paragraph [0003] as follows:

[0003] Providing an external source of power to a mobile device, such as a personal digital assistant[[s]] (“PDA”), mobile communication device, cellular phone, wireless two-way e-mail communication device, and others, requires design considerations with respect to both the mobile device and the power source. With regard to the mobile device, most mobile devices provide a distinct power interface for receiving power from a power source, for instance to recharge a battery, and a separate data interface for communicating. For example, many mobile devices presently use USB (Universal Serial Bus) interfaces for communicating and use a separate power interface, such as a barrel connector, for receiving power.

Please amend Page 6, paragraph [0016] as follows:

[0016] Turning now to the drawing figures, shown in Fig. 1 is a schematic diagram of an exemplary mobile communication device 10 which has an industry standard interface. The mobile communication device 10 is preferably a two-way communication device having at least voice or data communication capabilities. Preferably, the mobile device 10 is also capable of communicating over the Internet, for

example, via a radio frequency (“RF”) link. Examples of types of devices that could be classified as a mobile device 10 include a data messaging device, a two-way pager, a cellular telephone with data messaging capabilities, a wireless Internet appliance, a data communication device (with or without telephony capabilities), a personal digital assistant[[s]] (“PDA”), a wireless two-way e-mail communication device, and others.

Please amend Pages 11 and 12, paragraph [0029] as follows:

[0029] Coupled to the USB port 18 is a USB connector 54. The USB connector 54 is the physical component that couples the USE port 18 to the outside world. In the exemplary mobile device 10, the USB connector 54 is used to transmit and receive data from an external data/power source 56, receive power from the external data/power source 56, direct the transmitted/received data from/to the USB port 18, and direct the received power to the power subsystem 20.

Please amend Page 12, paragraph [0030] as follows:

[0030] The exemplary power subsystem 20 comprises a charging and power distribution subsystem 58 and a battery 60. The charging and power distribution subsystem 58 performs many functions. It may be used to transfer energy to the battery 60 from the external data/power source 56 to charge the battery 60 and also to distribute power to the many ~~power-requiring~~ power-requiring components within the mobile device 10. The charging subsystem 58 may be capable of determining the presence of a batter 60 and/or a power circuit coupled to the mobile device 10, such as an AC adapter, USB connection, or car adapter, which alternatively can act as power sources 56 to provide power for the mobile device 10 and to charge the battery 60.

Additionally, the charging subsystem 58 may have the ability to determine if a power source 56 is coupled to the mobile device 10 and, in the absence of such a coupling, cause the mobile device 10 to be powered by the battery 60.

Please amend Page 13, paragraph [0032] as follows:

[0032] Fig. 2 is a schematic diagram of a first embodiment of an adapter 100 that can be used to couple the mobile device 10 of fig. 1 to the data/power source 56 of fig. 1. In this example the adapter 100 is a USB adapter 100 that comprises a primary USB connector 102, a power converter 104, a plug unit 106, and an identification subsystem 108. The power converter is a known element in the art and typically includes at least one of the following components: switching converter, transformer, DC source, voltage regulator, linear regulator and rectifier. In the embodiment shown in fig. 2, the USB adapter 100 is shown coupling a mobile device 10 to one of one or more types of power sockets 110N, 110D, 110B, and ~~[[100]]~~ 110. Also shown in fig. 2 is an optional auxiliary USB connector 112 that can be used to couple the mobile device 10 to a data source (not shown) such as a personal computer.

Please amend Page 13 and Page 14, paragraph [0034] as follows:

[0034] The plug unit 106 is preferably a conventional plug unit that can be used to couple with a conventional power socket to receive power therefrom. For example, the plug unit 106 can be a ~~two-prong~~ two-prong or ~~three-prong~~ three-prong plug of the type used in North America that can couple to a North American AC power socket 110N that provides 115 VAC. In the embodiment shown in figure 2, the plug unit 106 can accept one or more types of plug adapters 114N, 114B, 114D, and 114 that are

configured to couple to the plug unit 106 and are further configured to directly mate with one or more types of power sockets 110N, 110D, 110B, and ~~[[100]]~~ 110. The plug unit 106 can be configured to receive energy from a power socket 110N, 110D, 110B, or ~~[[100]]~~ 110, either directly or through the use of a plug adapter, and is operative to transfer the received energy to the power converter 104.

Please amend Page 14, paragraph [0035] as follows:

[0035] The power converter 104 is operative to receive energy from a power socket 110N, 110D, 110B, or ~~[[100]]~~ 110 and to convert that received energy to a form that can be used by the mobile device 10. For example, the power converter 104 can be of conventional construction such as a switching power converter that converts 115 VAC to 5 VDC. Also, the power converter 104 could comprise a D.C. regulator circuit that converts a D.C. input to a D.C. output. The power converter 104 could also be adapted to accept a wide range of input energy levels and frequencies. Alternatively, the power converter 104 could be adapted to accept a limited range of input energy levels and frequencies, wherein the plug adapters are operable to convert the possible input energy levels and frequencies to a range that the power converter 104 can accommodate. The power converter 104 provides its energy output to the mobile device 10 via the Vbus and Gnd pins of the primary USB connector 102.

Please amend Page 14 and Page 15, paragraph [0036] as follows:

[0036] Through the use of a variety of different types of plug adapters, the USB adapter 100 can be adapted to receive energy from various types of power sockets 110N, 110D, 110B, or ~~[[100]]~~ 110. For example, using the appropriate plug adapter

114, 114B, 114D, and 114N, the USB adapter 100 can receive energy from a power socket such as an a 115 VAC North American power socket 110N, or a 12 VDC automobile power socket, or an air power socket, or others.

Please amend Page 15, paragraph [0037] as follows:

[0037] For example, in North America, a type "N" power socket is commonly available. The plug adapter 114N can be releasably attached to the plug unit 106 thereby allowing any North American power socket 114N to be used as a power source. When traveling to a locale which does not have the North American power socket 114N, an alternate plug adapter such as adapters 114, 114B, or 114D may be selected by the user, according to the power socket 110D, 110B, or 110 available at the locale. The plug adapter 114, 114B, or 114D may then be releasably attached to plug unit 106 in place of the plug adapter 114N, thereby allowing the USB power adapter 100 to connect to a local power supply via the local power ~~socket~~ socket. Various other plug adapters are envisioned that can be configured to operate with alternate power sources such as for instance car sockets.

Please amend Page 16, paragraph [0041] as follows:

[0041] The identification subsystem 108 provides an identification signal to the mobile device 10 that the power source is not a USB limited source. The identification signal could be the communication of a single voltage on one or more of the USB data lines, different voltages on the two data lines, a series of pulses or voltage level changes, or other types of electrical signals. The identification subsystem 108 that generates the identification signal could have multiple types of configurations. In one

embodiment, the identification subsystem 108 comprises a hard-wired connection of a single voltage level to both data lines. In another embodiment, the identification subsystem 108 comprises a USB controller that is operable to communicate an identification signal to the mobile device 10. Additional embodiments are contemplated. The identification subsystem 108 may optionally be configured to have the capability of electrically connecting or disconnecting the power output from the power converter 104 from the USB connector 102 and/or to connect or disconnect any data inputs from the USB adapter 100 to the USB connector 102.

Please amend Page 17, paragraph [0043] as follows:

[0043] The USB adapter 100 preferably provides a communication path between the D+ and D- pins of the Primary USB connector 102 and the D+ and D- pins of the auxiliary USB connector 112. In the embodiment shown, the communication path also traverses the identification subsystem 108. Alternatively, the communication path could bypass the identification subsystem 108. The USB adapter 100 can thus act as a ~~pass-through~~ pass-through device for communication between a USB hub or host and a mobile device 10.

Please amend Page 17 and Page 18, paragraph [0045] as follows:

[0045] When a USB adapter 100 is connected to a mobile device 10, the identification subsystem 108 of the USB adapter 100 preferably provides an identification signal to the mobile device 10 to notify the mobile device 10 that the device 10 is connected to a power source that is not subject to the power limits imposed by the USB specification. Preferably, the mobile device 10 is programmed to recognize

the identification signal and therefore recognizes that an identification signal has been transmitted by the USB adapter 100. After recognizing a valid identification signal, the mobile device 10[[,]] draws power through the USB adapter 100 without waiting for enumeration or charge negotiation.

Please amend Page 18, paragraph [0046] as follows:

[0046] The detection of the identification signal may be accomplished using a variety of methods. For example, the microprocessor 12 may detect the identification signal by detecting the presence of an abnormal data line condition at the USB port 18. The detection may also be accomplished through the use of other device subsystems 44 in the mobile device 10. The preferred identification signal results from the application of voltage signals greater than 2 volts to both the D+ and D- lines in the USB connector 54. The preferred method of identification is described below in greater detail with reference to Fig. 3.

Please amend Page 18, paragraph [0047] as follows:

[0047] At step 210, the mobile device 10 detects the presence of a voltage on the Vbus line of the USB connector 54 via the USB port 18. At step 220, the mobile device checks the state of the D+ and D- lines of USB connector 54. In the example shown in the drawings, the D+ and D- lines are compared to a 2V reference. Also, in this example, the identification subsystem 108 of the USB adapter 100 may have applied a logic high signal, such as +5V reference, to both the D+ and D- lines to identify the attached device as a USB adapter 100. If the voltages on both the D+ and D- lines of the USB connector are greater than 2 Volts (step 220), then the mobile

device 10 determines that the device connected to the USB connector 54 is not a typical USB host or hub and that a USB adapter 100 has been detected (step 230). The mobile device 10 can then charge the battery or otherwise use power provided via the Vbus and Gnd line sin the USB connector 54 (step 260) without waiting for enumeration.

Please amend Page 19, paragraph [0048] as follows:

[0048] If, however, after the mobile device 10 detects the presence of a voltage on the Vbus line of the USB connector 54 and determines that the voltages on both the D+ and D- lines of the USB connector 54 are not greater than 2 Volts (step 220), then the mobile device 10 determines that a USB host or hub has been detected (step 240). A typical USB host or hub weakly holds its D+ and D- lines at zero volts when it is not connected to another device. The mobile device 10 can then signal the USB host or hub to initiate the enumeration process (step 250) and can charge the battery or otherwise use power provided via the Vbus and Gnd lines in the USB connector 54 (step 260) in accordance with the power limits imposed by the USB specification. The enumeration process is typically initiated after the mobile device 10 applies approximately zero volts to the D-line and approximately 5 volts to the D+ line to inform the host of the mobile device's 10 presence and communication speed.

Please amend Page 19 and Page 20, paragraph [0050] as follows:

[0050] If the USB adapter 100[[,]] is coupled to the mobile device 10, and the mobile device 10 does not identify the USB adapter 100 through communications with the identification module 108, the mobile device 10 may stop drawing energy from the

Vbus and Gnd lines of the USB connector 54. This may occur, for example, if the mobile device 10 is not programmed to identify the USB adapter 100. The mobile device 10 may mistakenly identify the USB adapter 100 as a typical USB host or hub and await enumeration before drawing substantial energy. To guard against this, the USB adapter 100 can optionally be adapted to function with mobile devices that are not programmed to recognize the USB adapter 100.

Please amend Page 21, paragraph [0052] as follows:

[0052] Shown in fig. 4 is a schematic diagram of an additional exemplary embodiment of a USB adapter 300 that is coupled to a mobile device 10. The exemplary USB adapter 300 comprises a USB connector 302, a power converter 304, a plug unit 306, and an identification subsystem 308. The USB connector 302, plug unit 306, and identification subsystem 308[[,]] preferably correspond to the USB connector 102, plug unit 106, and identification subsystem 108 which were described earlier with respect to the first embodiment. Similar to the first embodiment, the additional embodiment may optionally be equipped with various plug adapters 314N, 314D, 314B, and 314 that preferably are releasably attachable to plug unit 306 so that the appropriate plug adapter 314N, 314D, 314B, or 314 can be selected by a user to allow the USB adapter 300 to couple to and receive energy from an available power socket 310N, 310D, 310B, or 310. The exemplary USB power converter 300 further comprises a charging subsystem 316 and battery receptacle 318 for coupling the USB adapter 300 to an external battery 320 that may be optionally coupled thereto.

Please amend Page 21, paragraph [0053] as follows:

[0053] The battery receptacle 318 provides a location for releasably coupling an external battery 320 thereto so that the external battery can be charged via the USB adapter 300. This provides the USB adapter 300 with a mechanism for charging, for example, a mobile device's primary or spare battery when the battery has been separated from or is not coupled to the mobile device 10.

AMENDMENTS TO THE CLAIMS:

This listing of claims will replace all prior versions and listings of claims in the application:

1-10. (Canceled)

11. (New) An adapter comprising:

a USB VBUS line and a USB communication path,

said adapter configured to supply current on the VBUS line without regard to at least one associated condition specified in a USB specification.

12. (New) The adapter of claim 11, wherein said associated condition is a current limit.

13. (New) The adapter of claim 11, wherein said current is supplied without USB enumeration.

14. (New) The adapter of claim 11, wherein said current is supplied in response to an abnormal data condition on said USB communication path.

15. (New) The adapter of claim 14, wherein said USB communication path includes a D+ line and a D- line.

16. (New) The adapter of claim 15, wherein said abnormal data condition is an abnormal data line condition on said D+ line and said D- line.

17. (New) The adapter of claim 16, wherein said abnormal data line condition is a logic high signal on each of said D+ and D- lines.

18. (New) The adapter of claim 17, wherein each said logic high signals is greater than 2V.

19. (New) The adapter of claim 12, wherein said current limit is 500mA.

20. (New) An adapter comprising:
a USB VBUS line and a USB communication path,
said adapter configured to supply current on the VBUS line without regard to at least one USB Specification imposed limit.

21. (New) The adapter of claim 20, wherein said USB Specification imposed limit is a current limit.

22. (New) The adapter of claim 20, wherein said current is supplied without USB enumeration.

23. (New) The adapter of claim 20, wherein said current is supplied in response to an abnormal data condition on said USB communication path.

24. (New) The adapter of claim 23, wherein said USB communication path includes a D+ line and a D- line.

25. (New) The adapter of claim 24, wherein said abnormal data condition is an abnormal data line condition on said D+ line and said D- line.

26. (New) The adapter of claim 25, wherein said abnormal data line condition is a logic high signal on each of said D+ and D- lines.

27. (New) The adapter of claim 26, wherein each said logic high signal is greater than 2V.

28. (New) The adapter of claim 21, wherein said current limit is 500mA.

REMARKS

Applicants submit this preliminary amendment to update the specification to reflect the priority chain and correct typographical and/or grammatical errors. Claims 1-10 have been canceled. New claims 11-28 have been added.

If there is any fee due in connection with the filing of this Preliminary Amendment, please charge the fee to Deposit Account 06-0916.

Respectfully submitted,

FINNEGAN, HENDERSON, FARABOW,
GARRETT & DUNNER, L.L.P.

Dated: June 28, 2012

By: /Yi Yu/
Yi Yu
Reg. No. 69,397
(571) 203-2700

MULTIFUNCTIONAL CHARGER SYSTEM AND METHOD

CROSS-REFERENCE TO RELATED APPLICATIONS

[0001] This is a continuation application of U.S. Patent Application No. 12/714,204 filed February 26, 2010, by Daniel M. Fischer, et al. and entitled "Multifunctional Charger System and Method," which is a continuation of U.S. Patent Application No. 12/268,297 filed November 10, 2008 now U.S. Patent No. 7,737,657 issued on June 15, 2010, by Daniel M. Fischer, et al. and entitled "System and Method for Charging a Battery in a Mobile Device," which is a continuation of U.S. Patent Application No. 11/749,680, filed May 16, 2007, now No. 7,453,233 issued on November 18, 2008 by Daniel M. Fischer, et al. and entitled "Adapter System and Method for Powering a Device," which is a continuation of U.S. Patent Application No. 11/175,885, filed on July 6, 2005, now U.S. Patent No. 7,239,111 issued on July 3, 2007, by Daniel M. Fischer, et al. and entitled "Universal Serial Bus Adapter for a Mobile Device," which is a continuation of U.S. Patent Application No. 10/087,629, filed on March 1, 2002, now U.S. Patent No. 6,936,936 issued on August 30, 2005, by Daniel M. Fischer, et al. and entitled "Multifunctional Charger System and Method," which claims priority from U.S. Provisional Application No. 60/273,021 filed March 1, 2001, by Daniel M. Fischer, et al. and entitled "System and Method for Adapting a USB to Provide Power for Charging a Mobile Device" and U.S. Provisional Application No. 60/330,486 filed October 23, 2001, by Daniel M. Fischer, et al. and entitled "Multifunctional Charger System and Method." Each of the above patent applications is hereby incorporated herein by reference in its entirety for all purposes.

BACKGROUND

[0002] This invention relates generally to power adapters. More particularly, the invention relates to power adapters for use with mobile devices.

[0003] Providing an external source of power to a mobile device, such as a personal digital assistants ("PDA"), mobile communication device, cellular phone, wireless two-way e-mail communication device, and others, requires design considerations with respect to both the mobile device and the power source. With regard to the mobile device, most mobile devices provide a distinct power interface for receiving power from a power source, for instance to recharge a battery, and a separate data interface for communicating. For example, many mobile devices presently use USB (Universal Serial Bus) interfaces for communicating and use a separate power interface, such as a barrel connector, for receiving power.

[0004] It is desirable, however, to have a combined power and data interface. The mobile devices that do have combined power and data interfaces typically use non-standard and sometimes proprietary interfaces. Consequently, combined interfaces for a particular manufacturer's mobile device may not be compatible with combined interfaces for mobile devices provided by other manufacturers.

[0005] Although the USB interface can be used as a power interface, the USB is typically not used for that purpose by mobile devices. In accordance with the USB specification, typical USB power source devices, such as hubs and hosts, require that a USB device participate in a host-initiated process called enumeration in order to be compliant with the current USB specification in drawing power from the USB interface.

Although a mobile device could be adapted to participate in enumeration when drawing power over the USB interface, it would be preferable in many situations, such as when a host would not be available, as often happens during normal use of a mobile device, to be able to utilize alternate power sources such as conventional AC outlets and DC car sockets that are not capable of participating in enumeration to supply power to the mobile device via a USB interface.

SUMMARY

[0006] An adapter for providing a source of power to a mobile device through an industry standard port is provided. In accordance with one aspect of the invention, the adapter comprises a plug unit, a power converter, a primary connector, and an identification subsystem. The plug unit is operative to couple the adapter to a power socket and operative to receive energy from the power socket. The power converter is electrically coupled to the plug unit and is operable to regulate the received energy from the power socket and to output a power requirement to the mobile device. The primary connector is electrically coupled to the power converter and is operative to couple to the mobile device and to deliver the outputted power requirement to the mobile device. The identification subsystem is electrically coupled to the primary connector and is operative to provide an identification signal.

[0007] In accordance with another aspect, a USB adapter for providing a source of power to a mobile device through a USB port is provided. The USB adapter comprises a plug unit, a power converter, a primary USB connector, and an identification subsystem. The plug unit is operative to couple the USB adapter to a power socket and operative to receive energy from the power socket. The power converter is

electrically coupled to the plug unit and is operable to regulate the received energy from the power socket and to output a power requirement to the mobile device. The primary USB connector is electrically coupled to the power converter and is operative to couple to the mobile device and to deliver the outputted power requirement to the mobile device. The identification subsystem is electrically coupled to the primary connector and is operative to provide an identification signal.

[0008] Another aspect provides a USB adapter for providing a source of power to a mobile device through a USB port. The USB adapter comprises a plug unit, a power converter, a primary USB connector, and an auxiliary USB adapter. The plug unit is operative to couple the USB adapter to a power socket and operative to receive energy from the power socket. The power converter is electrically coupled to the plug unit and is operable to regulate the received energy from the power socket and to output a power requirement to the mobile device. The primary USB connector is electrically coupled to the power converter and is operative to couple to the mobile device and to deliver the outputted power requirement to the mobile device. The auxiliary USB connector has data lines that are electrically coupled to the data lines of the primary USB connector.

[0009] Yet another aspect provides a method for providing energy to a mobile device using a USB adapter that comprises a plug unit, a primary USB connector, a power converter electrically coupled between the plug unit and the primary USB connector, and an identification subsystem electrically coupled to the primary USB connector. The method comprising the steps of coupling the USB connector to the mobile device, coupling the plug unit to a power socket, outputting a power requirement to the mobile device via the power converter and the USB connector, and providing an identification

signal to the mobile device, via the identification subsystem and the USB connector, that is operative to inform the mobile device that the USB adapter is not limited by the power limits imposed by the USB specification.

[0010] In accordance with another aspect, a powering system for a mobile device having a USB connector is provided. The powering system comprises a power distribution subsystem in the mobile device that is operable to receive energy through the USB connector and to distribute the energy to at least one component in the mobile device and a USB adapter that is operative to couple to the USB connector. The USB adapter comprises a plug unit for coupling to a power socket and that is operable to receive energy from the power socket, a power converter electrically coupled to the plug unit for regulating the received energy and for providing a power requirement to the power distribution subsystem, and an identification subsystem that is operable to transmit an identification signal that is operative to identify the USB adapter as not being limited by the power limits imposed by the USB specification.

BRIEF DESCRIPTION OF THE DRAWINGS

[0011] In order that the invention identified in the claims may be more clearly understood, preferred embodiments thereof will be described in detail by way of example, with reference to the accompanying drawings, in which:

[0012] Fig. 1 is a schematic diagram of an exemplary mobile device which has an industry standard interface;

[0013] Fig. 2 is a schematic diagram of a first embodiment of a USB adapter that is coupled to an exemplary mobile device;

[0014] Fig. 3 is a flow chart illustrating an exemplary use of a USB adapter with a mobile device; and

[0015] Fig. 4 is a schematic diagram of an additional exemplary embodiment of a USB adapter that is coupled to both an exemplary mobile device and an external battery.

DETAILED DESCRIPTION

Exemplary Mobile Device

[0016] Turning now to the drawing figures, shown in Fig. 1 is a schematic diagram of an exemplary mobile communication device **10** which has an industry standard interface. The mobile communication device **10** is preferably a two-way communication device having at least voice or data communication capabilities. Preferably, the mobile device **10** is also capable of communicating over the Internet, for example, via a radio frequency ("RF") link. Examples of types of devices that could be classified as a mobile device **10** include a data messaging device, a two-way pager, a cellular telephone with data messaging capabilities, a wireless Internet appliance, a data communication device (with or without telephony capabilities), a personal digital assistants ("PDA"), a wireless two-way e-mail communication device, and others.

[0017] The exemplary mobile device **10** comprises a microprocessor **12**, a communication subsystem **14**, input/output ("I/O") devices **16**, an industry standard interface **18** which in this example is a USB port, and a power subsystem **20**. The microprocessor **12** controls the overall operation of the mobile device **10**. The communication subsystem **14** provides the mobile device **10** with the ability to communicate wirelessly with external devices such as other mobile devices and other

computers. The I/O devices 16 provide the mobile device 10 with input/output capabilities for use with a device user. The USB port 18 provides the mobile device 10 with a serial port for linking directly with other computers and/or a means for receiving power from an external power source. The power subsystem 20 provides the mobile device 10 with a local power source.

[0018] The exemplary communication subsystem 14 comprises components such as a receiver 22, a transmitter 24, antenna elements 26 and 28, local oscillators (LOs) 30, and a processing module such as a digital signal processor (DSP) 32. The particular design of the communication subsystem 14 and the components used therein can vary. It would be apparent to one of ordinary skill in the art to design an appropriate communication subsystem using conventional methods and components to operate over a communication network 34 based on the parameters necessary to operate over that communication network. For example, a mobile device 10 geographically located in North America may include a communication subsystem 14 designed to operate within the Mobitex™ mobile communication system or DataTAC™ mobile communication system, whereas a mobile device 10 intended for use in Europe may incorporate a General Packet Radio Service (GPRS) communication subsystem 14.

[0019] Network access requirements will also vary depending upon the type of network 34. For example, in the Mobitex and DataTAC networks, mobile devices 10 are registered on the network using a unique personal identification number or PIN associated with each device. In GPRS networks however, network access is associated with a subscriber or user of a mobile device 10. A GPRS device therefore requires a subscriber identity module (not shown), commonly referred to as a SIM card, in order to

operate on a GPRS network. Without a SIM card, a GPRS device will not be fully functional. Local or non-network communication functions (if any) may be operable, but the mobile device **10** will be unable to carry out any functions involving communications over the network **34**.

[0020] When required, after the network registration or activation procedures have been completed, a mobile device **10** may send and receive communication signals over the network **34**. Signals received by the receiver antenna **26** through a communication network **34** are input to the receiver **22**, which may perform such common receiver functions as signal amplification, frequency down conversion, filtering, channel selection and the like, and in the exemplary system shown in Fig. 1, analog to digital conversion. Analog to digital conversion of a received signal allows more complex communication functions such as demodulation and decoding to be performed in a DSP **32**. Similarly, signals to be transmitted are processed, including modulation and encoding for example, by the DSP **32** and input to the transmitter **24** for digital to analog conversion, frequency up conversion, filtering, amplification and transmission over the communication network **34** via the transmitter antenna **28**.

[0021] Also, in the exemplary communication subsystem **14**, the DSP **32** processes communication signals and also provides for receiver and transmitter control. For example, the gains applied to communication signals in the receiver **22** and transmitter **24** may be adaptively controlled through automatic gain control algorithms implemented in the DSP **32**.

[0022] In implementing its control function, the microprocessor **12** in the exemplary mobile device **10** executes an operating system. The operating system software used

by the microprocessor **12** is preferably stored in a persistent store such as flash memory **36**, or alternatively read only memory (ROM) or similar storage element. The microprocessor **12** may also enable the execution of specific device applications, which preferably are also stored in a persistent store. The operating system, specific device applications, or parts thereof, may also be temporarily loaded into a volatile store such as in RAM **38**.

[0023] A predetermined set of applications which control basic device operations, including at least data and voice communication applications for example, will normally be installed on the mobile device **10** during manufacture. One such application loaded on the mobile device **10** could be a personal information manager (PIM) application. The PIM application preferably is an application for organizing and managing user inputted data items such as e-mail, calendar events, voice mails, appointments, and task items. The PIM data items may be stored in the RAM **38** and/or the flash memory **36**.

[0024] The PIM application preferably has the ability to send and receive data items, via the wireless network **34**. The PIM data items are preferably seamlessly integrated, synchronized and updated, via the wireless network **34**, with corresponding data items stored or associated with a host computer system (not shown) used by the device user. The synchronization of PIM data items is a process by which the PIM data items on the mobile device **10** and the PIM data items on the host computer system can be made to mirror each other.

[0025] There are several possible mechanisms for loading applications onto the mobile device **10**. For example, applications may be loaded onto the mobile device **10**

through the wireless network **34**, an auxiliary I/O subsystem **40**, the serial port **18**, a short-range communications subsystem **42**, such as an infrared ("IR") communication system, or any other suitable subsystem **44**. When loading the applications onto the mobile device **10**, the device user may install the applications in the RAM **38**, the flash memory **36**, or preferably a non-volatile store (not shown) such as ROM for execution by the microprocessor **12**. The available application installation mechanisms can increase the utility of the mobile device **10** by providing the device user with a way of upgrading the mobile device **10** with additional and/or enhanced on-device functions, communication-related functions, or both. For example, a secure communication application may be loaded onto the mobile device **10** that allows for electronic commerce functions or other financial transactions to be performed using the mobile device **10**.

[0026] The I/O devices **16** may be used to display and/or compose data communication messages. In one mode of operation, a signal received by the mobile device **10**, such as a text message or web page download, will be received and processed by the communication subsystem **14**, forwarded to the microprocessor **12**, which will preferably further process the received signal, and provide the processed signal to one or more of the I/O devices **16** such as a display **46**. Alternatively, a received signal such as a voice signal can be provided to a speaker **48**, or alternatively to an auxiliary I/O device **40**. In another mode of operation a device user may compose a data item such as an e-mail message using a keyboard **50** in cooperation with the display **46** and possibly an auxiliary I/O device **40**. Alternatively, a device user may

compose a voice message via a microphone **52**. The composed data item may then be transmitted over a communication network **34** using the communication subsystem **14**.

[0027] A short-range communications subsystem **42** may be provided in the mobile device **10** to allow the mobile device **10** to communicate with other systems or devices, which need not necessarily be similar to device **10**. For example, the short-range communications subsystem **42** may include an infrared device and associated circuitry and components or a Bluetooth™ communication module to allow the device **10** to communicate with similarly-enabled systems and devices.

[0028] The USB port **18** provides the mobile device **10** with a serial port for linking directly with other computers to exchange data and/or to receive power. The USB port **18** also provides the mobile device **10** with a means for receiving power from an external power source. For example, in a personal digital assistant (PDA)-type communication device, the USB port **18** could be used to allow the mobile device **10** to synchronize data with a user's desktop computer (not shown). The USB port **18** could also enable a user to set parameters in the mobile device **10** such as preferences through the use of an external device or software application. In addition the USB port **18** may also be used to provide a means for downloading information or software to the mobile device **10** without using the wireless communication network **34**. The USB port **18** can provide a direct and thus reliable and trusted connection that may for example be used to load an encryption key onto the mobile device **10** thereby enabling secure device communication.

[0029] Coupled to the USB port **18** is a USB connector **54**. The USB connector **54** is the physical component that couples the USB port to the outside world. In the

exemplary mobile device **10**, the USB connector **54** is used to transmit and receive data from an external data/power source **56**, receive power from the external data/power source **56**, direct the transmitted/received data from/to the USB port **18**, and direct the received power to the power subsystem **20**.

[0030] The exemplary power subsystem **20** comprises a charging and power distribution subsystem **58** and a battery **60**. The charging and power distribution subsystem **58** performs many functions. It may be used to transfer energy to the battery **60** from the external data/power source **56** to charge the battery **60** and also to distribute power to the many power requiring components within the mobile device **10**. The charging subsystem **58** may be capable of determining the presence of a battery **60** and/or a power circuit coupled to the mobile device **10**, such as an AC adapter, USB connection, or car adapter, which alternatively can act as power sources **56** to provide power for the mobile device **10** and to charge the battery **60**. Additionally, the charging subsystem **58** may have the ability to determine if a power source **56** is coupled to the mobile device **10** and, in the absence of such a coupling, cause the mobile device **10** to be powered by the battery **60**.

[0031] The power distributed by the charging and power distribution subsystem **58** may be derived from energy stored in the battery **60** and/or energy received from the external data/power source **56**. When the battery **60** is depleted, the charging and power distribution subsystem **58** transfers energy from the power source **56** to recharge the battery **60**. Optionally, the charging and power distribution subsystem **58** may also transfer energy from the power source **56** to other components in the mobile device **10** to power the mobile device **10** when the battery **60** has been depleted and is recharging.

When the data/power source **56** is not connected to the mobile device **10**, power for the device **10** is derived from the battery **60**.

Exemplary USB Adapter

[0032] Fig. 2 is a schematic diagram of a first embodiment of an adapter **100** that can be used to couple the mobile device **10** of fig. 1 to the data/power source **56** of fig. 1. In this example the adapter **100** is a USB adapter **100** that comprises a primary USB connector **102**, a power converter **104**, a plug unit **106**, and an identification subsystem **108**. The power converter is a known element in the art and typically includes at least one of the following components: switching converter, transformer, DC source, voltage regulator, linear regulator and rectifier. In the embodiment shown in fig. 2, the USB adapter **100** is shown coupling a mobile device **10** to one of one or more types of power sockets **110N**, **110D**, **110B**, and **100**. Also shown in fig. 2 is an optional auxiliary USB connector **112** that can be used to couple the mobile device **10** to a data source (not shown) such as a personal computer.

[0033] In the embodiment shown in fig. 2, the primary USB connector **102** is configured to mate with the USB connector **54** of the mobile device **10**. The USB adapter **100** is operable to provide power to the mobile device **10** through the Vbus and Gnd power pins in the USB connectors **54** and **102**. The USB adapter **100** also optionally provides a communication path for data across the D+ and D- data pins in the USB connectors **54** and **102**.

[0034] The plug unit **106** is preferably a conventional plug unit that can be used to couple with a conventional power socket to receive power therefrom. For example, the plug unit **106** can be a two prong or three prong plug of the type used in North America

that can couple to a North American AC power socket **110N** that provides 115 VAC. In the embodiment shown in figure 2, the plug unit **106** can accept one or more types of plug adapters **114N**, **114B**, **114D**, and **114** that are configured to couple to the plug unit **106** and are further configured to directly mate with one or more types of power sockets **110N**, **110D**, **110B**, and **100**. The plug unit **106** can be configured to receive energy from a power socket **110N**, **110D**, **110B**, or **100**, either directly or through the use of a plug adapter, and is operative to transfer the received energy to the power converter **104**.

[0035] The power converter **104** is operative to receive energy from a power socket **110N**, **110D**, **110B**, or **100** and to convert that received energy to a form that can be used by the mobile device **10**. For example, the power converter **104** can be of conventional construction such as a switching power converter that converts 115 VAC to 5 VDC. Also, the power converter **104** could comprise a D.C. regulator circuit that converts a D.C. input to a D.C. output. The power converter **104** could also be adapted to accept a wide range of input energy levels and frequencies. Alternatively, the power converter **104** could be adapted to accept a limited range of input energy levels and frequencies, wherein the plug adapters are operable to convert the possible input energy levels and frequencies to a range that the power converter can accommodate. The power converter **104** provides its energy output to the mobile device **10** via the Vbus and Gnd pins of the primary USB connector **102**.

[0036] Through the use of a variety of different types of plug adapters, the USB adapter **100** can be adapted to receive energy from various types of power sockets **110N**, **110D**, **110B**, or **100**. For example, using the appropriate plug adapter **114**, **114B**,

114D, and **114N**, the USB adapter **100** can receive energy from a power socket such as an 115 VAC North American power socket **110N**, or a 12 VDC automobile power socket, or an air power socket, or others.

[0037] For example, in North America, a type "N" power socket is commonly available. The plug adapter **114N** can be releasably attached to the plug unit **106** thereby allowing any North American power socket **114N** to be used as a power source. When traveling to a locale which does not have the North American power socket **114N**, an alternate plug adapter such as adapters **114**, **114B**, or **114D** may be selected by the user, according to the power socket **110D**, **110B**, or **100** available at the locale. The plug adapter **114**, **114B**, or **114D** may then be releasably attached to plug unit **106** in place of the plug adapter **114N**, thereby allowing the USB power adapter **100** to connect to a local power supply via the local power socket. Various other plug adapters are envisioned that can be configured to operate with alternate power sources such as for instance car sockets.

[0038] The power distribution and charging subsystem **58** of the mobile device **10** can selectively use the power provided on the Vbus and Gnd lines of the USB connector **54** to provide power to the mobile device **10**, charge the battery **60**, or both. A more detailed discussion of how the charging function of mobile device **10** can be implemented is described in United States Provisional Application No. 60/273021 filed on March 1st, 2001 and entitled "System and Method for Adapting a USB to Provide Power for Charging a Mobile Device" which has been incorporated herein by reference.

[0039] Typically when a mobile device **10** receives power over the USB from a USB host, it is required to draw power in accordance with the USB specification. The USB

specification specifies a process for transferring energy across the USB called enumeration and limits the electrical current that can flow across the USB.

[0040] The USB adapter **100** contributes to a system wherein a device **10** that follows the USB specification when coupled to a typical USB host via its USB port can be informed that the USB adapter **100** has been coupled to the device **10** and that the device **10** can now draw power without regard to the USB specification and the USB specification imposed limits.

[0041] The identification subsystem **108** provides an identification signal to the mobile device **10** that the power source is not a USB limited source. The identification signal could be the communication of a single voltage on one or more of the USB data lines, different voltages on the two data lines, a series of pulses or voltage level changes, or other types of electrical signals. The identification subsystem **108** that generates the identification signal could have multiple types of configurations. In one embodiment, the identification subsystem **108** comprises a hard-wired connection of a single voltage level to both data lines. In another embodiment, the identification subsystem **108** comprises a USB controller that is operable to communicate an identification signal to the mobile device. Additional embodiments are contemplated. The identification subsystem **108** may optionally be configured to have the capability of electrically connecting or disconnecting the power output from the power converter **104** from the USB connector **102** and/or to connect or disconnect any data inputs from the USB adapter **100** to the USB connector **102**.

[0042] In addition to providing power to the mobile device **10** over the primary USB connector **102**, the USB adapter **100** may optionally be equipped with an auxiliary USB

connector **112** that allows the USB adapter **100** to create a communication path between the mobile device **10** and some other device capable of communicating over the USB such as a personal computer, another mobile device or some other type of device.

[0043] The USB adapter **100** preferably provides a communication path between the D+ and D- pins of the Primary USB connector **102** and the D+ and D- pins of the auxiliary USB connector **112**. In the embodiment shown, the communication path also traverses the identification subsystem **108**. Alternatively, the communication path could bypass the identification subsystem **108**. The USB adapter **100** can thus act as a pass through device for communication between a USB hub or host and a mobile device **10**.

[0044] Optionally, the USB adapter **100** could also transfer energy from the power converter **104** to the auxiliary USB connector **112** thereby providing a device coupled to the auxiliary USB connector **112** with power. In this arrangement, the identification subsystem **108** could also provide an identification signal to the device coupled to the auxiliary USB connector **112** to inform that device that the power source is not a USB limited source.

Exemplary Illustration Of The Use of A USB Adapter With A Mobile Device

[0045] When a USB adapter **100** is connected to a mobile device **10**, the identification subsystem **108** of the USB adapter **100** preferably provides an identification signal to the mobile device **10** to notify the mobile device **10** that the device **10** is connected to a power source that is not subject to the power limits imposed by the USB specification. Preferably, the mobile device **10** is programmed to recognize the identification signal and therefore recognizes that an identification signal has been

transmitted by the USB adapter **100**. After recognizing a valid identification signal, the mobile device **10**, draws power through the USB adapter **100** without waiting for enumeration or charge negotiation.

[0046] The detection of the identification signal may be accomplished using a variety of methods. For example, the microprocessor **12** may detect the identification signal by detecting the presence of an abnormal data line condition at the USB port **18**. The detection may also be accomplished through the use of other device subsystems **44** in the mobile device **10**. The preferred identification signal results from the application of voltage signals greater than 2 volts to both the D+ and D- lines in the USB connector. The preferred method of identification is described below in greater detail with reference to Fig. 3.

[0047] At step **210**, the mobile device **10** detects the presence of a voltage on the Vbus line of the USB connector **54** via the USB port **18**. At step **220**, the mobile device checks the state of the D+ and D- lines of the USB connector. In the example shown in the drawings, the D+ and D- lines are compared to a 2V reference. Also, in this example, the identification subsystem **108** of the USB adapter **100** may have applied a logic high signal, such as +5V reference, to both the D+ and D- lines to identify the attached device as a USB adapter **100**. If the voltages on both the D+ and D- lines of the USB connector are greater than 2 Volts (step **220**), then the mobile device **10** determines that the device connected to the USB connector **54** is not a typical USB host or hub and that a USB adapter **100** has been detected (step **230**). The mobile device **10** can then charge the battery or otherwise use power provided via the Vbus and Gnd lines in the USB connector **54** (step **260**) without waiting for enumeration.

[0048] If, however, after the mobile device **10** detects the presence of a voltage on the Vbus line of the USB connector **54** and determines that the voltages on both the D+ and D- lines of the USB connector are not greater than 2 Volts (step **220**), then the mobile device **10** determines that a USB host or hub has been detected (step **240**). A typical USB host or hub weakly holds its D+ and D- lines at zero volts when it is not connected to another device. The mobile device **10** can then signal the USB host or hub to initiate the enumeration process (step **250**) and can charge the battery or otherwise use power provided via the Vbus and Gnd lines in the USB connector (step **260**) in accordance with the power limits imposed by the USB specification. The enumeration process is typically initiated after the mobile device **10** applies approximately zero volts to the D- line and approximately 5 volts to the D+ line to inform the host of the mobile device's **10** presence and communication speed.

[0049] Therefore, when a USB adapter **100** is coupled to the mobile device **10** and has been identified as a USB adapter **100**, the mobile device **10** can forego the enumeration process and charge negotiation process and immediately draw energy from the USB power adapter **100** at a desired rate, for instance at 5 unit loads, i.e. 500mA. While the mobile device **10** charges its battery using the USB adapter **100**, the mobile device **10** can disable its typical USB functions. If, however, the mobile device **10** detects that a USB host or hub is coupled to the mobile device **10**, the mobile device **10** can apply a voltage to the D+ line to indicate to the USB host or hub that the mobile device **10** is coupled thereto and await enumeration and USB charge negotiation.

[0050] If the USB adapter **100**, is coupled to the mobile device **10**, and the mobile device **10** does not identify the USB adapter **100** through communications with the

identification module **108**, the mobile device **10** may stop drawing energy from the Vbus and Gnd lines of the USB connector **54**. This may occur, for example, if the mobile device **10** is not programmed to identify the USB adapter **100**. The mobile device **10** may mistakenly identify the USB adapter **100** as a typical USB host or hub and await enumeration before drawing substantial energy. To guard against this, the USB adapter **100** can optionally be adapted to function with mobile devices that are not programmed to recognize the USB adapter **100**.

[0051] In that scenario, the USB adapter **100** can be adapted to provide energy to a mobile device by using the knowledge that the mobile device will draw energy from a connected device for a period of time before it stops drawing energy due to lack of enumeration. The USB adapter **100** can optionally provide power for charging a battery **60** in a mobile device by periodically switching the voltages on the Vbus and Gnd lines between on and off states. When the USB adapter **100** is coupled to the mobile device, the identification subsystem **108** can apply an on-voltage (5 V for example) between the Vbus and Gnd lines. The mobile device will draw energy while awaiting enumeration. After a period of time, the identification subsystem **108** can apply an off-voltage (0 volts) between the Vbus and Gnd lines thereby fooling the mobile device into determining that the unidentified USB device has been disconnected from the mobile device. The identification subsystem **108** can then reapply an on-voltage between the Vbus and Gnd lines. The mobile device will draw energy again while awaiting enumeration. This cycle can be repeated to periodically apply energy to the mobile device, for example, to recharge the battery **60** of the mobile device.

Additional Exemplary Embodiments Of USB Adapters

[0052] Shown in fig. 4 is a schematic diagram of an additional exemplary embodiment of a USB adapter 300 that is coupled to a mobile device 10. The exemplary USB adapter 300 comprises a USB connector 302, a power converter 304, a plug unit 306, and an identification subsystem 308. The USB connector 302, plug unit 306, and identification subsystem 308, preferably correspond to the USB connector 102, plug unit 106, and identification subsystem 108 which were described earlier with respect to the first embodiment. Similar to the first embodiment, the additional embodiment may optionally be equipped with various plug adapters 314N, 314D, 314B, and 314 that preferably are releasably attachable to plug unit 306 so that the appropriate plug adapter 314N, 314D, 314B, or 314 can be selected by a user to allow the USB adapter 300 to couple to and receive energy from an available power socket 310N, 310D, 310B, or 310. The exemplary USB power converter 300 further comprises a charging subsystem 316 and battery receptacle 318 for coupling the USB adapter 300 to an external battery 320 that may be optionally coupled thereto.

[0053] The battery receptacle 318 provide a location for releasably coupling an external battery 320 thereto so that the external battery can be charged via the USB adapter 300. This provides the USB adapter 300 with a mechanism for charging, for example, a mobile device's primary or spare battery when the battery has been separated from or is not coupled to the mobile device 10.

[0054] To accommodate this functionality, the power converter 304 is capable of providing the proper voltage levels for the USB connector 302 and also capable of providing necessary voltage and current levels to drive a battery charging subsystem

316. The power converter **304** is preferably a dual power converter that may be constructed using conventional or non-conventional architectures. With respect to the portion of the power converter **304** that provides energy to the USB connector **302**, that portion is preferably similar in construction and function to the power converter **104** of the first embodiment.

[0055] Preferably, the charging subsystem **316** performs in a substantially similar manner to charging subsystem **58** of the mobile device **10**. But, for efficiency and simplicity of design, certain aspects of the dual power converter **304** and the charging subsystem **316** may be combined, as both are local to the USB adapter **300**.

[0056] Other alternative embodiments of the USB adapter may include various combinations of components described above with respect to the first and additional embodiments. Another embodiment of the USB adapter may include a second or more auxiliary USB connectors. A USB adapter having one or more auxiliary USB connectors may optionally be configured such that one or more of the auxiliary USB connectors may have power from the USB adapter's power converter made available to it so that multiple USB devices may draw power simultaneously. Preferably, a USB adapter having multiple auxiliary USB connectors will be configured such that the data lines in the auxiliary connectors can, on a selective basis, be electrically connected to or disconnected from the data lines in the primary USB connector. This allows a mobile device connected to the primary USB connector to receive energy from the adapter regardless of whether a USB host or hub is connected to an auxiliary USB connector. It is also contemplated that a USB adapter may be embodied in a USB host or hub.

Conclusion

[0057] The embodiments described herein are examples of structures, systems or methods having elements corresponding to the elements of the invention recited in the claims. This written description may enable those skilled in the art to make and use embodiments having alternative elements that likewise correspond to the elements of the invention recited in the claims. The intended scope of the invention thus includes other structures, systems or methods that do not differ from the literal language of the claims, and further includes other structures, systems or methods with insubstantial differences from the literal language of the claims. Although the embodiments have been described with reference to the USB interface, it is contemplated that the invention could be applicable to devices and systems that use other standard interfaces such as the IEEE 1394 interface.

CLAIMS

What is claimed is:

1. (Original) A mobile device, the mobile device configurable for use in a wireless telecommunications network, comprising:
 - a Universal Serial Bus ("USB") interface configured to allow reception of a USB cable;
 - a charging subsystem, the charging subsystem operably connected to the USB interface V-bus power line;
 - the charging subsystem operably connectable to a battery, and configured to charge a battery if a battery is operably connected;
 - the charging system further configured to use power from the V-bus power line for the charging of a battery; and,
 - where the mobile device is configured to detect an identification signal at a D+ and a D- data line of the USB interface, the identification signal being different than USB enumeration.
2. (Original) The mobile device of claim 1 wherein the identification signal comprises a voltage level that is applied to at least one data line in the USB connector.
3. (Original) The mobile device of claim 1 wherein the identification signal is a result of using a resistance between the D+ and D- data lines.

Attorney Docket No. 10254-US-CNT[5]
4214-01510

4. (Original) The mobile device of claim 1 wherein the identification subsystem comprises a hard-wired connection of a voltage level to one or more data lines in the USB connector.

5. (Original) A mobile device, the mobile device configurable for use in a wireless telecommunications network, comprising:
- a Universal Serial Bus ("USB") interface configured to allow reception of a USB cable;
 - a charging subsystem, the charging subsystem operably connected to the USB interface V-bus power line;
 - the charging subsystem operably connectable to a battery, and configurable to charge a battery;
 - the charging system further configured to use power from the V-bus power line for the charging of a battery;
 - where data lines D+ and D- at the USB interface are configured to receive signals;
 - a microprocessor and memory usable to process the received signals, configured such that before USB enumeration an identification signal received at the D+ and D- lines indicating a charging connection is available is recognized by the device.
6. (Original) The mobile device of claim 5 wherein the identification signal comprises a voltage level that is applied to at least one data line in the USB connector.
7. (Original) The mobile device of claim 5 wherein the identification signal is a result of using a resistance between the D+ and D- data lines.

8. (Original) A method of charging a battery in a mobile device, the mobile device configurable for use in a wireless telecommunications network, comprising:
- providing a Universal Serial Bus ("USB") interface configured to allow reception of a USB cable, and, receiving power on a V-bus power line at the USB interface;
 - providing an operable connection between the power received at the USB interface on the V-bus power line and a charging subsystem;
 - having a battery in operable connection to the charging subsystem;
 - providing power to the battery using the charger subsystem; and,
 - detecting an identification signal at a D+ and a D- data line of the USB interface, the identification signal being different than USB enumeration.
9. (Original) The method claim 8 wherein the identification signal comprises a voltage level at least one data line in the USB connector.
10. (Original) The method claim 8 wherein the identification signal is a result of using a resistance between the D+ and D- data lines.

ABSTRACT

An adapter for providing a source of power to a mobile device through an industry standard port is provided. In accordance with one aspect of the invention, the adapter comprises a plug unit, a power converter, a primary connector, and an identification subsystem. The plug unit is operative to couple the adapter to a power socket and operative to receive energy from the power socket. The power converter is electrically coupled to the plug unit and is operable to regulate the received energy from the power socket and to output a power requirement to the mobile device. The primary connector is electrically coupled to the power converter and is operative to couple to the mobile device and to deliver the outputted power requirement to the mobile device. The identification subsystem is electrically coupled to the primary connector and is operative to provide an identification signal.

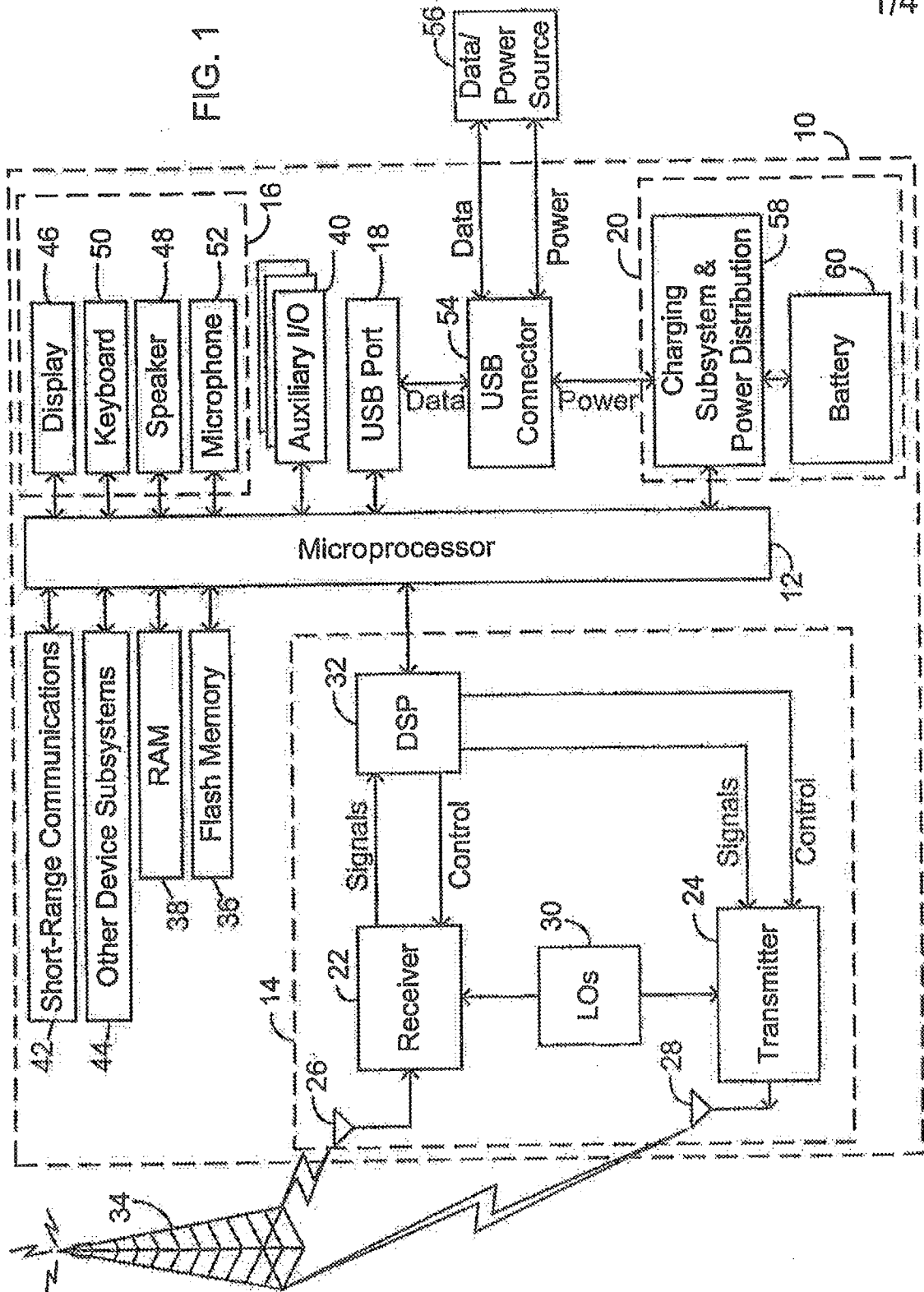

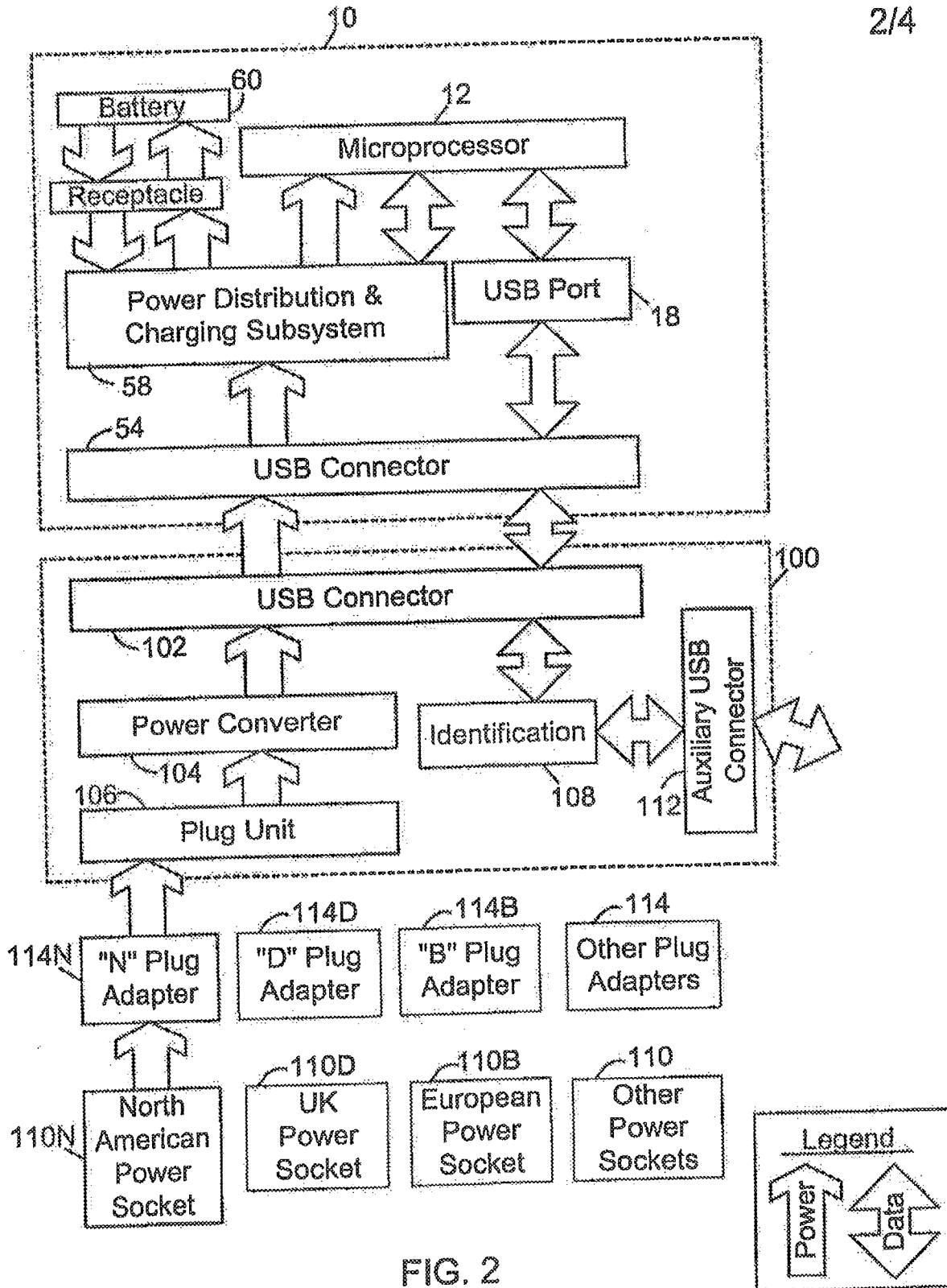

FIG. 2

3/4

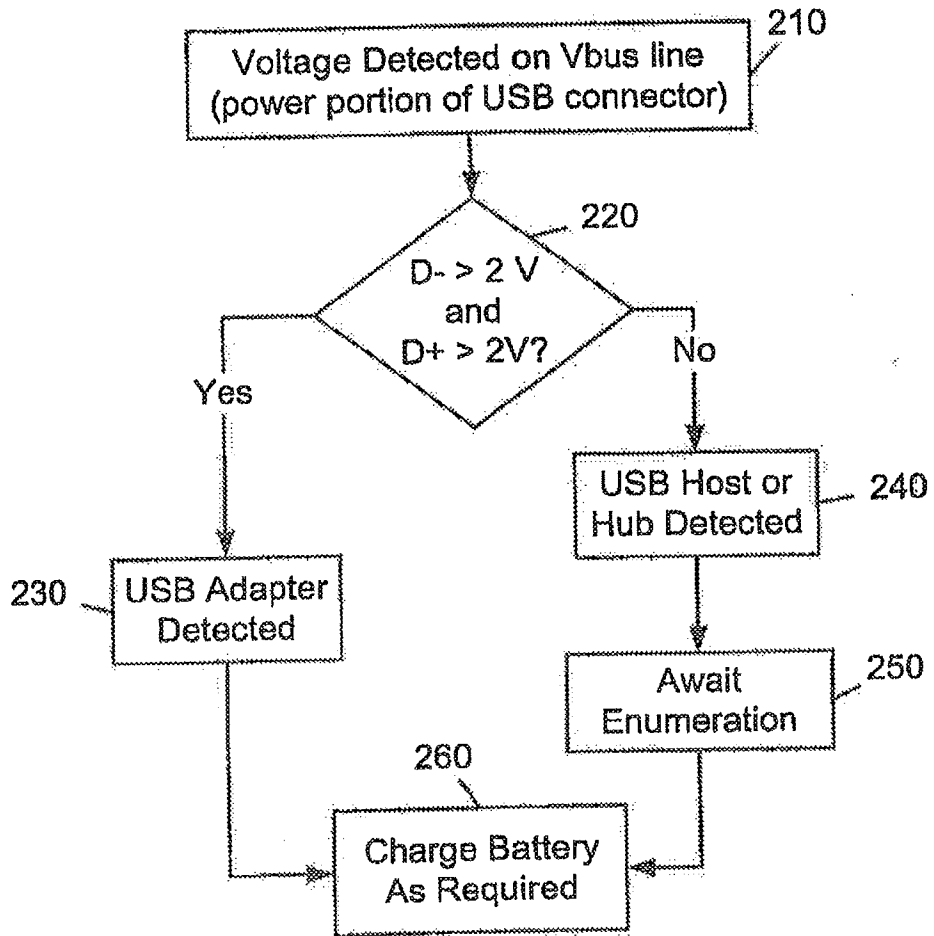

FIG. 3

4/4

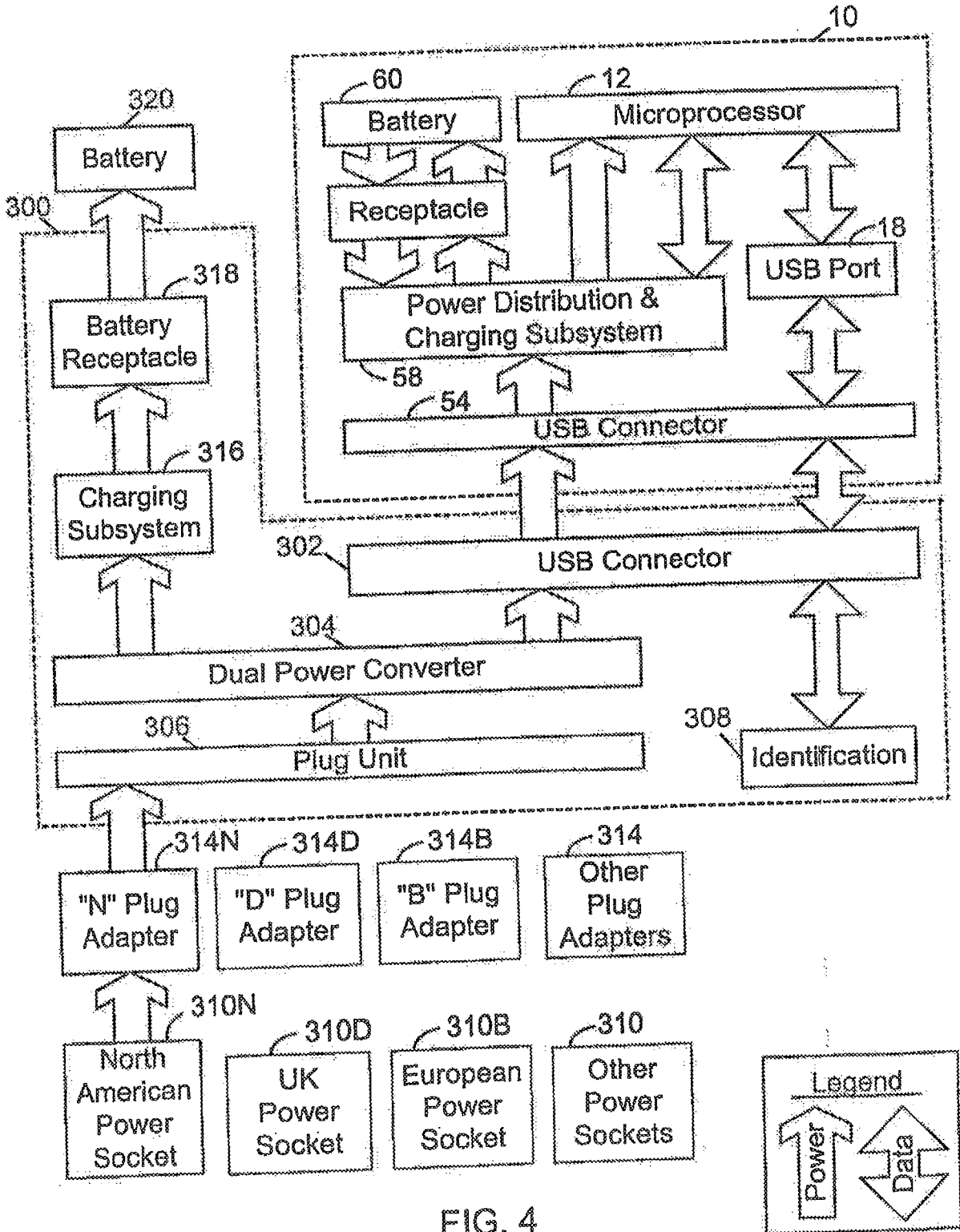

FIG. 4

Under the Paperwork Reduction Act of 1995, no persons are required to respond to a collection of information unless it contains a valid OMB control number.

DECLARATION FOR UTILITY OR DESIGN PATENT APPLICATION (37 CFR 1.63)	Attorney Docket Number	555255012294
	First Named Inventor	Daniel M. FISCHER
	COMPLETE IF KNOWN	
	Application Number	10 / 087/629
	Filing Date	March 01/02
	Group Art Unit	
<input type="checkbox"/> Declaration Submitted with Initial Filing	OR	<input checked="" type="checkbox"/> Declaration Submitted after Initial Filing (surcharge (37 CFR 1.16 (e)) required)
Examiner Name		

As a below named inventor, I hereby declare that:

My residence, mailing address, and citizenship are as stated below next to my name.

I believe I am the original, first and sole inventor (if only one name is listed below) or an original, first and joint inventor (if plural names are listed below) of the subject matter which is claimed and for which a patent is sought on the invention entitled:

MULTIFUNCTIONAL CHARGER SYSTEM AND METHOD

(Title of the Invention)

the specification of which

is attached hereto

OR

was filed on (MM/DD/YYYY) 03/01/2002 as United States Application Number or PCT International

Application Number 10/087,629 and was amended on (MM/DD/YYYY) (if applicable).

I hereby state that I have reviewed and understand the contents of the above identified specification, including the claims, as amended by any amendment specifically referred to above.

I acknowledge the duty to disclose information which is material to patentability as defined in 37 CFR 1.56, including for continuation-in-part applications, material information which became available between the filing date of the prior application and the national or PCT international filing date of the continuation-in-part application.

I hereby claim foreign priority benefits under 35 U.S.C. 119(a)-(d) or (f), or 365(b) of any foreign application(s) for patent, inventor's or plant breeder's rights certificate(s), or 365(a) of any PCT international application which designated at least one country other than the United States of America, listed below and have also identified below, by checking the box, any foreign application for patent, inventor's or plant breeder's rights certificate(s), or any PCT international application having a filing date before that of the application on which priority is claimed.

Prior Foreign Application Number(s)	Country	Foreign Filing Date (MM/DD/YYYY)	Priority Not Claimed	Certified Copy Attached?	
				YES	NO
			<input type="checkbox"/>	<input type="checkbox"/>	<input type="checkbox"/>
			<input type="checkbox"/>	<input type="checkbox"/>	<input type="checkbox"/>
			<input type="checkbox"/>	<input type="checkbox"/>	<input type="checkbox"/>
			<input type="checkbox"/>	<input type="checkbox"/>	<input type="checkbox"/>

Additional foreign application numbers are listed on a supplemental priority data sheet PTO/SB/02B attached hereto:

Burden Hour Statement: This form is estimated to take 21 minutes to complete. Time will vary depending upon the needs of the individual case. Any comments on the amount of time you are required to complete this form should be sent to the Chief Information Officer, U.S. Patent and Trademark Office, Washington, DC 20231. DO NOT SEND FEES OR COMPLETED FORMS TO THIS ADDRESS. SEND TO: Assistant Commissioner for Patents, Washington, DC 20231.

Under the Paperwork Reduction Act of 1995, no persons are required to respond to a collection of information unless it contains a valid OMB control number.

DECLARATION — Utility or Design Patent Application

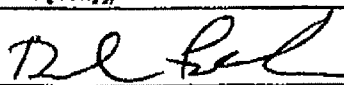
Direct all correspondence to: <input type="checkbox"/> Customer Number or Bar Code Label		OR <input checked="" type="checkbox"/> Correspondence address below	
Name F. Drexel Feeling, Esq.			
Address Jones, Day, Reavis & Pogue North Point, 901 Lakeside Avenue			
City Cleveland	State Ohio	ZIP 44114-1190	
Country USA	Telephone (216) 586-3939	Fax (216) 579-0212	
I hereby declare that all statements made herein of my own knowledge are true and that all statements made on information and belief are believed to be true; and further that these statements were made with the knowledge that willful false statements and the like so made are punishable by fine or imprisonment, or both, under 18 U.S.C. 1001 and that such willful false statements may jeopardize the validity of the application or any patent issued thereon.			
NAME OF SOLE OR FIRST INVENTOR :		<input type="checkbox"/> A petition has been filed for this unsigned inventor	
Given Name Daniel M. (first and middle [if any])		Family Name FISCHER or Surname	
Inventor's Signature 		Date Mar 1, 2002	
Residence: City Waterloo	State Ontario	Country CANADA	Citizenship Canadian
Mailing Address 295 Phillip Street			
City Waterloo	State Ontario	ZIP N2L 3W8	Country CANADA
NAME OF SECOND INVENTOR:		<input checked="" type="checkbox"/> A petition has been filed for this unsigned inventor	
Given Name Dan G. (first and middle [if any])		Family Name RADUT or Surname	
Inventor's Signature		Date	
Residence: City Waterloo	State Ontario	Country CANADA	Citizenship Canadian
Mailing Address 295 Phillip Street			
City Waterloo	State Ontario	ZIP N2L 3W8	Country CANADA
<input checked="" type="checkbox"/> Additional inventors are being named on the <u>2</u> supplemental Additional inventor(s) sheet(s) PTO/SB/02A attached hereto.			

[Page 2 of 2]

Under the Paperwork Reduction Act of 1995, no persons are required to respond to a collection of information unless it contains a valid OMB control number.

DECLARATION**ADDITIONAL INVENTOR(S)**
Supplemental Sheet
Page 1 of 2

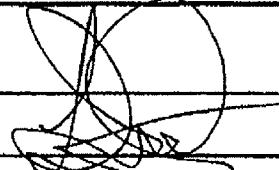
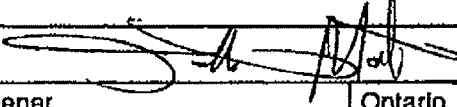
Name of Additional Joint Inventor, if any:		<input type="checkbox"/> A petition has been filed for this unsigned inventor	
Michael F.		HABICHER	
Given Name		Family Name or Surname	
Inventor's Signature 		Date Feb 28, 2002	
Residence: City	Ontario State	CANADA Country	Canadian Citizenship
295 Phillip Street Mailing Address			
Mailing Address			
Waterloo City	Ontario State	N2L 3W8 ZIP	CANADA Country
Name of Additional Joint Inventor, if any:		<input type="checkbox"/> A petition has been filed for this unsigned inventor	
Quang A.		LUONG	
Given Name		Family Name or Surname	
Inventor's Signature 		Date Feb 28, 2002	
Residence: City	Ontario State	CANADA Country	Canadian Citizenship
295 Phillip Street Mailing Address			
Mailing Address			
Waterloo City	Ontario State	N2L 3W8 ZIP	CANADA Country
Name of Additional Joint Inventor, if any:		<input type="checkbox"/> A petition has been filed for this unsigned inventor	
Jonathan T.		MALTON	
Given Name		Family Name or Surname	
Inventor's Signature 		Date Feb 28 / 2002	
Residence: City	Ontario State	CANADA Country	Canadian Citizenship
295 Phillip Street Mailing Address			
Mailing Address			
Waterloo City	Ontario State	N2L 3W8 ZIP	CANADA Country

Burden Hour Statement: This form is estimated to take 21 minutes to complete. Time will vary depending upon the needs of the individual case. Any comments on the amount of time you are required to complete this form should be sent to the Chief Information Officer, U.S. Patent and Trademark Office, Washington, DC 20231. DO NOT SEND FEES OR COMPLETED FORMS TO THIS ADDRESS. SEND TO: Assistant Commissioner for Patents, Washington, DC 20231.



5-0539
555255-012-294 C

DAN G. RADUT
300 REGINA STREET, NORTH
BUILDING 1, APT. 1207
WATERLOO, ONTARIO N2J 3B8
CANADA

COPY MAILED

SEP 09 2002

In re Application of
Fischer, et al.
Application No. 10/087,629
Filed: March 1, 2002
Attorney Docket No. 555255012294
For: MULTIFUNCTIONAL CHARGER SYSTEM:
AND METHOD

LETTER

OFFICE OF PETITIONS

Dear Sir:

You are named as an inventor in the above-identified United States patent application filed under the provisions of 35 U.S.C. 116 (United States Code) and 37 C.F.R. § 1.47(a), Rules of Practice in Patent Cases. Should a patent be granted on the application you will be designated therein as a joint inventor.

As a named inventor you are entitled to inspect any paper in the file wrapper of the application, order copies of all or any part thereof (at a prepaid cost as per 37 C.F.R. § 1.19) or make your position of record in the application. Alternatively, you may arrange to do any of the preceding through a registered patent attorney or agent presenting written authorization from you. If you care to join the application, counsel of record (see below) would presumably assist you. Joining in the application would entail the filing of an appropriate oath or declaration by you pursuant to 37 C.F.R. § 1.63.

Telephone inquiries regarding this communication should be directed to the undersigned at (703) 305-0310. Requests for information regarding your application should be directed to the File Information Unit at (703) 308-2733. Information regarding how to pay for and order a copy of the application, or a specific paper in the application, should be directed to Certification Division at (703) 308-9726 or 1-800-972-6382 (outside the Washington D.C. area).

Alesia M. Brown
Petitions Attorney
Office of Petitions
Office of the Deputy Commissioner
for Patent Examination Policy

CC: F. Drexel Feeling, Esq.
Jones, Day, Reavis & Pogue
901 Lakeside Avenue/North Point
Cleveland, OH 44114

DOCKETED
COPY TO CLIENT

PATENT

Attorney Docket No. 555255012294

IN THE UNITED STATES PATENT AND TRADEMARK OFFICE

In re application of: Daniel M. Fischer, Dan G. Radut, Michael F. Habicher, Quang A. Luong, Jonathan T. Malton

Serial No.: 10/087,629

Filed: March 1, 2002

For: MULTIFUNCTIONAL CHARGER SYSTEM AND METHOD

Art Unit: Not yet assigned

Examiner: Not yet assigned

ASSISTANT COMMISSIONER OF PATENTS
WASHINGTON, D.C. 20231

PETITION FOR FILING BY OTHER THAN
ALL THE INVENTORS UNDER 37 CFR § 1.47

In accordance with 37 CFR § 1.47 and MPEP §409.03(a) and (d), applicants Fischer, Habicher, Luong, and Malton hereby petition the Assistant Commissioner to accept the filing of this patent application on behalf of themselves and the joint inventor, Dan G. Radut, who refuses to join in the application for patent. The petition fee of \$130 under 37 CFR § 1.17(I) accompanies this petition.

CERTIFICATE OF MAILING

I hereby certify that this correspondence is being deposited with the United States Postal Service as first class mail in an envelope addressed to: Commissioner for Patents, Washington, D.C. 20231 on the date indicated below.

Debra L. Pejeau

Name

July 29, 2002
Date

Signature

Debra L. Pejeau

Page 1 of 2

CL-692976v1

Petitioners Ex. 1002
IPR USP 8,624,550
Page 67 of 174

As required by MPEP § 409.03(d), applicants enclose herein proof of the refusal of Mr. Radut to execute the application papers, in the form of a Declaration of David B. Cochran to whom the refusal to sign was made. In the Declaration, Mr. Cochran states that a bona fide attempt was made to present a copy of the application papers to Mr. Radut, and that Mr. Radut refused to sign the application papers. The Declaration by Mr. Cochran is deemed by the applicants to be sufficient proof of the refusal of Mr. Radut to sign.

In accordance with MPEP § 409.03(a) and (d), a Declaration signed by Messrs./Mmes. Fischer, Habicher, Luong and Malton with the signature block of Mr. Radut left blank is enclosed herein. The last known address of Mr. Radut is "300 Regina Street, North, Building I, Apt. 1207, Waterloo, Ontario N2J 3B8 Canada."

The Assistant Commissioner is hereby authorized to charge any additional fees which may be required by this paper only to Jones, Day Reavis & Pogue Deposit Account No. 501432, order no. 555255012294.

Respectfully Submitted,

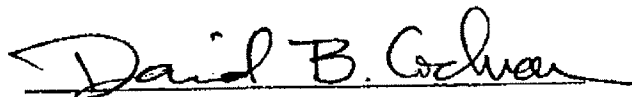

David B. Cochran
Registration No. 39,142
JONES, DAY, REAVIS & POGUE
901 Lakeside Avenue/North Point
Cleveland, OH 44114
(216) 586-3939

Date: _____

7/29/02

IN THE UNITED STATES PATENT AND TRADEMARK OFFICE

In re application of: Daniel M. Fischer, Dan G. Radut, Michael F. Habicher, Quang A. Luong, Jonathan T. Malton

Serial No.: 10/087,629

Filed: March 1, 2002

For: MULTIFUNCTIONAL CHARGER SYSTEM AND METHOD

Art Unit: Not yet assigned

Examiner: Not yet assigned

ASSISTANT COMMISSIONER OF PATENTS
WASHINGTON, D.C. 20231

DECLARATION OF DAVID B. COCHRAN

I hereby declare and state as follows:

1. I represent Research In Motion Limited ("RIM") in connection with the above-referenced patent application. This application names five inventors, Daniel M. Fischer, Dan G. Radut, Michael F. Habicher, Quang A. Luong, and Jonathan T. Malton.
2. Four of these inventors, Fischer, Habicher, Luong, and Malton, have signed the Declaration and Power of Attorney documents, which is being submitted to the USPTO along with this paper. Mr. Radut, however, who is no longer in the employ of RIM, refuses to sign the documents despite the fact that he signed an employment contract when beginning his employ obligating him to assist RIM in pursuing any such applications, even after his employment had ceased.
3. Prior to filing this application, a copy thereof was provided to each of the named inventors for their review and approval, including Mr. Radut.

4. On May 2, 2002, another copy of the application, along with the Declaration and Power of Attorney, was mailed to Mr. Radut's home address. Mr. Radut refused to sign the documents.

5. Between May 8 and May 15, 2002, Mr. Radut was contacted by telephone on several occasions regarding his willingness to sign the Declaration and Power of Attorney, and he refused to do so.

6. On June 19, 2002, I forwarded another copy of the application and the Declaration and Power of Attorney to Mr. Radut, again asking that he sign and return the papers, by June 27, 2002. I also called him on his home phone number to inquire as to whether he would be signing and returning the papers. He has refused to return any of my phone calls or to return the papers.

7. The last known address of Mr. Radut is 300 Regina Street, North, Building 1, Apt. 1207, Waterloo, Ontario N2J 3B8.

8. I hereby declare that all statements made herein of my own knowledge are true and that all statements made on information and belief are believed to be true; and further that these statements were made with knowledge that willful false statements and the like so made are punishable by fine or imprisonment, or both, under Section 1001 of Title 18 of the United States Code, and the such willful false testimony may jeopardize the validity of the application or any patent issuing thereon.

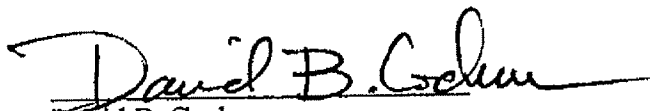
David B. Cochran

Electronic Patent Application Fee Transmittal

Application Number:	
Filing Date:	
Title of Invention:	MULTIFUNCTIONAL CHARGER SYSTEM AND METHOD
First Named Inventor/Applicant Name:	Daniel M. FISCHER
Filer:	Jeffrey A. Berkowitz/Sheila M. Mattingly
Attorney Docket Number:	11298.0188-08000

Filed as Large Entity

Utility under 35 USC 111(a) Filing Fees

Description	Fee Code	Quantity	Amount	Sub-Total in USD(\$)
Basic Filing:				
Utility application filing	1011	1	380	380
Utility Search Fee	1111	1	620	620
Utility Examination Fee	1311	1	250	250

Pages:

Claims:

Miscellaneous-Filing:

Petition:

Patent-Appeals-and-Interference:

Petitioners Ex. 1002

IPR USP 8,624,550

Page 71 of 174

Description	Fee Code	Quantity	Amount	Sub-Total in USD(\$)
Post-Allowance-and-Post-Issuance:				
Extension-of-Time:				
Miscellaneous:				
Total in USD (\$)				1250

Electronic Acknowledgement Receipt

EFS ID:	13137006
Application Number:	13536767
International Application Number:	
Confirmation Number:	5104
Title of Invention:	MULTIFUNCTIONAL CHARGER SYSTEM AND METHOD
First Named Inventor/Applicant Name:	Daniel M. FISCHER
Customer Number:	93377
Filer:	Jeffrey A. Berkowitz/Sheila M. Mattingly
Filer Authorized By:	Jeffrey A. Berkowitz
Attorney Docket Number:	11298.0188-08000
Receipt Date:	28-JUN-2012
Filing Date:	
Time Stamp:	18:56:31
Application Type:	Utility under 35 USC 111(a)

Payment information:

Submitted with Payment	yes
Payment Type	Credit Card
Payment was successfully received in RAM	\$1250
RAM confirmation Number	6851
Deposit Account	
Authorized User	

File Listing:

Document Number	Document Description	File Name	File Size (Bytes)	Multi-Page Message	Pages (if appl.)

Petitioners Ex. 1002

Fees: \$8,024,550

1	Transmittal of New Application	Transmittal.pdf	88249 18176469762f0c2dc7fe7bf1552260e5a7b50782	no	1
Warnings:					
Information:					
2	Application Data Sheet	ADS.pdf	387569 7a03a95a2cdeacd8ac3097a946f0dec478713873	no	5
Warnings:					
Information:					
This is not an USPTO supplied ADS fillable form					
3	Assignee showing of ownership per 37 CFR 3.73(b).	Statement.pdf	154937 aeba0131de79e3a2e1aa8345443851d9fd7735c5	no	2
Warnings:					
Information:					
4	Information Disclosure Statement (IDS) Form (SB08)	IDS.pdf	300885 536948f1fbaa02136e0ac910468a576bf9f4effd	no	6
Warnings:					
Information:					
This is not an USPTO supplied IDS fillable form					
5	Preliminary Amendment	Amendment.pdf	602267 841089987639bdc477c8de9d5e2fb42f7085d9d1	no	16
Warnings:					
Information:					
6	Specification	Specification.pdf	1102255 9b9feefe043edc739a9d087a0c34b38fc15e857a	no	28
Warnings:					
Information:					
7	Drawings-only black and white line drawings	Drawings.pdf	245958 495b85f58ab8dbaff57af564d72c089b1c798bf8	no	4
Warnings:					
Information:					
8	Oath or Declaration filed	Declaration.pdf	396094 9dcca4990f7452914a8d4118e8acfb3f67605a	no	8
Warnings:					
Information:					

9	Fee Worksheet (SB06)	fee-info.pdf	33177 <small>32c7247240053dc61b272e30f48b47ff65961d47</small>	no	2
---	----------------------	--------------	--	----	---

Warnings:

Information:

Total Files Size (in bytes):	3311391
-------------------------------------	---------

This Acknowledgement Receipt evidences receipt on the noted date by the USPTO of the indicated documents, characterized by the applicant, and including page counts, where applicable. It serves as evidence of receipt similar to a Post Card, as described in MPEP 503.

New Applications Under 35 U.S.C. 111

If a new application is being filed and the application includes the necessary components for a filing date (see 37 CFR 1.53(b)-(d) and MPEP 506), a Filing Receipt (37 CFR 1.54) will be issued in due course and the date shown on this Acknowledgement Receipt will establish the filing date of the application.

National Stage of an International Application under 35 U.S.C. 371

If a timely submission to enter the national stage of an international application is compliant with the conditions of 35 U.S.C. 371 and other applicable requirements a Form PCT/DO/EO/903 indicating acceptance of the application as a national stage submission under 35 U.S.C. 371 will be issued in addition to the Filing Receipt, in due course.

New International Application Filed with the USPTO as a Receiving Office

If a new international application is being filed and the international application includes the necessary components for an international filing date (see PCT Article 11 and MPEP 1810), a Notification of the International Application Number and of the International Filing Date (Form PCT/RO/105) will be issued in due course, subject to prescriptions concerning national security, and the date shown on this Acknowledgement Receipt will establish the international filing date of the application.

PATENT APPLICATION FEE DETERMINATION RECORD

Substitute for Form PTO-875

Application or Docket Number
13/536,767

APPLICATION AS FILED - PART I

(Column 1) (Column 2)

FOR	NUMBER FILED	NUMBER EXTRA
BASIC FEE (37 CFR 1.16(a), (b), or (c))	N/A	N/A
SEARCH FEE (37 CFR 1.16(k), (l), or (m))	N/A	N/A
EXAMINATION FEE (37 CFR 1.16(o), (p), or (q))	N/A	N/A
TOTAL CLAIMS (37 CFR 1.16(j))	18	minus 20 = *
INDEPENDENT CLAIMS (37 CFR 1.16(h))	2	minus 3 = *
APPLICATION SIZE FEE (37 CFR 1.16(s))	If the specification and drawings exceed 100 sheets of paper, the application size fee due is \$310 (\$155 for small entity) for each additional 50 sheets or fraction thereof. See 35 U.S.C. 41(a)(1)(G) and 37 CFR 1.16(s).	
MULTIPLE DEPENDENT CLAIM PRESENT (37 CFR 1.16(j))		

SMALL ENTITY

RATE(\$)	FEE(\$)
N/A	
N/A	
N/A	
TOTAL	

OR OTHER THAN SMALL ENTITY

RATE(\$)	FEE(\$)
N/A	380
N/A	620
N/A	250
x 60 =	0.00
x 250 =	0.00
	0.00
	0.00
TOTAL	1250

* If the difference in column 1 is less than zero, enter "0" in column 2.

APPLICATION AS AMENDED - PART II

(Column 1) (Column 2) (Column 3)

AMENDMENT A		CLAIMS REMAINING AFTER AMENDMENT		HIGHEST NUMBER PREVIOUSLY PAID FOR	PRESENT EXTRA
	Total (37 CFR 1.16(j))	*	Minus	**	=
	Independent (37 CFR 1.16(h))	*	Minus	***	=
	Application Size Fee (37 CFR 1.16(s))				
FIRST PRESENTATION OF MULTIPLE DEPENDENT CLAIM (37 CFR 1.16(j))					

SMALL ENTITY

RATE(\$)	ADDITIONAL FEE(\$)
x =	
x =	
TOTAL ADD'L FEE	

OR OTHER THAN SMALL ENTITY

RATE(\$)	ADDITIONAL FEE(\$)
x =	
x =	
TOTAL ADD'L FEE	

(Column 1) (Column 2) (Column 3)

AMENDMENT B		CLAIMS REMAINING AFTER AMENDMENT		HIGHEST NUMBER PREVIOUSLY PAID FOR	PRESENT EXTRA
	Total (37 CFR 1.16(j))	*	Minus	**	=
	Independent (37 CFR 1.16(h))	*	Minus	***	=
	Application Size Fee (37 CFR 1.16(s))				
FIRST PRESENTATION OF MULTIPLE DEPENDENT CLAIM (37 CFR 1.16(j))					

SMALL ENTITY

RATE(\$)	ADDITIONAL FEE(\$)
x =	
x =	
TOTAL ADD'L FEE	

OR OTHER THAN SMALL ENTITY

RATE(\$)	ADDITIONAL FEE(\$)
x =	
x =	
TOTAL ADD'L FEE	

* If the entry in column 1 is less than the entry in column 2, write "0" in column 3.

** If the "Highest Number Previously Paid For" IN THIS SPACE is less than 20, enter "20".

*** If the "Highest Number Previously Paid For" IN THIS SPACE is less than 3, enter "3".

The "Highest Number Previously Paid For" (Total or Independent) is the highest found in the appropriate box in column 1.



UNITED STATES PATENT AND TRADEMARK OFFICE

UNITED STATES DEPARTMENT OF COMMERCE
United States Patent and Trademark Office
Address: COMMISSIONER FOR PATENTS
P.O. Box 1450
Alexandria, Virginia 22313-1450
www.uspto.gov

Table with 4 columns: APPLICATION NUMBER (13/536,767), FILING OR 371(C) DATE (06/28/2012), FIRST NAMED APPLICANT (Daniel M. FISCHER), ATTY. DOCKET NO./TITLE (11298.0188-08000)

CONFIRMATION NO. 5104
FORMALITIES LETTER

93377
RIM/FINNEGAN
901 New York Avenue NW
Washington, DC 20001



Date Mailed: 07/20/2012

NOTICE TO FILE CORRECTED APPLICATION PAPERS

Filing Date Granted

An application number and filing date have been accorded to this application. The application is informal since it does not comply with the regulations for the reason(s) indicated below. Applicant is given TWO MONTHS from the date of this Notice within which to correct the informalities indicated below. Extensions of time may be obtained by filing a petition accompanied by the extension fee under the provisions of 37 CFR 1.136(a).

The required item(s) identified below must be timely submitted to avoid abandonment:

- Replacement drawings in compliance with 37 CFR 1.84 and 37 CFR 1.121(d) are required. The drawings submitted are not acceptable because:
• The drawings must be reasonably free from erasures and must be free from alterations, overwriting, interlineations, folds, and copy marks. See Figure(s) 1-4.
• A substitute specification excluding claims in compliance with 37 CFR 1.52, 1.121(b)(3), and 1.125 is required. The substitute specification must be submitted with markings and be accompanied by a clean version (without markings) as set forth in 37 CFR 1.125(c) and a statement that the substitute specification contains no new matter (see 37 CFR 1.125(b)). Since a preliminary amendment was present on the filing date of the application and such amendment is part of the original disclosure of the application, the substitute specification must include all of the desired changes made in the preliminary amendment. See 37 CFR 1.115 and 1.215.

Applicant is cautioned that correction of the above items may cause the specification and drawings page count to exceed 100 pages. If the specification and drawings exceed 100 pages, applicant will need to submit the required application size fee.

Replies should be mailed to:

Mail Stop Missing Parts
Commissioner for Patents
P.O. Box 1450
Alexandria VA 22313-1450

Registered users of EFS-Web may alternatively submit their reply to this notice via EFS-Web.
<https://portal.uspto.gov/authenticate/AuthenticateUserLocalEPF.html>

For more information about EFS-Web please call the USPTO Electronic Business Center at **1-866-217-9197** or visit our website at <http://www.uspto.gov/ebc>.

If you are not using EFS-Web to submit your reply, you must include a copy of this notice.

/eggolla/

Office of Data Management, Application Assistance Unit (571) 272-4000, or (571) 272-4200, or 1-888-786-0101



UNITED STATES PATENT AND TRADEMARK OFFICE

UNITED STATES DEPARTMENT OF COMMERCE
United States Patent and Trademark Office
Address: COMMISSIONER FOR PATENTS
P.O. Box 1450
Alexandria, Virginia 22313-1450
www.uspto.gov

APPLICATION NUMBER	FILING OR 371(C) DATE	FIRST NAMED APPLICANT	ATTY. DOCKET NO./TITLE
13/536,767	06/28/2012	Daniel M. FISCHER	11298.0188-08000

CONFIRMATION NO. 5104

POA ACCEPTANCE LETTER



93377
RIM/FINNEGAN
901 New York Avenue NW
Washington, DC 20001

Date Mailed: 07/20/2012

NOTICE OF ACCEPTANCE OF POWER OF ATTORNEY

This is in response to the Power of Attorney filed 06/28/2012.

The Power of Attorney in this application is accepted. Correspondence in this application will be mailed to the above address as provided by 37 CFR 1.33.

/tqlam/

Office of Data Management, Application Assistance Unit (571) 272-4000, or (571) 272-4200, or 1-888-786-0101



UNITED STATES PATENT AND TRADEMARK OFFICE

UNITED STATES DEPARTMENT OF COMMERCE
United States Patent and Trademark Office
Address: COMMISSIONER FOR PATENTS
P.O. Box 1450
Alexandria, Virginia 22313-1450
www.uspto.gov

Table with 7 columns: APPLICATION NUMBER, FILING or 371(c) DATE, GRP ART UNIT, FIL FEE REC'D, ATTY. DOCKET NO, TOT CLAIMS, IND CLAIMS. Row 1: 13/536,767, 06/28/2012, 2859, 1250, 11298.0188-08000, 18, 2

CONFIRMATION NO. 5104

93377
RIM/FINNEGAN
901 New York Avenue NW
Washington, DC 20001

FILING RECEIPT



Date Mailed: 07/20/2012

Receipt is acknowledged of this non-provisional patent application. The application will be taken up for examination in due course. Applicant will be notified as to the results of the examination. Any correspondence concerning the application must include the following identification information: the U.S. APPLICATION NUMBER, FILING DATE, NAME OF APPLICANT, and TITLE OF INVENTION. Fees transmitted by check or draft are subject to collection. Please verify the accuracy of the data presented on this receipt. If an error is noted on this Filing Receipt, please submit a written request for a Filing Receipt Correction. Please provide a copy of this Filing Receipt with the changes noted thereon. If you received a "Notice to File Missing Parts" for this application, please submit any corrections to this Filing Receipt with your reply to the Notice. When the USPTO processes the reply to the Notice, the USPTO will generate another Filing Receipt incorporating the requested corrections

Applicant(s)

Daniel M. FISCHER, Waterloo, CANADA;
Dan G. Radut, Waterloo, CANADA;
Michael F. Habicher, Toronto, CANADA;
Quang A. Luong, Missisauga, CANADA;
Jonathan T. Malton, Kitchener, CANADA;

Assignment For Published Patent Application

Research In Motion Limited, Waterloo, CANADA

Power of Attorney: The patent practitioners associated with Customer Number 93377

Domestic Priority data as claimed by applicant

This application is a CON of 13/175,509 07/01/2011 PAT 8232766
which is a CON of 12/905,934 10/15/2010 PAT 7986127
which is a CON of 12/714,204 02/26/2010 PAT 7834586
which is a CON of 12/268,297 11/10/2008 PAT 7737657
which is a CON of 11/749,680 05/16/2007 PAT 7453233
which is a CON of 11/175,885 07/06/2005 PAT 7239111
which is a CON of 10/087,629 03/01/2002 PAT 6936936
which claims benefit of 60/273,021 03/01/2001
and claims benefit of 60/330,486 10/23/2001

Foreign Applications (You may be eligible to benefit from the Patent Prosecution Highway program at the USPTO. Please see http://www.uspto.gov for more information.)

If Required, Foreign Filing License Granted: 07/18/2012

The country code and number of your priority application, to be used for filing abroad under the Paris Convention, is **US 13/536,767**

Projected Publication Date: To Be Determined - pending completion of Corrected Papers

Non-Publication Request: No

Early Publication Request: No

Title

MULTIFUNCTIONAL CHARGER SYSTEM AND METHOD

Preliminary Class

320

PROTECTING YOUR INVENTION OUTSIDE THE UNITED STATES

Since the rights granted by a U.S. patent extend only throughout the territory of the United States and have no effect in a foreign country, an inventor who wishes patent protection in another country must apply for a patent in a specific country or in regional patent offices. Applicants may wish to consider the filing of an international application under the Patent Cooperation Treaty (PCT). An international (PCT) application generally has the same effect as a regular national patent application in each PCT-member country. The PCT process **simplifies** the filing of patent applications on the same invention in member countries, but **does not result** in a grant of "an international patent" and does not eliminate the need of applicants to file additional documents and fees in countries where patent protection is desired.

Almost every country has its own patent law, and a person desiring a patent in a particular country must make an application for patent in that country in accordance with its particular laws. Since the laws of many countries differ in various respects from the patent law of the United States, applicants are advised to seek guidance from specific foreign countries to ensure that patent rights are not lost prematurely.

Applicants also are advised that in the case of inventions made in the United States, the Director of the USPTO must issue a license before applicants can apply for a patent in a foreign country. The filing of a U.S. patent application serves as a request for a foreign filing license. The application's filing receipt contains further information and guidance as to the status of applicant's license for foreign filing.

Applicants may wish to consult the USPTO booklet, "General Information Concerning Patents" (specifically, the section entitled "Treaties and Foreign Patents") for more information on timeframes and deadlines for filing foreign patent applications. The guide is available either by contacting the USPTO Contact Center at 800-786-9199, or it can be viewed on the USPTO website at <http://www.uspto.gov/web/offices/pac/doc/general/index.html>.

For information on preventing theft of your intellectual property (patents, trademarks and copyrights), you may wish to consult the U.S. Government website, <http://www.stopfakes.gov>. Part of a Department of Commerce initiative, this website includes self-help "toolkits" giving innovators guidance on how to protect intellectual property in specific countries such as China, Korea and Mexico. For questions regarding patent enforcement issues, applicants may call the U.S. Government hotline at 1-866-999-HALT (1-866-999-4158).

LICENSE FOR FOREIGN FILING UNDER
Title 35, United States Code, Section 184
Title 37, Code of Federal Regulations, 5.11 & 5.15

GRANTED

The applicant has been granted a license under 35 U.S.C. 184, if the phrase "IF REQUIRED, FOREIGN FILING LICENSE GRANTED" followed by a date appears on this form. Such licenses are issued in all applications where the conditions for issuance of a license have been met, regardless of whether or not a license may be required as set forth in 37 CFR 5.15. The scope and limitations of this license are set forth in 37 CFR 5.15(a) unless an earlier license has been issued under 37 CFR 5.15(b). The license is subject to revocation upon written notification. The date indicated is the effective date of the license, unless an earlier license of similar scope has been granted under 37 CFR 5.13 or 5.14.

This license is to be retained by the licensee and may be used at any time on or after the effective date thereof unless it is revoked. This license is automatically transferred to any related applications(s) filed under 37 CFR 1.53(d). This license is not retroactive.

The grant of a license does not in any way lessen the responsibility of a licensee for the security of the subject matter as imposed by any Government contract or the provisions of existing laws relating to espionage and the national security or the export of technical data. Licensees should apprise themselves of current regulations especially with respect to certain countries, of other agencies, particularly the Office of Defense Trade Controls, Department of State (with respect to Arms, Munitions and Implements of War (22 CFR 121-128)); the Bureau of Industry and Security, Department of Commerce (15 CFR parts 730-774); the Office of Foreign Assets Control, Department of Treasury (31 CFR Parts 500+) and the Department of Energy.

NOT GRANTED

No license under 35 U.S.C. 184 has been granted at this time, if the phrase "IF REQUIRED, FOREIGN FILING LICENSE GRANTED" DOES NOT appear on this form. Applicant may still petition for a license under 37 CFR 5.12, if a license is desired before the expiration of 6 months from the filing date of the application. If 6 months has lapsed from the filing date of this application and the licensee has not received any indication of a secrecy order under 35 U.S.C. 181, the licensee may foreign file the application pursuant to 37 CFR 5.15(b).

SelectUSA

The United States represents the largest, most dynamic marketplace in the world and is an unparalleled location for business investment, innovation and commercialization of new technologies. The USA offers tremendous resources and advantages for those who invest and manufacture goods here. Through SelectUSA, our nation works to encourage, facilitate, and accelerate business investment. To learn more about why the USA is the best country in the world to develop technology, manufacture products, and grow your business, visit SelectUSA.gov.

IN THE UNITED STATES PATENT AND TRADEMARK OFFICE

In re Application of:)
)
Daniel M. FISCHER et al.) Group Art Unit: 2859
)
Application No.: 13/536,767) Examiner: Unknown
)
Filed: June 28, 2012)
) Confirmation No.: 5104
For: MULTIFUNCTIONAL CHARGER)
SYSTEM AND METHOD)

Mail Stop Missing Parts

Commissioner for Patents
P.O. Box 1450
Alexandria, VA 22313-1450

Sir:

**RESPONSE TO NOTICE TO FILE
CORRECTED APPLICATION PAPERS**

In response to the communication of July 20, 2012, Applicants submit a substitute specification incorporating the changes requested in the preliminary amendment accompanying the filing of the application. A marked-up version showing changes in accordance with 37 C.F.R. § 1.125(c) has been provided, as well as a clean version without markings. The substitute specification contains no new matter. Additionally, Applicants submit replacement drawings for Figures 1-4.

Applicants note that the original drawings submitted with this application are fully in compliance with 37 CFR 1.84 and have been accepted for U.S. Application No. 13/175,509 without any objection. A copy of the Notice To File Corrected Application Papers is not attached since this response is being filed electronically (EFS-Web).

Marked-up Substitute Specification

MULTIFUNCTIONAL CHARGER SYSTEM AND METHOD

CROSS-REFERENCE TO RELATED APPLICATIONS

[0001] This is a continuation application of U.S. Patent Application No. 13/175,509, filed July 1, 2011, now U.S. Patent No. 8,232,766, issued on July 31, 2012, by Daniel M. Fischer, et al. and entitled “Multifunctional Charger System and Method,” which is a continuation of U.S. Patent Application No. 12/905,934, filed October 15, 2010, now U.S. Patent No. 7,986,127, issued on July 26, 2011, by Daniel M. Fischer, et al. and entitled “Multifunctional Charger System and Method,” which is a continuation of U.S. Patent Application No. 12/714,204, filed February 26, 2010, by Daniel M. Fischer, et al. and entitled “Multifunctional Charger System and Method,” which is a continuation of U.S. Patent Application No. 12/268,297, filed November 10, 2008, now U.S. Patent No. 7,737,657 issued on June 15, 2010, by Daniel M. Fischer, et al. and entitled “System and Method for Charging a Battery in a Mobile Device,” which is a continuation of U.S. Patent Application No. 11/749,680, filed May 16, 2007, now U.S. Patent No. 7,453,233 issued on November 18, 2008, by Daniel M. Fischer, et al. and entitled “Adapter System and Method for Powering a Device,” which is a continuation of U.S. Patent Application No. 11/175,885, filed on July 6, 2005, now U.S. Patent No. 7,239,111 issued on July 3, 2007, by Daniel M. Fischer, et al. and entitled “Universal Serial Bus Adapter for a Mobile Device,” which is a continuation of U.S. Patent Application No. 10/087,629, filed March 1, 2002, now U.S. Patent No. 6,936,936 issued on August 30, 2006, by Daniel M. Fischer, et al. and entitled “Multifunctional Charger System and Method,” which claims priority from U.S. Provisional Application no. 60/273,021, filed March 1, 2001, by Daniel

Marked-up Substitute Specification

M. Fischer, et al. and entitled “System and Method for Adapting a USB to Provide Power for Charging a Mobile Device” and U.S. Provisional Application No. 60/330,486, filed October 23, 2001, by Daniel M. Fischer, et al. and entitled “multifunctional Charger System and Method.” Each of the above patent applications is hereby incorporated herein by reference in its entirety for all purposes.

BACKGROUND

[0002] This invention relates generally to power adapters. More particularly, the invention relates to power adapters for use with mobile devices.

[0003] Providing an external source of power to a mobile device, such as a personal digital assistant[[s]] (“PDA”), mobile communication device, cellular phone, wireless two-way e-mail communication device, and others, requires design considerations with respect to both the mobile device and the power source. With regard to the mobile device, most mobile devices provide a distinct power interface for receiving power from a power source, for instance to recharge a battery, and a separate data interface for communicating. For example, many mobile devices presently use USB (Universal Serial Bus) interfaces for communicating and use a separate power interface, such as a barrel connector, for receiving power.

[0004] It is desirable, however, to have a combined power and data interface. The mobile devices that do have combined power and data interfaces typically use non-standard and sometimes proprietary interfaces. Consequently, combined interfaces for

Marked-up Substitute Specification

a particular manufacturer's mobile device may not be compatible with combined interfaces for mobile devices provided by other manufacturers.

[0005] Although the USB interface can be used as a power interface, the USB is typically not used for that purpose by mobile devices. In accordance with the USB specification, typical USB power source devices, such as hubs and hosts, require that a USB device participate in a host-initiated process called enumeration in order to be compliant with the current USB specification in drawing power from the USB interface. Although a mobile device could be adapted to participate in enumeration when drawing power over the USB interface, it would be preferable in many situations, such as when a host would not be available, as often happens during normal use of a mobile device, to be able to utilize alternate power sources such as conventional AC outlets and DC car sockets that are not capable of participating in enumeration to supply power to the mobile device via a USB interface.

SUMMARY

[0006] An adapter for providing a source of power to a mobile device through an industry standard port is provided. In accordance with one aspect of the invention, the adapter comprises a plug unit, a power converter, a primary connector, and an identification subsystem. The plug unit is operative to couple the adapter to a power socket and operative to receive energy from the power socket. The power converter is electrically coupled to the plug unit and is operable to regulate the received energy from the power socket and to output a power requirement to the mobile device. The primary

Marked-up Substitute Specification

connector is electrically coupled to the power converter and is operative to couple to the mobile device and to deliver the outputted power requirement to the mobile device. The identification subsystem is electrically coupled to the primary connector and is operative to provide an identification signal.

[0007] In accordance with another aspect, a USB adapter for providing a source of power to a mobile device through a USB port is provided. The USB adapter comprises a plug unit, a power converter, a primary USB connector, and an identification subsystem. The plug unit is operative to couple the USB adapter to a power socket and operative to receive energy from the power socket. The power converter is electrically coupled to the plug unit and is operable to regulate the received energy from the power socket and to output a power requirement to the mobile device. The primary USB connector is electrically coupled to the power converter and is operative to couple to the mobile device and to deliver the outputted power requirement to the mobile device. The identification subsystem is electrically coupled to the primary connector and is operative to provide an identification signal.

[0008] Another aspect provides a USB adapter for providing a source of power to a mobile device through a USB port. The USB adapter comprises a plug unit, a power converter, a primary USB connector, and an auxiliary USB adapter. The plug unit is operative to couple the USB adapter to a power socket and operative to receive energy from the power socket. The power converter is electrically coupled to the plug unit and is operable to regulate the received energy from the power socket and to output a power requirement to the mobile device. The primary USB connector is electrically

Marked-up Substitute Specification

coupled to the power converter and is operative to couple to the mobile device and to deliver the outputted power requirement to the mobile device. The auxiliary USB connector has data lines that are electrically coupled to the data lines of the primary USB connector.

[0009] Yet another aspect provides a method for providing energy to a mobile device using a USB adapter that comprises a plug unit, a primary USB connector, a power converter electrically coupled between the plug unit and the primary USB connector, and an identification subsystem electrically coupled to the primary USB connector. The method comprising the steps of coupling the USB connector to the mobile device, coupling the plug unit to a power socket, outputting a power requirement to the mobile device via the power converter and the USB connector, and providing an identification signal to the mobile device, via the identification subsystem and the USB connector, that is operative to inform the mobile device that the USB adapter is not limited by the power limits imposed by the USB specification.

[0010] In accordance with another aspect, a powering system for a mobile device having a USB connector is provided. The powering system comprises a power distribution subsystem in the mobile device that is operable to receive energy through the USB connector and to distribute the energy to at least one component in the mobile device and a USB adapter that is operative to couple to the USB connector. The USB adapter comprises a plug unit for coupling to a power socket and that is operable to receive energy from the power socket, a power converter electrically coupled to the plug unit for regulating the received energy and for providing a power requirement to the

Marked-up Substitute Specification

power distribution subsystem, and an identification subsystem that is operable to transmit an identification signal that is operative to identify the USB adapter as not being limited by the power limits imposed by the USB specification.

BRIEF DESCRIPTION OF THE DRAWINGS

[0011] In order that the invention identified in the claims may be more clearly understood, preferred embodiments thereof will be described in detail by way of example, with reference to the accompanying drawings, in which:

[0012] Fig. 1 is a schematic diagram of an exemplary mobile device which has an industry standard interface;

[0013] Fig. 2 is a schematic diagram of a first embodiment of a USB adapter that is coupled to an exemplary mobile device;

[0014] Fig. 3 is a flow chart illustrating an exemplary use of a USB adapter with a mobile device; and

[0015] Fig. 4 is a schematic diagram of an additional exemplary embodiment of a USB adapter that is coupled to both an exemplary mobile device and an external battery.

DETAILED DESCRIPTION

Exemplary Mobile Device

[0016] Turning now to the drawing figures, shown in Fig. 1 is a schematic diagram of an exemplary mobile communication device 10 which has an industry standard interface. The mobile communication device 10 is preferably a two-way communication device having at least voice or data communication capabilities. Preferably, the mobile

Marked-up Substitute Specification

device 10 is also capable of communicating over the Internet, for example, via a radio frequency (“RF”) link. Examples of types of devices that could be classified as a mobile device 10 include a data messaging device, a two-way pager, a cellular telephone with data messaging capabilities, a wireless Internet appliance, a data communication device (with or without telephony capabilities), a personal digital assistant[[s]] (“PDA”), a wireless two-way e-mail communication device, and others.

[0017] The exemplary mobile device 10 comprises a microprocessor 12, a communication subsystem 14, input/output (“I/O”) devices 16, an industry standard interface 18 which in this example is a USB port, and a power subsystem 20. The microprocessor 12 controls the overall operation of the mobile device 10. The communication subsystem 14 provides the mobile device 10 with the ability to communicate wirelessly with external devices such as other mobile devices and other computers. The I/O devices 16 provide the mobile device 10 with input/output capabilities for use with a device user. The USB port 18 provides the mobile device 10 with a serial port for linking directly with other computers and/or a means for receiving power from an external power source. The power subsystem 20 provides the mobile device 10 with a local power source.

[0018] The exemplary communication subsystem 14 comprises components such as a receiver 22, a transmitter 24, antenna elements 26 and 28, local oscillators (LOs) 30, and a processing module such as a digital signal processor (DSP) 32. The particular design of the communication subsystem 14 and the components used therein can vary. It would be apparent to one of ordinary skill in the art to design an appropriate

Marked-up Substitute Specification

communication subsystem using conventional methods and components to operate over a communication network 34 based on the parameters necessary to operate over that communication network. For example, a mobile device 10 geographically located in North America may include a communication subsystem 14 designed to operate within the Mobitex™ mobile communication system or DataTAC™ mobile communication system, whereas a mobile device 10 intended for use in Europe may incorporate a General Packet Radio Service (GPRS) communication subsystem 14.

[0019] Network access requirements will also vary depending upon the type of network 34. For example, in the Mobitex and DataTAC networks, mobile devices 10 are registered on the network using a unique personal identification number or PIN associated with each device. In GPRS networks however, network access is associated with a subscriber or user of a mobile device 10. A GPRS device therefore requires a subscriber identity module (not shown), commonly referred to as a SIM card, in order to operate on a GPRS network. Without a SIM card, a GPRS device will not be fully functional. Local or non-network communication functions (if any) may be operable, but the mobile device 10 will be unable to carry out any functions involving communications over the network 34.

[0020] When required, after the network registration or activation procedures have been completed, a mobile device 10 may send and receive communication signals over the network 34. Signals received by the receiver antenna 26 through a communication network 34 are input to the receiver 22, which may perform such common receiver functions as signal amplification, frequency down conversion, filtering, channel selection

Marked-up Substitute Specification

and the like, and in the exemplary system shown in Fig. 1, analog to digital conversion. Analog to digital conversion of a received signal allows more complex communication functions such as demodulation and decoding to be performed in a DSP 32. Similarly, signals to be transmitted are processed, including modulation and encoding for example, by the DSP 32 and input to the transmitter 24 for digital to analog conversion, frequency up conversion, filtering, amplification and transmission over the communication network 34 via the transmitter antenna 28.

[0021] Also, in the exemplary communication subsystem 14, the DSP 32 processes communication signals and also provides for receiver and transmitter control. For example, the gains applied to communication signals in the receiver 22 and transmitter 24 may be adaptively controlled through automatic gain control algorithms implemented in the DSP 32.

[0022] In implementing its control function, the microprocessor 12 in the exemplary mobile device 10 executes an operating system. The operating system software used by the microprocessor 12 is preferably stored in a persistent store such as flash memory 36, or alternatively read only memory (ROM) or similar storage element. The microprocessor 12 may also enable the execution of specific device applications, which preferably are also stored in a persistent store. The operating system, specific device applications, or parts thereof, may also be temporarily loaded into a volatile store such as in RAM 38.

[0023] A predetermined set of applications which control basic device operations, including at least data and voice communication applications for example, will normally

Marked-up Substitute Specification

be installed on the mobile device 10 during manufacture. One such application loaded on the mobile device 10 could be a personal information manager (PIM) application. The PIM application preferably is an application for organizing and managing user inputted data items such as e-mail, calendar events, voice mails, appointments, and task items. The PIM data items may be stored in the RAM 38 and/or the flash memory 36.

[0024] The PIM application preferably has the ability to send and receive data items, via the wireless network 34. The PIM data items are preferably seamlessly integrated, synchronized and updated, via the wireless network 34, with corresponding data items stored or associated with a host computer system (not shown) used by the device user. The synchronization of PIM data items is a process by which the PIM data items on the mobile device 10 and the PIM data items on the host computer system can be made to mirror each other.

[0025] There are several possible mechanisms for loading applications onto the mobile device 10. For example, applications may be loaded onto the mobile device 10 through the wireless network 34, an auxiliary I/O subsystem 40, the serial port 18, a short-range communications subsystem 42, such as an infrared ("IR") communication system, or any other suitable subsystem 44. When loading the applications onto the mobile device 10, the device user may install the applications in the RAM 38, the flash memory 36, or preferably a non-volatile store (not shown) such as ROM for execution by the microprocessor 12. The available application installation mechanisms can increase the utility of the mobile device 10 by providing the device user with a way of upgrading the

Marked-up Substitute Specification

mobile device 10 with additional and/or enhanced on-device functions, communication-related functions, or both. For example, a secure communication application may be loaded onto the mobile device 10 that allows for electronic commerce functions or other financial transactions to be performed using the mobile device 10.

[0026] The I/O devices 16 may be used to display and/or compose data communication messages. In one mode of operation, a signal received by the mobile device 10, such as a text message or web page download, will be received and processed by the communication subsystem 14, forwarded to the microprocessor 12, which will preferably further process the received signal, and provide the processed signal to one or more of the I/O devices 16 such as a display 46. Alternatively, a received signal such as a voice signal can be provided to a speaker 48, or alternatively to an auxiliary I/O device 40. In another mode of operation a device user may compose a data item such as an e-mail message using a keyboard 50 in cooperation with the display 46 and possibly an auxiliary I/O device 40. Alternatively, a device user may compose a voice message via a microphone 52. The composed data item may then be transmitted over a communication network 34 using the communication subsystem 14.

[0027] A short-range communications subsystem 42 may be provided in the mobile device 10 to allow the mobile device 10 to communicate with other systems or devices, which need not necessarily be similar to device 10. For example, the short-range communications subsystem 42 may include an infrared device and associated circuitry and components or a Bluetooth™ communication module to allow the device 10 to communicate with similarly-enabled systems and devices.

Marked-up Substitute Specification

[0028] The USB port 18 provides the mobile device 10 with a serial port for linking directly with other computers to exchange data and/or to receive power. The USB port 18 also provides the mobile device 10 with a means for receiving power from an external power source. For example, in a personal digital assistant (PDA)-type communication device, the USB port 18 could be used to allow the mobile device 10 to synchronize data with a user's desktop computer (not shown). The USB port 18 could also enable a user to set parameters in the mobile device 10 such as preferences through the use of an external device or software application. In addition the USB port 18 may also be used to provide a means for downloading information or software to the mobile device 10 without using the wireless communication network 34. The USB port 18 can provide a direct and thus reliable and trusted connection that may for example be used to load an encryption key onto the mobile device 10 thereby enabling secure device communication.

[0029] Coupled to the USB port 18 is a USB connector 54. The USB connector 54 is the physical component that couples the USE port 18 to the outside world. In the exemplary mobile device 10, the USB connector 54 is used to transmit and receive data from an external data/power source 56, receive power from the external data/power source 56, direct the transmitted/received data from/to the USB port 18, and direct the received power to the power subsystem 20.

[0030] The exemplary power subsystem 20 comprises a charging and power distribution subsystem 58 and a battery 60. The charging and power distribution subsystem 58 performs many functions. It may be used to transfer energy to the

Marked-up Substitute Specification

battery 60 from the external data/power source 56 to charge the battery 60 and also to distribute power to the many ~~power requiring~~ power-requiring components within the mobile device 10. The charging subsystem 58 may be capable of determining the presence of a batter 60 and/or a power circuit coupled to the mobile device 10, such as an AC adapter, USB connection, or car adapter, which alternatively can act as power sources 56 to provide power for the mobile device 10 and to charge the battery 60. Additionally, the charging subsystem 58 may have the ability to determine if a power source 56 is coupled to the mobile device 10 and, in the absence of such a coupling, cause the mobile device 10 to be powered by the battery 60.

[0031] The power distributed by the charging and power distribution subsystem 58 may be derived from energy stored in the battery 60 and/or energy received from the external data/power source 56. When the battery 60 is depleted, the charging and power distribution subsystem 58 transfers energy from the power source 56 to recharge the battery 60. Optionally, the charging and power distribution subsystem 58 may also transfer energy from the power source 56 to other components in the mobile device 10 to power the mobile device 10 when the battery 60 has been depleted and is recharging. When the data/power source 56 is not connected to the mobile device 10, power for the device 10 is derived from the battery 60.

Exemplary USB Adapter

[0032] Fig. 2 is a schematic diagram of a first embodiment of an adapter 100 that can be used to couple the mobile device 10 of fig. 1 to the data/power source 56 of fig. 1. In

Marked-up Substitute Specification

this example the adapter 100 is a USB adapter 100 that comprises a primary USB connector 102, a power converter 104, a plug unit 106, and an identification subsystem 108. The power converter is a known element in the art and typically includes at least one of the following components: switching converter, transformer, DC source, voltage regulator, linear regulator and rectifier. In the embodiment shown in fig. 2, the USB adapter 100 is shown coupling a mobile device 10 to one of one or more types of power sockets 110N, 110D, 110B, and ~~[[100]]~~ 110. Also shown in fig. 2 is an optional auxiliary USB connector 112 that can be used to couple the mobile device 10 to a data source (not shown) such as a personal computer.

[0033] In the embodiment shown in fig. 2, the primary USB connector 102 is configured to mate with the USB connector 54 of the mobile device 10. The USB adapter 100 is operable to provide power to the mobile device 10 through the Vbus and Gnd power pins in the USB connectors 54 and 102. The USB adapter 100 also optionally provides a communication path for data across the D+ and D- data pins in the USB connectors 54 and 102.

[0034] The plug unit 106 is preferably a conventional plug unit that can be used to couple with a conventional power socket to receive power therefrom. For example, the plug unit 106 can be a ~~two-prong~~ two-prong or ~~three-prong~~ three-prong plug of the type used in North America that can couple to a North American AC power socket 110N that provides 115 VAC. In the embodiment shown in figure 2, the plug unit 106 can accept one or more types of plug adapters 114N, 114B, 114D, and 114 that are configured to couple to the plug unit 106 and are further configured to directly mate with one or more

Marked-up Substitute Specification

types of power sockets 110N, 110D, 110B, and [[100]] 110. The plug unit 106 can be configured to receive energy from a power socket 110N, 110D, 110B, or [[100]] 110, either directly or through the use of a plug adapter, and is operative to transfer the received energy to the power converter 104.

[0035] The power converter 104 is operative to receive energy from a power socket 110N, 110D, 110B, or [[100]] 110 and to convert that received energy to a form that can be used by the mobile device 10. For example, the power converter 104 can be of conventional construction such as a switching power converter that converts 115 VAC to 5 VDC. Also, the power converter 104 could comprise a D.C. regulator circuit that converts a D.C. input to a D.C. output. The power converter 104 could also be adapted to accept a wide range of input energy levels and frequencies. Alternatively, the power converter 104 could be adapted to accept a limited range of input energy levels and frequencies, wherein the plug adapters are operable to convert the possible input energy levels and frequencies to a range that the power converter 104 can accommodate. The power converter 104 provides its energy output to the mobile device 10 via the Vbus and Gnd pins of the primary USB connector 102.

[0036] Through the use of a variety of different types of plug adapters, the USB adapter 100 can be adapted to receive energy from various types of power sockets 110N, 110D, 110B, or [[100]] 110. For example, using the appropriate plug adapter 114, 114B, 114D, and 114N, the USB adapter 100 can receive energy from a power socket such as [[an]] a 115 VAC North American power socket 110N, or a 12 VDC automobile power socket, or an air power socket, or others.

Marked-up Substitute Specification

[0037] For example, in North America, a type “N” power socket is commonly available. The plug adapter 114N can be releasably attached to the plug unit 106 thereby allowing any North American power socket 114N to be used as a power source. When traveling to a locale which does not have the North American power socket 114N, an alternate plug adapter such as adapters 114, 114B, or 114D may be selected by the user, according to the power socket 110D, 110B, or ~~[[100]]~~ 110 available at the locale. The plug adapter 114, 114B, or 114D may then be releasably attached to plug unit 106 in place of the plug adapter 114N, thereby allowing the USB power adapter 100 to connect to a local power supply via the local power ~~socket~~. socket. Various other plug adapters are envisioned that can be configured to operate with alternate power sources such as for instance car sockets.

[0038] The power distribution and charging subsystem 58 of the mobile device 10 can selectively use the power provided on the Vbus and Gnd lines of the USB connector 54 to provide power to the mobile device 10, charge the battery 60, or both. A more detailed discussion of how the charging function of mobile device 10 can be implemented is described in United States Provisional Application No. 60/273021 filed on March 1st, 2001 and entitled “System and Method for Adapting a USB to Provide Power for Charging a Mobile Device” which has been incorporated herein by reference.

[0039] Typically when a mobile device 10 receives power over the USB from a USB host, it is required to draw power in accordance with the USB specification. The USB specification specifies a process for transferring energy across the USB called enumeration and limits the electrical current that can flow across the USB.

Marked-up Substitute Specification

[0040] The USB adapter 100 contributes to a system wherein a device 10 that follows the USB specification when coupled to a typical USB host via its USB port can be informed that the USB adapter 100 has been coupled to the device 10 and that the device 10 can now draw power without regard to the USB specification and the USB specification imposed limits.

[0041] The identification subsystem 108 provides an identification signal to the mobile device 10 that the power source is not a USB limited source. The identification signal could be the communication of a single voltage on one or more of the USB data lines, different voltages on the two data lines, a series of pulses or voltage level changes, or other types of electrical signals. The identification subsystem 108 that generates the identification signal could have multiple types of configurations. In one embodiment, the identification subsystem 108 comprises a hard-wired connection of a single voltage level to both data lines. In another embodiment, the identification subsystem 108 comprises a USB controller that is operable to communicate an identification signal to the mobile device 10. Additional embodiments are contemplated. The identification subsystem 108 may optionally be configured to have the capability of electrically connecting or disconnecting the power output from the power converter 104 from the USB connector 102 and/or to connect or disconnect any data inputs from the USB adapter 100 to the USB connector 102.

[0042] In addition to providing power to the mobile device 10 over the primary USB connector 102, the USB adapter 100 may optionally be equipped with an auxiliary USB connector 112 that allows the USB adapter 100 to create a communication path

Marked-up Substitute Specification

between the mobile device 10 and some other device capable of communicating over the USB such as a personal computer, another mobile device or some other type of device.

[0043] The USB adapter 100 preferably provides a communication path between the D+ and D- pins of the Primary USB connector 102 and the D+ and D- pins of the auxiliary USB connector 112. In the embodiment shown, the communication path also traverses the identification subsystem 108. Alternatively, the communication path could bypass the identification subsystem 108. The USB adapter 100 can thus act as a ~~pass-through~~ pass-through device for communication between a USB hub or host and a mobile device 10.

[0044] Optionally, the USB adapter 100 could also transfer energy from the power converter 104 to the auxiliary USB connector 112 thereby providing a device coupled to the auxiliary USB connector 112 with power. In this arrangement, the identification subsystem 108 could also provide an identification signal to the device coupled to the auxiliary USB connector 112 to inform that device that the power source is not a USB limited source.

Exemplary Illustration Of The Use of A USB Adapter With A Mobile Device

[0045] When a USB adapter 100 is connected to a mobile device 10, the identification subsystem 108 of the USB adapter 100 preferably provides an identification signal to the mobile device 10 to notify the mobile device 10 that the device 10 is connected to a power source that is not subject to the power limits imposed by the USB specification.

Marked-up Substitute Specification

Preferably, the mobile device 10 is programmed to recognize the identification signal and therefore recognizes that an identification signal has been transmitted by the USB adapter 100. After recognizing a valid identification signal, the mobile device 10[[.]] draws power through the USB adapter 100 without waiting for enumeration or charge negotiation.

[0046] The detection of the identification signal may be accomplished using a variety of methods. For example, the microprocessor 12 may detect the identification signal by detecting the presence of an abnormal data line condition at the USB port 18. The detection may also be accomplished through the use of other device subsystems 44 in the mobile device 10. The preferred identification signal results from the application of voltage signals greater than 2 volts to both the D+ and D- lines in the USB connector 54. The preferred method of identification is described below in greater detail with reference to Fig. 3.

[0047] At step 210, the mobile device 10 detects the presence of a voltage on the Vbus line of the USB connector 54 via the USB port 18. At step 220, the mobile device checks the state of the D+ and D- lines of USB connector 54. In the example shown in the drawings, the D+ and D- lines are compared to a 2V reference. Also, in this example, the identification subsystem 108 of the USB adapter 100 may have applied a logic high signal, such as +5V reference, to both the D+ and D- lines to identify the attached device as a USB adapter 100. If the voltages on both the D+ and D- lines of the USB connector are greater than 2 Volts (step 220), then the mobile device 10 determines that the device connected to the USB connector 54 is not a typical USB host

Marked-up Substitute Specification

or hub and that a USB adapter 100 has been detected (step 230). The mobile device 10 can then charge the battery or otherwise use power provided via the Vbus and Gnd line sin the USB connector 54 (step 260) without waiting for enumeration.

[0048] If, however, after the mobile device 10 detects the presence of a voltage on the Vbus line of the USB connector 54 and determines that the voltages on both the D+ and D- lines of the USB connector 54 are not greater than 2 Volts (step 220), then the mobile device 10 determines that a USB host or hub has been detected (step 240). A typical USB host or hub weakly holds its D+ and D- lines at zero volts when it is not connected to another device. The mobile device 10 can then signal the USB host or hub to initiate the enumeration process (step 250) and can charge the battery or otherwise use power provided via the Vbus and Gnd lines in the USB connector 54 (step 260) in accordance with the power limits imposed by the USB specification. The enumeration process is typically initiated after the mobile device 10 applies approximately zero volts to the D-line and approximately 5 volts to the D+ line to inform the host of the mobile device's 10 presence and communication speed.

[0049] Therefore, when a USB adapter 100 is coupled to the mobile device 10 and has been identified as a USB adapter 100, the mobile device 10 can forego the enumeration process and charge negotiation process and immediately draw energy from the USB power adapter 100 at a desired rate, for instance at 5 unit loads, i.e. 500mA. While the mobile device 10 charges its battery using the USB adapter 100, the mobile device 10 can disable its typical USB functions. If, however, the mobile device 10 detects that a USB host or hub is coupled to the mobile device 10, the mobile device 10 can apply a

Marked-up Substitute Specification

voltage to the D+ line to indicate to the USB host or hub that the mobile device 10 is coupled thereto and await enumeration and USB charge negotiation.

[0050] If the USB adapter 100[[,]] is coupled to the mobile device 10, and the mobile device 10 does not identify the USB adapter 100 through communications with the identification module 108, the mobile device 10 may stop drawing energy from the Vbus and Gnd lines of the USB connector 54. This may occur, for example, if the mobile device 10 is not programmed to identify the USB adapter 100. The mobile device 10 may mistakenly identify the USB adapter 100 as a typical USB host or hub and await enumeration before drawing substantial energy. To guard against this, the USB adapter 100 can optionally be adapted to function with mobile devices that are not programmed to recognize the USB adapter 100.

[0051] In that scenario, the USB adapter 100 can be adapted to provide energy to a mobile device by using the knowledge that the mobile device will draw energy from a connected device for a period of time before it stops drawing energy due to lack of enumeration. The USB adapter 100 can optionally provide power for charging a battery 60 in a mobile device by periodically switching the voltages on the Vbus and Gnd lines between on and off states. When the USB adapter 100 is coupled to the mobile device, the identification subsystem 108 can apply an on-voltage (5 V for example) between the Vbus and Gnd lines. The mobile device will draw energy while awaiting enumeration. After a period of time, the identification subsystem 108 can apply an off-voltage (0 volts) between the Vbus and Gnd lines thereby fooling the mobile device into determining that the unidentified USB device has been disconnected from the mobile device. The

Marked-up Substitute Specification

identification subsystem 108 can then reapply an on-voltage between the Vbus and Gnd lines. The mobile device will draw energy again while awaiting enumeration. This cycle can be repeated to periodically apply energy to the mobile device, for example, to recharge the battery 60 of the mobile device.

Additional Exemplary Embodiments of USB Adapters

[0052] Shown in Fig. 4 is a schematic diagram of an additional exemplary embodiment of a USB adapter 300 that is coupled to a mobile device 10. The exemplary USB adapter 300 comprises a USB connector 302, a power converter 304, a plug unit 306, and an identification subsystem 308. The USB connector 302, plug unit 306, and identification subsystem 308 preferably correspond to the USB connector 102, plug unit 106, and identification subsystem 108 which were described earlier with respect to the first embodiment. Similar to the first embodiment, the additional embodiment may optionally be equipped with various plug adapters 314N, 314D, 314B, and 314 that preferably are releasably attachable to plug unit 306 so that the appropriate plug adapter 314N, 314D, 314B, or 314 can be selected by a user to allow the USB adapter 300 to couple to and receive energy from an available power socket 310N, 310D, 310B, or 310. The exemplary USB power converter 300 further comprises a charging subsystem 316 and battery receptacle 318 for coupling the USB adapter 300 to an external battery 320 that may be optionally coupled thereto.

[0053] The battery receptacle 318 provides a location for releasably coupling an external battery 320 thereto so that the external battery can be charged via the USB

Marked-up Substitute Specification

adapter 300. This provides the USB adapter 300 with a mechanism for charging, for example, a mobile device's primary or spare battery when the battery has been separated from or is not coupled to the mobile device 10.

[0054] To accommodate this functionality, the power converter 304 is capable of providing the proper voltage levels for the USB connector 302 and also capable of providing necessary voltage and current levels to drive a battery charging subsystem 316. The power converter 304 is preferably a dual power converter that may be constructed using conventional or non-conventional architectures. With respect to the portion of the power converter 304 that provides energy to the USB connector 302, that portion is preferably similar in construction and function to the power converter 104 of the first embodiment.

[0055] Preferably, the charging subsystem 316 performs in a substantially similar manner to charging subsystem 58 of the mobile device 10. But, for efficiency and simplicity of design, certain aspects of the dual power converter 304 and the charging subsystem 316 may be combined, as both are local to the USB adapter 300.

[0056] Other alternative embodiments of the USB adapter may include various combinations of components described above with respect to the first and additional embodiments. Another embodiment of the USB adapter may include a second or more auxiliary USB connectors. A USB adapter having one or more auxiliary USB connectors may optionally be configured such that one or more of the auxiliary USB connectors may have power from the USB adapter's power converter made available to it so that multiple USB devices may draw power simultaneously. Preferably, a USB

Marked-up Substitute Specification

adapter having multiple auxiliary USB connectors will be configured such that the data lines in the auxiliary connectors can, on a selective basis, be electrically connected to or disconnected from the data lines in the primary USB connector. This allows a mobile device connected to the primary USB connector to receive energy from the adapter regardless of whether a USB host or hub is connected to an auxiliary USB connector. It is also contemplated that a USB adapter may be embodied in a USB host or hub.

Conclusion

[0057] The embodiments described herein are examples of structures, systems or methods having elements corresponding to the elements of the invention recited in the claims. This written description may enable those skilled in the art to make and use embodiments having alternative elements that likewise correspond to the elements of the invention recited in the claims. The intended scope of the invention thus includes other structures, systems or methods that do not differ from the literal language of the claims, and further includes other structures, systems or methods with insubstantial differences from the literal language of the claims. Although the embodiments have been described with reference to the USB interface, it is contemplated that the invention could be applicable to devices and systems that use other standard interfaces such as the IEEE 1394 interface.

Marked-up Substitute Specification

ABSTRACT OF THE DISCLOSURE

An adapter for providing a source of power to a mobile device through an industry standard port is provided. In accordance with one aspect of the invention, the adapter comprises a plug unit, a power converter, a primary connector, and an identification subsystem. The plug unit is operative to couple the adapter to a power socket and operative to receive energy from the power socket. The power converter is electrically coupled to the plug unit and is operable to regulate the received energy from the power socket and to output a power requirement to the mobile device. The primary connector is electrically coupled to the power converter and is operative to couple to the mobile device and to deliver the outputted power requirement to the mobile device. The identification subsystem is electrically coupled to the primary connector and is operative to provide an identification signal.

Clean Version - Substitute Specification

MULTIFUNCTIONAL CHARGER SYSTEM AND METHOD

CROSS-REFERENCE TO RELATED APPLICATIONS

[0001] This is a continuation application of U.S. Patent Application No. 13/175,509, filed July 1, 2011, now U.S. Patent No. 8,232,766, issued on July 31, 2012, by Daniel M. Fischer, et al. and entitled "Multifunctional Charger System and Method," which is a continuation of U.S. Patent Application No. 12/905,934, filed October 15, 2010, now U.S. Patent No. 7,986,127, issued on July 26, 2011, by Daniel M. Fischer, et al. and entitled "Multifunctional Charger System and Method," which is a continuation of U.S. Patent Application No. 12/714,204, filed February 26, 2010, by Daniel M. Fischer, et al. and entitled "Multifunctional Charger System and Method," which is a continuation of U.S. Patent Application No. 12/268,297, filed November 10, 2008, now U.S. Patent No. 7,737,657 issued on June 15, 2010, by Daniel M. Fischer, et al. and entitled "System and Method for Charging a Battery in a Mobile Device," which is a continuation of U.S. Patent Application No. 11/749,680, filed May 16, 2007, now U.S. Patent No. 7,453,233 issued on November 18, 2008, by Daniel M. Fischer, et al. and entitled "Adapter System and Method for Powering a Device," which is a continuation of U.S. Patent Application No. 11/175,885, filed on July 6, 2005, now U.S. Patent No. 7,239,111 issued on July 3, 2007, by Daniel M. Fischer, et al. and entitled "Universal Serial Bus Adapter for a Mobile Device," which is a continuation of U.S. Patent Application No. 10/087,629, filed March 1, 2002, now U.S. Patent No. 6,936,936 issued on August 30, 2006, by Daniel M. Fischer, et al. and entitled "Multifunctional Charger System and Method," which claims priority from U.S. Provisional Application no. 60/273,021, filed March 1, 2001, by Daniel

Clean Version - Substitute Specification

M. Fischer, et al. and entitled "System and Method for Adapting a USB to Provide Power for Charging a Mobile Device" and U.S. Provisional Application No. 60/330,486, filed October 23, 2001, by Daniel M. Fischer, et al. and entitled "multifunctional Charger System and Method." Each of the above patent applications is hereby incorporated herein by reference in its entirety for all purposes.

BACKGROUND

[0002] This invention relates generally to power adapters. More particularly, the invention relates to power adapters for use with mobile devices.

[0003] Providing an external source of power to a mobile device, such as a personal digital assistant ("PDA"), mobile communication device, cellular phone, wireless two-way e-mail communication device, and others, requires design considerations with respect to both the mobile device and the power source. With regard to the mobile device, most mobile devices provide a distinct power interface for receiving power from a power source, for instance to recharge a battery, and a separate data interface for communicating. For example, many mobile devices presently use USB (Universal Serial Bus) interfaces for communicating and use a separate power interface, such as a barrel connector, for receiving power.

[0004] It is desirable, however, to have a combined power and data interface. The mobile devices that do have combined power and data interfaces typically use non-standard and sometimes proprietary interfaces. Consequently, combined interfaces for

Clean Version - Substitute Specification

a particular manufacturer's mobile device may not be compatible with combined interfaces for mobile devices provided by other manufacturers.

[0005] Although the USB interface can be used as a power interface, the USB is typically not used for that purpose by mobile devices. In accordance with the USB specification, typical USB power source devices, such as hubs and hosts, require that a USB device participate in a host-initiated process called enumeration in order to be compliant with the current USB specification in drawing power from the USB interface. Although a mobile device could be adapted to participate in enumeration when drawing power over the USB interface, it would be preferable in many situations, such as when a host would not be available, as often happens during normal use of a mobile device, to be able to utilize alternate power sources such as conventional AC outlets and DC car sockets that are not capable of participating in enumeration to supply power to the mobile device via a USB interface.

SUMMARY

[0006] An adapter for providing a source of power to a mobile device through an industry standard port is provided. In accordance with one aspect of the invention, the adapter comprises a plug unit, a power converter, a primary connector, and an identification subsystem. The plug unit is operative to couple the adapter to a power socket and operative to receive energy from the power socket. The power converter is electrically coupled to the plug unit and is operable to regulate the received energy from the power socket and to output a power requirement to the mobile device. The primary

Clean Version - Substitute Specification

connector is electrically coupled to the power converter and is operative to couple to the mobile device and to deliver the outputted power requirement to the mobile device. The identification subsystem is electrically coupled to the primary connector and is operative to provide an identification signal.

[0007] In accordance with another aspect, a USB adapter for providing a source of power to a mobile device through a USB port is provided. The USB adapter comprises a plug unit, a power converter, a primary USB connector, and an identification subsystem. The plug unit is operative to couple the USB adapter to a power socket and operative to receive energy from the power socket. The power converter is electrically coupled to the plug unit and is operable to regulate the received energy from the power socket and to output a power requirement to the mobile device. The primary USB connector is electrically coupled to the power converter and is operative to couple to the mobile device and to deliver the outputted power requirement to the mobile device. The identification subsystem is electrically coupled to the primary connector and is operative to provide an identification signal.

[0008] Another aspect provides a USB adapter for providing a source of power to a mobile device through a USB port. The USB adapter comprises a plug unit, a power converter, a primary USB connector, and an auxiliary USB adapter. The plug unit is operative to couple the USB adapter to a power socket and operative to receive energy from the power socket. The power converter is electrically coupled to the plug unit and is operable to regulate the received energy from the power socket and to output a power requirement to the mobile device. The primary USB connector is electrically

Clean Version - Substitute Specification

coupled to the power converter and is operative to couple to the mobile device and to deliver the outputted power requirement to the mobile device. The auxiliary USB connector has data lines that are electrically coupled to the data lines of the primary USB connector.

[0009] Yet another aspect provides a method for providing energy to a mobile device using a USB adapter that comprises a plug unit, a primary USB connector, a power converter electrically coupled between the plug unit and the primary USB connector, and an identification subsystem electrically coupled to the primary USB connector. The method comprising the steps of coupling the USB connector to the mobile device, coupling the plug unit to a power socket, outputting a power requirement to the mobile device via the power converter and the USB connector, and providing an identification signal to the mobile device, via the identification subsystem and the USB connector, that is operative to inform the mobile device that the USB adapter is not limited by the power limits imposed by the USB specification.

[0010] In accordance with another aspect, a powering system for a mobile device having a USB connector is provided. The powering system comprises a power distribution subsystem in the mobile device that is operable to receive energy through the USB connector and to distribute the energy to at least one component in the mobile device and a USB adapter that is operative to couple to the USB connector. The USB adapter comprises a plug unit for coupling to a power socket and that is operable to receive energy from the power socket, a power converter electrically coupled to the plug unit for regulating the received energy and for providing a power requirement to the

Clean Version - Substitute Specification

power distribution subsystem, and an identification subsystem that is operable to transmit an identification signal that is operative to identify the USB adapter as not being limited by the power limits imposed by the USB specification.

BRIEF DESCRIPTION OF THE DRAWINGS

[0011] In order that the invention identified in the claims may be more clearly understood, preferred embodiments thereof will be described in detail by way of example, with reference to the accompanying drawings, in which:

[0012] Fig. 1 is a schematic diagram of an exemplary mobile device which has an industry standard interface;

[0013] Fig. 2 is a schematic diagram of a first embodiment of a USB adapter that is coupled to an exemplary mobile device;

[0014] Fig. 3 is a flow chart illustrating an exemplary use of a USB adapter with a mobile device; and

[0015] Fig. 4 is a schematic diagram of an additional exemplary embodiment of a USB adapter that is coupled to both an exemplary mobile device and an external battery.

DETAILED DESCRIPTION

Exemplary Mobile Device

[0016] Turning now to the drawing figures, shown in Fig. 1 is a schematic diagram of an exemplary mobile communication device 10 which has an industry standard interface. The mobile communication device 10 is preferably a two-way communication device having at least voice or data communication capabilities. Preferably, the mobile

Clean Version - Substitute Specification

device 10 is also capable of communicating over the Internet, for example, via a radio frequency (“RF”) link. Examples of types of devices that could be classified as a mobile device 10 include a data messaging device, a two-way pager, a cellular telephone with data messaging capabilities, a wireless Internet appliance, a data communication device (with or without telephony capabilities), a personal digital assistant (“PDA”), a wireless two-way e-mail communication device, and others.

[0017] The exemplary mobile device 10 comprises a microprocessor 12, a communication subsystem 14, input/output (“I/O”) devices 16, an industry standard interface 18 which in this example is a USB port, and a power subsystem 20. The microprocessor 12 controls the overall operation of the mobile device 10. The communication subsystem 14 provides the mobile device 10 with the ability to communicate wirelessly with external devices such as other mobile devices and other computers. The I/O devices 16 provide the mobile device 10 with input/output capabilities for use with a device user. The USB port 18 provides the mobile device 10 with a serial port for linking directly with other computers and/or a means for receiving power from an external power source. The power subsystem 20 provides the mobile device 10 with a local power source.

[0018] The exemplary communication subsystem 14 comprises components such as a receiver 22, a transmitter 24, antenna elements 26 and 28, local oscillators (LOs) 30, and a processing module such as a digital signal processor (DSP) 32. The particular design of the communication subsystem 14 and the components used therein can vary. It would be apparent to one of ordinary skill in the art to design an appropriate

Clean Version - Substitute Specification

communication subsystem using conventional methods and components to operate over a communication network 34 based on the parameters necessary to operate over that communication network. For example, a mobile device 10 geographically located in North America may include a communication subsystem 14 designed to operate within the Mobitex™ mobile communication system or DataTAC™ mobile communication system, whereas a mobile device 10 intended for use in Europe may incorporate a General Packet Radio Service (GPRS) communication subsystem 14.

[0019] Network access requirements will also vary depending upon the type of network 34. For example, in the Mobitex and DataTAC networks, mobile devices 10 are registered on the network using a unique personal identification number or PIN associated with each device. In GPRS networks however, network access is associated with a subscriber or user of a mobile device 10. A GPRS device therefore requires a subscriber identity module (not shown), commonly referred to as a SIM card, in order to operate on a GPRS network. Without a SIM card, a GPRS device will not be fully functional. Local or non-network communication functions (if any) may be operable, but the mobile device 10 will be unable to carry out any functions involving communications over the network 34.

[0020] When required, after the network registration or activation procedures have been completed, a mobile device 10 may send and receive communication signals over the network 34. Signals received by the receiver antenna 26 through a communication network 34 are input to the receiver 22, which may perform such common receiver functions as signal amplification, frequency down conversion, filtering, channel selection

Clean Version - Substitute Specification

and the like, and in the exemplary system shown in Fig. 1, analog to digital conversion. Analog to digital conversion of a received signal allows more complex communication functions such as demodulation and decoding to be performed in a DSP 32. Similarly, signals to be transmitted are processed, including modulation and encoding for example, by the DSP 32 and input to the transmitter 24 for digital to analog conversion, frequency up conversion, filtering, amplification and transmission over the communication network 34 via the transmitter antenna 28.

[0021] Also, in the exemplary communication subsystem 14, the DSP 32 processes communication signals and also provides for receiver and transmitter control. For example, the gains applied to communication signals in the receiver 22 and transmitter 24 may be adaptively controlled through automatic gain control algorithms implemented in the DSP 32.

[0022] In implementing its control function, the microprocessor 12 in the exemplary mobile device 10 executes an operating system. The operating system software used by the microprocessor 12 is preferably stored in a persistent store such as flash memory 36, or alternatively read only memory (ROM) or similar storage element. The microprocessor 12 may also enable the execution of specific device applications, which preferably are also stored in a persistent store. The operating system, specific device applications, or parts thereof, may also be temporarily loaded into a volatile store such as in RAM 38.

[0023] A predetermined set of applications which control basic device operations, including at least data and voice communication applications for example, will normally

Clean Version - Substitute Specification

be installed on the mobile device 10 during manufacture. One such application loaded on the mobile device 10 could be a personal information manager (PIM) application. The PIM application preferably is an application for organizing and managing user inputted data items such as e-mail, calendar events, voice mails, appointments, and task items. The PIM data items may be stored in the RAM 38 and/or the flash memory 36.

[0024] The PIM application preferably has the ability to send and receive data items, via the wireless network 34. The PIM data items are preferably seamlessly integrated, synchronized and updated, via the wireless network 34, with corresponding data items stored or associated with a host computer system (not shown) used by the device user. The synchronization of PIM data items is a process by which the PIM data items on the mobile device 10 and the PIM data items on the host computer system can be made to mirror each other.

[0025] There are several possible mechanisms for loading applications onto the mobile device 10. For example, applications may be loaded onto the mobile device 10 through the wireless network 34, an auxiliary I/O subsystem 40, the serial port 18, a short-range communications subsystem 42, such as an infrared ("IR") communication system, or any other suitable subsystem 44. When loading the applications onto the mobile device 10, the device user may install the applications in the RAM 38, the flash memory 36, or preferably a non-volatile store (not shown) such as ROM for execution by the microprocessor 12. The available application installation mechanisms can increase the utility of the mobile device 10 by providing the device user with a way of upgrading the

Clean Version - Substitute Specification

mobile device 10 with additional and/or enhanced on-device functions, communication-related functions, or both. For example, a secure communication application may be loaded onto the mobile device 10 that allows for electronic commerce functions or other financial transactions to be performed using the mobile device 10.

[0026] The I/O devices 16 may be used to display and/or compose data communication messages. In one mode of operation, a signal received by the mobile device 10, such as a text message or web page download, will be received and processed by the communication subsystem 14, forwarded to the microprocessor 12, which will preferably further process the received signal, and provide the processed signal to one or more of the I/O devices 16 such as a display 46. Alternatively, a received signal such as a voice signal can be provided to a speaker 48, or alternatively to an auxiliary I/O device 40. In another mode of operation a device user may compose a data item such as an e-mail message using a keyboard 50 in cooperation with the display 46 and possibly an auxiliary I/O device 40. Alternatively, a device user may compose a voice message via a microphone 52. The composed data item may then be transmitted over a communication network 34 using the communication subsystem 14.

[0027] A short-range communications subsystem 42 may be provided in the mobile device 10 to allow the mobile device 10 to communicate with other systems or devices, which need not necessarily be similar to device 10. For example, the short-range communications subsystem 42 may include an infrared device and associated circuitry and components or a Bluetooth™ communication module to allow the device 10 to communicate with similarly-enabled systems and devices.

Clean Version - Substitute Specification

[0028] The USB port 18 provides the mobile device 10 with a serial port for linking directly with other computers to exchange data and/or to receive power. The USB port 18 also provides the mobile device 10 with a means for receiving power from an external power source. For example, in a personal digital assistant (PDA)-type communication device, the USB port 18 could be used to allow the mobile device 10 to synchronize data with a user's desktop computer (not shown). The USB port 18 could also enable a user to set parameters in the mobile device 10 such as preferences through the use of an external device or software application. In addition the USB port 18 may also be used to provide a means for downloading information or software to the mobile device 10 without using the wireless communication network 34. The USB port 18 can provide a direct and thus reliable and trusted connection that may for example be used to load an encryption key onto the mobile device 10 thereby enabling secure device communication.

[0029] Coupled to the USB port 18 is a USB connector 54. The USB connector 54 is the physical component that couples the USE port 18 to the outside world. In the exemplary mobile device 10, the USB connector 54 is used to transmit and receive data from an external data/power source 56, receive power from the external data/power source 56, direct the transmitted/received data from/to the USB port 18, and direct the received power to the power subsystem 20.

[0030] The exemplary power subsystem 20 comprises a charging and power distribution subsystem 58 and a battery 60. The charging and power distribution subsystem 58 performs many functions. It may be used to transfer energy to the

Clean Version - Substitute Specification

battery 60 from the external data/power source 56 to charge the battery 60 and also to distribute power to the many power-requiring components within the mobile device 10. The charging subsystem 58 may be capable of determining the presence of a batter 60 and/or a power circuit coupled to the mobile device 10, such as an AC adapter, USB connection, or car adapter, which alternatively can act as power sources 56 to provide power for the mobile device 10 and to charge the battery 60. Additionally, the charging subsystem 58 may have the ability to determine if a power source 56 is coupled to the mobile device 10 and, in the absence of such a coupling, cause the mobile device 10 to be powered by the battery 60.

[0031] The power distributed by the charging and power distribution subsystem 58 may be derived from energy stored in the battery 60 and/or energy received from the external data/power source 56. When the battery 60 is depleted, the charging and power distribution subsystem 58 transfers energy from the power source 56 to recharge the battery 60. Optionally, the charging and power distribution subsystem 58 may also transfer energy from the power source 56 to other components in the mobile device 10 to power the mobile device 10 when the battery 60 has been depleted and is recharging. When the data/power source 56 is not connected to the mobile device 10, power for the device 10 is derived from the battery 60.

Exemplary USB Adapter

[0032] Fig. 2 is a schematic diagram of a first embodiment of an adapter 100 that can be used to couple the mobile device 10 of fig. 1 to the data/power source 56 of fig. 1. In

Clean Version - Substitute Specification

this example the adapter 100 is a USB adapter 100 that comprises a primary USB connector 102, a power converter 104, a plug unit 106, and an identification subsystem 108. The power converter is a known element in the art and typically includes at least one of the following components: switching converter, transformer, DC source, voltage regulator, linear regulator and rectifier. In the embodiment shown in fig. 2, the USB adapter 100 is shown coupling a mobile device 10 to one of one or more types of power sockets 110N, 110D, 110B, and 110. Also shown in fig. 2 is an optional auxiliary USB connector 112 that can be used to couple the mobile device 10 to a data source (not shown) such as a personal computer.

[0033] In the embodiment shown in fig. 2, the primary USB connector 102 is configured to mate with the USB connector 54 of the mobile device 10. The USB adapter 100 is operable to provide power to the mobile device 10 through the Vbus and Gnd power pins in the USB connectors 54 and 102. The USB adapter 100 also optionally provides a communication path for data across the D+ and D- data pins in the USB connectors 54 and 102.

[0034] The plug unit 106 is preferably a conventional plug unit that can be used to couple with a conventional power socket to receive power therefrom. For example, the plug unit 106 can be a two-prong or three-prong plug of the type used in North America that can couple to a North American AC power socket 110N that provides 115 VAC. In the embodiment shown in figure 2, the plug unit 106 can accept one or more types of plug adapters 114N, 114B, 114D, and 114 that are configured to couple to the plug unit 106 and are further configured to directly mate with one or more types of power sockets

Clean Version - Substitute Specification

110N, 110D, 110B, and 110. The plug unit 106 can be configured to receive energy from a power socket 110N, 110D, 110B, or 110, either directly or through the use of a plug adapter, and is operative to transfer the received energy to the power converter 104.

[0035] The power converter 104 is operative to receive energy from a power socket 110N, 110D, 110B, or 110 and to convert that received energy to a form that can be used by the mobile device 10. For example, the power converter 104 can be of conventional construction such as a switching power converter that converts 115 VAC to 5 VDC. Also, the power converter 104 could comprise a D.C. regulator circuit that converts a D.C. input to a D.C. output. The power converter 104 could also be adapted to accept a wide range of input energy levels and frequencies. Alternatively, the power converter 104 could be adapted to accept a limited range of input energy levels and frequencies, wherein the plug adapters are operable to convert the possible input energy levels and frequencies to a range that the power converter 104 can accommodate. The power converter 104 provides its energy output to the mobile device 10 via the Vbus and Gnd pins of the primary USB connector 102.

[0036] Through the use of a variety of different types of plug adapters, the USB adapter 100 can be adapted to receive energy from various types of power sockets 110N, 110D, 110B, or 110. For example, using the appropriate plug adapter 114, 114B, 114D, and 114N, the USB adapter 100 can receive energy from a power socket such as a 115 VAC North American power socket 110N, or a 12 VDC automobile power socket, or an air power socket, or others.

Clean Version - Substitute Specification

[0037] For example, in North America, a type “N” power socket is commonly available. The plug adapter 114N can be releasably attached to the plug unit 106 thereby allowing any North American power socket 114N to be used as a power source. When traveling to a locale which does not have the North American power socket 114N, an alternate plug adapter such as adapters 114, 114B, or 114D may be selected by the user, according to the power socket 110D, 110B, or 110 available at the locale. The plug adapter 114, 114B, or 114D may then be releasably attached to plug unit 106 in place of the plug adapter 114N, thereby allowing the USB power adapter 100 to connect to a local power supply via the local power socket. Various other plug adapters are envisioned that can be configured to operate with alternate power sources such as for instance car sockets.

[0038] The power distribution and charging subsystem 58 of the mobile device 10 can selectively use the power provided on the Vbus and Gnd lines of the USB connector 54 to provide power to the mobile device 10, charge the battery 60, or both. A more detailed discussion of how the charging function of mobile device 10 can be implemented is described in United States Provisional Application No. 60/273021 filed on March 1st, 2001 and entitled “System and Method for Adapting a USB to Provide Power for Charging a Mobile Device” which has been incorporated herein by reference.

[0039] Typically when a mobile device 10 receives power over the USB from a USB host, it is required to draw power in accordance with the USB specification. The USB specification specifies a process for transferring energy across the USB called enumeration and limits the electrical current that can flow across the USB.

Clean Version - Substitute Specification

[0040] The USB adapter 100 contributes to a system wherein a device 10 that follows the USB specification when coupled to a typical USB host via its USB port can be informed that the USB adapter 100 has been coupled to the device 10 and that the device 10 can now draw power without regard to the USB specification and the USB specification imposed limits.

[0041] The identification subsystem 108 provides an identification signal to the mobile device 10 that the power source is not a USB limited source. The identification signal could be the communication of a single voltage on one or more of the USB data lines, different voltages on the two data lines, a series of pulses or voltage level changes, or other types of electrical signals. The identification subsystem 108 that generates the identification signal could have multiple types of configurations. In one embodiment, the identification subsystem 108 comprises a hard-wired connection of a single voltage level to both data lines. In another embodiment, the identification subsystem 108 comprises a USB controller that is operable to communicate an identification signal to the mobile device 10. Additional embodiments are contemplated. The identification subsystem 108 may optionally be configured to have the capability of electrically connecting or disconnecting the power output from the power converter 104 from the USB connector 102 and/or to connect or disconnect any data inputs from the USB adapter 100 to the USB connector 102.

[0042] In addition to providing power to the mobile device 10 over the primary USB connector 102, the USB adapter 100 may optionally be equipped with an auxiliary USB connector 112 that allows the USB adapter 100 to create a communication path

Clean Version - Substitute Specification

between the mobile device 10 and some other device capable of communicating over the USB such as a personal computer, another mobile device or some other type of device.

[0043] The USB adapter 100 preferably provides a communication path between the D+ and D- pins of the Primary USB connector 102 and the D+ and D- pins of the auxiliary USB connector 112. In the embodiment shown, the communication path also traverses the identification subsystem 108. Alternatively, the communication path could bypass the identification subsystem 108. The USB adapter 100 can thus act as a pass-through device for communication between a USB hub or host and a mobile device 10.

[0044] Optionally, the USB adapter 100 could also transfer energy from the power converter 104 to the auxiliary USB connector 112 thereby providing a device coupled to the auxiliary USB connector 112 with power. In this arrangement, the identification subsystem 108 could also provide an identification signal to the device coupled to the auxiliary USB connector 112 to inform that device that the power source is not a USB limited source.

Exemplary Illustration Of The Use of A USB Adapter With A Mobile Device

[0045] When a USB adapter 100 is connected to a mobile device 10, the identification subsystem 108 of the USB adapter 100 preferably provides an identification signal to the mobile device 10 to notify the mobile device 10 that the device 10 is connected to a power source that is not subject to the power limits imposed by the USB specification. Preferably, the mobile device 10 is programmed to recognize the identification signal

Clean Version - Substitute Specification

and therefore recognizes that an identification signal has been transmitted by the USB adapter 100. After recognizing a valid identification signal, the mobile device 10 draws power through the USB adapter 100 without waiting for enumeration or charge negotiation.

[0046] The detection of the identification signal may be accomplished using a variety of methods. For example, the microprocessor 12 may detect the identification signal by detecting the presence of an abnormal data line condition at the USB port 18. The detection may also be accomplished through the use of other device subsystems 44 in the mobile device 10. The preferred identification signal results from the application of voltage signals greater than 2 volts to both the D+ and D- lines in the USB connector 54. The preferred method of identification is described below in greater detail with reference to Fig. 3.

[0047] At step 210, the mobile device 10 detects the presence of a voltage on the Vbus line of the USB connector 54 via the USB port 18. At step 220, the mobile device checks the state of the D+ and D- lines of USB connector 54. In the example shown in the drawings, the D+ and D- lines are compared to a 2V reference. Also, in this example, the identification subsystem 108 of the USB adapter 100 may have applied a logic high signal, such as +5V reference, to both the D+ and D- lines to identify the attached device as a USB adapter 100. If the voltages on both the D+ and D- lines of the USB connector are greater than 2 Volts (step 220), then the mobile device 10 determines that the device connected to the USB connector 54 is not a typical USB host or hub and that a USB adapter 100 has been detected (step 230). The mobile device

Clean Version - Substitute Specification

10 can then charge the battery or otherwise use power provided via the Vbus and Gnd line in the USB connector 54 (step 260) without waiting for enumeration.

[0048] If, however, after the mobile device 10 detects the presence of a voltage on the Vbus line of the USB connector 54 and determines that the voltages on both the D+ and D- lines of the USB connector 54 are not greater than 2 Volts (step 220), then the mobile device 10 determines that a USB host or hub has been detected (step 240). A typical USB host or hub weakly holds its D+ and D- lines at zero volts when it is not connected to another device. The mobile device 10 can then signal the USB host or hub to initiate the enumeration process (step 250) and can charge the battery or otherwise use power provided via the Vbus and Gnd lines in the USB connector 54 (step 260) in accordance with the power limits imposed by the USB specification. The enumeration process is typically initiated after the mobile device 10 applies approximately zero volts to the D-line and approximately 5 volts to the D+ line to inform the host of the mobile device's 10 presence and communication speed.

[0049] Therefore, when a USB adapter 100 is coupled to the mobile device 10 and has been identified as a USB adapter 100, the mobile device 10 can forego the enumeration process and charge negotiation process and immediately draw energy from the USB power adapter 100 at a desired rate, for instance at 5 unit loads, i.e. 500mA. While the mobile device 10 charges its battery using the USB adapter 100, the mobile device 10 can disable its typical USB functions. If, however, the mobile device 10 detects that a USB host or hub is coupled to the mobile device 10, the mobile device 10 can apply a

Clean Version - Substitute Specification

voltage to the D+ line to indicate to the USB host or hub that the mobile device 10 is coupled thereto and await enumeration and USB charge negotiation.

[0050] If the USB adapter 100 is coupled to the mobile device 10, and the mobile device 10 does not identify the USB adapter 100 through communications with the identification module 108, the mobile device 10 may stop drawing energy from the Vbus and Gnd lines of the USB connector 54. This may occur, for example, if the mobile device 10 is not programmed to identify the USB adapter 100. The mobile device 10 may mistakenly identify the USB adapter 100 as a typical USB host or hub and await enumeration before drawing substantial energy. To guard against this, the USB adapter 100 can optionally be adapted to function with mobile devices that are not programmed to recognize the USB adapter 100.

[0051] In that scenario, the USB adapter 100 can be adapted to provide energy to a mobile device by using the knowledge that the mobile device will draw energy from a connected device for a period of time before it stops drawing energy due to lack of enumeration. The USB adapter 100 can optionally provide power for charging a battery 60 in a mobile device by periodically switching the voltages on the Vbus and Gnd lines between on and off states. When the USB adapter 100 is coupled to the mobile device, the identification subsystem 108 can apply an on-voltage (5 V for example) between the Vbus and Gnd lines. The mobile device will draw energy while awaiting enumeration. After a period of time, the identification subsystem 108 can apply an off-voltage (0 volts) between the Vbus and Gnd lines thereby fooling the mobile device into determining that the unidentified USB device has been disconnected from the mobile device. The

Clean Version - Substitute Specification

identification subsystem 108 can then reapply an on-voltage between the Vbus and Gnd lines. The mobile device will draw energy again while awaiting enumeration. This cycle can be repeated to periodically apply energy to the mobile device, for example, to recharge the battery 60 of the mobile device.

Additional Exemplary Embodiments of USB Adapters

[0052] Shown in Fig. 4 is a schematic diagram of an additional exemplary embodiment of a USB adapter 300 that is coupled to a mobile device 10. The exemplary USB adapter 300 comprises a USB connector 302, a power converter 304, a plug unit 306, and an identification subsystem 308. The USB connector 302, plug unit 306, and identification subsystem 308 preferably correspond to the USB connector 102, plug unit 106, and identification subsystem 108 which were described earlier with respect to the first embodiment. Similar to the first embodiment, the additional embodiment may optionally be equipped with various plug adapters 314N, 314D, 314B, and 314 that preferably are releasably attachable to plug unit 306 so that the appropriate plug adapter 314N, 314D, 314B, or 314 can be selected by a user to allow the USB adapter 300 to couple to and receive energy from an available power socket 310N, 310D, 310B, or 310. The exemplary USB power converter 300 further comprises a charging subsystem 316 and battery receptacle 318 for coupling the USB adapter 300 to an external battery 320 that may be optionally coupled thereto.

[0053] The battery receptacle 318 provides a location for releasably coupling an external battery 320 thereto so that the external battery can be charged via the USB

Clean Version - Substitute Specification

adapter 300. This provides the USB adapter 300 with a mechanism for charging, for example, a mobile device's primary or spare battery when the battery has been separated from or is not coupled to the mobile device 10.

[0054] To accommodate this functionality, the power converter 304 is capable of providing the proper voltage levels for the USB connector 302 and also capable of providing necessary voltage and current levels to drive a battery charging subsystem 316. The power converter 304 is preferably a dual power converter that may be constructed using conventional or non-conventional architectures. With respect to the portion of the power converter 304 that provides energy to the USB connector 302, that portion is preferably similar in construction and function to the power converter 104 of the first embodiment.

[0055] Preferably, the charging subsystem 316 performs in a substantially similar manner to charging subsystem 58 of the mobile device 10. But, for efficiency and simplicity of design, certain aspects of the dual power converter 304 and the charging subsystem 316 may be combined, as both are local to the USB adapter 300.

[0056] Other alternative embodiments of the USB adapter may include various combinations of components described above with respect to the first and additional embodiments. Another embodiment of the USB adapter may include a second or more auxiliary USB connectors. A USB adapter having one or more auxiliary USB connectors may optionally be configured such that one or more of the auxiliary USB connectors may have power from the USB adapter's power converter made available to it so that multiple USB devices may draw power simultaneously. Preferably, a USB

Clean Version - Substitute Specification

adapter having multiple auxiliary USB connectors will be configured such that the data lines in the auxiliary connectors can, on a selective basis, be electrically connected to or disconnected from the data lines in the primary USB connector. This allows a mobile device connected to the primary USB connector to receive energy from the adapter regardless of whether a USB host or hub is connected to an auxiliary USB connector. It is also contemplated that a USB adapter may be embodied in a USB host or hub.

Conclusion

[0057] The embodiments described herein are examples of structures, systems or methods having elements corresponding to the elements of the invention recited in the claims. This written description may enable those skilled in the art to make and use embodiments having alternative elements that likewise correspond to the elements of the invention recited in the claims. The intended scope of the invention thus includes other structures, systems or methods that do not differ from the literal language of the claims, and further includes other structures, systems or methods with insubstantial differences from the literal language of the claims. Although the embodiments have been described with reference to the USB interface, it is contemplated that the invention could be applicable to devices and systems that use other standard interfaces such as the IEEE 1394 interface.

Clean Version - Substitute Specification

ABSTRACT OF THE DISCLOSURE

An adapter for providing a source of power to a mobile device through an industry standard port is provided. In accordance with one aspect of the invention, the adapter comprises a plug unit, a power converter, a primary connector, and an identification subsystem. The plug unit is operative to couple the adapter to a power socket and operative to receive energy from the power socket. The power converter is electrically coupled to the plug unit and is operable to regulate the received energy from the power socket and to output a power requirement to the mobile device. The primary connector is electrically coupled to the power converter and is operative to couple to the mobile device and to deliver the outputted power requirement to the mobile device. The identification subsystem is electrically coupled to the primary connector and is operative to provide an identification signal.

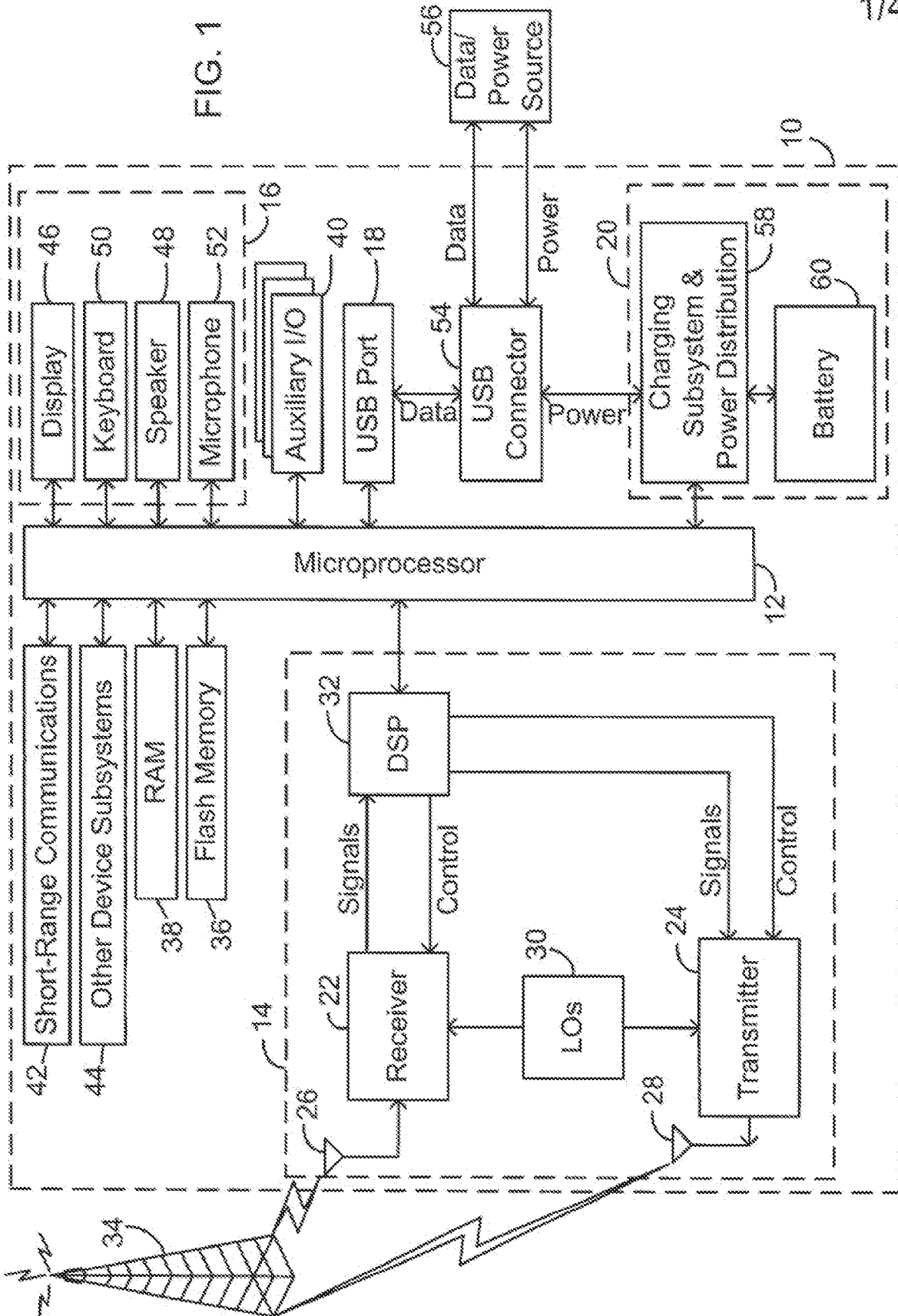

REPLACEMENT
DRAWING

2/4

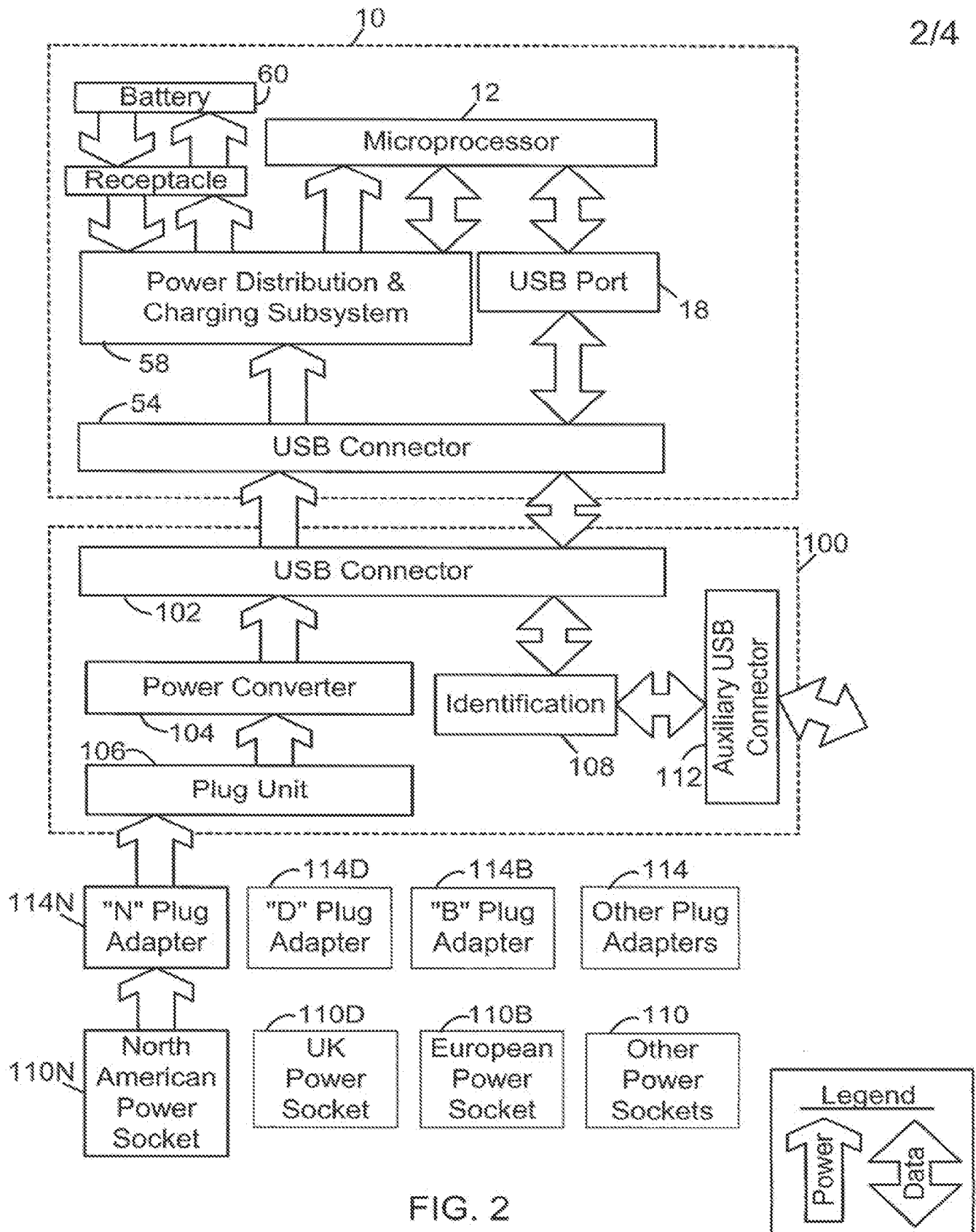

FIG. 2

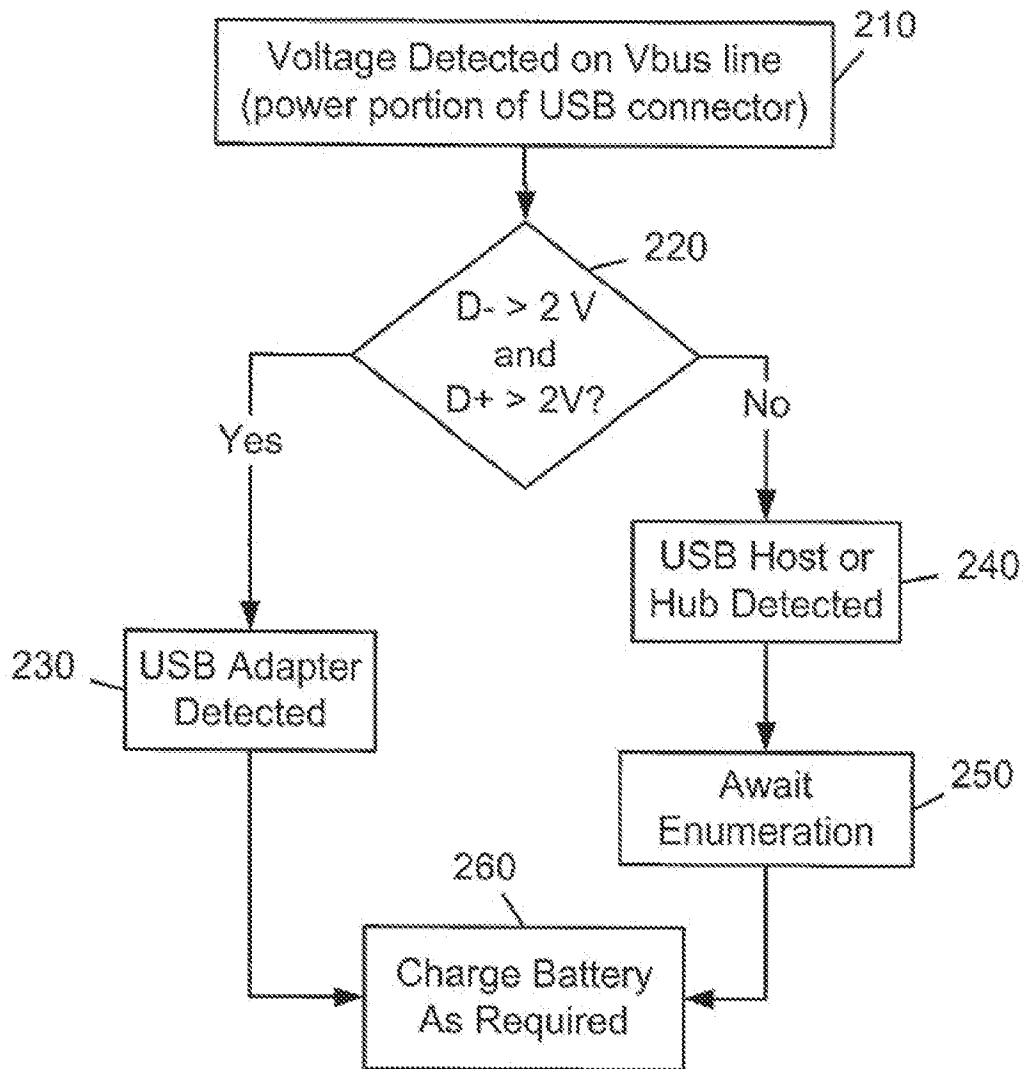

FIG. 3

REPLACEMENT
DRAWING

4/4

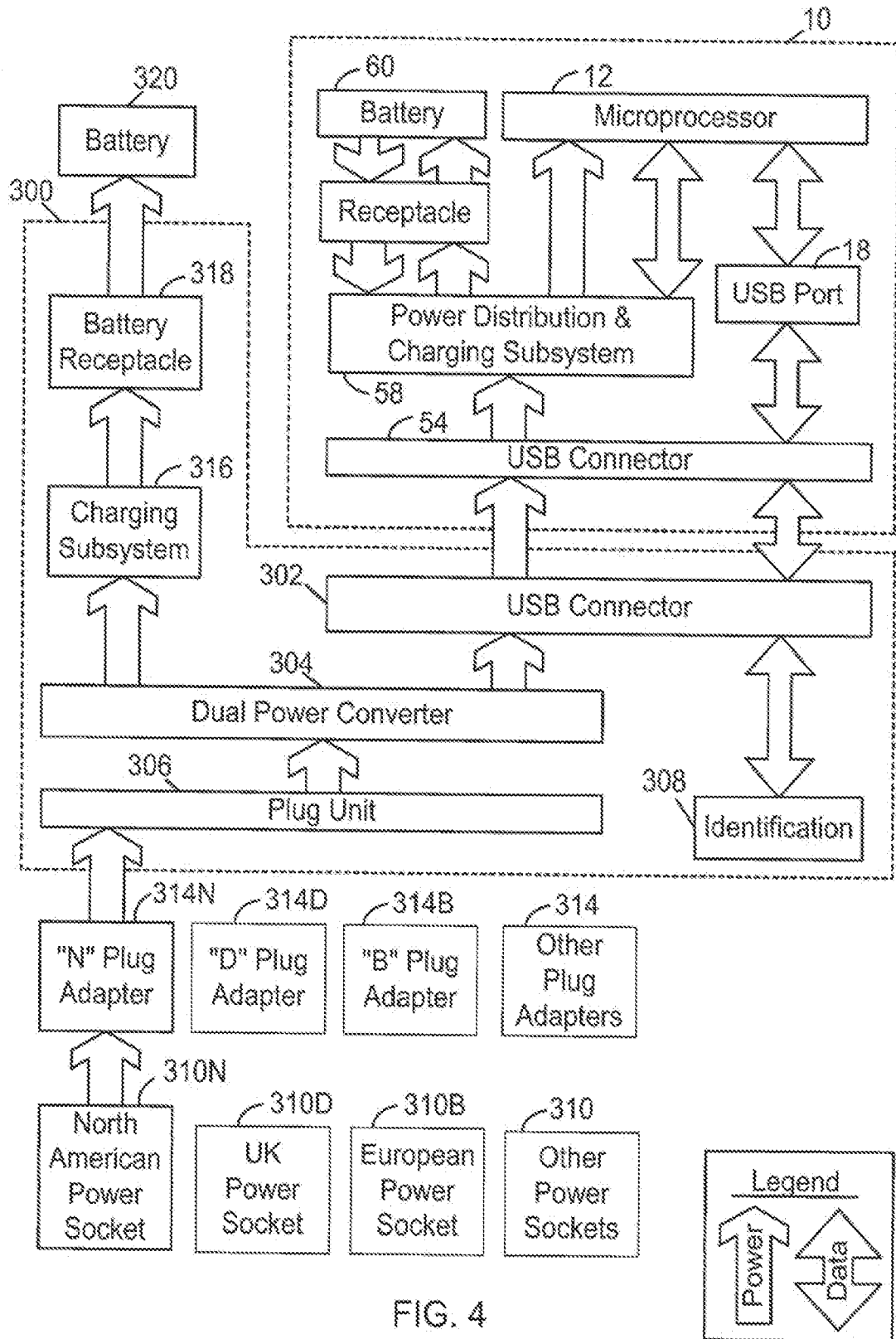

FIG. 4

Electronic Acknowledgement Receipt

EFS ID:	13465860
Application Number:	13536767
International Application Number:	
Confirmation Number:	5104
Title of Invention:	MULTIFUNCTIONAL CHARGER SYSTEM AND METHOD
First Named Inventor/Applicant Name:	Daniel M. FISCHER
Customer Number:	93377
Filer:	YI YU/Dianna Williams
Filer Authorized By:	YI YU
Attorney Docket Number:	11298.0188-08000
Receipt Date:	10-AUG-2012
Filing Date:	28-JUN-2012
Time Stamp:	11:00:29
Application Type:	Utility under 35 USC 111(a)

Payment information:

Submitted with Payment	no
------------------------	----

File Listing:

Document Number	Document Description	File Name	File Size(Bytes)/ Message Digest	Multi Part /.zip	Pages (if appl.)
1	Applicant Response to Pre-Exam Formalities Notice	response.pdf	57983 <small>0794048e93e81c3c43658d0212d1120a9a16a4cc</small>	no	2

Warnings:

Information:

Petitioners Ex. 1002

IPR USP 8,624,550

2	Specification	markedupspec.pdf	98752	no	25
			c3fab7a2ae48d30f916c187151563704172016e3		
Warnings:					
Information:					
3	Specification	cleanversubspec.pdf	97729	no	25
			6b078dabe7dd5e49f3ece7d57300e149ff873fd1		
Warnings:					
Information:					
4	Drawings-only black and white line drawings	replacementdrawings.pdf	868779	no	4
			a5213fe69a303c408c6a427bdae0ccad2620f00c		
Warnings:					
Information:					
Total Files Size (in bytes):				1123243	

This Acknowledgement Receipt evidences receipt on the noted date by the USPTO of the indicated documents, characterized by the applicant, and including page counts, where applicable. It serves as evidence of receipt similar to a Post Card, as described in MPEP 503.

New Applications Under 35 U.S.C. 111

If a new application is being filed and the application includes the necessary components for a filing date (see 37 CFR 1.53(b)-(d) and MPEP 506), a Filing Receipt (37 CFR 1.54) will be issued in due course and the date shown on this Acknowledgement Receipt will establish the filing date of the application.

National Stage of an International Application under 35 U.S.C. 371

If a timely submission to enter the national stage of an international application is compliant with the conditions of 35 U.S.C. 371 and other applicable requirements a Form PCT/DO/EO/903 indicating acceptance of the application as a national stage submission under 35 U.S.C. 371 will be issued in addition to the Filing Receipt, in due course.

New International Application Filed with the USPTO as a Receiving Office

If a new international application is being filed and the international application includes the necessary components for an international filing date (see PCT Article 11 and MPEP 1810), a Notification of the International Application Number and of the International Filing Date (Form PCT/RO/105) will be issued in due course, subject to prescriptions concerning national security, and the date shown on this Acknowledgement Receipt will establish the international filing date of the application.



UNITED STATES PATENT AND TRADEMARK OFFICE

UNITED STATES DEPARTMENT OF COMMERCE
United States Patent and Trademark Office
Address: COMMISSIONER FOR PATENTS
P.O. Box 1450
Alexandria, Virginia 22313-1450
www.uspto.gov

Table with 7 columns: APPLICATION NUMBER, FILING or 371(c) DATE, GRP ART UNIT, FIL FEE REC'D, ATTY.DOCKET.NO, TOT CLAIMS, IND CLAIMS. Row 1: 13/536,767, 06/28/2012, 2859, 1250, 11298.0188-08000, 18, 2

CONFIRMATION NO. 5104

UPDATED FILING RECEIPT

93377
RIM/FINNEGAN
901 New York Avenue NW
Washington, DC 20001



Date Mailed: 08/17/2012

Receipt is acknowledged of this non-provisional patent application. The application will be taken up for examination in due course. Applicant will be notified as to the results of the examination. Any correspondence concerning the application must include the following identification information: the U.S. APPLICATION NUMBER, FILING DATE, NAME OF APPLICANT, and TITLE OF INVENTION. Fees transmitted by check or draft are subject to collection. Please verify the accuracy of the data presented on this receipt. If an error is noted on this Filing Receipt, please submit a written request for a Filing Receipt Correction. Please provide a copy of this Filing Receipt with the changes noted thereon. If you received a "Notice to File Missing Parts" for this application, please submit any corrections to this Filing Receipt with your reply to the Notice. When the USPTO processes the reply to the Notice, the USPTO will generate another Filing Receipt incorporating the requested corrections

Applicant(s)

Daniel M. FISCHER, Waterloo, CANADA;
Dan G. Radut, Waterloo, CANADA;
Michael F. Habicher, Toronto, CANADA;
Quang A. Luong, Missisauga, CANADA;
Jonathan T. Malton, Kitchener, CANADA;

Assignment For Published Patent Application

Research In Motion Limited, Waterloo, CANADA

Power of Attorney: The patent practitioners associated with Customer Number 93377

Domestic Priority data as claimed by applicant

This application is a CON of 13/175,509 07/01/2011 PAT 8232766
which is a CON of 12/905,934 10/15/2010 PAT 7986127
which is a CON of 12/714,204 02/26/2010 PAT 7834586
which is a CON of 12/268,297 11/10/2008 PAT 7737657
which is a CON of 11/749,680 05/16/2007 PAT 7453233
which is a CON of 11/175,885 07/06/2005 PAT 7239111
which is a CON of 10/087,629 03/01/2002 PAT 6936936
which claims benefit of 60/273,021 03/01/2001
and claims benefit of 60/330,486 10/23/2001

Foreign Applications (You may be eligible to benefit from the Patent Prosecution Highway program at the USPTO. Please see http://www.uspto.gov for more information.)

If Required, Foreign Filing License Granted: 07/18/2012

The country code and number of your priority application, to be used for filing abroad under the Paris Convention, is **US 13/536,767**

Projected Publication Date: 11/22/2012

Non-Publication Request: No

Early Publication Request: No

Title

MULTIFUNCTIONAL CHARGER SYSTEM AND METHOD

Preliminary Class

320

PROTECTING YOUR INVENTION OUTSIDE THE UNITED STATES

Since the rights granted by a U.S. patent extend only throughout the territory of the United States and have no effect in a foreign country, an inventor who wishes patent protection in another country must apply for a patent in a specific country or in regional patent offices. Applicants may wish to consider the filing of an international application under the Patent Cooperation Treaty (PCT). An international (PCT) application generally has the same effect as a regular national patent application in each PCT-member country. The PCT process **simplifies** the filing of patent applications on the same invention in member countries, but **does not result** in a grant of "an international patent" and does not eliminate the need of applicants to file additional documents and fees in countries where patent protection is desired.

Almost every country has its own patent law, and a person desiring a patent in a particular country must make an application for patent in that country in accordance with its particular laws. Since the laws of many countries differ in various respects from the patent law of the United States, applicants are advised to seek guidance from specific foreign countries to ensure that patent rights are not lost prematurely.

Applicants also are advised that in the case of inventions made in the United States, the Director of the USPTO must issue a license before applicants can apply for a patent in a foreign country. The filing of a U.S. patent application serves as a request for a foreign filing license. The application's filing receipt contains further information and guidance as to the status of applicant's license for foreign filing.

Applicants may wish to consult the USPTO booklet, "General Information Concerning Patents" (specifically, the section entitled "Treaties and Foreign Patents") for more information on timeframes and deadlines for filing foreign patent applications. The guide is available either by contacting the USPTO Contact Center at 800-786-9199, or it can be viewed on the USPTO website at <http://www.uspto.gov/web/offices/pac/doc/general/index.html>.

For information on preventing theft of your intellectual property (patents, trademarks and copyrights), you may wish to consult the U.S. Government website, <http://www.stopfakes.gov>. Part of a Department of Commerce initiative, this website includes self-help "toolkits" giving innovators guidance on how to protect intellectual property in specific countries such as China, Korea and Mexico. For questions regarding patent enforcement issues, applicants may call the U.S. Government hotline at 1-866-999-HALT (1-866-999-4158).

LICENSE FOR FOREIGN FILING UNDER
Title 35, United States Code, Section 184
Title 37, Code of Federal Regulations, 5.11 & 5.15

GRANTED

The applicant has been granted a license under 35 U.S.C. 184, if the phrase "IF REQUIRED, FOREIGN FILING LICENSE GRANTED" followed by a date appears on this form. Such licenses are issued in all applications where the conditions for issuance of a license have been met, regardless of whether or not a license may be required as set forth in 37 CFR 5.15. The scope and limitations of this license are set forth in 37 CFR 5.15(a) unless an earlier license has been issued under 37 CFR 5.15(b). The license is subject to revocation upon written notification. The date indicated is the effective date of the license, unless an earlier license of similar scope has been granted under 37 CFR 5.13 or 5.14.

This license is to be retained by the licensee and may be used at any time on or after the effective date thereof unless it is revoked. This license is automatically transferred to any related applications(s) filed under 37 CFR 1.53(d). This license is not retroactive.

The grant of a license does not in any way lessen the responsibility of a licensee for the security of the subject matter as imposed by any Government contract or the provisions of existing laws relating to espionage and the national security or the export of technical data. Licensees should apprise themselves of current regulations especially with respect to certain countries, of other agencies, particularly the Office of Defense Trade Controls, Department of State (with respect to Arms, Munitions and Implements of War (22 CFR 121-128)); the Bureau of Industry and Security, Department of Commerce (15 CFR parts 730-774); the Office of Foreign Assets Control, Department of Treasury (31 CFR Parts 500+) and the Department of Energy.

NOT GRANTED

No license under 35 U.S.C. 184 has been granted at this time, if the phrase "IF REQUIRED, FOREIGN FILING LICENSE GRANTED" DOES NOT appear on this form. Applicant may still petition for a license under 37 CFR 5.12, if a license is desired before the expiration of 6 months from the filing date of the application. If 6 months has lapsed from the filing date of this application and the licensee has not received any indication of a secrecy order under 35 U.S.C. 181, the licensee may foreign file the application pursuant to 37 CFR 5.15(b).

SelectUSA

The United States represents the largest, most dynamic marketplace in the world and is an unparalleled location for business investment, innovation and commercialization of new technologies. The USA offers tremendous resources and advantages for those who invest and manufacture goods here. Through SelectUSA, our nation works to encourage, facilitate, and accelerate business investment. To learn more about why the USA is the best country in the world to develop technology, manufacture products, and grow your business, visit SelectUSA.gov.

PATENT APPLICATION FEE DETERMINATION RECORD

Substitute for Form PTO-875

Application or Docket Number
13/536,767

APPLICATION AS FILED - PART I

(Column 1) (Column 2)

FOR	NUMBER FILED	NUMBER EXTRA
BASIC FEE (37 CFR 1.16(a), (b), or (c))	N/A	N/A
SEARCH FEE (37 CFR 1.16(k), (l), or (m))	N/A	N/A
EXAMINATION FEE (37 CFR 1.16(o), (p), or (q))	N/A	N/A
TOTAL CLAIMS (37 CFR 1.16(j))	18	minus 20 = *
INDEPENDENT CLAIMS (37 CFR 1.16(h))	2	minus 3 = *
APPLICATION SIZE FEE (37 CFR 1.16(s))	If the specification and drawings exceed 100 sheets of paper, the application size fee due is \$310 (\$155 for small entity) for each additional 50 sheets or fraction thereof. See 35 U.S.C. 41(a)(1)(G) and 37 CFR 1.16(s).	
MULTIPLE DEPENDENT CLAIM PRESENT (37 CFR 1.16(j))		

SMALL ENTITY

RATE(\$)	FEE(\$)
N/A	
N/A	
N/A	
TOTAL	

OR OTHER THAN SMALL ENTITY

RATE(\$)	FEE(\$)
N/A	380
N/A	620
N/A	250
x 60 =	0.00
x 250 =	0.00
	0.00
	0.00
TOTAL	1250

* If the difference in column 1 is less than zero, enter "0" in column 2.

APPLICATION AS AMENDED - PART II

(Column 1) (Column 2) (Column 3)

AMENDMENT A		CLAIMS REMAINING AFTER AMENDMENT		HIGHEST NUMBER PREVIOUSLY PAID FOR	PRESENT EXTRA
	Total (37 CFR 1.16(j))	*	Minus	**	=
	Independent (37 CFR 1.16(h))	*	Minus	***	=
	Application Size Fee (37 CFR 1.16(s))				
FIRST PRESENTATION OF MULTIPLE DEPENDENT CLAIM (37 CFR 1.16(j))					

SMALL ENTITY

RATE(\$)	ADDITIONAL FEE(\$)
x =	
x =	
TOTAL ADD'L FEE	

OR OTHER THAN SMALL ENTITY

RATE(\$)	ADDITIONAL FEE(\$)
x =	
x =	
TOTAL ADD'L FEE	

(Column 1) (Column 2) (Column 3)

AMENDMENT B		CLAIMS REMAINING AFTER AMENDMENT		HIGHEST NUMBER PREVIOUSLY PAID FOR	PRESENT EXTRA
	Total (37 CFR 1.16(j))	*	Minus	**	=
	Independent (37 CFR 1.16(h))	*	Minus	***	=
	Application Size Fee (37 CFR 1.16(s))				
FIRST PRESENTATION OF MULTIPLE DEPENDENT CLAIM (37 CFR 1.16(j))					

SMALL ENTITY

RATE(\$)	ADDITIONAL FEE(\$)
x =	
x =	
TOTAL ADD'L FEE	

OR OTHER THAN SMALL ENTITY

RATE(\$)	ADDITIONAL FEE(\$)
x =	
x =	
TOTAL ADD'L FEE	

* If the entry in column 1 is less than the entry in column 2, write "0" in column 3.

** If the "Highest Number Previously Paid For" IN THIS SPACE is less than 20, enter "20".

*** If the "Highest Number Previously Paid For" IN THIS SPACE is less than 3, enter "3".

The "Highest Number Previously Paid For" (Total or Independent) is the highest found in the appropriate box in column 1.



UNITED STATES PATENT AND TRADEMARK OFFICE

UNITED STATES DEPARTMENT OF COMMERCE
United States Patent and Trademark Office
Address: COMMISSIONER FOR PATENTS
P.O. Box 1450
Alexandria, Virginia 22313-1450
www.uspto.gov

Table with 4 columns: APPLICATION NUMBER (13/536,767), FILING OR 371(C) DATE (06/28/2012), FIRST NAMED APPLICANT (Daniel M. FISCHER), ATTY. DOCKET NO./TITLE (11298.0188-08000)

CONFIRMATION NO. 5104

PUBLICATION NOTICE

93377
RIM/FINNEGAN
901 New York Avenue NW
Washington, DC 20001



Title: MULTIFUNCTIONAL CHARGER SYSTEM AND METHOD

Publication No. US-2012-0293113-A1
Publication Date: 11/22/2012

NOTICE OF PUBLICATION OF APPLICATION

The above-identified application will be electronically published as a patent application publication pursuant to 37 CFR 1.211, et seq. The patent application publication number and publication date are set forth above.

The publication may be accessed through the USPTO's publically available Searchable Databases via the Internet at www.uspto.gov. The direct link to access the publication is currently http://www.uspto.gov/patft/.

The publication process established by the Office does not provide for mailing a copy of the publication to applicant. A copy of the publication may be obtained from the Office upon payment of the appropriate fee set forth in 37 CFR 1.19(a)(1). Orders for copies of patent application publications are handled by the USPTO's Office of Public Records. The Office of Public Records can be reached by telephone at (703) 308-9726 or (800) 972-6382, by facsimile at (703) 305-8759, by mail addressed to the United States Patent and Trademark Office, Office of Public Records, Alexandria, VA 22313-1450 or via the Internet.

In addition, information on the status of the application, including the mailing date of Office actions and the dates of receipt of correspondence filed in the Office, may also be accessed via the Internet through the Patent Electronic Business Center at www.uspto.gov using the public side of the Patent Application Information and Retrieval (PAIR) system. The direct link to access this status information is currently http://pair.uspto.gov/. Prior to publication, such status information is confidential and may only be obtained by applicant using the private side of PAIR.

Further assistance in electronically accessing the publication, or about PAIR, is available by calling the Patent Electronic Business Center at 1-866-217-9197.

Office of Data Management, Application Assistance Unit (571) 272-4000, or (571) 272-4200, or 1-888-786-0101



UNITED STATES PATENT AND TRADEMARK OFFICE

UNITED STATES DEPARTMENT OF COMMERCE
United States Patent and Trademark Office
Address: COMMISSIONER FOR PATENTS
P.O. Box 1450
Alexandria, Virginia 22313-1450
www.uspto.gov

Table with columns: APPLICATION NO., FILING DATE, FIRST NAMED INVENTOR, ATTORNEY DOCKET NO., CONFIRMATION NO., EXAMINER, ART UNIT, PAPER NUMBER, NOTIFICATION DATE, DELIVERY MODE. Includes application details for Daniel M. FISCHER and examiner TSO, EDWARD H.

Please find below and/or attached an Office communication concerning this application or proceeding.

The time period for reply, if any, is set in the attached communication.

Notice of the Office communication was sent electronically on above-indicated "Notification Date" to the following e-mail address(es):

- regional-desk@finnegan.com
janet.weems@finnegan.com
portfolioprossecution@blackberry.com

DETAILED ACTION

Information Disclosure Statement

The IDS filed 6/28/2012 has been considered and placed of record. An initialed copy is attached herewith.

Specification

The disclosure should be carefully reviewed to ensure that any and all grammatical, idiomatic, and spelling or other minor errors are corrected.

Double Patenting

The nonstatutory double patenting rejection is based on a judicially created doctrine grounded in public policy (a policy reflected in the statute) so as to prevent the unjustified or improper timewise extension of the “right to exclude” granted by a patent and to prevent possible harassment by multiple assignees. A nonstatutory obviousness-type double patenting rejection is appropriate where the conflicting claims are not identical, but at least one examined application claim is not patentably distinct from the reference claim(s) because the examined application claim is either anticipated by, or would have been obvious over, the reference claim(s). See, e.g., *In re Berg*, 140 F.3d 1428, 46 USPQ2d 1226 (Fed. Cir. 1998); *In re Goodman*, 11 F.3d 1046, 29 USPQ2d 2010 (Fed. Cir. 1993); *In re Longi*, 759 F.2d 887, 225 USPQ 645 (Fed. Cir. 1985); *In re Van Ornum*, 686 F.2d 937, 214 USPQ 761 (CCPA 1982); *In re Vogel*, 422

Art Unit: 2859

F.2d 438, 164 USPQ 619 (CCPA 1970); and *In re Thorington*, 418 F.2d 528, 163 USPQ 644 (CCPA 1969).

A timely filed terminal disclaimer in compliance with 37 CFR 1.321(c) or 1.321(d) may be used to overcome an actual or provisional rejection based on a nonstatutory double patenting ground provided the conflicting application or patent either is shown to be commonly owned with this application, or claims an invention made as a result of activities undertaken within the scope of a joint research agreement.

Effective January 1, 1994, a registered attorney or agent of record may sign a terminal disclaimer. A terminal disclaimer signed by the assignee must fully comply with 37 CFR 3.73(b).

Claims 11-28 are rejected on the ground of nonstatutory obviousness-type double patenting as being unpatentable over claims 1-12 of U.S. Patent No. 7,986,127. Although the conflicting claims are not identical, they are not patentably distinct from each other because the claims are broader in some respect and narrower in other respect. For example, Applicant additionally claims a USB VBUS line while patent claims 11 and 12 claim only a USB port. Having a VBUS line would have been obvious if one of ordinary skill in the art wants to use the line for a 5V power output. Alternatively, Applicant claims 'at least one condition' while the patent claims 11 and 12 only claim either one condition or any condition. The pending claim matter is broader and would have encompassed the claimed matter of patent claims 11 and 12.

The other pending claims are various combinations of patent claims.

Art Unit: 2859

Conclusion

Any inquiry concerning this communication should be directed to the Examiner at the below-listed number. The Examiner can normally be reached on Mon-Thu and Sat from 9:00am-5:00pm.

The Examiner's SPE is Drew Dunn and he can be reached at 571.272.2312. The fax number for the organization where this application is assigned is 571.273.8300.

Information regarding the status of an application may be obtained from the Patent Application Information Retrieval (PAIR) system. Status information for published applications may be obtained from either Private PAIR or Public PAIR. Status information for unpublished applications is available through Private PAIR only. For more information about the PAIR system, see <http://pair-direct.uspto.gov>. Should you have questions on access to the Private PAIR system, contact the Electronic Business Center (EBC) at 866.217.9197 (toll-free). If you would like assistance from a USPTO Customer Service Representative or access to the automated information system, call 800.786.9199 (IN USA OR CANADA) or 571.272.1000.

/Edward H Tso/

EDWARD H TSO
Primary Examiner, AU 2859
571.272.2087

Notice of References Cited	Application/Control No. 13/536,767	Applicant(s)/Patent Under Reexamination FISCHER ET AL.	
	Examiner EDWARD TSO	Art Unit 2859	Page 1 of 1

U.S. PATENT DOCUMENTS

*	Document Number Country Code-Number-Kind Code	Date MM-YYYY	Name	Classification
*	A US-7,986,127	07-2011	Fischer et al.	320/111
	B US-			
	C US-			
	D US-			
	E US-			
	F US-			
	G US-			
	H US-			
	I US-			
	J US-			
	K US-			
	L US-			
	M US-			

FOREIGN PATENT DOCUMENTS

*	Document Number Country Code-Number-Kind Code	Date MM-YYYY	Country	Name	Classification
	N				
	O				
	P				
	Q				
	R				
	S				
	T				

NON-PATENT DOCUMENTS

*	Document Number Country Code-Number-Kind Code	Date MM-YYYY	Country	Name	Classification
		Include as applicable: Author, Title Date, Publisher, Edition or Volume, Pertinent Pages)			
	U				
	V				
	W				
	X				

*A copy of this reference is not being furnished with this Office action. (See MPEP § 707.05(a).)
Dates in MM-YYYY format are publication dates. Classifications may be US or foreign.

PATENT
Customer No. 93377
Attorney Docket No. 11298.0188-08

IN THE UNITED STATES PATENT AND TRADEMARK OFFICE

In re Application of:)	
)	
Daniel M. FISCHER et al.)	Parent Group Art Unit: 2858
)	
Application No.: Unknown)	Parent Examiner: Edward H. Tso
(Continuation of Appln. No. 13/175,509))	
)	
Filed: June 28, 2012)	
)	Confirmation No.: Unknown
For: MULTIFUNCTIONAL CHARGER)	
SYSTEM AND METHOD)	

Commissioner for Patents
P.O. Box 1450
Alexandria, VA 22313-1450

Sir:

INFORMATION DISCLOSURE STATEMENT UNDER 37 C.F.R. § 1.97(b)

Pursuant to 37 C.F.R. §§ 1.56 and 1.97(b), Applicants bring to the attention of the Examiner the listed documents on the attached listing. This Information Disclosure Statement is being filed concurrently with the continuation application.

Copies of the listed documents are not attached since they were submitted in the parent case (Application No. 13/175,509).

Applicants respectfully request that the Examiner consider the listed documents and indicate that they were considered by making appropriate notations on the attached form.

This submission does not represent that a search has been made or that no better art exists and does not constitute an admission that each or all of the listed documents are material or constitute "prior art." If the Examiner applies any of the

Application No.: Unknown
Customer No. 93377
Attorney Docket No.: 11298.0188-08

documents as prior art against any claim in the application and Applicants determine that the cited documents do not constitute "prior art" under United States law, Applicants reserve the right to present to the U.S. Patent and Trademark Office the relevant facts and law regarding the appropriate status of such documents.

Applicants further reserve the right to take appropriate action to establish the patentability of the disclosed invention over the listed documents, should one or more of the documents be applied against the claims of the present application.

If there is any fee due in connection with the filing of this Statement, please charge the fee to Deposit Account No. 06-0916.

Respectfully submitted,

FINNEGAN, HENDERSON, FARABOW,
GARRETT & DUNNER, L.L.P.

Dated: June 28, 2012

By: /Yi Yu/
Yi Yu
Reg. No. 69,397
(571) 203-2700

Doc code: IDS

Doc description: Information Disclosure Statement (IDS) Filed

PTO/SB/08a (01-10)

Approved for use through 07/31/2012. OMB 0651-0031

U.S. Patent and Trademark Office; U.S. DEPARTMENT OF COMMERCE

Under the Paperwork Reduction Act of 1995, no persons are required to respond to a collection of information unless it contains a valid OMB control number.

INFORMATION DISCLOSURE STATEMENT BY APPLICANT (Not for submission under 37 CFR 1.99)	Application Number		Unknown
	Filing Date		June 28, 2012
	First Named Inventor	Daniel M. Fischer	
	Art Unit		Unknown
	Examiner Name	Unknown	
	Attorney Docket Number		11298.0188-08000

U.S. PATENTS						
Examiner Initial*	Cite No	Patent Number	Kind Code ¹	Issue Date	Name of Patentee or Applicant of cited Document	Pages, Columns, Lines where Relevant Passages or Relevant Figures Appear
	1	3775659		1973-11-27	Carlsen, II	
	2	4433251		1984-02-21	Banks et al.	
	3	4510431		1985-04-09	Winkler	
	4	5173855		1992-12-22	Nielsen et al.	
	5	5229649		1993-07-20	Nielsen et al.	
	6	5272475		1993-12-21	Eaton et al.	
	7	5444378		1995-08-22	Rogers	
	8	5631503		1997-05-20	Cioffi	
	9	5638540		1997-06-10	Aldous	
	10	5651057		1997-07-22	Blood et al.	
	11	5769877		1998-06-23	Barreras, Sr.	
	12	5850113		1998-12-15	Weimer et al.	
	13	5939860		1999-08-17	William	
	14	6006088		1999-12-21	Couse	
	15	6104162		2000-08-15	Sanisbury et al.	
	16	6104759		2000-08-15	Carkner et al.	
	17	6130518		2000-10-10	Gabehart et al.	
	18	6138242		2000-10-24	Massman et al.	
	19	6184652		2001-02-06	Yang	
	20	6211649		2001-04-03	Matsuda	
	21	6252375		2001-06-26	Richter et al.	
	22	6255800		2001-07-03	Bork	
	23	6283789		2001-09-04	Tsai	
	24	6357011		2002-03-12	Gilbert	
	25	6397696		2002-06-04	Ogami	
	26	6663420		2003-12-16	Xiao	
	27	6668296		2003-12-23	Dougherty et al.	

Petitioners Ex. 1002

ALL REFERENCES CONSIDERED EXCEPT WHERE INDICATED THROUGH. /ET/

IPR US 8,624,550

INFORMATION DISCLOSURE STATEMENT BY APPLICANT (Not for submission under 37 CFR 1.99)	Application Number		Unknown	
	Filing Date		June 28, 2012	
	First Named Inventor	Daniel M. Fischer		
	Art Unit		Unknown	
	Examiner Name	Unknown		
	Attorney Docket Number		11298.0188-08000	

28	6738856		2004-05-18	Milley et al.	
29	7159132		2007-01-02	Takahashi et al.	
30	7170259		2007-01-30	Veselic	
31	7340627		2008-03-04	Harvey	
32	7629767		2009-12-08	Kang	
33	7631111		2009-12-08	Monks et al.	
34	7698490		2010-04-13	Terrell, II	
35	7737657		2010-06-15	Fischer, et al.	
36	7812565		2010-10-12	Bayne et al.	
37	7884570		2011-02-08	Purdy et al.	
38	7986127		2011-07-26	Fischer et al.	
39	7834586		2010-02-26	Fischer et al.	

U.S. PATENT APPLICATION PUBLICATIONS

Examiner Initial*	Cite No	Publication Number	Kind Code ¹	Publication Date	Name of Patentee or Applicant of cited Document	Pages, Columns, Lines where Relevant Passages or Relevant Figures Appear
	1	2001/0003205		2001-06-07	Gilbert	
	2	2003/0034898		2003-02-20	Shamoon et al.	
	3	2004/0063464		2004-04-01	Akam et al.	
	4	2004/0251878		2004-12-16	Veselic	
	5	2005/0269883		2005-12-08	Drader et al.	
	6	2006/0181241		2006-08-17	Veselic	
	7	2007/0108938		2007-05-17	Veselic	
	8	2009/0128091		2009-05-21	Purdy et al.	
	9	2009/0130874		2009-05-21	Englund	
	10	2010/0052620		2010-03-04	Wong	
	11	2010/0060233		2010-03-11	Kung et al.	
	12	2010/0201308		2010-08-12	Lindholm	
	13	2004/0251878		2004-12-16	Veselic	

INFORMATION DISCLOSURE STATEMENT BY APPLICANT (Not for submission under 37 CFR 1.99)	Application Number		Unknown	
	Filing Date		June 28, 2012	
	First Named Inventor	Daniel M. Fischer		
	Art Unit		Unknown	
	Examiner Name	Unknown		
	Attorney Docket Number		11298.0188-08000	

FOREIGN PATENT DOCUMENTS

Examiner Initial*	Cite No	Foreign Document Number	Country Code ²ⁱ	Kind Code ¹	Publication Date	Name of Patentee or Applicant of cited Document	Pages, Columns, Lines where Relevant Passages or Relevant Figures Appear	T ⁵
	1	0684680	EP		1995-11-29	Nokia Mobile Phones Ltd.		<input type="checkbox"/>
	2	1198049	EP		2002-04-17	Sony International (Eur.)		
	3	2001/01330	WO		2001-01-04	Cross Match Technologies, Inc.		
	4	2005063355	JP		2005-03-10	Matsushita Electric Inc. Co. Ltd.		
	5	2517333	CA		2002-09-01	Research in Motion Ltd.		

NON-PATENT LITERATURE DOCUMENTS

Examiner Initial*	Cite No	Include the name of the author (in CAPITAL LETTERS), title of the article (when appropriate), title of the item (book, magazine, journal, serial, symposium, catalog, etc.), date, page(s), volume-issue number(s), publisher, city and/or country where published.	T ⁵
	1	Canadian Office Action for Canadian Application No. 2,374,344 dated March 12, 2004 (3 pages)	<input type="checkbox"/>
	2	Charging Big Supercaps, Portable Design, p. 26, March 1997	
	3	Electric Double-Layer Capacitors, Vol. 2, October 25, 1996, (Japan, Tokin Corp., Cat. No. EC-200E)	
	4	Supercapacitor: User's Manual, Vol. 2, Japan, Tokin Corporation, January 1997 (47 pages)	
	5	U.S. Office Action for U.S. Application 10/087,629 dated September 7, 2004 (6 pages)	
	6	U.S. Office Action for U.S. Application 11/175,885 dated April 4, 2006 (5 pages)	
	7	U.S. Office Action for U.S. Application 11/175,885 dated October 20, 2005 (8 pages)	
	8	U.S. Office Action for U.S. Application 11/749,680 dated September 25, 2007 (9 pages)	
	9	U.S. Office Action for U.S. Application 12/174,204 dated August 5, 2010 (11 pages)	
	10	U.S. Office Action for U.S. Application 12/268,297 dated August 18, 2009 (9 pages)	
	11	U.S. Office Action for U.S. Application 12/905,934 dated November 29, 2010 (11 pages)	
	12	U.S. Office Action for U.S. Application No. 11/175,885 dated August 24, 2006 (6 pages)	
	13	U.S. Office Action for U.S. Application No. 12/714,204 dated August 5, 2010 (11 pages)	

INFORMATION DISCLOSURE STATEMENT BY APPLICANT (Not for submission under 37 CFR 1.99)	Application Number		Unknown	
	Filing Date		June 28, 2012	
	First Named Inventor		Daniel M. Fischer	
	Art Unit		Unknown	
	Examiner Name		Unknown	
	Attorney Docket Number		11298.0188-08000	

14	U.S. Office Action for US. Application 11/175,885 dated August 24, 2006 (6 pages)
15	U.S. Office Action for US. Application 13/175,487 dated December 12, 2011 (10 pages)

EXAMINER SIGNATURE

Examiner Signature	/Edward Tso/	Date Considered	05/19/2013
--------------------	--------------	-----------------	------------

*EXAMINER: Initial if reference considered, whether or not citation is in conformance with MPEP 609. Draw line through a citation if not in conformance and not considered. Include copy of this form with next communication to applicant.,

¹ See Kind Codes of USPTO Patent Document at www.USPTO.GOV or MPEP 901.04. ² Enter office that issued the document, by the two letter code (WIPO Standard ST.3). ³ For Japanese patent documents, the indication of the year of the reign of the Emperor must precede the serial number of the patent document. ⁴ Kind of document by the appropriate symbols as indicated on the document under WIPO Standard ST.16 if possible. ⁵ Applicant to place a check mark here if English language translation is attached.

Index of Claims 	Application/Control No. 13536767	Applicant(s)/Patent Under Reexamination FISCHER ET AL.
	Examiner EDWARD TSO	Art Unit 2859

✓	Rejected
=	Allowed

-	Cancelled
÷	Restricted

N	Non-Elected
I	Interference

A	Appeal
O	Objected

Claims renumbered in the same order as presented by applicant
 CPA
 T.D.
 R.1.47

CLAIM		DATE							
Final	Original	05/19/2013							
-	1	-							
-	2	-							
-	3	-							
-	4	-							
-	5	-							
-	6	-							
-	7	-							
-	8	-							
-	9	-							
-	10	-							
	11	✓							
	12	✓							
	13	✓							
	14	✓							
	15	✓							
	16	✓							
	17	✓							
	18	✓							
	19	✓							
	20	✓							
	21	✓							
	22	✓							
	23	✓							
	24	✓							
	25	✓							
	26	✓							
	27	✓							
	28	✓							

Search Notes 	Application/Control No. 13536767	Applicant(s)/Patent Under Reexamination FISCHER ET AL.
	Examiner EDWARD TSO	Art Unit 2859

CPC- SEARCHED		
Symbol	Date	Examiner

CPC COMBINATION SETS - SEARCHED		
Symbol	Date	Examiner

US CLASSIFICATION SEARCHED			
Class	Subclass	Date	Examiner
320	107, 111, 114, 140		

SEARCH NOTES			
Search Notes	Date	Examiner	
text search	5/2013	et	
class/subclass search	5/2013	et	
inventor search	5/2013	et	
foreign ipc search	5/2013	et	
DP considered against related patents	5/2013	et	

INTERFERENCE SEARCH			
US Class/ CPC Symbol	US Subclass / CPC Group	Date	Examiner

--	--

IN THE UNITED STATES PATENT AND TRADEMARK OFFICE

In re Application of:)
)
Daniel M. FISCHER et al.) Group Art Unit: 2859
)
Application No. 13/536,767) Examiner: Edward H. Tso
)
Filed: June 28, 2012)
)
For: MULTIFUNCTIONAL CHARGER) Confirmation No. 5104
)
SYSTEM AND METHOD)

Mail Stop: Amendment
Commissioner for Patents
P.O. Box 1450
Alexandria, VA 22313-1450

Sir:

REPLY TO OFFICE ACTION

Applicants submit this Reply in response to the Office Action mailed May 28, 2013. **Remarks/Arguments** begin on page 2 of this paper.

REMARKS

In the Office Action mailed May 28, 2013, the Examiner rejected claims 11-28 on the ground of non-statutory obviousness-type double patenting as being unpatentable over claims 1-12 of U.S. Patent No. 7,986,127 ("the '127 patent"). Applicants traverse the rejections made in the Office Action and respectfully request reconsideration for at least the reasons that follow.

I. Rejections under Nonstatutory Double Patenting

Applicants traverse the obviousness-type double patenting rejections and disagree with the Examiner's characterizations regarding the claims. However, solely in an effort to advance prosecution, Applicants file a terminal disclaimer with respect to the '127 patent, concurrently with this Reply. As such, Applicants respectfully request withdrawal of the nonstatutory double patenting rejections.

II. Conclusion

In view of the foregoing remarks, Applicants respectfully request reconsideration and reexamination of this application and the timely allowance of the pending claims.

Please grant any extensions of time required to enter this response and charge any additional required fees to deposit account No. 06-0916.

Respectfully submitted,

FINNEGAN, HENDERSON, FARABOW,
GARRETT & DUNNER, L.L.P.

Dated: August 7, 2013

By: /Yi Yu/
Yi Yu
Reg. No. 69,397
(571) 203-2700

Under the Paperwork Reduction Act of 1995, no persons are required to respond to a collection of information unless it displays a valid OMB control number.

**TERMINAL DISCLAIMER TO OBTAIN A DOUBLE PATENTING
REJECTION OVER A "PRIOR" PATENT**

Docket Number (Optional)
11298.0188-08000

In re Application of: Daniel M. FISCHER et al.

Application No.: 13/536,767

Filed: June 28, 2012

For: MULTIFUNCTIONAL CHARGER SYSTEM AND METHOD

The owner*, Research in Motion Limited, of 100 percent interest in the instant application hereby disclaims, except as provided below, the terminal part of the statutory term of any patent granted on the instant application which would extend beyond the expiration date of the full statutory term **prior patent** No. 7,986,127 as the term of said prior patent is defined in 35 U.S.C. 154 and 173, and as the term of said **prior patent** is presently shortened by any terminal disclaimer. The owner hereby agrees that any patent so granted on the instant application shall be enforceable only for and during such period that it and the **prior patent** are commonly owned. This agreement runs with any patent granted on the instant application and is binding upon the grantee, its successors or assigns.

In making the above disclaimer, the owner does not disclaim the terminal part of the term of any patent granted on the instant application that would extend to the expiration date of the full statutory term as defined in 35 U.S.C. 154 and 173 of the **prior patent**, "as the term of said **prior patent** is presently shortened by any terminal disclaimer," in the event that said **prior patent** later:

- expires for failure to pay a maintenance fee;
- is held unenforceable;
- is found invalid by a court of competent jurisdiction;
- is statutorily disclaimed in whole or terminally disclaimed under 37 CFR 1.321;
- has all claims canceled by a reexamination certificate;
- is reissued; or
- is in any manner terminated prior to the expiration of its full statutory term as presently shortened by any terminal disclaimer.

Check either box 1 or 2 below, if appropriate.

1. For submissions on behalf of a business/organization (e.g., corporation, partnership, university, government agency, etc.), the undersigned is empowered to act on behalf of the business/organization.

I hereby declare that all statements made herein of my own knowledge are true and that all statements made on information and belief are believed to be true; and further that these statements were made with the knowledge that willful false statements and the like so made are punishable by fine or imprisonment, or both, under Section 1001 of Title 18 of the United States Code and that such willful false statements may jeopardize the validity of the application or any patent issued thereon.

2. The undersigned is an attorney or agent of record. Reg. No. 36,743

_____/Jeffrey A. Berkowitz/_____
Signature Date

Jeffrey A. Berkowitz
Typed or printed name

571-203-2700
Telephone Number

- Terminal disclaimer fee under 37 CFR 1.20(d) included.

WARNING: Information on this form may become public. Credit card information should not be included on this form. Provide credit card information and authorization on PTO-2038.

*Statement under 37 CFR 3.73(b) is required if terminal disclaimer is signed by the assignee (owner).
Form PTO/SB/96 may be used for making this certification. See MPEP § 324.

This collection of information is required by 37 CFR 1.321. The information is required to obtain or retain a benefit by the public which is to file (and by the USPTO to process) an application. Confidentiality is governed by 35 U.S.C. 122 and 37 CFR 1.11 and 1.14. This collection is estimated to take 12 minutes to complete, including gathering, preparing, and submitting the completed application form to the USPTO. Time will vary depending upon the individual case. Any comments on the amount of time you require to complete this form and/or suggestions for reducing this burden, should be sent to the Chief Information Officer, U.S. Patent and Trademark Office, U.S. Department of Commerce, P.O. Box 1450, Alexandria, VA 22313-1450. DO NOT SEND FEES OR COMPLETED FORMS TO THIS ADDRESS. SEND TO: Commissioner for Patents, P.O. Box 1450, Alexandria, VA 22313-1450.

If you need assistance in completing the form, call 1-800-PTO-9199 and select option 2.

Privacy Act Statement

The **Privacy Act of 1974 (P.L. 93-579)** requires that you be given certain information in connection with your submission of the attached form related to a patent application or patent. Accordingly, pursuant to the requirements of the Act, please be advised that: (1) the general authority for the collection of this information is 35 U.S.C. 2(b)(2); (2) furnishing of the information solicited is voluntary; and (3) the principal purpose for which the information is used by the U.S. Patent and Trademark Office is to process and/or examine your submission related to a patent application or patent. If you do not furnish the requested information, the U.S. Patent and Trademark Office may not be able to process and/or examine your submission, which may result in termination of proceedings or abandonment of the application or expiration of the patent.

The information provided by you in this form will be subject to the following routine uses:

1. The information on this form will be treated confidentially to the extent allowed under the Freedom of Information Act (5 U.S.C. 552) and the Privacy Act (5 U.S.C. 552a). Records from this system of records may be disclosed to the Department of Justice to determine whether disclosure of these records is required by the Freedom of Information Act.
2. A record from this system of records may be disclosed, as a routine use, in the course of presenting evidence to a court, magistrate, or administrative tribunal, including disclosures to opposing counsel in the course of settlement negotiations.
3. A record in this system of records may be disclosed, as a routine use, to a Member of Congress submitting a request involving an individual, to whom the record pertains, when the individual has requested assistance from the Member with respect to the subject matter of the record.
4. A record in this system of records may be disclosed, as a routine use, to a contractor of the Agency having need for the information in order to perform a contract. Recipients of information shall be required to comply with the requirements of the Privacy Act of 1974, as amended, pursuant to 5 U.S.C. 552a(m).
5. A record related to an International Application filed under the Patent Cooperation Treaty in this system of records may be disclosed, as a routine use, to the International Bureau of the World Intellectual Property Organization, pursuant to the Patent Cooperation Treaty.
6. A record in this system of records may be disclosed, as a routine use, to another federal agency for purposes of National Security review (35 U.S.C. 181) and for review pursuant to the Atomic Energy Act (42 U.S.C. 218(c)).
7. A record from this system of records may be disclosed, as a routine use, to the Administrator, General Services, or his/her designee, during an inspection of records conducted by GSA as part of that agency's responsibility to recommend improvements in records management practices and programs, under authority of 44 U.S.C. 2904 and 2906. Such disclosure shall be made in accordance with the GSA regulations governing inspection of records for this purpose, and any other relevant (*i.e.*, GSA or Commerce) directive. Such disclosure shall not be used to make determinations about individuals.
8. A record from this system of records may be disclosed, as a routine use, to the public after either publication of the application pursuant to 35 U.S.C. 122(b) or issuance of a patent pursuant to 35 U.S.C. 151. Further, a record may be disclosed, subject to the limitations of 37 CFR 1.14, as a routine use, to the public if the record was filed in an application which became abandoned or in which the proceedings were terminated and which application is referenced by either a published application, an application open to public inspection or an issued patent.
9. A record from this system of records may be disclosed, as a routine use, to a Federal, State, or local law enforcement agency, if the USPTO becomes aware of a violation or potential violation of law or regulation.

Electronic Patent Application Fee Transmittal

Application Number:	13536767
Filing Date:	28-Jun-2012
Title of Invention:	MULTIFUNCTIONAL CHARGER SYSTEM AND METHOD
First Named Inventor/Applicant Name:	Daniel M. FISCHER
Filer:	YI YU/Mitty Watters
Attorney Docket Number:	11298.0188-08000

Filed as Large Entity

Utility under 35 USC 111(a) Filing Fees

Description	Fee Code	Quantity	Amount	Sub-Total in USD(\$)
Basic Filing:				
Pages:				
Claims:				
Miscellaneous-Filing:				
Petition:				
Patent-Appeals-and-Interference:				
Post-Allowance-and-Post-Issuance:				
Extension-of-Time:				

Description	Fee Code	Quantity	Amount	Sub-Total in USD(\$)
Miscellaneous:				
Statutory or Terminal Disclaimer	1814	1	160	160
Total in USD (\$)				160

Electronic Acknowledgement Receipt

EFS ID:	16522268
Application Number:	13536767
International Application Number:	
Confirmation Number:	5104
Title of Invention:	MULTIFUNCTIONAL CHARGER SYSTEM AND METHOD
First Named Inventor/Applicant Name:	Daniel M. FISCHER
Customer Number:	93377
Filer:	YI YU/Mitty Watters
Filer Authorized By:	YI YU
Attorney Docket Number:	11298.0188-08000
Receipt Date:	07-AUG-2013
Filing Date:	28-JUN-2012
Time Stamp:	12:20:16
Application Type:	Utility under 35 USC 111(a)

Payment information:

Submitted with Payment	yes
Payment Type	Credit Card
Payment was successfully received in RAM	\$160
RAM confirmation Number	9735
Deposit Account	
Authorized User	

File Listing:

Document Number	Document Description	File Name	File Size (Bytes)	Multi-Page Message	Pages (if appl.)
			8,024,550		

Petitioners Ex. 1002

Page 8 of 174

1	Amendment/Req. Reconsideration-After Non-Final Reject	018808_reply.pdf	58275	no	2
			3e26b1e860d7f71ab470618e316efbc8413 d276		
Warnings:					
Information:					
2	Terminal Disclaimer Filed	018808_termdiscl.pdf	157682	no	2
			68309cae85bd1f66d111cde7edad5b18e55 9371a		
Warnings:					
Information:					
3	Fee Worksheet (SB06)	fee-info.pdf	30145	no	2
			ecbfca1d957a15cdfcf39a5d1830ee86fadf7 38e		
Warnings:					
Information:					
Total Files Size (in bytes):			246102		

This Acknowledgement Receipt evidences receipt on the noted date by the USPTO of the indicated documents, characterized by the applicant, and including page counts, where applicable. It serves as evidence of receipt similar to a Post Card, as described in MPEP 503.

New Applications Under 35 U.S.C. 111

If a new application is being filed and the application includes the necessary components for a filing date (see 37 CFR 1.53(b)-(d) and MPEP 506), a Filing Receipt (37 CFR 1.54) will be issued in due course and the date shown on this Acknowledgement Receipt will establish the filing date of the application.

National Stage of an International Application under 35 U.S.C. 371

If a timely submission to enter the national stage of an international application is compliant with the conditions of 35 U.S.C. 371 and other applicable requirements a Form PCT/DO/EO/903 indicating acceptance of the application as a national stage submission under 35 U.S.C. 371 will be issued in addition to the Filing Receipt, in due course.

New International Application Filed with the USPTO as a Receiving Office

If a new international application is being filed and the international application includes the necessary components for an international filing date (see PCT Article 11 and MPEP 1810), a Notification of the International Application Number and of the International Filing Date (Form PCT/RO/105) will be issued in due course, subject to prescriptions concerning national security, and the date shown on this Acknowledgement Receipt will establish the international filing date of the application.

Application Number 	Application/Control No. 13/536,767	Applicant(s)/Patent under Reexamination FISCHER ET AL.	

Document Code - DISQ	Internal Document – DO NOT MAIL
-----------------------------	--

TERMINAL DISCLAIMER	<input checked="" type="checkbox"/> APPROVED	<input type="checkbox"/> DISAPPROVED
Date Filed : 07 AUG 2013	This patent is subject to a Terminal Disclaimer	

Approved/Disapproved by:

JAB



NOTICE OF ALLOWANCE AND FEE(S) DUE

93377 7590 09/05/2013
RIM/FINNEGAN
901 New York Avenue NW
Washington, DC 20001

Table with 2 columns: EXAMINER (TSO, EDWARD H), ART UNIT (2859), PAPER NUMBER (5104)

DATE MAILED: 09/05/2013

Table with 5 columns: APPLICATION NO., FILING DATE, FIRST NAMED INVENTOR, ATTORNEY DOCKET NO., CONFIRMATION NO.

13/536,767 06/28/2012 Daniel M. FISCHER 11298.0188-08000 5104

TITLE OF INVENTION: MULTIFUNCTIONAL CHARGER SYSTEM AND METHOD

Table with 7 columns: APPLN. TYPE, ENTITY STATUS, ISSUE FEE DUE, PUBLICATION FEE DUE, PREV. PAID ISSUE FEE, TOTAL FEE(S) DUE, DATE DUE

nonprovisional UNDISCOUNTED \$1780 \$300 \$0 \$2080 12/05/2013

THE APPLICATION IDENTIFIED ABOVE HAS BEEN EXAMINED AND IS ALLOWED FOR ISSUANCE AS A PATENT. PROSECUTION ON THE MERITS IS CLOSED. THIS NOTICE OF ALLOWANCE IS NOT A GRANT OF PATENT RIGHTS. THIS APPLICATION IS SUBJECT TO WITHDRAWAL FROM ISSUE AT THE INITIATIVE OF THE OFFICE OR UPON PETITION BY THE APPLICANT. SEE 37 CFR 1.313 AND MPEP 1308.

THE ISSUE FEE AND PUBLICATION FEE (IF REQUIRED) MUST BE PAID WITHIN THREE MONTHS FROM THE MAILING DATE OF THIS NOTICE OR THIS APPLICATION SHALL BE REGARDED AS ABANDONED. THIS STATUTORY PERIOD CANNOT BE EXTENDED. SEE 35 U.S.C. 151. THE ISSUE FEE DUE INDICATED ABOVE DOES NOT REFLECT A CREDIT FOR ANY PREVIOUSLY PAID ISSUE FEE IN THIS APPLICATION. IF AN ISSUE FEE HAS PREVIOUSLY BEEN PAID IN THIS APPLICATION (AS SHOWN ABOVE), THE RETURN OF PART B OF THIS FORM WILL BE CONSIDERED A REQUEST TO REAPPLY THE PREVIOUSLY PAID ISSUE FEE TOWARD THE ISSUE FEE NOW DUE.

HOW TO REPLY TO THIS NOTICE:

I. Review the ENTITY STATUS shown above. If the ENTITY STATUS is shown as SMALL or MICRO, verify whether entitlement to that entity status still applies.

If the ENTITY STATUS is the same as shown above, pay the TOTAL FEE(S) DUE shown above.

If the ENTITY STATUS is changed from that shown above, on PART B - FEE(S) TRANSMITTAL, complete section number 5 titled "Change in Entity Status (from status indicated above)".

For purposes of this notice, small entity fees are 1/2 the amount of undiscounted fees, and micro entity fees are 1/2 the amount of small entity fees.

II. PART B - FEE(S) TRANSMITTAL, or its equivalent, must be completed and returned to the United States Patent and Trademark Office (USPTO) with your ISSUE FEE and PUBLICATION FEE (if required). If you are charging the fee(s) to your deposit account, section "4b" of Part B - Fee(s) Transmittal should be completed and an extra copy of the form should be submitted. If an equivalent of Part B is filed, a request to reapply a previously paid issue fee must be clearly made, and delays in processing may occur due to the difficulty in recognizing the paper as an equivalent of Part B.

III. All communications regarding this application must give the application number. Please direct all communications prior to issuance to Mail Stop ISSUE FEE unless advised to the contrary.

IMPORTANT REMINDER: Utility patents issuing on applications filed on or after Dec. 12, 1980 may require payment of maintenance fees. It is patentee's responsibility to ensure timely payment of maintenance fees when due.

PART B - FEE(S) TRANSMITTAL

**Complete and send this form, together with applicable fee(s), to: Mail Mail Stop ISSUE FEE
 Commissioner for Patents
 P.O. Box 1450
 Alexandria, Virginia 22313-1450
 or Fax (571)-273-2885**

INSTRUCTIONS: This form should be used for transmitting the ISSUE FEE and PUBLICATION FEE (if required). Blocks 1 through 5 should be completed where appropriate. All further correspondence including the Patent, advance orders and notification of maintenance fees will be mailed to the current correspondence address as indicated unless corrected below or directed otherwise in Block 1, by (a) specifying a new correspondence address; and/or (b) indicating a separate "FEE ADDRESS" for maintenance fee notifications.

CURRENT CORRESPONDENCE ADDRESS (Note: Use Block 1 for any change of address)

Note: A certificate of mailing can only be used for domestic mailings of the Fee(s) Transmittal. This certificate cannot be used for any other accompanying papers. Each additional paper, such as an assignment or formal drawing, must have its own certificate of mailing or transmission.

93377 7590 09/05/2013
RIM/FINNEGAN
 901 New York Avenue NW
 Washington, DC 20001

Certificate of Mailing or Transmission

I hereby certify that this Fee(s) Transmittal is being deposited with the United States Postal Service with sufficient postage for first class mail in an envelope addressed to the Mail Stop ISSUE FEE address above, or being facsimile transmitted to the USPTO (571) 273-2885, on the date indicated below.

(Depositor's name)
(Signature)
(Date)

APPLICATION NO.	FILING DATE	FIRST NAMED INVENTOR	ATTORNEY DOCKET NO.	CONFIRMATION NO.
13/536,767	06/28/2012	Daniel M. FISCHER	11298.0188-08000	5104

TITLE OF INVENTION: MULTIFUNCTIONAL CHARGER SYSTEM AND METHOD

APPLN. TYPE	ENTITY STATUS	ISSUE FEE DUE	PUBLICATION FEE DUE	PREV. PAID ISSUE FEE	TOTAL FEE(S) DUE	DATE DUE
nonprovisional	UNDISCOUNTED	\$1780	\$300	\$0	\$2080	12/05/2013

EXAMINER	ART UNIT	CLASS-SUBCLASS
TSO, EDWARD H	2859	320-107000

<p>1. Change of correspondence address or indication of "Fee Address" (37 CFR 1.363).</p> <p><input type="checkbox"/> Change of correspondence address (or Change of Correspondence Address form PTO/SB/122) attached.</p> <p><input type="checkbox"/> "Fee Address" indication (or "Fee Address" Indication form PTO/SB/47; Rev 03-02 or more recent) attached. Use of a Customer Number is required.</p>	<p>2. For printing on the patent front page, list</p> <p>(1) the names of up to 3 registered patent attorneys or agents OR, alternatively, 1 _____</p> <p>(2) the name of a single firm (having as a member a registered attorney or agent) and the names of up to 2 registered patent attorneys or agents. If no name is listed, no name will be printed. 2 _____</p> <p>3 _____</p>
---	---

3. ASSIGNEE NAME AND RESIDENCE DATA TO BE PRINTED ON THE PATENT (print or type)

PLEASE NOTE: Unless an assignee is identified below, no assignee data will appear on the patent. If an assignee is identified below, the document has been filed for recordation as set forth in 37 CFR 3.11. Completion of this form is NOT a substitute for filing an assignment.

(A) NAME OF ASSIGNEE _____ (B) RESIDENCE: (CITY and STATE OR COUNTRY) _____

Please check the appropriate assignee category or categories (will not be printed on the patent) : Individual Corporation or other private group entity Government

<p>4a. The following fee(s) are submitted:</p> <p><input type="checkbox"/> Issue Fee</p> <p><input type="checkbox"/> Publication Fee (No small entity discount permitted)</p> <p><input type="checkbox"/> Advance Order - # of Copies _____</p>	<p>4b. Payment of Fee(s): (Please first reapply any previously paid issue fee shown above)</p> <p><input type="checkbox"/> A check is enclosed.</p> <p><input type="checkbox"/> Payment by credit card. Form PTO-2038 is attached.</p> <p><input type="checkbox"/> The Director is hereby authorized to charge the required fee(s), any deficiency, or credit any overpayment, to Deposit Account Number _____ (enclose an extra copy of this form).</p>
---	--

5. **Change in Entity Status** (from status indicated above)

- Applicant certifying micro entity status. See 37 CFR 1.29
- Applicant asserting small entity status. See 37 CFR 1.27
- Applicant changing to regular undiscounted fee status.

NOTE: Absent a valid certification of Micro Entity Status (see form PTO/SB/15A and 15B), issue fee payment in the micro entity amount will not be accepted at the risk of application abandonment.

NOTE: If the application was previously under micro entity status, checking this box will be taken to be a notification of loss of entitlement to micro entity status.

NOTE: Checking this box will be taken to be a notification of loss of entitlement to small or micro entity status, as applicable.

NOTE: The Issue Fee and Publication Fee (if required) will not be accepted from anyone other than the applicant; a registered attorney or agent; or the assignee or other party in interest as shown by the records of the United States Patent and Trademark Office.

Authorized Signature _____

Date _____

Typed or printed name _____

Registration No. _____

This collection of information is required by 37 CFR 1.311. The information is required to obtain or retain a benefit by the public which is to file (and by the USPTO to process) an application. Confidentiality is governed by 35 U.S.C. 122 and 37 CFR 1.14. This collection is estimated to take 12 minutes to complete, including gathering, preparing, and submitting the completed application form to the USPTO. Time will vary depending upon the individual case. Any comments on the amount of time you require to complete this form and/or suggestions for reducing this burden, should be sent to the Chief Information Officer, U.S. Patent and Trademark Office, U.S. Department of Commerce, P.O. Box 1450, Alexandria, Virginia 22313-1450. DO NOT SEND FEES OR COMPLETED FORMS TO THIS ADDRESS. SEND TO: Commissioner for Patents, P.O. Box 1450, Alexandria, Virginia 22313-1450.

Under the Paperwork Reduction Act of 1995, no persons are required to respond to a collection of information unless it displays a valid OMB control number.



UNITED STATES PATENT AND TRADEMARK OFFICE

UNITED STATES DEPARTMENT OF COMMERCE
United States Patent and Trademark Office
Address: COMMISSIONER FOR PATENTS
P.O. Box 1450
Alexandria, Virginia 22313-1450
www.uspto.gov

Table with 5 columns: APPLICATION NO., FILING DATE, FIRST NAMED INVENTOR, ATTORNEY DOCKET NO., CONFIRMATION NO.
13/536,767 06/28/2012 Daniel M. FISCHER 11298.0188-08000 5104

93377 7590 09/05/2013
RIM/FINNEGAN
901 New York Avenue NW
Washington, DC 20001

EXAMINER

TSO, EDWARD H

ART UNIT PAPER NUMBER

2859

DATE MAILED: 09/05/2013

Determination of Patent Term Adjustment under 35 U.S.C. 154 (b)

(application filed on or after May 29, 2000)

The Patent Term Adjustment to date is 0 day(s). If the issue fee is paid on the date that is three months after the mailing date of this notice and the patent issues on the Tuesday before the date that is 28 weeks (six and a half months) after the mailing date of this notice, the Patent Term Adjustment will be 0 day(s).

If a Continued Prosecution Application (CPA) was filed in the above-identified application, the filing date that determines Patent Term Adjustment is the filing date of the most recent CPA.

Applicant will be able to obtain more detailed information by accessing the Patent Application Information Retrieval (PAIR) WEB site (http://pair.uspto.gov).

Any questions regarding the Patent Term Extension or Adjustment determination should be directed to the Office of Patent Legal Administration at (571)-272-7702. Questions relating to issue and publication fee payments should be directed to the Customer Service Center of the Office of Patent Publication at 1-(888)-786-0101 or (571)-272-4200.

Privacy Act Statement

The Privacy Act of 1974 (P.L. 93-579) requires that you be given certain information in connection with your submission of the attached form related to a patent application or patent. Accordingly, pursuant to the requirements of the Act, please be advised that: (1) the general authority for the collection of this information is 35 U.S.C. 2(b)(2); (2) furnishing of the information solicited is voluntary; and (3) the principal purpose for which the information is used by the U.S. Patent and Trademark Office is to process and/or examine your submission related to a patent application or patent. If you do not furnish the requested information, the U.S. Patent and Trademark Office may not be able to process and/or examine your submission, which may result in termination of proceedings or abandonment of the application or expiration of the patent.

The information provided by you in this form will be subject to the following routine uses:

1. The information on this form will be treated confidentially to the extent allowed under the Freedom of Information Act (5 U.S.C. 552) and the Privacy Act (5 U.S.C. 552a). Records from this system of records may be disclosed to the Department of Justice to determine whether disclosure of these records is required by the Freedom of Information Act.
2. A record from this system of records may be disclosed, as a routine use, in the course of presenting evidence to a court, magistrate, or administrative tribunal, including disclosures to opposing counsel in the course of settlement negotiations.
3. A record in this system of records may be disclosed, as a routine use, to a Member of Congress submitting a request involving an individual, to whom the record pertains, when the individual has requested assistance from the Member with respect to the subject matter of the record.
4. A record in this system of records may be disclosed, as a routine use, to a contractor of the Agency having need for the information in order to perform a contract. Recipients of information shall be required to comply with the requirements of the Privacy Act of 1974, as amended, pursuant to 5 U.S.C. 552a(m).
5. A record related to an International Application filed under the Patent Cooperation Treaty in this system of records may be disclosed, as a routine use, to the International Bureau of the World Intellectual Property Organization, pursuant to the Patent Cooperation Treaty.
6. A record in this system of records may be disclosed, as a routine use, to another federal agency for purposes of National Security review (35 U.S.C. 181) and for review pursuant to the Atomic Energy Act (42 U.S.C. 218(c)).
7. A record from this system of records may be disclosed, as a routine use, to the Administrator, General Services, or his/her designee, during an inspection of records conducted by GSA as part of that agency's responsibility to recommend improvements in records management practices and programs, under authority of 44 U.S.C. 2904 and 2906. Such disclosure shall be made in accordance with the GSA regulations governing inspection of records for this purpose, and any other relevant (i.e., GSA or Commerce) directive. Such disclosure shall not be used to make determinations about individuals.
8. A record from this system of records may be disclosed, as a routine use, to the public after either publication of the application pursuant to 35 U.S.C. 122(b) or issuance of a patent pursuant to 35 U.S.C. 151. Further, a record may be disclosed, subject to the limitations of 37 CFR 1.14, as a routine use, to the public if the record was filed in an application which became abandoned or in which the proceedings were terminated and which application is referenced by either a published application, an application open to public inspection or an issued patent.
9. A record from this system of records may be disclosed, as a routine use, to a Federal, State, or local law enforcement agency, if the USPTO becomes aware of a violation or potential violation of law or regulation.

Notice of Allowability	Application No. 13/536,767	Applicant(s) FISCHER ET AL.	
	Examiner EDWARD TSO	Art Unit 2859	AIA (First Inventor to File) Status No

-- The MAILING DATE of this communication appears on the cover sheet with the correspondence address--

All claims being allowable, PROSECUTION ON THE MERITS IS (OR REMAINS) CLOSED in this application. If not included herewith (or previously mailed), a Notice of Allowance (PTOL-85) or other appropriate communication will be mailed in due course. **THIS NOTICE OF ALLOWABILITY IS NOT A GRANT OF PATENT RIGHTS.** This application is subject to withdrawal from issue at the initiative of the Office or upon petition by the applicant. See 37 CFR 1.313 and MPEP 1308.

1. This communication is responsive to TD filed 8/7/2013.
 A declaration(s)/affidavit(s) under **37 CFR 1.130(b)** was/were filed on _____.
2. An election was made by the applicant in response to a restriction requirement set forth during the interview on _____; the restriction requirement and election have been incorporated into this action.
3. The allowed claim(s) is/are 11-28. As a result of the allowed claim(s), you may be eligible to benefit from the **Patent Prosecution Highway** program at a participating intellectual property office for the corresponding application. For more information, please see http://www.uspto.gov/patents/init_events/oph/index.jsp or send an inquiry to PPHfeedback@uspto.gov.
4. Acknowledgment is made of a claim for foreign priority under 35 U.S.C. § 119(a)-(d) or (f).

Certified copies:

- a) All b) Some *c) None of the:
1. Certified copies of the priority documents have been received.
 2. Certified copies of the priority documents have been received in Application No. _____.
 3. Copies of the certified copies of the priority documents have been received in this national stage application from the International Bureau (PCT Rule 17.2(a)).
- * Certified copies not received: _____.

Applicant has THREE MONTHS FROM THE "MAILING DATE" of this communication to file a reply complying with the requirements noted below. Failure to timely comply will result in ABANDONMENT of this application.
THIS THREE-MONTH PERIOD IS NOT EXTENDABLE.

5. CORRECTED DRAWINGS (as "replacement sheets") must be submitted.
 including changes required by the attached Examiner's Amendment / Comment or in the Office action of Paper No./Mail Date _____.
Identifying indicia such as the application number (see 37 CFR 1.84(c)) should be written on the drawings in the front (not the back) of each sheet. Replacement sheet(s) should be labeled as such in the header according to 37 CFR 1.121(d).
6. DEPOSIT OF and/or INFORMATION about the deposit of BIOLOGICAL MATERIAL must be submitted. Note the attached Examiner's comment regarding REQUIREMENT FOR THE DEPOSIT OF BIOLOGICAL MATERIAL.

Attachment(s)

- | | |
|--|---|
| 1. <input type="checkbox"/> Notice of References Cited (PTO-892) | 5. <input type="checkbox"/> Examiner's Amendment/Comment |
| 2. <input type="checkbox"/> Information Disclosure Statements (PTO/SB/08),
Paper No./Mail Date _____ | 6. <input type="checkbox"/> Examiner's Statement of Reasons for Allowance |
| 3. <input type="checkbox"/> Examiner's Comment Regarding Requirement for Deposit
of Biological Material | 7. <input type="checkbox"/> Other _____ |
| 4. <input type="checkbox"/> Interview Summary (PTO-413),
Paper No./Mail Date _____ | |

/Edward Tso/
Primary Examiner, Art Unit 2859