

(12) **United States Patent**
Lee et al.

(10) **Patent No.:** **US 7,281,328 B2**
(45) **Date of Patent:** **Oct. 16, 2007**

(54) **METHOD OF FABRICATING RIGID-FLEXIBLE PRINTED CIRCUIT BOARD**

(75) Inventors: **Yang Je Lee**, Chungcheongbuk-do (KR); **Dek Gin Yang**, Chungcheongbuk-do (KR); **Jung Wook Hwang**, Gyeongsangnam-do (KR); **Kyu Hyok Yim**, Chungcheongbuk-do (KR); **Jung Hun Chai**, Jeollabuk-do (KR); **Young Ho Lee**, Daegu (KR); **Kwang Yune Kim**, Daejeon (KR); **Dong Gi An**, Chungcheongnam-do (KR)

(73) Assignee: **Samsung Electro-Mechanics Co., Ltd.**, Kyunggi-Do (KR)

(*) Notice: Subject to any disclaimer, the term of this patent is extended or adjusted under 35 U.S.C. 154(b) by 0 days.

(21) Appl. No.: **11/253,973**

(22) Filed: **Oct. 18, 2005**

(65) **Prior Publication Data**
US 2006/0101640 A1 May 18, 2006

(30) **Foreign Application Priority Data**
Oct. 28, 2004 (KR) 10-2004-0086731

(51) **Int. Cl.**
H01K 3/10 (2006.01)

(52) **U.S. Cl.** **29/852; 29/846; 29/847; 174/254; 174/262; 427/97.1; 427/97.7**

(58) **Field of Classification Search** 29/846, 29/847, 852; 174/262, 254, 255; 427/97.1, 427/97.7

See application file for complete search history.

(56) **References Cited**

U.S. PATENT DOCUMENTS

5,095,628 A * 3/1992 McKenney et al. 29/846
5,206,463 A * 4/1993 DeMaso et al. 174/254
6,745,463 B1 * 6/2004 Chou 29/852

FOREIGN PATENT DOCUMENTS

JP 2003-101167 A 4/2003

* cited by examiner

Primary Examiner—Richard Chang

(74) *Attorney, Agent, or Firm*—Darby & Darby P.C.

(57) **ABSTRACT**

The present invention is related to a method of fabricating a rigid-flexible printed circuit board. Specifically, this invention relates to a method of fabricating a rigid-flexible printed circuit board, in which an internal circuit pattern exposed for use in an external pad and a mounting pad is protected from external environments using a resist cover by window etching the base copper foil of a flexible region upon formation of an external circuit pattern as opposed to using a resist cover. Thus the number of fabrication processes and the fabrication costs are decreased and the increase in defect rates due to contamination is prevented, resulting in maximized reliability.

5 Claims, 7 Drawing Sheets

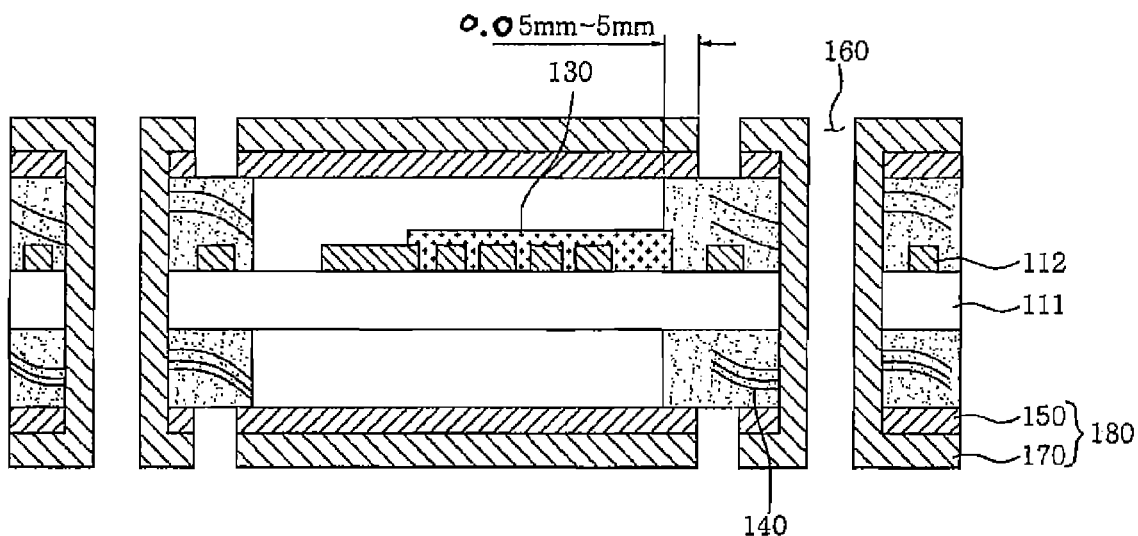

FIG. 1A
Prior Art

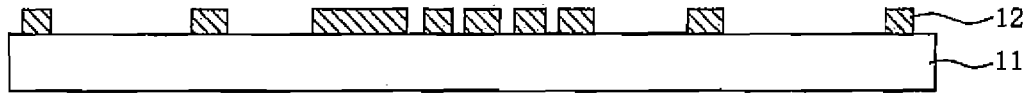

FIG. 1B
Prior Art

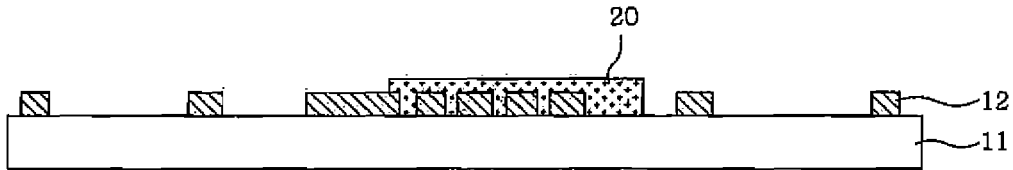

FIG. 1C
Prior Art

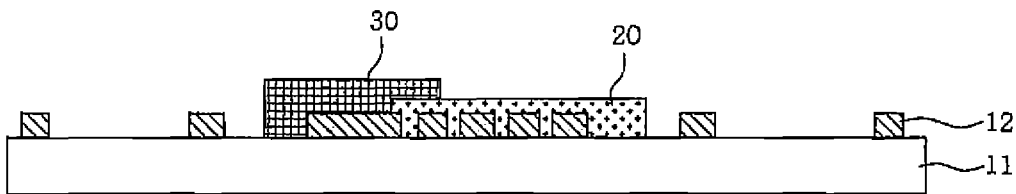

FIG. 1D
Prior Art

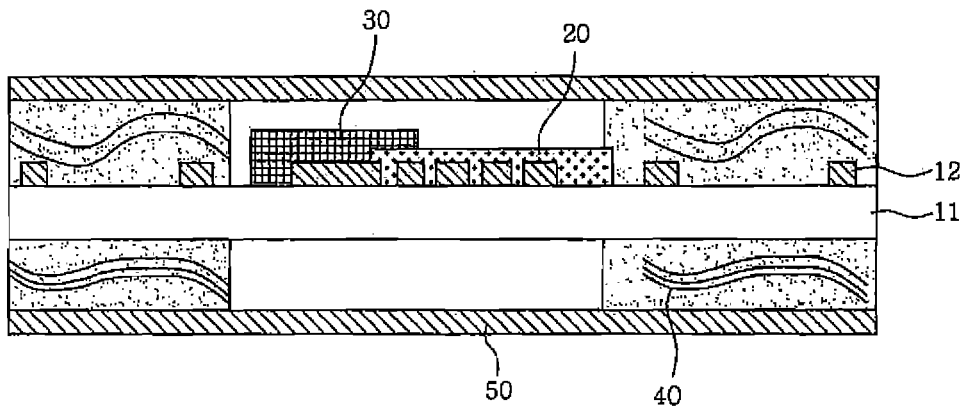

FIG. 1E
Prior Art

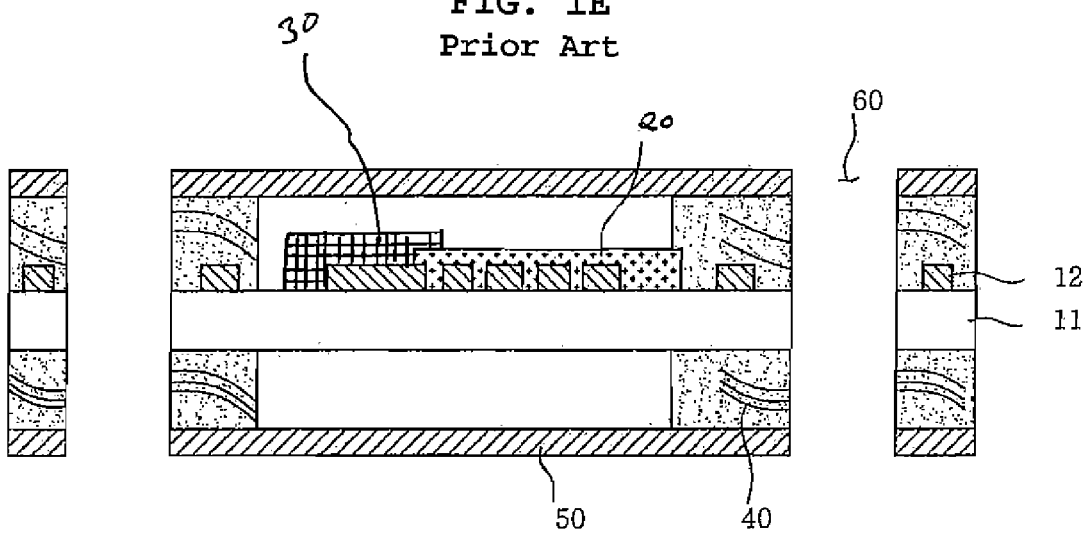

FIG. 1F
Prior Art

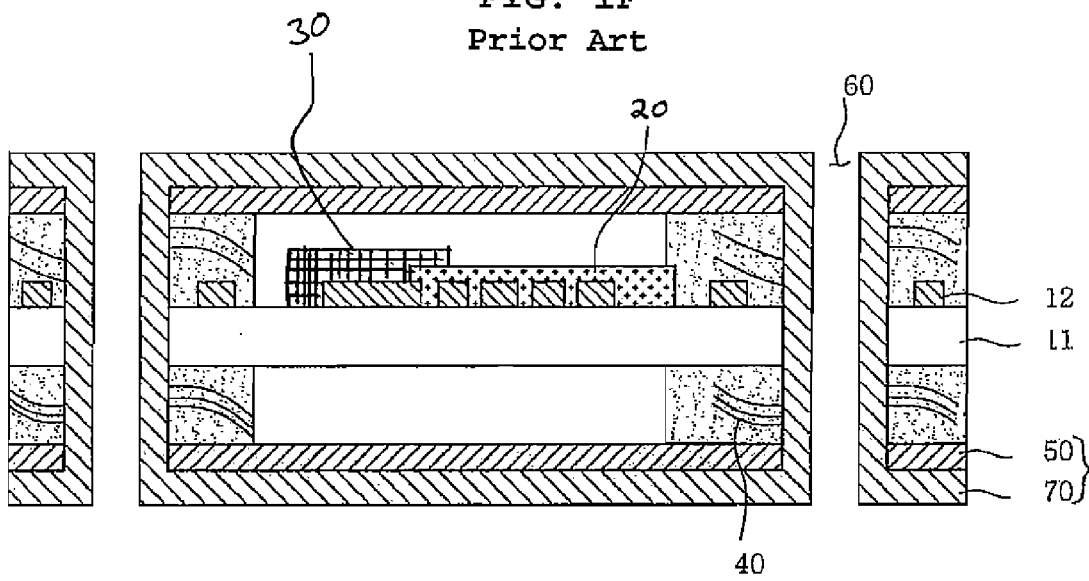

FIG. 1G
Prior Art

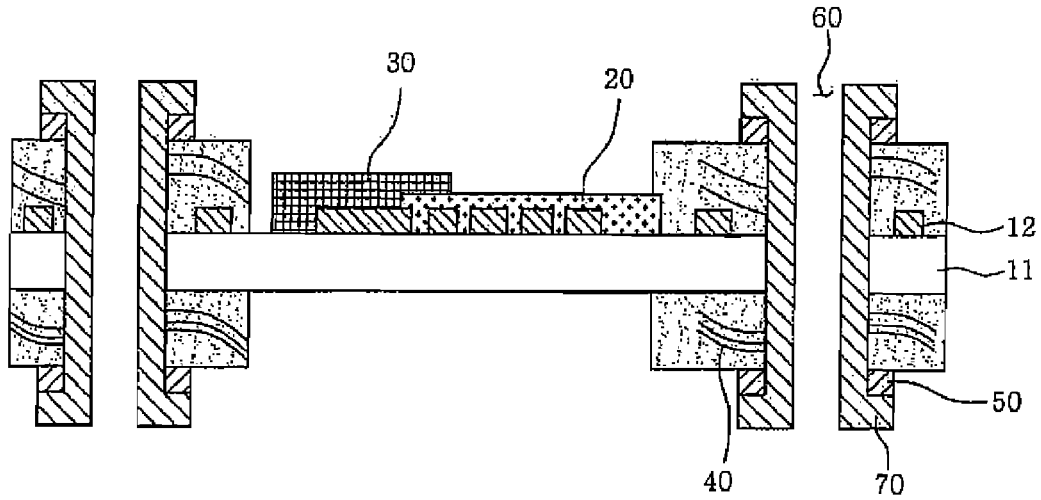

FIG. 1H
Prior Art

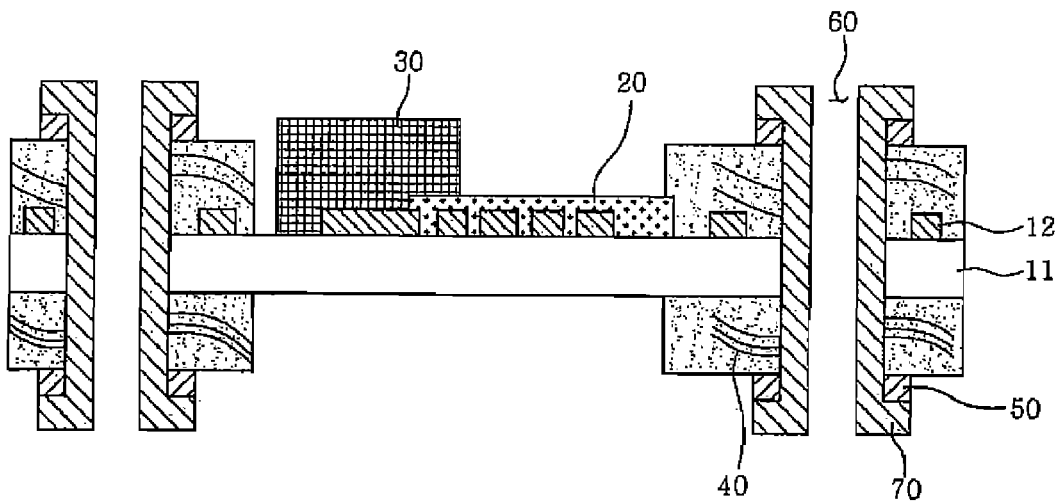

FIG. 1I
Prior Art

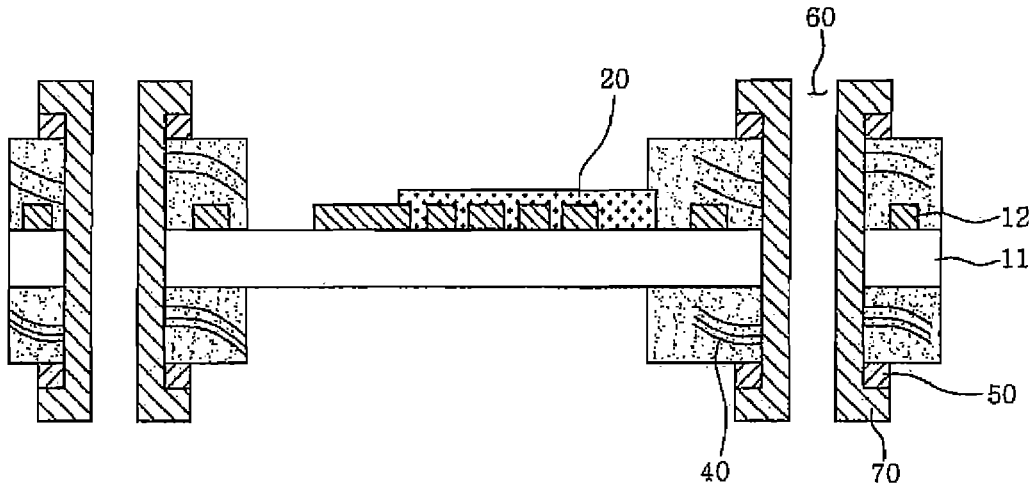

FIG. 2A

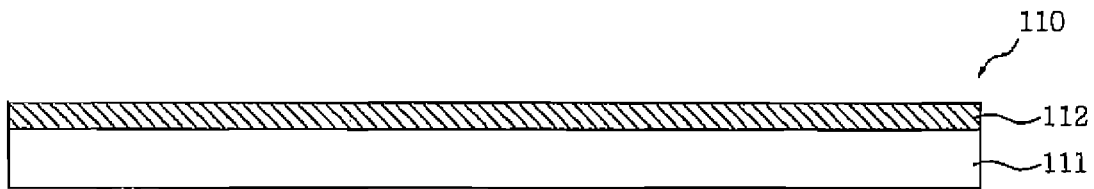

FIG. 2B

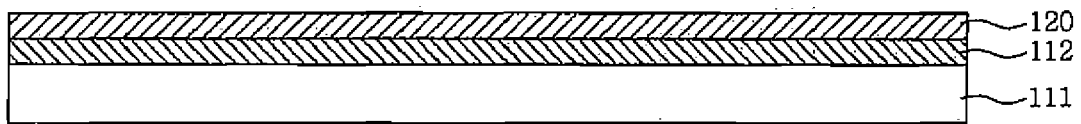

FIG. 2C

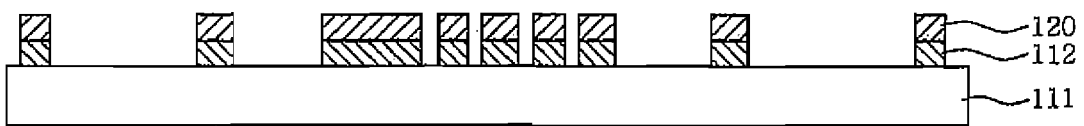
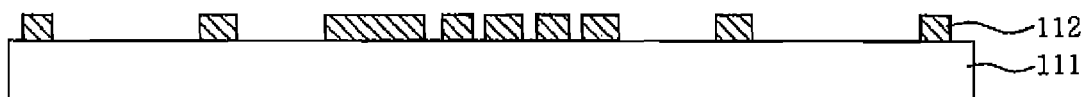

FIG. 2D



Explore Litigation Insights

Docket Alarm provides insights to develop a more informed litigation strategy and the peace of mind of knowing you're on top of things.

Real-Time Litigation Alerts



Keep your litigation team up-to-date with **real-time alerts** and advanced team management tools built for the enterprise, all while greatly reducing PACER spend.

Our comprehensive service means we can handle Federal, State, and Administrative courts across the country.

Advanced Docket Research



With over 230 million records, Docket Alarm's cloud-native docket research platform finds what other services can't. Coverage includes Federal, State, plus PTAB, TTAB, ITC and NLRB decisions, all in one place.

Identify arguments that have been successful in the past with full text, pinpoint searching. Link to case law cited within any court document via Fastcase.

Analytics At Your Fingertips



Learn what happened the last time a particular judge, opposing counsel or company faced cases similar to yours.

Advanced out-of-the-box PTAB and TTAB analytics are always at your fingertips.

API

Docket Alarm offers a powerful API (application programming interface) to developers that want to integrate case filings into their apps.

LAW FIRMS

Build custom dashboards for your attorneys and clients with live data direct from the court.

Automate many repetitive legal tasks like conflict checks, document management, and marketing.

FINANCIAL INSTITUTIONS

Litigation and bankruptcy checks for companies and debtors.

E-DISCOVERY AND LEGAL VENDORS

Sync your system to PACER to automate legal marketing.