

UNITED STATES PATENT AND TRADEMARK OFFICE

BEFORE THE PATENT TRIAL AND APPEAL BOARD

Samsung Electronics Co., Ltd. and Samsung Electronics America, Inc.,

Petitioners

v.

GUI Global Products, Ltd., D/B/A Gwee,

Patent Owner

Case IPR2021-00337

U.S. Patent No. 10,562,077

Petition for *Inter Partes* Review of

U.S. Patent No. 10,562,077

Table of Contents

I.	INTRODUCTION	1
II.	GROUND FOR STANDING (37 C.F.R. § 42.104(A)).....	1
III.	STATEMENT OF PRECISE RELIEF REQUESTED FOR EACH CLAIM CHALLENGED	1
	A. Claims for Which Review is Requested.....	1
	B. Statutory Grounds of Challenge.....	1
IV.	OVERVIEW OF THE '077 PATENT	3
	A. Disclosure of the '077 patent	3
	B. Prosecution History of the '077 patent.....	6
	C. The Challenged Claims Are Not Entitled To An Effective Filing Date Before November 3, 2011	7
V.	OVERVIEW OF THE PRIMARY PRIOR ART REFERENCE.....	9
	A. Overview of <i>Kim</i>	9
VI.	LEVEL OF ORDINARY SKILL IN THE ART	17
VII.	CLAIM CONSTRUCTION	17
VIII.	DETAILED EXPLANATION OF GROUNDS.....	18
	A. Ground 1: <i>Kim</i> Renders Obvious Claims 1-8	18
	1. Claim 1	19
	2. Claim 2.....	49
	3. Claim 3	49
	4. Claim 4.....	50

5.	Claim 5	50
6.	Claim 6	53
7.	Claims 7 and 8.....	55
B.	Ground 2: <i>Kim</i> and <i>Koh</i> Render Obvious Claim 11	56
1.	Claim 11	56
C.	Ground 3: <i>Kim</i> and <i>Lee</i> Render Obvious Claims 9-10 and 12-13	65
1.	Claim 9	65
2.	Claim 10.....	68
3.	Claim 12 and 13	69
IX.	THE DISCRETIONARY FACTORS FAVOR INSTITUTING TRIAL	70
A.	35 U.S.C. § 314(a).....	70
B.	35 U.S.C. § 325(d).....	75
X.	MANDATORY NOTICES UNDER 37 C.F.R. § 42.8.....	76
A.	Real Parties-in-Interest.....	76
B.	Related Matters.....	76
C.	Lead and Backup Counsel.....	77
D.	Service Information.....	77
XI.	FEES	77

PETITIONERS' EXHIBIT LIST

Exhibit No.	DESCRIPTION
1001	U.S. Patent No. 10,562,077
1002	Declaration of Sayfe Kiaei, Ph.D.
1003	Curriculum Vitae of Sayfe Kiaei, Ph.D.
1004	File History of U.S. Patent No. 10,562,077
1005	File History of U.S. Provisional Application No. 61/515,752
1006	Summary of all applications in the '077 patent's priority chain
1007	Excerpt of <i>GUI Global Products, Ltd., D/B/A Gwee v. Samsung Elecs. Co., Ltd., et al.</i> , Case No. 4:20-cv-2624 (S.D. Tex.), Gwee's P.R. 3-1 and 3-2 Disclosures (Nov. 6, 2020)
1008	File History of U.S. Patent No. 10,259,020
1009	File History of U.S. Patent No. 10,259,021
1010	U.S. Patent Application Publication 2010/0227642 to Kim <i>et al.</i>
1011	[RESERVED]
1012	Korean Patent Publication 10-2008-0093178 to Koh <i>et al.</i>
1013	U.S. Patent Application Publication 2010/0298032 to Lee <i>et al.</i>
1014	[RESERVED]
1015	U.S. Patent Application Publication 2008/0166005 to Terlizzi
1016	U.S. Patent Application Publication 2006/0152576 to Kiessling
1017	U.S. Patent Application Publication 2003/0164895 to Viinikanoja
1018	International Publication WO 2010/142290 to Birger
1019	U.S. Patent No. 6,809,774 to Yamazaki
1020	U.S. Patent No. 7,251,197 to Yoshida <i>et al.</i>
1021	U.S. Patent Application Publication 2011/0211297 to Griffin <i>et al.</i>
1022	U.S. Patent Application Publication 2006/0071746 to Lylyharju
1023	A Dictionary of Chemistry, 5th ed. (2004)
1024	Order granting [39] Motion to Consolidate Cases in <i>GUI Global Products, Ltd., D/B/A Gwee v. Samsung Elecs. Co., Ltd., et al.</i> , Case No. 4:20-cv-2624 (S.D. Tex.)
1025	Docket listing in <i>GUI Global Products, Ltd., D/B/A Gwee v. Samsung Elecs. Co., Ltd., et al.</i> , Case No. 4:20-cv-2624 (S.D. Tex.)
1026	Joint Motion for Scheduling Order in <i>GUI Global Products, Ltd., D/B/A Gwee v. Samsung Elecs. Co., Ltd., et al.</i> , Case No. 4:20-cv-2624 (S.D. Tex.)
1027	Letter from Jin-Suk Park to John Edmonds, dated December 29, 2020

Exhibit No.	DESCRIPTION
1028	[RESERVED]
1029	Bluetooth Audio/Video Remote Control Profile, rev. 13 (April 16, 2007)
1030	“Application Data” with respect to U.S. Patent No. 10,562,077 retrieved from PTO Public PAIR system

I. INTRODUCTION

Petitioners Samsung Electronics Co., Ltd. and Samsung Electronics America, Inc. (“Samsung” or “Petitioners”) request *inter partes* review of claims 1-13 of U.S. Patent No. 10,562,077 (“the ’077 patent”).

II. GROUNDS FOR STANDING (37 C.F.R. § 42.104(A))

Petitioners certify that the ’077 patent is available for *inter partes* review (“IPR”) and Petitioners are not barred or estopped from requesting IPR to challenge the claims on the grounds herein. Petitioners file this Petition within one year of service of Patent Owner’s (“PO”) complaint against Petitioners in district court. *See GUI Global Products, Ltd., D/B/A Gwee v. Samsung Elecs. Co., Ltd., et al.*, Case No. 4:20-cv-2624 (S.D. Tex.) (Samsung Electronics America, Inc. served 7/29/2020).

III. STATEMENT OF PRECISE RELIEF REQUESTED FOR EACH CLAIM CHALLENGED

A. Claims for Which Review is Requested

Samsung respectfully requests review of claims 1-13 (“challenged claims”) of the ’077 patent and cancellation of these claims under 35 U.S.C. § 311 as unpatentable.

B. Statutory Grounds of Challenge

Claims 1-13 should be cancelled as unpatentable on the following grounds:

Ground 1: Claims 1-8 are unpatentable under AIA 35 U.S.C. § 103 as being

obvious over U.S. Patent Application Publication 2010/0227642 (“*Kim*”) (EX1010);

Ground 2: Claim 11 is unpatentable under AIA 35 U.S.C. § 103 as being obvious over *Kim* in view of Korean Patent Publication 10-2008-0093178 (“*Koh*”) (EX1012)¹;

Ground 3: Claims 9-10 and 12-13 are unpatentable under AIA 35 U.S.C. § 103 as being obvious over *Kim* in view of U.S. Patent Application Publication 2010/0298032 (“*Lee*”) (EX1013).

As further explained below in Section IV.C, the challenged claims are not entitled to an effective filing date earlier than November 3, 2011.² *Kim* published on September 9, 2010. *Koh* published on October 21, 2008. *Lee* published on November 25, 2010. Thus, each of *Kim*, *Koh*, and *Lee* qualify as prior art at least

¹ EX1012 is a compilation comprising the English-language translation of *Koh* (EX1012, 1-15), and its Korean language version (*id.*, 16-30), and an affidavit required by 37 C.F.R. § 42.63(b) (in the form of a declaration as permitted by 37 C.F.R. § 42.2) (*id.*, 31).

² While for purposes of this proceeding Samsung asserts that the challenged claims are not entitled to a priority date earlier than November 3, 2011, Samsung reserves the right to challenge any priority claims(s) made by PO with respect to the '077 patent in this proceeding or in the district court litigation.

under AIA 35 U.S.C. § 102(a)(1).³

According to the “Application Data” information on the Public Patent Application Information Retrieval system, the ’077 patent was examined under the provisions of the America Invents Act (“AIA”). EX1030, 1. All of the references relied on in this petition would remain prior art under § 102, and the challenged claims would still be unpatentable under § 103, even if the Board determines that the ’077 patent is subject to pre-AIA law.

IV. OVERVIEW OF THE ’077 PATENT

A. Disclosure of the ’077 patent

The ’077 patent is generally directed to a cleaning component for cleaning a lens or view screen of an electronic device that “is configured to selectively couple to the at least one case or some other substrate using a magnetic attractive force.” EX1001, Abstract.

According to the ’077 patent, “[c]leaning lenses has long been an issue for the users of devices employing them” (*id.*, 1:44-45), and “[c]leaning the view screen of a portable electronic device can be problematic” because “[c]arrying appropriate

³ The exceptions in AIA 35 U.S.C. § 102(b) are inapplicable to *Koh*. The exceptions are also inapplicable to *Kim* when the challenged claims are properly accorded a priority date no earlier than November 3, 2011.

cleaning materials is sometimes a problem” (*id.*, 1:65-2:5). Thus, the ’077 patent states “it would be desirable ... to incorporate into [the portable electronic device] the cleaning apparatus” and that “it would also be desirable ... to provide a cleaning component that can be carried on an electronic device case.” *Id.*, 2:9-15.

To remedy the perceived problems in the art, the ’077 patent purports to disclose several embodiments such as, for example, “a method of cleaning a view screen of an electronic device” (*id.*, 2:19-24), “a cleaning component for use on an electronic device view” (*id.*, 2:25-29), and “a switching device for use with a portable electronic device having a view screen” (*id.*, 4:1-16).

While the bulk of the ’077 patent describes methods of cleaning and aspects of a cleaning device, it mentions that “[i]n addition to their cleaning functionality, the cleaning components of the application have a functionality of being able to activ[ate] magnetic switches on devices having such switches.” *Id.*, 11:63-66. In one embodiment, the cleaning device may also have “additional functionality such as a remote control, laser pointer or the like” and, paradoxically, the cleaning device “may or may not include cleaning capabilities but will include a rare earth magnet or magnets.” *Id.*, 16:31-43. Functionality may also include, “pointing devices,” “remote functionality,” “flash drive,” “earplugs,” “credit card reader, microphone, and the like.” *Id.*, 16:49-59.

The ’077 patent further discloses a switching device for use in a portable

electronic device having a view screen. *Id.*, 17:55-56. This embodiment is shown below:

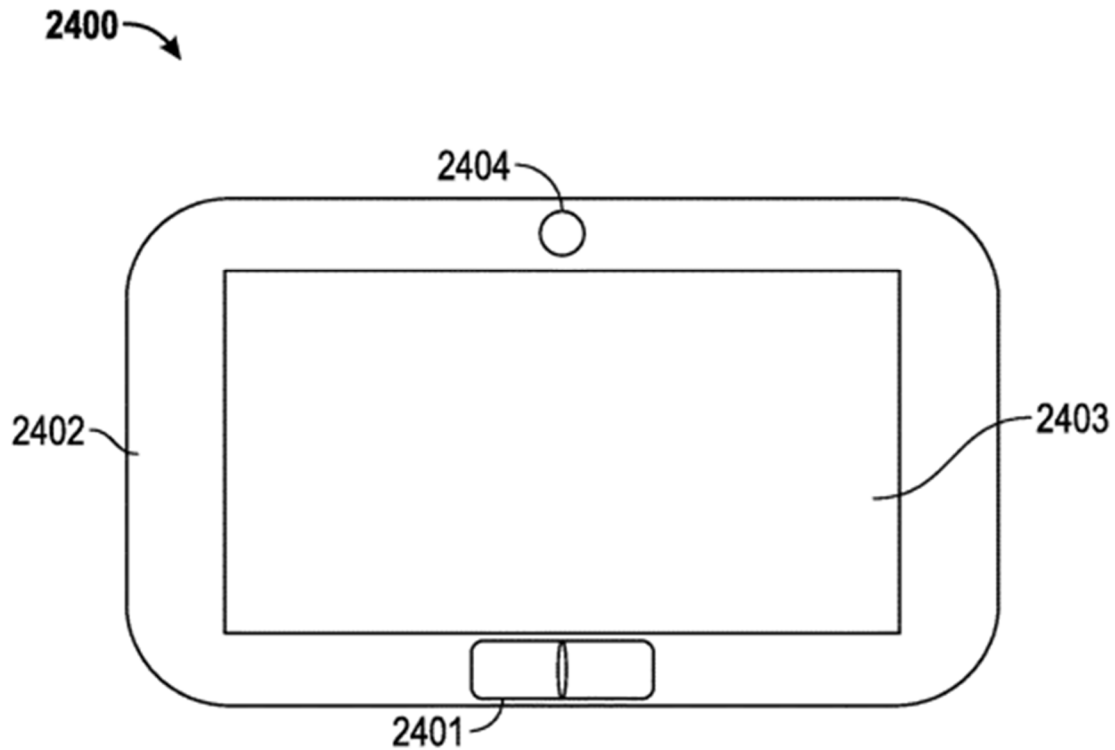

FIG. 24

EX1001, FIG. 24.

The “switching device (2401) is selectively coupled to the front of the portable electronic device 2402 outside of the view screen 2403.” *Id.*, 18:8-10. A side view of the switching device 2401 is shown below:

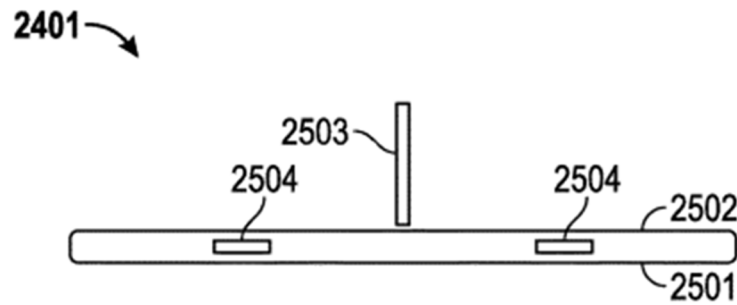

FIG. 25

EX1001, FIG. 25.

The '077 patent further discloses that the switching devices have a functionality of being able to “active[ate] magnetic switches on devices having such switches.” *Id.*, 20:15-16.

B. Prosecution History of the '077 patent

The '077 patent issued on February 18, 2020, from U.S. Application No. 16/460,770 (“the '770 application”) filed July 2, 2019. The '770 application claims priority to International Application No. PCT/US2012/049562 (“the '562 PCT application”) filed on August 3, 2012, through five intervening continuation applications. The '562 PCT application in turn claims priority to nine U.S. provisional patent applications filed between August 5, 2011 and June 18, 2012. Exhibit 1006 summarizes the relationship of all the applications in the '077 patent’s priority chain.

The originally-filed claims of the '077 patent included the limitation “the portable switching device is configured to activate, deactivate or send into

hibernation the portable electronic device,” which was the basis on which the examiner had allowed two earlier-filed related patents. EX1004, 38; EX1008, 155-158; EX1009, 152-153. The ’077 patent issued without any rejections. EX1004, 301-304.

C. The Challenged Claims Are Not Entitled To An Effective Filing Date Before November 3, 2011

For purposes of this proceeding, Samsung asserts that the challenged claims are not entitled to a priority date earlier than November 3, 2011.⁴

The Board can consider the challenged claims’ priority date. *See SAP Am., Inc. v. Lakshmi Arunachalam*, IPR2014-00414, Paper 24 at 22 (Aug. 17, 2015). The ’077 patent can claim priority to an earlier application only if the earlier application, *inter alia*, provides an adequate written description for the claims. 35 U.S.C. §120; *Anascape, Ltd. v. Nintendo of Am., Inc.*, 601 F.3d 1333, 1334-35 (Fed. Cir. 2010). “[T]he hallmark of written description is disclosure.” *Ariad Pharm., Inc. v. Eli Lilly & Co.*, 598 F.3d 1336, 1351 (Fed. Cir. 2010) (en banc). “Entitlement to a filing date does not extend to subject matter which is not disclosed, but would be obvious over what is expressly disclosed. It extends only to that which is disclosed.... a prior application itself must describe an invention, and do so in sufficient detail that one

⁴ See footnote 2.

skilled in the art can clearly conclude that the inventor invented the claimed invention as of the filing date sought.” *Lockwood v. Am. Airlines, Inc.*, 107 F.3d 1565, 1571-72 (Fed. Cir. 1997).

U.S. Provisional Application No. 61/515,752 (“the ’752 provisional application”)—which was filed on August 5, 2011—fails to provide adequate written description of at least the following limitations of claim 1: “***a portable switching device***”⁵; “***the switching device*** and the electronic device are configured to selectively couple to each other employing magnetic force”; and “***the portable switching device*** is configured to activate, deactivate or send into hibernation the portable electronic device.” EX1001, claim 1; *see generally* EX1005. In fact, the ’752 provisional application is completely silent about “switching devices” in any form. EX1002, ¶38.

Because the ’752 provisional application does not provide adequate written description of at least the above claim limitations, the challenged claims are entitled to a priority date no earlier than November 3, 2011—the filing date of U.S. Provisional Application No. 61/555,310.⁶ Indeed, PO appears to concede this point.

⁵ All bold/italics/color emphases are added unless noted otherwise.

⁶ *See* footnote 2. Samsung also reserves all rights to raise arguments under 35 U.S.C. §112 in the district court litigation.

EX1007, 7. Notably, in identifying the '077 patent's priority chain in the district court litigation, PO made no mention of the '752 provisional application. *Id.*

V. OVERVIEW OF THE PRIMARY PRIOR ART REFERENCE

A. Overview of *Kim*

Kim discloses devices to enable a user to activate and deactivate an electronic device with a separate switching device—and does so using the same features claimed in the '077 patent. EX1002, ¶39. More particularly, *Kim*'s disclosure is directed to *mobile terminals*, such as mobile phones, smart phones, personal digital assistants, portable multimedia players (PMP) and/or navigators. EX1010, ¶¶69-70.

Kim describes the structure and functionality of the mobile terminal with respect to a number of interrelated embodiments. *Kim* teaches that the disclosed embodiments “may be used singly and/or by being combined together.” EX1010, ¶179; EX1002, ¶¶41, 48. *Kim* initially discusses various features that are common to the mobile terminals. For example, *Kim* states that “FIG. 1 is a block diagram of a mobile terminal” including “a wireless communication unit 110, an audio/video (A/V) input unit 120, a user input unit 130, a sensing unit 140, an output unit 150, a memory 160, an interface unit 170, a controller 180 and a power supply 190.” EX1010, ¶72. *Kim* discloses the mobile terminal including “more or less” components than shown in Figure 1. *Id.*, ¶71. Figure 1 is reproduced below:

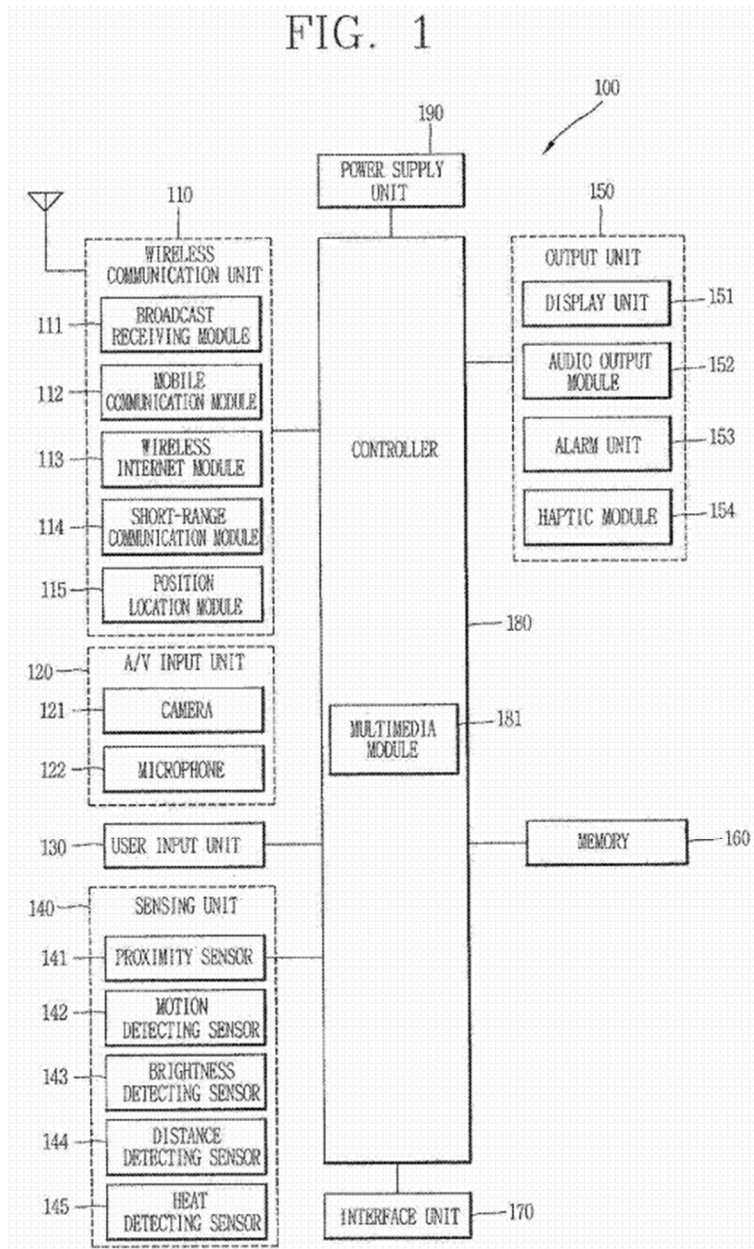

EX1010, FIG. 1.

Kim provides detailed descriptions of each of these “units,” for example, describing the A/V unit 120 as including a camera and the sensing unit 140 as detecting an open/close status of the mobile terminal 100. *See id.*, ¶¶73-119 (describing the various units and modules in the mobile terminal).

Kim teaches the mobile terminal including “a main device (first device) 100 and one or more sub-devices (second devices) 300a to 300n that can be detachably attached to the main device.” EX1010, ¶181. Figure 7 illustrates this concept:

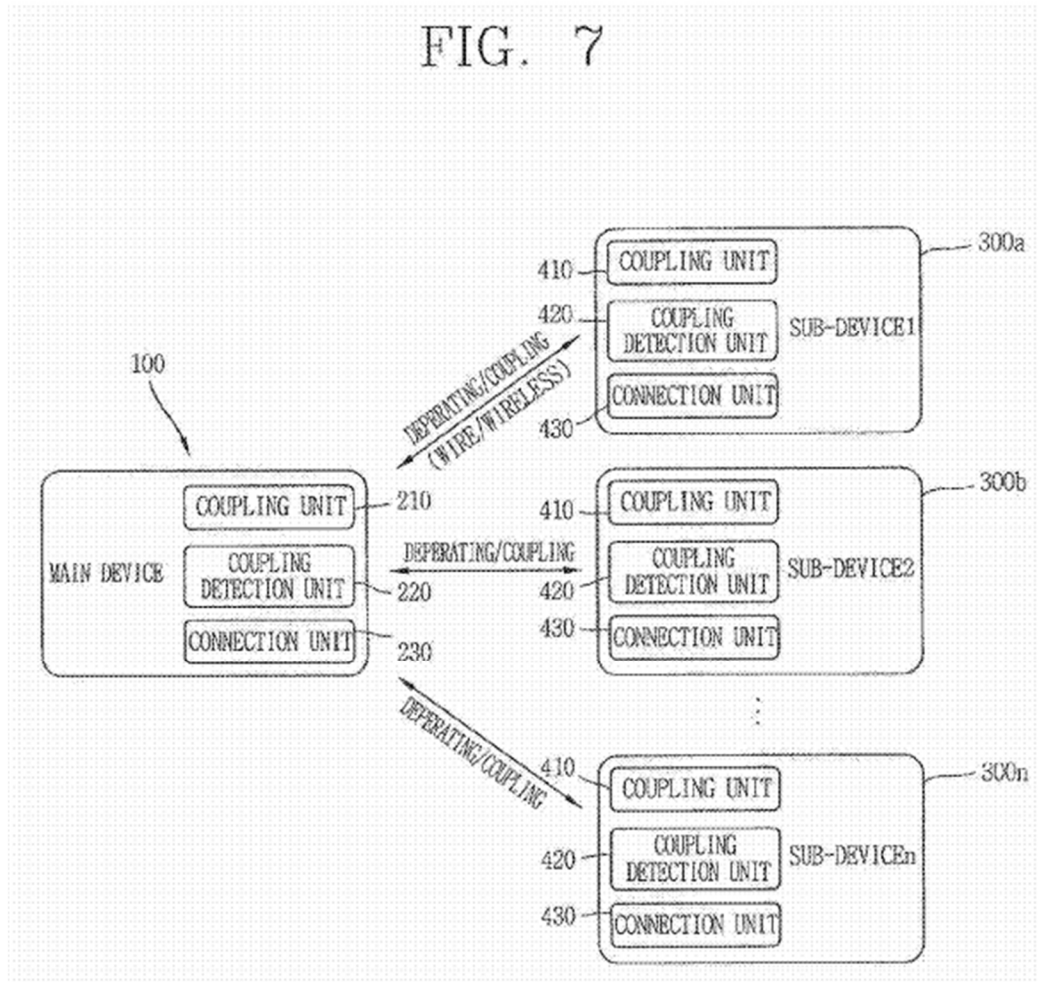

EX1010, FIG. 7.

Kim discloses the main device 100 including all the elements of the mobile terminal as described with respect to Figure 1, and additionally including a coupling unit, coupling detection unit, and a connection unit. *Id.*, ¶182. *Kim* also discloses configuring the sub-devices 300 “to include all the same elements as those of the

main device.” *Id.*, ¶187. Thus, *Kim* discloses the main device and the sub-devices each including suitable combinations of components, hardware and/or functionality as disclosed, for example, in *Kim*’s various embodiments (including Figure 1). EX1002, ¶¶42-48.

Kim describes at least five types of main devices that structurally combine with at least one sub-device. For example, the main device can be a folder-type (*e.g.*, Figures 11A-11E), slide-type (*e.g.*, Figures 12A-12E), swivel-type (*e.g.*, Figures 13A-13D), a bar-type (*e.g.*, Figures 14A-14D), and/or a watch-type (*e.g.*, Figures 15A-15D). *Id.*, ¶210. In one embodiment, the folder-type main device is comprised of a first body 100a connected to a second body 100b such that they “may be folded or unfolded” and the sub-device 300 overlaps and couples to the first body 100a of the main device using coupling member 510.⁷ *Id.*, ¶¶217-218, FIG. 11B. *Kim* further explains that the main device “may be folded or unfolded regardless of the coupling or separating of the sub-device.” *Id.*, ¶218.

⁷ Although Figure 11B and the accompanying discussion describe the sub-device 300 coupling to the first body 100a of the main device, *Kim* states that this is merely “for ... brevity” and that the sub-device “may be overlapped to be coupled to [either] one of the first and second bodies” of the main device. *Id.*, ¶217.

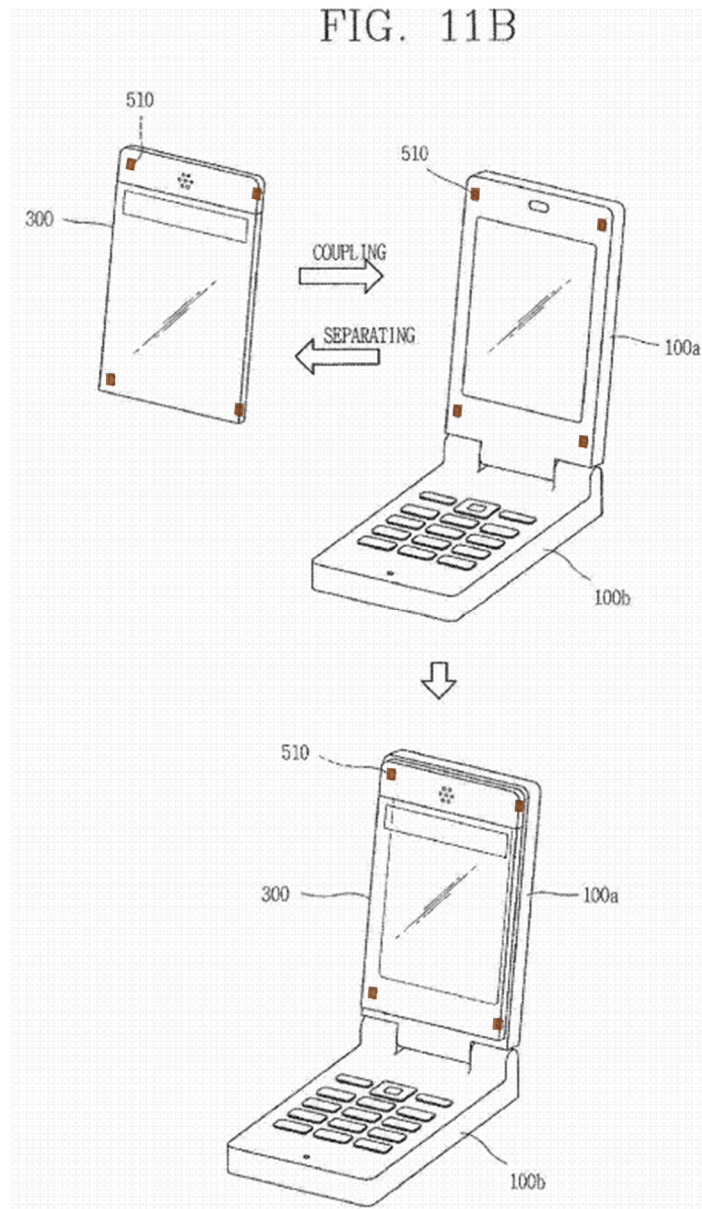

EX1010, FIG. 11B.

Kim explains that the coupling members 510 (brown), can be complementary recesses and hooks, or magnets. *Id.*, ¶¶218, 220.

Kim includes similar disclosures with respect to the watch-type embodiment of the main device. For example, *Kim*'s Figure 15A discloses a watch-type main

device having a first body 100a and second body 100b that are connected and can be opened or closed in a manner similar to the embodiment shown in Figure 11B (EX1010, ¶256), and further discloses a sub-device 300 overlapping and coupling to either the first body or the second body as shown, for example, in Figure 15B (*id.*, ¶260).⁸

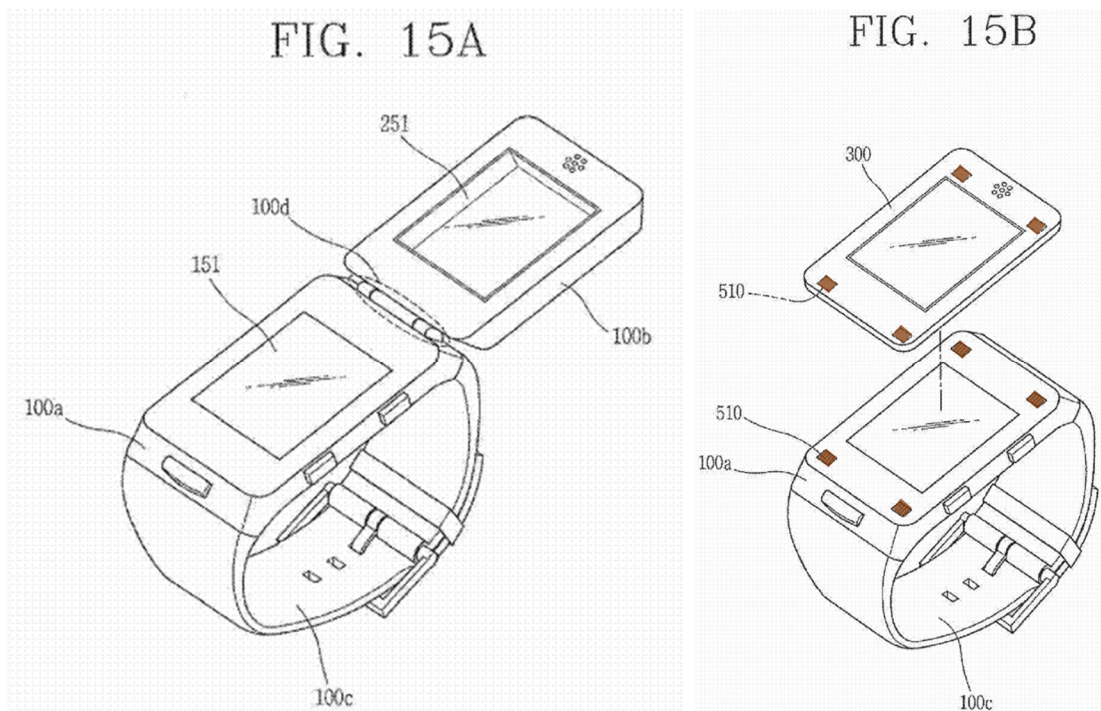

EX1010, FIGS. 15A, 15B.

⁸ Although Figure 15B shows the sub-device coupled to the body 100a and does not show the body 100b, *Kim* explains this is merely for the sake of brevity. See EX1010, ¶260 (“The method of coupling the sub-device in an overlapping manner to the second body will now be described for the sake of brevity.”).

Kim also discloses various functionality of the main device and the sub-device dependent on their coupling state. *Id.*, ¶¶267-268. In particular, *Kim* discloses that the main device and sub-device operate differently when coupled and uncoupled from each other. *Id.*, ¶¶270, 274 (“The controller 180 differently controls the operations (e.g., display) of the main device 100 and the sub-device 300 according to an engaged state.”). For example, *Kim* explains that “when the main device 100 and the sub-device 300 are engaged ..., the controller 180 displays a menu display method or menu items that can be conveniently manipulated ... upon detection of it.” *Id.*, ¶275. As illustrated in Figure 17A, for example,⁹ a screen is activated to display a specific menu when the sub-device is inserted and interacts with the main device:

⁹ Here *Kim* also explains that a “bar type mobile terminal [is] described as an example for the sake of brevity.” EX1010, ¶273.

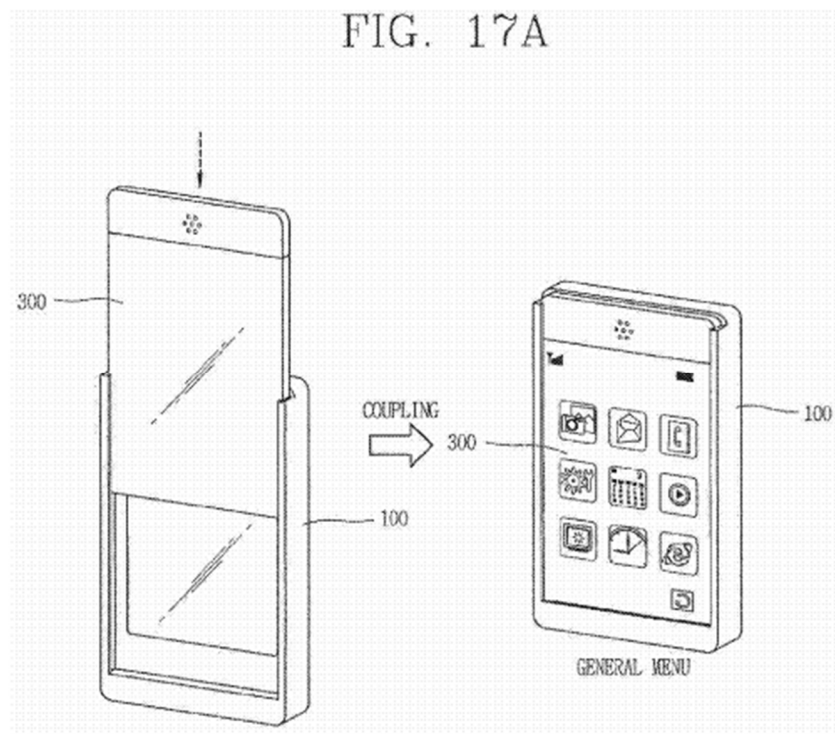

EX1010, FIG. 17A.

Kim also explains that coupling and decoupling the sub-device from the main device turns the power to the display of the main device on and off. EX1010, ¶¶299-302, FIG. 24. *Kim* additionally discloses the sub-device turning the main device on or off through user interaction with the sub-device. *Id.*, ¶¶316-319, 417-418, FIGs. 27, 42.

Kim further discloses a user controlling various applications of a personal computer (e.g., a desktop computer, a notebook computer, etc.) by using the sub-device 300. *Id.* ¶342. The sub-device establishes a short-range communication path between the two devices to control various applications of the personal computer.

Id., ¶343. The user executes music files or video files of the personal computer through a touch input via the sub-device 300. *Id.*, ¶344, FIG. 31.

VI. LEVEL OF ORDINARY SKILL IN THE ART

A person of ordinary skill in the art at the time of the alleged invention of the '077 patent (“POSITA”), which for purposes of this proceeding is no earlier than November 3, 2011, would have had a bachelor’s degree in electrical engineering, computer science, or a similar field and one year of experience in consumer electronics product design. The POSITA could have also obtained similar knowledge and experience through other means. EX1002, ¶¶21-22.

VII. CLAIM CONSTRUCTION

The claims should be construed “in accordance with the ordinary and customary meaning of such claim as understood by one of ordinary skill in the art and the prosecution history pertaining to the patent.” 37 C.F.R. § 42.100(b); *see also Phillips v. AWH Corp.*, 415 F.3d 1303 (Fed. Cir. 2005) (en banc). Petitioners are unaware of any “prior claim construction determination” related to the '077 patent. *See* 37 C.F.R. § 42.100(b).

The Board only construes the claims when necessary to resolve the underlying

controversy in the IPR.¹⁰ *Toyota Motor Corp. v. Cellport Systems, Inc.*, IPR2015-00633, Paper No. 11 at 16 (Aug. 14, 2015) (citing *Vivid Techs., Inc. v. Am. Sci. & Eng'g, Inc.*, 200 F.3d 795, 803 (Fed. Cir. 1999)). Here, given the close correlation and substantial identity between the prior art references and the challenged claims, Petitioners believe that no express constructions of the claims are necessary to assess whether the prior art reads on the challenged claims.

VIII. DETAILED EXPLANATION OF GROUNDS

A. Ground 1: *Kim* Renders Obvious Claims 1-8

Ground 1 sets forth an obviousness ground based on the combination of *Kim*'s watch-type main device incorporating features described with respect to other embodiments.

¹⁰ Petitioners intend to argue in the district court that Applicants acted as their own lexicographer with respect to the term “portable electronic device” to mean “portable electronic device having a view screen” or a substantially similar construction. The challenged claims are unpatentable in view of the grounds presented here regardless of whether the Board adopts such a construction. Petitioners reserve all rights to raise additional claim construction arguments in other proceedings. For example, comparing the claims to the accused products may raise controversies that require construction.

1. Claim 1

a. “A system comprising:”

To the extent the preamble is limiting, *Kim* discloses this feature. EX1002, ¶¶79-95. For example, *Kim* discloses a mobile terminal comprising a main device and sub-device(s) detachably coupled to the main device. EX1010, ¶181, Claim 1; EX1002, ¶79. *Kim*'s Figure 7, reproduced below, illustrates this point by reference to main device 100 and sub-devices 300a to 300n:

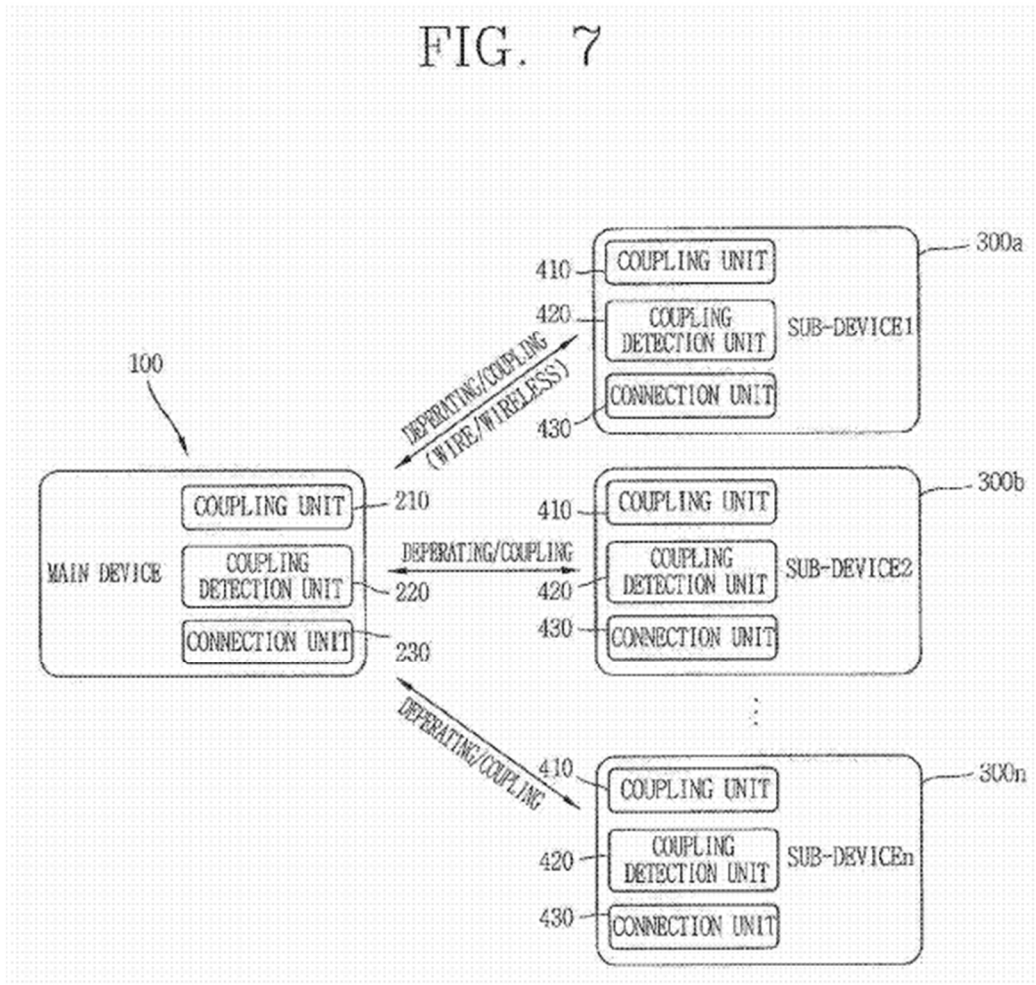

EX1010, FIG. 7.

As discussed above in Section V.A, *Kim* teaches the main device having different form factors, including a folder-type main device or a watch-type main device. EX1010, ¶¶210-222, 255-262, FIGs. 11A-11E, 15A-15D; EX1002, ¶¶80-83. *Kim* discloses an embodiment of the watch-type main device having a first body 100a attached to a band part 100c, and a second body 100b attached to the first body 100a. The two bodies 100a and 100b are connected by hinge 100d so that the second body 100b can be opened or closed in a folding manner. EX1010, ¶256, FIG. 15A.

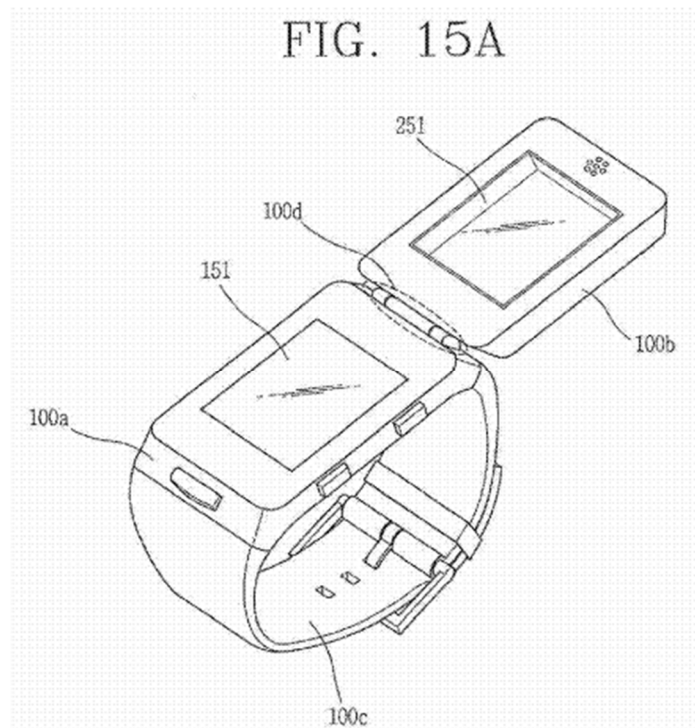

EX1010, FIG. 15A.

Kim additionally discloses a sub-device detachably coupling to such a watch-type main device. *Id.*, ¶¶260-261. Specifically, *Kim* discloses that “[a] method of ***coupling the third body (i.e., the sub-device)*** ... to one of the first and second bodies

in a state that the first and second bodies are coupled will now be described.” *Id.*, ¶260, *see also id.* ¶217 (disclosing with respect to the similar folder-type embodiment of Figure 11B that a “third body may be ... coupled to one of the first and second bodies in a state that the first and second bodies are coupled.”). However, “for the sake of brevity,” the discussion that immediately follows with respect to Figure 15B relates to “coupling the sub-device in an overlapping manner to the second body.” *Id.*, ¶260.

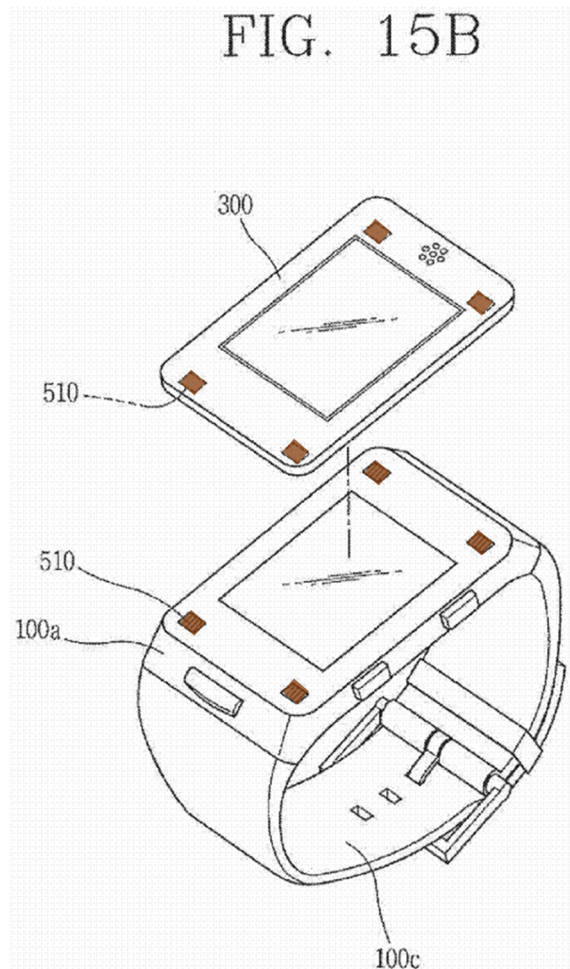

EX1010, FIG. 15B

Kim teaches that “a coupling member 510 [annotated brown] for fixing the sub-device is provided on at least one side of the second body, and the sub-device may be adjusted to the position where the coupling member is formed, and pressed to be coupled.” *Id.*, ¶261.

Accordingly, a POSITA would have understood *Kim* to disclose an embodiment of the mobile terminal in which a watch-type main device comprises a first body 100a connected to a second body 100b by a hinge 100d so that the first and second bodies can be opened or closed in a folding manner, and wherein the mobile terminal further comprises *a sub-device 300 detachably coupled to the second body 100b*. EX1002, ¶¶82-85. Below is a schematic representation of such a mobile terminal. *Id.*, ¶85. For ease of reference, Petitioners refer to the embodiment below as “Figure A” throughout this Petition.

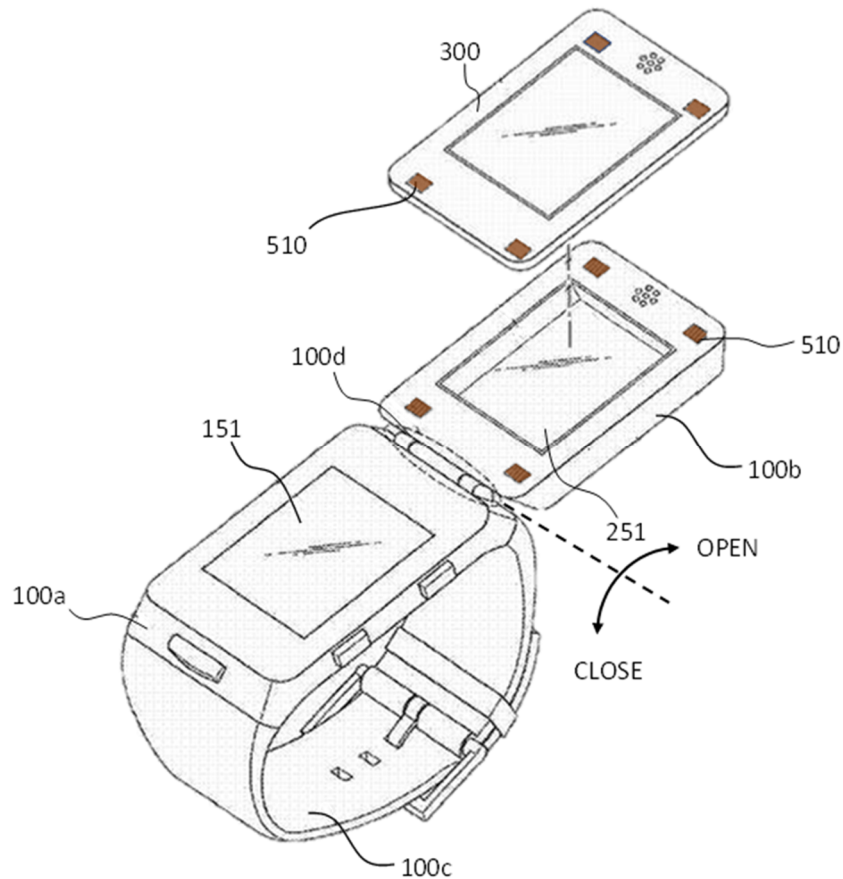
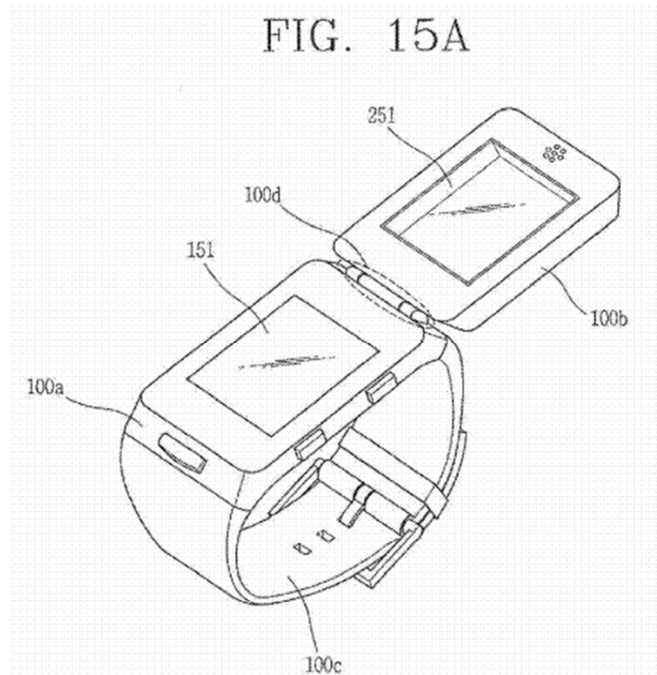
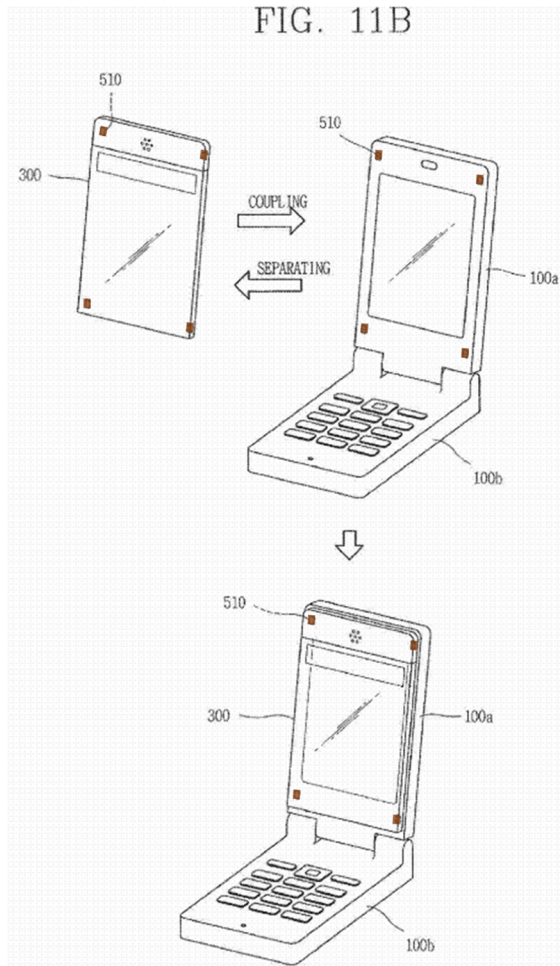

Figure A (based on *Kim*'s disclosure)

A POSITA would have understood that in the embodiment shown above, a sub-device 300 detachably couples to the main device's second body 100b through coupling members 510 (brown). *Kim* further discloses that coupling members 510 can be recesses/hooks or magnets. EX1010, ¶¶185, 218; EX1002, ¶¶83-86.

To the extent that PO argues that *Kim* does not disclose the embodiment shown in Figure A, such an embodiment would have been obvious to a POSITA in view of *Kim*'s disclosure. EX1002, ¶¶87-95. A POSITA would have recognized that the watch-type embodiment shown in Figures 15A is similar and closely related

to the folder-type embodiments shown in Figures 11B. EX1002, ¶¶88-90.



EX1010, FIGS. 11B, 15A.

For example, in both embodiments the main device comprises a first body and a second body connected to each other by a hinge so that the two bodies can open or close in a folding manner. EX1002, ¶¶88-89. With respect to both embodiments, *Kim* discloses using coupling members 510 (which can be magnets) to detachably couple the sub-device to the main device. EX1010, ¶¶212, 218, 220, 261; EX1002,

¶¶88-89. *Kim* also provides similar disclosures regarding the structure and functionality the folder-type and watch-type embodiments. EX1002, ¶¶88-89.

A POSITA would have recognized that because of the similarities between *Kim*'s folder-type and watch-type embodiments, *Kim*'s disclosure with respect to Figure 11B could have been adapted and applied to detachably couple sub-device 300 to the second body 100b of the watch-type embodiment in the manner shown in Figure A. EX1002, ¶¶90. Doing so would have been obvious to a POSITA because *Kim* itself suggests the modification. More particularly, *Kim* states that the embodiments it describes "may be used singly and/or by being combined together." EX1010, ¶¶179. Having reviewed the embodiment disclosed in *Kim*'s Figure 11B, a POSITA would have recognized the feasibility and desirability of modifying the embodiment of *Kim*'s Figure 15A to detachably couple sub-device 300 to the second body 100b using coupling members 510. EX1002, ¶¶90-95.

The modification would have further been obvious to a POSITA. EX1002, ¶¶90-95. For example, they would have amounted to use of a known technique (coupling a sub-device to a folder-type main device having first and second bodies using coupling members) to improve a similar device (a watch-type main device having two bodies that connect to each other in a folding manner) to obtain predictable results (detachably couple the sub-device to the main device's second body using coupling members). EX1002, ¶¶93-94.

Thus, at least because *Kim*'s mobile terminal is made up of a main device and a sub-device, a POSITA would have understood that the mobile terminal is a "system." EX1002, ¶¶79, 95. A POSITA would have further understood that one particular embodiment of such a system disclosed or suggested by *Kim* is a system in which a watch-type main device has first and second bodies connected by a hinge so that the first and second bodies can be opened or closed in a folding manner, with a sub-device detachably coupled to one of the two bodies of the main device using coupling members such as magnets or complementary recesses/hooks. EX1002, ¶¶83-84, 95.

b. "a portable switching device coupled to a portable electronic device; wherein:"

Kim discloses or suggests this feature. EX1002, ¶¶96-101. For example, *Kim* discloses detachably coupling a sub-device 300 to a main device 100. EX1010, ¶181; EX1002, ¶96.

As explained above in Section V.A, *Kim*'s disclosure focuses on *mobile* terminals such as mobile phones, smart phones, or portable multimedia players. EX1010, ¶¶69-70. *Kim* expressly discloses that a mobile terminal is a "portable terminal." *Id.*, ¶5. Additionally, a POSITA would have recognized that the watch-type main device and associated sub-device shown in Figure A was portable because it was designed to be worn on a user's wrist. Thus, the mobile terminal and all of its

components—the main device and sub-device—are “portable.” EX1002, ¶97.

Kim explains that the sub-device (“portable electronic device”) includes the same components as the main device, such as display unit 251, a controller 280, and a power supply unit 290. EX1010, ¶198. A POSITA would have understood that a display unit, controller, and power supply unit comprise electronic components and, thus, the sub-device is an “electronic device.” EX1002, ¶¶98-99.

Kim discloses that the main device (“switching device”) “may detect whether or not the sub-device 300 is coupled or separated Accordingly, when the sub-device 300 is coupled to the main device 100, the main device 100 may automatically change its operation mode *or an operation mode of the sub-device.*” EX1010, ¶¶195, 270 (describing controlling the sub-device’s state and operation based on its coupling status). Thus, a POSITA would have understood that the main device changes (“switches”) the state and/or operation of the sub-device based on whether the two are coupled. Accordingly, a POSITA would have recognized that the main device is a “portable switching device.” EX1002, ¶¶100-101.

- c. **“the switching device and the electronic device are configured to selectively couple to each other employing magnetic force;”**

Kim discloses or suggests this feature. EX1002, ¶¶102-109. For example, as noted above in Section V.A, *Kim* discloses that the main device (“switching device”) and the sub-device (“electronic device”) detachably couple (“are configured to

selectively couple to each other”) by way of coupling members 510 which can be magnets (“employing magnetic force”). EX1010, ¶203; EX1002, ¶102.

PO may argue that the embodiment shown in Figure A above would not have used magnets to detachably couple the sub-device 300 to the second body 100b of the watch-type main device because *Kim* states, with respect to Figure 15B, that “coupling member 510 for fixing the sub-device” to the second body is “pressed to be coupled.” EX1010, ¶261. Such an argument is misplaced and should be rejected. EX1002, ¶¶103-105.

A POSITA would have recognized that *Kim* discloses that the coupling members 510 can be magnets or complementary recesses/hooks. EX1010, ¶¶203, 218, 220, 261; EX1002, ¶104. *Kim*’s reference to “pressing” to couple the sub-device to the main device is not inconsistent with the concept of using magnets. EX1010, ¶233. A POSITA would have understood that when two magnets (*e.g.*, one in the sub-device and another in the second body of the main device) having opposite polarities are pressed together, they will couple to each other through the application of magnetic force. *Id.*

Even if the Board were to conclude that the concept of “pressing” only encompasses mechanical coupling (*e.g.*, complementary recesses/hooks) and not magnetic coupling, it would have been obvious to a POSITA to use magnets as coupling members 510 in the embodiment shown in Figure A instead of or in

addition to recesses/hooks. Making the modification would have been obvious because it would have amounted to substituting one known element (magnets) for another (recesses/hooks) to obtain predictable results (detachably coupling the sub-device to the main device.). EX1002, ¶105.

Additionally, *Kim* discloses with respect to the folder-type embodiment of Figures 11B and 11E using magnets or hooks/recesses as the coupling members 510. EX1010, ¶¶218, 220; EX1002, ¶¶107-108. As discussed above in Section VIII.A.1.a, a POSITA would have recognized the similarity and applicability of the disclosures with respect to the folder-type embodiment of Figure 11B to the watch-type embodiments of Figures 15A-15B. EX1002, ¶106. Thus, the modification would also have been obvious as merely the use of a known technique (using magnets to couple the sub-device to the main device in the folder-type embodiment of Figure 11B) to improve similar devices (the watch-type main device shown in Figure A having a detachable sub-device) in the same way (to detachably couple the sub-device to the main device using magnets). EX1002, ¶108.

A POSITA would have had a reasonable expectation of success because *Kim* discloses that magnets were a known and effective technique for coupling a sub-device to a main device. EX1010, ¶203 (“[C]oupling members 510 such as a magnet may be respectively attached to one side of the main device 100 and one side of the sub-device 300, to easily couple or separate (i.e. couple or de-couple) the main

device 100 and the sub-device.”); EX1002, ¶109.

d. “the switching device comprises a first case;”

Kim discloses this feature. EX1002, ¶110. For example, in the watch-type embodiment shown in Figure A (*see* Section VIII.A.1.a), the mobile terminal comprises a watch-type main device (“switching device”) having first body 100a and second body 100b. *Kim* further discloses “the body” of the mobile terminal (*e.g.*, first body 100a and second body 100b of the watch-type embodiment shown in Figure A) having “a case (casing, housing, cover, etc.) that forms an exterior of the terminal. The case may be divided into a front case 101 and a rear case 102. Various electric/electronic parts may be provided in a space between the front case 101 and the rear case 102.” EX1010, ¶¶124-125. Accordingly, a POSITA would have understood *Kim* to disclose that the first body 100a and second body 100b of the watch-type embodiment shown in Figure A comprise a case. EX1002, ¶110.

e. “the electronic device comprises a second case and an electronic circuit that is responsive to the switching device;”

Kim discloses or suggests this feature. EX1002, ¶¶111-116. For example, *Kim* discloses the sub-device 300 including a frame 303 surrounding the outer edges of the body 302 and the display unit 251 to improve firmness. EX1010, ¶199. A POSITA would have understood the “frame” to be a case because, just like a case, a frame also protects the components of the device. EX1002, ¶111; *see also* EX1001,

5:65-6:3 (describing “case” broadly).

To the extent that PO argues that *Kim* does not sufficiently disclose or suggest the sub-device (“electronic device”) having a case, it would have been obvious as well as common sense to a POSITA to include a case to protect the components of the sub-device. EX1002, ¶¶113-114; *see also B/E Aerospace, Inc. v. C&D Zodiac, Inc.*, 962 F.3d 1373, 1380-81 (Fed. Cir. 2020) (finding “no error in the Board's conclusion that a skilled artisan would have used common sense to incorporate a second recess” because the technology was “simple” and it merely repeated an existing element). *Kim* discloses the sub-device comprising the same components as the main device. EX1010, ¶187; EX1002, ¶114. It would have been a matter of common sense to use a case, as does the main device, to enclose such components so as to hold the components in a discrete mobile form factor as well as to protect them against physical damage. EX1002, ¶114.

Kim also discloses that the sub-device (“electronic device”) comprises an electronic circuit that is “responsive” to the main device (“switching device”). EX1002, ¶115. As explained in Section V.A, *Kim* discloses the sub-device including the same components as in Figure 1, such as “a wireless communication unit 110, an audio/video (A/V) input unit 120, a user input unit 130, a sensing unit 140, an output unit 150, a memory 160, an interface unit 170, a controller 180 and a power supply 190” (EX1010, FIG. 1, ¶72), and that the units can be implemented in

hardware (*id.*, ¶121). In one implementation, “the sub-device comprises a display unit 251, a controller 280, and a power supply unit 290.” *Id.* ¶198. A POSITA would have understood that these components comprise electronic circuits. EX1002, ¶115.

Kim further discloses that, in operation, the main device controls the electronic circuits of the sub-device. EX1002, ¶116. For example, *Kim* discloses the main device changing the state and/or operation of the sub-device when the sub-device is coupled to the main device. EX1010, ¶¶195, 270, 273-275; *see also infra* Section VIII.A.1.h. Accordingly, *Kim* discloses a sub-device (“electronic device”) having electronic circuit components such as a display, controller, power supply, etc. (“comprises ... an electronic circuit”) whose state and/or operation are changed by (“responsive to”) the main device (“switching device”). EX1002, ¶116.

f. “a first magnet is fully disposed within the electronic device;”

Kim discloses or suggests this feature. EX1002, ¶¶117-125. For example, as explained above in Sections VIII.A.1.a and VIII.A.1.c, *Kim* discloses or suggests using magnets as the coupling members 510 to detachably couple the sub-device (“electronic device”) to the watch-type main device. A POSITA would have recognized that in the watch-type embodiment shown in Figure A, the magnets (coupling members 510 annotated brown) would have been fully disposed within

the sub-device (“electronic device”) because they are shown to be in the sub-device and flush with the surface of the sub-device. EX1002, ¶¶117-119.

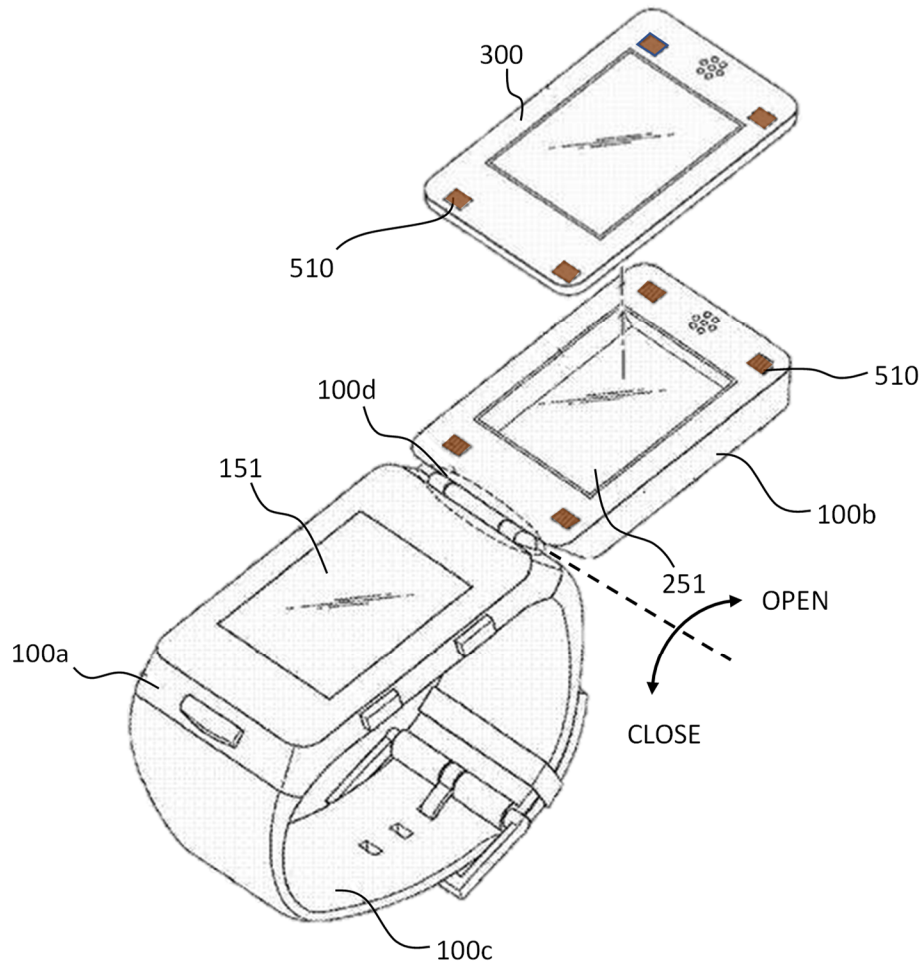

Figure A (based on *Kim*'s disclosure)

To the extent that PO argues that *Kim* does not explicitly state that the magnets are “fully” disposed in the sub-device, a POSITA would have found it obvious to “fully” dispose the magnets within the sub-device 300 and the second body 100b to conveniently attach the sub-device to the main device. EX1002, ¶120.

Making the magnets “fully” disposed within the sub-device (“electronic

device”) was one of three choices available to a POSITA—*i.e.*, fully disposed, not fully disposed, or external. EX1002, ¶121; *KSR Int’l Co. v. Teleflex Inc.*, 550 U.S. 398, 421 (2007) (“When there is a design need or market pressure to solve a problem and there are a finite number of identified, predictable solutions, a person of ordinary skill has good reason to pursue the known options within his or her technical grasp.”); *Uber Techs., Inc. v. X One, Inc.*, 957 F.3d 1334, 1339-40 (Fed. Cir. 2020) (finding it obvious to substitute server-side plotting for terminal-side plotting because they were both well known in the art and were the only two identified, predictable solutions for transmitting a map and plotting locations). Moreover, the ’077 patent does not disclose any critical or unexpected results associated with having the magnets fully disposed within the electronic device. EX1002, ¶121.

It would also have been a matter of obvious engineering choice for a POSITA to fully dispose the magnets within the sub-device and the main device’s second body, for example, to reduce the profile of the joined components and allow a flush interface between the sub-device and the main device, thereby reducing the space that the combined devices occupy and reducing the risk of the sub-device detaching from the main device. EX1002, ¶122. Indeed, it was known to a POSITA to use this known technique (*i.e.*, fully disposing magnets within an electronic device) to create a flush interface between magnetically coupled components. EX1002, ¶¶123-

124 (citing EX1015, ¶307).¹¹ Thus, making the magnets fully disposed within the sub-device would have been the application of a known technique (magnets fully disposed within an electronic device) to a known device (the sub-device) to yield a predictable result (incorporating a magnet within a sub-device). EX1002, ¶125.

- g. “the electronic device comprises at least one element selected from the group consisting of beveled edges, ridges, recessed areas, grooves, slots, indented shapes, bumps, raised shapes, and combinations thereof; configured to correspond to complementary surface elements on the switching device;”**

Kim discloses or suggests this feature. EX1002, ¶126-141. For example, *Kim*

¹¹ To the extent that EX1015 (*Terlizzi*), EX1016 (*Kiessling*), EX1017 (*Viinikanoja*), EX1018 (*Birger*), EX1019 (*Yamazaki*), EX1020 (*Yoshida*), EX1021 (*Griffin*), EX1022 (*Lylyharju*), EX1023 (Dictionary of Chemistry), or EX1029 (Bluetooth A/V Remote Control Profile) are cited in this Petition, it is merely to demonstrate a POSITA’s knowledge and/or as evidence that a POSITA would have been motivated to make the combinations in the manner discussed in this Petition.

KSR Int’l Co. v. Teleflex Inc., 550 U.S. 398, 420 (2007) (“[A]ny need or problem known in the field of endeavor at the time of invention and addressed by the patent can provide a reason for combining the elements in the manner claimed.”). These exhibits are not part of the unpatentability grounds.

discloses the main device (“switching device”) having coupling unit 210 “configured to mechanically couple the main device and the sub-devices.” EX1010, ¶183. The coupling unit “may be changed in various structures (or configurations) according to types ... of mobile terminals.” *Id.*, ¶185. Likewise, *Kim* teaches the sub-device (“electronic device”) including a coupling unit 410 “configured in a structure (or configuration) corresponding to the coupling unit 210 of the main device.” *Id.*, ¶186.

As discussed above in Sections VIII.A.1.a and VIII.A.1.c, with respect to the embodiment shown in Figure A, *Kim* discloses or suggests detachably coupling the sub-device (“electronic device”) to the main device (“switching device”) using magnets as the coupling members 510. However, *Kim* also discloses that the coupling members 510 can be complementary recesses/hooks on the sub-device and the main device. EX1010, ¶218 (“[F]or example, a recess or a hook is formed at one side of the first body of the main device, and the third body [*i.e.*, sub-device] 300 may be coupled by using the recess or the hook.”). Although this discussion is with respect to the embodiment of Figure 11B, as discussed above in Section VIII.A.1.a, a POSITA would have recognized that the disclosures with respect to Figure 11B could be adapted and applied to the watch-type embodiment shown in Figure A. EX1002, ¶128.

Kim discloses that when recesses/hooks are used, one feature (*e.g.*, hooks) is on the sub-device and the corresponding feature (*e.g.*, recesses) is on the main

device. EX1010, ¶218. A POSITA would have understood that to engage with the recesses in the main device, the hooks on the sub-device would have to be “raised shapes” (*i.e.*, extend beyond the plane of the surface of the sub-device in order to engage recessed areas in the plane of the surface of the main device). EX1002, ¶129.

A POSITA would have been motivated to incorporate both magnetic and mechanical (*e.g.*, recesses/hooks) techniques for detachably coupling the sub-device and the main device of the embodiment shown in Figure A because it would have provided more secure coupling between the two components with less propensity for accidental or unintentional detachment of the sub-device from the main device. EX1002, ¶130. Indeed, it was known to use both magnetic and mechanical attachment techniques to achieve a more secure (yet still detachable) coupling between two devices in an electronic system. EX1002, ¶¶130-137 (citing EX1018, 10:26-11:2; EX1012, ¶¶19, 46-48).¹²

Indeed, *Kim* itself suggests incorporating multiple coupling techniques to connect a sub-device to a main device. For example, *Kim* discloses an embodiment with respect to Figure 11E (folder-type main device reproduced below) in which the

¹² With respect to *Birger*, see footnote 11. While Ground 2 argues that claim 10 is obvious over *Kim* in view of *Koh*, *Koh* is being used here as evidence to demonstrate a POSITA’s general knowledge. *Koh* is not part of Ground 1.

sub-device is detachably coupled to the main device using both hinge parts 550/551, as well as coupling members 510 (brown), which *Kim* teaches can be magnets. EX1010, ¶220; EX1002, ¶¶138-140.

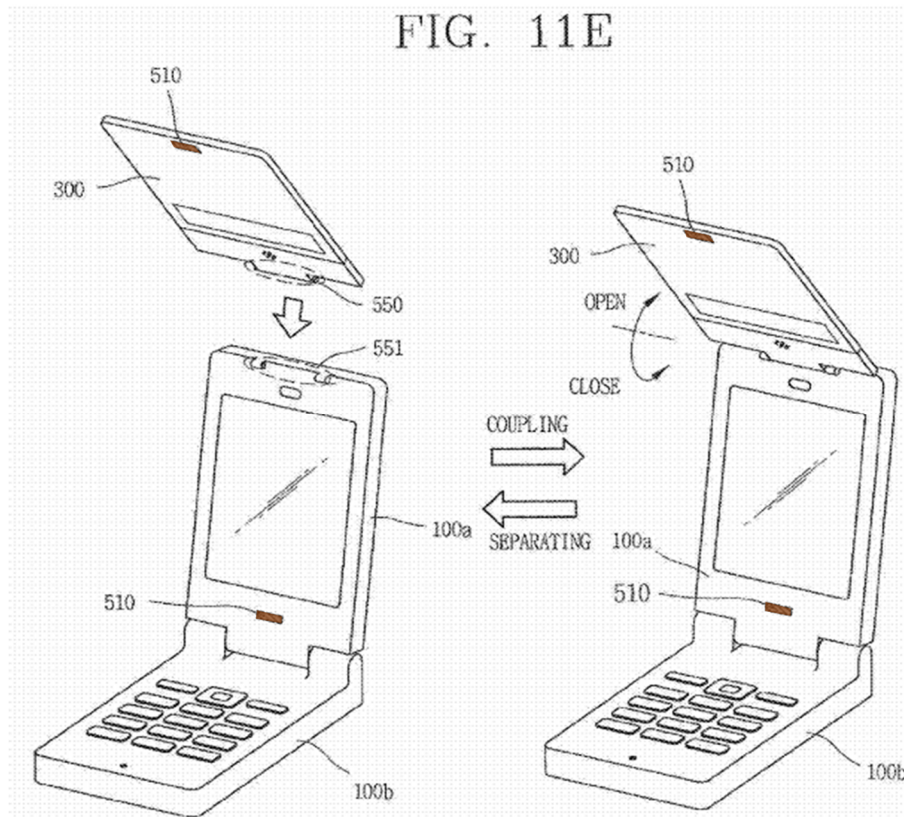

EX1010, FIG. 11E.

Thus, *Kim* confirms what a POSITA knew—using multiple techniques (mechanical and magnetic) to couple a sub-device to a main device to achieve a more secure coupling. EX1002, ¶140. And as already noted, a POSITA would have recognized that the disclosures with respect to the folder-type embodiment (*e.g.*, Figure 11E) could be adapted and applied to the watch-type embodiment shown in Figure A. *Id.*; *see* Section VIII.A.1.a.

Accordingly, it would have been obvious to modify the watch-type embodiment shown in Figure A to incorporate hooks into the sub-device (“electronic device comprises at least one element selected from the group consisting of ... raised shapes”) that engage recesses in the main device (“configured to correspond to complementary surface elements on the switching device”). EX1002, ¶141. Doing so would have amounted to no more than combining prior art elements (magnetic coupling and mechanical coupling) according to known methods (as was known to a POSITA) to yield predictable results (a more secure, but still detachable coupling between the sub-device and the main device). *Id.*

h. “the portable switching device is configured to activate, deactivate or send into hibernation the portable electronic device;”

Kim discloses or suggests this feature. EX1002, ¶¶142-156. As discussed in Section VIII.A.1.b, *Kim* discloses the main device (“portable switching device”) changing the state and/or operation of the sub-device (“portable electronic device”) based on the detected coupling state. EX1010, ¶¶195, 259, 270.

For example, with reference to Figures 17A-17B (17A reproduced below), *Kim* discloses the main device’s “controller 180 differently control[ling] the operation (e.g., display) of the main device 100 and the sub-device 300 according to

an engaged state.”¹³ *Id.*, ¶274. When the sub-device and the main device are coupled, “*the controller 180 displays a menu display method or menu items*” *Id.*, ¶275.

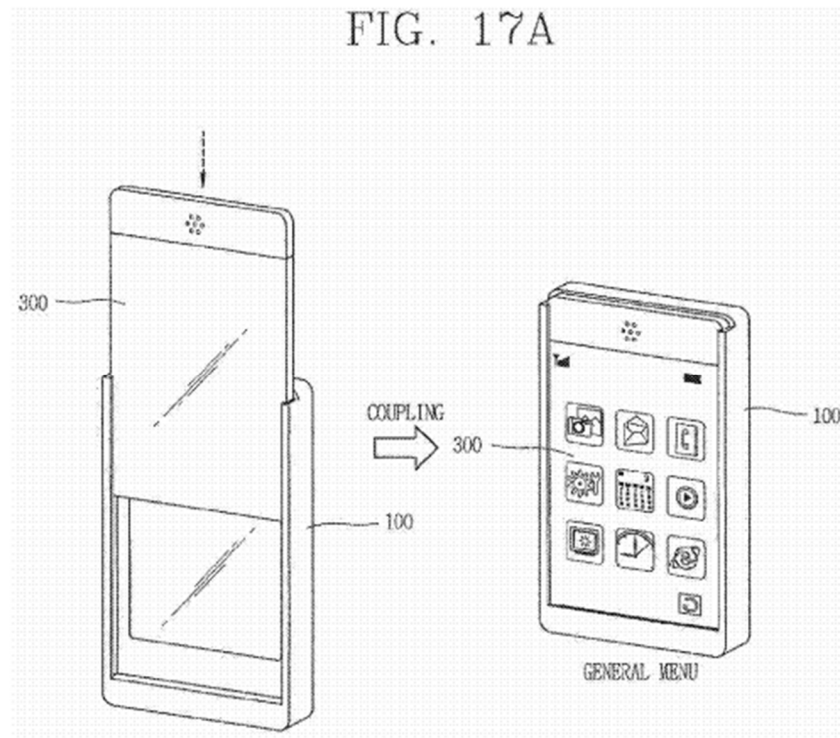

EX1010, FIG. 17A.

¹³ Although the disclosure is with regard to a bar-type mobile terminal, *Kim* states that a “bar type mobile terminal [is] described *as an example for the sake of brevity.*” EX1010, ¶273. A POSITA would have understood that the functionality described with respect to Figure 17A is equally applicable to watch-type mobile terminals (*e.g.*, a sub-device having a display is coupled to a watch-type main device so as to cover a display of the main device). EX1002, ¶144.

A POSITA would have recognized from the figure above that prior to coupling (as shown on the left) the sub-device is inactive (*e.g.*, its display is shown to be off), and after coupling a menu is displayed. EX1002, ¶¶143, 145. A POSITA would have understood that in implementations in which the sub-device’s display is non-transparent—which *Kim* discloses as acceptable (EX1002, ¶146)—the controller 180 would necessarily display the menu shown on the right on the sub-device’s display, which would have required activating the sub-device (*e.g.*, turning on its display). Accordingly, *Kim* discloses the main device’s controller 180 (“portable switching device”) causing (“is configured) the sub-device to turn on (*e.g.*, its display) to display the menu (“to activate ... the portable electronic device”). EX1002, ¶147.

To the extent that PO argues that *Kim* does not sufficiently disclose that the sub-device is activated by the main device upon coupling, it would have been obvious to a POSITA to have the controller 180 activate the sub-device (*e.g.*, its display) to show the menu when the sub-device and the main device are coupled. EX1002, ¶¶148-149. *Kim* discloses that the controller 180 activates a display (EX1010, ¶¶274-276), and it would have been obvious to a POSITA to have the controller activate the sub-device and its display because it was one of two choices available to a POSITA to display the menu shown on Figure 17A—*i.e.*, activate the sub-device and its display or activate the main device display. EX1002, ¶149; *KSR*

Int'l Co. v. Teleflex Inc., 550 U.S. at 421.

Additionally, *Kim* discloses the sub-device changing the state and/or operation of the main device to save power. EX1010, ¶¶299-302, 316-319, 417-418, FIGs. 24, 27, 42; EX1002, ¶¶150-152. For example, *Kim* discloses the sub-device remotely turning the main device on or off. EX1010, ¶¶316-319, FIG. 27. It would have been obvious to a POSITA to implement this same functionality in the main device—*i.e.*, the main device turning the sub-device (or its screen) on or off. EX1002, ¶153.

A POSITA would have been motivated to make the modification because it would have allowed the user to have additional flexibility to control the sub-device and would have been consistent with *Kim*'s teachings to have the main device control the state and/or operation of the sub-device. EX1002, ¶¶154-156. And because *Kim* discloses the sub-device having a small battery or no battery at all (EX1010, ¶186), a POSITA would have been motivated to modify the main device to remotely and conveniently turn off the sub-device in order to conserve its limited power in instances when it is decoupled and not being used (EX1002, ¶154).

As *Kim* explains that the sub-device includes the same components as the main device (EX1010, ¶198), a POSITA would have recognized that *Kim*'s mobile terminal includes the necessary components to make the modification (EX1002, ¶155). The modification would have amounted to no more than combining prior art

elements according to known methods (the components already in the mobile terminal that allow the sub-device to remotely turn the main device on or off) to yield predictable results (allowing the main device to remotely turn the sub-device on or off). *Id.*

Additionally, modifying the main device to remotely turn the sub-device on or off would have been no more than the application of known techniques (having one device turn another device on or off) to improve a similar device (Kim's main device) in the same way (enabling the main device to control the state and/or operation of the sub-device to turn the sub-device on or off). EX1002, ¶156.

i. “the electronic device plays, pauses and/or changes the volume of a remote device;”

Kim discloses this feature. EX1002, ¶¶157-158.

As discussed above in Section V.A, in addition to controlling applications on the main device, *Kim* also discloses the sub-device controlling various applications of a personal computer (“remote device”) through short-range radio communication. EX1010, ¶¶342-343; EX1002, ¶157. Specifically, the sub-device executes music files or video files of the personal computer through a touch input via the sub-device. *Id.*, ¶344. A POSITA would have understood executing music or video files to comprise starting or stopping playback of those files on the personal computer. EX1002, ¶158. For example, Figure 31 depicts the sub-device with a “play” function

key (grey) for playing multimedia on a personal computer through short-range communication.

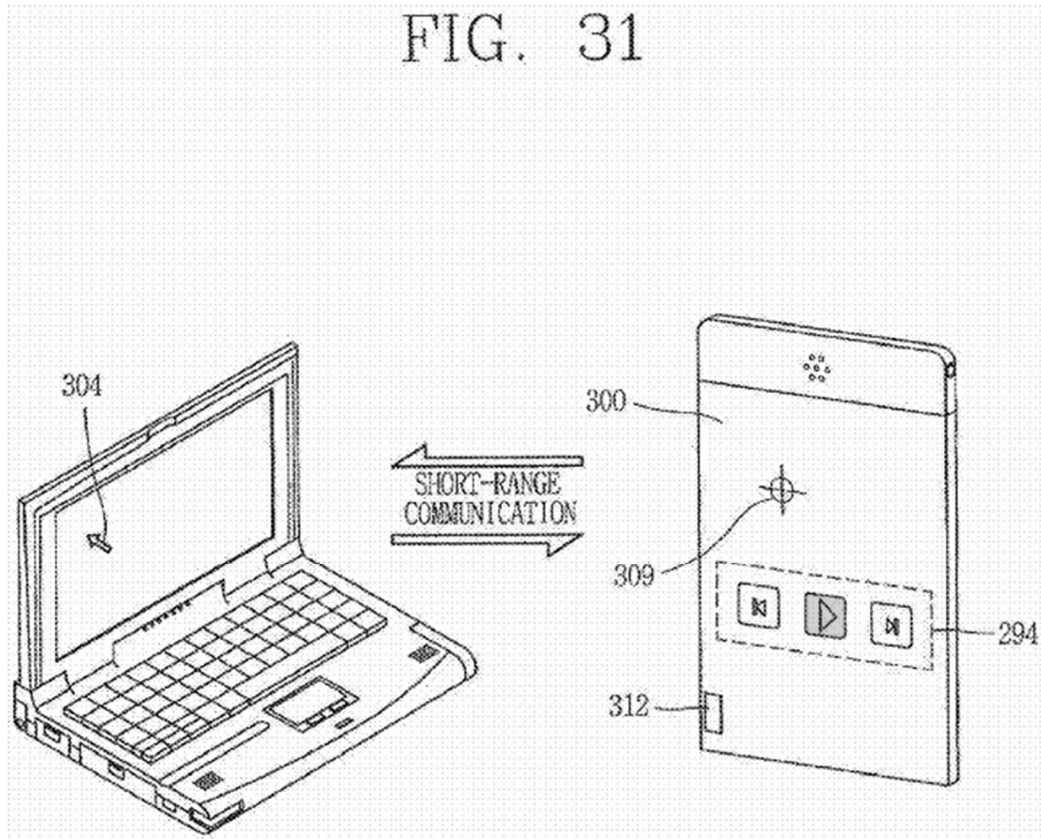

EX1010, FIG. 31.

Thus, a POSITA would have understood that the sub-device (“electronic device”) at least plays music or video on a personal computer through short-range communication (“plays ... a remote device”). EX1002, ¶158.

j. “the switching device includes a lid and hinge attaching the lid to the switching device;”

Kim discloses or suggests this feature. EX1002, ¶¶159-165. As discussed above in Section VIII.A.1.a, *Kim* discloses or suggests the watch-type embodiment

as shown below:

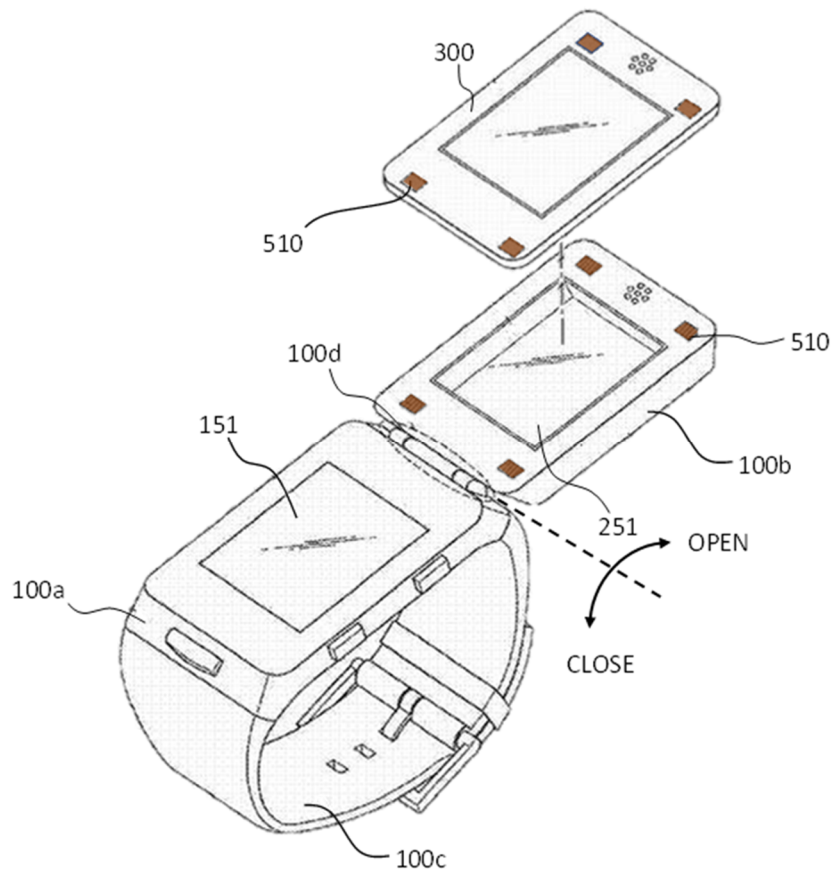

Figure A (based on *Kim*'s disclosure)

A POSITA would have understood the second body 100b is commonly referred to as a “lid.” EX1002, ¶¶159-164 (explaining that POSITA commonly referred to the cover of a folding-type or flip-type electronic device as a “lid”) (citing, *e.g.*, EX1020, 12:58-65, FIG. 13; EX1021, ¶¶2-3, 37; EX1022, Abstract, ¶24, FIG. 1).¹⁴

Accordingly, *Kim* discloses a watch-type main device (“switching device”)

¹⁴ See footnote 11.

including a second body 100b that acts as a cover for the first body 100a (“lid”), and that the second body 100b is connected to the watch-type main device by hinge 100d (“hinge attaching the lid to the switching device.”). EX1002, ¶165.

k. “the lid is recessed to configure to the electronic device; and”

Kim discloses or suggests this feature. EX1002, ¶¶166-170.

As explained above in Section VIII.A.1.a, *Kim* discloses or suggests a system comprising a sub-device 300 detachably coupled to the second body 100b of a watch-type main device using coupling members 510 (*e.g.*, recesses/hooks). As also explained above in Section VIII.A.1.g, *Kim* discloses incorporating recesses into the second body 100b and hooks into the sub-device 300 to detachably couple the two. And for the reasons explained above in Section VIII.A.1.j, a POSITA would have understood the second body 100b in the embodiment shown in Figure A to be the “lid.” Accordingly, *Kim* discloses or suggests the second body 100b (“lid”) having recesses (“is recessed”) configured to engage with the hooks on the sub-device 300 (“to configure to the electronic device”). EX1002, ¶167.

Additionally, it would have been obvious to a POSITA to incorporate a recess in the second body 100b of the main device shown in Figure A that generally conforms to the shape of and receives the sub-device 300 in a manner similar to that disclosed in *Kim*’s Figure 10A. EX1010, ¶203 (disclosing that the main device

having a “recess 520 corresponding to the shape and size of the sub-device”), FIG. 10A; EX1002, ¶¶168-170.

I. “when coupled, the first case functions to protect the second case.”

Kim discloses or suggests this feature. EX1002, ¶¶171-174. As discussed above in Section VIII.A.1.a, *Kim* discloses or suggests the embodiment shown in Figure A (reproduced again below) in which a sub-device 300 detachably couples to the watch-type main device’s second body 100b.

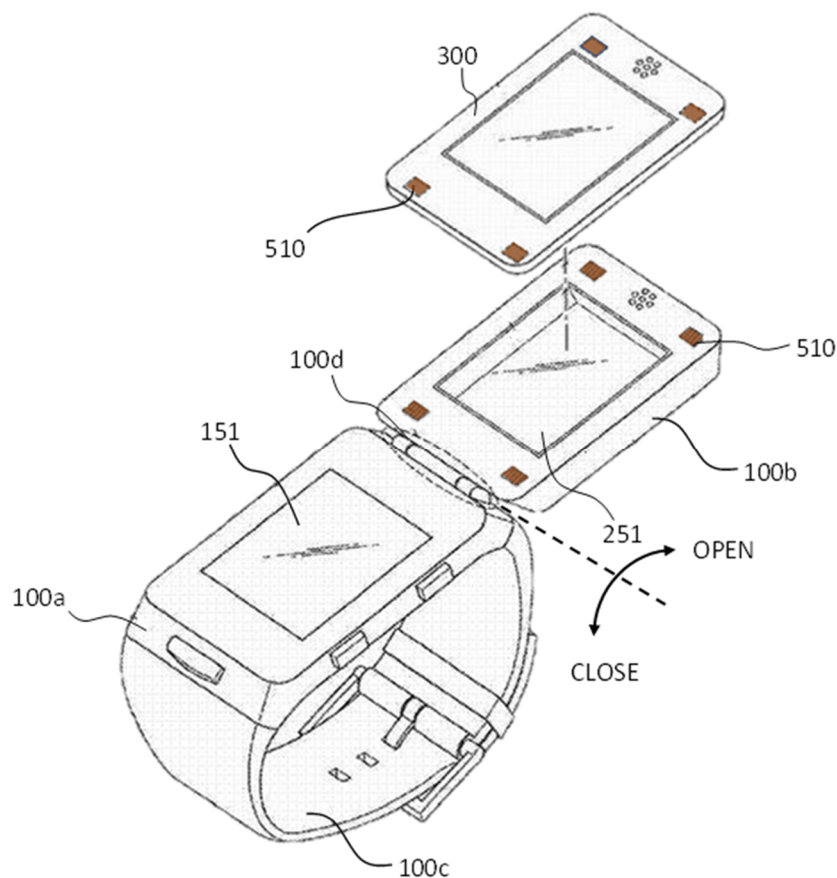

Figure A (based on *Kim*’s disclosure)

In such an embodiment, the second body 100b and first body 100a are connected by a hinge 100d so that the first and second bodies can be opened or closed in a folding manner. EX1010, ¶256; EX1002, ¶172. *Kim* discloses that the main device's first and second bodies can close even when the sub-device 300 is coupled to the second body 100b. EX1010, ¶218 (“[T]he first body 100a and the second body 100b may be folded or unfolded regardless of the coupling or separating of the sub device.”).

In the embodiment shown in Figure A, the main device's first body 100a and second body 100b comprise a case (“first case”) (*see* Section VIII.A.1.d), and the sub-device 300 also comprises a case (“second case”) (*see* Section VIII.A.1.e). A POSITA would have recognized that when the sub-device 300 is coupled to the second body 100b and the second body is folded to cover the first body 100a (“when coupled”), the first body 100a's and the second body 100b's case (“first case”) encloses and protects (“functions to protect”) the sub-device's case (“second case”). EX1002, ¶¶173-174; *see also* EX1010, ¶185 (disclosing that when the sub-device is attached to the main device, the sub-device is fixed “such that the sub-devices are *not* moved, *shattered* or released after being coupled at accurate positions”), ¶193 (“In addition, a cover may be provided to prevent the sub-device from being separated undesirably after it is coupled.”).

2. Claim 2

- a. “The system of claim 1 wherein the switching device has a first lens.”**

Kim discloses or suggests this feature. EX1002, ¶¶175-179. For example, *Kim* discloses the main device having “an audio/video (A/V) input unit 120” (*id.*, ¶72), including a camera 121, (*id.*, ¶84). A POSITA would have understood cameras suitable for incorporating into portable consumer electronic devices of the type disclosed in *Kim* to include a lens. EX1002, ¶¶175-178 (citing, *e.g.*, EX1016, ¶34; EX1017, Abstract; EX1019, 1:7-11).¹⁵ Accordingly, *Kim* discloses or suggests the main device (“switching device”) including a lens. EX1002, ¶179.

3. Claim 3

- a. The system of claim 1 wherein the electronic device has a second lens.”**

Kim discloses or suggests this feature. EX1002, ¶¶180-182. For example, *Kim* discloses the sub-device (“electronic device”) including a camera. EX1010, ¶¶84, 200. A POSITA would have understood cameras suitable for incorporating into portable consumer electronic devices of the type disclosed in *Kim* to include a lens. EX1002, ¶¶180-181 (citing, *e.g.*, EX1016, ¶34; EX1017, Abstract; EX1019,

¹⁵ See footnote 11.

1:7-11).¹⁶ Accordingly, *Kim* discloses or suggests the sub-device (“electronic device”) including a lens. EX1002, ¶182.

4. Claim 4

- a. “The system of claim 1 wherein the lid has a second magnet disposed within it.”**

Kim discloses or suggests this feature. EX1002, ¶183. As explained in Sections VIII.A.1.a and VIII.A.1.f, *Kim* discloses or suggests the watch-type embodiment shown in Figure A having a second body 100b that includes magnets for coupling the sub-device 300 to the second body. A POSITA would have understood the second body 100b to be a lid. *See* Section VIII.A.1.j Accordingly, *Kim* discloses or suggests a watch-type main device having a second body 100b (“lid”) having magnets (“a second magnet disposed within it”). EX1002, ¶183.

5. Claim 5

- a. “The system of claim 4 wherein the lid is configured to employ the second magnet to secure the lid in a closed position.”**

Kim discloses or suggests this feature. EX1002, ¶¶184-194.

As explained above in Sections VIII.A.1.a, VIII.A.1.j and VIII.A.4.a, *Kim* discloses or suggests a watch-type main device having a second body 100b (“lid”) including magnets (“magnets disposed within it”). *Kim* further describes that the

¹⁶ *See* footnote 11.

first and second bodies of the watch-type main device can be in an open or closed position with respect to each other. EX1010, ¶256; *see also id.*, ¶218; EX1002, ¶185.

In the watch-type embodiment shown in Figure A, it would have been obvious to a POSITA to use one or more of the magnets in the second body 100b to secure the second body 100b (“lid”) in a closed position with respect to the first body 100a by coupling to the first body. Doing so would have prevented the lid from unintentionally opening, for example, from movement of a user’s arm. EX1002, ¶186. Using one or more magnets in the lid of a folder-type portable electronic device to secure the lid in a closed position was a technique that was well-known to a POSITA. EX1002, ¶¶186-187 (citing, *e.g.*, EX1021, ¶¶82, 88).¹⁷

Kim itself also discloses this technique for securing a first body that is in a folding-type relationship to a second body. More particularly, *Kim* discloses (and illustrates in connection with Figure 11E) that when the sub-device is connected to the main device by hinges, “coupling members 510 may be additionally provided to prevent the [sub-device] from being moved after it is folded.” EX1010, ¶220; EX1002, ¶188.

¹⁷ *See* footnote 11.

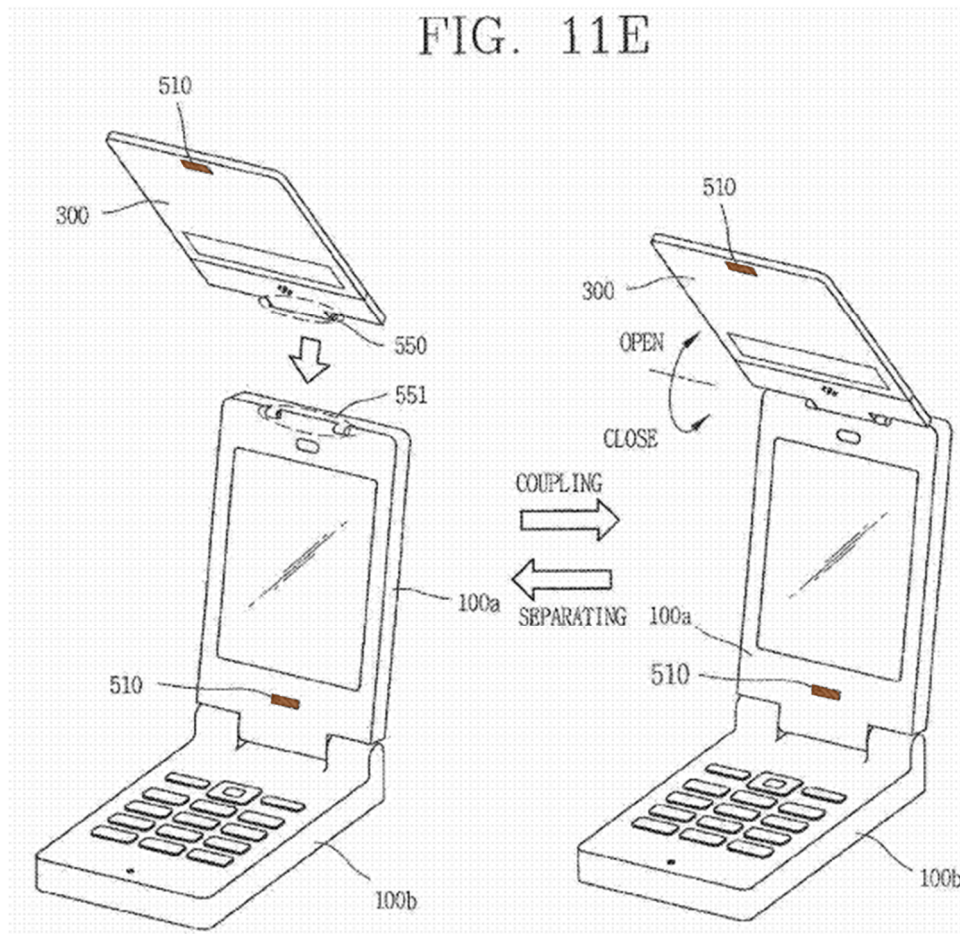

EX1010, FIG. 11E.

Kim discloses magnets as suitable coupling members 510 (brown). EX1010, ¶220; EX1002, ¶¶188-190. A POSITA would also have understood that the technique illustrated in Figure 11E could be adapted and applied to secure the second body 100b to the first body 100a when the two were in a closed position. EX1002, ¶191.

Modifying the watch-type embodiment shown in Figure A in the manner well-known in the art, and indeed disclosed by *Kim's* Figure 11E, would have been obvious because it would have amounted to no more than the application of a known

technique (using a magnet to secure a lid in a closed position) to improve similar devices (the watch-type embodiment shown in Figure A in which the first and second bodies can be folded into a closed position) in the same way (securing the second body to the first body in a closed position using a magnet). EX1002, ¶192.

Notably claim 5 does not require that the sub-device (“electronic device”) is coupled to the main device when the “lid” is secured in the closed position. A POSITA would have understood that the main device of the watch-type embodiment shown in Figure A can close or open regardless of whether the sub-device 300 is coupled to the main device. EX1002, ¶193. Thus, a POSITA would have understood that at least when the sub-device 300 is not coupled to the main device, a magnet in the second body 100b (“lid”) interacts with the first body 100a (e.g., an opposite polarity magnet or a magnetically attractable surface in the first body 100a) to secure the second body 100b in a closed position. EX1002, ¶194.

6. Claim 6

- a. **“The system of claim 1 wherein the electronic device has a tab or knob configured to be manipulated by an external force.”**

Kim discloses or suggests this feature. EX1002, ¶¶195-197. For example, *Kim* discloses that “the sub-device may include function keys ... on its front side or its side portion.” EX1010, ¶200. A user manipulates the function keys to perform certain functions on the sub-device. *Id.*; EX1002, ¶195. Annotated Figure 9C shows

these function keys (red) labeled as KEY0 through KEY4:

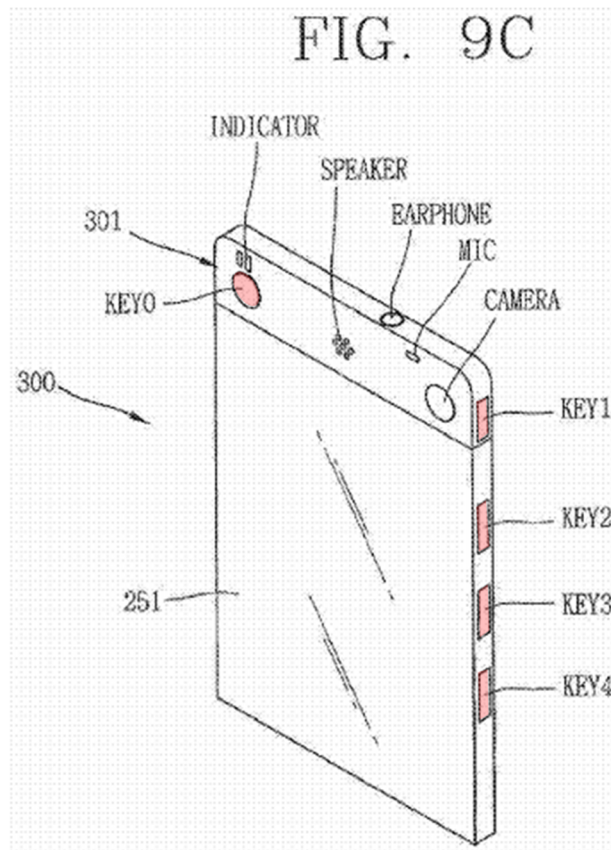

EX1010, FIG. 9C.

Kim further discloses that a user input unit (e.g., function keys KEY0 through KEY4) “may adopt any mechanism of a tactile manner that enables a user to perform a manipulation action by experiencing a tactile feeling.” EX1010, ¶129; EX1002, ¶196. For example, *Kim* discloses the mobile terminal including “a jog wheel and/or jog switch.” EX1010, ¶87.

Accordingly, *Kim* discloses or suggests the sub-device (“electronic device”) having keys (“tab or knob”) that can be manipulated by a user (“configured to be

manipulated by an external force”). EX1002, ¶197.

7. Claims 7 and 8

- a. Claim 7: “The system of claim 3 wherein the first case is configured to be nonabrasive to the second lens.”**
- b. Claim 8: “The system of claim 2 wherein the second case is configured to be nonabrasive to the first lens.”**

Kim discloses or suggests the features in each of claims 7 and 8. EX1002, ¶¶198-201.

Kim is directed to a mobile terminal comprising a main device and a sub-device that detachably coupled to each other. EX1002, ¶199. As discussed above in Sections VIII.A.1.d and VIII.A.1.e, *Kim* discloses or suggests that each of the main device and the sub-device comprise a case to enclose and/or protect their respective electronic components. *Kim* discloses such cases “may be formed by injection molding of synthetic resin or may be formed of metal substance such as stainless steel (STS), titanium (ti) or the like.” EX1010, ¶126. A POSITA would have understood synthetic resin to be used to make various forms of plastics. EX1002, ¶199 (citing EX1023, 3, 5).¹⁸

A POSITA would also have understood that plastic and metal substances are

¹⁸ See footnote 11.

material that can be used to form surfaces that are non-abrasive to the lens/view screen. Indeed, these materials are the same ones the '077 patent identifies as suitable for making non-abrasive surfaces. EX1001, 6:5-8 (“protective cases, often made of ... rigid are [sic] flexible plastic, that serve to prevent scratches and blemishes”), 16:5-14 (making switch/cleaner from “plastic or even metal.”). Thus, *Kim* discloses making the main device’s case (“first case”) or the sub-device’s case (“second case”) using plastic or metal which are the same materials identified in the '077 patent for making surfaces non-abrasive to the lens (“configured to be non-abrasive to the [second/first] lens”). EX1002, ¶200.

B. Ground 2: *Kim* and *Koh* Render Obvious Claim 11

1. Claim 11

- a. “The system of claim 1 wherein the electronic device is wireless earplugs.”**

Kim in combination with *Koh* discloses or suggests this feature. EX1002, ¶¶203-232.

As explained above in Section VIII.A.1.a, *Kim* discloses or suggests a system comprising a sub-device detachably coupled to the second body 100b of a watch-type main device using coupling members 510 (brown), as shown below:

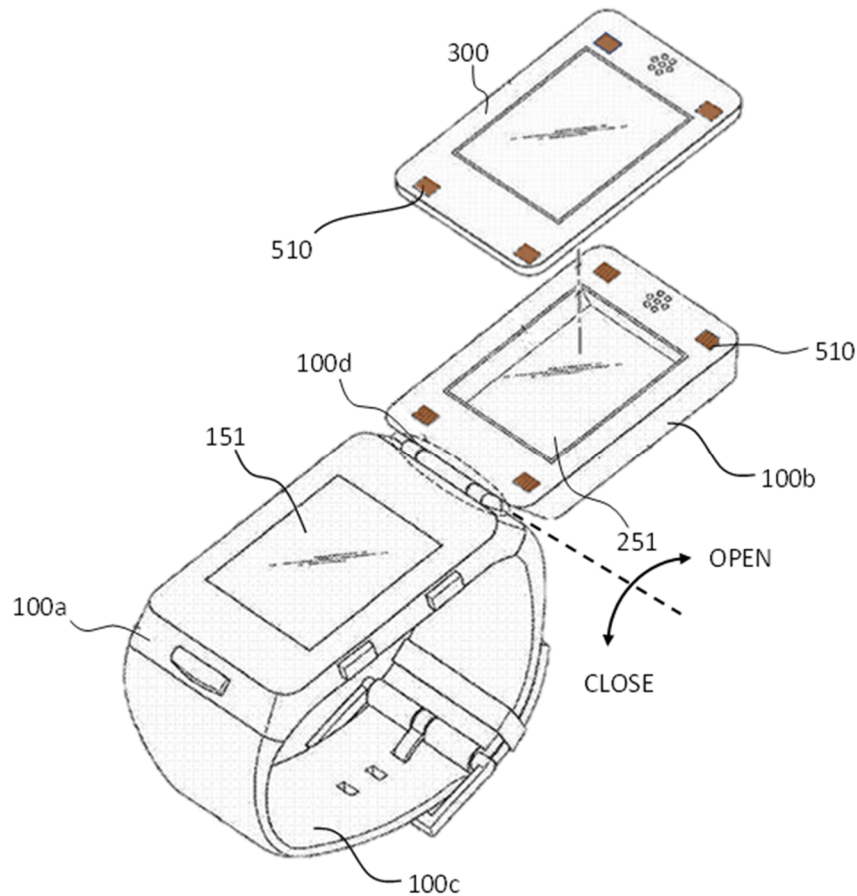
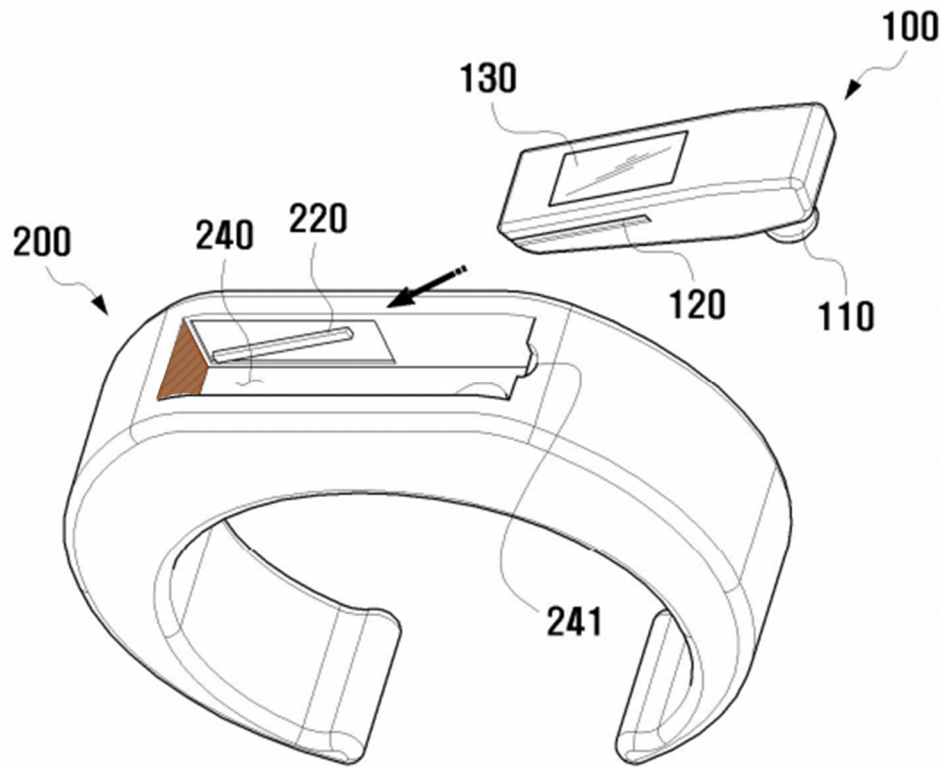

Figure A (based on *Kim*'s disclosure)

Kim further discloses configuring sub-device 300 (“electronic device”) “in one of various forms such as ... [an] ear phone” and that “in this case, the coupling unit 210 of the main device may be configured to have a structure (or shape) that can attach the sub-device 300 to the interior of [sic] the exterior of the main device.” *Id.*, ¶¶194, 445 (“[T]he second body 300 may be used as a Bluetooth headset.”); *see also id.*, ¶266; EX1002, ¶¶208-210. Finally, *Kim* discloses detachably coupling one or more sub-devices to the main device. EX1010, ¶181.

Accordingly, a POSITA would have understood *Kim* to disclose or suggest an embodiment of the mobile terminal in which a watch-type main device comprises a first body 100a and a second body 100b connected to each other by hinge 100d so that the two bodies can be opened or closed in a folding manner, and wherein the mobile terminal further comprises one or more wireless earphones or headsets (*i.e.*, sub-devices) detachably coupled to the first body 100a or the second body 100b. EX1002, ¶¶211-212. *Kim*, however, does not include a discussion of example techniques for coupling wireless earphone/headset sub-devices with a watch-type device.

Koh discloses “a portable electronic device module that is easy to couple and convenient to store by sliding and coupling a portable electronic device to an electronic device storage unit.” EX1012, ¶12. In one embodiment, *Koh* describes the “portable electronic device module” as a wireless headset (*id.*, ¶27), using Bluetooth (*id.*, ¶29), and that the “electronic device storage unit 200 comprises a fastening unit to be worn on a user’s wrist” (*id.*, ¶36). Figure 4A, reproduced below, shows the wireless headset 100 as it is to be coupled into the storage unit 200:



EX1012, FIG. 4A.

Koh explains that the wireless headset is stored in a compartment (240) formed in the storage unit 200 and “coupled in a sliding manner by inserting the coupling protrusion 220 of the electronic device storage unit 200 into the guide groove 120 of the wireless headset 100.” *Id.*, ¶¶37-46. The coupling protrusion is used to lock the headset in place. *Id.*, ¶46. The storage unit 200 can also include a magnet in the cross-hatched area of the compartment (240) (brown), and the headset can include a magnet of opposite polarity on the surface of the headset. *Id.*, ¶48. The two magnets attract each other such that “when the wireless headset is coupled to the electronic device storage unit, the magnets may be attracted to one other so as

to be coupled.” *Id.*, ¶19. *Koh* also discloses the wireless headset including a display unit 130, “typically formed on a surface opposite to the surface on which the speaker unit 110 is formed, so that the user can easily see the display unit 130 from the outside.” EX1012, ¶¶30, 33.

A POSITA would have understood *Koh*’s teachings for detachably coupling a wireless headset to a watch-type device to be suitable for use with *Kim*’s watch-type mobile terminal. EX1002, ¶¶213-218. For example, *Koh* discloses using magnets and complementary protrusions/guide grooves to detachably couple a wireless headset to a watch-type device. EX1012, ¶¶46-49. A POSITA would have understood that the coupling techniques disclosed by *Koh* were compatible with and could be adapted and applied to the second body 100b of *Kim*’s watch-type main device in place of the coupling members 510 when sub-device 300 is a wireless earphone and/or a Bluetooth headset. Ex1002, ¶218. Below is a schematic representation of an example mobile terminal as a POSITA would have understood is disclosed or suggested by *Kim* in view of *Koh*. *Id.*

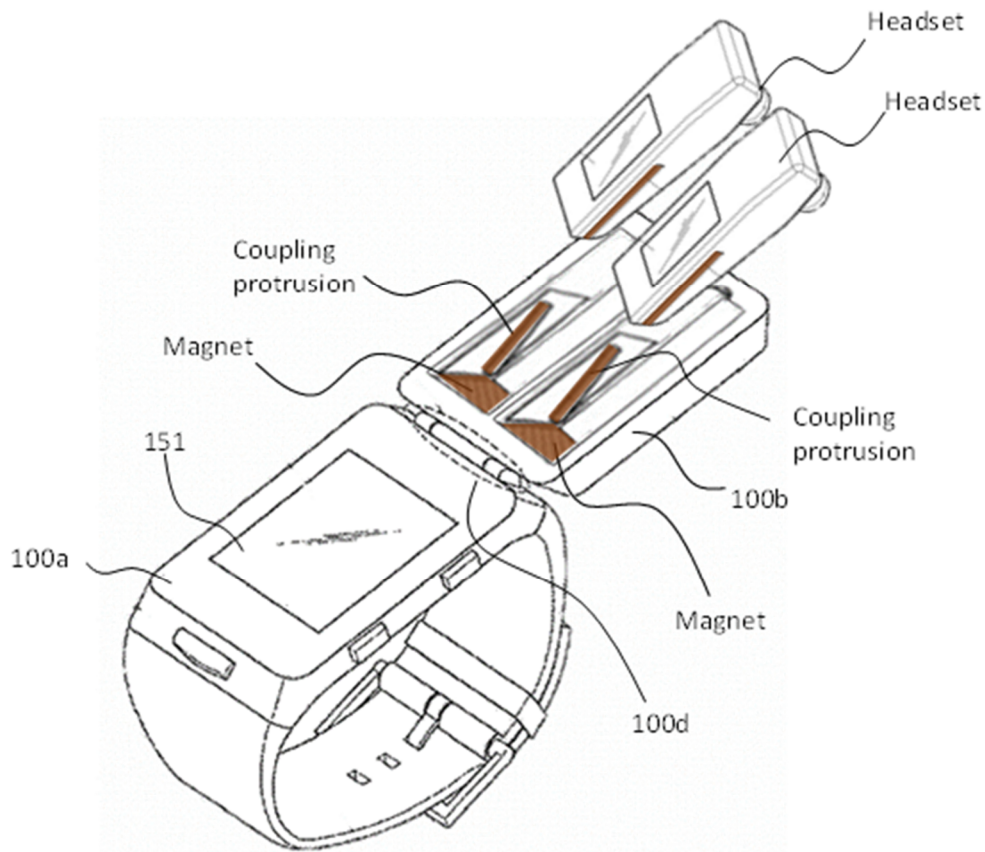

In the example *Kim-Koh* watch-type mobile terminal shown above, the sub-devices (wireless headsets) detachably couple within a recess in a second body 100b (“lid”) of the main device via magnets and complementary protrusions/guide grooves (brown). The main device, in turn, comprises a first body 100a connected to the second body 100b by a hinge 100d so that the first and second bodies can be opened or closed in a folding manner. *Id.*, ¶219.

The manner in which *Kim*’s main device controls the state and/or operation of the sub-device is not dependent on the specific form factor of the main device or the sub-device. EX1002, ¶220. A POSITA would have understood that in the *Kim-Koh*

system, the watch-type main device would continue to control the state and/or operation of the wireless earphone/headset sub-device in the same manner as discussed above. *Id.*; see *supra* Sections VIII.A.1.b and VIII.A.1.h (discussing the main device controlling the state and/or operation of the sub-device). A POSITA would have further known that Bluetooth headsets are capable of controlling media on a remote device, and would have found it obvious to incorporate such functionality into the *Kim-Koh* headset because *Kim* states that the sub-device can “execute music files or video files of the personal computer through a touch input via the sub-device.” EX1010, ¶344; EX1002, ¶¶221-226 (citing, *e.g.*, EX1029, 9 (§1.1), 15-16 (§§2.3.1.2, 2.3.1.3); EX1018, 8:1-7)¹⁹

A POSITA would have found it obvious to incorporate *Koh*’s teachings with *Kim*’s watch-type mobile terminal. *Kim* discloses detachably coupling wireless earphones/headsets to the watch-type main device and configuring the main device to have a structure (or shape) to attach the earphones to the interior of the main device. EX1010, ¶194. *Kim* also discloses that the sub-device 300 can be a Bluetooth headset. *Id.*, ¶445. But since *Kim* does not provide additional detail regarding how to implement these features, a POSITA would have been motivated to identify a compatible device and to locate additional detail regarding techniques

¹⁹ See footnote 11.

for detachably coupling earphone(s) to *Kim*'s watch-type main device. EX1002, ¶219.

A POSITA would have been motivated to combine *Koh*'s disclosure with *Kim*'s for several reasons. *Id.*, ¶¶228-231. For example, *Koh* discloses a technique for detachably coupling a wireless headset to a device having a watch-type form factor. *Compare* EX1012, ¶¶46-49 (describing coupling and decoupling of the wireless headset and storage device and explaining that when the wireless headset is coupled to the storage unit the combination acts as a wristwatch) *with* EX1010, ¶¶181, 194, 255 (disclosing a main device having a watch-type form factor detachably coupling to a sub-device, such as earphones). *Koh* provides additional detail regarding how to detachably couple wireless headset(s) to the watch-type main device. EX1012, ¶¶46-49; *see also* EX1010, ¶¶193-194 (explaining that the earphone sub-device can be “coupled to the main device 100 such that it is inserted into the interior of the main device”); *see also* EX1002, ¶¶228-231 (explaining why a POSITA would have been motivated to combine *Koh* and *Kim*).

A POSITA would have realized that the combination of *Kim* and *Koh* would have amounted to no more than combining known prior art elements (*Kim*'s watch-type main device and *Koh*'s teaching of how to detachably couple a wireless headset to such a device) according to known methods (using magnets and complementary protrusions/grooves, which are discussed in both *Kim* and *Koh*) to yield predictable

results (detachably coupling wireless headset sub-devices to *Kim*'s watch-type main device). EX1002, ¶230.

To the extent PO argues that *Koh*'s disclosure cannot be directly incorporated into *Kim*'s system, such an argument would be factually incorrect for the reasons discussed above. In any event, “[t]he test for obviousness is not whether the features of a secondary reference may be bodily incorporated into the structure of the primary reference, but rather whether a skilled artisan would have been motivated to combine the teachings of the prior art references to achieve the claimed invention.” *Allied Erecting & Dismantling Co. v. Genesis Attachments, LLC*, 825 F.3d 1373, 1381 (Fed. Cir. 2016) (citations omitted); *see also Elbrus Int'l Ltd. v. Samsung Elecs. Co.*, 738 F. App'x 694, 698-99 (Fed. Cir. 2018) (“[PO]’s argument that combining [references] would lead to an unworkable circuit is ‘basically irrelevant.’ ... [A] person of ordinary skill would have been able to make ‘simple adjustments’ to the circuit to make it work.”); *ClassCo, Inc. v. Apple, Inc.*, 838 F.3d 1214, 1219 (Fed. Cir. 2016) (“The rationale of KSR does not support ClassCo's theory that a person of ordinary skill can only perform combinations of a puzzle element A with a perfectly fitting puzzle element B.”).

Although *Koh* discloses detachably coupling one wireless headset to the watch-type device, it would have been obvious to a POSITA to detachably couple two wireless headsets to *Kim*'s watch-type main device. For example, *Kim* discloses

detachably coupling more than one sub-device to the main device. EX1010, ¶181, FIG. 7. *Kim* also discloses the mobile terminal being a portable multimedia player. EX1010, ¶69; *see also id.*, ¶135 (disclosing a mobile terminal that “implement[s] a stereo function” with two speakers). A POSITA would have been motivated to detachably couple two wireless earphones/headsets to *Kim*’s watch-type device because doing so would permit a user to listen to stereo audio using two earphones/headsets instead of listening to mono audio through one earphone/headset. EX1002, ¶232. Incorporating two detachable wireless earphones/headsets into *Kim*’s watch-type mobile terminal would have been well within the skill of a POSITA as it would have entailed merely implementing *Koh*’s techniques with respect to two wireless earphones/headsets instead of one. *Id.*

C. Ground 3: *Kim* and *Lee* Render Obvious Claims 9-10 and 12-13

1. Claim 9

- a. “The system of claim 1 wherein the first magnet is employed in actuating the electronic circuit.”**

Kim in combination with *Lee* discloses or suggests this feature. EX1002, ¶¶234-243. As explained above in Sections VIII.A.1.a and VIII.A.1.f, *Kim* discloses or suggests a mobile terminal system comprising a sub-device having magnets (“first magnet”) detachably coupled to the watch-type main device’s second body 100b. *Kim* further discloses or suggests the mobile terminal detecting coupling of the sub-

device and the main device, and changing a state and/or operation of the sub-device based on the detected coupling status, for example, turning the sub-device (or a component, *e.g.*, its display) on or off. EX1010, ¶¶181-185, 195, 270, 273-276, 299-302, FIGs. 7, 17A-17B, 24; *see also* Section VIII.A.1.h.

Lee discloses a mobile terminal that, like *Kim*, can be a phone or a personal digital assistant having a folding-type form factor. EX1013, ¶¶27, 71. The mobile terminal includes sensing unit 140 to sense whether the mobile terminal is open or closed. *Id.*, ¶¶28, 44. *Lee* discloses implementing the sensing unit using a Hall sensor to detect changes to a magnetic field (*e.g.*, based on the proximity of a magnet to the Hall sensor). *Id.*, ¶¶79, 119; EX1002, ¶¶237-239.

A POSITA would have understood *Lee*'s Hall sensor to be suitable for use in *Kim*'s mobile terminal system. EX1002, ¶240. For example, *Kim* discloses or suggests coupling a sub-device to a main device using magnets, and *Lee* discloses a Hall sensor to detect changes in a magnetic field created by a magnet to determine whether two bodies are coupled to each other. Thus, a POSITA would have understood the *Kim-Lee* system to disclose or suggest a watch-type main device with a second body 100b having a Hall sensor to detect the coupling status of the sub-device to the main device by detecting changes in a magnetic field created by the magnet in the sub-device 300. In such a system, changes in the magnetic field created by the magnet in the sub-device (“first magnet”) are detected by the Hall

sensor in the second body 100b, causing the sub-device (or a component, *e.g.*, its display) (“electronic circuit”) to turn on (“the first magnet ... is employed in actuating the electronic circuit”). *Id.*

A POSITA would have been motivated to combine *Kim*’s and *Lee*’s disclosures for several reasons. EX1002, ¶¶241-243. For example, *Lee* is directed to a system that is comparable to and compatible with the systems disclosed in *Kim*. Compare EX1013, ¶¶27-70 (discussing mobile electronic devices having folder-type and slide-type form factors), with EX1010, ¶¶69-122 (discussing mobile electronic devices, including those having folder-type and slide-type form factors); EX1002, ¶¶241-242. *Lee* also provides additional detail regarding how to use a Hall sensor and a magnet to detect the coupling status of two bodies. EX1013, ¶¶119-121. A POSITA would have realized that the combination of *Kim* and *Lee* would have amounted to no more than the combination of known prior art elements (the mobile system of *Kim* detecting the coupling status of a sub-device to a main device, and the Hall sensor and magnet of *Lee* for detecting the coupling status of two bodies) to yield predictable results (detecting the coupling status of the sub-device and a main device using a magnet on the sub-device and a Hall sensor on the main device). EX1002, ¶243.

2. Claim 10

- a. “The system of claim 4 wherein the second or a third magnet is employed in the lid to actuate the electronic circuit.”**

Kim in combination with *Lee* discloses or suggests this feature. EX1002, ¶¶244-247.

For the reasons discussed in Section VIII.C.1.a, it would have been obvious to a POSITA to incorporate *Lee*'s Hall sensor into *Kim*'s mobile terminal in which a sub-device is coupled to a main device using magnets to detect the coupling status of the sub-device to the main device. Further, as explained above in Sections VIII.A.1.a and VIII.A.4.a, in the watch-type embodiment shown in Figure A, second body 100b (“lid”) includes magnets (“second or a third magnet ... in the lid”) to detachably couple the second body to the sub-device.

In the embodiment of the *Kim-Lee* system discussed with respect to claim 9, the Hall sensor is deployed in the second body 100b and the magnet that is detected by the Hall sensor is deployed in the sub-device. It would have been obvious to a POSITA to arrange the *Kim-Lee* system so that the Hall sensor is deployed in the sub-device and the magnet that is detected by the Hall sensor is deployed in the second body 100b. EX1002, ¶246. In such an arrangement, the magnet in the second body 100b (“second or a third magnet ... in the lid”) is detected by the Hall sensor in the sub-device, causing the sub-device (or a component, *e.g.*, its display)

(“electronic circuit”) to activate (“second or a third magnet is employed ... to actuate the electronic circuit”). *Id.*

Incorporating *Lee*’s Hall sensor in *Kim*’s sub-device would have been obvious to a POSITA as one of two available choices—*i.e.*, Hall sensor in sub-device/magnet to be detected in second body, or magnet to be detected in sub-device/Hall sensor in second body. EX1002, ¶247; *KSR*, 550 U.S. at 421. Furthermore, *Kim* discloses that the sub-device can have the same components as the main device. EX1010, ¶187. Thus, incorporating the Hall sensor in the sub-device in order to employ the magnets in the second body (“second or a third magnet”) in turning on (“actuating”) the sub-device (e.g., its display) (“electronic circuit”) would have been the application of a known technique (using a Hall sensor and a magnet to detect whether two bodies are coupled) to a known device (the watch-type mobile terminal disclosed or suggested by *Kim*) to yield a predictable result (detect the coupling of the sub-device to the main device). EX1002, ¶247.

3. Claim 12 and 13

- a. **“The system of claim 1 wherein the system further comprises a sensor that can be activated using a magnet.”**
- b. **“The system of claim 5 wherein the system further comprises a sensor that can be actuated using a magnet.”**

Kim in combination with *Lee* discloses or suggests these features. Ex1002,

¶¶248-249. As discussed above in Sections VIII.C.1.a and VIII.C.2.a, *Kim* in combination with *Lee* discloses or suggests a system having a Hall sensor (“a sensor”) that detects changes to a magnetic field caused by a magnet (“can be activated/actuated using a magnet”).²⁰ *Id.*

IX. THE DISCRETIONARY FACTORS FAVOR INSTITUTING TRIAL

A. 35 U.S.C. § 314(a)

PO has initiated two lawsuits related to the '077 patent in the Southern District of Texas (“SDTX”)—one against Petitioners (4:20-cv-2624) and a second against Apple (4:20-cv-2652)—which have been consolidated for pre-trial purposes. EX1024. The lawsuit against Samsung is partially STAYED (EX1025, 8 (entry dated 11/20/2020)) pending decisions on motions by Apple and Samsung to transfer their respective litigations to the Northern District of California (“NDCA”). On December 16, 2020, the parties submitted their respective positions on scheduling issues. EX1026. The district court has not yet ruled on the parties’ proposals.

As PO has proposed that trial not occur until at least eight months *after* a FWD would issue (*see* discussion of factor 2), the Board need not undertake a *Fintiv*

²⁰ A POSITA would have understood the '077 patent to use the terms “activate” and “actuate” synonymously. EX1002, ¶249.

analysis. *Snap, Inc. v. SRK Technology LLC*, IPR2020-00820, Paper 15, at 7 (Oct. 21, 2020) (designated precedential as to *Fintiv* discussion) (quoting *Apple, Inc. v. Fintiv, Inc.*, IPR2020-00019, Paper 11, at 6 (Mar. 20, 2020)) (“These factors relate to whether efficiency, fairness and the merits support the exercise of authority to deny institution in view of an ***earlier trial date in the parallel proceeding.***”). Even if considered, the weight of the factors favor institution.

1. Potential for a District Court Stay. The lawsuit against Samsung is already subject to a partial stay pending resolution of the transfer and scheduling issues. EX1025, 8 (entry dated 11/20/2020). Should the district court deny transfer, Samsung intends to seek a full stay in favor of IPR.²¹ The district court has exhibited a willingness to stay proceedings before the Board has instituted trial and even after some discovery has occurred, ***even if opposed.*** See, e.g., *ConocoPhillips Co. v. In-Depth Compressive Seismic, Inc.*, 4:18-cv-00803, Dkt. 111 (S.D. Tex. Oct. 31, 2019) (granting opposed motion to stay after all patent-rule deadlines had passed and the court had already entered a Markman Order); *Neuro Cardiac Techs., LLC v. LivaNova, Inc.*, 2018 WL 4901035, at *5 (S.D. Tex. Oct. 9, 2018) (granting opposed motion to stay before institution decision); *Transocean Offshore Deepwater*

²¹ If the case is transferred to the NDCA, Samsung intends to seek a stay from the NDCA court.

Drilling, Inc. v. Seadrill Ams., Inc., 2015 WL 6394436, at *6 (S.D. Tex. Oct. 22, 2015) (same); *e-Watch Inc. v. Avigilon Corp.*, 2013 WL 12141359, at *2 (S.D. Tex. Nov. 15, 2013) (same); *Lubrizol Specialty Prod., Inc. v. Baker Hughes Inc.*, 2017 WL 2255579, at *2 (S.D. Tex. May 23, 2017) (granting opposed motion to stay after IPRs were instituted).

2. Trial Date Relative to Final Written Decision Due Date.

On December 16, 2020, PO and Petitioners submitted their respective positions on scheduling issues in the event the court does not transfer the case to the NDCA. EX1026. Petitioners argued that except for certain preliminary patent-rule disclosures, scheduling issues should be deferred until after the court rules on the transfer issue. *Id.*, 5-6, 19. While PO argued in favor of setting a schedule through trial, notably, ***PO proposed that trial should be no earlier than March 2023*** (or perhaps as late as May 2023). *Id.*, 1-4, 17. Thus, even under PO's own best-case view, ***trial would occur eight months after a FWD*** would be expected in this proceeding. Moreover, PO acknowledged that its proposed schedule may need to be further modified based on when (or if) the court grants transfer. *Id.*, 3.

Additionally, Petitioners have been diligent, and this Petition is filed seven months prior to the statutory bar date,²² and over four months before Petitioners are

²² Petitioners calculate the statutory bar date as July 29, 2021. *See* Section II.

likely to be required to serve preliminary invalidity contentions. EX1026, 13, 19 (both parties proposed that preliminary invalidity contentions be served on May 12, 2021); *Snap*, IPR2020-00820, Paper 15, at 11 (noting that filing the petition expeditiously weighs against denying institution).

3. *Investment in the Parallel Proceeding.* As already noted, the district court proceeding against Samsung is partially stayed and the court has not yet entered a new trial date. Even under PO’s own best-case view, in July 2021—when the Board decides institution—the start of claim construction briefing will still be three months away. EX1026, 14 (opening claim construction brief due 10/6/2021); *Snap*, IPR2020-00820, Paper 15, at 10 (noting that if at time of institution decision the district court has not issued orders related to the patent, this fact weighs against denying institution). By the time of the expected FWD in this proceeding in July 2022, under PO’s own best-case view, expert discovery will not have yet completed, summary judgment briefing would not have started, and ***trial will be at least eight months away***. EX1026, 16-17. *Sotera Wireless, Inc. v. Masimo Corp.*, IPR2020-01019, Paper 12, at 16 (Dec. 1, 2020) (precedential as to *Fintiv* discussion) (in support of decision to institute trial, noting that “much work remains in the parallel proceeding as it relates to invalidity” including that “expert reports are not yet due, and substantive motion practice is yet to come”).

4. *Overlap of Issues.* Samsung challenges all claims of the '077 patent, whereas PO has asserted only claims 1, 2, 4, 6-10, 12, 14, 16, 17, and 19 in the district court litigation. Accordingly, a material number of the challenged claims *will not be addressed by the trial* in the district court. *See Seven Networks*, IPR 2020-00156, Paper 10, at 21. Samsung has a substantial interest in resolving the patentability of all challenged claims, which only the Board is in a position to assess. Furthermore, in the unlikely event the district court trial occurs prior to a FWD, Petitioners have stipulated to PO that, if IPR is instituted, they will not rely on any of *Kim, Koh, or Lee* to assert invalidity of any claim of the '020 patent in the parallel litigation. EX1027.

5. *Parties.* The district court action against Samsung and the trial here involve the same parties.²³ *But see Cisco Sys., Inc. v. Ramot at Tel Aviv Univ. Ltd.*, IPR2020-00122, Paper 15, at 10 (May 15, 2020) (APJ Crumbley, dissenting) (noting that weighing this factor against a petitioner when the parties in IPR are the same in related litigation, could “tip the scales against a petitioner merely for being a defendant in the district court.” This “would seem to be contrary to the goal of

²³ PO has also initiated a district court action against Apple. The *Apple* litigation has been consolidated with the *Samsung* case for pre-trial purposes. EX1024.

providing district court litigants an alternative venue to resolve questions of patentability.”).

6. *Other Consideration.* As the *Fintiv* panel noted, “if the merits of a ground raised in the petition seem particularly strong on the preliminary record ... the institution of a trial may serve the interest of overall system efficiency and integrity” *Fintiv*, IPR2020-00019, Paper 11, at 14-15 (addressing factor 6). As referenced in detail in the instant Petition (with reference to Dr. Kiaei’s Declaration), the challenged claims were clearly disclosed in the prior art. For at least this reason, *Fintiv* factor 6 strongly favors institution. *See, e.g., Seven Networks*, IPR2020-00156, Paper 10, at 20-21 (finding that *Fintiv* factor 6 weighs strongly in favor of Petition” based on Petitioner’s “strong showing on the merits”).

Samsung therefore respectfully submits that the *Fintiv* factors favor institution and that discretionary denial of this Petition would be neither appropriate nor equitable.

B. 35 U.S.C. § 325(d)

The Board should likewise not exercise its discretion under § 325(d) to deny institution of Samsung’s petition. There are no references presented in this petition that were previously before the Office.

X. MANDATORY NOTICES UNDER 37 C.F.R. § 42.8

A. Real Parties-in-Interest

Petitioners identify themselves as the real parties-in-interest.

B. Related Matters

Samsung is concurrently filing requests for *inter partes* review of U.S. Patents 10,259,020; 10,259,021; and 10,589,320. Each of these patents shares a common claim of priority with the '077 patent.

Attached to this petition as EX1006 is a chart identifying all patents/applications that are in the same family as the '077 patent.

To the best knowledge of Samsung, the '077 patent is or has been involved in the following district court litigations:

Name	No.	Court	Filed
<i>GUI Global Products, Ltd. d/b/a Gwee v. Samsung Elecs. Co., Ltd. and Samsung Electronics America, Inc.</i>	4:20-cv-02624	S.D. Tex.	Jul. 27, 2020
<i>GUI Global Products, Ltd. d/b/a Gwee v. Apple, Inc.</i>	4:20-cv-02652	S.D. Tex.	Jul. 28, 2020

To the best knowledge of Samsung, the '077 patent has not been challenged

in any *inter partes* review prior to this proceeding.

C. Lead and Backup Counsel

Lead Counsel	Back-Up Counsel
Ali R. Sharifahmadian, Reg. No. 48,202 (ali.sharifahmadian@arnoldporter.com) Arnold & Porter Kaye Scholer LLP 601 Massachusetts Ave., NW Washington, DC 20001-3743 Tel: 202-942-5000 Fax: 202-942-5999	Jin-Suk Park, Reg. No. 50,678 (jin.park@arnoldporter.com) J. Christopher Moulder, Reg. No. 70,490 (chris.moulder@arnoldporter.com) Mark A. Patrick, Reg. No. 72,958 (mark.patrick@arnoldporter.com) Arnold & Porter Kaye Scholer LLP 601 Massachusetts Ave., NW Washington, DC 20001-3743 Tel: 202-942-5000 Fax: 202-942-5999

D. Service Information

Please address all correspondence to lead and back-up counsel at the addresses shown above. Petitioner consents to electronic service by e-mail.

XI. FEES

Petitioners concurrently electronically submit the required fees for this Petition. The Board is authorized to charge Arnold & Porter Kaye Scholer LLP's deposit account, No. 50-2387, for any fee deficiency.

Date: December 29, 2020

Respectfully submitted,

/Ali R. Sharifahmadian/
Ali R. Sharifahmadian, Lead Counsel
Reg. No. 48,202

CERTIFICATE OF COMPLIANCE

The undersigned hereby certifies that the foregoing Petition for *Inter Partes* Review contains 13,455 words, excluding those portions identified in 37 C.F.R. § 42.24(a), as measured by the word-processing system used to prepare this paper.

/Ali R. Sharifahmadian/
Ali R. Sharifahmadian (Reg. No. 48,202)
Counsel for Petitioners

CERTIFICATE OF SERVICE

I certify that on December 29, 2020, I caused a true and correct copy of the foregoing Petition for *Inter Partes* Review of U.S. Patent No. 10,562,077 and supporting exhibits to be served via overnight delivery on the Patent Owner at the following correspondence address of record as listed on PAIR:

Mossman, Kumar & Tyler PC
P.O. Box 421239
Houston TX 77242

A courtesy copy was also sent via electronic mail to Patent Owner's litigation counsel listed below:

Ernest Boyd (butchboyd@butchboydlawfirm.com)
John Edmonds (jedmonds@ip-lit.com)
Steve Schlather (sschlather@ip-lit.com)
Barrett H. Reasoner (breasoner@gibbsbruns.com)
Mark Giugliano (mgiugliano@gibbsbruns.com)
Mike Absmeier (mabsmeier@gibbsbruns.com)
Alistair Dawson (adawson@beckredde.com)
Michael Richardson (mrichardson@beckredde.com)
Garrett Brawley (gbrawley@beckredde.com)
Patrick Redmon (predmon@beckredde.com)
Jorge Gutierrez (jgutierrez@gibbsbruns.com)

/Ali R. Sharifahmadian/

Ali R. Sharifahmadian (Reg. No. 48,202)
Counsel for Petitioners