



US 20060071746A1

(19) **United States**

(12) **Patent Application Publication**
Lylyharju

(10) **Pub. No.: US 2006/0071746 A1**

(43) **Pub. Date: Apr. 6, 2006**

(54) **VIBRATION AND LOCKING SYSTEM**

(52) **U.S. Cl. 335/205**

(75) **Inventor: Marko Lylyharju, Salo (FI)**

(57) **ABSTRACT**

Correspondence Address:
BANNER & WITCOFF
1001 G STREET N W
SUITE 1100
WASHINGTON, DC 20001 (US)

There is being disclosed a portable electronic apparatus, such as a mobile phone, comprising a body and at least partly covering lid pivotally mounted to the body by a hinge. The apparatus includes a permanent magnet and an electromagnetic coil for generating a controllable magnetic flux between the lid and the body of the portable electronic apparatus. By supplying a current through a wire in the coil suspended between the poles of the permanent magnet the wire experiences a magnetic force. An embodiment can be used for vibrating the portable electronic apparatus, locking the lid and the body of the apparatus together and indicating a position of the lid.

(73) **Assignee: Nokia Corporation, Espoo (FI)**

(21) **Appl. No.: 10/956,139**

(22) **Filed: Oct. 4, 2004**

Publication Classification

(51) **Int. Cl.**
H01H 9/00 (2006.01)

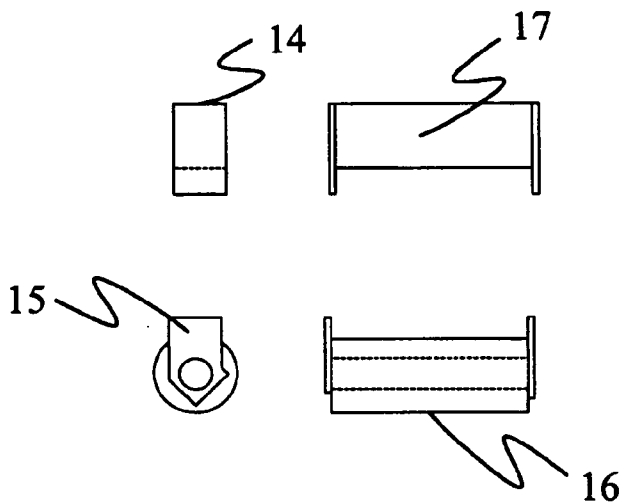
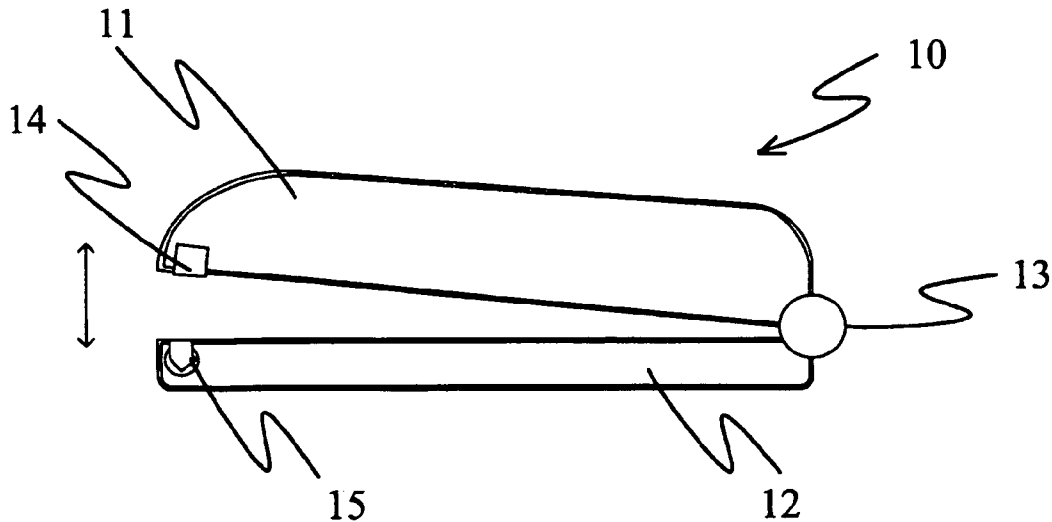

Samsung v. GUI
IPR2021-00335
Exhibit 1022

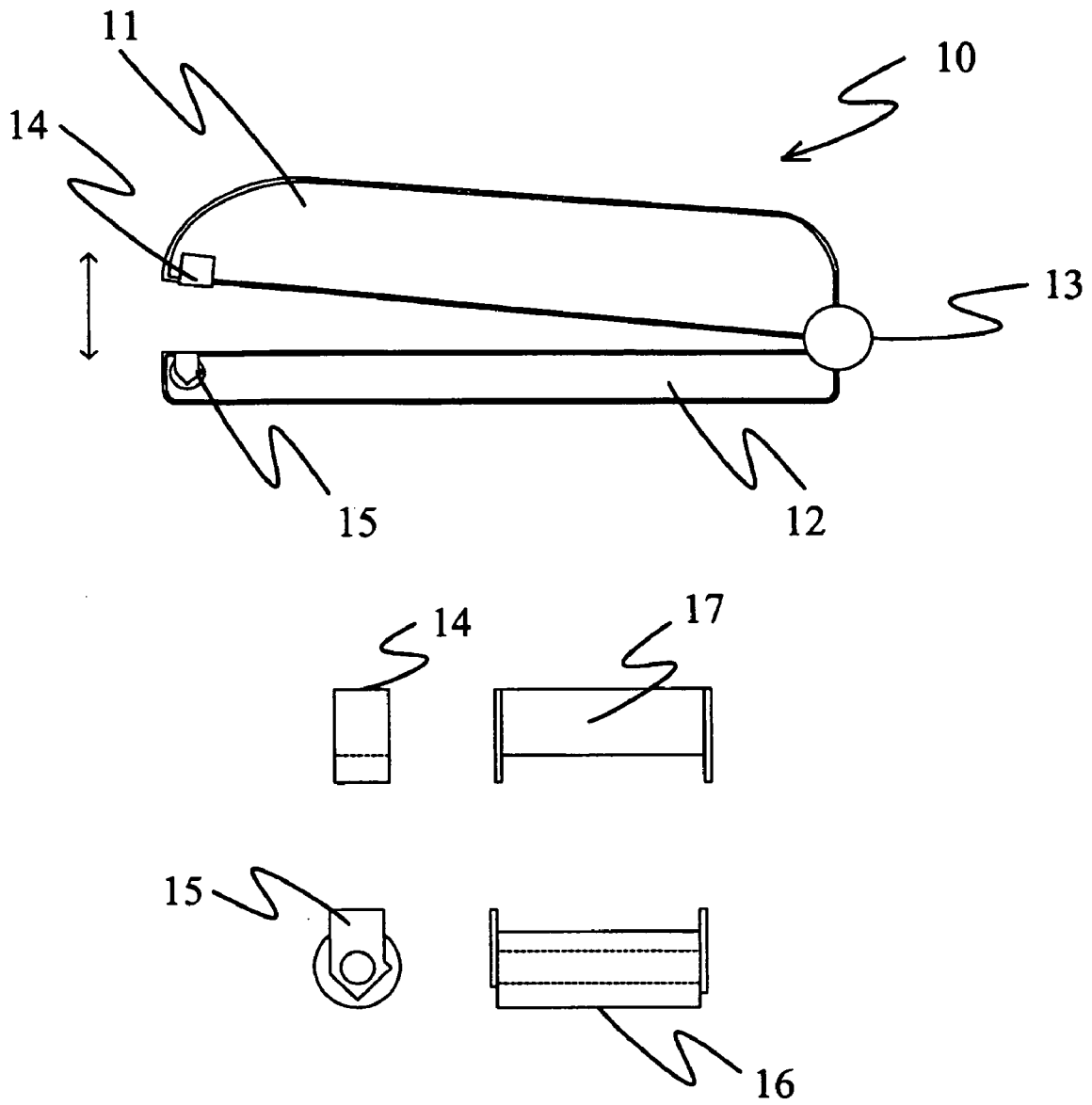

Fig. 1

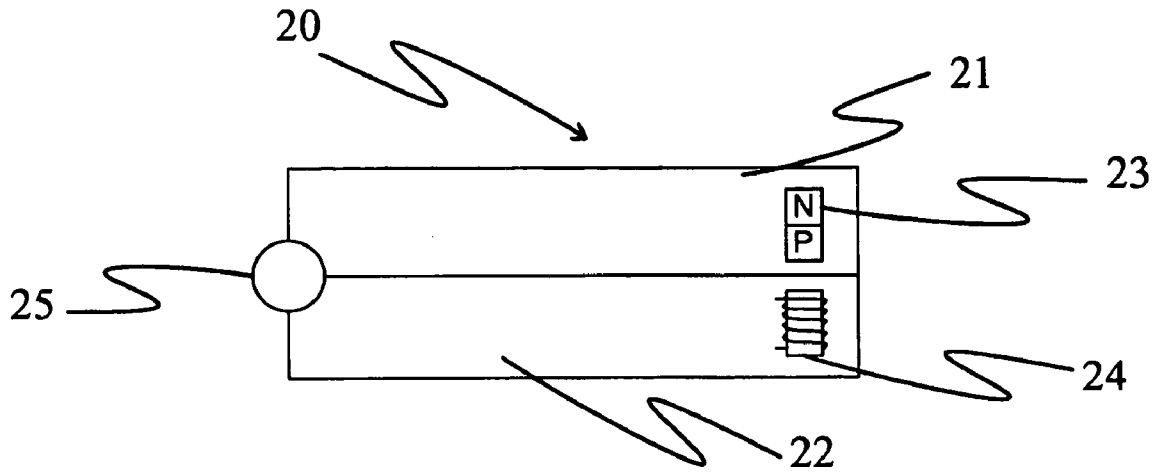

Fig. 2

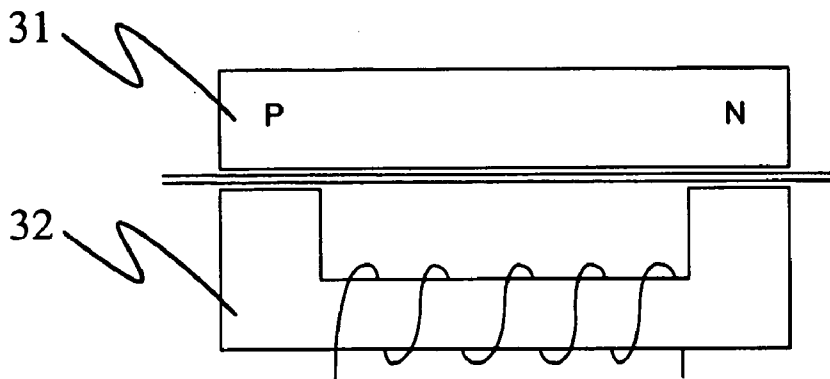

Fig. 3

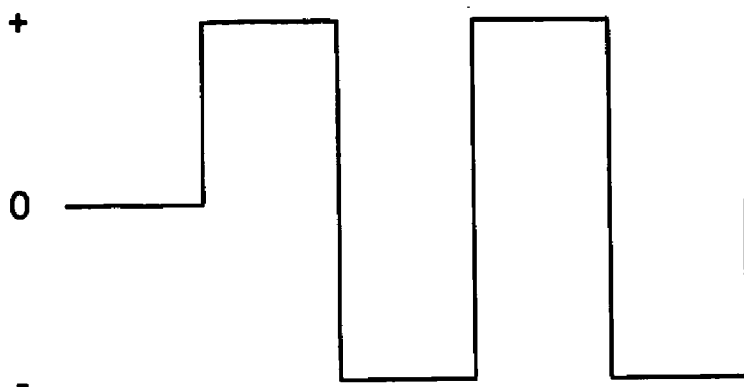

Fig. 4a

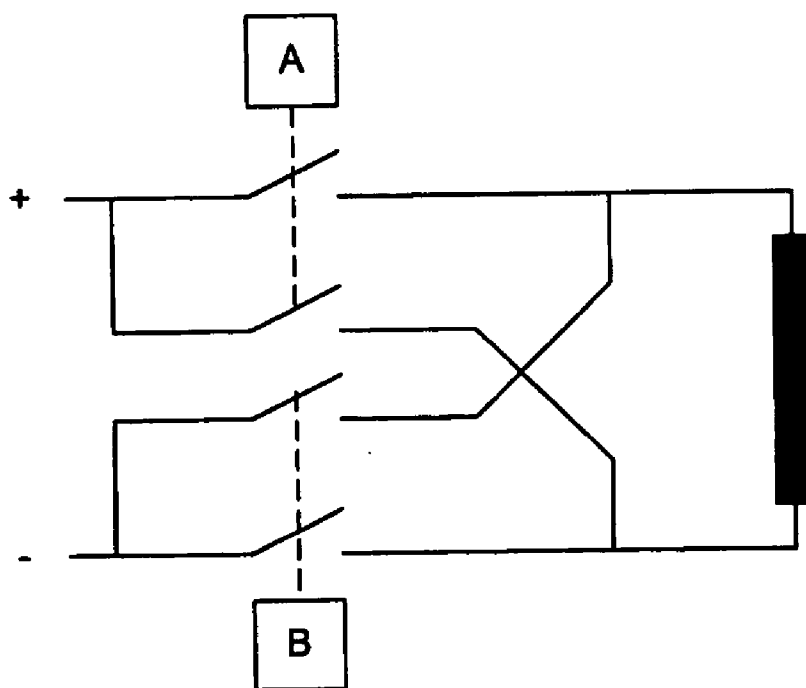

Fig. 4b

VIBRATION AND LOCKING SYSTEM

TECHNICAL FIELD OF THE INVENTION

[0001] The invention concerns a portable electronic apparatus according to a preamble of claim 1. Furthermore, the invention concerns a mobile phone according to a preamble of claim 19. Still furthermore, the invention concerns a portable electronic apparatus system according to a preamble of claim 37.

BACKGROUND ART

[0002] Portable electronic apparatuses, such as mobile phones and personal digital assistants, are typically equipped with a generator that provides a vibration alarm. A small-sized dc motor arranged into the apparatus is used as a source of vibration, in which the vibration is generated by the small weights. The weights are mounted eccentrically on the shaft of the dc motor. When the dc motor is started the weights are rotated with the shaft generating vibration due to the inertial force of the eccentric weight. The vibration propagates to the apparatus and causes alert to the user. The dc motor can be used as the source of vibration if there is enough space available in the interior of the portable electronic apparatus. If the space is limited by the physical size of the portable electronic apparatus the size of the dc motor should be reduced respectively. Furthermore, this kind of solution is expensive and therefore generally unsatisfactory.

[0003] The above problems are emphasized in the portable electronic apparatuses consisting of a body and a lid pivotally mounted to the body by a hinge, for example in the mobile phones of shell type. The lid of the apparatus is movable between an open and a closed position and provided conventionally with a locking mechanism in the body of the apparatus. The locking mechanism is typically mechanical comprising for example a spring for tensioning the lid to the closed position and a release button for releasing the lid to the open position. The foldable structure of the portable electronic apparatus reduces the space required for the components used in the apparatus.

SUMMARY OF THE INVENTION

[0004] It is therefore an object of the invention to provide a portable electronic apparatus, a mobile phone and a portable electronic apparatus system to better meet the foldable structure requirements than in the known art.

[0005] This object is achieved by the portable electronic apparatus according to claim 1. In accordance with further aspects of the invention, there is also provided a mobile phone according to claim 19 and a portable electronic apparatus system according to claim 37. Furthermore, there is being provided the use of such apparatuses.

[0006] The invention utilizes magnetic flux generating means for generating a controllable magnetic flux between the lid and the body of the portable electronic apparatus which means requires less space for the implementation, thereby enabling to follow the structural, functional and design requirements of the portable electronic apparatus.

[0007] Furthermore, the weight of the portable electronic apparatus can be reduced since a movable mass used for

the movements of the pivotally mounted lid can be detected electrically. Furthermore, forces enabling the magnetic flux between the lid of the apparatus and the body of the apparatus are generated.

[0008] In further embodiments, the magnetic flux generating means comprises a permanent magnet and an electromagnetic coil that is so disposed as to intersect a magnetic flux of the permanent magnet for generating the controllable magnetic flux.

[0009] In further embodiments of the invention, the permanent magnet is adapted to be supported by a conductor to conduct a magnetic field and mounted to the lid of the portable electronic apparatus, and the electromagnetic coil is adapted to be supported by a body of the electromagnetic coil and mounted to the body of the portable electronic apparatus. Furthermore, the magnets are arranged so that the lid being in a closed position, that is placing the lid substantially flush with the body of the portable electronic apparatus, one of the magnetic poles of the permanent magnet is positioned upon the beginning of the electromagnetic coil, and the other magnetic pole of the permanent magnet is positioned upon the end of the electromagnetic coil.

[0010] According to another further embodiments of the invention the permanent magnet has a shape of oblong and is supported by the conductors in the both ends of the permanent magnet. In addition, the electromagnetic coil has a shape of cylinder and is supported by the conductors in the both ends of the coil and by a conductor rod positioned axially in the centre of the cylinder coil. The conductors are made of steel, for example.

[0011] In another further embodiments of the invention, the lid of the portable electronic apparatus and the body of the portable electronic apparatus are adapted to be locked together. Furthermore, in another further embodiments of the invention, the lid and the body of the portable electronic apparatus are locked together by the controllable magnetic flux.

[0012] According to further embodiments of the invention the lid and the body of the portable electronic apparatus are adapted to be locked together by the magnetic forces of the controllable magnetic flux. Thus, the lid and the body of the portable electronic apparatus are adapted to be locked together either by the magnetic attraction or by the magnetic repulsion.

[0013] In another further embodiments of the invention, the vibration of the portable electronic apparatus is generated by the controllable magnetic flux. That is the vibration of the portable electronic apparatus is due to the interaction of a current signal of varying pulses passing through the electromagnetic coil and the magnetic field. Such varying current signal may be a sine wave or a saw-tooth wave and advantageously a square wave. The frequency of the current signal may be dependent on either the natural frequency of the components arranged in the portable electronic apparatus, such as the lid, or the audible frequency or both. Furthermore, in another further embodiments of the invention, the frequency of the current signal supplied to the coil is audible frequency. Such frequency may be constant.

Explore Litigation Insights

Docket Alarm provides insights to develop a more informed litigation strategy and the peace of mind of knowing you're on top of things.

Real-Time Litigation Alerts



Keep your litigation team up-to-date with **real-time alerts** and advanced team management tools built for the enterprise, all while greatly reducing PACER spend.

Our comprehensive service means we can handle Federal, State, and Administrative courts across the country.

Advanced Docket Research



With over 230 million records, Docket Alarm's cloud-native docket research platform finds what other services can't. Coverage includes Federal, State, plus PTAB, TTAB, ITC and NLRB decisions, all in one place.

Identify arguments that have been successful in the past with full text, pinpoint searching. Link to case law cited within any court document via Fastcase.

Analytics At Your Fingertips



Learn what happened the last time a particular judge, opposing counsel or company faced cases similar to yours.

Advanced out-of-the-box PTAB and TTAB analytics are always at your fingertips.

API

Docket Alarm offers a powerful API (application programming interface) to developers that want to integrate case filings into their apps.

LAW FIRMS

Build custom dashboards for your attorneys and clients with live data direct from the court.

Automate many repetitive legal tasks like conflict checks, document management, and marketing.

FINANCIAL INSTITUTIONS

Litigation and bankruptcy checks for companies and debtors.

E-DISCOVERY AND LEGAL VENDORS

Sync your system to PACER to automate legal marketing.