



US007068684B1

(12) **United States Patent**
Suder et al.

(10) **Patent No.:** **US 7,068,684 B1**
(45) **Date of Patent:** **Jun. 27, 2006**

(54) **QUALITY OF SERVICE IN A VOICE OVER IP TELEPHONE SYSTEM**

(75) Inventors: **Eric G. Suder**, Plano, TX (US);
Harold E. A. Hansen, II, Plano, TX (US)

(73) Assignee: **Estech Systems, Inc.**, Plano, TX (US)

(*) Notice: Subject to any disclaimer, the term of this patent is extended or adjusted under 35 U.S.C. 154(b) by 877 days.

(21) Appl. No.: **09/775,018**

(22) Filed: **Feb. 1, 2001**

(51) **Int. Cl.**
H04L 12/66 (2006.01)
H04J 1/02 (2006.01)
H04J 1/14 (2006.01)
H04M 11/00 (2006.01)

(52) **U.S. Cl.** **370/493**; 370/352; 370/496;
379/93.29; 379/93.09

(58) **Field of Classification Search** 370/229,
370/352, 353, 401, 230, 389, 493, 494, 495,
370/535, 395.42, 395.21, 433, 443, 444,
370/445

See application file for complete search history.

(56) **References Cited**

U.S. PATENT DOCUMENTS

5,119,372	A *	6/1992	Verbeek	370/230
5,751,791	A *	5/1998	Chen et al.	379/88.13
5,878,120	A *	3/1999	O'Mahony	379/93.09
5,982,779	A	11/1999	Krishnakumar et al.	370/447
6,504,926	B1 *	1/2003	Edelson et al.	379/390.01
6,515,996	B1 *	2/2003	Tonnby et al.	370/401
6,535,521	B1 *	3/2003	Barghouti et al.	370/462
6,587,433	B1 *	7/2003	Borella et al.	370/230
6,678,280	B1 *	1/2004	Kim et al.	370/429

6,735,209	B1 *	5/2004	Cannon et al.	370/401
6,760,429	B1 *	7/2004	Hung et al.	379/265.09
6,785,261	B1 *	8/2004	Schuster et al.	370/352
6,798,768	B1 *	9/2004	Gallick et al.	370/352
6,839,341	B1 *	1/2005	Nakajima	370/352
6,876,648	B1 *	4/2005	Lee	370/353

OTHER PUBLICATIONS

Harry Newton, *Newton's Telecom Dictionary*, 16th Edition, copyright 2000, pp. 126-127.

Avaya Communication, "Avaya IP Telephone," available via the Internet at www.lucent.com/enterprise/solutions/eclips/pdf/black13_white_paper.pdf, Nov. 9, 2000.

Avaya Communication, "Quality of Service (QoS) considerations with 4600 Series IP Telephones," available via the Internet at www.lucent.com/enterprise/solutions/eclips/pdf/QoSwhite_paper.pdf, Jan. 29, 2000.

* cited by examiner

Primary Examiner—Hanh Nguyen

(74) *Attorney, Agent, or Firm*—Kelly K. Kordzik; Winstead Sechrest & Minick P.C.

(57) **ABSTRACT**

An information handling system comprises a TCP/IP network connecting a hub to a multimedia server and the hub to a data server, and the hub to an IP telephony device that is then coupled to a network device. Data sent from the network device is addressed for transmission to the data server and is transmitted through the IP telephony device to the TCP/IP network. The IP telephony device monitors when an amount of data being received over the network falls below a predetermined threshold. If this occurs, the IP telephony device will send a signal to the multimedia server, which will then generate a congestion signal to send to all or selected IP telephony devices in the network to throttle data being received by the IP telephony devices from their respective connected network devices.

61 Claims, 13 Drawing Sheets

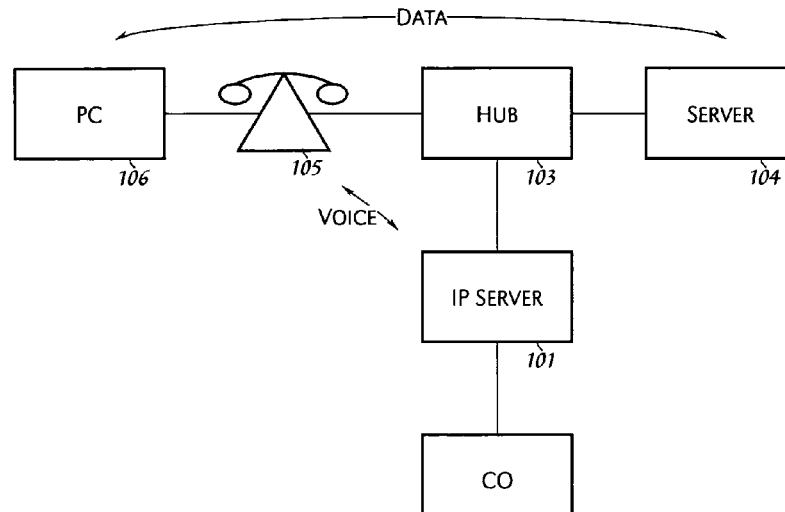

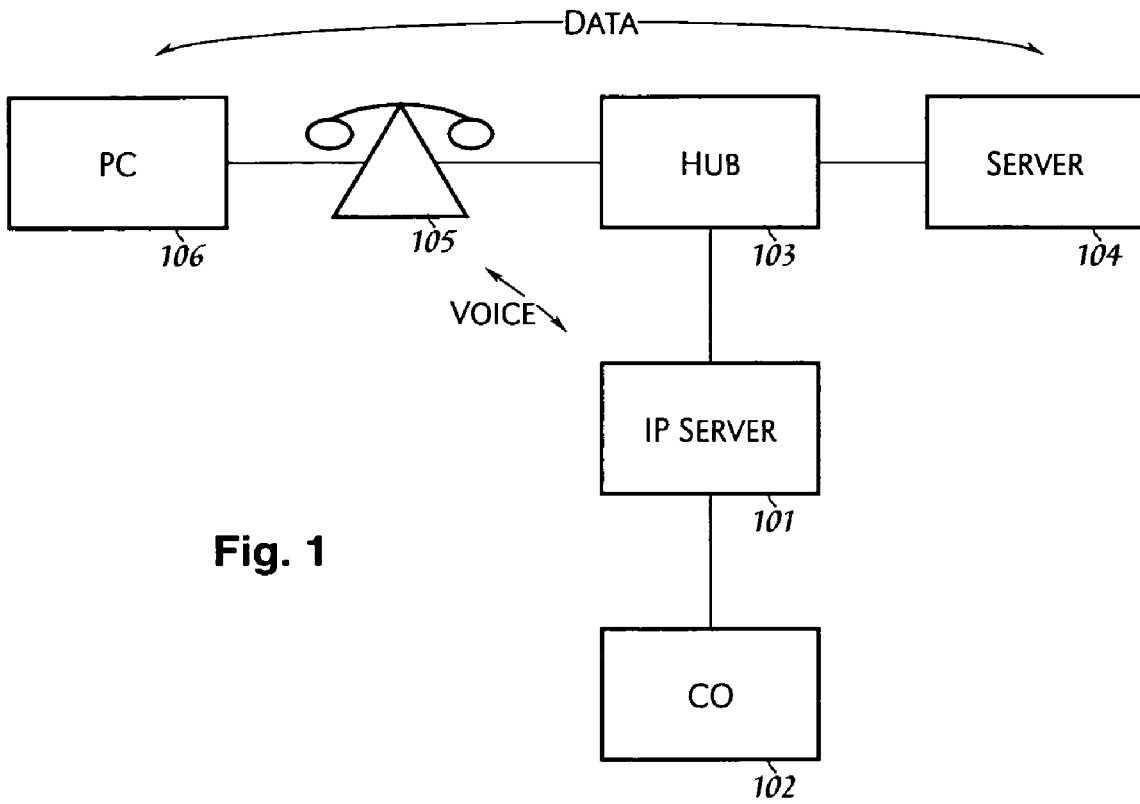

Fig. 1

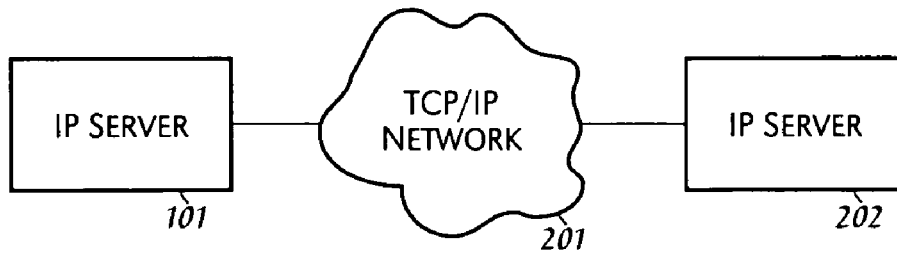

Fig. 2

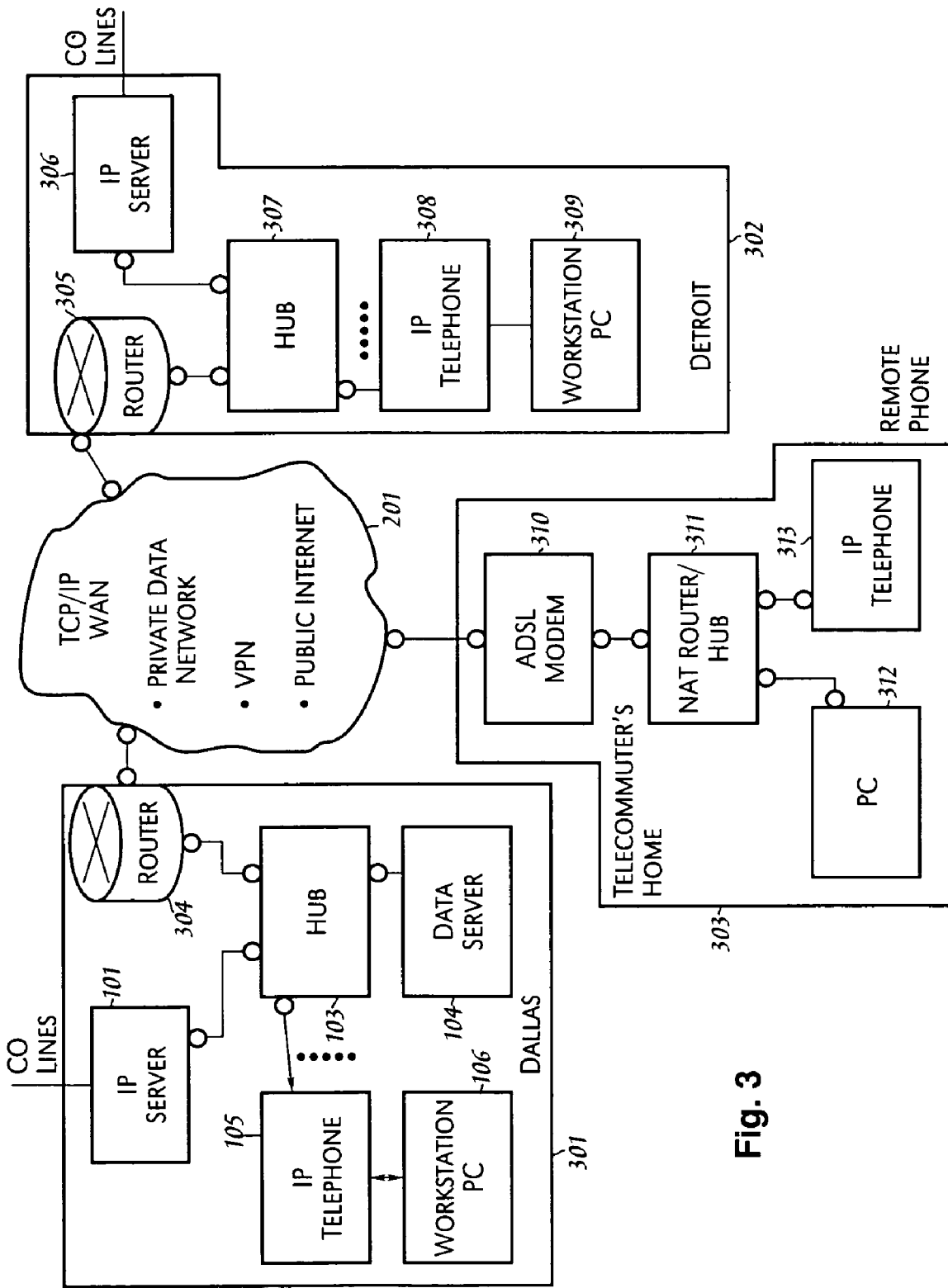

Fig. 3

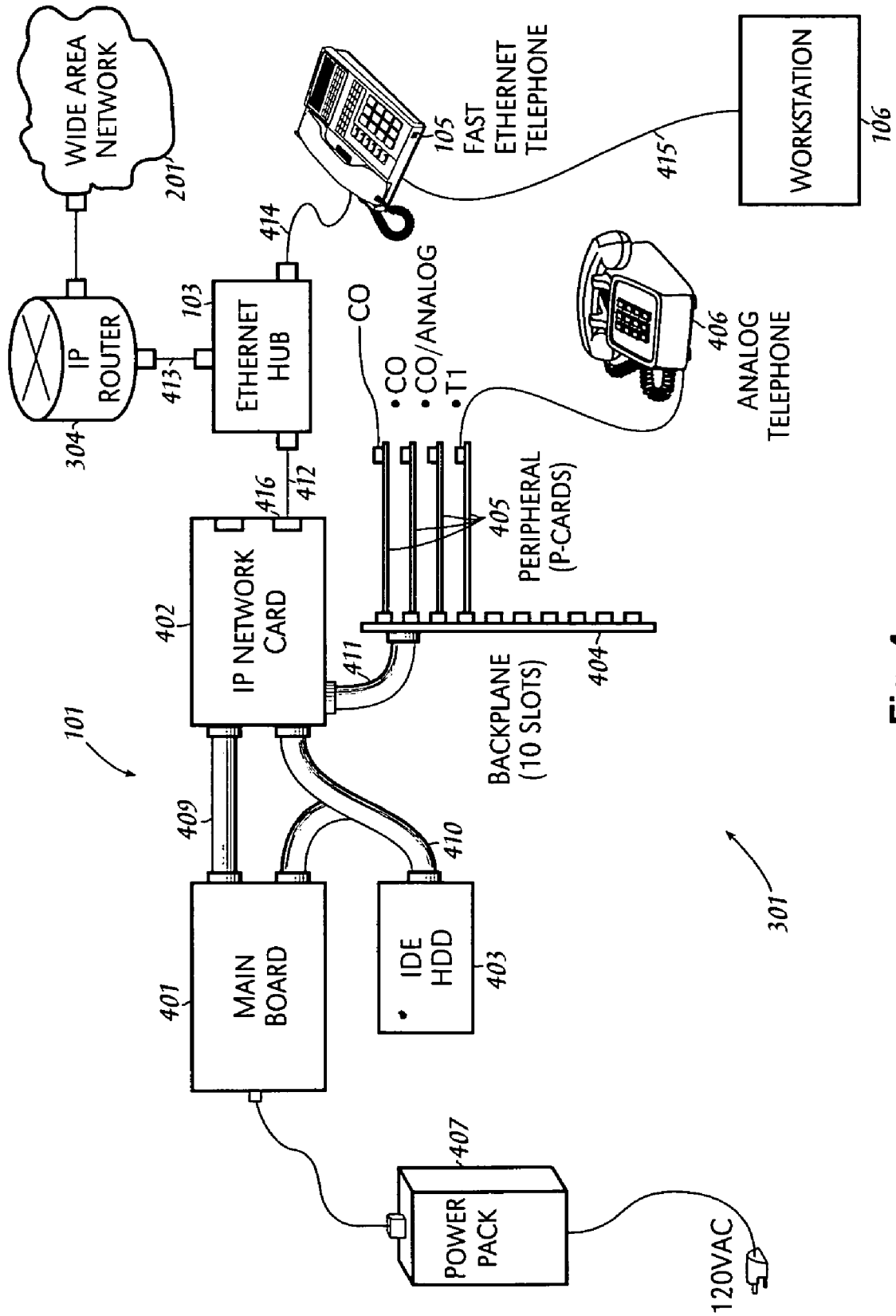

Fig. 4

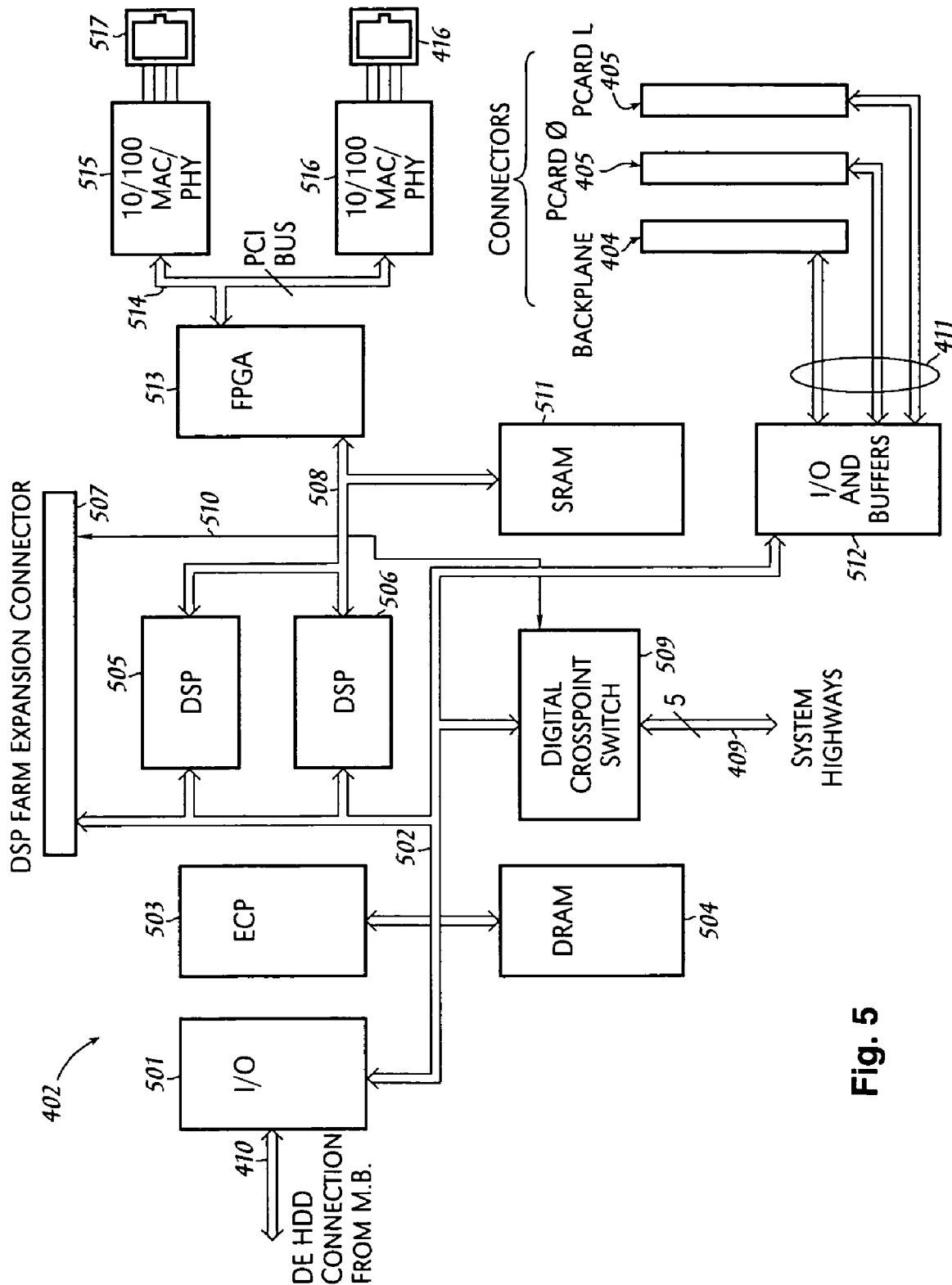

Fig. 5

Explore Litigation Insights

Docket Alarm provides insights to develop a more informed litigation strategy and the peace of mind of knowing you're on top of things.

Real-Time Litigation Alerts



Keep your litigation team up-to-date with **real-time alerts** and advanced team management tools built for the enterprise, all while greatly reducing PACER spend.

Our comprehensive service means we can handle Federal, State, and Administrative courts across the country.

Advanced Docket Research



With over 230 million records, Docket Alarm's cloud-native docket research platform finds what other services can't. Coverage includes Federal, State, plus PTAB, TTAB, ITC and NLRB decisions, all in one place.

Identify arguments that have been successful in the past with full text, pinpoint searching. Link to case law cited within any court document via Fastcase.

Analytics At Your Fingertips



Learn what happened the last time a particular judge, opposing counsel or company faced cases similar to yours.

Advanced out-of-the-box PTAB and TTAB analytics are always at your fingertips.

API

Docket Alarm offers a powerful API (application programming interface) to developers that want to integrate case filings into their apps.

LAW FIRMS

Build custom dashboards for your attorneys and clients with live data direct from the court.

Automate many repetitive legal tasks like conflict checks, document management, and marketing.

FINANCIAL INSTITUTIONS

Litigation and bankruptcy checks for companies and debtors.

E-DISCOVERY AND LEGAL VENDORS

Sync your system to PACER to automate legal marketing.