



(19) **United States**

(12) **Patent Application Publication** (10) **Pub. No.: US 2007/0123171 A1**
Slamka et al. (43) **Pub. Date: May 31, 2007**

(54) **COMMUNICATION OF AUDIO CONTROL SIGNALS FOR WIRELESS AUDIO HEADPHONES**

Publication Classification

(51) **Int. Cl.**
H04B 7/00 (2006.01)
(52) **U.S. Cl.** **455/66.1**

(76) Inventors: **Milan Slamka**, Camas, WA (US); **Todd Yuzuriha**, Vancouver, WA (US)

Correspondence Address:
IPSOLON LLP
111 SW COLUMBIA
SUITE 710
PORTLAND, OR 97201 (US)

(57) **ABSTRACT**

A wireless audio headphone communication system has an audio input for receiving an audio signal from an audio source. A wireless transceiver receives and transmits radio frequency communications with a wireless audio headphone, the communications including an audio control signal that conforms to a wireless audio control protocol of a wireless communication protocol. A converter converts the audio control signal between the wireless audio control protocol transceived by the wireless transceiver and a local control protocol for controlling the audio source.

(21) Appl. No.: **11/223,767**

(22) Filed: **Sep. 9, 2005**

Related U.S. Application Data

(60) Provisional application No. 60/608,659, filed on Sep. 10, 2004.

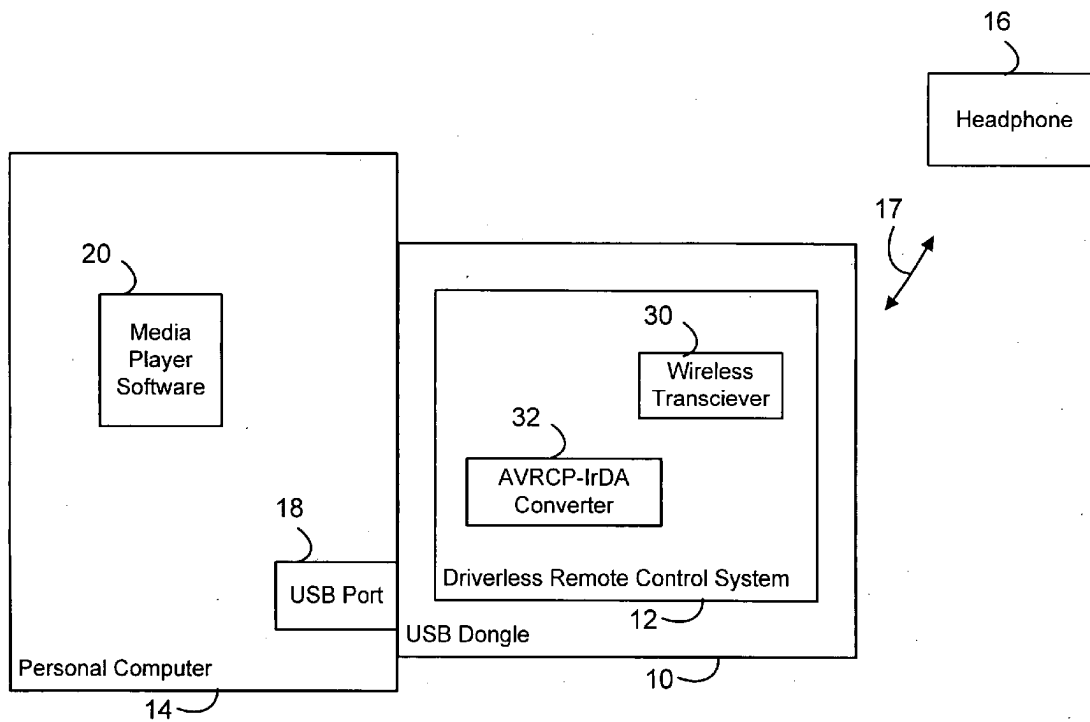

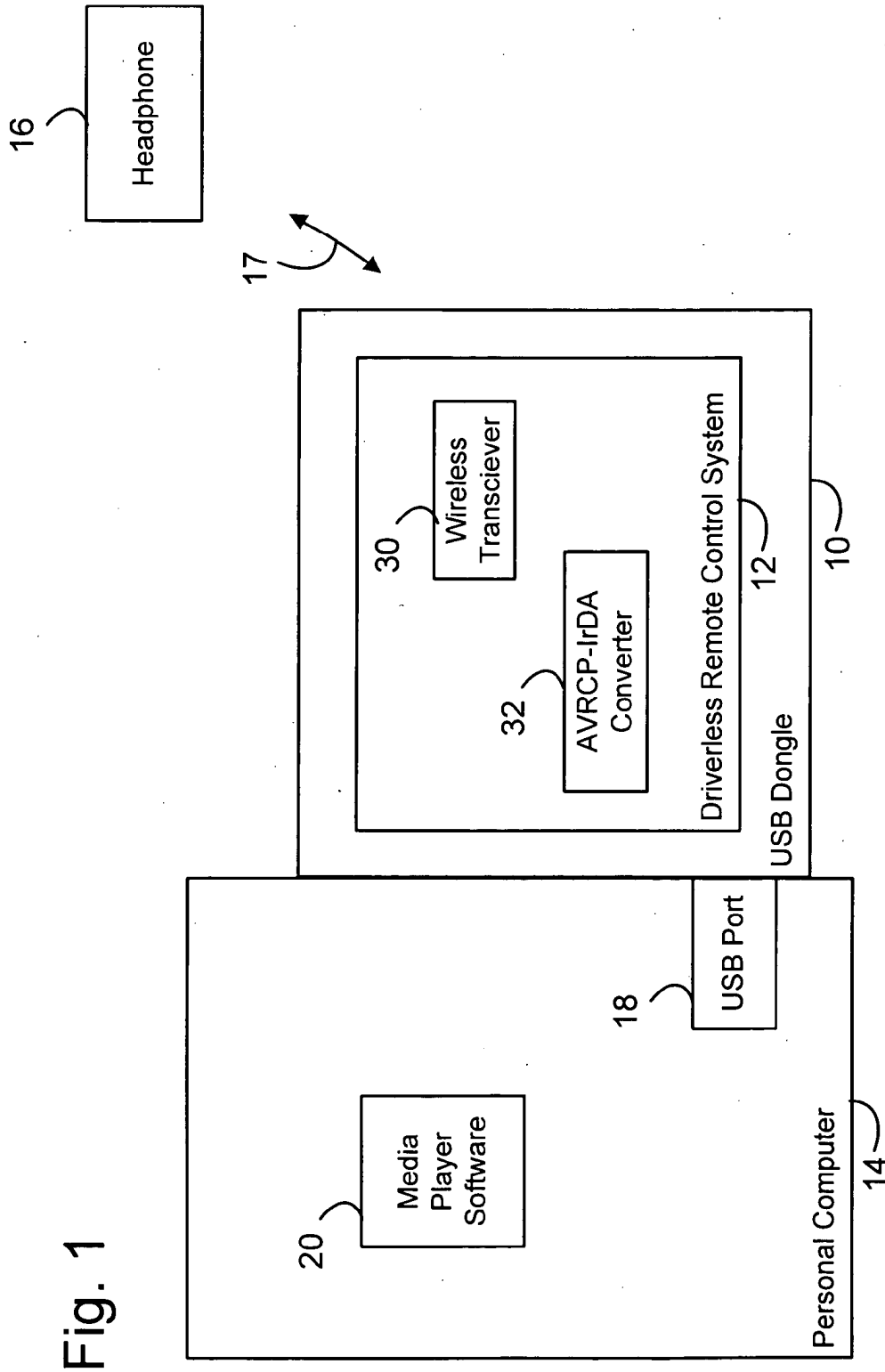
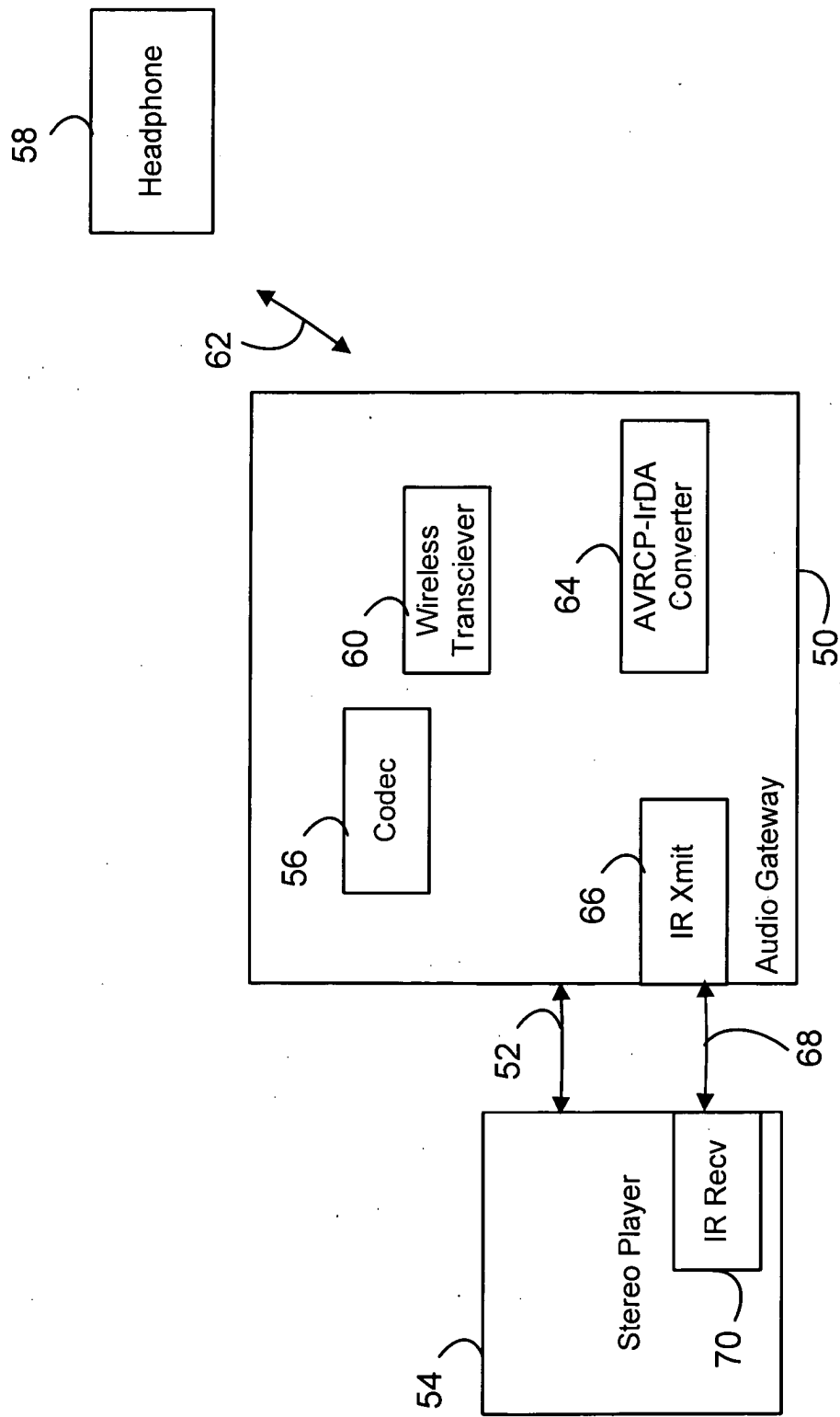

Fig. 1

Fig. 2



COMMUNICATION OF AUDIO CONTROL SIGNALS FOR WIRELESS AUDIO HEADPHONES

TECHNICAL FIELD

[0001] The present invention relates to communicating audio control signals for wireless headphones and, in particular, to a wireless audio headphone communication system for communicating such signals.

BACKGROUND AND THE SUMMARY OF THE INVENTION

[0002] Stereo headphones and other audio output devices that conform to the Audio Profile of the Bluetooth® radio frequency (RF) wireless standard can utilize or control sources of audio content from a variety of Bluetooth®-enabled audio platforms, such as IPAQ™ portable players, iPOD™, portable players, MP3 portable players, media player software on personal computers, home stereo systems, etc. In particular, the Bluetooth® specification includes an “Audio Video Remote Control Protocol” (AVRCP) that provides for control of a content source (e.g., portable player or media player software on a personal computer) from a content sink (e.g., a Bluetooth® headphone) over a wireless radio frequency (RF) link. The Audio Video Remote Control Protocol (AVRCP) also provides for control of the content sink from the content source over the wireless RF link. The control features may include remote control of functions such as Play, Pause, Volume UP, Volume Down, Forward and Previous track.

[0003] Typically, headphone architecture must include particular elements such as input/output (I/O) components, switches, firmware, etc. to implement remote control features according to the AVRCP. Content sources that are embedded in products like portable players (e.g., IPAQ™, iPOD™, and MP3 portable players) require embedded drivers that are specific for these products. For example, model-dependant Widcomm™ drivers are used in IPAQ™ portable players and some personal computers with embedded Bluetooth® stacks. Products such as personal computers (e.g., laptop computers or desktop computers) that do not have embedded Bluetooth® modules require a Bluetooth® digital dongle, or other RF module, and appropriate driver software, which is available from a variety of sources such as Widcomm, IVT, etc.

[0004] Large numbers of existing personal computers do not have embedded Bluetooth® RF modules or the corresponding driver software. Even with Bluetooth® digital dongles or other RF modules connected to them, such personal computers would further require model-dependent drivers for Audio Profile Bluetooth® devices, like stereo headphones, to provide control of a content source (e.g., media player software) over the wireless RF link. Promulgation of such a wide variety of drivers can be expensive for the provider, and accessing and installing the correct drivers can be difficult for users.

[0005] Accordingly, the present invention provides a wireless audio headphone communication system having an audio input for receiving an audio signal from an audio source, a wireless transceiver for receiving and transmitting radio frequency communications with a wireless audio head-

wireless communication protocol, and a converter for converting the audio control signal between the wireless audio control protocol transceived by the wireless transceiver and a local control protocol for controlling the audio source.

[0006] In one implementation, the present invention provides a universal USB dongle (e.g., a USB “stick”) that requires no source-specific software drivers and that will operate on any computing device with a USB source connection, such as a personal computer (i.e., laptop or desktop). In one implementation, the universal USB dongle conforms to the Audio Profile of the Bluetooth® wireless standard as an Audio Profile device, enumerating as an audio device to the source (e.g., personal computer) and providing full control from or to the source or the sink (e.g., a wireless stereo headphone). The source may have a variety of players (e.g., software players) to deliver music or other content to the headphone. As a USB device the universal dongle operates in a plug and play manner, independent of the platform and software.

[0007] Additional objects and advantages of the present invention will be apparent from the detailed description of the preferred embodiment thereof, which proceeds with reference to the accompanying drawings.

BRIEF DESCRIPTION OF THE DRAWINGS

[0008] FIG. 1 is a block diagram of a USB dongle with a driverless audio device RF remote control system.

[0009] FIG. 2 is a block diagram of an audio gateway as an alternative embodiment of the present invention.

DETAILED DESCRIPTION OF PREFERRED EMBODIMENTS

[0010] FIG. 1 is a block diagram of a universal serial bus (USB) dongle or “stick” 10 with a driverless audio device RF remote control system 12. Driverless audio device RF remote control system 12 provides remote control between, for example, a personal computer 14 and a headphone 16 that communicate over a radio frequency (RF) link 17 that is based on a wireless standard like Bluetooth®. Driverless audio device RF remote control system 12 operates without installation of a remote control software driver onto personal computer 14.

[0011] Personal computer 14 includes a USB port 18 into which USB dongle 10 is plugged. Media player software 20 on personal computer 14 provides audio content that is transmitted to and played on headphone 16 according to remote control signals transmitted between computer 14 and headphone 16. It will be appreciated that reference to the Bluetooth® wireless standard is merely as an example and that RF link 17 could operate according to any wireless standard.

[0012] Remote control system 12 includes a wireless (e.g., Bluetooth®) transceiver system or module 30 for transmitting audio content from computer 14 to headphone 16 and for transmitting remote control commands between headphone 16 and computer 14. For example, the remote control commands may include functions such as Play, Pause, Volume Up, Volume Down, Forward and Previous Track that are selected by user manipulation of controls on head-

commands are transmitted and received in accordance with the "Audio Video Remote Control Protocol" (AVRCP) of the Bluetooth® standard.

[0013] An AVRCP-IrDA converter 32 provides conversion or translation between AVRCP remote control commands and corresponding computer system commands based upon a widely-supported computer protocol or standard such as the Infrared Data Association (IrDA) standard that is widely available in personal computers with short-range infrared transceivers. The AVRCP remote control commands correspond to a wireless audio control protocol (e.g., for transmitting control signals to and from headphone 16). The IrDA control signals correspond to device control protocols that can control computer audio sources (e.g., media software) and are widely available on personal computers without requiring separate installation of specific drivers. Accordingly, the AVRCP-IrDA converter 32 may generally be referred to as a converter between wireless audio control protocols and local computer device control protocols.

[0014] In an implementation directed to a personal computer employing the Windows® operating system, for example, the Winsock API allows IrDA control signals to access and control Human Interface Device (HID) commands. HID commands are typically used to command devices that are used by humans to control the operation of computer systems, such as keyboards and pointing devices (e.g., standard mouse devices, trackballs, and joysticks), front-panel controls (e.g., GUI knobs, switches, buttons, sliders), etc. This allows widely available short-range infrared transceivers that adhere to the Infrared Data Association (IrDA) standard (e.g., non-Windows® devices) to communicate with and control Windows®-based applications. The IrDA protocols are open and are designed to support non-PC devices.

[0015] In operation the Winsock API exposes the IrDA TinyTP protocol to the applications writer. A non-Windows® device that implements the TinyTP protocol will be able to exchange data with Windows®-based applications such as Jukebox Windows Media Player or another existing software play source. IrDA is uniquely suited for public access applications because the connector can be completely sealed and because the IrDA connectivity model does not require that connected devices be treated as PC-peripherals. This means that there is no persistent relationship between IrDA devices, nor are there any device drivers to install to enable connectivity.

[0016] It will be appreciated, therefore, that the present invention includes translation of AVRCP commands at the dongle 10 to appropriate IR commands for a forward control path (i.e., sink-to-source), as well as translation of IR commands to AVRCP commands for a reverse control path (i.e., source-to-sink). For example, converter 32 converts AVRCP-format remote control commands such as Play, Pause, Volume Up, Volume Down, Forward and Previous Track that are selected by user manipulation of controls on headphone 16 into corresponding IrDA control signals that are delivered to computer 14 via wireless link 17, wireless transceiver 30, and USB port 18. The converted corresponding IrDA control signals access and control Human Interface Device (HID) commands that control media playback

[0017] Likewise, converter 32 can convert IrDA-format remote control commands into corresponding AVRCP control signals that are delivered from computer 14 to headphone 16 via USB port 18, wireless transceiver 30, and wireless link 17.

[0018] FIG. 2 is a block diagram of an audio gateway 50, sometimes referred to as an IR-RF converter unit, as an alternative embodiment of the present invention. Audio gateway 50 is connected to receive an analog audio signal over a wired link 52 from an analog audio source, such as a stereo player 54. Wired link could employ conventional audio-style RCA-type connectors, for example. Audio gateway 50 includes a codec 56 that receives the analog audio signal and generates a corresponding digital one. The digital audio signal is provided to a wireless RF (e.g., Bluetooth®) transceiver 60 for RF transmission over an RF link 62 to a headphone 58 to be heard by a user.

[0019] Remote control commands may be transmitted between headphone 58 and stereo player 54 (e.g., from headphone 58 to stereo 54). For example, the remote control commands may include functions such as Play, Pause, Volume Up, Volume Down, Forward and Previous Track that are selected by user manipulation of controls on headphone 58 and implemented by stereo player 54. The remote control commands are transmitted and received at audio gateway 50 in accordance with the "Audio Video Remote Control Protocol" (AVRCP) of the Bluetooth® standard.

[0020] An AVRCP-IrDA converter 64 provides conversion or translation between the AVRCP remote, control commands transmitted by headphone 58 over.

[0021] RF link 62 and corresponding stereo control commands based upon a widely-supported protocol or standard such as IrDA. IrDA is the Infrared Data Association (IrDA) standard that is widely used in remote control of audio-visual equipment. Wireless RF transceiver 60 delivers the control signals to AVRCP-IrDA converter 64, which converts them to the IrDA format for transmission by an IR transmitter 66 over an IR link 68. An IR receiver 70 of stereo player 54 receives the IrDA control signals and responds accordingly.

[0022] It will be appreciated that audio gateway 50 could be connected to analog audio sources other than a stereo. For example, audio gateway could receive an analog audio signal from the audio output of a personal computer (e.g., laptop or desktop). Such a configuration could be used if the personal computer does not include a USB port or if the existing USB ports are not available due to other uses. In this instance, audio gateway 50 would receive the analog audio signal in the manner described above and control signals could be return over IR link 68 to an IrDA transceiver on the computer.

[0023] Having described and illustrated the principles of our invention with reference to an illustrated embodiment, it will be recognized that the illustrated embodiment can be modified in arrangement and detail without departing from such principles. It should be understood that the programs, processes, or methods described herein are not related or limited to any particular type of computer apparatus, unless indicated otherwise. Various types of general purpose or specialized computer systems, including those with multiple

Explore Litigation Insights

Docket Alarm provides insights to develop a more informed litigation strategy and the peace of mind of knowing you're on top of things.

Real-Time Litigation Alerts



Keep your litigation team up-to-date with **real-time alerts** and advanced team management tools built for the enterprise, all while greatly reducing PACER spend.

Our comprehensive service means we can handle Federal, State, and Administrative courts across the country.

Advanced Docket Research



With over 230 million records, Docket Alarm's cloud-native docket research platform finds what other services can't. Coverage includes Federal, State, plus PTAB, TTAB, ITC and NLRB decisions, all in one place.

Identify arguments that have been successful in the past with full text, pinpoint searching. Link to case law cited within any court document via Fastcase.

Analytics At Your Fingertips



Learn what happened the last time a particular judge, opposing counsel or company faced cases similar to yours.

Advanced out-of-the-box PTAB and TTAB analytics are always at your fingertips.

API

Docket Alarm offers a powerful API (application programming interface) to developers that want to integrate case filings into their apps.

LAW FIRMS

Build custom dashboards for your attorneys and clients with live data direct from the court.

Automate many repetitive legal tasks like conflict checks, document management, and marketing.

FINANCIAL INSTITUTIONS

Litigation and bankruptcy checks for companies and debtors.

E-DISCOVERY AND LEGAL VENDORS

Sync your system to PACER to automate legal marketing.