



(11)

**EP 2 272 259 B1**

(12) **EUROPEAN PATENT SPECIFICATION**

(45) Date of publication and mention of the grant of the patent:  
**18.07.2012 Bulletin 2012/29**

(51) Int Cl.:  
**H04R 1/02<sup>(2006.01)</sup>**

(21) Application number: **09731146.8**

(86) International application number:  
**PCT/US2009/039754**

(22) Date of filing: **07.04.2009**

(87) International publication number:  
**WO 2009/126614 (15.10.2009 Gazette 2009/42)**

(54) **WIRELESS EARPHONE THAT TRANSITIONS BETWEEN WIRELESS NETWORKS**

**DRAHTLOSER KOPFHÖRER MIT ÜBERGANG ZWISCHEN DRAHTLOSEN NETZWERKEN**

**ÉCOUTEUR SANS FIL QUI EFFECTUE DES TRANSITIONS ENTRE DES RÉSEAUX SANS FIL**

(84) Designated Contracting States:  
**AT BE BG CH CY CZ DE DK EE ES FI FR GB GR HR HU IE IS IT LI LT LU LV MC MK MT NL NO PL PT RO SE SI SK TR**

- **KOSS, Michael, J.**  
**Milwaukee**  
**WI 53217 (US)**
- **SAGAN, Michael**  
**Marshall**  
**WI 53559 (US)**
- **RECKAMP, Steven**  
**Sun Prairie**  
**WI 53590-3812 (US)**

(30) Priority: **07.04.2008 US 123265 P**

(43) Date of publication of application:  
**12.01.2011 Bulletin 2011/02**

(60) Divisional application:  
**12167648.0**

(73) Proprietor: **Koss Corporation**  
**Milwaukee, WI 53212 (US)**

(74) Representative: **Parry, Simon James et al**  
**Mewburn Ellis LLP**  
**33 Gutter Lane**  
**London**  
**EC2V 8AS (GB)**

(72) Inventors:

- **PELLAND, Michael, J.**  
**Princeton**  
**WI 54968-8738 (US)**

(56) References cited:  
**WO-A1-2007/139578 US-A1- 2005 198 233**  
**US-A1- 2007 049 198 US-A1- 2007 116 316**  
**US-A1- 2007 165 875 US-A1- 2008 062 939**

**EP 2 272 259 B1**

**Bose Exhibit 1009**  
**Bose v. Koss**

Note: Within nine months of the publication of the mention of the grant of the European patent in the European Patent Bulletin, any person may give notice to the European Patent Office of opposition to that patent, in accordance with the Implementing Regulations. Notice of opposition shall not be deemed to have been filed until the opposition fee has been paid. (Art. 99(1) European Patent Convention).

**Description**

## PRIORITY CLAIM

**[0001]** The present application claims priority to United States provisional application serial number 61/123,265, filed April 7, 2008.

## BACKGROUND

**[0002]** Digital audio players, such as MP3 players and iPods, that store and play digital audio files, are very popular. Such devices typically comprise a data storage unit for storing and playing the digital audio, and a headphone set that connects to the data storage unit, usually with a 1/4" or a 3.5 mm jack and associated cord. Often the headphones are in-ear type headphones. The cord, however, between the headphones and the data storage unit can be cumbersome and annoying to users, and the length of the cord limits the physical distance between the data storage unit and the headphones. Accordingly, some cordless headphones have been proposed, such as the Monster iFreePlay cordless headphones from Apple Inc., which include a docking port on one of the earphones that can connect directly to an iPod Shuffle. Because they have the docking port, however, the Monster iFreePlay cordless headphones from Apple are quite large and are not in-ear type phones. Recently, cordless headphones that connect wirelessly via IEEE 802.11 to a WLAN-ready laptop or personal computer (PC) have been proposed, but such headphones are also quite large and not in-ear type phones.

**[0003]** US2007/0165875A1 discloses a multiple-antennae wireless multimedia headset having peer-to-peer networking capability and which is configured for convenient hand off between multiple wireless interfaces.

**[0004]** According to a first aspect of the present invention, there is provided an earphone as defined in claim 1.

**[0005]** According to a second aspect of the present invention, there is provided a method as defined in claim 19

**[0006]** When the data source and the earphone are out of range via the ad hoc wireless network, they may transition automatically to a common infrastructure wireless network (e.g., a wireless LAN). If there is no common infrastructure wireless network for both the data source and the earphone, the earphone may connect via an available infrastructure wireless network to a host server. The host server may, for example, broadcast streaming audio to the earphone and/or transmit to the earphone a network address (e.g., an Internet Protocol (IP) address) for a network-connected content server that streams digital audio. The earphone may then connect to the content server using the IP address. The content server may be an Internet radio server, including, for example, an Internet radio server that broadcasts streaming audio from the data source or some other content.

**[0007]** These and other advantageous, unique as-

pects of the wireless earphone are described below.

## FIGURES

**[0008]** Various embodiments of the present invention are described herein by way of example in conjunction with the following figures, wherein:

Figures 1A-1E are views of a wireless earphone according to various embodiments of the present invention;

Figures 2A-2D illustrate various communication modes for a wireless earphone according to various embodiments of the present invention;

Figure 3 is a block diagram of a wireless earphone according to various embodiments of the present invention;

Figures 4A-4B show the wireless earphone connected to another device according to various embodiments of the present invention;

Figure 5 is a diagram of a process implemented by a host server according to various embodiments of the present invention;

Figure 6 is a diagram of a process implemented by the wireless earphone to transition automatically between wireless networks according to various embodiments of the present invention;

Figures 7, 8 and 10 illustrate communication systems involving the wireless earphone according to various embodiments of the present invention;

Figure 9 is a diagram of a headset including a wireless earphone and a microphone according to various embodiments of the present invention; and

Figure 11 is a diagram of a pair of wireless earphones with a dongle according to various embodiments of the present invention.

## DESCRIPTION

**[0009]** In one general aspect, the present invention is directed to a wireless earphone that receives streaming audio data via ad hoc wireless networks and infrastructure wireless networks, and that transitions seamlessly between wireless networks. The earphone may comprise one or more in-ear, on-ear, or over-ear speaker elements. Two exemplary in-ear earphone shapes for the wireless earphone 10 are shown in Figures 1A and 1B, respectively, although in other embodiments the earphone may take different shapes and the exemplary shapes shown in Figures 1A and 1B are not intended to be limiting. In one embodiment, the earphone transitions automatically and seamlessly, without user intervention, between communication modes. That is, the earphone may transition automatically from an ad hoc wireless network to an infrastructure wireless network, without user intervention. As used herein, an "ad hoc wireless network" is a network where two (or more) wireless-capable devices, such as the earphone and a data source, com-

municate directly and wirelessly, without using an access point. An "infrastructure wireless network," on the other hand, is a wireless network that uses one or more access points to allow a wireless-capable device, such as the wireless earphone, to connect to a computer network, such as a LAN or WAN (including the Internet).

**[0010]** Figures 1A and 1B show example configurations for a wireless earphone 10 according to various embodiments of the present invention. The examples shown in Figures 1A and 1B are not limiting and other configurations are within the scope of the present invention. As shown in Figures 1A and 1B, the earphone 10 may comprise a body 12. The body 12 may comprise an ear canal portion 14 that is inserted in the ear canal of the user of the earphone 10. In various embodiments, the body 12 also may comprise an exterior portion 15 that is not inserted into user's ear canal. The exterior portion 15 may comprise a knob 16 or some other user control (such as a dial, a pressure-activated switch, lever, etc.) for adjusting the shape of the ear canal portion 14. That is, in various embodiments, activation (e.g. rotation) of the knob 16 may cause the ear canal portion 14 to change shape so as to, for example, radially expand to fit snugly against all sides of the user's ear canal. Further details regarding such a shape-changing earbud earphone are described in application PCT/US08/88656, filed 31 December 2008, entitled "Adjustable Shape Earphone,". The earphone 10 also may comprise a transceiver circuit housed within the body 12. The transceiver circuit, described further below, may transmit and receive the wireless signals, including receive streaming audio for playing by the earphone 10. The transceiver circuit may be housed in the exterior portion 15 of the earphone 10 and/or in the ear canal portion 14.

**[0011]** Although the example earphones 10 shown in Figures 1A and 1B include a knob 16 for adjusting the shape of the ear canal portion 14, the present invention is not so limited, and in other embodiments, different means besides a knob 16 may be used to adjust the ear canal portion 14. In addition, in other embodiments, the earphone 10 may not comprise a shape-changing ear canal portion 14.

**[0012]** In various embodiments, the user may wear two discrete wireless earphones 10: one in each ear. In such embodiments, each earphone 10 may comprise a transceiver circuit. In such embodiments, the earphones 10 may be connected by a string or some other cord-type connector to keep the earphones 10 from being separated.

**[0013]** In other embodiments, as shown in Figure 1C, a headband 19 may connect the two (left and right) earphones 10. The headband 19 may be an over-the-head band, as shown in the example of Figure 1C, or the headband may be a behind-the-head band. In embodiments comprising a headband 19, each earphone 10 may comprise a transceiver circuit; hence, each earphone 10 may receive and transmit separately the wireless communication signals. In other embodiments comprising a head-

band 19, only one earphone 10 may comprise the transceiver circuit, and a wire may run along the headband 19 to the other earphone 10 to connect thereby the transceiver circuit to the acoustic transducer in the earphone that does not comprise the transceiver circuit. The embodiment shown in Figure 1C comprises on-ear earphones 10; in other embodiments, in-ear or over-ear earphones may be used.

**[0014]** In other embodiments, the earphone 10 may comprise a hanger bar 17 that allows the earphone 10 to clip to, or hang on, the user's ear, as shown in the illustrated embodiment of Figures 1D-1E. Figure 1D is a perspective view of the earphone and Figure 1E is a side view according to one embodiment. As shown in the illustrated embodiment, the earphone 10 may comprise dual speaker elements 106-A, 106-B. One of the speaker elements (the smaller one) 106-A is sized to fit into the cavum concha of the listener's ear and the other element (the larger one) 106-B is not. The listener may use the hanger bar to position the earphone on the listener's ear. In that connection, the hanger bar may comprise a horizontal section that rests upon the upper external curvature of the listener's ear behind the upper portion of the auricula (or pinna). The earphone may comprise a knurled knob that allows the user to adjust finely the distance between the horizontal section of the hanger bar and the speaker elements, thereby providing, in such embodiments, another measure of adjustability for the user. More details regarding such a dual element, adjustable earphone may be found in United States provisional patent application Serial No. 61/054,238.

**[0015]** Figures 2A-2D illustrate various communication modes for a wireless data communication system involving the earphone 10 according to embodiments of the present invention. As shown in Figure 2A, the system comprises a data source 20 in communication with the earphone 10 via an ad hoc wireless network 24. The earphone 10, via its transceiver circuit (described in more detail below), may communicate wirelessly with a data source 20, which may comprise a wireless network adapter 22 for transmitting the digital audio wirelessly. For example, the data source 20 may be a digital audio player (DAP), such as an mp3 player or an iPod, or any other suitable digital audio playing device, such as a laptop or personal computer, that stores and/or plays digital audio files. In other embodiments, the data source 20 may generate analog audio, and the wireless network adapter 22 may encode the analog audio into digital format for transmission to the earphone 10.

**[0016]** The wireless network adapter 22 may be an integral part of the data source 20, or it may be a separate device that is connected to the data source 20 to provide wireless connectivity for the data source 20. For example, the wireless network adapter 22 may comprise a wireless network interface card (WNIC) or other suitable transceiver that plugs into a USB port or other port or jack of the data source 20 (such as a TRS connector) to stream data, e.g., digital audio files, via a wireless network (e.g.,

the ad hoc wireless network 24 or an infrastructure wireless network). The digital audio transmitted from the data source 20 to the earphone 10 via the wireless networks may comprise compressed or uncompressed audio. Any suitable file format may be used for the audio, including mp3, lossy or lossless WMA, Vorbis, Musepack, FLAC, WAV, AIFF, AU, or any other suitable file format.

**[0017]** When in range, the data source 20 may communicate with the earphone 10 via the ad hoc wireless network 24 using any suitable wireless communication protocol, including Wi-Fi (e.g., IEEE 802.11a/b/g/n), WiMAX (IEEE 802.16), Bluetooth, Zigbee, UWB, or any other suitable wireless communication protocol. For purposes of the description to follow, it is assumed that the data source 20 and the earphone 10 communicate using a Wi-Fi protocol, although the invention is not so limited and other wireless communication protocols may be used in other embodiments of the invention. The data source 20 and the earphone 10 are considered in range for the ad hoc wireless network 24 when the signal strengths (e.g., the RSSI) of the signals received by the two devices are above a threshold minimum signal strength level. For example, the data source 20 and the earphone 10 are likely to be in range for an ad hoc wireless network when they are in close proximity, such as when the wearer of the earphone 10 has the data source 20 on his/her person, such as in a pocket, strapped to their waist or arm, or holding the data source in their hand.

**[0018]** When the earphone 10 and the data source 20 are out of range for the ad hoc wireless network 24, that is, when the received signals degrade below the threshold minimum signal strength level, both the earphone 10 and the data source 20 may transition automatically to communicate over an infrastructure wireless network (such as a wireless LAN (WLAN) 30 that is in the range of both the earphone 10 and the data source 20, as shown in Figure 2B. The earphone 10 and the data source 20 (e.g., the wireless network adapter 22) may include firmware, as described further below, that cause the components to make the transition to a common infrastructure wireless network 30 automatically and seamlessly, e.g., without user intervention. The earphone 10 may cache the received audio in a buffer or memory for a time period before playing the audio. The cached audio may be played after the connection over the ad hoc wireless network is lost to give the earphone 10 and the data source 20 time to connect via the infrastructure wireless network.

**[0019]** For example, as shown in Figure 2B, the infrastructure network may comprise an access point 32 that is in the range of both the data source 20 and the earphone 10. The access point 32 may be an electronic hardware device that acts as a wireless access point for, and that is connected to, a wired and/or wireless data communication network 33, such as a LAN or WAN, for example. The data source 20 and the earphone 10 may both communicate wirelessly with the access point 32 using the appropriate network data protocol (a Wi-Fi pro-

ocol, for example). The data source 20 and the earphone 10 may both transition automatically to an agreed-upon WLAN 30 that is in the range of both devices when they cannot communicate satisfactorily via the ad hoc wireless network 24. A procedure for specifying an agreed-upon infrastructure wireless network 30 is described further below. Alternatively, the infrastructure wireless network 30 may have multiple access points 32a-b, as shown in Figure 2C. In such an embodiment, the data source 20 may communicate wirelessly with one access point 32b and the earphone 10 may communicate wirelessly with another access point 32a of the same infrastructure wireless network 30. Again, the data source 20 and the earphone 10 may transition to an agreed-upon WLAN.

**[0020]** If there is no suitable common infrastructure wireless network over which the earphone 10 and the data source 20 can communicate, as shown in Fig. 2D, the earphone 10 may transition to communicate with an access point 32a for an available (first) wireless network (e.g., WLAN) 30a that is in the range of the earphone 10. In this mode, the earphone 10 may connect via the wireless network 30a to a network-enabled host server 40. The host server 40 may be connected to the wireless network 30a via an electronic data communication network 42, such as the Internet. In one mode, the host server 40 may transmit streaming digital audio via the networks 33a, 42 to the earphone 10. In another mode, the host server 40 may transmit to the earphone 10 a network address, such as an Internet Protocol (IP) address, for a streaming digital audio content server 70 on the network 42. Using the received IP address, the earphone 10 may connect to the streaming digital audio content server 70 via the networks 30a, 42 to receive and process digital audio from the streaming digital audio content server 70.

**[0021]** The digital audio content server 70 may be, for example, an Internet radio station server. The digital audio content server 70 may stream digital audio over the network 42 (e.g., the Internet), which the earphone 10 may receive and process. In one embodiment, the streaming digital audio content server 70 may stream digital audio received by the streaming digital audio content server 70 from the data source 20. For example, where the data source 20 is a wireless-capable device, such as a portable DAP, the data source 20 may connect to the streaming digital audio content server 70 via a wireless network 30b and the network 42. Alternatively, where for example the data source 20 is non-wireless-capable device, such as a PC, the data source 20 may have a direct wired connection to the network 42. After being authenticated by the streaming digital audio content server 70, the data source 20 may stream digital audio to the streaming digital audio content server 70, which may broadcast the received digital audio over the network 42 (e.g., the Internet). In such a manner, the user of the earphone 10 may listen to audio from the data source 20 even when (i) the earphone 10 and the data source 20 are not in communication via an ad hoc wire-



less network 24 and (ii) the earphone 10 and the data source 20 are not in communication via a common local infrastructure wireless network 30.

**[0022]** Figure 3 is a block diagram of the earphone 10 according to various embodiments of the present invention. In the illustrated embodiment, the earphone 10 comprises a transceiver circuit 100 and related peripheral components. As shown in Figure 3, the peripheral components of the earphone 10 may comprise a power source 102, a microphone 104, one or more acoustic transducers 106 (e.g., speakers), and an antenna 108. The transceiver circuit 100 and some of the peripheral components (such as the power source 102 and the acoustic transducers 106) may be housed within the body 12 of the earphone 10 (see Figure 1). Other peripheral components, such as the microphone 104 and the antenna 108 may be external to the body 12 of the earphone 10. In addition, some of the peripheral components, such as the microphone 104, are optional in various embodiments.

**[0023]** In various embodiments, the transceiver circuit 100 may be implemented as a single integrated circuit (IC), such as a system-on-chip (SoC), which is conducive to miniaturizing the components of the earphone 10, which is advantageous if the earphone 10 is to be relatively small in size, such as an in-ear earphone (see Figures 1A-1B for example). In alternative embodiments, however, the components of the transceiver circuit 100 could be realized with two or more discrete ICs or other components, such as separate ICs for the processors, memory, and RF (e.g., Wi-Fi) module, for example.

**[0024]** The power source 102 may comprise, for example, a rechargeable or non-rechargeable battery (or batteries). In other embodiments, the power source 102 may comprise one or more ultracapacitors (sometimes referred to as supercapacitors) that are charged by a primary power source. In embodiments where the power source 102 comprises a rechargeable battery cell or an ultracapacitor, the battery cell or ultracapacitor, as the case may be, may be charged for use, for example, when the earphone 10 is connected to a docking station or computer. The docking station may be connected to or part of a computer device, such as a laptop computer or PC. In addition to charging the rechargeable power source 102, the docking station and/or computer may facilitate downloading of data to and/or from the earphone 10. In other embodiments, the power source 102 may comprise capacitors passively charged with RF radiation, such as described in U.S. Patent No. 7,027,311. The power source 102 may be coupled to a power source control module 103 of transceiver circuit 100 that controls and monitors the power source 102.

**[0025]** The acoustic transducer(s) 106 may be the speaker element(s) for conveying the sound to the user of the earphone 10. According to various embodiments, the earphone 10 may comprise one or more acoustic transducers 106. For embodiments having more than one transducer, one transducer may be larger than the

other transducer, and a crossover circuit (not shown) may transmit the higher frequencies to the smaller transducer and may transmit the lower frequencies to the larger transducer. More details regarding dual element earphones are provided in U.S. Patent 5,333,206, assigned to Koss Corporation, which is incorporated herein by reference in its entirety.

**[0026]** The antenna 108 may receive and transmit the wireless signals from and to the wireless networks 24, 30. A RF (e.g., Wi-Fi) module 110 of the transceiver circuit 100 in communication with the antenna 108 may, among other things, modulate and demodulate the signals transmitted from and received by the antenna 108. The RF module 110 communicates with a baseband processor 112, which performs other functions necessary for the earphone 10 to communicate using the Wi-Fi (or other communication) protocol.

**[0027]** The baseband processor 112 may be in communication with a processor unit 114, which may comprise a microprocessor 116 and a digital signal processor (DSP) 118. The microprocessor 116 may control the various components of the transceiver circuit 100. The DSP 114 may, for example, perform various sound quality enhancements to the digital audio received by the baseband processor 112, including noise cancellation and sound equalization. The processor unit 114 may be in communication with a volatile memory unit 120 and a non-volatile memory unit 122. A memory management unit 124 may control the processor unit's access to the memory units 120, 122. The volatile memory 122 may comprise, for example, a random access memory (RAM) circuit. The non-volatile memory unit 122 may comprise a read only memory (ROM) and/or flash memory circuits. The memory units 120, 122 may store firmware that is executed by the processor unit 114. Execution of the firmware by the processor unit 114 may provide various functionality for the earphone 10, such as the automatic transition between wireless networks as described herein. The memory units 120, 122 may also cache received digital audio.

**[0028]** A digital-to-analog converter (DAC) 125 may convert the digital audio from the processor unit 114 to analog form for coupling to the acoustic transducer(s) 106. An I<sup>2</sup>S interface 126 or other suitable serial or parallel bus interface may provide the interface between the processor unit 114 and the DAC 125. An analog-to-digital converter (ADC) 128, which also communicates with the I<sup>2</sup>S interface 126, may convert analog audio signals picked up by the microphone 104 for processing by the processor unit 114.

**[0029]** The transceiver circuit 100 also may comprise a USB or other suitable interface 130 that allows the earphone 10 to be connected to an external device via a USB cable or other suitable link. As shown in Figure 4A, the external device may be a docking station 200 connected to a computer device 202. Also, in various embodiments, the earphone 10 could be connected directly to the computer 202 without the docking station 200. In

addition, the external device may be a DAP 210, as shown in Figure 4B. In that way, the earphone 10 could connect directly to a data source 20, such as the DAP 210 or the computer 202, through the USB port 130. In addition, through the USB port 130, the earphone 10 may connect to a PC 202 or docking station 202 to charge up the power source 102 and/or to get downloads (e.g., data or firmware).

**[0030]** According to various embodiments, the earphone 10 may have an associated web page that a user may access through the host server 40 (see Figure 2D) or some other server. An authenticated user could log onto the website from a client computing device 50 (e.g., laptop, PC, handheld computer device, etc., including the data source 20) (see Figure 2D) to access the web page for the earphone 10 to set various profile values for the earphone 10. For example, at the web site, the user could set various content features and filters, as well as adjust various sound control features, such as treble, bass, frequency settings, noise cancellation settings, etc. In addition, the user could set preferred streaming audio stations, such as preferred Internet radio stations or other streaming audio broadcasts. That way, instead of listening to streaming audio from the data source 20, the user could listen to Internet radio stations or other streaming audio broadcasts received by the earphone 10. In such an operating mode, the earphone user, via the web site, may prioritize a number of Internet radio stations or other broadcast sources (hosted by streaming digital audio content servers 70). With reference to Figure 7, the host server 40 may send the IP address for the earphone user's desired (e.g., highest priority) Internet radio station to the earphone 10. A button 11 on the earphone 10, such as on the rotating dial 16 as shown in the examples of Figures 1A and 1B, may allow the user to cycle through the preset preferred Internet radio stations. That is, for example, when the user presses the button 11, an electronic communication may be transmitted to the host server 40 via the wireless network 30, and in response to receiving the communication, the host server 40 may send the IP address for the user's next highest rated Internet radio station via the network 42 to the earphone 10. The earphone 10 may then connect to the streaming digital audio content server 70 for that Internet radio station using the IP address provided by the host server 40. This process may be repeated, e.g., cycled through, for each preset Internet radio station configured by the user of the earphone 10.

**[0031]** At the web site for the earphone 10 hosted on the host server 40, in addition to establishing the identification of digital audio sources (e.g., IDs for the user's DAP or PC) and earphones, the user could set parental or other user controls. For example, the user could restrict certain Internet radio broadcasts based on content or parental ratings, etc. That is, for example, the user could configure a setting through the web site that prevents the host server 40 from sending an IP address for a streaming digital audio content server 70 that broadcasts explicit

content based on a rating for the content. In addition, if a number of different earphones 10 are registered to the same user, the user could define separate controls for the different earphones 10 (as well as customize any other preferences or settings particular to the earphones 10, including Internet radio stations, sound quality settings, etc. that would later be downloaded to the earphones 10). In addition, in modes where the host server 40 streams audio to the earphone 10, the host server 40 may log the files or content streamed to the various earphones 10, and the user could view at the web site the files or content that were played by the earphones 10. In that way, the user could monitor the files played by the earphones 10.

**[0032]** In addition, the host server 40 may provide a so-called eavesdropping function according to various embodiments. The eavesdropping service could be activated via the web site. When the service is activated, the host server 40 may transmit the content that it is delivering to a first earphone 10a to another, second earphone 10b, as shown in Figure 8. Alternatively, the host server 40 may transmit to the second earphone 10b the most recent IP address for a streaming digital audio content server 70 that was sent to the first earphone 10a. The second earphone 10b may then connect to the streaming digital audio content server 70 that the first earphone 10a is currently connected. That way, the user of the second earphone 10b, which may be a parent, for example, may directly monitor the content being received by the first earphone 10a, which may belong to a child of the parent.

**[0033]** This function also could be present in the earphones 10 themselves, allowing a parent (or other user) to join an ad-hoc wireless network and listen to what their child (or other listener) is hearing. For example, with reference to Figure 10, a first earphone 10a may receive wireless audio, such as from the data source 20 or some other source, such as the host server 40. The first earphone 10a may be programmed with firmware to broadcast the received audio to a second earphone 10b via an ad hoc wireless network 24. That way, the wearer of the second earphone 10b can monitor in real-time the content being played by the first earphone 10a.

**[0034]** At the web site, the user may also specify the identification number ("ID") of their earphone(s) 10, and the host server 40 may translate the ID to the current internet protocol (IP) addresses for the earphone 10 and for the data source 20. This allows the user to find his or her data source 20 even when it is behind a firewall or on a changing IP address. That way, the host server 40 can match the audio from the data source 20 to the appropriate earphone 10 based on the specified device ID. The user also could specify a number of different data sources 20. For example, the user's DAP may have one specified IP address and the user's home (or work) computer may have another specified IP address. Via the web site hosted by the host server 40, the user could specify or prioritize from which source (e.g., the user's

DAP or computer) the earphone 10 is to receive content.

**[0035]** The host server 40 (or some other server) may also push firmware upgrades and/or data updates to the earphone 10 using the IP addresses of the earphone 10 via the networks 30, 42. In addition, a user could download the firmware upgrades and/or data updates from the host server 40 to the client computing device 202 (see Figure 4A) via the Internet, and then download the firmware upgrades and/or data updates to the earphone 10 when the earphone 10 is connected to the client computer device 202 (such as through a USB port and/or the docking station 200).

**[0036]** Whether the downloads are transmitted wirelessly to the earphone 10 or via the client computing device 202 may depend on the current data rate of the earphone 10 and the quantity of data to be transmitted to the earphone 10. For example, according to various embodiments, as shown in the process flow of Figure 5, the host server 40 may be programmed, at step 50, to make a determination, based on the current data rate for the earphone 10 and the size of the update, whether the update should be pushed to the earphone 10 wirelessly (e.g., via the WLAN 30a in Figure 2D). If the update is too large and/or the current data rate is too low that the performance of the earphone 10 will be adversely affected, the host server 40 may refrain from pushing the update to the earphone 10 wirelessly and wait instead to download the update to the client computing device 202 at step 51. Conversely, if the host server 40 determines that, given the size of the update and the current data rate for the earphone 10 that the performance of the earphone 10 will not be adversely affected, the host server 40 may transmit the update wirelessly to the earphone 10 at step 52.

**[0037]** As mentioned above, the processor unit 114 of the speakerphones 14 may be programmed, via firmware stored in the memory 120, 122, to have the ability to transition automatically from the ad hoc wireless network 24 to an infrastructure wireless network 30 (such as a WLAN) when the quality of the signal on the ad hoc wireless network 24 degrades below a suitable threshold (such as when the data source 20 is out of range for an ad hoc wireless network). In that case, the earphone 10 and the data source 20 may connect to a common infrastructure wireless network (e.g., WLAN) (see, for example, Figures 2B-2C). Through the web site for the earphone 10, described above, the user could specify a priority of infrastructure wireless networks 30 for the data source 20 and the earphone 10 to connect to when the ad hoc wireless network 24 is not available. For example, the user could specify a WLAN servicing his/her residence first, a WLAN servicing his/her place of employment second, etc. During the time that the earphone 10 and the data source 20 are connected via the ad hoc wireless network 24, the earphone 10 and the data source 20 may exchange data regarding which infrastructure networks are in range. When the earphone 10 and the data source 20 are no longer in range for the ad

hoc wireless network 24 (that is, for example, the signals between the device degrade below an acceptable level), they may both transition automatically to the highest prioritized infrastructure wireless network whose signal strength is above a certain threshold level. That way, even though the earphone 10 and the data source 20 are out of range for the ad hoc wireless network 24, the earphone 10 may still receive the streaming audio from the data source 20 via the infrastructure wireless network 30 (see Figs. 2B-2C).

**[0038]** When none of the preferred infrastructure networks is in range, the earphone 10 may connect automatically to the host server 40 via an available infrastructure wireless network 30 (see Fig. 2D), e.g., the infrastructure wireless network 30 having the highest RSSI and to which the earphone 10 is authenticated to use. The host server 40, as mentioned above, may transmit IP addresses to the earphone 10 for streaming digital audio content servers 70 or the host sever 40 may stream digital audio to the earphone 10 itself when in this communication mode.

**[0039]** Figure 6 is a diagram of the process flow, according to one embodiment, implemented by the transceiver circuit 100 of the earphone 10. The process shown in Figure 6 may be implemented in part by the processor unit 114 executing firmware stored in a memory unit 120, 122 of the transceiver circuit 100. At step 61, the earphone 10 may determine if it can communicate with the data source 20 via an ad hoc wireless network 24. That is, the earphone 10 may determine if the strength of the wireless signals from the data source 20 exceed some minimum threshold. If so, the data source 20 and the earphone 10 may communicate wirelessly via the ad hoc wireless network 24 (see Figure 2A). While in this communication mode, at step 62, the data source 20 and the earphone 10 also may exchange data regarding the local infrastructure wireless networks, if any, in the range of the data source 20 and the earphone 10, respectively. For example, the earphone 10 may transmit the ID of local infrastructure wireless networks 30 that the earphone 10 can detect whose signal strength (e.g., RSSI) exceeds some minimum threshold level. Similarly, the data source 20 may transmit the ID the local infrastructure wireless networks 30 that the data source 20 can detect whose signal strength (e.g., RSSI) exceeds some minimum threshold level. The earphone 10 may save this data in a memory unit 120, 122. Similarly, the data source 20 may store in memory the wireless networks that the earphone 10 is detected.

**[0040]** The data source 20 and the earphone 10 may continue to communicate via the ad hoc wireless network mode 24 until they are out of range (e.g., the signal strengths degrade below a minimum threshold level). If an ad hoc wireless network 24 is not available at block 61, the transceiver circuit 100 and the data source 20 may execute a process, shown at block 63, to connect to the user's highest prioritized infrastructure wireless network 30. For example, of the infrastructure wireless

networks whose signal strength exceeded the minimum threshold for both the earphone 10 and the data source 20 determined at step 62, the earphone 10 and the data source 20 may both transition to the infrastructure wireless network 30 having the highest priority, as previously set by the user (see Figures 2B-2C, for example). For example, if the user's highest prioritized infrastructure wireless network 30 is not available, but the user's second highest prioritized infrastructure wireless network 30 is, the earphone 10 and the data source 20 may both transition automatically to the user's second highest prioritized infrastructure wireless network 30 at block 64. As shown by the loop with block 65, the earphone 10 and the data source 20 may continue to communicate via one of the user's prioritized infrastructure wireless networks 30 as long as the infrastructure wireless network 30 is available. If the infrastructure wireless network becomes unavailable, the process may return to block 61.

**[0041]** If, however, no ad hoc wireless network and none of the user's prioritized infrastructure wireless networks are available, the earphone 10 may transition automatically to connect to the host server 40 at block 66 (see Figure 2D) using an available infrastructure wireless network 30. At block 67, the host server 40 may transmit an IP address to the earphone 10 for one of the streaming digital audio content servers 70, and at block 68 the earphone 10 may connect to the streaming digital audio content server 70 using the received IP address. At step 69, as long as the earphone 10 is connected to the streaming digital audio content server 70, the earphone 10 may continue to communicate in this mode. However, if the earphone 10 loses its connection to the digital audio content server 70, the process may return to block 61 in one embodiment. As mentioned above, at block 67, instead of sending an IP address for a streaming digital audio content server 70, the host server 40 may stream digital audio to the earphone 10. The user, when configuring their earphone 10 preferences via the web site, may specify and/or prioritize whether the host server 40 is to send IP addresses for the streaming digital audio content servers 70 and/or whether the host server 40 is to stream audio to the earphone 10 itself.

**[0042]** In another embodiment, the earphone 10 may be programmed to transition automatically to the host server 40 when the earphone 10 and the data source 20 are not in communication via the ad hoc wireless network 24. That is, in such an embodiment, the earphone 10 may not try to connect via a local infrastructure wireless network 30 with the data source 20, but instead transition automatically to connect to the host server 40 (see Figure 2D).

**[0043]** In various embodiments, as shown in Figure 1B, the button 11 or other user selection device that allows the wearer of the earphone 10 to indicate approval and/or disapproval of songs or other audio files listened to by the wearer over an Internet radio station. The approval/disapproval rating, along with metadata for the song received by the earphone 10 with the streaming

audio, may be transmitted from the transceiver circuit 100 of the earphone 10 back to the host server 40, which may log the songs played as well as the ratings for the various songs/audio files. In addition to being able to view the logs at the website, the host server 40 (or some other server) may send an email or other electronic communication to the earphone user, at a user specified email address or other address, which the user might access from their client communication device 50 (see Figure 2D). The email or other electronic communication may contain a listing of the song/audio files for which the user gave approval ratings using the button 11 or other user selection device. Further, the email or other electronic communication may provide a URL link for a URL at which the user could download song/audio files that the user rated (presumably song/audio files for which the user gave an approval rating). In some instances, the user may be required to pay a fee to download the song/audio file.

**[0044]** The user song ratings also may be used by the host server 40 to determine the user's musical preferences and offer new music that the user might enjoy. More details about generating user play lists based on song ratings may be found in published U.S. patent applications Pub. No. 2006/0212444, Pub. No. 2006/0206487, and Pub. No. 2006/0212442, and U.S. Patent 7,003,515, which are incorporated herein by reference in their entirety.

**[0045]** In addition or alternatively, the user could log onto a web site hosted by the host server 40 (or some other server) to view the approval/disapproval ratings that the user made via the button 11 on the earphone 10. The web site may provide the user with the option of downloading the rated songs/audio files (for the host server 40 or some other server system) to their client computer device 50. The user could then have their earphone 10 connect to their client computer device 50 as a data source 20 via an ad hoc wireless network 24 (see Figure 2A) or via an infrastructure wireless network (see Figures 2B-2D) to listen to the downloaded songs. In addition, the user could download the song files from their client computer device 50 to their DAP and listen to the downloaded song files from their DAP by using their DAP as the data source 20 in a similar manner.

**[0046]** Another application of the headsets may be in vehicles equipped with Wi-Fi or other wireless network connectivity. Published PCT application WO 2007/136620, which is incorporated herein by reference, discloses a wireless router for providing a Wi-Fi or other local wireless network for a vehicle, such as a car, truck, boat, bus, etc. In a vehicle having a Wi-Fi or other local wireless network, the audio for other media systems in the vehicle could be broadcast over the vehicle's wireless network. For example, if the vehicle comprises a DVD player, the audio from the DVD system could be transmitted to the router and broadcast over the vehicle's network. Similarly, the audio from terrestrial radio stations, a CD player, or an audio cassette player could be broad-

cast over the vehicle's local wireless network. The vehicle's passengers, equipped with the earphones 10, could cycle through the various audio broadcasts (including the broadcasts from the vehicle's media system as well as broadcasts from the host server 40, for example) using a selection button 11 on the earphone 10. The vehicle may also be equipped with a console or terminal, etc., through which a passenger could mute all of the broadcasts for direct voice communications, for example.

**[0047]** As described above, the earphones 10 may also include a microphone 104, as shown in the example of Figure 9. The headset 90 shown in Figure 9 includes two earphones 10, both of which may include a transceiver circuit 100 or only one of which may include the transceiver circuit, as discussed above. The microphone 104 could be used to broadcast communications from one earphone wearer to another earphone wearer. For example, one wearer could activate the microphone by pressing a button 92 on the headset 90. The headset 90 may then transmit a communication via an ad hoc wireless network 24 or other wireless network to a nearby recipient (or recipients) equipped with a headset 90 with a transceiver circuit 100 in one or both of the earphones 10. When such communication is detected by the recipient's headset 90, the streaming audio received over the wireless network by the recipient's headset 90 may be muted, and the intercom channel may be routed to the transducer(s) of the recipient's headset 90 for playing for the recipient. This functionality may be valuable and useful where multiple wearers of the headsets 90 are in close proximity, such as on motorcycles, for example.

**[0048]** Another exemplary use of the earphones 10 is in a factory, warehouse, construction site, or other environment that might be noisy. Persons (e.g., workers) in the environment could use the earphones 10 for protection from the surrounding noise of the environment. From a console or terminal, a person (e.g., a supervisor) could select a particular recipient for a communication over the Wi-Fi network (or other local wireless network). The console or terminal may have buttons, dials, or switches, etc., for each user/recipient, or it could have one button or dial through which the sender could cycle through the possible recipients. In addition, the console or terminal could have a graphical user interface, through which the sender may select the desired recipient(s).

**[0049]** As mentioned above, the earphones 10 may comprise a USB port. In one embodiment, as shown in Figure 11, the user may use an adapter 150 that connects to the USB port of each earphone 10. The adapter 150 may also have a plug connector 152, such as a 3.5 mm jack, which allows the user to connect the adapter 150 to devices having a corresponding port for the connector 152. When the earphones 10 detect a connection via their USB interfaces in such a manner, the Wi-Fi (or other wireless protocol) components may shut down or go into sleep mode, and the earphones 10 will route standard headphone level analog signals to the transducer(s) 106. This may be convenient in environments where wireless

communications are not permitted, such as airplanes, but where there is a convenient source of audio contact. For example, the adapter 150 could plug into a person's DAP. The DSP 118 of the earphone 10 may still be operational in such a non-wireless mode to provide noise cancellation and any applicable equalization.

**[0050]** The examples presented herein are intended to illustrate potential and specific implementations of the embodiments. It can be appreciated that the examples are intended primarily for purposes of illustration for those skilled in the art. No particular aspect of the examples is/are intended to limit the scope of the described embodiments.

**[0051]** According to various embodiments, therefore, the present invention is directed to an earphone 10 that comprises a body 12, where the body 12 comprises: (i) at least one acoustic transducer 106 for converting an electrical signal to sound; (ii) an antenna 108; and (iii) a transceiver circuit 100 in communication with the at least one acoustic transducer 106 and the antenna 108. The transceiver circuit 100 is for receiving and transmitting wireless signals via the antenna 108, and the transceiver circuit 100 is for outputting the electrical signal to the at least one acoustic transducer 106. The wireless transceiver circuit also comprises firmware, which when executed by the transceiver circuit, causes the transceiver circuit to: (i) receive digital audio wirelessly from a data source 20 via an ad hoc wireless network 24 when the data source 20 is in wireless communication range with the earphone 10 via the ad hoc wireless network 24; and (ii) when the data source 20 is not in wireless communication range with the earphone 10 via the ad hoc wireless network 24, transition automatically to receive digital audio via an infrastructure wireless network 30.

**[0052]** According to various implementations, the data source may comprise a portable digital audio player, such as an MP3 player, iPod, or laptop computer, or a non-portable digital audio player, such as a personal computer. In addition, the transceiver circuit 100 may comprise: (i) a wireless communication module 110 (such as a Wi-Fi or other wireless communication protocol module); (ii) a processor unit 114 in communication with the wireless communication module 110; (iii) a non-volatile memory unit 122 in communication with the processor unit 114; and (iv) a volatile memory 120 unit in communication with the processor unit 114. The infrastructure wireless network may comprise a WLAN. The transceiver circuit 100 may receive digital audio from the data source 20 via the infrastructure wireless network 30 when the data source 20 is not in wireless communication range with the earphone 10 via the ad hoc wireless network 24. The transceiver circuit firmware, when executed by the transceiver circuit 100, may cause the transceiver circuit 100 of the earphone 10 to transition automatically to a pre-set infrastructure wireless network 30 that the data source 20 transitions to when the data source 20 is not in wireless communication range with the earphone 10 via the ad hoc wireless network 24 and when the pre-set infrastruc-

ture wireless network 30 is in range of both the earphone 10 and the data source 20. In addition, the transceiver circuit firmware, when executed by the transceiver circuit 100, may cause the transceiver circuit 100 of the earphone 10 to transmit data via the ad hoc wireless network 24 to the data source 20 regarding one or more infrastructure wireless networks 30 detected by the transceiver circuit 100 when the earphone 10 and the data source 20 are communicating via the ad hoc wireless network 24.

**[0053]** In addition, the transceiver circuit firmware, when executed by the transceiver circuit 100, may cause the transceiver circuit 100 of the earphone 10 to connect to a host server 40 via an available infrastructure wireless network 30 when the data source 20 is not in wireless communication range with the earphone 10 via the ad hoc wireless network 24. The earphone 10 may receive streaming digital audio from the host server 40 via the infrastructure wireless network 30. In addition, the earphone 10 may receive a first network address for a first streaming digital audio content server 70 from the host server 40 via the infrastructure wireless network 30. In addition, the earphone 10 may comprise a user control, such as button 11, dial, pressure switch, or other type of user control, that, when activated, causes the earphone 10 to transmit an electronic request via the infrastructure wireless network 30 to the host server 40 for a second network address for a second streaming digital audio content server 70.

**[0054]** In other embodiments, the present invention is directed to a system that comprises: (i) a data source 20 for wirelessly transmitting streaming digital audio; and (ii) a wireless earphone 10 that is in wireless communication with the data source 20. In yet other embodiments, the present invention is directed to a communication system that comprises: (i) a host server 40; (ii) a first streaming digital audio content server 70 that is connected to the host server 40 via a data network 42; and (iii) a wireless earphone 10 that is in communication with the host server 40 via a wireless network 30. The host server 40 is programmed to transmit to the earphone 10 a first network address for the first streaming digital audio content server 70 on the data network 42. The host server 40 and the streaming digital audio content server(s) 70 each may comprise one or more processor circuits and one or more memory circuits (e.g., ROM circuits and/or RAM circuits).

**[0055]** In yet another embodiment, the present invention is directed to a headset that comprises: (i) a first earphone 10a that comprises one or more acoustic transducers 10b for converting a first electrical signal to sound; and (ii) a second earphone 10b, connected to the first earphone 10a, wherein the second earphone 10b comprises one or more acoustic transducers 10b for converting a second electrical signal to sound. In one embodiment, the first earphone 10a comprises: (i) a first antenna 108; and (ii) a first transceiver circuit 100 in communication with the one or more acoustic transducers 106 of the first earphone 10a and in communication with the first antenna 108. The first transceiver circuit 100 is for receiving and transmitting wireless signals via the first antenna 108, and for outputting the first electrical signal to the one or more acoustic transducers 10b of the first earphone 10a. The first transceiver circuit 100 also may comprise firmware, which when executed by the first transceiver circuit 100, causes the first transceiver circuit 100 to: (i) receive digital audio wirelessly from a data source 20 via an ad hoc wireless network 24 when the data source 20 is in wireless communication range with the first earphone 10a via the ad hoc wireless network 24; and (ii) when the data source 20 is not in wireless communication range with the first earphone 10a via the ad hoc wireless network 24, transition automatically to receive digital audio via an infrastructure wireless network 30.

**[0056]** In various implementations, the headset further may comprise a head band 19 that is connected to the first and second earphones 10. In addition, the headset 19 further may comprise a microphone 104 having an output connected to the first transceiver circuit 100. In one embodiment, the first transceiver circuit 100 is for outputting the second electrical signal to the one or more acoustic transducers 106 of the second earphone 10b. In another embodiment, the second earphone 10b comprises: (i) a second antenna 108; and (ii) a second transceiver circuit 100 in communication with the one or more acoustic transducers 106 of the second earphone 10b and in communication with the second antenna 108. The second transceiver circuit 100 is for receiving and transmitting wireless signals via the second antenna 108, and for outputting the second electrical signal to the one or more acoustic transducers 106 of the second earphone 10b. The second transceiver circuit 100 may comprise firmware, which when executed by the second transceiver circuit 100, causes the second transceiver circuit 100 to: (i) receive digital audio wirelessly from the data source 20 via the ad hoc wireless network 24 when the data source 20 is in wireless communication range with the second earphone 10b via the ad hoc wireless network 24; and (ii) when the data source 20 is not in wireless communication range with the second earphone 10b via the ad hoc wireless network 24, transition automatically to receive digital audio via the infrastructure wireless network 30.

**[0057]** In addition, according to various embodiments, the first earphone 10a may comprise a first data port and the second earphone 10b may comprise a second data port. In addition, the headset may further comprise an adapter or dongle 150 connected to the first data port of the first earphone 10a and to the second data port of the second earphone 10b, wherein the adapter 150 comprises an output plug connector 152 for connecting to a remote device.

**[0058]** In addition, according to other embodiments, the present invention is directed to a method that comprises the steps of: (i) receiving, by a wireless earphone, via an ad hoc wireless network, digital audio from a data source when the data source is in wireless communication range with the wireless earphone via the ad hoc wireless network; and (ii) outputting the digital audio to one or more acoustic transducers of the wireless earphone.

tion with the earphone via the ad hoc wireless network; (ii) converting, by the wireless earphone, the digital audio to sound; and (iii) when the data source is not in wireless communication with the earphone, transitioning automatically, by the earphone, to receive digital audio via an infrastructure wireless network.

**[0059]** In various implementations, the step of transitioning automatically by the earphone to receive digital audio via an infrastructure wireless network may comprise transitioning automatically to receive digital audio from the data source via an infrastructure wireless network when the data source is not in wireless communication range with the earphone via the ad hoc wireless network. In addition, the method may further comprise the step of receiving by the wireless earphone from the data source via the ad hoc wireless network data regarding one or more infrastructure wireless networks detected by data source when the earphone and the data source are communicating via the ad hoc wireless network.

**[0060]** In addition, the step of transitioning automatically by the earphone to receive digital audio via an infrastructure wireless network comprises may transitioning automatically to receive digital audio from a host sever via the infrastructure wireless network when the data source is not in wireless communication range with the earphone via the ad hoc wireless network. Additionally, the step of transitioning automatically by the earphone to receive digital audio via an infrastructure wireless network may comprise: (i) receiving, by the wireless earphone via the infrastructure wireless network, from a host server connected to the infrastructure wireless network, a network address for a streaming digital audio content server; and (ii) connecting, by the wireless earphone, to the streaming digital audio content server using the network address received from the host server.

**[0061]** It is to be understood that the figures and descriptions of the embodiments have been simplified to illustrate elements that are relevant for a clear understanding of the embodiments, while eliminating, for purposes of clarity, other elements. For example, certain operating system details for the various computer-related devices and systems are not described herein. Those of ordinary skill in the art will recognize, however, that these and other elements may be desirable in a typical processor or computer system. Because such elements are well known in the art and because they do not facilitate a better understanding of the embodiments, a discussion of such elements is not provided herein.

**[0062]** In general, it will be apparent to one of ordinary skill in the art that at least some of the embodiments described herein may be implemented in many different embodiments of software, firmware and/or hardware. The software and firmware code may be executed by a processor or any other similar computing device. The software code or specialized control hardware that may be used to implement embodiments is not limiting. For example, embodiments described herein may be implemented in computer software using any suitable compu-

ter software language type. Such software may be stored on any type of suitable computer-readable medium or media, such as, for example, a magnetic or optical storage medium. The operation and behavior of the embodiments may be described without specific reference to specific software code or specialized hardware components. The absence of such specific references is feasible, because it is clearly understood that artisans of ordinary skill would be able to design software and control hardware to implement the embodiments based on the present description with no more than reasonable effort and without undue experimentation.

**[0063]** Moreover, the processes associated with the present embodiments may be executed by programmable equipment, such as computers or computer systems and/or processors. Software that may cause programmable equipment to execute processes may be stored in any storage device, such as, for example, a computer system (nonvolatile) memory, an optical disk, magnetic tape, or magnetic disk. Furthermore, at least some of the processes may be programmed when the computer system is manufactured or stored on various types of computer-readable media.

**[0064]** A "computer," "computer system," "host," "host server," "server," or "processor" may be, for example and without limitation, a processor, microcomputer, minicomputer, server, mainframe, laptop, personal data assistant (PDA), wireless e-mail device, cellular phone, pager, processor, fax machine, scanner, or any other programmable device configured to transmit and/or receive data over a network. Such components may comprise: one or more processor circuits; and one more memory circuits, including ROM circuits and RAM circuits. Computer systems and computer-based devices disclosed herein may include memory for storing certain software applications used in obtaining, processing, and communicating information. It can be appreciated that such memory may be internal or external with respect to operation of the disclosed embodiments. The memory may also include any means for storing software, including a hard disk, an optical disk, floppy disk, ROM (read only memory), RAM (random access memory), PROM (programmable ROM), EEPROM (electrically erasable PROM) and/or other computer-readable media.

**[0065]** In various embodiments disclosed herein, a single component may be replaced by multiple components and multiple components may be replaced by a single component to perform a given function or functions. Except where such substitution would not be operative, such substitution is within the intended scope of the embodiments. Any servers described herein, such as the host server 40, for example, may be replaced by a "server farm" or other grouping of networked servers (such as server blades) that are located and configured for cooperative functions. It can be appreciated that a server farm may serve to distribute workload between/among individual components of the farm and may expedite computing processes by harnessing the collective and coop-

erative power of multiple servers. Such server farms may employ load-balancing software that accomplishes tasks such as, for example, tracking demand for processing power from different machines, prioritizing and scheduling tasks based on network demand and/or providing backup contingency in the event of component failure or reduction in operability.

[0066] While various embodiments have been described herein, it should be apparent that various modifications, alterations, and adaptations to those embodiments may occur to persons skilled in the art with attainment of at least some of the advantages.

**Claims**

**1.** An earphone comprising:

a body, wherein the body comprises:

at least one acoustic transducer (106) for converting an analog electrical signal to sound;  
 an antenna (108); and  
 a transceiver circuit (100) in communication with the at least one acoustic transducer and the antenna, wherein the transceiver circuit is for receiving and transmitting wireless signals via the antenna, and wherein the transceiver circuit is for outputting the analog electrical signal to the at least one acoustic transducer, and wherein the wireless transceiver circuit comprises firmware, which when executed by the transceiver circuit, causes the transceiver circuit to:

receive digital audio wirelessly from a data source (20) via an ad hoc wireless network (24) after establishing a wireless communication link with the ad hoc wireless network and when the data source is in wireless communication range with the earphone via the ad hoc wireless network;  
 transmit via the ad hoc wireless network to the data/source, data regarding one or more infrastructure wireless networks detected by the transceiver circuit that have a signal strength above a threshold minimum signal strength level when the earphone and the data source are communicating via the ad hoc wireless network, wherein the data comprises identification data for the one or more infrastructure wireless networks; and  
 when the data source is not in wireless communication range with the ear-

phone via the ad hoc wireless network, transition automatically to receive digital audio via a first infrastructure wireless network (33), the earphone being **characterised in that** the transceiver circuit receives digital audio from the data source via the first infrastructure wireless network when the data source is not in wireless communication range with the earphone via the ad hoc wireless network.

**2.** The earphone of claim 1, wherein the transceiver circuit comprises:

a wireless communication module;  
 a processor unit in communication with the wireless communication module;  
 a non-volatile memory unit in communication with the processor unit; and  
 a volatile memory unit in communication with the processor unit.

**3.** The earphone of claim 2, wherein the wireless communication module comprises a Wi-Fi communication module.

**4.** The earphone of claim 1, wherein the firmware, when executed by the transceiver circuit, causes the transceiver circuit of the earphone to connect to a host server via a second infrastructure wireless network when (1) the data source is not in wireless communication range with the earphone via the ad hoc wireless network and (2) the data source and the earphone are not in wireless communication via the first infrastructure wireless network.

**5.** The earphone of claim 1, wherein the firmware, when executed by the transceiver circuit, causes the transceiver circuit of the earphone to connect to a host server via the infrastructure wireless network when the data source is not in wireless communication range with the earphone via the ad hoc wireless network.

**6.** The earphone of claim 5, wherein the earphone is for receiving streaming digital audio from the host server via the infrastructure wireless network.

**7.** The earphone of claim 5, wherein the earphone is for receiving a first network address for a first streaming digital audio content server from the host server via the infrastructure wireless network.

**8.** The earphone of claim 7, wherein the earphone comprises a user control that, when activated, causes the earphone to submit an electronic request via the infrastructure wireless network to the host server for



- a second network address for a second streaming digital audio content server.
9. The earphone of claim 8, wherein the user control comprises a button. 5
10. A system comprising:
- a wireless earphone according to claim 1; and  
a said data source for wirelessly transmitting streaming digital audio. 10
11. A system according to claim 10, further comprising a host server that is in communication with the wireless earphone via the infrastructure wireless network. 15
12. A system according to claim 11, wherein the firmware of the transceiver circuit of the wireless earphone, when executed by the transceiver circuit, causes the transceiver circuit of the earphone to connect to the host server via the infrastructure wireless network when the data source is not in wireless communication range with the earphone via the ad hoc wireless network. 20 25
13. A system according to claim 11, wherein the host server is for streaming digital audio to the earphone via the infrastructure wireless network. 30
14. A system according to claim 11, wherein the host server is for transmitting a first network address for a first streaming digital audio content server to the earphone via the infrastructure wireless network. 35
15. A system according to claim 12 further comprising a web page for the wireless earphone through which a user is capable of configuring one or more settings for the wireless earphone. 40
16. A system according to claim 10, or an earphone according to claim 1, wherein the data source comprises a digital audio player.
17. A system according to claim 10, or an earphone according to claim 1, wherein the infrastructure wireless network comprises a WLAN. 45
18. A system according to claim 10, or an earphone according to claim 1, wherein the infrastructure wireless network is a pre-set infrastructure wireless network that the data source transitions to when the data source is not in wireless communication range with the earphone via the ad hoc wireless network and when the pre-set infrastructure wireless network is in range of both the earphone and the data source. 50 55
19. A method of receiving wireless digital audio by a wireless earphone, the wireless earphone comprising:
- a body, wherein the body comprises:
- at least one acoustic transducer for converting an analog electrical signal to sound; an antenna; and  
a transceiver circuit in communication with the at least one acoustic transducer and the antenna, wherein the transceiver circuit is for receiving and transmitting wireless signals via the antenna, and  
wherein the transceiver circuit is for outputting the analog electrical signal to the at least one acoustic transducer, and  
wherein the wireless transceiver circuit comprises firmware, and  
wherein the method comprises: after establishing a wireless communication link with an ad hoc wireless network,  
receiving, by the wireless earphone, via the ad hoc wireless network, digital audio from a data source when the data source is in wireless communication with the earphone via the ad hoc wireless network;  
transmitting by the wireless earphone, via the ad hoc wireless network to the data source, data regarding one or more infrastructure wireless networks detected by the transceiver circuit that have a signal strength above a threshold minimum signal strength level when the earphone and the data source are communicating via the ad hoc wireless network, wherein the data comprises identification data for the one or more infrastructure wireless networks; converting, by the wireless earphone, the digital audio to sound the method being **characterised by:**
- when the data source is not in wireless communication range with the earphone via the ad hoc wireless network, transitioning automatically, by the earphone, to receive digital audio via a first infrastructure wireless network, and receiving digital audio from the data source via the first infrastructure wireless network when the data source is not in wireless communication range with the earphone via the ad hoc wireless network.
20. The method of claim 19, wherein transitioning automatically by the earphone to receive digital audio via the first infrastructure wireless network comprises transitioning automatically to receive digital audio from a host sever via the first infrastructure wireless

network when the data source is not in wireless communication range with the earphone via the ad hoc wireless network.

21. The method of claim 19, wherein transitioning automatically by the earphone to receive digital audio via the first infrastructure wireless network comprises:

receiving, by the wireless earphone via the first infrastructure wireless network, from a host server connected to the first infrastructure wireless network, a network address for a streaming digital audio content server; and connecting, by the wireless earphone, to the streaming digital audio content server using the network address received from the host server.

## Patentansprüche

1. Kopfhörer, umfassend:

einen Körper, wobei der Körper Folgendes umfasst:

zumindest einen Schallwandler (106) zur Umwandlung eines analogen elektrischen Signals in Ton;

eine Antenne (108); und

eine Sendeempfängerschaltung (100) in Datenübertragungsverbindung mit dem zumindest einen Schallwandler und der Antenne, wobei die Sendeempfängerschaltung zum Empfangen und Senden von Funksignalen über die Antenne dient, und worin die Sendeempfängerschaltung zur Ausgabe des analogen elektrischen Signals an den zumindest einen Schallwandler dient, und worin die Funk-Sendeempfängerschaltung Firmware umfasst, die bei Ausführung durch die Sendeempfängerschaltung bewirkt, dass die Sendeempfängerschaltung

über Funk digitale Audiosignale von einer Datenquelle (20) über ein Ad-hoc-Funknetz (24) empfängt, nachdem eine Funkdatenübertragungsverbindung mit dem Ad-hoc-Funknetz hergestellt wurde und wenn sich die Datenquelle in Funkdatenübertragungsreichweite des Kopfhörers über das Ad-hoc-Funknetz befindet;

über das Ad-hoc-Funknetz Daten bezüglich eines oder mehrerer, durch die Sendeempfängerschaltung detektierter Infrastruktur-Funknetze, die eine Signalstärke über einem minimalen Signalstärken-Schwellenwert aufweisen, an die Datenquelle überträgt, wenn der Kopfhörer und die Daten-

quelle über das Ad-hoc-Funknetz Daten austauschen, wobei die Daten Identifikationsdaten für eines oder mehrere Infrastruktur-Funknetze umfassen; und,

wenn die Datenquelle sich nicht in Funkdatenübertragungsreichweite des Kopfhörers über das Ad-hoc-Funknetz befindet, automatisch zum Empfang von digitalen Audiosignalen über ein erstes Infrastruktur-Funknetz (33) wechselt, wobei der Kopfhörer **dadurch gekennzeichnet, dass** die Sendeempfängerschaltung digitale Audiosignale von der Datenquelle über das erste Infrastruktur-Funknetz empfängt, wenn die Datenquelle sich nicht in Funkdatenübertragungsreichweite des Kopfhörers über das Ad-hoc-Funknetz befindet.

2. Kopfhörer nach Anspruch 1, wobei die Sendeempfängerschaltung Folgendes umfasst:

ein Funkdatenübertragungsmodul; eine Verarbeitungseinheit in Datenübertragungsverbindung mit dem Funkdatenübertragungsmodul;

eine nichtflüchtige Speichereinheit in Datenübertragungsverbindung mit der Prozessoreinheit; und

eine flüchtige Speichereinheit in Datenübertragungsverbindung mit der Prozessoreinheit.

3. Kopfhörer nach Anspruch 2, wobei das Funkdatenübertragungsmodul ein WLAN-Datenübertragungsmodul umfasst.

4. Kopfhörer nach Anspruch 1, wobei die Firmware bei Ausführung durch die Sendeempfängerschaltung bewirkt, dass die Sendeempfängerschaltung des Kopfhörers sich über ein zweites Infrastruktur-Funknetz mit einem Host-Server verbindet, wenn (1) die Datenquelle sich nicht im Funkdatenübertragungsbereich des Kopfhörers über das Ad-hoc-Funknetz befindet und (2) die Datenquelle und der Kopfhörer sich nicht in Funkdatenübertragung mit dem ersten Infrastruktur-Funknetz befinden.

5. Kopfhörer nach Anspruch 1, wobei die Firmware bei Ausführung durch die Sendeempfängerschaltung bewirkt, dass die Sendeempfängerschaltung des Kopfhörers sich über das Infrastruktur-Funknetz mit einem Host-Server verbindet, wenn die Datenquelle sich nicht in Funkdatenübertragungsreichweite des Kopfhörers über das Ad-hoc-Funknetz befindet.

6. Kopfhörer nach Anspruch 5, wobei der Kopfhörer zum Empfangen eines digitalen Audiodatenstroms vom Host-Server über das Infrastruktur-Funknetz ausgebildet ist.

7. Kopfhörer nach Anspruch 5, wobei der Kopfhörer zum Empfangen einer ersten Netzwerkadresse für einen ersten, einen digitalen Audioinhalt-Datenstrom aussendenden Server vom Host-Server über das Infrastruktur-Funknetz dient. 5
8. Kopfhörer nach Anspruch 7, wobei der Kopfhörer eine Benutzersteuerung umfasst, die bei Aktivierung dazu führt, dass der Kopfhörer über das Infrastruktur-Funknetz eine elektronische Anfrage bezüglich einer zweiten Netzwerkadresse für einen zweiten, einen digitalen Audioinhalt-Datenstrom aussendenden Server an den Host-Server sendet. 10
9. Kopfhörer nach Anspruch 8, wobei die Benutzersteuerung einen Knopf umfasst. 15
10. System, umfassend:  
einen Funkkopfhörer nach Anspruch 1; und die Datenquelle zur Funkübertragung eines digitalen Audiodatenstroms. 20
11. System nach Anspruch 10, das weiters einen Host-Server umfasst, der über das Infrastruktur-Funknetz in Datenübertragungsverbindung mit dem Funkkopfhörer steht. 25
12. System nach Anspruch 11, wobei die Firmware der Sendeempfängerschaltung des Funkkopfhörers bei Ausführung durch die Sendeempfängerschaltung bewirkt, dass die Sendeempfängerschaltung des Kopfhörers sich über das Infrastruktur-Funknetz mit dem Host-Server verbindet, wenn die Datenquelle sich nicht in Funkdatenübertragungsreichweite des Kopfhörers über das Ad-hoc-Funknetz befindet. 30 35
13. System nach Anspruch 11, wobei der Host-Server zum Streamen von digitalen Audiodaten zum Kopfhörer über das Infrastruktur-Funknetz dient. 40
14. System nach Anspruch 11, wobei der Host-Server zur Übertragung einer ersten Netzwerkadresse für einen ersten, einen digitalen Audioinhalt-Datenstrom aussendenden Server zum Kopfhörer über das Infrastruktur-Funknetz dient. 45
15. System nach Anspruch 12, das weiters eine Webseite für einen Funkkopfhörer umfasst, über welche ein Benutzer eine oder mehrere Einstellungen für den Funkkopfhörer konfigurieren kann. 50
16. System nach Anspruch 10 oder Kopfhörer nach Anspruch 1, wobei die Datenquelle einen digitalen Audioabspieler umfasst. 55
17. System nach Anspruch 10 oder Kopfhörer nach Anspruch 1, wobei das Infrastruktur-Funknetz ein WLAN umfasst.
18. System nach Anspruch 10 oder Kopfhörer nach Anspruch 1, wobei das Infrastruktur-Funknetz ein voreingestelltes Infrastruktur-Funknetz ist, auf das die Datenquelle umschaltet, wenn die Datenquelle sich nicht in Funkdatenübertragungsreichweite des Kopfhörers über das Ad-hoc-Funknetz befindet und wenn das voreingestellte Infrastruktur-Funknetz sich in Reichweite von sowohl dem Kopfhörer als auch der Datenquelle befindet.
19. Verfahren zum Empfangen eines digitalen Funkaudiosignals über einen Funkkopfhörer, wobei der Funkkopfhörer Folgendes umfasst:  
einen Körper, wobei der Körper Folgendes umfasst:  
zumindest einen Schallwandler zur Umwandlung eines analogen elektrischen Signals in Ton; eine Antenne; und eine Sendeempfängerschaltung in Datenübertragungsverbindung mit dem zumindest einen Schallwandler und der Antenne, wobei die Sendeempfängerschaltung zum Empfangen und Senden von Funksignalen über die Antenne dient, und  
worin die Sendeempfängerschaltung zur Ausgabe des analogen elektrischen Signals an den zumindest einen Schallwandler dient, und  
worin die Funk-Sendeempfängerschaltung Firmware umfasst, und  
worin das Verfahren Folgendes umfasst:  
nach der Herstellung einer Funkdatenübertragungsverbindung mit einem Ad-hoc-Funknetz,  
das Empfangen von digitalen Audiosignalen von einer Datenquelle durch den Funkkopfhörer über das Ad-hoc-Funknetz, wenn sich die Datenquelle in Funkdatenübertragungsverbindung mit dem Kopfhörer über das Ad-hoc-Funknetz befindet;  
das Übertragen von Daten bezüglich eines oder mehrerer, durch die Sendeempfängerschaltung detektierter Infrastruktur-Funknetze, die eine Signalstärke über einem minimalen Signalstärken-Schwellenwert aufweisen, durch den Funkkopfhörer über das Ad-hoc-Funknetz an die Datenquelle, wenn der Kopfhörer und die Datenquelle über das Ad-hoc-Funknetz Daten austauschen, wobei die Daten Identifikationsdaten für eines oder mehrere Infrastruktur-Funknetze umfassen;  
Umwandeln der digitalen Audiosignale in Ton durch den Funkkopfhörer, wobei das

Verfahren **dadurch gekennzeichnet, dass:**

wenn die Datenquelle sich nicht in Funkdatenübertragungsbereich des Kopfhörers über das Ad-hoc-Funknetz befindet, der Kopfhörer automatisch zum Empfang von digitalen Audiosignalen über ein erstes Infrastruktur-Funknetz wechselt und digitale Audiosignale von der Datenquelle über das erste Infrastruktur-Funknetz empfängt, wenn die Datenquelle sich nicht in Funkdatenübertragungsbereich des Kopfhörers über das Ad-hoc-Funknetz befindet.

20. Verfahren nach Anspruch 19, worin das automatische Wechseln des Kopfhörers zum Empfangen von digitalen Audiosignalen über das erste Infrastruktur-Funknetz das automatische Wechseln zum Empfangen von digitalen Audiosignalen von einem Host-Server über das erste Infrastruktur-Funknetz umfassen, wenn die Datenquelle sich nicht in Funkdatenübertragungsbereich des Kopfhörers über das Ad-hoc-Funknetz befindet.

21. Verfahren nach Anspruch 19, worin das automatische Wechseln des Kopfhörers zum Empfangen von digitalen Audiosignalen über das erste Infrastruktur-Funknetz Folgendes umfasst:

das Empfangen einer Netzwerkadresse für einen ersten, einen digitalen Audioinhalt-Datenstrom aussendenden Server von einem Host-Server, der mit dem ersten Infrastruktur-Funknetz verbunden ist, durch den Funkkopfhörer über das erste Infrastruktur-Funknetz; und das Verbinden mit dem einen digitalen Audioinhalt-Datenstrom aussendenden Server durch den Funkkopfhörer unter Verwendung der vom Host-Server erhaltenen Netzwerkadresse.

## Revendications

1. Écouteur comprenant:

un corps, dans lequel le corps comprend:

au moins un transducteur acoustique (106) pour convertir un signal électrique analogique en son;  
une antenne (108); et  
un circuit d'émission - réception (100) en communication avec ledit au moins un transducteur acoustique et l'antenne, dans lequel le circuit d'émission - réception est

destiné à recevoir et à transmettre, par le biais de l'antenne, des signaux sans fil, et dans lequel le circuit d'émission - réception est destiné à générer en sortie le signal électrique analogique vers ledit au moins un transducteur acoustique, et dans lequel le circuit d'émission - réception sans fil comprend un micrologiciel, lequel, lorsqu'il est exécuté par le circuit d'émission - réception, amène le circuit d'émission - réception à:

recevoir, par voie radioélectrique, des données audio numériques à partir d'une source de données (20), par l'intermédiaire d'un réseau sans fil ad hoc (24), suite à l'établissement d'une liaison de communication sans fil avec le réseau sans fil ad hoc, et lorsque la source de données se situe dans une plage de communication sans fil avec l'écouteur, par l'intermédiaire du réseau sans fil ad hoc;

transmettre, par l'intermédiaire du réseau sans fil ad hoc, à la source de données, des données connexes à un ou plusieurs réseaux sans fil d'infrastructure détectés par le circuit d'émission - réception, qui présentent une puissance de signal supérieure à un niveau seuil de puissance de signal minimum, lorsque l'écouteur et la source de données communiquent par l'intermédiaire du réseau sans fil ad hoc, dans lequel les données comprennent des données d'identification pour ledit un ou lesdits plusieurs réseaux sans fil d'infrastructure; et

lorsque la source de données n'est pas située dans une plage de communication sans fil avec l'écouteur par l'intermédiaire du réseau sans fil ad hoc, mettre en oeuvre une transition automatique en vue de recevoir des données audio numériques par l'intermédiaire d'un premier réseau sans fil d'infrastructure (33), l'écouteur étant **caractérisé en ce que** le circuit d'émission - réception reçoit des données audio numériques en provenance de la source de données via le premier réseau sans fil d'infrastructure, lorsque la source de données n'est pas située dans la plage de communication sans fil avec l'écouteur par l'intermédiaire du réseau sans fil ad hoc.

2. Écouteur selon la revendication 1, dans lequel le circuit d'émission - réception comprend:

- un module de communication sans fil;  
une unité de traitement en communication avec le module de communication sans fil;  
une unité de mémoire non volatile en communication avec l'unité de traitement; et  
une unité de mémoire volatile en communication avec l'unité de traitement.
3. Écouteur selon la revendication 2, dans lequel le module de communication sans fil comprend un module de communication WiFi.
4. Écouteur selon la revendication 1, dans lequel le micrologiciel, lorsqu'il est exécuté par le circuit d'émission - réception, amène le circuit d'émission - réception de l'écouteur à se connecter à un serveur hôte, par l'intermédiaire d'un second réseau sans fil d'infrastructure, lorsque (1) la source de données n'est pas située dans la plage de communication sans fil avec l'écouteur par l'intermédiaire du réseau sans fil ad hoc, et (2) la source de données et l'écouteur ne sont pas en communication sans fil via le premier réseau sans fil d'infrastructure.
5. Écouteur selon la revendication 1, dans lequel le micrologiciel, lorsqu'il est exécuté par le circuit d'émission - réception, amène le circuit d'émission - réception de l'écouteur à se connecter à un serveur hôte par l'intermédiaire du réseau sans fil d'infrastructure, lorsque la source de données n'est pas située dans la plage de communication sans fil avec l'écouteur par l'intermédiaire du réseau sans fil ad hoc.
6. Écouteur selon la revendication 5, dans lequel l'écouteur est destiné à recevoir des données audio numériques diffusées en continu en provenance du serveur hôte par l'intermédiaire du réseau sans fil d'infrastructure.
7. Écouteur selon la revendication 5, dans lequel l'écouteur est destiné à recevoir une première adresse de réseau pour un premier serveur de contenu de données audio numériques diffusées en continu en provenance du serveur hôte par l'intermédiaire du réseau sans fil d'infrastructure.
8. Écouteur selon la revendication 7, dans lequel l'écouteur comporte une commande d'utilisateur qui, lorsqu'elle est actionnée, amène l'écouteur à soumettre une demande électronique, par l'intermédiaire du réseau sans fil d'infrastructure, au serveur hôte, concernant une seconde adresse de réseau d'un second serveur de contenu de données audio numériques diffusées en continu.
9. Écouteur selon la revendication 8, dans lequel la commande d'utilisateur comprend un bouton.
10. Système comprenant:  
un écouteur sans fil selon la revendication 1; et  
une dite source de données destinée à transmettre, par voie hertzienne, des données audio numériques diffusées en continu.
11. Système selon la revendication 10, comprenant en outre un serveur hôte en communication avec l'écouteur sans fil, par l'intermédiaire du réseau sans fil d'infrastructure.
12. Système selon la revendication 11, dans lequel le micrologiciel du circuit d'émission - réception de l'écouteur sans fil, lorsqu'il est exécuté par le circuit d'émission - réception, amène le circuit d'émission - réception de l'écouteur à se connecter au serveur hôte par l'intermédiaire du réseau sans fil d'infrastructure, lorsque la source de données n'est pas située dans la plage de communication sans fil avec l'écouteur, par l'intermédiaire du réseau sans fil ad hoc.
13. Système selon la revendication 11, dans lequel le serveur hôte est destiné à diffuser en continu des données audio numériques vers l'écouteur, par l'intermédiaire du réseau sans fil d'infrastructure.
14. Système selon la revendication 11, dans lequel le serveur hôte est destiné à transmettre une première adresse de réseau d'un premier serveur de contenu de données audio numériques diffusées en continu à l'écouteur, par l'intermédiaire du réseau sans fil d'infrastructure.
15. Système selon la revendication 12, comprenant en outre une page web pour l'écouteur sans fil, à travers laquelle un utilisateur est apte à configurer un ou plusieurs paramètres de l'écouteur sans fil.
16. Système selon la revendication 10, ou écouteur selon la revendication 1, dans lequel la source de données comprend un lecteur de données audio numériques.
17. Système selon la revendication 10, ou écouteur selon la revendication 1, dans lequel le réseau sans fil d'infrastructure comprend un réseau local sans fil, WLAN.
18. Système selon la revendication 10, ou écouteur selon la revendication 1, dans lequel le réseau sans fil d'infrastructure est un réseau sans fil d'infrastructure prédéfini vers lequel la source de données transite lorsque la source de données n'est pas située dans la plage de communication sans fil avec l'écouteur, par l'intermédiaire du réseau sans fil ad hoc, et lorsque le réseau sans fil d'infrastructure prédéfini est

situé dans la plage de communication de l'écouteur et de la source de données.

19. Procédé destiné à recevoir des données audio numériques sans fil par le biais d'un écouteur sans fil, l'écouteur sans fil comprenant:

un corps, dans lequel le corps comprend:

au moins un transducteur acoustique pour convertir un signal électrique analogique en son;

une antenne; et

un circuit d'émission - réception en communication avec ledit au moins un transducteur acoustique et l'antenne, dans lequel le circuit d'émission - réception est destiné à recevoir et à transmettre des signaux sans fil par l'intermédiaire de l'antenne; et

dans lequel le circuit d'émission - réception est destiné à générer en sortie le signal électrique analogique vers ledit au moins un transducteur acoustique; et

dans lequel le circuit d'émission - réception sans fil comprend un micrologiciel; et

dans lequel le procédé comprend les étapes ci-dessous consistant à, suite à l'établissement d'une liaison de communication sans fil avec un réseau sans fil ad hoc:

recevoir, par le biais de l'écouteur sans fil, par l'intermédiaire du réseau sans fil ad hoc, des données audio numériques en provenance d'une source de données, lorsque la source de données est en communication sans fil avec l'écouteur par l'intermédiaire du réseau sans fil ad hoc;

transmettre, par le biais de l'écouteur sans fil, par l'intermédiaire du réseau sans fil ad hoc, à la source de données, des données connexes à un ou plusieurs réseaux sans fil d'infrastructure détectés par le circuit d'émission - réception, lesquelles présentent une puissance de signal supérieure à un niveau seuil de puissance de signal minimum, lorsque l'écouteur et la source de données communiquent par l'intermédiaire du réseau sans fil ad hoc, dans lequel les données comprennent des données d'identification pour ledit un ou lesdits plusieurs réseaux sans fil d'infrastructure;

convertir, par le biais de l'écouteur sans fil, les données audio numériques en son, le procédé étant caractérisé par les étapes ci-dessous consistant à:

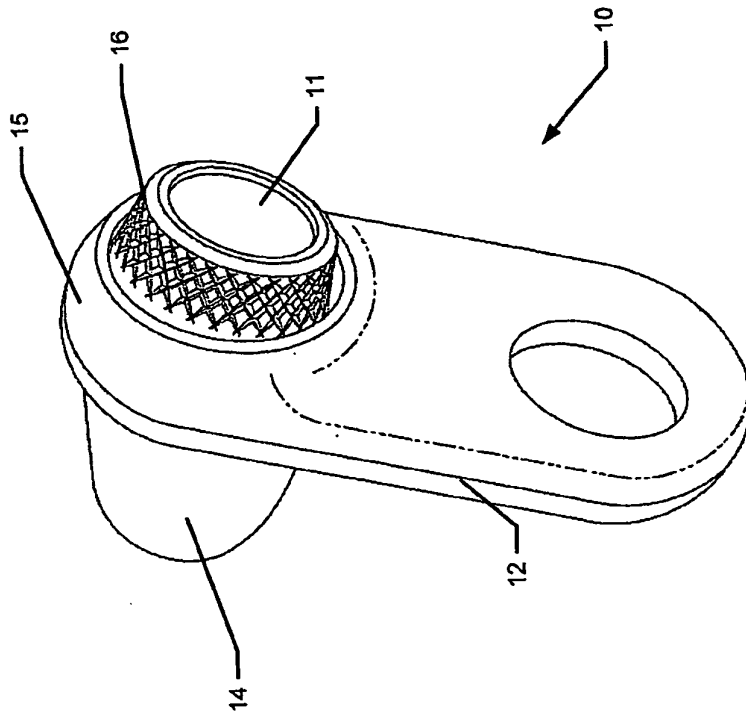
lorsque la source de données n'est pas située dans la plage de communication sans fil avec l'écouteur, par l'intermédiaire du réseau sans fil ad hoc, mettre en oeuvre une transition automatique, par l'écouteur, en vue de recevoir des données audio numériques via un premier réseau sans fil d'infrastructure, et recevoir des données audio numériques provenant de la source de données, via le premier réseau sans fil d'infrastructure, lorsque la source de données n'est pas située dans la plage de communication sans fil avec l'écouteur, par l'intermédiaire du réseau sans fil ad hoc.

20. Procédé selon la revendication 19, dans lequel l'étape de transition automatique, par l'écouteur, en vue de recevoir les données audio numériques par l'intermédiaire du premier réseau sans fil d'infrastructure, consiste à mettre en oeuvre une transition automatique en vue de recevoir des données audio numériques à partir d'un serveur hôte par l'intermédiaire du premier réseau sans fil d'infrastructure, lorsque la source de données n'est pas située dans la plage de communication sans fil avec l'écouteur par l'intermédiaire du réseau sans fil ad hoc.

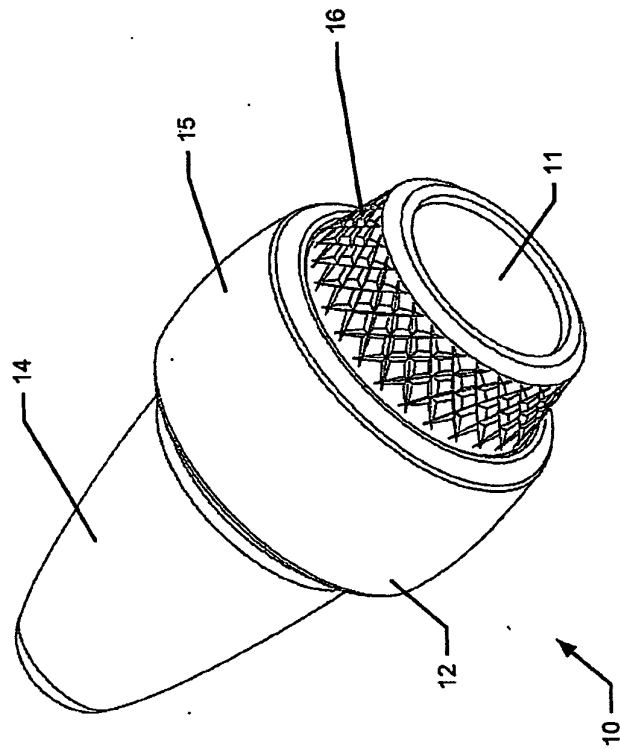
21. Procédé selon la revendication 19, dans lequel l'étape de transition automatique, par l'écouteur, en vue de recevoir les données audio numériques par l'intermédiaire du premier réseau sans fil d'infrastructure, comprend les étapes ci-dessous consistant à:

recevoir, par le biais de l'écouteur sans fil, par l'intermédiaire du premier réseau sans fil d'infrastructure, à partir d'un serveur hôte connecté au premier réseau sans fil d'infrastructure, une adresse de réseau pour un serveur de contenu de données audio numériques diffusées en continu; et

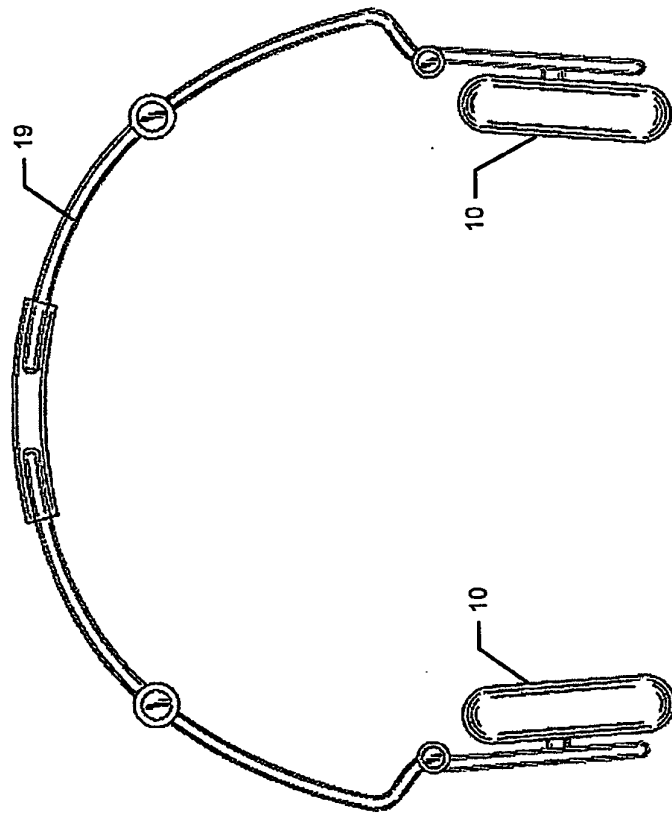
se connecter, par le biais de l'écouteur sans fil, au serveur de contenu de données audio numériques diffusées en continu, en utilisant l'adresse de réseau reçue à partir du serveur hôte.



**Fig. 1B**

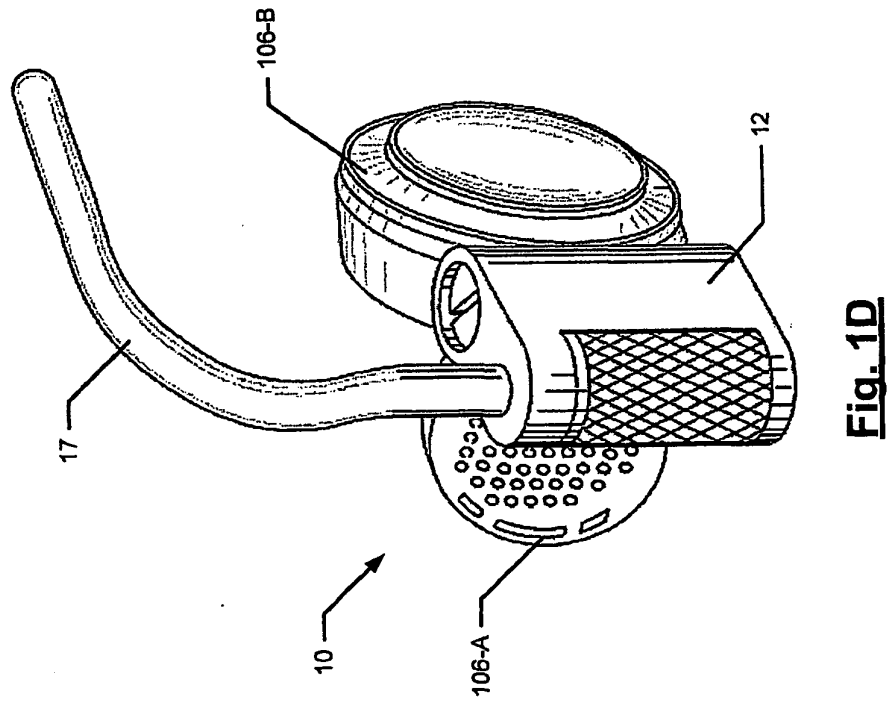
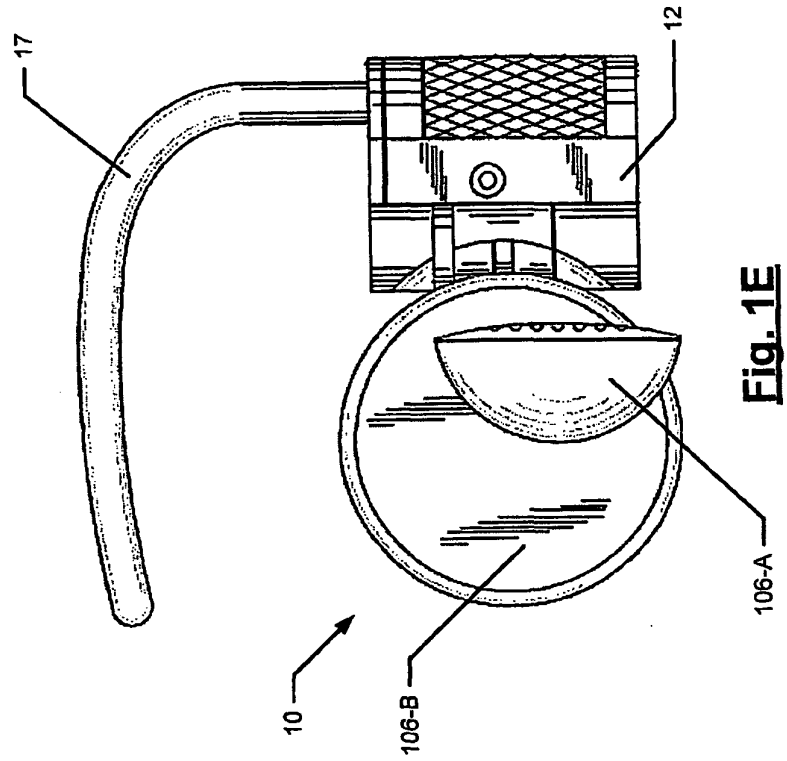


**Fig. 1A**

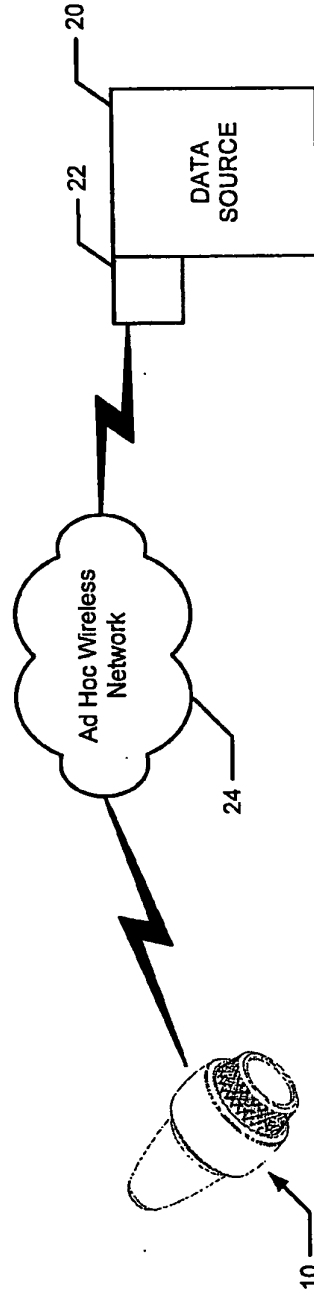


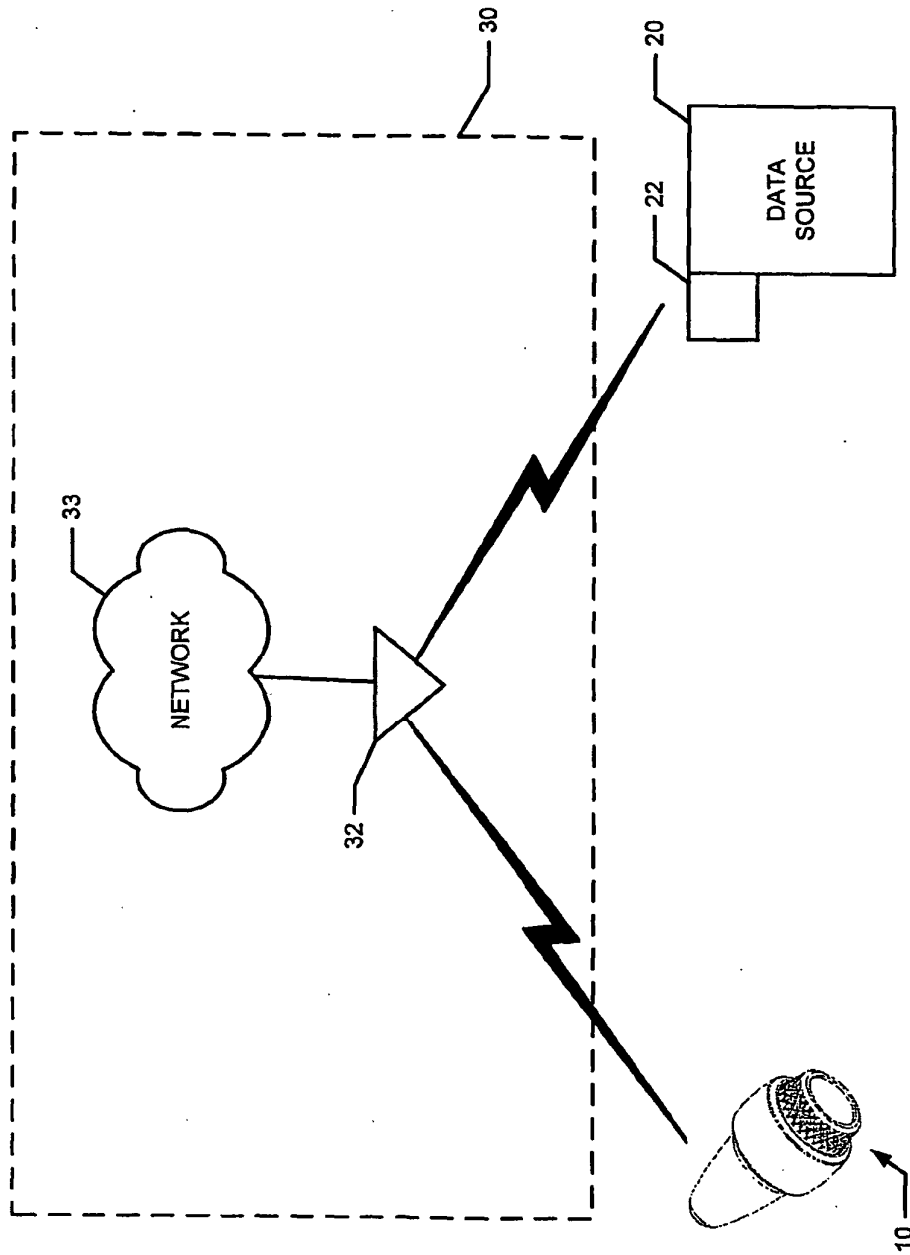
**Fig. 1C**



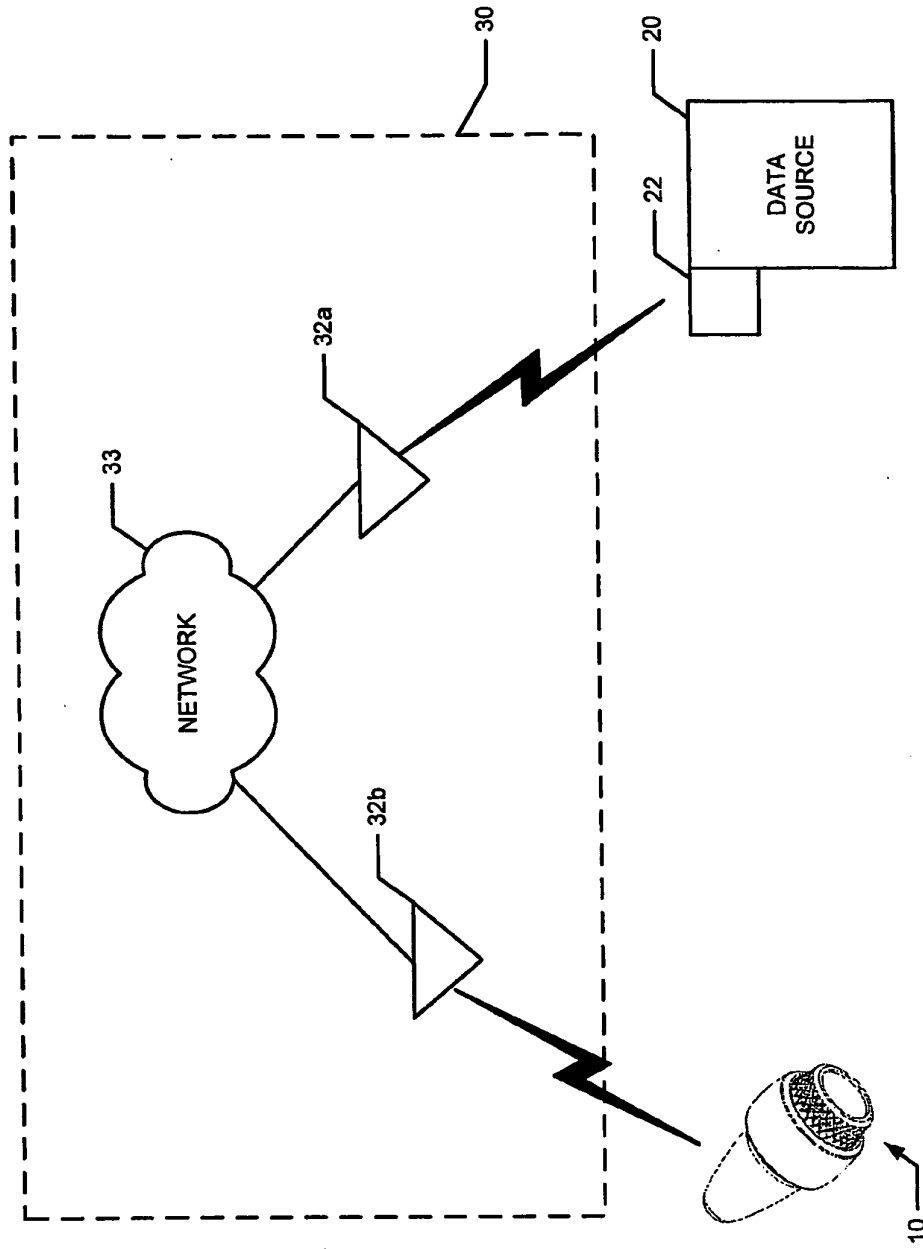


**Fig. 2A**

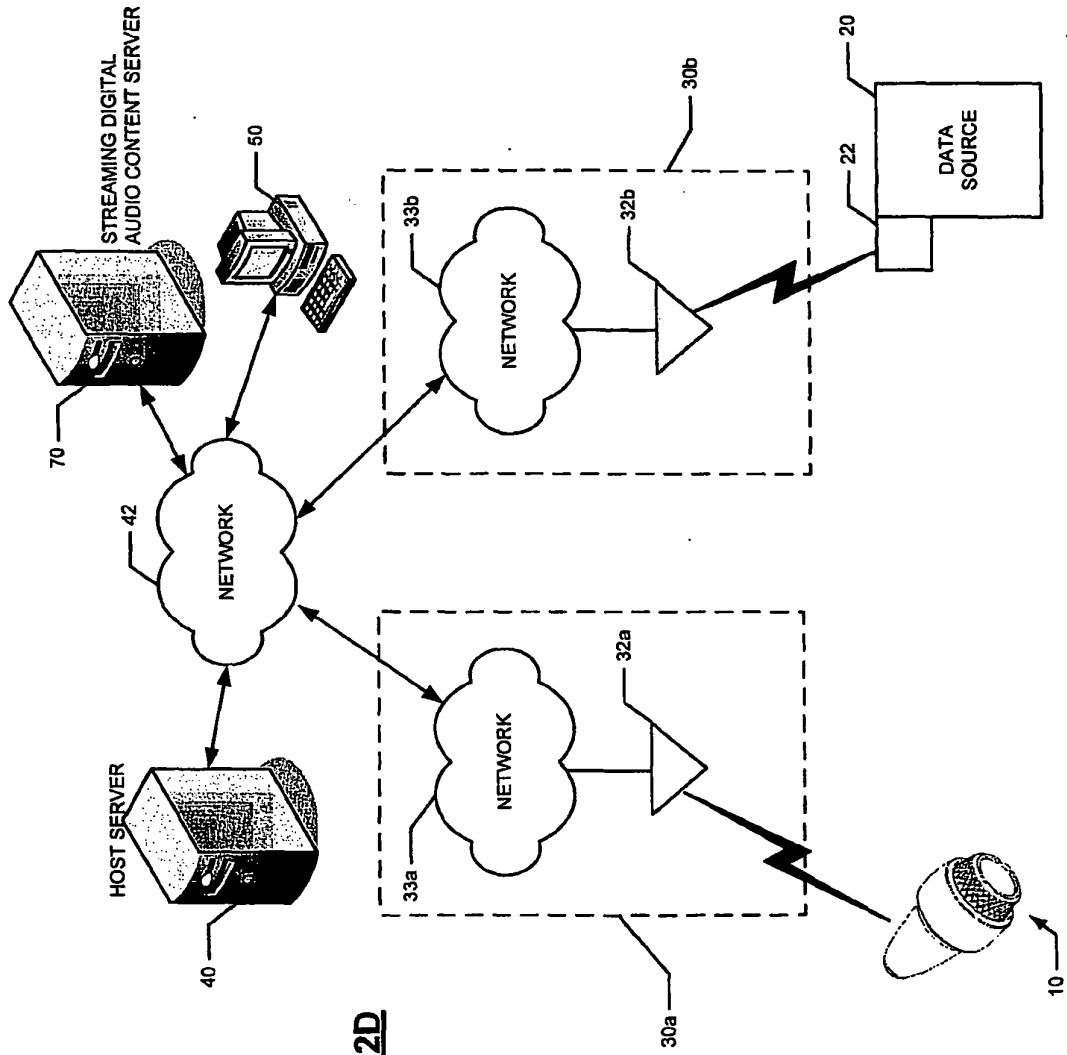




**Fig. 2B**



**Fig. 2C**



**Fig. 2D**

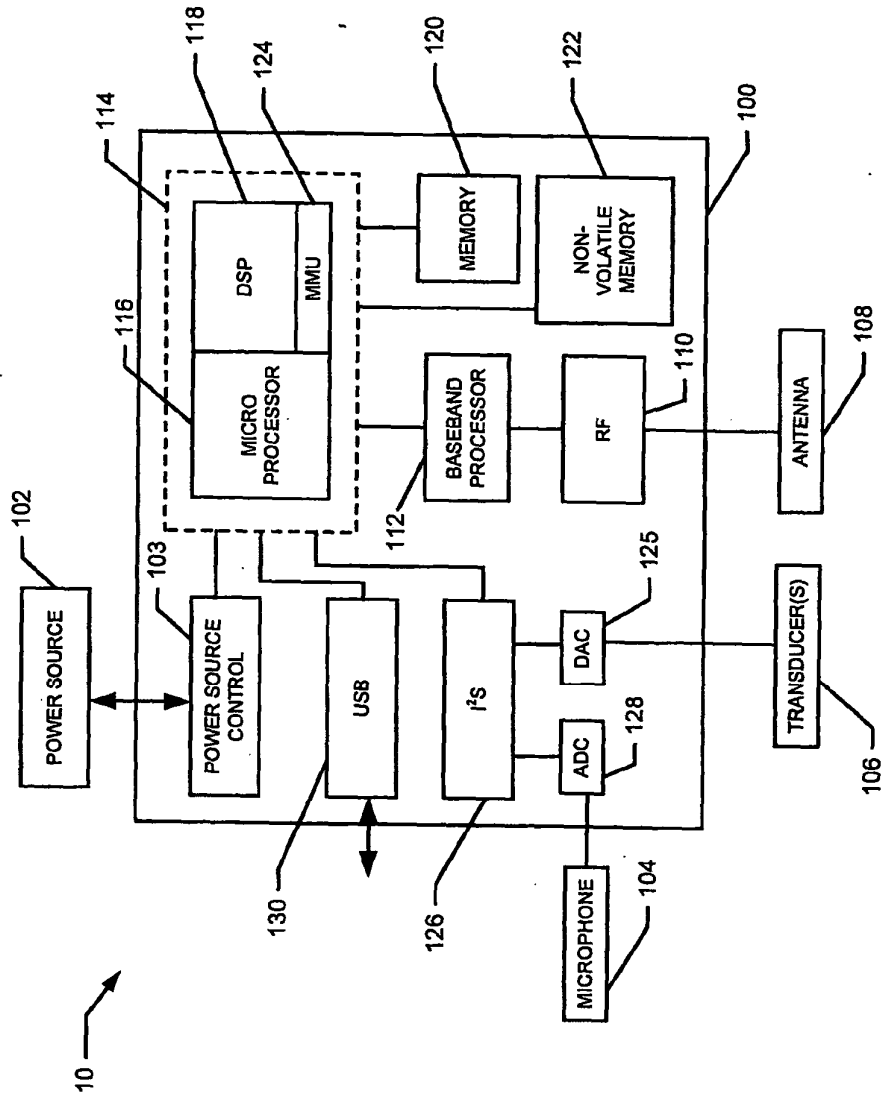


Fig. 3

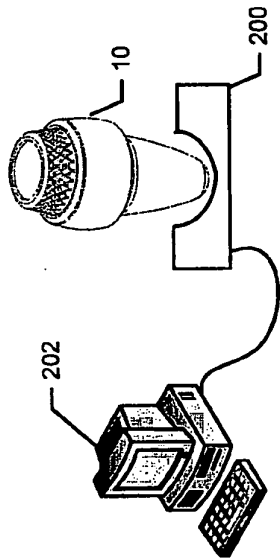


Fig. 4A

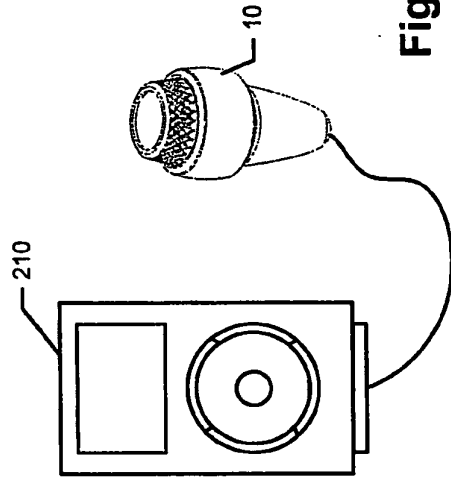
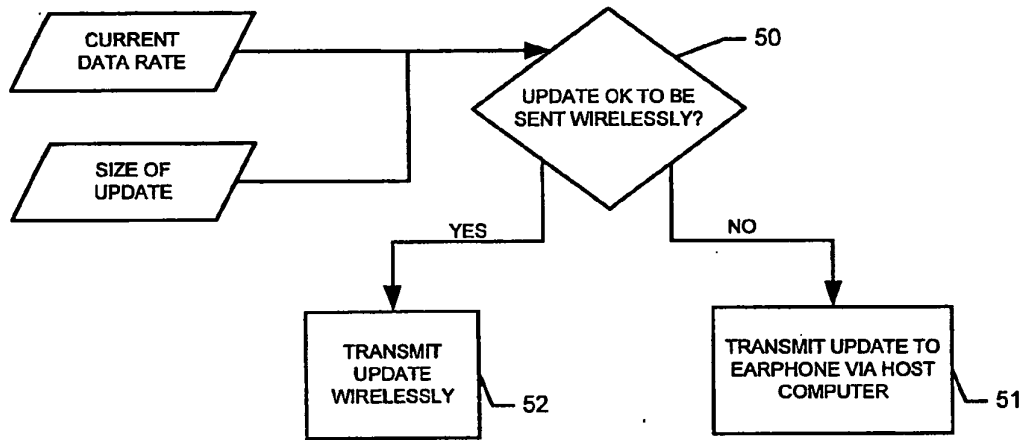
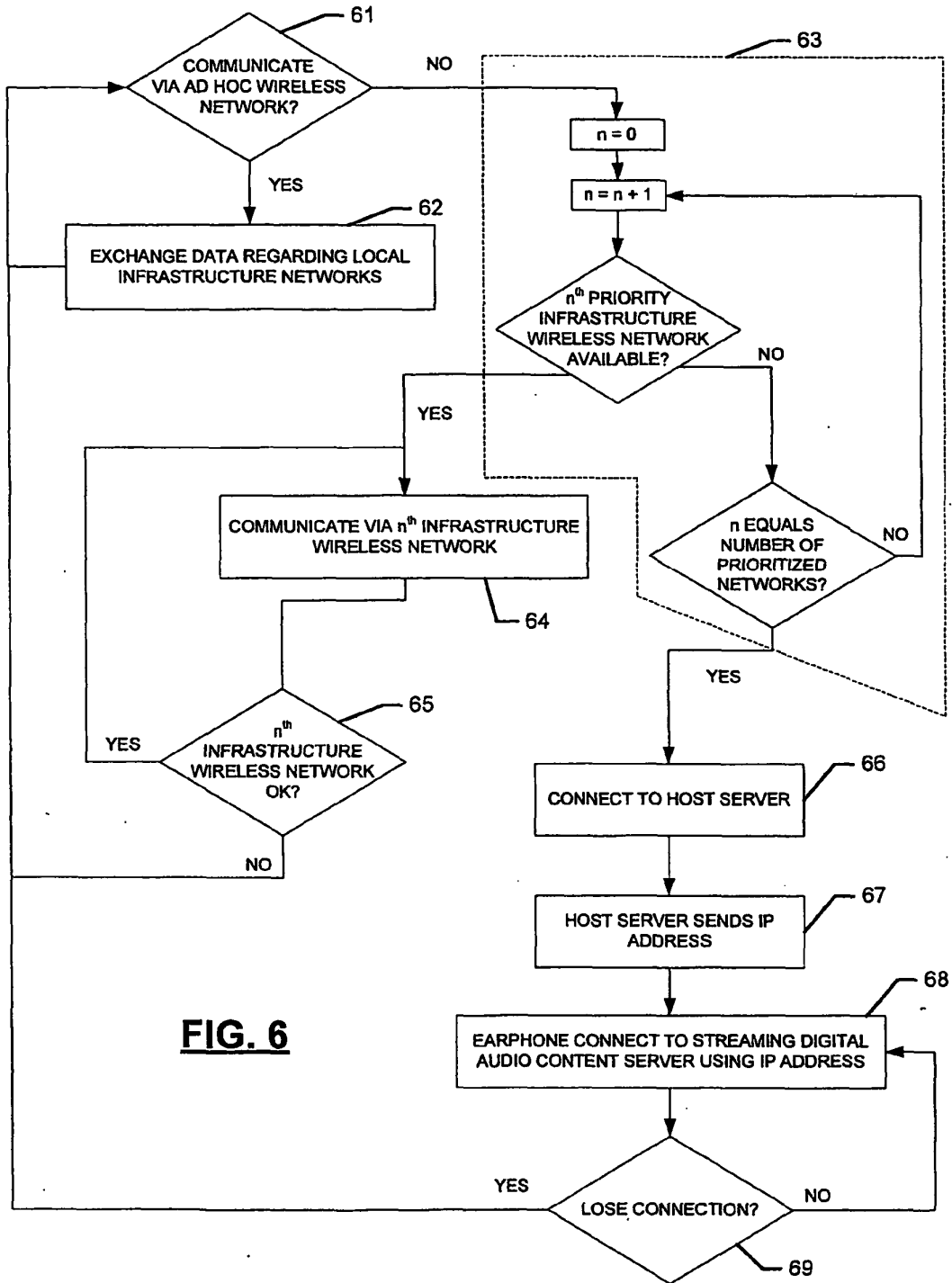


Fig. 4B

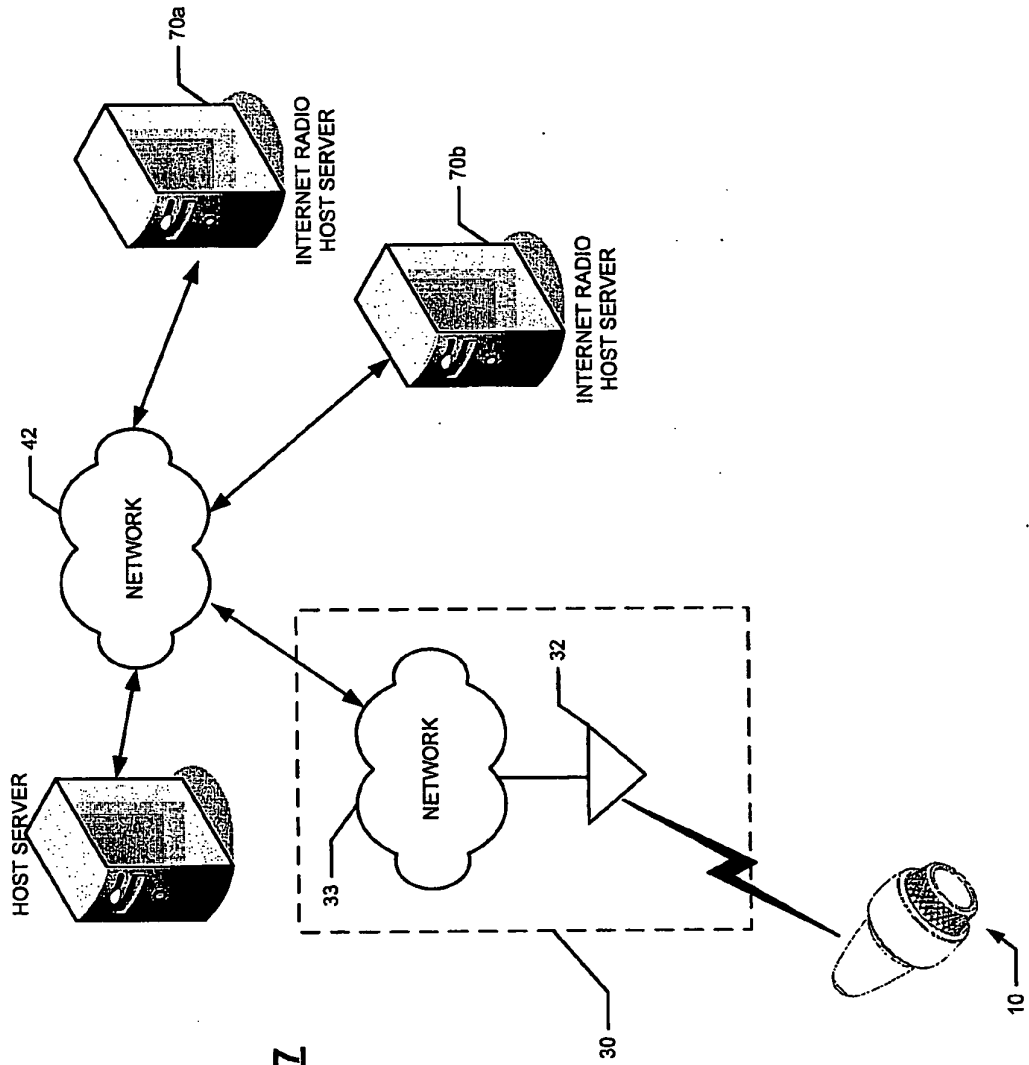


**Fig. 5**

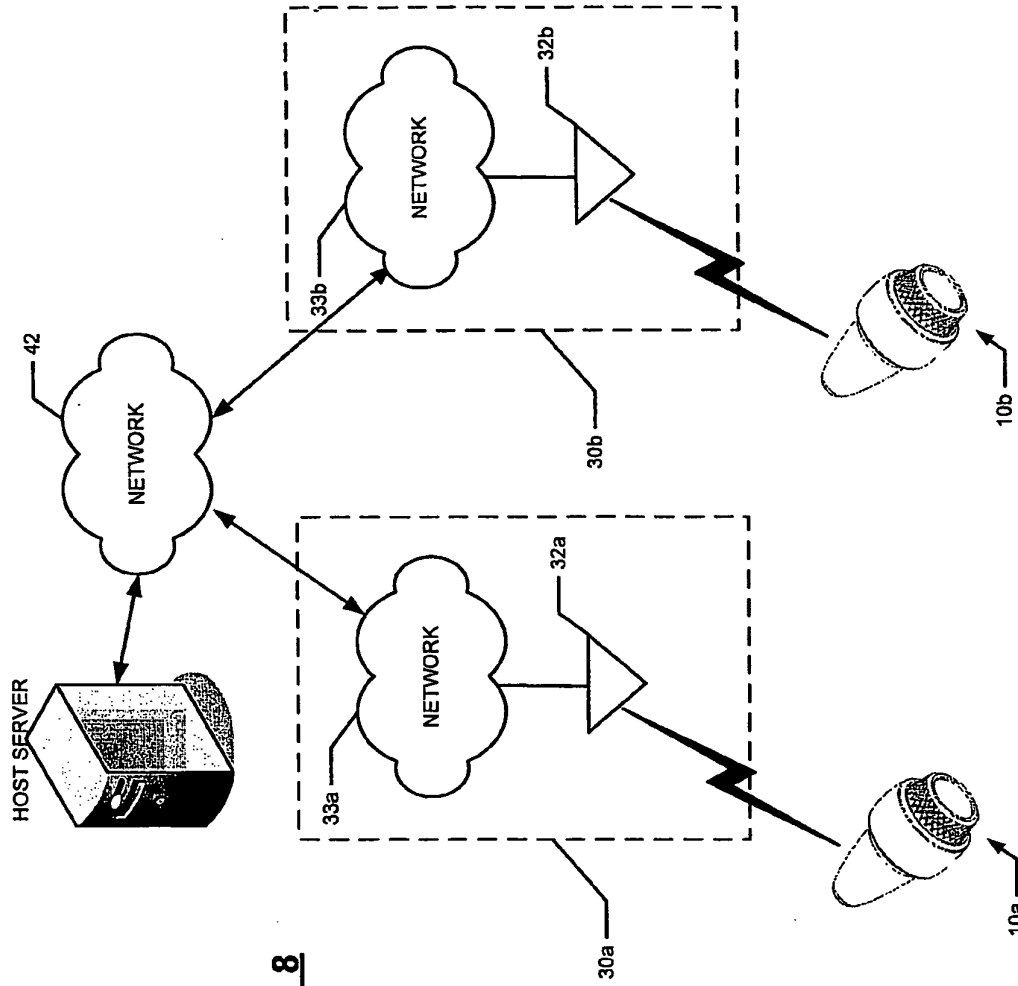




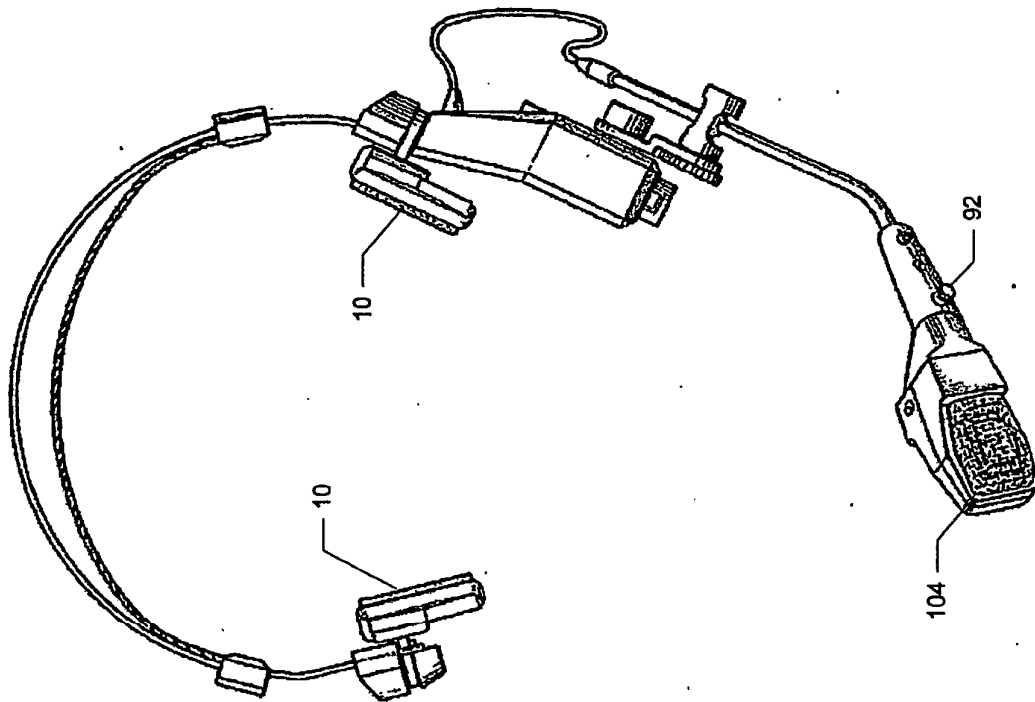
**FIG. 6**



**Fig. 7**

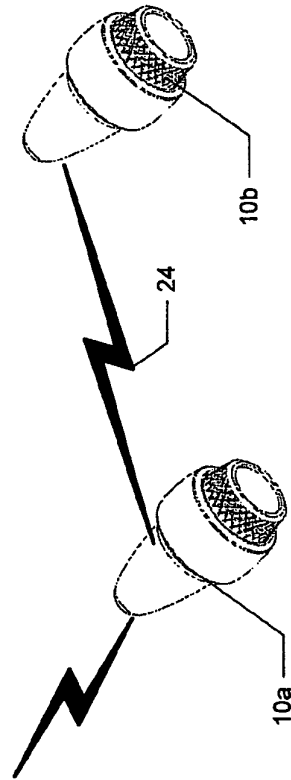


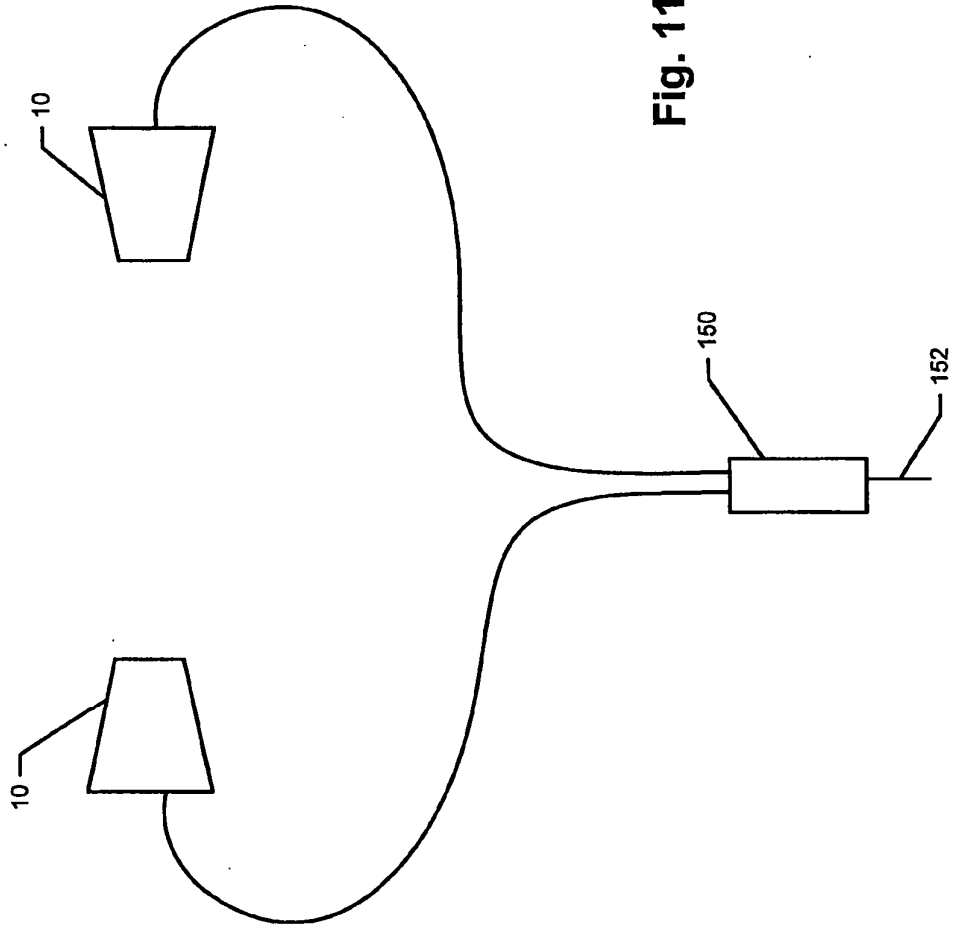
**Fig. 8**



**Fig. 9**

**Fig. 10**





**Fig. 11**

**REFERENCES CITED IN THE DESCRIPTION**

*This list of references cited by the applicant is for the reader's convenience only. It does not form part of the European patent document. Even though great care has been taken in compiling the references, errors or omissions cannot be excluded and the EPO disclaims all liability in this regard.*

**Patent documents cited in the description**

- US 61123265 B [0001]
- US 20070165875 A1 [0003]
- US 0888656 W [0010]
- US 61054238 B [0014]
- US 7027311 B [0024]
- US 5333206 A [0025]
- US 20060212444 A [0044]
- US 20060206487 A [0044]
- US 20060212442 A [0044]
- US 7003515 B [0044]
- WO 2007136620 A [0046]