

US010258265B1

(12) **United States Patent**
Poeze et al.

(10) **Patent No.:** **US 10,258,265 B1**
(45) **Date of Patent:** ***Apr. 16, 2019**

(54) **MULTI-STREAM DATA COLLECTION SYSTEM FOR NONINVASIVE MEASUREMENT OF BLOOD CONSTITUENTS**

(71) Applicant: **MASIMO CORPORATION**, Irvine, CA (US)

(72) Inventors: **Jeroen Poeze**, Rancho Santa Margarita, CA (US); **Marcelo Lamego**, Cupertino, CA (US); **Sean Merritt**, Lake Forest, CA (US); **Cristiano Dalvi**, Lake Forest, CA (US); **Hung Vo**, Fountain Valley, CA (US); **Johannes Bruinsma**, Opeinde (NL); **Ferdyan Lesmana**, Irvine, CA (US); **Massi Joe E. Kiani**, Laguna Niguel, CA (US); **Greg Olsen**, Trabuco Canyon, CA (US)

(73) Assignee: **MASIMO CORPORATION**, Irvine, CA (US)

(*) Notice: Subject to any disclaimer, the term of this patent is extended or adjusted under 35 U.S.C. 154(b) by 0 days.

This patent is subject to a terminal disclaimer.

(21) Appl. No.: **16/212,440**

(22) Filed: **Dec. 6, 2018**

Related U.S. Application Data

(63) Continuation of application No. 14/981,290, filed on Dec. 28, 2015, which is a continuation of application (Continued)

(51) **Int. Cl.**
A61B 5/1455 (2006.01)
A61B 5/00 (2006.01)
A61B 5/145 (2006.01)

(52) **U.S. Cl.**
CPC **A61B 5/1455** (2013.01); **A61B 5/14532** (2013.01); **A61B 5/14546** (2013.01); (Continued)

(58) **Field of Classification Search**
CPC . **A61B 5/0205**; **A61B 5/1455**; **A61B 5/14551**; **A61B 5/14552**; **A61B 5/14532**; (Continued)

(56) **References Cited**

U.S. PATENT DOCUMENTS

3,910,701 A 10/1975 Henderson et al.
4,114,604 A 9/1978 Shaw et al.
(Continued)

FOREIGN PATENT DOCUMENTS

EP 419223 3/1991
EP 1 518 494 3/2005
(Continued)

OTHER PUBLICATIONS

US 8,845,543 B2, 09/2014, Diab et al. (withdrawn)
(Continued)

Primary Examiner — Eric F Winakur
Assistant Examiner — Chu Chuan Liu

(74) *Attorney, Agent, or Firm* — Knobbe Martens Olson & Bear LLP

(57) **ABSTRACT**

The present disclosure relates to noninvasive methods, devices, and systems for measuring various blood constituents or analytes, such as glucose. In an embodiment, a light source comprises LEDs and super-luminescent LEDs. The light source emits light at least wavelengths of about 1610 nm, about 1640 nm, and about 1665 nm. In an embodiment, the detector comprises a plurality of photodetectors arranged in a special geometry comprising one of a substantially (Continued)

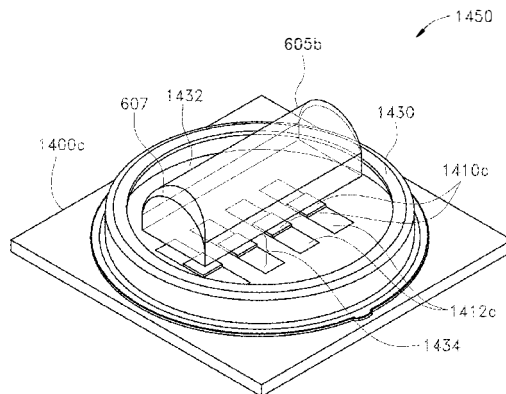

Masimo Ex. 2025
Apple v. Masimo
IPR2021-00209

linear substantially equal spaced geometry, a substantially linear substantially non-equal spaced geometry, and a substantially grid geometry.

30 Claims, 65 Drawing Sheets

Related U.S. Application Data

No. 12/829,352, filed on Jul. 1, 2010, now Pat. No. 9,277,880, which is a continuation of application No. 12/534,827, filed on Aug. 3, 2009, now abandoned, and a continuation-in-part of application No. 12/497,528, filed on Jul. 2, 2009, now Pat. No. 8,577,431, which is a continuation-in-part of application No. 29/323,409, filed on Aug. 25, 2008, now Pat. No. Des. 621,516, and a continuation-in-part of application No. 29/323,408, filed on Aug. 25, 2008, now Pat. No. Des. 606,659, said application No. 12/829,352 is a continuation-in-part of application No. 12/497,523, filed on Jul. 2, 2009, now Pat. No. 8,437,825, which is a continuation-in-part of application No. 29/323,409, and a continuation-in-part of application No. 29/323,408.

(60) Provisional application No. 61/086,060, filed on Aug. 4, 2008, provisional application No. 61/086,108, filed on Aug. 4, 2008, provisional application No. 61/086,063, filed on Aug. 4, 2008, provisional application No. 61/086,057, filed on Aug. 4, 2008, provisional application No. 61/091,732, filed on Aug. 25, 2008, provisional application No. 61/078,228, filed on Jul. 3, 2008, provisional application No. 61/078,207, filed on Jul. 3, 2008.

(52) **U.S. Cl.**
 CPC *A61B 5/14552* (2013.01); *A61B 5/6816* (2013.01); *A61B 5/6826* (2013.01); *A61B 5/6829* (2013.01); *A61B 5/6838* (2013.01); *A61B 5/6843* (2013.01); *A61B 2562/0233* (2013.01); *A61B 2562/04* (2013.01); *A61B 2562/046* (2013.01); *A61B 2562/146* (2013.01)

(58) **Field of Classification Search**
 CPC . A61B 5/14546; A61B 5/6829; A61B 5/6843; A61B 5/6826; A61B 5/6816; A61B 5/6838
 See application file for complete search history.

(56) **References Cited**

U.S. PATENT DOCUMENTS

4,258,719 A 3/1981 Lewyn
 4,267,844 A 5/1981 Yamanishi
 4,438,338 A 3/1984 Stitt
 4,444,471 A 4/1984 Ford et al.
 4,653,498 A 3/1987 New, Jr. et al.
 4,655,225 A 4/1987 Dahne et al.
 4,684,245 A 8/1987 Goldring
 4,709,413 A 11/1987 Forrest
 4,755,676 A 7/1988 Gaalema et al.
 4,781,195 A 11/1988 Martin
 4,805,623 A 2/1989 Jöbsis
 4,880,304 A 11/1989 Jaeb et al.
 4,960,128 A 10/1990 Gordon et al.
 4,964,408 A 10/1990 Hink et al.
 5,028,787 A 7/1991 Rosenthal et al.
 5,035,243 A 7/1991 Muz
 5,041,187 A 8/1991 Hink et al.

5,043,820 A 8/1991 Wyles et al.
 5,069,213 A 12/1991 Polczynski
 5,069,214 A 12/1991 Samaras et al.
 5,077,476 A 12/1991 Rosenthal
 5,086,229 A 2/1992 Rosenthal et al.
 D326,715 S 6/1992 Schmidt
 5,122,925 A 6/1992 Inpyun
 5,131,391 A 7/1992 Sakai et al.
 5,137,023 A 8/1992 Mendelson et al.
 5,159,929 A 11/1992 McMillen et al.
 5,163,438 A 11/1992 Gordon et al.
 5,222,295 A 6/1993 Dorris, Jr.
 5,222,495 A 6/1993 Clarke et al.
 5,222,496 A 6/1993 Clarke et al.
 5,249,576 A 10/1993 Goldberger et al.
 5,250,342 A 10/1993 Lang
 5,278,627 A 1/1994 Aoyagi et al.
 5,297,548 A 3/1994 Pologe
 5,319,355 A 6/1994 Russek
 5,337,744 A 8/1994 Branigan
 5,337,745 A 8/1994 Benaron
 5,341,805 A 8/1994 Stavridi et al.
 5,362,966 A 11/1994 Rosenthal et al.
 D353,195 S 12/1994 Savage et al.
 D353,196 S 12/1994 Savage et al.
 5,377,676 A 1/1995 Vari et al.
 D356,870 S 3/1995 Ivers et al.
 D359,546 S 6/1995 Savage et al.
 5,427,093 A 6/1995 Ogawa et al.
 5,431,170 A 7/1995 Mathews
 D361,840 S 8/1995 Savage et al.
 5,437,275 A 8/1995 Amundsen et al.
 5,441,054 A 8/1995 Tsuchiya
 D362,063 S 9/1995 Savage et al.
 5,452,717 A 9/1995 Branigan et al.
 D363,120 S 10/1995 Savage et al.
 5,456,252 A 10/1995 Vari et al.
 5,479,934 A 1/1996 Imran
 5,482,034 A 1/1996 Lewis et al.
 5,482,036 A 1/1996 Diab et al.
 5,490,505 A 2/1996 Diab et al.
 5,490,506 A 2/1996 Takatani et al.
 5,494,043 A 2/1996 O'Sullivan et al.
 5,511,546 A 4/1996 Hon
 5,533,511 A 7/1996 Kaspari et al.
 5,534,851 A 7/1996 Russek
 5,551,422 A 9/1996 Simonsen et al.
 5,553,615 A 9/1996 Carim et al.
 5,553,616 A 9/1996 Ham et al.
 5,561,275 A 10/1996 Savage et al.
 5,562,002 A 10/1996 Lalin
 5,590,649 A 1/1997 Caro et al.
 5,601,079 A * 2/1997 Wong A61B 5/14532
 600/322
 5,602,924 A 2/1997 Durand et al.
 D378,414 S 3/1997 Allen et al.
 5,625,458 A 4/1997 Alfano et al.
 5,632,272 A 5/1997 Diab et al.
 5,638,816 A 6/1997 Kiani-Azarbayjany et al.
 5,638,818 A 6/1997 Diab et al.
 5,645,440 A 7/1997 Tobler et al.
 5,676,143 A 10/1997 Simonsen et al.
 5,685,299 A 11/1997 Diab et al.
 D390,666 S 2/1998 Lagerlof
 D393,830 S 4/1998 Tobler et al.
 5,743,262 A 4/1998 Lepper, Jr. et al.
 5,750,927 A 5/1998 Baltazar
 5,752,914 A 5/1998 Delonzor et al.
 5,758,644 A 6/1998 Diab et al.
 5,760,910 A 6/1998 Lepper, Jr. et al.
 5,766,131 A 6/1998 Kondo et al.
 5,769,785 A 6/1998 Diab et al.
 5,782,757 A 7/1998 Diab et al.
 5,785,659 A 7/1998 Caro et al.
 5,791,347 A 8/1998 Flaherty et al.
 5,792,052 A 8/1998 Isaacson et al.
 5,810,734 A 9/1998 Caro et al.
 5,823,950 A 10/1998 Diab et al.
 5,826,885 A 10/1998 Helgeland

(56)

References Cited

U.S. PATENT DOCUMENTS

5,830,131	A	11/1998	Caro et al.	6,470,199	B1	10/2002	Kopotic et al.
5,833,618	A	11/1998	Caro et al.	RE37,922	E	12/2002	Sharan
D403,070	S	12/1998	Maeda et al.	6,501,975	B2	12/2002	Diab et al.
5,851,178	A	12/1998	Aronow	6,505,059	B1	1/2003	Kollias et al.
5,860,919	A	1/1999	Kiani-Azarbayjany et al.	6,515,273	B2	2/2003	Al-Ali
5,890,929	A	4/1999	Mills et al.	6,519,487	B1	2/2003	Parker
5,902,235	A	5/1999	Lewis et al.	6,522,521	B2	2/2003	Mizuno et al.
5,903,357	A	5/1999	Colak	6,525,386	B1	2/2003	Mills et al.
5,904,654	A	5/1999	Wohltmann et al.	6,526,300	B1	2/2003	Kiani et al.
5,919,134	A	7/1999	Diab	6,541,756	B2	4/2003	Schulz et al.
5,934,925	A	8/1999	Tobler et al.	6,542,764	B1	4/2003	Al-Ali et al.
5,940,182	A	8/1999	Lepper, Jr. et al.	6,580,086	B1	6/2003	Schulz et al.
5,957,840	A	9/1999	Terasawa et al.	6,584,336	B1	6/2003	Ali et al.
D414,870	S	10/1999	Saltzstein et al.	6,595,316	B2	7/2003	Cybulski et al.
5,995,855	A	11/1999	Kiani et al.	6,597,932	B2	7/2003	Tian et al.
5,997,343	A	12/1999	Mills et al.	6,597,933	B2	7/2003	Kiani et al.
6,002,952	A	12/1999	Diab et al.	6,606,509	B2	8/2003	Schmitt
6,011,986	A	1/2000	Diab et al.	6,606,511	B1	8/2003	Ali et al.
6,027,452	A	2/2000	Flaherty et al.	D481,459	S	10/2003	Nahm
6,036,642	A	3/2000	Diab et al.	6,632,181	B2	10/2003	Flaherty et al.
6,045,509	A	4/2000	Caro et al.	6,636,759	B2	10/2003	Robinson
6,049,727	A	4/2000	Crothall	6,639,668	B1	10/2003	Trepagnier
6,067,462	A	5/2000	Diab et al.	6,639,867	B2	10/2003	Shim
6,081,735	A	6/2000	Diab et al.	6,640,116	B2	10/2003	Diab
6,088,607	A	7/2000	Diab et al.	6,643,530	B2	11/2003	Diab et al.
6,110,522	A	8/2000	Lepper, Jr. et al.	6,650,917	B2	11/2003	Diab et al.
6,124,597	A	9/2000	Shehada	6,654,624	B2	11/2003	Diab et al.
6,128,521	A	10/2000	Marro et al.	6,658,276	B2	12/2003	Kiani et al.
6,129,675	A	10/2000	Jay	6,661,161	B1	12/2003	Lanzo et al.
6,144,866	A	11/2000	Miesel et al.	6,668,185	B2	12/2003	Toida
6,144,868	A	11/2000	Parker	6,671,531	B2	12/2003	Al-Ali et al.
6,151,516	A	11/2000	Kiani-Azarbayjany et al.	6,678,543	B2	1/2004	Diab et al.
6,152,754	A	11/2000	Gerhardt et al.	6,681,133	B2	1/2004	Chaiken et al.
6,157,850	A	12/2000	Diab et al.	6,684,090	B2	1/2004	Ali et al.
6,165,005	A	12/2000	Mills et al.	6,684,091	B2	1/2004	Parker
6,172,743	B1	1/2001	Kley et al.	6,697,656	B1	2/2004	Al-Ali
6,181,958	B1	1/2001	Steuer et al.	6,697,657	B1	2/2004	Shehada et al.
6,184,521	B1	2/2001	Coffin, IV et al.	6,697,658	B2	2/2004	Al-Ali
6,206,830	B1	3/2001	Diab et al.	RE38,476	E	3/2004	Diab et al.
6,223,063	B1	4/2001	Chaiken et al.	6,699,194	B1	3/2004	Diab et al.
6,229,856	B1	5/2001	Diab et al.	6,714,804	B2	3/2004	Al-Ali et al.
6,232,609	B1	5/2001	Snyder et al.	RE38,492	E	4/2004	Diab et al.
6,236,872	B1	5/2001	Diab et al.	6,721,582	B2	4/2004	Trepagnier et al.
6,241,683	B1	6/2001	Macklem et al.	6,721,585	B1	4/2004	Parker
6,253,097	B1	6/2001	Aronow et al.	6,725,075	B2	4/2004	Al-Ali
6,256,523	B1	7/2001	Diab et al.	6,728,560	B2	4/2004	Kollias et al.
6,263,222	B1	7/2001	Diab et al.	6,735,459	B2	5/2004	Parker
6,278,522	B1	8/2001	Lepper, Jr. et al.	6,745,060	B2	6/2004	Diab et al.
6,278,889	B1	8/2001	Robinson	6,748,254	B2	6/2004	O'Neil et al.
6,280,213	B1	8/2001	Tobler et al.	6,760,607	B2	7/2004	Al-Ali
6,285,896	B1	9/2001	Tobler et al.	6,770,028	B1	8/2004	Ali et al.
6,301,493	B1	10/2001	Marro et al.	6,771,994	B2	8/2004	Kiani et al.
6,317,627	B1	11/2001	Ennen et al.	6,792,300	B1	9/2004	Diab et al.
6,321,100	B1	11/2001	Parker	6,813,511	B2	11/2004	Diab et al.
D452,012	S	12/2001	Phillips	6,816,010	B2	11/2004	Seetharaman et al.
6,325,761	B1	12/2001	Jay	6,816,241	B2	11/2004	Grubisic et al.
6,334,065	B1	12/2001	Al-Ali et al.	6,816,741	B2	11/2004	Diab
6,343,223	B1	1/2002	Chin et al.	6,822,564	B2	11/2004	Al-Ali
6,343,224	B1	1/2002	Parker	6,826,419	B2	11/2004	Diab et al.
6,345,194	B1	2/2002	Nelson et al.	6,830,711	B2	12/2004	Mills et al.
6,349,228	B1	2/2002	Kiani et al.	6,850,787	B2	2/2005	Weber et al.
6,353,750	B1	3/2002	Kimura et al.	6,850,788	B2	2/2005	Al-Ali
6,360,113	B1	3/2002	Dettling	6,852,083	B2	2/2005	Caro et al.
6,360,114	B1	3/2002	Diab et al.	D502,655	S	3/2005	Huang
6,360,115	B1	3/2002	Greenwald et al.	6,861,639	B2	3/2005	Al-Ali
D455,834	S	4/2002	Donars et al.	6,898,452	B2	5/2005	Al-Ali et al.
6,368,283	B1	4/2002	Xu et al.	6,912,413	B2	6/2005	Rantala et al.
6,371,921	B1	4/2002	Caro et al.	6,920,345	B2	7/2005	Al-Ali et al.
6,377,829	B1	4/2002	Al-Ali	D508,862	S	8/2005	Behar et al.
6,388,240	B2	5/2002	Schulz et al.	6,931,268	B1	8/2005	Kiani-Azarbayjany et al.
6,397,091	B2	5/2002	Diab et al.	6,934,570	B2	8/2005	Kiani et al.
6,430,437	B1	8/2002	Marro	6,939,305	B2	9/2005	Flaherty et al.
6,430,525	B1	8/2002	Weber et al.	6,943,348	B1	9/2005	Coffin, IV
D463,561	S	9/2002	Fukatsu et al.	6,950,687	B2	9/2005	Al-Ali
6,463,311	B1	10/2002	Diab	D510,625	S	10/2005	Widener et al.
				6,961,598	B2	11/2005	Diab
				6,970,792	B1	11/2005	Diab
				6,979,812	B2	12/2005	Al-Ali
				6,985,764	B2	1/2006	Mason et al.

(56)

References Cited

U.S. PATENT DOCUMENTS

6,993,371	B2	1/2006	Kiani et al.	7,440,787	B2	10/2008	Diab
D514,461	S	2/2006	Harju	7,454,240	B2	11/2008	Diab et al.
6,995,400	B2	2/2006	Mizuyoshi	7,467,002	B2	12/2008	Weber et al.
6,996,427	B2	2/2006	Ali et al.	7,469,157	B2	12/2008	Diab et al.
6,999,904	B2	2/2006	Weber et al.	7,471,969	B2	12/2008	Diab et al.
7,003,338	B2	2/2006	Weber et al.	7,471,971	B2	12/2008	Diab et al.
7,003,339	B2	2/2006	Diab et al.	7,483,729	B2	1/2009	Al-Ali et al.
7,015,451	B2	3/2006	Dalke et al.	7,483,730	B2	1/2009	Diab et al.
7,024,233	B2	4/2006	Ali et al.	7,489,958	B2	2/2009	Diab et al.
7,027,849	B2	4/2006	Al-Ali	7,496,391	B2	2/2009	Diab et al.
7,030,749	B2	4/2006	Al-Ali	7,496,393	B2	2/2009	Diab et al.
7,039,449	B2	5/2006	Al-Ali	D587,657	S	3/2009	Al-Ali et al.
7,041,060	B2	5/2006	Flaherty et al.	7,499,741	B2	3/2009	Diab et al.
7,044,918	B2	5/2006	Diab	7,499,835	B2	3/2009	Weber et al.
7,047,054	B2	5/2006	Benni	7,500,950	B2	3/2009	Al-Ali et al.
7,067,893	B2	6/2006	Mills et al.	7,509,153	B2	3/2009	Blank et al.
7,092,757	B2	8/2006	Larson et al.	7,509,154	B2	3/2009	Diab et al.
7,096,052	B2	8/2006	Mason et al.	7,509,494	B2	3/2009	Al-Ali
7,096,054	B2	8/2006	Abdul-Hafiz et al.	7,510,849	B2	3/2009	Schurman et al.
7,132,641	B2	11/2006	Schulz et al.	7,519,327	B2	4/2009	White
7,142,901	B2	11/2006	Kiani et al.	7,526,328	B2	4/2009	Diab et al.
7,149,561	B2	12/2006	Diab	7,530,942	B1	5/2009	Diab
D535,031	S	1/2007	Barrett et al.	7,530,949	B2	5/2009	Al Ali et al.
D537,164	S	2/2007	Shigemori et al.	7,530,955	B2	5/2009	Diab et al.
7,186,966	B2	3/2007	Al-Ali	7,563,110	B2	7/2009	Al-Ali et al.
7,190,261	B2	3/2007	Al-Ali	7,596,398	B2	9/2009	Al-Ali et al.
7,215,984	B2	5/2007	Diab	7,601,123	B2	10/2009	Tweed et al.
7,215,986	B2	5/2007	Diab	7,606,606	B2	10/2009	Laakkonen
7,221,971	B2	5/2007	Diab	D603,966	S	11/2009	Jones et al.
7,225,006	B2	5/2007	Al-Ali et al.	7,618,375	B2	11/2009	Flaherty
7,225,007	B2	5/2007	Al-Ali	D606,659	S	12/2009	Kiani et al.
RE39,672	E	6/2007	Shehada et al.	7,647,083	B2	1/2010	Al-Ali et al.
7,230,227	B2	6/2007	Wilcken et al.	D609,193	S	2/2010	Al-Ali et al.
D547,454	S	7/2007	Hsieh	7,657,294	B2	2/2010	Eghbal et al.
7,239,905	B2	7/2007	Kiani-Azarbayjany et al.	7,657,295	B2	2/2010	Coakley et al.
7,245,953	B1	7/2007	Parker	7,657,296	B2	2/2010	Raridan et al.
D549,830	S	8/2007	Behar et al.	D614,305	S	4/2010	Al-Ali et al.
7,254,429	B2	8/2007	Schurman et al.	RE41,317	E	5/2010	Parker
7,254,431	B2	8/2007	Al-Ali	7,726,209	B2	6/2010	Ruotoistenmaki
7,254,433	B2	8/2007	Diab et al.	7,729,733	B2	6/2010	Al-Ali et al.
7,254,434	B2	8/2007	Schulz et al.	7,734,320	B2	6/2010	Al-Ali
D550,364	S	9/2007	Glover et al.	7,761,127	B2	7/2010	Al-Ali et al.
D551,350	S	9/2007	Lorimer et al.	7,761,128	B2	7/2010	Al-Ali et al.
7,272,425	B2	9/2007	Al-Ali	7,764,982	B2	7/2010	Dalke et al.
7,274,955	B2	9/2007	Kiani et al.	D621,516	S	8/2010	Kiani et al.
D553,248	S	10/2007	Nguyen	7,791,155	B2	9/2010	Diab
D554,263	S	10/2007	Al-Ali	7,801,581	B2	9/2010	Diab
7,280,858	B2	10/2007	Al-Ali et al.	7,809,418	B2	10/2010	Xu
7,289,835	B2	10/2007	Mansfield et al.	7,822,452	B2	10/2010	Schurman et al.
7,292,883	B2	11/2007	De Felice et al.	RE41,912	E	11/2010	Parker
7,295,866	B2	11/2007	Al-Ali	7,844,313	B2	11/2010	Kiani et al.
D562,985	S	2/2008	Brefka et al.	7,844,314	B2	11/2010	Al-Ali
7,328,053	B1	2/2008	Diab et al.	7,844,315	B2	11/2010	Al-Ali
7,332,784	B2	2/2008	Mills et al.	7,862,523	B2	1/2011	Ruotoistenmaki
7,340,287	B2	3/2008	Mason et al.	7,865,222	B2	1/2011	Weber et al.
7,341,559	B2	3/2008	Schulz et al.	7,873,497	B2	1/2011	Weber et al.
7,343,186	B2	3/2008	Lamego et al.	7,880,606	B2	2/2011	Al-Ali
D566,282	S	4/2008	Al-Ali et al.	7,880,626	B2	2/2011	Al-Ali et al.
D567,125	S	4/2008	Okabe et al.	7,891,355	B2	2/2011	Al-Ali et al.
7,355,512	B1	4/2008	Al-Ali	7,894,868	B2	2/2011	Al-Ali et al.
7,356,365	B2	4/2008	Schurman	7,899,506	B2	3/2011	Xu et al.
7,365,923	B2	4/2008	Hargis et al.	7,899,507	B2	3/2011	Al-Ali et al.
D569,001	S	5/2008	Omaki	7,899,518	B2	3/2011	Trepagnier et al.
D569,521	S	5/2008	Omaki	7,904,132	B2	3/2011	Weber et al.
7,371,981	B2	5/2008	Abdul-Hafiz	7,909,772	B2	3/2011	Popov et al.
7,373,193	B2	5/2008	Al-Ali et al.	7,910,875	B2	3/2011	Al-Ali
7,373,194	B2	5/2008	Weber et al.	7,919,713	B2	4/2011	Al-Ali et al.
7,376,453	B1	5/2008	Diab et al.	7,937,128	B2	5/2011	Al-Ali
7,377,794	B2	5/2008	Al Ali et al.	7,937,129	B2	5/2011	Mason et al.
7,377,899	B2	5/2008	Weber et al.	7,937,130	B2	5/2011	Diab et al.
7,383,070	B2	6/2008	Diab et al.	7,941,199	B2	5/2011	Kiani
7,395,189	B2	7/2008	Qing et al.	7,951,086	B2	5/2011	Flaherty et al.
7,415,297	B2	8/2008	Al-Ali et al.	7,957,780	B2	6/2011	Lamego et al.
7,428,432	B2	9/2008	Ali et al.	7,962,188	B2	6/2011	Kiani et al.
7,438,683	B2	10/2008	Al-Ali et al.	7,962,190	B1	6/2011	Diab et al.
				7,976,472	B2	7/2011	Kiani
				7,988,637	B2	8/2011	Diab
				7,990,382	B2	8/2011	Kiani
				7,991,446	B2	8/2011	Ali et al.

(56)

References Cited

U.S. PATENT DOCUMENTS

8,000,761	B2	8/2011	Al-Ali	8,457,707	B2	6/2013	Kiani
8,008,088	B2	8/2011	Bellott et al.	8,463,349	B2	6/2013	Diab et al.
RE42,753	E	9/2011	Kiani-Azarbayjany et al.	8,466,286	B2	6/2013	Bellot et al.
8,019,400	B2	9/2011	Diab et al.	8,471,713	B2	6/2013	Poeze et al.
8,028,701	B2	10/2011	Al-Ali et al.	8,473,020	B2	6/2013	Kiani et al.
8,029,765	B2	10/2011	Bellott et al.	8,483,787	B2	7/2013	Al-Ali et al.
8,036,728	B2	10/2011	Diab et al.	8,489,364	B2	7/2013	Weber et al.
8,044,998	B2	10/2011	Heenan	8,498,684	B2	7/2013	Weber et al.
8,046,040	B2	10/2011	Ali et al.	8,504,128	B2	8/2013	Blank et al.
8,046,041	B2	10/2011	Diab et al.	8,509,867	B2	8/2013	Workman et al.
8,046,042	B2	10/2011	Diab et al.	8,515,509	B2	8/2013	Bruinsma et al.
8,048,040	B2	11/2011	Kiani	8,523,781	B2	9/2013	Al-Ali
8,050,728	B2	11/2011	Al-Ali et al.	8,529,301	B2	9/2013	Al-Ali et al.
RE43,169	E	2/2012	Parker	8,532,727	B2	9/2013	Ali et al.
8,118,620	B2	2/2012	Al-Ali et al.	8,532,728	B2	9/2013	Diab et al.
8,126,528	B2	2/2012	Diab et al.	D692,145	S	10/2013	Al-Ali et al.
8,126,531	B2	2/2012	Crowley	8,547,209	B2	10/2013	Kiani et al.
8,128,572	B2	3/2012	Diab et al.	8,548,548	B2	10/2013	Al-Ali
8,130,105	B2	3/2012	Al-Ali et al.	8,548,549	B2	10/2013	Schurman et al.
8,145,287	B2	3/2012	Diab et al.	8,548,550	B2	10/2013	Al-Ali et al.
8,150,487	B2	4/2012	Diab et al.	8,560,032	B2	10/2013	Al-Ali et al.
8,175,672	B2	5/2012	Parker	8,560,034	B1	10/2013	Diab et al.
8,180,420	B2	5/2012	Diab et al.	8,570,167	B2	10/2013	Al-Ali
8,182,443	B1	5/2012	Kiani	8,570,503	B2	10/2013	Vo
8,185,180	B2	5/2012	Diab et al.	8,571,617	B2	10/2013	Reichgott et al.
8,190,223	B2	5/2012	Al-Ali et al.	8,571,618	B1	10/2013	Lamego et al.
8,190,227	B2	5/2012	Diab et al.	8,571,619	B2	10/2013	Al-Ali et al.
8,203,438	B2	6/2012	Kiani et al.	8,577,431	B2	11/2013	Lamego et al.
8,203,704	B2	6/2012	Merritt et al.	8,581,732	B2	11/2013	Al-Ali et al.
8,219,170	B2	7/2012	Hausmann et al.	8,584,345	B2	11/2013	Al-Ali et al.
8,224,411	B2	7/2012	Al-Ali et al.	8,588,880	B2	11/2013	Abdul-Hafiz et al.
8,228,181	B2	7/2012	Al-Ali	8,600,467	B2	12/2013	Al-Ali et al.
8,229,532	B2	7/2012	Davis	8,602,971	B2	12/2013	Farr
8,229,533	B2	7/2012	Diab et al.	8,606,342	B2	12/2013	Diab
8,233,955	B2	7/2012	Al-Ali et al.	8,615,290	B2	12/2013	Lin et al.
8,244,325	B2	8/2012	Al-Ali et al.	8,626,255	B2	1/2014	Al-Ali et al.
8,255,026	B1	8/2012	Al-Ali	8,630,691	B2	1/2014	Lamego et al.
8,255,027	B2	8/2012	Al-Ali et al.	8,634,889	B2	1/2014	Al-Ali et al.
8,255,028	B2	8/2012	Al-Ali et al.	8,641,631	B2	2/2014	Sierra et al.
8,260,577	B2	9/2012	Weber et al.	8,652,060	B2	2/2014	Al-Ali
8,265,723	B1	9/2012	McHale et al.	8,655,004	B2	2/2014	Prest et al.
8,274,360	B2	9/2012	Sampath et al.	8,663,107	B2	3/2014	Kiani
8,289,130	B2	10/2012	Nakajima et al.	8,666,468	B1	3/2014	Al-Ali
8,301,217	B2	10/2012	Al-Ali et al.	8,667,967	B2	3/2014	Al-Ali et al.
8,306,596	B2	11/2012	Schurman et al.	8,670,811	B2	3/2014	O'Reilly
8,310,336	B2	11/2012	Muhsin et al.	8,670,814	B2	3/2014	Diab et al.
8,315,683	B2	11/2012	Al-Ali et al.	8,676,286	B2	3/2014	Weber et al.
RE43,860	E	12/2012	Parker	8,682,407	B2	3/2014	Al-Ali
8,332,006	B2	12/2012	Naganuma et al.	RE44,823	E	4/2014	Parker
8,337,403	B2	12/2012	Al-Ali et al.	RE44,875	E	4/2014	Kiani et al.
8,346,330	B2	1/2013	Lamego	8,688,183	B2	4/2014	Bruinsma et al.
8,353,842	B2	1/2013	Al-Ali et al.	8,690,799	B2	4/2014	Telfort et al.
8,355,766	B2	1/2013	MacNeish, III et al.	8,700,112	B2	4/2014	Kiani
8,359,080	B2	1/2013	Diab et al.	8,702,627	B2	4/2014	Telfort et al.
8,364,223	B2	1/2013	Al-Ali et al.	8,706,179	B2	4/2014	Parker
8,364,226	B2	1/2013	Diab et al.	8,712,494	B1	4/2014	MacNeish, III et al.
8,364,389	B2	1/2013	Dorogusker et al.	8,715,206	B2	5/2014	Telfort et al.
8,374,665	B2	2/2013	Lamego	8,718,735	B2	5/2014	Lamego et al.
8,380,272	B2	2/2013	Barrett et al.	8,718,737	B2	5/2014	Diab et al.
8,385,995	B2	2/2013	Al-Ali et al.	8,718,738	B2	5/2014	Blank et al.
8,385,996	B2	2/2013	Smith et al.	8,720,249	B2	5/2014	Al-Ali
8,388,353	B2	3/2013	Kiani et al.	8,721,541	B2	5/2014	Al-Ali et al.
8,399,822	B2	3/2013	Al-Ali	8,721,542	B2	5/2014	Al-Ali et al.
8,401,602	B2	3/2013	Kiani	8,723,677	B1	5/2014	Kiani
8,405,608	B2	3/2013	Al-Ali et al.	8,740,792	B1	6/2014	Kiani et al.
8,414,499	B2	4/2013	Al-Ali et al.	8,754,776	B2	6/2014	Poeze et al.
8,418,524	B2	4/2013	Al-Ali	8,755,535	B2	6/2014	Telfort et al.
8,421,022	B2	4/2013	Rozenfeld	8,755,856	B2	6/2014	Diab et al.
8,423,106	B2	4/2013	Lamego et al.	8,755,872	B1	6/2014	Marinow
8,428,674	B2	4/2013	Duffy et al.	8,760,517	B2	6/2014	Sarwar et al.
8,428,967	B2	4/2013	Olsen et al.	8,761,850	B2	6/2014	Lamego
8,430,817	B1	4/2013	Al-Ali et al.	8,764,671	B2	7/2014	Kiani
8,437,825	B2	5/2013	Dalvi et al.	8,768,423	B2	7/2014	Shakespeare et al.
8,455,290	B2	6/2013	Siskavich	8,771,204	B2	7/2014	Telfort et al.
8,457,703	B2	6/2013	Al-Ali	8,777,634	B2	7/2014	Kiani et al.
				8,781,543	B2	7/2014	Diab et al.
				8,781,544	B2	7/2014	Al-Ali et al.
				8,781,549	B2	7/2014	Al-Ali et al.
				8,788,003	B2	7/2014	Schurman et al.

(56)

References Cited

U.S. PATENT DOCUMENTS

8,790,268	B2	7/2014	Al-Ali	9,241,662	B2	1/2016	Al-Ali et al.
8,801,613	B2	8/2014	Al-Ali et al.	9,245,668	B1	1/2016	Vo et al.
8,821,397	B2	9/2014	Al-Ali et al.	9,259,185	B2	2/2016	Abdul-Hafiz et al.
8,821,415	B2	9/2014	Al-Ali et al.	9,267,572	B2	2/2016	Barker et al.
8,830,449	B1	9/2014	Lamego et al.	9,277,880	B2	3/2016	Poeze et al.
8,831,700	B2	9/2014	Schurman et al.	9,289,167	B2	3/2016	Diab et al.
8,840,549	B2	9/2014	Al-Ali et al.	9,295,421	B2	3/2016	Kiani et al.
8,847,740	B2	9/2014	Kiani et al.	9,307,928	B1	4/2016	Al-Ali et al.
8,849,365	B2	9/2014	Smith et al.	9,311,382	B2	4/2016	Varoglu et al.
8,852,094	B2	10/2014	Al-Ali et al.	9,323,894	B2	4/2016	Kiani
8,852,994	B2	10/2014	Wojtczuk et al.	D755,392	S	5/2016	Hwang et al.
8,868,147	B2	10/2014	Stippick et al.	9,326,712	B1	5/2016	Kiani
8,868,150	B2	10/2014	Al-Ali et al.	9,333,316	B2	5/2016	Kiani
8,870,792	B2	10/2014	Al-Ali et al.	9,339,220	B2	5/2016	Lamego et al.
8,886,271	B2	11/2014	Kiani et al.	9,341,565	B2	5/2016	Lamego et al.
8,888,539	B2	11/2014	Al-Ali et al.	9,351,673	B2	5/2016	Diab et al.
8,888,708	B2	11/2014	Diab et al.	9,351,675	B2	5/2016	Al-Ali et al.
8,892,180	B2	11/2014	Weber et al.	9,357,665	B2	5/2016	Myers et al.
8,897,847	B2	11/2014	Al-Ali	9,364,181	B2	6/2016	Kiani et al.
8,909,310	B2	12/2014	Lamego et al.	9,368,671	B2	6/2016	Wojtczuk et al.
8,911,377	B2	12/2014	Al-Ali	9,370,325	B2	6/2016	Al-Ali et al.
8,912,909	B2	12/2014	Al-Ali et al.	9,370,326	B2	6/2016	McHale et al.
8,920,317	B2	12/2014	Al-Ali et al.	9,370,335	B2	6/2016	Al-Ali et al.
8,921,699	B2	12/2014	Al-Ali et al.	9,375,185	B2	6/2016	Ali et al.
8,922,382	B2	12/2014	Al-Ali et al.	9,386,953	B2	7/2016	Al-Ali
8,929,964	B2	1/2015	Al-Ali et al.	9,386,961	B2	7/2016	Al-Ali et al.
8,942,777	B2	1/2015	Diab et al.	9,392,945	B2	7/2016	Al-Ali et al.
8,948,834	B2	2/2015	Diab et al.	9,397,448	B2	7/2016	Al-Ali et al.
8,948,835	B2	2/2015	Diab	9,489,081	B2	11/2016	Anzures et al.
8,965,471	B2	2/2015	Lamego	9,497,534	B2	11/2016	Prest et al.
8,983,564	B2	3/2015	Al-Ali	9,526,430	B2	12/2016	Srinivas et al.
8,989,831	B2	3/2015	Al-Ali et al.	9,553,625	B2	1/2017	Hatanaka et al.
8,996,085	B2	3/2015	Kiani et al.	9,591,975	B2	3/2017	Dalvi et al.
8,998,809	B2	4/2015	Kiani	9,593,969	B2	3/2017	King
9,028,429	B2	5/2015	Telfort et al.	9,651,405	B1	5/2017	Gowreesunker et al.
9,037,207	B2	5/2015	Al-Ali et al.	9,668,676	B2	6/2017	Culbert
9,060,721	B2	6/2015	Reichgott et al.	9,668,680	B2	6/2017	Bruinsma et al.
9,066,666	B2	6/2015	Kiani	9,699,546	B2	7/2017	Qian et al.
9,066,680	B1	6/2015	Al-Ali et al.	9,716,937	B2	7/2017	Qian et al.
9,072,437	B2	7/2015	Paalasmaa	9,717,425	B2	8/2017	Kiani et al.
9,072,474	B2	7/2015	Al-Ali et al.	9,723,997	B1	8/2017	Lamego
9,078,560	B2	7/2015	Schurman et al.	9,781,984	B2	10/2017	Baranski et al.
9,081,889	B2	7/2015	Ingrassia, Jr. et al.	9,838,775	B2	12/2017	Qian et al.
9,084,569	B2	7/2015	Weber et al.	9,848,823	B2	12/2017	Raghuram et al.
9,095,316	B2	8/2015	Welch et al.	9,866,671	B1	1/2018	Thompson et al.
9,106,038	B2	8/2015	Telfort et al.	9,867,575	B2	1/2018	Maani et al.
9,107,625	B2	8/2015	Telfort et al.	9,898,049	B2	2/2018	Myers et al.
9,107,626	B2	8/2015	Al-Ali et al.	9,918,646	B2	3/2018	Singh Alvarado et al.
9,113,831	B2	8/2015	Al-Ali	9,952,095	B1	4/2018	Hotelling et al.
9,113,832	B2	8/2015	Al-Ali	10,039,080	B2	7/2018	Miller et al.
9,119,595	B2	9/2015	Lamego	10,055,121	B2	8/2018	Chaudhri et al.
9,131,881	B2	9/2015	Diab et al.	10,066,970	B2	9/2018	Gowreesunker et al.
9,131,882	B2	9/2015	Al-Ali et al.	10,076,257	B2	9/2018	Lin et al.
9,131,883	B2	9/2015	Al-Ali	10,078,052	B2	9/2018	Ness et al.
9,131,917	B2	9/2015	Telfort et al.	2002/0099279	A1	7/2002	Pfeiffer et al.
9,138,180	B1	9/2015	Coverston et al.	2006/0005944	A1	1/2006	Wang et al.
9,138,182	B2	9/2015	Al-Ali et al.	2006/0025659	A1	2/2006	Kiguchi et al.
9,138,192	B2	9/2015	Weber et al.	2006/0076473	A1	4/2006	Wilcken et al.
9,142,117	B2	9/2015	Muhsin et al.	2007/0149864	A1	6/2007	Laakkonen
9,153,112	B1	10/2015	Kiani et al.	2007/0238955	A1	10/2007	Tearney et al.
9,153,121	B2	10/2015	Kiani et al.	2007/0293792	A1	12/2007	Sliwa et al.
9,161,696	B2	10/2015	Al-Ali et al.	2008/0130232	A1	6/2008	Yamamoto
9,161,713	B2	10/2015	Al-Ali et al.	2008/0139908	A1	6/2008	Kurth
9,167,995	B2	10/2015	Lamego et al.	2009/0030327	A1	1/2009	Chance
9,176,141	B2	11/2015	Al-Ali et al.	2009/0043180	A1	2/2009	Tschautscher et al.
9,186,102	B2	11/2015	Bruinsma et al.	2009/0129102	A1	5/2009	Xiao et al.
9,192,312	B2	11/2015	Al-Ali	2009/0247984	A1	10/2009	Lamego et al.
9,192,329	B2	11/2015	Al-Ali	2009/0259114	A1	10/2009	Johnson et al.
9,192,351	B1	11/2015	Telfort et al.	2009/0275844	A1	11/2009	Al-Ali
9,195,385	B2	11/2015	Al-Ali et al.	2009/0306487	A1	12/2009	Crowe et al.
9,210,566	B2	12/2015	Ziemianska et al.	2010/0004518	A1	1/2010	Vo et al.
9,211,072	B2	12/2015	Kiani	2010/0030040	A1	2/2010	Poeze et al.
9,211,095	B1	12/2015	Al-Ali	2010/0217102	A1	8/2010	LeBoeuf et al.
9,218,454	B2	12/2015	Kiani et al.	2011/0001605	A1	1/2011	Kiani et al.
9,226,696	B2	1/2016	Kiani	2011/0004082	A1	1/2011	Poeze et al.
				2011/0082711	A1	4/2011	Poeze et al.
				2011/0105854	A1	5/2011	Kiani et al.
				2011/0105865	A1	5/2011	Yu et al.
				2011/0208015	A1	8/2011	Welch et al.

(56)		References Cited					
		U.S. PATENT DOCUMENTS					
2011/0213212	A1	9/2011	Al-Ali	2014/0333440	A1	11/2014	Kiani
2011/0230733	A1	9/2011	Al-Ali	2014/0336481	A1	11/2014	Shakespeare et al.
2011/0237911	A1	9/2011	Lamego et al.	2014/0343436	A1	11/2014	Kiani
2012/0059267	A1	3/2012	Lamego et al.	2015/0018650	A1	1/2015	Al-Ali et al.
2012/0179006	A1	7/2012	Jansen et al.	2015/0173671	A1	6/2015	Paalasmaa et al.
2012/0209082	A1	8/2012	Al-Ali	2015/0255001	A1	9/2015	Haughav et al.
2012/0209084	A1	8/2012	Olsen et al.	2015/0281424	A1	10/2015	Vock et al.
2012/0227739	A1	9/2012	Kiani	2015/0318100	A1	11/2015	Rothkopf et al.
2012/0283524	A1	11/2012	Kiani et al.	2015/0351697	A1	12/2015	Weber et al.
2012/0296178	A1	11/2012	Lamego et al.	2015/0351704	A1	12/2015	Kiani et al.
2012/0319816	A1	12/2012	Al-Ali	2015/0359429	A1	12/2015	Al-Ali et al.
2012/0330112	A1	12/2012	Lamego et al.	2015/0366472	A1	12/2015	Kiani
2013/0023775	A1	1/2013	Lamego et al.	2015/0366507	A1	12/2015	Blank
2013/0041591	A1	2/2013	Lamego	2015/0374298	A1	12/2015	Al-Ali et al.
2013/0045685	A1	2/2013	Kiani	2015/0380875	A1	12/2015	Coverston et al.
2013/0046204	A1	2/2013	Lamego et al.	2016/0000362	A1	1/2016	Diab et al.
2013/0060147	A1	3/2013	Welch et al.	2016/0007930	A1	1/2016	Weber et al.
2013/0096405	A1	4/2013	Garfio	2016/0019360	A1	1/2016	Pahwa et al.
2013/0096936	A1	4/2013	Sampath et al.	2016/0023245	A1	1/2016	Zadesky et al.
2013/0190581	A1	7/2013	Al-Ali et al.	2016/0029932	A1	2/2016	Al-Ali
2013/0197328	A1	8/2013	Diab et al.	2016/0029933	A1	2/2016	Al-Ali et al.
2013/0211214	A1	8/2013	Olsen	2016/0038045	A1	2/2016	Shapiro
2013/0243021	A1	9/2013	Siskavich	2016/0045118	A1	2/2016	Kiani
2013/0253334	A1	9/2013	Al-Ali et al.	2016/0051157	A1	2/2016	Waydo
2013/0296672	A1	11/2013	O'Neil et al.	2016/0051158	A1	2/2016	Silva
2013/0317370	A1	11/2013	Dalvi et al.	2016/0051205	A1	2/2016	Al-Ali et al.
2013/0324808	A1	12/2013	Al-Ali et al.	2016/0058302	A1	3/2016	Raghuram et al.
2013/0331670	A1	12/2013	Kiani	2016/0058309	A1	3/2016	Han
2013/0338461	A1	12/2013	Lamego et al.	2016/0058312	A1	3/2016	Han et al.
2014/0012100	A1	1/2014	Al-Ali et al.	2016/0058338	A1	3/2016	Schurman et al.
2014/0034353	A1	2/2014	Al-Ali et al.	2016/0058347	A1	3/2016	Reichgott et al.
2014/0051953	A1	2/2014	Lamego et al.	2016/0058356	A1	3/2016	Raghuram et al.
2014/0058230	A1	2/2014	Abdul-Hafiz et al.	2016/0058370	A1	3/2016	Raghuram et al.
2014/0066783	A1	3/2014	Kiani et al.	2016/0066823	A1	3/2016	Al-Ali et al.
2014/0077956	A1	3/2014	Sampath et al.	2016/0066824	A1	3/2016	Al-Ali et al.
2014/0081100	A1	3/2014	Muhsin et al.	2016/0066879	A1	3/2016	Telfort et al.
2014/0081175	A1	3/2014	Telfort	2016/0071392	A1	3/2016	Hankey et al.
2014/0094667	A1	4/2014	Schurman et al.	2016/0072429	A1	3/2016	Kiani et al.
2014/0100434	A1	4/2014	Diab et al.	2016/0073967	A1	3/2016	Lamego et al.
2014/0114199	A1	4/2014	Lamego et al.	2016/0081552	A1	3/2016	Wojtczuk et al.
2014/0120564	A1	5/2014	Workman et al.	2016/0095543	A1	4/2016	Telfort et al.
2014/0121482	A1	5/2014	Merritt et al.	2016/0095548	A1	4/2016	Al-Ali et al.
2014/0121483	A1	5/2014	Kiani	2016/0103598	A1	4/2016	Al-Ali et al.
2014/0127137	A1	5/2014	Bellott et al.	2016/0113527	A1	4/2016	Al-Ali et al.
2014/0129702	A1	5/2014	Lamego et al.	2016/0143548	A1	5/2016	Al-Ali
2014/0135588	A1	5/2014	Al-Ali et al.	2016/0154950	A1	6/2016	Nakajima et al.
2014/0142401	A1	5/2014	Al-Ali et al.	2016/0157780	A1	6/2016	Rimminen et al.
2014/0155712	A1	6/2014	Lamego et al.	2016/0166183	A1	6/2016	Poeze et al.
2014/0163344	A1	6/2014	Al-Ali	2016/0166210	A1	6/2016	Al-Ali
2014/0163402	A1	6/2014	Lamego et al.	2016/0192869	A1	7/2016	Kiani et al.
2014/0166076	A1	6/2014	Kiani et al.	2016/0196388	A1	7/2016	Lamego
2014/0171146	A1	6/2014	Ma et al.	2016/0197436	A1	7/2016	Barker et al.
2014/0171763	A1	6/2014	Diab	2016/0213281	A1	7/2016	Eckerbom et al.
2014/0180038	A1	6/2014	Kiani	2016/0213309	A1	7/2016	Sannholm et al.
2014/0180154	A1	6/2014	Sierra et al.	2016/0256058	A1	9/2016	Pham et al.
2014/0194709	A1	7/2014	Al-Ali et al.	2016/0256082	A1	9/2016	Ely et al.
2014/0194711	A1	7/2014	Al-Ali	2016/0267238	A1	9/2016	Nag
2014/0194766	A1	7/2014	Al-Ali et al.	2016/0287181	A1	10/2016	Han et al.
2014/0206963	A1	7/2014	Al-Ali	2016/0296173	A1	10/2016	Culbert
2014/0213864	A1	7/2014	Abdul-Hafiz et al.	2016/0296174	A1	10/2016	Isikman et al.
2014/0243627	A1	8/2014	Diab et al.	2016/0310027	A1	10/2016	Han
2014/0266790	A1	9/2014	Al-Ali et al.	2016/0378069	A1	12/2016	Rothkopf
2014/0275808	A1	9/2014	Poeze et al.	2016/0378071	A1	12/2016	Rothkopf
2014/0275835	A1	9/2014	Lamego et al.	2017/0007183	A1	1/2017	Dusan et al.
2014/0275871	A1	9/2014	Lamego et al.	2017/0010858	A1	1/2017	Prest et al.
2014/0275872	A1	9/2014	Merritt et al.	2017/0074897	A1	3/2017	Mermel et al.
2014/0275881	A1	9/2014	Lamego et al.	2017/0084133	A1	3/2017	Cardinali et al.
2014/0288400	A1	9/2014	Diab et al.	2017/0086689	A1	3/2017	Shui et al.
2014/0296664	A1	10/2014	Bruinsma et al.	2017/0086742	A1	3/2017	Harrison-Noonan et al.
2014/0303520	A1	10/2014	Telfort et al.	2017/0086743	A1	3/2017	Bushnell et al.
2014/0316228	A1	10/2014	Blank et al.	2017/0094450	A1	3/2017	Tu et al.
2014/0323825	A1	10/2014	Al-Ali et al.	2017/0164884	A1	6/2017	Culbert et al.
2014/0330092	A1	11/2014	Al-Ali et al.	2017/0248446	A1	8/2017	Gowreesunker et al.
2014/0330098	A1	11/2014	Merritt et al.	2017/0273619	A1	9/2017	Alvarado et al.
2014/0330099	A1	11/2014	Al-Ali et al.	2017/0281024	A1	10/2017	Narasimhan et al.
				2017/0293727	A1	10/2017	Klaassen et al.
				2017/0325698	A1	11/2017	Allec et al.
				2017/0325744	A1	11/2017	Allec et al.
				2017/0340209	A1	11/2017	Klaassen et al.

(56)

References Cited

U.S. PATENT DOCUMENTS

2017/0340219 A1 11/2017 Sullivan et al.
 2017/0347885 A1 12/2017 Tan et al.
 2017/0354332 A1 12/2017 Lamego
 2017/0354795 A1 12/2017 Blahnik et al.
 2017/0358239 A1 12/2017 Arney et al.
 2017/0358240 A1 12/2017 Blahnik et al.
 2017/0358242 A1 12/2017 Thompson et al.
 2017/0360306 A1 12/2017 Narasimhan et al.
 2017/0366657 A1 12/2017 Thompson et al.
 2018/0014781 A1 1/2018 Clavelle et al.
 2018/0025287 A1 1/2018 Mathew et al.
 2018/0042556 A1 2/2018 Shahparnia et al.
 2018/0049694 A1 2/2018 Singh Alvarado et al.
 2018/0050235 A1 2/2018 Tan et al.
 2018/0055375 A1 3/2018 Martinez et al.
 2018/0055390 A1 3/2018 Kiani
 2018/0055439 A1 3/2018 Pham et al.
 2018/0056129 A1 3/2018 Narasimha Rao et al.
 2018/0078151 A1 3/2018 Allec et al.
 2018/0078182 A1 3/2018 Chen et al.
 2018/0110469 A1 4/2018 Maani et al.
 2018/0153418 A1 6/2018 Sullivan et al.
 2018/0164853 A1 6/2018 Myers et al.
 2018/0196514 A1 7/2018 Allec et al.
 2018/0228414 A1 8/2018 Shao et al.
 2018/0238734 A1 8/2018 Hotelling et al.
 2018/0279956 A1 10/2018 Waydo et al.

FOREIGN PATENT DOCUMENTS

JP 05-325705 A 12/1993
 JP 08-185864 7/1996
 JP 2001-66990 3/2001
 JP 2001-087250 A 4/2001
 JP 2002-500908 A 1/2002
 JP 2003-024276 A 1/2003
 JP 2003-508104 A 3/2003
 JP 2003-265444 A 9/2003
 JP 2006-177837 A 7/2006
 JP 2006-198321 A 8/2006
 JP 2007-389463 A 11/2007
 JP 2008-099222 A 4/2008
 JP 5756752 6/2015
 WO WO 1993/12712 7/1993
 WO WO 1999/000053 1/1999
 WO WO 1999/01704 7/1999
 WO WO 2000/25112 5/2000
 WO WO 2001/09589 2/2001
 WO WO 2010/003134 1/2010
 WO WO 2014/149781 9/2014
 WO WO 2014/158820 10/2014

OTHER PUBLICATIONS

U.S. Appl. No. 12/534,827, Multi-Stream Data Collection System for Noninvasive Measurement of Blood Constituents, filed Aug. 3, 2009.

U.S. Appl. No. 14/981,290, Multi-Stream Data Collection System for Noninvasive Measurement of Blood Constituents, filed Dec. 28, 2015.

U.S. Appl. No. 16/212,537, Multi-Stream Data Collection System for Noninvasive Measurement of Blood Constituents, filed Dec. 6, 2018.

U.S. Appl. No. 14/064,055, Multi-Stream Sensor for Noninvasive Measurement of Blood Constituents, filed Oct. 25, 2013.

U.S. Appl. No. 15/660,743, Noise Shielding for a Noninvasive Device, filed Jul. 26, 2017.

U.S. Appl. No. 12/497,506, Heat Sink for Noninvasive Medical Sensor, filed Jul. 2, 2009.

PCT International Search Report, App. No. PCT/US2010/047899, Date of Actual Completion of Search: Jan. 26, 2011, 4 pages.

International Search Report and Written Opinion for PCT/US2009/049638, dated Jan. 7, 2010.

International Search Report issued in Application No. PCT/US2009/052756, dated Feb. 10, 2009 in 14 pages.

International Preliminary Report on Patentability and Written Opinion of the International Searching Authority issued in Application No. PCT/US2009/049638, dated Jan. 5, 2011 in 9 pages.

International Preliminary Report on Patentability and Written Opinion of the International Searching Authority issued in Application No. PCT/US2009/052756, dated Feb. 8, 2011 in 8 pages.

Burritt, Mary F.; Current Analytical Approaches to Measuring Blood Analytes; vol. 36; No. 8(B); 1990.

Hall, et al., Jeffrey W.; Near-Infrared Spectrophotometry: A New Dimension in Clinical Chemistry; vol. 38; No. 9; 1992.

Kuenstner, et al., J. Todd; Measurement of Hemoglobin in Unlysed Blood by Near-Infrared Spectroscopy; vol. 48; No. 4, 1994.

Manzke, et al., B., Multi Wavelength Pulse Oximetry in the Measurement of Hemoglobin Fractions; SPIE, vol. 2676, Apr. 24, 1996.

Naumenko, E. K.; Choice of Wavelengths for Stable Determination of Concentrations of Hemoglobin Derivatives from Absorption Spectra of Erythrocytes; vol. 63; No. 1; pp. 60-66 Jan.-Feb. 1996; Original article submitted Nov. 3, 1994.

Schmitt, Joseph M.; Simple Photon Diffusion Analysis of the Effects of Multiple Scattering on Pulse Oximetry; Mar. 14, 1991; revised Aug. 30, 1991.

Schmitt, et al., Joseph M.; Measurement of Blood Hematocrit by Dual-Wavelength near-IR Photoplethysmography; vol. 1641; 1992.

Schnapp, et al., L.M.; Pulse Oximetry. Uses and Abuses.; Chest 1990; 98; 1244-1250 DOI 10.1378/Chest.98.5.1244.

<http://www.masimo.com/rainbow/pronto.htm> Noninvasive & Immediate Hemoglobin Testing, printed on Aug. 20, 2009.

<http://www.masimo.com/pulseOximeter/Rad5.htm>; Signal Extraction Pulse Oximeter, printed on Aug. 20, 2009.

http://blogderoliveira.blogspot.com/2008_02_01_archive.html; Ricardo Oliveira, printed on Aug. 20, 2009.

<http://www.masimo.com/rad-57/>; Noninvasive Measurement of Methemoglobin, Carboxyhemoglobin and Oxyhemoglobin in the blood. Printed on Aug. 20, 2009.

<http://amivital.ugr.es/blog/?tag+spo2>; Monitorizacion de la hemoglobina . . . y mucho mas, printed on Aug. 20, 2009.

<http://www.masimo.com/spco/>; Carboxyhemoglobin Noninvasive > Continuous > Immediate, printed on Aug. 20, 2009.

<http://www.masimo.com/PARTNERS/WELCHALLYN.htm>; Welch Allyn Expands Patient Monitor Capabilities with Masimo Pulse Oximetry Technology, printed on Aug. 20, 2009.

<http://www.masimo.com/pulseOximeter/PPO.htm>; Masimo Personal Pulse Oximeter, printed on Aug. 20, 2009.

<http://www.masimo.com/generalFloor/system.htm>; Masimo Patient SafetyNet System at a Glance, printed on Aug. 20, 2009.

<http://www.masimo.com/partners/GRASEBY.htm>; Graseby Medical Limited, printed on Aug. 20, 2009.

Japanese Office Action, re JP Application No. 2011-516895, dated Sep. 2, 2014, with translation.

Japanese Notice of Allowance, re JP Application No. 2011-516895, dated May 12, 2015, no translation.

European Office Action issued in application No. 10763901.5 dated Jan. 11, 2013.

European Office Action issued in application No. 10763901.5 dated Aug. 27, 2014.

European Office Action issued in application No. 10763901.5 dated Aug. 6, 2015.

European Office Action issued in Application No. 09791157.2, dated Jun. 20, 2016.

Kanukurthy et al., "Data Acquisition Unit for an Implantable Multi-Channel Optical Glucose Sensor", Electro/Information Technology Conference, Chicago, IL, USA, May 17-20, 2007, pp. 1-6.

Smith, "The Pursuit of Noninvasive Glucose: 'Hunting the Deceitful Turkey'", 2006.

Small et al., "Data Handling Issues for Near-Infrared Glucose Measurements", <http://www.ieee.org/organizations/pubs/newsletters/leos/apr98/datahandling.htm>, accessed Nov. 27, 2007.

* cited by examiner

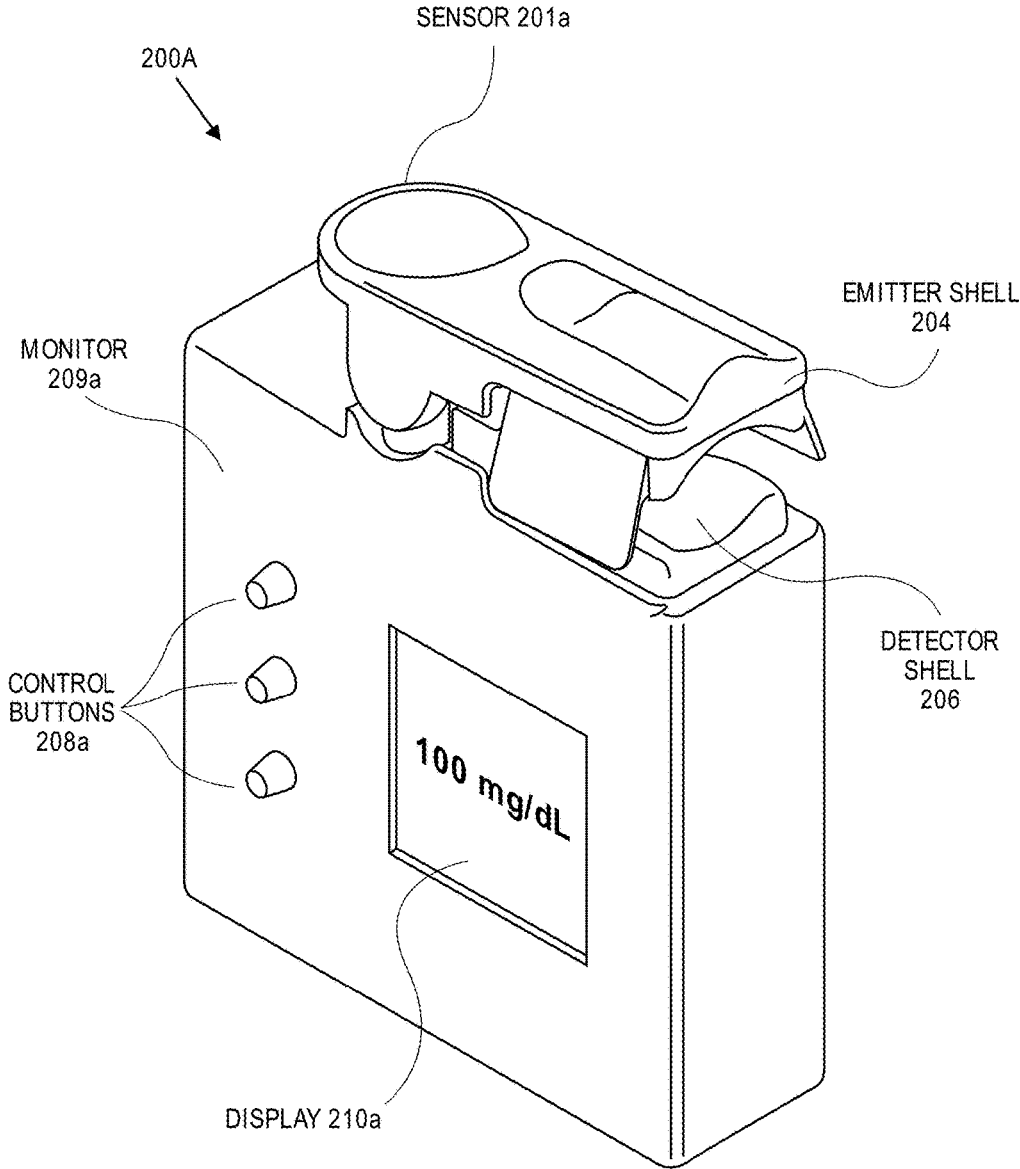

FIG. 2A

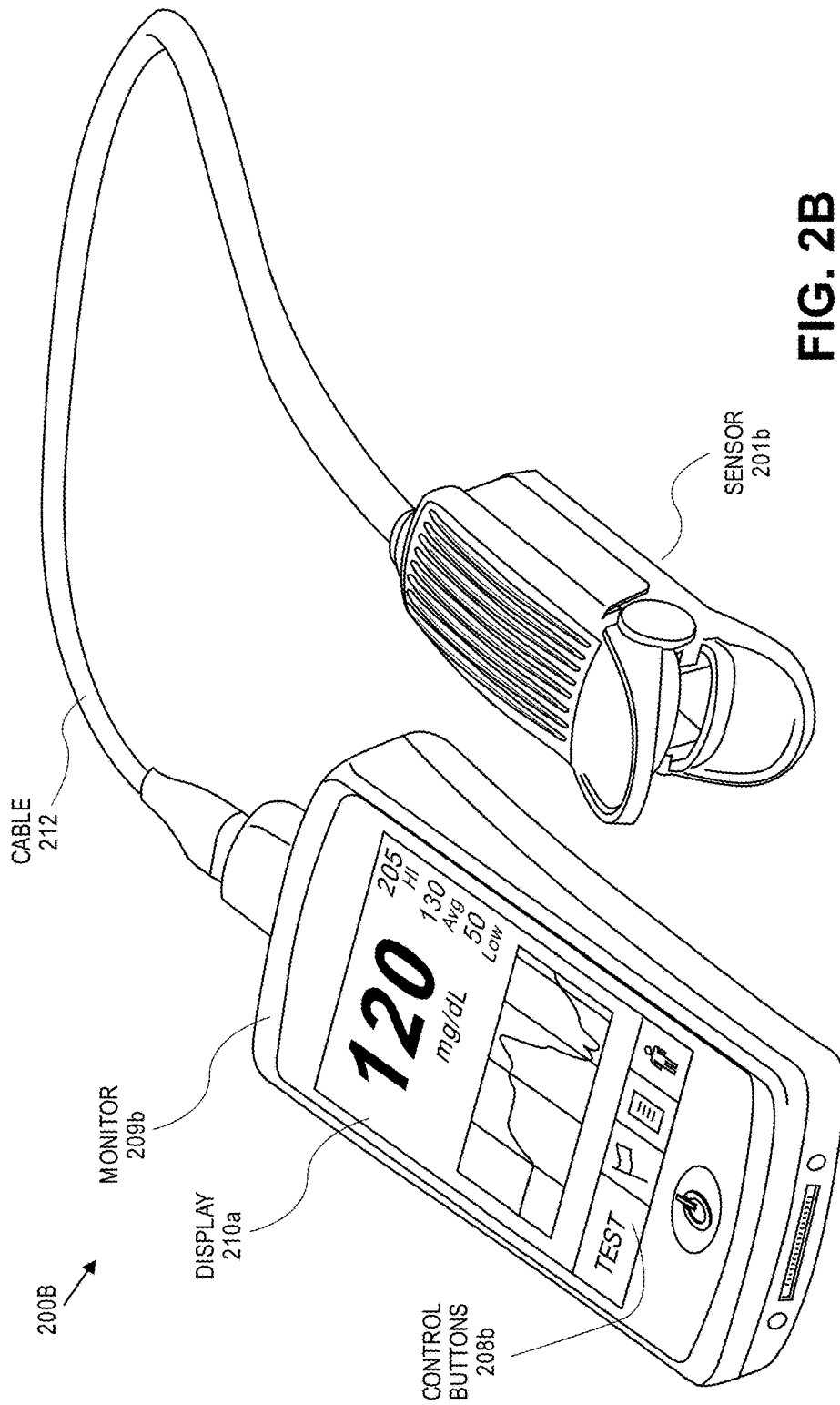

FIG. 2B

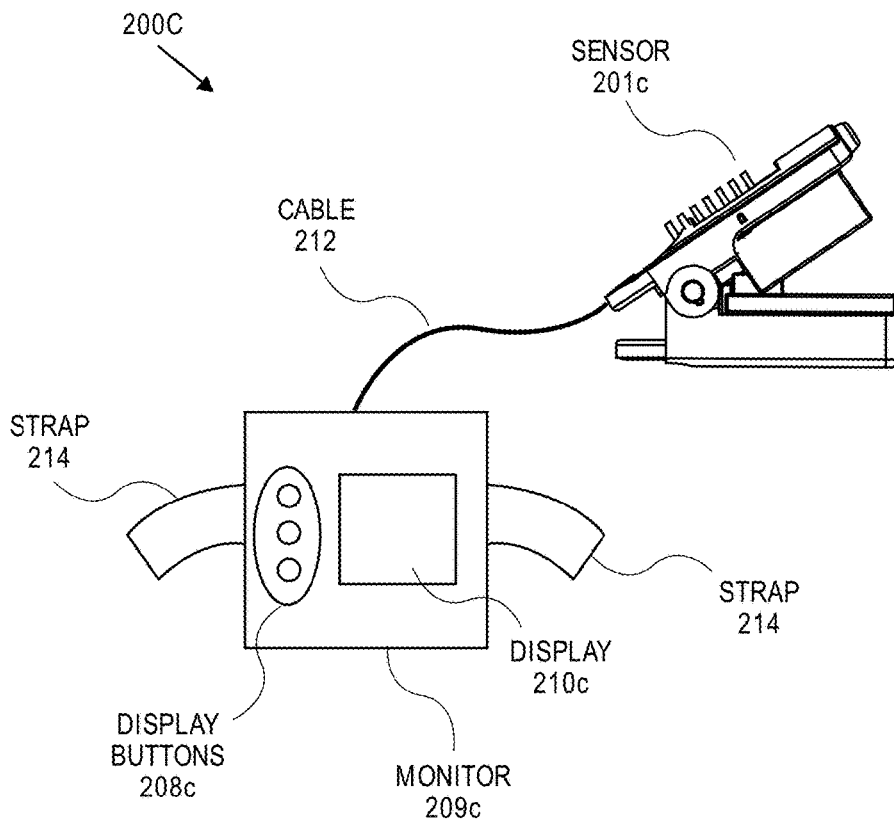

FIG. 2C

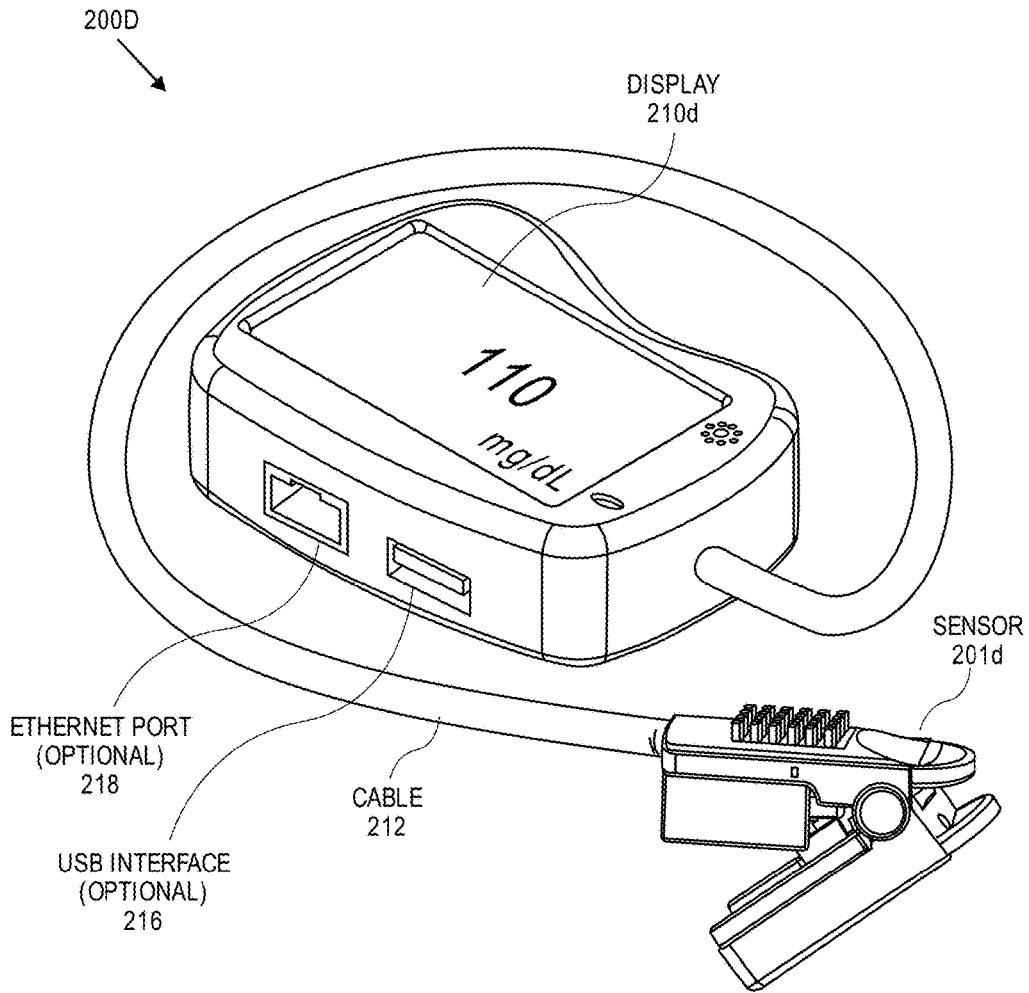

FIG. 2D

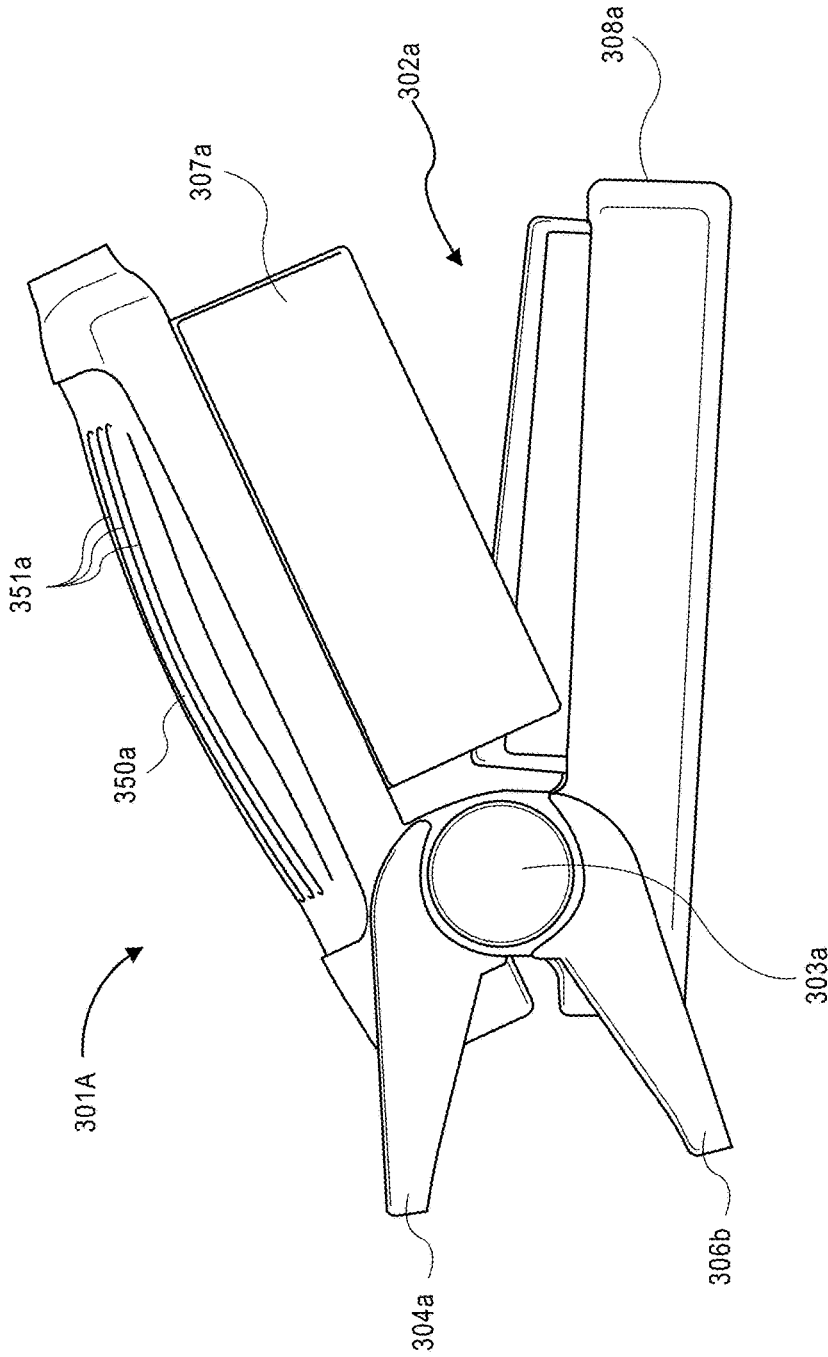

FIG. 3A

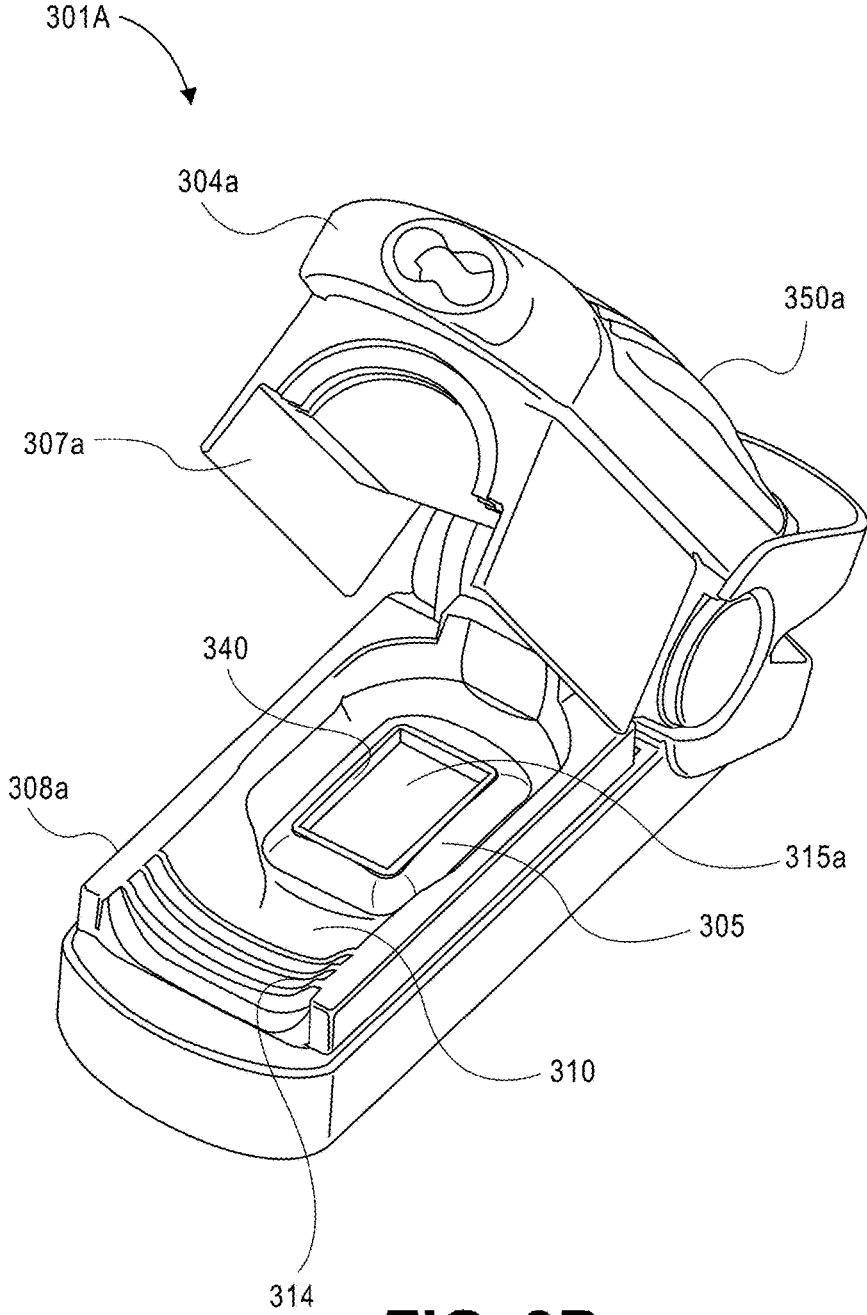

FIG. 3B

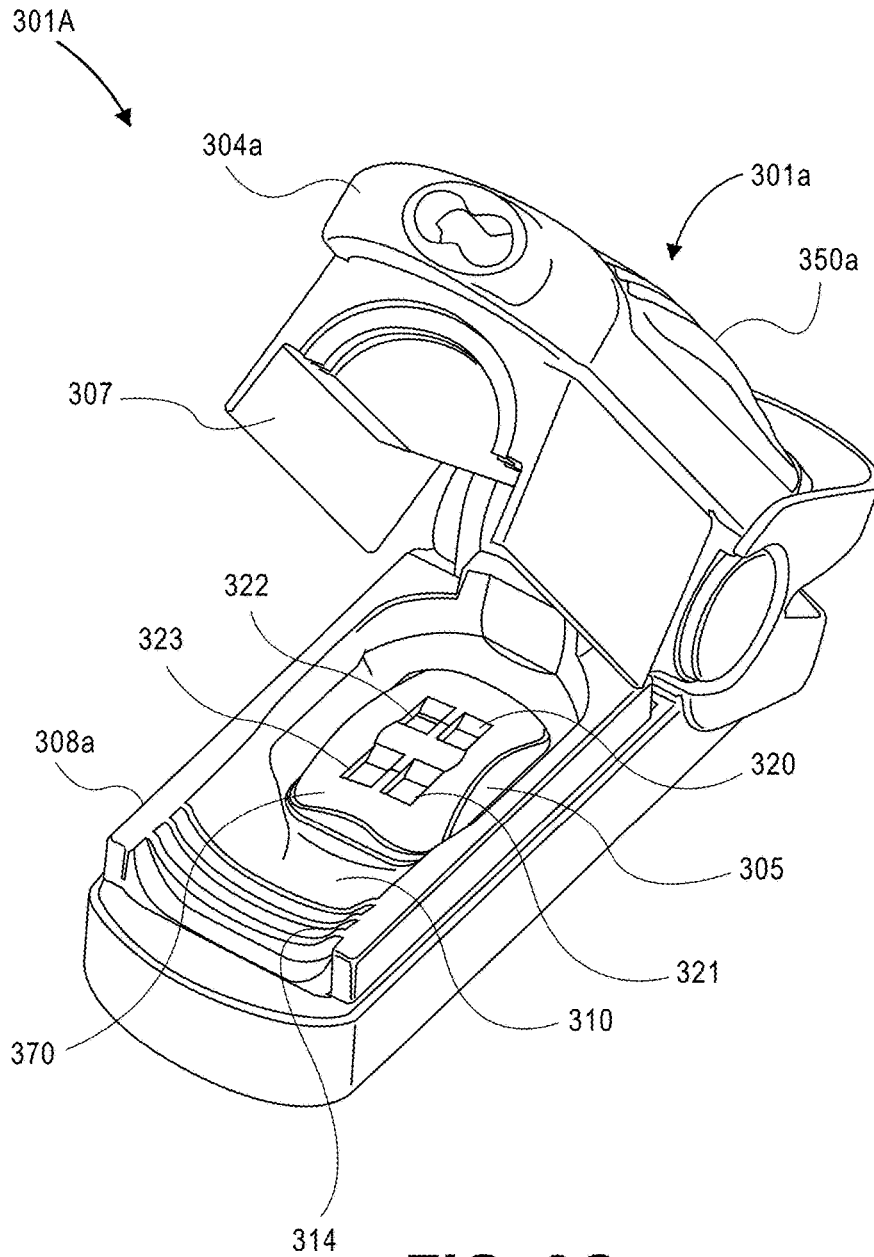

FIG. 3C

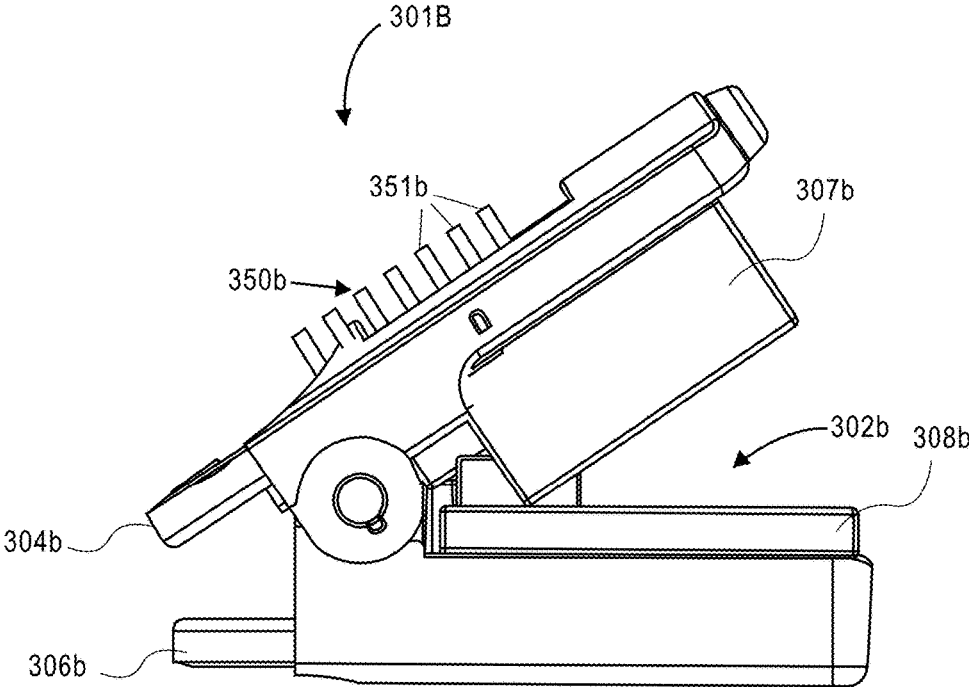

FIG. 3D

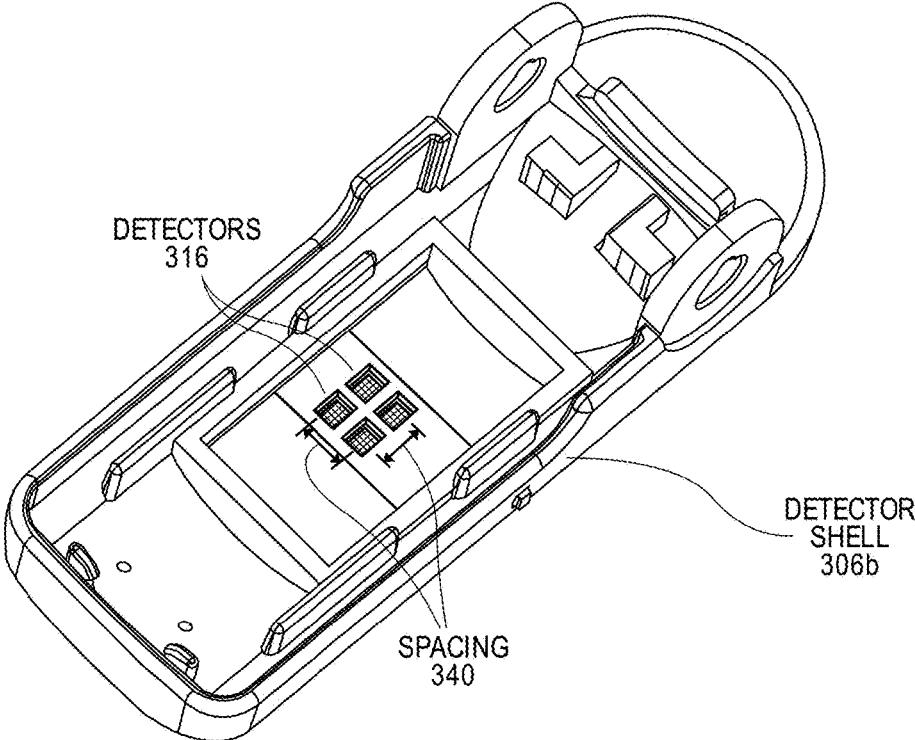

FIG. 3E

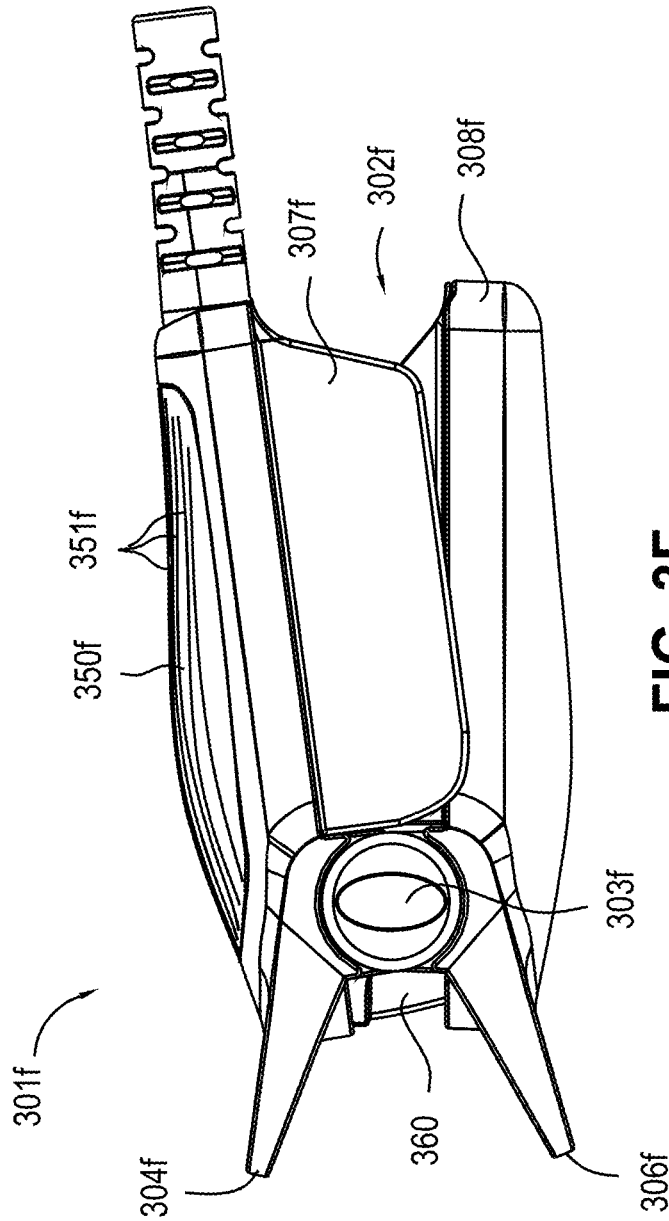

FIG. 3F

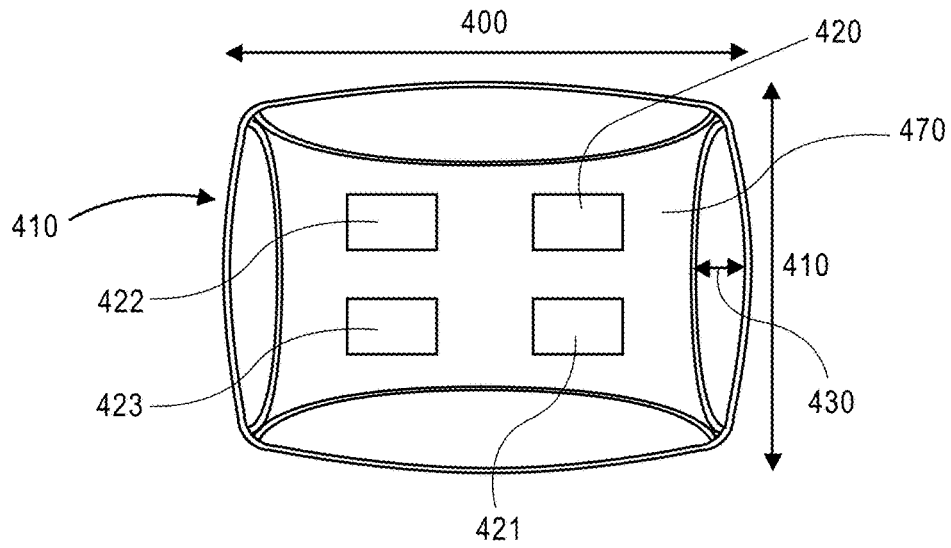

FIG. 4A

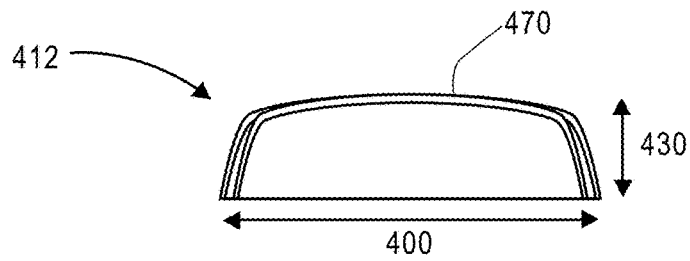

FIG. 4B

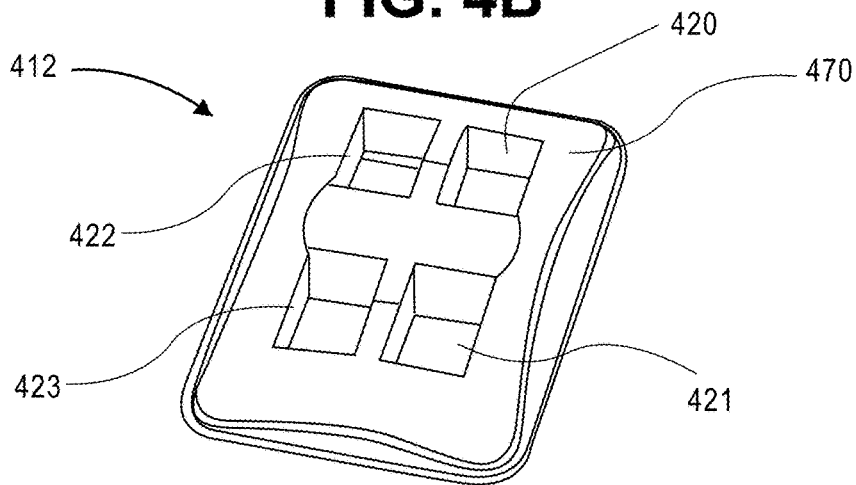

FIG. 4C

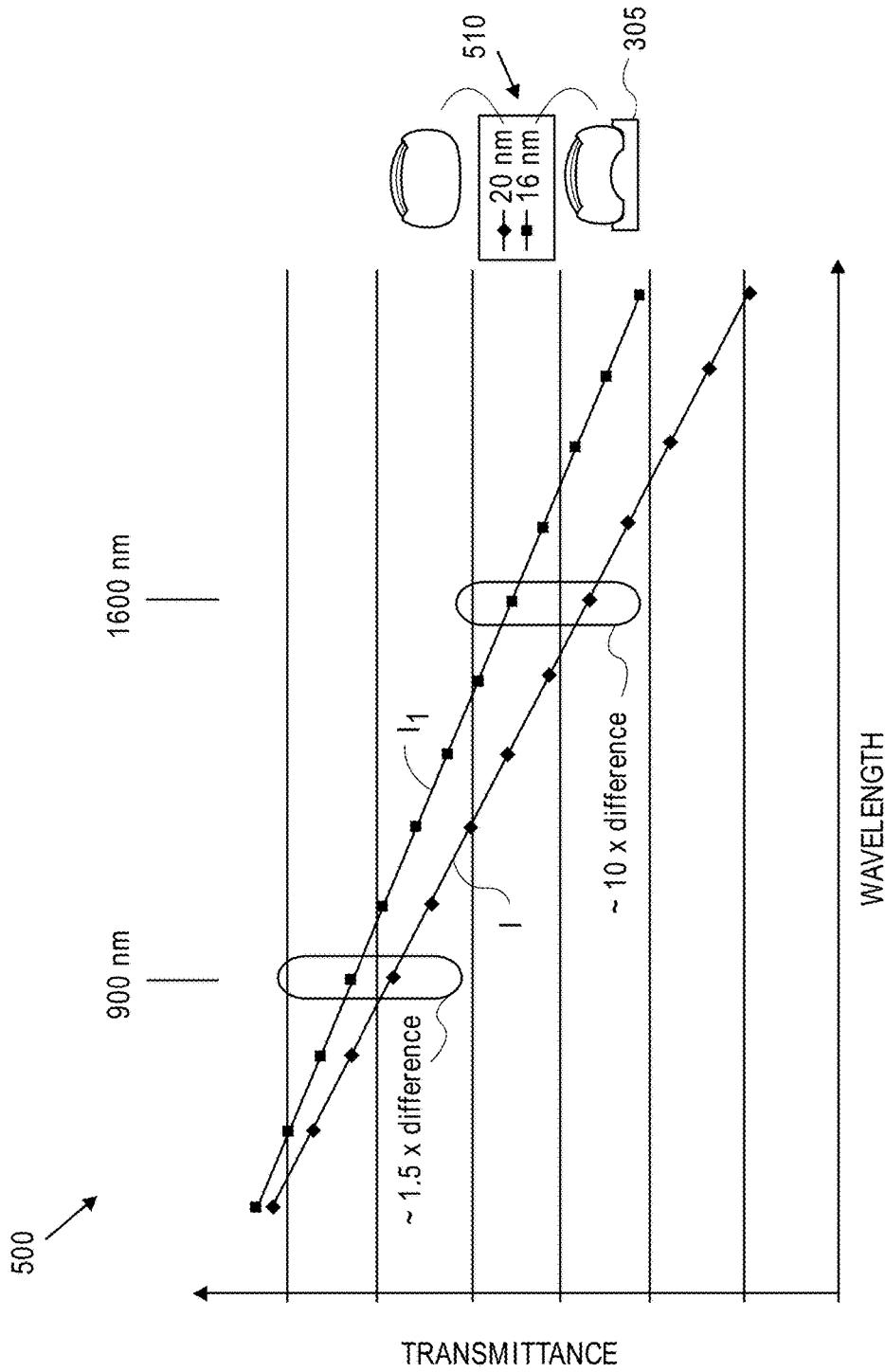

FIG. 5

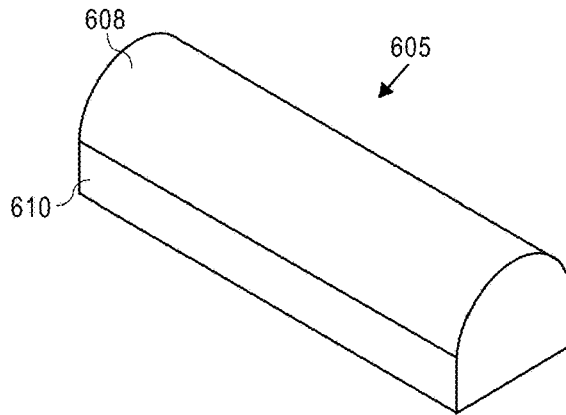

FIG. 6A

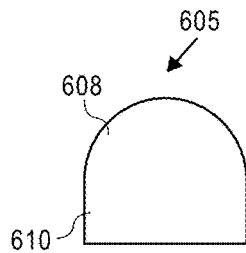

FIG. 6B

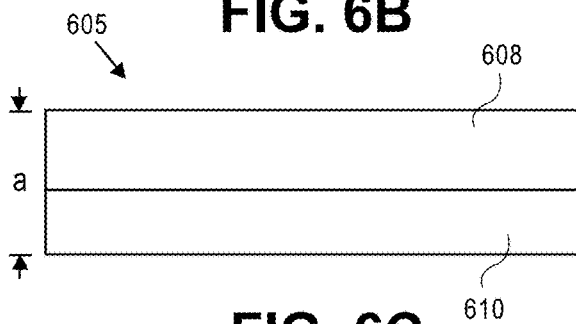

FIG. 6C

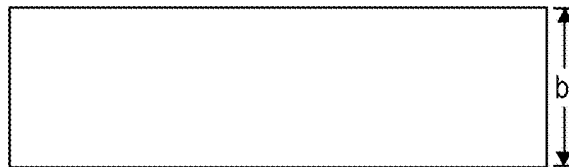

FIG. 6D

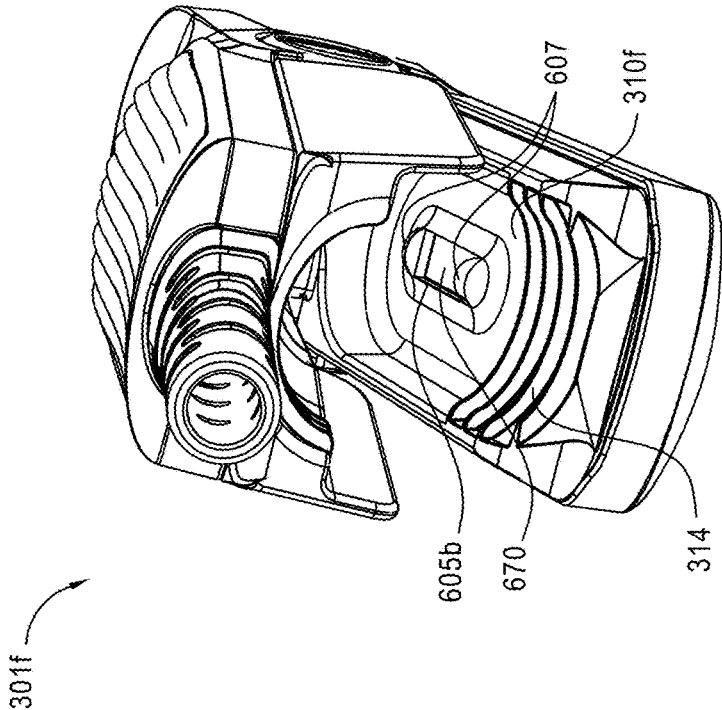

FIG. 6E

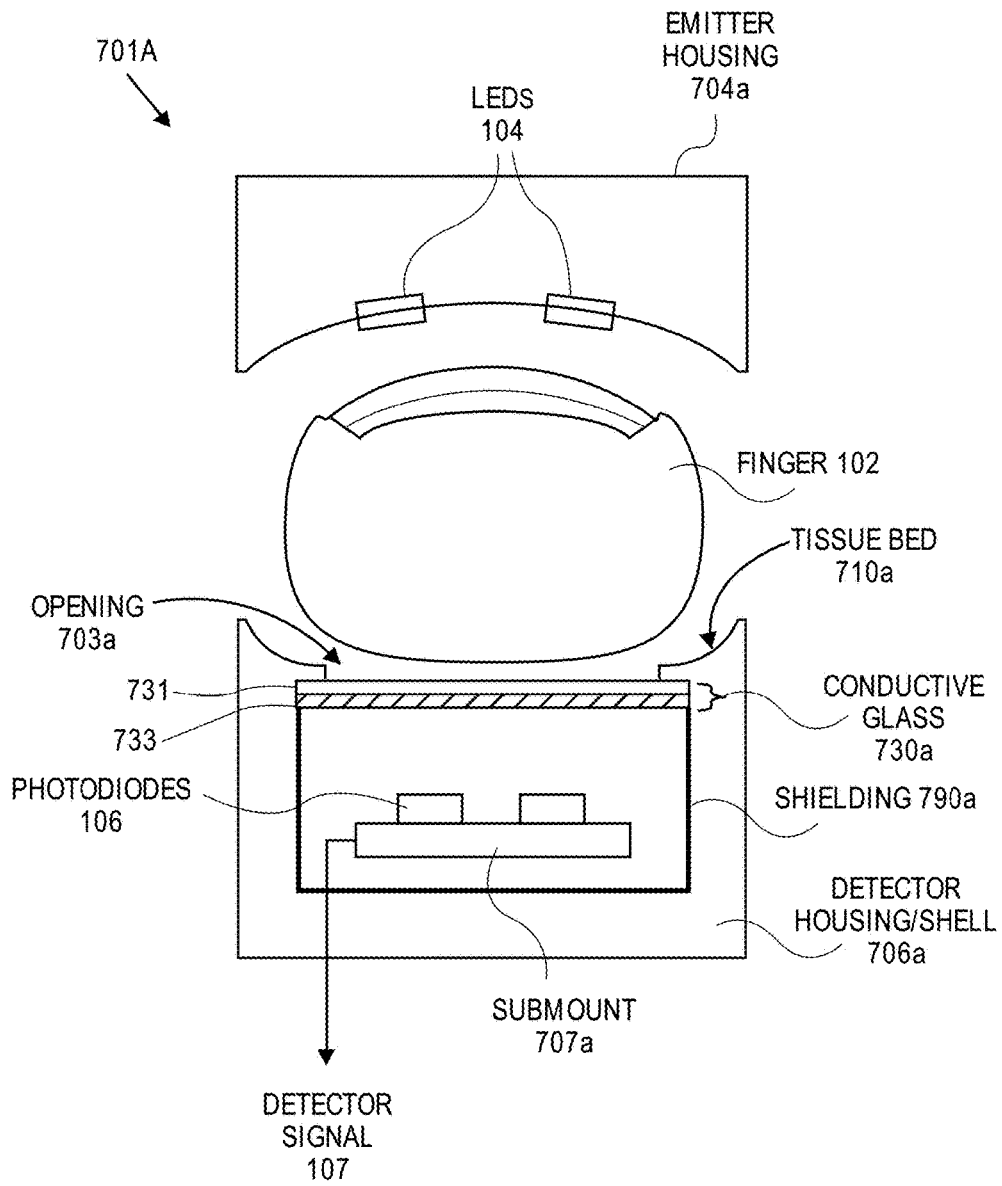

FIG. 7A

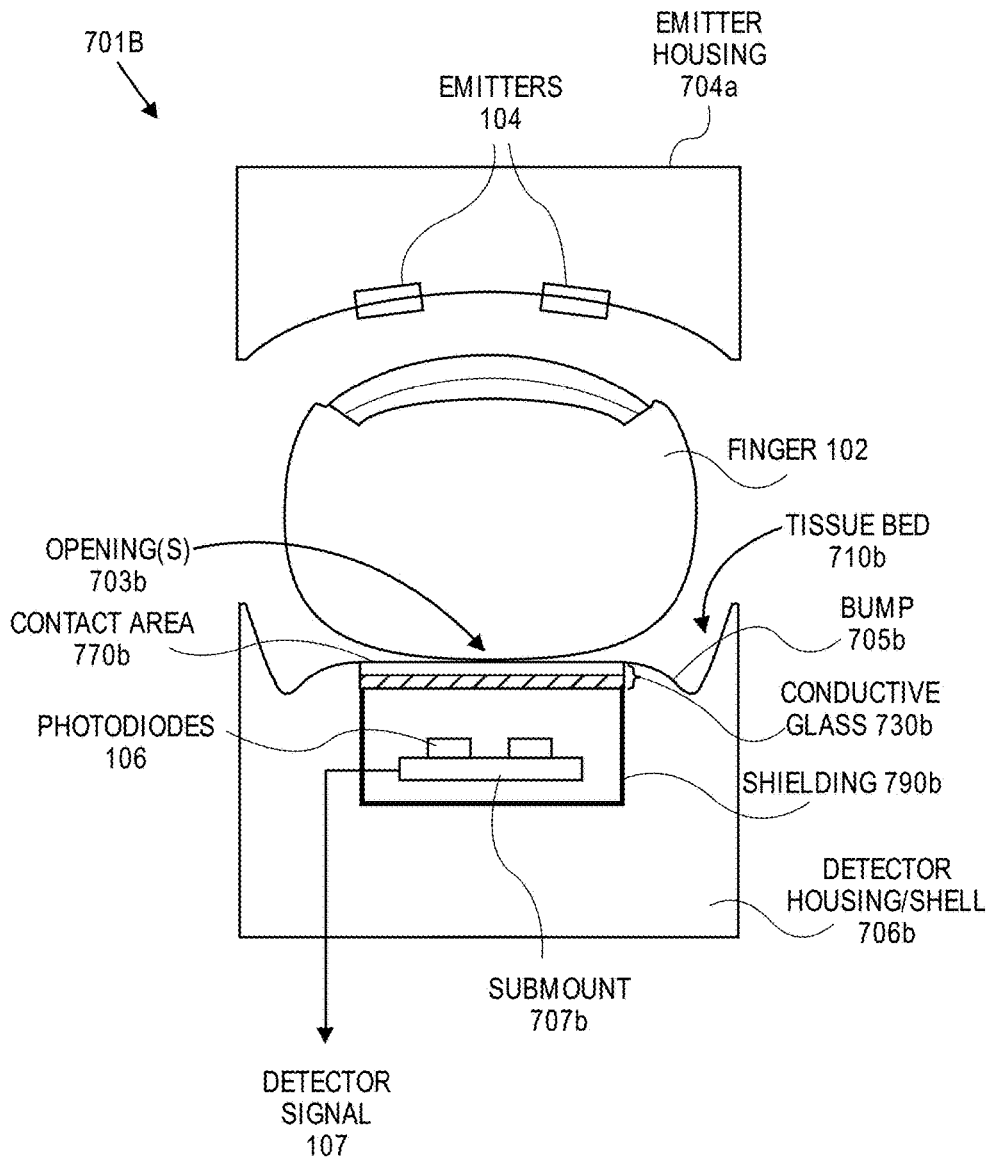

FIG. 7B

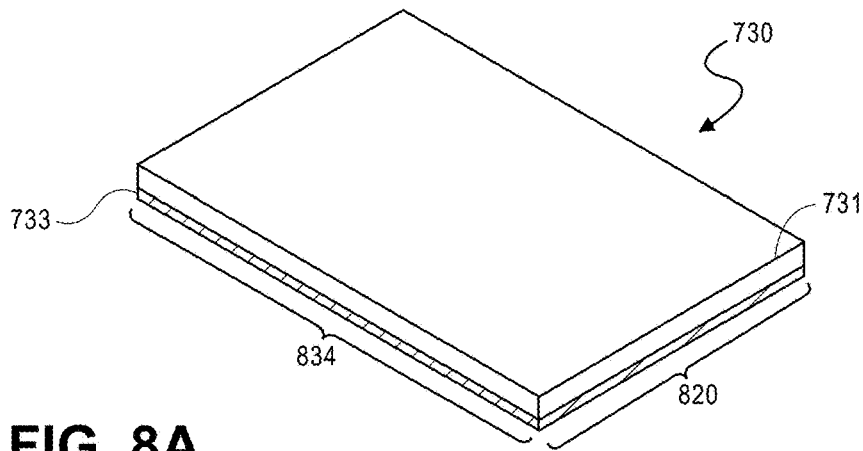

FIG. 8A

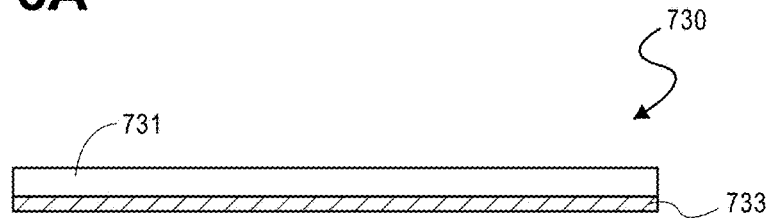

FIG. 8B

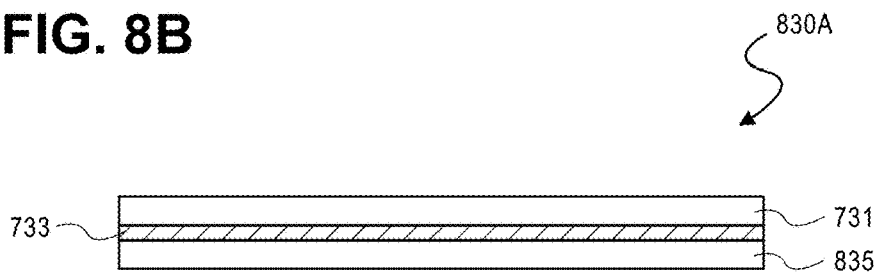

FIG. 8C

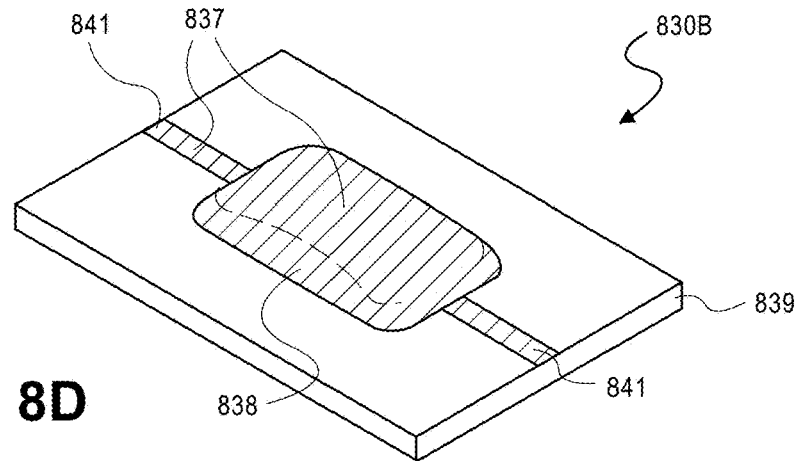

FIG. 8D

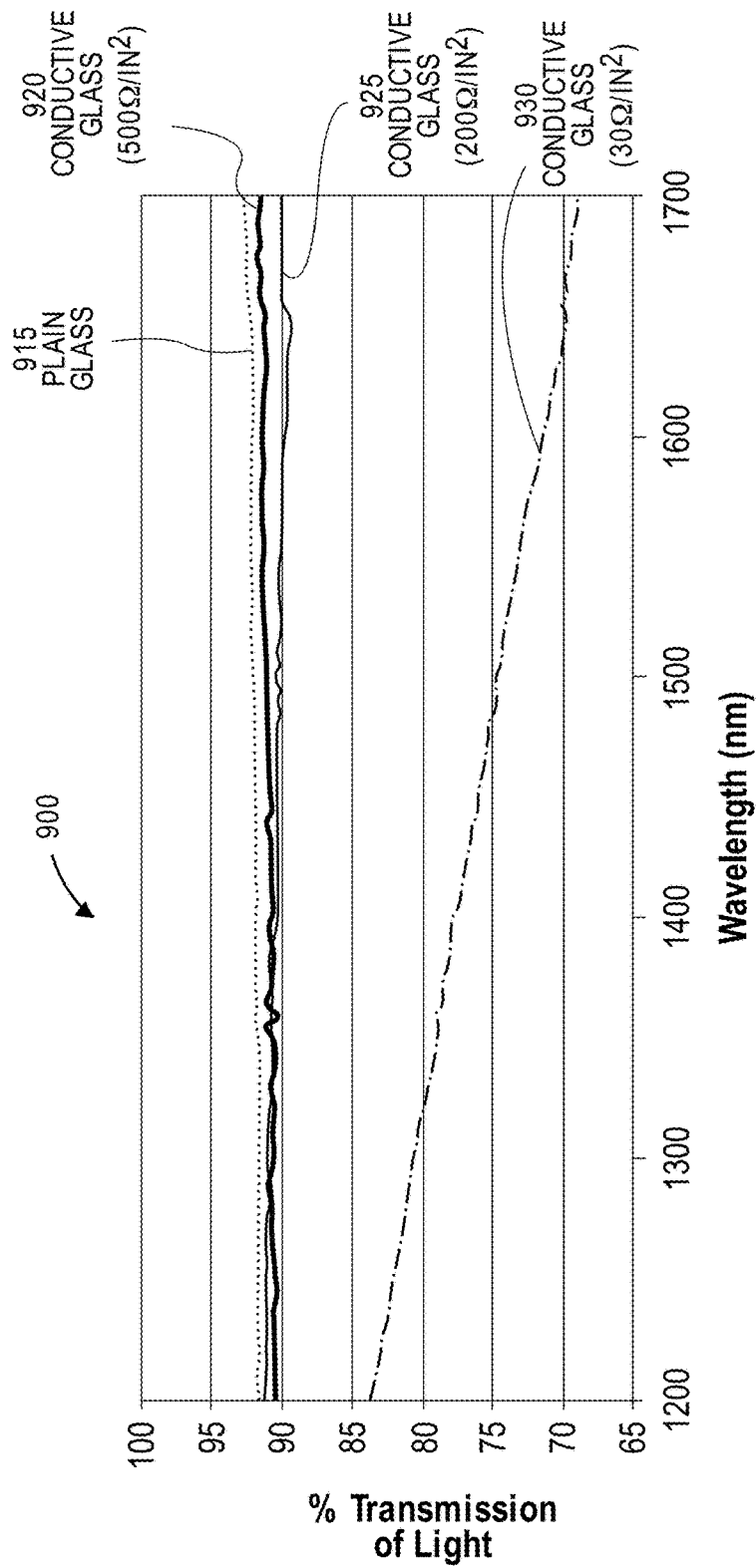

FIG. 9

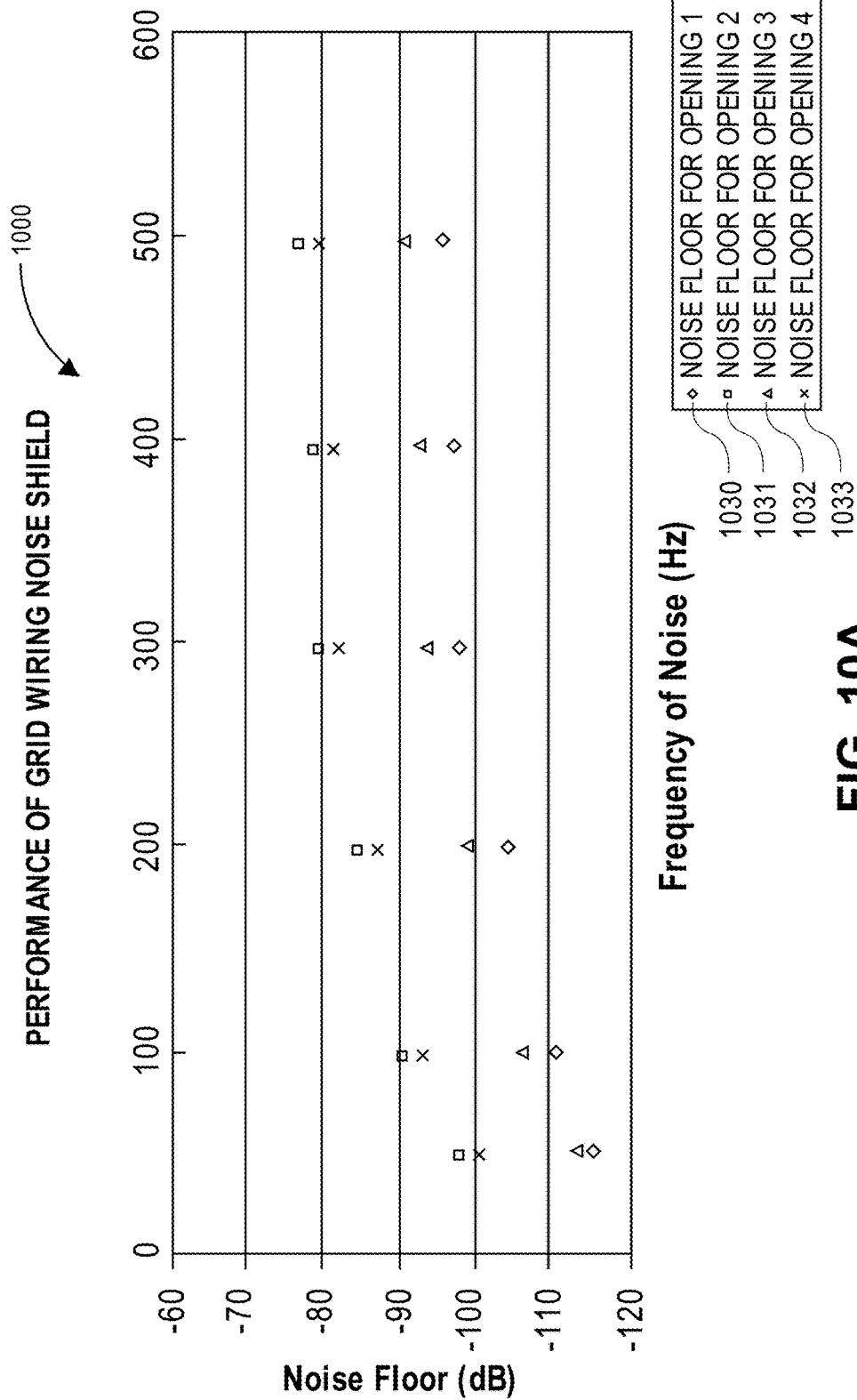
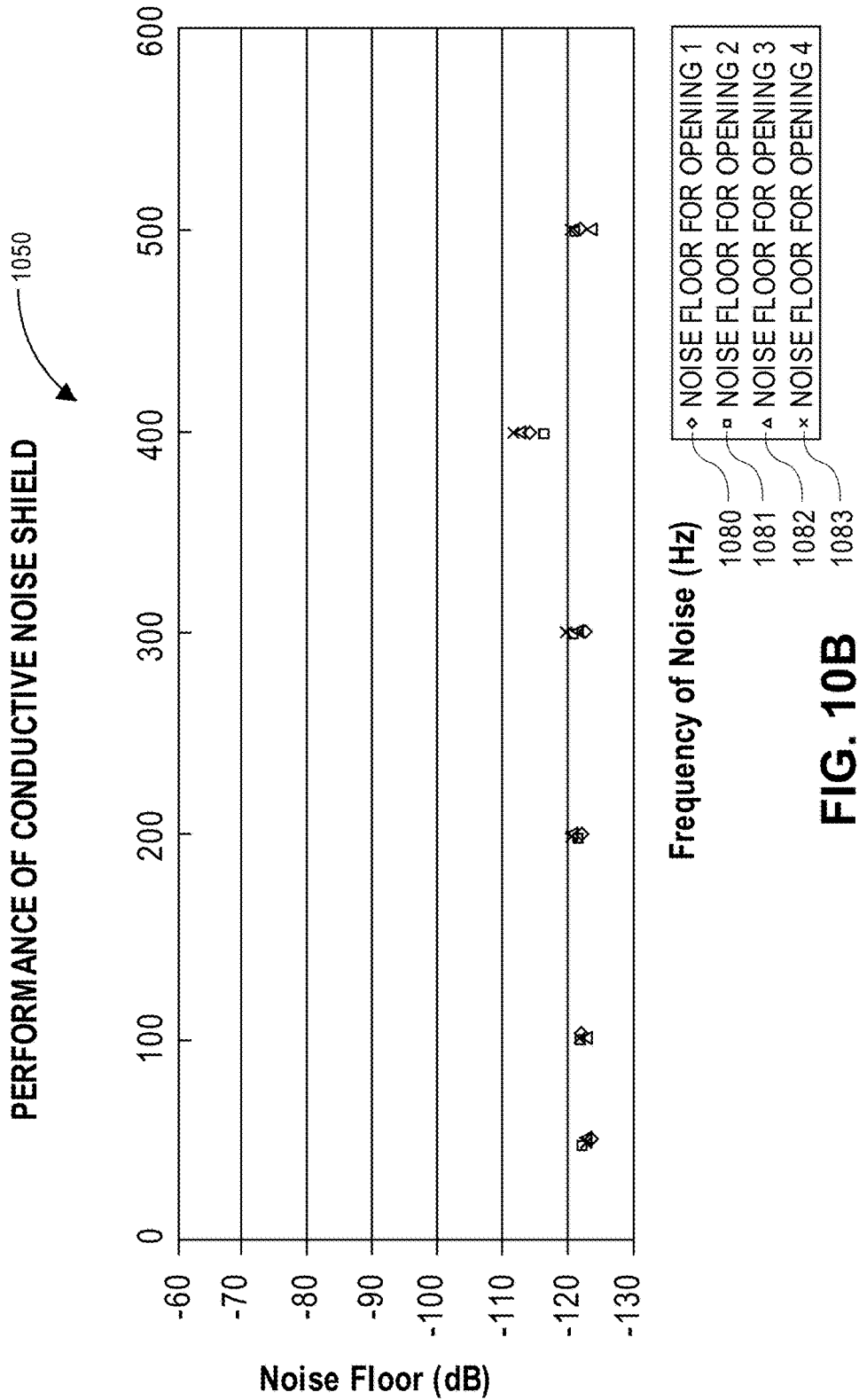
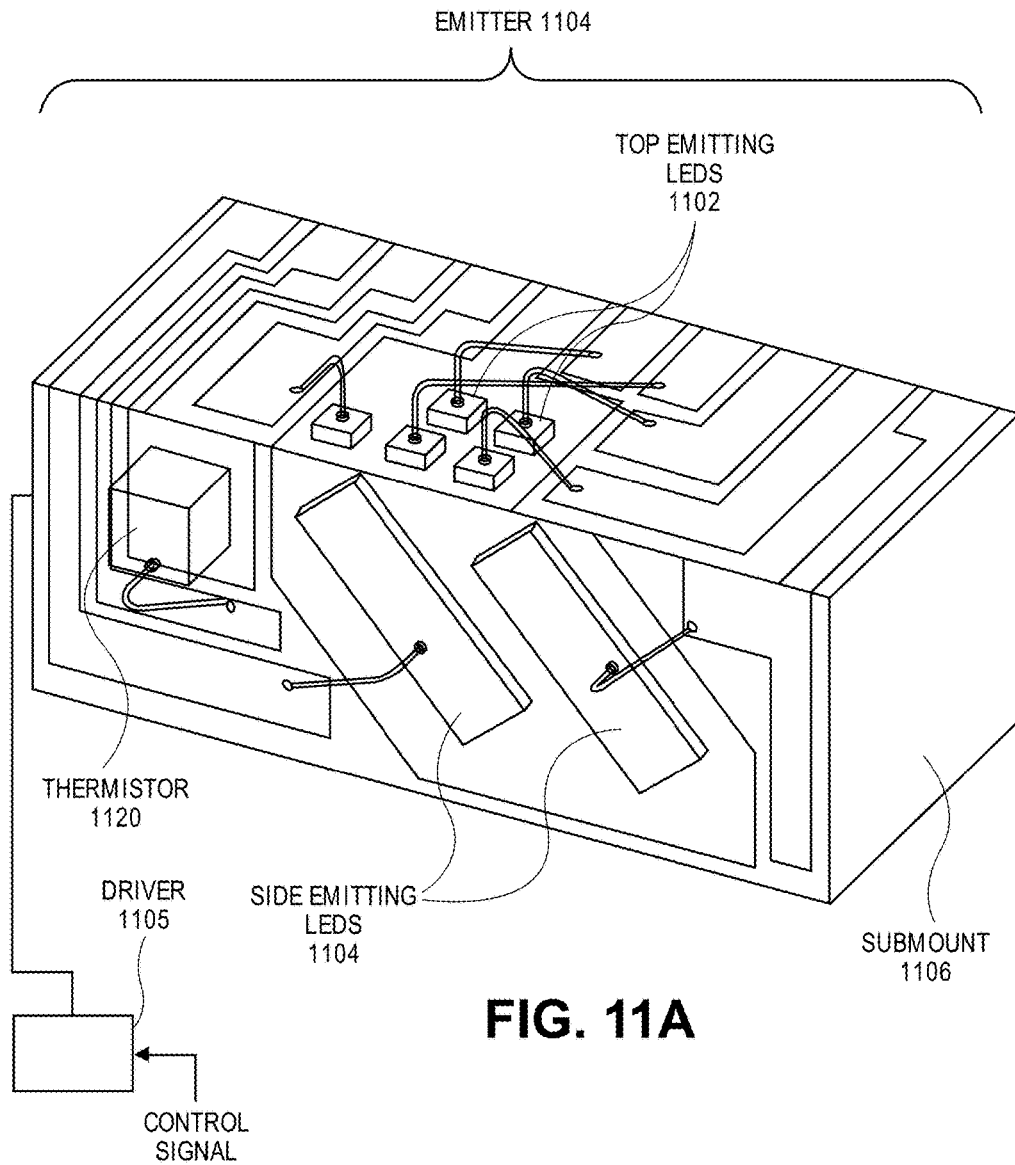

FIG. 10A





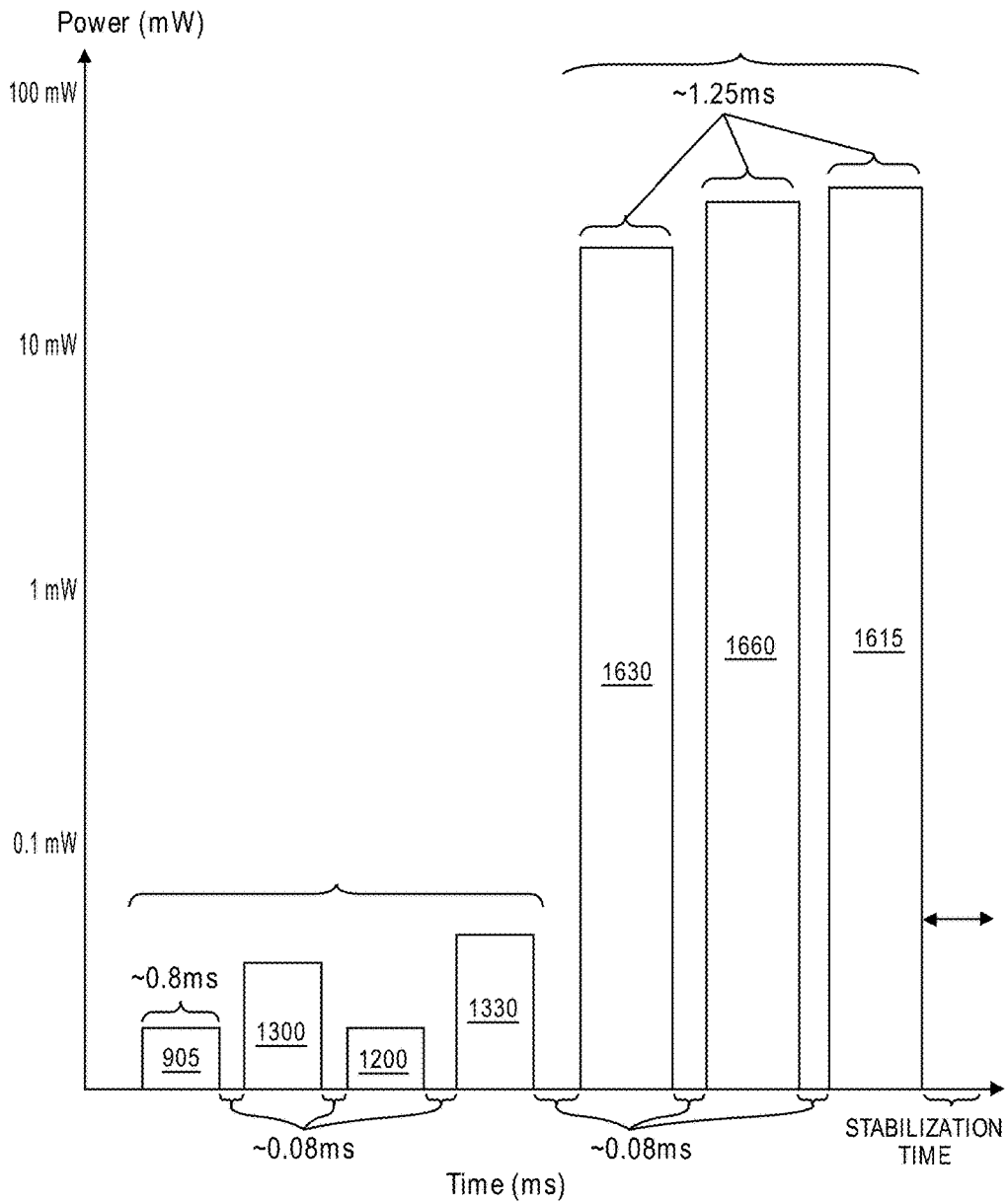

FIG. 11B

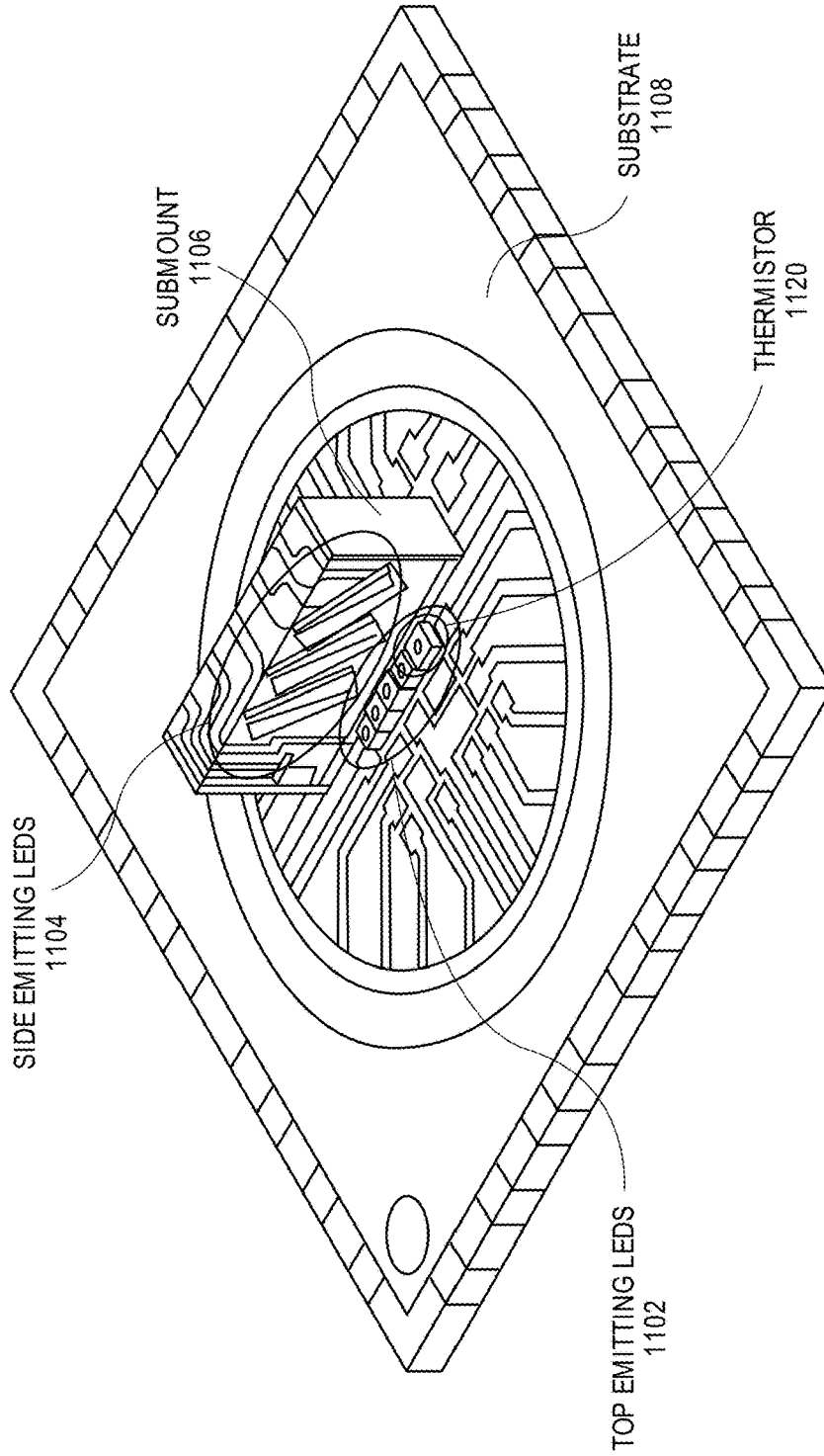

FIG. 11C

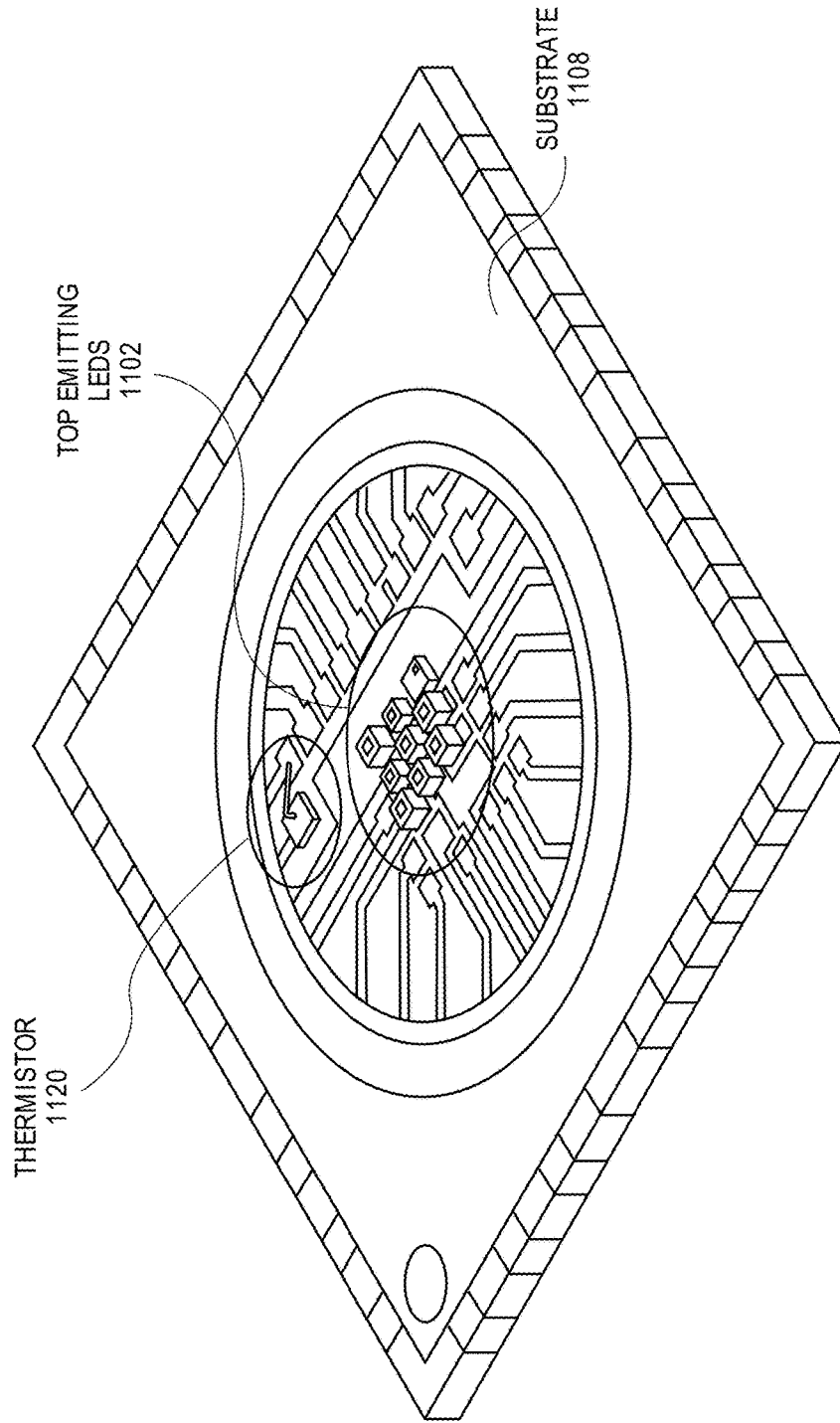

FIG. 11D

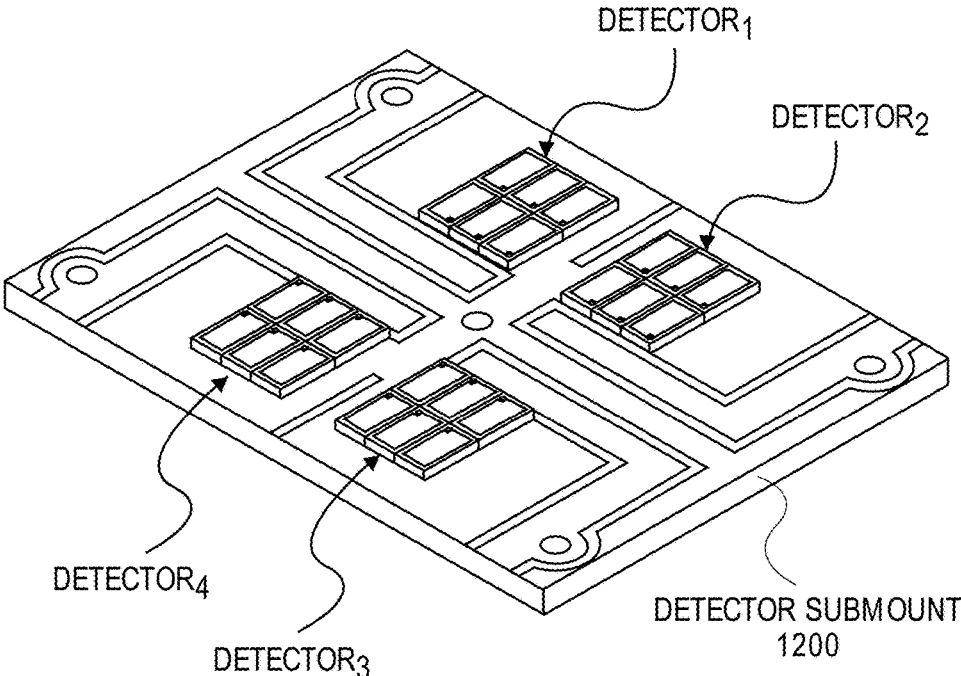

FIG. 12A

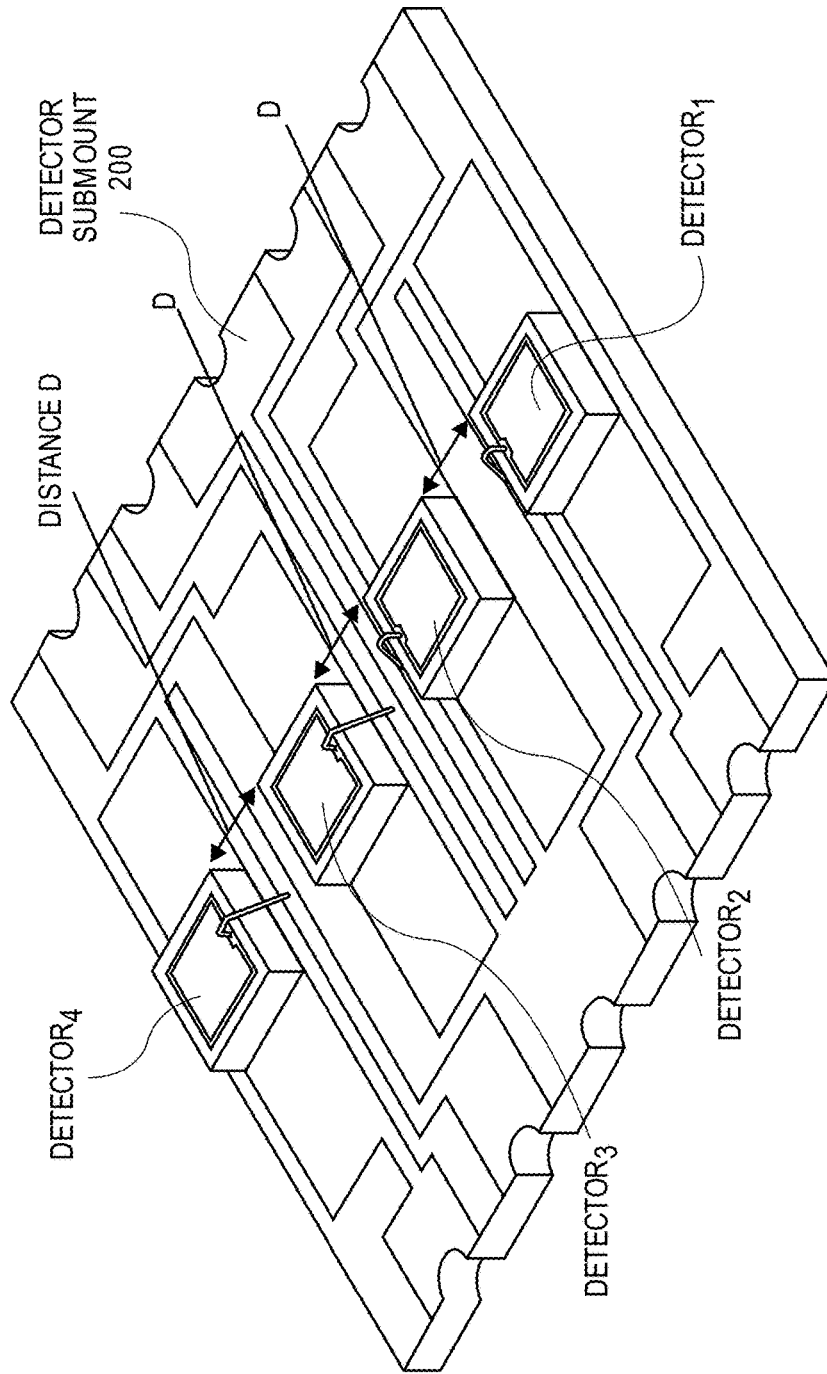

FIG. 12B

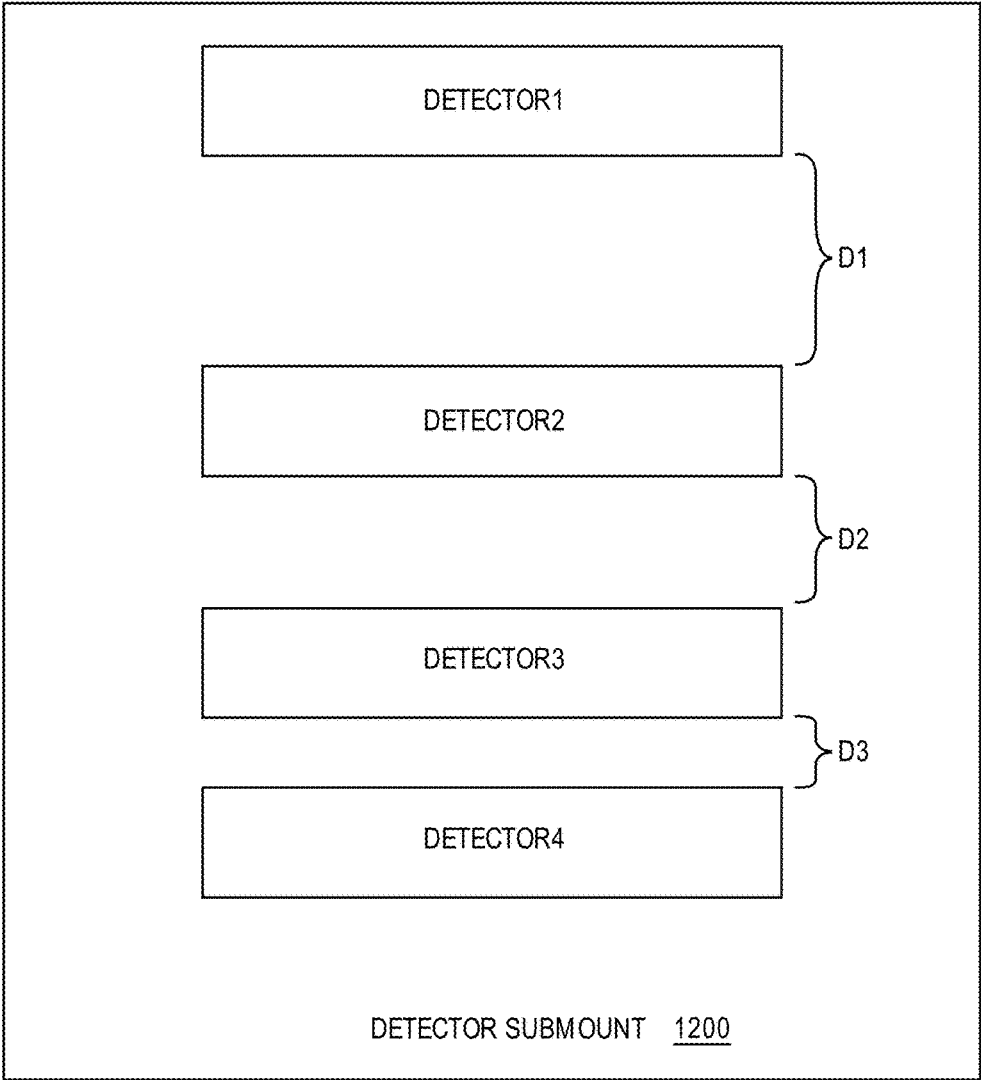

FIG. 12C

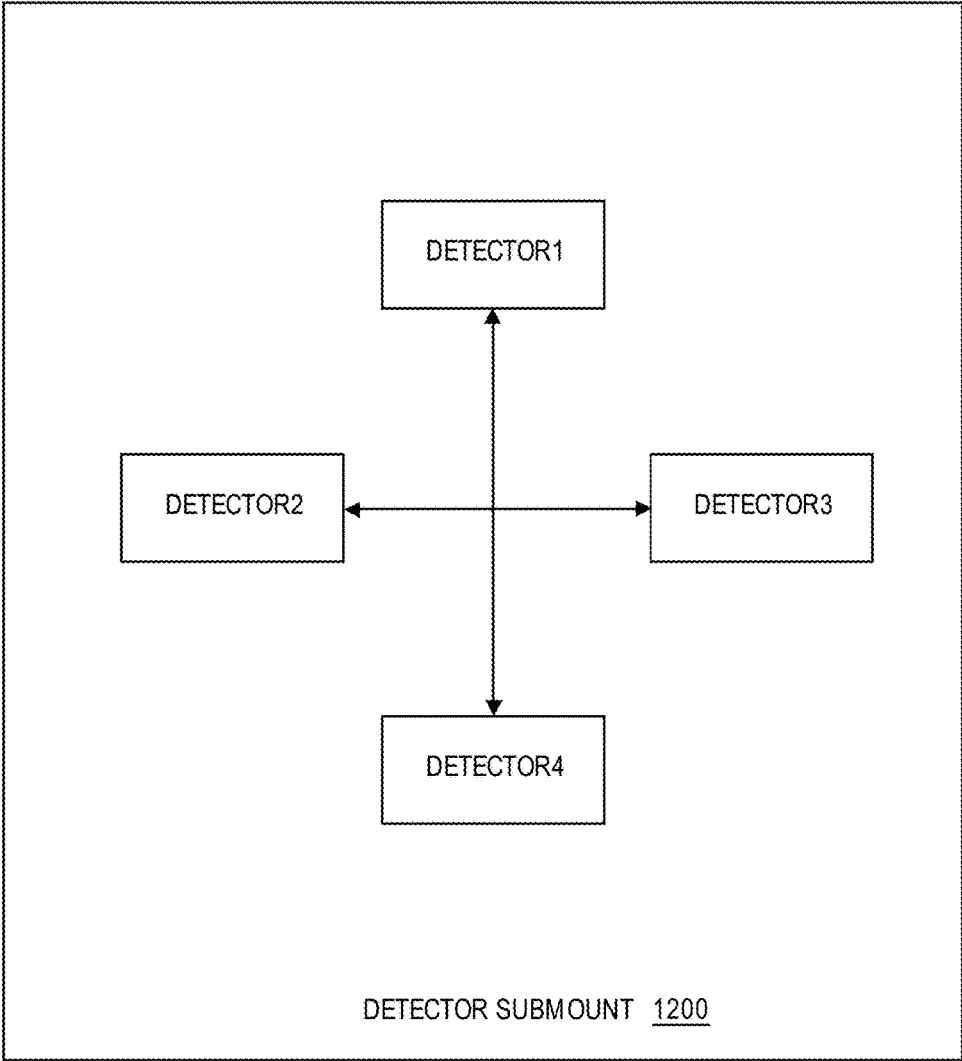

FIG. 12D

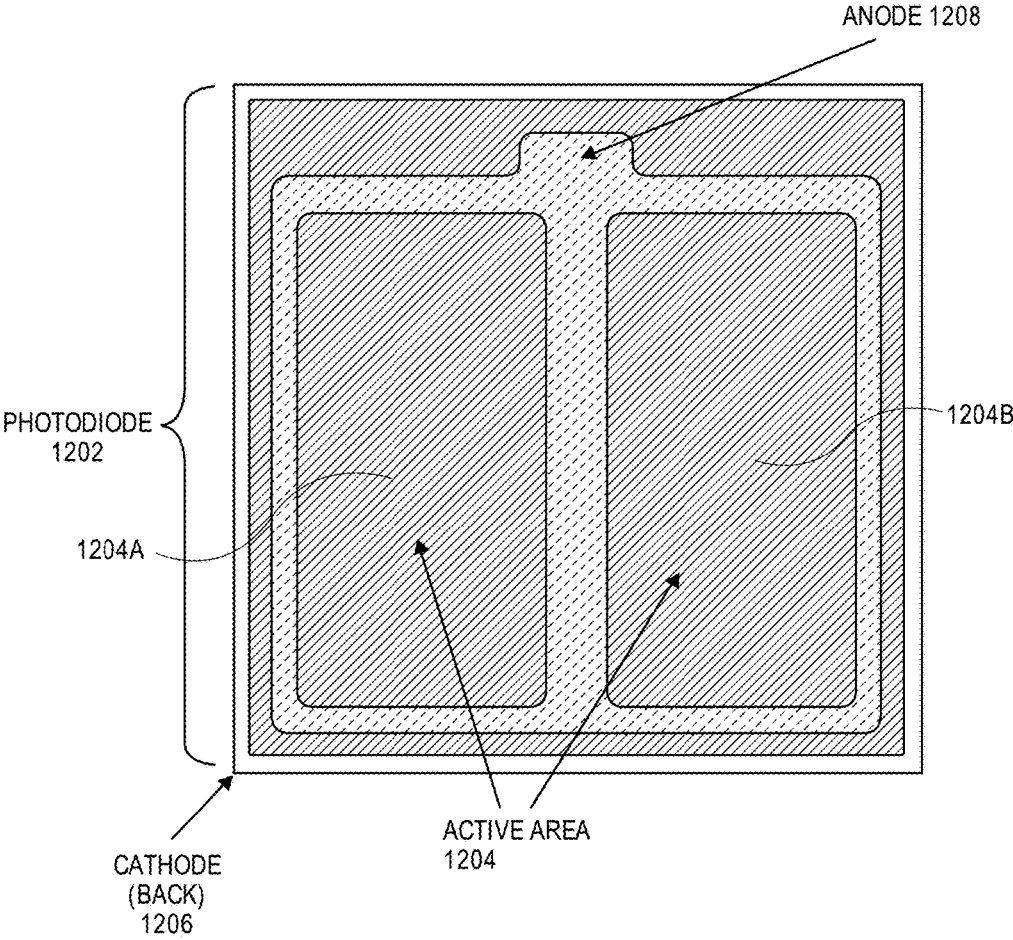

FIG. 12E

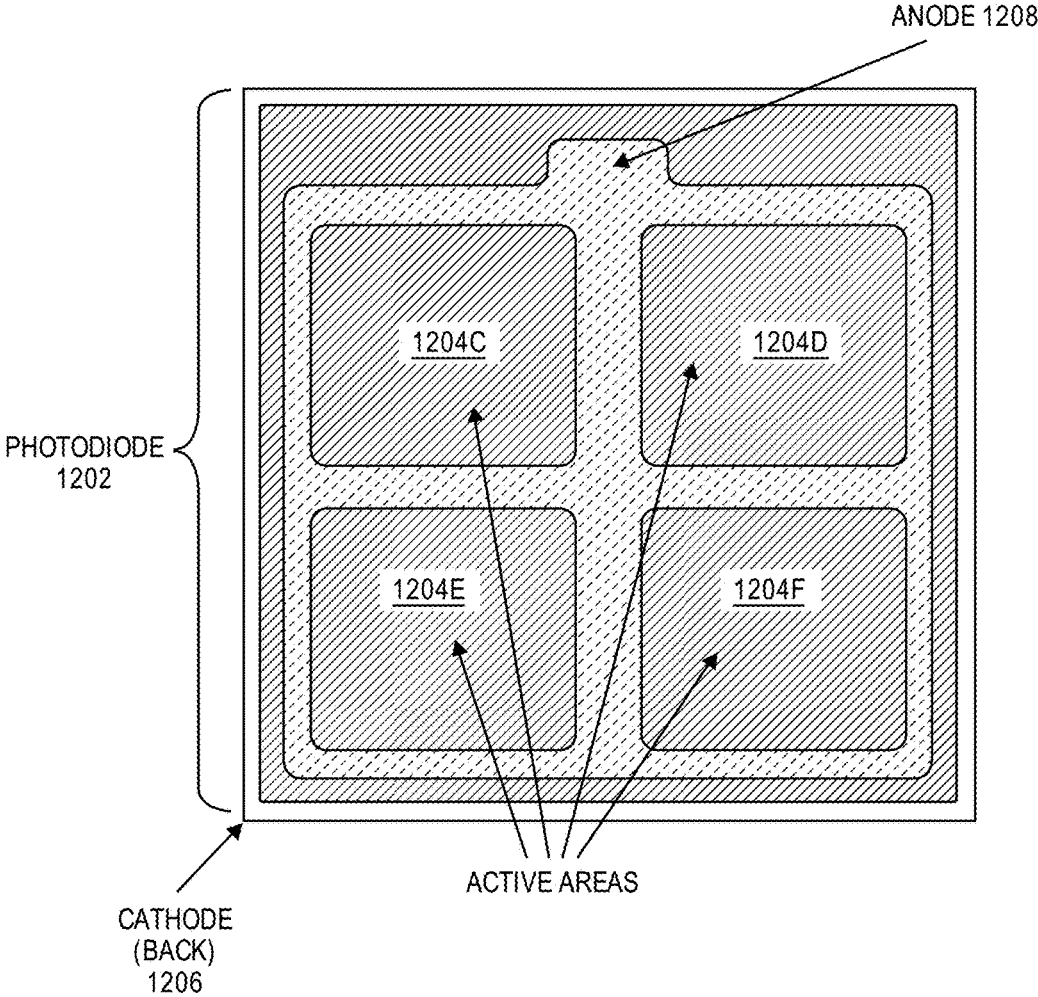

FIG. 12F

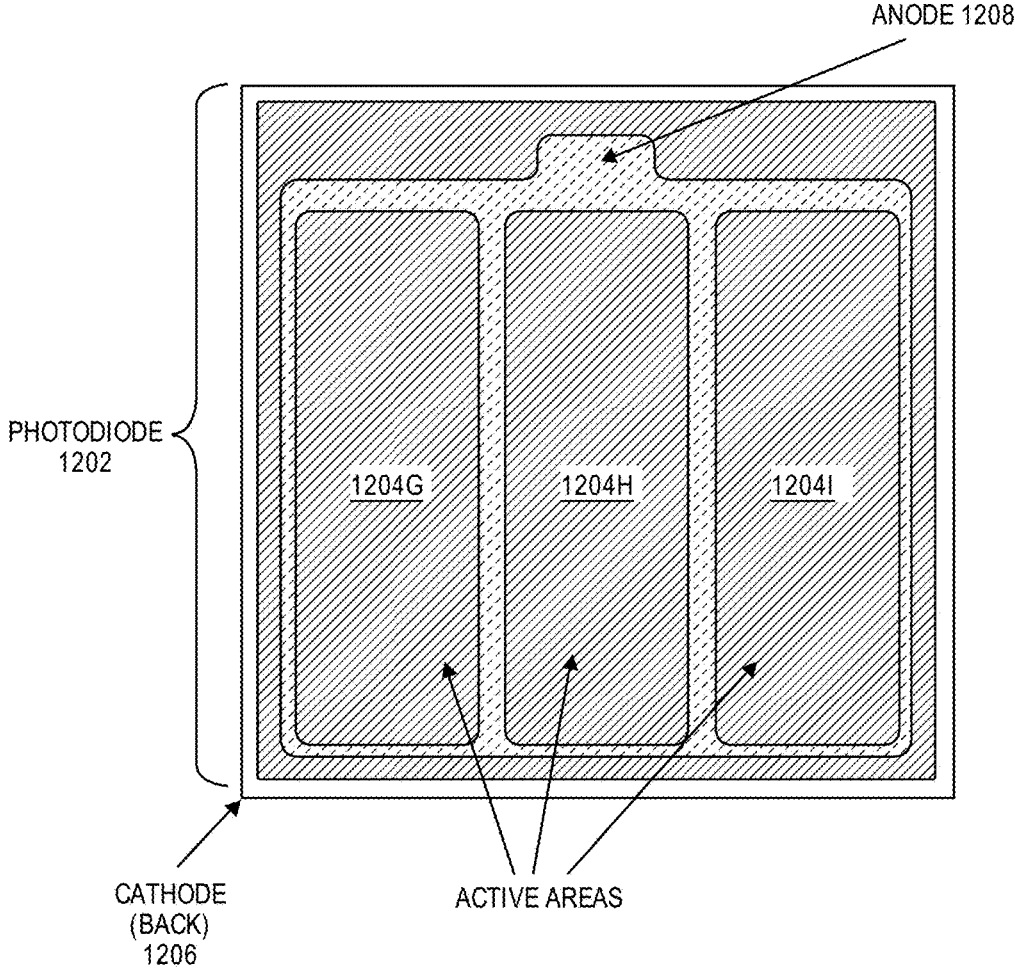

FIG. 12G

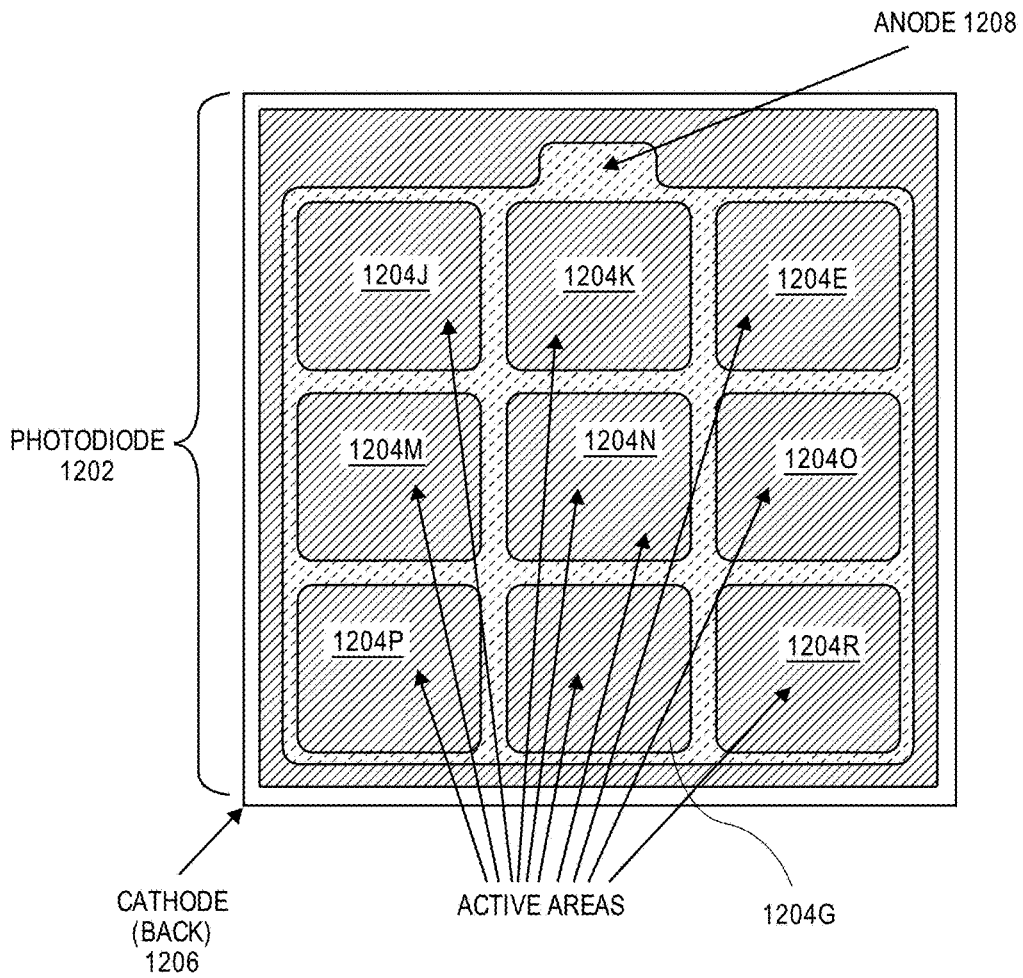

FIG. 12H

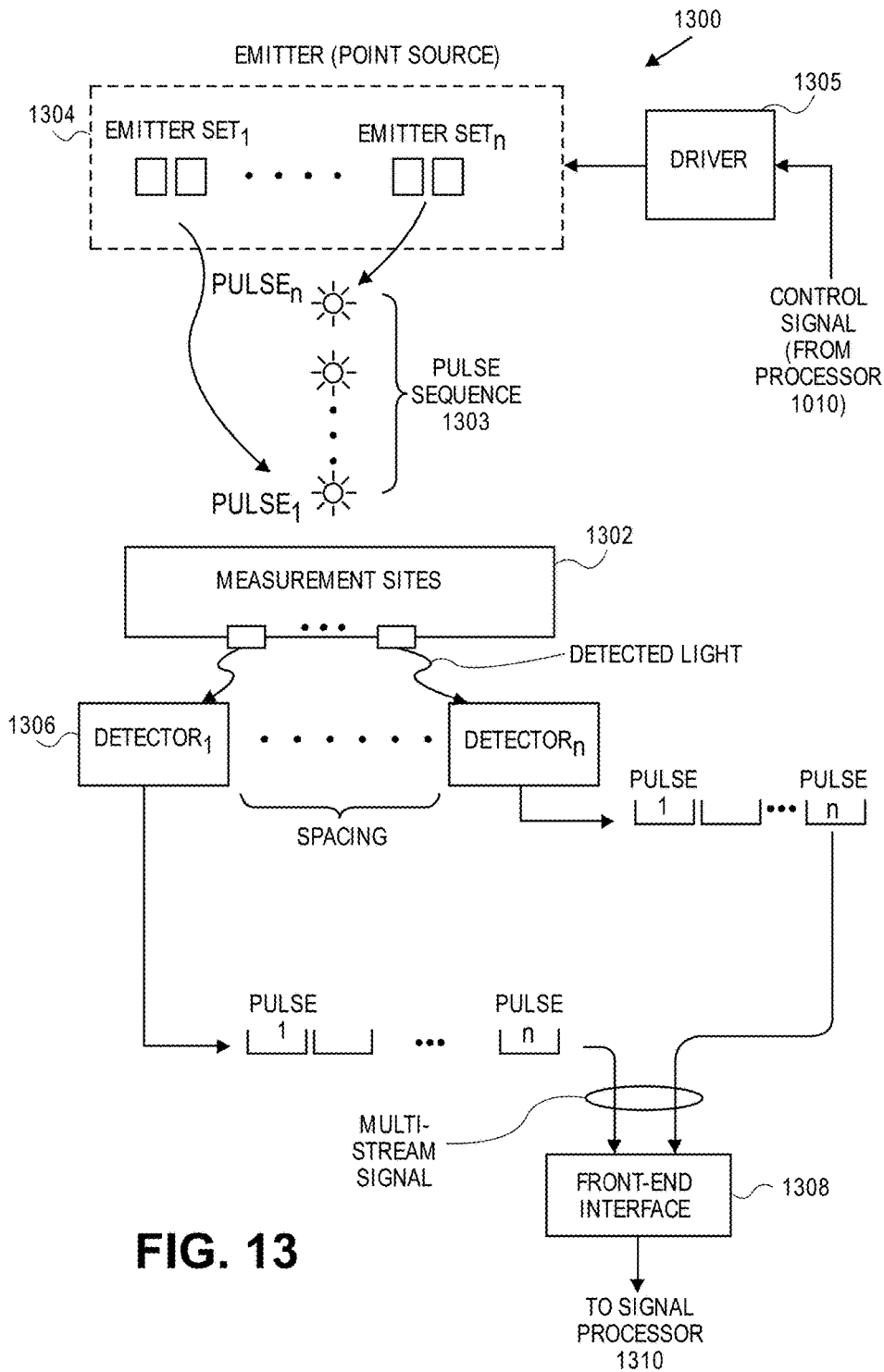

FIG. 13

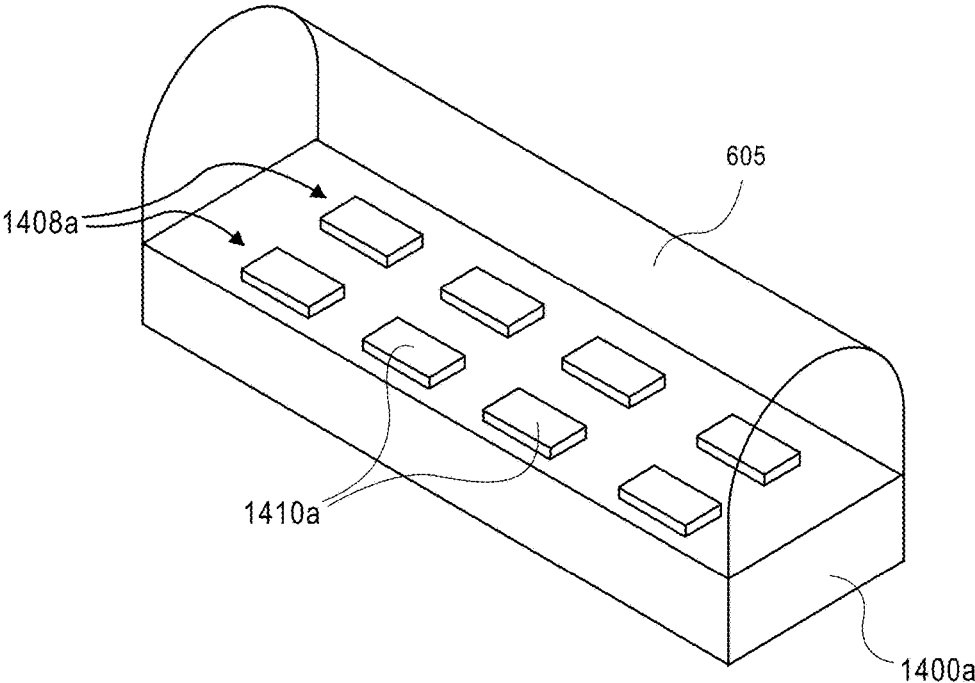

FIG. 14A

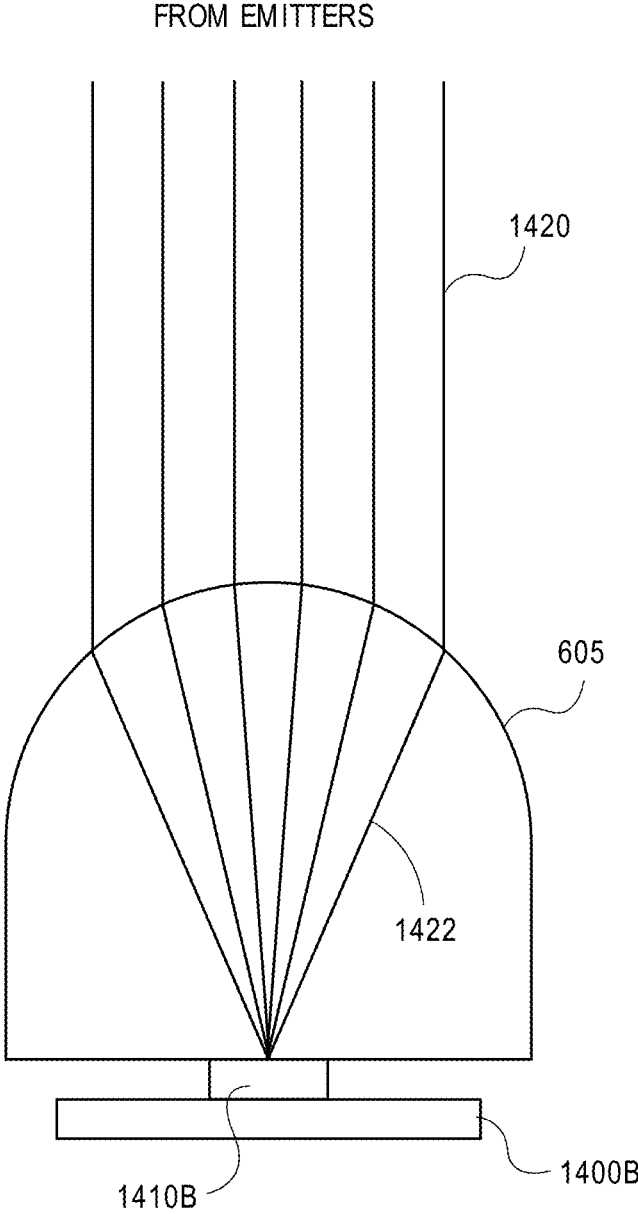

FIG. 14B

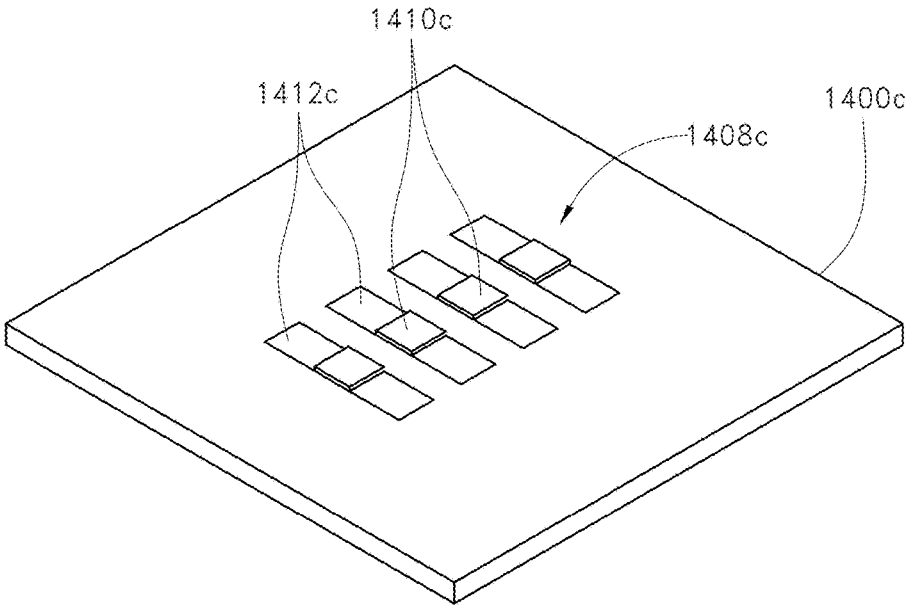

FIG. 14C

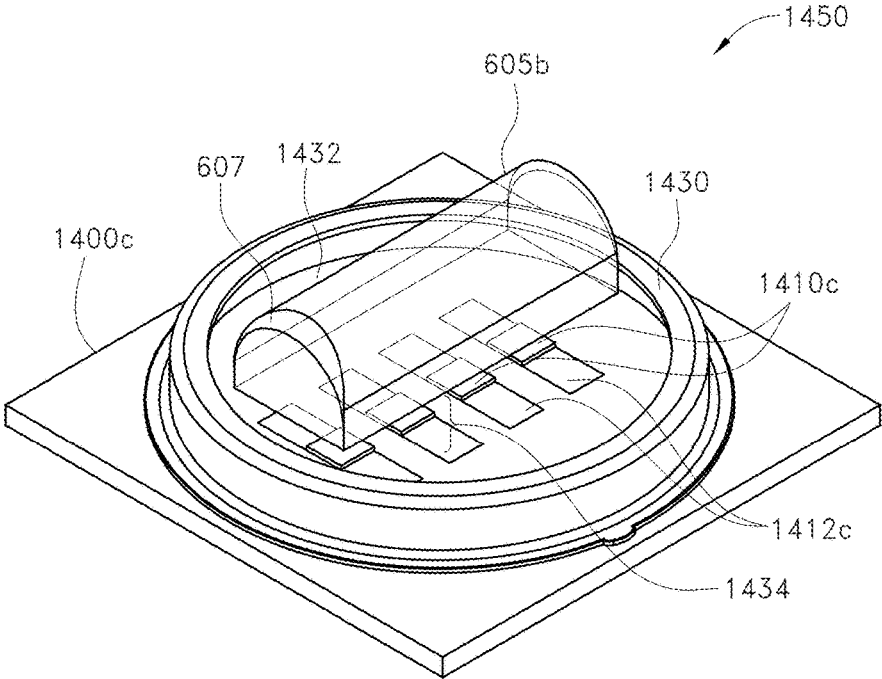

FIG. 14D

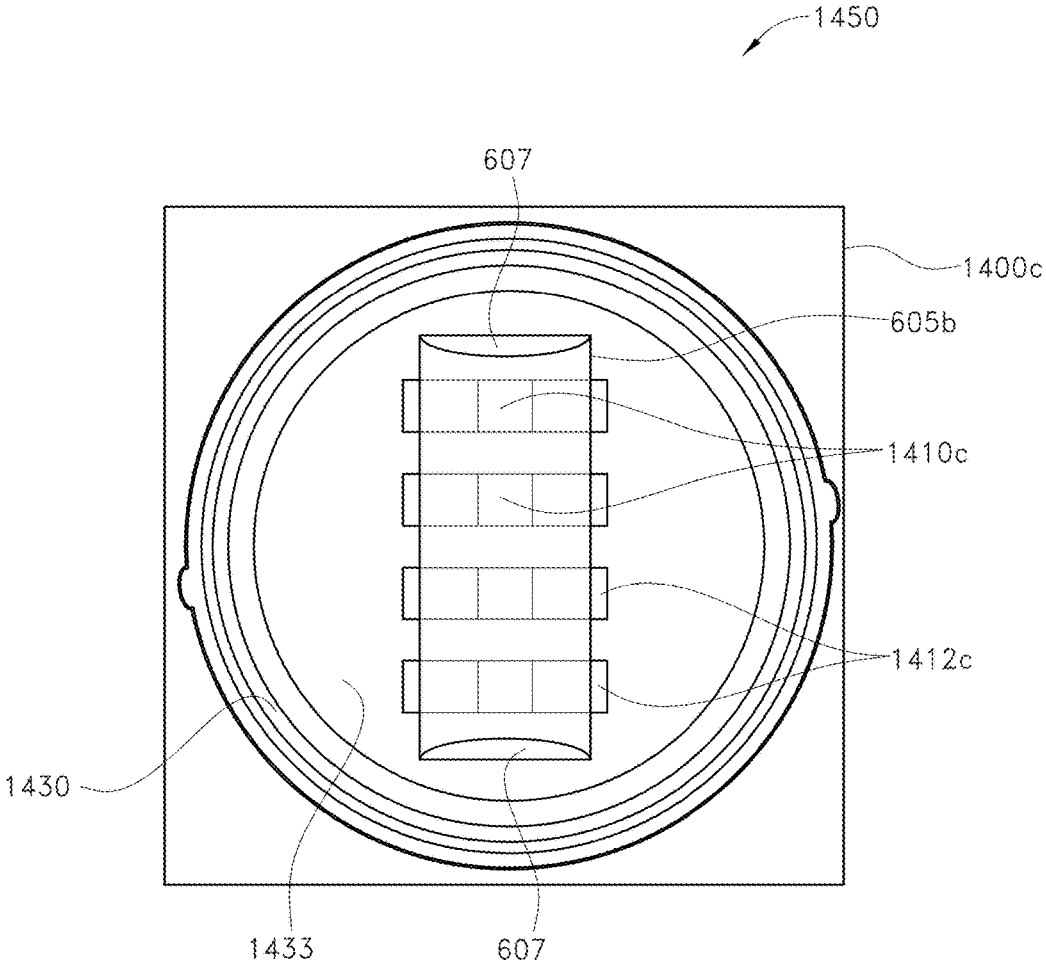

FIG. 14E

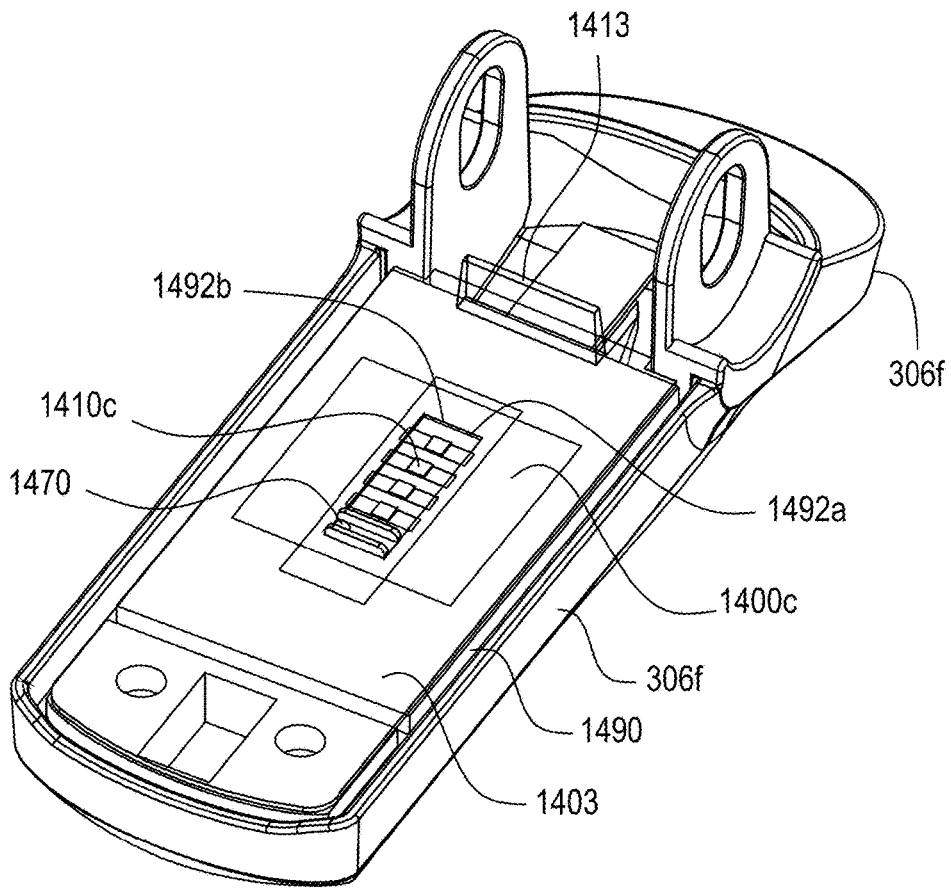

FIG. 14F

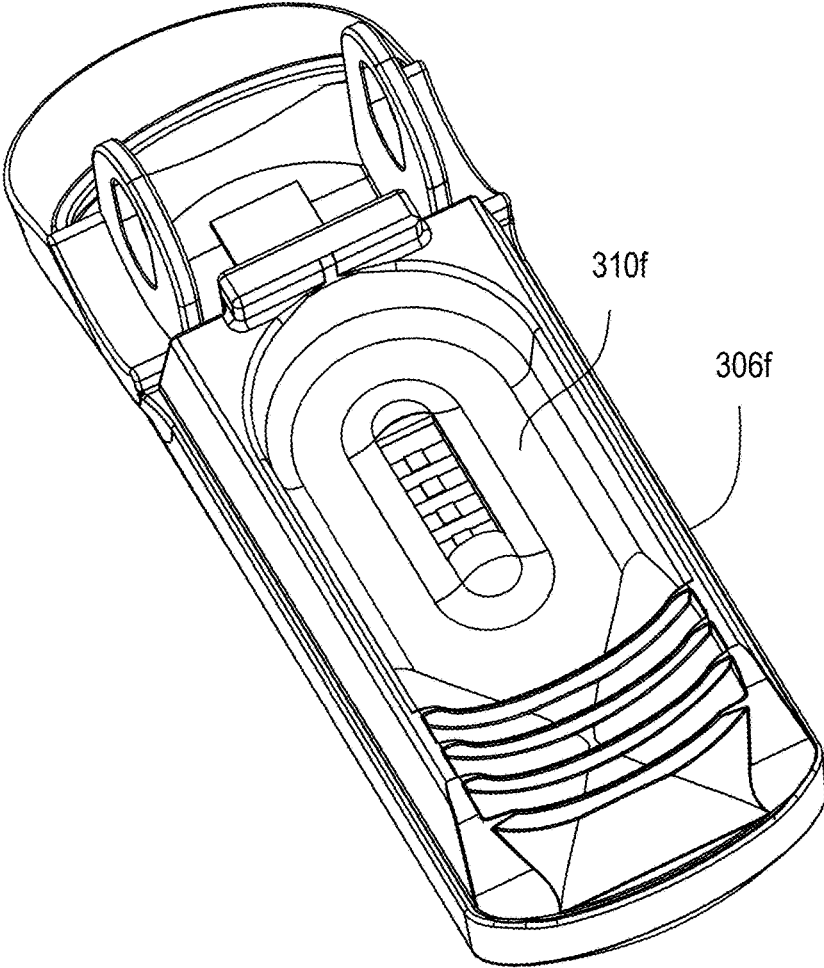

FIG. 14G

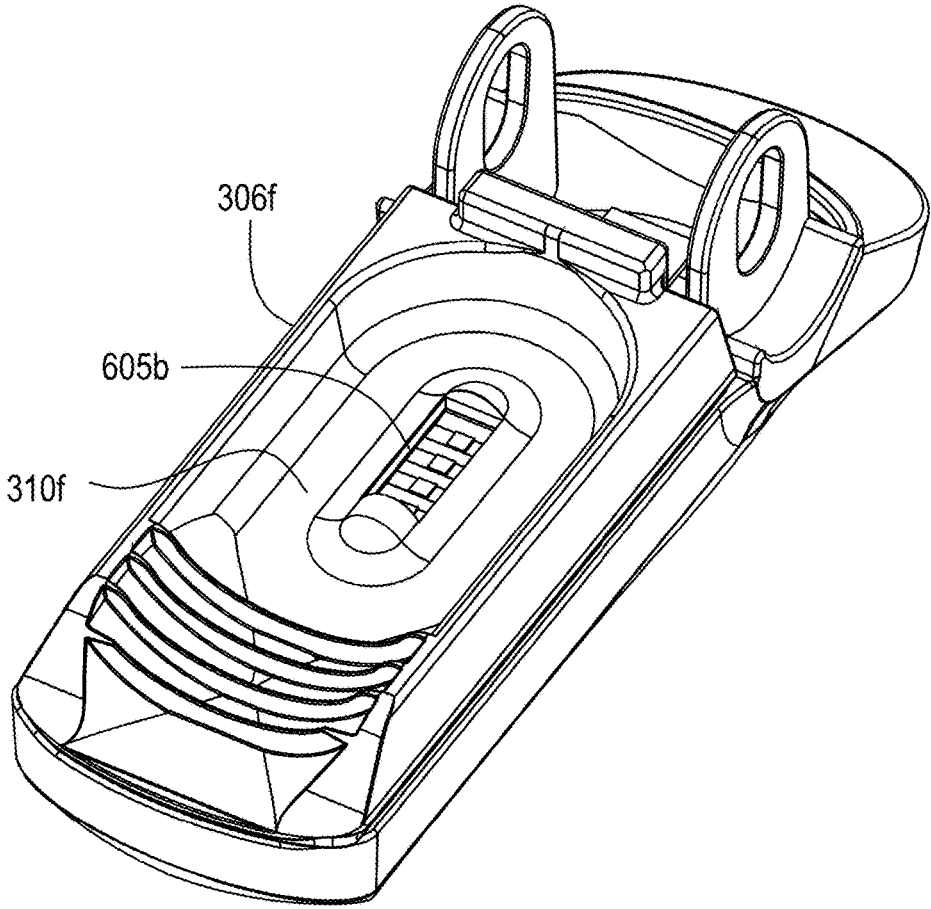

FIG. 14H

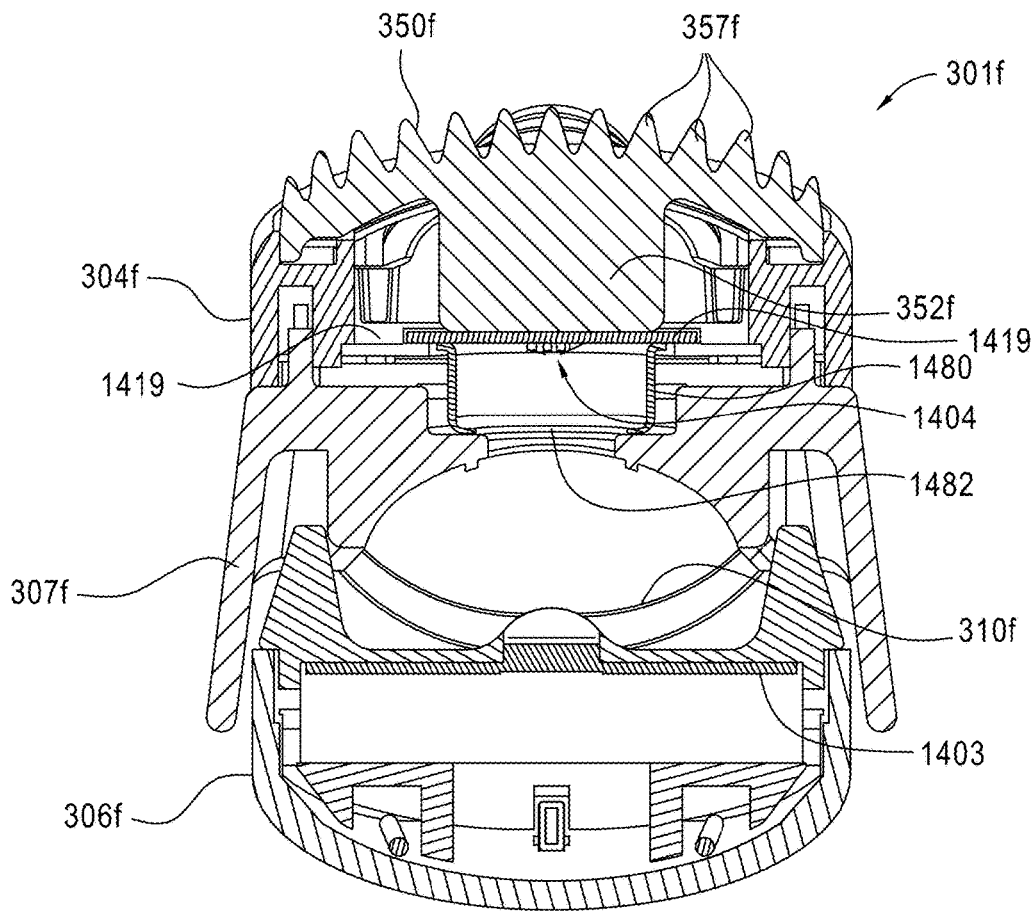

FIG. 14I

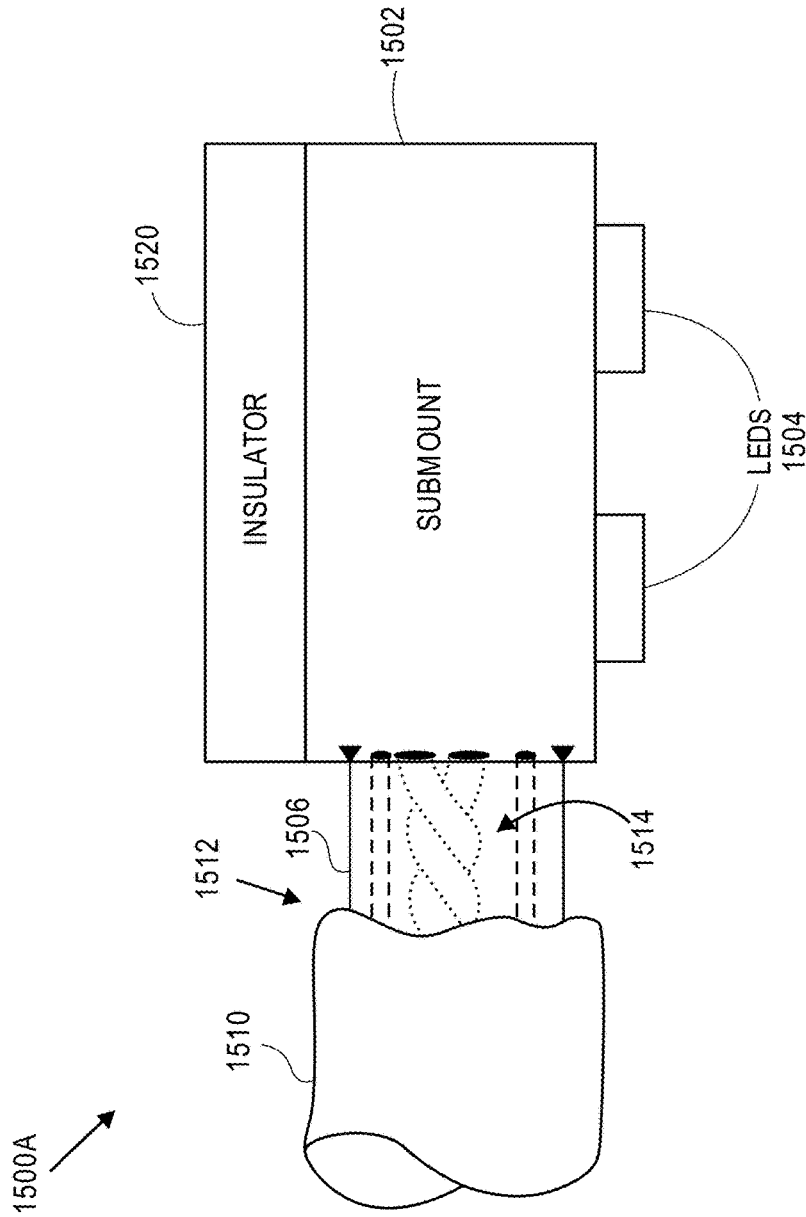

FIG. 15A

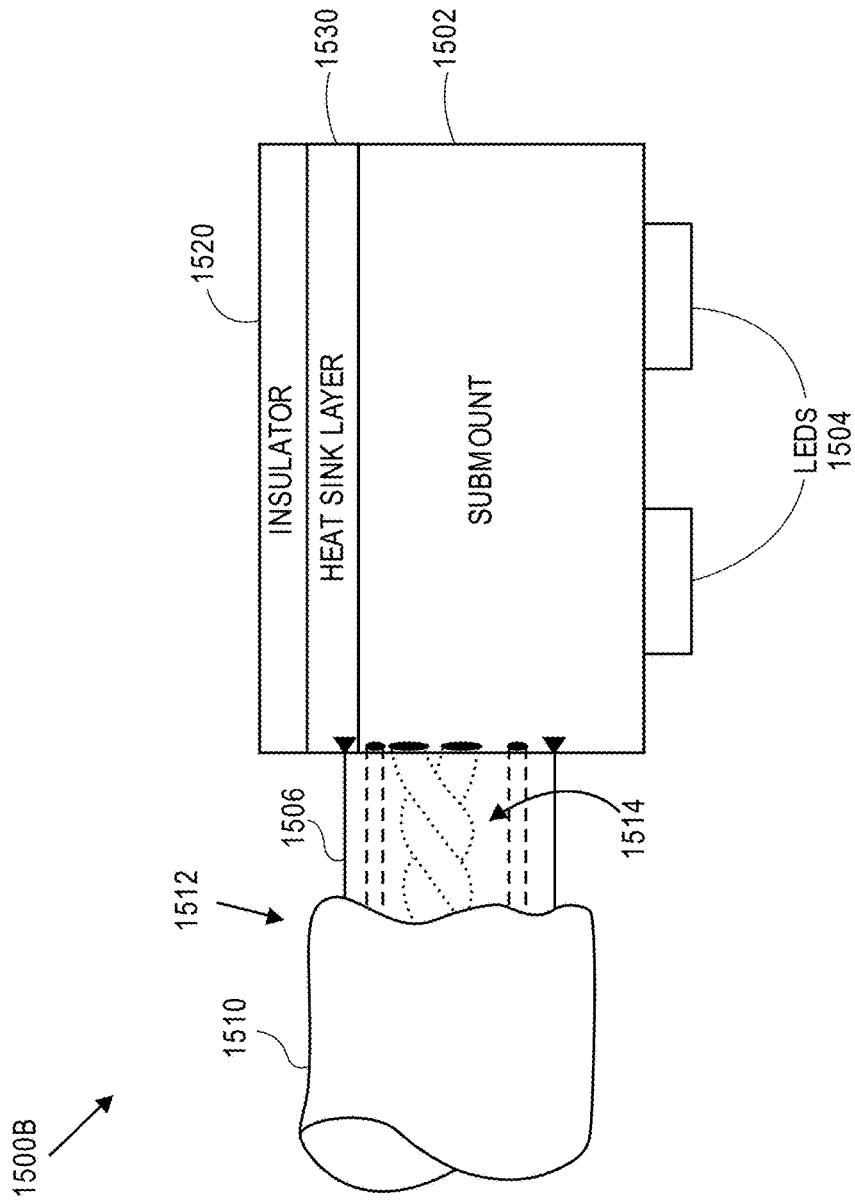

FIG. 15B

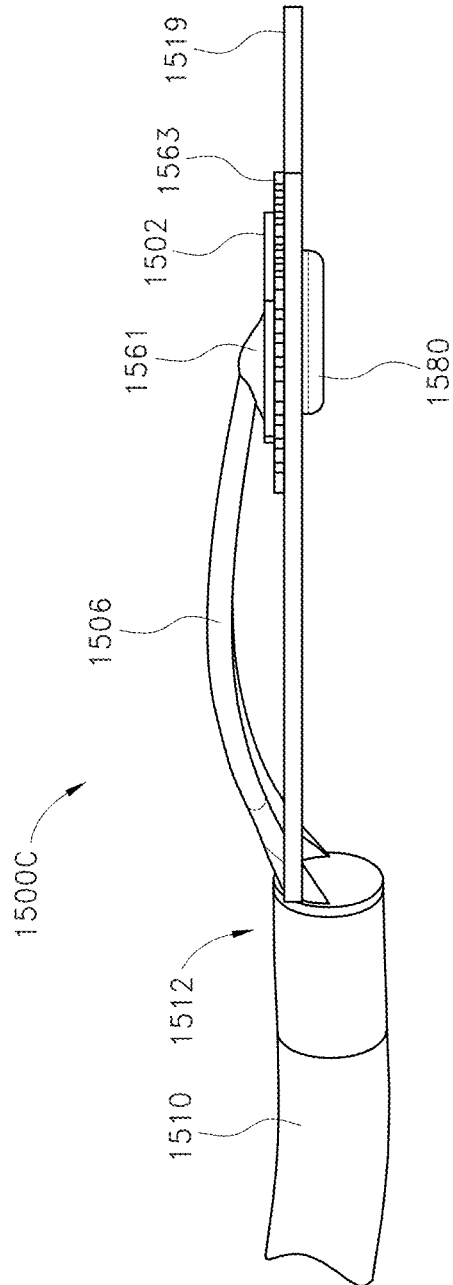

FIG. 150C

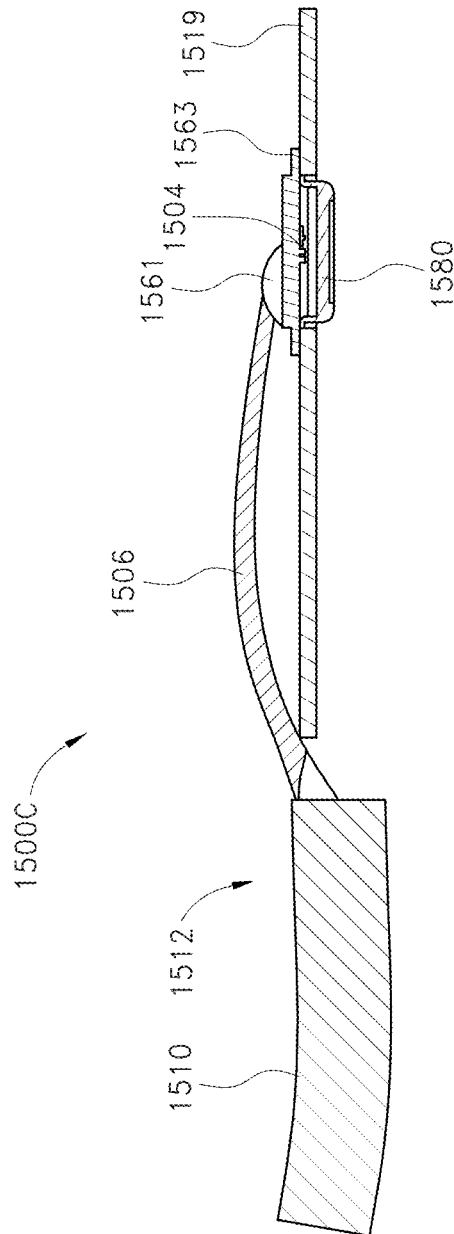

FIG. 15D

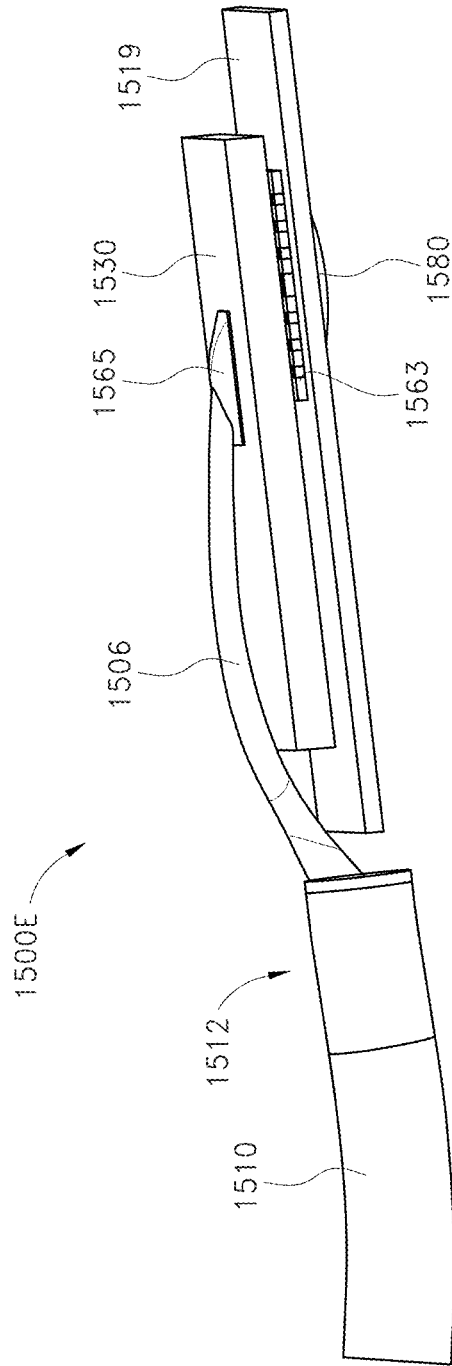

FIG. 15E

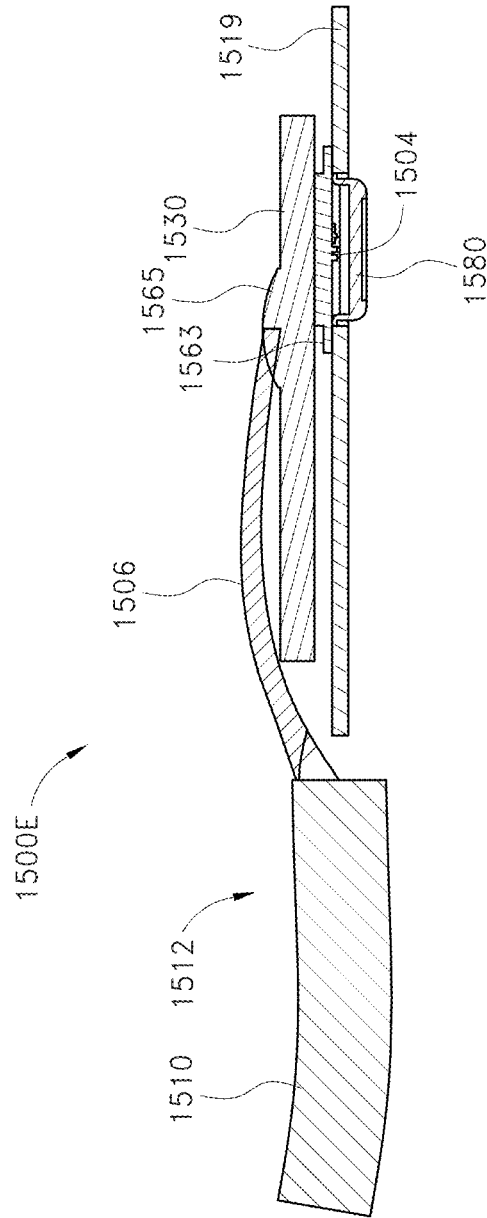

FIG. 15F

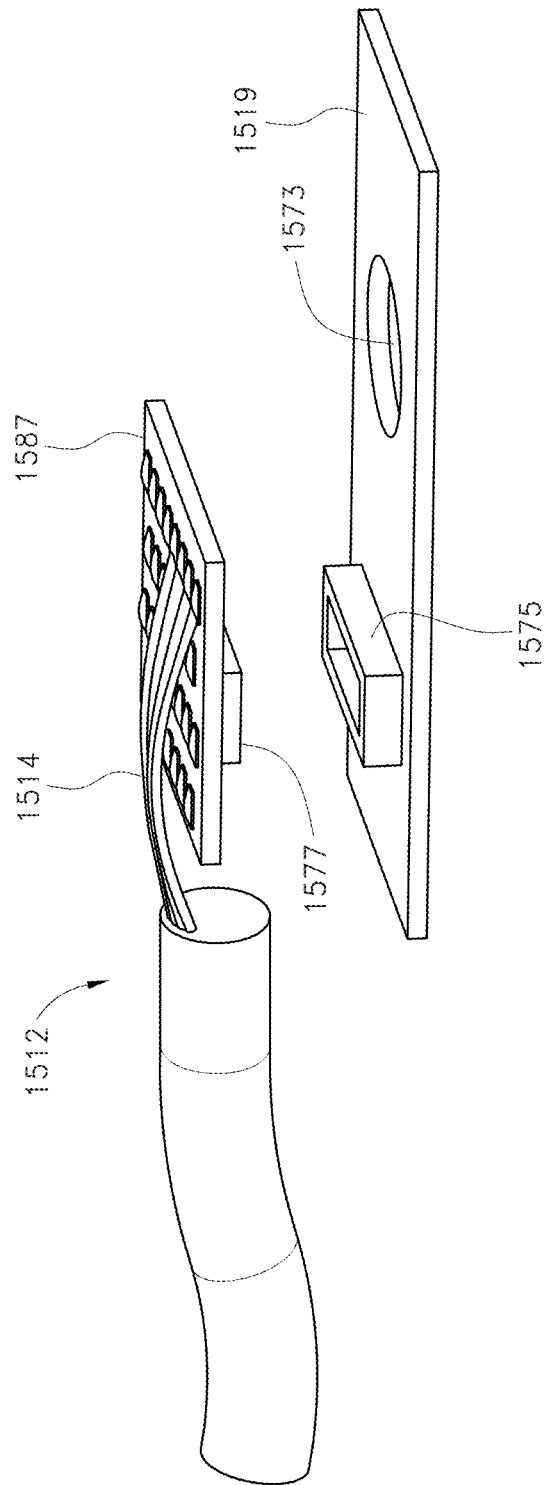

FIG. 15G

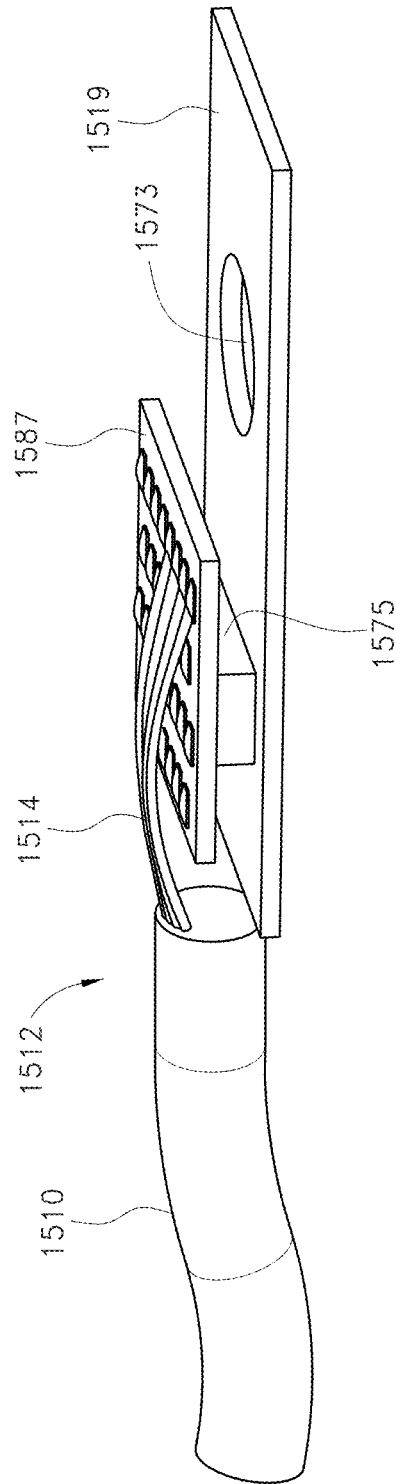

FIG. 15H

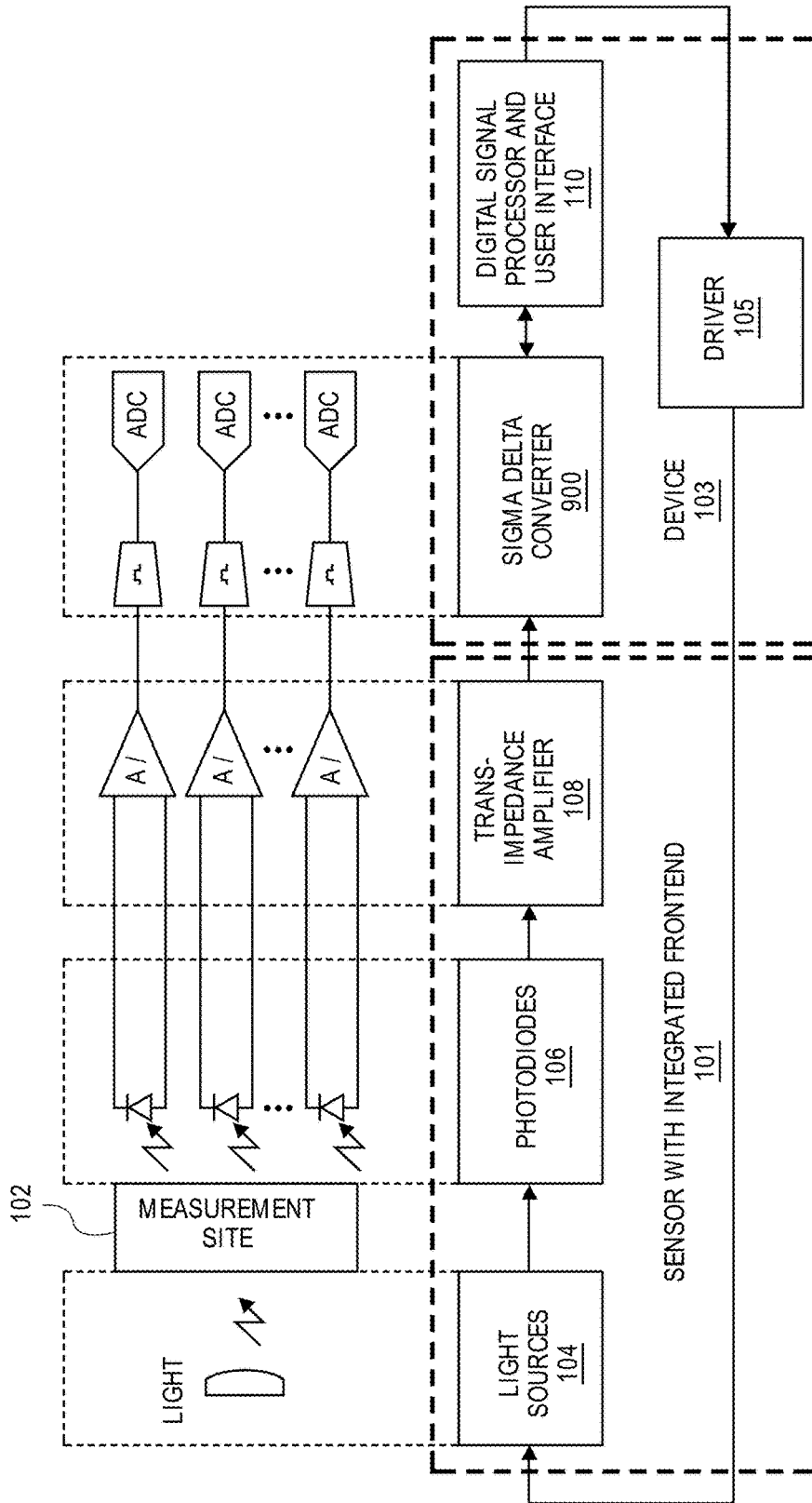

FIG. 151

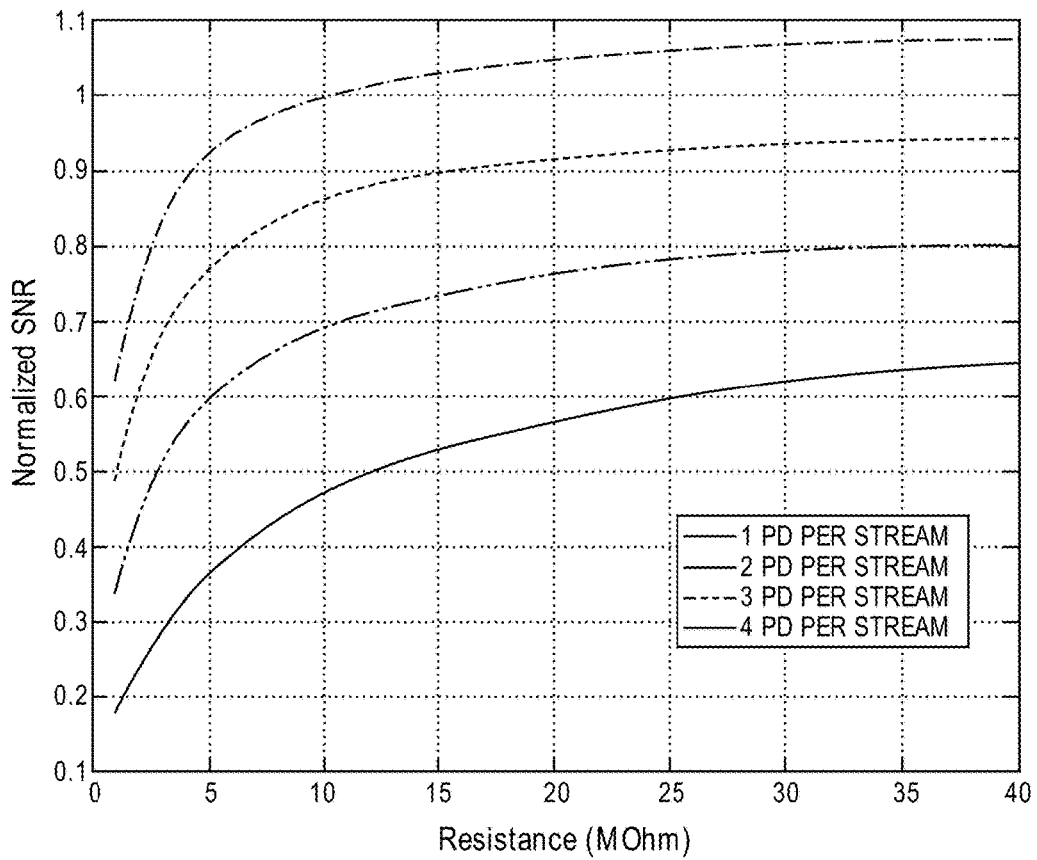
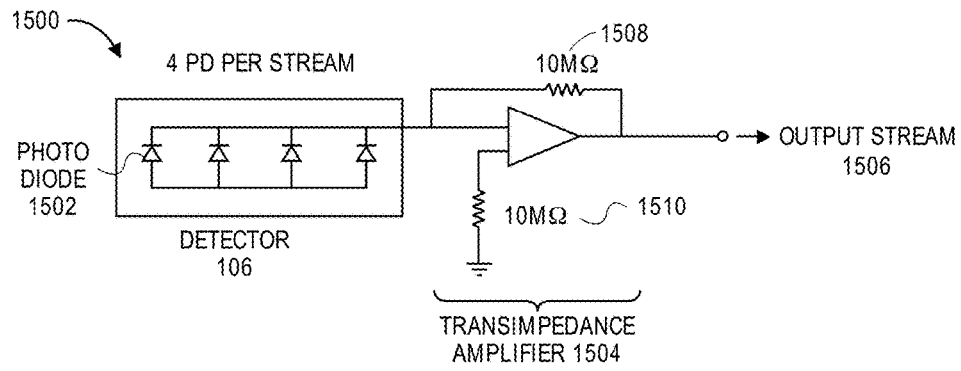

FIG. 15J



VS.

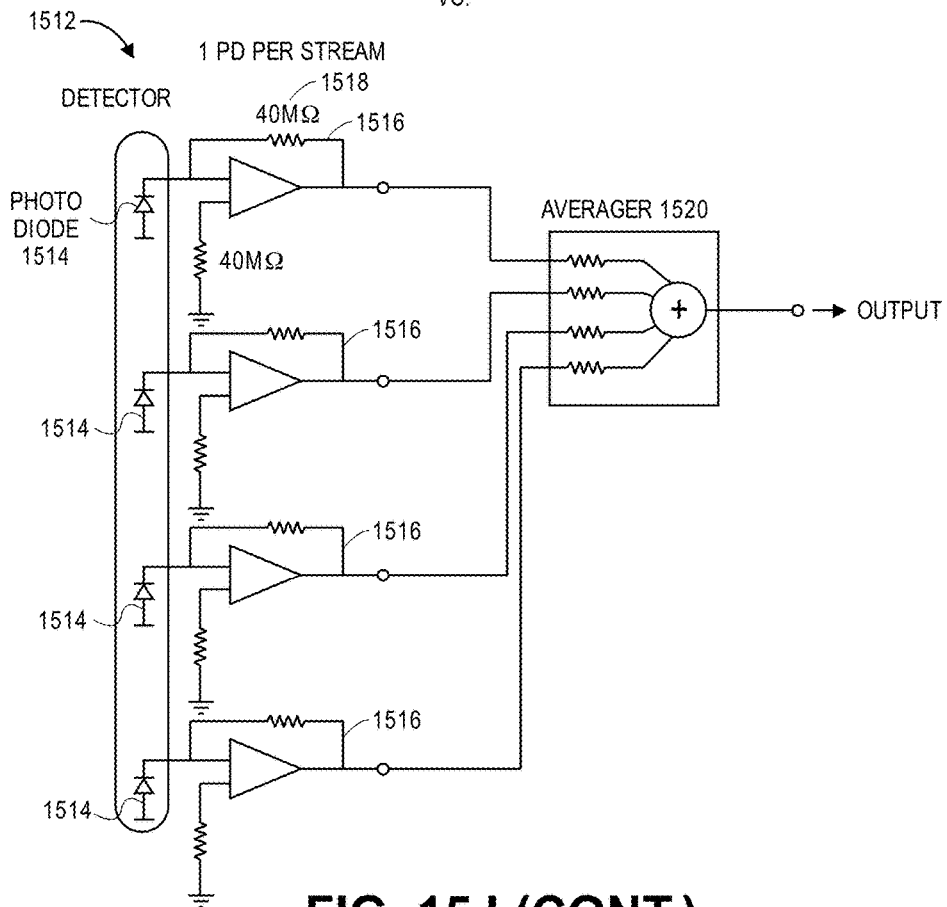

FIG. 15J (CONT.)

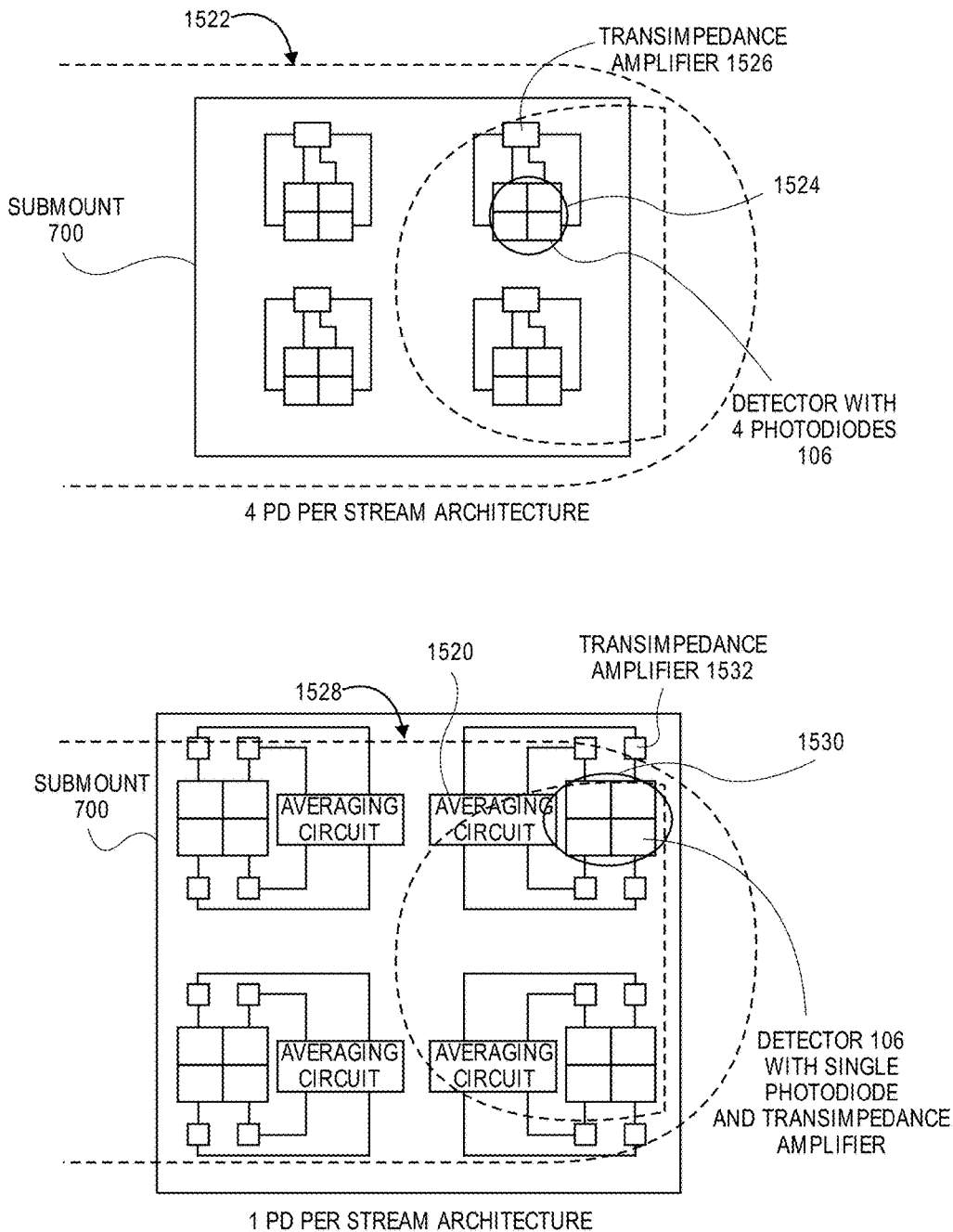

FIG. 15K

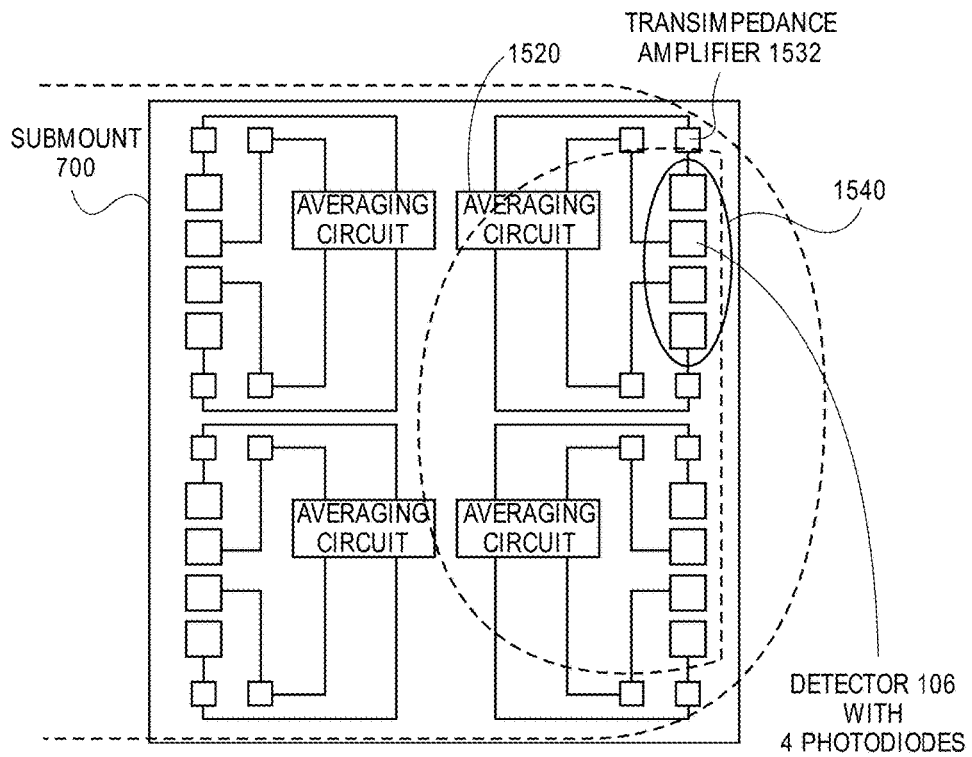
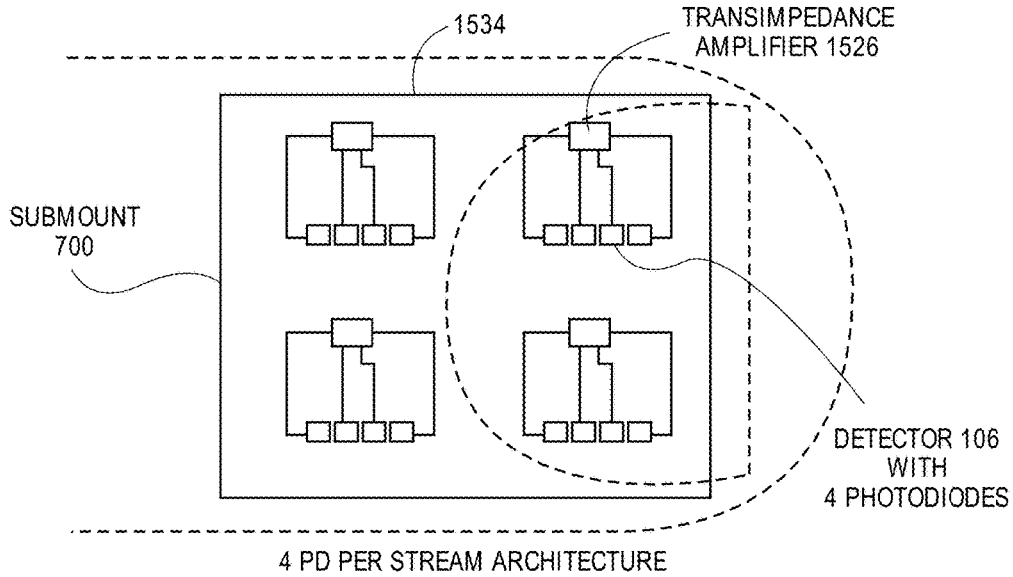
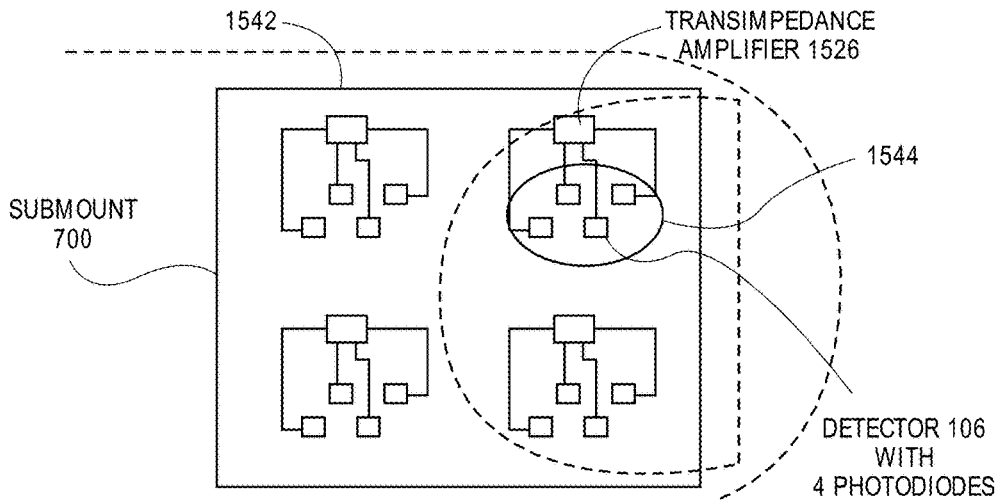
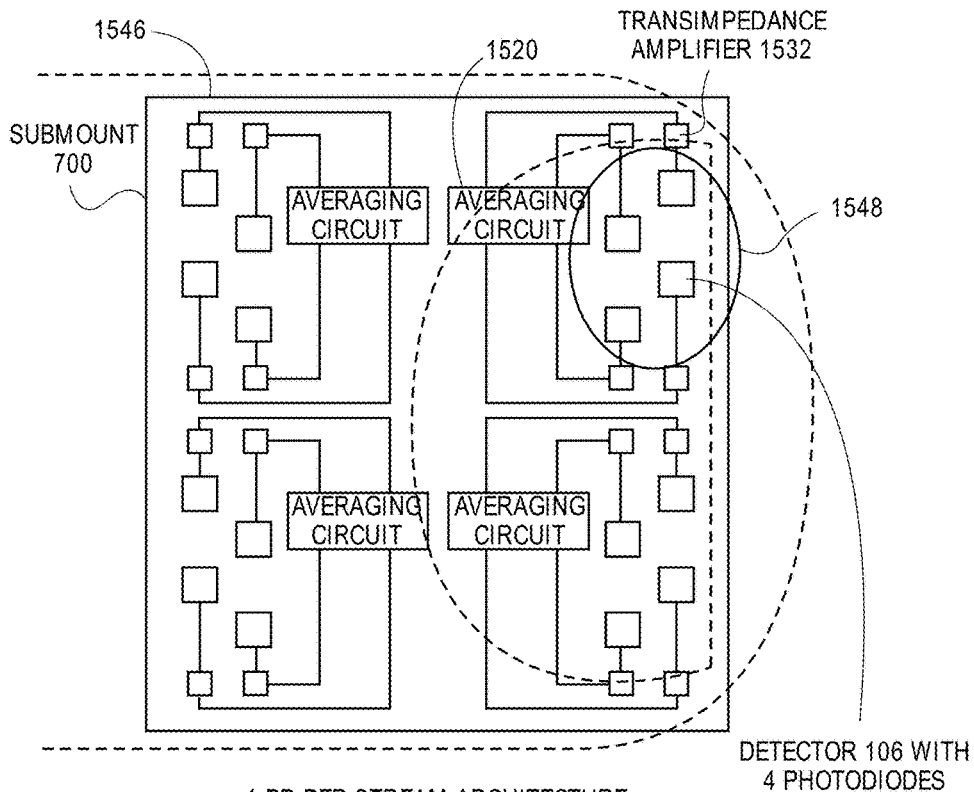

FIG. 15K (CONT.)



4 PD PER STREAM ARCHITECTURE



1 PD PER STREAM ARCHITECTURE

FIG. 15K (CONT.)

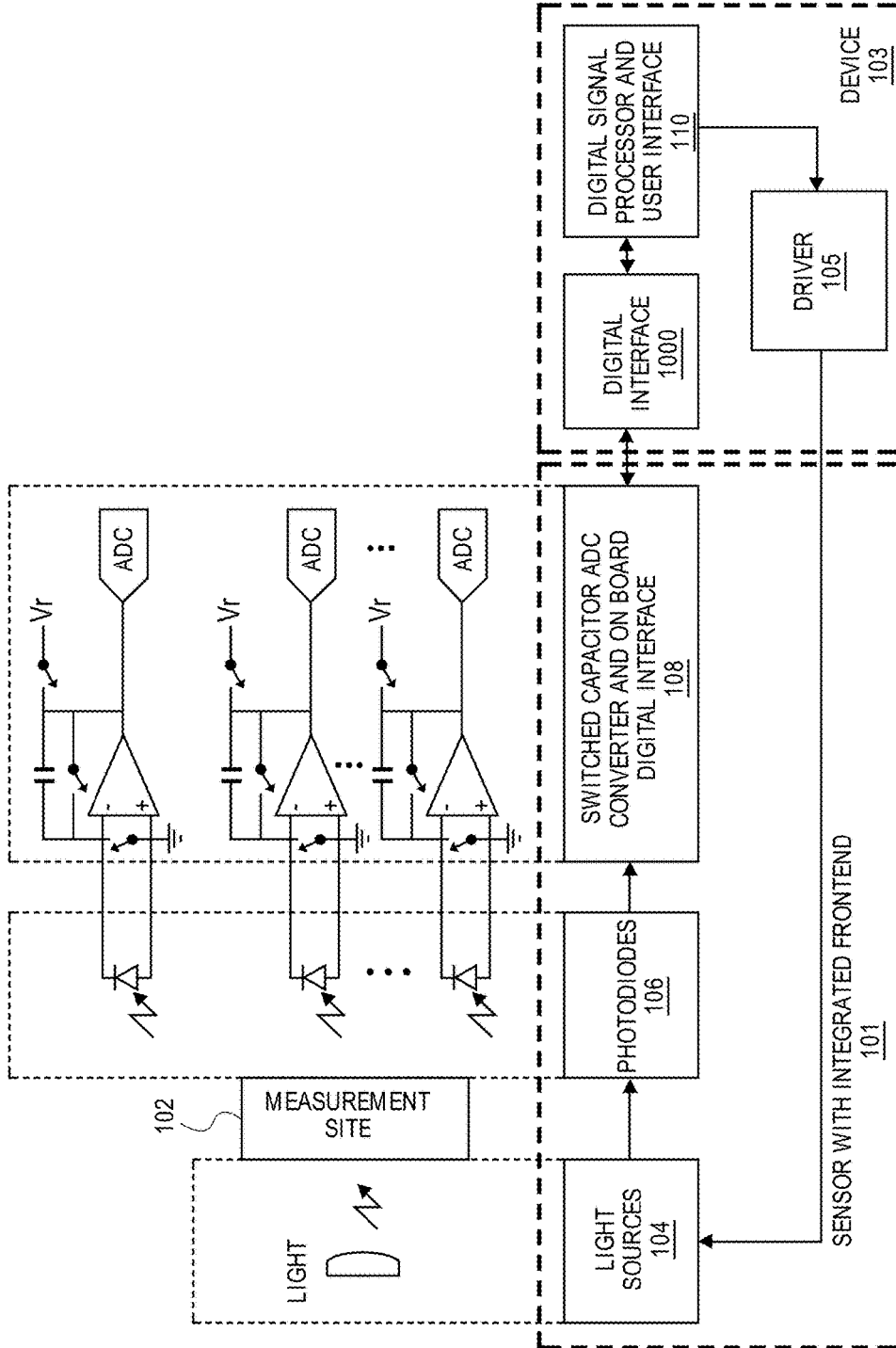

FIG. 15L

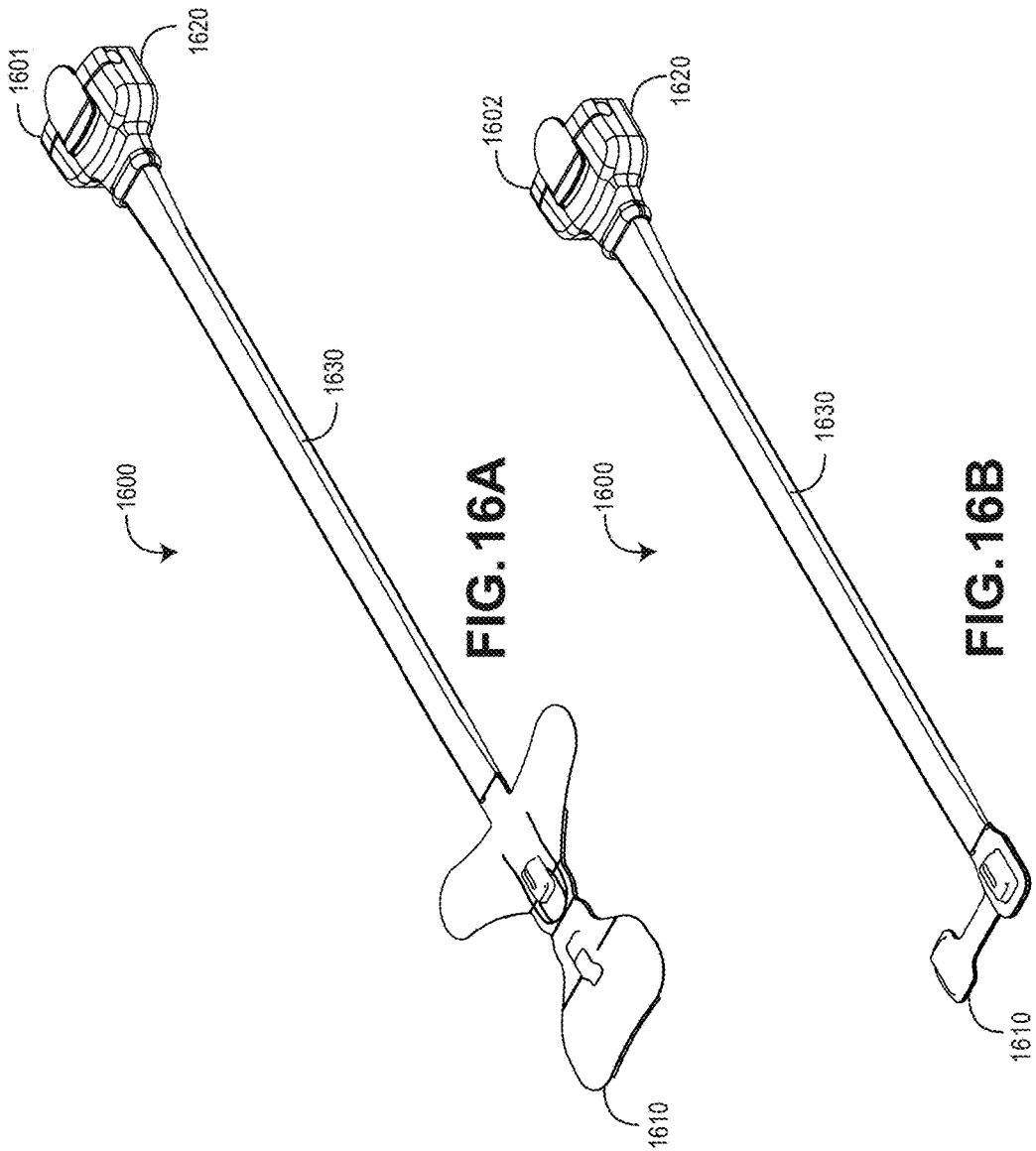

FIG. 16A

FIG. 16B

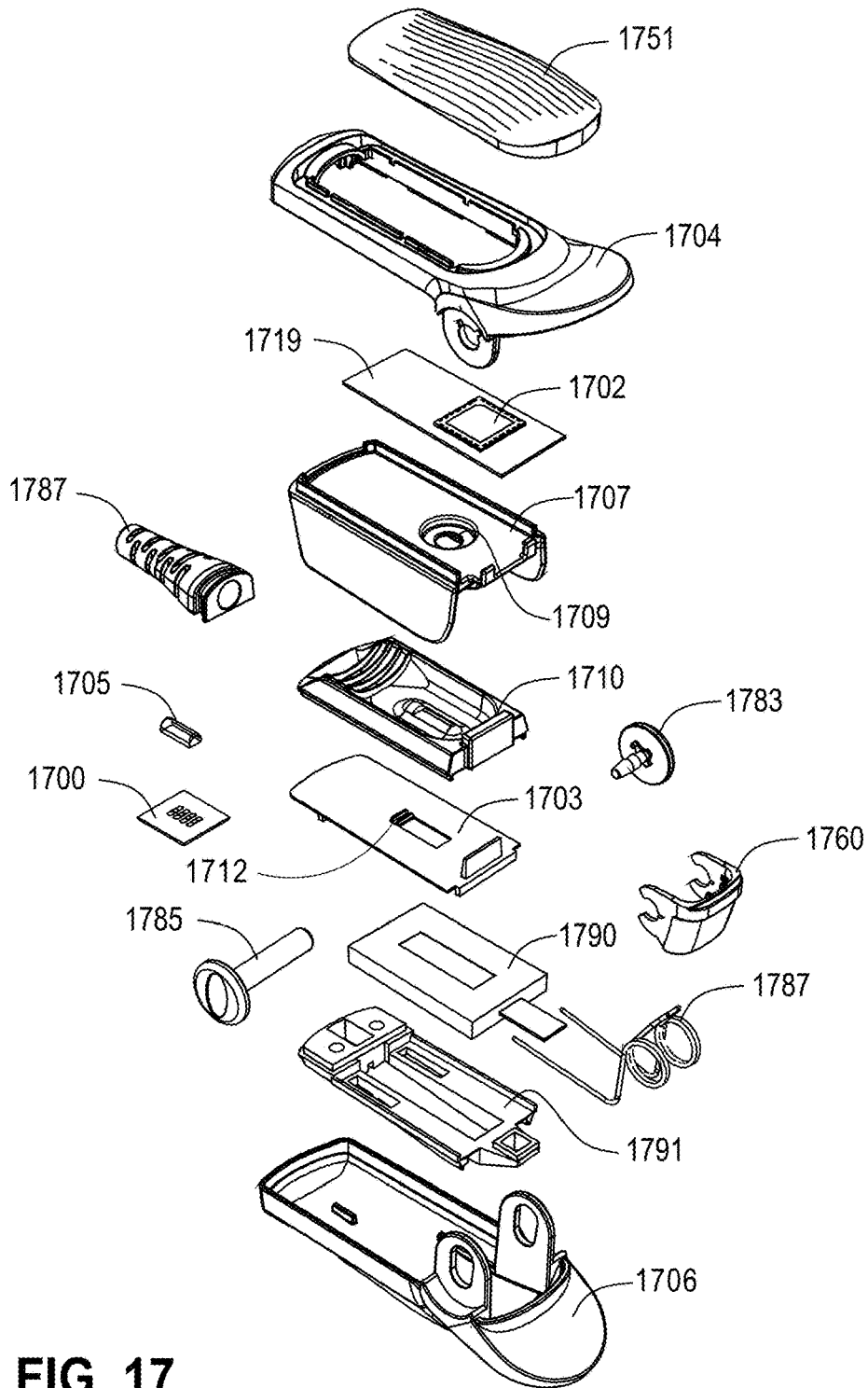

FIG. 17

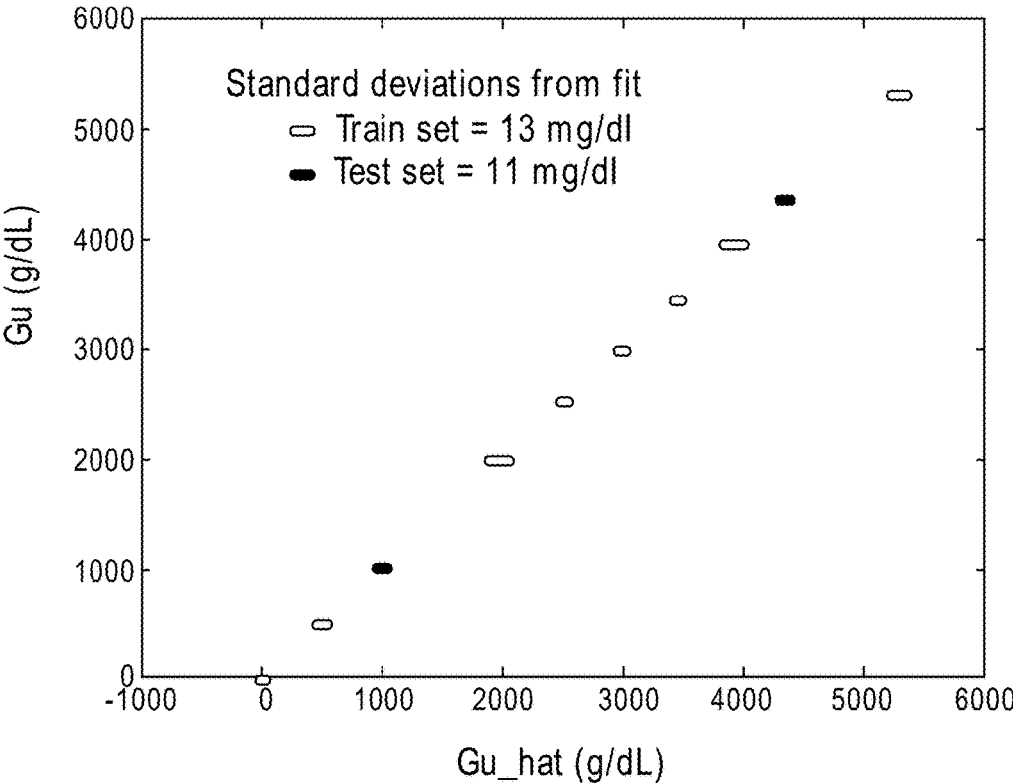

FIG. 18

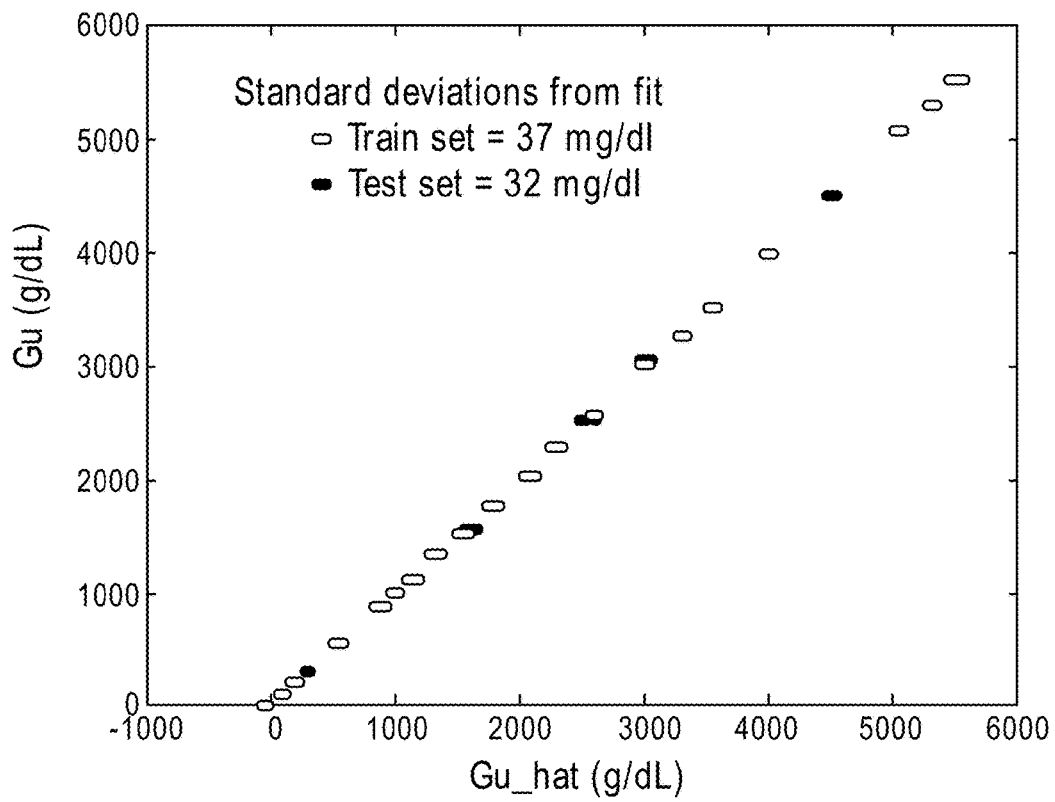

FIG. 19

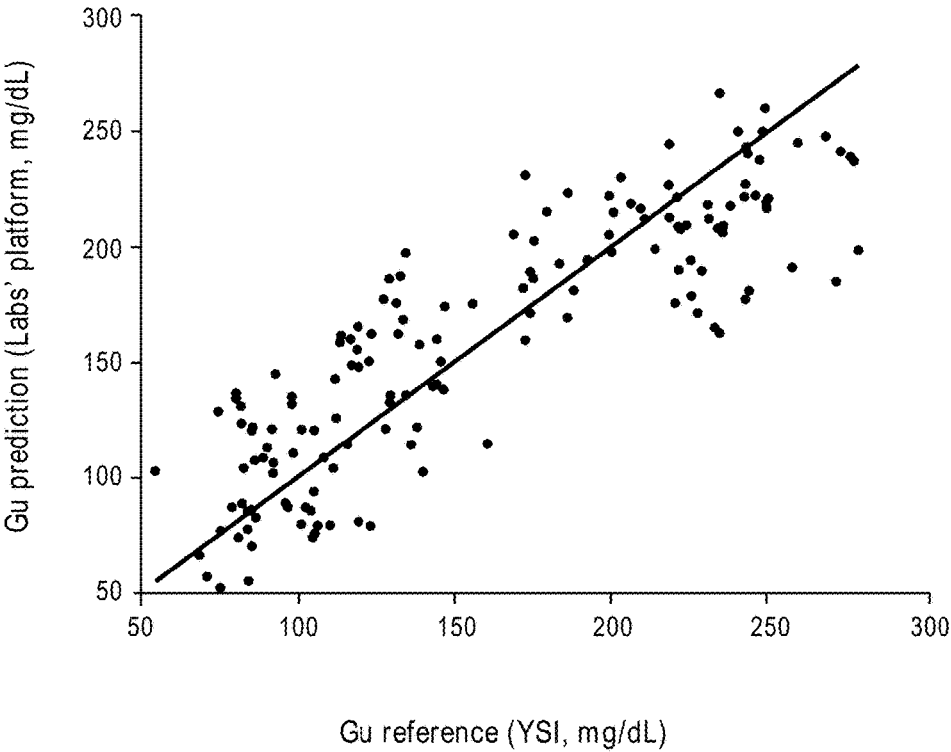

FIG. 20

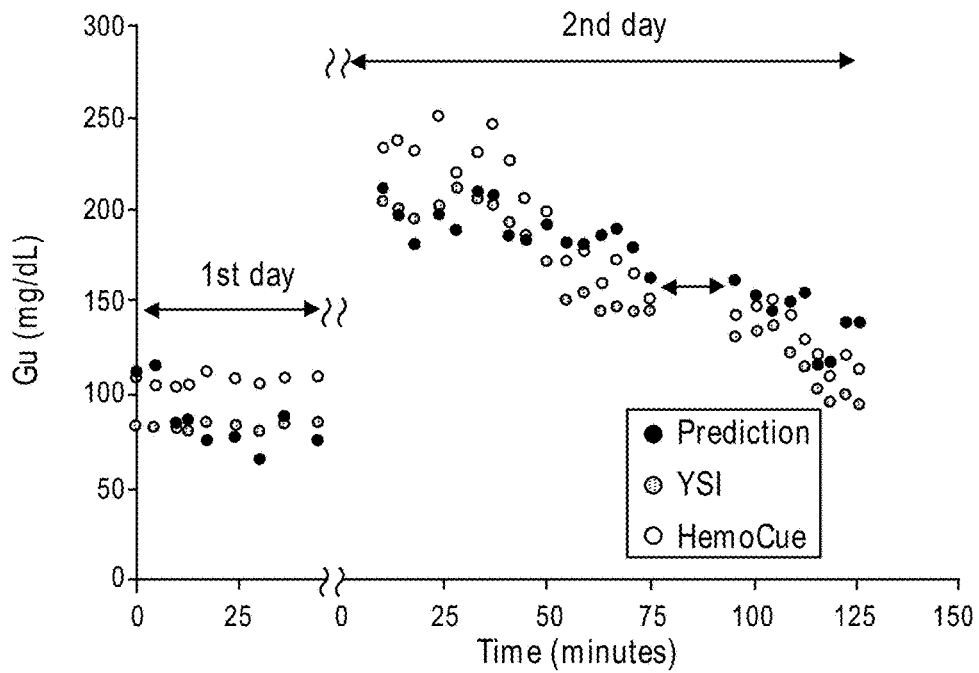

FIG. 21

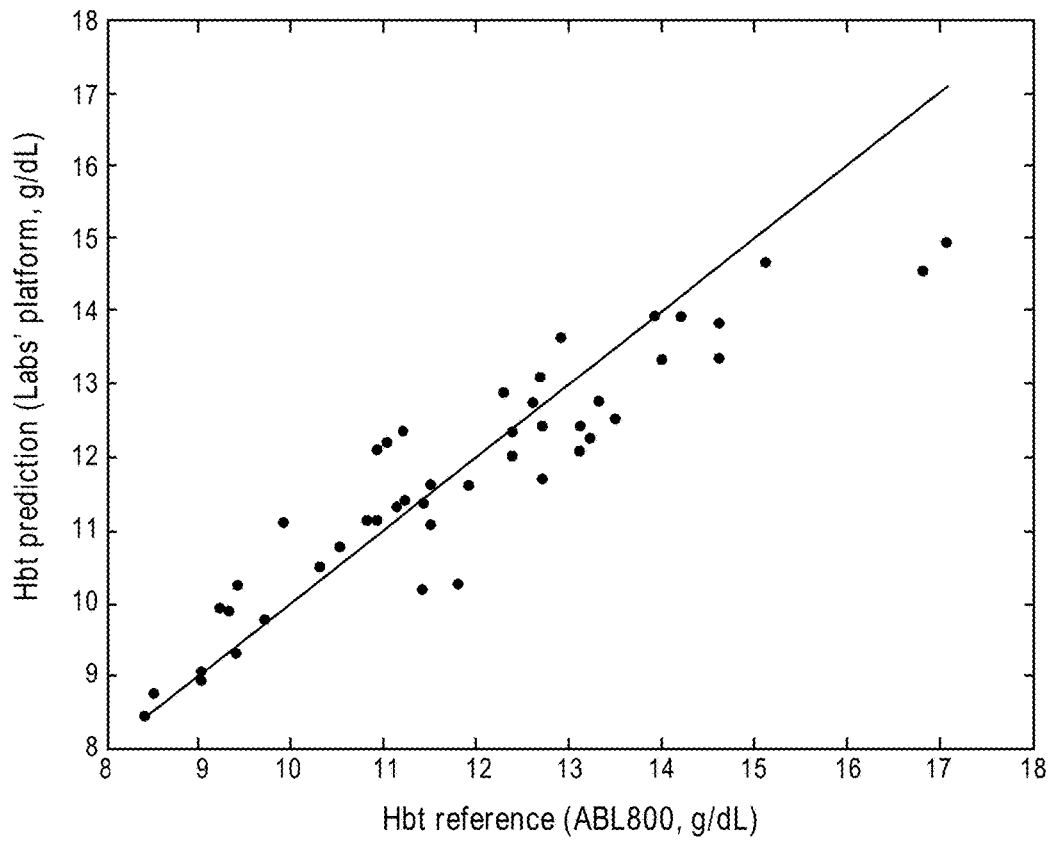

FIG. 22

MULTI-STREAM DATA COLLECTION SYSTEM FOR NONINVASIVE MEASUREMENT OF BLOOD CONSTITUENTS

RELATED APPLICATIONS

This application is a continuation of U.S. patent application Ser. No. 14/981,290 filed Dec. 28, 2015, which is a continuation of U.S. patent application Ser. No. 12/829,352 filed Jul. 1, 2010, which is a continuation of U.S. patent application Ser. No. 12/534,827 filed Aug. 3, 2009, which claims the benefit of priority under 35 U.S.C. § 119(e) of the following U.S. Provisional Patent Application Nos. 61/086,060 filed Aug. 4, 2008, 61/086,108 filed Aug. 4, 2008, 61/086,063 filed Aug. 4, 2008, 61/086,057 filed Aug. 4, 2008, and 61/091,732 filed Aug. 25, 2008. U.S. patent application Ser. No. 12/829,352 is also a continuation-in-part of U.S. patent application Ser. No. 12/497,528 filed Jul. 2, 2009, which claims the benefit of priority under 35 U.S.C. § 119(e) of the following U.S. Provisional Patent Application Nos. 61/086,060 filed Aug. 4, 2008, 61/086,108 filed Aug. 4, 2008, 61/086,063 filed Aug. 4, 2008, 61/086,057 filed Aug. 4, 2008, 61/078,228 filed Jul. 3, 2008, 61/078,207 filed Jul. 3, 2008, and 61/091,732 filed Aug. 25, 2008. U.S. patent application Ser. No. 12/497,528 also claims the benefit of priority under 35 U.S.C. § 120 as a continuation-in-part of the following U.S. Design Patent application Nos. 29/323,409 filed Aug. 25, 2008 and Ser. No. 29/323,408 filed Aug. 25, 2008. U.S. patent application Ser. No. 12/829,352 is also a continuation-in-part of U.S. patent application Ser. No. 12/497,523 filed Jul. 2, 2009, which claims the benefit of priority under 35 U.S.C. § 119(e) of the following U.S. Provisional Patent Application Nos. 61/086,060 filed Aug. 4, 2008, 61/086,108 filed Aug. 4, 2008, 61/086,063 filed Aug. 4, 2008, 61/086,057 filed Aug. 4, 2008, 61/078,228 filed Jul. 3, 2008, 61/078,207 filed Jul. 3, 2008, and 61/091,732 filed Aug. 25, 2008. U.S. patent application Ser. No. 12/497,523 also claims the benefit of priority under 35 U.S.C. § 120 as a continuation-in-part of the following U.S. Design Patent application Nos. 29/323,409 filed Aug. 25, 2008 and Ser. No. 29/323,408 filed Aug. 25, 2008.

This application is related to the following U.S. Patent Applications:

App. No.	Filing Date	Title	Attorney Docket
12/497,528	Jul. 2, 2009	Noise Shielding for Noninvasive Device Contoured Protrusion for Improving Spectroscopic Measurement of Blood Constituents	MASCER.006A
12/497,523	Jul. 2, 2009	Heat Sink for Noninvasive Medical Sensor	MASCER.007A
12/497,506	Jul. 2, 2009	Multi-Stream Sensor Front Ends for Non-Invasive Measurement of Blood Constituents	MASCER.011A
12/534,812	Aug. 3, 2009	Multi-Stream Sensor for Non-Invasive Measurement of Blood Constituents	MASCER.003A
12/534,823	Aug. 3, 2009	Multi-Stream Emitter for Non-Invasive Measurement of Blood Constituents	MASCER.004A
12/534,825	Aug. 3, 2009		CERCA.005A

The foregoing applications are hereby incorporated by reference in their entirety.

BACKGROUND

The standard of care in caregiver environments includes patient monitoring through spectroscopic analysis using, for

example, a pulse oximeter. Devices capable of spectroscopic analysis generally include a light source(s) transmitting optical radiation into or reflecting off a measurement site, such as, body tissue carrying pulsing blood. After attenuation by tissue and fluids of the measurement site, a photo-detection device(s) detects the attenuated light and outputs a detector signal(s) responsive to the detected attenuated light. A signal processing device(s) process the detector(s) signal (s) and outputs a measurement indicative of a blood constituent of interest, such as glucose, oxygen, met hemoglobin, total hemoglobin, other physiological parameters, or other data or combinations of data useful in determining a state or trend of wellness of a patient.

In noninvasive devices and methods, a sensor is often adapted to position a finger proximate the light source and light detector. For example, noninvasive sensors often include a clothespin-shaped housing that includes a contoured bed conforming generally to the shape of a finger.

SUMMARY

This disclosure describes embodiments of noninvasive methods, devices, and systems for measuring a blood constituent or analyte, such as oxygen, carbon monoxide, methemoglobin, total hemoglobin, glucose, proteins, glucose, lipids, a percentage thereof (e.g., saturation) or for measuring many other physiologically relevant patient characteristics. These characteristics can relate, for example, to pulse rate, hydration, trending information and analysis, and the like.

In an embodiment, the system includes a noninvasive sensor and a patient monitor communicating with the non-invasive sensor. The non-invasive sensor may include different architectures to implement some or all of the disclosed features. In addition, an artisan will recognize that the non-invasive sensor may include or may be coupled to other components, such as a network interface, and the like. Moreover, the patient monitor may include a display device, a network interface communicating with any one or combination of a computer network, a handheld computing device, a mobile phone, the Internet, or the like. In addition, embodiments may include multiple optical sources that emit light at a plurality of wavelengths and that are arranged from the perspective of the light detector(s) as a point source.

In an embodiment, a noninvasive device is capable of producing a signal responsive to light attenuated by tissue at a measurement site. The device may comprise an optical source and a plurality of photodetectors. The optical source is configured to emit optical radiation at least at wavelengths between about 1600 nm and about 1700 nm. The photode-

3

tectors are configured to detect the optical radiation from said optical source after attenuation by the tissue of the measurement site and each output a respective signal stream responsive to the detected optical radiation.

In an embodiment, a noninvasive, physiological sensor is capable of outputting a signal responsive to a blood analyte present in a monitored patient. The sensor may comprise a sensor housing, an optical source, and photodetectors. The optical source is positioned by the housing with respect to a tissue site of a patient when said housing is applied to the patient. The photodetectors are positioned by the housing with respect to said tissue site when the housing is applied to the patient with a variation in path length among at least some of the photodetectors from the optical source. The photodetectors are configured to detect a sequence of optical radiation from the optical source after attenuation by tissue of the tissue site. The photodetectors may be each configured to output a respective signal stream responsive to the detected sequence of optical radiation. An output signal responsive to one or more of the signal streams is then usable to determine the blood analyte based at least in part on the variation in path length

In an embodiment, a method of measuring an analyte based on multiple streams of optical radiation measured from a measurement site is provided. A sequence of optical radiation pulses is emitted to the measurement site. At a first location, a first stream of optical radiation is detected from the measurement site. At least at one additional location different from the first location, an additional stream of optical radiation is detected from the measurement site. An output measurement value indicative of the analyte is then determined based on the detected streams of optical radiation.

In various embodiments, the present disclosure relates to an interface for a noninvasive sensor that comprises a front-end adapted to receive an input signals from optical detectors and provide corresponding output signals. In an embodiment, the front-end is comprised of switched-capacitor circuits that are capable of handling multiple streams of signals from the optical detectors. In another embodiment, the front-end comprises transimpedance amplifiers that are capable of handling multiple streams of input signals. In addition, the transimpedance amplifiers may be configured based on the characteristics of the transimpedance amplifier itself, the characteristics of the photodiodes, and the number of photodiodes coupled to the transimpedance amplifier.

In disclosed embodiments, the front-ends are employed in noninvasive sensors to assist in measuring and detecting various analytes. The disclosed noninvasive sensor may also include, among other things, emitters and detectors positioned to produce multi-stream sensor information. An artisan will recognize that the noninvasive sensor may have different architectures and may include or be coupled to other components, such as a display device, a network interface, and the like. An artisan will also recognize that the front-ends may be employed in any type of noninvasive sensor.

In an embodiment, a front-end interface for a noninvasive, physiological sensor comprises: a set of inputs configured to receive signals from a plurality of detectors in the sensor; a set of transimpedance amplifiers configured to convert the signals from the plurality of detectors into an output signal having a stream for each of the plurality of detectors; and an output configured to provide the output signal.

In an embodiment, a front-end interface for a noninvasive, physiological sensor comprises: a set of inputs configured to receive signals from a plurality of detectors in the sensor; a

4

set of switched capacitor circuits configured to convert the signals from the plurality of detectors into a digital output signal having a stream for each of the plurality of detectors; and an output configured to provide the digital output signal.

In an embodiment, a conversion processor for a physiological, noninvasive sensor comprises: a multi-stream input configured to receive signals from a plurality of detectors in the sensor, wherein the signals are responsive to optical radiation from a tissue site; a modulator that converts the multi-stream input into a digital bit-stream; and a signal processor that produces an output signal from the digital bit-stream.

In an embodiment, a front-end interface for a noninvasive, physiological sensor comprises: a set of inputs configured to receive signals from a plurality of detectors in the sensor; a set of respective transimpedance amplifiers for each detector configured to convert the signals from the plurality of detectors into an output signal having a stream for each of the plurality of detectors; and an output configured to provide the output signal.

In certain embodiments, a noninvasive sensor interfaces with tissue at a measurement site and deforms the tissue in a way that increases signal gain in certain desired wavelengths.

In some embodiments, a detector for the sensor may comprise a set of photodiodes that are arranged in a spatial configuration. This spatial configuration may allow, for example, signal analysis for measuring analytes like glucose. In various embodiments, the detectors can be arranged across multiple locations in a spatial configuration. The spatial configuration provides a geometry having a diversity of path lengths among the detectors. For example, the detector in the sensor may comprise multiple detectors that are arranged to have a sufficient difference in mean path length to allow for noise cancellation and noise reduction.

In an embodiment, a physiological, noninvasive detector is configured to detect optical radiation from a tissue site. The detector comprises a set of photodetectors and a conversion processor. The set of photodetectors each provide a signal stream indicating optical radiation from the tissue site. The set of photodetectors are arranged in a spatial configuration that provides a variation in path lengths between at least some of the photodetectors. The conversion processor that provides information indicating an analyte in the tissue site based on ratios of pairs of the signal streams.

The present disclosure, according to various embodiments, relates to noninvasive methods, devices, and systems for measuring a blood analyte, such as glucose. In the present disclosure, blood analytes are measured noninvasively based on multi-stream infrared and near-infrared spectroscopy. In some embodiments, an emitter may include one or more sources that are configured as a point optical source. In addition, the emitter may be operated in a manner that allows for the measurement of an analyte like glucose. In embodiments, the emitter may comprise a plurality of LEDs that emit a sequence of pulses of optical radiation across a spectrum of wavelengths. In addition, in order to achieve the desired SNR for detecting analytes like glucose, the emitter may be driven using a progression from low power to higher power. The emitter may also have its duty cycle modified to achieve a desired SNR.

In an embodiment, a multi-stream emitter for a noninvasive, physiological device configured to transmit optical radiation in a tissue site comprises: a set of optical sources arranged as a point optical source; and a driver configured to drive the at least one light emitting diode and at least one optical source to transmit near-infrared optical radiation at

5

sufficient power to measure an analyte in tissue that responds to near-infrared optical radiation.

In an embodiment, an emitter for a noninvasive, physiological device configured to transmit optical radiation in a tissue site comprises: a point optical source comprising an optical source configured to transmit infrared and near-infrared optical radiation to a tissue site; and a driver configured to drive the point optical source at a sufficient power and noise tolerance to effectively provide attenuated optical radiation from a tissue site that indicates an amount of glucose in the tissue site.

In an embodiment, a method of transmitting a stream of pulses of optical radiation in a tissue site is provided. At least one pulse of infrared optical radiation having a first pulse width is transmitted at a first power. At least one pulse of near-infrared optical radiation is transmitted at a power that is higher than the first power.

In an embodiment, a method of transmitting a stream of pulses of optical radiation in a tissue site is provided. At least one pulse of infrared optical radiation having a first pulse width is transmitted at a first power. At least one pulse of near-infrared optical radiation is then transmitted, at a second power that is higher than the first power.

For purposes of summarizing the disclosure, certain aspects, advantages and novel features of the inventions have been described herein. It is to be understood that not necessarily all such advantages can be achieved in accordance with any particular embodiment of the inventions disclosed herein. Thus, the inventions disclosed herein can be embodied or carried out in a manner that achieves or optimizes one advantage or group of advantages as taught herein without necessarily achieving other advantages as can be taught or suggested herein.

BRIEF DESCRIPTION OF THE DRAWINGS

Throughout the drawings, reference numbers can be used to indicate correspondence between referenced elements. The drawings are provided to illustrate embodiments of the inventions described herein and not to limit the scope thereof.

FIG. 1 illustrates a block diagram of an example data collection system capable of noninvasively measuring one or more blood analytes in a monitored patient, according to an embodiment of the disclosure;

FIGS. 2A-2D illustrate an exemplary handheld monitor and an exemplary noninvasive optical sensor of the patient monitoring system of FIG. 1, according to embodiments of the disclosure;

FIGS. 3A-3C illustrate side and perspective views of an exemplary noninvasive sensor housing including a finger bed protrusion and heat sink, according to an embodiment of the disclosure;

FIG. 3D illustrates a side view of another example noninvasive sensor housing including a heat sink, according to an embodiment of the disclosure;

FIG. 3E illustrates a perspective view of an example noninvasive sensor detector shell including example detectors, according to an embodiment of the disclosure;

FIG. 3F illustrates a side view of an example noninvasive sensor housing including a finger bed protrusion and heat sink, according to an embodiment of the disclosure;

FIGS. 4A through 4C illustrate top elevation, side and top perspective views of an example protrusion, according to an embodiment of the disclosure;

6

FIG. 5 illustrates an example graph depicting possible effects of a protrusion on light transmittance, according to an embodiment of the disclosure;

FIGS. 6A through 6D illustrate perspective, front elevation, side and top views of another example protrusion, according to an embodiment of the disclosure;

FIG. 6E illustrates an example sensor incorporating the protrusion of FIGS. 6A through 6D, according to an embodiment of the disclosure;

FIGS. 7A through 7B illustrate example arrangements of conductive glass that may be employed in the system of FIG. 1, according to embodiments of the disclosure.

FIGS. 8A through 8D illustrate an example top elevation view, side views, and a bottom elevation view of the conductive glass that may be employed in the system of FIG. 1, according to embodiments of the disclosure;

FIG. 9 shows example comparative results obtained by an embodiment of a sensor;

FIGS. 10A and 10B illustrate comparative noise floors of various embodiments of the present disclosure;

FIG. 11A illustrates an exemplary emitter that may be employed in the sensor, according to an embodiment of the disclosure;

FIG. 11B illustrates a configuration of emitting optical radiation into a measurement site for measuring blood constituents, according to an embodiment of the disclosure;

FIG. 11C illustrates another exemplary emitter that may be employed in the sensor according to an embodiment of the disclosure;

FIG. 11D illustrates another exemplary emitter that may be employed in the sensor according to an embodiment of the disclosure.

FIG. 12A illustrates an example detector portion that may be employed in an embodiment of a sensor, according to an embodiment of the disclosure;

FIGS. 12B through 12D illustrate exemplary arrangements of detectors that may be employed in an embodiment of the sensor, according to some embodiments of the disclosure;

FIGS. 12E through 12H illustrate exemplary structures of photodiodes that may be employed in embodiments of the detectors, according to some embodiments of the disclosure;

FIG. 13 illustrates an example multi-stream operation of the system of FIG. 1, according to an embodiment of the disclosure;

FIG. 14A illustrates another example detector portion having a partially cylindrical protrusion that can be employed in an embodiment of a sensor, according to an embodiment of the disclosure;

FIG. 14B depicts a front elevation view of the partially cylindrical protrusion of FIG. 14A;

FIGS. 14C through 14E illustrate embodiments of a detector submount;

FIGS. 14F through 14H illustrate embodiment of portions of a detector shell;

FIG. 14I illustrates a cutaway view of an embodiment of a sensor;

FIGS. 15A through 15F illustrate embodiments of sensors that include heat sink features;

FIGS. 15G and 15H illustrate embodiments of connector features that can be used with any of the sensors described herein;

FIG. 15I illustrates an exemplary architecture for a transimpedance-based front-end that may be employed in any of the sensors described herein;

FIG. 15J illustrates an exemplary noise model for configuring the transimpedance-based front-ends shown in FIG. 15I;

FIG. 15K shows different architectures and layouts for various embodiments of a sensor and its detectors;

FIG. 15L illustrates an exemplary architecture for a switched-capacitor-based front-end that may be employed in any of the sensors described herein;

FIGS. 16A and 16B illustrate embodiments of disposable optical sensors;

FIG. 17 illustrates an exploded view of certain components of an example sensor; and

FIGS. 18 through 22 illustrate various results obtained by an exemplary sensor of the disclosure.

DETAILED DESCRIPTION

The present disclosure generally relates to non-invasive medical devices. In the present disclosure, a sensor can measure various blood constituents or analytes noninvasively using multi-stream spectroscopy. In an embodiment, the multi-stream spectroscopy can employ visible, infrared and near infrared wavelengths. As disclosed herein, the sensor is capable of noninvasively measuring blood analytes or percentages thereof (e.g., saturation) based on various combinations of features and components.

In various embodiments, the present disclosure relates to an interface for a noninvasive glucose sensor that comprises a front-end adapted to receive an input signals from optical detectors and provide corresponding output signals. The front-end may comprise, among other things, switched capacitor circuits or transimpedance amplifiers. In an embodiment, the front-end may comprise switched capacitor circuits that are configured to convert the output of sensor's detectors into a digital signal. In another embodiment, the front-end may comprise transimpedance amplifiers. These transimpedance amplifiers may be configured to match one or more photodiodes in a detector based on a noise model that accounts for characteristics, such as the impedance, of the transimpedance amplifier, characteristics of each photodiode, such as the impedance, and the number of photodiodes coupled to the transimpedance amplifier.

In the present disclosure, the front-ends are employed in a sensor that measures various blood analytes noninvasively using multi-stream spectroscopy. In an embodiment, the multi-stream spectroscopy can employ visible, infrared and near infrared wavelengths. As disclosed herein, the sensor is capable of noninvasively measuring blood analytes, such as glucose, total hemoglobin, methemoglobin, oxygen content, and the like, based on various combinations of features and components.

In an embodiment, a physiological sensor includes a detector housing that can be coupled to a measurement site, such as a patient's finger. The sensor housing can include a curved bed that can generally conform to the shape of the measurement site. In addition, the curved bed can include a protrusion shaped to increase an amount of light radiation from the measurement site. In an embodiment, the protrusion is used to thin out the measurement site. This allows the light radiation to pass through less tissue, and accordingly is attenuated less. In an embodiment, the protrusion can be used to increase the area from which attenuated light can be measured. In an embodiment, this is done through the use of a lens which collects attenuated light exiting the measurement site and focuses onto one or more detectors. The protrusion can advantageously include plastic, including a hard opaque plastic, such as a black or other colored plastic,

helpful in reducing light noise. In an embodiment, such light noise includes light that would otherwise be detected at a photodetector that has not been attenuated by tissue of the measurement site of a patient sufficient to cause the light to adequately included information indicative of one or more physiological parameters of the patient. Such light noise includes light piping.

In an embodiment, the protrusion can be formed from the curved bed, or can be a separate component that is positionable with respect to the bed. In an embodiment, a lens made from any appropriate material is used as the protrusion. The protrusion can be convex in shape. The protrusion can also be sized and shaped to conform the measurement site into a flat or relatively flat surface. The protrusion can also be sized to conform the measurement site into a rounded surface, such as, for example, a concave or convex surface. The protrusion can include a cylindrical or partially cylindrical shape. The protrusion can be sized or shaped differently for different types of patients, such as an adult, child, or infant. The protrusion can also be sized or shaped differently for different measurement sites, including, for example, a finger, toe, hand, foot, ear, forehead, or the like. The protrusion can thus be helpful in any type of noninvasive sensor. The external surface of the protrusion can include one or more openings or windows. The openings can be made from glass to allow attenuated light from a measurement site, such as a finger, to pass through to one or more detectors. Alternatively, some of all of the protrusion can be a lens, such as a partially cylindrical lens.

The sensor can also include a shielding, such as a metal enclosure as described below or embedded within the protrusion to reduce noise. The shielding can be constructed from a conductive material, such as copper, in the form of a metal cage or enclosure, such as a box. The shielding can include a second set of one or more openings or windows. The second set of openings can be made from glass and allow light that has passed through the first set of windows of the external surface of the protrusion to pass through to one or more detectors that can be enclosed, for example, as described below.

In various embodiments, the shielding can include any substantially transparent, conductive material placed in the optical path between an emitter and a detector. The shielding can be constructed from a transparent material, such as glass, plastic, and the like. The shielding can have an electrically conductive material or coating that is at least partially transparent. The electrically conductive coating can be located on one or both sides of the shielding, or within the body of the shielding. In addition, the electrically conductive coating can be uniformly spread over the shielding or may be patterned. Furthermore, the coating can have a uniform or varying thickness to increase or optimize its shielding effect. The shielding can be helpful in virtually any type of non-invasive sensor that employs spectroscopy.

In an embodiment, the sensor can also include a heat sink. In an embodiment, the heat sink can include a shape that is functional in its ability to dissipate excess heat and aesthetically pleasing to the wearer. For example, the heat sink can be configured in a shape that maximizes surface area to allow for greater dissipation of heat. In an embodiment, the heat sink includes a metallicized plastic, such as plastic including carbon and aluminum to allow for improved thermal conductivity and diffusivity. In an embodiment, the heat sink can advantageously be inexpensively molded into desired shapes and configurations for aesthetic and functional purposes. For example, the shape of the heat sink can

be a generally curved surface and include one or more fins, undulations, grooves or channels, or combs.

The sensor can include photocommunicative components, such as an emitter, a detector, and other components. The emitter can include a plurality of sets of optical sources that, in an embodiment, are arranged together as a point source. The various optical sources can emit a sequence of optical radiation pulses at different wavelengths towards a measurement site, such as a patient's finger. Detectors can then detect optical radiation from the measurement site. The optical sources and optical radiation detectors can operate at any appropriate wavelength, including, as discussed herein, infrared, near infrared, visible light, and ultraviolet. In addition, the optical sources and optical radiation detectors can operate at any appropriate wavelength, and such modifications to the embodiments desirable to operate at any such wavelength will be apparent to those skilled in the art.

In certain embodiments, multiple detectors are employed and arranged in a spatial geometry. This spatial geometry provides a diversity of path lengths among at least some of the detectors and allows for multiple bulk and pulsatile measurements that are robust. Each of the detectors can provide a respective output stream based on the detected optical radiation, or a sum of output streams can be provided from multiple detectors. In some embodiments, the sensor can also include other components, such as one or more heat sinks and one or more thermistors.

The spatial configuration of the detectors provides a geometry having a diversity of path lengths among the detectors. For example, a detector in the sensor may comprise multiple detectors that are arranged to have a sufficient difference in mean path length to allow for noise cancellation and noise reduction. In addition, walls may be used to separate individual photodetectors and prevent mixing of detected optical radiation between the different locations on the measurement site. A window may also be employed to facilitate the passing of optical radiation at various wavelengths for measuring glucose in the tissue.

In the present disclosure, a sensor may measure various blood constituents or analytes noninvasively using spectroscopy and a recipe of various features. As disclosed herein, the sensor is capable of non-invasively measuring blood analytes, such as, glucose, total hemoglobin, methemoglobin, oxygen content, and the like. In an embodiment, the spectroscopy used in the sensor can employ visible, infrared and near infrared wavelengths. The sensor may comprise an emitter, a detector, and other components. In some embodiments, the sensor may also comprise other components, such as one or more heat sinks and one or more thermistors.

In various embodiments, the sensor may also be coupled to one or more companion devices that process and/or display the sensor's output. The companion devices may comprise various components, such as a sensor front-end, a signal processor, a display, a network interface, a storage device or memory, etc.

A sensor can include photocommunicative components, such as an emitter, a detector, and other components. The emitter is configured as a point optical source that comprises a plurality of LEDs that emit a sequence of pulses of optical radiation across a spectrum of wavelengths. In some embodiments, the plurality of sets of optical sources may each comprise at least one top-emitting LED and at least one super luminescent LED. In some embodiments, the emitter comprises optical sources that transmit optical radiation in the infrared or near-infrared wavelengths suitable for detecting blood analytes like glucose. In order to achieve the desired SNR for detecting analytes like glucose, the emitter

may be driven using a progression from low power to higher power. In addition, the emitter may have its duty cycle modified to achieve a desired SNR.

The emitter may be constructed of materials, such as aluminum nitride and may include a heat sink to assist in heat dissipation. A thermistor may also be employed to account for heating effects on the LEDs. The emitter may further comprise a glass window and a nitrogen environment to improve transmission from the sources and prevent oxidative effects.

The sensor can be coupled to one or more monitors that process and/or display the sensor's output. The monitors can include various components, such as a sensor front end, a signal processor, a display, etc.

The sensor can be integrated with a monitor, for example, into a handheld unit including the sensor, a display and user controls. In other embodiments, the sensor can communicate with one or more processing devices. The communication can be via wire(s), cable(s), flex circuit(s), wireless technologies, or other suitable analog or digital communication methodologies and devices to perform those methodologies. Many of the foregoing arrangements allow the sensor to be attached to the measurement site while the device is attached elsewhere on a patient, such as the patient's arm, or placed at a location near the patient, such as a bed, shelf or table. The sensor or monitor can also provide outputs to a storage device or network interface.

Reference will now be made to the Figures to discuss embodiments of the present disclosure.

FIG. 1 illustrates an example of a data collection system **100**. In certain embodiments, the data collection system **100** noninvasively measure a blood analyte, such as oxygen, carbon monoxide, methemoglobin, total hemoglobin, glucose, proteins, glucose, lipids, a percentage thereof (e.g., saturation) or for measuring many other physiologically relevant patient characteristics. The system **100** can also measure additional blood analytes and/or other physiological parameters useful in determining a state or trend of wellness of a patient.

The data collection system **100** can be capable of measuring optical radiation from the measurement site. For example, in some embodiments, the data collection system **100** can employ photodiodes defined in terms of area. In an embodiment, the area is from about 1 mm²-5 mm² (or higher) that are capable of detecting about 100 nanoamps (nA) or less of current resulting from measured light at full scale. In addition to having its ordinary meaning, the phrase "at full scale" can mean light saturation of a photodiode amplifier (not shown). Of course, as would be understood by a person of skill in the art from the present disclosure, various other sizes and types of photodiodes can be used with the embodiments of the present disclosure.

The data collection system **100** can measure a range of approximately about 2 nA to about 100 nA full scale. The data collection system **100** can also include sensor front-ends that are capable of processing and amplifying current from the detector(s) at signal-to-noise ratios (SNRs) of about 100 decibels (dB) or more, such as about 120 dB in order to measure various desired analytes. The data collection system **100** can operate with a lower SNR if less accuracy is desired for an analyte like glucose.

The data collection system **100** can measure analyte concentrations, including glucose, at least in part by detecting light attenuated by a measurement site **102**. The measurement site **102** can be any location on a patient's body, such as a finger, foot, ear lobe, or the like. For convenience, this disclosure is described primarily in the context of a

11

finger measurement site **102**. However, the features of the embodiments disclosed herein can be used with other measurement sites **102**.

In the depicted embodiment, the system **100** includes an optional tissue thickness adjuster or tissue shaper **105**, which can include one or more protrusions, bumps, lenses, or other suitable tissue-shaping mechanisms. In certain embodiments, the tissue shaper **105** is a flat or substantially flat surface that can be positioned proximate the measurement site **102** and that can apply sufficient pressure to cause the tissue of the measurement site **102** to be flat or substantially flat. In other embodiments, the tissue shaper **105** is a convex or substantially convex surface with respect to the measurement site **102**. Many other configurations of the tissue shaper **105** are possible. Advantageously, in certain embodiments, the tissue shaper **105** reduces thickness of the measurement site **102** while preventing or reducing occlusion at the measurement site **102**. Reducing thickness of the site can advantageously reduce the amount of attenuation of the light because there is less tissue through which the light must travel. Shaping the tissue in to a convex (or alternatively concave) surface can also provide more surface area from which light can be detected.

The embodiment of the data collection system **100** shown also includes an optional noise shield **103**. In an embodiment, the noise shield **103** can be advantageously adapted to reduce electromagnetic noise while increasing the transmittance of light from the measurement site **102** to one or more detectors **106** (described below). For example, the noise shield **103** can advantageously include a conductive coated glass or metal grid electrically communicating with one or more other shields of the sensor **101** or electrically grounded. In an embodiment where the noise shield **103** includes conductive coated glass, the coating can advantageously include indium tin oxide. In an embodiment, the indium tin oxide includes a surface resistivity ranging from approximately 30 ohms per square inch to about 500 ohms per square inch. In an embodiment, the resistivity is approximately 30, 200, or 500 ohms per square inch. As would be understood by a person of skill in the art from the present disclosure, other resistivities can also be used which are less than about 30 ohms or more than about 500 ohms. Other conductive materials transparent or substantially transparent to light can be used instead.

In some embodiments, the measurement site **102** is located somewhere along a non-dominant arm or a non-dominant hand, e.g., a right-handed person's left arm or left hand. In some patients, the non-dominant arm or hand can have less musculature and higher fat content, which can result in less water content in that tissue of the patient. Tissue having less water content can provide less interference with the particular wavelengths that are absorbed in a useful manner by blood analytes like glucose. Accordingly, in some embodiments, the data collection system **100** can be used on a person's non-dominant hand or arm.

The data collection system **100** can include a sensor **101** (or multiple sensors) that is coupled to a processing device or physiological monitor **109**. In an embodiment, the sensor **101** and the monitor **109** are integrated together into a single unit. In another embodiment, the sensor **101** and the monitor **109** are separate from each other and communicate one with another in any suitable manner, such as via a wired or wireless connection. The sensor **101** and monitor **109** can be attachable and detachable from each other for the convenience of the user or caregiver, for ease of storage, sterility issues, or the like. The sensor **101** and the monitor **109** will now be further described.

12

In the depicted embodiment shown in FIG. 1, the sensor **101** includes an emitter **104**, a tissue shaper **105**, a set of detectors **106**, and a front-end interface **108**. The emitter **104** can serve as the source of optical radiation transmitted towards measurement site **102**. As will be described in further detail below, the emitter **104** can include one or more sources of optical radiation, such as LEDs, laser diodes, incandescent bulbs with appropriate frequency-selective filters, combinations of the same, or the like. In an embodiment, the emitter **104** includes sets of optical sources that are capable of emitting visible and near-infrared optical radiation.

In some embodiments, the emitter **104** is used as a point optical source, and thus, the one or more optical sources of the emitter **104** can be located within a close distance to each other, such as within about a 2 mm to about 4 mm. The emitters **104** can be arranged in an array, such as is described in U.S. Publication No. 2006/0211924, filed Sep. 21, 2006, titled "Multiple Wavelength Sensor Emitters," the disclosure of which is hereby incorporated by reference in its entirety. In particular, the emitters **104** can be arranged at least in part as described in paragraphs [0061] through [0068] of the aforementioned publication, which paragraphs are hereby incorporated specifically by reference. Other relative spatial relationships can be used to arrange the emitters **104**.

For analytes like glucose, currently available non-invasive techniques often attempt to employ light near the water absorbance minima at or about 1600 nm. Typically, these devices and methods employ a single wavelength or single band of wavelengths at or about 1600 nm. However, to date, these techniques have been unable to adequately consistently measure analytes like glucose based on spectroscopy.

In contrast, the emitter **104** of the data collection system **100** can emit, in certain embodiments, combinations of optical radiation in various bands of interest. For example, in some embodiments, for analytes like glucose, the emitter **104** can emit optical radiation at three (3) or more wavelengths between about 1600 nm to about 1700 nm. In particular, the emitter **104** can emit optical radiation at or about 1610 nm, about 1640 nm, and about 1665 nm. In some circumstances, the use of three wavelengths within about 1600 nm to about 1700 nm enable sufficient SNRs of about 100 dB, which can result in a measurement accuracy of about 20 mg/dL or better for analytes like glucose.

In other embodiments, the emitter **104** can use two (2) wavelengths within about 1600 nm to about 1700 nm to advantageously enable SNRs of about 85 dB, which can result in a measurement accuracy of about 25-30 mg/dL or better for analytes like glucose. Furthermore, in some embodiments, the emitter **104** can emit light at wavelengths above about 1670 nm. Measurements at these wavelengths can be advantageously used to compensate or confirm the contribution of protein, water, and other non-hemoglobin species exhibited in measurements for analytes like glucose conducted between about 1600 nm and about 1700 nm. Of course, other wavelengths and combinations of wavelengths can be used to measure analytes and/or to distinguish other types of tissue, fluids, tissue properties, fluid properties, combinations of the same or the like.

For example, the emitter **104** can emit optical radiation across other spectra for other analytes. In particular, the emitter **104** can employ light wavelengths to measure various blood analytes or percentages (e.g., saturation) thereof. For example, in one embodiment, the emitter **104** can emit optical radiation in the form of pulses at wavelengths about 905 nm, about 1050 nm, about 1200 nm, about 1300 nm, about 1330 nm, about 1610 nm, about 1640 nm, and about

13

1665 nm. In another embodiment, the emitter **104** can emit optical radiation ranging from about 860 nm to about 950 nm, about 950 nm to about 1100 nm, about 1100 nm to about 1270 nm, about 1250 nm to about 1350 nm, about 1300 nm to about 1360 nm, and about 1590 nm to about 1700 nm. Of course, the emitter **104** can transmit any of a variety of wavelengths of visible or near-infrared optical radiation.

Due to the different responses of analytes to the different wavelengths, certain embodiments of the data collection system **100** can advantageously use the measurements at these different wavelengths to improve the accuracy of measurements. For example, the measurements of water from visible and infrared light can be used to compensate for water absorbance that is exhibited in the near-infrared wavelengths.

As briefly described above, the emitter **104** can include sets of light-emitting diodes (LEDs) as its optical source. The emitter **104** can use one or more top-emitting LEDs. In particular, in some embodiments, the emitter **104** can include top-emitting LEDs emitting light at about 850 nm to 1350 nm.

The emitter **104** can also use super luminescent LEDs (SLEDs) or side-emitting LEDs. In some embodiments, the emitter **104** can employ SLEDs or side-emitting LEDs to emit optical radiation at about 1600 nm to about 1800 nm. Emitter **104** can use SLEDs or side-emitting LEDs to transmit near infrared optical radiation because these types of sources can transmit at high power or relatively high power, e.g., about 40 mW to about 100 mW. This higher power capability can be useful to compensate or overcome the greater attenuation of these wavelengths of light in tissue and water. For example, the higher power emission can effectively compensate and/or normalize the absorption signal for light in the mentioned wavelengths to be similar in amplitude and/or effect as other wavelengths that can be detected by one or more photodetectors after absorption. However, the embodiments of the present disclosure do not necessarily require the use of high power optical sources. For example, some embodiments may be configured to measure analytes, such as total hemoglobin (tHb), oxygen saturation (SpO₂), carboxyhemoglobin, methemoglobin, etc., without the use of high power optical sources like side emitting LEDs. Instead, such embodiments may employ other types of optical sources, such as top emitting LEDs. Alternatively, the emitter **104** can use other types of sources of optical radiation, such as a laser diode, to emit near-infrared light into the measurement site **102**.

In addition, in some embodiments, in order to assist in achieving a comparative balance of desired power output between the LEDs, some of the LEDs in the emitter **104** can have a filter or covering that reduces and/or cleans the optical radiation from particular LEDs or groups of LEDs. For example, since some wavelengths of light can penetrate through tissue relatively well, LEDs, such as some or all of the top-emitting LEDs can use a filter or covering, such as a cap or painted dye. This can be useful in allowing the emitter **104** to use LEDs with a higher output and/or to equalize intensity of LEDs.

The data collection system **100** also includes a driver **111** that drives the emitter **104**. The driver **111** can be a circuit or the like that is controlled by the monitor **109**. For example, the driver **111** can provide pulses of current to the emitter **104**. In an embodiment, the driver **111** drives the emitter **104** in a progressive fashion, such as in an alternating manner. The driver **111** can drive the emitter **104** with a series of pulses of about 1 milliwatt (mW) for some wavelengths that can penetrate tissue relatively well and from

14

about 40 mW to about 100 mW for other wavelengths that tend to be significantly absorbed in tissue. A wide variety of other driving powers and driving methodologies can be used in various embodiments.

The driver **111** can be synchronized with other parts of the sensor **101** and can minimize or reduce jitter in the timing of pulses of optical radiation emitted from the emitter **104**. In some embodiments, the driver **111** is capable of driving the emitter **104** to emit optical radiation in a pattern that varies by less than about 10 parts-per-million.

The detectors **106** capture and measure light from the measurement site **102**. For example, the detectors **106** can capture and measure light transmitted from the emitter **104** that has been attenuated or reflected from the tissue in the measurement site **102**. The detectors **106** can output a detector signal **107** responsive to the light captured or measured. The detectors **106** can be implemented using one or more photodiodes, phototransistors, or the like.

In addition, the detectors **106** can be arranged with a spatial configuration to provide a variation of path lengths among at least some of the detectors **106**. That is, some of the detectors **106** can have the substantially, or from the perspective of the processing algorithm, effectively, the same path length from the emitter **104**. However, according to an embodiment, at least some of the detectors **106** can have a different path length from the emitter **104** relative to other of the detectors **106**. Variations in path lengths can be helpful in allowing the use of a bulk signal stream from the detectors **106**. In some embodiments, the detectors **106** may employ a linear spacing, a logarithmic spacing, or a two or three dimensional matrix of spacing, or any other spacing scheme in order to provide an appropriate variation in path lengths.

The front end interface **108** provides an interface that adapts the output of the detectors **106**, which is responsive to desired physiological parameters. For example, the front end interface **108** can adapt a signal **107** received from one or more of the detectors **106** into a form that can be processed by the monitor **109**, for example, by a signal processor **110** in the monitor **109**. The front end interface **108** can have its components assembled in the sensor **101**, in the monitor **109**, in connecting cabling (if used), combinations of the same, or the like. The location of the front end interface **108** can be chosen based on various factors including space desired for components, desired noise reductions or limits, desired heat reductions or limits, and the like.

The front end interface **108** can be coupled to the detectors **106** and to the signal processor **110** using a bus, wire, electrical or optical cable, flex circuit, or some other form of signal connection. The front end interface **108** can also be at least partially integrated with various components, such as the detectors **106**. For example, the front end interface **108** can include one or more integrated circuits that are on the same circuit board as the detectors **106**. Other configurations can also be used.

The front end interface **108** can be implemented using one or more amplifiers, such as transimpedance amplifiers, that are coupled to one or more analog to digital converters (ADCs) (which can be in the monitor **109**), such as a sigma-delta ADC. A transimpedance-based front end interface **108** can employ single-ended circuitry, differential circuitry, and/or a hybrid configuration. A transimpedance-based front end interface **108** can be useful for its sampling rate capability and freedom in modulation/demodulation algorithms. For example, this type of front end interface **108**

can advantageously facilitate the sampling of the ADCs being synchronized with the pulses emitted from the emitter 104.

The ADC or ADCs can provide one or more outputs into multiple channels of digital information for processing by the signal processor 110 of the monitor 109. Each channel can correspond to a signal output from a detector 106.

In some embodiments, a programmable gain amplifier (PGA) can be used in combination with a transimpedance-based front end interface 108. For example, the output of a transimpedance-based front end interface 108 can be output to a PGA that is coupled with an ADC in the monitor 109. A PGA can be useful in order to provide another level of amplification and control of the stream of signals from the detectors 106. Alternatively, the PGA and ADC components can be integrated with the transimpedance-based front end interface 108 in the sensor 101.

In another embodiment, the front end interface 108 can be implemented using switched-capacitor circuits. A switched-capacitor-based front end interface 108 can be useful for, in certain embodiments, its resistor-free design and analog averaging properties. In addition, a switched-capacitor-based front end interface 108 can be useful because it can provide a digital signal to the signal processor 110 in the monitor 109.

As shown in FIG. 1, the monitor 109 can include the signal processor 110 and a user interface, such as a display 112. The monitor 109 can also include optional outputs alone or in combination with the display 112, such as a storage device 114 and a network interface 116. In an embodiment, the signal processor 110 includes processing logic that determines measurements for desired analytes, such as glucose, based on the signals received from the detectors 106. The signal processor 110 can be implemented using one or more microprocessors or subprocessors (e.g., cores), digital signal processors, application specific integrated circuits (ASICs), field programmable gate arrays (FPGAs), combinations of the same, and the like.

The signal processor 110 can provide various signals that control the operation of the sensor 101. For example, the signal processor 110 can provide an emitter control signal to the driver 111. This control signal can be useful in order to synchronize, minimize, or reduce jitter in the timing of pulses emitted from the emitter 104. Accordingly, this control signal can be useful in order to cause optical radiation pulses emitted from the emitter 104 to follow a precise timing and consistent pattern. For example, when a transimpedance-based front end interface 108 is used, the control signal from the signal processor 110 can provide synchronization with the ADC in order to avoid aliasing, cross-talk, and the like. As also shown, an optional memory 113 can be included in the front-end interface 108 and/or in the signal processor 110. This memory 113 can serve as a buffer or storage location for the front-end interface 108 and/or the signal processor 110, among other uses.

The user interface 112 can provide an output, e.g., on a display, for presentation to a user of the data collection system 100. The user interface 112 can be implemented as a touch-screen display, an LCD display, an organic LED display, or the like. In addition, the user interface 112 can be manipulated to allow for measurement on the non-dominant side of patient. For example, the user interface 112 can include a flip screen, a screen that can be moved from one side to another on the monitor 109, or can include an ability to reorient its display indicia responsive to user input or device orientation. In alternative embodiments, the data

collection system 100 can be provided without a user interface 112 and can simply provide an output signal to a separate display or system.

A storage device 114 and a network interface 116 represent other optional output connections that can be included in the monitor 109. The storage device 114 can include any computer-readable medium, such as a memory device, hard disk storage, EEPROM, flash drive, or the like. The various software and/or firmware applications can be stored in the storage device 114, which can be executed by the signal processor 110 or another processor of the monitor 109. The network interface 116 can be a serial bus port (RS-232/RS-485), a Universal Serial Bus (USB) port, an Ethernet port, a wireless interface (e.g., WiFi such as any 802.1x interface, including an internal wireless card), or other suitable communication device(s) that allows the monitor 109 to communicate and share data with other devices. The monitor 109 can also include various other components not shown, such as a microprocessor, graphics processor, or controller to output the user interface 112, to control data communications, to compute data trending, or to perform other operations.

Although not shown in the depicted embodiment, the data collection system 100 can include various other components or can be configured in different ways. For example, the sensor 101 can have both the emitter 104 and detectors 106 on the same side of the measurement site 102 and use reflectance to measure analytes. The data collection system 100 can also include a sensor that measures the power of light emitted from the emitter 104.

FIGS. 2A through 2D illustrate example monitoring devices 200 in which the data collection system 100 can be housed. Advantageously, in certain embodiments, some or all of the example monitoring devices 200 shown can have a shape and size that allows a user to operate it with a single hand or attach it, for example, to a patient's body or limb. Although several examples are shown, many other monitoring device configurations can be used to house the data collection system 100. In addition, certain of the features of the monitoring devices 200 shown in FIGS. 2A through 2D can be combined with features of the other monitoring devices 200 shown.

Referring specifically to FIG. 2A, an example monitoring device 200A is shown, in which a sensor 201a and a monitor 209a are integrated into a single unit. The monitoring device 200A shown is a handheld or portable device that can measure glucose and other analytes in a patient's finger. The sensor 201a includes an emitter shell 204a and a detector shell 206a. The depicted embodiment of the monitoring device 200A also includes various control buttons 208a and a display 210a.

The sensor 201a can be constructed of white material used for reflective purposes (such as white silicone or plastic), which can increase the usable signal at the detector 106 by forcing light back into the sensor 201a. Pads in the emitter shell 204a and the detector shell 206a can contain separated windows to prevent or reduce mixing of light signals, for example, from distinct quadrants on a patient's finger. In addition, these pads can be made of a relatively soft material, such as a gel or foam, in order to conform to the shape, for example, of a patient's finger. The emitter shell 204a and the detector shell 206a can also include absorbing black or grey material portions to prevent or reduce ambient light from entering into the sensor 201a.

In some embodiments, some or all portions of the emitter shell 204a and/or detector shell 206a can be detachable and/or disposable. For example, some or all portions of the

17

shells **204a** and **206a** can be removable pieces. The removability of the shells **204a** and **206a** can be useful for sanitary purposes or for sizing the sensor **201a** to different patients. The monitor **209a** can include a fitting, slot, magnet, or other connecting mechanism to allow the sensor **201c** to be

removably attached to the monitor **209a**.
The monitoring device **200a** also includes optional control buttons **208a** and a display **210a** that can allow the user to control the operation of the device. For example, a user can operate the control buttons **208a** to view one or more measurements of various analytes, such as glucose. In addition, the user can operate the control buttons **208a** to view other forms of information, such as graphs, histograms, measurement data, trend measurement data, parameter combination views, wellness indications, and the like. Many parameters, trends, alarms and parameter displays could be output to the display **210a**, such as those that are commercially available through a wide variety of noninvasive monitoring devices from Masimo® Corporation of Irvine, Calif.

Furthermore, the controls **208a** and/or display **210a** can provide functionality for the user to manipulate settings of the monitoring device **200a**, such as alarm settings, emitter settings, detector settings, and the like. The monitoring device **200a** can employ any of a variety of user interface designs, such as frames, menus, touch-screens, and any type of button.

FIG. 2B illustrates another example of a monitoring device **200B**. In the depicted embodiment, the monitoring device **200B** includes a finger clip sensor **201b** connected to a monitor **209b** via a cable **212**. In the embodiment shown, the monitor **209b** includes a display **210b**, control buttons **208b** and a power button. Moreover, the monitor **209b** can advantageously include electronic processing, signal processing, and data storage devices capable of receiving signal data from said sensor **201b**, processing the signal data to determine one or more output measurement values indicative of one or more physiological parameters of a monitored patient, and displaying the measurement values, trends of the measurement values, combinations of measurement values, and the like.

The cable **212** connecting the sensor **201b** and the monitor **209b** can be implemented using one or more wires, optical fiber, flex circuits, or the like. In some embodiments, the cable **212** can employ twisted pairs of conductors in order to minimize or reduce cross-talk of data transmitted from the sensor **201b** to the monitor **209b**. Various lengths of the cable **212** can be employed to allow for separation between the sensor **201b** and the monitor **209b**. The cable **212** can be fitted with a connector (male or female) on either end of the cable **212** so that the sensor **201b** and the monitor **209b** can be connected and disconnected from each other. Alternatively, the sensor **201b** and the monitor **209b** can be coupled together via a wireless communication link, such as an infrared link, radio frequency channel, or any other wireless communication protocol and channel.

The monitor **209b** can be attached to the patient. For example, the monitor **209b** can include a belt clip or straps (see, e.g., FIG. 2C) that facilitate attachment to a patient's belt, arm, leg, or the like. The monitor **209b** can also include a fitting, slot, magnet, LEMO snap-click connector, or other connecting mechanism to allow the cable **212** and sensor **201b** to be attached to the monitor **209b**.

The monitor **209b** can also include other components, such as a speaker, power button, removable storage or memory (e.g., a flash card slot), an AC power port, and one or more network interfaces, such as a universal serial bus interface or an Ethernet port. For example, the monitor **209b**

18

can include a display **210b** that can indicate a measurement for glucose, for example, in mg/dL. Other analytes and forms of display can also appear on the monitor **209b**.

In addition, although a single sensor **201b** with a single monitor **209b** is shown, different combinations of sensors and device pairings can be implemented. For example, multiple sensors can be provided for a plurality of differing patient types or measurement sites or even patient fingers.

FIG. 2C illustrates yet another example of monitoring device **200C** that can house the data collection system **100**. Like the monitoring device **200B**, the monitoring device **200C** includes a finger clip sensor **201c** connected to a monitor **209c** via a cable **212**. The cable **212** can have all of the features described above with respect to FIG. 2B. The monitor **209c** can include all of the features of the monitor **200B** described above. For example, the monitor **209c** includes buttons **208c** and a display **210c**. The monitor **209c** shown also includes straps **214c** that allow the monitor **209c** to be attached to a patient's limb or the like.

FIG. 2D illustrates yet another example of monitoring device **200D** that can house the data collection system **100**. Like the monitoring devices **200B** and **200C**, the monitoring device **200D** includes a finger clip sensor **201d** connected to a monitor **209d** via a cable **212**. The cable **212** can have all of the features described above with respect to FIG. 2B. In addition to having some or all of the features described above with respect to FIGS. 2B and 2C, the monitoring device **200D** includes an optional universal serial bus (USB) port **216** and an Ethernet port **218**. The USB port **216** and the Ethernet port **218** can be used, for example, to transfer information between the monitor **209d** and a computer (not shown) via a cable. Software stored on the computer can provide functionality for a user to, for example, view physiological data and trends, adjust settings and download firmware updates to the monitor **209b**, and perform a variety of other functions. The USB port **216** and the Ethernet port **218** can be included with the other monitoring devices **200A**, **200B**, and **200C** described above.

FIGS. 3A through 3C illustrate more detailed examples of embodiments of a sensor **301a**. The sensor **301a** shown can include all of the features of the sensors **100** and **200** described above.

Referring to FIG. 3A, the sensor **301a** in the depicted embodiment is a clothespin-shaped clip sensor that includes an enclosure **302a** for receiving a patient's finger. The enclosure **302a** is formed by an upper section or emitter shell **304a**, which is pivotably connected with a lower section or detector shell **306a**. The emitter shell **304a** can be biased with the detector shell **306a** to close together around a pivot point **303a** and thereby sandwich finger tissue between the emitter and detector shells **304a**, **306a**.

In an embodiment, the pivot point **303a** advantageously includes a pivot capable of adjusting the relationship between the emitter and detector shells **304a**, **306a** to effectively level the sections when applied to a tissue site. In another embodiment, the sensor **301a** includes some or all features of the finger clip described in U.S. Publication No. 2006/0211924, incorporated above, such as a spring that causes finger clip forces to be distributed along the finger. Paragraphs [0096] through [0105], which describe this feature, are hereby specifically incorporated by reference.

The emitter shell **304a** can position and house various emitter components of the sensor **301a**. It can be constructed of reflective material (e.g., white silicone or plastic) and/or can be metallic or include metalized plastic (e.g., including carbon and aluminum) to possibly serve as a heat sink. The emitter shell **304a** can also include absorbing opaque mate-

rial, such as, for example, black or grey colored material, at various areas, such as on one or more flaps 307a, to reduce ambient light entering the sensor 301a.

The detector shell 306a can position and house one or more detector portions of the sensor 301a. The detector shell 306a can be constructed of reflective material, such as white silicone or plastic. As noted, such materials can increase the usable signal at a detector by forcing light back into the tissue and measurement site (see FIG. 1). The detector shell 306a can also include absorbing opaque material at various areas, such as lower area 308a, to reduce ambient light entering the sensor 301a.

Referring to FIGS. 3B and 3C, an example of finger bed 310 is shown in the sensor 301b. The finger bed 310 includes a generally curved surface shaped generally to receive tissue, such as a human digit. The finger bed 310 includes one or more ridges or channels 314. Each of the ridges 314 has a generally convex shape that can facilitate increasing traction or gripping of the patient's finger to the finger bed. Advantageously, the ridges 314 can improve the accuracy of spectroscopic analysis in certain embodiments by reducing noise that can result from a measurement site moving or shaking loose inside of the sensor 301a. The ridges 314 can be made from reflective or opaque materials in some embodiments to further increase SNR. In other implementations, other surface shapes can be used, such as, for example, generally flat, concave, or convex finger beds 310.

Finger bed 310 can also include an embodiment of a tissue thickness adjuster or protrusion 305. The protrusion 305 includes a measurement site contact area 370 (see FIG. 3C) that can contact body tissue of a measurement site. The protrusion 305 can be removed from or integrated with the finger bed 310. Interchangeable, different shaped protrusions 305 can also be provided, which can correspond to different finger shapes, characteristics, opacity, sizes, or the like.

Referring specifically to FIG. 3C, the contact area 370 of the protrusion 305 can include openings or windows 320, 321, 322, and 323. When light from a measurement site passes through the windows 320, 321, 322, and 323, the light can reach one or more photodetectors (see FIG. 3E). In an embodiment, the windows 320, 321, 322, and 323 mirror specific detector placements layouts such that light can impinge through the protrusion 305 onto the photodetectors. Any number of windows 320, 321, 322, and 323 can be employed in the protrusion 305 to allow light to pass from the measurement site to the photodetectors.

The windows 320, 321, 322, and 323 can also include shielding, such as an embedded grid of wiring or a conductive glass coating, to reduce noise from ambient light or other electromagnetic noise. The windows 320, 321, 322, and 323 can be made from materials, such as plastic or glass. In some embodiments, the windows 320, 321, 322, and 323 can be constructed from conductive glass, such as indium tin oxide (ITO) coated glass. Conductive glass can be useful because its shielding is transparent, and thus allows for a larger aperture versus a window with an embedded grid of wiring. In addition, in certain embodiments, the conductive glass does not need openings in its shielding (since it is transparent), which enhances its shielding performance. For example, some embodiments that employ the conductive glass can attain up to an about 40% to about 50% greater signal than non-conductive glass with a shielding grid. In addition, in some embodiments, conductive glass can be useful for shielding noise from a greater variety of directions than non-conductive glass with a shielding grid.

Turning to FIG. 3B, the sensor 301a can also include a shielding 315a, such as a metal cage, box, metal sheet, perforated metal sheet, a metal layer on a non-metal material, or the like. The shielding 315a is provided in the depicted embodiment below or embedded within the protrusion 305 to reduce noise. The shielding 315a can be constructed from a conductive material, such as copper. The shielding 315a can include one or more openings or windows (not shown). The windows can be made from glass or plastic to thereby allow light that has passed through the windows 320, 321, 322, and 323 on an external surface of the protrusion 305 (see FIG. 3C) to pass through to one or more photodetectors that can be enclosed or provided below (see FIG. 3E).

In some embodiments, the shielding cage for shielding 315a can be constructed in a single manufactured component with or without the use of conductive glass. This form of construction may be useful in order to reduce costs of manufacture as well as assist in quality control of the components. Furthermore, the shielding cage can also be used to house various other components, such as sigma delta components for various embodiments of front end interfaces 108.

In an embodiment, the photodetectors can be positioned within or directly beneath the protrusion 305 (see FIG. 3E). In such cases, the mean optical path length from the emitters to the detectors can be reduced and the accuracy of blood analyte measurement can increase. For example, in one embodiment, a convex bump of about 1 mm to about 3 mm in height and about 10 mm² to about 60 mm² was found to help signal strength by about an order of magnitude versus other shapes. Of course other dimensions and sizes can be employed in other embodiments. Depending on the properties desired, the length, width, and height of the protrusion 305 can be selected. In making such determinations, consideration can be made of protrusion's 305 effect on blood flow at the measurement site and mean path length for optical radiation passing through openings 320, 321, 322, and 323. Patient comfort can also be considered in determining the size and shape of the protrusion.

In an embodiment, the protrusion 305 can include a pliant material, including soft plastic or rubber, which can somewhat conform to the shape of a measurement site. Pliant materials can improve patient comfort and tactility by conforming the measurement site contact area 370 to the measurement site. Additionally, pliant materials can minimize or reduce noise, such as ambient light. Alternatively, the protrusion 305 can be made from a rigid material, such as hard plastic or metal.

Rigid materials can improve measurement accuracy of a blood analyte by conforming the measurement site to the contact area 370. The contact area 370 can be an ideal shape for improving accuracy or reducing noise. Selecting a material for the protrusion 305 can include consideration of materials that do not significantly alter blood flow at the measurement site. The protrusion 305 and the contact area 370 can include a combination of materials with various characteristics.

The contact area 370 serves as a contact surface for the measurement site. For example, in some embodiments, the contact area 370 can be shaped for contact with a patient's finger. Accordingly, the contact area 370 can be sized and shaped for different sizes of fingers. The contact area 370 can be constructed of different materials for reflective purposes as well as for the comfort of the patient. For example,

21

the contact area **370** can be constructed from materials having various hardness and textures, such as plastic, gel, foam, and the like.

The formulas and analysis that follow with respect to FIG. **5** provide insight into how selecting these variables can alter transmittance and intensity gain of optical radiation that has been applied to the measurement site. These examples do not limit the scope of this disclosure.

Referring to FIG. **5**, a plot **500** is shown that illustrates examples of effects of embodiments of the protrusion **305** on the SNR at various wavelengths of light. As described above, the protrusion **305** can assist in conforming the tissue and effectively reduce its mean path length. In some instances, this effect by the protrusion **305** can have significant impact on increasing the SNR.

According to the Beer Lambert law, a transmittance of light (I) can be expressed as follows: $I = I_0 * e^{-m * b * c}$, where I_0 is the initial power of light being transmitted, m is the path length traveled by the light, and the component “ $b * c$ ” corresponds to the bulk absorption of the light at a specific wavelength of light. For light at about 1600 nm to about 1700 nm, for example, the bulk absorption component is generally around 0.7 mm^{-1} . Assuming a typical finger thickness of about 12 mm and a mean path length of 20 mm due to tissue scattering, then $I = I_0 * e^{(-20 * 0.7)}$.

In an embodiment where the protrusion **305** is a convex bump, the thickness of the finger can be reduced to 10 mm (from 12 mm) for some fingers and the effective light mean path is reduced to about 16.6 mm from 20 mm (see box **510**). This results in a new transmittance, $I_1 = I_0 * e^{(-16.6 * 0.7)}$. A curve for a typical finger (having a mean path length of 20 mm) across various wavelengths is shown in the plot **500** of FIG. **5**. The plot **500** illustrates potential effects of the protrusion **305** on the transmittance. As illustrated, comparing I and I_1 results in an intensity gain of $e^{(-16.6 * 0.7)} / e^{(-20 * 0.7)}$, which is about a 10 times increase for light in the about 1600 nm to about 1700 nm range. Such an increase can affect the SNR at which the sensor can operate. The foregoing gains can be due at least in part to the about 1600 nm to about 1700 nm range having high values in bulk absorptions (water, protein, and the like), e.g., about 0.7 mm^{-1} . The plot **500** also shows improvements in the visible/near-infrared range (about 600 nm to about 1300 nm).

Turning again to FIGS. **3A** through **3C**, an example heat sink **350a** is also shown. The heat sink **350a** can be attached to, or protrude from an outer surface of, the sensor **301a**, thereby providing increased ability for various sensor components to dissipate excess heat. By being on the outer surface of the sensor **301a** in certain embodiments, the heat sink **350a** can be exposed to the air and thereby facilitate more efficient cooling. In an embodiment, one or more of the emitters (see FIG. **1**) generate sufficient heat that inclusion of the heat sink **350a** can advantageously allow the sensor **301a** to remain safely cooled. The heat sink **350a** can include one or more materials that help dissipate heat, such as, for example, aluminum, steel, copper, carbon, combinations of the same, or the like. For example, in some embodiments, the emitter shell **304a** can include a heat conducting material that is also readily and relatively inexpensively moldable into desired shapes and forms.

In some embodiments, the heat sink **350a** includes metalized plastic. The metalized plastic can include aluminum and carbon, for example. The material can allow for improved thermal conductivity and diffusivity, which can increase commercial viability of the heat sink. In some embodiments, the material selected to construct the heat sink **350a** can include a thermally conductive liquid crystalline

22

polymer, such as CoolPoly® D5506, commercially available from Cool Polymers®, Inc. of Warwick, R.I. Such a material can be selected for its electrically non-conductive and dielectric properties so as, for example, to aid in electrical shielding. In an embodiment, the heat sink **350a** provides improved heat transfer properties when the sensor **301a** is active for short intervals of less than a full day's use. In an embodiment, the heat sink **350a** can advantageously provide improved heat transfers in about three (3) to about four (4) minute intervals, for example, although a heat sink **350a** can be selected that performs effectively in shorter or longer intervals.

Moreover, the heat sink **350a** can have different shapes and configurations for aesthetic as well as for functional purposes. In an embodiment, the heat sink is configured to maximize heat dissipation, for example, by maximizing surface area. In an embodiment, the heat sink **350a** is molded into a generally curved surface and includes one or more fins, undulations, grooves, or channels. The example heat sink **350a** shown includes fins **351a** (see FIG. **3A**).

An alternative shape of a sensor **301b** and heat sink **350b** is shown in FIG. **3D**. The sensor **301b** can include some or all of the features of the sensor **301a**. For example, the sensor **301b** includes an enclosure **302b** formed by an emitter shell **304b** and a detector shell **306b**, pivotably connected about a pivot **303a**. The emitter shell **304b** can also include absorbing opaque material on one or more flaps **307b**, and the detector shell **306a** can also include absorbing opaque material at various areas, such as lower area **308b**. However, the shape of the sensor **301b** is different in this embodiment. In particular, the heat sink **350b** includes comb protrusions **351b**. The comb protrusions **351b** are exposed to the air in a similar manner to the fins **351a** of the heat sink **350a**, thereby facilitating efficient cooling of the sensor **301b**.

FIG. **3E** illustrates a more detailed example of a detector shell **306b** of the sensor **301b**. The features described with respect to the detector shell **306b** can also be used with the detector shell **306a** of the sensor **301a**.

As shown, the detector shell **306b** includes detectors **316**. The detectors **316** can have a predetermined spacing **340** from each other, or a spatial relationship among one another that results in a spatial configuration. This spatial configuration can purposefully create a variation of path lengths among detectors **316** and the emitter discussed above.

In the depicted embodiment, the detector shell **316** can hold multiple (e.g., two, three, four, etc.) photodiode arrays that are arranged in a two-dimensional grid pattern. Multiple photodiode arrays can also be useful to detect light piping (e.g., light that bypasses measurement site **102**). In the detector shell **316**, walls can be provided to separate the individual photodiode arrays to prevent or reduce mixing of light signals from distinct quadrants. In addition, the detector shell **316** can be covered by windows of transparent material, such as glass, plastic, or the like, to allow maximum or increased transmission of power light captured. In various embodiments, the transparent materials used can also be partially transparent or translucent or can otherwise pass some or all of the optical radiation passing through them. As noted, this window can include some shielding in the form of an embedded grid of wiring, or a conductive layer or coating.

As further illustrated by FIG. **3E**, the detectors **316** can have a spatial configuration of a grid. However, the detectors **316** can be arranged in other configurations that vary the path length. For example, the detectors **316** can be arranged in a linear array, a logarithmic array, a two-dimensional

23

array, a zig-zag pattern, or the like. Furthermore, any number of the detectors **316** can be employed in certain embodiments.

FIG. 3F illustrates another embodiment of a sensor **301f**. The sensor **301f** can include some or all of the features of the sensor **301a** of FIG. 3A described above. For example, the sensor **301f** includes an enclosure **302f** formed by an upper section or emitter shell **304f**, which is pivotably connected with a lower section or detector shell **306f** around a pivot point **303f**. The emitter shell **304f** can also include absorbing opaque material on various areas, such as on one or more flaps **307f**, to reduce ambient light entering the sensor **301f**. The detector shell **306f** can also include absorbing opaque material at various areas, such as a lower area **308f**. The sensor **301f** also includes a heat sink **350f**, which includes fins **351f**.

In addition to these features, the sensor **301f** includes a flex circuit cover **360**, which can be made of plastic or another suitable material. The flex circuit cover **360** can cover and thereby protect a flex circuit (not shown) that extends from the emitter shell **304f** to the detector shell **306f**. An example of such a flex circuit is illustrated in U.S. Publication No. 2006/0211924, incorporated above (see FIG. 46 and associated description, which is hereby specifically incorporated by reference). The flex circuit cover **360** is shown in more detail below in FIG. 17.

In addition, sensors **301a-f** has extra length—extends to second joint on finger—Easier to place, harder to move due to cable, better for light piping

FIGS. 4A through 4C illustrate example arrangements of a protrusion **405**, which is an embodiment of the protrusion **305** described above. In an embodiment, the protrusion **405** can include a measurement site contact area **470**. The measurement site contact area **470** can include a surface that molds body tissue of a measurement site, such as a finger, into a flat or relatively flat surface.

The protrusion **405** can have dimensions that are suitable for a measurement site such as a patient's finger. As shown, the protrusion **405** can have a length **400**, a width **410**, and a height **430**. The length **400** can be from about 9 to about 11 millimeters, e.g., about 10 millimeters. The width **410** can be from about 7 to about 9 millimeters, e.g., about 8 millimeters. The height **430** can be from about 0.5 millimeters to about 3 millimeters, e.g., about 2 millimeters. In an embodiment, the dimensions **400**, **410**, and **430** can be selected such that the measurement site contact area **470** includes an area of about 80 square millimeters, although larger and smaller areas can be used for different sized tissue for an adult, an adolescent, or infant, or for other considerations.

The measurement site contact area **470** can also include differently shaped surfaces that conform the measurement site into different shapes. For example, the measurement site contact area **470** can be generally curved and/or convex with respect to the measurement site. The measurement site contact area **470** can be other shapes that reduce or even minimize air between the protrusion **405** and the measurement site. Additionally, the surface pattern of the measurement site contact area **470** can vary from smooth to bumpy, e.g., to provide varying levels of grip.

In FIGS. 4A and 4C, openings or windows **420**, **421**, **422**, and **423** can include a wide variety of shapes and sizes, including for example, generally square, circular, triangular, or combinations thereof. The windows **420**, **421**, **422**, and **423** can be of non-uniform shapes and sizes. As shown, the windows **420**, **421**, **422**, and **423** can be evenly spaced out in a grid like arrangement. Other arrangements or patterns of

24

arranging the windows **420**, **421**, **422**, and **423** are possible. For example, the windows **420**, **421**, **422**, and **423** can be placed in a triangular, circular, or linear arrangement. In some embodiments, the windows **420**, **421**, **422**, and **423** can be placed at different heights with respect to the finger bed **310** of FIG. 3. The windows **420**, **421**, **422**, and **423** can also mimic or approximately mimic a configuration of, or even house, a plurality of detectors.

FIGS. 6A through 6D illustrate another embodiment of a protrusion **605** that can be used as the tissue shaper **105** described above or in place of the protrusions **305**, **405** described above. The depicted protrusion **605** is a partially cylindrical lens having a partial cylinder **608** and an extension **610**. The partial cylinder **608** can be a half cylinder in some embodiments; however, a smaller or greater portion than half of a cylinder can be used. Advantageously, in certain embodiments, the partially cylindrical protrusion **605** focuses light onto a smaller area, such that fewer detectors can be used to detect the light attenuated by a measurement site.

FIG. 6A illustrates a perspective view of the partially cylindrical protrusion **605**. FIG. 6B illustrates a front elevation view of the partially cylindrical protrusion **605**. FIG. 6C illustrates a side view of the partially cylindrical protrusion **605**. FIG. 6D illustrates a top view of the partially cylindrical protrusion **605**.

Advantageously, in certain embodiments, placing the partially cylindrical protrusion **605** over the photodiodes in any of the sensors described above adds multiple benefits to any of the sensors described above. In one embodiment, the partially cylindrical protrusion **605** penetrates into the tissue and reduces the path length of the light traveling in the tissue, similar to the protrusions described above.

The partially cylindrical protrusion **605** can also collect light from a large surface and focus down the light to a smaller area. As a result, in certain embodiments, signal strength per area of the photodiode can be increased. The partially cylindrical protrusion **605** can therefore facilitate a lower cost sensor because, in certain embodiments, less photodiode area can be used to obtain the same signal strength. Less photodiode area can be realized by using smaller photodiodes or fewer photodiodes (see, e.g., FIG. 14). If fewer or smaller photodiodes are used, the partially cylindrical protrusion **605** can also facilitate an improved SNR of the sensor because fewer or smaller photodiodes can have less dark current.

The dimensions of the partially cylindrical protrusion **605** can vary based on, for instance, a number of photodiodes used with the sensor. Referring to FIG. 6C, the overall height of the partially cylindrical protrusion **605** (measurement "a") in some implementations is about 1 to about 3 mm. A height in this range can allow the partially cylindrical protrusion **605** to penetrate into the pad of the finger or other tissue and reduce the distance that light travels through the tissue. Other heights, however, of the partially cylindrical protrusion **605** can also accomplish this objective. For example, the chosen height of the partially cylindrical protrusion **605** can be selected based on the size of the measurement site, whether the patient is an adult or child, and so on. In an embodiment, the height of the protrusion **605** is chosen to provide as much tissue thickness reduction as possible while reducing or preventing occlusion of blood vessels in the tissue.

Referring to FIG. 6D, the width of the partially cylindrical protrusion **605** (measurement "b") can be about 3 to about 5 mm. In one embodiment, the width is about 4 mm. In one embodiment, a width in this range provides good penetration

25

of the partially cylindrical protrusion **605** into the tissue to reduce the path length of the light. Other widths, however, of the partially cylindrical protrusion **605** can also accomplish this objective. For example, the width of the partially cylindrical protrusion **605** can vary based on the size of the measurement site, whether the patient is an adult or child, and so on. In addition, the length of the protrusion **605** could be about 10 mm, or about 8 mm to about 12 mm, or smaller than 8 mm or greater than 12 mm.

In certain embodiments, the focal length (f) for the partially cylindrical protrusion **605** can be expressed as:

$$f = \frac{R}{n-1},$$

where R is the radius of curvature of the partial cylinder **608** and n is the index of refraction of the material used. In certain embodiments, the radius of curvature can be between about 1.5 mm and about 2 mm. In another embodiment, the partially cylindrical protrusion **605** can include a material, such as nBK7 glass, with an index of refraction of around 1.5 at 1300 nm, which can provide focal lengths of between about 3 mm and about 4 mm.

A partially cylindrical protrusion **605** having a material with a higher index of refraction such as nSF11 glass (e.g., $n=1.75$ at 1300 nm) can provide a shorter focal length and possibly a smaller photodiode chip, but can also cause higher reflections due to the index of refraction mismatch with air. Many types of glass or plastic can be used with index of refraction values ranging from, for example, about 1.4 to about 1.9. The index of refraction of the material of the protrusion **605** can be chosen to improve or optimize the light focusing properties of the protrusion **605**. A plastic partially cylindrical protrusion **605** could provide the cheapest option in high volumes but can also have some undesired light absorption peaks at wavelengths higher than 1500 nm. Other focal lengths and materials having different indices of refraction can be used for the partially cylindrical protrusion **605**.

Placing a photodiode at a given distance below the partially cylindrical protrusion **605** can facilitate capturing some or all of the light traveling perpendicular to the lens within the active area of the photodiode (see FIG. **14**). Different sizes of the partially cylindrical protrusion **605** can use different sizes of photodiodes. The extension **610** added onto the bottom of the partial cylinder **608** is used in certain embodiments to increase the height of the partially cylindrical protrusion **605**. In an embodiment, the added height is such that the photodiodes are at or are approximately at the focal length of the partially cylindrical protrusion **605**. In an embodiment, the added height provides for greater thinning of the measurement site. In an embodiment, the added height assists in deflecting light piped through the sensor. This is because light piped around the sensor passes through the side walls of the added height without being directed toward the detectors. The extension **610** can also further facilitate the protrusion **605** increasing or maximizing the amount of light that is provided to the detectors. In some embodiments, the extension **610** can be omitted.

FIG. **6E** illustrates another view of the sensor **301f** of FIG. **3F**, which includes an embodiment of a partially cylindrical protrusion **605b**. Like the sensor **301A** shown in FIGS. **3B** and **3C**, the sensor **301f** includes a finger bed **310f**. The finger bed **310f** includes a generally curved surface shaped generally to receive tissue, such as a human digit. The finger

26

bed **310f** also includes the ridges or channels **314** described above with respect to FIGS. **3B** and **3C**.

The example of finger bed **310f** shown also includes the protrusion **605b**, which includes the features of the protrusion **605** described above. In addition, the protrusion **605b** also includes chamfered edges **607** on each end to provide a more comfortable surface for a finger to slide across (see also FIG. **14D**). In another embodiment, the protrusion **605b** could instead include a single chamfered edge **607** proximal to the ridges **314**. In another embodiment, one or both of the chamfered edges **607** could be rounded.

The protrusion **605b** also includes a measurement site contact area **670** that can contact body tissue of a measurement site. The protrusion **605b** can be removed from or integrated with the finger bed **310f**. Interchangeable, differently shaped protrusions **605b** can also be provided, which can correspond to different finger shapes, characteristics, opacity, sizes, or the like.

FIGS. **7A** and **7B** illustrate block diagrams of sensors **701** that include example arrangements of conductive glass or conductive coated glass for shielding. Advantageously, in certain embodiments, the shielding can provide increased SNR. The features of the sensors **701** can be implemented with any of the sensors **101**, **201**, **301** described above. Although not shown, the partially cylindrical protrusion **605** of FIG. **6** can also be used with the sensors **701** in certain embodiments.

For example, referring specifically to FIG. **7A**, the sensor **701a** includes an emitter housing **704a** and a detector housing **706**. The emitter housing **704a** includes LEDs **104**. The detector housing **706a** includes a tissue bed **710a** with an opening or window **703a**, the conductive glass **730a**, and one or more photodiodes for detectors **106** provided on a submount **707a**.

During operation, a finger **102** can be placed on the tissue bed **710a** and optical radiation can be emitted from the LEDs **104**. Light can then be attenuated as it passes through or is reflected from the tissue of the finger **102**. The attenuated light can then pass through the opening **703a** in the tissue bed **710a**. Based on the received light, the detectors **106** can provide a detector signal **107**, for example, to the front end interface **108** (see FIG. **1**).

In the depicted embodiment, the conductive glass **730** is provided in the opening **703**. The conductive glass **730** can thus not only permit light from the finger to pass to the detectors **106**, but it can also supplement the shielding of the detectors **106** from noise. The conductive glass **730** can include a stack or set of layers. In FIG. **7A**, the conductive glass **730a** is shown having a glass layer **731** proximate the finger **102** and a conductive layer **733** electrically coupled to the shielding **790a**.

In an embodiment, the conductive glass **730a** can be coated with a conductive, transparent or partially transparent material, such as a thin film of indium tin oxide (ITO). To supplement electrical shielding effects of a shielding enclosure **790a**, the conductive glass **730a** can be electrically coupled to the shielding enclosure **790a**. The conductive glass **730a** can be electrically coupled to the shielding **704a** based on direct contact or via other connection devices, such as a wire or another component.

The shielding enclosure **790a** can be provided to encompass the detectors **106** to reduce or prevent noise. For example, the shielding enclosure **790a** can be constructed from a conductive material, such as copper, in the form of a metal cage. The shielding or enclosure can include an opaque material to not only reduce electrical noise, but also ambient optical noise.

27

In some embodiments, the shielding enclosure **790a** can be constructed in a single manufactured component with or without the use of conductive glass. This form of construction may be useful in order to reduce costs of manufacture as well as assist in quality control of the components. Furthermore, the shielding enclosure **790a** can also be used to house various other components, such as sigma delta components for various embodiments of front end interfaces **108**.

Referring to FIG. 7B, another block diagram of an example sensor **701b** is shown. A tissue bed **710b** of the sensor **701b** includes a protrusion **705b**, which is in the form of a convex bump. The protrusion **705b** can include all of the features of the protrusions or tissue shaping materials described above. For example, the protrusion **705b** includes a contact area **370** that comes in contact with the finger **102** and which can include one or more openings **703b**. One or more components of conductive glass **730b** can be provided in the openings **703**. For example, in an embodiment, each of the openings **703** can include a separate window of the conductive glass **730b**. In an embodiment, a single piece of the conductive glass **730b** can be used for some or all of the openings **703b**. The conductive glass **730b** is smaller than the conductive glass **730a** in this particular embodiment.

A shielding enclosure **790b** is also provided, which can have all the features of the shielding enclosure **790a**. The shielding enclosure **790b** is smaller than the shielding enclosure **790a**; however, a variety of sizes can be selected for the shielding enclosures **790**.

In some embodiments, the shielding enclosure **790b** can be constructed in a single manufactured component with or without the use of conductive glass. This form of construction may be useful in order to reduce costs of manufacture as well as assist in quality control of the components. Furthermore, the shielding enclosure **790b** can also be used to house various other components, such as sigma delta components for various embodiments of front end interfaces **108**.

FIGS. 8A through 8D illustrate a perspective view, side views, and a bottom elevation view of the conductive glass described above with respect to the sensors **701a**, **701b**. As shown in the perspective view of FIG. 8A and side view of FIG. 8B, the conductive glass **730** includes the electrically conductive material **733** described above as a coating on the glass layer **731** described above to form a stack. In an embodiment where the electrically conductive material **733** includes indium tin oxide, surface resistivity of the electrically conductive material **733** can range approximately from 30 ohms per square inch to 500 ohms per square inch, or approximately 30, 200, or 500 ohms per square inch. As would be understood by a person of skill in the art from the present disclosure, other resistivities can also be used which are less than 30 ohms or more than 500 ohms. Other transparent, electrically conductive materials can be used as the material **733**.

Although the conductive material **733** is shown spread over the surface of the glass layer **731**, the conductive material **733** can be patterned or provided on selected portions of the glass layer **731**. Furthermore, the conductive material **733** can have uniform or varying thickness depending on a desired transmission of light, a desired shielding effect, and other considerations.

In FIG. 8C, a side view of a conductive glass **830a** is shown to illustrate an embodiment where the electrically conductive material **733** is provided as an internal layer between two glass layers **731**, **835**. Various combinations of integrating electrically conductive material **733** with glass

28

are possible. For example, the electrically conductive material **733** can be a layer within a stack of layers. This stack of layers can include one or more layers of glass **731**, **835**, as well as one or more layers of conductive material **733**. The stack can include other layers of materials to achieve desired characteristics.

In FIG. 8D, a bottom perspective view is shown to illustrate an embodiment where a conductive glass **830b** can include conductive material **837** that occupies or covers a portion of a glass layer **839**. This embodiment can be useful, for example, to create individual, shielded windows for detectors **106**, such as those shown in FIG. 3C. The conductive material **837** can be patterned to include an area **838** to allow light to pass to detectors **106** and one or more strips **841** to couple to the shielding **704** of FIG. 7.

Other configurations and patterns for the conductive material can be used in certain embodiments, such as, for example, a conductive coating lining periphery edges, a conductive coating outlaid in a pattern including a grid or other pattern, a speckled conductive coating, coating outlaid in lines in either direction or diagonally, varied thicknesses from the center out or from the periphery in, or other suitable patterns or coatings that balance the shielding properties with transparency considerations.

FIG. 9 depicts an example graph **900** that illustrates comparative results obtained by an example sensor having components similar to those disclosed above with respect to FIGS. 7 and 8. The graph **900** depicts the results of the percentage of transmission of varying wavelengths of light for different types of windows used in the sensors described above.

A line **915** on the graph **900** illustrates example light transmission of a window made from plain glass. As shown, the light transmission percentage of varying wavelengths of light is approximately 90% for a window made from plain glass. A line **920** on the graph **900** demonstrates an example light transmission percentage for an embodiment in which a window is made from glass having an ITO coating with a surface resistivity of 500 ohms per square inch. A line **925** on the graph **900** shows an example light transmission for an embodiment in which a window is made from glass that includes a coating of ITO oxide with a surface resistivity of 200 ohms per square inch. A line **930** on the graph **900** shows an example light transmission for an embodiment in which a window is made from glass that includes a coating of ITO oxide with a surface resistivity of 30 ohms per square inch.

The light transmission percentage for a window with currently available embedded wiring can have a light transmission percentage of approximately 70%. This lower percentage of light transmission can be due to the opacity of the wiring employed in a currently available window with wiring. Accordingly, certain embodiments of glass coatings described herein can employ, for example, ITO coatings with different surface resistivity depending on the desired light transmission, wavelengths of light used for measurement, desired shielding effect, and other criteria.

FIGS. 10A through 10B illustrate comparative noise floors of example implementations of the sensors described above. Noise can include optical noise from ambient light and electro-magnetic noise, for example, from surrounding electrical equipment. In FIG. 10A, a graph **1000** depicts possible noise floors for different frequencies of noise for an embodiment in which one of the sensors described above included separate windows for four (4) detectors **106**. One or more of the windows included an embedded grid of wiring as a noise shield. Symbols **1030-1033** illustrate the

noise floor performance for this embodiment. As can be seen, the noise floor performance can vary for each of the openings and based on the frequency of the noise.

In FIG. 10B, a graph 1050 depicts a noise floor for frequencies of noise 1070 for an embodiment in which the sensor included separate openings for four (4) detectors 106 and one or more windows that include an ITO coating. In this embodiment, a surface resistivity of the ITO used was about 500 ohms per square inch. Symbols 1080-1083 illustrate the noise floor performance for this embodiment. As can be seen, the noise floor performance for this embodiment can vary less for each of the openings and provide lower noise floors in comparison to the embodiment of FIG. 10A.

FIG. 11A illustrates an example structure for configuring the set of optical sources of the emitters described above. As shown, an emitter 104 can include a driver 1105, a thermistor 1120, a set of top-emitting LEDs 1102 for emitting red and/or infrared light, a set of side-emitting LEDs 1104 for emitting near infrared light, and a submount 1106.

The thermistor 1120 can be provided to compensate for temperature variations. For example, the thermistor 1120 can be provided to allow for wavelength centroid and power drift of LEDs 1102 and 1104 due to heating. In addition, other thermistors can be employed, for example, to measure a temperature of a measurement site. The temperature can be displayed on a display device and used by a caregiver. Such a temperature can also be helpful in correcting for wavelength drift due to changes in water absorption, which can be temperature dependent, thereby providing more accurate data useful in detecting blood analytes like glucose. In addition, using a thermistor or other type of temperature sensitive device may be useful for detecting extreme temperatures at the measurement site that are too hot or too cold. The presence of low perfusion may also be detected, for example, when the finger of a patient has become too cold. Moreover, shifts in temperature at the measurement site can alter the absorption spectrum of water and other tissue in the measurement site. A thermistor's temperature reading can be used to adjust for the variations in absorption spectrum changes in the measurement site.

The driver 1105 can provide pulses of current to the emitter 1104. In an embodiment, the driver 1105 drives the emitter 1104 in a progressive fashion, for example, in an alternating manner based on a control signal from, for example, a processor (e.g., the processor 110). For example, the driver 1105 can drive the emitter 1104 with a series of pulses to about 1 milliwatt (mW) for visible light to light at about 1300 nm and from about 40 mW to about 100 mW for light at about 1600 nm to about 1700 nm. However, a wide number of driving powers and driving methodologies can be used. The driver 1105 can be synchronized with other parts of the sensor and can minimize or reduce any jitter in the timing of pulses of optical radiation emitted from the emitter 1104. In some embodiments, the driver 1105 is capable of driving the emitter 1104 to emit an optical radiation in a pattern that varies by less than about 10 parts-per-million; however other amounts of variation can be used.

The submount 1106 provides a support structure in certain embodiments for aligning the top-emitting LEDs 1102 and the side-emitting LEDs 1104 so that their optical radiation is transmitted generally towards the measurement site. In some embodiments, the submount 1106 is also constructed of aluminum nitride (AlN) or beryllium oxide (BEO) for heat dissipation, although other materials or combinations of materials suitable for the submount 1106 can be used.

FIG. 11B illustrates a configuration of emitting optical radiation into a measurement site for measuring a blood constituent or analyte like glucose. In some embodiments, emitter 104 may be driven in a progressive fashion to minimize noise and increase SNR of sensor 101. For example, emitter 104 may be driven based on a progression of power/current delivered to LEDs 1102 and 1104.

In some embodiments, emitter 104 may be configured to emit pulses centered about 905 nm, about 1050 nm, about 1200 nm, about 1300 nm, about 1330 nm, about 1610 nm, about 1640 nm, and about 1665 nm. In another embodiment, the emitter 104 may emit optical radiation ranging from about 860 nm to about 950 nm, about 950 nm to about 1100 nm, about 1100 nm to about 1270 nm, about 1250 nm to about 1350 nm, about 1300 nm to about 1360 nm, and about 1590 nm to about 1700 nm. Of course, emitter 104 may be configured to transmit any of a variety of wavelengths of visible, or near-infrared optical radiation.

For purposes of illustration, FIG. 11B shows a sequence of pulses of light at wavelengths of around 905 nm, around 1200 nm, around 1300 nm, and around 1330 nm from top emitting LEDs 1102. FIG. 11B also shows that emitter 104 may then emit pulses centered at around 1630 nm, around 1660 nm, and around 1615 nm from side emitting LEDs 1104. Emitter 104 may be progressively driven at higher power/current. This progression may allow driver circuit 105 to stabilize in its operations, and thus, provide a more stable current/power to LEDs 1102 and 1104.

For example, as shown in FIG. 11B, the sequence of optical radiation pulses are shown having a logarithmic-like progression in power/current. In some embodiments, the timing of these pulses is based on a cycle of about 400 slots running at 48 kHz (e.g. each time slot may be approximately 0.02 ms or 20 microseconds). An artisan will recognize that term "slots" includes its ordinary meaning, which includes a time period that may also be expressed in terms of a frequency. In the example shown, pulses from top emitting LEDs 1102 may have a pulse width of about 40 time slots (e.g., about 0.8 ms) and an off period of about 4 time slots in between. In addition, pulses from side emitting LEDs 1104 (e.g., or a laser diode) may have a pulse width of about 60 time slots (e.g., about 1.25 ms) and a similar off period of about 4 time slots. A pause of about 70 time slots (e.g. 1.5 ms) may also be provided in order to allow driver circuit 105 to stabilize after operating at higher current/power.

As shown in FIG. 11B, top emitting LEDs 1102 may be initially driven with a power to approximately 1 mW at a current of about 20-100 mA. Power in these LEDs may also be modulated by using a filter or covering of black dye to reduce power output of LEDs. In this example, top emitting LEDs 1102 may be driven at approximately 0.02 to 0.08 mW. The sequence of the wavelengths may be based on the current requirements of top emitting LEDs 502 for that particular wavelength. Of course, in other embodiments, different wavelengths and sequences of wavelengths may be output from emitter 104.

Subsequently, side emitting LEDs 1104 may be driven at higher powers, such as about 40-100 mW and higher currents of about 600-800 mA. This higher power may be employed in order to compensate for the higher opacity of tissue and water in measurement site 102 to these wavelengths. For example, as shown, pulses at about 1630 nm, about 1660 nm, and about 1615 nm may be output with progressively higher power, such as at about 40 mW, about 50 mW, and about 60 mW, respectively. In this embodiment, the order of wavelengths may be based on the optical characteristics of that wavelength in tissue as well as the

current needed to drive side emitting LEDs **1104**. For example, in this embodiment, the optical pulse at about 1615 nm is driven at the highest power due to its sensitivity in detecting analytes like glucose and the ability of light at this wavelength to penetrate tissue. Of course, different wavelengths and sequences of wavelengths may be output from emitter **104**.

As noted, this progression may be useful in some embodiments because it allows the circuitry of driver circuit **1105** to stabilize its power delivery to LEDs **1102** and **1104**. Driver circuit **1105** may be allowed to stabilize based on the duty cycle of the pulses or, for example, by configuring a variable waiting period to allow for stabilization of driver circuit **1105**. Of course, other variations in power/current and wavelength may also be employed in the present disclosure.

Modulation in the duty cycle of the individual pulses may also be useful because duty cycle can affect the signal noise ratio of the system **100**. That is, as the duty cycle is increased so may the signal to noise ratio.

Furthermore, as noted above, driver circuit **1105** may monitor temperatures of the LEDs **1102** and **1104** using the thermistor **1120** and adjust the output of LEDs **1102** and **1104** accordingly. Such a temperature may be to help sensor **101** correct for wavelength drift due to changes in water absorption, which can be temperature dependent.

FIG. **11C** illustrates another exemplary emitter that may be employed in the sensor according to an embodiment of the disclosure. As shown, the emitter **104** can include components mounted on a substrate **1108** and on submount **1106**. In particular, top-emitting LEDs **1102** for emitting red and/or infrared light may be mounted on substrate **1108**. Side emitting LEDs **1104** may be mounted on submount **1106**. As noted, side-emitting LEDs **1104** may be included in emitter **104** for emitting near infrared light.

As also shown, the sensor of FIG. **11C** may include a thermistor **1120**. As noted, the thermistor **1120** can be provided to compensate for temperature variations. The thermistor **1120** can be provided to allow for wavelength centroid and power drift of LEDs **1102** and **1104** due to heating. In addition, other thermistors (not shown) can be employed, for example, to measure a temperature of a measurement site. Such a temperature can be helpful in correcting for wavelength drift due to changes in water absorption, which can be temperature dependent, thereby providing more accurate data useful in detecting blood analytes like glucose.

In some embodiments, the emitter **104** may be implemented without the use of side emitting LEDs. For example, certain blood constituents, such as total hemoglobin, can be measured by embodiments of the disclosure without the use of side emitting LEDs. FIG. **11D** illustrates another exemplary emitter that may be employed in the sensor according to an embodiment of the disclosure. In particular, an emitter **104** that is configured for a blood constituent, such as total hemoglobin, is shown. The emitter **104** can include components mounted on a substrate **1108**. In particular, top-emitting LEDs **1102** for emitting red and/or infrared light may be mounted on substrate **1108**.

As also shown, the emitter of FIG. **11D** may include a thermistor **1120**. The thermistor **1120** can be provided to compensate for temperature variations. The thermistor **1120** can be provided to allow for wavelength centroid and power drift of LEDs **1102** due to heating.

FIG. **12A** illustrates a detector submount **1200** having photodiode detectors that are arranged in a grid pattern on the detector submount **1200** to capture light at different

quadrants from a measurement site. One detector submount **1200** can be placed under each window of the sensors described above, or multiple windows can be placed over a single detector submount **1200**. The detector submount **1200** can also be used with the partially cylindrical protrusion **605** described above with respect to FIG. **6**.

The detectors include photodiode detectors **1-4** that are arranged in a grid pattern on the submount **1200** to capture light at different quadrants from the measurement site. As noted, other patterns of photodiodes, such as a linear row, or logarithmic row, can also be employed in certain embodiments.

As shown, the detectors **1-4** may have a predetermined spacing from each other, or spatial relationship among one another that result in a spatial configuration. This spatial configuration can be configured to purposefully create a variation of path lengths among detectors **106** and the point light source discussed above.

Detectors may hold multiple (e.g., two, three, four, etc.) photodiode arrays that are arranged in a two-dimensional grid pattern. Multiple photodiode arrays may also be useful to detect light piping (i.e., light that bypasses measurement site **102**). As shown, walls may separate the individual photodiode arrays to prevent mixing of light signals from distinct quadrants. In addition, as noted, the detectors may be covered by windows of transparent material, such as glass, plastic, etc., to allow maximum transmission of power light captured. As noted, this window may comprise some shielding in the form of an embedded grid of wiring, or a conductive layer or coating.

FIGS. **12B** through **12D** illustrate a simplified view of exemplary arrangements and spatial configurations of photodiodes for detectors **106**. As shown, detectors **106** may comprise photodiode detectors **1-4** that are arranged in a grid pattern on detector submount **1200** to capture light at different quadrants from measurement site **102**.

As noted, other patterns of photodiodes may also be employed in embodiments of the present disclosure, including, for example, stacked or other configurations recognizable to an artisan from the disclosure herein. For example, detectors **106** may be arranged in a linear array, a logarithmic array, a two-dimensional array, and the like. Furthermore, an artisan will recognize from the disclosure herein that any number of detectors **106** may be employed by embodiments of the present disclosure.

For example, as shown in FIG. **12B**, detectors **106** may comprise photodiode detectors **1-4** that are arranged in a substantially linear configuration on submount **1200**. In this embodiment shown, photodiode detectors **1-4** are substantially equally spaced apart (e.g., where the distance D is substantially the same between detectors **1-4**).

In FIG. **12C**, photodiode detectors **1-4** may be arranged in a substantially linear configuration on submount **1200**, but may employ a substantially progressive, substantially logarithmic, or substantially semi-logarithmic spacing (e.g., where distances $D1 > D2 > D3$). This arrangement or pattern may be useful for use on a patient's finger and where the thickness of the finger gradually increases.

In FIG. **12D**, a different substantially grid pattern on submount **1200** of photodiode detectors **1-4** is shown. As noted, other patterns of detectors may also be employed in embodiments of the present invention.

FIGS. **12E** through **12H** illustrate several embodiments of photodiodes that may be used in detectors **106**. As shown in these figures, a photodiode **1202** of detector **106** may comprise a plurality of active areas **1204**. These active areas

204 may be coupled together via a common cathode 1206 or anode 1208 in order to provide a larger effective detection area.

In particular, as shown in FIG. 12E, photodiode 1202 may comprise two (2) active areas 1204a and 1204b. In FIG. 12F, photodiode 1202 may comprise four (4) active areas 1204c-f. In FIG. 12G, photodiode 1202 may comprise three (3) active areas 1204g-i. In FIG. 12H, photodiode 1202 may comprise nine (9) active areas 1204j-r. The use of smaller active areas may be useful because smaller active areas can be easier to fabricate and can be fabricated with higher purity. However, one skilled in the art will recognize that various sizes of active areas may be employed in the photodiode 1202.

FIG. 13 illustrates an example multi-stream process 1300. The multi-stream process 1300 can be implemented by the data collection system 100 and/or by any of the sensors described above. As shown, a control signal from a signal processor 1310 controls a driver 1305. In response, an emitter 1304 generates a pulse sequence 1303 from its emitter (e.g., its LEDs) into a measurement site or sites 1302. As described above, in some embodiments, the pulse sequence 1303 is controlled to have a variation of about 10 parts per million or less. Of course, depending on the analyte desired, the tolerated variation in the pulse sequence 1303 can be greater (or smaller).

In response to the pulse sequence 1300, detectors 1 to n (n being an integer) in a detector 1306 capture optical radiation from the measurement site 1302 and provide respective streams of output signals. Each signal from one of detectors 1-n can be considered a stream having respective time slots corresponding to the optical pulses from emitter sets 1-n in the emitter 1304. Although n emitters and n detectors are shown, the number of emitters and detectors need not be the same in certain implementations.

A front end interface 1308 can accept these multiple streams from detectors 1-n and deliver one or more signals or composite signal(s) back to the signal processor 1310. A stream from the detectors 1-n can thus include measured light intensities corresponding to the light pulses emitted from the emitter 1304.

The signal processor 1310 can then perform various calculations to measure the amount of glucose and other analytes based on these multiple streams of signals. In order to help explain how the signal processor 1310 can measure analytes like glucose, a primer on the spectroscopy employed in these embodiments will now be provided.

Spectroscopy is premised upon the Beer-Lambert law. According to this law, the properties of a material, e.g., glucose present in a measurement site, can be deterministically calculated from the absorption of light traveling through the material. Specifically, there is a logarithmic relation between the transmission of light through a material and the concentration of a substance and also between the transmission and the length of the path traveled by the light. As noted, this relation is known as the Beer-Lambert law.

The Beer-Lambert law is usually written as:

Absorbance $A = m \cdot b \cdot c$, where:

m is the wavelength-dependent molar absorptivity coefficient (usually expressed in units of $M^{-1} \text{ cm}^{-1}$);

b is the mean path length; and

c is the analyte concentration (e.g., the desired parameter).

In spectroscopy, instruments attempt to obtain the analyte concentration (c) by relating absorbance (A) to transmittance (T). Transmittance is a proportional value defined as:

$T = I/I_0$, where:

I is the light intensity measured by the instrument from the measurement site; and

I_0 is the initial light intensity from the emitter.

Absorbance (A) can be equated to the transmittance (T) by the equation:

$$A = -\log T$$

Therefore, substituting equations from above:

$$A = -\log(I/I_0)$$

In view of this relationship, spectroscopy thus relies on a proportional-based calculation of $-\log(I/I_0)$ and solving for analyte concentration (c).

Typically, in order to simplify the calculations, spectroscopy will use detectors that are at the same location in order to keep the path length (b) a fixed, known constant. In addition, spectroscopy will employ various mechanisms to definitively know the transmission power (I_0), such as a photodiode located at the light source. This architecture can be viewed as a single channel or single stream sensor, because the detectors are at a single location.

However, this scheme can encounter several difficulties in measuring analytes, such as glucose. This can be due to the high overlap of absorption of light by water at the wavelengths relevant to glucose as well as other factors, such as high self-noise of the components.

Embodiments of the present disclosure can employ a different approach that in part allows for the measurement of analytes like glucose. Some embodiments can employ a bulk, non-pulsatile measurement in order to confirm or validate a pulsatile measurement. In addition, both the non-pulsatile and pulsatile measurements can employ, among other things, the multi-stream operation described above in order to attain sufficient SNR. In particular, a single light source having multiple emitters can be used to transmit light to multiple detectors having a spatial configuration.

A single light source having multiple emitters can allow for a range of wavelengths of light to be used. For example, visible, infrared, and near infrared wavelengths can be employed. Varying powers of light intensity for different wavelengths can also be employed.

Secondly, the use of multiple-detectors in a spatial configuration allow for a bulk measurement to confirm or validate that the sensor is positioned correctly. This is because the multiple locations of the spatial configuration can provide, for example, topology information that indicates where the sensor has been positioned. Currently available sensors do not provide such information. For example, if the bulk measurement is within a predetermined range of values, then this can indicate that the sensor is positioned correctly in order to perform pulsatile measurements for analytes like glucose. If the bulk measurement is outside of a certain range or is an unexpected value, then this can indicate that the sensor should be adjusted, or that the pulsatile measurements can be processed differently to compensate, such as using a different calibration curve or adjusting a calibration curve. This feature and others allow the embodiments to achieve noise cancellation and noise reduction, which can be several times greater in magnitude than what is achievable by currently available technology.

In order to help illustrate aspects of the multi-stream measurement approach, the following example derivation is provided. Transmittance (T) can be expressed as:

$$T = e^{-m \cdot b \cdot c}$$

In terms of light intensity, this equation can also be rewritten as:

$$I/I_o = e^{-m*b*c}$$

Or, at a detector, the measured light (I) can be expressed as:

$$I = I_o * e^{-m*b*c}$$

As noted, in the present disclosure, multiple detectors (1 to n) can be employed, which results in $I_1 \dots I_n$ streams of measurements. Assuming each of these detectors have their own path lengths, $b_1 \dots b_n$, from the light source, the measured light intensities can be expressed as:

$$I_n = I_o * e^{-m*b_n*c}$$

The measured light intensities at any two different detectors can be referenced to each other. For example:

$$I_1/I_n = (I_o * e^{-m*b_1*c}) / (I_o * e^{-m*b_n*c})$$

As can be seen, the terms, I_o , cancel out and, based on exponent algebra, the equation can be rewritten as:

$$I_1/I_n = e^{-m*(b_1-b_n)*c}$$

From this equation, the analyte concentration (c) can now be derived from bulk signals $I_1 \dots I_n$ and knowing the respective mean path lengths b_1 and b_n . This scheme also allows for the cancelling out of I_o , and thus, noise generated by the emitter **1304** can be cancelled out or reduced. In addition, since the scheme employs a mean path length difference, any changes in mean path length and topological variations from patient to patient are easily accounted. Furthermore, this bulk-measurement scheme can be extended across multiple wavelengths. This flexibility and other features allow embodiments of the present disclosure to measure blood analytes like glucose.

For example, as noted, the non-pulsatile, bulk measurements can be combined with pulsatile measurements to more accurately measure analytes like glucose. In particular, the non-pulsatile, bulk measurement can be used to confirm or validate the amount of glucose, protein, etc. in the pulsatile measurements taken at the tissue at the measurement site(s) **1302**. The pulsatile measurements can be used to measure the amount of glucose, hemoglobin, or the like that is present in the blood. Accordingly, these different measurements can be combined to thus determine analytes like blood glucose.

FIG. **14A** illustrates an embodiment of a detector submount **1400a** positioned beneath the partially cylindrical protrusion **605** of FIG. **6** (or alternatively, the protrusion **605b**). The detector submount **1400a** includes two rows **1408a** of detectors **1410a**. The partially cylindrical protrusion **605** can facilitate reducing the number and/or size of detectors used in a sensor because the protrusion **605** can act as a lens that focuses light onto a smaller area.

To illustrate, in some sensors that do not include the partially cylindrical protrusion **605**, sixteen detectors can be used, including four rows of four detectors each. Multiple rows of detectors can be used to measure certain analytes, such as glucose or total hemoglobin, among others. Multiple rows of detectors can also be used to detect light piping (e.g., light that bypasses the measurement site). However, using more detectors in a sensor can add cost, complexity, and noise to the sensor.

Applying the partially cylindrical protrusion **605** to such a sensor, however, could reduce the number of detectors or rows of detectors used while still receiving the substantially same amount of light, due to the focusing properties of the protrusion **605** (see FIG. **14B**). This is the example situation illustrated in FIG. **14**—two rows **1408a** of detectors **1410a** are used instead of four. Advantageously, in certain embodi-

ments, the resulting sensor can be more cost effective, have less complexity, and have an improved SNR, due to fewer and/or smaller photodiodes.

In other embodiments, using the partially cylindrical protrusion **605** can allow the number of detector rows to be reduced to one or three rows of four detectors. The number of detectors in each row can also be reduced. Alternatively, the number of rows might not be reduced but the size of the detectors can be reduced. Many other configurations of detector rows and sizes can also be provided.

FIG. **14B** depicts a front elevation view of the partially cylindrical protrusion **605** (or alternatively, the protrusion **605b**) that illustrates how light from emitters (not shown) can be focused by the protrusion **605** onto detectors. The protrusion **605** is placed above a detector submount **1400b** having one or more detectors **1410b** disposed thereon. The submount **1400b** can include any number of rows of detectors **1410**, although one row is shown.

Light, represented by rays **1420**, is emitted from the emitters onto the protrusion **605**. These light rays **1420** can be attenuated by body tissue (not shown). When the light rays **1420** enter the protrusion **605**, the protrusion **605** acts as a lens to refract the rays into rays **1422**. This refraction is caused in certain embodiments by the partially cylindrical shape of the protrusion **605**. The refraction causes the rays **1422** to be focused or substantially focused on the one or more detectors **1410b**. Since the light is focused on a smaller area, a sensor including the protrusion **605** can include fewer detectors to capture the same amount of light compared with other sensors.

FIG. **14C** illustrates another embodiment of a detector submount **1400c**, which can be disposed under the protrusion **605b** (or alternatively, the protrusion **605**). The detector submount **1400c** includes a single row **1408c** of detectors **1410c**. The detectors are electrically connected to conductors **1412c**, which can be gold, silver, copper, or any other suitable conductive material.

The detector submount **1400c** is shown positioned under the protrusion **605b** in a detector subassembly **1450** illustrated in FIG. **14D**. A top-down view of the detector subassembly **1450** is also shown in FIG. **14E**. In the detector subassembly **1450**, a cylindrical housing **1430** is disposed on the submount **1400c**. The cylindrical housing **1430** includes a transparent cover **1432**, upon which the protrusion **605b** is disposed. Thus, as shown in FIG. **14D**, a gap **1434** exists between the detectors **1410c** and the protrusion **605b**. The height of this gap **1434** can be chosen to increase or maximize the amount of light that impinges on the detectors **1410c**.

The cylindrical housing **1430** can be made of metal, plastic, or another suitable material. The transparent cover **1432** can be fabricated from glass or plastic, among other materials. The cylindrical housing **1430** can be attached to the submount **1400c** at the same time or substantially the same time as the detectors **1410c** to reduce manufacturing costs. A shape other than a cylinder can be selected for the housing **1430** in various embodiments.

In certain embodiments, the cylindrical housing **1430** (and transparent cover **1432**) forms an airtight or substantially airtight or hermetic seal with the submount **1400c**. As a result, the cylindrical housing **1430** can protect the detectors **1410c** and conductors **1412c** from fluids and vapors that can cause corrosion. Advantageously, in certain embodiments, the cylindrical housing **1430** can protect the detectors **1410c** and conductors **1412c** more effectively than currently-available resin epoxies, which are sometimes applied to solder joints between conductors and detectors.

37

In embodiments where the cylindrical housing **1430** is at least partially made of metal, the cylindrical housing **1430** can provide noise shielding for the detectors **1410c**. For example, the cylindrical housing **1430** can be soldered to a ground connection or ground plane on the submount **1400c**, which allows the cylindrical housing **1430** to reduce noise. In another embodiment, the transparent cover **1432** can include a conductive material or conductive layer, such as conductive glass or plastic. The transparent cover **1432** can include any of the features of the noise shields **790** described above.

The protrusion **605b** includes the chamfered edges **607** described above with respect to FIG. 6E. These chamfered edges **607** can allow a patient to more comfortably slide a finger over the protrusion **605b** when inserting the finger into the sensor **301f**.

FIG. 14F illustrates a portion of the detector shell **306f**, which includes the detectors **1410c** on the substrate **1400c**. The substrate **1400c** is enclosed by a shielding enclosure **1490**, which can include the features of the shielding enclosures **790a**, **790b** described above (see also FIG. 17). The shielding enclosure **1490** can be made of metal. The shielding enclosure **1490** includes a window **1492a** above the detectors **1410c**, which allows light to be transmitted onto the detectors **1410c**.

A noise shield **1403** is disposed above the shielding enclosure **1490**. The noise shield **1403**, in the depicted embodiment, includes a window **1492a** corresponding to the window **1492a**. Each of the windows **1492a**, **1492b** can include glass, plastic, or can be an opening without glass or plastic. In some embodiments, the windows **1492a**, **1492b** may be selected to have different sizes or shapes from each other.

The noise shield **1403** can include any of the features of the conductive glass described above. In the depicted embodiment, the noise shield **1403** extends about three-quarters of the length of the detector shell **306f**. In other embodiments, the noise shield **1403** could be smaller or larger. The noise shield **1403** could, for instance, merely cover the detectors **1410c**, the submount **1400c**, or a portion thereof. The noise shield **1403** also includes a stop **1413** for positioning a measurement site within the sensor **301f**. Advantageously, in certain embodiments, the noise shield **1403** can reduce noise caused by light piping.

A thermistor **1470** is also shown. The thermistor **1470** is attached to the submount **1400c** and protrudes above the noise shield **1403**. As described above, the thermistor **1470** can be employed to measure a temperature of a measurement site. Such a temperature can be helpful in correcting for wavelength drift due to changes in water absorption, which can be temperature dependent, thereby providing more accurate data useful in detecting blood analytes like glucose.

In the depicted embodiment, the detectors **1410c** are not enclosed in the cylindrical housing **1430**. In an alternative embodiment, the cylindrical housing **1430** encloses the detectors **1410c** and is disposed under the noise shield **1403**. In another embodiment, the cylindrical housing **1430** encloses the detectors **1410c** and the noise shield **1403** is not used. If both the cylindrical housing **1430** and the noise shield **1403** are used, either or both can have noise shielding features.

FIG. 14G illustrates the detector shell **306f** of FIG. 14F, with the finger bed **310f** disposed thereon. FIG. 14H illustrates the detector shell **306f** of FIG. 14G, with the protrusion **605b** disposed in the finger bed **310f**.

38

FIG. 14I illustrates a cutaway view of the sensor **301f**. Not all features of the sensor **301f** are shown, such as the protrusion **605b**. Features shown include the emitter and detector shells **304f**, **306f**, the flaps **307f**, the heat sink **350f** and fins **351f**, the finger bed **310f**, and the noise shield **1403**.

In addition to these features, emitters **1404** are depicted in the emitter shell **304f**. The emitters **1404** are disposed on a submount **1401**, which is connected to a circuit board **1419**. The emitters **1404** are also enclosed within a cylindrical housing **1480**. The cylindrical housing **1480** can include all of the features of the cylindrical housing **1430** described above. For example, the cylindrical housing **1480** can be made of metal, can be connected to a ground plane of the submount **1401** to provide noise shielding, and can include a transparent cover **1482**.

The cylindrical housing **1480** can also protect the emitters **1404** from fluids and vapors that can cause corrosion. Moreover, the cylindrical housing **1480** can provide a gap between the emitters **1404** and the measurement site (not shown), which can allow light from the emitters **1404** to even out or average out before reaching the measurement site.

The heat sink **350f**, in addition to including the fins **351f**, includes a protuberance **352f** that extends down from the fins **351f** and contacts the submount **1401**. The protuberance **352f** can be connected to the submount **1401**, for example, with thermal paste or the like. The protuberance **352f** can sink heat from the emitters **1404** and dissipate the heat via the fins **351f**.

FIGS. 15A and 15B illustrate embodiments of sensor portions **1500A**, **1500B** that include alternative heat sink features to those described above. These features can be incorporated into any of the sensors described above. For example, any of the sensors above can be modified to use the heat sink features described below instead of or in addition to the heat sink features of the sensors described above.

The sensor portions **1500A**, **1500B** shown include LED emitters **1504**; however, for ease of illustration, the detectors have been omitted. The sensor portions **1500A**, **1500B** shown can be included, for example, in any of the emitter shells described above.

The LEDs **1504** of the sensor portions **1500A**, **1500B** are connected to a substrate or submount **1502**. The submount **1502** can be used in place of any of the submounts described above. The submount **1502** can be a non-electrically conducting material made of any of a variety of materials, such as ceramic, glass, or the like. A cable **1512** is attached to the submount **1502** and includes electrical wiring **1514**, such as twisted wires and the like, for communicating with the LEDs **1504**. The cable **1512** can correspond to the cables **212** described above.

Although not shown, the cable **1512** can also include electrical connections to a detector. Only a portion of the cable **1512** is shown for clarity. The depicted embodiment of the cable **1512** includes an outer jacket **1510** and a conductive shield **1506** disposed within the outer jacket **1510**. The conductive shield **1506** can be a ground shield or the like that is made of a metal such as braided copper or aluminum. The conductive shield **1506** or a portion of the conductive shield **1506** can be electrically connected to the submount **1502** and can reduce noise in the signal generated by the sensor **1500A**, **1500B** by reducing RF coupling with the wires **1514**. In alternative embodiments, the cable **1512** does not have a conductive shield. For example, the cable **1512** could be a twisted pair cable or the like, with one wire of the twisted pair used as a heat sink.

Referring specifically to FIG. 15A, in certain embodiments, the conductive shield 1506 can act as a heat sink for the LEDs 1504 by absorbing thermal energy from the LEDs 1504 and/or the submount 1502. An optional heat insulator 1520 in communication with the submount 1502 can also assist with directing heat toward the conductive shield 1506. The heat insulator 1520 can be made of plastic or another suitable material. Advantageously, using the conductive shield 1506 in the cable 1512 as a heat sink can, in certain embodiments, reduce cost for the sensor.

Referring to FIG. 15B, the conductive shield 1506 can be attached to both the submount 1502 and to a heat sink layer 1530 sandwiched between the submount 1502 and the optional insulator 1520. Together, the heat sink layer 1530 and the conductive shield 1506 in the cable 1512 can absorb at least part of the thermal energy from the LEDs and/or the submount 1502.

FIGS. 15C and 15D illustrate implementations of a sensor portion 1500C that includes the heat sink features of the sensor portion 1500A described above with respect to FIG. 15A. The sensor portion 1500C includes the features of the sensor portion 1500A, except that the optional insulator 1520 is not shown. FIG. 15D is a side cutaway view of the sensor portion 1500C that shows the emitters 1504.

The cable 1512 includes the outer jacket 1510 and the conductive shield 1506. The conductive shield 1506 is soldered to the submount 1502, and the solder joint 1561 is shown. In some embodiments, a larger solder joint 1561 can assist with removing heat more rapidly from the emitters 1504. Various connections 1563 between the submount 1502 and a circuit board 1519 are shown. In addition, a cylindrical housing 1580, corresponding to the cylindrical housing 1480 of FIG. 14I, is shown protruding through the circuit board 1519. The emitters 1504 are enclosed in the cylindrical housing 1580.

FIGS. 15E and 15F illustrate implementations of a sensor portion 1500E that includes the heat sink features of the sensor portion 1500B described above with respect to FIG. 15B. The sensor portion 1500E includes the heat sink layer 1530. The heat sink layer 1530 can be a metal plate, such as a copper plate or the like. The optional insulator 1520 is not shown. FIG. 15F is a side cutaway view of the sensor portion 1500E that shows the emitters 1504.

In the depicted embodiment, the conductive shield 1506 of the cable 1512 is soldered to the heat sink layer 1530 instead of the submount 1502. The solder joint 1565 is shown. In some embodiments, a larger solder joint 1565 can assist with removing heat more rapidly from the emitters 1504. Various connections 1563 between the submount 1502 and a circuit board 1519 are shown. In addition, the cylindrical housing 1580 is shown protruding through the circuit board 1519. The emitters 1504 are enclosed in the cylindrical housing 1580.

FIGS. 15G and 15H illustrate embodiments of connector features that can be used with any of the sensors described above with respect to FIGS. 1 through 15F. Referring to FIG. 15G, the circuit board 1519 includes a female connector 1575 that mates with a male connector 1577 connected to a daughter board 1587. The daughter board 1587 includes connections to the electrical wiring 1514 of the cable 1512. The connected boards 1519, 1587 are shown in FIG. 15H. Also shown is a hole 1573 that can receive the cylindrical housing 1580 described above.

Advantageously, in certain embodiments, using a daughter board 1587 to connect to the circuit board 1519 can enable connections to be made more easily to the circuit board 1519. In addition, using separate boards can be easier

to manufacture than a single circuit board 1519 with all connections soldered to the circuit board 1519.

FIG. 15I illustrates an exemplary architecture for front-end interface 108 as a transimpedance-based front-end. As noted, front-end interfaces 108 provide an interface that adapts the output of detectors 106 into a form that can be handled by signal processor 110. As shown in this figure, sensor 101 and front-end interfaces 108 may be integrated together as a single component, such as an integrated circuit. Of course, one skilled in the art will recognize that sensor 101 and front end interfaces 108 may comprise multiple components or circuits that are coupled together.

Front-end interfaces 108 may be implemented using transimpedance amplifiers that are coupled to analog to digital converters in a sigma delta converter. In some embodiments, a programmable gain amplifier (PGA) can be used in combination with the transimpedance-based front-ends. For example, the output of a transimpedance-based front-end may be output to a sigma-delta ADC that comprises a PGA. A PGA may be useful in order to provide another level of amplification and control of the stream of signals from detectors 106. The PGA may be an integrated circuit or built from a set of micro-relays. Alternatively, the PGA and ADC components in converter 900 may be integrated with the transimpedance-based front-end in sensor 101.

Due to the low-noise requirements for measuring blood analytes like glucose and the challenge of using multiple photodiodes in detector 106, the applicants developed a noise model to assist in configuring front-end 108. Conventionally, those skilled in the art have focused on optimizing the impedance of the transimpedance amplifiers to minimize noise.

However, the following noise model was discovered by the applicants:

$$\text{Noise} = \sqrt{aR + bR^2},$$

aR is characteristic of the impedance of the transimpedance amplifier; and

bR^2 is characteristic of the impedance of the photodiodes in detector and the number of photodiodes in detector 106.

The foregoing noise model was found to be helpful at least in part due to the high SNR required to measure analytes like glucose. However, the foregoing noise model was not previously recognized by artisans at least in part because, in conventional devices, the major contributor to noise was generally believed to originate from the emitter or the LEDs. Therefore, artisans have generally continued to focus on reducing noise at the emitter.

However, for analytes like glucose, the discovered noise model revealed that one of the major contributors to noise was generated by the photodiodes. In addition, the amount of noise varied based on the number of photodiodes coupled to a transimpedance amplifier. Accordingly, combinations of various photodiodes from different manufacturers, different impedance values with the transimpedance amplifiers, and different numbers of photodiodes were tested as possible embodiments.

In some embodiments, different combinations of transimpedance to photodiodes may be used. For example, detectors 1-4 (as shown, e.g., in FIG. 12A) may each comprise four photodiodes. In some embodiments, each detector of four photodiodes may be coupled to one or more transimpedance

41

amplifiers. The configuration of these amplifiers may be set according to the model shown in FIG. 15J.

Alternatively, each of the photodiodes may be coupled to its own respective transimpedance amplifier. For example, transimpedance amplifiers may be implemented as integrated circuits on the same circuit board as detectors 1-4. In this embodiment, the transimpedance amplifiers may be grouped into an averaging (or summing) circuit, which are known to those skilled in the art, in order to provide an output stream from the detector. The use of a summing amplifier to combine outputs from several transimpedance amplifiers into a single, analog signal may be helpful in improving the SNR relative to what is obtainable from a single transimpedance amplifier. The configuration of the transimpedance amplifiers in this setting may also be set according to the model shown in FIG. 15J.

As yet another alternative, as noted above with respect to FIGS. 12E through 12H, the photodiodes in detectors 106 may comprise multiple active areas that are grouped together. In some embodiments, each of these active areas may be provided its own respective transimpedance. This form of pairing may allow a transimpedance amplifier to be better matched to the characteristics of its corresponding photodiode or active area of a photodiode.

As noted, FIG. 15J illustrates an exemplary noise model that may be useful in configuring transimpedance amplifiers. As shown, for a given number of photodiodes and a desired SNR, an optimal impedance value for a transimpedance amplifier could be determined.

For example, an exemplary “4 PD per stream” sensor 1502 is shown where detector 106 comprises four photodiodes 1502. The photodiodes 1502 are coupled to a single transimpedance amplifier 1504 to produce an output stream 1506. In this example, the transimpedance amplifier comprises 10 MO resistors 1508 and 1510. Thus, output stream 1506 is produced from the four photodiodes (PD) 1502. As shown in the graph of FIG. 15J, the model indicates that resistance values of about 10 MO may provide an acceptable SNR for analytes like glucose.

However, as a comparison, an exemplary “1 PD per stream” sensor 1512 is also shown in FIG. 15J. In particular, sensor 1512 may comprise a plurality of detectors 106 that each comprises a single photodiode 1514. In addition, as shown for this example configuration, each of photodiodes 1514 may be coupled to respective transimpedance amplifiers 1516, e.g., 1 PD per stream. Transimpedance amplifiers are shown having 40 MO resistors 1518. As also shown in the graph of FIG. 15J, the model illustrates that resistance values of 40 MO for resistors 1518 may serve as an alternative to the 4 photodiode per stream architecture of sensor 1502 described above and yet still provide an equivalent SNR.

Moreover, the discovered noise model also indicates that utilizing a 1 photodiode per stream architecture like that in sensor 1512 may provide enhanced performance because each of transimpedance amplifiers 1516 can be tuned or optimized to its respective photodiodes 1518. In some embodiments, an averaging component 1520 may also be used to help cancel or reduce noise across photodiodes 1518.

For purposes of illustration, FIG. 15K shows different architectures (e.g., four PD per stream and one PD per stream) for various embodiments of a sensor and how components of the sensor may be laid out on a circuit board or substrate. For example, sensor 1522 may comprise a “4 PD per stream” architecture on a submount 700 in which each detector 106 comprises four (4) photodiodes 1524. As shown for sensor 1522, the output of each set of four

42

photodiodes 1524 is then aggregated into a single transimpedance amplifier 1526 to produce a signal.

As another example, a sensor 1528 may comprise a “1 PD per stream” architecture on submount 700 in which each detector 106 comprises four (4) photodiodes 1530. In sensor 1528, each individual photodiode 1530 is coupled to a respective transimpedance amplifier 1532. The output of the amplifiers 1532 may then be aggregated into averaging circuit 1520 to produce a signal.

As noted previously, one skilled in the art will recognize that the photodiodes and detectors may be arranged in different fashions to optimize the detected light. For example, sensor 1534 illustrates an exemplary “4 PD per stream” sensor in which the detectors 106 comprise photodiodes 1536 arranged in a linear fashion. Likewise, sensor 1538 illustrates an exemplary “1 PD per stream” sensor in which the detectors comprise photodiodes 1540 arranged in a linear fashion.

Alternatively, sensor 1542 illustrates an exemplary “4 PD per stream” sensor in which the detectors 106 comprise photodiodes 1544 arranged in a two-dimensional pattern, such as a zig-zag pattern. Sensor 1546 illustrates an exemplary “1 PD per stream” sensor in which the detectors comprise photodiodes 1548 also arranged in a zig-zag pattern.

FIG. 15L illustrates an exemplary architecture for a switched-capacitor-based front-end. As shown, front-end interfaces 108 may be implemented using switched capacitor circuits and any number of front-end interfaces 108 may be implemented. The output of these switched capacitor circuits may then be provided to a digital interface 1000 and signal processor 110. Switched capacitor circuits may be useful in system 100 for their resistor free design and analog averaging properties. In particular, the switched capacitor circuitry provides for analog averaging of the signal that allows for a lower smaller sampling rate (e.g., 2 KHz sampling for analog versus 48 KHz sampling for digital designs) than similar digital designs. In some embodiments, the switched capacitor architecture in front end interfaces 108 may provide a similar or equivalent SNR to other front end designs, such as a sigma delta architecture. In addition, a switched capacitor design in front end interfaces 108 may require less computational power by signal processor 110 to perform the same amount of decimation to obtain the same SNR.

FIGS. 16A and 16B illustrate embodiments of disposable optical sensors 1600. In an embodiment, any of the features described above, such as protrusion, shielding, and/or heat sink features, can be incorporated into the disposable sensors 1600 shown. For instance, the sensors 1600 can be used as the sensors 101 in the system 100 described above with respect to FIG. 1. Moreover, any of the features described above, such as protrusion, shielding, and/or heat sink features, can be implemented in other disposable sensor designs that are not depicted herein.

The sensors 1600 include an adult/pediatric sensor 1610 for finger placement and a disposable infant/neonate sensor 1602 configured for toe, foot or hand placement. Each sensor 1600 has a tape end 1610 and an opposite connector end 1620 electrically and mechanically interconnected via a flexible coupling 1630. The tape end 1610 attaches an emitter and detector to a tissue site. Although not shown, the tape end 1610 can also include any of the protrusion, shielding, and/or heat sink features described above. The emitter illuminates the tissue site and the detector generates

a sensor signal responsive to the light after tissue absorption, such as absorption by pulsatile arterial blood flow within the tissue site.

The sensor signal is communicated via the flexible coupling 1630 to the connector end 1620. The connector end 1620 can mate with a cable (not shown) that communicates the sensor signal to a monitor (not shown), such as any of the cables or monitors shown above with respect to FIGS. 2A through 2D. Alternatively, the connector end 1620 can mate directly with the monitor.

FIG. 17 illustrates an exploded view of certain of the components of the sensor 301f described above. A heat sink 1751 and a cable 1781 attach to an emitter shell 1704. The emitter shell attaches to a flap housing 1707. The flap housing 1707 includes a receptacle 1709 to receive a cylindrical housing 1480/1580 (not shown) attached to an emitter submount 1702, which is attached to a circuit board 1719.

A spring 1787 attaches to a detector shell 1706 via pins 1783, 1785, which hold the emitter and detector shells 1704, 1706 together. A support structure 1791 attaches to the detector shell 1706, which provides support for a shielding enclosure 1790. A noise shield 1713 attaches to the shielding enclosure 1790. A detector submount 1700 is disposed inside the shielding enclosure 1790. A finger bed 1710 provides a surface for placement of the patient's finger. Finger bed 1710 may comprise a gripping surface or gripping features, which may assist in placing and stabilizing a patient's finger in the sensor. A partially cylindrical protrusion 1705 may also be disposed in the finger bed 1710. As shown, finger bed 1710 attaches to the noise shield 1703. The noise shield 1703 may be configured to reduce noise, such as from ambient light and electromagnetic noise. For example, the noise shield 1703 may be constructed from materials having an opaque color, such as black or a dark blue, to prevent light piping.

Noise shield 1703 may also comprise a thermistor 1712. The thermistor 1712 may be helpful in measuring the temperature of a patient's finger. For example, the thermistor 1712 may be useful in detecting when the patient's finger is reaching an unsafe temperature that is too hot or too cold. In addition, the temperature of the patient's finger may be useful in indicating to the sensor the presence of low perfusion as the temperature drops. In addition, the thermistor 1712 may be useful in detecting a shift in the characteristics of the water spectrum in the patient's finger, which can be temperature dependent.

Moreover, a flex circuit cover 1706 attaches to the pins 1783, 1785. Although not shown, a flex circuit can also be provided that connects the circuit board 1719 with the submount 1700 (or a circuit board to which the submount 1700 is connected). A flex circuit protector 1760 may be provided to provide a barrier or shield to the flex circuit (not shown). In particular, the flex circuit protector 1760 may also prevent any electrostatic discharge to or from the flex circuit. The flex circuit protector 1760 may be constructed from well known materials, such as a plastic or rubber materials.

FIG. 18 shows the results obtained by an exemplary sensor 101 of the present disclosure that was configured for measuring glucose. This sensor 101 was tested using a pure water ex-vivo sample. In particular, ten samples were prepared that ranged from 0-55 mg/dL. Two samples were used as a training set and eight samples were then used as a test population. As shown, embodiments of the sensor 101 were able to obtain at least a standard deviation of 13 mg/dL in the training set and 11 mg/dL in the test population.

FIG. 19 shows the results obtained by an exemplary sensor 101 of the present disclosure that was configured for measuring glucose. This sensor 101 was tested using a turbid ex-vivo sample. In particular, 25 samples of water/glucose/Lysozin were prepared that ranged from 0-55 mg/dL. Five samples were used as a training set and 20 samples were then used as a test population. As shown, embodiments of sensor 101 were able to obtain at least a standard deviation of 37 mg/dL in the training set and 32 mg/dL in the test population.

FIGS. 20 through 22 shows other results that can be obtained by an embodiment of system 100. In FIG. 20, 150 blood samples from two diabetic adult volunteers were collected over a 10-day period. Invasive measurements were taken with a YSI glucometer to serve as a reference measurement. Noninvasive measurements were then taken with an embodiment of system 100 that comprised four LEDs and four independent detector streams. As shown, the system 100 obtained a correlation of about 85% and Arms of about 31 mg/dL.

In FIG. 21, 34 blood samples were taken from a diabetic adult volunteer collected over a 2-day period. Invasive measurements were also taken with a glucometer for comparison. Noninvasive measurements were then taken with an embodiment of system 100 that comprised four LEDs in emitter 104 and four independent detector streams from detectors 106. As shown, the system 100 was able to attain a correlation of about 90% and Arms of about 22 mg/dL.

The results shown in FIG. 22 relate to total hemoglobin testing with an exemplary sensor 101 of the present disclosure. In particular, 47 blood samples were collected from nine adult volunteers. Invasive measurements were then taken with a CO-oximeter for comparison. Noninvasive measurements were taken with an embodiment of system 100 that comprised four LEDs in emitter 104 and four independent detector channels from detectors 106. Measurements were averaged over 1 minute. As shown, the testing resulted in a correlation of about 93% and Arms of about 0.8 mg/dL.

Conditional language used herein, such as, among others, "can," "could," "might," "may," "e.g.," and the like, unless specifically stated otherwise, or otherwise understood within the context as used, is generally intended to convey that certain embodiments include, while other embodiments do not include, certain features, elements and/or states. Thus, such conditional language is not generally intended to imply that features, elements and/or states are in any way required for one or more embodiments or that one or more embodiments necessarily include logic for deciding, with or without author input or prompting, whether these features, elements and/or states are included or are to be performed in any particular embodiment.

While certain embodiments of the inventions disclosed herein have been described, these embodiments have been presented by way of example only, and are not intended to limit the scope of the inventions disclosed herein. Indeed, the novel methods and systems described herein can be embodied in a variety of other forms; furthermore, various omissions, substitutions and changes in the form of the methods and systems described herein can be made without departing from the spirit of the inventions disclosed herein. The claims and their equivalents are intended to cover such forms or modifications as would fall within the scope and spirit of certain of the inventions disclosed herein.

What is claimed is:

1. A noninvasive optical physiological measurement device adapted to be worn by a wearer, the noninvasive

45

optical physiological measurement device providing an indication of a physiological parameter of the wearer comprising:

- a plurality of emitters of different wavelengths;
 - a housing having a surface and a circular wall protruding from the surface;
 - at least four detectors arranged on the surface and spaced apart from each other, the at least four detectors configured to output one or more signals responsive to light from the one or more light emitters attenuated by body tissue, the one or more signals indicative of a physiological parameter of the wearer; and
 - a light permeable cover arranged above at least a portion of the housing, the light permeable cover comprising a protrusion arranged to cover the at least four detectors.
2. The noninvasive optical physiological measurement device of claim 1, wherein the light permeable cover is attached to the housing and forms an airtight or substantially airtight seal enclosing the at least four detectors.
 3. The noninvasive optical physiological measurement device of claim 2, wherein the circular wall creates a gap between the surface and the light permeable cover.
 4. The noninvasive optical physiological measurement device of claim 2, wherein the housing provides noise shielding for the at least four detectors.
 5. The noninvasive optical physiological measurement device of claim 4, wherein the light permeable cover comprises a conductive layer configured to shield the at least four detectors from noise.
 6. The noninvasive optical physiological measurement device of claim 3, wherein the protrusion comprises a continuous protrusion.
 7. The noninvasive optical physiological measurement device of claim 6, wherein the continuous protrusion comprises a convex protrusion.
 8. The noninvasive optical physiological measurement device of claim 6, wherein the light permeable cover is comprised of a rigid material.
 9. The noninvasive optical physiological measurement device of claim 8, wherein the light permeable cover is configured to be positioned between the at least four detectors and tissue of a user when the noninvasive optical physiological measurement device is worn by the user.
 10. The noninvasive optical physiological measurement device of claim 9, wherein the light permeable cover is configured to press against and at least partially deform tissue of the user when the noninvasive optical physiological measurement device is worn by the user.
 11. The noninvasive optical physiological measurement device of claim 10, wherein the light permeable cover is configured to act as a tissue shaper and conform tissue of the user to at least a portion of an external surface shape of the light permeable cover when the noninvasive optical physiological measurement device is worn by the user.
 12. The noninvasive optical physiological measurement device of claim 11, wherein the light permeable cover is configured to reduce a mean path length of light traveling to the at least four detectors.
 13. The noninvasive optical physiological measurement device of claim 11, wherein the at least four detectors are evenly spaced from one another.
 14. The noninvasive optical physiological measurement device of claim 1, wherein the light permeable cover is configured to reduce a mean path length of light traveling to the at least four detectors.
 15. The noninvasive optical physiological measurement device of claim 13, wherein the light permeable cover

46

concentration window is configured to increase a signal to noise ratio of the noninvasive optical physiological measurement device.

16. The noninvasive optical physiological measurement device of claim 13, wherein the light permeable cover is configured to increase a signal strength per area of the at least four detectors.
17. The noninvasive optical physiological measurement device of claim 1, wherein the physiological parameter is pulse rate.
18. The noninvasive optical physiological measurement device of claim 1, wherein the physiological parameter is at least one of: glucose, oxygen, oxygen saturation, methemoglobin, total hemoglobin, carboxyhemoglobin, or carbon monoxide.
19. The noninvasive optical physiological measurement device of claim 1, wherein the noninvasive optical physiological measurement device is a disposable or a reusable device.
20. The noninvasive optical physiological measurement device of claim 1, wherein a first detector is arranged spaced apart from a second detector, and a third detector arranged spaced apart from a fourth detector.
21. The noninvasive optical physiological measurement device of claim 20, wherein the first detector is arranged across a central axis from the second detector and the third detector is arranged across the central axis from the fourth detector, wherein the first, second, third and fourth detectors form a cross pattern about the central axis.
22. The noninvasive optical physiological measurement device of claim 20, wherein the noninvasive optical physiological measurement device provides a variation in optical path length to the at least four detectors.
23. The noninvasive optical physiological measurement device of claim 1, wherein the noninvasive optical physiological measurement device is comprised as part of a mobile monitoring device.
24. The noninvasive optical physiological measurement device of claim 23, wherein the mobile monitoring device includes a touch-screen display.
25. A physiological monitoring system comprising:
 - the noninvasive optical physiological measurement device of claim 1; and
 - a processor configured to receive the one or more signals and communicate physiological measurement information to a mobile phone.
26. A noninvasive optical physiological measurement device adapted to be worn by a wearer providing an indication of a physiological parameter of the wearer comprising:
 - a plurality of emitters of different wavelengths;
 - a circular housing comprising a surface with a raised edge;
 - at least four detectors arranged on the surface, wherein a first detector is arranged spaced apart from a second detector, and a third detector arranged spaced apart from a fourth detector; and
 - a cover of the circular housing comprising a lens portion, the lens portion comprising a protrusion in optical communication with the at least four detectors, wherein the at least four detectors are configured to output one or more signals responsive to light from the one or more light emitters attenuated by body tissue, the one or more signals indicative of a physiological parameter of the wearer.
27. The noninvasive optical physiological measurement device of claim 26, wherein the first detector is arranged

across a central axis from the second detector and the third detector is arranged across the central axis from the fourth detector, wherein the first, second, third and fourth detectors form a cross pattern about the central axis.

28. The noninvasive optical physiological measurement device of claim 26, wherein the at least four detectors are arranged in a grid pattern such that the first detector and the second detector are arranged across from each other on opposite sides of a central point along a first axis, and the third detector and the fourth detector are arranged across from each other on opposite sides of the central point along a second axis which is perpendicular to the first axis.

29. The noninvasive optical physiological measurement device of claim 27, wherein the physiological parameter is pulse rate.

30. The noninvasive optical physiological measurement device of claim 27, wherein the physiological parameter is at least one of: glucose, oxygen, oxygen saturation, methemoglobin, total hemoglobin, carboxyhemoglobin, or carbon monoxide.

* * * * *

UNITED STATES PATENT AND TRADEMARK OFFICE
CERTIFICATE OF CORRECTION

PATENT NO. : 10,258,265 B1
APPLICATION NO. : 16/212440
DATED : April 16, 2019
INVENTOR(S) : Jeroen Poeze et al.

Page 1 of 1

It is certified that error appears in the above-identified patent and that said Letters Patent is hereby corrected as shown below:

In the Specification

In Column 25 at Line 18, After “where” insert --R--.

In Column 40 at Line 39 (approx.), After “ $Noise = \sqrt{aR + bR^2}$,” insert --where:--.

In Column 41 at Line 35, Change “MO” to --M Ω --.

In Column 41 at Line 38, Change “MO” to --M Ω --.

In Column 41 at Line 47, Change “MO” to --M Ω --.

In Column 41 at Line 49, Change “MO” to --M Ω --.

In the Claims

In Column 45 at Line 22, In Claim 3, change “cove.” to --cover.--.

In Column 45 at Line 63, In Claim 14, change “claim 1,” to --claim 13,--.

In Column 46 at Line 1, In Claim 15, before “is” delete “concentration window”.

Signed and Sealed this
Twenty-second Day of October, 2019

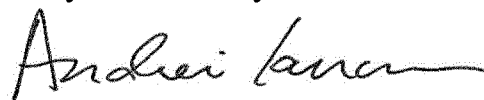

Andrei Iancu
Director of the United States Patent and Trademark Office