



US007660203B2

(12) **United States Patent**
Barakat et al.

(10) **Patent No.:** **US 7,660,203 B2**
(45) **Date of Patent:** **Feb. 9, 2010**

(54) **SYSTEMS AND METHODS FOR SEISMIC DATA ACQUISITION EMPLOYING ASYNCHRONOUS, DECOUPLED DATA SAMPLING AND TRANSMISSION**

(75) Inventors: **Simon Barakat**, Chilly-Mazarin (FR); **Kambiz Iranpour**, Oslo (NO); **Daniel H. Golparian**, Oslo (NO)

(73) Assignee: **WesternGeco L.L.C.**, Houston, TX (US)

(*) Notice: Subject to any disclaimer, the term of this patent is extended or adjusted under 35 U.S.C. 154(b) by 242 days.

(21) Appl. No.: **11/683,883**

(22) Filed: **Mar. 8, 2007**

(65) **Prior Publication Data**

US 2008/0219094 A1 Sep. 11, 2008

(51) **Int. Cl.**
G01V 1/22 (2006.01)

(52) **U.S. Cl.** **367/76; 367/63**

(58) **Field of Classification Search** **367/59, 367/63, 76**

See application file for complete search history.

(56) **References Cited**

U.S. PATENT DOCUMENTS

6,002,640	A *	12/1999	Harmon	367/76
6,044,453	A	3/2000	Paver		
6,049,882	A	4/2000	Paver		
6,055,620	A	4/2000	Paver et al.		
6,148,392	A	11/2000	Liu		
2002/0193947	A1	12/2002	Chamberlain		
2003/0174582	A1	9/2003	Scott		
2004/0105341	A1	6/2004	Chamberlain et al.		

2005/0047275	A1	3/2005	Chamberlain		
2005/0276162	A1	12/2005	Brinkmann et al.		
2006/0009911	A1	1/2006	Burkholder et al.		
2006/0018196	A1	1/2006	Chamberlain		
2006/0192625	A1	8/2006	Sorrells et al.		
2006/0203614	A1	9/2006	Harmon		
2006/0215588	A1	9/2006	Yoon		
2006/0226916	A1	10/2006	Florescu et al.		
2006/0251081	A1	11/2006	Choksi		
2007/0025484	A1 *	2/2007	Laine et al.	375/355

OTHER PUBLICATIONS

- <http://apachepersonal.miun.se/~benoel/asynch.htm>.
- <http://web.mit.edu/newsoffice/2006/batteries-0208.html>.
- <http://www.javvin.com/>.
- <http://www.networkdictionary.com/wireless/WPAN.php?PHPSESSID=354101c49bc9d97659791acaecddca6>.
- <http://www.tutorial-reports.com/wireless/wimax/tutorial.php>.
- <http://www.westerngeco.com/q-technology>.

* cited by examiner

Primary Examiner—Ian J Lobo

(74) *Attorney, Agent, or Firm*—Ari Pramudji; Richard V. Wells; Kevin McEnaney

(57) **ABSTRACT**

Systems and methods for asynchronously acquiring seismic data are described, one system comprising one or more seismic sources, a plurality of sensor modules each comprising a seismic sensor, an A/D converter for generating digitized seismic data, a digital signal processor (DSP), and a sensor module clock; a seismic data recording station; and a seismic data transmission sub-system comprising a high precision clock, the sub-system allowing transmission of at least some of the digitized seismic data to the recording station, wherein each sensor module is configured to periodically receive from the sub-system an amount of the drift of its clock relative to the high precision clock.

11 Claims, 3 Drawing Sheets

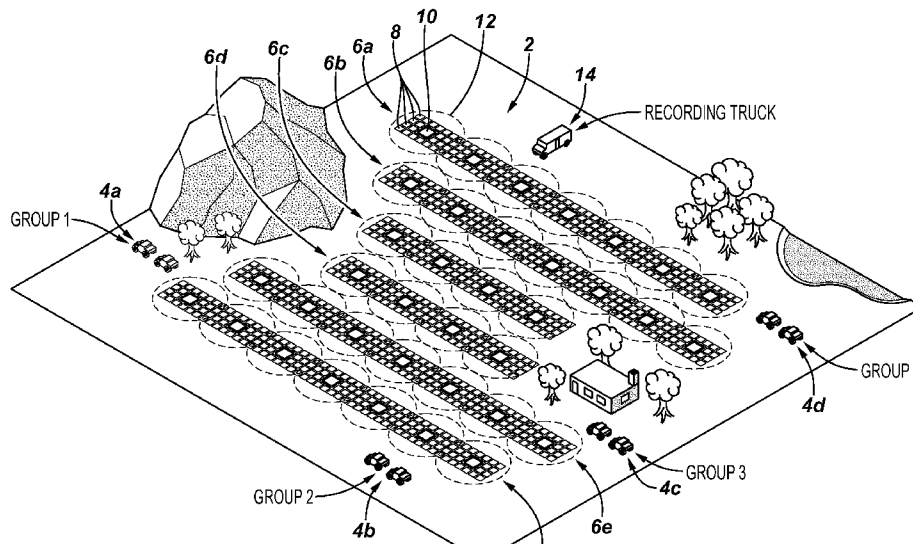

FIG. 1

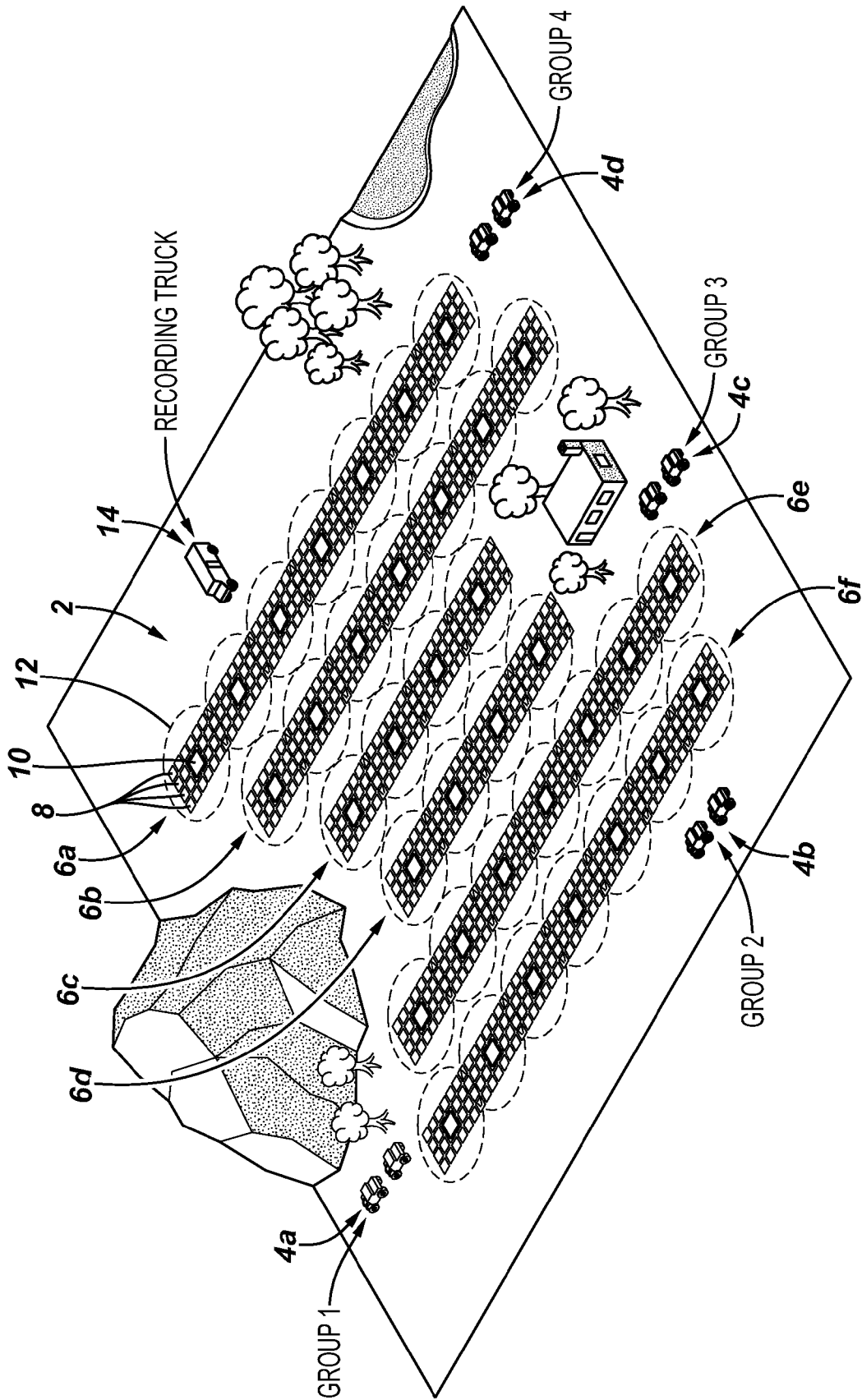

FIG. 2

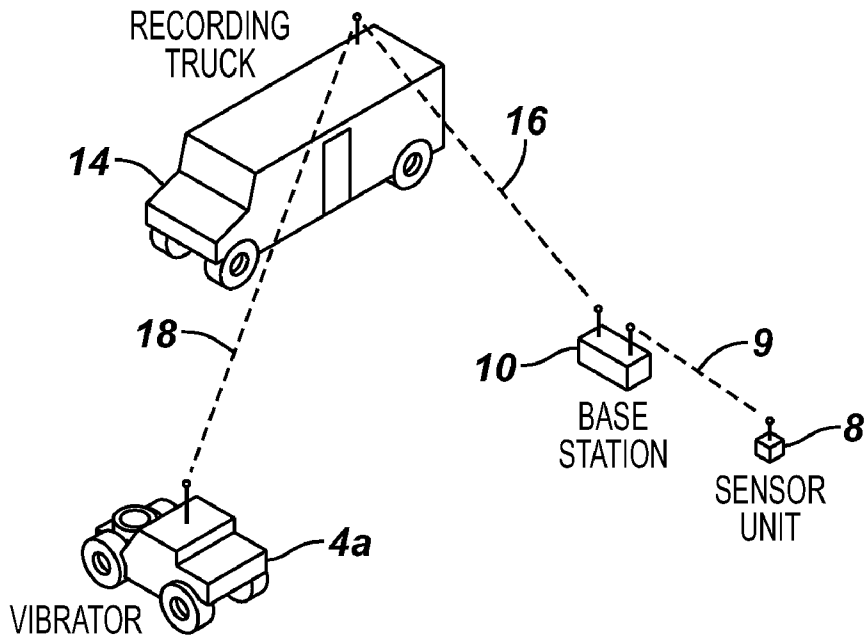

FIG. 3

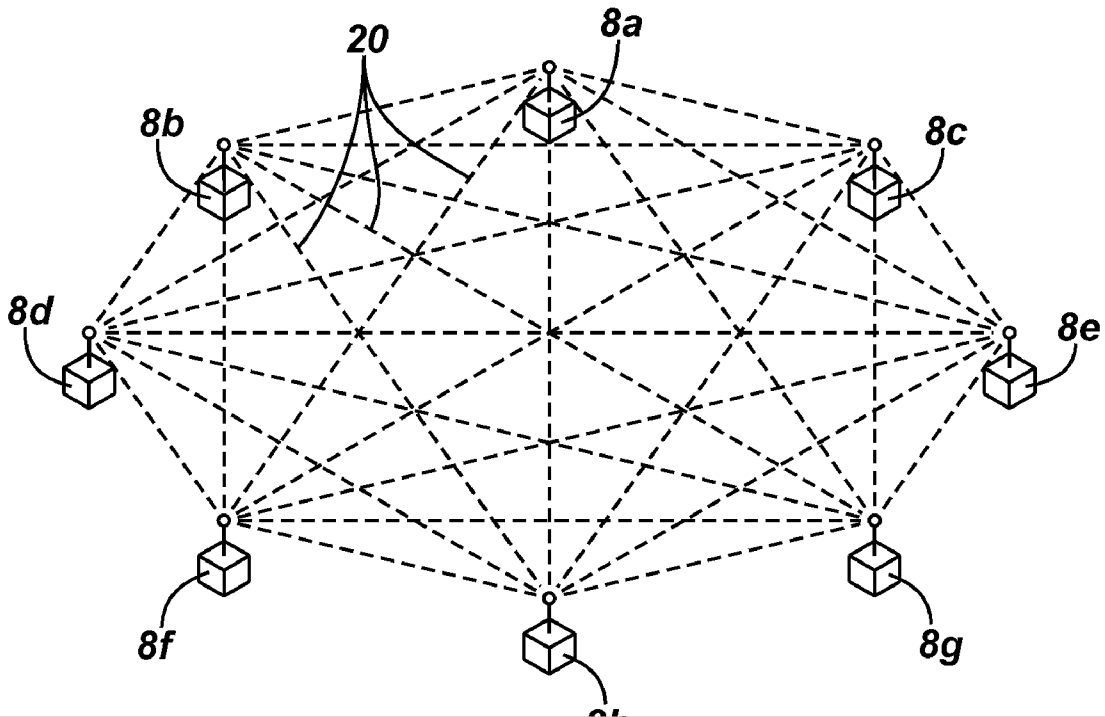

FIG. 4

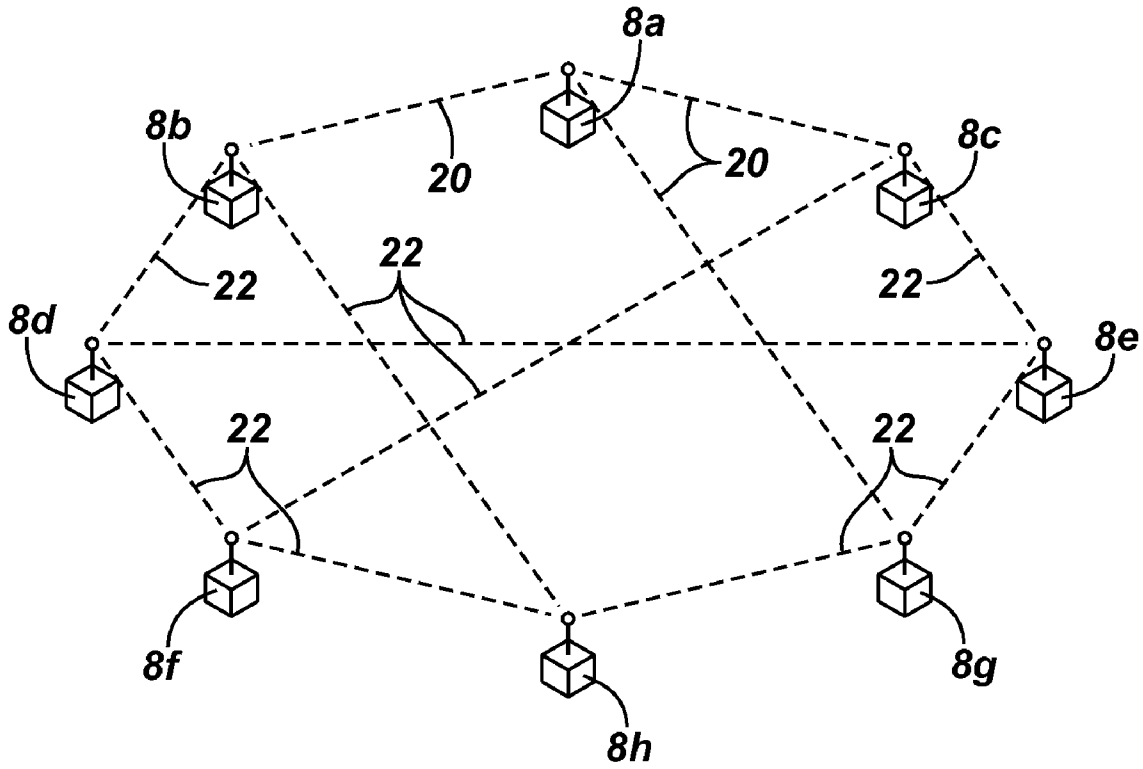
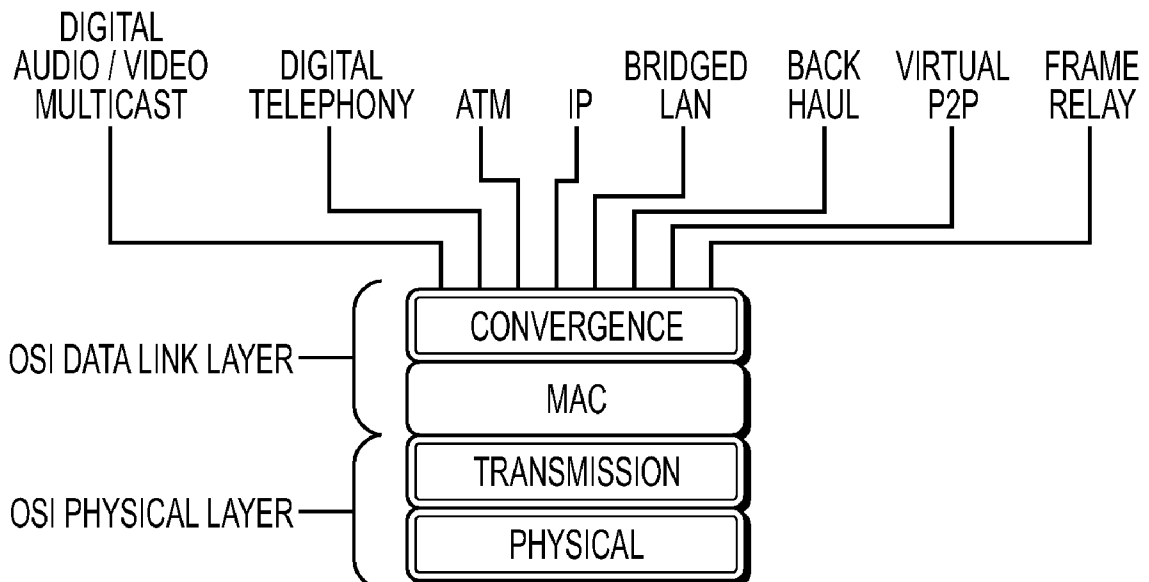

FIG. 5



1

**SYSTEMS AND METHODS FOR SEISMIC
DATA ACQUISITION EMPLOYING
ASYNCHRONOUS, DECOUPLED DATA
SAMPLING AND TRANSMISSION**

BACKGROUND OF THE INVENTION

1. Field of Invention

The present invention relates to the field of seismic data acquisition systems and methods of using same. More specifically, the invention relates to systems and methods for seismic data acquisition in which the seismic sampling is decoupled from data transmission using asynchronous digital signal processors for data sampling, and interpolation for synchronizing the sampling.

2. Related Art

Land seismic acquisition aims to capture the acoustic and elastic energy that has propagated through the subsurface. This energy may be generated by one or more surface sources such as vibratory sources (vibrators). The vibrators produce a pressure signal that propagates through the earth into the various subsurface layers. Here elastic waves are formed through interaction with the geologic structure in the subsurface layers. Elastic waves are characterized by a change in local stress in the subsurface layers and a particle displacement, which is essentially in the same plane as the wavefront. Acoustic and elastic waves are also known as pressure and shear waves. Acoustic and elastic waves are collectively referred to as the seismic wavefield.

The structure in the subsurface may be characterized by physical parameters such as density, compressibility, and porosity. A change in the value of these parameters is referred to as an acoustic or elastic contrast and may be indicative of a change in subsurface layers, which may contain hydrocarbons. When an acoustic or elastic wave encounters an acoustic or elastic contrast, some part of the waves will be reflected back to the surface and another part of the wave will be transmitted into deeper parts of the subsurface. The elastic waves that reach the land surface may be measured by motion sensors (measuring displacement, velocity, or acceleration, such as geophones, accelerometers, and the like) located on the land. The measurement of elastic waves at the land surface may be used to create a detailed image of the subsurface including a quantitative evaluation of the physical properties such as density, compressibility, porosity, etc. This is achieved by appropriate processing of the seismic data.

Seismic sensor units typically also contain the electronics needed to digitize and record the seismic data. In one known embodiment, each sensor unit is connected to a land seismic cable, which is connected via cables to a recording instrument on a surface vehicle or other surface facility such as a platform. The land seismic cable provides electric power and the means for transferring the recorded and digitized seismic signals to the recording instrument. In other embodiments, there have been efforts to reduce the use of cables in performing land seismic, with movement toward wireless land seismic systems and methods.

Seismic sampling in a typical seismic sensor network (whether wired or wireless) may comprise up to tens of thousands or more seismic sensors measuring the seismic vibrations for oil and gas exploration. Each sensor with an analogue output has its output converted to a digital signal by an analog to digital converter (ADC) that is in turn connected to a digital signal processing (DSP) unit. Every sampling unit has its own clock frequency that drifts over time relative to the

2

centralized recording unit. The individual sampling ADC/DSP units are traditionally phase-synchronized to the data transmission line clock by an electronic phase-locked loop (PLL).

While these systems and methods have enjoyed some success, there remains room for improvement. It is of utmost important in seismic acquisition to phase synchronize the sampling of all the sampling units. However, presently known systems and methods are more expensive and less flexible due to the above-mentioned individual sampling ADC/DSP units being phase-synchronized to the data transmission line clock by an electronic phase-locked loop. There is a need in the seismic data acquisition arts for systems and methods wherein the transmission of data is decoupled from sampling of the data, and that eliminate the costly and inflexible electronic phase locking loop, while still ensuring that the output sampling frequency of each signal processing unit is phase synchronized with the data transmission line clock. The present invention is devoted to addressing one or more of these needs.

SUMMARY OF THE INVENTION

In accordance with the present invention, systems and methods for seismic data acquisition are described which reduce or overcome short-comings of previously known systems and methods wherein the transmission of data is coupled to sampling of the data. Systems and methods of seismic data acquisition in accordance with the invention eliminate the costly and inflexible electronic phase locking loop. In the inventive systems and methods, the drift of each clock associated with a seismic sensor is periodically measured and/or calculated relative to the data transmission line clock (which may be the master clock), and interpolation techniques are used to adjust for the sensor clock drift. In this way the output sampling frequency of each signal processing unit is phase synchronized with the data transmission line clock without the use of an electronic phase locked loop circuit. Systems and methods of the invention allow more efficient seismic data acquisition, for example 2-D, 3-D and 4-D land seismic data acquisition, such as during exploration for underground hydrocarbon-bearing reservoirs, or monitoring existing reservoirs. Electromagnetic signals may be used to transfer data to and/or from the sensor units, to transmit power, and/or to receive instructions to operate the sensor units.

A first aspect of the invention is seismic data acquisition system comprising:

- one or more seismic sources (which may be land sources, such as vibrators, explosive charges, and the like, or marine sources, such as air-guns, vibrators, and the like);
 - a sensor system (which may be suitable for land seismic or marine seismic) for acquiring and/or monitoring analog seismic sensor data, the sensor system comprising a plurality of sensor modules each configured to asynchronously sample seismic data and comprising a seismic sensor, an A/D converter (ADC) for generating digitized seismic data, a digital signal processor (DSP), and a sensor module clock;
 - a seismic data recording station, and
 - a seismic data transmission sub-system comprising a high precision clock, the sub-system allowing the DSP to transmit at least some of the digitized seismic data to the recording station,
- wherein each sensor module receives periodically from the

Explore Litigation Insights

Docket Alarm provides insights to develop a more informed litigation strategy and the peace of mind of knowing you're on top of things.

Real-Time Litigation Alerts



Keep your litigation team up-to-date with **real-time alerts** and advanced team management tools built for the enterprise, all while greatly reducing PACER spend.

Our comprehensive service means we can handle Federal, State, and Administrative courts across the country.

Advanced Docket Research



With over 230 million records, Docket Alarm's cloud-native docket research platform finds what other services can't. Coverage includes Federal, State, plus PTAB, TTAB, ITC and NLRB decisions, all in one place.

Identify arguments that have been successful in the past with full text, pinpoint searching. Link to case law cited within any court document via Fastcase.

Analytics At Your Fingertips



Learn what happened the last time a particular judge, opposing counsel or company faced cases similar to yours.

Advanced out-of-the-box PTAB and TTAB analytics are always at your fingertips.

API

Docket Alarm offers a powerful API (application programming interface) to developers that want to integrate case filings into their apps.

LAW FIRMS

Build custom dashboards for your attorneys and clients with live data direct from the court.

Automate many repetitive legal tasks like conflict checks, document management, and marketing.

FINANCIAL INSTITUTIONS

Litigation and bankruptcy checks for companies and debtors.

E-DISCOVERY AND LEGAL VENDORS

Sync your system to PACER to automate legal marketing.