



[54] **COMPUTER SYSTEM INCLUDING A DEVICE WITH A PLURALITY OF IDENTIFIERS**

[75] Inventors: **Takashi Oeda; Kiyoshi Honda**, both of Yokohama; **Naoto Matsunami**, Fujisawa; **Minoru Yoshida**, Odawara, all of Japan

[73] Assignee: **Hitachi, Ltd.**, Tokyo, Japan

[21] Appl. No.: **31,880**

[22] Filed: **Mar. 16, 1993**

[30] **Foreign Application Priority Data**

Mar. 16, 1992 [JP] Japan ..... 4-058102

[51] Int. Cl.<sup>6</sup> ..... **G06F 12/06**

[52] U.S. Cl. .... **395/480; 395/497.04**

[58] Field of Search ..... **395/325, 650, 395/405, 480, 497.04; 364/246.3**

[56] **References Cited**

**U.S. PATENT DOCUMENTS**

3,988,719	10/1976	Whitby et al. ....	340/172.5
4,855,905	8/1989	Estrada et al. .	
4,922,410	5/1990	Morikawa et al. .	
4,924,210	5/1990	Matsui et al. ....	340/572
4,945,512	7/1990	Dakarske et al. ....	365/49
4,958,341	9/1990	Hemmady et al. ....	370/60.1
5,097,414	3/1992	Tone .....	395/425
5,206,937	4/1993	Goto .....	395/325
5,303,359	4/1994	Suzuki .....	395/100
5,321,816	6/1994	Rogan et al. ....	395/200
5,355,453	10/1994	Row et al. ....	395/200
5,379,184	1/1995	Barraza et al. ....	361/685
5,410,680	4/1995	Challa et al. ....	395/500

**OTHER PUBLICATIONS**

PCs & Workstations, Jul. 1, 1991 Computer World, "External SCSI drives Announced" p. 38.  
 Computer World Apr. 10, 1989 p. 42, "PCs & Workstations New Products".

Computer World Feb. 6, 1989 p. 51, Microcomputing "New Products".

"An AFS™-Based Mass Storage System At The Pittsburgh Supercomputing Center" Danial Nydick et al, 1991, pp. 117-122.

"Filtering of Network Addresses in Real Time by Sequential Decoding" Wolstenholme, 1988, pp. 55-59.

ANSI X3.131-1986, 1986 pp. 14-17, 25-41.

Microsoft MS-DOS Operating System Version 5.0, User's Guide & Reference, 1991 pp. 147-159.

*Primary Examiner*—Jack B. Harvey

*Assistant Examiner*—Paul R. Myers

*Attorney, Agent, or Firm*—Antonelli, Terry, Stout & Kraus, LLP

[57] **ABSTRACT**

A host computer is connected with a magnetic disk storage device by an SCSI bus. In the magnetic disk storage device, a plurality of partitions are set in a disk drive unit and have device identifiers (ID's) respectively allocated thereto as SCSI ID's=1, 2 and 3, which are supported by a disk controller. When the host computer has acquired the control of the SCSI bus through arbitration and has selected, for example, the partition with the device identifier SCSI ID=1, the disk controller permits the host computer to access the partition in response to the selection. Since the partitions are different in attributes, properties etc., they appear as magnetic disk storage devices that are separate from one another when viewed from the host computer. Thus, the single magnetic disk storage device can be managed as a plurality of storage devices of different nature.

**8 Claims, 6 Drawing Sheets**

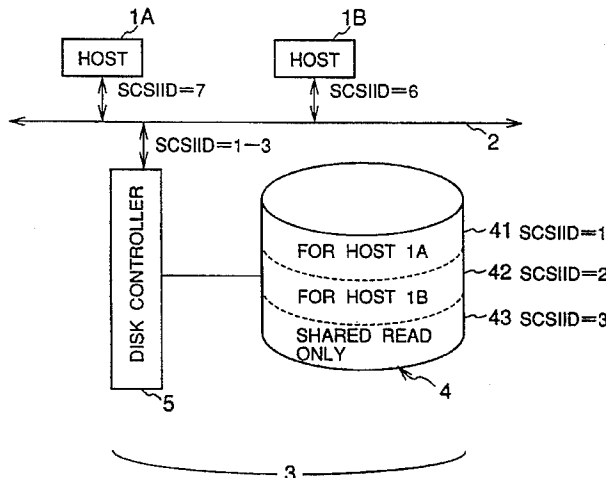

FIG. 1

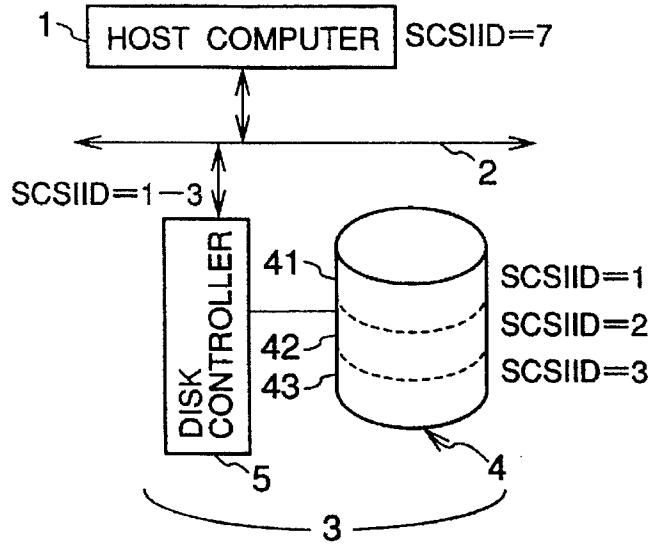

FIG. 2

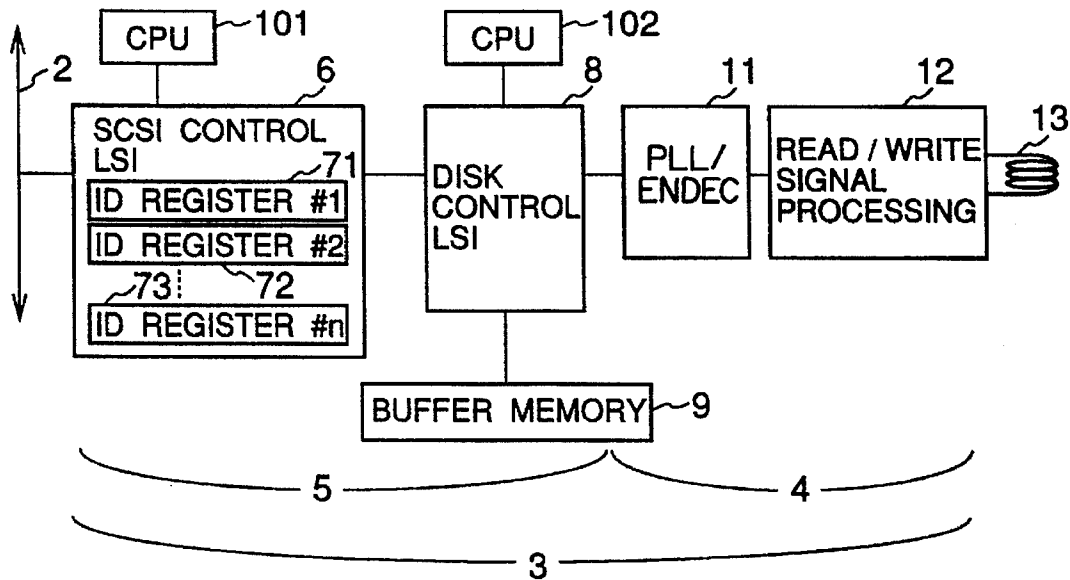

FIG. 3

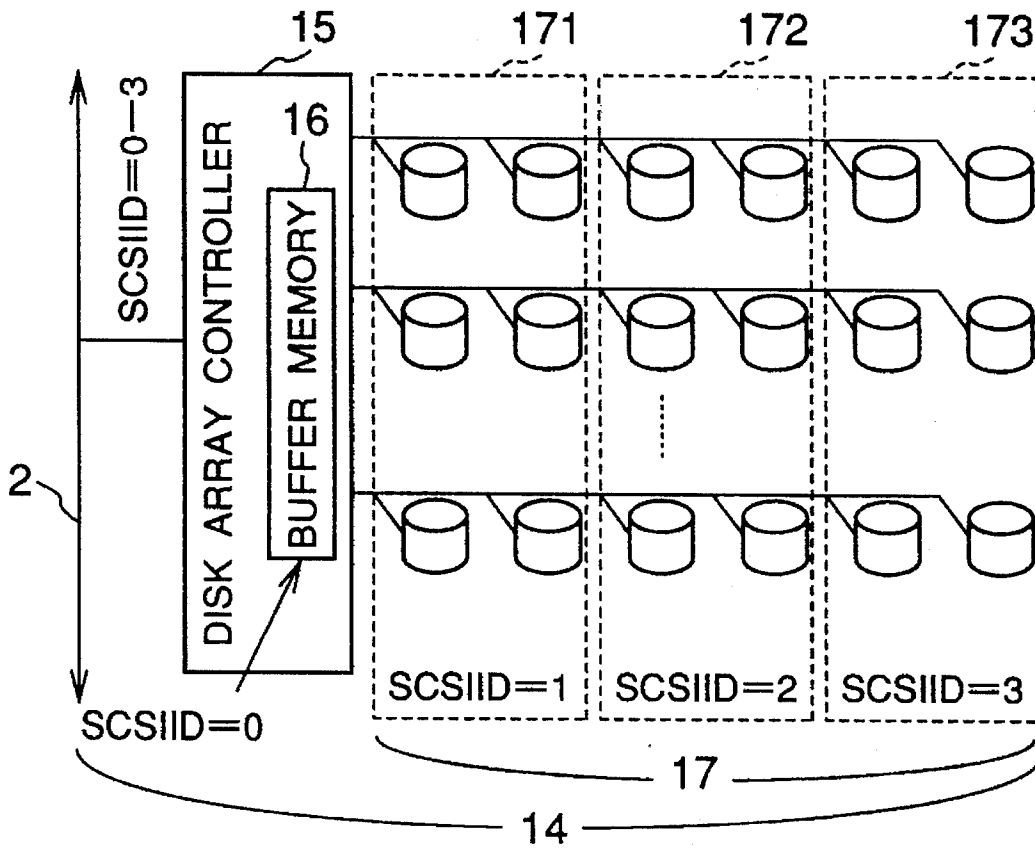

FIG.4

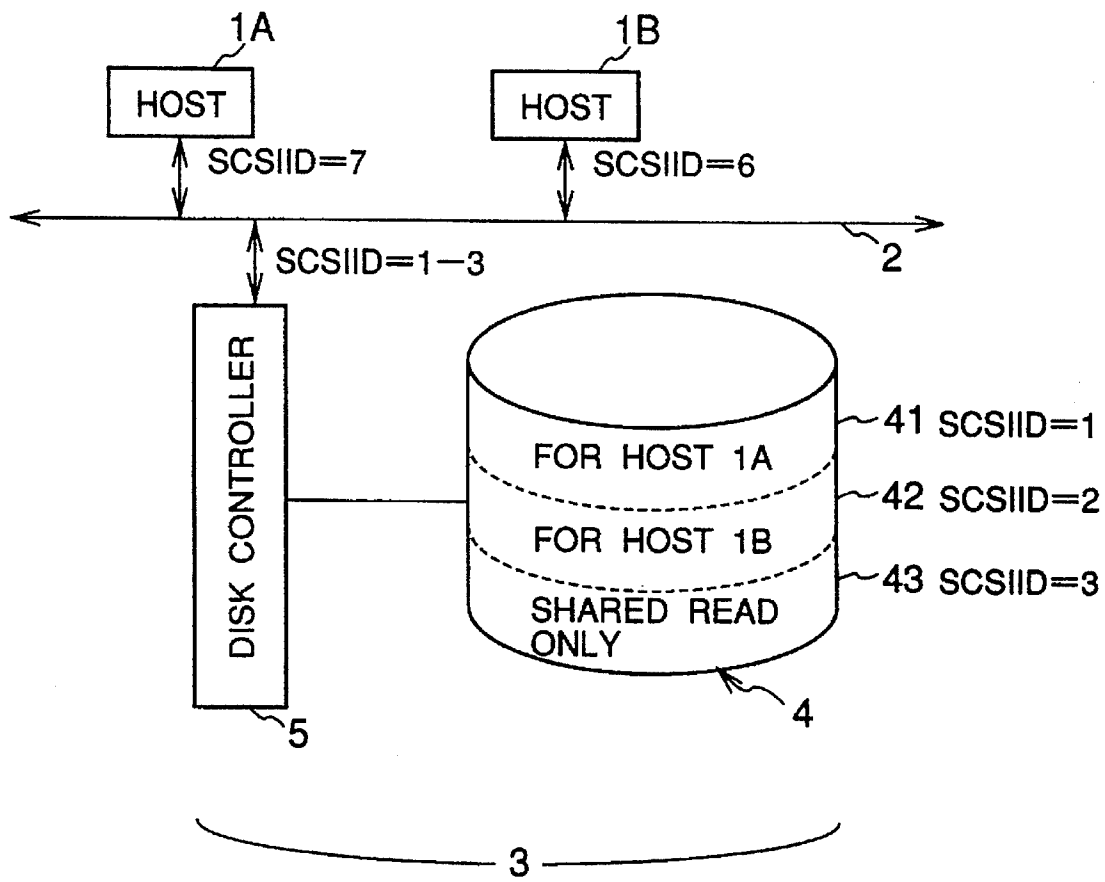
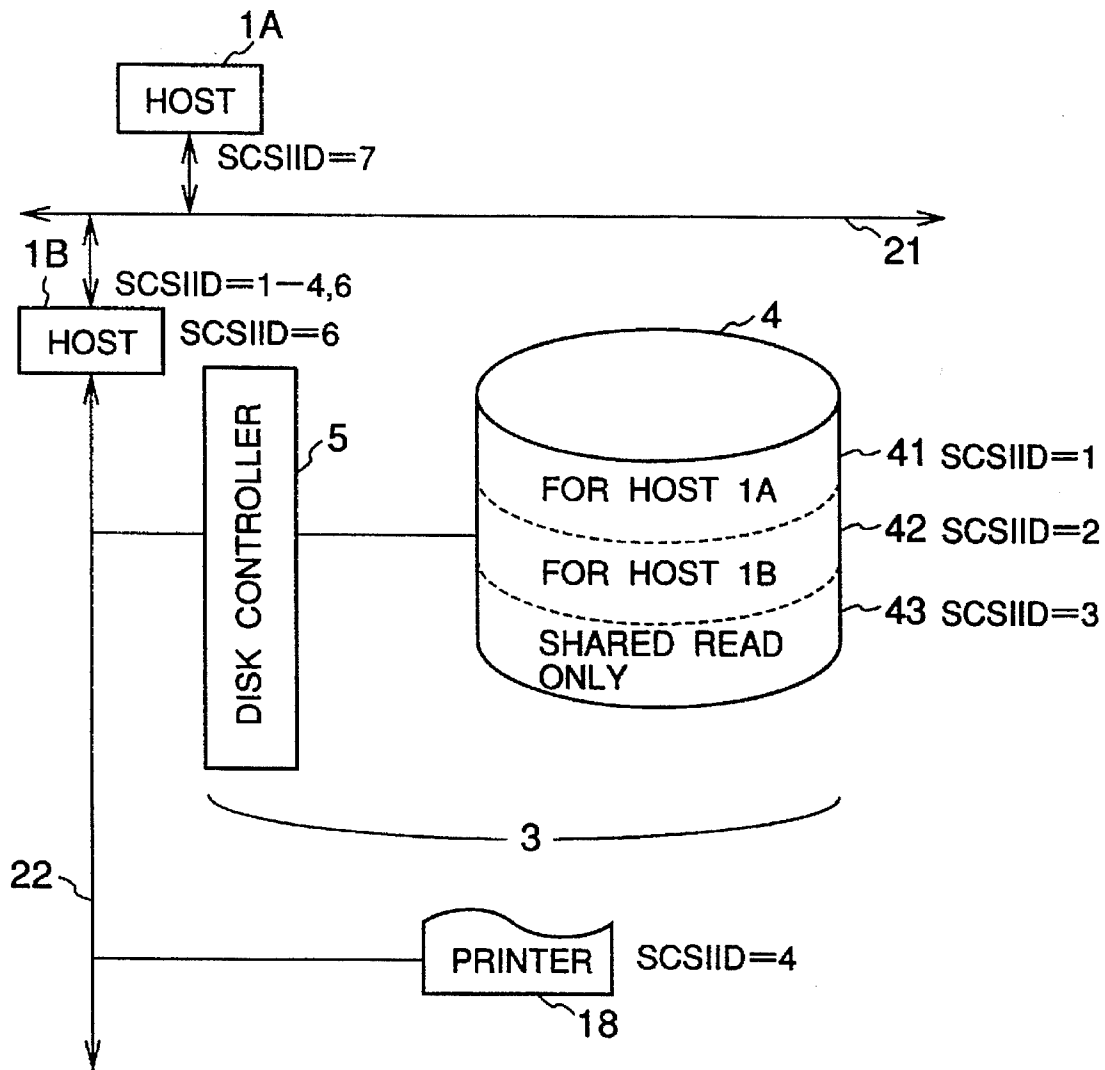

FIG.5



# Explore Litigation Insights

Docket Alarm provides insights to develop a more informed litigation strategy and the peace of mind of knowing you're on top of things.

## Real-Time Litigation Alerts



Keep your litigation team up-to-date with **real-time alerts** and advanced team management tools built for the enterprise, all while greatly reducing PACER spend.

Our comprehensive service means we can handle Federal, State, and Administrative courts across the country.

## Advanced Docket Research



With over 230 million records, Docket Alarm's cloud-native docket research platform finds what other services can't. Coverage includes Federal, State, plus PTAB, TTAB, ITC and NLRB decisions, all in one place.

Identify arguments that have been successful in the past with full text, pinpoint searching. Link to case law cited within any court document via Fastcase.

## Analytics At Your Fingertips



Learn what happened the last time a particular judge, opposing counsel or company faced cases similar to yours.

Advanced out-of-the-box PTAB and TTAB analytics are always at your fingertips.

## API

Docket Alarm offers a powerful API (application programming interface) to developers that want to integrate case filings into their apps.

## LAW FIRMS

Build custom dashboards for your attorneys and clients with live data direct from the court.

Automate many repetitive legal tasks like conflict checks, document management, and marketing.

## FINANCIAL INSTITUTIONS

Litigation and bankruptcy checks for companies and debtors.

## E-DISCOVERY AND LEGAL VENDORS

Sync your system to PACER to automate legal marketing.