



Artisan Technology Group is your source for quality new and certified-used/pre-owned equipment

- FAST SHIPPING AND DELIVERY
- TENS OF THOUSANDS OF IN-STOCK ITEMS
- EQUIPMENT DEMOS
- HUNDREDS OF MANUFACTURERS SUPPORTED
- LEASING/MONTHLY RENTALS
- ITAR CERTIFIED SECURE ASSET SOLUTIONS

SERVICE CENTER REPAIRS

Experienced engineers and technicians on staff at our full-service, in-house repair center

InstraView[™] REMOTE INSPECTION

Remotely inspect equipment before purchasing with our interactive website at www.instraview.com

WE BUY USED EQUIPMENT

Sell your excess, underutilized, and idle used equipment. We also offer credit for buy-backs and trade-ins. www.artisanng.com/WeBuyEquipment

LOOKING FOR MORE INFORMATION?

Visit us on the web at www.artisanng.com for more information on price quotations, drivers, technical specifications, manuals, and documentation

Contact us: (888) 88-SOURCE | sales@artisanng.com | www.artisanng.com

THE
ADVANCED ENERGY[®]
MDX MAGNETRON DRIVE

Version: domestic input voltage (200/208 V ac)

ADVANCED ENERGY
INDUSTRIES, INC

1600 Prospect Parkway
Fort Collins, Colorado 80525
(303)221-4670
Telex #45-0938

PN: 5700092-D
March 1993

To ensure years of dependable service, Advanced Energy® products are thoroughly tested and designed to be among the most reliable and highest quality systems available worldwide. All parts and labor carry our standard 1-year warranty.

For Customer Service, call:

AE, Colorado office	(303) 221-0108 (24-hour line) Fax: (303) 221-5583
AE, California office	(408) 263-8784 (8 a.m. to 5 p.m. Pacific Standard Time — California only) Fax: (408) 263-8992
AE, Northeast office	(508) 371-1381 Fax: (508) 369-1305
AE, Japanese office	81 (03) 3222-1311 Fax: 81 (03) 3222-1315
AE, German office	49 (0711) 777-87-18 Fax: 49 (0711) 777-87-00
all others	contact your local service center—see the list on the next page

©1991, Advanced Energy Industries, Inc

All rights reserved. Printed in the United States of America. This manual is supplied to enable the reader to safely install, operate, and service the equipment described herein. Making copies of any part of this manual for any purpose other than these is a violation of U.S. copyright law.

In the interest of providing even better equipment, Advanced Energy Industries, Inc., reserves the right to make product changes without notification or obligation. To the best of our knowledge, the information contained in this manual is the most accurate available as of the date on the title page.

For more information, write Advanced Energy Industries, Inc., 1600 Prospect Parkway, Fort Collins, CO 80525.

AE Service Centers

<u>Company Name</u>	<u>Phone/Fax Numbers</u>
Vacutec AB Sweden	46 (0) 40-437270 Fax: 46 (0) 40-435538
Gambetti Kenologia snc Italy	39 (02) 9055660 Fax: 39 (02) 9052778
Segen Technologies, Ltd. Israel	972 (03) 9363106 Fax: 972 (03) 9362030
Zeus Co., Ltd. Korea	82 (02) 577-3181 Fax: 82 (02) 576-3199
Schmidt Scientific Taiwan	886 (02) 5013468 Fax: 886 (02) 25029692

Returning Units for Repair

Before returning any product for repair and/or adjustment, call AE Customer Service and discuss the problem with them. Be prepared to give them the serial number of the unit and the reason for the proposed return. This consultation call will allow Customer Service to determine if the unit must actually be returned for the problem to be corrected. Such technical consultation is always available at no charge.

If you return a unit without first getting authorization from Customer Service, and that unit is found to be functional, you will have to pay a retest and calibration fee, and all shipping charges.

Upgrading Units

AE will upgrade older units for a fee (a percentage of the current list price, based on the age of the unit. Such an upgraded unit will carry a 6-month warranty (which will be added to any time remaining on the original warranty).

WARNING

SAFE OPERATING PROCEDURES AND PROPER USE OF THE EQUIPMENT ARE THE RESPONSIBILITY OF THE USER OF THIS SYSTEM.

Advanced Energy Industries, Inc., provides information on its products and associated hazards, but it assumes no responsibility for the after-sale operation of the equipment or the safety practices of the owner or operator.

This equipment produces potentially lethal high-voltage and high-current energy. You should read this manual and understand its contents before you attempt to hook up or operate the equipment it describes. Follow all safety precautions. **Never defeat interlocks or grounds.**



DANGER! All personnel who work with or who are exposed to this equipment must take precautions to protect themselves against serious or possibly fatal bodily injury.

DO NOT BE CARELESS AROUND THIS EQUIPMENT.

CONGRATULATIONS ...

On your purchase of AE's MDX magnetron drive, which is designed for continuous hard use into a vacuum environment. Advanced circuit design and calibrated instrumentation make these units the most accurate, most efficient, and most versatile in the world today.

The Advanced Energy® MDX magnetron drive provides exceptional efficiency from line to load, quick response to changes in the load, and extremely low stored energy in the the output filter. Its many optional configurations and standard features also make it a highly adaptable power supply.

With an MDX you can regulate power, current, or voltage. You can choose any of these methods of output regulation at any time without turning the output off.

Three interfaces are available: a control panel (connected or remote), an analog/digital port, and an RS-232 port. Control can be given exclusively to any or/e interface or distributed among two or three of them.

Each MDX is equipped with a built-in impedance-matching transformer. These transformers are available in low-impedance, standard-impedance, and high-impedance configurations.

The standard ARC-OUT™ arc-suppression circuitry provides outstanding suppression and quenching of arcs, cutting off the energy that feeds hot spots. The ARC-CHECK™ option goes one step further and eliminates destructive short-inducing flakes.

Typical applications include dc sputtering with RF bias, basic magnetron sputtering, cathodic-arc deposition (sputter etching), and dc-biased RF sputtering.

CONTENTS

INTRODUCTION

Read This Page!	vii
Overview of the Manual	ix
Interpreting the Manual	xi

PART I GETTING TO KNOW YOUR MDX MAGNETRON DRIVE

1. WHAT IT IS

Table of Contents	1-3
General Description	1-5
Typical Applications	1-9
Specifications	1-17

2. HOW IT WORKS

Table of Contents	2-1
Theory of Operation	2-3
Connectors	2-7
Status Information	2-13
Interfacing	2-25

PART II OPERATING YOUR MDX MAGNETRON DRIVE

3. PREPARING FOR USE

Table of Contents	3-3
Setting Up	3-5
Making Rear Panel Connections	3-13
First-time Operation	3-31

4. CHOOSING MODES/SETTINGS

Table of Contents	4-1
Output Regulation	4-5
Program Mode	4-5
Lock Mode	4-19
Remotes	4-21
Tap Selection	4-27
Impedance Options	4-45
Line Voltage Changes	4-47
Master/Slave Operation	4-49

5. USING THE SPECIAL FEATURES/OPTIONS

Table of Contents	5-1
ARC-CHECK™	5-3
Fast Ramp	5-5
Contactors Hold	5-7



PART III LEARNING MORE ABOUT YOUR MAGNETRON DRIVE

6. OPERATING NOTES

DC Bias DC-1

7. HOOK-UP NOTES

Grounding Gmd-1

TROUBLESHOOTING GUIDE

APPENDIX

Warranty and claims information

Index

Schematics

READ THIS PAGE!

We know that some of you want to start the magnetron drive now and that you don't feel you have time to read the entire manual. Below is a list of the subsections you will need to read in order to get started. We also think that you will find **Overview of the Manual** (page ix) and **Interpreting the Manual** (page xi) useful. They are very short sections, and are intended to guide you through the manual.

Overview of the Manual explains the organization of the manual, so that you can more quickly find what you need. **Interpreting the Manual** explains the type conventions (what it means when a word appears in capitalized italic type, for instance), and what the five icons (symbols) mean.

- Physical specifications page 1-19
- Connectors page 2-7
- Setting up page 3-5
- Start-up procedures page 3-29
- Control panel switches and LEDs page 2-15, 2-17, 2-21, 2-25
- Line voltage changes page 4-47

INTRODUCTION

OVERVIEW OF THE MANUAL

The main table of contents is a general outline of major topics covered in the manual. It contains only the main headings within each chapter so that you can skim it and get a general idea of what is contained here, without having to look at a lot of headings. When you turn to one of the six chapters, you will find a detailed table of contents that lists every heading in that particular chapter. This will help you to quickly decide which page contains the information you are looking for. Throughout the manual, the chapter titles are printed at the top right-hand corner of each odd-numbered page.

Part I contains two chapters: What It Is, and How It Works. What It Is gives a general overview of the MDX magnetron drive, its various features and configurations, and typical applications. A detailed description of the functional specifications and a list of the physical specifications are also included.

How It Works contains a functional block diagram and important information on connections, including listings of all input, output, and reference pins. Status indicators and messages (and suggested responses) are briefly discussed, and functions that are available through each of the interfaces are described. The transmission parameters for the Host (RS-232) port are also included in this section, as are several tables detailing recognized commands and explaining possible responses to those commands.

Part II consists of three chapters: Preparing for Use, Choosing Modes/Settings, and Using the Special Features. Preparing for Use provides information on connection and wiring options, spacing and cooling requirements, and start-up procedures.

Choosing Modes/Settings contains information on selecting one of the three methods of output regulation: power, current, or voltage. The subsection on "program" mode describes the target controls and various programmable setpoints and timers. Accessing functions through the analog/digital ("User") interface is discussed. Step-by-step procedures are provided for changing taps and line voltage settings. Also included is an explanation of the impedance options and a table that shows the maximum output current for various MDX models. Special considerations for systems that use both "master" and "slave" MDX units are briefly examined.



Using the Special Features describes the **contactor hold** function, which is standard, and the optional ARC-CHECK™ and **fast ramp** features.

Part III contains two technical operating notes: one on dc bias and one on grounding considerations.

INTERPRETING THE MANUAL

Type Conventions

To help you quickly pick out what is being discussed, the manual presents certain words and phrases in type that is different from the rest of the text.

Pin and line names appear in capitalized italics (*RAMP IN.A*). Labels that are on the MDX (switches, indicators, etc.) generally appear in boldface capital letters (**MODIFY**). Exceptions are port names, which simply begin with a capital letter (User port).

Specific messages that will appear on the control panel meters are indicated by quotation marks ("E-02"). Functions are printed in boldface lowercase letters (**contactor hold**).

How to Use the Symbols

 **Safety notes.** Important notes concerning potential harm to people.

 **Warning notes.** Important notes concerning possible harm to this unit or associated equipment.

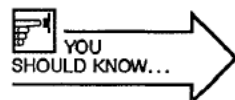
 **Operating notes.** More thoughts on how to use the extended features provided.



Hook-up and interfacing notes. General practices concerning input and output power connections, or used in connecting communication and control interfaces.

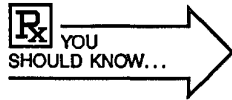

Service notes. General practices to be used in maintaining this equipment in top running condition.

GETTING TO KNOW YOUR
MDX MAGNETRON DRIVE

CONTENTS

General Description	1-5
Output Impedance Range	1-5
Output Regulation	1-5
Interfaces	1-5
Microprocessor Advantages	1-6
Displays	1-6
Built-in Protection	1-6
Arc-suppression Circuitry	1-6
Sophisticated Options	1-6
Typical Applications	1-9
Basic Magnetron Sputtering	1-9
Factory Configuration (Negative Output)	1-9
Optimum Configuration (Positive or Negative Output)	1-10
Optimum Configuration (Floating Output)	1-12
DC Sputtering with RF Bias	1-13
DC-biased RF Sputtering	1-15
Specifications	1-17
Functional Specifications	1-17
Physical Specifications	1-19

GENERAL DESCRIPTION

The dc magnetron drives in the MDX series prove just how convenient and efficient advanced high-frequency switchmode power supplies are.

They...

- are light and compact
- are highly efficient (low heat emission)
- provide excellent regulation and stability
- have a highly reliable solid state design
- are modular
- store very little energy in the output filter

These magnetron drives exhibit superior output response time, low output ripple voltage, and considerable space savings over lower frequency designs. The internal microprocessor ensures ease of use, and the modular design allows the supplies to be easily serviced.

Output Impedance Range

Each MDX is equipped with a built-in impedance-matching transformer. These tap-selectable transformers are available in high Z, standard Z, or low Z configurations. With the proper transformer and tap (see pages 4-27 and 4-45), load impedances requiring voltages from 400 V to 1250 V can be accommodated.

Plasma strike voltages are available on all taps — levels reach as high as 1500 V, depending on the model. The full rated power output for each MDX is available throughout the range of each tap.

Output Regulation

The MDX can be used as a power, current, or voltage source, depending on the method of output regulation selected. Since setpoint levels are stored in nonvolatile memory, they can be used in recovering from input power interruptions and to ensure repeatability from run to run.

Interfaces

The MDX can be controlled from a variety of attached or remote control panels, an analog/digital connector, or an RS-232 serial data port. The RS-232 (Host) interface provides access to all operating parameters and control functions. The analog/digital (User) interface provides data logging capability and access to a number of features.



Microprocessor Advantages

The internal microprocessor checks for proper circuit operation while supervising all operating parameters. System diagnostics run when the unit is initially powered up. Messages are displayed in response to errors. The most recent power settings and conditions (such as target life remaining and amount of time that the MDX has been producing output), are retained in nonvolatile memory.

Displays

Instrumentation and status readings are taken and interpreted by the internal microprocessor, then displayed on digital front panel displays and LED indicators. Power, voltage, current, ramp time, run time, target selection, target life, and interlock status are examples of the parameters that are displayed.

Built-in Protection

The MDX has complete internal protection for output overvoltage, over-current, and overpower conditions. The key switch on the front panel can be used to restrict access to adjustable parameters. Three separate pins on the User port, and corresponding front-panel indicators, are provided for safety-related inputs such as vacuum, water, and auxiliary (user-specified) interlocks.

Arc-suppression Circuitry

ARC-OUT™ provides multilevel suppression and quenching of different types of arcs. An added advantage is that ARC-OUT reduces target burn-in time and material loss. This feature also prevents energy from being dumped into hot spots by sensing a drop in impedance and immediately shutting the power off. Start-up after an arc is controlled so that the hot spots cool before power is reapplied, thus preventing repeated arcing.

Sophisticated Options

Fast Ramp. This feature reduces the minimum time for the power supply to ramp to the setpoint, a major benefit for applications with very short cycles.

Control Panels. The MDX is available with a standard control panel, passive front panel, or a combination of a passive front panel and remote control panel (standard or minipanel). Foldout illustrations of the control/front panels appear at the end of the second chapter.

ARC CHECK™. This proprietary feature eliminates continuous low-impedance conditions in certain vacuum environments, such as those in

WHAT IT IS

cathodic arc processes. When recovering from a low-impedance condition, the MDX automatically ramps up slowly in current regulation. As the chamber impedance increases (with the removal of excess ions), the power supply automatically crosses over to the previously selected method of output regulation (power or voltage). Timing and current magnitudes can be adjusted to protect sensitive targets and system components.

TYPICAL APPLICATIONS

Basic Magnetron Sputtering

Three output configurations are possible for the MDX: negative output voltage, positive output voltage, and floating ground. Provisions within the MDX chassis allow you to tie either the anode or the cathode to ground; alternatively, you can let the output float with respect to ground by not grounding either the anode or the cathode.



Danger! An understanding of grounding and the proper hookup of grounds is essential to personnel safety and is necessary for the proper operation of your system. In all cases you must connect the chassis ground stud on the rear of the MDX to earth-ground with the lowest possible impedance (see operating note on grounding methods and definitions, page 7-1).

Factory Configuration (negative output)

Most MDX applications require a negative output voltage, which in turn requires that the anode be connected to ground. The MDX is shipped with a safety jumper installed as shown in Fig. 1-1 to make this ground connection, although this is not the optimum configuration. The reason is related to safety — most people associate the braided shield layer of a coaxial cable with a ground connection. If we shipped products with no internal ground, it is conceivable that a system could be configured with a lethal voltage on the coaxial cable's sheath. This would be extremely dangerous because of the possibility that people could unknowingly be exposed to such a voltage at the connectors.

The disadvantage of having an installed ground is that additional grounds invariably do exist in the system. This means that there are two or more ground paths in the system. When multiple ground paths exist, the chassis is made to conduct some of this current. This current flow can cause a loss of instrumentation accuracy, electrical noise, and heating of the chassis or connectors and joints; it may even raise the ground-reference voltage level so that external and internal control signals either control the MDX erratically or not at all. Thus the best system performance is obtained using the "optimum configuration (positive or negative output)" described next.

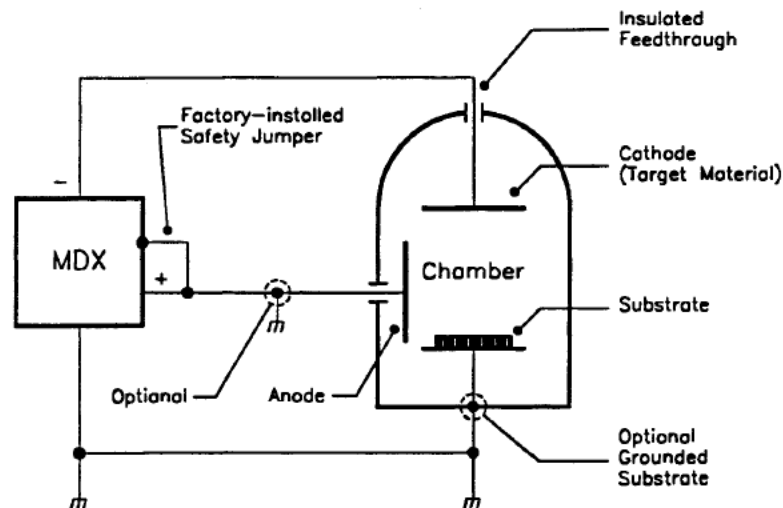

Figure 1-1. Factory configuration (factory-installed safety jumper).

Optimum Configuration (positive or negative output)

The configuration that AE recommends is illustrated in Fig. 1-2, which shows an independently grounded anode at the chamber, forcing all return current through the anode return path. The design of the chamber may use the chamber wall, special internal shielding structure, or the substrate holder as the actual anode. With this setup, only one current path will exist, thus eliminating the problems caused by multiple returns.

Make certain that you have established a good ground at the chamber anode or the ground reference will be lost. The integrity of this ground connection should be checked as part of a periodic maintenance schedule to ensure continued optimum performance and safety. Whenever a system is configured in this manner, it is recommended that secondary dielectric shielding be installed over all parts of the coaxial cable and connectors that are exposed.

When this connection degrades, as it will over time, the system could become unsafe (as described in the two preceding paragraphs); more likely, performance will be lost. This slow loss of performance can be subtle and very difficult to detect. Some indications of ground degradation are loss of instrumentation accuracy, symptoms of increased noise such as display flicker and jittery data-logging lines, secondary plasma development between the target and the closest point at ground potential, change in the appearance of the chamber plasma at known power levels, and increasingly erratic behavior of the power supply or the system controller.

WHAT IT IS

All of these considerations hold true when the MDX is used in the positive output voltage (grounded cathode) configuration.

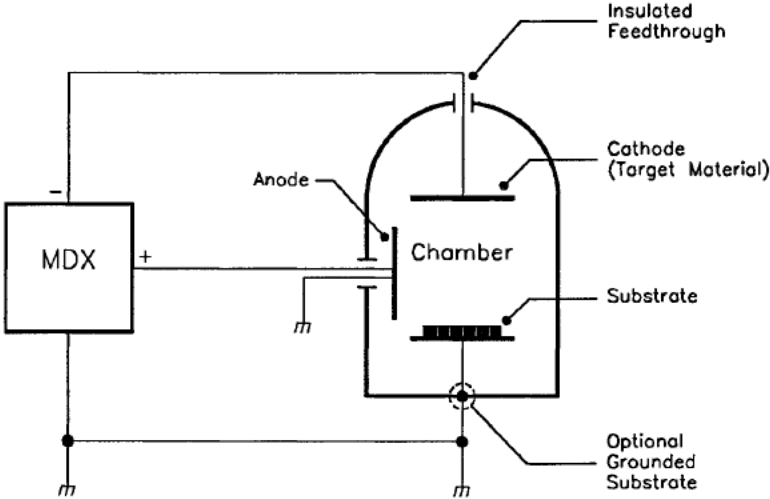

Figure 1-2. Optimum grounding configuration (negative output).

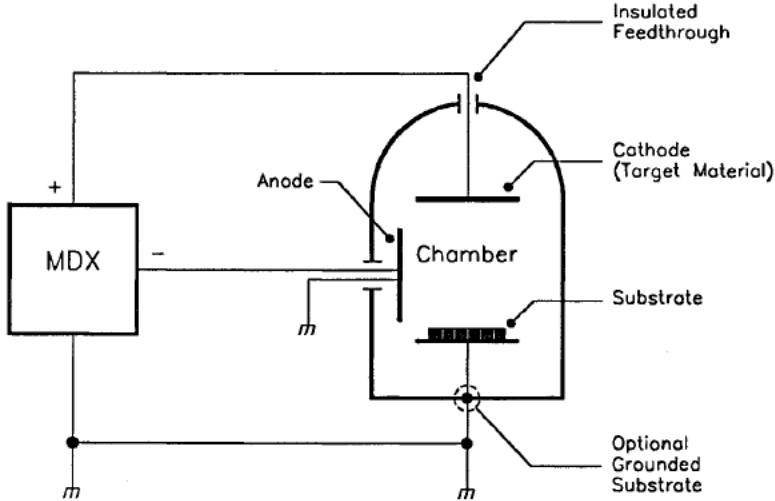

Figure 1-3. Optimum grounding configuration (positive output).

Optimum Configuration (floating output)

In some applications it is desirable to bias the positive or negative output of the MDX with another power supply. This supply may be another dc supply or an RF supply. The MDX may be biased by a voltage of up to ± 400 V referenced to its own (MDX) chassis ground. Figure 1-4 illustrates a typical configuration of this type.

When using the MDX in this configuration, it is again very important to provide a good chassis ground for each power supply. Further, all power supply chassis grounds should be connected at one common point. All interconnecting power supply output lines and connectors must be fully insulated to protect personnel from accidental exposure to potentially lethal voltages.

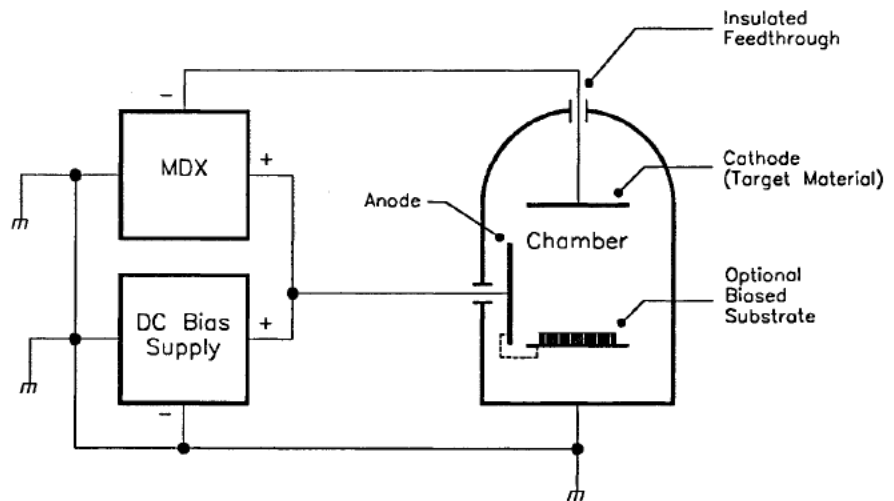

Figure 1-4. Floating-output configuration.

DC Sputtering with RF Bias



WARNING! You must place an ac blocking filter in series with the output of the dc power supply if your system uses a dc power supply in combination with an ac power supply that has an output frequency greater than 50 kHz.

In this application (see the illustration on the next page), proper installation of the RF generator and tuner is critical to proper operation of the system. Proper installation includes good, solid, RF grounding and dc installation.

An RF filter must be placed between the dc output and the chamber because 13.56 MHz can damage the typical dc magnetron power supply. There is no need to put a filter between the RF tuner output and the chamber because Advanced Energy® tuners provide a dc block.

The purpose of this type of installation is to elevate the potential on the biased substrate. With proper installation and programming, an Advanced Energy® RFX can control the developed dc bias on the substrate (see the operating note on dc bias, page 6-3).

This extra control parameter (RF bias) may provide higher deposition rates or better film structure. The results will vary with each application. Biasing alters the ion and acceleration potentials, and these altered potentials provide the desired results.

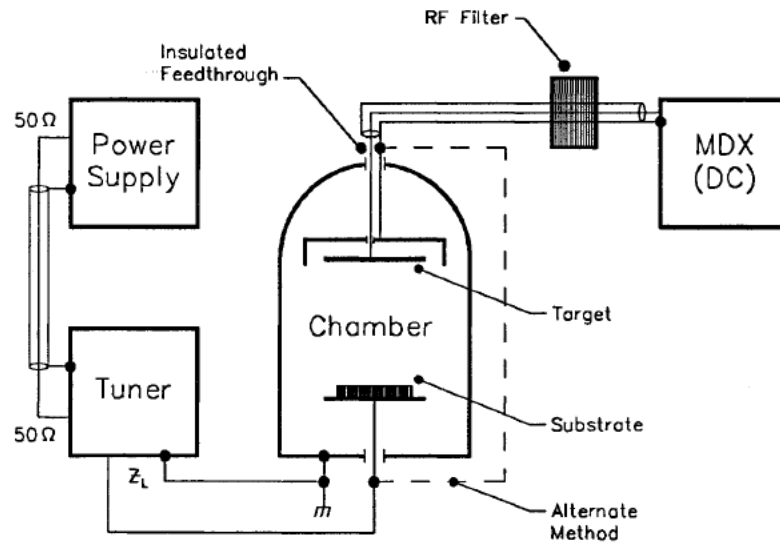

Figure 1- 5. Typical configuration for dc sputtering with RF bias.

DC-biased RF Sputtering



WARNING! You must place an ac blocking filter in series with the output of the dc power supply if your system uses a dc power supply in combination with an ac power supply that has an output frequency greater than 50 kHz.

Figure 1-6 (on the next page) shows a typical RF sputtering application, where the target shield and chamber walls are referenced to ground, but the substrate is directly biased with a dc power supply. This could be a planar magnetron or an “S” gun installation.

Improper grounding of the tuner, chamber, and MDX will result in radio frequency interference (RFI), which is often evidenced in this application by chattering valves or your computer behaving erratically.



DANGER! Lethal high-voltage potentials will be present if the tuner, chamber, and MDX are not properly grounded.

Some RF sputtering applications require a length of cable between the tuner output and the vacuum feedthrough. This type of connection should only be used, with extreme caution, if there is no way to mount the tuner directly to the vacuum feedthrough. The impedance transformation that takes place within the interconnect cable can create large circulating currents on this cable. The power dissipated is a function of I^2R losses. This formula shows that any increase in circulating current greatly increases the losses in the cable.

In light of this fact, a teflon dielectric cable should be used because teflon has a more favorable thermal characteristic than other cable materials. The teflon will minimize migration of the center conductor due to overheating, thus reducing the probability of the center conductor shorting to the outer sheath.

A key consideration in any RF installation is the RF return path. **Power supply/tuner connection:** The power supply is usually connected to the tuning network through a coaxial cable, and the braided shield on this cable acts as an adequate RF return for this section of the circuit. **Tuner/chamber connection:** Pay special attention to the connection between the tuning

network and chamber. On all Advanced Energy® tuners, the aluminum chassis provides the RF return path. Ideally, this chassis should be bolted directly onto the vacuum chamber, thus establishing good surface contact. If this is not possible, connect the tuner and chamber with a solid copper strap. Avoid using braid — the fine strands within the braid form a highly inductive path and may melt from overheating. Also avoid using stainless steel hardware — steel is a poor conductor at high frequencies because of its ferromagnetic properties.

Brass hardware is most commonly used because brass is a good conductor and is readily available.

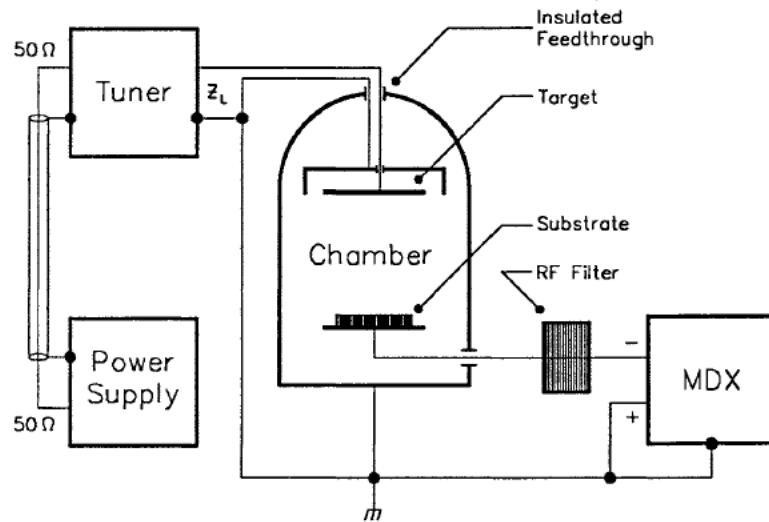

Figure 1-6. Typical configuration for RF sputtering with dc bias.

SPECIFICATIONS

Functional Specifications

Mode of Control	<p>Program — full control is available from all interfaces.</p> <p>Lock— front-panel control is limited to output on/off, emergency stop, and test functions; also, setpoints can be viewed for whatever method of output regulation (power, current, or voltage) was selected in program mode.</p> <p>Off — all functions are disabled.</p>
Control Signal Sources	Output can be controlled from the control panel, the host-remote (RS-232) interface, or the user-remote interface. Control of output regulation, ramp time, output on/off, or target select can be split between the User port and the control panel or between the User port and the Host port.
Methods of Output Regulation	The value that remains constant when the MDX is producing output can be power, current, or voltage.
Programmable Setpoints	An output level (up to the unit's maximum rated output) can be programmed for power, current, or voltage.
Target Supervision	One of eight target-life counters (0-7) can be selected either remotely or from a control panel. Target life can be specified and monitored from a host computer or from a control panel (1-9900 kWh).
Arc Suppression	Arc conditions are quickly detected and MDX output is quickly modified to prevent damage to the target and substrate.



PART I

Dual Meters	Two digital meters on the control panel display output information in kilowatts, volts, or amps, regardless of whether output is presently being produced in power, current, or voltage regulation; they display power, voltage, or current setpoint for the selected method of output regulation.
Timers and Counters	Select a ramp time (600 ms - 99 min.; see page 5-5 for a discussion of the fast ramp range) or a run time (0.01-99 min.; 0.01-99 sec. with fast ramp); specify how long output can be out of setpoint without triggering an alarm (0.01-2.55 min.); or program a target life (1-9900 kWh).
Fault Conditions	The faults that will cause the MDX to shut off output are interlock, input power, over-temperature, and out of setpoint (if this feature is activated). Other conditions that cause output to be shut off: the EMERGENCY STOP button has been pushed, or the time programmed on the run timer has been exceeded.

Physical Specifications

Input Voltages 200 V ac or 208 V ac rms \pm 10%, 50/60 Hz, three-phase "Y" connection; maximum ground leakage current less than 3.5 mA.

Input Current 200 V ac or 208 V ac full load; see table below for maximums.

<u>MDX Model</u>	<u>Maximum Current (at -10% input line voltage)</u>
MDX 5K	19 A
MDX 10K	38 A
MDX 15K	57 A
MDX 20K	76 A
MDX 25K	95 A
MDX 30K	114 A

Output Power See table below for details.

<u>Output Power</u>	<u>Chassis Per System</u>	<u>Output Ripple Voltage (% rms)</u>	<u>Output Ripple Frequency</u>
0-5000 W	1	5	50 kHz
0-10,000 W	1	2	100 kHz
0-15,000 W	2	2	100 kHz
0-20,000 W	2	2	100 kHz
0-25,000 W	3	2	100 kHz
0-30,000 W	3	2	100 kHz

Output Display Accuracy Within 2% of actual output level or 0.2% of maximum rated output level, whichever is greater.

Target Accumulator Target life is displayed in 1-kWh increments; the counter is updated every 4.7 ms.

Methods of Control Full or restricted access, local or remote control, programmed or manual operation.



PART I

Output Connector	UHF type, Amphenol part number 83-822 (mate supplied) or terminal block.
Output Cable	RG-8U coaxial cable and/or discrete cables.
Size	7" (H) x 19" (W) x 19" (D) (17.8 cm x 48.3 cm x 48.3 cm).
Weight	MDX 5K model: 55 lb. (25 kg). MDX 10K model: 71 lb. (32.3 kg).
Ambient Temperature:	
Operating	Minimum 0°C, maximum 40°C (maximum value of average over 24 hr.:35°C). If the units are enclosed in cabinets, the operator will ascertain the temperature at the place of instalation and ensure that the macimum ambient temperature is not exceeded.
Storage	Minimum -25°C, maximum 55°C.
Transportation	Minimum -25°C, maximum 55°C (for short periods of up to 24 hr., the maximum is 70°C).
Coolant Temperature	Air (gas) minimum 0°C, maximum 35°C.
Coolant Flow Parameters:	
Contamination	Cooling air should be free of corrosive vapors and particles, conductive particles, and particles that could become conductive after exposure to moisture.
Humidity	15-85% relative humidity; no condensation or icing.
Atmospheric Pressure:	
Operating	800 mbar minimum (approx. 2000 m above sea level).
Storage	800 mbar minimum (approx. 2000 m above sea level).
Transportation	660 mbar minimum (approx. 3265 m above sea level).

WHAT IT IS

Output Parameters

The table below indicates the maximum current that can be produced at each tap. It also shows the range of output voltages available at each tap, *when the MDX is in voltage regulation* (see page 4-3).

Tap No.	Output Volt. Range	MDX 5K	MDX 10K	MDX 15K	MDX 20K	MDX 25K	MDX 30K
Maximum Output Current: Low Impedance ("Low Z")							
1	0 V to 500 V	12.50 A	25.00 A	37.50 A	50.00 A	62.50 A	75.00 A
2	0 V to 640 V	10.00 A	20.00 A	30.00 A	40.00 A	50.00 A	60.00 A
3	0 V to 800 V	7.75 A	15.50 A	23.50 A	31.00 A	38.75 A	46.50 A
Maximum Output Current: Standard Impedance ("Standard Z")							
1	0 V to 600 V	10.00 A	20.00 A	30.00 A	40.00 A	50.00 A	60.00 A
2	0 V to 800 V	8.00 A	16.00 A	24.00 A	32.00 A	40.00 A	48.00 A
3	0 V to 1000 V	6.25 A	12.50 A	18.75 A	25.00 A	31.25 A	37.50 A
Maximum Output Current: High Impedance ("High Z")							
1	0 V to 775 V	8.00 A	16.00 A	24.00 A	32.00 A	40.00 A	48.00 A
2	0 V to 1000 V	6.40 A	12.80 A	19.20 A	25.60 A	32.00 A	38.40 A
3	0 V to 1250 V	5.00 A	10.00 A	15.00 A	20.00 A	25.00 A	30.00 A

CONTENTS

Theory of Operation.....	2-3
Connectors.....	2-7
Input Power Connector.....	2-7
Output Connector.....	2-7
Remote Control Panel Connector.....	2-7
Analog/Digital I/O Port.....	2-8
Pin-description Table.....	2-8
Host RS-232 Port.....	2-10
Pin-description Table.....	2-10
Cathode Port (Minipanel).....	2-10
Master/Slave Interface Connectors.....	2-11
Status Information.....	2-13
Status Signals.....	2-13
Indicators.....	2-15
Status Indicator LEDs—Control Panels.....	2-15
Status Indicator LEDs—Passive Front Panel.....	2-16
LEDs on Switches.....	2-17
Digital Meter LEDs.....	2-21
Messages.....	2-23
Interfacing.....	2-25
Control Panel Controls.....	2-25
User Port Functions.....	2-31
Host Port.....	2-33
Transmission Parameters.....	2-33
Requests for Data.....	2-34
S ("status change") Commands.....	2-36
Commands To Set Variables.....	2-38
Responses to Requests for Interlock Status.....	2-40
Responses to Requests for System Status.....	2-41
Key to Translating Hexadecimal Characters.....	2-42
Translating Responses to Status Requests.....	2-43

THEORY OF OPERATION

The MDX magnetron drive is a sophisticated and intelligent dc power supply designed exclusively for use into vacuum environments. The figure below and the following paragraphs outline the theory of operation.

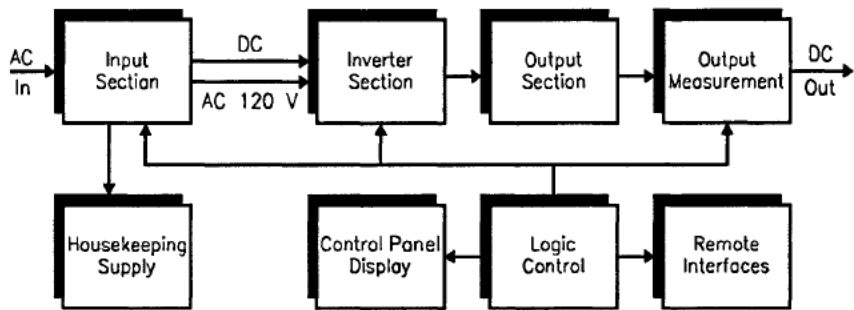

Figure 2-1. MDX functional block diagram.

Input

In the input section, ac line voltage is applied through the circuit breaker to a three-phase contactor. The contactor, when closed, delivers the line voltage to a rectifier bridge, where it is converted to dc. The dc voltage is applied to bus capacitors through soft-start circuitry. This bus provides dc voltage to the inverter section. The input section also supplies 120 V ac to the housekeeping and inverter sections.

Housekeeping Supply

The housekeeping supply section provides ± 24 V dc to power the logic circuitry and control panel.

Inverter

The inverter section converts dc to pulse-width-modulated, 25-kHz ac voltage by alternating the current through two sets of switching transistors (see Figs. 2-2 and 2-3 on the next page).

Output

In the output section, an isolation transformer steps up the 25-kHz ac voltage from the inverter section and sends it to a full-wave rectifier bridge. The resulting dc then passes out through a filter network and through the output measurement section.

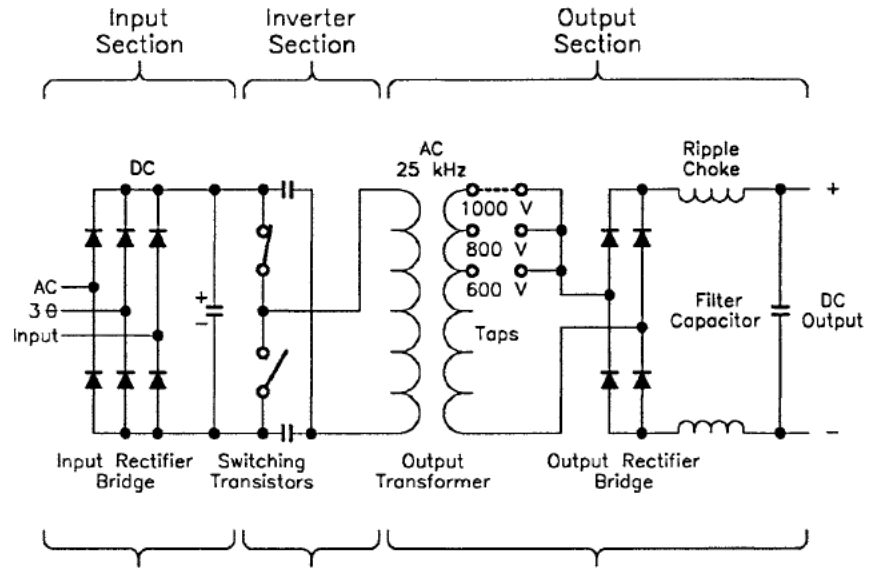

Figure 2-2. Illustration of switching theory.

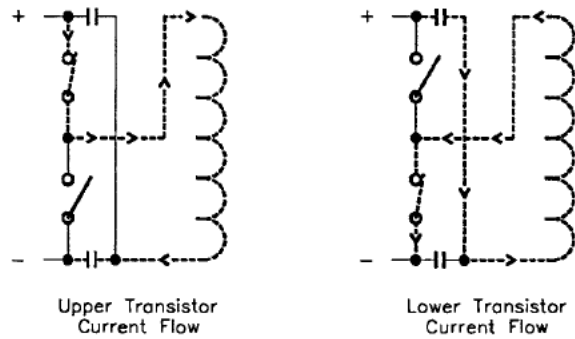

Figure 2-3. Detail of Fig. 2-2, illustrating current flow through switching transistors (dashed lines represent flow).

HOW IT WORKS

Output Measurement

The output measurement section measures current and voltage, and calculates power. These signals are conditioned to 0-5 V dc and sent to both the logic control and remote interfaces sections.

Logic Control

The microprocessor in the logic control section uses operator-supplied parameters and setpoints to control the output. This section is also responsible for providing status information to the operator through all interfaces and for controlling the input section.

Control Panel Display

The display on the control panel communicates (RS-232) operator-supplied inputs to the logic control section and provides the operator with status information.

Remote Interfaces

Both remote interfaces communicate operator-supplied inputs to the logic control section from the Host port (RS-232) and the User port (analog and digital) and provide the operator with status information.

CONNECTORS

Input Power Connector

The ac line input connection is provided by means of a five-position, high-current, feedthrough terminal block (TB) on the rear panel (see foldouts at the end of this chapter). Labels on the input terminal shield and below each terminal position on the rear panel show line (A, B, C), 120 V ac NEUT, and protective earth-ground connections (GND).

See page 3-13 for details on making this connection.

Output Connector

The cable for the output connection is not included with the MDX, but can be purchased from AE separately.

Two types of output connectors are available: a UHF type connector (Amphenol 83-822) or a two-pin terminal block.

Remote Control Panel Connector

Connections for a remote Advanced Energy® display panel are made through a 25-pin, female, D subminiature connector. See page 3-26 for details on making this connection. An MDX with a full-function front panel (that is, a control panel that is an integrated part of the unit) will not function correctly if a remote panel is connected to the **DISPLAY** port.

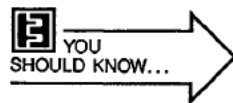

This connector was designed for connecting an Advanced Energy® standard remote control panel or minipanel only. The communications format between Advanced Energy® display panels and the MDX is different than the RS-232 host communications format. An incorrect connection could damage the MDX.

Analog/Digital I/O Port

The User interface, located on the rear panel, is a 37-pin, female, D subminiature connector. Its associated male connector, connector shell, and jack post screws are included in the hardware kit. The table below provides information about each pin. See page 3-17 for details on making this connection.

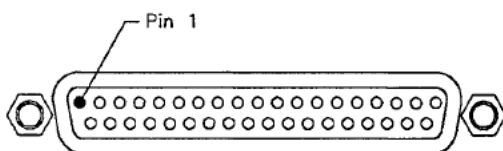

Pin-description Table

The User connector is primarily an “analog” interface that allows the use of a remote controller. **Note:** An “.A” appended to a pin name indicates an analog signal; a “.D” indicates a digital signal. A bar over a signal name indicates that the signal is true when low.

Pin No.	Pin Name	Description	Refer to
1	$\overline{CS1.D}$	output, used with <i>pin 20</i> , 0-15 V	p. 3-18
2	$\overline{OUTPUT.D}$	output, 0-15 V	p. 3-18
3	$\overline{SETPOINT.D}$	output, 0-15 V	p. 3-18
4	TARGET 0.D	input, used with <i>pins 34</i> and <i>35</i> , 0-15 V	p. 3-18
5	I REG.D	input, used with <i>pin 6</i> , 0-15 V	p. 3-18
6	P REG.D	input, used with <i>pin 5</i> , 0-15 V	p. 3-19
7	$\overline{ON.D}$	input, 0-15 V	p. 3-19
8	OUT OF SETPOINT.D	input from slave unit, 0-15 V	p. 3-19
9	OUT COM.A	dedicated return for analog outputs	p. 3-19
10	IN COM.A	dedicated return for analog inputs	p. 3-19
11	$\overline{AUX.D}$	input, 0-15 V	p. 3-19
12	$\overline{VAC.D}$	input, 0-15 V	p. 3-19
13	$\overline{WATER.D}$	input, 0-15 V	p. 3-19
14	OFF.D	input, 0-15 V	p. 3-19
15	RESTORE.D	input, 0-15 V	p. 3-20
16	REMOTE CONTACTOR HOLD.D	input, 0-15 V	p. 3-20
17	unassigned		

HOW IT WORKS

Pin No.	Pin Name	Description	Refer to
18	15 V	output (100 mA max.)	
19	INTLK COM.D	dedicated return for interlock string	p. 3-20
20	$\overline{CS2.D}$	output, used with <i>pin 1</i> , 0-15 V	p. 3-20
21	$\overline{ARC.D}$	output, 0-15 V	p. 3-20
22	$\overline{EOTL.D}$	output, 0-15 V	p. 3-21
23	V OUT.A	output, 0-5 V	p. 3-21
24	P OUT.A	output, 0-5 V	p. 3-21
25	I OUT.A	output, 0-5 V	p. 3-21
26	RAMP IN.A	input, 0-5 V	p. 3-21
27	LEVEL IN.A	input, 0-5 V	p. 3-21
28	unassigned		
29	AUX I OUT.A	output, 0-5 V	p. 3-21
30	KWH OUT.A	output, 0-5 V	p. 3-22
31	LEVEL OUT.A	output, 0-5 V	p. 3-22
32	REF.A	5 V, reference level only (5 mA max.)	p. 3-22
33	unassigned		
34	TARGET 2.D	input, used with <i>pins 4</i> and <i>35</i> , 0-15 V	p. 3-22
35	TARGET 1.D	input, used with <i>pins 4</i> and <i>34</i> , 0-15 V	p. 3-22
36	IN COM.D	common, used interchangeably with <i>pin 19</i>	p. 3-22
37	OUT COM.D	dedicated return for digital outputs	p. 3-22

Host RS-232 Port

Connections for a host-remote computer are made through a 25-pin, female, D subminiature connector. The table below provides information about each pin. See page 3-17 for details on making this connection.

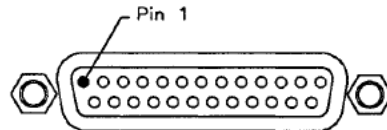

Pin-description Table

Note: An ".A" appended to a pin name indicates an analog signal; a ".D" indicates a digital signal.

Pin	Name	Description
1	COM.D	data common
2	TXD.D	data from MDX
3	RXD.D	data to MDX
4	unassigned	
5	unassigned	
6	DSR.D	data set ready (connect to <i>pin 7</i>)
7	COM.D	data common
8-25	unassigned	

Cathode Port (Minipanel)

This port, which appears only on the minipanel (see the foldout at the end of this chapter), provides external indication of what target counter has been selected with the **CATHODE** switches on the front of the minipanel. The illustration on the next page shows internal relays with contacts that close between pairs of pins as the target counters are selected.

Selecting this counter:	Makes contact between these pins:
1	4 and 5
2	8 and 9
3	1 and 6

HOW IT WORKS

The contacts are rated for:
10 VA
130 V ac
100 V dc
500 mA switching
1500 mA carrying
normally open

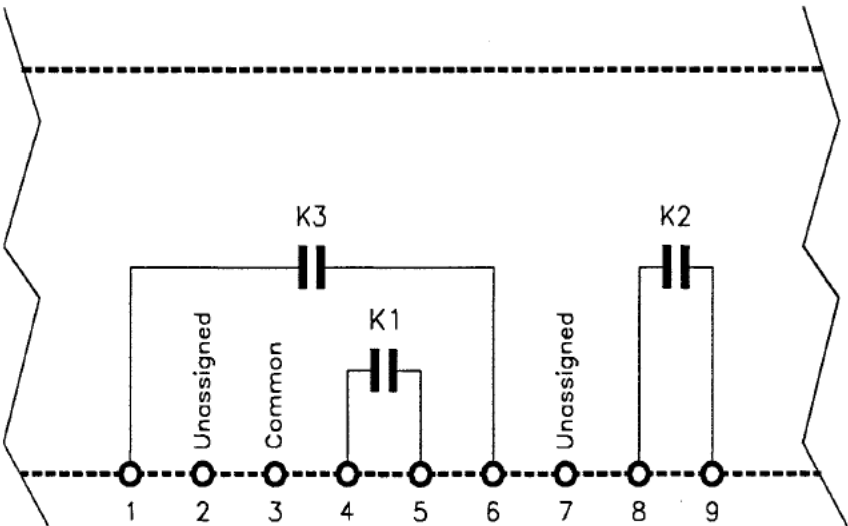

Figure 2-4. Graphic representation of each of the internal contacts that is made when one of three possible target-life counters is selected.

Master/Slave Interface Connectors

MASTER INTERCONNECT is a 15-pin, male, D subminiature connector, which appears on MDX master units. **SLAVE INTERCONNECT** is a 15-pin, female, D subminiature connector, which appears on MDX slave units.

Stand-alone MDXs do not have an interconnect port.

Refer to page 3-28 and page 4-49 for more information.

STATUS INFORMATION

Status Signals

The MDX can be externally monitored by means of output lines on the User port. Digital signals are 0-15 V; analog signals are 0-5 V.

Pin	Name	Functional Status
1 & 20 2	$\overline{CS1.D}$ & $\overline{CS2.D}$ $\overline{OUTPUT.D}$	Indicate what target has been selected. Indicates that the contactor is closed and that output has been turned on when the signal goes low.
3	$\overline{SETPOINT.D}$	Indicates that the output is equal to the requested setpoint when the signal goes low.
21	$\overline{ARC.D}$	Indicates that an arc has been detected (i.e., the impedance of the chamber dropped enough to cause the amount of current produced by the MDX to reach the built-in overcurrent trip point) when the signal goes low.
22	$\overline{EOTL.D}$	Indicates that programmed target life (for selected target-life counter) has ended when the signal goes low.
23	$V\ OUT.A$	Varying 0-5 V signal representing the output voltage.
24	$P\ OUT.A$	Varying 0-5 V signal representing the output power.
25	$I\ OUT.A$	Varying 0-5 V signal representing the output current.
30	$KWH\ OUT.A$	Varying 0-5 V signal representing the amount of kilowatt-hours remaining in the target life.
31	$LEVEL\ OUT.A$	Varying 0-5 V signal representing the programmed setpoint.

Indicators

MDX functions can be monitored by checking 1) the 10 status indicator LEDs that are in the center of the standard control panel and above the **MODIFY** knob or the 9 status indicators on the minipanel that are above the **REMOTE** switches (see foldout illustrations at the end of this chapter), 2) the LEDs on the switches, and 3) the LEDs located on or near the two digital meters. (There are only five LEDs on a passive front panel—see page 2-16.)

Status Indicator LEDs—Control Panels

A group of LEDs are clustered together on the control panels. To distinguish them from the switch LEDs and the digital meter LEDs, they are referred to in this manual as “status indicator LEDs.” There are 10 of these LEDs on the standard control panel and 9 on the minipanel (the **AUXILIARY** LED is not on the minipanel). The table below provides details.

<u>Status Indicator LED</u>	<u>Functional Status</u>
ARC	Lights to indicate that the impedance of the chamber dropped enough to cause the amount of current produced by the MDX to reach the built-in overcurrent trip point; indicates that an arc has been assumed and the ARC-OUT circuit has been activated. (An alarm will also sound.)
RAMP	Lights when output is ramping toward setpoint; flashes when ramp is paused; goes out when setpoint is reached.
SETPOINT	Lights when output is equal to the programmed setpoint; flashes (and alarm sounds) when the output is turned on and is not equal to the programmed setpoint; goes out when output is turned off. Note: This LED only lights or flashes when the PLASMA LED is lit.
PLASMA	Lights to indicate that output is on <i>and</i> output current is greater than 1/1024 of the maximum current available for that MDX model (see table on page 1-21).
OUTPUT	Lights to indicate that output has been turned on.



PART I

TARGET LIFE	Flashes (and an alarm sounds) when programmed target life ends (i.e., when the target-life counter has reached zero).
TEMP	Flashes to indicate that the MDX's internal temperature is too high and output was turned off.
WATER	Lights when $\overline{WATER.D}$ is grounded and OUTPUT OFF has been pressed (thus resetting the unit, see page 2-17); flashes when connection to ground is interrupted, indicating that output has been turned off.
VACUUM	Lights when $\overline{VAC.D}$ is grounded and OUTPUT OFF has been pressed (thus resetting the unit, see page 2-17); flashes when connection to ground is interrupted, indicating that output has been turned off.
AUXILIARY	Lights when $\overline{AUX.D}$ is grounded and OUTPUT OFF has been pressed (thus resetting the unit, see page 2-17); flashes when connection to ground is interrupted, indicating that output has been turned off. Note: This LED is not on the minipanel (however, output will be turned off if this condition exists).

Status Indicator LEDs—Passive Front Panel

POWER	Lights to indicate that the breaker is on (indication is for that unit only).
ARC	Lights when an arc is sensed; indicates that the ARC-OUT circuit has been activated.
OUTPUT	Lights to indicate that output has been turned on.
SETPOINT	Lights when output is equal to the programmed setpoint; goes out when output is not equal to the programmed setpoint, or output is turned off.
TEMP	Lights to indicate that the MDX's internal temperature is too high and output was turned off.

HOW IT WORKS

LEDs on Switches

LEDs in the centers of the switches on the standard control panel light and flash to convey a variety of information. Similarly, miniature pushbutton switches on the minipanel light and flash. In the table below, the name of the standard control panel switch is listed first, then the name of the minipanel switch, if it is different.

Switch LEDs	Functional Status
LEFT DISPLAY, ACTUAL minipanel: DISPLAY (lighted pushbutton switch)	Is always on, indicating that the value for any of the three parameters listed on the left digital meter (top meter on minipanel) can be displayed.
OUTPUT OFF	Lights when the MDX is not producing output; flashes when reset is required. Reset is required for the following conditions: <ul style="list-style-type: none">• MDX is powered up in program or lock mode• control is returned to the control panel from the Host port• the MODE key switch is moved from OFF to LOCK or PROG• <i>User pin 14 (OFF.D)</i> is not connected to <i>User pin 19 (INTLK COM.D)</i>• an interlock condition has not been satisfied• the EMERGENCY STOP button has been pushed In general, pressing OUTPUT OFF will reset the MDX, causing the LED to stop flashing (it will still be lit). This will not work if <i>User pin 14 (OFF.D)</i> is not connected to <i>User pin 19 (INTLK COM.D)</i> ; these pins must be connected before you can reset by pressing OUTPUT OFF . This will also not work if an interlock condition has not been satisfied.
OUTPUT ON	Lights when output is turned on.
REGULATION, POWER and CURRENT	The POWER LED lights when power regulation has been selected; the CURRENT LED lights when current regulation has been selected; both the POWER and CURRENT



PART I

LEDs light when voltage regulation has been selected.

When you hold in the **CURRENT** switch and then momentarily press the **SETPT** switch, the **CURRENT** LED remains lit, and the **SETPT**, **AMPS**, and **MINUTES** LEDs begin flashing. This indicates that you can modify the displayed value (shown in hundredths of minutes, i.e., 0.50 means 1/2 min.) for the out-of-setpoint timer (see discussion, page 4-17).

LEVEL

Lights when the **LEVEL** switch is being held in (the **SETPT** LED will also light); flashes if the **LEVEL** switch is pressed during a ramp, indicating that pause has been activated (the **RAMP** and **SETPT** LEDs will also flash).

This LED will also light after a ramp, indicating that the output can be modified without pressing the **LEVEL** switch.

RAMP

Lights when **RAMP** switch is held in (indicating that the displayed ramp time can be modified). Also, the LED on the **SETPT** switch lights and the **MINUTES** LED associated with the right digital meter lights (bottom meter on the minipanel). If you momentarily press **SETPT**, the LED on the **RAMP** switch will go out (and the **SETPT** and **MINUTES** LEDs will flash, indicating that you can modify the run-time value, displayed in hundredths of minutes; see page 4-15).

RIGHT DISPLAY, SETPT *minipanel:* DISPLAY, SETPT (lighted pushbutton switch)

Lights when selected, indicating that you can view 1) the setpoint for whatever method of output regulation (power, current, or voltage) that has been selected from the control panel or host (regardless of whether output is on or off), 2) the number of the selected target-life counter (page 4-5), or 3) how much ramp time has been programmed (page 4-10).

Flashes when used in conjunction with other switches (**TARGET**, **RAMP**, **CURRENT**,

HOW IT WORKS

RIGHT DISPLAY, ACTUAL
minipanel: DISPLAY,
ACTUAL (lighted
pushbutton switch)

POWER, VOLTAGE) to activate certain features.

Lights when selected, indicating that it can be used to toggle through the parameters associated with the right digital meter (bottom meter on minipanel). An LED will light beside the selected parameter, and the appropriate value will be displayed on the digital meter. Depending on which of the five parameters you select, you can view 1) actual output power, 2) actual output voltage, 3) actual output current, 4) kilowatt-hours remaining on the selected target-life counter, or 5) the ramp/run-time counter (counting down during a ramp, counting up during a run). If no run time is programmed, the counter will simply count the number of minutes the unit has run.

REMOTES, HOST

Lights to indicate that the Host port has control of the MDX. **Note:** If any of the other three **REMOTES** LEDs are lit (see next paragraph), the User port will have overriding control of the corresponding function.

REMOTES, LEVEL and RAMP and ON

Light to indicate that the User port has control of the corresponding function (**output setpoint ("level")**, **ramp time**, and **output power on/off**).

TARGET

Lights when the **TARGET** switch is held in, indicating that the target-life counter can be modified (0-9900 kWh). Flashes when you hold it in and momentarily press **SETPT** (which indicates that a different target counter can be selected). The number of a target counter selected from the User port will be preceded by a hyphen (example: no -5).



PART I

Minipanel only:
VERNIER (lighted
pushbutton switch)

Lights when pressed to indicate that
adjustments made with the **MODIFY** knob
will have finer resolution.

CATHODE (lighted
pushbutton switches)

Light when selected, indicating the selected
target-life counter (press **1** for counter 1,
press **2** for counter 2, press both **1** and **2** for
counter 3).

HOW IT WORKS

Digital Meter LEDs

Three LEDs are located on the left digital meter (they appear to the right of the top digital meter on the minipanel), and five LEDs are located on the right digital meter (to the right of the bottom digital meter on the minipanel). These LEDs indicate what parameter is being displayed on the associated digital meter. (See the front panel foldouts at the end of this chapter.)

Digital Meter LED

Functional Status

KW

Lights when selected with one of the **ACTUAL** toggle switches (the lighted pushbutton switch that is labeled **DISPLAY** on the minipanel controls the top digital meter; the switch labeled **ACTUAL, DISPLAY** controls the bottom meter); the actual output power will be displayed on the corresponding digital meter (or on both digital meters, if you select **KW** for both).

VOLTS

Lights when selected with one of the **ACTUAL** toggle switches (the lighted pushbutton switch that is labeled **DISPLAY** on the minipanel controls the top digital meter; the switch labeled **ACTUAL, DISPLAY** controls the bottom meter); the actual output voltage will be displayed on one of the digital meters (or on both digital meters, if you select **VOLTS** for both).

AMPS

Lights when selected with one of the **ACTUAL** toggle switches (the lighted pushbutton switch that is labeled **DISPLAY** on the minipanel controls the top digital meter; the switch labeled **ACTUAL, DISPLAY** controls the bottom meter); the actual output current will be displayed on one of the corresponding digital meters (or on both digital meters, if you select **AMPS** for both).
Flashes (along with **MINUTES** and **SETPT** LEDs) when the out-of-setpoint timer can be modified (see page 4-17).

KWH

Lights when selected with the **RIGHT DISPLAY, ACTUAL** toggle switch (lighted

pushbutton switch is labeled **DISPLAY, ACTUAL** on the minipanel and controls the bottom digital meter); the kilowatt-hour counter (see page 4-5) will be displayed on the right, or bottom, digital meter. If the **RIGHT DISPLAY, SETPT** switch (lighted pushbutton switch is labeled **SETPT** on the minipanel and controls the bottom digital meter) is pressed at this point, the **KWH** LED will remain lit but the digital meter will now display the number of the target-life counter.

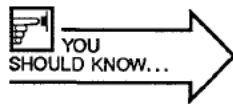

A hyphen in front of the target number indicates that the target-life counter was selected through the User (analog/digital) interface. If there is no hyphen, the counter was selected from either the control panel or a host controller.

MINUTES

Is associated with the right digital meter (bottom digital meter on the minipanel). **Rule of thumb:** This LED flashes for anything relating to run time, is statically lit for anything relating to ramp time.

Flashes 1) to indicate that the out-of-setpoint timer can be modified (**AMPS** LED and **SETPT** LEDs will also flash, see discussion of this timer on page 4-17); 2) to indicate that the ramp/run-time counter (see pages 4-10 and 4-15) is tracking run time (timer counts up); 3) to indicate run time can be modified (**RAMP** LED goes out, **SETPT** and **MINUTES** flash).

Lights 1) to indicate ramp time can be modified (**RAMP**, **SETPT**, and **MINUTES** LEDs are all lit); 2) to indicate that the counter is tracking ramp time (timer counts down).

Messages

<u>Message</u>	<u>Condition/Response</u>
"EOFF"	This word appears on both digital meters when the EMERGENCY STOP button is pushed in. The message will clear when the EMERGENCY STOP button is pulled out and the OUTPUT OFF switch is pressed (if <i>User pin 15</i> is connected to <i>User pin 19</i>).
"OFF"	This word appears on both digital meters when the MODE key switch is set to OFF .
"FAIL"	This word appears on the left (or top) digital meter when one of the "E" error messages is displayed on the right (or bottom) digital meter. It will clear when the righthand (or bottom) message is cleared.
"E-01"	The MDX has failed the internal software test; run the test again.
"E-02"	One (or more) control panel switches is stuck.
"E-10"	Communication failure between MDX control panel microprocessor and internal MDX microprocessor; will clear itself if communication is restored.
"E-12"	Out-of-setpoint shutdown — Output was turned off because the MDX was not able to produce output equal to the programmed setpoint level in the amount of time specified by the operator; press OUTPUT OFF to clear message.
"E-13"	Soft-start failed in MDX (internal MDX bus voltage failed to reach soft-start level); press OUTPUT OFF to clear message.



PART I

"E-14"

Internal MDX bus voltage is too high; press **OUTPUT OFF** to clear message.

"E-17"

Internal MDX bus voltage is too low; press **OUTPUT OFF** to clear message.

INTERFACING

The hierarchy that the MDX uses as a guide when it must give default control to an interface is:

1. control panel (remote or attached)
2. Host (RS-232) port
3. User (analog/digital) port

Control Panel Controls

TEST

Conducts a test of the LEDs if held down while output is on; conducts a test of the switches, LEDs, and communications between the control panel and the MDX's main microprocessor if held down while output is off.

LEFT DISPLAY, ACTUAL *minipanel*: lighted DISPLAY pushbutton switch

Toggles through parameters that can be viewed: **KW, VOLTS, AMPS**. The appropriate LED on the left digital meter will light and the actual power, voltage, or current value will be displayed. (On the minipanel, the lighted pushbutton switch affects the top meter.)

OUTPUT OFF

Turns off output; resets the interlock string after the interlock conditions have been satisfied. When the **OUTPUT OFF** LED is flashing (see page 2-17), pressing **OUTPUT OFF** will cause it to stop flashing, except if *OFF.D* (User pin 14) is not connected to *INTLK COM* (User pin 19) or if any of the interlock conditions have not been satisfied (see wiring diagrams on page 3-25).

OUTPUT ON

Turns on output if the control panel has control of the **on/off** function, all interlock conditions are satisfied, and the **OUTPUT OFF** LED is not flashing. If a setpoint value has been specified, the MDX will produce output at that level (within 600 ms for standard MDX if no ramp time is specified;



PART I

REGULATION, POWER and CURRENT

within 250 ms (standard factory setting, see page 5-5 for available range) with **fast ramp** option if no ramp time is specified).

Selects what method of output regulation the MDX will use (if the control panel has control of the **LEVEL** function). Pressing the **POWER** switch chooses the power method, pressing the **CURRENT** switch chooses the current method, and pressing both **POWER** and **CURRENT** together chooses the voltage method. See Output Regulation, page 4-3, for a detailed discussion.

MODIFY knob
minipanel: has a separate
VERNIER switch

Is used primarily in conjunction with the **LEVEL**, **RAMP**, and **TARGET** switches to choose values while programming one of the functions accessible through these switches. Two adjustment ranges are available: normal and vernier (push knob in for vernier, which provides finer resolution). During a pause in a ramp, the **MODIFY** knob can be used to adjust the output to a level anywhere between 0 and the maximum output for the unit. The **MODIFY** knob can also be used to control the output level after the output has reached the programmed setpoint (i.e., the unit is neither ramping nor pausing).

LEVEL

Allows an output setpoint to be programmed. Press and hold this switch and turn the **MODIFY** knob to reach the desired setpoint level. The pause function is activated when **LEVEL** is momentarily pressed while the MDX is ramping to the setpoint (the **LEVEL** LED will flash). The **MODIFY** knob can be used during a pause to adjust the output level. To release the pause, press **LEVEL** again. Once the setpoint has been reached, output can be modified without pressing **LEVEL**.

RAMP

Allows a ramp time (amount of time the MDX will take to reach the programmed output setpoint) to be programmed. Press and hold this switch to display any previously

HOW IT WORKS

RIGHT DISPLAY, SETPT
minipanel: **DISPLAY,**
SETPT (lighted pushbutton
switch)

programmed ramp time on the right digital meter (bottom meter on the minipanel). To change the ramp time, turn the **MODIFY** knob while holding in the **RAMP** switch. This switch can also be used to set the run timer (see page 4-15).

Performs, in conjunction with other switches, a variety of duties. Press **SETPT** to display on the right digital meter the setpoint for the method of output regulation that has been selected with the **REGULATION** switches. (On the minipanel, the pushbutton switch affects the bottom meter.) After using the **RIGHT DISPLAY, ACTUAL** (see below) switch to toggle to **KWH**, press **SETPT** to display the number of the active target-life counter. After you have toggled to **MINUTES**, press **SETPT** to display the amount of time the MDX has been programmed to run before shutting off the output.

Pressing the **SETPT** and **LEVEL** switches simultaneously causes the setpoint level to be displayed continuously (until **RIGHT DISPLAY, ACTUAL** is pressed).

Press and hold the **SETPT** and **POWER** switches simultaneously to display the maximum output power (in kilowatts), the impedance option, and the tap number to be displayed (see page 4-27, page 4-43, and "**MDX Config**" data request on page 2-34). Press and hold the **SETPT**, **POWER**, and **CURRENT** switches simultaneously to display the last two digits of the MDX software and the number of the target-life counter selected from the User port (similar to response to "**Misc.**" data request, page 2-34).

RIGHT DISPLAY, ACTUAL

Toggles through parameters that can be viewed: the first three are **KW**, **VOLTS**, **AMPS**. The appropriate LED on the right (or bottom) digital meter will light and the actual

power, voltage, or current value will be displayed (so far, this is just like what happens with the other digital meter). Pressing **SETPT** after toggling to one of these parameters causes the corresponding programmed setpoint to be displayed on the right (or bottom) digital meter. Additional parameters that can be viewed on this digital meter are **KWH** and **MINUTES**.

Toggle to **KWH** (the appropriate LED associated with the digital meter will light) to view the target-life counter. This counter counts down, subtracting the kilowatt-hours that have been used from the programmed target life (see Target Controls, page 4-5), so you see how many kilowatt-hours are left (the counter will count down in increments of 1 kWh). Toggle to **MINUTES** to view the run-time counter, which shows how much time remains before the MDX automatically shuts off the output. (See page 4-15 for a discussion of using and disabling the run-timer function.)

REMOTES, HOST

Determines whether the MDX is controlled from the control panel or the Host port. Press the switch to transfer control between these interfaces. When control is transferred from the Host port to the control panel, the **OUTPUT OFF LED** will flash. Press the **OUTPUT OFF** switch to cancel the flashing before pressing the **OUTPUT ON** switch.

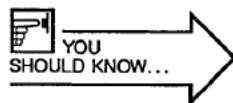

The **HOST** switch will not transfer control to the Host port unless *Host pin 6* is connected to *Host pin 7* (see page 3-17). Also note that if any of the other three **REMOTES** LEDs (see below) are lit, the User port will have overriding control of the corresponding function(s).

REMOTES, LEVEL

Gives control of the output setpoint and method of output regulation to the User port.

HOW IT WORKS

Press the switch to transfer control between this interface and whatever other interface has control (control panel or Host port). If *User pin 27 (LEVEL IN.A)* is not connected (see pages 3-21 and 3-25), the setpoint will default to zero.

REMOTES, RAMP

Gives control of the ramp timer to the User port. Press the switch to transfer control between this interface and whatever other interface has control (control panel or Host port). If *User pin 26 (RAMP IN.A)* is not connected (see pages 3-21 and 3-25), the ramp time will default to zero.

REMOTES, ON

Gives control of the **output on** function to the User port. Press the switch to transfer control between this interface and whatever other interface has control (control panel or Host port). When control is transferred from the User port to the control panel, the **OUTPUT OFF** LED will flash. Press the **OUTPUT OFF** switch to cancel the flashing before pressing the **OUTPUT ON** switch.



DANGER! The **OUTPUT OFF** switch will turn output off even if the unit is under control of the User port. However, if *User pins 14 and 7 (OFF.D and ON.D)* are connected to *User pin 19 (INTLKCOM)* and **REMOTES ON** is selected, the output will turn on immediately after the **OUTPUT OFF** switch is released. (See Two-wire Control, page 3-23.)

TARGET

Allows target-life counter to be programmed (see discussion of target controls, pages 4-5 and 4-6).

MODE key switch

Selects controlling mode:

- **OFF**

Disables all functions. Both digital meters will display "Off".

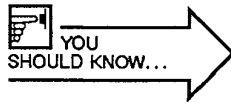

Turning the key switch from **OFF** to either **LOCK** or **PROG** causes the LED on the **OUTPUT OFF** switch to flash. Press the **OUTPUT OFF** switch to continue (and cancel the flashing).

- **LOCK**

Restricts operation to turning output on and off, selecting and viewing the displays available on the digital meters, and running the test function. All setpoint values, method of regulation, and site of control that were specified in **PROG** (program) mode are retained, but cannot be changed from the control panel.

- **PROG**

Provides full access from all interfaces to all functions, settings, and parameters.

EMERGENCY STOP button

Opens the contactor immediately and shuts off output when pushed in. When you pull the button back out, you must also reset the unit by pressing **OUTPUT OFF** (and *User pin 15* must be connected to *User pin 19*).

User Port Functions

Many of the functions that are available from the control panel are also available through the user-remote interface. The exceptions are:

- cannot transfer control from one interface to another
- cannot store parameters (they are only in effect when the MDX is looking at the User pins; if the voltage on the pins changes, the specific parameter changes)
- cannot specify target life
- cannot pause during a ramp
- cannot set the modes that are selected with the **MODE** key switch
- cannot modify run time
- cannot set out-of-setpoint timer

The available functions include:

- selecting active target-life counters
- turning output on and off
- specifying method of output regulation
- monitoring the system interlock string
- setting ramp time
- specifying output setpoint
- monitoring output parameters and status
- cannot use diagnostic features

Three of the **REMOTES** switches can be used in any combination to give control to the User port. When the **LEVEL** LED is lit, both method of regulation (power, current, voltage) and setpoint can be specified from the User port by using *pins* 5, 6, and 27. When the **RAMP** LED is lit, a ramp time can be set by using *pin* 26. When the **ON** LED is lit, output power can be turned on and off with *pins* 7 and 14.

A target-counter number can be specified from the User port any time by using *pins* 4, 34, and 35.

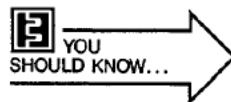

When **0** is selected from the control panel with the **MODIFY** knob, whatever target-life counter has been selected with the User pins will be active. If no target has been selected with the User pins, target 0 is the default. See page 4-5 for information on selecting target-life counters.



PART I

The parameters that can be monitored through the User port are:

<u>Parameter</u>	<u>Associated pins</u>
is output enabled	<i>pin 2</i>
has setpoint level been reached	<i>pin 3</i>
which target-life counter is active (0-3)	<i>pins 1, 20</i>
has an arc been detected	<i>pin 21</i>
has programmed target life ended	<i>pin 22</i>
what is output voltage	<i>pin 23</i>
what is output power	<i>pin 24</i>
what is output current	<i>pin 25</i>
how much time remains on the target-life counter	<i>pin 30</i>
what is the setpoint level	<i>pin 31</i>

Host Port

First the **MODE** key switch must be set to **PROG** or **LOCK** and *Host pin 6* must be low. Then you can enable the Host port by pressing the **REMOTES, HOST** switch; the LED on the switch will light. (On the minipanel you press the miniature pushbutton switch, causing the switch to light.)

You can do everything from the host computer that you can do from the control panel, except that you cannot set the modes that are selected with the **MODE** key switch.

Transmission Parameters

RS-232 ASCII format
1200 baud
even parity
1 start bit, 7 data bits, two stop bits

Host pin 6 (DSR) must be connected to *Host pin 7 (COM)* before the MDX will recognize communication on the Host port.

The MDX sends data through *Host pin 2 (TXD)*; this pin must be connected to *pin 3* on the RS-232 host computer's connector.

The MDX receives data through *Host pin 3 (RXD)*; this pin must be connected to *pin 2* on the RS-232 host computer's connector.

All data requests and commands must end with a carriage return (<cr>). Note that responses from the MDX will also end with a carriage return.



PART I

Table 2-1. Requests for Data

In this table, the final letter of the response (in the "Format of Response" and "Example of Response" columns) is merely the data request command letter repeated as a verification of what command was sent. Also note that:

- <cr> = carriage return
- # = hexadecimal number
- D = digital number

Data Request from Host	Format of Response	Example of Response	Explanation of the Example Response
G<cr> Misc.	DD#DG	01C7G	First 2 digits (01) = software revision level Third digit (C) is acknowledging host control Fourth digit (7) = target-life counter selected from the User port (see page 4-7).
I<cr> Actual Current	DDDDI	0567I	Actual output current = 5.67 A (for current, a decimal point is implied between the second and third digits).
J<cr> Run Timer	DDDDJ	0630J	The run-time counter has been set to shut the MDX off after 6.30 min. (for time, a decimal point is implied between the second and third digits).
K<cr> Interlock Status	####K	7800K	Status of interlock string (see Tables 2-4 and 2-6 to interpret response); also, whether an out-of-setpoint shutdown has occurred. In this case, output is off because <i>User pin 14</i> is high, and the water, vacuum, and auxiliary interlock conditions have not been met.
L<cr> Output Setpt	DDDDL	0865L	Output setpoint: 8.65 kW, 865 V, or 8.65 A, depending on what method of output regulation has been selected.
M<cr> Ramp Time Left	DDDDM	0133M	The time remaining in the ramp is 1.33 min. After the ramp is completed, run time will be displayed in response to the M<cr> command.
N<cr> MDX Config	DDDDN	2501N	First two digits = maximum output power (25 kW) Third digit = designation of impedance range (0 = "standard Z," 1 = "low Z," 2 = "high Z") Fourth digit = tap number (tap 1 in this case)
P<cr> Ramp Output	DDDDP	0265P	Output level during a ramp: 2.65 kW, 265 V, or 2.65 A, depending on what method of output regulation has been selected.
Q<cr> Out-of-setpt Limit	DDDDQ	0010Q	The MDX has been programmed to turn off output if it is out of setpoint for 0.10 min.

HOW IT WORKS

Data Request from Host	Format of Response	Example of Response	Explanation of the Example Response
R<cr> Ramp Timer	DDDDR	1234R	Ramp time has been set for 12.34 min.
S<cr> System Status	#####S	8048S	Status of the system. See Tables 2-5 and 2-6 to interpret the response. In this case, the MDX is set for power regulation, a plasma exists, and the host computer is in control.
T<cr> Target Life Left	DDDDT	0921T	The kilowatt-hours remaining on the selected target-life counter is 921 kWh.
U<cr> Target Config	00DDU	0013U	The fourth digit represents the number of the selected target-life counter — 3 in this case. The third digit indicates how the target number was selected; here the "1" means that it was selected from either the front panel or host computer. A "0" would mean that the target was selected from the User port.
V<cr> Actual Voltage	DDDDV	0430V	Actual output voltage = 430 V.
W<cr> Actual Power	DDDDW	0300W	Actual output power = 3 kW (for power, a decimal point is implied between the second and third digits).
Z<cr> Max Output	DDDDZ	1) 0600Z 2) 5000Z 3) 0625Z	Maximum output that is possible for this MDX model, given the selected voltage tap and method of regulation (see tables on pages 1-19 and 1-21 for possible maximums in various configurations): 1) 600 V (standard MDX 5K, tap 1, voltage regulation) 2) 5000 W (standard MDX 5K, tap 1, power regulation) 3) 6.25 A (standard MDX 5K, tap 3, current regulation)



PART I

Table 2-2. S (status change) Commands

These commands automatically echo back to the host screen. Note that:
<cr> = carriage return

<u>Command</u>	<u>Action Requested</u>	<u>Condition*</u>
S0<cr>	turn output off/reset	NA
S1<cr>	turn output on	1, 2
S2<cr>	pause ramp	NA
S3<cr>	resume ramp	NA
S4<cr>	use power regulation	1, 2, 3
S5<cr>	use current regulation	1, 2, 3
S6<cr>	use voltage regulation	1, 2, 3
S8<cr>	override control panel setting and give full control of MDX to Host port	1
S9<cr>	return full control from Host port to control panel	1, 2
SA<cr>	transfer control of setpoint and method of regulation from Host port to User port	1, 2
SB<cr>	transfer control of setpoint and method of regulation from User port to Host port	1, 2
SC<cr>	transfer control of ramp timer from Host port to User port	1, 2
SD<cr>	transfer control of ramp timer from User port to Host port	1, 2
SE<cr>	transfer control of output on/off from Host port to User port	1, 2
SF<cr>	transfer control of output on/off from User port to Host port	1, 2

*Conditions are listed on the next page.

HOW IT WORKS

Conditions:

- 1 = *Host pin 6 (DSR)* is low, i.e., *Host pins 6 (DSR) and 7 (COM)* are connected.
- 2 = MDX is under control of host computer (in response to a system status request, bit 3 = 1 for the fourth character).
- 3 = Setpoint level is not under control of the User port (in response to a system status request, bit 2 = 0 for the fourth character).



PART I

Table 2-3. Commands To Set Variables

These commands are not echoed; to verify the command you sent, send the appropriate data request (see Table 2-1). Also note that:

- <cr> = carriage return
- # = hexadecimal number
- D = digital number

Command	Function	Example	Condition*
JDDDD<cr> Set Run Timer	Sets run-time counter; decimal point between second and third digits is implied (00.01-99.00 min., shown in hundredths of minutes); specify J0000 to disable this function.	J0480 (4.8 min.)	1, 2
LDDDD<cr> Set Output Level	Sets output setpoint (kW, A, or V); decimal point between second and third digits is implied.	L0950 (9.5 kW, A, or V)	1
RDDDD<cr> Set Ramp Timer	Sets ramp timer; decimal point between second and third digits is implied (00.01-99.00, shown in hundredths of minutes); specify R0000 to disable this function.	R0120 (1.2 min.)	1, 3
TDDDD<cr> Set Target Life	Sets value (0001-9900, shown in kilowatt-hours) for the target-life counter that has been selected with <i>User pins 4, 34, and 35</i> ; specify T0000 to disable this function.	T0088 (88 kWh)	1
QDDDD<cr> Set Out-of- setpt Timer	Sets out-of-setpoint timer (0.01-2.55, shown in hundredths of minutes); decimal point between second and third digits is implied; specify Q0000 to disable this function.	Q0015 (0.15 min.)	1
UDDDD<cr> Select Target	Selects one of eight target-life counters (0-7).	U0001 (target 1)	1

*Conditions are listed on the next page.

HOW IT WORKS

***Conditions:**

- 1 = The fourth character of the response to a system status request (S<cr>) must be 8-F (i.e., the MDX must be under host control).
- 2 = The fourth character of the response to a system status request (S<cr>) must be 0-3 or 8-B (i.e., the setpoint must not be under control of the User interface).
- 3 = The fourth character of the response to a system status request (S<cr>) must be 0, 1, 4, 5, 8, 9, C, or D (i.e., the ramp timer must not be under control of the User interface).

Table 2-4. Responses to Requests for Interlock Status (K<cr>)

The form of the response is #####K. See pages 2-43 and 2-44 for a discussion of how to interpret this response, or see Table 2-6 to translate the hexadecimal characters found in the response to the bit conditions for each character that is listed below. The “first character” is the one farthest left in the response.

First Character

if bit 3=1	emergency stop activated
if bit 2=1	output is off because <i>User pin 14 (OFF.D)</i> is high
if bit 1=1	water interlock condition has not been met
if bit 0=1	vacuum interlock condition has not been met

Second Character

if bit 3=1	auxiliary interlock condition has not been met
if bit 2=1	NA
if bit 1=1	NA
if bit 0=1	control panel key switch set to OFF

Third Character

if bit 3=1	internal MDX bus voltage is too low (below factory-set limit)
if bit 2=1	internal MDX bus voltage is too high (above factory-set limit)
if bit 1=1	NA
if bit 0=1	NA

Fourth Character

if bit 3=1	soft start failure
if bit 2=1	out-of-setpoint shutdown
if bit 1=1	NA
if bit 0=1	1) one of the hardware interlock conditions has not been met <i>or</i> 2) an S8<cr> command was not followed by an S0<cr> command (to reset the bit) <i>or</i> 3) <i>Host pin 6</i> is not connected to <i>Host pin 7</i> , <i>or</i> 4) bus voltage is too low

HOW IT WORKS

Table 2-5. Responses to Requests for System Status (S<cr>)

The form of the response is ####S. See pages 2-43 and 2-44 for a discussion of how to interpret this response, or see Table 2-6 to translate the hexadecimal characters found in the response to the bit conditions for each character that is listed below.

First Character

if bit 3=1 and bit 2=0	MDX is in power regulation
if bit 2=1 and bit 3=0	MDX is in current regulation
if bit 2=1 and bit 3=1	MDX is in voltage regulation
if bit 1=1	ramp has been paused
if bit 0=1	an arc has been sensed (this bit will not reset until the S<cr> command is sent)

Second Character

if bit 3=1	ramp is in progress
if bit 2=1	plasma is indicated
if bit 1=1	ramp (if any) is complete and output setpoint level has been reached
if bit 0=1	output is on

Third Character

if bit 3=1	output has been turned on
if bit 2=1	either 1) the interlock string is broken, 2) host-remote control was requested from the host controller, or 3) the specified run time is over
if bit 1=1	the target-life counter has reached the end of the programmed target life
if bit 0=1	illegal command

Fourth Character

if bit 3 = 1	MDX is under host-remote control
if bit 2 = 1	setpoint ("level") is under user-remote control
if bit 1 = 1	ramp timer is under user-remote control
if bit 0 = 1	output on/off function is under user-remote control



PART I

Table 2-6. Key To Translating Hexadecimal Characters

This table serves as a quick reference for translating the hexadecimal characters contained in responses to interlock status requests (K<cr>) (Table 2-4) and system status requests (S<cr>) (Table 2-5) into binary numbers.

<u>Hex. Character</u>	<u>Bit 3</u>	<u>Bit 2</u>	<u>Bit 1</u>	<u>Bit 0</u>
0	0	0	0	0
1	0	0	0	1
2	0	0	1	0
3	0	0	1	1
4	0	1	0	0
5	0	1	0	1
6	0	1	1	0
7	0	1	1	1
8	1	0	0	0
9	1	0	0	1
A	1	0	1	0
B	1	0	1	1
C	1	1	0	0
D	1	1	0	1
E	1	1	1	0
F	1	1	1	1

Translating Responses to Status Requests

In the two examples that follow, the letters "K" and "S" are merely repetitions of the command letters — this serves to confirm that you really typed K and not J, or S and not T. Each of the four hexadecimal characters that precede the command letter is a message in itself. Table 2-6 allows you to quickly convert each hexadecimal character to a binary number. Then Table 2-4 or Table 2-5 can be used to interpret what each character means by converting each binary number to a message.

Example of translating a response to an interlock status request (K<cr>):
7800K

K

confirmation of command letter

7

1. go to Table 2-6 and find "7" in the first column; look across the other columns to see that 7 means that bits 2, 1, and 0 are set to 1
2. go to Table 2-4 and look under "first character"
bit 2=1, so *User pin 14* is high
bit 1=1, so the water interlock is not satisfied
bit 0=1, so the vacuum interlock is not satisfied

8

1. go to Table 2-6 and find "8" in the first column; look across the other columns to see that 8 means that bit 3 is set to 1
2. go to Table 2-4 and look under "second character"
bit 3=1, so the auxiliary interlock is not satisfied

0

As you can see from Table 2-6, a 0 in the response means that no bits are set to 1, and so a 0 is just a space filler.



PART I

Example of translating a response to a system status request (S<cr>): **8048S**

S

confirmation of command letter

8

1. go to Table 2-6 and find "8" in the first column; look across the other columns to see that 8 means that bit 3 is set to 1
2. go to Table 2-5 and look under "first character" bit 3=1 and bit 2=0, so the method of regulation is power

0

1. As you can see from Table 2-6, a 0 in the response means that no bits are set to 1, and so a 0 is just a space filler.

4

1. go to Table 2-6 and find "4" in the first column; look across the other columns to see that 4 means that bit 2 = 1
2. go to Table 2-5 and look under "third character" bit 2=1, so either 1) the interlock string is broken (send the K<cr> command to request the interlock status), 2) host-remote control was requested from the host controller (merely send S0<cr> to reset (see Table 2-2)), or 3) the specified run time is over

8

1. go to Table 2-6 and find "8" in the first column; look across the other columns to see that 8 means that bit 3 = 1
2. go to Table 2-5 and look under "fourth character" bit 3=1, so the MDX is in host-remote control

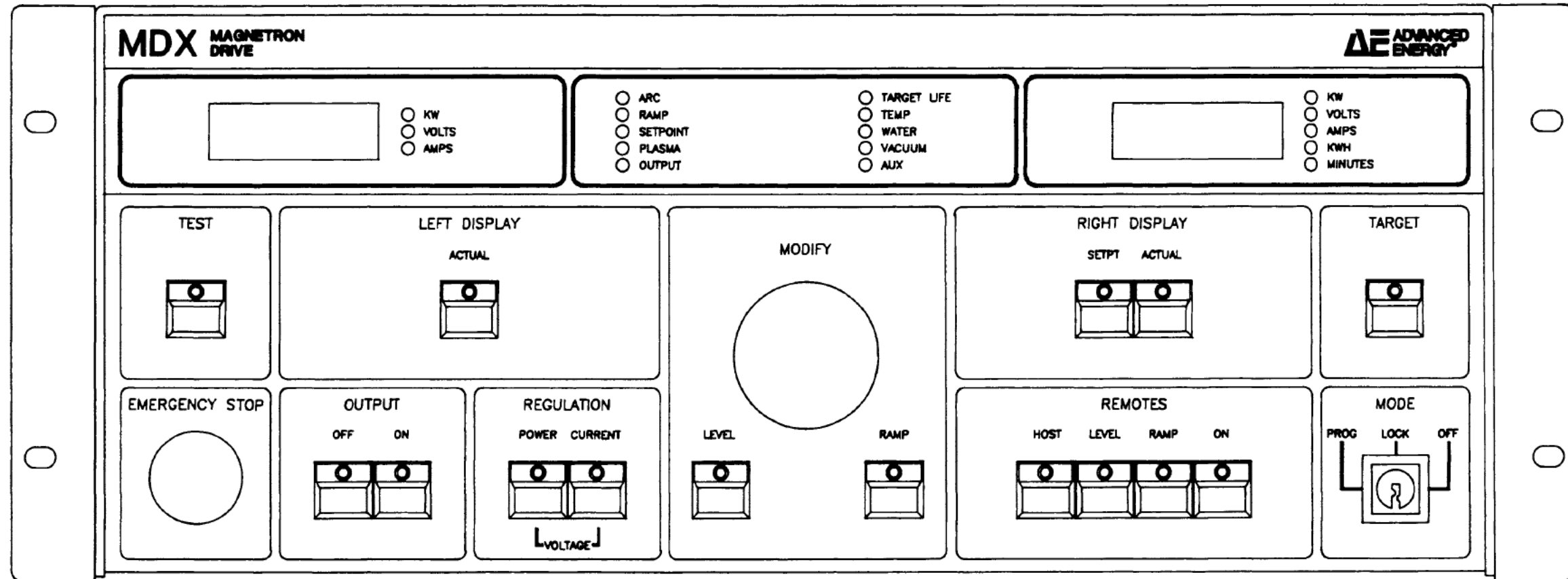

MDX 208 Standard Control Panel, Front View

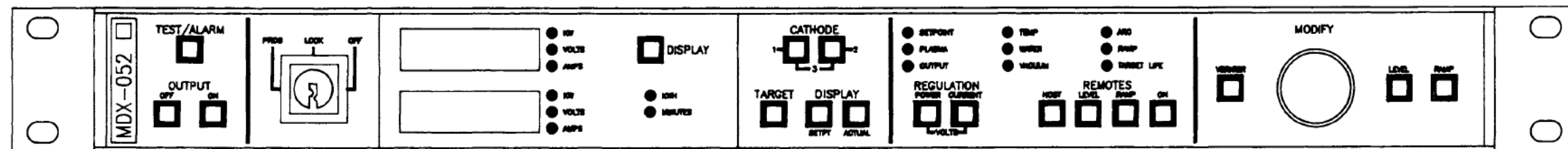

MDX Minipanel, Front View

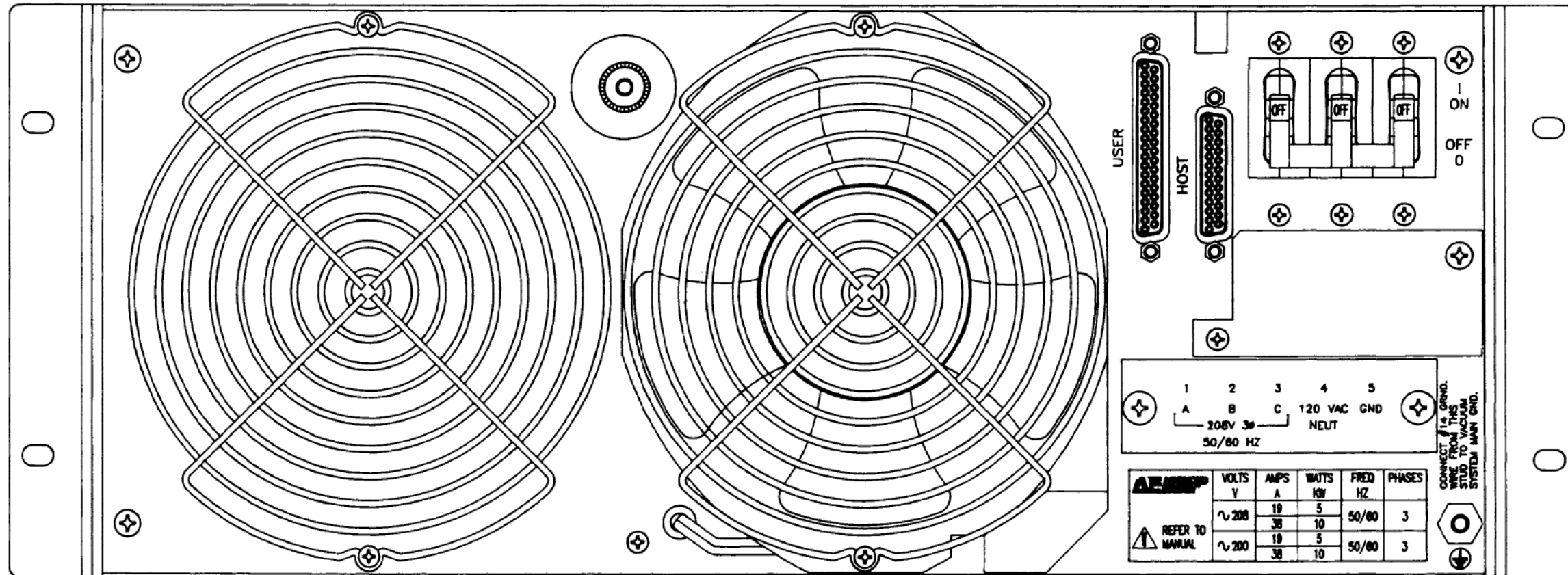

MDX 208, 5K, Rear View
 The front view is the same as the front view of the MDX 208 standard control panel

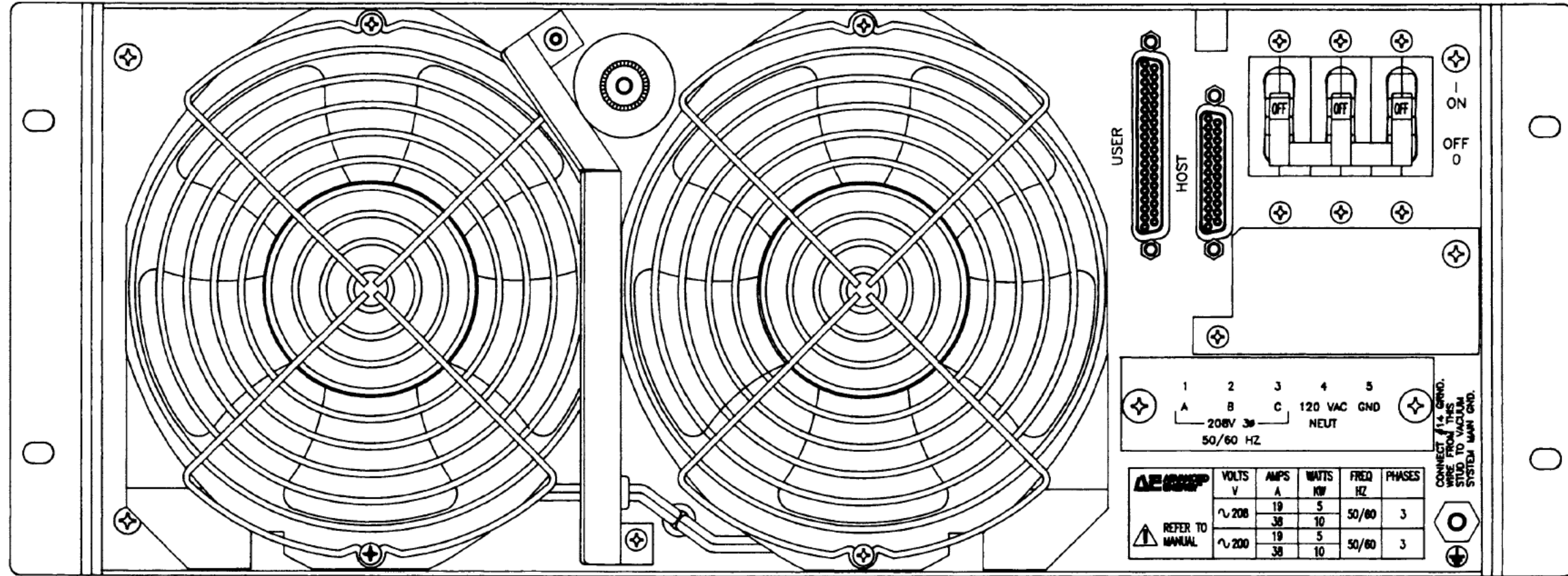

MDX 208, Rear View

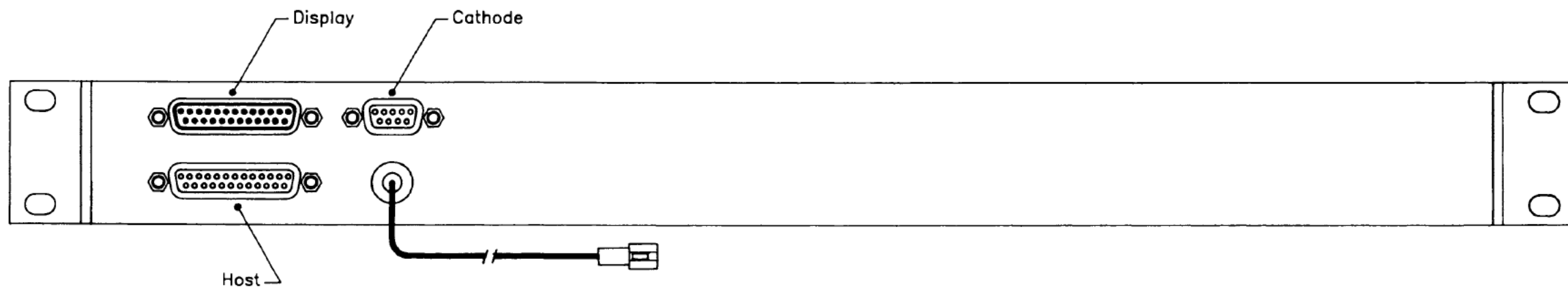

MDX Minipanel, Rear View

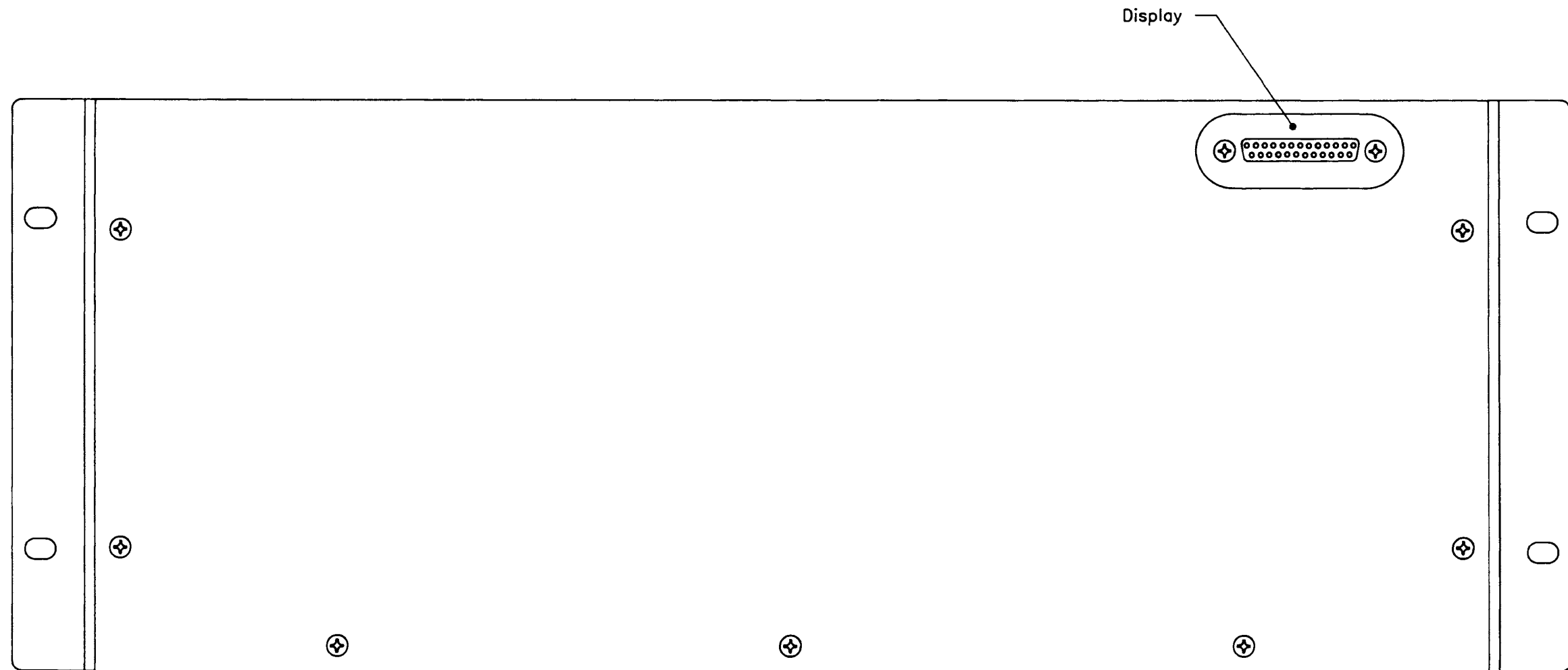

MDX Remote Control Panel, Rear View
The front view is the same as the front view
of the MDX 208 standard control panel

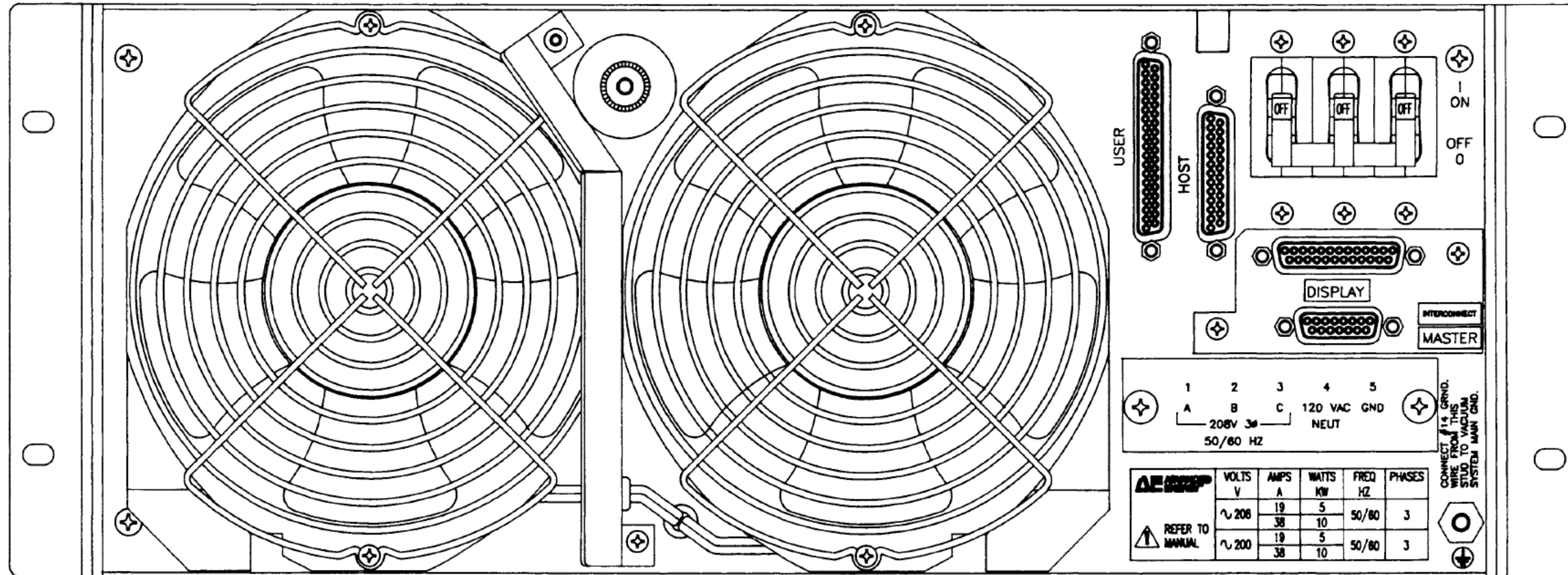

MDX 208 Master, Rear View

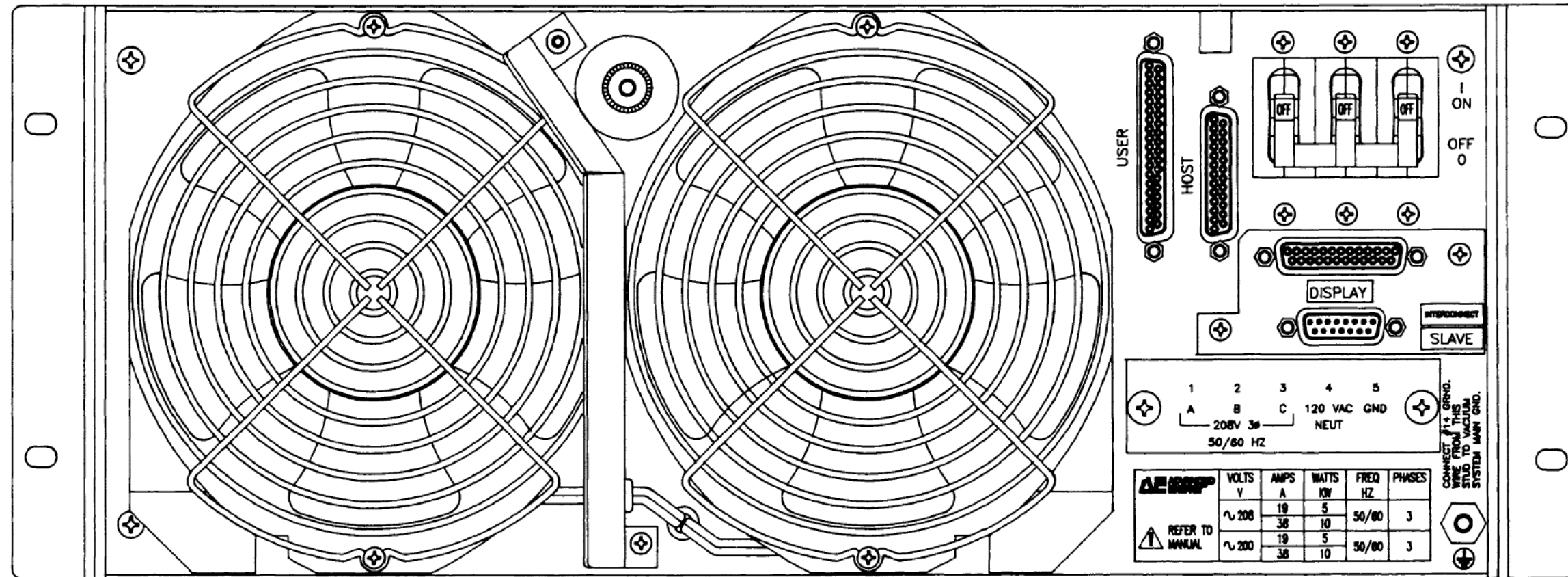

MDX 208 Slave, Rear View

OPERATING YOUR MDX
MAGNETRON DRIVE

PREPARING FOR USE

CONTENTS

Setting Up	3-5
Unpacking	3-5
Design Considerations	3-5
Spacing Requirements	3-7
Cooling Requirements	3-9
Making Rear Panel Connections	3-13
Grounding	3-13
Connecting Input Power	3-14
Standard "Y" Connection	3-15
Delta Connection	3-15
Connecting the Output	3-17
Connecting for Host-remote Control	3-18
Connecting for User-remote Control	3-18
Signal Descriptions: User I/O Pins	3-19
Wiring Options	3-24
Three-wire Control	3-24
Two-wire Control	3-24
External Monitoring of Output	3-25
External Programming of Ramp Timer/Setpoint ...	3-26
Normal Interlock Connection	3-26
Cheater Plug	3-27
Connecting a Remote Control Panel	3-27
Display Bypass Plug	3-28
Connecting for Master/Slave Operation	3-28
Disconnecting	3-29
First-time Operation	3-31
Start-up Procedure	3-31

PREPARING FOR USE

SETTING UP

Unpacking

Unpack and inspect your MDX magnetron drive power supply carefully. Check for obvious physical damage. If no damage is apparent, proceed to make the connections. If you do see signs of shipping damage, contact Advanced Energy Industries, Inc., and the carrier immediately. Save the shipping container for submitting necessary claims to the carrier.

Design Considerations

All MDX models are designed to mount in a standard 19-inch (48.26-cm) rack by means of the rack ears attached to the power supply. The MDX is an air-cooled power supply, so it is important to ensure that adequate ventilation is provided. Later in this section you will find discussions of spacing and cooling requirements for both rack and cabinet mounting.

PREPARING FOR USE

Spacing Requirements

- The clearance between either side of the MDX and the enclosure must be 1 inch (25 mm).
- The clearance between the top of the MDX and the top of the enclosure must be 1 inch (25 mm).
- The clearance between power supplies must be 1 inch (25 mm).
- The clearance between the fan grills on the rear of the MDX and the enclosure must be 9 inches (229 mm), with adequate ventilation (see pages 3-9 through 3-11).

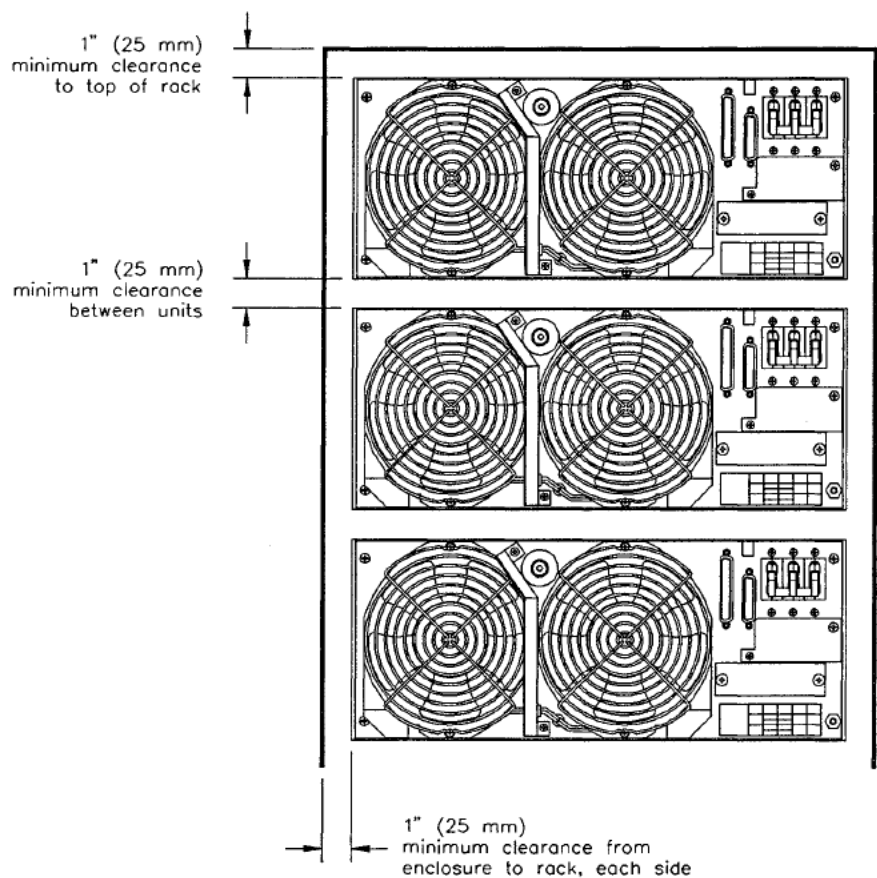

Figure 3-1. Illustration of top, side, and inter-unit clearance requirements for MDX units stacked in a cabinet.

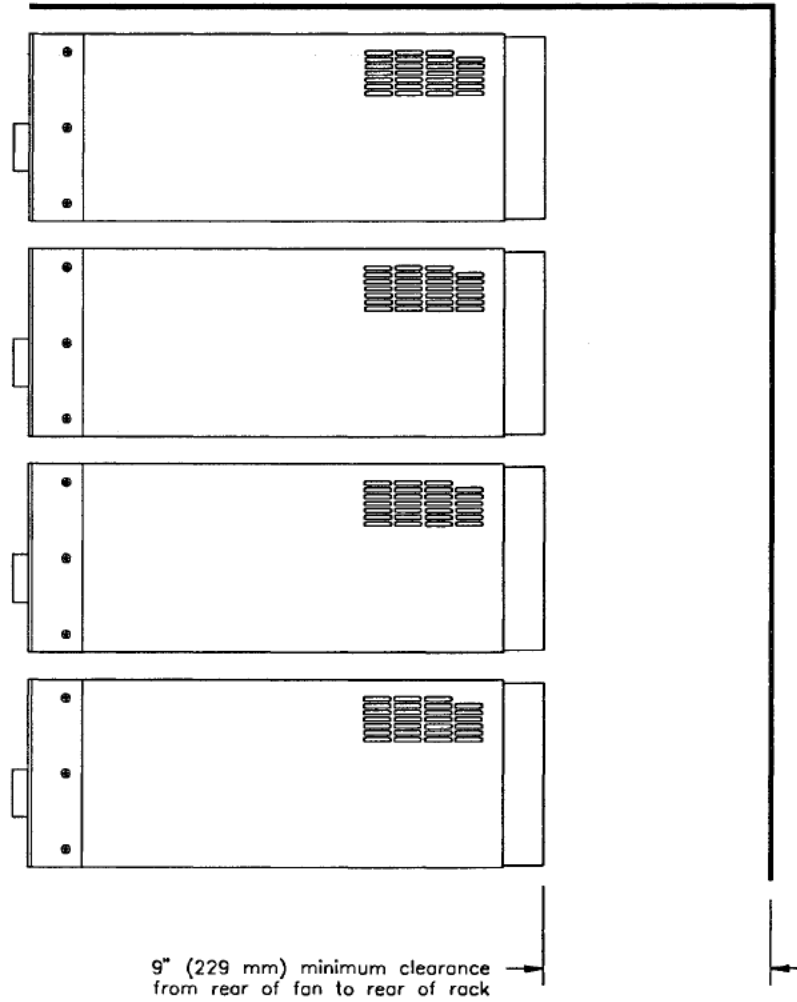

Figure 3-2. Illustration of rear clearance requirements for MDX units stacked in a cabinet.

PREPARING FOR USE

Cooling Requirements

For the MDX to be sufficiently cooled, the cabinet must be configured to:

- bring in coolant air of the correct temperature (35°C maximum)
- distribute input (coolant) air to the power supplies
- prevent exhaust air from circulating back and becoming input air
- exhaust the hot air from the cabinet with minimal airflow restriction

You will also need to add air baffles to the rack to prevent exhaust air from recirculating.

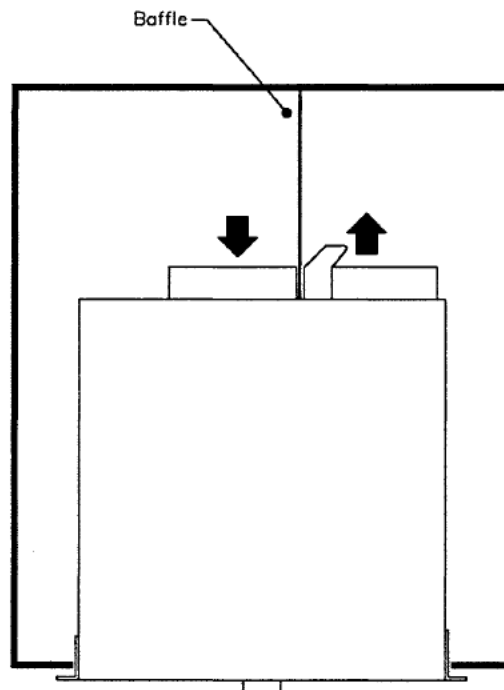

Figure 3-3. Graphic representation of the view looking down on the top of an MDX in a rack. The arrows show the direction of air flow.

The following is a synopsis of the principles to follow when designing a cabinet containing a “stack” of MDX power supplies.

Each MDX is cooled by two fans on the rear panel of the unit. The inlet fan blows air into the unit and the exhaust fan blows the heated exhaust air out. Since these fans are next to each other, you will need to place a deflection plate between them so that the exhaust air is not drawn back into the unit by the inlet fan.

Each MDX requires 200 CFM of inlet air. A cabinet opening of approximately 30 square inches (193.5 cm²) is required to accommodate the inlet fan. At a full load of 10 kW, each unit dissipates 1.1 kW internally and produces 200 CFM of exhaust air. A cabinet opening of 30 square inches (193.5 cm²) is also required to accommodate the exhaust fan.

As an example, a cabinet containing six power supplies (see Fig. 3-4 on the next page) would require a total inlet area of 180 square inches (1161 cm²) — that is, 6 units x 30 square inches per unit. One method would be to perforate a total area of 180 square inches (1161 cm²) on the side or rear of the cabinet. For the exhaust fan, however, it is preferable to locate the opening entirely on the rear of the cabinet. An important consideration during cabinet design is the need for a physical barrier separating the hot exhaust air from the inlet air used for cooling. To be most effective, such a barrier should extend from the topmost power supply to the bottom power supply.

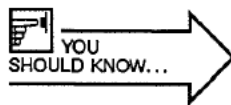

Note: Multiply the number of power supplies by 30 square inches (193.5 cm²) to get the inlet area for **one side** of the cabinet. You will also need to provide the same exhaust area for the other side of the cabinet.

In this example, all six units will exhaust into the rear of the cabinet (6 units x 1.1 kW per unit = 6.6 kW total). We recommend that a fan or a blower be mounted near the top of the cabinet to help move the hot exhaust air out of the cabinet and away from the power supplies.

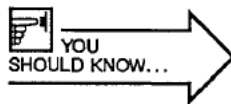

Note: 1.1 kW is equal to 62.6 BTUs per minute.

PREPARING FOR USE

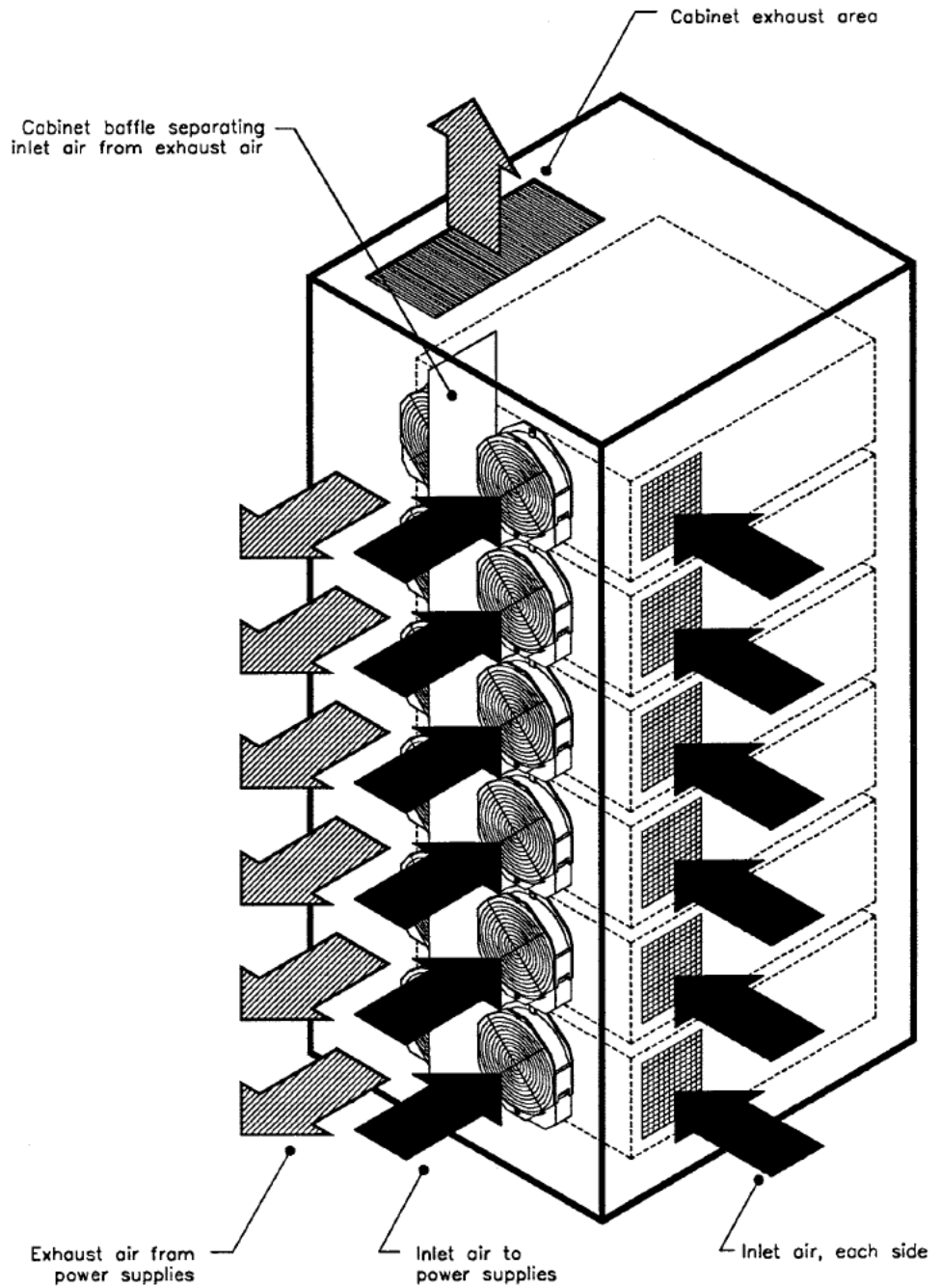

Figure 3-4. Illustration of the cooling pattern for six MDX units enclosed in a cabinet.

PREPARING FOR USE

MAKING REAR PANEL CONNECTIONS

Grounding

A protective earth terminal stud is located below and to the right of the main input terminal block (see foldouts of rear panel, end of Chapter 2). This terminal is connected internally to the main terminal block ground position indicated by the GND label (fifth terminal).



DANGER! Connect the protective earth terminal on the MDX rear panel to protective earth/ground before making any other connection.

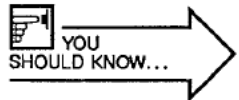

For optimum performance, ground the chassis stud to the chamber ground.

In multi-unit configurations (master/slave combinations, providing from 20 kW to 80 kW), the MDX will operate more reliably and be less sensitive to spurious noise if both the MDX chassis and the system are grounded. The preferred method of chassis grounding is to daisy-chain a flat copper braid of AWG-14 equivalency between units. To further reduce noise between units, this braid should be as short as possible. Use only one lead to connect the system ground block to the daisy-chained units.

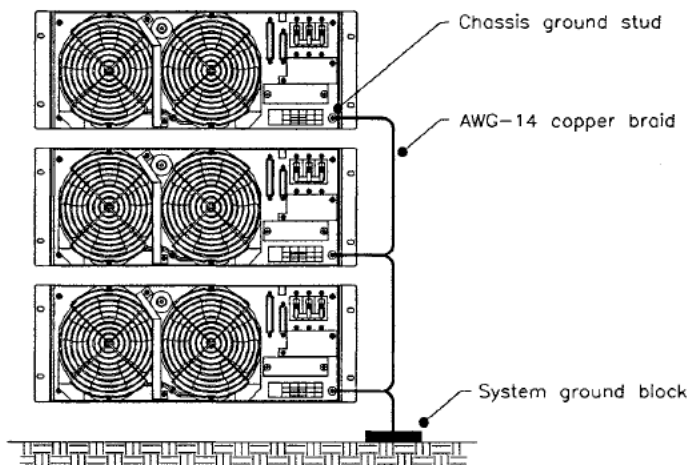

Connecting Input Power

The standard line voltages are either 200 V ac rms or 208 V ac rms, three phase, 50/60 Hz. All power supplies leave the factory with their input and output voltages identified on an enclosed test checklist.

Any changes to the voltage setting require internal hardware changes. **Do not apply power until these changes are made!** Turn to page 4-47 for instructions.

The line input connection is provided by means of a five-position, high-current, feedthrough terminal block (TB) on the rear panel (see next page). Labels on the TB input terminal shield and below each terminal position show line (A, B, C), neutral (120 V ac NEUT), and protective earth-ground connections (GND). A specific phase rotation is not required on any MDX model.

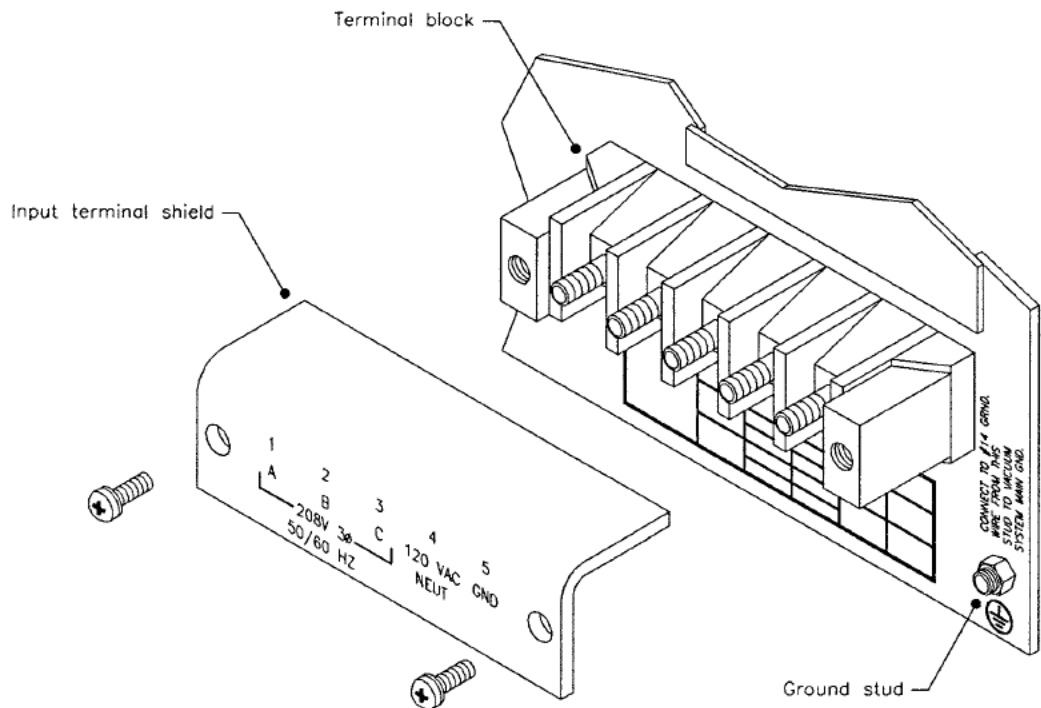

PREPARING FOR USE

Connect input power to terminal block contacts with stranded wire of a gauge recommended by local building codes. A ring lug terminal is recommended to fit over the UNC-10-32 stud of the terminal block. All connections to protective earth/ground terminals must have a star-washer below the ring lug terminal.

Remove the input terminal shield from the terminal block so that you can install the line cord. After you install the line cord, mount the input terminal shield on the standoffs.



DANGER! Before making any other connection, connect the ground terminal to protective earth-ground.

Standard “Y” Connection

The standard input connection is normally derived from “Y” connected sources. By bringing the neutral lead to the power supply, 120 V ac is obtained between terminal 3 and terminal 4 of the input terminal block (see the illustration on the next page). This 120 V ac is used to power the internal logic of the power supply. The power supply will not function without this 120 V ac input.



WARNING! If you have a “Y” connected source, but choose to use an auxiliary transformer, do not connect the neutral line from the power source to terminal 4 on the power supply (see the illustration on the next page). A phase to neutral short circuit could result.

Delta Connection

If you have a delta connected source, an auxiliary transformer is required to generate 120 V ac between input terminals 3 and 4 (see the illustration on the next page).



PART II

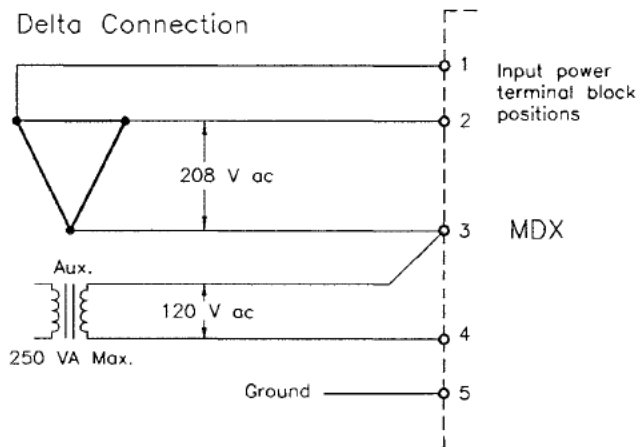
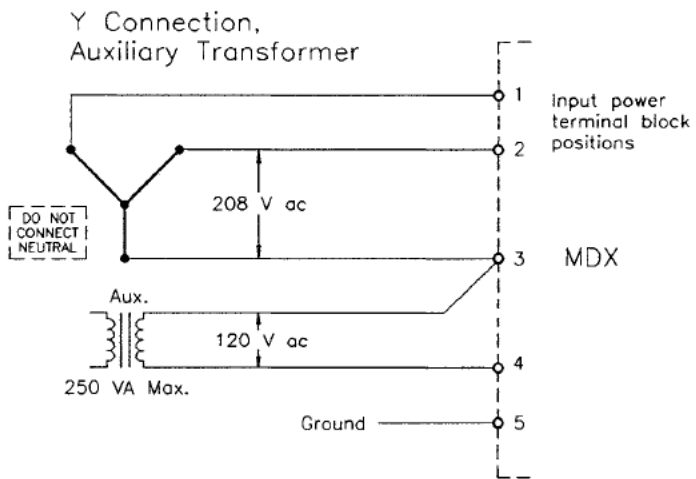
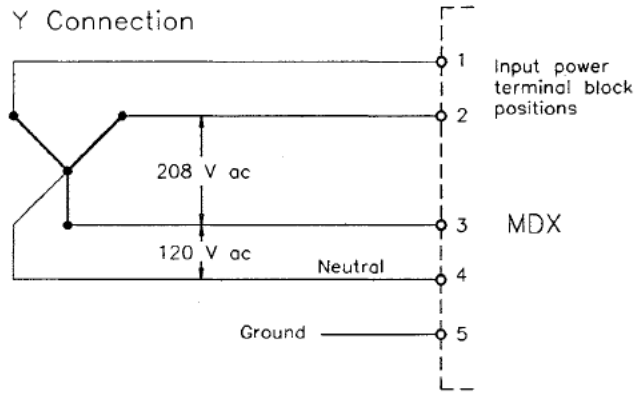

PREPARING FOR USE

Connecting the Output

A female UHF-type output connector is standard on the MDX. The output connection is made by means of a male UHF-type connector (Amphenol 83-822), which AE provides. The cable for the output connection is not included with the MDX, but can be purchased from AE separately.

Upon request, a two-pin terminal block is also available.

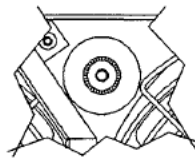

UHF, Female (provided)

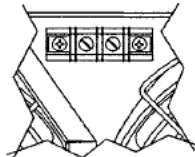

Terminal Block (optional)

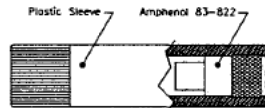

Sleeve Assembly (provided)

Connecting for Host-remote Control

Connect a computer to the Host port for host-remote control of the MDX. Connect *Host pin 6 (DSR.D)* to *Host pin 7 (COM.D)* ; connect *Host pin 2 (TXD.D)* to *pin 3* of the connector on the host controller; connect *Host pin 3 (RXD.D)* to *pin 2* of the connector on the host controller. Make sure the **MODE** key switch is set to **PROG** or **LOCK**. A pin-description table is on page 2-10.

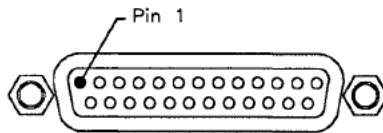

Connecting for User-remote Control

Control is given to the User port if the **MODE** key switch is set to **PROG** or **LOCK** and one or more of the **REMOTES** switches is selected. A detailed description of each signal begins on the next page. Following that are several wiring diagrams that illustrate three- and two-wire control, external output monitoring, external ramp timer and setpoint programming, the normal interlock connection, and the "cheater" plug.

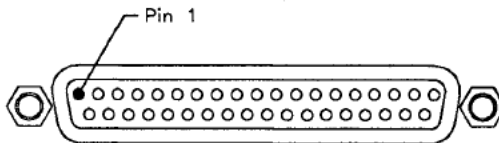

YOU SHOULD KNOW...



A quick-reference pin-description table for this port is on pages 2-8 and 2-9.

PREPARING FOR USE

Signal Descriptions: User I/O Pins

pin 1. $\overline{CS1.D}$. This 0-15 V output signal, in conjunction with *pin 20 ($\overline{CS2.D}$)* tells an external device (such as the Advanced Energy® cathode-switching box) which of three (possibly four, depending on the external device) target-life counters the MDX has been set to decrement (as specified from either the control panel or *User pins 4, 34, and 35*). This signal will sink 35 mA, and should be referenced to *OUT COM.D (pin 37)*. It is internally pulled up to 15 V through a 10-k Ω resistor, and its impedance is 100 Ω .

Target-life Counter	Condition of Signal	
	<u>pin 1</u>	<u>pin 20</u>
0	high	high
1	low	high
2	high	low
3	low	low

pin 2. $\overline{OUTPUT.D}$. When high, this 0-15 V output signal indicates that the output is off (and that the contactor is open if **contactor hold** has not been selected). When low, it indicates that output is on (and that the contactor is closed, whether or not **hold contactor** has been selected) and will ramp up to whatever setpoint has been specified (the **OUTPUT LED** on the front panel will also light). It will sink 35 mA, and should be referenced to *OUT COM.D (pin 37)*. It is internally pulled up to 15 V through a 10-k Ω resistor, and its impedance is 100 Ω .

pin 3. $\overline{SETPOINT.D}$. This 0-15 V output signal indicates that the output is equal to the requested setpoint by going low (the **SETPOINT LED** on the front panel will also light). It will sink 35 mA, and should be referenced to *OUT COM.D (pin 37)*. It is internally pulled up to 15 V through a 10-k Ω resistor, and its impedance is 100 Ω .

pin 4. $TARGET 0.D$. This input signal, in conjunction with *pins 35 and 34 ($TARGET 1.D$ and $TARGET 2.D$)*, allows an external source to specify which target-life counter the MDX should decrement. It should be referenced to *IN COM.D (pin 36)*. **Note:** An open input defaults to high (15 V); a shorted input is a low (0 V \pm 0.5 V).

pin 5. $I REG.D$. When the MDX is in remote-level control, this input signal is used in conjunction with *pin 6 ($P REG.D$)* to set the method of output



PART II

regulation (see page 4-3), or to transfer control to the control panel or host (whichever interface is active). An open input defaults high to 15 V; a low input is $0\text{ V} \pm 0.5\text{ V}$. It should be referenced to *IN COM.D* (pin 36).

pin 6. P REG.D. When the MDX is in remote-level control, this input signal is used in conjunction with *pin 5 (I REG.D)* to set the method of output regulation (see page 4-3), or to transfer control to the control panel or host (whichever interface is active). An open input defaults high to 15 V; a low input is $0\text{ V} \pm 0.5\text{ V}$. It should be referenced to *IN COM.D* (pin 36).

pin 7. $\overline{ON.D}$. This input signal is used to turn on output from the user-remote interface. **REMOTES ON** must first have been selected from the control panel (or SE<cr> (see page 2-36) must have been sent from a host controller), which transfers control to *ON.D*. Momentary closure between *ON.D* and *IN COM.D* (pin 36) will turn on output power if *OFF.D* is connected to *IN COM.D* (see page 3-23).

pin 8. OUT OF SETPOINT.D. This is an input signal from a slave unit. The master MDX is provided with information on whether the slave is operating at setpoint or not. (See pages 4-49 through 4-51 for a discussion of master/slave operation.)

pin 9. OUT COM.A. This signal is a dedicated return to internal system ground, then to chassis ground, and finally to protective earth/ground. All analog outputs should be referenced to this pin.

pin 10. IN COM.A. This signal is a dedicated return to internal system ground, then to chassis ground, and finally to protective earth/ground. All analog inputs should be referenced to this pin.

pin 11. $\overline{AUX.D}$. This input signal, in conjunction with *$\overline{VAC.D}$* (pin 12) and *$\overline{WATER.D}$* (pin 13), monitors the system interlock string. If the interlock conditions are not all satisfied (auxiliary, vacuum, and water), either 1) the main contactor will not close, or 2) if the contactor is already closed, it will open when the interlock string is interrupted. In addition, the appropriate status LED (**WATER, VACUUM, AUXILIARY**) will flash and an alarm will sound from the control panel. This pin should be referenced to *INTLK COM.D* (pin 19).

pin 12. $\overline{VAC.D}$. See discussion of *pin 11 ($\overline{AUX.D}$)*.

pin 13. $\overline{WATER.D}$. See discussion of *pin 11 ($\overline{AUX.D}$)*.

pin 14. OFF.D. When high, this input signal overrides all commands and forces the MDX to shut off output power, opens the main contactor (unless **contactor hold** has been selected), resets interlocks, and silences all alarms except the one indicating that target life has ended. This signal performs the

PREPARING FOR USE

same function as does the **OUTPUT OFF** switch on the front panel, unless **contactor hold** has been selected. It should be referenced to *IN COM.D* (pin 36).

pin 15. RESTORE.D. This 0-15 V input signal must be low to clear the "EOFF" message (caused by pressing the **EMERGENCY STOP** button). Once the message is cleared, you can reset the MDX (press **OUTPUT OFF** or toggle *OFF.D* (pin 14) high, then low).

pin 16. REMOTE CONTACTOR HOLD.D. This input signal is used to request **contactor hold**. When this signal is high, the main and soft start contactors will close and open as output is turned on and off; when it is low, the contactors will remain closed after the first time the dc bus is energized, regardless of whether output is being produced or not. It is internally pulled up to 15 V through a 10-k Ω resistor.

pin 17. unassigned.

pin 18. 15 V. This signal supplies 15 V dc to the status LEDs on passive displays (both master and slave units). It will source a maximum of 100 mA.

pin 19. INTLK COM.D. This common is used interchangeably with *INCOM.D* (pin 36). It is a dedicated return to internal system ground, then to chassis ground, and finally to protective earth/ground. We recommend that all signals in the interlock string be referenced to this pin.

pin 20. CS2.D. This 0-15 V output signal, in conjunction with *pin 1 (CS1.D)*, tells an external device (such as the Advanced Energy® cathode-switching box) which of the target-life counters the MDX has been set to decrement (as specified from either the control panel or *User pins 4, 34, and 35*). This signal will sink 35 mA, and should be referenced to *OUT COM.D* (pin 37). It is internally pulled up to 15 V through a 10-k Ω resistor, and its impedance is 100 Ω .

Target-life Counter	Condition of Signal	
	<u>pin 1</u>	<u>pin 20</u>
0	high	high
1	low	high
2	high	low
3	low	low



PART II

pin 21. $\overline{ARC.D}$. This 0-15 V output signal will go low whenever an arc is detected at the MDX output and will remain low until the arc is cleared (and the software has had time to acknowledge this fact). It will sink 35 mA, and should be referenced to *OUT COM.D (pin 37)*. It is internally pulled up to 15 V through a 10-k Ω resistor, and its impedance is 100 Ω .

pin 22. $\overline{EOTL.D}$. This 0-15 V output signal goes low when the target-life counter reaches zero, thus indicating that target life has ended ("end of target life"). The **TARGET LIFE** LED will also flash. This signal will sink 75 mA, and should be referenced to *OUT COM.D (pin 37)*. It is internally pulled up to 15 V through a 10-k Ω resistor, and its impedance is 100 Ω .

*pin 23. *V OUT.A*.* This output provides a fully buffered 0-5 V signal representing output voltage: $5\text{ V} \pm 2\% = 1000\text{ V dc}$ for standard Z and low Z models or 1250 V dc for high Z models. It should be referenced to *OUT COM.A (pin 9)*; its impedance is 100 Ω . When the open circuit output voltage is 1600 V dc, the voltage on *pin 23* is 8 V dc. It will sink and source 50 mA.

*pin 24. *P OUT.A*.* This output provides a fully buffered 0-5 V signal representing output power: $5\text{ V} \pm 2\% =$ maximum rated output for the supply (5000 W for an MDX 5K, 10,000 W for an MDX 10K, etc., see table on page 1-19). It should be referenced to *OUT COM.A (pin 9)*; its impedance is 100 Ω . It will sink and source 50 mA.

*pin 25. *I OUT. A*.* This output provides a fully buffered 0-5 V signal representing output current the supply can produce ($5\text{ V} \pm 2\% = 10\text{ A}$ for a standard MDX 5K, 20 A for a standard MDX 10K, etc., see table on page 1-21). It should be referenced to *OUT COM.A (pin 9)*; its impedance is 100 Ω . It will sink and source 50 mA.

*pin 26. *RAMP IN.A*.* This input signal is used to remotely program ramp time (see Fig. 3-8, page 3-25). A span of 0-5 V corresponds to ramp time: 5 V = maximum ramp time (10 min. $\pm 1\%$) when **REMOTES RAMP** has been selected on the front panel. This signal should be referenced to *IN COM.A (pin 10)*.

*pin 27. *LEVEL IN.A*.* This input signal is used to remotely program the output level (see Fig. 3-8, page 3-25). A span of 0-5 V corresponds to output: When **REMOTES LEVEL** has been selected on the control panel, 5 V = actual maximum output level (10 A, 1000 V, 5 kW for a standard MDX 5K; 20 A, 1000 V, 10 kW for a standard MDX 10K, etc.) $\pm 2\%$, or $\pm 0.2\%$ of the maximum output level, whichever is greater. This signal should be referenced to *IN COM.A (pin 10)*.

pin 28. unassigned.

PREPARING FOR USE

pin 29. AUX I OUT.A. This output is specifically provided to drive a slave unit (see pages 4-49 through 4-51 for details on master/slave operation). It provides a fully buffered 0-5 V signal representing output current the supply can produce (10 A for a standard MDX 5K, 20 A for a standard MDX 10K, etc., see page 1-21). It will source and sink 5 mA through a 2-k Ω resistor. It should be referenced to *OUT COM.A (pin 9)*; its impedance is 100 Ω .

pin 30. KWH OUT.A. This output provides a fully buffered 0-5 V signal representing the amount of kilwatt-hours remaining in the target life: 5 V \pm 2% = 1000 kWh (updated in 1-kWh increments). It will source and sink 5 mA through a 2-k Ω resistor. It should be referenced to *OUT COM.A (pin 9)*; its impedance is 100 Ω .

pin 31. LEVEL OUT.A. This output provides a fully buffered 0-5 V signal representing the magnetron drive's programmed setpoint level: 5 V = maximum setpoint. It will source and sink 5 mA through a 2-k Ω resistor. It should be referenced to *OUT COM.A (pin 9)*; its impedance is 100 Ω . **Note:** Setpoint level can only be measured if the output is on.

pin 32. REF.A. This output signal provides an accurate 5 V reference (5 V \pm 10 mV). It should be referenced to *IN COM.A (pin 10)*; its impedance is 100 Ω . **Note:** Limit current to 5 mA.

pin 33. unassigned.

pin 34. TARGET 2.D. This input signal is used in conjunction with *pins 4* and *35 (TARGET 0.D and TARGET 1.D)* to specify one of eight possible targets. The MDX microprocessor uses this information to keep track of the kilowatt usage for all eight targets. **Note:** An open input defaults to high (15 V); a shorted input is a low (0 V \pm 0.5 V).

pin 35. TARGET 1.D. This input signal is used in conjunction with *pins 4* and *34 (TARGET 0.D and TARGET 2.D)* to specify one of eight possible targets. The MDX microprocessor uses this information to keep track of the kilowatt usage for all eight targets. **Note:** An open input defaults to high (15 V); a shorted input is a low (0 V \pm 0.5 V).

pin 36. IN COM.D. This common is used interchangeably with *INTLK COM.D (pin 19)*. It is a dedicated return to internal system ground, then to chassis ground, and finally to protective earth-ground. We recommend that all digital inputs, except the interlock signals, be referenced to this pin.

pin 37. OUT COM.D. This signal is a dedicated return to internal system ground, then to chassis ground, and finally to protective earth-ground. All digital outputs should be referenced to this pin.

Wiring Options

Three-wire Control

If you want to use both an on switch and an off switch, select this wiring option (see Fig. 3-5). Momentary contact of $\overline{ON.D}$ (pin 7) with *IN COM.D* (pin 36, ground) will cause output to turn on. However, *OFF.D* (pin 14) must be pulled low before output can be turned on. You can prevent output from coming on by letting *OFF.D* (pin 14) float high.

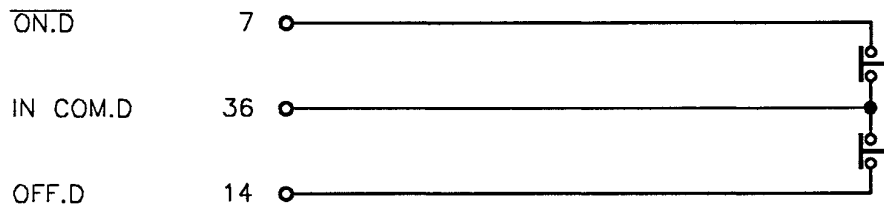

Figure 3-5. Wiring diagram for three-wire control.

Two-wire Control

You might want to connect pins 7 and 14 ($\overline{ON.D}$ and *OFF.D*) and control them as one input (see Fig. 3-6). Two-wire control is useful if your system's on/off requirements are simple. That is, if you want to use one device (such as a relay) to control the MDX rather than using one device to control the on function and one device to control the off function, this method may be more convenient for you. When pins 7 and 14 are connected to User pin 19 (*INTLK COM.D*), the output will turn on immediately after the **OUTPUT OFF** switch is released (and **REMOTES, ON** is selected).



DANGER! Remember that pressing and releasing **OUTPUT OFF** to reset the MDX will cause output to come on immediately if User pins 7, 14, and 19 are connected (thus requesting output on) and if **REMOTES, ON** is selected.

If you let User pins 7 and 14 float high while output is being produced, output will be turned off and the **OUTPUT OFF** switch LED will flash. Pressing **OUTPUT OFF** in this case will not stop the flashing. You must pull pin 14/pin 7 low to reset the unit (see warning, above).

PREPARING FOR USE

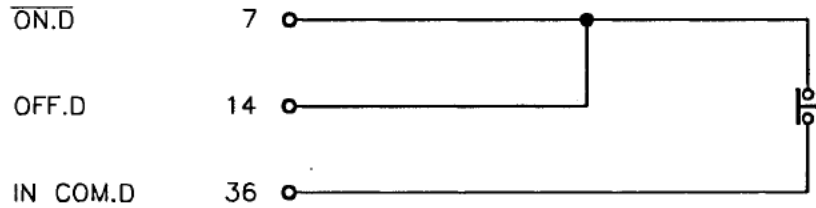

Figure 3-6. Wiring diagram for two-wire control.

External Monitoring of Output

In cases where there is no control panel or host computer, an external device can be hooked up to display what voltage, power, or current level the MDX is producing. For each of the outputs, 5 V represents full rated output (that is, for a standard MDX 5K: 1000 V, 5000 W, or 10 A; see tables on pages 1-19 and 1-21 for values produced by other models).

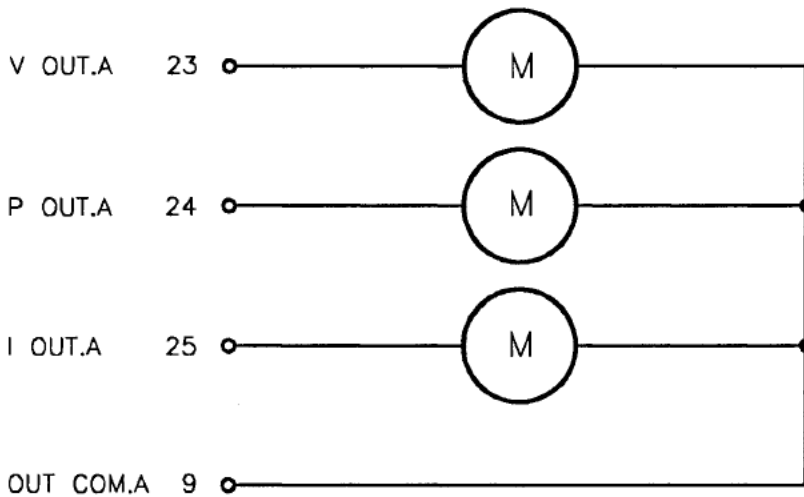

Figure 3-7. Wiring diagram for externally monitoring the output.

External Programming of Ramp Timer and Setpoint

The next figure shows how to wire the input lines so that you can specify output setpoint level and ramp time from an external source. You will also need to specify method of output regulation — see page 4-23 and read about pins 5 and 6 on pages 3-18 and 3-19.

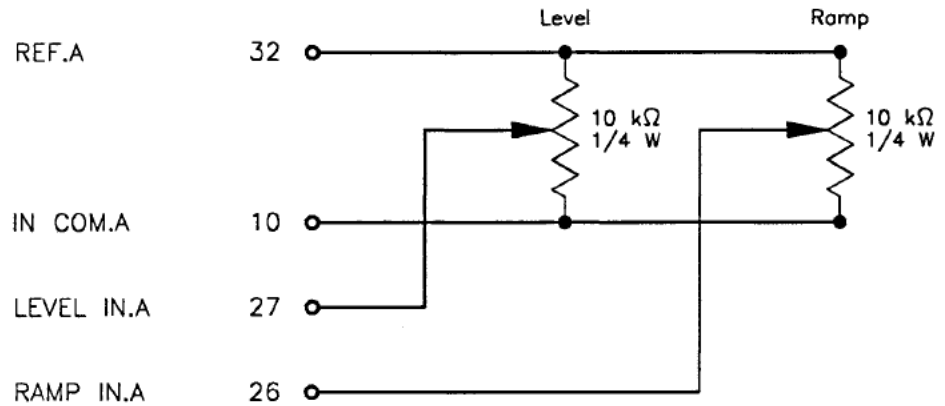

Figure 3-8. Wiring diagram for externally programming the ramp timer and the output setpoint.

Normal Interlock Connection

The following figure shows how to wire if you want to take advantage of the interlock lines by connecting them to sensors. For example, $\overline{AUX.D}$ can be used to warn if a door is open, $\overline{VAC.D}$ to indicate if the chamber contains a vacuum, and $\overline{WATER.D}$ to warn of problems with the cooling system for the magnetron. If any connection is open, the interlock string is broken and output will not come on. Similarly, if any connection opens during operation, the output will be turned off and the appropriate LED will flash.

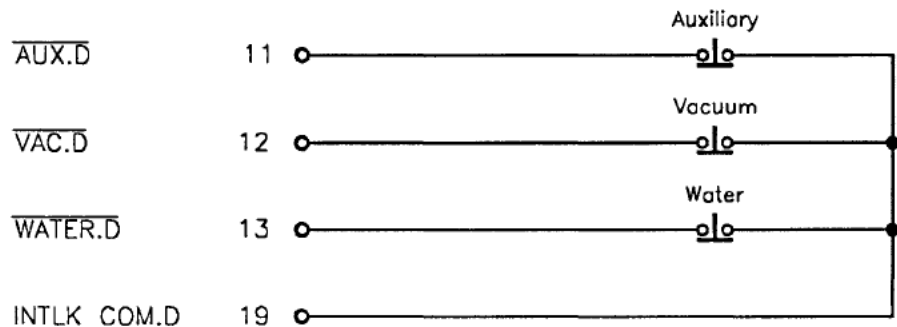
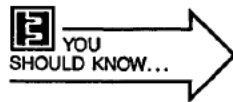

Figure 3-9. Wiring diagram for a normal interlock setup.

PREPARING FOR USE

Cheater Plug

The “cheater plug” (see Fig. 3-10) that came attached to the User connector makes it possible for you to run the MDX essentially right out of the box, without making any wiring adjustments. You can continue to use the cheater plug if you want to ignore (“cheat”) the interlock lines.



If the User port won't be used, you must leave the cheater plug attached to the MDX.



WARNING! You are defeating the interlocks if you use the cheater plug.

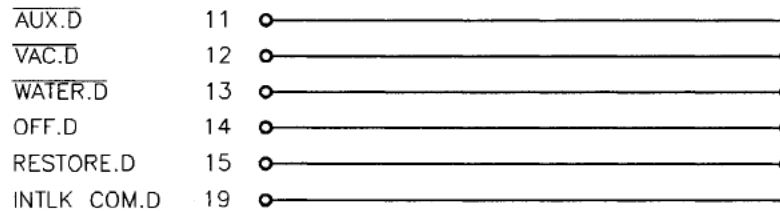
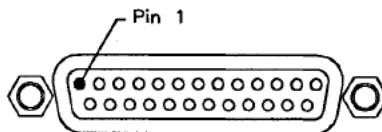

Figure 3-10. Wiring diagram for the “cheater” plug.

Connecting a Remote Control Panel

You can connect an Advanced Energy® control/display panel to your MDX with a 25-pin, female, D subminiature connector. The corresponding port on the MDX rear panel is labeled **DISPLAY**. Do not connect a remote panel to this port if your MDX has a full-function front panel.

Note that this connector was designed for connecting an Advanced Energy® standard remote control panel or minipanel only. The communications format between Advanced Energy® display panels and the MDX is different than the RS-232 host communications format. An incorrect connection could damage the MDX.



Display Bypass Plug

This plug is used with a master unit that has a passive (limited function) front panel and that has no minipanel or remote panel connected to the Display port. The display bypass plug makes connections that are necessary for the MDX to operate without a full-function control panel.

If this plug is not attached to the **DISPLAY** connector on the rear panel (for the location of this connector, see the foldouts at the end of chapter 2), the unit will not come on (it will behave as if it has a key switch set to the **OFF** position).

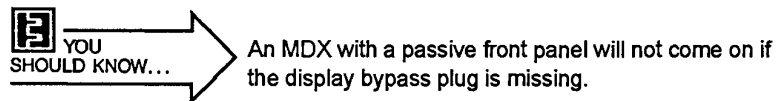

Connecting for Master\Slave Operation

A more detailed discussion of the considerations involved in operating a master/slave system is found on pages 4-49 through 4-51. The information below and on the next page is meant for quick reference only.

Connect input power to each chassis just as you would for the 10K model (refer to page 3-13).

Interconnect the master and slave units with the supplied 30-inch multi-conductor cable by attaching its 15-pin connectors to the connectors on each MDX rear panel (**INTERCONNECT MASTER** or **INTERCONNECT SLAVE**). Since the connectors on the ends of the cable are different on each end, you cannot connect them incorrectly.

Connect the MDX to the load by attaching the cable or wires (as on page 3-15 or 3-16) to the output connector on the rear panel of the master unit. Do the same for the slave unit(s). When connecting to the load, make sure that the positive conductors of both master and slave units are connected to the same point. Repeat this process for the negative conductors. (An illustration showing two properly interconnected units is in Master/Slave Operation, page 4-50.)

PREPARING FOR USE

Make sure that the tap selection is be the same for all interconnected units (see page 4-27).

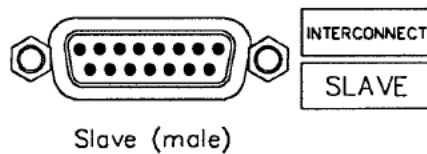
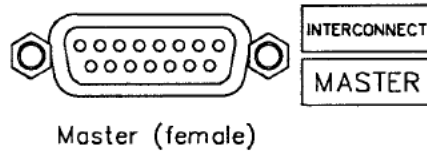

Disconnecting

Disconnect the MDX from all voltage sources before opening it for any adjustment, replacement, maintenance, or repair.



DANGER! Internal components may remain live for 1 min. after the MDX has been disconnected.

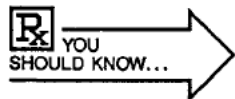

Make sure replacement fuses are of the same rating and specific type as those being replaced.

PREPARING FOR USE

FIRST-TIME OPERATION

Start-up Procedure

This procedure assumes that a control panel (standard or minipanel) is being used.

1. Make sure that the necessary external inputs are supplied (refer to signal descriptions on pages 3-18 through 3-22) or that the “cheater plug” is installed on the User connector on the rear of the MDX (see page 3-26).
2. Set the **MODE** key switch to **OFF**.
3. Connect the output connector (see details on page 3-15).
4. Turn on the breaker at rear of unit. Both monitors will display “OFF”.
5. Turn the **MODE** key switch to **LOCK**. The monitors will display zeros. The alarm will sound and the **OUTPUT OFF LED** will blink. Press **OUTPUT OFF** to silence the alarm and cause the **OUTPUT OFF LED** to stop blinking (it will still be lit).
6. Turn the **MODE** key switch to **PROG**. Select a regulation mode (**POWER**, **CURRENT**, **VOLTAGE**, see page 4-3).
7. To set ramp rate, press **RAMP** and hold while using the **MODIFY** knob. The value will be displayed on the right display. (A vernier adjustment is also available if you need to set the rate in smaller increments — see the discussion of control panel controls in the second chapter.) Release the **RAMP** switch when the desired value is reached.
8. To set output level, press **LEVEL** and hold while using the **MODIFY** knob. The value will be displayed on the right display. Release the **LEVEL** switch when the desired value is reached.



DANGER! The next step will result in high voltage levels at the output connector. Take appropriate steps to prevent electrical shock.



PART II

9. Press **ON**. The main contactor will close, the **ARC** LED will momentarily light, and the **OUTPUT**, **RAMP**, and **PLASMA** LEDs will light. The output will ramp to the selected setpoint level, causing the **RAMP** LED to go out, the **SETPOINT** LED to light, and the end-of-ramp alarm to sound.

10. Press the **OUTPUT OFF** switch any time to turn off output.

CHOOSING MODES/SETTINGS

CONTENTS

Output Regulation	4-5
Power	4-3
Current	4-3
Voltage	4-4
Program Mode	4-5
Target Controls	4-5
Setpoints and Timers	4-9
Setpoint Level	4-9
Ramp Timer	4-10
Pausing During a Ramp	4-11
Run Timer	4-15
Out-of-setpoint Timer	4-16
Lock Mode	4-19
Remotes	4-21
Host	4-10
User	4-23
Level	4-23
Ramp	4-24
On/Off	4-24
Target	4-24
Tap Selection	4-27
Tap-changing Procedure—Detailed	4-37
Tap-changing Procedure—Abbreviated	4-43
Impedance Options	4-45
Line Voltage Changes	4-47
Master/Slave Operation	4-49
Setpoint LEDs	4-51

CHOOSING MODES/SETTINGS

OUTPUT REGULATION

The product of the MDX magnetron drive is referred to generically as "output" throughout this manual because it is possible to regulate power, current, or voltage. You can choose one of these three methods of output regulation at any time without disturbing the output.

If you switch from one method of regulation to another **while output is on**, the appropriate level at the instant of change will become the new setpoint. For example: If the MDX is regulating power and the setpoint level is 1500 W (voltage level is 500 V and current level is 3 A), and you select voltage regulation, the new setpoint will be 500 V. If you switch method of regulation **while output is off**, however, the setpoint will be set to zero.

Method of regulation can be selected from any active interface. See page 4-23 for User port control and page 4-21 for Host port control.

Power

Power regulation is selected from the control panel by pressing the **POWER** switch under the **REGULATION** label (the LED on the switch will light).

From a host computer, send the S4<cr> command (see page 2-36) to select power regulation.

From the User interface, *pin 5 (I REG.D)* must be high and *pin 6 (P REG.D)* must be low.

Current

Current regulation is selected from the control panel by pressing the **CURRENT** switch under the **REGULATION** label (the LED on the switch will light).

From a host computer, send the S5<cr> command (see page 2-36) to select current regulation.

From the User interface, *pin 5 (I REG.D)* must be low and *pin 6 (P REG.D)* must be high.



PART II

Voltage

Voltage regulation is selected from the control panel by pressing both the **POWER** and **CURRENT** switches under the **REGULATION** label (both LEDs on the switches will light).

From a host computer, send the S6<cr> command (see page 2-36) to select voltage regulation.

From the User interface, both *pin 5 (I REG.D)* and *pin 6 (P REG.D)* must be high.

CHOOSING MODES/SETTINGS

PROGRAM MODE

Program mode is selected by turning the **MODE** key switch on the control panel to **PROG**, and provides full access to all functions, settings, and parameters.

Mode of control cannot be specified from either the Host or the User interface.

Target Controls

Target control functions allow you to choose from one of eight target-life counters, set the timer (target life), and monitor the kilowatt-hours left on the timer.

Control Panel

For a detailed discussion of the controls, see pages 2-25 through 2-30; for explanations of the various LEDs, see pages 2-15 through 2-22.

To see what target-life counter is active:

- Make sure the LED is lit on the **RIGHT DISPLAY, ACTUAL** switch (press this switch if the LED is not lit).
- Toggle to the **KWH** LED on the right meter with the **RIGHT DISPLAY, ACTUAL** switch (on the minipanel: the **DISPLAY** switch affects the bottom meter).
- Press the **SETPT** switch momentarily (the LED on the switch will light).

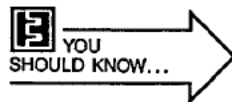

If the displayed target number was selected from the User port, it will be preceded by a hyphen (no -0)

To select a target-life counter:

- Make sure output is off.
- Press and hold the **TARGET** switch.
- Press the **SETPT** switch momentarily.
- Use the **MODIFY** knob to choose 0-7.
- Release the **TARGET** switch.



To quickly see how much time remains on the active target-life counter:

- Press and hold the **TARGET** switch.

To continuously display the time remaining on the active target-life counter:

- Press the **RIGHT DISPLAY, ACTUAL** switch if the LED on this switch is not already lit.
- Toggle to the **KWH** LED on the right meter with the **RIGHT DISPLAY, ACTUAL** switch (on the minipanel: the **DISPLAY** switch affects the bottom meter).

To set the selected target-life counter:

- Press and hold the **TARGET** switch.
- Use the **MODIFY** knob to enter a value (1-9900 kWh).
- Release the **TARGET** switch.

When the programmed target life ends (i.e., when the counter reaches zero), the **TARGET LIFE** status indicator LED (see page 2-16) will flash and an alarm will sound from the control panel.

- Press the **TARGET** switch momentarily to silence the alarm (the LED will continue to flash).
- Enter another target-life value (see previous page) or disable the function by turning the **MODIFY** knob to the left until four hyphens (—) appear on the right (or bottom) meter.

Host Interface

Three requests for data (see table on page 2-34) elicit information relating to target control functions:

- **G<cr>** — The fourth digit in the response to this command is the number of the selected target-life counter.
- **T<cr>** — The response to this command will tell you how many kilowatt-hours remain on the selected target-life counter.
- **U<cr>** — The fourth digit in the response to this command is the number of the selected target-life counter; the third digit indicates how the target-life counter was selected (see page 2-35 for more detail).

Two variable-setting commands (see table on page 2-38) affect target control functions:

- **TDDDD<cr>** — This command sets the kilowatt-hours for the selected target-life counter.
- **UDDDD<cr>** — This command selects one of eight target-life counters (0-7).

CHOOSING MODES/SETTINGS

User Interface

You cannot set the target-life counter from this port; however, you can specify which target-life counter (0-7) is active.

Use *pins 4, 34, and 35* to select a target-life counter (see detailed descriptions of User pins beginning on page 3-18). The following table details how to select a counter.

Target-life Counter	Condition of Signal		
	<i>pin 34</i>	<i>pin 35</i>	<i>pin 4</i>
0	high	high	high
1	high	high	low
2	high	low	high
3	high	low	low
4	low	high	high
5	low	high	low
6	low	low	high
7	low	low	low

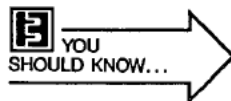

A target-life counter selected with the User pins will be active when -0 is selected from the control panel with the MODIFY knob.

Parameters that can be monitored from the User port are:

Parameter	User pins
The number of the active target-life counter (0-3)	<i>pins 1 and 20</i>
Whether programmed target life has ended	<i>pin 22</i>
The amount of time remaining on the target-life counter	<i>pin 30</i>

CHOOSING MODES/SETTINGS

Setpoints and Timers

Setpoint Level

You can program an output setpoint level whether or not output is being produced. If you change method of output regulation (see page 4-3) while output is off, the previously entered setpoint will be lost. If, however, you change method of output regulation while output is on, the appropriate level at the instant of change will become the new setpoint.

Control Panel:

If output is off:

1. Press the **LEVEL** switch and hold. The LEDs on the **LEVEL** switch and **SETPT** switch will light.
2. Use the **MODIFY** knob to specify the desired setpoint level (displayed on the right, or bottom, meter).
3. Release the **LEVEL** switch.

If output is on, and ramp is over:

1. The LED on the **LEVEL** switch will light, indicating that the setpoint level can be modified without pressing the **LEVEL** switch.
2. Use the **MODIFY** knob to specify the desired setpoint level (displayed on the right, or bottom, meter when the **SETPT** switch LED is lit).

The **SETPOINT** status indicator LED (see page 2-15 or 2-16) lights when output is equal to the programmed setpoint; it flashes (and alarm sounds) when the output is not equal to the programmed setpoint. This LED only lights or flashes when the **PLASMA** LED is lit.

Host Interface:

Five requests for data (see table on page 2-34) elicit information relating to actual output and setpoint levels:

- **I<cr>** — The response to this command will tell you how much current is actually being produced at that moment.
- **V<cr>** — The response to this command will tell you how much voltage is actually being produced at that moment.
- **W<cr>** — The response to this command will tell you how much power is actually being produced at that moment.
- **L<cr>** — The response to this command will tell you what the output setpoint level is for the selected method of output regulation.
- **Z<cr>** — The response to this command will tell you the maximum output level that is possible for this MDX model.



The variable-setting command (see table on page 2-38) used to set output level:

- **LDDDD<cr>** — This command sets the output setpoint for the selected method of output regulation.

Two other commands (“S” commands, see page 2-36) relate to the output setpoint:

- **SA<cr>** — This command transfers control of setpoint and method of output regulation from the Host port to the User port.
- **SB<cr>** — This command transfers control of setpoint and method of output regulation from the User port to the Host port.

User Interface:

Both setpoint level and method of output regulation can be specified when **REMOTES, LEVEL** is selected from the control panel (see page 2-29) or the **SC<cr>** command is sent from a host controller (see page 2-36).

Pin 27 (LEVEL IN.A) is used to program output setpoint level (see detailed signal description on page 3-21).

Parameters that can be monitored from the User port are:

Parameter	User pins
Setpoint level	<i>pin 31</i>
Whether programmed output setpoint level has been attained	<i>pin 3</i>

Ramp Timer

You can program the amount of time (600 ms - 99 min.; also see discussion of **fast ramp**, page 5-5) the MDX will take to reach the programmed output setpoint from the control panel, a host controller, or the User port. You can cause a ramp to pause and modify the output level from the control panel (see page 4-11). You can request a ramp pause and modify the output level from a host controller (see pages 4-11 and 4-12). You cannot cause a ramp to pause from the User port.

Control Panel:

1. Press and hold the **RAMP** switch. The LEDs on the **RAMP** switch and the **SETPT** switch will be statically lit, as will the **MINUTES** LED associated with the right, or bottom, meter.
2. Use the **MODIFY** knob to alter the ramp time displayed on the right, or bottom, meter.
3. Release the **RAMP** switch.

Host Interface:

CHOOSING MODES/SETTINGS

Three requests for data (see table on page 2-34) elicit information relating to the ramp timer:

- M<cr> — The response to this command will tell you how much time remains in the ramp (after the ramp is completed, run time will be displayed in response to this command).
- P<cr> — The response to this command will tell you what the output level is during the ramp, at that moment.
- R<cr> — The response to this command will tell you how much time has been programmed into the ramp timer.

The variable-setting command (see table on page 2-38) used to set the ramp timer:

- RDDDD<cr>

Two other commands ("S" commands, see page 2-36) relate to the ramp timer:

- SC<cr> — This command transfers control of the ramp timer from the Host port to the User port.
- SD<cr> — This command transfers control of the ramp timer from the User port to the Host port.

Pausing During a Ramp

If output is being produced, and a ramp is in progress, you can cause the ramp to pause (Fig. 4-1). The MDX will continue to produce output at the level it had reached when the pause was requested. During the ramp pause you can change the value of the output level (from 0 to the maximum output for your unit). The MDX will immediately produce output at whatever level you specify (see Figs. 4-2, 4-3, and 4-4).

When the pause is released, the MDX will respond in one of two ways. If the new output level is at the programmed setpoint or above it, the MDX will assume that the ramp is over (Figs. 4-2 and 4-3). If the new level is below the programmed setpoint (Fig. 4-4), the MDX will use whatever programmed ramp time remains to reach the setpoint (see Setpoint Level, page 4-9).

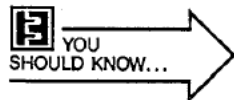

You cannot cause a ramp to pause from the User interface.

Control Panel:

1. Press the **LEVEL** switch and release. The LEDs on the **LEVEL** switch, **SETPT** switch, and **RAMP** switch will flash, indicating that ramp pause is active.
2. Use the **MODIFY** knob to alter the output level displayed on the right, or bottom, meter (do not confuse this value with the programmed setpoint level).
3. Press the **LEVEL** switch again to resume the ramp from the newly specified output level.

Host Interface:

1. Send the S2<cr> command to pause the ramp.
 - 1a. Optional: Use LDDDD<cr> command to request a new setpoint.
2. Send the S3<cr> command to resume the ramp.

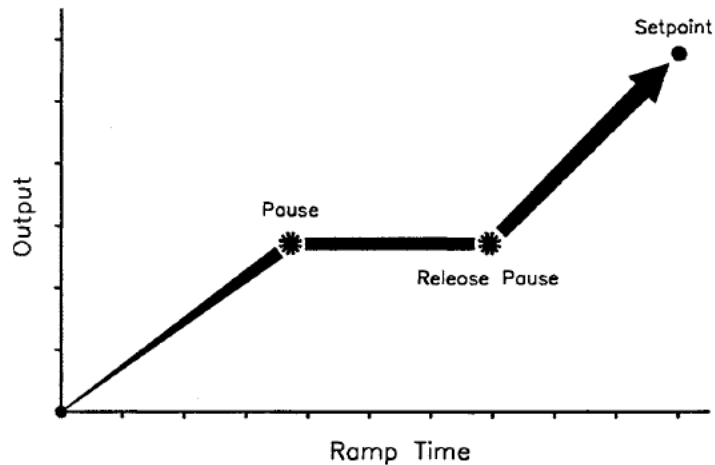
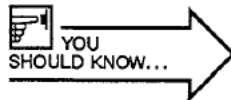

Figure 4-1. Graphic representation of a ramp pause; no adjustment to the output level is made during the pause.



You can disable the ramp timer by turning the **MODIFY** knob to the left until four hyphens (—) appear on the meter.

During a ramp the timer counts down and the **MINUTES** LED will be statically lit (during a run the timer counts up and the **MINUTES** LED will flash).

CHOOSING MODES/SETTINGS

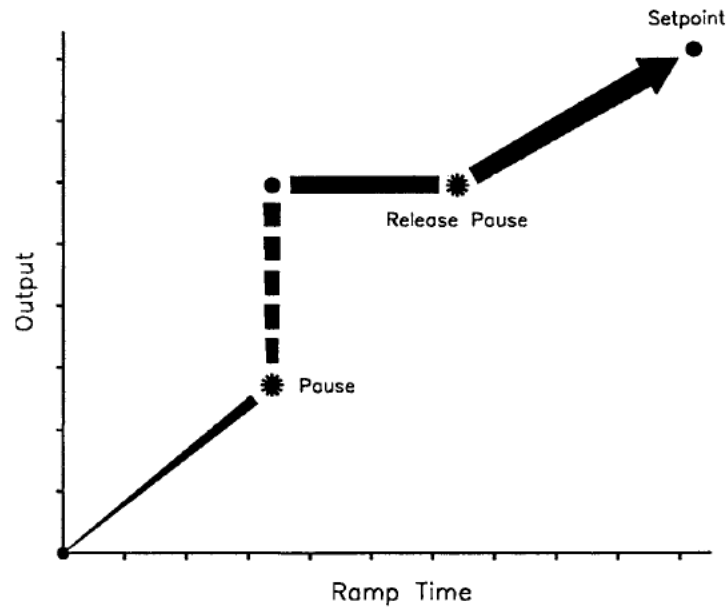

Figure 4-2. Graphic representation of a ramp pause; the output level has been adjusted upward during the pause, but is still lower than the setpoint.

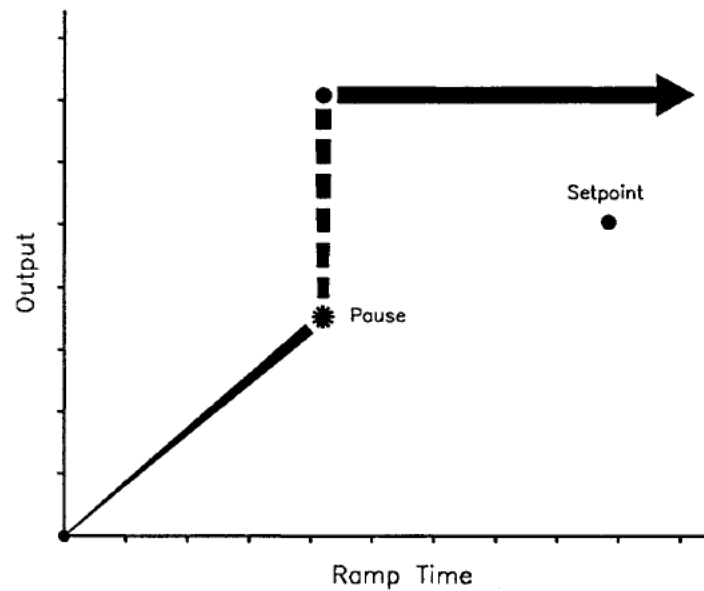

Figure 4-3. Graphic representation of a ramp pause; the output level has been adjusted during the pause so that it is greater than the original setpoint.

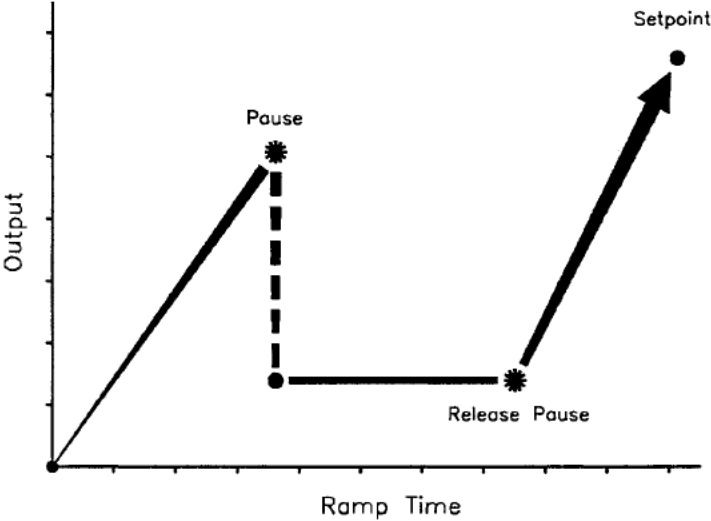

Figure 4-4. Graphic representation of a ramp pause; the output level has been adjusted downward during the pause.

CHOOSING MODES/SETTINGS

Run Timer

The MDX can be programmed from the control panel or a host controller to shut off output after running for a specified amount of time (0.01-99 min.). The run timer cannot be set from the User port.

Control Panel:

1. Press and hold the **RAMP** switch. The LED on the **RAMP** switch will light.
2. Momentarily press the **SETPT** switch. The LED on the **RAMP** switch will go out and the LED on the **SETPT** switch will flash, as will the **MINUTES** LED associated with the right, or bottom, meter.
3. Use the **MODIFY** knob to alter the run-time value (up to 99 min.), displayed in hundredths of minutes on the right, or bottom, meter.
4. Release the **RAMP** switch.

At the end of the programmed run time, output will be turned off, the LED on the **OUTPUT OFF** switch will flash, and an alarm will sound. Pressing **OUTPUT OFF** will stop the flashing and silence the alarm.

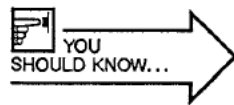

You can disable the run timer by turning the **MODIFY** knob to the left until four hyphens (—) appear on the meter.

During a run the timer counts up and the **MINUTES** LED will flash (during a ramp the timer counts down and the **MINUTES** LED will be statically lit).

Host Interface:

Two requests for data (see table on page 2-34) elicit information relating to the run timer:

- **J<cr>** — The response to this command will tell you how long the MDX will run before output is automatically shut off.
- **M<cr>** — After the ramp is over, the response to this command will tell you how long the MDX has been producing output (since the ramp ended).

The variable-setting command (see table on page 2-38) used to set the run timer:

- **JDDDD<cr>**

Out-of-setpoint Timer

This timer is used to control the amount of time that the MDX can produce output that is not equal to the programmed setpoint level. If it can't reach or maintain the programmed level within the specified 0.01 to 2.55 min. (the timer begins after any ramp is completed), it will shut off output. This timer cannot be programmed from the User port.

Control Panel:

1. Press and hold the **CURRENT** switch. The LED on the **CURRENT** switch will light.
2. Momentarily press the **SETPT** switch. The LED on the **SETPT** switch will flash, as will the **AMPS** and **MINUTES** LEDs associated with the right, or bottom, meter.
3. Use the **MODIFY** knob to alter the value displayed on the right, or bottom, meter.
4. Release the **CURRENT** switch.

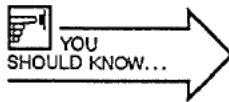

You can disable the out-of-setpoint timer by turning the **MODIFY** knob to the left until four hyphens (—) appear on the meter. This allows an out-of-setpoint condition to be continued indefinitely.

If output has been shut off because the programmed setpoint level could not be reached or maintained in the specified amount of time:

- "FAIL" will be displayed on the left, or top, meter
- "E-12" (see page 2-23) will be displayed on the right, or bottom, meter
- the **OUTPUT OFF** switch LED will flash
- an alarm will sound

Press the **OUTPUT OFF** switch to clear the messages, stop the flashing, and silence the alarm.

CHOOSING MODES/SETTINGS

Host Interface:

Two requests for data (see table on page 2-34) elicit information relating to the out-of-setpoint timer:

- Q<cr> — The response to this command will tell you how much time the MDX will operate out of setpoint before it shuts off the output.
- K<cr> — The response to this command will indicate if an out-of-setpoint shutdown has occurred.

The variable-setting command (see table on page 2-38) used to set the out-of-setpoint timer:

- QDDDD<cr>

CHOOSING MODES/SETTINGS

LOCK MODE

When the **MODE** key switch is set to **LOCK**, operation from a control panel is restricted to turning output on and off, selecting and viewing the displays available on the digital meters, and running the test function. All setpoint values, the method of output regulation, and the active interface that were specified in program mode are retained, but cannot be changed.

All functions are still available from the User interface, providing **LEVEL**, **RAMP**, and/or **ON** were selected from the control panel before the key switch was set to **LOCK**. All functions are also still available from the Host interface (including the ability to give control of specific functions to the User interface).

CHOOSING MODES/SETTINGS

REMOTES

Host

The Host port is enabled when the **REMOTES, HOST** switch LED is lit, *Host pin 6* is low, and the **MODE** key switch is set to **PROG** or **LOCK**. If you have a control/display panel, press the **REMOTES, HOST** switch, causing its LED to light. You can “force” host-remote control from the host computer with the `S8<cr>` command (see page 2-36).

All of the functions that are available from the control panel are also available through the host-remote interface, including transferring control among the interfaces if you are also using a control panel and/or the User port. A more detailed description of these functions can be found in the Program Mode section, which begins on page 4-5.

See page 2-33 for transmission parameters and conditions that must be satisfied. The pin-description table for the Host port appears on page 2-10.

Several commands can be used 1) to elicit a variety of status information from the MDX (see page 2-34), 2) to set variables (see page 2-38) such as output setpoint or amount of ramp time, and 3) to control MDX functions (see page 2-36).

CHOOSING MODES/SETTINGS

User

With a control/display panel, control is given to the User port when the **MODE** key switch is set to **PROG** or **LOCK** and when the **LEVEL**, **RAMP**, and **ON** switches under **REMOTES** are all selected. Partial control can be given to the User port by selecting only one or two of these switches.

The active target-life counter can always be specified with the appropriate User pins. The target-life counter specified with the User pins will become active if the number requested either from the control panel or the host computer is -0 (however, target 0 is the default if no target-life counter has been selected from the User port).

Level

From the control panel, press **REMOTES**, **LEVEL** to transfer control of the method of output regulation (*pins 5 and 6*) and output setpoint level (*pin 27*) to the User port (see detailed description of User pins beginning on page 3-18). From the Host interface, use command **SA<cr>** to transfer control of these parameters to the User port (see "S" commands, page 2-36).

- To select voltage regulation, both *pin 5 (I REG.D)* and *pin 6 (P REG.D)* must be high.
- To select power regulation, *pin 5 (I REG.D)* must be high and *pin 6 (P REG.D)* must be low.
- To select current regulation, *pin 5 (I REG.D)* must be low and *pin 6 (P REG.D)* must be high.

<u>Method of Output Regulation</u>	<u>Condition of Signal</u>	
	<u>pin 5</u>	<u>pin 6</u>
voltage	high	high
power	high	low
current	low	high
transfers control of this parameter from the User interface to the control panel or host computer (whichever interface is active)	low	low

- Use *pin 27 (LEVEL IN.A)* to set the desired output level.
- Use *pin 31 (LEVEL OUT.A)* to monitor the output level.

Ramp

From the control panel, press **REMOTES, RAMP** to transfer control of the ramp timer (*pin 26*) to the User port (see detailed description of User pins beginning on page 3-18). From the Host interface, use command **SC<cr>** to transfer control of this parameter to the User port (see “S” commands, page 2-36).

- Use *pin 26 (RAMP IN.A)* to set the timer.

On/Off

From the control panel, press **REMOTES, ON** to transfer control of **output on/off** (*pins 7 and 14*) to the User port (see detailed description of User pins beginning on page 3-18). From the Host interface, use command **SE<cr>** to transfer control of this parameter to the User port (see “S” commands, page 2-36).

- Use *pin 7 (ON.D)* to turn output on.
- Use *pin 14 (OFF.D)* to turn output off (see discussion of two-wire and three-wire control on page 3-23).



OFF.D will override all commands and force the MDX to shut off output power.

Target

You do not have to transfer control of target-related functions to the User port because they are always available. The exception is that a target-life value cannot be set from this interface.

User pins 4, 34, and 35 are used to specify which target-life counter is active (see table on page 4-7).

CHOOSING MODES/SETTINGS

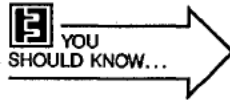

Any target-life counter previously selected with the User pins becomes active when **-0** is selected as the target-life counter from the control panel with the **MODIFY** knob.

- Use *pins 1* and *20* to check the number of the active target-life counter (0-3).
- Use *pin 22* to see if programmed target life has ended.
- Use *pin 30* to see how much time remains on the target-life counter.

CHOOSING MODES/SETTINGS

TAP SELECTION

Each MDX has three possible voltage taps so that three different output ranges can be selected for each unit. This is true whether the output transformer is a low Z, standard Z, or high Z (see table on page 4-45). The same three voltage taps are available no matter which input voltage (200 V or 208 V) has been selected.

In general each MDX leaves the factory set for its lowest tap position (tap 1), but another tap position can be requested when the unit is ordered.

The next several pages explain how to choose a different tap. Figure 4-13 (page 4-40) shows the relative positions of the printed circuit boards and logic tray.

It is well worth taking the time to figure out which specific voltage tap will work best for your process. We recommend that you run your process as close to the center of a tap range as possible — this minimizes the possibility of variations in load impedance exceeding the limits of the tap.

The chamber impedance may vary widely from process to process. If you have a wide range of chamber impedances or use a broad range of target materials, you will probably have a broad impedance range. This range may be so broad that it exceeds the possible range available with a single tap. In this case, you may actually want a supply that delivers more power than you need so that you can run all your processes without having to continually change taps. The two examples that follow, and the graphs that appear in the appendix, are intended to help you determine what will work best for your situation.

In Example 1, the impedance range fits within the limits of the tap at all power settings; in Example 2, the impedance range exceeds the limits of the tap at the desired power setting of 9.2 kW.

Example 1

The power supply in this example is an MDX 10K standard Z, the method of regulation is power, and the operating level is 9.2 kW. We have assumed typical operating voltages for both a new target and a target near the end of its useful life.

target when <i>new</i>	580 V
target at end of target life (<i>EOTL</i>)	480 V

To calculate the operating currents, use $Current = \frac{Power}{Voltage}$

current for <i>new</i> target	$\frac{9.2\text{ kW}}{580\text{ V}} = 15.86\text{ A}$
current at <i>EOTL</i>	$\frac{9.2\text{ kW}}{480\text{ V}} = 19.16\text{ A}$

Now you have the voltage range and current range for the target over its useful life. The voltage and current values for the target when it is new and then at EOTL have been plotted on Fig. 4-5 (page 4-31). Notice that the impedance at both target stages falls within the boundaries of tap 1.

You can go a step farther and calculate the impedance for the target at both stages by using the calculation $Target\ Impedance = \frac{Target\ Voltage}{Target\ Current}$

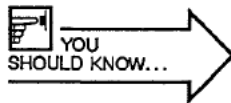

If you are specifying a new power supply, you should perform the above step first, with your current equipment. Note that these measurements are only accurate at the power level used to make them (here, 9.2 kW). Each target and its associated process parameters produce a unique environment in which the target impedance changes as the power changes. Therefore, the impedances must be determined for each target/process combination.

CHOOSING MODES/SETTINGS

$$\text{impedance for } \textit{new} \text{ target} \quad \frac{580 \text{ V}}{15.86 \text{ A}} = 36.6 \Omega$$

$$\text{impedance at } \textit{EOTL} \quad \frac{480 \text{ V}}{19.16 \text{ A}} = 25.05 \Omega$$

The impedances have been plotted on Fig. 4-6 (page 4-32); once again you can see that both impedances fall within the boundaries of the range available with tap 1. Therefore, selecting tap 1 will enable the power supply to operate throughout the life of the target at a power setting of 9.2 kW.

Example 2

The power supply in this example is an MDX 10K standard Z, the method of regulation is power, and the operating level is 9.2 kW. We have assumed typical operating voltages for both a new target and a target near the end of its useful life (this value is lower than in Example 1).

$$\text{target when } \textit{new} \quad 580 \text{ V}$$

$$\text{target at end of target life (EOTL)} \quad 450 \text{ V}$$

To calculate the operating currents, use $\text{Current} = \frac{\text{Power}}{\text{Voltage}}$

$$\text{current for } \textit{new} \text{ target} \quad \frac{9.2 \text{ kW}}{580 \text{ V}} = 15.86 \text{ A}$$

$$\text{current at } \textit{EOTL} \quad \frac{9.2 \text{ kW}}{450 \text{ V}} = 20.44 \text{ A}$$

Now you have the voltage range and current range for the target over its useful life. The voltage and current values for the target when it is new and then at EOTL have been plotted on Fig. 4-7 (page 4-33). Notice that the EOTL current, 20.44 A, is out of the range of tap 1.

You can go a step farther and calculate the impedance for the target at both stages by using the calculation $\text{Target Impedance} = \frac{\text{Target Voltage}}{\text{Target Current}}$

$$\text{impedance for } \textit{new} \text{ target} \quad \frac{580 \text{ V}}{15.86 \text{ A}} = 36.6 \Omega$$

$$\text{impedance at } \textit{EOTL} \quad \frac{450 \text{ V}}{20.44 \text{ A}} = 22 \Omega$$



PART II

The impedances have been plotted on Fig. 4-8 (page 4-34); you can see that the EOTL impedance is out of the range of tap 1. This situation is indicated on the MDX front panel by the **SETPPOINT** status indicator LED flashing and an alarm sounding because the supply cannot reach the setpoint (refer to page 2-15). An "E-12" message may appear on one of the digital meters (see discussion of messages on page 2-23).

One option for addressing this problem is to stop using the target when the maximum current for the tap is reached. Another option is to reduce the power level until the **SETPPOINT** LED once again is statically lit, indicating that the MDX is operating within limits.

A third possibility is to use an MDX model that produces more power. The two impedances have been plotted on Fig. 4-9 (page 4-35), which shows the impedance boundaries for the three taps available on the MDX 15K; you can see that both fit within the tap 1 boundaries. A rule of thumb: The broader the impedance range, the higher the power capability needs to be if that range is going to fit within the boundaries of a single tap.

CHOOSING MODES/SETTINGS

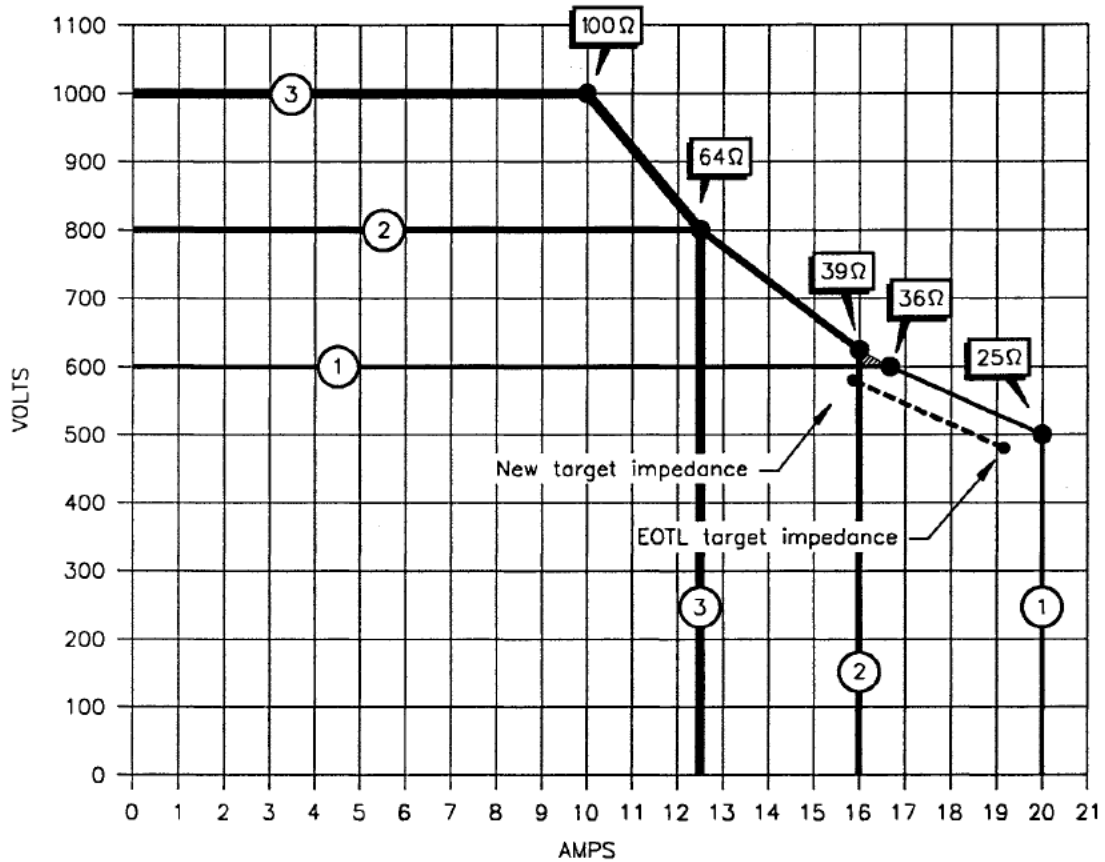

Figure 4-5. Graph with the voltage and current values plotted for the Example 1 target both when it is new and when it is near the end of its useful life. The impedances at both target stages fall within the boundaries of tap 1. Note: The shading represents an impedance area not covered by the MDX when it is regulating voltage.

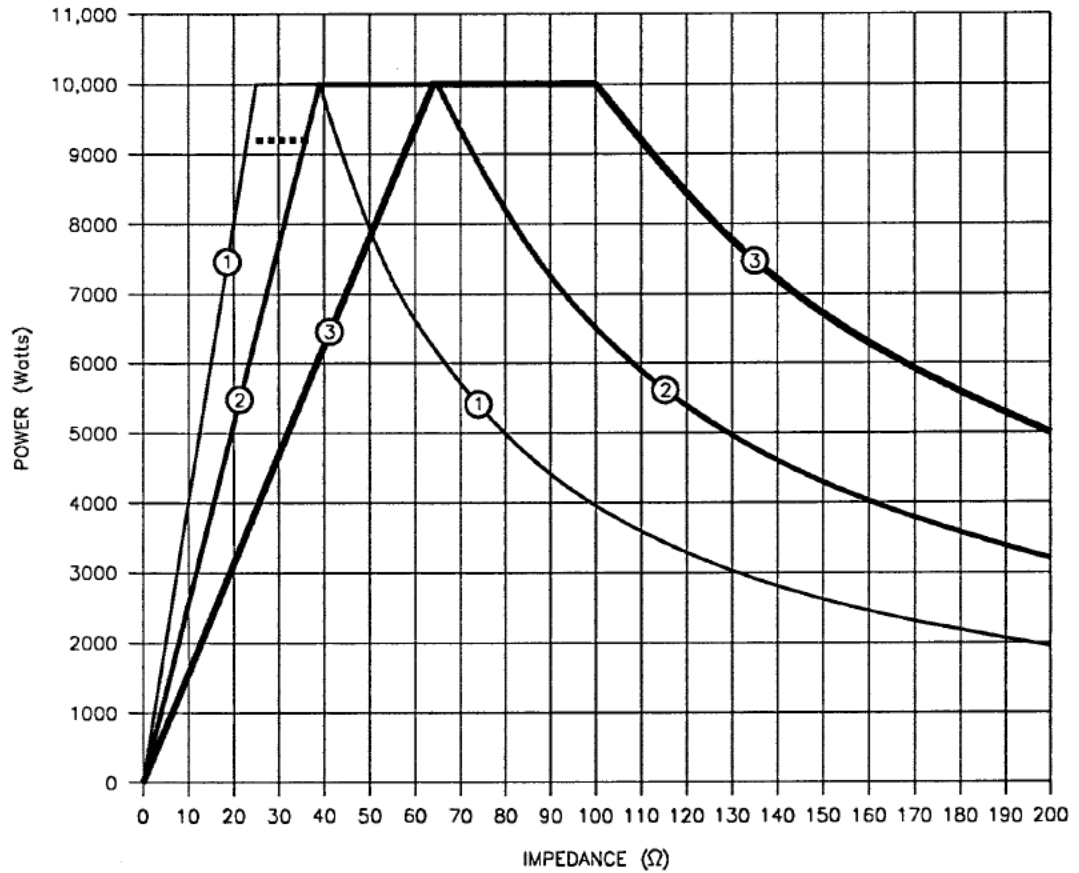

Figure 4-6. Graph with the impedances plotted for the Example 1 target both when it is new and when it is near the end of its useful life.

CHOOSING MODES/SETTINGS

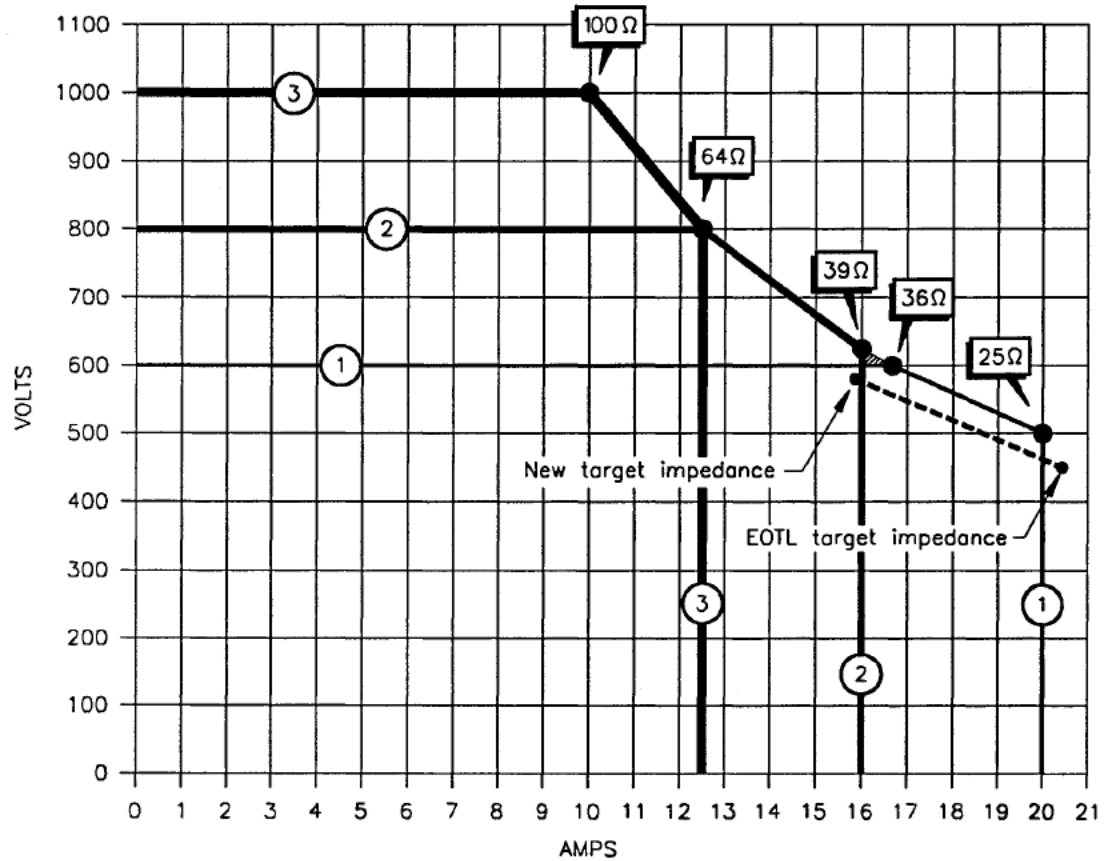

Figure 4-7. Graph with the voltage and current values plotted for the Example 2 target both when it is new and when it is near the end of its useful life (EOTL). The EOTL current is out of the range of tap 1. Note: The shading represents an impedance area not covered by the MDX when it is regulating voltage.

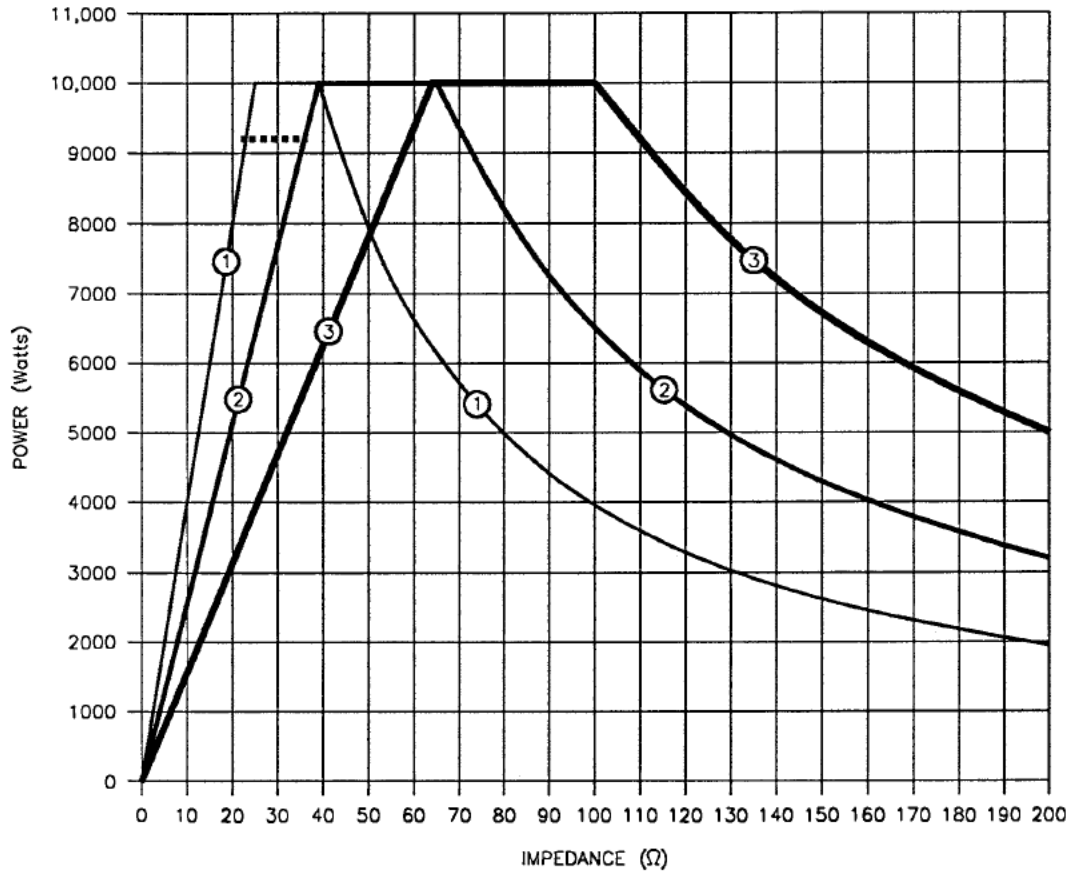

Figure 4-8. Graph with the impedances plotted for the Example 2 target both when it is new and when it is near the end of its useful life.

CHOOSING MODES/SETTINGS

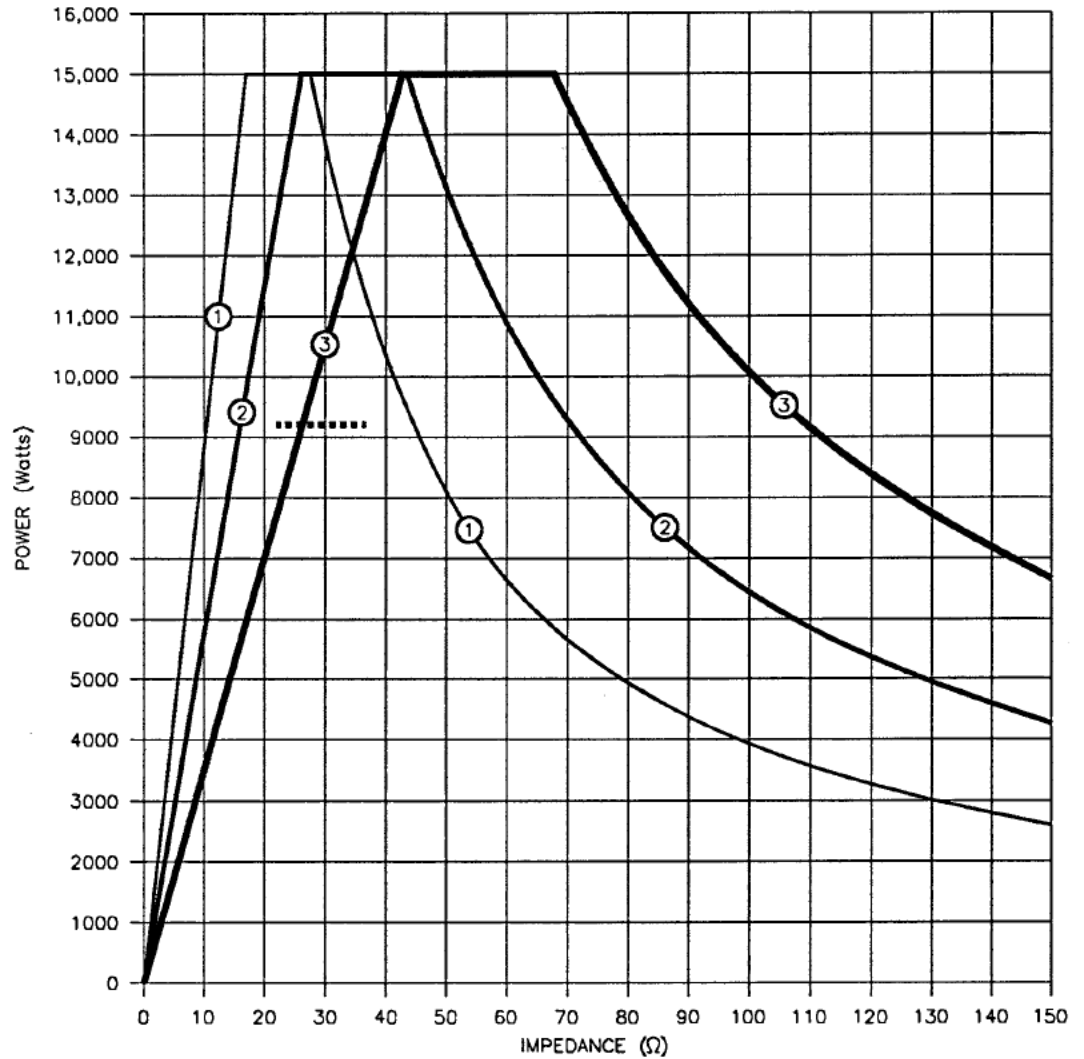

Figure 4-9. Graph with the voltage and current values plotted for the Example 2 target both when it is new and when it is near the end of its useful life (EOTL). Since we have switched to an MDX model capable of producing 15,000 W, both target stages fall within the boundaries of tap 1.

CHOOSING MODES/SETTINGS

Tap-changing Procedure — Detailed



DANGER! Make sure that the input power to the MDX has been removed — the MDX must be without input power for 1 min. to allow all capacitors to discharge. Ensure that all units in multi-supply systems are off, and that no power is present at the MDX output.

1. Remove the black metal top cover by removing the six black screws.
2. Remove the smoke-colored safety shields by removing the black oval-head screws. Under the safety shield is the logic tray. The logic tray covers the top of the MDX and begins at the right side of the chassis (as you look from the front panel end into the top of the MDX). Three boards — the transducer, logic, and predrive — plug into the motherboard (see Fig. 4-12 on page 4-41; also see the safety shield illustration on page 4-42). The motherboard is mounted on the metal logic tray.
3. To remove the logic tray, disconnect the **USER, HOST, DISPLAY, MF1,** and **MF2** cables from the motherboard.



WARNING! Label the output wires before you disconnect them so that you can reconnect them exactly as they were. Improper connections will reverse the polarity of the power supply, possibly damaging attached hardware.

4. Now remove the five screws (six screws on MDX units with two power modules) that secure the logic tray to the chassis.
5. Lift the logic tray straight up. **Note:** Be sure to lift straight up or the logic tray will bind on the four guide posts. When the logic tray is almost out, it will catch on the right side of the chassis. The logic tray will come free if you lift the left side of the logic tray to clear all four guide posts. Set the tray down carefully to keep from bending the bottom pins.
6. Toward the rear of the unit is a narrow “tap-select board” with one red end. If the unit has two modules, the board will be long enough to reach both modules. Remove the two screws (for each module) that hold the tap-select board in place and move it to the desired position.

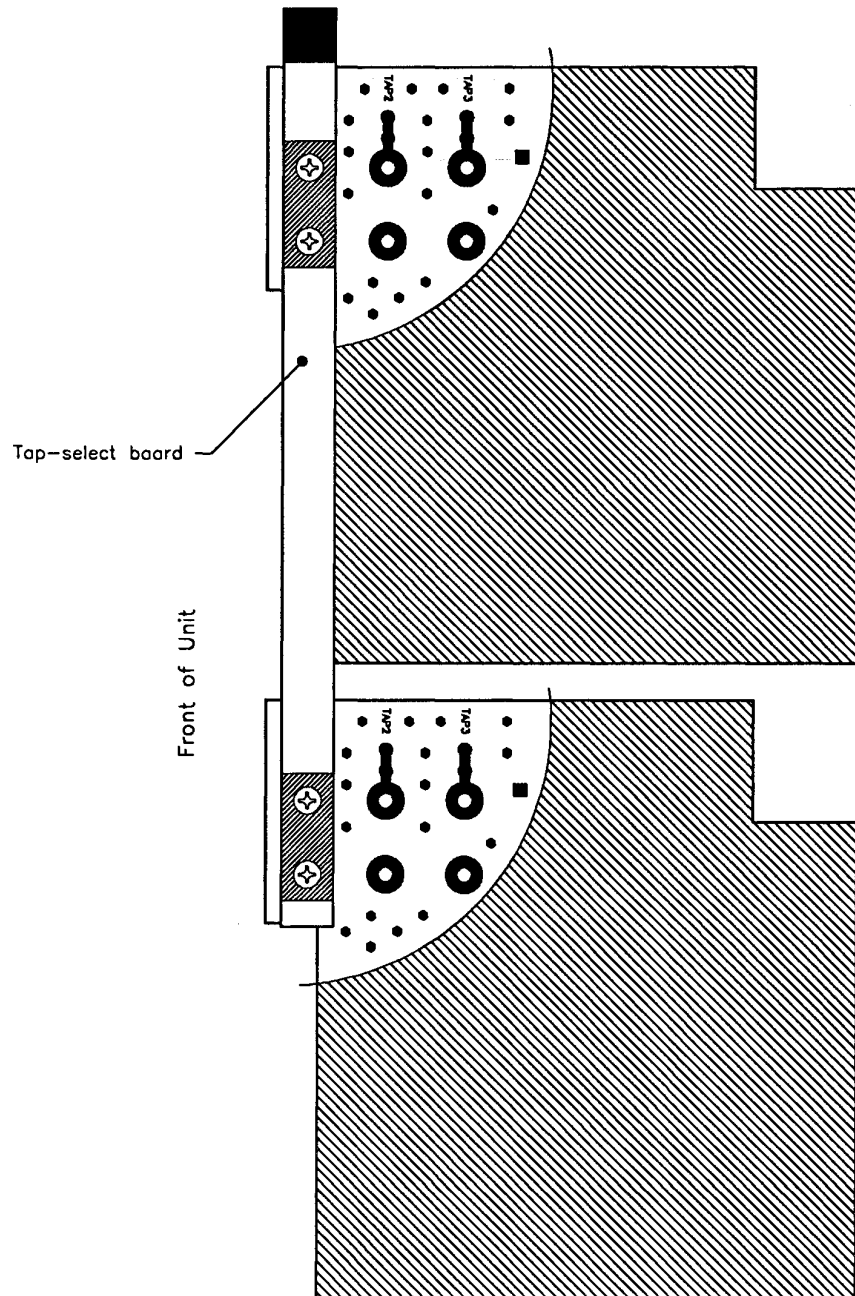

Figure 4-10. Tap-select board placed correctly to select tap 1 for an MDX with two power modules (the board will be shorter in units with only one power module).

CHOOSING MODES/SETTINGS

7. Check the bottom of the logic tray. There are two groups of six pins protruding through the logic tray.
8. Re-install the logic tray. Make sure that the logic tray slides straight down. Push the rear right corner down securely and re-insert the screws that hold the logic tray to the chassis.
9. Use an ohmmeter to check for continuity between the below-listed pairs of pins on the predrive board. The reading should be $1 \Omega \pm 0.25 \Omega$ between the pins in each pair. *Pin 1* of each connector is to the rear of the unit.



WARNING! If all readings are not within the the above-specified range, remove the logic tray and check for correct pin alignment.

For all units, check:

J1, pin 1 and *J1, pin 3*
J2, pin 7 and *J2, pin 8*
J1, pin 6 and *J1, pin 7*

For 10K models, also check:

J101, pin 1 and *J101, pin 3*
J102, pin 7 and *J102, pin 8*
J101, pin 6 and *J101, pin 7*

10. Secure the logic tray to the chassis with the five screws (six on models with two power modules) that you removed earlier.
11. Change the microprocessor tap selection by moving the plug on **P2** to the appropriate position (see the figure and the table on the next page). The tap specified with this plug must match the tap specified with the tap-select board (in step 6).



WARNING! The same tap must be specified with the plug on **P2** (on the motherboard) and with the tap-select board on the power module. If the specified taps are different, the maximum limits for voltage and current will be wrong, and the MDX may be damaged.

To select:

Tap 1
Tap 2
Tap 3

Connect these pins:

pins 1 and 2
pins 2 and 3
pins 3 and 4

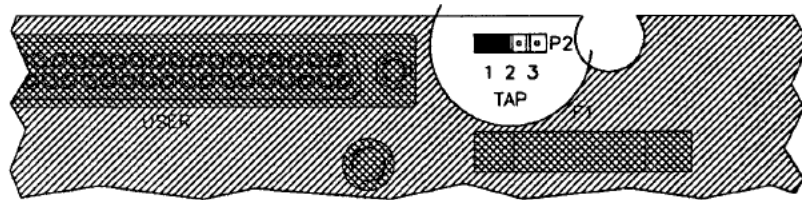

Figure 4-11. The P2 connector on the motherboard (also see Fig. 4-12). Here, tap 1 has been specified with the plug (shown as a dark rectangle).

12. Reconnect the **USER, HOST, DISPLAY, MF1, and MF2** cables. Reconnect the two output wires (one is black and one is white) to the transducer board — remember not to reverse these wires.
13. Replace the smoke-colored safety shields by replacing the oval-head screws. Don't pinch ribbon cables between safety shield and logic tray.
14. Turn on the power to the MDX by turning on the breaker on the rear panel. Verify that the green LEDs (labeled **REAR DRIVE** and **FORWARD DRIVE** on the safety shield) are lighted (there is one set of two on 5K models, two sets of two on 10K models). The MDX is now ready to test.
15. Specify that the method of output regulation is power (see page 4-3); set the output level at 0.2 kW.
16. Turn on the output and monitor the yellow LEDs that are under the **DRIVE COMMAND** label on the large safety shield, on the left side of the predrive board for 5K models, or on both the left and right sides of the predrive board on 10K models. If one of the LEDs is **brightly** lit, one or more of the six pins on the bottom of the logic tray is bent. In this case you must turn off the input power and remove the logic tray (steps 3-5). If the yellow LEDs are very **dimly** lit, the MDX is ready to operate.
17. Turn off the output.
18. Reinstall the top cover and replace the six screws.

CHOOSING MODES/SETTINGS

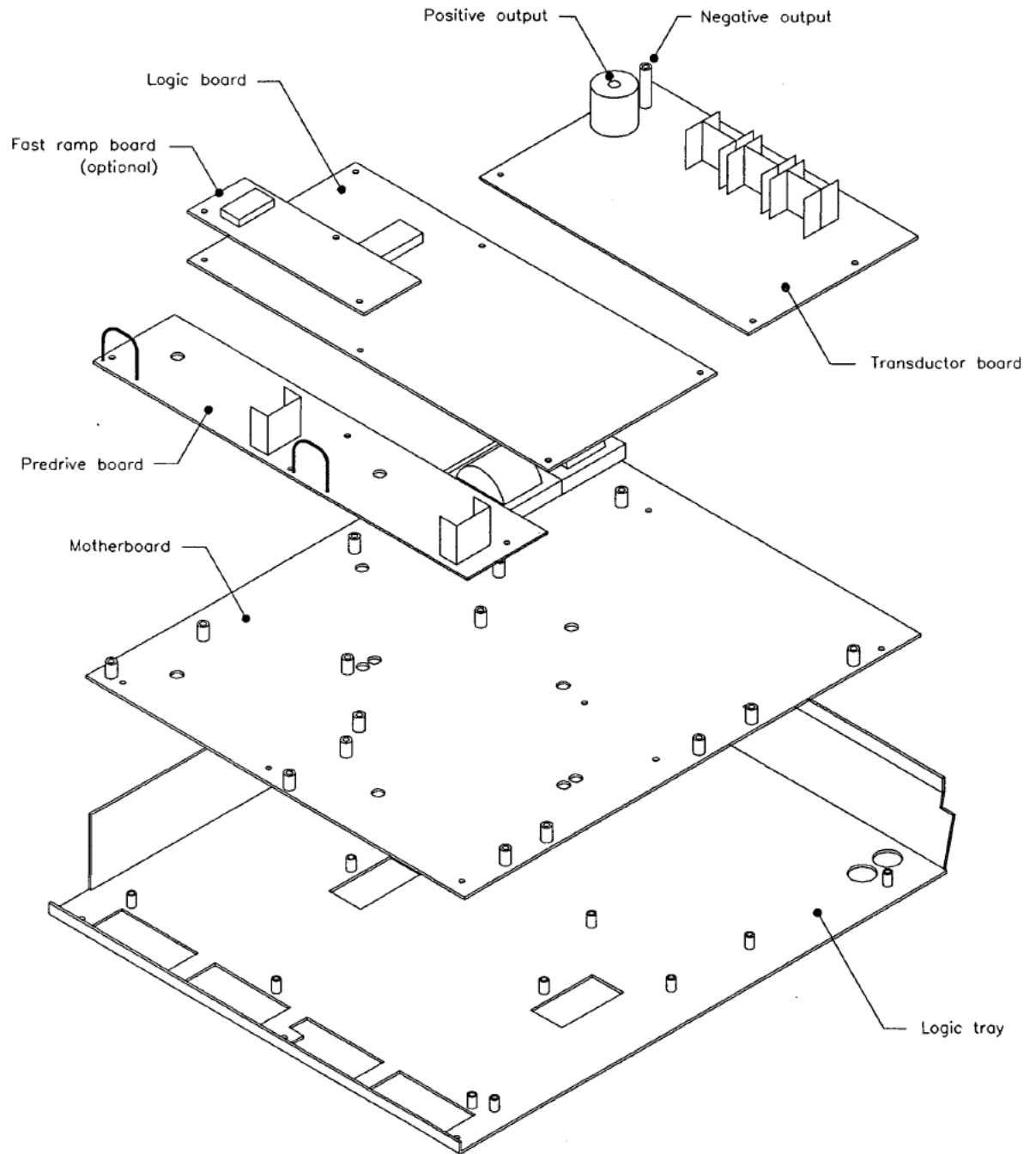

Figure 4-12. Exploded illustration showing the relative positions of some of the printed circuit boards inside the MDX chassis.

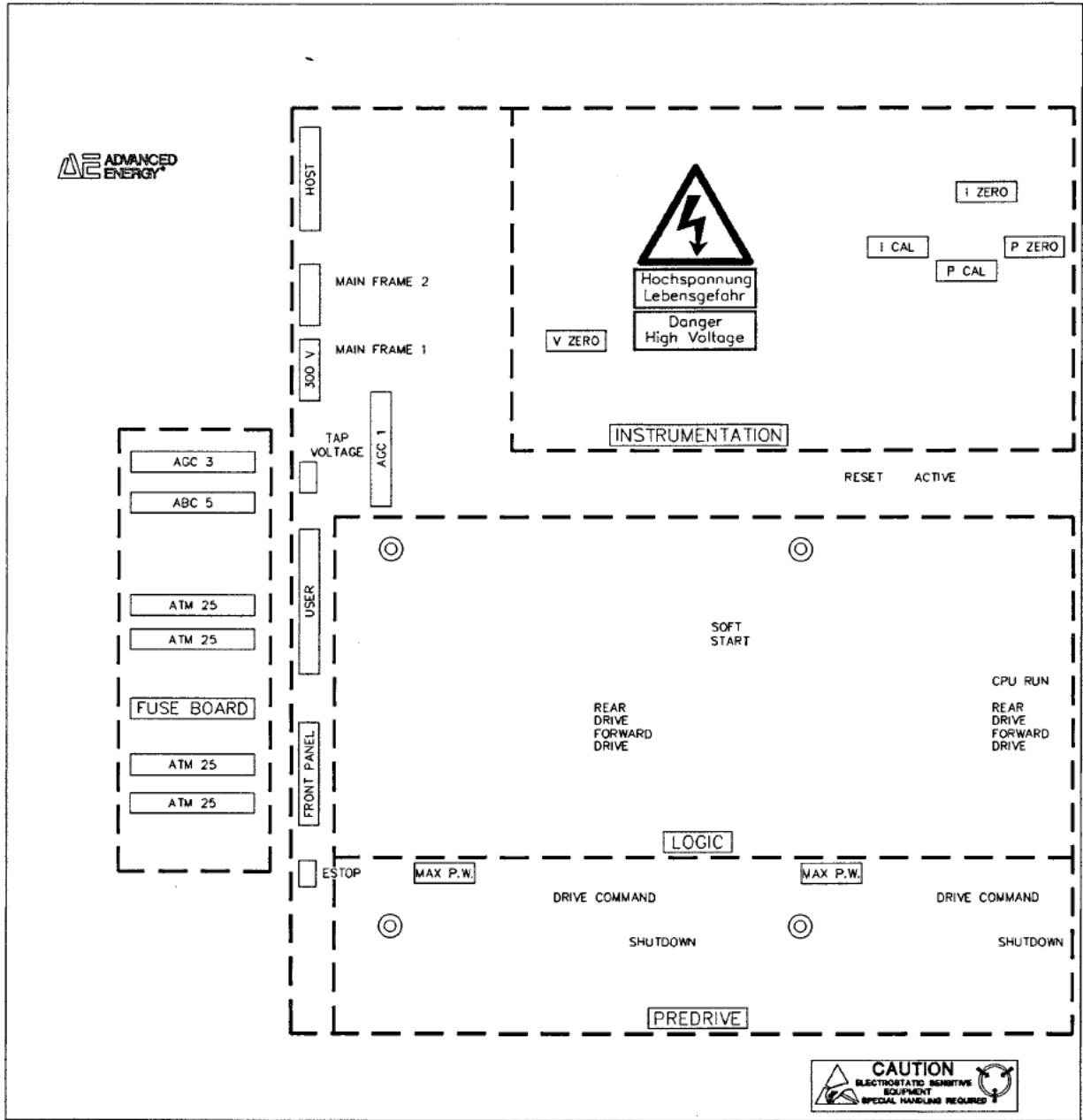

Figure 4-13. The MDX safety shield.

CHOOSING MODES/SETTINGS

Tap-changing Procedure — Abbreviated

The following is an abbreviated procedure for quick reference. A more detailed, step-by-step procedure is provided on page 4-37 for the first-time user.

1. Turn line power off.
2. Remove cover and safety shield.
3. Remove cables; label and disconnect output wires.
4. Remove logic tray.
5. Set tap positions and correct voltage range:
 - power module #1
 - power module #2
6. Reinstall logic tray.
7. Move the jumper at P2 on the motherboard to the desired tap position.
8. Check connections on predrive board.
9. Reinstall cables and reconnect output wires.
10. Replace safety shield.
11. Turn on line power.
12. Check green LEDs.
13. Specify power regulation.
14. Turn on output and check yellow LEDs on predrive board.
15. Turn off output.
16. Re-install top cover.

CHOOSING MODES/SETTINGS

IMPEDANCE OPTIONS

Each MDX is equipped with a built-in impedance-matching transformer. These transformers are available in high-impedance ("high Z"), standard-impedance ("standard Z"), and low-impedance ("low Z") configurations. You can further modify the load impedance ranges that the transformer will accept by selecting from one of three taps.

Depending on the transformer configuration and tap setting (see page 4-49), load impedances requiring voltages from 400 V to 1250 V can be accommodated. Impedance-range graphs for the various combinations are shown in the appendix. Below is a table that shows the maximum current that can be produced at each tap. It also shows the range of output voltages available at each tap, **when the unit is in voltage regulation**. If current or power regulation has been selected, the MDX may actually produce a higher voltage in order to reach the current or power setpoint.

Tap No.	Output Volt. Range	MDX 5K	MDX 10K	MDX 15K	MDX 20K	MDX 25K	MDX 30K
Maximum Output Current: Low Impedance ("Low Z")							
1	0 V to 500 V	12.50 A	25.00 A	37.50 A	50.00 A	62.50 A	75.00 A
2	0 V to 640 V	10.00 A	20.00 A	30.00 A	40.00 A	50.00 A	60.00 A
3	0 V to 800 V	7.75 A	15.50 A	23.50 A	31.00 A	38.75 A	46.50 A
Maximum Output Current: Standard Impedance ("Standard Z")							
1	0 V to 600 V	10.00 A	20.00 A	30.00 A	40.00 A	50.00 A	60.00 A
2	0 V to 800 V	8.00 A	16.00 A	24.00 A	32.00 A	40.00 A	48.00 A
3	0 V to 1000 V	6.25 A	12.50 A	18.75 A	25.00 A	31.25 A	37.50 A
Maximum Output Current: High Impedance ("High Z")							
1	0 V to 775 V	8.00 A	16.00 A	24.00 A	32.00 A	40.00 A	48.00 A
2	0 V to 1000 V	6.40 A	12.80 A	19.20 A	25.60 A	32.00 A	38.40 A
3	0 V to 1250 V	5.00 A	10.00 A	15.00 A	20.00 A	25.00 A	30.00 A

CHOOSING MODES/SETTINGS

LINE VOLTAGE CHANGES

The input voltage for MDX models can be either 200 V ac or 208 V ac. It may occasionally be necessary to modify the voltage setting from one to the other. If so, the following hardware change is required:

- change overvoltage/undervoltage settings



DANGER! Make sure that the input power to the MDX has been removed before attempting this procedure. The MDX must be without input power for 1 min. to allow all capacitors to discharge.

1. Remove the black metal top cover by removing the eight black screws.
2. Remove the smoke-colored safety shield by removing the black oval-head screws. The logic tray covers most of the top of the MDX (about three-quarters of the exposed area) and begins at the right side of the chassis (as you look from the front panel end into the top of the MDX). Three boards—the transducer, logic, and predrive—plug into the motherboard (see the illustration on page 4-41; also see the safety shield illustration on page 4-42). The motherboard is mounted on the logic tray.
3. Remove the four screws from the transducer board (the PC board directly under the **INSTRUMENTATION** label on the large safety shield and unplug it (do not remove the cables) so that you can set the overvoltage (OV) and undervoltage (UV) trip levels. Open all switches on **S4** (on the motherboard, see the illustration on the next page), and then close only the switch that agrees with the input line voltage.



WARNING! If you fail to set the overvoltage and undervoltage levels so that they correspond to the input voltage, the MDX will shut off prematurely due to line voltage fluctuations.

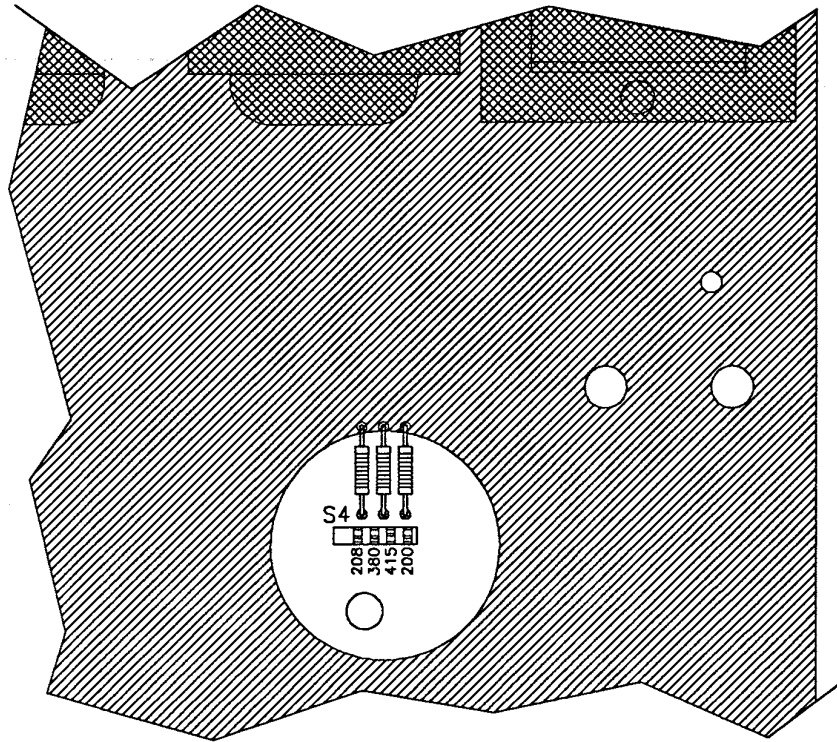

Figure 4-14. The S4 switch on the motherboard (refer to illustration showing the relative positions of the printed circuit boards, on page 4-41).

The correct internal dc bus OV and UV trip levels for each input voltage setting are shown in the table below.

<u>Input Line Voltage</u>	<u>DC Bus OV Trip Level*</u>	<u>DC Bus UV Trip Level*</u>
200 V ac, three phase	315 V	226 V
208 V ac, three phase	333 V	238 V

*±1% tolerance of the trip level voltage

4. Re-install the transducer board and replace the four screws that secure it.
5. Re-install the safety shield and replace the oval-head screws that secure it; re-install the top cover and replace the six screws that secure it.

CHOOSING MODES/SETTINGS

MASTER/SLAVE OPERATION

If you have an MDX power supply that produces more than 10 kW (15K or 20K models, for example), you have a master unit and one or more slave units. For the most part, setting up and operating such a master/slave power supply is the same as setting up and operating a single-chassis 5K or 10K model. The following is a summary of considerations.

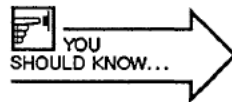

Note: To upgrade an MDX 10K model to a 15K or 20K model, you will need a slave unit, an interconnect cable, and software for the master unit. In some cases, hardware changes may also be required. Contact Customer Service for more information.

Connect input power to each chassis just as you would for the 10K model (see page 3-14).

To interconnect the master and slave units, connect the 30-inch multi-conductor cable with 15-pin connectors (supplied) to the connectors on each MDX rear panel (**MASTER INTERCONNECT** or **SLAVE INTERCONNECT**). **Note:** The connectors on the ends of the cable are different on each end, so that they cannot be incorrectly connected.

To ensure reliable operation and less sensitivity to noise, ground both the MDX chassis and the system by daisy-chaining a flat copper braid between units. See the discussion and illustration on page 3-13.

Connect the MDX to the load by attaching the cable or wires (see page 3-15) to the output connector on the rear panel of the master unit. Do the same for the slave unit(s). When connecting to the load, make sure that the positive conductors of both master and slave units are connected to the same point. Repeat this process for the negative conductors.

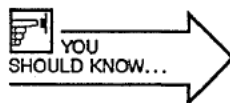

A bus junction box is available from AE that is designed to parallel outputs.

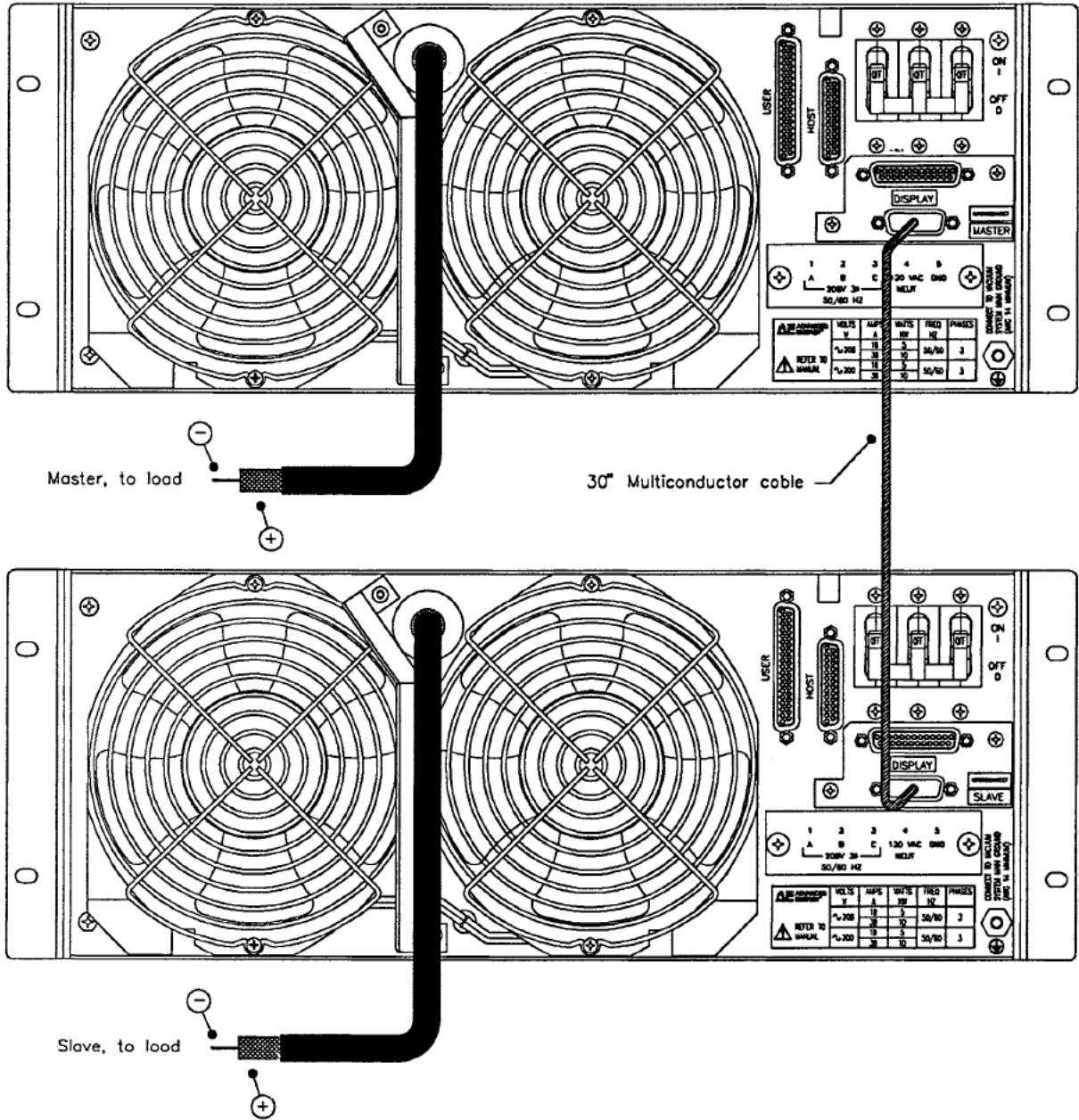

Figure 4-15. Rear view of an interconnected master and slave MDX system.

CHOOSING MODES/SETTINGS

Make sure that:

- the output configuration (i.e., negative, positive, or floating output) is the same for all units (pages 1-9 and 3-15)
- the tap selection is the same for all interconnected units (see page 4-27 and the tap-changing procedure on page 4-37).

A slave unit is equipped with a passive front panel and is labeled **SLAVE**. The five status indicator LEDs are discussed on page 2-16.

Setpoint LEDs

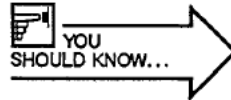

In a master/slave configuration, it is very important to monitor the **SETPOINT** LEDs of all units because the displayed **ACTUAL** power or current value will not necessarily reflect reality unless all **SETPOINT** LEDs are lit.

If the master unit is at setpoint (i.e., it is producing its portion of the required output), the **ACTUAL** value displayed on the control-panel meter will always be the requested setpoint level (due to an internal assumption made by the master unit). It is possible, however, that the slave unit is not producing its portion of the required output, or that its breaker has not been turned on. The only way to be sure is to watch the **SETPOINT** LEDs.

If the slave is not delivering the correct amount of power, its **SETPOINT** LED will not be lit. If the master unit is equipped with a minipanel or standard control panel, the **SETPOINT** LED will flash. If the master has a passive front panel, the **SETPOINT** LED will not be lit.

USING THE SPECIAL FEATURES/OPTIONS

CONTENTS

ARC-CHECK™	5-3
Fast Ramp	5-5
Contactor Hold	5-7

USING THE SPECIAL FEATURES/OPTIONS

ARC-CHECK

ARC-CHECK™ is a companion to ARC-OUT™ arc-suppression circuitry. It enhances performance in continuous low-impedance processes such as cathodic arc deposition and applications that produce conductive flakes. Flakes short out the power supply. These shorts have some of the characteristics of arcs, which confuses the ARC-OUT circuit. ARC-CHECK was developed to deal with these arc-like process phenomena.

The ARC-CHECK circuitry is designed to eliminate short-inducing flakes in applications where it is impractical to keep the chamber extremely clean.

If the MDX is operating under either voltage or power regulation, and an arc-like condition occurs, the ARC-OUT circuitry will immediately respond to the perceived arc. If the arc-like condition proves not to actually be a normal plasma arc, it will still be present after ARC-OUT has acted.

ARC-OUT will attempt to extinguish the "arc" for 50 ms. If the condition has not been cleared in 50 ms, ARC-CHECK takes over. ARC-CHECK takes control and reduces the MDX's output level to zero and then ramps the output to the maximum current available (with the unit's present tap setting, see table on page 4-45). If this current is enough to remove the short, output voltage rises. When the voltage (or power) reaches the operating conditions of the previously selected method of output regulation, ARC-CHECK returns control to that circuitry. If the short is not removed by the time the out-of-setpoint timer runs out, the MDX turns off output and displays the "E-12" message (see page 2-23).

Maximum current will be delivered into the short until either the flake is destroyed or output is shut off. Use the out-of-setpoint timer (page 4-17) to specify how long the MDX can operate at this level before automatically shutting off.



WARNING! If you do not set a limit on how long the MDX can drive maximum current into the flake, the target, other equipment, and/or the MDX could be damaged.

This feature was not designed to be used when the MDX is set for current regulation.

USING THE SPECIAL FEATURES/OPTIONS

FAST RAMP

The minimum limit for a normal ramp is 600 ms; a ramp set at any value less than 0.6 sec. will still take 600 ms, due to software limitations.

The **fast ramp** feature allows a much shorter ramp time to be specified. To select this feature, set ramp time (see page 4-10) to four hyphens from the control panel or four zeros from the Host interface.

When **fast ramp** is selected, the range for both the run timer and the ramp timer will change from 0-99 minutes to 0-99 seconds. The **MINUTES** LED will flash (rather than being statically lit) to remind you that seconds and not minutes are being counted.

The available range of fast-ramp times is 50 ms to 1 sec.; the exact time that an MDX will use when **fast ramp** is specified can be adjusted with an internal potentiometer, which is set at the factory to your specification. To make the adjustment yourself:

1. Turn the **MODE** key switch to **OFF**.
2. Remove the black metal top cover by removing the six black screws.
3. Remove the smoke-colored safety shield by removing the black oval-head screws. The logic tray covers about three-quarters of the exposed area.
4. Turn on the main circuit breaker on the rear panel.
5. Use a frequency counter to monitor the frequency at **TP-2** on the fast ramp printed circuit board (pcb), which is mounted above the front left corner of the logic pcb (see the illustration on page 4-41).

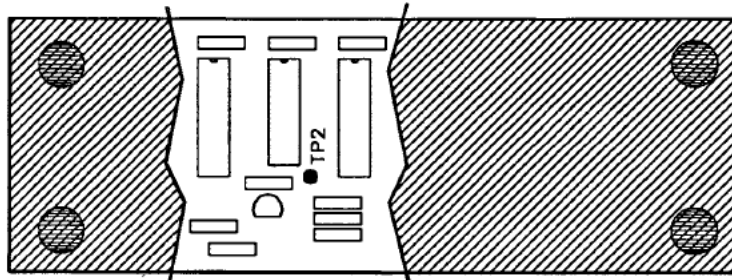

Figure 5-1. Illustration showing location of TP-2 on the fast ramp printed circuit board (the figure on page 4-41 shows the relative positions of the printed circuit boards).



PART II

6. Adjust the **R5** potentiometer for the desired frequency, calculated using the formula: Ramp Time = 1024 divided by frequency at **TP-2**. Use **R3** to make fine adjustments.

7. Turn off the main circuit breaker.

8. Replace the safety shield and top cover.

USING THE SPECIAL FEATURES/OPTIONS

CONTACTOR HOLD

The help prolong the life of the main and soft-start contactors, the MDX is equipped with a **remote contactor hold** feature. If your process run times are short, you may want to specify that the contactors stay energized after the first start cycle. With this feature, when *User pin 16 (REMOTE CONTACTOR HOLD.D)* is low, the contactors will remain closed after the first time the dc bus is energized, regardless of whether output is being produced or not. If the pin is high, the contactors will close and open as output is turned on and off.

You can also choose permanent **contactor hold**, which is similar to **remote contactor hold** except that the contactor is controlled internally. With this configuration, the contactors can only be opened by turning the **MODE** key switch to **OFF**. Interlock faults and bus voltage faults will also open the contactors.

You select one of the **contactor hold** options with a switch on the motherboard, using the following procedure.



DANGER! Make sure that the input power to the MDX has been removed before attempting this procedure. The MDX must be without input power for 1 min. to allow all capacitors to discharge.

1. Remove the black metal top cover by removing the six black screws.
2. Remove the smoke-colored safety shield by removing the black oval-head screws. Under this safety shield is the logic tray, which covers most of the top of the MDX. The motherboard is mounted on the logic tray; three boards (transducer, predrive, and logic) plug into the motherboard.
3. Remove the screws that hold the logic board in place (refer to the labels on the safety shield to determine which board is the logic board), and lift it out carefully.
4. You can now see switch **S5** on the motherboard. Set it to the **CLOSE** position for **contactor hold** or to the **OPEN** position for **remote contactor hold**.

5. Re-install the logic board, taking care to align the connector pins on the motherboard with the corresponding sockets on the logic board. Be sure that none of the pins are bent — you should be able to see all pins protruding up through the logic board. Replace the screws that hold the logic board in place.
6. Replace the smoke-colored safety shield by replacing the oval-head screws.
7. Re-install the top cover and replace the six screws.

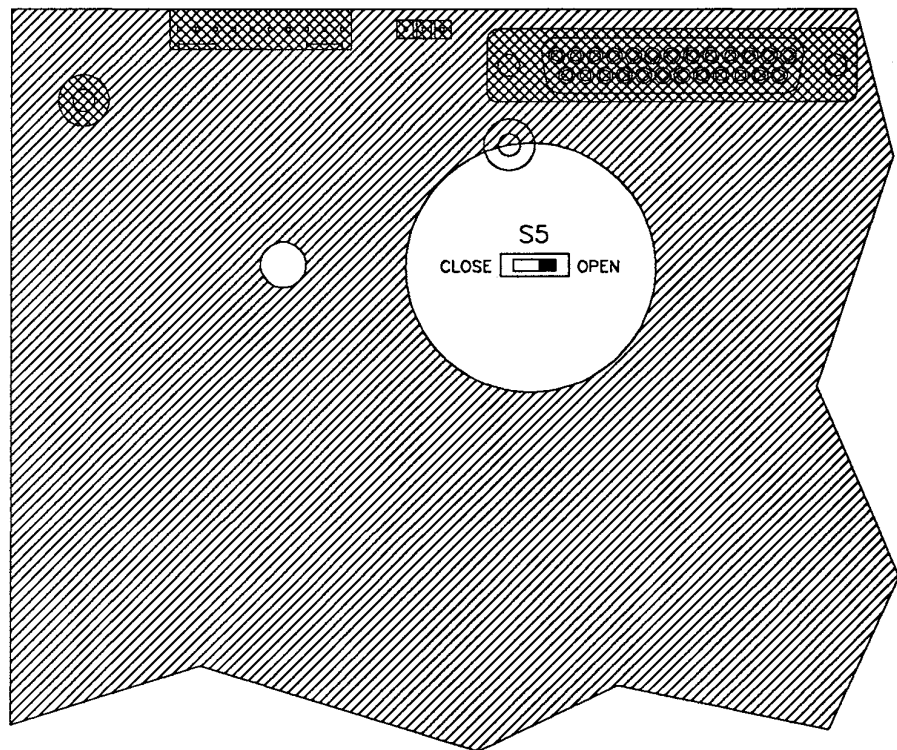

Figure 5-2. Illustration showing location of S5 switch on the motherboard (refer to Fig. 4-13, which shows the relative positions of the printed circuit boards, on page 4-48).

LEARNING MORE ABOUT
YOUR MAGNETRON DRIVE



DC BIAS

“Dc bias” refers to the dc component of the RF power that is developed between the cathode and the anode of a typical RF plasma vacuum system. This dc component is blocked from the RF generator by the capacitors that are used in the impedance-matching networks.

The dc potential is a controllable parameter. It is also a valuable indicator that itself changes in response to changes in other process parameters. Some of the parameters that affect dc bias are molecular densities and ratios of process gases, cathode/anode surface area ratios, pressure regimes and stability, and RF power densities. While some of these parameters are controllable, others are fixed and so must be worked around.

The amount of dc bias that is developed within a process system depends upon the system design or the process being run. Although a systems manufacturer can use modeling or empirical data to predict the dc bias that should be expected with a specific system or process, a power supply manufacturer cannot.

In any case, you can determine dc bias by measuring it yourself with a high-voltage probe.



DANGER! Lethal high-voltage and high-current potentials are present during the measurement of dc bias. Extreme caution is required to ensure the safety of yourself and of those working with you. Carelessness can cause severe burns, paralysis, or instant death.

Measure dc bias at the RF feedthrough. The farther the probe is from the feedthrough, the less accurate the measurement. This is because dc bias decreases with distance from the feedthrough due to electrical loss. A convenient point for taking this measurement, if you are using an Advanced Energy® impedance-matching network, is inside the impedance-matching network itself, at the output of the series capacitor.

Dc bias can be regulated in two ways, the choice of which depends upon the process or application. The mutually exclusive choices result in either maximum range or maximum resolution.

If you choose maximum range, run the RF generator at maximum power when you measure dc bias. In the more advanced, microprocessor-controlled RF generators, a normalization (calibration) function makes it possible to tailor the process to the dc bias regulation. With one of these generators, maximum power will also equate with maximum dc bias. By normalizing for the maximum dc bias, the process will have the widest range of available dc biases.

If resolution of the dc bias control is more important, set your system up for a "typical" process before you measure dc bias. The new microprocessor-controlled generators will calibrate the dc bias over a smaller power cross section, thus providing a higher resolution over a smaller area of operation.

Since what is best for one application will not necessarily be best for another application, you may calibrate for either resolution or range, and then later repeat the process for the other possibility.



GROUNDING

Current seeks the path of lowest resistance. If several paths are characterized by similar impedances, the current flow may randomly switch paths. This switching may appear as oscillations and cause interference ("noise") with electronic equipment. The goal in any system design is to provide a known, fixed, lowest impedance path. The way to do this is to provide good grounding.

Grounding is important for a variety of reasons:

- it ensures safety of personnel
- it protects equipment
- it is necessary for agency approvals
- it prevents electromagnetic radiation
- it prevents electromagnetic interference
- it provides a known reference for control signals

Grounding requirements and standards are set and promulgated by various commercial and governmental agencies. Information is available from UL, CSA, VDE, FCC, IEEE, SAE, CISPR, and many local government agencies. Always check whatever documents are mandated by your local authorities. This note is intended to provide a broad overview of grounding issues and considerations.

AC and DC Grounding

In the real world there is a significant difference between the techniques used to provide a good dc ground and those used to provide a good ac ground. Just because a system has a very low dc resistance to earth-ground does not at all imply that it has a good ac earth-ground, or vice versa. A dc ground connection requires conductors and connectors with adequate cross-sectional area for the current to be carried; these conductors and connectors must also be made of material with very little resistance.

An ac ground requires conductors and connectors with adequate surface area for the current to be carried; however, the conductors and connectors must also have very little inductive reactance or capacitive reactance to ensure the lowest possible impedance. This becomes more critical as the frequency increases into the RF range.

The major safety issue concerning improperly grounded equipment is that people can come in contact with dangerous voltages. Although this danger is usually viewed as being caused by dc or 50/60 Hz ac voltages, this is not necessarily the case. The multimeter is a typical measuring instrument used to determine whether or not a system or component is grounded. A multimeter is designed to measure dc voltage and current, ac voltage and current, and resistance. However, it is not sensitive to high-frequency energy and often will not even detect the presence of RF energy, much less give accurate readings. ***Since RF can be present without being detected by common means, there is a significant potential for harm to personnel from RF surface burns, arcs that penetrate the skin, and other such injuries.***

Equipment designed to measure RF energy is expensive and bulky, and must be calibrated over narrow frequency ranges. Most facilities do not have this kind of equipment on hand. It is therefore very important that all appropriate personnel (those involved in design, installation, maintenance, and operations) are knowledgeable about all aspects of grounding for electrical energies, from dc through RF.



DANGER! Operating and maintenance personnel must have the correct training before setting up and maintaining high-energy electrical equipment.

While significant numbers of RF problems are caused by improper grounding of RF power supplies used in a process, all plasma systems produce some RF energy that must be taken into account when the system is designed. As examples: Plasma arcs are like small lightning bolts that cause broad-band RF interference; a plasma chamber is a type of oscillator and radiates RF energy if not shielded; electric motors/relays/solenoids can produce RF energy when they are actuated; even microcomputers used in instruments and controllers can produce RF energy that can cause problems with other circuits. Each one of these sources may interfere with the proper operation of electronic instruments and controls within the system. In the worst cases, this energy can cause noise in equipment at some distance from the source, often hundreds of feet or more away.

Symptoms of Noise Problems

Some grounding problems are inevitable in complex and high-power systems. A good system developer understands grounding problems and, therefore, has a development lab with good earth grounds. This ensures that the new system works well during construction and testing. However, a common occurrence is that when it is installed at a customer's site, nothing works. This is typically due to poor earth-grounding techniques.



Similarly, noise problems will not always surface during the development phase of the components that will be used in the system. This is because a manufacturer cannot simulate the exact environment in which the components (power supplies, for instance) will be used. Noise problems tend not to show up until the component is installed and operating in its intended environment. Then, after a few minutes or hours of normal operation, the system finds itself someplace out in left field. Inputs are ignored and outputs are gibberish. The system may respond to a reset, or it may have to be turned off and then back on again, at which point it commences operating as though nothing had happened. There may be an obvious cause, such as an electrostatic discharge from somebody's finger to a keyboard, or the upset occurs every time another machine is turned on or off. Or there may be no obvious cause, and nothing the operator can do will make the upset repeat itself. But a few minutes, or a few hours, or a few days later it happens again.

One symptom of electrical noise problems is randomness, both in the occurrence of the problem and in what the system does in its failure. All operational upsets that occur at seemingly random intervals are not necessarily caused by noise in the system. Marginal bus voltages, inadequate decoupling, rarely encountered software conditions, or timing coincidences can produce upsets that seem to occur randomly. On the other hand, some noise sources can produce upsets downright periodically. Nevertheless, the more difficult it is to characterize an upset as to cause and effect, the more likely it is to be a noise problem.

Types and Sources of Electrical Noise

The name given to electrical noises other than those that are inherent in the circuit components (such as thermal noise) is EMI: electromagnetic interference. Motors, power switches, fluorescent lights, electrostatic discharges, etc., are sources of EMI. There is a veritable alphabet soup of EMI types, and these are briefly described below.

Supply Line Transients

Anything that switches heavy current loads on to or off of ac or dc power lines will cause large transients in these power lines. Switching a vacuum pump on or off, for example, can put a large voltage spike onto the ac power lines.

The basic mechanism behind supply line transients is shown in Fig. 1. The battery represents any power source, ac or dc. The coils represent the line inductance between the power source and the switchable loads R1 and R2. If both loads are drawing current, the line current flowing through the line inductance establishes a magnetic field of some value. Then, when one of the loads is switched off, the field due to that component of the line current

collapses, generating transient voltages, $v=L(di/dt)$, which try to maintain the current at its original level. That's called an "inductive kick." Because of contact bounce, transients are generated whether the switch is being opened or closed, but they're worse when the switch is being opened.

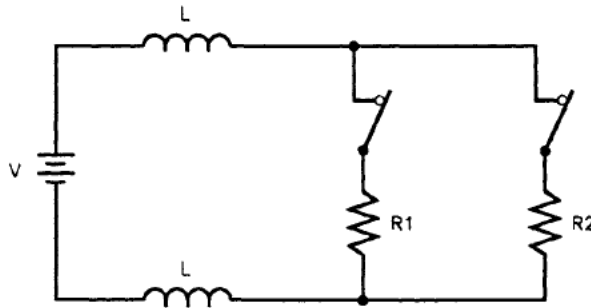

Figure 1. Supply line transients.

An inductive kick of one type or another is involved in most line transients. Other mechanisms for line transients exist, involving noise pickup on the lines. The noise voltages are then conducted to a susceptible circuit right along with the power.

EMP and RFI

Anything that produces arcs or sparks will radiate electromagnetic pulses (EMP) or radio-frequency interference (RFI). Spark discharges have probably caused more software upsets in digital equipment than any other single noise source. The upsetting mechanism is the EMP produced by the spark. The EMP induces transients in the circuit, which are what actually cause the upset.

Arcs and sparks occur in plasma chambers, electron-beam systems, and magnetron sputtering systems; in associated equipment such as electric motors and switches; and in static discharges. Electric motors that have commutator bars produce an arc as the brushes pass from one bar to the next. Dc motors and the "universal" (ac/dc) motors that are used to power hand tools are the kinds that have commutator bars. In switches, the same inductive kick that puts transients on the supply lines will cause an opening or closing switch to throw a spark. Vacuum systems contain vacuum pumps, solenoid valves, motors, power supplies, and many other noise producers.

ESD

Electrostatic discharge (ESD) is the spark that occurs when a person picks up a static charge from walking across a carpet, and then discharges it into a keyboard, or whatever else can be touched. Walking across a carpet in a dry climate, a person can accumulate a static voltage of 35 kV. The current pulse



from an electrostatic discharge has an extremely fast rise time — typically, 4 A/nsec. Figure 2 shows ESD waveforms that have been observed by some investigators of ESD phenomena.

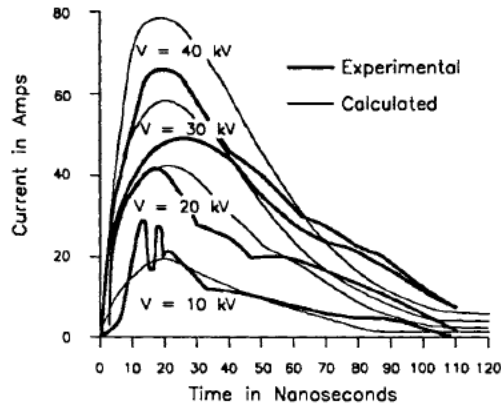

(a)

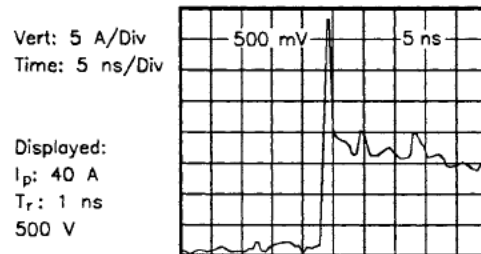

(b)

Figure 2. Waveforms of electrostatic discharge currents from a hand-held metallic object.

It is enlightening to calculate the $L(di/dt)$ voltage required to drive an ESD current pulse through a couple of inches of straight wire. Two inches of straight wire has about 50 nH of inductance. That's not very much, but using 50 nH for L and 4 A/nsec for di/dt gives an $L(di/dt)$ drop of about 200 V. Recent observations by W.M. King suggest even faster rise times (Fig. 2B) and the occurrence of multiple discharges during a single discharge event.

Obviously, ESD sensitivity needs to be considered in the design of equipment that is going to be used in difficult industrial environments. Although humidity is controlled in many IC clean rooms, this is not the case in many other clean rooms. Any time large volumes of air are moved, electrostatic energy will build

up. This can cause ESD problems for a system's control circuitry, whether in the system computer, a power supply's microprocessor, an electronic vacuum pump, or a critical endpoint detector such as an RGA computer.

Ground Noise

Currents in ground lines are another source of noise. These can be 60-Hz currents from the power lines, or RF hash, or crosstalk from other signals that are sharing this particular wire as a signal return line. Noise in the ground lines is often referred to as a "ground loop" problem. The basic concept of the ground loop is shown in Fig. 3. The problem is that true earth-ground is not really at the same potential in all locations. If the two ends of a wire are earth-grounded at different locations, the voltage difference between the two "ground" points can drive significant currents (several amperes) through the wire. Consider the wire to be part of a loop which contains, in addition to the wire, a voltage source that represents the difference in potential between the two ground points, and you have the classical "ground loop." By extension, the term is used to refer to any unwanted (and often unexpected) currents in a ground line.

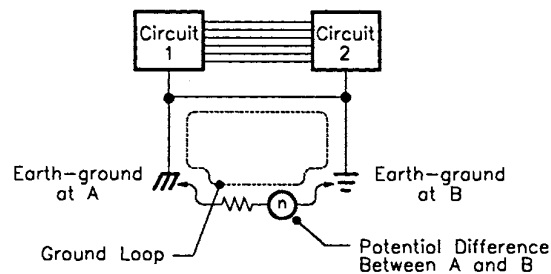

Figure 3. Illustration of a ground loop.

"Radiated" and "Conducted" Noise

Radiated noise is noise that arrives at the victim circuit in the form of electromagnetic radiation, such as EMP and RFI. It causes trouble by inducing extraneous voltages in the circuit. Conducted noise is noise that arrives at the victim circuit already in the form of an extraneous voltage, typically via the ac or dc power lines.

You can defend against radiated noise by carefully designing layouts and using effective shielding techniques. You can defend against conducted noise with filters and suppressors, although layouts and grounding techniques are important here, too.



Types of Failures and Failure Mechanisms

A major problem that EMI can cause in digital systems is intermittent operational malfunction. These software upsets occur when the system is in operation at the time an EMI source is activated, and are usually characterized by a loss of information or a jump in the execution of the program to some random location in memory. The person who has to iron out such problems is tempted to say the program counter went crazy. There is usually no damage to the hardware, and normal operation can resume as soon as the EMI has passed or the source is de-activated. Resuming normal operation usually requires manual or automatic reset, and possibly re-entering of lost information.

Electrostatic discharges from operating personnel can cause not only software upsets, but also permanent ("hard") damage to the system. For this to happen the system doesn't even have to be in operation. Sometimes the permanent damage is latent, meaning the initial damage may be marginal and require further aggravation through operating stress and time before permanent failure takes place. Sometimes the damage is hidden.

Current Loops

The first thing most people learn about electricity is that current won't flow unless it can flow in a closed loop. This simple fact is sometimes temporarily forgotten by the overworked engineer who has spent the past several years mastering the intricacies of the DO loop, the timing loop, the feedback loop, and maybe even the ground loop.

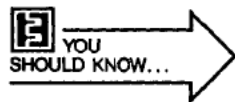

The simple current loop probably owes its apparent demise to the invention of the ground symbol. By a stroke of the pen you avoid having to draw the return paths of most of the current loops in the circuit. Then "ground" turns into an infinite current sink, so that any current that flows into it is gone and forgotten. Forgotten it may be, but it's not gone. It must return to its source, so that its path will by all the laws of nature form a closed loop.

The physical geometry of a given current loop is the key to why it generates EMI, why it's susceptible to EMI, and how to shield it. Specifically, it's the area of the loop that matters.

Any flow of current generates a magnetic field with an intensity that varies inversely to the distance from the wire that carries the current. Two parallel wires conducting currents $+I$ and $-I$ (as in signal feed and return lines) would generate a nonzero magnetic field near the wires if the distance from a given point to one wire is noticeably different than the distance from the same point

to the other wire, but farther away (relative to the wire spacing). Where the distances from a given point to either wire are about the same, the fields from both wires tend to cancel out.

Thus, maintaining proximity between feed and return paths is an important way to minimize their interference with other signals. The way to maintain their proximity is essentially to minimize their loop area. And, because the mutual inductance from current loop A to current loop B is the same as the mutual inductance from current loop B to current loop A, a circuit that doesn't radiate interference doesn't receive it either.

Thus, from the standpoint of reducing both generation of EMI and susceptibility to EMI, the hard rule is to keep loop areas small. To say that loop areas should be minimized is the same as saying the circuit inductance should be minimized. Inductance is by definition the constant of proportionality between current and the magnetic field it produces: $\phi = LI$. Holding the feed and return wires close together so as to promote field cancellation can be described either as minimizing the loop area or as minimizing L. It's the same thing.

Shielding

There are three basic kinds of shields: shielding against capacitive coupling, shielding against inductive coupling, and RF shielding. Capacitive coupling is electric field coupling, so shielding against it amounts to shielding against electric fields. As will be seen, this is relatively easy. Inductive coupling is magnetic field coupling, so shielding against it is shielding against magnetic fields. This is a little more difficult. Strangely enough, this type of shielding does not in general involve the use of magnetic materials. RF shielding, the classical "metallic barrier" against all sorts of electromagnetic fields, is what most people picture when they think about shielding. Its effectiveness depends partly on the selection of the shielding material, but mostly, as it turns out, on the treatment of its seams and the geometry of its openings.

Shielding Against Capacitive Coupling

Capacitive coupling involves the passage of interfering signals through mutual or stray capacitances that aren't shown on the circuit diagram, but which the experienced engineer knows are there. Capacitive coupling to your body is what would cause an unstable oscillator to change its frequency when you reach your hand over the circuit, for example. More importantly, in a digital system it causes crosstalk in multi-wire cables.

The way to block capacitive coupling is to enclose the circuit or conductor you want to protect in a metal shield. That's called an electrostatic or Faraday shield. If coverage is 100%, the shield does not have to be grounded, but it usually is, to ensure that circuit-to-shield capacitances go to signal reference



ground rather than acting as feedback and crosstalk elements. Besides, from a mechanical point of view, grounding it is almost inevitable.

A grounded Faraday shield can be used to break capacitive coupling between a noisy circuit and a victim circuit, as shown in Fig. 4. Figure 4A shows two circuits capacitively coupled through the stray capacitance between them. In Figure 4B the stray capacitance is intercepted by a grounded Faraday shield, so that interference currents are shunted to ground. For example, a grounded plane can be inserted between PCBs (printed circuit boards) to eliminate most of the capacitive coupling among them.

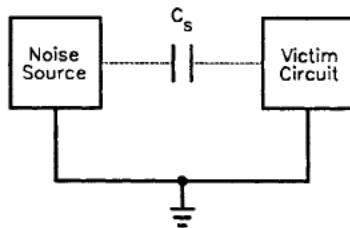

(a) Capacitive Coupling

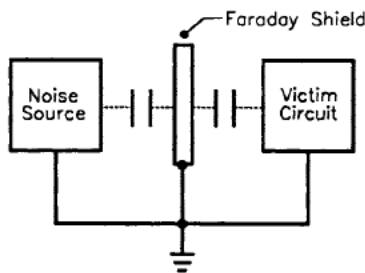

(b) Electrostatic Shielding

Figure 4. Use of Faraday shield.

Shielding Against Inductive Coupling

With inductive coupling, the physical mechanism involved is a magnetic flux density B from some external interference source that links with a current loop in the victim circuit, and generates a voltage in the loop in accordance with Lenz's law: $v = NA(dB/dt)$, where in this case $N = 1$ and A is the area of the current loop in the victim circuit.

There are two aspects to defending a circuit against inductive coupling. One aspect is to try to minimize the offensive fields at their source. This is done by minimizing the area of the current loop at the source so as to promote field cancellation, as described in the section on current loops. The other aspect is to minimize the inductive pickup in the victim circuit by minimizing the area of that current loop, since, from Lenz's law, the induced voltage is proportional to this area. So the two aspects really involve the same corrective action: Minimize the areas of the current loops. In other words, minimizing the offensiveness of a circuit inherently minimizes its susceptibility.

Shielding against inductive coupling means nothing more nor less than controlling the dimensions of the current loops in the circuit. We will look at two examples of this type of "shielding": the coaxial cable and the twisted pair.

The Coaxial Cable. Figure 5 shows a coaxial cable carrying a current I from a signal source to a receiving load. The shield carries the same current as the center conductor. Outside the shield, the magnetic field produced by $+I$ flowing in the center conductor is cancelled by the field produced by $-I$ flowing in the shield. To the extent that the cable is ideal in producing zero external magnetic field, it is immune to inductive pickup from external sources. The cable effectively adds zero area to the loop. This is true only if the shield carries the same current as does the center conductor.

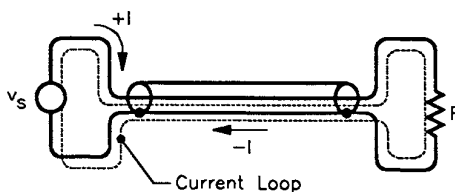

Figure 5. External to the shield, $\phi = 0$

In the real world, both the signal source and the receiving load are likely to have one end connected to a common signal ground. In that case, should the cable be grounded at one end, both ends, or neither end? The answer is that it should be grounded at both ends. Figure 6A shows the situation when the cable shield is grounded at only one end. In that case the current loop runs down the center conductor of the cable, then back through the common ground connection. The loop area is not well defined. The shield not only does not carry the same current as the center conductor, but it doesn't carry any current at all. There is no field cancellation at all. The shield has no effect whatsoever on either the generation of EMI or susceptibility to EMI. (It is, however, still effective as an electrostatic shield, or at least it would be if the shield coverage were 100%.)



HOOK-UP NOTES

Figure 6B shows the situation when the cable is grounded at both ends. Does the shield carry all of the return current, or only a portion of it on account of the shunting effect of the common ground connection? The answer to that question depends on the frequency content of the signal. In general, the current loop will follow the path of least impedance. At low frequencies, 0 Hz to several kilohertz, where the inductive reactance is insignificant, the current will follow the path of least resistance. Above a few kilohertz, where inductive reactance predominates, the current will follow the path of least inductance. The path of least inductance is the path of minimum loop area. Hence, for higher frequencies the shield carries virtually the same current as the center conductor, and is therefore effective against both generation and reception of EMI.

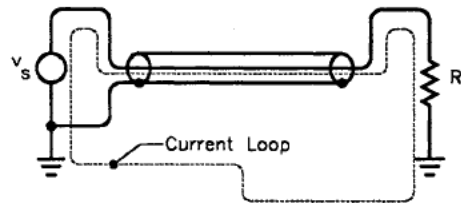

(a) Shield Has No Effect

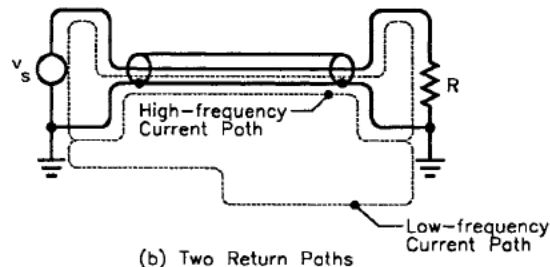

(b) Two Return Paths

Figure 6. Use of coaxial cable.

Note that we have now introduced the infamous “ground loop” problem, as shown in Fig. 7A. Fortunately, a digital system has some built-in immunity to moderate ground loop noise. In a noisy environment, however, you can break the ground loop and still maintain the shielding effectiveness of the coaxial cable by inserting an optical coupler, as shown in Fig. 7B. What the optical coupler does, basically, is allow you to redefine the signal source as being ungrounded, so that the optically coupled end of the cable need not be grounded; this still lets the shield carry the same current as the center conductor. Obviously, if the signal source weren’t grounded in the first place, the optical coupler wouldn’t be needed.

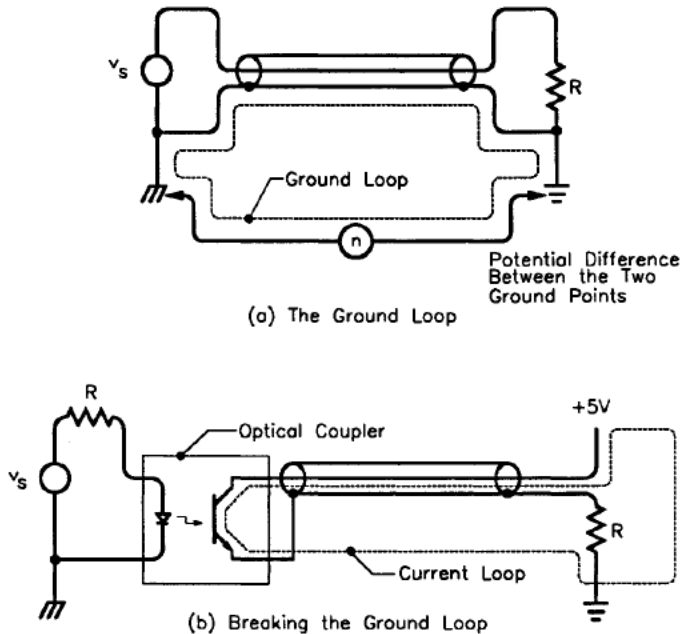

Figure 7. Use of optical coupler.

The Twisted Pair. A cheaper way to minimize loop area is to run the feed and return wires right next to each other. This isn't as effective as a coaxial cable in minimizing loop area. An ideal coaxial cable adds zero area to the loop, whereas merely keeping the feed and return wires next to each other is bound to add a finite area.

However, two things work to make this cheaper method almost as good as a coaxial cable. First, coaxial cables are not ideal. If the shield current isn't evenly distributed around the center conductor at every cross-section of the cable (it isn't), then field cancellation external to the shield is incomplete. Since field cancellation is incomplete, the effective area added to the loop by the cable isn't zero. Second, in the cheaper method the feed and return wires can be twisted together. This not only maintains their proximity, but the noise picked up in one twist tends to cancel out the noise picked up in the next twist down the line. Thus the "twisted pair" turns out to be about as good a shield against inductive coupling as coaxial cable is.

The twisted pair does not, however, provide electrostatic shielding (i.e., shielding against capacitive coupling). Another operational difference is that the coaxial cable works better at higher frequencies. This is primarily because



the twisted pair adds more capacitive loading to the signal source than does the coaxial cable. The twisted pair is normally considered useful up to only about 1 MHz; the coaxial cable is considered useful up to 1 GHz.

RF Shielding

A time-varying electric field generates a time-varying magnetic field, and vice versa. Far from the source of a time-varying EM field, the ratio of the amplitudes of the electric and magnetic fields is always 377Ω . Up close to the source of the fields, however, this ratio can be quite different, and dependent on the nature of the source. The field where the ratio is near 377Ω is called the far field, and the field where the ratio is significantly different from 377Ω is called the near field. The ratio itself is called the wave impedance, E/H .

The near field goes out about one-sixth of a wavelength from the source. At 1MHz this is about 150 ft., and at 10 MHz it's about 15 ft. That means that if an EMI source is in the same room with the victim circuit, it's likely to be a near field problem. The reason this matters is that in the near field an RF interference problem could be almost entirely due to E-field coupling or H-field coupling, and that could influence the choice of an RF shield or whether an RF shield will help at all.

In the near field of a whip antenna, the E/H ratio is higher than 377Ω , which means it's mainly an E-field generator. A wire-wrap post can be a whip antenna. Interference from a whip antenna would be by electric field coupling, which is basically capacitive coupling. Methods to protect a circuit from capacitive coupling, such as a Faraday shield, would be effective against RF interference from a whip antenna. A gridded-ground structure would be less effective.

In the near field of a loop antenna, the E/H ratio is lower than 377Ω , which means it's mainly an H-field generator. Any current loop is a loop antenna. Interference from a loop antenna would be by magnetic field coupling, which is basically the same as inductive coupling. Methods to protect a circuit from inductive coupling, such as a gridded-ground structure, would be effective against RF interference from a loop antenna. A Faraday shield would be less effective.

A more difficult case of RF interference, near field or far field, may require a genuine metallic RF shield. The idea behind RF shielding is that time-varying EMI fields induce currents in the shielding material. The induced currents dissipate energy in two ways: I^2R losses in the shielding material and radiation losses as they re-radiate their own EM fields. The energy for both of these mechanisms is drawn from the impinging EMI fields —thus the EMI is weakened as it penetrates the shield.

More formally, the I^2R losses are referred to as absorption loss, and the re-radiation is called reflection loss. As it turns out, absorption loss is the primary shielding mechanism for H-fields, and reflection loss is the primary shielding mechanism for E-fields. Reflection loss, being a surface phenomenon, is pretty much independent of the thickness of the shielding material. Both loss mechanisms, however, are dependent on the frequency (ω) of the impinging EMI field, and on the permeability (μ) and conductivity (σ) of the shielding material. These loss mechanisms vary approximately as follows:

$$\text{reflection loss to an E-field (in dB)} \sim \log \frac{\sigma}{\omega \mu}$$

$$\text{absorption loss to an H-field (in dB)} \sim t \sqrt{\omega \sigma \mu}$$

Where:

t = the thickness of the shielding material.

The first expression indicates that 1) E-field shielding is more effective if the shield material is highly conductive and less effective if the shield is ferromagnetic, and 2) that low-frequency fields are easier to block than high-frequency fields. This is shown in Fig. 8.

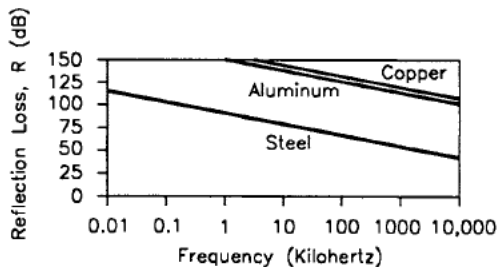

Figure 8. E-field shielding.

Copper and aluminum both have the same permeability, but copper is slightly more conductive, and so provides slightly greater reflection loss to an E-field. Steel is less effective for two reasons. First, it has a somewhat elevated permeability due to its iron content, and, second, as tends to be the case with magnetic materials, it is less conductive.

On the other hand, according to the expression for absorption loss to an H-field, H-field shielding is more effective at higher frequencies and with shield material that has both high conductivity and high permeability. In practice, however, selecting steel for its high permeability involves some compromise in conductivity. But the increase in permeability more than makes up for the



decrease in conductivity, as can be seen in Fig. 9. This figure also shows the effect of shield thickness.

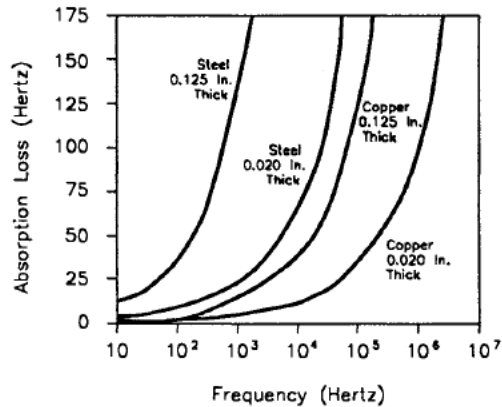

Figure 9. H-field shielding.

A composite of E-field and H-field shielding is shown in Fig. 10. However, this type of data is meaningful only in the far field. In the near field, the EMI could be 90% H-field, in which case the reflection loss is irrelevant. It would be advisable then to beef up the absorption loss, at the expense of reflection loss, by choosing steel. A better conductor than steel might be less expensive, but it would also be ineffective.

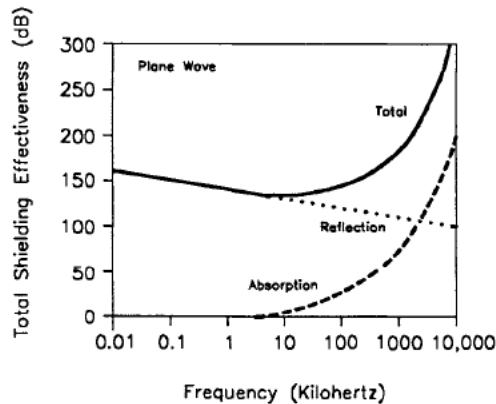

Figure 10. E- and H-field shielding.

A characteristic that can be exploited for low-frequency magnetic fields is the ability of a high-permeability material such as mumetal to divert the field by presenting a very low reluctance path to the magnetic flux. Above a few kilohertz, however, the permeability of such materials is the same as steel.

In actual fact the selection of a shielding material turns out to be less important than the presence of seams, joints and holes in the physical structure of the enclosure. The shielding mechanisms are related to the induction of currents in the shield material, but the currents must be allowed to flow freely. If they have to detour around slots and holes, as shown in Fig. 11, the shield loses much of its effectiveness.

As can be seen in Fig. 11, the severity of the detour has less to do with the area of the hole than it does with the geometry of the hole. Comparing Fig. 11C with Fig. 11D shows that a long narrow discontinuity such as a seam can cause more RF leakage than a line of holes with larger total area. A person who is responsible for designing or selecting rack or chassis enclosures for an EMI environment needs to be familiar with the techniques that are available for maintaining electrical continuity across seams. Information on these techniques is available in the references at the end of this note.

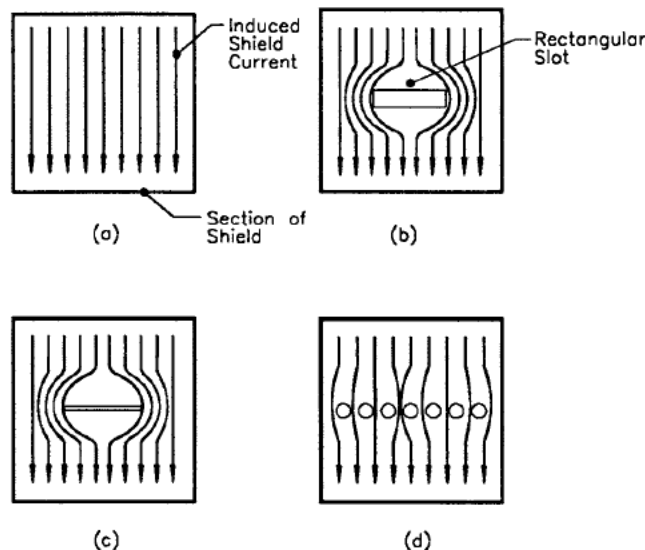

Figure 11. Effect of shield discontinuity on magnetically induced shield current.



Grounds

There are two kinds of grounds: earth ground (safety ground) and signal ground. The earth is not an equipotential surface, so earth-ground potential varies. In addition, its other electrical properties are not conducive to its use as a return conductor in a circuit. However, circuits are often connected to earth ground for protection against shock hazards. The other kind of ground, signal ground, is an arbitrarily selected reference node in a circuit—the node with respect to which other node voltages in the circuit are measured.

Earth Ground

The standard U.S. three-wire, single-phase ac power distribution system is represented in Fig. 12. The white wire is earth-grounded at the service entrance. If a load circuit has a metal enclosure or chassis, and if the black wire develops a short to the enclosure, there will be a shock hazard to operating personnel, unless the enclosure itself is earth-grounded. If the enclosure is earth-grounded, a short results in a blown fuse rather than a “hot” enclosure. The earth-ground connection to the enclosure is called a safety ground. The advantage of the three-wire power system is that it distributes a safety ground along with the power.

Note that the safety-ground wire carries no current, except in case of a fault, so that at least for low frequencies it's at earth-ground potential along its entire length. The voltage of the white wire, on the other hand, may be several volts different than the voltage of ground, due to the IR drop along its length.

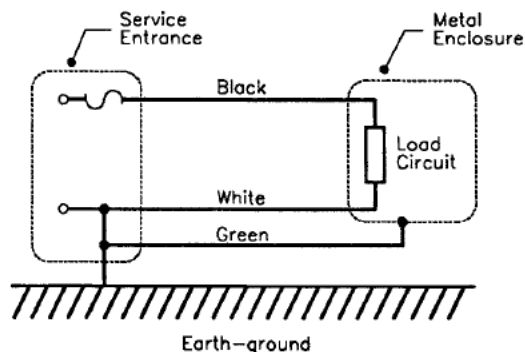

Figure 12. Single-phase power distribution.

In high-power systems and systems that radiate high levels of noise, it is common practice to provide each system with an individual earth-ground. This is done by driving a copper stake or stakes into the ground under or very close to the frame of the system, even to the extent of drilling holes through concrete floors.

In multistory buildings it is even more difficult to provide a low-impedance, secure connection to the earth. Many times this is done by using a copper pipe that provides water to the system. This practice is suspect because the water pipe may travel a considerable distance before making contact with the earth, and thus may have a relatively high impedance/resistance. In a multistory system, a heavy copper strap should connect the system frame to an earth-ground stake by the shortest possible path.

All earth-ground connections should be made with 1-1.5 in. copper strap whenever possible. This practice provides a low-impedance path for both dc and ac.

In many areas the soil is very dry and has high electrical resistance. This is cured by providing a grid of stakes or a mat of copper wires, and a means of continually wetting the earth around the stakes or grid.

In the past, the earth around the ground stake was saturated with copper sulfate. However, the toxicity of copper sulfate combined with its high solubility endangers groundwater supplies, and so this practice is now illegal. Other, nontoxic electrolytes are sometimes used, depending on local laws.

Signal Ground

Signal ground is a single point in a circuit that is designated to be the reference node for the circuit. Commonly, wires that connect to this single point are also referred to as "signal ground." In some circles "power supply common" or PSC is the preferred terminology for these conductors. In any case, the manner in which these wires connect to the actual reference point is the basis of distinction among three kinds of signal-ground wiring methods: series, parallel, and multipoint (shown in Fig. 13).

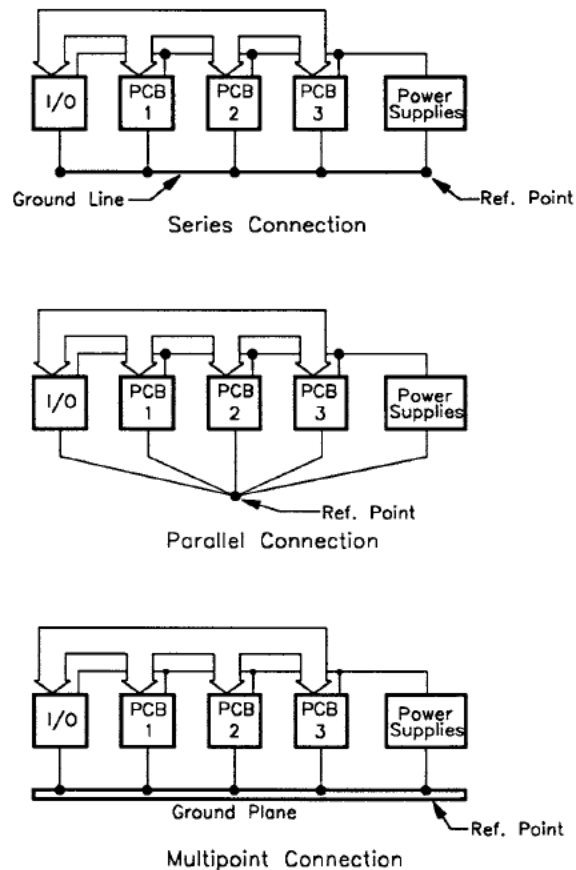

Figure 13. Three ways to wire the grounds.

The series connection is pretty common because it's simple and economical. It's the noisiest of the three, however, due to common-ground impedance coupling between the circuits. When several circuits share a ground wire, currents from one circuit, flowing through the finite impedance of the common ground line, cause variations in the ground potential of the other circuits. Given that the currents in a digital system tend to be spiked, and that the common impedance is mainly inductive reactance, the variations could be bad enough to cause bit errors in high current or particularly noisy situations.

The parallel connection eliminates common-ground impedance problems, but uses a lot of wire. Other disadvantages are that the impedance of the individual ground lines can be very high, and the ground lines themselves can become sources of EMI.

In the multipoint system, ground impedance is minimized by using a ground plane with the various circuits connected to it by very short ground leads. This type of connection would be used mainly in RF circuits above 10 MHz.

Practical Grounding

A combination of series and parallel ground-wiring methods can be used to trade off economic and electrical considerations. The idea is to run series connections for circuits that have similar noise properties, and connect them at a single reference point, as in the parallel method (shown in Fig. 14).

In Fig. 14, the “noisy and high current signal ground” connects to things like motors and relays. The hardware ground is the safety-ground connection to chassis, racks, and cabinets. It’s a mistake to use the hardware ground as a return path for signal currents because it’s fairly noisy (for example, it’s the hardware ground that receives an ESD spark) and tends to have high resistance due to joints and seams.

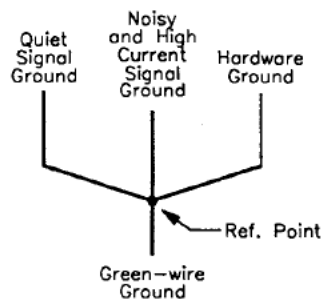

Figure 14. Parallel connection of series grounds.

Screws and bolts don’t always make good electrical connections because of galvanic action, corrosion, and dirt. These kinds of connections may work well at first, and then cause mysterious maladies as the system ages.



HOOK-UP NOTES

Figure 15 illustrates a grounding system for a typical power supply setup in a vacuum-process system, showing an application of the series/parallel ground-wiring method. Ground lines 1 and 2 are normally required by code but cannot be relied upon in high-power systems. Ground lines 3, 4, and 5 illustrate series grounding.

Ground lines 6 and 7 illustrate parallel grounding. They ensure that power supply 1 (PS1) and power supply 2 (PS2) are integral parts of the system grounding scheme (the utility connection is usually not a quality ground). Ground line 8 provides the primary system earth-ground connection.

Current return 9 ensures a current return path for the power supply output and should not be confused with the ground lines (1 through 8). See the typical applications discussed on pages 1-9 through 1-16 for instructions on how to connect this line with the earth-ground terminal.

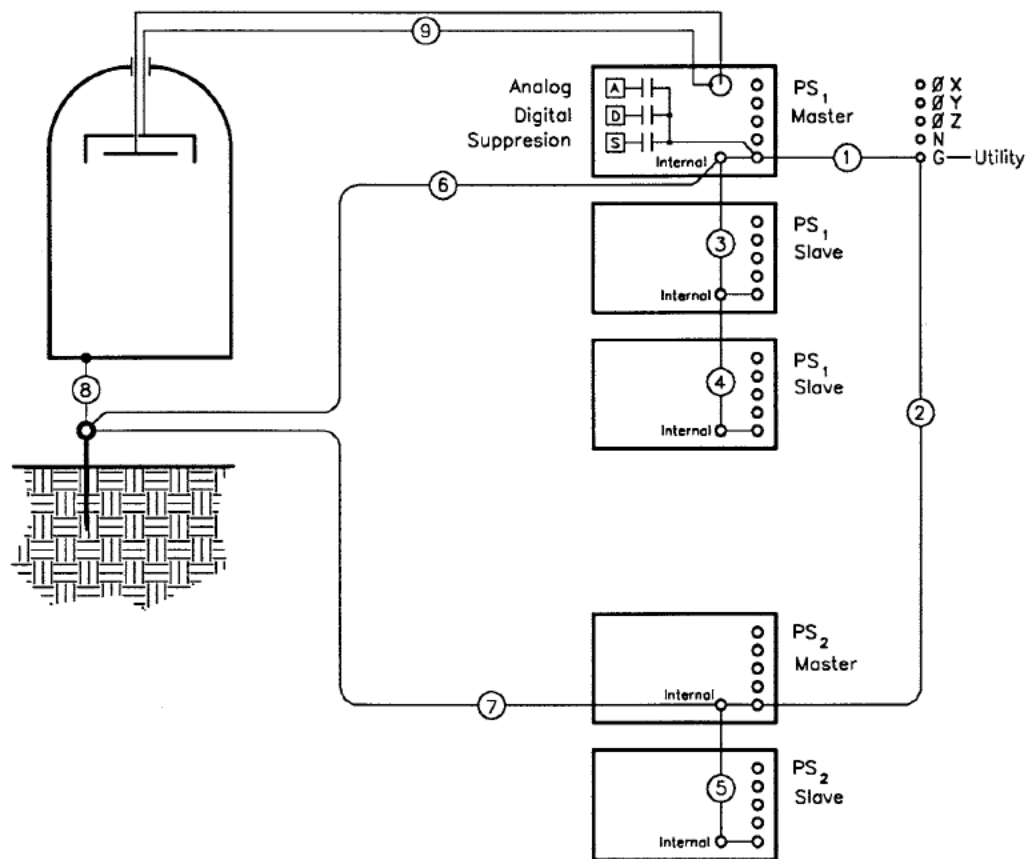

Figure 15. Grounding connections for power supplies in a process system.

The separation of grounds shown in Fig. 16 is similar to what is shown in Fig. 15, but here it is shown at the PCB level. Currents in multiplexed LED displays tend to put a lot of noise on the ground and supply lines because of the constant switching and changing involved in the scanning process. The segment driver ground is relatively quiet, since it doesn't conduct the LED currents. The digit-driver ground is noisier, and should be provided with a separate path to the PCB ground terminal, even if the PCB ground layout is gridded. The LED feed and return current paths should be laid out on opposite sides of the board like parallel flat conductors.

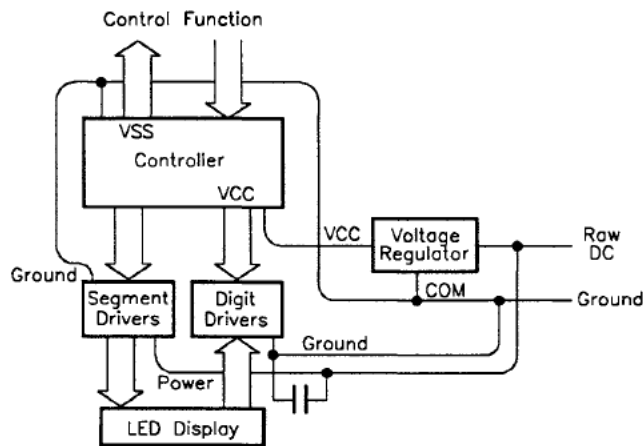

Figure 16. Separate ground for multiplexed LED display.

Figure 17 shows right and wrong ways to make ground connections in racks. Note that the safety ground connections from panel to rack are made through ground straps, not panel screws. Rack 1 correctly connects signal ground to rack ground only at the single reference point. Rack 2 incorrectly connects signal ground to rack ground at two points, creating a ground loop around points 1, 2, 3, 4, 1.

Breaking the "electronics ground" connection to point 1 eliminates the ground loop, but leaves signal ground in rack 2 sharing a ground impedance with the relatively noisy hardware ground to the reference point: In fact, it may end up using hardware ground as a return path for signal and power supply currents. This will probably cause more problems than the ground loop.

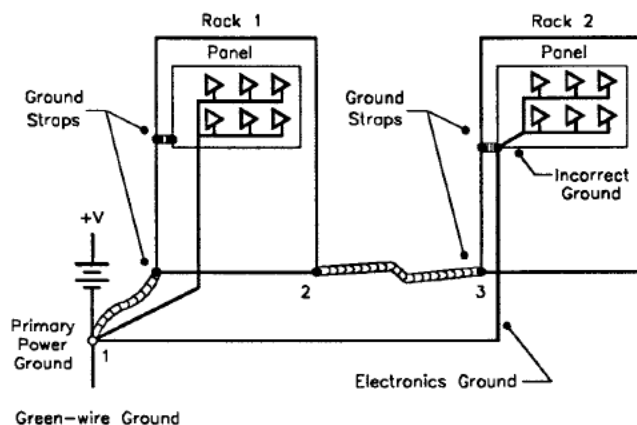

Figure 17. Electronic circuits mounted in equipment racks should have separate ground connections. Rack 1 shows correct grounding; rack 2 shows incorrect grounding.

Braided Cable

Ground impedance problems can sometimes be eliminated by using braided cable. The reduction in impedance is due to skin effect: At higher frequencies the current tends to flow along the surface of a conductor rather than uniformly through its bulk. While this effect tends to increase the impedance of a given conductor, it also indicates the way to minimize impedance—to manipulate the shape of the cross-section so as to provide more surface area. For its bulk, braided cable is almost pure surface.

Depending on the length of the cable and the actual frequencies involved, there may be situations where braided cable is not desirable. The individual strands of wire in the braided cable may present a high inductance to RF and actually impede current flow. For high-power RF applications, it is usually best to use a wide copper strap.



Glossary

Digital ground	Ground-line connections for nondifferential-input, paired signal wires. These wires are paired for noise-rejection purposes. The ground wire of the pair may be connected to an individual ground connection or to a common ground connection.
Data signal ground	
Analog signal ground	
Signal common	A return conductor (usually low current) common to several circuits.
Power common	
Common return	
RF return	The path or paths that RF energy uses to return to its source (such as an RF generator). RF energy is a surface phenomenon and may travel over the surface of insulated wires, chassis, frames, floors, or equipment faces. Special methods must be used to ensure that there is a solid earth-ground in systems that produce or use RF energy.
Ground	A terminal intended to ensure, by means of a special connection, the grounding (earthing) of part of an apparatus when properly connected to an earth electrode.
Earth ground	
Grounding conductor	The conductor that is used to establish ground and that connects a piece of equipment or device to the ground electrode.
Ground electrode	A conductor, group of conductors, mat, or grid, in intimate contact with the earth for the purpose of providing a connection with ground. This electrode determines the lowest ground potential for an electrical system.
Ground loop	A potentially detrimental loop formed when two or more points in an electrical system that are normally at ground potential are connected by an additional conducting path.

HOOK-UP NOTES

Earth resistivity	A measurement of the electrical resistance of a unit volume of soil. The common unit of measure is the ohm-meter, which is the resistance measured between faces of a cubic meter of soil by driving ground electrodes into the earth 1 m apart to a depth of 1 m.
Conducted interference	Interference resulting from conducted radio-frequency noise, switching spikes, lightning strikes, or conducted electrical noise (produced by the operation of other equipment) that enters equipment by direct coupling.
Radiated interference	Interference resulting from radiated electromagnetic energy that enters equipment.
Impedance	Symbol, Z. Unit, ohm (Ω). The total opposition offered by a circuit to the flow of ac current. It may be expressed as a vector sum of resistance (the "real" part) and reactance (the "imaginary" part), or as a magnitude and phase angle. Capacitive reactance increases as frequency decreases; inductive reactance increases as frequency increases.
Resistance	Symbol, R. Unit, ohm (Ω). The simple opposition to current flow. The "real" part of impedance. Defined as that factor by which the mean-square conduction current must be multiplied to determine the corresponding power lost by dissipation as heat or other permanent radiation loss of electromagnetic energy from the circuit.



Parting Thoughts

The references by Ott and by White were the main sources of information for the original article from which most of the material in this note was taken. According to that article, reference 4 "is probably the finest treatment currently available on the subject."

Courses and seminars on the subject of electromagnetic interference are given regularly throughout the year. Information on these can be obtained from:

IEEE Electromagnetic Compatibility Society

- EMC Education Committee
345 East 47th Street
New York, NY 10017
Phone: (212) 752-6800
- Don White Consultants, Inc.
International Training Centre
P. O. Box D
Gainesville, VA 22065
Phone: (703) 347-0030

The EMC Education committee has available a videotape: "Introduction to EMC — A Video Training Tape," by Henry Ott. Don White Consultants offers a series of training courses on many different aspects of electromagnetic compatibility. Most organizations that sponsor EMC courses also offer in-plant presentations.

Reprinted in part by permission of Intel Corporation, Copyright/Intel Corporation, 1982.

References

1. Clark, O.M. 1979. Electrostatic Discharge Protection Using Silicon Transient Suppressors. Proceedings of the Electrical Overstress/Electrostatic Discharge Symposium. Reliability Analysis Center, Rome Air Development Center.
2. King, W. M. and D. Reynolds. 1981. Personnel Electrostatic Discharge: Impulse Waveforms Resulting From ESD of Humans Directly and Through Small Hand-held Metallic Objects Intervening in the Discharge Path. In: Proceedings of the IEEE Symposium on Electromagnetic Compatibility, pp. 577-590.
3. Ott, H. 1981. Digital Circuit Grounding and Interconnection. In: Proceedings of the IEEE Symposium on Electromagnetic Compatibility, pp. 292-297.
4. Ott, H. 1976. Noise Reduction Techniques in Electronic Systems. New York: Wiley.
5. 1981 Interference Technology Engineers' Master (ITEM) Directory and Design Guide. R. and B. Enterprises, P. O. Box 328, Plymouth Meeting, PA 19426.
6. Smith, L. Nov. 1979. A Watchdog Circuit for Microcomputer Based Systems. Digital Design, pp. 78-79.
7. TranZorb Quick Reference Guide. General Semi-conductor Industries, P.O. Box 3078, Tempe, AZ 85281.
8. Tucker, T.J. 1968. Spark Initiation Requirements of a Secondary Explosive. Annals of the New York Academy of Sciences, Vol. 152, Article I, pp. 643-653.
9. White, D. 1973. Electromagnetic Interference and Compatibility, Vol. 3: EMI Control Methods and Techniques. Don White Consultants.
10. White, D. 1981. EMI Control in the Design of Printed Circuit Boards and Backplanes. Don White Consultants.

Troubleshooting Guide

These troubleshooting procedures assume that an Advanced Energy® control panel is connected to the power supply. The control panel can be mounted directly on the power supply or can be a remote panel. Below is a list of the most common problems you may encounter.



DANGER! The operating voltages of this power supply can be several thousand volts above or below ground. Use extreme caution when any part of the power supply, other than the control panel, is exposed. The voltages present inside the power supply are dangerous and can be lethal.

Wait at least 5 minutes after turning the power switch to the off position before attempting internal troubleshooting.

Whenever you make a change to the MDX output or need to check anything inside the power supply, first turn off the output and the circuit breaker.

<u>Problem/Fault Indication</u>	<u>Refer To</u>
Control panel LEDs off, circuit breaker on	Chart 1
INTERLOCK LEDs flashing	Chart 2
Output won't turn on from control panel	Chart 3
Output won't turn on from User I/O port	Chart 4
FAIL E-01 message	Chart 5
FAIL E-02 message	Chart 6
FAIL E-10 message	Chart 7
FAIL E-12 message	Chart 8
FAIL E-13 message	Chart 9
FAIL E-14 message	Chart 10
FAIL E-17 message	Chart 11
ARC LED lit	Chart 12
SETPOINT LED flashing	Chart 13
No output in power or current regulation	Chart 14
No output in voltage regulation	Chart 15
Output shuts off unexpectedly	Chart 16

Troubleshooting Guide

Chart 1. Control panel LEDs off, circuit breaker on.

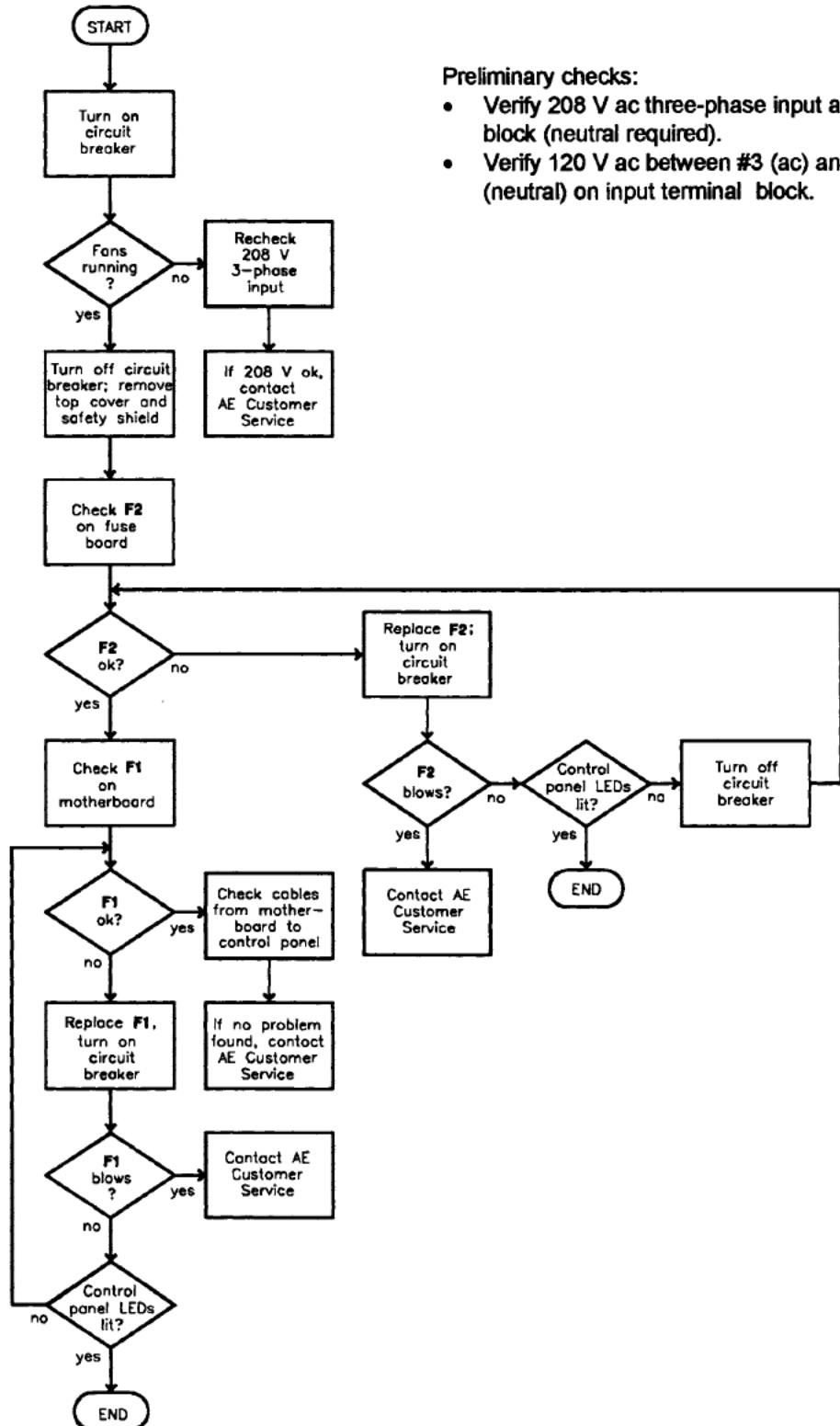

Preliminary checks:

- Verify 208 V ac three-phase input at terminal block (neutral required).
- Verify 120 V ac between #3 (ac) and #4 (neutral) on input terminal block.



Troubleshooting Guide

Chart 2. Interlock LEDs flashing.

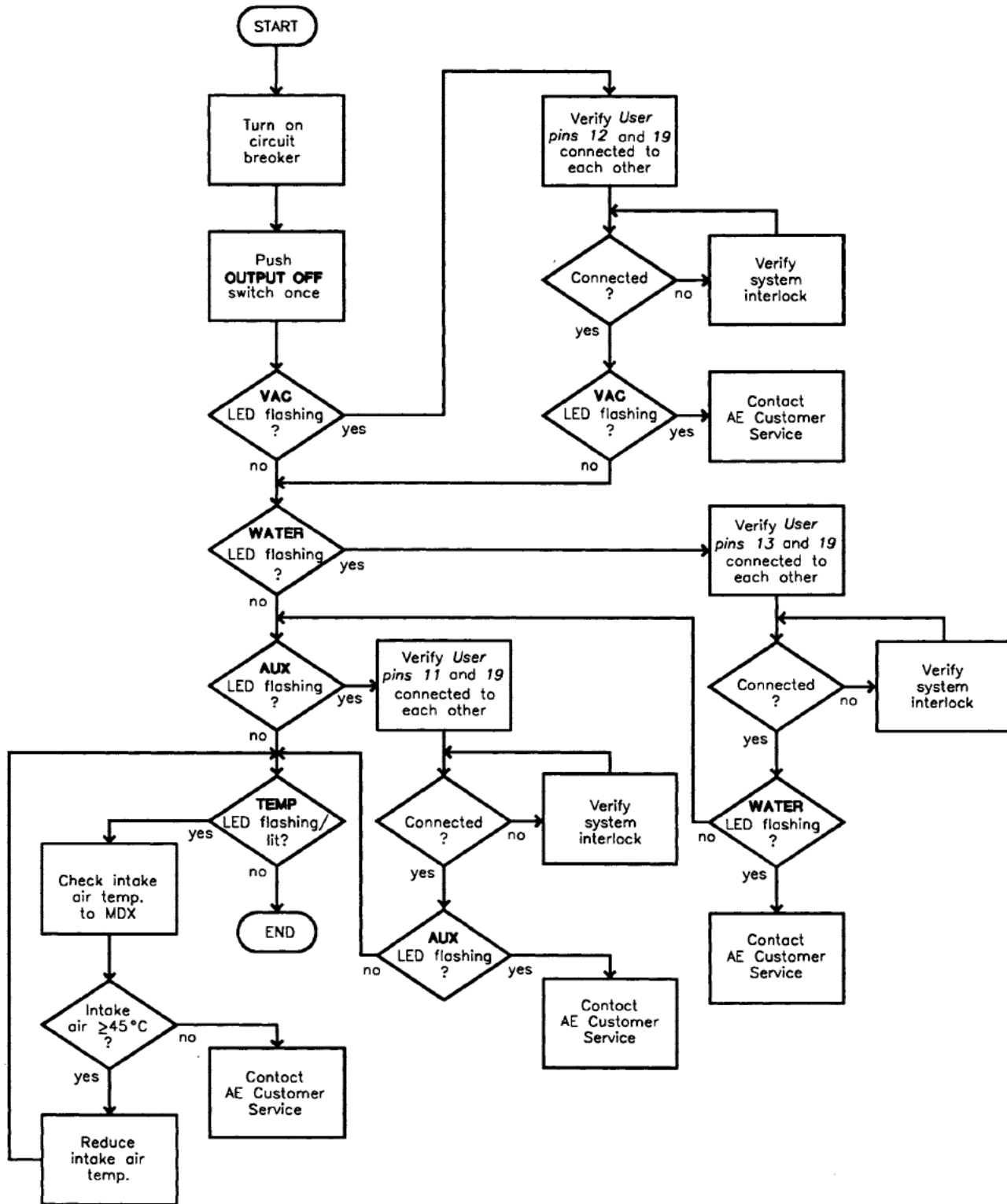

Troubleshooting Guide

Chart 3. Output won't turn on from control panel.

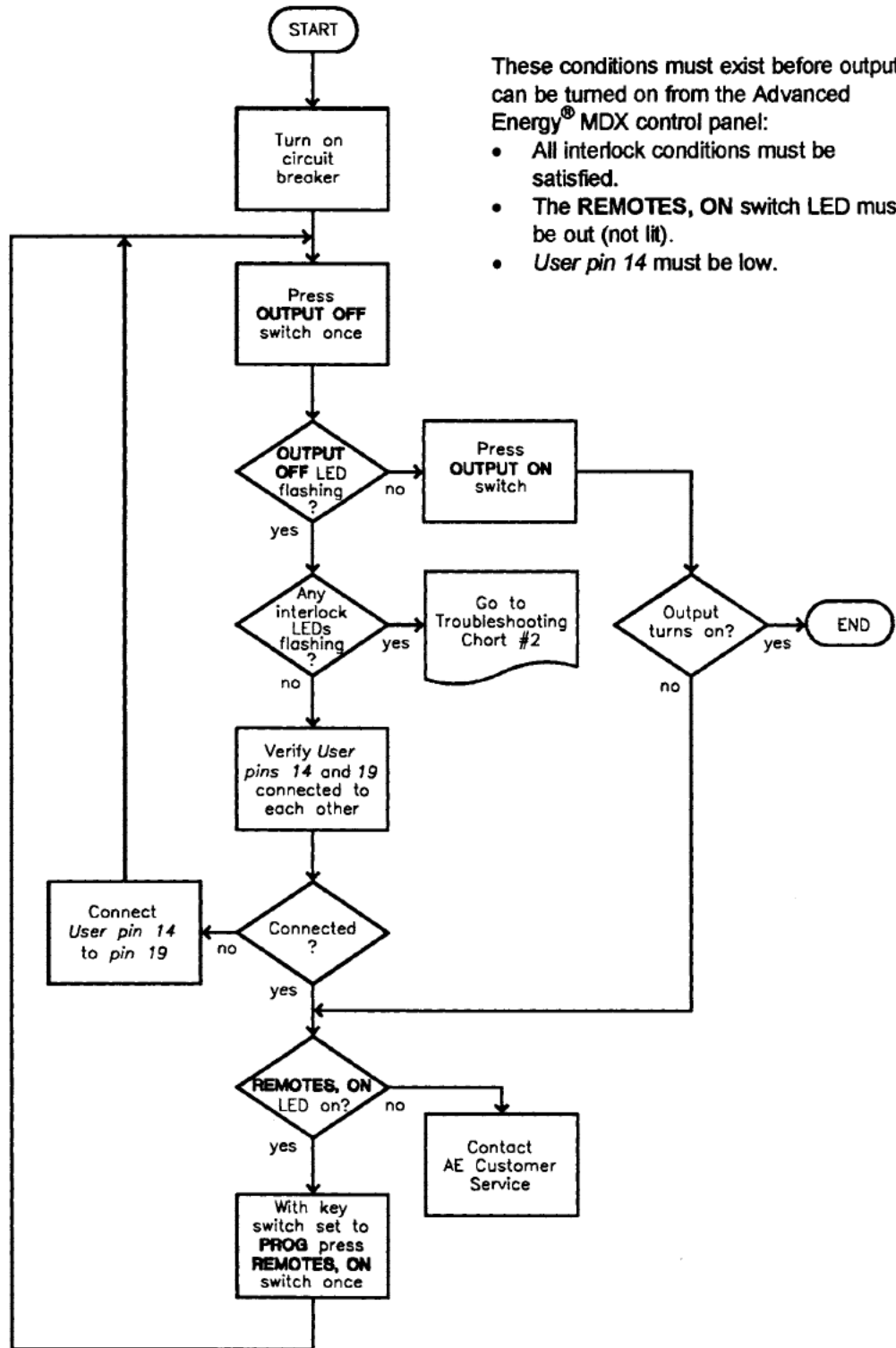



Troubleshooting Guide

Chart 4. Output won't turn on from User I/O port.

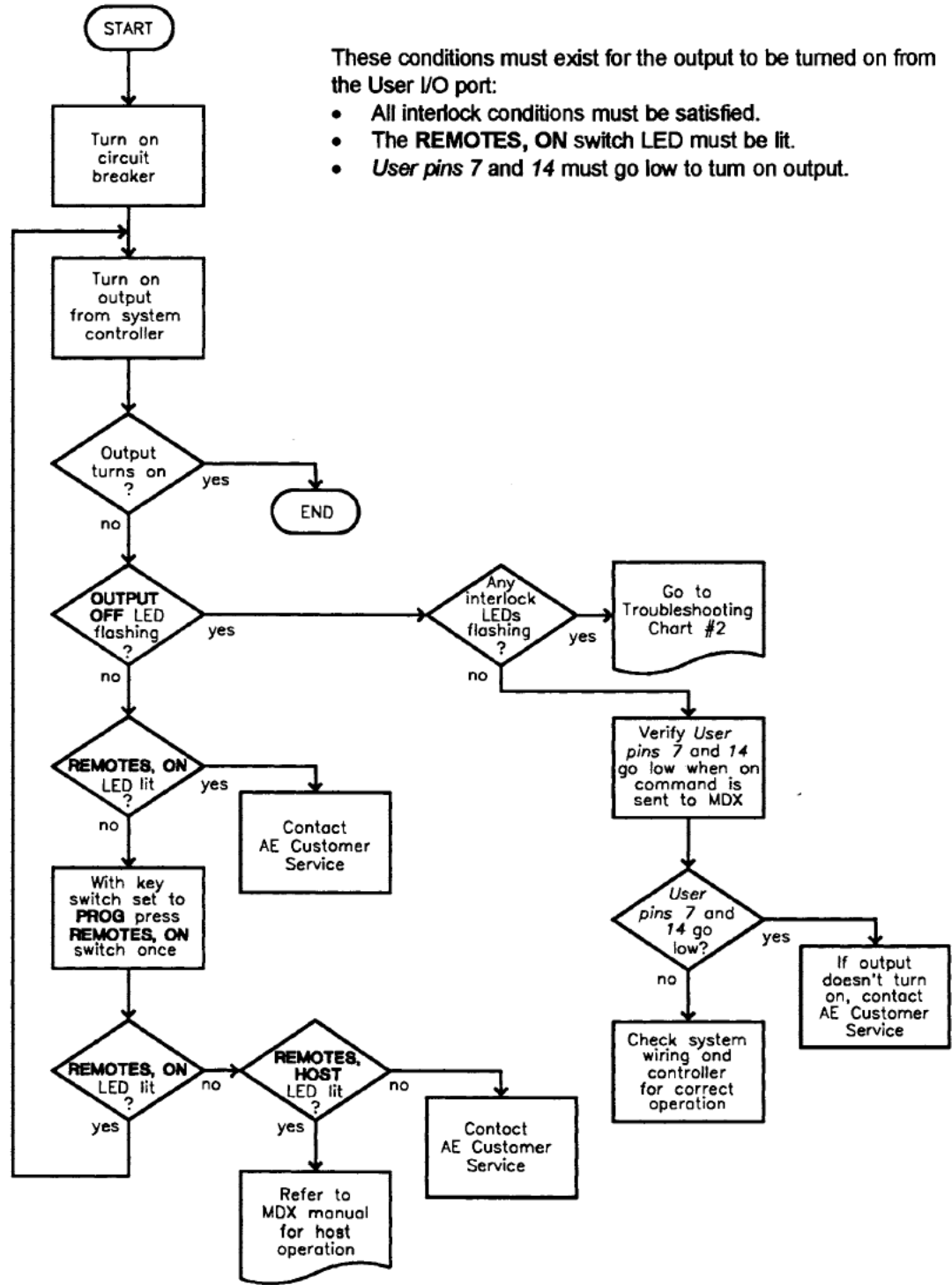

Troubleshooting Guide

Chart 5. FAIL E-01 Message.

Try to clear this message by pressing the **OUTPUT OFF** switch or turning the circuit breaker off and then on. Contact AE Customer Service if the problem continues.



Troubleshooting Guide

Chart 6. FAIL E-02 message.

This message indicates that one or more control panel switches are stuck "on." Make sure all switches are unstuck, and then press the **OUTPUT OFF** switch to clear the message. Contact AE Customer Service if the problem continues.

Troubleshooting Guide

Chart 7. FAIL E-10 Message.

The display panel and the control logic communicate by means of the RS-232 protocol. The "E-10" message indicates that the panel is not recognizing communications from the logic. The most common reason for this is noise. Try the following:

- Check the ac input line for noise and a good sine wave.
- Check the grounds and minimize induced noise.
- Check the routing and connection of the remote display cable.

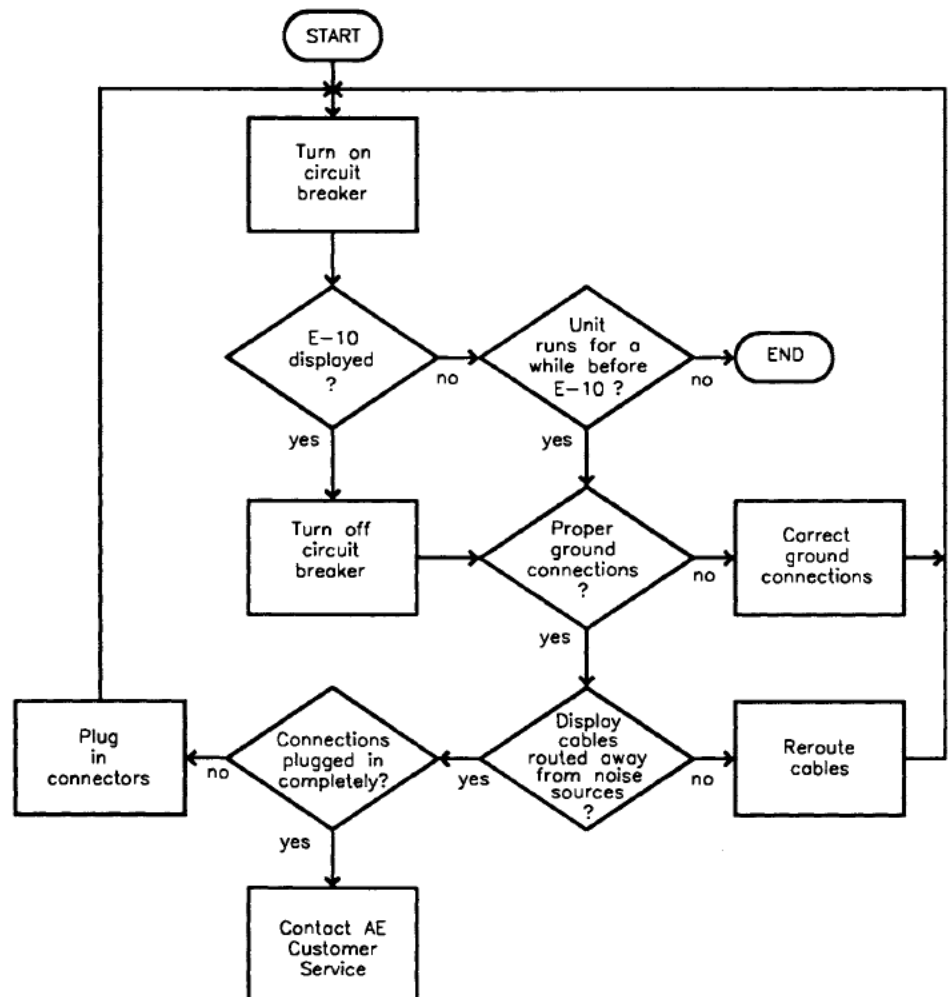



Troubleshooting Guide

Chart 8. FAIL E-12 message.

The MDX has an out-of-setpoint timer that is accessible when you hold down the **REGULATION, CURRENT** switch and momentarily press the **RIGHT DISPLAY, SETPT** switch. This timer tracks the amount of time that the MDX is unable to maintain output at the operator-specified setpoint level. The "E-12" message is displayed when the amount of time the MDX is "out of setpoint" exceeds an operator-specified amount of time.

Possible causes:

- The operator-specified time that the MDX can be out of setpoint is too short for output to turn on.
- Either the operator-specified time that the MDX can be out of setpoint is too short for the process or there is a problem with the process.

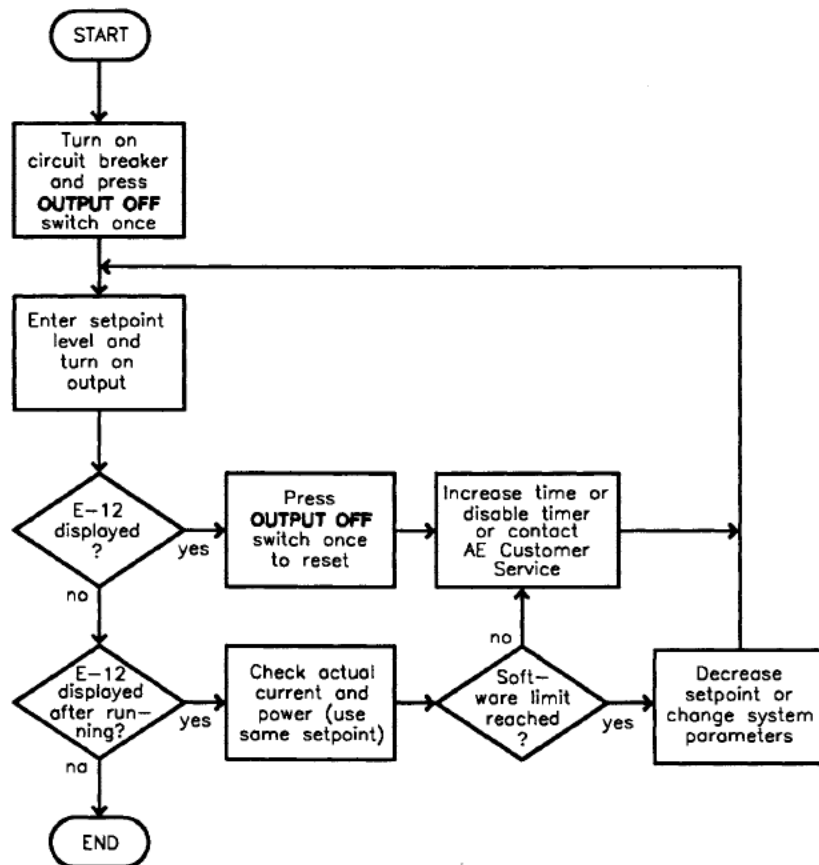

Troubleshooting Guide

Chart 9. FAIL E-13 Message.

This message indicates that the MDX has had a "soft start" failure. A soft start is a relatively slow charging of the high-voltage dc bus capacitor inside the MDX through an internal resistor. The high-voltage dc bus is used as the power source for the switching transistors that ultimately direct the power to the output. An "E-13" message indicates that the high-voltage dc bus capacitor has not reached the minimum level necessary for a soft start.

Things to try:

1. Make sure that the ac input line voltage is within AE's recommended specifications (see user manual), and check ground connections.
2. Check the soft start fuse (F1) on the fuse board inside the MDX.
3. Make sure that the main contactor closes when output is turned on (you should hear a loud snap when the contactor closes).
4. Check the MF1 and MF2 plug connections on the motherboard.
5. Check for the following sequence when output is turned on:
 - a. LED 1 (yellow) on the logic PCB lights
 - b. the main contactor closes (listen for loud snap)
 - c. LED 2 (red) on the logic PCB lights

If one or more of these things don't happen, contact AE Customer Service.

A troubleshooting flowchart appears on the next page.



Troubleshooting Guide

Chart 9. FAIL E-13 message (continued).

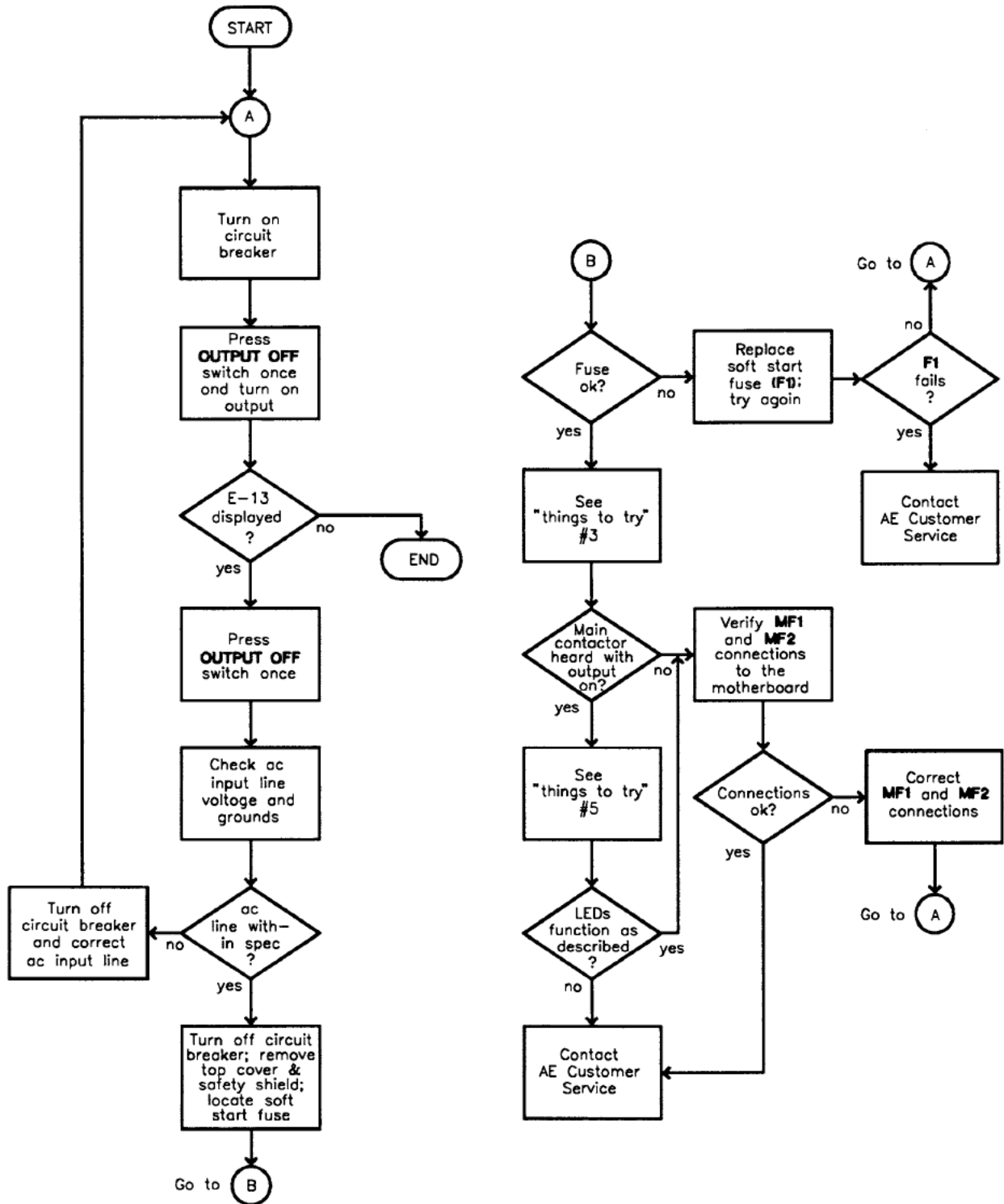

Troubleshooting Guide

Chart 10. FAIL E-14 Message.

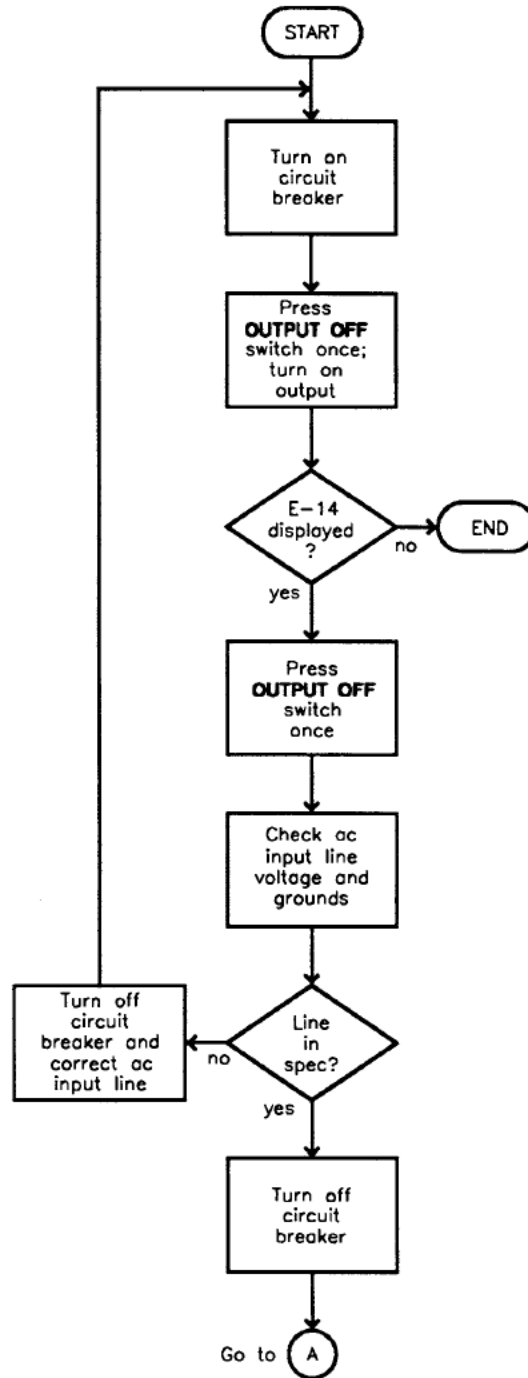

This message indicates that the internal high-voltage bus has exceeded an acceptable level. Things to try:

1. Check that the ac input line voltage meets AE's recommended specification (see user manual).
2. Check the ground connections.
3. Check for the following sequence when output is turned on:
 - a. LED 1 (yellow) on the logic PCB lights
 - b. the main contactor closes (listen for loud snap)
 - c. LED 2 (red) on the logic PCB lights

If one or more of these things don't happen, contact AE Customer Service.

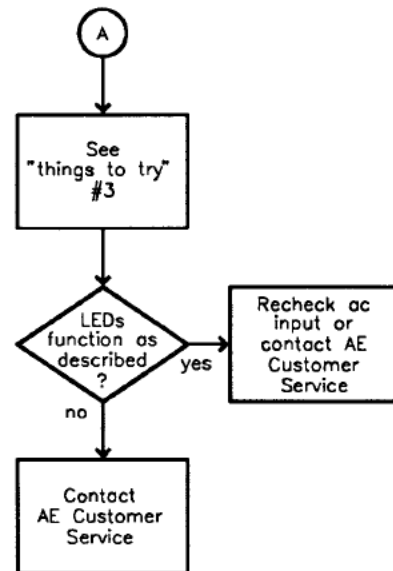



Troubleshooting Guide

Chart 11. FAIL E-17 message.

This message indicates that although satisfactory bus conditions were initially achieved, presently the bus voltage has dropped below an acceptable level.

Things to try:

1. Make sure that the ac input line voltage is within AE's recommended specifications (see user manual).
2. Check the ground connections.
3. Check for the following sequence when output is turned on:
 - a. LED 1 (yellow) on the logic PCB lights
 - b. the main contactor closes (listen for loud snap)
 - c. LED 2 (red) on the logic PCB lights

If one or more of these things don't happen, contact AE Customer Service (the cause may be a failed power module).

A troubleshooting flowchart appears on the next page.

Troubleshooting Guide

Chart 11. FAIL E-17 Message (continued).

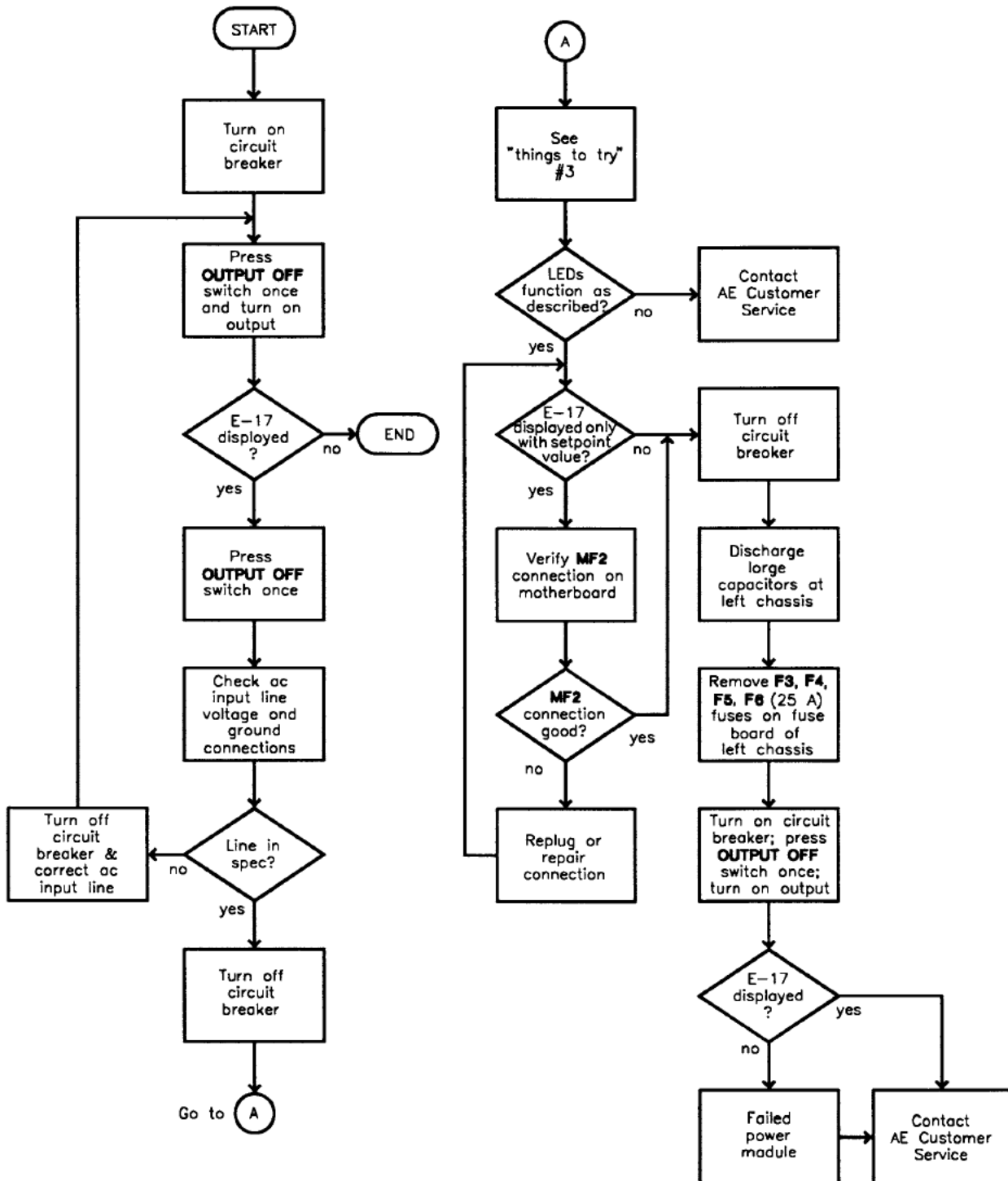



Troubleshooting Guide

Chart 12. ARC LED lit.

The **ARC LED** lights when the output of the MDX is recognizing an overcurrent condition. Possible causes:

1. short in the chamber
2. chamber feedthrough cracked
3. faulty connection
4. failed power module inside MDX (contact AE Customer Service)

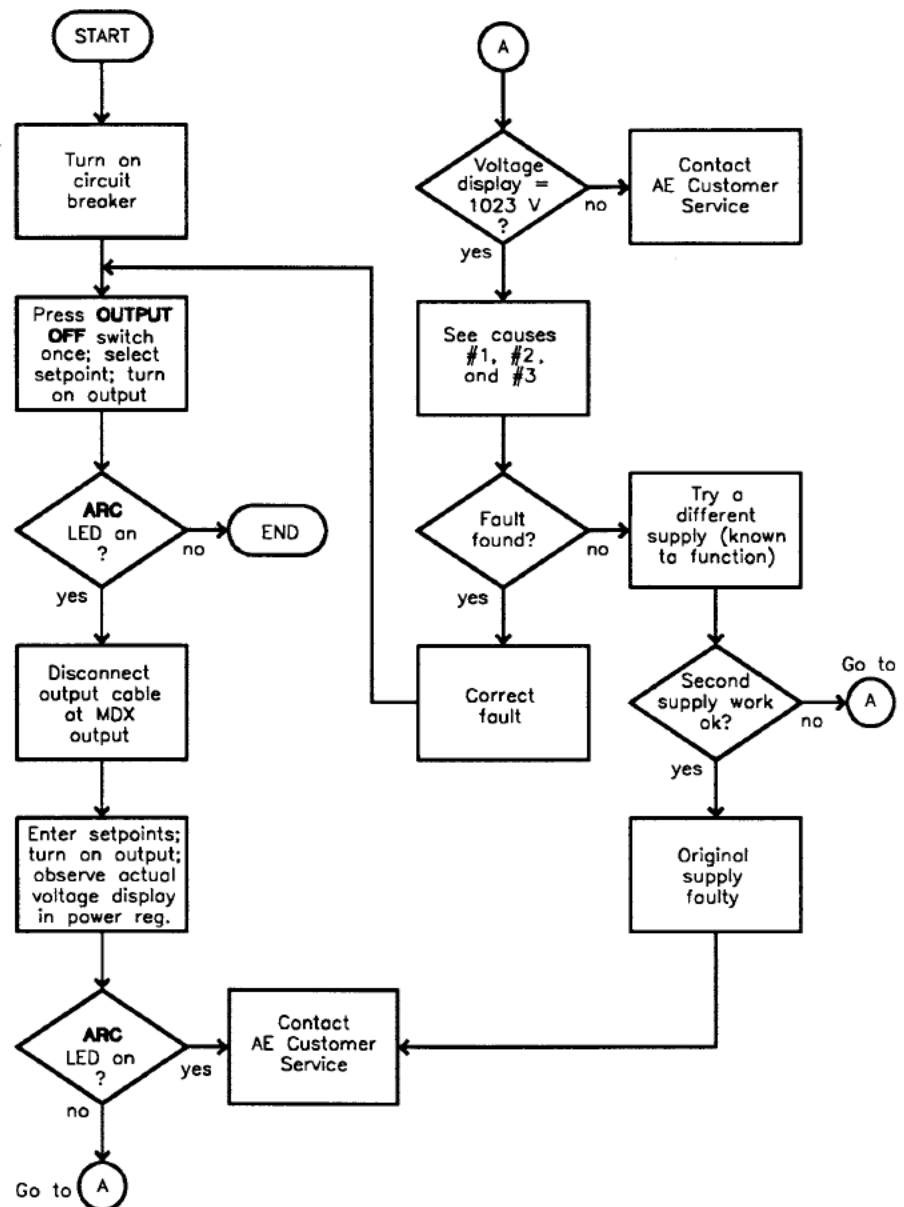

Troubleshooting Guide

Chart 13. SETPOINT LED flashing.

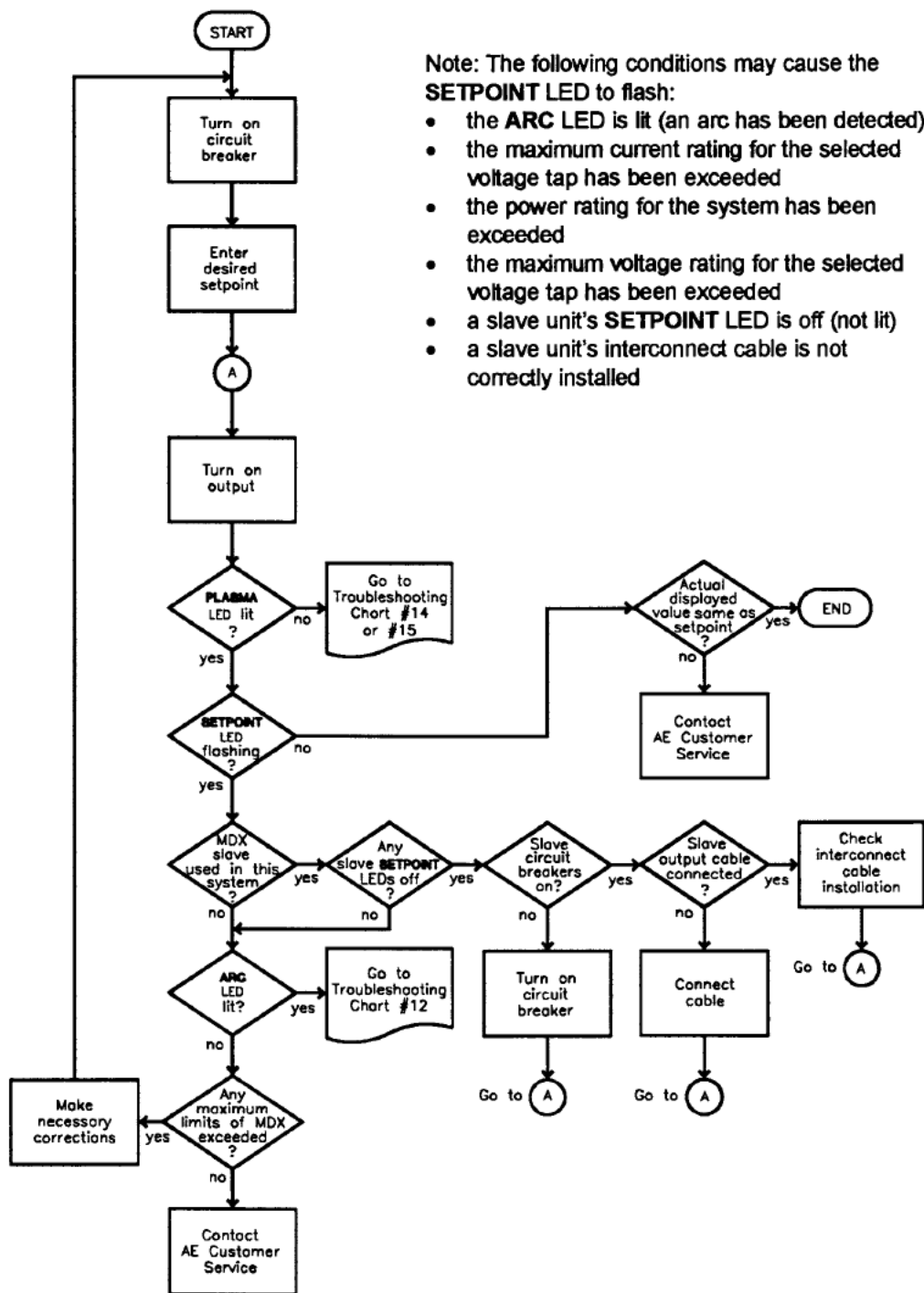



Troubleshooting Guide

Chart 14. No output in power or current regulation.

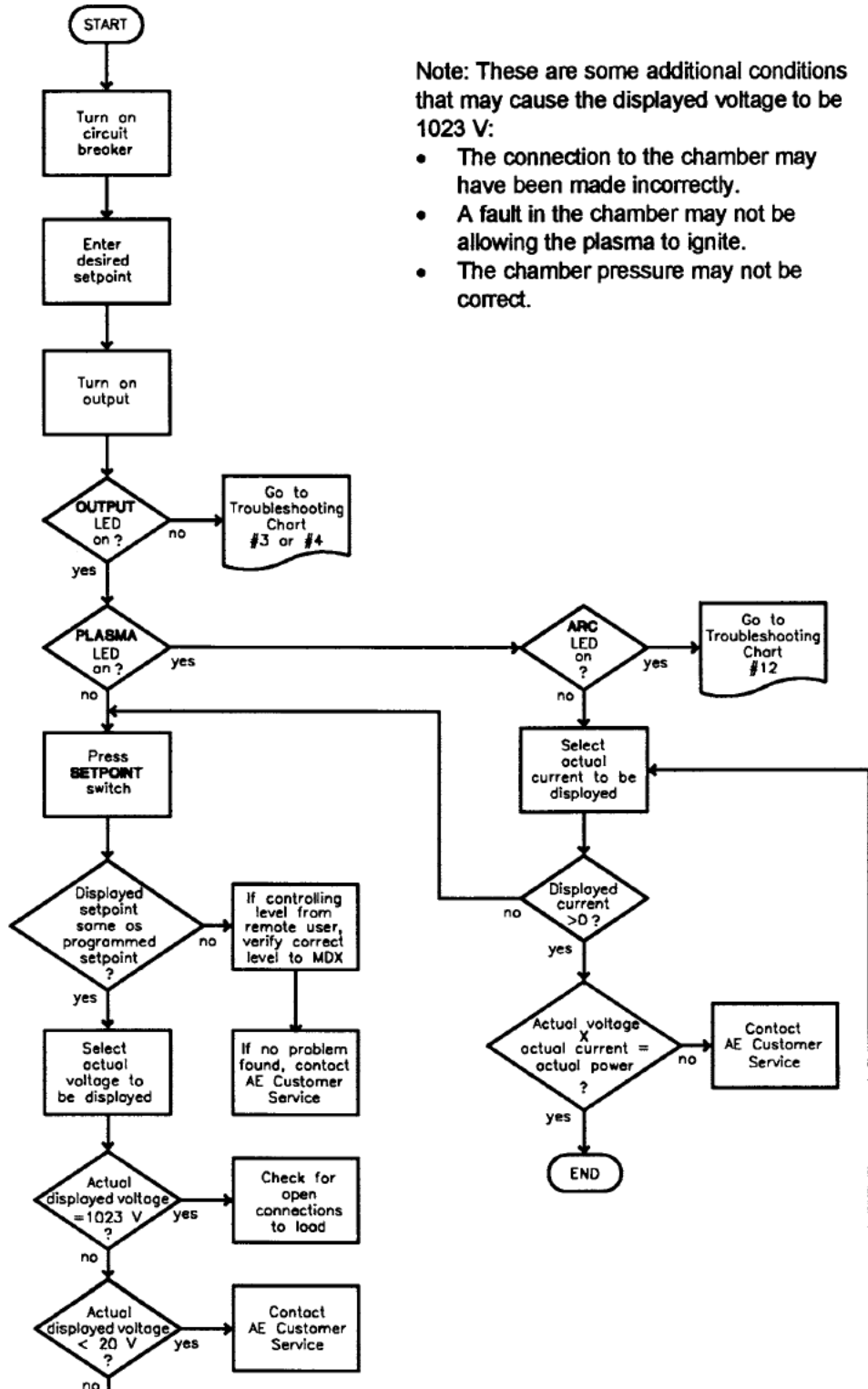

Note: These are some additional conditions that may cause the displayed voltage to be 1023 V:

- The connection to the chamber may have been made incorrectly.
- A fault in the chamber may not be allowing the plasma to ignite.
- The chamber pressure may not be correct.

Troubleshooting Guide

Chart 15. No output in voltage regulation.

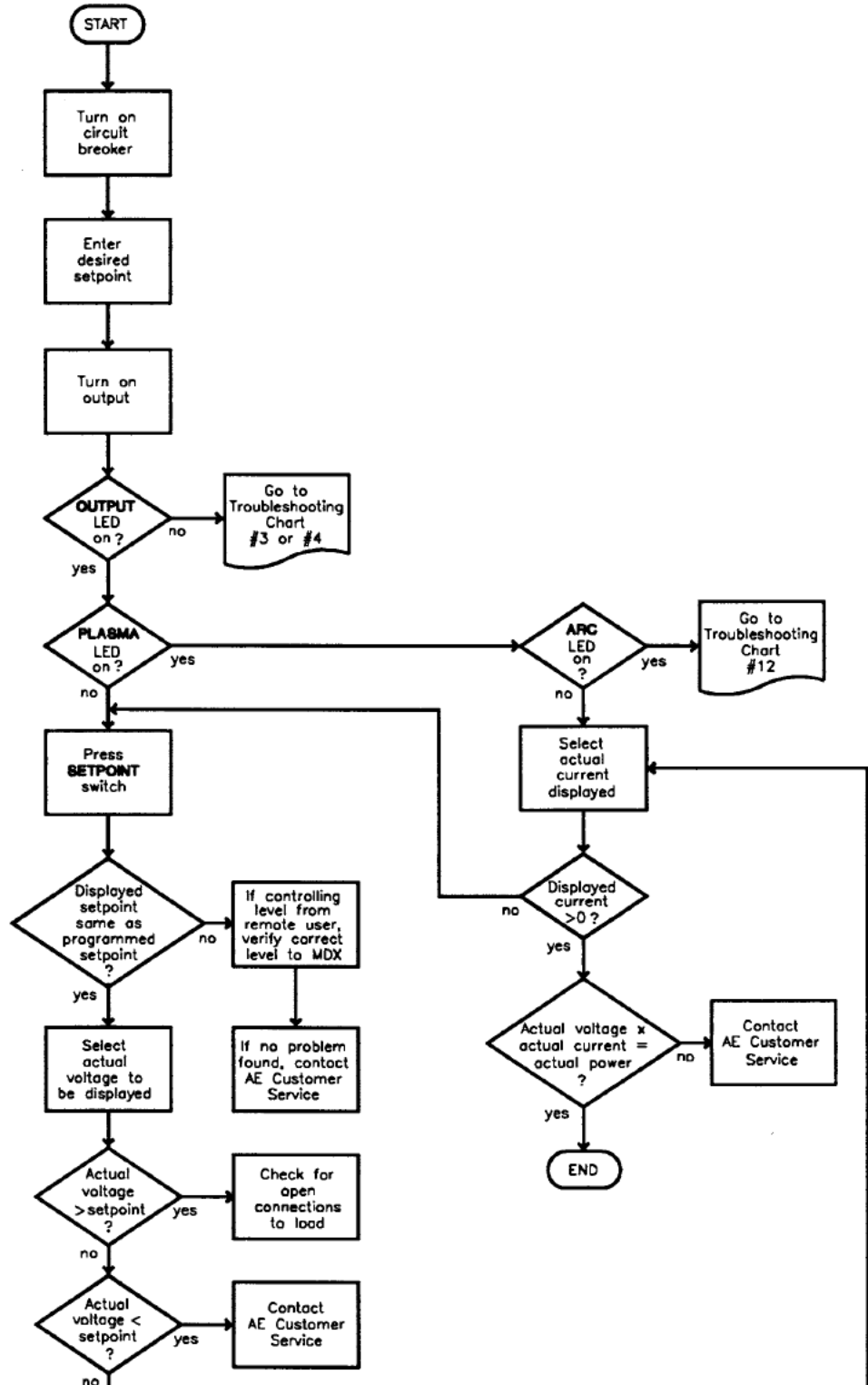

Trbl - 19



Troubleshooting Guide

Chart 16. Output shuts off unexpectedly.

Possible causes of output shutting off unexpectedly:

- The MDX ran for the user-specified amount of time and then turned off. the **OUTPUT OFF** switch LED will flash when the run time has ended.
- *User pin 14* goes high. The **OUTPUT OFF** switch LED flashes when this line is high.
- One or more interlock lines have gone high. The **INTERLOCK** LED and the **OUTPUT OFF** switch LED will flash when an interlock line is high.
- A condition has occurred that is causing "E-12," "E-13," "E-14," or "E-17" to be displayed.
- Control has been switched either to or away from a host controller. Output always shuts off when host-remote control is either selected or "de-selected."
- The intake air temperature has exceeded 45°C. The **TEMP** LED will flash (Advanced Energy[®] control panel) or light (Advanced Energy[®] passive front panel).
- The **remote on** function is disabled.

Troubleshooting Guide

Chart 16. Output shuts off unexpectedly (continued).

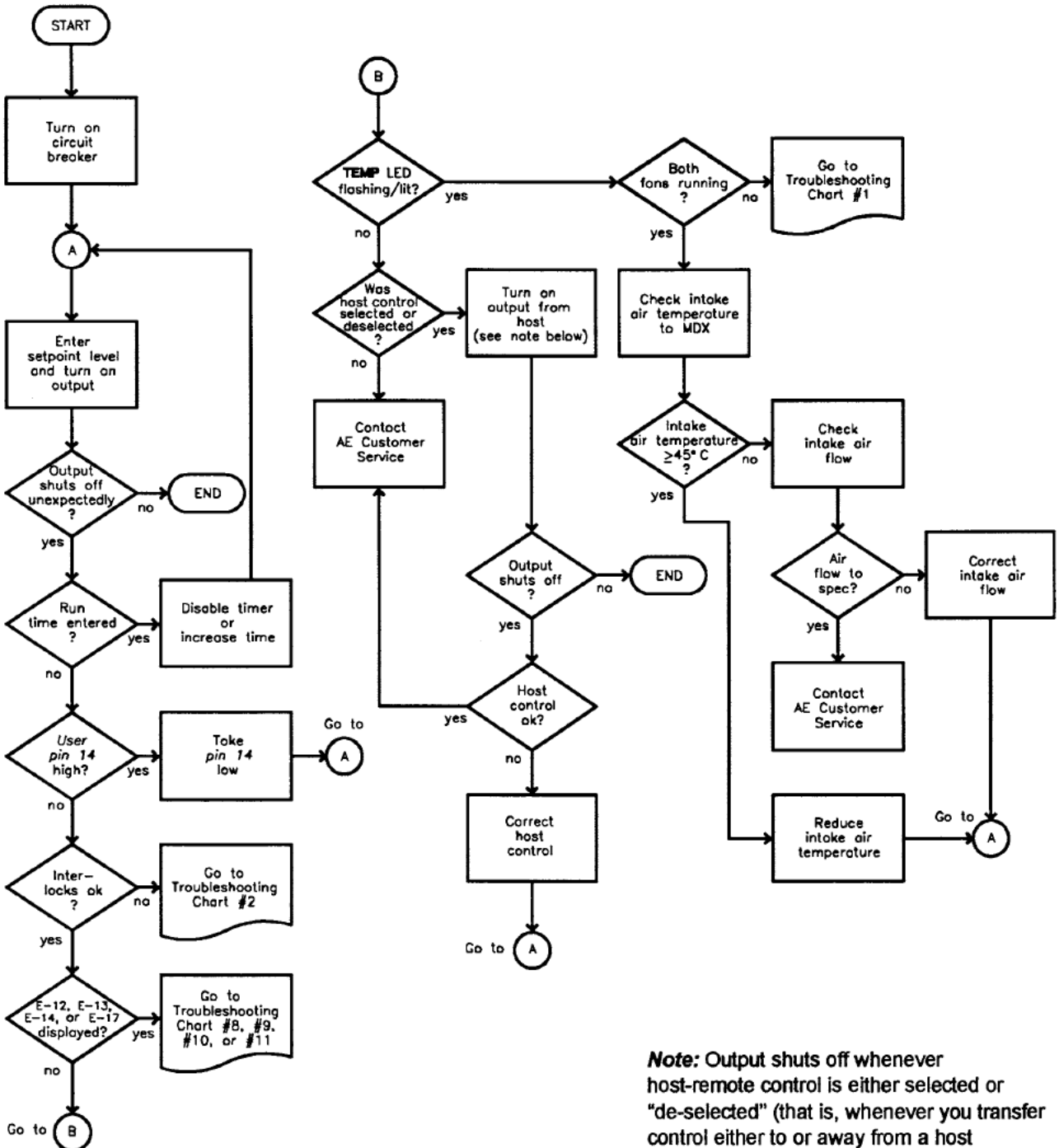



APPENDIX



APPENDIX

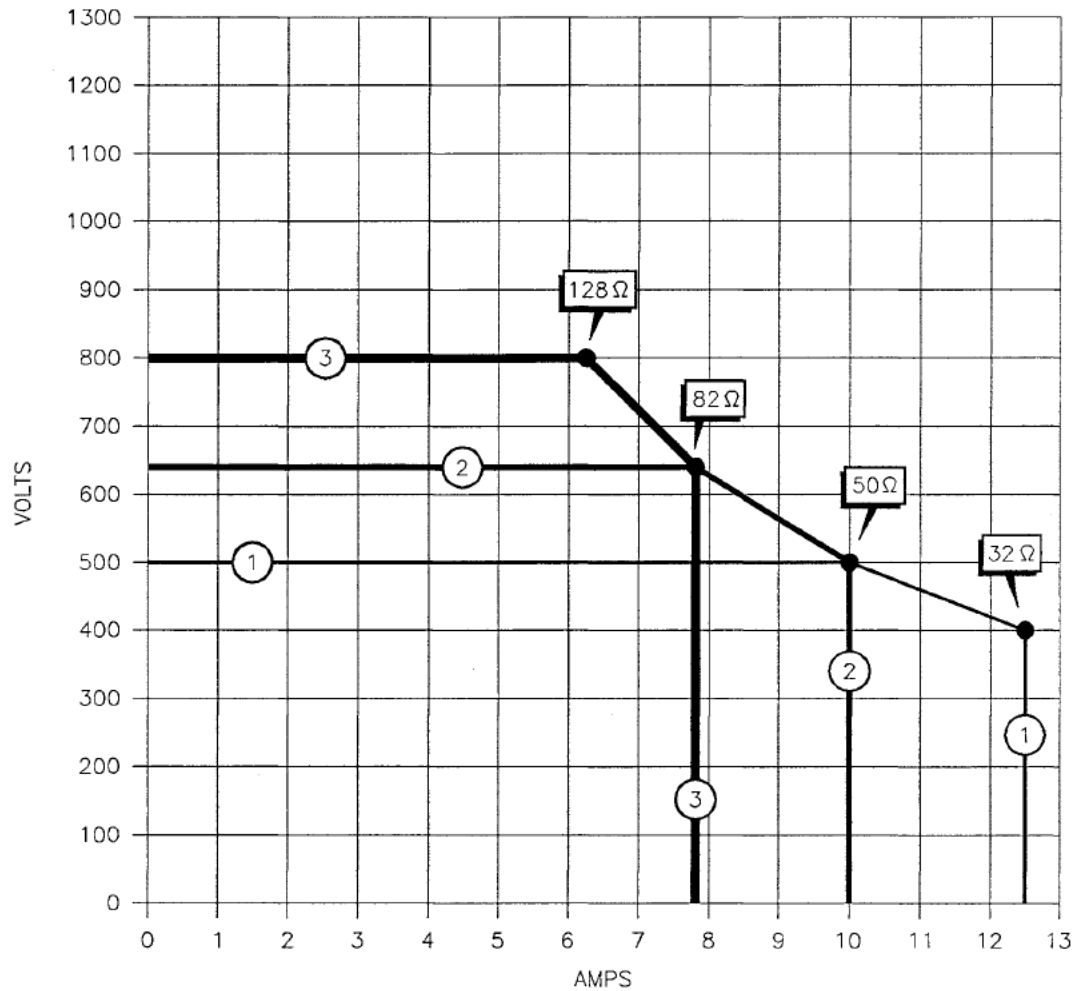

Figure A-1. Voltage and current limits for an MDX model 5K, "low Z" configuration. Each numbered "envelope" shows the boundaries for each of the three available taps. The impedance ranges for the taps are shown by the four labeled arrows. Note: The voltage may actually be slightly higher than shown here if the MDX is operating in current or power regulation. See the impedance-range graph in Fig. A-19.

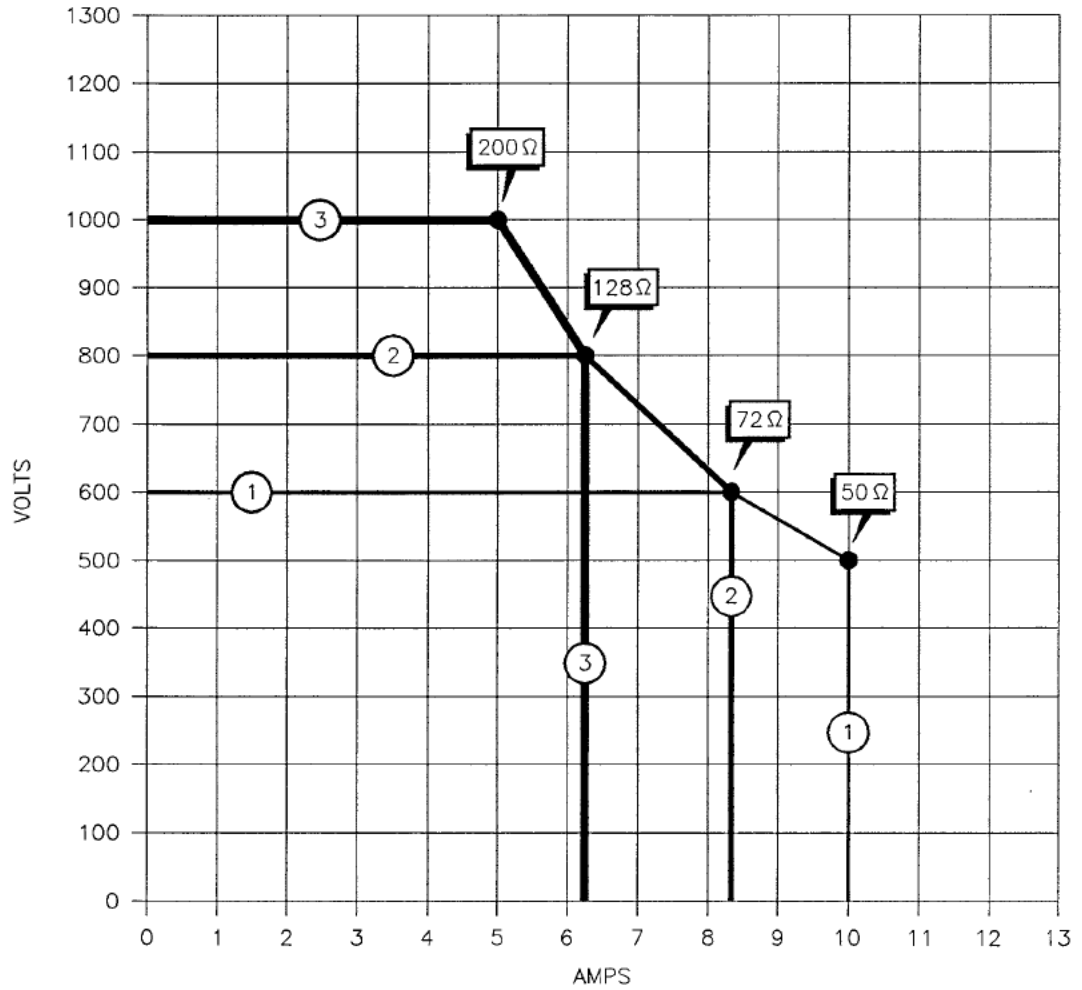

Figure A-2. Voltage and current limits for an MDX model 5K, "standard Z" configuration. Each numbered "envelope" shows the boundaries for each of the three available taps. The impedance ranges for the taps are shown by the four labeled arrows. Note: The voltage may actually be slightly higher than shown here if the MDX is operating in current or power regulation. See the impedance-range graph in Fig A-20.

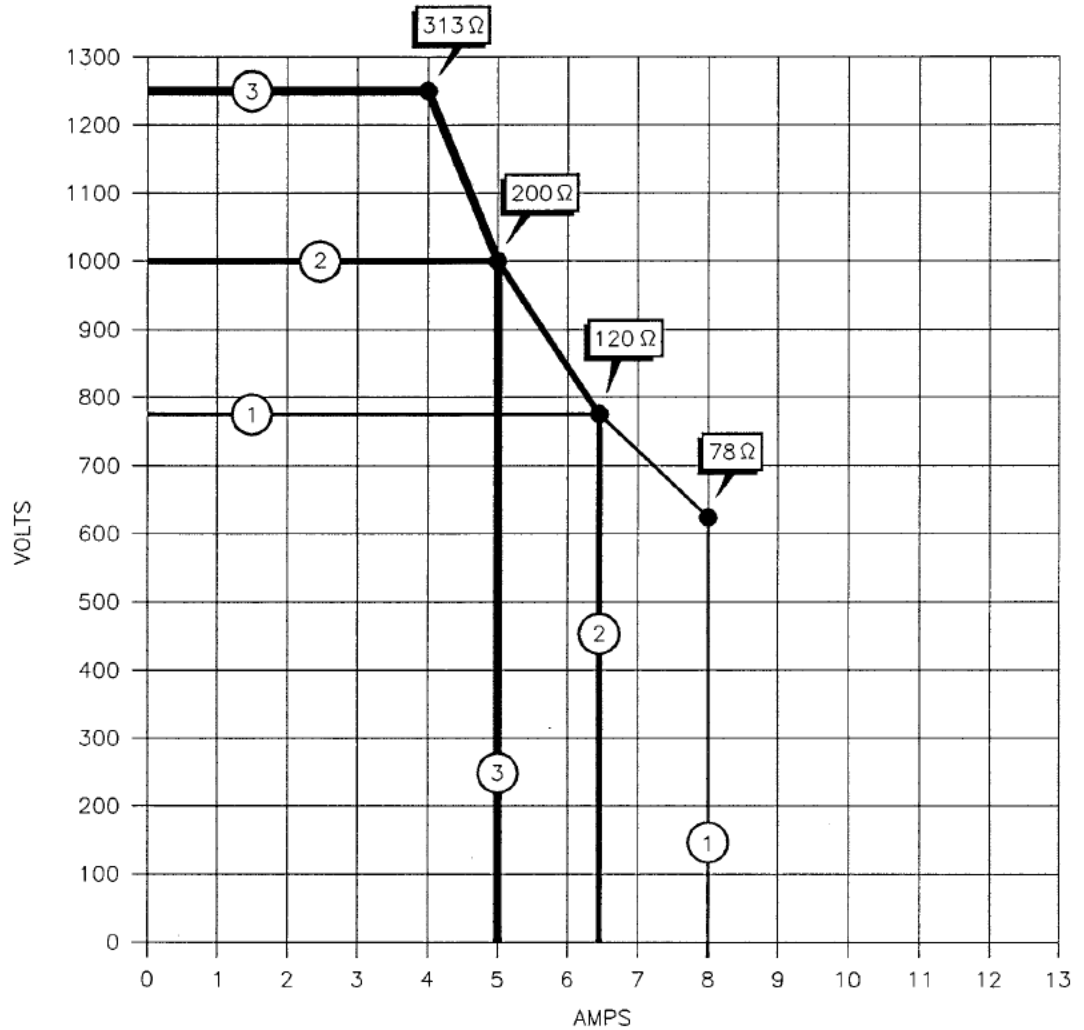

Figure A-3. Voltage and current limits for an MDX model 5K, "high Z" configuration. Each numbered "envelope" shows the boundaries for each of the three available taps. The impedance ranges for the taps are shown by the four labeled arrows. Note: The voltage may actually be slightly higher than shown here if the MDX is operating in current or power regulation. See the impedance-range graph in Fig. A-21.

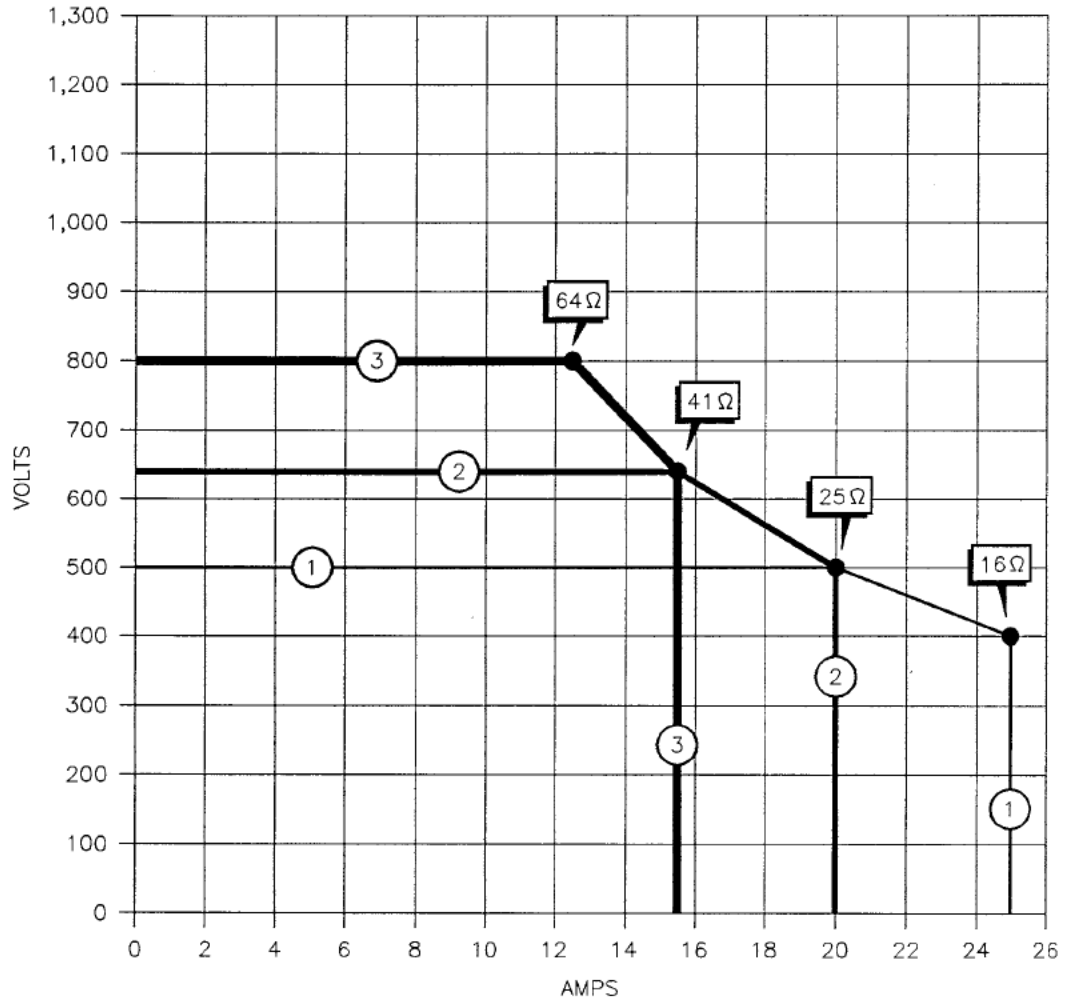

Figure A-4. Voltage and current limits for an MDX model 10K, "low Z" configuration. Each numbered "envelope" shows the boundaries for each of the three available taps. The impedance ranges for the taps are shown by the four labeled arrows. Note: The voltage may actually be slightly higher than shown here if the MDX is operating in current or power regulation. See the impedance-range graph in Fig. A-22.

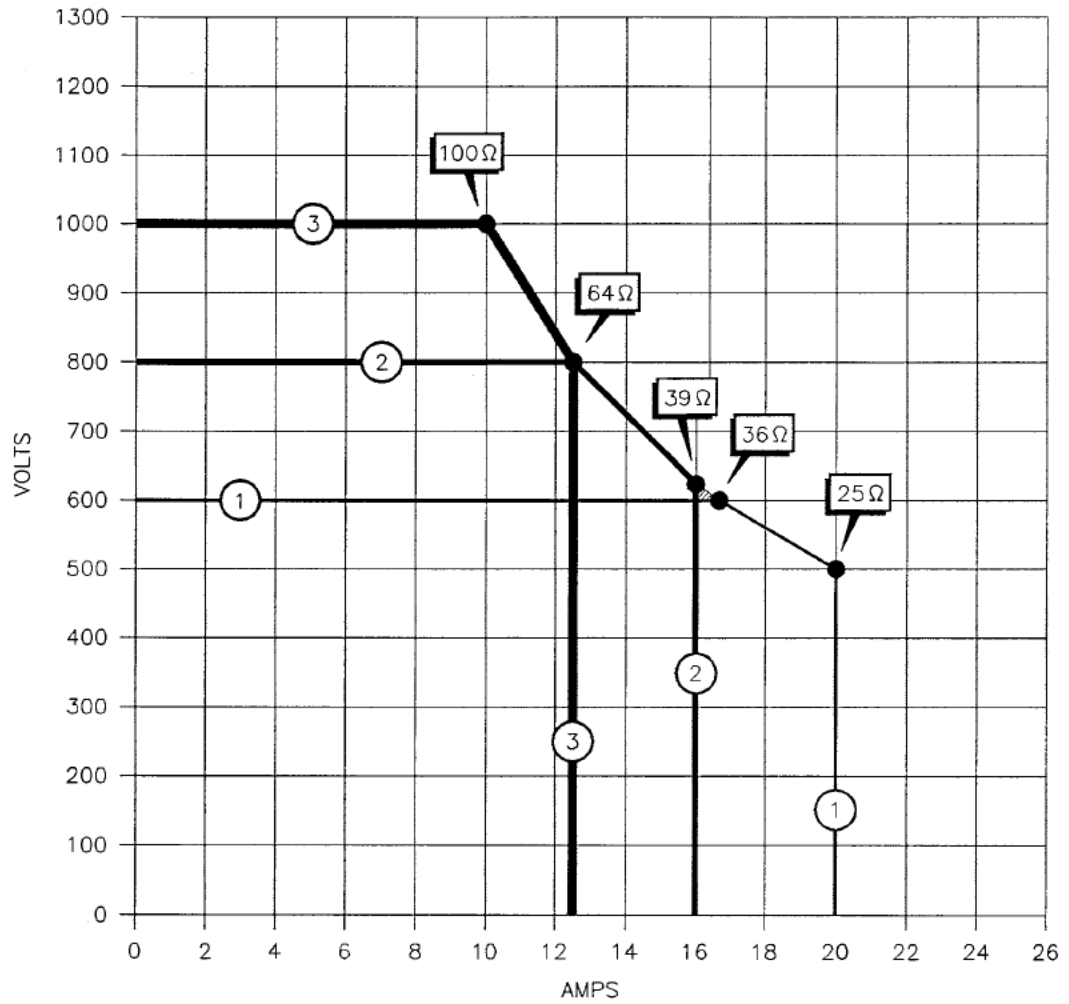

Figure A-5. Voltage and current limits for an MDX model 10K, "standard Z" configuration. Each numbered "envelope" shows the boundaries for each of the three available taps. The impedance ranges for the taps are shown by the four labeled arrows. Note: The voltage may actually be slightly higher than shown here if the MDX is operating in current or power regulation. See the impedance-range graph in Fig. A-23.

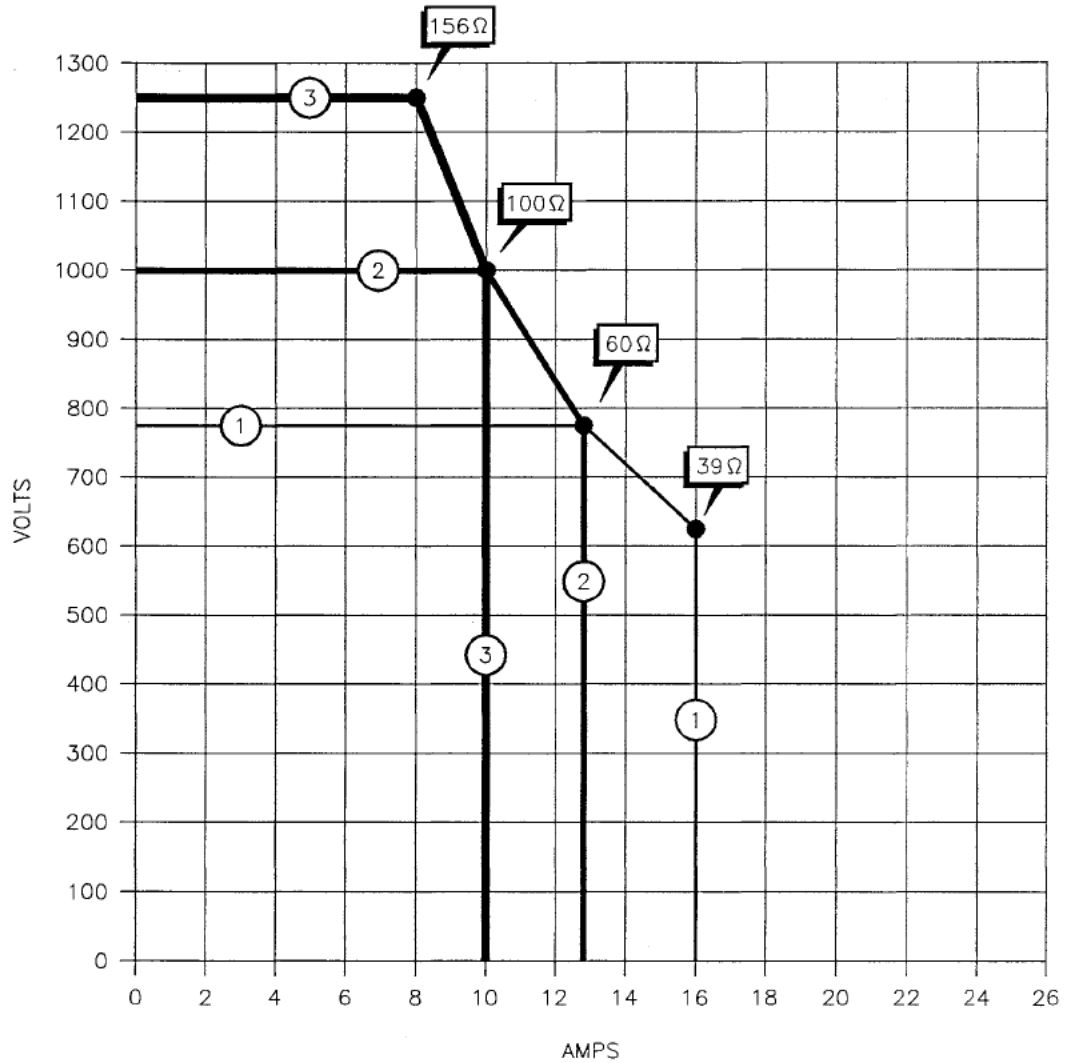

Figure A-6. Voltage and current limits for an MDX model 10K, "high Z" configuration. Each numbered "envelope" shows the boundaries for each of the three available taps. The impedance ranges for the taps are shown by the four labeled arrows. Note: The voltage may actually be slightly higher than shown here if the MDX is operating in current or power regulation. See the impedance-range graph in Fig. A-24.

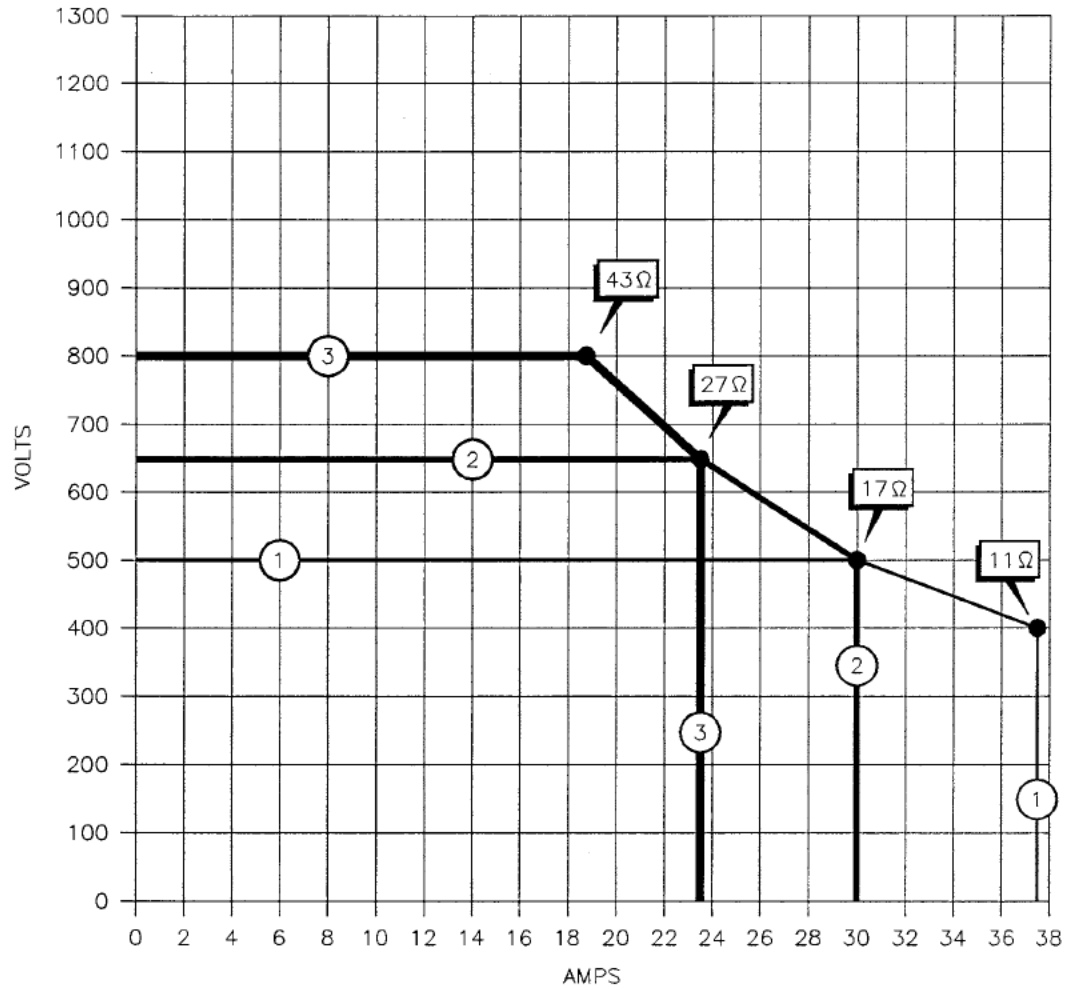

Figure A-7. Voltage and current limits for an MDX model 15K, "low Z" configuration. Each numbered "envelope" shows the boundaries for each of the three available taps. The impedance ranges for the taps are shown by the four labeled arrows. Note: The voltage may actually be slightly higher than shown here if the MDX is operating in current or power regulation. See the impedance-range graph in Fig. A-25.

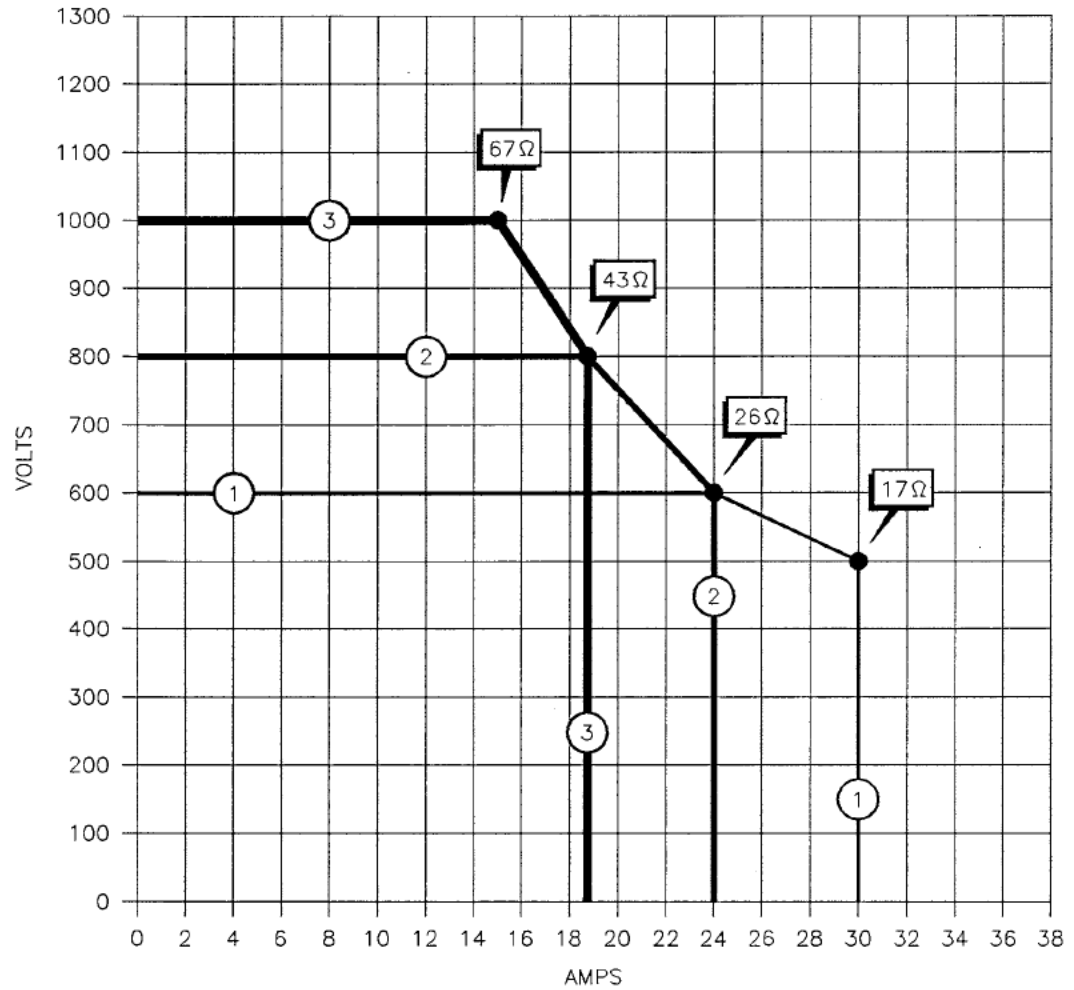

Figure A-8. Voltage and current limits for an MDX model 15K, "standard Z" configuration. Each numbered "envelope" shows the boundaries for each of the three available taps. The impedance ranges for the taps are shown by the four labeled arrows. Note: The voltage may actually be slightly higher than shown here if the MDX is operating in current or power regulation. See the Impedance-range graph in Fig. A-26.

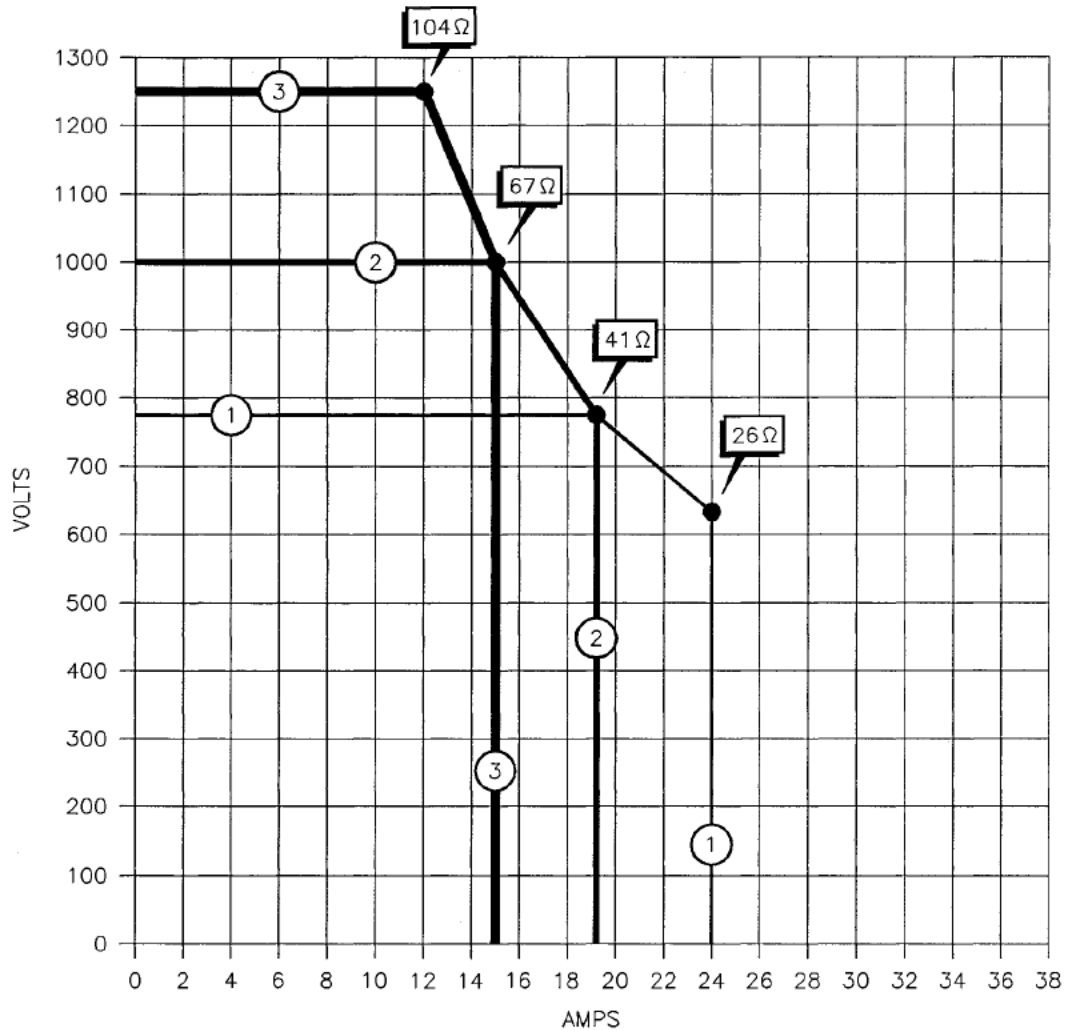

Figure A-9. Voltage and current limits for an MDX model 15K, "high Z" configuration. Each numbered "envelope" shows the boundaries for each of the three available taps. The impedance ranges for the taps are shown by the four labeled arrows. Note: The voltage may actually be slightly higher than shown here if the MDX is operating in current or power regulation. See the impedance-range graph in Fig. A-27.

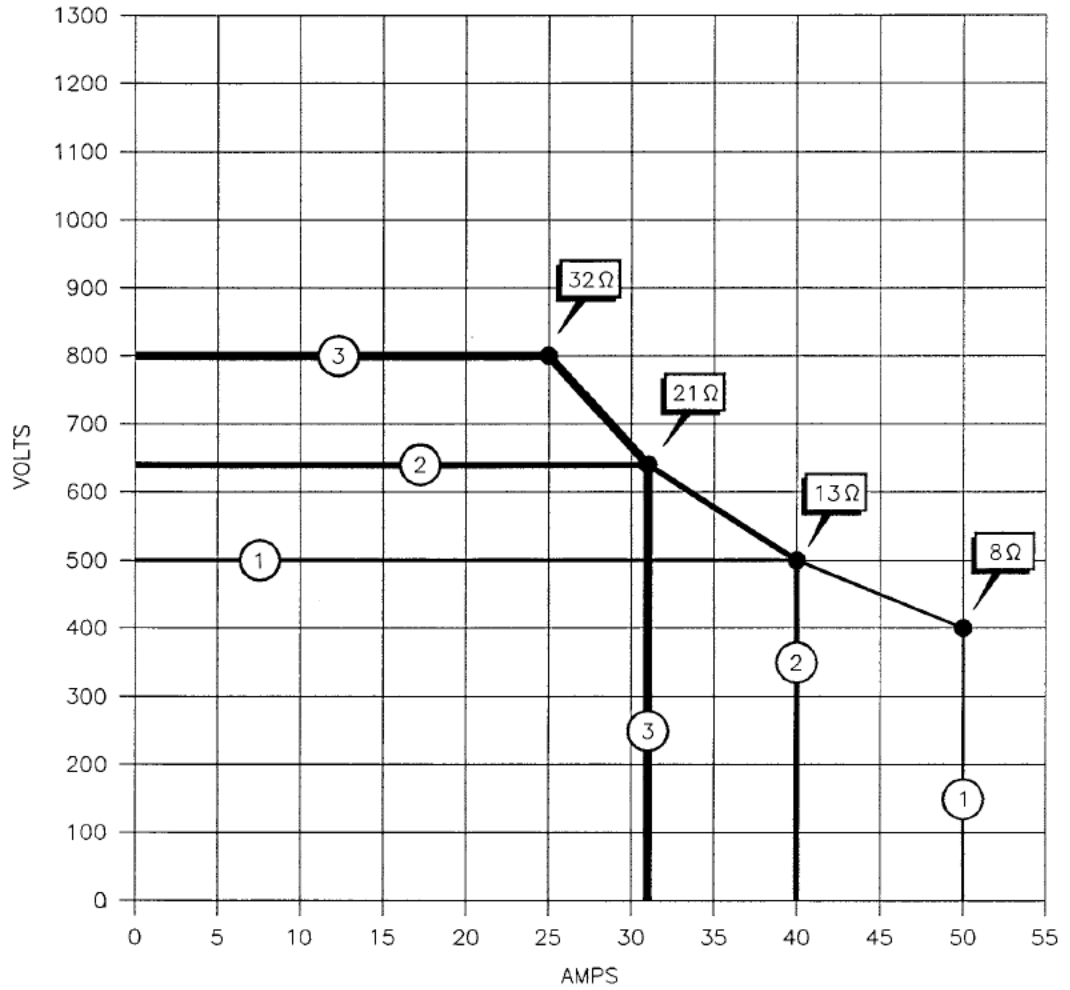

Figure A-10. Voltage and current limits for an MDX model 20K, "low Z" configuration. Each numbered "envelope" shows the boundaries for each of the three available taps. The impedance ranges for the taps are shown by the four labeled arrows. Note: The voltage may actually be slightly higher than shown here if the MDX is operating in current or power regulation. See the impedance-range graph in Fig. A-28.

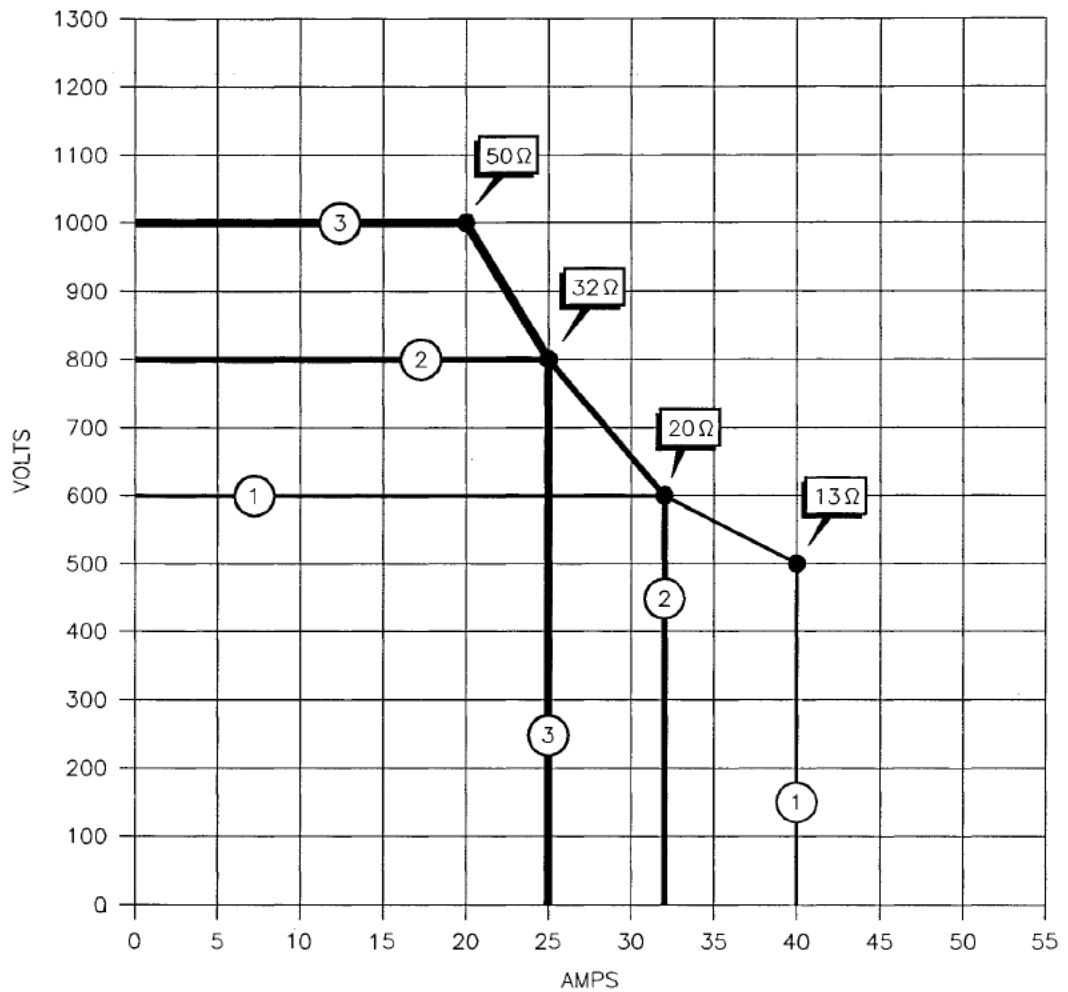

Figure A-11. Voltage and current limits for an MDX model 20K, "standard Z" configuration. Each numbered "envelope" shows the boundaries for each of the three available taps. The impedance ranges for the taps are shown by the four labeled arrows. Note: The voltage may actually be slightly higher than shown here if the MDX is operating in current or power regulation. See the impedance-range graph in Fig. A-29.

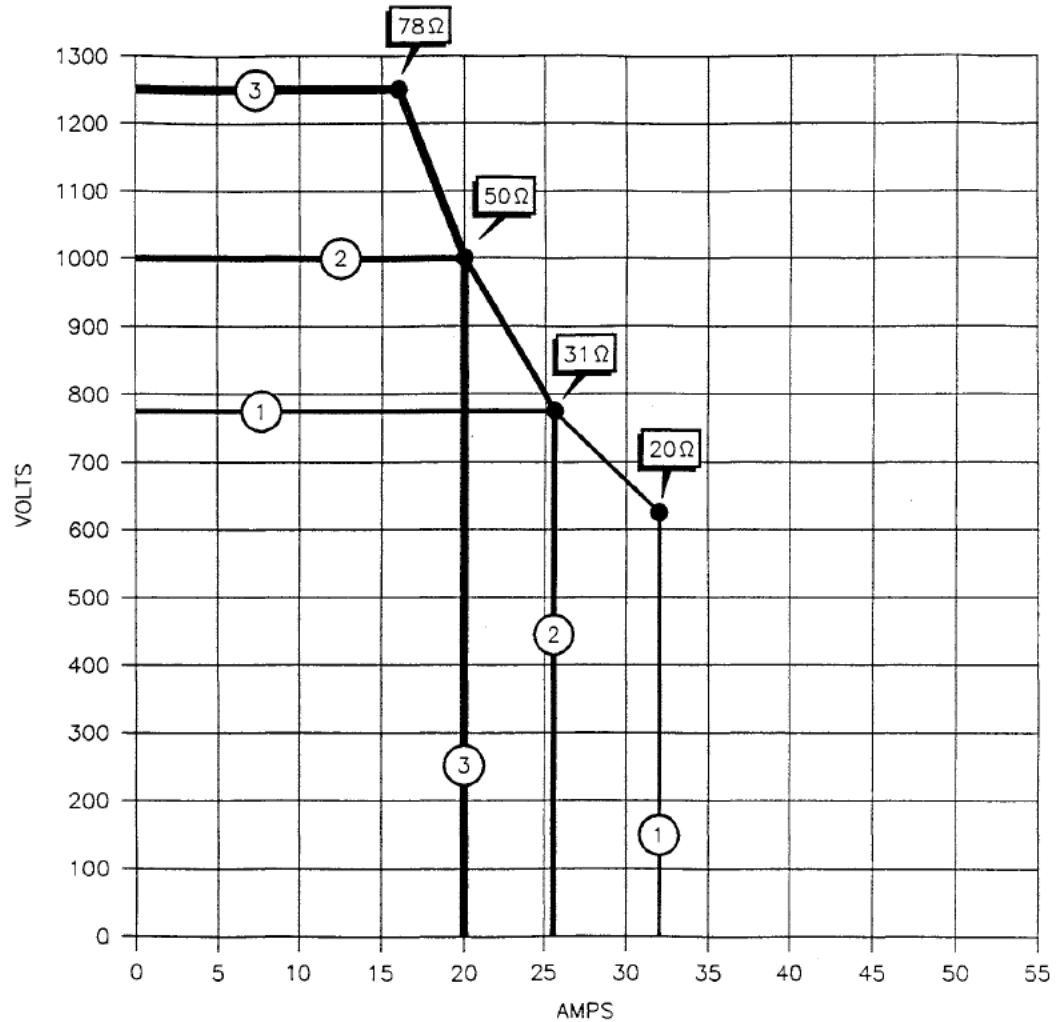

Figure A-12. Voltage and current limits for an MDX model 20K, "high Z" configuration. Each numbered "envelope" shows the boundaries for each of the three available taps. The impedance ranges for the taps are shown by the four labeled arrows. Note: The voltage may actually be slightly higher than shown here if the MDX is operating in current or power regulation. See the impedance-range graph in Fig. A-30.

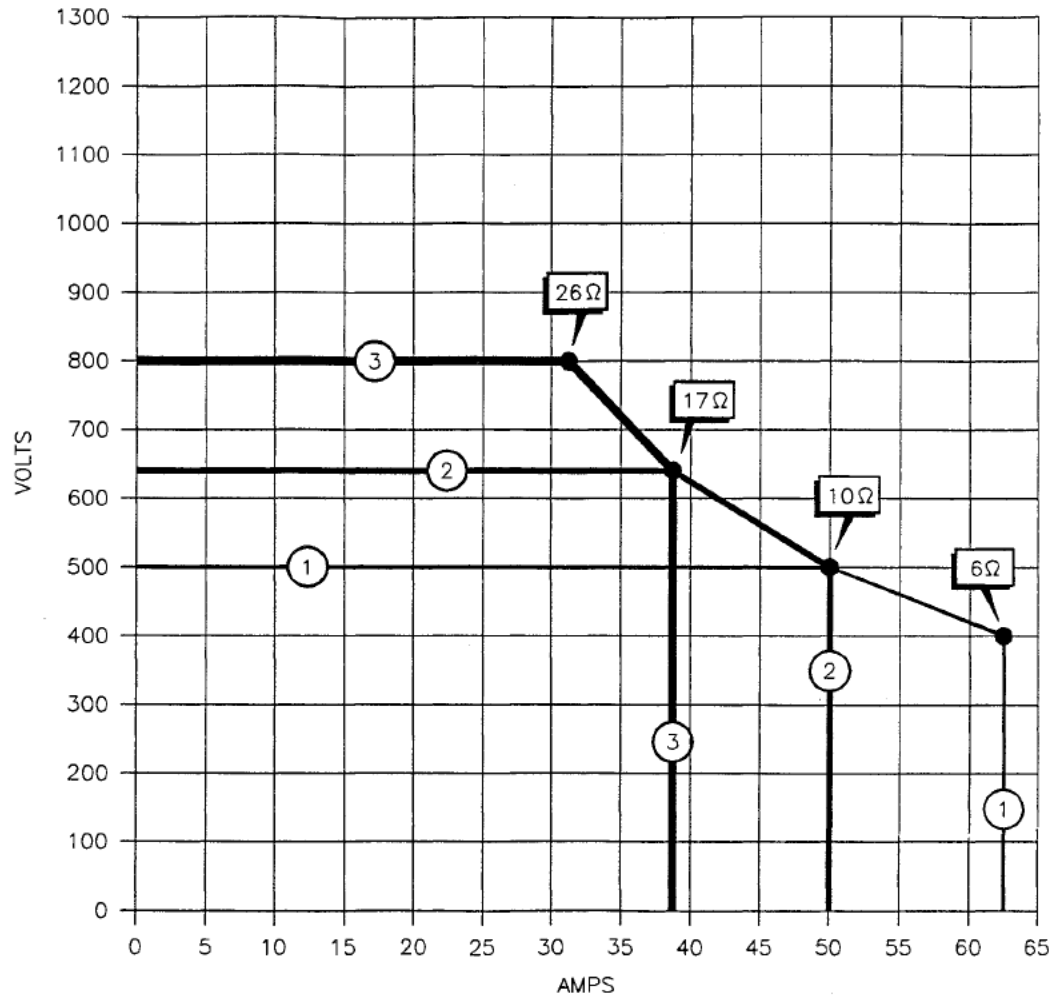

Figure A-13. Voltage and current limits for an MDX model 25K, "low Z" configuration. Each numbered "envelope" shows the boundaries for each of the three available taps. The impedance ranges for the taps are shown by the four labeled arrows. Note: The voltage may actually be slightly higher than shown here if the MDX is operating in current or power regulation. See the impedance-range graph in Fig. A-31.

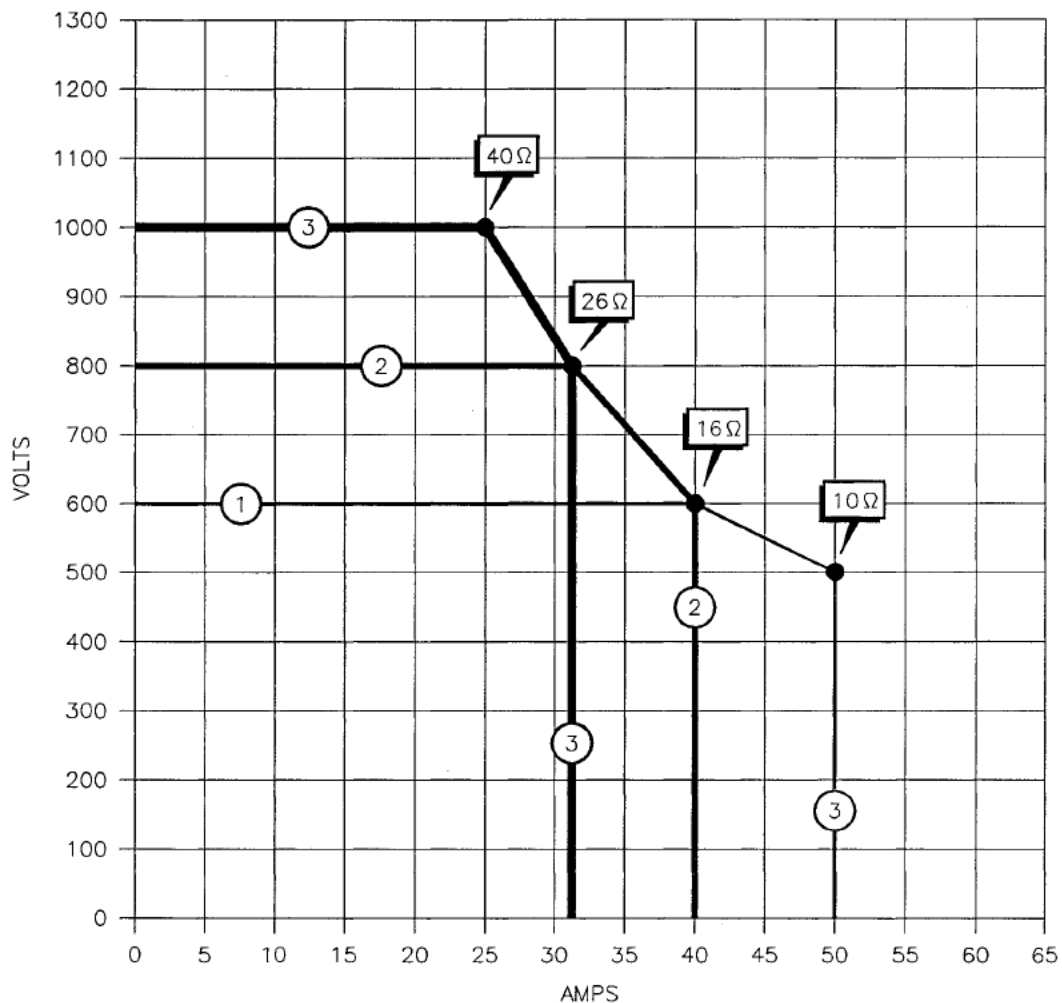

Figure A-14. Voltage and current limits for an MDX model 25K, "standard Z" configuration. Each numbered "envelope" shows the boundaries for each of the three available taps. The impedance ranges for the taps are shown by the four labeled arrows. Note: The voltage may actually be slightly higher than shown here if the MDX is operating in current or power regulation. See the impedance-range graph in Fig. A-32.

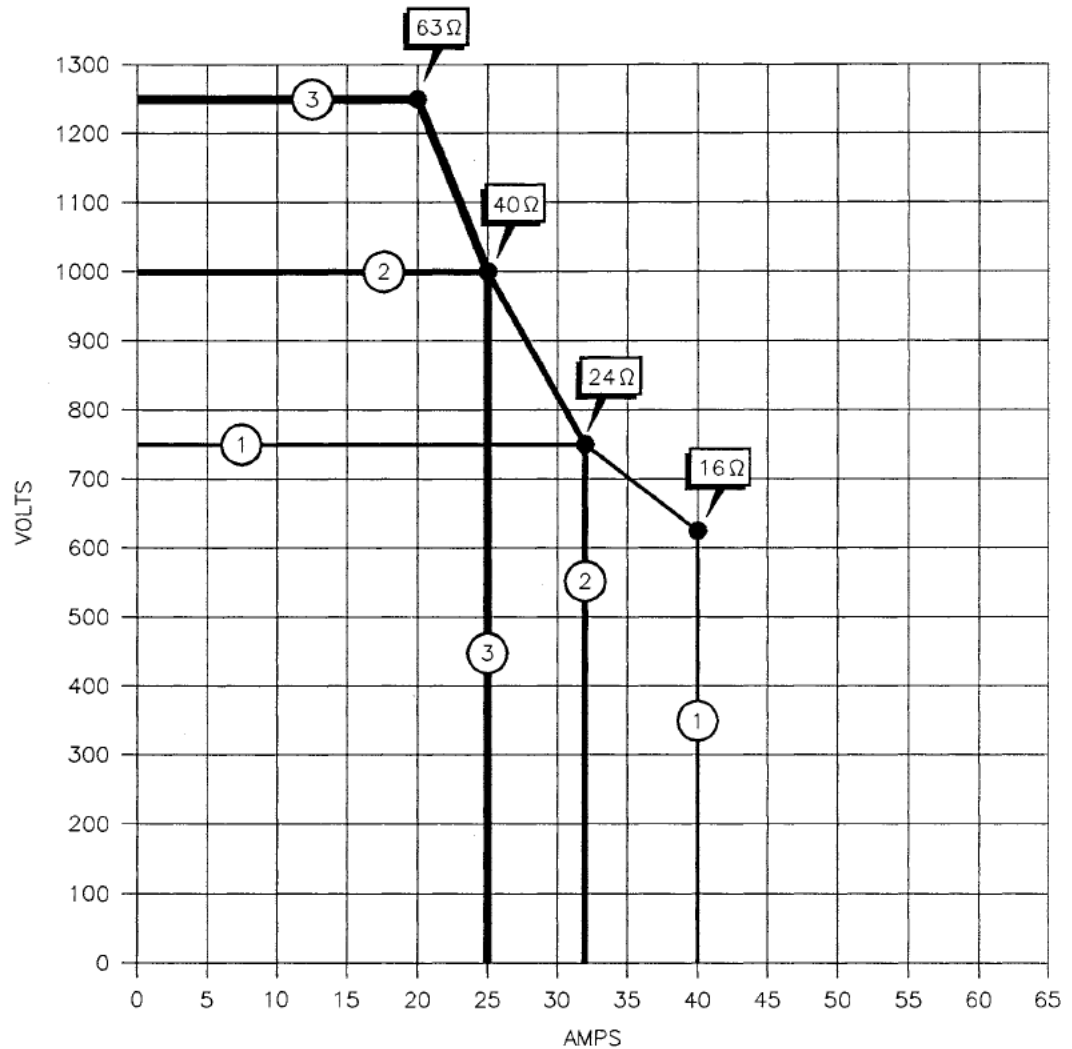

Figure A-15. Voltage and current limits for an MDX model 25K, "high Z" configuration. Each numbered "envelope" shows the boundaries for each of the three available taps. The impedance ranges for the taps are shown by the four labeled arrows. Note: The voltage may actually be slightly higher than shown here if the MDX is operating in current or power regulation. See the impedance-range graph in Fig. A-33.

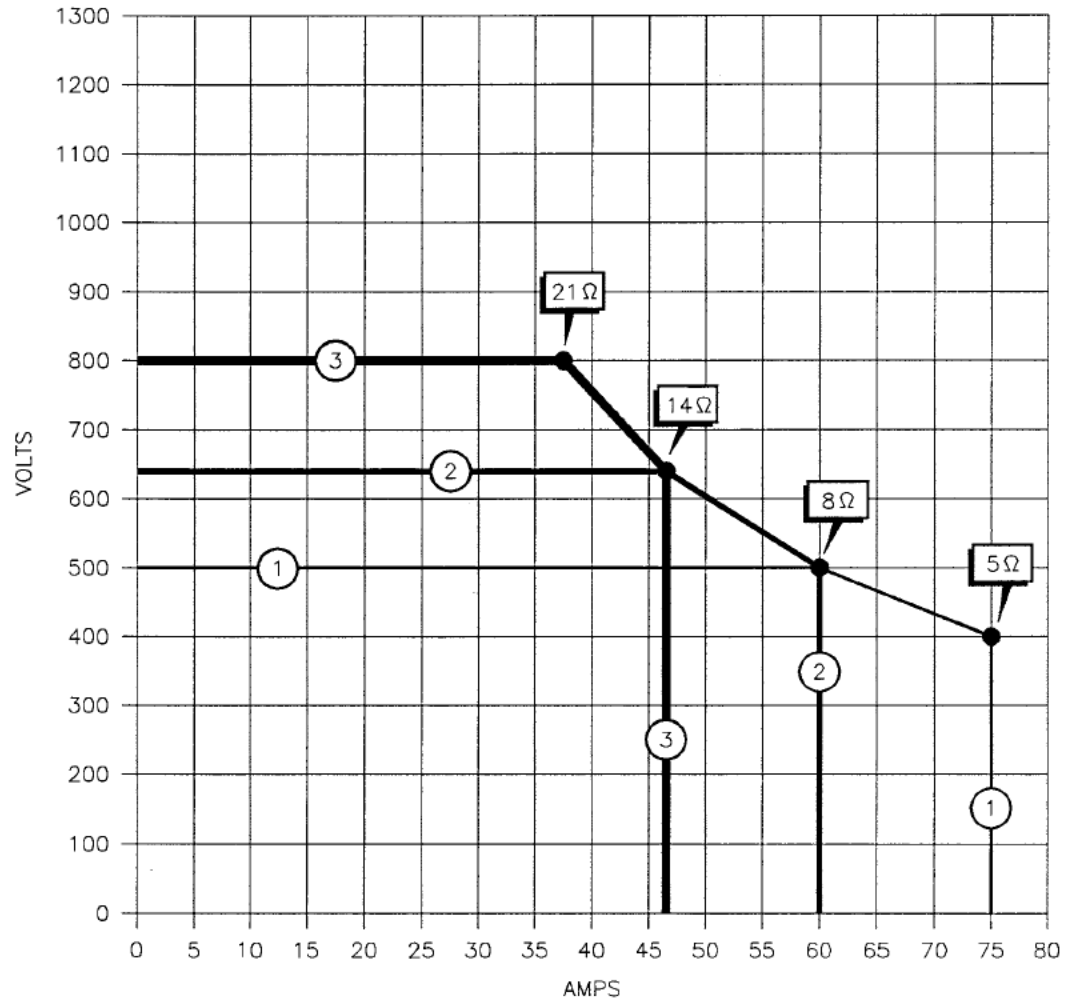

Figure A-16. Voltage and current limits for an MDX model 30K, "low Z" configuration. Each numbered "envelope" shows the boundaries for each of the three available taps. The impedance ranges for the taps are shown by the four labeled arrows. Note: The voltage may actually be slightly higher than shown here if the MDX is operating in current or power regulation. See the impedance-range graph in Fig. A-34.

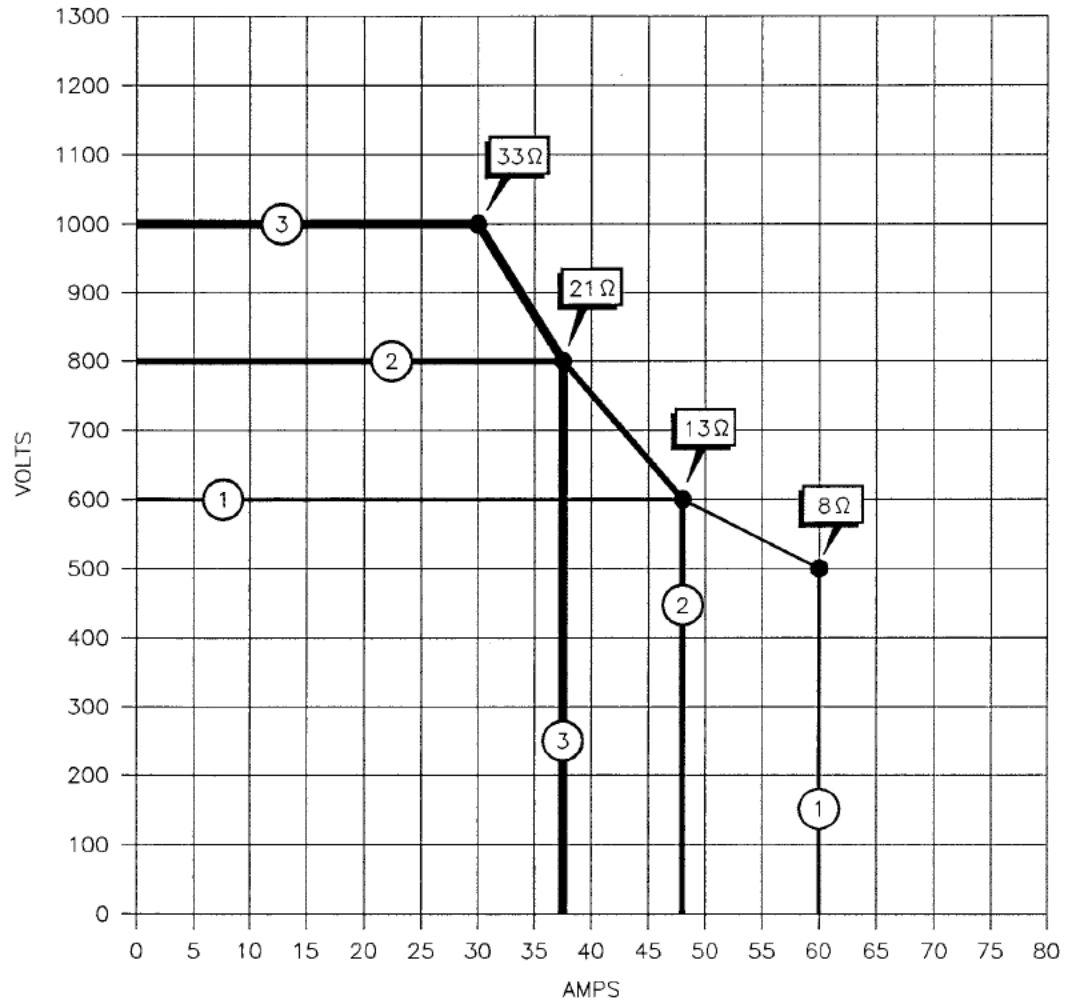

Figure A-17. Voltage and current limits for an MDX model 30K, "standard Z" configuration. Each numbered "envelope" shows the boundaries for each of the three available taps. The impedance ranges for the taps are shown by the four labeled arrows. Note: The voltage may actually be slightly higher than shown here if the MDX is operating in current or power regulation. See the impedance-range graph in Fig. A-35.

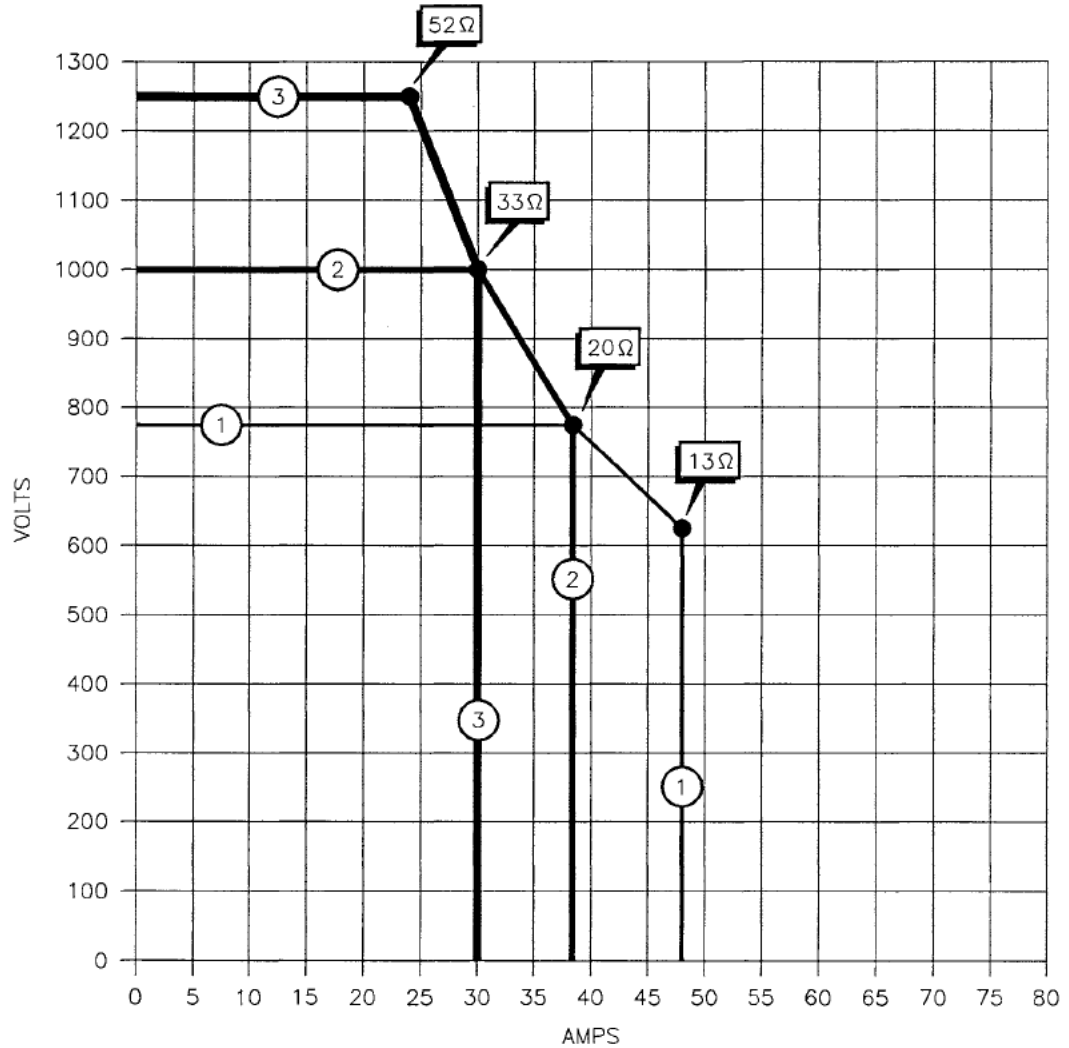

Figure A-18. Voltage and current limits for an MDX model 30K, "high Z" configuration. Each numbered "envelope" shows the boundaries for each of the three available taps. The impedance ranges for the taps are shown by the four labeled arrows. Note: The voltage may actually be slightly higher than shown here if the MDX is operating in current or power regulation. See the impedance-range graph in Fig. A-36.

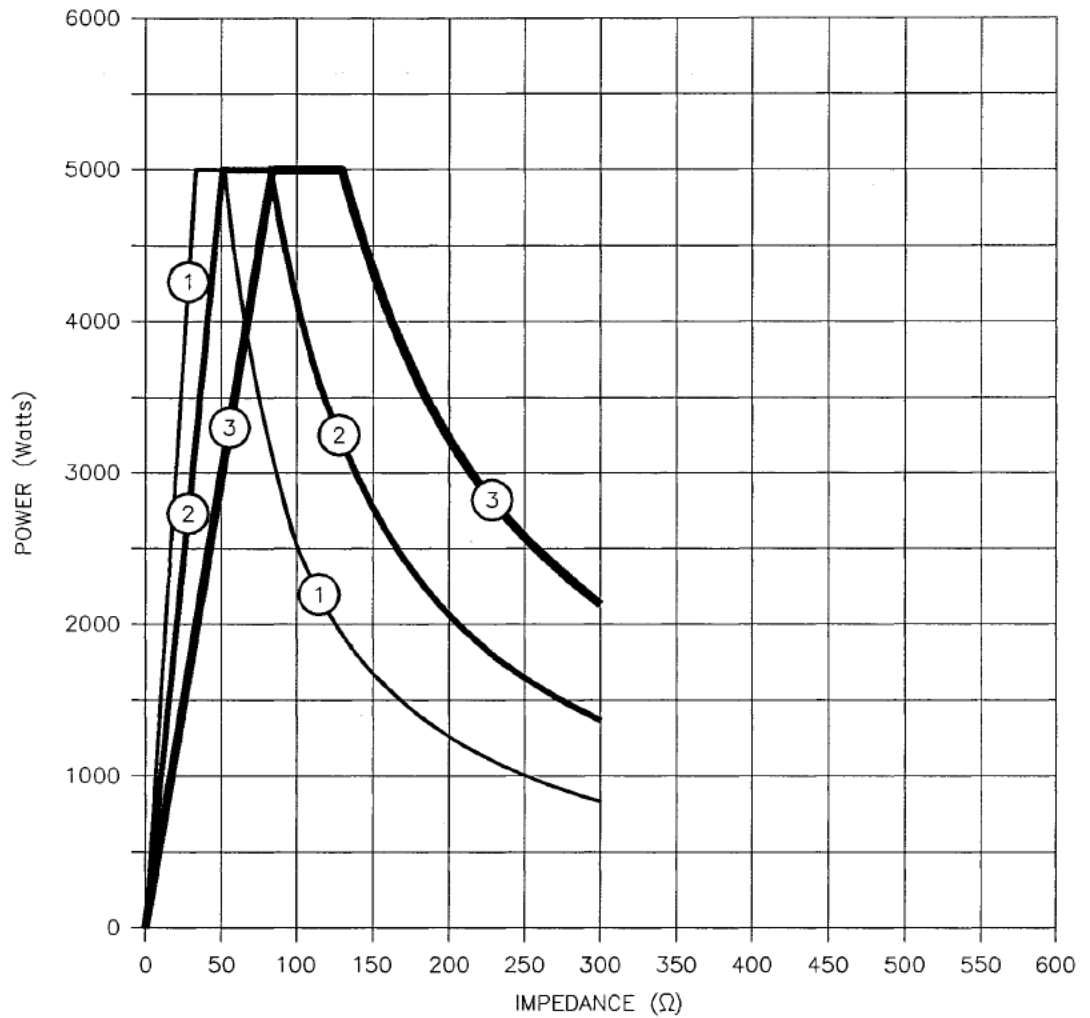

Figure A-19. Impedance-range graph for an MDX model 5K, "low Z" configuration. Shown are the three overlapping ranges of impedance values that can be accommodated with either tap 1, 2, or 3. The range that can be accommodated with tap 1 is enclosed by the lines labeled "1"; similarly, the lines that enclose the other two ranges are labeled "2" and "3." Also see Fig. A-1.

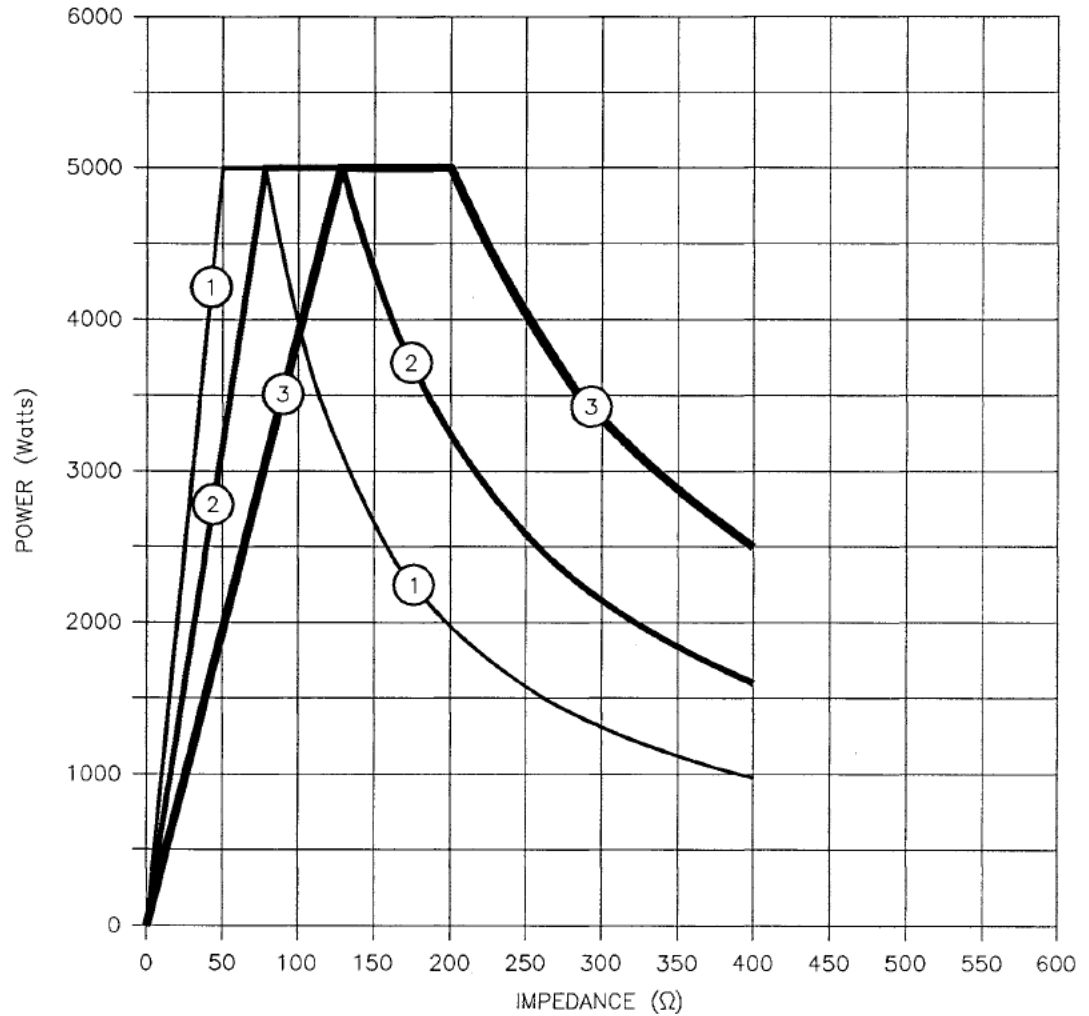

Figure A-20. Impedance-range graph for an MDX model 5K, "standard Z" configuration. Shown are the three overlapping ranges of impedance values that can be accommodated with either tap 1, 2, or 3. The range that can be accommodated with tap 1 is enclosed by the lines labeled "1"; similarly, the lines that enclose the other two ranges are labeled "2" and "3." Also see Fig. A-2.

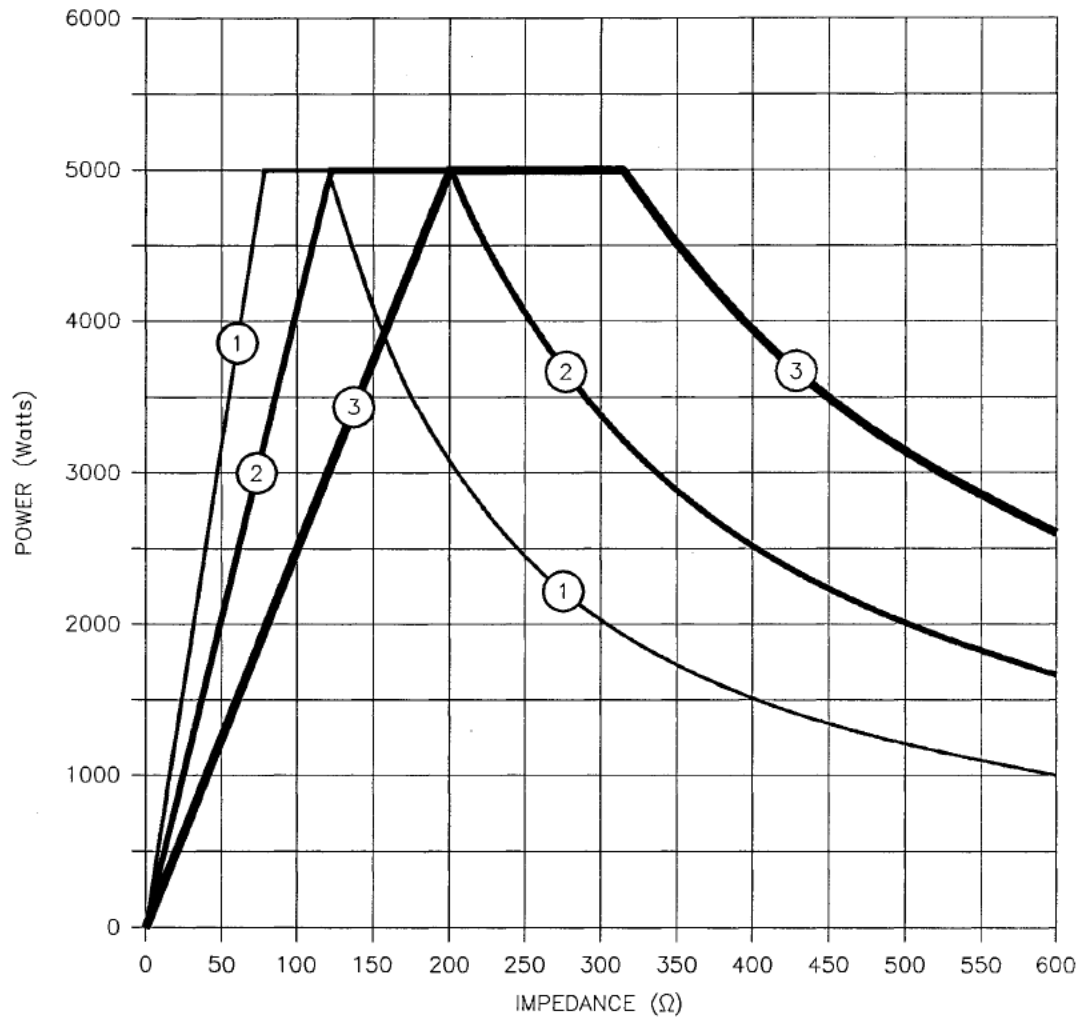

Figure A-21. Impedance-range graph for an MDX model 5K, "high Z" configuration. Shown are the three overlapping ranges of impedance values that can be accommodated with either tap 1, 2, or 3. The range that can be accommodated with tap 1 is enclosed by the lines labeled "1"; similarly, the lines that enclose the other two ranges are labeled "2" and "3." Also see Fig. A-3.

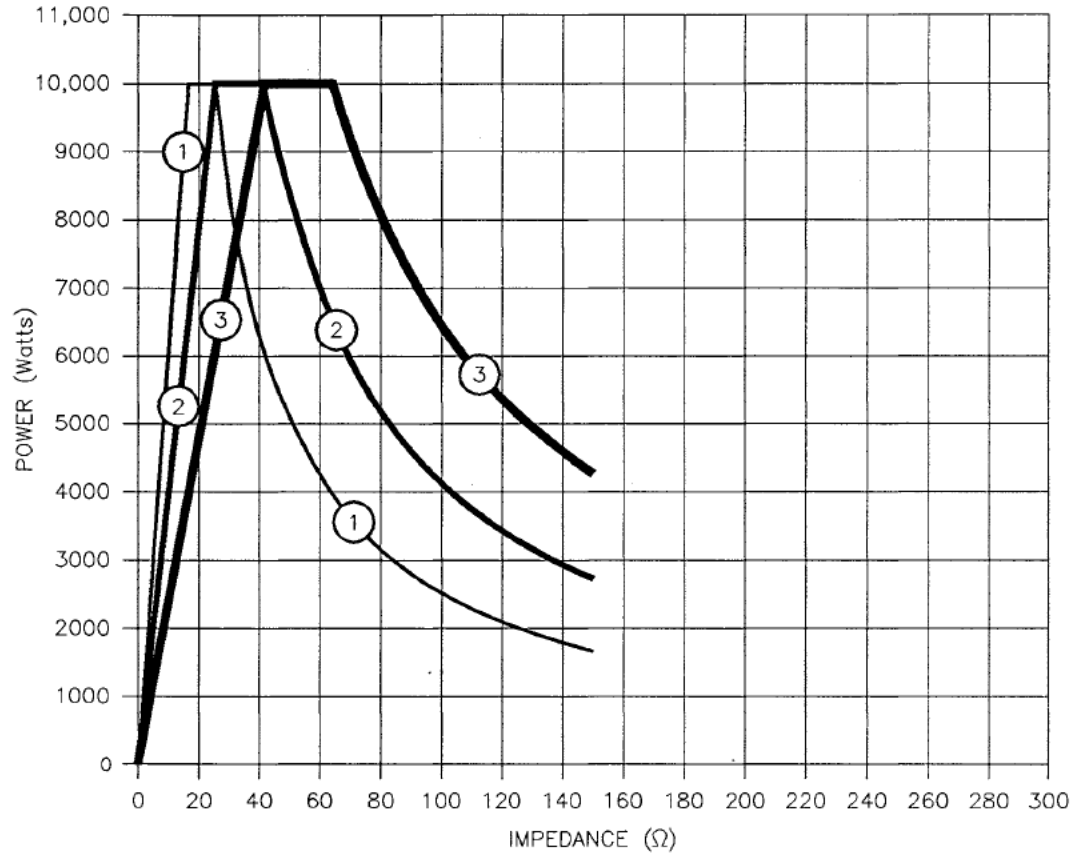

Figure A-22. Impedance-range graph for an MDX model 10K, "low Z" configuration. Shown are the three overlapping ranges of impedance values that can be accommodated with either tap 1, 2, or 3. The range that can be accommodated with tap 1 is enclosed by the lines labeled "1"; similarly, the lines that enclose the other two ranges are labeled "2" and "3." Also see Fig. A-4.

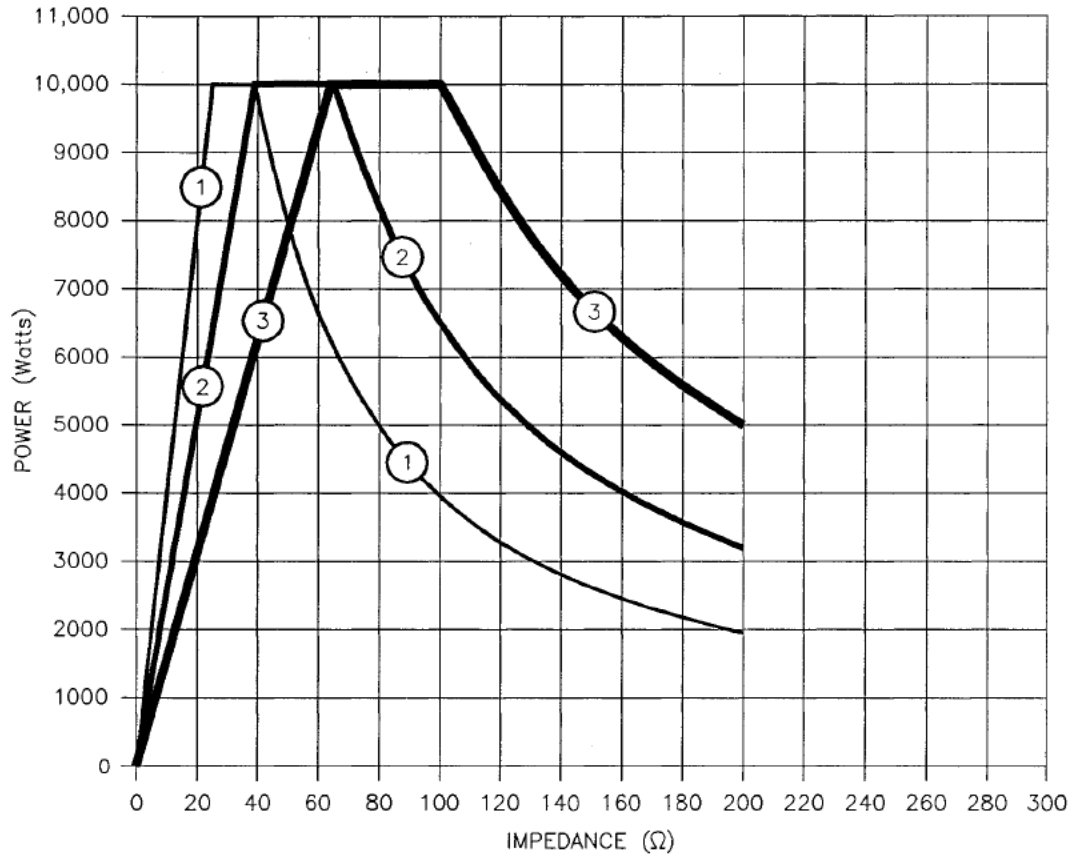

Figure A-23. Impedance-range graph for an MDX model 10K, "standard Z" configuration. Shown are the three overlapping ranges of impedance values that can be accommodated with either tap 1, 2, or 3. The range that can be accommodated with tap 1 is enclosed by the lines labeled "1"; similarly, the lines that enclose the other two ranges are labeled "2" and "3." Also see Fig. A-5.

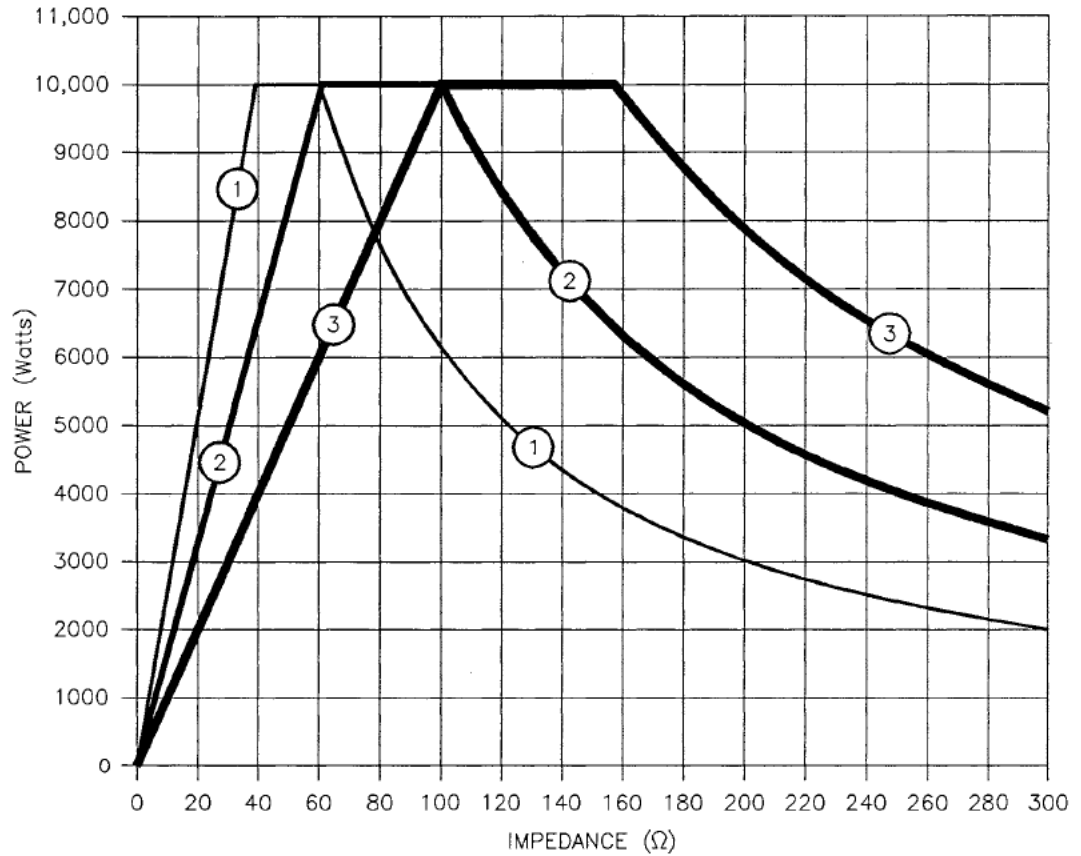

Figure A-24. Impedance-range graph for an MDX model 10K, "high Z" configuration. Shown are the three overlapping ranges of impedance values that can be accommodated with either tap 1, 2, or 3. The range that can be accommodated with tap 1 is enclosed by the lines labeled "1"; similarly, the lines that enclose the other two ranges are labeled "2" and "3." Also see Fig. A-6.

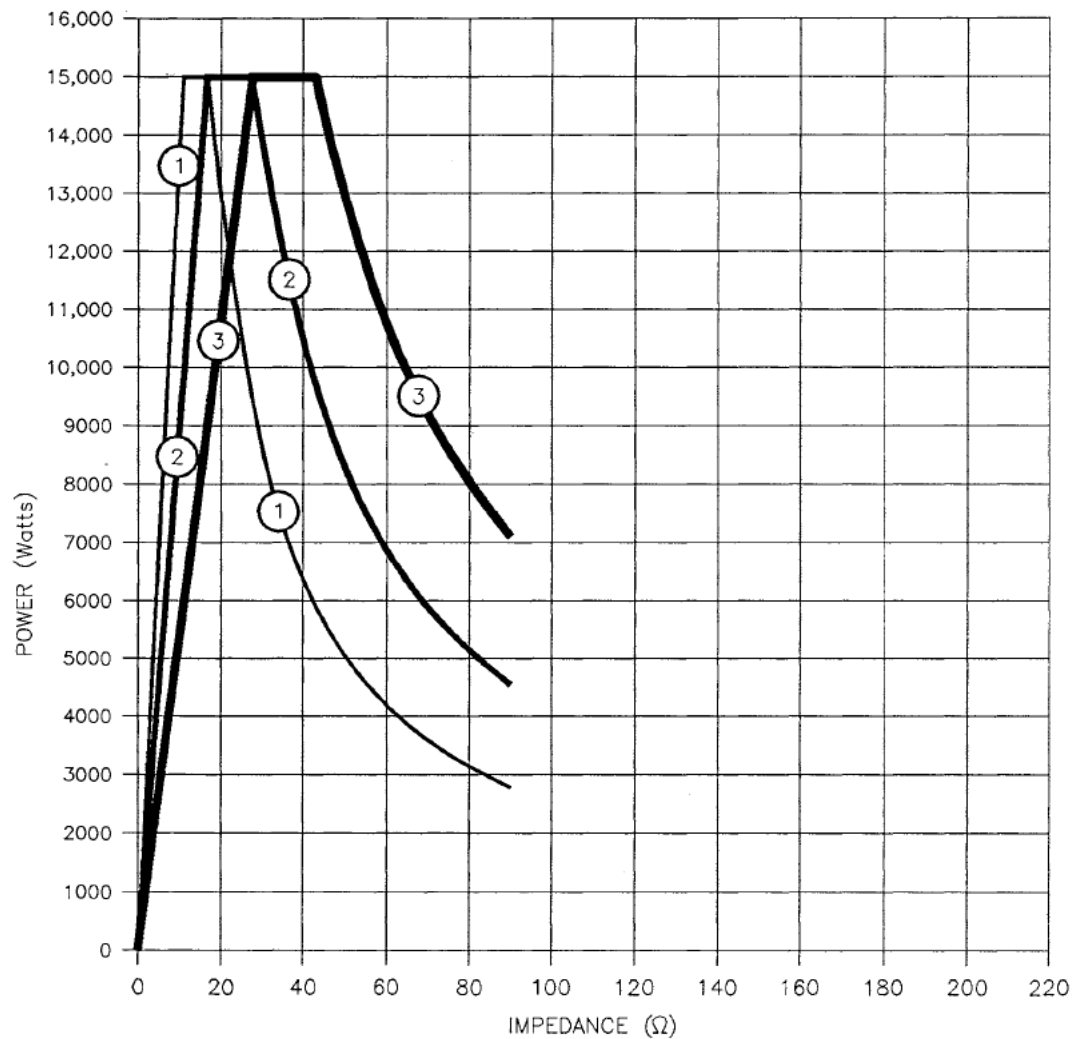

Figure A-25. Impedance-range graph for an MDX model 15K, "low Z" configuration. Shown are the three overlapping ranges of impedance values that can be accommodated with either tap 1, 2, or 3. The range that can be accommodated with tap 1 is enclosed by the lines labeled "1"; similarly, the lines that enclose the other two ranges are labeled "2" and "3." Also see Fig. A-7.

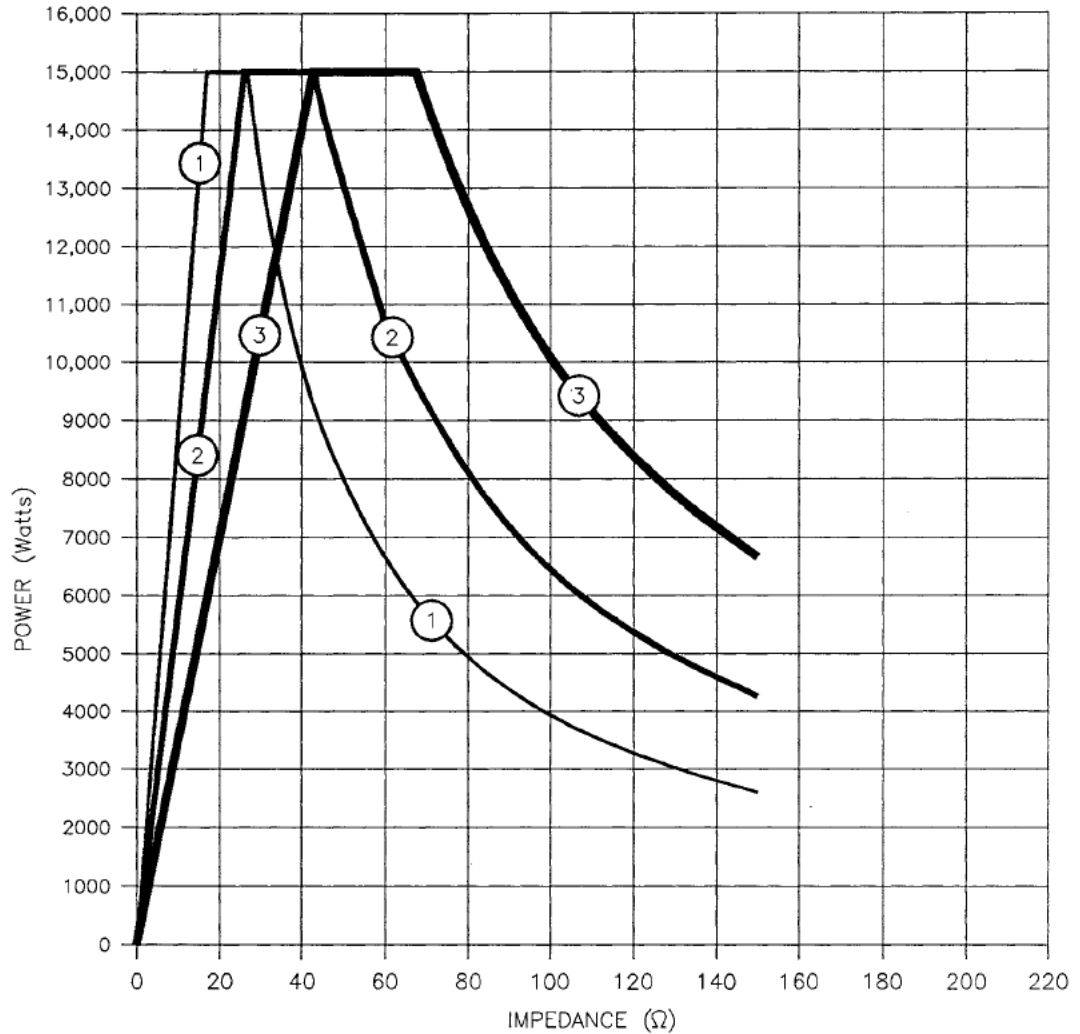

Figure A-26. Impedance-range graph for an MDX model 15K, "standard Z" configuration. Shown are the three overlapping ranges of impedance values that can be accommodated with either tap 1, 2, or 3. The range that can be accommodated with tap 1 is enclosed by the lines labeled "1"; similarly, the lines that enclose the other two ranges are labeled "2" and "3." Also see Fig. A-8.

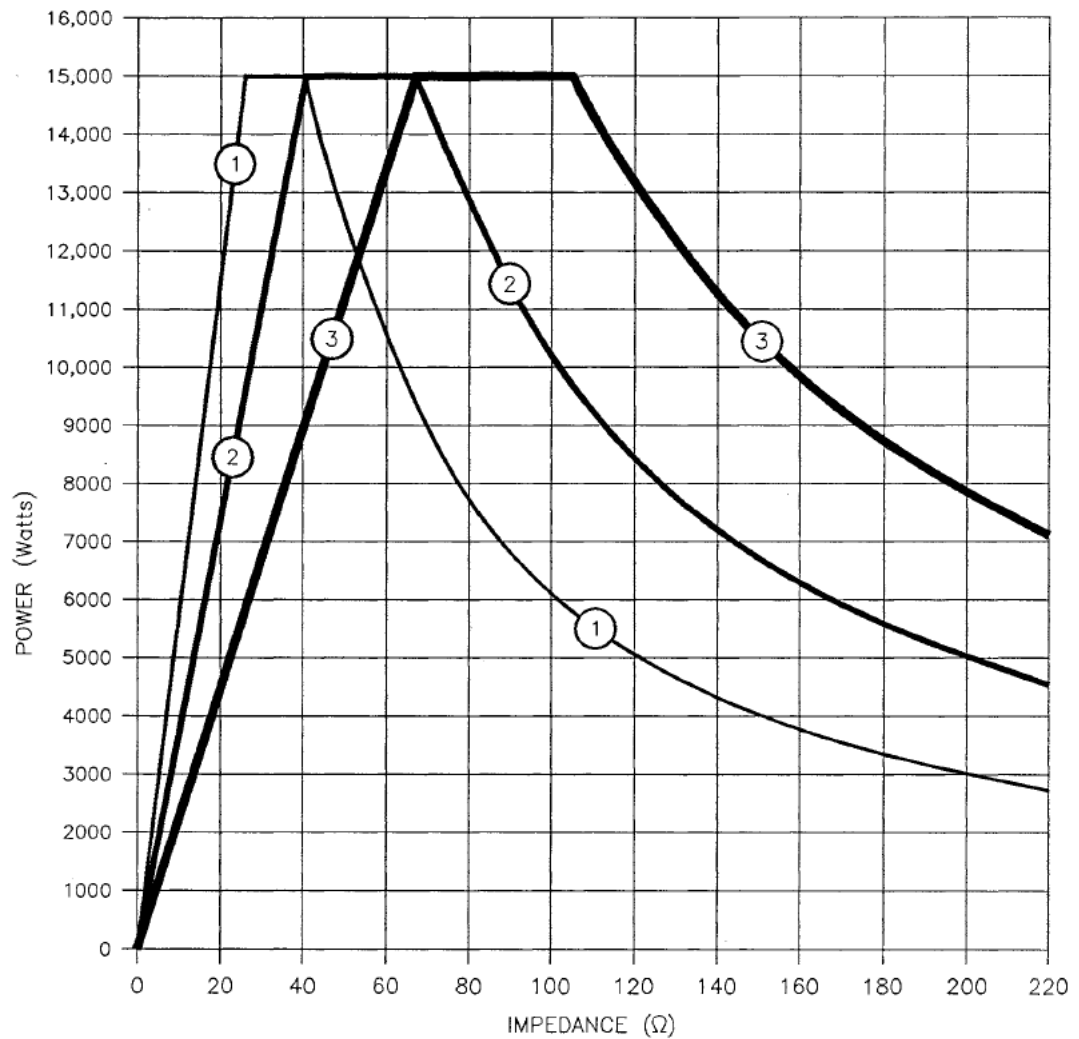

Figure A-27. Impedance-range graph for an MDX model 15K, "high Z" configuration. Shown are the three overlapping ranges of impedance values that can be accommodated with either tap 1, 2, or 3. The range that can be accommodated with tap 1 is enclosed by the lines labeled "1"; similarly, the lines that enclose the other two ranges are labeled "2" and "3." Also see Fig. A-9.

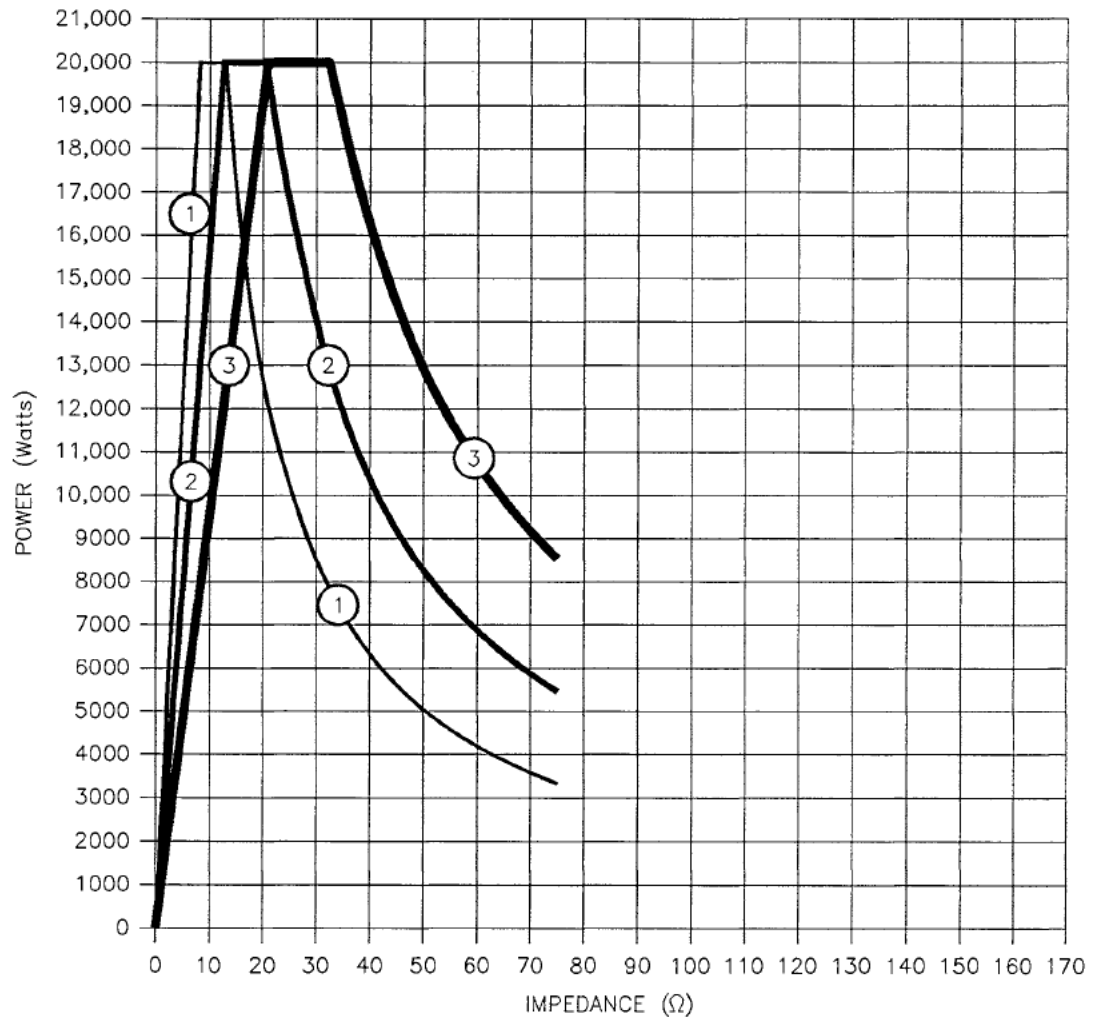

Figure A-28. Impedance-range graph for an MDX model 20K, "low Z" configuration. Shown are the three overlapping ranges of impedance values that can be accommodated with either tap 1, 2, or 3. The range that can be accommodated with tap 1 is enclosed by the lines labeled "1"; similarly, the lines that enclose the other two ranges are labeled "2" and "3." Also see Fig. A-10.

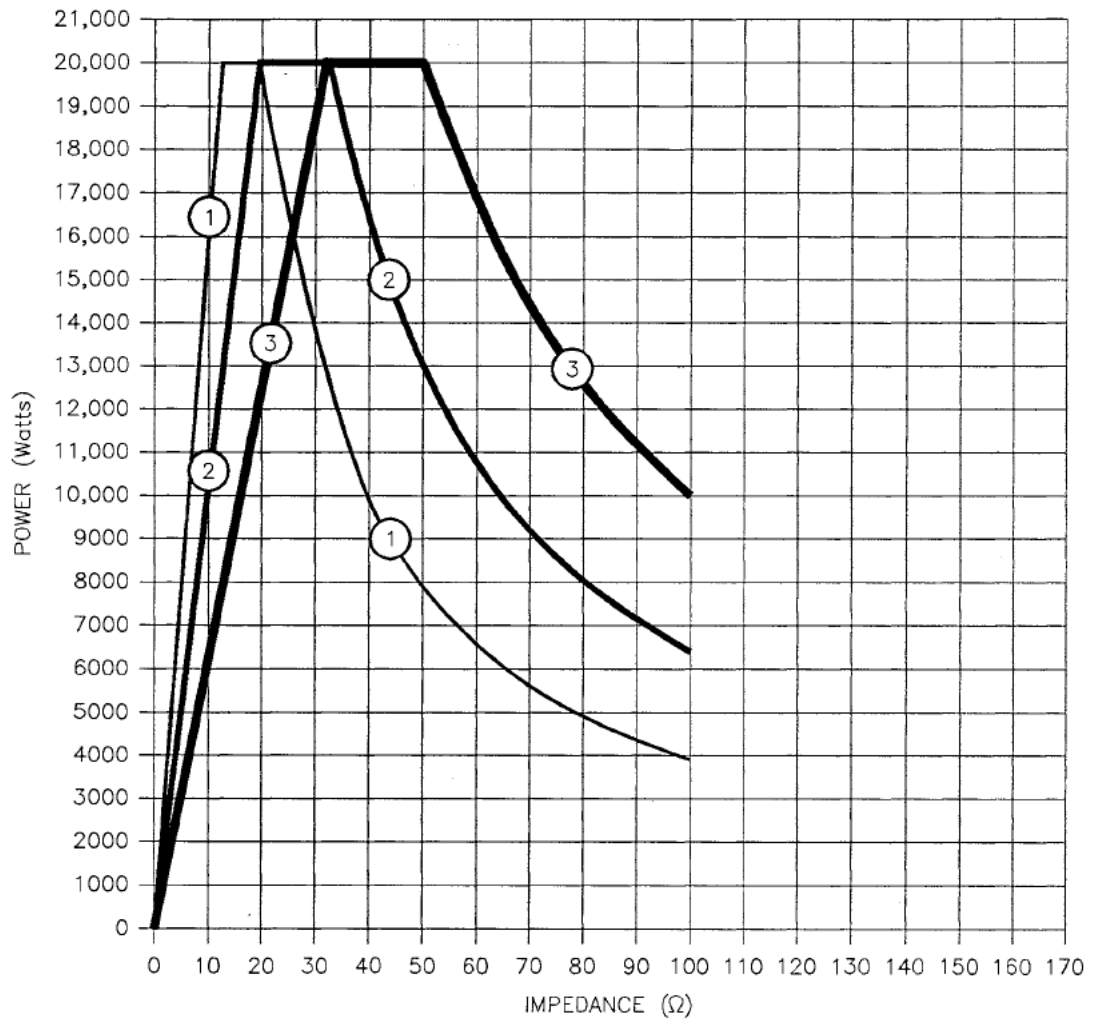

Figure A-29. Impedance-range graph for an MDX model 20K, "standard Z" configuration. Shown are the three overlapping ranges of impedance values that can be accommodated with either tap 1, 2, or 3. The range that can be accommodated with tap 1 is enclosed by the lines labeled "1"; similarly, the lines that enclose the other two ranges are labeled "2" and "3." Also see Fig. A-11.

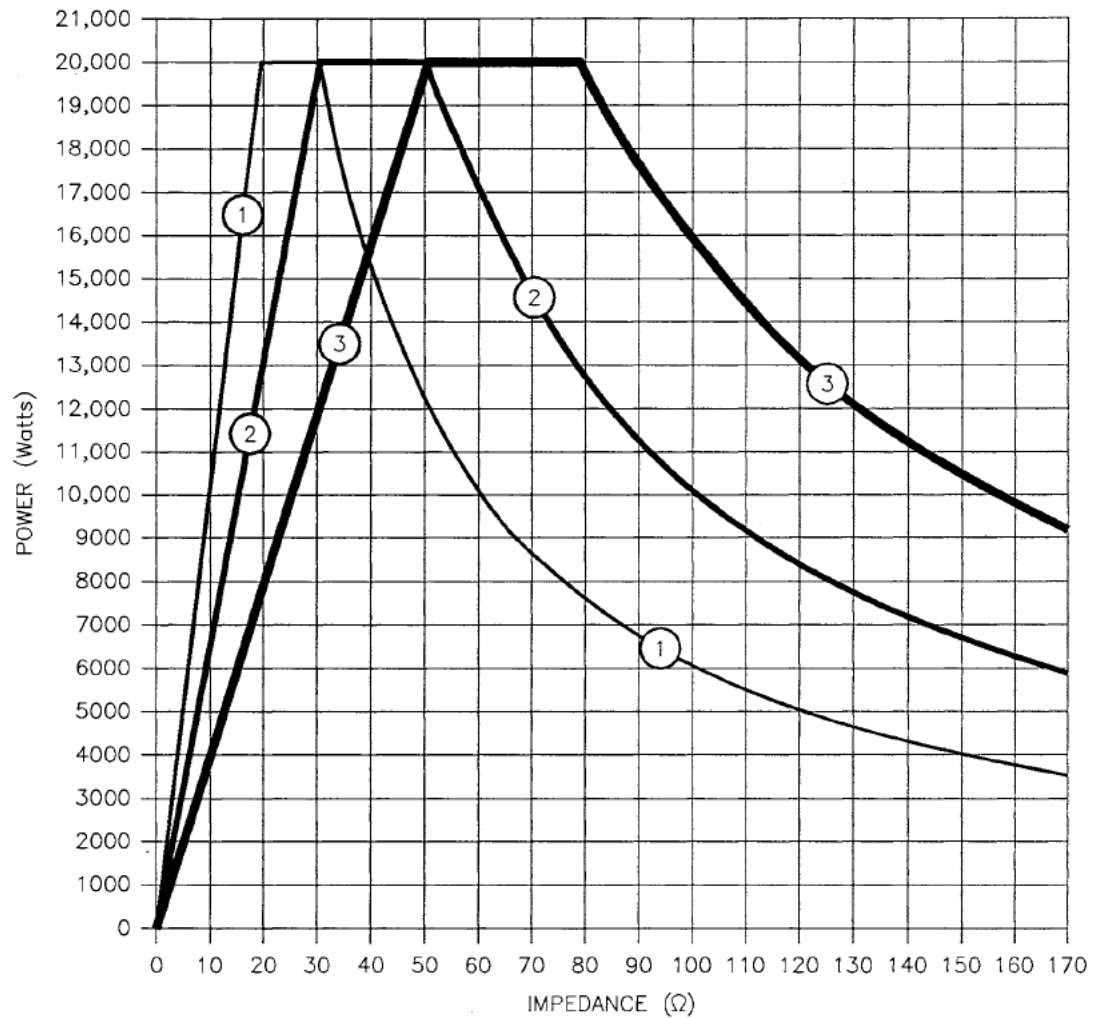

Figure A-30. Impedance-range graph for an MDX model 20K, "high Z" configuration. Shown are the three overlapping ranges of impedance values that can be accommodated with either tap 1, 2, or 3. The range that can be accommodated with tap 1 is enclosed by the lines labeled "1"; similarly, the lines that enclose the other two ranges are labeled "2" and "3." Also see Fig. A-12.

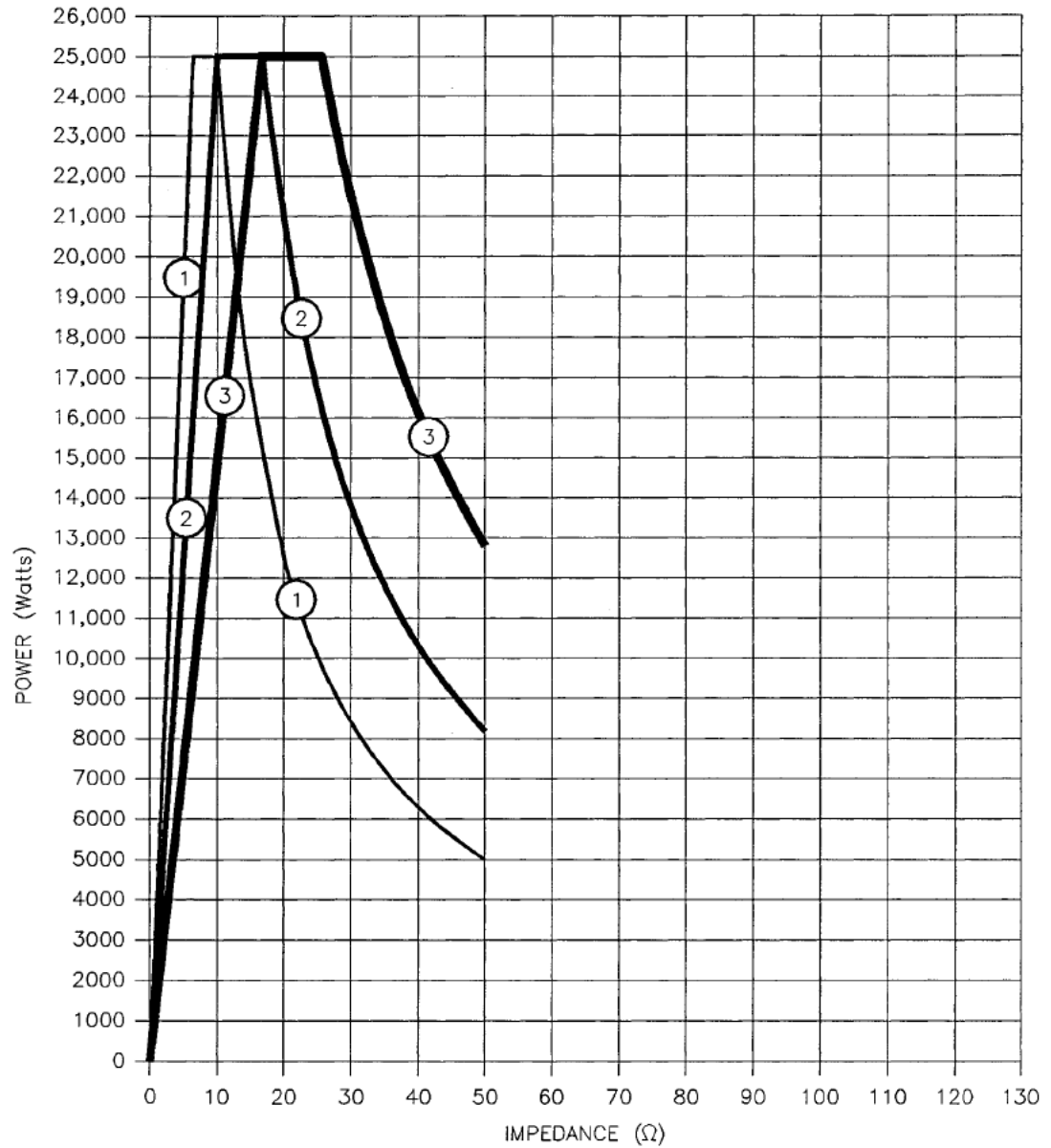

Figure A-31. Impedance-range graph for an MDX model 25K, "low Z" configuration. Shown are the three overlapping ranges of impedance values that can be accommodated with either tap 1, 2, or 3. The range that can be accommodated with tap 1 is enclosed by the lines labeled "1"; similarly, the lines that enclose the other two ranges are labeled "2" and "3." Also see Fig. A-13.

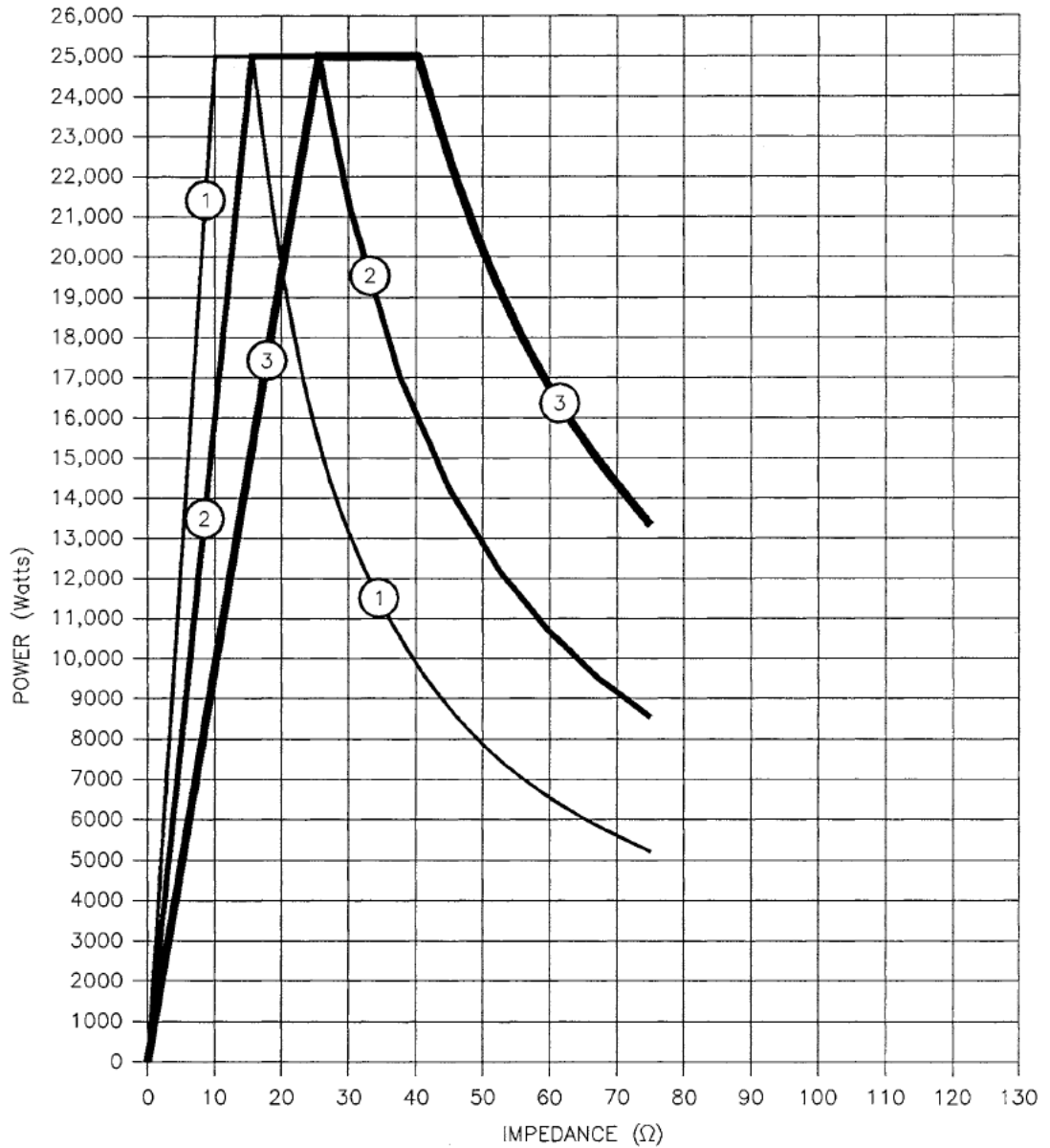

Figure A-32. Impedance-range graph for an MDX model 25K, "standard Z" configuration. Shown are the three overlapping ranges of impedance values that can be accommodated with either tap 1, 2, or 3. The range that can be accommodated with tap 1 is enclosed by the lines labeled "1"; similarly, the lines that enclose the other two ranges are labeled "2" and "3." Also see Fig. A-14.

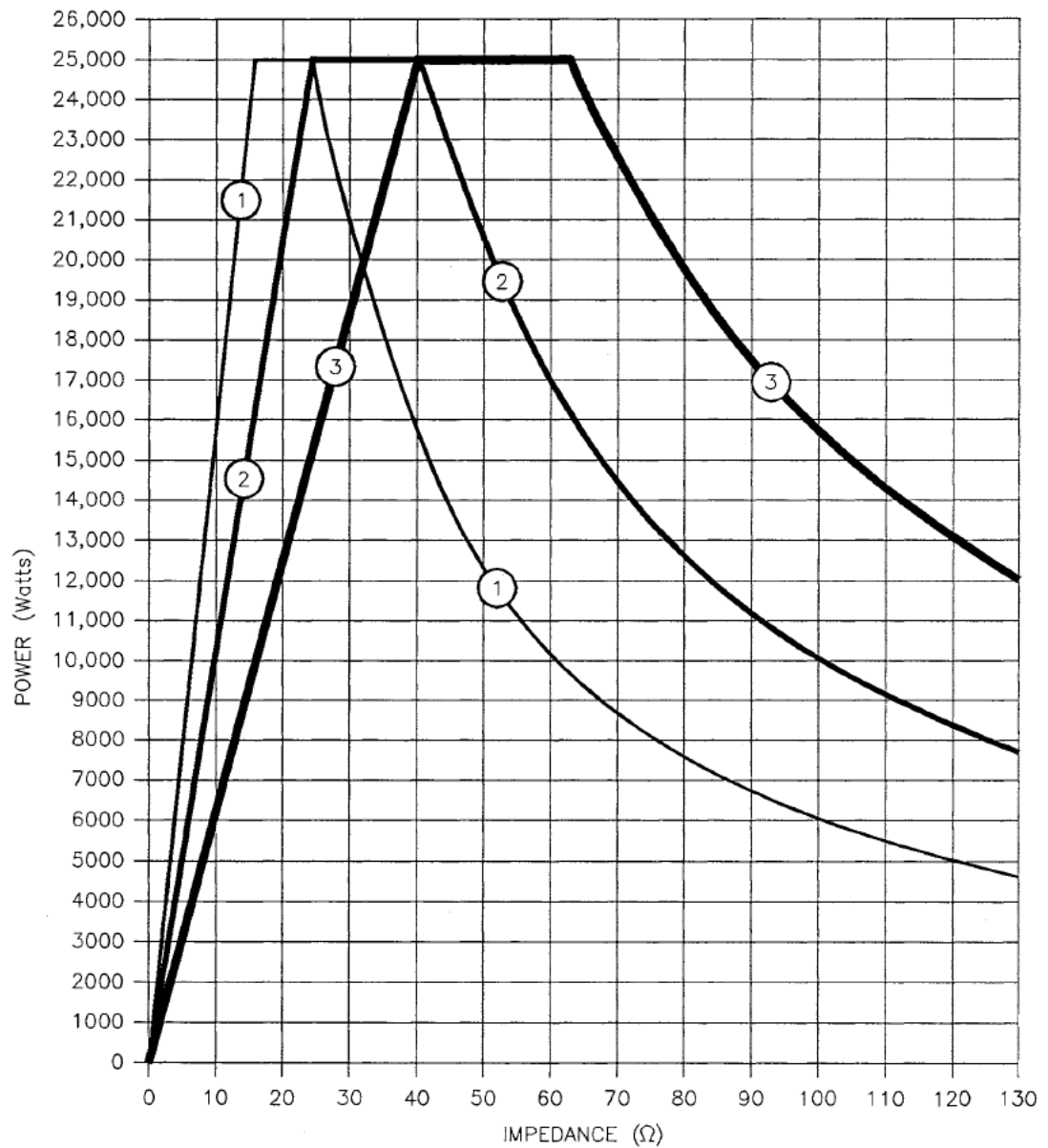

Figure A-33. Impedance-range graph for an MDX model 25K, "high Z" configuration. Shown are the three overlapping ranges of impedance values that can be accommodated with either tap 1, 2, or 3. The range that can be accommodated with tap 1 is enclosed by the lines labeled "1"; similarly, the lines that enclose the other two ranges are labeled "2" and "3." Also see Fig. A-15.

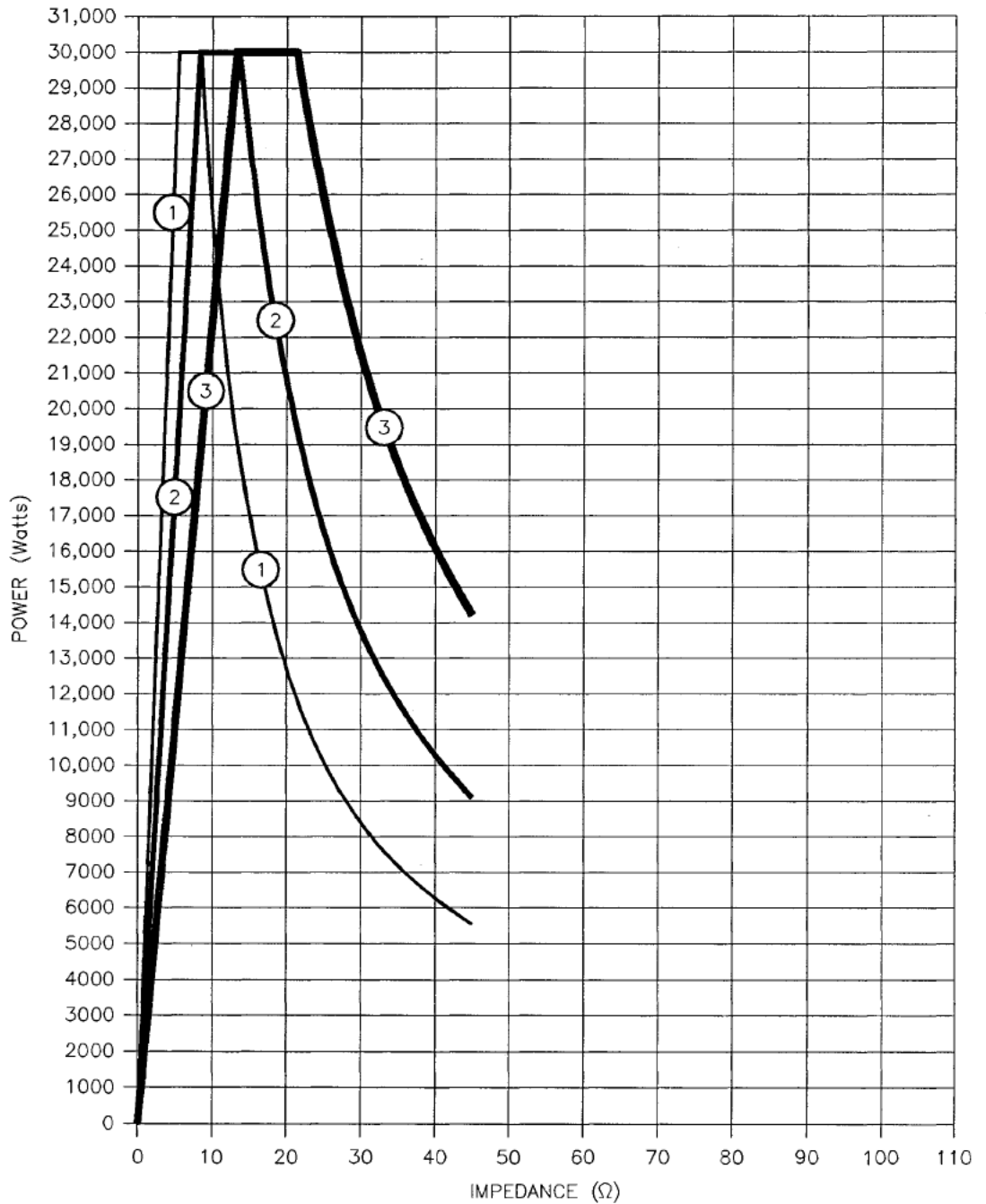

Figure A-34. Impedance-range graph for an MDX model 30K, "low Z" configuration. Shown are the three overlapping ranges of impedance values that can be accommodated with either tap 1, 2, or 3. The range that can be accommodated with tap 1 is enclosed by the lines labeled "1"; similarly, the lines that enclose the other two ranges are labeled "2" and "3." Also see Fig. A-16.

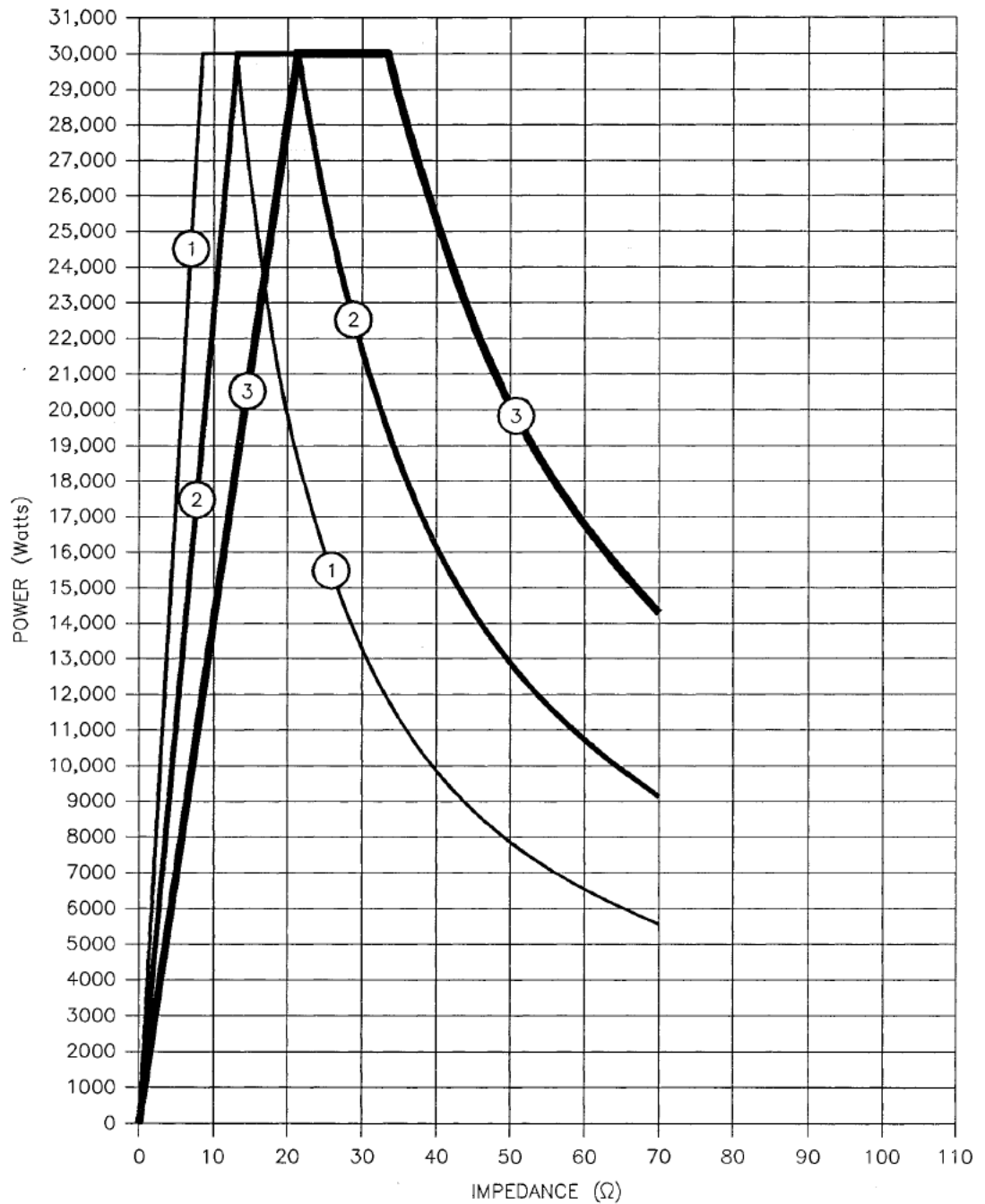

Figure A-35. Impedance-range graph for an MDX model 30K, "standard Z" configuration. Shown are the three overlapping ranges of impedance values that can be accommodated with either tap 1, 2, or 3. The range that can be accommodated with tap 1 is enclosed by the lines labeled "1"; similarly, the lines that enclose the other two ranges are labeled "2" and "3." Also see Fig. A-17.

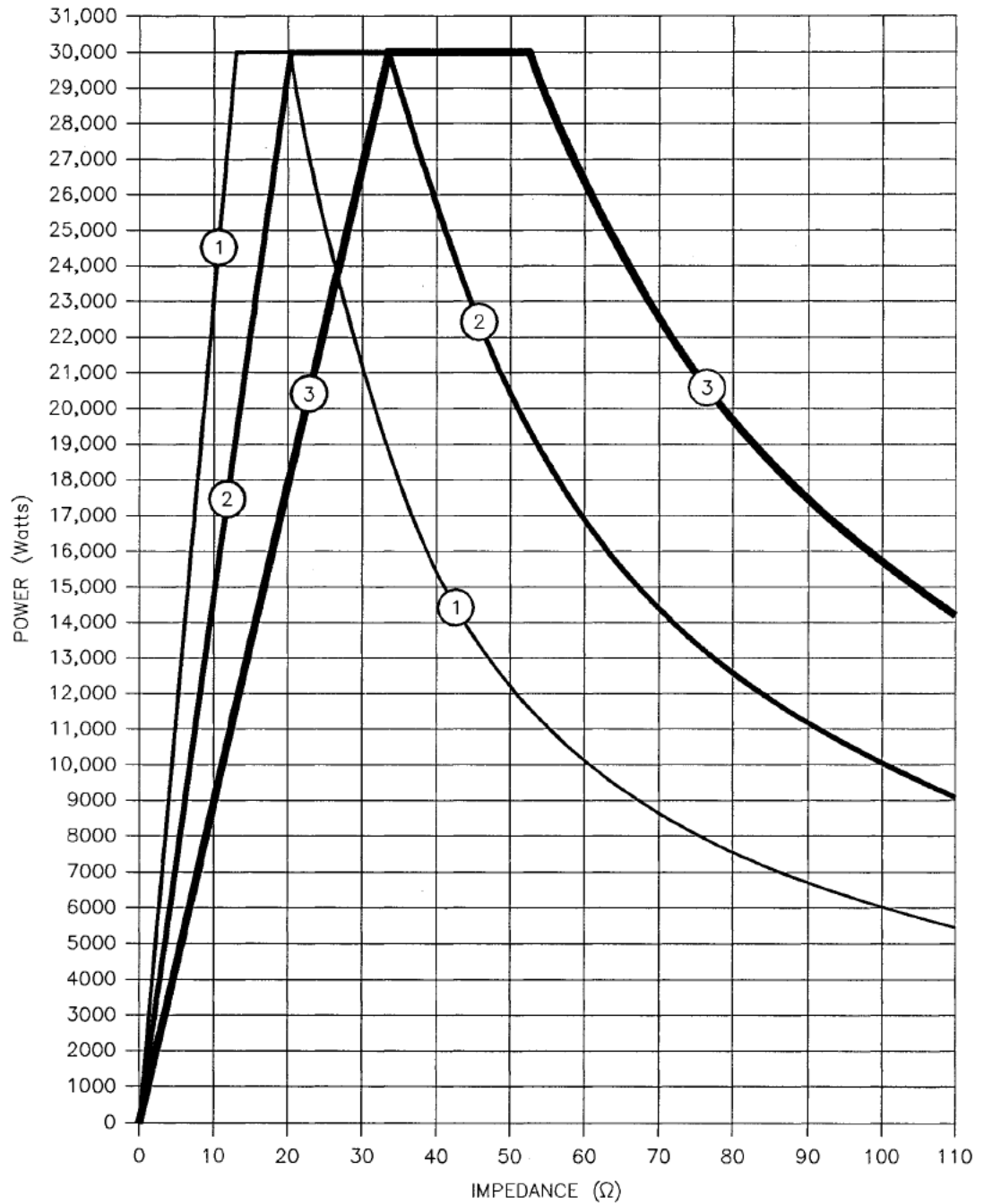

Figure A-36. Impedance-range graph for an MDX model 30K, "high Z" configuration. Shown are the three overlapping ranges of impedance values that can be accommodated with either tap 1, 2, or 3. The range that can be accommodated with tap 1 is enclosed by the lines labeled "1"; similarly, the lines that enclose the other two ranges are labeled "2" and "3." Also see Fig. A-18.

Warranty Claims

Advanced Energy® products are warranted to be free from failures due to defects in material and workmanship for 12 months after they are shipped from the factory (please see warranty statement, below, for details).

In order to claim shipping or handling damage, you must inspect the delivered goods and report such damage to AE within 30 days of your receipt of the goods. Please note that failing to report any damage within this period is the same as acknowledging that the goods were received undamaged.

For a warranty claim to be valid, it must:

- be made within the applicable warranty period
- include the product serial number and a full description of the circumstances giving rise to the claim
- have been assigned a return authorization number (see below) by AE Customer Service

All warranty work will be performed at an authorized AE service center (see list of contacts at the front of the manual). You are responsible for obtaining authorization (see details below) to return any defective units, prepaying the freight costs, and ensuring that the units are returned to an authorized AE service center. AE will return the repaired unit (freight prepaid) to you by second-day air shipment (or ground carrier for local returns); repair parts and labor will be provided free of charge. Whoever ships the unit (either you or AE) is responsible for properly packaging and adequately insuring the unit.

Authorized Returns

Before returning any product for repair and/or adjustment, call AE Customer Service and discuss the problem with them. Be prepared to give them the serial number of the unit and the reason for the proposed return. This consultation call will allow Customer Service to determine if the unit must actually be returned for the problem to be corrected. Such technical consultation is always available at no charge.

Units that are returned without authorization from AE Customer Service and that are found to be functional will not be covered under the warranty (see warranty statement, below). That is, you will have to pay a retest and calibration fee, and all shipping charges.

Upgrading Units

AE's products are continually changing as ways to improve them are discovered. AE is happy to upgrade older units so that they reflect recent improvements. The fee for upgrading a unit will be a percentage of the current list price, based on the age of the unit. Such an upgraded unit will carry a 6-month warranty (which will be added to any time remaining on the original warranty). Contact Customer Service for specifics on getting an older unit upgraded to the current revision level.

Warranty

The seller makes no express or implied warranty that the goods are merchantable or fit for any particular purpose except as specifically stated in printed AE specifications. The sole responsibility of the Seller shall be that it will manufacture the goods in accordance with its published specifications and that the goods will be free from defects in material and workmanship. The seller's liability for breach of an expressed warranty shall exist only if the goods are installed, started in operation, and tested in conformity with the seller's published instructions. The seller expressly excludes any warranty whatsoever concerning goods that have been subject to misuse, negligence, or accident, or that have been altered or repaired by anyone other than the seller or the seller's duly authorized agent. This warranty is expressly made in lieu of any and all other warranties, express or implied, unless otherwise agreed to in writing. The warranty period is 12 months after the date the goods are shipped from AE. In all cases, the seller has sole responsibility for determining the cause and nature of the failure, and the seller's determination with regard thereto shall be final.

5559001

INDEX

A

applications	1-9
arc	
ARC-CHECK	1-7, 5-3
ARC-OUT	1-6, 5-3

B

baud rate	2-33
---------------------	------

C

cabinet configuration	3-10
cheater plug	3-27
configurations for magnetron sputtering	
factory (negative output)	1-9
optimum (floating output)	1-12
optimum (positive or negative output)	1-10
connectors/ports	
analog/digital I/O port	2-8, 3-17
cathode port	2-10
host RS-232 port	2-10, 3-18
input power	2-7, 3-14
master/slave interface	2-11, 3-28
output	2-7, 3-17
remote control panel	2-7, 3-27
contactor hold function	5-7
cooling requirements	3-9
current regulation	4-3

D

dc bias	6-3
design considerations	3-5
disconnecting	3-29
display bypass plug	3-28

E

error messages	2-23
--------------------------	------

F

fast ramp	5-5
functional block diagram	2-3

G

grounding	3-13
---------------------	------

H

Host port	
connector	2-10
location	2-47
transmission parameters	2-33
host-remote control	2-33, 4-21

I

interfaces	1-5
interfacing	
control hierarchy	2-25
Host port	2-33
minipanel controls	2-25, 2-45
minipanel rear panel	2-47
rear panel	2-47
remote control panel, rear view	2-49
standard control panel controls	2-25, 2-45
User port	2-31

L

line voltage changes	4-47
lock mode	4-19

M

master/slave operation	4-53
setpoint LEDs	4-55
messages	2-23
minipanel	
cathode port	2-10
digital meter LEDs	2-21
switch LEDs	2-17

O

out-of-setpoint timer	4-17
output impedance	1-5, 1-21, 4-43
output regulation	1-5, 4-3
overtemperature	1-18, 2-16
over/undervoltage settings	4-49

P

passive front panel	
status indicator LEDs	2-16
pausing during a ramp	4-11
power regulation	4-3
program mode	
setpoints and timers	4-9
target controls	4-5

R

ramp timer	4-10
remote operation — Host port	
commands to set variables	2-38
key to translating hexadecimal characters	2-42
requests for data	2-34
responses to requests for interlock status	2-40
responses to requests for system status	2-41
S (status change) commands	2-36
translating responses to status requests	2-43
run timer	4-15

S

signal descriptions	
User port	3-19
setpoint level	4-9
setting up	3-5
spacing requirements	3-7
specifications	
functional	1-17
physical	1-19
start-up procedure	3-31
status information	
messages	2-23
digital meter LEDs	2-21
signals	2-13
status indicator LEDs — control panels	2-15
status indicator LEDs — passive front panel	2-16
switch LEDs	2-17

T

tap selection	4-27
tap changing	4-37, 4-43
target-life counter	4-5, 4-24
theory of operation	2-3
transmission parameters	2-33
typical applications	
basic magnetron sputtering	1-9
dc sputtering with RF bias	1-13
dc-biased RF sputtering	1-14

U

User port	
connector	2-8
location	2-47
pin-description table	2-8
signal descriptions	3-18
user-remote control	2-31, 4-23
method of output regulation	4-23
on/off	4-24
output setpoint level	4-23
ramp	4-24
target	4-24



Artisan Technology Group is your source for quality new and certified-used/pre-owned equipment

- FAST SHIPPING AND DELIVERY
- TENS OF THOUSANDS OF IN-STOCK ITEMS
- EQUIPMENT DEMOS
- HUNDREDS OF MANUFACTURERS SUPPORTED
- LEASING/MONTHLY RENTALS
- ITAR CERTIFIED SECURE ASSET SOLUTIONS

SERVICE CENTER REPAIRS

Experienced engineers and technicians on staff at our full-service, in-house repair center

InstraView™ REMOTE INSPECTION

Remotely inspect equipment before purchasing with our interactive website at www.instraview.com ↗

WE BUY USED EQUIPMENT

Sell your excess, underutilized, and idle used equipment. We also offer credit for buy-backs and trade-ins

www.artisanng.com/WeBuyEquipment ↗

LOOKING FOR MORE INFORMATION?

Visit us on the web at www.artisanng.com ↗ for more information on price quotations, drivers, technical specifications, manuals, and documentation

Contact us: (888) 88-SOURCE | sales@artisanng.com | www.artisanng.com