

(19) World Intellectual Property Organization
International Bureau



(43) International Publication Date
30 August 2001 (30.08.2001)

PCT

(10) International Publication Number
WO 01/63000 A2

(51) International Patent Classification⁷: C23C 14/00

[US/US]; 14435 South 48th Street, Phoenix, AZ 85044 (US).

(21) International Application Number: PCT/US01/04563

(22) International Filing Date: 14 February 2001 (14.02.2001)

(74) Agents: LAZAR, Dale, S. et al.; Pillsbury Winthrop LLP, 1100 New York Avenue, N.W. Washington, DC 20005 (US).

(25) Filing Language: English

(26) Publication Language: English

(30) Priority Data:
60/185,068 25 February 2000 (25.02.2000) US

(81) Designated States (national): AE, AG, AL, AM, AT, AU, AZ, BA, BB, BG, BR, BY, BZ, CA, CH, CN, CR, CU, CZ, DE, DK, DM, DZ, EE, ES, FI, GB, GD, GE, GH, GM, HR, HU, ID, IL, IN, IS, JP, KE, KG, KP, KR, KZ, LC, LK, LR, LS, LT, LU, LV, MA, MD, MG, MK, MN, MW, MX, MZ, NO, NZ, PL, PT, RO, RU, SD, SE, SG, SI, SK, SL, TJ, TM, TR, TT, TZ, UA, UG, US, UZ, VN, YU, ZA, ZW.

(71) Applicant (for all designated States except US): TOKYO ELECTRON LIMITED [JP/JP]; TBS Broadcast Center, 3-6 Akasaka 5-chome, Minato-ku, Tokyo 107 (JP).

(84) Designated States (regional): ARIPO patent (GH, GM, KE, LS, MW, MZ, SD, SL, SZ, TZ, UG, ZW), Eurasian patent (AM, AZ, BY, KG, KZ, MD, RU, TJ, TM), European patent (AT, BE, CH, CY, DE, DK, ES, FI, FR, GB, GR, IE,

(72) Inventor; and
(75) Inventor/Applicant (for US only): JOHNSON, Wayne

[Continued on next page]

(54) Title: METHOD AND APPARATUS FOR DEPOSITING FILMS



WO 01/63000 A2

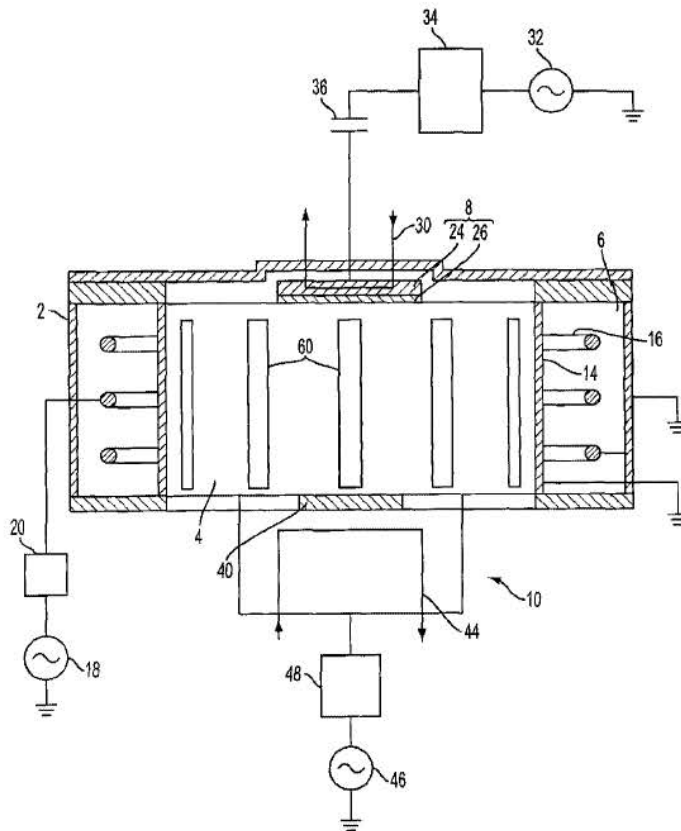

(57) Abstract: A method and apparatus for performing physical vapor deposition of a layer on a substrate, composed of a deposition chamber enclosing a plasma region for containing an ionizable gas; an electromagnetic field generating system surrounding the plasma region for inductively coupling an electromagnetic field into the plasma region to ionize the gas and generate and maintain a high density, low potential plasma; a source of deposition material including a solid target constituting a source of material to be deposited onto the substrate; a unit associated with the target for electrically biasing the target in order to cause ions in the plasma to strike the target and sputter material from the target; and a substrate holder for holding the substrate at a location to permit material sputtered from the target to be deposited on the substrate.



IT, LU, MC, NL, PT, SE, TR), OAPI patent (BF, BJ, CF, CG, CI, CM, GA, GN, GW, ML, MR, NE, SN, TD, TG).

For two-letter codes and other abbreviations, refer to the "Guidance Notes on Codes and Abbreviations" appearing at the beginning of each regular issue of the PCT Gazette.

Published:

— *without international search report and to be republished upon receipt of that report*

TITLE OF THE INVENTION

METHOD AND APPARATUS FOR DEPOSITING FILMS

This International Application claims benefit of U.S. Application No. 60/185,068
5 filed February 25, 2000.

BACKGROUND OF THE INVENTION

The present invention relates to the deposition of films, or layers, primarily in the
fabrication of integrated circuits, but also in the manufacture of other products.

Integrated circuit fabrication procedures are composed of a variety of operations,
10 including operations for depositing thin films on a semiconductor substrate, or wafer.
Typically, a large number of identical integrated circuits are formed on such a wafer, which is
then cut, or diced, into individual circuit chips.

Given the small dimensions of these integrated circuits, the quality of each deposited
layer or film has a decisive influence on the quality of the resulting integrated circuit.
15 Basically, the quality of a film is determined by its physical uniformity, including the
uniformity of its thickness and its homogeneity.

In particular, several process steps require the ability to deposit high quality thin
conductive films and to deposit conducting material in both high aspect ratio trenches and
vias (and/or contacts).

20 According to the current state of the art, films, or layers, are deposited on a substrate
according to two types of techniques: physical vapor deposition (PVD), which encompasses
various forms of sputtering; and chemical vapor deposition (CVD). According to each type
of procedure, a layer of material composed of a plurality of atoms or molecules of elements
or compounds, commonly referred to collectively as "adatoms", is deposited upon a substrate
25 in a low pressure region.

In typical PVD procedures, a target material is sputtered to eject adatoms that then
diffuse through the low pressure region and condense on the surface of the substrate on which
the layer is to be deposited. This material forms a layer on the substrate surface.

Continuation of this process leads to the growth of a thin film. The sputtering itself is a

physical process which involves accelerating heavy ions from an ionized gas, such as argon, toward the target surface, where the ions act to dislodge and eject adatoms of the target material as a result of momentum exchange which occurs upon collision of the ions with the target surface.

5 On the other hand, in CVD procedures, two or more gases are introduced into a vacuum chamber where they react to form products. One of these products will be deposited as a layer on the substrate surface, while the other product or products are pumped out of the low pressure region.

10 Both types of deposition processes are advantageously performed with the assistance of a plasma created in the low pressure region. In the case of PVD processes, it is essential to provide a primary plasma to generate the ions that will be used to bombard the target. However, in these processes, a secondary plasma may be formed to assist the deposition process itself. In particular, a secondary plasma can serve to enhance the mobility of adatoms in proximity to the substrate surface.

15 Although CVD processes are widely used in the semiconductor fabrication industry, processes of this type have been found to possess certain disadvantages. For example, in order to employ CVD for a particular deposition operation, it is necessary to be able to create a chemical reaction that will produce, as one reaction product, the material to be deposited. In contrast, in theory, any material, including dielectric and conductive materials, can be
20 deposited by PVD and this is the process of choice when deposition must be performed while maintaining the substrate temperature within predetermined limits, and particularly when deposition is to be performed while the substrate is at a relatively low temperature.

 A film composed of a dielectric material can be formed by PVD either by directly sputtering a target made of the dielectric material, or by performing a reactive sputtering
25 operation in which a conductive material is sputtered from a target and the sputtered conductive material then reacts with a selected gas to produce the dielectric material that is to be deposited. One exemplary target material utilized for direct sputtering is silicon dioxide. PVD can also be used for conductive layers.

 The simplest known PVD structure has the form of a planar diode which consists of
30 two parallel plate electrodes that define cathode constructed to serve as the target and an anode which supports the substrate. A plasma is maintained between the cathode and anode

and electrons emitted from the cathode by ion bombardment enter the plasma as primary electrons and serve to maintain the plasma.

While a target made of a conductive material can be biased with a DC power supply, a target made of a dielectric material must be biased with high frequency, and particularly RF power, which can also assist the generation of ions in the plasma. The RF power is supplied to the target by a circuit arrangement including, for example, a blocking capacitor, in order to cause the applied RF power to result in the development of a DC self-bias on the target.

Since the planar diode configuration is not suitable for efficient generation of ions, DC and RF magnetron configurations have been developed for producing a magnetic field having field lines that extend approximately parallel to the target surface. This magnetic field confines electrons emitted from the target within a region neighboring the target surface, thereby improving ionization efficiency and the creation of higher plasma densities for a given plasma region pressure.

Additional configurations followed including the variety of cylindrical magnetrons. Several versions of the cylindrical magnetron variation have appeared in the patent prior art, in particular, the family of U.S. Patents Nos. 4,132,613, 4,132,613, 4,132,612, 4,116,794, 4,116,793, 4,111,782, 4,041,353, 3,995,187, 3,884,793 and 3,878,085.

As described in Thornton in "Influence of Apparatus Geometry and Deposition Conditions on the Structure and Topography of Thick Sputtered Coatings", J. Vac. Sci. Technol., Vol 11, No 4, 666-670 (1974), the structure of a deposited metal film is dependent on both the temperature of the substrate and the gas pressure within the plasma region. The highest film quality can be achieved when the substrate is at a relatively low temperature and conditions are created to effect a certain level of bombardment of the substrate with ions from the plasma while the film is being formed. When optimum conditions are established, a dense, high quality thin film which is substantially free of voids and anomalies can be achieved.

It is known in the art that bombardment of the substrate with ions having energies under 200 eV, and preferably not greater than 30 eV, and more preferably between 10 and 30 eV, can result in the formation of dielectric films having optimum characteristics. This has been found to be true in the case of, for example, thin films of SiO₂ and TiO₂.

Explore Litigation Insights

Docket Alarm provides insights to develop a more informed litigation strategy and the peace of mind of knowing you're on top of things.

Real-Time Litigation Alerts



Keep your litigation team up-to-date with **real-time alerts** and advanced team management tools built for the enterprise, all while greatly reducing PACER spend.

Our comprehensive service means we can handle Federal, State, and Administrative courts across the country.

Advanced Docket Research



With over 230 million records, Docket Alarm's cloud-native docket research platform finds what other services can't. Coverage includes Federal, State, plus PTAB, TTAB, ITC and NLRB decisions, all in one place.

Identify arguments that have been successful in the past with full text, pinpoint searching. Link to case law cited within any court document via Fastcase.

Analytics At Your Fingertips



Learn what happened the last time a particular judge, opposing counsel or company faced cases similar to yours.

Advanced out-of-the-box PTAB and TTAB analytics are always at your fingertips.

API

Docket Alarm offers a powerful API (application programming interface) to developers that want to integrate case filings into their apps.

LAW FIRMS

Build custom dashboards for your attorneys and clients with live data direct from the court.

Automate many repetitive legal tasks like conflict checks, document management, and marketing.

FINANCIAL INSTITUTIONS

Litigation and bankruptcy checks for companies and debtors.

E-DISCOVERY AND LEGAL VENDORS

Sync your system to PACER to automate legal marketing.