



- [54] **MAGNETOOPTIC LAYER AND A PROCESS FOR ITS FABRICATION**
- [75] Inventors: **Karl-Friedrich Doessel**, Wiesbaden;
Bernd Fischer, Wiesbaden-Nordenstadt;
Ernst G. Schlosser, Kelkheim;
Guenther Schmidt, Niedernhausen, all of Germany
- [73] Assignee: **Hoechst Aktiengesellschaft**, Frankfurt am Main, Germany
- [21] Appl. No.: **224,190**
- [22] Filed: **Apr. 7, 1994**

FOREIGN PATENT DOCUMENTS

0126589	11/1984	European Pat. Off. .
0217096	4/1987	European Pat. Off. .
0225141	10/1987	European Pat. Off. .
0227480	7/1987	European Pat. Off. .
0229292	7/1987	European Pat. Off. .
3309483	9/1983	Germany .
3536210	4/1986	Germany .
3642161	6/1988	Germany .
009855	1/1985	Japan .
243844	12/1985	Japan .
243840	12/1985	Japan .
048148	3/1986	Japan .
184940	7/1988	Japan .
63-188843	8/1988	Japan .
2169742	7/1986	United Kingdom .

Related U.S. Application Data

- [63] Continuation of Ser. No. 785,880, Nov. 4, 1991, abandoned, which is a continuation of Ser. No. 480,496, Feb. 16, 1990, abandoned.

Foreign Application Priority Data

- Feb. 16, 1989 [DE] Germany 39 04 611.7
- [51] Int. Cl.⁶ **G11B 5/66**; B32B 5/16; C23C 14/00
- [52] U.S. Cl. **428/332**; 428/336; 428/610; 428/684 ML; 428/684 SC; 428/684.6 R; 428/684 NF; 428/684 MM; 428/684 T; 428/684 RF; 428/684 XS; 428/900; 428/638; 204/192.1; 204/192.2; 204/192.26; 363/13
- [58] Field of Search 428/694 ML, 694 SC, 428/694 GR, 900, 694 NF, 694 MM, 694 IS, 332, 336, 610, 694 XS; 369/13; 204/192.1, 192.2, 192.26

References Cited

U.S. PATENT DOCUMENTS

4,293,621	10/1981	Togami	428/694
4,649,519	3/1987	Sun et al.	365/122
4,670,356	6/1987	Sato et al.	428/693
4,694,358	9/1987	Muchnik et al.	360/59
4,740,430	4/1988	Frankenthal et al.	428/630

OTHER PUBLICATIONS

- S. Takayama, et al., "Magnetic and Magneto-Optical Properties of Tb-Fe-Co Amorphous Films", J. Appl. Phys. 61(7), Apr. 1, 1987, American Institute of Physics, pp. 2610-2616.
- S. Asari, et al. "Preparation of a Magneto-Optical Disk Using a Rare Earth-Transition Metal Alloy Target", J. Vac. Sci. Technol. A5(4), Jul./Aug. 1987, pp. 1949-1951.
- E. Schultheiss, et al., "Production Technology for Magneto-optic Data Storage Media", Solid State Technology/Mar. 1988, pp. 107-112.

(List continued on next page.)

Primary Examiner—Leszek Kilman
Attorney, Agent, or Firm—Foley & Lardner

[57] ABSTRACT

A magneto-optic layer made from rare-earth metals and transition metals exhibits a gradient in the alloy composition over the layer depth, and has a coercive field strength of more than 8 kOe in the temperature range of $\Delta T=100^\circ \text{C}$. around the compensation temperature T_{comp} . The layer is fabricated with a dynamic sputter process, in which the substrates to be coated are led past one or a plurality of sputter targets, arranged in a common plane parallel to the track of the substrates. A mask is located between the sputter targets and the substrates.

38 Claims, 6 Drawing Sheets

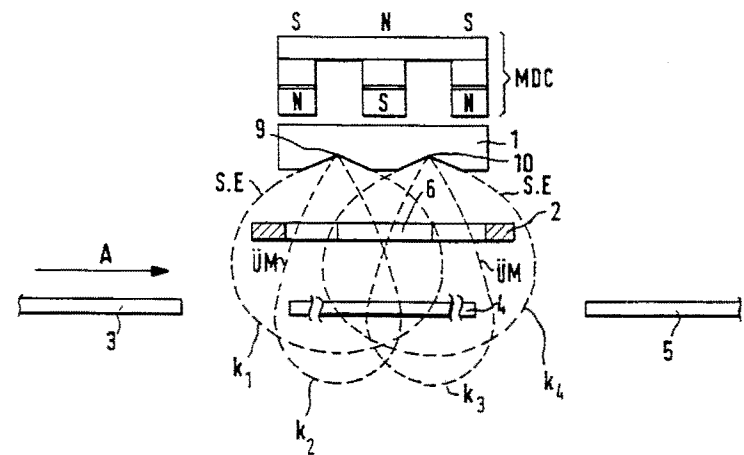

OTHER PUBLICATIONS

Masahiko Takahash et al., "Study on Recorded Domain Characteristics of Magneto-Optical TbFeCo Disks," *Journal of Applied Physics*, vol. 64 (1), Jul. 1, 1988, pp. 262-269.

S. Takayama et al., "Magnetic and Magneto-Optical Properties of Tb-Fe-Co Amorphous Films," *Journal of Applied Physics*, vol. 61 (7), Apr. 1, 1987, pp. 2610-2616.

S. Asari et al., "Preparation of a Magneto-Optical Disk Using a Rare Earth-Transition Metal Alloy Target," *J. Vac. Sci. Technol.*, vol. A 5 (4), Jul./Aug. 1987, pp. 1949-1951.

E. Schultheiss, "Production Technology for Magneto-optic Data Storage Media," *Solid State Technology*, Mar., 1988, pp. 107-112.

M. H. Kryder et al., "Stability of Perpendicular Domains in Thermomagnetic Recording Materials," pp. 236-241.

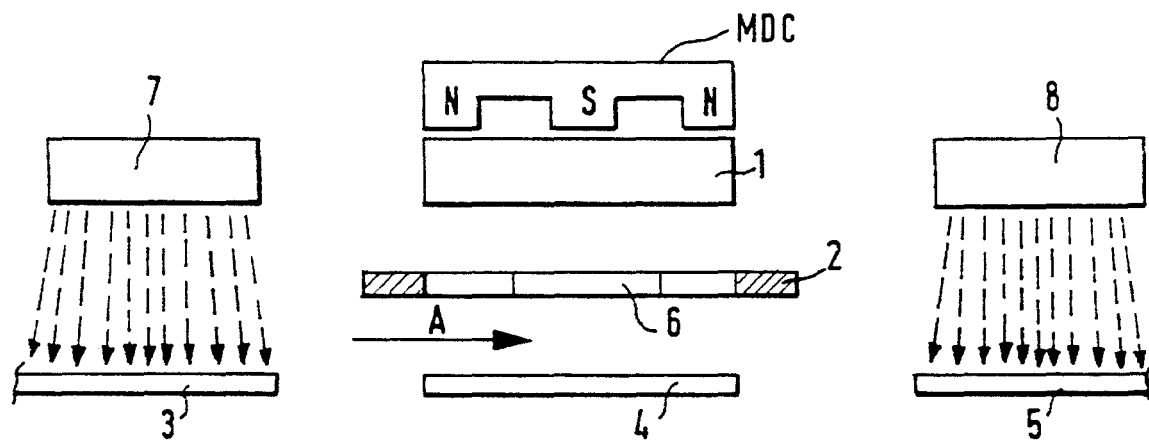
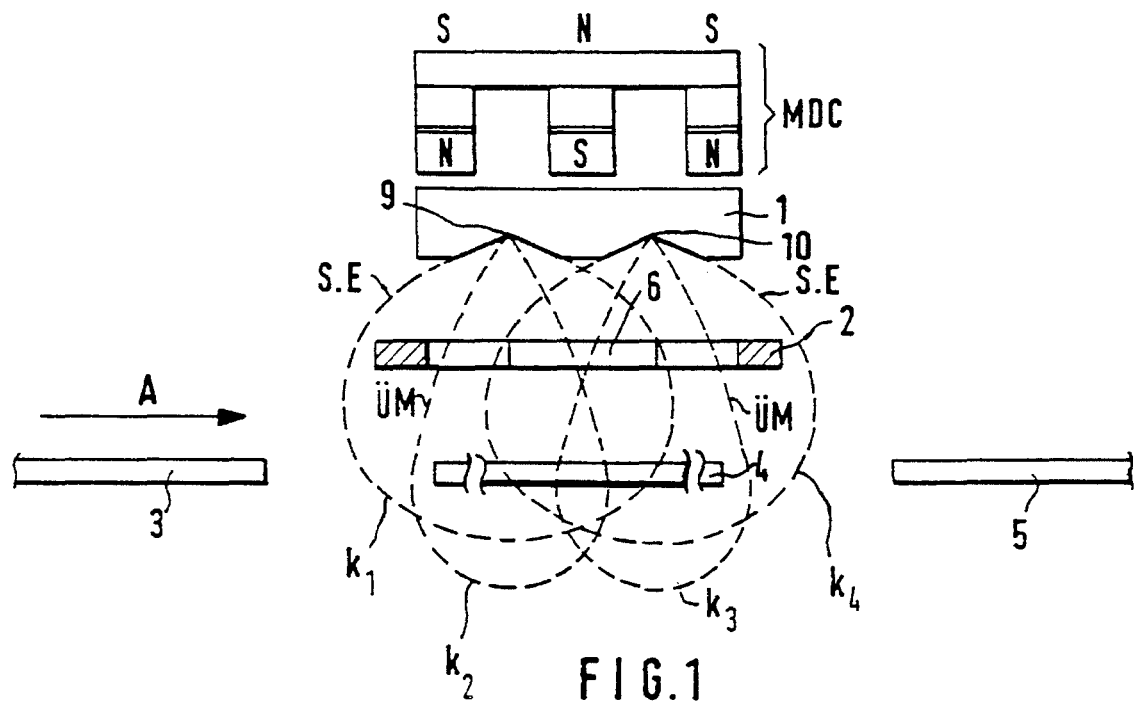

FIG. 2

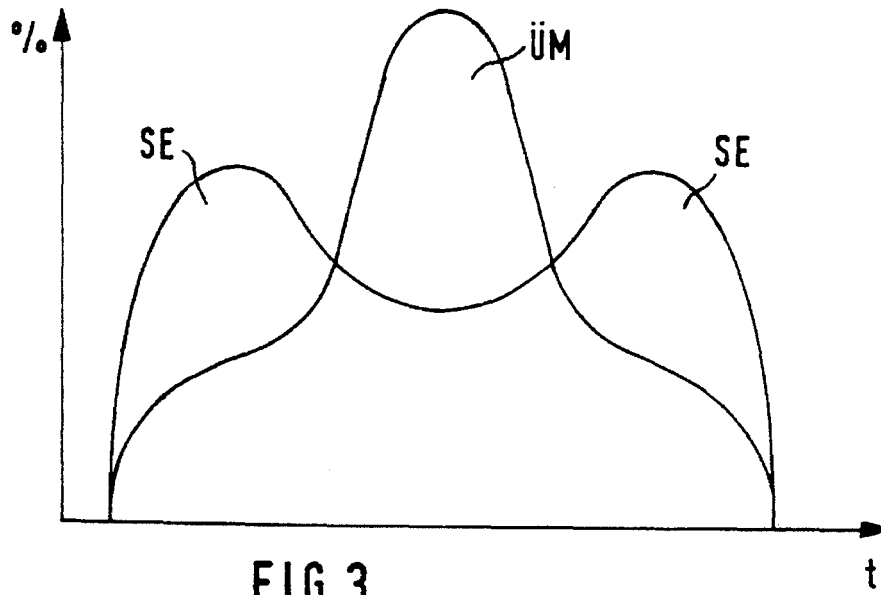

FIG.3

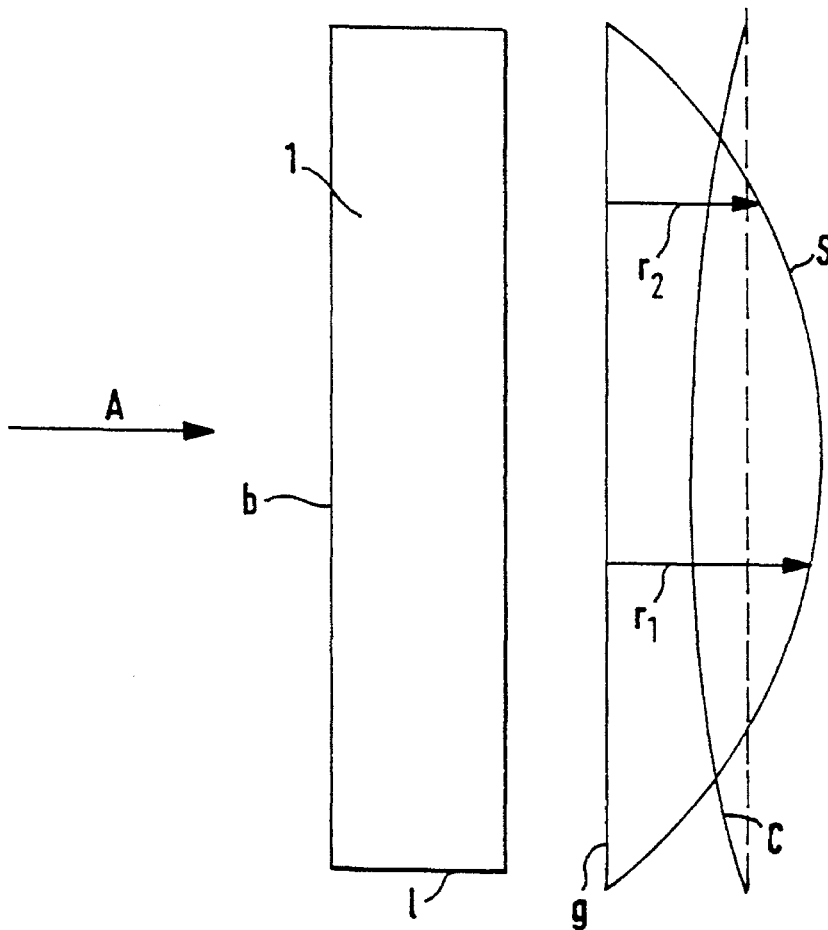

FIG.4

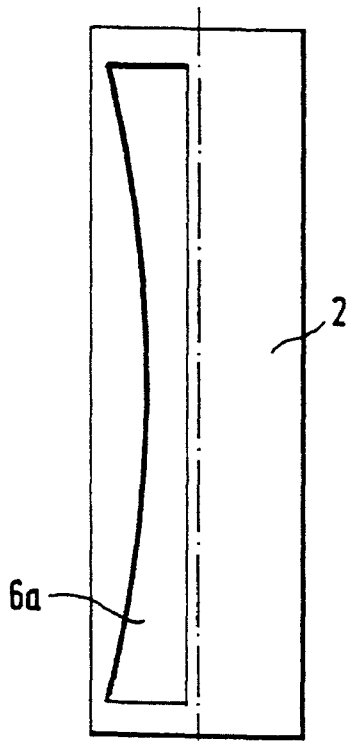

FIG. 5A

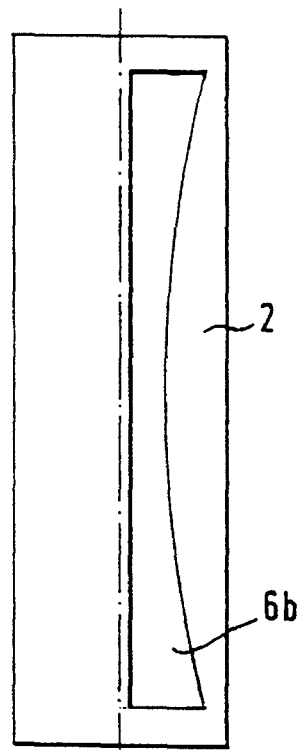

FIG. 5B

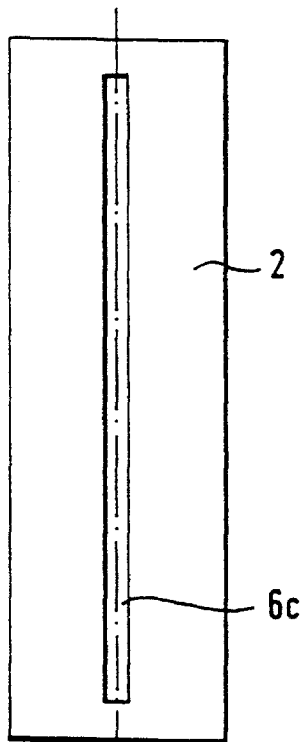

FIG. 5C

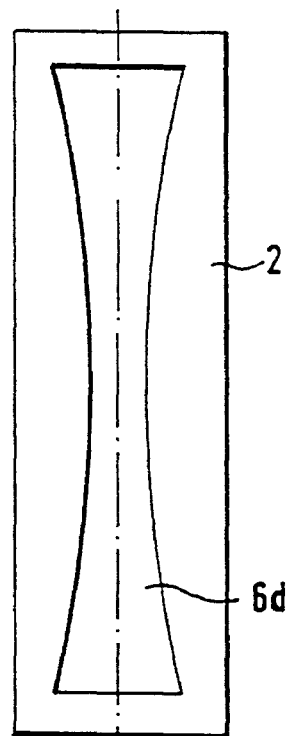

FIG. 5D

Explore Litigation Insights

Docket Alarm provides insights to develop a more informed litigation strategy and the peace of mind of knowing you're on top of things.

Real-Time Litigation Alerts



Keep your litigation team up-to-date with **real-time alerts** and advanced team management tools built for the enterprise, all while greatly reducing PACER spend.

Our comprehensive service means we can handle Federal, State, and Administrative courts across the country.

Advanced Docket Research



With over 230 million records, Docket Alarm's cloud-native docket research platform finds what other services can't. Coverage includes Federal, State, plus PTAB, TTAB, ITC and NLRB decisions, all in one place.

Identify arguments that have been successful in the past with full text, pinpoint searching. Link to case law cited within any court document via Fastcase.

Analytics At Your Fingertips



Learn what happened the last time a particular judge, opposing counsel or company faced cases similar to yours.

Advanced out-of-the-box PTAB and TTAB analytics are always at your fingertips.

API

Docket Alarm offers a powerful API (application programming interface) to developers that want to integrate case filings into their apps.

LAW FIRMS

Build custom dashboards for your attorneys and clients with live data direct from the court.

Automate many repetitive legal tasks like conflict checks, document management, and marketing.

FINANCIAL INSTITUTIONS

Litigation and bankruptcy checks for companies and debtors.

E-DISCOVERY AND LEGAL VENDORS

Sync your system to PACER to automate legal marketing.