

V以下では電流は大きく減少し、これはスパッタリングの酸欠による被覆および低い電圧におけるスパッタリング効果の減少のためである。500V以上では高周波成分を有する電圧で流れる電流は第3図の純直流電流の場合より小さい。明らかにここではプラズマの影響を受けている。

第5図は電極5に印加される変調電圧を示している。これは-420Vの直流電圧に振幅140Vの高周波電圧を重ねたものである。この電圧は処理室のアルゴン圧が 7×10^{-3} ミリバールのとき、アルミニウムがスパッタリングさら酸素との酸化が起こる場合は、優先的に印加される。高周波の有効電力は20Wに設定され電極5を流れる直流電流は約1.14Aである。

第6図は純アルゴン雰囲気下における電流電圧特性を示し、ここにはプラズマについての高周波の効果がはっきり示されている。純直流動作における電流電圧特性を示す測定値はX印で表わされ、変調電圧での電流電圧特性を示す測定値はO印で表わされている。陰極5での高周波電力はこ

ラトニー (Vralny) の観測と矛盾する。それによれば二極管高周波変調された直流電圧が印加されると、直流放電電流が著しく増加するという。プラトニーによって示された高周波電力約200Wは所与の直流電流および高周波電力の約43%である。これが実際に陰極上に効果のある高周波電力であるかどうかは述べられていない。

第6図において、直流陰極電圧の減少に伴ない、高周波変調のときの直流放電電流はゆっくりと減少を続ける。350V以下のときの直流放電電流は純直流の放電より大きい値である。純直流電流の放電は290Vでなくなるが、高周波変調放電の直流成分は減少して純高周波放電の固有直流電位である140Vでゼロになる。

このようにマグネトロンの場合、純高周波の放電の直流電位と純直流の放電範囲との間において、高周波変調の直流を用いた場合、直流電流成分の増加が観察される。反応的処理にとって2番目に重要であるこの範囲において、高周波放電の高いイオン化効果が決定される。

こで約20Wである。この有効電力は純直流の場合および高周波の場合のスパッタリング率を比較して決定された。第6図においては2つの本質的な事項が認められる。すなわち、直流マグネトロン放電のための典型的な電力密度 $10W/cm^2$ (第6図においては約 $600V/0.8A$)から開始して、同一の直流電圧のときの直流の放電電流は重畳高周波電力20Wのときすでに、ゼロになっている。すなわち、変調振幅が約140Vのとき電流は0.18Aだけ減少する。

磁界に支持された直流マグネトロン放電用として、直流電流の約5%の高周波変調は強烈的な効果を有している。直流出力電力は約100W (= $2.3W/cm^2$) 減少される。明らかに高周波電界は陰極5の前で循環している電子のドリフト電流を妨害する。高周波電界に追跡できる電子はさらに陰極5から取り除かれる。このことは電子の衝突率が減少することを意味する。これと関連して電子のドリフト損失も減少する。

この結果は純二極管スパッタリング動作中のブ

純二極管スパッタリングにおけるプラトニーによる結論および観察は一般に本発明にとってはあまり重要ではないこの効果に関連している。

定電力の高周波変調による直流マグネトロン放電で広い範囲において、直流電流を減少させることのほとんど予見できず実際には歓迎されない効果は、反応動作中に増加された第2電子発生量によりターゲットを部分的に酸化することで十分補償される。この効果の程度は使用される物質および気体に依る。アルゴン/酸素の雰囲気中におけるAl, Si, Snおよびアルゴル/酸素の雰囲気中におけるAlおよびSiについてはその効果は実験によってすでに確認済みである。

4. 図面の簡単な説明

第1図は本発明による装置の基本的構成図、第2図は公知の直流マグネトロン・スパッタリング装置において圧力 7×10^{-3} ミリバールのもとで、陰極電圧の関数としての陰極電流、スパッタリング率およびスパッタリング出力を示す図、第3図はアルゴン圧 7×10^{-3} ミリバール、酸素濃

量6.7 SCCM/分で一定およびアルミニウムのターゲットのもとにおける直流陰極電圧の関数としての陰極電流および陰極分圧を示す図、第4図はアルゴン圧 7×10^{-2} ミリバール、陰極流量6.7 SCCM/分で一定、振幅140Vの重畳高周波電圧およびアルミニウムのターゲットのもとで直流陰極電圧の関数としての陰極電流および陰極分圧を示す図、第5図は交流電圧が重ねられた直流陰極電圧を示す図、第6図は純アルゴン雰囲気下において直流陰極電圧および直流電圧と重畳交流電圧との組合電圧の関数としての陰極電流を示す図である。

1---基板、2---絶縁層、3---ターゲット、5---陰極、7、8、9---永久磁石、10---直流電源、24、25---コンテナ、30---高周波電源

特許出願人 レイボルト アクチーエ
ンゲゼルシャフト

代理人 弁理士 鈴木 弘 男

FIG.6

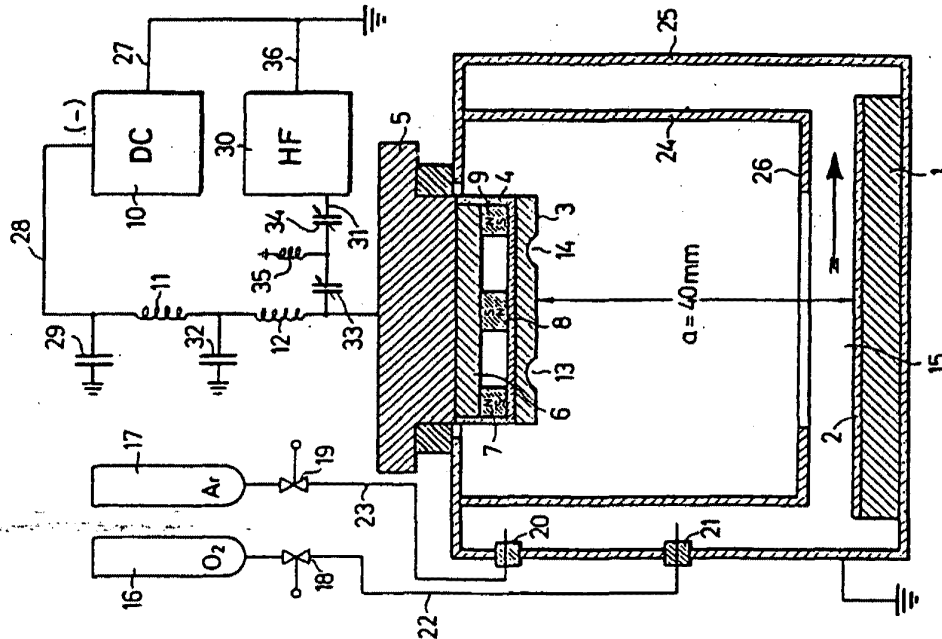
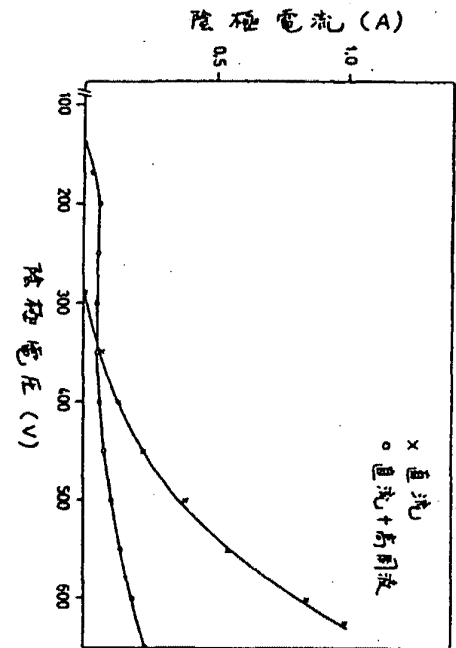

FIG.1

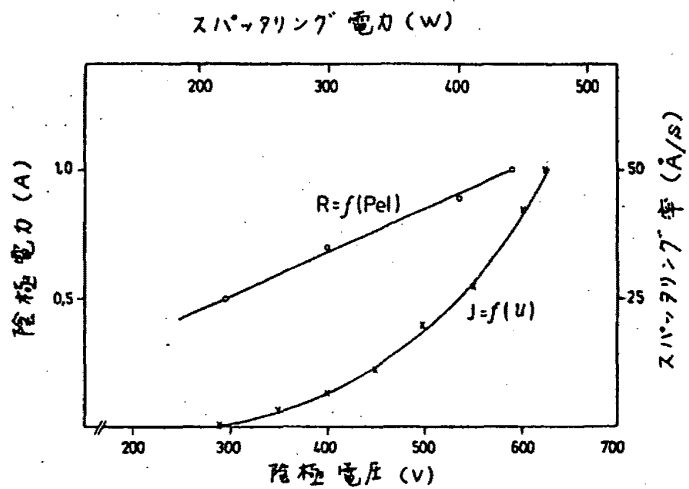

FIG. 2

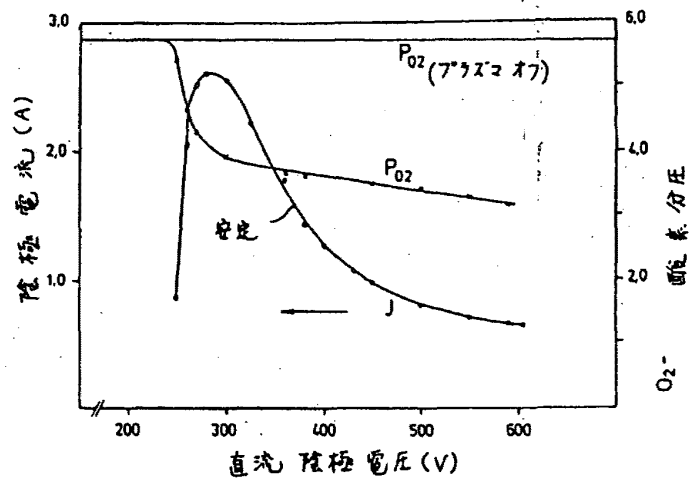

FIG. 4

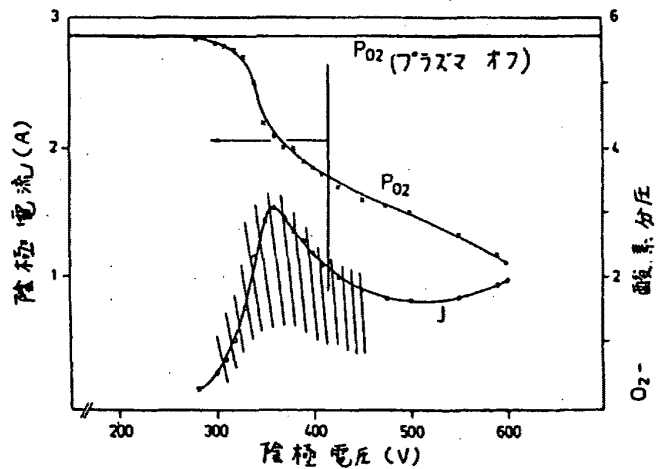

FIG. 3

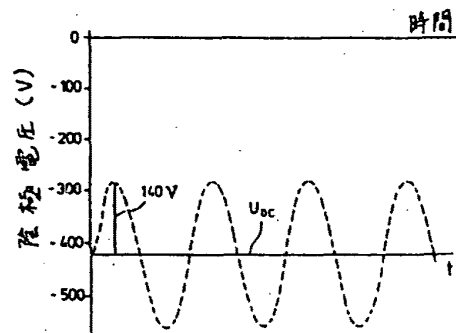

FIG. 5



INTERNATIONAL APPLICATION PUBLISHED UNDER THE PATENT COOPERATION TREATY (PCT)

<p>(51) International Patent Classification ⁷ : C03C 13/04, H01S 3/06</p>	A1	<p>(11) International Publication Number: WO 00/21898 (43) International Publication Date: 20 April 2000 (20.04.00)</p>
<p>(21) International Application Number: PCT/KR99/00609 (22) International Filing Date: 11 October 1999 (11.10.99) (30) Priority Data: 1998/42713 13 October 1998 (13.10.98) KR (71) Applicant: SAMSUNG ELECTRONICS CO., LTD. [KR/KR]; 416, Maetan-dong, Paldal-gu, Suwon-city, Kyunggi-do 442-373 (KR). (72) Inventors: HEO, Jong; 8-401, Kyosoo Apt., Jigok-dong, Nam-gu, Pohang-city, Kyungsangbuk-do 790-390 (KR). LEE, Dong-chin; 7/1, 94-10, Onchun 1-dong, Tongrae-gu, Pusan 607-061 (KR). PARK, Se-ho; 246-55, Junggok 1-dong, Kwangjin-gu, Seoul 143-221 (KR). JUNG, Sun-tae; 602-1503, Taeyoung Apt., 1075, Hogae-dong, Tongan-gu, Anyang-city, Kyungki-do 431-080 (KR). KIM, Hyoun-soo; 801-1002 Jinheung Apt., Imae-dong, Bundang-gu, Sungnam-city, Kyungki-do 463-060 (KR). (74) Agent: LEE, Young-pil; The Cheonghwa Building, 1571-18, Seocho-dong, Seocho-gu, Seoul 137-073 (KR).</p>	<p>(81) Designated States: AU, CA, CN, JP, RU, European patent (AT, BE, CH, CY, DE, DK, ES, FI, FR, GB, GR, IE, IT, LU, MC, NL, PT, SE). Published <i>With international search report. Before the expiration of the time limit for amending the claims and to be republished in the event of the receipt of amendments.</i></p>	
<p>(54) Title: OPTICAL FIBER FOR LIGHT AMPLIFIER</p>		
<p>(57) Abstract</p> <p>An optical fiber used for an optical amplifier, which is formed by doping glass with rare-earth ions. Both praseodymium ions (Pr⁺³) and erbium ions (Er⁺³) are used as the rare-earth ions, and the glass is a fluoride glass or a sulfide glass. The optical fiber can be used at both wavelengths of 1.3 μm and 1.55 μm. The light amplification efficiency of an optical amplifier made of the optical fiber can be improved compared to an optical amplifier formed of only Pr⁺³ or only Er⁺³.</p>		

FOR THE PURPOSES OF INFORMATION ONLY

Codes used to identify States party to the PCT on the front pages of pamphlets publishing international applications under the PCT.

AL	Albania	ES	Spain	LS	Lesotho	SI	Slovenia
AM	Armenia	FI	Finland	LT	Lithuania	SK	Slovakia
AT	Austria	FR	France	LU	Luxembourg	SN	Senegal
AU	Australia	GA	Gabon	LV	Latvia	SZ	Swaziland
AZ	Azerbaijan	GB	United Kingdom	MC	Monaco	TD	Chad
BA	Bosnia and Herzegovina	GE	Georgia	MD	Republic of Moldova	TG	Togo
BB	Barbados	GH	Ghana	MG	Madagascar	TJ	Tajikistan
BE	Belgium	GN	Guinea	MK	The former Yugoslav Republic of Macedonia	TM	Turkmenistan
BF	Burkina Faso	GR	Greece	ML	Mali	TR	Turkey
BG	Bulgaria	HU	Hungary	MN	Mongolia	TT	Trinidad and Tobago
BJ	Benin	IE	Ireland	MR	Mauritania	UA	Ukraine
BR	Brazil	IL	Israel	MW	Malawi	UG	Uganda
BY	Belarus	IS	Iceland	MX	Mexico	US	United States of America
CA	Canada	IT	Italy	NE	Niger	UZ	Uzbekistan
CF	Central African Republic	JP	Japan	NL	Netherlands	VN	Viet Nam
CG	Congo	KE	Kenya	NO	Norway	YU	Yugoslavia
CH	Switzerland	KG	Kyrgyzstan	NZ	New Zealand	ZW	Zimbabwe
CI	Côte d'Ivoire	KP	Democratic People's Republic of Korea	PL	Poland		
CM	Cameroon	KR	Republic of Korea	PT	Portugal		
CN	China	KZ	Kazakstan	RO	Romania		
CU	Cuba	LC	Saint Lucia	RU	Russian Federation		
CZ	Czech Republic	LI	Liechtenstein	SD	Sudan		
DE	Germany	LK	Sri Lanka	SE	Sweden		
DK	Denmark	LR	Liberia	SG	Singapore		
EE	Estonia						

OPTICAL FIBER FOR LIGHT AMPLIFIER

Technical Field

The present invention relates to optical fibers for use in a light amplifier,
5 and more particularly, to an optical fiber for use in a light amplifier which can
be used at wavelengths of both 1.3 μm and 1.55 μm .

Background Art

The wavelength of light used in optical communications has been
10 shifted from a wavelength of 1.3 μm to a wavelength of 1.55 μm . In general,
praseodymium ions (Pr^{+3}) which are used to dope an optical fiber, are used to
amplify an optical signal having a wavelength of 1.3 μm while erbium ion (Er^{+3})
which are used to dope an optical fiber, are used to amplify an optical signal
having a wavelength of 1.55 μm .

15 U.S. Patent No. 5,486,947 discloses an optical fiber for use in an optical
amplifier, which are capable of operating with optical sufficient optical gain at
the 1.3 μm wavelength. The optical fiber is a fluoride glass optical fiber
containing rare earth metal ions in a core glass, wherein the refractive index
difference between the core and a cladding layer is above 1.4%, and the glass
20 contains lead difluoride (PbF_2) in a proportion of 25 mol % or less based on the
total composition for forming the glass.

Now, both wavelengths of 1.3 μm and 1.55 μm are used in many optical
communications related fields. Thus, different parts which are suitable for
each wavelength, are required to construct an optical circuit, so that
25 development cost increases in addition to switching cost for switching the
wavelengths.

Disclosure of the Invention

An object of the present invention is to provide an optical fiber for use
30 in an optical amplifier, which can be used for both the 1.3 μm and 1.55 μm
bands.

According to an aspect of the present invention, there is provided an optical fiber for an optical amplifier, which is formed by doping glass with rare-earth ions, wherein both praseodymium ions (Pr^{+3}) and erbium ions (Er^{+3}) are used as the rare-earth ions, and the glass is a fluoride glass or a sulfide glass.

5 Preferably, the content of Pr^{+3} is 100–1000 ppm and the content of Er^{+3} is 100–5000 ppm. If the Pr^{+3} and Er^{+3} content is outside the above range, light amplification efficiency is undesirably lowered. Also, the mixing ratio of Pr^{+3} to Er^{+3} , by weight, may be between 1:1 and 1:3. If the ratio of Pr^{+3} to Er^{+3} exceeds the above ratio, fluorescence emission quantity at the wavelength of
10 1.55 μm is decreased. Conversely, if the ratio of Pr^{+3} to Er^{+3} is less than the above ratio, the amplification at the wavelength of 1.3 μm unfavorably decreased.

Brief Description of the Drawings

15 FIG. 1 shows the fluorescence emission spectrum at wavelengths of 1.3 μm and 1.55 μm according to the amount of Er^{+3} in optical fibers, when a laser beam having a wavelength of 980 nm is irradiated onto an optical fiber which is formed by doping glass made of $\text{Ge}_{29}\text{As}_8\text{Ga}_1\text{S}_{62}$ with Pr^{+3} and Er^{+3} , wherein the fluorescence emission at the wavelength of 1.3 μm is caused by the
20 electron transition of Pr^{3+} from the $^1\text{G}_4$ level to the $^3\text{H}_5$ level in Pr^{+3} doped fibers, and that at the wavelength of 1.55 μm is caused by the transition $^4\text{I}_{13/2}$ – $^4\text{I}_{15/2}$ in Er^{3+} doped fibers ;

FIG. 2 is a graph showing the fluorescence lifetime of Pr^{+3} at the $^1\text{G}_4$ level and of Er^{+3} at the $^4\text{I}_{13/2}$ level and $^4\text{I}_{11/2}$ level according to the amount of
25 Er^{+3} in optical fibers, when a laser beam having a wavelength of 980 nm is irradiated onto an optical fiber which is formed by doping a $\text{Ge}_{29}\text{As}_8\text{Ga}_1\text{S}_{62}$ glass with Pr^{+3} and Er^{+3} ;

FIG. 3 is a diagram illustrating energy transfer between Pr^{+3} and Er^{+3} ions;

30 FIG. 4 shows the fluorescence emission spectrum at the wavelength of 1.3 μm by the electron transition of Pr^{+3} from the $^1\text{G}_4$ level to the $^3\text{H}_5$ level when a laser beam having a wavelength of 1020 nm is irradiated onto an optical fiber which is formed by doping a $\text{Ge}_{29}\text{As}_8\text{Ga}_1\text{S}_{62}$ glass with Pr^{+3} ;

FIG. 5 shows the fluorescence emission spectrum at the wavelength of 1.55 μm by the electron transition of Er^{+3} from the $^4\text{I}_{13/2}$ level to the $^4\text{I}_{15/2}$ level when a laser beam having a wavelength of 980 nm is irradiated onto an optical fiber which is formed by doping a $\text{Ge}_{29}\text{As}_8\text{Ga}_1\text{S}_{62}$ glass with Er^{+3} ; and

5 FIG. 6 shows the fluorescence emission spectrum at the wavelengths of 1.3 μm and 1.55 μm according to the amount of Pr^{+3} in optical fibers, when a laser beam having a wavelength of 980 nm is irradiated onto an optical fiber which is formed by doping a $\text{Ge}_{29}\text{As}_8\text{Ga}_1\text{S}_{62}$ glass with Pr^{+3} and Er^{+3} , wherein the fluorescence emission at the wavelength of 1.3 μm is due to the electron
10 transition of Pr^{3+} from the $^1\text{G}_4$ level to the $^3\text{H}_5$ level, and that at the wavelength of 1.55 μm is due to the electron transition of Er^{3+} from the $^4\text{I}_{13/2}$ level to the $^4\text{I}_{15/2}$ level.

Best mode for carrying out the Invention

15 The present invention provides an optical fiber for use in a light amplifier, which can be used at wavelengths of both 1.3 μm and 1.55 μm , by using a laser beam having a wavelength of 980 nm as a light source for exciting an optical fiber formed of Pr^{+3} and Er^{+3} . In the present invention, the term "fibers" refers to shapes with a wide range of diameters, not merely thin
20 fibers. For example, a fiber may have diameter of 5 to 100mm. In the present invention, the fiber contains Pr^{+3} and Er^{+3} , wherein the maximum absorption peak of Er^{+3} in a laser beam having wavelength 980 nm is at the $^4\text{I}_{11/2}$ level. In this case, two ions are simultaneously excited, so that Pr^{+3} emits fluorescence at 1.3 μm and Er^{+3} emits fluorescence at 1.55 μm . In particular,
25 as shown in FIG. 3, the fluorescence lifetime of Pr^{+3} at the $^1\text{G}_4$ level is elongated due to the energy transfer from Er^{+3} , so that light amplification efficiency is improved compared to a conventional optical fiber containing only Pr^{+3} .

30 Preferably, in the present invention, a fluoride or sulfide glass is used to minimize lattice vibration relaxation of Pr^{+3} from the $^1\text{G}_4$ level to $^3\text{F}_4$ level. The fluoride glass may be a ZBLAN glass which is a fluoride containing zirconium (Zr), barium (Ba), lanthanum (La), aluminum (Al) and sodium (Na), and the sulfide glass may be a germanium-arsenic-gallium-sulfur (Ge-As-Ga-

S) or Ge-As-S glass. Here, using the sulfide glass can further minimize the lattice vibration relaxation of Pr^{+3} from the $^1\text{G}_4$ level to the $^3\text{F}_4$ level compared to the case of using the fluoride glass. However, using the fluoride glass rather than a sulfide glass generally makes the manufacture of optical fiber easier.

5 In order to maximize the light amplification efficiency at both wavelengths of $1.3\ \mu\text{m}$ and $1.55\ \mu\text{m}$, the mixing weight ratio of Pr^{+3} and Er^{+3} is adjusted to be between 1:1 and 1:3.

Hereinafter, the present invention will be described using the following examples. However, these examples are merely illustrative and the present
10 invention is not limited thereto.

Comparative Example 1

Ge, As, Ga and S having a purity of 99.999% or more, were weighted in an atomic ratio of 29:8:1:62 in a glove box where the content of hydroxy
15 (OH) group and oxygen was maintained to be 10 ppm or less, and Pr metal powder was added in amount of 300 ppm to give the Pr^{+3} .

After filling a SiO_2 test tube with the above composition, the test tube was left under a vacuum condition of 0.1 mTorr for a predetermined period of time. Then, the test tube was made airtight by sealing it with an oxy-propane
20 flame.

Following this, the test tube was put into a rocking furnace such that the composition comprised in the test tube was completely mixed, and the resultant was kept at 950°C for 12 hours. Then, the test tube was quenched in air, and heated in a furnace which was set at 400°C for 1 hour. After the
25 heating process, the test tube was slowly cooled to room temperature and broken into pieces, resulting in an optical fiber formed of a Pr^{+3} -doped sulfide glass of $\text{Ge}_{29}\text{As}_8\text{Ga}_1\text{S}_{62}$ in which the amount of lattice vibration relaxation was slight. The optical fiber was cut into a disc shape (having a diameter of 10 mm and a thickness of 3 mm) and polished.

30 Then, the fluorescence spectrum and fluorescence lifetime of the resultant were measured using a laser beam having a wavelength of 1017 nm as a source of light excitation. At this wavelength, Pr^{+3} at the $^1\text{G}_4$ level showed a maximum light absorption.

As a result, the fluorescence emission at a wavelength of 1.3 μm , which was caused by electron transition of Pr^{+3} from the $^1\text{G}_4$ level to $^3\text{H}_5$ level, was observed (see FIG. 4), and the fluorescence lifetime was 305 μsec (see FIG. 2).

5

Comparative Example 2

An optical fiber was manufactured in the same manner as in Comparative Example 1 except that Er^{+3} was used instead of Pr^{+3} . Er_2S_3 was used as the source of Er^{+3} . Then, the optical fiber was cut into a disc shape (having a diameter of 10 mm and a thickness of 3 mm) and polished. Then, the fluorescence spectrum and fluorescence lifetime of the resultant were measured using a laser beam having a wavelength of 980 nm as a source of light excitation. At this wavelength, Er^{+3} at the $^4\text{I}_{11/2}$ level showed a maximum light absorption.

15 As a result, the fluorescence emission at a wavelength of 1.55 μm , which was caused by electron transition of Er^{+3} from the $^4\text{I}_{13/2}$ level to $^4\text{I}_{15/2}$ level, was observed (see FIG. 5), and the fluorescence lifetime at the $^4\text{I}_{11/2}$ and $^4\text{I}_{13/2}$ levels was 2100 μsec and 3400 μsec , respectively (see FIG. 2)

20 Example 1

An optical fiber was manufactured in the same manner as in Comparative Example 1 except that Er^{+3} was further added in the amount of 300 ppm together with 300 ppm of Pr^{+3} . Then, the optical fiber was cut into a disc shape (having a diameter of 10 mm and a thickness of 3 mm) and polished. Then, the fluorescence spectrum and fluorescence lifetime of the resultant were measured using a laser beam having a wavelength of 980 nm as a source of light excitation. At this wavelength, Er^{+3} at the $^4\text{I}_{11/2}$ level showed a maximum light absorption.

25 As a result, the fluorescence emission of Pr^{+3} , which was caused by electron transition from $^1\text{G}_4$ level to $^3\text{H}_5$ level and that of Er^{+3} , which was caused by electron transition from $^4\text{I}_{13/2}$ level to $^4\text{I}_{15/2}$ level were observed simultaneously at the wavelengths of 1.3 μm and 1.55 μm , respectively (see

FIG. 1 (a)). The intensity of fluorescence was increased at each wavelength compared to that of Comparative Examples 1-2. Also, the fluorescence lifetime of Pr^{+3} at the $^1\text{G}_4$ level was 605 μsec , and the fluorescence lifetime of Er^{+3} at the $^4\text{I}_{11/2}$ and $^4\text{I}_{13/2}$ levels was 824 μsec and 3120 μsec , respectively (see FIG. 2).

According to Example 1, as shown in FIG. 3, the simultaneous fluorescence emission at the wavelengths of 1.3 μm and 1.55 μm was due to the effective energy transfer indicated by "b". Thus, the optical fiber obtained in Example 1 can be used at wavelengths of both 1.3 μm and 1.55 μm .

Also, the fluorescence lifetime of Pr^{+3} at the $^1\text{G}_4$ level was markedly elongated to 605 μsec compared to Comparative Example 1, and the light amplification efficiency at the wavelength of 1.3 μm was further improved by adding both Pr^{+3} and Er^{+3} . However, the fluorescence lifetime of Er^{+3} at the $^4\text{I}_{11/2}$ level was 3120 μsec , which is lower than in Comparative Example 2, thus lowering light amplification efficiency. This is due to the energy transfer indicated by "e".

Example 2

An optical fiber was manufactured in the same manner as in Comparative Example 1 except that 500 ppm of Er^{+3} was further added together with 300 ppm of Pr^{+3} . Then, the optical fiber was cut into a disc shape (having a diameter of 10 mm and a thickness of 3 mm) and polished. Then, the fluorescence spectrum and fluorescence lifetime of the resultant were measured using a laser beam having a wavelength of 980 nm as a source of light excitation. At this wavelength, Er^{+3} at the $^4\text{I}_{11/2}$ level showed a maximum light absorption.

As a result, the fluorescence emission of Pr^{+3} , which was caused by electron transition from $^1\text{G}_4$ level to $^3\text{H}_5$ level and that of Er^{+3} , which was caused by electron transition from $^4\text{I}_{13/2}$ level to $^4\text{I}_{15/2}$ level were observed simultaneously at the wavelengths of 1.3 μm and 1.55 μm , respectively (see FIG. 1 (b)). The intensity of fluorescence was increased at each wavelength

compared to that of the Comparative Examples 1-2. Also, the fluorescence lifetime of Pr^{+3} at the $^1\text{G}_4$ level was 760 μsec , and the fluorescent lifetime of Er^{+3} at the $^4\text{I}_{11/2}$ and $^4\text{I}_{13/2}$ levels was 1740 μsec and 2910 μsec , respectively (see FIG. 2).

5 According to Example 2, as shown in FIG. 3, the simultaneous fluorescence emission at the wavelengths of 1.3 μm and 1.55 μm was due to the effective energy transfer indicated by "b". Also, the fluorescence lifetime of Pr^{+3} at the $^1\text{G}_4$ level was markedly elongated to 760 μsec compared to Comparative Example 1 and Example 1, and the fluorescence
10 lifetime of Er^{+3} at the $^4\text{I}_{13/2}$ level was decreased to 2910 μsec , compared to Comparative Example 2 and Example 1.

From the above result, it can be understood that the energy transfer indicated by "b" and "e" occur more effectively as the content of Er^{+3} increases. However, the fluorescence lifetime of Er^{+3} at the $^4\text{I}_{11/2}$ level was
15 increased to 1740 μsec , compared to Example 1. As a result, it was concluded that as Er^{+3} , which is not involved in the energy transfer indicated by "b", increases, the energy transfer degree in the direction indicated by "b" decreases.

20 Example 3

An optical fiber was manufactured in the same manner as in Comparative Example 1 except that 700 ppm of Er^{+3} was further added together with 300 ppm of Pr^{+3} . Then, the optical fiber was cut into a disc shape (having a diameter of 10 mm and a thickness of 3 mm) and polished.
25 Then, the fluorescence spectrum and fluorescence lifetime of the resultant were measured using a laser beam having a wavelength of 980 nm as a source of light excitation. At this wavelength, Er^{+3} at the $^4\text{I}_{11/2}$ level showed a maximum light absorption.

As a result, the fluorescence emission of Pr^{+3} , which was caused by
30 electron transition from $^1\text{G}_4$ level to $^3\text{H}_5$ level and that of Er^{+3} , which was caused by electron transition from $^4\text{I}_{13/2}$ level to $^4\text{I}_{15/2}$ level were observed simultaneously at the wavelengths of 1.3 μm and 1.55 μm , respectively (see

FIG. 1 (c)). The intensity of fluorescence was increased at each wavelength compared to that of Examples 1-2. Also, the fluorescence lifetime of Pr^{+3} at the $^1\text{G}_4$ level was 769 μsec , and the fluorescence lifetime of Er^{+3} at the $^4\text{I}_{11/2}$ and $^4\text{I}_{13/2}$ levels was 1760 μsec and 2920 μsec , respectively (see FIG. 2).

5 According to Example 3, as the content of Er^{+3} increased, the fluorescence lifetime of Pr^{+3} at the $^1\text{G}_4$ level was slightly increased. This was due to an increase in energy transfer indicated by "b" shown in FIG. 3. However, because Er^{3+} was contributed for elongating the fluorescence lifetime at the $^4\text{I}_{11/2}$ and $^4\text{I}_{13/2}$ levels, the ratio of Er^{+3} associated with the
10 energy transfer indicated by "b" and "e" was decreased, thus resulting in a slight increase in fluorescence lifetime of Pr^{+3} at the $^1\text{G}_4$ level. That is, the light amplification efficiency at the wavelength of 1.55 μm showed a tendency to increase with an increase in the fluorescence lifetime of Er^{+3} at the $^4\text{I}_{13/2}$ level.

15

Example 4

An optical fiber was manufactured in the same manner as in Comparative Example 1 except that 1000 ppm of Er^{+3} was further added together with 300 ppm of Pr^{+3} . Then, the optical fiber was cut into a disc
20 shape (having a diameter of 10 mm and a thickness of 3 mm) and polished. Then, the fluorescence spectrum and fluorescence lifetime of the resultant were measured using a laser beam having a wavelength of 980 nm as a source of light excitation. At this wavelength, Er^{+3} at the $^4\text{I}_{11/2}$ level showed a maximum light absorption.

25 As a result, the fluorescence emission of Pr^{+3} , which was caused by electron transition from $^1\text{G}_4$ level to $^3\text{H}_5$ level and that of Er^{+3} , which was caused by electron transition from $^4\text{I}_{13/2}$ level to $^4\text{I}_{15/2}$ level were observed simultaneously at the wavelengths of 1.3 μm and 1.55 μm , respectively (see FIG. 1 (d)). The intensity of fluorescence was increased at each wavelength
30 compared to that of Examples 1-3. Also, the fluorescence lifetime of Pr^{+3} at the $^1\text{G}_4$ level was 881 μsec , and the fluorescent lifetime of Er^{+3} at the $^4\text{I}_{11/2}$ and $^4\text{I}_{13/2}$ levels was 2030 μsec and 3340 μsec , respectively (see FIG. 2).

According to Example 4, as shown in FIG. 3, the simultaneous fluorescence emission at the wavelength of 1.3 μm by Pr^{+3} at the $^1\text{G}_4$ level, and at the wavelength of 1.55 μm by Er^{+3} at the $^4\text{I}_{13/2}$ level, was due to effective energy transfer indicated by "b". Also, the fluorescence lifetime of Er^{+3} at the $^4\text{I}_{11/2}$ and $^4\text{I}_{13/2}$ levels showed the maximum levels. Thus, it can be understood that the mixing ratio of Pr^{+3} and Er^{+3} in this embodiment shows the maximum light amplification efficiency at both 1.3 μm and 1.55 μm .

10 Example 5

An optical fiber was manufactured by the same manner as in Comparative Example 1 except that 1500 ppm of Er^{+3} was further added together with 300 ppm of Pr^{+3} . Then, the optical fiber was cut into a disc shape (having a diameter of 10 mm and a thickness of 3 mm) and polished. Then, the fluorescence spectrum and fluorescence lifetime of the resultant were measured using a laser beam having a wavelength of 980 nm as a source of light excitation. At this wavelength, Er^{+3} at the $^4\text{I}_{11/2}$ level showed a maximum light absorption.

As a result, the fluorescence emission of Pr^{+3} , which was caused by electron transition from $^1\text{G}_4$ level to $^3\text{H}_5$ level and that of Er^{+3} , which was caused by electron transition from $^4\text{I}_{13/2}$ level to $^4\text{I}_{15/2}$ level were observed simultaneously at the wavelengths of 1.3 μm and 1.55 μm , respectively (see FIG. 1 (e)). The intensity of fluorescence was saturated, i.e., at the maximum level, at each wavelength. Also, the fluorescence lifetime of Pr^{+3} at the $^1\text{G}_4$ level was 794 μsec , and the fluorescence lifetime of Er^{+3} at the $^4\text{I}_{11/2}$ and $^4\text{I}_{13/2}$ levels was 1870 μsec and 3240 μsec , respectively (see FIG. 2).

According to Example 5, as shown in FIG. 3, the simultaneous fluorescence emission at the wavelength of 1.3 μm by Pr^{+3} at the $^1\text{G}_4$ level and at the wavelength of 1.55 μm by Er^{+3} at the $^4\text{I}_{13/2}$ level was due to effective energy transfer indicated by "b". The fluorescence lifetime of Er^{+3} at the $^4\text{I}_{11/2}$ and $^4\text{I}_{13/2}$ levels was slightly decreased compared to Example 4, because the energy transfer indicated by "b" and "e" were saturated.

Example 6

Ge, Ga and S having a purity of 99.999% or more, were weighted in an atomic ratio of 25:5:70 in a glove box where the content of hydroxy (OH) group and oxygen was maintained to be 10 ppm or less, and 300 ppm of Pr⁺³ and 300 ppm of Er⁺³ were added.

After filling a SiO₂ test tube with the composition, the test tube was left under a vacuum condition of 0.1 mTorr for a predetermined period of time. Then, the test tube was made airtight by sealing it with an oxy-propane flame.

Following this, the test tube was put into a rocking furnace such that the composition comprised in the test tube was completely mixed, and the resultant was kept at 950°C for 12 hours. Then, the test tube was quenched in air, and heated in a furnace which was set at 260°C for 1 hour. After the heating process, the test tube was slowly cooled to room temperature and broken into pieces, resulting in an optical fiber formed of a Pr⁺³ and Er⁺³ doped sulfide glass of Ge₂₅Ga₅S₇₀ in which the amount of lattice vibration relaxation was slight.

The optical fiber was cut into a disc shape (having a diameter of 10 mm and a thickness of 3 mm) and polished. Then, the fluorescence spectrum and fluorescence lifetime of the resultant were measured using a laser beam having a wavelength of 980 nm as a source of light excitation. At this wavelength, Er⁺³ at the ⁴I_{11/2} level showed a maximum light absorption.

As a result, the fluorescence emission of Pr⁺³, which was caused by electron transition from ¹G₄ level to ³H₅ level and that of Er⁺³, which was caused by electron transition from ⁴I_{13/2} level to ⁴I_{15/2} level were observed simultaneously at the wavelengths of 1.3 μm and 1.55 μm, respectively (see FIG. 6 (a)).

According to Example 6, it can be understood that both a Ge-GA-S glass doped with Pr⁺³ and Er⁺³ and a Ge-As-Ga-S glass doped with Pr⁺³ and Er⁺³ can be used as a material of an optical amplifier which can be used at both 1.3 μm and 1.55 μm.

Example 7

An optical fiber was manufactured in the same manner as in Example 6 except that the amount of Pr^{+3} was increased to 500 ppm. Then, the optical fiber was cut into a disc shape (having a diameter of 10 mm and a thickness of 3 mm) and polished. Then, the fluorescence spectrum and fluorescence lifetime of the resultant were measured using a laser beam having a wavelength of 980 nm as a source of light excitation. At this wavelength, Er^{+3} at the $^4\text{I}_{11/2}$ level showed a maximum light absorption.

As a result, the fluorescence emission of Pr^{+3} , which was caused by electron transition from $^1\text{G}_4$ level to $^3\text{H}_5$ level and that of Er^{+3} , which was caused by electron transition from $^4\text{I}_{13/2}$ level to $^4\text{I}_{15/2}$ level were observed simultaneously at the wavelengths of 1.3 μm and 1.55 μm , respectively (see FIG. 6 (b)). Also, as the amount of Pr^{+3} was increased, energy transfer in directions indicated by "b" and "e" in FIG. 3 increased. As a result, the fluorescence intensity of Pr^{+3} at the $^1\text{G}_4$ level increased at the wavelength of 1.3 μm , whereas that of Er^{+3} at the $^4\text{I}_{13/2}$ level decreased at the wavelength of 1.55 μm . However, the rate at which the fluorescence intensity increases at 1.3 μm is slower than the rate at which the fluorescence intensity decreases at 1.55 μm , and thus it can be inferred that the energy transfer indicated by "e" is more rapid than that indicated by "b".

Summing up the results, it can be understood that increasing the concentration of Pr^{+3} is undesirable.

Industrial Applicability

As described above, the optical fiber used in an optical amplifier according to the present invention can be applied to both wavelengths of 1.3 μm and 1.55 μm , improving light amplification efficiency compared to a conventional optical fiber amplifier containing only Pr^{+3} .

What is claimed is:

1. An optical fiber for an optical amplifier, which is formed by doping glass with rare-earth ions, wherein both praseodymium ions (Pr^{+3}) and erbium ions (Er^{+3}) are used as the rare-earth ions, and the glass is a
5 fluoride glass or a sulfide glass.
2. The optical fiber of claim 1, wherein the sulfide glass is a germanium-arsenic-gallium-sulfide (Ge-As-Ga-S) glass or a Ge-As-S glass.
- 10 3. The optical fiber of claim 1, wherein the fluoride glass is a ZBLAN glass containing zirconium (Zr), barium (Ba), lanthanum (La), aluminum (Al) and sodium (Na).
4. The optical fiber of claim 1, wherein the mixing weight ratio of
15 Pr^{+3} to Er^{+3} is between 1:1 and 1:3.
5. The optical fiber of claim 1, wherein a laser having a wavelength capable of absorbing Er^{+3} is used as a light source for exciting the optical fiber.
20
6. The optical fiber of claim 1, wherein the content of Pr^{+3} is 100~1000 ppm and the content of Er^{+3} is 100~5000 ppm.

1/6

FIG. 1

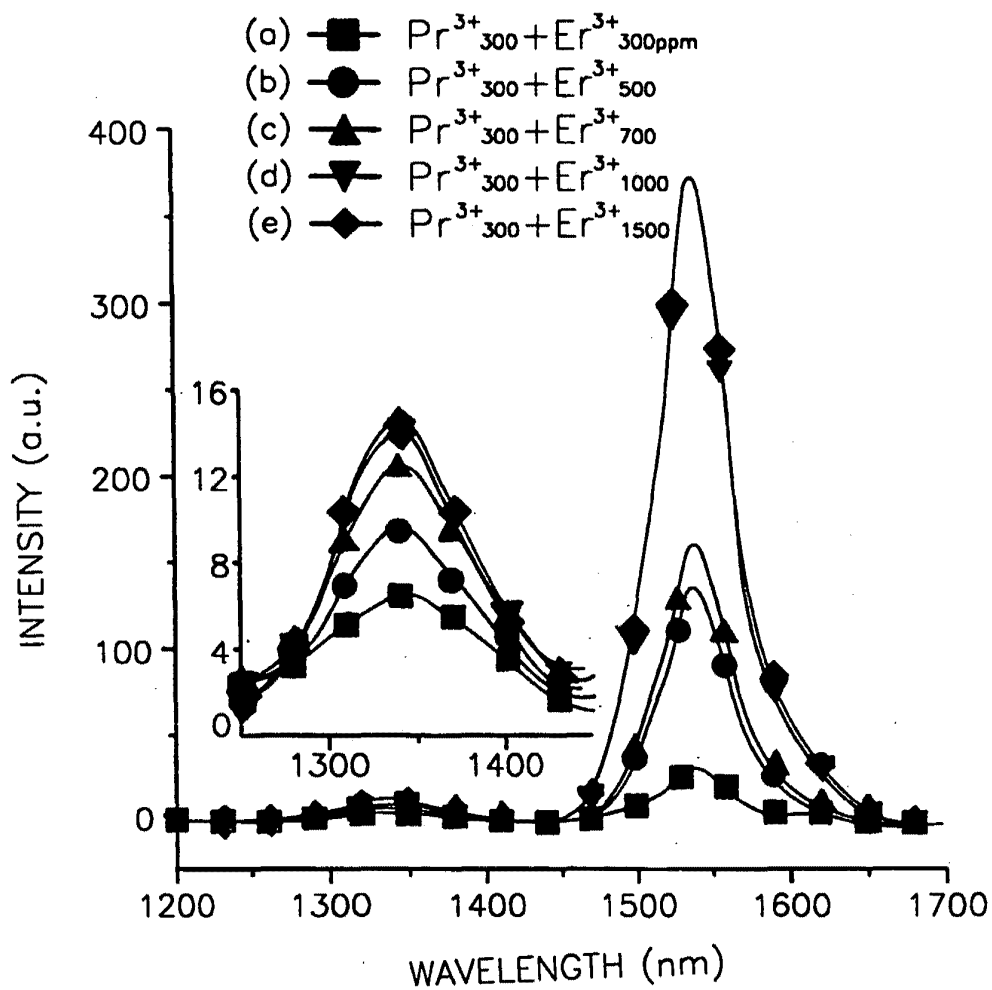

2/6

FIG. 2

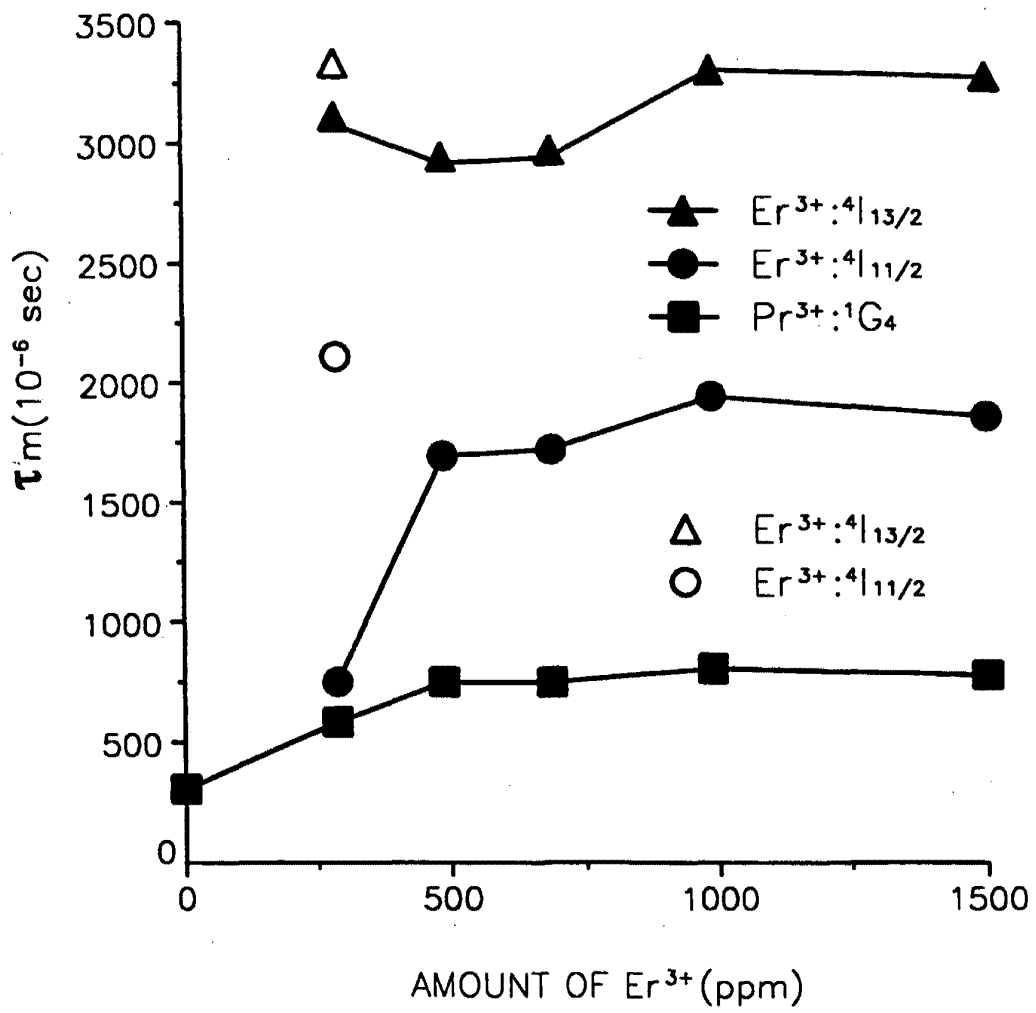

3/6

FIG. 3

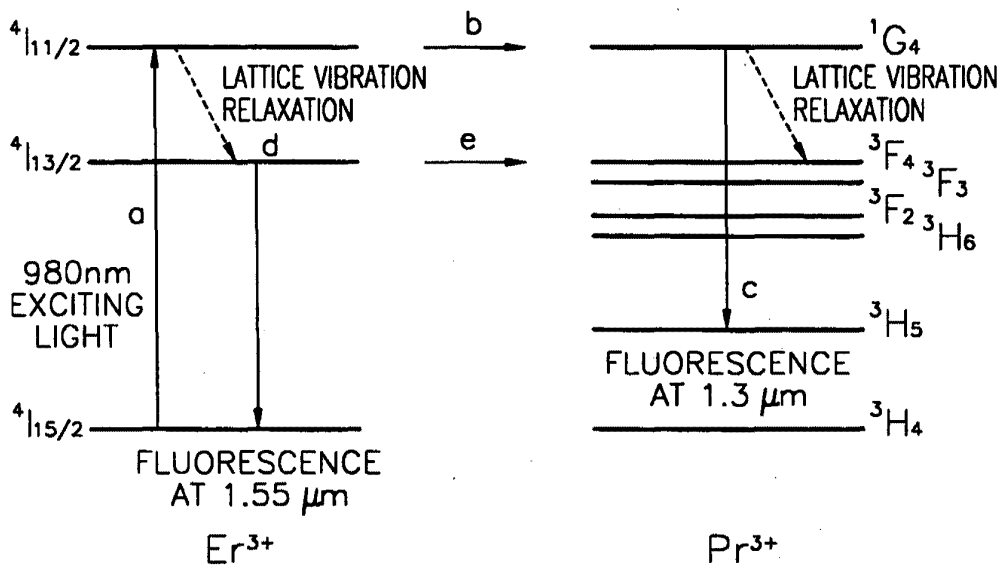

4/6

FIG. 4

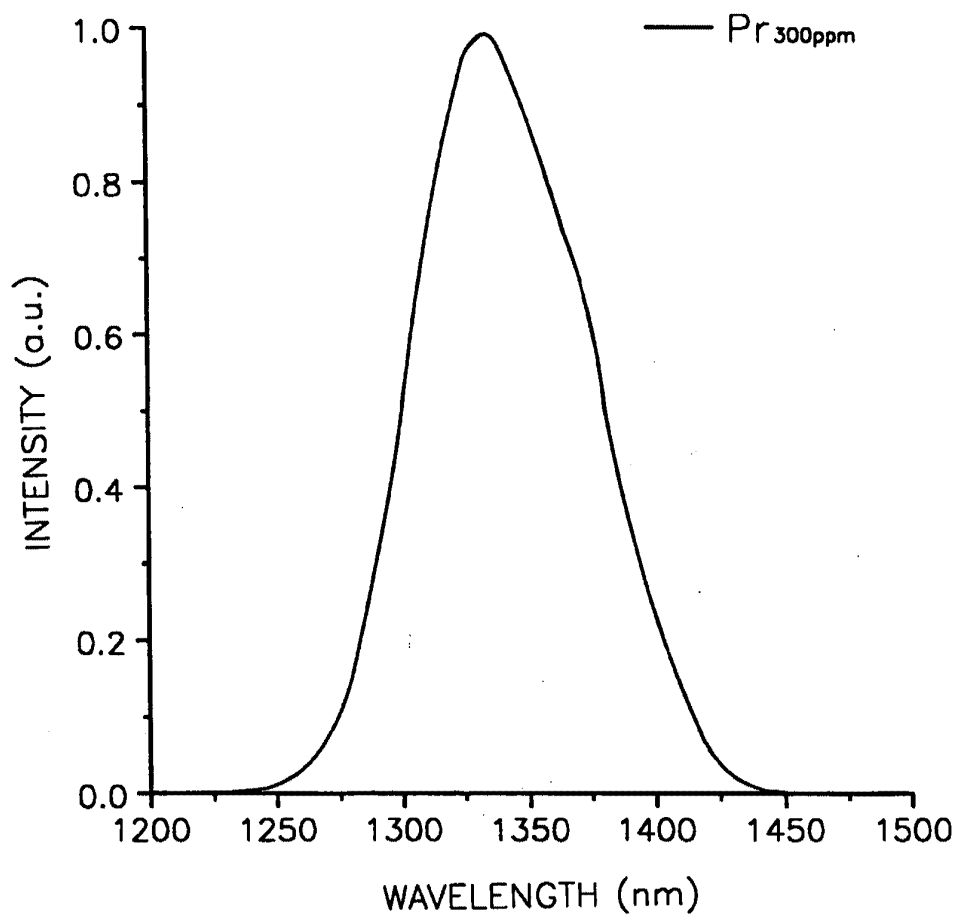

5/6

FIG. 5

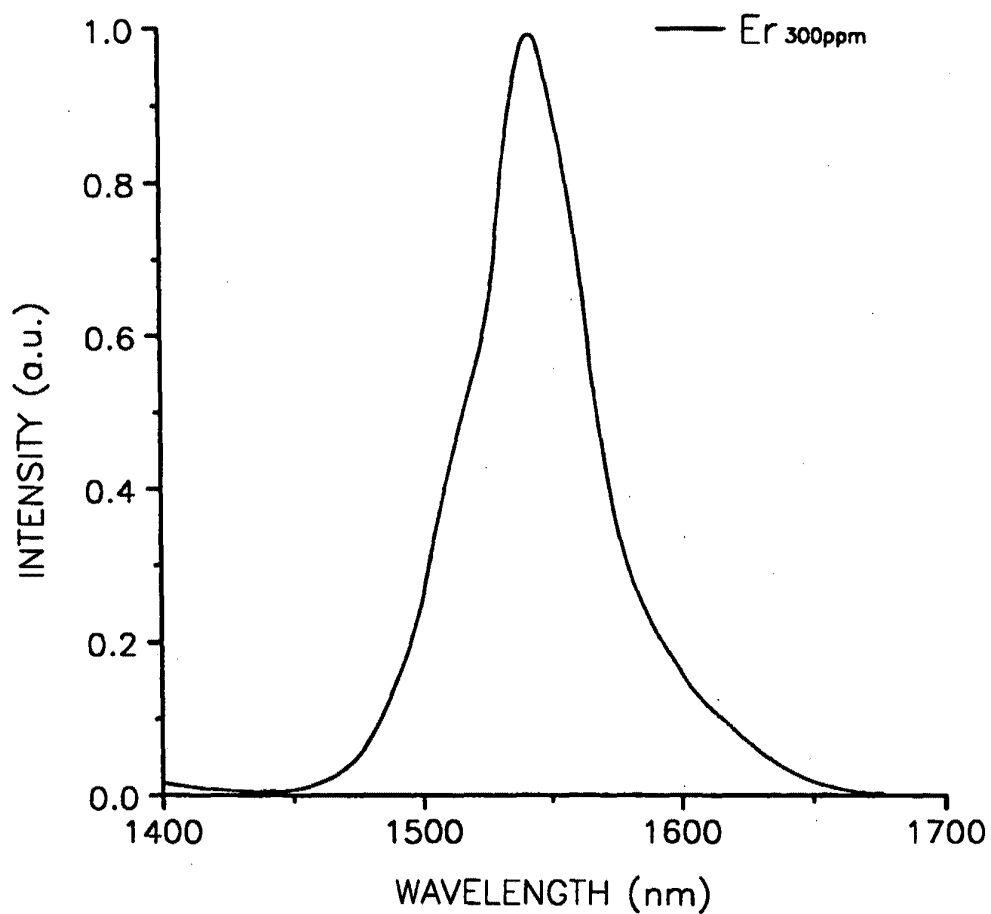

6/6

FIG. 6

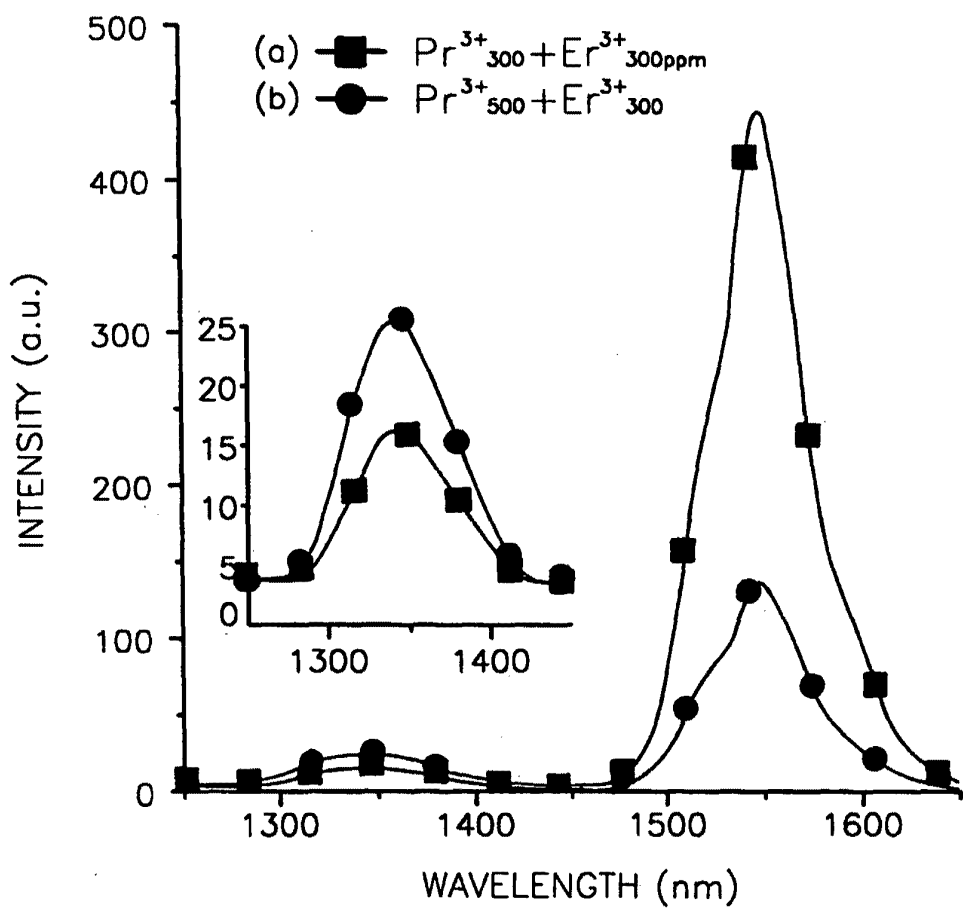

INTERNATIONAL SEARCH REPORT

International application No.
PCT/KR 99/00609

A. CLASSIFICATION OF SUBJECT MATTER IPC ⁷ : C 03 C 13/04; H 01 S 3/06 According to International Patent Classification (IPC) or to both national classification and IPC		
B. FIELDS SEARCHED Minimum documentation searched (classification system followed by classification symbols) IPC ⁷ : C 03 C; H 01 S Documentation searched other than minimum documentation to the extent that such documents are included in the fields searched Electronic data base consulted during the international search (name of data base and, where practicable, search terms used) WPI, EPODOC, PAJ		
C. DOCUMENTS CONSIDERED TO BE RELEVANT		
Category*	Citation of document, with indication, where appropriate, of the relevant passages	Relevant to claim No.
A	US 5486947 A (OHISHI et al.), 23 January 1996 (23.01.96), abstract; column 2, line 45 - column 3, line 58; example 29.	1,3-6
A	EP 0511069 A1 (ALCATEL N.V.), 28 October 1992 (28.10.92), claim 1; column 2, lines 1-9.	1,3
A	JP 08-104533 A (NIPPON TELEGRAPH), 23 April 1996 (23.04.96), (abstract), [online] [retrieved on 24 November 1999 (24.11.99)]. Retrieved from: EPO PAJ Database. -----	1
<input type="checkbox"/> Further documents are listed in the continuation of Box C. <input checked="" type="checkbox"/> See patent family annex.		
* Special categories of cited documents: „A“ document defining the general state of the art which is not considered to be of particular relevance „E“ earlier application or patent but published on or after the international filing date „L“ document which may throw doubts on priority claim(s) or which is cited to establish the publication date of another citation or other special reason (as specified) „O“ document referring to an oral disclosure, use, exhibition or other means „P“ document published prior to the international filing date but later than the priority date claimed „T“ later document published after the international filing date or priority date and not in conflict with the application but cited to understand the principle or theory underlying the invention „X“ document of particular relevance; the claimed invention cannot be considered novel or cannot be considered to involve an inventive step when the document is taken alone „Y“ document of particular relevance; the claimed invention cannot be considered to involve an inventive step when the document is combined with one or more other such documents, such combination being obvious to a person skilled in the art „&“ document member of the same patent family		
Date of the actual completion of the international search 24 November 1999 (24.11.99)	Date of mailing of the international search report 18 February 2000 (18.02.00)	
Name and mailing address of the ISA/AT Austrian Patent Office Kohlmarkt 8-10; A-1014 Vienna Facsimile No. 1/53424/200	Authorized officer Hauswirth Telephone No. 1/53424/136	

Form PCT/ISA/210 (second sheet) (July 1998)

INTERNATIONAL SEARCH REPORT
Information on patent family members

International application No.
PCT/KR 99/00609

Patent document cited in search report			Publication date	Patent family member(s)			Publication date
US	A	5486947	23-01-1996	US	A	5351335	27-09-1994
				DE	C0	69223720	05-02-1998
				DE	T2	69223720	23-04-1998
				EP	A2	535798	07-04-1993
				EP	A3	535798	15-09-1993
				EP	A2	733600	25-09-1996
				EP	A3	733600	02-01-1997
				EP	B1	535798	29-12-1997
				EP	B1	733600	12-01-2000
				JP	A2	6069584	11-03-1994
				JP	B2	2772349	02-07-1998
EP	A1	511069	28-10-1992	AT	E	122180	15-05-1995
EP	B1	511069	03-05-1995	CA	AA	2066549	23-10-1992
				CA	AA	2066549	22-10-1993
				CA	C	2066549	31-12-1996
				DE	C0	69202296	08-06-1995
				DE	T2	69202296	07-09-1995
				ES	T3	2071451	16-06-1995
				FR	A1	2675592	23-10-1992
				FR	B1	2675592	16-07-1993
				JP	A2	5183227	23-07-1993
				US	A	5185847	09-02-1993
JP	A2	8104533	23-04-1996			none	

07/28/05 10/101,863

Best Available Copy

(19)  **Europäisches Patentamt**
European Patent Office
Office européen des brevets



(11) **EP 1 092 689 A1**

(12) **EUROPÄISCHE PATENTANMELDUNG**

(43) Veröffentlichungstag:
18.04.2001 Patentblatt 2001/16

(51) Int. Cl.⁷: **C03C 17/36**

(21) Anmeldenummer: **00119591.6**

(22) Anmeldetag: **07.09.2000**

(84) Benannte Vertragsstaaten:
**AT BE CH CY DE DK ES FI FR GB GR IE IT LI LU
MC NL PT SE**
Benannte Erstreckungsstaaten:
AL LT LV MK RO SI

- Köppel, Andreas
63695 Glauburg (DE)
- Bender, Marcus
35606 Solms (DE)

(30) Priorität: **11.10.1999 DE 19948839**

(74) Vertreter:
**Herrmann-Trentepohl, Werner, Dipl.-Ing.
Patentanwälte
Herrmann-Trentepohl
Grosse - Bockhorni & Partner
Forstenrieder Allee 59
81476 München (DE)**

(71) Anmelder: **BPS Alzenau GmbH
63754 Alzenau (DE)**

(72) Erfinder:
• **Stollenwerk, Johannes, Prof. Dr.
51503 Rösraath (DE)**

(54) **Leitende transparente Schichten und Verfahren zu ihrer Herstellung**

(57) Auf einem Substrat aus Glas (1) ist eine Grundschicht (2) aus Indium-Cer-Oxid und darauf eine dünne Kupfer enthaltende Silberschicht (3), beide hergestellt durch DC-Zerstäubung, aufgebracht. Darauf befindet sich eine weitere Indium-Cer-Oxidschicht (4), welche durch AC-überlagerte DC-Zerstäubung hergestellt wird.

Dieses Schichtsystem weist sehr niedere Flächenwiderstände bei gleichzeitig hoher Durchlässigkeit im sichtbaren Spektralbereich, also einen hohen Haackeschen Gütefaktor auf.

Fig.1

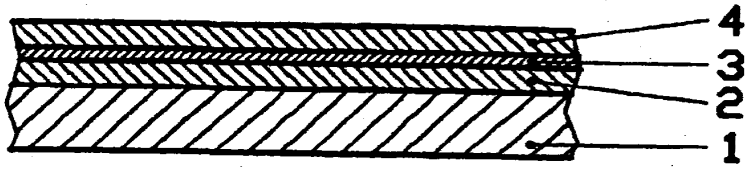

EP 1 092 689 A1

Beschreibung

[0001] Die Erfindung betrifft leitende transparente Schichten nach dem Oberbegriff des Patentanspruchs 1 sowie ein Verfahren zur Herstellung dieser leitenden transparenten Schichten nach Patentanspruch 6.

[0002] Leitende transparente Schichten werden heute in der Displaytechnik, in der Optoelektronik sowie als Architekturglas vielfältig eingesetzt. Dabei wird einerseits eine möglichst hohe Transmission im sichtbaren Spektralbereich und andererseits eine möglichst hohe Leitfähigkeit beziehungsweise ein möglichst niedriger Flächenwiderstand angestrebt. Als Mass für die Güte leitender transparenter Schichten kann der Haakesche Gütefaktor $\Phi_{TC} = T^{10}/R_S$, definiert in Journal of Applied Physics, Vol. 47, Seite 4086 bis 4089 (1976), verwendet werden. Dabei bedeuten T die optische Transmission der Schicht (als Bruchteil der auffallenden Strahlung) und R_S den Flächenwiderstand in Ω_{sq} . So besitzt beispielsweise eine Schicht mit einer Transmission von 90% und einem Flächenwiderstand von $3 \Omega_{sq}$ einen Haakeschen Gütefaktor von $0,116 \Omega^{-1}$. Eine Schicht mit einer Transmission von 80% und einem Flächenwiderstand von $5 \Omega_{sq}$ besitzt einen Gütefaktor von $0,021 \Omega^{-1}$.

[0003] Eine weitere wichtige Eigenschaft eines solchen Schichtsystems ist seine Ätzbarkeit. Diese hängt von seiner chemischen Zusammensetzung und seiner Dicke ab. Für eine kurze Ätzzeit und gute Kantenschärfe ist es wichtig, dass die Schichtdicke möglichst klein ist, d.h. unter 100 nm beträgt.

[0004] Zur Erzielung hoher Gütefaktoren ist es vorteilhaft, Schichtsysteme aus oxidischen und metallischen Schichten zu kombinieren. So ist es bekannt, sehr dünne Silberschichten zwischen dünne Oxidschichten einzulagern. Durch die Einlagerung zwischen Oxidschichten wird die Silberschicht einerseits stabilisiert und geschützt, andererseits wird gleichzeitig ihre Reflexion vermindert und dadurch die Transmission erhöht. Diese Schichtkombinationen besitzen ferner den Vorteil einer geringen Gesamtschichtdicke, nämlich 100 nm oder weniger, verglichen mit einer Schicht aus Indium-Zinn-Oxid mit vergleichbarem Flächenwiderstand, die eine Dicke von über 500 nm aufweist (S. H. Shin und Koautoren, Thin Solid Films 341 (1999) 225 - 229). Damit können Ätzprozesse, wie sie bei der Herstellung von Displays üblich sind, schneller und mit geringerer Unterätzung hergestellt werden.

[0005] Solche Schichtsysteme sind z. B. beschrieben in: EP 0 599 071 A1, JP 10062602 A und im Artikel von K. K. Choi und Koautoren, Thin Solid Films 341 (1999) 152 - 155.

[0006] In der EP 0 599 071 A1 wird ein Schichtsystem mit der Schichtfolge Indium-Zinn-Oxid, Silber bzw. verschiedene Silberlegierungen, Indium-Zinn-Oxid beschrieben. Durch einstündige Temperung bei 300°C lassen sich Schichten mit einem Flächenwiderstand von $3,2 \Omega_{sq}$ und gleichzeitig guter Transmission im

sichtbaren Bereich herstellen. Für die Wellenlängen 435, 545 und 610 nm ergibt sich ein gemittelter Haakescher Gütefaktor von 0,066. Nachteilig ist jedoch die für Displayanwendungen nötige nachträgliche Temperaturbehandlung, da diese einen zusätzlichen Arbeitsschritt bedeutet.

[0007] In der JP 10062602 A wird ein ähnliches Schichtsystem beschrieben. Hier wird eine dünne Silberschicht mit mindestens 1,5 At.-% Goldbeimengung zwischen Oxidschichten, bestehend aus Zinnoxid und Indiumoxid sowie geringen Beimengungen anderer Oxide, eingebettet. Damit werden Schichten mit einem Flächenwiderstand von $4 - 20 \Omega_{sq}$ und hoher Durchlässigkeit bei 550 nm erhalten. Die erhöhten Kosten durch die Goldbeimengung und der relativ hohe Flächenwiderstand müssen als Nachteile angesehen werden.

[0008] In Thin Solid Films 341 beschreiben K. K. Choi und Koautoren ein Schichtsystem bestehend aus Indium-Zinn-Oxid gefolgt von einer Silberschicht und als Deckschicht wiederum Indium-Zinn-Oxid. Zur Verbesserung der Leitfähigkeit werden die Schichten aus Indium-Zinn-Oxid bei 200°C, die Silberschicht jedoch bei Raumtemperatur abgeschieden. Doch durch die Erwärmung vor Abscheidung der zweiten Schicht aus Indium-Zinn-Oxid werden die Eigenschaften der Silberschicht bezüglich optischer Transmission und elektrischer Leitfähigkeit ungünstig beeinflusst. Im besten Fall wurden Schichten mit einem Flächenwiderstand von $4 \Omega_{sq}$ und einer Transmission von 90% bei 550 nm erzielt.

[0009] Es ist weiterhin bekannt, dass bei spezieller Wahl der Materialien und Beschichtungsparameter transparente leitende Schichtsysteme mit 2,93 Ω_{sq} und Transmissionswerten (gegen Luft gemessen) von 89,2 % bei 435 nm, 92,4 % bei 545 nm und 82,2 % bei 610 nm mit einer Gesamtschichtdicke von 86,5 nm hergestellt werden können. Dieser transparente Leiter besitzt für die drei genannten Wellenlängen einen mittleren Haakeschen Gütefaktor von $0,104 \text{ Ohm}^{-1}$.

[0010] Im Displaybereich für grossflächige flache LCD-Displays oder Computermonitore mit Bild diagonalen vorzugsweise über 17" werden nun transparente Elektroden mit noch niedrigerem Flächenwiderstand bei gleichzeitig hoher Durchlässigkeit im sichtbaren Bereich, d. h. einem hohem Haakeschem Gütefaktor, benötigt. Dies ist durch die Bildgrösse, die hohe Auflösung und Pixelzahl sowie die höhere Geschwindigkeit dieser Displays bedingt. Diese Anforderungen können mit den bisher bekannten Verfahren nicht mehr erfüllt werden.

[0011] Die vorliegende Erfindung macht sich zur Aufgabe, die Nachteile des Standes der Technik zu beheben, insbesondere einen noch niedrigeren Flächenwiderstand bei einem hohen Haakeschen Gütefaktor zu erreichen.

[0012] Diese Aufgabe wird gelöst durch ein Schichtsystem nach Anspruch 1 sowie durch ein Verfahren nach Anspruch 6. Die abhängigen Patentansprüche beschreiben weitere bevorzugte Ausführungen der

Erfindung.

[0013] Ein erfindungsgemässes Schichtsystem nach Anspruch 1 umfasst mindestens 2 Oxidschichten und eine dazwischen gelagerte Silberschicht und weist einen Flächenwiderstand von weniger als $2,9 \Omega_{sq}$, vorzugsweise $2,5 \Omega_{sq}$ und geringer auf, bei einem über die Wellenlängen 435, 545 und 610 nm gemittelten Haackeschen Gütefaktor von grösser als $0,085 \Omega^{-1}$.

[0014] Dabei ist es aus Gründen der Farbneutralität günstig, wenn bei einem Flächenwiderstand von $2,5 \Omega_{sq}$ die optische Transmission bei 435 nm mindestens 89 %, bei 545 nm mindestens 88 % und bei 610 nm mindestens 75 % beträgt. Damit ist gewährleistet, dass die Beschichtung in Durchsicht möglichst neutral erscheint.

[0015] Besonders gute Ergebnisse werden erzielt, wenn die Dicke der beiden Oxidschichten vorteilhafterweise unter 50 nm, vorzugsweise zwischen 30 und 40 nm, und die Dicke der Silberschicht unter 20 nm, vorzugsweise bei 15 nm, gewählt wird.

[0016] Die Entspiegelungswirkung der Oxidschichten wird besonders gut, wenn die Oxidschicht neben Indium 5 bis 10 At.-% Cer enthält.

[0017] Die Stabilität der Silberschicht wird durch Beigabe von bis zu 10 Gew.-% Kupfer erhöht. Besonders wirksam zeigten sich Beigaben von 0,5 bis 3 % und insbesondere 0,5 bis 1 %.

[0018] Bei der Herstellung des beschriebenen Schichtsystems ist es entscheidend, wie in Anspruch 6 und weiteren abhängigen Ansprüchen beschrieben, dass die Aufbringung der zweiten Oxidschicht nicht mit reiner DC-Zerstäubung, sondern mit einer gepulsten DC-Zerstäubung oder mit einer AC-überlagerten DC-Zerstäubung erfolgt. Die AC-Überlagerung wird beispielsweise dadurch erzeugt, dass das Ausgangssignal über ein Filter auf die mit einer DC-Stromversorgung gespeiste Sputterquelle eingekoppelt wird. Eine weitere Möglichkeit besteht beispielsweise auch darin, die DC-Stromversorgung entsprechend zu modulieren oder zu tasten (choppieren). Es sind also verschiedene Modulationen möglich.

[0019] Die AC-Frequenz sollte zwischen 1 und 50 MHz, vorzugsweise zwischen 10 und 20 MHz, liegen, um besonders gute Ergebnisse zu erreichen.

[0020] Im Weiteren wird mit Vorteil der AC-Anteil, definiert durch das Verhältnis der eingespeisten DC- und AC-Leistung, zwischen 10 und 90 %, vorzugsweise zwischen 30 und 50 %, eingestellt.

[0021] Besonders geeignet erwies sich eine totale Leistungsdichte (AC und DC) von 1 bis 3 W/cm^2 , vorzugsweise von 2 bis $2,2 \text{ W/cm}^2$.

[0022] Als Zerstäubungsmethode wird Magnetronsputtern bevorzugt.

[0023] Die Vorteile dieses Verfahrens können wie folgt zusammengefasst werden:

[0024] Durch die Erhaltung der guten Leitfähigkeit der dünnen Silberschicht durch die Art der Aufbringung der zweiten Oxidschicht kann die optische Transmission

hoch gehalten werden. Ohne das erfindungsgemässe Vorgehen müsste zur Erzielung dieser Leitfähigkeit die Dicke der Silberschicht erhöht werden, was unvermeidlich zu einer deutlicheren Verringerung der Transmission und damit zu einer wesentlichen Verschlechterung des Haackeschen Gütefaktors führen würde.

[0025] Die Herstellung solcher Schichten an Hand des erfindungsgemässen Verfahrens soll nun an dem nachfolgenden Beispiel beschrieben werden.

[0026] Die Glas-Substrate aus herkömmlichem dünnen Floatglas oder Maschinenglas werden in herkömmlicher Weise gereinigt und dann in eine Zerstäubungsanlage eingebracht. Die Vakuumkammer wird abgepumpt und nach Erreichung des nötigen Vakuums mit der Aufstäubung der ersten Oxidschicht aus Indium- und Ceroxid begonnen. Diese Oxidschicht wird teilreaktiv von einem Oxidtarget abgestäubt, d. h. in einer Argonatmosphäre von ca. $2,2 \times 10^{-3} \text{ hPa}$ mit einer Beimischung von Sauerstoff von maximal 5 %. Dieser Zerstäubungsprozess ist ein reiner DC-Prozess. Typische Zerstäubungsraten sind 5 bis $8 \text{ nm} \times \text{m} / \text{min} \times \text{cm}^2 \text{ W}$. Anschliessend erfolgt als reiner nicht-reaktiver DC-Prozess das Aufstäuben der Silberschicht. Hier liegen die typischen Zerstäubungsraten bei 12 bis $15 \text{ nm} \times \text{m} / \text{min} \times \text{cm}^2 \text{ W}$. Ihm schliesst sich das Aufstäuben der zweiten Oxidschicht mit einer AC-überlagerten DC-Zerstäubung an. Dabei liegt der AC-Anteil, definiert durch das Verhältnis der eingespeisten DC- und AC-Leistung, zwischen 30 und 50 %. Die AC-Frequenz liegt bei 13,56 MHz. Nach Beendigung des Zerstäubungsprozesses werden die beschichteten Gläser durch eine Schleuse oder durch Fluten der Kammer an Luft ausgebracht. In einem anschliessenden Ätzprozess werden die Substrate dann strukturiert und zu Displays weiterverarbeitet.

[0027] Im folgenden ist die Erfindung in den Figuren 1 und 2 an Hand von Ausführungsbeispielen erläutert.

Fig. 1 zeigt schematisch und im Querschnitt ein erfindungsgemässes Schichtsystem.

Fig. 2 zeigt die im sichtbaren Spektralbereich gegen Luft gemessene optische Transmission eines erfindungsgemässen Schichtsystems mit einem Flächenwiderstand von $2,5 \Omega_{sq}$.

[0028] In der Fig. 1 bedeuten 1 das Glassubstrat, auf welches das erfindungsgemässe Schichtsystem aufgebracht wird, 2 eine Indium-Cer-Oxidschicht, 3 eine Kupfer-dotierte Silber-Schicht, und 4 eine abschliessende Indium-Cer-Oxidschicht.

[0029] Das Glassubstrat 1 ist z. B. ein handelsübliches Floatglas mit 1,1 mm Dicke. Es können aber auch andere Glasdicken und andere Gläser, z. B. Maschinenglas, benützt werden.

[0030] Darauf wird durch teilreaktive DC-Zerstäubung von einem Oxidtarget, bestehend aus vorzugsweise 90 bis 95 At.-% Indium und 5 bis 10 At.-% Cer,

eine Oxidschicht 2 mit der geometrischen Dicke von 30 bis 37 nm abgeschlossen.

[0031] Auf diese Oxidschicht 2 wird eine Silber-schicht 3 mit 0,5 bis 10 % Kupfer-Beimengung, vorzugsweise 0,5 bis 3% und insbesondere 0,5 bis 1% Kupfer, in einem reinen DC-Zerstäubungsprozess in einer Argonatmosphäre in einer Dicke von 15 nm aufgebracht.

[0032] Auf die Schicht 3 aus Silber/Kupfer wird direkt eine zweite Indium-Cer-Oxidschicht 4, ebenfalls mit der geometrischen Dicke von 30 bis 37 nm, abgeschlossen. Dies erfolgt jedoch mit einem AC-überlagerten DC-Zerstäubungsprozess. Dabei liegt der AC-Anteil, definiert durch das Verhältnis der eingespeisten DC- und AC-Leistung, zwischen 10 und 90 %, vorzugsweise zwischen 30 und 50 %. Die AC-Frequenz liegt zwischen 1 und 50 MHz, vorzugsweise zwischen 10 und 20 MHz.

[0033] Optional kann nach der Silber/Kupfer-Schicht eine Schutzschicht aus Oxiden von Titan- oder Nickellegierungen mittels DC-Magnetron-Zerstäubung aufgebracht werden.

[0034] In der Fig. 2 ist die optische Durchlässigkeit (gemessen gegen Luft) eines erfindungsgemässen Schichtsystems mit einem Flächenwiderstand von $2,5 \Omega_{sq}$ in Abhängigkeit von der Wellenlänge im Spektralbereich 400 bis 800 nm dargestellt. Bei 435 nm werden 89,8 %, bei 545 nm 88,4 % und bei 610 nm 75,4 % erreicht. Der über diese drei Wellenlängen gemittelte Haackesche Gütefaktor beträgt $0,092 \Omega^{-1}$.

Patentansprüche

1. Leitendes transparentes Schichtsystem mit zwei Oxidschichten (2,4) und einer dazwischen gelagerten Silber-Schicht (3) auf einem Substrat (1), **dadurch gekennzeichnet, dass** bei einem Flächenwiderstand R_s von $< 2,9 \Omega_{sq}$, vorzugsweise $< 2,5 \Omega_{sq}$ und weniger, der mittlere Haackesche Gütefaktor des Schichtsystems für die Wellenlängen 435, 545 und 610 nm ($\Phi_{Tc} = T^{10}/R_s$) $> 0,085 \Omega^{-1}$ beträgt.
2. Schichtsystem nach Anspruch 1, **dadurch gekennzeichnet, dass** bei einem Flächenwiderstand von $2,5 \Omega_{sq}$ die Durchlässigkeit T bei 435 nm mindestens 89 %, bei 545 nm mindestens 88 % und bei 610 nm mindestens 75% beträgt.
3. Schichtsystem nach einem der vorangehenden Ansprüche, **dadurch gekennzeichnet, dass** die Dicke des Schichtsystems < 100 nm, vorzugsweise 80 bis 90 nm beträgt, wobei die Dicke der Silber-schicht (3) bei < 20 nm, vorzugsweise bei 15 nm, und die Dicke der beiden Oxidschichten (2,4) bei < 50 nm, vorzugsweise zwischen 30 und 40 nm, liegt.
4. Schichtsystem nach einem der vorangehenden

Ansprüche, **dadurch gekennzeichnet, dass** die Oxidschichten (2,4) Indium und Cer enthalten, vorzugsweise 90 bis 95 At.-% Indium und 5 bis 10 At.-% Cer.

5. Schichtsystem nach einem der vorangehenden Ansprüche, **dadurch gekennzeichnet, dass** die Silber-Schicht (3) bis zu 10 Gew.-% Kupfer enthält, vorzugsweise im Bereich 0,5 bis 3 % und insbesondere 0,5 bis 1 %.
6. Verfahren zur Herstellung eines leitenden transparenten Schichtsystems nach einem der vorangehenden Ansprüche, **dadurch gekennzeichnet, dass** bei der Aufbringung der zweiten Oxidschicht (4) eine gepulste DC-Zerstäubung oder eine AC-überlagerte DC-Zerstäubung verwendet wird.
7. Verfahren nach Anspruch 6, **dadurch gekennzeichnet, dass** eine AC-Überlagerung mit einer Frequenz zwischen 1 und 50 MHz, vorzugsweise zwischen 10 und 20 MHz vorgenommen wird.
8. Verfahren nach Anspruch 6 und 7, **dadurch gekennzeichnet, dass** der AC-Anteil, definiert durch das Verhältnis der eingespeisten DC- und AC-Leistung, zwischen 10 und 90 %, vorzugsweise zwischen 30 und 50 % liegt.
9. Verfahren nach Anspruch 6, 7 und 8, **dadurch gekennzeichnet, dass** die totale Leistungsdichte (AC und DC) im Bereich 1 bis 3 W/cm^2 , vorzugsweise aber bei 2 bis 2.2 W/cm^2 liegt.
10. Verfahren nach Anspruch 6 bis 9, **dadurch gekennzeichnet, dass** als Zerstäubungsverfahren Magnetronzerstäubung gewählt wird.
11. Leitendes transparentes Schichtsystem nach Anspruch 1 bis 5, **dadurch gekennzeichnet, dass** es nach dem Verfahren nach den Ansprüchen 6 bis 10 gefertigt wurde.
12. Leitendes transparentes Schichtsystem als transparente Elektroden für grossflächige Displays nach Anspruch 1 bis 5, **dadurch gekennzeichnet, dass** es nach dem Verfahren nach den Ansprüchen 6 bis 10 gefertigt wurde.

Best Available Copy

Fig.1

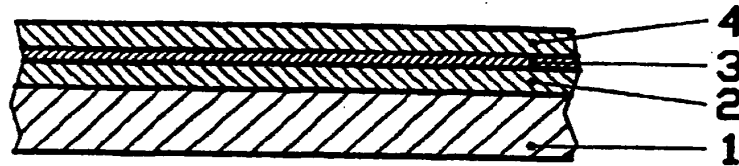
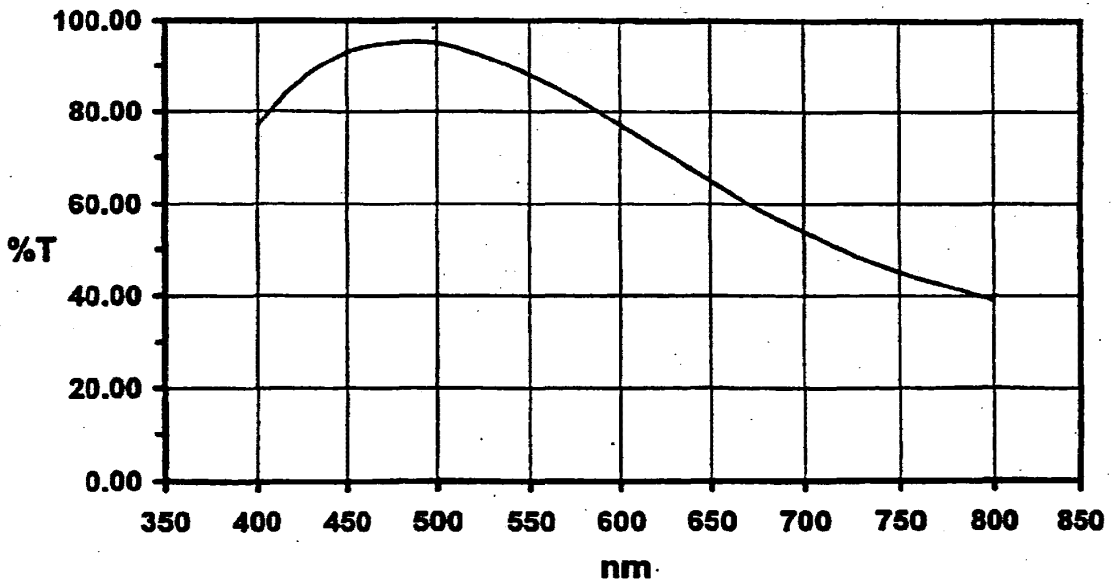

Fig.2





Europäisches
Patentamt

EUROPÄISCHER TEILRECHERCHENBERICHT

der nach Regel 45 des Europäischen Patent-
übereinkommens für das weitere Verfahren als
europäischer Recherchenbericht gilt

Nummer der Anmeldung

EP 00 11 9591

EINSCHLÄGIGE DOKUMENTE			
Kategorie	Kennzeichnung des Dokuments mit Angabe, soweit erforderlich der maßgeblichen Teile	Betrifft Anspruch	KLASSIFIKATION DER ANMELDUNG (Int.Cl.7)
X	US 4 565 719 A (HIGGINS PATRICK K ET AL) 21. Januar 1986 (1986-01-21) * Anspruch 1; Tabelle 3 *	4	C03C17/36
X	GB 2 126 256 A (TOYODA CHUO KENKYUSHO KK) 21. März 1984 (1984-03-21) * Ansprüche 1-15; Beispiel 1 *	4-12	
A	DATABASE WPI Section Ch, Week 199015 Derwent Publications Ltd., London, GB; Class A32, AN 1990-113453 XP002159490 & JP 02 066158 A (UNITIKA LTD), 6. März 1990 (1990-03-06) * Zusammenfassung *	4	
P.A	GB 2 344 600 A (SONY CORP) 14. Juni 2000 (2000-06-14) * Ansprüche 1-4 *	4,5	
			RECHERCHIERTE SACHGEBIETE (Int.Cl.7)
			C03C
UNVOLLSTÄNDIGE RECHERCHE			
<p>Die Rechercheneinstellung ist der Auffassung, daß ein oder mehrere Ansprüche, den Vorschriften des EPU in einem solchen Umfang nicht entsprechen bzw. entsprechen, daß sinnvolle Ermittlungen über den Stand der Technik für diese Ansprüche nicht, bzw. nur teilweise, möglich sind.</p> <p>Vollständig recherchierte Patentansprüche:</p> <p>Unvollständig recherchierte Patentansprüche:</p> <p>Nicht recherchierte Patentansprüche:</p> <p>Grund für die Beschränkung der Recherche:</p> <p style="text-align: center;">Siehe Ergänzungsblatt C</p>			
Forscherort		Abschlußdatum der Recherche	
DEN HAAG		6. Februar 2001	
		Prüfer	
		Reedijk, A	
KATEGORIE DER GENANNTEN DOKUMENTEN			
<p>X : von besonderer Bedeutung allein betrachtet Y : von besonderer Bedeutung in Verbindung mit einer anderen Veröffentlichung derselben Kategorie A : technologischer Hintergrund O : nachschriftliche Offenbarung P : Zwischenliteratur</p> <p>T : der Erfindung zugrunde liegende Theorien oder Grundsätze E : älteres Patendokument, das jedoch erst am oder nach dem Anmeldedatum veröffentlicht worden ist D : in der Anmeldung angeführtes Dokument L : aus anderen Gründen angeführtes Dokument</p> <p>& : Mitglied der gleichen Patentfamilie, übereinstimmendes Dokument</p>			

EPO FORM 1603 03 82 (PAC/09)



Europäisches
Patentamt

UNVOLLSTÄNDIGE RECHERCHE
ERGÄNZUNGSBLATT C

Nummer der Anmeldung
EP 00 11 9591

Vollständig recherchierte Ansprüche:
4-12

Nicht recherchierte Ansprüche:
1-3

Grund für die Beschränkung der Recherche:

Die geltenden Patentansprüche 1-3 sind auf ein Produkt, das (u.a.)
mittels folgender Parameter definiert wird, zu beziehen:

P1: Haackesche Gütefaktor bei einem Flächenwiderstandsbereich.
Die Verwendung dieser Parameter muss im gegebenen Zusammenhang als Mangel
an Klarheit im Sinne von Art. 84 EPÜ erscheinen. Es ist unmöglich, die
vom Anmelder gewählten Parameter mit dem zu vergleichen, was der Stand
der Technik hierzu offenbart. Der Mangel an Klarheit ist dergestalt, daß
er eine sinnvolle vollständige Recherche unmöglich macht. Daher wurde die
Recherche beschränkt auf die Teile mit Bezug auf Ausführungsbeispiele,
wie sie in der Beschreibung auf Seite 4 und Patentansprüche 4-12 erwähnt
sind.

**ANHANG ZUM EUROPÄISCHEN RECHERCHENBERICHT
ÜBER DIE EUROPÄISCHE PATENTANMELDUNG NR.**

EP 00 11 9591

In diesem Anhang sind die Mitglieder der Patentfamilien der im obengenannten europäischen Recherchenbericht angeführten Patentdokumente angegeben.
Die Angaben über die Familienmitglieder entsprechen dem Stand der Datei des Europäischen Patentamts am
Diese Angaben dienen nur zur Unterrichtung und erfolgen ohne Gewähr.

06-02-2001

Im Recherchenbericht angeführtes Patentdokument	Datum der Veröffentlichung	Mitglied(er) der Patentfamilie	Datum der Veröffentlichung
US 4565719 A	21-01-1986	CA 1243523 A EP 0106223 A JP 59131449 A	25-10-1988 25-04-1984 28-07-1984
GB 2126256 A	21-03-1984	JP 59031147 A DE 3329504 A	20-02-1984 23-02-1984
JP 2066158 A	06-03-1990	KEINE	
GB 2344600 A	14-06-2000	JP 2000171601 A NL 1013664 A	23-06-2000 13-06-2000

EPC FORM P0481

Für nähere Einzelheiten zu diesem Anhang : siehe Amtsblatt des Europäischen Patentamts, Nr.12/82

(19)



Europäisches Patentamt
European Patent Office
Office européen des brevets



(11)

EP 1 068 899 A1

BEST AVAILABLE COPY

(12)

EUROPEAN PATENT APPLICATION

(43) Date of publication:
17.01.2001 Bulletin 2001/03

(51) Int Cl.7: B01J 35/00, B01J 37/34

(21) Application number: 00114185.2

(22) Date of filing: 13.07.2000

(84) Designated Contracting States:
AT BE CH CY DE DK ES FI FR GB GR IE IT LI LU
MC NL PT SE
Designated Extension States:
AL LT LV MK RO SI

- Mori, Kenji
3-chome, Chuo-ku, Osaka-shi, Osaka (JP)
- Kijima, Yoshifumi
3-chome, Chuo-ku, Osaka-shi, Osaka (JP)
- Kawahara, Tetsuro
3-chome, Chuo-ku, Osaka-shi, Osaka (JP)
- Doushita, Kazuhiro
3-chome, Chuo-ku, Osaka-shi, Osaka (JP)
- Inomata, Hiroyuki
3-chome, Chuo-ku, Osaka-shi, Osaka (JP)

(30) Priority: 14.07.1999 JP 20059499

(71) Applicant: Nippon Sheet Glass Co., Ltd.
Osaka-shi, Osaka (JP)

(74) Representative: HOFFMANN - EITLÉ
Patent- und Rechtsanwälte
Arabellastrasse 4
81925 München (DE)

(72) Inventors:
• Ogino, Etsuo
3-chome, Chuo-ku, Osaka-shi, Osaka (JP)

(54) Multilayer structure and process for producing the same

(57) A conductive sinter obtained from a mixture of titanium oxide particles and 2.5% by weight niobium oxide particles is used as a target in direct current sputtering to form a photocatalytically active film mainly comprising titanium oxide on a glass substrate. The target has a surface resistance of 500 Ω/□ or lower and the sputtering is conducted while heating the substrate at

230°C. The photocatalytically active film is based on an amorphous matrix. This process is free from problems of a conventional process in which a photocatalytically active titanium oxide film is deposited by reactive sputtering using titanium metal as a target. The problems are that the substrate needs to be heated to 350°C or higher and that the deposited film does not have high photocatalytic activity.

FIG. 1

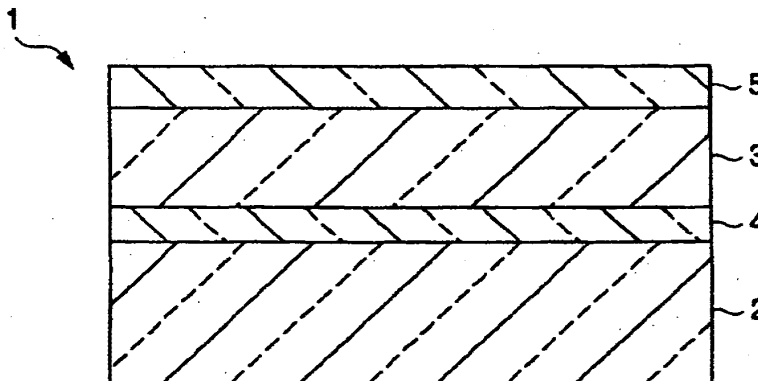

EP 1 068 899 A1

Description**FIELD OF THE INVENTION**

5 **[0001]** The present invention relates to a multilayer structure which functions as a photocatalyst and can render its surface hydrophilic upon irradiation with ultraviolet rays or visible rays. The present invention further relates to a process for producing the same.

BACKGROUND OF THE INVENTION

10 **[0002]** Members comprising a substrate coated with a titanium oxide film functioning as a photocatalyst are used in various applications. Such members are applicable to various articles so as to take advantage of the hydrophilicity resulting from their photocatalytic function for various purposes such as, e.g., antifogging, cleaning by rain, cleaning by water washing, and antifouling. For example, in the case of articles wherein the substrate is a glass plate, such as, e.g., windshields and sideview mirrors for vehicles, window glasses for buildings, and mirrors, a technique is used in which the substrate is coated with a photocatalyst film whose surface becomes hydrophilic and is thereby prevented from being clouded with steam or covered with adherent waterdrops.

15 **[0003]** JP-A-10-278165 (the term "JP-A" as used herein means an "unexamined published Japanese patent application") discloses a technique in which a metal target comprising titanium as the main component is used to conduct sputtering in an oxygen-containing atmosphere and the resulting deposit is heated to thereby form on a glass plate a photocatalyst film having anatase crystals and excellent resistance to abrasion and wearing.

20 **[0004]** However, in order for the technique described above to form a titanium oxide film having photocatalytic activity, it is necessary that a titanium oxide film should be deposited on a substrate heated to 300°C or higher or that a titanium oxide film which has been deposited on a substrate having room temperature should be heated to a temperature as high as 600°C or higher. Furthermore, there has been a problem that in the reactive sputtering in which a titanium metal target is used in an oxygen-containing atmosphere, the glow discharge becomes unstable as an electrically insulating oxide accumulates on the titanium metal surface and, as a result, a titanium oxide film cannot be stably obtained.

25 **[0005]** JP-A-10-310653 discloses a technique in which an anatase titanium oxide film or rutile titanium oxide film is deposited on a glass plate by the sol coating method, organic titanate method, electron beam vapor deposition method, or the like. There is a description therein to the effect that the energy band gap between the conductive band and the valence band in a titanium oxide film functioning as a photocatalyst is regulated by incorporating a metal oxide selected from ruthenium oxide, cobalt oxide, cerium oxide, chromium oxide, rhodium oxide, and vanadium oxide to thereby effectively obtain hydrophilicity.

30 **[0006]** However, the technique described above has had a problem that a step of heating at a temperature as high as 350°C or higher is necessary for obtaining a crystalline titanium oxide film having photocatalytic activity, resulting in a complicated production process.

35 **[0007]** JP-A-1-92176 discloses a technique in which a titanium oxide photocatalyst film is deposited on a glass plate by reactive sputtering using titanium metal as a sputtering target and this titanium oxide film is doped with ions of a metal such as niobium, cobalt, or chromium by ion implantation to improve catalytic activity.

40 **[0008]** However, the technique described above has had drawbacks that an expensive ion injector is necessary for injecting metal ions in a glass by ion injection, and that it is virtually difficult to deposit a photocatalytically active film on a glass having a relatively large area, such as a window glass for buildings, etc., on an industrial scale.

SUMMARY OF THE INVENTION

45 **[0009]** The present invention has been achieved in order to overcome the problems described above.

[0010] One object of the present invention is to provide a multilayer structure comprising a substrate and formed thereon a film having satisfactory photocatalytic activity and practical antifouling properties.

50 **[0011]** Another object of the present invention is to provide a process for producing a multilayer structure comprising a substrate and formed thereon a film having photocatalytic activity and antifouling properties.

55 **[0012]** According to the first embodiment of the present invention provides, there is provided a process for producing a multilayer structure comprising a substrate and formed thereon a film mainly comprising titanium oxide and having photocatalytic activity, which comprises sputtering a conductive sinter target obtained by sintering a mixture of particles of titanium oxide and particles of at least one metal oxide selected from the group consisting of niobium oxide, tantalum oxide, vanadium oxide, zirconium oxide, tin oxide, chromium oxide and copper oxide, in an atmosphere capable of having a regulated vacuum to form the film mainly comprising titanium oxide and having photocatalytic activity on the substrate.

5 [0013] The film mainly comprising titanium oxide (hereinafter referred to as "titanium oxide film") in the present invention is obtained by sputtering, in an atmosphere capable of having a regulated vacuum, a conductive target obtained by sintering a mixture of particles of titanium oxide as the main component and particles of at least one metal oxide, as a minor component, selected from the group consisting of niobium oxide, tantalum oxide, vanadium oxide, zirconium oxide, tin oxide, chromium oxide and copper oxide. The surrounding gas when sputtering that can be used is an inert gas such as argon or a mixed gas comprising an inert gas and oxygen.

10 [0014] Especially when an oxygen-containing atmosphere having a reduced pressure is used in order to sputter a titanium oxide film which does not have a considerable deficiency of oxygen as compared with the stoichiometric amount and is transparent in the visible region, the target surface is inhibited from being covered with an electrically insulating substance because a small oxygen amount is sufficient for the atmosphere.

15 [0015] The target used in the present invention, which is an oxide sinter containing titanium oxide as the main component, is electrically conductive in such a degree that electric current can flow through the surface thereof. It is preferred that a direct current glow discharge be used to bombard the conductive target and thereby deposit a film. This is because a direct current power source, which is relatively inexpensive, can be used to generate a stable glow discharge and deposit a photocatalytically active titanium oxide film on a substrate.

20 [0016] The target having conductivity for use in the present invention can be obtained by sufficiently mixing particles, preferably fine particles, of titanium oxide with particles, preferably fine particles, of at least one metal oxide selected from the group consisting of niobium oxide, tantalum oxide, vanadium oxide, tin oxide, chromium oxide and copper oxide, and forming the powder mixture into a given shape by pressure molding. Conventional cold pressing or hot pressing method can be used for this pressure molding.

25 [0017] The conductivity of the target for use in the present invention is preferably such that the surface resistance thereof is $500 \Omega/\square$ or lower, in order to maintain a glow discharge for sputtering the target over a long period of time to thereby form a titanium oxide film in a stable manner. If the surface resistance exceeds $500 \Omega/\square$; it is not preferable in that the glow discharge is apt to be interrupted. From the standpoint of even more stably maintaining a glow discharge over a long period of time, the surface resistance of the target is more preferably $50 \Omega/\square$ or lower.

30 [0018] In the present invention, the formation of a photocatalytically active titanium oxide film is preferably conducted at a substrate temperature of 170°C or higher. If the substrate temperature is lower than 170°C , it is undesirable in that the titanium oxide film obtained has insufficient resistance to abrasion and wearing and has low photocatalytic activity. From this standpoint, the substrate temperature is more preferably 200°C or higher.

[0019] On the other hand, if the substrate temperature exceeds 270°C during film formation, the titanium oxide film tends to have a higher degree of anatase crystal orientation and, unexpectedly, the photocatalytic activity thereof decreases gradually. From this standpoint, the substrate temperature during film deposition is preferably 270°C or lower, more preferably 250°C or lower.

35 [0020] Preferred metal oxides to be contained in titanium oxide in the present invention are niobium oxide, vanadium oxide and tantalum oxide because these metal oxides are effective not only in relatively easily maintaining a glow discharge necessary for sputtering the sinter target but in obtaining a titanium oxide film having enhanced photocatalytic activity. Of those, niobium oxide is most preferable.

40 [0021] The oxygen content of the sputtering gas atmosphere (gas composition introduced into the film-formation chamber) is preferably less than 80 vol%, more preferably less than 60 vol%, from the standpoint of increasing the deposition rate of film formation.

45 [0022] According to the second embodiment of the present invention, there is provided a multilayer structure comprising a substrate and formed thereon a film mainly comprising titanium oxide and having photocatalytic activity (hereinafter referred to as "titanium oxide film"), wherein the film contains as a minor component at least one metal oxide selected from the group consisting of niobium oxide, tantalum oxide, vanadium oxide, zirconium oxide, tin oxide, chromium oxide and copper oxide and is substantially amorphous when analyzed by X-ray diffraction method.

50 [0023] In the case where the titanium oxide film formed is composed of crystals, many grain boundaries are present therein. Electron-hole pairs which have been excited by light in the titanium oxide film are trapped by many lattice defects present on those grain boundaries, so that the number of electron-hole pairs present on the film surface, which contribute to photocatalytic activity, is reduced. Because of this, such a titanium oxide film has reduced photocatalytic activity. In contrast, the multilayer structure of the present invention is reduced in the trapping since it mainly comprises an amorphous matrix. This constitution is thought to bring about a high photoexcitation efficiency. The multilayer structure of the present invention therefore has high photocatalytic activity.

55 [0024] The titanium oxide film is characterized in that it is less apt to have a crystalline structure because the titanium oxide contains a small amount of one or more metal oxides. The film thickness of the titanium oxide film is preferably 150 nm to 500 nm.

[0025] In the present invention, the content of the metal oxide(s) as a minor component in the titanium oxide is preferably 1% by weight or higher, more preferably 2.5% by weight or higher. If the content of metal oxides as a minor component in the film is lower than 1% by weight, it is undesirable in that not only stable photocatalytic activity is difficult

to obtain but also the target is less apt to retain conductivity (electricity-passing properties) in a degree so as to conduct sputtering in a stable manner, making it difficult to stably form a titanium oxide film.

[0026] On the other hand, the content of the metal oxide(s) as a minor component is preferably 10% by weight or lower, more preferably 5% by weight or lower. This is because if the content of the metal oxide(s) exceeds 10% by weight, the content of titanium oxide decreases in relative amount, resulting in lowering photocatalytic activity.

[0027] In the present invention, preferred metal oxides as the minor component are niobium oxide, vanadium oxide and tantalum oxide from the standpoints of obtaining high photocatalytic activity and forming a stable glow discharge to form a titanium oxide film with satisfactory reproducibility. Especially preferred from such standpoints is niobium oxide.

[0028] Usable substrates include ones made of inorganic materials such as glasses and ceramics and ones made of organic materials such as plastics because in the process of the present invention, film formation on substrates is possible at relatively low temperature. Examples of applications of such substrates include window glasses for buildings and vehicles, exterior and interior materials for buildings, Braun tubes, PDP displays, liquid-crystal display panels, optical recording media, magnetic recording media, and members or housings of domestic electrical appliances or OA apparatus.

[0029] In the case where a glass plate, especially one containing alkali components, such as a soda-lime silicate composition, is used as a substrate, it is preferred to dispose, between this glass substrate and a titanium oxide film, a primer film serving to prevent the alkali components of the substrate from dissolving in the titanium oxide film. From the standpoint of further improving antifouling properties, it is preferred to partly or wholly coat the titanium oxide film of the present invention with a hydrophilic film.

BRIEF DESCRIPTION OF THE DRAWINGS

[0030] Fig. 1 is a sectional view showing one embodiment of the multilayer structure according to the present invention.

[0031] Fig. 2 is a graphic presentation showing the influence of substrate temperature during titanium oxide film formation on residual triolein amount.

[0032] Fig. 3 is a graphic presentation showing the influence of substrate temperature during titanium oxide film formation on the crystalline structure of the film.

[0033] Reference Numerals in the drawings are as follows:

- 1: Multilayer structure of the present invention
- 2: Glass substrate
- 3: Photocatalytically active film mainly comprising titanium oxide
- 4: Primer film
- 5: Hydrophilic film

DETAILED DESCRIPTION OF THE INVENTION

[0034] Embodiments of the present invention will be explained in detail below.

[0035] Fig. 1 is a sectional view showing one embodiment of the multilayer structure according to the present invention. This multilayer structure 1 comprises a glass substrate 2 and, superposed on one side thereof in this order, a primer film 4 comprising silicon dioxide serving to prevent alkali dissolution, a titanium oxide film 3 having photocatalytic activity, and a hydrophilic film 5. Fig. 2 is a graphic presentation showing the influence of the substrate temperature during titanium oxide film formation on the residual triolein amount. Fig. 3 is a graphic presentation showing the influence of the substrate temperature during titanium oxide film formation on the crystalline structure of the film.

[0036] Examples of the glass substrate include plates made of a soda-lime silicate glass, alkali borosilicate glass and aluminoborosilicate glass. Examples of plastic substrates include substrates made of a polycarbonate resin, acrylic resin and polystyrene resin. In the case of using a substrate containing an alkali component, e.g., sodium ions, as in a soda-lime silicate glass, it is preferred to dispose a film of a metal oxide such as silicon dioxide as an alkali dissolution preventive film between the substrate and a titanium oxide film in order to prevent the alkali component, which is apt to move within the glass, from coming into the titanium oxide film from the glass. Silicon dioxide can be film-formed by conventional technique such as sputtering, CVD or a method using an aqueous solution containing hydrosilicofluoric acid supersaturated with silicon dioxide. The thickness of this silicon dioxide film is preferably from 10 to 100 nm.

[0037] The sinter target used in forming a photocatalytically active titanium oxide film according to the present invention is produced by, for example, the following manner. Titanium oxide and niobium oxide each are regulated so as to have a particle diameter of from about 0.01 to 50 μm . The niobium oxide is mixed with the titanium oxide in an amount of from 1 to 10% by weight based on the weight of the titanium oxide, and this mixture is molded into a given

shape by cold isostatic pressing in water in which the powder mixture is pressed at 3 t/cm². The resulting molded product is degreased at 400 to 500°C, preliminarily burned in an oxygen atmosphere at 1300 to 1500°C for 4 to 6 hours, and then subjected to hot isostatic pressing at 1,350 to 1,450°C under a pressure of about 100 MPa in an atmosphere comprising argon and oxygen.

[0038] Conductivity is imparted to the sputtering target according to the present invention to such a degree that the target is not charged during sputtering with a direct current glow discharge. From the standpoint of easily obtaining such target surface conductivity, preferred metal oxides for use as the minor component are niobium oxide, vanadium oxide and tantalum oxide. Especially preferred is niobium oxide.

[0039] By using the oxide sinter target which is not charged, sputtering can be conducted with a direct current glow discharge. The partial oxygen pressure of the atmosphere used for this sputtering may be lower than that in the reactive sputtering method in which titanium metal is used as a target. Even when the sputtering is conducted over a long period of time, the accumulation of an electrically insulating substance on the target surface can be inhibited. The sputtering atmosphere is regulated so as to have a pressure of from 1 to 5 mTorr in magnetron sputtering (MS) or dual magnetron sputtering (DMS). For maintaining this pressure, the gas to be introduced into the film-formation chamber is preferably regulated so as to have a composition having an oxygen content of from 0.5 to 10% by volume.

[0040] The primer film used as an alkali dissolution preventive film in the present invention may be a film of a metal oxide or a film of a nitride. Especially preferred are silicon dioxide, silicon nitride and silicon oxynitride because these compounds show satisfactory adhesiveness to glass plates and titanium oxide films.

[0041] In the present invention, both hydrophilicity and antifouling properties can be imparted to the substrate more satisfactorily by coating the titanium oxide film with a hydrophilic film transparent to ultraviolet or visible light. Preferred examples of this hydrophilic film include silicon dioxide films or films containing silicon dioxide as the main component.

[0042] Methods for forming the primer film or hydrophilic film are not particularly limited, and conventional methods can be used, such as sputtering, CVD using an organosilane as a starting material, and a method using an aqueous hydrosilicofluoric acid solution supersaturated with silicon dioxide.

[0043] The present invention will be explained in more detail below by reference to the following Examples and Comparative Examples, but it should be understood that the invention is not construed as being limited thereto. In each of those Examples and Comparative Examples, the following conditions were used in forming a titanium oxide film.

Target size: 38 cm (length) x 13 cm (width) x 6 mm (thickness)

Sputtering power: 3 kW

Pressure of sputtering atmosphere: 3 mTorr

Gas introduced: argon/oxygen mixed gas or oxygen gas

Substrate heating: various temperatures according to experiments in the range of from room temperature (about 25°C) to 350°C.

EXAMPLE 1

[0044] A mixture of 2.5% by weight niobium oxide and 97.5% by weight titanium oxide was molded into the shape shown above by cold isostatic pressing in water at a pressure of 3 t/cm². This molded product was degreased at 450°C, preliminarily burned in an oxygen atmosphere at 1,400°C for 5 hours, and then subjected to hot isostatic pressing at 1,400°C under a pressure of about 100 MPa in an atmosphere composed of argon and a small proportion of oxygen.

[0045] The oxide sinter target thus obtained had a surface resistance of 5 Ω/□. Using this target, a titanium oxide film having a thickness of 250 nm was formed on a 30 cm-square float glass plate having a soda-lime silicate composition under the film-formation conditions shown in Table 1. The substrate temperature during film-formation was regulated to 230°C. Thus, Sample 1 was obtained. The titanium oxide film of the multilayer structure obtained was examined for photocatalytic performance (triolein-decomposing ability and contact angle with water) and crystalline state. Antifouling performance also was evaluated.

[0046] The examination and evaluation methods are as follows.

[0047] Film crystallinity: Crystalline state of the film was judged based on X-ray diffraction peaks obtained with CuK_α line (50 kV, 200 mA).

[0048] Triolein-decomposing ability: The side coated with the titanium oxide film was coated with about 2 mg of triolein. The film side of this sample was then irradiated with black light (containing ultraviolet) at an intensity of 3 mW/cm². After 43 hours, the residual triolein amount was determined and shown in terms of %.

[0049] Antifouling performance: The multilayer structure was exposed outdoors for 2 months, and the surface thereof was then visually examined. The adhesion of fouling substances, such as waterdrop marks resulting from rain or dust particles, was evaluated and indicated by O, Δ or X. The results of this comparative evaluation, in which the fouled state of the glass plate not coated with a titanium oxide film is taken as X, are shown in Table 1.

EP 1 068 899 A1

X: Considerable adhesion of fouling substances derived from waterdrops, etc., and the sample looked white in terms of reflected light.

Δ: Slightly reduced adhesion of fouling substances.

O: Even more reduced adhesion of fouling substances, and the sample looked less white in terms of reflected light.

[0050] The results of the evaluation of Sample 1 obtained are shown in Table 1. Table 1 shows the following.

[0051] In X-ray diffraction analysis, no diffraction peak characteristic of crystals was observed in the titanium oxide film of Sample 1. The film was hence found to be amorphous. This titanium oxide film had a residual triolein amount of 0% and a contact angle with pure water of as small as 9 degrees, showing that the surface thereof was satisfactorily hydrophilic. Furthermore, the antifouling performance thereof was rated as O, which is the best.

EXAMPLES 2 TO 4

[0052] Multilayer structure Samples 2 to 4 were produced in the same manner as in Example 1, except that the content of niobium oxide was changed to 1.0% by weight, 5.0% by weight and 10.0% by weight, respectively. The evaluation results for these samples are shown in Table 1. In each sample, the titanium oxide film was amorphous when analyzed by the X-ray diffraction method, and the surface thereof was hydrophilic and had an antifouling effect based on photocatalytic function.

Table 1

Sample No.	Titanium oxide target		Titanium oxide film				
	Minor metal oxide		Surface resistance (Ω/□)	Crystallinity	Triolein-decomposing ability, residual amount (%)	Contact angle with water (degree)	Anti-fouling performance
	Ingredient	Content (wt%)					
Sample 1	Nb ₂ O ₅	2.5	10	amorphous	0	9	O
Sample 2	Nb ₂ O ₅	1.0	5	amorphous	4	11	O
Sample 3	Nb ₂ O ₅	5.0	10	amorphous	2	9	O
Sample 4	Nb ₂ O ₅	10.0	20	amorphous	6	11	O
(Notes) Substrate temperature: 230°C Titanium oxide film thickness: 250 nm							

EXAMPLE 5

[0053] A multilayer structure sample was produced in the same manner as in Example 1, except that prior to the titanium oxide film formation, a primer film of silicon dioxide having a thickness of 50 nm was formed by high-frequency sputtering using quartz glass as a target. Multilayer structure Sample 5 thus obtained was subjected to the film evaluations in the same manner as in Example 1, and the results obtained are shown in Table 2.

EXAMPLE 6

[0054] A multilayer structure sample was produced in the same manner as in Example 3. Thereafter, a hydrophilic film of silicon dioxide was formed on the titanium oxide film of the sample by high-frequency sputtering using quartz glass as a target. Multilayer structure Sample 6 thus obtained was subjected to the film evaluations in the same manner as in Example 1, and the results obtained are shown in Table 2. The results for Sample 1, which had neither a primer film nor a hydrophilic film, are also shown in Table 2 for the sake of comparison.

[0055] Table 2 shows that Sample 5 and Sample 6 both had satisfactory triolein-decomposing ability and that especially in Sample 6, the surface of the multilayer structure had improved hydrophilicity.

55 50 45 40 35 30 25 20 15 10 5

Table 2

Sample No.	Primer film		Hydrophilic film		Titanium oxide film			
	Material	Thickness (nm)	Material	Thickness (nm)	Crystallinity	Triolein-decomposing ability, residual amount (%)	Contact angle with water (degree)	Anti-fouling performance
Sample 5	SiO ₂	50	none		amorphous	0	9	○
Sample 6	SiO ₂	50	SiO ₂	10	amorphous	27	7	○
Sample 1	none		none		amorphous	0	9	○
(Notes) Nb ₂ O ₅ content: 2.5 wt% Substrate temperature: 230°C Substrate thickness: 250 nm								

EP 1 068 899 A1

EXAMPLES 7 TO 12

[0056] Multilayer structure Samples 7 to 12 were produced in the same manner as in Example 1, except that the niobium oxide was replaced with each of the various metal oxides shown in Table 3. These multilayer structures were examined for photocatalytic performance in the same manner as in Example 1, and the results obtained are shown in Table 3. The titanium oxide sinter targets respectively containing those metal oxides each had such a surface resistance that a glow discharge could be stably generated. It was further found that the multilayer structures obtained had satisfactory photocatalytic performance and antifouling performance based on it.

Table 3

Sample No.	Titanium oxide target		Titanium oxide film				
	Minor metal oxide		Surface resistance (Ω/\square)	Crystallinity	Triolein-decomposing ability, residual amount (%)	Contact angle with water (degree)	Anti-fouling performance
	Ingredient	Content (wt%)					
Sample 7	Ta ₂ O ₅	2.5	10	amorphous	7	10	○
Sample 8	V ₂ O ₅	2.5	5	amorphous	8	10	○
Sample 9	ZrO ₂	2.5	30	amorphous	5	10	○
Sample 10	SnO ₂	2.5	15	amorphous	9	11	○
Sample 11	Cr ₂ O ₃	2.5	30	amorphous	10	12	○
Sample 12	CuO	2.5	15	amorphous	8	11	○
(Notes) Film thickness: 250 nm Substrate temperature: 230°C							

EXAMPLES 13 TO 16

[0057] Multilayer structure samples were produced in the same manner as in Example 1, except that the substrate temperature was changed to 170°C, 200°C, 250°C and 270°C, respectively, for the purpose of examining the influence of the substrate temperature during film deposition on the photocatalytic activity of the titanium oxide film. The evaluation results for the samples obtained are shown in Table 4 together with the results for Sample 1.

COMPARATIVE EXAMPLES 1 TO 4

[0058] Multilayer structure samples were produced in the same manner as in Example 1, except that the substrate temperature was changed to room temperature (no heating), 150°C, 300°C and 350°C, respectively. The evaluation results for Comparative Samples 1 to 4 thus obtained are shown in Table 4.

55

50

45

40

35

30

25

20

15

10

5

Table 4

Sample No.	Titanium oxide target		Substrate		Titanium oxide film			
	Minor metal oxide		Temperature (°C)	Thickness (nm)	Crystallinity	Triolein-decomposing ability, residual amount (%)	Contact angle with water (degree)	Anti-fouling performance
	Ingredient	Content (wt%)						
Comparative Sample 1	Nb ₂ O ₅	2.5	room temp	250	amorphous	96	22	×
Comparative Sample 2	Nb ₂ O ₅	2.5	150	250	amorphous	93	21	×
Sample 13	Nb ₂ O ₅	2.5	170	250	amorphous	25	13	○
Sample 14	Nb ₂ O ₅	2.5	200	250	amorphous	9	11	○
Sample 1	Nb ₂ O ₅	2.5	230	250	amorphous	0	9	○
Sample 15	Nb ₂ O ₅	2.5	250	250	amorphous	6	9	○
Sample 16	Nb ₂ O ₅	2.5	270	250	amorphous	9	10	○
Comparative Sample 3	Nb ₂ O ₅	2.5	300	250	anatase	32	14	△
Comparative Sample 4	Nb ₂ O ₅	2.5	350	250	anatase	73	17	△

EP 1 068 899 A1

[0059] Table 4 shows that from the standpoint of imparting sufficient photocatalytic activity to the titanium oxide film, the substrate temperature during film formation is preferably 170°C or higher and 270°C or lower. Fig. 2 shows a plot of the relationship between the found values of residual triolein amount shown in Table 4 and the substrate temperatures during film formation shown in Table 4. As the substrate temperature rises beyond 150°C, the residual triolein amount abruptly decreases, i.e., photocatalytic activity increases. On the other hand, as the substrate temperature lowers from 350°C, the residual triolein amount decreases, i.e., photocatalytic activity increases. It can be seen from this relationship that high photocatalytic activity is obtained when the substrate temperature is from 170 to 270°C, and even higher catalytic activity (a reduced residual triolein amount) is obtained when the substrate temperature is from 200 to 250°C.

[0060] Fig. 3 shows X-ray diffraction charts for the titanium oxide films of the samples for which substrate temperatures of room temperature (no substrate heating), 150°C, 230°C and 300°C had been used, respectively. In the samples for which substrate temperatures of 300°C and 350°C had been used respectively, the diffraction peak attributable to the (101) plane of anatase crystals was observed. In contrast, the sample for which the substrate had not been heated and the samples for which substrate temperatures of 150°C and 230°C had respectively been used each showed no diffraction peak, showing that the titanium oxide films of these samples were substantially amorphous.

[0061] From the Examples and Comparative Examples given above, it could be seen that when a titanium oxide film is formed at substrate temperatures not lower than 300°C, the titanium oxide film deposited is not amorphous but composed of anatase crystals and this titanium oxide film has reduced photocatalytic activity (an increased residual triolein amount). Namely, it was found that a titanium oxide film having satisfactory photocatalytic activity is obtained at relatively low temperatures (nearly the same as or lower than the heat resistance temperatures of organic resin materials and the like, which are around 250°C).

[0062] The samples for which substrate temperatures of room temperature and 150°C had been used had low photocatalytic activity whereas the samples for which substrate temperatures ranging from 170°C to 270°C had been used had high photocatalytic activity, despite the fact that these two groups of samples had such a common property that the titanium oxide film was amorphous when analyzed by the X-ray diffraction method. Although the reason for this has not been elucidated, it is presumed that in each of the samples in the latter group, microcrystals not detectable by the X-ray diffraction method are present in the amorphous matrix and make some contribution to photocatalytic activity.

EXAMPLES 17 TO 19

[0063] Multilayer structure Samples 17 to 19 were produced in the same manner as in Example 1, except that the thickness of the titanium oxide film was changed to 50 nm, 100 nm and 500 nm, respectively, for the purpose of examining the influence of titanium oxide film thickness on photocatalytic performance. The evaluation results for these samples are shown in Table 5 together with the results for Sample 1. It was found that as the film thickness increases, both the value of residual triolein amount, as a measure of triolein-decomposing ability, and the value of contact angle with water decrease.

55 50 45 40 35 30 25 20 15 10 5

Table 5

Sample No.	Titanium oxide target		Substrate		Titanium oxide film			
	Minor metal oxide		Temperature (°C)	Thickness (nm)	Crystallinity	Triolein-decomposing ability, residual amount (%)	Contact angle with water (degree)	Anti-fouling performance
	Ingredient	Content (wt%)						
Sample 17	Nb ₂ O ₅	2.5	230	50	amorphous	91	21	X
Sample 18	Nb ₂ O ₅	2.5	230	100	amorphous	57	16	Δ
Sample 1	Nb ₂ O ₅	2.5	230	250	amorphous	0	9	○
Sample 19	Nb ₂ O ₅	2.5	230	500	amorphous	0	8	○

EP 1 068 899 A1

11

EXAMPLE 20

[0064] Multilayer structure Sample 20 was produced in the same manner as in Example 1, except that the composition of the surrounding gas was changed in order to examine the influence of the sputtering gas atmosphere (gas composition introduced into the film-formation chamber) used for titanium oxide film formation on photocatalytic performance. The results of the examinations of the titanium oxide film obtained are shown in Table 6 together with the results for Sample 1. It was found that a high oxygen concentration in the atmosphere gives a titanium oxide film comprising anatase crystals and having reduced triolein-decomposing ability. Namely, this experiment showed that for forming a titanium oxide film having high photocatalytic activity, it is advantageous to conduct film formation in an atmosphere containing a small amount of oxygen.

Table 6

Sample No.	Titanium oxide target	Substrate temperature (°C)	Surrounding gas composition, oxygen/argon (vol%)	Titanium oxide film			
	Nb ₂ O ₅ amount (wt%)			Crystallinity	Triolein-decomposing ability, residual amount (%)	Contact angle with water (degree)	Anti-fouling performance
Sample 20	2.5	230	60/40	anatase	50	17	△
Sample 1	2.5	230	6/94	amorphous	0	9	○

COMPARATIVE EXAMPLE 5

[0065] Using titanium metal as a target, a titanium oxide film having a thickness of 250 nm was formed by direct-current sputtering on a 30 cm-square float glass plate having a soda-lime silicate composition under the conditions shown in Table 7 to produce a multilayer structure. The gas composition of the atmosphere used for sputtering was regulated so as to have an oxygen content of 100% in order to secure transparency of the titanium oxide. Comparative Sample 5 of multilayer structure thus obtained was evaluated. As a result, the sample had poor triolein-decomposing ability as shown in Table 7.

COMPARATIVE EXAMPLE 6

[0066] Sputtering was conducted in the same manner as in Comparative Example 5, except that the substrate temperature was changed to 350°C. Thus, Comparative Sample 6 of multilayer structure was produced. Although the titanium oxide film of this multilayer structure had an anatase crystal structure, it had low triolein-decomposing ability (a large residual triolein amount) and insufficient antifouling performance.

55 50 45 40 35 30 25 20 15 10 5

Table 7

Sample No.	Target	Substrate temperature (°C)	Surrounding gas composition, oxygen/argon (vol%)	Titanium oxide film			
				Crystallinity	Triolein-decomposing ability, residual amount (%)	Contact angle with water (degree)	Anti-fouling performance
Comparative Sample 5	titanium metal	230	100/0	anatase	89	22	X
Comparative Sample 6	titanium metal	350	100/0	anatase	75	19	Δ

13

EP 1 068 899 A1

[0067] The above results show that in order for the conventional reactive sputtering method using titanium metal as a target to obtain a titanium oxide film having photocatalytic activity, the substrate should be heated to a temperature as high as 350°C, and that the photocatalytic activity thus obtained is not so high. The results further show that a titanium oxide film having photocatalytic activity cannot be obtained at a substrate temperature of 230°C, i.e., a titanium oxide film having high catalytic activity cannot be obtained at low temperatures.

[0068] The above Examples and Comparative Examples demonstrate that according to the process of the present invention for producing a multilayer structure, films having high catalytic activity can be obtained at relatively low substrate temperatures of 270°C or lower. The Examples further demonstrate that the photocatalytically active titanium oxide films obtained have antifouling properties and are practically useful.

[0069] According to the process of the present invention for producing a multilayer structure, a photocatalytically active titanium oxide film is formed on a substrate by sputtering in an atmosphere capable of having a regulated vacuum using a conductive sinter target obtained by sintering a mixture of particles of titanium oxide and particles of at least one metal oxide selected from the group consisting of niobium oxide, tantalum oxide, vanadium oxide, zirconium oxide, tin oxide, chromium oxide and copper oxide. Consequently, a multilayer structure having a photocatalytically active film can be produced at high rate without the necessity of heating the substrate at high temperature.

[0070] As a result, it has become possible to produce a multilayer structure using a large glass plate as a substrate, such as a window glass, using a sputtering apparatus having a simplified heating mechanism. The equipment cost can hence be reduced.

[0071] Since lower substrate temperatures can be used in substrate heating, a photocatalytically active film can be formed on organic resin substrates and the like.

[0072] Furthermore, by regulating the conductivity of the sinter target so that the surface resistance thereof is 500 Ω/\square or lower, not only a multilayer structure can be produced with a direct current glow discharge continuing stably, but also a film having enhanced catalytic activity can be obtained when the substrate is heated to 170 to 270°C.

[0073] The multilayer structure of the present invention has a titanium oxide film which contains as a minor component at least one metal oxide selected from the group consisting of niobium oxide, tantalum oxide, vanadium oxide, zirconium oxide, tin oxide, chromium oxide and copper oxide, and which is substantially amorphous when analyzed by the X-ray diffraction method. Due to this constitution, the multilayer structure has high photocatalytic activity.

[0074] By regulating the content of the metal oxide(s) as the minor component to 1 to 10% by weight, the titanium oxide film can be an amorphous film having high photocatalytic activity.

[0075] Furthermore, by interposing, between the substrate and the titanium oxide film, a primer film which serves to prevent any alkali component of the substrate from dissolving in the titanium oxide film, the photocatalytic activity of the multilayer structure can be made to last over long period of time. Moreover, by partly or wholly coating the titanium oxide film with a hydrophilic film, the surface of the multilayer structure can be made more hydrophilic and the antifouling properties can be enhanced.

Claims

1. A process for producing a multilayer structure comprising a substrate and formed thereon a film mainly comprising titanium oxide and having photocatalytic activity, which comprises forming the film by sputtering a conductive sinter target obtained by sintering a mixture of particles of titanium oxide and particles of at least one metal oxide selected from the group consisting of niobium oxide, tantalum oxide, vanadium oxide, zirconium oxide, tin oxide, chromium oxide and copper oxide, in an atmosphere capable of having a regulated vacuum.
2. The process for producing a multilayer structure as claimed in claim 1, wherein the target has a conductivity such that the surface resistance thereof is 500 Ω/\square or lower, and the sputtering is conducted with a direct current glow discharge.
3. The process for producing a multilayer structure as claimed in claim 1, wherein the film mainly comprising titanium oxide is formed while heating the substrate at a temperature of from 170 to 270°C.
4. The process for producing a multilayer structure as claimed in claim 3, wherein the film mainly comprising titanium oxide is formed while heating the substrate at a temperature of from 200 to 250°C.
5. The process for producing a multilayer structure as claimed in claim 1, wherein the metal oxide is niobium oxide.
6. A multilayer structure comprising a substrate and formed thereon a film mainly comprising titanium oxide and having photocatalytic activity, said film containing as a minor component at least one metal oxide selected from

EP 1 068 899 A1

the group consisting of niobium oxide, tantalum oxide, vanadium oxide, zirconium oxide, tin oxide, chromium oxide and copper oxide, and being substantially amorphous when analyzed by the X-ray diffraction method.

- 5
7. The multilayer structure as claimed in claim 6, wherein the substantially amorphous film mainly comprising titanium oxide comprises an amorphous matrix containing microcrystals.
8. The multilayer structure as claimed in claim 6, wherein the content of the metal oxide as the minor component in the film mainly comprising titanium oxide is from 1 to 10% by weight.
- 10
9. The multilayer structure as claimed in claim 8, wherein the metal oxide as the minor component is niobium oxide.
10. The multilayer structure as claimed in claim 6, which has, interposed between the substrate and the film consisting mainly of titanium oxide, a primer film which serves to prevent any alkali component of the substrate from dissolving in the film mainly comprising titanium oxide.
- 15
11. The multilayer structure as claimed in claim 6, wherein the film mainly comprising titanium oxide is coated with a hydrophilic film.
- 20
12. The multilayer structure as claimed in claim 11, wherein the primer film and the hydrophilic film each is a film of silicon dioxide.
- 25
- 30
- 35
- 40
- 45
- 50
- 55

FIG. 1

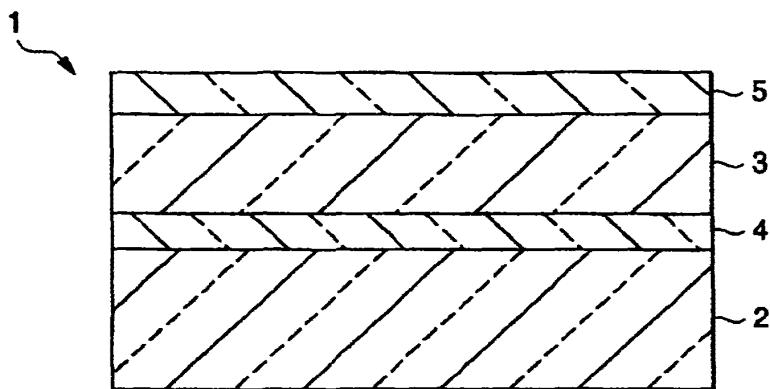

FIG. 2

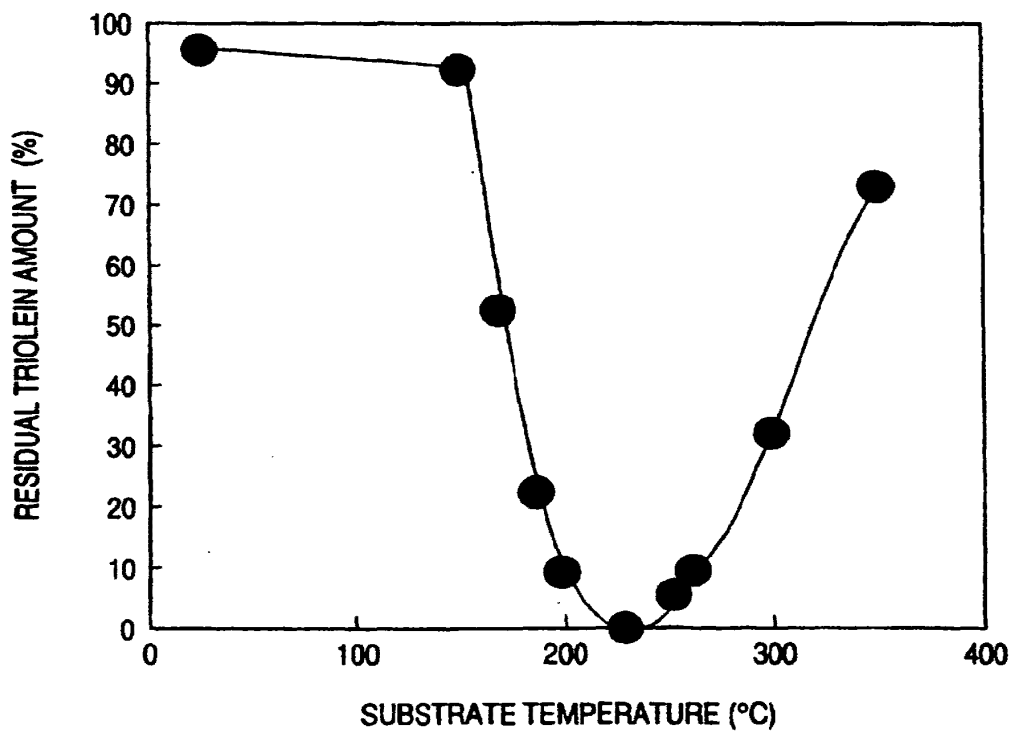
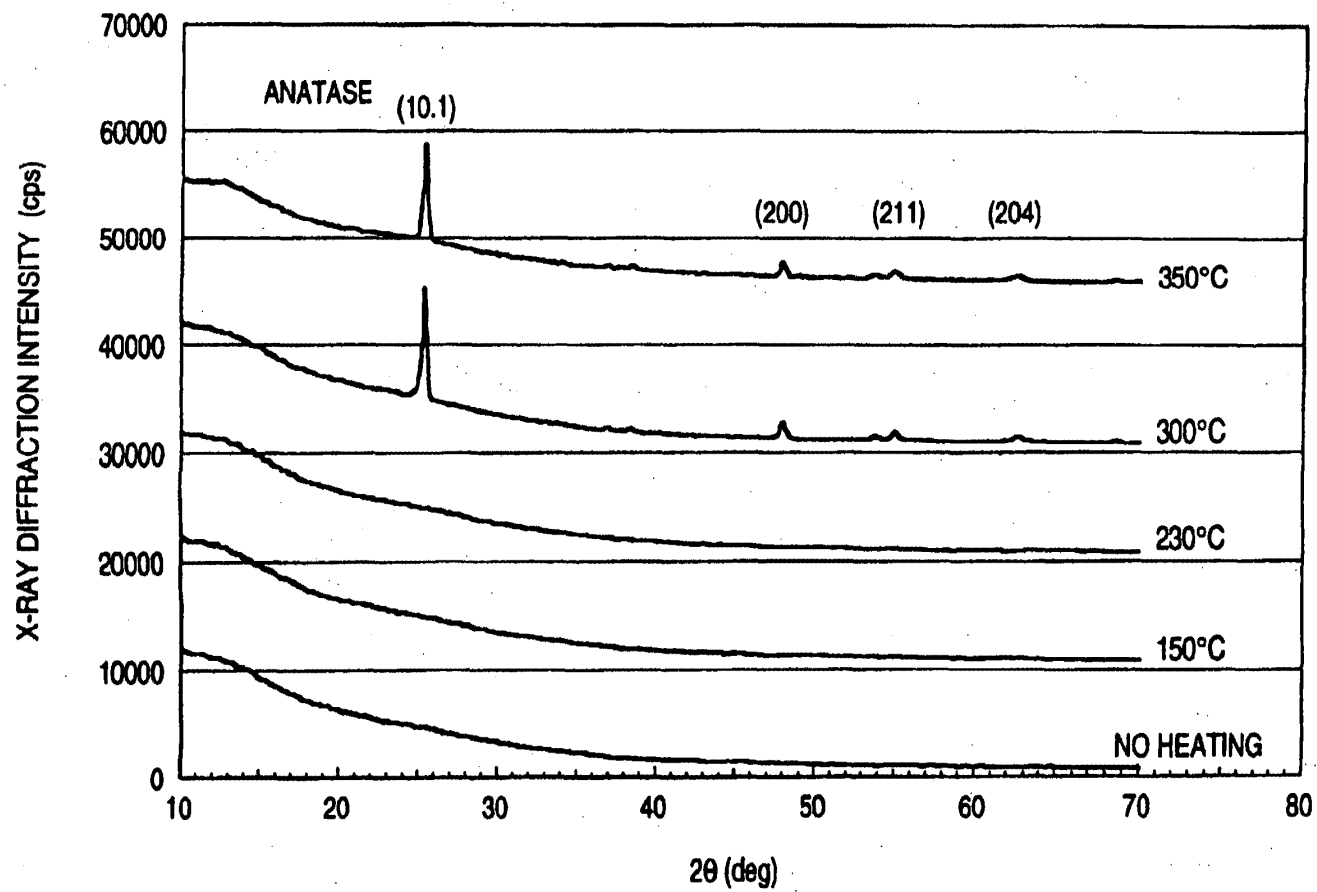

FIG. 3





European Patent Office

EUROPEAN SEARCH REPORT

Application Number
EP 00 11 4185

DOCUMENTS CONSIDERED TO BE RELEVANT			
Category	Citation of document with indication, where appropriate, of relevant passages	Relevant to claim	CLASSIFICATION OF THE APPLICATION (Int.Cl.7)
A	<p>DATABASE WPI Section Ch, Week 199930 Derwent Publications Ltd., London, GB; Class D15, AN 1999-352578 XP002149112 & JP 11 130434 A (BRIDGESTONE CORP), 18 May 1999 (1999-05-18) * abstract *</p> <p>---</p>		<p>B01J35/00 B01J37/34</p>
A	<p>DATABASE WPI Section Ch, Week 199924 Derwent Publications Ltd., London, GB; Class D15, AN 1999-283348 XP002149113 & JP 11 092176 A (BRIDGESTONE CORP), 6 April 1999 (1999-04-06) * abstract *</p> <p>---</p>		
A	<p>DATABASE WPI Section Ch, Week 199901 Derwent Publications Ltd., London, GB; Class J04, AN 1999-003984 XP002149114 & JP 10 278165 A (ASAHI GLASS CO LTD), 20 October 1998 (1998-10-20) * abstract *</p> <p>---</p>		<p>TECHNICAL FIELDS SEARCHED (Int.Cl.7)</p> <p>B01J</p>
A	<p>DATABASE WPI Section Ch, Week 199706 Derwent Publications Ltd., London, GB; Class D15, AN 1997-060199 XP002149115 & JP 08 309204 A (BRIDGESTONE CORP), 26 November 1996 (1996-11-26) * abstract *</p> <p>----</p>		
The present search report has been drawn up for all claims			
Place of search THE HAGUE		Date of completion of the search 4 October 2000	Examiner Thion, M
<p>CATEGORY OF CITED DOCUMENTS</p> <p>X : particularly relevant if taken alone Y : particularly relevant if combined with another document of the same category A : technological background O : non-written disclosure P : intermediate document</p> <p>T : theory or principle underlying the invention E : earlier patent document, but published on, or after the filing date D : document cited in the application L : document cited for other reasons</p> <p>& : member of the same patent family, corresponding document</p>			

EPO FORM 1503 03 02 (IP/04/201)

**ANNEX TO THE EUROPEAN SEARCH REPORT
ON EUROPEAN PATENT APPLICATION NO.**

EP 00 11 4185

This annex lists the patent family members relating to the patent documents cited in the above-mentioned European search report. The members are as contained in the European Patent Office EDP file on
The European Patent Office is in no way liable for these particulars which are merely given for the purpose of information.

04-10-2000

Patent document cited in search report	Publication date	Patent family member(s)	Publication date
JP 11130434 A	18-05-1999	NONE	
JP 11092176 A	06-04-1999	NONE	
JP 10278165 A	20-10-1998	NONE	
JP 8309204 A	26-11-1996	NONE	

EPO FORM P0459

For more details about this annex : see Official Journal of the European Patent Office, No. 12/82

THIS PAGE BLANK (USPTO)

THIS PAGE BLANK (USPTO)

THIS PAGE BLANK (USPTO)

**This Page is Inserted by IFW Indexing and Scanning
Operations and is not part of the Official Record**

BEST AVAILABLE IMAGES

Defective images within this document are accurate representations of the original documents submitted by the applicant.

Defects in the images include but are not limited to the items checked:

- BLACK BORDERS**
- IMAGE CUT OFF AT TOP, BOTTOM OR SIDES**
- FADED TEXT OR DRAWING**
- BLURRED OR ILLEGIBLE TEXT OR DRAWING**
- SKEWED/SLANTED IMAGES**
- COLOR OR BLACK AND WHITE PHOTOGRAPHS**
- GRAY SCALE DOCUMENTS**
- LINES OR MARKS ON ORIGINAL DOCUMENT**
- REFERENCE(S) OR EXHIBIT(S) SUBMITTED ARE POOR QUALITY**
- OTHER: _____**

IMAGES ARE BEST AVAILABLE COPY.

As rescanning these documents will not correct the image problems checked, please do not report these problems to the IFW Image Problem Mailbox.

THIS PAGE BLANK (USPTO)

Best Available Copy



Europäisches Patentamt
European Patent Office
Office européen des brevets



Publication number: **0 639 655 A1**

EUROPEAN PATENT APPLICATION

Application number: **94111669.1**
Date of filing: **26.07.94**

Int. Cl.⁶: **C23C 14/00, C23C 14/34, H01J 37/32**

Priority: **28.07.93 JP 205704/93**
Date of publication of application: **22.02.95 Bulletin 95/08**
Designated Contracting States: **BE DE FR GB**
Applicant: **ASAHI GLASS COMPANY LTD.**
1-2, Marunouchi 2-chome
Chiyoda-ku
Tokyo 100 (JP)
Inventor: **Shimizu, Junichi, Asahi Glass Company Ltd.**
Chuo Kenkyusho,
1150, Hazawa-cho,
Kanagawa-ku
Yokohama-shi,
Kanagawa-ken (JP)
Inventor: **Watanabe, Shujiro, Asahi Glass Company Ltd.**
Chuo Kenkyusho,
1150, Hazawa-cho,
Kanagawa-ku
Yokohama-shi,
Kanagawa-ken (JP)
Inventor: **Takaki, Satoru, AG TECHNOLOGY CO., LTD.**
1160, Matsubara
Hazawa-cho,

Kanagawa-ku
Yokohama-shi,
Kanagawa-ken (JP)
Inventor: **Osaki, Hisashi, Asahi Glass Company Ltd.**
Chuo Kenkyusho,
1150, Hazawa-cho,
Kanagawa-ku
Yokohama-shi,
Kanagawa-ken (JP)
Inventor: **Oyama, Takuji, Asahi Glass Company Ltd.**
Chuo Kenkyusho,
1150, Hazawa-cho,
Kanagawa-ku
Yokohama-shi,
Kanagawa-ken (JP)
Inventor: **Ando, Eiichi, Asahi Glass Company Ltd.**
Kashima Kojo,
25, Oaza-higashiwada,
Kamisu-cho,
Kashima-gun,
Ibaraki-ken (JP)

Representative: **Wächtershäuser, Günter, Prof. Dr.**
Patentanwalt
Tal 29
D-80331 München (DE)

Method and apparatus for sputtering.

A sputtering method comprises applying a negative voltage intermittently in a constant periodic cycle to a cathode disposed in a vacuum chamber, wherein the negative voltage is intermittently applied so that a time during which the negative voltage is not applied includes a time during which the voltage is controlled to be zero volt in a range of from 10 μ s to 10 ms, and the zero voltage time is equal to or longer than the time required by one arcing from its generation to extinction.

EP 0 639 655 A1

FIGURE 2

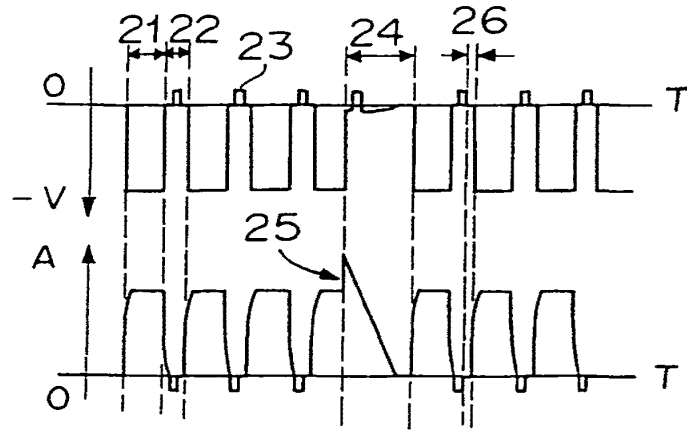

The present invention relates to a sputtering method in which a pulse-like DC voltage is applied, a film-deposition method by sputtering, an apparatus for obtaining sputtering and a power processing portion for sputtering.

A cathode for DC sputtering (hereinbelow, referred to as sputtering) can not be used for forming a film of high quality at a high deposition rate unless a problem of abnormal discharge is overcome.

Various causes are considered concerning the abnormal discharge occurring around the cathode (hereinbelow, referred to as arcing). As one of the causes, electric charges are accumulated on a small insulating substance, which is deposited or grown on the surface of a target material, and the electric charges cause arcing to a potentially opposite site, e.g. a substrate on which a film is to be formed, an anode electrode, the inner wall of a vacuum chamber or the surface of the target.

The arcing occurs frequently in a case that an insulating film is produced from a conductive target material by reactive sputtering. When the arcing is generated, arcing energy concentrates locally to a portion of the target surface in a reactive gas atmosphere, this forming an insulation or insulations, whereby the arcing happens frequently in a series. Accordingly, a stable glow discharge effective to sputtering can not be maintained; a sputtering rate becomes unstable and the production of films of uniform quality is impossible. Occasionally, a substrate on which a film is formed is damaged by arcing, or a mechanical component constituting a cathode or a target material or a cathode is molten by arcing.

In order to avoid the above-mentioned disadvantage, a method of using electric power of a high frequency such as 13.56 MHz has been used.

Recently, a technique of preventing arcing by using a waveform proposed in Japanese Unexamined Patent Publication Nos. 148644/1993 and 331634/1993 or using a device to obtain such waveform (the device is commercialized as SPARC-LE by Advanced Energy in U.S.A. Namely, the waveform having a frequency of several kHz which is comparable to the effect obtained by a discharge in 13.56 MHz by applying a pulse-like positive electric potential of about 5 μ s-10 μ s is applied in a periodic cycle to a cathode so that positive electric charges accumulated on a small insulating substance, which is deposited or grown on the surface of a target material are neutralized by attracting electrons in plasma.

Recently, another technique of neutralization of a potential difference on the target surface has been developed as seen in U.S.P. 5,082,546. Namely, an alternating current having an intermediate frequency such as several tens kHz is applied to a pair of closely disposed cathodes to ignite glow discharges between the two cathodes alternately. In this case, when the electric potential of the cathodes is negative, sputtering is conducted, and when the electric potential is positive, positive electric charges accumulated on a small insulating substance, which is deposited or grown on the surface of a target material are neutralized by attracting electrons in plasma.

The sputtering method using a radio frequency power source having 13.56 MHz is believed to suppress arcing because an insulation can be sputtered. However, it is difficult to form a sputtering apparatus using a radio frequency power source of 13.56 MHz because a power source having an output of 10 kW or more is large and expensive, and an impedance-matching circuit of high voltage and large current is needed.

A sputtering method wherein DC power is used to apply a positive potential intermittently and the power is intermittently off is a useful technique because a potential difference on the target surface can be neutralized and the generation of arcing at the initial stage can be suppressed. Thus, the generation of arcing could be effectively suppressed in comparison with the ordinary DC sputtering method. However, this method has no ability of sputtering an insulating substance unlike the sputtering method using 13.56 MHz, and accordingly, arcing occurs when a continuous discharge is conducted for a long time. When the arcing is generated, discharge energy concentrates locally on the target surface in a reactive gas atmosphere, which further forms an insulation or insulations and results in arcing frequently in a series.

Namely, the neutralization of potential difference on the target surface by applying a positive voltage or 0 voltage intermittently is effective only to a small insulating substance accumulated with a small amount of electric charges if the application time of positive voltage or 0 voltage is short. Accordingly, it is impossible to obtain complete neutralization of an insulating substance accumulated with a large amount of electric charges by sputtering for a long time or of an insulating substance having a large amount of electric charges produced by arcing, with use of a simple intermittent DC power.

In the sputtering method of applying an alternating current to the two closely disposed cathodes, an alternating current of several tens kHz is used. Accordingly, it can be said that this method uses the same principle as the sputtering method with use of the before-mentioned intermittent DC power, i.e. a potential difference on the target surface is neutralized. Further, in this method, the same electrode is used as a cathode and an anode. Accordingly, there is an advantage that when the electrode is used as a cathode, the surface of it is sputtered and cleaned, and when it is used as an anode, the surface is always cleaned whereby a continuous discharge can be stably carried out for a long time. However, this method requires

the two closely disposed cathodes and an AC power source of several tens kHz. Accordingly, it is impossible to suppress arcing and stabilize a normal discharge in a simple manner with use of a currently used DC sputtering apparatus.

As another cause of the occurrence of arcing, when a target material is eroded by sputtering, minute protrusions appear in the surface of the target material depending on the kind of material. An electric field concentrates to the protrusions whereby arcing occurs at a local portion. Accordingly, the composition of the target material is changed whereby a portion having a different sputtering yield may appear and uniform sputtering of target surface can not be obtained.

In particular, when an ITO (indium-tin-oxide) film is to be produced by the sputtering method, and when an ITO target or an IT (indium-tin) target is used, indium oxide which is believed to be sub oxide, or a large number of minute black protrusions (hereinbelow, referred to as nodules), are produced on the target surface during continuous sputtering, and the deposition rate of the ITO film is gradually decreased. Further, the arcing frequently occurs, whereby small pieces of the target material scattering by the arcing deposit on the substrate to reduce the quality of the ITO film.

As a common technique to remove the protrusions formed by the erosion of the target is to physically remove them by causing a discharge in an inert gas atmosphere such as Ar gas, i.e. sputter-etching.

Further, when the ITO target is used, a method of removing the nodules by a discharge in a N₂ gas atmosphere is proposed in Japanese Unexamined Patent Publication No. 293767/1992.

However, the above-mentioned methods are only effective under the condition that a vacuum chamber is maintained vacuum after the nodules have been formed, and they can not suppress the occurrence of arcing and can not realize a method of a long time stably discharge.

As another technique, there is a method of improving the surface condition of the target formed by the erosion of the target, by increasing the density of a target material of ITO in sintering. However, this method pushes up the cost of the target material and effect can not be expected.

As another technique, there is a method of increasing the density of power at the sputtering to change the erosion of the target. When the density of power is simply increased, the frequency of occurrence of arcing increases and a discharge energy of arcing also increases. So, this method increases adverse effects of the arcing.

It is an object of the present invention to provide a sputtering method, a film-deposition method by sputtering, an apparatus for obtaining sputtering and a power processing portion for sputtering whereby arcing is effectively controlled and a larger power can be supplied quickly to deposit a film of high quality with high deposition rate for a long time.

In accordance with the present invention, there is provided a sputtering method, a film-forming method by sputtering and an apparatus for sputtering and a power processing part for sputtering wherein the negative voltage is intermittently applied so that a time during which the negative voltage is not applied includes a time during which the voltage is controlled to be zero volt in a range of from 10 μs to 10 ms, and the zero voltage time is equal to or longer than the time required by one arcing from its generation to extinction.

It is possible in principle to realize the above-mentioned methods, apparatus and the power processing portion of the present invention with use of an ordinary DC power source if such a function that the arcing at the initial stage is detected to quickly stop the output and the output is again produced after the passing of the time of the extinction of arcing, is added to a DC power source. However, when a detection circuit of arcing is actually installed in the power source, it is necessary to detect through a power source cable an abnormal condition of current or voltage supplied from the positive pole to the negative pole by the power source.

Such method of detection can only detect arcing between the cathode electrode as a target material and the anode electrode disposed near the target material. However, a slight arcing at the initial stage which starts on the surface of the cathode material can not be detected because the slight arcing is filtered by the impedance of the power source cable and the circuit constant of the power source circuit. Namely, only a relatively large arcing which is produced as a result of the slight arcing at the initial stage can be detected.

Since the time of extinction of the relatively large arcing between the cathode and anode is in the order of ms, it is necessary to stop the output from the power source for more than several ms. Further, since the size of an insulation formed on the surface of the target material at the time of generation of arcing already becomes large, the arcing occurs frequently. Accordingly, an abnormal state of output is detected from the DC power source, the shut-off of several ms is repeated, and it is very difficult to continue the normal sputtering operation.

For the above-mentioned reasons, the slight arcing can not be detected in a case that the ordinary DC power source is used for sputtering, and there will be a problem such that the shutting-off of more than

several ms is repeated when a large arcing occurring subsequent to the slight arcing takes place.

The inventors of this application have found through intensive observations of the waveform of arcing that the crest value (the maximum value of the waveform of current) in initial arcing before a large arcing takes place in a series and the time of extinction of the initial arcing are substantially constant when the same apparatus is used.

Therefore, they have found that the progress of arcing in a series can be prevented by minimizing the energy of arcing. Specifically, the sputtering method comprises applying a negative voltage intermittently in a constant periodic cycle to a cathode disposed in a vacuum chamber, wherein the negative voltage is intermittently applied so that a time during which the negative voltage is not applied includes a time during which the voltage is controlled to be zero volt in a range of from 10 μ s to 10 ms, and the zero voltage time is equal to or longer than the time required by one arcing from its generation to extinction.

The slight arcing can be seen with a waveform observing device such as an oscilloscope or the like.

Further, they have found through intensive observations of the waveform of arcing that a time from the application of a negative voltage to the generation of the initial arcing is substantially constant when the construction of the apparatus is the same.

Therefore, they have found that by using a voltage waveform wherein the time during which the negative voltage is intermittently applied is within a range of from 10 μ s to 10 ms and is equal to or shorter than the period of time from the application of the negative voltage to the generation of arcing, the accumulation of electric charges on an insulation having a small surface area on the surface of a target can be minimized; the voltage is controlled to be zero volt before the arcing takes place, and the electric charges are neutralized by plasma near the target, whereby the frequency of occurrence of the initial arcing can be reduced.

As described above, it is possible to continue sputtering operations for a long time by specifying the time during which the voltage is controlled to zero volt, and this effect can be increased by specifying the time during which the negative voltage is intermittently applied.

In drawings:

Figure 1 is a diagram showing intermittent waveforms according to an embodiment of the present invention;

Figure 2 is a diagram showing intermittent waveforms in a case of applying a positive potential according to an embodiment of the present invention;

Figure 3 is a diagram showing a sputtering apparatus according to a first embodiment of the present invention;

Figure 4 is a circuit diagram showing an embodiment of an intermittent power processing portion of the present invention;

Figure 5 is a diagram showing the sputtering apparatus according to a second embodiment of the present invention;

Figure 6 is a first graph showing the effect of the present invention;

Figure 7 is a second graph showing the effect of the present invention;

Figure 8 is a diagram showing the sputtering apparatus according to a third embodiment of the present invention;

Figure 9 is a diagram showing an intermittent waveform of an embodiment of the present invention;

Figure 10 is a diagram showing an intermittent waveform according to an embodiment of the present invention; and

Figure 11 is a diagram showing an intermittent waveform according to an embodiment of the present invention.

Preferred embodiments of the present invention will be described with reference to the drawings.

Figure 1 shows waveforms according to an embodiment of the present invention wherein the upper portion shows a waveform of voltage and the lower portion shows a waveform of current. Reference numeral 1 indicates a time during which a negative voltage is intermittently applied (hereinbelow, referred to as an ON time), numeral 2 designates a time during which the voltage is controlled to be zero voltage (hereinbelow, referred to as a zero volt time) and numeral 3 shows a waveform produced when arcing takes place. In Figure 1, when the zero volt time is longer than the ON time, power efficiency becomes poor. However, the waveform is simple because the power is simply turning-on and off. Accordingly, it is advantageous in construction when the power source portion has a sufficient capacity.

On the other hand, the inventors of the present invention have found that the neutralization of charging to an insulation can be effectively done in a shorter time by using a voltage waveform wherein there is a time during which a positive voltage is applied in a range of from 1 μ s to 20 μ s in part of the zero volt time. By combining this waveform with the above-mentioned specified ON time, a waveform having excellent

power efficiency can be obtained.

Further, they have found to suppress the occurrence of arcing for a long time and with excellent power efficiency by suitably determining the zero volt time, which is equal to or longer than the time of extinction of arcing, only just after the arcing.

5 Figure 2 shows the waveform obtained by the application of a positive voltage. In Figure 2, the upper portion shows the waveform of voltage and the lower portion shows the waveform of current. Reference numeral 21 indicates an ON time which is in a range of from 10 μ s to 10 ms and which is equal to or shorter than the time from the rise of voltage to the generation of an arc discharge in the initial arcing.

10 Numeral 22 indicates a zero volt time, which is determined by a time 23 during which a positive potential is applied and a time 26 for a zero volt after the time 23.

The zero volt time just before the time 23 during which a positive potential is applied is preferably short. However, a constant time of 1 μ s to 2 μ s is actually set to protect the switching element.

15 It is not necessary that the time 23 during which a positive potential is applied is a long time, but it may be a time which is sufficient to apply the voltage to a large-sized target, and a time of about 5 μ s to 20 μ s is preferable. The value of a positive potential can be a potential sufficient to apply the voltage to an actual target, and may be 200 V or lower.

It is desirable that the zero volt time 22 can be adjusted depending on a situation of process by adjusting the time 26 after the application of a positive potential.

20 Namely, a desirable result can be obtained by adjusting the zero volt time 26 so as to form the zero volt time 22 equal to or longer than the time of extinction of a slight arcing even when a slight arcing smaller than a reference value for detection set in a detection circuit takes place.

Numeral 25 indicates the waveform of arcing. The zero volt time 24 just after the occurrence of arcing is equal to or longer than the time for extinction of the arcing.

25 It is preferable that the above-mentioned conditions can be changed because the optimum values are different depending on the material for sputtering and the construction of the cathode electrode.

The function of the present invention is as follows.

In the present invention, by repeating ON/OFF, a potential difference on the target surface can be eliminated to prevent the occurrence of arcing. Accordingly, a stable discharge can be maintained in comparison with a conventional DC sputtering.

30 If arcing takes place, the arcing can be completely distinguished by giving a sufficiently long zero volt time before the voltage is ON, whereby the magnitude of the arcing can be maintained small. Further, the initial arcing appears sometime after the rise of voltage. Accordingly, a waveform wherein a time during which the voltage is controlled to be ON is in a range of from 10 μ s to 10 ms and equal to or shorter than a time of from the rise of voltage to the generation of the initial arcing is used, a potential on the surface of a target is neutralized, whereby the frequency of occurrence of arcing and the magnitude of the arcing can be reduced.

By the above-mentioned function, the frequency of occurrence of the initial arcing and the magnitude of the arcing can be kept small, and a stable sputtering can be continued for a long time even with a large power.

40 When the waveform shown in the upper portion of Figure 2 wherein a positive potential is added for a short time in the zero volt time is used, a potential difference on the target surface can be effectively eliminated to thereby prevent the occurrence of arcing. Accordingly, a stable discharge can be maintained for a long time in comparison with use of the ordinary DC sputtering.

45 Further, by determining the zero volt time 24 to be longer than the time of extinction of arcing just after the arcing 25 has been detected, the frequency of occurrence and the magnitude of the arcing at the initial stage can be kept small, and a stable sputtering can be continued for a long time even with a large power.

Even when a slight arcing whose value is smaller than a reference value of detection set in the detection circuit takes place, a further stable sputtering can be continued by adjusting the zero volt time 26 so that the zero volt time 22 is longer than the time of extinction of the slight arcing.

50 Figure 3 shows an embodiment of the power source device for realizing the above-mentioned sputtering method.

The power source device of the present invention preferably has a sputtering power generating portion and a power processing portion which should be separately disposed. In Figure 3, numeral 31 designates a sputtering power generating portion, numeral 32 designates a power processing portion, numeral 33 designates a vacuum chamber, numeral 34 designates a cathode electrode, numeral 35 designate anode electrodes and numeral 36 designates a substrate.

In this embodiment, the power processing portion 32 can be disposed closer to the cathode electrode 34 than the sputtering power generating portion 31, whereby the length of a power source cable between

the output terminal of the power processing portion 32 and the cathode electrode 34 can be the shortest to thereby minimize the inductance of the power source cable. Accordingly, the waveform of an intermittent DC voltage can be applied to the cathode electrode 34 without any distortion.

Figure 4 shows the construction of the power processing portion 32 of the present invention.

5 The power processing portion 32 comprises a first switching circuit 41 as main circuit, a second switching circuit 42 for applying a positive potential, a control circuit (not shown) for a switching element for controlling the first and second circuits and a power measuring circuit (not shown) for measuring current, voltage, and power for sputtering.

10 The first switching circuit 41 is connected in series between the negative pole of the sputtering voltage generating portion 31 and the cathode electrode 34. The first switching circuit 41 is composed of a semiconductor switching device and a coil for protecting the same and is operable to change a sputtering power to an intermittent power. It has a switching speed of 10 μ s (100 kHz) for ON/OFF. The second switching circuit 42 is composed of a semiconductor switching device and a coil for protecting the same, and is so operable that power of DC power source 43 which supplies an optional value of positive potential
15 to the cathode electrode 34 is applied to the cathode electrode 34, beside of the sputtering power generating portions 31.

The second switching circuit 42 is operated only when the first switching circuit 41 as the main circuit is an OFF state. A time of applying a positive potential in an ON state can be about 20 μ s in maximum.

20 It is preferable that the power source 43 for applying a positive potential is of about 200 V in maximum, but it can be determined optionally.

By adjusting a turning on time of the semiconductor switching device of the second switching circuit 42 to be about 20 μ s or less immediately after the semiconductor switching circuit of the first switching circuit 41 has been turning off, a positive potential of about 200 V or less can be applied to the cathode electrode 34, whereby the occurrence of arcing can be suppressed and the waveform having excellent power efficiency as shown in Figure 2 can be produced.

The control circuit for the semiconductor switching device is capable of controlling the turning-on time to be 5 μ s or more for the first switching circuit and the turning-off time to be 5 μ s or more for the same, and capable of turning-on the second switching circuit for less than the time of turning-off the first switching circuit and within a range of from 1 μ s to 20 μ s when the first switching circuit is turned off.

30 It is possible that the first switching circuit is in a normally ON state while omitting the zero volt time. The adjustment allows to use the conventional DC sputtering.

The circuit for measuring current, voltage or power for sputtering has a function to measure a current value, a voltage value and a power value effective to the sputtering and a function to compare the measured values with predetermined reference values to detect arcing. In this case, it is especially effective to judge
35 whether the current value or both the current value and the voltage value are higher or lower.

The control circuit for the semiconductor switching device has a function to control the zero volt time 24 immediately after the occurrence of arcing. The zero volt time can be optionally set to be in a range of from 100 μ s to 10 ms.

40 Further, when the arcing is detected upon the judgement as to whether or not the sputtering current value or voltage value (or the impedance at the arcing) is higher or lower, the semiconductor switching device of the switching circuit 41 operates so that the zero volt time is longer than the time of extinction of arcing, only immediately after the arcing, whereby the magnitude of arcing can be minimized and a stable sputtering can be continued for a long time.

45 Further, a smoothing circuit 44 is preferably disposed at the side of the input terminal of the power processing portion, whereby the waveforms of voltage and current at the output terminal of the power generating portion 31 can be substantially in a direct current form.

The power generating portion generally has a function to feed-back the voltage, current or power at the output terminal so that it can be kept constant. The function may cause hunting on controlling.

50 However, since the hunting can be prevented by the smoothing circuit 44, the ordinary DC power source can be used. Accordingly, the ordinary sputtering DC power source may be used for the sputtering power generating portion 31. In this case, the present invention can be practiced with a conventional sputtering apparatus with the power processing portion 32.

55 In the sputtering method of the present invention, it is preferable to measure and display the average value of power per period (hereinafter referred to as the effective value, see formula 1 given hereinafter). By displaying the effective value, the film-deposition rate can be controlled in the same manner as use of the power for the conventional DC sputtering even when any type of waveform is used for sputtering.

Further, it is preferable that the effective value is fed-back to the sputtering power generating portion 31 for a constant voltage control, a constant current control or a constant power control.

When a sputtering apparatus having a plurality of cathode electrodes disposed in a vacuum chamber is used and an intermittent power waveform is supplied to each of the cathode electrode, interference such as a beat may appear. Accordingly, the power processing portion should have a function to shift the phase of waveform.

5 Figure 8 shows an embodiment of the sputtering apparatus of the present invention. In this embodiment, two cathode electrodes 82a, 82b and anode electrodes 83a, 83b are disposed in a vacuum chamber so that sputtering is conducted simultaneously to a substrate 85. Power generating means 81a and 81b supply power intermittently wherein the phases of voltage waveform are shifted to each other, whereby interference of plasma such as a beat or the like can be eliminated and a stable plasma 84 is produced.

10 Further, the waveforms shown in Figure 1 or Figure 2 can be produced by combining the apparatus with the power source as shown in Figure 3. Thus, the optimum waveform can be supplied by satisfying the conditions of process.

In the sputtering apparatus of the present invention, the frequency of occurrence of arcing can be reduced even when a reactive sputtering is conducted. Further, a larger power can be supplied to the cathode stably, and the optimum intermittent power can be expected and supplied to meet various sputtering processes. Accordingly, the sputtering apparatus of the present invention has high ability of film-deposition.

A thin film composed mainly of silicon oxide formed by the sputtering method of the present invention is of higher quality than a thin film obtained by a DC sputtering.

20 The thin film composed mainly of silicon oxide formed by the sputtering method and the sputtering apparatus of the present invention is of high quality since no arcing takes place during the sputtering so that attachment of particles is little. Further, it is believed that since there is no fluctuation in the sputtering condition due to arcing, a uniform film with little microscopic defects can be obtained. Further, it is believed that excellent film quality with little defects can be obtained, since sputtering is carried out intermittently with an interval of every period, whereby a very thin film is intermittently formed on the substrate with an interval of every period, and film-deposition is carried out while an oxidation reaction on the substrate is completed during every period.

Thus, it is possible to obtain an excellent thin film composed mainly of silicon oxide which has little defects macroscopically or microscopically, whereby a high alkali barrier property can be obtained even when the film is formed on a low temperature substrate.

A thin film composed mainly of silicon nitride formed by the sputtering method or the sputtering apparatus of the present invention is of higher quality than a thin film obtained by the DC sputtering.

35 The thin film composed mainly of silicon nitride formed by the sputtering method of the present invention is of high quality since it is unnecessary to heat the substrate, no arcing takes place during the sputtering so that attachment of particles is little. Further, it is believed that since there is no fluctuation in the sputtering condition due to arcing, a uniform film with little microscopic defects can be obtained. Further, it is believed that excellent film quality with little defects can be obtained, since sputtering is carried out intermittently with an interval of every period, whereby a very thin film is intermittently formed on the substrate with an interval of every period, and film-deposition is carried out while a nitriding reaction on the substrate is completed during every period.

40 Thus, it is possible to obtain an excellent thin film composed mainly of silicon nitride which has little defects macroscopically or microscopically, whereby a high alkali barrier property can be obtained even when the film is formed on a low temperature substrate.

45 If the concentration of nitrogen in sputtering gas is adjusted and/or power to be supplied to a silicon target is adjusted so that the composition ratio of silicon nitride (atomic molar ratio of N/Si) will be within a range of from 1.25 to 1.36, it is possible to produce silicon nitride having an excellent alkali barrier property.

In the film-deposition method of a transparent conductive film by the sputtering method of the present invention, a negative voltage is intermittently applied and power of a large power density is instantaneously supplied, and at the same time, problems of nodules of sub oxide on the target material which reduce the sputtering rate and an arcing in sputtering can be eliminated. Thus, the film-deposition method of the present invention is excellent in productivity.

55 As sputtering targets, there are a sputtering target composed mainly of tin or tin oxide containing metal antimony or an antimony compound, a sputtering target composed mainly of indium or indium oxide containing tin and a sputtering target composed mainly of zinc or zinc oxide containing a simple substance or a compound of at least one metal selected from the group consisting of aluminum, gallium, indium, boron and silicon.

Sputtering power used for the method and apparatus of the present invention is preferably have a voltage waveform to be applied to a target, as shown in Figure 1 wherein an application time of negative

voltage is in a range of from 10 μ s to 10 ms and a non-application time is in a range of from 10 μ s to 100 ms, or a voltage waveform to be applied to a target as shown in Figure 2 wherein an application time of negative voltage is in a range of from 10 μ s to 10 ms and an application time of negative voltage and a non-application time is in a range of from 10 μ s to 100 ms.

5 Further, setting of the value of negative voltage ($-V_N$ in Figure 9) is important for suppressing formation of nodules, which is an object of the present invention. As expressed in formula 5, arcing and formation of nodules of sub oxide on the target surface can be effectively suppressed by adjusting the negative application voltage ($-V_N$) so that the average value W_A of the intermittently supplied power is from 2 to 10 times the average value W of the power per period (hereinafter referred to as the effective value W).

10 The effective value W of the power is as represented by the formula 1 where T is the period. If this is applied to the case of the waveform as shown in Figure 2, W is as shown by the formula 2.

On the other hand, the average power W_A within the time when sputtering actually takes place (when the negative voltage is applied) (a_1 in Figure 9) are as shown by the formula 3. Further, in Figure 2, the average voltage is $V_A = (-V_N)$, and if this is inserted, W_a is as shown by the formula 4.

15 To effectively remove nodules, it is preferred that the average value W_A of power is from 2 to 10 times the effective value W of the power, as shown by the formula 5. If this is applied to the case of the waveform as shown in Figure 2, the formula 6 is obtained. Therefore, ($-V_N$), a_1 ($10 \mu\text{s} \leq a_1 \leq 10 \text{ms}$), and b_1 ($10 \mu\text{s} \leq b_1 \leq 100 \text{ms}$) should be adjusted to satisfy the formula 6.

20 Good results can be obtained especially when the average value of intermittent electric power density ω_A (see formula 7) is within a range of from 2.5 W/cm² to 30 W/cm².

In this case, the waveform may not necessarily be a precise rectangular waveform as shown in Figure 9, and ($-V_A$), a_1 and b_1 may be optimized depending upon the size and condition of the target and the particular apparatus.

25 In a case where positive voltage is applied as shown in Figure 10 or 11, application of such positive voltage does not serve effectively for sputtering, and accordingly, in the calculation of the formulas 1 to 7, V_p is to be taken as 0.

The film-deposition rate of the transparent conductive film can easily be controlled by the effective value W of the intermittently supplied sputtering power. For example, in a case where by the method of the present invention, it is intended to obtain the desired film-deposition rate obtained by the conventional DC sputtering method, the desired film-deposition rate can be obtained by adjusting the effective value W of the intermittently supplied power to the same level as the DC electric power value.

30 Namely, an equation of "the film-deposition rate by the conventional DC sputtering method/the DC power = the film-deposition rate according to the present invention/the effective value W of power" substantially holds good.

35 Thus, the film-deposition rate can be adjusted by adjusting the zero volt time so that the effective power value W corresponds to the power of the conventional DC sputtering, and the quality of a film deposited on the substrate can be kept and a stable sputtering is obtained for a long time.

40

45

50

55

Formula 1

5

$$W = \frac{1}{T} \int_0^T V(t) I(t) dt$$

Formula 2

10

$$W = \frac{(-V_N)}{a_1 + b_1} \int_0^{a_1} I(t) dt$$

Formula 3

15

$$W_A = \frac{1}{a_1} \int_0^{a_1} V(t) I(t) dt$$

Formula 4

20

$$W_A = \frac{-V_N}{a_1} \int_0^{a_1} I(t) dt$$

25

Formula 5 $2W \leq W_A \leq 10W$

Formula 6

30

$$2 \leq \frac{W_A}{W} = \frac{a_1 + b_1}{a_1} \leq 10$$

Formula 7

35

$$\omega_A = \frac{W_A}{S} \quad S : \text{Target surface area}$$

40

Now, the present invention will be described in detail with reference to Examples. However, it should be understood that the present invention is by no means restricted by such specific Examples.

EXAMPLE 1

45

Figure 5 shows an example of the sputtering apparatus of the present invention.

In Figure 5, reference numeral 51 designates a DC power source for generating intermittently a negative DC voltage, numeral 52 designates a cathode electrode with a target material, numeral 53 designates an anode electrode, numeral 54 designates a substrate to be subjected to a film-deposition treatment, numeral 55 designates an area of glow discharge effective to sputtering, numeral 56 designates a slight arcing produced on the surface of the target and numeral 57 designates arcing produced between the cathode electrode and the anode electrode.

50

In the present invention, output from the DC power source generating an intermittent DC voltage may not be of a rectangular wave, but may be of a trapezoidal, a triangular or a sign waveform to obtain the same effect. Further, in construction of the power source circuit, the waveform can be produced by oscillation in the power source itself or the output of the DC power source may be processed by a semiconductor switching element to form an intermittent waveform. In either case, the effect of the present invention is the same.

55

In the apparatus having the construction shown in Figure 5, using a planar magnetron cathode having an area of 10×80 cm, a target material of boron-doped silicon, and a gas mixture of argon and oxygen having a ratio of 1:1, as introducing gas, a film of SiO_2 doped with boron was deposited by sputtering on a substrate under a discharging pressure of 3.0×10^{-3} Torr and an effective power value of 2 kW. When a DC discharge was conducted, arcing suddenly and frequently took place after about 2 minutes and 30 seconds and the sputtering could not be continued.

Sputtering was conducted in the same manner as above except that an intermittent direct current was used wherein in the waveform shown in the upper portion of Figure 1, an ON time during which a negative voltage is applied was $100 \mu\text{s}$ and a zero volt time was $40 \mu\text{s}$. As a result, arcing gradually increased and the frequency of occurrence of the arcing after about 30 minutes was about 60 times/min.

In observing the current waveform during arcing and measuring a time of extinction of the initial arcing, there was detected 160 to $180 \mu\text{s}$.

Sputtering was conducted in the same manner as above except that an intermittent direct current was used wherein the ON time was $100 \mu\text{s}$ and the zero volt time was $200 \mu\text{s}$. As a result, the frequency of occurrence of arcing after about 60 min was about 60 times/min. In this case, the initial arcing frequently took place after $90 \mu\text{s}$ to $100 \mu\text{s}$ of the rise of voltage.

Sputtering was conducted in the same manner as above except that an intermittent direct current was used wherein the ON time was $80 \mu\text{s}$ and the zero volt time was $200 \mu\text{s}$. There was found that the frequency of occurrence of arcing after about 60 min was about 30 times/min. The frequency of occurrence of arcing in the above-mentioned four tests is shown in Figure 6. In the measurement of arcing, a current value 10% or more than the maximum value of ordinary current waveform was used as a detection level in the oscilloscope and the number of occurrence detected was recorded.

EXAMPLE 2

A cathode having an area of 40×300 cm, aluminum-doped silicon as a target material and a gas mixture of argon and oxygen having a ratio of 2:10 as introducing gas were used in the apparatus shown in Figure 5. Sputtering was conducted under a discharge pressure of 2.0×10^{-3} Torr and at an effective power value of 13 kW to deposit a film of SiO_2 doped with aluminum on a substrate.

When a direct current was used for discharge, arcing suddenly took place after about 35 min and the sputtering could not be continued. In observing the waveform during the discharge, a time of extinction of the initial arcing was about $400 \mu\text{s}$.

Sputtering was conducted in the same manner as above except that the waveform shown in the upper portion of Figure 1 was used wherein the zero volt time was $500 \mu\text{s}$ and the ON time was $500 \mu\text{s}$. A time required for the occurrence of the initial arcing was about $220 \mu\text{s}$ after the rise of voltage.

Sputtering was conducted in the same manner as above except that the ON time was $220 \mu\text{s}$ and the zero volt time was $500 \mu\text{s}$. The frequency of occurrence of arcing was 20 times/min or lower even after the lapse of 4 hrs.

The frequency of occurrence of arcing in the case of using a direct current and the case of using the intermittent waveform wherein the ON time is $220 \mu\text{s}$ and the zero volt time is $500 \mu\text{s}$ is shown in Figure 8. The condition of detecting arcing is the same as that of Example 1.

EXAMPLE 3

In a vacuum chamber, N-type silicon (phosphorus doped single crystal) having a specific resistance of $1.2 \Omega \cdot \text{cm}$ was placed as a target on a cathode, and on the opposite side of the target, a soda lime glass sheet was disposed as a substrate. The vacuum chamber was evacuated to 1×10^{-5} Torr. Then, a gas mixture of argon and oxygen was introduced as sputtering gas, and conductance was adjusted so that the pressure is 2×10^{-3} Torr.

Then, the voltage as shown in the upper portion of Figure 2 was applied to the cathode. Here, the ON time 21 was $50 \mu\text{s}$ which is the same as the time of starting the initial arcing and the zero volt time 22 was $50 \mu\text{s}$ which is the same as the time of extinction of the initial arcing in which the time 23 for applying a positive potential was about $12 \mu\text{s}$. Here, the negative voltage was adjusted so that the application power in the application of this voltage was 500 W. The positive voltage was kept to be 100 V.

The substrate temperature was maintained to be at room temperature, and an electric discharge was started at an oxygen concentration in the sputtering gas of 60%. After the pre-discharge of 5 min, the shutter was opened, and the film-deposition time was adjusted so that the thickness of film was 250 \AA , whereby a thin film composed mainly of silicon oxide was deposited on a soda lime glass substrate.

When 120 min passed after the initiation of discharge, a film was deposited on another soda lime glass substrate. However, little arcing was observed.

COMPARATIVE EXAMPLE 1

5 Sputtering was conducted to deposit a film in the same manner as Example 3 except that an intermittent DC voltage having the waveform as shown in the upper portion of Figure 1 was applied to the cathode wherein the ON time was 50 μ s and the zero volt time was 25 μ s.

10 Although little arcing was observed just after the initiation of film-deposition, occurrence of arcing was observed with the lapse of time, and continuous discharge of red-hot particles was observed on the target surface at the completion of film-deposition.

When 120 min passed after the initiation of discharge, a film was deposited on another soda lime glass substrate. Arcing took place very frequently.

15 COMPARATIVE EXAMPLE 2

Sputtering was conducted in the same manner as Example 3 except that a radio frequency voltage of 13.56 MHz was applied to the cathode.

20 After 120 min from the initiation of discharge, a film was deposited on another soda lime glass substrate. In this case, there was no arcing.

The coated side of each of the coated glass obtained in Example 3 and Comparative Examples 1 and 2 was contacted with pure water at 90 °C for 24 hours, whereupon the amount of out diffused sodium atoms (μ g/cm²) in this pure water was measured by atomic absorptiometry. Results are shown in Table 1.

25 Table 1

	Film-deposition after 5 min from initiation of discharge	Film-deposition after 120 min from initiation of discharge
30 Example 3	0.02	0.02
Comparative Example 1	1.3	5.6
Comparative Example 2	0.32	0.31

35 As is clear from the above Example and Comparative Examples, according to the present invention, it is possible to form a thin film of silicon oxide having a high alkali barrier property without heating the substrate for a long period of time and in a stable manner. Further, since the film-deposition is conducted by the DC sputtering, deposition of a film with a large area or a film-deposition at a high speed can be facilitated, whereby application to e.g. a transparent conductive substrate for liquid crystal can be made possible on an industrial production scale.

40 EXAMPLE 4

N-type silicon having a specific resistance of 1.2 Ω ·cm and a surface area of 160 mm \times 40 mm was used as a target, and the voltage as shown in the upper portion of Figure 2 was applied to the targets. Here, 45 the negative voltage was adjusted so that the application power in the application of this voltage was 200 W. The positive voltage was kept to be 100 V. Other conditions was the same as those of Example 3.

Discharge was started at an oxygen concentration in sputtering gas of 40%. After 5 min, the shutter was opened to deposit a film of silicon nitride having a thickness of 200 Å on a flat soda lime silicate glass at room temperature.

50 Then, when 120 min passed after the initiation of discharge, the shutter was again opened to deposit a silicon nitride film of 200 Å on another soda lime glass substrate. During the film-deposition operations, no arcing was observed.

55 COMPARATIVE EXAMPLE 3

Sputtering was conducted in the same manner as in Example 4 except for application of a DC power of 200 W. In film-deposition after 5 min from the initiation of discharge, no arcing was observed.

After 120 min from the initiation of discharge, film-deposition was conducted on another soda lime glass substrate. In this case, arcing frequently took place, and discharge of red-hot particles from the target surface was observed.

5 COMPARATIVE EXAMPLE 4

Sputtering was conducted in the same manner as in Example 4 except N-type silicon having a specific resistance of $1.5 \Omega \cdot \text{cm}$ and a diameter of 6 inches was used as a target, the nitrogen concentration in sputtering gas was adjusted to 100%, and a radio frequency voltage of 13.56 MHz was applied so that a
10 power of 300 W was supplied.

When 120 min passed after the initiation of discharge, a film was deposited on another soda lime glass substrate. No arcing was observed.

15 COMPARATIVE EXAMPLE 5

Films of silicon nitride each having a film thickness of 200 \AA were deposited on flat soda lime silicate glass substrates at a temperature of about 600°C by CVD method in each case that the ratio of ammonia gas/silane gas in material gas was 3, 5, 10 or 15.

The coated side of each of the coated glass obtained by Example 4 and Comparative Examples 3 to 5
20 was contacted with pure water at 90°C for 24 hours, whereupon the amount of sodium atom out diffused into the pure water from soda lime glass through silicon nitride film was measured by atomic absorption spectrometry. The results of Example 4 and Comparative Examples 3 and 4 are shown in Table 2 and the results of Comparative Example 5 are shown in Table 3.

25

30

35

40

45

50

55

55

50

45

40

35

30

25

20

15

10

5

Table 2

	Film-deposition after 5 min from initiation of discharge		Film-deposition after 120 min from initiation of discharge	
	Composition (N/Si)	Amount of out diffused Na ($\mu\text{g}/\text{cm}^2$)	Composition (N/Si)	Amount of out diffused Na ($\mu\text{g}/\text{cm}^2$)
Example 4	1.33	0.005	1.33	0.005
Comparative Example 3	1.33	0.008	1.32	0.91
Comparative Example 4	1.36	0.015	1.36	0.015

14

EP 0 639 655 A1

Table 3

Ratio of ammonia/silane	3	5	10	15
Composition (N/si)	1.27	1.36	1.49	1.56
Amount of out diffused Na ($\mu\text{g}/\text{cm}^2$)	0.047	0.038	0.056	0.062

In comparing Examples with Comparative Examples described above, silicon nitride film deposited by the present invention shows that the amount of out diffused sodium atoms through this film is low, and there is clear superiority in the present invention.

Further, it is understood that the silicon nitride film having a high alkali barrier property can be deposited stably for a long period of time.

Further, it becomes possible to deposit a silicon nitride film having a high alkali barrier property without heating the substrate, and coating of alkali barrier on a substrate having a low heat resistance is possible.

EXAMPLE 5

By using an ordinary magnetron sputtering device as shown in Figure 5, the voltage as shown in the upper portion of Figure 1 wherein the ON time was 100 μs and the zero volt time was 400 μs , was applied to an indium oxide target 52 containing 10 wt% of tin. As a substrate 54 on which a film is to be deposited, non-alkali glass (AN glass by Asahi Glass Company Ltd.) previously heated to 200 °C was used.

A film-deposition chamber was evacuated to 1×10^{-5} Torr or lower. Then, argon gas containing 1 vol% of oxygen gas was introduced so that gas pressure was 3×10^{-3} Torr. Sputtering power was adjusted to be 1.1 kW in terms of effective value.

EXAMPLE 6

Sputtering was conducted in the same manner as in Example 5 except that the voltage as shown in Figure 2 wherein the ON time 21 was 100 μs , the application time of positive voltage 23 having an amplitude of about 10% to the power value in the application of a negative voltage was 10 μs and the zero volt time 26 was 390 μs .

COMPARATIVE EXAMPLE 6

Sputtering was conducted in the same manner as in Example 5 except that the conventional magnetron sputtering apparatus and the conventional DC sputtering power source were used.

Occurrence of nodules after continuous sputtering of 23 hours, the frequency of occurrence of arcing and the characteristic of ITO films were examined on Examples 5 and 6 and Comparative Example 6.

	Comparative Example 6	Example 5	Example 6
Formation of nodules (after sputtering for 23 hours)	Many nodules were observed the entire erosion region except for the erosion center	Almost nil	Almost nil
Frequency of arcing (after film-sputtering for 23 hours)	15 times/min or more	3 times/min or less	Once/min or less
Specific resistance of ITO film ($\Omega \cdot \text{cm}$) Immediately after initiation of film-sputtering	1.9×10^{-4}	1.9×10^{-4}	1.9×10^{-4}
Specific resistance of ITO film (after film-sputtering for 23 hours)	4.0×10^{-4}	2.0×10^{-4}	1.9×10^{-4}
Change in the sputtering rate (after sputtering for 23 hours)	Decreased by about 40%	Almost nil	Almost nil

As seen in Table 4, occurrence of nodules is slight even after continuous sputtering for 23 hours (a target of a thickness of 6 nm was completely digged down) and there is no substantial reduction in sputtering rate. Further, the frequency of occurrence of arcing is reduced to about 1/5 - 1/3 in comparison with the conventional sputtering method shown in Comparative Examples. The specific resistance of ITO film is substantially the same as that of a sample by the conventional sputtering method.

In Comparative Examples, the decrease of the sputtering rate was remarkable by about 40%. The specific resistance is reduced from $1.9 \times 10^{-4} \Omega \cdot \text{cm}$ (at the initial stage of sputtering) to $4 \times 10^{-4} \Omega \cdot \text{cm}$ due to the reduction of sputtering rate. Nodules were very rigid and it was necessary to conduct mechanical grinding for cleaning.

5 The film-deposition method for a transparent conductive film and the film-deposition apparatus of the present invention exhibit excellent effect in depositing a transparent conductive film without stopping film-deposition steps, which reduce productivity, and to suppress occurrence of nodules of sub oxide on the target surface which causes reduction in sputtering rate. Further, it provides excellent effect to suppress arcing which causes defects in the transparent conductive film. Since arcing can be suppressed, a large
10 electric power can be used and a high film-deposition rate is obtainable in comparison with the conventional DC sputtering method.

Further, use of the power processing portion of the present invention suppresses arcing without adding an arcing preventing circuit which is used for a conventional DC sputtering power source. Further, by controlling the effective value of intermittently supplied power, conditions for film-deposition can be
15 controlled in the same manner as the conventional DC sputtering method, and a transparent conductive film having the same property as the conventional film can be obtained.

In accordance with the present invention, since a potential difference on the target surface is eliminated and occurrence of arcing is prevented, a stable discharge can be maintained in comparison with a conventional DC sputtering.

20 The frequency of occurrence and the scale of initial arcing can be small, a stable sputtering can be continued for a long period of time even when a large power is used. Further, excellent efficiency of electric power is obtainable.

The sputtering apparatus of the present invention can reduce the frequency of occurrence of arcing even in a case of reactive sputtering, and a large electric power can be supplied stably to the cathode.
25 Accordingly, it has high film-deposition ability.

The power processing portion of the present invention is of a simple structure and is applicable to a conventional sputtering apparatus so that sputtering by a pulse-like intermittent DC power can be realized.

By using the power processing portion of the present invention, an intermittent voltage waveform can be easily optimized depending on the size of apparatus, material, electric power used and the scale of initial
30 arcing.

In the film-deposition method of a thin film composed mainly of silicon oxide according to the present invention, since arcing is not generated during film-deposition, a film having high quality and little attachment of particles can be obtained.

35 Further, in the film-deposition method of a thin film composed mainly of silicon nitride according to the present invention, since arcing is not generated during film-deposition, a thin film of high quality and little attachment of particles can be obtained.

The film-deposition method for an ITO film of the present invention can provide stable operations for a long period of time because arcing can be prevented and occurrence of nodules of sub oxide formed on the target surface can be suppressed while the quality of a film and the film-deposition rate are the same as
40 those obtained by the conventional DC sputtering method.

Claims

1. A sputtering method which comprises applying a negative voltage intermittently in a constant periodic
45 cycle to a cathode disposed in a vacuum chamber, wherein the negative voltage is intermittently applied so that a time during which the negative voltage is not applied includes a time during which the voltage is controlled to be zero volt in a range of from $10 \mu\text{s}$ to 10ms , and the zero voltage time is equal to or longer than the time required by one arcing from its generation to extinction.
- 50 2. The sputtering method according to Claim 1, wherein the time during which the negative voltage is applied is within a range of from $10 \mu\text{s}$ to 10ms and is equal to or shorter than the period of time from the application of the negative voltage to the generation of arcing.
- 55 3. The sputtering method according to Claim 1, wherein the time during which the voltage is controlled to be zero voltage includes a period of time during which a positive voltage is applied within a range of from $1 \mu\text{s}$ to $20 \mu\text{s}$.

4. The sputtering method according to any one of Claims 1 to 3, wherein the time during which the voltage is controlled to be zero volt is immediately after arcing.
5. A sputtering apparatus comprising a cathode disposed in a vacuum chamber, a sputtering power generating portion and a power processing portion, the cathode being applied with an intermittent negative voltage, wherein the wherein the negative voltage is intermittently applied so that a time during which the negative voltage is not applied includes a time during which the voltage is controlled to be zero volt in a range of from 10 μ s to 10 ms, and the zero voltage time is equal to or longer than the time required by one arcing from its generation to extinction.
6. The sputtering apparatus according to Claim 5, wherein the power processing portion is disposed closer to the cathode than the sputtering power generating portion.
7. The sputtering apparatus according to Claim 5, wherein a plurality of cathodes, sputtering power generating portions and power processing portions are provided, and the plurality of power processing portions are synchronously operated to produce waveforms having a different phase.
8. A power processing portion for a sputtering apparatus having a cathode to which a negative voltage is intermittently applied, wherein:
- the power processing portion comprises a first switching circuit, a second switching circuits, a control circuit for a switching element and a circuit for measuring current, voltage or power for sputtering
 - the first and the second switching circuits are respectively formed of a semiconductor switching device and a protection circuit for protecting the device;
 - the first switching circuit is connected in series between the negative pole of the sputtering power generating portion and the cathode electrode;
 - the second switching circuit is connected in series between the cathode electrode and a DC power source, other than the sputtering power generating portion, for supplying a positive potential to the cathode electrode.
 - the control circuit for the semiconductor switching device is capable of controlling a turning-on time of 5 μ s or more for the first switching circuit and a turning-off time of 5 μ s or more for the same, and capable of turning-on the second switching circuit for less than the time of turning-off the first switching circuit and within a range of from 1 μ s to 20 μ s when the first switching circuit is turned off; and
 - the circuit for measuring current, voltage or power for sputtering has a function to measure a current value, a voltage value or a power value effective to sputtering and a function to compare the measured values with predetermined reference values to detect arcing.
9. The power processing portion according to claim 8, which further comprises a smoothing circuit to change the waveform of voltage at an output terminal of the sputtering power generating portion to be a DC voltage waveform.
10. A film-deposition method by sputtering a thin film composed mainly of silicon oxide by applying a negative voltage intermittently in a constant periodic cycle to a cathode composed mainly of silicon in a vacuum chamber and using oxygen and/or inert gas as sputtering gas, wherein the negative voltage is intermittently applied so that a time during which the negative voltage is not applied includes a time during which the voltage is controlled to be zero volt in a range of from 10 μ s to 10 ms, and the zero voltage time is equal to or longer than the time required by one arcing from its generation to extinction.
11. A film-deposition method by sputtering a thin film composed mainly of silicon nitride by applying a negative voltage intermittently in a constant periodic cycle to a cathode composed mainly of silicon in a vacuum chamber and using nitrogen and/or inert gas as sputtering gas, wherein the negative voltage is intermittently applied so that a time during which the negative voltage is not applied includes a time during which the voltage is controlled to be zero volt in a range of from 10 μ s to 10 ms, and the zero voltage time is equal to or longer than the time required by one arcing from its generation to extinction.
12. The film-deposition method according to Claim 11, wherein the composition ratio of the silicon nitride (atomic molar ratio of N/Si) is 1.25 to 1.36.

- 5 13. The film-deposition method by sputtering a transparent conductive thin film composed mainly of oxide by using a sputtering target capable of forming a transparent conductive film, disposed in a vacuum chamber, applying a negative voltage intermittently and using oxygen and/or inert gas as sputtering gas, wherein the negative voltage is intermittently applied so that a time during which the negative voltage is not applied includes a time during which the voltage is controlled to be zero volt in a range of from 10 μ s to 10 ms, and the zero voltage time is equal to or longer than the time required by one arcing from its generation to extinction.
- 10 14. The film-deposition method according to Claim 13, wherein the sputtering target is composed mainly of tin or tin oxide.
15. The film-deposition method according to Claim 14, wherein the sputtering target contains metal antimony or an antimony compound.
- 15 16. The film-deposition method according to Claim 13, wherein the sputtering target is composed mainly of indium or indium oxide.
17. The film-deposition method according to Claim 16, wherein the sputtering target contains tin.
- 20 18. The film-deposition method according to Claim 13, wherein the sputtering target is composed mainly of zinc or zinc oxide.
- 25 19. The film-deposition method according to Claim 18, wherein the sputtering target contains a simple substance or a compound of at least one metal selected from the group consisting of aluminum, gallium, indium, boron and silicon.
- 30
- 35
- 40
- 45
- 50
- 55

FIGURE 1

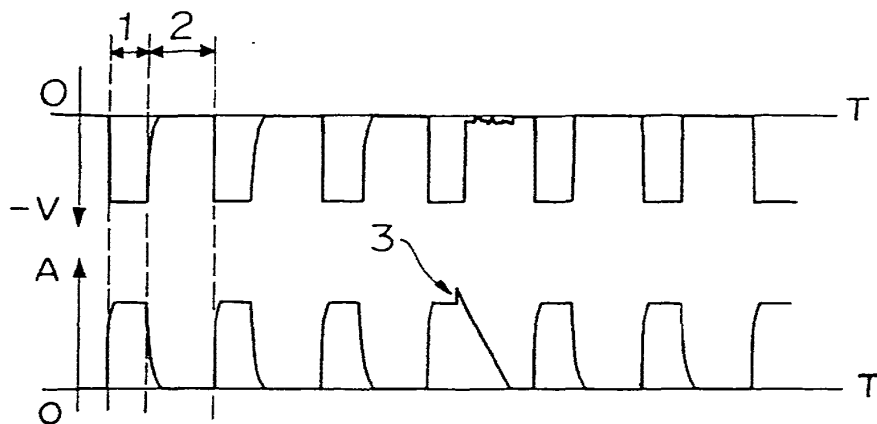

FIGURE 2

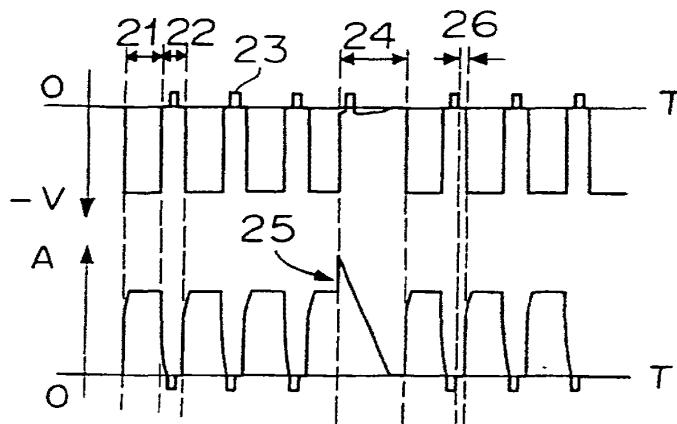

FIGURE 3

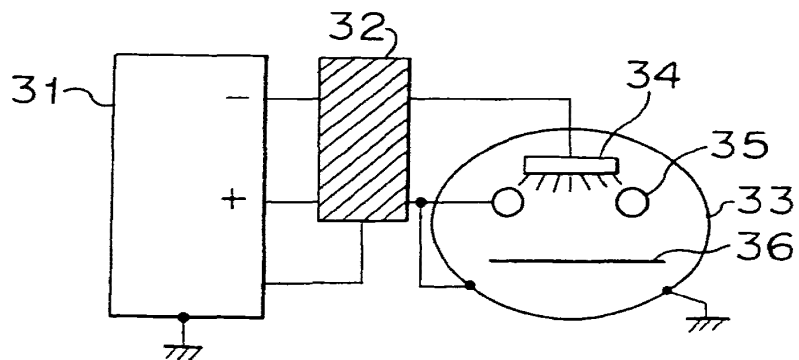

FIGURE 4

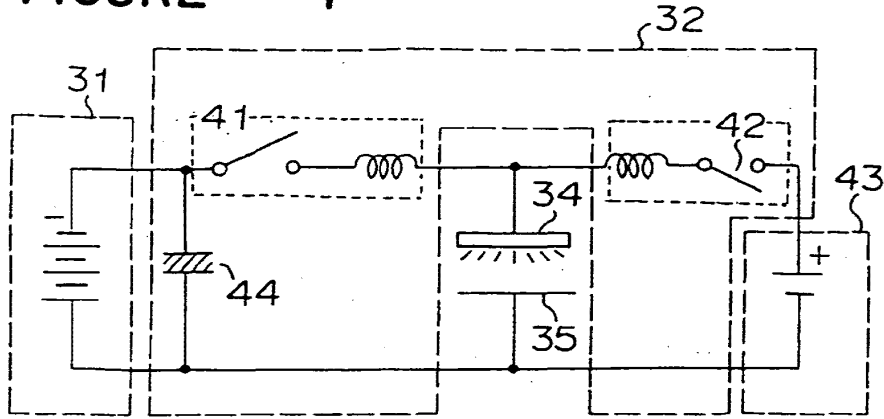

FIGURE 5

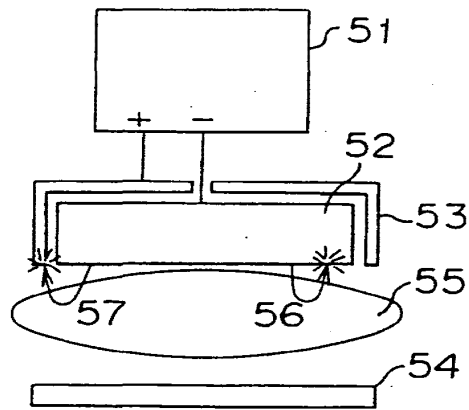

FIGURE 6

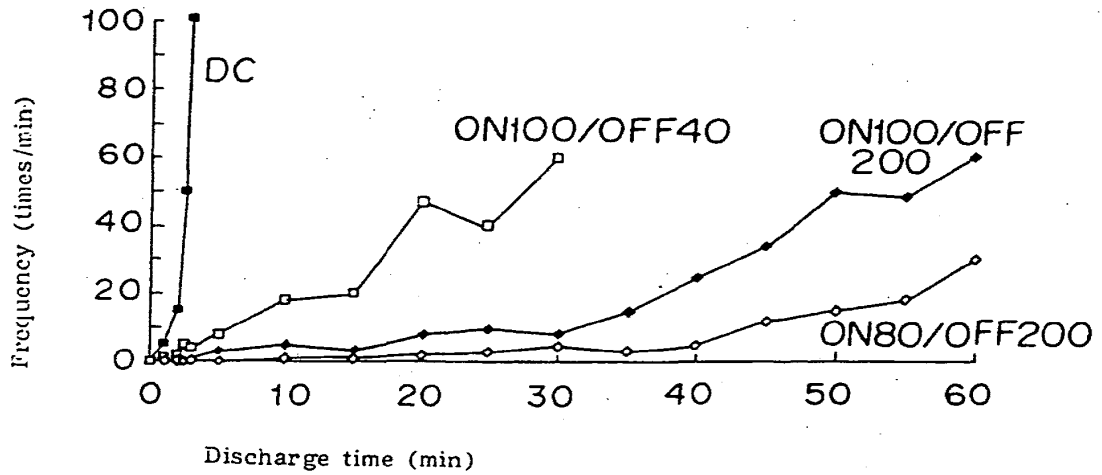

FIGURE 7

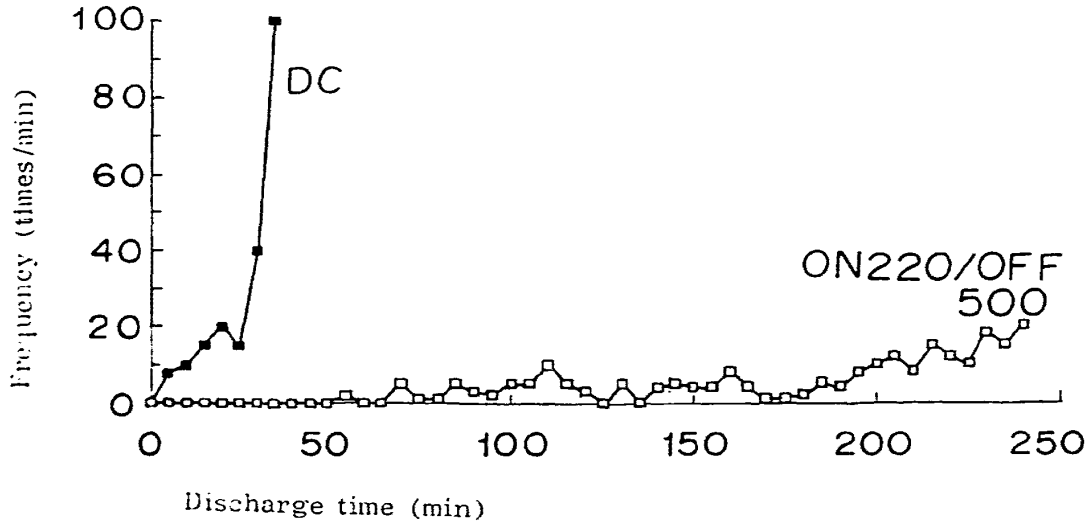

FIGURE 8

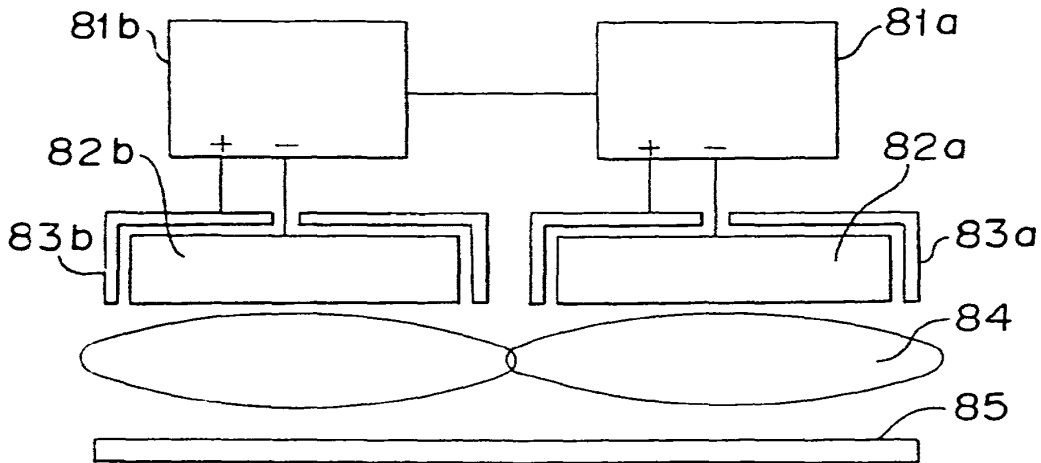

FIGURE 9

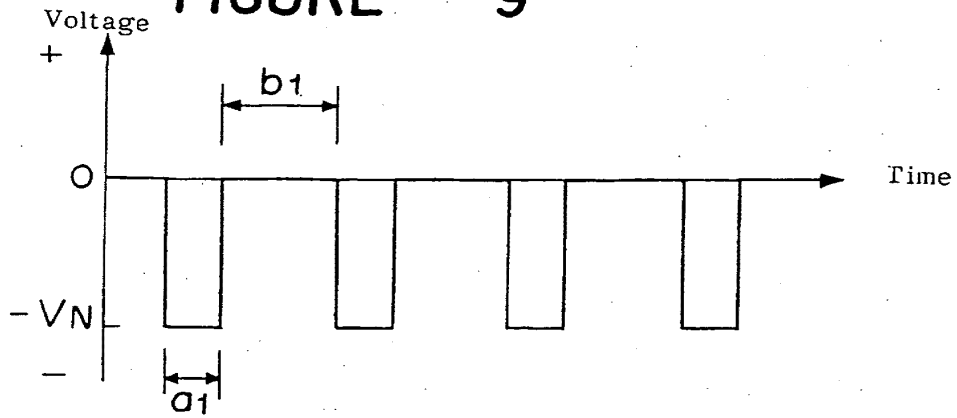

FIGURE 10

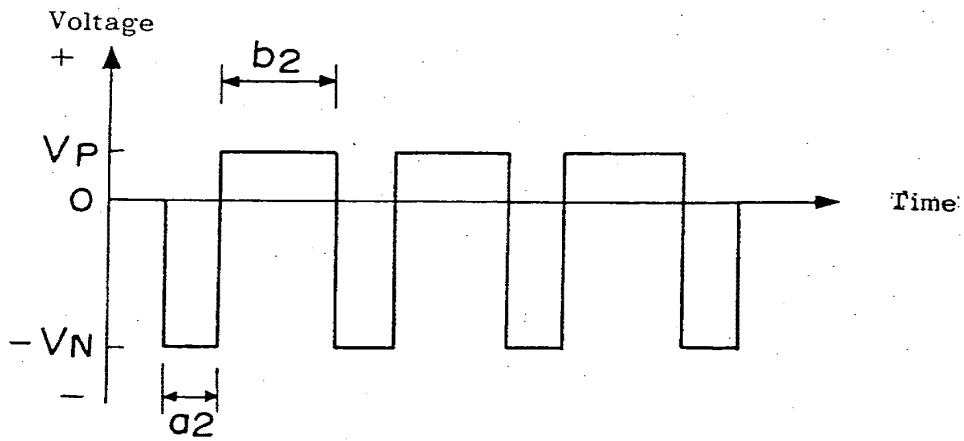
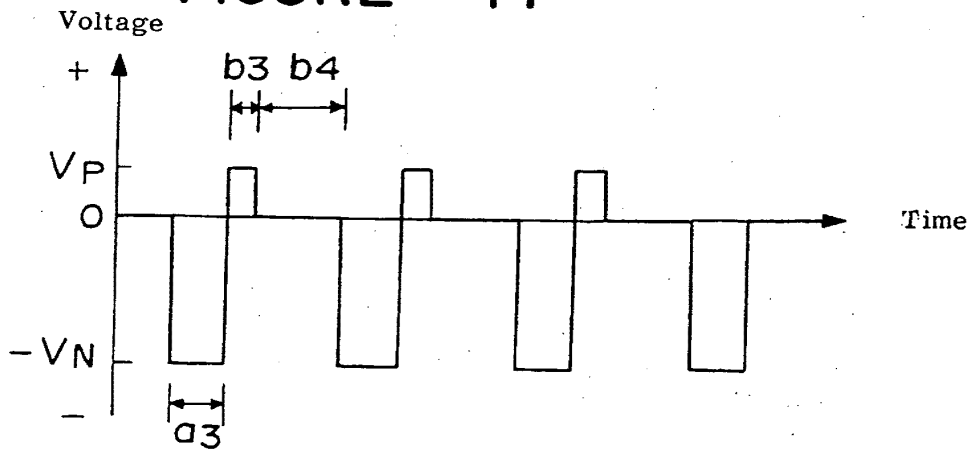

FIGURE 11





European Patent
Office

EUROPEAN SEARCH REPORT

Application Number
EP 94 11 1669

DOCUMENTS CONSIDERED TO BE RELEVANT			
Category	Citation of document with indication, where appropriate, of relevant passages	Relevant to claim	CLASSIFICATION OF THE APPLICATION (Int.Cl.6)
A	THIRD INTERNATIONAL CONFERENCE ON PLASMA SURFACE ENGINEERING, GARMISCH-PARTENKIRCHEN, GERMANY, 26-29 OCT. 1992, ISSN 0257-8972, SURFACE AND COATINGS TECHNOLOGY, 1 OCT. 1993, SWITZERLAND, PAGE(S) 177 - 182 Frach P et al 'Aspects and results of long-term stable deposition of Al/sub 2/O/sub 3/ with high rate pulsed reactive magnetron sputtering' * page 180, left column, line 2 - right column, line 2 *	1-19	C23C14/00 C23C14/34 H01J37/32
X A	EP-A-0 275 018 (GRUN R) 20 July 1988 * column 4, line 40 - line 50; claims 1-4 *	5 1-4,6-19	
A	WO-A-87 05053 (QUAZI) * page 28, line 3 - line 12; claim 1 *	1-19	
A	PATENT ABSTRACTS OF JAPAN vol. 14, no. 90 (C-0691) 20 February 1990 & JP-A-01 301 856 (SHIMADSU CORP) 6 December 1989 * abstract *	1-19	TECHNICAL FIELDS SEARCHED (Int.Cl.6) C23C H01J H03J
A	CIP 93 PROCEEDINGS, 6 June 1993, FR pages 66 - 68, XP399216 B. STAUDER ET AL 'A METHOD FOR SUPPRESSING THE HYSTERESIS EFFECT IN REACTIVE SPUTTERING' * page 67, line 9 - line 21 *	1-19	
A	WO-A-91 02103 (THE BOC GROUP INC) * claims 1,2 *	10-19	
The present search report has been drawn up for all claims			
Place of search THE HAGUE		Date of completion of the search 18 November 1994	Examiner Ekhult, H
CATEGORY OF CITED DOCUMENTS X : particularly relevant if taken alone Y : particularly relevant if combined with another document of the same category A : technological background O : non-written disclosure P : intermediate document		T : theory or principle underlying the invention E : earlier patent document, but published on, or after the filing date D : document cited in the application L : document cited for other reasons ----- & : member of the same patent family, corresponding document	

EPO FORM 150 (04.8) (P04/C01)

**This Page is Inserted by IFW Indexing and Scanning
Operations and is not part of the Official Record**

BEST AVAILABLE IMAGES

Defective images within this document are accurate representations of the original documents submitted by the applicant.

Defects in the images include but are not limited to the items checked:

- BLACK BORDERS**
- IMAGE CUT OFF AT TOP, BOTTOM OR SIDES**
- FADED TEXT OR DRAWING**
- BLURRED OR ILLEGIBLE TEXT OR DRAWING**
- SKEWED/SLANTED IMAGES**
- COLOR OR BLACK AND WHITE PHOTOGRAPHS**
- GRAY SCALE DOCUMENTS**
- LINES OR MARKS ON ORIGINAL DOCUMENT**
- REFERENCE(S) OR EXHIBIT(S) SUBMITTED ARE POOR QUALITY**
- OTHER: _____**

IMAGES ARE BEST AVAILABLE COPY.

As rescanning these documents will not correct the image problems checked, please do not report these problems to the IFW Image Problem Mailbox.

THIS PAGE BLANK (USPTO)

Ref #	Hits	Search Query	DBs	Default Operator	Plurals	Time Stamp
L1	1652	band with reject with filter	US-PGPUB; USPAT	OR	OFF	2005/07/29 15:41
L2	52349	DC and RF	US-PGPUB; USPAT	OR	OFF	2005/07/29 15:31
L3	824596	@ad>"20020316" or @rlad>"20020316"	US-PGPUB; USPAT	OR	OFF	2005/07/29 15:18
L4	338	1 and 2	US-PGPUB; USPAT	OR	OFF	2005/07/29 15:18
L5	271	4 not 3	US-PGPUB; USPAT	OR	OFF	2005/07/29 15:20
L6	1694	204/192.12.ccls.	US-PGPUB; USPAT	OR	OFF	2005/07/29 15:21
L7	3	5 and 6	US-PGPUB; USPAT	OR	OFF	2005/07/29 15:21
L8	180836	"438"/\$.ccls or "257"/\$.ccls. or 29/25.01.ccls.	US-PGPUB; USPAT	OR	OFF	2005/07/29 15:23
L9	2	5 and 8	US-PGPUB; USPAT	OR	OFF	2005/07/29 15:23
L12	50121	"204"/\$.ccls.	US-PGPUB; USPAT	OR	OFF	2005/07/29 15:24
L13	5	5 and 12	US-PGPUB; USPAT	OR	OFF	2005/07/29 15:27
L14	1	("20040077161").PN.	US-PGPUB; USPAT	OR	OFF	2005/07/29 15:28
L15	976	(pulsed with DC) and RF	US-PGPUB; USPAT	OR	OFF	2005/07/29 15:32
L16	5	1 and 15	US-PGPUB; USPAT	OR	OFF	2005/07/29 15:32
L17	4	16 not 3	US-PGPUB; USPAT	OR	OFF	2005/07/29 15:36
L18	162768	notch	US-PGPUB; USPAT	OR	OFF	2005/07/29 15:37
L19	422	1 and 18	US-PGPUB; USPAT	OR	OFF	2005/07/29 15:37
L20	1	15 and 19	US-PGPUB; USPAT	OR	OFF	2005/07/29 15:37
L21	1937	band with rejection with filter	US-PGPUB; USPAT	OR	OFF	2005/07/29 15:38
L22	15	15 and 21	US-PGPUB; USPAT	OR	OFF	2005/07/29 15:38
L23	1	22 not 3	US-PGPUB; USPAT	OR	OFF	2005/07/29 15:38
L24	42828	band with pass with filter	US-PGPUB; USPAT	OR	OFF	2005/07/29 15:41

Search History 7/29/05 4:03:26 PM Page 1

C:\Documents and Settings\Mestrada\My Documents\EAST\Workspaces\10101863b.wsp

L25	31	15 and 24	US-PGPUB; USPAT	OR	OFF	2005/07/29 15:42
L26	13	25 not 3	US-PGPUB; USPAT	OR	OFF	2005/07/29 15:42



UNITED STATES PATENT AND TRADEMARK OFFICE

UNITED STATES DEPARTMENT OF COMMERCE
United States Patent and Trademark Office
Address: COMMISSIONER FOR PATENTS
P.O. Box 1450
Alexandria, Virginia 22313-1450
www.uspto.gov

APPLICATION NO.	FILING DATE	FIRST NAMED INVENTOR	ATTORNEY DOCKET NO.	CONFIRMATION NO.
10/101,863	03/16/2002	Hongmei Zhang	M-12245 US	6938

22852 7590 08/04/2005

FINNEGAN, HENDERSON, FARABOW, GARRETT & DUNNER
LLP
901 NEW YORK AVENUE, NW
WASHINGTON, DC 20001-4413

EXAMINER

ESTRADA, MICHELLE

ART UNIT PAPER NUMBER

2823

DATE MAILED: 08/04/2005

Please find below and/or attached an Office communication concerning this application or proceeding.

Office Action Summary	Application No. 10/101,863	Applicant(s) ZHANG ET AL. 
	Examiner Michelle Estrada	Art Unit 2823

-- The MAILING DATE of this communication appears on the cover sheet with the correspondence address --
Period for Reply

A SHORTENED STATUTORY PERIOD FOR REPLY IS SET TO EXPIRE 3 MONTH(S) FROM THE MAILING DATE OF THIS COMMUNICATION.

- Extensions of time may be available under the provisions of 37 CFR 1.136(a). In no event, however, may a reply be timely filed after SIX (6) MONTHS from the mailing date of this communication.
- If the period for reply specified above is less than thirty (30) days, a reply within the statutory minimum of thirty (30) days will be considered timely.
- If NO period for reply is specified above, the maximum statutory period will apply and will expire SIX (6) MONTHS from the mailing date of this communication.
- Failure to reply within the set or extended period for reply will, by statute, cause the application to become ABANDONED (35 U.S.C. § 133). Any reply received by the Office later than three months after the mailing date of this communication, even if timely filed, may reduce any earned patent term adjustment. See 37 CFR 1.704(b).

Status

- 1) Responsive to communication(s) filed on 13 July 2005.
- 2a) This action is FINAL. 2b) This action is non-final.
- 3) Since this application is in condition for allowance except for formal matters, prosecution as to the merits is closed in accordance with the practice under *Ex parte Quayle*, 1935 C.D. 11, 453 O.G. 213.

Disposition of Claims

- 4) Claim(s) 1-14 and 20-24 is/are pending in the application.
4a) Of the above claim(s) _____ is/are withdrawn from consideration.
- 5) Claim(s) _____ is/are allowed.
- 6) Claim(s) 1-13 and 20 is/are rejected.
- 7) Claim(s) 14 and 21-24 is/are objected to.
- 8) Claim(s) _____ are subject to restriction and/or election requirement.

Application Papers

- 9) The specification is objected to by the Examiner.
- 10) The drawing(s) filed on _____ is/are: a) accepted or b) objected to by the Examiner.
Applicant may not request that any objection to the drawing(s) be held in abeyance. See 37 CFR 1.85(a).
Replacement drawing sheet(s) including the correction is required if the drawing(s) is objected to. See 37 CFR 1.121(d).
- 11) The oath or declaration is objected to by the Examiner. Note the attached Office Action or form PTO-152.

Priority under 35 U.S.C. § 119

- 12) Acknowledgment is made of a claim for foreign priority under 35 U.S.C. § 119(a)-(d) or (f).
a) All b) Some * c) None of:
1. Certified copies of the priority documents have been received.
 2. Certified copies of the priority documents have been received in Application No. _____.
 3. Copies of the certified copies of the priority documents have been received in this National Stage application from the International Bureau (PCT Rule 17.2(a)).
- * See the attached detailed Office action for a list of the certified copies not received.

Attachment(s)

- | | |
|--|---|
| 1) <input type="checkbox"/> Notice of References Cited (PTO-892) | 4) <input type="checkbox"/> Interview Summary (PTO-413)
Paper No(s)/Mail Date. _____ |
| 2) <input type="checkbox"/> Notice of Draftsperson's Patent Drawing Review (PTO-948) | 5) <input type="checkbox"/> Notice of Informal Patent Application (PTO-152) |
| 3) <input checked="" type="checkbox"/> Information Disclosure Statement(s) (PTO-1449 or PTO/SB/08)
Paper No(s)/Mail Date <u>7/13/05</u> . | 6) <input type="checkbox"/> Other: _____ |

DETAILED ACTION

Continued Examination Under 37 CFR 1.114

A request for continued examination under 37 CFR 1.114, including the fee set forth in 37 CFR 1.17(e), was filed in this application after final rejection. Since this application is eligible for continued examination under 37 CFR 1.114, and the fee set forth in 37 CFR 1.17(e) has been timely paid, the finality of the previous Office action has been withdrawn pursuant to 37 CFR 1.114. Applicant's submission filed on 7/13/05 has been entered.

Applicant's arguments with respect to claims 1 and 20 have been considered but are moot in view of the new ground(s) of rejection.

Claim Rejections - 35 USC § 102

The following is a quotation of the appropriate paragraphs of 35 U.S.C. 102 that form the basis for the rejections under this section made in this Office action:

A person shall be entitled to a patent unless –

(b) the invention was patented or described in a printed publication in this or a foreign country or in public use or on sale in this country, more than one year prior to the date of application for patent in the United States.

Claims 1, 8, 10-13 and 20 are rejected under 35 U.S.C. 102(b) as being anticipated by Smolanoff et al. (6,117,279).

With respect to claim 1, Smolanoff et al. disclose providing pulsed DC power (21) through a filter (22) to a target (16) (Col. 5, lines 50-55); providing RF bias power to a

Art Unit: 2823

substrate (15) positioned opposite the target (Col. 5, lines 60-65); providing process gas between the target and the substrate (Col. 7, lines 25-28); wherein the filter protects a pulsed DC power supply (21) from the bias power, and wherein a plasma is created between the target and the substrate (Col. 6, lines 8-13).

With respect to claim 8, Smolanoff et al. disclose wherein the process gas includes a mixture of oxygen and argon (Col. 7, lines 21-27).

With respect to claim 10, Smolanoff et al. disclose wherein the process gas further includes nitrogen (Col. 7, lines 25-26).

With respect to claim 11, Smolanoff et al. disclose wherein providing pulsed DC power to a target includes providing pulsed DC power to a target which has an area larger than that of the substrate (See fig. 1).

With respect to claim 12, Smolanoff et al. disclose further including uniformly sweeping the target with a magnetic field (Col. 6, lines 1-7).

With respect to claim 13, Smolanoff et al. disclose wherein uniformly sweeping the target with a magnetic field includes sweeping a magnet in one direction across the target where the magnet extends beyond the target in the opposite direction (Col. 6, lines 1-6).

With respect to claim 20, Smolanoff et al. disclose conditioning a target; preparing the substrate; adjusting the bias power to the substrate; setting the process gas flow; and applying pulsed DC power to the target to deposit the film (Col. 5, line 55-Col. 7, line 50).

Claim Rejections - 35 USC § 103

The following is a quotation of 35 U.S.C. 103(a) which forms the basis for all obviousness rejections set forth in this Office action:

(a) A patent may not be obtained though the invention is not identically disclosed or described as set forth in section 102 of this title, if the differences between the subject matter sought to be patented and the prior art are such that the subject matter as a whole would have been obvious at the time the invention was made to a person having ordinary skill in the art to which said subject matter pertains. Patentability shall not be negated by the manner in which the invention was made.

Claims 2-6 are rejected under 35 U.S.C. 103(a) as being unpatentable over Smolanoff et al. as applied to claims 1, 8, 10-13 and 20 above, and further in view of Fukui et al. (5,755,938).

With respect to claims 2-4 and 6, One of ordinary skill in the art would have been led to the recited temperature, DC power, time pulse and bias power to routine experimentation to achieve a desire layer thickness, device dimension, device associated characteristics and device density on the finished wafer in view of the range of values disclosed.

In addition, the selection of temperature, DC power, time pulse and bias power, its obvious because it is a matter of determining optimum process conditions by routine experimentation with a limited number of species of result effective variables. These claims are prima facie obvious without showing that the claimed ranges achieve unexpected results relative to the prior art range. In re Woodruff, 16 USPQ2d 1935, 1937 (Fed. Cir. 1990). See also In re Huang, 40 USPQ2d 1685, 1688 (Fed. Cir. 1996)(claimed ranges or a result effective variable, which do not overlap the prior art ranges, are unpatentable unless they produce a new and unexpected result which is different in kind and not merely in degree from the results of the prior art). See also In

re Boesch, 205 USPQ 215 (CCPA) (discovery of optimum value of result effective variable in known process is ordinarily within skill or art) and In re Aller, 105 USPQ 233 (CCPA 1995) (selection of optimum ranges within prior art general conditions is obvious).

Note that the specification contains no disclosure of either the critical nature of the claimed temperature, DC power, time pulse and bias power or any unexpected results arising therefrom. Where patentability is said to be based upon particular chosen temperature, DC power, time pulse and bias power or upon another variable recited in a claim, the Applicant must show that the chosen temperature, DC power, time pulse and bias power are critical. In re Woodruf, 919 F.2d 1575, 1578, 16 USPQ2d 1934, 1936 (Fed. Cir. 1990).

With respect to claim 5, Smolanoff et al. do not specifically disclose wherein the filter is a band reject filter at the frequency of the bias power.

Fukui et al. disclose a sputtering process wherein the DC power supply (28) is connected through a band-pass filter (27) at the frequency of the bias power.

It would have been within the scope of one of ordinary skill in the art to combine the teachings of Smolanoff et al. and Fukui et al. to enable the filter type of Smolanoff et al. to be the same according to the teachings of Fukui et al. because one of ordinary skill in the art would have been motivated to look to alternative suitable types of filters for the disclosed filter step of Smolanoff et al. and art recognized suitability for an

intended purpose has been recognized to be motivation to combine. See MPEP 2144.07.

Claims 7 and 9 are rejected under 35 U.S.C. 103(a) as being unpatentable over Smolanoff et al. as applied to claims 1, 8, 10-13 and 20 above, and further in view of Le et al. (2003/0077914).

Smolanoff et al. do not disclose wherein the film is an upper cladding layer of a waveguide structure and the bias power is optimized to provide planarization.

With respect to claim 7, Le et al. disclose wherein the film is an upper cladding layer of a waveguide structure and the bias power is optimized to provide planarization Page 5, Paragraph [0075].

It would have been within the scope of one of ordinary skill in the art to combine the teachings of Smolanoff et al. and Le et al. to enable the film material of Smolanoff et al. to be the same according to the teachings of Le et al. because one of ordinary skill in the art would have been motivated to look to alternative suitable film materials for the disclosed film formation step of Smolanoff et al. and art recognized suitability for an intended purpose has been recognized to be motivation to combine. See MPEP 2144.07.

With respect to claim 9, Le et al. disclose wherein the oxygen flow is adjusted to adjust the index of refraction of the film (Page 5, Paragraph [0076]).

Allowable Subject Matter

Claims 14 and 21-24 are objected to as being dependent upon a rejected base claim, but would be allowable if rewritten in independent form including all of the limitations of the base claim and any intervening claims.

Conclusion

Any inquiry concerning this communication or earlier communications from the examiner should be directed to Michelle Estrada whose telephone number is 571-272-1858. The examiner can normally be reached on Monday through Friday.

If attempts to reach the examiner by telephone are unsuccessful, the examiner's supervisor, Matthew Smith can be reached on 571-272-1907. The fax phone number for the organization where this application or proceeding is assigned is 571-273-8300.

Any inquiry of a general nature or relating to the status of this application or proceeding should be directed to the receptionist whose telephone number is 571-272-2800.

Information regarding the status of an application may be obtained from the Patent Application Information Retrieval (PAIR) system. Status information for published applications may be obtained from either Private PAIR or Public PAIR. Status information for unpublished applications is available through Private PAIR only. For more information about the PAIR system, see <http://pair-direct.uspto.gov>. Should

Application/Control Number: 10/101,863
Art Unit: 2823

Page 8

you have questions on access to the Private PAIR system, contact the Electronic Business Center (EBC) at 866-217-9197 (toll-free).



Michelle Estrada
Patent Examiner
Art Unit 2823

ME
July 29, 2005

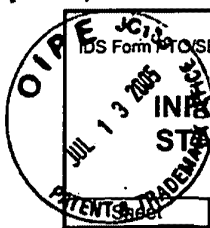

US Form PTO/SB/08: Substitute for form 1449A/PTO

INFORMATION DISCLOSURE STATEMENT BY APPLICANT

(Use as many sheets as necessary)

1 of 1

Complete if Known	
Application Number	10/101,863
Filing Date	March 16, 2002
First Named Inventor	ZHANG, Hongmei
Art Unit	2823
Examiner Name	ESTRADA, Michelle
Attorney Docket Number	9140.0016-00

U.S. PATENTS AND PUBLISHED U.S. PATENT APPLICATIONS					
Examiner Initials ¹	Cite No. ¹	Document Number	Issue or Publication Date MM-DD-YYYY	Name of Patentee or Applicant of Cited Document	Pages, Columns, Lines, Where Relevant Passages or Relevant Figures Appear
		Number-Kind Code ² (if known)			
<i>ME</i>		US-2004/0077161	04-22-2004	Chen et al.	
<i>ME</i>		US-2003/0175142	09-18-2003	Milonopoulou et al.	
<i>ME</i>		US-2003/0077914	04-24-2003	Le et al.	
<i>ME</i>		US-6,361,662	03-26-2002	Chiba et al.	
<i>ME</i>		US-6,281,142	08-28-2001	Basceri et al.	
<i>ME</i>		US-6,117,279	09-12-2000	Smolanoff et al.	

already cited in PTO-892 filed 2/24/04 ME

Note: Submission of copies of U.S. Patents and published U.S. Patent Applications is not required.

FOREIGN PATENT DOCUMENTS						
Examiner Initials ¹	Cite No. ¹	Foreign Patent Document	Publication Date MM-DD-YYYY	Name of Patentee or Applicant of Cited Document	Pages, Columns, Lines, Where Relevant Passages or Relevant Figures Appear	Translation ⁶
		Country Code ³ Number ⁴ Kind Code ⁵ (if known)				

NON PATENT LITERATURE DOCUMENTS			
Examiner Initials ¹	Cite No. ¹	Include name of the author (in CAPITAL LETTERS), title of the article (when appropriate), title of the item (book, magazine, journal, serial, symposium, catalog, etc.), date, page(s), volume-issue number(s), publisher, city and/or country where published.	Translation ⁶
<i>ME</i>		Office Action dated March 25, 2005, received in Application No. 10/954,182 (Attorney Docket No. 09140.0016-01000).	

Examiner Signature: <i>Michelle Estrada</i>	Date Considered:	7/29/05
---	------------------	---------

EXAMINER: Initial if reference considered, whether or not citation is in conformance with MPEP 609. Draw line through citation if not in conformance and not considered. Include copy of this form with next communication to applicant.

EXPRESS MAIL LABEL NO.
EV 727732935 US



UNITED STATES PATENT AND TRADEMARK OFFICE

UNITED STATES DEPARTMENT OF COMMERCE
 United States Patent and Trademark Office
 Address: COMMISSIONER FOR PATENTS
 P.O. Box 1450
 Alexandria, Virginia 22313-1450
 www.uspto.gov



Bib Data Sheet

CONFIRMATION NO. 6938

SERIAL NUMBER 10/101,863	FILING DATE 03/16/2002 RULE	CLASS 438	GROUP ART UNIT 2823	ATTORNEY DOCKET NO. M-12245 US
-----------------------------	---------------------------------------	--------------	------------------------	-----------------------------------

APPLICANTS

Hongmei Zhang, San Jose, CA;
 Mukundan Narasimhan, San Jose, CA;
 Ravi B. Mullapudi, San Jose, CA; Richard E. Demaray, Portola Valley, CA;

** CONTINUING DATA *****
none

** FOREIGN APPLICATIONS *****
none

IF REQUIRED, FOREIGN FILING LICENSE GRANTED ** SMALL ENTITY **
 ** 05/17/2002

Foreign Priority claimed <input type="checkbox"/> yes <input checked="" type="checkbox"/> no	STATE OR COUNTRY CA	SHEETS DRAWING 27	TOTAL CLAIMS 39	INDEPENDENT CLAIMS 32
35 USC 119 (a-d) conditions met <input type="checkbox"/> yes <input type="checkbox"/> no <input checked="" type="checkbox"/> Met after interview	EXAMINER'S SIGNATURE <i>[Signature]</i>	INITIALS <i>[Initials]</i>		
Verified and Acknowledged				

ADDRESS
 22852
 FINNEGAN, HENDERSON, FARABOW, GARRETT & DUNNER
 LLP
 901 NEW YORK AVENUE, NW
 WASHINGTON, DC
 20001-4413

TITLE
 Biased pulse DC reactive sputtering of oxide films

FILING FEE RECEIVED	FEES: Authority has been given in Paper No. _____ to charge/credit DEPOSIT ACCOUNT No. _____ for following:	<input type="checkbox"/> All Fees <input type="checkbox"/> 1.16 Fees (Filing) <input type="checkbox"/> 1.17 Fees (Processing Ext. of time)
---------------------	---	--

690		<input type="checkbox"/> 1.18 Fees (Issue) <input type="checkbox"/> Other _____ <input type="checkbox"/> Credit
-----	--	---

ISSUE SLIP STAPLE AREA (for additional cross-references)

ORIGINAL		ISSUING CLASSIFICATION	
CLASS	SUBCLASS	CLASS	SUBCLASS (ONE SUBCLASS PER BLOCK)

Continued on Issue Slip Inside File Jacket

INDEX OF CLAIMS

Rejected (Through numeral) Canceled N Non-elected A Appeal
Advanced I Prioritized Interference O Objected

Claim	Date	Claim	Date	Claim	Date
1		51		101	
2		52		102	
3		53		103	
4		54		104	
5		55		105	
6		56		106	
7		57		107	
8		58		108	
9		59		109	
10		60		110	
11		61		111	
12		62		112	
13		63		113	
14		64		114	
15		65		115	
16		66		116	
17		67		117	
18		68		118	
19		69		119	
20		70		120	
21		71		121	
22		72		122	
23		73		123	
24		74		124	
25		75		125	
26		76		126	
27		77		127	
28		78		128	
29		79		129	
30		80		130	
31		81		131	
32		82		132	
33		83		133	
34		84		134	
35		85		135	
36		86		136	
37		87		137	
38		88		138	
39		89		139	
40		90		140	
41		91		141	
42		92		142	
43		93		143	
44		94		144	
45		95		145	
46		96		146	
47		97		147	
48		98		148	
49		99		149	
50		100		150	

If more than 150 claims or 9 actions staple additional sheet here

BEST AVAILABLE COPY

Search Notes



Application No.

10/101,863

Examiner

Michelle Estrada

Applicant(s)

ZHANG ET AL.

Art Unit

2823

SEARCHED			
Class	Subclass	Date	Examiner
438	769	2/12/04	<i>aje</i>
438	770		
438	771		
438	787		
438	788		
427	533		
204	192.12		
204	192.15	2/12/2004	<i>aje</i>

INTERFERENCE SEARCHED			
Class	Subclass	Date	Examiner

SEARCH NOTES (INCLUDING SEARCH STRATEGY)		
	DATE	EXMR
See East search attached	2/12/2004	<i>aje</i>
See last search attached	7/29/05	<i>aje</i>

12-07-05

2823
IFW
\$

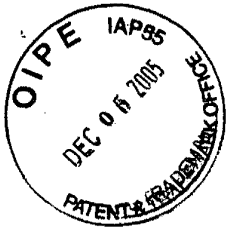

PATENT
Customer No. 22,852
Attorney Docket No. 9140.0016-00

IN THE UNITED STATES PATENT AND TRADEMARK OFFICE

In re Application of:)	
)	
ZHANG, Hongmei et al.)	Group Art Unit: 2823
)	
Application No.: 10/101,863)	Examiner: ESTRADA, Michelle
)	
Filed: March 16, 2002)	
)	
For: BIASED PULSE DC REACTIVE)	Confirmation No.: 6938
SPUTTERING OF OXIDE FILMS)	

MAIL STOP AMENDMENT

Commissioner for Patents
P.O. Box 1450
Alexandria, VA 22313-1450

Sir:

AMENDMENT AND RESPONSE TO OFFICE ACTION

In reply to the Office Action mailed August 4, 2005, the period for response having been extended to December 4, 2005 (a Sunday) by a request for extension of one month with authorization for the Commissioner to charge the fee of \$120.00 to Deposit Account No. 06-0916, please amend the above-identified application as follows:

Amendments to the Claims are reflected in the listing of claims in this paper beginning on page 2.

Remarks/Arguments follow the amendment sections of this paper beginning on page 5.

AMENDMENTS TO THE CLAIMS:

This listing of claims will replace all prior versions and listings of claims in the application:

1. (Currently amended) A method of depositing a film on a substrate, comprising:
providing pulsed DC power through a filter to a target;
providing RF bias power to a substrate positioned opposite the target; and
providing process gas between the target and the substrate,
wherein the filter protects a pulsed DC power supply from the bias power, ~~and~~
wherein a plasma is created ~~between the target and the substrate~~ by application of the
pulsed DC power to the target; and
wherein the film is deposited by exposure of the substrate to the plasma.
2. (Previously Presented): The method of Claim 1, further including holding the temperature of the substrate substantially constant.
3. (Previously Presented): The method of Claim 1, wherein providing pulsed DC power through the filter includes supplying up to about 10 kW of power at a frequency of between about 40 kHz and about 350 kHz and a reverse time pulse between about 1.3 and 5 μ s.
4. (Previously Presented): The method of Claim 1, wherein providing bias power to the substrate includes supplying up to 1000 W of RF power to the substrate.
5. (Previously Presented): The method of Claim 4, wherein the filter is a band reject filter at the frequency of the bias power.
6. (Previously Presented): The method of claim 4, wherein the bias power is zero.
7. (Previously Presented): The method of Claim 1, wherein the film is an upper cladding layer of a waveguide structure and the bias power is optimized to provide planarization.
8. (Previously Presented): The method of Claim 1, wherein the process gas includes a mixture of Oxygen and Argon.

9. (Previously Presented): The method of Claim 9, wherein the Oxygen flow is adjusted to adjust the index of refraction of the film.
10. (Previously Presented): The method of Claim 8, wherein the process gas further includes nitrogen.
11. (Previously Presented): The method of Claim 1, wherein providing pulsed DC power to a target includes providing pulsed DC power to a target which has an area larger than that of the substrate.
12. (Previously Presented): The method of Claim 1, further including uniformly sweeping the target with a magnetic field.
13. (Previously Presented): The method of Claim 12, wherein uniformly sweeping the target with a magnetic field includes sweeping a magnet in one direction across the target where the magnet extends beyond the target in the opposite direction.
14. (Currently amended): ~~The method of Claim 1, further including~~ A method of depositing a film on a substrate, comprising:
providing pulsed DC power through a filter to a target;
providing RF bias power to a substrate positioned opposite the target; and
providing process gas between the target and the substrate, and
depositing a film on the backside of the target-12,
wherein the filter protects a pulsed DC power supply from the bias power, and
wherein a plasma is created between the target and the substrate.
- 15.-19. (Canceled).
20. (Currently amended): A method of depositing a film on a substrate, comprising:
conditioning a target;
preparing the substrate;
adjusting a RF bias power to the substrate;
setting a process gas flow; and
applying pulsed DC power to the target through a filter to create a plasma ~~and deposit the~~

film,

wherein the substrate is exposed to the plasma to deposit the film.

21. (Currently amended): ~~The method of Claim 20,~~ A method of depositing a film on a substrate, comprising:

conditioning a target;

preparing the substrate;

adjusting a RF bias power to the substrate;

setting a process gas flow; and

applying pulsed DC power to the target through a filter to create a plasma and deposit the film,

wherein conditioning the target includes sputtering with the target in a metallic mode to remove the surface of the target and sputtering with the target in poisonous mode to prepare the surface.

22. (Previously Presented): The method of Claim 21, wherein setting the process gas flow includes adjusting constituents in order to adjust the index of refraction of the film.

23. (Previously Presented): The method of Claim 21, wherein applying pulsed DC power includes setting the frequency in order to adjust the index of refraction of the film.

24. (Previously Presented): The method of Claim 21, further including adjusting a temperature of the substrate in order to adjust the index of refraction of the film.

25.-39. (Canceled).

REMARKS

Claims 1-14 and 20-24 are pending in the above identified application. The Examiner has rejected claims 1-13 and 20, and objected to claims 14 and 21-24. With this paper, Applicants have amended claims 1, 14, 20, and 21. Applicants herein traverse the Examiner's rejections.¹

Claim Rejections Under 35 U.S.C. § 102

The Examiner rejected claims 1, 8, 10-13 and 20 under 35 U.S.C. § 102(b) as being anticipated by U.S. Patent No. 6,117,279 ("Smolanoff"). However, Smolanoff does not recite that "a plasma is created by application of the pulsed DC power to the target; and wherein the film is deposited by exposure of the substrate to the plasma," as is recited in claim 1, or "applying pulsed DC power to the target through a filter to create a plasma wherein the substrate is exposed to the plasma to deposit the film," as is recited in claim 20.

As is taught in Smolanoff,

A further objective of the present invention is to provide a method and apparatus for ionized physical vapor deposition that utilizes a magnetron magnetic field source to provide a main plasma for sputtering coating material efficiently from a sputtering target and that employs a secondary plasma by which is produced a high ionization fraction of the material sputtered from the target. A more particular objective of the present invention is to provide such a method and apparatus in which the loss of charged particles from the secondary plasma is minimized or reduced.

(Smolanoff, col. 3, lines 1-10). Further, Smolanoff teaches that:

According to certain principles of the present invention, an ionized physical vapor deposition (IPVD) method and apparatus are provided utilizing a target energized with a DC or pulsed DC source to energize a main plasma adjacent to a sputtering target and an RF reactively coupled source to energize a secondary

¹ The Examiner has made a number of statements that characterize the prior art or characterize the claims. Applicants do not necessarily agree or acquiesce in any of these characterizations, even if those characterizations are not specifically addressed in this paper.

plasma in the space between the target and a substrate oriented preferably parallel to the target at the opposite end of a sputtering chamber. The space in which the secondary plasma is generated is bounded by electrically conductive structure that is electrically floating and presents a high impedance to the RF source. This structure is further connected through a low pass filter which provides a low impedance DC path to ground or to some other potential.

(Smolanoff, col. 3, lines 51-64). Therefore, Smolanoff teaches that a secondary plasma created by RF coils is created between the target and the substrate, in addition to the plasma created at the target. Deposition is performed by exposing the substrate to the secondary plasma, not the main plasma adjacent to the sputtering target. Therefore, Smolanoff fails to teach that “a plasma is created by application of the pulsed DC power to the target; and wherein the film is deposited by exposure of the substrate to the plasma,” as is recited in claim 1, or “applying pulsed DC power to the target through a filter to create a plasma wherein the substrate is exposed to the plasma to deposit the film,” as is recited in claim 20.

Furthermore, although Smolanoff states that the target “can be energized with a DC or pulsed DC source to energize a main plasma,” (Smolanoff, col. 3, lines 53-45), Applicants contend that Smolanoff has not enabled utilization of a pulsed DC power source in an environment with RF energy. Smolanoff’s may teach an RF filter between the DC source and the target, but provides no description of that filter. It is Applicants’ experience that the exposure of a pulsed DC power supply to an RF environment often leads to destruction of the pulsed DC power supply. Smolanoff has enabled utilization of a DC power supply, but not a pulsed DC power supply.

As discussed above, claims 1 and 20 are allowable over Smolanoff. Claims 8 and 10-13, which depend from claim 1, are therefore allowable over Smolanoff for at least the same reasons as is claim 1.

Claim Rejections under 35 U.S.C. § 103

Claims 2-6

The Examiner has rejected claims 2-6 under 35 U.S.C. § 103(a) as being unpatentable over Smolanoff in view of U.S. Patent No. 5,755,938 (“Fukui”). As discussed above, claim 1 is allowable over Smolanoff. Fukui does not cure the defects in the teachings of Smolanoff. Therefore, claims 2-6, which depend from claim 1, are allowable for at least the same reasons as is claim 1.

Claims 7 and 9

The Examiner has further rejected claims 7 and 9 under 35 U.S.C. § 103(a) as being unpatentable over Smolanoff in view of Le et al. (2003/0077914) (“Le”). As discussed above, claim 1 is allowable over Smolanoff. Le does not cure the defects in the teachings of Smolanoff. Therefore, claims 7 and 9, which depend from claim 1, are allowable for at least the same reasons as is claim 1.

Allowable Subject Matter

The Examiner has indicated that claims 14 and 21-24 would be allowable if rewritten in independent form including all of the limitations of the base claim and any intervening claims. Claims 14 and 21, from which claims 22-24 depend, have been rewritten as suggested by the Examiner.

Conclusion

In view of the foregoing amendments and remarks, Applicants respectfully request reconsideration and reexamination of this application and the timely allowance of the pending claims.

Please grant any extensions of time required to enter this response and charge any additional required fees to Deposit Account No. 06-0916.

Respectfully submitted,

FINNEGAN, HENDERSON, FARABOW,
GARRETT & DUNNER, L.L.P.

Dated: December 5, 2005

By: *Gary J. Edwards for 45,681*
Gary J. Edwards
Reg. No. 41,008

**EXPRESS MAIL LABEL NO.
EV 758329165 US**

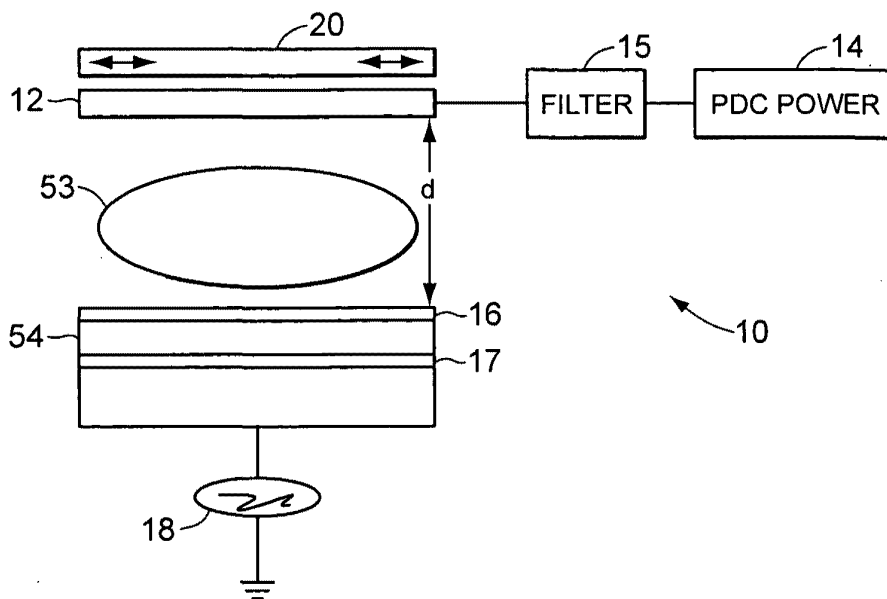

FIG. 1A

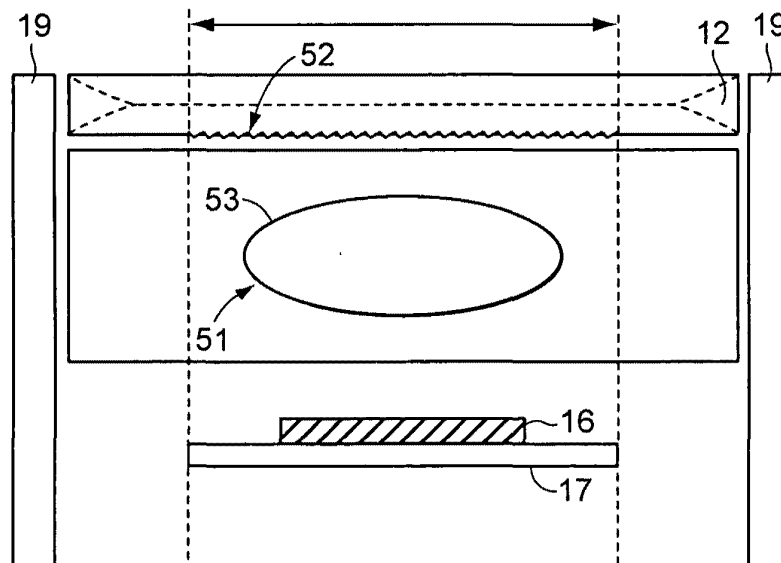

FIG. 1B

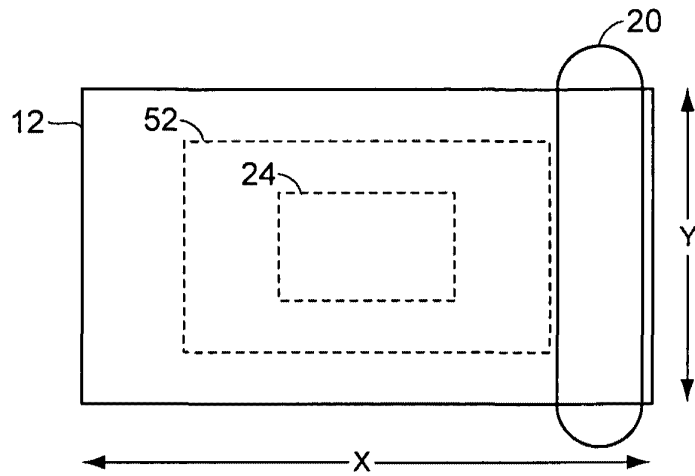

FIG. 2

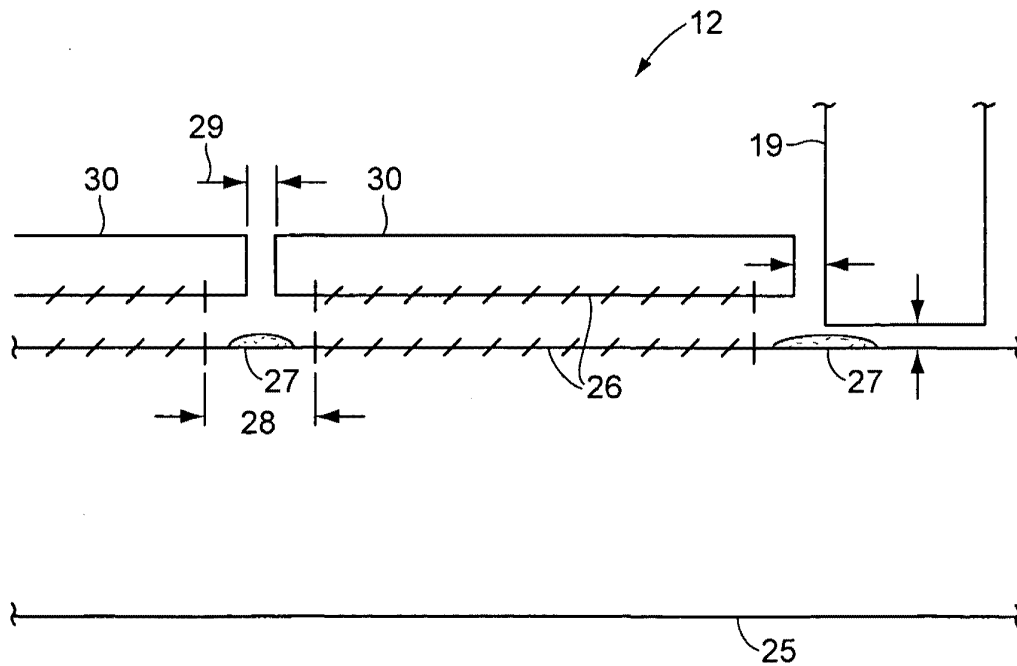

FIG. 3

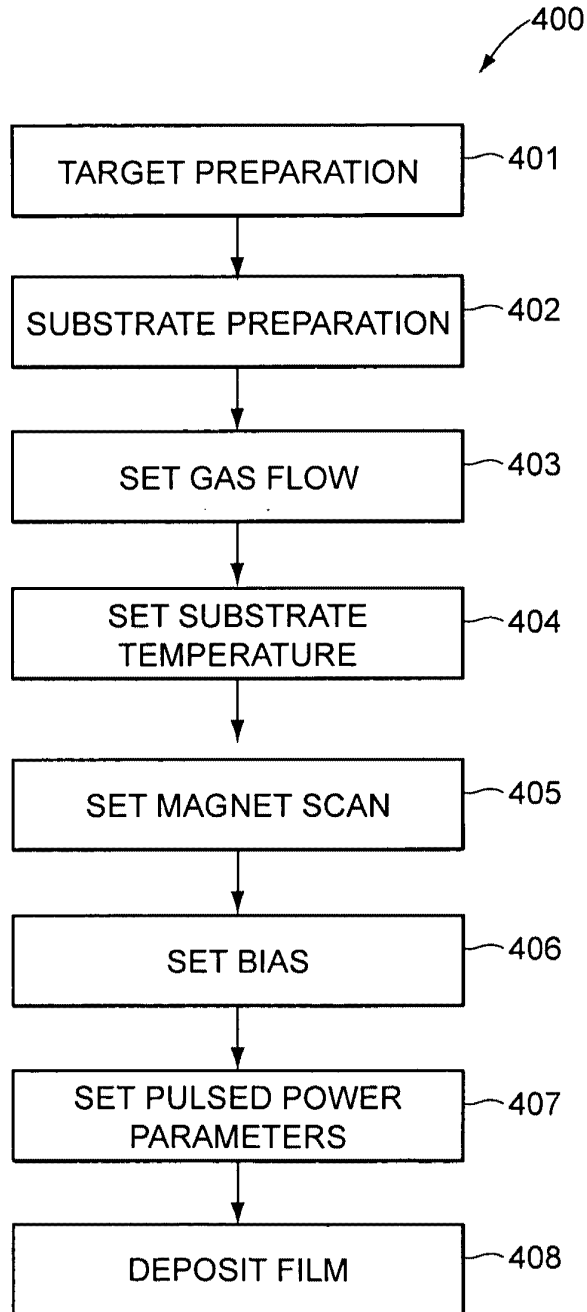

FIG. 4

4/27



TARGET VOLTAGE vs. OXYGEN FLOW

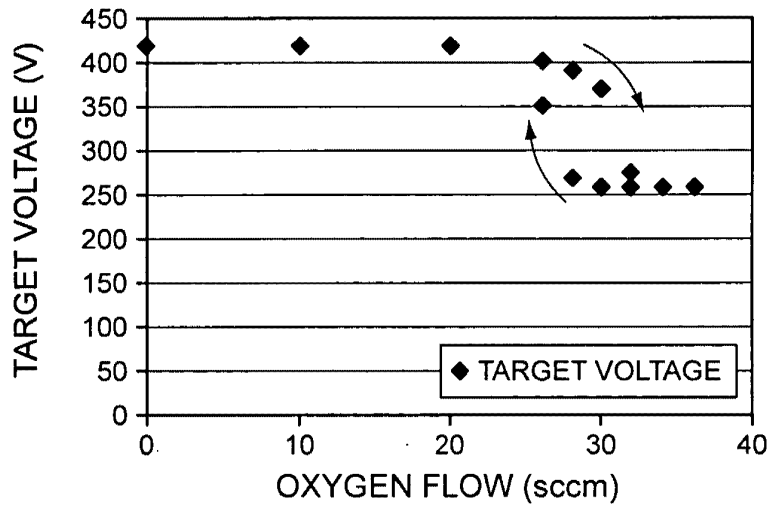

FIG. 5

LIFE TIME AND PL vs. ANNEAL TEMPERATURE

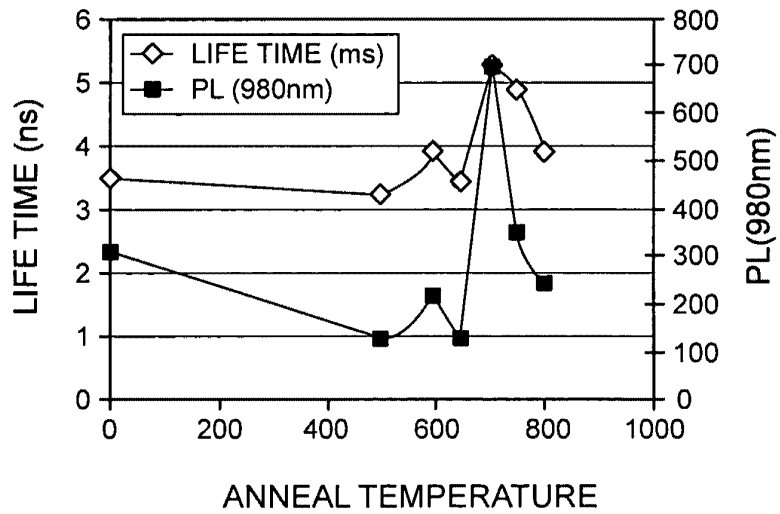

FIG. 6



Alumino Silicates Index Drift in Burn-in Cycle
(As Deposited from Al/Si Cast Metal Targets)

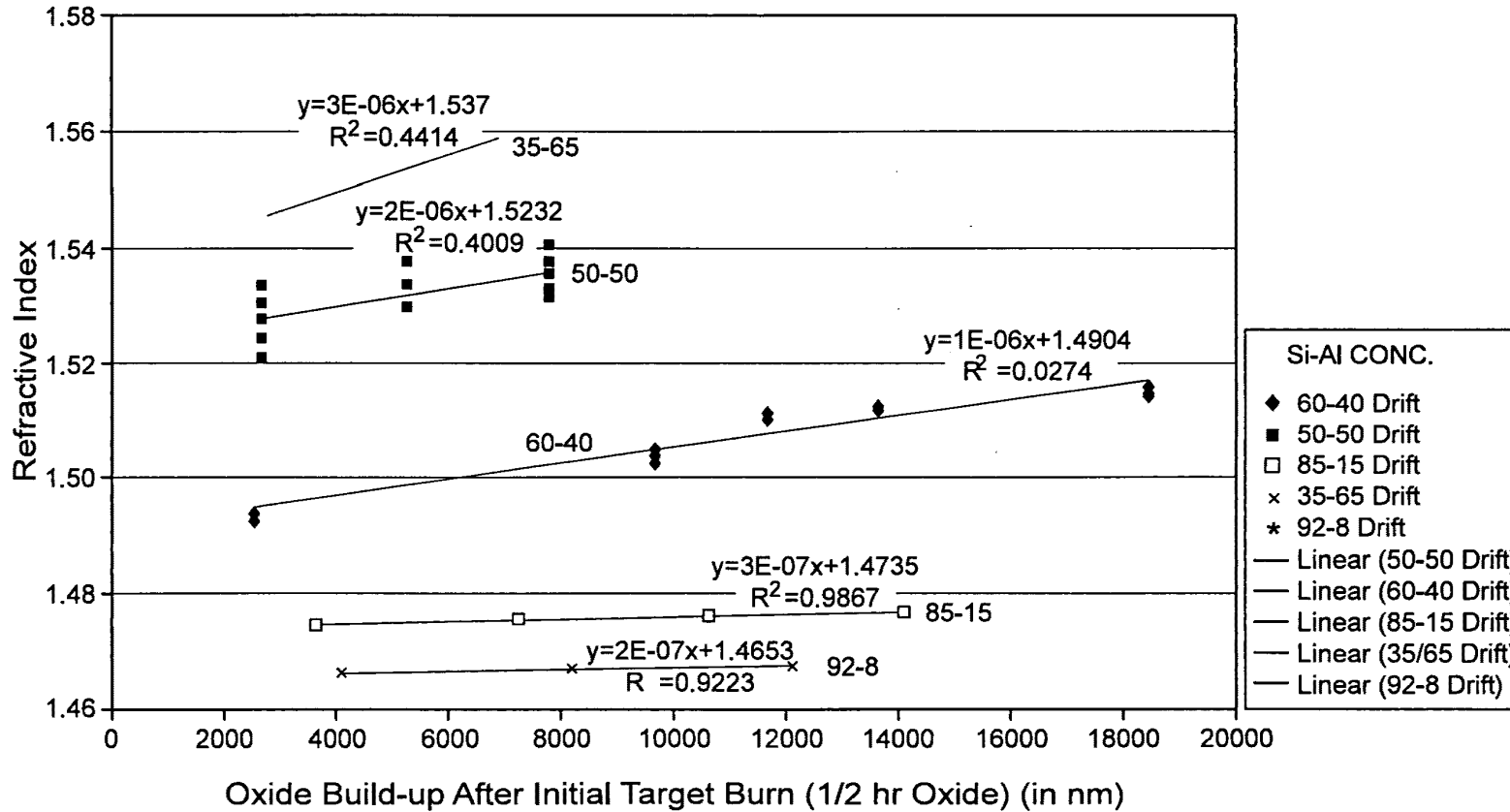

FIG. 7

5/27

REPLACEMENT SHEET
Inventors: Hongmei ZHANG et al.
Application No. 10/101,863
Title: BIASED PULSE DC REACTIVE
SPUTTERING OF OXIDE FILMS

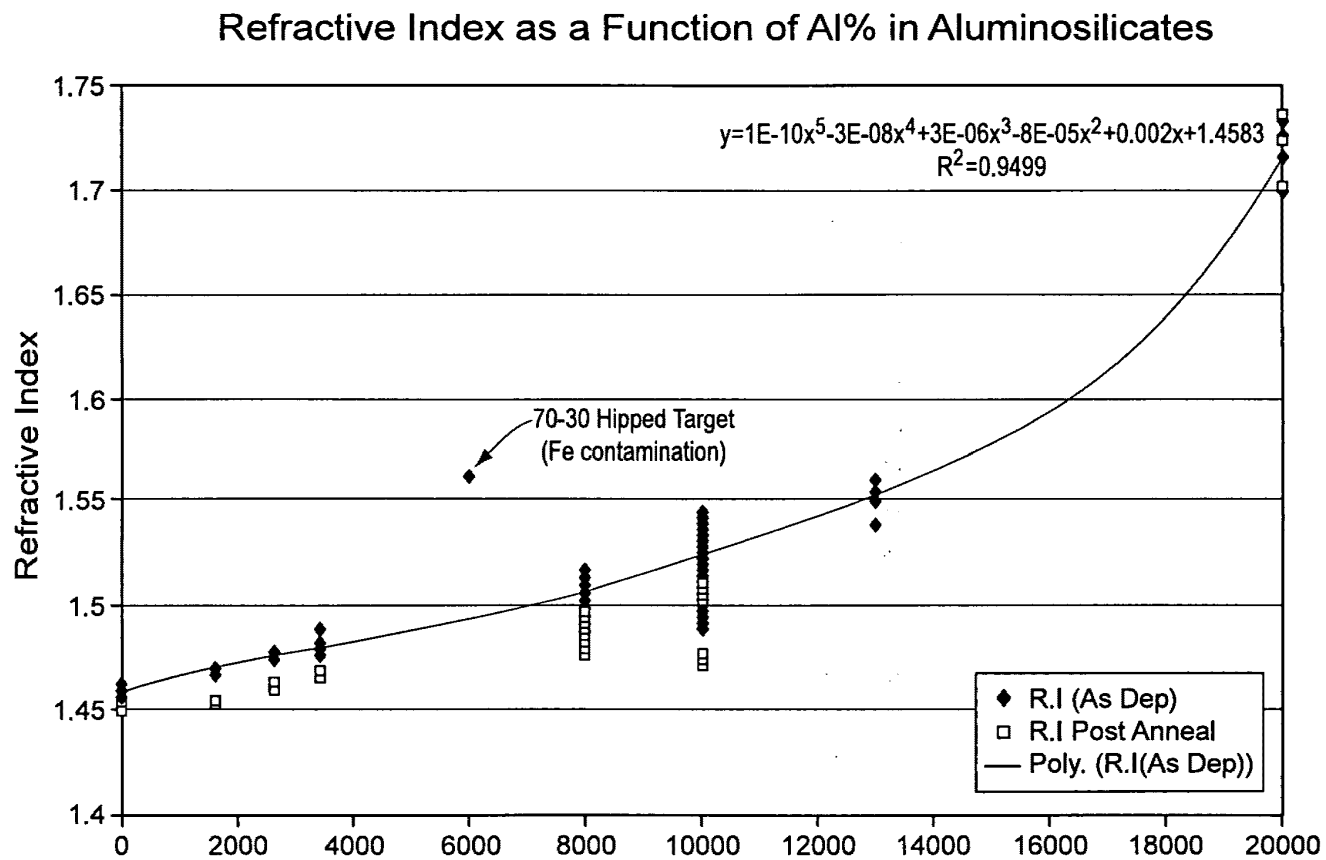

FIG. 8

REPLACEMENT SHEET
 Inventors: Hongmei ZHANG et al.
 Application No. 10/101,863
 Title: BIASED PULSE DC REACTIVE
 SPUTTERING OF OXIDE FILMS

6/27

Material (Er/Yb/Al/Si)	Expected index (Post anneal)	Actual index (Post anneal)	Process Conditions (Annealed 725c 30min)
0.8/0.8/41.4/57	1.506	1.510	6KW, Ar-60,02-28sccm, 120Khz, 2.2us, 60mm T-W Space, 4-5mm T-M Space, 0-400W Bias
1.6/0.5/49/48.9	1.526	1.528	6KW, Ar-60,02-28sccm, 120Khz, 2.2us, 60mm T-W Space, 4-5mm T-M Space, 0-400W Bias
0/0/8/92	1.452	1.456- 1.459	4.5KW, Ar-30-60,02-28-44, 120-200Khz, 2.2us, 60-85mm T-W Space, 4-5mm T-M Space, 0-400W Bias
0/0/40/60	1.504	1.486- 1.501	3.0-4.5KW, Ar-30,02-44, 75-200Khz, 2.2-3.0us, 60-85mm T-W Space, 4-5mm T-M Space, 0-400W Bias
0/0/50/50	1.520	1.491- 1.503	4.0-5KW, Ar-30,02-44, 75-200Khz, 2.2-3.0us, 60-85mm T-W Space, 4-5mm T-M Space, 0-400W Bias
0/0/65/35	1.544	1.545- 1.560	4.5-5.5KW, Ar-75-90,0285-100, 200Khz, 2.2us, 85mm T-W Space, 4-5mm T-M Space, 0-400W Bias
0/0/30/70	1.490	1.562 (high Fe content)	5.0KW, Ar-75,02-100, 200Khz, 2.2us, 85mm T-W Space, 4-5mm T-M Space, 0-400W Bias
1.5/0/48.5/50	1.523	1.509- 1.513	6KW, Ar-60,02-28sccm, 120Khz, 2.2us, 60mm T-W Space, 4-5mm T-M Space, 0-400W Bias

FIG. 9

REPLACEMENT SHEET
 Inventors: Hongmei ZHANG et al.
 Application No. 10/101,863
 Title: BIASED PULSE DC REACTIVE
 SPUTTERING OF OXIDE FILMS

7/27

Bias Power (Watts)	DC Power (KW)	Pulsing Freq (KHz)	Reverse Time (μ s)	Ar Flow (sccms)	O2 Flow (sccms)	Wafer Position	Target To Wafer Spacing (mm)	Refractive Index Avg (@1550nm)	Refractive Index STD (@1550nm)	Dep Rate (μ m/Hr)
150	4.5	200	2.2	100	100	1	55	1.461508	0.000535	0.957654
150	4.5	200	2.2	100	100	2	55	1.462329	0.000376	0.962581
400	4.5	200	2.2	100	100	1	55	1.462774	0.000103	0.814007
400	4.5	200	2.2	100	100	2	55	1.463583	0.000095	0.824566

8/27

REPLACEMENT SHEET
 Inventors: Hongmei ZHANG et al.
 Application No. 10/101,863
 Title: BIASED PULSE DC REACTIVE
 SPUTTERING OF OXIDE FILMS

FIG. 10

+

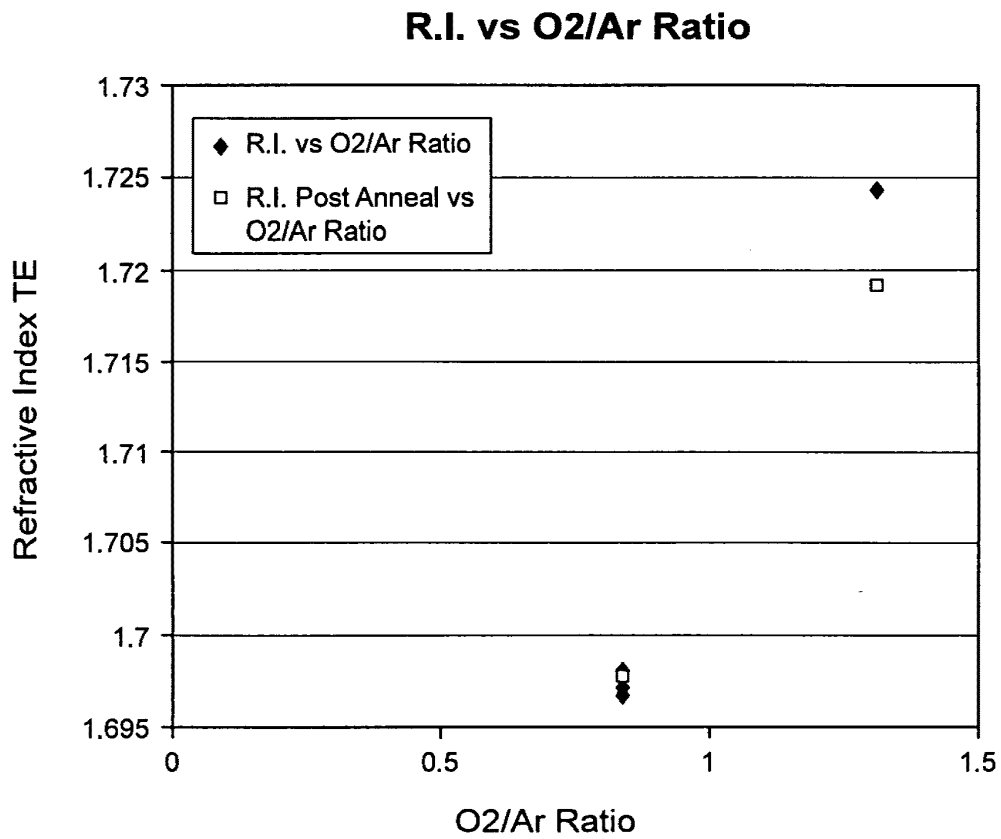

FIG. 11

REPLACEMENT SHEET
Inventors: Hongmei ZHANG et al.
Application No. 10/101,863
Title: BIASED PULSE DC REACTIVE
SPUTTERING OF OXIDE FILMS

9/27

+

+

R.I. Vs Pulsing Frequency for Alumina

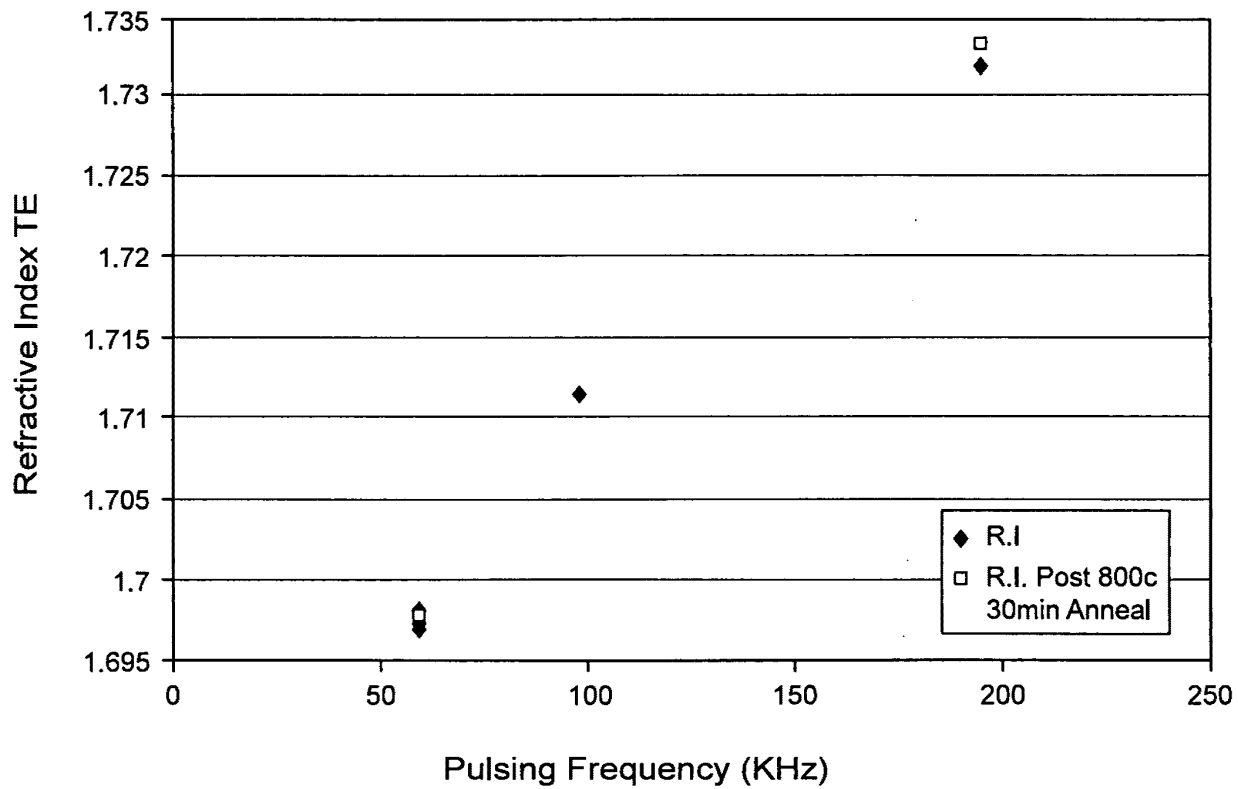

FIG. 12

10/27

REPLACEMENT SHEET
Inventors: Hongmei ZHANG et al.
Application No. 10/101,863
Title: BIASED PULSE DC REACTIVE
SPUTTERING OF OXIDE FILMS

+



Index and Dep Rate Drifts Pre & Post Anneal Target 92-8 AKT 4300 Based Reactor

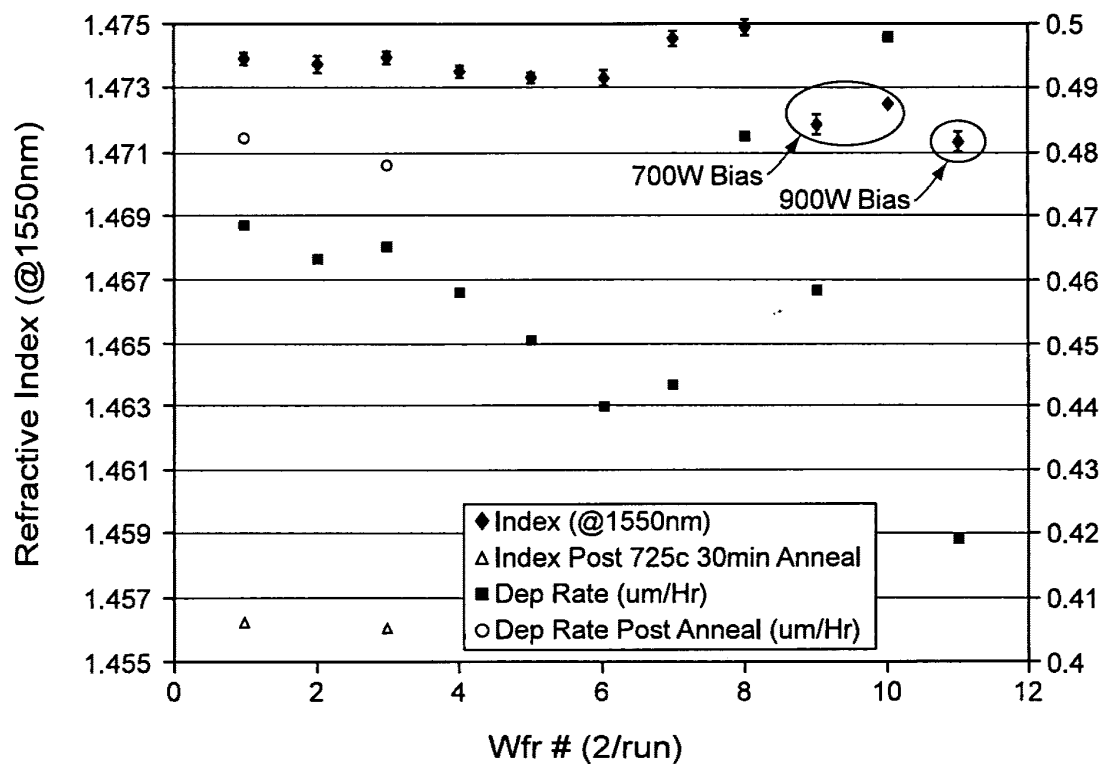

FIG. 13

11/27

REPLACEMENT SHEET
Inventors: Hongmei ZHANG et al.
Application No. 10/101,863
Title: BIASED PULSE DC REACTIVE
SPUTTERING OF OXIDE FILMS





Index Drift Control Target Comp 83-17 (AKT-1600 Based Reactor)

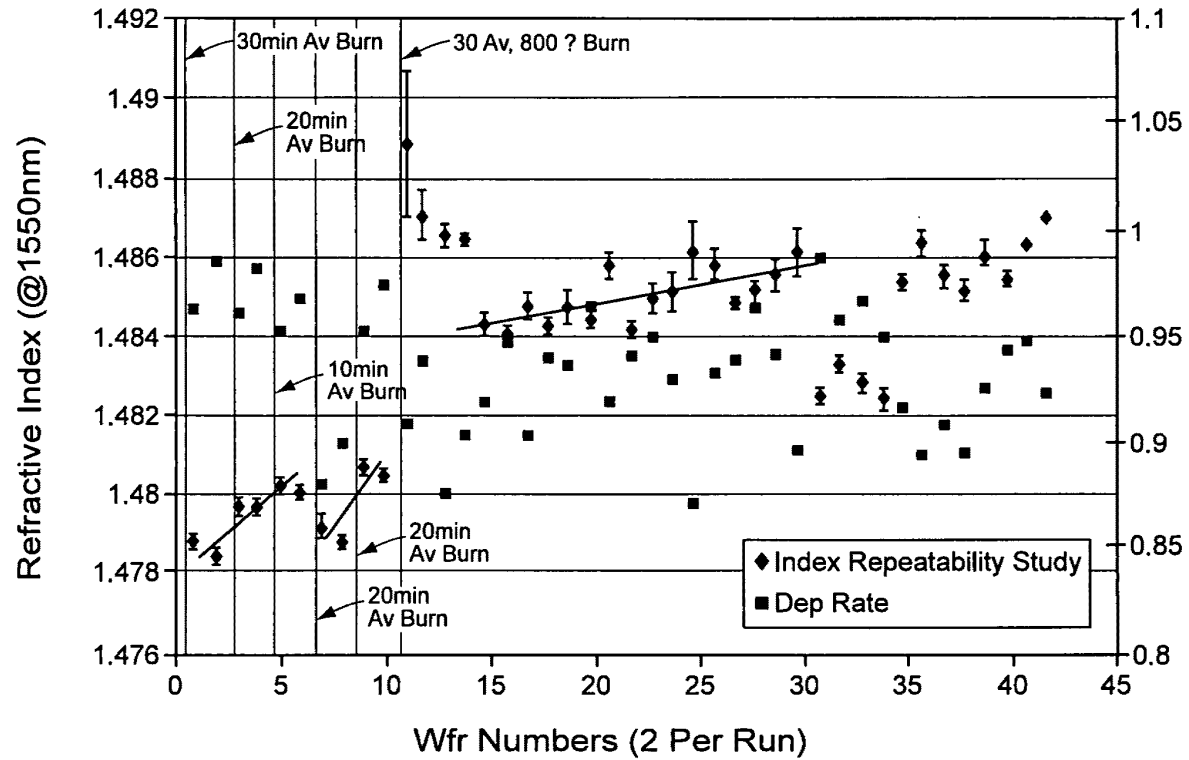

FIG. 14

12/27

REPLACEMENT SHEET
Inventors: Hongmei ZHANG et al.
Application No. 10/101,863
Title: BIASED PULSE DC REACTIVE
SPUTTERING OF OXIDE FILMS





Index Drift Control 83-17 Target/AKT 1600 Based Reactor

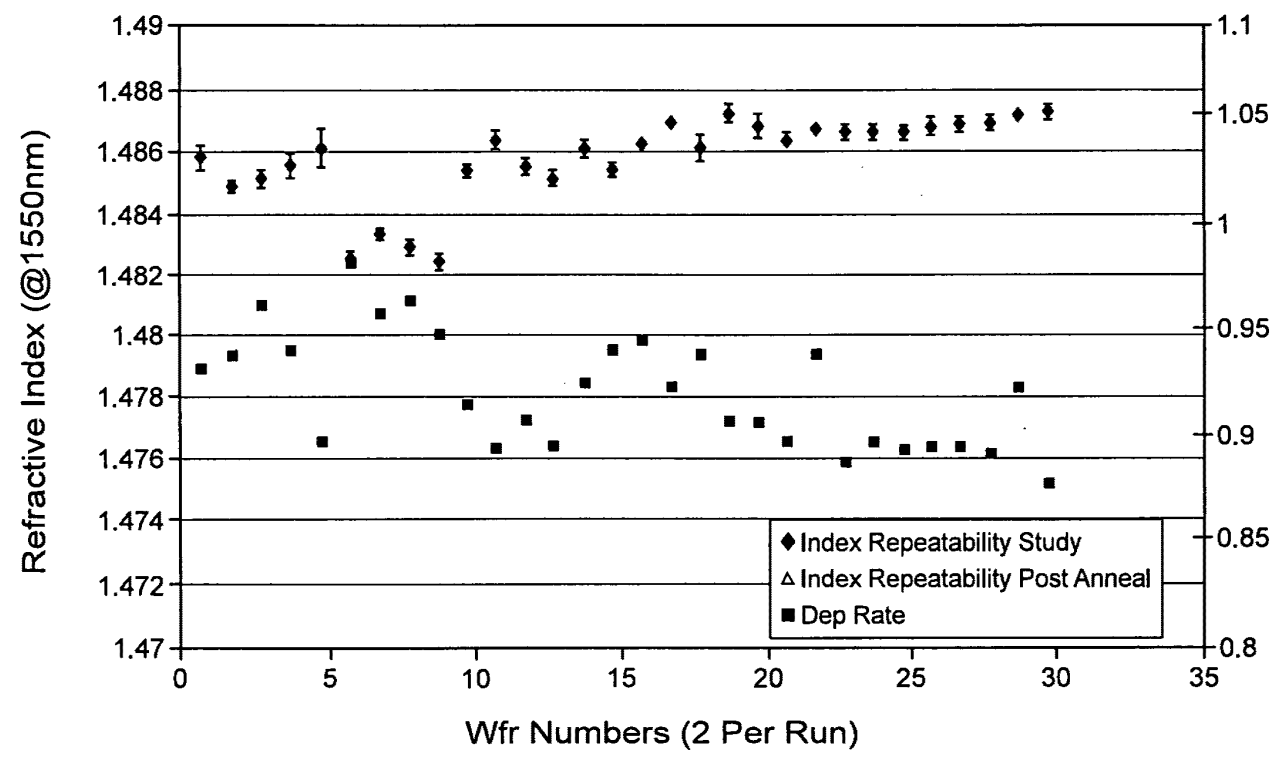

FIG. 15

13/27

REPLACEMENT SHEET
Inventors: Hongmei ZHANG et al.
Application No. 10/101,863
Title: BIASED PULSE DC REACTIVE
SPUTTERING OF OXIDE FILMS



14/27

+

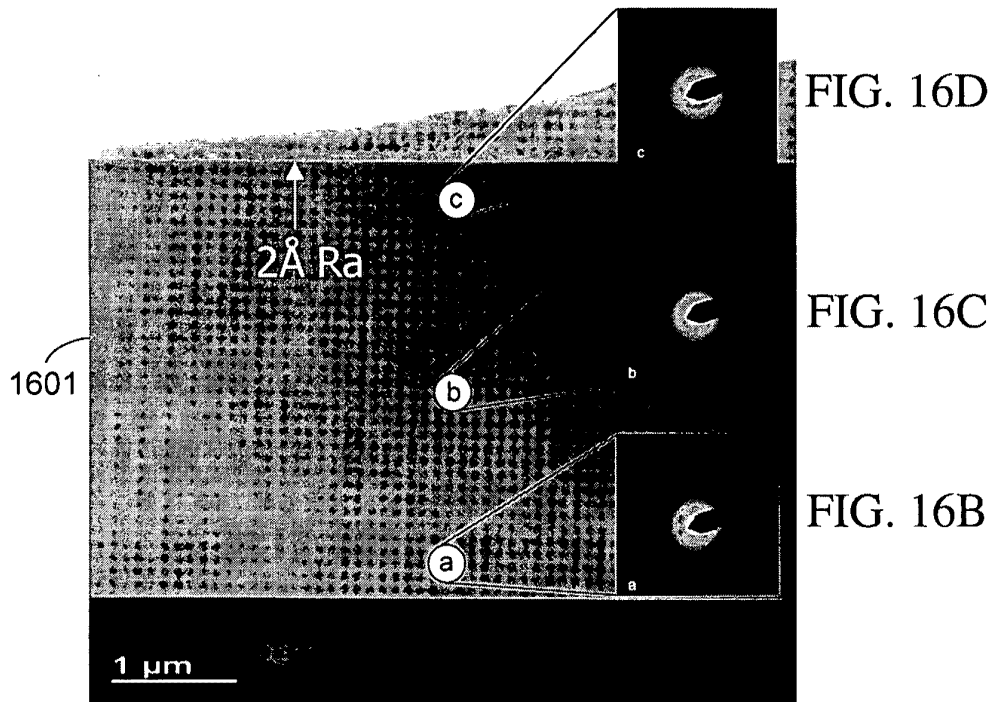
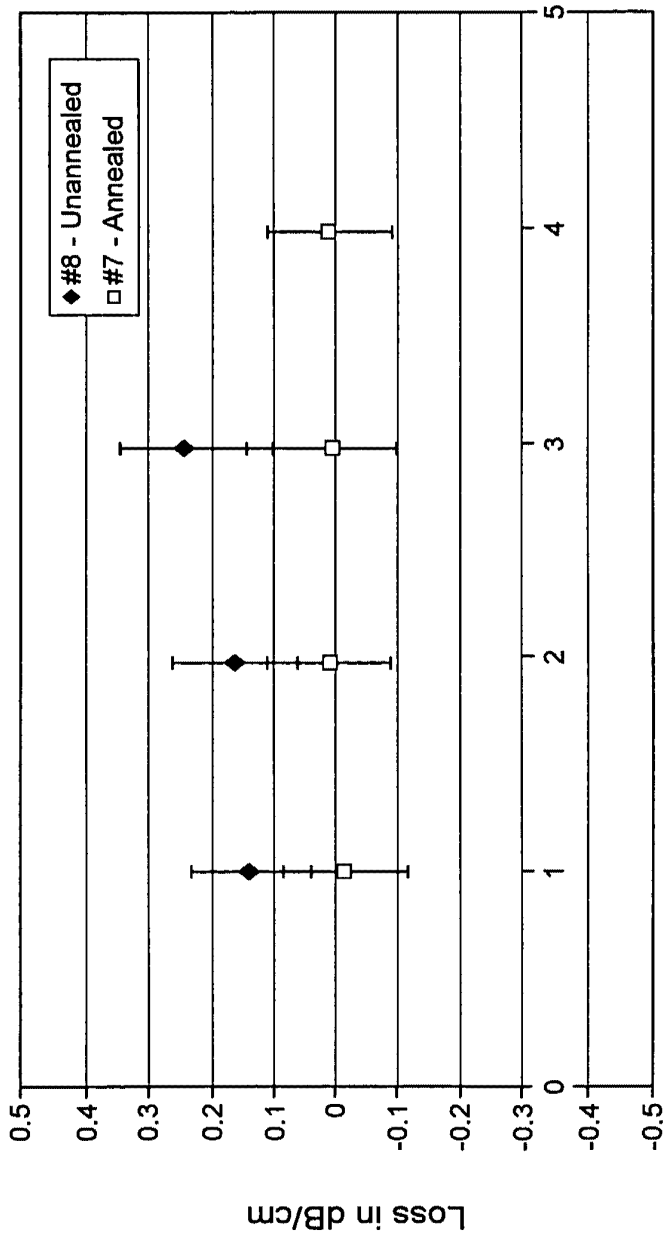

FIG. 16A

SYMMORPHIX PVD ALUMINOSILICATE

+



Path (cm)

FIG. 17



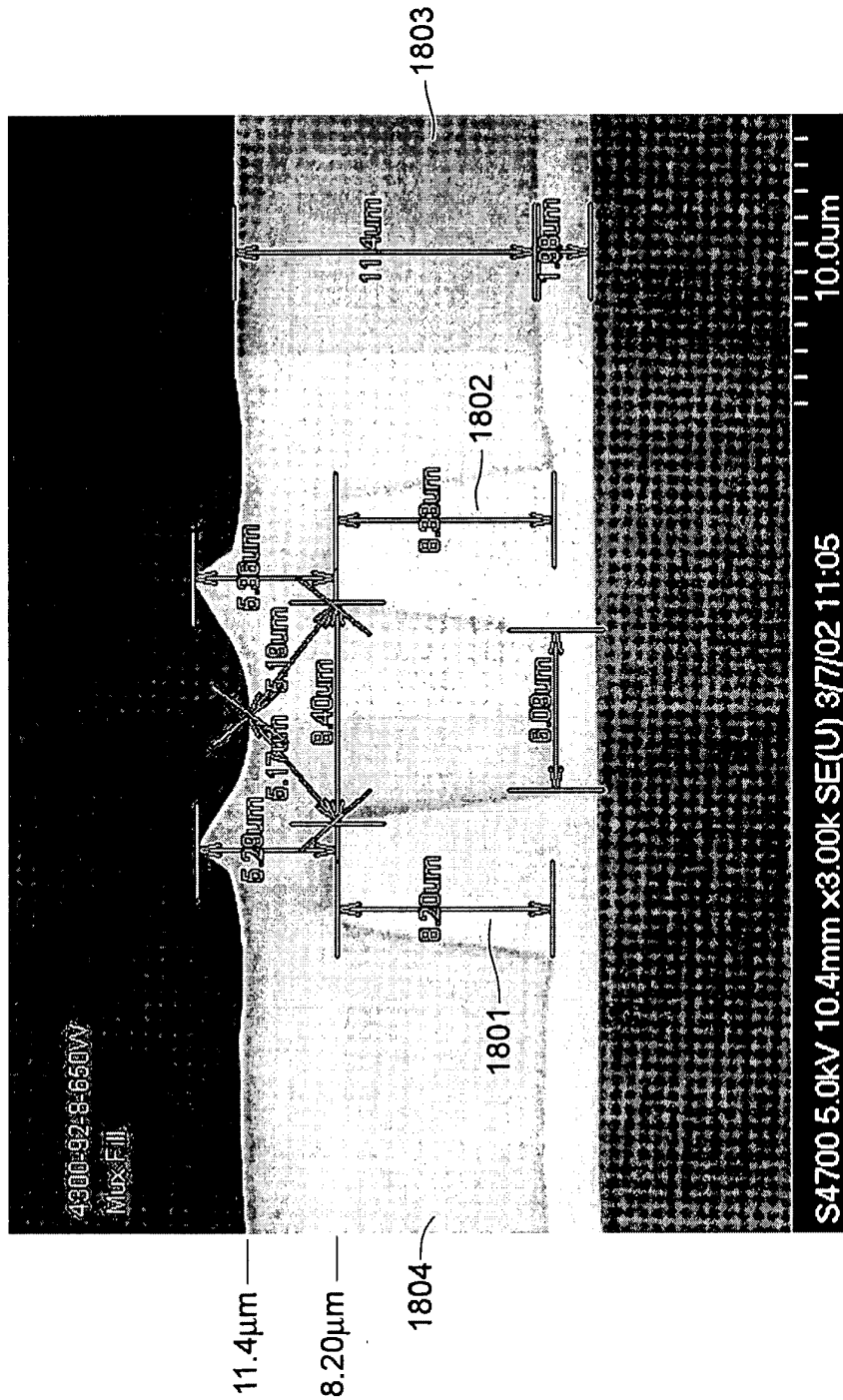

FIG. 18

17/27

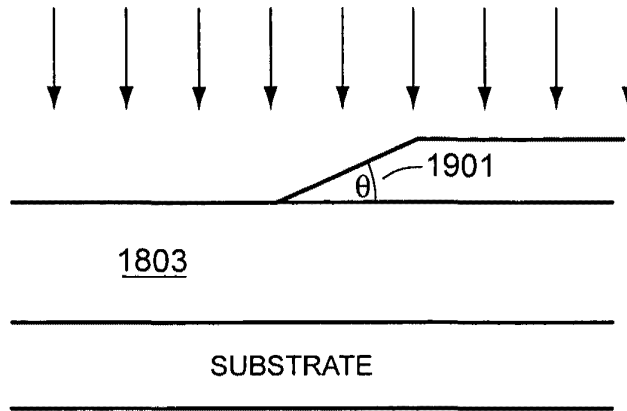

FIG. 19

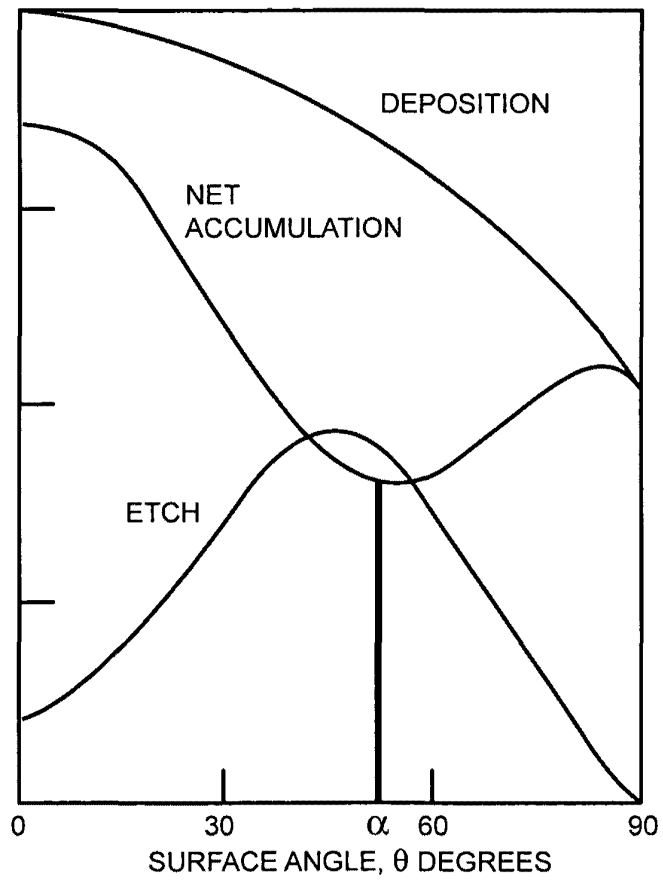

FIG. 20

18/27

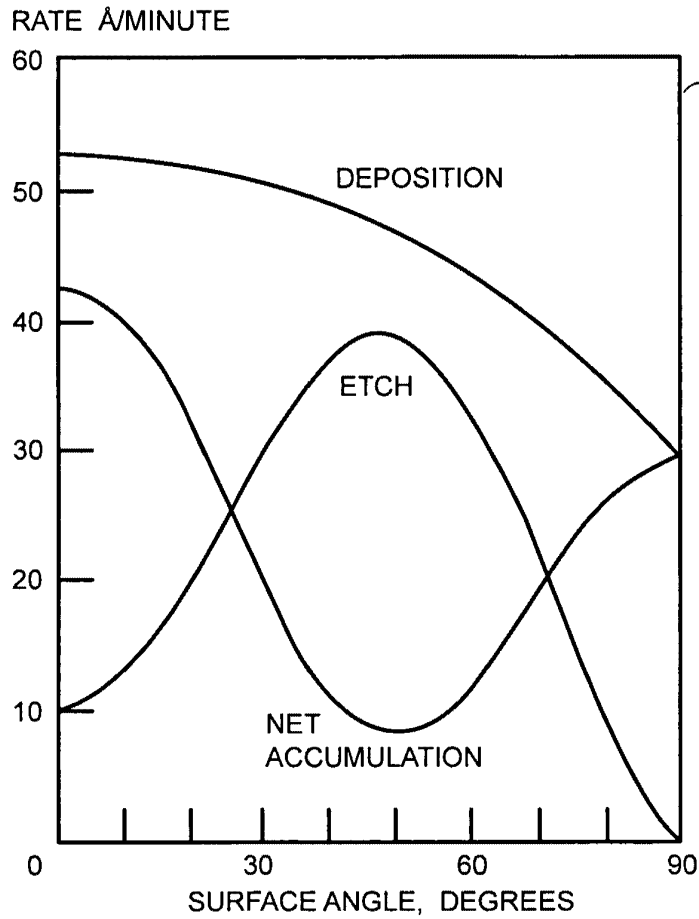

FIG. 21

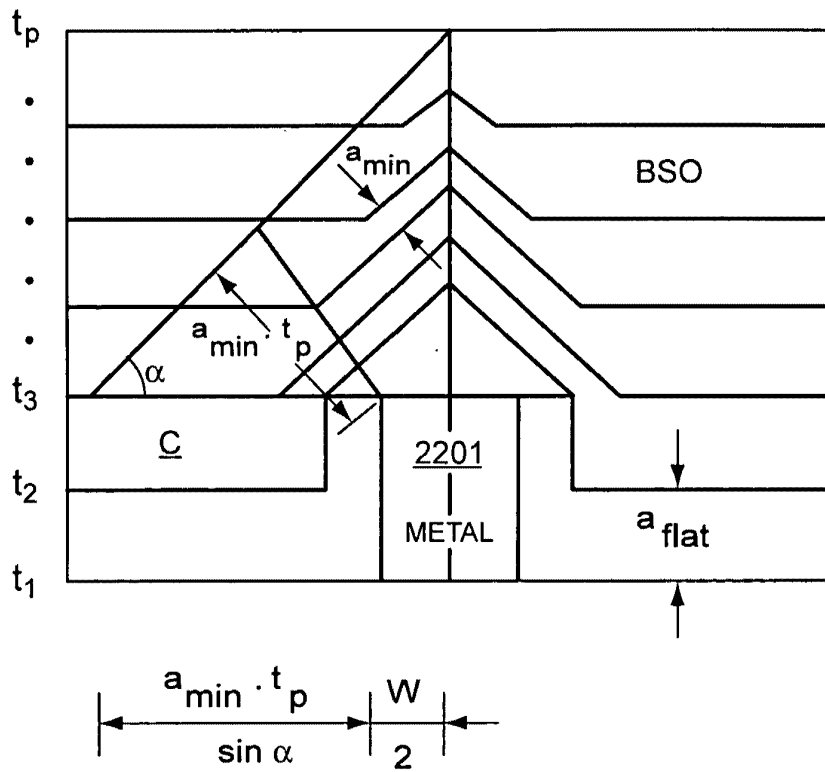

FIG. 22

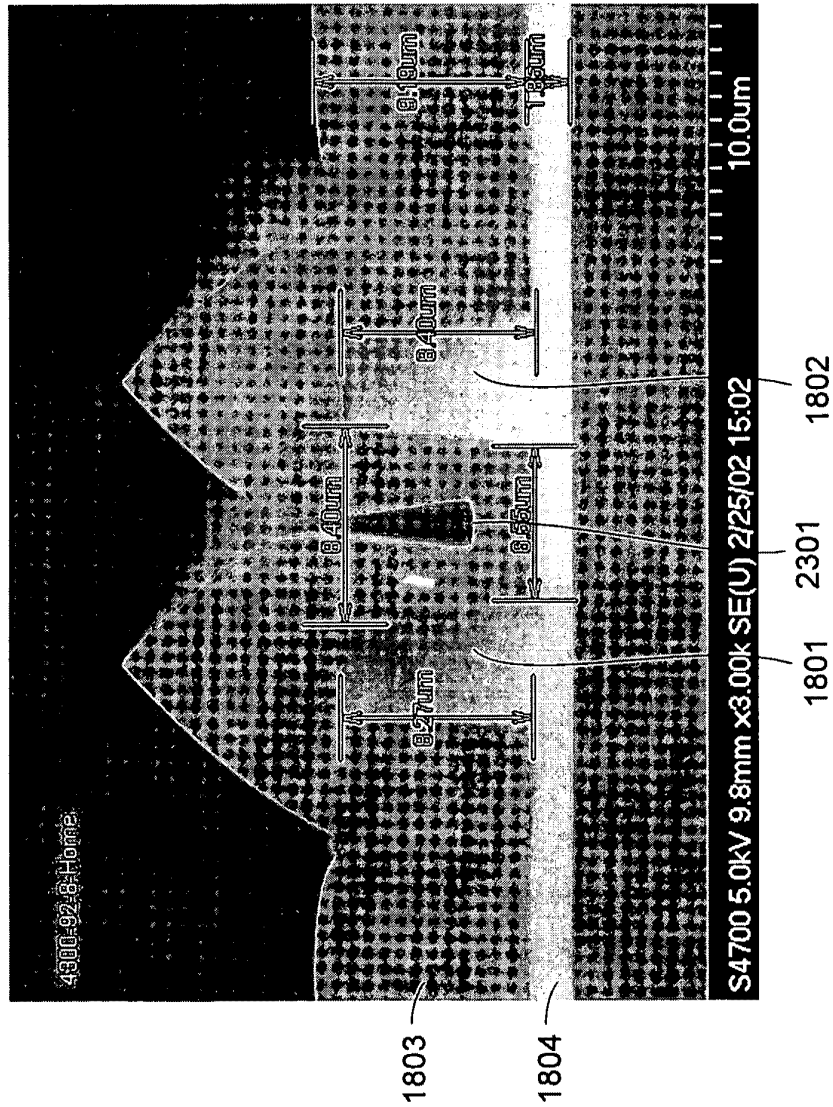

FIG. 23

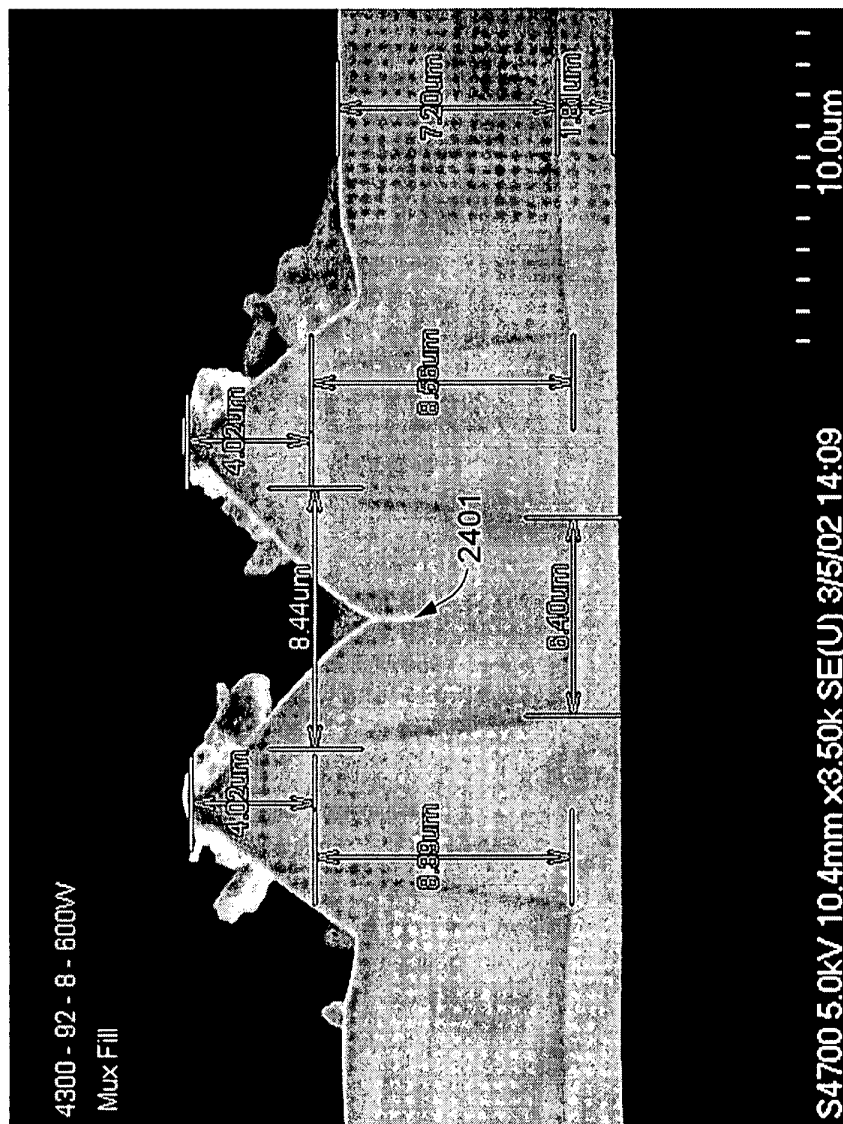

FIG. 24



22/27

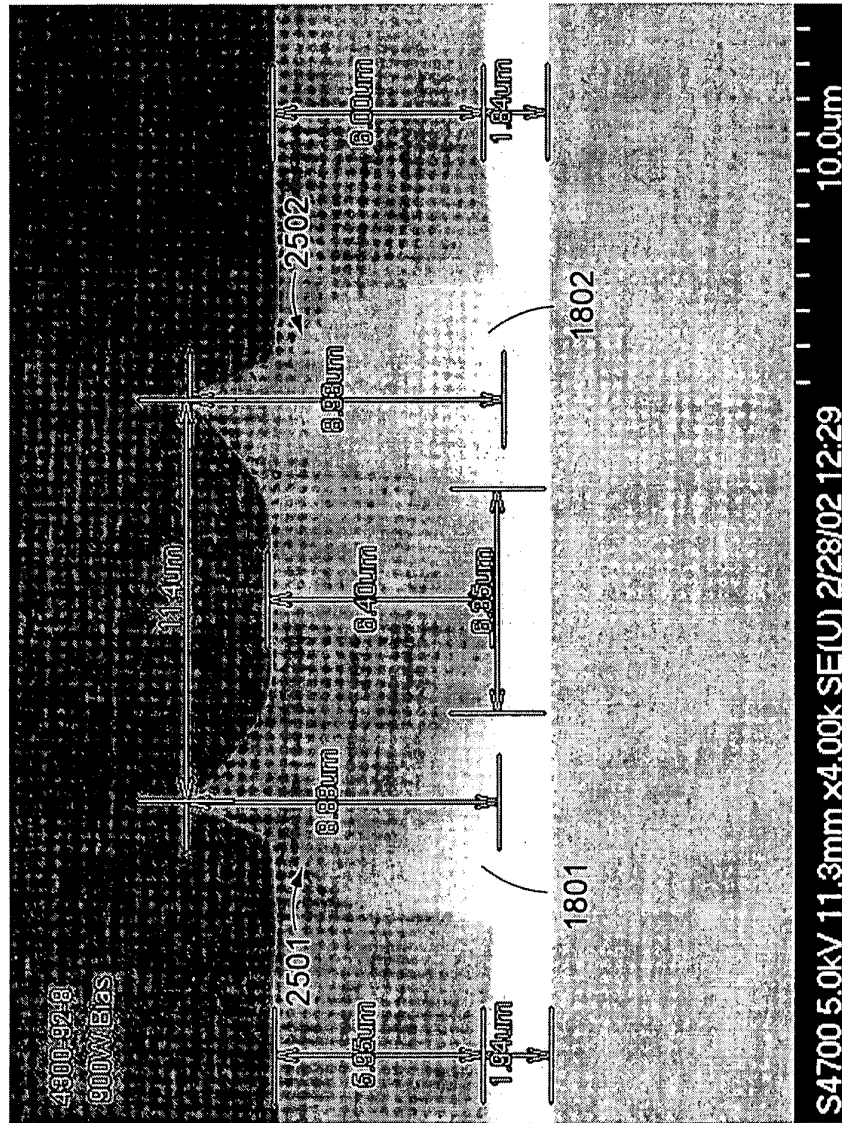

FIG. 25

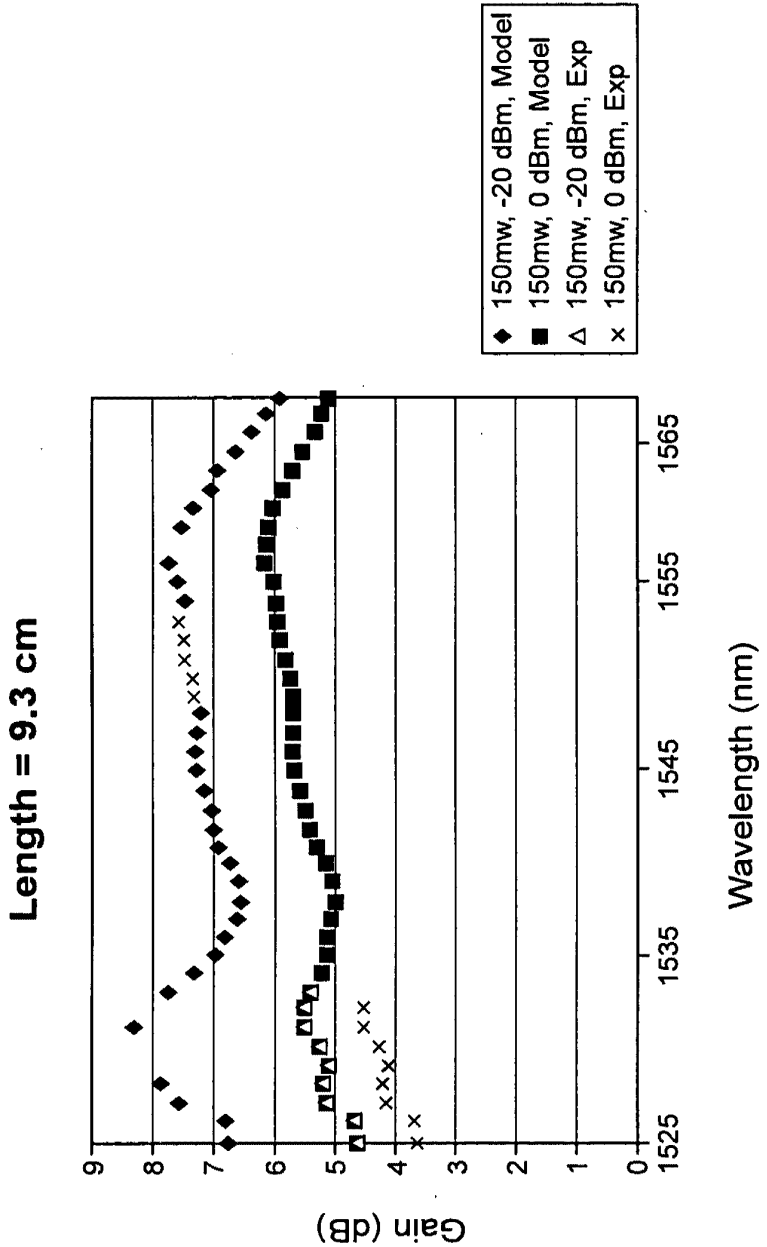

FIG. 26



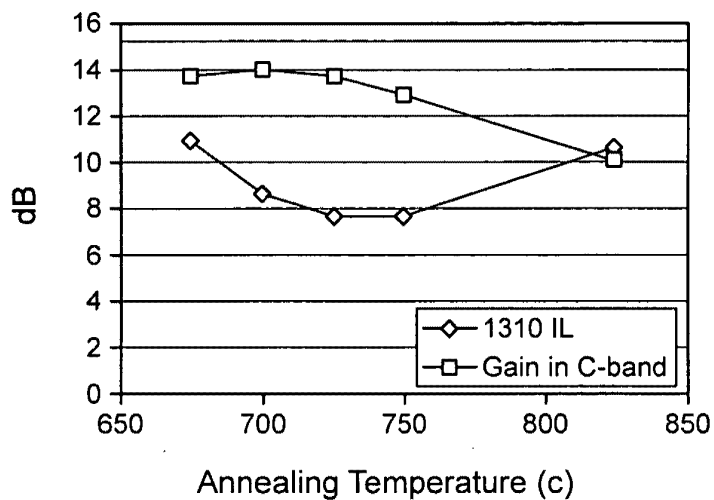

FIG. 27

Life Time and Up-conversion vs. Annealing Temperature

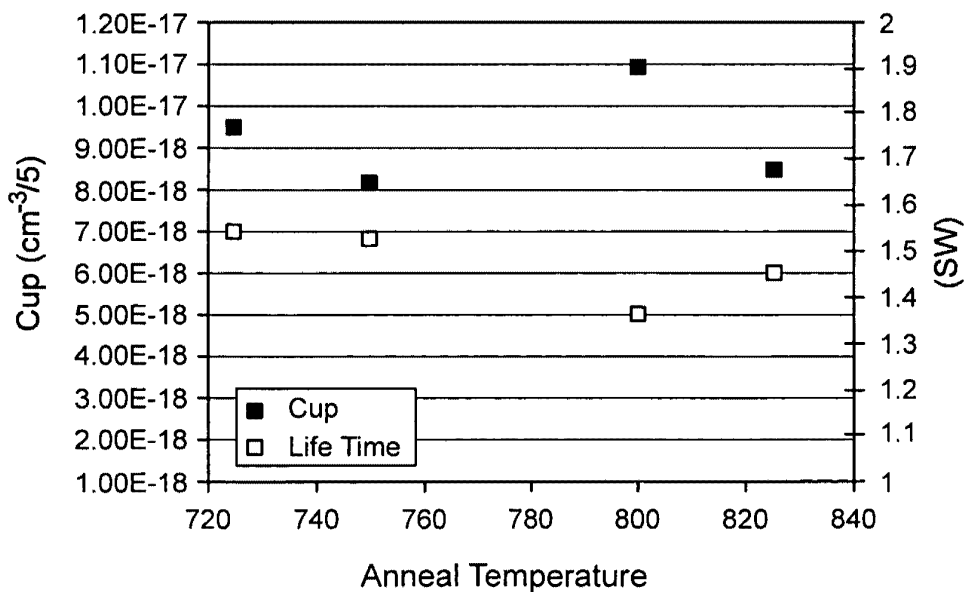

FIG. 28

25/27

Index and Thickness

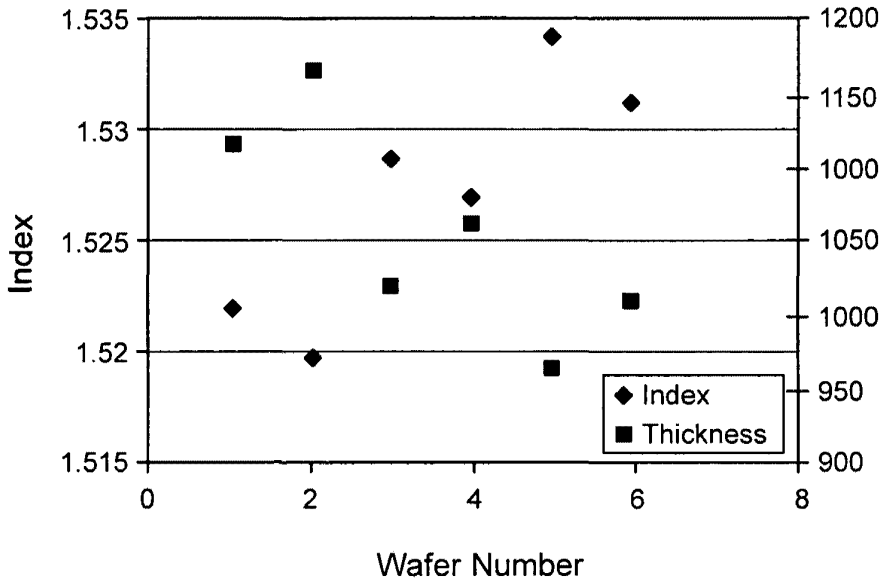

FIG. 29

532nm PL/um

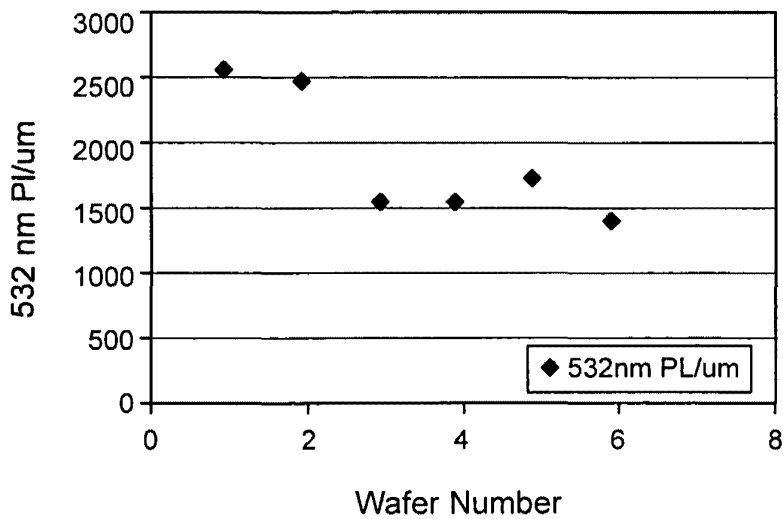

FIG. 30

26/27

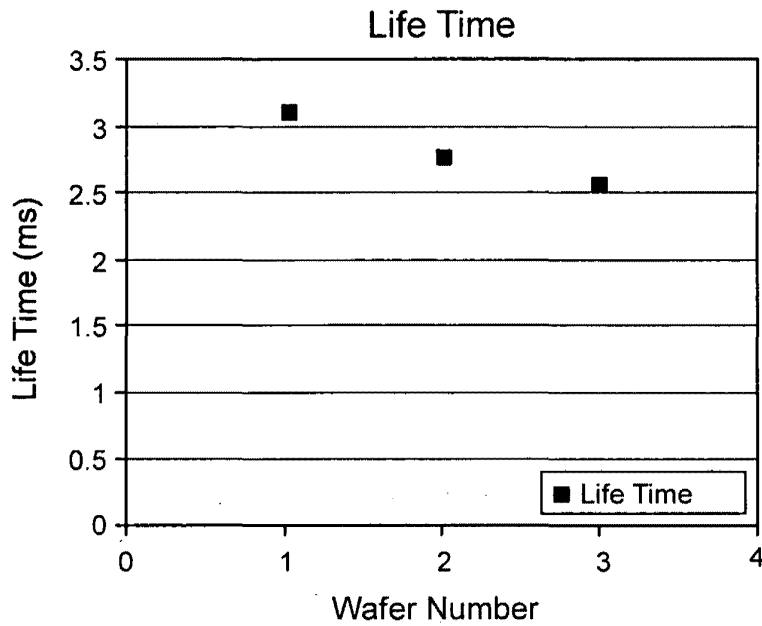

FIG. 31

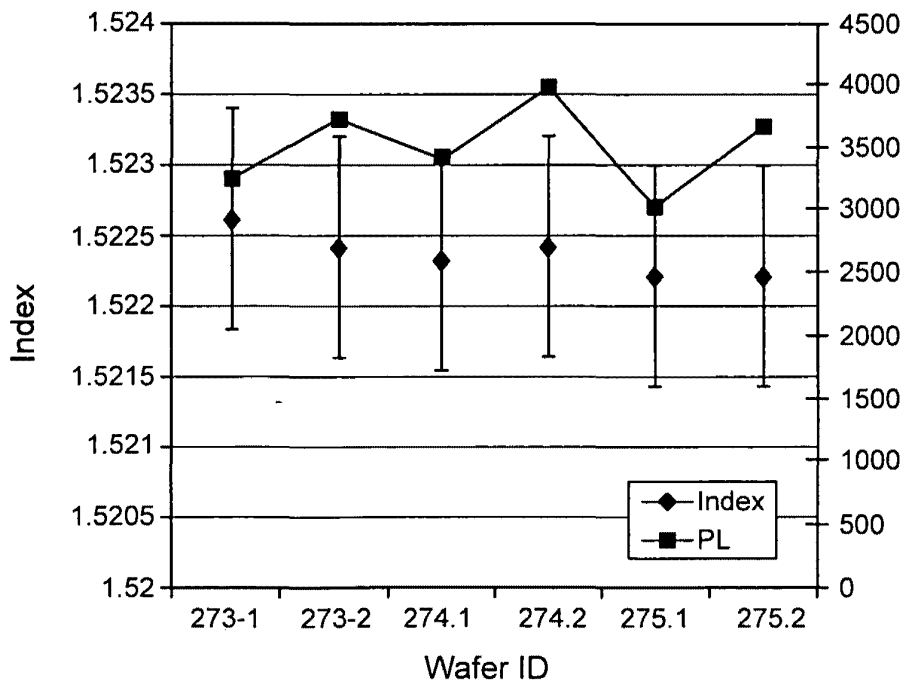

FIG. 32

27/27

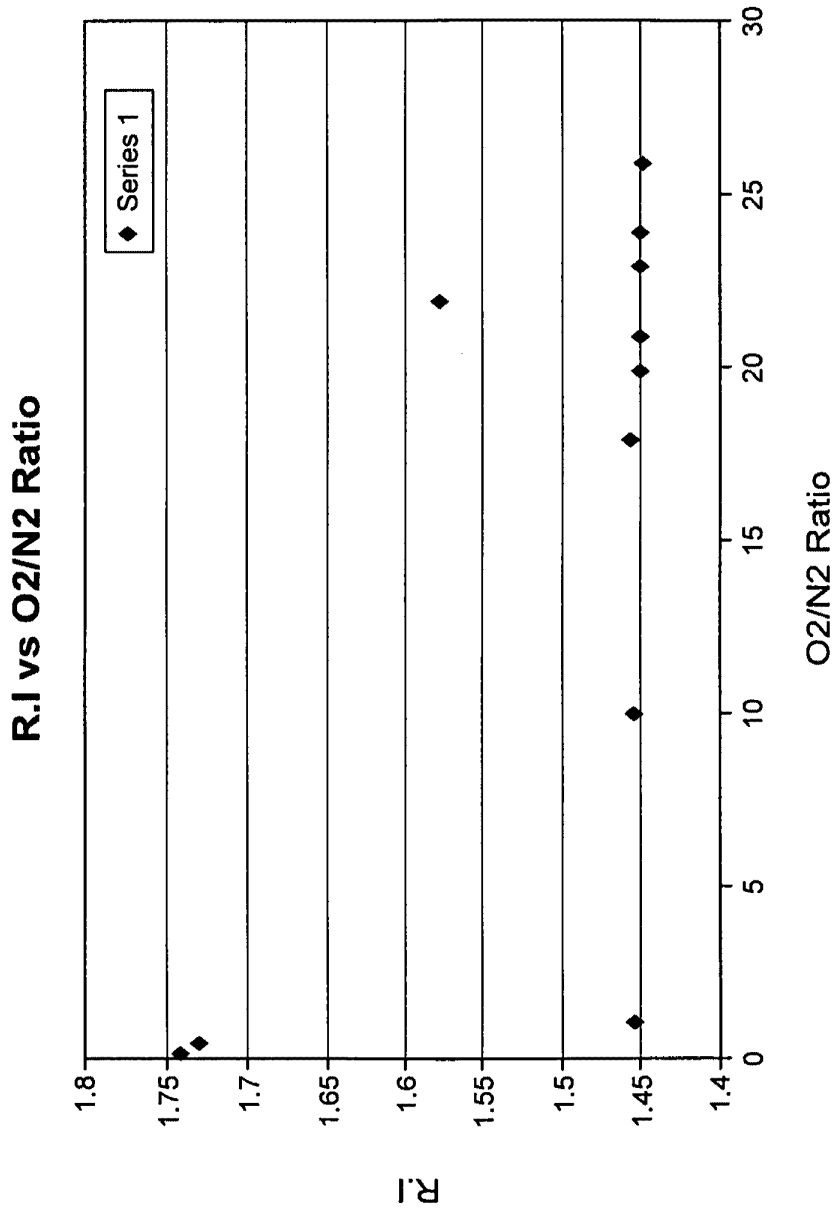

FIG. 33



PATENT
Customer No. 22,852
Attorney Docket No. 9140.0016-00

IN THE UNITED STATES PATENT AND TRADEMARK OFFICE

In re Application of:)	
)	
ZHANG, Hongmei et al.)	Group Art Unit: 2823
)	
Application No.: 10/101,863)	Examiner: ESTRADA, Michelle
)	
Filed: March 16, 2002)	
)	
For: BIASED PULSE DC REACTIVE)	Confirmation No.: 6938
SPUTTERING OF OXIDE FILMS)	

MAIL STOP AMENDMENT
Commissioner for Patents
P.O. Box 1450
Alexandria, VA 22313-1450

Sir:

PETITION FOR EXTENSION OF TIME

Applicants petition for a one month extension of time to reply to the Office action of August 4, 2005. The Commissioner is hereby authorized to charge the fee of \$120.00 to Deposit Account No. 06-0916.

Please grant any extensions of time required to enter this response and charge any additional required fees to our deposit account 06-0916.

Respectfully submitted,

FINNEGAN, HENDERSON, FARABOW,
GARRETT & DUNNER, L.L.P.

Dated: December 5, 2005

By: *Gary J. Edwards* 45,681
for Gary J. Edwards
Reg. No. 41,008

**EXPRESS MAIL LABEL NO.
EV 758329165 US**

12/08/2005 EAREGAY1 00000041 060916 10101863

01 FC:1251 120.00 DA



PATENT
Customer No. 22,852
Attorney Docket No. 9140.0016-00

IN THE UNITED STATES PATENT AND TRADEMARK OFFICE

In re Application of:)	
)	
ZHANG, Hongmei et al.)	Group Art Unit: 2823
)	
Application No.: 10/101,863)	Examiner: ESTRADA, Michelle
)	
Filed: March 16, 2002)	
)	
For: BIASED PULSE DC REACTIVE)	Confirmation No.: 6938
SPUTTERING OF OXIDE FILMS)	

MAIL STOP AMENDMENT
Commissioner for Patents
P.O. Box 1450
Alexandria, VA 22313-1450

Sir:

FOURTH SUPPLEMENTAL INFORMATION DISCLOSURE STATEMENT
UNDER 37 C.F.R. § 1.97(c)

Pursuant to 37 C.F.R. §§ 1.56 and 1.97(c), Applicants bring to the attention of the Examiner the documents on the attached listing. This Information Disclosure Statement is being filed after the events recited in Section 1.97(b) but, to the undersigned's knowledge, before the mailing date of either a Final action, Quayle action, or a Notice of Allowance. Under the provisions of 37 C.F.R. § 1.97(c), the Commissioner is hereby authorized to charge the fee of \$180.00 to Deposit Account No. 06-0916 as specified by Section 1.17(p).

Copies of the listed non-patent literature documents are attached. Copies of the U.S. patents and patent publications are not enclosed.

Applicants respectfully request that the Examiner consider the listed documents and indicate that they were considered by making appropriate notations on the attached form.

12/08/2005 EAREGAY1 00000041 060916 10101863
02 FC:1806 180.00 DA

This submission does not represent that a search has been made or that no better art exists and does not constitute an admission that each or all of the listed documents are material or constitute "prior art." If the Examiner applies any of the documents as prior art against any claims in the application and Applicants determine that the cited documents do not constitute "prior art" under United States law, Applicants reserve the right to present to the office the relevant facts and law regarding the appropriate status of such documents.

Applicants further reserve the right to take appropriate action to establish the patentability of the disclosed invention over the listed documents, should one or more of the documents be applied against the claims of the present application.

If there is any fee due in connection with the filing of this Statement, please charge the fee to our Deposit Account No. 06-0916.

Respectfully submitted,

FINNEGAN, HENDERSON, FARABOW,
GARRETT & DUNNER, L.L.P.

Dated: December 5, 2005

By: *Sinda J. Mayr* 45,681
for Gary J. Edwards
Reg. No. 41,008

**EXPRESS MAIL LABEL NO.
EV 758329165 US**

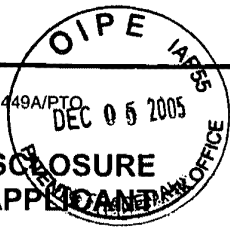

IDS Form PTO/SB/08: Substitute for form 1449A/PTO			Complete if Known	
INFORMATION DISCLOSURE STATEMENT BY APPLICANT <i>(Use as many sheets as necessary)</i>			Application Number	10/101,863
			Filing Date	March 16, 2002
			First Named Inventor	Hongmei ZHANG
			Art Unit	2823
			Examiner Name	ESTRADA, Michelle
			Attorney Docket Number	9140.0016-00
Sheet	1	of	1	

U.S. PATENTS AND PUBLISHED U.S. PATENT APPLICATIONS					
Examiner Initials	Cite No. ¹	Document Number	Issue or Publication Date MM-DD-YYYY	Name of Patentee or Applicant of Cited Document	Pages, Columns, Lines, Where Relevant Passages or Relevant Figures Appear
		Number-Kind Code ² (if known)			
		5,478,456	12-26-1995	Humpal et al.	
		6,846,765 B2	1-25-2005	Imamura et al.	

Note: Submission of copies of U.S. Patents and published U.S. Patent Applications is not required.

FOREIGN PATENT DOCUMENTS							
Examiner Initials	Cite No. ¹	Foreign Patent Document		Publication Date MM-DD-YYYY	Name of Patentee or Applicant of Cited Document	Pages, Columns, Lines, Where Relevant Passages or Relevant Figures Appear	Translation ⁹
		Country Code ³	Number ⁴ Kind Code ⁵ (if known)				

NON PATENT LITERATURE DOCUMENTS			
Examiner Initials	Cite No. ¹	Include name of the author (in CAPITAL LETTERS), title of the article (when appropriate), title of the item (book, magazine, journal, serial, symposium, catalog, etc.), date, page(s), volume-issue number(s), publisher, city and/or country where published.	Translation ⁹
		DOREY, R.A., "Low temperature micromoulding of functional ceramic devices," Grant summary for GR/S84156/01 for the UK Engineering and Physical Sciences Research Council, 2 pages (2004).	
		HOWSON, R.P., "The reactive sputtering of oxides and nitrides," <i>Pure & Appl. Chem.</i> 66(6):1311-1318 (1994).	
		Office Action issued September 21, 2005 in U.S. Application No. 11/100,856 (Attorney Docket No. 09140.0015-01).	
		Office Action issued on August 8, 2005 in U.S. Serial No. 10/101,341 (Attorney Docket No. 09140-0017-00).	
		Office Action issued on October 3, 2005 in U.S. Application No. 10/650,461 (Attorney Docket No. 09140-0025-00).	
		Office Action issued on October 19, 2005 in U.S. Application No. 10/851,542 (Attorney Docket No. 09140.0033-00).	

**EXPRESS MAIL LABEL NO.
EV 758329165 US**

Examiner Signature		Date Considered	
--------------------	--	-----------------	--

EXAMINER: Initial if reference considered, whether or not citation is in conformance with MPEP 609. Draw line through citation if not in conformance and not considered. Include copy of this form with next communication to applicant.

PATENT APPLICATION FEE DETERMINATION RECORD
Effective December 8, 2004

10/10/863

CLAIMS AS FILED - PART I

	(Column 1)	(Column 2)
TOTAL CLAIMS		
FOR	NUMBER FILED	NUMBER EXTRA
TOTAL CHARGEABLE CLAIMS	minus 20= *	
INDEPENDENT CLAIMS	minus 3 = *	
MULTIPLE DEPENDENT CLAIM PRESENT <input type="checkbox"/>		

* If the difference in column 1 is less than zero, enter "0" in column 2

SMALL ENTITY TYPE

OR OTHER THAN SMALL ENTITY

RATE	FEE		RATE	FEE
BASIC FEE	150.00	OR	BASIC FEE	300.00
X\$ 25=		OR	X\$50=	
X100=		OR	X200=	
+180=		OR	+360=	
TOTAL		OR	TOTAL	

CLAIMS AS AMENDED - PART II

	(Column 1)	(Column 2)	(Column 3)
AMENDMENT A	12/05/05 CLAIMS REMAINING AFTER AMENDMENT	HIGHEST NUMBER PREVIOUSLY PAID FOR	PRESENT EXTRA
Total	* 19	Minus ** 20	=
Independent	* 4	Minus *** 3	= 1
FIRST PRESENTATION OF MULTIPLE DEPENDENT CLAIM <input type="checkbox"/>			

SMALL ENTITY

OR OTHER THAN SMALL ENTITY

RATE	ADDITIONAL FEE		RATE	ADDITIONAL FEE
X\$ 25=		OR	X\$50=	
X100=		OR	X200=	20000
+180=		OR	+360=	
TOTAL ADDIT. FEE		OR	TOTAL ADDIT. FEE	20000

	(Column 1)	(Column 2)	(Column 3)
AMENDMENT B	CLAIMS REMAINING AFTER AMENDMENT	HIGHEST NUMBER PREVIOUSLY PAID FOR	PRESENT EXTRA
Total	*	Minus **	=
Independent	*	Minus ***	=
FIRST PRESENTATION OF MULTIPLE DEPENDENT CLAIM <input type="checkbox"/>			

RATE	ADDITIONAL FEE		RATE	ADDITIONAL FEE
X\$ 25=		OR	X\$50=	
X100=		OR	X200=	
+180=		OR	+360=	
TOTAL ADDIT. FEE		OR	TOTAL ADDIT. FEE	

	(Column 1)	(Column 2)	(Column 3)
AMENDMENT C	CLAIMS REMAINING AFTER AMENDMENT	HIGHEST NUMBER PREVIOUSLY PAID FOR	PRESENT EXTRA
Total	*	Minus **	=
Independent	*	Minus ***	=
FIRST PRESENTATION OF MULTIPLE DEPENDENT CLAIM <input type="checkbox"/>			

RATE	ADDITIONAL FEE		RATE	ADDITIONAL FEE
X\$ 25=		OR	X\$50=	
X100=		OR	X200=	
+180=		OR	+360=	



UNITED STATES PATENT AND TRADEMARK OFFICE

A

UNITED STATES DEPARTMENT OF COMMERCE
United States Patent and Trademark Office
Address: COMMISSIONER FOR PATENTS
P.O. Box 1450
Alexandria, Virginia 22313-1450
www.uspto.gov

APPLICATION NO.	FILING DATE	FIRST NAMED INVENTOR	ATTORNEY DOCKET NO.	CONFIRMATION NO.
10/101,863	03/16/2002	Hongmei Zhang	M-12245 US	6938

22852 7590 02/14/2006

FINNEGAN, HENDERSON, FARABOW, GARRETT & DUNNER
LLP
901 NEW YORK AVENUE, NW
WASHINGTON, DC 20001-4413

EXAMINER

ESTRADA, MICHELLE

ART UNIT PAPER NUMBER

2823

DATE MAILED: 02/14/2006

Please find below and/or attached an Office communication concerning this application or proceeding.

Office Action Summary	Application No. 10/101,863	Applicant(s) ZHANG ET AL ,	
	Examiner Michelle Estrada	Art Unit 2823	

-- The MAILING DATE of this communication appears on the cover sheet with the correspondence address --

Period for Reply

A SHORTENED STATUTORY PERIOD FOR REPLY IS SET TO EXPIRE 3 MONTH(S) OR THIRTY (30) DAYS, WHICHEVER IS LONGER, FROM THE MAILING DATE OF THIS COMMUNICATION.

- Extensions of time may be available under the provisions of 37 CFR 1.136(a). In no event, however, may a reply be timely filed after SIX (6) MONTHS from the mailing date of this communication.
- If NO period for reply is specified above, the maximum statutory period will apply and will expire SIX (6) MONTHS from the mailing date of this communication.
- Failure to reply within the set or extended period for reply will, by statute, cause the application to become ABANDONED (35 U.S.C. § 133). Any reply received by the Office later than three months after the mailing date of this communication, even if timely filed, may reduce any earned patent term adjustment. See 37 CFR 1.704(b).

Status

- 1) Responsive to communication(s) filed on 05 December 2005.
- 2a) This action is **FINAL**. 2b) This action is non-final.
- 3) Since this application is in condition for allowance except for formal matters, prosecution as to the merits is closed in accordance with the practice under *Ex parte Quayle*, 1935 C.D. 11, 453 O.G. 213.

Disposition of Claims

- 4) Claim(s) 1-14 and 20-24 is/are pending in the application.
4a) Of the above claim(s) _____ is/are withdrawn from consideration.
- 5) Claim(s) 14 and 21-24 is/are allowed.
- 6) Claim(s) 1-13 and 20 is/are rejected.
- 7) Claim(s) _____ is/are objected to.
- 8) Claim(s) _____ are subject to restriction and/or election requirement.

Application Papers

- 9) The specification is objected to by the Examiner.
- 10) The drawing(s) filed on 05 December 2005 is/are: a) accepted or b) objected to by the Examiner.
Applicant may not request that any objection to the drawing(s) be held in abeyance. See 37 CFR 1.85(a).
Replacement drawing sheet(s) including the correction is required if the drawing(s) is objected to. See 37 CFR 1.121(d).
- 11) The oath or declaration is objected to by the Examiner. Note the attached Office Action or form PTO-152.

Priority under 35 U.S.C. § 119

- 12) Acknowledgment is made of a claim for foreign priority under 35 U.S.C. § 119(a)-(d) or (f).
a) All b) Some * c) None of:
1. Certified copies of the priority documents have been received.
2. Certified copies of the priority documents have been received in Application No. _____.
3. Copies of the certified copies of the priority documents have been received in this National Stage application from the International Bureau (PCT Rule 17.2(a)).

* See the attached detailed Office action for a list of the certified copies not received.

Attachment(s)

- | | |
|--|---|
| 1) <input type="checkbox"/> Notice of References Cited (PTO-892) | 4) <input type="checkbox"/> Interview Summary (PTO-413)
Paper No(s)/Mail Date. _____ |
| 2) <input type="checkbox"/> Notice of Draftsperson's Patent Drawing Review (PTO-948) | 5) <input type="checkbox"/> Notice of Informal Patent Application (PTO-152) |
| 3) <input checked="" type="checkbox"/> Information Disclosure Statement(s) (PTO-1449 or PTO/SB/08)
Paper No(s)/Mail Date <u>12/5/05</u> . | 6) <input type="checkbox"/> Other: _____ |

DETAILED ACTION

Claim Rejections - 35 USC § 102

The following is a quotation of the appropriate paragraphs of 35 U.S.C. 102 that form the basis for the rejections under this section made in this Office action:

A person shall be entitled to a patent unless –

(b) the invention was patented or described in a printed publication in this or a foreign country or in public use or on sale in this country, more than one year prior to the date of application for patent in the United States.

Claims 1, 8, 10-13 and 20 are rejected under 35 U.S.C. 102(b) as being anticipated by Smolanoff et al. (6,117,279).

With respect to claim 1, Smolanoff et al. disclose providing pulsed DC power (21) through a filter (22) to a target (16) (Col. 5, lines 50-55); providing RF bias power to a substrate (15) positioned opposite the target (Col. 5, lines 60-65); providing process gas between the target and the substrate (Col. 7, lines 25-28); wherein the filter protects a pulsed DC power supply (21) from the bias power, and wherein a plasma is created by application of the pulsed DC power to the target (Col. 6, lines 8-13); and wherein the film is deposited by exposure of the substrate to the plasma (Col. 6, lines 30-33).

With respect to claim 8, Smolanoff et al. disclose wherein the process gas includes a mixture of oxygen and argon (Col. 7, lines 21-27).

With respect to claim 10, Smolanoff et al. disclose wherein the process gas further includes nitrogen (Col. 7, lines 25-26).

With respect to claim 11, Smolanoff et al. disclose wherein providing pulsed DC power to a target includes providing pulsed DC power to a target which has an area larger than that of the substrate (See fig. 1).

With respect to claim 12, Smolanoff et al. disclose further including uniformly sweeping the target with a magnetic field (Col. 6, lines 1-7).

With respect to claim 13, Smolanoff et al. disclose wherein uniformly sweeping the target with a magnetic field includes sweeping a magnet in one direction across the target where the magnet extends beyond the target in the opposite direction (Col. 6, lines 1-6).

With respect to claim 20, Smolanoff et al. disclose conditioning a target; preparing the substrate; adjusting the bias power to the substrate; setting the process gas flow; and applying pulsed DC power to the target to deposit the film (Col. 5, line 55-Col. 7, line 50).

Claim Rejections - 35 USC § 103

The following is a quotation of 35 U.S.C. 103(a) which forms the basis for all obviousness rejections set forth in this Office action:

(a) A patent may not be obtained though the invention is not identically disclosed or described as set forth in section 102 of this title, if the differences between the subject matter sought to be patented and the prior art are such that the subject matter as a whole would have been obvious at the time the invention was made to a person having ordinary skill in the art to which said subject matter pertains. Patentability shall not be negated by the manner in which the invention was made.

Claims 2-6 are rejected under 35 U.S.C. 103(a) as being unpatentable over Smolanoff et al. as applied to claims 1, 8, 10-13 and 20 above, and further in view of Fukui et al. (5,755,938).

With respect to claims 2-4 and 6, One of ordinary skill in the art would have been led to the recited temperature, DC power, time pulse and bias power to routine experimentation to achieve a desire layer thickness, device dimension, device

associated characteristics and device density on the finished wafer in view of the range of values disclosed.

In addition, the selection of temperature, DC power, time pulse and bias power, its obvious because it is a matter of determining optimum process conditions by routine experimentation with a limited number of species of result effective variables. These claims are prima facie obvious without showing that the claimed ranges achieve unexpected results relative to the prior art range. In re Woodruff, 16 USPQ2d 1935, 1937 (Fed. Cir. 1990). See also In re Huang, 40 USPQ2d 1685, 1688 (Fed. Cir. 1996)(claimed ranges or a result effective variable, which do not overlap the prior art ranges, are unpatentable unless they produce a new and unexpected result which is different in kind and not merely in degree from the results of the prior art). See also In re Boesch, 205 USPQ 215 (CCPA) (discovery of optimum value of result effective variable in known process is ordinarily within skill or art) and In re Aller, 105 USPQ 233 (CCPA 1995) (selection of optimum ranges within prior art general conditions is obvious).

Note that the specification contains no disclosure of either the critical nature of the claimed temperature, DC power, time pulse and bias power or any unexpected results arising therefrom. Where patentability is said to be based upon particular chosen temperature, DC power, time pulse and bias power or upon another variable recited in a claim, the Applicant must show that the chosen temperature, DC power, time pulse and bias power are critical. In re Woodruff, 919 F.2d 1575, 1578, 16 USPQ2d 1934, 1936 (Fed. Cir. 1990).

With respect to claim 5, Smolanoff et al. do not specifically disclose wherein the filter is a band reject filter at the frequency of the bias power.

Fukui et al. disclose a sputtering process wherein the DC power supply (28) is connected through a band-pass filter (27) at the frequency of the bias power.

It would have been within the scope of one of ordinary skill in the art to combine the teachings of Smolanoff et al. and Fukui et al. to enable the filter type of Smolanoff et al. to be the same according to the teachings of Fukui et al. because one of ordinary skill in the art would have been motivated to look to alternative suitable types of filters for the disclosed filter step of Smolanoff et al. and art recognized suitability for an intended purpose has been recognized to be motivation to combine. See MPEP 2144.07.

Claims 7 and 9 are rejected under 35 U.S.C. 103(a) as being unpatentable over Smolanoff et al. as applied to claims 1, 8, 10-13 and 20 above, and further in view of Le et al. (2003/0077914).

Smolanoff et al. do not disclose wherein the film is an upper cladding layer of a waveguide structure and the bias power is optimized to provide planarization.

With respect to claim 7, Le et al. disclose wherein the film is an upper cladding layer of a waveguide structure and the bias power is optimized to provide planarization
Page 5, Paragraph [0075].

It would have been within the scope of one of ordinary skill in the art to combine the teachings of Smolanoff et al. and Le et al. to enable the film material of Smolanoff et al. to be the same according to the teachings of Le et al. because one of ordinary skill in the art would have been motivated to look to alternative suitable film materials for the disclosed film formation step of Smolanoff et al. and art recognized suitability for an intended purpose has been recognized to be motivation to combine. See MPEP 2144.07.

With respect to claim 9, Le et al. disclose wherein the oxygen flow is adjusted to adjust the index of refraction of the film (Page 5, Paragraph [0076]).

Allowable Subject Matter

Claims 14 and 21-24 are allowed.

Response to Arguments

Applicant's arguments filed 12/5/05 have been fully considered but they are not persuasive. Applicant argues that deposition is performed by exposing the substrate to the secondary plasma, not the main plasma adjacent to the sputtering target. However, the process of Col. 5- Col. 6 of Smolanoff et al. deposits a thin film on the substrate 15 by exposure to the main plasma (Col. 6, lines 30-33). The additional teachings of the reference, like creating a secondary plasma, do not render invalid the teachings relied on.

Applicant argues that Smolanoff has enabled utilization of a DC power supply, but not a pulsed DC power supply. However, Smolanoff discloses that a pulsed DC power can be used and would work in the process described at Col. 5-Col. 6.

Conclusion

THIS ACTION IS MADE FINAL. Applicant is reminded of the extension of time policy as set forth in 37 CFR 1.136(a).

A shortened statutory period for reply to this final action is set to expire **THREE MONTHS** from the mailing date of this action. In the event a first reply is filed within **TWO MONTHS** of the mailing date of this final action and the advisory action is not mailed until after the end of the **THREE-MONTH** shortened statutory period, then the shortened statutory period will expire on the date the advisory action is mailed, and any extension fee pursuant to 37 CFR 1.136(a) will be calculated from the mailing date of the advisory action. In no event, however, will the statutory period for reply expire later than **SIX MONTHS** from the mailing date of this final action.

Any inquiry concerning this communication or earlier communications from the examiner should be directed to Michelle Estrada whose telephone number is 571-272-1858. The examiner can normally be reached on Monday through Friday.

If attempts to reach the examiner by telephone are unsuccessful, the examiner's supervisor, Matthew Smith can be reached on 571-272-1907. The fax phone number for the organization where this application or proceeding is assigned is 571-273-8300.

Any inquiry of a general nature or relating to the status of this application or proceeding should be directed to the receptionist whose telephone number is 571-272-2800.

Information regarding the status of an application may be obtained from the Patent Application Information Retrieval (PAIR) system. Status information for published applications may be obtained from either Private PAIR or Public PAIR. Status information for unpublished applications is available through Private PAIR only. For more information about the PAIR system, see <http://pair-direct.uspto.gov>. Should you have questions on access to the Private PAIR system, contact the Electronic Business Center (EBC) at 866-217-9197 (toll-free).



Michelle Estrada
Primary Examiner
Art Unit 2823

ME
February 8, 2006



REPLACEMENT SHEET
Inventors: Hongmei ZHANG et al.
Application No. 10/101,863
Title: BIASED PULSE DC REACTIVE
SPUTTERING OF OXIDE FILMS

1/27

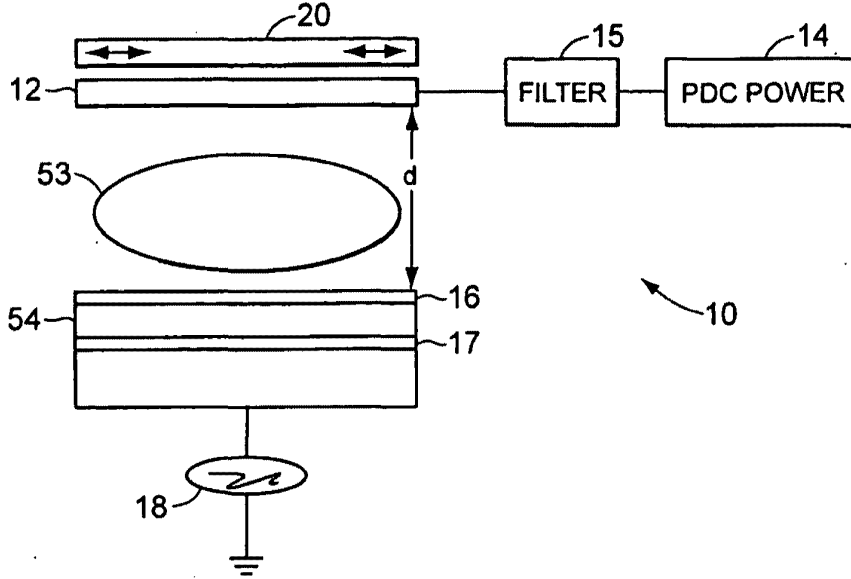

FIG. 1A

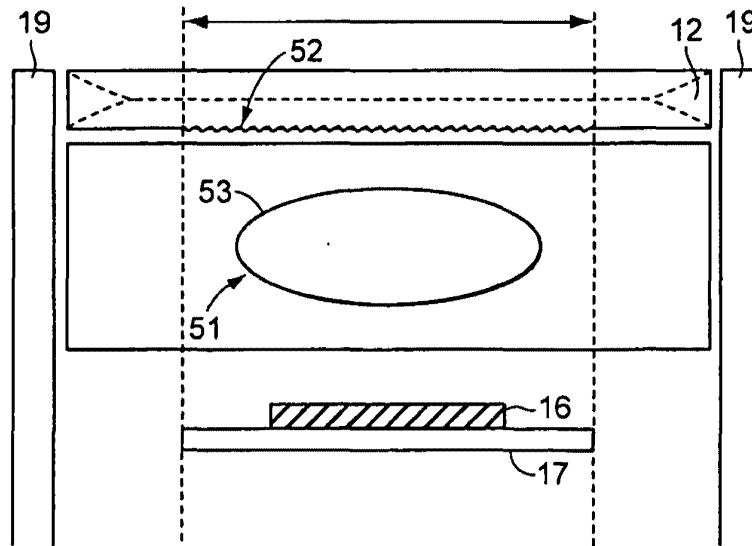

FIG. 1B

Approved
MJE
2/8/06

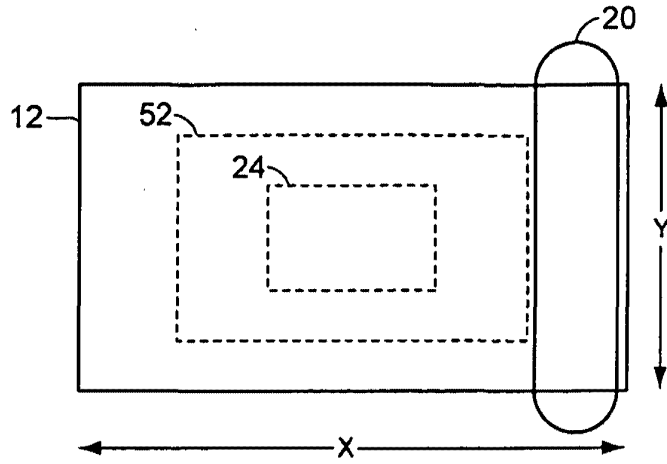

FIG. 2

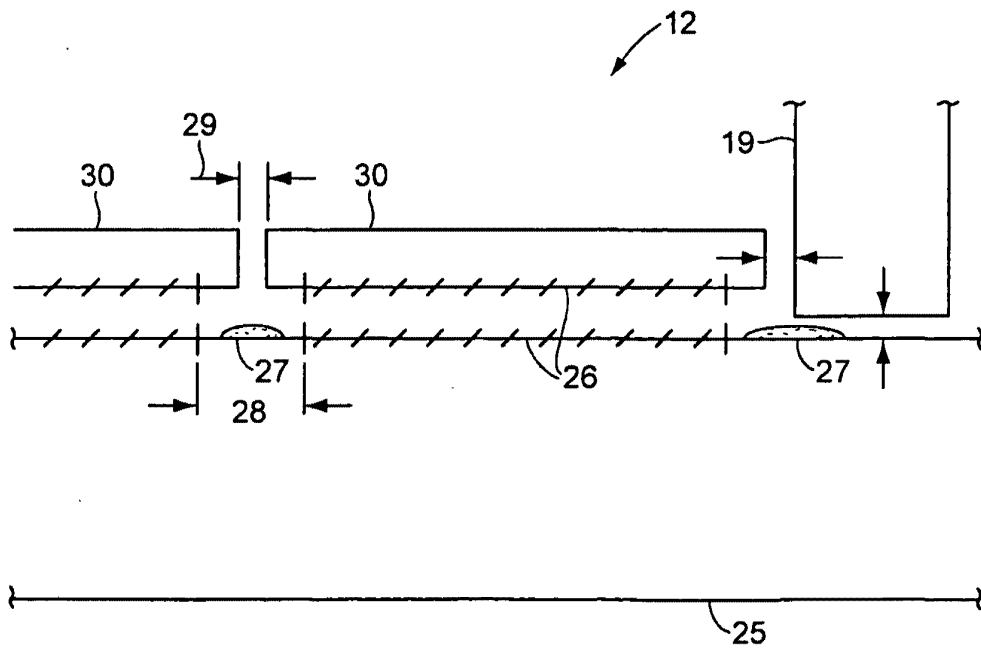

FIG. 3



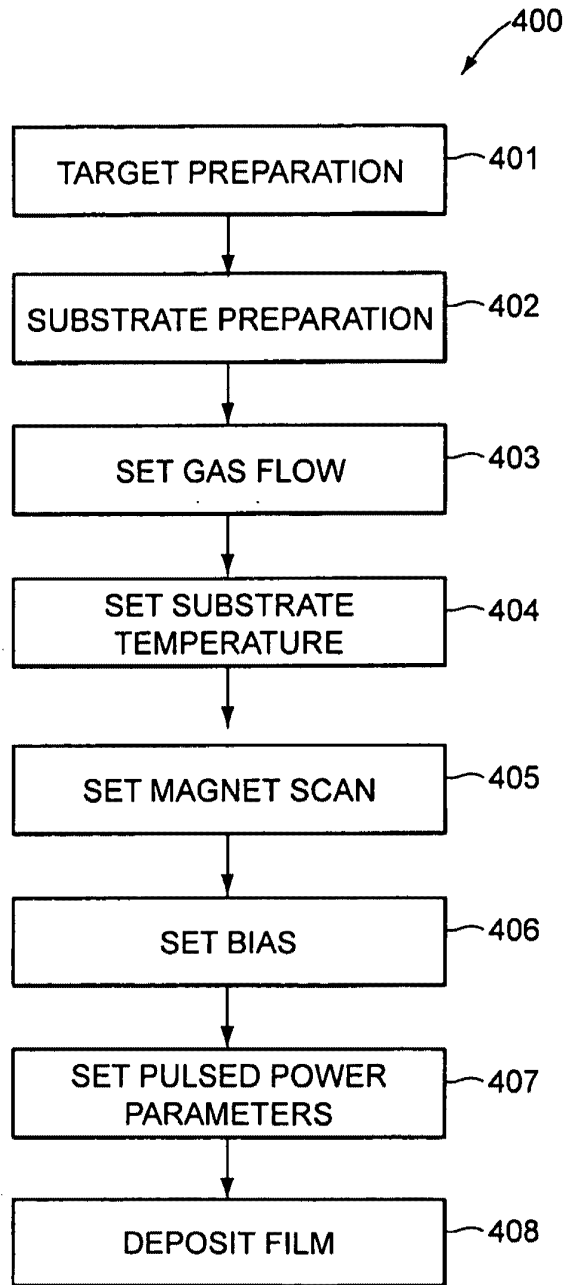

FIG. 4

4/27

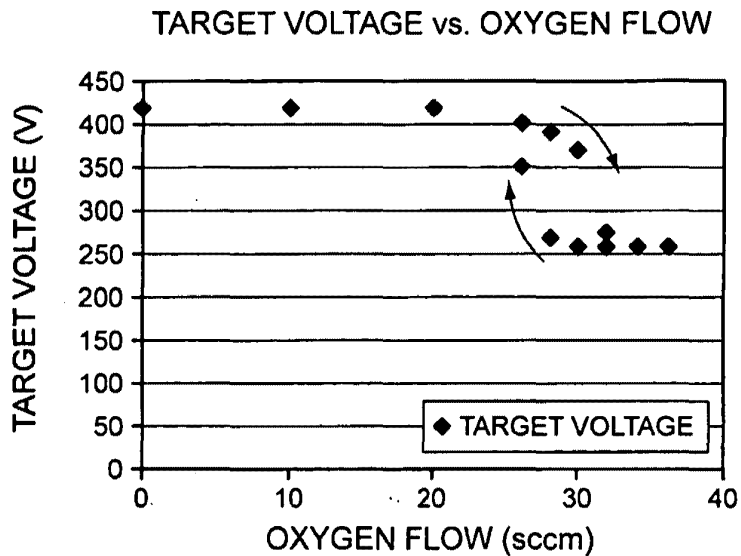

FIG. 5

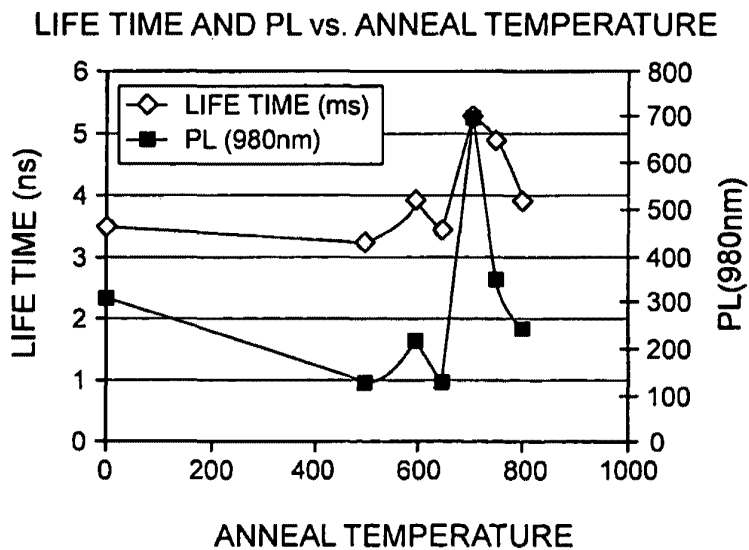

FIG. 6

Alumino Silicates Index Drift in Burn-in Cycle
(As Deposited from Al/Si Cast Metal Targets)

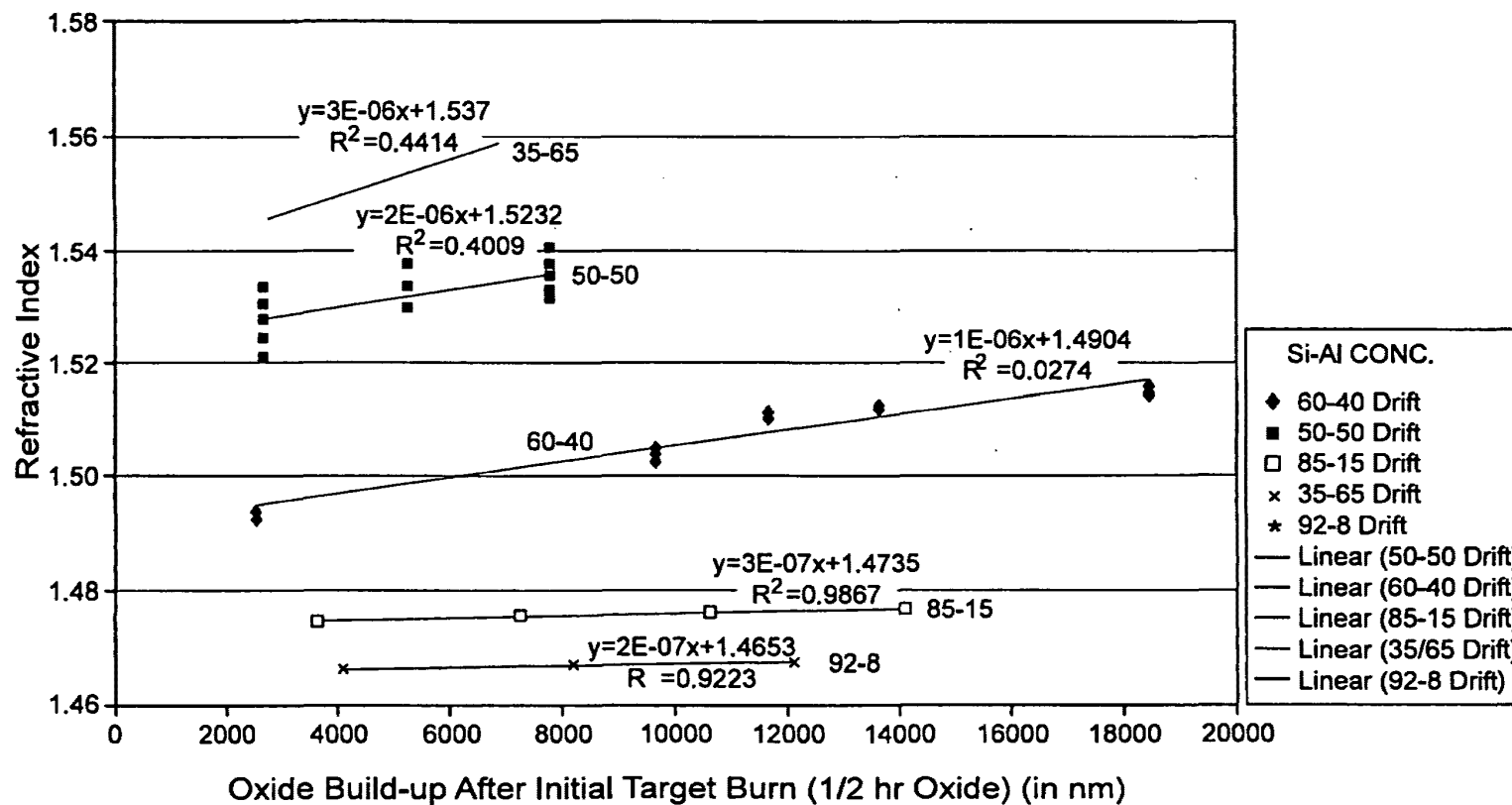

FIG. 7

5/27

REPLACEMENT SHEET
Inventors: Hongmei ZHANG et al.
Application No. 10/101,863
Title: BIASED PULSE DC REACTIVE
SPUTTERING OF OXIDE FILMS

Refractive Index as a Function of Al% in Aluminosilicates

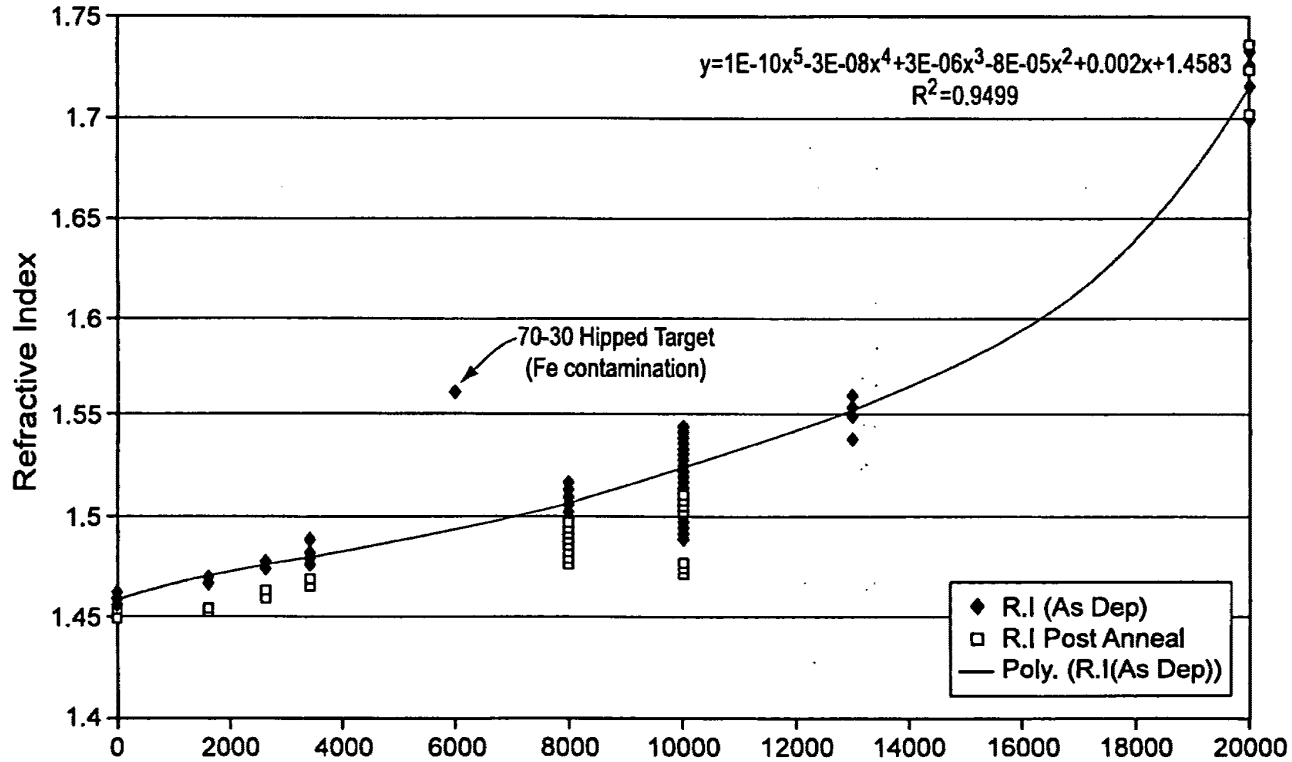

FIG. 8

REPLACEMENT SHEET
 Inventors: Hongmei ZHANG et al.
 Application No. 10/101,863
 Title: BIASED PULSE DC REACTIVE
 SPUTTERING OF OXIDE FILMS

6/27

Material (Er/Yb/Al/Si)	Expected index (Post anneal)	Actual index (Post anneal)	Process Conditions (Annealed 725c 30min)
0.8/0.8/41.4/57	1.506	1.510	6KW, Ar-60,02-28sccm, 120Khz, 2.2us, 60mm T-W Space, 4-5mm T-M Space, 0-400W Bias
1.6/0.5/49/48.9	1.526	1.528	6KW, Ar-60,02-28sccm, 120Khz, 2.2us, 60mm T-W Space, 4-5mm T-M Space, 0-400W Bias
0/0/8/92	1.452	1.456- 1.459	4.5KW, Ar-30-60,02-28-44, 120-200Khz, 2.2us, 60-85mm T-W Space, 4-5mm T-M Space, 0-400W Bias
0/0/40/60	1.504	1.486- 1.501	3.0-4.5KW, Ar-30,02-44, 75-200Khz, 2.2-3.0us, 60-85mm T-W Space, 4-5mm T-M Space, 0-400W Bias
0/0/50/50	1.520	1.491- 1.503	4.0-5KW, Ar-30,02-44, 75-200Khz, 2.2-3.0us, 60-85mm T-W Space, 4-5mm T-M Space, 0-400W Bias
0/0/65/35	1.544	1.545- 1.560	4.5-5.5KW, Ar-75-90,0285-100, 200Khz, 2.2us, 85mm T-W Space, 4-5mm T-M Space, 0-400W Bias
0/0/30/70	1.490	1.562 (high Fe content)	5.0KW, Ar-75,02-100, 200Khz, 2.2us, 85mm T-W Space, 4-5mm T-M Space, 0-400W Bias
1.5/0/48.5/50	1.523	1.509- 1.513	6KW, Ar-60,02-28sccm, 120Khz, 2.2us, 60mm T-W Space, 4-5mm T-M Space, 0-400W Bias

FIG. 9

7/27

REPLACEMENT SHEET
 Inventors: Hongmei ZHANG et al.
 Application No. 10/101,863
 Title: BIASED PULSE DC REACTIVE
 SPUTTERING OF OXIDE FILMS

Bias Power (Watts)	DC Power (KW)	Pulsing Freq (KHz)	Reverse Time (μ s)	Ar Flow (sccms)	O2 Flow (sccms)	Wafer Position	Target To Wafer Spacing (mm)	Refractive Index Avg (@1550nm)	Refractive Index STD (@1550nm)	Dep Rate (μ m/Hr)
150	4.5	200	2.2	100	100	1	55	1.461508	0.000535	0.957654
150	4.5	200	2.2	100	100	2	55	1.462329	0.000376	0.962581
400	4.5	200	2.2	100	100	1	55	1.462774	0.000103	0.814007
400	4.5	200	2.2	100	100	2	55	1.463583	0.000095	0.824566

REPLACEMENT SHEET
 Inventors: Hongmei ZHANG et al.
 Application No. 10/101,863
 Title: BIASED PULSE DC REACTIVE
 SPUTTERING OF OXIDE FILMS

8/27

FIG. 10

9/27

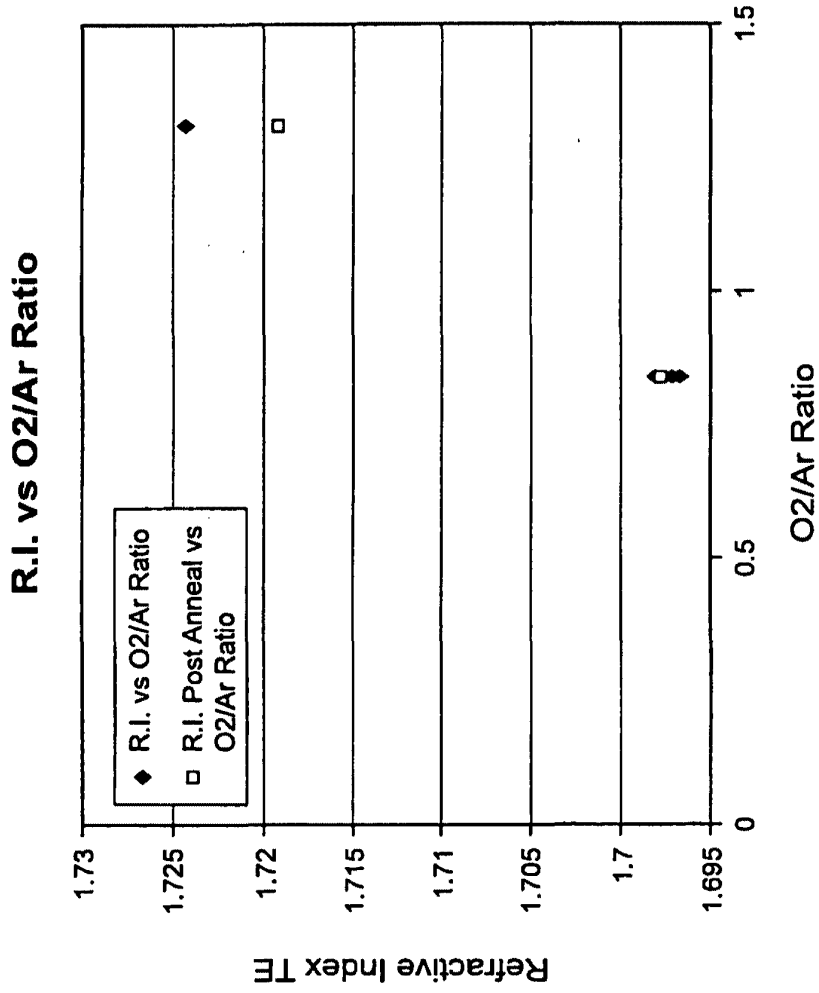

FIG. 11

10/27

+

R.I. Vs Pulsing Frequency for Alumina

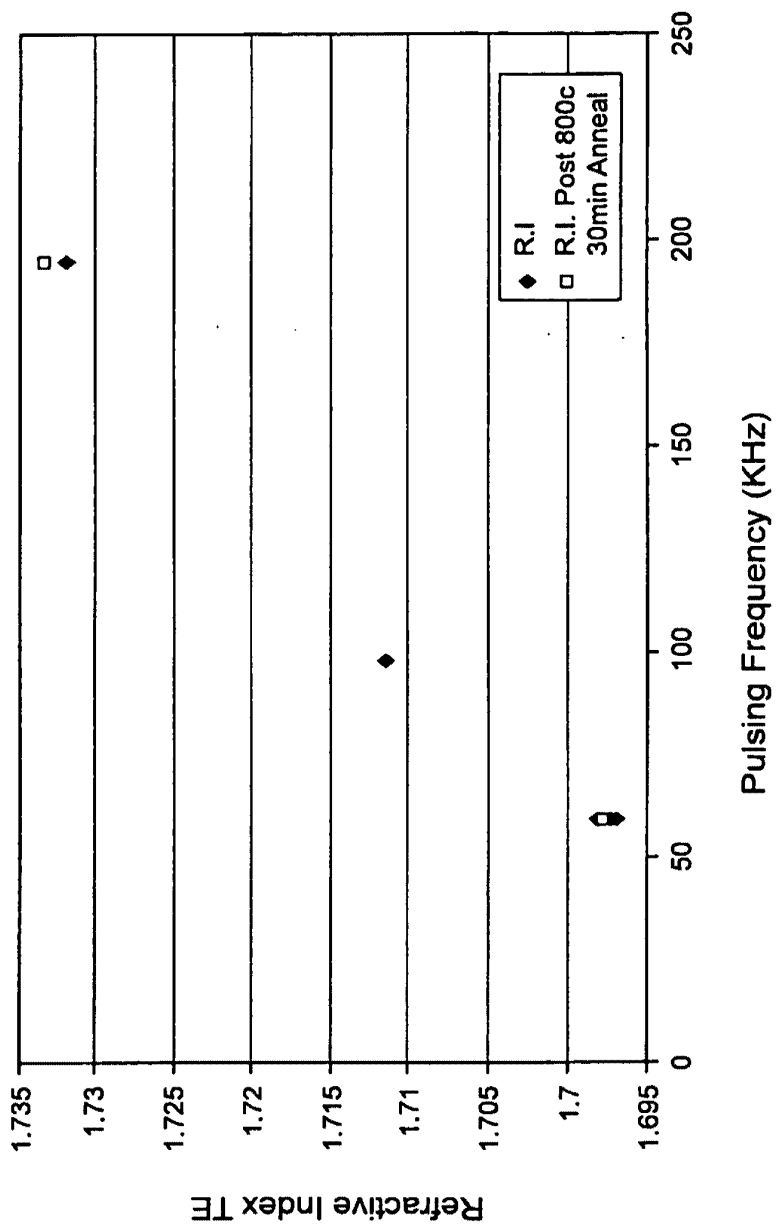

FIG. 12

+



Index and Dep Pate Drifts Pre & Post Anneal Target 92-8 AKT 4300 Based Reactor

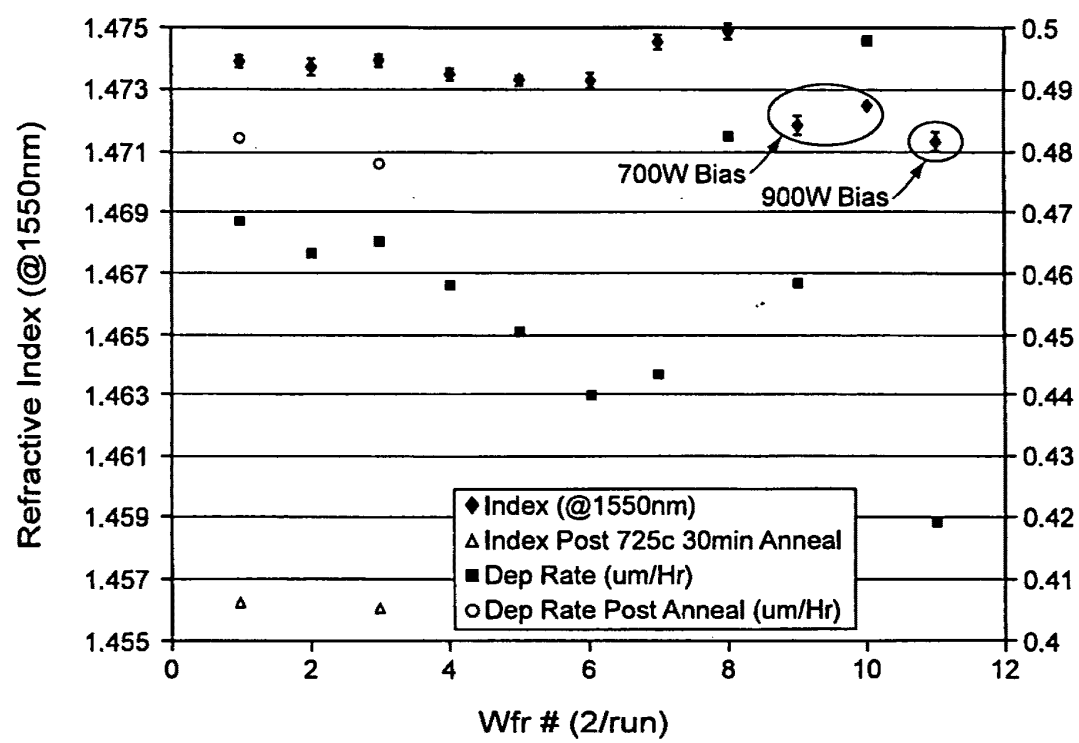

FIG. 13

REPLACEMENT SHEET
Inventors: Hongmei ZHANG et al.
Application No. 10/101,863
Title: BIASED PULSE DC REACTIVE
SPUTTERING OF OXIDE FILMS
11/27





Index Drift Control Target Comp 83-17 (AKT-1600 Based Reactor)

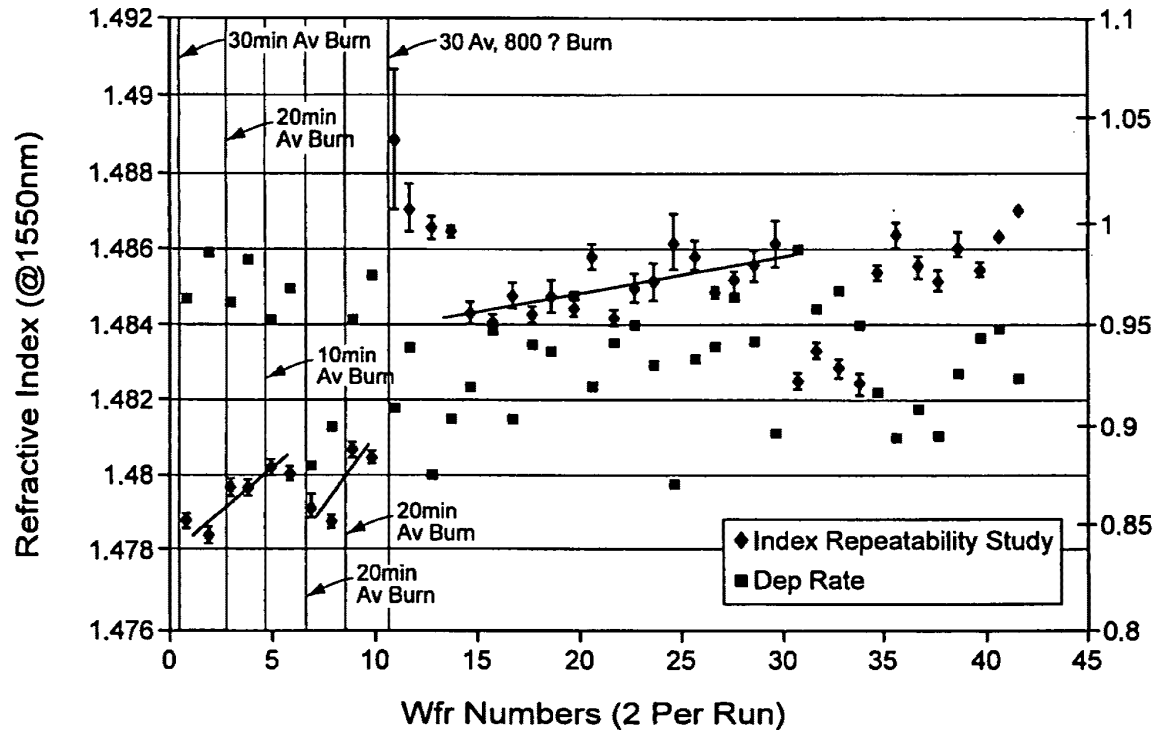

FIG. 14

12/27

REPLACEMENT SHEET
Inventors: Hongmei ZHANG et al.
Application No. 10/101,863
Title: BIASED PULSE DC REACTIVE
SPUTTERING OF OXIDE FILMS



+

Index Drift Control 83-17 Target/AKT 1600 Based Reactor

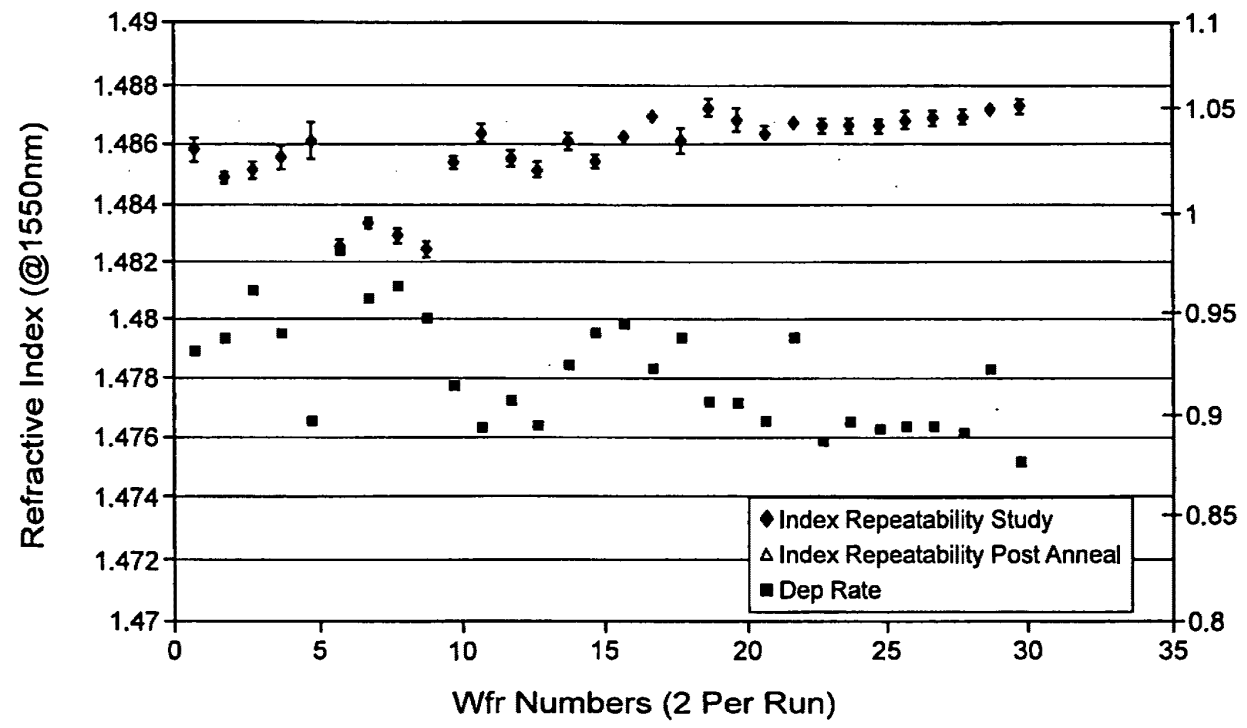

FIG. 15

REPLACEMENT SHEET
Inventors: Hongmei ZHANG et al.
Application No. 10/101,863
Title: BIASED PULSE DC REACTIVE
SPUTTERING OF OXIDE FILMS

13/27

+

+

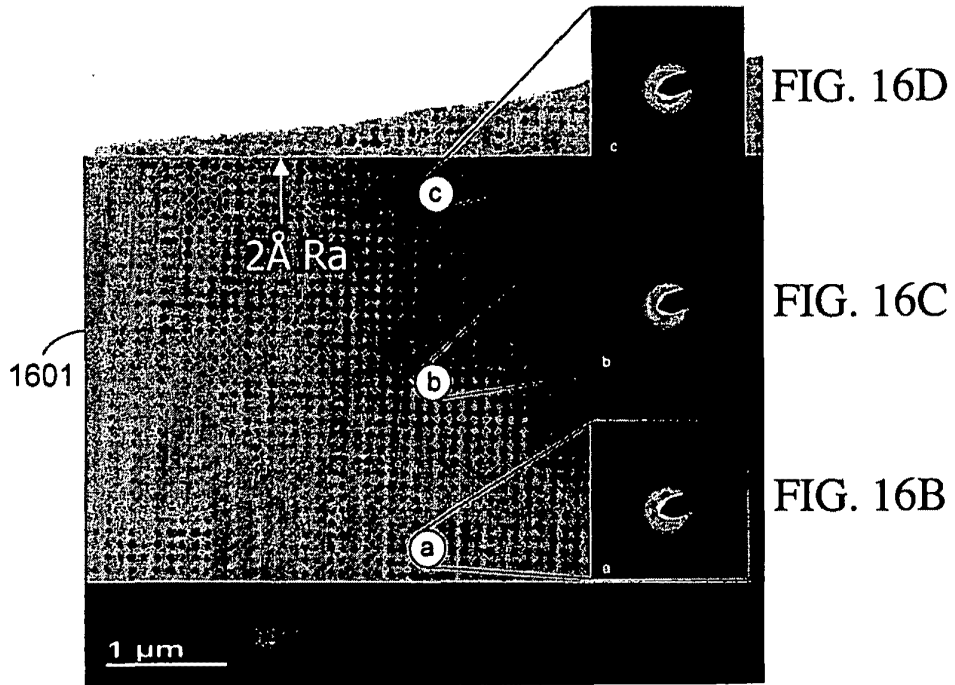

FIG. 16A

SYMMORPHIX PVD ALUMINOSILICATE

+

15/27

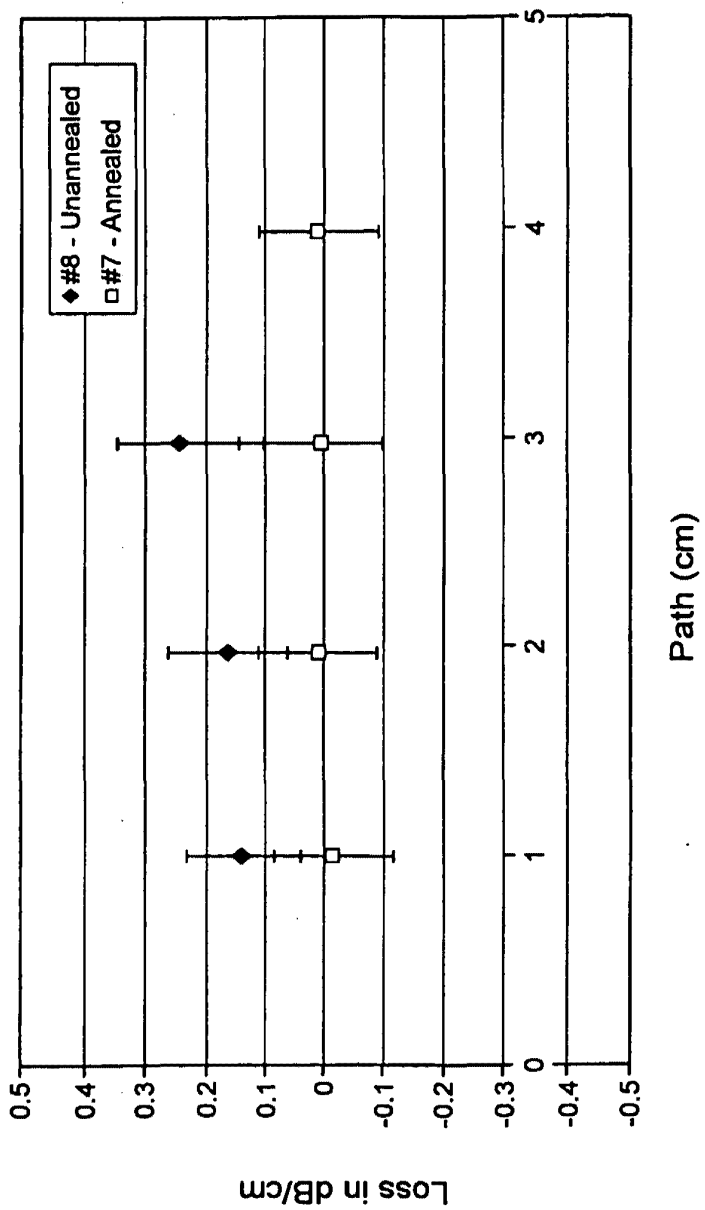

FIG. 17

16/27

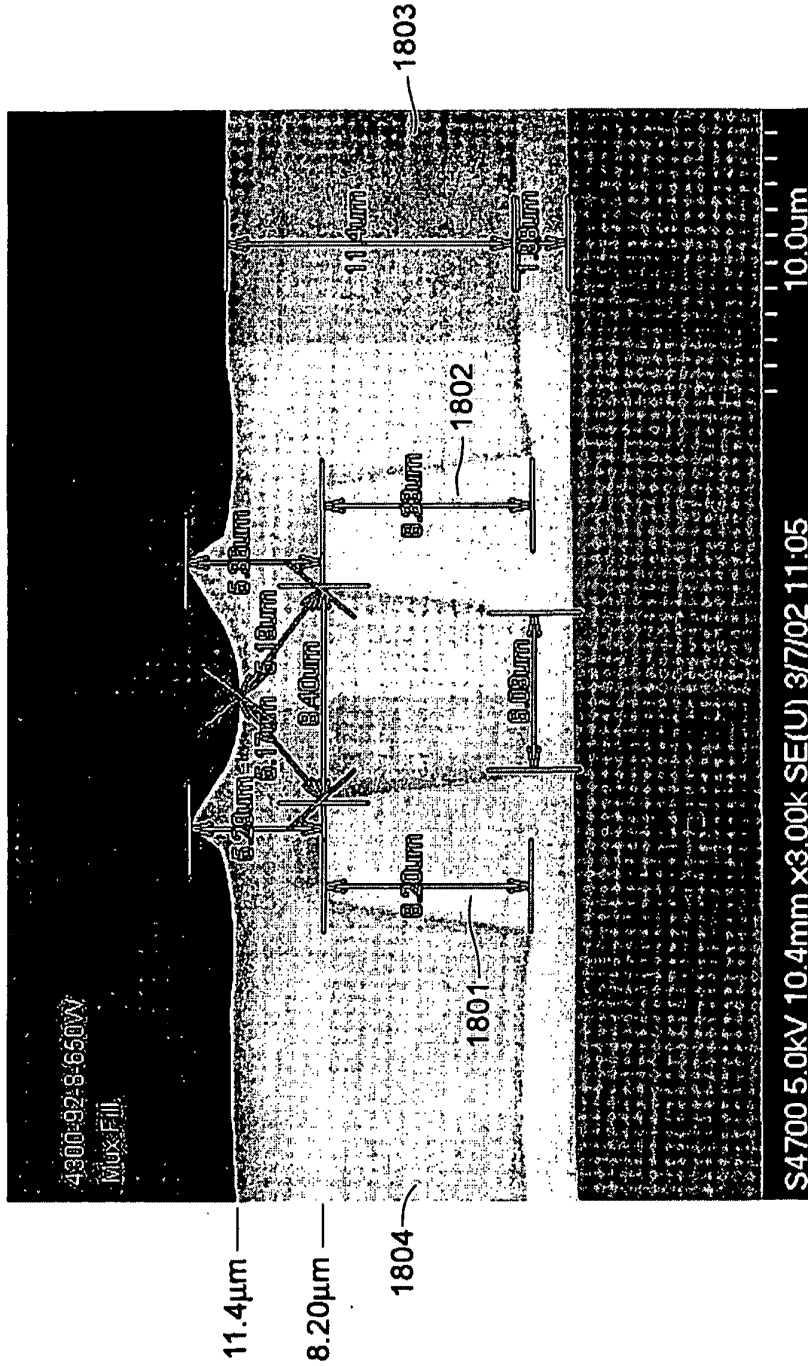

FIG. 18

17/27

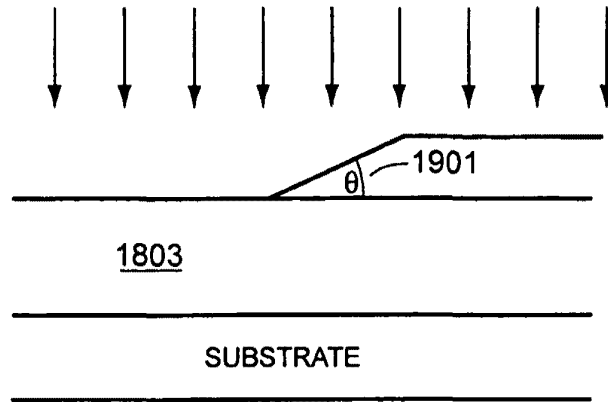

FIG. 19

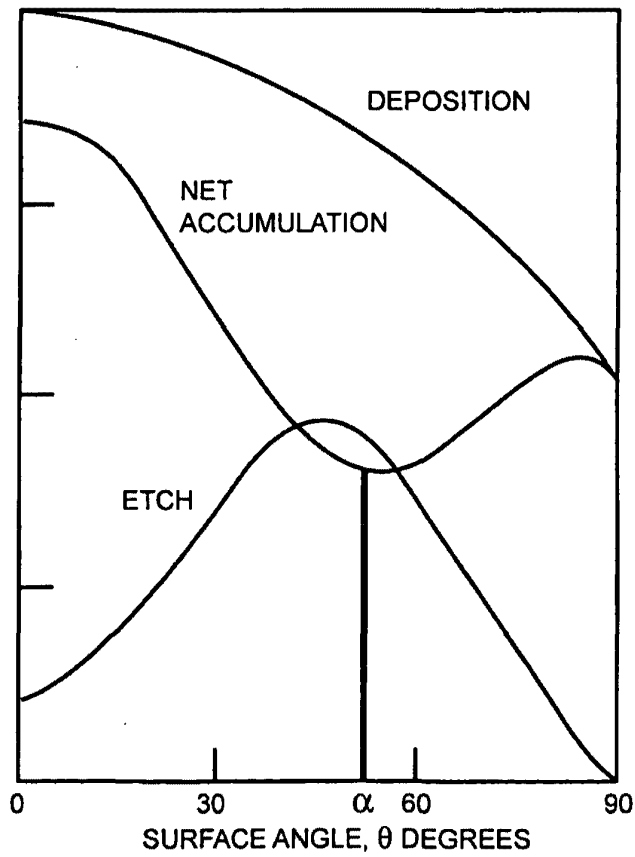

FIG. 20

18/27

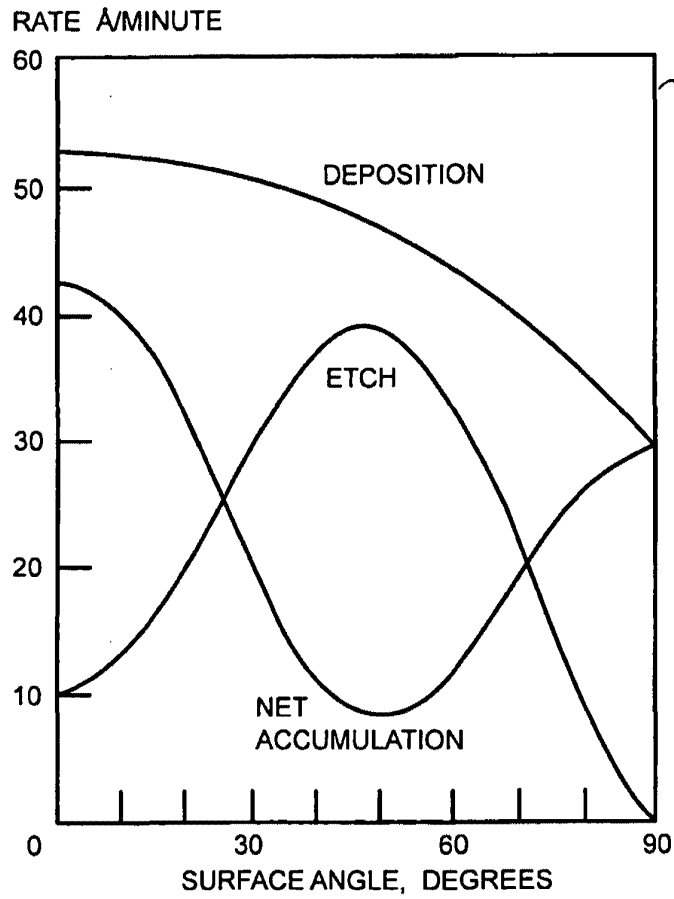

FIG. 21

+

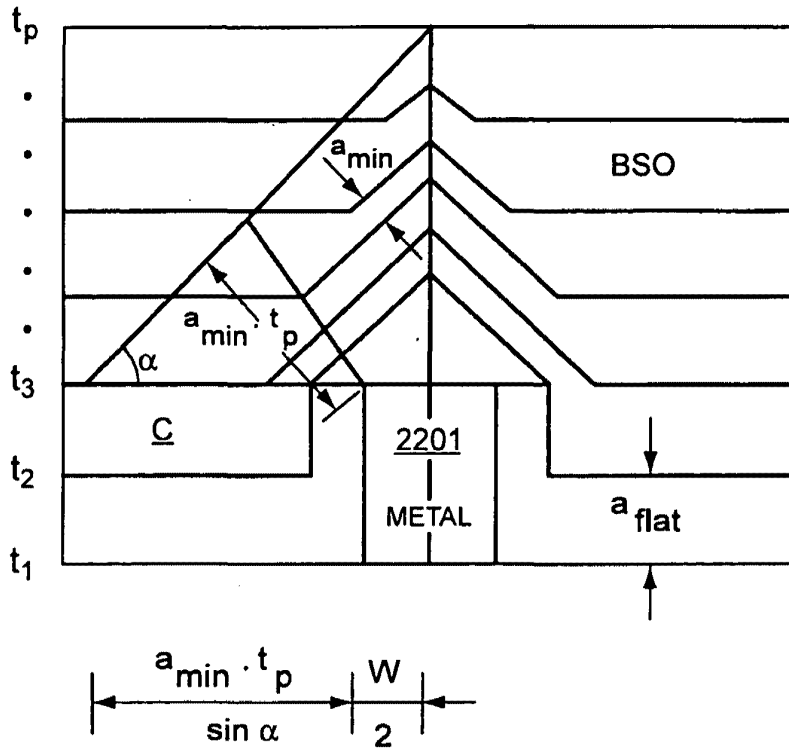

FIG. 22

+

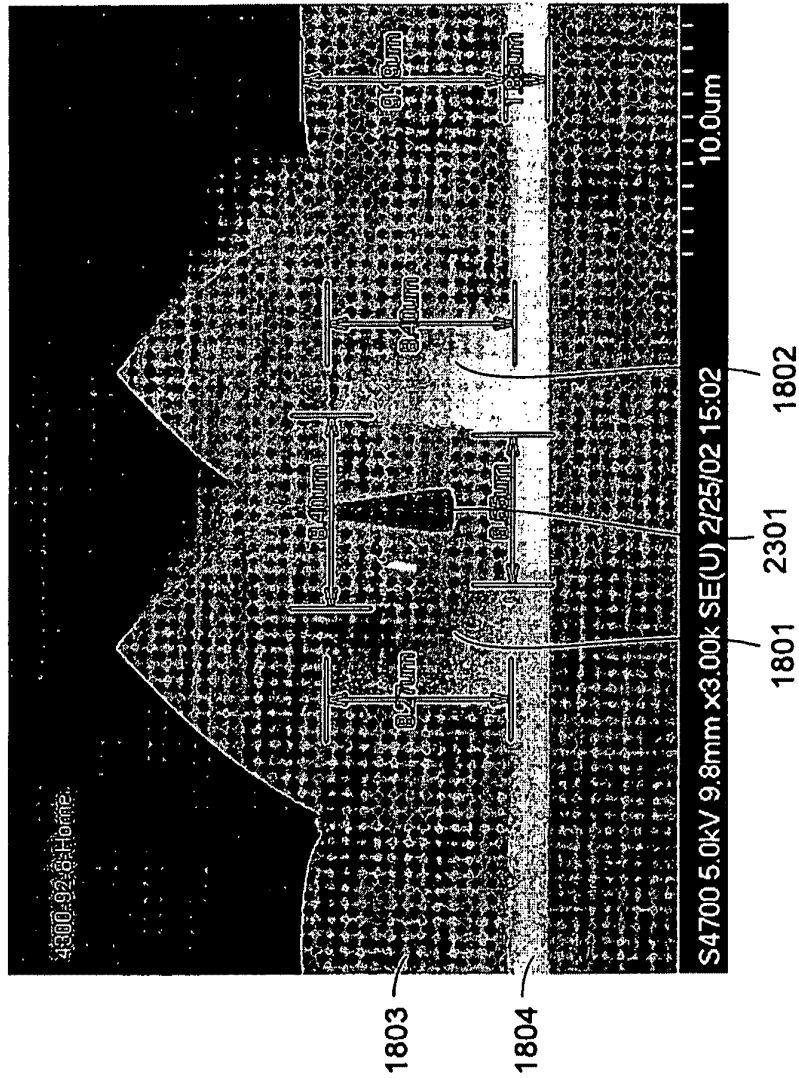

FIG. 23

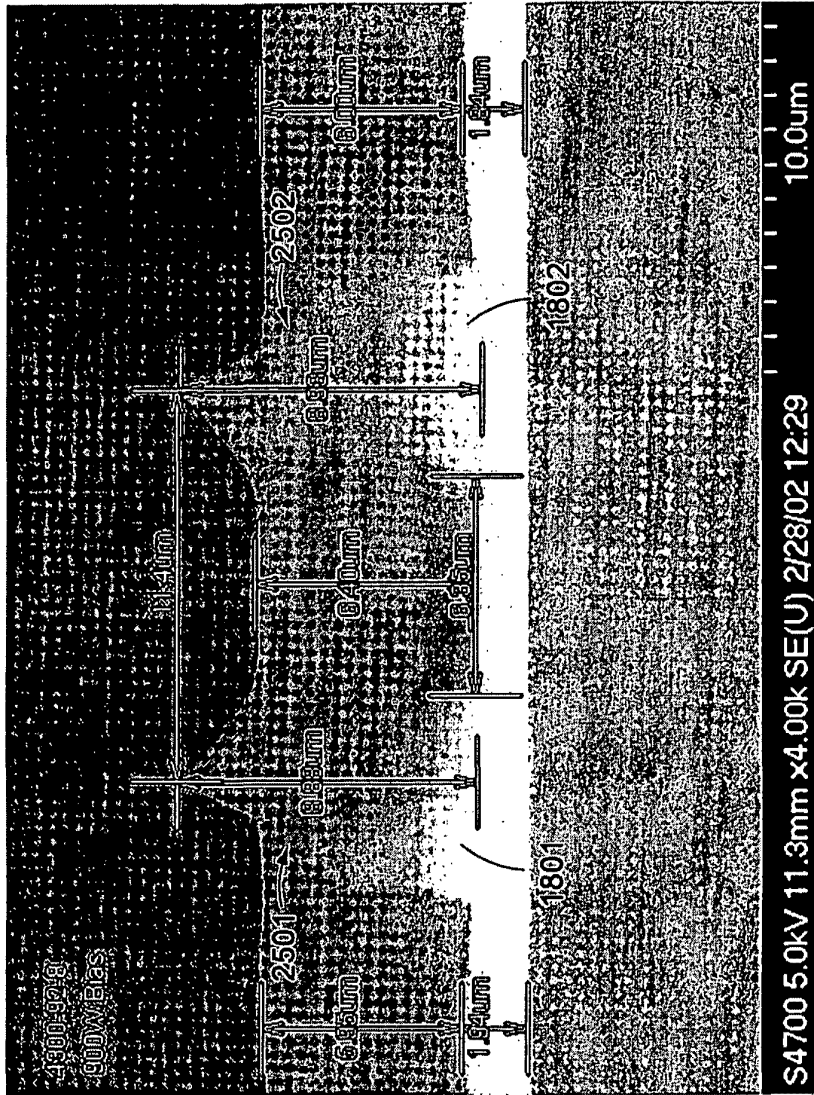

FIG. 25

+

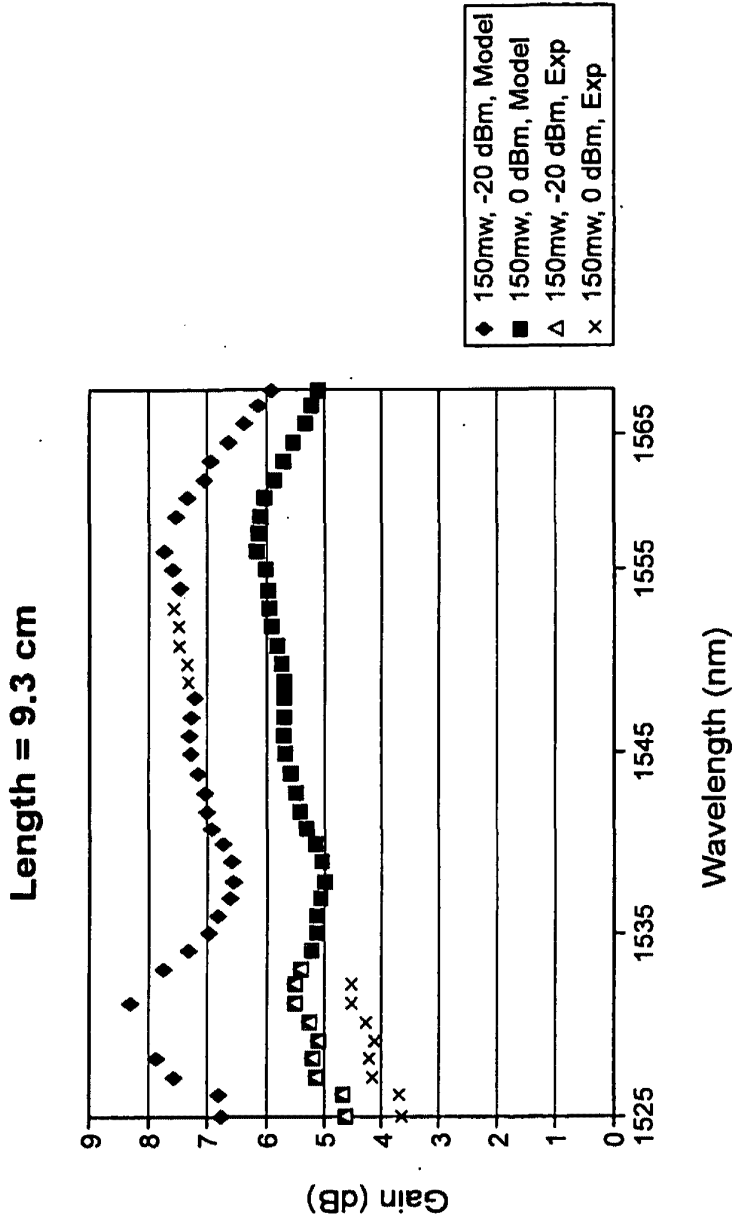

FIG. 26

+

24/27

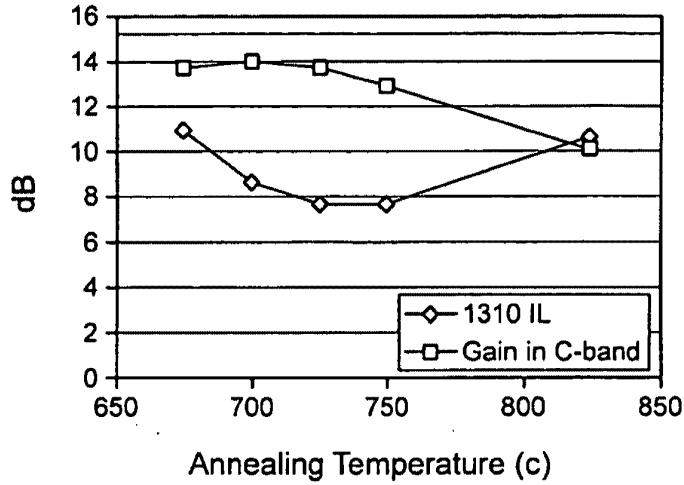

FIG. 27

Life Time and Up-conversion vs. Annealing Temperature

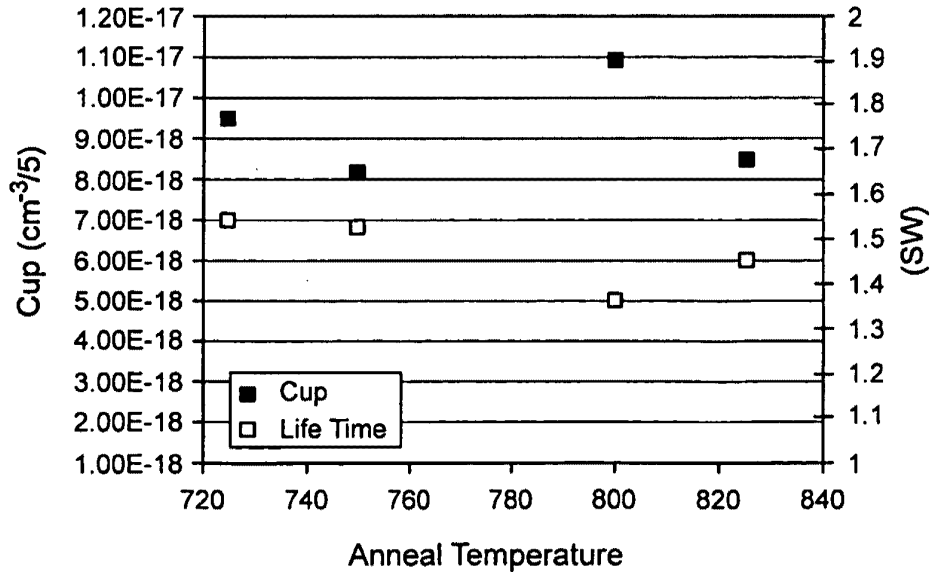

FIG. 28

25/27

+

Index and Thickness

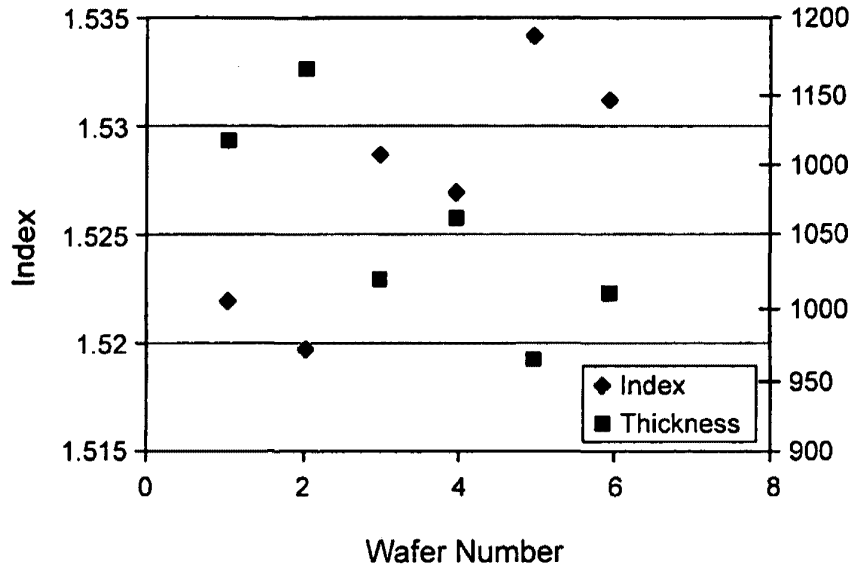

FIG. 29

532nm PL/um

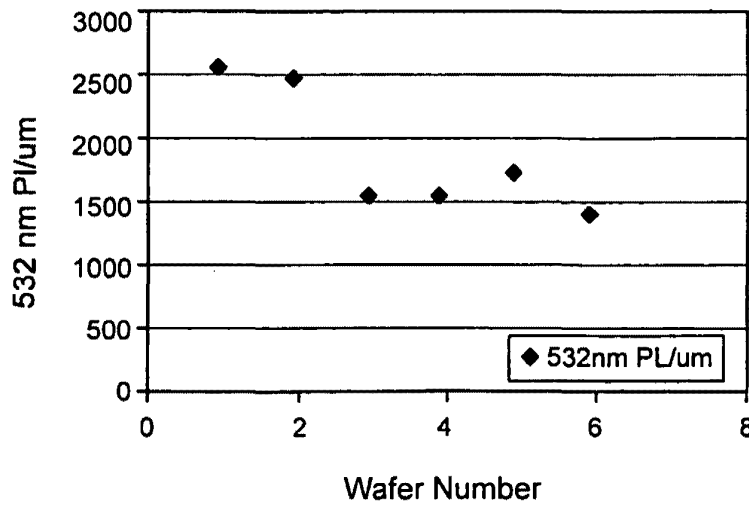

FIG. 30

+

26/27

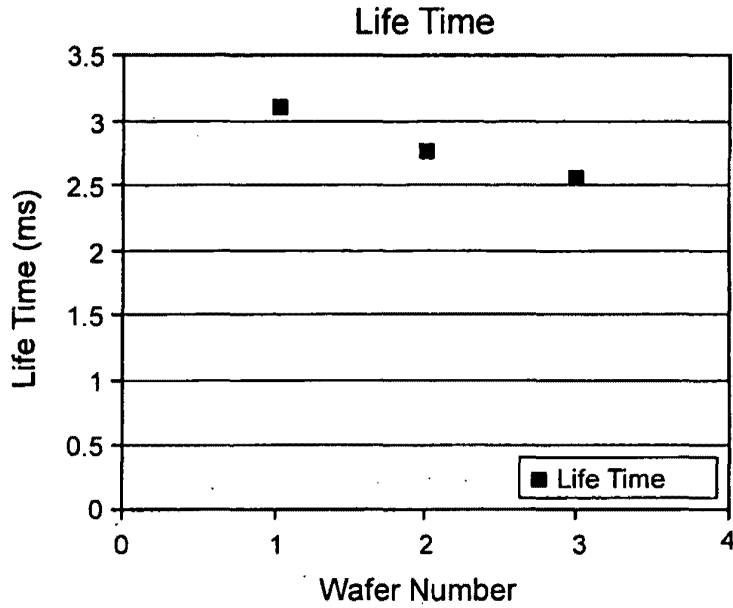

FIG. 31

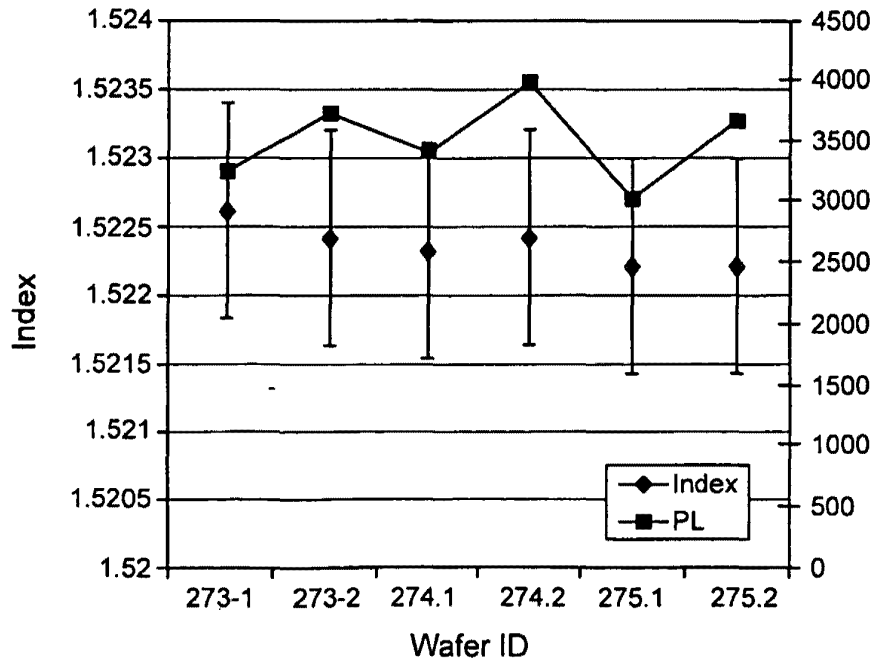

FIG. 32

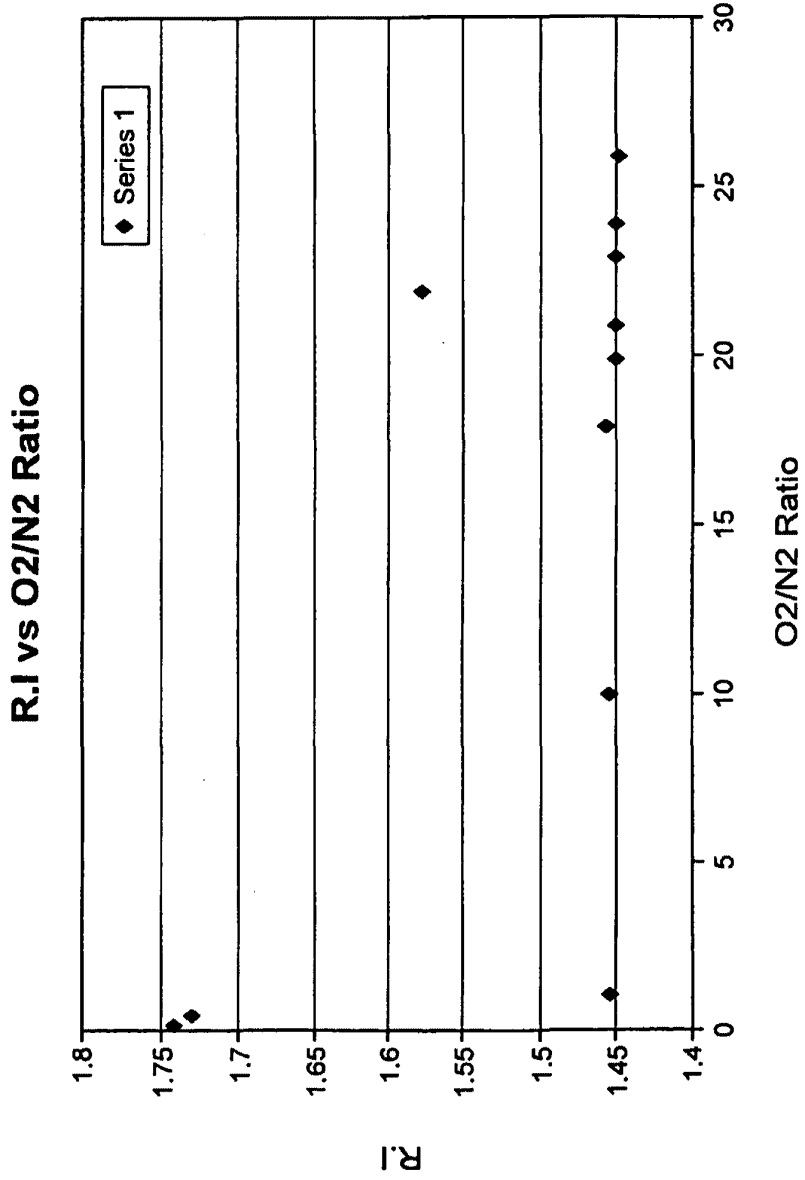
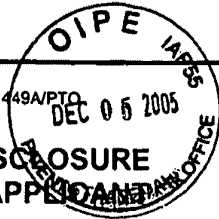

FIG. 33



IDS Form PTO/SB/08: Substitute for form 1449A/PTO			Complete if Known		
INFORMATION DISCLOSURE STATEMENT BY APPLICANT <small>(Use as many sheets as necessary)</small>			Application Number	10/101,863	
			Filing Date	March 16, 2002	
			First Named Inventor	Hongmei ZHANG	
			Art Unit	2823	
			Examiner Name	ESTRADA, Michelle	
Sheet	1	of	1	Attorney Docket Number	9140.0016-00

U.S. PATENTS AND PUBLISHED U.S. PATENT APPLICATIONS					
Examiner Initials	Cite No. ¹	Document Number	Issue or Publication Date MM-DD-YYYY	Name of Patentee or Applicant of Cited Document	Pages, Columns, Lines, Where Relevant Passages or Relevant Figures Appear
		Number-Kind Code ² (if known)			
<i>[Signature]</i>		5,478,456	12-26-1995	Humpal et al.	
		6,846,765 B2	1-25-2005	Imamura et al.	

Note: Submission of copies of U.S. Patents and published U.S. Patent Applications is not required.

FOREIGN PATENT DOCUMENTS						
Examiner Initials	Cite No. ¹	Foreign Patent Document	Publication Date MM-DD-YYYY	Name of Patentee or Applicant of Cited Document	Pages, Columns, Lines, Where Relevant Passages or Relevant Figures Appear	Translation ⁶
		Country Code ³ Number ⁴ Kind Code ⁵ (if known)				

NON PATENT LITERATURE DOCUMENTS			
Examiner Initials	Cite No. ¹	Include name of the author (in CAPITAL LETTERS), title of the article (when appropriate), title of the item (book, magazine, journal, serial, symposium, catalog, etc.), date, page(s), volume-issue number(s), publisher, city and/or country where published.	Translation ⁶
<i>[Signature]</i>		DOREY, R.A., "Low temperature micromoulding of functional ceramic devices," Grant summary for GR/S84156/01 for the UK Engineering and Physical Sciences Research Council, 2 pages (2004).	
<i>[Signature]</i>		HOWSON, R.P., "The reactive sputtering of oxides and nitrides," <i>Pure & Appl. Chem.</i> 66(6):1311-1318 (1994).	
<i>[Signature]</i>		Office Action issued September 21, 2005 in U.S. Application No. 11/100,856 (Attorney Docket No. 09140.0015-01).	
<i>[Signature]</i>		Office Action issued on August 8, 2005 in U.S. Serial No. 10/101,341 (Attorney Docket No. 09140-0017-00).	
<i>[Signature]</i>		Office Action issued on October 3, 2005 in U.S. Application No. 10/650,461 (Attorney Docket No. 09140-0025-00).	
<i>[Signature]</i>		Office Action issued on October 19, 2005 in U.S. Application No. 10/851,542 (Attorney Docket No. 09140.0033-00).	

EXPRESS MAIL LABEL NO.
EV 758329165 US

Examiner Signature	<i>Michelle Estrada</i>	Date Considered	2/8/06
--------------------	-------------------------	-----------------	--------

EXAMINER: Initial if reference considered, whether or not citation is in conformance with MPEP 609. Draw line through citation if not in conformance and not considered. Include copy of this form with next communication to applicant.



PATENT
Customer No. 22,852
Attorney Docket No. 9140.0016-00

IN THE UNITED STATES PATENT AND TRADEMARK OFFICE

In re Application of:)	
)	
ZHANG, Hongmei et al.)	Group Art Unit: 2823
)	
Application No.: 10/101,863)	Examiner: ESTRADA, Michelle
)	
Filed: March 16, 2002)	
)	
For: BIASED PULSE DC REACTIVE)	Confirmation No.: 6938
SPUTTERING OF OXIDE FILMS)	

MAIL STOP RCE
Commissioner for Patents
P.O. Box 1450
Alexandria, VA 22313-1450

Sir:

AMENDMENT AND RESPONSE TO OFFICE ACTION

In reply to the Office Action mailed February 14, 2006, and filed concurrently with a Request for Continued Examination, Applicants propose that this application be amended as follows:

Amendments to the Claims are reflected in the listing of claims in this paper beginning on page 2.

Remarks/Arguments follow the amendment sections of this paper beginning on page 5.

AMENDMENTS TO THE CLAIMS:

This listing of claims will replace all prior versions and listings of claims in the application:

1. (Cancelled)
2. (Currently Amended): The method of Claim ~~4~~21, further including holding the temperature of the substrate substantially constant.
3. (Currently Amended): The method of Claim ~~4~~21, wherein ~~providing~~applying pulsed DC power through the filter includes supplying up to about 10 kW of power at a frequency of between about 40 kHz and about 350 kHz and a reverse time pulse between about 1.3 and 5 μ s.
4. (Currently Amended): The method of Claim ~~4~~21, wherein ~~providing~~adjusting an RF bias power to the substrate includes supplying up to 1000 W of RF power to the substrate.
5. (Currently Amended): The method of Claim 4, wherein the filter is a band rejection filter at the frequency of the bias power.
6. (Currently Amended): The method of claim 4, wherein the RF bias power is zero.
7. (Currently Amended): The method of Claim ~~4~~21, wherein the film is an upper cladding layer of a waveguide structure and the RF bias power is optimized to provide planarization.
8. (Currently Amended): The method of Claim ~~4~~21, wherein ~~the~~a process gas of the process gas flow includes a mixture of Oxygen and Argon.
9. (Currently Amended): The method of Claim ~~9~~8, wherein the ~~Oxygen flow~~mixture is adjusted to adjust the index of refraction of the film.
10. (Currently Amended): The method of Claim 8, wherein the ~~process gas~~mixture further includes nitrogen.
11. (Currently Amended): The method of Claim ~~4~~21, wherein ~~providing~~applying pulsed DC power to ~~the~~a target includes ~~providing~~adjusting pulsed DC power to a target which has an area

larger than that of the substrate.

12. (Currently Amended): The method of Claim ~~12~~21, further including uniformly sweeping the target with a magnetic field.

13. (Previously Presented): The method of Claim 12, wherein uniformly sweeping the target with a magnetic field includes sweeping a magnet in one direction across the target where the magnet extends beyond the target in the opposite direction.

14. (Previously Presented): A method of depositing a film on a substrate, comprising:
providing pulsed DC power through a filter to a target;
providing RF bias power to a substrate positioned opposite the target; and
providing process gas between the target and the substrate, and
depositing a film on the backside of the target,
wherein the filter protects a pulsed DC power supply from the bias power, and
wherein a plasma is created between the target and the substrate.

15.-20. (Cancelled).

21. (Currently Amended): A method of depositing a film on a substrate, comprising:
conditioning a target;
preparing the substrate;
adjusting an RF bias power to the substrate;
setting a process gas flow; and
applying pulsed DC power to the target through a filter to create a plasma and deposit the film,

wherein conditioning the target includes sputtering with the target in a metallic mode to remove the surface of the target and sputtering with the target in poisonous mode to prepare the surface.

22. (Previously Presented): The method of Claim 21, wherein setting the process gas flow includes adjusting constituents in order to adjust the index of refraction of the film.

23. (Previously Presented): The method of Claim 21, wherein applying pulsed DC power

includes setting the frequency in order to adjust the index of refraction of the film.

24. (Previously Presented): The method of Claim 21, further including adjusting a temperature of the substrate in order to adjust the index of refraction of the film.

25.-39. (Canceled).

REMARKS

Claims 1-14 and 20-24 are pending in the above identified application. The Examiner has rejected claims 1-13 and 20, and allowed claims 14 and 21-24. With this paper, Applicants have amended claims 2-12 to depend upon allowed claim 21, and amended claim 21 for a typographical error, and cancelled claims 1 and 20. Applicants reserve the right to pursue claims 1 and 20 in a separate application.

The Examiner rejected claims 1, 8, 10-13, and 20 under 35 U.S.C. § 102(b) as being anticipated by Smolanoff et al. (6,117,279). Further, the Examiner rejected claims 2-6 under 35 U.S.C. § 103(a) as being unpatentable over Smolanoff et al. and further in view of Fukui et al. (5,755,938). Without agreeing or acquiescing with the Examiner's comments regarding the claims and the prior art, Applicants have canceled claims 1 and 20 and amended claims 8, 2-6, and 10-13 to depend from allowed claim 21. Therefore, claims 2- 6, 8, and 10-13 are allowable for at least the same reasons as is claim 21.

The Examiner has allowed claims 14 and 21-24.

Conclusion

Applicant respectfully requests that this Amendment be entered by the Examiner, placing claims 2-14 and 21-24 in condition for allowance. Applicants submit that the proposed amendments of claims 2-12 and 21 do not raise new issues or necessitate the undertaking of any additional search of the art by the Examiner, since all of the elements and their relationships claimed were either earlier claimed or inherent in the claims as examined. Therefore, this Amendment should allow for immediate action by the Examiner.

In view of the foregoing remarks, Applicants submit that this claimed invention, as amended, is neither anticipated nor rendered obvious in view of the prior art references cited

against this application. Applicants therefore request the entry of this Amendment, the Examiner's reconsideration and reexamination of the application, and the timely allowance of the pending claims.

Please grant any extensions of time required to enter this response and charge any additional required fees to our deposit account 06-0916.

Respectfully submitted,

FINNEGAN, HENDERSON, FARABOW,
GARRETT & DUNNER, L.L.P.

Dated: February 24, 2006

By: _____

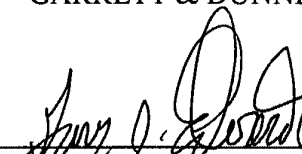

Gary J. Edwards
Reg. No. 41,008

EXPRESS MAIL LABEL NO. EV 746094839 US

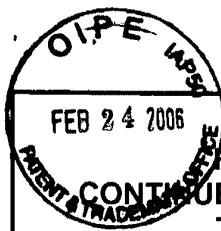

2-27-06

Rce/28235

REQUEST FOR CONTINUED EXAMINATION (RCE) TRANSMITTAL Address to: Mail Stop RCE Commissioner for Patents P.O. Box 1450 Alexandria, VA 22313-1450	Application Number: 10/101,863	Confirmation Number: 6938
	Filing Date: March 16, 2002	
	First Named Inventor: ZHANG, Hongmei	
	Group Art Unit: 2823	
	Examiner: ESTRADA, Michelle	
	Attorney Docket Number: 9140.0016-00	
Attorney Customer Number: 22,852		

This is a Request for Continued Examination (RCE) under 37 C.F.R. § 1.114 of the above-identified application.

Request for Continued Examination (RCE) practice under 37 C.F.R. § 1.114 does not apply to any utility or plant application filed prior to June 8, 1995, or to any design application.

1. **Submission required under 37 C.F.R. § 1.114: Note: If the RCE is proper, any previously filed unentered amendments and amendments enclosed with the RCE will be entered in the order in which they were filed unless applicant instructs otherwise.** If applicant does not wish to have any previously filed unentered amendment(s) entered, applicant must request non-entry of such amendment.

a. Previously submitted. If a final Office action is outstanding, any amendments filed after the final Office action may be considered as a submission even if this box is not checked.

i. Consider the arguments in the Appeal Brief or Reply Brief previously filed on _____.

ii. Other _____

b. **DO NOT ENTER** the amendment(s) previously filed on _____. An alternate submission is attached.

c. Enclosed submission: .

i. Amendment/Reply

ii. Affidavit(s)/Declaration(s)

iii. Information Disclosure Statement

iv. Other _____

2. Miscellaneous

a. Suspension of action on the above-mentioned application is requested under 37 C.F.R. § 1.103(c) for a period of months. (Period of suspension shall not exceed 3 months; fee under 37 C.F.R. § 1.17(i) required.)

b. Other _____

3. Fees

a. The filing fee is calculated as follows:

i. \$790.00 RCE fee required under 37 C.F.R. § 1.17(e)

ii. Petition for extension of time for (Months) \$

iii. Other _____

b. The Commissioner is hereby authorized to charge the fee of \$790.00 to Deposit Account No. 06-0916.

c. The Commissioner is authorized to charge any deficiencies in the filing fees, or credit any overpayments to Deposit Account No. 06-0916.

Signature of Applicant, Attorney, or Agent Required

Name: Gary J. Edwards	Reg. No.: 41,008
Signature:	Date: February 24, 2006

EXPRESS MAIL LABEL NO.
EV 746094839 US

02/27/2006 HTECKLU1 00000098 060916 10101863
 01 FC:1801 790.00 DA



PATENT
Customer No. 22,852
Attorney Docket No. 9140.0016-00

IN THE UNITED STATES PATENT AND TRADEMARK OFFICE

In re Application of:)	
)	
ZHANG, Hongmei et al.)	Group Art Unit: 2823
)	
Application No.: 10/101,863)	Examiner: ESTRADA, Michelle
)	
Filed: March 16, 2002)	
)	
For: BIASED PULSE DC REACTIVE)	Confirmation No.: 6938
SPUTTERING OF OXIDE FILMS)	

MAIL STOP RCE
Commissioner for Patents
P.O. Box 1450
Alexandria, VA 22313-1450

Sir:

FIFTH SUPPLEMENTAL INFORMATION DISCLOSURE STATEMENT
UNDER 37 C.F.R. § 1.97(b)

Pursuant to 37 C.F.R. §§ 1.56 and 1.97(b), Applicants bring to the attention of the Examiner the documents on the attached listing. This Information Disclosure Statement is being filed before the mailing date of a first Office Action after the filing of a Request for Continued Examination in the above-referenced application.

Copies of the listed foreign and non-patent literature documents are attached. Copies of the U.S. patents and patent publications are not enclosed.

Applicants respectfully request that the Examiner consider the listed documents and indicate that they were considered by making appropriate notations on the attached form.

This submission does not represent that a search has been made or that no better art exists and does not constitute an admission that each or all of the listed documents are material or

constitute "prior art." If the Examiner applies any of the documents as prior art against any claims in the application and Applicants determine that the cited documents do not constitute "prior art" under United States law, Applicants reserve the right to present to the office the relevant facts and law regarding the appropriate status of such documents.

Applicants further reserve the right to take appropriate action to establish the patentability of the disclosed invention over the listed documents, should one or more of the documents be applied against the claims of the present application.

If there is any fee due in connection with the filing of this Statement, please charge the fee to our Deposit Account No. 06-0916.

Respectfully submitted,

FINNEGAN, HENDERSON, FARABOW,
GARRETT & DUNNER, L.L.P.

Dated: February 24, 2006

By: _____

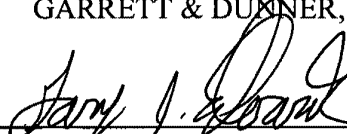
Gary J. Edwards
Reg. No. 41,008

**EXPRESS MAIL LABEL NO.
EV 746094839 US**

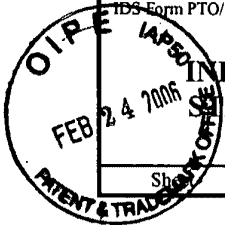

US Form PTO/SB/08: Substitute for form 1449A/PTO		<i>Complete if Known</i>	
INFORMATION DISCLOSURE STATEMENT BY APPLICANT (Use as many sheets as necessary)		Application Number	10/101,863
		Filing Date	March 16, 2002
		First Named Inventor	ZHANG, Hongmei
		Art Unit	2823
		Examiner Name	ESTRADA, Michelle
Attorney Docket Number	9140.0016-00		
Sheet 1 of 3			

U.S. PATENTS AND PUBLISHED U.S. PATENT APPLICATIONS					
Examiner Initials ⁷	Cite No. ¹	Document Number	Issue or Publication Date MM-DD-YYYY	Name of Patentee or Applicant of Cited Document	Pages, Columns, Lines, Where Relevant Passages or Relevant Figures Appear
		Number-Kind Code ² (if known)			
		US-3,309,302	03-14-1967	Heil	
		US-5,338,625	08-16-1994	Bates et al.	
		US-5,561,004	10-01-1996	Bates et al.	
		US-5,930,046	07-27-1999	Solberg et al.	
		US-6,242,129 B1	06-05-2001	Johnson	
		US-6,280,875 B1	08-28-2001	Kwak et al.	
		US-6,376,027 B1	04-23-2002	Lee et al.	
		US-6,632,563 B1	10-14-2003	Krasnov et al.	
		US-6,683,244 B2	01-27-2004	Fujimori et al.	
		US 2002/0001746 A1	01-03-2002	Jenson	
		US 2002/0076133 A1	06-20-2002	Li et al.	
		US 2002/0140103 A1	10-03-2002	Kloster et al.	
		US 2003/0178637 A1	09-25-2003	Chen et al.	

Note: Submission of copies of U.S. Patents and published U.S. Patent Applications is not required.

FOREIGN PATENT DOCUMENTS						
Examiner Initials ⁷	Cite No. ¹	Foreign Patent Document	Publication Date MM-DD-YYYY	Name of Patentee or Applicant of Cited Document	Pages, Columns, Lines, Where Relevant Passages or Relevant Figures Appear	Translation ⁶
		Country Code ³ Number ⁴ Kind Code ⁵ (if known)				
		WO 2004/106581 A2	12-09-2004	Symmorphix, Inc.		
		WO 2004/106582 A2	12-09-2004	Symmorphix, Inc.		

NON PATENT LITERATURE DOCUMENTS			
Examiner Initials ⁷	Cite No. ¹	Include name of the author (in CAPITAL LETTERS), title of the article (when appropriate), title of the item (book, magazine, journal, serial, symposium, catalog, etc.), date, page(s), volume-issue number(s), publisher, city and/or country where published.	Translation ⁶
		KIM, H-K. and YOON, Y., "Characteristics of rapid-thermal-annealed LiCoO ₂ cathode film for an all-solid-state thin film microbattery," <i>J. Vac. Sci. Technol. A</i> 22(4):1182-1187 (2004).	
		Response to Office Action filed on October 17, 2005 in U.S. Application No. 10/291,179 (Attorney Docket No. 09140-0001-00).	

Examiner Signature		Date Considered	
--------------------	--	-----------------	--

EXAMINER: Initial if reference considered, whether or not citation is in conformance with MPEP 609. Draw line through citation if not in conformance and not considered. Include copy of this form with next communication to applicant.

EXPRESS MAIL LABEL NO.
EV 746094839 US

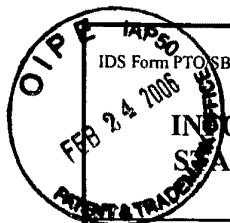

IDS Form PTO/SB/08: Substitute for form 1449A/PTO

INFORMATION DISCLOSURE STATEMENT BY APPLICANT

(Use as many sheets as necessary)

Sheet 2 of 3

Complete if Known

Application Number	10/101,863
Filing Date	March 16, 2002
First Named Inventor	ZHANG, Hongmei
Art Unit	2823
Examiner Name	ESTRADA, Michelle
Attorney Docket Number	9140.0016-00

NON PATENT LITERATURE DOCUMENTS

	Final Office Action issued on December 14, 2005 in U.S. Application No. 10/291,179 (Attorney Docket No. 09140-0001-00).	
	PCT Invitation to Pay Additional Fees for PCT/US01/22750, dated March 13, 2002 (Attorney Docket No. 09140.0002-00304).	
	PCT International Search Report for PCT/US01/22750, dated July 19, 2002 (Attorney Docket No. 09140.0002-00304).	
	PCT Written Opinion for PCT/US01/22750, dated July 23, 2002 (Attorney Docket No. 09140.0002-00304).	
	PCT International Preliminary Examination Report for PCT/US01/22750, dated October 8, 2002 (Attorney Docket No. 09140.0002-00304).	
	Office Action issued on November 28, 2005 in U.S. Application No. 09/903,081 (Attorney Docket No. 09140-0014-00).	
	Response to Office Action filed on December 21, 2005 in Application No. 10/954,182 (Attorney Docket No. 09140.0016-01).	
	Response to Office Action filed on July 25, 2005 in Application No. 10/954,182 (Attorney Docket No. 09140.0016-01).	
	Office Action issued on October 25, 2005, in U.S. Appl. No. 10/954,182 (Attorney Docket No. 09140-0016-01000).	
	Response to Office Action filed on November 8, 2005, in U.S. Application No. 10/101,341 (Attorney Docket No. 09140-0017-00).	
	Office Action issued on February 13, 2006, in U.S. Application No. 10/101,341 (Attorney Docket No. 09140-0017-00).	
	Response to Office Action filed on January 3, 2006 in U.S. Application No. 10/650,461 (Attorney Docket No. 09140-0025-00).	
	PCT International Preliminary Examination Report mailed April 15, 2004 in PCT/US03/24809 (Attorney Docket No. 09140-0025-00304).	
	Office Action issued on December 2, 2005 in U.S. Application No. 10/789,953 (Attorney Docket No. 09140.0030-00).	
	Specification and Preliminary Amendment as filed for U.S. Appl. No. 11/297,057 (Attorney Docket No. 09140.0030-01).	
	Office Action issued on March 24, 2005 in U.S. Application No. 10/851,542 (Attorney Docket No. 09140.0033-00).	
	Response to Office Action dated July 25, 2005 in U.S. Application No. 10/851,542 (Attorney Docket No. 09140-0033-00).	
	Response to Office Action filed January 19, 2006 in U.S. Application No. 10/851,542 (Attorney Docket No. 09140.0033-00).	

Examiner Signature		Date Considered	
--------------------	--	-----------------	--

EXAMINER: Initial if reference considered, whether or not citation is in conformance with MPEP 609. Draw line through citation if not in conformance and not considered. Include copy of this form with next communication to applicant.

**EXPRESS MAIL LABEL NO.
EV 746094839 US**

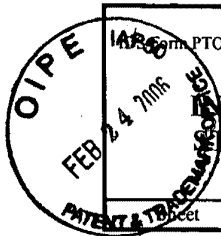

PTO/SB/08: Substitute for form 1449A/PTO INFORMATION DISCLOSURE STATEMENT BY APPLICANT (Use as many sheets as necessary)		<i>Complete if Known</i>	
		<i>Application Number</i>	10/101,863
		<i>Filing Date</i>	March 16, 2002
		<i>First Named Inventor</i>	ZHANG, Hongmei
		<i>Art Unit</i>	2823
		<i>Examiner Name</i>	ESTRADA, Michelle
		<i>Attorney Docket Number</i>	9140.0016-00
Sheet	3	of	3

NON PATENT LITERATURE DOCUMENTS	
	PCT International Search Report and Written Opinion for Application No. PCT/US2004/014524 dated March 2, 2005 (Attorney Docket No. 09140.0033-00304).
	PCT International Preliminary Report on Patentability for Application No. PCT/US2004/014524, dated December 8, 2005 (Attorney Docket No. 09140.0033-00304).
	PCT International Search Report for Application No. PCT/US2004/014523 dated January 17, 2005 (Attorney Docket No. 09140.0034-00304).
	PCT Written Opinion for Application No. PCT/US2004/014523 dated January 17, 2005 (Attorney Docket No. 09140.0034-00304).
	PCT International Preliminary Report on Patentability for Application No. PCT/US2004/014523, dated December 8, 2005 (Attorney Docket No. 09140.0034-00304).
	Specification as filed for U.S. Appl. No. 11/297,057 (Attorney Docket No. 09140.0042-00).

Examiner Signature		Date Considered	
--------------------	--	-----------------	--

EXAMINER: Initial if reference considered, whether or not citation is in conformance with MPEP 609. Draw line through citation if not in conformance and not considered. Include copy of this form with next communication to applicant.

EXPRESS MAIL LABEL NO.
EV 746094839 US

(12) INTERNATIONAL APPLICATION PUBLISHED UNDER THE PATENT COOPERATION TREATY (PCT)

(19) World Intellectual Property
Organization
International Bureau



(43) International Publication Date
9 December 2004 (09.12.2004)

PCT

(10) International Publication Number
WO 2004/106581 A2

- (51) International Patent Classification⁷: C23C 14/08, 14/34
- (21) International Application Number: PCT/US2004/014523
- (22) International Filing Date: 21 May 2004 (21.05.2004)
- (25) Filing Language: English
- (26) Publication Language: English
- (30) Priority Data: 60/473,379 23 May 2003 (23.05.2003) US
- (71) Applicant (for all designated States except US): SYM-MORPHIX, INC. [US/US]; 1278 Reamwood Avenue, Sunnyvale, CA 94089-2233 (US).
- (72) Inventors; and
- (75) Inventors/Applicants (for US only): DEMARAY, Richard, Ernest [US/US]; 190 Fawn Lane, Portola Valley, CA 94028 (US). NARASIMHAN, Mukundan [IN/US]; 293 Bluefield Drive, San Jose, CA 91536 (US).
- (74) Agent: GARRETT, Arthur, S.; Finnegan, Henderson, Farabow, Garrett & Dunner, L.L.P., 1300 I Street N.W., Washinton, D.C. 20005-3315 (US).
- (81) Designated States (unless otherwise indicated, for every kind of national protection available): AE, AG, AL, AM, AT, AU, AZ, BA, BB, BG, BR, BW, BY, BZ, CA, CH, CN, CO, CR, CU, CZ, DE, DK, DM, DZ, EC, EE, EG, ES, FI, GB, GD, GE, GH, GM, HR, HU, ID, IL, IN, IS, JP, KE, KG, KP, KR, KZ, LC, LK, LR, LS, LT, LU, LV, MA, MD, MG, MK, MN, MW, MX, MZ, NA, NI, NO, NZ, OM, PG, PH, PL, PT, RO, RU, SC, SD, SE, SG, SK, SL, SY, TJ, TM, TN, TR, TT, TZ, UA, UG, US, UZ, VC, VN, YU, ZA, ZM, ZW.
- (84) Designated States (unless otherwise indicated, for every kind of regional protection available): ARIPO (BW, GH, GM, KE, LS, MW, MZ, NA, SD, SL, SZ, TZ, UG, ZM, ZW), Eurasian (AM, AZ, BY, KG, KZ, MD, RU, TJ, TM), European (AT, BE, BG, CH, CY, CZ, DE, DK, EE, ES, FI, FR, GB, GR, HU, IE, IT, LU, MC, NL, PL, PT, RO, SE, SI, SK, TR), OAPI (BF, BJ, CF, CG, CI, CM, GA, GN, GQ, GW, ML, MR, NE, SN, TD, TG).
- Published:
— without international search report and to be republished upon receipt of that report
- For two-letter codes and other abbreviations, refer to the "Guidance Notes on Codes and Abbreviations" appearing at the beginning of each regular issue of the PCT Gazette.



WO 2004/106581 A2

(54) Title: TRANSPARENT CONDUCTIVE OXIDES

(57) Abstract: A method of deposition of a transparent conductive film from a metallic target is presented. A method of forming a transparent conductive oxide film according to embodiments of the present invention include depositing the transparent conductive oxide film in a pulsed DC reactive ion process with substrate bias, and controlling at least one process parameter to affect at least one characteristic of the conductive oxide film. The resulting transparent oxide film, which in some embodiments can be an indium-tin oxide film, can exhibit a wide range of material properties depending on variations in process parameters. For example, varying the process parameters can result in a film with a wide range of resistive properties and surface smoothness of the film.

BEST AVAILABLE COPY

Transparent Conductive Oxides

Related Applications

[0001] The present application claims priority to U.S. Provisional Application 60/473,379, "Transparent Conductive Oxides from a Metallic Target," by R. Ernest Demaray and Mukundan Narasimhan, filed on May 23, 2003, herein incorporated by reference in its entirety.

Background

1. Field of the Invention

[0002] The present invention is related to deposition of oxides on a substrate and, in particular, deposition of transparent conductive oxides.

2. Discussion of Related Art

[0003] Transparent conductive oxides have a wide variety of uses, including applications to solar cells, organic light emitting diodes (OLEDs), electric field devices, current devices (i.e. touch screens), energy efficient windows, conductive anti-reflective devices, electromagnetic interference shields, heaters, transparent electrodes, coatings for cathode ray tube (CRT) displays, to name only a few. Another important application is for touch sensitive MEMS devices, such as those used, for example, in fingerprint sensors and such. In many cases, the electrical properties of the conducting film is of great importance.

[0004] Specifically, for OLED applications, films deposited with current technologies are generally rough, resulting in stress risers and field concentration issues, that can cause leakage. Further, asperities in the resulting film can induce lifetime dependent defects in nearest neighbor films that can shorten device lifetimes. Additionally, the brightness of the emergent light from the OLED can be reduced.

[0005] Transparent conductive oxides have been deposited from ceramic targets by RF magnetron sputtering. However, the surface of properties of the resulting films often include nodules or asperities which can cause arcing, defects, surface roughness, and other deleterious effects in the resulting film. Additionally, ceramic targets tend to be more expensive to produce than metallic targets.

[0006] Previous attempts at deposition of transparent conductive oxides, for example indium tin oxide (ITO), with metallic targets have presented numerous

problems, including small process windows, problems in process controllability, a disappearing anode effect, and particle deposition on the film. Such attempts have been abandoned. Deposition with ceramic targets has also been difficult, including problems with particles, nodule formation, and arching during deposition. In both cases, film smoothness has presented major difficulties. Additionally, control of film parameters such as, for example, resistivity and transparency has been difficult.

[0007] Therefore, there is need for cost effective deposition of smoother layers of transparent conductive oxides with greater control over layer properties such as resistivity and transparency.

Summary

[0008] In accordance with the present invention, a method of depositing of a transparent conductive film from a metallic target is presented. A method of forming a transparent conductive oxide film according to embodiments of the present invention includes depositing the transparent conductive oxide film in a pulsed DC reactive ion process with substrate bias, and controlling at least one process parameter to provide at least one characteristic of the conductive oxide film at a particular value.

[0009] A method of depositing a transparent conductive oxide film on a substrate according to some embodiments of the invention, then, includes placing the substrate in a reaction chamber, adjusting power to a pulsed DC power supply coupled to a target in the reaction chamber, adjusting an RF bias power coupled to the substrate, adjusting gas flow into the reaction chamber, and providing a magnetic field at the target in order to direct deposition of the transparent conductive oxide film on the substrate in a pulsed-dc biased reactive-ion deposition process, wherein the transparent conductive oxide film has a particular characteristic.

[0010] The resulting transparent oxide film, which can be deposited according to some embodiments of the present invention, can be an indium-tin oxide (ITO) film. An ITO film can have a wide range of material properties depending on variations in process parameters. For example, varying the process parameters according to some embodiments of the present invention can result in a wide range of resistive properties and surface smoothness of the film.

[0011] These and other embodiments of the invention are further discussed below

with reference to the following figures.

Short Description of the Figures

[0012] Figures 1A and 1B illustrate a pulsed-DC biased reactive ion deposition apparatus that can be utilized in the methods of depositing according to the present invention.

[0013] Figure 2 shows an example of a target that can be utilized in the reactor illustrated in Figures 1A and 1B

[0014] Figure 3A shows an Atomic Force Microscopy (AFM) image of an indium-tin-oxide (ITO) process according to some embodiments of the present invention.

[0015] Figure 3B shows an Atomic Force Microscopy (AFM) image of another ITO process deposited using a process according to some embodiments of the present invention.

[0016] Figure 4 shows the variation of bulk resistivity of an ITO layer according to some embodiments of the present invention as a function of the oxygen flow for two different target powers before and after a 250 °C anneal in vacuum.

[0017] Figure 5 shows the variation of the sheet resistance of an ITO layer according to some embodiments of the present invention as a function of the oxygen flow used for two different target powers before and after a 250 °C anneal in vacuum.

[0018] Figure 6 shows the target current and voltage (min and max) as a function of oxygen flow.

[0019] Figure 7 shows the thickness change in layers of ITO according to embodiments of the present invention as a function of oxygen flow.

[0020] Figure 8 illustrates the relationship between oxygen flow and oxygen partial pressure for a metallic target.

[0021] Figures 9A-9D illustrate the smoothness of transparent conductive oxides deposited with ceramic targets according to the present invention.

[0022] In the figures, elements having the same designation have the same or similar function.

Detailed Description

[0023] Deposition of materials by pulsed-DC biased reactive ion deposition is described in U.S. Patent Application Serial No. 10/101863, entitled "Biased Pulse DC Reactive Sputtering of Oxide Films," to Hongmei Zhang, et al., filed on March 16, 2002. Preparation of targets is described in U.S. Patent Application Serial No. 10/101,341, entitled "Rare-Earth Pre-Alloyed PVD Targets for Dielectric Planar Applications," to Vassiliki Milonopoulou, et al., filed on March 16, 2002. U.S. Patent Application Serial No. 10/101863 and U.S. Patent Application Serial No. 10/101,341 are each assigned to the same assignee as is the present disclosure and each is incorporated herein in their entirety. Deposition of oxide materials has also been described in U.S. Patent No. 6,506,289, which is also herein incorporated by reference in its entirety. Transparent oxide films are deposited utilizing processes similar to those specifically described in U.S. Patent No. 6,506,289 and U.S. Application Serial No. 10/101863.

[0024] Figure 1A shows a schematic of a reactor apparatus 10 for sputtering material from a target 12 according to the present invention. In some embodiments, apparatus 10 may, for example, be adapted from an AKT-1600 PVD (400 X 500 mm substrate size) system from Applied Komatsu or an AKT-4300 (600 X 720 mm substrate size) system from Applied Komatsu, Santa Clara, CA. The AKT-1600 reactor, for example, has three deposition chambers connected by a vacuum transport chamber. These Komatsu reactors can be modified such that pulsed DC power is supplied to the target and RF power is supplied to the substrate during deposition of a material film.

[0025] Apparatus 10 includes target 12 which is electrically coupled through a filter 15 to a pulsed DC power supply 14. In some embodiments, target 12 is a wide area sputter source target, which provides material to be deposited on a substrate 16. Substrate 16 is positioned parallel to and opposite target 12. Target 12 functions as a cathode when power is applied to it and is equivalently termed a cathode. Application of power to target 12 creates a plasma 53. Substrate 16 is capacitively coupled to an electrode 17 through an insulator 54. Electrode 17 can be coupled to an RF power supply 18. A magnet 20 is scanned across the top of target 12.

[0026] For pulsed reactive dc magnetron sputtering, as performed by apparatus 10,

the polarity of the power supplied to target 12 by power supply 14 oscillates between negative and positive potentials. During the positive period, the insulating layer on the surface of target 12 is discharged and arcing is prevented. To obtain arc free deposition, the pulsing frequency exceeds a critical frequency that can depend on target material, cathode current and reverse time. High quality oxide films can be made using reactive pulse DC magnetron sputtering as shown in apparatus 10.

[0027] Pulsed DC power supply 14 can be any pulsed DC power supply, for example an AE Pinnacle plus 10K by Advanced Energy, Inc. With this DC power supply, up to 10 kW of pulsed DC power can be supplied at a frequency of between 0 and 350 KHz. The reverse voltage can be 10% of the negative target voltage. Utilization of other power supplies can lead to different power characteristics, frequency characteristics and reverse voltage percentages. The reverse time on this embodiment of power supply 14 can be adjusted between 0 and 5 μ s.

[0028] Filter 15 prevents the bias power from power supply 18 from coupling into pulsed DC power supply 14. In some embodiments, power supply 18 can be a 2 MHz RF power supply, for example a Nova-25 power supply made by ENI, Colorado Springs, Co.

[0029] In some embodiments, filter 15 can be a 2 MHz sinusoidal band rejection filter. In some embodiments, the band width of the filter can be approximately 100 kHz. Filter 15, therefore, prevents the 2 MHz power from the bias to substrate 16 from damaging power supply 18.

[0030] However, both RF and pulsed DC deposited films are not fully dense and may have columnar structures. Columnar structures can be detrimental to thin film applications. By applying a RF bias on wafer 16 during deposition, the deposited film can be densified by energetic ion bombardment and the columnar structure can be substantially eliminated.

[0031] In the AKT-1600 based system, for example, target 12 can have an active size of about 675.70 X 582.48 by 4 mm in order to deposit films on substrate 16 that have dimension about 400 X 500 mm. The temperature of substrate 16 can be held at between -50 °C and 500 °C. The distance between target 12 and substrate 16 can be between about 3 and about 9 cm. Process gas can be inserted into the chamber of

apparatus 10 at a rate up to about 200 sccm while the pressure in the chamber of apparatus 10 can be held at between about .7 and 6 millitorr. Magnet 20 provides a magnetic field of strength between about 400 and about 600 Gauss directed in the plane of target 12 and is moved across target 12 at a rate of less than about 20-30 ' sec/scan. In some embodiments utilizing the AKT 1600 reactor, magnet 20 can be a race-track shaped magnet with dimensions about 150 mm by 600 mm.

[0032] Figure 2 illustrates an example of target 12. A film deposited on a substrate positioned on carrier sheet 17 directly opposed to region 52 of target 12 has good thickness uniformity. Region 52 is the region shown in Figure 1B that is exposed to a uniform plasma condition. In some implementations, carrier 17 can be coextensive with region 52. Region 24 shown in Figure 2 indicates the area below which both physically and chemically uniform deposition can be achieved, for example where physical and chemical uniformity provide refractive index uniformity. Figure 2 indicates region 52 of target 12 that provides thickness uniformity is, in general, larger than region 24 of target 12 providing thickness and chemical uniformity. In optimized processes, however, regions 52 and 24 may be coextensive.

[0033] In some embodiments, magnet 20 extends beyond area 52 in one direction, for example the Y direction in Figure 2, so that scanning is necessary in only one direction, for example the X direction, to provide a time averaged uniform magnetic field. As shown in Figures 1A and 1B, magnet 20 can be scanned over the entire extent of target 12, which is larger than region 52 of uniform sputter erosion. Magnet 20 is moved in a plane parallel to the plane of target 12.

[0034] The combination of a uniform target 12 with a target area 52 larger than the area of substrate 16 can provide films of highly uniform thickness. Further, the material properties of the film deposited can be highly uniform. The conditions of sputtering at the target surface, such as the uniformity of erosion, the average temperature of the plasma at the target surface and the equilibration of the target surface with the gas phase ambient of the process are uniform over a region which is greater than or equal to the region to be coated with a uniform film thickness. In addition, the region of uniform film thickness is greater than or equal to the region of the film which is to have highly uniform optical properties such as index of refraction,

density, transmission or absorptivity.

[0035] Target 12 can be formed of any materials. Typically metallic materials, for example, include combinations of In and Sn. Therefore, in some embodiments, target 12 includes a metallic target material formed from intermetallic compounds of optical elements such as Si, Al, Er and Yb. Additionally, target 12 can be formed, for example, from materials such as La, Yt, Ag, Au, and Eu. To form optically active films on substrate 16, target 12 can include rare-earth ions. In some embodiments of target 12 with rare earth ions, the rare earth ions can be pre-alloyed with the metallic host components to form intermetallics. See U.S. Application Serial No. 10/101,341. Typical ceramic target materials include alumina, silica, alumina silicates, and other such materials.

[0036] In some embodiments of the invention, material tiles are formed. These tiles can be mounted on a backing plate to form a target for apparatus 10. A wide area sputter cathode target can be formed from a close packed array of smaller tiles. Target 12, therefore, may include any number of tiles, for example between 2 to 20 individual tiles. Tiles can be finished to a size so as to provide a margin of non-contact, tile to tile, less than about 0.010" to about 0.020" or less than half a millimeter so as to eliminate plasma processes that may occur between adjacent ones of tiles 30. The distance between tiles of target 12 and the dark space anode or ground shield 19 in Figure 1B can be somewhat larger so as to provide non contact assembly or to provide for thermal expansion tolerance during process chamber conditioning or operation.

[0037] As shown in Figure 1B, a uniform plasma condition can be created in the region between target 12 and substrate 16 in a region overlying substrate 16. A plasma 53 can be created in region 51, which extends under the entire target 12. A central region 52 of target 12 can experience a condition of uniform sputter erosion. As discussed further below, a layer deposited on a substrate placed anywhere below central region 52 can then be uniform in thickness and other properties (i.e., dielectric, optical index, or material concentrations). In addition, region 52 in which deposition provides uniformity of deposited film can be larger than the area in which the deposition provides a film with uniform physical or optical properties such as

chemical composition or index of refraction. In some embodiments, target 12 is substantially planar in order to provide uniformity in the film deposited on substrate 16. In practice, planarity of target 12 can mean that all portions of the target surface in region 52 are within a few millimeters of a planar surface, and can be typically within 0.5 mm of a planar surface.

[0038] Reactive gases that provide a constant supply of ionic oxygen to keep the target surface oxidized can be provided to expand the process window. Some examples of the gases that can be utilized for controlling surface oxidation are CO₂, water vapor, hydrogen, N₂O, fluorine, helium, and cesium. Additionally, a feedback control system can be incorporated to control the oxygen partial pressure in the reactive chamber. Therefore, a wide range of oxygen flow rates can be controlled to keep a steady oxygen partial pressure in the resulting plasma. Other types of control systems such as target voltage control and optical plasma emission control systems can also be utilized to control the surface oxidation of the target. As shown in Figure 1A, power to target 12 can be controlled in a feedback loop at supply 14. Further, oxygen partial pressure controller 20 can control either oxygen or argon partial pressures in plasma 53.

[0039] In some embodiments, transparent conductive oxides can be deposited on various substrates utilizing an indium-tin (In/Sn) metallic target. A series of depositions on glass in accordance with the present invention is illustrated in Table I. The parameters in the process column of Table I are in the format (pulsed DC power/RF bias power/pulsing frequency/reverse time/deposition time/Ar flow (sccms)/O₂ flow (sccms)). An indium-tin (In/Sn: 90%/10% by weight) target using a reactive-pulsed DC (RPDC) process such as that described in U.S. Application Serial No. 10/101,863 was utilized. A power supply with 2MHz RF bias applied to substrate 16 was utilized in the process. Along with the process parameters for each of the separate depositions, each defined by a "Slot" number in the first column, the target voltage, and target current ranges for each of the depositions is also listed.

[0040] Table 2 shows the results obtained by using the process parameters in Table 1. The results include the sheet resistance, thickness, bulk resistivity, and refractive indices of the resulting films. Again, the first column indicates the slot

number of the deposition. The process for each slot number is reiterated in column 2 of Table 2. The sheet resistance of selected ones of the films resulting from the deposition is listed in the third column and the uniformity of the sheet resistance is indicated in the fourth column. The thickness of the film and its uniformity of each of the films deposited by the indicated process is indicated in the fifth and sixth columns. The bulk resistance of selected ones of the films, ρ , is also indicated. Additionally, the refractive index taken at 632 nm is indicated along with the film uniformity of that index. The comments section of Table 2 indicates whether the resulting film is transparent, translucent, or metallic in character.

[0041] Figure 3A shows the Atomic Force Microscopy (AFM) image of an ITO film produced by the process identified in slot #5 in tables 1 and 2. That process, with particularly low oxygen flow rates (24 sccm), produced a rough film with an Ra of about 70 Å and an Rms of about 90 Å. The film also appears to be metallic with this particular oxygen flow and the film roughness is high. Such a film could be applicable to large surface area requirements, for example solar cell applications. While not being limited by any particular theory, it is suspected that the roughness of this film reflects the sub-stoichiometric nature of the film caused by insufficient oxygen flow in the plasma. As can be seen in Figure 3B, where the oxygen flow during deposition has been significantly increased to about 36 sccm, the film is smooth.

[0042] Figure 3B shows an Atomic Force Microscopy (AFM) image of an ITO film deposited using the process described in slot #19 of Tables 1 and 2. In that process, the oxygen flow rate is increased to 36 sccm. The film appears to be transparent and conductive and the surface roughness is ~6 Å Ra and Rms of about 13 Å, which is acceptable for OLED requirements. As can be seen from Figures 3A and 3B, variation in oxygen partial pressure (as indicated by increased flow rate) has a large influence on the characteristics of the resulting deposited film.

[0043] The resistivity of the film layer and the smoothness of the film layer can be related. In general, the higher the resistivity of the film layer, the smoother the film layer. Figure 4 shows the variation of bulk resistivity of the ITO as a function of the oxygen flow rate used for two different target powers before and after a 250 °C anneal

in vacuum. The bulk resistivity of the film exhibits a sudden transition downward as the oxygen flow rate is lowered. This transition occurs when the target surface becomes metallic from being poisoned with oxygen. The data utilized to form the graph shown in Figure 4 has been taken from Tables 1 and 2.

[0044] Figure 5 shows the variation of the sheet resistance of an ITO film as function of the O₂ flow used for two different target powers before and after a 250C anneal in vacuum. As shown in Figure 5, the sheet resistance follows similar trends as the bulk resistivity of the film.

[0045] Figure 6 shows the target current and voltage (min and max) as a function of the oxygen flow rate. The target voltage increases as the oxygen flow rate is lowered. It could be seen here that at a 40 sccm oxygen flow rate through repeated depositions, the target voltage is not constant. This illustrates the utility of a target voltage feedback control system that adjusts the power supplied to target 12 to hold the target voltage constant. Therefore, as shown in Figure 1A, PDC power 14 can include feedback loop to control the voltage on target 12.

[0046] Figure 7 shows the thickness change of a resulting film as a function of oxygen flow rate in sccm. The thickness of the film increases as the oxygen flow decreases but this could make opaque metallic films and so choosing the correct oxygen flow and utilizing an oxygen flow feedback control system to control material characteristics such as, for example, transparency or conductivity can be desirable.

[0047] In some embodiments, instead of oxygen flow rate, oxygen partial pressure can be controlled with a feedback system 20 (see Figure 1A). Controlling the oxygen partial pressure can provide better control over the oxygen content of the plasma, and therefore the oxygen content of the resulting films, and allows better control over the film characteristics. Figure 8 illustrates the relationship between the flow rate and partial pressure. As can be seen from Figure 8, in order to reach the saturated region (e.g., when target 12 is completely poisoned with oxygen), no increase in flow rate is required. In some embodiments, reactor 10 can include a partial pressure feedback loop controller 20 that controls the oxygen flow in order to maintain a desired partial pressure of oxygen in the plasma. Such a controller can be the IRESS system, that can be purchased from Advanced Energy, Inc., Ft. Collins, Colorado. It has been

found that film parameters such as resistivity, smoothness, and transparency can be highly dependent on oxygen partial pressures, and therefore these characteristics of the resulting deposited layer can be controlled by adjusting the oxygen partial pressures.

[0048] Some embodiments of the present invention can be deposited with ceramic targets. An example target is an ITO (In/Sn 90/10) ceramic target can be utilized. Table 3 illustrates some example processes for deposition of ITO utilizing a ceramic target according to the present invention. Bulk resistivity, sheet resistance, resistance, thicknesses, deposition rates, and index of refraction of the resulting films are shown along with the process parameters utilized in the deposition. Figure 9A shows an AFM depiction of a transparent conductive oxide film corresponding to run #10 in Table 3. Figure 9B shows an AFM depiction of a transparent conductive oxide film corresponding to run #14 in Table 3. Figure 9C shows an AFM depiction of a transparent conductive oxide film corresponding to run #16 in Table 3. Figure 9D shows an AFM depiction of a transparent conductive oxide film layer corresponding to run #6 in Table 3.

[0049] Figures 9A through 9D illustrate the roughnesses of selective depositions of ITO deposited utilizing the ceramic target. In Figure 9A, the roughest surface shown, the film was deposited using 3kW RF power, 100W bias, 3 sccm O₂ and 60 sccm Ar at a temperature of 280 °C. The layer grew to a thickness of 1200 Å in 100 seconds of deposition time and exhibited a sheet resistance of 51 ohms/sq. The roughness illustrated in Figure 9A is characterized by an Ra=2.3 nm and R_{MS} of 21 nm.

[0050] The ITO film shown in Figure 9B was deposited using 3 kW RF power, 300 W bias, 3 sccm O₂ and 60 sccm Ar at a temperature of 280 °C. The layer illustrated in Figure 9B grew to a thickness of 1199 Å in 100 sec. The layer in Figure 9B exhibited a sheet resistance of 39 ohms/sq. The roughness illustrated in Figure 9B is characterized by an Ra=1.1 nm and R_{max} of 13 nm.

[0051] The ITO film shown in Figure 9C was deposited using 3 kW RF power, 300 W bias, 3 sccm O₂, 30 sccm Ar at a temperature of 280 °C. The layer grew to a thickness of 1227 Å in 100 seconds of deposition time and exhibited a sheet resistance

of 57 ohms/sq. The roughness illustrated in Figure 9C can be characterized by an $R_a=0.88$ nm and a R_{max} of 19.8 nm.

[0052] Figure 9D was deposited using 1.5 kW RF power, 300 W bias, 0 sccm O_2 , 30 sccm Ar at a temperature of 280 C. The layer grew to a thickness of 580 Å in 100 seconds of deposition time and exhibited a sheet resistance of 106 ohms/sq. The roughness illustrated in Figure 9C can be characterized by an $R_a=0.45$ nm and an R_{max} of 4.6 nm.

[0053] Utilizing the example depositions described herein, the roughness and resistivity of a transparent oxide film can be tuned to particular applications. In general, particularly high resistivities can be obtained, which are useful for touch sensitive devices. As shown in Table 3, the sheet resistance ranged from about 39 Ω /sq for trial # 14 to a high of 12,284 Ω /sq for trial #1. Careful variation of the process parameters, therefore, allow control of sheet resistance over an extremely broad range. Low resistivities can be obtained by adjusting the process parameters for uses in devices such as OLEDs and MEMS display devices. As is illustrated in Table 3, the bulk resistivity can be controlled to be between about $2E-4$ micro-ohms-cm to about 0.1 micro-ohms-cm. Additionally, other parameters such as refractive index and transparency of the film can be controlled.

[0054] Further, deposition of transparent conductive oxide layers, for example ITO, can be doped with rare-earth ions, for example erbium or cerium, can be utilized to form color-conversion layers and light-emission sources. In some embodiments, a rare-earth doped target can be made in a single piece to insure uniformity of doping. Co-doping can be accomplished in the target.

[0055] Similar processes for other metallic conductive oxides can also be developed. For example, deposition of zinc oxide films. Further, as can be seen in the examples shown in Table 3, low temperature depositions can be performed. For example, transparent conductive oxides according to the present invention can be deposited at temperatures as low as about 100 °C. Such low temperature depositions can be important for depositions on temperature sensitive materials such as plastics.

[0056] Other thin film layers according to the present invention include deposition of other metal oxides to form conducting and semi-conducting films. Thin films

formed according to the present invention can be utilized in many devices, including, but not limited to, displays, photovoltaics, photosensors, touchscreens, and EMI shielding.

[0057] Embodiments of the invention disclosed here are examples only and are not intended to be limiting. Further, one skilled in the art will recognize variations in the embodiments of the invention described herein which are intended to be included within the scope and spirit of the present disclosure. As such, the invention is limited only by the following claims.

Table I

Slot #	Process	Target Voltage (V)		Target Current (Amps)	
		Min	Max	Mix	Max
14	1.5kw/100w/200khz/2.2µs/300s/20Ar/80O ₂	244	252	5.94	6.14
15	1.5kw/100w/200khz/2.2µs/300s/20Ar/40O ₂	254	263	5.7	5.9
17	1.5kw/100w/200khz/2.2µs/300s/20Ar/40O ₂	252	260	5.76	5.96
19	1.5kw/100w/200khz/2.2µs/300s/20Ar/36O ₂	254	263	5.72	5.92
21	1.5kw/100w/200khz/2.2µs/300s/20Ar/30O ₂	255	268	5.76	5.9
1	1kw/100w/200khz/2.2µs/300s/20Ar/ 80O ₂	224	233	4.32	4.5
2	1kw/100w/200khz/2.2µs/300s/20Ar/ 36O ₂	231	243	4.12	4.3
3	1kw/100w/200khz/2.2µs/300s/20Ar/ 32O ₂	232	242	4.12	4.28
4	1kw/100w/200khz/2.2µs/300s/20Ar/ 28O ₂	237	243	4.1	4.22
5	1kw/100w/200khz/2.2µs/300s/20Ar/ 24O ₂	233	243	4.1	4.34
6	1kw/100w/200khz/2.2µs/300s/20Ar/ 28O ₂	231	245	4.12	4.3

Table II

Slot #	Process	Rs (Ohms/Sq)	Rs unif %	Th (nm)	Th std 1sig	Bulk Rho (μ Ohm-cm)	R.I (@632nm)	R.I Unif (%)	Comments
14	1.5kw/100w/200khz/2.2 μ s/ 300s/20Ar/80O2			38.59	0.16		1.980758	0.000005	transparent
15	1.5kw/100w/200khz/2.2 μ s/ 300s/20Ar/40O2	94112	2	57.28	0.51	539073.5	1.951452	0.029342	translucent
17	1.5kw/100w/200khz/2.2 μ s/ 300s/20Ar/40O2	33927	60.282	58.48	1.37	198405.1	1.936166	0.040957	translucent
19	1.5kw/100w/200khz/2.2 μ s/ 300s/20Ar/36O2	7335.32	72.49	67.75	1.03	49696.8	1.980746	0.000018	translucent
21	1.5kw/100w/200khz/2.2 μ s/ 300s/20Ar/30O2	22.3507	2.995	80		178.8			metallic
1	1kw/100w/200khz/2.2 μ s/ 300s/20Ar/80O2			26.69	0.32		1.980326	0.00096	transparent
2	1kw/100w/200khz/2.2 μ s/ 300s/20Ar/36O2			36.4	0.13		1.980756	0.000003	transparent
3	1kw/100w/200khz/2.2 μ s/ 300s/20Ar/32O2			39.3	0.15		1.980761	0	transparent
4	1kw/100w/200khz/2.2 μ s/ 300s/20Ar/28O2			44.02	0.24		1.98076	0.000001	transparent
5	1kw/100w/200khz/2.2 μ s/ 300s/20Ar/24O2	58.1031	7.467	50		290.5			metallic
6	1kw/100w/200khz/2.2 μ s/ 300s/20Ar/28O2	58.0992	10.566	45		261.4			metallic

Table III

<u>Trial</u>	<u>Run (sec)</u>	<u>Target Power (kW)</u>	<u>Bias/W</u>	<u>O2</u>	<u>Ar</u>	<u>T (oC)</u>	<u>Rs (Ohms/Sq)</u>	<u>Rs (non-unif)</u>	<u>Bulk Rho (uOhmcm)</u>	<u>Thic kness (Å)</u>	<u>n</u>	<u>DepRate (A/sec)</u>	<u>Target /V</u>	<u>Target/I</u>
14	100	3	300	3	60	280	38.69	4.07%	4.64E-04	1200	1.864	12		
16	100	3	300	3	30	280	56.90	7.94%	6.98E-04	1227	1.888	12.27	288-308	9.86-10.42
10	100	3	100	3	60	280	50.98	11.89%	6.25E-04	1225	1.933	12.25	265-275	10.92-11.36
4	100	1.5	100	3	30	280	383.62	21.72%	2.09E-03	543.9	2.016	5.439	238-251	5.98-6.32
8	100	1.5	300	3	30	280	504.02	7.23%	2.44E-03	483.5	2.082	4.835	239-250	5.98-6.33
2	100	1.5	100	3	30	280	402.52	26.80%	2.10E-03	520.7	2.056	5.207	225-239	6.46-6.68
6	100	1.5	300	0	30	280	106.21	6.12%	6.17E-04	580.5	1.945	5.805	237-250	5.98-6.38
12	100	3	100	4	30	280	374.34	19.43%	4.18E-03	1116	1.917	11.16	285-300	9.98-10.52
15	100	3	300	4	30	100	6264.69	58.18%	6.81E-02	1087	1.897	10.87	282-304	10.00-10.62
7	100	1.5	200	4	30	100	7509.45	44.14%	2.95E-02	392.3	2.149	3.923	237-250	6.02-6.32
1	100	1.5	100	4	30	100	12284.82	112.55%	4.78E-02	389.1	2.236	3.891	238-250	6.04-6.32

Table III (Cont.)

11	100	3	100	3	60	100	631.77	49.40%	7.30E-03	1155	1.958	11.55	266-273	10.96-11.38
9	100	3	100	0	30	100	43.78	7.47%	5.55E-04	1268	1.945	12.68	288-307	9.78-10.42
5	100	1.5	200	3	60	100	1293.53	14.82%	5.88E-03	454.8	2.149	4.548	225-235	6.46-6.68
3	100	1.5	100	4	60	100	4154.43	28.25%	1.78E-02	428.8	2.211	4.288	226-235	6.44-6.64
13	100	3	200	0	60	100	49.05	7.24%	6.16E-04	1256	1.913	12.56	264-275	10.96-11.38
18	100	2.25	100	3	30	100	1476.79	21.54%	1.10E-02	744.5	2.044	7.445	263-277	8.08-8.56
17	100	1.5	150	0	60	100	157.23	8.83%	9.91E-04	630.5	1.931	6.305	225-231	6.48-6.74
19	100	2.25	150	3	60	100	526.72	13.01%	4.29E-03	814.2	2.021	8.142	247-255	8.78-9.14

Claims

We claim:

1. A method of forming a transparent conductive oxide film, comprising:
depositing the transparent conductive oxide film in a pulsed DC reactive ion process with substrate bias; and
controlling at least one process parameter to provide at least one characteristic of the conductive oxide film at a particular value.
2. The method of claim 1, wherein controlling at least one process parameter includes controlling the oxygen partial pressure.
3. The method of claim 1, wherein the transparent conductive oxide film includes indium-tin oxide.
4. The method of claim 1, wherein the at least one characteristic includes sheet resistance.
5. The method of claim 1, wherein the at least one characteristic includes film roughness.
6. The method of claim 5, wherein the transparent conductive oxide film includes an indium-tin oxide film and the film roughness is characterized by R_a less than about 10 nm with R_{ms} of less than about 20 nm.
7. The method of claim 4, wherein the bulk resistance can be varied between about 2×10^{-4} micro-ohms-cm to about 0.1 micro-ohms-cm.
8. The method of claim 1, wherein the at least one process parameter includes a power supplied to a target.
9. The method of claim 1, wherein the at least one process parameter includes an oxygen partial pressure.
10. The method of claim 1, wherein the at least one process parameter includes bias power.
11. The method of claim 1, wherein the at least one process parameter includes deposition temperature.
12. The method of claim 1, wherein the at least one process parameter includes an argon partial pressure.
13. The method of claim 1, further including supplying a metallic target.

14. The method of claim 1, further including supplying a ceramic target.
15. The method of claim 1, wherein the transparent conductive oxide film is doped with at least one rare-earth ions.
16. The method of claim 15, wherein the at least one rare-earth ions includes erbium.
17. The method of claim 15, wherein the at least one rare-earth ions includes cerium.
18. A method of depositing a transparent conductive oxide film on a substrate, comprising:
 - placing the substrate in a reaction chamber;
 - adjusting power to a pulsed DC power supply coupled to a target in the reaction chamber;
 - adjusting an RF bias power coupled to the substrate;
 - adjusting gas flow into the reaction chamber; and
 - providing a magnetic field at the target in order to direct deposition of the transparent conductive oxide film on the substrate in a pulsed-dc biased reactive-ion deposition process, wherein the transparent conductive oxide film exhibits at least one particular property.
19. The method of claim 18, wherein at least one particular property of the transparent conductive oxide film is determined by parameters of the pulsed-dc biased reactive ion deposition process.
20. The method of claim 19, wherein the at least one particular property includes resistivity of the transparent conductive oxide film.
21. The method of claim 19, wherein the transparent conductive oxide film includes an indium-tin oxide film.
22. The method of claim 19, wherein the parameters include oxygen partial pressure.
23. The method of claim 19, wherein the parameters include bias power.
24. The method of claim 18, wherein the target can include at least one rare-earth ions.
25. The method of claim 24, wherein the at least one rare-earth ions includes erbium.
26. The method of claim 24, wherein the at least one rare-earth ion includes cerium.

1/9

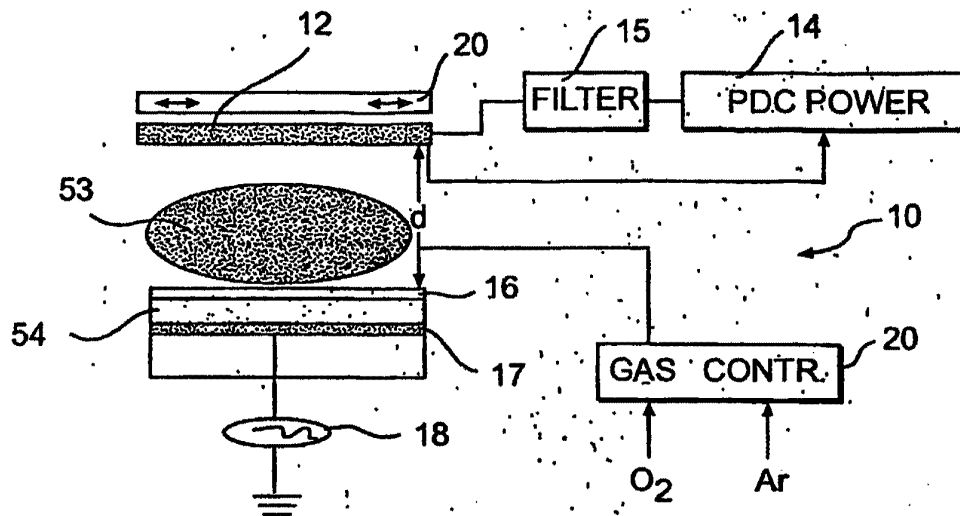

FIG. 1A

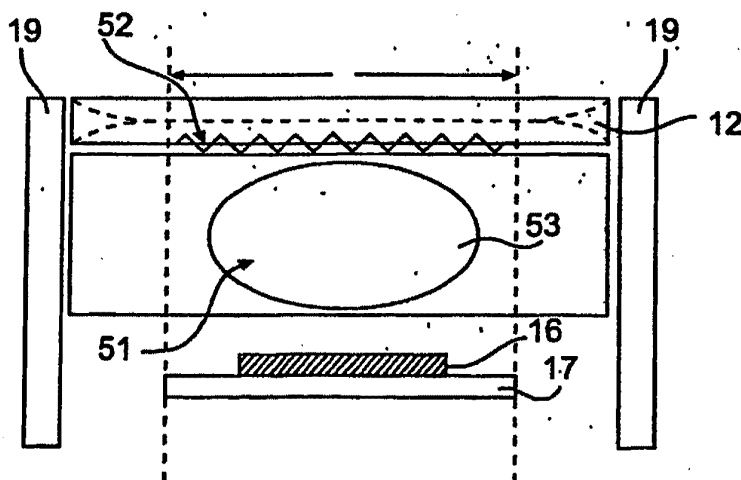

FIG. 1B

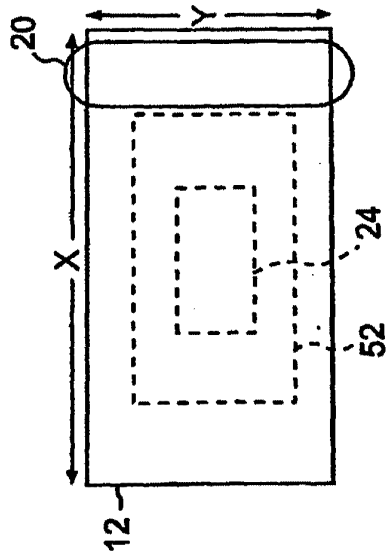
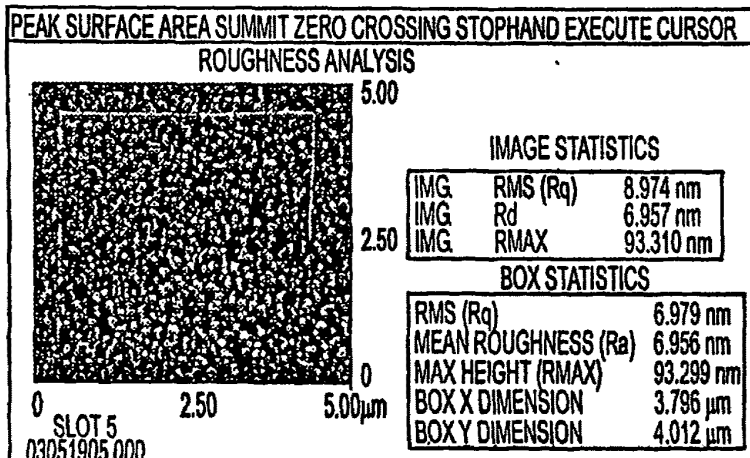

FIG. 2



PEAK OFF AREA OFF SUMMIT OFF ZERO CROSS. OFF BOX CURSOR

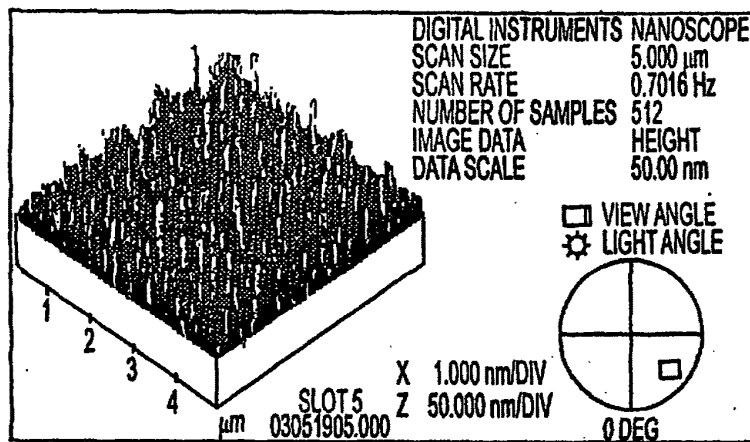
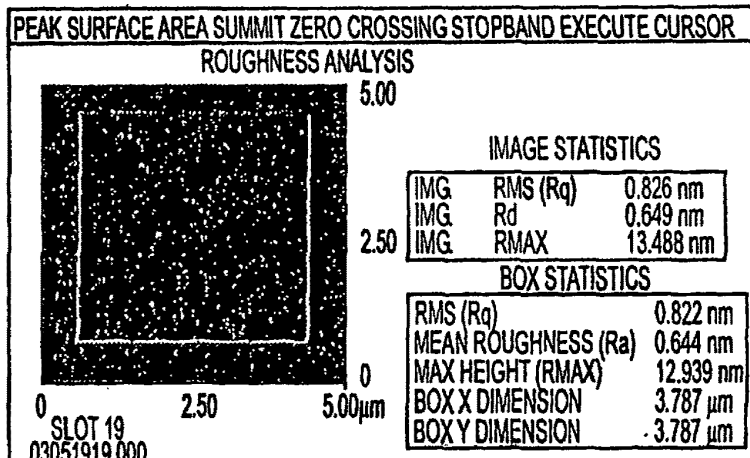

FIG. 3A



PEAK OFF AREA OFF SUMMIT OFF ZERO CROSS. OFF BOX CURSOR

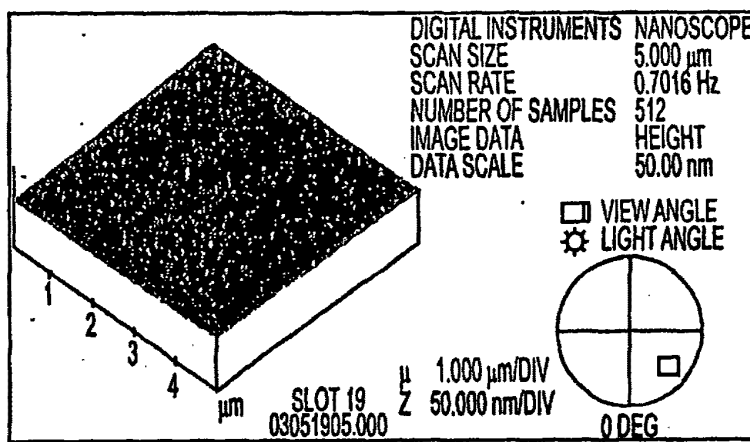

FIG. 3B

3/9

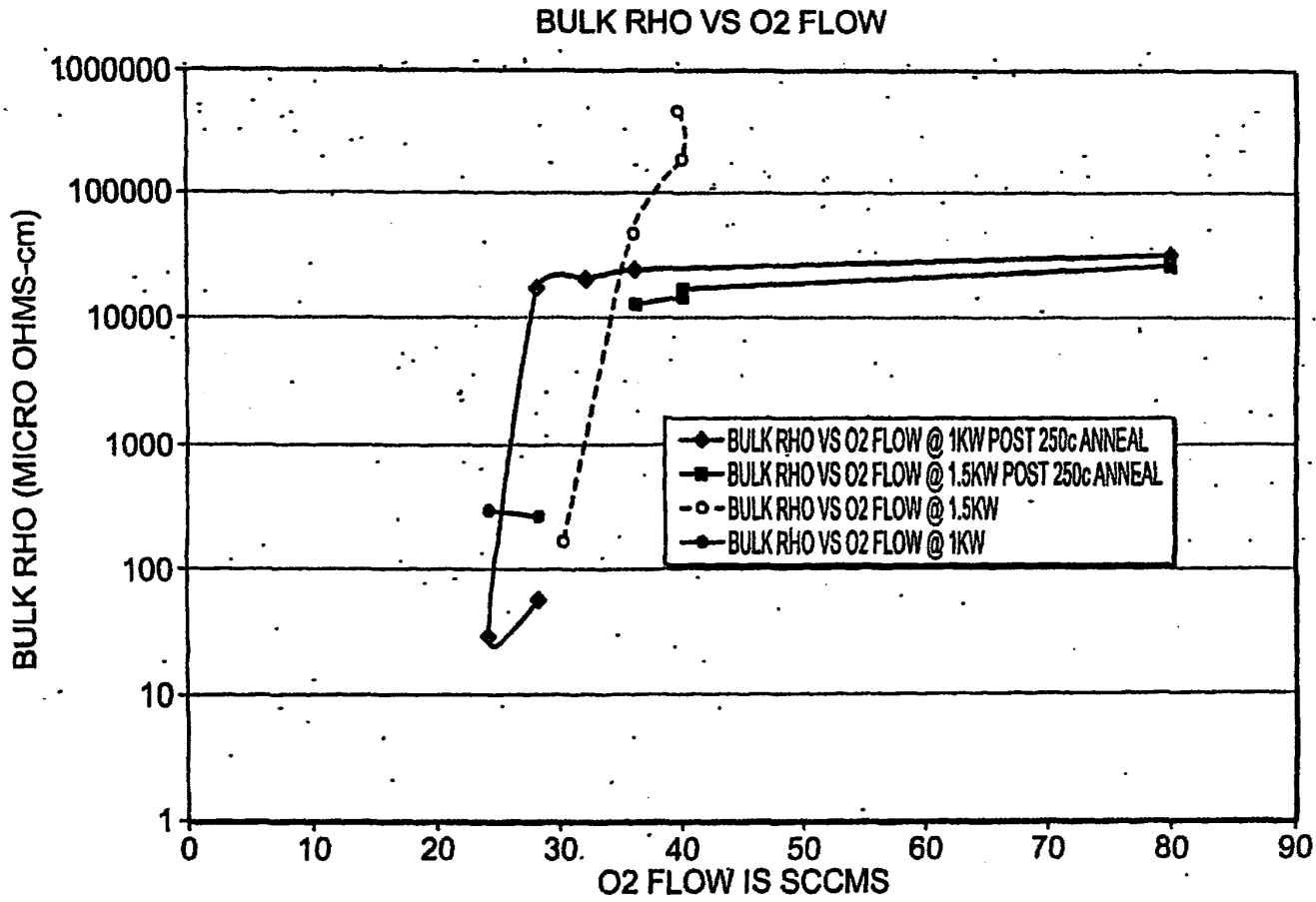

FIG. 4

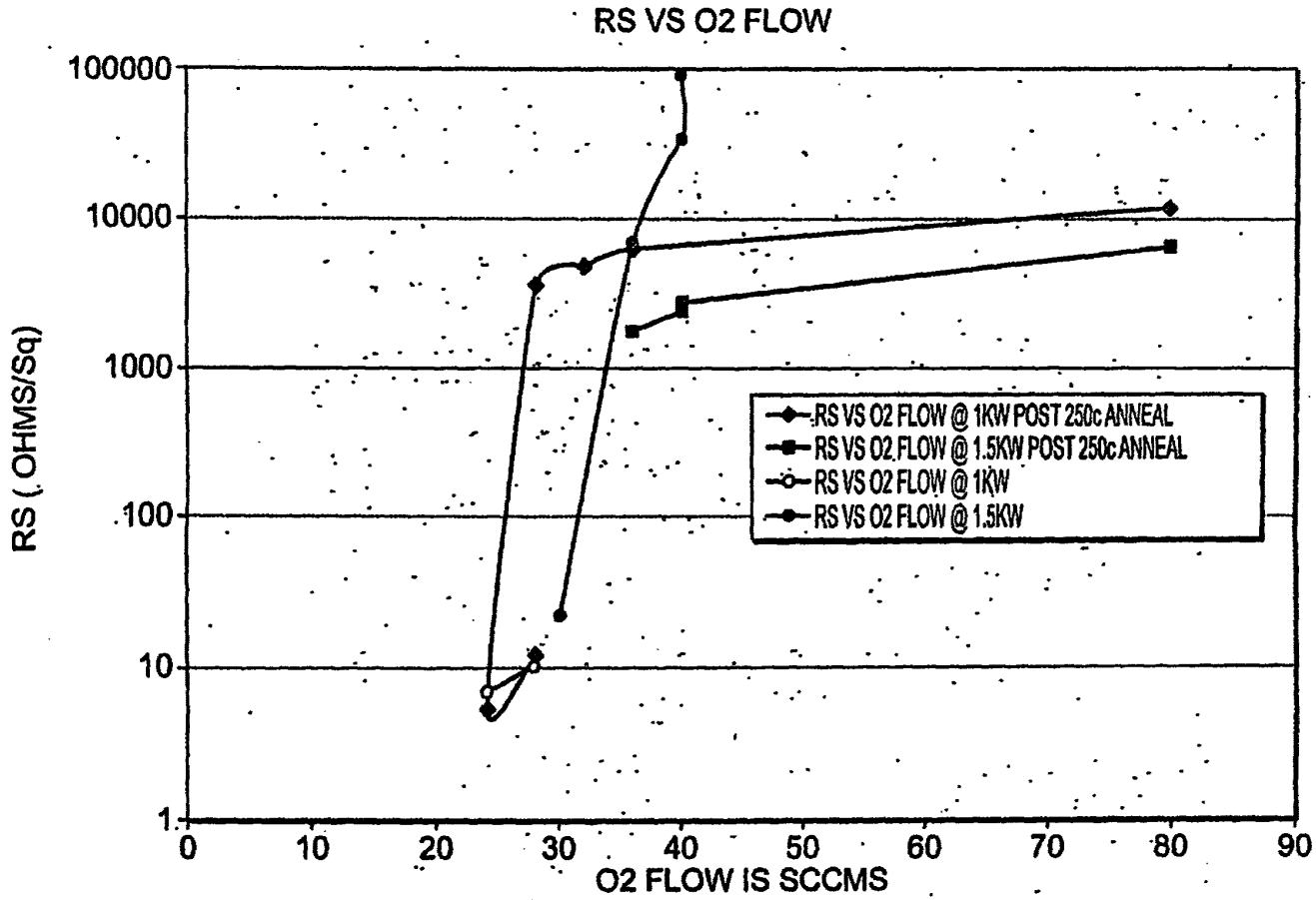

FIG. 5

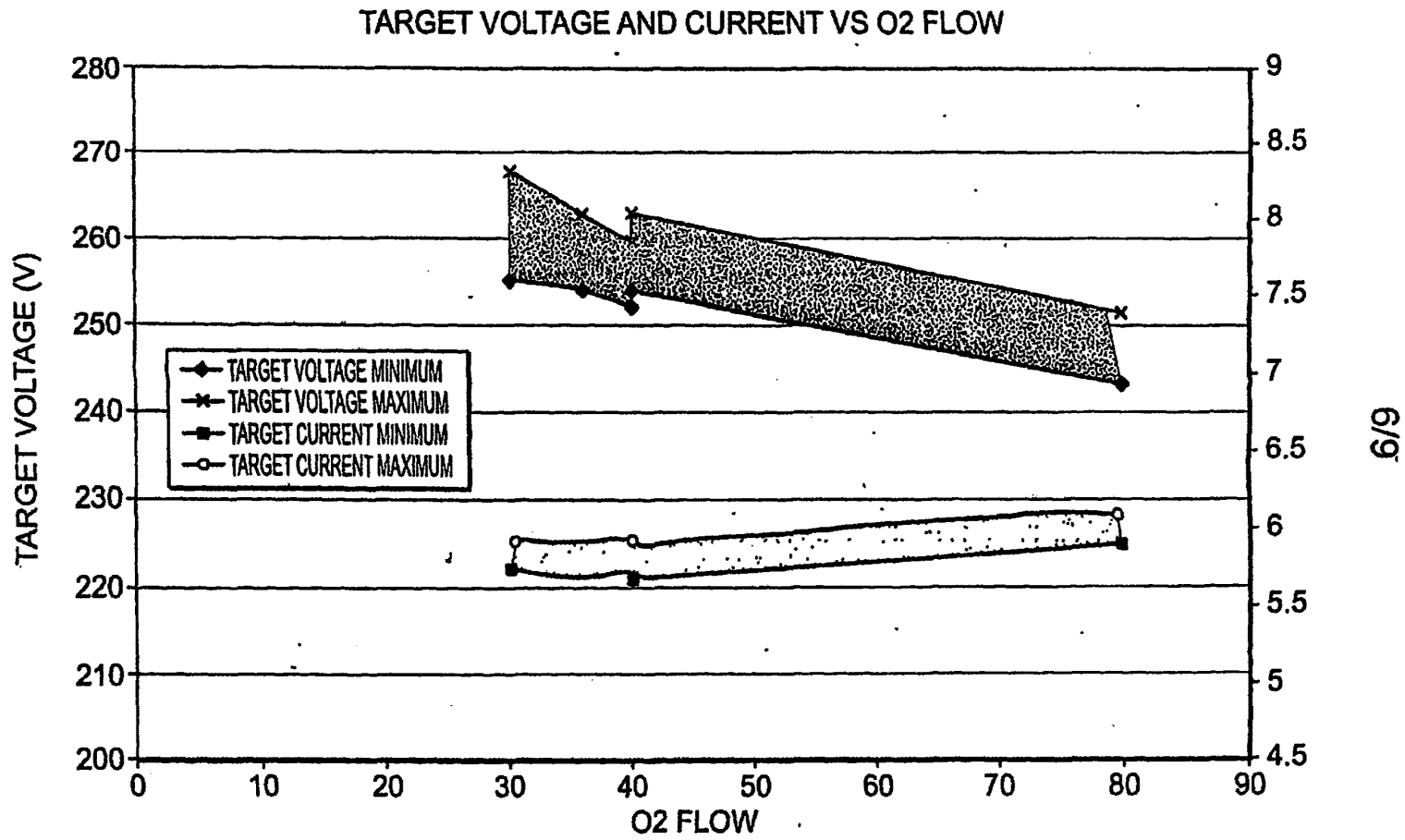

FIG. 6

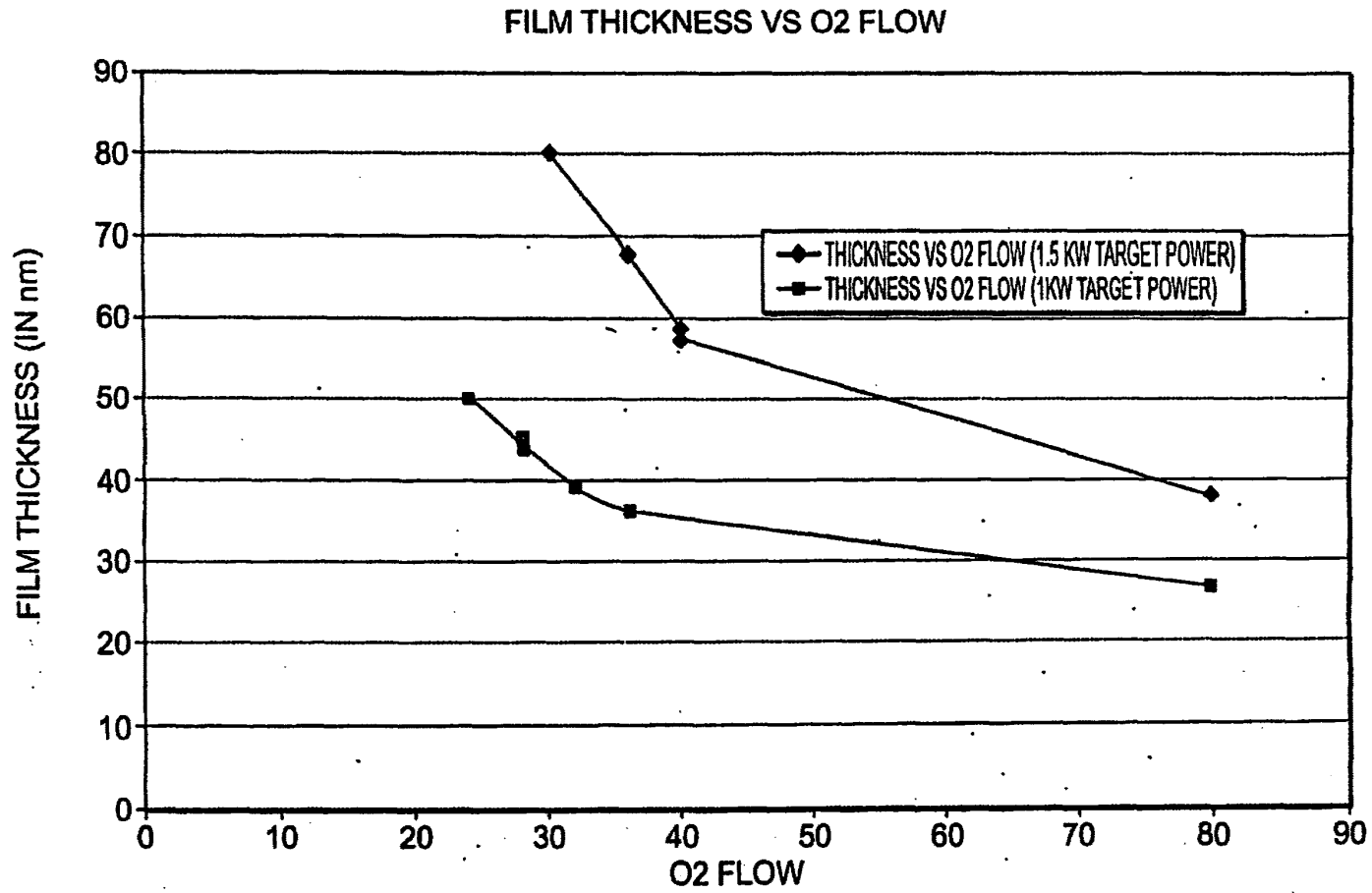

FIG. 7

7/9

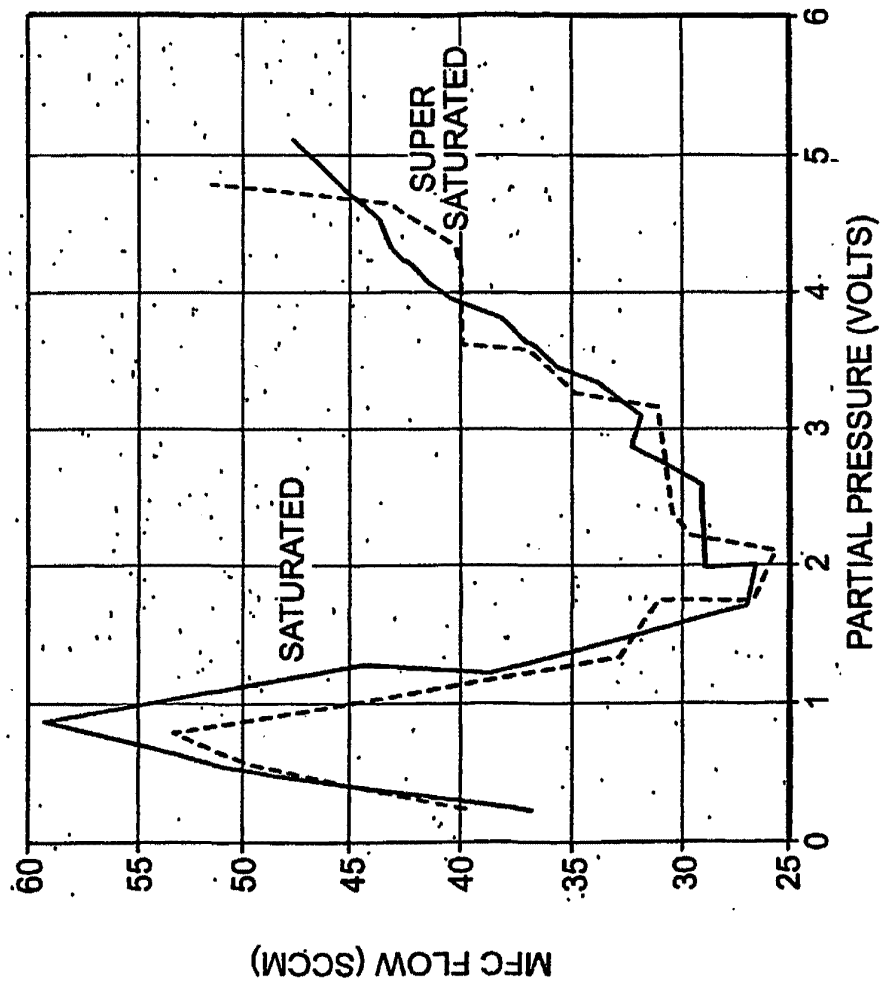

FIG. 8

SUBSTITUTE SHEET (RULE 26)

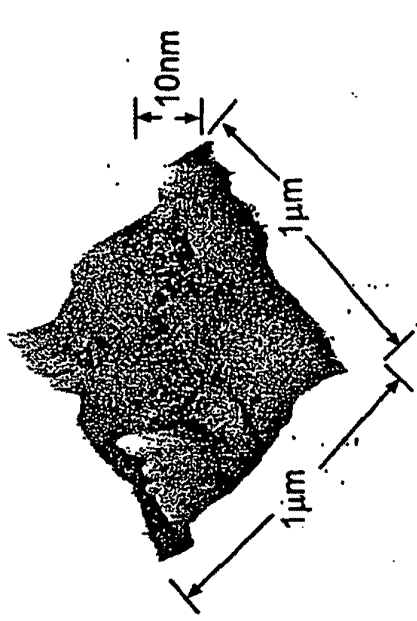

FIG. 9B

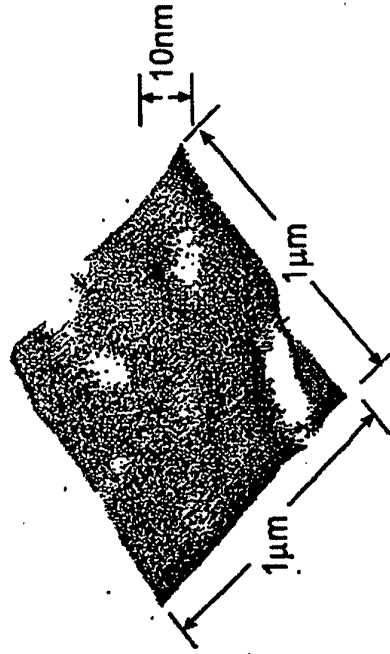

FIG. 9D

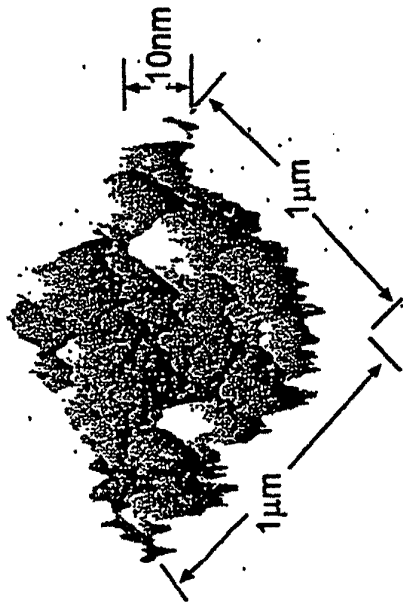

FIG. 9A

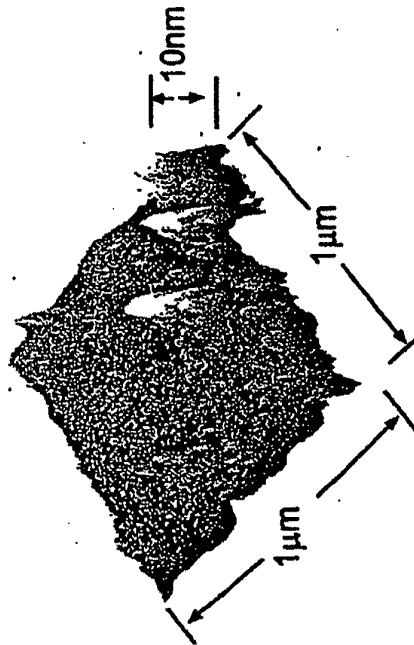

FIG. 9C

**This Page is Inserted by IFW Indexing and Scanning
Operations and is not part of the Official Record**

BEST AVAILABLE IMAGES

Defective images within this document are accurate representations of the original documents submitted by the applicant.

Defects in the images include but are not limited to the items checked:

- BLACK BORDERS
- IMAGE CUT OFF AT TOP, BOTTOM OR SIDES
- FADED TEXT OR DRAWING
- BLURRED OR ILLEGIBLE TEXT OR DRAWING
- SKEWED/SLANTED IMAGES
- COLOR OR BLACK AND WHITE PHOTOGRAPHS
- GRAY SCALE DOCUMENTS
- LINES OR MARKS ON ORIGINAL DOCUMENT
- REFERENCE(S) OR EXHIBIT(S) SUBMITTED ARE POOR QUALITY
- OTHER: _____

IMAGES ARE BEST AVAILABLE COPY.

As rescanning these documents will not correct the image problems checked, please do not report these problems to the IFW Image Problem Mailbox.

(19) World Intellectual Property
Organization
International Bureau



(43) International Publication Date
9 December 2004 (09.12.2004)

PCT

(10) International Publication Number
WO 2004/106582 A2

- (51) International Patent Classification⁷: C23C 14/14, 14/08, 14/34, H01L 21/316
- (21) International Application Number: PCT/US2004/014524
- (22) International Filing Date: 21 May 2004 (21.05.2004)
- (25) Filing Language: English
- (26) Publication Language: English
- (30) Priority Data: 60/473,375 23 May 2003 (23.05.2003) US
- (71) Applicant (for all designated States except US): SYM-MORPHIX, INC. [US/US]; 1278 Reamwood Avenue, Sunnyvale, CA 94089-2233 (US).
- (72) Inventors; and
- (75) Inventors/Applicants (for US only): DEMARAY, Richard, Ernest [US/US]; 190 Fawn Lane, Portola Valley, CA 94028 (US). ZHANG, Hongmei [US/US]; 1330 Rodney Drive, San Jose, CA 95118 (US). NARASIMHAN, Mukundan [IN/US]; 293 Bluefield Drive, San Jose, CA 95136 (US). MILONOPOULOU, Vassiliki [GR/US]; 6160 Paseo Pueblo Drive, San Jose, CA 95120 (US).
- (74) Agent: GARRETT, Arthur, S.; Finnegan, Henderson, Farabow, Garrett & Dunner, L.L.P., 1300 I Street N.W., Washinton, D.C. 20005-3315 (US).
- (81) Designated States (unless otherwise indicated, for every kind of national protection available): AE, AG, AL, AM, AT, AU, AZ, BA, BB, BG, BR, BW, BY, BZ, CA, CH, CN, CO, CR, CU, CZ, DE, DK, DM, DZ, EC, EE, EG, ES, FI, GB, GD, GE, GH, GM, HR, HU, ID, IL, IN, IS, JP, KE, KG, KP, KR, KZ, LC, LK, LR, LS, LT, LU, LV, MA, MD, MG, MK, MN, MW, MX, MZ, NA, NI, NO, NZ, OM, PG, PH, PL, PT, RO, RU, SC, SD, SE, SG, SK, SL, SY, TJ, TM, TN, TR, TT, TZ, UA, UG, US, UZ, VC, VN, YU, ZA, ZM, ZW.
- (84) Designated States (unless otherwise indicated, for every kind of regional protection available): ARIPO (BW, GH, GM, KE, LS, MW, MZ, NA, SD, SL, SZ, TZ, UG, ZM, ZW), Eurasian (AM, AZ, BY, KG, KZ, MD, RU, TJ, TM), European (AT, BE, BG, CH, CY, CZ, DE, DK, EE, ES, FI, FR, GB, GR, HU, IE, IT, LU, MC, NL, PL, PT, RO, SE, SI, SK, TR), OAPI (BF, BJ, CF, CG, CI, CM, GA, GN, GQ, GW, ML, MR, NE, SN, TD, TG).

Published:

— without international search report and to be republished upon receipt of that report

For two-letter codes and other abbreviations, refer to the "Guidance Notes on Codes and Abbreviations" appearing at the beginning of each regular issue of the PCT Gazette.



WO 2004/106582 A2

(54) Title: ENERGY CONVERSION AND STORAGE FILMS AND DEVICES BY PHYSICAL VAPOR DEPOSITION OF TITANIUM AND TITANIUM OXIDES AND SUB-OXIDES

(57) Abstract: High density oxide films are deposited by a pulsed-DC, biased reactive sputtering process from a titanium containing target to form high quality titanium containing oxide films. A method of forming a titanium based layer or film according to the present invention includes depositing a layer of titanium containing oxide by pulsed-DC, biased reactive sputtering process on a substrate. In some embodiments, the layer is TiO₂. In some embodiments, the layer is a sub-oxide of Titanium. In some embodiments, the layer is Ti_xO_y, wherein x is between about 1 and about 4 and y is between about 1 and about 7. In some embodiments, the layer can be doped with one or more rare-earth ions. Such layers are useful in energy and charge storage, and energy conversion technologies.

BEST AVAILABLE COPY

**Energy Conversion and Storage Films and Devices by Physical Vapor Deposition
of Titanium and Titanium Oxides and sub-Oxides**

Related Applications

The present invention claims priority to U.S. Provisional Application Serial No. 60/473,375, "Energy Conversion and Storage Devices by Physical Vapor Deposition of Titanium Oxides and Sub-Oxides," by Richard E. Demaray and Hong Mei Zhang, filed on May 23, 2003, herein incorporated by reference in its entirety.

Background

1. Field of the Invention

[0001] The present invention is related to fabrication of thin films for planar energy and charge storage and energy conversion and, in particular, thin films deposited of titanium and titanium oxides, sub oxides, and rare earth doped titanium oxides and sub oxides for planar energy and charge storage and energy conversion.

2. Discussion of Related Art

[0002] Currently, titanium oxide layers are not utilized commercially in energy storage, charge storage, or energy conversion systems because such layers are difficult to deposit, difficult to etch, are known to have large concentrations of defects, and have poor insulation properties due to a propensity for oxygen deficiency and the diffusion of oxygen defects in the layers. Additionally, amorphous titania is difficult to deposit due to its low recrystallization temperature (about 250 °C), above which the deposited layer is often a mixture of crystalline anatase and rutile structures.

[0003] However, such amorphous titania layers, if they can be deposited in sufficient quality, have potential due to their high optical index, $n \sim 2.7$, and their high dielectric constant, k less than or equal to about 100. Further, they have substantial chemical stability. There are no known volatile halides and titania is uniquely resistant to mineral acids. Amorphous titania is thought to have the further advantage that there are no grain boundary mechanisms for electrical breakdown, chemical corrosion, or optical scattering. It is also well known that the sub oxides of titanium have unique and useful properties. *See, e.g.,* Hayfield, P.C.S., "Development of a

New Material- Monolithic Ti_4O_7 Ebonix Ceramic”, Royal Society Chemistry, ISBN 0-85405-984-3, 2002. Titanium monoxide, for example, is a conductor with a uniquely stable resistivity with varying temperature. Additionally, Ti_2O_3 , which can be pinkish in color, is known to have semiconductor type properties. However, these materials have not found utilization because of their difficult manufacture in films and their susceptibility to oxidation. Further, Ti_4O_7 demonstrates both useful electrical conductivity and unusual resistance to oxidation. Ti_4O_7 , however, is also difficult to fabricate, especially in thin film form.

[0004] Additional to the difficulty of fabricating titanium oxide or sub oxide materials in useful thin film form, it also has proven difficult to dope these materials with, for example, rare earth ions, in useful or uniform concentration.

[0005] Therefore, utilization of titanium oxide and suboxide films, with or without rare earth doping, has been significantly limited by previously available thin film processes. If such films could be deposited, their usefulness in capacitor, battery, and energy conversion and storage technologies would provide for many value-added applications:

[0006] Current practice for construction of capacitor and resistor arrays and for thin film energy storage devices is to utilize a conductive substrate or to deposit the metal conductor or electrode, the resistor layer, and the dielectric capacitor films from various material systems. Such material systems for vacuum thin films, for example, include copper, aluminum, nickel, platinum, chrome, or gold depositions, as well as conductive oxides such as ITO, doped zinc oxide, or other conducting materials.

[0007] Materials such as chrome-silicon monoxide or tantalum nitride are known to provide resistive layers with 100 parts per million or less resistivity change per degree Centigrade for operation within typical operating parameters. A wide range of dielectric materials such as silica, silicon nitride, alumina, or tantalum pentoxide can be utilized for the capacitor layer. These materials typically have dielectric constants k of less than about twenty four (24). In contrast, TiO_2 either in the pure rutile phase or in the pure amorphous state can demonstrate a dielectric constant as high as 100. See, e.g., R. B. van Dover, “Amorphous Lanthanide-Doped TiO_2 Dielectric Films,”

Appl. Phys Lett., Vol. 74, no. 20, p. 3041-43 (May 17, 1999).

[0008] It is well known that the dielectric strength of a material decreases with increasing value of dielectric constant k for all dielectric films. A 'figure of merit' (FM) is therefore obtained by the product of the dielectric constant k and the dielectric strength measured in Volts per cm of dielectric thickness. Capacitive density of 10,000 to 12,000 pico Farads /mm² is very difficult to achieve with present conductors and dielectrics. Current practice for reactive deposition of titanium oxide has achieved a figure-of-merit, FM, of about 50 (k MV/cm). See J.-Y. Kim et al., "Frequency-Dependent Pulsed Direct Current Magnetron Sputtering of Titanium Oxide Films," J. Vac. Sci. Technol. A 19(2), Mar/Apr 2001.

[0009] Therefore, there is an ongoing need for titanium oxide and titanium sub-oxide layers, and rare-earth doped titanium oxide and titanium sub-oxide layers, for various applications.

Summary

[0010] In accordance with the present invention, high density oxide films are deposited by a pulsed-DC, biased, reactive sputtering process from a titanium containing target. A method of forming a titanium based layer or film according to the present invention includes depositing a layer of titanium containing oxide by pulsed-DC, biased reactive sputtering process on a substrate. In some embodiments, the layer is TiO₂. In some embodiments, the layer is a sub-oxide of Titanium. In some embodiments, the layer is Ti_xO_y wherein x is between about 1 and about 4 and y is between about 1 and about 7.

[0011] In some embodiments of the invention, the figure of merit of the layer is greater than 50. In some embodiments of the invention, the layer can be deposited between conducting layers to form a capacitor. In some embodiments of the invention, the layer includes at least one rare-earth ion. In some embodiments of the invention, the at least one rare-earth ion includes erbium. In some embodiments of the invention, the erbium doped layer can be deposited between conducting layers to form a light-emitting device. In some embodiments of the invention, the erbium doped layer can be an optically active layer deposited on a light-emitting device. In some embodiments of the invention, the layer can be a protective layer. In some

embodiments, the protective layer can be a catalytic layer.

[0012] In some embodiments of the invention, the layer and a TiO_2 layer can be deposited between conducting layers to form a capacitor with decreased roll-off characteristics with decreasing thickness of the TiO_2 layer. In some embodiments, the TiO_2 layer can be a layer deposited according to some embodiments of the present invention.

[0013] These and other embodiments of the present invention are further discussed below with reference to the following figures.

Short Description of the Figures

[0014] Figures 1A and 1B illustrate a pulsed-DC biased reactive ion deposition apparatus that can be utilized in the deposition according to the present invention.

[0015] Figure 2 shows an example of a target that can be utilized in the reactor illustrated in Figures 1A and 1B.

[0016] Figures 3A and 3B illustrate various configurations of layers according to embodiments of the present invention.

[0017] Figures 4A and 4B illustrate further various configurations of layers according to embodiments of the present invention.

[0018] Figure 5 shows another layer structure involving one or more layers according to the present invention.

[0019] Figure 6 shows a transistor gate with a TiO_y layer according to the present invention.

[0020] Figure 7 illustrates the roll-off of the dielectric constant with decreasing film thickness.

[0021] Figure 8 illustrates data points from a bottom electrode that helps reduce or eliminate the roll-off illustrated in Figure 7.

[0022] Figures 9A and 9B illustrate an SEM cross-section of a Ti_4O_7 target obtained from Ebonex™ and an SEM cross section of the $\text{Ti}_4\text{O}_{6.8}$ film deposited from the Ebonex™ target according to the present invention.

[0023] Figure 10 shows the industry standard of thin-film capacitor performance in comparison with layers according to some embodiments of the present invention.

[0024] Figure 11 shows the performance of various thin films deposited according

to the present invention in a capacitor structure.

[0025] Figure 12 shows a cross-section TEM and diffraction pattern amorphous and crystalline layers of TiO₂ on n++ wafers.

[0026] Figure 13 shows a comparison of the leakage current for TiO₂ films according to embodiments of the present invention with and without erbium ion doping.

[0027] Figures 14A and 14B show a photoluminescence signal measured from a 5000 Å layer of 10% erbium containing TiO₂ deposited from a 10% erbium doped TiO conductive target and a photoluminescence signal measured from the same layer after a 30 minute 250 °C anneal.

[0028] In the figures, elements having the same designation have the same or similar functions.

Detailed Description

[0029] Miniaturization is driving the form factor of portable electronic components. Thin film dielectrics with high dielectric constants and breakdown strengths allow production of high density capacitor arrays for mobile communications devices and on-chip high-dielectric capacitors for advanced CMOS processes. Thick film dielectrics for high energy storage capacitors allow production of portable power devices.

[0030] Some embodiments of films deposited according to the present invention have a combination of high dielectric and high breakdown voltages. Newly developed electrode materials allow the production of very thin films with high capacitance density. The combination of high dielectric and high breakdown voltages produce thick films with new levels of available energy storage according to $E=1/2CV^2$.

[0031] Deposition of materials by pulsed-DC biased reactive ion deposition is described in U.S. Patent Application Serial No. 10/101863, entitled "Biased Pulse DC Reactive Sputtering of Oxide Films," to Hongmei Zhang, et al., filed on March 16, 2002. Preparation of targets is described in U.S. Patent Application Serial No. 10/101,341, entitled "Rare-Earth Pre-Alloyed PVD Targets for Dielectric Planar Applications," to Vassiliki Milonopoulou, et al., filed on March 16, 2002. U.S. Patent

Application Serial No. 10/101863 and U.S. Patent Application Serial No. 10/101,341 are each assigned to the same assignee as is the present disclosure and each is incorporated herein in their entirety. Additionally, deposition of materials is further described in U.S. Patent 6,506,289, which is also herein incorporated by reference in its entirety.

[0032] Figure 1A shows a schematic of a reactor apparatus 10 for sputtering of material from a target 12 according to the present invention. In some embodiments, apparatus 10 may, for example, be adapted from an AKT-1600 PVD (400 X 500 mm substrate size) system from Applied Komatsu or an AKT-4300 (600 X 720 mm substrate size) system from Applied Komatsu, Santa Clara, CA. The AKT-1600 reactor, for example, has three deposition chambers connected by a vacuum transport chamber. These AKT reactors can be modified such that pulsed DC (PDC) power is supplied to the target and RF power is supplied to the substrate during deposition of a material film. The PDC power supply 14 can be protected from RF bias power 18 by use of a filter 15 coupled between PDC power supply 14 and target 12.

[0033] Apparatus 10 includes a target 12 which is electrically coupled through a filter 15 to a pulsed DC power supply 14. In some embodiments, target 12 is a wide area sputter source target, which provides material to be deposited on substrate 16. Substrate 16 is positioned parallel to and opposite target 12. Target 12 functions as a cathode when power is applied to it and is equivalently termed a cathode. Application of power to target 12 creates a plasma 53. Substrate 16 is capacitively coupled to an electrode 17 through an insulator 54. Electrode 17 can be coupled to an RF power supply 18. Magnet 20 is scanned across the top of target 12.

[0034] For pulsed reactive dc magnetron sputtering, as performed by apparatus 10, the polarity of the power supplied to target 12 by power supply 14 oscillates between negative and positive potentials. During the positive period, the insulating layer on the surface of target 12 is discharged and arcing is prevented. To obtain arc free deposition, the pulsing frequency exceeds a critical frequency that depends on target material, cathode current and reverse time. High quality oxide films can be made using reactive pulsed DC magnetron sputtering in apparatus 10.

[0035] Pulsed DC power supply 14 can be any pulsed DC power supply, for example

an AE Pinnacle plus 10K by Advanced Energy, Inc. With this example supply, up to 10 kW of pulsed DC power can be supplied at a frequency of between 0 and 350 KHz. In some embodiments, the reverse voltage is 10% of the negative target voltage. Utilization of other power supplies will lead to different power characteristics, frequency characteristics, and reverse voltage percentages. The reverse time on this embodiment of power supply 14 can be adjusted to between 0 and 5 μ s.

[0036] Filter 15 prevents the bias power from power supply 18 from coupling into pulsed DC power supply 14. In some embodiments, power supply 18 can be a 2 MHz RF power supply, for example a Nova-25 power supply made by ENI, Colorado Springs, Co.

[0037] Therefore, filter 15 can be a 2 MHz band sinusoidal rejection filter. In some embodiments, the bandwidth of the filter can be approximately 100 kHz. Filter 15, therefore, prevents the 2 MHz power from the bias to substrate 16 from damaging power supply 18.

[0038] However, both RF sputtered and pulsed DC sputtered films are not fully dense and may typically have columnar structures. These columnar structures are detrimental to thin film applications. By applying a RF bias on wafer 16 during deposition, the deposited film can be densified by energetic ion bombardment and the columnar structure can be substantially eliminated or completely eliminated.

[0039] In the AKT-1600 based system, for example, target 12 can have an active size of about 675.70 X 582.48 by 4 mm in order to deposit films on substrate 16 that have dimension about 400 X 500 mm. The temperature of substrate 16 can be held at between -50C and 500C by introduction of back-side gas in a physical or electrostatic clamping of the substrate, thermo-electric cooling, electrical heating, or other methods of active temperature control. In Figure 1A, a temperature controller 22 is shown to control the temperature of substrate 16. The distance between target 12 and substrate 16 can be between about 3 and about 9 cm. Process gas can be inserted into the chamber of apparatus 10 at a rate up to about 200 sccm while the pressure in the chamber of apparatus 10 can be held at between about .7 and 6 millitorr. Magnet 20 provides a magnetic field of strength between about 400 and about 600 Gauss directed

in the plane of target 12 and is moved across target 12 at a rate of less than about 20-30 sec/scan. In some embodiments utilizing the AKT 1600 reactor, magnet 20 can be a race-track shaped magnet with dimension about 150 mm by 600 mm.

[0040] Figure 2 illustrates an example of target 12. A film deposited on a substrate positioned on carrier sheet 17 directly opposed to region 52 of target 12 has good thickness uniformity. Region 52 is the region shown in Figure 1B that is exposed to a uniform plasma condition. In some implementations, carrier 17 can be coextensive with region 52. Region 24 shown in Figure 2 indicates the area below which both physically and chemically uniform deposition can be achieved, where physical and chemical uniformity provide refractive index uniformity, for example. Figure 2 indicates that region 52 of target 12 that provides thickness uniformity is, in general, larger than region 24 of target 12 providing thickness and chemical uniformity. In optimized processes, however, regions 52 and 24 may be coextensive.

[0041] In some embodiments, magnet 20 extends beyond area 52 in one direction, the Y direction in Figure 2, so that scanning is necessary in only one direction, the X direction, to provide a time averaged uniform magnetic field. As shown in Figures 1A and 1B, magnet 20 can be scanned over the entire extent of target 12, which is larger than region 52 of uniform sputter erosion. Magnet 20 is moved in a plane parallel to the plane of target 12.

[0042] The combination of a uniform target 12 with a target area 52 larger than the area of substrate 16 can provide films of highly uniform thickness. Further, the material properties of the film deposited can be highly uniform. The conditions of sputtering at the surface of target 12, such as the uniformity of erosion, the average temperature of the plasma at the target surface and the equilibration of the target surface with the gas phase ambient of the process are uniform over a region which is greater than or equal to the region to be coated with a uniform film thickness. In addition, the region of uniform film thickness is greater than or equal to the region of the film which is to have highly uniform optical properties such as index of refraction, density, transmission, or absorptivity.

[0043] Target 12 can be formed of any materials, but is typically metallic materials such as, for example, combinations of In and Sn. Therefore, in some embodiments,

target 12 includes a metallic target material formed from intermetallic compounds of optical elements such as Si, Al, Er and Yb. Additionally, target 12 can be formed, for example, from materials such as La, Yt, Ag, Au, and Eu. To form optically active films on substrate 16, target 12 can include rare-earth ions. In some embodiments of target 12 with rare earth ions, the rare earth ions can be pre-alloyed with the metallic host components to form intermetallics. *See* U.S. Application Serial No. 10/101,341. [0044] In several embodiments of the invention, material tiles are formed. These tiles can be mounted on a backing plate to form a target for apparatus 10. A wide area sputter cathode target can be formed from a close packed array of smaller tiles. Target 12, therefore, may include any number of tiles, for example between 2 to 20 individual tiles. Tiles are finished to a size so as to provide a margin of non-contact, tile to tile, less than about 0.010" to about 0.020" or less than half a millimeter so as to eliminate plasma processes that may occur between adjacent ones of the tiles. The distance between the tiles of target 12 and the dark space anode or ground shield 19 in Figure 1B can be somewhat larger so as to provide non contact assembly or provide for thermal expansion tolerance during processing, chamber conditioning, or operation.

[0045] As shown in Figure 1B, a uniform plasma condition can be created in the region between target 12 and substrate 16 in a region overlying substrate 16. A plasma 53 can be created in region 51, which extends under the entire target 12. A central region 52 of target 12, can experience a condition of uniform sputter erosion. As discussed further below, a layer deposited on a substrate placed anywhere below central region 52 can then be uniform in thickness and other properties (i.e., dielectric, optical index, or material concentrations). In addition, region 52 in which deposition provides uniformity of deposited film can be larger than the area in which the deposition provides a film with uniform physical or optical properties such as chemical composition or index of refraction. In some embodiments, target 12 is substantially planar in order to provide uniformity in the film deposited on substrate 16. In practice, planarity of target 12 can mean that all portions of the target surface in region 52 are within a few millimeters of a planar surface, and can be typically within 0.5 mm of a planar surface.

[0046] Figure 3A illustrates deposition of a layer 102 according to the present invention deposited on a substrate 101. In some embodiments, layer 102 can be a conducting protective layer of TiO_y . Figure 3B shows a first layer 102 according to the present invention deposited over a second layer 103, which can also be a layer according to some embodiments of the present invention. In some embodiments, first layer 102 can be a conducting protective layer and second layer 103 can be a titanium or other conducting layer. Layer 103 is deposited on substrate 101.

[0047] The fabrication of high density capacitor and resistor arrays as well as high energy storage solid state devices can be accomplished with embodiments of processes according to the present invention on a wide variety of substrates such as silicon wafers or glass or plastic sheets at low temperature and over wide area. With reference to Figure 3B, layer 102 can be an amorphous film of TiO_2 , which is deposited by a process such as that described in U.S. Application Serial No. 10/101,341. Utilization or formation of a conducting layer 103 such as TiO or Ti_4O_7 between a conducting layer of titanium, which is substrate 101, and the dielectric TiO_2 layer 102 is shown in the present invention to substantially reduce or eliminate the 'roll off' of the dielectric constant k with decreasing film thickness below about 1000 Angstroms. Consequently, capacitors fabricated from titanium on low temperature substrates result in high value planar capacitors and capacitor arrays with very high capacitive density and low electrical leakage. Such electrical arrays are useful for shielding and filtering and buffering high frequency and may be used in stationary as well as in portable electronic devices.

[0048] In particular, the low temperature deposition of amorphous titania capacitors provides for the fabrication of integrated passive electronic circuits on plastic and glass. It also provides for the integration of such devices on other electronic devices and arrays at low temperature.

[0049] Similarly, a conducting layer of TiO or Ti_4O_7 as layer 103 in Figure 3B, deposited between a conducting layer of titanium as layer 101 and a layer of titania as layer 102 of Figure 3B can be deposited so as to provide an increase in the surface smoothness by planarization of the titanium in layer 101 or other metallurgical conductive substrate layer 101 of Figure 3B. Consequently, roughness or asperity

based defects can be minimized or eliminated. As an example, charge injection from a metallurgical electrode can be decreased at the interface with a dielectric. The titanium based dielectric layer can be formed on a smooth conducting oxide layer, which according to some theories can prevent charge depletion of the high k dielectric layer, decrease point charge accumulation and support dipole formation at the conductor-dielectric interface, sometimes referred to as dipole coupling. These features are important to prevent the roll-off of the dielectric strength of the dielectric layer as the layer thickness is decreased below about 1000 Å. It is consequently useful in the formation of thin layers having high capacitive value.

[0050] A thick film of dielectric material may be deposited having a high dielectric strength for the storage of electrical energy. Such energy is well known to increase with the square of the applied Voltage. For example, in Figure 3B layer 102 can be a thick layer of dielectric according to the present invention. Layer 104 in Figure 3B, then, can be a conducting layer deposited on layer 102 while layer 103 is a conducting layer deposited between a substrate 101 and layer 102 to form a capacitor. As the dielectric strength of the amorphous dielectric layer of layer 102 increases in proportion to its thickness, the energy storage also increases effectively as the square of the thickness. It is shown that both record capacitance density and electrical energy storage density result for films according to the present invention. For thick film applications, smoothing of the metallurgical electrode by a conductive sub-oxide can decrease leakage at the interface in high voltage applications.

[0051] Protective conductive sub-oxide films of titanium can also be deposited on conductive and insulating substrates to protect them from harmful chemical attack while acting as conducting layers. For example, as illustrated in Figure 3A layer 102 can be a protective conductive sub-oxide film deposited on substrate 101. These layers can be used to protect an electrode, which can be substrate 101, from oxidation in the gas phase and in the liquid phase as well as the solid phase. Examples of such applications include electrolytic energy storage or as an active electrode surface for catalytic reactions and energy conversion such as in the oxygen-hydrogen fuel cell. Transparent oxides and semi-transparent sub-oxides can be deposited sequentially so that the conducting sub-oxides are protected by the transparent non-conducting oxides

for purposes of photovoltaic or electrochromic energy conversion devices. It is well known that organic based photovoltaic cells are enhanced by the presence of titania in the organic absorbing layer. Layers according to the present invention can be utilized both for the conductivity of electricity, the enhancement of the organic absorber, as well as the overall protection of the device.

[0052] TiO_2 layers, for example, can photocatalytically produce ozone in the presence of sunlight. However, in the course of such activity, the TiO_2 layer can build up a fixed charge. Absent a metallurgical conductor, as shown in Figure 3B layer 102 can be a catalytic oxide while layer 103 can be a conducting suboxide while substrate 101 is a dielectric substrate such as glass or plastic and layer 104 is absent. In such a two-layer device, where the oxide is provided on the surface of the sub-oxide, the sub-oxide can form an electrode so that electric charge can be conducted to the oxide layer for enhanced photochemical photolysis such as in an AC device, or for the purpose of charge dissipation.

[0053] Protective conductive sub-oxide films of titanium can also be deposited on conductive and insulating substrates to protect them from harmful chemical attack while acting as conducting layers for electrolytic energy storage or as an active electrode for catalytic energy conversion. Transparent and semi-transparent oxides can be deposited sequentially so that the conducting suboxides are protected by the transparent non-conducting oxide for purposes of protecting layered devices. Alternatively, it is well known that certain crystalline suboxides of titania, collectively referred to as Magnelli phases, possess unusual levels of durability to mineral acid solutions and other corrosive gaseous or liquid environments. Hayfield, P.C.S., "Development of a New Material- Monolithic Ti_4O_7 Ebonix Ceramic", Royal Society Chemistry, ISBN 0-85405-984-3, 2002 describes these in detail and discusses many applications of the monolithic suboxides. Hayfield also explains that the basis of conductivity of sub-oxides is due to the presence of the Ti^{+2} cation in layers having the stoichiometry TiO . Of the several compositions, Ti_4O_7 in particular is known to possess both useful conductivity and also chemical resistance to both anodization, which would decrease its conductivity, as well as reduction, which would decrease its chemical durability. Therefore, as shown in Figure 3A, substrate 101 can be a

metallurgical substrate such as aluminum or titanium and layer 102 can be Ti_4O_7 . An example is the catalytic of H_2 and O_2 to make water and electricity.

[0054] In this disclosure, an amorphous coating layer according to embodiments of the present invention, derived from a crystalline target of Ti_4O_7 , can obtain a similar composition as described above, measured as $Ti_4O_{6.8}$. Similar useful levels of chemical conductivity can be obtained. The sputtered film was dense, adherent, and also displayed robust durability to immersion in concentrated mineral acid and oxidizing solution. A similar material was deposited directly from a titanium target using the subject reactive sputtering process.

[0055] The increased density of the amorphous sputtered film according to embodiments of the present invention such as film 102 shown in Figure 3A can provide high levels of impermeability. Planarization can also be achieved by layer 102 over structures on substrate 101. Layer 102 can therefore achieve 'atomic' smooth surfaces on otherwise rough substrates. The sputtering process according to the present invention also allows the formation of a continuous range of stoichiometry between what are, in their crystalline environment, 'line compounds' with whole number integer ratios of titanium cations to oxygen atoms. In the present amorphous films, as long as one Ti^{+2} has a nearest neighbor cation in the amorphous glass matrix with the Ti^{+2} valence, conductive paths will be available in the sputtered film.

[0056] The sputtered sub-oxides also have the advantage that they can be layered, without removal from the vacuum system, with metallic titanium, other sub-oxides, as well as TiO_2 for connection to electrical conduction and insulation. This feature provides the utility of multiplayer depositions by integrated processes in one vacuum chamber. Where thick films of a particular sub-oxide are desired, a target 12 (Figure 1) fabricated of the desired sub-oxide can be utilized. TiO is particularly a good conductor and possesses very stable resistivity with temperature variation. Ti_2O_3 is a semiconductor. The higher oxygen-containing Magnelli compositions obtain higher resistivity as well as increased chemical stability and robustness and can be utilized as a resistive layer or as a protective, conductive layer.

[0057] Erbium doped TiO_2 is known to display useful levels of

photoluminescence. And rare earth doped titanium oxide is known to display decreased levels of electrical leakage current under conditions of high electrical field. Layer 102 of Figure 3B, deposited according to some embodiments of the present invention, then can be erbium doped TiO_2 and therefore displays very high level of breakdown and very low leakage under electrical stress. Additionally, a capacitor can be formed by deposition of conductors as layers 103 and 104 on a substrate 101. Consequently, capacitive and energy storage devices formed from rare earth doped layers formed according to the present invention are extremely useful for very high field applications such as capacitors, high voltage dielectric batteries, and electro luminescent devices and also for low-leakage devices.

[0058] A TiO or erbium-doped TiO target, target 12 of Figure 1A, can be formed by mixing of TiO powder or TiO powder and Erbium or Erbium-Oxide powder. TiO powder can be formed from the partial oxygenation in a controlled furnace. The mixed powder is then hipped under a controlled environment (for example hydrogen or CO_2) to a high density to form tiles. As discussed above, such tiles can be mounted to form target 12. Additionally, other rare-earth doped titanium containing targets can be formed in the same fashion.

[0059] As an example, a layer of erbium doped titania or titania containing alloy deposited by means of the present invention, could be coupled as a continuous oxide layer to a photo diode constructed proximate to dielectric layer 102 of Figure 3A. Such an arrangement could provide an optical means for the measurement of the applied electrical field or the leakage current.

[0060] Alternatively, such a rare earth doped dielectric layer 102 might be coupled to conducting transparent oxides so that a light wave device might be provided for the conversion of electrical energy to light energy. In another embodiment, a titanium oxide containing a rare earth ion can be deposited directly on a light emitting diode device so that the rare earth ion can absorb some or all of the light emitted by the diode and re-fluoresce that light at another wavelength. In this embodiment, layer 102 can be a rare earth containing titanium oxide or sub oxide and substrate 101 includes a light emitting diode. An example of this may be the conversion of blue light from a LED to yellow-green light by layer 102. In that case,

layer 102 may be cerium doped titanium oxide or sub-oxide. Partial absorption of the blue light by layer 102 with conversion to yellow-green light by layer 102 would result in a white light source. Other colors of light can be obtained by doping the titanium oxide or sub-oxide with other rare earth ions.

[0061] Figures 4A and 4B illustrate further stackings of layers according to embodiments of the present invention. For example, layer 201 can be a TiO_2 dielectric protective deposited over a conducting layer 103 on substrate 101. Figure 4B can show dielectric protective layer 201 deposited over conducting protective layer 102 of TiO_y , which is deposited on a metal conducting layer 103 on substrate 101. The TiO_y conducting protective layer can act as a smoothing layer, resulting in a better barrier layer in dielectric 201. The end result is a better roll-off characteristic than has previously been obtained.

[0062] In general, layer 102 can be formed of any Ti_xO_y layer or rare earth doped Ti_xO_y layer according to the present invention. As illustrated here, layers of various compositions of Ti_xO_y , with or without rare-earth doping, have various properties. In some embodiments of the invention, x can be between about 1 and about 4 and y can be between about 1 and about 7.

[0063] Figure 5 shows an example of a capacitor stack according to the present invention. A metal conducting layer 103 is deposited on substrate 101. A conducting protective layer 102 is deposited over conducting layer 103 and a TiO_2 dielectric protective layer is deposited over the protective conducting layer 102. Another protective conducting layer 102 can be deposited over the TiO_2 dielectric layer and a metal layer can be deposited over the protective conducting layer 102. The resulting capacitor stack has upper and lower smoothing due to the two TiO_y layers and results in improved roll-off characteristics in the dielectric constant. Such capacitor stacks can be very useful in energy storage devices.

[0064] Figure 6 shows a transistor structure according to the present invention. A source 401, drain 402 and gate structure 404 are deposited on a semiconducting substrate 403. An intermediate dielectric 400 can then be deposited over the source, drain and gate structure. A protective conducting layer 102, which can be formed of TiO_y , can then be deposited over an opening in the intermediate dielectric layer 400

followed by a conducting layer 103. The protective conducting layer 102 prevents roll-off of the gate dielectric 404.

Example 1. Deposition of Ti₄O₇ film

[0065] In this example, Ti₄O₇ films were deposited using a Pulse DC scanning magnetron PVD process as was previously described in U.S. Application Serial No. 10/101,341. The target was a about 1mm thick, about 16.5x12.5 mm² tiles of titanium oxide target obtained from a sheet of Ebonex™ which compounded of bulk Ti₄O₇ was bonded onto a backing plate. Ebonex™ can be obtained from Atraverda Ltd., Oakham Business Park, Mansfield, UK. A pulsed DC generator from Advanced Energy (Pinnacle Plus) was used as the target power supply. The pulsing frequency can be varied from 0-350 KHz. Reversed duty cycle can be varied from 1.3μs to 5μs depending on the pulsing frequency. Target power was fixed at 2 KW and pulsing frequency was 200KHz during deposition, Ar flow rate is 100sccm. The deposition rate at this condition is 14Å/sec over a 40 by 50 cm substrate 101. A 100 W at 2 MHz bias was supplied to the substrate. The bias power supply can be an RF supply produced by ENI.

[0066] Utilizing the above parameters, a layer 102 of Figure 3A was deposited on a substrate 101 of 150mm p-type Si wafer. The sheet resistance was measured using 4 point probe to be 140 ohms/sq, with film thickness of 1.68μm. The resistivity of the resulting film is measured to be 0.023 ohms-cm. The composition of film was determined using EDX to be Ti₄O_{6.8}.

Example 2. Deposition of TiO₂ on Ti-Ti₄O₇ film Stack

[0067] In this example, TiO₂ films were deposited using a 2MHz RF biased, Pulse DC scanning magnetron PVD process as was previously described in U.S. Application Serial No. 10/101,341. The substrate size can be up to 600x720mm². The target was a ~7mm thick, ~630x750 mm² Ti plate of 99.9% purity. A pulsed DC generator, or PDC power supply from Advanced Energy (Pinnacle Plus) was used as the target power supply. The pulsing frequency can be varied from 0-350 KHz. Reversed duty cycle can be varied from 1.3μs to 5μs depending on the pulsing

frequency. An ENI RF generator and ENI Impedance matching unit were used for the substrate bias. A 100 W with a 2 MHz RF generator, which can be an EFI supply, was utilized. The chamber base pressure was kept below 2×10^{-7} Torr. The substrate temperature was below 200°C during deposition.

[0068] A systematic DOE (design of experiments) were carried out on both n++ type bare Si wafers and Al metallized wafers. All n++ wafers were HF cleaned just before loading into the chamber for deposition. A series of 150nm thick, Al films were deposited onto the bare Si wafers using the same PVD system at low temperature (<100°C).

[0069] The total PDC target power, pulsing frequency, oxygen partial pressure, and substrate bias power were variables in the DOE. Total gas flow of Ar and O₂ were kept constant at 100 sccm. The PDC target power was between 4 and 7 kW with a pulsing frequency of between 100 and 250 kHz. The oxygen flow rate ranged from 30 to 60%. The bias power ranged from 0 to 300 W at 2 Mhz. Both dielectric strength and breakdown voltage were measured using a mercury probe. Film thickness in this DOE range from 100nm to 270nm.

[0070] Therefore, with reference to Figure 3B, layer 101 is the Si wafer substrate, layer 103 is the 150 nm thick Al layer, layer 102 is the Ti₄O₇ layer, and layer 104 is TiO₂. Figure 7 shows the thickness dependence of the dielectric constant of layer 102, showing the roll off effect. The capacitance of the layer stack 101, 103, 102, and 104 was measured with a mercury electrode impressed upon layer 104 and coupled to layer 103. The precise thickness of dielectric layer 104 was measured optically. The dielectric constant of layer 104 was then calculated from the measured capacitance. As shown in Figure 7, the TiO₂ film thickness decreases, so does the dielectric constant of the TiO₂ film.

[0071] However, this roll-off effect can be greatly reduced or eliminated in certain embodiments of the present invention. Figure 8 shows two additional data points shown as circles which represent the dielectric constant of thin TiO₂ layers for layer 104 with Ti-Ti₄O₇ deposited as layer 102 of Figure 3B.

Example 3. Deposition of TiO₂ on Ti-TiO_x (x<2) film Stack

[0072] A layer of TiO₂ was deposited on a titanium coated substrate. About 2000 Å of Ti metal was deposited at 7KW of PDC target power, with Ar flow of 100 sccm and bias power of 200W. After Ti deposition, TiO₂ was deposited in the same chamber without oxide burn in. This process resulted in a Ti-TiO_y-TiO₂ (y<2) film stack. The k value of a 200Å film was as high as 60.

[0073] Figures 9A and 9B illustrate an SEM cross-section of a Ti₄O₇ Ebonex™ target (Figure 9A) and an SEM cross section of the Ti₄O_{6.8} layer (Figure 9B) deposited from the Ebonex™ target according to the present invention. The deposited film shows smooth deposition of the layer. The Ebonex™ target shown in Figure 9A shows an open porosity material with high roughness. The deposited layer shown in Figure 9B, however, shows a highly dense layer with a smooth surface condition.

[0074] Table I shows the effects of the dielectric properties of TiO₂ deposited according the present invention in comparison with previously obtained values. The values for the previously obtained reactive sputtering was taken from the paper "Frequency-Dependent Pulsed Direct Current magnetron Sputtering of Titanium Oxide Films," by J. Y. Kim et al., J. Vac. Sci. Techn., A 19(2), Mar/Apr. 2001. The values for PDC PVD with bias was experimentally obtained from layers deposited as described in Example 2 above.

Table I

Process	V _{bd} (Mv/cm)	K	FM
Reactive Sputtering	0.46 ~ 1.35	34 ~ 65.9	19 ~ 50
PDC physical Vapor Deposition with Bias	3.48	83	288

[0075] As can be seen from Table I, the breakdown voltage V_{bd} is significantly improved in layers according to the present invention. Further, the dielectric constant of the resulting layer is also higher. The figure of merit (FM) then for the deposited

layer was 288, very much higher than that report by Kim et al. The reference Kim et al. was the reference reporting the best quality TiO₂ films available at the time of filing of the prior application to which this disclosure claims priority.

[0076] Figure 10 shows data of capacitance made with layers according to the present invention in processes as described in Example 2 above are shown in comparison with available industry values. As is observed in Figure 10, layers of TiO₂ deposited according to the present invention have higher dielectric breakdown voltages than other dielectric films utilized in industry, which is represented by the solid line. However, due to the roll-off in dielectric constant K in films below about 1000 Å in thickness (as is indicated in the top two points in Figure 10), a capacitance density above about 5000 or 6000 pF/mm² could not be achieved using thinner films. This is also shown in Figure 7.

[0077] However, combined with the use of a conductive sub-oxide and the higher dielectric constant of thinner films as shown in Figure 11, a capacitance density of 12000 pF/mm² can be achieved with a 500 Å thickness film and a capacitance density of greater than 24000 pF/mm² can be achieved with a 220 Å film, as is shown in Figure 11. These film stacks were deposited as described in Example 3 above.

[0078] Figure 12 shows a deposited layer 102 on a substrate 101 formed of n⁺⁺ silicon wafer. Layer 102 is formed of TiO₂ deposited according to the present invention. As shown in the SEM cross-section, the TiO₂ layer shows several layers. A layer 1201 is formed of SiO₂ formed on substrate 101 and is formed about 20 Å thick. An amorphous layer 1202 of thickness about 250 Å is then formed above layer 1201. Finally, a crystalline TiO₂ layer 1203 is formed about 4000 Å thick. In some embodiments of the present invention, a continuous deposition on a substrate results in a first amorphous layer deposited at initially cooler temperature followed by a further crystalline layer deposited during the increased temperature of the process. A diffraction pattern inset in Figure 12 illustrates the crystalline nature of layer 1203.

[0079] Table II tabulates data taken from a number of bi-layer film such as that shown in Figure 12 and completely amorphous films formed by repeated initial deposition layers at cool deposition conditions. Films near 1000 Å of thickness are compared and display similar values for the dielectric constant. However, the

amorphous film exhibits much higher dielectric breakdown strengths. Due to the similar thickness and values of the dielectric constant, the two films exhibit similar values for capacitance. However, the amorphous film illustrates superior breakdown voltage and therefore has a higher figure of merit (FM). These trends are more pronounced in the thicker films with thicknesses close to 2000 Å. In this case, the values of the dielectric constant and capacitance are nearly identical but again there is a significantly higher breakdown voltage in the amorphous film, which results in a significant improvement in the figure of merit for the amorphous films.

Table II

Film Thickness (nm)	k	V _{bd} (MV/cm)	FM	C (pF/mm ²)	Breakdown Voltage (V)	Film Morphology
969	63	3.6	227	540	348	Bi-layer
1036	62	6.4	396	538	660	Amorphous
2020	98	3.5	335	429	705	Bi-Layer
2322	98	5.5	539	429	1110	Amorphous

[0080] Therefore, it is clear that amorphous TiO₂ films have much better performance. As discussed above, those layers are the result of low temperature depositions. Therefore, as was demonstrated with the data shown in Table II, one method of producing thick amorphous TiO₂ layers is to simply utilize a sequence of low temperature depositions, halting the deposition prior to thermal heating of the depositing film. However, this method can take a significant amount of production time for thick films. Another embodiment of obtaining thick TiO₂ amorphous films is to apply active cooling to the substrate in an amount sufficient to provide continuously amorphous TiO₂ films.

[0081] Figure 13 shows a comparison of the leakage current for TiO₂ films according to embodiments of the present invention with and without erbium ion doping. The lower data points in Figure 13 are from capacitors formed from films deposited from a 10 at. % Er doped TiO target. The target was electrically

conductive. One example of the 10% doped film of 1000 Å thickness was formed with 60 sccm Ar, 6 sccm O₂, with a target power of 3 kW, bias power of 100 W, with a deposition time of 200 sec on a metal coated glass wafer. With the metal coating forming a copper titanium lower electrode and a titanium copper gold upper electrode patterned as 1X1 mm, discrete capacitors was then formed. The layers corresponding to the upper data points were deposited from a pure titanium target with no erbium doping on a TaN substrate with an evaporated platinum upper electrode. This structure of the bottom data is illustrated in Figure 4B where, for example, layer 101 is a glass substrate, layer 103 is a copper titanium layer, layer 102 is the erbium doped TiO₂ layer, and layer 201 is a titanium copper gold layer.

[0082] As can be seen in Figure 13, the leakage current density is reduced by many orders of magnitude by addition of erbium.

[0083] Figures 14A and 14B show a photoluminescence signal with excitation at 580 nm and measurement at 1.53 μm, measured from a 5000 Å layer of 10% erbium containing TiO₂ deposited from a 10% erbium doped TiO conductive target and a photoluminescence signal measured from the same layer after a 30 minute 250 °C anneal, respectively. Table III shows similar data for several layers deposited from the erbium-doped TiO conductive target.

Table III

Thickness	Before Anneal	Anneal (°C)	After Anneal
5000 Å	6704	150	5809
5000 Å	6493	200	4042
5000 Å	6669	250	2736
5000 Å	6493	300	3983
1 μm	6884	150	6743
1 μm	5197	200	3685
1 μm	6253	250	3612
1 μm	5324	300	3381

[0084] According to some explanations of the reduction of leakage current in layers as illustrated by Figure 13, fast electrons that have sufficient energy to excite

the erbium ion would cause the rare earth ion to undergo excitation upon electron impact or passage within a distance sufficient for energy exchange. Consequently, the leakage current electrons capable of causing ionization within the dielectric oxide would be reduced by electron collisions with erbium ions. Excited state ions have at least two relaxation mechanisms for disposal of the energy: radiative and non-radiative. In radiative relaxation, the excited ion emits light. In non-radiative relaxation, the excited ion undergoes a cooperative process with vibrational modes of its host dielectric oxide and produces a vibration which is the elemental form of heat. In the data illustrated in Figure 13, it was not possible to observe light in the leakage test, but photoluminescence was observed from optical excitation of the similar 10% Er doped TiO₂ deposited from the 10% Er doped TiO conductive target, as shown in Table III.

[0085] As can be seen from the data in Table III, an erbium doped layer of titanium oxide was shown to fluoresce strongly under optical excitation by light of a wavelength 580 nm, using a Phillips PhotoLuminescence Microscope, model no. PLM-100. The target was electrically conductive and sputtered at a higher rate and a lower oxygen partial pressure than characteristic of a metallic titanium target. One example of the 10% doped film of 2,032 angstroms was 60 sccm Ar, 6 sccm O₂, with a target power of 3 kW, bias power of 100 W, with a deposition time of 300 sec.

[0086] The level of photoluminescence observed from the layer was similar to that obtained in as-deposited and annealed films providing commercial levels of optical absorption and fluorescence for applications to planar waveguide amplifiers having at least 15 dB gain for signals as weak as -40dB at the 1.5 micron wavelength utilized for photonic C band communications.

[0087] Such a device can be illustrated with Figure 3B, where layer 103 can be a conductive layer deposited on substrate 101, layer 102 can be a rare-earth doped TiO₂ layer deposited according to embodiments of the present invention, and layer 104 can be a further conductive layer or a conductive transparent layer to form an metal-insulating-metal (MIM) capacitor structure. Such a structure could function as a light emitting layer under either DC or AC electrical excitation. In another embodiment, layer 103 can be a lift-off layer such as CaF₂ or other organic material, layer 102 is

the rare-earth doped TiO₂ layer, and layer 104 is absent, then upon lift-off or upon transfer of layer 102, a free standing or applied layer having electroluminescent or photoluminescent applications can be provided over a selected device.

[0088] Thin films according to the present invention can be utilized in advanced display devices, electrical energy storage and conversion, and to form optical and electronic films with scratch resistance and barrier properties. Advanced display product applications include OLED encapsulation, barriers for flexible polymer substrates, outcoupling mirrors and anti-reflection coatings, transparent conducting oxides, and semiconducting materials for active matrix displays. Electrical energy storage and conversion applications include high density capacitor arrays for mobile communication devices, on-chip high "K" capacitors for advanced CMOS, and high voltage energy storage for portable power devices. Other applications include touch-sensitive devices and durable bar code scanners and see-through sensors as well as implantable biometric devices.

[0089] The embodiments described in this disclosure are examples only and are not intended to be limiting. Further, the present invention is not intended to be limited by any particular theory or explanation presented to explain experimental results. As such, examples of titanium oxide and titanium sub-oxide films illustrated herein and their applications are not intended to be limiting. One skilled in the art may contemplate further applications or films that are intended to be within the spirit and scope of the present invention. As such, the invention is limited only by the following claims.

Claims

We claim:

1. A method of forming a titanium based layer, comprising:
depositing a layer of titanium containing oxide by pulsed-DC, biased reactive sputtering process on a substrate.
2. The method of claim 1, wherein the layer is TiO₂.
3. The method of claim 2, wherein the figure of merit of the layer is greater than 50.
4. The method of claim 2, wherein the layer is deposited between conducting layers to form a capacitor.
5. The method of claim 2, wherein the layer includes at least one rare-earth ion.
6. The method of claim 5, wherein the layer is deposited between conducting layers to form a capacitor.
7. The method of claim 5, wherein the at least one rare-earth ion includes erbium.
8. The method of claim 5, wherein the layer is deposited between conducting layers to form a light-emitting device.
9. The method of claim 5, wherein the layer is an optically active layer deposited on a light-emitting device.
10. The method of claim 5, wherein the layer is an optically active layer applied to a light-emitting device.
11. The method of claim 1, wherein the layer is a sub-oxide of Titanium.
12. The method of claim 11, wherein the figure of merit of the layer is greater than 50.
13. The method of claim 11, wherein the layer is deposited between conducting layers to form a capacitor.
14. The method of claim 11, wherein the layer includes at least one rare-earth ion.
15. The method of claim 14, wherein the layer is deposited between conducting layers to form a capacitor.
16. The method of claim 14, wherein the at least one rare-earth ion includes erbium.
17. The method of claim 14, wherein the layer is deposited between conducting layers to form a light-emitting device.

18. The method of claim 14, wherein the layer is an optically active layer deposited on a light-emitting device.
19. The method of claim 14, wherein the layer is an optically active layer applied to a light-emitting device.
20. The method of claim 2, wherein the layer is a protective layer.
21. The method of claim 20, wherein the protective layer is a catalytic layer.
22. The method of claim 20, wherein the protective layer includes at least one rare-earth ion.
23. The method of claim 1, wherein the layer is Ti_xO_y , wherein x is between about 1 and about 4 and y is between about 1 and about 7.
24. The method of claim 23, wherein the figure of merit of the layer is greater than 50.
25. The method of claim 23, further including depositing an TiO_2 layer on the layer wherein the layer and the TiO_2 layers are deposited between conducting layers to form a capacitor with decreased roll-off characteristics with decreasing thickness of the TiO_2 layer.
26. The method of claim 23, wherein the TiO_2 layer is an amorphous layer deposited by a pulsed DC, biased, reactive ion process.
27. The method of claim 23, wherein the layer includes at least one rare-earth ion.
28. The method of claim 27, wherein the at least one rare-earth ion includes erbium.
29. The method of claim 27, wherein the layer is deposited between conducting layers to form a light-emitting device.
30. The method of claim 27, wherein the layer is an optically active layer deposited on a light-emitting device.
31. The method of claim 27, wherein the layer is an optically active layer applied to a light-emitting device.
32. The method of claim 23, wherein the layer is a conducting oxide.
33. The method of claim 32, wherein the substrate is a conducting electrode and the layer is a protective layer.
34. The method of claim 33, wherein the protective layer is a catalytic layer.

35. The method of claim 33, wherein the protective layer includes at least one rare-earth ion.
36. The method of claim 32, wherein the substrate is a dielectric and the layer is a protective layer.
37. The method of claim 36, wherein the protective layer is a catalytic layer.
38. The method of claim 1, further including
controlling the temperature of the substrate during deposition.
39. The method of claim 38, wherein controlling the temperature includes active temperature control.
40. The method of claim 1, wherein the layer is an amorphous layer.
41. The method of claim 1, wherein the substrate includes a transistor structure.
42. A titanium based layer, comprising:
a layer compounded from titanium and oxygen deposited by pulsed-DC, biased reactive sputtering process on a substrate.
43. The layer of claim 42, wherein the layer is TiO_2 .
44. The layer of claim 43, wherein the figure of merit of the layer is greater than 50.
45. The layer of claim 43, wherein the layer is deposited between conducting layers to form a capacitor.
46. The layer of claim 43, wherein the layer includes at least one rare-earth ion.
47. The layer of claim 46, wherein the layer is deposited between conducting layers to form a capacitor.
48. The layer of claim 46, wherein the at least one rare-earth ion includes erbium.
49. The layer of claim 46, wherein the layer is deposited between conducting layers to form a light-emitting device.
50. The layer of claim 46, wherein the layer is an optically active layer deposited on a light-emitting device.
51. The layer of claim 46, wherein the layer is an optically active layer applied to a light-emitting device.
52. The layer of claim 42, wherein the layer is sub-oxide of Titanium.
53. The layer of claim 52, wherein the figure of merit is greater than 50.

54. The layer of claim 52, wherein the layer is deposited between conducting layers to form a capacitor.
55. The layer of claim 52, wherein the layer includes at least one rare-earth ion.
56. The layer of claim 55, wherein the layer is deposited between conducting layers to form a capacitor.
57. The layer of claim 55, wherein the at least one rare-earth ion includes erbium.
58. The layer of claim 55, wherein the layer is deposited between conducting layers to form a light-emitting device.
59. The layer of claim 55, wherein the layer is an optically active layer deposited on a light-emitting device.
60. The layer of claim 55, wherein the layer is an optically active layer applied to a light-emitting device.
61. The layer of claim 43, wherein the layer is a protective layer.
62. The layer of claim 61, wherein the protective layer is a catalytic layer.
63. The layer of claim 61, wherein the protective layer includes at least one rare-earth ion.
64. The layer of claim 42, wherein the layer is Ti_xO_y wherein x is between about 1 and about 4 and y is between about 1 and about 7.
65. The layer of claim 64, wherein the figure of merit is greater than 50.
66. The layer of claim 64, further including depositing an TiO_2 layer on the layer wherein the layer and the TiO_2 layers are deposited between conducting layers to form a capacitor with decreased roll-off characteristics with decreasing thickness of the TiO_2 layer.
67. The layer of claim 64, wherein the TiO_2 layer is an amorphous layer deposited by a pulsed DC, biased, reactive ion process.
68. The layer of claim 64, wherein the layer includes at least one rare-earth ion.
69. The layer of claim 68, wherein the at least one rare-earth ion includes erbium.
70. The layer of claim 68, wherein the layer is deposited between conducting layers to form a light-emitting device.
71. The layer of claim 68, wherein the layer is an optically active layer deposited on a light-emitting device.

72. The layer of claim 68, wherein the layer is an optically active layer applied to a light-emitting device.
73. The layer of claim 64, wherein the layer is a conducting oxide.
74. The layer of claim 73, wherein the substrate is a conducting electrode and the layer is a protective layer.
75. The layer of claim 74, wherein the protective layer is a catalytic layer.
76. The layer of claim 74, wherein the protective layer includes at least one rare-earth ion.
77. The layer of claim 73, wherein the substrate is a dielectric and the layer is a protective layer.
78. The layer of claim 77, wherein the protective layer is a catalytic layer.
79. The layer of claim 42, further including
 - controlling the temperature of the substrate during deposition.
80. The layer of claim 79, wherein controlling the temperature includes active temperature control.
81. The layer of claim 42, wherein the substrate includes a transistor structure.
82. The layer of claim 42, wherein the layer is an amorphous layer.
83. A target, comprising:
 - hipped TiO having composition TiO.
84. The target of claim 83, further including at least one rare-earth dopant.
85. A method of forming a target, comprising:
 - forming a TiO powder;
 - mixing the TiO powder to form a mix;
 - hipping the mix under a controlled atmosphere to form tiles; and
 - forming a target from the tiles.
86. The method of claim 85, further including mixing at least one rare-earth oxide powder with the mix.
87. The method of claim 86, wherein the at least one rare-earth oxide includes erbium oxide.

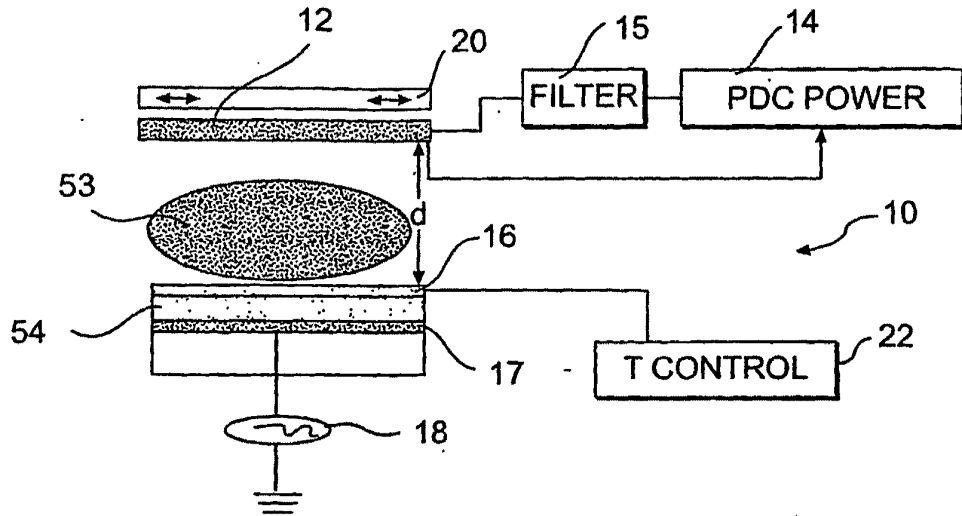

FIG. 1A

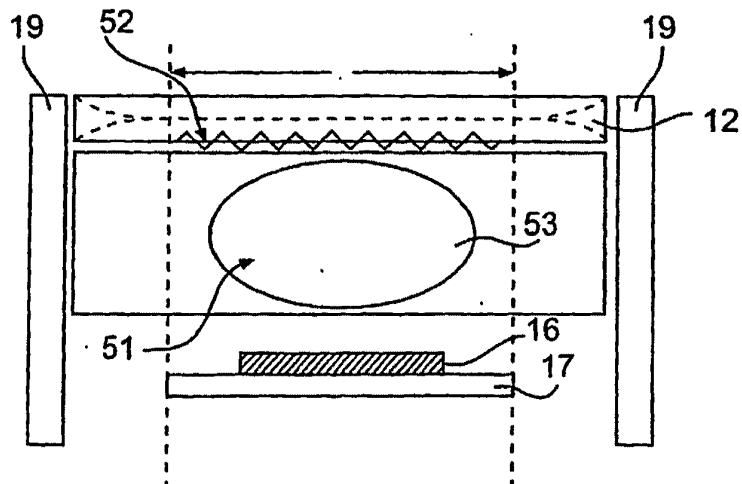

FIG. 1B

2/15

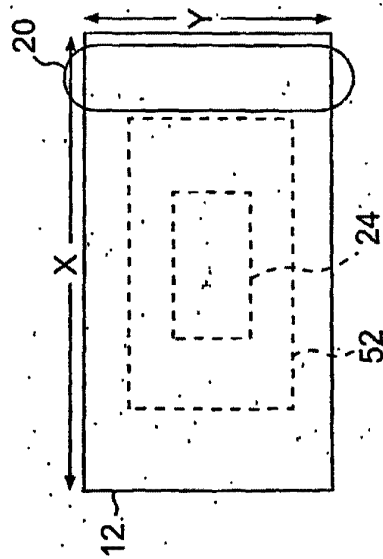

FIG. 2

3/15

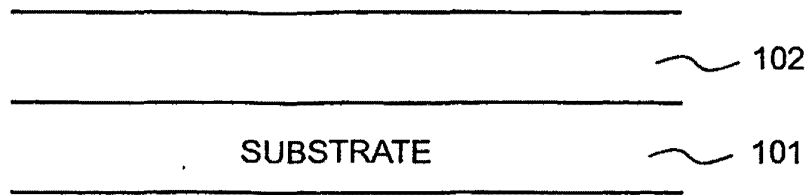

FIG. 3A

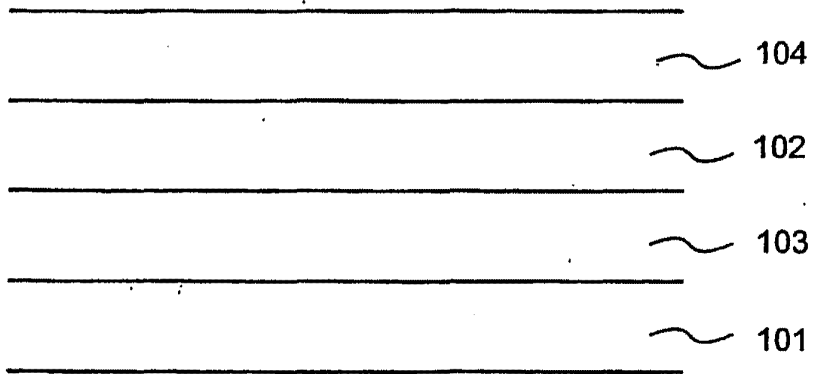

FIG. 3B

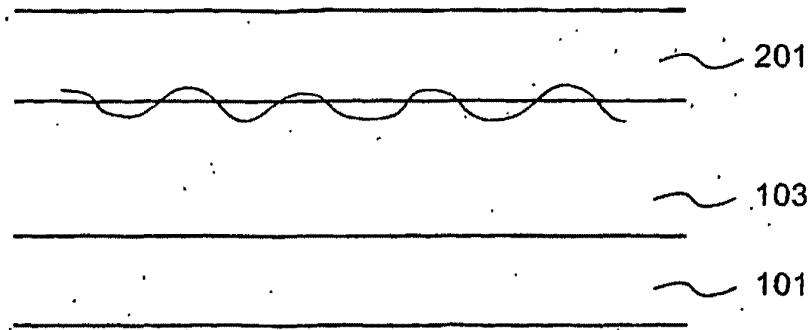

FIG. 4A

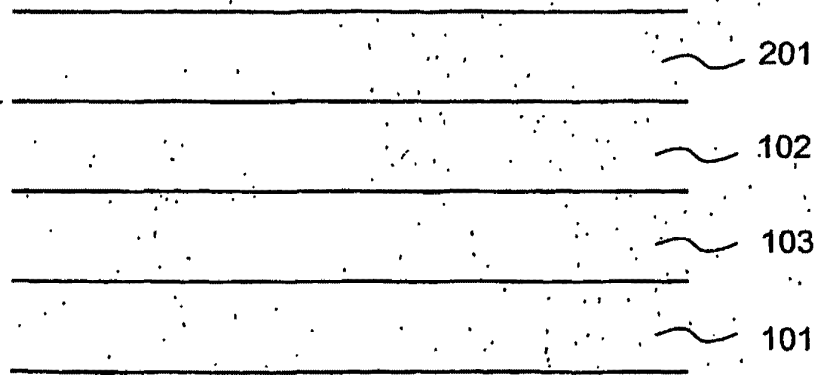

FIG. 4B

5/15

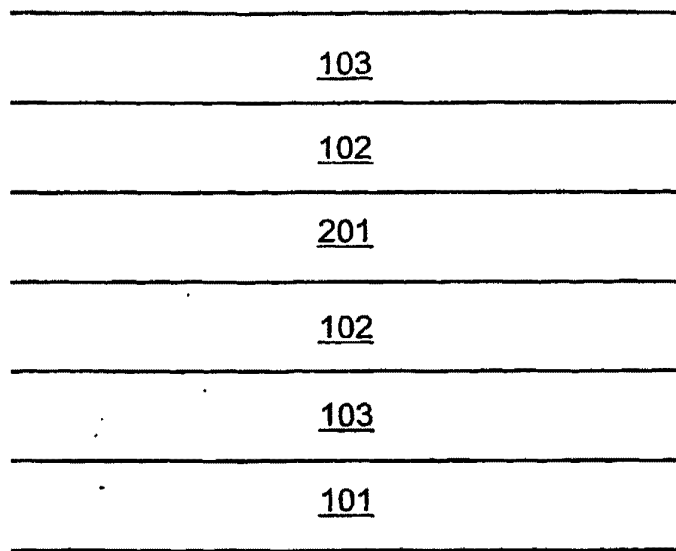

FIG. 5

6/15

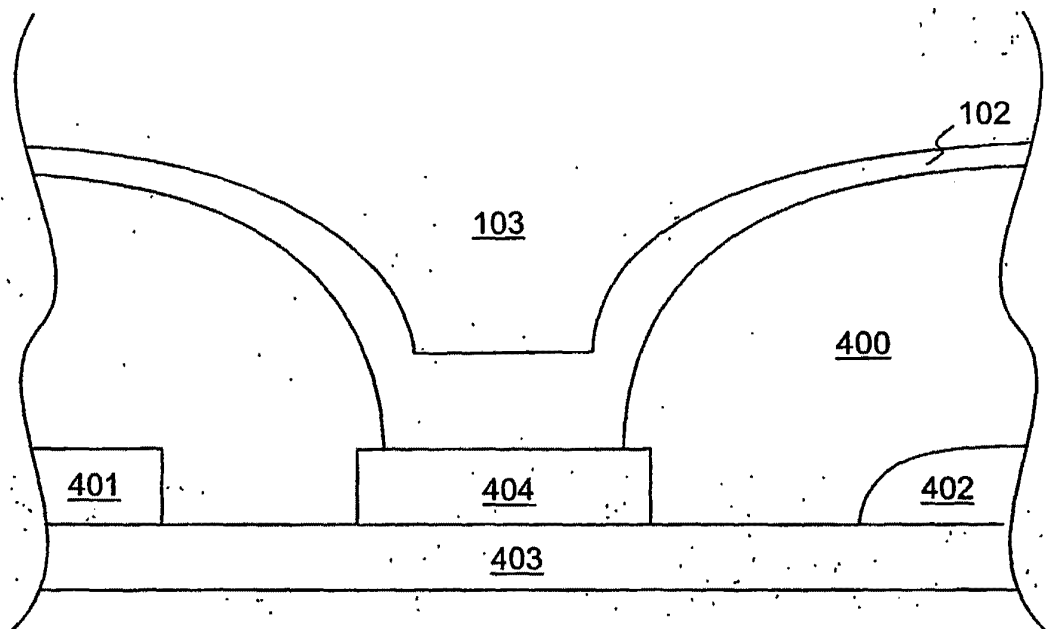

FIG. 6

7/15

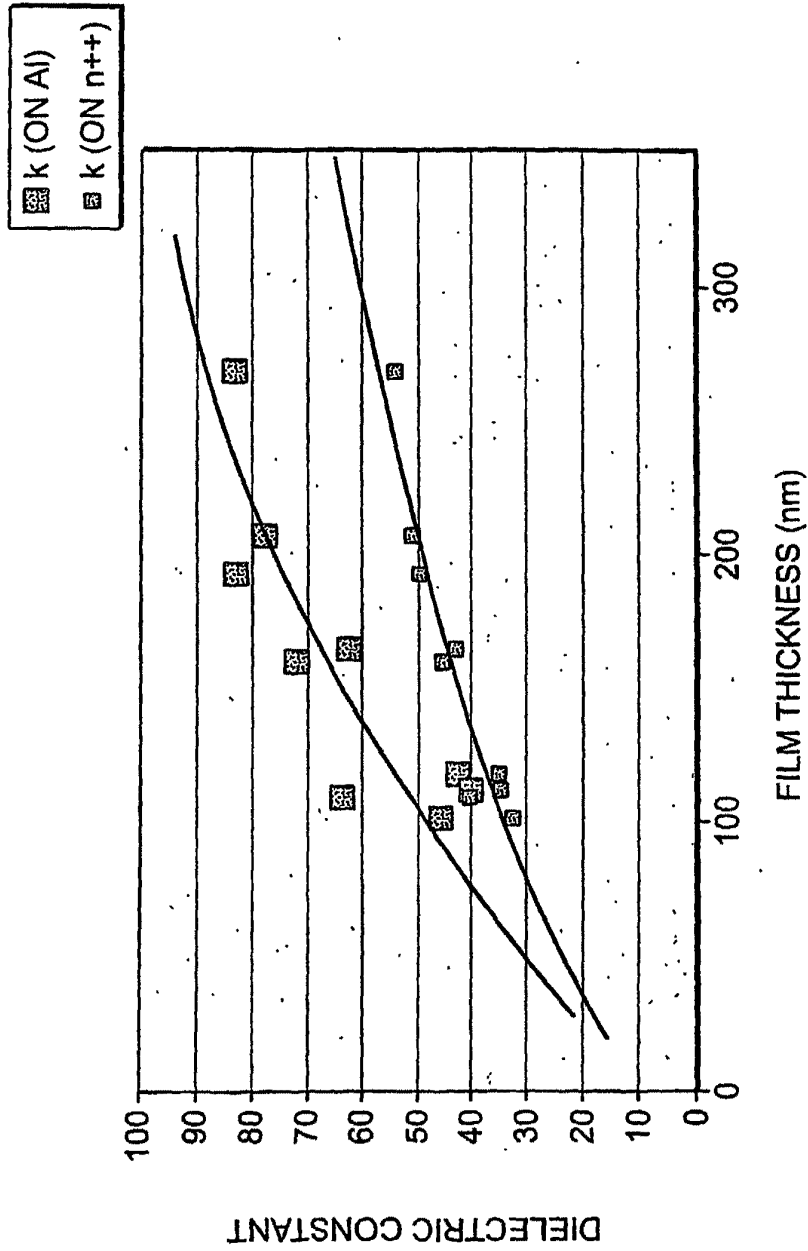

FIG. 7

8/15

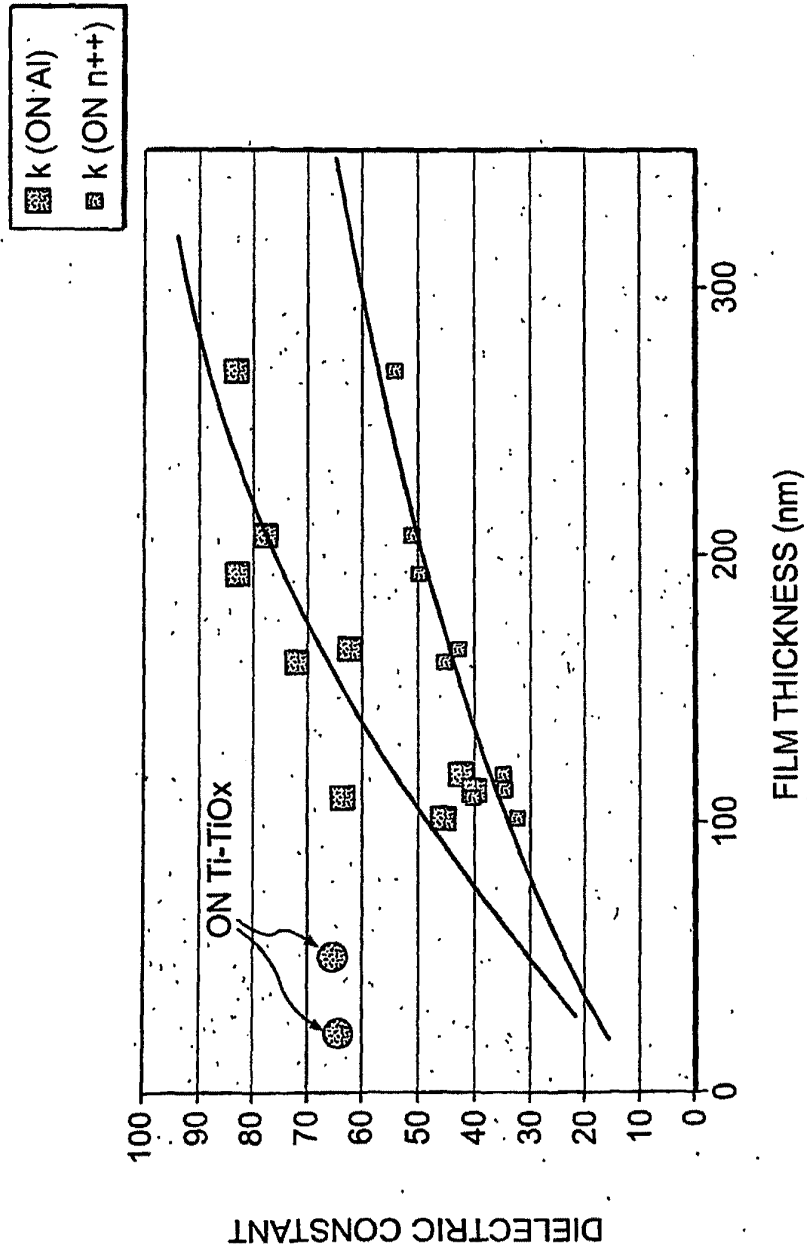

FIG. 8

SUBSTITUTE SHEET (RULE 26)

9/15

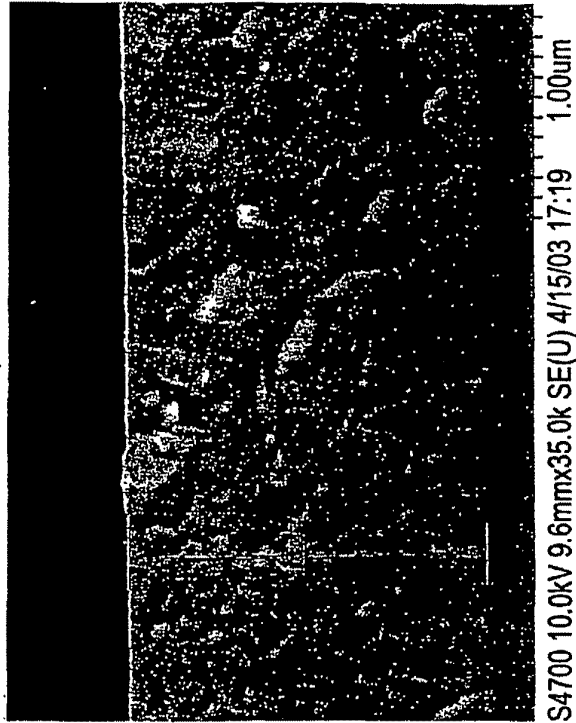

FIG. 9B

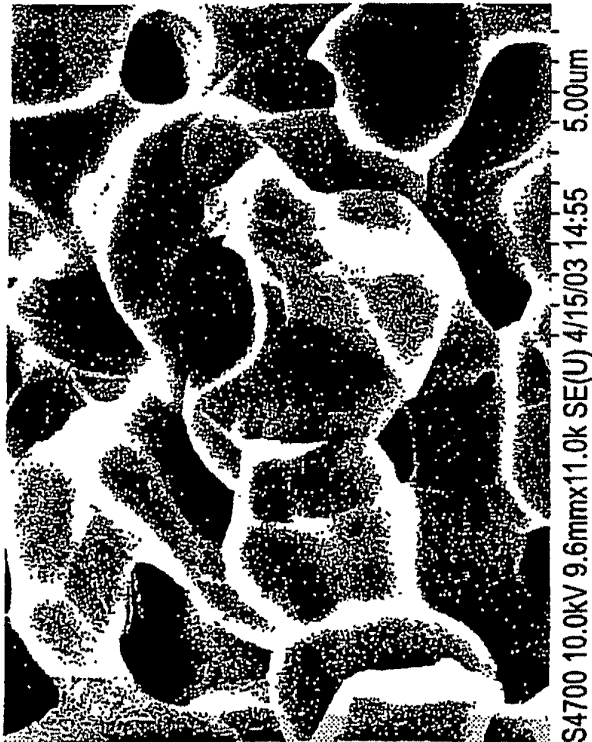

FIG. 9A

SUBSTITUTE SHEET (RULE 26)

10/15

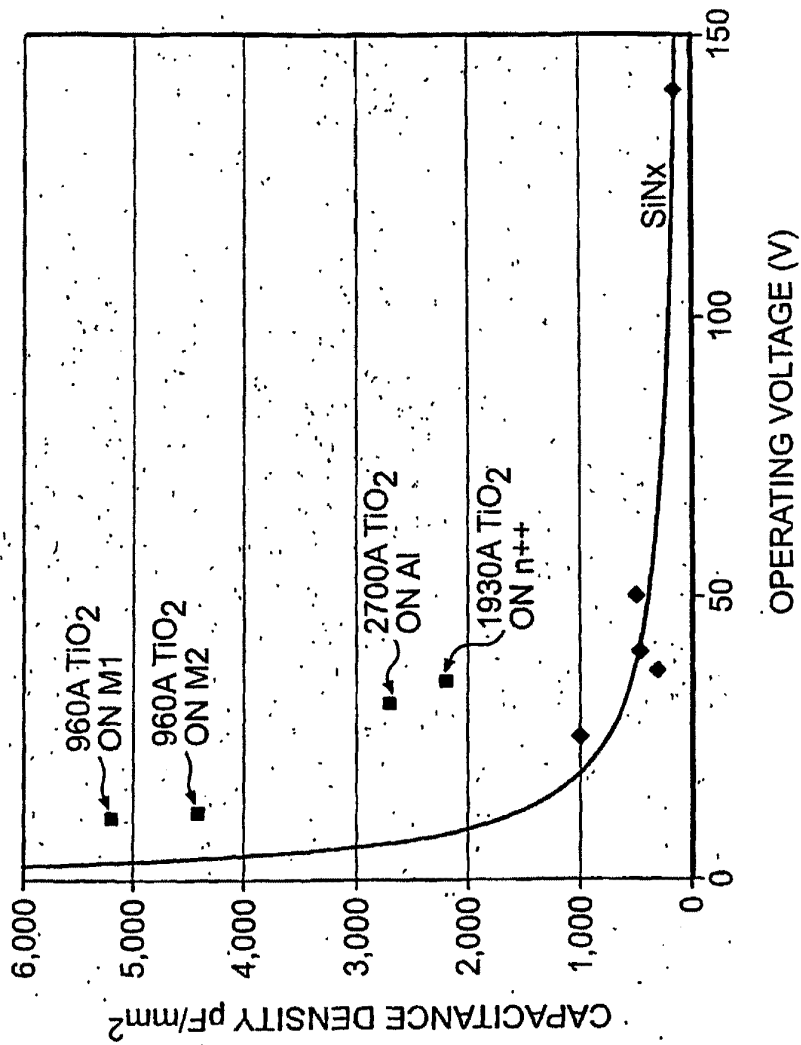

FIG. 10

11/15

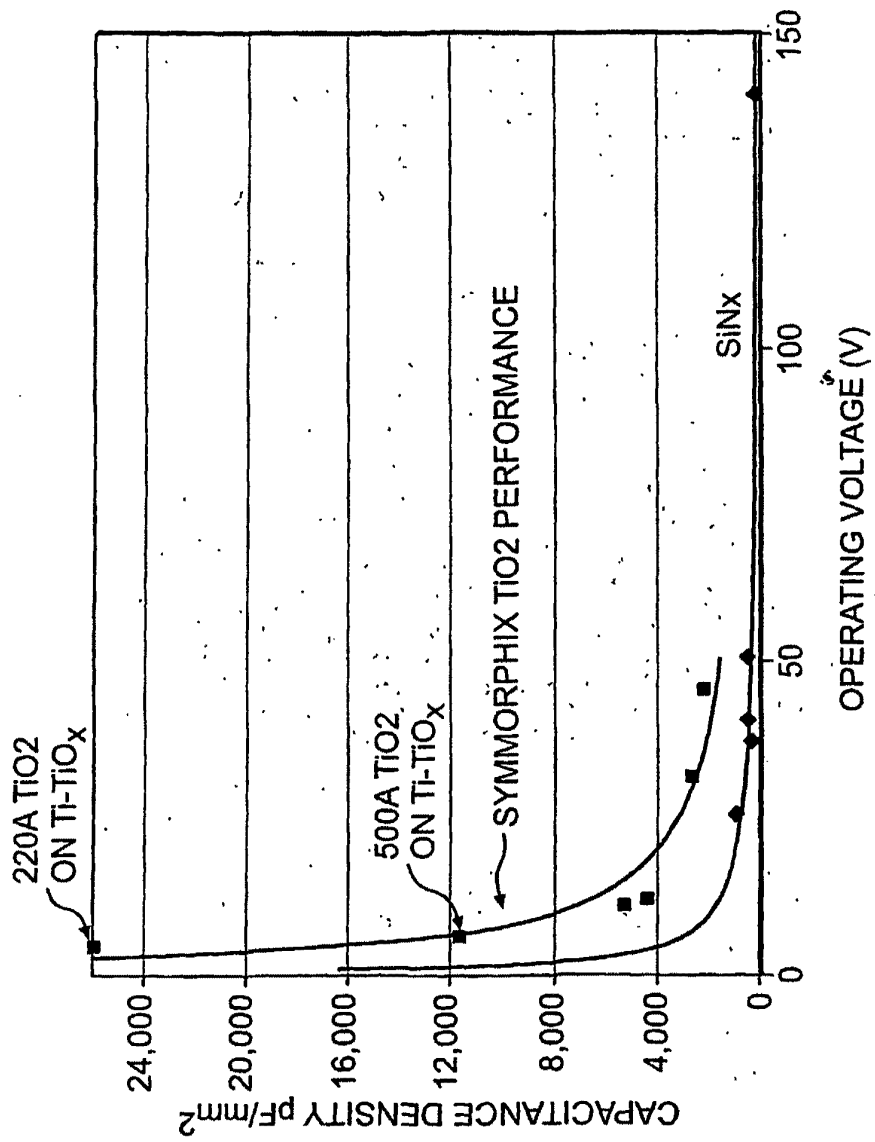

FIG. 11

12/15

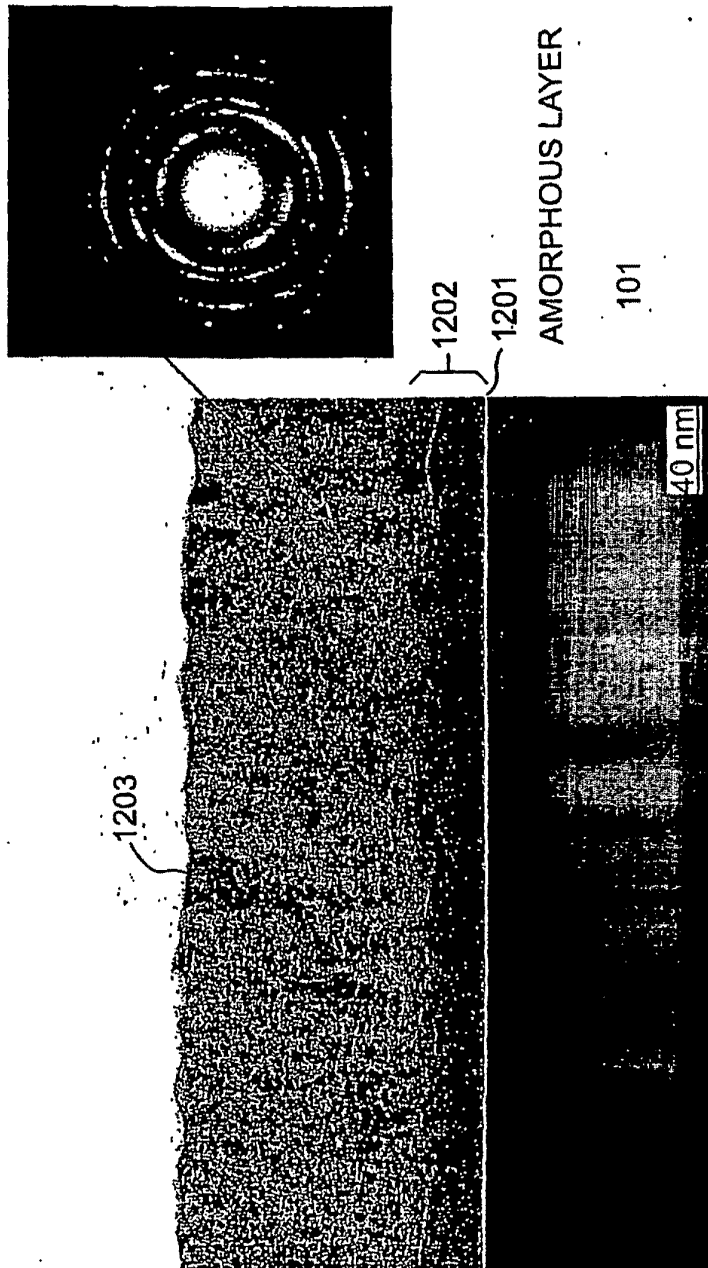

FIG. 12

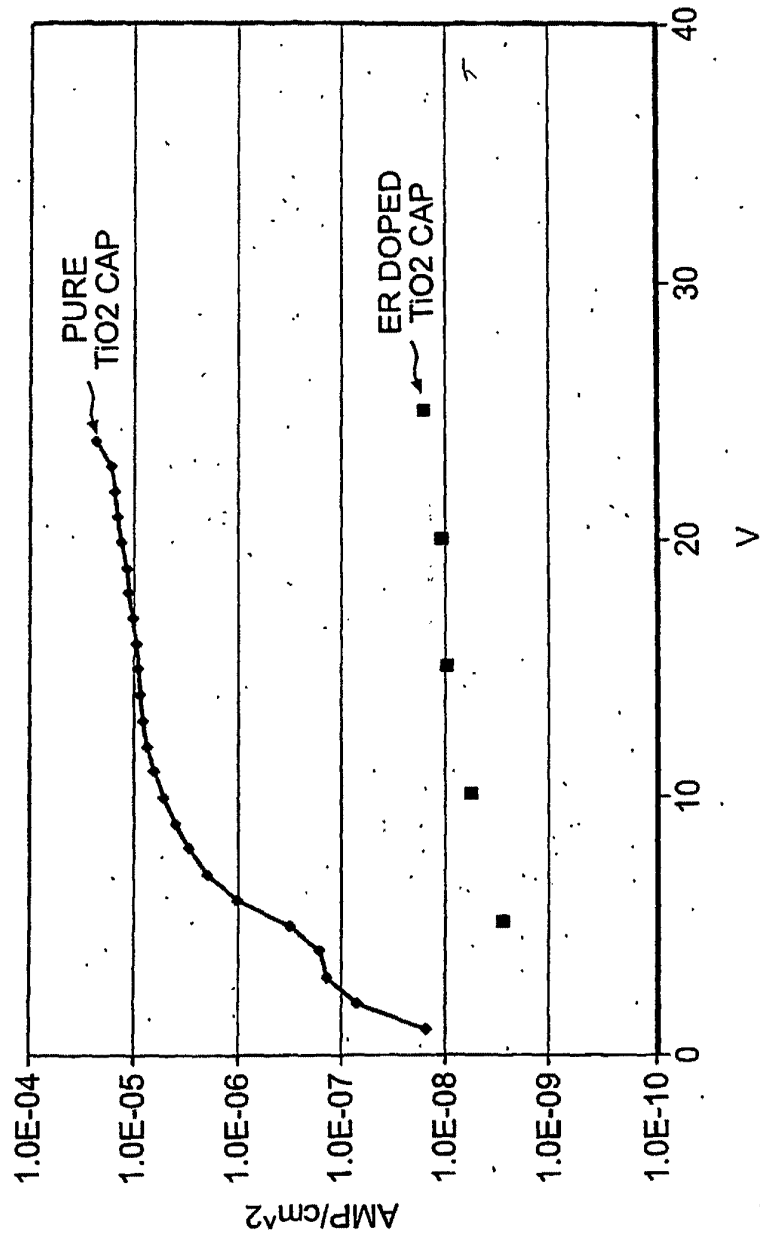
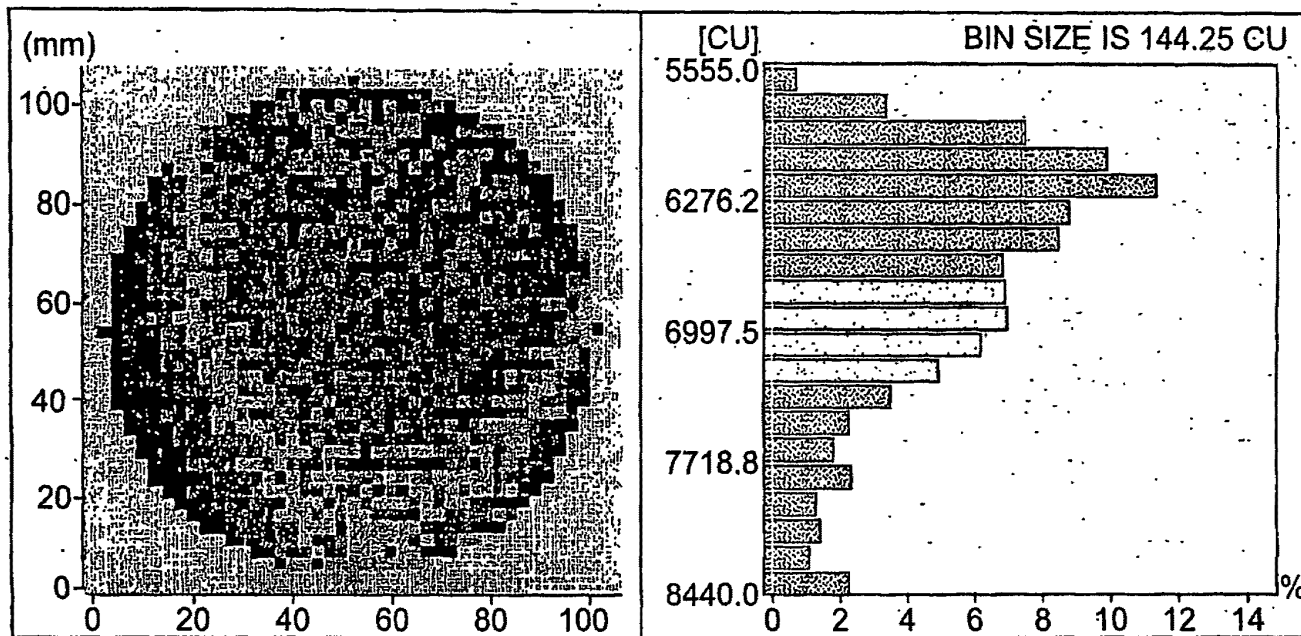

FIG. 13

TIOER-3-SWM
[2-5000A]

INTENSITY AT A DISCRETE WAVELENGTH
2004 MAR 05 13:37

PHILIPS
[PLM 100: 100]



INTENSITY - AVERAGE (O) : 6669.1 (643.7) CU
 - UNIFORMITY : 9.7%
 - MEDIAN : 6541.5 CU
 - 10% : 5946.4 CU
 - 90% : 7607.3 CU
 SAMPLE WAVELENGTH : 1530.0 nm

INTENSITY - UNDER 32.0%
 - OVER 0.0%

FIG. 14A

SUBSTITUTE SHEET (RULE 26)

TIOER-3-SWM
[2-5000A]

INTENSITY AT A DISCRETE WAVELENGTH
2004 MAR 08 08:00

PHILIPS
[PLM 100: 100]

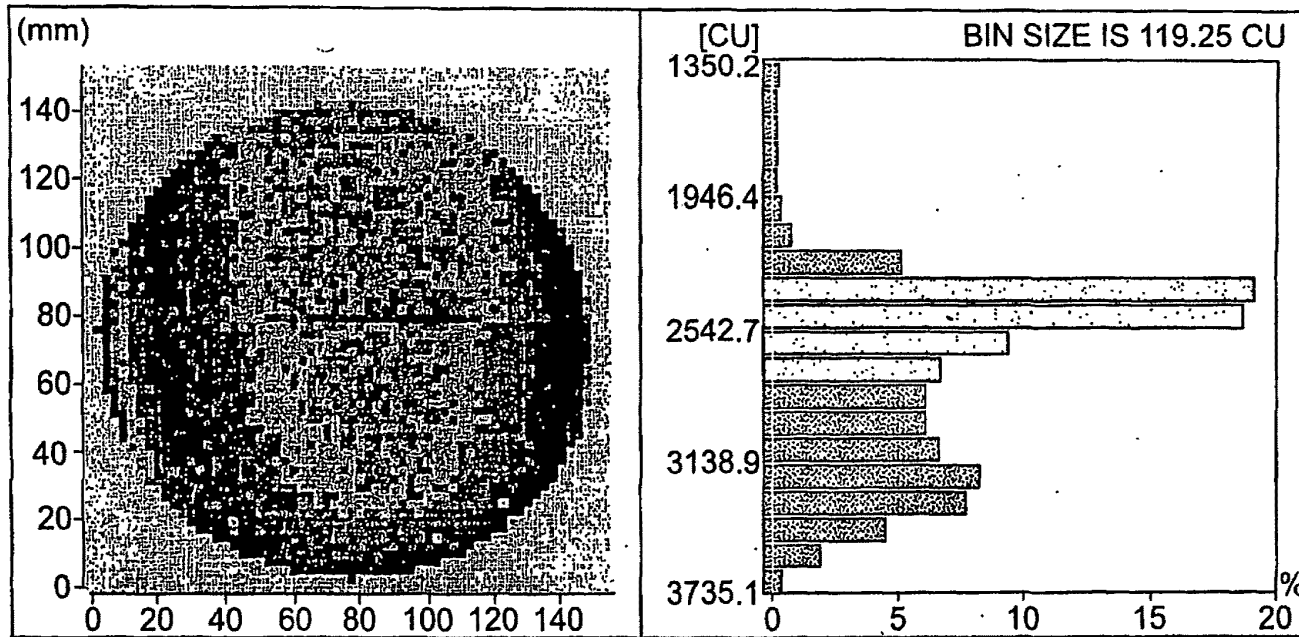

INTENSITY - AVERAGE (O) : 2736.0 (382.3) CU
- UNIFORMITY : 14.0 %
- MEDIAN : 2615.1 CU
- 10% : 2330.0 CU
- 90% : 3307.5CU
SAMPLE WAVELENGTH : 1530.0 nm

INTENSITY -UNDER 34.9%
-OVER 0.0 %

FIG. 14B

W/O 2004/106582

15/15

PCT/US2004/014524

**This Page is Inserted by IFW Indexing and Scanning
Operations and is not part of the Official Record**

BEST AVAILABLE IMAGES

Defective images within this document are accurate representations of the original documents submitted by the applicant.

Defects in the images include but are not limited to the items checked:

- BLACK BORDERS
- IMAGE CUT OFF AT TOP, BOTTOM OR SIDES
- FADED TEXT OR DRAWING
- BLURRED OR ILLEGIBLE TEXT OR DRAWING
- SKEWED/SLANTED IMAGES
- COLOR OR BLACK AND WHITE PHOTOGRAPHS
- GRAY SCALE DOCUMENTS
- LINES OR MARKS ON ORIGINAL DOCUMENT
- REFERENCE(S) OR EXHIBIT(S) SUBMITTED ARE POOR QUALITY
- OTHER: _____

IMAGES ARE BEST AVAILABLE COPY.

As rescanning these documents will not correct the image problems checked, please do not report these problems to the IFW Image Problem Mailbox.

3-01-06

IFW 2823

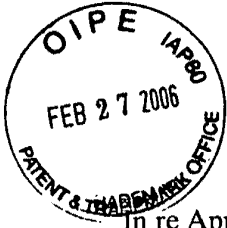

PATENT
Customer No. 22,852
Attorney Docket No. 9140.0016-00

IN THE UNITED STATES PATENT AND TRADEMARK OFFICE

In re Application of:)	
)	
ZHANG, Hongmei et al.)	Group Art Unit: 2823
)	
Application No.: 10/101,863)	Examiner: ESTRADA, Michelle
)	
Filed: March 16, 2002)	
)	
For: BIASED PULSE DC REACTIVE)	Confirmation No.: 6938
SPUTTERING OF OXIDE FILMS)	

MAIL STOP AMENDMENT

Commissioner for Patents
P.O. Box 1450
Alexandria, VA 22313-1450

Sir:

SIXTH SUPPLEMENTAL INFORMATION DISCLOSURE STATEMENT
UNDER 37 C.F.R. § 1.97(b)

Pursuant to 37 C.F.R. §§ 1.56 and 1.97(b), Applicants bring to the attention of the Examiner the documents on the attached listing. This Information Disclosure Statement is being filed before the mailing date of a first Office Action after the filing of a Request for Continued Examination in the above-referenced application.

Copies of the U.S. patents and patent publications cited are not enclosed.

Applicants respectfully request that the Examiner consider the listed documents and indicate that they were considered by making appropriate notations on the attached form.

This submission does not represent that a search has been made or that no better art exists and does not constitute an admission that each or all of the listed documents are material or constitute "prior art." If the Examiner applies any of the documents as prior art against any

claims in the application and Applicants determine that the cited documents do not constitute "prior art" under United States law, Applicants reserve the right to present to the office the relevant facts and law regarding the appropriate status of such documents.

Applicants further reserve the right to take appropriate action to establish the patentability of the disclosed invention over the listed documents, should one or more of the documents be applied against the claims of the present application.

If there is any fee due in connection with the filing of this Statement, please charge the fee to our Deposit Account No. 06-0916.

Respectfully submitted,

FINNEGAN, HENDERSON, FARABOW,
GARRETT & DUNNER, L.L.P.

Dated: February 27, 2006

By: 

Gary J. Edwards

Reg. No. 41,008

**EXPRESS MAIL LABEL NO.
EV 860819704 US**

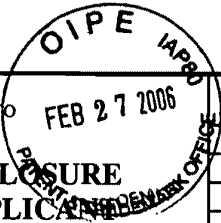

Complete if Known

INFORMATION DISCLOSURE STATEMENT BY APPLICANT

(Use as many sheets as necessary)

Sheet	1	of	1	Application Number	10/101,863
				Filing Date	March 16, 2002
				First Named Inventor	ZHANG, Hongmei
				Art Unit	2823
				Examiner Name	ESTRADA, Michelle
				Attorney Docket Number	9140.0016-00

U.S. PATENTS AND PUBLISHED U.S. PATENT APPLICATIONS

Examiner Initials ⁷	Cite No. ¹	Document Number	Issue or Publication Date MM-DD-YYYY	Name of Patentee or Applicant of Cited Document	Pages, Columns, Lines, Where Relevant Passages or Relevant Figures Appear
		Number-Kind Code ² (if known)			
		US 5,909,346	06-01-1999	Malhotra et al.	
		US 6,000,603	12-14-1999	Koskenmaki et al.	
		US 6,133,670	10-17-2000	Rodgers et al.	
		US 6,356,694 B1	03-12-2002	Weber	
		US 6,768,855 B1	07-27-2004	Bakke et al.	
		US 6,683,749 B2	01-27-2004	Daby et al.	

Note: Submission of copies of U.S. Patents and published U.S. Patent Applications is not required.

FOREIGN PATENT DOCUMENTS

Examiner Initials ⁷	Cite No. ¹	Foreign Patent Document	Publication Date MM-DD-YYYY	Name of Patentee or Applicant of Cited Document	Pages, Columns, Lines, Where Relevant Passages or Relevant Figures Appear	Translation ⁶
		Country Code ³ Number ⁴ Kind Code ⁵ (if known)				

NON PATENT LITERATURE DOCUMENTS

Examiner Initials ⁷	Cite No. ¹	Include name of the author (in CAPITAL LETTERS), title of the article (when appropriate), title of the item (book, magazine, journal, serial, symposium, catalog, etc.), date, page(s), volume-issue number(s), publisher, city and/or country where published.	Translation ⁶

Examiner Signature		Date Considered	
--------------------	--	-----------------	--

EXAMINER: Initial if reference considered, whether or not citation is in conformance with MPEP 609. Draw line through citation if not in conformance and not considered. Include copy of this form with next communication to applicant.

**EXPRESS MAIL LABEL NO.
EV 860819704 US**

03-02-06

2423
TFW



PATENT
Customer No. 22,852
Attorney Docket No. 9140.0016-00

IN THE UNITED STATES PATENT AND TRADEMARK OFFICE

In re Application of:)	
)	
ZHANG, Hongmei et al.)	Group Art Unit: 2823
)	
Application No.: 10/101,863)	Examiner: ESTRADA, Michelle
)	
Filed: March 16, 2002)	
)	
For: BIASED PULSE DC REACTIVE)	Confirmation No.: 6938
SPUTTERING OF OXIDE FILMS)	

MAIL STOP AMENDMENT

Commissioner for Patents
P.O. Box 1450
Alexandria, VA 22313-1450

Sir:

SEVENTH SUPPLEMENTAL INFORMATION DISCLOSURE STATEMENT
UNDER 37 C.F.R. § 1.97(b)

Pursuant to 37 C.F.R. §§ 1.56 and 1.97(b), Applicants bring to the attention of the Examiner the documents on the attached listing. This Information Disclosure Statement is being filed before the mailing date of a first Office Action after the filing of a Request for Continued Examination in the above-referenced application.

A copy of the document cited is enclosed.

Applicants respectfully request that the Examiner consider the listed document and indicate that it was considered by making appropriate notations on the attached form.

This submission does not represent that a search has been made or that no better art exists and does not constitute an admission that each or all of the listed documents are material or constitute "prior art." If the Examiner applies any of the documents as prior art against any

claims in the application and Applicants determine that the cited documents do not constitute "prior art" under United States law, Applicants reserve the right to present to the office the relevant facts and law regarding the appropriate status of such documents.

Applicants further reserve the right to take appropriate action to establish the patentability of the disclosed invention over the listed document, should one or more of the documents be applied against the claims of the present application.

If there is any fee due in connection with the filing of this Statement, please charge the fee to our Deposit Account No. 06-0916.

Respectfully submitted,

FINNEGAN, HENDERSON, FARABOW,
GARRETT & DUNNER, L.L.P.

Dated: February 28, 2006

By: 

Gary J. Edwards
Reg. No. 41,008

**EXPRESS MAIL LABEL NO.
EV 860819602 US**

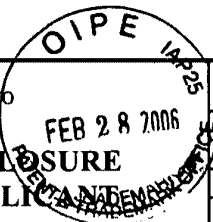

IDS Form PTO/SB/08: Substitute for form 1449A/PTD		<i>Complete if Known</i>	
INFORMATION DISCLOSURE STATEMENT BY APPLICANT <i>(Use as many sheets as necessary)</i>		Application Number	10/101,863
		Filing Date	March 16, 2002
		First Named Inventor	ZHANG, Hongmei
		Art Unit	2823
		Examiner Name	ESTRADA, Michelle
Sheet	1	of	1
		Attorney Docket Number	9140.0016-00

U.S. PATENTS AND PUBLISHED U.S. PATENT APPLICATIONS					
Examiner Initials*	Cite No. ¹	Document Number	Issue or Publication Date MM-DD-YYYY	Name of Patentee or Applicant of Cited Document	Pages, Columns, Lines, Where Relevant Passages or Relevant Figures Appear
		Number-Kind Code ² (if known)			

Note: Submission of copies of U.S. Patents and published U.S. Patent Applications is not required.

FOREIGN PATENT DOCUMENTS						
Examiner Initials*	Cite No. ¹	Foreign Patent Document	Publication Date MM-DD-YYYY	Name of Patentee or Applicant of Cited Document	Pages, Columns, Lines, Where Relevant Passages or Relevant Figures Appear	Translation ⁶
		Country Code ³ Number ⁴ Kind Code ⁵ (if known)				

NON PATENT LITERATURE DOCUMENTS			
Examiner Initials*	Cite No. ¹	Include name of the author (in CAPITAL LETTERS), title of the article (when appropriate), title of the item (book, magazine, journal, serial, symposium, catalog, etc.), date, page(s), volume-issue number(s), publisher, city and/or country where published.	Translation ⁶
		Response to Office Action filed February 17, 2006 in U.S. Application No. 11/100,856 (Attorney Docket No. 09140.0015-01).	

Examiner Signature		Date Considered	
--------------------	--	-----------------	--

EXAMINER: Initial if reference considered, whether or not citation is in conformance with MPEP 609. Draw line through citation if not in conformance and not considered. Include copy of this form with next communication to applicant.

**EXPRESS MAIL LABEL NO.
EV 860819602 US**

BCE filed 2-24-06

PTO/SB/06(12-04)

Approved for use through 7/1/2006 OMB 041-0032
U.S. Patent and Trademark Office; U.S. DEPARTMENT OF COMMERCE

Under the Paperwork Reduction Act of 1995, no person is required to respond to a collection of information unless it displays a valid OMB control number.

PATENT APPLICATION FEE DETERMINATION RECORD

Substitute for Form PTO-875 Effective December 8, 2004

Application or Docket Number

10101803

APPLICATION AS FILED - PART I

(Column 1)		(Column 2)	SMALL ENTITY		OR	OTHER THAN SMALL ENTITY	
FOR	NUMBER FILED	NUMBER EXTRA	RATE (\$)	FEE (\$)		RATE (\$)	FEE (\$)
BASIC FEE (37 CFR 1.16(a), (b), or (c))	N/A	N/A	N/A	150.00		N/A	300.00
SEARCH FEE (37 CFR 1.16(k), (l), or (m))	N/A	N/A	N/A	\$250		N/A	\$600
EXAMINATION FEE (37 CFR 1.16(d), (p), or (q))	N/A	N/A	N/A	\$100		N/A	\$200
TOTAL CLAIMS (37 CFR 1.16(g))	minus 20 =		X\$ 25 =		OR	X\$50 =	
INDEPENDENT CLAIMS (37 CFR 1.16(h))	minus 3 =		X100 =			X200 =	
APPLICATION SIZE FEE (37 CFR 1.16(n))	If the specification and drawings exceed 100 sheets of paper, the application size fee due is \$250 (\$125 for small entity) for each additional 50 sheets or fraction thereof. See 35 U.S.C. 41(a)(1)(G) and 37 CFR 1.16(s).						
MULTIPLE DEPENDENT CLAIM PRESENT (37 CFR 1.16(i))			+180=			+360=	
			TOTAL			TOTAL	

* If the difference in column 1 is less than zero, enter "0" in column 2.

APPLICATION AS AMENDED - PART II

AMENDMENT A	(Column 1)	(Column 2)	(Column 3)	SMALL ENTITY		OR	OTHER THAN SMALL ENTITY	
	CLAIMS REMAINING AFTER AMENDMENT	HIGHEST NUMBER PREVIOUSLY PAID FOR	PRESENT EXTRA	RATE (\$)	ADDITIONAL FEE (\$)		RATE (\$)	ADDITIONAL FEE (\$)
22406	Total (37 CFR 1.16(n))	Minus	39	X\$ 25 =		OR	X\$50 =	
	Independent (37 CFR 1.16(h))	Minus	5	X100 =		OR	X200 =	
Application Size Fee (37 CFR 1.16(s))						OR		
FIRST PRESENTATION OF MULTIPLE DEPENDENT CLAIM (37 CFR 1.16(i))				+180=		OR	+360=	
				TOTAL ADD'L FEE		OR	TOTAL ADD'L FEE	

AMENDMENT B	(Column 1)	(Column 2)	(Column 3)	SMALL ENTITY		OR	OTHER THAN SMALL ENTITY	
	CLAIMS REMAINING AFTER AMENDMENT	HIGHEST NUMBER PREVIOUSLY PAID FOR	PRESENT EXTRA	RATE (\$)	ADDITIONAL FEE (\$)		RATE (\$)	ADDITIONAL FEE (\$)
	Total (37 CFR 1.16(n))	Minus		X\$ 25 =		OR	X\$50 =	
	Independent (37 CFR 1.16(h))	Minus		X100 =		OR	X200 =	
Application Size Fee (37 CFR 1.16(s))						OR		
FIRST PRESENTATION OF MULTIPLE DEPENDENT CLAIM (37 CFR 1.16(i))				+180=		OR	+360=	
				TOTAL ADD'L FEE		OR	TOTAL ADD'L FEE	

- If the entry in column 1 is less than the entry in column 2, write "0" in column 3.
- If the "Highest Number Previously Paid For" IN THIS SPACE is less than 20, enter "20".
- If the "Highest Number Previously Paid For" IN THIS SPACE is less than 3, enter "3".
- The "Highest Number Previously Paid For" (Total or Independent) is the highest number found in the appropriate box in column 1.

A collection of information is required by 37 CFR 1.16. The information is required to obtain or retain a benefit by the public which is to file (and by the PTO to process) an application. Confidentiality is governed by 35 U.S.C. 122 and 37 CFR 1.14. This collection is estimated to take 12 minutes to complete, including gathering, preparing, and submitting the completed application form to the USPTO. Time will vary depending upon the individual case. Any comments the amount of time you require to complete this form and/or suggestions for reducing this burden, should be sent to the Chief Information Officer, U.S. Patent & Trademark Office, U.S. Department of Commerce, P.O. Box 1450, Alexandria, VA 22313-1450. DO NOT SEND FEES OR COMPLETED FORMS TO THIS OFFICE. SEND TO: Commissioner for Patents, P.O. Box 1460, Alexandria, VA 22313-1460.

If you need assistance in completing the form, call 1-800-PTO-9199 and select option 2.

CLAIMS ONLY

Application Number

10/10/863

Filing Date

Applicant(s)

2-24-86

* May be used for additional claims or amendments

CLAIMS	AS FILED		AFTER FIRST AMENDMENT		AFTER SECOND AMENDMENT		*		*		*		
	Indep.	Depend.	Indep.	Depend.	Indep.	Depend.	Indep.	Depend.	Indep.	Depend.	Indep.	Depend.	
1							51						
2							52						
3							53						
4							54						
5							55						
6							56						
7							57						
8							58						
9							59						
10							60						
11							61						
12							62						
13							63						
14							64						
15							65						
16							66						
17							67						
18							68						
19							69						
20							70						
21							71						
22							72						
23							73						
24							74						
25							75						
26							76						
27							77						
28							78						
29							79						
30							80						
31							81						
32							82						
33							83						
34							84						
35							85						
36							86						
37							87						
38							88						
39							89						
40							90						
41							91						
42							92						
43							93						
44							94						
45							95						
46							96						
47							97						
48							98						
49							99						
50							100						
Total Indep.			2				Total Indep.						
Total Depend.			15				Total Depend.						
Total Claims			17				Total Claims						

03-06-06

TFW
2823

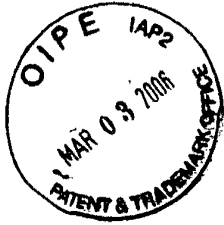

PATENT
Customer No. 22,852
Attorney Docket No. 9140.0016-00

IN THE UNITED STATES PATENT AND TRADEMARK OFFICE

In re Application of:)	
ZHANG, Hongmei et al.)	Group Art Unit: 2823
Application No.: 10/101,863)	Examiner: ESTRADA, Michelle
Filed: March 16, 2002)	
For: BIASED PULSE DC REACTIVE SPUTTERING OF OXIDE FILMS)	Confirmation No.: 6938

MAIL STOP AMENDMENT

Commissioner for Patents
P.O. Box 1450
Alexandria, VA 22313-1450

Sir:

EIGHTH SUPPLEMENTAL INFORMATION DISCLOSURE STATEMENT
UNDER 37 C.F.R. § 1.97(b)

Pursuant to 37 C.F.R. §§ 1.56 and 1.97(b), Applicants bring to the attention of the Examiner the documents on the attached listing. This Information Disclosure Statement is being filed before the mailing date of a first Office Action after the filing of a Request for Continued Examination in the above-referenced application.

A copy of the document cited is enclosed.

Applicants respectfully request that the Examiner consider the listed document and indicate that it was considered by making appropriate notations on the attached form.

This submission does not represent that a search has been made or that no better art exists and does not constitute an admission that each or all of the listed documents are material or constitute "prior art." If the Examiner applies any of the documents as prior art against any

claims in the application and Applicants determine that the cited documents do not constitute "prior art" under United States law, Applicants reserve the right to present to the office the relevant facts and law regarding the appropriate status of such documents.

Applicants further reserve the right to take appropriate action to establish the patentability of the disclosed invention over the listed document, should one or more of the documents be applied against the claims of the present application.

If there is any fee due in connection with the filing of this Statement, please charge the fee to our Deposit Account No. 06-0916.

Respectfully submitted,

FINNEGAN, HENDERSON, FARABOW,
GARRETT & DUNNER, L.L.P.

Dated: March 3, 2006

By:

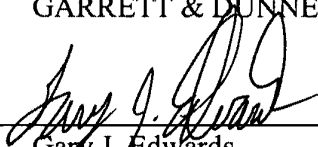

Gary J. Edwards

Reg. No. 41,008

**EXPRESS MAIL LABEL NO.
EV 860819633 US**

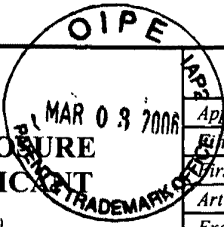

IDS Form PTO/SB/08: Substitute for form 1449A/PTO			<i>Complete if Known</i>		
INFORMATION DISCLOSURE STATEMENT BY APPLICANT <i>(Use as many sheets as necessary)</i>			Application Number	10/101,863	
			Filing Date	March 16, 2002	
			First Named Inventor	ZHANG, Hongmei	
			Art Unit	2823	
			Examiner Name	ESTRADA, Michelle	
Sheet	1	of	1	Attorney Docket Number	9140.0016-00

U.S. PATENTS AND PUBLISHED U.S. PATENT APPLICATIONS					
Examiner Initials ²	Cite No. ¹	Document Number	Issue or Publication Date MM-DD-YYYY	Name of Patentee or Applicant of Cited Document	Pages, Columns, Lines, Where Relevant Passages or Relevant Figures Appear
		Number-Kind Code ² (if known)			
		US 6,290,821 B1	09-18-2001	McLeod	

Note: Submission of copies of U.S. Patents and published U.S. Patent Applications is not required.

FOREIGN PATENT DOCUMENTS						
Examiner Initials ²	Cite No. ¹	Foreign Patent Document	Publication Date MM-DD-YYYY	Name of Patentee or Applicant of Cited Document	Pages, Columns, Lines, Where Relevant Passages or Relevant Figures Appear	Translation ⁶
		Country Code ³ Number ⁴ Kind Code ⁵ (if known)				

NON PATENT LITERATURE DOCUMENTS			
Examiner Initials ²	Cite No. ¹	Include name of the author (in CAPITAL LETTERS), title of the article (when appropriate), title of the item (book, magazine, journal, serial, symposium, catalog, etc.), date, page(s), volume-issue number(s), publisher, city and/or country where published.	Translation ⁶
		Response to Office Action filed February 20, 2002, for US Patent No. 6,506,289 (Atty. Docket No. 09140-0002-01).	
		Response to Office Action filed July 17, 2002, for US Patent No. 6,506,289 (Atty. Docket No. 09140-0002-01).	
		Response to Office Action filed February 28, 2006 in U.S. Application No. 09/903,081 (Attorney Docket No. 09140-0014-00).	
		Response to Office Action filed March 2, 2006 in U.S. Application No. 10/789,953 (Attorney Docket No. 09140.0030-00).	

Examiner Signature		Date Considered	
--------------------	--	-----------------	--

EXAMINER: Initial if reference considered, whether or not citation is in conformance with MPEP 609. Draw line through citation if not in conformance and not considered. Include copy of this form with next communication to applicant.

**EXPRESS MAIL LABEL NO.
EV 860819633 US**

EAST Search History

Ref #	Hits	Search Query	DBs	Default Operator	Plurals	Time Stamp
L1	14	sputter\$3 with metallic with (poison or poisonous)	US-PGPUB; USPAT	OR	OFF	2006/03/16 16:23
L2	1083543	@ad>"20020316" or @rlad>"20020316"	US-PGPUB; USPAT	OR	OFF	2006/03/16 16:22
L3	8	1 not 2	US-PGPUB; USPAT	OR	OFF	2006/03/16 16:22
L4	5	sputter\$3 with metallic with (poison or poisonous) with target	US-PGPUB; USPAT	OR	OFF	2006/03/16 16:24
L5	1	4 not 2	US-PGPUB; USPAT	OR	OFF	2006/03/16 16:23
L6	14	(sputter\$3 with metallic with (poison or poisonous)) same target	US-PGPUB; USPAT	OR	OFF	2006/03/16 16:24
L7	8	6 not 2	US-PGPUB; USPAT	OR	OFF	2006/03/16 16:25
L8	8	3 and 7	US-PGPUB; USPAT	OR	OFF	2006/03/16 16:28
L9	458	backside with target	US-PGPUB; USPAT	OR	OFF	2006/03/16 16:28
L10	19	"pulsed DC" and "RF bias" and plasma and filter	US-PGPUB; USPAT	OR	OFF	2006/03/16 16:30
L11	4	10 not 2	US-PGPUB; USPAT	OR	OFF	2006/03/16 16:30
L12	1	11 and 9	US-PGPUB; USPAT	OR	OFF	2006/03/16 16:30
L13	79	"pulsed DC" and "RF bias"	US-PGPUB; USPAT	OR	OFF	2006/03/16 16:31
L14	5	9 and 13	US-PGPUB; USPAT	OR	OFF	2006/03/16 16:30
L15	1	14 not 2	US-PGPUB; USPAT	OR	OFF	2006/03/16 16:30
L16	4869	"pulsed DC" or "RF bias"	US-PGPUB; USPAT	OR	OFF	2006/03/16 16:31
L17	50	9 and 16	US-PGPUB; USPAT	OR	OFF	2006/03/16 16:31
L18	27	17 not 2	US-PGPUB; USPAT	OR	OFF	2006/03/16 16:35
L19	1	("6290821").PN.	US-PGPUB; USPAT	OR	OFF	2006/03/16 16:36
L20	6	((("5909346") or ("6000603") or ("6133670") or ("6356694") or ("6768855") or ("6683749"))).PN.	US-PGPUB; USPAT	OR	OFF	2006/03/16 17:07

EAST Search History

L21	13	("20020001746" "20020076133" "20020140103" "20030178637" "3309302" "5338625" "5561004" "5930046" "6242129" "6280875" "6376027" "6632563" "6683244"). PN.	US-PGPUB; USPAT	OR	OFF	2006/03/16 17:07
-----	----	---	--------------------	----	-----	------------------



UNITED STATES PATENT AND TRADEMARK OFFICE

UNITED STATES DEPARTMENT OF COMMERCE
United States Patent and Trademark Office
Address: COMMISSIONER FOR PATENTS
P.O. Box 1450
Alexandria, Virginia 22313-1450
www.uspto.gov

Table with 5 columns: APPLICATION NO., FILING DATE, FIRST NAMED INVENTOR, ATTORNEY DOCKET NO., CONFIRMATION NO.
Row 1: 10/101,863, 03/16/2002, Hongmei Zhang, M-12245 US, 6938
Row 2: 22852, 7590, 03/22/2006, [EXAMINER: ESTRADA, MICHELLE]
Row 3: [ART UNIT: 2823], [PAPER NUMBER]

FINNEGAN, HENDERSON, FARABOW, GARRETT & DUNNER LLP
901 NEW YORK AVENUE, NW
WASHINGTON, DC 20001-4413

DATE MAILED: 03/22/2006

Please find below and/or attached an Office communication concerning this application or proceeding.

Office Action Summary	Application No. 10/101,863	Applicant(s) ZHANG ET AL.	
	Examiner Michelle Estrada	Art Unit 2823	

-- The MAILING DATE of this communication appears on the cover sheet with the correspondence address --

Period for Reply

A SHORTENED STATUTORY PERIOD FOR REPLY IS SET TO EXPIRE 3 MONTH(S) OR THIRTY (30) DAYS, WHICHEVER IS LONGER, FROM THE MAILING DATE OF THIS COMMUNICATION.

- Extensions of time may be available under the provisions of 37 CFR 1.136(a). In no event, however, may a reply be timely filed after SIX (6) MONTHS from the mailing date of this communication.
- If NO period for reply is specified above, the maximum statutory period will apply and will expire SIX (6) MONTHS from the mailing date of this communication.
- Failure to reply within the set or extended period for reply will, by statute, cause the application to become ABANDONED (35 U.S.C. § 133). Any reply received by the Office later than three months after the mailing date of this communication, even if timely filed, may reduce any earned patent term adjustment. See 37 CFR 1.704(b).

Status

- 1) Responsive to communication(s) filed on 24 February 2006.
- 2a) This action is FINAL. 2b) This action is non-final.
- 3) Since this application is in condition for allowance except for formal matters, prosecution as to the merits is closed in accordance with the practice under *Ex parte Quayle*, 1935 C.D. 11, 453 O.G. 213.

Disposition of Claims

- 4) Claim(s) 2-14 and 21-24 is/are pending in the application.
4a) Of the above claim(s) _____ is/are withdrawn from consideration.
- 5) Claim(s) 14 is/are allowed.
- 6) Claim(s) 2-14 and 21-24 is/are rejected.
- 7) Claim(s) _____ is/are objected to.
- 8) Claim(s) _____ are subject to restriction and/or election requirement.

Application Papers

- 9) The specification is objected to by the Examiner.
- 10) The drawing(s) filed on _____ is/are: a) accepted or b) objected to by the Examiner.
Applicant may not request that any objection to the drawing(s) be held in abeyance. See 37 CFR 1.85(a).
Replacement drawing sheet(s) including the correction is required if the drawing(s) is objected to. See 37 CFR 1.121(d).
- 11) The oath or declaration is objected to by the Examiner. Note the attached Office Action or form PTO-152.

Priority under 35 U.S.C. § 119

- 12) Acknowledgment is made of a claim for foreign priority under 35 U.S.C. § 119(a)-(d) or (f).
a) All b) Some * c) None of:
1. Certified copies of the priority documents have been received.
2. Certified copies of the priority documents have been received in Application No. _____.
3. Copies of the certified copies of the priority documents have been received in this National Stage application from the International Bureau (PCT Rule 17.2(a)).

* See the attached detailed Office action for a list of the certified copies not received.

Attachment(s)

- | | |
|--|---|
| 1) <input checked="" type="checkbox"/> Notice of References Cited (PTO-892) | 4) <input type="checkbox"/> Interview Summary (PTO-413)
Paper No(s)/Mail Date. _____ |
| 2) <input type="checkbox"/> Notice of Draftsperson's Patent Drawing Review (PTO-948) | 5) <input type="checkbox"/> Notice of Informal Patent Application (PTO-152) |
| 3) <input checked="" type="checkbox"/> Information Disclosure Statement(s) (PTO-1449 or PTO/SB/08)
Paper No(s)/Mail Date <u>2/24/06, 2/27/06, 2/28/06, 3/3/06</u> | 6) <input type="checkbox"/> Other: _____ |

DETAILED ACTION

Continued Examination Under 37 CFR 1.114

A request for continued examination under 37 CFR 1.114, including the fee set forth in 37 CFR 1.17(e), was filed in this application after final rejection. Since this application is eligible for continued examination under 37 CFR 1.114, and the fee set forth in 37 CFR 1.17(e) has been timely paid, the finality of the previous Office action has been withdrawn pursuant to 37 CFR 1.114. Applicant's submission filed on 2/24/06 has been entered.

Claim Rejections - 35 USC § 103

The following is a quotation of 35 U.S.C. 103(a) which forms the basis for all obviousness rejections set forth in this Office action:

(a) A patent may not be obtained though the invention is not identically disclosed or described as set forth in section 102 of this title, if the differences between the subject matter sought to be patented and the prior art are such that the subject matter as a whole would have been obvious at the time the invention was made to a person having ordinary skill in the art to which said subject matter pertains. Patentability shall not be negated by the manner in which the invention was made.

Claims 10-13 and 21 rejected under 35 U.S.C. 103(a) as being unpatentable over Smolanoff et al. (6,117,279) in view of Fu et al. (6,306,265).

With respect to claim 21, Smolanoff et al. disclose providing pulsed DC power (21) through a filter (22) to a target (16) (Col. 5, lines 50-55); providing RF bias power to a substrate (15) positioned opposite the target (Col. 5, lines 60-65); providing process gas between the target and the substrate (Col. 7, lines 25-28); wherein the filter protects a pulsed DC power supply (21) from the bias power, and wherein a plasma is created

Art Unit: 2823

by application of the pulsed DC power to the target (Col. 6, lines 8-13); and wherein the film is deposited by exposure of the substrate to the plasma (Col. 6, lines 30-33).

Smolanoff et al. do not clearly disclose wherein conditioning the target includes sputtering with the target in a metallic mode to remove the surface of the target and sputtering with the target in a poisonous mode to prepare the surface.

Fu et al. disclose wherein conditioning the target includes sputtering with the target in a metallic mode to remove the surface of the target and sputtering with the target in a poisonous mode to prepare the surface (Col. 19, lines 35-40).

It would have been within the scope of one of ordinary skill in the art to combine the teachings of Smolanoff et al. and Fu et al. to enable the conditioning step of Smolanoff et al. to be performed according to the teachings of Fu et al. because one of ordinary skill in the art would have been motivated to look to alternative suitable methods of performing the disclosed conditioning step of Smolanoff et al. and art recognized suitability for an intended purpose has been recognized to be motivation to combine. See MPEP 2144.07.

With respect to claim 8, Smolanoff et al. disclose wherein the process gas includes a mixture of oxygen and argon (Col. 7, lines 21-27).

With respect to claim 10, Smolanoff et al. disclose wherein the process gas further includes nitrogen (Col. 7, lines 25-26).

With respect to claim 11, Smolanoff et al. disclose wherein providing pulsed DC power to a target includes providing pulsed DC power to a target which has an area larger than that of the substrate (See fig. 1).

Art Unit: 2823

With respect to claim 12, Smolanoff et al. disclose further including uniformly sweeping the target with a magnetic field (Col. 6, lines 1-7).

With respect to claim 13, Smolanoff et al. disclose wherein uniformly sweeping the target with a magnetic field includes sweeping a magnet in one direction across the target where the magnet extends beyond the target in the opposite direction (Col. 6, lines 1-6).

Claims 2-6 and 22-24 are rejected under 35 U.S.C. 103(a) as being unpatentable over Smolanoff et al. in view of Fu et al. as applied to claims 8, 10-13 and 21 above, and further in view of Fukui et al. (5,755,938).

With respect to claims 2-4, 6 and 22-24, One of ordinary skill in the art would have been led to the recited temperature, DC power, gas flow, time pulse and bias power to routine experimentation to achieve a desire layer thickness, device dimension, device associated characteristics and device density on the finished wafer in view of the range of values disclosed.

In addition, the selection of temperature, DC power, gas flow, time pulse and bias power, its obvious because it is a matter of determining optimum process conditions by routine experimentation with a limited number of species of result effective variables. These claims are prima facie obvious without showing that the claimed ranges achieve unexpected results relative to the prior art range. In re Woodruff, 16 USPQ2d 1935, 1937 (Fed. Cir. 1990). See also In re Huang, 40 USPQ2d 1685, 1688 (Fed. Cir. 1996)(claimed ranges or a result effective variable, which do not overlap the prior art

Art Unit: 2823

ranges, are unpatentable unless they produce a new and unexpected result which is different in kind and not merely in degree from the results of the prior art). See also *In re Boesch*, 205 USPQ 215 (CCPA) (discovery of optimum value of result effective variable in known process is ordinarily within skill or art) and *In re Aller*, 105 USPQ 233 (CCPA 1995) (selection of optimum ranges within prior art general conditions is obvious).

Note that the specification contains no disclosure of either the critical nature of the claimed temperature, DC power, gas flow, time pulse and bias power or any unexpected results arising therefrom. Where patentability is said to be based upon particular chosen temperature, DC power, gas flow, time pulse and bias power or upon another variable recited in a claim, the Applicant must show that the chosen temperature, DC power, gas flow, time pulse and bias power are critical. *In re Woodruf*, 919 F.2d 1575, 1578, 16 USPQ2d 1934, 1936 (Fed. Cir. 1990).

With respect to claim 5, Smolanoff et al. do not specifically disclose wherein the filter is a band reject filter at the frequency of the bias power.

Fukui et al. disclose a sputtering process wherein the DC power supply (28) is connected through a band-pass filter (27) at the frequency of the bias power.

It would have been within the scope of one of ordinary skill in the art to combine the teachings of Smolanoff et al. and Fukui et al. to enable the filter type of Smolanoff et al. to be the same according to the teachings of Fukui et al. because one of ordinary skill in the art would have been motivated to look to alternative suitable types of filters

Art Unit: 2823

for the disclosed filter step of Smolanoff et al. and art recognized suitability for an intended purpose has been recognized to be motivation to combine. See MPEP 2144.07.

Claims 7 and 9 are rejected under 35 U.S.C. 103(a) as being unpatentable over Smolanoff et al. in view of Fu et al. as applied to claims 8, 10-13 and 21 above, and further in view of Le et al. (2003/0077914).

The combination of Smolanoff et al. and Fu et al. does not disclose wherein the film is an upper cladding layer of a waveguide structure and the bias power is optimized to provide planarization.

With respect to claim 7, Le et al. disclose wherein the film is an upper cladding layer of a waveguide structure and the bias power is optimized to provide planarization Page 5, Paragraph [0075].

It would have been within the scope of one of ordinary skill in the art to combine the teachings of Smolanoff et al., Fu et al. and Le et al. to enable the film material of Smolanoff et al. to be the same according to the teachings of Le et al. because one of ordinary skill in the art would have been motivated to look to alternative suitable film materials for the disclosed film formation step of Smolanoff et al. and art recognized suitability for an intended purpose has been recognized to be motivation to combine. See MPEP 2144.07.

With respect to claim 9, Le et al. disclose wherein the oxygen flow is adjusted to adjust the index of refraction of the film (Page 5, Paragraph [0076]).

Allowable Subject Matter

Claim 14 is allowed.

Conclusion

Any inquiry concerning this communication or earlier communications from the examiner should be directed to Michelle Estrada whose telephone number is 571-272-1858. The examiner can normally be reached on Monday through Friday.

If attempts to reach the examiner by telephone are unsuccessful, the examiner's supervisor, Matthew Smith can be reached on 571-272-1907. The fax phone number for the organization where this application or proceeding is assigned is 571-273-8300.

Any inquiry of a general nature or relating to the status of this application or proceeding should be directed to the receptionist whose telephone number is 571-272-2800.

Information regarding the status of an application may be obtained from the Patent Application Information Retrieval (PAIR) system. Status information for published applications may be obtained from either Private PAIR or Public PAIR. Status information for unpublished applications is available through Private PAIR only. For more information about the PAIR system, see <http://pair-direct.uspto.gov>. Should you have questions on access to the Private PAIR system, contact the Electronic Business Center (EBC) at 866-217-9197 (toll-free).



Michelle Estrada
Primary Examiner
Art Unit 2823

ME
March 16, 2006

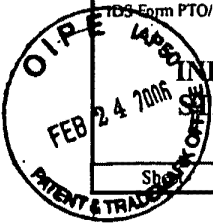

US Form PTO/SB/08: Substitute for form 1449A/PTO INFORMATION DISCLOSURE STATEMENT BY APPLICANT (Use as many sheets as necessary)			<i>Complete if Known</i>	
Application Number	10/101,863			
Filing Date	March 16, 2002			
First Named Inventor	ZHANG, Hongmei			
Art Unit	2823			
Examiner Name	ESTRADA, Michelle			
Attorney Docket Number	9140.0016-00			
Sheet	1	of	3	

U.S. PATENTS AND PUBLISHED U.S. PATENT APPLICATIONS					
Examiner Initials*	Cite No. ¹	Document Number	Issue or Publication Date MM-DD-YYYY	Name of Patentee or Applicant of Cited Document	Pages, Columns, Lines, Where Relevant Passages or Relevant Figures Appear
		Number-Kind Code ³ (if known)			
[Signature]		US-3,309,302	03-14-1967	Heil	
		US-5,338,625	08-16-1994	Bates et al.	
		US-5,561,004	10-01-1996	Bates et al.	
		US-5,930,046	07-27-1999	Solberg et al.	
		US-6,242,129 B1	06-05-2001	Johnson	
		US-6,280,875 B1	08-28-2001	Kwak et al.	
		US-6,376,027 B1	04-23-2002	Lee et al.	
		US-6,632,563 B1	10-14-2003	Krasnov et al.	
		US-6,683,244 B2	01-27-2004	Fujimori et al.	
		US 2002/0001746 A1	01-03-2002	Jenson	
		US 2002/0076133 A1	06-20-2002	Li et al.	
		US 2002/0140103 A1	10-03-2002	Kloster et al.	
		US 2003/0178637 A1	09-25-2003	Chen et al.	

Note: Submission of copies of U.S. Patents and published U.S. Patent Applications is not required.

FOREIGN PATENT DOCUMENTS						
Examiner Initials*	Cite No. ¹	Foreign Patent Document	Publication Date MM-DD-YYYY	Name of Patentee or Applicant of Cited Document	Pages, Columns, Lines, Where Relevant Passages or Relevant Figures Appear	Translation ⁶
		Country Code ³ Number ⁴ Kind Code ⁵ (if known)				
[Signature]		WO 2004/106581 A2	12-09-2004	Symmorphix, Inc.		
		WO 2004/106582 A2	12-09-2004	Symmorphix, Inc.		

NON PATENT LITERATURE DOCUMENTS			
Examiner Initials*	Cite No. ¹	Include name of the author (in CAPITAL LETTERS), title of the article (when appropriate), title of the item (book, magazine, journal, serial, symposium, catalog, etc.), date, page(s), volume-issue number(s), publisher, city and/or country where published.	Translation ⁶
[Signature]		KIM, H-K. and YOON, Y., "Characteristics of rapid-thermal-annealed LiCoO ₂ cathode film for an all-solid-state thin film microbattery," <i>J. Vac. Sci. Technol. A</i> 22(4):1182-1187 (2004).	
[Signature]		Response to Office Action filed on October 17, 2005 in U.S. Application No. 10/291,179 (Attorney Docket No. 09140-0001-00).	

Examiner Signature	<i>Michelle Estrada</i>	Date Considered	3/16/06
--------------------	-------------------------	-----------------	---------

EXAMINER: Initial if reference considered, whether or not citation is in conformance with MPEP 609. Draw line through citation if not in conformance and not considered. Include copy of this form with next communication to applicant.

EXPRESS MAIL LABEL NO.
EV 746094839 US

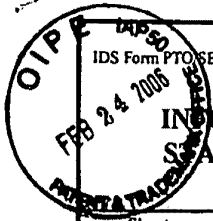

IDS Form PTO/SB/08: Substitute for form 1449A/PTO

INFORMATION DISCLOSURE STATEMENT BY APPLICANT

(Use as many sheets as necessary)

Sheet	2	of	3	Application Number	10/101,863
-------	---	----	---	--------------------	------------

Complete if Known

Application Number	10/101,863
Filing Date	March 16, 2002
First Named Inventor	ZHANG, Hongmei
Art Unit	2823
Examiner Name	ESTRADA, Michelle
Attorney Docket Number	9140.0016-00

NON PATENT LITERATURE DOCUMENTS

<i>ME</i>	Final Office Action issued on December 14, 2005 in U.S. Application No. 10/291,179 (Attorney Docket No. 09140-0001-00).	
<i>ME</i>	PCT Invitation to Pay Additional Fees for PCT/US01/22750, dated March 13, 2002 (Attorney Docket No. 09140.0002-00304).	
<i>ME</i>	PCT International Search Report for PCT/US01/22750, dated July 19, 2002 (Attorney Docket No. 09140.0002-00304).	
<i>ME</i>	PCT Written Opinion for PCT/US01/22750, dated July 23, 2002 (Attorney Docket No. 09140.0002-00304).	
<i>ME</i>	PCT International Preliminary Examination Report for PCT/US01/22750, dated October 8, 2002 (Attorney Docket No. 09140.0002-00304).	
<i>ME</i>	Office Action issued on November 28, 2005 in U.S. Application No. 09/903,081 (Attorney Docket No. 09140-0014-00).	
<i>ME</i>	Response to Office Action filed on December 21, 2005 in Application No. 10/954,182 (Attorney Docket No. 09140.0016-01).	
<i>ME</i>	Response to Office Action filed on July 25, 2005 in Application No. 10/954,182 (Attorney Docket No. 09140.0016-01).	
<i>ME</i>	Office Action issued on October 25, 2005, in U.S. Appl. No. 10/954,182 (Attorney Docket No. 09140-0016-01000).	
<i>ME</i>	Response to Office Action filed on November 8, 2005, in U.S. Application No. 10/101,341 (Attorney Docket No. 09140-0017-00).	
<i>ME</i>	Office Action issued on February 13, 2006, in U.S. Application No. 10/101,341 (Attorney Docket No. 09140-0017-00).	
<i>ME</i>	Response to Office Action filed on January 3, 2006 in U.S. Application No. 10/650,461 (Attorney Docket No. 09140-0025-00).	
<i>ME</i>	PCT International Preliminary Examination Report mailed April 15, 2004 in PCT/US03/24809 (Attorney Docket No. 09140-0025-00304).	
<i>ME</i>	Office Action issued on December 2, 2005 in U.S. Application No. 10/789,953 (Attorney Docket No. 09140.0030-00).	
<i>ME</i>	Specification and Preliminary Amendment as filed for U.S. Appl. No. 11/297,057 (Attorney Docket No. 09140.0030-01).	
<i>ME</i>	Office Action issued on March 24, 2005 in U.S. Application No. 10/851,542 (Attorney Docket No. 09140.0033-00).	
<i>ME</i>	Response to Office Action dated July 25, 2005 in U.S. Application No. 10/851,542 (Attorney Docket No. 09140-0033-00).	
<i>ME</i>	Response to Office Action filed January 19, 2006 in U.S. Application No. 10/851,542 (Attorney Docket No. 09140.0033-00).	

Examiner Signature: <i>Michelle Estrada</i>	Date Considered: <i>3/16/06</i>
---	---------------------------------

EXAMINER: Initial if reference considered, whether or not citation is in conformance with MPEP 609. Draw line through citation if not in conformance and not considered. Include copy of this form with next communication to applicant.

EXPRESS MAIL LABEL NO.
EV 746094839 US

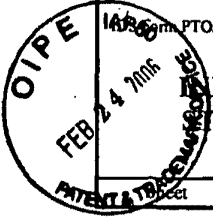

PTO/SB/08: Substitute for form 1449A/PTO		Complete if Known	
INFORMATION DISCLOSURE STATEMENT BY APPLICANT (Use as many sheets as necessary)		<i>Application Number</i>	10/101,863
		<i>Filing Date</i>	March 16, 2002
		<i>First Named Inventor</i>	ZHANG, Hongmei
		<i>Art Unit</i>	2823
		<i>Examiner Name</i>	ESTRADA, Michelle
		<i>Attorney Docket Number</i>	9140.0016-00
3	of	3	

NON PATENT LITERATURE DOCUMENTS		
<i>[Signature]</i>	PCT International Search Report and Written Opinion for Application No. PCT/US2004/014524 dated March 2, 2005 (Attorney Docket No. 09140.0033-00304).	
<i>[Signature]</i>	PCT International Preliminary Report on Patentability for Application No. PCT/US2004/014524, dated December 8, 2005 (Attorney Docket No. 09140.0033-00304).	
<i>[Signature]</i>	PCT International Search Report for Application No. PCT/US2004/014523 dated January 17, 2005 (Attorney Docket No. 09140.0034-00304).	
<i>[Signature]</i>	PCT Written Opinion for Application No. PCT/US2004/014523 dated January 17, 2005 (Attorney Docket No. 09140.0034-00304).	
<i>[Signature]</i>	PCT International Preliminary Report on Patentability for Application No. PCT/US2004/014523, dated December 8, 2005 (Attorney Docket No. 09140.0034-00304).	
<i>[Signature]</i>	Specification as filed for U.S. Appl. No. 11/297,057 (Attorney Docket No. 09140.0042-00).	

<i>Michelle Estrada</i>	Date Considered	<i>3/16/06</i>
-------------------------	-----------------	----------------

EXAMINER: Initial if reference considered, whether or not citation is in conformance with MPEP 609. Draw line through citation if not in conformance and not considered. Include copy of this form with next communication to applicant.

EXPRESS MAIL LABEL NO.
EV 746094839 US

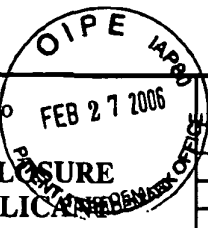

IDS Form PTO/SB/08: Substitute for form 1449A/PTO		<i>Complete if Known</i>	
INFORMATION DISCLOSURE STATEMENT BY APPLICANT <i>(Use as many sheets as necessary)</i>		Application Number	10/101,863
		Filing Date	March 16, 2002
		First Named Inventor	ZHANG, Hongmei
		Art Unit	2823
		Examiner Name	ESTRADA, Michelle
Sheet	1	of	1
		Attorney Docket Number	9140.0016-00

U.S. PATENTS AND PUBLISHED U.S. PATENT APPLICATIONS					
Examiner Initials ⁵	Cite No. ¹	Document Number	Issue or Publication Date MM-DD-YYYY	Name of Patentee or Applicant of Cited Document	Pages, Columns, Lines, Where Relevant Passages or Relevant Figures Appear
		Number-Kind Code ² (if known)			
		US 5,909,346	06-01-1999	Malhotra et al.	
		US 6,000,603	12-14-1999	Koskenmaki et al.	
		US 6,133,670	10-17-2000	Rodgers et al.	
		US 6,356,694 B1	03-12-2002	Weber	
		US 6,768,855 B1	07-27-2004	Bakke et al.	
		US 6,683,749 B2	01-27-2004	Daby et al.	

Note: Submission of copies of U.S. Patents and published U.S. Patent Applications is not required.

FOREIGN PATENT DOCUMENTS						
Examiner Initials ⁵	Cite No. ¹	Foreign Patent Document	Publication Date MM-DD-YYYY	Name of Patentee or Applicant of Cited Document	Pages, Columns, Lines, Where Relevant Passages or Relevant Figures Appear	Translation ⁶
		Country Code ³ Number ⁴ Kind Code ⁵ (if known)				

NON PATENT LITERATURE DOCUMENTS			
Examiner Initials ⁵	Cite No. ¹	Include name of the author (in CAPITAL LETTERS), title of the article (when appropriate), title of the item (book, magazine, journal, serial, symposium, catalog, etc.), date, page(s), volume-issue number(s), publisher, city and/or country where published.	Translation ⁶

Examiner Signature		Date Considered	3/16/04
--------------------	--	-----------------	---------

EXAMINER: Initial if reference considered, whether or not citation is in conformance with MPEP 609. Draw line through citation if not in conformance and not considered. Include copy of this form with next communication to applicant.

EXPRESS MAIL LABEL NO.
EV 860819704 US

IDS Form PTO/SB/08: Substitute for form 1449A/PTD

Complete if Known

INFORMATION DISCLOSURE STATEMENT BY APPLICANT <i>(Use as many sheets as necessary)</i>	Application Number	10/101,863
	Filing Date	March 16, 2002
	First Named Inventor	ZHANG, Hongmei
	Art Unit	2823
	Examiner Name	ESTRADA, Michelle
Sheet 1 of 1	Attorney Docket Number	9140.0016-00

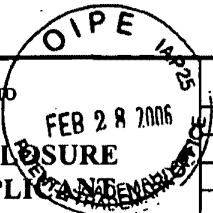

U.S. PATENTS AND PUBLISHED U.S. PATENT APPLICATIONS					
Examiner Initials ¹	Cite No. ¹	Document Number	Issue or Publication Date MM-DD-YYYY	Name of Patentee or Applicant of Cited Document	Pages, Columns, Lines, Where Relevant Passages or Relevant Figures Appear
		Number-Kind Code ² (if known)			

Note: Submission of copies of U.S. Patents and published U.S. Patent Applications is not required.

FOREIGN PATENT DOCUMENTS						
Examiner Initials ¹	Cite No. ¹	Foreign Patent Document	Publication Date MM-DD-YYYY	Name of Patentee or Applicant of Cited Document	Pages, Columns, Lines, Where Relevant Passages or Relevant Figures Appear	Translation ⁴
		Country Code ³ Number ⁴ Kind Code ⁵ (if known)				

NON PATENT LITERATURE DOCUMENTS			
Examiner Initials ¹	Cite No. ¹	Include name of the author (in CAPITAL LETTERS), title of the article (when appropriate), title of the item (book, magazine, journal, serial, symposium, catalog, etc.), date, page(s), volume-issue number(s), publisher, city and/or country where published.	Translation ⁴
		Response to Office Action filed February 17, 2006 in U.S. Application No. 11/100,856 (Attorney Docket No. 09140.0015-01).	

copy missing

Examiner Signature	<i>Michelle Estrada</i>	Date Considered	3/16/06
--------------------	-------------------------	-----------------	---------

EXAMINER: Initial if reference considered, whether or not citation is in conformance with MPEP 609. Draw line through citation if not in conformance and not considered. Include copy of this form with next communication to applicant.

**EXPRESS MAIL LABEL NO.
EV 860819602 US**

IDS Form PTO/SB/08: Substitute for form 1449A/PTO

Complete if Known

**INFORMATION DISCLOSURE
STATEMENT BY APPLICANT**

(Use as many sheets as necessary)

Sheet	1	of	1	Application Number	10/101,863
				Filing Date	March 16, 2002
				First Named Inventor	ZHANG, Hongmei
				Art Unit	2823
				Examiner Name	ESTRADA, Michelle
				Attorney Docket Number	9140.0016-00

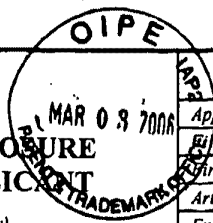

U.S. PATENTS AND PUBLISHED U.S. PATENT APPLICATIONS					
Examiner Initials ⁷	Cite No. ¹	Document Number	Issue or Publication Date MM-DD-YYYY	Name of Patentee or Applicant of Cited Document	Pages, Columns, Lines, Where Relevant Passages or Relevant Figures Appear
		Number-Kind Code ² (if known)			
ME		US 6,290,821 B1	09-18-2001	McLeod	

Note: Submission of copies of U.S. Patents and published U.S. Patent Applications is not required.

FOREIGN PATENT DOCUMENTS						
Examiner Initials ⁷	Cite No. ¹	Foreign Patent Document	Publication Date MM-DD-YYYY	Name of Patentee or Applicant of Cited Document	Pages, Columns, Lines, Where Relevant Passages or Relevant Figures Appear	Translation ⁶
		Country Code ³ Number ⁴ Kind Code ⁵ (if known)				

NON PATENT LITERATURE DOCUMENTS			
Examiner Initials ⁷	Cite No. ¹	Include name of the author (in CAPITAL LETTERS), title of the article (when appropriate), title of the item (book, magazine, journal, serial, symposium, catalog, etc.), date, page(s), volume-issue number(s), publisher, city and/or country where published.	Translation ⁶
ME		Response to Office Action filed February 20, 2002, for US Patent No. 6,506,289 (Atty. Docket No. 09140-0002-01).	
ME		Response to Office Action filed July 17, 2002, for US Patent No. 6,506,289 (Atty. Docket No. 09140-0002-01).	
ME		Response to Office Action filed February 28, 2006 in U.S. Application No. 09/903,081 (Attorney Docket No. 09140-0014-00).	
ME		Response to Office Action filed March 2, 2006 in U.S. Application No. 10/789,953 (Attorney Docket No. 09140.0030-00).	

Examiner Signature: <i>Michelle Estrada</i>	Date Considered: <i>3/16/06</i>
---	---------------------------------

EXAMINER: Initial if reference considered, whether or not citation is in conformance with MPEP 609. Draw line through citation if not in conformance and not considered. Include copy of this form with next communication to applicant.

**EXPRESS MAIL LABEL NO.
EV 860819633 US**

Notice of References Cited	Application/Control No. 10/101,863	Applicant(s)/Patent Under Reexamination ZHANG ET AL.	
	Examiner Michelle Estrada	Art Unit 2823	Page 1 of 1

U.S. PATENT DOCUMENTS

*	Document Number Country Code-Number-Kind Code	Date MM-YYYY	Name	Classification
*	A US-6,306,265 B1	10-2001	Fu et al.	204/192.12
	B US-			
	C US-			
	D US-			
	E US-			
	F US-			
	G US-			
	H US-			
	I US-			
	J US-			
	K US-			
	L US-			
	M US-			

FOREIGN PATENT DOCUMENTS

*	Document Number Country Code-Number-Kind Code	Date MM-YYYY	Country	Name	Classification
	N				
	O				
	P				
	Q				
	R				
	S				
	T				

NON-PATENT DOCUMENTS

*	Include as applicable: Author, Title Date, Publisher, Edition or Volume, Pertinent Pages)
U	
V	
W	
X	

*A copy of this reference is not being furnished with this Office action. (See MPEP § 707.05(a).)
Dates in MM-YYYY format are publication dates. Classifications may be US or foreign.

Search Notes



Application No.	Applicant(s)	
10/101,863	ZHANG ET AL.	
Examiner	Art Unit	
Michelle Estrada	2823	

SEARCHED			
Class	Subclass	Date	Examiner
438	769	2/12/04	<i>aje</i>
438	770		
438	771		
438	787		
438	788		
427	533		
204	192.12		
204	192.15	2/12/2004	<i>aje</i>

INTERFERENCE SEARCHED			
Class	Subclass	Date	Examiner

SEARCH NOTES (INCLUDING SEARCH STRATEGY)		
	DATE	EXMR
See East search attached	2/12/2004	<i>aje</i>
See last search attached	7/29/05	<i>aje</i>
See East search attached	3/16/06	<i>aje</i>



PATENT
Customer No. 22,852
Attorney Docket No. 9140.0016-00

IN THE UNITED STATES PATENT AND TRADEMARK OFFICE

In re Application of:)	
)	
ZHANG, Hongmei et al.)	Group Art Unit: 2823
)	
Application No.: 10/101,863)	Examiner: ESTRADA, Michelle
)	
Filed: March 16, 2002)	
)	
For: BIASED PULSE DC REACTIVE)	Confirmation No.: 6938
SPUTTERING OF OXIDE FILMS)	

MAIL STOP AMENDMENT
Commissioner for Patents
P.O. Box 1450
Alexandria, VA 22313-1450

Sir:

AMENDMENT AND RESPONSE TO OFFICE ACTION

In reply to the Office Action mailed March 22, 2006, Applicants propose that this application be amended as follows:

Amendments to the Claims are reflected in the listing of claims in this paper beginning on page 2.

Remarks/Arguments follow the amendment sections of this paper beginning on page 6.

Attachment to this amendment include Declaration of R. E. Demaray under 37 C.F.R.

§1.132.

AMENDMENTS TO THE CLAIMS:

This listing of claims will replace all prior versions and listings of claims in the application:

1. (Cancelled)
2. (Previously presented): The method of Claim 21, further including holding the temperature of the substrate substantially constant.
3. (Previously presented): The method of Claim 21, wherein applying pulsed DC power through the filter includes supplying up to about 10 kW of power at a frequency of between about 40 kHz and about 350 kHz and a reverse time pulse between about 1.3 and 5 μ s.
4. (Previously presented): The method of Claim 21, wherein adjusting an RF bias power to the substrate includes supplying up to 1000 W of RF power to the substrate.
5. (Canceled).
6. (Previously presented): The method of claim 4, wherein the RF bias power is zero.
7. (Previously presented): The method of Claim 21, wherein the film is an upper cladding layer of a waveguide structure and the RF bias power is optimized to provide planarization.
8. (Previously presented): The method of Claim 21, wherein a process gas of the process gas flow includes a mixture of Oxygen and Argon.
9. (Previously presented): The method of Claim 8, wherein the mixture is adjusted to adjust the index of refraction of the film.
10. (Previously presented): The method of Claim 8, wherein the mixture further includes nitrogen.
11. (Previously presented): The method of Claim 21, wherein applying pulsed DC power to the target includes adjusting pulsed DC power to a target which has an area larger than that of the substrate.

12. (Previously presented): The method of Claim 21, further including uniformly sweeping the target with a magnetic field.

13. (Previously Presented): The method of Claim 12, wherein uniformly sweeping the target with a magnetic field includes sweeping a magnet in one direction across the target where the magnet extends beyond the target in the opposite direction.

14. (Previously Presented): A method of depositing a film on a substrate, comprising:
providing pulsed DC power through a filter to a target;
providing RF bias power to a substrate positioned opposite the target; and
providing process gas between the target and the substrate, and
depositing a film on the backside of the target,
wherein the filter protects a pulsed DC power supply from the bias power, and
wherein a plasma is created between the target and the substrate.

15.-20. (Cancelled).

21. (Currently amended): A method of depositing a film on a substrate, comprising:
conditioning a target;
preparing the substrate;
adjusting an RF bias power to the substrate;
setting a process gas flow; and
applying pulsed DC power to the target through a filter to create a plasma and deposit the film,

wherein conditioning the target includes sputtering with the target in a metallic mode to remove the surface of the target and sputtering with the target in poisonous mode to prepare the surface, and

wherein the filter is a band rejection filter at a frequency of the bias power.

22. (Previously Presented): The method of Claim 21, wherein setting the process gas flow includes adjusting constituents in order to adjust the index of refraction of the film.

23. (Previously Presented): The method of Claim 21, wherein applying pulsed DC power

includes setting the frequency in order to adjust the index of refraction of the film.

24. (Previously Presented): The method of Claim 21, further including adjusting a temperature of the substrate in order to adjust the index of refraction of the film.

25.-39. (Canceled).

40. (New): The method of claim 21, wherein the band rejection filter is a narrow band-pass filter.

41. (New): The method of claim 21, wherein a bandwidth of the band rejection filter is about 100 kHz.

42. (New): The method of claim 21, wherein the frequency of the RF bias is about 2 MHz.

43. (New): A method of depositing a film on a substrate, comprising:
 preparing the substrate;
 adjusting an RF bias power to the substrate;
 setting a process gas flow; and
 applying pulsed DC power to a target through a band rejection filter at a frequency of the bias power.

44. (New): The method of claim 43, wherein a bandwidth of the band rejection filter is about 100 kHz.

45. (New): The method of claim 43, wherein the frequency of the RF bias is about 2 MHz.

46. (New): The method of Claim 43, wherein applying pulsed DC power includes supplying up to about 10 kW of power at a frequency of between about 40 kHz and about 350 kHz and a reverse time pulse between about 1.3 and 5 μ s.

47. (New): The method of Claim 43, further including holding the temperature of the substrate substantially constant.

48. (New): The method of Claim 43, wherein adjusting an RF bias power to the substrate includes supplying up to 1000 W of RF power to the substrate.

49. (New): The method of Claim 43, further including uniformly sweeping the target with a magnetic field.

50. (New): The method of Claim 49, wherein uniformly sweeping the target with a magnetic field includes sweeping a magnet in one direction across the target where the magnet extends beyond the target in the opposite direction.

REMARKS

Claims 2-14 and 21-24 are pending in this application. The Examiner has allowed claim 14 and rejected claims 2-14 and 21-24. Applicants have amended claim 21, canceled claim 5, and added new claims 40-50. Applicants traverse the Examiner's rejection and request reconsideration of the pending claims.

Information Disclosure Statement

One of the references cited in the Seventh Supplemental Information Disclosure Statement submitted on February 27, 2006, was not initialed by the Examiner. Therefore, Applicants have listed such reference for the Examiner to initial in the enclosed Ninth Supplemental Information Disclosure Statement.

Additionally, the Examiner states the Dayco reference "Response to Office Action filed February 17, 2006 in U.S. Application No. 11/100,856 (Attorney Docket No. 09140.0015-01)" was not attached with the Eighth Supplemental Information Disclosure Statement filed on February 28, 2006. Therefore, Applicants have provided a copy and re-listed such Dayco reference on the attached Ninth Supplemental Information Disclosure Statement for the Examiner's initials.

Claim Rejections under 35 U.S.C. § 103

The Examiner has rejected claims 2-13 and 21-24 under 35 U.S.C. § 103 over various combinations of Smolanoff et al. (U.S. Patent No. 6,117,279), Fu et al. (U.S. Patent No. 6,3065,265), Fukui et al. (U.S. Patent No. 5,755,938), and Le et al. (U.S. Application No. 2003/0077914). Specific rejections are further discussed below.

In making a rejection under 35 U.S.C. § 103(a), the Examiner must establish the three elements of a *prima facie* case of obviousness. MPEP § 2142. First, the Examiner must show that the prior art references teach all elements of the claims. Second, the Examiner must show

that the prior art provides the reason or motivation to make the claimed combination. The mere fact that references can be combined does not create a *prima facie* case of obviousness.

Moreover, the motivation to combine cannot come from the applicant's own disclosure but must come from the prior art itself. Additionally, no motivation to combine references exists where doing so would render one of the prior art references unsatisfactory for its intended purpose.

Third, the Examiner must prove that there is a reasonable expectation of success in combining the prior art references. As further discussed below, the Examiner has not met this burden.

I. Claims 2-4, 6-13, and 21-24 are allowable because the cited prior art does not collectively teach all of the elements of the claims.

Claims 2-6, 8, 10-13, and 21-24

The Examiner has rejected claims 8, 10-13, and 21 under 35 U.S.C. 103(a) as being unpatentable over Smolanoff et al. (6,117,279) in view of Fu et al. (6,306,265). Claims 2-6 and 22-24 are rejected over Smolanoff et al. in view of Fu et al. as applied to claims 8, 10-13, and 21 and further in view of Fukui et al. (5,755,938). Claim 21 has been amended to recite "a band rejection filter at a frequency of the bias power," which is substantially the limitation of claim 5. Claim 5 has been canceled.

As the Examiner states, Smolanoff does not teach "a band rejection filter at a frequency of the bias power," as is recited in claim 21. (*See*, Office Action, page 5). As stated in the Declaration of Ernest Demeray filed with this amendment under 37 C.F.R. §1.132, the filter protecting the pulsed DC power supply from the RF power of the bias is an aspect of the claimed invention. The filter must pass the pulsed DC signal without unduly affecting the shape of that signal while rejecting the RF power. Therefore, the filter passes all frequencies except for the

frequency of the bias power itself. As stated in the Declaration of Ernest Demeray, other filter designs resulted in a distortion of the pulsed DC signal or in leakage of RF power back to the pulsed DC power supply -- resulting in the catastrophic failure of the power supply.

The Examiner relies on Fukui for this element. However, Fukui does not teach a “band rejection filter at a frequency of the bias power.” As stated in Fukui,

[a]lso connected to the first electrode 20 is a dc power supply 28 through a band-pass filter 27 such as a low-pass filter for adjustment of impedance. The band-pass filter 27 serves to adjust the circuit impedance to have an infinite value so that no RF waves are superposed on a dc power from the dc power supply 28.

(Fukui, col. 6, lines 31-36). Fukui teaches a band pass filter, specifically a low-pass filter, which would not protect the DC power supply from RF and which would unreasonably distort the pulsed-dc shape. Further, there is no indication that the band-pass filter of Fukui is related to the frequency of the bias power supply. A band pass filter, below at or above the frequency of the RF bias, will not protect the pulsed DC power supply from catastrophic failure as a result of the RF power. Further, a band pass filter does not allow the broad frequency range required for the square wave of the pulsed-DC supply to reach the substrate.

Therefore, as discussed above, claim 21 is allowable over Smollanoff, Fu, and Fukui. Claims 2-4, 6-13, 22-24, and new claims 40-41 depend from claim 21 and are therefore allowable for at least the same reasons as is claim 21.

Claims 7 and 9

The Examiner rejected claims 7 and 9 under 35 U.S.C. § 103(a) as being unpatentable over Smolanoff et al. in view of Fu et al. as applied to claims 8, 10-13, and 21, and further in view of Le et al. (2003/0077914). Claims 7 and 9 depend from claim 21. Le does not cure the defects in the teachings of Smolanoff, Fu, or Fukui.

New Claims

Claims 42-50 have been added to this application. Claim 42 is similar in scope to claim 21 except for the limitation regarding conditioning the target. Claims 43-50 are similar to dependent claims from claim 21. Therefore, claims 42-50 are allowable over the cited art.

Conclusion

In view of the foregoing remarks, Applicants submit that this claimed invention, as amended, is neither anticipated nor rendered obvious in view of the prior art references cited against this application. Applicants therefore request the entry of this Amendment, the Examiner's reconsideration and reexamination of the application, and the timely allowance of the pending claims.

Please grant any extensions of time required to enter this response and charge any additional required fees to our deposit account 06-0916.

Respectfully submitted,

FINNEGAN, HENDERSON, FARABOW,
GARRETT & DUNNER, L.L.P.

Dated: June 12, 2006

By: _____

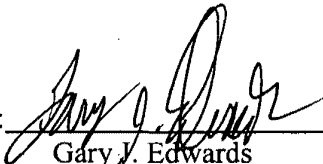
Gary J. Edwards
Reg. No. 41,008

Attachment: Declaration of Dr. R.E. Demaray under 37 C.F.R. §1.132

**EXPRESS MAIL LABEL NO.
EV 860818108 US**



PATENT
Customer No. 22,852
Attorney Docket No. 9140.0016-00

IN THE UNITED STATES PATENT AND TRADEMARK OFFICE

In re Application of:)	
)	
ZHANG, Hongmei et al.)	Group Art Unit: 2823
)	
Application No.: 10/101,863)	Examiner: ESTRADA, Michelle
)	
Filed: March 16, 2002)	
)	
For: BIASED PULSE DC REACTIVE)	Confirmation No.: 6938
SPUTTERING OF OXIDE FILMS)	

MAIL STOP AMENDMENT

Commissioner for Patents
P.O. Box 1450
Alexandria, VA 22313-1450

Declaration of Dr. R. E. Demaray under 37 C.F.R. §1.132

I, Dr. R. Ernest Demaray, declare as follows:

1. I am currently the President and Chief Technology Officer of Symmorphix, Inc., and have served as the Chairman of the Board, the Chief Executive Officer, and the Chief Technology Officer during the history of Symmorphix, Inc. I have been with Symmorphix for the past eight years. I was previously employed at Applied Materials, Inc., of Santa Clara as General Manager and Managing Director of the PVD division of Applied Komatsu. Since receiving my B.S. in Physical Chemistry in 1972, I have worked in the semiconductor equipment field for more than 34 years. I received a Ph.D. in Chemical Physics from the University of California at Santa Cruz in 1977.

2. I am an inventor of U.S. Application Serial No. 10/101, 863. At Symmorphix, my co-inventors and I developed a pulsed-DC, RF-biased deposition apparatus and various deposition methods utilized in that apparatus for deposition of thin film oxides and dielectrics. To my knowledge, the combination of pulsed-DC with RF bias applied to the substrate of an RF power

applied to the deposition chamber had not been disclosed or demonstrated previous to my invention.

3. During development of the deposition chambers and methods claimed in this application, we damaged a number (more than six units) of pulsed-DC power supplies due to RF bias power coupling through the plasma into the pulsed-dc power supply. We utilized the Advanced Energy Pinnacle Plus power supply, which produced a 10 kW square wave at a frequency of from 180 kHz to 300 KHz together with a pulse reverse time from 1.3 to 5.0 μ sec. Utilizing a band-pass filter between the pulsed-DC power supply and the plasma, however, will not protect the pulsed-DC power supply from the RF bias and will also unduly distort the square-wave of the pulsed-DC power signal applied to the target, which detrimentally affects the deposition conditions.

4. My co-inventors and I developed the band-rejection filter described in the specification and claimed in U.S. Application Serial No. 10/101, 863 to overcome the problem of catastrophic failure of the pulsed-DC power supply output electrometer circuit during operation. We discovered that a band-rejection filter, which is a filter that passes all of the frequencies of the square wave power supply except within a narrow band centered on the RF frequency of the RF bias, protected the pulsed-DC power supply from the RF energy while not distorting the pulses generated by the pulsed-DC power supply applied to the target.

5. I have further studied the art cited by the Examiner, namely Smolanoff et al. (U.S. Patent No. 6,117,279) (Smolanoff), Fu et al. (U.S. Patent No. 6,306,265) (Fu), Fukui et al. (U.S. Patent No. 5,755,938) (Fukui), and Le et al. (U.S. Publication No. 2003/0077914) (Le). None of these references teach a pulsed-DC system that allows an RF bias in a fashion that would not damage the pulsed-DC power supply if actually implemented as shown and described. None of these references describe a band-rejection filter at a frequency of the bias power.

6. Smolanoff discloses a reactor where the target is coupled through a filter to a DC source. No description of the filter is provided. However, in the chamber described in Smolanoff, RF power can be supplied to the target, to a secondary plasma generated below the target, and to the

substrate itself. A pulsed-DC power supply without the protection disclosed in the present application would catastrophically fail under these conditions. .

7. Fu describes a PVD sputtering chamber with no pulsed-dc and no filter to protect a pulsed-dc power supply. Therefore, Fu also does not describe a band rejection filter centered at the frequency of an RF bias.

8. Fukui describes a band-pass filter (specifically a low pass filter) coupled between the pulsed-dc power supply and the filter. Again, a band-pass filter does not protect the pulsed-DC power supply, as is required, and will distort the pulsed-DC square wave. Further, Fukui indicates that “[t]he band-pass filter 27 serves to adjust the circuit impedance to have an infinite value so that no RF waves are superposed on a dc power from the dc power supply 28.” (Fukui, col. 6, lines 33-36). This is quite the opposite of what occurs in our applications, where the RF signal is superimposed on the pulsed DC power signal in the plasma, to which the substrate is exposed. Therefore, Fukui does not teach a band-rejection filter at the frequency of the RF bias.

9. Le describes neither a biased power nor a filter and simply teaches an un-biased deposition process. Therefore, Le does not teach a band rejection filter.

10. I hereby declare that all statements made herein of my own knowledge are true and that all statements made on information and belief are believed to be true; and further that these statements were made with the knowledge that willful false statements and the like so made are punishable by fine or imprisonment, or both, under Section 1001 of Title 18 of the United States Code, and that such willful false statements may jeopardize the validity of the application or any patent issued thereon.

Date

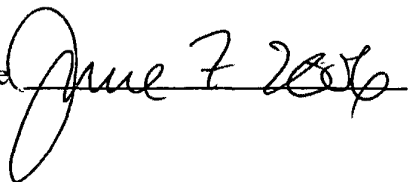

By:

R. Ernest Demaray



06-14-06

2823 \$ / BSW

PATENT
Customer No. 22,852
Attorney Docket No. 9140.0016-00

IN THE UNITED STATES PATENT AND TRADEMARK OFFICE

In re Application of:)	
)	
ZHANG, Hongmei et al.)	Group Art Unit: 2823
)	
Application No.: 10/101,863)	Examiner: ESTRADA, Michelle
)	
Filed: March 16, 2002)	
)	
For: BIASED PULSE DC REACTIVE)	Confirmation No.: 6938
SPUTTERING OF OXIDE FILMS)	

MAIL STOP AMENDMENT

Commissioner for Patents
P.O. Box 1450
Alexandria, VA 22313-1450

Sir:

NINTH SUPPLEMENTAL INFORMATION DISCLOSURE STATEMENT
UNDER 37 C.F.R. § 1.97(c)

Pursuant to 37 C.F.R. §§ 1.56 and 1.97(c), Applicants bring to the attention of the Examiner the documents on the attached listing. This Ninth Supplemental Information Disclosure Statement is being filed after the events recited in Section 1.97(b) but, to the undersigned's knowledge, before the mailing date of either a Final action, Quayle action, or a Notice of Allowance. Under the provisions of 37 C.F.R. § 1.97(c), the Commissioner is hereby authorized to charge the fee of \$180.00 to Deposit Account No. 06-0916 as specified by Section 1.17(p).

Copies of the listed foreign and non-patent literature documents are attached. Copies of the U.S. patents and patent publications are not enclosed.

06/15/2006 MAHMED1 00000056 060916 10101863
01 FC:1806 180.00 DA

Applicants respectfully request that the Examiner consider the listed documents and indicate that they were considered by making appropriate notations on the attached form.

This submission does not represent that a search has been made or that no better art exists and does not constitute an admission that each or all of the listed documents are material or constitute "prior art." If the Examiner applies any of the documents as prior art against any claims in the application and Applicants determine that the cited documents do not constitute "prior art" under United States law, Applicants reserve the right to present to the office the relevant facts and law regarding the appropriate status of such documents.

Applicants further reserve the right to take appropriate action to establish the patentability of the disclosed invention over the listed documents, should one or more of the documents be applied against the claims of the present application.

If there is any fee due in connection with the filing of this Statement, please charge the fee to our Deposit Account No. 06-0916.

Respectfully submitted,

FINNEGAN, HENDERSON, FARABOW,
GARRETT & DUNNER, L.L.P.

Dated: June 12, 2006

By: _____

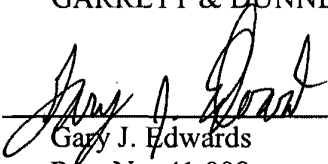
Gary J. Edwards
Reg. No. 41,008

EXPRESS MAIL LABEL NO.
EV 860818108 US

Complete if Known

Application Number	10/101,863
Filing Date	March 16, 2002
First Named Inventor	ZHANG, Hongmei
Art Unit	2823
Examiner Name	ESTRADA, Michelle
Attorney Docket Number	9140.0016-00

INFORMATION DISCLOSURE STATEMENT BY APPLICANT

(Use as many sheets as necessary)

Sheet 1 of 2

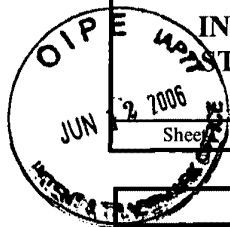

U.S. PATENTS AND PUBLISHED U.S. PATENT APPLICATIONS

Examiner Initials*	Cite No. ¹	Document Number	Issue or Publication Date MM-DD-YYYY	Name of Patentee or Applicant of Cited Document	Pages, Columns, Lines, Where Relevant Passages or Relevant Figures Appear
		Number-Kind Code ² (if known)			
		US 4,082,569	04-04-1978	Evans, Jr.	
		US 5,472,795	12-05-1995	Atita	
		US 5,645,626	07-08-1997	Edlund et al.	
		US 5,702,829	12-30-1997	Paidassi et al.	
		US 6,045,626	04-04-2000	Yano et al.	
		US 6,673,716 B1	01-06-2004	D'Couto et al.	
		US 6,683,749 B2	01-27-2004	Daby et al.	
		US 6,884,327 B2	04-26-2005	Pan et al.	
		US 2002/0115252 A1	08-22-2002	Haukka et al.	
		US 2003/0035906 A1	02-20-2003	Memarian et al.	
		US 2004/0043557 A1	03-04-2004	Haukka et al.	
		US 2005/0048802 A1	03-03-2005	Zhang et al.	
		US 2005/0183946 A1	08-25-2005	Pan et al.	
		US 2006/0054496 A1	03-16-2006	Zhang et al.	
		US 2006/0057283 A1	03-16-2006	Zhang et al.	
		US 2006/0057304 A1	03-16-2006	Zhang et al.	
		US 2006/0071592 A1	04-06-2006	Narasimhan et al.	

Note: Submission of copies of U.S. Patents and published U.S. Patent Applications is not required.

FOREIGN PATENT DOCUMENTS

Examiner Initials*	Cite No. ¹	Foreign Patent Document	Publication Date MM-DD-YYYY	Name of Patentee or Applicant of Cited Document	Pages, Columns, Lines, Where Relevant Passages or Relevant Figures Appear	Translation ⁶
		Country Code ³ Number ⁴ Kind Code ⁵ (if known)				
		JP 7-224379 A	08-22-1995	Ulvac Japan Ltd		Abstract

Examiner Signature		Date Considered	
--------------------	--	-----------------	--

EXAMINER: Initial if reference considered, whether or not citation is in conformance with MPEP 609. Draw line through citation if not in conformance and not considered. Include copy of this form with next communication to applicant.

**EXPRESS MAIL LABEL NO.
EV 860818108 US**

IDS Form PTO/SB/08: Substitute for form 1449A/PTO		<i>Complete if Known</i>	
INFORMATION DISCLOSURE STATEMENT BY APPLICANT <i>(Use as many sheets as necessary)</i>		<i>Application Number</i>	10/101,863
		<i>Filing Date</i>	March 16, 2002
		<i>First Named Inventor</i>	ZHANG, Hongmei
		<i>Art Unit</i>	2823
		<i>Examiner Name</i>	ESTRADA, Michelle
		<i>Attorney Docket Number</i>	9140.0016-00
Sheet	2	of	2

NON PATENT LITERATURE DOCUMENTS			
Examiner Initials ⁷	Cite No. ¹	Include name of the author (in CAPITAL LETTERS), title of the article (when appropriate), title of the item (book, magazine, journal, serial, symposium, catalog, etc.), date, page(s), volume-issue number(s), publisher, city and/or country where published.	Translation ⁶
		BARBIER, D., "Performances and potential applications of erbium doped planar waveguide amplifiers and lasers," <i>Proc. OAA</i> , Victoria, BC, Canada, pp. 58-63 (July 21-23, 1997).	
		KELLY, P.J. et al., "A novel technique for the deposition of aluminum-doped zinc oxide films," <i>Thin Solid Films</i> 426(1-2):111-116 (2003).	
		TOMASZEWSKI, H. et al., "Ytria-stabilized zirconia thin films grown by reactive r.f. magnetron sputtering," <i>Thin Solid Films</i> 287:104-109 (1996).	
		Response to Final Office Action filed April 14, 2006, in U.S. Appl. No. 10/291,179 (Atty. Docket No. 9140.0001-00).	
		Office Action mailed April 27, 2006, in U.S. Appl. No. 10/291,179 (Atty. Docket No. 9140.0001-00).	
		Final Office Action mailed May 8, 2006 in U.S. Application No. 09/903,081 (Attorney Docket No. 09140-0014-00).	
		Response to Office Action filed February 17, 2006 in U.S. Application No. 11/100,856 (Attorney Docket No. 09140.0015-01).	
		Office Action issued on March 9, 2006, in U.S. Appl. No. 10/954,182 (Attorney Docket No. 09140-0016-01000).	
		Response to Office Action filed on May 15, 2006, in U.S. Application No. 10/101,341 (Attorney Docket No. 09140-0017-00).	
		Final Office Action issued on May 19, 2006 in U.S. Application No. 10/789,953 (Attorney Docket No. 09140.0030-00).	
		Office Action from Singapore Patent Office in Appl. No. 200505388-9, dated March 20, 2006 (Atty. Docket No. 9140.0030-00256).	
		Office Action mailed April 19, 2006 in U.S. Application No. 10/851,542 (Attorney Docket No. 09140.0033-00).	

Examiner Signature	Date Considered	
--------------------	-----------------	--

EXAMINER: Initial if reference considered, whether or not citation is in conformance with MPEP 609. Draw line through citation if not in conformance and not considered. Include copy of this form with next communication to applicant.

EXPRESS MAIL LABEL NO.
EV 860818108 US

(19)



JAPANESE PATENT OFFICE

(COPY)

PATENT ABSTRACTS OF JAPAN

(11) Publication number: 07224379 A

(43) Date of publication of application: 22.08.95

(51) Int. Cl. C23C 14/34

(21) Application number: 06017653

(22) Date of filing: 14.02.94

(71) Applicant: ULVAC JAPAN LTD

(72) Inventor: OTA ATSUSHI, HAGA HIDEAKI, TANI NORIAKI, SUU KOUKOU, KOMATSU TAKASHI, NAKAMURA KYUZO, MOMONO TAKESHI, KAWAMURA HIROAKI, SUZUKI IKUO, IKEDA SATOSHI, ISHIKAWA MICHIO, OTA YOSHIFUMI, MATSUMOTO MASAHIRO

(54) SPUTTERING METHOD AND DEVICE THEREFOR

(57) Abstract

PURPOSE: To form a film at a high rate without generating an abnormal discharge for a long time at the time of sputtering a conductive target in a gaseous reactant atmosphere by DC sputtering by applying a positive potential on a negative-potential target in the form of a pulse.

CONSTITUTION: A substrate and a conductive target are opposed in a vacuum treating chamber, and the target is sputtered in a gaseous reactant atmosphere by DC sputtering to form a thin film on the substrate. In this case, a device with a power source to apply a positive potential on a negative potential connected to the target is used, and a positive potential is applied on the negative-potential target in the form of a pulse at the frequency of 5-400kHz to conduct sputtering. The electron in the plasma is attracted by the positive potential to neutralize the plus ion accumulated on the insulator and high-resistance film, and the abnormal discharge due to an arc discharge is not generated.

COPYRIGHT: (C)1995,JPO

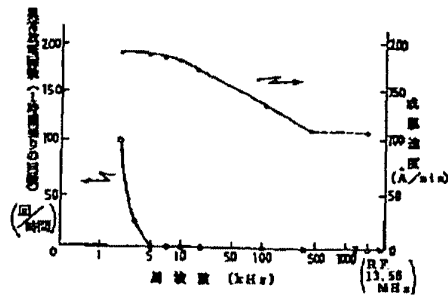

mimosa

(51) Int.Cl. ⁸	識別記号	庁内整理番号	F I	技術表示箇所
C 2 3 C 14/34	R	8414-4K		
	A	8414-4K		
	M	8414-4K		

審査請求 未請求 請求項の数 4 O L (全 5 頁)

(21) 出願番号 特願平6-17653
 (22) 出願日 平成6年(1994)2月14日



(71) 出願人 000231464
 日本真空技術株式会社
 神奈川県茅ヶ崎市萩園2500番地
 (72) 発明者 太田 淳
 千葉県山武郡山武町横田523 日本真空技術株式会社千葉超材料研究所内
 (72) 発明者 羽賀 日出明
 千葉県山武郡山武町横田523 日本真空技術株式会社千葉超材料研究所内
 (72) 発明者 谷 典明
 千葉県山武郡山武町横田523 日本真空技術株式会社千葉超材料研究所内
 (74) 代理人 弁理士 北村 欣一 (外2名)
 最終頁に続く

(54) 【発明の名称】 スパッタ方法およびそのスパッタ装置

(57) 【要約】

【目的】 反応ガス雰囲気中で直流スパッタ法により導電性ターゲットにスパッタリングを行っても高速成膜が可能であり、かつ、長時間スパッタリングを行っても異常放電のないスパッタ成膜が出来るスパッタ方法。

【構成】 反応ガス雰囲気中で直流スパッタ法により導電性ターゲットにスパッタリングを行って基板上に薄膜を形成するスパッタ法において、負電位の導電性ターゲットに正電位を一定の周波数でパルス状に印加しながらスパッタリングする。

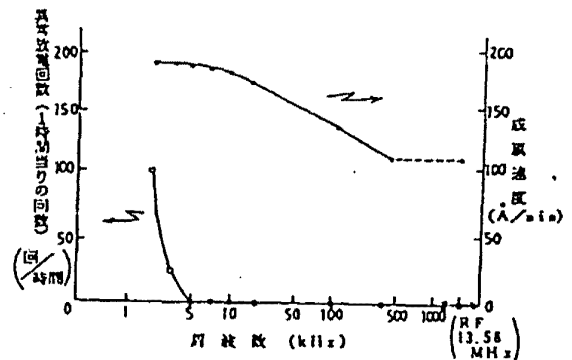

PTO 99-4732
 S.T.I.C. Translations Branch

【特許請求の範囲】

【請求項1】 反応ガス雰囲気中で直流スパッタ法により導電性ターゲットにスパッタリングを行って基板上に薄膜を形成するスパッタ法において、負電位の導電性ターゲットに正電位を周波数5～400kHzでパルス状に印加しながらスパッタリングすることを特徴とするスパッタ方法。

【請求項2】 前記導電性ターゲットはSi、Al、Ta、Ti、C、ITO、ZnO、SnO₂またはこれらの合金であり、また、反応ガスはN₂、O₂、H₂、NH₃、CO、CO₂、CH₄、C₂H₂、H₂Oのいずれか1つまたは2つ以上の混合ガスであることを特徴とする請求項第1項に記載のスパッタ方法。

【請求項3】 真空処理室内に基板と導電性ターゲットを対向させて設け、反応ガス雰囲気中で直流スパッタ法により導電性ターゲットにスパッタリングを行って基板上に薄膜を形成するスパッタ装置において、負電位に正電位を周波数5～400kHzでパルス状に印加する電源を導電性ターゲットに接続したことを特徴とするスパッタ装置。

【請求項4】 前記導電性ターゲットはSi、Al、Ta、Ti、C、ITO、ZnO、SnO₂またはこれらの合金であり、また、反応ガスはN₂、O₂、H₂、NH₃、CO、CO₂、CH₄、C₂H₂、H₂Oのいずれか1つまたは2つ以上の混合ガスであることを特徴とする請求項第3項に記載のスパッタ装置。

【発明の詳細な説明】

【0001】

【産業上の利用分野】本発明はスパッタ方法およびそのスパッタ装置に関し、更に詳しくは、反応ガス雰囲気中で導電性ターゲットにスパッタリングを行うスパッタ方法およびそのスパッタ装置に関する。

【0002】

【従来の技術】従来から、反応ガス雰囲気中で導電性ターゲットにスパッタリングを行って基板上に誘電体膜、光学膜、保護膜等の膜を成膜するスパッタ方法に用いられるスパッタ装置としては、真空処理室内に基板とターゲットカソードを対向して設け、該ターゲットカソードに導電性ターゲットを装着し、真空処理室内を所定の雰囲気とした状態でターゲットに所定電圧を印加してターゲットにスパッタリングを行う装置が知られている。

【0003】そして、スパッタリング時の電源としては直流電源、または例えば13.56MHzの高周波電源を用いている。

【0004】

【発明が解決しようとする課題】前記従来のスパッタ装置を用いて基板上に誘電体膜、光学膜、保護膜等の膜を成膜する際、高周波電源を用いるRFスパッタリングは長時間異常放電なしに成膜することが可能であるが、成膜速度が遅いという問題がある。

【0005】また、前記従来のスパッタ装置を用いて基板上に誘電体膜、光学膜、保護膜等の膜を成膜する際、直流電源を用いるDCスパッタリングは成膜速度は速いが、スパッタリングの経時と共に、ターゲット表面に絶縁物や高抵抗膜が堆積するため、異常放電を起こすという問題がある。

【0006】スパッタリング中に異常放電が発生すると欠陥のない均質な膜を成膜する上で致命的な悪影響を及ぼす。

【0007】従って、従来のスパッタ装置では通常RFスパッタリングを行っているが、高速成膜を必要とする場合は、DCスパッタリングを行い、ターゲット表面に絶縁物や高抵抗膜が堆積しないようにターゲット全面に亘ってエロージョン化するようにしているが、異常放電を十分に除去することが出来ない。

【0008】本発明はかかる問題点を解消し、反応ガス雰囲気中でスパッタリングを行っても高速成膜が可能であり、かつ、長時間スパッタリングを行っても異常放電のないスパッタ成膜の可能なスパッタ方法およびそれに用いるスパッタ装置を提供することを目的とする。

【0009】

【課題を解決するための手段】本発明のスパッタ方法は、反応ガス雰囲気中で直流スパッタ法により導電性ターゲットにスパッタリングを行って基板上に薄膜を形成するスパッタ法において、負電位の導電性ターゲットに正電位を周波数5～400kHzでパルス状に印加しながらスパッタリングすることを特徴とする。

【0010】また、前記導電性ターゲットはSi、Al、Ta、Ti、C、ITO、ZnO、SnO₂またはこれらの合金とし、また、反応ガスはN₂、O₂、H₂、NH₃、CO、CO₂、CH₄、C₂H₂、H₂Oのいずれか1つまたは2つ以上の混合ガスとしてもよい。

【0011】本発明のスパッタ装置は、真空処理室内に基板と導電性ターゲットを対向させて設け、反応ガス雰囲気中で直流スパッタ法により導電性ターゲットにスパッタリングを行って基板上に薄膜を形成するスパッタ装置において、負電位に正電位を周波数5～400kHzでパルス状に印加する電源を導電性ターゲットに接続したことを特徴とする。

【0012】また、前記導電性ターゲットはSi、Al、Ta、Ti、C、ITO、ZnO、SnO₂またはこれらの合金とし、また、反応ガスはN₂、O₂、H₂、NH₃、CO、CO₂、CH₄、C₂H₂、H₂Oのいずれか1つまたは2つ以上の混合ガスとしてもよい。

【0013】

【作用】反応ガス雰囲気中で導電性ターゲットに直流電源より直流電圧を印加し、スパッタリングを行うとターゲットはスパッタされて基板上に薄膜が形成される。

【0014】長時間連続してスパッタリングを行うと、ターゲット上に堆積した絶縁物や高低抗膜上に不活性ガスまたは反応ガスのプラス(+)イオンが蓄積される。このプラス(+)イオンの電荷がターゲット間、エロージョン部、アース電極等とアーク放電を引き起こして異常放電の原因となる。

【0015】この異常放電でターゲット材、絶縁物、高低抗膜が粒子状となって飛散し、基板上に付着し、成膜された薄膜の欠陥となる。

【0016】ターゲットに直流電圧を印加してDCスパッタリングを行う際、負電位のターゲットに正電位を一定の周波数でパルス状に印加すると、正電位によりプラズマ中の電子を引き寄せ、ターゲット上に堆積した絶縁物、高低抗膜上に蓄積するプラス(+)イオンの電荷を中和し、アーク放電による異常放電を防止する。

【0017】その際、ターゲットに印加する正電位の印加時間は負電位の時間に比べて極めて短くとも効果があるため、成膜速度は直流電流のみによる成膜速度より数%の減少となる程度であり、この成膜速度は高周波13.56MHzスパッタ時の成膜速度よりも高い。

【0018】

【実施例】以下添付図面に従って本発明の実施例について説明する。

【0019】図1は、スパッタ装置の1例を示すもので、図中、1は真空処理室を示す。

【0020】真空処理室1を外部のクライオポンプのような真空ポンプ等の真空排気系2にバルブ3を介して接続し、該真空処理室1内の真空度を調節自在とすると共に、真空処理室1内に基板4とターゲットカソード5とを対向に配置し、該ターゲットカソード5の前面に導電性ターゲット6をロウ材でボンディングするようにしたまた、該真空処理室1内にガス導入管7を介してガスポンプ等のガス供給源8よりスパッタガスを導入するようにした。図示例ではガス導入管7を分岐し、一方の分岐管9aにガス圧調節弁10aを介して不活性ガス(例えばアルゴンガス)のガス供給源8aを接続し、他方の分岐管9bにガス圧調節弁10bを介して反応ガス(例えば窒素ガス)のガス供給源8bを接続した。

【0021】また、ターゲットカソード5に直流電源11をパルスユニット12を介して接続し、パルスユニット12を調節して導電性ターゲット6に負電位と正電位を所定の周波数でパルス状に印加するようにした。

【0022】また、ターゲットカソード5の背面側にマグネトロンスパッタのためのマグネット13を配置して、ターゲットカソード5に取り付けられた導電性ターゲット6の表面にマグネトロンスパッタに必要な磁場を与えるようにした。

【0023】次に、図1装置を用いて本発明のスパッタ方法の具体的実施例について説明する。

【0024】実施例1

先ず、真空処理室1内に基板4と、ターゲットカソード5に導電性ターゲット6としてケイ素(Si)製ターゲットを装着した。

【0025】続いて、真空処理室1内を真空排気系2により 6.7×10^{-4} Pa (5×10^{-3} Torr)に排気した後、真空処理室1内にガス供給源8aからのアルゴン(Ar)ガスと、ガス供給源8bからの窒素(N₂)ガスとから成る反応ガスをガス導入管7を介して導入して、該真空処理室1内のスパッタ圧が 6.7×10^{-4} Pa (5×10^{-3} Torr)となるようにした。次に基板4上に形成される窒化ケイ素(SiN_x)の屈折率が2.03となるようにArガスとN₂ガスの流量をそれぞれ100sccmと50sccmに調整した後、DCマグネトロンスパッタ法により導電性ターゲット6に直流電源11より直流電力3kWを印加し、負電位のターゲット6に正電位をパルスユニット12より周波数を2kHzから400kHzに変化させながらパルス状(図2参照)に印加し、スパッタリングを行って基板4上に膜厚900Åの窒化ケイ素(SiN_x)膜を形成した。尚、負電位のターゲットにパルス状に印加する正電位の印加時間は周波数10kHzまでの場合は10μsecとし、周波数10kHzを超えて100kHzまでの場合は5μsecとし、周波数100kHzを超えた場合は1μsecとした。また、DCマグネトロンスパッタ時の磁場強度を250Oeとした。

【0026】そして異常放電回数と成膜速度を負電位の導電性ターゲット6に印加する正電位の周波数毎に測定した。得られた測定結果を図3に示す。

【0027】図3から明らかなように負電位に印加する正電位の周波数の増加に伴い、異常放電回数は減少し、周波数が5kHz以上ではその回数はほとんど0になり、これ以上の周波数で正電位を負電位のターゲットに印加すれば異常放電が発生しないことが分かる。また、負電位に印加する正電位の周波数が400kHz(時間1μsec)の場合は、通常の高周波電源(13.56MHz)とほぼ同じ成膜速度となり、400kHz以上の周波数では正電位の印加は意味がない。従って、負電位のターゲットに印加する正電位の周波数範囲は5~400kHzであることが確認された。

【0028】また、周波数範囲5~400kHzでの成膜速度は高周波電源(13.56MHz)よりも高い成膜速度である。

【0029】反応ガス雰囲気中で直流スパッタ法により導電性ターゲットにスパッタリングを行うと、ターゲット上の非エロージョン部分に絶縁物または高低抗膜が堆積し、従来の直流電源でターゲットに負の電位を放電し続けると、絶縁物上にプラス(+)の電荷が蓄積し、ターゲット、エロージョン部、アース電極との間でアーク放電を起こし、電荷を放出する。その結果異常放電が発生することになるが、本発明では図2に示すように負電位に正電位を周期的に、即ち一定の周波数で印加することにより前記の電荷を補償して異常放電の発生を防止するようにしている。

【0030】実施例2

反応ガスとして酸素(O₂)ガスを用い、スパッタ圧を6.7×10⁻¹Pa(5×10⁻³Torr)とし、直流電力を2kWとし、基板上に形成される酸化ケイ素(SiO_x)の屈折率が1.46となるように酸素流量を調整した以外は前記実施例1と同様の方法でDCマグネトロンスパッタ法によりターゲットにスパッタリングを行って基板上に膜厚1000Åの酸化ケイ素(SiO_x)膜を形成した。

【0031】そして異常放電回数を負電位のターゲットに印加する正電位の周波数毎に測定した。得られた測定結果を図4に示す。

【0032】図4から明らかなように負電位に印加する正電位の周波数は約5kHzで異常放電をほぼ防止し得ることが分かる。

【0033】尚、図4におけるSiNxの測定結果(黒丸印)は前記実施例1の測定結果を参考のために記載したものである。

【0034】実施例3

導電性ターゲットとしてグラファイト(C)を用い、反応ガスとしてメタン(CH₄)ガスを用い、スパッタ圧を6.7×10⁻¹Pa(5×10⁻³Torr)とし、直流電力を2kWとした以外は前記実施例1と同様の方法でDCマグネトロンスパッタ法によりターゲットにスパッタリングを行って基板上に膜厚200Åのダイヤモンドライクカーボン(DLC)膜を形成した。

【0035】そして異常放電回数を負電位のターゲットに印加する正電位の周波数毎に測定した。得られた測定結果を図4に示す。

【0036】図4から明らかなように負電位に印加する正電位の周波数は約5kHzで異常放電をほぼ防止し得ることが分かる。

【0037】前記実施例1, 2, 3の結果から、導電性ターゲット材料、放電状態によりプラス(+)の電荷の蓄積量が異なるため、異常放電はターゲットに印加する周波数に大きく依存する。従って、周波数5kHz以上であれば、種々のターゲット材料でもスパッタリング中の異常放電を大幅に減少することが出来ることになる。

【0038】実施例4

導電性ターゲットとしてアルミニウム(Al)、チタン(Ti)、タンタル(Ta)、またはこれらの合金例えばAl-2at%Tiを用い、反応ガスとして窒素(N₂)、酸素(O₂)、水素(H₂)、一酸化炭素(CO)、二酸化炭素(CO₂)、アンモニア(NH₃)、水(H₂O)を単独、或いは2種以上を用い、これらを種々組み合わせし、その他の条件を前記実施例1と同様にしてDCマグネトロンスパッタ法により基板上に酸化物、窒化物、炭化物のいずれかの薄膜を形成したが、負電位に印加する正電位が周波数5kHz以上ではスパッタリング中に異常放電の発生は見られなかった。

【0039】また、前記実施例1では導電性ターゲットにSiを用い、反応ガスとして窒素ガスを用いて基板上に窒化ケイ素(SiNx)膜を形成したが、導電性ターゲットとしてSiの代わりにIn₂O₃-SnO₂焼結体(ITO)、酸化亜鉛(ZnO)、酸化スズ(SnO₂)を用い、反応ガスとして窒素ガスの代わりに酸素(O₂)、一酸化炭素(CO)、二酸化炭素(CO₂)、水(H₂O)等の酸素を含むガス、またはそのガスに水素ガス(H₂)混合したガスを用い、負電位のターゲットに印加する正電位の周波数を5~400kHzとした直流スパッタ法(DCマグネトロンスパッタ法)により基板上に透明導電膜であるITO、ZnO、SnO₂の薄膜を形成することが出来る。

【0040】図1装置では負電位に一定の周波数で正電位をパルス状に印加する電源装置として直流電源とパルス電源の組み合わせた装置としたが、これに限定されるものではなく、図2に示すような負電位に正電位が周期的(パルス状)に印加される一体型の電源装置としてもよい。

【0041】

【発明の効果】本発明のスパッタ方法によるときは、反応ガス雰囲気中で、負電位の導電性ターゲットに正電位を一定の周波数でパルス状に印加しながらスパッタリングを行うようにしたので、スパッタリング中にターゲット上に堆積した絶縁物、高抵抗膜上に蓄積するプラスイオンの電荷を中和することが出来て、アーク放電による異常放電を防止しながら長時間に亘って速い成膜速度で基板上に欠陥のない均質な薄膜を形成することが出来る効果がある。

【0042】また、本発明のスパッタ装置によるときは、導電性ターゲットに負電位に正電位を一定の周波数でパルス状に印加する電源を接続するようにしたので、アーク放電による異常放電を防止しながら長時間に亘って速い成膜速度で基板上に欠陥のない均質な薄膜を形成することが出来るスパッタ装置を提供する効果がある。

【図面の簡単な説明】

【図1】本発明のスパッタ方法を実施するためのスパッタ装置の1例の概略断面側面図。

【図2】図1装置による導電性ターゲットに印加される電位のモデル図。

【図3】本発明スパッタ方法の1実施例における成膜時の周波数と異常放電回数との関係、並びに周波数と成膜速度との関係を示す特性線図。

【図4】本発明スパッタ方法の他の実施例における成膜時の周波数と異常放電回数との関係を示す特性線図。

【符号の説明】

- 1 真空処理室、 2 真空排気系、 4 基板、 6 導電性ターゲット、 7 ガス導入管、 8 スパッタガス供給源、 11 直流電源、 12 パルスユニット。

【図1】

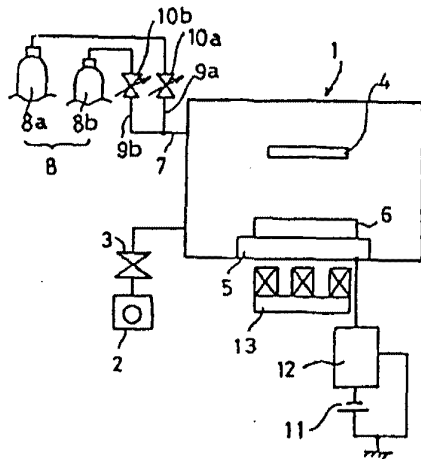

【図3】

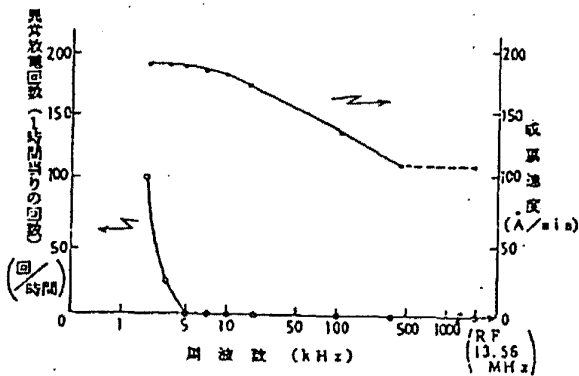

【図2】

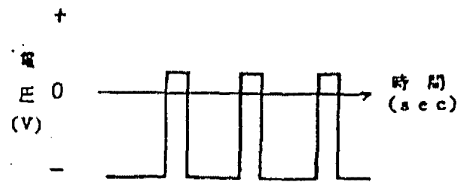

【図4】

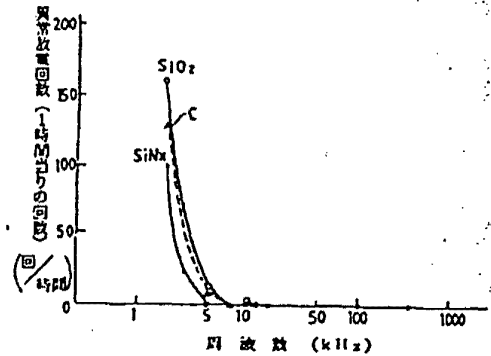

フロントページの続き

- (72)発明者 榑 紅▲こう▼
千葉県山武郡山武町横田523 日本真空技術株式会社千葉超材料研究所内
- (72)発明者 小松 孝 ✓
千葉県山武郡山武町横田523 日本真空技術株式会社千葉超材料研究所内
- (72)発明者 中村 久三 ✓
千葉県山武郡山武町横田523 日本真空技術株式会社千葉超材料研究所内
- (72)発明者 梶野 健 ✓
千葉県山武郡山武町横田523 日本真空技術株式会社千葉超材料研究所内
- (72)発明者 川村 裕明 ✓
千葉県山武郡山武町横田523 日本真空技術株式会社千葉超材料研究所内

- (72)発明者 鈴木 孤生
千葉県山武郡山武町横田523 日本真空技術株式会社千葉超材料研究所内
- (72)発明者 池田 智
千葉県山武郡山武町横田523 日本真空技術株式会社千葉超材料研究所内
- (72)発明者 石川 道夫
千葉県山武郡山武町横田523 日本真空技術株式会社千葉超材料研究所内
- (72)発明者 太田 賀文
千葉県山武郡山武町横田523 日本真空技術株式会社千葉超材料研究所内
- (72)発明者 松本 昌弘
千葉県山武郡山武町横田523 日本真空技術株式会社千葉超材料研究所内

file filed 2-24-06

Approved for use through 10/1/2006 OMB 0311-0032
 U.S. Patent and Trademark Office; U.S. DEPARTMENT OF COMMERCE

Under the Paperwork Reduction Act of 1995, no person is required to respond to a collection of information unless it displays a valid OMB control number.

PATENT APPLICATION FEE DETERMINATION RECORD

Substitute for Form PTO-876 Effective December 8, 2004

Application or Docket Number

10101803

APPLICATION AS FILED - PART I

(Column 1) (Column 2)

SMALL ENTITY

OR

OTHER THAN SMALL ENTITY

FOR	NUMBER FILED	NUMBER EXTRA
BASIC FEE (37 CFR 1.16(a), (b) or (c))	N/A	N/A
SEARCH FEE (37 CFR 1.16(a), (b), or (c))	N/A	N/A
EXAMINATION FEE (37 CFR 1.16(a), (b), or (c))	N/A	N/A
TOTAL CLAIMS (37 CFR 1.16(d))	minus 20 =	
INDEPENDENT CLAIMS (37 CFR 1.16(e))	minus 3 =	
APPLICATION SIZE FEE (37 CFR 1.16(f))	If the specification and drawings exceed 100 sheets of paper, the application size fee due is \$260 (\$125 for small entity) for each additional 50 sheets or fraction thereof. See 35 U.S.C. 41(a)(1)(G) and 37 CFR 1.16(f).	
MULTIPLE DEPENDENT CLAIM PRESENT (37 CFR 1.16(h))		

RATE (\$)	FEE (\$)
N/A	150.00
N/A	\$250
N/A	\$100
X\$ 25	
X100	
+180=	
TOTAL	

RATE (\$)	FEE (\$)
N/A	300.00
N/A	\$600
N/A	\$200
X\$50	
X200	
+360=	
TOTAL	

* If the difference in column 1 is less than zero, enter "0" in column 2.

APPLICATION AS AMENDED - PART II

(Column 1) (Column 2) (Column 3)

SMALL ENTITY

OR

OTHER THAN SMALL ENTITY

AMENDMENT A	CLAIMS REMAINING AFTER AMENDMENT	MINUS	HIGHEST NUMBER PREVIOUSLY PAID FOR	PRESENT EXTRA
	<i>22406</i>	<i>17</i>	Minus	<i>39</i>
Total (37 CFR 1.16(g))				
Independent (37 CFR 1.16(h))	<i>2</i>	Minus	<i>5</i>	
Application Size Fee (37 CFR 1.16(i))				
FIRST PRESENTATION OF MULTIPLE DEPENDENT CLAIM (37 CFR 1.16(j))				

RATE (\$)	ADDITIONAL FEE (\$)
X\$ 25	
X100	
+180=	
TOTAL ADD'L FEE	

RATE (\$)	ADDITIONAL FEE (\$)
X\$50	
X200	
+360=	
TOTAL ADD'L FEE	

6-12-06

AMENDMENT B	CLAIMS REMAINING AFTER AMENDMENT	MINUS	HIGHEST NUMBER PREVIOUSLY PAID FOR	PRESENT EXTRA
		<i>27</i>	Minus	<i>39</i>
Total (37 CFR 1.16(g))				
Independent (37 CFR 1.16(h))	<i>3</i>	Minus	<i>5</i>	
Application Size Fee (37 CFR 1.16(i))				
FIRST PRESENTATION OF MULTIPLE DEPENDENT CLAIM (37 CFR 1.16(j))				

RATE (\$)	ADDITIONAL FEE (\$)
X\$ 25	
X100	
+180=	
TOTAL ADD'L FEE	

RATE (\$)	ADDITIONAL FEE (\$)
X\$50	
X200	
+360=	
TOTAL ADD'L FEE	

If the entry in column 1 is less than the entry in column 2, write "0" in column 3.
 * If the Highest Number Previously Paid For IN THIS SPACE is less than 20, enter "20".
 ** If the Highest Number Previously Paid For IN THIS SPACE is less than 3, enter "3".
 The Highest Number Previously Paid For (Total or Independent) is the highest number found in the appropriate box in column 1.
 A collection of information is required by 37 CFR 1.16. The information is required to obtain or retain a benefit by the public which is to file (and by the PTO to process) an application. Confidentiality is governed by 35 U.S.C. 122 and 37 CFR 1.14. This collection is estimated to take 12 minutes to complete, including gathering, preparing, and submitting the completed application form to the USPTO. Time will vary depending upon the individual case. Any comments the amount of time you require to complete this form and/or suggestions for reducing this burden, should be sent to the Chief Information Officer, U.S. Patent & Trademark Office, U.S. Department of Commerce, P.O. Box 1450, Alexandria, VA 22313-1450. DO NOT SEND FEES OR COMPLETED FORMS TO THIS ADDRESS. SEND TO: Commissioner for Patents, P.O. Box 1460, Alexandria, VA 22313-1460.

If you need assistance in completing the form, call 1-800-PTO-9199 and select option 2

Index of Claims

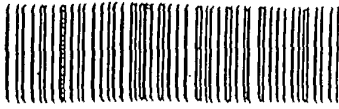

Application No.

10/10/863

Applicant(s)

Examiner

Art Unit

✓	Rejected
⊖	Allowed

-	(Through numeral) Cancelled
+	Restricted

N	Non-Elected
I	Interference

A	Appeal
O	Objected

Claim		Date		Claim		Date		Claim		Date	
Final	Original			Final	Original			Final	Original		
1	✓			51				101			
2	✓			52				102			
3	✓			53				103			
4	✓			54				104			
5	✓			55				105			
6	✓			56				106			
7	✓			57				107			
8	✓			58				108			
9	✓			59				109			
10	✓			60				110			
11	✓			61				111			
12	✓			62				112			
13	✓			63				113			
14	✓			64				114			
15	✓			65				115			
16	✓			66				116			
17	✓			67				117			
18	✓			68				118			
19	✓			69				119			
20	✓			70				120			
21	✓			71				121			
22	✓			72				122			
23	✓			73				123			
24	✓			74				124			
25	✓			75				125			
26	✓			76				126			
27	✓			77				127			
28	✓			78				128			
29	✓			79				129			
30	✓			80				130			
31	✓			81				131			
32	✓			82				132			
33	✓			83				133			
34	✓			84				134			
35	✓			85				135			
36	✓			86				136			
37	✓			87				137			
38	✓			88				138			
39	✓			89				139			
40	✓			90				140			
41	✓			91				141			
42	✓			92				142			
43	✓			93				143			
44	✓			94				144			
45	✓			95				145			
46	✓			96				146			
47	✓			97				147			
48	✓			98				148			
49	✓			99				149			
50	✓			100				150			

07-17-06

IFW
2823
\$



PATENT
Customer No. 22,852
Attorney Docket No. 9140.0016-00

IN THE UNITED STATES PATENT AND TRADEMARK OFFICE

In re Application of:)	
)	
ZHANG, Hongmei et al.)	Group Art Unit: 2823
)	
Application No.: 10/101,863)	Examiner: ESTRADA, Michelle
)	
Filed: March 16, 2002)	
)	
For: BIASED PULSE DC REACTIVE)	Confirmation No.: 6938
SPUTTERING OF OXIDE FILMS)	

MAIL STOP AMENDMENT

Commissioner for Patents
P.O. Box 1450
Alexandria, VA 22313-1450

Sir:

TENTH SUPPLEMENTAL INFORMATION DISCLOSURE STATEMENT
UNDER 37 C.F.R. § 1.97(c)

Pursuant to 37 C.F.R. §§ 1.56 and 1.97(c), Applicants bring to the attention of the Examiner the documents on the attached listing. This Tenth Supplemental Information Disclosure Statement is being filed after the events recited in Section 1.97(b) but, to the undersigned's knowledge, before the mailing date of either a Final action, Quayle action, or a Notice of Allowance. Under the provisions of 37 C.F.R. § 1.97(c), the Commissioner is hereby authorized to charge the fee of \$180.00 to Deposit Account No. 06-0916 as specified by Section 1.17(p).

Copies of the listed foreign and non-patent literature documents are attached. Copies of the U.S. patents and patent publications are not enclosed.

07/18/2006 RMEBRAHT 00000101 060916 10101863
01 FC:1806 180.00 DA

Applicants respectfully request that the Examiner consider the listed documents and indicate that they were considered by making appropriate notations on the attached form.

This submission does not represent that a search has been made or that no better art exists and does not constitute an admission that each or all of the listed documents are material or constitute "prior art." If the Examiner applies any of the documents as prior art against any claims in the application and Applicants determine that the cited documents do not constitute "prior art" under United States law, Applicants reserve the right to present to the office the relevant facts and law regarding the appropriate status of such documents.

Applicants further reserve the right to take appropriate action to establish the patentability of the disclosed invention over the listed documents, should one or more of the documents be applied against the claims of the present application.

If there is any fee due in connection with the filing of this Statement, please charge the fee to our Deposit Account No. 06-0916.

Respectfully submitted,

FINNEGAN, HENDERSON, FARABOW,
GARRETT & DUNNER, L.L.P.

Dated: July 13, 2006

By: _____

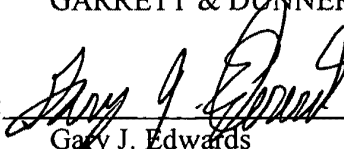
Gary J. Edwards
Reg. No. 41,008

**EXPRESS MAIL LABEL NO.
EV 860818417 US**

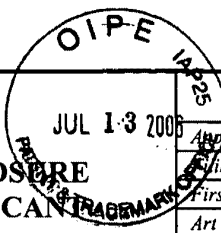

IDS Form PTO/SB/08: Substitute for form 1449A/PTO		<i>Complete if Known</i>	
INFORMATION DISCLOSURE STATEMENT BY APPLICANT <i>(Use as many sheets as necessary)</i>		Application Number	10/101,863
		Filing Date	March 16, 2002
		First Named Inventor	ZHANG, Hongmei
		Art Unit	2823
		Examiner Name	ESTRADA, Michelle
		Attorney Docket Number	9140.0016-00
Sheet	1	of	2

U.S. PATENTS AND PUBLISHED U.S. PATENT APPLICATIONS					
Examiner Initials ²	Cite No. ¹	Document Number	Issue or Publication Date	Name of Patentee or Applicant of Cited Document	Pages, Columns, Lines, Where Relevant Passages or Relevant Figures Appear
		Number-Kind Code ² (if known)	MM-DD-YYYY		
		US 4,710,940	12-01-1987	Sipes, Jr.	
		US 4,785,459	11-15-1988	Baer	
		US 5,435,826	07-25-1995	Sakakibara et al.	
		US 5,512,147	04-30-1996	Bates et al.	
		US 5,569,520	10-29-1996	Bates	
		US 5,597,660	01-28-1997	Bates et al.	
		US 5,612,152	03-18-1997	Bates	
		US 6,168,884 B1	01-02-2001	Neudecker et al.	
		US 6,236,793 B1	05-22-2001	Lawrence et al.	
		US 6,242,132 B1	06-05-2001	Neudecker et al.	
		US 6,365,300 B1	04-02-2002	Ota et al.	
		US 6,760,520 B1	07-06-2004	Medin et al.	
		US 6,818,356 B1	11-16-2004	Bates	
		US 2001/0031122 A1	10-18-2001	Lackritz et al.	
		US 2003/0185266 A1	10-02-2003	Henrichs	
		US 2006/0134522 A1	06-22-2006	Zhang et al.	

Note: Submission of copies of U.S. Patents and published U.S. Patent Applications is not required.

FOREIGN PATENT DOCUMENTS						
Examiner Initials ²	Cite No. ¹	Foreign Patent Document	Publication Date	Name of Patentee or Applicant of Cited Document	Pages, Columns, Lines, Where Relevant Passages or Relevant Figures Appear	Translation ⁶
		Country Code ³ Number ⁴ Kind Code ⁵ (if known)	MM-DD-YYYY			

Examiner Signature	Date Considered	
--------------------	-----------------	--

EXAMINER: Initial if reference considered, whether or not citation is in conformance with MPEP 609. Draw line through citation if not in conformance and not considered. Include copy of this form with next communication to applicant.

EXPRESS MAIL LABEL NO.
EV 860818417 US

IDS Form PTO/SB/08: Substitute for form 1449A/PTO		<i>Complete if Known</i>	
INFORMATION DISCLOSURE STATEMENT BY APPLICANT <i>(Use extra sheets as necessary)</i>		<i>Application Number</i>	10/101,863
		<i>Filing Date</i>	March 16, 2002
		<i>First Named Inventor</i>	ZHANG, Hongmei
		<i>Art Unit</i>	2823
		<i>Examiner Name</i>	ESTRADA, Michelle
Sheet	2	of	2
		<i>Attorney Docket Number</i>	9140.0016-00

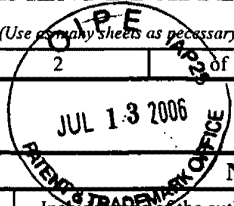

NON PATENT LITERATURE DOCUMENTS			
Examiner Initials ⁷	Cite No. ¹	Include name of the author (in CAPITAL LETTERS), title of the article (when appropriate), title of the item (book, magazine, journal, serial, symposium, catalog, etc.), date, page(s), volume-issue number(s), publisher, city and/or country where published.	Translation ⁶
		COCORULLO, G. et al., "Amorphous silicon waveguides and light modulators for integrated photonics realized by low-temperature plasma-enhanced chemical-vapor deposition," <i>Optics Lett.</i> 21(24):2002-2004 (1996).	
		Notice of Allowance mailed August 6, 2002, for US Patent No. 6,506,289 (Atty. Docket No. 09140.0002-01).	
		Final Office Action mailed June 9, 2006 in U.S. Appl. No. 11/100,856 (Atty. Docket No. 09140.0015-01).	
		Office Action issued on March 23, 2006, in U.S. Application No. 10/650,461 (Atty. Docket No. 09140-0025-00).	
		Specification as filed September 2, 2005, for U.S. Appl. No. 11/218,652 (Atty. Docket No. 09140.0052-00000).	

Examiner Signature		Date Considered	
--------------------	--	-----------------	--

EXAMINER: Initial if reference considered, whether or not citation is in conformance with MPEP 609. Draw line through citation if not in conformance and not considered. Include copy of this form with next communication to applicant.

EXPRESS MAIL LABEL NO.
EV 860818417 US

8-17-06

IFW 2823



PATENT
Customer No. 22,852
Attorney Docket No. 9140.0016-00

IN THE UNITED STATES PATENT AND TRADEMARK OFFICE

In re Application of:)	
)	
ZHANG, Hongmei et al.)	Group Art Unit: 2823
)	
Application No.: 10/101,863)	Examiner: ESTRADA, Michelle
)	
Filed: March 16, 2002)	
)	
For: BIASED PULSE DC REACTIVE)	Confirmation No.: 6938
SPUTTERING OF OXIDE FILMS)	

MAIL STOP AMENDMENT

Commissioner for Patents
P.O. Box 1450
Alexandria, VA 22313-1450

Sir:

ELEVENTH SUPPLEMENTAL INFORMATION DISCLOSURE STATEMENT
UNDER 37 C.F.R. § 1.97(c)

Pursuant to 37 C.F.R. §§ 1.56 and 1.97(c), Applicants bring to the attention of the Examiner the documents on the attached listing. This Eleventh Supplemental Information Disclosure Statement is being filed after the events recited in Section 1.97(b) but, to the undersigned's knowledge, before the mailing date of either a Final action, Quayle action, or a Notice of Allowance. Under the provisions of 37 C.F.R. § 1.97(c), the Commissioner is hereby authorized to charge the fee of \$180.00 to Deposit Account No. 06-0916 as specified by Section 1.17(p).

Copies of the listed foreign and non-patent literature documents are attached. Copies of the U.S. patents and patent publications are not enclosed.

English translations of the non-English language documents are enclosed.

4

Applicants respectfully request that the Examiner consider the listed documents and indicate that they were considered by making appropriate notations on the attached form.

This submission does not represent that a search has been made or that no better art exists and does not constitute an admission that each or all of the listed documents are material or constitute "prior art." If the Examiner applies any of the documents as prior art against any claims in the application and Applicants determine that the cited documents do not constitute "prior art" under United States law, Applicants reserve the right to present to the office the relevant facts and law regarding the appropriate status of such documents.

Applicants further reserve the right to take appropriate action to establish the patentability of the disclosed invention over the listed documents, should one or more of the documents be applied against the claims of the present application.

If there is any fee due in connection with the filing of this Statement, please charge the fee to our Deposit Account No. 06-0916.

Respectfully submitted,

FINNEGAN, HENDERSON, FARABOW,
GARRETT & DUNNER, L.L.P.

Dated: August 15, 2006

By: _____

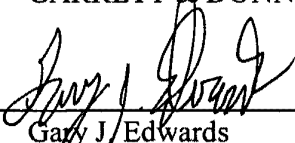

Gary J. Edwards
Reg. No. 41,008

**EXPRESS MAIL LABEL NO.
EV 746096525 US**

Complete if Known

**INFORMATION DISCLOSURE
STATEMENT BY APPLICANT**

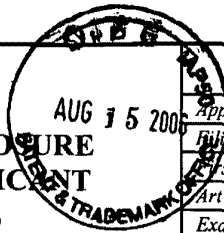
(Use as many sheets as necessary)



Sheet	1	of	2	Application Number	10/101,863
				Filing Date	March 16, 2002
				First Named Inventor	ZHANG, Hongmei
				Art Unit	2823
				Examiner Name	ESTRADA, Michelle
				Attorney Docket Number	9140.0016-00

U.S. PATENTS AND PUBLISHED U.S. PATENT APPLICATIONS

Examiner Initials ²	Cite No. ¹	Document Number	Issue or Publication Date MM-DD-YYYY	Name of Patentee or Applicant of Cited Document	Pages, Columns, Lines, Where Relevant Passages or Relevant Figures Appear
		Number-Kind Code ² (if known)			
		US 5,433,835	07/18/1995	Demaray	
		US 6,288,835 B1	09/11/2001	Nilsson et al.	
		US 6,452,717 B1	09/17/2002	Endo	
		US 2002/0014406 A1	02/07/2002	Takashima	

Note: Submission of copies of U.S. Patents and published U.S. Patent Applications is not required.

FOREIGN PATENT DOCUMENTS

Examiner Initials ²	Cite No. ¹	Foreign Patent Document	Publication Date MM-DD-YYYY	Name of Patentee or Applicant of Cited Document	Pages, Columns, Lines, Where Relevant Passages or Relevant Figures Appear	Translation ⁶
		Country Code ³ Number ⁴ Kind Code ⁵ (if known)				
		DE 37 38 738 C1	01/26/1989	Degussa AG		Yes
		JP 5-230642 A	09/07/1993	Nissin High Voltage Co., Ltd.		Yes
		WO 99/61674 A1	12/02/1999	Universiteit Gent		
		WO 2006/063308 A2	06/15/2006	Symmorphix, Inc.		

NON PATENT LITERATURE DOCUMENTS

Examiner Initials ²	Cite No. ¹	Include name of the author (in CAPITAL LETTERS), title of the article (when appropriate), title of the item (book, magazine, journal, serial, symposium, catalog, etc.), date, page(s), volume-issue number(s), publisher, city and/or country where published.	Translation ⁶
		AGRAWAL, G.P., in: <u>Fiber-Optic Communication Systems</u> , 2nd Edition, John Wiley & Sons, New York, pp. 361-399 and 415 (1997).	
		<u>ASM Handbook</u> , Formerly Ninth Edition, Metals Handbook, Volume 15, Casting, Davis et al. (Eds.), ASM International, pp. 372-373, 376-383, and 410-411 (1988).	
		MASUDA, H. & KAWAI, S., "Wide-band and gain-flattened hybrid fiber amplifier consisting of an EDFA and a multiwavelength pumped raman amplifier," <i>IEEE Photonics Technology Lett.</i> 11(6):647-649 (1999).	
		SNOEKS, E. et al., "Cooperative upconversion in erbium-implanted soda-lime silicate glass optical waveguides," <i>J. Opt. Soc. Am. B</i> 12(8):1468-1474 (1995).	
		Response to Office Action filed July 27, 2006, in U.S. Appl. No. 10/291,179 (Atty. Docket No. 9140.0001-00).	
		Notice of Allowance mailed March 25, 2004 for US Patent No. 6,827,826 (Atty. Docket No. 09140.0002-02).	

Examiner Signature	Date Considered
--------------------	-----------------

EXAMINER: Initial if reference considered, whether or not citation is in conformance with MPEP 609. Draw line through citation if not in conformance and not considered. Include copy of this form with next communication to applicant.

**EXPRESS MAIL LABEL NO.
EV 746096525 US**

IDS Form PTO/SB/08: Substitute for form 1449A/PTO			<i>Complete if Known</i>	
INFORMATION DISCLOSURE STATEMENT BY APPLICANT <i>(Use as many sheets as necessary)</i>			<i>Application Number</i>	10/101,863
			<i>Filing Date</i>	March 16, 2002
			<i>First Named Inventor</i>	ZHANG, Hongmei
			<i>Art Unit</i>	2823
			<i>Examiner Name</i>	ESTRADA, Michel
			<i>Attorney Docket Number</i>	9140.0016-00
Sheet	2	of	2	

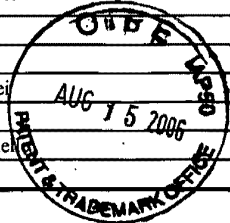

NON PATENT LITERATURE DOCUMENTS			
		Notice of Allowance issued on October 8, 2002, in U.S. Patent No. 6,533,907 (Atty. Docket No. 09140-0004-00).	
		Notice of Allowance issued on October 21, 2004, in U.S. Application No. 10/101,492 (Atty. Docket No. 09140-0015-00).	
		Response to Office Action filed on August 9, 2006 in Application No. 10/954,182 (Atty. Docket No. 09140.0016-01).	
		Office Action issued on August 2, 2006, in U.S. Application No. 10/101,341 (Atty. Docket No. 09140-0017-00).	
		Response to Office Action filed on July 24, 2006, in U.S. Application No. 10/650,461 (Atty. Docket No. 09140-0025-00).	
		Response to Office Action filed July 26, 2006 in U.S. Application No. 10/851,542 (Atty. Docket No. 09140.0033-00).	

Examiner Signature		Date Considered	
--------------------	--	-----------------	--

EXAMINER: Initial if reference considered, whether or not citation is in conformance with MPEP 609. Draw line through citation if not in conformance and not considered. Include copy of this form with next communication to applicant.

**EXPRESS MAIL LABEL NO.
EV 746096525 US**

(19) World Intellectual Property Organization
International Bureau



(43) International Publication Date
15 June 2006 (15.06.2006)

PCT

(10) International Publication Number
WO 2006/063308 A2

(51) International Patent Classification:
B05D 5/12 (2006.01) H01M 10/38 (2006.01)
H01M 4/52 (2006.01) C23C 14/34 (2006.01)

(74) Agent: EDWARDS, Gary, J.; Finnegan, Henderson,
Farabow, Garrett & Dunner LLP, 901 New York Avenue,
Washington, D.C., District of Columbia 20001-4413 (US).

(21) International Application Number:
PCT/US2005/044781

(81) Designated States (unless otherwise indicated, for every
kind of national protection available): AE, AG, AL, AM,
AT, AU, AZ, BA, BB, BG, BR, BW, BY, BZ, CA, CH, CN,
CO, CR, CU, CZ, DE, DK, DM, DZ, EC, EE, EG, ES, FI,
GB, GD, GE, GH, GM, HR, HU, ID, IL, IN, IS, JP, KE,
KG, KM, KN, KP, KR, KZ, LC, LK, LR, LS, LT, LU, LV,
LY, MA, MD, MG, MK, MN, MW, MX, MZ, NA, NG, NI,
NO, NZ, OM, PG, PH, PL, PT, RO, RU, SC, SD, SE, SG,
SK, SL, SM, SY, TJ, TM, TN, TR, TT, TZ, UA, UG, US,
UZ, VC, VN, YU, ZA, ZM, ZW.

(22) International Filing Date:
7 December 2005 (07.12.2005)

(25) Filing Language: English

(26) Publication Language: English

(30) Priority Data:
60/634,818 8 December 2004 (08.12.2004) US
60/651,363 8 February 2005 (08.02.2005) US

(84) Designated States (unless otherwise indicated, for every
kind of regional protection available): ARIPO (BW, GH,
GM, KE, LS, MW, MZ, NA, SD, SL, SZ, TZ, UG, ZM,
ZW), Eurasian (AM, AZ, BY, KG, KZ, MD, RU, TJ, TM),
European (AT, BE, BG, CH, CY, CZ, DE, DK, EE, ES, FI,
FR, GB, GR, HU, IE, IS, IT, LT, LU, LV, MC, NL, PL, PT,
RO, SE, SI, SK, TR), OAPI (BF, BJ, CF, CG, CI, CM, GA,
GN, GQ, GW, ML, MR, NE, SN, TD, TG).

(71) Applicant (for all designated States except US): SYM-
MORPHIX, INC. [US/US]; 1278 Reamwood Avenue,
Sunnyvale, CA 94089-2233 (US).

(72) Inventors; and

(75) Inventors/Applicants (for US only): ZHANG, Hongmel
[US/US]; 1330 Rodney Drive, San Jose, CA 95118 (US).
DEMARAY, Richard, E. [US/US]; 190 Fawn Lane, Por-
tola Valley, CA 94028 (US). SHAO, May [US/US]; 5401
Nectar Circle, Elk Grove, CA 95757 (US).

Published:

— without international search report and to be republished
upon receipt of that report

For two-letter codes and other abbreviations, refer to the "Guid-
ance Notes on Codes and Abbreviations" appearing at the begin-
ning of each regular issue of the PCT Gazette.

(54) Title: DEPOSITION OF LiCoO₂

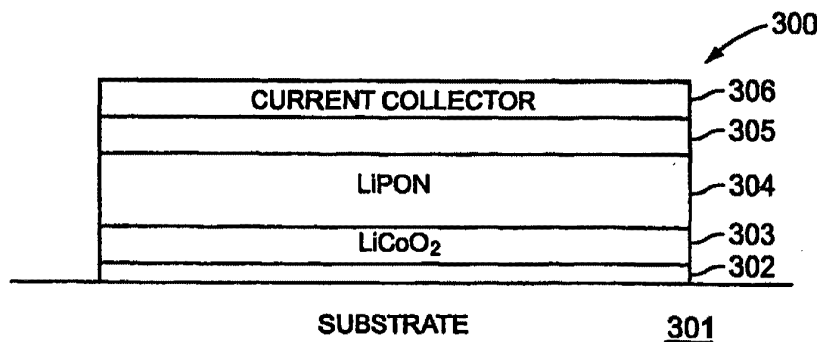

(57) Abstract: In accordance with the present invention, deposition of LiCoO₂ layers in a pulsed-dc physical vapor deposition process is presented. Such a deposition can provide a low-temperature, high deposition rate deposition of a crystalline layer of Li-CoO₂ with a desired <101> or <003> orientation. Some embodiments of the deposition addresses the need for high rate deposition of LiCoO₂ films, which can be utilized as the cathode layer in a solid state rechargeable Li battery. Embodiments of the process according to the present invention can eliminate the high temperature (>700°C) anneal step that is conventionally needed to crystallize the LiCoO₂ layer. Some embodiments of the process can improve a battery utilizing the LiCoO₂ layer by utilizing a rapid thermal anneal process with short ramp rates.

WO 2006/063308 A2

66

DEPOSITION OF LiCoO_2

RELATED APPLICATION

[001] The present application claims priority to Provisional Application No. 60/651,363, filed on February 8, 2005, by Hongmei Zhang and Richard E. Demaray, and to Provisional Application No. 60/634,818, filed on December 8, 2004, by the same inventors, each of which are herein incorporated by reference in their entirety.

BACKGROUND

1. Field of the Invention

[002] The present invention is related to thin-film solid-state batteries and, in particular, the deposition of LiCoO_2 films and layers for battery manufacture.

2. Discussion of Related Art

[003] Solid-state thin-film batteries are typically formed by stacking thin films on a substrate in such a way that the films cooperate to generate a voltage. The thin films typically include current collectors, a cathode, an anode, and an electrolyte. The thin films can be deposited utilizing a number of deposition processes, including sputtering and electroplating. Substrates suitable for this application have conventionally been high temperature materials capable of withstanding at least one high temperature anneal process to at least 700 °C for up to about 2 hours in air so as to crystallize the LiCoO_2 film. Such a substrate can be any suitable material with appropriate structural and material properties, for example a semiconductor wafer, metallic sheet (e.g., titanium or zirconium), ceramic such as alumina, or other material capable of withstanding subsequent high temperature processing in

the presence of the LiCoO_2 , which can experience significant interfacial reactions with most materials utilized in a battery during these temperature cycles.

[004] Other lithium containing mixed metal oxides besides LiCoO_2 , including Ni, Nb, Mn, V, and sometimes also Co, but including other transition metal oxides, have been evaluated as crystalline energy storage cathode materials. Typically, the cathode material is deposited in amorphous form and then the material is heated in an anneal process to form the crystalline material. In LiCoO_2 , for example, an anneal at or above 700°C transforms the deposited amorphous film to a crystalline form. Such a high temperature anneal, however, severely limits the materials that can be utilized as the substrate, induces destructive reaction with the lithium containing cathode material and often requires the use of expensive noble metals such as gold. Such high thermal budget processes (i.e., high temperatures for extended periods of time) are incompatible with semiconductor or MEM device processing and limit the choice of substrate materials, increase the cost, and decrease the yield of such batteries. The inventors are unaware of a process disclosed in the art that allows production of cathodic lithium films for a battery structure where a post-deposition anneal process has a low enough thermal budget to allow production of functional structures on low temperature materials such as stainless steel, aluminum, or copper foil.

[005] It is known that crystallization of amorphous LiCoO_2 on precious metals can be achieved. An example of this crystallization is discussed in Kim et al., where a conventional furnace anneal at 700°C for 20 minutes of an amorphous layer of LiCoO_2 on a precious metal achieves crystallization of the LiCoO_2 material, as shown by x-ray diffraction data. Kim, Han-Ki and Yoon, Young Soo, "Characteristics of rapid-thermal-annealed LiCoO_2 cathode film for an all-solid-state thin film microbattery," J. Vac. Sci. Techn. A 22(4), Jul/Aug 2004. In Kim et al., the LiCoO_2 film was deposited on a platinum film that was deposited on a high-temperature MgO/Si substrate. In Kim et al, it was shown that such

a crystalline film is capable of constituting the Li⁺ ion containing cathode layer of a functional all solid-state Li⁺ ion battery. However, it is of continuing interest for the manufacture of solid state Li⁺ ion batteries to further reduce the thermal budget of the post deposition anneal, both in time and in temperature, so as to enable the manufacture of such batteries without the need for expensive precious metal nucleation, barrier layers, or expensive high-temperature substrates.

[006] There are many references that disclose an ion beam assisted process that can provide a LiCoO₂ film that demonstrates some observable crystalline composition by low angle x-ray diffraction (XRD). Some examples of these are found in U.S. Patent Applications 09/815,983 (Publication No. US 2002/001747), 09/815,621 (Publication No. US 2001/0032666), and 09/815,919 (Publication No. US 2002/0001746). These references disclose the use of a second front side ion beam or other ion source side-by-side with a deposition source so as to obtain a region of overlap of the flux of ions with the flux of LiCoO₂ vapor at the substrate surface. None of these references disclose film temperature data or other temperature data of the film during deposition to support an assertion of low temperature processing.

[007] It is very difficult to form a uniform deposition either by sputtering a material layer or by bombardment with an ion flux. Utilization of two uniform simultaneous distributions from two sources that do not occupy the same position and extent with respect to the substrate enormously increases the difficulties involved in achieving a uniform material deposition. These references do not disclose a uniform materials deposition, which is required for reliable production of thin-film batteries. A well understood specification for material uniformity for useful battery products is that a 5% one-sigma material uniformity is standard in thin film manufacturing. About 86% of the films with this uniformity will be found acceptable for battery production.

[008] It is even more difficult to scale a substrate to manufacturing scale, such as 200 mm or 300 mm. Indeed, in the references discussed above that utilize both a sputtering deposition and an ion beam deposition, only small area targets and small area substrates are disclosed. These references disclose a single feasibility result. No method for achieving a uniform distribution from two separate front side sources has been disclosed in these references.

[009] Further, conventional materials and production processes can limit the energy density capacity of the batteries produced, causing a need for more batteries occupying more volume. It is specifically desirable to produce batteries that have large amounts of stored energy per unit volume in order to provide batteries of low weight and low volume.

[010] Therefore, there is a need for a low temperature process for depositing crystalline material, for example LiCoO_2 material, onto a substrate.

SUMMARY

[011] In accordance with the present invention, deposition of LiCoO_2 layers in a pulsed-dc physical vapor deposition process is presented. Such a deposition can provide a low-temperature, high deposition rate deposition of a crystalline layer of LiCoO_2 with a desired $\langle 101 \rangle$ orientation. Some embodiments of the deposition address the need for high rate deposition of LiCoO_2 films, which can be utilized as the cathode layer in a solid state rechargeable Li battery. Embodiments of the process according to the present invention can eliminate the high temperature ($>700^\circ\text{C}$) anneal step that is conventionally needed to crystallize the LiCoO_2 layer.

[012] A method of depositing a LiCoO_2 layer according to some embodiments of the present invention includes placing a substrate in a reactor; flowing a gaseous mixture including argon and oxygen through the reactor; and applying pulsed-DC power to a target

formed of LiCoO_2 positioned opposite the substrate. In some embodiments, a LiCoO_2 layer is formed on the substrate. Further, in some embodiments the LiCoO_2 layer is a crystalline layer of orientation $\langle 101 \rangle$.

[013] In some embodiments, a stacked battery structure can be formed. The stacked battery structure includes one or more battery stacks deposited on a thin substrate, wherein each battery stack includes: a conducting layer, a crystalline LiCoO_2 layer deposited over the conducting layer, a LiPON layer deposited over the LiCoO_2 layer, and an anode deposited over the LiPON layer. A top conducting layer can be deposited over the one or more battery stacks.

[014] In some embodiments, a battery structure can be formed in a cluster tool. A method of producing a battery in a cluster tool includes loading a substrate into a cluster tool; depositing a conducting layer over the substrate in a first chamber of the cluster tool; depositing a crystalline LiCoO_2 layer over the conducting layer in a second chamber of the cluster tool; depositing a LiPON layer over the LiCoO_2 layer in a third chamber of the cluster tool; depositing an anode layer over the LiCoO_2 layer in a fourth chamber; and depositing a second conducting layer over the LiPON layer in a fifth chamber of the cluster tool.

[015] A fixture for holding a thin substrate can include a top portion and a bottom portion, wherein the thin substrate is held when the top portion is attached to the bottom portion.

[016] These and other embodiments of the invention are further discussed below with reference to the following figures. It is to be understood that both the foregoing general description and the following detailed description are exemplary and explanatory only and are not restrictive of the invention, as claimed. Further, specific explanations or theories regarding the deposition or performance of certain layers during deposition processes or in the performance of devices incorporating those layers are presented for explanation only and

are not to be considered limiting with respect to the scope of the present disclosure or the claims.

BRIEF DESCRIPTION OF THE DRAWINGS

[017] Figures 1A and 1B illustrate a pulsed-DC biased reactive deposition apparatus that can be utilized in the methods of depositing according to the present invention.

[018] Figure 2 shows an example of a target that can be utilized in the reactor illustrated in Figures 1A and 1B.

[019] Figure 3 illustrates a thin-film battery design according to some embodiments of the present invention.

[020] Figures 4A and 4B show an x-ray diffraction analysis of and an SEM photograph of a LiCoO_2 film deposited according to embodiments of the present invention.

[021] Figures 5A through 5F show SEM photographs of LiCoO_2 films according to some embodiments of the present invention.

[022] Figure 5G shows x-ray diffraction data corresponding to the depositions shown in Figures 5B-5F.

[023] Figure 6A illustrates a layer of LiCoO_2 deposited according to some embodiments of the present invention on a thin substrate.

[024] Figure 6B illustrates a layer of LiCoO_2 deposited according to some embodiments of the present invention over a conducting layer on a thin substrate.

[025] Figures 7A, 7B, 7C, and 7D illustrate a thin substrate mount and mask arrangement that can be utilized in the deposition of LiCoO_2 layers deposited according to some embodiments of the present invention.

[026] Figure 8 illustrates a cluster tool that can be utilized to form batteries with LiCoO_2 layers deposited according to some embodiments of the present invention.

[027] Figures 9A and 9B illustrate examples of stacked batter structures with LiCoO₂ layers deposited according to some embodiments of the present invention.

[028] Figures 10A through 10D illustrate deposition and anneal steps for LiCoO₂ deposited over an iridium layer on a silicon wafer.

[029] Figures 11A through 11D illustrate a single layer battery formed over an iridium layer according to some embodiments of the present invention.

[030] Figures 12A through 12L illustrate deposition of a crystalline LiCoO₂ layer on a silicon or alumina substrate.

[031] Figures 13A through 13F illustrate rapid thermal anneal processes for LiCoO₂ layers deposited according to the present invention.

[032] Figures 14A through 14D illustrate several anneal processes utilized with a LiCoO₂ film deposited according to embodiments of the present invention.

[033] Figures 15A and 15B illustrate the effects of ramp-time in a rapid thermal anneal of LiCoO₂ films deposited according to the present invention.

[034] Figure 16 illustrates thickness uniformity of a LiCoO₂ film deposited according to some embodiments of the present invention.

[035] Figure 17 illustrates battery charge and discharge profiles of a battery formed utilizing a LiCoO₂ film according to some embodiments of the present invention.

[036] In the figures, elements having the same designation have the same or similar functions.

DETAILED DESCRIPTION

[037] In accordance with embodiments of the present invention, LiCoO₂ films are deposited on a substrate by a pulsed-dc physical vapor deposition (PVD) process. In contrast to, for example, Kim et al., LiCoO₂ films according to some embodiments of the present

invention provide a crystalline LiCoO_2 film as deposited on a substrate at a substrate temperature as low as about 220°C during deposition, without the use of a metallic nucleation or barrier underlying film. The as-deposited crystalline LiCoO_2 films can be easily ripened to very high crystalline condition by anneal at about 700°C for as little as 5 minutes without the use of an underlying precious metal film. In addition, the as deposited crystalline films, when positioned on a noble metal film can be annealed at much further reduced temperatures, for example as low as 400 to 500°C , providing for deposition, annealing, and production of solid state batteries on lower temperature substrates.

[038] In the present application, a single, extended source is described which has been scaled to $400\text{mm} \times 500\text{mm}$ for production achieving a LiCoO_2 uniformity of 3% one-sigma measured at 25 points at a deposition rate of 1.2 microns thickness an hour over an area of 2000 cm^2 , without the need for secondary front side ion source or ion assistance.

[039] In one example process, a LiCoO_2 film was deposited utilizing a conductive ceramic LiCoO_2 target as described herein, with pulsed-dc power of 4 kW, no bias, with 60 sccm Ar and 20 sccm O_2 gas flows. A 3000 Angstrom layer of crystalline LiCoO_2 was deposited on a substrate area of $400 \times 500\text{ mm}$. As demonstrated in Figure 16, film thickness uniformity was located at about 25 locations spaced uniformly across the substrate using a felt marker pen to lift off a portion of the film in each location. High precision white-light interferometry was utilized to measure the film thickness in each location by measuring the step height from the substrate to film surface. All 25 thickness measurements demonstrated a 3% one-sigma uniformity in the film thickness over $400 \times 500\text{ mm}$ substrate area. As shown in Figure 16, a film was deposited with average thickness of about $2.96\text{ }\mu\text{m}$ with a maximum of $3.09\text{ }\mu\text{m}$ and a minimum of $2.70\text{ }\mu\text{m}$ and standard deviation of 0.093. Thickness data was taken at points spaced 0.65 mm apart on the surface of the film. The film thickness therefore showed 3% one-sigma uniformity over the shown surface area.

[040] On other depositions utilizing this process, a temperature measurement of the substrate during deposition showed that the substrate remained at less than 224 °C.

Temperature measurements were performed utilizing a temperature sticker purchased from Omega Engineering, Stamford, Ct (Model no. TL-F-390, active from 199-224 °C).

[041] Moreover, in some embodiments, films deposited according to the present invention can have a deposition rate of from about 10 to about 30 times higher than processes in conventional films. Deposition thicknesses and times of deposition for films deposited according to the present invention are illustrated in Table I. Furthermore, films according to the present invention can be deposited on wide area substrates having a surface area from 10 to 50 times the surface area of prior sputtering processes, resulting in much higher productivity and much lower cost of manufacture, thereby providing high-volume, low-cost batteries.

[042] Further, conventional deposition processes without ion sources are capable of depositing amorphous LiCoO_2 layers, but do not deposit crystalline LiCoO_2 layers. Surprisingly, depositions according to some embodiment of the present invention, deposit a LiCoO_2 layer with substantial crystallinity readily measured by x-ray diffraction techniques. In some embodiments, the crystallinity of the as-deposited LiCoO_2 layers is sufficient to be utilized in a battery structure with no further thermal processing. In some embodiments, crystallinity of the as-deposited LiCoO_2 layers are improved by thermal processes with low thermal budgets, which can be compatible with films deposited on low-temperature substrates.

[043] Further, as-deposited the stoichiometry of some LiCoO_2 layers deposited according to some embodiments of the present invention shows that this layer is sufficient for utilization in a battery. With the demonstrated ability to deposit a LiCoO_2 film with crystallinity and with sufficient stoichiometry, a battery utilizing as-deposited LiCoO_2 films

can be produced. Heat treating the LiCoO_2 layers may improve the crystallinity and lower the impedance.

[044] In some embodiments, a crystalline layer of LiCoO_2 with a $\langle 101 \rangle$ or a $\langle 003 \rangle$ crystalline orientation is deposited directly on the substrate. Deposition of crystalline material can eliminate or lessen the need of a subsequent high temperature anneal or precious-metal layers to crystallize and orient the film. Removing the high temperature anneal allows for formation of battery structures on light-weight and low temperature substrates such as stainless steel foil, copper foil, aluminum foil, and plastic sheet, reducing both the weight and the cost of batteries while retaining the energy density storage capabilities of Li-based batteries. In some embodiments, a crystalline LiCoO_2 layer can be deposited on a precious metal layer, such as platinum or iridium, resulting in a further significant lowering of the ripening thermal budget required to improve crystallinity.

[045] Deposition of materials by pulsed-DC biased reactive ion deposition is described in U.S. Patent Application Serial No. 10/101863, entitled "Biased Pulse DC Reactive Sputtering of Oxide Films," to Hongmei Zhang, et al., filed on March 16, 2002. Preparation of targets is described in U.S. Patent Application Serial No. 10/101,341, entitled "Rare-Earth Pre-Alloyed PVD Targets for Dielectric Planar Applications," to Vassiliki Milonopoulou, et al., filed on March 16, 2002. U.S. Patent Application Serial No. 10/101863 and U.S. Patent Application Serial No. 10/101,341 are each assigned to the same assignee as is the present disclosure and each is incorporated herein in their entirety. Deposition of oxide materials has also been described in U.S. Patent No. 6,506,289, which is also herein incorporated by reference in its entirety. Transparent oxide films can be deposited utilizing processes similar to those specifically described in U.S. Patent No. 6,506,289 and U.S. Application Serial No. 10/101863.

[046] Figure 1A shows a schematic of a reactor apparatus 10 for sputtering material from a target 12 according to the present invention. In some embodiments, apparatus 10 may, for example, be adapted from an AKT-1600 PVD (400 X 500 mm substrate size) system from Applied Komatsu or an AKT-4300 (600 X 720 mm substrate size) system from Applied Komatsu, Santa Clara, CA. The AKT-1600 reactor, for example, has three deposition chambers connected by a vacuum transport chamber. These AKT reactors can be modified such that pulsed DC power is supplied to the target and RF power is supplied to the substrate during deposition of a material film. Apparatus 10 can also be a Phoenix Gen III PVD cluster tool made by Symmorphix, which is specifically designed for pulsed-dc processes such as is described herein.

[047] Apparatus 10 includes target 12 which is electrically coupled through a filter 15 to a pulsed DC power supply 14. In some embodiments, target 12 is a wide area sputter source target, which provides material to be deposited on a substrate 16. Substrate 16 is positioned parallel to and opposite target 12. Target 12 functions as a cathode when power is applied to it from the pulsed DC power supply 14 and is equivalently termed a cathode. Application of power to target 12 creates a plasma 53. Substrate 16 is capacitively coupled to an electrode 17 through an insulator 54. Electrode 17 can be coupled to an RF power supply 18. A magnet 20 is scanned across the top of target 12.

[048] For pulsed reactive dc magnetron sputtering, as performed by apparatus 10, the polarity of the power supplied to target 12 by power supply 14 oscillates between negative and positive potentials. During the positive period, the insulating layer on the surface of target 12 is discharged and arcing is prevented. To obtain arc free deposition, the pulsing frequency exceeds a critical frequency that can depend on target material, cathode current and reverse time. High quality oxide films can be made using reactive pulse DC magnetron sputtering as shown in apparatus 10.

[049] Pulsed DC power supply 14 can be any pulsed DC power supply, for example an AE Pinnacle plus 10K by Advanced Energy, Inc. With this DC power supply, up to 10 kW of pulsed DC power can be supplied at a frequency of between 0 and 350 kHz. The reverse voltage can be 10% of the negative target voltage. Utilization of other power supplies can lead to different power characteristics, frequency characteristics, and reverse voltage percentages. The reverse time on this embodiment of power supply 14 can be adjusted between 0 and 5 μ s.

[050] Filter 15 prevents the bias power from power supply 18 from coupling into pulsed DC power supply 14. In some embodiments, power supply 18 can be a 2 MHz RF power supply, for example a Nova-25 power supply made by ENI, Colorado Springs, Co.

[051] In some embodiments, filter 15 can be a 2 MHz sinusoidal band rejection filter. In some embodiments, the band width of the filter can be approximately 100 kHz. Filter 15, therefore, prevents the 2 MHz power from the bias to substrate 16 from damaging power supply 14 and allow passage of the pulsed-dc power and frequency.

[052] Pulsed DC deposited films are not fully dense and may have columnar structures. Columnar structures can be detrimental to thin film applications such as barrier films and dielectric films, where high density is important, due to the boundaries between the columns. The columns act to lower the dielectric strength of the material, but may provide diffusion paths for transport or diffusion of electrical current, ionic current, gas, or other chemical agents such as water. In the case of a solid state battery, a columnar structure containing crystallinity as derived from processes according to the present invention is beneficial for battery performance because it allows better Li transport through the boundaries of the material.

[053] In the Phoenix system, for example, target 12 can have an active size of about 800.00 X 920.00 mm by 4 to 8 mm in order to deposit films on substrate 16 that have

dimension about 600 X 720 mm. The temperature of substrate 16 can be adjusted to between -50 °C and 500 °C. The distance between target 12 and substrate 16 can be between about 3 and about 9 cm (in some embodiments, between 4.8 and 6 cm are used). Process gas can be inserted into the chamber of apparatus 10 at a rate up to about 200 sccm while the pressure in the chamber of apparatus 10 can be held at between about .7 and 6 milliTorr. Magnet 20 provides a magnetic field of strength between about 400 and about 600 Gauss directed in the plane of target 12 and is moved across target 12 at a rate of less than about 20-30 sec/scan. In some embodiments utilizing the Phoenix reactor, magnet 20 can be a race-track shaped magnet with dimensions about 150 mm by 800 mm.

[054] Figure 2 illustrates an example of target 12. A film deposited on a substrate positioned on carrier sheet 17 directly opposed to region 52 of target 12 has good thickness uniformity. Region 52 is the region shown in Figure 1B that is exposed to a uniform plasma condition. In some implementations, carrier 17 can be coextensive with region 52. Region 24 shown in Figure 2 indicates the area below which both physically and chemically uniform deposition can be achieved, for example where physical and chemical uniformity provide refractive index uniformity, oxide film uniformity, or metallic film uniformity. Figure 2 indicates region 52 of target 12 that provides thickness uniformity, which is, in general, larger than region 24 of target 12 providing thickness and chemical uniformity to the deposited film. In optimized processes, however, regions 52 and 24 may be coextensive.

[055] In some embodiments, magnet 20 extends beyond area 52 in one direction, for example the Y direction in Figure 2, so that scanning is necessary in only one direction, for example the X direction, to provide a time averaged uniform magnetic field. As shown in Figures 1A and 1B, magnet 20 can be scanned over the entire extent of target 12, which is larger than region 52 of uniform sputter erosion. Magnet 20 is moved in a plane parallel to the plane of target 12.

[056] The combination of a uniform target 12 with a target area 52 larger than the area of substrate 16 can provide films of highly uniform thickness. Further, the material properties of the film deposited can be highly uniform. The conditions of sputtering at the target surface, such as the uniformity of erosion, the average temperature of the plasma at the target surface, and the equilibration of the target surface with the gas phase ambient of the process are uniform over a region which is greater than or equal to the region to be coated with a uniform film thickness. In addition, the region of uniform film thickness is greater than or equal to the region of the film which is to have highly uniform electrical, mechanical, or optical properties such as index of refraction, stoichiometry, density, transmission, or absorptivity.

[057] Target 12 can be formed of any materials that provide the correct stoichiometry for LiCoO_2 deposition. Typical ceramic target materials include oxides of Li and Co as well as metallic Li and Co additions and dopants such as Ni, Si, Nb, or other suitable metal oxide additions. In the present disclosure, target 12 can be formed from LiCoO_2 for deposition of LiCoO_2 film.

[058] In some embodiments of the invention, material tiles are formed. These tiles can be mounted on a backing plate to form a target for apparatus 10. A wide area sputter cathode target can be formed from a close packed array of smaller tiles. Target 12, therefore, may include any number of tiles, for example between 2 and 60 individual tiles. Tiles can be finished to a size so as to provide a margin of edge-wise non-contact, tile to tile, less than about 0.010" to about 0.020" or less than half a millimeter so as to eliminate plasma processes that may occur between adjacent ones of tiles 30. The distance between tiles of target 12 and the dark space anode or ground shield 19 in Figure 1B can be somewhat larger so as to provide non contact assembly or to provide for thermal expansion tolerance during process chamber conditioning or operation.

[059] As shown in Figure 1B, a uniform plasma condition can be created in the region between target 12 and substrate 16 in a region overlying substrate 16. A plasma 53 can be created in region 51, which extends under the entire target 12. A central region 52 of target 12 can experience a condition of uniform sputter erosion. As discussed further herein, a layer deposited on a substrate placed anywhere below central region 52 can then be uniform in thickness and other properties (i.e., dielectric, optical index, or material concentrations). In some embodiments, target 12 is substantially planar in order to provide uniformity in the film deposited on substrate 16. In practice, planarity of target 12 can mean that all portions of the target surface in region 52 are within a few millimeters of a planar surface, and can be typically within 0.5 mm of a planar surface.

[060] Figure 3 shows a battery structure with a LiCoO_2 layer deposited according to some embodiments of the present invention. As shown in Figure 3, a metallic current collection layer 302 is deposited on a substrate 301. In some embodiments, current collection layer 302 can be patterned in various ways before deposition of a LiCoO_2 layer 303. Also according to some embodiments, LiCoO_2 layer 303 can be a deposited crystalline layer. In some embodiments of the invention, layer 303 is crystalline without the necessity of a crystallizing heat treatment. Therefore, substrate 301 can be a silicon wafer, titanium metal, alumina, or other conventional high temperature substrate, but may also be a low temperature material such as plastic, glass, or other material which could be susceptible to damage from the high temperature crystallizing heat treatment. This feature can have the great advantage of decreasing the expense and weight of battery structures formed by the present invention. The low temperature deposition of the LiCoO_2 allows for successive depositions of battery layers, one upon another. Such a process would have the advantage that successive layers of battery structure would be obtained in a stacked condition without the inclusion of a substrate

layer. The stacked layered battery would provide higher specific energy density as well as low impedance operation for charging and discharging.

[061] In some embodiments, an oxide layer can be deposited on substrate 301. For example, a silicon oxide layer can be deposited on a silicon wafer. Other layers can be formed between conducting layer 302 and substrate 301.

[062] As further shown in Figure 3, a LiPON layer 304 ($\text{Li}_x\text{PO}_y\text{N}_z$) is deposited over LiCoO_2 layer 303. LiPON layer 304 is the electrolyte for battery 300 while LiCoO_2 layer 303 acts as the cathode. A metallic conducting layer 305 can be deposited over the LiPON layer 304 in order to complete the battery. Metallic conducting layer 305 can include lithium adjacent to LiPON layer 304.

[063] An anode 305 is deposited over LiPON layer 304. Anode 305 can be, for example an evaporated lithium metal. Other materials such as, for example, nickel can also be utilized. A current collector 306, which is a conducting material, is then deposited over at least a portion of anode 305.

[064] A Li based thin film battery operates by transport of Li ions in the direction from current collector 306 to current collector 302 in order to hold the voltage between current collector 306 and current collector 302 at a constant voltage. The ability for battery structure 300 to supply steady current, then, depends on the ability of Li ions to diffuse through LiPON layer 304 and LiCoO_2 layer 303. Li transport through bulk cathode LiCoO_2 layer 303 in a thin film battery occurs by the way of grains or grain boundaries. Without being restricted in this disclosure to any particular theory of transport, it is believed that the grains with their planes parallel to substrate 302 will block the flow of Li ions while grains oriented with planes perpendicular to substrate 301 (i.e., oriented parallel to the direction of Li ion flow) facilitate the Li diffusion. Therefore, in order to provide a high-current battery

structure, LiCoO₂ layer 303 should include crystals oriented in the <101> direction or <003> direction.

[065] In accordance with the present invention, LiCoO₂ films can be deposited on substrate 302 with a pulsed-DC biased PVD system as was described above. In addition, an AKT 1600 PVD system can be modified to provide an RF bias, which is available in the Phoenix system, and an Advanced Energy Pinnacle plus 10K pulsed DC power supply can be utilized to provide power to a target. The pulsing frequency of the power supply can vary from about 0 to about 350 KHz. The power output of the power supply is between 0 and about 10 kW. A target of densified LiCoO₂ tiles having a resistivity in the range of about 3 to about 10 kΩ can be utilized with dc-sputtering.

[066] In some embodiments, LiCoO₂ films are deposited on Si wafers. Gas flows containing Oxygen and Argon can be utilized. In some embodiments, the Oxygen to Argon ratio ranges from 0 to about 50% with a total gas flow of about 80 sccm. The pulsing frequency ranges from about 200 kHz to about 300 kHz during deposition. RF bias can also be applied to the substrate. In many trials, the deposition rates vary from about 2 Angstrom/(kW sec) to about 1 Angstrom/(kW sec) depending on the O₂/Ar ratio as well as substrate bias.

[067] Table I illustrates some example depositions of LiCoO₂ according to the present invention. XRD (x-Ray Diffraction) results taken on the resulting thin films illustrate that films deposited according to the present invention are crystalline films, often with highly textured grain sizes as large as about 150 nm. The dominant crystal orientation appears to be sensitive to the O₂/Ar ratio. For certain O₂/Ar ratios (~10%), as-deposited films exhibit a preferred orientation in the <101> direction or the <003> direction with poorly developed <003> planes.

[068] Figures 4A and 4B illustrate an XRD Analysis and SEM cross section, respectively, of the LiCoO_2 film deposited as Example 15 in Table I. Such a LiCoO_2 film was deposited on Si wafer with 2kW of target power, a frequency of 300 kHz, with 60 sccm Ar and 20 sccm of O_2 for a substrate with an initial temperature of about 30°C. As shown in the XRD analysis of Figure 4A, a strong $\langle 101 \rangle$ peak is indicated showing a strong orientation of LiCoO_2 crystals in the desired $\langle 101 \rangle$ crystallographic direction. The SEM cross section shown in Figure 4B further shows the columnar structure of the film having the $\langle 101 \rangle$ direction and the grain boundaries of the resulting LiCoO_2 crystals.

[069] Figures 5A through 5F show SEM cross sections of further example depositions of LiCoO_2 crystals according to the present invention. In each of the examples, deposition of the LiCoO_2 film was performed on a Si wafer with target power of about 2 kW and frequency of about 250 kHz. The LiCoO_2 film shown in Figure 5A corresponds to the example deposition Example 1 in Table I. In the deposition of the LiCoO_2 film shown in Figure 5A, no bias power was utilized with an argon flow rate of about 80 sccm and an oxygen flow rate of about 0 sccm. A deposition rate of about 1.45 $\mu\text{m/hr}$ was achieved over the full substrate area of 400 X 500 mm. Further, as is indicated in the cross section shown in Figure 5A, a $\langle 101 \rangle$ orientation of the LiCoO_2 was achieved.

[070] The rate of deposition of the LiCoO_2 layer shown in Figure 5A is very high, likely due to the relatively high conductivity or low resistivity of the ceramic LiCoO_2 oxide sputter target. A target resistance of 10 kOhms was measured by means of an Ohm meter over a distance of about 4 cm on the surface of target 12. This high rate allows the manufacture of the 3 micron or thicker LiCoO_2 layer required for the battery at high rate over a wide area in short times, resulting in very high productivity and very low cost. Target resistance on the order of about 500 k Ω over the same distance by the same measurement technique or higher would not allow for such a high sputter efficiency or high rate of

deposition at such a low target power. The resistance of conventional target materials can be unmeasurably high. A resistance of 100 k Ω over about 4 cm of surface will result in high sputter efficiency and high rate of deposition. Further, because deposition rates typically scale nearly linearly with target power, a deposition at 6 kW will yield a deposition rate of approximately 3 $\mu\text{m/hr}$, which is a very desirable rate of deposition for manufacturability of Li-based thin-film solid-state batteries on a surface area of 400 X 500 mm^2 .

[071] The LiCoO_2 layer shown in Figure 5B is deposited under the conditions listed as Example 7 in Table I. Again, no bias was utilized in the deposition. An argon flow rate of about 72 sccm and an oxygen flow rate of about 8 sccm was utilized. The deposition rate was significantly reduced to about 0.85 $\mu\text{m/hr}$. Further, although a $\langle 101 \rangle$ crystallinity can be discerned, that $\langle 101 \rangle$ crystallinity is not as pronounced as that exhibited in the deposition of the film shown in Figure 5A.

[072] The LiCoO_2 film shown in Figure 5C was deposited according to Example 3 in Table I. In this deposition, 100 W of bias power is applied to the substrate. Further, an argon flow rate of 72 sccm, and an oxygen flow rate of 8 sccm was utilized. The deposition rate was about 0.67 $\mu\text{m/hr}$. Therefore, the application of bias in comparison with the LiCoO_2 film shown in Figure 5B further reduced the deposition rate (from 0.85 $\mu\text{m/hr}$ of the example shown in Figure 5B to 0.67 $\mu\text{m/hr}$ of the example shown in Figure 5C). Further, the desired $\langle 101 \rangle$ directionality of formed crystals appears to be further degraded.

[073] The LiCoO_2 film shown in Figure 5D corresponds to Example 4 in Table I. In this deposition, the Ar/O_2 ratio was increased. As is shown in Figure 5D, increasing the Ar/O_2 ratio improves crystallinity. With respect to the example illustrated in Figure 5C, the deposition illustrated in Figure 5D was performed with an argon flow of about 76 sccm and an oxygen flow of about 4 sccm as well as retaining the 100 W bias to the substrate. The

LiCoO₂ deposition rate was improved to 0.79 μm/hr from a rate of 0.67 μm/hr illustrated in Figure 5C.

[074] In the example deposition illustrated in Figure 5E corresponding to Example 5 in Table I. The substrate temperature was set at about 200°C while the bias power remained at about 100 W. The argon flow rate was set at about 76 sccm and the oxygen flow rate was set at about 4 sccm. The resulting deposition rate for the LiCoO₂ layer was about 0.74 μm/hr.

[075] In the example deposition illustrated in Figure 5F, which corresponds with Example 6 of Table I, the argon flow rate was set at about 74 sccm and the oxygen flow rate was set at about 6 sccm, resulting in a LiCoO₂ deposition rate of about 0.67 μm/hr. Therefore, increasing both argon and oxygen flow rate over the deposition illustrated in Figure 5E resulted in a lower deposition rate.

[076] Figure 5G illustrates XRD data corresponding to Figures 5F, 5D, 5C, 5E, and 5B, respectively. As illustrated in Figure 5G, as-deposited crystalline LiCoO₂ is deposited in these processes.

[077] The data show clearly that an as-deposited crystalline film of LiCoO₂ can be obtained under several of the process conditions, as shown in Table II. In particular, very high rates of deposition with low power are obtained along with the oriented crystalline structure for the process conditions according to embodiments of the present invention.

[078] Figure 6A illustrates a layer of LiCoO₂ 602 deposited on a thin substrate 601 according to some embodiments of the present invention. Higher lithium-ion mobilities can be achieved utilizing crystalline LiCoO₂ cathode films 602 deposited on a thin substrate 601 that has thickness comparable to that of the battery stack itself, rather than a thickness many or tens of times that of the battery stack. Such a film can lead to faster charging and discharging rates. Substrate 601 can be formed of a thin metallic sheet (e.g., aluminum,

titanium, stainless steel, or other suitable thin metallic sheet), can be formed of a polymer or plastic material, or may be formed of a ceramic or glass material. As shown in Figure 6B, if substrate 601 is an insulating material, a conducting layer 603 can be deposited between substrate 601 and LiCoO_2 layer 602.

[079] Depositing materials on a thin substrate involves holding and positioning the substrate during deposition. Figures 7A, 7B, 7C, and 7D illustrate a reusable fixture 700 for holding a thin film substrate. As shown in Figure 7A, reusable fixture 700 includes a top portion 701 and a bottom portion 702 that snap together. Thin substrate 601 is positioned between top portion 701 and bottom portion 702. As shown in Figure 7B, top portion 701 and bottom portion 702 are such that substrate 601 is brought into tension and subsequently clamped as top portion 701 is closed into bottom portion 702. Substrate 601 can be easily held by fixture 700 so that substrate 601 can be handled and positioned. In some embodiments, the corners of substrate 601, areas 703, are removed so that substrate 601 is more easily stretched by avoiding "wrap-around" corner clamping effects when top portion 701 is closed into bottom portion 702.

[080] As shown in Figure 7C, a mask 712 can be attached to fixture 700. In some embodiments, fixture 700 includes guides in order to align fixture 700 with respect to mask 712. In some embodiments, mask 712 may be attached to fixture 700 and travel with fixture 700. Mask 712 can be positioned at any desired height above substrate 601 in fixture 700. Therefore, mask 712 can function as either a contact or proximity mask. In some embodiments, mask 712 is formed of another thin substrate mounted in a fixture similar to fixture 700.

[081] As shown in Figure 7C and 7D, fixture 700 and mask 712 can be positioned relative to mount 710. Mount 710, for example, can be a susceptor, mount, or an electrostatic chuck of a processing chamber such as that shown in Figures 1A and 1B. Fixture 700 and

mask 712 can have features that allow for ready alignment with respect to each other and with respect to mount 710. In some embodiments, mask 712 is resident in the processing chamber and aligned with fixture 700 during positioning of fixture 700 on mount 710, as shown in Figure 7D.

[082] Utilizing fixture 700 as shown in Figures 7A, 7B, 7C, and 7D allows processing of a thin film substrate in a processing chamber. In some embodiments, thin film substrates can be about 10 μm or more. Further, thin film substrate 601, once mounted within fixture 700, can be handled and moved from process chamber to process chamber. Therefore, a multiprocessor chamber system can be utilized to form stacks of layers, including one or more layers of LiCoO_2 deposited according to embodiments of the present invention.

[083] Figure 8 illustrates a cluster tool 800 for processing thin film substrates. Cluster tool 800 can, for example, include load lock 802 and load lock 803, through which mounted thin film substrate 601 is loaded and a resultant device is removed from cluster tool 800. Chambers 804, 805, 806, 807, and 808 are processing chambers for depositions of materials, heat treatments, etching, or other processes. One or more of chambers 804, 805, 806, 807, and 808 can be a pulsed-DC PVD chamber such as that discussed above with respect to Figures 1A and 1B and within which a LiCoO_2 film deposited according to embodiments of the present invention may be deposited.

[084] Processing chambers 804, 805, 806, 807, and 808 as well as load locks 802 and 803 are coupled by transfer chamber 801. Transfer chamber 801 includes substrate transfer robotics to shuttle individual wafers between processing chambers 804, 805, 806, 807, and 808 and load locks 802 and 803.

[085] In production of a conventional thin-film battery, ceramic substrates are loaded into load lock 803. A thin metallic layer can be deposited in chamber 804, followed

by a LiCoO_2 deposition performed in chamber 805. The substrate is then removed through load lock 803 for an in-air heat treatment external to cluster tool 800. The treated wafer is then reloaded into cluster tool 800 through load lock 802. A LiPON layer can be deposited in chamber 806. The wafer is then again removed from cluster tool 800 for deposition of the lithium anode layer, or sometimes chamber 807 can be adapted to deposition of the lithium anode layer. A second metallic layer is deposited in chamber 808 to form a charge collector and anode collector. The finished battery structure is then off-loaded from cluster tool 800 in load lock 802. Wafers are shuttled from chamber to chamber by robotics in transfer chamber 801.

[086] A battery structure produced according to the present invention could utilize thin film substrates loaded in a fixture such as fixture 700. Fixture 700 is then loaded into load lock 803. Chamber 804 may still include deposition of a conducting layer. Chamber 805 then includes deposition of a LiCoO_2 layer according to embodiments of the present invention. A LiPON layer can then be deposited in chamber 806. Chamber 807 may still be adapted to deposition of a lithium rich material such as lithium metal and chamber 808 can be utilized for deposition of the conducting layer of the current collector. In this process, no heat treatment is utilized to crystallize the LiCoO_2 layer.

[087] Another advantage of a thin film battery process is the ability to stack battery structures. In other words, substrates loaded into cluster tool 800 may traverse process chambers 804, 805, 806, 807, and 808 multiple times in order to produce multiply stacked battery structures. Figures 9A and 9B illustrate such battery structures.

[088] Figure 9A illustrates a parallel coupled stacking. As shown in Figure 9A, a substrate 601, which for example can be a plastic substrate, is loaded into load lock 803. A conducting layer 603, for example about $2\ \mu\text{m}$ of aluminum, copper, iridium or other material, acts as a bottom current collector. Conducting layer 603, for example, can be

deposited in chamber 804. A LiCoO_2 layer 602 is then deposited on conducting layer 603. LiCoO_2 layer 602 can be about 3-10 μm and can be deposited in chamber 805 according to embodiments of the present invention. The wafer can then be moved to chamber 806 where a LiPON layer 901 of thickness of about .5 to about 2 μm can be deposited. In chamber 807, an anode layer 902, for example a lithium metal layer of up to about 10 μm , can then be deposited in chamber 807. A second conducting layer 903 can then be deposited over anode layer 902. A second battery stack can then be deposited over the first battery stack formed by metal layer 603, LiCoO_2 layer 602, LiPON layer 901, lithium layer 902, and current collection conduction layer 903. Over current collection conducting layer 903, another lithium layer 902 is formed. Another LiPON layer 901 is formed over lithium layer 902. Another LiCoO_2 layer 602 is formed over LiPON layer 901 and finally another metal layer 603 is formed over LiCoO_2 layer 602. In some embodiments, further stackings can be formed. In some embodiments, metal layers 603 and 903 differ in the mask utilized in deposition so that tabs are formed for electrical coupling of layers.

[089] As discussed above, any number of individual battery stacks can be formed such that parallel battery formations are formed. Such a parallel arrangement of battery stacking structure can be indicated as Current collector/ LiCoO_2 /LiPON/Anode/current collector/Anode/LiPON/ LiCoO_2 /current collector/ LiCoO_2 . . . /current collector. Figure 9B illustrates an alternative stacking corresponding to the battery structure current collector/ LiCoO_2 /LiPON/anode/current collector/ LiCoO_2 /LiPON/anode/current collector . . . /current collector. In this case, a series arrangement battery stacking structure is formed because the individual battery stacks share anodes.

[090] To form the structures shown in Figures 9A and 9B, substrates are rotated again through the chambers of cluster tool 800 in order to deposit the multiple sets of batteries. In general, a stack of any number of batteries can be deposited in this fashion.

[091] In some embodiments, stoichiometric LiCoO_2 can be deposited on iridium. Figures 10A through 10D illustrate an anneal procedure for Li-Co deposition over an iridium layer that has been deposited on a Si wafer. The LiCoO_2 deposition was accomplished as discussed above with a target power of 2 kW, no bias power, reverse time of 1.6 μs , a pulsing frequency of 300 kHz, with 60 sccm Ar flow and 20 sccm of O_2 flow, with no pre-heat for 7200 sec. As a result, a layer of LiCoO_2 of about 1.51 μm was deposited.

[092] Figures 10A through 10D show XRD analysis of both as-deposited and annealed layers of LiCoO_2 deposited as discussed above. The XRD analysis of the as-deposited layer demonstrates a shallow peak at $2\theta = 18.85^\circ$ denoting a $\langle 003 \rangle$ orientation of crystalline LiCoO_2 , a sharper peak at about $2\theta = 38.07^\circ$ corresponding with the desired $\langle 101 \rangle$ crystallographic direction, and a peak at $2\theta = 40.57^\circ$ corresponding to the $\langle 111 \rangle$ direction of iridium. However, the position of the $\langle 101 \rangle$ LiCoO_2 peak indicates that the $\langle 101 \rangle$ LiCoO_2 peak is nonstoichiometric LiCoO_2 . In order to be useful as a battery layer, stoichiometric LiCoO_2 provides for the best Li transport. One of ordinary skill in the art will notice that careful adjustment of deposition parameters can provide stoichiometric LiCoO_2 of desired orientation.

[093] Figure 10B shows an XRD analysis of the sample shown in figure 10A after a 300°C anneal in air for 2 hours. As shown in Figure 10B, the XRD peak corresponding to $\langle 003 \rangle$ LiCoO_2 grows, indicating crystallization of LiCoO_2 into the $\langle 003 \rangle$ direction. Further, the $\langle 101 \rangle$ peak of LiCoO_2 shifts slightly to $2\theta = 38.53^\circ$, indicating a more stoichiometric crystallization of the $\langle 101 \rangle$ LiCoO_2 . However, the crystalline LiCoO_2 is still not stoichiometric after this anneal. One of ordinary skill in the art will notice that longer anneals and/or further adjustment of the deposited stoichiometry may result in usefully oriented stoichiometric LiCoO_2 layers with anneal temperatures at 300 °C or less. Consequently, low temperature materials such as polymers, glass, or metal may be utilized as the substrate.

[094] Figure 10C illustrates an XRD analysis from the sample after a subsequent 500°C anneal in air for 2 hours. As shown in Figure 10C, more of the LiCoO_2 crystallizes into the $\langle 003 \rangle$ layer. Further, the $\langle 101 \rangle$ LiCoO_2 peak shifts again to $2\theta = 39.08^\circ$, indicating crystallization of a $\langle 012 \rangle$ layer of LiCoO_2 . In this case, the $\langle 012 \rangle$ LiCoO_2 crystal is stoichiometric and therefore allows for efficient Li transport. One of ordinary skill in the art will notice that longer anneals and/or further adjustment of the deposited stoichiometry may result in usefully oriented stoichiometric LiCoO_2 layers with anneal temperatures at 500°C or less. Consequently, low temperature materials such as polymers, glass, or metal may be utilized as the substrate.

[095] Figure 10D illustrates an XRD analysis of the sample after a subsequent anneal of 700°C in air for 2 hours. As shown in Figure 10D, the $\langle 003 \rangle$ LiCoO_2 peak disappears, but the $\langle 012 \rangle$ LiCoO_2 peak remains relatively the same as that shown in the 500°C anneal illustrated in Figure 10C.

[096] Figures 10A through 10D demonstrate deposition of $\langle 101 \rangle$ LiCoO_2 at low temperature over an iridium layer. Subsequent anneals to 500°C may be desired to change the stoichiometry of the $\langle 101 \rangle$ LiCoO_2 layer, but anneals to 700 °C do not appear to be necessary. With anneal temperatures less than 500°C, depositions of a LiCoO_2 layer over a conducting iridium layer can be accomplished on glass, aluminum foil, plastic, or other low temperature substrate material. Anneal temperatures of less than 500°C but greater than 300°C or lengthening the time of lower temperature anneals may also result in desired orientations of stoichiometric crystalline LiCoO_2 .

[097] Figures 11A through 11D illustrate formation of a single-layer battery according to some embodiments of the present invention. As shown in Figure 11A, a lift-off layer 1102 can be deposited on a substrate 1101. Further, an iridium layer 1103 can be

deposited over lift-off layer 1102. In some embodiments, substrate 1101 can be plastic, glass, Al foil, Si wafer, or any other material. Lift-off layer 1102 can be any lift off layer and can be a polymer layer such as polyimide, an inorganic layer such as CaF_2 or carbon, or an adhesive layer that loses its adhesion as a result of, for example, oxidation, heat, or light. Lift-off layers are well known. Iridium layer 1103 can be from about 500 Å or more.

[098] As shown in Figure 11B, a LiCoO_2 layer is deposited over iridium layer 1103 as was discussed above. In some embodiments, an anneal can be performed at this step. In some embodiments, further layers of the battery may be deposited before an anneal step is performed. In some embodiments, a stoichiometric LiCoO_2 layer of a useful crystalline orientation may result in the as-deposited LiCoO_2 with no further anneals necessary.

[099] Figure 11C illustrates deposition of a LiPON layer 1105 over the LiCoO_2 layer, deposition of a Li layer 1106 over LiPON layer 1105, and deposition of an electrode layer 1107 over Li layer 1106. In some embodiments, an anneal step of up to 500°C as discussed above may be performed here.

[0100] As shown in Figure 11D, the resulting single-layer battery formed from iridium layer 1103, LiCoO_2 layer 1104, LiPON layer 1105, Li layer 1106, and electrode layer 1107 can be "lifted off" from substrate 1101. Such a single-layer battery can be a free-standing battery of thickness about 5 μm or greater. Such a battery, without the requirement of a substrate 1101, is well known to have the potential of energy storage of greater than about 1 kW-hr/liter.

[0101] As an alternative to a lift-off process as described in Figures 11A through 11D, a substrate may be removed during anneal leaving a single-layer battery. Further, in some embodiments, substrate 1101 can be removed by a solvent, etching, or a photo process. Further, single-layer batteries may be combined or stacked in any fashion to provide a device of greater energy storage at a particular voltage.

[0102] Figures 12A through 12L illustrate the crystallinity of as-grown and post anneal LiCoO_2 layers according to samples 31 and 32 illustrated in Table I. Samples 31 and 32 were formed in the same deposition, utilizing a silicon substrate and an alumina substrate, respectively.

[0103] Figure 12A illustrates an XRD analysis of the as-deposited LiCoO_2 film on Al_2O_3 substrate (Example 32 in Table I). A broad $\langle 003 \rangle$ crystalline LiCoO_2 peak is observed. The remaining peaks in the analysis, which are not labeled in Figure 12A, result from the Al_2O_3 substrate. The $\langle 003 \rangle$ peak is characteristic of the layered structure in the as-deposited crystalline LiCoO_2 film according to embodiments of the present invention.

[0104] Figure 12B illustrates the crystallinity of the LiCoO_2 film shown in Figure 12A after a 2 hr 700 °C anneal. As shown in Figure 12B, the $\langle 003 \rangle$ peak becomes sharper and higher, indicating better crystallinity. As shown in Figures 12G through 12J, in comparison with figures 12C through 12F, the columnar structure ripens with the anneal and the grain size becomes larger with anneal. Figure 12B also shows $\langle 012 \rangle$ and $\langle 006 \rangle$ crystallinity peaks.

[0105] Figure 12C through 12F show SEM photos of the granularity of the as-deposited film corresponding to Example 32 in Figure I. Figures 12G through 12J show SEM photos of the granularity of the annealed film, as illustrated in Figure 12B. A comparison of Figures 12C through 12F with 12G through 12J illustrate the increased granularity resulting from the anneal process.

[0106] Figure 12K illustrates a fracture cross-section SEM that illustrates the morphology of the as-deposited crystalline film corresponding to Example 31 in Table I. Figure 12L illustrate a similar cross-section SEM corresponding to the film grown according to Example 32 in Table I.

[0107] Figures 13A through 13J illustrate rapid thermal anneal processes applied to a LiCoO_2 layer as in Example 49 of Table I. In that example, LiCoO_2 is deposited on alumina with a 2 kW pulsed DC power with no bias. Argon flow as set to 60 sccm and oxygen flow was set to 20 sccm. The deposition parameters are nearly identical with those of Example 32 in Table I, therefore XRD data for the as-deposited films are shown in Figure 12A. Figure 13A shows XRD data after a 15 minute 700 °C anneal in an argon atmosphere. Ramp-up time (room temperature to 700 °C) is 45 sec and ramp-down time (700 °C to about 300 °C) occurred over 10 min. At 300 °C, the sample is removed from the rapid-thermal-anneal (RTA) oven and cooled in air to room temperature. As shown in Figure 13A, substantial crystallinity is obtained. Figure 13B shows XRD data after a RTA as described with Figure 13A in an argon/oxygen atmosphere. The argon/oxygen ratio was 3:1.

[0108] As shown in a comparison of Figures 13A and 13B, more crystallinity is observed in an argon only RTA than with a RTA performed in the presence of oxygen. This is further illustrated in a comparison of Figures 13C and 13D with Figures 13E and 13F. Figures 13C and 13D show the granularity of the LiCoO_2 film after the RTA illustrated in Figure 13A. Figures 13E and 13F show the granularity of the LiCoO_2 film after the RTA illustrated in Figure 13B. As is observed, the granularity shown in Figures 13C and 13D (which differ in magnification) is better than that shown in Figures 13E and 13F (which also differ in magnification).

[0109] Figures 14A through 14D illustrate several anneal processes with the Example 37 of Table I. In that example, LiCoO_2 was deposited on alumina utilizing a pulsed-dc process with 2kW of power and 100 W of bias with an argon flow of 60 sccm and an oxygen flow of 20 sccm.

[0110] Figure 14A shows an SEM photo of an as-deposited LiCoO_2 film according to the process illustrated in Example 37 of Table I. Figure 14B shows an SEM photo of

LiCoO₂ film according to the process illustrated in Example 37 of Table I, annealed conventionally with a two-hour 700 °C anneal. Figures 14C and 14D show SEM photos of a LiCoO₂ film according to the process illustrated in Example 37 of Table I, annealed in an RTA process at 700 °C. The ramp-up and ramp-down times in the RTA process is illustrated above. Figure 14C shows an SEM photo of a LiCoO₂ film after an RTA process at 700 °C for five minutes whereas Figure 14D shows an SEM photo of a LiCoO₂ film after an RTA process at 700 °C for fifteen minutes. It is clear from a comparison of Figures 14C and 14D with Figure 14B, that much better granularity is achieved with the low thermal-budget RTA process rather than the conventional furnace anneal. A low thermal-budget RTA process allows for deposition of such films on low temperature substrates.

[0111] Figures 15A and 15B show SEM photos of a LiCoO₂ film that was annealed in an RTA process utilizing two different ramp-up times, illustrating the effects of the ramp time in the RTA process. A LiCoO₂ film was deposited on an alumina substrate according to the process described as Example 51 in Table I. The film shown in Figure 15A was annealed with a 45 sec ramp-up time (i.e., room temperature to 700 °C in 45 sec). The film shown in Figure 15B was annealed with a 240 sec ramp-up time. Both films were held at 700 °C for five minutes. As shown in a comparison between Figures 15A and 15B, it is clear that a short anneal ramp-up times yield better granularity than longer ramp-up times.

[0112] Figure 17 illustrates battery charge and discharge profiles of a battery structure formed utilizing LiCoO₂ films according to embodiments of the present invention. The LiCoO₂ film in the battery profiled in Figure 17 was deposited according to Example 54 in Table I. The LiCoO₂ film was deposited on an alumina substrate with a gold current collector. The LiCoO₂ film was annealed utilizing a fast-ramp (45 sec) RTA process as was described above. A 1.5 μm LiPON layer was then deposited with a standard RF deposition process without bias in a modified AKT reactor. A lithium anode and a nickel current

collector were then deposited. Data was taken at 0.33 mA, 1.65 mA, 3.3 mA, 16.5 mA, 33 mA, and 66 mA. As observed, the battery was capable of storing an exceptional 25 mA/cm² at voltages greater than 2.0 V.

[0113] One skilled in the art will recognize variations and modifications of the examples specifically discussed in this disclosure. These variations and modifications are intended to be within the scope and spirit of this disclosure. As such, the scope is limited only by the following claims.

TABLE I

Example #	Target Power (kW)	Bias Power (W)	Reverse Time (μ s)	Frequency (kHz)	Ar (sccm)	O ₂ (sccm)	Initial Substrate Temperature (temperature during deposit) ($^{\circ}$ C)	Deposition Time (sec)	Film Thickness (μ m)
1	2	0	1.6	250	80	0	30	10000	3.9
2	2	0		250	72	8	30	7200	1.7
3	2	100		250	72	8	30	7200	1.34
4	2	100		250	76	4	30	7200	1.57
5	2	100		250	76	4	200	7200	1.3
6	2	100		250	74	6	200	7200	1.3
7	2	0		300	72	8	30	7200	1.58
8	2	0		300	74	6	30	7200	
9	2	100		300	74	6	30	7200	
10	2	100		300	72	8	30	7200	
11	2	100		300	70	10	30	7200	
12	2	0		300	70	10	30	7200	
13	2	0		300	72	8	30	7200	1.58
14	2	0		300	74	6	30	7200	
15	2	0		300	60	20	30	7200	
16	2	0		300	50	30	30	7200	
17	2	200		300	60	20	30	7200	
18	2	50		300	60	20	30	7200	
19	2	0		300	70	10	30	7200	
20	2	0		300	65	15	30	7200	
21	3	0		300	65	15	30	7200	
22	2	0	1.6	250	60	20	30	7200	
23	3	0	1.6	250	60	20	30	7200	
24	2	0	1.6	250	60	20	30 (NPH)	7200	

WO 2006/063308

PCT/US2005/044781

25	2	0	1.6	250	60	20	10min heat 30min coc	7200	
26	2	0	1.6	250	60	20	no preheat	9000	
27	2	0		300	60	20	no preheat	7200	
28	2	0		300	60	20	15min heat, 10min	7200	
29	2	0		250	60	20	no preheat		
30	2	0		250	60	20	10min, 10min		
31	2	0	1.3	300	60	20	30 (220)	7200	4.81
32	2	0	1.3	300	60	20	30 (220)	7200	4.74
33	2	0	1.3	300	22.5	7.5	30 (220)	7200	3.99
34	2	0	1.3	300	22.5	7.5	30 (220)	7200	3.93
35	2	0	1.3	300	37.5	12.5	30 (220)	7200	3.64
36	2	0	1.3	300	37.5	12.5	30 (220)	7200	3.54
37	2	100	1.3	300	60	20	30 (220)	7200	4.54
38	2	200	1.3	300	60	20	30 (220)	7200	4.84
39	2	100	1.3	300	37.5	12.5	30 (220)	7200	4.30
40	2	100	1.3	300	22.5	7.5	30 (220)	7200	3.77
41	2	200	1.3	300	37.5	12.5	30 (220)	7200	3.92
42	2	200	1.3	300	60	20	400	7200	3.77
43	2	0	1.3	300	22.5	7.5	30(220)	7200	3.24
44	2	0	1.3	300	60	20	30(220)	7200	3.88
45	2	0	1.3	300	60	20	30(220)	3600	1.78
46	2	200	1.3	300	60	20	30(220)	3600	1.87
47	2	200	1.3	300	22.5	7.5	30(220)	3600	1.52
48	2	0	1.3	300	60	20	30(220)	6000	1.12
49	2	0	1.3	300	60	20	30(220)	10800	1.89
50	2	0	1.3	300	60	20	30(220)	14400	2.52
51	2	100	1.3	300	60	20	30(220)	10000	1.57
52	2	100	1.3	300	60	20	30(220)	10000	2.11
53	2	100	1.3	300	60	20	30(220)	6000	2.70

54	2	100	1.3	300	60	20	30(220)	6000	2.70
----	---	-----	-----	-----	----	----	---------	------	------

WO 2006/063308

TABLE II

Example #	Phase	Lattice	Texture	d_{101} [Å]	2θ [°]	crystallite size [Å]
15	LiCoO ₂	rhombohedral	strong [101]	2.376(1)	37.83	~1300
16	LiCoO ₂	Rhombohedral	strong [101]	2.375(1)	37.85	~750
17	Co	cubic	random	--	--	<50
18	Co	cubic	random	--	--	<50
19	LiCoO ₂	rhombohedral	strong [101]	2.370(1)	37.93	~1400
20	LiCoO ₂	rhombohedral	strong [101]	2.372(1)	37.90	~1500
21	LiCoO ₂	rhombohedral	strong [101]	2.370(1)	37.92	~1700
PDF	LiCoO ₂	Rhombohedral	random	2.408(1)	37.31	--

PCT/US2005/044781

34

WHAT IS CLAIMED IS:

1. A method of depositing a LiCoO_2 layer, comprising:
placing a substrate in a reactor;
flowing a gaseous mixture including argon and oxygen through the reactor; and
applying pulsed DC power to a target formed of LiCoO_2 positioned opposite the
substrate,
wherein a crystalline layer of LiCoO_2 is deposited over the substrate.
2. The method of claim 1, further including applying an RF bias to the substrate.
3. The method of claim 1, wherein the crystalline layer is $\langle 101 \rangle$ oriented.
4. The method of claim 1, wherein the crystalline layer is $\langle 003 \rangle$ oriented.
5. The method of claim 1, wherein a grain size of the crystalline layer is between
about 750 Å and about 1700 Å.
6. The method of claim 1 wherein the substrate is a material chosen from a set
comprised of silicon, polymers, glasses, ceramics, and metals.
7. The method of claim 1, further including preheating the substrate to a temperature
of about 200 °C.
8. The method of claim 1, wherein the substrate is a low temperature substrate.
9. The method of claim 8, wherein the low temperature substrate is one of a set of
substrates including glass, plastic, and metal foil.
10. The method of claim 1, further including depositing an oxide layer on the
substrate.
11. The method of claim 10, wherein the oxide layer is a silicon dioxide layer.
12. The method of claim 3, wherein the crystalline layer is deposited at a rate of
greater than 1 μm per hour.

13. The method of claim 1 wherein the target is a ceramic LiCoO_2 sputter target with a resistance measured across about 4 cm of surface of less than about 500 k Ω .
14. The method of claim 1, further including depositing a metal layer on the substrate.
15. The method of claim 14, wherein the metal layer is iridium.
16. The method of claim 14, wherein the metal layer is platinum.
17. The method of claim 1, further including annealing the crystalline layer with a low thermal budget.
18. The method of claim 17, wherein annealing the crystalline layer includes annealing to 700°C in a rapid thermal anneal process for a period of time less than about 10 minutes.
19. The method of claim 14, further including annealing the LiCoO_2 layer at a temperature of less than or equal to about 500°C.
20. The method of claim 14, further including annealing the LiCoO_2 layer at a temperature of less than or equal to about 400°C.
21. A battery structure, comprising:
 - a crystalline LiCoO_2 layer deposited over a low-temperature substrate.
22. The structure of claim 21, further including a conducting layer deposited between the crystalline LiCoO_2 layer and the low-temperature substrate.
23. The structure of claim 22, wherein the conducting layer is an iridium layer.
24. The structure of claim 22, wherein the conducting layer is a platinum layer.
25. The structure of claim 21, further including a LiPON layer deposited over the LiCoO_2 layer.
26. The structure of claim 21, further including a second conducting layer deposited over the LiCoO_2 layer.

27. A stacked battery structure, comprising:

one or more battery stacks deposited on a thin substrate, wherein each battery stack comprises:

a conducting layer,

a LiCoO₂ layer deposited as a crystalline layer over the conducting layer,

a LiPON layer deposited over the crystalline LiCoO₂ layer,

an anode layer deposited over the LiPON layer; and

a top conducting layer deposited over the one or more battery stacks.

28. The stacked battery structure of claim 27, wherein the battery stacks form a parallel stacked battery structure.

29. The stacked battery structure of claim 27, wherein the battery stacks form a series stacked battery structure.

30. The stacked battery structure of claim 27, wherein the conducting layer is a metal layer deposited on a substrate.

31. The stacked battery structure of claim 30, wherein the metal layer is an iridium layer.

32. The stacked battery structure of claim 30, wherein the metal layer is a platinum layer.

33. The stacked battery structure of claim 30, wherein the substrate is a low temperature substrate.

34. The stacked battery structure of claim 27, wherein the conducting layer is a metallic foil.

35. The stacked battery structure of claim 34, wherein the metallic foil is formed of a metal from a group consisting of copper, gold, platinum, aluminum, stainless steel and other nickel or cobalt based super alloy.

36. A method of producing a battery, comprising:
- loading a substrate into a cluster tool;
 - depositing a crystalline LiCoO_2 layer over a conducting layer in a chamber of the cluster tool with a pulsed-dc PVD process.
37. The method of claim 36, wherein depositing a crystalline LiCoO_2 layer includes depositing crystalline LiCoO_2 through a mask.
38. The method of claim 36, further including
- depositing a conducting layer on the substrate.
39. The method of claim 36, further including depositing a LiPON layer over the LiCoO_2 layer.
40. The method of claim 39, further including deposition an anode over the LiPON layer.
41. The method of claim 40, further including depositing a conducting layer over the anode.
42. The method of claim 36, wherein the conducting layer is an iridium layer.
43. A fixture for holding a thin substrate, comprising:
- a top portion; and
 - a bottom portion, wherein
- the thin substrate is held when the top portion is attached to the bottom portion.

1/27

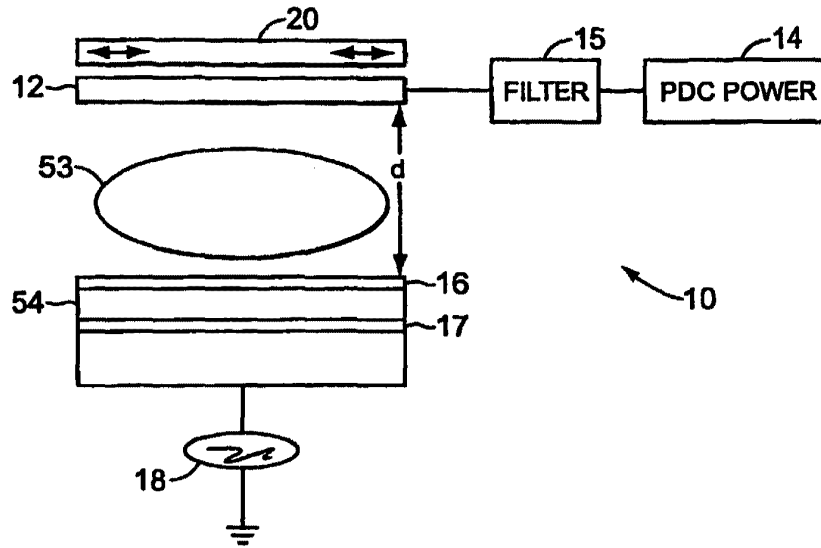

FIG. 1A

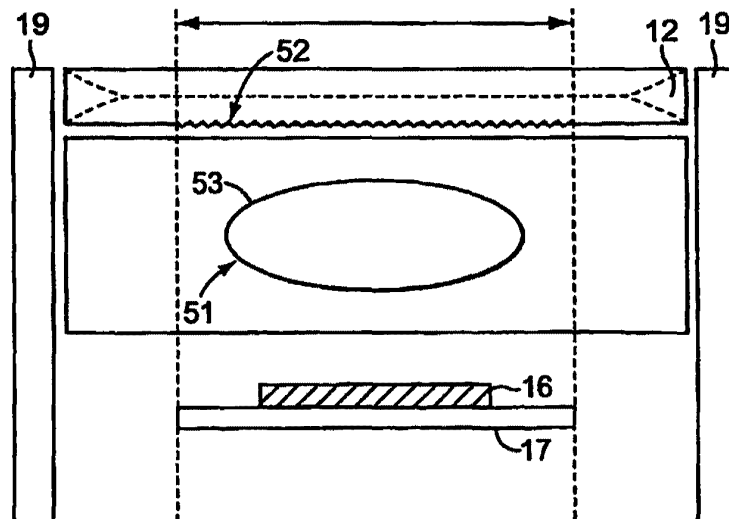

FIG. 1B

SUBSTITUTE SHEET (RULE 26)

2/27

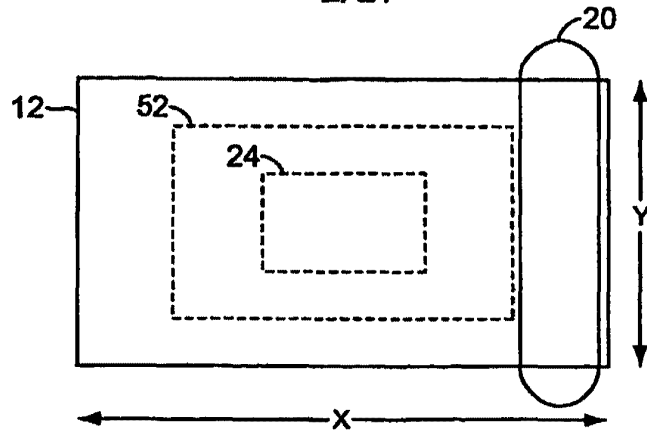

FIG. 2

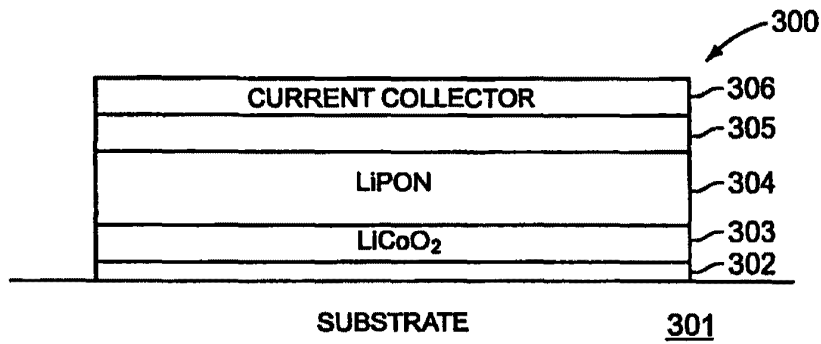

FIG. 3

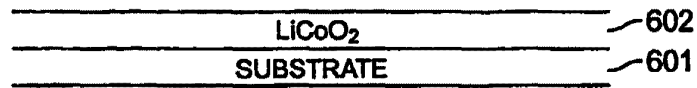

FIG. 6A

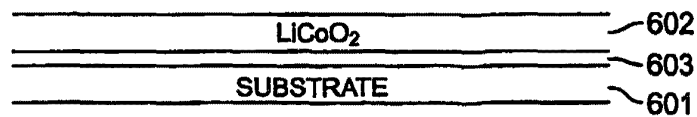

FIG. 6B

SUBSTITUTE SHEET (RULE 26)

3/27

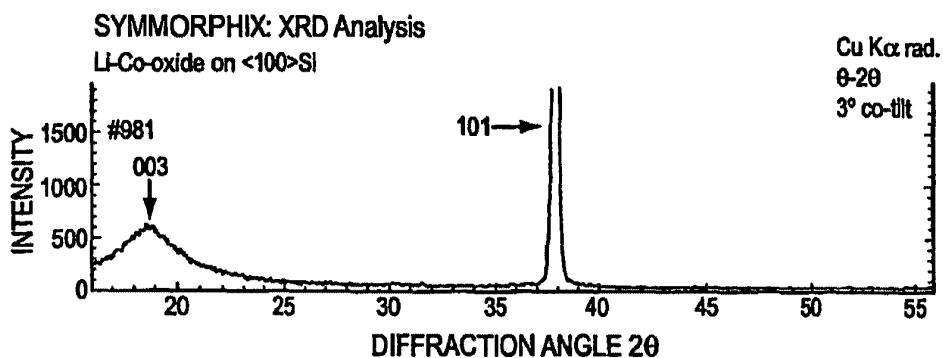

FIG. 4A

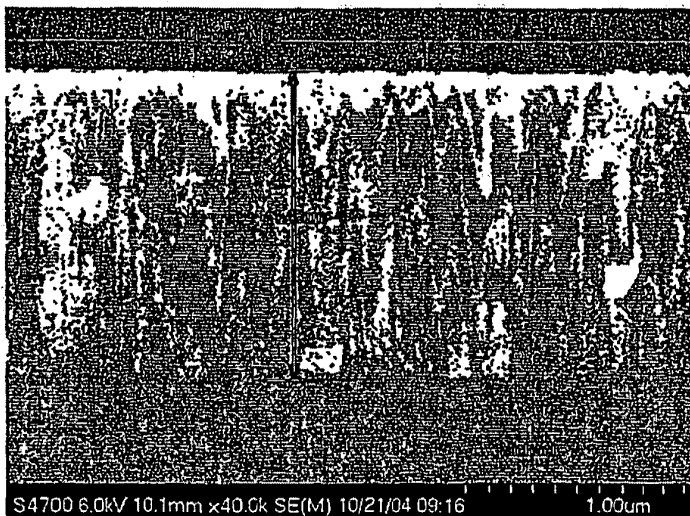

FIG. 4B

SUBSTITUTE SHEET (RULE 26)

4/27

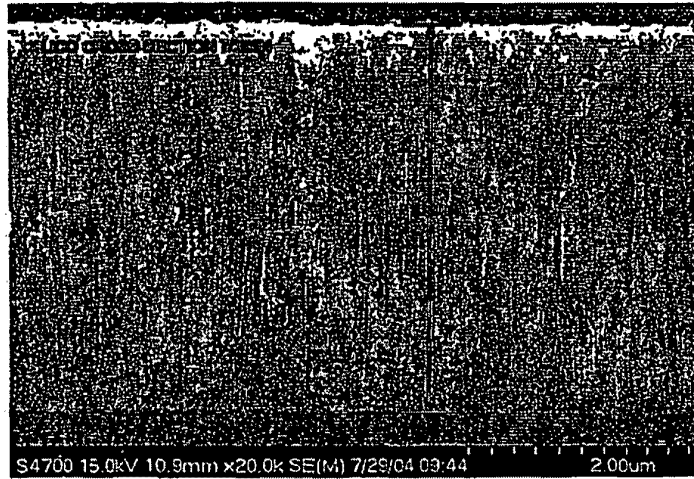

FIG. 5A



FIG. 5B

SUBSTITUTE SHEET (RULE 26)

5/27

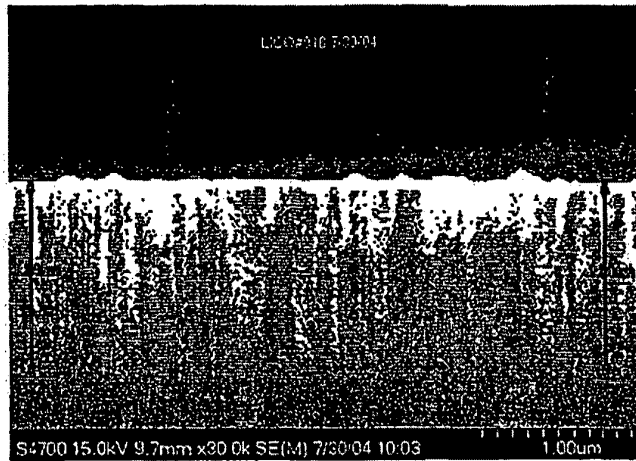

FIG. 5C

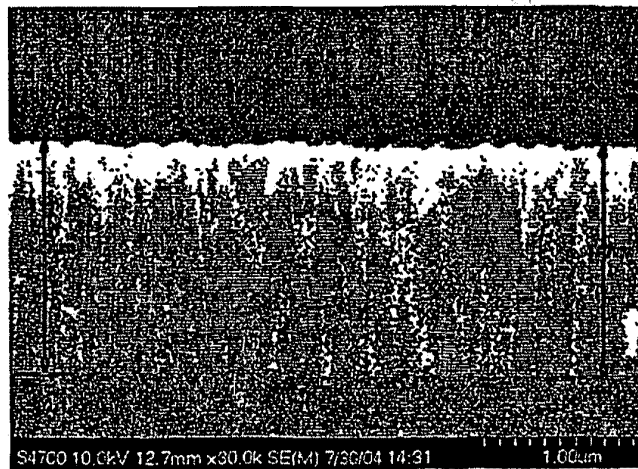

FIG. 5D

SUBSTITUTE SHEET (RULE 26)

6/27

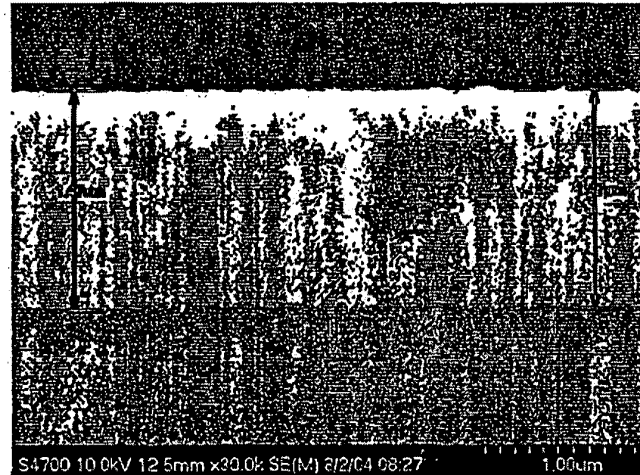

FIG. 5E

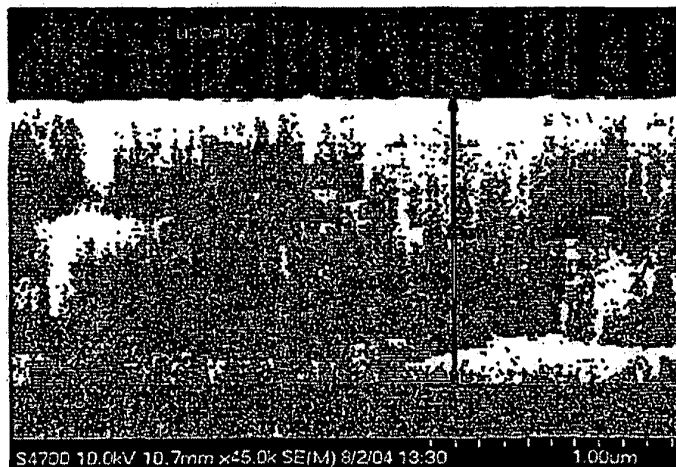

FIG. 5F

SUBSTITUTE SHEET (RULE 26)

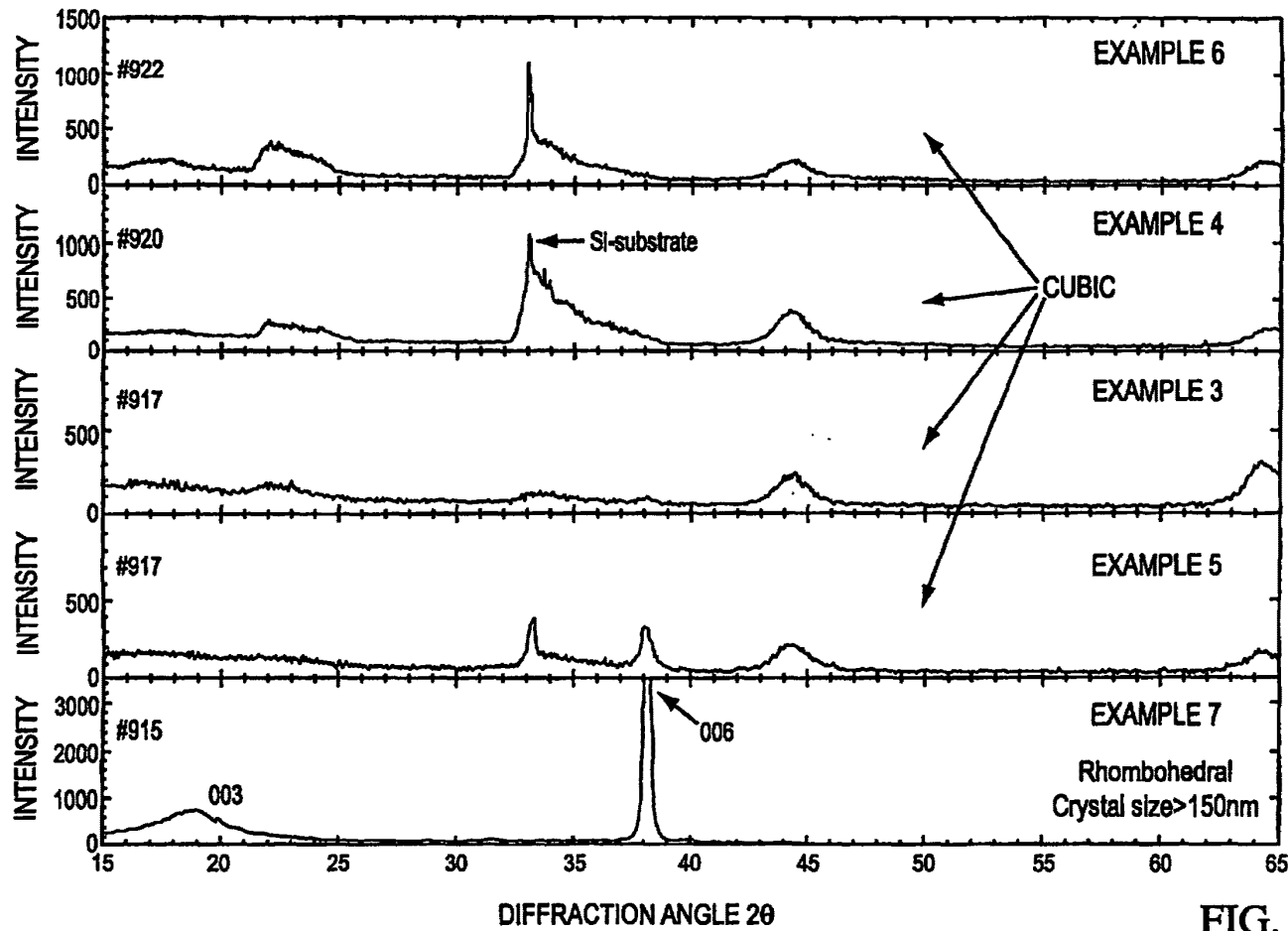

FIG. 5G

7/27

8/27

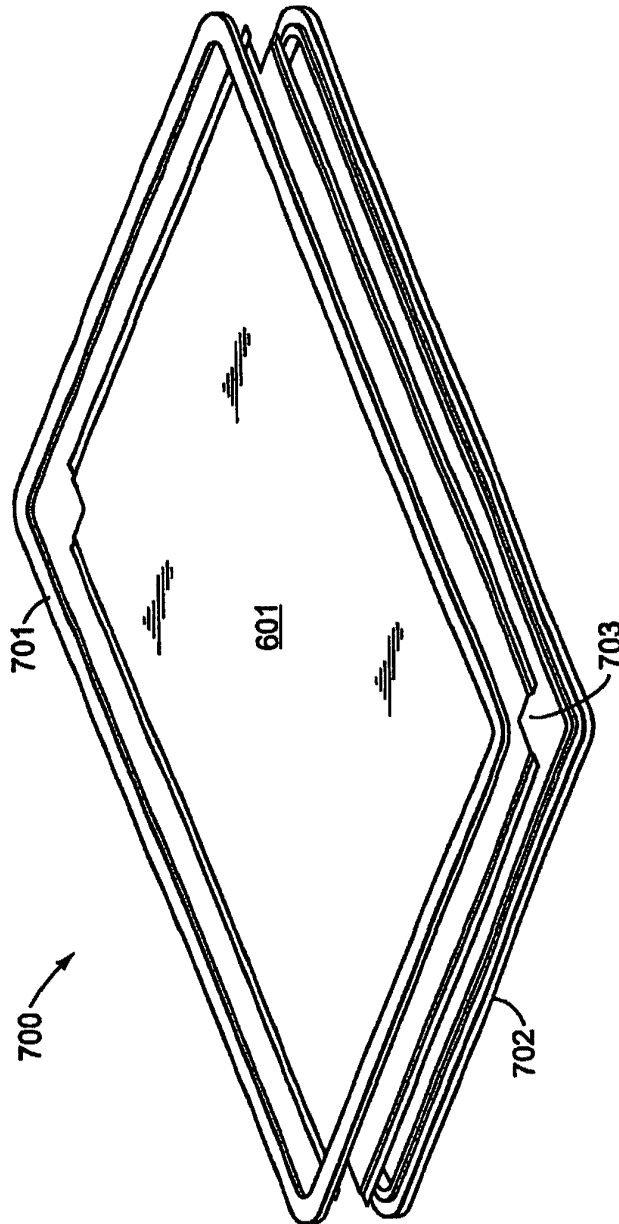

FIG. 7A

SUBSTITUTE SHEET (RULE 26)

9/27

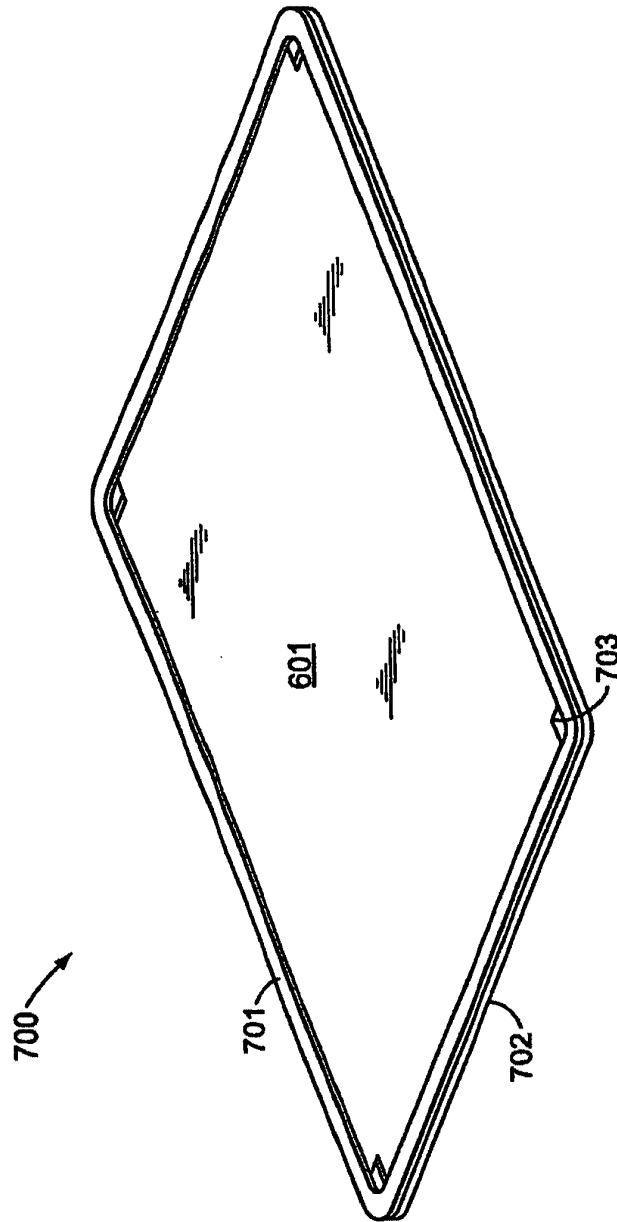

FIG. 7B

SUBSTITUTE SHEET (RULE 26)

10/27

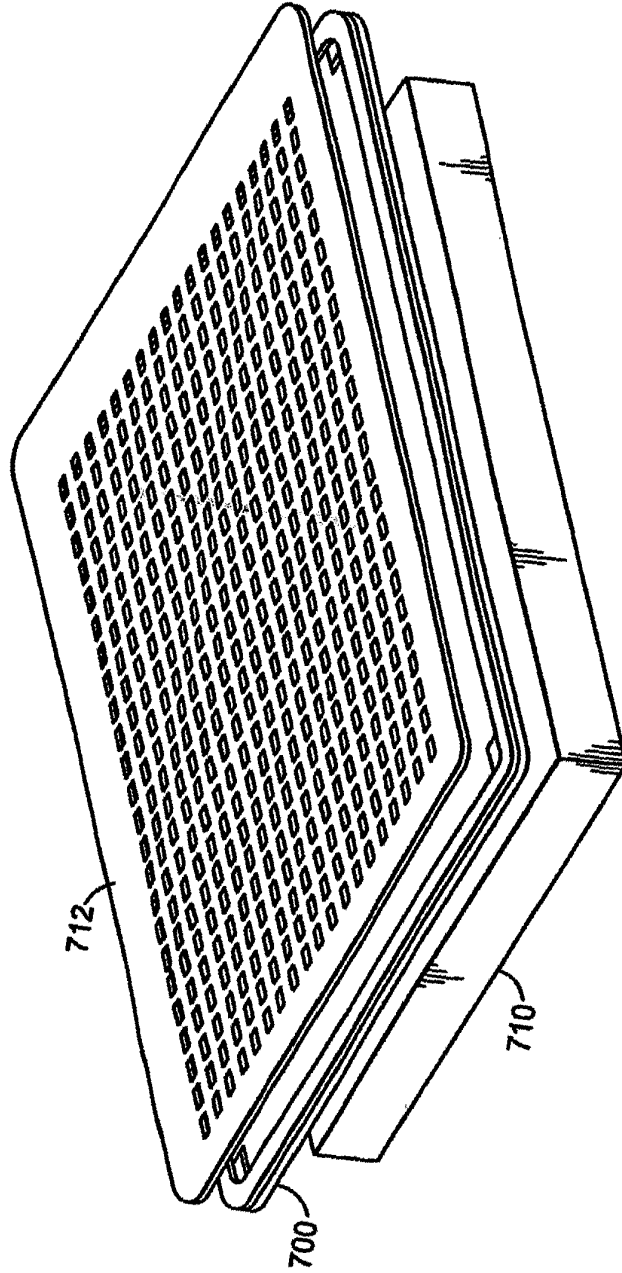

FIG. 7C

SUBSTITUTE SHEET (RULE 26)

11/27

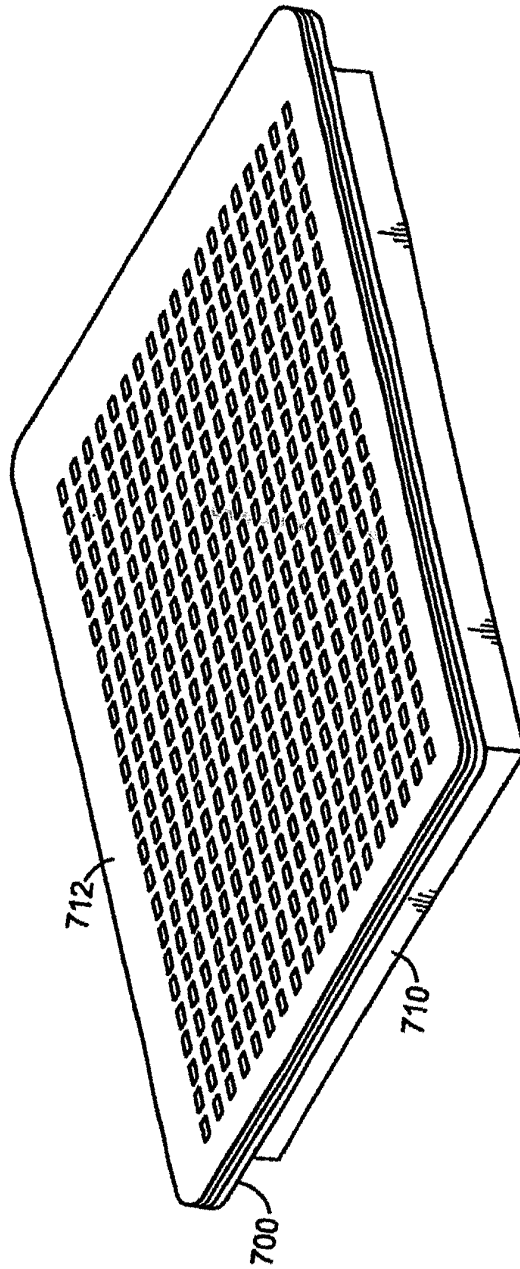

FIG. 7D

SUBSTITUTE SHEET (RULE 26)

12/27

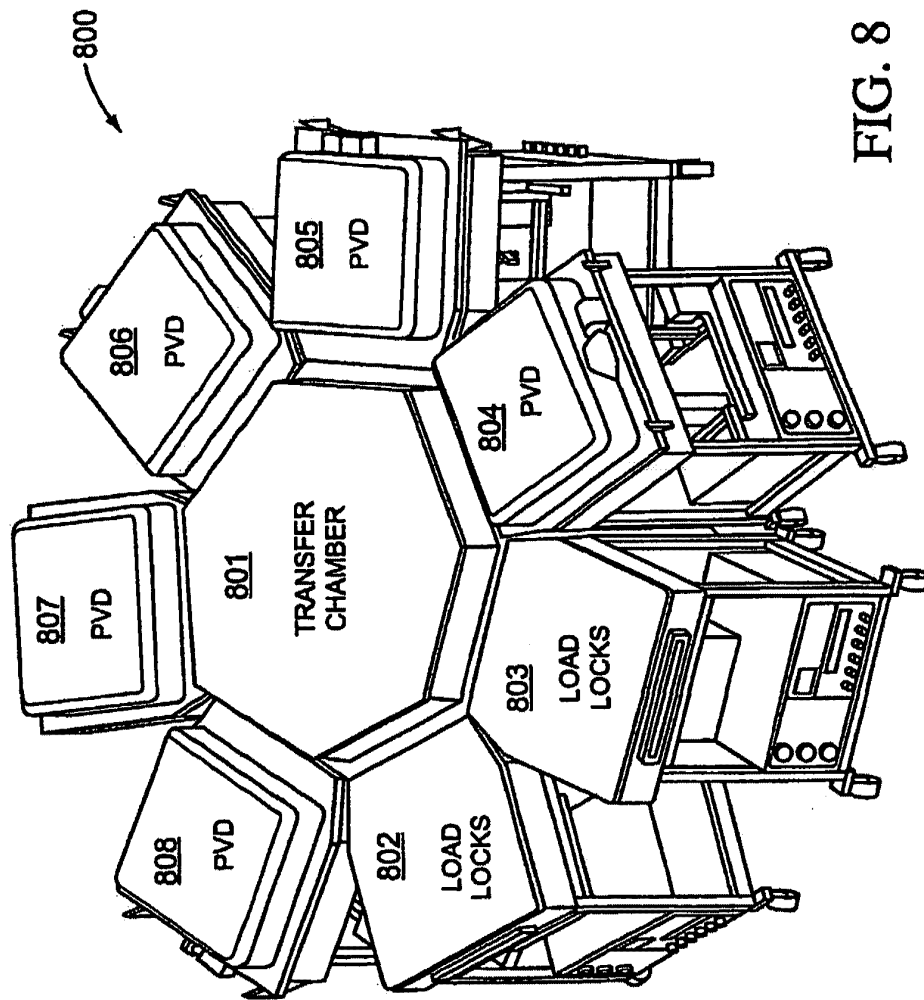

FIG. 8

SUBSTITUTE SHEET (RULE 26)

13/27

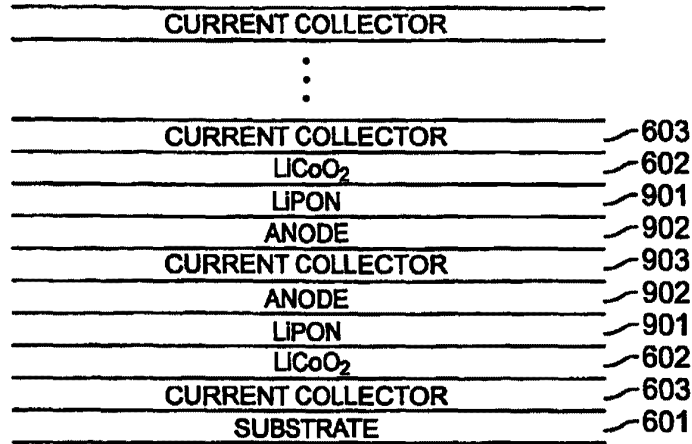

FIG. 9A

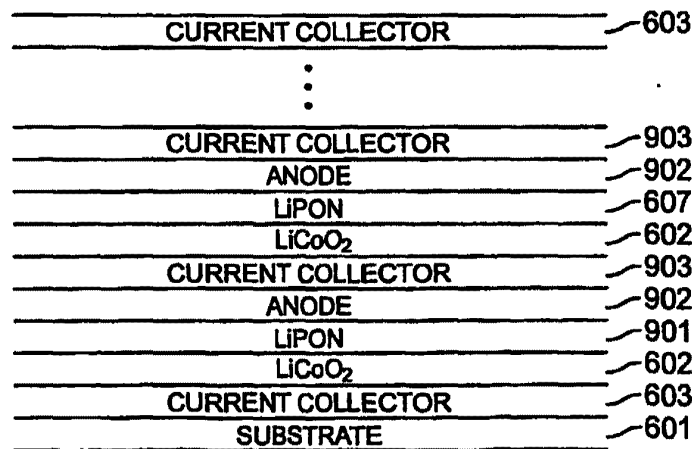

FIG. 9B

SUBSTITUTE SHEET (RULE 26)

SUBSTITUTE SHEET (RULE 26)

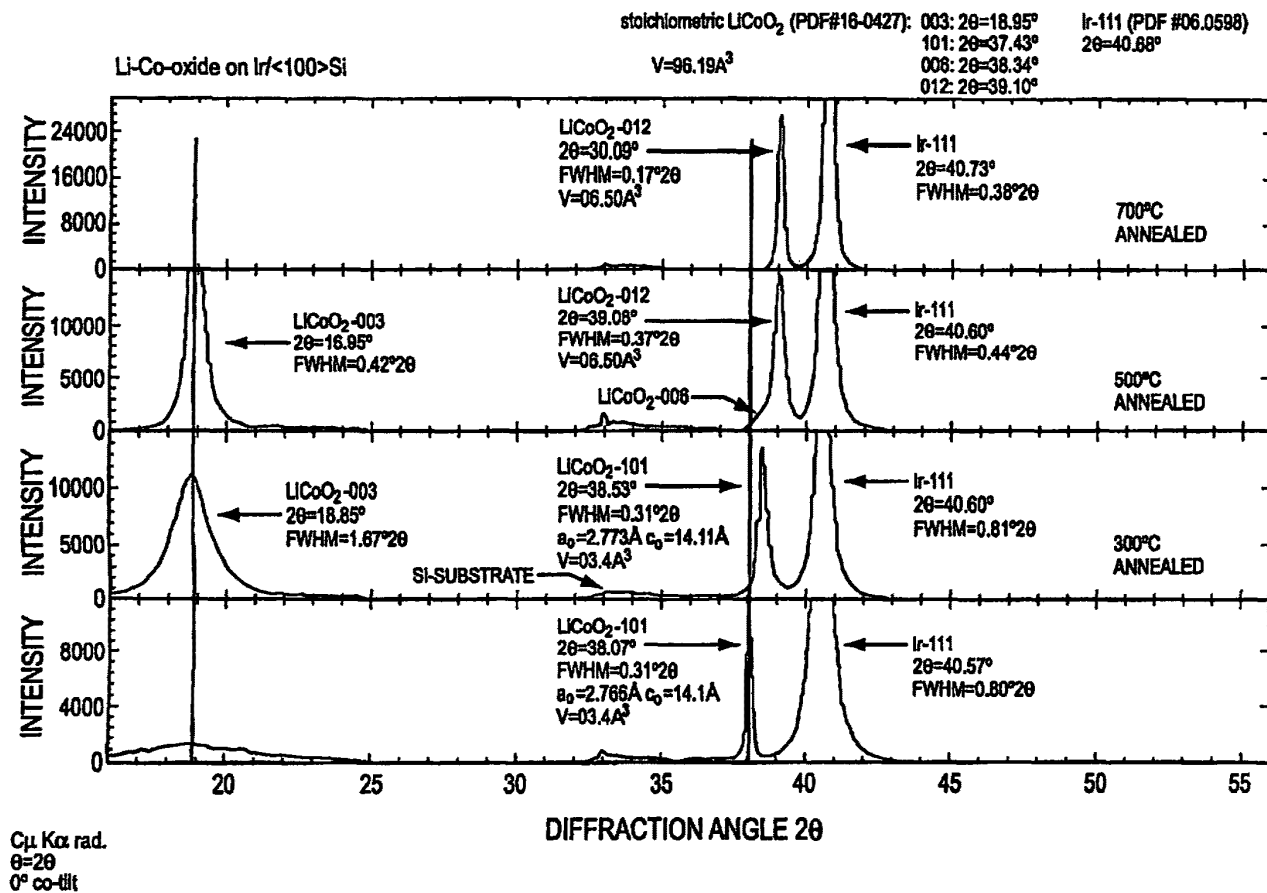

FIG. 10D

FIG. 10C

FIG. 10B

FIG. 10A

14/27

15/27

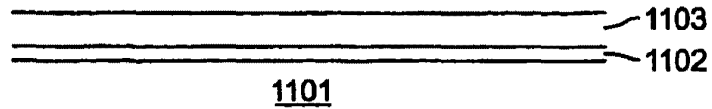

FIG. 11A

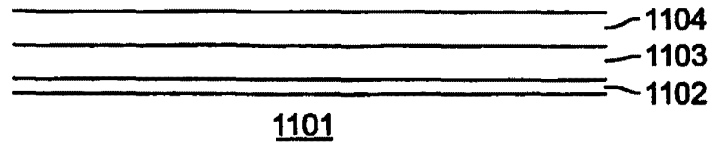

FIG. 11B

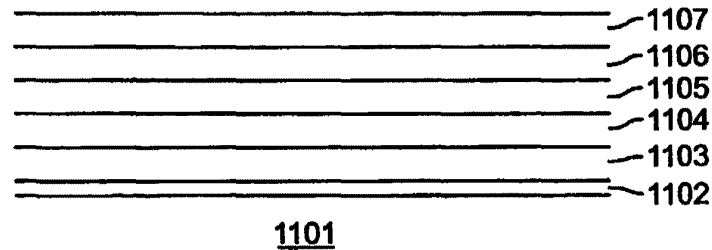

FIG. 11C

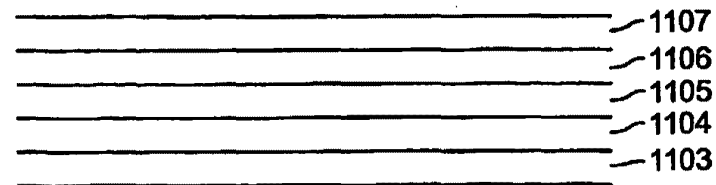
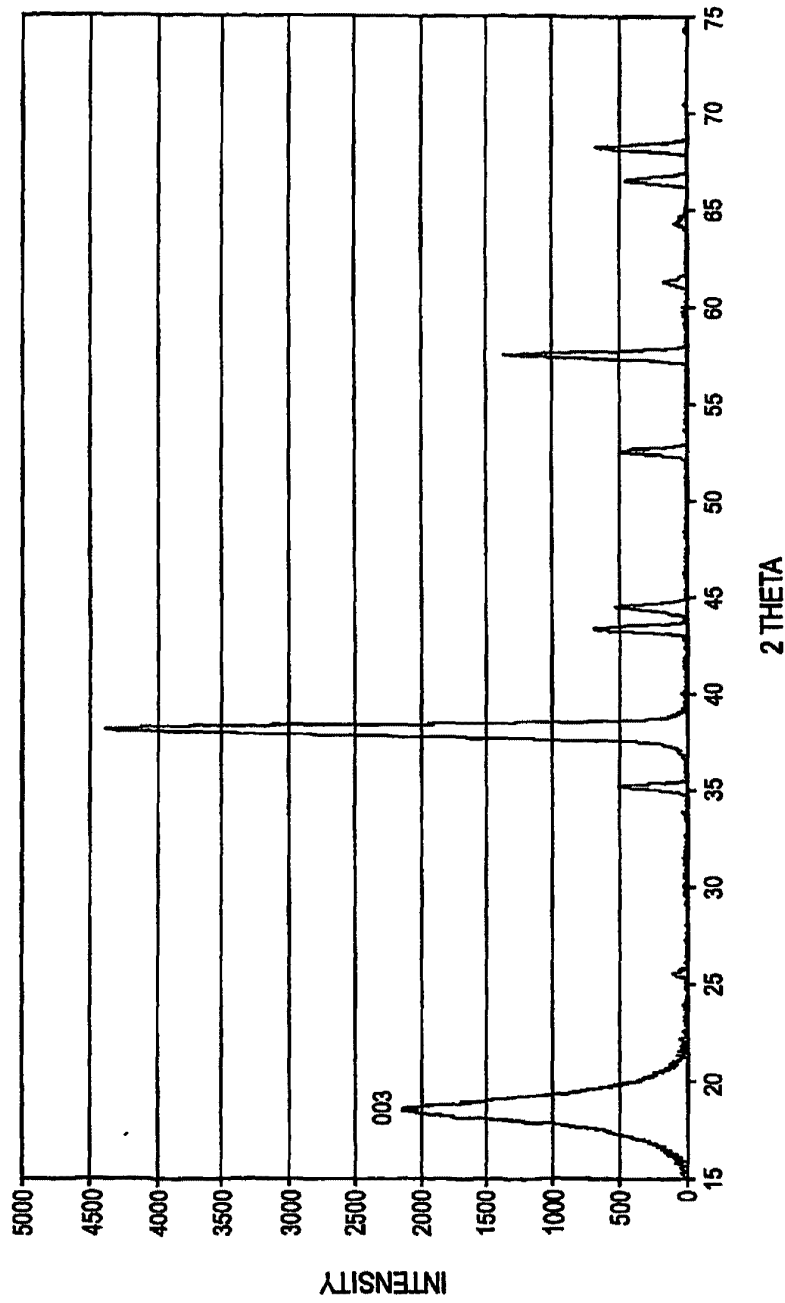

FIG. 11D

SUBSTITUTE SHEET (RULE 26)

16/27



2 THETA
FIG. 12A

SUBSTITUTE SHEET (RULE 26)

17/27

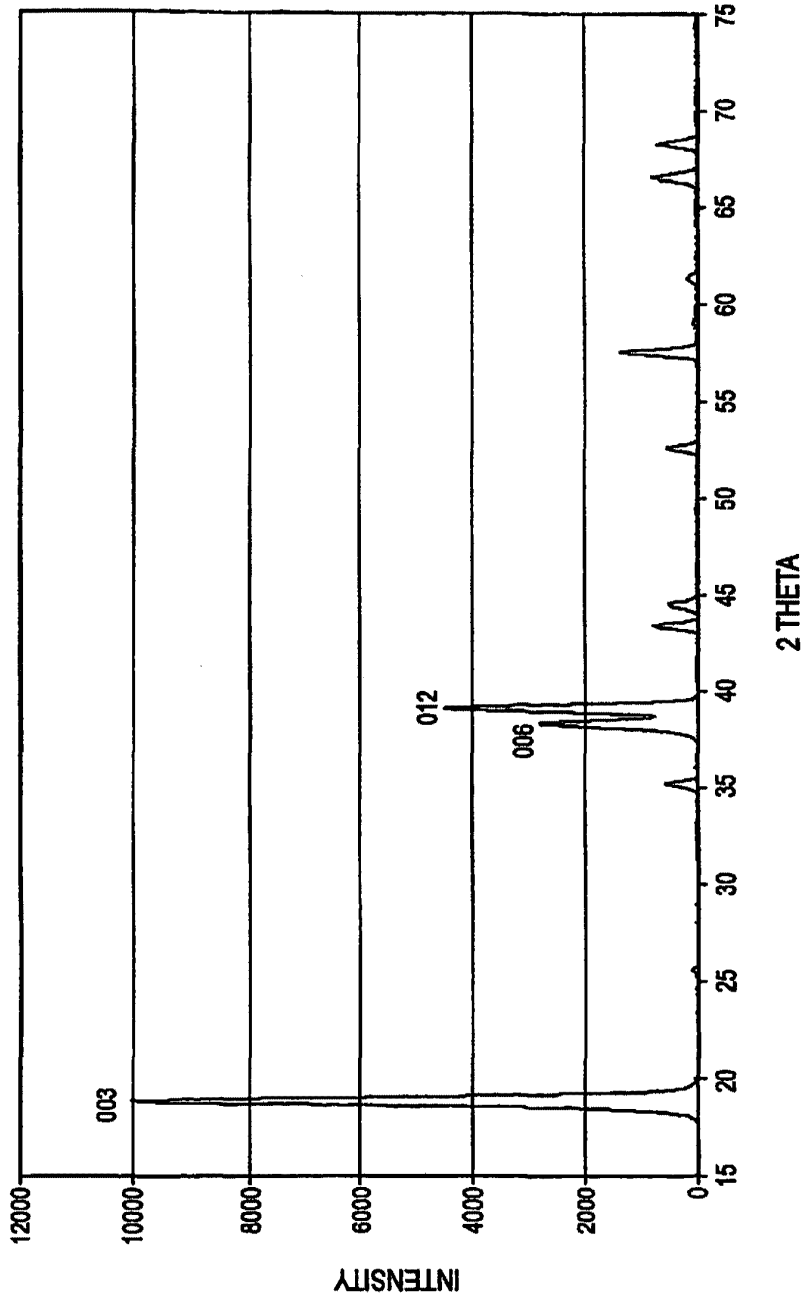

FIG. 12B

SUBSTITUTE SHEET (RULE 26)

18/27



FIG. 12D

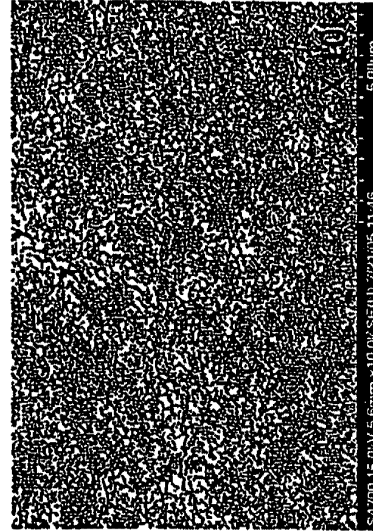

FIG. 12F



FIG. 12C



FIG. 12E

BEST AVAILABLE COPY

SUBSTITUTE SHEET (RULE 26)

19/27



FIG. 12H

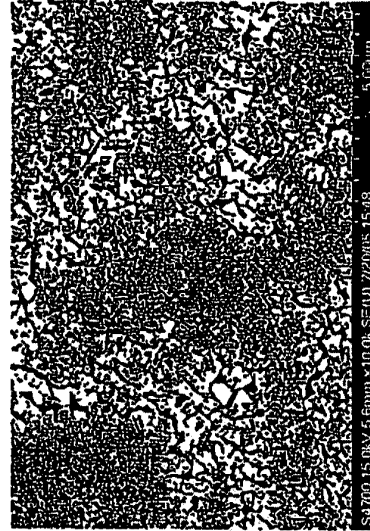

FIG. 12J

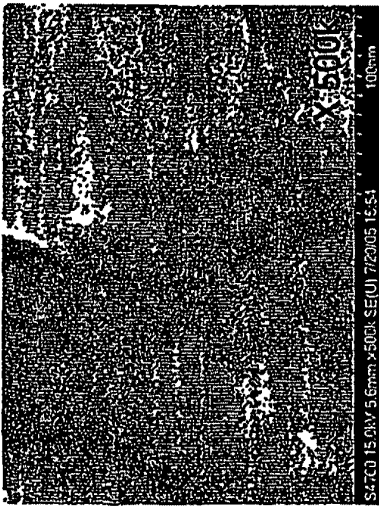

FIG. 12G



FIG. 12I

BEST AVAILABLE COPY

SUBSTITUTE SHEET (RULE 26)

20/27

FIG. 12L

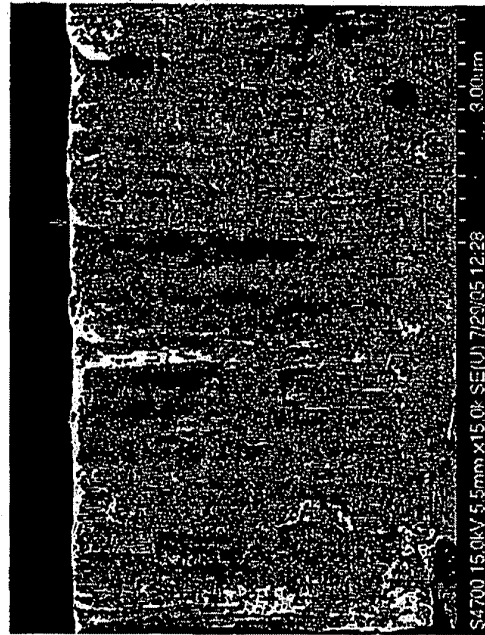

On alumina

FIG. 12K



On Si

BEST AVAILABLE COPY

SUBSTITUTE SHEET (RULE 26)

21/27

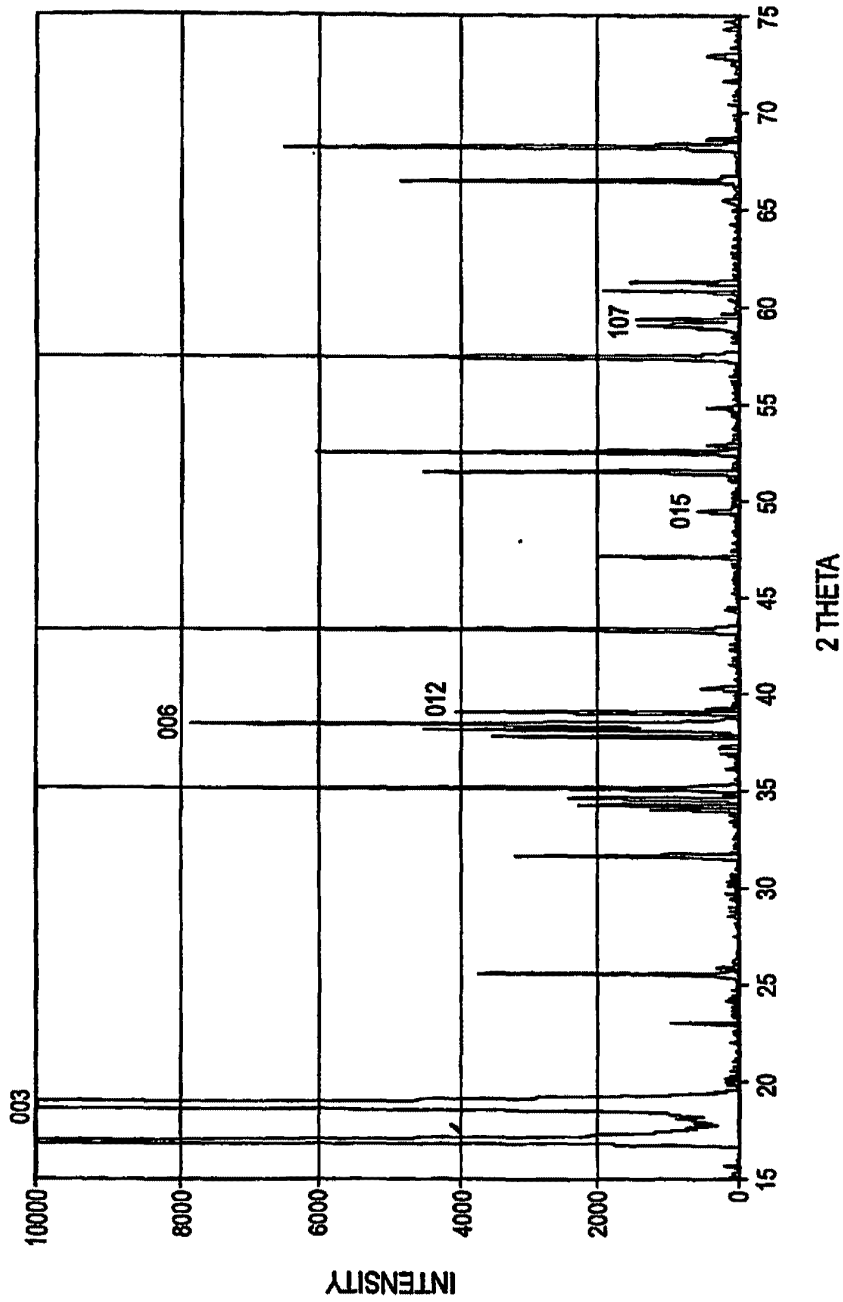
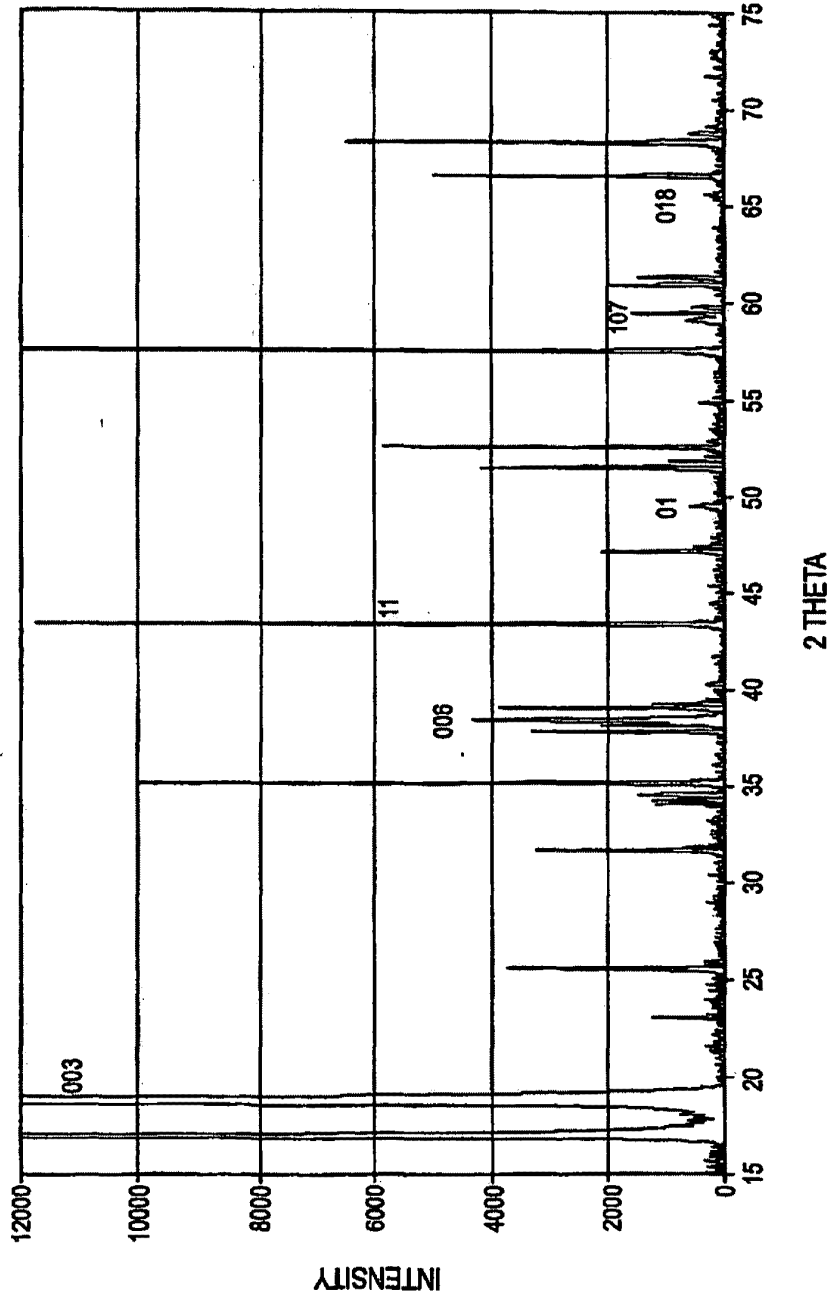

FIG. 13A

SUBSTITUTE SHEET (RULE 26)

22/27



2 THETA

FIG. 13B

SUBSTITUTE SHEET (RULE 26)

FIG. 13E



FIG. 13F

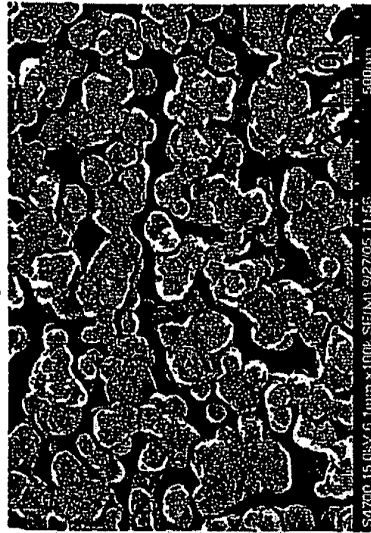

In Ar/O₂ (3/1)

FIG. 13C



FIG. 13D



In Ar

BEST AVAILABLE COPY

FIG. 14B



700CX2h

FIG. 14D



RTA-700C15m

FIG. 14A



As deposited

FIG. 14C



RTA-5m

BEST AVAILABLE COPY

25/27



FIG. 15A

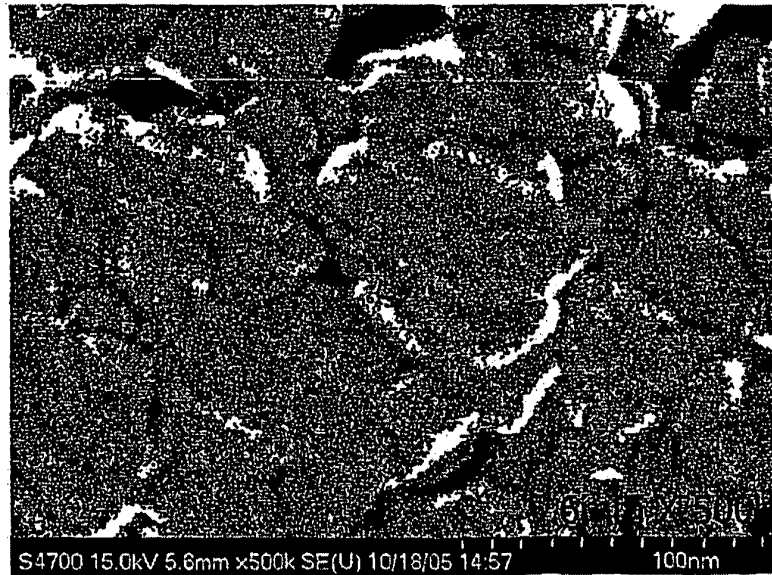

FIG. 15B

SUBSTITUTE SHEET (RULE 26)

BEST AVAILABLE COPY

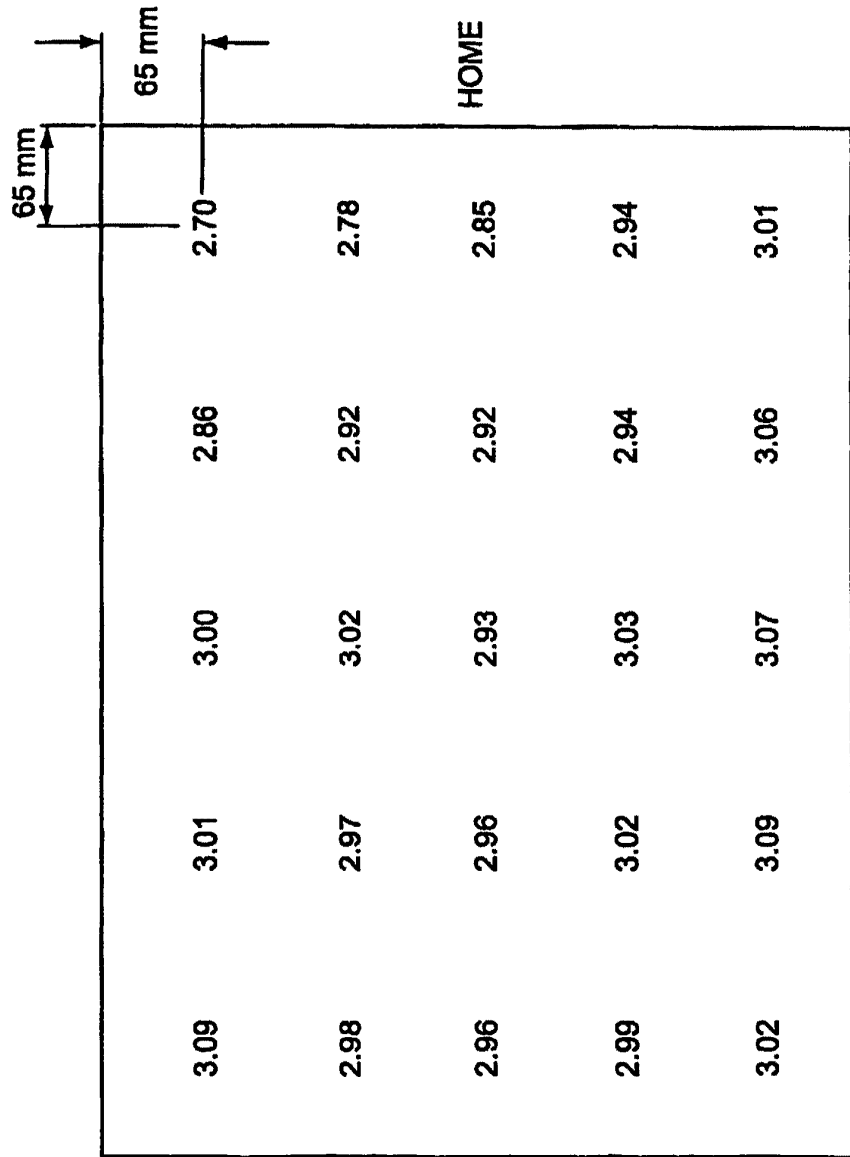

FIG. 16

27/27

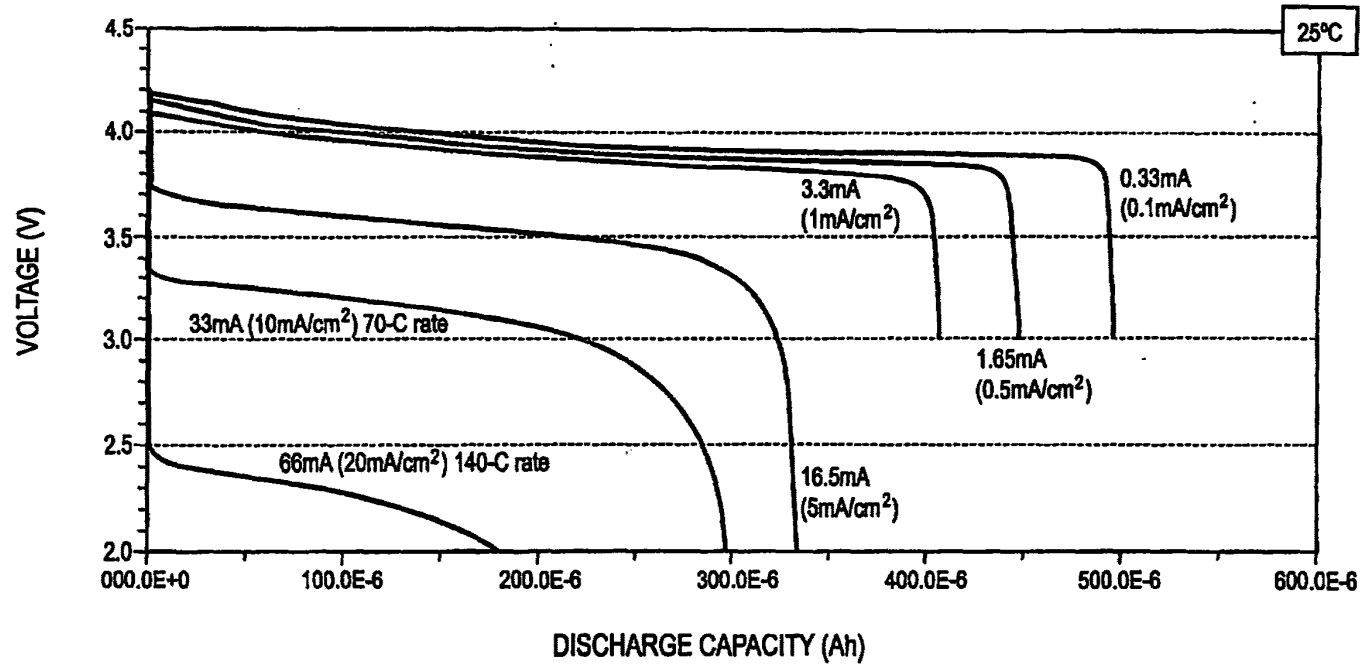

FIG. 17

SUBSTITUTE SHEET (RULE 26)



INTERNATIONAL APPLICATION PUBLISHED UNDER THE PATENT COOPERATION TREATY (PCT)

<p>(51) International Patent Classification ⁶ : C23C 4/10, 4/12, 14/34</p>	<p>A1</p>	<p>(11) International Publication Number: WO 99/61674 (43) International Publication Date: 2 December 1999 (02.12.99)</p>
<p>(21) International Application Number: PCT/EP99/03599 (22) International Filing Date: 26 May 1999 (26.05.99) (30) Priority Data: 98870120.7 26 May 1998 (26.05.98) EP (71) Applicant (for all designated States except US): UNIVER- SITEIT GENT [BE/BE]; St. Pietersnieuwstraat 25, B-9000 Gent (BE). (72) Inventors; and (75) Inventors/Applicants (for US only): HOSTE, Serge [BE/BE]; Gaverse steenweg 579, B-9280 Merelbeke (BE). PERSYN, Frans [BE/BE]; Oude boomgaardlaan 23, B-9080 Lochrist (BE). VAN DRIESSCHE, Isabel [BE/BE]; Wareslagstraat 94, B-9250 Waasmunster (BE). (74) Agents: BIRD, William et al.; Bird Goën & Co., Termerestraat 1, B-3020 Winksele (BE).</p>	<p>(81) Designated States: JP, US, European patent (AT, BE, CH, CY, DE, DK, ES, FI, FR, GB, GR, IE, IT, LU, MC, NL, PT, SE). Published With international search report.</p>	

(54) Title: SPRAYING METHOD TO FORM A THICK COATING AND PRODUCTS OBTAINED

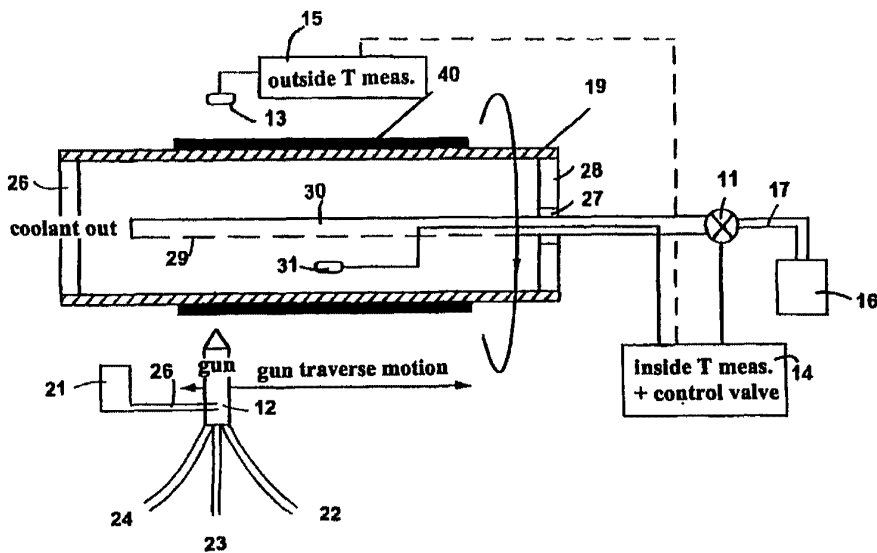

(57) Abstract

A method and an apparatus for spraying materials onto a substrate to produce a coating thereon is described which allows very thick layers of complex metal oxides to be produced. The apparatus and method are particularly suitable for producing superconducting coatings.

32

FOR THE PURPOSES OF INFORMATION ONLY

Codes used to identify States party to the PCT on the front pages of pamphlets publishing international applications under the PCT.

AL	Albania	ES	Spain	LS	Lesotho	SI	Slovenia
AM	Armenia	FI	Finland	LT	Lithuania	SK	Slovakia
AT	Austria	FR	France	LU	Luxembourg	SN	Senegal
AU	Australia	GA	Gabon	LV	Latvia	SZ	Swaziland
AZ	Azerbaijan	GB	United Kingdom	MC	Monaco	TD	Chad
BA	Bosnia and Herzegovina	GE	Georgia	MD	Republic of Moldova	TG	Togo
BB	Barbados	GH	Ghana	MG	Madagascar	TJ	Tajikistan
BE	Belgium	GN	Guinea	MK	The former Yugoslav Republic of Macedonia	TM	Turkmenistan
BF	Burkina Faso	GR	Greece	ML	Mali	TR	Turkey
BG	Bulgaria	HU	Hungary	MN	Mongolia	TT	Trinidad and Tobago
BJ	Benin	IE	Ireland	MR	Mauritania	UA	Ukraine
BR	Brazil	IL	Israel	MW	Malawi	UG	Uganda
BY	Belarus	IS	Iceland	MX	Mexico	US	United States of America
CA	Canada	IT	Italy	NE	Niger	UZ	Uzbekistan
CF	Central African Republic	JP	Japan	NL	Netherlands	VN	Viet Nam
CG	Congo	KE	Kenya	NO	Norway	YU	Yugoslavia
CH	Switzerland	KG	Kyrgyzstan	NZ	New Zealand	ZW	Zimbabwe
CI	Côte d'Ivoire	KP	Democratic People's Republic of Korea	PL	Poland		
CM	Cameroon	KR	Republic of Korea	PT	Portugal		
CN	China	KZ	Kazakistan	RO	Romania		
CU	Cuba	LC	Saint Lucia	RU	Russian Federation		
CZ	Czech Republic	LI	Liechtenstein	SD	Sudan		
DE	Germany	LK	Sri Lanka	SE	Sweden		
DK	Denmark	LR	Liberia	SG	Singapore		
EE	Estonia						

SPRAYING METHOD TO FORM A THICK COATING AND PRODUCTS OBTAINED

The present invention relates an apparatus and a method of spraying to form a coating on flat or curved substrates, for example, either as part of the direct
5 formation of metallic or ceramic coatings such as superconductive or piezo-
electric layers or for the production of targets for sputtering magnetrons having
coatings which are precursors of such layers.

TECHNICAL BACKGROUND

10 From EP-A-286 135 it is known to flame spray complex ceramic materials
onto a substrate such as a tape to form a superconducting layer. It is suggested to
pre-heat the substrate to temperatures above 540°C and to cool the coating
slowly. It is further recommended to treat the coating in an atmosphere containing
one of the components of the superconducting ceramic. An oxy-acetylene flame is
15 used for the flame spraying. Thickness of up to 3 mm are described.

It is also known from US 5,196,400 to plasma spray a coating onto a target
for use in a sputtering magnetron to sputter a Y-Ba-CuO superconductor coating.
Deposition of only a thin target coating of 0.5 mm is reported.

The production of superconducting powders using flame spraying is
20 reported in US 5,140,005. An oxy-acetylene flame is used. It is tacitly accepted
that the high temperature of the flame changes the stoichiometric ratios of the
components and that this has to be compensated by increasing the more volatile
components in the original mixtures. US 5,045,365 describes a method of cooling
a oxy-acetylene flame-sprayed substrate with water. Without special precautions,
25 water cooling is unsuitable for superconductors due to the water vapour produced.

EP-A-355 736 describes production of flat targets with metal oxides up to
a layer thickness of 3 mm. WO 98/0833 describes the production of < 20 micron
thick layers of superconducting metal oxide mixtures.

The article by Murakami et. al. "Rapidly Solidified Thick Deposit Layers
30 of Fe-C-Mo Alloys by Flame Spraying" describes up to 1.5 mm thick rapidly

CONFIRMATION COPY

cooled thick layers of Fe-C-Mo alloys by flame spraying. Special precautions were taken to produce dense layers, e.g. direct application of cryogenic gas on the coating during application.

EP-A-586 809 describes the metal spraying application of a layer of
5 relatively homogeneous material (nickel coated silicon) which is much easier to handle than the heterogeneous oxide mixtures contemplated by the present invention. Layer thicknesses of up to 8 mm are described but 3 to 5 mm is preferred. Various layers are proposed including a Ni-Al layer for improving adhesion between the deposited layer and the substrate. A Ni-Al adhesion
10 promoter is known from DE-A-33 18 828.

Plasma spraying of superconducting materials is described in EP-A-288711 up to a thickness of 250 micron.

It is an object of the present invention to provide an apparatus and a method of spraying heterogeneous metal oxides to form a ceramic coating on flat
15 or curved substrates.

It is a further object of the present invention to provide an apparatus and a method of spraying heterogeneous metal oxides to form a thick walled ceramic coating on flat or curved substrates which is structurally sound.

It is a further object of the present invention to provide an apparatus and a
20 method of spraying to form a thick walled coating of a superconducting ceramic material.

It is still a further object of the present invention to provide an apparatus and a method of spraying suitable for forming a thick walled ceramic coating on flat or curved targets to be used in a sputtering magnetron.

25 It is still another object of the present invention to provide a method of producing a (magnetron) vacuum sputtering target as well as the target itself with improved thermal and electrical conductivity and high mechanical strength using a spraying process employing dedicated powder formulations.

30 SUMMARY OF THE INVENTION

One aspect of the present invention is to provide a substrate with a coating of a combination of metal oxides having a thickness greater than 3 mm more preferably greater than 5 mm and most preferably greater than 8 mm. Preferably, the coating is deposited by spraying, e.g. flame or plasma spraying. Preferably, the substrate is cylindrical and is more preferably is suitable as a cylindrical target substrate for a sputtering magnetron. The combination of oxides preferably comprises at least a superconductive precursor or a superconductor. The thermal conductivity of the deposited material is preferably between 1 and 5 $\text{Wm}^{-1}\text{K}^{-1}$. When deposited on a steel substrate the thermal conductivity of the composite preferably lies within the range 25 to 125 $\text{Wm}^{-1}\text{K}^{-1}$. These values are particularly preferred for $\text{YBa}_2\text{Cu}_3\text{O}_7$ coatings. Preferably, an adhesion promoter layer is applied onto the substrate before application of the coating of the metal oxide combination. The adhesion promoter may be a layer of Ni-Al or a layer of an In-alloy, for example. The deposited coating is preferably impact resistant, e.g. withstands impact of a 0.036 kg steel ball from a height of 2 metres. Preferably, about 20% or up to 30% of a noble metal is included in the oxide material to improve electrical and thermal properties of the deposited layer. The noble metal is preferably silver. The noble metal may be included as a salt or oxide, e.g. silver nitrate or silver oxide, in the material to be sprayed. Preferably, the electrical resistivity of the deposited layer is lower than 15×10^{-6} Ohm.m, more preferably lower than 10×10^{-6} and most preferably less than 5×10^{-6} Ohm.m. Values below 1×10^{-6} Ohm.m can be achieved. Up to 30% of a noble metal such as silver may be added to lower the resistivity. These values are particularly preferred for $\text{YBa}_2\text{Cu}_3\text{O}_7$ coatings.

The electrical, thermal and mechanical properties of the coating deposited in accordance with the present invention should be sufficient that the deposited layer can be applied to a suitable substrate by means of a sputtering magnetron preferably at a static sputtering deposition speed of at least 5 nm/minute, more preferably, at 20 nm/minute and most preferably at at least 40 nm/minute.

When a superconductor precursor or a superconductive material is

deposited, at least 10% of the coating is in the superconducting phase, more preferably 15%. This may be assisted by a subsequent limited thermal treatment, e.g. 3 hours and 940°C, after deposition.

5 The present invention also includes a method of depositing by spraying a superconductor precursor layer onto a cylindrical target for a sputtering magnetron, the layer having a thickness of at least 3 mm, and at least 10% of the layer being in a superconductive phase. The present invention also includes a method of depositing by spraying a layer onto a substrate, the layer having a thickness of at least 5 mm, and the coating comprising metal oxides.

10 In accordance with one aspect of the present invention a flame spraying apparatus is provided for depositing a metal oxide combination onto a substrate to produce a coating thereon, comprising: a burner for producing a flame; an inlet for feeding material to be sprayed through the flame, the flame imparting a temperature to the material to be sprayed of 1500°C or less, preferably 1200°C or
15 less. Preferably the temperature imparted may be a little higher than the melting point of the powder to be sprayed, e.g. 600 to 1000°C for some metal oxides. Preferably, the thickness of the deposited coating is greater than 3 mm more preferably greater than 5 mm and most preferably greater than 8 mm.

Another aspect of the present invention is to provide a flame spraying
20 apparatus for depositing a metal oxide combination onto a substrate to produce a coating thereon, comprising: a flame spraying gun; and a cooling system for the substrate, the cooling system including a device for bringing a cryogenic fluid into contact with the substrate. Preferably, the thickness of the deposited coating is greater than 3 mm more preferably greater than 5 mm and most preferably greater
25 than 8 mm. The input material for the sprayer may be a liquid solution of soluble compounds (e.g. nitrates) which decompose thermally into ceramic component oxides, liquid slurries of the ceramic components or metal powders, or dry metal or ceramic powders or precursors of the ceramic components, e.g. nitrates, of such powders.

30 The present invention may provide a method of flame spraying a

combination of metal oxide materials onto a substrate to produce a coating thereon, comprising: generating a flame; feeding the material to be sprayed through the flame, the flame imparting a temperature to the material to be sprayed of 1500°C or less, preferably 1200°C or less. Preferably the temperature imparted
5 may be a little higher than the melting point of the powder to be sprayed, e.g. 600 to 1000°C for some metal oxides.

The present invention may also provide a method of flame spraying metal oxide combinations onto a substrate to produce a coating thereon, comprising: generating a flame for spraying the materials; and cooling the substrate by
10 bringing a cryogenic fluid into contact with the substrate.

The present invention may also provide a method of flame spraying a superconducting ceramic material or a precursor thereof onto a substrate to produce a coating thereon, comprising: generating a flame for spraying the ceramic material; depositing the coating on the substrate; and during deposition of
15 the coating, cooling the substrate so that the solidified coating thereon has a temperature between room temperature (~25°C) and 150°C, preferably room temperature (~25°C) and 100°C. Water or cryogenic fluid cooling are particularly preferred.

One linking concept between the above methods and apparatus is control
20 of the total heat energy into the spraying/coating system. This can be achieved by careful control of parameters which influence the energy input such as spraying distance, spray head traverse speed, rotation speed of a cylindrical substrate, powder dwell time in the hot exit plume from the spray head, particle velocity exiting the spray head, cooling method and rate of cooling the substrate during
25 coating deposition.

The present invention also includes a method of reconditioning a target for a sputtering magnetron by flame spraying or atmospheric plasma spraying as well as a reconditioned target as made in accordance with the method. The target material or coating is preferably a ceramic coating, in particular a
30 superconducting or superconductor precursor coating.

The final coating is preferably a metallic or ceramic layer, in particular a superconducting or piezo-electric layer or a precursor thereof. The present invention includes a method of spray drying a liquid to form a powder suitable for flame spraying. The spray dried powder may be sintered. The present invention
5 also includes a manufacturing method for depositing a coating on a substrate comprising the steps of: spray drying a precursor liquid to form a powder and flame spraying the powder to form a coating on a substrate. The substrate may be a target for a sputtering magnetron and the final coating may sputtered onto a final substrate in the sputtering magnetron. The ceramic powder may be sintered after
10 the spray drying step. The flame of the flame spray gun preferably imparts a temperature to the powder to be sprayed of 1500°C or less, preferably 1200°C or less. Preferably the temperature imparted may be a little higher than the melting point of the powder to be sprayed, e.g. 600 to 1000°C for some metal oxides. During flame spraying the target is preferably cooled by bringing a cryogenic
15 fluid into contact with the target. In particular the cooling device should maintain the solidified coating at a temperature between room temperature (~25°C) and 150°C, more preferably between room temperature (~25°C) and 100 °C.

The present invention includes an apparatus for spray drying a liquid to form a powder suitable for flame spraying. The present invention may also
20 include an apparatus for depositing a coating on a substrate comprising: a spray drier for drying a precursor liquid to a powder, and a flame sprayer for flame spraying the powder to form a coating on a substrate. The substrate may be a target for a magnetron. Additionally, a sputtering magnetron for sputtering the final coating onto the final substrate using the target may be provided. The flame
25 of the flame spray gun preferably imparts a temperature to the powder to be sprayed of slightly above the melting point of the sprayed material. Preferably the temperature imparted is 1500°C or less, preferably 1200°C or less. Temperatures of 600 to 850 °C may be suitable for some metal oxides. In the flame sprayer a cooling system for the target is preferably provided, the cooling system including
30 a device for bringing a cryogenic fluid into contact with the target. In particular

the cooling device should maintain the solidified coating at a temperature between room temperature ($\sim 25^{\circ}\text{C}$) and 150°C , more preferably between room temperature ($\sim 25^{\circ}\text{C}$) and 100°C .

The above methods may be used, for example, either as part of the direct
5 formation of superconductive or piezo-electric layers on the substrate, e.g. a tape, or for the production of coatings on targets for use in a sputtering magnetron to sputter a superconducting layer onto a final substrate. The present invention may provide oxide sputtering targets supporting very high power dissipation thus enabling high sputter deposition rates of at least 50 nm/min .

10 The dependent claims describe additional individual embodiments of the present invention. The present invention will now be described with reference to the following drawings.

BRIEF DESCRIPTION OF THE DRAWINGS

15 Fig. 1 is a schematic representation of a flame spraying apparatus in accordance with one embodiment of the present invention.

Fig. 2 is a schematic representation of a flame spraying apparatus in accordance with another embodiment of the present invention.

20 Fig. 3 is a schematic representation of a spray drying apparatus in accordance with another embodiment of the present invention.

DESCRIPTION OF THE ILLUSTRATIVE EMBODIMENTS

The present invention will be described with reference to certain specific
embodiments and with reference to certain specific drawings but the invention is
25 not limited thereto but only by the claims. In particular, the present invention will mainly be described with reference to the deposition of a superconductor precursor or superconductive coatings but the invention is not limited thereto but may be used advantageously with other heterogeneous coatings such as ceramic coatings, particularly those having special properties such as piezo-electric
30 coatings and in particular coatings which contain components which can be

degraded by high temperatures or which are more volatile than other components. More particularly the present invention will be described with reference to the manufacture of $\text{YBa}_2\text{Cu}_3\text{O}_7$ superconducting powders and coatings but the invention is not limited thereto but only by the claims. Further one way of

5 carrying out the present invention will be described with reference to low temperature flame spraying but the present invention is not limited thereto. By carrying out the invention in accordance with the processing details and principles described below thick layer (greater than 3 mm, more preferably greater than 5 mm and most preferably greater than 8 mm) metal oxide combination coatings

10 suitable for use as a sputtering magnetron target have been applied by oxy-acetylene flame spraying with water cooling or by atmospheric pressure or low-pressure plasma spraying to substrates including cylindrical substrates used in rotating cathode magnetrons. During plasma spraying gasses may be used such as argon or mixtures of argon and other gasses to shield the plasma spray. Also the

15 present invention will mainly be described with reference to an input to the flame spraying head of spray dried powder. The present invention is not limited thereto but includes other forms of input materials such as a mixture of the metal oxides, including slurries thereof or mixtures of precursors of metal oxides such as metal nitrates as well as slurries and solutions thereof.

20 Fig. 1 is a schematic diagram of the flame spraying apparatus 10 in accordance with a first embodiment of the present invention. A flame spraying gun is represented schematically at 12. The gun 12 may be a commercially available flame spraying gun as for instance available from Sulzer Metco, Westbury, NY, USA or a high velocity oxy-fuel spraying gun available from the

25 same company. The gun 12 may be provided with an air pincher. The gun 12 may be fed with fuel gas in pipe 22, oxygen in pipe 23 and gun cooling air in pipe 24. Additional gases may be supplied to the gun 12 as described for instance in US 5,273,957 or EP-A-413 296. Material to be coated is fed in powder or liquid form, e.g. a dry powder, a slurry of the powder and a liquid or in solution, to the

30 gun via conduit 26 from hopper 21. Gun 12 is mounted on a drive (not shown)

which provides the necessary movements of the gun 12 to coat the substrate 19. When substrate 19 is a cylindrical target, for instance, for a rotating cathode magnetron, this may be rotated and the movements of the gun 12 may be simple reciprocating movements parallel to the axis of the target 19. If the substrate 19 is a flat rectangular or circular plate, the movements may be provided by a suitable robot and may be complex, e.g. including rotational cycloidal motions. For rapid deposition several guns 12 may spray the same substrate 19 at the same time.

The fuel gas for the gun 12 may be selected from one of acetylene, propylene, hydrogen or similar fuels but the present invention is not necessarily limited thereto. Particularly preferred in one embodiment of the present invention is a fuel with a lower calorific value such as one of ethylene, natural or town gas, butane or propane as these provide a lower temperature flame than acetylene and butane is particularly preferred as it gives a stable easily controllable flame and is considered safer than acetylene if powders containing copper compounds are used. It is generally accepted that oxy-acetylene flames have temperatures of 2000 °C and more. It is preferred in accordance with an embodiment of the present invention if the flame of the flame spraying gun 12 imparts a temperature only sufficient to just melt the powder to be sprayed. Temperatures of 1500 °C or less and preferably 1200 °C or less are preferred and temperatures between 600 and 1000 °C may be more preferable. These low flame temperatures minimise decomposition of the ceramic powder components during flame spraying. Moreover, they limit the impact of evaporation of the materials to be flame sprayed and allow a deposition efficiency of more than 80%, i.e. more than 80% of the solid mass originally introduced into the gun 12, becomes attached to the substrate 19. Mechanically stable, scratch resistant flame sprayed coatings are produced with these low temperatures.

The gun 12 is preferably held at 7 to 15 cm from the substrate 19 to be coated but this depends upon the size of the flame. Similar coatings have been obtained using both oxy-acetylene flame spraying and plasma spraying. Attention must be paid to the energy taken up by the sprayed particles during the spraying

and the transfer of this energy to the substrate. Intensive cooling of the substrate is preferred which may be on the side of the substrate remote from the deposited layer and/or on the same side. By altering the velocity of the particles in the flame or plasma the dwell time therein may be altered, thus limiting the energy uptake
5 by the particles.

The material of substrate 19 preferably has a high melt temperature and a high thermal conductivity and when the substrate 19 is to be used as a target for a sputtering magnetron a good electrical conductivity is preferable. It is also preferred if the thermal expansion of the substrate material is similar to that of the
10 ceramic coating to be applied. In accordance with embodiments of the present invention low temperature flame spraying and/or intense cooling of the substrate 19 allows the use of substrates 19 with a thermal expansion coefficient up to at least twice or down to at least a half of the thermal expansion coefficient of the ceramic coating. A non-limiting list of suitable materials may be steel, iron,
15 stainless steel, copper or copper alloys, however the low temperature flame spraying process in accordance with the present invention, either independently or in combination with intense cryogenic cooling of the substrate 19, allows other materials to be used such as paper, cardboard or polymeric materials. Preferably, the substrate 19 should be free of grease and dry before deposition. Preferably,
20 the outer surface of metals is sand blasted and then lapped with abrasive materials. Buffer layers between the substrate and the sprayed coating may be used such as Ni-Al or an In-alloy. These may be applied by flame or plasma spraying before application of the metal oxide coating. .

Where the substrate 19 is rigid it may be mounted in a suitable jig. For
25 example, a cylindrical substrate 19 is preferably mounted in a rotating device such as a lathe. The substrate 19 may be held by rotatable chucks at each end thereof. The temperature of the solidified flame sprayed coating 40 on the surface of the substrate 19 is preferably measured by a temperature sensor 13, 15. The sensor head 13 is preferably a remote sensing optical head which is not in contact with
30 the surface 40 of the flame sprayed coating. The temperature to be measured is of

the solidified coating 40 and not that of the coating immediately on impacting the substrate 19 which may have a higher temperature. Hence, the temperature sensor 13 is preferably mounted so that it lags behind the impact position of the flame sprayed materials a little. In addition a temperature sensor 31 may be provided
5 inside the substrate 19 for further control of the deposition process. Control of deposition temperature is an important aspect of the present invention. Control of temperature affects the amount of thermal stress in the coating, a low stress reducing the possibility of cracks forming in the coating.

In accordance with one embodiment of the present invention a means for
10 intense cooling of the substrate 19 is provided. This is preferably a cryogenic cooler comprising a supply 16 of cryogenic fluid and a delivery system 11, 14, 17, 29, 30. The delivery system may be adapted to the form of the substrate 19. For example, for a cylindrical substrate 19 the cooling device may be a conduit 17 for supplying the cryogenic fluid to a control valve 11, a conduit 30 with regularly
15 spaced holes 29 for distribution of the cryogenic fluid inside the substrate 19 and a control device 14 for receiving the output of the temperature sensor 13, 15 and for controlling the operation of the control valve 11 so as to maintain the surface temperature of the solidified coating 40 to within a certain range. Particularly preferred is a temperature range from room temperature (25 to 30°C) to 150 °C
20 and more preferably room temperature to 100 °C. These low temperatures avoid thermal stresses between the coating 40 and the substrate 19 providing a good bond and good coating density, hardness and scratch resistance thus helping to ensure the long term stability of such a coating. Using a cryogenic fluid such as liquid nitrogen (77 °K) is quite advantageous and economical as it does not
25 require the complication of perfectly sealed rotating inlets and outlets to the substrate 19 when water or other liquid coolants are used. Additionally, cryogenic fluids such as liquid nitrogen produce large temperature gradients, thus increasing the thermal sink-effect. Other liquid coolants such as water are not excluded from the present invention.

30 The cylindrical substrate 19 may be sealed by a seal 26 at one end and with

a rotating seal 28 at the other. The seal 28 may be provided with a sealed feedthrough 27 for the supply of cryogenic fluid. If water cooling is used, rotating seals at both ends of the cylindrical substrate are considered very important to prevent escape of water vapour into the deposition environment. In accordance with an embodiment of the present invention it is preferred if the ends 26, 27 allow escape of a cryogenic fluid which then forms a shield gas around substrate 19 during the spraying process. Particularly preferred cryogenic fluids are liquid nitrogen, liquid oxygen and liquid air. With some complex ceramic materials, one or more components may be reduced in the spraying process. For such materials it may be advantageous to use a shield gas including oxygen, e.g. liquid air or liquid oxygen, which may help to reoxidise the reduced component. On the other hand with other complex ceramics it may be advantageous to reduce the contact time with oxygen at high temperatures, under which conditions liquid nitrogen would be preferred, or a reducing gas may be included such as hydrogen. It is preferable to control the atmosphere in the vicinity of the substrate 19 during coating deposition to prevent the presence of excessive water vapour and in particular to prevent condensation of water on the substrate 19. This may be achieved by generally air conditioning the air around the substrate 19 to reduce its dew point.

It is preferred if the deposition rate is selected in order to maintain the substrate surface temperatures mentioned above. Assuming the cylindrical substrate as shown in Fig. 1, the rotation speed of the substrate 19, the linear speed of the gun 12 and the rate of material exiting the gun 12 may be controlled to achieve the temperatures specified above. For instance, it has been found that when using cylindrical substrates made of stainless steel of 15 cm diameter and up to 40 cm long, a powder delivery of 5-10 g/min was suitable to produce 3 -10 mm coatings when depositing a $\text{YBa}_2\text{Cu}_3\text{O}_7$ layer. The rotational speed of the substrate 19 may be in the range 10 to 100 RPM with a surface speed in the range 1 to 40 m/min and the longitudinal feed of the gun 12 in the range 1-3 m/min, typically 2 m/min. The deposition rate per reciprocating pass of the gun 12 may be 10 to 50 micron thickness of the coating. About 10% to 15% of the deposited

coating had maintained the lattice structure of the powder and exhibited superconducting properties. It will be appreciated by the skilled person that increasing the deposition speed, deposition thickness per pass or the flame temperature or reducing the thermal conductivity of the substrate material will

5 increase the thermal load on the cooling system and adjustments of one or more of these parameters may be necessary to obtain satisfactory coatings. The thermal conductivity of the deposited material is preferably between 1 and $5 \text{ Wm}^{-1}\text{K}^{-1}$. When deposited on a steel substrate the thermal conductivity preferably lies within the range 25 to $125 \text{ Wm}^{-1}\text{K}^{-1}$. These values are particularly preferred for

10 $\text{YBa}_2\text{Cu}_3\text{O}_7$ coatings. Preferably, an adhesion promoter layer is applied onto the substrate before application of the coating of the metal oxide combination. The adhesion promoter may be a layer of Ni-Al or a layer of an In-alloy, for example. The deposited coating is preferably impact resistant, e.g. withstands impact of a 0.036 kg steel ball from a height of 2 metres. Preferably, about 20% or up to 30%

15 of a noble metal is included in the oxide material to improve electrical and thermal properties of the deposited layer. The noble metal is preferably silver. The noble metal may be included as a salt or oxide, e.g. silver nitrate or silver oxide, in the material to be sprayed. Preferably, the electrical resistivity of the deposited layer is lower than $15 \times 10^{-6} \text{ Ohm.m}$, more preferably lower than $10 \times$

20 10^{-6} and most preferably less than $5 \times 10^{-6} \text{ Ohm.m}$. Values below $1 \times 10^{-6} \text{ Ohm.m}$ can be achieved. Up to 30% of a noble metal such as silver may be added to lower the resistivity. These values are particularly preferred for $\text{YBa}_2\text{Cu}_3\text{O}_7$ coatings.

Fig. 2 is a schematic representation of a further embodiment of the flame spraying process and apparatus in accordance with the present invention.

25 Components in Fig. 2 with the same reference numbers as in Fig. 1 refer to equivalent items. The substrate 19 in accordance with this embodiment is a foil or sheet of metal, plastic or other flexible material which is wound from a pay-off spool 32 to a take-up spool 36. Where the final coating 40 cannot be spooled, the foil with coating 14 may be drawn linearly from the pay-off spool 32 and cut into

30 lengths. The coating 40, which may be a superconducting layer, is flame sprayed

with a flame spray gun 12 similar to the one described with respect to Fig. 1. In particular it is preferable to use a fuel with a lower calorific value than acetylene such as natural or town gas, butane or propane. Preferably, the temperature of the flame of the gun 12 imparts a temperature of 1500 °C or less, more preferably 5 1200 °C or less to the material being sprayed through the flame. This material may be in the form of powder either of finished components of the coating 40, e.g. oxides, or precursors thereof, e.g. nitrates, or may be in the form of a slurry of powders, e.g. oxides, or a solution, e.g. of nitrates. Gun 12 may be controlled by hand or more preferably by a robot to provide zigzag motions across the width 10 of foil 19 thus applying an even coating 40. Preferably a layer of 10 to 50 micron thickness is applied in each pass.

The temperature of the coating 40 may be monitored by one or more optical sensors 13, 15. The temperature of the foil 19 is regulated by means of a cryogenic fluid supplied from a container 16 to a series of holes or jets 29 via 15 conduit 17, a controllable valve 11 and a conduit 30. The valve 11 is controlled by a controller 14 to maintain the temperature of the foil as determined by the sensor 13, 15 to less than 400 °C, preferably less than 150 °C and most preferably between 50 and 100 °C. Such low temperatures allow a wide range of materials for substrate 19 including polymeric materials, cellulosic materials as well as 20 metals. Although only one controller 14 is shown the present invention includes several controllers each with its own controllable cryogenic cooling device 11, 29, 30 for individually controlling the temperature of different parts of the foil 19 or coating 40. Optionally, an optical encoder 34 may be attached to a roller 35. The optical encoder may be read with an optical sensor 37, 38, the pulse frequency 25 generated in the sensor 37, 38 being proportional to the linear speed of the foil 19. This value may also be used by the controller 14 to control the complete process to maintain the temperatures and coating thicknesses mentioned above.

When producing superconducting coatings 40, it is preferred if there is no condensation of water onto the coating 40 nor onto the foil 19 so it is preferred if 30 the atmosphere around the deposition equipment is air conditioned to reduce the

dew point to below ambient temperature. Preferably the coated substrates in accordance with this invention are preferably stored for long periods in a plastic bag filled with a dry inert gas such as dry nitrogen. One aspect of the present invention is the flame spraying of powders which already have superconducting properties in the powder form. Using the methods in accordance with the present invention it is possible to flame spray such coatings and retain 10% to 15% of superconducting property of the coating 40 produced without extensive post-heat treatments.

The superconducting and/or ceramic powder and/or metallic powder to be used for flame spraying is preferably homogeneous, exhibits the appropriate rheological properties and correct stoichiometry to generate the required properties in the final coating. Typical preferred densities for superconducting powders may lie in the range 4 to 5 g/cm³. A non-limiting list of suitable materials which may be flame sprayed as powders, slurries or liquid solutions in accordance with the present invention are: superconducting materials such as R₁Ba₂Cu₃O_y where R is Y, La, Nd, Sm, Eu, Gd, Dy, Ho, Er, Tm, Yb, Lu; or Bi_{2-x}Pb_xSr₂Ca_{n-1}Cu_nO_y, Tl₂Ba₂Ca_{n-1}Cu_nO_{2n+3}, HgBa₂Ca_{n-1}Cu_nO_{2n+2+δ}; or Ba₂Ca_{n-1}O_{2n+2}, or CaBa₂Ca_{n-1}Cu_nO_{2n+δ}; or cuprate high temperature superconductors of the general formula A_mE₂R_{n-1}Cu_nO_{2n+m+2} where A, E, R are selected from various cations such as A = Bi, Tl, Hg, Pb, Cu or a lanthanide element, E = Ba or Sr and R = Ca or rare earth element; or piezo-electric ceramics, for example, with the general formula M(Zr_xTi_{1-x})O₃ where M = Pb, Ba or Sr; or refractory ceramic oxides, nitrides, carbides or phosphates, e.g. Al₂O₃, MgO, Zr_xO_y; or metals and their alloys.

In accordance with a further embodiment of the present invention a method is provided for production of suitable ceramic powders. By starting from aqueous solutions containing the salts of the metals in the correct proportions a reactive precursor powder can be obtained using commercially available spray drying equipment in batches of kilograms. The type of salt (mostly nitrates) should preferably be compatible with thermal decomposition to oxides in further

processes such as sintering or flame spraying. In accordance with the present invention spray dried nitrate powders may be flame sprayed directly or the powders may first be sintered and then flame sprayed.

A spray drying system 50 in accordance with an embodiment of the present invention for the delivery of powder suitable for subsequent flame spraying is shown schematically in Fig. 3. The input liquid is drawn from a suitable source 53 via a peristaltic pump 54 to a spray head 71. Pressurised air 51 is drawn in through an air dryer and optional pre-heater 52 to the spray head 71 by a suction device such as a fan 63 at the end of the generally closed system. The liquid from source 53 enters the spray head 71 which is cooled by any suitable means 55 to prevent clogging due to early evaporation of the liquid. The liquid is atomised in a co-current two fluid nozzle 71 by the dry pressurised air 51 and discharged it into a chamber 56 where it dries to a powder. The liquid from source 53 may be a solution of suitable nitrates or a slurry of the relevant oxides with the addition of other agents such as binders.

Air 65 is drawn in by fan 63 over a heater 64 and introduced into chamber 56 via a ring orifice 72 which surrounds the outlet of the spray head 71. The air 65 also heats the spray head 71. The circumferential air flow 65 guides the evaporating liquid in chamber 56 and helps to prevent the powder sticking to the walls of the chamber 56. The air throughput of fan 63 is chosen so that powder of the correct grain size is swept from chamber 56 through an optional heater section 58 into a powder collector 59. Heavier particles settle out in trap 57 and are removed from the bottom of chamber 56.

The powder collector 59 may be any suitable device such as a cyclone, a bag filter or an electrostatic filter although a cyclone is preferred. The cyclone discharges the powder into a removable container 60 sealed to the bottom of the cyclone 59. Spent air is removed via the trap 61 and scrubbed in scrubber 12 to remove impurities. The final clean air is exhausted to atmosphere by the fan 63 which controls air flow through the system.

The control system 66 - 70 for the process functions as follows. The

rotational speed of the centrifugal air pump 53, the temperature of the heating element 64 and the flow of the atomised air are set with controller 67, 70. Air flow is measured by gauge 68. The temperature of the hot air 65 and the air in the tube leading from the chamber 56 to the optional heater 58 is monitored using
5 thermocouples 66, whereas final powder temperature is monitored by temperature sensor 69.

After spray drying, the powder may be sintered in a single step. For example, to produce a superconducting powder of the general formula $\text{YBa}_2\text{Cu}_3\text{O}_7$ with optional Ag, the required nitrates are dissolved in water in the
10 correct stoichiometric proportions and spray dried as indicated above. The nitrates are then reduced to oxides by sintering at 920 - 960 °C for 40 to 60 hours. Optionally the nitrates may first be reduced by heating in air at 780 °C for 10 hours before sintering at the above temperatures and times. The $\text{YBa}_2\text{Cu}_3\text{O}_7$ powder produced by this procedure is superconducting. On aspect of the present
15 invention is to produce powders with superconducting properties by spray drying and optional sintering and then to flame spray these superconductive powders at the lowest flame temperatures necessary to obtain melting of the powder and coating formation on the substrate while cooling the coating in the fastest possible way. By this procedure the crystal structure present in the superconducting
20 powder is disturbed as little as possible by the flame spraying process. Of course, melting the powder during flame spraying causes complete loss of crystal organisation if the time in the melt is long. By lowering the flame temperature and shortening the time in the melt phase by cooling the coating very rapidly in accordance with the present invention, some local crystal organisation is kept in
25 the final flame sprayed coating, e.g. about 10% of the final coating is in the superconducting phase, thus providing a coating on the substrate with an optimum starting condition for further heat processing to develop full superconducting properties. The addition of the metallic silver enhances the thermal and mechanical properties in later flame spraying and magnetron sputtering.

30 Alternatively, the powder for flame spraying may be spray dried from

slurries of the relevant oxides in the correct stoichiometric proportions with the optional addition of silver in the above apparatus in accordance with the present invention. For instance, in the manufacture of a ceramic material the mixture of oxides may be produced by individually sieving them to 40 micron and then
5 mixing in the correct proportions to obtain the stoichiometric proportions in the final coating. A quantity of deionised water is added of about 60% by weight of the powder as well as a quantity of an organic binder such as PVA (polyvinyl acetate) equal to about 2% by weight of the powder and then mixed into a slurry. The slurry is then spray dried as described above resulting in powder with a grain
10 size from 30 to 50 micron. Generally, spray dried oxide slurries do not require sintering before flame spraying. The organic binder may be burnt out during flame spraying or in a special sintering step.

Spray drying of 10% by weight nitrate solutions generally produce grain sizes of 3 micron on average with at least 90% of the grains between 0.5 and 5
15 microns. In order to obtain the required grain size it is preferable to sinter as mentioned above. Light grinding and sieving of this sintered powder may produce a mass fraction of more than 80% with grain sizes between 40 and 80 micron. By the variation of appropriate concentrations of the solution of the aqueous media
53, and/or the addition of binders and/or the spray drying of slurries rather than
20 solutions, allows control of the grain size in the final powder to between 2 and 100 microns. For example, the present invention includes the addition of organic binders such as polyvinyl acetate (PVA) to the liquid to be spray dried to control grain size in the final powder. Such binders may be burnt out in a later high
temperature process such as sintering. An average grain size of 40 to 80 microns
25 is preferred for good flame spray deposition. The final powder may be lightly milled and sieved to be improve the homogeneity of grain sizes.

One aspect of the present invention is the inclusion of silver metal in the final superconducting ceramic coating. This is achieved as mentioned above by inclusion of about 20% to 30% by weight of the ceramic materials of silver nitrate
30 when nitrate solutions are spray dried and the flame sprayed or by addition of

Ag₂O powder in an oxide slurry which is then spray dried and flame sprayed. The addition of silver in the flame sprayed material is beneficial for the inter-grain adhesion and heat dispersal during flame spraying thus yielding a strong and dense coating. The silver improves the thermal and electrical conductivity of the flame sprayed coating which is beneficial to the sputtering process when the substrate is used as a sputtering target. The improved conductivities allow higher power throughput for the magnetron than targets not containing silver.

The flame spraying process in accordance with the present invention allows the reconditioning of targets for sputtering magnetrons. It is well known that the presence of a static race-track plasma on a magnetron target during sputtering results in an erosion groove and poor target utilisation. Using the flame spraying process of the present invention such a worn target may be reconditioned by spraying the appropriate target material into the erosion groove and building up the target to its former thickness in these regions. By providing the intensive cryogenic cooling described above, the general target temperature may be kept below 400 °C, preferably below 150°C and most preferably between room temperature (~25°C) and 100°C. These low temperatures result in little damage to the existing target material while still providing a mechanically strong coating in the old erosion grooves. Such a process is particularly economic when the target material is expensive such as superconducting materials. The flame spraying gun 12 described above may be hand held and the contour of the erosion groove in the used target followed building up the lost material slowly, preferably 10 to 50 micron per pass. Preferably the gun 12 is controlled by a robot which is programmed to execute the correct motions with the gun 12 to fill up the erosion groove in the target.

While the invention has been shown and described with reference to preferred embodiments, it will be understood by those skilled in the art that various changes or modifications in form and detail may be made without departing from the scope and spirit of this invention as defined in the attached claims.

CLAIMS

1. A composite comprising: a substrate and a coating deposited on said substrate, the coating being deposited by spraying, the thickness of the coating being at least 5 mm, more preferably greater than 8mm, the coating comprising metal oxides.
- 5
2. The composite according to claim 1, wherein the coating comprises a superconductor precursor and at least 10% of the coating is in a superconductive phase
- 10
3. The composite according to claim 1 or 2, wherein the composite is a target for a sputtering magnetron.
4. The composite according to claim 3, wherein the target is cylindrical.
- 15
5. The target for a sputtering magnetron comprising: a cylindrical substrate and a coating deposited on said substrate, the coating being deposited by spraying, the thickness of the coating being at least 3mm, more preferably at least 5 mm, most preferably greater than 8mm, the coating comprising a superconductor precursor and at least 10% of the coating is in a superconductive phase.
- 20
6. The target or a composite in accordance with any previous claim, wherein the coating has a thermal conductivity of between 1 and 5 $\text{Wm}^{-1}\text{K}^{-1}$.
7. The target or a composite in accordance with any previous claim, wherein the
- 25
- thermal conductivity of the composite or the target through the substrate and the coating is in the range 25 to 125 $\text{Wm}^{-1}\text{K}^{-1}$.
8. The target or a composite in accordance with any previous claim, wherein the coating has an electrical resistivity of lower than 15×10^{-6} Ohm.m, more preferably
- 30
- lower than 10×10^{-6} and most preferably less than 5×10^{-6} Ohm.m.

9. The target or a composite in accordance with any previous claim, wherein the coating can withstand impact of a 0.036 kg steel ball from a height of 1 metre, preferably from 1.5 metre.
- 5
10. The target or a composite in accordance with any previous claim, wherein the spraying is one of plasma spraying and flame spraying.
11. A method of depositing by spraying a superconductor precursor layer onto a cylindrical target for a sputtering magnetron, the layer having a thickness of at least 3 mm, and at least 10% of the layer being in a superconductive phase.
- 10
12. A method of depositing by spraying a layer onto a substrate, the layer having a thickness of at least 5 mm, and the coating comprising metal oxides.
- 15
13. The method according to claim 11 or 12, wherein the spraying step is one of flame spraying and low-pressure or atmospheric pressure plasma spraying.
14. The method according to claim 13, wherein the spraying step includes spraying a material through a spraying head, the material being in the form of a powder, a slurry or a solution.
- 20
15. A method of reconditioning a used target for a sputtering magnetron having an erosion groove in the target material, comprising the step of: flame or atmospheric pressure plasma spraying target material into the erosion groove.
- 25
16. A reconditioned target for a sputtering magnetron, comprising:
an erosion groove in the target material; and target material flame sprayed or atmospheric plasma sprayed into said groove to restore the thickness of the target material to that of the unused material.
- 30

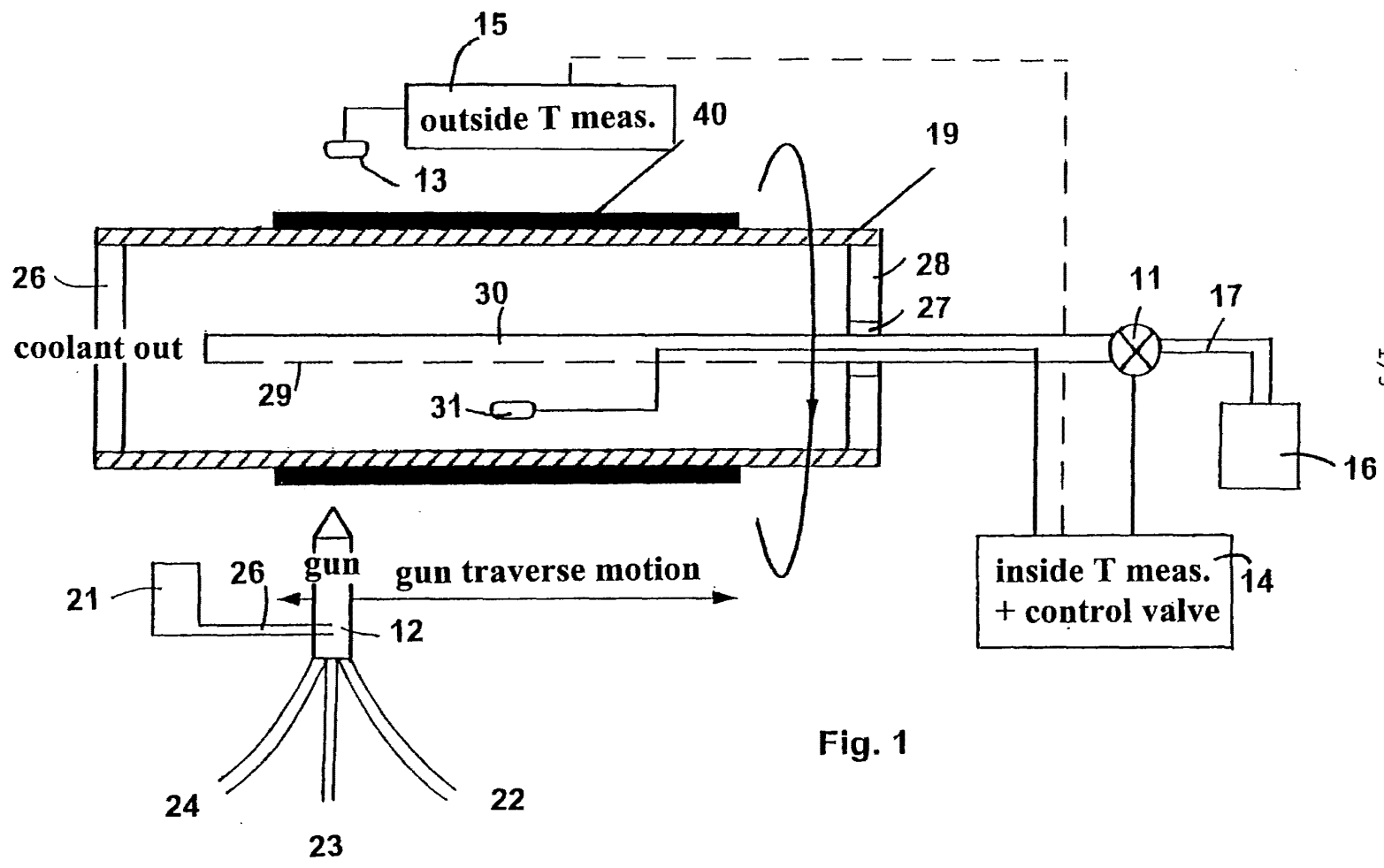

Fig. 1

1/3

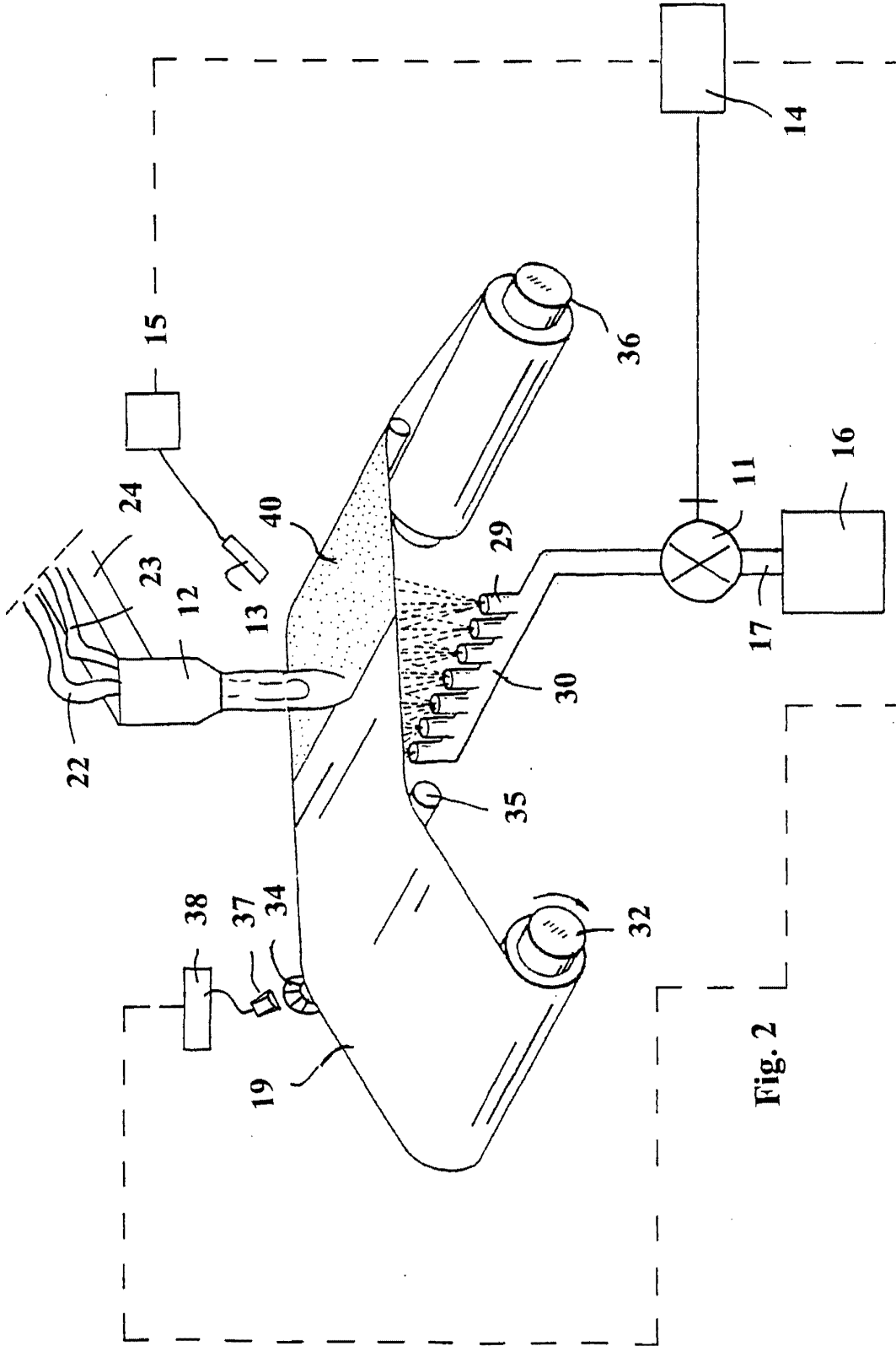

Fig. 2

SUBSTITUTE SHEET (RULE 26)

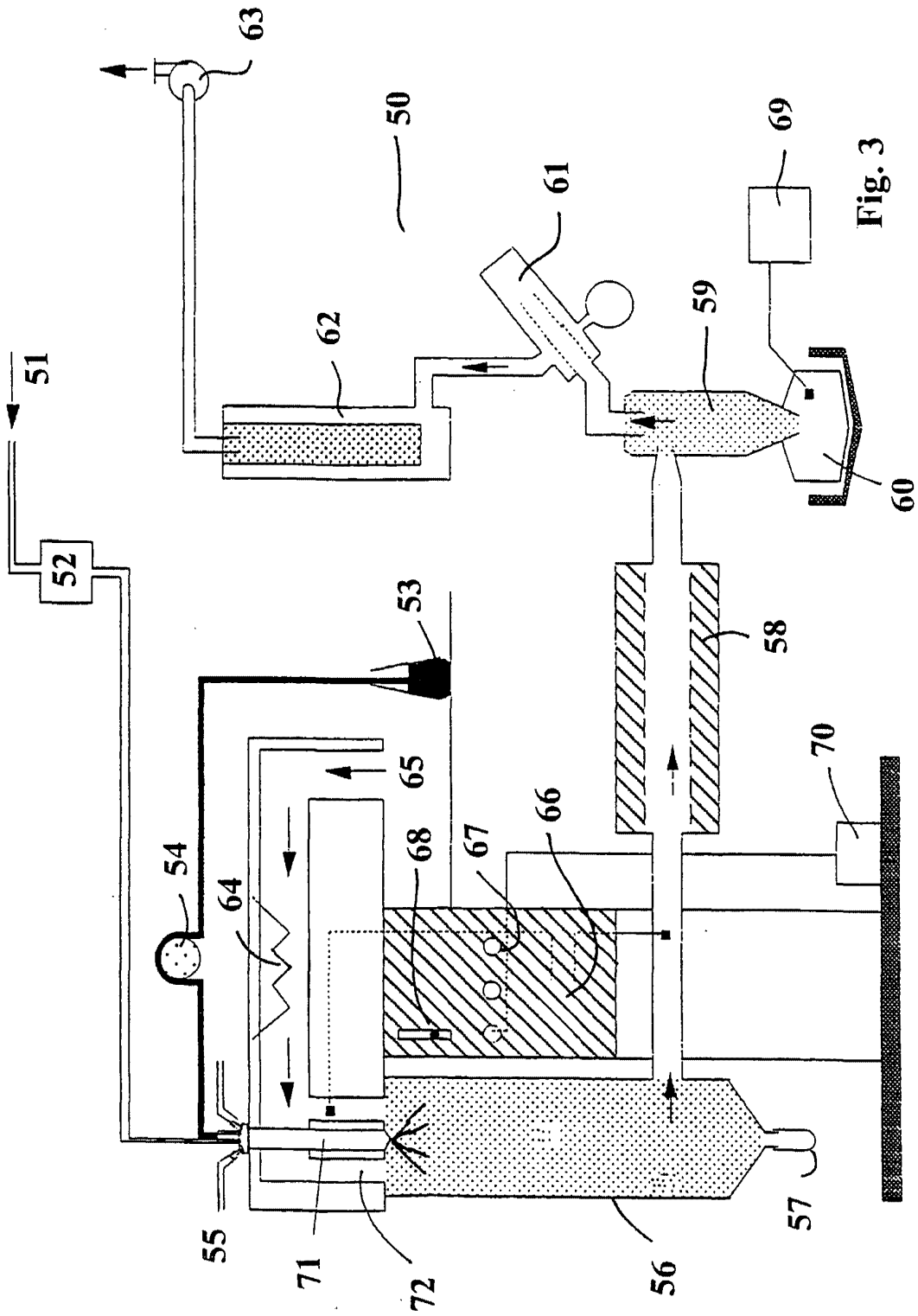

Fig. 3

INTERNATIONAL SEARCH REPORT

International Application No
PCT/EP 99/03599

A. CLASSIFICATION OF SUBJECT MATTER IPC 6 C23C4/10 C23C4/12 C23C14/34		
According to International Patent Classification (IPC) or to both national classification and IPC		
B. FIELDS SEARCHED Minimum documentation searched (classification system followed by classification symbols) IPC 6 C23C		
Documentation searched other than minimum documentation to the extent that such documents are included in the fields searched		
Electronic data base consulted during the international search (name of data base and, where practical, search terms used)		
C. DOCUMENTS CONSIDERED TO BE RELEVANT		
Category *	Citation of document, with indication, where appropriate, of the relevant passages	Relevant to claim No.
X	US 5 196 400 A (CHEN CHIOU T ET AL) 23 March 1993 (1993-03-23) cited in the application column 3, line 52 - column 4, line 16 ---	1-5, 10-14
X	EP 0 330 196 A (PERKIN ELMER CORP) 30 August 1989 (1989-08-30) page 5, line 20 - line 25; claims 1,8 ---	1,2,10, 12-14
X	CH 648 358 A (CASTOLIN SA) 15 March 1985 (1985-03-15) claim 1 ---	1,10, 12-14
X	DD 277 471 A (MANSFELD KOMBINAT W PIECK VEB) 4 April 1990 (1990-04-04) page 2, line 21 - line 23 ---	15,16
	-/--	
<input checked="" type="checkbox"/> Further documents are listed in the continuation of box C. <input checked="" type="checkbox"/> Patent family members are listed in annex.		
* Special categories of cited documents :		
"A" document defining the general state of the art which is not considered to be of particular relevance "E" earlier document but published on or after the international filing date "L" document which may throw doubts on priority claim(s) or which is cited to establish the publication date of another citation or other special reason (as specified) "O" document referring to an oral disclosure, use, exhibition or other means "P" document published prior to the international filing date but later than the priority date claimed		"T" later document published after the international filing date or priority date and not in conflict with the application but cited to understand the principle or theory underlying the invention "X" document of particular relevance; the claimed invention cannot be considered novel or cannot be considered to involve an inventive step when the document is taken alone "Y" document of particular relevance; the claimed invention cannot be considered to involve an inventive step when the document is combined with one or more other such documents, such combination being obvious to a person skilled in the art. "&" document member of the same patent family
Date of the actual completion of the international search <p style="text-align: center;">9 September 1999</p>		Date of mailing of the international search report <p style="text-align: center;">16/09/1999</p>
Name and mailing address of the ISA European Patent Office, P.B. 5818 Patentlaan 2 NL - 2280 HV Rijswijk Tel. (+31-70) 340-2040, Tx. 31 651 epo nl, Fax: (+31-70) 340-3018		Authorized officer <p style="text-align: center;">Patterson, A</p>

Form PCT/ISA210 (second sheet) (July 1992)

INTERNATIONAL SEARCH REPORT

International Application No
PCT/EP 99/03599

C.(Continuation) DOCUMENTS CONSIDERED TO BE RELEVANT		
Category *	Citation of document, with indication, where appropriate, of the relevant passages	Relevant to claim No.
X	DE 40 15 387 A (LEYBOLD AG) 21 November 1991 (1991-11-21) the whole document ---	15, 16
A	EP 0 377 073 A (MITSUBISHI METAL CORP) 11 July 1990 (1990-07-11) page 3, line 41 - line 57; table 2 page 7, line 7 - line 23; table 4 -----	5-8

INTERNATIONAL SEARCH REPORT

International application No.

PCT/EP 99/03599

Box I Observations where certain claims were found unsearchable (Continuation of item 1 of first sheet)

This International Search Report has not been established in respect of certain claims under Article 17(2)(a) for the following reasons:

1. Claims Nos.:
because they relate to subject matter not required to be searched by this Authority, namely:

2. Claims Nos.: 9
because they relate to parts of the International Application that do not comply with the prescribed requirements to such an extent that no meaningful International Search can be carried out, specifically:
SEE FURTHER INFORMATION SHEET

3. Claims Nos.:
because they are dependent claims and are not drafted in accordance with the second and third sentences of Rule 6.4(a).

Box II Observations where unity of invention is lacking (Continuation of item 2 of first sheet)

This International Searching Authority found multiple inventions in this international application, as follows:

SEE FURTHER INFORMATION SHEET

1. As all required additional search fees were timely paid by the applicant, this International Search Report covers all searchable claims.

2. As all searchable claims could be searched without effort justifying an additional fee, this Authority did not invite payment of any additional fee.

3. As only some of the required additional search fees were timely paid by the applicant, this International Search Report covers only those claims for which fees were paid, specifically claims Nos.:

4. No required additional search fees were timely paid by the applicant. Consequently, this International Search Report is restricted to the invention first mentioned in the claims; it is covered by claims Nos.:

Remark on Protest

- The additional search fees were accompanied by the applicant's protest.
 No protest accompanied the payment of additional search fees.

INTERNATIONAL SEARCH REPORT

International Application No. PCT/EP 99 03599

FURTHER INFORMATION CONTINUED FROM PCT/ISA/ 210

This International Searching Authority found multiple (groups of) inventions in this international application, as follows:

1. Claims: 1-8,10-14

Claims for a composite comprising an oxide-containing coating deposited by spraying and having a certain minimum thickness, a sputter target having a layer of a superconductor precursor, also deposited by spraying and having a minimum thickness, and methods for producing each of these products, respectively.

2. Claims: 15,16

Reconditioned sputter target and method for its manufacture by flame or plasma spraying material into the sputtered erosion groove.

The only common concept linking subjects 1 and 2 is the application of spraying for depositing layers of material. Since this feature is known from many prior art documents (see for example search report) there is effectively no common concept to connect the two groups of claims. Furthermore, while subject 1 addresses the problem of producing relatively thick deposits of oxides by means of spraying, subject 2 solves the unrelated problem of spraying an unspecified material to repair local damage on a target.

Therefore there is a lack of unity between the two subjects.

Nevertheless, since the EPO has already searched the subject-matter of claims 15 and 16 in connection with the priority application EP98870120, an International search report is issued for both subjects.

INTERNATIONAL SEARCH REPORT

International Application No. PCT/EP 99 03599

FURTHER INFORMATION CONTINUED FROM PCT/ISA/ 210

Continuation of Box I.2

Claims Nos.: 9

Claim 9 relates to a product defined (inter alia) by reference to the following parameter:

the result of a test involving impact of a ball consisting of an unspecified steel, wherein both the weight of the ball and the height from which it is dropped are arbitrarily chosen.

The use of this parameter in the present context is considered to lead to a lack of clarity within the meaning of Article 6 PCT. It is impossible to compare the parameter the applicant has chosen to employ with what is set out in the prior art. The lack of clarity is such as to render a meaningful complete search impossible. Consequently, the search has been restricted to the remaining claims

The applicant's attention is drawn to the fact that claims relating to inventions in respect of which no international search report has been established need not be the subject of an international preliminary examination (Rule 66.1(e) PCT). The applicant is advised that the EPO policy when acting as an International Preliminary Examining Authority is normally not to carry out a preliminary examination on matter which has not been searched. This is the case irrespective of whether or not the claims are amended following receipt of the search report or during any Chapter II procedure.

INTERNATIONAL SEARCH REPORT

Information on patent family members

International Application No

PCT/EP 99/03599

Patent document cited in search report	Publication date	Patent family member(s)	Publication date
US 5196400 A	23-03-1993	NONE	
EP 0330196 A	30-08-1989	CN 1036286 A JP 1309952 A	11-10-1989 14-12-1989
CH 648358 A	15-03-1985	NONE	
DD 277471 A	04-04-1990	NONE	
DE 4015387 A	21-11-1991	NONE	
EP 0377073 A	11-07-1990	JP 2156079 A JP 2157150 A KR 9507087 B US 5077269 A KR 9507088 B	15-06-1990 15-06-1990 30-06-1995 31-12-1991 30-06-1995

Form PCT/ISA/210 (patent family annex) (July 1992)

TO: Mr. Gary Edwards COMPANY:

PTO 06-6046

German Patent No. DE 37 38 738 C1

POWDER-METALLURGICAL PROCESS FOR THE PREPARATION OF TARGETS

Dr. Stephan Schittny et al.

UNITED STATES PATENT AND TRADEMARK OFFICE
WASHINGTON, D.C. AUGUST 2006
TRANSLATED BY THE MCELROY TRANSLATION COMPANY

FEDERAL REPUBLIC OF GERMANY
GERMAN PATENT OFFICE
PATENT NO. DE 37 38 738 C1
(Patentschrift)

Int. Cl.⁴: B 22 F 7/00
H 01 L 21/203

Filing No.: P 37 38 738.3-24

Filing Date: November 14, 1987

Publication Date of Patent Grant: January 26, 1989

POWDER-METALLURGICAL PROCESS FOR THE PREPARATION OF TARGETS

[Pulvermetallurgisches Verfahren zur Herstellung von Targets]

Inventors: Dr. Stephan Schittny et al.

Patent Holder: Degussa AG

Publications Taken in Consideration
For Judging Patentability: DE 35 37 191 A1

Claims

1. Process for the preparation of highly pure mechanically stable and dense targets of rare earths and the transition metals iron, cobalt and/or nickel for cathode evaporation and vaporization installations by means of the action of pressure and temperature on a corresponding powder mixture in an inert-gas atmosphere or under vacuum, characterized in that the rare earths are inserted with the corresponding transition metals in the form of master alloys.

2. The process of Claim 1, characterized in that master alloys having a eutectic composition are inserted.

Description

The invention pertains to a process for the preparation of highly pure, mechanically stable and dense targets of rare earths and the transition metals iron, cobalt and/or nickel for cathode

evaporation and vaporization installations by means of the action of pressure and temperature on a corresponding powder mixture in an inert-gas atmosphere or under vacuum

Targets are required in installations for cathode evaporation and for the vaporization of objects. With the aid of cathode evaporation (sputtering) and vaporization, a thin layer can be produced on a substrate, the applications for which span from functional layers in electronics and data systems engineering through corrosion-protective layers and anti-abrasion layers to optical layers for decorative and thermic purposes.

In cathode evaporation, an electrical gas discharge occurs between cathode (target) and counter electrode, during which impacting ions eject particles of atomic size from the target, which condense on substrates arranged in the area of the counter electrode.

Either inert gases such as argon or helium, or reactive gases, such as oxygen, nitrogen or acetylene are put in at low pressure as a gas discharge atmosphere.

In inert gas sputtering, the target commonly is composed of the material of which the layer to be formed shall be composed, while in reactive sputtering, ejected target particles react with the reaction gas and are condensed as a layer in the form of a reaction product.

In the vaporization process, the target material is thermally vaporized in a vacuum by means of electron beam heating or resistance heating and deposited as a thin layer on the substrate.

Targets commonly can be prepared using melting technology with corresponding secondary processing by means of non-cutting and tensioning processes or with powder metallurgy, by means of compressing and sintering corresponding powders or powder mixtures.

For target materials, which owing to their composition contain higher portions of brittle phases, preparation processes using melting technology prove to be problematic, since such targets when cooling after casting exhibit fissures owing to thermal stress and can crumble into pieces. In addition, such materials cannot for the most part be mechanically machined, such that certain desirable target geometries cannot be prepared.

Powder-metallurgical processes exhibit problems with those target materials containing higher portions of reaction-sensitive components and that react, e.g., with atmospheric oxygen. Due to the large specific surface area of the powder and the resulting reactivity, high-value target qualities having low oxygen content cannot be produced using powder metallurgy.

In addition, products prepared using powder metallurgy for the most part exhibit a partially open residual porosity, which is intolerable for oxygen sensitive target materials due to the potential oxidation of the entire target.

These preparation difficulties appear particularly for targets containing a predominance of rare earths and transition metals.

A powder-metallurgical process for the preparation of targets of rare earths and the transition metals iron, cobalt and nickel is known from DE-OS 35 37 191, for which a powder mixture of rare earths and the aforementioned transition metals is subjected to hot forming under decreased pressure and under inert gas at temperatures below the eutectic point, with a brittle intermetallic compound developing at the boundary between the rare earth metal and the transition metal. This process has the disadvantage that hot forming must be carried out expensively for a minimum of at least two hours, by means of which noticeable quantities of brittle intermetallic phases are formed, that powder preparation for rare earths is associated with difficulties and that the oxygen content in the powder of rare earths is still relatively high.

It was thus the problem of the present invention to develop a process for the preparation of highly pure, mechanically stable and dense targets of rare earths and the transition metals iron, cobalt and/or nickel for cathode evaporation and vaporization installations by means of the action of pressure and temperature on a corresponding powder mixture in an inert-gas atmosphere or under vacuum that without great technical expense supplies a product containing limited portions of and a fine distribution of brittle phases and as little oxygen as possible.

This problem is solved in accordance with the invention by means of the fact that the rare earths are inserted with the corresponding transition metals in the form of master alloys.

Preferably, master alloys having a eutectic composition are inserted.

Reaction sensitive rare earths are processed into powders and/or shavings not as such, but as master alloys of rare earths and the corresponding transition metals, which in comparison to pure components feature lower melting points, are well intermixed with powders and/or shavings of the transition metals and are compacted into targets. The compacting of said mixture can be carried out by means of sintering, hot-rolling, hot-pressing, hot-forging, high-temperature isostatic pressing or combinations thereof in a vacuum or under inert gas.

The conditions for compacting (temperature, pressure, time, degree of deformation) are selected such that a mechanically stable compound material emerges, the grain structure of which, as a non-equilibrium state, features only limited portions of brittle equilibrium phases formed by means of diffusion at the boundaries of the rare earth phases and the transition metal phases. Through the use of master alloys between rare earths and transition metals, relatively low compacting temperatures and brief compacting times can be selected. This leads to a decreased technical expense and to a limited formation of diffusion zones of brittle non-equilibrium phases at the contact locations of the powder grains and in the grains.

Surprisingly, it has been shown that fundamentally simpler, highly pure and low-oxygen powders or shavings can be prepared out of master alloys of rare earths with corresponding transition metals rather than out of pure rare earths. These master alloys may be used to produce shavings and powders, e.g., by means of machining, such as milling or filing under protective

gas, which is not possible without difficulty with pure rare earth metals, owing to their ductility, even with subsequent grinding. During the comminution process, the brittle phase portions of the most extremely fine grain structure of master alloys causes the formation of particles having a suitable grain shape and grain size distribution, enabling a powder preparation having a good yield and very low oxygen content (< 500 ppm).

Likewise in powder preparation by means of inert gas atomization, lower values of impurities and more limited oxygen content in the powder are achieved from lower melting master alloys owing to lower reaction rates with the crucible material and with the atmosphere at lower process temperatures and owing to the briefer residence time in the installation. Moreover, the atomization parameters (superheating, cooling rates, process gas pressure, etc.) can be optimized to a wide degree, such that the powder yield and the grain fraction can be adjusted more favorably in comparison to atomization of pure rare earths.

Surprisingly, the use of master alloys of rare earths and transition metals leads to compacting times considerably briefer in comparison to those with the use of pure rare earths, signifying a significant economic advantage of this process.

As a rule, compacting times are less than one hour and, more often than not, less than 30 minutes. Apart from this, targets prepared in accordance with the invention exhibit more favorable mechanical and magnetic properties in comparison to targets produced with powder metallurgy from pure metals. As has been shown, this is based on an advantageous distribution of portions present in the grain structure of free iron, cobalt and/or nickel, on the limited quantities of intermetallic phases and on the residual eutectic originating from the master alloys.

The following examples shall explain the process in accordance with the invention in greater detail:

1) In order to prepare highly pure, compact, mechanically stable sputter targets, first a master alloy of 80 atom% terbium and 20 atom% iron is prepared in a vacuum induction oven (10^{-5} Pa). Subsequent pulverization and further processing is carried out exclusively under argon protective gas. With the aid of a wave-milling cutter, the ingot is machined to a coarse powder. A terbium-iron powder having an average grain size $\leq 105 \mu\text{m}$ and having a yield of 70-80% is obtained by means of subsequent grinding in a ball mill. The desired target composition of, e.g., 67 atom% iron, 25 atom% terbium and 8 atom% cobalt is regulated by means of a 20 minute mixing of the corresponding iron, cobalt and master alloy powder quantities in an asymmetric moved mixer.

The processes of high-temperature isostatic pressing (HIP), hot-rolling and hot-forging in a capsule were employed in order to compact the powder mixture into targets.

For high-temperature isostatic pressing, process parameters of 820°C final temperature, 200 Mpa pressure and 20 minute residence time at the final temperature were selected. Sheet

steel cans were used as containers, which prior to being brought into the installation were evacuated at 300°C for over 3 hours. This produces mechanically stable, machinable molding bodies featuring a non-equilibrium grain structure of iron grains, zones of intermetallic phases and residual eutectic. The density is > 99% of the theoretical density, the oxygen content less than 1200 ppm. Longer residence times of, e. g., 1-2 hours at 820°C result in a wide reaching formation of large-surface zones of the intermetallic equilibrium phases, which causes an undesirable brittleness of the grain structure. It is for this reason that residence times as brief as possible are to be observed.

For compacting by means of hot-rolling, the powder mixture is filled in a sheet iron capsule, which is evacuated and welded shut. Conversion occurs at 650°C up to a degree of conversion of approximately 60% in several passes in a period of few minutes. After removal of the capsule material, a stable, highly pure target is yielded having a density of \approx 99% of the theoretical density and an oxygen content of 1200 ppm. The grain structure is of a form similar to that for compacting by means of high-temperature isostatic pressing.

For hot-forging, the powder mixture likewise is filled in a sheet steel can and evacuated. The forging process can be carried out at 800°C in a 200 ton forge. The achievable density is, at 60% conversion \approx 99% of the theoretical density.

2. A different type of powder preparation is atomization of a melt in an inert-gas flow. For the use of low-melting point master alloys of the composition 66 atom% gadolinium, 18 atom% iron and 16 atom% cobalt having a melting temperature of approximately 620°C, an atomizing temperature of 700-800°C can be selected. This comparatively very low atomizing temperature enables, for extremely reactive rare earth materials, the preparation of low-oxygen, very pure master alloy powders, since the reaction of the melt with the crucible material and with the atmosphere is comparatively limited. Moreover, the master alloy melt exhibits a favorable viscosity and surface tension at these temperatures, such that the atomized powder features good yields of e.g., 80-90% at a grain size \leq 88 μm . With the aid of the mixing and compacting processes described in Example 1, highly pure, compact, stable molding bodies having oxygen contents < 1000 ppm likewise are obtained. The non-equilibrium grain structures in turn are composed of iron grains, zones of intermetallic phases and residual eutectic.

Since the intermetallic phases are present in a fine distribution in the master alloys, and the grain structure is not very brittle, the blend portion of free iron can be reduced in comparison with the intermetallic phases by varying the composition of the master alloys. The magnetic properties of the targets, which are important for magnetron sputtering, can be improved by said means.

19 BUNDESREPUBLIK
DEUTSCHLAND



DEUTSCHES
PATENTAMT

12 Patentschrift
11 DE 3738738 C1

51 Int. Cl. 4:
B22F 7/00
H 01 L 21/203

21 Aktenzeichen: P 37 38 738.3-24
22 Anmeldetag: 14. 11. 87
43 Offenlegungstag: —
45 Veröffentlichungstag
der Patenterteilung: 26. 1. 89

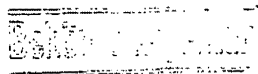

DE 3738738 C1

Innerhalb von 3 Monaten nach Veröffentlichung der Erteilung kann Einspruch erhoben werden

73 Patentinhaber:
Degussa AG, 6000 Frankfurt, DE

72 Erfinder:
Schittny, Stephan, Dr.-Ing., 8755 Alzenau, DE;
Berchtold, Lorenz, Dr.-Ing., 6450 Hanau, DE; Haußelt,
Jürgen, Dr.-Ing., 8755 Alzenau, DE; Kaster,
Wolfgang, Dipl.-Ing., 5449 Mörsdorf, DE; Englisch,
Udo, 6458 Rodenbach, DE

55 Für die Beurteilung der Patentfähigkeit
in Betracht gezogene Druckschriften:
DE 35 37 191 A1

54 Pulvermetallurgisches Verfahren zur Herstellung von Targets

Zur Herstellung von hochreinen, mechanisch stabilen und dichten Targets aus seltenen Erden und den Übergangsmetallen Eisen, Kobalt und Nickel auf pulvermetallurgischem Weg vermeidet man hohe Gehalte und ungünstige Verteilungen an spröden Phasen und größere Sauerstoffgehalte im Werkstoff durch Verwendung von Vorlegierungen aus seltenen Erden und den Übergangsmetallen anstelle reinen seltenen Erden.

DE 3738738 C1

Patentansprüche

1. Verfahren zur Herstellung von hochreinen mechanisch stabilen und dichten Targets für Kathodenzerstäubungs- und Bedampfanlagen aus Seltenen Erden und den Übergangsmetallen Eisen, Kobalt und/oder Nickel durch Einwirkung von Druck und Temperatur auf entsprechende Pulvergemische in Inertgasatmosphäre oder unter Vakuum, dadurch gekennzeichnet, daß die Seltenen Erden in Form von Vorlegierungen mit den entsprechenden Übergangsmetallen eingesetzt werden.
2. Verfahren nach Anspruch 1, dadurch gekennzeichnet, daß Vorlegierungen mit eutektischer Zusammensetzung eingesetzt werden.

Beschreibung

Die Erfindung betrifft ein Verfahren zur Herstellung von hochreinen, mechanisch stabilen und dichten Targets für Kathodenzerstäubungs- und Bedampfanlagen aus Seltenen Erden und den Übergangsmetallen Eisen, Kobalt und/oder Nickel durch Einwirkung von Druck und Temperatur auf entsprechende Pulvergemische in Inertgasatmosphäre oder unter Vakuum.

Targets werden in Anlagen zur Kathodenzerstäubung und zur Bedampfung von Gegenständen benötigt. Mit Hilfe der Kathodenzerstäubung (Sputtern) und des Bedampfens können dünne Schichten auf Substraten erzeugt werden, deren Anwendung von funktionalen Schichten in der Elektronik und Datentechnik über Korrosions- und Verschleißschutzschichten bis zu optischen Schichten für dekorative und wärmetechnische Zwecke reicht.

Beim Kathodenzerstäuben findet zwischen Kathode (Target) und Gegenelektrode eine elektrische Gasentladung statt, bei der von den aufprallenden Ionen aus dem Target Teilchen von atomarer Größe herausgeschlagen und auf Substraten, die im Bereich der Gegenelektrode angeordnet sind, niedergeschlagen werden.

Als Gasentladungsatmosphäre werden entweder inerte Gase, wie beispielsweise Argon oder Helium, oder reaktive Gase, wie z. B. Sauerstoff, Stickstoff oder Acetylen, bei geringem Druck eingesetzt.

Beim Inertgassputtern besteht das Target üblicherweise aus dem Material, aus dem die zu bildende Schicht bestehen soll, während beim Reaktivputtern die herausgeschlagenen Targetteilchen mit dem Reaktionsgas reagieren und in Form eines Reaktionsproduktes als Schicht niedergeschlagen werden.

Bei den Bedampfungsverfahren wird das Targetmaterial im Vakuum durch Elektronenstrahl- oder Widerstandsbeheizung thermisch verdampft und als dünne Schicht auf dem Substrat abgeschieden.

Die Targets können üblicherweise schmelztechnisch hergestellt werden mit entsprechender Nachbearbeitung durch umformende und spannende Verfahren, oder pulvermetallurgisch durch Pressen und Sintern entsprechender Pulver bzw. Pulvergemische.

Bei Targetmaterialien, die aufgrund ihrer Zusammensetzung höhere Anteile an spröden Phasen enthalten, erweisen sich schmelztechnische Herstellverfahren als problematisch, da solche Targets beim Abkühlen nach dem Gießen aufgrund von thermischen Spannungen Risse aufweisen und in Stücke zerfallen können. Darüber hinaus sind solche Materialien meist nicht mechanisch bearbeitbar, so daß bestimmte wünschenswerte Targetgeometrien nicht herstellbar sind.

Pulvermetallurgische Verfahren zeigen bei denjenigen Targetmaterialien Probleme, die höhere Anteile an reaktionsempfindlichen Komponenten enthalten, und z. B. mit dem Luftsauerstoff reagieren. Wegen der großen spezifischen Oberfläche der Pulver und der daraus resultierenden Reaktionsfreudigkeit lassen sich keine hochwertigen Targetqualitäten mit niedrigem Sauerstoffgehalt pulvermetallurgisch herstellen.

Außerdem weisen pulvermetallurgisch hergestellte Produkte meist eine zum Teil offene Restporosität auf, die bei sauerstoffempfindlichen Targetmaterialien wegen der möglichen Oxidation des gesamten Targets nicht tolerierbar ist.

Diese Herstellungsschwierigkeiten treten insbesondere bei Targets auf, die überwiegend Seltene Erden und Übergangsmetalle enthalten.

Aus der DE-OS 35 37 191 ist ein pulvermetallurgisches Verfahren zur Herstellung von Targets aus Seltenen Erden und den Übergangsmetallen Eisen, Kobalt und Nickel bekannt, bei dem ein Pulvergemisch aus Seltenen Erden und den genannten Übergangsmetallen unter vermindertem Druck und unter Inertgas bei Temperaturen unterhalb des eutektischen Punktes einer Warmverformung unterzogen wird, wobei sich eine spröde intermetallische Verbindung an der Grenzfläche zwischen dem Seltenen Erdmetall und dem Übergangsmetall ausbildet. Dieses Verfahren hat den Nachteil, daß die Warmverformung aufwendig mindestens zwei Stunden lang erfolgen muß, wodurch sich bemerkbare Mengen an spröden intermetallischen Phasen bilden, daß die Pulverherstellung bei den Seltenen Erden mit Schwierigkeiten verbunden ist und der Sauerstoffgehalt im Pulver der Seltenen Erden noch relativ hoch ist.

Es war daher Aufgabe der vorliegenden Erfindung, ein Verfahren zur Herstellung von hochreinen, mechanisch stabilen und dichten Targets für Kathodenzerstäubungs- und Bedampfanlagen aus Seltenen Erden und den Übergangsmetallen Eisen, Kobalt und/oder Nickel durch Einwirkung von Druck und Temperatur auf entsprechende Pulvergemische in Inertgasatmosphäre oder unter Vakuum zu entwickeln, das ohne großen technischen Aufwand ein Produkt liefert, das geringe Anteile und eine feine Verteilung an spröden Phasen und möglichst wenig Sauerstoff enthält.

Diese Aufgabe wird erfindungsgemäß dadurch gelöst, daß die Seltenen Erden in Form von Vorlegierungen mit den entsprechenden Übergangsmetallen eingesetzt werden.

Vorzugsweise werden Vorlegierungen mit eutektischer Zusammensetzung eingesetzt.

Die reaktionsempfindlichen Seltenen Erden werden nicht als solche, sondern als Vorlegierungen aus Seltenen Erden und den entsprechenden Übergangsmetallen, die im Vergleich zu den reinen Komponenten niedrigere Schmelzpunkte aufweisen, zu Pulvern und/oder Spänen verarbeitet, mit Pulvern und/oder Spänen der Übergangsmetalle gut durchmischt und zu Targets kompaktiert. Die Kompaktierung dieser Mischung kann durch Sintern, Warmwalzen, Heißpressen, Warmschmieden, Heißisostatische Preßverfahren oder Kombinationen daraus im Vakuum oder unter Inertgas erfolgen.

Die Kompaktierungsbedingungen (Temperatur, Druck, Zeit, Umformungsgrad) werden so gewählt, daß ein mechanisch stabiles Verbundmaterial entsteht, dessen Gefüge als Ungleichgewichtszustand nur geringe Anteile an spröden Gleichgewichtsphasen aufweist, die durch Diffusion an den Grenzflächen der Seltenen Erdphasen und der Übergangsmetallphasen gebildet wer-

den. Durch die Verwendung von Vorlegierungen zwischen Seltenen Erden und Übergangsmetallen können relativ niedrige Kompaktierungstemperaturen und kurze Kompaktierungszeiten ausgewählt werden. Das führt zu einem verminderten technischen Aufwand und zu einer geringen Ausbildung von Diffusionszonen aus spröden Ungleichgewichtsphasen an den Berührungstellen der Pulverkörner und in den Körnern.

Es hat sich überraschenderweise gezeigt, daß aus Vorlegierungen der Seltenen Erden mit den entsprechenden Übergangsmetallen wesentlich einfacher, hochreine und sauerstoffarme Pulver oder Späne herstellbar sind als aus den reinen Seltenen Erden. Aus diesen Vorlegierungen lassen sich z. B. durch spanende Bearbeitung, wie Fräsen oder Feilen, unter Schutzgas Späne und Pulver erzeugen, was bei den reinen Seltenen Erd-Metallen auf Grund ihrer Duktilität auch mit nachfolgendem Mahlen nicht ohne Schwierigkeiten möglich ist. Die spröden Phasenanteile des äußerst feinen Gefüges der Vorlegierungen bewirken beim Zerkleinerungsvorgang die Bildung von Partikeln mit geeigneter Kornform und Korngrößenverteilung, so daß eine Pulverherstellung mit guter Ausbeute und sehr niedrigem Sauerstoffgehalt (< 500 ppm) möglich ist.

Ebenso werden bei der Pulverherstellung durch Inertgasverdüsen aus den niedriger schmelzenden Vorlegierungen aufgrund der bei den tieferen Prozeßtemperaturen geringeren Reaktionsgeschwindigkeiten mit dem Tiegelmateriale und mit der Atmosphäre und aufgrund der kürzeren Verweilzeit in der Anlage, niedrigere Werte an Verunreinigungen und geringere Sauerstoffgehalte im Pulver erzielt. Desweiteren lassen sich hier die Verdüsungparameter (Überhitzung, Abkühlrate, Prozeßgasdruck usw.) in weiten Maßen optimieren, so daß die Pulverausbeute und die Kornfraktion im Vergleich zur Verdüsung der reinen Seltenen Erden günstiger eingestellt werden können.

Die Verwendung von Vorlegierungen aus Seltenen Erden und Übergangsmetallen führt im Vergleich zur Verwendung der reinen Seltenen Erden überraschenderweise zu wesentlich kürzeren Kompaktierungszeiten, was einen bedeutenden wirtschaftlichen Vorteil dieses Verfahrens bedeutet.

Die Kompaktierungszeiten liegen in der Regel unterhalb einer Stunde, meist unterhalb von 30 Minuten. Darüber hinaus zeigen die erfindungsgemäß hergestellten Targets im Vergleich zu Targets, die pulvermetallurgisch aus den reinen Metallen hergestellt wurden, günstigere mechanische und magnetische Eigenschaften. Dies beruht, wie sich gezeigt hat, auf einer vorteilhaften Verteilung der im Gefüge vorhandenen Anteile an freiem Eisen, Kobalt und/oder Nickel, an den geringen Mengen intermetallischer Phasen und an dem aus den Vorlegierungen stammenden Resteutektikum.

Die folgenden Beispiele sollen das erfindungsgemäße Verfahren näher erläutern:

1) Zur Herstellung von hochreinen, kompakten, mechanisch stabilen Sputtertargets wird zuerst eine Vorlegierung aus 80 Atom% Terbium und 20 Atom% Eisen in einem Vakuuminduktionsofen (10^{-5} Pa) hergestellt. Die anschließende Pulverisierung und Weiterverarbeitung erfolgt ausschließlich unter Argon-Schutzgas. Mit Hilfe eines Wellenfräasers wird der Gußblock zu grobem Pulver zerspant. Durch anschließendes Mahlen in einer Kugelmühle erhält man ein Terbium-Eisenpulver mit einer mittleren Korngröße ≤ 105 μm und mit einer Ausbeute

von 70–80%. Die gewünschte Targetzusammensetzung von z. B. 67 Atom% Eisen, 25 Atom% Terbium und 8 Atom% Kobalt wird durch 20 minütiges Mischen der entsprechenden Eisen-, Kobalt- und Vorlegierungspulvermengen in einem Taumelmischer eingestellt.

Zum Kompaktieren der Pulvermischung zu Targets wurden die Verfahren des Heißisostatischen Pressens (HIP) des Warmwalzens und des Heißschmiedens in einer Kapsel angewendet.

Beim Heißisostatischen Pressen werden als Prozeßparameter 820°C Endtemperatur, 200 MPa Druck und 20 min Haltezeit bei Endtemperatur gewählt. Als Behälter wurden Stahlblechkannen verwendet, die vor Einbringen in die Anlage bei 300°C über 3 Stunden evakuiert wurden. Man erhält auf diese Weise mechanisch stabile, bearbeitbare Formkörper, die ein Ungleichgewichtsgefüge aus Eisenkörnern, Zonen von intermetallischen Phasen und Resteutektikum aufweisen. Die Dichte ist $> 99\%$ der theoretischen Dichte, der Sauerstoffgehalt liegt unterhalb 1200 ppm. Längere Haltezeiten von z. B. 1–2 Stunden bei 820°C haben eine weitgehende Ausbildung von großflächigen Zonen der intermetallischen Gleichgewichtsphasen zur Folge, was eine unerwünschte Versprödung des Gefüges bedingt. Es sind daher möglichst kurze Haltezeiten einzuhalten.

Für das Kompaktieren durch Warmwalzen wird das Pulvergemisch in eine Eisenblechkapsel eingefüllt, die evakuiert und zugeschweißt wird. Die Umformung erfolgt bei 650°C bis zu einem Umformgrad von ca. 60% in mehreren Stichen in einem Zeitraum von wenigen Minuten. Nach Enternen des Kapselmateriale ergibt sich ein stabiles, hochreines Target mit einer Dichte von $\approx 99\%$ der theoretischen Dichte und einem Sauerstoffgehalt von 1200 ppm. Das Gefüge ist ähnlich ausgebildet wie bei der Kompaktierung durch Heißisostatisches Pressen.

Beim Heißschmieden wird die Pulvermischung ebenfalls in eine Blechkanne gefüllt und evakuiert. Der Schmiedevorgang kann bei 800°C in einer 200 to Schmelze durchgeführt werden. Die erzielbare Dichte beträgt bei 60% Umformung $\approx 99\%$ der theoretischen Dichte.

2. Eine andere Art der Pulverherstellung ist das Verdüsen einer Schmelze im Inertgasstrom. Bei Benutzung von niedrigschmelzenden Vorlegierungen der Zusammensetzung 66 Atom% Gadolinium, 18 Atom% Eisen und 16 Atom% Kobalt mit einer Schmelztemperatur von ca. 620°C kann eine Verdüsungstemperatur von 700–800°C gewählt werden. Diese vergleichsweise sehr niedrige Verdüsungstemperatur ermöglicht bei den extrem reaktionsfreudigen Seltenen Erd-Materialien die Herstellung von sauerstoffarmen, sehr reinen Vorlegungspulvern, da die Reaktion der Schmelze mit dem Tiegelmateriale und der Atmosphäre vergleichsweise gering ist. Des weiteren zeigt die Vorlegungsschmelze bei dieser Temperatur eine günstige Viskosität und Oberflächenspannung, so daß die verdüsten Pulver gute Ausbeuten von z. B. 80–90% bei einer Korngröße ≤ 88 μm aufweisen. Mit Hilfe der in Beispiel 1 beschriebenen Misch- und Kompaktierungsverfahren erhält man ebenfalls hochreine, kompakte, stabile Formkörper mit Sauerstoffgehalten < 1000 ppm. Die Ungleichge-

wichtsgefüge bestehen wiederum aus Eisenkörnern, Zonen von intermetallischen Phasen und Resteutektikum.

Da die intermetallischen Phasen in den Vorlegierungen fein verteilt vorliegen, und das Gefüge nicht sehr verspröden, lassen sich die Mengenanteile an freiem Eisen im Vergleich zu den intermetallischen Phasen durch Variation der Zusammensetzung der Vorlegierungen reduzieren. Die magnetischen Eigenschaften der Targets, die für das Magnetron-sputtern wichtig sind, lassen sich hierdurch verbessern.

15

20

25

30

35

40

45

50

55

60

65

MACHINE-ASSISTED TRANSLATION (MAT):

(19)【発行国】 日本国特許庁（JP）	(19)[ISSUING COUNTRY] Japan Patent Office (JP)
(12)【公報種別】 公開特許公報（A）	(12)[GAZETTE CATEGORY] Laid-open Kokai Patent (A)
(11)【公開番号】 特開平 5-230642	(11)[KOKAI NUMBER] Unexamined Japanese Patent Heisei 5-230642
(43)【公開日】 平成5年（1993）9月7日	(43)[DATE OF FIRST PUBLICATION] September 7, Heisei 5 (1993. 9.7)
(54)【発明の名称】 スパッタ・ターゲット	(54)[TITLE OF THE INVENTION] Sputter target
(51)【国際特許分類第5版】 C23C 14/34 8414-4K H01J 37/08 9069-5E 37/30 9172-5E	(51)[IPC 5] C23C 14/34 8414-4K H01J 37/08 9069-5E 37/30 Z 9172-5E Z
【審査請求】 未請求	[REQUEST FOR EXAMINATION] No
【請求項の数】 2	[NUMBER OF CLAIMS] 2
【全页数】 3	[NUMBER OF PAGES] 3
(21)【出願番号】 特願平 4-69981	(21)[APPLICATION NUMBER] Japanese Patent Application Heisei 4-69981

(22) 【出願日】 (22)[DATE OF FILING]
平成4年(1992)2月21日 February 21, Heisei 4 (1992. 2.21)
日

(71) 【出願人】 (71)[PATENTEE/ASSIGNEE]

【識別番号】 [ID CODE]
000226688 000226688

【氏名又は名称】 [NAME OR APPELLATION]
日新ハイボルテージ株式会社 Nissin-High Voltage Co., Ltd.

【住所又は居所】 [ADDRESS OR DOMICILE]
京都府京都市右京区梅津高畝町
47番地

(72) 【発明者】 (72)[INVENTOR]

【氏名】 [NAME OR APPELLATION]
馬場 隆 Baba, Takashi

【住所又は居所】 [ADDRESS OR DOMICILE]
京都府京都市右京区梅津高畝町
47番地 日新ハイボルテージ
株式会社内

(72) 【発明者】 (72)[INVENTOR]

【氏名】 [NAME OR APPELLATION]
武山 邦彦 Takeyama, Kunihiko

【住所又は居所】 [ADDRESS OR DOMICILE]
京都府京都市右京区梅津高畝町
47番地 日新ハイボルテージ
株式会社内

(74) 【代理人】

(74)[AGENT]

【弁理士】

[PATENT ATTORNEY]

【氏名又は名称】

[NAME OR APPELLATION]

成田 擴其

Narita, Hiroshi

(57) 【要約】

(57)[ABSTRACT OF THE DISCLOSURE]

【目的】

[PURPOSE]

ターゲット材の加熱による割れを防止すること。

Prevent the crack by heat of a target material.

【構成】

[CONSTITUTION]

所要の元素を含むターゲット材 1 はボンディング材 2 によってバックングプレート 3 に固着されている。ターゲット材 1 にスリ割り溝（或いは切り込み、カッティングによる溝）4 を設け、ターゲット材 1 を多数の小区画 1₁ に分割する。ターゲット材の厚さ方向位置での伸びの差等が小さくなり、ターゲット材の割れを防ぐことができる。予め作っておいたターゲット材の小片をバックングプレートに貼り付けても良い。

The target material 1 containing a required element adheres to the backing plate 3 by the bonding material 2.

It provides the offset rate slot (or an incision, the slot by cutting) 4 in a target material 1, and partitions a target material 1 into many subsection 1₁.

The difference of the elongation in the thickness direction position of a target material etc. becomes smaller, it can prevent the crack of a target material.

It is sufficient to bond on a backing plate the fragment of the target material made beforehand.

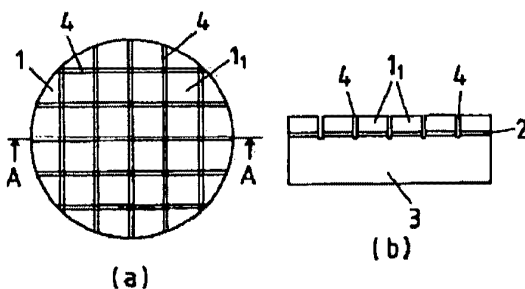

【特許請求の範囲】**[CLAIMS]****【請求項 1】**

バックングプレートに固着されたターゲット材がスリ割り溝によって多数の小区画に分割されているか、又はターゲット材の多数の小片がタイル貼り状にバックングプレートに固着されていることを特徴とするスパッタ・ターゲット。

[CLAIM 1]

A sputter target, in which the target material which adhered to the backing plate is partitioned into many subsections by the offset rate slot, or many fragments of a target material adhere to the backing plate in the shape of a tile sticking.

【請求項 2】

請求項 1 のスパッタ・ターゲットを備えていることを特徴とするスパッタ型イオン源。

[CLAIM 2]

A sputter type ion source, which has the sputter target of Claim 1.

【発明の詳細な説明】**[DETAILED DESCRIPTION OF THE INVENTION]****【0001】****[0001]****【産業上の利用分野】**

本発明は、加熱によるターゲット材の割れを防いだスパッタ型イオン源等に用いるスパッタ・ターゲットに関する。

[INDUSTRIAL APPLICATION]

This invention relates to the sputter target which is used for the sputter type ion source which prevents the crack of the target material by heat.

【0002】**[0002]****【従来技術】**

スパッタ型イオン源、イオンビームスパッタリング装置等におけるスパッタ・ターゲットは、

[PRIOR ART]

As shown in the front elevation of FIG.4(a), and sectional drawing of said (b) in the A-A, the sputter target in a sputter type ion source, an

図4 (a) の正面図、そのA-A線での同 (b) の断面図に示すように、プラズマイオン、イオンビームでスパッタされる所要の元素を含む板状のターゲット材1をボンディング材2によってバックングプレート3に固着して構成されている。ターゲット材1はスパッタ時、周囲のプラズマとプラズマイオン、或いはイオンビームの衝撃により加熱されるから、その冷却のためにバックングプレート3は冷却ホルダーに取り付けられている。

ion-beam-sputtering apparatus, etc. adheres to a backing plate 3, and the bonding material 2 comprises the tabular target material 1 containing the required element by which a sputter is carried out from a plasma ion and an ion beam.

A target material 1 is heated by the shock of the surrounding plasma, a plasma ion, or an ion beam at the time of a sputter, therefore

The backing plate 3 is attached to the cooling holder for the cooling.

【0003】

[0003]

【発明が解決しようとする課題】

かかるスパッタ・ターゲットのサイズが直径50mm程度の大きさのものになると、ターゲット材1が熱伝導の悪い材質の場合には、スパッタ時、ターゲット材1の厚み方向位置での熱膨張による伸びに大きな差が生じる等の理由により、ターゲット材が割れてしまうことがある。

[PROBLEM TO BE SOLVED BY THE INVENTION]

When the size of this sputter target becomes the size which is diameter 50 mm degree and a target material 1 is the bad material of a heat conduction, a target material may break for the reasons of a big difference arising on the elongation by the thermal expansion in the thickness direction position of a target material 1 at the time of a sputter.

【0004】

[0004]

本発明は、プラズマやイオンによる加熱で、ターゲット材が割れることを防止したスパッタ・ターゲットの提供を目的とするものである。

This invention aims to provide the sputter target which prevents the crack of a target material by heating by the plasma or an ion.

【0005】

【課題を解決するための手段】
 本発明は、スパッタ・ターゲットにおいて、バックングプレートに固着されたターゲット材がスリ割り溝によって多数の小区面に分割されているか、又は、ターゲット材の多数の小片がタイル貼り状にバックングプレートに固着されていることを主たる特徴とするものであり、そして、かかるスパッタ・ターゲットをスパッタ型イオン源に用いたことを特徴とするものである。

[0005]

[MEANS TO SOLVE THE PROBLEM]

As for this invention, in a sputter target, the target material which adhered to the backing plate is partitioned into many subsections by the offset rate slot, or many fragments of a target material adhere to a backing plate in the shape of a tile sticking.

And this sputter target is used for the sputter type ion source.

It is characterized by the above-mentioned.

【0006】

【作用】
 ターゲット材がスリ割り或いは小片のタイル貼り形式により、小さく分割されているから、各分割域における加熱による熱膨張が他の分割域に波及することがないから、ターゲット材の厚み方向位置での伸びの差等が小さく抑えられ、スパッタ・ターゲットの割れが生じない。そして、かかるターゲットをスパッタ型イオン源に用いることにより、イオンビームが安定して引出せる。

[0006]

[OPERATION]

The target material is small partitioned according to an offset rate or the tile sticking form of a fragment, therefore

Since the thermal expansion by the heat in each partition region does not affect another partition region, the difference of the elongation in the thickness direction position of a target material etc. is restrained small, the crack of a sputter target does not arise.

And it can pull out an ion beam with stability by using this target for a sputter type ion source.

【0007】

[0007]

【実施例】

本考案の実施例について図面を参照して説明する。図1(a)、

(b)はスリ割り形式によるスパッタ・ターゲットの正面図及びそのA-A線での断面図である。バックングプレート3にボンディング材2で固着されたターゲット材1に、基盤の目状にスリ割り溝(スリ割りないし切り込み、カッティングによる溝)4を設け、ターゲット材1を一边が10mm程度の多数の小区画1₁に小分割する。スリ割り溝4は、少なくともターゲット材部分に形成されていれば充分であるが、図1(b)ではバックングプレート3にまで達しているものを示している。

【0008】

図2(a)、(b)はタイル貼り形式のスパッタ・ターゲットの正面図とそのA-A線での断面図であり、予めターゲット材を一边が10mm程度の小片1₂に分割しておき、かかる多数のターゲット材の小片1₂をボンディング材2によって、タイル貼り形式でバックングプレート3に固着する。

【0009】

このように、ターゲット材1は、何れも一边が10mm程度の小区画ないしは小片1₁、1₂に分

[EXAMPLES]

With reference to drawing, it demonstrates the Example of this design.

FIG. 1 (a), (b) is the front elevation of the sputter target by offset rate form, and sectional drawing in the A-A.

It provides the offset rate slot (an offset rate or an incision, slot by cutting) 4 in the target material 1 which adhered to the backing plate 3 by the bonding material 2 in a grid pattern, and one side small-partitions a target material 1 into many subsection 1₁ which are 10 mm level.

If the offset rate slot 4 is formed in the target material part at least, it is enough.

However, FIG.1(b) shows what has reached even the backing plate 3.

[0008]

FIG. 2 (a), (b) is the front elevation and sectional drawing in an A-A of the sputter target of tile sticking form.

One side partitions the target material into fragment 1₂ which is 10 mm level beforehand, and it adheres fragment 1₂ of the target material of these many to a backing plate 3 in tile sticking form by the bonding material 2.

[0009]

Thus, the target material 1 is partitioned into the subsection whose one side is all 10 mm level or fragment 1₁, and 1₂, therefore

割されているから、ターゲット材1のスパッタ時に発熱、加熱が生じて、ターゲット材等の熱膨張は、各小区画、小片1₁、1₂内に限定されて、他の部分には波及せず、各小区画、小片1₁、1₂の厚み方向位置での伸びの差は小さく抑えられるから、ターゲット材に割れが発生しない。

【0010】

プラズマ・スパッタ型負イオン源では、スパッタ・ターゲット表面で発生した負イオンをイオン源の出口にビームとして集束させるために、スパッタ・ターゲットの表面を球面状にえぐった形とする場合がある。このようにすると、ターゲット材の周辺部では、その厚みは5mm程度に達し、スパッタ材が割れる可能性が高くなる。図3(a)及び(b)は、かかる負イオン源のスパッタ・ターゲットにスリ割りを実施したものの正面図と、そのA-A線での断面図である。図1に示したものと同様に、表面が球面状にえぐられたターゲット材1をボンディング材2によってバックアッププレート3に固着しておき、スリ割り溝4を形成することによって、ターゲット材1を多数の小区画に分割する。加熱によるスパッタ・ターゲットの割れが防止で

Even if heat generation and heat arise at the time of the sputter of a target material 1, thermal expansion, such as a target material, is limited in each subsection, fragment 1₁, and 1₂, it does not affect the other part but the difference of the elongation in the thickness direction position of each subsection, fragment 1₁, and 1₂ is restrained small, therefore A crack does not occur in a target material.

[0010]

In the source of a plasma sputter type negative ion, in order to converge as a beam the negative ion generated on the sputter target surface on the outlet of an ion source, it may make the surface of a sputter target into the form scooped out to the spherical shape.

If it does in this way, in the periphery part of a target material, the thickness will amount to 5 mm level, possibility that a sputter material will break becomes higher.

Although FIG.3(a) and (b) implemented the offset rate at the sputter target of this source of a negative ion, they are a front elevation and sectional drawing in the A-A.

It partitions a target material 1 into many subsections by the surface's adhering to the backing plate 3 the target material 1 scooped out by the spherical shape by the bonding material 2 like what was shown in FIG. 1, and forming the offset rate slot 4.

It can prevent the crack of the sputter target by heat, therefore

It becomes possible to pull out a beam more stably than an ion source.

きるから、イオン源より安定にビームを引出すことが可能になる。図2と同様に、タイル貼り形式を実施してもよい。

It is sufficient to implement tile sticking form like FIG. 2.

【0011】

[0011]

【発明の効果】

本発明は以上説明したように、ターゲット材が小さく分割されているから、スパッタ時に、ターゲット材における厚み方向の熱膨張による伸びの差等を小さく抑えることができ、ターゲット材の割れを防止することができる。

[ADVANTAGE OF THE INVENTION]

As for this invention, as explained above, the target material is partitioned small, therefore At the time of a sputter, it can restrain small the difference of the elongation by the thermal expansion of the thickness direction in a target material etc., and can prevent the crack of a target material.

【0012】

そして、本発明によるスパッタ・ターゲットをイオン源に用いることにより、イオンビームを安定に引出すことができ、特に表面が球面状にえぐられたスパッタ・ターゲットの場合に効果的である。

[0012]

And in the case of the sputter target with which it could pull out the ion beam stably, and particularly the surface was scooped out by the spherical shape, it is effective by using the sputter target by this invention for an ion source.

【図面の簡単な説明】

[BRIEF DESCRIPTION OF THE DRAWINGS]

【図1】

本発明の実施例の正面図及び断面図である。

[FIG. 1]

It is the front elevation and sectional drawing of an Example of this invention.

【図2】

他の実施例の正面図及び断面図である。

[FIG. 2]

It is the front elevation and sectional drawing of another Example.

【図 3】
 更に他の実施例の正面図及び断面図である。

[FIG. 3]
 Furthermore, it is the front elevation and sectional drawing of another Example.

【図 4】
 従来のスパッタ・ターゲットの正面図及び断面図である。

[FIG. 4]
 It is the front elevation and sectional drawing of a sputter target of the past.

【符号の説明】
 1,1₁,1₂ ターゲット材
 2 ボンディング材
 3 バックングプレート
 4 スリ割り溝

[DESCRIPTION OF SYMBOLS]
 1,1₁,1₂ target material
 2 Bonding material
 3 Backing plate
 4 Offset rate slot

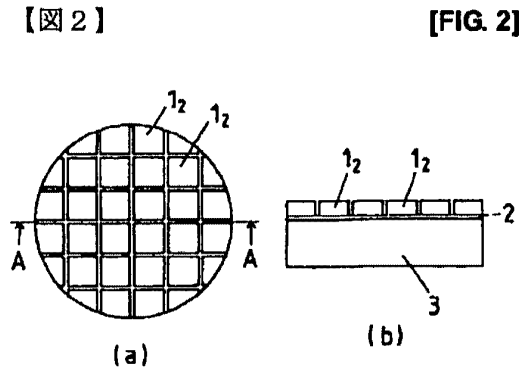
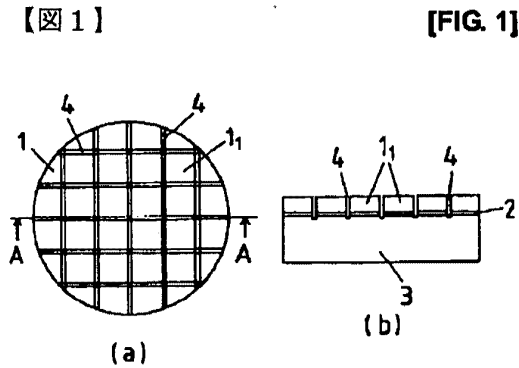

【図 3】

[FIG. 3]

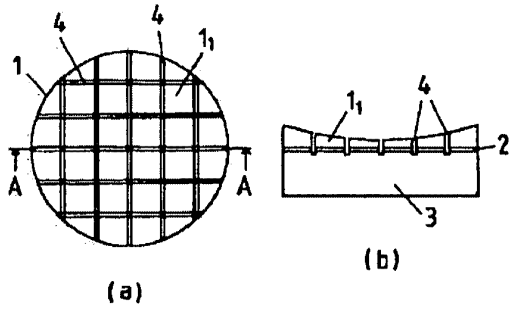

【図 4】

[FIG. 4]

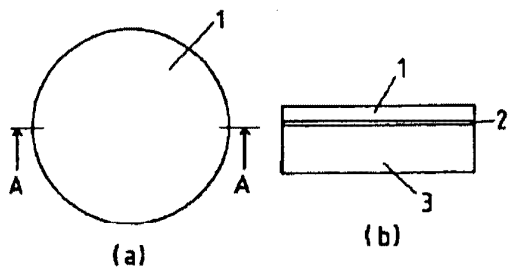

THOMSON SCIENTIFIC TERMS AND CONDITIONS

Thomson Scientific Ltd shall not in any circumstances be liable or responsible for the completeness or accuracy of any Thomson Scientific translation and will not be liable for any direct, indirect, consequential or economic loss or loss of profit resulting directly or indirectly from the use of any translation by any customer.

Thomson Scientific Ltd. is part of The Thomson Corporation

Please visit our website:

["www.THOMSONDERWENT.COM"](http://www.THOMSONDERWENT.COM) (English)

["www.thomsonscientific.jp"](http://www.thomsonscientific.jp) (Japanese)

(19) 日本国特許庁 (J P)

(12) 公開特許公報 (A)

(11) 特許出願公開番号

特開平5-230642

(43) 公開日 平成5年(1993)9月7日

(51) Int.Cl. ⁵	識別記号	庁内整理番号	F I	技術表示箇所
C 2 3 C	14/34	8414-4K		
H 0 1 J	37/08	9069-5E		
	37/30	Z 9172-5E		

審査請求 未請求 請求項の数2(全3頁)

(21) 出願番号	特願平4-69981	(71) 出願人	000226688 日新ハイボルテージ株式会社 京都府京都市右京区梅津高畝町47番地
(22) 出願日	平成4年(1992)2月21日	(72) 発明者	馬場 隆 京都府京都市右京区梅津高畝町47番地 日 新ハイボルテージ株式会社内
		(72) 発明者	武山 邦彦 京都府京都市右京区梅津高畝町47番地 日 新ハイボルテージ株式会社内
		(74) 代理人	弁理士 成田 擴其

(54) 【発明の名称】 スパッタ・ターゲット

(57) 【要約】

【目的】 ターゲット材の加熱による割れを防止すること。

【構成】 所要の元素を含むターゲット材1はボンディング材2によってバックングプレート3に固着されている。ターゲット材1にスリ割り溝(或いは切り込み、カッティングによる溝)4を設け、ターゲット材1を多数の小区画1₁に分割する。ターゲット材の厚さ方向位置での伸びの差等が小さくなり、ターゲット材の割れを防ぐことができる。予め作っておいたターゲット材の小片をバックングプレートに貼り付けても良い。

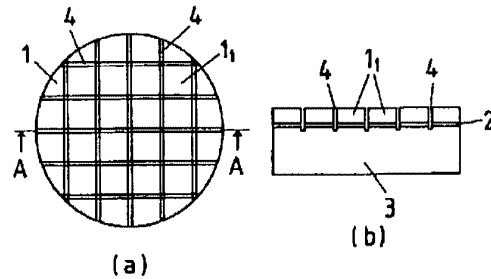

【特許請求の範囲】

【請求項1】 バッキングプレートに固着されたターゲット材がスリ割り溝によって多数の小区画に分割されているか、又はターゲット材の多数の小片がタイル貼り状にバッキングプレートに固着されていることを特徴とするスパッタ・ターゲット。

【請求項2】 請求項1のスパッタ・ターゲットを備えていることを特徴とするスパッタ型イオン源。

【発明の詳細な説明】

【0001】

【産業上の利用分野】本発明は、加熱によるターゲット材の割れを防いだスパッタ型イオン源等に用いるスパッタ・ターゲットに関する。

【0002】

【従来の技術】スパッタ型イオン源、イオンビームスパッタリング装置等におけるスパッタ・ターゲットは、図4(a)の正面図、そのA-A線での同(b)の断面図に示すように、プラズマイオン、イオンビームでスパッタされる所要の元素を含む板状のターゲット材1をボンディング材2によってバッキングプレート3に固着して構成されている。ターゲット材1はスパッタ時、周囲のプラズマとプラズマイオン、或いはイオンビームの衝撃により加熱されるから、その冷却のためにバッキングプレート3は冷却ホルダーに取り付けられている。

【0003】

【発明が解決しようとする課題】かかるスパッタ・ターゲットのサイズが直径50mm程度の大きさのものになると、ターゲット材1が熱伝導の悪い材質の場合には、スパッタ時、ターゲット材1の厚み方向位置での熱膨張による伸びに大きな差が生じる等の理由により、ターゲット材が割れてしまうことがある。

【0004】本発明は、プラズマやイオンによる加熱で、ターゲット材が割れることを防止したスパッタ・ターゲットの提供を目的とするものである。

【0005】

【課題を解決するための手段】本発明は、スパッタ・ターゲットにおいて、バッキングプレートに固着されたターゲット材がスリ割り溝によって多数の小区画に分割されているか、又は、ターゲット材の多数の小片がタイル貼り状にバッキングプレートに固着されていることを主たる特徴とするものであり、そして、かかるスパッタ・ターゲットをスパッタ型イオン源に用いたことを特徴とするものである。

【0006】

【作用】ターゲット材がスリ割り或いは小片のタイル貼り形式により、小さく分割されているから、各分割域における加熱による熱膨張が他の分割域に波及することがないから、ターゲット材の厚み方向位置での伸びの差等が小さく抑えられ、スパッタ・ターゲットの割れが生じない。そして、かかるターゲットをスパッタ型イオン源

に用いることにより、イオンビームが安定して引出せる。

【0007】

【実施例】本発明の実施例について図面を参照して説明する。図1(a)、(b)はスリ割り形式によるスパッタ・ターゲットの正面図及びそのA-A線での断面図である。バッキングプレート3にボンディング材2で固着されたターゲット材1に、基板の目状にスリ割り溝(スリ割らないし切り込み、カッティングによる溝)4を設け、ターゲット材1を一辺が10mm程度の多数の小区画1₁に小分割する。スリ割り溝4は、少なくともターゲット材部分に形成されていれば充分であるが、図1(b)ではバッキングプレート3にまで達しているものを示している。

【0008】図2(a)、(b)はタイル貼り形式のスパッタ・ターゲットの正面図とそのA-A線での断面図であり、予めターゲット材を一辺が10mm程度の小片1₂に分割しておき、かかる多数のターゲット材の小片1₂をボンディング材2によって、タイル貼り形式でバッキングプレート3に固着する。

【0009】このように、ターゲット材1は、何れも一辺が10mm程度の小区画ないしは小片1₁、1₂に分割されているから、ターゲット材1のスパッタ時に発熱、加熱が生じて、ターゲット材等の熱膨張は、各小区画、小片1₁、1₂内に限定されて、他の部分には波及せず、各小区画、小片1₁、1₂の厚み方向位置での伸びの差は小さく抑えられるから、ターゲット材に割れが発生しない。

【0010】プラズマ・スパッタ型負イオン源では、スパッタ・ターゲット表面で発生した負イオンをイオン源の出口にビームとして集束させるために、スパッタ・ターゲットの表面を球面状にえぐった形とする場合がある。このようにすると、ターゲット材の周辺部では、その厚みは5mm程度に達し、スパッタ材が割れる可能性が高くなる。図3(a)及び(b)は、かかる負イオン源のスパッタ・ターゲットにスリ割りを実施したものの正面図と、そのA-A線での断面図である。図1に示したものと同様に、表面が球面状にえぐられたターゲット材1をボンディング材2によってバッキングプレート3に固着しておき、スリ割り溝4を形成することによって、ターゲット材1を多数の小区画に分割する。加熱によるスパッタ・ターゲットの割れが防止できるから、イオン源より安定にビームを引出すことが可能になる。図2と同様に、タイル貼り形式を実施してもよい。

【0011】

【発明の効果】本発明は以上説明したように、ターゲット材が小さく分割されているから、スパッタ時に、ターゲット材における厚み方向の熱膨張による伸びの差等を小さく抑えることができ、ターゲット材の割れを防止することができる。

3

【0012】そして、本発明によるスパッタ・ターゲットをイオン源に用いることにより、イオンビームを安定に引出すことができ、特に表面が球面状にえぐられたスパッタ・ターゲットの場合に効果的である。

【図面の簡単な説明】

【図1】本発明の実施例の正面図及び断面図である。

【図2】他の実施例の正面図及び断面図である。

【図3】更に他の実施例の正面図及び断面図である。

4

【図4】従来のスパッタ・ターゲットの正面図及び断面図である。

【符号の説明】

- 1, 1₁, 1₂ ターゲット材
- 2 ボンディング材
- 3 パッキングプレート
- 4 スリ割り溝

【図1】

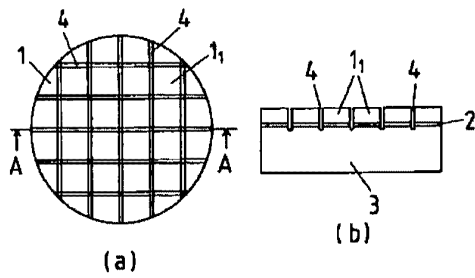

【図2】

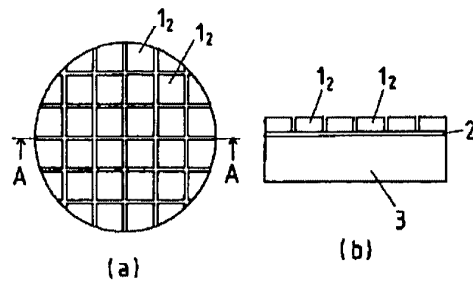

【図3】

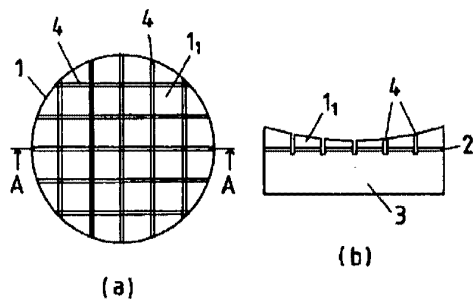

【図4】

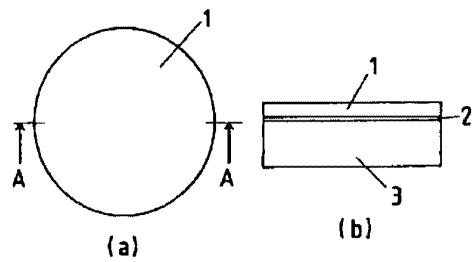



UNITED STATES PATENT AND TRADEMARK OFFICE

UNITED STATES DEPARTMENT OF COMMERCE
United States Patent and Trademark Office
Address: COMMISSIONER FOR PATENTS
P.O. Box 1450
Alexandria, Virginia 22313-1450
www.uspto.gov

APPLICATION NO.	FILING DATE	FIRST NAMED INVENTOR	ATTORNEY DOCKET NO.	CONFIRMATION NO.
10/101,863	03/16/2002	Hongmei Zhang	M-12245 US	6938

22852 7590 09/06/2006

FINNEGAN, HENDERSON, FARABOW, GARRETT & DUNNER
LLP
901 NEW YORK AVENUE, NW
WASHINGTON, DC 20001-4413

EXAMINER

ESTRADA, MICHELLE

ART UNIT PAPER NUMBER

2823

DATE MAILED: 09/06/2006

Please find below and/or attached an Office communication concerning this application or proceeding.

Office Action Summary	Application No. 10/101,863	Applicant(s) ZHANG ET AL.	
	Examiner Michelle Estrada	Art Unit 2823	

-- The MAILING DATE of this communication appears on the cover sheet with the correspondence address --

Period for Reply

A SHORTENED STATUTORY PERIOD FOR REPLY IS SET TO EXPIRE 3 MONTH(S) OR THIRTY (30) DAYS, WHICHEVER IS LONGER, FROM THE MAILING DATE OF THIS COMMUNICATION.

- Extensions of time may be available under the provisions of 37 CFR 1.136(a). In no event, however, may a reply be timely filed after SIX (6) MONTHS from the mailing date of this communication.
- If NO period for reply is specified above, the maximum statutory period will apply and will expire SIX (6) MONTHS from the mailing date of this communication.
- Failure to reply within the set or extended period for reply will, by statute, cause the application to become ABANDONED (35 U.S.C. § 133). Any reply received by the Office later than three months after the mailing date of this communication, even if timely filed, may reduce any earned patent term adjustment. See 37 CFR 1.704(b).

Status

- 1) Responsive to communication(s) filed on 12 June 2006.
- 2a) This action is **FINAL**. 2b) This action is non-final.
- 3) Since this application is in condition for allowance except for formal matters, prosecution as to the merits is closed in accordance with the practice under *Ex parte Quayle*, 1935 C.D. 11, 453 O.G. 213.

Disposition of Claims

- 4) Claim(s) 2-4,6-14 and 21-50 is/are pending in the application.
4a) Of the above claim(s) _____ is/are withdrawn from consideration.
- 5) Claim(s) 14 is/are allowed.
- 6) Claim(s) 2-4,6-13 and 21-50 is/are rejected.
- 7) Claim(s) _____ is/are objected to.
- 8) Claim(s) _____ are subject to restriction and/or election requirement.

Application Papers

- 9) The specification is objected to by the Examiner.
- 10) The drawing(s) filed on _____ is/are: a) accepted or b) objected to by the Examiner.
Applicant may not request that any objection to the drawing(s) be held in abeyance. See 37 CFR 1.85(a).
Replacement drawing sheet(s) including the correction is required if the drawing(s) is objected to. See 37 CFR 1.121(d).
- 11) The oath or declaration is objected to by the Examiner. Note the attached Office Action or form PTO-152.

Priority under 35 U.S.C. § 119

- 12) Acknowledgment is made of a claim for foreign priority under 35 U.S.C. § 119(a)-(d) or (f).
a) All b) Some * c) None of:
1. Certified copies of the priority documents have been received.
2. Certified copies of the priority documents have been received in Application No. _____.
3. Copies of the certified copies of the priority documents have been received in this National Stage application from the International Bureau (PCT Rule 17.2(a)).

* See the attached detailed Office action for a list of the certified copies not received.

Attachment(s)

- | | |
|---|---|
| 1) <input type="checkbox"/> Notice of References Cited (PTO-892) | 4) <input type="checkbox"/> Interview Summary (PTO-413)
Paper No(s)/Mail Date. _____ |
| 2) <input type="checkbox"/> Notice of Draftsperson's Patent Drawing Review (PTO-948) | 5) <input type="checkbox"/> Notice of Informal Patent Application |
| 3) <input checked="" type="checkbox"/> Information Disclosure Statement(s) (PTO/SB/08)
Paper No(s)/Mail Date <u>8/15/06, 6/12/06</u> . | 6) <input type="checkbox"/> Other: _____ |

DETAILED ACTION

The Declaration under 37 CFR 1.132 filed June 12, 2006 is insufficient to overcome the rejection of claims 21 and 43 based upon Smolanoff et al. in view of Fu et al. as set forth in the last Office action because: using an specific type of filter is a matter of design choice depending on the quality of product needed, and it is obvious that the filter is going to work at certain frequencies. Furthermore, the limitation "the filter is a band rejection filter at a frequency of the bias power" is a structural limitation in a method claim, so no matter what filter is used, as long as the same result is achieved.

Applicant's arguments with respect to claims 21 and 43 have been considered but are moot in view of the new ground(s) of rejection.

Claim Rejections - 35 USC § 103

The following is a quotation of 35 U.S.C. 103(a) which forms the basis for all obviousness rejections set forth in this Office action:

(a) A patent may not be obtained though the invention is not identically disclosed or described as set forth in section 102 of this title, if the differences between the subject matter sought to be patented and the prior art are such that the subject matter as a whole would have been obvious at the time the invention was made to a person having ordinary skill in the art to which said subject matter pertains. Patentability shall not be negated by the manner in which the invention was made.

Claims 10-13, 21 and 40-45 are rejected under 35 U.S.C. 103(a) as being unpatentable over Smolanoff et al. (6,117,279) in view of Fu et al. (6,306,265).

With respect to claims 21, 40 and 43, Smolanoff et al. disclose providing pulsed DC power (21) through a filter (22) to a target (16) (Col. 5, lines 50-55); providing RF bias power to a substrate (15) positioned opposite the target (Col. 5, lines 60-65); providing process gas between the target and the substrate (Col. 7, lines 25-28); wherein the filter protects a pulsed DC power supply (21) from the bias power, and wherein a plasma is created by application of the pulsed DC power to the target (Col. 6, lines 8-13); and wherein the film is deposited by exposure of the substrate to the plasma (Col. 6, lines 30-33); using an specific type of filter is a matter of design choice depending on the quality of product needed, and it is obvious that the filter is going to work at certain frequencies. Furthermore, the limitation "the filter is a band rejection filter at a frequency of the bias power" is a structural limitation in a method claim, so no matter what filter is used, as long as the same result is achieved, as explained above.

Smolanoff et al. do not clearly disclose wherein conditioning the target includes sputtering with the target in a metallic mode to remove the surface of the target and sputtering with the target in a poisonous mode to prepare the surface.

Fu et al. disclose wherein conditioning the target includes sputtering with the target in a metallic mode to remove the surface of the target and sputtering with the target in a poisonous mode to prepare the surface (Col. 19, lines 35-40).

It would have been within the scope of one of ordinary skill in the art to combine the teachings of Smolanoff et al. and Fu et al. to enable the conditioning step of Smolanoff et al. to be performed according to the teachings of Fu et al. because one of ordinary skill in the art would have been motivated to look to

Art Unit: 2823

alternative suitable methods of performing the disclosed conditioning step of Smolanoff et al. and art recognized suitability for an intended purpose has been recognized to be motivation to combine. See MPEP 2144.07.

With respect to claim 8, Smolanoff et al. disclose wherein the process gas includes a mixture of oxygen and argon (Col. 7, lines 21-27).

With respect to claim 10, Smolanoff et al. disclose wherein the process gas further includes nitrogen (Col. 7, lines 25-26).

With respect to claim 11, Smolanoff et al. disclose wherein providing pulsed DC power to a target includes providing pulsed DC power to a target which has an area larger than that of the substrate (See fig. 1).

With respect to claims 12 and 49, Smolanoff et al. disclose further including uniformly sweeping the target with a magnetic field (Col. 6, lines 1-7).

With respect to claims 13 and 50, Smolanoff et al. disclose wherein uniformly sweeping the target with a magnetic field includes sweeping a magnet in one direction across the target where the magnet extends beyond the target in the opposite direction (Col. 6, lines 1-6).

Claims 2-4, 6 and 22-24 are rejected under 35 U.S.C. 103(a) as being unpatentable over Smolanoff et al. in view of Fu et al. as applied to claims 8, 10-13 and 21 above, and further in view of the following comments.

With respect to claims 2-4, 6 and 22-24, 41, 42, 44-48, One of ordinary skill in the art would have been led to the recited temperature, DC power, gas flow, time pulse and bias power to routine experimentation to achieve a desired layer thickness, device dimension, device associated characteristics and device density on the finished wafer in view of the range of values disclosed.

In addition, the selection of temperature, DC power, gas flow, time pulse and bias power, is obvious because it is a matter of determining optimum process conditions by routine experimentation with a limited number of species of result effective variables. These claims are prima facie obvious without showing that the claimed ranges achieve unexpected results relative to the prior art range. In re Woodruff, 16 USPQ2d 1935, 1937 (Fed. Cir. 1990). See also In re Huang, 40 USPQ2d 1685, 1688 (Fed. Cir. 1996)(claimed ranges or a result effective variable, which do not overlap the prior art ranges, are unpatentable unless they produce a new and unexpected result which is different in kind and not merely in degree from the results of the prior art). See also In re Boesch, 205 USPQ 215 (CCPA) (discovery of optimum value of result effective variable in known process is ordinarily within skill or art) and In re Aller, 105 USPQ 233 (CCPA 1995) (selection of optimum ranges within prior art general conditions is obvious).

Note that the specification contains no disclosure of either the critical nature of the claimed temperature, DC power, gas flow, time pulse and bias

Art Unit: 2823

power or any unexpected results arising therefrom. Where patentability is said to be based upon particular chosen temperature, DC power, gas flow, time pulse and bias power or upon another variable recited in a claim, the Applicant must show that the chosen temperature, DC power, gas flow, time pulse and bias power are critical. *In re Woodruf*, 919 F.2d 1575, 1578, 16 USPQ2d 1934, 1936 (Fed. Cir. 1990).

Claims 7 and 9 are rejected under 35 U.S.C. 103(a) as being unpatentable over Smolanoff et al. in view of Fu et al. as applied to claims 8, 10-13 and 21 above, and further in view of Le et al. (2003/0077914).

The combination of Smolanoff et al. and Fu et al. does not disclose wherein the film is an upper cladding layer of a waveguide structure and the bias power is optimized to provide planarization.

With respect to claim 7, Le et al. disclose wherein the film is an upper cladding layer of a waveguide structure and the bias power is optimized to provide planarization Page 5, Paragraph [0075].

It would have been within the scope of one of ordinary skill in the art to combine the teachings of Smolanoff et al., Fu et al. and Le et al. to enable the film material of Smolanoff et al. to be the same according to the teachings of Le et al. because one of ordinary skill in the art would have been motivated to look to alternative suitable film materials for the disclosed film formation step of Smolanoff et al. and art recognized suitability for an intended purpose has been recognized to be motivation to combine. See MPEP 2144.07.

With respect to claim 9, Le et al. disclose wherein the oxygen flow is adjusted to adjust the index of refraction of the film (Page 5, Paragraph [0076]).

Allowable Subject Matter

Claim 14 is allowed.

Conclusion

Any inquiry concerning this communication or earlier communications from the examiner should be directed to Michelle Estrada whose telephone number is 571-272-1858. The examiner can normally be reached on Monday through Friday.

If attempts to reach the examiner by telephone are unsuccessful, the examiner's supervisor, Matthew Smith can be reached on 571-272-1907. The fax phone number for the organization where this application or proceeding is assigned is 571-273-8300.

Any inquiry of a general nature or relating to the status of this application or proceeding should be directed to the receptionist whose telephone number is 571-272-2800.

Information regarding the status of an application may be obtained from the Patent Application Information Retrieval (PAIR) system. Status information for published applications may be obtained from either Private PAIR or Public PAIR. Status information for unpublished applications is available through Private PAIR only. For more information about the PAIR system, see <http://pair->

Art Unit: 2823

direct.uspto.gov. Should you have questions on access to the Private PAIR system, contact the Electronic Business Center (EBC) at 866-217-9197 (toll-free).



Michelle Estrada
Primary Examiner
Art Unit 2823

ME
September 5, 2006

Complete if Known

INFORMATION DISCLOSURE STATEMENT BY APPLICANT

(Use as many sheets as necessary)

Sheet	1	of	2	Application Number	10/101,863
				Filing Date	March 16, 2002
				First Named Inventor	ZHANG, Hongmei
				Art Unit	2823
				Examiner Name	ESTRADA, Michelle
				Attorney Docket Number	9140.0016-00

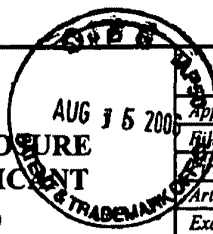

U.S. PATENTS AND PUBLISHED U.S. PATENT APPLICATIONS

Examiner Initials*	Cite No. ¹	Document Number	Issue or Publication Date MM-DD-YYYY	Name of Patentee or Applicant of Cited Document	Pages, Columns, Lines, Where Relevant Passages or Relevant Figures Appear
		Number-Kind Code ² (if known)			
<i>[Signature]</i>		US 5,433,835	07/18/1995	Demaray	
<i>[Signature]</i>		US 6,288,835 B1	09/11/2001	Nilsson et al.	
<i>[Signature]</i>		US 6,452,717 B1	09/17/2002	Endo	
<i>[Signature]</i>		US 2002/0014406 A1	02/07/2002	Takashima	

Note: Submission of copies of U.S. Patents and published U.S. Patent Applications is not required.

FOREIGN PATENT DOCUMENTS

Examiner Initials*	Cite No. ¹	Foreign Patent Document	Publication Date MM-DD-YYYY	Name of Patentee or Applicant of Cited Document	Pages, Columns, Lines, Where Relevant Passages or Relevant Figures Appear	Translation ⁶
		Country Code ² Number ⁴ Kind Code ³ (if known)				
<i>[Signature]</i>		DE 37 38 738 C1	01/26/1989	Degussa AG		Yes
<i>[Signature]</i>		JP 5-230642 A	09/07/1993	Nissin High Voltage Co., Ltd.		Yes
<i>[Signature]</i>		WO 99/61674 A1	12/02/1999	Universiteit Gent		
<i>[Signature]</i>		WO 2006/063308 A2	06/15/2006	Symmorphix, Inc.		

NON PATENT LITERATURE DOCUMENTS

Examiner Initials*	Cite No. ¹	Include name of the author (in CAPITAL LETTERS), title of the article (when appropriate), title of the item (book, magazine, journal, serial, symposium, catalog, etc.), date, page(s), volume-issue number(s), publisher, city and/or country where published.	Translation ⁶
<i>[Signature]</i>		AGRAWAL, G.P., in: <u>Fiber-Optic Communication Systems</u> , 2nd Edition, John Wiley & Sons, New York, pp. 361-399 and 415 (1997).	
<i>[Signature]</i>		ASM Handbook, Formerly Ninth Edition, Metals Handbook, Volume 15, Casting, Davis et al. (Eds.), ASM International, pp. 372-373, 376-383, and 410-411 (1988).	
<i>[Signature]</i>		MASUDA, H. & KAWAI, S., "Wide-band and gain-flattened hybrid fiber amplifier consisting of an EDFA and a multiwavelength pumped raman amplifier," <i>IEEE Photonics Technology Lett.</i> 11(6):647-649 (1999).	
<i>[Signature]</i>		SNOEKS, E. et al., "Cooperative upconversion in erbium-implanted soda-lime silicate glass optical waveguides," <i>J. Opt. Soc. Am. B</i> 12(8):1468-1474 (1995).	
<i>[Signature]</i>		Response to Office Action filed July 27, 2006, in U.S. Appl. No. 10/291,179 (Atty. Docket No. 9140.0001-00).	
<i>[Signature]</i>		Notice of Allowance mailed March 25, 2004 for US Patent No. 6,827,826 (Atty. Docket No. 09140.0002-02).	

Examiner Signature	<i>Michelle Estrada</i>	Date Considered	8/28/06
--------------------	-------------------------	-----------------	---------

EXAMINER: Initial if reference considered, whether or not citation is in conformance with MPEP 609. Draw line through citation if not in conformance and not considered. Include copy of this form with next communication to applicant.

EXPRESS MAIL LABEL NO.
EV 746096525 US

IDS Form PTO/SB/08: Substitute for form 1449A/PTO			<i>Complete if Known</i>	
INFORMATION DISCLOSURE STATEMENT BY APPLICANT <i>(Use as many sheets as necessary)</i>			<i>Application Number</i>	10/101,863
			<i>Filing Date</i>	March 16, 2002
			<i>First Named Inventor</i>	ZHANG, Hongmei
			<i>Art Unit</i>	2823
			<i>Examiner Name</i>	ESTRADA, Michelle
			<i>Attorney Docket Number</i>	9140.0016-00
Sheet	2	of	2	

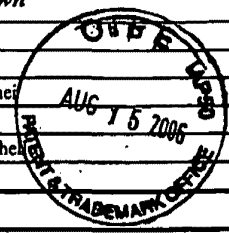

NON PATENT LITERATURE DOCUMENTS		
[Signature]		Notice of Allowance issued on October 8, 2002, in U.S. Patent No. 6,533,907 (Atty. Docket No. 09140-0004-00).
[Signature]		Notice of Allowance issued on October 21, 2004, in U.S. Application No. 10/101,492 (Atty. Docket No. 09140-0015-00).
[Signature]		Response to Office Action filed on August 9, 2006 in Application No. 10/954,182 (Atty. Docket No. 09140.0016-01).
[Signature]		Office Action issued on August 2, 2006, in U.S. Application No. 10/101,341 (Atty. Docket No. 09140-0017-00).
[Signature]		Response to Office Action filed on July 24, 2006, in U.S. Application No. 10/650,461 (Atty. Docket No. 09140-0025-00).
[Signature]		Response to Office Action filed July 26, 2006 in U.S. Application No. 10/851,542 (Atty. Docket No. 09140.0033-00).

Examiner Signature	<i>Michelle Estrada</i>	Date Considered	<i>8/28/06</i>
--------------------	-------------------------	-----------------	----------------

EXAMINER: Initial if reference considered, whether or not citation is in conformance with MPEP 609. Draw line through citation if not in conformance and not considered. Include copy of this form with next communication to applicant.

EXPRESS MAIL LABEL NO.
EV 746096525 US

IDS Form PTO/SB/08: Substitute for form 1449A/PTO

Complete if Known

INFORMATION DISCLOSURE STATEMENT BY APPLICANT

(Use as many sheets as necessary)

Sheet 1 of 2

Application Number	10/101,863
Filing Date	March 16, 2002
First Named Inventor	ZHANG, Hongmei
Art Unit	2823
Examiner Name	ESTRADA, Michelle
Attorney Docket Number	9140.0016-00

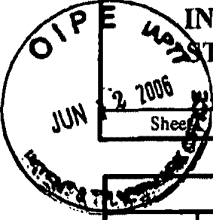

U.S. PATENTS AND PUBLISHED U.S. PATENT APPLICATIONS

Examiner Initials ¹	Cite No. ¹	Document Number	Issue or Publication Date MM-DD-YYYY	Name of Patentee or Applicant of Cited Document	Pages, Columns, Lines, Where Relevant Passages or Relevant Figures Appear
		Number-Kind Code ² (if known)			
<i>ME</i>		US 4,082,569	04-04-1978	Evans, Jr.	
		US 5,472,795	12-05-1995	Atita	
		US 5,645,626	07-08-1997	Edlund et al.	
		US 5,702,829	12-30-1997	Paidassi et al.	
		US 6,045,626	04-04-2000	Yano et al.	
		US 6,673,716 B1	01-06-2004	D' Couto et al.	
		US 6,683,749 B2	01-27-2004	Daby et al.	
		US 6,884,327 B2	04-26-2005	Pan et al.	
		US 2002/0115252 A1	08-22-2002	Haukka et al.	
		US 2003/0035906 A1	02-20-2003	Memarian et al.	
		US 2004/0043557 A1	03-04-2004	Haukka et al.	
		US 2005/0048802 A1	03-03-2005	Zhang et al.	
		US 2005/0183946 A1	08-25-2005	Pan et al.	
		US 2006/0054496 A1	03-16-2006	Zhang et al.	
		US 2006/0057283 A1	03-16-2006	Zhang et al.	
		US 2006/0057304 A1	03-16-2006	Zhang et al.	
		US 2006/0071592 A1	04-06-2006	Narasimhan et al.	

Note: Submission of copies of U.S. Patents and published U.S. Patent Applications is not required.

FOREIGN PATENT DOCUMENTS

Examiner Initials ¹	Cite No. ¹	Foreign Patent Document	Publication Date MM-DD-YYYY	Name of Patentee or Applicant of Cited Document	Pages, Columns, Lines, Where Relevant Passages or Relevant Figures Appear	Translation ⁶
		Country Code ³ Number ⁴ Kind Code ⁵ (if known)				
<i>ME</i>		JP 7-224379 A	08-22-1995	Ulvac Japan Ltd		Abstract

Examiner Signature: *Michelle Estrada* Date Considered: *8/28/04*

EXAMINER: Initial if reference considered, whether or not citation is in conformance with MPEP 609. Draw line through citation if not in conformance and not considered. Include copy of this form with next communication to applicant.

**EXPRESS MAIL LABEL NO.
EV 860818108 US**

IDS Form PTO/SB/08: Substitute for form 1449A/PTO			Complete if Known		
INFORMATION DISCLOSURE STATEMENT BY APPLICANT <i>(Use as many sheets as necessary)</i>			<i>Application Number</i>	10/101,863	
			<i>Filing Date</i>	March 16, 2002	
			<i>First Named Inventor</i>	ZHANG, Hongmei	
			<i>Art Unit</i>	2823	
			<i>Examiner Name</i>	ESTRADA, Michelle	
Sheet	2	of	2	<i>Attorney Docket Number</i>	9140.0016-00

NON PATENT LITERATURE DOCUMENTS			
Examiner Initials ⁵	Cite No. ¹	Include name of the author (in CAPITAL LETTERS), title of the article (when appropriate), title of the item (book, magazine, journal, serial, symposium, catalog, etc.), date, page(s), volume-issue number(s), publisher, city and/or country where published.	Translation ⁶
ME		BARBIER, D., "Performances and potential applications of erbium doped planar waveguide amplifiers and lasers," <i>Proc. OAA</i> , Victoria, BC, Canada, pp. 58-63 (July 21-23, 1997).	
ME		KELLY, P.J. et al., "A novel technique for the deposition of aluminum-doped zinc oxide films," <i>Thin Solid Films</i> 426(1-2):111-116 (2003).	
ME		TOMASZEWSKI, H. et al., "Yttria-stabilized zirconia thin films grown by reactive r.f. magnetron sputtering," <i>Thin Solid Films</i> 287:104-109 (1996).	
ME		Response to Final Office Action filed April 14, 2006, in U.S. Appl. No. 10/291,179 (Atty. Docket No. 9140.0001-00).	
ME		Office Action mailed April 27, 2006, in U.S. Appl. No. 10/291,179 (Atty. Docket No. 9140.0001-00).	
ME		Final Office Action mailed May 8, 2006 in U.S. Application No. 09/903,081 (Attorney Docket No. 09140-0014-00).	
ME		Response to Office Action filed February 17, 2006 in U.S. Application No. 11/100,856 (Attorney Docket No. 09140.0015-01).	
ME		Office Action issued on March 9, 2006, in U.S. Appl. No. 10/954,182 (Attorney Docket No. 09140-0016-01000).	
ME		Response to Office Action filed on May 15, 2006, in U.S. Application No. 10/101,341 (Attorney Docket No. 09140-0017-00).	
ME		Final Office Action issued on May 19, 2006 in U.S. Application No. 10/789,953 (Attorney Docket No. 09140.0030-00).	
ME		Office Action from Singapore Patent Office in Appl. No. 200505388-9, dated March 20, 2006 (Atty. Docket No. 9140.0030-00256).	
ME		Office Action mailed April 19, 2006 in U.S. Application No. 10/851,542 (Attorney Docket No. 09140.0033-00).	

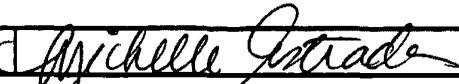
Examiner Signature		Date Considered	8/28/06
--------------------	---	-----------------	---------

EXAMINER: Initial if reference considered, whether or not citation is in conformance with MPEP 609. Draw line through citation if not in conformance and not considered. Include copy of this form with next communication to applicant.

**EXPRESS MAIL LABEL NO.
EV 860818108 US**

BEST AVAILABLE COPY

Index of Claims



Application No.

10/10/863

Applicant(s)

Examiner

Art Unit

✓	Rejected
	Allowed

-	(Through numeral) Cancelled
+/-	Restricted

N	Non-Elected
I	Interference

A	Appeal
O	Objected

Claim		Date	Claim		Date	Claim		Date
Final	Original		Final	Original		Final	Original	
		2/5/04						
	✓		51			101		
	2		52			102		
	3		53			103		
	4		54			104		
	5		55			105		
	6		56			106		
	7		57			107		
	8		58			108		
	9		59			109		
	10		60			110		
	11		61			111		
	12		62			112		
	13		63			113		
	14		64			114		
	15		65			115		
	16		66			116		
	17		67			117		
	18		68			118		
	19		69			119		
	20		70			120		
	21		71			121		
	22		72			122		
	23		73			123		
	24		74			124		
	25		75			125		
	26		76			126		
	27		77			127		
	28		78			128		
	29		79			129		
	30		80			130		
	31		81			131		
	32		82			132		
	33		83			133		
	34		84			134		
	35		85			135		
	36		86			136		
	37		87			137		
	38		88			138		
	39		89			139		
	40		90			140		
	41		91			141		
	42		92			142		
	43		93			143		
	44		94			144		
	45		95			145		
	46		96			146		
	47		97			147		
	48		98			148		
	49		99			149		
	50		100			150		



UNITED STATES PATENT AND TRADEMARK OFFICE

10

UNITED STATES DEPARTMENT OF COMMERCE
United States Patent and Trademark Office
Address: COMMISSIONER FOR PATENTS
P.O. Box 1450
Alexandria, Virginia 22313-1450
www.uspto.gov

APPLICATION NO.	FILING DATE	FIRST NAMED INVENTOR	ATTORNEY DOCKET NO.	CONFIRMATION NO.
10/101,863	03/16/2002	Hongmei Zhang	9140.0016-00	6938
22852	7590	01/23/2007	EXAMINER	
FINNEGAN, HENDERSON, FARABOW, GARRETT & DUNNER LLP 901 NEW YORK AVENUE, NW WASHINGTON, DC 20001-4413			ESTRADA, MICHELLE	
			ART UNIT	PAPER NUMBER
			2823	
			MAIL DATE	DELIVERY MODE
			01/23/2007	PAPER

Please find below and/or attached an Office communication concerning this application or proceeding.

Interview Summary	Application No.	Applicant(s)	
	10/101,863	ZHANG ET AL.	
	Examiner	Art Unit	
	Michelle Estrada	2823	

All participants (applicant, applicant's representative, PTO personnel):

- (1) Michelle Estrada. (3) Richard Demaray.
(2) Gary Edwards. (4) Hongmei Zhang.

Date of Interview: 18 January 2007.

Type: a) Telephonic b) Video Conference
c) Personal [copy given to: 1) applicant 2) applicant's representative]

Exhibit shown or demonstration conducted: d) Yes e) No.
If Yes, brief description: _____.

Claim(s) discussed: 21 and 43.

Identification of prior art discussed: Smolanoff et al.

Agreement with respect to the claims f) was reached. g) was not reached. h) N/A.

Substance of Interview including description of the general nature of what was agreed to if an agreement was reached, or any other comments: Applicants explained the basis of the invention and the difference over Smolanoff reference with respect to the pulsed DC power. Applicants will amend claims 21 and 43 to further clarify the invention. Further consideration and search would be needed for the new limitations in the claims.

(A fuller description, if necessary, and a copy of the amendments which the examiner agreed would render the claims allowable, if available, must be attached. Also, where no copy of the amendments that would render the claims allowable is available, a summary thereof must be attached.)

THE FORMAL WRITTEN REPLY TO THE LAST OFFICE ACTION MUST INCLUDE THE SUBSTANCE OF THE INTERVIEW. (See MPEP Section 713.04). If a reply to the last Office action has already been filed, APPLICANT IS GIVEN A NON-EXTENDABLE PERIOD OF THE LONGER OF ONE MONTH OR THIRTY DAYS FROM THIS INTERVIEW DATE, OR THE MAILING DATE OF THIS INTERVIEW SUMMARY FORM, WHICHEVER IS LATER, TO FILE A STATEMENT OF THE SUBSTANCE OF THE INTERVIEW. See Summary of Record of Interview requirements on reverse side or on attached sheet.

MICHELLE ESTRADA
PRIMARY EXAMINER

Examiner Note: You must sign this form unless it is an Attachment to a signed Office action.

Examiner's signature, if required

02-08-07

IFW

2823/15

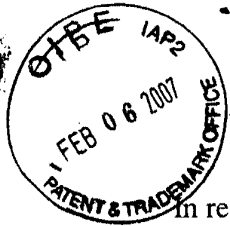

PATENT
Customer No. 22,852
Attorney Docket No. 9140.0016-00

IN THE UNITED STATES PATENT AND TRADEMARK OFFICE

In re Application of:)	
)	
ZHANG, Hongmei et al.)	Group Art Unit: 2823
)	
Application No.: 10/101,863)	Examiner: ESTRADA, Michelle
)	
Filed: March 16, 2002)	
)	
For: BIASED PULSE DC REACTIVE)	Confirmation No.: 6938
SPUTTERING OF OXIDE FILMS)	

MAIL STOP AMENDMENT

Commissioner for Patents
P.O. Box 1450
Alexandria, VA 22313-1450

Sir:

AMENDMENT AND RESPONSE TO OFFICE ACTION

In reply to the Office Action mailed September 6, 2006, and the Interview Summary, mailed January 23, 2007, the period for response having been extended to February 6, 2007, by a request for extension of one month with authorization for the Commissioner to charge the fee to Deposit Account No. 06-0916, Applicants propose that this application be amended as follows:

Amendments to the Claims are reflected in the listing of claims in this paper beginning on page 2.

Remarks/Arguments follow the amendment sections of this paper beginning on page 6.