

# Silicon Processing

for the VLSI Era  
Volume 1 - Process Technology  
Second Edition

S. Wolf and R.N. Tauber

**DISCLAIMER**

This publication is based on sources and information believed to be reliable, but the authors and Lattice Press disclaim any warranty or liability based on or relating to the contents of this publication.

Published by:

**LATTICE PRESS**

Post Office Box 340

Sunset Beach, California 90742, U.S.A.

Cover design by Roy Montibon, New Archetype Publishing, Los Angeles, CA.

Copyright © 2000 by Lattice Press.

All rights reserved. No part of this book may be reproduced or transmitted in any form or by any means, electronic or mechanical, including photocopying, recording or by any information storage and retrieval system without written permission from the publisher, except for the inclusion of brief quotations in a review.

**Library of Congress Cataloging in Publication Data**

Wolf, Stanley and Tauber, Richard N.

Silicon Processing for the VLSI Era

Volume 1: Process Technology

Includes Index

1. Integrated circuits-Very large scale integration. 2. Silicon. I. Title

ISBN 0-9616721-6-1

9 8 7 6 5 4 3 2

PRINTED IN THE UNITED STATES OF AMERICA

## 11.2 SPUTTER DEPOSITION FOR ULSI

*Sputtering* is a term used to describe the mechanism in which atoms are ejected from the surface of a material when that surface is struck by sufficiently energetic particles. It has become the dominant technique for depositing a variety of metallic films in VLSI and ULSI fabrication, including aluminum alloys, titanium, titanium:tungsten, titanium nitride, tantalum, and cobalt.

Sputtering displaced the original PVD technique for depositing metal films (evaporation) for the following reasons:

1. Sputtering can be accomplished from large-area targets, which simplifies the problem of depositing films with uniform thickness over large wafers.
2. Film thickness control is relatively easily achieved by selecting a constant set of operating conditions, and then adjusting the deposition time to reach it.
3. The alloy composition of sputter-deposited films can be more tightly (and easily) controlled than that of evaporated films.
4. Many important film properties, such as step coverage and grain structure can be controlled by varying the negative bias and heat applied to the wafers. Other film properties (including stress and adhesion), can be controlled by altering such process parameters as power & pressure.
5. The surface of the substrates can be sputter-cleaned in vacuum prior to initiating film deposition (and the surface is not exposed again to ambient after such cleaning).
6. There is sufficient material in most sputter targets to allow many deposition runs before target replacement is necessary.
7. Device damage from x-rays generated during electron-beam evaporation is eliminated (although some other radiation damage may still occur).

As is true with other processes, however, sputtering also has its drawbacks. They include:

1. Sputtering processes involve high capital equipment costs;
2. Since the process is carried out in low-medium vacuum ranges (compared to the high vacuum conditions under which evaporation is conducted), there is greater possibility of incorporating impurities into the deposited film.
3. Better step coverage can generally be achieved using CVD.

In general, the sputtering process consists of four steps:

1. Ions are generated and directed at a target.
2. The ions sputter target atoms;
3. The ejected (sputtered) atoms are transported to the substrate.
4. Upon reaching the substrate they condense and form a thin film.

Although it is of interest to note that sputtering can be conducted by generating the energetic incident ions by other means (e.g., ion beams), in virtually all VLSI and ULSI sputtering processes their source is a glow-discharge. The discussion of sputtering in this section will be limited to *glow-discharge sputtering*.<sup>4,5,6</sup>

### 11.2.1 Introduction to Glow Discharge Physics

The energetic particles used to strike target materials to be sputtered in ULSI sputter deposition systems are generated by glow-discharges.<sup>4,5</sup> A *glow-discharge* is a self-sustaining type of plasma (a *plasma* is defined as a partially ionized gas containing an equal number of positive and negative charges as well as some number of neutral gas particles). In Fig. 11-3 a simple *dc-diode type* system that can be employed to study properties of glow discharges used in

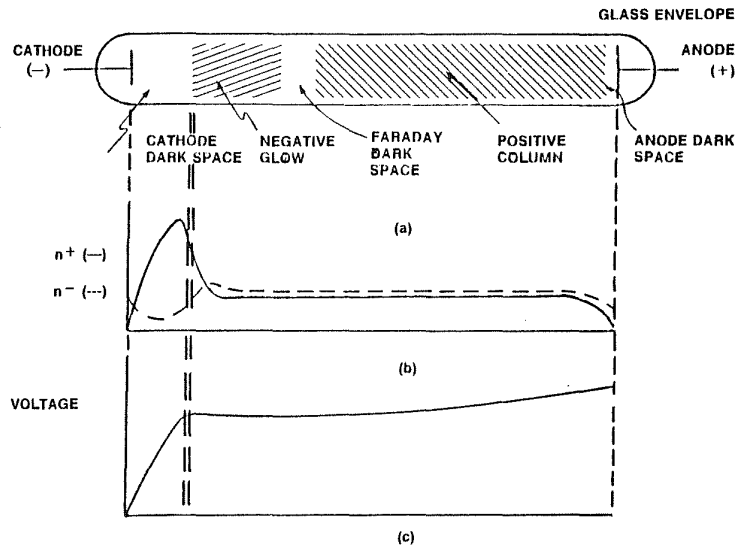

**Fig. 11-3** (a) Structure of a glow discharge in a dc diode system. (b) Charged particle concentration in a glow discharge. (c) Voltage variation in a dc diode glow discharge.

sputtering is shown. It consists of a glass tube that is evacuated and then re-filled with a gas at low pressure. Within the tube there are two electrodes (a positively charged *anode* and a negatively charged *cathode*) and a dc potential difference is applied between them.

### 11.2.2 The Creation of Glow Discharges

Consider the system shown in Fig. 11-3 to examine the case when a tube is filled with Ar at an initial pressure of 1 torr, the distance between the electrodes is 15 cm, and a 1.5 kV potential difference is applied between them. At the outset no current flows in the circuit, as all the Ar gas atoms are neutral and there are no charged particles in the gas. The full 1.5 kV is thus dropped between the two electrodes. If a free electron enters the tube (most likely created from the ionization of an Ar atom by a passing cosmic ray), it will be accelerated by the electric field existing between the electrodes (whose magnitude is:  $E = V/d = 1.5 \text{ kV}/15 \text{ cm} = 100 \text{ V/cm}$ ).

The average distance that a free electron will travel at  $P = 1$  torr before colliding with an Ar atom (i.e., the mean free path  $\lambda$ ) is 0.0122 cm (Chap. 3). Most electron-atom collisions are *elastic*, in which virtually no energy is transferred between the electron and gas atom. Such elastic collisions occur because the mass of the electron is much smaller than that of the atom. Thus, the minimum distance an electron must travel before it can undergo an *inelastic* collision (in which significant energy is transferred to the atom, either by the excitation of an atomic electron to a higher energy level, or to cause its escape from the atom) is about ten times  $\lambda$ , or 0.122 cm. If this is the minimum distance that must be traveled by electrons between inelastic collisions, there must be a significant number of electron path lengths in the range of 0.5–1.0 cm. If a free electron travels 1 cm in the 100 V/cm electric field, it will have picked up 100 eV of kinetic energy. With this amount of energy, the free electron can transfer enough energy to an Ar electron to cause it to be excited or ionized. If this transferred energy  $E$  is less than the ionization potential (e.g.,  $11.5 \text{ eV} < E < 15.7 \text{ eV}$  for Ar), the orbital electron will be excited to a

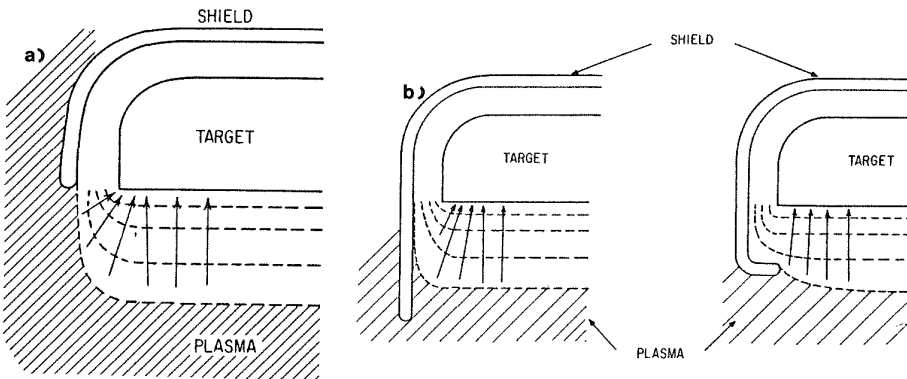

**Fig. 11-7** (a) Potential distribution in vicinity of cathode shield (b) Reducing rim effect by extending cathode shield. (c) Reducing rim effect by wrapping shield around the cathode.<sup>8</sup> From L. Maissel and R. Glang, Eds., *Handbook of Thin Film Technology* 1970. Reprinted by permission of McGraw-Hill Book Co.

dark space however, the ion production rate becomes reduced, and the voltage across the electrodes must rise to increase the secondary electron emission. Such a glow is known as an *obstructed glow*. In most practical sputter deposition systems the glow is obstructed. That is, in order to most effectively collect the sputtered material onto the substrate, the anode (on which the wafers are sometimes mounted) is placed as close to the cathode as possible (typically just far enough away to avoid extinguishing the negative glow).

It is typically necessary to insure that sputtering is allowed to occur only at the front side of the target, as the backside contains cooling coils and attachment fixtures which are definitely not to be sputtered. To guarantee that no sputtering takes place except from desired surfaces, a shield of metal (at a potential equal to that of the anode) is placed at a distance less than the Crookes dark space at all other cathode surfaces (Fig. 11-7). Since no discharge will occur between two electrode surfaces separated by less than this distance, such shielding (termed *dark-space shielding*) is effective in preventing sputtering from unwanted cathode surfaces.

### 11.3 THE PHYSICS OF SPUTTERING

When a solid surface is bombarded by atoms, ions, or molecules, many phenomena occur. The kinetic energy of the impinging particles largely dictates which are the most probable events. For low energy particles (<10 eV), most interactions occur only at the surface of the target material. At very low energies (<5 eV) such events are limited to reflection or physisorption of the bombarding species. For low energies which exceed the binding energy of the target material (5–10 eV), surface migration and surface damage effects can take place. At much higher energies (>10 keV), the impinging particles travel well into the bulk of the sample before slowing down and depositing their energy. Thus, such particles are most likely to be embedded in the target, and this mechanism is the basis of ion-implantation. At energies between the two extremes, two other effects also arise: 1) some fraction of the energy of the impinging ions is transferred to the solid in the form of heat, and lattice damage; and 2) another fraction of such energy causes atoms from the surface to be dislodged and ejected into the gas phase (*sputtering*).

# Explore Litigation Insights

Docket Alarm provides insights to develop a more informed litigation strategy and the peace of mind of knowing you're on top of things.

## Real-Time Litigation Alerts



Keep your litigation team up-to-date with **real-time alerts** and advanced team management tools built for the enterprise, all while greatly reducing PACER spend.

Our comprehensive service means we can handle Federal, State, and Administrative courts across the country.

## Advanced Docket Research



With over 230 million records, Docket Alarm's cloud-native docket research platform finds what other services can't. Coverage includes Federal, State, plus PTAB, TTAB, ITC and NLRB decisions, all in one place.

Identify arguments that have been successful in the past with full text, pinpoint searching. Link to case law cited within any court document via Fastcase.

## Analytics At Your Fingertips



Learn what happened the last time a particular judge, opposing counsel or company faced cases similar to yours.

Advanced out-of-the-box PTAB and TTAB analytics are always at your fingertips.

## API

Docket Alarm offers a powerful API (application programming interface) to developers that want to integrate case filings into their apps.

## LAW FIRMS

Build custom dashboards for your attorneys and clients with live data direct from the court.

Automate many repetitive legal tasks like conflict checks, document management, and marketing.

## FINANCIAL INSTITUTIONS

Litigation and bankruptcy checks for companies and debtors.

## E-DISCOVERY AND LEGAL VENDORS

Sync your system to PACER to automate legal marketing.