



HANDBOOK of RADIO & WIRELESS TECHNOLOGY

Stan Gibilisco

Library of Congress Cataloging-in-Publication Data

Gibilisco, Stan.
Handbook of radio and wireless technology / Stan Gibilisco.
p. cm.
Includes index.
ISBN 0-07-023024-2
1. Radio. 2. Wireless communication systems. I. Title.
TK6550.G515 1998
621.382—dc21 98-8471
CIP

McGraw-Hill



A Division of The McGraw-Hill Companies

Copyright © 1999 by The McGraw-Hill Companies, Inc. All rights reserved. Printed in the United States of America. Except as permitted under the United States Copyright Act of 1976, no part of this publication may be reproduced or distributed in any form or by any means, or stored in a data base or retrieval system, without the prior written permission of the publisher.

1 2 3 4 5 6 7 8 9 0 DOC/DOC 9 0 3 2 1 0 9 8

ISBN 0-07-023024-2

The sponsoring editor for this book was Scott Grillo, the editing supervisor was Stephen M. Smith, and the production supervisor was Pamela A. Pelton. It was set in Vendome ICG by Joanne Morbit and Michele Zito of McGraw-Hill's Hightstown, N.J., Professional Book Group composition unit.

McGraw-Hill books are available at special quantity discounts to use as premiums and sales promotions, or for use in corporate training programs. For more information, please write to the Director of Special Sales, McGraw-Hill, 11 West 19th Street, New York, NY 10011. Or contact your local bookstore.



This book is printed on recycled, acid-free paper containing a minimum of 50% recycled de-inked fiber.

Information contained in this work has been obtained by The McGraw-Hill Companies, Inc. ("McGraw-Hill") from sources believed to be reliable. However, neither McGraw-Hill nor its authors guarantee the accuracy or completeness of any information published herein and neither McGraw-Hill nor its authors shall be responsible for any errors, omissions, or damages arising out of use of this information. This work is published with the understanding that McGraw-Hill and its authors are supplying information, but are not attempting to render engineering or other professional services. If such services are required, the assistance of an appropriate professional should be sought.

will radiate. Parasitic arrays, such as the Yagi antenna and the quad antenna, operate on this principle.

Selective Filters

The term *selective filter* refers to circuits designed to tailor the way an electronic circuit or system responds to signals at various frequencies. There are many kinds of selective filters. Some are used at AF; others are used at RF.

Bandpass Filter

Any resonant circuit, or combination of resonant circuits, designed to discriminate against all frequencies except a specific frequency f_0 , or a band of frequencies between two limiting frequencies f_0 and f_1 , is called a *bandpass filter*. In a parallel LC circuit, a bandpass filter shows a high impedance at the desired frequency or frequencies, and a low impedance at unwanted frequencies. In a series LC configuration, the filter has a low impedance at the desired frequency or frequencies, and a high impedance at unwanted frequencies. Figure 2-9A shows a simple parallel-tuned LC bandpass filter; Fig. 2-9B shows a simple series-tuned LC bandpass filter.

Some bandpass filters are built with components other than actual coils and capacitors, but all such filters operate on the same principle. The *crystal filter* uses piezoelectric materials, usually quartz, to obtain a bandpass response. A *mechanical filter* uses vibration resonances of certain substances, usually ceramics. In optics, a simple color filter, discriminating against all light wavelengths except within a certain range, is a form of bandpass filter.

Bandpass filters are sometimes designed to have very sharp, defined, resonant frequencies. Sometimes the resonance is spread out over a fairly wide range. The *attenuation-versus-frequency characteristic* of a bandpass filter is called the *bandpass response*. A bandpass filter can have a single, well-defined resonant frequency f_0 , as shown in Fig. 2-9C, or the response might be more or less rectangular, having two well-defined limit frequencies f_0 and f_1 , as shown at D. The bandwidth might be only a few hertz, such as with an audio filter designed for reception of Morse code. Or the bandwidth might be several megahertz, as in a helical filter

Figure 2-9

At A, elementary parallel-resonant bandpass filter. At B, elementary series-resonant bandpass filter. At C, sharp bandpass response. At D, broad bandpass response.

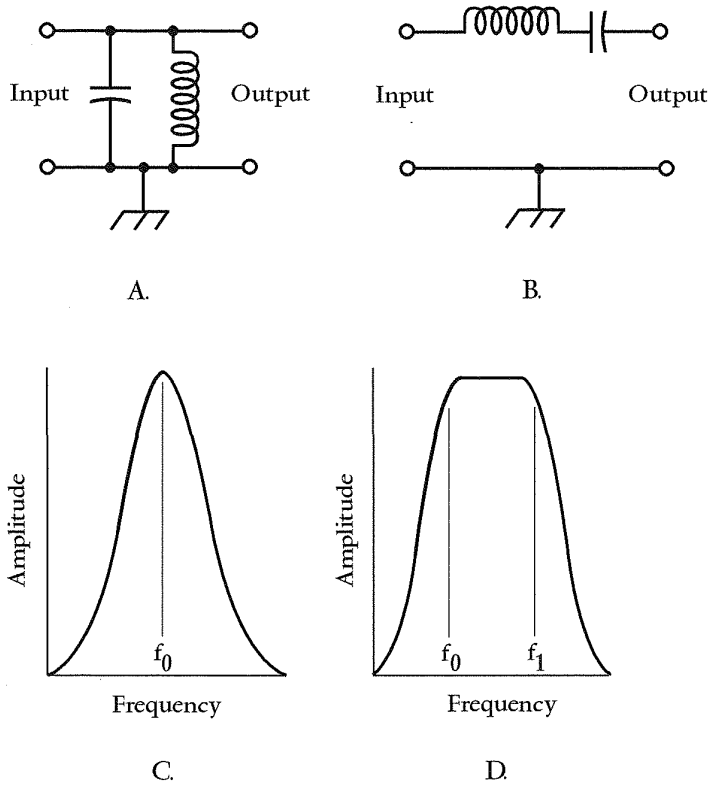

designed for the front end of a VHF or UHF radio receiver. A bandpass response is always characterized by high attenuation at all frequencies except within a particular range. The actual attenuation at desired frequencies is called the *insertion loss*.

Band-Rejection Filter

A *band-rejection filter*, also called a *band-stop filter*, is a resonant circuit designed to pass energy at all frequencies, except within a certain range. The attenuation is greatest at the resonant frequency f_0 , or between two limiting frequencies f_0 and f_1 . Figure 2-9E shows a simple parallel-resonant LC band-rejection filter; drawing F shows a simple series-resonant LC band-rejection filter. Note the similarity between band-rejection and bandpass filters. The fundamental difference is that

Figure 2-9 (cont.)

At E, elementary parallel-resonant band-rejection filter. At F, elementary series-resonant band-rejection filter. At G, sharp band-rejection response. At H, broad band-rejection response.

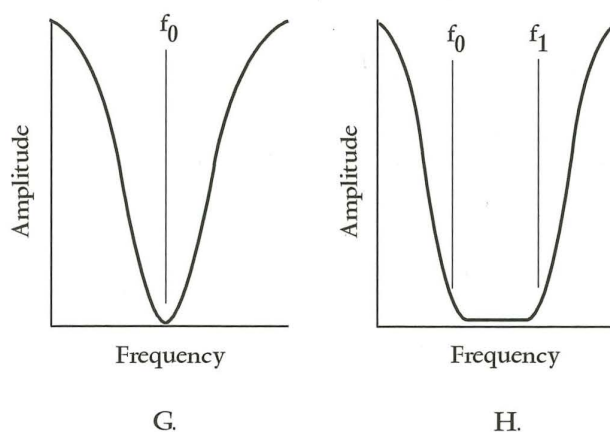
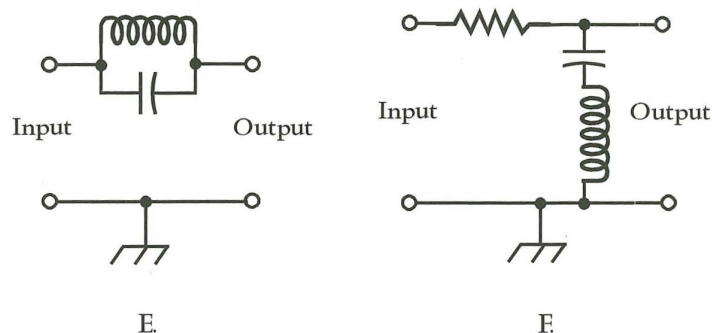

the band-rejection filter consists of parallel LC circuits connected in series with the signal path, or series LC circuits in parallel with the signal path; in bandpass filters, series-resonant circuits are connected in series, and parallel-resonance circuits in parallel.

Band-rejection filters need not necessarily be made up of coils and capacitors, but they often are. Quartz crystals are sometimes used as band-rejection filters. Lengths of transmission line, either short-circuited or open, are useful as band-rejection filters at the higher radio frequencies. A common example of a band-rejection filter is a *parasitic suppressor*, used in high-power RF amplifiers.

All band-rejection filters show an attenuation-versus-frequency characteristic marked by low loss at all frequencies except within a prescribed range. Figure 2-9G and H shows two types of band-rejection response. A sharp response (at G) occurs at or near a single resonant frequency f_0 . A

Explore Litigation Insights

Docket Alarm provides insights to develop a more informed litigation strategy and the peace of mind of knowing you're on top of things.

Real-Time Litigation Alerts



Keep your litigation team up-to-date with **real-time alerts** and advanced team management tools built for the enterprise, all while greatly reducing PACER spend.

Our comprehensive service means we can handle Federal, State, and Administrative courts across the country.

Advanced Docket Research



With over 230 million records, Docket Alarm's cloud-native docket research platform finds what other services can't. Coverage includes Federal, State, plus PTAB, TTAB, ITC and NLRB decisions, all in one place.

Identify arguments that have been successful in the past with full text, pinpoint searching. Link to case law cited within any court document via Fastcase.

Analytics At Your Fingertips



Learn what happened the last time a particular judge, opposing counsel or company faced cases similar to yours.

Advanced out-of-the-box PTAB and TTAB analytics are always at your fingertips.

API

Docket Alarm offers a powerful API (application programming interface) to developers that want to integrate case filings into their apps.

LAW FIRMS

Build custom dashboards for your attorneys and clients with live data direct from the court.

Automate many repetitive legal tasks like conflict checks, document management, and marketing.

FINANCIAL INSTITUTIONS

Litigation and bankruptcy checks for companies and debtors.

E-DISCOVERY AND LEGAL VENDORS

Sync your system to PACER to automate legal marketing.