

UNITED STATES PATENT AND TRADEMARK OFFICE

---

BEFORE THE PATENT TRIAL AND APPEAL BOARD

---

APPLIED MATERIALS, INC.,  
Petitioner,

v.

DEMARAY LLC,  
Patent Owner.

---

IPR2021-00103  
Patent 7,544,276 B2

---

Before CHRISTOPHER L. CRUMBLEY, KRISTINA M. KALAN, and  
KIMBERLY McGRAW, *Administrative Patent Judges*.

KALAN, *Administrative Patent Judge*.

DECISION  
Granting Institution of *Inter Partes* Review  
35 U.S.C. § 314

## I. INTRODUCTION

Applied Materials, Inc. (“Petitioner”) filed a Petition (Paper 1, “Pet.”) requesting an *inter partes* review of claims 1–13 of U.S. Patent No. 7,544,276 B2 (Ex. 1001, “the ’276 patent”). Demaray LLC (“Patent Owner”) filed a Preliminary Response to the Petition (Paper 8, “Prelim. Resp.”). Pursuant to our authorization (Paper 9), Petitioner filed a Reply (Paper 10, “Reply”), and Patent Owner filed a Sur-Reply (Paper 12, “Sur-Reply”). Petitioner also filed a Petitioner’s Notice Regarding Multiple Petitions (Paper 2 (“Notice”)) to which Patent Owner filed a Response (Paper 7 (“Notice Response”)).

To institute an *inter partes* review, we must determine that the information presented in the Petition shows “there is a reasonable likelihood that the petitioner would prevail with respect to at least 1 of the claims challenged in the petition.” 35 U.S.C. § 314(a). For the reasons discussed below, after considering the parties’ submissions and the evidence of record, we determine that Petitioner has demonstrated a reasonable likelihood of prevailing with respect to at least one claim of the ’276 patent. Patent Owner has not provided us with a persuasive reason to exercise our discretion to deny institution. Thus, we institute an *inter partes* review.

At this preliminary stage of the proceeding, we have not made a final determination as to the patentability of any challenged claim or any factual or legal issue underlying the patentability inquiry. Any final determination will be based on the record developed during trial. We place Patent Owner on express notice that any argument not asserted in a timely-filed Response to the Petition, or in another manner permitted during trial, shall be deemed waived, even if that argument was presented in the Preliminary Response.

*A. Related Proceedings*

The parties identify IPR2021-00105 as another proceeding filed by Petitioner against the '276 patent. Pet. 2; Paper 6, 1. Patent Owner also identifies IPR2021-00104 and IPR2021-00106, which challenge U.S. Patent No. 7,381,657 B2, as related matters. Paper 6, 1.

The parties also identify *Demaray LLC v. Samsung Electronics Co., Ltd.*, No. 6-20-cv-00636 (W.D. Tex.) (“Samsung Litigation”); *Demaray LLC v. Intel Corporation*, No. 6-20-cv-00634 (W.D. Tex.) (“Intel Litigation”); and *Applied Materials, Inc. v. Demaray LLC*, No. 5-20-cv-05676 (N.D. Cal.) (“California Litigation”) as related matters. Pet. 1; Paper 6, 1. Each of these proceedings involves the '276 patent. *Id.*

*B. Real Parties-In-Interest*

Petitioner identifies Intel Corporation, Samsung Electronics Co., Ltd., Samsung Electronics America, Inc., Samsung Semiconductor, Inc., Samsung Austin Semiconductor, LLC, and itself as real parties-in-interest. Pet. 1. Patent Owner identifies itself as the real party-in-interest. Paper 6, 1.

*C. The '276 Patent*

The '276 patent, titled “Biased Pulse DC Reactive Sputtering of Oxide Films,” relates to “deposition of oxide and oxynitride films and, in particular, to deposition of oxide and oxynitride films by pulsed DC reactive sputtering.” Ex. 1001, code (54), 1:12–14. The '276 patent discloses that typically, radio frequency (“RF”) sputtering has been used for deposition of oxide dielectric films, but arcing can occur between sputtering target tiles used to make such films, which causes contamination of the deposited films. *Id.* at 2:25–30. The '276 patent further states that reactors for RF sputtering, particularly their power systems, are complicated. *Id.* at 2:30–38. The '276 patent discloses that reactive DC magnetron sputtering of nonconductive

oxides “is done rarely” because insulating surfaces accumulate charge during deposition and result in arcing, which “can damage the power supply, produce particles and degrade the properties of deposited oxide films.” *Id.* at 4:44–52.

Figure 1A of the '276 patent is reproduced below.

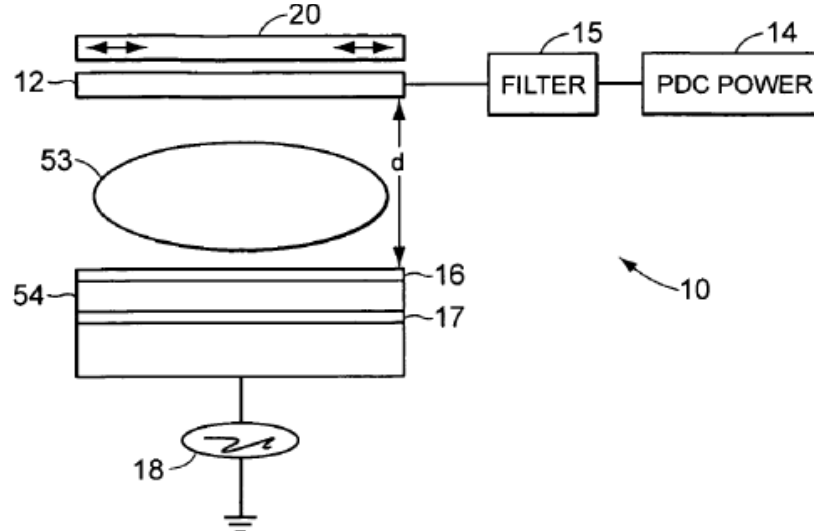

FIG. 1A

Figure 1A depicts a pulsed DC sputtering reactor. *Id.* at 3:26–27. The '276 patent describes reactor apparatus 10 for sputtering of material from target 12. *Id.* at 5:7–9. Magnet 20 is scanned across the top of target 12, which reduces local erosion of target 12 during sputtering. *Id.* at 5:28–29, 8:47–55. Substrate 16 is opposite and parallel to target 12. *Id.* at 5:23–24. Substrate 16 is capacitively coupled to electrode 17 via insulator 54. *Id.* at 5:26–27. Electrode 17 can be coupled to RF power supply 18. *Id.* at 5:27–28. The '276 patent explains that columnar structures in a deposited film can be detrimental for optical wave guide applications, but applying an RF bias on substrate 16 during deposition can substantially eliminate columnar structures. *Id.* at 5:60–67. The '276 patent discloses that target 12

functions as a cathode when power is applied to it, which creates plasma 53. *Id.* at 5:24–26.

Target 12 is electrically coupled through filter 15 to pulsed DC power supply 14. *Id.* at 5:19–20. The '276 patent discloses that the polarity of the power supplied to target 12 by the pulsed DC power supply 14 oscillates between negative and positive potentials. *Id.* at 5:30–33. According to the '276 patent, the insulating layer on the surface of target 12 discharges during the positive period, which prevents arcing. *Id.* at 5:33–35. The '276 patent discloses that the pulsing frequency must exceed a critical frequency, which depends on a target material, cathode current, and reverse time. *Id.* at 5:35–37.

Reactor apparatus 10 further includes filter 15, which prevents RF power supply 18 from coupling into pulsed DC power supply 14. *Id.* at 5:50–51. According to the '276 patent, filter 15 can be a 2 MHz band rejection filter when a 2 MHz power supply is used for RF power supply 18. *Id.* at 5:51–55. The '276 patent discloses that “the band width of the filter 15 can be approximately 100 kHz.” *Id.* at 5:55–57.

#### *D. Illustrative Claim*

Claims 1 and 6 of the '276 patent are independent. Claim 1 is representative and is reproduced below:

1. A reactor according to the present invention, comprising:
  - a target area for receiving a target;
  - a substrate area opposite the target area for receiving a substrate;
  - a pulsed DC power supply coupled to the target area, the pulsed DC power supply providing alternating negative and positive voltages to the target;
  - an RF bias power supply coupled to the substrate; and

# Explore Litigation Insights

Docket Alarm provides insights to develop a more informed litigation strategy and the peace of mind of knowing you're on top of things.

## Real-Time Litigation Alerts



Keep your litigation team up-to-date with **real-time alerts** and advanced team management tools built for the enterprise, all while greatly reducing PACER spend.

Our comprehensive service means we can handle Federal, State, and Administrative courts across the country.

## Advanced Docket Research



With over 230 million records, Docket Alarm's cloud-native docket research platform finds what other services can't. Coverage includes Federal, State, plus PTAB, TTAB, ITC and NLRB decisions, all in one place.

Identify arguments that have been successful in the past with full text, pinpoint searching. Link to case law cited within any court document via Fastcase.

## Analytics At Your Fingertips



Learn what happened the last time a particular judge, opposing counsel or company faced cases similar to yours.

Advanced out-of-the-box PTAB and TTAB analytics are always at your fingertips.

## API

Docket Alarm offers a powerful API (application programming interface) to developers that want to integrate case filings into their apps.

## LAW FIRMS

Build custom dashboards for your attorneys and clients with live data direct from the court.

Automate many repetitive legal tasks like conflict checks, document management, and marketing.

## FINANCIAL INSTITUTIONS

Litigation and bankruptcy checks for companies and debtors.

## E-DISCOVERY AND LEGAL VENDORS

Sync your system to PACER to automate legal marketing.