



APPLICATION NO.	ISSUE DATE	PATENT NO.	ATTORNEY DOCKET NO.	CONFIRMATION NO.
15/002,791	05/14/2019	10289131	EFACT.011C2	4939

20995            7590            04/24/2019  
KNOBBE MARTENS OLSON & BEAR LLP  
2040 MAIN STREET  
FOURTEENTH FLOOR  
IRVINE, CA 92614

### ISSUE NOTIFICATION

The projected patent number and issue date are specified above.

#### **Determination of Patent Term Adjustment under 35 U.S.C. 154 (b)** (application filed on or after May 29, 2000)

The Patent Term Adjustment is 331 day(s). Any patent to issue from the above-identified application will include an indication of the adjustment on the front page.

If a Continued Prosecution Application (CPA) was filed in the above-identified application, the filing date that determines Patent Term Adjustment is the filing date of the most recent CPA.

Applicant will be able to obtain more detailed information by accessing the Patent Application Information Retrieval (PAIR) WEB site (<http://pair.uspto.gov>).

Any questions regarding the Patent Term Extension or Adjustment determination should be directed to the Office of Patent Legal Administration at (571)-272-7702. Questions relating to issue and publication fee payments should be directed to the Application Assistance Unit (AAU) of the Office of Data Management (ODM) at (571)-272-4200.

APPLICANT(s) (Please see PAIR WEB site <http://pair.uspto.gov> for additional applicants):

EcoFactor, Inc., Redwood City, CA;  
John Douglas Steinberg, Millbrae, CA;

The United States represents the largest, most dynamic marketplace in the world and is an unparalleled location for business investment, innovation, and commercialization of new technologies. The USA offers tremendous resources and advantages for those who invest and manufacture goods here. Through SelectUSA, our nation works to encourage and facilitate business investment. To learn more about why the USA is the best country in the world to develop technology, manufacture products, and grow your business, visit [SelectUSA.gov](http://SelectUSA.gov).



UNITED STATES PATENT AND TRADEMARK OFFICE

UNITED STATES DEPARTMENT OF COMMERCE
United States Patent and Trademark Office
Address: COMMISSIONER FOR PATENTS
P.O. Box 1450
Alexandria, Virginia 22313-1450
www.uspto.gov

Table with 5 columns: APPLICATION NO., FILING DATE, FIRST NAMED INVENTOR, ATTORNEY DOCKET NO., CONFIRMATION NO.
15/002,791 01/21/2016 John Douglas Steinberg EFACT.011C2 4939

7590 04/05/2019
KNOBBE MARTENS OLSON & BEAR LLP
2040 MAIN STREET
FOURTEENTH FLOOR
IRVINE, CA 92614

EXAMINER

OJHA, AJAY

ART UNIT PAPER NUMBER

2824

NOTIFICATION DATE DELIVERY MODE

04/05/2019

ELECTRONIC

NOTICE OF NON-COMPLIANT INFORMATION DISCLOSURE STATEMENT

An Information Disclosure Statement (IDS) filed 4.2.19 in the above-identified application fails to meet the requirements of 37 CFR 1.97(d) for the reason(s) specified below. Accordingly, the IDS will be placed in the file, but the information referred to therein has not been considered.

The IDS is not compliant with 37 CFR 1.97(d) because:

- X The IDS lacks a statement as specified in 37 CFR 1.97(e).
The IDS lacks the fee set forth in 37 CFR 1.17(p).
The IDS was filed after the issue fee was paid. Applicant may wish to consider filing a petition to withdraw the application from issue under 37 CFR 1.313(c) to have the IDS considered. See MPEP 1308.

Handwritten signature and contact information: 571-272-4200 or 1-888-786-0101, Application Assistance Unit, Office of Data Management

<b>INFORMATION DISCLOSURE STATEMENT BY APPLICANT</b>	Application No.	15/002,791
	Filing Date	January 21, 2016
	First Named Inventor	John Douglas Steinberg
	Art Unit	2824
<i>(Multiple sheets used when necessary)</i>	Examiner	Ojha, Ajay
SHEET 1 OF 2	Attorney Docket No.	EFACT.011C2

<b>U.S. PATENT DOCUMENTS</b>					
Examiner Initials	Cite No.	Document Number <i>Number - Kind Code (if known)</i> Example: 1,234,567 B1	Publication Date MM-DD-YYYY	Name	Pages, Columns, Lines Where Relevant Passages or Relevant Figures Appear
	1	9,353,965	05/31/2016	Goyal et al.	
	2	9,534,805	01/03/2017	Matsuoka et al.	
	3	2007/0107450	05/17/2007	Sasao et al.	
	4	2010/0070234	03/18/2010	Steinberg et al.	
	5	2011/0118857	05/19/2011	Bodnar	
	6	2012/0066168	03/15/2012	Fadell et al.	
	7	2014/0074300	03/13/2014	Shilts et al.	
	8	2014/0207292	07/24/2014	Ramagem	
	9	2015/0227846	08/13/2015	Mercer et al.	
	10	2015/0300892	10/22/2015	Malhotra et al.	
	11	2015/0378373	12/31/2015	Sprinkle et al.	
	12	2016/0047565	02/18/2016	Robinson	
	13	2016/0241538	08/18/2016	Khurana et al.	
	14	2016/0290672	10/06/2016	Arensmeier	
	15	2017/0123391	05/04/2017	Sinha et al.	
	16	2017/0234562	08/17/2017	Ribbich et al.	
	17	2017/0268797	09/21/2017	Mowris et al.	
	18	2017/0322530	11/09/2017	Al-Mohssen et al.	
	19	2017/0328777	11/16/2017	Zeckendorf et al.	
	20	2018/0058711	03/01/2018	Taplin	
	21	2018/0245810	08/30/2018	Berka et al.	
	22	2018/0259400	09/13/2018	Steinberg et al.	
	23	2018/0313567	11/01/2018	Steinberg	
	24	2018/0321093	11/08/2018	Steinberg et al.	

<b>NON PATENT LITERATURE DOCUMENTS</b>
--

Examiner Signature	Date Considered
<p><b>*Examiner:</b> Initial if reference considered, whether or not citation is in conformance with MPEP 609. Draw line through citation if not in conformance and not considered. Include copy of this form with next communication to applicant.</p>	

T<sup>1</sup> - Place a check mark in this area when an English language <sup>0003</sup> Translation is attached.

<b>INFORMATION DISCLOSURE STATEMENT BY APPLICANT</b>	Application No.	15/002,791
	Filing Date	January 21, 2016
	First Named Inventor	John Douglas Steinberg
	Art Unit	2824
<i>(Multiple sheets used when necessary)</i>	Examiner	Ojha, Ajay
SHEET 2 OF 2	Attorney Docket No.	EFACT.011C2

Examiner Initials	Cite No.	Include name of the author (in CAPITAL LETTERS), title of the article (when appropriate), title of the item (book, magazine, journal, serial, symposium, catalog, etc.), date, page(s), volume-issue number(s), publisher, city and/or country where published.	T <sup>1</sup>
	<b>25</b>	Anonymous: "Process Control", Garfixia Software Architectures, August 31, 2008, Retrieved from the Internet: URL: <a href="http://www.dossier-andreas.neVsoftware.com/architecture/process_control.html">http://www.dossier-andreas.neVsoftware.com/architecture/process_control.html</a> , pages 1-1.	
	<b>26</b>	Communication in European Application No. 11818805.1 dated October 11, 2018 (EFACT.013EP).	

30247716

Examiner Signature	Date Considered
<p><b>*Examiner:</b> Initial if reference considered, whether or not citation is in conformance with MPEP 609. Draw line through citation if not in conformance and not considered. Include copy of this form with next communication to applicant.</p>	

T<sup>1</sup> - Place a check mark in this area when an English language Translation is attached.

## Electronic Patent Application Fee Transmittal

<b>Application Number:</b>	15002791			
<b>Filing Date:</b>	21-Jan-2016			
<b>Title of Invention:</b>	SYSTEM AND METHOD FOR USING A WIRELESS DEVICE AS A SENSOR FOR AN ENERGY MANAGEMENT SYSTEM			
<b>First Named Inventor/Applicant Name:</b>	John Douglas Steinberg			
<b>Filer:</b>	John R. King/Amy Durrant			
<b>Attorney Docket Number:</b>	EFACT.011C2			
Filed as Small Entity				
<b>Filing Fees for Utility under 35 USC 111(a)</b>				
<b>Description</b>	<b>Fee Code</b>	<b>Quantity</b>	<b>Amount</b>	<b>Sub-Total in USD(\$)</b>
<b>Basic Filing:</b>				
<b>Pages:</b>				
<b>Claims:</b>				
<b>Miscellaneous-Filing:</b>				
<b>Petition:</b>				
<b>Patent-Appeals-and-Interference:</b>				
<b>Post-Allowance-and-Post-Issuance:</b>				
UTILITY APPL ISSUE FEE	2501	1	500	500

Description	Fee Code	Quantity	Amount	Sub-Total in USD(\$)
<b>Extension-of-Time:</b>				
<b>Miscellaneous:</b>				
<b>Total in USD (\$)</b>				<b>500</b>

## Electronic Acknowledgement Receipt

<b>EFS ID:</b>	35605185
<b>Application Number:</b>	15002791
<b>International Application Number:</b>	
<b>Confirmation Number:</b>	4939
<b>Title of Invention:</b>	SYSTEM AND METHOD FOR USING A WIRELESS DEVICE AS A SENSOR FOR AN ENERGY MANAGEMENT SYSTEM
<b>First Named Inventor/Applicant Name:</b>	John Douglas Steinberg
<b>Customer Number:</b>	20995
<b>Filer:</b>	John R. King/Melissa Ramirez
<b>Filer Authorized By:</b>	John R. King
<b>Attorney Docket Number:</b>	EFACT.011C2
<b>Receipt Date:</b>	02-APR-2019
<b>Filing Date:</b>	21-JAN-2016
<b>Time Stamp:</b>	16:07:26
<b>Application Type:</b>	Utility under 35 USC 111(a)

### Payment information:

Submitted with Payment	yes
Payment Type	CARD
Payment was successfully received in RAM	\$500
RAM confirmation Number	040319INTEFSW16080400
Deposit Account	111410
Authorized User	Melissa Ramirez

The Director of the USPTO is hereby authorized to charge indicated fees and credit any overpayment as follows:

37 CFR 1.16 (National application filing, search, and examination fees)

37 CFR 1.17 (Patent application and reexamination processing fees)

--	--	--	--	--	--

**File Listing:**

Document Number	Document Description	File Name	File Size(Bytes)/ Message Digest	Multi Part /.zip	Pages (if appl.)
1	Issue Fee Payment (PTO-85B)	EFACT-011C2_issuefee.pdf	218219	no	1
			658a2c264ed3e007207c5c30f2df3b4a4963e2c3		

**Warnings:**

**Information:**

2	Miscellaneous Incoming Letter	EFACT-011C2_comments.pdf	16465	no	2
			57ad1fc9d375bb0087fb8c4a5df0909e55cd0179		

**Warnings:**

**Information:**

3		EFACT-011C2_IDS.pdf	40185	yes	3
			4eba9d39f2ff86120f9462dce9f837d4d7eddbde		

**Multipart Description/PDF files in .zip description**

Document Description	Start	End
Transmittal Letter	1	1
Information Disclosure Statement (IDS) Form (SB08)	2	3

**Warnings:**

**Information:**

4	Non Patent Literature	EFACT-011C2_ref25.pdf	249715	no	2
			3c72fa4d0b9ed7e83a4a26ab3eedd22454092569		

**Warnings:**

**Information:**

5	Non Patent Literature	EFACT-011C2_ref26.pdf	899813	no	11
			798e622cb23f112753b857f93305734637b61155		

**Warnings:**

**Information:**

0008



6	Fee Worksheet (SB06)	fee-info.pdf	30308	no	2
			c23e7e694c4a7b67cfb16f824a6346cbaefa2f37		

**Warnings:**

**Information:**

<b>Total Files Size (in bytes):</b>	1454705
-------------------------------------	---------

**This Acknowledgement Receipt evidences receipt on the noted date by the USPTO of the indicated documents, characterized by the applicant, and including page counts, where applicable. It serves as evidence of receipt similar to a Post Card, as described in MPEP 503.**

**New Applications Under 35 U.S.C. 111**

**If a new application is being filed and the application includes the necessary components for a filing date (see 37 CFR 1.53(b)-(d) and MPEP 506), a Filing Receipt (37 CFR 1.54) will be issued in due course and the date shown on this Acknowledgement Receipt will establish the filing date of the application.**

**National Stage of an International Application under 35 U.S.C. 371**

**If a timely submission to enter the national stage of an international application is compliant with the conditions of 35 U.S.C. 371 and other applicable requirements a Form PCT/DO/EO/903 indicating acceptance of the application as a national stage submission under 35 U.S.C. 371 will be issued in addition to the Filing Receipt, in due course.**

**New International Application Filed with the USPTO as a Receiving Office**

**If a new international application is being filed and the international application includes the necessary components for an international filing date (see PCT Article 11 and MPEP 1810), a Notification of the International Application Number and of the International Filing Date (Form PCT/RO/105) will be issued in due course, subject to prescriptions concerning national security, and the date shown on this Acknowledgement Receipt will establish the international filing date of the application.**

**PART B - FEE(S) TRANSMITTAL**

Complete and send this form, together with applicable fee(s), by mail or fax, or via EFS-Web.

By mail, send to: **Mail Stop ISSUE FEE**  
 Commissioner for Patents  
 P.O. Box 1450  
 Alexandria, Virginia 22313-1450

By fax, send to: (571)-273-2885

**INSTRUCTIONS:** This form should be used for transmitting the **ISSUE FEE** and **PUBLICATION FEE** (if required). Blocks 1 through 5 should be completed where appropriate. All further correspondence including the Patent, advance orders and notification of maintenance fees will be mailed to the current correspondence address as indicated unless corrected below or directed otherwise in Block 1, by (a) specifying a new correspondence address; and/or (b) indicating a separate "FEE ADDRESS" for maintenance fee notifications.

CURRENT CORRESPONDENCE ADDRESS (Note: Use Block 1 for any change of address)

Note: A certificate of mailing can only be used for domestic mailings of the Fee(s) Transmittal. This certificate cannot be used for any other accompanying papers. Each additional paper, such as an assignment or formal drawing, must have its own certificate of mailing or transmission.

20995 7590 01/04/2019  
**KNOBBE MARTENS OLSON & BEAR LLP**  
 2040 MAIN STREET  
 FOURTEENTH FLOOR  
 IRVINE, CA 92614

**Certificate of Mailing or Transmission**

I hereby certify that this Fee(s) Transmittal is being deposited with the United States Postal Service with sufficient postage for first class mail in an envelope addressed to the Mail Stop ISSUE FEE address above, or being transmitted to the USPTO via EFS-Web or by facsimile to (571) 273-2885, on the date below.

(Typed or printed name)
(Signature)
(Date)

APPLICATION NO.	FILING DATE	FIRST NAMED INVENTOR	ATTORNEY DOCKET NO.	CONFIRMATION NO.
15/002,791	01/21/2016	John Douglas Steinberg	EFACT.011C2	4939

TITLE OF INVENTION: SYSTEM AND METHOD FOR USING A WIRELESS DEVICE AS A SENSOR FOR AN ENERGY MANAGEMENT SYSTEM

APPLN. TYPE	ENTITY STATUS	ISSUE FEE DUE	PUBLICATION FEE DUE	PREV. PAID ISSUE FEE	TOTAL FEE(S) DUE	DATE DUE
nonprovisional	SMALL	\$500	\$0.00	\$0.00	\$500	04/04/2019

EXAMINER	ART UNIT	CLASS-SUBCLASS
OJHA, AJAY	2824	700-276000

1. Change of correspondence address or indication of "Fee Address" (37 CFR 1.363).

- Change of correspondence address (or Change of Correspondence Address form PTO/SB/122) attached.
- "Fee Address" indication (or "Fee Address" Indication form PTO/SB/47; Rev 03-09 or more recent) attached. **Use of a Customer Number is required.**

2. For printing on the patent front page, list  
 (1) The names of up to 3 registered patent attorneys or agents OR, alternatively,  
 (2) The name of a single firm (having as a member a registered attorney or agent) and the names of up to 2 registered patent attorneys or agents. If no name is listed, no name will be printed.

- 1 Knobbe, Martens,
- 2 Olson & Bear, LLP
- 3 \_\_\_\_\_

3. ASSIGNEE NAME AND RESIDENCE DATA TO BE PRINTED ON THE PATENT (print or type)

PLEASE NOTE: Unless an assignee is identified below, no assignee data will appear on the patent. If an assignee is identified below, the document must have been previously recorded, or filed for recordation, as set forth in 37 CFR 3.11 and 37 CFR 3.81(a). Completion of this form is NOT a substitute for filing an assignment.

(A) NAME OF ASSIGNEE: **EcoFactor, Inc.**  
 (B) RESIDENCE: (CITY and STATE OR COUNTRY) **Redwood City, CA**

Please check the appropriate assignee category or categories (will not be printed on the patent):  Individual  Corporation or other private group entity  Government

4a. Fees submitted:  Issue Fee  Publication Fee (if required)  Advance Order - # of Copies \_\_\_\_\_

4b. Method of Payment: (Please first reapply any previously paid fee shown above)

- Electronic Payment via EFS-Web  Enclosed check  Non-electronic payment by credit card (Attach form PTO-2038)
- The Director is hereby authorized to charge ~~the required fee(s)~~ any deficiency, or credit any overpayment to Deposit Account No. 11-1410

5. Change in Entity Status (from status indicated above)

- Applicant certifying micro entity status. See 37 CFR 1.29
- Applicant asserting small entity status. See 37 CFR 1.27
- Applicant changing to regular undiscounted fee status.

NOTE: Absent a valid certification of Micro Entity Status (see forms PTO/SB/15A and 15B), issue fee payment in the micro entity amount will not be accepted at the risk of application abandonment.  
 NOTE: If the application was previously under micro entity status, checking this box will be taken to be a notification of loss of entitlement to micro entity status.  
 NOTE: Checking this box will be taken to be a notification of loss of entitlement to small or micro entity status, as applicable.

NOTE: This form must be signed in accordance with 37 CFR 1.31 and 1.33. See 37 CFR 1.4 for signature requirements and certifications.

Authorized Signature /John R. King/ Date April 2, 2019  
 Typed or printed name John R. King Registration No. 34,362

**IN THE UNITED STATES PATENT AND TRADEMARK OFFICE**

Inventor : John Douglas Steinberg  
App. No. : 15/002,791  
Filed : January 21, 2016  
For : SYSTEM AND METHOD FOR USING A WIRELESS DEVICE  
AS A SENSOR FOR AN ENERGY MANAGEMENT SYSTEM  
Examiner : Ajay Ojha  
Art Unit : 2824  
Conf. No. : 4939

**COMMENTS ON STATEMENT OF REASONS FOR ALLOWANCE****Mail Stop Amendment**

Commissioner for Patents  
P.O. Box 1450  
Alexandria, VA 22313-1450

Dear Sir:

In response to the Statement of Reasons for Allowance in the Notice of Allowance mailed January 4, 2019, Applicant respectfully submits the following comments.

Applicant respectfully disagrees with the Examiner's statement of reasons for allowance to the extent that the limitations recited by the Examiner are not present in all of the claims. Also, to the extent that there is any implication that the patentability of the claims rests on the recitation of a single feature, Applicant respectfully disagrees with the Examiner's Statement because it is the combination of features that makes the claims patentable.

**Application No.: 15/002,791**  
**Filing Date: January 21, 2016**

Applicant submits that the claims of the present application are allowable because each of the claims recites a combination of features that are not taught or suggested by the prior art.

Respectfully submitted,  
KNOBBE, MARTENS, OLSON & BEAR, LLP

Dated: April 2, 2019

By: John R. King  
John R. King  
Registration No. 34,362  
Attorney of Record  
Customer No. 20,995  
(949) 760-0404

30247574

**INFORMATION DISCLOSURE STATEMENT**

First Inventor : John Douglas Steinberg  
App. No. : 15/002,791  
Filed : January 21, 2016  
For : SYSTEM AND METHOD FOR USING A WIRELESS DEVICE AS  
A SENSOR FOR AN ENERGY MANAGEMENT SYSTEM  
Examiner : Ojha, Ajay  
Art Unit : 2824  
Conf. No. : 4939

**Mail Stop Issue Fee**

Commissioner for Patents  
P.O. Box 1450  
Alexandria, VA 22313-1450

**References and Listing**

Pursuant to 37 CFR 1.56, an Information Disclosure Statement listing references is provided herewith. Copies of any listed foreign and non-patent literature references are being submitted.

**No Disclaimers**

To the extent that anything in the Information Disclosure Statement or the listed references could be construed as a disclaimer of any subject matter supported by the present application, Applicant hereby rescinds and retracts such disclaimer.

**Timing of Disclosure**

This Information Disclosure Statement is being filed after the mailing date of a final action or after the mailing date of a Notice of Allowance. Please place these references in the file in accordance with 37 CFR 1.97(i).

Respectfully submitted,  
KNOBBE, MARTENS, OLSON & BEAR, LLP

Dated: April 2, 2019

By: John R. King/  
John R. King  
Registration No. 34,362  
Registered Practitioner  
Customer No. 20,995  
(949) 760-0404



UNITED STATES DEPARTMENT OF COMMERCE
United States Patent and Trademark Office
Address: COMMISSIONER FOR PATENTS
P.O. Box 1450
Alexandria, Virginia 22313-1450
www.uspto.gov

NOTICE OF ALLOWANCE AND FEE(S) DUE

20995 7590 01/04/2019
KNOBBE MARTENS OLSON & BEAR LLP
2040 MAIN STREET
FOURTEENTH FLOOR
IRVINE, CA 92614

Table with 2 columns: EXAMINER (OJHA, AJAY), ART UNIT (2824), PAPER NUMBER.

DATE MAILED: 01/04/2019

Table with 5 columns: APPLICATION NO. (15/002,791), FILING DATE (01/21/2016), FIRST NAMED INVENTOR (John Douglas Steinberg), ATTORNEY DOCKET NO. (EFACT.011C2), CONFIRMATION NO. (4939)

TITLE OF INVENTION: SYSTEM AND METHOD FOR USING A WIRELESS DEVICE AS A SENSOR FOR AN ENERGY MANAGEMENT SYSTEM

Table with 7 columns: APPLN. TYPE (nonprovisional), ENTITY STATUS (SMALL), ISSUE FEE DUE (\$500), PUBLICATION FEE DUE (\$0.00), PREV. PAID ISSUE FEE (\$0.00), TOTAL FEE(S) DUE (\$500), DATE DUE (04/04/2019)

THE APPLICATION IDENTIFIED ABOVE HAS BEEN EXAMINED AND IS ALLOWED FOR ISSUANCE AS A PATENT. PROSECUTION ON THE MERITS IS CLOSED. THIS NOTICE OF ALLOWANCE IS NOT A GRANT OF PATENT RIGHTS. THIS APPLICATION IS SUBJECT TO WITHDRAWAL FROM ISSUE AT THE INITIATIVE OF THE OFFICE OR UPON PETITION BY THE APPLICANT. SEE 37 CFR 1.313 AND MPEP 1308.

THE ISSUE FEE AND PUBLICATION FEE (IF REQUIRED) MUST BE PAID WITHIN THREE MONTHS FROM THE MAILING DATE OF THIS NOTICE OR THIS APPLICATION SHALL BE REGARDED AS ABANDONED. THIS STATUTORY PERIOD CANNOT BE EXTENDED. SEE 35 U.S.C. 151. THE ISSUE FEE DUE INDICATED ABOVE DOES NOT REFLECT A CREDIT FOR ANY PREVIOUSLY PAID ISSUE FEE IN THIS APPLICATION. IF AN ISSUE FEE HAS PREVIOUSLY BEEN PAID IN THIS APPLICATION (AS SHOWN ABOVE), THE RETURN OF PART B OF THIS FORM WILL BE CONSIDERED A REQUEST TO REAPPLY THE PREVIOUSLY PAID ISSUE FEE TOWARD THE ISSUE FEE NOW DUE.

HOW TO REPLY TO THIS NOTICE:

I. Review the ENTITY STATUS shown above. If the ENTITY STATUS is shown as SMALL or MICRO, verify whether entitlement to that entity status still applies. If the ENTITY STATUS is the same as shown above, pay the TOTAL FEE(S) DUE shown above. If the ENTITY STATUS is changed from that shown above, on PART B - FEE(S) TRANSMITTAL, complete section number 5 titled "Change in Entity Status (from status indicated above)". For purposes of this notice, small entity fees are 1/2 the amount of undiscounted fees, and micro entity fees are 1/2 the amount of small entity fees.

II. PART B - FEE(S) TRANSMITTAL, or its equivalent, must be completed and returned to the United States Patent and Trademark Office (USPTO) with your ISSUE FEE and PUBLICATION FEE (if required). If you are charging the fee(s) to your deposit account, section "4b" of Part B - Fee(s) Transmittal should be completed and an extra copy of the form should be submitted. If an equivalent of Part B is filed, a request to reapply a previously paid issue fee must be clearly made, and delays in processing may occur due to the difficulty in recognizing the paper as an equivalent of Part B.

III. All communications regarding this application must give the application number. Please direct all communications prior to issuance to Mail Stop ISSUE FEE unless advised to the contrary.

IMPORTANT REMINDER: Maintenance fees are due in utility patents issuing on applications filed on or after Dec. 12, 1980. It is patentee's responsibility to ensure timely payment of maintenance fees when due. More information is available at www.uspto.gov/PatentMaintenanceFees.

**PART B - FEE(S) TRANSMITTAL**

Complete and send this form, together with applicable fee(s), by mail or fax, or via EFS-Web.

By mail, send to: **Mail Stop ISSUE FEE**  
**Commissioner for Patents**  
**P.O. Box 1450**  
**Alexandria, Virginia 22313-1450**

By fax, send to: **(571)-273-2885**

**INSTRUCTIONS:** This form should be used for transmitting the **ISSUE FEE** and **PUBLICATION FEE** (if required). Blocks 1 through 5 should be completed where appropriate. All further correspondence including the Patent, advance orders and notification of maintenance fees will be mailed to the current correspondence address as indicated unless corrected below or directed otherwise in Block 1, by (a) specifying a new correspondence address; and/or (b) indicating a separate "FEE ADDRESS" for maintenance fee notifications.

CURRENT CORRESPONDENCE ADDRESS (Note: Use Block 1 for any change of address)

Note: A certificate of mailing can only be used for domestic mailings of the Fee(s) Transmittal. This certificate cannot be used for any other accompanying papers. Each additional paper, such as an assignment or formal drawing, must have its own certificate of mailing or transmission.

20995                      7590                      01/04/2019  
**KNOBBE MARTENS OLSON & BEAR LLP**  
**2040 MAIN STREET**  
**FOURTEENTH FLOOR**  
**IRVINE, CA 92614**

**Certificate of Mailing or Transmission**

I hereby certify that this Fee(s) Transmittal is being deposited with the United States Postal Service with sufficient postage for first class mail in an envelope addressed to the Mail Stop ISSUE FEE address above, or being transmitted to the USPTO via EFS-Web or by facsimile to (571) 273-2885, on the date below.

(Typed or printed name)
(Signature)
(Date)

APPLICATION NO.	FILING DATE	FIRST NAMED INVENTOR	ATTORNEY DOCKET NO.	CONFIRMATION NO.
15/002,791	01/21/2016	John Douglas Steinberg	EFACT.011C2	4939

**TITLE OF INVENTION: SYSTEM AND METHOD FOR USING A WIRELESS DEVICE AS A SENSOR FOR AN ENERGY MANAGEMENT SYSTEM**

APPLN. TYPE	ENTITY STATUS	ISSUE FEE DUE	PUBLICATION FEE DUE	PREV. PAID ISSUE FEE	TOTAL FEE(S) DUE	DATE DUE
nonprovisional	SMALL	\$500	\$0.00	\$0.00	\$500	04/04/2019

EXAMINER	ART UNIT	CLASS-SUBCLASS
OJHA, AJAY	2824	700-276000

<p><b>1. Change of correspondence address or indication of "Fee Address" (37 CFR 1.363).</b></p> <p><input type="checkbox"/> Change of correspondence address (or Change of Correspondence Address form PTO/SB/122) attached.</p> <p><input type="checkbox"/> "Fee Address" indication (or "Fee Address" Indication form PTO/SB/47; Rev 03-09 or more recent) attached. <b>Use of a Customer Number is required.</b></p>	<p><b>2. For printing on the patent front page, list</b></p> <p>(1) The names of up to 3 registered patent attorneys or agents OR, alternatively, _____ 1</p> <p>(2) The name of a single firm (having as a member a registered attorney or agent) and the names of up to 2 registered patent attorneys or agents. If no name is listed, no name will be printed. _____ 2</p> <p>_____ 3</p>
--	--

**3. ASSIGNEE NAME AND RESIDENCE DATA TO BE PRINTED ON THE PATENT (print or type)**

PLEASE NOTE: Unless an assignee is identified below, no assignee data will appear on the patent. If an assignee is identified below, the document must have been previously recorded, or filed for recordation, as set forth in 37 CFR 3.11 and 37 CFR 3.81(a). Completion of this form is NOT a substitute for filing an assignment.

(A) NAME OF ASSIGNEE \_\_\_\_\_ (B) RESIDENCE: (CITY and STATE OR COUNTRY) \_\_\_\_\_

Please check the appropriate assignee category or categories (will not be printed on the patent) :  Individual  Corporation or other private group entity  Government

4a. Fees submitted:  Issue Fee  Publication Fee (if required)  Advance Order - # of Copies \_\_\_\_\_

4b. Method of Payment: (Please first reapply any previously paid fee shown above)

Electronic Payment via EFS-Web  Enclosed check  Non-electronic payment by credit card (Attach form PTO-2038)

The Director is hereby authorized to charge the required fee(s), any deficiency, or credit any overpayment to Deposit Account No. \_\_\_\_\_

**5. Change in Entity Status** (from status indicated above)

Applicant certifying micro entity status. See 37 CFR 1.29

Applicant asserting small entity status. See 37 CFR 1.27

Applicant changing to regular undiscounted fee status.

**NOTE:** Absent a valid certification of Micro Entity Status (see forms PTO/SB/15A and 15B), issue fee payment in the micro entity amount will not be accepted at the risk of application abandonment.

**NOTE:** If the application was previously under micro entity status, checking this box will be taken to be a notification of loss of entitlement to micro entity status.

**NOTE:** Checking this box will be taken to be a notification of loss of entitlement to small or micro entity status, as applicable.

**NOTE:** This form must be signed in accordance with 37 CFR 1.31 and 1.33. See 37 CFR 1.4 for signature requirements and certifications.

Authorized Signature \_\_\_\_\_ Date \_\_\_\_\_

Typed or printed name \_\_\_\_\_ Registration No. \_\_\_\_\_



UNITED STATES PATENT AND TRADEMARK OFFICE

UNITED STATES DEPARTMENT OF COMMERCE
United States Patent and Trademark Office
Address: COMMISSIONER FOR PATENTS
P.O. Box 1450
Alexandria, Virginia 22313-1450
www.uspto.gov

Table with 5 columns: APPLICATION NO., FILING DATE, FIRST NAMED INVENTOR, ATTORNEY DOCKET NO., CONFIRMATION NO.
Row 1: 15/002,791, 01/21/2016, John Douglas Steinberg, EFACT.011C2, 4939
Row 2: 20995, 7590, 01/04/2019, EXAMINER OJHA, AJAY
Row 3: ART UNIT 2824, PAPER NUMBER

20995 7590 01/04/2019
KNOBBE MARTENS OLSON & BEAR LLP
2040 MAIN STREET
FOURTEENTH FLOOR
IRVINE, CA 92614

DATE MAILED: 01/04/2019

Determination of Patent Term Adjustment under 35 U.S.C. 154 (b)
(Applications filed on or after May 29, 2000)

The Office has discontinued providing a Patent Term Adjustment (PTA) calculation with the Notice of Allowance.

Section 1(h)(2) of the AIA Technical Corrections Act amended 35 U.S.C. 154(b)(3)(B)(i) to eliminate the requirement that the Office provide a patent term adjustment determination with the notice of allowance. See Revisions to Patent Term Adjustment, 78 Fed. Reg. 19416, 19417 (Apr. 1, 2013). Therefore, the Office is no longer providing an initial patent term adjustment determination with the notice of allowance. The Office will continue to provide a patent term adjustment determination with the Issue Notification Letter that is mailed to applicant approximately three weeks prior to the issue date of the patent, and will include the patent term adjustment on the patent. Any request for reconsideration of the patent term adjustment determination (or reinstatement of patent term adjustment) should follow the process outlined in 37 CFR 1.705.

Any questions regarding the Patent Term Extension or Adjustment determination should be directed to the Office of Patent Legal Administration at (571)-272-7702. Questions relating to issue and publication fee payments should be directed to the Customer Service Center of the Office of Patent Publication at 1-(888)-786-0101 or (571)-272-4200.



## OMB Clearance and PRA Burden Statement for PTOL-85 Part B

The Paperwork Reduction Act (PRA) of 1995 requires Federal agencies to obtain Office of Management and Budget approval before requesting most types of information from the public. When OMB approves an agency request to collect information from the public, OMB (i) provides a valid OMB Control Number and expiration date for the agency to display on the instrument that will be used to collect the information and (ii) requires the agency to inform the public about the OMB Control Number's legal significance in accordance with 5 CFR 1320.5(b).

The information collected by PTOL-85 Part B is required by 37 CFR 1.311. The information is required to obtain or retain a benefit by the public which is to file (and by the USPTO to process) an application. Confidentiality is governed by 35 U.S.C. 122 and 37 CFR 1.14. This collection is estimated to take 30 minutes to complete, including gathering, preparing, and submitting the completed application form to the USPTO. Time will vary depending upon the individual case. Any comments on the amount of time you require to complete this form and/or suggestions for reducing this burden, should be sent to the Chief Information Officer, U.S. Patent and Trademark Office, U.S. Department of Commerce, P.O. Box 1450, Alexandria, Virginia 22313-1450. DO NOT SEND FEES OR COMPLETED FORMS TO THIS ADDRESS. SEND TO: Commissioner for Patents, P.O. Box 1450, Alexandria, Virginia 22313-1450. Under the Paperwork Reduction Act of 1995, no persons are required to respond to a collection of information unless it displays a valid OMB control number.

### Privacy Act Statement

**The Privacy Act of 1974 (P.L. 93-579)** requires that you be given certain information in connection with your submission of the attached form related to a patent application or patent. Accordingly, pursuant to the requirements of the Act, please be advised that: (1) the general authority for the collection of this information is 35 U.S.C. 2(b)(2); (2) furnishing of the information solicited is voluntary; and (3) the principal purpose for which the information is used by the U.S. Patent and Trademark Office is to process and/or examine your submission related to a patent application or patent. If you do not furnish the requested information, the U.S. Patent and Trademark Office may not be able to process and/or examine your submission, which may result in termination of proceedings or abandonment of the application or expiration of the patent.

The information provided by you in this form will be subject to the following routine uses:

1. The information on this form will be treated confidentially to the extent allowed under the Freedom of Information Act (5 U.S.C. 552) and the Privacy Act (5 U.S.C. 552a). Records from this system of records may be disclosed to the Department of Justice to determine whether disclosure of these records is required by the Freedom of Information Act.
2. A record from this system of records may be disclosed, as a routine use, in the course of presenting evidence to a court, magistrate, or administrative tribunal, including disclosures to opposing counsel in the course of settlement negotiations.
3. A record in this system of records may be disclosed, as a routine use, to a Member of Congress submitting a request involving an individual, to whom the record pertains, when the individual has requested assistance from the Member with respect to the subject matter of the record.
4. A record in this system of records may be disclosed, as a routine use, to a contractor of the Agency having need for the information in order to perform a contract. Recipients of information shall be required to comply with the requirements of the Privacy Act of 1974, as amended, pursuant to 5 U.S.C. 552a(m).
5. A record related to an International Application filed under the Patent Cooperation Treaty in this system of records may be disclosed, as a routine use, to the International Bureau of the World Intellectual Property Organization, pursuant to the Patent Cooperation Treaty.
6. A record in this system of records may be disclosed, as a routine use, to another federal agency for purposes of National Security review (35 U.S.C. 181) and for review pursuant to the Atomic Energy Act (42 U.S.C. 218(c)).
7. A record from this system of records may be disclosed, as a routine use, to the Administrator, General Services, or his/her designee, during an inspection of records conducted by GSA as part of that agency's responsibility to recommend improvements in records management practices and programs, under authority of 44 U.S.C. 2904 and 2906. Such disclosure shall be made in accordance with the GSA regulations governing inspection of records for this purpose, and any other relevant (i.e., GSA or Commerce) directive. Such disclosure shall not be used to make determinations about individuals.
8. A record from this system of records may be disclosed, as a routine use, to the public after either publication of the application pursuant to 35 U.S.C. 122(b) or issuance of a patent pursuant to 35 U.S.C. 151. Further, a record may be disclosed, subject to the limitations of 37 CFR 1.14, as a routine use, to the public if the record was filed in an application which became abandoned or in which the proceedings were terminated and which application is referenced by either a published application, an application open to public inspection or an issued patent.
9. A record from this system of records may be disclosed, as a routine use, to a Federal, State, or local law enforcement agency, if the USPTO becomes aware of a violation or potential violation of law or regulation.

<b>Notice of Allowability</b>	<b>Application No.</b> 15/002,791	<b>Applicant(s)</b> Steinberg, John Douglas	
	<b>Examiner</b> AJAY OJHA	<b>Art Unit</b> 2824	<b>AIA Status</b> No

**-- The MAILING DATE of this communication appears on the cover sheet with the correspondence address--**

All claims being allowable, PROSECUTION ON THE MERITS IS (OR REMAINS) CLOSED in this application. If not included herewith (or previously mailed), a Notice of Allowance (PTOL-85) or other appropriate communication will be mailed in due course. **THIS NOTICE OF ALLOWABILITY IS NOT A GRANT OF PATENT RIGHTS.** This application is subject to withdrawal from issue at the initiative of the Office or upon petition by the applicant. See 37 CFR 1.313 and MPEP 1308.

- 1.  This communication is responsive to Request for Continued Examination (RCE) - 09/21/2018.
  - A declaration(s)/affidavit(s) under **37 CFR 1.130(b)** was/were filed on \_\_\_\_\_.
- 2.  An election was made by the applicant in response to a restriction requirement set forth during the interview on \_\_\_\_\_; the restriction requirement and election have been incorporated into this action.
- 3.  The allowed claim(s) is/are 1-18. As a result of the allowed claim(s), you may be eligible to benefit from the **Patent Prosecution Highway** program at a participating intellectual property office for the corresponding application. For more information, please see [http://www.uspto.gov/patents/init\\_events/pph/index.jsp](http://www.uspto.gov/patents/init_events/pph/index.jsp) or send an inquiry to [PPHfeedback@uspto.gov](mailto:PPHfeedback@uspto.gov).
- 4.  Acknowledgment is made of a claim for foreign priority under 35 U.S.C. § 119(a)-(d) or (f).

**Certified copies:**

- a)  All      b)  Some      \*c)  None of the:
  - 1.  Certified copies of the priority documents have been received.
  - 2.  Certified copies of the priority documents have been received in Application No. \_\_\_\_\_.
  - 3.  Copies of the certified copies of the priority documents have been received in this national stage application from the International Bureau (PCT Rule 17.2(a)).

\* Certified copies not received: \_\_\_\_\_.

Applicant has THREE MONTHS FROM THE "MAILING DATE" of this communication to file a reply complying with the requirements noted below. Failure to timely comply will result in ABANDONMENT of this application.

**THIS THREE-MONTH PERIOD IS NOT EXTENDABLE.**

- 5.  CORRECTED DRAWINGS (as "replacement sheets") must be submitted.
  - including changes required by the attached Examiner's Amendment / Comment or in the Office action of Paper No./Mail Date \_\_\_\_\_.

**Identifying indicia such as the application number (see 37 CFR 1.84(c)) should be written on the drawings in the front (not the back) of each sheet. Replacement sheet(s) should be labeled as such in the header according to 37 CFR 1.121(d).**
- 6.  DEPOSIT OF and/or INFORMATION about the deposit of BIOLOGICAL MATERIAL must be submitted. Note the attached Examiner's comment regarding REQUIREMENT FOR THE DEPOSIT OF BIOLOGICAL MATERIAL.

**Attachment(s)**

- 1.  Notice of References Cited (PTO-892)
- 2.  Information Disclosure Statements (PTO/SB/08), Paper No./Mail Date 09/21/2018.
- 3.  Examiner's Comment Regarding Requirement for Deposit of Biological Material \_\_\_\_\_.
- 4.  Interview Summary (PTO-413), Paper No./Mail Date. \_\_\_\_\_.
- 5.  Examiner's Amendment/Comment
- 6.  Examiner's Statement of Reasons for Allowance
- 7.  Other \_\_\_\_\_.

/AJAY OJHA/  
Primary Examiner, Art Unit 2824

## ***DETAILED ACTION***

### ***General Remarks***

1. The present application, filed on or after March 16, 2013, is being examined under the first inventor to file provisions of the AIA.
2. In the event the determination of the status of the application as subject to AIA 35 U.S.C. 102 and 103 (or as subject to pre-AIA 35 U.S.C. 102 and 103) is incorrect, any correction of the statutory basis for the rejection will not be considered a new ground of rejection if the prior art relied upon, and the rationale supporting the rejection, would be the same under either status.
3. When responding to this office action, applicants are advised to provide the examiner with line numbers and page numbers in the application and/or references cited to assist the examiner in locating appropriate paragraphs.
4. Per MPEP 2111 and 2111.01, the claims are given their broadest reasonable interpretation and the words of the claims are given their plain meaning consistent with the specification without importing claim limitations from the specification.
5. Applicants seeking an interview with the examiner, including **WebEx Video Conferencing**, are encouraged to fill out the online Automated Interview Request (AIR) form (<http://www.uspto.gov/patent/uspto-automated-interview-request-air-form.html>). See MPEP §502.03, §713.01(II) and Interview Practice for additional details.
6. Status of claim(s) *to be treated* in this office action:
  - a. Independent: 1 and 10.
  - b. Amended: 1 and 10.
  - c. Pending: 1-18.

***IDS***

7. Applicant's IDS(s) submitted on 09/21/2018 is/are in compliance with the provisions of 37 CFR 1.97. Accordingly, the information disclosure statement has/have considered by the examiner and made of record.

***Continued Examination Under 37 CFR 1.114***

8. A request for continued examination under 37 CFR 1.114, including the fee set forth in 37 CFR 1.17(e), was filed in this application after final rejection. Since this application is eligible for continued examination under 37 CFR 1.114, and the fee set forth in 37 CFR 1.17(e) has been timely paid, the finality of the previous Office action has been withdrawn pursuant to 37 CFR 1.114. Applicant's submission filed on 09/21/2018 has been entered.

***Response to Arguments***

9. Applicant's arguments, see page(s) 6-7, filed 09/21/2018, with respect to claim(s) 1-18 have been fully considered and are persuasive. The rejection of claim(s) 1-18 has been withdrawn.

***Allowable Subject Matter***

10. **Claim(s) 1-18 are allowed.**

11. The following is an examiner's statement of reasons for allowance:

**The closest prior art to the present invention is US 20080281472 A1 ("Podgorny") and US 20090065596 A1 ("Seem").**

Podgorny discloses a building automation system, and, more particularly, to an Internet-centric, open, extensible software and hardware framework supporting all aspects of control and monitoring of a smart building ecosphere. The present invention further relates to an "intelligent," real-time control system capable of both autonomous process control and interaction with system users and system administrators, which is configured to accommodate functional extensions and a broad array of sensors and control devices. The system allows individuals to communicate, monitor and adjust their personal

environmental preferences (temperature, light, humidity, white noise, etc.) much like they would in an automobile, via the Internet. The system is equipped with an occupancy sensor that recognizes the presence and identity of the individual. A built-in expert system can make decisions based on data from multiple sources so that the system can alter its activity to conserve energy while maintaining users' comfort.

Seem discloses a method for providing control to a building zone uses a building automation system and a portable wireless device located within the building zone. The method includes the step of identifying the portable wireless device using wireless communications. The method further includes retrieving information from a memory device specific to the identified portable wireless device. The retrieved information comprises a user preference relating to the building automation system. The method further includes adjusting a parameter of the building automation system based on the retrieved information.

**Re: Independent Claim 1 (and dependent claim(s) 2-9)**, there is no teaching or suggestion in the prior art of record to provide:

monitoring an activity status of at least one wireless device associated with one or more occupants of said structure, wherein said wireless device comprises a graphic user interface that can be used to view video content, wherein use of said wireless device comprises at least one of cursor movement, keystrokes or other user interface actions intended to alter a state of said wireless device;

*determining a probability that the specific activity status of said wireless device is associated with the use of said wireless device by a specific occupant or occupants of said structure, where said probability is determined in part by the video content of the program or channel being viewed by said occupant on or with said wireless device and where said video content is not explicitly related to temperature setpoints;*

**Re: Independent Claim 10 (and dependent claim(s) 11-18)**, there is no teaching or suggestion in the prior art of record to provide:

an application comprising one or more computer processors that receives data regarding an activity status of said wireless device and whether said thermostat is set to said first temperature setpoint,

*said application determining a probability that the specific activity status of said wireless device is associated with the use of said wireless device by a specific occupant or occupants of said structure, where said probability is determined in part by the video content of the program or channel being viewed by said occupant on or with said wireless device and where said video content is not explicitly related to temperature setpoints;*

Missing elements in the closest art gives rise to the innovation in the current invention.

Any comments considered necessary by applicant must be submitted no later than the payment of the issue fee and, to avoid processing delays, should preferably accompany the issue fee. Such submissions should be clearly labeled "Comments on Statement of Reasons for Allowance."

***Conclusion***

12. Any inquiry concerning this communication or earlier communications from the examiner should be directed to AJAY OJHA whose telephone number is 571-272-8936. The examiner can normally be reached on M-F, 7:30AM to 5:00PM (EST).

If attempts to reach the examiner by telephone are unsuccessful, the examiner's supervisor, Richard Elms can be reached on 571-272-1869. The fax phone number for the organization where this application or proceeding is assigned is 571-273-8300.

13. Information regarding the status of an application may be obtained from the Patent Application Information Retrieval (PAIR) system. Status information for published applications may be obtained from either Private PAIR or Public PAIR. Status information for unpublished applications is available through Private PAIR only. For more information about the PAIR system, see <http://pair-direct.uspto.gov>. Should you have questions on access to the Private PAIR system, contact the Electronic Business Center (EBC) at 866-217-9197 (toll-free). If you would like assistance from a USPTO Customer Service Representative or access to the automated information system, call 800-786-9199 (IN USA OR CANADA) or 571-272-1000.

/AJAY OJHA/  
Primary Examiner, Art Unit 2824  
ajay.ojha@uspto.gov

<b>Search Notes</b> 	<b>Application/Control No.</b> 15/002,791	<b>Applicant(s)/Patent Under Reexamination</b> Steinberg, John Douglas
	<b>Examiner</b> AJAY OJHA	<b>Art Unit</b> 2824

CPC - Searched*		
Symbol	Date	Examiner
F24F11/006; F24F11/70; F24F11/62; F24F11/30; G05B15/02; G06N7/005; G05D23/1902; F24F11/56; F24F2120/12; F24F2120/10; F24F11/63; F24F11/46; F24F2120/20; F24F2140/60; F24F2120/14	02/13/2018	AO
Refreshed search.	06/11/2018	AO
Refreshed search.	12/20/2018	AO

CPC Combination Sets - Searched*		
Symbol	Date	Examiner

US Classification - Searched*			
Class	Subclass	Date	Examiner

\* See search history printout included with this form or the SEARCH NOTES box below to determine the scope of the search.

Search Notes		
Search Notes	Date	Examiner
Inventor, assignee, classification and text search. See search history.	02/13/2018	AO
Refreshed search. See search history.	06/11/2018	AO
Refreshed search. See search history.	12/20/2018	AO

Interference Search			
US Class/CPC Symbol	US Subclass/CPC Group	Date	Examiner
G05D	G05D23/00; G05D23/1902	12/20/2018	AO
F24F	F24F11/006; F24F11/70; F24F11/62; F24F11/30; F24F2120/12; F24F2120/10; F24F11/63; F24F11/46; F24F2120/20; F24F2140/60; F24F2120/14	12/20/2018	AO

/AJAY OJHA/ Primary Examiner, Art Unit 2824	
--	--



<p><b><i>Search Notes</i></b></p> 	<p><b>Application/Control No.</b></p> <p>15/002,791</p>	<p><b>Applicant(s)/Patent Under Reexamination</b></p> <p>Steinberg, John Douglas</p>
	<p><b>Examiner</b></p> <p>AJAY OJHA</p>	<p><b>Art Unit</b></p> <p>2824</p>

<p>/AJAY OJHA/ Primary Examiner, Art Unit 2824</p>	
--	--



<b>Issue Classification</b> 	<b>Application/Control No.</b> 15/002,791	<b>Applicant(s)/Patent Under Reexamination</b> Steinberg, John Douglas
	<b>Examiner</b> AJAY OJHA	<b>Art Unit</b> 2824

CPC					Type	Version
Symbol						
G05D	/	23	/	00	F	2013-01-01
G05D	/	23	/	1902	I	2013-01-01
G05B	/	15	/	02	I	2013-01-01
G06N	/	7	/	005	I	2013-01-01
F24F	/	11	/	30	I	2018-01-01
F24F	/	11	/	62	I	2018-01-01
F24F	/	11	/	70	I	2018-01-01
F24F	/	2120	/	10	A	2018-01-01
F24F	/	2120	/	12	A	2018-01-01
F24F	/	2120	/	14	A	2018-01-01
F24F	/	2140	/	60	A	2018-01-01
F24F	/	2120	/	20	A	2018-01-01
F24F	/	11	/	63	A	2018-01-01
F24F	/	11	/	56	A	2018-01-01
F24F	/	11	/	46	A	2018-01-01

CPC Combination Sets				
Symbol	Type	Set	Ranking	Version
/				

NONE	<b>Total Claims Allowed:</b>	
(Assistant Examiner)	(Date)	18
/AJAY OJHA/ Primary Examiner, Art Unit 2824	20 December 2018	O.G. Print Claim(s)
(Primary Examiner)	(Date)	1
		O.G. Print Figure
		2 and 7

<b>Issue Classification</b> 	<b>Application/Control No.</b> 15/002,791	<b>Applicant(s)/Patent Under Reexamination</b> Steinberg, John Douglas
	<b>Examiner</b> AJAY OJHA	<b>Art Unit</b> 2824

<b>INTERNATIONAL CLASSIFICATION</b>			
<b>CLAIMED</b>			
G05D	/	23	/ 00

<b>NON-CLAIMED</b>			
/	/	/	/

<b>US ORIGINAL CLASSIFICATION</b>	
<b>CLASS</b>	<b>SUBCLASS</b>

<b>CROSS REFERENCES(S)</b>						
<b>CLASS</b>	<b>SUBCLASS (ONE SUBCLASS PER BLOCK)</b>					

NONE		<b>Total Claims Allowed:</b>	
(Assistant Examiner)	(Date)	18	
/AJAY OJHA/ Primary Examiner, Art Unit 2824	20 December 2018	O.G. Print Claim(s)	O.G. Print Figure
(Primary Examiner)	(Date)	1	2 and 7

<b>Issue Classification</b> 	<b>Application/Control No.</b> 15/002,791	<b>Applicant(s)/Patent Under Reexamination</b> Steinberg, John Douglas
	<b>Examiner</b> AJAY OJHA	<b>Art Unit</b> 2824

Claims renumbered in the same order as presented by applicant
  CPA
  T.D.
  R.1.47

CLAIMS															
Final	Original	Final	Original	Final	Original	Final	Original	Final	Original	Final	Original	Final	Original	Final	Original

NONE	<b>Total Claims Allowed:</b>	
(Assistant Examiner)	(Date)	18
/AJAY OJHA/ Primary Examiner, Art Unit 2824	20 December 2018	O.G. Print Claim(s)
(Primary Examiner)	(Date)	1
		O.G. Print Figure
		2 and 7

PTO/SB/08 Equivalent

<b>INFORMATION DISCLOSURE STATEMENT BY APPLICANT</b>	Application No.	15/002791
	Filing Date	January 21, 2016
	First Named Inventor	John Douglas Steinberg
	Art Unit	2824
<i>(Multiple sheets used when necessary)</i>	Examiner	Ojha, Ajay
SHEET 1 OF 1	Attorney Docket No.	EFACT.011C2

<b>U.S. PATENT DOCUMENTS</b>					
Examiner Initials	Cite No.	Document Number <i>Number - Kind Code (if known)</i> Example: 1,234,567 B1	Publication Date MM-DD-YYYY	Name	Pages, Columns, Lines Where Relevant Passages or Relevant Figures Appear
	1	9,791,839	10/17/2017	Matsuoka et al.	
	2	10,018,371 (EFACT.007C2)	07/10/2018	Steinberg et al.	
	3	10,048,706 (EFACT.014A)	08/14/2018	Hublou et al.	
	4	2018/0216841	08/02/2018	Steinberg	

<b>FOREIGN PATENT DOCUMENTS</b>						
Examiner Initials	Cite No.	Foreign Patent Document <i>Country Code-Number-Kind Code</i> Example: JP 1234567 A1	Publication Date MM-DD-YYYY	Name	Pages, Columns, Lines Where Relevant Passages or Relevant Figures Appear	T <sup>1</sup>

<b>NON PATENT LITERATURE DOCUMENTS</b>			
Examiner Initials	Cite No.	Include name of the author (in CAPITAL LETTERS), title of the article (when appropriate), title of the item (book, magazine, journal, serial, symposium, catalog, etc.), date, page(s), volume-issue number(s), publisher, city and/or country where published.	T <sup>1</sup>

29094481

Examiner Signature /AJAY OJHA/	Date Considered 12/20/2018
--------------------------------	----------------------------

**\*Examiner:** Initial if reference considered, whether or not citation is in conformance with MPEP 609. Draw line through citation if not in conformance and not considered. Include copy of this form with next communication to applicant.

~~ALL REFERENCES CONSIDERED EXCEPT WHERE LINED THROUGH. /A.O./~~  
 T<sup>1</sup> - Place a check mark in this area when an English language Translation is attached.

## EAST Search History

## EAST Search History (Prior Art)

Ref #	Hits	Search Query	DBs	Default Operator	Plurals	Time Stamp
L3	815045	(video SAME computer)	US-PGPUB; USPAT; USOCR; FPRS; EPO; IBM_TDB	OR	ON	2018/12/20 13:58
L4	22410	3 AND (video SAME computer) AND (monitor SAME temperature)	US-PGPUB; USPAT; USOCR; FPRS; EPO; IBM_TDB	OR	ON	2018/12/20 13:59
L5	14573	3 AND (video SAME computer) AND (monitor WITH temperature)	US-PGPUB; USPAT; USOCR; FPRS; EPO; IBM_TDB	OR	ON	2018/12/20 14:00
L6	884	3 AND (video SAME computer) SAME (monitor WITH temperature)	US-PGPUB; USPAT; USOCR; FPRS; EPO; IBM_TDB	OR	ON	2018/12/20 14:00
L7	653	3 AND (video WITH computer) SAME (monitor WITH temperature)	US-PGPUB; USPAT; USOCR; FPRS; EPO; IBM_TDB	OR	ON	2018/12/20 14:00
L8	18	3 AND (video WITH computer) SAME (monitor WITH temperature) SAME (user ADJ interface)	US-PGPUB; USPAT; USOCR; FPRS; EPO; IBM_TDB	OR	ON	2018/12/20 14:01
L9	277	(monitor WITH temperature) SAME (user ADJ interface) AND (HVAC)	US-PGPUB; USPAT; USOCR; FPRS; EPO; IBM_TDB	OR	ON	2018/12/20 14:05
L10	35	(monitor WITH temperature) SAME (user	US-	OR	ON	2018/12/20

		ADJ interface SAME (computer laptop) AND (HVAC)	PGPUB; USPAT; USOCR; FPRS; EPO; IBM_TDB			14:06
L13	0	((monitor WITH temperature) SAME (user ADJ interface SAME (computer laptop)) AND (HVAC) AND (probability AND activit AND user AND content AND video))	US- PGPUB; USPAT; USOCR; FPRS; EPO; IBM_TDB	OR	ON	2018/12/20 14:36
L15	0	(12/181258).APP.	USPAT; USOCR	OR	ON	2018/12/20 14:53
L16	1	(12/041472).APP.	USPAT; USOCR	OR	ON	2018/12/20 14:55
L18	68545	(G05D23/00; F24F11/006; F24F11/70; F24F11/62; F24F11/30; G05B15/02; G06N7/005; G05D23/1902; F24F11/56; F24F2120/12; F24F2120/10; F24F11/63; F24F11/46; F24F2120/20; F24F2140/60; F24F2120/14).cpc.	US- PGPUB; USPAT; USOCR; FPRS; EPO; IBM_TDB	OR	ON	2018/12/20 14:56
S1	149	(("STEINBERG") near3 ("John")).INV.	US- PGPUB; USPAT; USOCR	OR	ON	2018/02/07 09:39
S2	78	("EcoFactor").AS,AANM.	US- PGPUB; USPAT; USOCR; FPRS; EPO; IBM_TDB	OR	ON	2018/02/07 09:40
S3	46883	(F24F11/006; F24F11/70; F24F11/62; F24F11/30; G05B15/02; G06N7/005; G05D23/1902; F24F11/56; F24F2120/12; F24F2120/10; F24F11/63; F24F11/46; F24F2120/20; F24F2140/60; F24F2120/14).cpc.	US- PGPUB; USPAT; USOCR; FPRS; EPO; IBM_TDB	OR	ON	2018/02/07 10:02
S4	3	(S1 S2) AND (HVAC AND temperature AND user\$1 AND wireless).CLM.	US- PGPUB; USPAT; USOCR; FPRS; EPO; IBM_TDB	OR	ON	2018/02/07 10:03
S5	15	("9244470")	US- PGPUB; USPAT; USOCR; FPRS; EPO; IBM_TDB	OR	ON	2018/02/07 10:11
S6	9	("9244470")	USPAT	OR	ON	2018/02/07 10:12
S7	25	("20040117330"   "20090065596"   "20150025691"   "6700224"	US- PGPUB;	OR	ON	2018/02/07 18:05



		"20130173064"   "20040133314"   "5348074"   "7869907"   "8850348"   "9057649"   "20140316581"   "20150120235"   "7206670"   "20130178985").PN.	USPAT; USOCR; FPRS; EPO; IBM_TDB			
S8	4	("20080281472" "20090065596")	US-PGPUB; USPAT; USOCR; FPRS; EPO; IBM_TDB	OR	ON	2018/02/07 18:12
S10	32	(US-20010025349-\$   US-20040117330-\$   US-20040133314-\$   US-20080083834-\$   US-20090005070-\$   US-20090018673-\$   US-20090057426-\$   US-20090062970-\$   US-20090271013-\$   US-20130073094-\$   US-20170241662-\$   US-20170336090-\$   US-20180087793-\$   US-20180087795-\$   US-1234567-\$   US-4270693-\$   US-4702305-\$   US-4702413-\$   US-5297838-\$   US-5454511-\$   US-5706190-\$   US-5839654-\$   US-6216956-\$   US-6223544-\$   US-6449534-\$   US-6454177-\$   US-6845918-\$   US-6981383-\$   US-7983795-\$   US-9709292-\$   US-9939333-\$).DID.	US-PGPUB; USPAT; USOCR; FPRS; EPO; IBM_TDB	OR	ON	2018/06/11 10:22
S11	31	("0015616"   "20010025349"   "20040117330"   "20040133314"   "20080083834"   "20090005070"   "20090018673"   "20090057426"   "20090062970"   "20090271013"   "20130073094"   "20170241662"   "20170336090"   "20180087793"   "20180087795"   "4270693"   "4702305"   "4702413"   "5297838"   "5454511"   "5706190"   "5839654"   "6216956"   "6223544"   "6449534"   "6454177"   "6845918"   "6981383"   "7983795"   "9709292"   "9939333").PN.	US-PGPUB; USPAT	OR	ON	2018/06/11 14:20
S12	9	("20160061474"   "9244470"   "9279594"   "20060283965"   "20080083234"   "20090065596").PN.	US-PGPUB; USPAT; USOCR; FPRS; EPO; IBM_TDB	OR	ON	2018/06/11 18:03
S13	3	(WO-2009036764-\$ ).DID.	US-PGPUB; USPAT; USOCR; FPRS; EPO; IBM_TDB	OR	ON	2018/06/11 18:36
S14	0	(desktop ADJ us\$3 WITH control ADJ3 temperature)	US-PGPUB; USPAT; USOCR; FPRS; EPO; IBM_TDB	OR	ON	2018/06/11 18:38
S15	18	(desktop ADJ us\$3 WITH control WITH environment)	US-PGPUB;	OR	ON	2018/06/11 18:43

			USPAT; USOCR; FPRS; EPO; IBM_TDB			
S16	147	(desktop ADJ usage)	US- PGPUB; USPAT; USOCR; FPRS; EPO; IBM_TDB	OR	ON	2018/06/11 18:49
S17	0	S16 AND (desktop ADJ usage WITH air\$1conditioning)	US- PGPUB; USPAT; USOCR; FPRS; EPO; IBM_TDB	OR	ON	2018/06/11 18:50
S18	11	S16 AND (desktop ADJ usage WITH environment\$2)	US- PGPUB; USPAT; USOCR; FPRS; EPO; IBM_TDB	OR	ON	2018/06/11 18:51
S19	0	S16 AND (smart SAME room ADJ temperatuer ADJ control)	US- PGPUB; USPAT; USOCR; FPRS; EPO; IBM_TDB	OR	ON	2018/06/11 18:55
S20	0	(smart SAME room ADJ temperatuer ADJ control)	US- PGPUB; USPAT; USOCR; FPRS; EPO; IBM_TDB	OR	ON	2018/06/11 18:56
S21	0	(smart ADJ temperatuer ADJ control)	US- PGPUB; USPAT; USOCR; FPRS; EPO; IBM_TDB	OR	ON	2018/06/11 18:56
S22	0	(wire\$1less ADJ device ADJ aware WITH thermostat)	US- PGPUB; USPAT; USOCR; FPRS; EPO; IBM_TDB	OR	ON	2018/06/11 18:56
S23	2024	(smart ADJ thermostat)	US- PGPUB; USPAT; USOCR; FPRS; EPO; IBM_TDB	OR	ON	2018/06/11 19:00

S24	6	S23 AND (smart ADJ thermostat) SAME ((computer desktop TV) ADJ2 usage)	US-PGPUB; USPAT; USOCR; FPRS; EPO; IBM_TDB	OR	ON	2018/06/11 19:01
S25	17235	(occupant NEAR10 detect\$3)	US-PGPUB; USPAT; USOCR; FPRS; EPO; IBM_TDB	OR	ON	2018/06/11 19:05
S27	13997	(occupant NEAR5 detect\$3)	US-PGPUB; USPAT; USOCR; FPRS; EPO; IBM_TDB	OR	ON	2018/06/11 19:06
S28	9	S27 AND (occupant NEAR5 detect\$3) SAME ((computer desktop) WITH use)	US-PGPUB; USPAT; USOCR; FPRS; EPO; IBM_TDB	OR	ON	2018/06/11 19:07
S29	7	S27 AND (occupant NEAR5 detect\$3) SAME (CUBICLE)	US-PGPUB; USPAT; USOCR; FPRS; EPO; IBM_TDB	OR	ON	2018/06/11 19:10
S30	8	smart ADJ building ADJ energy ADJ management	US-PGPUB; USPAT; USOCR; FPRS; EPO; IBM_TDB	OR	ON	2018/06/11 19:17
S31	1	(12/041472).APP.	USPAT; USOCR	OR	ON	2018/06/11 19:39
S32	181	("20030216837"   "20040225649"   "20050234596"   "20050275525"   "20060026972"   "20060111816"   "5097672"   "6067477"   "6604023"   "6756998"   "6792319"   "6832120"   "6912429"   "7055759"   "7130719"   "7187986"   "7343226"   "7436292"   "7440809"   "7480534"   "7529646").PN. OR ("7904209").URPN.	US-PGPUB; USPAT; USOCR	OR	ON	2018/06/11 19:39
S33	154	S32 AND (computer)	US-PGPUB; USPAT; USOCR	OR	ON	2018/06/11 19:43
S34	145	S32 AND (computer) AND user	US-PGPUB; USPAT; USOCR	OR	ON	2018/06/11 19:43

S35	76	S32 AND (computer) NEAR10 user	US- PGPUB; USPAT; USOCR	OR	ON	2018/06/11 19:43
-----	----	--------------------------------	----------------------------------	----	----	---------------------

## EAST Search History (I nterference)

Ref #	Hits	Search Query	DBs	Default Operator	Plurals	Time Stamp
L11	0	((monitor WITH temperature) SAME (user ADJ interface SAME (computer laptop)) AND (HVAC) AND (probability AND activit AND user AND content AND video)).CLM.	USPAT	OR	ON	2018/12/20 14:35
L14	10068	(F24F11/006; F24F11/70; F24F11/62; F24F11/30; G05B15/02; G06N7/005; G05D23/1902; F24F11/56; F24F2120/12; F24F2120/10; F24F11/63; F24F11/46; F24F2120/20; F24F2140/60; F24F2120/14).cpc.	USPAT	OR	ON	2018/12/20 14:36
L17	10183	(G05D23/00; F24F11/006; F24F11/70; F24F11/62; F24F11/30; G05B15/02; G06N7/005; G05D23/1902; F24F11/56; F24F2120/12; F24F2120/10; F24F11/63; F24F11/46; F24F2120/20; F24F2140/60; F24F2120/14).cpc.	USPAT	OR	ON	2018/12/20 14:55

12/ 20/ 2018 3:03:56 PM

C:\ Users\ aojha\ Documents\ EAST\ Workspaces\ 15002791.wsp

## Bibliographic Data

Application No: 15/002,791

Foreign Priority claimed:  Yes  No

35 USC 119 (a-d) conditions met:  Yes  No

Met After Allowance

Verified and Acknowledged: /AJAY OJHA/

Examiner's Signature

Initials

Title:

SYSTEM AND METHOD FOR USING A WIRELESS DEVICE AS  
A SENSOR FOR AN ENERGY MANAGEMENT SYSTEM

---

FILING or 371(c) DATE	CLASS	GROUP ART UNIT	ATTORNEY DOCKET NO.
01/21/2016	700	2824	EFACT.011C2
<b>RULE</b>			

### APPLICANTS

EcoFactor, Inc., Redwood City, CA, UNITED STATES

### INVENTORS

John Douglas Steinberg Millbrae, CA, UNITED STATES

### CONTINUING DATA

This application is a CON of 13470074 05/11/2012 PAT 9244470

13470074 is a CON of 12502064 07/13/2009 PAT 8180492

12502064 has PRO of 61134714 07/14/2008

### FOREIGN APPLICATIONS

#### IF REQUIRED, FOREIGN LICENSE GRANTED\*\*

02/04/2016

#### \*\* SMALL ENTITY \*\*

### STATE OR COUNTRY

UNITED STATES

### ADDRESS

KNOBBE MARTENS OLSON & BEAR LLP

2040 MAIN STREET

FOURTEENTH FLOOR

IRVINE, CA 92614

UNITED STATES

### FILING FEE RECEIVED

\$800

Under the Paperwork Reduction Act of 1995, no persons are required to respond to a collection of information unless it contains a valid OMB control number.

### REQUEST FOR CONTINUED EXAMINATION(RCE)TRANSMITTAL (Submitted Only via EFS-Web)

Application Number	15/002,791	Filing Date	2016-01-21	Docket Number (if applicable)	EFACT.011C2	Art Unit	2824
First Named Inventor	John Douglas Steinberg			Examiner Name	Ajay Ojha		

**This is a Request for Continued Examination (RCE) under 37 CFR 1.114 of the above-identified application.**  
Request for Continued Examination (RCE) practice under 37 CFR 1.114 does not apply to any utility or plant application filed prior to June 8, 1995, or to any design application. The Instruction Sheet for this form is located at WWW.USPTO.GOV

#### SUBMISSION REQUIRED UNDER 37 CFR 1.114

Note: If the RCE is proper, any previously filed unentered amendments and amendments enclosed with the RCE will be entered in the order in which they were filed unless applicant instructs otherwise. If applicant does not wish to have any previously filed unentered amendment(s) entered, applicant must request non-entry of such amendment(s).

Previously submitted. If a final Office action is outstanding, any amendments filed after the final Office action may be considered as a submission even if this box is not checked.

Consider the arguments in the Appeal Brief or Reply Brief previously filed on \_\_\_\_\_

Other \_\_\_\_\_

Enclosed

Amendment/Reply

Information Disclosure Statement (IDS)

Affidavit(s)/ Declaration(s)

Other \_\_\_\_\_

#### MISCELLANEOUS

Suspension of action on the above-identified application is requested under 37 CFR 1.103(c) for a period of months \_\_\_\_\_  
(Period of suspension shall not exceed 3 months; Fee under 37 CFR 1.17(i) required)

Other \_\_\_\_\_

#### FEES

**The RCE fee under 37 CFR 1.17(e) is required by 37 CFR 1.114 when the RCE is filed.**

The Director is hereby authorized to charge any underpayment of fees, or credit any overpayments, to Deposit Account No 111410

#### SIGNATURE OF APPLICANT, ATTORNEY, OR AGENT REQUIRED

<input checked="" type="checkbox"/> Patent Practitioner Signature
<input type="checkbox"/> Applicant Signature

Signature of Registered U.S. Patent Practitioner			
Signature	John King/	Date (YYYY-MM-DD)	2018-09-21
Name	John King	Registration Number	34362

This collection of information is required by 37 CFR 1.114. The information is required to obtain or retain a benefit by the public which is to file (and by the USPTO to process) an application. Confidentiality is governed by 35 U.S.C. 122 and 37 CFR 1.11 and 1.14. This collection is estimated to take 12 minutes to complete, including gathering, preparing, and submitting the completed application form to the USPTO. Time will vary depending upon the individual case. Any comments on the amount of time you require to complete this form and/or suggestions for reducing this burden, should be sent to the Chief Information Officer, U.S. Patent and Trademark Office, U.S. Department of Commerce, P.O. Box 1450, Alexandria, VA 22313-1450.

*If you need assistance in completing the form, call 1-800-PTO-9199 and select option 2.*

## Privacy Act Statement

The Privacy Act of 1974 (P.L. 93-579) requires that you be given certain information in connection with your submission of the attached form related to a patent application or patent. Accordingly, pursuant to the requirements of the Act, please be advised that: (1) the general authority for the collection of this information is 35 U.S.C. 2(b)(2); (2) furnishing of the information solicited is voluntary; and (3) the principal purpose for which the information is used by the U.S. Patent and Trademark Office is to process and/or examine your submission related to a patent application or patent. If you do not furnish the requested information, the U.S. Patent and Trademark Office may not be able to process and/or examine your submission, which may result in termination of proceedings or abandonment of the application or expiration of the patent.

The information provided by you in this form will be subject to the following routine uses:

1. The information on this form will be treated confidentially to the extent allowed under the Freedom of Information Act (5 U.S.C. 552) and the Privacy Act (5 U.S.C. 552a). Records from this system of records may be disclosed to the Department of Justice to determine whether the Freedom of Information Act requires disclosure of these records.
2. A record from this system of records may be disclosed, as a routine use, in the course of presenting evidence to a court, magistrate, or administrative tribunal, including disclosures to opposing counsel in the course of settlement negotiations.
3. A record in this system of records may be disclosed, as a routine use, to a Member of Congress submitting a request involving an individual, to whom the record pertains, when the individual has requested assistance from the Member with respect to the subject matter of the record.
4. A record in this system of records may be disclosed, as a routine use, to a contractor of the Agency having need for the information in order to perform a contract. Recipients of information shall be required to comply with the requirements of the Privacy Act of 1974, as amended, pursuant to 5 U.S.C. 552a(m).
5. A record related to an International Application filed under the Patent Cooperation Treaty in this system of records may be disclosed, as a routine use, to the International Bureau of the World Intellectual Property Organization, pursuant to the Patent Cooperation Treaty.
6. A record in this system of records may be disclosed, as a routine use, to another federal agency for purposes of National Security review (35 U.S.C. 181) and for review pursuant to the Atomic Energy Act (42 U.S.C. 218(c)).
7. A record from this system of records may be disclosed, as a routine use, to the Administrator, General Services, or his/her designee, during an inspection of records conducted by GSA as part of that agency's responsibility to recommend improvements in records management practices and programs, under authority of 44 U.S.C. 2904 and 2906. Such disclosure shall be made in accordance with the GSA regulations governing inspection of records for this purpose, and any other relevant (i.e., GSA or Commerce) directive. Such disclosure shall not be used to make determinations about individuals.
8. A record from this system of records may be disclosed, as a routine use, to the public after either publication of the application pursuant to 35 U.S.C. 122(b) or issuance of a patent pursuant to 35 U.S.C. 151. Further, a record may be disclosed, subject to the limitations of 37 CFR 1.14, as a routine use, to the public if the record was filed in an application which became abandoned or in which the proceedings were terminated and which application is referenced by either a published application, an application open to public inspections or an issued patent.
9. A record from this system of records may be disclosed, as a routine use, to a Federal, State, or local law enforcement agency, if the USPTO becomes aware of a violation or potential violation of law or regulation.



---

**INFORMATION DISCLOSURE STATEMENT**

First Inventor :	John Douglas Steinberg
App. No. :	15/002791
Filed :	January 21, 2016
For :	SYSTEM AND METHOD FOR USING A WIRELESS DEVICE AS A SENSOR FOR AN ENERGY MANAGEMENT SYSTEM
Examiner :	Ojha, Ajay
Art Unit :	2824
Conf. No. :	4939

**Mail Stop RCE**

Commissioner for Patents  
P.O. Box 1450  
Alexandria, VA 22313-1450

**References and Listing**

Pursuant to 37 CFR 1.56, an Information Disclosure Statement listing references is provided herewith.

**No Disclaimers**

To the extent that anything in the Information Disclosure Statement or the listed references could be construed as a disclaimer of any subject matter supported by the present application, Applicant hereby rescinds and retracts such disclaimer.

**Timing of Disclosure**

This Information Disclosure Statement is being filed within three months of the filing date or date of national phase entry, with an RCE or before receipt of a First Office Action after an RCE, and no fee is believed to be required.

**Application No.: 15/002791**  
**Filing Date: January 21, 2016**

The Commissioner is hereby authorized to charge any additional fees which may be required, or credit any overpayment, to Account No. 11-1410.

Respectfully submitted,

KNOBBE, MARTENS, OLSON & BEAR, LLP

Dated: September 21, 2018

By: /John R. King/

John R. King  
Registration No. 34,362  
Registered Practitioner  
Customer No. 20995  
(949) 760-0404

29094656

<b>INFORMATION DISCLOSURE STATEMENT BY APPLICANT</b>	Application No.	15/002791
	Filing Date	January 21, 2016
	First Named Inventor	John Douglas Steinberg
	Art Unit	2824
<i>(Multiple sheets used when necessary)</i>	Examiner	Ojha, Ajay
SHEET 1 OF 1	Attorney Docket No.	EFACT.011C2

<b>U.S. PATENT DOCUMENTS</b>					
Examiner Initials	Cite No.	Document Number <i>Number - Kind Code (if known)</i> Example: 1,234,567 B1	Publication Date MM-DD-YYYY	Name	Pages, Columns, Lines Where Relevant Passages or Relevant Figures Appear
	1	9,791,839	10/17/2017	Matsuoka et al.	
	2	10,018,371 (EFACT.007C2)	07/10/2018	Steinberg et al.	
	3	10,048,706 (EFACT.014A)	08/14/2018	Hublou et al.	
	4	2018/0216841	08/02/2018	Steinberg	

<b>FOREIGN PATENT DOCUMENTS</b>						
Examiner Initials	Cite No.	Foreign Patent Document <i>Country Code-Number-Kind Code</i> Example: JP 1234567 A1	Publication Date MM-DD-YYYY	Name	Pages, Columns, Lines Where Relevant Passages or Relevant Figures Appear	T <sup>1</sup>

<b>NON PATENT LITERATURE DOCUMENTS</b>			
Examiner Initials	Cite No.	Include name of the author (in CAPITAL LETTERS), title of the article (when appropriate), title of the item (book, magazine, journal, serial, symposium, catalog, etc.), date, page(s), volume-issue number(s), publisher, city and/or country where published.	T <sup>1</sup>

29094481

Examiner Signature	Date Considered
<p><b>*Examiner:</b> Initial if reference considered, whether or not citation is in conformance with MPEP 609. Draw line through citation if not in conformance and not considered. Include copy of this form with next communication to applicant.</p>	

T<sup>1</sup> - Place a check mark in this area when an English language <sup>0043</sup> Translation is attached.

**IN THE UNITED STATES PATENT AND TRADEMARK OFFICE**

First Inventor	:	John Douglas Steinberg
App. No.	:	15/002,791
Filed	:	January 21, 2016
For	:	SYSTEM AND METHOD FOR USING A WIRELESS DEVICE AS A SENSOR FOR AN ENERGY MANAGEMENT SYSTEM
Examiner	:	Ojha, Ajay
Art Unit	:	2824
Conf. No.	:	4939

**RESPONSE TO FINAL OFFICE ACTION DATED JUNE 15, 2018****Mail Stop RCE**

Commissioner for Patents  
P.O. Box 1450  
Alexandria, VA 22313-1450

Dear Commissioner:

In response to the Final Office Action dated June 15, 2018, Applicant respectfully submits the following in connection with a Request for Continued Examination under 37 C.F.R. § 1.114:

**Amendments to the Claims** are reflected in the listing of claims which begins on page 2 of this paper.

**Remarks/Arguments** begin on page 6 of this paper.

### AMENDMENTS TO THE CLAIMS

Please amend Claims 1 and 10 as indicated below.

1. (Currently Amended) A method for varying temperature setpoints for an HVAC system comprising:

storing at least a first HVAC temperature setpoint and at least a second HVAC temperature setpoint;

monitoring an activity status of at least one wireless device associated with one or more occupants of said structure, wherein said wireless device comprises a graphic user interface that can be used to view video content, wherein use of said wireless device comprises at least one of cursor movement, keystrokes or other user interface actions intended to alter a state of said wireless device;

determining a probability that the specific activity status of said wireless device is associated with the use of said wireless device by a specific occupant or occupants of said structure, where said probability is determined in part by the video content of the program or channel being viewed by said occupant on or with said wireless device and where said video content is not explicitly related to temperature setpoints;

determining whether a current HVAC temperature setpoint associated with said HVAC system is set to said first HVAC temperature setpoint or said second temperature setpoint;

prompting said one or more users, wherein said prompting sends a message to said wireless device recommending a change to said current HVAC temperature setpoint for said HVAC system;

in response to said prompting, receiving input from said one or more users; and

keeping said current HVAC temperature setpoint based upon said input from said one or more users.

2. (Original) The method of Claim 1 wherein said wireless device is a remote control.

3. (Original) The method of Claim 1 wherein said wireless device is a wireless phone.

4. (Original) The method of Claim 3 wherein said wireless phone is connected to a cellular network.

5. (Original) The method of Claim 1 wherein said wireless device is a tablet computer.

6. (Original) The method of Claim 1 wherein said first and second HVAC temperature setpoints are stored in a database associated with a remote server.

7. (Original) The method of Claim 1 in which said wireless device communicates with a remote server.

8. (Original) The method of Claim 1 further comprising adjusting said current HVAC temperature setpoint with a remote computer.

9. (Original) The method of Claim 1 in which said first HVAC temperature setpoint is varied automatically based on said input from said one or more users.

10. (Currently Amended) A system for altering the setpoint on a thermostat for space conditioning of a structure comprising:

at least one thermostat having at least a first temperature setpoint and at least a second temperature setpoint;

at least one wireless device associated with one or more occupants of said structure, wherein said wireless device comprises a graphic user interface that can be used to view video content, wherein use of said wireless device comprises at least one of cursor movement, keystrokes or other user interface actions intended to alter a state of said wireless device;

an application comprising one or more computer processors that receives data regarding an activity status of said wireless device and whether said thermostat is set to said first temperature setpoint,

said application determining a probability that the specific activity status of said wireless device is associated with the use of said wireless device by a specific occupant or occupants of said structure, where said probability is determined in part by the video content of the program or channel being viewed by said occupant on or with said wireless device and where said video content is not explicitly related to temperature setpoints;

said application prompting said one or more users wherein said application provides electronic notice to one or more of said users of said wireless device that said thermostat is set to one of said first temperature setpoint or said second temperature setpoint; and

wherein said application in response to said prompting, receives input from said one or more users; and

wherein said current temperature setpoint is set based upon said input from said one or more users.

11. (Original) The system of Claim 10 wherein said wireless device is a remote controller.

12. (Original) The system of Claim 10 wherein said wireless device is a wireless phone.

13. (Original) The system of Claim 12 wherein said wireless phone is connected to a cellular network.

14. (Original) The system of Claim 10 said wireless device is a tablet computer.

15. (Original) The system of Claim 10 wherein said first and second temperature setpoints are stored in a database associated with a remote server.

16. (Original) The system of Claim 10 wherein said wireless device communicates with a remote server.

17. (Original) The system of Claim 10 further comprising a remote computer that varies said first temperature setpoint.

18. (Original) The system of Claim 10 in which said first temperature setpoint is varied automatically based on said input from said one or more users.



## REMARKS

The June 15, 2018 Office Action was based upon pending Claims 1-18. This Amendment amends Claims 1 and 10. Thus, after entry of this Amendment, Claims 1-18 are pending and presented for further consideration.

### **REJECTION OF CLAIMS 1-18 UNDER 35 U.S.C. § 112**

Claims 1-18 were rejected under 35 U.S.C. § 112, second paragraph, as being indefinite for failing to particularly point out and distinctly claim the subject matter which Applicant regards as the invention. The Examiner found that the limitation in independent claims 1 and 10 claiming “the program or channel being viewed” lacked sufficient antecedent in the claims.

Applicant has amended claims 1 and 10 to provide antecedent basis for the limitations.

### **REJECTION OF CLAIMS 1-18 ARE REJECTED UNDER 35 U.S.C. § 103(a)**

Claims 1-18 are rejected under 35 U.S.C. § 103(a) as being unpatentable over U.S. Publication No. 2008/0281472 to Podgorny (hereinafter “Podgorny”) in view of U.S. Publication No. 2009/0065596 to Seem (hereinafter “Seem”).

The Examiner found that the limitation “where said probability is determined in part by content of the program or channel being viewed by said occupant on or with said wireless device” is disclosed in ¶ 0065 of Seem. Applicant respectfully disagrees. Paragraph 0065 of Seem, in its entirety, provides:

“Referring now to FIG. 9, a flow chart of a process **900** for providing a user interface for updating user comfort preferences is shown, according to an exemplary embodiment. The user interface may be similar to interface **702** shown in FIGS. 7A and 7B. **A control system can generate and display a user interface for use by a local and remote user for entering comfort preferences (step 902).** The control system can receive the input (step **904**) after various prompting by the user

**Application No.:** 15/002,791  
**Filing Date:** January 21, 2016

interface, and store or update the comfort preferences in a database and/or in memory configured to associate the preferences with a unique identifier of a user's portable electronic device (step **906**). The comfort preferences can be used by, for example, process **800** to adjust a building automation system setting." (Emphasis Added)

Applicant submits that Seem merely discloses the use of an interface for adjusting temperature settings on the user's portable electronic device. It does not disclose using said device for viewing unrelated programming, or for inferring information about the user from said programming. In contrast, the subject invention expressly discloses such use.

"For example, if computer **104** indicates to server **106** that the computer is being used to watch golf, the server may conclude that an adult male is watching; if computer **104** indicates that it is being used to watch children's programming, server **106** may conclude that a child is watching. In step **1410** the server transmits a query to the user in order to verify the match, asking, in effect, 'Is that you. Bob?'" (Application at ¶40.)

Applicant believes this distinction should be sufficient to overcome the Examiner's objection. However, Applicant has further amended the independent claims to make the distinction more explicit.

Applicant respectfully submits that the submitted amendments overcome the Examiner's objections, and that the application is now in condition for allowance.

#### **OTHER APPLICATIONS OF ASSIGNEE**

Applicant wishes to draw the Examiner's attention to the following applications owned by of the present application's assignee:

<b>Inventors</b>	<b>Appl. No.</b>	<b>Filing Date</b>	<b>Attorney Docket No.</b>	<b>Title</b>
Steinberg et al.	60/963,183 Now Expired	08/03/07	EFACT.003PR	System And Method For Using A Network Of Thermostats As Tool To Verify Peak Demand Reduction

**Application No.:** 15/002,791  
**Filing Date:** January 21, 2016

<b>Inventors</b>	<b>Appl. No.</b>	<b>Filing Date</b>	<b>Attorney Docket No.</b>	<b>Title</b>
Steinberg et al.	60/994,011 Now Expired	09/17/07	EFACT.005PR	System And Method For Calculating The Thermal Mass Of A Building
Steinberg et al.	12/183,949 Now Pat. 7,908,116	07/31/08	EFACT.004A	System And Method For Using A Network Of Thermostats As Tool To Verify Peak Demand Reduction
Steinberg et al.	12/183,990 Now Pat. 7,908,117	07/31/08	EFACT.003A	System And Method For Using A Network Of Thermostats As Tool To Verify Peak Demand Reduction
Steinberg et al.	12/211,690 Now Pat. 8,019,567	09/16/08	EFACT.006A	System And Method For Evaluating Changes In The Efficiency Of An HVAC System
Steinberg et al.	12/211,733 Now Pat. 7,848,900	09/16/08	EFACT.005A	System And Method For Calculating The Thermal Mass Of A Building
Steinberg et al.	61/215,657 Now Expired	05/08/09	EFACT.009PR	System, Method And Apparatus For Just-In-Time Conditioning Using A Thermostat
Steinberg	61/215,816 Now Expired	05/11/09	EFACT.008PR	System, Method And Apparatus For Dynamically Variable Compressor Delay In Thermostat To Reduce Energy Consumption
Steinberg et al.	61/215,999 Now Expired	05/12/09	EFACT.007PR	System, Method And Apparatus For Identifying Manual Inputs To And Adaptive Programming Of A Thermostat
Cheung et al.	12/498,142 Now Pat. 8,010,237	07/06/09	EFACT.010A	System And Method For Using Ramped Setpoint Temperature Variation With Networked Thermostats To Improve Efficiency
Steinberg	12/502,064 Now Pat. 8,180,492	07/13/09	EFACT.011A	System And Method For Using A Networked Electronic Device As An Occupancy Sensor For An Energy Management System
Steinberg et al.	12/773,690 Now Pat. 8,498,753	05/04/10	EFACT.009A	System, Method And Apparatus For Just-In-Time Conditioning Using A Thermostat

**Application No.:** 15/002,791  
**Filing Date:** January 21, 2016

<b>Inventors</b>	<b>Appl. No.</b>	<b>Filing Date</b>	<b>Attorney Docket No.</b>	<b>Title</b>
Steinberg	12/774,580 Now Pat. 8,740,100	05/05/10	EFACT.008A	System, Method And Apparatus For Dynamically Variable Compressor Delay In Thermostat To Reduce Energy Consumption
Steinberg et al.	12/778,052 Now Pat. 8,596,550	05/11/10	EFACT.007A	System, Method And Apparatus For Identifying Manual Inputs To And Adaptive Programming Of A Thermostat
Steinberg	12/788,246 Now Pat. 8,556,188	05/26/10	EFACT.012A	System And Method For Using A Mobile Electronic Device To Optimize An Energy Management System
Steinberg	12/860,821 Now Pat. 8,090,477	08/20/10	EFACT.013A	System And Method For Optimizing Use Of Plug-In Air Conditioners And Portable Heaters
Steinberg et al.	12/959,225 Now Pat. 8,131,497	12/02/10	EFACT.005C1	System And Method For Calculating The Thermal Mass Of A Building
Steinberg et al.	13/037,162 Now Pat. 8,131,506	02/28/11	EFACT.004C1	System And Method For Using A Network Of Thermostats As Tool To Verify Peak Demand Reduction
Cheung et al.	13/219,381 Now Pat. 9,134,710	08/26/11	EFACT.010C1	System And Method For Using Ramped Setpoint Temperature Variation With Networked Thermostats To Improve Efficiency
Steinberg et al.	13/230,610 Now Pat. 8,423,322	09/12/11	EFACT.006C1	System And Method For Evaluating Changes In The Efficiency Of An HVAC System
Steinberg	13/329,117 Now Pat. 8,340,826	12/16/11	EFACT.013C1	System And Method For Optimizing Use Of Plug-In Air Conditioners And Portable Heaters
Steinberg et al.	13/409,697 Now Pat. 8,412,488	03/01/12	EFACT.004C2	System And Method For Using A Network Of Thermostats As Tool To Verify Peak Demand Reduction
Steinberg et al.	13/409,729 Now Pat. 8,886,488	03/01/12	EFACT.005C2	System And Method For Calculating The Thermal Mass Of A Building

**Application No.:** 15/002,791  
**Filing Date:** January 21, 2016

<b>Inventors</b>	<b>Appl. No.</b>	<b>Filing Date</b>	<b>Attorney Docket No.</b>	<b>Title</b>
Steinberg	13/470,074 Now Pat. 9,244,470	05/11/12	EFACT.011C1	System And Method For Using A Wireless Device As A Sensor For An Energy Management System
Hublou et al.	13/523,697 Published As 2013/0338837	06/14/12	EFACT.014A	System And Method For Optimizing Use Of Individual HVAC Units In Multi-Unit Chiller-Based Systems
Steinberg	13/725,447 Now Pat. 8,712,590	12/21/12	EFACT.013C2	System And Method For Optimizing Use Of Plug-In Air Conditioners And Portable Heaters
Steinberg et al.	13/852,577 Now Pat. 8,738,327	03/28/13	EFACT.004C3	System And Method For Using A Network Of Thermostats As Tool To Verify Peak Demand Reduction
Steinberg et al.	13/858,710 Now Pat. 8,751,186	04/08/13	EFACT.005C3	System And Method For Calculating The Thermal Mass Of A Building
Steinberg et al.	13/861,189 Now Pat. 9,057,649	04/11/13	EFACT.006C2	System And Method For Evaluating Changes In The Efficiency Of An HVAC System
Steinberg et al.	13/952,253 Abandoned	07/26/13	EFACT.009C1	System, Method And Apparatus For Just-In-Time Conditioning Using A Thermostat
Steinberg	14/048,932 Now Pat. 8,840,033	10/08/13	EFACT.012C1	System And Method For Using A Mobile Electronic Device To Optimize An Energy Management System
Steinberg et al.	14/082,675 Now Pat. 9,194,597	11/18/13	EFACT.007C1	System, Method And Apparatus For Identifying Manual Inputs To And Adaptive Programming Of A Thermostat
Steinberg	14/263,762 Now Pat. 9,188,994	04/28/14	EFACT.013C3	System And Method For Optimizing Use Of Plug-In Air Conditioners And Portable Heaters
Steinberg et al.	14/285,384 Published As 2015/0043615 Abandoned	05/22/14	EFACT.004C4	System And Method For Using A Network Of Thermostats As Tool To Verify Peak Demand Reduction
Steinberg	14/292,377 Now Pat. 9,279,594	05/30/14	EFACT.008C1	System, Method And Apparatus For Dynamically Variable Compressor Delay In Thermostat To Reduce Energy Consumption

**Application No.:** 15/002,791  
**Filing Date:** January 21, 2016

<b>Inventors</b>	<b>Appl. No.</b>	<b>Filing Date</b>	<b>Attorney Docket No.</b>	<b>Title</b>
Steinberg	14/491,554 Now Pat. 9,709,292	09/19/14	EFACT.012C2	System And Method For Using A Mobile Electronic Device To Optimize An Energy Management System
Steinberg et al.	14/527,433 Published As 2015/0120235 Abandoned	10/29/14	EFACT.005C4	System And Method For Calculating The Thermal Mass Of A Building
Steinberg et al.	14/731,221 Now Pat. 9,939,333	06/04/15	EFACT.006C3	System And Method For Evaluating Changes In The Efficiency Of An HVAC System
Cheung et al.	14/842,134 Published As 2016/0061474	09/01/15	EFACT.010C2	System And Method For Using Ramped Setpoint Temperature Variation With Networked Thermostats To Improve Efficiency
Steinberg et al.	14/878,872 Now Pat. 10,018,371	10/08/15	EFACT.007C2	System, Method And Apparatus For Identifying Manual Inputs To And Adaptive Programming Of A Thermostat
Steinberg	14/920,063 Abandoned	10/22/15	EFACT.013C4	System And Method For Optimizing Use Of Plug-In Air Conditioners And Portable Heaters
Steinberg	15/002,791 Published As 2016/0138822	01/21/16	EFACT.011C2	System And Method For Using A Wireless Device As A Sensor For An Energy Management System
Steinberg	15/047,352 Now Pat. 9,982,905	02/18/16	EFACT.008C2	System, Method And Apparatus For Dynamically Variable Compressor Delay In Thermostat To Reduce Energy Consumption
Steinberg et al.	15/060,226 Published As 2016/0258822 Now Abandoned	03/03/16	EFACT.005C5	System And Method For Calculating The Thermal Mass Of A Building
Steinberg et al.	15/097,078 Published As 2016/0363337	04/12/16	EFACT.009C2	System, Method And Apparatus For Just-In-Time Conditioning Using A Thermostat
Steinberg et al.	15/426,882 Published As 2017/0241662	02/07/17	EFACT.005C6	System And Method For Calculating The Thermal Mass Of A Building

**Application No.:** 15/002,791  
**Filing Date:** January 21, 2016

<b>Inventors</b>	<b>Appl. No.</b>	<b>Filing Date</b>	<b>Attorney Docket No.</b>	<b>Title</b>
Steinberg	15/616,719 Published As 2017/0336090	06/07/17	EFACT.012C3	System And Method For Using A Mobile Electronic Device To Optimize An Energy Management System
Okita et al.	15/707,686	09/18/17	EFACT.018A2	Message-Based Demand Response Systems And Methods
Okita et al.	15/707,735	09/18/17	EFACT.018A1	Message-Based Demand Response Systems And Methods
Okita et al.	15/707,753	09/18/17	EFACT.018A3	Occupancy Determination Using Energy Consumption Indications
Okita et al.	15/707,769	09/18/17	EFACT.019A2	Systems And Methods For Acclimatization-Based Variable Thermostat Settings
Okita et al.	15/707,829	09/18/17	EFACT.019A1	Systems And Methods For Humidity-Based Variable Thermostat Settings
Okita et al.	15/707,873	09/18/17	EFACT.019A3	Systems And Methods For Fan Delay-Based Variable Thermostat Settings
Okita et al.	15/713,318 Published As 2018/0087795	09/22/17	EFACT.017A2	Multi-Function Thermostat
Okita et al.	15/713,358 Published As 2018/0087793	09/22/17	EFACT.017A1	Multi-Function Thermostat
Steinberg et al.	15/836,688 Now Abandoned	12/08/17	EFACT.004C5	System And Method For Using A Network Of Thermostats As Tool To Verify Peak Demand Reduction
Steinberg	15/841,039 Published As 2018/0216841	12/13/17	EFACT.013C5	System And Method For Optimizing Use Of Plug-In Air Conditioners And Portable Heaters
Steinberg et al.	15/905,251	02/26/18	EFACT.006D1	System And Method For Evaluating Changes In The Efficiency Of An HVAC System
Steinberg	15/965,339	04/27/18	EFACT.008C3	System, Method And Apparatus For Dynamically Variable Compressor Delay In Thermostat To Reduce Energy Consumption

**Application No.:** 15/002,791  
**Filing Date:** January 21, 2016

<b>Inventors</b>	<b>Appl. No.</b>	<b>Filing Date</b>	<b>Attorney Docket No.</b>	<b>Title</b>
Steinberg et al.	15/994,532	05/31/18	EFACT.004C6	System And Method For Using A Network Of Thermostats As Tool To Verify Peak Demand Reduction
Steinberg et al.	16/028,230	07/05/18	EFACT.007C3	System, Method And Apparatus For Identifying Manual Inputs To And Adaptive Programming Of A Thermostat

Applicant notes that cited references, office actions, responses and notices of allowance currently exist or will exist for the above-referenced matters. Applicant also understands that the Examiner has access to sophisticated online Patent Office computing systems that provide ready access to the full file histories of these matters including, for example, specifications, drawings, pending claims, cited art, office actions, responses, declarations, and notices of allowance.

Rather than submit copies these file histories, Applicant respectfully requests that the Examiner continue to review these file histories online for past, current, and future information about these matters. Also, if the Examiner cannot readily access these file histories, the Applicant would be pleased to provide any portion of any of the file histories at any time upon specific Examiner request.

**SUPPLEMENTAL INFORMATION DISCLOSURE STATEMENT**

Submitted concurrently herewith is a Supplemental Information Disclosure Statement citing references for consideration. Applicant respectfully requests the Examiner to consider the pending claims in connection with these references in order to make the references of record.

**NO DISCLAIMERS OR DISAVOWALS**

Although the present communication may include alterations to the application or claims, or characterizations of claim scope or referenced art, Applicant is not conceding in this application that previously pending claims are not patentable over the cited



**Application No.:** 15/002,791  
**Filing Date:** January 21, 2016

references. Rather, any alterations or characterizations are being made to facilitate expeditious prosecution of this application.

Applicant reserves the right to pursue at a later date any previously pending or other broader or narrower claims that capture any subject matter supported by the present disclosure, including subject matter found to be specifically disclaimed herein or by any prior prosecution.

Accordingly, reviewers of this or any parent, child or related prosecution history shall not reasonably infer that Applicant has made any disclaimers or disavowals of any subject matter supported by the present application.

### **CONCLUSION**

Applicants have endeavored to address all of the Examiner's concerns as expressed in the outstanding Office Action. In light of the above remarks, reconsideration and withdrawal of the outstanding rejections is specifically requested.

Please charge any additional fees, including any fees for additional extension of time, or credit overpayment to Deposit Account No. 11-1410.

Respectfully submitted,

KNOBBE, MARTENS, OLSON & BEAR, LLP

Dated: 09/21/18

By: /John R. King/  
John R. King  
Registration No. 34,362  
Registered Practitioner  
Customer No. 20,995  
(949) 760-0404

28500605

## Electronic Patent Application Fee Transmittal

<b>Application Number:</b>	15002791
<b>Filing Date:</b>	21-Jan-2016
<b>Title of Invention:</b>	SYSTEM AND METHOD FOR USING A WIRELESS DEVICE AS A SENSOR FOR AN ENERGY MANAGEMENT SYSTEM
<b>First Named Inventor/Applicant Name:</b>	John Douglas Steinberg
<b>Filer:</b>	John R. King
<b>Attorney Docket Number:</b>	EFACT.011C2

Filed as Small Entity

### Filing Fees for Utility under 35 USC 111(a)

Description	Fee Code	Quantity	Amount	Sub-Total in USD(\$)
<b>Basic Filing:</b>				
<b>Pages:</b>				
<b>Claims:</b>				
<b>Miscellaneous-Filing:</b>				
<b>Petition:</b>				
<b>Patent-Appeals-and-Interference:</b>				
<b>Post-Allowance-and-Post-Issuance:</b>				
<b>Extension-of-Time:</b>				

Description	Fee Code	Quantity	Amount	Sub-Total in USD(\$)
Extension - 1 month with \$0 paid	2251	1	100	100
<b>Miscellaneous:</b>				
RCE- 1ST REQUEST	2801	1	650	650
<b>Total in USD (\$)</b>				<b>750</b>

## Electronic Acknowledgement Receipt

<b>EFS ID:</b>	33795594
<b>Application Number:</b>	15002791
<b>International Application Number:</b>	
<b>Confirmation Number:</b>	4939
<b>Title of Invention:</b>	SYSTEM AND METHOD FOR USING A WIRELESS DEVICE AS A SENSOR FOR AN ENERGY MANAGEMENT SYSTEM
<b>First Named Inventor/Applicant Name:</b>	John Douglas Steinberg
<b>Customer Number:</b>	20995
<b>Filer:</b>	John R. King/Gustavo Lopez
<b>Filer Authorized By:</b>	John R. King
<b>Attorney Docket Number:</b>	EFACT.011C2
<b>Receipt Date:</b>	21-SEP-2018
<b>Filing Date:</b>	21-JAN-2016
<b>Time Stamp:</b>	20:02:22
<b>Application Type:</b>	Utility under 35 USC 111(a)

### Payment information:

Submitted with Payment	yes
Payment Type	CARD
Payment was successfully received in RAM	\$750
RAM confirmation Number	092418INTEFSW20031900
Deposit Account	111410
Authorized User	Gustavo Lopez

The Director of the USPTO is hereby authorized to charge indicated fees and credit any overpayment as follows:

37 CFR 1.16 (National application filing, search, and examination fees)

37 CFR 1.17 (Patent application and reexamination processing fees)

--	--	--	--	--	--

**File Listing:**

Document Number	Document Description	File Name	File Size(Bytes)/ Message Digest	Multi Part /.zip	Pages (if appl.)
1	Request for Continued Examination (RCE)	RCE.pdf	1349980	no	3
			dd5ab7cc5d1ab78b52cc8857b32905ce9f46685c		

**Warnings:**

**Information:**

2	Transmittal Letter	IDS_Trans.pdf	18566	no	2
			915744b1ee749143123a9b8004f1eebb785706e4		

**Warnings:**

**Information:**

3	Information Disclosure Statement (IDS) Form (SB08)	IDS.pdf	22840	no	1
			a8cb686afd84f87ae20d3939641a6289534282de		

**Warnings:**

**Information:**

This is not an USPTO supplied IDS fillable form

4		Amends.pdf	67895	yes	14
			9403afe5da3bcf9617a57ee9326a33d37f063081		

**Multipart Description/PDF files in .zip description**

Document Description	Start	End
Amendment Submitted/Entered with Filing of CPA/RCE	1	1
Claims	2	5
Applicant Arguments/Remarks Made in an Amendment	6	14

**Warnings:**

**Information:**

5	Fee Worksheet (SB06)	fee-info.pdf	32456	no	2
			f4d8b093debd8ab0568087d87249ddaef7397a00f		

**Warnings:**

**Information:**

<b>Total Files Size (in bytes):</b>	1491737
-------------------------------------	---------

**This Acknowledgement Receipt evidences receipt on the noted date by the USPTO of the indicated documents, characterized by the applicant, and including page counts, where applicable. It serves as evidence of receipt similar to a Post Card, as described in MPEP 503.**

**New Applications Under 35 U.S.C. 111**

**If a new application is being filed and the application includes the necessary components for a filing date (see 37 CFR 1.53(b)-(d) and MPEP 506), a Filing Receipt (37 CFR 1.54) will be issued in due course and the date shown on this Acknowledgement Receipt will establish the filing date of the application.**

**National Stage of an International Application under 35 U.S.C. 371**

**If a timely submission to enter the national stage of an international application is compliant with the conditions of 35 U.S.C. 371 and other applicable requirements a Form PCT/DO/EO/903 indicating acceptance of the application as a national stage submission under 35 U.S.C. 371 will be issued in addition to the Filing Receipt, in due course.**

**New International Application Filed with the USPTO as a Receiving Office**

**If a new international application is being filed and the international application includes the necessary components for an international filing date (see PCT Article 11 and MPEP 1810), a Notification of the International Application Number and of the International Filing Date (Form PCT/RO/105) will be issued in due course, subject to prescriptions concerning national security, and the date shown on this Acknowledgement Receipt will establish the international filing date of the application.**

Under the Paperwork Reduction Act of 1995, no persons are required to respond to a collection of information unless it displays a valid OMB control number.

<b>PATENT APPLICATION FEE DETERMINATION RECORD</b> Substitute for Form PTO-875	Application or Docket Number 15/002,791	Filing Date 01/21/2016	<input type="checkbox"/> To be Mailed
---	--	---------------------------	---------------------------------------

ENTITY:  LARGE  SMALL  MICRO

**APPLICATION AS FILED - PART I**

FOR	(Column 1) NUMBER FILED	(Column 2) NUMBER EXTRA	RATE (\$)	FEE (\$)
<input type="checkbox"/> BASIC FEE (37 CFR 1.16(a), (b), or (c))	N/A	N/A	N/A	
<input type="checkbox"/> SEARCH FEE (37 CFR 1.16(k), (i), or (m))	N/A	N/A	N/A	
<input type="checkbox"/> EXAMINATION FEE (37 CFR 1.16(o), (p), or (q))	N/A	N/A	N/A	
TOTAL CLAIMS (37 CFR 1.16(i))	minus 20 = *		x \$40 =	
INDEPENDENT CLAIMS (37 CFR 1.16(h))	minus 3 = *		x \$210 =	
<input type="checkbox"/> APPLICATION SIZE FEE (37 CFR 1.16(s))	If the specification and drawings exceed 100 sheets of paper, the application size fee due is \$310 (\$155 for small entity) for each additional 50 sheets or fraction thereof. See 35 U.S.C. 41(a)(1)(G) and 37 CFR 1.16(s).			
<input type="checkbox"/> MULTIPLE DEPENDENT CLAIM PRESENT (37 CFR 1.16(j))				
* If the difference in column 1 is less than zero, enter "0" in column 2.			TOTAL	

**APPLICATION AS AMENDED - PART II**

		(Column 1)		(Column 2)	(Column 3)	RATE (\$)	ADDITIONAL FEE (\$)
<b>AMENDMENT</b>	09/21/2018	CLAIMS REMAINING AFTER AMENDMENT		HIGHEST NUMBER PREVIOUSLY PAID FOR	PRESENT EXTRA		
	Total (37 CFR 1.16(i))	* 18	Minus	** 20	= 0	x \$50 =	0
	Independent (37 CFR 1.16(h))	* 2	Minus	*** 3	= 0	x \$230 =	0
<input type="checkbox"/> Application Size Fee (37 CFR 1.16(s))							
<input type="checkbox"/> FIRST PRESENTATION OF MULTIPLE DEPENDENT CLAIM (37 CFR 1.16(j))							
						TOTAL ADD'L FEE	0
<b>AMENDMENT</b>		CLAIMS REMAINING AFTER AMENDMENT		HIGHEST NUMBER PREVIOUSLY PAID FOR	PRESENT EXTRA		
	Total (37 CFR 1.16(i))	*	Minus	**	=	x \$0 =	
	Independent (37 CFR 1.16(h))	*	Minus	***	=	x \$0 =	
<input type="checkbox"/> Application Size Fee (37 CFR 1.16(s))							
<input type="checkbox"/> FIRST PRESENTATION OF MULTIPLE DEPENDENT CLAIM (37 CFR 1.16(j))							
						TOTAL ADD'L FEE	
* If the entry in column 1 is less than the entry in column 2, write "0" in column 3.						LIE	
** If the "Highest Number Previously Paid For" IN THIS SPACE is less than 20, enter "20".						zuriashwork zenebe	
*** If the "Highest Number Previously Paid For" IN THIS SPACE is less than 3, enter "3".							
The "Highest Number Previously Paid For" (Total or Independent) is the highest number found in the appropriate box in column 1.							

This collection of information is required by 37 CFR 1.16. The information is required to obtain or retain a benefit by the public which is to file (and by the USPTO to process) an application. Confidentiality is governed by 35 U.S.C. 122 and 37 CFR 1.14. This collection is estimated to take 12 minutes to complete, including gathering, preparing, and submitting the completed application form to the USPTO. Time will vary depending upon the individual case. Any comments on the amount of time you require to complete this form and/or suggestions for reducing this burden, should be sent to the Chief Information Officer, U.S. Patent and Trademark Office, U.S. Department of Commerce, P.O. Box 1450, Alexandria, VA 22313-1450. DO NOT SEND FEES OR COMPLETED FORMS TO THIS ADDRESS. **SEND TO: Commissioner for Patents, P.O. Box 1450, Alexandria, VA 22313-1450.**

*If you need assistance in completing the form, call 1-800-PTO-9199 and select option 2.*



UNITED STATES PATENT AND TRADEMARK OFFICE

UNITED STATES DEPARTMENT OF COMMERCE  
**United States Patent and Trademark Office**  
Address: COMMISSIONER FOR PATENTS  
P.O. Box 1450  
Alexandria, Virginia 22313-1450  
www.uspto.gov

APPLICATION NO.	FILING DATE	FIRST NAMED INVENTOR	ATTORNEY DOCKET NO.	CONFIRMATION NO.
15/002,791	01/21/2016	John Douglas Steinberg	EFACT.011C2	4939
20995	7590	06/15/2018	EXAMINER	
KNOBBE MARTENS OLSON & BEAR LLP			OJHA, AJAY	
2040 MAIN STREET			ART UNIT	
FOURTEENTH FLOOR			PAPER NUMBER	
IRVINE, CALIFORNIA 92614			2824	
UNITED STATES OF AMERICA			NOTIFICATION DATE	
			DELIVERY MODE	
			06/15/2018	
			ELECTRONIC	

**Please find below and/or attached an Office communication concerning this application or proceeding.**

The time period for reply, if any, is set in the attached communication.

Notice of the Office communication was sent electronically on above-indicated "Notification Date" to the following e-mail address(es):

efiling@knobbe.com  
jayna.cartee@knobbe.com



<b>Office Action Summary</b>	<b>Application No.</b> 15/002,791	<b>Applicant(s)</b> Steinberg, John Douglas	
	<b>Examiner</b> AJAY OJHA	<b>Art Unit</b> 2824	<b>AIA Status</b> No

*-- The MAILING DATE of this communication appears on the cover sheet with the correspondence address --*

**Period for Reply**

A SHORTENED STATUTORY PERIOD FOR REPLY IS SET TO EXPIRE 3 MONTHS FROM THE MAILING DATE OF THIS COMMUNICATION.

- Extensions of time may be available under the provisions of 37 CFR 1.136(a). In no event, however, may a reply be timely filed after SIX (6) MONTHS from the mailing date of this communication.
- If NO period for reply is specified above, the maximum statutory period will apply and will expire SIX (6) MONTHS from the mailing date of this communication.
- Failure to reply within the set or extended period for reply will, by statute, cause the application to become ABANDONED (35 U.S.C. § 133). Any reply received by the Office later than three months after the mailing date of this communication, even if timely filed, may reduce any earned patent term adjustment. See 37 CFR 1.704(b).

**Status**

- 1)  Responsive to communication(s) filed on Amendment/Req.-After Non-Final Reject - 05/15/2018.  
 A declaration(s)/affidavit(s) under **37 CFR 1.130(b)** was/were filed on \_\_\_\_\_.
- 2a)  This action is **FINAL**.                      2b)  This action is non-final.
- 3)  An election was made by the applicant in response to a restriction requirement set forth during the interview on \_\_\_\_\_; the restriction requirement and election have been incorporated into this action.
- 4)  Since this application is in condition for allowance except for formal matters, prosecution as to the merits is closed in accordance with the practice under *Ex parte Quayle*, 1935 C.D. 11, 453 O.G. 213.

**Disposition of Claims\***

- 5)  Claim(s) 1-18 is/are pending in the application.  
    5a) Of the above claim(s) \_\_\_\_\_ is/are withdrawn from consideration.
- 6)  Claim(s) \_\_\_\_\_ is/are allowed.
- 7)  Claim(s) 1-18 is/are rejected.
- 8)  Claim(s) \_\_\_\_\_ is/are objected to.
- 9)  Claim(s) \_\_\_\_\_ are subject to restriction and/or election requirement

\* If any claims have been determined allowable, you may be eligible to benefit from the **Patent Prosecution Highway** program at a participating intellectual property office for the corresponding application. For more information, please see [http://www.uspto.gov/patents/init\\_events/pph/index.jsp](http://www.uspto.gov/patents/init_events/pph/index.jsp) or send an inquiry to [PPHfeedback@uspto.gov](mailto:PPHfeedback@uspto.gov).

**Application Papers**

- 10)  The specification is objected to by the Examiner.
- 11)  The drawing(s) filed on \_\_\_\_\_ is/are: a)  accepted or b)  objected to by the Examiner.  
    Applicant may not request that any objection to the drawing(s) be held in abeyance. See 37 CFR 1.85(a).  
    Replacement drawing sheet(s) including the correction is required if the drawing(s) is objected to. See 37 CFR 1.121(d).

**Priority under 35 U.S.C. § 119**

- 12)  Acknowledgment is made of a claim for foreign priority under 35 U.S.C. § 119(a)-(d) or (f).

**Certified copies:**

- a)  All      b)  Some\*\*      c)  None of the:
- 1.  Certified copies of the priority documents have been received.
- 2.  Certified copies of the priority documents have been received in Application No. \_\_\_\_\_.
- 3.  Copies of the certified copies of the priority documents have been received in this National Stage application from the International Bureau (PCT Rule 17.2(a)).

\*\* See the attached detailed Office action for a list of the certified copies not received.

**Attachment(s)**

- 1)  Notice of References Cited (PTO-892)
- 2)  Information Disclosure Statement(s) (PTO/SB/08a and/or PTO/SB/08b)  
    Paper No(s)/Mail Date 05/15/2018.
- 3)  Interview Summary (PTO-413)  
    Paper No(s)/Mail Date \_\_\_\_\_.
- 4)  Other: \_\_\_\_\_.

## DETAILED ACTION

### *General Remarks*

1. The present application is being examined under the pre-AIA first to invent provisions.
2. When responding to this office action, applicants are advised to provide the examiner with line numbers and page numbers in the application and/or references cited to assist the examiner in locating appropriate paragraphs.
3. Per MPEP 2111 and 2111.01, the claims are given their broadest reasonable interpretation and the words of the claims are given their plain meaning consistent with the specification without importing claim limitations from the specification.
4. Applicants seeking an interview with the examiner, including WebEx Video Conferencing, are encouraged to fill out the online Automated Interview Request (AIR) form (<http://www.uspto.gov/patent/uspto-automated-interview-request-air-form.html>). See MPEP §502.03, §713.01(II) and Interview Practice for additional details.
5. Status of claim(s) *to be treated* in this office action:
  - a. Independent: 1 and 10.
  - b. Amended: 1 and 10.
  - c. Pending: 1-18.

### *IDS*

6. Applicant's IDS(s) submitted on 05/15/2018 is/are in compliance with the provisions of 37 CFR 1.97. Accordingly, the information disclosure statement has/have considered by the examiner and made of record.

***Double Patenting***

7. Double Patenting rejection against US 9,244,470 has been withdrawn in view of the Terminal Disclaimer approved on 05/15/2018.

***Claim Rejections - 35 USC § 112***

8. **Claims 1-18 rejected under 35 U.S.C. 112(b) or 35 U.S.C. 112 (pre-AIA), second paragraph, as being indefinite for failing to particularly point out and distinctly claim the subject matter which the inventor or a joint inventor, or for pre-AIA the applicant regards as the invention.**

**Amended Claims 1 and 10 (and dependent claims 2-9 and 11-18)**, recites the limitation "the program or channel being viewed" in lines 13 and 16 respectively. There is insufficient antecedent basis for this limitation in the claim.

***Claim Rejections - 35 USC § 103***

9. The following is a quotation of AIA 35 U.S.C. 103 which forms the basis for all obviousness rejections set forth in this Office action:

A patent for a claimed invention may not be obtained, notwithstanding that the claimed invention is not identically disclosed as set forth in section 102 of this title, if the differences between the claimed invention and the prior art are such that the claimed invention as a whole would have been obvious before the effective filing date of the claimed invention to a person having ordinary skill in the art to which the claimed invention pertains. Patentability shall not be negated by the manner in which the invention was made.

10. **Claim(s) 1-18 is/are rejected under AIA 35 U.S.C. 103 as being unpatentable over US 2008/0281472 (hereinafter "Podgorny") in view of US 2009/0065596 (hereinafter "Seem").**

**Re: Independent Claim 1**, Podgorny discloses a method for varying temperature setpoints for an HVAC system (Podgorny abstract) comprising:

storing at least a first HVAC temperature setpoint (Podgorny ¶¶ [0092] and [0019] "user preferences stored" in occupied/non-occupied) and at least a second HVAC temperature setpoint

Art Unit: 2824

(Podgorny ¶¶ [0009] and [0019] describe occupancy and non-occupancy and ¶ [0092] describe storing temperature setpoints and table 2 occupancy and high/low, min/max temperature setting fields);

monitoring an activity status of at least one wireless device (Podgorny FIG. 2 element 508 wireless device) associated with one or more occupants of said structure (Podgorny ¶ [0083] "detects the presence of the user in the Environmental Zone" which means monitoring an activity status of at least one wireless device associated with one or more occupants of said structure), wherein said wireless device comprises a graphic user interface (Podgorny ¶ [0027] "graphical user interface" and ¶¶ [0067], [0080]), wherein use of said wireless device comprises at least one of cursor movement, keystrokes or other user interface actions intended to alter a state of said wireless device (Podgorny ¶ [0083] "keyboard activity monitoring");

determining a probability that the specific activity status of said wireless device (Podgorny ¶ [0093] "identifying the person and transferring his/her environmental preferences to the proper cubicle, together with the person's VoIP phone number" and ¶ [0005]) is associated with the use of said wireless device by a specific occupant or occupants of said structure (Podgorny abstract "autonomous process control" is automatic and "occupancy sensor that recognizes the presence");

determining whether a current HVAC temperature setpoint associated with said HVAC system is set to said first HVAC temperature setpoint or said second temperature setpoint (Podgorny ¶ [0021] "maintain the environmental parameters temperature" which examiner interpreted that to maintain temperature it determine HVAC temperature setpoint associated with HVAC system and ¶¶ [0008], [0029]-[0030] and [0063]);

Podgorny fails to disclose:

where said probability is determined in part by content of the program or channel being viewed by said occupant on or with said wireless device;

prompting said one or more users, wherein said prompting sends a message to said wireless device recommending a change to said current HVAC temperature setpoint for said HVAC system;

in response to said prompting, receiving input from said one or more users; and keeping said current HVAC temperature setpoint based upon said input from said one or more users.

Seem discloses:

where said probability is determined in part by content of the program or channel being viewed by said occupant on or with said wireless device (Seem Fig. 9 and ¶ [0065] discloses how user presence can be determined based on interaction of the user with the User Interface program that generates the User Interface in step 902);

prompting said one or more users (Seem ¶ [0062] “user to specify any number of personal comfort settings” which means prompting said one or more users based on said determining that said one or more of said user's input should be obtained and ¶ [0065]), wherein said prompting sends a message to said wireless device recommending a change to said current HVAC temperature setpoint for said HVAC system (Seem Figs. 8-9 and ¶ [0065] “prompting by the user interface” which means prompting sends a message to said wireless device recommending a change to said current HVAC temperature setpoint for said HVAC system);

in response to said prompting, receiving input from said one or more users (Seem ¶ [0065] “process 800 to adjust a building automation system setting” which means in response to said prompting, receiving input from said one or more users); and

keeping said current HVAC temperature setpoint based upon said input from said one or more users (Seem Fig. 11 element 1120 “adjust HVAC for normal conditions” which examiner interpreted as current setting based on the input from users and paragraph 0070).

Podgorny and Seem disclose home automation and HVAC control system. Seem discloses message communication to various wireless devices including personal wireless devices. It would have

been obvious to a person of ordinary skill in the art before the effective filing date of the claimed invention, to modify the above HVAC control system, as taught by Podgorny, and incorporating the sending wireless messages, as taught by Seem in order to improve control of environmental conditions to reflecting individual preferences, as suggested by Seem (Seem ¶ [0003]).

**Re: Independent Claim 10,** Podgorny discloses a system for altering the setpoint on a thermostat for space conditioning of a structure (Podgorny Figs. 1 and 22) comprising:

at least one thermostat having at least a first temperature setpoint (Podgorny ¶¶ [0092] and [0019] "user preferences stored" in occupied/non-occupied) and at least a second temperature setpoint (Podgorny ¶¶ [0009] and [0019] describe occupancy and non-occupancy and ¶ [0092] describe storing temperature setpoints and table 2 occupancy and high/low, min/max temperature setting fields);

at least one wireless device (Podgorny FIG. 2 element 508 wireless device) associated with one or more occupants of said structure (Podgorny ¶ [0083] "detects the presence of the user in the Environmental Zone" which means monitoring an activity status of at least one wireless device associated with one or more occupants of said structure), wherein said wireless device comprises a graphic user interface (Podgorny ¶ [0027] "graphical user interface" and ¶¶ [0067], [0080]), wherein use of said wireless device comprises at least one of cursor movement, keystrokes or other user interface actions intended to alter a state of said wireless device (Podgorny ¶ [0083] "keyboard activity monitoring");

an application comprising one or more computer processors that receives data regarding an activity status of said wireless device (Podgorny ¶ [0059] "status monitoring and data collection") and whether said thermostat is set to said first temperature setpoint (Podgorny ¶ [0089] "occupancy sensor shuts the system down when users are away from their workstations" which means thermostat is set to said first temperature setpoint that indicates said structure is not occupied and ¶¶ [0009] and [0019]),

Art Unit: 2824

said application determining a probability that the specific activity status of said wireless device is associated with the use of said wireless device (Podgorny ¶ [0093] “identifying the person and transferring his/her environmental preferences to the proper cubicle, together with the person's VoIP phone number” and Podgorny ¶ [0005]) by a specific occupant or occupants of said structure (Podgorny abstract “autonomous process control” is automatic and “occupancy sensor that recognizes the presence”);

Podgorny fails to disclose:

where said probability is determined in part by content of the program or channel being viewed by said occupant on or with said wireless device;

said application prompting said one or more users wherein said application provides electronic notice to one or more of said users of said wireless device that said thermostat is set to one of said first temperature setpoint or said second temperature setpoint; and

wherein said application in response to said prompting, receives input from said one or more users; and

wherein said current temperature setpoint is set based upon said input from said one or more users.

Seem discloses:

where said probability is determined in part by content of the program or channel being viewed by said occupant on or with said wireless device (Seem Fig. 9 and ¶ [0065] discloses how user presence can be determined based on interaction of the user with the User Interface program that generates the User Interface in step 902);

said application prompting said one or more users wherein said application provides electronic notice to one or more of said users of said wireless device that said thermostat (Podgorny ¶ [0062] “user to specify any number of personal comfort settings” which means prompting said one or more users

based on said determining that said one or more of said user's input should be obtained and ¶ [0065]) is set to one of said first temperature setpoint or said second temperature setpoint (Podgorny Figs. 8-9 and ¶ [0065] "prompting by the user interface" which means prompting sends a message to said wireless device recommending a change to said current HVAC temperature setpoint for said HVAC system); and

wherein said application in response to said prompting, receives input from said one or more users (Podgorny ¶ [0065] "process 800 to adjust a building automation system setting" which means in response to said prompting, receiving input from said one or more users); and

wherein said current temperature setpoint is set based upon said input from said one or more users (Podgorny Fig. 11 element 1120 "adjust HVAC for normal conditions" which examiner interpreted as current setting based on the input from users and ¶ [0070]).

Podgorny and Seem disclose home automation and HVAC control system. Seem discloses message communication to various wireless devices including personal wireless devices. It would have been obvious to a person of ordinary skill in the art before the effective filing date of the claimed invention, to modify the above HVAC control system, as taught by Podgorny, and incorporating the sending wireless messages, as taught by Seem in order to improve control of environmental conditions to reflecting individual preferences, as suggested by Seem (Seem ¶ [0003]).

**Re: Claims 2 and 11,** Podgorny and Seem discloses all the limitations of claims 1 or 10 on which these claims depend. They further disclose:

wherein said wireless device is a remote control (Seem ¶ [0067] "remote control 1006 may be configured to wirelessly communicate" and Fig. 10 which means wireless device is a remote control and ¶ [0043] describes "portable wireless device 306" which is a wireless device and it is a remote control).



**Re: Claims 3 and 12**, Podgorny and Seem discloses all the limitations of claims 1 or 10 on which these claims depend. They further disclose:

wherein said wireless device is a wireless phone (Seem ¶ [0043] “cell phone, PDA, or any other device with transmitting capability”, here “cell phone is a wireless phone”, which means wireless device is a wireless phone).

**Re: Claims 4 and 13**, Podgorny and Seem discloses all the limitations of claims 3 or 12 on which these claims depend. They further disclose:

wherein said wireless phone is connected to a cellular network (Podgorny ¶ [0005] “wireless converged networks” which means wireless phone is connected to a cellular network).

**Re: Claims 5 and 14**, Podgorny and Seem discloses all the limitations of claims 1 or 10 on which these claims depend. They further disclose:

wherein said wireless device is a tablet computer (Seem Figs. 2, 3 and ¶¶ [0029]-[0032], [0043] disclose multiple portable device, e.g. 104 construed as a tablet and 306)

**Re: Claims 6 and 15**, Podgorny and Seem discloses all the limitations of claims 1 or 10 on which these claims depend. They further disclose:

wherein said first and second HVAC temperature setpoints are stored in a database associated with a remote server (Seem ¶ [0008] " server computer further includes a processing circuit for accessing a memory device storing the program code" and “program code for adjusting the building automation” which examiner interpreted that it a remote server and first and second HVAC

temperature setpoints are stored in a database associated with the remote server and Fig. 2 element 130 is the “server”).

**Re: Claims 7 and 16,** Podgorny and Seem discloses all the limitations of claims 1 or 10 on which these claims depend. They further disclose:

in which said wireless device communicates with a remote server (Seem ¶ [0032] “140 configured to accept a signal or input from various portable wireless devices” and Fig. 2 shows that wireless devices are communicating with a server, element 130 of Fig. 2 is a “server” and elements 502, 506 and 508 of Fig. 2 are “wireless device”).

**Re: Claims 8 and 17,** Podgorny and Seem discloses all the limitations of claims 1 or 10 on which these claims depend. They further disclose:

further comprising adjusting said current HVAC temperature setpoint with a remote computer (Podgorny abstract, the user controlling "over the internet" at a remote computer and Seem at et. ¶ [0026], [0029] and Fig. 2 describe same limitations).

**Re: Claims 9 and 18,** Podgorny and Seem discloses all the limitations of claims 1 or 10 on which these claims depend. They further disclose:

in which said first HVAC temperature setpoint is varied automatically based on said input from said one or more users (Podgorny abstract" autonomous process control and interaction with system users”, which means first HVAC temperature setpoint is varied automatically (autonomous) based on said input from one or more users).

***Response to Arguments***

11. Applicant's arguments with respect to claim(s) 1-18 have been considered but are moot because the arguments do not apply to the new ground(s) of rejection presented in this Office action, necessitated by the applicant's amendment.

### ***Conclusion***

12. Applicant's amendment necessitated the new ground(s) of rejection presented in this Office action. Accordingly, **THIS ACTION IS MADE FINAL**. See MPEP § 706.07(a). Applicant is reminded of the extension of time policy as set forth in 37 CFR 1.136(a).

A shortened statutory period for reply to this final action is set to expire THREE MONTHS from the mailing date of this action. In the event a first reply is filed within TWO MONTHS of the mailing date of this final action and the advisory action is not mailed until after the end of the THREE-MONTH shortened statutory period, then the shortened statutory period will expire on the date the advisory action is mailed, and any extension fee pursuant to 37 CFR 1.136(a) will be calculated from the mailing date of the advisory action. In no event, however, will the statutory period for reply expire later than SIX MONTHS from the mailing date of this final action.

13. Any inquiry concerning this communication or earlier communications from the examiner should be directed to AJAY OJHA whose telephone number is (571)272-8936. The examiner can normally be reached on M-F, 7:30AM to 5:00PM (EST).

If attempts to reach the examiner by telephone are unsuccessful, the examiner's supervisor, Richard Elms can be reached on (571)272-1869. The fax phone number for the organization where this application or proceeding is assigned is 571-273-8300.

14. Information regarding the status of an application may be obtained from the Patent Application Information Retrieval (PAIR) system. Status information for published applications may be obtained from either Private PAIR or Public PAIR. Status information for unpublished applications is available through Private PAIR only. For more information about the PAIR system, see <http://pair-direct.uspto.gov>. Should you have questions on access to the Private PAIR system, contact the Electronic Business Center (EBC) at 866-217-9197 (toll-free). If you would like assistance from a USPTO Customer

Art Unit: 2824

Service Representative or access to the automated information system, call 800-786-9199 (IN USA OR CANADA) or 571-272-1000.

/AJAY OJHA/

Primary Examiner, Art Unit 2824

ajay.ojha@uspto.gov

<b>Search Notes</b> 	<b>Application/Control No.</b> 15/002,791	<b>Applicant(s)/Patent Under Reexamination</b> Steinberg, John Douglas
	<b>Examiner</b> AJAY OJHA	<b>Art Unit</b> 2824

CPC - Searched*		
Symbol	Date	Examiner
F24F11/006; F24F11/70; F24F11/62; F24F11/30; G05B15/02; G06N7/005; G05D23/1902; F24F11/56; F24F2120/12; F24F2120/10; F24F11/63; F24F11/46; F24F2120/20; F24F2140/60; F24F2120/14	02/13/2018	AO
Refreshed search.	06/11/2018	AO

CPC Combination Sets - Searched*		
Symbol	Date	Examiner

US Classification - Searched*			
Class	Subclass	Date	Examiner

\* See search history printout included with this form or the SEARCH NOTES box below to determine the scope of the search.

Search Notes		
Search Notes	Date	Examiner
Inventor, assignee, classification and text search. See search history.	02/13/2018	AO
Refreshed search. See search history.	06/11/2018	AO

Interference Search			
US Class/CPC Symbol	US Subclass/CPC Group	Date	Examiner

/AJAY OJHA/ Primary Examiner, Art Unit 2824	
--	--

<b><i>Index of Claims</i></b> 	<b>Application/Control No.</b> 15/002,791	<b>Applicant(s)/Patent Under Reexamination</b> Steinberg, John Douglas
	<b>Examiner</b> AJAY OJHA	<b>Art Unit</b> 2824

✓	<b>Rejected</b>
=	<b>Allowed</b>

-	<b>Cancelled</b>
÷	<b>Restricted</b>

N	<b>Non-Elected</b>
I	<b>Interference</b>

A	<b>Appeal</b>
O	<b>Objected</b>

CLAIMS									
<input type="checkbox"/> Claims renumbered in the same order as presented by applicant <input type="checkbox"/> CPA <input type="checkbox"/> T.D. <input type="checkbox"/> R.1.47									
CLAIM		DATE							
Final	Original	02/13/2018	06/11/2018						
	1	✓	✓						
	2	✓	✓						
	3	✓	✓						
	4	✓	✓						
	5	✓	✓						
	6	✓	✓						
	7	✓	✓						
	8	✓	✓						
	9	✓	✓						
	10	✓	✓						
	11	✓	✓						
	12	✓	✓						
	13	✓	✓						
	14	✓	✓						
	15	✓	✓						
	16	✓	✓						
	17	✓	✓						
	18	✓	✓						

## EAST Search History

## EAST Search History (Prior Art)

Ref #	Hits	Search Query	DBs	Default Operator	Plurals	Time Stamp
L2	9	("20160061474"   "9244470"   "9279594"   "20060283965"   "20080083234"   "20090065596").PN.	US-PGPUB; USPAT; USOCR; FPRS; EPO; IBM_TDB	OR	ON	2018/06/11 18:03
L3	3	(WO-2009036764-\$ ).DID.	US-PGPUB; USPAT; USOCR; FPRS; EPO; IBM_TDB	OR	ON	2018/06/11 18:36
L4	0	(desktop ADJ us\$3 WITH control ADJ3 temperature)	US-PGPUB; USPAT; USOCR; FPRS; EPO; IBM_TDB	OR	ON	2018/06/11 18:38
L5	18	(desktop ADJ us\$3 WITH control WITH environment)	US-PGPUB; USPAT; USOCR; FPRS; EPO; IBM_TDB	OR	ON	2018/06/11 18:43
L6	147	(desktop ADJ usage)	US-PGPUB; USPAT; USOCR; FPRS; EPO; IBM_TDB	OR	ON	2018/06/11 18:49
L7	0	6 AND (desktop ADJ usage WITH air\$1 conditioning)	US-PGPUB; USPAT; USOCR; FPRS; EPO; IBM_TDB	OR	ON	2018/06/11 18:50
L8	11	6 AND (desktop ADJ usage WITH environment\$2)	US-PGPUB; USPAT; USOCR; FPRS; EPO; IBM_TDB	OR	ON	2018/06/11 18:51
L9	0	6 AND (smart SAME room ADJ temperatuer	US-	OR	ON	2018/06/11



		ADJ control)	PGPUB; USPAT; USOCR; FPRS; EPO; IBM_TDB			18:55
L10	0	(smart SAME room ADJ temperatuer ADJ control)	US-PGPUB; USPAT; USOCR; FPRS; EPO; IBM_TDB	OR	ON	2018/06/11 18:56
L11	0	(smart ADJ temperatuer ADJ control)	US-PGPUB; USPAT; USOCR; FPRS; EPO; IBM_TDB	OR	ON	2018/06/11 18:56
L12	0	(wireless ADJ device ADJ aware WITH thermostat)	US-PGPUB; USPAT; USOCR; FPRS; EPO; IBM_TDB	OR	ON	2018/06/11 18:56
L13	2024	(smart ADJ thermostat)	US-PGPUB; USPAT; USOCR; FPRS; EPO; IBM_TDB	OR	ON	2018/06/11 19:00
L14	6	13 AND (smart ADJ thermostat) SAME ((computer desktop TV) ADJ2 usage)	US-PGPUB; USPAT; USOCR; FPRS; EPO; IBM_TDB	OR	ON	2018/06/11 19:01
L15	17235	(occupant NEAR10 detect\$3)	US-PGPUB; USPAT; USOCR; FPRS; EPO; IBM_TDB	OR	ON	2018/06/11 19:05
L17	13997	(occupant NEAR5 detect\$3)	US-PGPUB; USPAT; USOCR; FPRS; EPO; IBM_TDB	OR	ON	2018/06/11 19:06
L18	9	17 AND (occupant NEAR5 detect\$3) SAME ((computer desktop) WITH use)	US-PGPUB; USPAT; USOCR; FPRS; EPO;	OR	ON	2018/06/11 19:07

L19	7	17 AND (occupant NEAR5 detect\$3) SAME (CUBICLE)	US-PGPUB; USPAT; USOCR; FPRS; EPO; IBM_TDB	OR	ON	2018/06/11 19:10
L20	8	smart ADJ building ADJ energy ADJ management	US-PGPUB; USPAT; USOCR; FPRS; EPO; IBM_TDB	OR	ON	2018/06/11 19:17
L21	1	(12/041472).APP.	USPAT; USOCR	OR	ON	2018/06/11 19:39
L22	181	("20030216837"   "20040225649"   "20050234596"   "20050275525"   "20060026972"   "20060111816"   "5097672"   "6067477"   "6604023"   "6756998"   "6792319"   "6832120"   "6912429"   "7055759"   "7130719"   "7187986"   "7343226"   "7436292"   "7440809"   "7480534"   "7529646").PN. OR ("7904209").URPN.	US-PGPUB; USPAT; USOCR	OR	ON	2018/06/11 19:39
L23	154	22 AND (computer)	US-PGPUB; USPAT; USOCR	OR	ON	2018/06/11 19:43
L24	145	22 AND (computer) AND user	US-PGPUB; USPAT; USOCR	OR	ON	2018/06/11 19:43
L25	76	22 AND (computer) NEAR10 user	US-PGPUB; USPAT; USOCR	OR	ON	2018/06/11 19:43
S1	149	((("STEINBERG") near3 ("John")).INV.	US-PGPUB; USPAT; USOCR	OR	ON	2018/02/07 09:39
S2	78	("EcoFactor").AS,AANM.	US-PGPUB; USPAT; USOCR; FPRS; EPO; IBM_TDB	OR	ON	2018/02/07 09:40
S3	46883	(F24F11/006; F24F11/70; F24F11/62; F24F11/30; G05B15/02; G06N7/005; G05D23/1902; F24F11/56; F24F2120/12; F24F2120/10; F24F11/63; F24F11/46; F24F2120/20; F24F2140/60; F24F2120/14).cpc.	US-PGPUB; USPAT; USOCR; FPRS; EPO; IBM_TDB	OR	ON	2018/02/07 10:02
S4	3	(S1 S2) AND (HVAC AND temperature AND user\$1 AND wireless).CLM.	US-PGPUB; USPAT; USOCR;	OR	ON	2018/02/07 10:03

			FPRS; EPO; IBM_TDB			
S5	15	("9244470")	US- PGPUB; USPAT; USOCR; FPRS; EPO; IBM_TDB	OR	ON	2018/02/07 10:11
S6	9	("9244470")	USPAT	OR	ON	2018/02/07 10:12
S7	25	("20040117330"   "20090065596"   "20150025691"   "6700224"   "20130173064"   "20040133314"   "5348074"   "7869907"   "8850348"   "9057649"   "20140316581"   "20150120235"   "7206670"   "20130178985").PN.	US- PGPUB; USPAT; USOCR; FPRS; EPO; IBM_TDB	OR	ON	2018/02/07 18:05
S8	4	("20080281472" "20090065596")	US- PGPUB; USPAT; USOCR; FPRS; EPO; IBM_TDB	OR	ON	2018/02/07 18:12
S10	32	(US-20010025349-\$   US-20040117330-\$   US-20040133314-\$   US-20080083834-\$   US-20090005070-\$   US-20090018673-\$   US-20090057426-\$   US-20090062970-\$   US-20090271013-\$   US-20130073094-\$   US-20170241662-\$   US-20170336090-\$   US-20180087793-\$   US-20180087795-\$   US-1234567-\$   US-4270693-\$   US- 4702305-\$   US-4702413-\$   US-5297838-\$   US-5454511-\$   US-5706190-\$   US- 5839654-\$   US-6216956-\$   US-6223544-\$   US-6449534-\$   US-6454177-\$   US- 6845918-\$   US-6981383-\$   US-7983795-\$   US-9709292-\$   US-9939333-\$).DID.	US- PGPUB; USPAT; USOCR; FPRS; EPO; IBM_TDB	OR	ON	2018/06/11 10:22
S11	31	("0015616"   "20010025349"   "20040117330"   "20040133314"   "20080083834"   "20090005070"   "20090018673"   "20090057426"   "20090062970"   "20090271013"   "20130073094"   "20170241662"   "20170336090"   "20180087793"   "20180087795"   "4270693"   "4702305"   "4702413"   "5297838"   "5454511"   "5706190"   "5839654"   "6216956"   "6223544"   "6449534"   "6454177"   "6845918"   "6981383"   "7983795"   "9709292"   "9939333").PN.	US- PGPUB; USPAT	OR	ON	2018/06/11 14:20

**EAST Search History (I nterference)**

&lt; This search history is empty &gt;

**6/ 11/ 2018 8:58:11 PM****C:\ Users\ aojha\ Documents\ EAST\ Workspaces\ 15002791.wsp**



<b>INFORMATION DISCLOSURE STATEMENT BY APPLICANT</b>	Application No.	15/002,791
	Filing Date	January 21, 2016
	First Named Inventor	John Douglas Steinberg
	Art Unit	2824
(Multiple sheets used when necessary)	Examiner	Ojha, Ajay
SHEET 1 OF 2	Attorney Docket No.	EFACT.011C2

U.S. PATENT DOCUMENTS					
Examiner Initials	Cite No.	Document Number <i>Number - Kind Code (if known)</i> Example: 1,234,567 B1	Publication Date MM-DD-YYYY	Name	Pages, Columns, Lines Where Relevant Passages or Relevant Figures Appear
	1	15/616,719	06/07/2017	Steinberg, et al.	
	2	4,270,693	06/02/1981	Hayes	
	3	4,702,305	10/27/1987	Beckey et al.	
	4	4,702,413	10/27/1987	Beckey et al.	
	5	5,297,838	03/15/1994	Juravich	
	6	5,454,511	10/03/1995	Van Ostrand et al.	
	7	5,706,190	01/06/1998	Russ et al.	
	8	5,839,654	11/24/1998	Weber	
	9	6,216,956	04/17/2001	Ehlers et al.	
	10	6,223,544	05/01/2001	Seem	
	11	6,449,534	09/10/2002	Stewart	
	12	6,454,177	09/24/2002	Sasao et al.	
	13	6,845,918	01/25/2005	Rotondo	
	14	6,981,383	01/03/2006	Shah et al.	
	15	7,983,795	07/19/2011	Josephson et al.	
	16	9,709,292 (EFACT.012C2)	07/18/2017	Steinberg	
	17	9,939,333 (EFACT.006C3)	04/10/2018	Steinberg et al.	
	18	2001/0025349	09/27/2001	Sharood et al.	
	19	2004/0117330	06/17/2004	Ehlers et al.	
	20	2004/0133314	07/08/2004	Ehlers et al.	
	21	2008/0083834	04/10/2008	Krebs et al.	
	22	2009/0005070	01/01/2009	Forstall et al.	
	23	2009/0018673	01/15/2009	Dushane et al.	
	24	2009/0057426	03/05/2009	Sullivan et al.	
	25	2009/0062970	03/05/2009	Forbes et al.	
	26	2009/0271013	10/29/2009	Chen	
	27	2013/0073094	03/21/2013	Knapton et al.	
	28	2017/0241662	08/24/2017	Steinberg et al.	

Examiner Signature	Date Considered
<p><b>*Examiner:</b> Initial if reference considered, whether or not citation is in conformance with MPEP 609. Draw line through citation if not in conformance and not considered. Include copy of this form with next communication to applicant.</p>	

T<sup>1</sup> - Place a check mark in this area when an English language Translation is attached.

ALL REFERENCES CONSIDERED EXCEPT WHERE LINED THROUGH. /A.O./

<b>INFORMATION DISCLOSURE STATEMENT BY APPLICANT</b>	Application No.	15/002,791	
	Filing Date	January 21, 2016	
	First Named Inventor	John Douglas Steinberg	
	Art Unit	2824	
<i>(Multiple sheets used when necessary)</i>		Examiner	Ojha, Ajay
SHEET 2 OF 2		Attorney Docket No.	EFACT.011C2

U.S. PATENT DOCUMENTS					
Examiner Initials	Cite No.	Document Number <i>Number - Kind Code (if known)</i> Example: 1,234,567 B1	Publication Date MM-DD-YYYY	Name	Pages, Columns, Lines Where Relevant Passages or Relevant Figures Appear
	<b>29</b>	2017/0336090	11/23/2017	Steinberg	
	<b>30</b>	2018/0087793	03/29/2018	Okita et al.	
	<b>31</b>	2018/0087795	03/29/2018	Okita et al.	

FOREIGN PATENT DOCUMENTS						
Examiner Initials	Cite No.	Foreign Patent Document <i>Country Code-Number-Kind Code</i> Example: JP 1234567 A1	Publication Date MM-DD-YYYY	Name	Pages, Columns, Lines Where Relevant Passages or Relevant Figures Appear	T <sup>1</sup>
	<b>32</b>	EP 1102500 A2	05/23/2001	Lucent Technologies Inc.		
	<b>33</b>	EP 2372263 A2	05/10/2011	Mitsubishi Electric Corporation		
	<b>34</b>	GB 2408592 A	06/01/2005	Oswald		
	<b>35</b>	WO 2009/036764 A2	03/26/2009	Danfoss A/S		
	<b>36</b>	WO 2011/100427 A2	08/18/2011	Enphase Energy, Inc.		
	<b>37</b>	WO 2011/011404 A1	01/27/2011	Allure Energy, Inc.		

NON PATENT LITERATURE DOCUMENTS			
Examiner Initials	Cite No.	Include name of the author (in CAPITAL LETTERS), title of the article (when appropriate), title of the item (book, magazine, journal, serial, symposium, catalog, etc.), date, page(s), volume-issue number(s), publisher, city and/or country where published.	T <sup>1</sup>
	<b>38</b>	Office Action in Canadian Application No. 2800491 dated December 7, 2016 (EFACT.012CA).	
	<b>39</b>	Search Report in European Application No. 11787067.5 dated August 14, 2017 (EFACT.012EP).	
	<b>40</b>	Extended Search Report for European Application No. 11818805.1 dated June 9, 2017 (EFACT.013EP).	
	<b>41</b>	Examination Report in Australian Application No. 2013274827 dated April 11, 2017 (EFACT.014AU).	
	<b>42</b>	Extended Search Report for European Application No. 13804057.1 dated June 1, 2016 (EFACT.014EP).	

28280430

Examiner Signature /AJAY OJHA/	Date Considered 06/11/2018
--------------------------------	----------------------------

\***Examiner:** Initial if reference considered, whether or not citation is in conformance with MPEP 609. Draw line through citation if not in conformance and not considered. Include copy of this form with next communication to applicant.

T<sup>1</sup> - Place a check mark in this area when an English language Translation is attached.

0086  
ALL REFERENCES CONSIDERED EXCEPT WHERE LINED THROUGH. /A.O./

Electronic Petition Request	<b>TERMINAL DISCLAIMER TO OBIVIATE A DOUBLE PATENTING REJECTION OVER A "PRIOR" PATENT</b>
-----------------------------	---

Application Number	15002791
--------------------	----------

Filing Date	21-Jan-2016
-------------	-------------

First Named Inventor	John Steinberg
----------------------	----------------

Attorney Docket Number	EFACT.011C2
------------------------	-------------

Title of Invention	SYSTEM AND METHOD FOR USING A WIRELESS DEVICE AS A SENSOR FOR AN ENERGY MANAGEMENT SYSTEM
--------------------	---

- Filing of terminal disclaimer does not obviate requirement for response under 37 CFR 1.111 to outstanding Office Action
- This electronic Terminal Disclaimer is not being used for a Joint Research Agreement.

Owner	Percent Interest
EcoFactor, Inc.	100%

The owner(s) with percent interest listed above in the instant application hereby disclaims, except as provided below, the terminal part of the statutory term of any patent granted on the instant application which would extend beyond the expiration date of the full statutory term of prior patent number(s)

9244470

as the term of said prior patent is presently shortened by any terminal disclaimer. The owner hereby agrees that any patent so granted on the instant application shall be enforceable only for and during such period that it and the prior patent are commonly owned. This agreement runs with any patent granted on the instant application and is binding upon the grantee, its successors or assigns.

In making the above disclaimer, the owner does not disclaim the terminal part of the term of any patent granted on the instant application that would extend to the expiration date of the full statutory term of the prior patent, "as the term of said prior patent is presently shortened by any terminal disclaimer," in the event that said prior patent later:

- expires for failure to pay a maintenance fee;
- is held unenforceable;
- is found invalid by a court of competent jurisdiction;
- is statutorily disclaimed in whole or terminally disclaimed under 37 CFR 1.321;
- has all claims canceled by a reexamination certificate;
- is reissued; or
- is in any manner terminated prior to the expiration of its full statutory term as presently shortened by any terminal disclaimer.

Terminal disclaimer fee under 37 CFR 1.20(d) is included with Electronic Terminal Disclaimer request.

I certify, in accordance with 37 CFR 1.4(d)(4), that the terminal disclaimer fee under 37 CFR 1.20(d) required for this terminal disclaimer has already been paid in the above-identified application.

Applicant claims the following fee status:

- Small Entity
- Micro Entity
- Regular Undiscounted

I hereby declare that all statements made herein of my own knowledge are true and that all statements made on information and belief are believed to be true; and further that these statements were made with the knowledge that willful false statements and the like so made are punishable by fine or imprisonment, or both, under Section 1001 of Title 18 of the United States Code and that such willful false statements may jeopardize the validity of the application or any patent issued thereon.

THIS PORTION MUST BE COMPLETED BY THE SIGNATORY OR SIGNATORIES

I certify, in accordance with 37 CFR 1.4(d)(4) that I am:

- An attorney or agent registered to practice before the Patent and Trademark Office who is of record in this application  
Registration Number 34362
- A sole inventor
- A joint inventor; I certify that I am authorized to sign this submission on behalf of all of the inventors as evidenced by the power of attorney in the application
- A joint inventor; all of whom are signing this request

Signature	/John R. King/
Name	John R. King

\*Statement under 37 CFR 3.73(b) is required if terminal disclaimer is signed by the assignee (owner).  
Form PTO/SB/96 may be used for making this certification. See MPEP § 324.



## Electronic Patent Application Fee Transmittal

<b>Application Number:</b>	15002791			
<b>Filing Date:</b>	21-Jan-2016			
<b>Title of Invention:</b>	SYSTEM AND METHOD FOR USING A WIRELESS DEVICE AS A SENSOR FOR AN ENERGY MANAGEMENT SYSTEM			
<b>First Named Inventor/Applicant Name:</b>	John Douglas Steinberg			
<b>Filer:</b>	John R. King/Daniela Lopez			
<b>Attorney Docket Number:</b>	EFACT.011C2			
Filed as Small Entity				
<b>Filing Fees for Utility under 35 USC 111(a)</b>				
<b>Description</b>	<b>Fee Code</b>	<b>Quantity</b>	<b>Amount</b>	<b>Sub-Total in USD(\$)</b>
<b>Basic Filing:</b>				
STATUTORY OR TERMINAL DISCLAIMER	2814	1	160	160
<b>Pages:</b>				
<b>Claims:</b>				
<b>Miscellaneous-Filing:</b>				
<b>Petition:</b>				
<b>Patent-Appeals-and-Interference:</b>				
<b>Post-Allowance-and-Post-Issuance:</b>				

Description	Fee Code	Quantity	Amount	Sub-Total in USD(\$)
<b>Extension-of-Time:</b>				
<b>Miscellaneous:</b>				
<b>Total in USD (\$)</b>				<b>160</b>

Doc Code: DISQ.E.FILE

Document Description: Electronic Terminal Disclaimer – Approved

Application No.: 15002791

Filing Date: 21-Jan-2016

Applicant/Patent under Reexamination: Steinberg

Electronic Terminal Disclaimer filed on May 15, 2018

APPROVED

**This patent is subject to a terminal disclaimer**

DISAPPROVED

Approved/Disapproved by: Electronic Terminal Disclaimer automatically approved by EFS-Web

U.S. Patent and Trademark Office

## Electronic Acknowledgement Receipt

<b>EFS ID:</b>	32627280
<b>Application Number:</b>	15002791
<b>International Application Number:</b>	
<b>Confirmation Number:</b>	4939
<b>Title of Invention:</b>	SYSTEM AND METHOD FOR USING A WIRELESS DEVICE AS A SENSOR FOR AN ENERGY MANAGEMENT SYSTEM
<b>First Named Inventor/Applicant Name:</b>	John Douglas Steinberg
<b>Customer Number:</b>	20995
<b>Filer:</b>	John R. King/Daniela Lopez
<b>Filer Authorized By:</b>	John R. King
<b>Attorney Docket Number:</b>	EFACT.011C2
<b>Receipt Date:</b>	15-MAY-2018
<b>Filing Date:</b>	21-JAN-2016
<b>Time Stamp:</b>	13:58:57
<b>Application Type:</b>	Utility under 35 USC 111(a)

### Payment information:

Submitted with Payment	yes
Payment Type	CARD
Payment was successfully received in RAM	\$160
RAM confirmation Number	051618INTEFSW13585400
Deposit Account	111410
Authorized User	Daniela Lopez

The Director of the USPTO is hereby authorized to charge indicated fees and credit any overpayment as follows:

37 CFR 1.16 (National application filing, search, and examination fees)

37 CFR 1.17 (Patent application and reexamination processing fees)

--	--	--	--	--	--

**File Listing:**

Document Number	Document Description	File Name	File Size(Bytes)/ Message Digest	Multi Part /.zip	Pages (if appl.)
1	Terminal Disclaimer-Filed (Electronic)	eTerminal-Disclaimer.pdf	33591	no	2
			0505c632aee721658b84df4891dba2e86db5f5ea		

**Warnings:**

**Information:**

2	Fee Worksheet (SB06)	fee-info.pdf	30693	no	2
			019095dfe7c217a81aa1394ddd86308193179557		

**Warnings:**

**Information:**

<b>Total Files Size (in bytes):</b>	64284
-------------------------------------	-------

**This Acknowledgement Receipt evidences receipt on the noted date by the USPTO of the indicated documents, characterized by the applicant, and including page counts, where applicable. It serves as evidence of receipt similar to a Post Card, as described in MPEP 503.**

**New Applications Under 35 U.S.C. 111**

**If a new application is being filed and the application includes the necessary components for a filing date (see 37 CFR 1.53(b)-(d) and MPEP 506), a Filing Receipt (37 CFR 1.54) will be issued in due course and the date shown on this Acknowledgement Receipt will establish the filing date of the application.**

**National Stage of an International Application under 35 U.S.C. 371**

**If a timely submission to enter the national stage of an international application is compliant with the conditions of 35 U.S.C. 371 and other applicable requirements a Form PCT/DO/EO/903 indicating acceptance of the application as a national stage submission under 35 U.S.C. 371 will be issued in addition to the Filing Receipt, in due course.**

**New International Application Filed with the USPTO as a Receiving Office**

**If a new international application is being filed and the international application includes the necessary components for an international filing date (see PCT Article 11 and MPEP 1810), a Notification of the International Application Number and of the International Filing Date (Form PCT/RO/105) will be issued in due course, subject to prescriptions concerning national security, and the date shown on this Acknowledgement Receipt will establish the international filing date of the application.**

**IN THE UNITED STATES PATENT AND TRADEMARK OFFICE**

First Inventor	:	John Douglas Steinberg
App. No.	:	15/002,791
Filed	:	January 21, 2016
For	:	SYSTEM AND METHOD FOR USING A WIRELESS DEVICE AS A SENSOR FOR AN ENERGY MANAGEMENT SYSTEM
Examiner	:	Ojha, Ajay
Art Unit	:	2824
Conf. No.	:	4939

**RESPONSE TO OFFICE ACTION DATED FEBRUARY 16, 2018****Mail Stop Amendment**

Commissioner for Patents  
P.O. Box 1450  
Alexandria, VA 22313-1450

Dear Commissioner:

In response to the Office Action dated February 16, 2018, Applicant respectfully submits the following amendments and comments.

**Amendments to the Claims** are reflected in the listing of claims which begins on page 2 of this paper.

**Remarks/Arguments** begin on page 5 of this paper.

### AMENDMENTS TO THE CLAIMS

Please amend Claims 1 and 10 as indicated below.

1. (Currently Amended) A method for varying temperature setpoints for an HVAC system comprising:

storing at least a first HVAC temperature setpoint and at least a second HVAC temperature setpoint;

monitoring an activity status of at least one wireless device associated with one or more occupants of said structure, wherein said wireless device comprises a graphic user interface, wherein use of said wireless device comprises at least one of cursor movement, keystrokes or other user interface actions intended to alter a state of said wireless device;

determining a probability that the specific activity status of said wireless device is associated with the use of said wireless device by a specific occupant or occupants of said structure, where said probability is determined in part by content of the program or channel being viewed by said occupant on or with said wireless device;

determining whether a current HVAC temperature setpoint associated with said HVAC system is set to said first HVAC temperature setpoint or said second temperature setpoint;

prompting said one or more users, wherein said prompting sends a message to said wireless device recommending a change to said current HVAC temperature setpoint for said HVAC system;

in response to said prompting, receiving input from said one or more users; and

keeping said current HVAC temperature setpoint based upon said input from said one or more users.

2. (Original) The method of Claim 1 wherein said wireless device is a remote control.

3. (Original) The method of Claim 1 wherein said wireless device is a wireless phone.

4. (Original) The method of Claim 3 wherein said wireless phone is connected to a cellular network.

5. (Original) The method of Claim 1 wherein said wireless device is a tablet computer.

6. (Original) The method of Claim 1 wherein said first and second HVAC temperature setpoints are stored in a database associated with a remote server.

7. (Original) The method of Claim 1 in which said wireless device communicates with a remote server.

8. (Original) The method of Claim 1 further comprising adjusting said current HVAC temperature setpoint with a remote computer.

9. (Original) The method of Claim 1 in which said first HVAC temperature setpoint is varied automatically based on said input from said one or more users.

10. (Currently Amended) A system for altering the setpoint on a thermostat for space conditioning of a structure comprising:

at least one thermostat having at least a first temperature setpoint and at least a second temperature setpoint;

at least one wireless device associated with one or more occupants of said structure, wherein said wireless device comprises a graphic user interface, wherein use of said wireless device comprises at least one of cursor movement, keystrokes or other user interface actions intended to alter a state of said wireless device;



an application comprising one or more computer processors that receives data regarding an activity status of said wireless device and whether said thermostat is set to said first temperature setpoint,

said application determining a probability that the specific activity status of said wireless device is associated with the use of said wireless device by a specific occupant or occupants of said structure, where said probability is determined in part by content of the program or channel being viewed by said occupant on or with said wireless device;

said application prompting said one or more users wherein said application provides electronic notice to one or more of said users of said wireless device that said thermostat is set to one of said first temperature setpoint or said second temperature setpoint; and

wherein said application in response to said prompting, receives input from said one or more users; and

wherein said current temperature setpoint is set based upon said input from said one or more users.

11. (Original) The system of Claim 10 wherein said wireless device is a remote controller.

12. (Original) The system of Claim 10 wherein said wireless device is a wireless phone.

13. (Original) The system of Claim 12 wherein said wireless phone is connected to a cellular network.

14. (Original) The system of Claim 10 said wireless device is a tablet computer.

15. (Original) The system of Claim 10 wherein said first and second temperature setpoints are stored in a database associated with a remote server.

**Application No.: 15/002,791**

**Filing Date: January 21, 2016**

16. (Original) The system of Claim 10 wherein said wireless device communicates with a remote server.

17. (Original) The system of Claim 10 further comprising a remote computer that varies said first temperature setpoint.

18. (Original) The system of Claim 10 in which said first temperature setpoint is varied automatically based on said input from said one or more users.

**Application No.: 15/002,791**  
**Filing Date: January 21, 2016**

## **REMARKS**

The February 16, 2018 Office Action was based upon pending Claims 1-18. This Amendment amends Claims 1 and 10.

Thus, after entry of this Amendment, Claims 1-18 are pending and presented for further consideration.

### **REJECTION OF CLAIMS 1-18 UNDER 35 U.S.C. § 103(a)**

In the February 16, 2018 Office Action, Claims 1-18 were rejected under 35 U.S.C. § 103(a) as being unpatentable over U.S. Publication No. 2008/0281472 to Podgorny, et al. (hereinafter "Podgorny") in view of U.S. Publication No. 2009/0065596 to Seem, et al. (hereinafter "Seem").

In response, Applicant has amended independent claims 1 and 10 to include limitations relating to the content the wireless device is being used to consume. See, e.g., Fig 8. Neither Podgorny nor Seem discuss using the content being viewed by an occupant to inform the determination of HVAC settings.

Accordingly, Applicant respectfully requests allowance of the amended claims.

### **REJECTION OF CLAIMS FOR OBVIOUSNESS-TYPE DOUBLE PATENTING**

The Examiner rejected the pending claims under obviousness-type double patenting as being unpatentable over the claims of U.S. Patent No. 9,244,470.

In response, Applicant submits herewith a Terminal Disclaimer in compliance with 37 C.F.R. §1.321(b) and (c). Accordingly, Applicant respectfully requests that the obviousness-type double patenting rejection be withdrawn.

### **OTHER APPLICATIONS OF ASSIGNEE**

Applicant wishes to draw the Examiner's attention to the following applications owned by of the present application's assignee:

**Application No.: 15/002,791**  
**Filing Date: January 21, 2016**

<b>Inventors</b>	<b>Appl. No.</b>	<b>Filing Date</b>	<b>Attorney Docket No.</b>	<b>Title</b>
Steinberg et al.	60/963,183 Now Expired	08/03/07	EFACT.003PR	System And Method For Using A Network Of Thermostats As Tool To Verify Peak Demand Reduction
Steinberg et al.	60/994,011 Now Expired	09/17/07	EFACT.005PR	System And Method For Calculating The Thermal Mass Of A Building
Steinberg et al.	12/183,990 Now Pat. 7,908,117	07/31/08	EFACT.003A	System And Method For Using A Network Of Thermostats As Tool To Verify Peak Demand Reduction
Steinberg et al.	12/183,949 Now Pat. 7,908,116	07/31/08	EFACT.004A	System And Method For Using A Network Of Thermostats As Tool To Verify Peak Demand Reduction
Steinberg et al.	12/211,733 Now Pat. 7,848,900	09/16/08	EFACT.005A	System And Method For Calculating The Thermal Mass Of A Building
Steinberg et al.	12/211,690 Now Pat. 8,019,567	09/16/08	EFACT.006A	System And Method For Evaluating Changes In The Efficiency Of An HVAC System
Steinberg et al.	61/215,657 Now Expired	05/08/09	EFACT.009PR	System, Method And Apparatus For Just-In-Time Conditioning Using A Thermostat
Steinberg	61/215,816 Now Expired	05/11/09	EFACT.008PR	System, Method And Apparatus For Dynamically Variable Compressor Delay In Thermostat To Reduce Energy Consumption
Steinberg et al.	61/215,999 Now Expired	05/12/09	EFACT.007PR	System, Method And Apparatus For Identifying Manual Inputs To And Adaptive Programming Of A Thermostat
Cheung et al.	12/498,142 Now Pat. 8,010,237	07/06/09	EFACT.010A	System And Method For Using Ramped Setpoint Temperature Variation With Networked Thermostats To Improve Efficiency

**Application No.: 15/002,791**  
**Filing Date: January 21, 2016**

Inventors	Appl. No.	Filing Date	Attorney Docket No.	Title
Steinberg	12/502,064 Now Pat. 8,180,492	07/13/09	EFACT.011A	System And Method For Using A Networked Electronic Device As An Occupancy Sensor For An Energy Management System
Steinberg et al.	12/773,690 Now Pat. 8,498,753	05/04/10	EFACT.009A	System, Method And Apparatus For Just-In-Time Conditioning Using A Thermostat
Steinberg	12/774,580 Now Pat. 8,740,100	05/05/10	EFACT.008A	System, Method And Apparatus For Dynamically Variable Compressor Delay In Thermostat To Reduce Energy Consumption
Steinberg et al.	12/778,052 Now Pat. 8,596,550	05/11/10	EFACT.007A	System, Method And Apparatus For Identifying Manual Inputs To And Adaptive Programming Of A Thermostat
Steinberg	12/788,246 Now Pat. 8,556,188	05/26/10	EFACT.012A	System And Method For Using A Mobile Electronic Device To Optimize An Energy Management System
Steinberg	12/860,821 Now Pat. 8,090,477	08/20/10	EFACT.013A	System And Method For Optimizing Use Of Plug-In Air Conditioners And Portable Heaters
Steinberg et al.	12/959,225 Now Pat. 8,131,497	12/02/10	EFACT.005C1	System And Method For Calculating The Thermal Mass Of A Building
Steinberg et al.	13/037,162 Now Pat. 8,131,506	02/28/11	EFACT.004C1	System And Method For Using A Network Of Thermostats As Tool To Verify Peak Demand Reduction
Cheung et al.	13/219,381 Now Pat. 9,134,710	08/26/11	EFACT.010C1	System And Method For Using Ramped Setpoint Temperature Variation With Networked Thermostats To Improve Efficiency
Steinberg et al.	13/230,610 Now Pat. 8,423,322	09/12/11	EFACT.006C1	System And Method For Evaluating Changes In The Efficiency Of An HVAC System
Steinberg	13/329,117 Now Pat. 8,340,826	12/16/11	EFACT.013C1	System And Method For Optimizing Use Of Plug-In Air Conditioners And Portable Heaters

**Application No.: 15/002,791**  
**Filing Date: January 21, 2016**

<b>Inventors</b>	<b>Appl. No.</b>	<b>Filing Date</b>	<b>Attorney Docket No.</b>	<b>Title</b>
Steinberg et al.	13/409,697 Now Pat. 8,412,488	03/01/12	EFACT.004C2	System And Method For Using A Network Of Thermostats As Tool To Verify Peak Demand Reduction
Steinberg et al.	13/409,729 Now Pat. 8,886,488	03/01/12	EFACT.005C2	System And Method For Calculating The Thermal Mass Of A Building
Steinberg	13/470,074 Now Pat. 9,244,470	05/11/12	EFACT.011C1	System And Method For Using A Wireless Device As A Sensor For An Energy Management System
Hublou et al.	13/523,697 Published As 2013/0338837	06/14/12	EFACT.014A	System And Method For Optimizing Use Of Individual HVAC Units In Multi-Unit Chiller-Based Systems
Steinberg	13/725,447 Now Pat. 8,712,590	12/21/12	EFACT.013C2	System And Method For Optimizing Use Of Plug-In Air Conditioners And Portable Heaters
Steinberg et al.	13/852,577 Now Pat. 8,738,327	03/28/13	EFACT.004C3	System And Method For Using A Network Of Thermostats As Tool To Verify Peak Demand Reduction
Steinberg et al.	13/858,710 Now Pat. 8,751,186	04/08/13	EFACT.005C3	System And Method For Calculating The Thermal Mass Of A Building
Steinberg et al.	13/861,189 Now Pat. 9,057,649	04/11/13	EFACT.006C2	System And Method For Evaluating Changes In The Efficiency Of An HVAC System
Steinberg et al.	13/952,253 Abandoned	07/26/13	EFACT.009C1	System, Method And Apparatus For Just-In-Time Conditioning Using A Thermostat
Steinberg	14/048,932 Now Pat. 8,840,033	10/08/13	EFACT.012C1	System And Method For Using A Mobile Electronic Device To Optimize An Energy Management System
Steinberg et al.	14/082,675 Now Pat. 9,194,597	11/18/13	EFACT.007C1	System, Method And Apparatus For Identifying Manual Inputs To And Adaptive Programming Of A Thermostat
Steinberg	14/263,762 Now Pat. 9,188,994	04/28/14	EFACT.013C3	System And Method For Optimizing Use Of Plug-In Air Conditioners And Portable Heaters

**Application No.: 15/002,791**  
**Filing Date: January 21, 2016**

<b>Inventors</b>	<b>Appl. No.</b>	<b>Filing Date</b>	<b>Attorney Docket No.</b>	<b>Title</b>
Steinberg et al.	14/285,384 Abandoned	05/22/14	EFACT.004C4	System And Method For Using A Network Of Thermostats As Tool To Verify Peak Demand Reduction
Steinberg	14/292,377 Now Pat. 9,279,594	05/30/14	EFACT.008C1	System, Method And Apparatus For Dynamically Variable Compressor Delay In Thermostat To Reduce Energy Consumption
Steinberg	14/491,554 Now Pat. 9,709,292	09/19/14	EFACT.012C2	System And Method For Using A Mobile Electronic Device To Optimize An Energy Management System
Steinberg et al.	14/527,433 Abandoned	10/29/14	EFACT.005C4	System And Method For Calculating The Thermal Mass Of A Building
Steinberg et al.	14/731,221 Published As 2015/0345822	06/04/15	EFACT.006C3	System And Method For Evaluating Changes In The Efficiency Of An HVAC System
Cheung et al.	14/842,134 Published As 2016/0061474	09/01/15	EFACT.010C2	System And Method For Using Ramped Setpoint Temperature Variation With Networked Thermostats To Improve Efficiency
Steinberg et al.	14/878,872 Published As 2016/0091219	10/08/15	EFACT.007C2	System, Method And Apparatus For Identifying Manual Inputs To And Adaptive Programming Of A Thermostat
Steinberg	14/920,063 Abandoned	10/22/15	EFACT.013C4	System And Method For Optimizing Use Of Plug-In Air Conditioners And Portable Heaters
Steinberg	15/002,791 Published As 2016/0138822	01/21/16	EFACT.011C2	System And Method For Using A Wireless Device As A Sensor For An Energy Management System
Steinberg	15/047352 Published As 2016/0238270	02/18/16	EFACT.008C2	System, Method And Apparatus For Dynamically Variable Compressor Delay In Thermostat To Reduce Energy Consumption
Steinberg et al.	15/060,226 Now Abandoned	03/03/16	EFACT.005C5	System And Method For Calculating The Thermal Mass Of A Building

**Application No.: 15/002,791**  
**Filing Date: January 21, 2016**

<b>Inventors</b>	<b>Appl. No.</b>	<b>Filing Date</b>	<b>Attorney Docket No.</b>	<b>Title</b>
Steinberg et al.	15/097,078 Published As 2016/0363337	04/12/16	EFACT.009C2	System, Method And Apparatus For Just-In-Time Conditioning Using A Thermostat
Steinberg et al.	15/426,882 Published As 2017/0241662	02/07/17	EFACT.005C6	System And Method For Calculating The Thermal Mass Of A Building
Steinberg	15/616,719 Published As 2017/0336090	06/07/17	EFACT.012C3	System And Method For Using A Mobile Electronic Device To Optimize An Energy Management System
Okita et al.	15/707,735	09/18/17	EFACT.018A1	Message-Based Demand Response Systems And Methods
Okita et al.	15/707,686	09/18/17	EFACT.018A2	Message-Based Demand Response Systems And Methods
Okita et al.	15/707,753	09/18/17	EFACT.018A3	Occupancy Determination Using Energy Consumption Indications
Okita et al.	15/707,829	09/18/17	EFACT.019A1	Systems And Methods For Humidity-Based Variable Thermostat Settings
Okita et al.	15/707,769	09/18/17	EFACT.019A2	Systems And Methods For Acclimatization-Based Variable Thermostat Settings
Okita et al.	15/707,873	09/18/17	EFACT.019A3	Systems And Methods For Fan Delay-Based Variable Thermostat Settings
Okita et al.	15/713,358 Published As 2018/0087793	09/22/17	EFACT.017A1	Multi-Function Thermostat
Okita et al.	15/713,318 Published As 2018/0087795	09/22/17	EFACT.017A2	Multi-Function Thermostat
Steinberg et al.	15/836,688	12/08/17	EFACT.004C5	System And Method For Using A Network Of Thermostats As Tool To Verify Peak Demand Reduction
Steinberg	15/841,039	12/13/17	EFACT.013C5	System And Method For Optimizing Use Of Plug-In Air Conditioners And Portable Heaters



**Application No.:** 15/002,791  
**Filing Date:** January 21, 2016

<b>Inventors</b>	<b>Appl. No.</b>	<b>Filing Date</b>	<b>Attorney Docket No.</b>	<b>Title</b>
Steinberg et al.	15/905,251	02/26/18	EFACT.006D1	System And Method For Evaluating Changes In The Efficiency Of An HVAC System

Applicant notes that cited references, office actions, responses and notices of allowance currently exist or will exist for the above-referenced matters. Applicant also understands that the Examiner has access to sophisticated online Patent Office computing systems that provide ready access to the full file histories of these matters including, for example, specifications, drawings, pending claims, cited art, office actions, responses, declarations, and notices of allowance.

Rather than submit copies these file histories, Applicant respectfully requests that the Examiner continue to review these file histories online for past, current, and future information about these matters. Also, if the Examiner cannot readily access these file histories, the Applicant would be pleased to provide any portion of any of the file histories at any time upon specific Examiner request.

**SUPPLEMENTAL INFORMATION DISCLOSURE STATEMENT**

Submitted concurrently herewith is a Supplemental Information Disclosure Statement citing references for consideration. Applicant respectfully requests the Examiner to consider the pending claims in connection with these references in order to make the references of record.

**NO DISCLAIMERS OR DISAVOWALS**

Although the present communication may include alterations to the application or claims, or characterizations of claim scope or referenced art, Applicant is not conceding in this application that previously pending claims are not patentable over the cited references. Rather, any alterations or characterizations are being made to facilitate expeditious prosecution of this application.

**Application No.: 15/002,791**  
**Filing Date: January 21, 2016**

Applicant reserves the right to pursue at a later date any previously pending or other broader or narrower claims that capture any subject matter supported by the present disclosure, including subject matter found to be specifically disclaimed herein or by any prior prosecution.

Accordingly, reviewers of this or any parent, child or related prosecution history shall not reasonably infer that Applicant has made any disclaimers or disavowals of any subject matter supported by the present application.

### **CONCLUSION**

Applicants have endeavored to address all of the Examiner's concerns as expressed in the outstanding Office Action. In light of the above remarks, reconsideration and withdrawal of the outstanding rejections is specifically requested.

Please charge any additional fees, including any fees for additional extension of time, or credit overpayment to Deposit Account No. 11-1410.

Respectfully submitted,

KNOBBE, MARTENS, OLSON & BEAR, LLP

Dated: May 15, 2018

By: John R. King  
John R. King  
Registration No. 34,362  
Registered Practitioner  
Customer No. 20,995

28280674

**INFORMATION DISCLOSURE STATEMENT**

First Inventor	: John Douglas Steinberg
App. No.	: 15/002,791
Filed	: January 21, 2016
For	: SYSTEM AND METHOD FOR USING A WIRELESS DEVICE AS A SENSOR FOR AN ENERGY MANAGEMENT SYSTEM
Examiner	: Ojha, Ajay
Art Unit	: 2824
Conf. No.	: 4939

Mail Stop Amendment  
Commissioner for Patents  
P.O. Box 1450  
Alexandria, VA 22313-1450

**References and Listing**

Pursuant to 37 CFR 1.56, an Information Disclosure Statement listing references is provided herewith. Copies of any listed foreign and non-patent literature references are being submitted.

**No Disclaimers**

To the extent that anything in the Information Disclosure Statement or the listed references could be construed as a disclaimer of any subject matter supported by the present application, Applicant hereby rescinds and retracts such disclaimer.

**Timing of Disclosure**

This Information Disclosure Statement is being filed after receipt of a First Office Action, but before the mailing date of a Final Action and before the mailing date of a Notice of Allowance. This Statement is accompanied by the fees set forth in 37 CFR 1.17(p).

**Application No.: 15/002,791**  
**Filing Date: January 21, 2016**

The Commissioner is hereby authorized to charge any additional fees which may be required or to credit any overpayment to Account No. 11-1410.

Respectfully submitted,  
KNOBBE, MARTENS, OLSON & BEAR, LLP

Dated: May 15, 2018

By: /John R. King/  
John R. King  
Registration No. 34,362  
Registered Practitioner  
Customer No. 20,995  
(949) 760-0404

28280620

<b>INFORMATION DISCLOSURE STATEMENT BY APPLICANT</b>	Application No.	15/002,791
	Filing Date	January 21, 2016
	First Named Inventor	John Douglas Steinberg
	Art Unit	2824
<i>(Multiple sheets used when necessary)</i>	Examiner	Ojha, Ajay
SHEET 1 OF 2	Attorney Docket No.	EFACT.011C2

<b>U.S. PATENT DOCUMENTS</b>					
Examiner Initials	Cite No.	Document Number <i>Number - Kind Code (if known)</i> Example: 1,234,567 B1	Publication Date MM-DD-YYYY	Name	Pages, Columns, Lines Where Relevant Passages or Relevant Figures Appear
	1	15/616,719	06/07/2017	Steinberg, et al.	
	2	4,270,693	06/02/1981	Hayes	
	3	4,702,305	10/27/1987	Beckey et al.	
	4	4,702,413	10/27/1987	Beckey et al.	
	5	5,297,838	03/15/1994	Juravich	
	6	5,454,511	10/03/1995	Van Ostrand et al.	
	7	5,706,190	01/06/1998	Russ et al.	
	8	5,839,654	11/24/1998	Weber	
	9	6,216,956	04/17/2001	Ehlers et al.	
	10	6,223,544	05/01/2001	Seem	
	11	6,449,534	09/10/2002	Stewart	
	12	6,454,177	09/24/2002	Sasao et al.	
	13	6,845,918	01/25/2005	Rotondo	
	14	6,981,383	01/03/2006	Shah et al.	
	15	7,983,795	07/19/2011	Josephson et al.	
	16	9,709,292 (EFACT.012C2)	07/18/2017	Steinberg	
	17	9,939,333 (EFACT.006C3)	04/10/2018	Steinberg et al.	
	18	2001/0025349	09/27/2001	Sharood et al.	
	19	2004/0117330	06/17/2004	Ehlers et al.	
	20	2004/0133314	07/08/2004	Ehlers et al.	
	21	2008/0083834	04/10/2008	Krebs et al.	
	22	2009/0005070	01/01/2009	Forstall et al.	
	23	2009/0018673	01/15/2009	Dushane et al.	
	24	2009/0057426	03/05/2009	Sullivan et al.	
	25	2009/0062970	03/05/2009	Forbes et al.	
	26	2009/0271013	10/29/2009	Chen	
	27	2013/0073094	03/21/2013	Knapton et al.	
	28	2017/0241662	08/24/2017	Steinberg et al.	

Examiner Signature	Date Considered
<p><b>*Examiner:</b> Initial if reference considered, whether or not citation is in conformance with MPEP 609. Draw line through citation if not in conformance and not considered. Include copy of this form with next communication to applicant.</p>	

T<sup>1</sup> - Place a check mark in this area when an English language Translation is attached.

<b>INFORMATION DISCLOSURE STATEMENT BY APPLICANT</b>	Application No.	15/002,791
	Filing Date	January 21, 2016
	First Named Inventor	John Douglas Steinberg
	Art Unit	2824
<i>(Multiple sheets used when necessary)</i>	Examiner	Ojha, Ajay
SHEET 2 OF 2	Attorney Docket No.	EFACT.011C2

<b>U.S. PATENT DOCUMENTS</b>					
Examiner Initials	Cite No.	Document Number <i>Number - Kind Code (if known)</i> Example: 1,234,567 B1	Publication Date MM-DD-YYYY	Name	Pages, Columns, Lines Where Relevant Passages or Relevant Figures Appear
	<b>29</b>	2017/0336090	11/23/2017	Steinberg	
	<b>30</b>	2018/0087793	03/29/2018	Okita et al.	
	<b>31</b>	2018/0087795	03/29/2018	Okita et al.	

<b>FOREIGN PATENT DOCUMENTS</b>						
Examiner Initials	Cite No.	Foreign Patent Document <i>Country Code-Number-Kind Code</i> Example: JP 1234567 A1	Publication Date MM-DD-YYYY	Name	Pages, Columns, Lines Where Relevant Passages or Relevant Figures Appear	T <sup>1</sup>
	<b>32</b>	EP 1102500 A2	05/23/2001	Lucent Technologies Inc.		
	<b>33</b>	EP 2372263 A2	05/10/2011	Mitsubishi Electric Corporation		
	<b>34</b>	GB 2408592 A	06/01/2005	Oswald		
	<b>35</b>	WO 2009/036764 A2	03/26/2009	Danfoss A/S		
	<b>36</b>	WO 2011/100427 A2	08/18/2011	Enphase Energy, Inc.		
	<b>37</b>	WO 2011/011404 A1	01/27/2011	Allure Energy, Inc.		

<b>NON PATENT LITERATURE DOCUMENTS</b>			
Examiner Initials	Cite No.	Include name of the author (in CAPITAL LETTERS), title of the article (when appropriate), title of the item (book, magazine, journal, serial, symposium, catalog, etc.), date, page(s), volume-issue number(s), publisher, city and/or country where published.	T <sup>1</sup>
	<b>38</b>	Office Action in Canadian Application No. 2800491 dated December 7, 2016 EFACT.012CA).	
	<b>39</b>	Search Report in European Application No. 11787067.5 dated August 14, 2017 (EFACT.012EP).	
	<b>40</b>	Extended Search Report for European Application No. 11818805.1 dated June 9, 2017 (EFACT.013EP).	
	<b>41</b>	Examination Report in Australian Application No. 2013274827 dated April 11, 2017 (EFACT.014AU).	
	<b>42</b>	Extended Search Report for European Application No. 13804057.1 dated June 1, 2016 (EFACT.014EP).	

28280430

Examiner Signature	Date Considered
* <b>Examiner:</b> Initial if reference considered, whether or not citation is in conformance with MPEP 609. Draw line through citation if not in conformance and not considered. Include copy of this form with next communication to applicant.	

T<sup>1</sup> - Place a check mark in this area when an English language Translation is attached.



(12) **EUROPEAN PATENT APPLICATION**

(43) Date of publication:  
**23.05.2001 Bulletin 2001/21**

(51) Int Cl.7: **H04Q 7/22**

(21) Application number: **00309805.0**

(22) Date of filing: **06.11.2000**

(84) Designated Contracting States:  
**AT BE CH CY DE DK ES FI FR GB GR IE IT LI LU  
 MC NL PT SE TR**  
 Designated Extension States:  
**AL LT LV MK RO SI**

(72) Inventor: **Richton, Robert Ellis  
 Morris, New Jersey 07940 (US)**

(74) Representative:  
**Watts, Christopher Malcolm Kelway, Dr. et al  
 Lucent Technologies (UK) Ltd,  
 5 Mornington Road  
 Woodford Green Essex, IG8 0TU (GB)**

(30) Priority: **15.11.1999 US 440048**

(71) Applicant: **LUCENT TECHNOLOGIES INC.  
 Murray Hill, New Jersey 07974-0636 (US)**

(54) **Method and apparatus for a wireless telecommunications system that provides location-based action services**

(57) A wireless telecommunications system uses location or position information to initiate actions on behalf of travelers. As position information of a wireless mobile unit is received, it is compared to stored position information of a remote location, such as a home. As the traveler approaches his home, and gets within a certain distance of home, a signal is then sent to a controller within his home to perform an action or instruct the performance of an action.

**FIG. 4A**

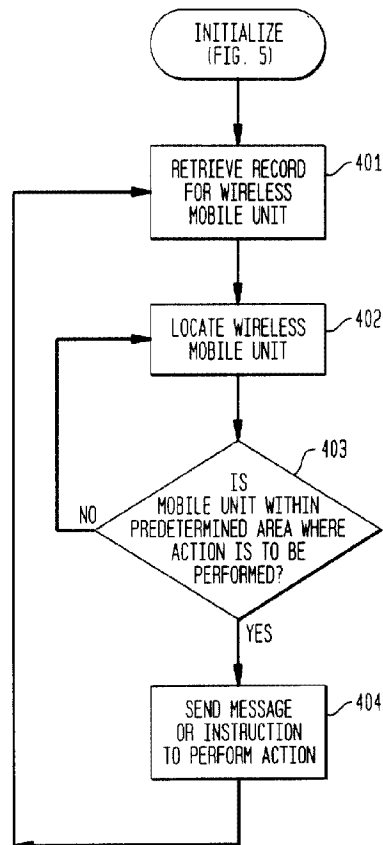

**EP 1 102 500 A2**

**Description****Field Of The Invention**

[0001] The present invention relates to telecommunications in general, and, more particularly, to a wireless telecommunications system.

**Description Of Related Art**

[0002] FIG. 1 depicts a schematic diagram of a portion of a known wireless telecommunications system, providing wireless telecommunications service to a number of wireless mobile units (e.g., wireless mobile units 101-1 through 101-3) that are situated within a geographic region. The heart of a typical wireless telecommunications system is a wireless switching center ("WSC") 120. Typically, the WSC 120 is connected to a plurality of base stations (e.g., base stations 103-1 through 103-5) that are dispersed throughout the geographic region serviced by the system and to the local and long-distance telephone and data networks (e.g., local-office 130, local-office 138 and toll-office 140). WSC 120 is responsible for, among other things, establishing and maintaining a call between a first wireless mobile unit and a second wireless mobile unit or, alternatively, between a wireless mobile unit and a wireline mobile unit (e.g., wireless mobile unit 150), which is connected to the system via the local and/or long-distance networks.

[0003] The geographic region serviced by a wireless telecommunications system is partitioned into a number of spatially distinct areas called "cells." As depicted in FIG. 1, each cell is schematically represented by a hexagon. In practice, however, each cell has an irregular shape that depends on the topography of the terrain surrounding the cell. Typically, each cell contains a base station, which comprises the radios and antennas that the base station uses to communicate with wireless mobile units in that cell and also comprises the transmission equipment that the base station uses to communicate with the WSC 120. However, locating wireless mobile units within a cell was often difficult.

[0004] Recently, global position systems (GPS) have been developed to the point where they are very cheap to implement. Thus, such systems may soon be prevalent in wireless mobile units to determine precise location thereof. In addition, in the area of wireless technology, assisted GPS is being developed to improve on normal GPS for position or location detection in wireless mobile units. Further, other known systems already exist (such as known triangulation methods) for precisely locating wireless mobile units. And still others are constantly being developed. Therefore, a need exists to create other uses for the location or position information of wireless mobile units.

[0005] Increasingly complex modern life leaves many people eager for means of simplifying their busy lives.

Moreover, there is a tendency to enjoy automating even simple tasks-like automatic opening of garage doors. More and more, such automation is finding its way into homes and offices today. Actions such as turning on lights, ovens, heating/cooling systems, etc. are often done automatically in homes. Familiar systems like these are time based, i.e., based on times of the day. However, as people arrive in their homes at varying times due to irregular work hours, or arrive in their offices at varying times due to irregular home hours, a need exists for automating actions based on something other than time.

**Summary of the Invention**

[0006] The present invention is directed to a wireless telecommunications system that uses location or position information to initiate actions on behalf of travelers. As position information is received, it is compared to position information of a remote location, such as a home. As the traveler approaches his home, and gets within a certain distance of home a signal is then sent to a controller within his home to perform an action or instruct an action. These actions can include varying temperature within the home, for example.

**Brief Description Of The Drawings**

[0007] The present invention will become more fully understood from the detailed description given hereafter and the accompanying drawings which are given by way of illustration only, and thus are not limiting of the present invention, wherein like reference numerals represent like elements and wherein,

FIG. 1 is a schematic diagram of a known wireless telecommunications system;

FIG. 2 is a schematic diagram of a wireless telecommunications system including the location-action server of an embodiment of the present invention;

FIG. 3 is a block diagram of the salient components of the location action server of FIG. 2 in conjunction with components of a remote location for performing an action;

FIGS. 4a and 4b are flowcharts illustrating operation at the server and at the remote location;

FIG. 5 is a flowchart depicting the registration steps involved in establishing a location-based action;

FIG. 6 illustrates the controller for controlling/performing exemplary actions; and

FIG. 7 illustrates an example of a location-based ac-



tions.

### Detailed Description

**[0008]** The illustrative embodiment of the present invention enables the use of both the telecommunications capability and the location-finding capability of a wireless telecommunications system. These capabilities are combined to drive actions in the users home, office, or other specified location. In general, the illustrative embodiment performs two fundamentally distinct steps. In accordance with the first step, the movement of a wireless mobile unit is located and an incoming data stream of the user's location is maintained. In accordance with the second step, the illustrative embodiment sets geographically based criteria, at the direction of the user, by which location-based actions are imposed. When the geographically based criteria are met, the wireless system initiates processes resulting in location-dependent actions.

**[0009]** FIG. 2 is a schematic diagram of a wireless telecommunication system including the location-action server 221 of a preferred embodiment of the present invention. The system includes a wireless switching center (WSC) 220 connecting the location-action server 221 with base stations 203-1 through 203-4, wherein it is understood that the number of base stations is exemplary only. Such a system is capable of: (1) providing wireless telecommunications service to wireless mobile unit 201, including location-based services based on location of the wireless mobile unit 201; (2) monitoring the movement (changing location) of wireless mobile unit 201 as it remotely travels; and (3) providing location-based actions based on the observed changing locations of wireless mobile unit 201. The location server 221 is responsible for providing all location-based action services for wireless mobile unit 201.

**[0010]** FIG. 3 is a block diagram of the salient components of location-action server 221. The location-action server 221 includes a location-action controller 301. The location-action controller 301 is connected to each of a location-action service database 302; location determining server 303; input device such as a console of an operator 304; and location action and preferences server 305. Location action and preferences server 305 is the part of the location-action server 221 that maintains a profile for each supported user and "understands" the actions that can be taken on behalf of users, e.g., opening a door, turn power onto a given appliance, etc. The location-action and preferences server translates actions from location-action service database 302 into simple commands that can be transmitted to the item/appliance that will perform the action. Further, the location-action and preferences server 305 "understands" the user's preferences (e.g., preference for turning appliances on when user has approached within 2 miles, and opening door when user has approached within 50 feet, for example). The location-action and preferences

server 305 matches user's actions and preferences and maintains the user's specified actions and preferences as a user profile, to be invoked whenever the user calls for location-based action services.

**[0011]** Location-action controller 301 is, for example, a computer programmed to orchestrate location-based action services. Further, location-action controller 301 controls the operation of the other elements in location-action server center 221.

**[0012]** Location-action service database 302 is a database or memory that contains, among other things, digitized maps of geographic areas serviced by the location-action server 221 and WSC 220. These are used for comparison with a current location of a wireless mobile unit 201 to determine whether to impose the desired actions. The geographic data and related data may be embodied in a Geographic Information System (GIS), for example. Location-action service database 302 further preferably contains not only the GIS database, but also GIS processing software that enables geographic functions, chiefly determining proximity relationships that enable the functionality described herein as will be explained in more detail hereafter. Some personal preferences may also be established in location-action service database 302, which may create an understanding for the automated processing of concepts such as the home of the user of a wireless mobile unit 201; the user's, office, or other places that correspond to a set geographic area that will be conveniently referred to by such common labels as home/office hereafter.

**[0013]** Location-action service database 302 further preferably stores a list of actions to be performed in association with a designated wireless mobile unit 201 and the geographic area (distance/proximity thresholds) that will be considered to meet a criteria for initiating control of actions to be performed. These can be customized by the user. For example, actions performed when a user approaches/leaves his/her home/office include physical actions such as adjusting environmental conditions (e.g. temperature) and/or lighting, activating/deactivating a home security system, warming an oven, opening/closing garage doors, etc. (when the wireless mobile unit has satisfied a geographic relationship with the remote location, such as coming within a predetermined distance thereof, for example). Such actions are performed at the direction of a home-based central controller 330, such as a home computer (PC) for example. This central controller 330 performs the action, such as sorting email when a user is within 5 miles of his office for example; or directs another action/action controller 320 to perform the action. Any action which can be controlled by a remote signal (which necessarily includes an action performable by any electronic or electrical device) is contemplated to be within the scope of the present invention. This action/action controller 320 can be a controller of a thermostat, light switch, garage door opener, etc. Thus, a remote control system 310 includes a central controller 330 for actions performed directly

thereon, such as email sorting for example, and optionally one or more action/action controller(s) 320. The central controller 330 of the remote control system 310 receives signals instructing performance/control of actions from location-action controller 301 through the WSC 220 and phone lines, either wireless or land-lines, connected to central controller 330 in a known manner.

**[0014]** Note that while central controller 330 may be employed at the location where these services are performed, its' presence is not essential to the methods disclosed herein. The increasing availability of "smart" appliances (e.g. internet enabled and addressable) make central controller 330 less necessary, especially in the future. Thus, it should be understood that remote control system 310 could include merely "smart" appliances themselves, with actions being directly controlled by location-action controller 301.

**[0015]** Location determining server 303 determines the location of a wireless mobile unit 201 when requested to do so by location-action controller 301 and provides location-action controller 301 with that information when it is obtained. The location of wireless mobile unit 201 can be determined in a number of known ways including global positioning systems (GPS) and assisted GPS used in conjunction with wireless mobile units, and other known techniques such as triangulation, for example. How the location information is obtained is not limitative of the present invention. Location-action controller 301, in conjunction with location-action and preference server 305, determines the identification of wireless mobile units for which location determining server 303 monitors and identifies position/location information.

**[0016]** Location-action and preference server 305 works in conjunction with location-action controller 301 to determine which wireless mobile units are to be monitored; what are location thresholds at which actions are to be performed; what actions are to be performed when thresholds are exceeded; etc. The functioning of location-action and preference server 305 includes the set-up and authorization of users and may use Wireless Intelligent network authorization procedures such as those used for set-up of other wireless services such as call-waiting, voice-activated dialing, etc. Details of the functioning of such service profiles will be familiar to those of ordinary skill in the art, as will their set-up, maintenance and termination. This can be a service that a wireless mobile unit user signs up for, for example. The functioning of the location-action and preference server 305 further includes performing of threshold tests and invoking services, when appropriate, as will be described further with regard to Figs. 4 and 5 and their accompanying explanations.

**[0017]** Operator's console 304 enables travelers (users) to call the location action server 221 to request a service or change of wireless mobile unit 201 in preference in a user's wireless service file, for example. Thus, stored actions/thresholds can be modified. Alternatively, the operator's console 304 could be replaced by auto-

ated processes, linked to menus in the wireless mobile unit 201 of the user, for example. Some of the functionality described above can be automated by using an understanding of related user preferences, such as the options for different output devices that the user may tie to his/her wireless service file, which may be located elsewhere in the wireless network.

**[0018]** FIG. 4a is a flowchart of the operation of an illustrative embodiment of the present invention, wherein position/location movement of a wireless mobile unit is tracked as it travels during a trip and wherein that information is then used in near realtime to initiate location-based actions. In doing so, the illustrative embodiment performs two fundamentally distinct, major steps: (1) specifying the desired services by the recording actions to be taken on behalf of the user and the geographic conditions under which those actions will be performed, and (2) the continuous monitoring of the user's location against the geographic criteria (threshold position for comparison) for the action: if the conditions are met the action will be performed; if conditions are not met, position/location monitoring will continue as long as the basis for the service remains.

**[0019]** Prior to step 401 in FIG. 4a, a user of a wireless mobile unit initially decides to subscribe to a location-based action service. The user must have a specific designatable location in mind (which will generally be a familiar location such as home or office or a friend's home, for example), and a specific action or set of actions to be performed at the designated location (it should be noted that the specific actions could be programmed in a home or office PC as will be described with regard to Fig. 6). These actions may be associated with routine events, such as coming to the office to begin the work day or coming home at the end of the work day. The actions are performed based on the fact that the user is about to be physically present at the designated location, i.e., the actions are performed when a user is within a certain distance of the designated location based upon a location of the wireless mobile unit which is with the user.

**[0020]** Additionally, prior to step 401 of Fig. 4a, the wireless network ascertains that the user is authorized for location-based action services—a step which implies the user has a wireless mobile unit that can be located routinely with little impact on the network. This will often be the case.

**[0021]** Initially, the process begins with step 401 of Fig. 4a wherein the process is initialized at the location-action server 221. Information regarding actions to be performed, locations at which actions are to be performed, threshold positions at which actions are to be initiated, etc., are stored at location-action server 221. Thus the user essentially subscribes for the service and defines the parameters. This process will be described in more detail with regard to Fig. 5.

**[0022]** As previously stated, the steps involved in establishing parameters defining where, when, to whom,

and what actions are to be performed are described in Fig. 5, further defining step 401 of Fig. 4. Initially, in step 502, the service to be involved is established. A user interface at the wireless mobile unit 201 might include other services, for example. The user invokes the location-based action service by initializing, either through a menu on his/her wireless mobile phone or through a similar mechanism such as that which could be provided over the Internet. Alternatives to invoking over the Internet include speaking to an operator or using an IPA (Intelligent Personal Agent). Those skilled in the art will recognize how to construct these various alternative devices for invoking/starting the service, but the menu interface is described further here.

**[0023]** Once in the menu for location-based actions, this user interface presents a list of actions and a list of locations, for example. In more advanced versions, nearly free-form inputs could exist, such that any action that could be understood by an intelligent module of the computer controlling the ultimate actions could be included. The list of actions include opening/unlocking a door, turning on equipment, raising or lowering temperature in the designated target location (such as home or office for example), or any other common actions. Actions ultimately performed in the designated target location within the scope of the present application include all actions which can commonly be driven simply by turning on power. For example, in the case where the actions are to be taken in a "smart home" (as will be described in more detail regarding Fig. 6), the home wiring is built such that all electric power outlets can be computer-controlled, and the home computer can be simply "told" to apply power at a given outlet/circuit or group ("macro") of outlet/circuits. The application of power will then open the garage door, turn on specified equipment, etc.

**[0024]** Besides specifying the action to be performed in Step 502, the user must specify the geographic conditions under which the service will be invoked in step 503. These are further defined in steps 504 and 506. This establishes the location where actions are performed; the "location-basis" under which actions are performed; and when actions are performed.

**[0025]** First the user specifies the designated site (target location) that is to be the basis of the action in step 504. The site may be chosen from a pre-programmed stored list, including such items as "home," "office," "secondary office," or "mother's house," etc. These sites, while using familiar names, will be translated by the location action controller 301 into street addresses, latitude/longitude, UTM (Universal Transverse Mercator), or a similar location designation scheme that can be dealt with by a Geographic Information System (GIS). This, and all other selected information is stored at location-action server 221, in a location-action service database 302.

**[0026]** The geographic criteria or relationship(threshold position/location at which actions are triggered) is

set in Step 505 as the Site Relation Condition. The most common criteria will be proximity. For example, as a proximity threshold the user sets 5 miles such that when the wireless mobile unit 201 is within 5 miles of the designated target location (e.g., his home), then the determined geographic relationship with the designated target will be satisfied and an action will be triggered (e.g., adjust environmental conditions such as temperature or humidity). It should be noted that services could also include entry onto a particular road, municipality, or any geographic area as a triggering threshold for satisfying a geographic relationship. Conversely, it can include leaving any geographic area or reaching a certain distance away from an area or a specific location. Thus, when a user is leaving and is one mile from home, environmental conditions in the home can be automatically adjusted so as not to waste power. Many possible variations can be invoked, particularly if provisioned via a graphical interface such as that included in common GIS or Desktop Mapping schemes (see for examples, the ARC/Info products from ESRI of Redlands, CA, or MapInfo from MapInfo, Inc, Troy, NY).

**[0027]** Once the user has specified (1) the action to be taken (e.g. adjusting environmental conditions such as temperature), (2) the location wherein the action should be taken (e.g. "home"), and (3) the criteria or geographic relationship (typically distance within which to invoke the action such as "5 miles" from home, for example), the initialization is nearly complete. However, the system may require other internal settings. The most obvious of these is the tolerance, which can be set in step 506. By tolerance, for example, this refers to the fact that when specifying "perform this action when I am within 1 mile  $\pm$  100 meters", the  $\pm$  part is yet to be specified. Because of its subtlety, this part may be specified by the system rather than by the user, for example. The initialization Step 401 is completed by writing the Full Record of Condition in Step 507, which writes the information in Location Action Service Database 302. In step 508, it then indicates that the Location Action Controller 301 may begin its process of verification/authentication, and proceed to begin controlling the service.

**[0028]** Once the process has been initialized, the wireless network then monitors the location of the wireless mobile unit 201 of the user at regular intervals. Note the wireless mobile unit 201 may contain the functionality needed to locate itself, and may send results to the location service controller 301 (through a controlling base station and WSC 220); such as through GPS or modified GPS circuitry within the wireless mobile unit 201 itself. Alternatively, the location can be determined in a known manner through triangulation using base station information, etc., either at the location action server 221 or WSC 220. Those familiar with wireless location technology/functioning will recognize that for the services disclosed herein, it does not matter whether location results are calculated in the network or in the wireless mobile unit 201 itself.

**[0029]** For example, and as is clear to those skilled in the art, there are various ways in which the illustrative embodiment can ascertain the location of wireless mobile unit 201. For example, wireless mobile unit 201 can include a satellite position system receiver (e.g., a Global Positioning System (GPS) receiver, etc.) so that wireless mobile unit 201 can determine its own latitude and longitude. In such a case, wireless mobile unit 201 provides its location to a controlling base station, WSC 220, and eventually to location action server 221 when requested. An example of such an arrangement is taught in U.S. Patent 5,479,482, entitled "Cellular Terminal For Providing Public Emergency Call Location Information," issued Dec. 26, 1995.

**[0030]** In accordance with another technique, wireless mobile unit 201 and location determining server 303 may share the task of computing the latitude and longitude of wireless mobile unit 201. In such a case, wireless mobile unit 201 provides an indicium of its location, through a controlling base station and WSC 220, to location determining server 303 of location action server 221 when requested. An example of such an arrangement is described by G. Vannucci and R.E. Richton in pending U.S. Patent applications Serial No. 08/927,432, and 08/927,434.

**[0031]** In accordance with other techniques, either wireless mobile unit 201 or base stations 203-1 through 203-4 use of terrestrial triangulation techniques, in a well-known fashion, determine the location of wireless mobile unit 201 based on the time-of-arrival or direction-of-arrival of signals transmitted from each other. It will be clear to those skilled in the art how to determine the location of wireless mobile unit 201 for the purposes of the present invention, and that the reporting of the location to location determining server 303 (from the base stations through WSC 220) at regular intervals requires merely adding a timer, for example. It will similarly be clear to those skilled in the art that wireless location determination systems will have a certain inherent accuracy, and that they generally report a confidence or uncertainty level and that that level might need to be considered when invoking any location-based service. Factoring in consideration of the areas of uncertainty will be part of any location-based service but will not be described at length here, as the considerations should be evident. For example, when criteria for invoking services are examined, the uncertainty/confidence must be considered. Depending on the nature of the action/service, different confidence levels might appropriately be invoked. However, because this is a secondary factor in invoking location-based action services, its use would probably be better left to the administrative parts of location-based services rather than set by users in most cases.

**[0032]** Following initialization of the service as explained in Fig. 5, the process may begin at Step 401 within the location-action server 221. In step 401, a record of the wireless mobile unit 201, the location cri-

teria or geographic relationship (designated target, threshold, etc.) and the action to be taken is established. This information is stored in a record in a location action service database 302, in association with information identifying the wireless mobile unit 201 (such as its phone number, for example) and in association with information identifying the target location where the actions are to be performed (such as the phone number of a user's office, home, etc.). It should be noted that the record stored in the location-action service database 302 may include all necessary information to carry out the instructing of the action, or may be linked to existing information, such as a known telephone number of the wireless mobile unit 201 and/or known home or office numbers of a user. The aforementioned record and other stored information may be stored in a geographically oriented database, such as are associated with GISs. Location action controller 301 records that such a record exists. At this point in the location-action controller 301 initiates the criteria checking shown in steps 402 and 403.

**[0033]** The criteria checking steps 402 and 403 are the heart of the system. In step 402, the location of wireless mobile unit 201 is continually determined/received. This is done at periodic intervals, e.g., once per second. Next, in step 403, the retrieved criteria are checked at regular intervals, typically timed to mesh with the timing of step 402. For example, in step 403 it is determined whether or not the location information received in step 402 indicates that the wireless mobile unit has satisfied the geographic relationship with the target location, e.g. is it within a threshold distance (e.g., 5 miles) of the target location (e.g., "home"). These two timed processes are "merged" in a manner to check whether the location of the wireless mobile unit of the user meets the criteria or geographic relationship with the target that has been set.

**[0034]** It should be noted that the record storage and criteria checking of steps 401-403 need not be limited to a single wireless mobile unit or to a single target location. For example, if a family has two wireless phones, for example, then they may designate that the actions take place when either of the two wireless phones meets the set geographic relationship. This can be set and stored in location-action service database 302. Further, one set of actions can be triggered by either wireless phone meeting a first geographic relationship with a home of the users, for example, and a second set of actions can be stored in association with only one of the wireless phones, for office related actions, for example.

**[0035]** In addition, for a single wireless mobile unit, multiple geographic relationships can be stored in association therewith, with similar or different actions to be performed. Thus, when a wireless mobile unit of a user satisfies a first set geographic relationship with a first target location (e.g. home), a first set of actions will be triggered at the home. When the same wireless mobile unit satisfies a second set geographic relationship with

a second target location (e.g. office), a second set of actions will be triggered at the office. Accordingly, upon the wireless mobile unit satisfying either of the set geographic relationships with either of the respective target locations, a controls signal will be sent to the respective target to trigger the respective action(s). Therefore, information identifying one or more various wireless mobile units can be stored in association with information of various target remote locations and in association with various set geographic relationships thereof and actions to be performed.

**[0036]** Further, it should be noted that the monitoring performed in step 402 can be provided to applications other than those in step 403. Further, step 402 can be performed using criteria established outside of step 401. Also note that there will be service provisioning steps that the providers of services described here will undertake before users can employ any steps in Figure 4a. These provisioning steps would include, for example, initiate billing and check that the end-to-end communications protocols required for subsequent steps of the service disclosed are ready. Authentication/security functions may also be established to further protect users against unauthorized disclosures of data regarding their whereabouts (position/location), which many would want to keep private. Methods to perform such provisioning steps are well-known to those skilled in the art, as these are normal functions of public telephone networks for well-known services such as call waiting, caller-ID, etc.

**[0037]** If the criteria are met in step 403, a control signal or instruction to perform an action is sent in step 404. This is easily accomplished since the location-action server 221 knows the phone number of the remote location where the action is to be performed. If not, location of the wireless mobile unit 201 is monitored in step 402. As noted previously, the action is carried by the location action server 221 sending a prearranged control signal to the remote central computer 330, which in turn directly causes the action to occur (either at central controller 330 for computer actions such as sorting email, for example, or by controlling a remote action/action controller 320 such as a thermostat controller for adjusting environmental conditions such as temperature). If the criteria are not met, the condition is checked again (periodically).

**[0038]** In the case where the criteria is met in step 403, the location-action controller 301, having "deduced" that the criteria has been met by comparing the criteria stored in location-action database 302 with the most recent location determination result from the location determining server 303, sends a signal to invoke the action. This may include calling a specific telephone number (e.g., the home or office telephone number for the user). One of ordinary skill in the art familiar with this type of pre-programmed controller will recognize that a variety of signals may be used from this point to establish, validate, and invoke the computer-to-computer

communications that enables this step (from location-action server 221 to the remote control system 310). The communications may take place via the Public Switched Telephone Network (PSTN) or any ordinary or extraordinary means.

**[0039]** The home/office computer (central controller 330) of remote control system 310 that receives the instructions to invoke the action is previously set up to acknowledge the received instruction. Upon receipt of a return acknowledgment, the location-action controller 301 will either cycle to the next service it performs on behalf of the particular user described here, or will stop the processes for that user. An external stop signal, either invoked by the user or a system administrator, can also stop the process at step 403. This external stop signal is typical of administrative steps that are not shown explicitly in the Figures, but whose presence is both required for a practical system and evident to those skilled in the art.

**[0040]** Fig. 4b is a flowchart illustrating the steps performed at the designated target location, such as at the user's home. Initially, a central controller 330 of remote control system 310 monitors whether or not an instruction to perform an action has been received in step 410. If no instruction has been received, the system merely continues to monitor for receipt of such a signal. However, if the signal has been received from location-action controller 310 of location-action server 221, through the phone lines (either land-line, or wireless) in step 420 it determines which actions are to be performed based on the signal received. Thereafter, in step 430, the central controller the performance of the action by either performing the action itself (if the action is a computer action such as sorting email, for example), or sends a signal to a remote device or controller of a device 320 to perform the action.

**[0041]** For example, if the action is adjusting temperature, a signal is sent to a thermostat controller, where the signal itself merely controls a thermostat so as to adjust the temperature. It should be noted that the specific parameters of adjusting the temperature or even specific actions to be taken at the remote control system 310 can be programmed therein, such as at the central controller 330 for example. Alternatively, some information could be prestored at location-action service database 302 of location-action server 221, such that a certain signal is sent when a user has departed his home by 1 mile and another signal is sent when a user has arrived within 5 miles of his home, with the actual action to be performed being stored in central controller 330. In such an instance, upon receiving an arrival signal from the location-action server 221, the central controller 330 can perform a first set of actions such as raising the temperature in the house, turning the lights on, opening the garage door, etc. If a second signal is sent from location-action server 221 indicating that a user has departed his home by a predetermined distance for example, then the central controller 330 can be pro-

grammed to perform a different set of actions, such as locking all doors, closing a garage door, lowering temperature in the house, closing a garage door, etc. It should be clear to those of ordinary skill in the art that all variations and permutations thereof are also within the scope of the present invention.

**[0042]** Fig. 6 illustrates the central controller 330, in a preferred embodiment thereof. As previously stated, such a central controller 330 can include, for example, a home computer. As such, the home computer will include a display portion 610, a CPU 650 connected to the display portion 610, and further connected to memory 680 and an input device 690. The CPU 650 is further connected via input port 660 to a phone line for receiving information from location-action controller 301 of location-action server 221, for example; and an output port 670 for outputting information to control the carrying out of various actions such as adjusting temperature, opening a garage door, turning on and off lights, etc. As previously stated, the specific actions to be performed can be programmed using CPU 650, memory 680, and input device 690 within the central controller 330 itself; certain groups of actions can be performed therein when a particular arrival or departure signal is received from location-action controller 301 of location-action server 221 for example; or specific instruction signals can be received by CPU 650 from location-action controller 301 of location-action server 221 dictating exactly which actions are to be performed or controlled by central controller 330.

**[0043]** Fig. 6 further illustrates specific elements displayed on display portion 610 of central controller 330, indicating which actions may be performed. It should be noted that the various actions indicated on display portion 610 of Fig. 6 are merely indicated illustrative purposes only and should not be deemed limiting of the present invention.

**[0044]** First display areas 620a and 620b may, for example, display a symbol indicating a particular action to be performed. The specific word or phrase corresponding to the symbol may optionally be displayed in area 630a and 630b for example. Further, in a separate display area 640a and 640b, it can be indicated whether or not a particular action is ON or OFF. By such a system, using display portion 610 as a touch screen for example, a user can easily program specific actions to be performed when a signal is received from a location-action controller 301 of a location-action server 221 in conjunction with the present application. Additionally, although not shown in Fig. 6, specific control of various actions can take place at the central controller 330 in a similar manner, such as setting the exact that the temperature the home should reach. These "variable parameters" of an action are probably best programmed at central controller 330.

**[0045]** Software for controlling various devices, such as a coffee pot, lights, etc. is known from companies such as Active Home™, which currently activate devices

in the home based upon a particular time of day for example. Accordingly, similar programming is carried out in connection with the present invention, utilizing location information and external control from a location-action controller 301 of a location-action server 221 in place of the known "time of day" control. Accordingly, in a system wherein a user desires to determine which particular action should take place in his or her home when he is within a particular distance from the home (either arriving or departing), the use of a central controller 330 as shown in Fig. 6 is ideal. As such, a user can turn various functions ON so that when an arrival signal is received from location-action controller 301 of location-action server 221, several actions are performed. Alternatively, the user can cancel some actions if, for example, the user does not desire to turn the coffee pot ON each time he arrives; or can vary the parameters of certain actions (adjusting the temperature by 5 degrees instead of 3 degrees for example).

**[0046]** Fig. 6 also depicts an arrival macro and a departure macro. As such, a user can string a plurality of tasks together in a macro so that, for example, each time he leaves his house and exceeds the predetermined threshold, such as 1 mile for example, three tasks will be performed (i.e., the lights will be turned OFF, the temperature will be lowered, and the garage door will be shut). Similarly, an arrival macro can be determined and prestored such that when a user is within 5 miles of his home, for example, two tasks will be performed (such as raising the temperature by 5 degrees and turning the lights ON, for example). As such, the actions are more easily controlled by the user.

**[0047]** Figs. 7a and 7b illustrate one particular example of the system of the present application. Fig. 7a indicating the steps performed at the location-action server 221; and Fig. 7b indicating the steps performed at the remote control system 310.

**[0048]** In step 710, a record for a wireless mobile unit 201 is retrieved and the location of the wireless mobile unit 201 is monitored. Thereafter, in step 720, actions to be performed are determined, such as adjusting temperature for example, and a threshold distance (as a set geographic relationship) along with the target location, is also determined (namely 5 miles from the home for example). Alternatively, instead of determining exactly which actions are to be performed, a threshold need merely be determined such that if the threshold is met, a signal will be sent from location-action controller to central controller 330 indicating that an action is to be performed; with the action itself being determined at the central controller 330 based upon receipt of an arrival or departure signal for example (such as in a departure/arrival macro).

**[0049]** Thereafter, in step 730, it is determined whether or not the wireless mobile unit 201 meets the threshold, namely is the wireless mobile unit 201 within 5 miles of the user's home, for example. If not, the system returns to step 710 and the location or position of the wire-

less mobile unit 201 is continually monitored. If so, the system moves to step 740 wherein a signal is sent to the central controller 330 of the user's home. This is done, for example, since the location-action controller 301 knows the home number of the user, stored in association with the telephone number of the wireless mobile unit 201. Thus, a signal can be sent to the user's home via the existing phone lines.

**[0050]** Fig. 7b illustrates the actions performed at the user's home, for example. Namely, the central controller 330 monitors the phone lines for a control signal from the location-action controller 301 in step 750. In step 760, a signal is received. Thereafter, in step 770, it determines which actions are to be performed, either from the received signal itself or from actions preprogrammed in the computer such as actions which are part of a stored departure macro or an arrival macro, as previously explained with regard to Fig. 6 for example. Thereafter, the action of adjusting the temperature (for example) is performed by the central controller 330 either controlling the temperature (action) itself, or sending a signal to an action controller 320, such as a thermostat controller, for adjusting the temperature. For temperature adjustment, and for other specific actions, exactly how much to adjust the temperature can be specifically stored, for example at the computer or central controller 330 of the user so as to be easily adjustable to the user. When a signal to adjust the temperature is received from the location-action controller 301, the computer can then determine how much to adjust the temperature and output a signal for appropriate control thereof.

**[0051]** The invention being thus described, it will be obvious that the same may be varied in many ways.

**[0052]** For example, the structure of location-action service data base 302 is not limiting and need only store, in some fashion, the required information. How information is stored is not limitive of the present invention. Further, the location of the various components of the location-action server 221 is not limitive of the present invention. The components can be in a single unit as shown in Fig. 3, or can be located apart from location-action controller 301. Only operative connection between the components is important. The location-action server 221 of Fig. 3 is merely a description of a preferred structure.

## Claims

### 1. An apparatus comprising:

a controller, adapted to receive information indicating position of a wireless communications device;

a memory, adapted to store information identifying the wireless communication device and

position information of a remote location stored in association with the information identifying the wireless communication device, the controller being adapted to output a control signal to the remote location instructing initiation of an action at the remote location upon received information indicating that the position of the wireless communication device has satisfied a geographic relationship with the remote location.

2. The apparatus of claim 1, wherein the geographic relationship is satisfied when the position of the wireless communication device is within a designated distance of the remote location.
3. The apparatus of claim 1, wherein the controller is adapted to compare position information of the wireless communication device to stored position information of the remote location and is adapted to determine when the wireless communication device has satisfied the geographic relationship.
4. The apparatus of claim 1, wherein the wireless communication device is a wireless phone.
5. The apparatus of claim 1, wherein the position information indicating position of the wireless communication device is received from a global positioning system (GPS) within the wireless communication device.
6. The apparatus of claim 1, wherein the position information indicating position of the wireless communication device is received from an assisted global positioning system (assisted GPS).
7. The apparatus of claim 1, wherein the action initiated at the remote location includes operating a door.
8. The apparatus of claim 1, wherein the action initiated at the remote location includes adjusting environmental conditions at the remote location.
9. The apparatus of claim 1, wherein the action initiated at the remote location includes sorting email.
10. The apparatus of claim 1, wherein the memory stores position information of a plurality of remote locations in association with the information identifying a wireless communication device.
11. The apparatus of claim 10, wherein the controller is adapted to output a control signal to one of the plurality of remote locations upon receiving information indicating that the position of the wireless communication device is within a designated distance of the one of the plurality of the remote locations.

12. The apparatus of claim 1, wherein the memory stores information identifying a plurality of wireless communication devices in association with position information of the remote location. 5
13. The apparatus of claim 12, wherein the controller is adapted to output a control signal to the remote location upon receiving a signal indicating that the position of one of the plurality of wireless communication devices is within a designated distance of the remote location. 10
14. The apparatus of claim 11, wherein the memory stores information identifying a plurality of wireless communication devices in association with position information of at least one of the plurality of remote locations. 15
15. The apparatus of claim 14, wherein the controller is adapted to output a control signal to one of the remote locations upon receiving a signal indicating that the position of an associated one of the plurality of wireless communication devices is within a designated distance of the one of the remote locations. 20
16. The apparatus of claim 1, wherein a telephone number identifies the remote location, and the controller is adapted to output the control signal using the telephone number of the remote location. 25
17. The apparatus of claim 16, wherein the controller is adapted to output the control signal to the remote location through telephone lines. 30
18. The apparatus of claim 16, wherein the controller is adapted to output the control signal to the remote location through wireless communication. 35
19. The apparatus of claim 1, wherein the stored information identifying the wireless communication device includes a telephone number. 40
20. The apparatus of claim 1, wherein the control signal adapted to be output to the remote location identifies the action to be initiated. 45
21. The apparatus of claim 1, wherein the control signal adapted to be output to the remote location does not identify the action to be initiated, the action being variable at the remote location. 50
22. An apparatus comprising:
- a memory, adapted to store information identifying a wireless communication device and position information of a remote location stored in association with the information identifying the wireless communication device; and
- a controller, adapted to output a control signal to the remote location instructing initiation of an action at the remote location upon determining that a position of the wireless communication device has satisfied a geographic relationship with the remote location.
23. The apparatus of claim 22, wherein the position of the wireless communication device is determined at the controller through triangulation.
24. The apparatus of claim 22, wherein the geographic relationship is satisfied when the position of the wireless communication device is within a designated distance of the remote location.
25. A system, comprising:
- a first controller, adapted to receive information indicating position of a wireless communication device;
- a memory adapted to store information identifying the wireless communication device and position information of a remote location stored in association with the information identifying the wireless communication device; and
- a second controller, located at the remote location, adapted to initiate an action at the remote location upon receiving a control signal from the first controller, the first controller adapted to send the control signal to the second controller upon receiving a signal indicating that the position of the wireless communication device has satisfied a geographical relationship with the remote location.
26. The system of claim 25, wherein the geographic relationship is satisfied when the position of the wireless communication device is within a designated distance of the remote location.
27. The system of claim 25, wherein the second controller, upon receiving the control signal from, the first controller, is adapted to initiate the action by outputting a signal to a device at the remote location.
28. The system of claim 27, wherein the second controller is adapted to output the signal to open/close a door at the remote location.
29. The system of claim 27, wherein the second controller is adapted to output the signal to adjust environmental conditions at the remote location.
30. The system of claim 25, wherein the second con-



- troller, upon receiving the control signal from the first controller, is adapted to initiate the action by performing a programmed task.
31. The system of claim 30, wherein the programmed task is adjustable at the second controller.
32. The system of claim 30, wherein a parameter of the programmed task is adjustable at the second controller.
33. The system of claim 30, wherein the programmed task includes sorting email.
34. The system of claim 25, wherein the first controller is adapted to compare position information of the wireless communication device to stored position information of remote location and is adapted to determine when the wireless communication device has satisfied the geographic relationship based upon the comparison.
35. The system of claim 25, wherein the wireless communication device is a wireless phone.
36. The system of claim 25, wherein the position information indicating position of the wireless communication device is received from a global positioning system (GPS) within the wireless communication device.
37. The system of claim 25, wherein the position information indicating position of the wireless communication device is received from an assisted global positioning system (assisted GPS).
38. The system of claim 25, wherein the memory stores position information of a plurality of remote locations in association with the information identifying a wireless communication device.
39. The system of claim 38, wherein the first controller is adapted to output a control signal to one of the plurality of remote locations upon receiving information indicating that the position of the wireless communication device is within a designated distance of the one of the plurality of the remote locations.
40. The system of claim 25, wherein the memory stores information identifying a plurality of wireless communication devices in association with position information of the remote location.
41. The system of claim 40, wherein the first controller is adapted to output a signal to the remote location upon receiving a signal indicating that the position of one of the plurality of wireless communication devices is within a designated distance of the remote location.
42. The system of claim 39, wherein the memory stores information identifying a plurality of wireless communication devices in association with position information of at least one of the plurality of remote locations.
43. The system of claim 42, wherein the first controller is adapted to output a control signal to one of the remote locations upon receiving a signal indicating that the position of an associated one of the plurality of wireless communication devices is within a designated distance of the one of the remote locations.
44. The system of claim 25, wherein a telephone number identifies the remote location, and the controller is adapted to output the control signal using the telephone number of the remote location.
45. The system of claim 44, wherein the first controller is adapted to output the control signal to the second controller at the remote location through telephone lines.
46. The system of claim 44, wherein the first controller is adapted to output the control signal to the second controller at the remote location through wireless communication.
47. The system of claim 25, wherein the stored information identifying the wireless communication device includes a telephone number.
48. A method, comprising:  
 storing position information of a remote location in association with information identifying a wireless communication device;  
 receiving information indicating a position of the wireless device; and  
 outputting a control signal to the remote location instructing initiation of an action upon the received information indicating that the position of the wireless communication has satisfied a geographic relationship with the remote location.
49. The method of claim 48, wherein the geographic relationship is satisfied when the wireless communication device is within a designated distance of the remote location.
50. The method of claim 48, further comprising:  
 comparing the received position information of the wireless communication device to the stored

position information of the remote location and outputting the control signal based upon the comparison.

- 51. The method of claim 48, wherein the information indicating position is received from a wireless phone. 5
- 52. The method of claim 48, wherein the action initiated at the remote location includes operating a door. 10
- 53. The method of claim 48, wherein the action initiated at the remote location includes adjusting environmental conditions at the remote location.
- 54. The method of claim 48, wherein the action initiated at the remote location includes sorting email. 15
- 55. The method of claim 48, wherein storing includes storing position information of a plurality of remote locations in association with information identifying a wireless communication device. 20
- 56. The method of claim 55, wherein outputting includes outputting a control signal to one of the plurality of remote locations upon receiving information indicating that the position of the wireless communication device is within a designated distance of the one of the plurality of the remote locations. 25
- 57. The method of claim 48, wherein the information identifying a wireless communication device includes a telephone number. 30
- 58. The method of claim 48, wherein a telephone number of the remote location is stored in association with the position information and information identifying the wireless communication device. 35
- 59. The method of claim 58, wherein the control signal is output to the remote location through telephone lines. 40
- 60. The method of claim 58, wherein the control signal is output to the remote location through wireless communication. 45
- 61. The method of claim 48, further comprising: initiating the action at the remote location upon receiving the output control signal. 50
- 62. The method of claim 48, further comprising: outputting a signal to a controller to operate a door at the remote location upon receiving the output control signal. 55
- 63. The method of claim 48, further comprising: outputting a signal to a control device to adjust environmental conditions at the remote location up-

on receiving the output control signal.

- 64. The method of claim 48, further comprising: sorting email at the remote location upon receiving the output control signal.

**FIG. 1**  
(PRIOR ART)

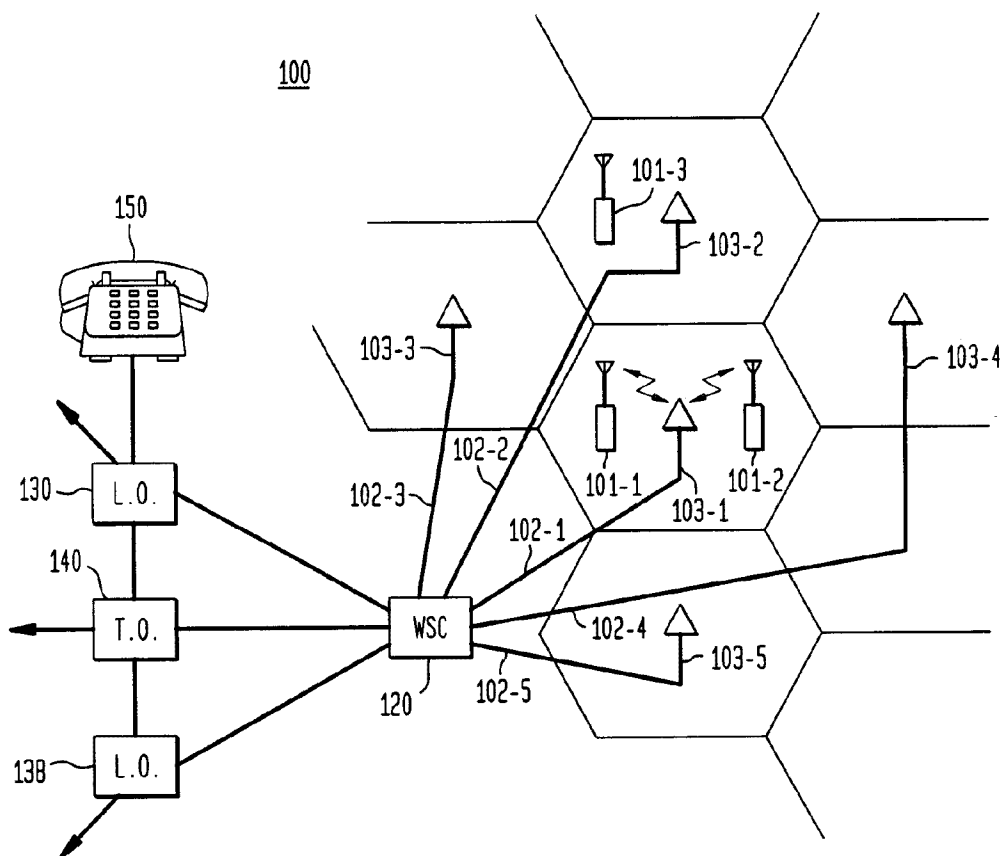

FIG. 2

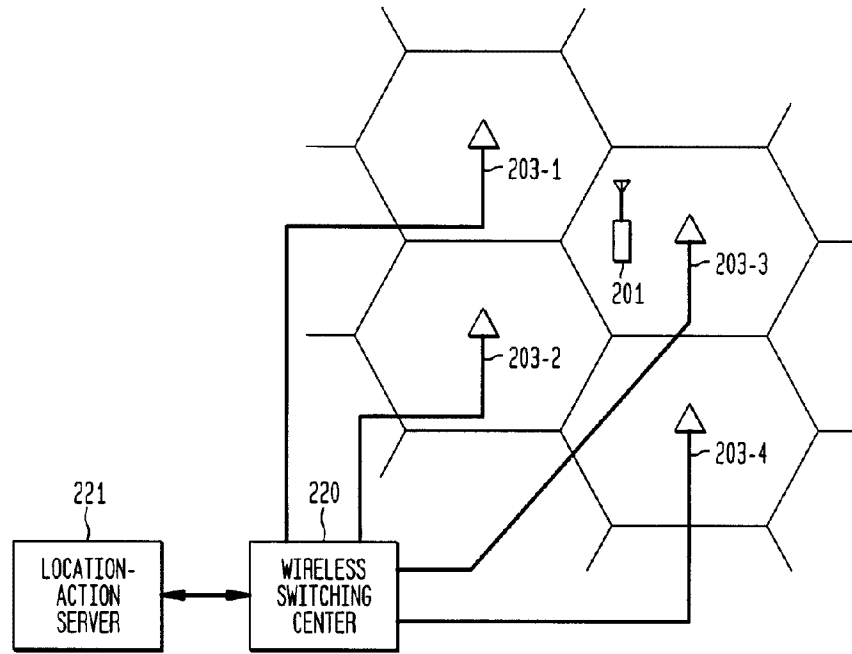

FIG. 3

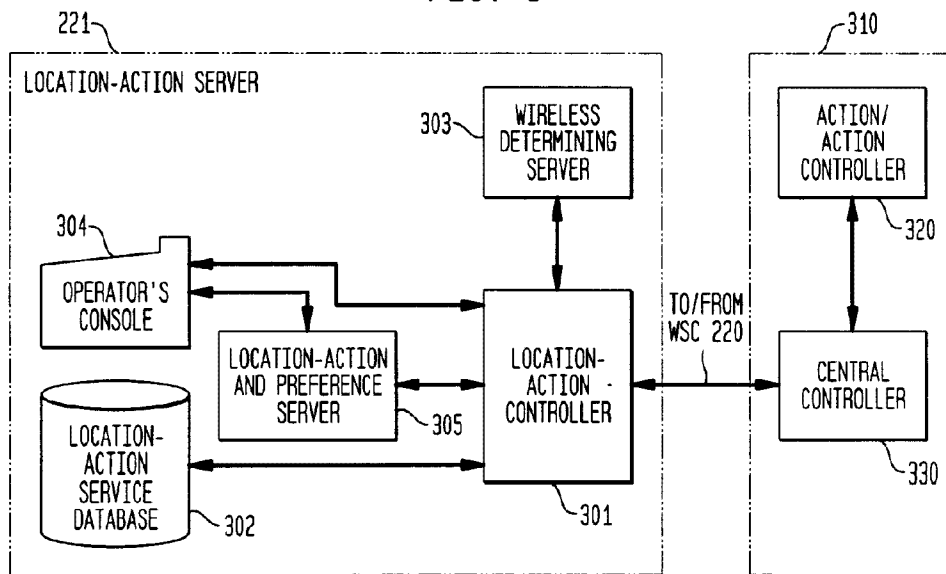

FIG. 4A

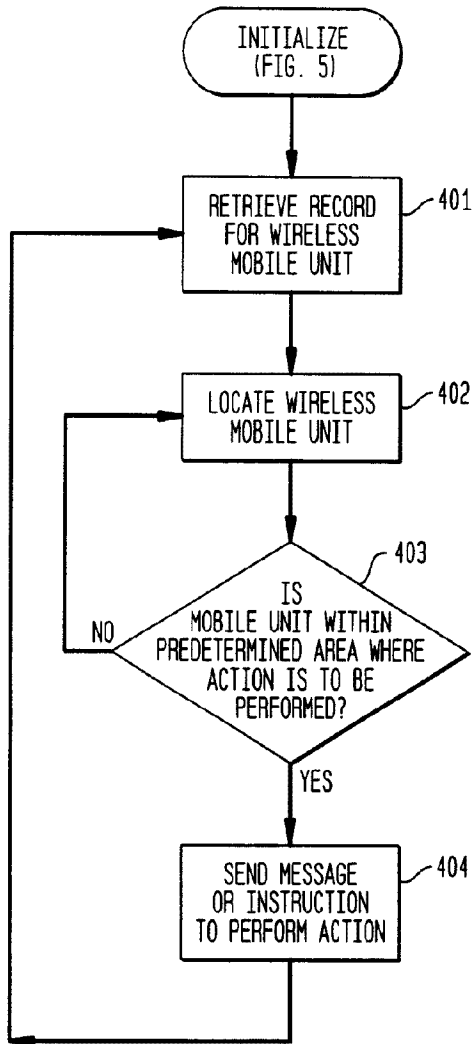

FIG. 4B

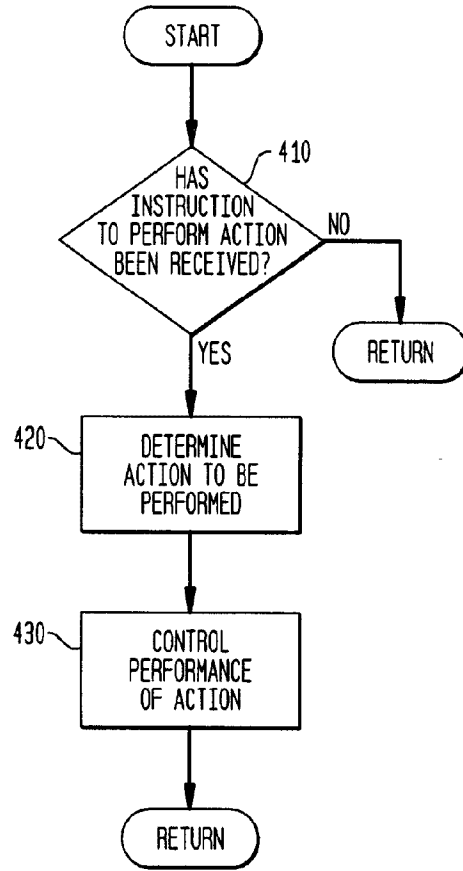

FIG. 5

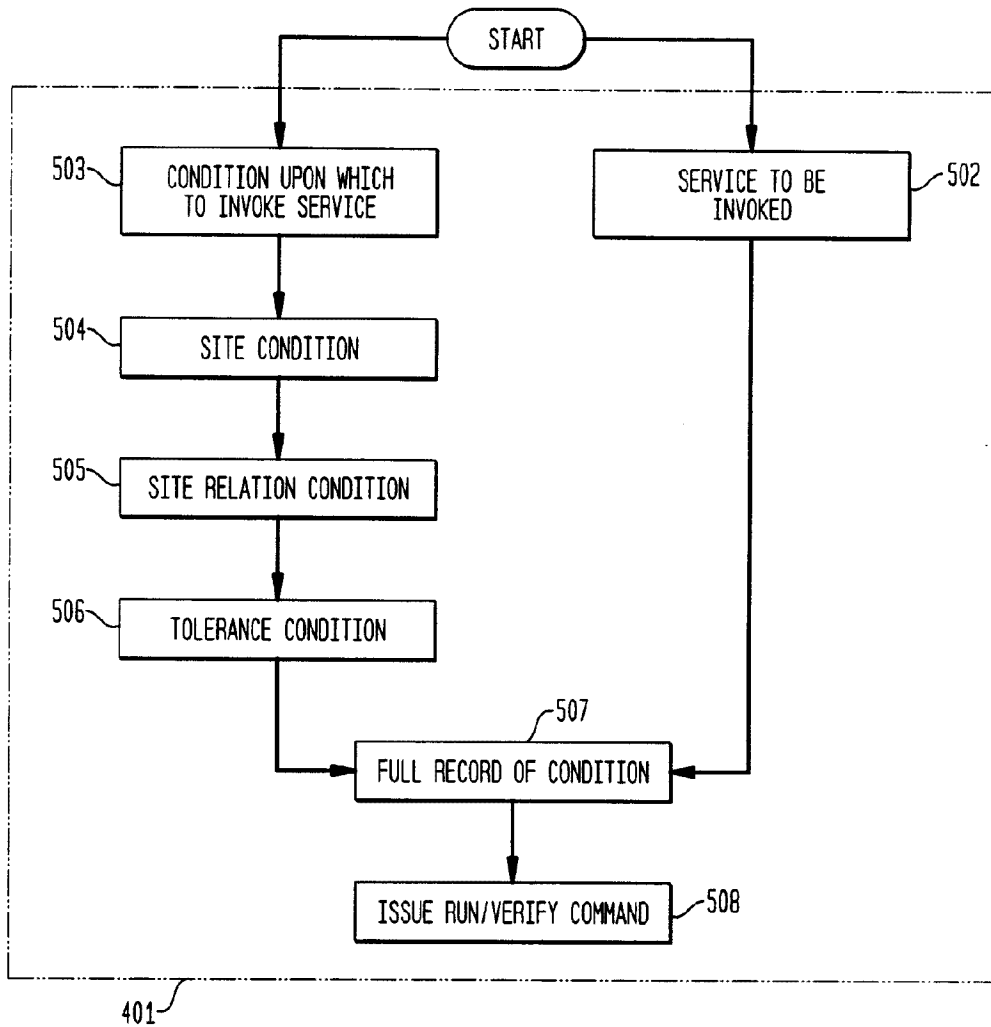

FIG. 6

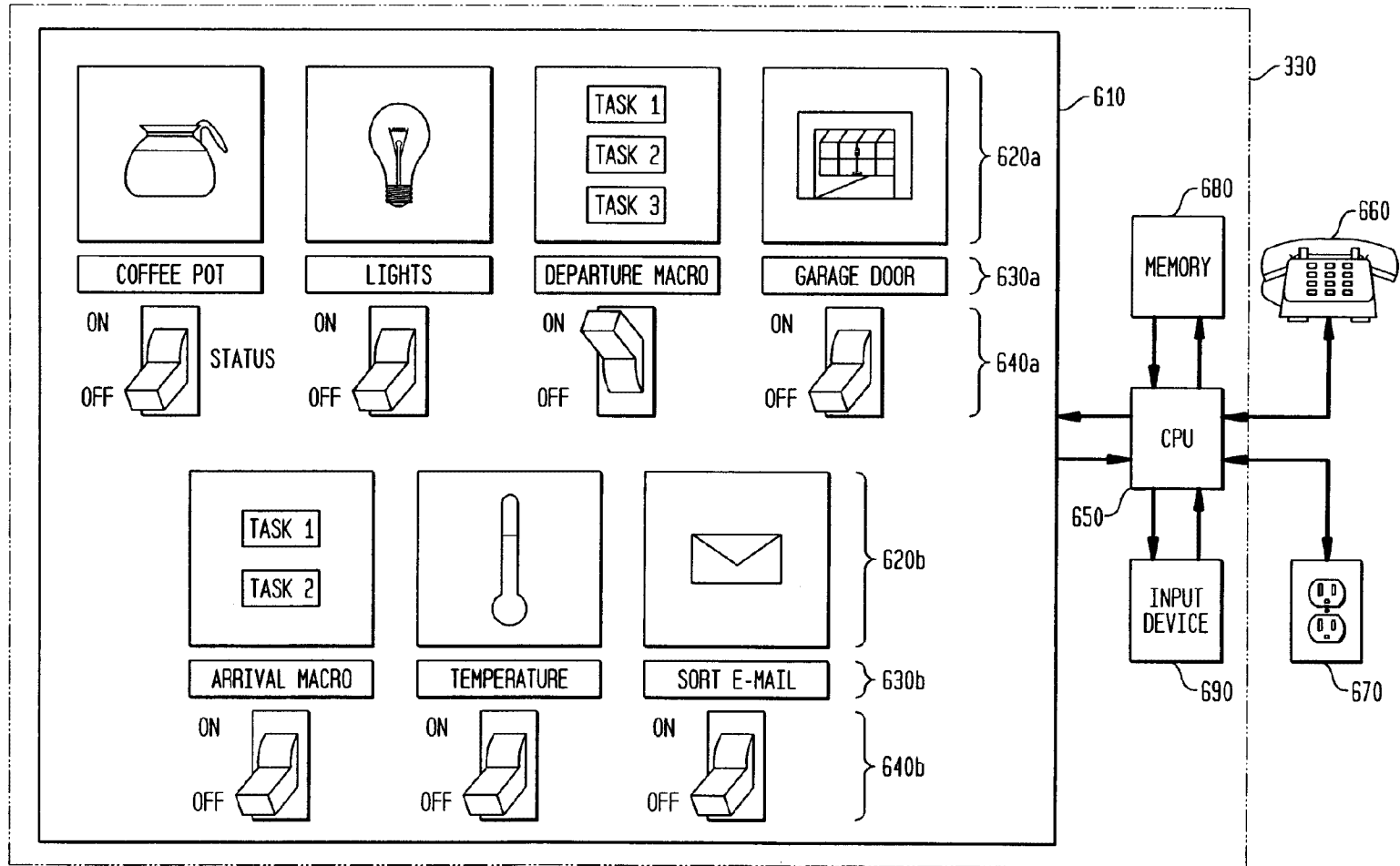

FIG. 7A

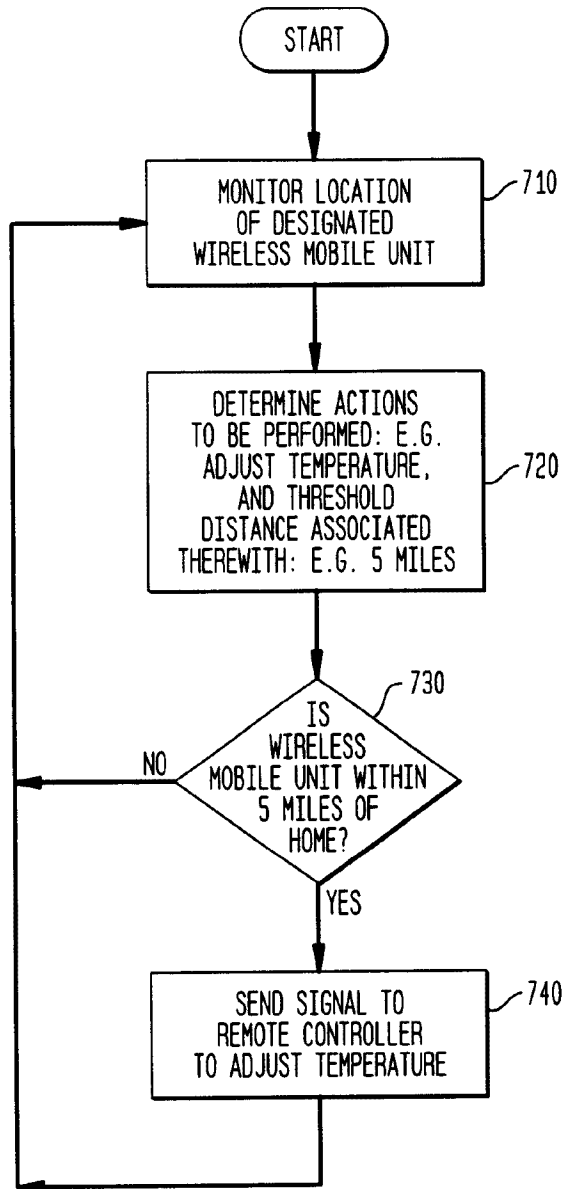
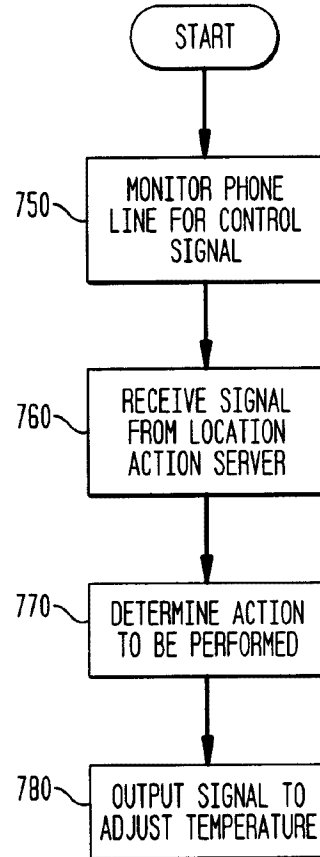

FIG. 7B







(11) **EP 2 372 263 A2**

(12) **EUROPEAN PATENT APPLICATION**

(43) Date of publication:  
**05.10.2011 Bulletin 2011/40**

(51) Int Cl.:  
**F24F 11/00 (2006.01)**

(21) Application number: **11002456.9**

(22) Date of filing: **24.03.2011**

(84) Designated Contracting States:  
**AL AT BE BG CH CY CZ DE DK EE ES FI FR GB GR HR HU IE IS IT LI LT LU LV MC MK MT NL NO PL PT RO RS SE SI SK SM TR**  
Designated Extension States:  
**BA ME**

(72) Inventors:  
• **Nikovski, Daniel**  
**Brookline, MA 02446 (US)**  
• **Laughman, Christopher**  
**Waltham, MA 02451 (US)**

(30) Priority: **24.03.2010 US 730326**

(74) Representative: **Pfenning, Meinig & Partner GbR**  
**Patent- und Rechtsanwälte**  
**Theresienhöhe 13**  
**80339 München (DE)**

(71) Applicant: **Mitsubishi Electric Corporation**  
**Tokyo 100-8310 (JP)**

(54) **Method for controlling a heating, ventilation, and air conditioning (HVAC) system**

(57) A method controls a heating, ventilation, and air conditioning (HVAC) system by determining a travel time from a mobile site to a fixed site, and determining a conditioning time for a HVAC system at the fixed site. The

HVAC is maintained in an ON state if the travel time is less than the conditioning time, and otherwise maintaining the HVAC in an OFF state, and wherein the conditioning time is determined using a building thermal model.

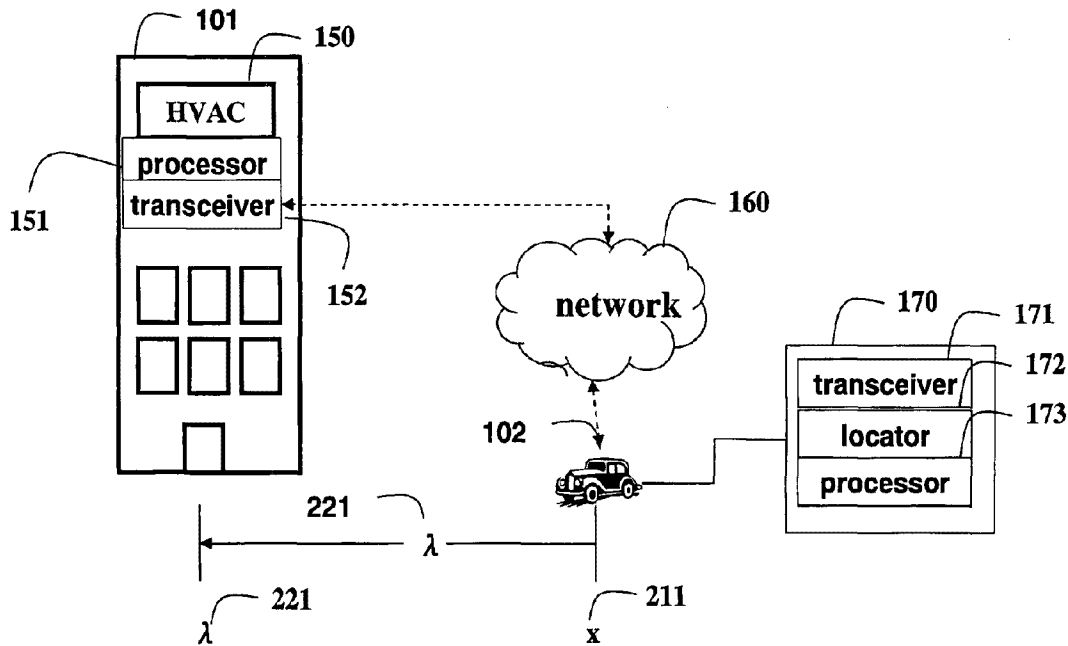

**Figure 1**

**EP 2 372 263 A2**

**Description****Field of the Invention**

[0001] The invention relates generally to the field of heating, ventilation, and air conditioning (HVAC) systems, and more particularly to energy saving programmable HVAC systems.

**Background of the Invention**

[0002] Heating, ventilation, and air conditioning (HVAC) systems consume a large amount of energy. Commonly, heating and cooling operations for an environment are controlled automatically with one or more thermostats. A thermostat can be located centrally, or thermostats can be distributed. Typically, the operation of the HVAC system is according to preset temperature limits.

[0003] Because many environments may be unoccupied at times, this wastes energy. Occupancy can be determined with motion detectors. However, the time required to heat or cool the environment to the desirable temperature takes considerable time, perhaps longer than the time that the environment is occupied.

[0004] An operation schedule can be used. However, this is impractical when the occupancy period is irregular, or the schedule changes frequently. Schedules also do not accommodate holidays, vacations, travel, unplanned absence, and other changes to the occupancy routine. Thus, the schedule is only a best guess of occupancy.

[0005] One system augments manual and programmable home thermostats by using just-in-time heating and cooling based on travel-to-home distance obtained from location-aware mobile phones, Gupta et al., "Adding GPS-Control to Traditional Thermostats: An Exploration of Potential Energy Savings and Design Challenges," Book Pervasive Computing, Volume 5538/2009, pp. 95-114, May 2009. The system starts heating or cooling an inhabitable space only when the time necessary for the space's occupant to reach that space becomes lower than the time it would take to bring the space to a comfortable temperature.

[0006] That system used a GPS-enabled device such as a telephone to determine a user's current location, and a publicly available mapping system (MapQuest) to compute the time to reach the space to be conditioned from the user's current location.

[0007] In order to compute the time necessary to bring the space to a comfortable temperature, that system uses empirical data stored in heating/cooling look-up tables. For a given combination of indoor and outdoor temperature, the table stores the time it would take to heat or cool the space to a comfortable temperature. Each table is specific to the heating/cooling system type installed at the particular location. That system lacks generalization, because the tables must be individually constructed for each residence from measurements. Furthermore, the

observed data from a limited time period typically would not include all possible combinations of indoor and outdoor temperatures that might be encountered in the future.

5 [0008] Another disadvantage of that system is the need to constantly re-compute and compare the travel time and conditioning time. Since the GPS-enabled mobile device is typically powered by a battery, constant communication between the device and the conditioned space would quickly drain the mobile device's battery, and is also likely to result in costly data communications traffic.

**Summary of the Invention**

15 [0009] A method controls a heating, ventilation, air conditioning (HVAC) system by determining a travel time from a mobile site to a fixed site, and determining a conditioning time for a HVAC system at the fixed site based on pre-computed building thermal models.

20 [0010] The HVAC is maintained in an ON state if the travel time is less than the conditioning time, and otherwise maintaining the HVAC in an OFF state, and wherein the conditioning time is determined using a building thermal model.

25 [0011] The mobile device carried by the spaces occupant and the building HVAC system installed at the conditioned space communicate according to a protocol that results in minimal data traffic.

**Brief Description of the Drawings****[0012]**

35 Figure 1 is a schematic of a system for controlling a HVAC system according to embodiments of the invention;

40 Figure 2A is a flow diagram for controlling a HVAC system according to embodiments of the invention;

Figure 2B is a state transition diagram for controlling the HVAC system according to embodiments of the invention;

45 Figure 3 is a table of conditional logic used by embodiments of the invention; and

50 Figures 4A-4B are graphs of environmental conditions as a function of travel time.

**Detailed Description of the Preferred Embodiment**

55 [0013] The embodiments of our invention provide a method for operating a heating, ventilation, and air conditioning (HVAC) system. The method uses a travel time for a person to reach the environment being controlled, and the conditioning time of the HVAC system.

**[0014]** Figure 1 shows a fixed site (a workplace) 101, and a mobile site 102 at a location  $x$  211, e.g., the mobile site is traveling to the fixed site. The mobile site includes a person destined for the fixed site. The mobile site can be a car, public transportation, a bicycle, or a person carrying a mobile communications device 170. The device 170 includes a mobile transceiver 171, a mobile locator 172, and a mobile processor 173.

**[0015]** The fixed site 101 includes a HVAC system 150, which is connected to a fixed processor 151 and a fixed transceiver 152 similar to the mobile transceiver 171. In a simplest form, the HVAC system includes a boiler, and perhaps air circulation means.

**[0016]** The fixed site and the mobile site can communicate with each other via a network 160, e.g., the Internet, using the transceivers 152 and 171.

**[0017]** The travel time  $\lambda$  221 for the mobile site to arrive at the fixed site 101 can be estimated from the locations  $x$  211 of the mobile site 102. The locations can be sensed using the locator 172, e.g. a global positioning system (GPS), or a mobile communication device, e.g., mobile telephone in the vehicle, and the location of the mobile site is provided by a mobile telephone service provider. The locator can also be a Bluetooth device communicating with a fixed-location Bluetooth beacon. The travel time can also consider traffic and weather conditions between the mobile and fixed sites, as available via the network.

**[0018]** As shown in Fig. 2A, the fixed site estimates 230 the conditioning time  $\Theta$  231 from environmental conditions 229 and a building thermal model 228. The environmental conditions can include the external temperature and direct sunlight illumination at the fixed site. It is assumed these are constant or slowly varying, and if not, they can be adjusted for diurnal and annual variations, and according to weather forecasts, also readily available via the network.

**[0019]** The building thermal model 228 represents the thermal response of the building to the environmental conditions (e.g., external temperature, sunlight) and the operation of the HVAC system 150 that actively moves heat in or out of the building. A popular type of building thermal model is a grey-box model, where the building is modeled as a thermal circuit. The building thermal model can include factors such as thermal gain and transmission through windows, convection and conduction, shading and insulation. The building thermal model tracks the state of the building continuously and for any amount of heat supplied by the HVAC system 150, and can predict the future evolution of the internal temperature of the building. In order to compute the conditioning time  $\Theta$  231, the building thermal model is used to determine the future evolution of the internal temperature for the case when the HVAC system 150 is operated at full power. The time necessary for the internal temperature to reach a comfortable threshold, e.g. 70F, is determined to be the conditioning time  $\Theta$  231.

**[0020]** A difference 240 between the travel time 221

and the conditioning time 231 is then used to determine how the operation 250 of the HVAC system 150 is maintained.

**[0021]** As shown in Figure 2B, the HVAC is maintained in an OFF state 261 until the conditioning time constraint 262 is satisfied. Then, the HVAC is maintained in an ON state 263 until the conditioning time constraint 264 is satisfied. Namely, the HVAC is maintained in an ON state if the travel time is less than the conditioning time, and otherwise the HVAC is maintained in an OFF state. The travel time 221 is based on probabilistic information obtained from previous traveling patterns, considering the mode of travel, the time of day, the date and the day of the week. The travel time can also be based on schedules of public transportation. The travel time can be determined at either the fixed or mobile location. The travel time can be periodically transmitted, or either the fixed or the mobile site can initiate the communication of the travel time explicitly.

**[0022]** Figure 2A shows our method. The location  $x$  211 of the mobile site is periodically sensed 210. The locations can be used to estimate 220 the travel time  $\lambda$  221 to the fixed site. A threshold time  $\epsilon$  239 can be used to avoid rapid transitions between the ON and OFF states, which decreases efficiency.

**[0023]** Figure 3 shows the logic used by an embodiment of our invention to schedule communication between the fixed and mobile sites. In this embodiment, there is no regularly scheduled communication, either the fixed or mobile site can initiate a communication. Figure 3 shows the currently maintained states 301 of the HVAC system, the sites 302, and the constraints 303 based on the travel time  $\lambda$ , the conditioning time  $\Theta$  and the threshold time  $\epsilon$ .

**[0024]** Whenever there is a communication between the sites, the mobile site communicates the travel time  $\lambda$  221 to the fixed site, and the fixed site communicates the conditioning time  $\Theta$  231, and the currently maintained state 301 of the HVAC system to the mobile site. The fixed site stores  $\lambda$  and the mobile site stores  $\Theta$ . For each current state 301 of the HVAC, a communication is initiated by the site 302, when the constraint 303 becomes true for the corresponding state of the HVAC system.

**[0025]** As shown respectively in Figures 4A and 4B, it should be noted that when the HVAC system is ON, the system can operate in various modes. For example, if the travel is relatively large, then the HVAC can condition the environment slowly over a long period. That is the output of the HVAC system 'ramps-up' slowly. This minimizes energy consumption. If the travel time changes, the conditioning time can change accordingly. If the travel time is short, the HVAC might need to operate at maximum capacity to reach the desired internal environment condition. That is, the conditioning time is approximately proportional to the travel time.

Thus, in one embodiment, the travel time from the mobile site to the fixed site is determined, and an operation of the HVAC system is set according to the travel time.

**[0026]** In another embodiment, multiple instances of the method can collaborate to minimize communications by the mobile site. For example, the person associated with the mobile site can be at the fixed workplace site and a fixed residence. In this case, the travel time and condition time can be determined for each sites, depending on whether the person is going to work, or coming home.

**[0027]** The HVAC system can be for an environment that can be occupied by multiple individuals. In this case, the travel time, conditioning time, and conditional logic are determined for each individual, and the HVAC is maintained in the ON state when any one condition indicates that this should be the case, and in the OFF state when all conditions indicate that this should not be the case.

**[0028]** In the case wherein N individuals share the same environment, but have different preferences for the environmental condition, the fixed site can calculate a separate  $\Theta$  for each occupant ( $\Theta_1, \Theta_2, \Theta_3 \dots \Theta_N$ ), and

each mobile site can communicate a separate  $\lambda, \epsilon, (\lambda_1, \lambda_2, \lambda_3, \dots, \lambda_N)$ . Furthermore, the HVAC system can use a separate threshold time  $\epsilon$  for each occupant ( $\epsilon_1, \epsilon_2, \epsilon_3 \dots \epsilon_N$ ). The HVAC transitions to the ON state when any of the conditioning times ( $\Theta_1, \Theta_2, \Theta_3 \dots \Theta_N$ ) is greater than its corresponding travel time ( $\lambda_1, \lambda_2, \lambda_3, \dots, \lambda_N$ ). The HVAC transitions to the OFF state when  $\Theta_N$  plus a threshold time  $\epsilon_N$  is less than the travel time  $\lambda_N$  for all corresponding Ns.

**[0029]** It should be noted that the method can also be used for other equipment, e.g., lighting, in which case  $\Theta=0$ , boilers, coffee makers, and water coolers. For desktop computers, the conditioning time is the time required to activate the computer, and  $\Theta$  is a constant.

**[0030]** Thus, in the general case, the system is any equipment in or for an environment that needs to be maintained in an ON state when individuals are in the environment, and in an OFF state when the environment is unoccupied. The system is most effective at saving energy when the conditioning time is significantly greater than zero, so that the system can assure the comfort of occupants by starting to condition the space significantly before the occupants arrive, but at the same time is less than the travel time of the occupants for long periods, so that it can safely conserve energy during such periods.

**[0031]** Although the invention has been described by way of examples of preferred embodiments, it is to be understood that various other adaptations and modifications may be made within the spirit and scope of the invention. Therefore, it is the object of the appended claims to cover all such variations and modifications as come within the true spirit and scope of the invention.

## Claims

1. A method for controlling a heating, ventilation, and air conditioning (HVAC) system, comprising the steps:

determining a travel time from a mobile site to a fixed site;  
determining a conditioning time for a HVAC system at the fixed site; and  
maintaining the HVAC in an ON state if the travel time is less than the conditioning time, and otherwise maintaining the HVAC in an OFF state, wherein the conditioning time is determined using a building thermal model, and wherein the steps are performed in a processor.

2. The method of claim 1, wherein the conditioning time includes a threshold time.

3. The method of claim 1, wherein the mobile site includes a mobile transceiver and a mobile locator; and wherein the fixed site includes a fixed transceiver; and wherein the processor includes a fixed processor at the fixed site and a mobile processor at the mobile site.

4. The method of claim 1, wherein the fixed site and the mobile site communicate via a network.

5. The method of claim 3, wherein the mobile locator is a global positioning system.

6. The method of claim 3, wherein the mobile locator is a Bluetooth device communicating with a fixed-location Bluetooth beacon.

7. The method of claim 3, wherein the mobile locator is a mobile telephone, and a location of the mobile site is provided by a mobile telephone service provider.

8. The method of claim 1, wherein the travel time is determined from locations of the mobile site.

9. The method of claim 1, wherein the travel time depends on traffic and weather conditions.

10. The method of claim 1, wherein the travel time is based on probabilistic information obtained from previous traveling patterns, and considers a mode of travel, time of day, date, and day of week.

11. The method of claim 1, wherein the travel time is determined based on schedules of public transportation.

12. The method of claim 1, wherein the travel time is

- determined at either the fixed site or the mobile site.
- 13.** The method of claim 1, wherein the travel time is transmitted to the fixed site periodically.
- 14.** The method of claim 1, wherein the travel time is transmitted at a request by either the fixed site or the mobile site.
- 15.** The method of claim 1, wherein the conditioning time is constant.
- 16.** The method of claim 1, wherein the conditioning time is adjusted for diurnal and annual variations, and according to weather forecasts.
- 17.** The method of claim 1, wherein the conditioning time is adjusted for internal environmental conditions at the fixed site.
- 18.** The method of claim 1, wherein the conditioning time maximizes performance of the HVAC system.
- 19.** The method of claim 1, wherein the mobile site and the fixed site communicate the travel time and the conditioning time only if any of the following constraints is true:
- HVAC is OFF, site is fixed, and  $\Theta > \lambda$ ;
  - HVAC is OFF, site is mobile, and  $\lambda < \Theta$ ;
  - HVAC is ON, site is fixed, and  $\Theta < \lambda - \epsilon$ ;
  - HVAC is ON, site is mobile, and  $\lambda > \Theta + \epsilon$ ;
- where  $\lambda$  is the travel time,  $\Theta$  is the conditioning time, and  $\epsilon$  is a threshold time.
- 20.** The method of claim 1, where the conditioning time is approximately proportional to the travel time.
- 21.** The method of claim 1, wherein there are N multiple mobile sites that each communicate travel times  $\lambda$  to the fixed site and the HVAC system turns ON when any of the travel times  $\lambda_N$  is less than the conditioning time  $\Theta$  and turns OFF when all of the travel times  $\lambda_N$  are greater than the conditioning time  $\Theta$  plus a threshold time  $\epsilon$ .
- 22.** The method of claim 21, in which the fixed site estimates a separate conditioning time  $\Theta_N$  for each of N multiple mobile sites.
- 23.** The method of claim 1, wherein the conditioning time is slowly varying.
- 24.** The method of claim 1, wherein the model considers thermal gain and transmission through windows, convection and conduction, shading and insulation.
- 25.** The method of claim 24, wherein the conditioning time satisfies a thermal property constraint.
- 26.** A method for controlling a heating, ventilation, air conditioning (HVAC) system, comprising the steps:
- determining a travel time from a mobile site to a fixed site including a HVAC system; and
  - setting an operation of the HVAC system according to the travel time.

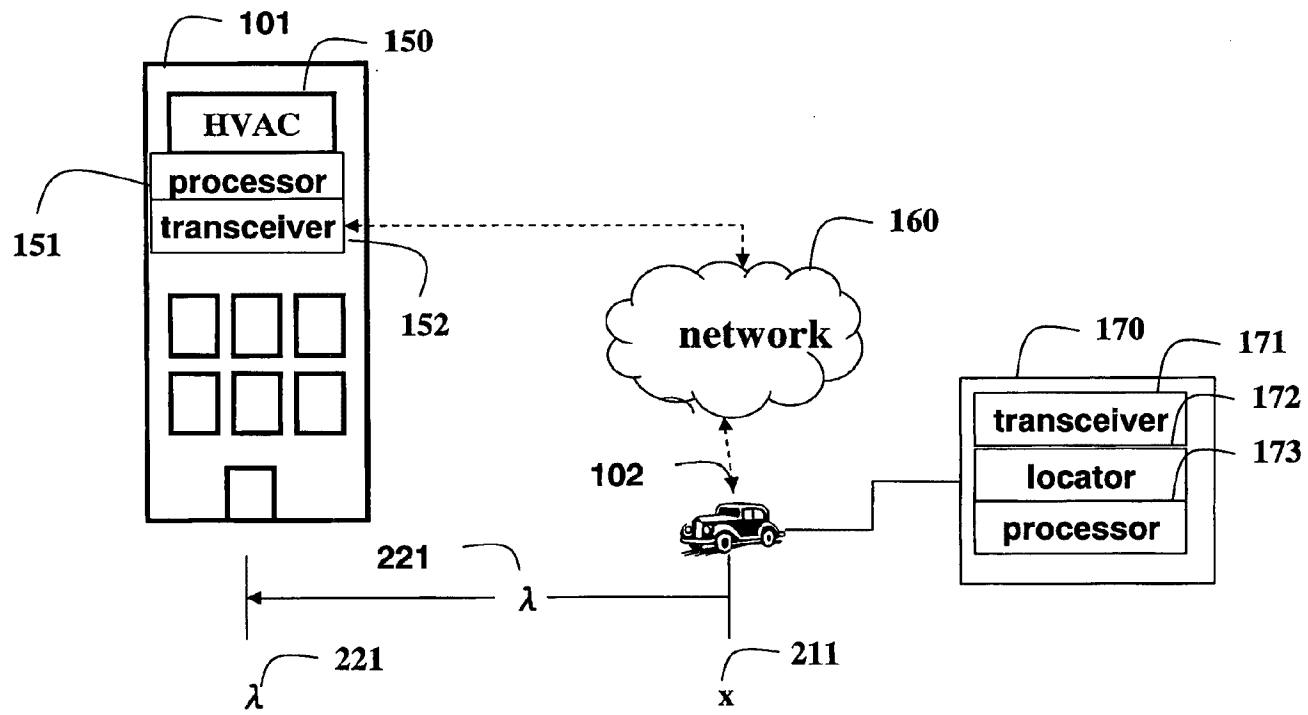

Figure 1

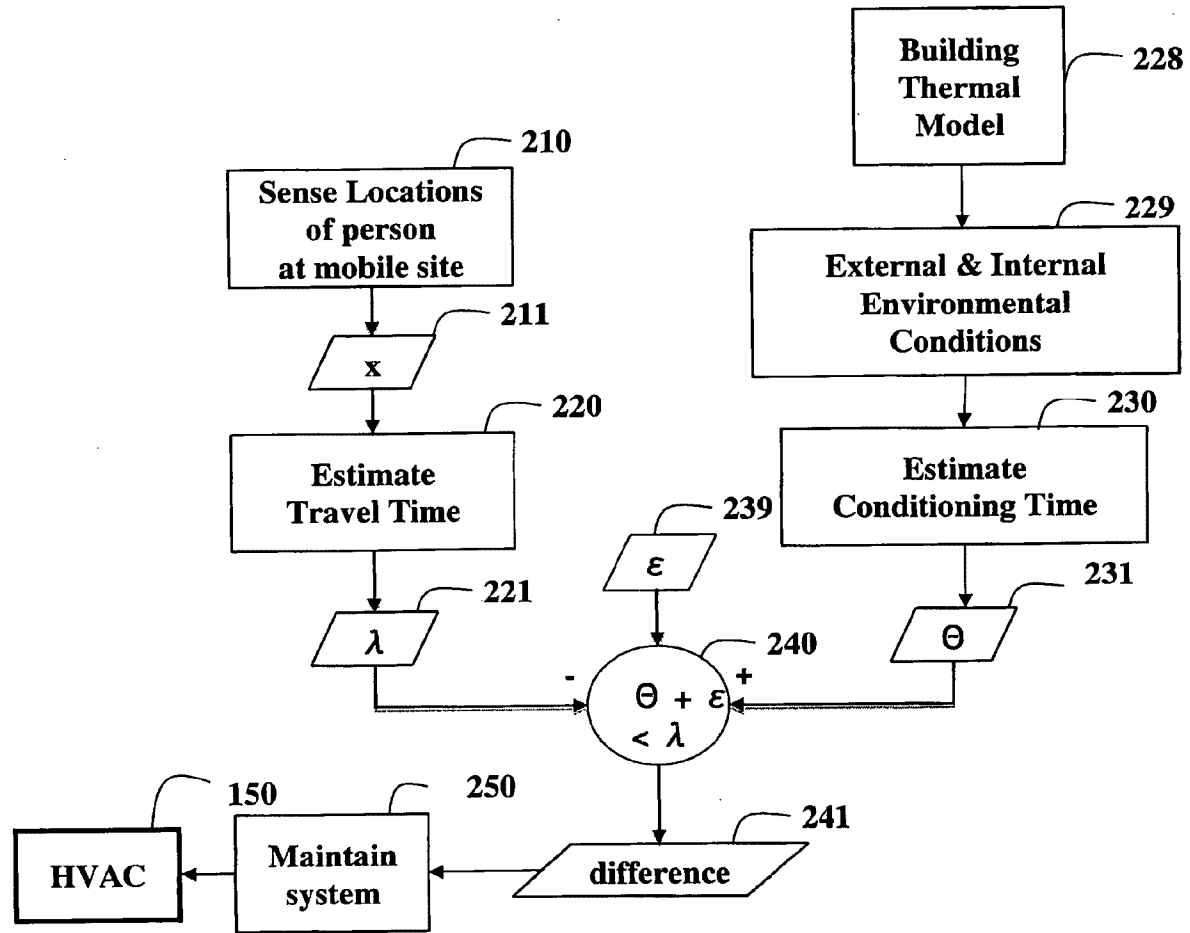

Figure 2A

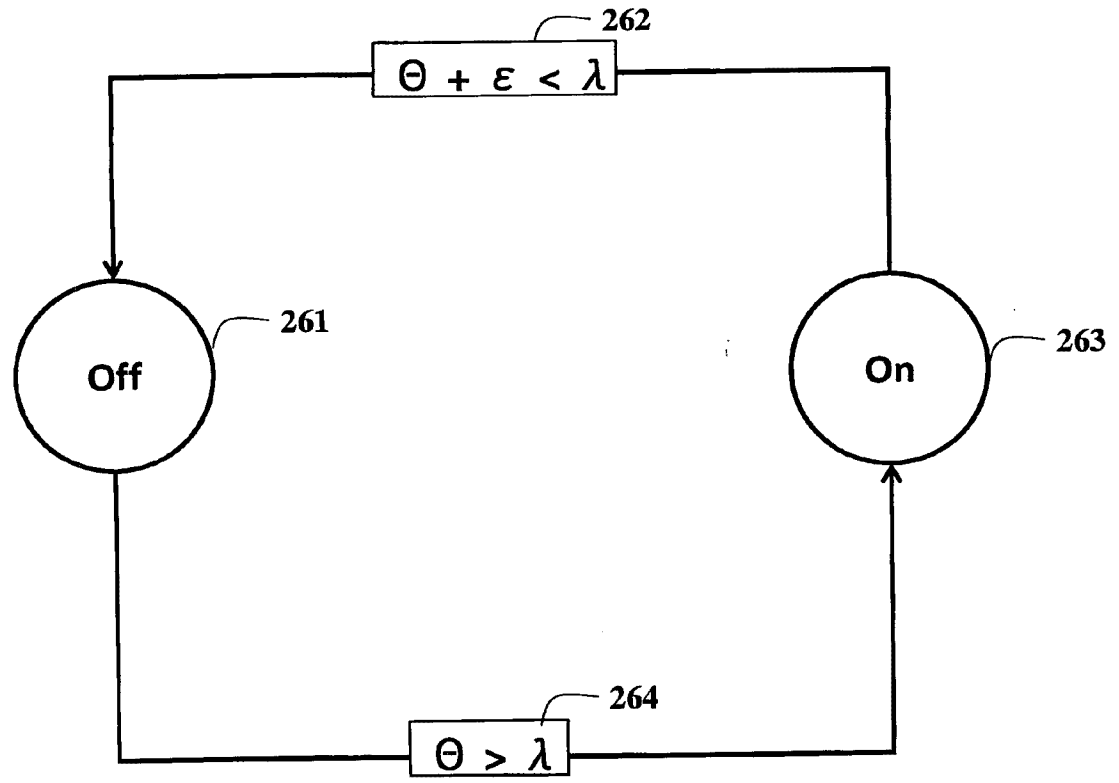

Figure 2B



Logic for Transmissions		
HVAC State	Site	Constraint
OFF	fixed	$\theta > \lambda$
OFF	mobile	$\lambda < \theta$
ON	fixed	$\theta < \lambda - \epsilon$
ON	mobile	$\lambda > \theta + \epsilon$

301                      302                      303

**Figure 3**

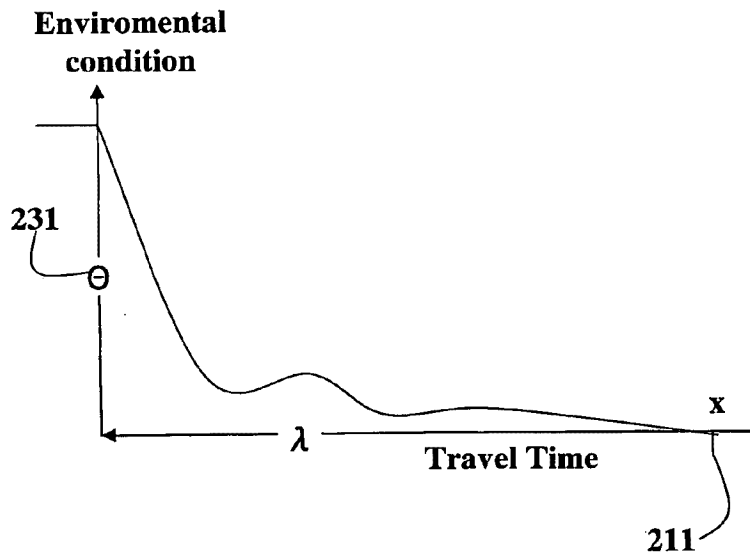

Figure 4A

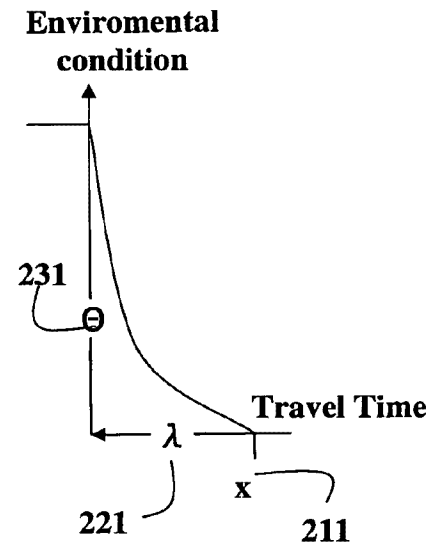

Figure 4B

REFERENCES CITED IN THE DESCRIPTION

*This list of references cited by the applicant is for the reader's convenience only. It does not form part of the European patent document. Even though great care has been taken in compiling the references, errors or omissions cannot be excluded and the EPO disclaims all liability in this regard.*

**Non-patent literature cited in the description**

- **GUPTA et al.** Adding GPS-Control to Traditional Thermostats: An Exploration of Potential Energy Savings and Design Challenges. *Book Pervasive Computing*, May 2009, 95-114 [0005]

(21) Application No: 0327583.1

(22) Date of Filing: 27.11.2003

(71) Applicant(s):  
**James Ian Oswald**  
97 Coventry Road, Burbage, HINCKLEY,  
Leicestershire, LE10 2HN, United Kingdom

**Stephen John Tamsett**  
6 Turville Close, Burbage, HINCKLEY,  
Leicestershire, LE10 2GZ, United Kingdom

(72) Inventor(s):  
**James Ian Oswald**  
**Stephen John Tamsett**

(74) Agent and/or Address for Service:  
**Serjeants**  
25 The Crescent, King Street, LEICESTER,  
LE1 6RX, United Kingdom

(51) INT CL<sup>7</sup>:  
**F24F 11/00 , G05B 13/04 // G05D 23/19 , G06F 1/26**

(52) UK CL (Edition X ):  
**G3N NGBA1 N262 N402B N404**

(56) Documents Cited:  
**GB 2212949 A EP 0883050 A1**  
**WO 2002/090914 A1 US 5197666 A**

(58) Field of Search:  
UK CL (Edition W ) **G3N**  
INT CL<sup>7</sup> **F24F, G05B, G05D, G06F**  
Other: **ONLINE: WPI, EPODOC, JAPIO.**

(54) Abstract Title: **Household energy management system**

(57) A household energy management system uses measurements of the household electricity supply 4 to identify and to determine the energy consumption of individual household appliances. From these measurements, models can be built of the behaviour of the occupants of the house, the thermal properties of the house and the efficiency of the appliances. Using the models, the household appliances - in particular heating and cooling appliances - can be controlled to optimize energy efficiency; and maintenance programmes for the appliances and for the house itself can be recommended to the householder or arranged with a service company.

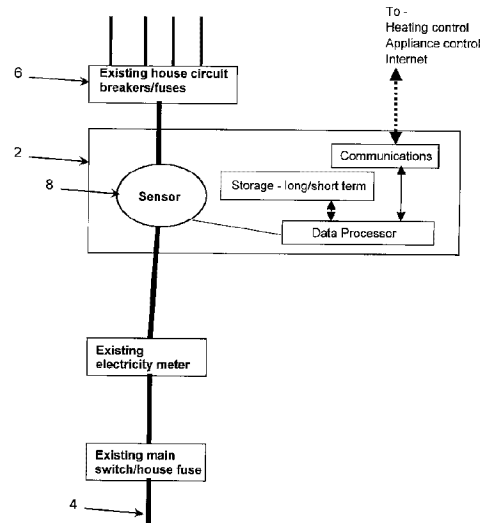

Figure 1

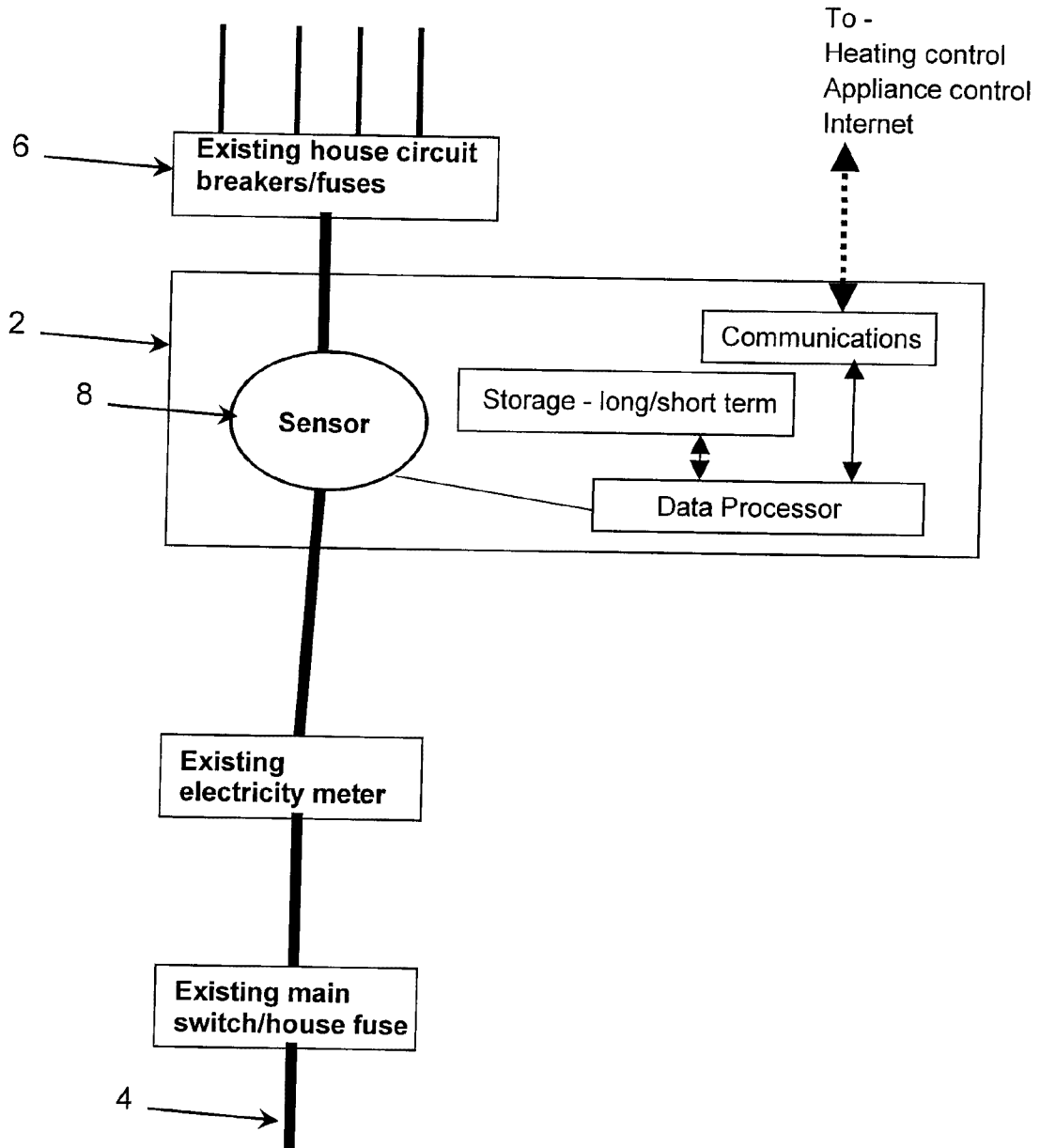

Figure 1

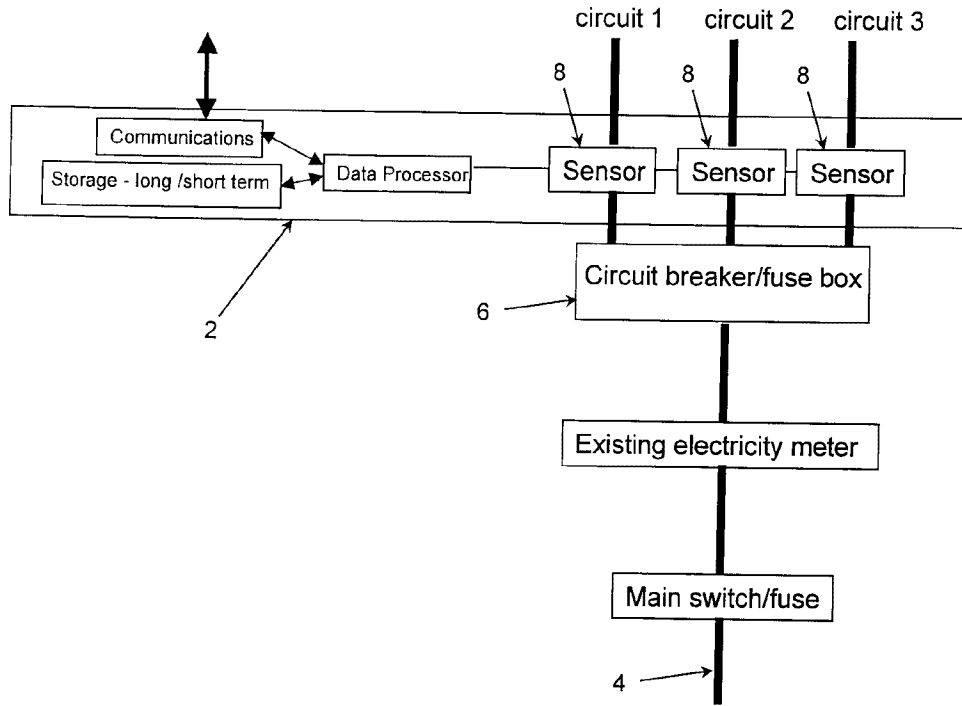

Figure 2

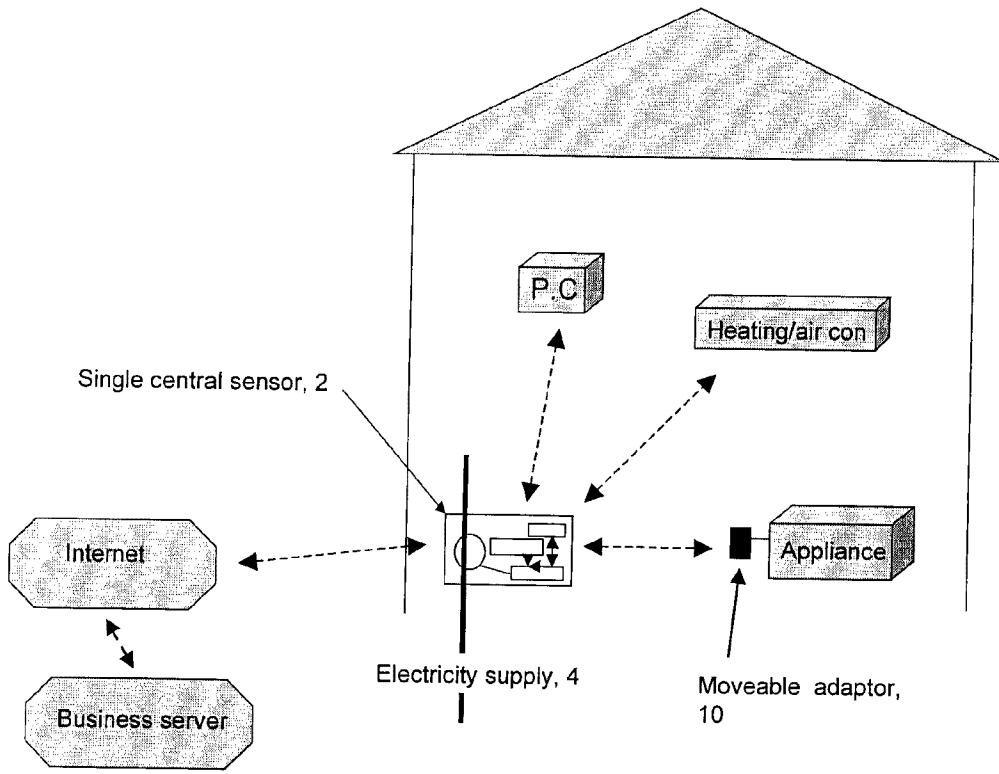
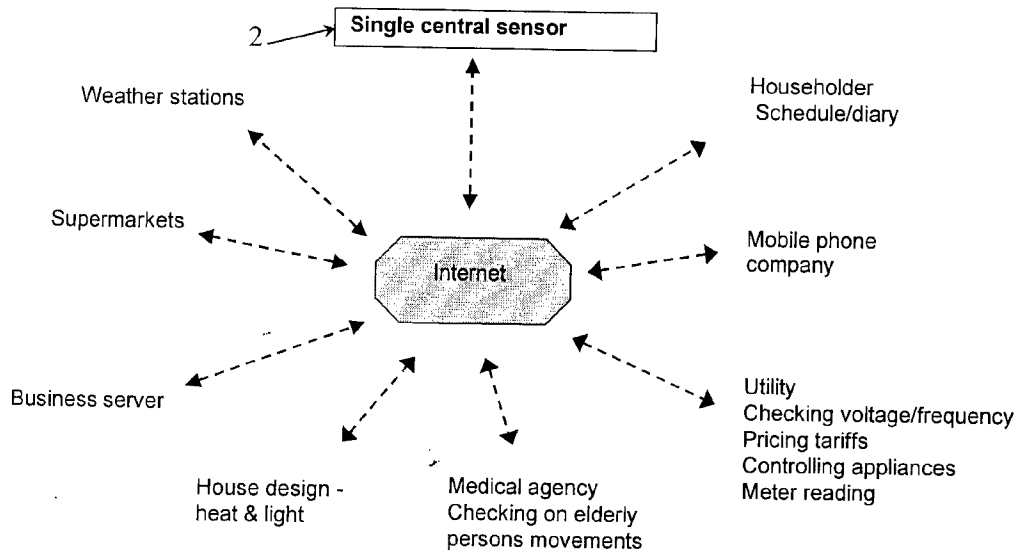
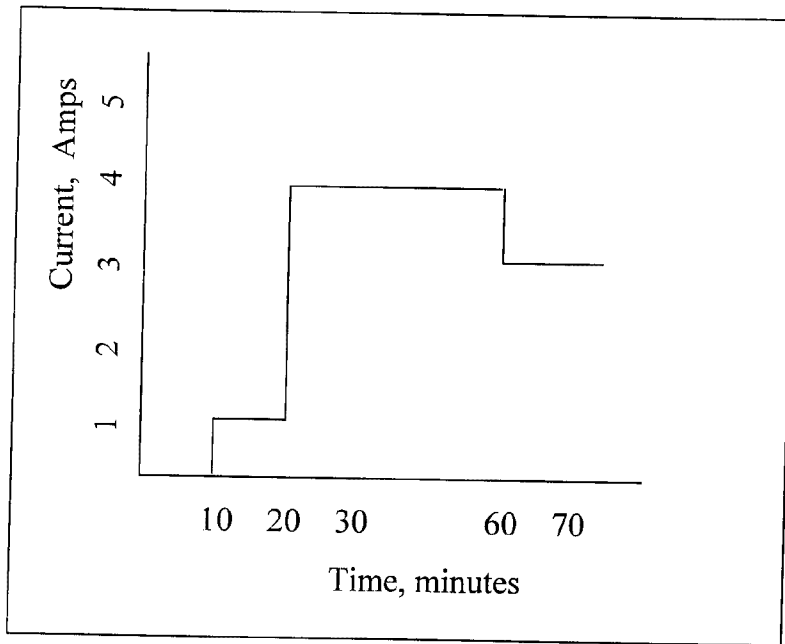

Figure 3

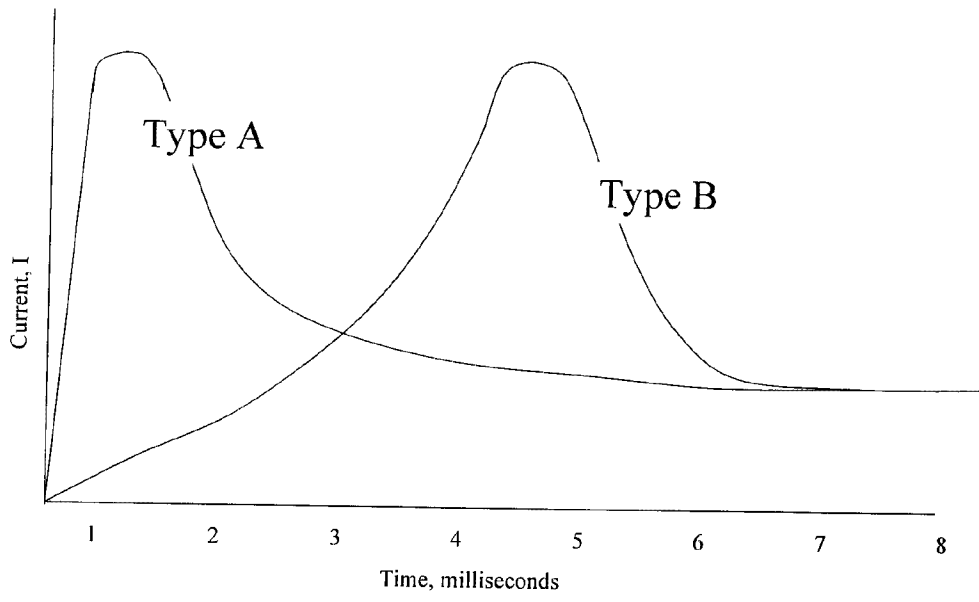

**Figure 4**

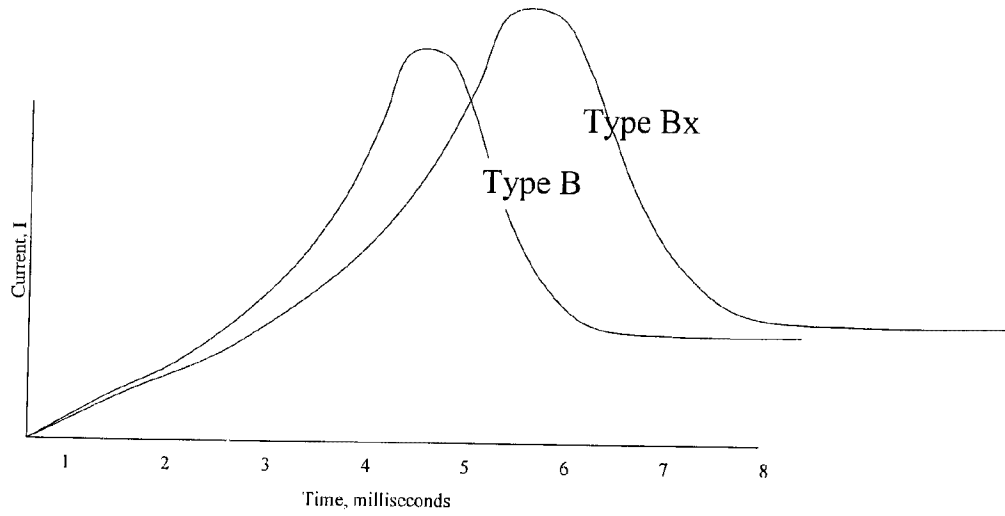



**Figure 5**



**Figure 6**



**Figure 7**

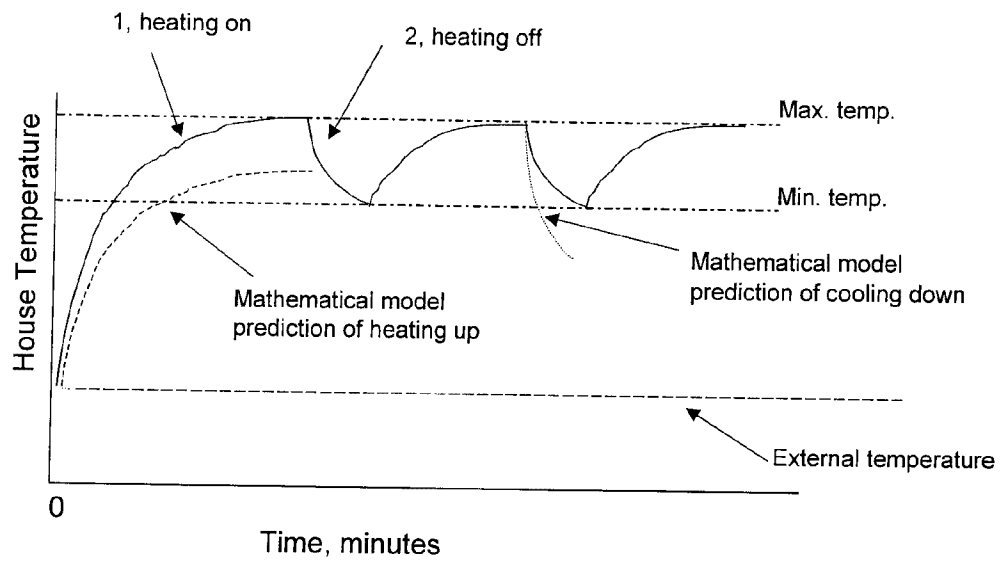

**Figure 8**

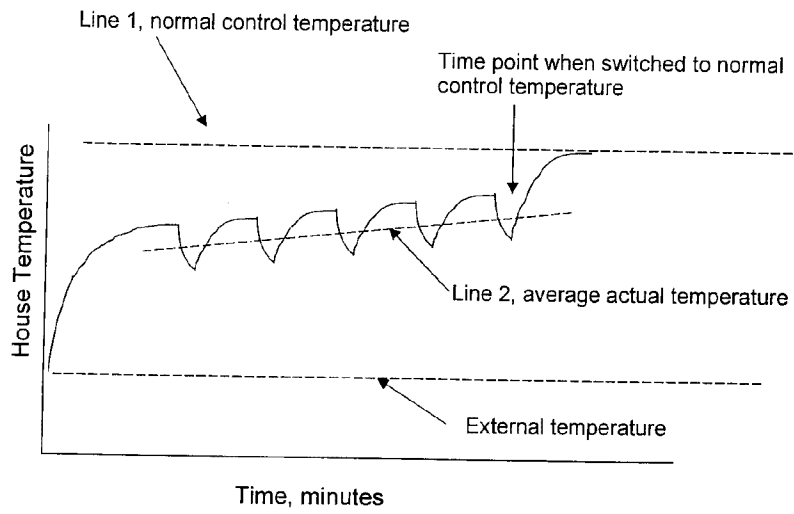

**Figure 9**

- 1 -

TITLE

Household energy management system

DESCRIPTIONTechnical field

The invention relates to the field of household energy management and in particular to ways in which the behaviour of the occupants of a house, the thermal properties of the house and the operation of household appliances can be measured and modelled, in order to control the household appliances in a certain way or to recommend courses of action to the users of the system such that energy use by the household is made more efficient.

Throughout this specification, the words “house” and “household” are used for convenience but those words are not to be interpreted as limiting the scope of the invention to the context of separate, domestic dwellings. Among other things, the word “house” is intended to include within its scope an apartment, an office, a hotel room or a part of any of the aforesaid.

Background of the invention

There have been a number of patents in this field in recent years, which describe new hardware solutions to achieving a computer/Internet-controlled house and provide improved control of the energy consumption in the household.

In general the prior art in the computer-controlled house control uses several electricity sensors (one per appliance/wall socket) to monitor the electrical activities in a house. This large number of additional devices is complicated and costly. By basing the system on a single sensor it would be more suitable for retrofitting to existing houses with existing appliances.

US patent 5572438 by Ehlers describes a house system, which uses a first and a second microcomputer to monitor and control the energy in the household. The patent mainly describes the hardware required to deliver the improvements – microcomputer, current

sensors, appliance control and communication links to the outside world. The system requires a current sensor on each appliance. The hardware requirements for this system seem excessive and expensive to retrofit into an existing household.

US patent application 2003/0050737 by Osann describes another arrangement of hardware, which suggests changing all or several of the electrical wall sockets within the house. It includes suggestions of including video cameras, intercom, and motion detector and temperature sensor in each of these replacement wall outlets. This appears an excessive use of technology with an extensive requirement for hardware and installation work by skilled electricians. Many of these features will not be valued by householders who are happy to not have video cameras in the house. The main financial saving to the householder is through improved temperature control and the additional systems seem excessive. However, the patent application does describe (in claims 81 and 82) a method whereby all of the house electrical current changes can be monitored from a single location in or near the circuit breakers. This seems a much simpler and cheaper approach, which will suit retrofitting of existing houses. However, this idea can be used more effectively with further analytical/mathematical tools run on a computer and with additional moveable adaptors to which it can communicate, as described herein.

An electronic control system for a house is currently on sale from Honeywell Controls under the registered trade mark Hometronic. The system is described on their web site at [http://content.honeywell.com/uk/press/hometronic\\_dayinthelife.htm](http://content.honeywell.com/uk/press/hometronic_dayinthelife.htm). The Hometronic system uses a single central controller to determine on and off times for appliances and heating appliances around the house. It can connect to the Internet and be controlled via the web from anywhere in the world. However, it relies on one control device being attached to one appliance to provide on/off control and this makes it an expensive system to retrofit.

US patent 5115967 describes a mathematical method of predicting the transient thermal behaviour of a house climate control system (heating/cooling system).

It is already known to use infrared sensors to determine occupancy in the house and to use this information to control house energy systems. An example of this is given in US patent 6324008.

US patent application 2002/0095269 discloses an appliance monitoring system, in which a subsystem incorporated in each appliance monitors parameters such as the number of cycles and the energy consumption of the appliance. In the event that the appliance needs attention, the system alerts the user or a service centre.

Microchip Technology Inc is a supplier of microchips. They have posted an article entitled "Microchip watt-hour Meter using PIC16C923 and CS5460" on their web site at <http://www.microchip.com/1010/suppdoc/appnote/all/an220/index.htm> on how to use one of their chips to make a watt hour meter. The power measurement integrated circuit CS5460 from Cirrus Logic/Crystal Power Measurement is used with the microcontroller PIC16C923 to make a power meter. The CS5460 measures the instantaneous voltage and current four thousand times a second and uses these measurements to compute instantaneous power,  $V_{RMS}$ ,  $I_{RMS}$  and accumulated energy. Once the accumulated energy has increased by 10 Watt.seconds a pulse is generated at the output pin (EOUT pin) for counting by another device to form a consumption meter. The article explains how to use this device to record total power consumption.

#### Summary of the invention

In a first aspect, the invention provides a household energy management system comprising at least one sensing means, which measures energy use by occupants of the house; a modelling means, which uses the energy measurements from the sensing means to build a model of the behaviour of the occupants; and a control means, which controls the operation of one or more household appliances in the house on the basis of the model.

The modelling means may build a predictive model of the pattern of behaviour of the occupants over time, in which case the predictive model may be continually refined in response to new measurements by the sensing means.



A model of the predicted behaviour of the occupants of a house allows more efficient use of the appliances in the house. For example, the predictive model may predict the times when the house will be occupied in order for the control means to control the operation of one or more household appliances, such as heating or cooling appliances, on the basis of the predicted times when the house will be occupied.

Additionally, or alternatively, the modelling means may build a temporary model of the current behaviour of the occupants.

A model of the current behaviour of the occupants of a house also allows more efficient use of the appliances in the house. For example, the temporary model may allow the control means to control the operation of heating or cooling appliances to achieve a desired temperature according to the current level of activity of the occupants.

The model of the behaviour of the occupants may include a determination of whether the house is occupied. To assist in this, the modelling means may have an interface with an intruder alarm system in the house and may receive signals indicative of the location of the occupants derived from, for example, a mobile phone network or a global positioning system. In a further enhancement, the modelling means can use the location signals to predict when the occupants may return to the house.

One application of the behaviour modelling means is to trigger an alert when an unexpected pattern of behaviour is detected. For example it may warn when an elderly person becomes immobile or when activity is detected in the house while the occupants are away.

Preferably, the sensing means measures electrical activity within the house. The sensing means may comprise a moveable sensor for location between an electricity supply outlet and an individual electrical appliance to measure the energy use by that appliance; or a fixed sensor on the household electricity supply to measure the respective energy uses of

a plurality of electrical appliances connected to the supply. The optimum combination is one fixed sensor and a few moveable sensors, as described below.

In a second aspect, the invention provides a household energy management system, comprising one or more temperature sensors for measuring the temperature inside the house; a source of information about the temperature outside the house; a modelling means, which uses the inside and outside temperature measurements to derive a transient thermal model of the house, which can predict changes in the inside temperature on the basis of the information about the outside temperature; means for comparing the derived transient thermal model with a reference transient thermal model; and means for warning a user of the system when the derived model differs from the reference model by more than a predetermined limit.

The temperature sensor inside the house may be a thermostat or other temperature control device forming part of the household heating system; and it need not send temperature readings continuously to the household energy management system but may, for example, only inform the energy management system when the inside temperature has reached a value at which heating or cooling appliances are switched on or off.

The transient thermal model may additionally make use of information about the wind speed and/or humidity outside the house. As the source of the information about the outside temperature and/or wind speed and/or humidity, the system may comprise one or more sensors outside the house or it may comprise means for receiving broadcast weather information. The weather information may be broadcast as part of a radio or television signal or via a cable or telephone link or, preferably, over the Internet.

If the reference transient thermal model is a standard model for the type of house in which the system is installed, then the warning means can warn the user that the thermal properties of the house are poor relative to similar houses.

If the derived transient thermal model is periodically updated, then the reference transient thermal model may be a derived transient thermal model for the same house from an earlier period, whereby the warning means can warn the user that the thermal properties of the house are deteriorating.

The modelling means may also be responsive to the operation of heating or cooling appliances in the house, whereby the warning means can warn the user of poor or deteriorating performance of the appliances and may automatically summon an engineer to repair the appliances. For example, the system can identify the optimum time for boiler maintenance by comparing the boiler's heating ability with its specification or with its past performance.

A further use of the transient thermal model is to provide a basis for a control means to control the operation of heating or cooling appliances in order to achieve a desired temperature in the house at a given time, using the minimum amount of energy or, if the cost of energy varies during the day, the cheapest amount of energy. Thus the system can determine when the house heating or cooling needs to come on to meet the desired temperature at the given time, rather than always turning on the heating at a fixed, programmed time.

The control means can also be used to switch the heating or cooling appliances periodically on and off at intervals determined in accordance with the transient thermal model to maintain the temperature in the house within a desired range, without the use of a thermostat.

In a third aspect, the invention provides a household energy management system, comprising at least one sensor on the household electricity supply for measuring the instantaneous total power delivered by the electricity supply; means for identifying electrical appliances connected to the supply on the basis of their respective start-up characteristics when the appliances are switched on; means for comparing the sensed start-up characteristics with reference characteristics; and means for warning a user of the

system when the sensed characteristics differ from the reference characteristics by more than a predetermined limit.

The comparison means may further compare operating characteristics and/or shut down characteristics of the appliances with corresponding reference characteristics.

The system may further comprise means for recording the total time of operation and/or the number of cycles of operation of each appliance, which can be compared against a database of lifetime expectancy and reliability for different appliances. The database may be a local database, internal to the system, or a shared database, accessed via an external network. In the case of a shared database, means are preferably provided for updating the shared database with measured lifetime and reliability data for appliances connected to the system.

The system may further comprise modelling means receiving signals from the comparison means and from the database in order to recommend to the user of the system a program of maintenance or replacement of the appliance.

A household energy management system in accordance with the invention, which monitors the energy consumption of household appliances, can also act as an electricity meter and may indicate the electricity consumption reading to the householder or transmit the reading directly to the electricity provider. If the system is networked to the electricity provider, then the provider can inform the system of changing electricity prices. The system may simply inform the user of these prices or it may be programmed to control household appliances so as to minimize the energy costs to the householder. For example, it may be more cost-effective to increase the background temperature of the house by operating electrical heating appliances at a time of day when electricity is relatively cheap in order to reduce the amount of heating required when demand is at its peak. Alternatively, the electricity provider may be given direct control of the electrical heating appliances.

Similarly, if the system is networked to a gas supplier, then the supplier can inform the system of changing gas prices. The system may simply inform the user of these prices or it may be programmed to control household gas appliances, such as a gas-fired central heating boiler, so as to minimize the energy costs to the householder. Alternatively, the energy management system or the gas supplier itself may be given direct control of the gas supply via an electrically-operated gas valve.

Methods of operating a household energy management system in accordance with the first, second and third aspects of the invention are also provided.

The modelling functions associated with any of the aspects of the invention may be carried out locally, by computing means provided as part of the system within the house; or remotely, by external computing means accessed via a telecommunications network.

The system allows for standard appliances to be used. Intelligent appliances containing communications and minicomputers can be included but are not essential for this invention. The invention concentrates on using electrical sensors external to existing appliances and linking this to powerful analytical mathematical modelling.

The overall system benefits include:

- Reduced energy consumption.
- Improved householder comfort.
- Improved maintenance and utilisation of expensive capital appliances in the house.
- Reduced cost to the householder through improved energy tariffs.
- Recommending energy saving measures to the householder based on actual measurements of the householder's behaviour, the thermal efficiency of the house and the operational efficiency of household appliances.

#### The drawings

Figure 1 shows a first way of installing a single central sensor in accordance with the invention into a household electricity supply.

Figure 2 shows a second way of installing a single central sensor in accordance with the invention into a household electricity supply.

Figure 3 shows the communication links between the single central sensor and the other parts of the system according to the invention.

Figure 4 shows various Internet services to which the system according to the invention may link.

Figure 5 illustrates how the current in a household electricity supply may vary with time.

Figure 6 illustrates the current start-up characteristics of two household appliances

Figure 7 illustrates how the start-up characteristic of an appliance may change over time

Figure 8 shows how a transient thermal model in accordance with the invention may be revised.

Figure 9 shows how a transient thermal model in accordance with the invention may be used to control temperature with no feedback.

### Description of preferred embodiments

#### **A typical system**

Consider a system, which uses a single central sensor to monitor the flow of electricity into the house. It records/analyses the data in great detail – not only on a minute by minute basis but also the instant an appliance is turned on it analyses the starting current in detail over milliseconds. In this way it determines which appliance has been turned on and how long it has been on for and at what time of day it has been used. It builds mathematical models of:

- All appliances used in the house and their pattern of use
- The house's transient thermal behaviour under heating and cooling conditions

The system is intended not just to monitor the electrical system or the gas heating system but to link the monitoring of gas and electricity together to allow a whole system understanding to be achieved and provide better optimisation of the total energy use within the house. For example, sudden changes in electrical activity can indicate that the

householder has returned home early from work and elicit a heating response within the controller to increase the house temperature.

These sensors include not only a single central sensor at the point of entry of electricity to the house but also adaptors, which plug into standard wall sockets. The adaptors allow the collection of detailed information and control the appliances they are connected to.

The analysis is performed on computers either local to the house or on the Internet. Communications between the various system items use standard known communication systems i.e. phone, radio, Internet or communication by power cable.

#### **The single central sensor (Figures 1 and 2)**

The single central sensor 2 shown in Figure 1 is connected between the electric power cable to the house 4 and the house circuit breakers/distribution board 6, or in other words at the electrical point of entry to the house. The sensor 8 is used to monitor multiple devices. In more advanced versions, greater resolution may be possible by locating a sensor on each ring main out of the electricity meter, as shown in Figure 2.

The single central sensor 2 monitors the electrical power feeding into the house (e.g. current, voltage and power factor), stores appropriate data and analyses the data to determine what is happening with the house's appliances and with the occupants. The single central sensor 2 contains electronic computing capability including storage (long and short term), processing power, battery back up (not shown) and communications capability with the wider network and local devices.

#### **Communications (Figures 3 and 4)**

Existing communication methods will be used with the system to allow communication between all parts of the system including Internet servers, databases of information, the single central sensor 2, the moveable adaptors 10, the householder's personal computer and the householder's mobile phone etc, as shown in Figure 3. These existing communication methods include the well-known methods of linking by telephone, radio,

cable and communications by power cable. The system designer will simply use the most appropriate available technology to achieve the communication required. Figure 4 illustrates in more detail the type of information that may be sent to and from the system over the Internet, as well as the sources and recipients of that information.

### **Stored data**

The data acquired will be stored on a database. This will include data of appliance characteristics, times appliances are on and off and derived data. It can be stored either within the house in some form of small computer, perhaps as part of the single central sensor 2, or on a more powerful server on the Internet-based network of computers.

### **Monitoring appliance use (Figures 5 and 6)**

The system can determine the starting and stopping of appliances used in the house by monitoring the magnitude of current step changes. Consider the example shown in Figure 5. At time 10 minutes an electric light of current 1 Amp is turned on. Ten minutes later a heater of 3 Amp rating is turned on and at time 60 minutes the electric light is turned off. At this point in time the system knows that the light has been on for 50 minutes and knows its power and can therefore calculate the energy consumed by the light (kW.h). At the end of the day the system is able to summarise how much energy each of the house's appliances has used during the day. This can be provided as a summary to the householder such as on a web page or email.

The actual type of appliance started can be determined by analysing the start-up characteristics. As shown in Figure 6, some appliances have quicker response characteristics than others. Type A and Type B have similar final operating currents but they differ in start-up characteristic. Type A has a quick peak in current, suggesting that it is a resistive load like a light bulb, which has a low resistance when cold but this resistance increases once it is hot and consequently the current falls. Type B takes longer to reach its peak current, perhaps indicating that it is a motor with a magnetic reluctance rather than a resistance and a starting inertia quite different to the type A appliance. The system can recognise the appliances by comparing them to a pre-programmed store of



characteristics, which are loaded on the single central sensor 2. These signature characteristics will be pre-programmed into the single central sensor 2 before installation in the house, so it can recognise what is being turned on and off. Alternatively the system can learn the signatures during use.

It will be possible to teach the system to recognise a new appliance if it is not immediately recognised from the data bank of known appliances. For example, if the householder starts using an old valve-driven radio which is not previously known, the single central sensor system may identify that an 'unknown appliance' has been used and email the householder asking what the appliance is. By replying, the householder will teach the system to recognise the valve radio for next time. This new characteristic can be used by the householder's system and also sent electronically to the other single central sensors on the Internet network for use in other houses.

Clearly a householder will use some appliances of identical power rating and very similar start up characteristic such as similar light bulbs. The single central sensor has two ways to address this issue. It can determine the difference by noticing small differences in start-up characteristic which arise from small changes in reluctance and resistance due to cable length differences or it can make a best approximation to what is happening in the house. Any approximation will lead to some uncertainty and error, however few appliances are exactly identical and so the error will be small. Alternatively moveable adaptors 10 can be used between the appliance and the fixed wall outlet. These are explained in more detail below.

New versions of control software can be sent to the single central sensor 2 through the network communications.

### **Initiating the system**

On first installing the system it may be best if the householder runs through an initiation sequence whereby each appliance is turned on and off in a predefined sequence. For example, the householder might be asked to follow the following initiation sequence:

- Turn all household appliances off
- Turn all appliances in Bedroom 1 on
- Turn all appliances off
- Bedroom 2 all on
- Turn all appliances off
- Bedroom 3 all on
- Turn all appliances off
- Kitchen all on
- Turn all appliances off
- Living room all on
- Etc

This method allows the system to learn in which room each appliance is kept. For example the 30W radio might be in Bedroom 1. This helps communications between householder and computer if the location of appliances is known. An initiation sequence like this is already described in US Patent application 2003/0050737.

The householder will be able to access data records of appliance use and so will be able to inform the system of the whereabouts of any appliances that the system cannot directly deduce. So for example if the householder can see that the system did not correctly identify that a TV had been moved from the lounge to bedroom 1 the householder will be able to update this over the Internet interface (standard HTML web pages with radio buttons etc).

#### **Alternative way to teach the system to recognise appliances**

An alternative way to teach the system to recognise appliances is to include at least one moveable adaptor 10 as part of the system. This is an adaptor which fits between the appliance power plug and the fixed wall outlet.

It may contain electronics that allow it to measure the current flowing into the appliance, in much the same way as the single central sensor 2 and communicate this to the single central sensor.

Alternatively, the moveable adaptor 10 may just include a transponder, which sends a simple signal to the single central sensor 2 informing it that current is flowing. In this way the single central sensor 2 can associate any transponder signals from the adaptor 10 with the instantaneous changes in household current already detected by the single central sensor 2.

The moveable plug adaptor 10 will help with identification of identical appliances. For example, if two appliances are turned on at the same instant in time it may become difficult to determine what has happened. In general this can probably be ignored, as it is unlikely that appliances will turn on over the same millisecond and any errors introduced in this way will be a small part of the total electrical consumption.

However it may be prudent to use an adaptor 10 with high consumption appliances so that more detailed data can be provided to the system. If, for example, a washing machine were fitted with one of these then the adaptor 10 would signal when current flows through it and the single central sensor 2 would know the difference between this appliance and other general appliances being turned on in the house.

The adaptor 10 could also be used to turn on and off the appliance, whereby the system could manage the appliance to run at night when electricity is cheaper.

A further advantage of the moveable adaptor 10 is that it can be moved to a different wall outlet. For example, if the system recognised and learned the behaviour of a refrigerator at the first outlet it could email the householder and request the householder to move the adaptor to a new outlet. The message might read: *'At 18:06 this evening an appliance was turned on of 60 watts and the system can not determine what it is. Please move Mobile Adaptor 3 from current location on refrigerator to the outlet socket using this*

*appliance and allow the system to learn the characteristics of this appliance. Thank you—  
Click here if you do not want another email reminder of this event.'*

Eventually the householder may settle on having a few of these mobile adaptors 10 in the house, some of which are permanently connected to important appliances and are used to monitor and control these appliances directly. The remainder of these moveable units 10 may be moved around the house at the discretion of the householder and in sympathy with requests from the networked control system.

Another advantage of using a moveable adaptor 10 is that it could recognise which appliances use significant electricity even when turned off or in standby mode. It is common for household appliances to use built in transformers, which use considerable energy heating the transformer even when the appliance is effectively turned off. The adaptor will inform the central monitor of power at all times and the system can then recognise that the appliance is consuming whilst in standby mode and send an email to the householder recommending that the appliance be disconnected from the mains when not in use.

Whenever the householder buys a new appliance he would be best advised to connect it with an adaptor 10 for the first few days of operation so that the system can learn the start and stop characteristics of the appliance. This allows the system to evaluate the consumption rate of the appliance and email recommendations to the householder such as above.

The adaptor 10 could be fitted with additional devices to provide location information to the system. For example it could emit a radio signal which is used to triangulate its physical position in space. In this way the central detector could determine the physical location of appliances such as upstairs, 3 metres north, 1 metre east. In this way a detailed map of both the appliances and the location of a householder using an appliance can be pinpointed. This all helps to populate a detailed appliance database and improve communication between the system and householder.

By having a mobile adaptor 10 and rotating it between electrical sockets, the system can use fewer special adaptors than the prior art systems which have permanently fixed adaptors.

### **Behaviour pattern analysis**

Analysing the stored data can provide information on the householder's patterns of behaviour. It will be possible to observe patterns of behaviour over a weekly basis. For example, the system can notice that every Tuesday the television is switched on at the same time of day and notice on Fridays that the householder gets home 2 hours later than on other workdays. Having detected these patterns of behaviour, the system can alter the control of appliances to provide improved comfort and cost to the householder. This is particularly useful in optimising high energy-consuming appliances such as heating and air conditioning. So on the days that the householder is expected home late the system can defer heating the house to its full temperature until just before the householder is expected. Other applications would be to cook or defrost food in anticipation of the householder's arrival, to complete a washing machine cycle at a time when the householder is likely to be available to remove the washing or to record automatically a television programme that the householder regularly watches. The householder would have to agree to this level of autonomous control and would interface with the computer via the communications network either through a web page or through an interface panel within the house.

### **Instantaneous behaviour analysis**

In addition to building a model of the historical behaviour of the occupants of the house, the system can detect the instantaneous behaviour at any one instant and this can be used to modify the energy control parameters.

Appliances are generally turned on when an occupant of the house presses a switch. The system can use this to determine what activity is taking place within the house. At any

one instant in time the behaviour model can probably deduce how many occupants are in the house, where they are and a rough idea of what they are doing. This could be used to

- control the temperature of the room the occupants are in. Other rooms could be heated to a lower temperature (if individual room temperature control is available).
- recognize a sudden change of behaviour such as an unexpected reduction in activity of an elderly or infirm person. The change in behaviour pattern can be used to email a warning to a nearby relative.

The single central sensor system can alter the control temperature of the house if the householder is obviously active or has gone out. The activity level of the householder can be inferred from the appliances detected within the house. For example, if the householder is using the vacuum cleaner the system might decide to reduce the control temperature within the house until the cleaning has stopped. A reduction in temperature can both reduce the energy consumed by the house and also make the environment more comfortable for the householder whilst they are exercising with the vacuum cleaner. On the other hand, if the system knows that only one person lives in the house and has noticed that the TV is switched on, it may be reasonable to deduce that the householder is static and a slight increase in house temperature would be more comfortable. If two people are in the house then a gated logic decision is required in the control functions to ensure the warmest state is chosen (e.g. the temperature is warmed for a static person even if other one is using the vacuum cleaner)

Alternatively, if the burglar alarm is set, then the system can deduce that all occupants of the house are out and lower the house temperature. A special transponder could be included in the burglar alarm to communicate directly with the single central sensor to inform it that the alarm is set and all occupants are out of the house.

The position and movement of the householder can be noted from the householder's mobile phone and the location detected by the phone network. If the wider system includes access to the mobile phone network then the distance of the householder from their home can be determined and if the householder is far away then the house

temperature can be lowered. For example if the transient model says the house can be heated up to full temperature within 30 minutes and the householder is known to be more than 30 minutes away then the heating system can be turned off completely.

Location information could also be provided based on other monitored activities of the householder. For example, if the householder is using a computer at his/her workplace, then that computer or an Internet service provider could relay the householder's location to the household energy management system. The system could also be networked with other locating systems, such as a congestion charging system that would monitor the location of the householder's car.

In summary, the household temperature can be linked to the activity of the householder and his actual location rather than being linked to a time clock as with current house heating systems.

### **Meter reading**

The system builds up and records detailed energy consumption data and by integrating this over time it can record the total energy (kW.h) used and so become an energy meter. This allows billing information to be sent to the customer and the utility directly over the communications network, as shown in Figure 4.

Not only can the system determine the total energy consumption over the day or week, but it also knows what time of day these units of electricity are used. This enables it to be used by a utility selling electricity to offer the customer variable tariffs during the day or during the week or month. So a customer could chose a tariff arrangement, which gives low price electricity most of the time but very expensive electricity at peak times of demand. This option is already available industrially but is too expensive to meter for small scale domestic users. A customer choosing such a tariff arrangement would save money by getting a better rate for general consumption and as long as consumption is minimised during peak hours would save overall. (It should be noted that in the U.K.'s electricity market, peak hourly electricity prices during the year can reach 100 times

average electricity price and so it would be important for the householder to know when to cut back.)

This variable tariff system could become quite sophisticated offering different rates over the course of one day and different rates from day to day. The customer could be kept informed of these tariffs over the Internet interface available through the total networked system or through daily emailed updates of any rate changes.

The system can identify when the householder operates high consumption appliances and may benefit by altering the time of operating these appliances – e.g. turning the washing machine on at a night when electricity is cheaper.

#### **Interaction with energy utility**

The system described can be integrated to communicate directly with the supplier of energy. For example a feature can be included, which allows the electricity supplier to turn appliances on and off to smooth the peak demand which occurs on the grid network. The householder would benefit through a price reduction under such an arrangement.

It is also possible to allow the gas supplier to control the gas heating of a house. For example, on the coldest winter days the gas supplier knows that demand is going to peak at its highest level of the year and may not have the capacity to pass enough gas down the pipelines to meet demand. With the proposed system it is possible for the networked houses to have heating turned on a few hours early such that the house is pre-warmed before peak demand time. Although this is likely to increase the total gas consumption it will reduce the peak demand later in the day and has this operational benefit to the gas supplier who can avoid building additional gas transmission pipelines and pumping equipment. The customer can be encouraged to buy into this scheme through improved annual prices.



### **Monitoring electrical quality**

The single central sensor 2 located at the point of electrical entry to the house can be used to monitor the quality of electricity supplied to the building. In this way it can monitor not only total loss of power during power cuts and its duration but also alterations in frequency, brief spikes of power, dips in voltage. This information can be useful to the householder in monitoring the quality of electricity supplied. If the electricity does not meet requirements, the householder has the opportunity of demanding compensation or improvements from the supplier with the evidence provided by the single central sensor 2. Communication could again be achieved through the Internet, such as web page access or email.

### **Appliance health monitoring (Figure 7)**

The system can be used to compare the start-up characteristics of each appliance on a day-by-day basis. In this way the system can monitor the health of the householder's appliances and warn of problems. For example, an electric motor in a washing machine may have a start-up characteristic when new of Type B, as shown in Figure 7. However, the characteristic of the motor will change as the motor ages and the bearings stiffen and the brushes wear. Towards the end of normal life, the brushes may arc and the motor will take longer and/or require more current to reach speed. This can be monitored by the single central sensor 2. The analysis software can detect these changed characteristics (such as a move to characteristic Type B<sub>x</sub>) and compare them to known acceptable behaviour. If the appliance falls outside predetermined limits then an alarm (e.g. an email/text message) can be sent to either the householder or a maintenance technician who can arrive and fix the motor before it fails. Early warning like this provides the householder with preventative maintenance, which reduces the inconvenience and cost of unexpected failures.

The single central sensor could monitor for arcing across the brushes of a motor and to include this function it would monitor for electrical noise during continuous operation, and not just the motor start-up characteristics.

The system will be able to carry out optimisation calculations and recommend to the householder whether an appliance is worth repairing or is best replaced. For example, it may calculate that the washing machine, which is about to fail, has a high probability of further failures (based on a database of typical failure rates). It may find that the cost of two repairs in succession combined with say improved energy consumption of the latest appliance would mean that the householder would be best to replace the appliance rather than repair it. An appropriate message can be sent to the customer with or without an option to buy a replacement appliance through the system. This sort of calculation could be quite detailed including interest rates, probability of failure rates and details on spare parts costs, a database of known appliances and their life expectancies. It offers an online optimisation cost calculation, which is not currently feasible to a householder.

A further appliance health monitoring method is available through counting the number of cycles and hours of operation an appliance has completed. In this way any appliance can be monitored for life consumed and an estimate made of remaining life based on a database of typical expected lifetimes for appliances such as fridges, freezers, cookers or heating boilers. This database could even include model specific data for improved accuracy.

Over time the networked system would learn by itself and build its own life expectancy databases from its own data. This database would be useful as a way of evaluating the value of different appliances and recommending longer-lived appliances for householders to buy.

### **Transient thermal model**

A transient thermal model of the house can be generated and validated by the system. It can be used to:

- Determine when the heating should be turned on and off and so optimise the use of the heat consumed.
- Carry out health monitoring of the heating/insulation systems and recommend maintenance actions.

- Compare the house to other houses or standard models of average houses

A transient thermal model of the house heating is a mathematical model of the house heating characteristics including terms for the steady state heat loss and also terms for its transient thermal performance. For example, a heavy, brick built house will take longer to heat up and cool down than a lightweight, wooden/fibreboard construction and terms in the mathematical model are included for mass, thickness and specific heat of materials etc.

Terms in the thermal model would include:

- Heat transfer coefficient inside house.
- Heat transfer coefficient outside house – terms including effect of wind, rain, humidity etc.
- Temperature inside.
- Temperature outside.
- Materials of construction including thickness, thermal insulation qualities, mass, specific heat.
- Wind resistance of apertures such as doors and windows.

These parameters can be estimated at first from the householder informing the system of the age of house and its type of construction. From then on the model will measure the actual response of the house to varying thermal conditions and adapt the mathematical model until a good fit is obtained between actual response and mathematically modelled response. This is illustrated in Figure 8.

At time 0 the heating is turned on and the actual temperature rises (as shown by Line 1) until it reaches the control temperature at its peak and the heating is turned off. From here the temperature falls according to Line 2 until the minimum temperature is recorded and the heating is started up again. By sensing the electrical operation of heating controls such as a thermostat or gas valve, the single central sensor 2 will detect the time points when the maximum and minimum temperatures are reached and it can compare the actual

times to the mathematically predicted response. Differences in these two will demand the software changes the coefficient terms in the model until the best fit with all known data is achieved. For the first few days the system may be inaccurate, but later once a larger database of known heating and cooling times is known the mathematical model will become increasingly accurate.

The system can use network data to improve validity. For example it can be informed of local weather from existing Internet weather databases which have weather information from nearby weather stations.

### **Improved heating control**

In traditional systems the householder uses a time controller to define when the heating (or air conditioning) should turn on and off. With the use of the transient thermal model, the householder can now define when the house is to reach the controlled temperature schedule rather than when to start heating. This allows the single central sensor system to calculate the optimum time to turn on. For example, say the householder returns home at 17:30 in the evening and wants the house at the desired temperature at 17:30. The system can use the transient model to calculate the time it will take to reach the desired temperature: on a cold windy day this might be 1 hour and on a mild day it might be 30 minutes. In this way the heating system is turned on for the minimum time and the house consumes the minimum heat energy.

### **Control to a lower temperature than the thermostat set temperature (Figure 9)**

The transient thermal model can be used to provide a crude control system without referring to the house thermocouple temperature sensor. This would allow the system to control to a reduced temperature (Line 2) without alteration to the existing thermostat fitted to an existing house heating system, which is set at a higher temperature (Line 1). Figure 9 shows how this would happen. The transient model would be used to determine how fast the house heats up and cools down and the heating appliance (such as a gas boiler) would be turned on and off in response to the mathematical prediction of internal temperature in order to maintain the temperature close to a desired average. This does not

require a house thermocouple for feedback, which means it would have a tendency to drift in temperature, as seen in the slope of Line 2 in Figure 9. This is unacceptable in the long term but may serve for short periods when temperatures below the house thermostat set point are required.

### **Thermal efficiency monitoring**

The validated thermal transient model can be used to compare the house to national house norms. In this way the thermal characteristics of the house can be compared to acceptance limits and weaknesses in the house thermal characteristics can be identified and remedied. For example the system may notice that the house cools down unusually quickly on windy days and yet has a normal cooling characteristic under still air conditions. This will indicate that the house is susceptible to wind and is therefore draughty. An email could be sent to the householder or maintenance contractor to investigate and remedy the situation.

Each of the terms in the thermal transient model can be compared in this manner and the house can be evaluated including the specific heat properties of building materials. Energy saving measures that are recommended in this way are thus based on actual measurements of the house characteristics, rather than generic recommendations which are given to all householders.

### **Heating health monitoring**

The transient thermal model can be used to determine the operational health of the heating system within the house. As explained previously, the system will continuously adjust coefficients within the transient thermal model to ensure it aligns with the true house thermal response. Over months of operation, these coefficients will drift as the thermal characteristics of the house worsen with age. This will be most noticeable with a heating boiler as it becomes fouled through use – the house will begin to take longer to heat up. This gradual drift in characteristics can be used to monitor the degradation of the heating boiler and when a predetermined limit is met then maintenance action can be recommended to the householder or service provider. This active monitoring of boiler

health will provide the householder with more optimal expenditure on maintenance, rather than just maintaining the boiler annually when it may still be in good condition.

It may be thought that a simpler health monitoring system would be to just monitor the time it takes for the house heating to reach temperature, without the use of the transient thermal model. However such a simple system makes no allowance for the changes in weather conditions that occur. By using the transient thermal model as the basis, changes in weather are automatically accounted for within the model leaving just deterioration in boiler efficiency as the remaining explanation for deteriorating performance.

On a system where the single central sensor 2 has difficulty detecting changes such as the electrically powered gas valve opening on the gas boiler, a special house thermostat that communicates with the single central sensor 2 can be used. This thermostat acts as a normal house thermostat – switching open and closed as the temperature rises and falls through set limits. However, it communicates this to the single central sensor 2 so that the system can still determine when temperature limits are reached and the transient thermal model can still be aligned with the real thermal response.

### **Managing the system**

The system described is capable of making decisions for the householder on a minute by minute basis. Initially it will do this in a pre-programmed way – making assumptions about house temperature and timings that are best estimates. However, the system needs a method of improving, learning and adapting to the particular householder's preferences. The householder can do this by informing the system as to whether the result is acceptable. For example, if the householder finds the temperature one day to be too cool in the morning, the householder could open a web page interface window on the system's Internet interface and click appropriate pages to instruct the system that the wrong response was achieved. The more this is done the more the system will adapt to the actual preferences of the user.

CLAIMS

1. A household energy management system, comprising:
  - at least one sensing means, which measures energy use by occupants of the house;
  - a modelling means, which uses the energy measurements from the sensing means to build a model of the behaviour of the occupants; and
  - a control means, which controls the operation of one or more household appliances in the house on the basis of the model.
2. A household energy management system according to claim 1, wherein the modelling means builds a predictive model of the pattern of behaviour of the occupants over time.
3. A household energy management system according to claim 2, wherein the modelling means continually refines the model in response to new measurements by the sensing means.
4. A household energy management system according to claim 2 or claim 3, wherein the predictive model predicts the times when the house will be occupied and the control means controls the operation of one or more household appliances on the basis of the predicted times when the house will be occupied.
5. A household energy management system according to claim 4, wherein the control means controls the operation of heating or cooling appliances to achieve a desired temperature when the model predicts that the house will be occupied.
6. A household energy management system according to claim 5, wherein the control means controls the operation of the heating or cooling appliances in such a way as to minimize the amount of energy used to achieve the desired temperature.

7. A household energy management system according to any preceding claim, wherein the modelling means builds a temporary model of the current behaviour of the occupants.
8. A household energy management system according to claim 7, wherein the control means controls the operation of heating or cooling appliances to achieve a desired temperature according to the current level of activity of the occupants.
9. A household energy management system according to any preceding claim, wherein the model of the behaviour of the occupants includes a determination of whether the house is occupied.
10. A household energy management system according to claim 9, wherein the modelling means has an interface with an intruder alarm system in the house and uses signals received from the intruder alarm in its determination of whether the house is occupied.
11. A household energy management system according to claim 9 or claim 10, wherein the system receives signals indicating the location of the occupants when they are not in the house and wherein the modelling means uses the location signals in its determination of whether the house is occupied.
12. A household energy management system according to claim 11, wherein the modelling means further uses the location signals to predict when the occupants might return to the house.
13. A household energy management system according to claim 11 or claim 12, wherein the locations of the occupants are determined by a mobile telephone network or by a global positioning system.



14. A household energy management system according to any preceding claim, further comprising alerting means, which trigger an alert when an unexpected pattern of behaviour by the occupants of the house is detected.
15. A household energy management system according to any preceding claim, wherein the sensing means measures electrical activity within the house.
16. A household energy management system according to claim 15, wherein at least one sensing means comprises a moveable sensor for location between an electricity supply outlet and an individual electrical appliance to measure the energy use by that appliance.
17. A household energy management system according to claim 15 or claim 16, wherein at least one sensing means comprises a fixed sensor on the household electricity supply to measure the respective energy uses of a plurality of electrical appliances connected to the supply, the sensor comprising means for measuring the instantaneous total power delivered by the electricity supply and means for identifying the appliances on the basis of their respective start-up characteristics when the appliances are switched on.
18. A household energy management system, comprising:
  - one or more temperature sensors for measuring the temperature inside the house;
  - a source of information about the temperature outside the house;
  - a modelling means, which uses the inside and outside temperature measurements to derive a transient thermal model of the house, which can predict changes in the inside temperature on the basis of the information about the outside temperature;
  - means for comparing the derived transient thermal model with a reference transient thermal model; and
  - means for warning a user of the system when the derived model differs from the reference model by more than a predetermined limit.

19. A household energy management system according to claim 18, further comprising a source of information about the wind speed and/or humidity outside the house, which is used by the modelling means to derive the transient thermal model of the house.
20. A household energy management system according to claim 18 or claim 19, further comprising one or more sensors outside the house, which are the source of the information about the outside temperature and/or wind speed and/or humidity.
21. A household energy management system according to any of claims 18 to 20, further comprising means for receiving broadcast weather information, which is the source of the information about the outside temperature and/or wind speed and/or humidity.
22. A household energy management system according to any of claims 18 to 21, wherein the reference transient thermal model is a standard model for the type of house in which the system is installed.
23. A household energy management system according to claim 22, wherein the warning means warns the user that the thermal properties of the house are poor.
24. A household energy management system according to any of claims 18 to 21, wherein the derived transient thermal model is periodically updated; and wherein the reference transient thermal model is a derived transient thermal model from an earlier period.
25. A household energy management system according to claim 24, wherein the warning means warns the user that the thermal properties of the house have deteriorated.
26. A household energy management system according to claim 24 or claim 25, further comprising means for informing the modelling means when heating or cooling appliances in the house are operated, whereby the modelling means models the thermal

response of the house to operation of the appliances and whereby the warning means warns the user of poor efficiency or deteriorating efficiency of the appliances.

27. A household energy management system according to claim 26, wherein the warning means further comprises signalling means for summoning an engineer to repair the inefficient appliances.

28. A household energy management system according to claim 26 or claim 27, wherein the means for informing the modelling means when heating or cooling appliances in the house are operated includes sensing means for measuring electrical activity within the house.

29. A household energy management system according to claim 28, wherein at least one sensing means comprises a fixed sensor on the household electricity supply to measure the respective energy uses of electrical appliances connected to the supply, the sensor comprising means for measuring the instantaneous total power delivered by the electricity supply and means for identifying the appliances on the basis of their respective start-up characteristics when the appliances are switched on.

30. A household energy management system according to any of claims 18 to 29, further comprising a control means, which controls the operation of heating or cooling appliances based on the predictions of the transient thermal model, in order to achieve a desired temperature in the house at a given time using the minimum amount of energy.

31. A household energy management system according to claim 30, wherein the control means switches the heating or cooling appliances periodically on and off at intervals determined in accordance with the transient thermal model to maintain the temperature in the house within a desired range, without the use of a thermostat.

32. A household energy management system, comprising:  
at least one sensor on the household electricity supply for measuring the instantaneous total power delivered by the electricity supply;

means for identifying electrical appliances connected to the supply on the basis of their respective start-up characteristics when the appliances are switched on;

means for comparing the sensed start-up characteristics with reference characteristics; and

means for warning a user of the system when the sensed characteristics differ from the reference characteristics by more than a predetermined limit.

33. A household energy management system according to claim 32, wherein the comparison means further compares operating characteristics and/or shut down characteristics of the appliances with corresponding reference characteristics.

34. A household energy management system according to claim 32 or claim 33, further comprising means for recording the total time of operation and/or the number of cycles of operation of each appliance.

35. A household energy management system according to claim 34, including means for accessing a database of lifetime expectancy and reliability for different appliances, against which the logged data can be compared.

36. A household energy management system according to claim 35, wherein the means for accessing the database provide access to a database on an external network; and wherein the means for accessing the database also allow the database to be updated with measured lifetime and reliability data for appliances connected to the system.

37. A household energy management system according to claim 35 or claim 36, further comprising modelling means receiving signals from the comparison means and from the database in order to recommend to the user of the system a program of maintenance or replacement of the appliance.

38. A household energy management system according to any of claims 32 to 37, further comprising means for recording the quality of the electricity supply.

39. An energy management network, comprising:  
storage means for storing a database of lifetime expectancy and reliability for different household appliances;  
a plurality of household energy management systems in accordance with any of claim 35 to 38; and  
a network to which the storage means and the energy management systems are connected to enable communication of data between the database and the energy management systems.
40. A method of operating a household energy management system, comprising the steps of:  
measuring energy use by occupants of the house;  
using the energy measurements to build a model of the behaviour of the occupants; and  
controlling the operation of one or more household appliances on the basis of the model.
41. A method of operating a household energy management system, comprising the steps of:  
measuring the temperature inside the house;  
receiving information about the temperature outside the house; and  
using the inside and outside temperature measurements to derive a transient thermal model of the house, which can predict changes in the inside temperature on the basis of the information about the outside temperature;  
comparing the derived transient thermal model with a reference transient thermal model; and  
warning a user of the system when the derived model differs from the reference model by more than a predetermined limit.
42. A method of operating a household energy management system, comprising the steps of:

measuring the instantaneous total power delivered by the household electricity supply;

identifying electrical appliances connected to the supply on the basis of their respective start-up characteristics when the appliances are switched on;

comparing the sensed start-up characteristics with reference characteristics; and

warning a user of the system when the sensed characteristics differ from the reference characteristics by more than a predetermined limit.

## **Amendments to the claims have been filed as follows**

### CLAIMS

1. A household energy management system, comprising:
  - at least one sensing means, which measures energy use by occupants of the house;
  - a modelling means, which uses the energy measurements from the sensing means to build a model of the behaviour of the occupants; and
  - a control means, which controls the operation of one or more household appliances in the house on the basis of the model.
2. A household energy management system according to claim 1, wherein the modelling means builds a predictive model of the pattern of behaviour of the occupants over time.
3. A household energy management system according to claim 2, wherein the modelling means continually refines the model in response to new measurements by the sensing means.
4. A household energy management system according to claim 2 or claim 3, wherein the predictive model predicts the times when the house will be occupied and the control means controls the operation of one or more household appliances on the basis of the predicted times when the house will be occupied.
5. A household energy management system according to claim 4, wherein the control means controls the operation of heating or cooling appliances to achieve a desired temperature when the model predicts that the house will be occupied.
6. A household energy management system according to claim 5, wherein the control means controls the operation of the heating or cooling appliances in such a way as to minimize the amount of energy used to achieve the desired temperature.

7. A household energy management system according to any preceding claim, wherein the modelling means builds a temporary model of the current behaviour of the occupants.
8. A household energy management system according to claim 7, wherein the control means controls the operation of heating or cooling appliances to achieve a desired temperature according to a current level of activity of the occupants as modelled in the temporary model of the current behaviour of the occupants.
9. A household energy management system according to any preceding claim, wherein the model of the behaviour of the occupants includes a determination of whether the house is occupied.
10. A household energy management system according to claim 9, wherein the modelling means has an interface with an intruder alarm system in the house and uses signals received from the intruder alarm in its determination of whether the house is occupied.
11. A household energy management system according to claim 9 or claim 10, wherein the system receives signals indicating the location of the occupants when they are not in the house and wherein the modelling means uses the location signals in its determination of whether the house is occupied.
12. A household energy management system according to claim 11, wherein the modelling means further uses the location signals to predict when the occupants might return to the house.
13. A household energy management system according to claim 11 or claim 12, wherein the locations of the occupants are determined by a mobile telephone network or by a global positioning system.



14. A household energy management system according to any preceding claim, wherein the sensing means measures electrical activity within the house.
15. A household energy management system according to claim 14, wherein at least one sensing means comprises a moveable sensor for location between an electricity supply outlet and an individual electrical appliance to measure the energy use by that appliance.
16. A household energy management system according to claim 14 or claim 15, wherein at least one sensing means comprises a fixed sensor on the household electricity supply to measure the respective energy uses of a plurality of electrical appliances connected to the supply, the sensor comprising means for measuring the instantaneous total power delivered by the electricity supply and means for identifying the appliances on the basis of their respective start-up characteristics when the appliances are switched on.
17. A method of operating a household energy management system, comprising the steps of:
- measuring energy use by occupants of the house;
  - using the energy measurements to build a model of the behaviour of the occupants; and
  - controlling the operation of one or more household appliances on the basis of the model.



INVESTOR IN PEOPLE

Application No: GB 0327583.1  
Claims searched: 1-17, 40

57

Examiner: Tyrone Moore  
Date of search: 13 April 2004

### Patents Act 1977 : Search Report under Section 17

#### Documents considered to be relevant:

Category	Relevant to claims	Identity of document and passage or figure of particular relevance
X	1, 14, 18	GB 2212949 A (STONECREST LIMITED) Whole Document.
X	1, 14, 18	WO 2002/090914 A1 (EMERSON RETAIL SERVICES INC) Whole Document.
A		EP 0883050 A1 (ELECTRICITE DE FRANCE) See WPI abstract. AN - 1999 - 011837 [02]
A		US 5197666 (WEDEKIND) Whole Document.

#### Categories:

X	Document indicating lack of novelty or inventive step	A	Document indicating technological background and/or state of the art.
Y	Document indicating lack of inventive step if combined with one or more other documents of same category.	P	Document published on or after the declared priority date but before the filing date of this invention.
&	Member of the same patent family	E	Patent document published on or after, but with priority date earlier than, the filing date of this application.

#### Field of Search:

Search of GB, EP, WO & US patent documents classified in the following areas of the UKC<sup>w</sup>:

G3N

Worldwide search of patent documents classified in the following areas of the IPC<sup>7</sup>:

F24F; G05B; G05D; G06F

The following online and other databases have been used in the preparation of this search report :

WPI, EPODOC, JAPIO.

(19) World Intellectual Property Organization  
International Bureau



(43) International Publication Date  
26 March 2009 (26.03.2009)

PCT

(10) International Publication Number  
**WO 2009/036764 A2**

(51) International Patent Classification:  
G05D 23/19 (2006.01)

(74) Agent: DANFOSS A/S; Patent Departemnt, DK-6430 Nordbor (DK).

(21) International Application Number:  
PCT/DK2008/000331

(81) Designated States (unless otherwise indicated, for every kind of national protection available): AE, AG, AL, AM, AO, AT, AU, AZ, BA, BB, BG, BH, BR, BW, BY, BZ, CA, CH, CN, CO, CR, CU, CZ, DE, DK, DM, DO, DZ, EC, EE, EG, ES, FI, GB, GD, GE, GH, GM, GT, HN, HR, HU, ID, IL, IN, IS, JP, KE, KG, KM, KN, KP, KR, KZ, LA, LC, LK, LR, LS, LT, LU, LY, MA, MD, ME, MG, MK, MN, MW, MX, MY, MZ, NA, NG, NI, NO, NZ, OM, PG, PH, PL, PT, RO, RS, RU, SC, SD, SE, SG, SK, SL, SM, ST, SV, SY, TJ, TM, TN, TR, TT, TZ, UA, UG, US, UZ, VC, VN, ZA, ZM, ZW.

(22) International Filing Date:  
19 September 2008 (19.09.2008)

(25) Filing Language: English

(26) Publication Language: English

(30) Priority Data:  
PA 2007 01362 20 September 2007 (20.09.2007) DK

(71) Applicant (for all designated States except US): DANFOSS A/S [DK/DK]; DK-6430 Nordborg (DK).

(84) Designated States (unless otherwise indicated, for every kind of regional protection available): ARIPO (BW, GH, GM, KE, LS, MW, MZ, NA, SD, SL, SZ, TZ, UG, ZM, ZW), Eurasian (AM, AZ, BY, KG, KZ, MD, RU, TJ, TM), European (AT, BE, BG, CH, CY, CZ, DE, DK, EE, ES, FI, FR, GB, GR, HR, HU, IE, IS, IT, LT, LU, LV, MC, MT, NL, NO, PL, PT, RO, SE, SI, SK, TR), OAPI (BF, BJ, CF, CG, CI, CM, GA, GN, GQ, GW, ML, MR, NE, SN, TD, TG).

(72) Inventors; and

(75) Inventors/Applicants (for US only): IVANG, Lone [DK/DK]; Sundmarksvej 22, DK-6400 Sønderborg (DK). GARM, Fester [DK/DK]; Funderholmevej 62, DK-8600 Silkeborg (DK). ANDERSEN, Ejner, Kobberø [DK/DK]; Flædbækvej 5, Elstrup, DK-6430 Nordborg (DK). SØRENSEN, Benny, M. [DK/DK]; Ellegade 1, DK-6300 Graasten (DK).

Published:

— without international search report and to be republished upon receipt of that report

(54) Title: DISTANCE REGULATED ENERGY CONSUMING DEVICES

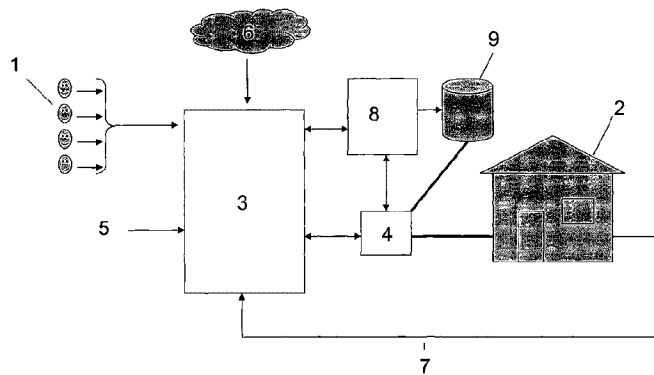

Fig. 1

(57) Abstract: This invention relates to a unique occupancy-based electronic control of energy consuming devices, such as household devices like, but not limited to, thermostats, HVAC systems, radiators in general, or any device consuming energy even though no users of the device are present. The control and/or regulation is based on the distance and velocity of the inhabitants relative to the household. An additional feature is a peak load management system ensuring to store energy in energy reservoirs prior to load peaks on the electricity distribution network, using this energy during the load peaks.

WO 2009/036764 A2

## DISTANCE REGULATED ENERGY CONSUMING DEVICES

### 5 Background of the invention

Many residential homes in e.g. the USA only have one thermostat controlling the whole house. The thermostat is often located next to the main entrance, making installations very standardized and easy to handle.

10 Furthermore, a large share of these households are only equipped with a simple heating/cooling electro-mechanical thermostat without any possibility of programming. In the few households having a programmable thermostat, this is highly dependant on the owner being able to program it correctly. The world wide waste of such energy resources gives a huge

15 potential for energy savings.

Further, the consumption of electricity is not evenly distributed over the year, not even over the day. About two to four times a day, normally in the morning and in the evening, the consumption of electricity is very high,

20 causing load peaks on the electricity distribution network. Sometimes the peaks are so big that black-outs occur.

This invention relates to the reduction of the consumption energy when it is not needed.

25

### Summary of the invention

This invention relates to a unique occupancy-based electronic control of energy consuming devices, such as household devices like HVAC

30 systems, or any other devices consuming energy even when no inhabitants or persons are using or even being close to the devices.

The basic feature of this invention is to adjust the energy consuming devices according to residents/users locations, where the locations are provided by their cell phone/mobile phone or any other portable device being trackable or traceable in geographic location and in time (either via  
5 GPS or triangulating), in the following being referred to as their position identification device or devices..

One preferred, but non-limiting, example of the invention relates to the control of a thermostat controlling the cooling and heating of a household  
10 by a HVAC system. The idea of the invention, therefore, is to facilitate energy savings by allowing the HVAC systems to drift off when the comfort temperature is not required, as the house is not occupied.

The underlying principle being that the household thermostat will be so  
15 intelligent that the energy saving will happen automatically without the household members actually having to do something for it and without compromising on the comfort.

The idea for the occupancy-based electronic thermostat example is that:  
20

1. If no persons are at home, the thermostat will automatically alter the set-point away from the specified comfort temperature.
2. The occupancy detection is built-in and will be linked to the  
25 household members' position identification device.
3. By linking to the individual position identification device ,it will be possible to off-set the comfort temperature in accordance with the household members' distance to the home (being at work, in  
30 school, on holiday etc.); ensuring that the comfort temperature will be re-established before their return by tracking the distance.

4. Additionally, the system will also be able to receive information about the current weather, making automatic night set-back etc., possible via the phone system.
- 5 The concept naturally bears the potential to be expanded to include other applications – e.g. terminating stand-by functions while the household is not occupied.

In an optional, and additional, more advanced embodiment of the present invention, the energy control system maps the individual resident's in a given single household based on their patterns of movement, where the maps vary in a number of dimensions or parameters, such as the residents distance from household, travelling speed, the time of day, the week and the month.

The energy control system, preferably adaptively, learns the resident's typical behaviours and patterns of movement by their position identification device, and uses these to predict a given behaviour of a resident, what the continuation of this behaviour will be, and when the resident will be expected to arrive at the household.

The energy control system preferably uses a dynamic model with deviation control to form the map of the single resident's patterns of movement, based on data obtained automatically from the individual resident's position identification devices. This method gives the energy control system the possibility to fully automatically optimize the overall efficiency of the energy usage in the household.

The energy control system enables convenient and fully automatic energy saving in any household by allowing the climate comfort zone (temperature, humidity, amount of circulated air, incoming sunlight) drift away from a pre-defined zone of the resident's, when the household is not

occupied. Furthermore, the energy control system will switch off all non-essential energy users e.g. TV, PC, DVD, entertainment centre, electric tooth brush and etc. when no one is around to use them. At the same time, the energy control system pays attention to possible return of any resident  
5 to ensure that the climate comfort zone is restored before arrival and ensure that the electric equipment is ready to use again. The essence being that the energy saving is convenient and does not cause any lack of comfort for the residents.

10 Additional to the resident's location, travelling speed and the time and date, the energy control system may combine the ambient environmental conditions, the resident's location information and the indoor environmental conditions to adjust the indoor temperature and also adjust other environmental parameters, like humidity, amount of circulated and/or  
15 re-circulated air to control the indoor air pollution.

The energy control system can be installed in houses, apartments, small offices/commercial buildings, or any other place where an improved energy reduction may be obtained by tracking the users of the place,  
20 compared to for example an energy consumption pre-programmed in time.

The energy control system can be split up into independent units or incorporated into one single, combined unit.

25 In an additional or alternative embodiment of the present invention, the system comprises peak load management.

Since peaks in the local, regional and national energy consumption are predictable through historic data, the energy control system ensures  
30 lowering of the temperature of the household before the peaks occur, perhaps by some offset point temperature predetermined or optionally being calculated based on parameters such as the time for raising the

5

temperature back to the initial value and the distance and e.g. velocity of the inhabitants relative to the household, and the external conditions such as internal and external humidity, external temperature and weather conditions, cloudiness etc.

5

In this embodiment the system may comprise means for storing energy in any manner as known in the art such as batteries, such means shall in the following in general be referred to as energy reservoirs. The system then comprises a storage management system able to ensure that energy is  
10 stored in the energy reservoirs prior to the peak load, and then used during the peak load period, thereby reducing the load on the power grid. This will reduce the load peaks, and give a more evenly spread electricity consumption. Further, it will reduce the amount of standby power plant needed by the energy companies; it will reduce the end user's electricity  
15 bill by reducing the need for electricity in peak periods, where electricity is very expensive.

For short and unpredictable peaks, the storage management system can be allowed to overrule the energy control system temporarily turning of  
20 non-essential energy using devices, but also more essential energy using devices such as fridge, freezer, oven, electric heaters to respond to the peak.

#### Figures:

25

Fig. 1: Schematic view of the controller according to the invention

#### Detailed description

30 Fig. 1 describes the basic idea of the invention, where four users (1) of one or a plural of energy consuming devices (4), the users (4) also referred to as residents (1) of a house (2), are at positions which are



distant from the house (2). 'House' is to be understood as any place where energy consuming devices (4) may be present. Each resident has a position identification device, such as a cell phone with GPS. The positions of the residents (1) are identified by tracking or tracing their position identification devices, e.g. by means of GPS positioned therein, or by simple triangulation to identify the position of the position identification devices relative to the antennas, as done by the telephone companies as a standard.

10 In the following the control of indoor temperature is used as an example, but any energy consuming device, and any combination of any number of energy consuming devices, also applies to the invention.

The device or devices (4) to be controlled or regulated may therefore be a HVAC system, but could alternatively or additionally be for example a TV, radio etc.

The indoor temperature is registered by a sensor. The energy control system comprises a controller (3) connected to all the residents (1) position identification devices enabling the controller (3) to alter the temperature, when the house is not occupied.

The controller (3) is simple to use and install, and may preferably be battery powered. A built-in radio frequency transmitter sends information to e.g. the radiator or floor heating thermostats all over the house (2).

Knowing the position of the residents (1) at any given time also makes it possible to predict residents (1) travelling speeds, and comparing the last known positions to the present locations, enabling the controller (3) to adjust not only the temperature of the house, but also the time in which the offset is increased or decreased.

The distance from the house to the nearest resident is used to determine the offset of the controller (3) ensuring that the indoor temperature is always at the desired level, when the house is occupied.

- 5 The use of individual controllers (3) makes it possible to keep different temperatures in the house (2) and still benefit from the energy savings by offsetting the temperature in the house (2) when it is not occupied, the controllers (3) will just offset from different temperatures.
- 10 As the controller (3) always knows the position of each household resident (1), then no programming is necessary, the controller (3) will alter the temperature accordingly.

The controller (3) in a preferred embodiment learns (possible adaptively) the basic patterns of behaviour of the residents (1), enabling it with some degree of certainty to predict a following movement of a resident (1) given a specific behaviour, especially when the resident(s) arrive within some predetermined distance of the house (2). A plural of such basic patterns will be created, or mapped, for each resident (1), where such a map or

20 basic pattern is a plural of data sets, where a data set as at least position(s) of the residents(s) (1) and the time (at day, possible also the calendar date). Optionally the estimated velocity of the resident(s) (1) also is included in the data(s) where the new data set(s) combined with at least one earlier resident data set (the at least two data sets) is used to choose

25 to which of the established maps or basic patterns of the resident(s) (1) the at least two data sets makes the best fit, using this map or basic pattern to estimate the following behaviour and thereby when the resident is expected to arrive back to the house (2).

- 30 The energy control system, or the controller (3) of the energy control system, always monitors the resident's location at a pre-determined frequency, being the frequency at which data sets are being established;

this frequency will gradually be reduced over time to a minimum as the energy control system device learns and creates the maps or resident's basic patterns of behaviour. This frequency will be increased when residents changes their basic pattern or just when they divert significantly  
5 from any of the known maps or basic patterns of behaviour, and will decrease again when a new pattern is learned or mapped, or the resident falls back to the previous or another of the basic patterns or maps. This feature will prolong the standby time of their position identification devices, like cell phones (GPS device or similar).

10

A plural of such predetermined distances to the house (2) may be defined, also called zones, possibly with individual zones being defined for each resident (1), and possibly determined automatically from their typical basic behaviours. These zones have individual different distances from the  
15 house (2) and may be used to establish how to weight the maps and/or predictions of behaviours, so that they are given an increasing weight or importance for a decreasing distance to the house (2).

A number of additional parameters may be included into the algorithm,  
20 such as any calendar and time data, or external or outdoor environmental conditions (6) (temperature, humidity, rainy conditions, time of day, time of month, time of year etc.), the indoor environmental conditions (7) (temperature, humidity etc.), also being used as feedback parameters, and predetermined (user predetermined) indoor set points (5), such as the  
25 preferred indoor temperature set point. Among the environmental conditions (6) and (7) could be air temperature and humidity, where such parameters can be used by an adaptive regulator to predict the time needed to for example re-cool/heat the house to the set point (5), and in general being parts of an algorithm being dynamic in time, the adjustments  
30 of the device(s) (4) depending as well on the behaviours of the residents (1) and on the surrounding indoor and outdoor conditions, and in a more

advanced embodiment, also for example on the weather forecast possibly received from the internet.

As an example, the energy control system thermostat will regulate the temperature up or down (relative to a set point) according to the outdoor temperature, when all residents are away from household – and thereby enable energy savings. The off-set of temperature is regulated according to the shortest distance of resident to household combined with the maps learned by the energy control system device – ensuring that a set point comfort temperature is reached before return of any household resident.

The system may further take other ambient environmental conditions like rain, snow, wind, humidity, into consideration, increasing the predictability of the time needed to reach the indoor comfort environment, hence increasing the efficiency of the energy usage.

Other non-limiting examples of applications of the energy control system of the invention could be used is:

Regulating indoor lighting according to the amount of incoming sunlight. This will help save energy by actively increasing or decreasing the amount of reflected sunlight in relation to a more efficient cooling, heating of the building and optimized the indoor lighting.

Regulating of thermal load and the amount of air pollution (gases and the like given off by devices (4) for example when cooking in an oven) in the household to optimize the HVAC system according to the outdoor temperature, and the number of resident's present in the household present. The amount of air pollution is determined by the number of persons in the house and the number of electrical equipment work. The energy control system can therefore regulate the air pollution by controlling the circulated, re-circulated air and turn off non-essential stand-

by equipment (TV, PC, DVD, entertainment centre, electric tooth brush etc).

5 The energy control system may comprise micro switches, which can also be used to start and stop both essential and non-essential electric equipment fully automatically or by remote activation (e.g. from cell phone), where such equipment devices (4) could be washing machines, pre-heat pool etc..

10 In an further advanced embodiment of the invention, the energy control system comprises a peak load manager (8) combined with the energy control system controller (3) , where the peak load manager (8) controls an energy reservoir device (9) supporting minimizing peak load disturbance on the electricity grid. This is done, regardless if the household is occupied  
15 or not. The temperature of the household is decreased or increased, depending on outdoor conditions; prior to the peak (predictable peaks).By doing this, the household can maintain a comfortable indoor climate for a longer period of time increasing the on/off hysteresis, using the household as an energy accumulator.

20 In case of unpredictable peaks on the power grid, the non-essential stand-by equipment can be turned off for a longer time frame and essential equipment (freezer, refrigerator, AC, etc.) for a short time frame, thereby reducing the load on the electricity grid.

25 Any number of imaginable devices and systems may be controlled and/or regulated by the energy control system of the present invention.

30 One example is that the energy control system may automatically ensure the switching on of the burglar alarm.

As an additional feature, the energy control system may comprise a 'family finder' that can provide the location of any resident's cell phone upon request.

- 5 The separate devices of this invention are preferably standard devices as they are known in the art, such as the controller (3) and the peak load manager (8) preferably being computer micro chips with a software, and the energy reservoir devices (9) preferably are batteries of any kind known in the art. The needed data transfers, such as information's and
- 10 instructions for the devices (4), the controller (8), the peak load manager (8) etc. may be by wire or wireless, and may be transferred by the telephone net or by internet or any other known system for transferring such data.

Claims:

1. Method of regulating the energy consumption of a device (4), the  
5 method comprising the regulation of the energy consuming device (4) in  
dependence of the position of the user (1) of the device (4), wherein this  
position is used to calculate the distance between the device (4) and the  
user (1).
- 10 2. Method according to claim 1, wherein the position of the user (1) and  
the time of day gives a data set, and where such data sets are used to  
generate maps of the typical daily behaviours of said users (1), said maps  
thus being a plural of data sets, and where the maps are used to estimate  
the users (1) following behaviour and regulates the device(s) (4) based on  
15 this estimate.
3. Method as in claim 2, wherein the position of the user is registered  
through a cell phone or a mobile phone, either by triangulation or by a  
built-in GPS in the cell phone or mobile phone.
- 20 4. Method as in claim 3, wherein the velocity of the user (1) relative to the  
device is also a part of the regulation.
5. Method as in claim 1, wherein external and internal environmental  
25 conditions to the house (2) also are used to regulated the energy  
consuming device(s) (4), such as humidity, temperature, rainy conditions,  
cloudiness etc.
6. Method a in any of the preceding claims, wherein the method further  
30 stores energy in energy reservoirs (9) prior to predictable peaks in the  
power grid and uses this energy to run the energy consuming device(s) (4)  
during the predictable peak.

7. An energy control system to regulate the energy consumption of energy consuming device(s) (4), the energy control system comprising;

- at least one portable position identification device being worn by at least one user (1) of the energy consuming device(s) (4) ,
- a controller (3),

Wherein said controller (3) at a frequency acquires and generates a data set for each portable position identification device, the data set at least comprising the present geographic position and the time of day, whereby the portable identification devices moves, and where such data sets are used to generate maps of the typical daily behaviours of said users (1), said maps being a collection of data sets, and where the maps are used to estimate the users (1) following behaviour and regulates the device(s) (4) based on this estimate.

15

8. Energy control system as in claim 5, wherein the system further comprises a peak load manager (8) controlling an energy reservoir device (9).

20 9. Energy control system according to claim 6 or 7, wherein the energy control system is connected to the telephone net and/or the internet, receiving information being used by the controller (3).



1/1

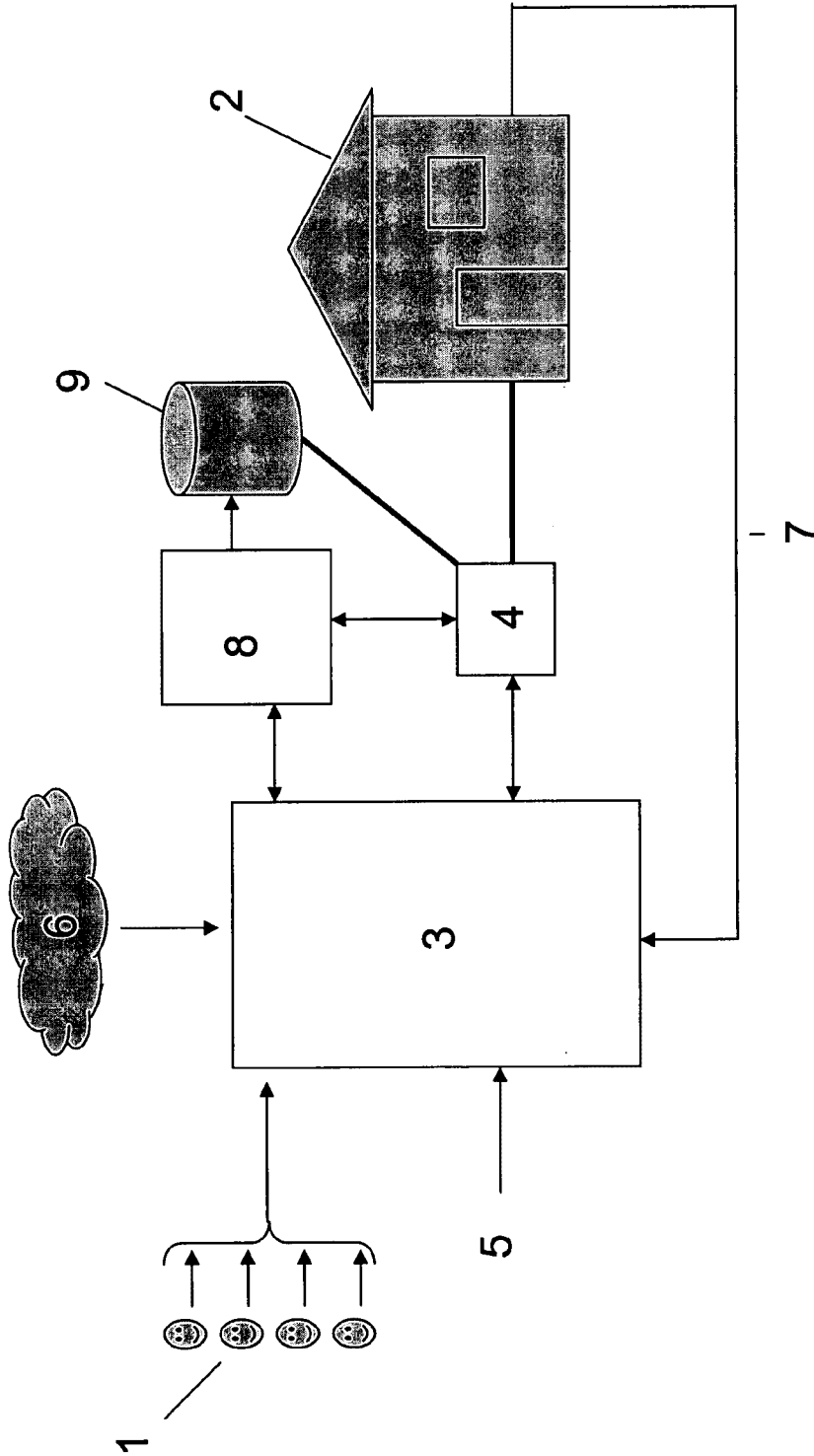

Fig. 1



(51) International Patent Classification:  
G06Q 50/00 (2006.01)

(21) International Application Number:  
PCT/US2011/024346

(22) International Filing Date:  
10 February 2011 (10.02.2011)

(25) Filing Language: English

(26) Publication Language: English

(30) Priority Data:  
61/337,999 12 February 2010 (12.02.2010) US  
13/023,347 8 February 2011 (08.02.2011) US

(71) Applicant (for all designated States except US): EN-PHASE ENERGY, INC. [US/US]; 201 1st Street Suite 300, Petaluma, California 94952 (US).

(72) Inventors; and

(75) Inventors/Applicants (for US only): LEE, Leesa [US/US]; 402 Headlands Court, Sausalito, California 94965 (US). ZAZUETA-HALL, Ilen [US/US]; 7196 Lynch Road, Sebastopol, California 95472 (US). ASBO, Magnus [US/US]; 4 Tilden Lane, Petaluma, California 94952 (US).

(74) Agent: BRUSH, Robert M.; Moser IP Law Group, 1030 Broad Street, Suite 203, Shrewsbury, New Jersey 07702 (US).

(81) Designated States (unless otherwise indicated, for every kind of national protection available): AE, AG, AL, AM, AO, AT, AU, AZ, BA, BB, BG, BH, BR, BW, BY, BZ, CA, CH, CL, CN, CO, CR, CU, CZ, DE, DK, DM, DO, DZ, EC, EE, EG, ES, FI, GB, GD, GE, GH, GM, GT, HN, HR, HU, ID, IL, IN, IS, JP, KE, KG, KM, KN, KP, KR, KZ, LA, LC, LK, LR, LS, LT, LU, LY, MA, MD, ME, MG, MK, MN, MW, MX, MY, MZ, NA, NG, NI, NO, NZ, OM, PE, PG, PH, PL, PT, RO, RS, RU, SC, SD, SE, SG, SK, SL, SM, ST, SV, SY, TH, TJ, TM, TN, TR, TT, TZ, UA, UG, US, UZ, VC, VN, ZA, ZM, ZW.

(84) Designated States (unless otherwise indicated, for every kind of regional protection available): ARIPO (BW, GH, GM, KE, LR, LS, MW, MZ, NA, SD, SL, SZ, TZ, UG, ZM, ZW), Eurasian (AM, AZ, BY, KG, KZ, MD, RU, TJ, TM), European (AL, AT, BE, BG, CH, CY, CZ, DE, DK, EE, ES, FI, FR, GB, GR, HR, HU, IE, IS, IT, LT, LU, LV, MC, MK, MT, NL, NO, PL, PT, RO, RS, SE, SI, SK, SM, TR), OAPI (BF, BJ, CF, CG, CI, CM, GA, GN, GQ, GW, ML, MR, NE, SN, TD, TG).

Published:

— without international search report and to be republished upon receipt of that report (Rule 48.2(g))

(54) Title: METHOD AND APPARATUS FOR SMART CLIMATE CONTROL

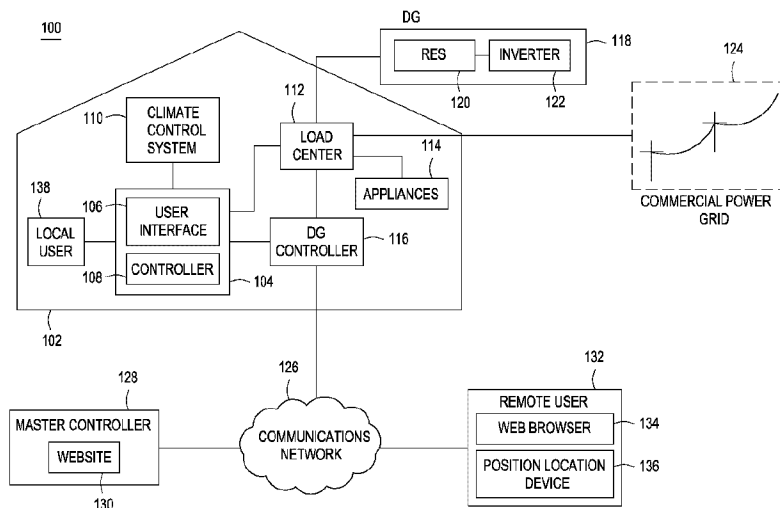

FIG. 1

(57) Abstract: A method and apparatus for controlling climate within a building. In one embodiment, the apparatus comprises a smart climate unit for (i) obtaining distributed generator (DG) information pertaining to operation of a DG that generates power for the building, and (ii) controlling at least one climate condition within the building based on at least one of the DG information, local input, or remote input.

WO 2011/100427 A2

PATENT  
Attorney Docket No.: EE043PCT

## METHOD AND APPARATUS FOR SMART CLIMATE CONTROL

### BACKGROUND OF THE INVENTION

#### Field of the Invention

[0001] Embodiments of the present disclosure relate generally to climate control within a building, and, in particular, smart climate control within the building.

#### Description of the Related Art

[0002] Current worldwide growth in demand for energy is leading to a durable increase in energy usage and a rapid depletion of existing fossil fuels to supply the required energy. Many of today's energy users are in search of ways to utilize energy more efficiently and limit their overall energy consumption. In some cases, energy users may employ distributed generators (DGs) for harvesting power from renewable energy sources, such as solar, wind, hydro, or the like, in order to offset their usage of energy derived from fossil fuels.

[0003] For many energy users, climate control within residential and commercial buildings, i.e., heating, air conditioning, humidity control, and the like, represents one of the largest areas of energy consumption. Given that many buildings are unoccupied over extended periods of time, such as during daytime hours when homeowners are away from their homes or evening hours when workers are away from their businesses, appropriately managing the climate within a building during such times provides an opportunity to reduce energy consumption.

[0004] Therefore, there is a need in the art for a method and apparatus for efficiently controlling a climate within a building.

### SUMMARY OF THE INVENTION

[0005] Embodiments of the present invention generally relate to a method and apparatus for controlling climate within a building. In one embodiment, the apparatus comprises a smart climate unit for (i) obtaining distributed generator (DG) information pertaining to operation of a DG that generates power for the building, and (ii) controlling at least one climate condition within the building based on at least one of the DG information, local input, or remote input.

190905-1

1

PATENT  
Attorney Docket No.: EE043PCT

### **BRIEF DESCRIPTION OF THE DRAWINGS**

[0006] So that the manner in which the above recited features of the present invention can be understood in detail, a more particular description of the invention, briefly summarized above, may be had by reference to embodiments, some of which are illustrated in the appended drawings. It is to be noted, however, that the appended drawings illustrate only typical embodiments of this invention and are therefore not to be considered limiting of its scope, for the invention may admit to other equally effective embodiments.

[0007] Figure 1 is a block diagram of a system employing smart climate control in accordance with one or more embodiments of the present invention;

[0008] Figure 2 is a block diagram of a smart climate unit controller in accordance with one or more embodiments of the present invention;

[0009] Figure 3 is a block diagram of a distributed generator (DG) controller in accordance with one or more embodiments of the present invention;

[0010] Figure 4 is a depiction of a smart climate unit in accordance with one or more embodiments of the present invention;

[0011] Figure 5 is a block diagram of a method for smart climate control in accordance with one or more embodiments of the present invention; and

[0012] Figure 6 is a block diagram of a method for location-based climate control in accordance with one or more embodiments of the present invention.

### **DETAILED DESCRIPTION**

[0013] Figure 1 is a block diagram of a system 100 employing smart climate control in accordance with one or more embodiments of the present invention. This diagram only portrays one variation of the myriad of possible system configurations. The present invention can function in a variety of environments and systems.

[0014] The system 100 comprises a building 102, such as a residential or commercial building, coupled to a distributed generator (DG) 118 and a commercial

## PATENT

Attorney Docket No.: EE043PCT

power grid 124. The building 102 comprises a smart climate unit 104, a climate control system 110, a load center 112, one or more appliances 114, and a DG controller 116. The commercial power grid 124 is coupled to the appliances 114 via the load center 112 for providing power to the appliances 114.

**[0015]** The DG system 119 comprises a renewable energy source (RES) 120 coupled to an inverter 122. The RES 120 may be any type of system for generating DC power from a renewable form of energy, such as wind, solar, hydro, and the like. The inverter 122 converts the generated DC power to AC power that is commercial power grid compliant and couples the AC power to the load center 112. The generated AC power may be further coupled from the load center 112 to the one or more appliances 114 and/or to the commercial power grid 124. Additionally or alternatively, generated energy may be stored for later use; for example, the generated energy may be stored utilizing batteries, heated water, hydro pumping, H<sub>2</sub>O-to-hydrogen conversion, or the like.

**[0016]** In some embodiments, the inverter 122 may be a plurality of inverters utilized to convert the DC power from the RES 120 to AC power; for example, the RES 120 may comprise a plurality of photovoltaic (PV) modules where each PV module is coupled to an inverter in a one-to-one correspondence. Additionally, one or more DC/DC converters may be utilized within the DG 118, for example, coupled between the RES 120 and the inverter 122.

**[0017]** The DG controller 116 is coupled to the load center 112 and provides operational control of the DG 118 via the inverter 122. In some embodiments, the DG controller 116 provides such control utilizing power line communication (PLC) to communicate with the DG 118; additionally or alternatively, the DG controller 116 may utilize other types of wired and/or wireless techniques for communicating with the DG 118. The DG controller 116 is further communicatively coupled to a master controller 128 via a communications network 126 (e.g., the Internet) for sending information to/receiving information from the master control 128 pertaining to the operation of the DG 118. The DG controller 116 may utilize wired and/or wireless techniques for coupling to the communications network 126; in some embodiments,

PATENT

Attorney Docket No.: EE043PCT

the DG controller 116 may be coupled to the communications network 126 via a commercially available router.

**[0018]** In accordance with one or more embodiments of the present invention, the smart climate unit 104 is coupled to the climate control system 110 for driving the climate control system 110 to control the climate (heating, cooling, humidity, heat pump activity, and the like) within the building 102. The smart climate unit 104 provides status displays (e.g., current temperature, humidity level, settings, and the like) and user-controls locally and remotely to allow both local and remote users to gauge current climate conditions and settings and make adjustments as needed. Additionally, the smart climate unit 104 provides location-based control of the climate control system 110 (i.e., control of the climate control system 110 based on the locations of one or more users). The smart climate unit 104 is further coupled to the DG controller 116 for obtaining information related to the operation of the DG 118 (e.g., power production information). The smart climate unit 104 may then utilize such DG information to control the climate within the building 102.

**[0019]** The smart climate unit 104 may be wall mounted or positioned on a desk, table, or the like, and comprises a user interface 106 and a smart climate unit controller 108. The controller 108 provides local control of the smart climate unit 104 via the user interface 106. In some embodiments, the smart climate unit 104 may comprise an available (i.e., "off the shelf") thermostat device which, for example, comprises components such as a microprocessor and memory, and is suitably modified in accordance with the invention described herein.

**[0020]** The user interface 106 provides display capabilities (e.g., to display current status, settings, time of use rates, or the like) and user controls for operatively controlling the smart climate unit 104, for example, by touch screen, buttons, knobs, or the like. Additionally or alternatively, the smart climate unit 104 may be directly coupled to a display and/or an input/output device, such as a personal computer, personal digital assistant, or the like, for providing the user interface 106. In such embodiments, the smart climate unit 104 may be coupled to

## PATENT

Attorney Docket No.: EE043PCT

the device by wired techniques or wireless techniques, for example utilizing standards such as IEEE 802.11, Zigbee, Z-Wave, or the like.

**[0021]** The user interface 106 allows a local user 138 to configure the smart climate unit 104 for initial use and to manually change current settings of the smart climate unit 104 (e.g., increase current temperature, decrease current humidity, or the like). Additionally, the local user 138 may, via the user interface 106, generate and/or change one or more climate control profiles utilized by the smart climate unit 104 for operating the climate control system 110. Such climate control profiles may specify climate control parameters (e.g., preferred temperature, humidity, heat pump settings, and the like) based on criteria such as time, energy mode, user preference, user location, weather conditions, and the like. For example, time-based climate control profiles may specify settings that are based on time of day, day of week, month of year, groupings of certain hours and/or days (e.g., waking/sleeping time, working from home, pet-sitting, vacation periods, holidays), and the like. Energy mode-based climate control profiles may specify settings that are based on criteria related to energy usage, such as energy saver mode, time of use (TOU) rates, current energy consumption, supply conditions (e.g., energy production by the DG 118), peak energy consumption times, and the like. User preference-based climate control profiles may specify preferred settings for one or more users. Location-based climate control profiles may specify settings that are based on proximity of one or more users and/or current travel speed of the one or more users. Weather-based profiles may specify settings that are based on current and/or predicted weather conditions. The smart climate unit 104 may provide a "wizard" function for assisting the local user 138 to initially configure, program, and/or operate the smart climate unit 104.

**[0022]** In addition to providing the local control functionality described above, the controller 108 provides remote control of the smart climate unit 104, allowing a remote user 132 to remotely obtain analogous displays and control for the smart climate unit 104. The smart climate unit controller 108 is communicatively coupled to the communications network 126 such that the remote user 132 may utilize a conventional web browser 134 to remotely access and operate the smart climate

## PATENT

Attorney Docket No.: EE043PCT

unit 104. For example, the remote user 132 may access a website 130 supported by the master controller 128 (or a server having access to the master controller 128) to access the smart climate unit 104 via a password protected portal. The remote user 132 may then execute control of the smart climate unit 104 as if the remote user 132 were local to the smart climate unit 104. For example, the remote user 132 may perform initial configuration of the smart control unit 104 (e.g., utilizing the "wizard"), change current settings of the smart climate unit 104, create new or change existing climate control profiles for the smart climate unit 104, or similarly operate the smart climate unit 104. The remote user 132 may access the smart climate unit 104 in such a manner utilizing any suitable device that provides the web browser 134, such as a smart cell phone, a personal digital assistant, a personal computer, or the like. Additionally, the website 130 may support a plurality of smart climate units 104 deployed within other areas of the building 102 (e.g., different floors) or other buildings.

**[0023]** The smart climate unit controller 108 further provides location-based climate control for the building 102 based on a location of one or more users. For example, the controller 108 may provide climate control for the building 102 based on a location of the remote user 132. In some embodiments, the smart climate unit controller 108 utilizes a position location device 136 as a proxy for determining a location of the remote user 132 and operating the climate control system 110 based on the determined location. The position location device 136 may be any device for locating people and/or assets, e.g., a cell phone, a global positioning system (GPS), a personal digital assistant, ON-STAR service, or the like. For example, the smart climate unit controller 108 may determine the location of the remote user's cell phone utilizing a global positioning satellite (GPS) receiver of the cell phone, cell-triangulation features of the cell phone, or the like. The smart climate unit controller 108 may then drive the climate control system 110 to suitably adjust the temperature and/or humidity within the building 102 based on the determined location of the remote user 132. For example, the smart climate unit controller 108 may leverage existing site information, such as an address of the building 102, to control the



PATENT

Attorney Docket No.: EE043PCT

climate control system 110 based on the remote user's proximity to the building 102 as well as speed of approaching the building 102.

**[0024]** In order to determine appropriate climate settings for the building 102 based on the location of the remote user 132, the smart climate unit controller 108 may maintain one or more location-based climate control profiles associated with the remote user 132. For example, the location-based climate control profiles may specify that air conditioning be turned on when the remote user 132 (i.e., utilizing the position location device 136 as a user-proxy) is within a predefined distance of the building 102, that a certain temperature and/or humidity level be maintained when the remote user 132 is within the building 102, or the like. The smart climate unit controller 108 may additionally factor in travel speed of the remote user 132 in addition to the remote user's distance from the building 102 for suitably operating the climate control system 110. The smart climate unit controller 108 may also maintain location-based climate control profiles for additional users (such as the local user 138) and/or groups of users (such as a family group), utilizing corresponding cell phones/other wireless portable devices as proxies for the additional users. The smart climate unit 104 may utilize the location of each user at a particular time to affect settings. For example, if a wife is home alone, her personal climate control profile will prevail, while if one or more family members are home, a "family" climate control profile will prevail.

**[0025]** In addition to providing local and remote programming capabilities, the smart climate unit 104 also provides climate and/or energy consumption data, statistics, and/or reports both locally and remotely. For example, the smart climate unit 104 may provide reports of climate control statistics during pre-defined or user-defined periods (e.g., total hours cooling, total hours heating, or the like) and/or energy related statistics (e.g., energy saver mode hours, energy consumption for cooling, energy consumption for heating, or the like). Such data, statistics, and/or reports may be displayed via the user interface 106 and/or the web browser 134, for example, as bar charts, pie charts, in spreadsheet format, or the like, as well as stored for future use. In some embodiments, the smart climate unit 104 may be coupled to a local printer for printing out desired reports/statistics and/or may allow

PATENT

Attorney Docket No.: EE043PCT

for downloading of report data in various formats, such as Comma Separated Values (CSV) format, for further analysis.

**[0026]** In some embodiments, the smart climate unit 104 may regulate energy consumption utilizing demand management. For example, based upon supply conditions, such as energy production by the DG 118, peak energy consumption times, time of use (TOU) rates, or the like, the smart climate unit 104 may optimally control the climate control system 110 for achieving a desired level of energy consumption (e.g., optimizing energy consumption versus cost), as well as control consumption decisions, energy storage decisions, or the like. Further, the smart climate unit 104 may additionally or alternatively control the climate control system 110 based on externally generated requests to regulate energy consumption. For example, the smart climate unit 104 may receive a request from an electric company (e.g., communicated via the powerline or the communications network 126) to regulate energy consumption in order to assist with peak load balancing; the smart climate unit 104 may then control the climate control system 110 accordingly. Additionally, the smart climate unit 104 may access current and/or predicted weather-related information, for example at weather websites via the communications network 126, and/or comprise weather-related sensors, and utilize such information for controlling the climate control system 110. For example, the smart climate unit 104 may evaluate potential power generation by the DG 118 based on current and/or predicted weather conditions and factor such information into establishing settings for the climate control system 110. The smart climate unit 104 may further utilize weather-related information to “learn” timeframes for adjusting temperature and/or humidity within the building 102, for example, based on external weather conditions. The smart climate unit 104 may then factor in the learned timeframes when operating the climate control system 110, for example, during application of any of the climate control profiles.

**[0027]** In some alternative embodiments, the appliances 114 may comprise one or more “smart” appliances that are controlled by the smart climate unit 104, for example, based on energy consumption, TOU rates, user proximity, or the like.

## PATENT

Attorney Docket No.: EE043PCT

**[0028]** Figure 2 is a block diagram of a smart climate unit controller 108 in accordance with one or more embodiments of the present invention. The smart climate unit controller 108 comprises a transceiver 202 communicatively coupled to the DG controller 116. The transceiver 202 may utilize wireless (e.g., based on standards such as IEEE 802.11, Zigbee, Z-wave, or the like) and/or wired communication techniques for such communication.

**[0029]** The transceiver 202 is further coupled to at least one central processing unit (CPU) 204, and the CPU 204 is additionally coupled to support circuits 206 and a memory 208. The CPU 204 may comprise one or more conventionally available microprocessors. Alternatively, the CPU 204 may include one or more application specific integrated circuits (ASIC). The support circuits 206 are well known circuits used to promote functionality of the CPU 204. Such circuits include, but are not limited to, a cache, power supplies, clock circuits, buses, network cards, input/output (I/O) circuits, and the like.

**[0030]** The memory 208 may comprise random access memory, read only memory, removable disk memory, flash memory, and various combinations of these types of memory. The memory 208 is sometimes referred to as main memory and may, in part, be used as cache memory or buffer memory. The memory 208 generally stores an operating system (OS) 210 of the smart climate unit controller 108. The OS 210 may be one of a number of available operating systems for microcontrollers and/or microprocessors. In some embodiments where the smart climate unit 104 comprises a commercially available thermostat device, the OS 210 may be a default OS of the thermostat device.

**[0031]** The memory 208 may store various forms of application software, such as a smart climate unit control module 212 for operatively controlling the smart climate unit 104 as previously described with respect to Figure 1. Additionally, the memory 208 may store data 214 related to the operation of the smart climate unit 104. Such data may include climate control profiles for operating the climate control system 110 (e.g., profiles that are time-based, user location-based, user preference-based, or energy mode-based); archived statistics and/or reports for climate control data,

## PATENT

Attorney Docket No.: EE043PCT

energy consumption/production data, and/or weather related data; learned climate control behaviors (e.g., timeframes for temperature and/or humidity adjustments or the like); and/or any other data related to the operation of the smart climate unit 104. Additionally, the data 214 may include data pertaining to the operation of the DG 118, for example, for use in demand management control of the climate control system 110.

**[0032]** Figure 3 is a block diagram of a DG controller 116 in accordance with one or more embodiments of the present invention. The DG controller 116 comprises a transceiver 302 communicatively coupled to the smart climate unit controller 108 as well as the communications network 126. The transceiver 302 may utilize wireless (e.g., based on standards such as IEEE 802.11, Zigbee, Z-wave, or the like) and/or wired communication techniques for such communication; in some embodiments, the DG controller 116 may be coupled to the communications network 126 via a commercially available router.

**[0033]** The transceiver 302 is further coupled to at least one central processing unit (CPU) 304, and the CPU 304 is additionally coupled to support circuits 306 and a memory 308. The CPU 304 may comprise one or more conventionally available microprocessors. Alternatively, the CPU 304 may include one or more application specific integrated circuits (ASIC). The support circuits 306 are well known circuits used to promote functionality of the CPU 304. Such circuits include, but are not limited to, a cache, power supplies, clock circuits, buses, network cards, input/output (I/O) circuits, and the like.

**[0034]** The memory 308 may comprise random access memory, read only memory, removable disk memory, flash memory, and various combinations of these types of memory. The memory 308 is sometimes referred to as main memory and may, in part, be used as cache memory or buffer memory. The memory 308 generally stores an operating system (OS) 310 of the DG controller 116. The OS 310 may be one of a number of available operating systems for microcontrollers and/or microprocessors, such as, but not limited to, but not limited to, SOLARIS from SUN Microsystems, Inc., AIX from IBM Inc., HP-UX from Hewlett Packard

PATENT

Attorney Docket No.: EE043PCT

Corporation, LINUX from Red Hat Software, Windows 2000 from Microsoft Corporation, and the like.

**[0035]** The memory 308 may store various forms of application software, such as a DG control module 312 for operatively controlling the DG 118 (i.e., via the inverter 122). Additionally, the memory 308 may store data 314 related to the operation of the DG 118, such as power production data or the like. The DG controller 116 may provide at least a portion of the data 314 to the smart climate unit controller 108 for use in operating the climate control system 110 as previously described.

**[0036]** The master controller 128 (not shown) is a type of controller, analogous to the DG controller 116, which may contain additional elements, such as application software for managing a plurality of DGs 118 as well as application software for managing the website 130.

**[0037]** Figure 4 is a depiction of a smart climate unit 104 in accordance with one or more embodiments of the present invention. The display interface 106 of the smart climate unit 104 comprises user controls 402 for adjusting settings of the smart climate unit 104. The user controls 402 may include buttons, knobs, touch screen features, or the like, for obtaining menus for operating the smart climate unit 104, displaying climate control related information (e.g., TOU rates, external weather conditions, energy consumption, or the like), increasing or decreasing current temperature and/or humidity levels, creating climate control profiles, viewing/changing saved information (such as any of the data 214), and controlling other features of the smart climate unit 104.

**[0038]** The display interface 106 additionally comprises a date/time display 404 for displaying the current date and/or time; a climate status display 406 for displaying information related to the current climate of the building 102 as well as current settings, such as current temperature and/or humidity, target temperature and/or humidity, current operating mode (e.g., heat, air conditioning), or the like.

**[0039]** The display interface 106 further comprises an energy mode display 408 for displaying information related to the current energy mode (e.g., current mode is

## PATENT

Attorney Docket No.: EE043PCT

normal or energy saver, current cost per kilowatt hour, or the like); a communications status indicator 410 for displaying the current status of the communications link, for example, to the DG controller 116; and an energy usage display 412 for displaying information pertaining to current energy consumption (e.g., power status is low/normal/high, cost per kilowatt hour, or the like). The display interface 106 may further comprise additional controls for operating the smart climate unit 104 and/or additional displays for presenting information related to the smart climate unit 104 as previously described.

**[0040]** Figure 5 is a block diagram of a method 500 for smart climate control in accordance with one or more embodiments of the present invention. In some embodiments, such as the embodiments described below, a smart climate unit is located within a commercial or residential building for locally and/or remotely operating a climate control system (e.g., to control temperature, humidity, heat pump activity, or the like) of the building (e.g., the smart climate unit 104 within the building 102 for driving the climate control system 110). The smart climate unit may further be coupled to a DG controller for receiving information pertaining to the operation of a DG that supplies power to the building, and the smart climate unit may utilize such information when operating the climate control system. Additionally, the DG controller may be coupled to a master controller, a remote user, or the like, via a communications network such as the Internet.

**[0041]** The method 500 begins at step 502 and proceeds to step 504, where a user desires to access the smart climate unit. If the user is within the building, the user may locally access the smart climate unit and the method 500 proceeds to step 506; alternatively, if the user is remotely located, the user may remotely access the smart climate unit and the method 500 proceeds to step 508. At step 506, the user may locally access the smart climate unit via a user interface of the smart climate unit, such as a touch screen display, buttons, knobs, or the like. Additionally or alternatively, the smart climate unit may be coupled to a separate display and/or input/output device, such as a personal computer, a personal digital assistant, or the like, for presenting a user interface to the user.

## PATENT

Attorney Docket No.: EE043PCT

**[0042]** At step 508, the remotely located user may log in to the smart climate unit via a conventional web browser, for example as previously described with respect to Figure 1. The user may log in to the smart climate unit utilizing any suitable device that supports the web browser, such as a smart cell phone, a personal computer, a personal digital assistant, or the like. In some embodiments, the user may log in to the smart climate unit via a password protected portal.

**[0043]** Once the user has accessed the smart climate unit locally at step 506 or remotely at step 508, the method 500 proceeds to step 510. At step 510, a determination is made whether the user is performing an initial configuration of the smart climate unit. If the result of the determination at step 510 is yes, the method 500 proceeds to step 512 where the user performs the initial configuration. As part of the initial configuration, the user may manually set climate-related parameters to adjust current conditions (e.g., desired temperature, humidity) as well as generate one or more climate control profiles which may be stored within the smart climate unit for automatically operating the smart climate unit. Such profiles may specify climate control settings (e.g., preferred temperature, humidity, heat pump settings, and the like) based on criteria such as date/time, energy mode, user preference, user location, weather conditions, and the like. For example, time-based profiles may specify settings based on time of day, day of week, month of year, groupings of certain hours and/or days (e.g., waking/sleeping time, working from home, pet sitting, vacation periods, holidays), and the like. Energy mode-based profiles may specify settings that are based on criteria related to energy usage, such as energy saver mode, TOU rates, current energy consumption, supply conditions (e.g., energy production by a DG providing power to the building), peak energy consumption times, and the like. User preference-based profiles may specify preferred settings for one or more users. Location-based profiles may specify settings based on proximity of one or more users and/or current travel speed of the one or more users. Weather-based profiles may specify settings that are based on current and/or predicted weather conditions.

**[0044]** The smart climate unit may provide a "wizard" functionality for assisting the user during the initial configuration as well as during subsequent operation.

## PATENT

Attorney Docket No.: EE043PCT

Once the initial configuration of the smart climate unit is completed, the method 500 proceeds to step 522. If, at step 510, the result of the determination is no, the method 500 proceeds to step 514. At step 514, the user may decide to change current settings of the smart climate unit and the method 500 proceeds to step 516; program the smart climate unit and the method 500 proceeds to step 518; or generate/access reports from the smart climate unit and the method 500 proceeds to step 520. The smart climate unit wizard may assist the user at any of the steps 516, 518, or 520.

**[0045]** At step 516, the user may adjust any of the current settings of the smart climate unit, such as temperature, humidity level, heat pump operation, energy mode, or the like; additionally, the user may activate/terminate any of the climate control profiles. The method 500 then proceeds to step 522.

**[0046]** At step 518, the user may create new or modify existing climate control profiles. The method 500 then proceeds to step 522.

**[0047]** At step 520, the user may generate current data and/or reports, as well as access archived data and/or reports, related to the operation of the smart climate unit. Such data and/or reports may be presented as pie charts, bar charts, spreadsheets, or the like, and may include information pertaining to climate control statistics during pre-defined or user-defined periods (e.g., total hours cooling, total hours heating, or the like); energy related statistics (e.g., energy saver mode hours, energy consumption for cooling, energy consumption for heating, or the like); current and/or predicted weather conditions; learned climate control behaviors (e.g., timeframes for temperature and/or humidity adjustments or the like); and/or any other data related to the operation of the smart climate unit. Additionally, the user may obtain data and/or reports pertaining to the operation of a distributed generator (DG) that provides power for the building, for example, as related to the operation of the smart climate unit.

**[0048]** The user may save generated data and/or reports within the smart climate unit; in some embodiments, the smart climate unit may be locally coupled to a separate storage device for storing data and/or reports and/or a printer for printing desired data and/or reports. The method 500 then proceeds to step 522.



## PATENT

Attorney Docket No.: EE043PCT

**[0049]** At step 522, the smart climate unit controls the building's climate control system based upon the user's settings (i.e., manual settings and/or climate control profiles). In some embodiments, the smart climate unit may additionally regulate energy consumption utilizing demand management. For example, based upon supply conditions, such as energy production by a DG coupled to the building, peak energy consumption times, TOU rates, or the like, the smart climate unit may optimally control the climate control system for achieving a desired level of energy consumption (e.g., optimizing energy consumption versus cost). Further, the smart climate unit may additionally or alternatively control the building's climate control system based on externally generated requests to regulate energy consumption. For example, the smart climate unit may receive a request from an electric company (e.g., communicated via the powerline or the communications network) to regulate energy consumption in order to assist with peak load balancing; the smart climate unit may then control the climate control system accordingly. At step 524, a determination is made whether to continue. If the result of such determination is yes, the method 500 returns to step 514; if the result of such determination is no, the method 500 proceeds to step 526 where it ends.

**[0050]** Figure 6 is a block diagram of a method 600 for location-based climate control in accordance with one or more embodiments of the present invention. In some embodiments, such as the embodiment described below, a smart climate unit (e.g., the smart climate unit 104) is located within a residential or commercial building for operating the climate control system (e.g., to control temperature, humidity, heat pump activity, or the like) of the building. The smart climate unit contains one or more location-based climate control profiles (e.g., the climate control profiles previously described) for automatically operating the smart climate unit based on pre-set preferences of one or more users who access the building. The smart climate unit may further be coupled to a DG controller for receiving information pertaining to the operation of a DG that supplies power to the building, and the smart climate unit may utilize such information when operating the climate control system

**[0051]** The method 600 starts at step 602 and proceeds to step 604. At step 604, the smart climate unit communicates with one or more position location devices

PATENT

Attorney Docket No.: EE043PCT

for determining locations of each applicable user. A position location device may be any device for locating people and/or assets, e.g., a cell phone, a global positioning system (GPS), a personal digital assistant, ON-STAR service, or the like. The smart climate unit obtains information from the position location device or devices, such as longitude and latitude coordinates, for determining the location of the one or more users.

**[0052]** The method 600 proceeds to step 606, where the smart climate unit determines a current location for each applicable user based on the position information obtained from the position location device or devices. For example, a user's cell phone number may be entered as part of their location-based climate control profile. The smart climate unit may then obtain position information that identifies a current position of the user's cell phone, for example, based on a global positioning satellite (GPS) receiver of the cell phone, cell-triangulation features of the cell phone, or the like. The smart climate unit utilizes the positioning information to determine a current location of the cell phone as a proxy for the user's location.

**[0053]** The smart climate unit may determine the user's location as an absolute position, e.g., a position based on longitude and latitude, other types of absolute coordinates, landmarks, or the like. Additionally or alternatively, the user's position may be determined as a relative position; for example, the user's distance from the building may be determined based on existing site information, such as an address of the building stored within the smart climate unit. As part of determining the user's current location, the smart climate unit may access databased information, such as addresses, information pertaining to landmarks, coordinates, or the like.

**[0054]** The smart climate unit may additionally determine a travel speed of the user; for example, the smart climate unit may obtain the travel speed from the position location device, compute the travel speed based on position information obtained from the position location device, or determine the travel speed by other techniques.

**[0055]** The method 600 proceeds to step 608. At step 608, location-based climate control profiles corresponding to the applicable users are accessed. The

## PATENT

Attorney Docket No.: EE043PCT

location-based climate control profiles may be stored within the smart climate unit and/or external to the unit, and comprise desired climate settings (e.g., temperature, humidity, and/or heat pump control) for the users along with rules for operating the climate control system based on the locations of the users. For example, a first user's climate control profile may specify a preferred temperature and humidity setting, and may specify that the climate control system be activated to generate the desired temperature and humidity when the first user is within a certain number of miles of the building.

**[0056]** The method 600 proceeds to step 610, where the smart climate unit correlates the accessed location-based climate control profile information with the current user locations for determining suitable operative control of the climate control system. In some embodiments, the smart climate unit may "learn" timeframes required to reach certain temperature and/or humidity levels within the building, for example, based on external and/or predicted weather conditions, and factor in such learned information when operating the climate control system. At step 612 the smart climate unit operates the climate control system accordingly to adjust the building's climate based on the user locations. The smart climate unit may continually coordinate information (e.g., location data, user travel speed data, location-based climate control profile data) for a plurality of users at a plurality of different locations to optimally control the climate control system based on each user's location and preferences.

**[0057]** The method 600 then proceeds to step 614 where it ends.

**[0058]** The foregoing description of embodiments of the invention comprises a number of elements, devices, circuits and/or assemblies that perform various functions as described. These elements, devices, circuits, and/or assemblies are exemplary implementations of means for performing their respectively described functions.

**[0059]** While the foregoing is directed to embodiments of the present invention, other and further embodiments of the invention may be devised without departing

PATENT  
Attorney Docket No.: EE043PCT

from the basic scope thereof, and the scope thereof is determined by the claims that follow.

PATENT  
Attorney Docket No.: EE043PCT

**CLAIMS:**

1. An apparatus for controlling climate within a building, comprising:  
a smart climate unit for (i) obtaining distributed generator (DG) information pertaining to operation of a DG that generates power for the building, and (ii) controlling at least one climate condition within the building based on at least one of the DG information, local input, or remote input.
2. The apparatus of claim 1, wherein the smart climate unit controls the at least one climate condition based on at least one of a climate control profile or a location of a user.
3. The apparatus of claim 2, wherein the climate control profile specifies at least one climate control setting based on at least one of time, energy mode, user preference, user location, or weather information.
4. The apparatus of claim 2, wherein the smart climate unit controls the at least one climate condition based on a travel speed of the user.
5. The apparatus of claim 2, wherein the smart climate unit determines the location of the user based on a position location device.
6. The apparatus of claim 1, wherein the smart climate unit controls the at least one climate condition using demand management.
7. The apparatus of claim 1, wherein the smart climate unit learns climate control information over time and uses the learned climate control information for controlling the at least one climate condition.
8. The apparatus as in any of claims 1-7, further comprising the DG.
9. A method for controlling climate within a building, comprising:

## PATENT

Attorney Docket No.: EE043PCT

receiving distributed generator (DG) information pertaining to the operation of a DG that couples power to the building;

determining at least one setting for controlling at least one climate condition within the building based on at least one of the DG information, local input, or remote input; and

operating a climate control system of the building based on the at least one setting.

10. The method of claim 9, wherein the at least one setting is determined based on at least one of a climate control profile or demand management.

11. The method of claim 10, wherein the climate control profile specifies the at least one setting based on at least one of time, energy mode, user preference, user location, or weather information.

12. The method of claim 9, further comprising determining a location of a user, wherein the at least one setting is determined based on the location.

13. The method of claim 12, further comprising determining a travel speed of the user, wherein the at least one setting is further determined based on the travel speed.

14. The method of claim 12, further comprising receiving position information corresponding to a position location device, wherein the location is determined based on the position information.

15. The method of claim 9, further comprising learning climate control information over time, wherein the at least one setting is determined based on the learned climate control information.

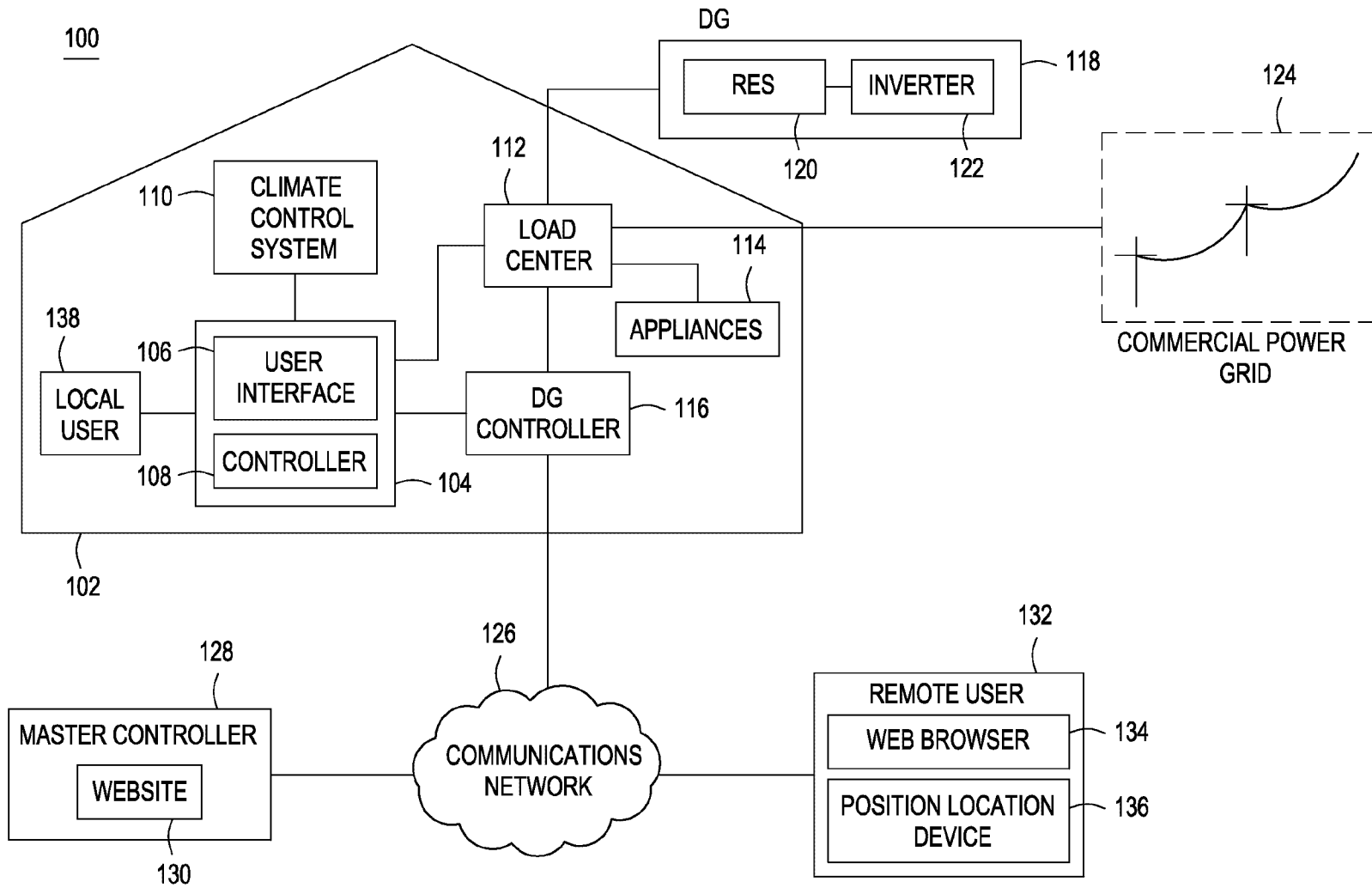

FIG. 1

FIG. 2

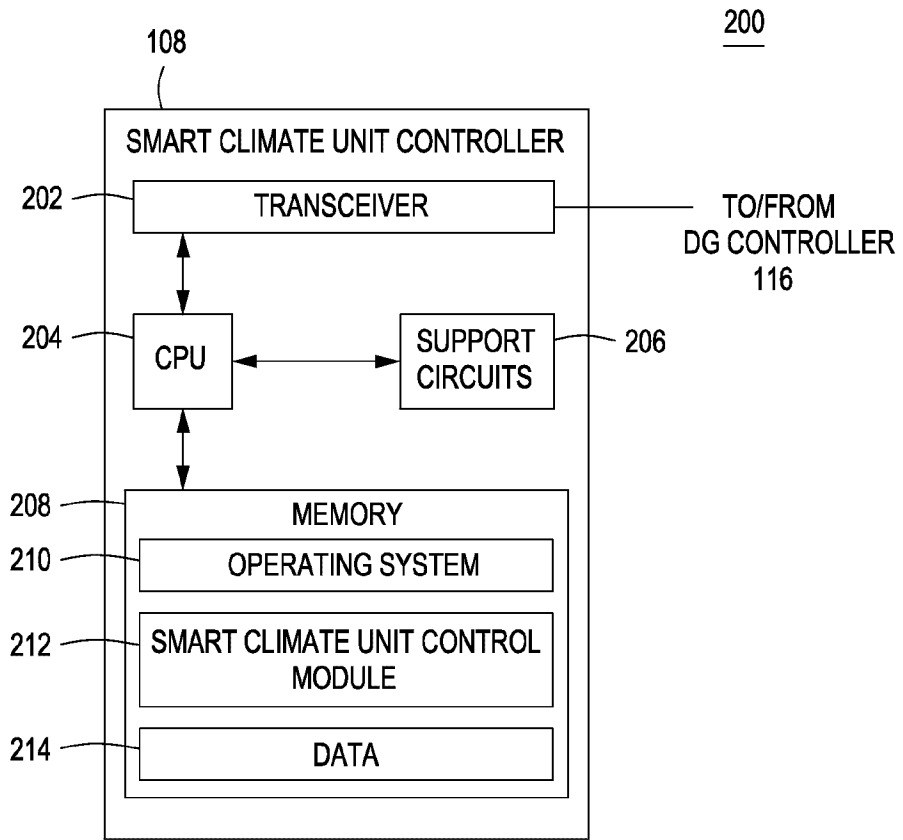
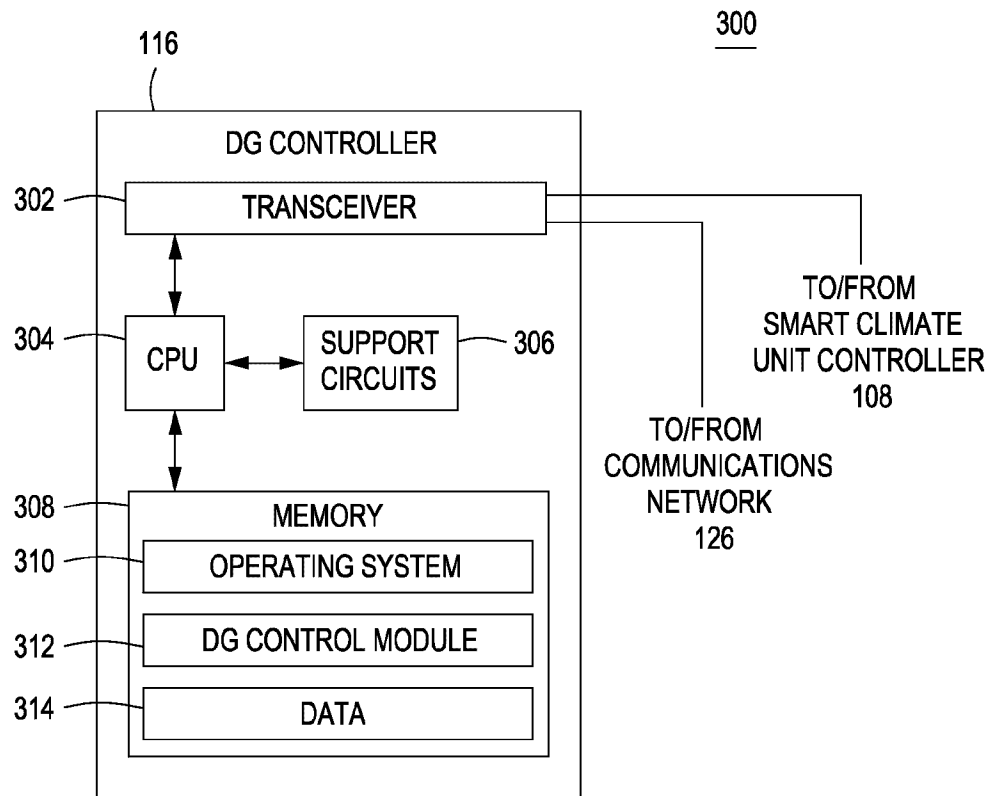

FIG. 3





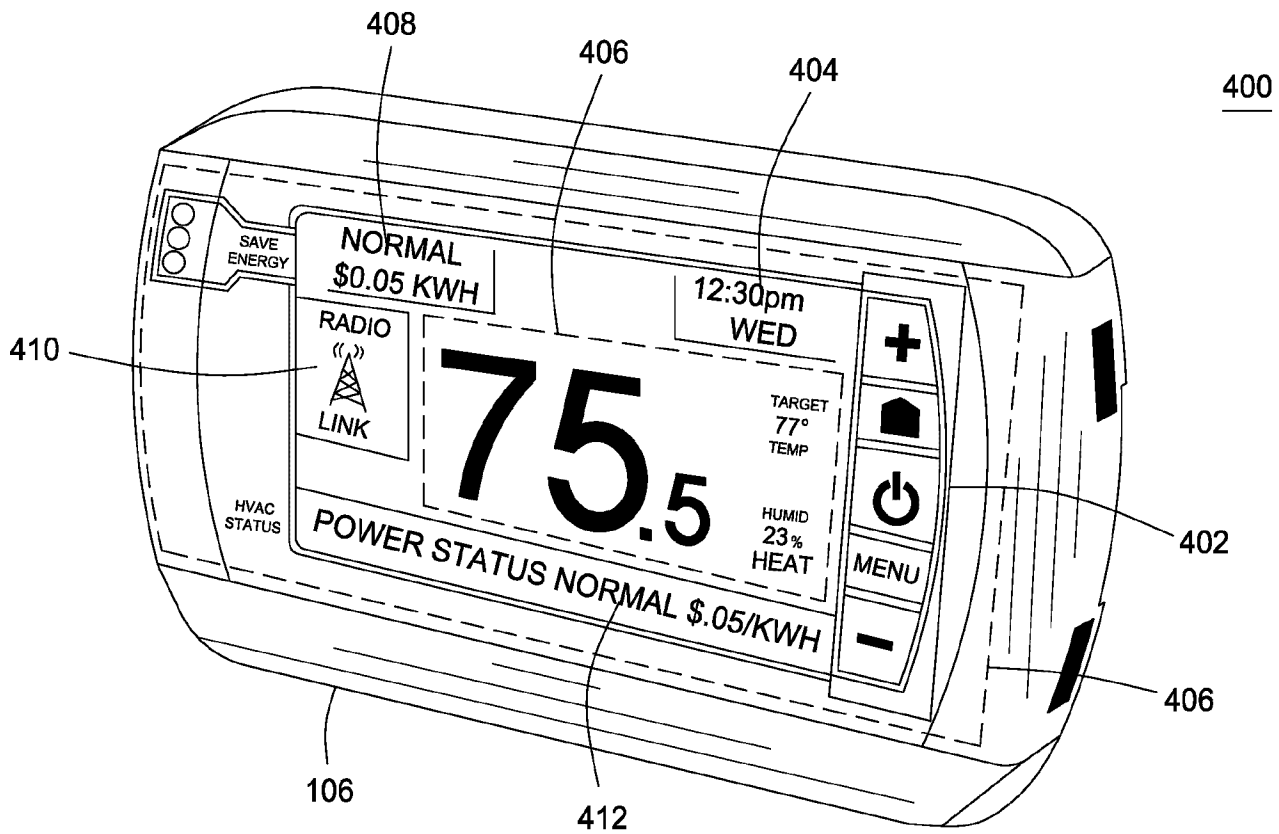

FIG. 4

4/5

500

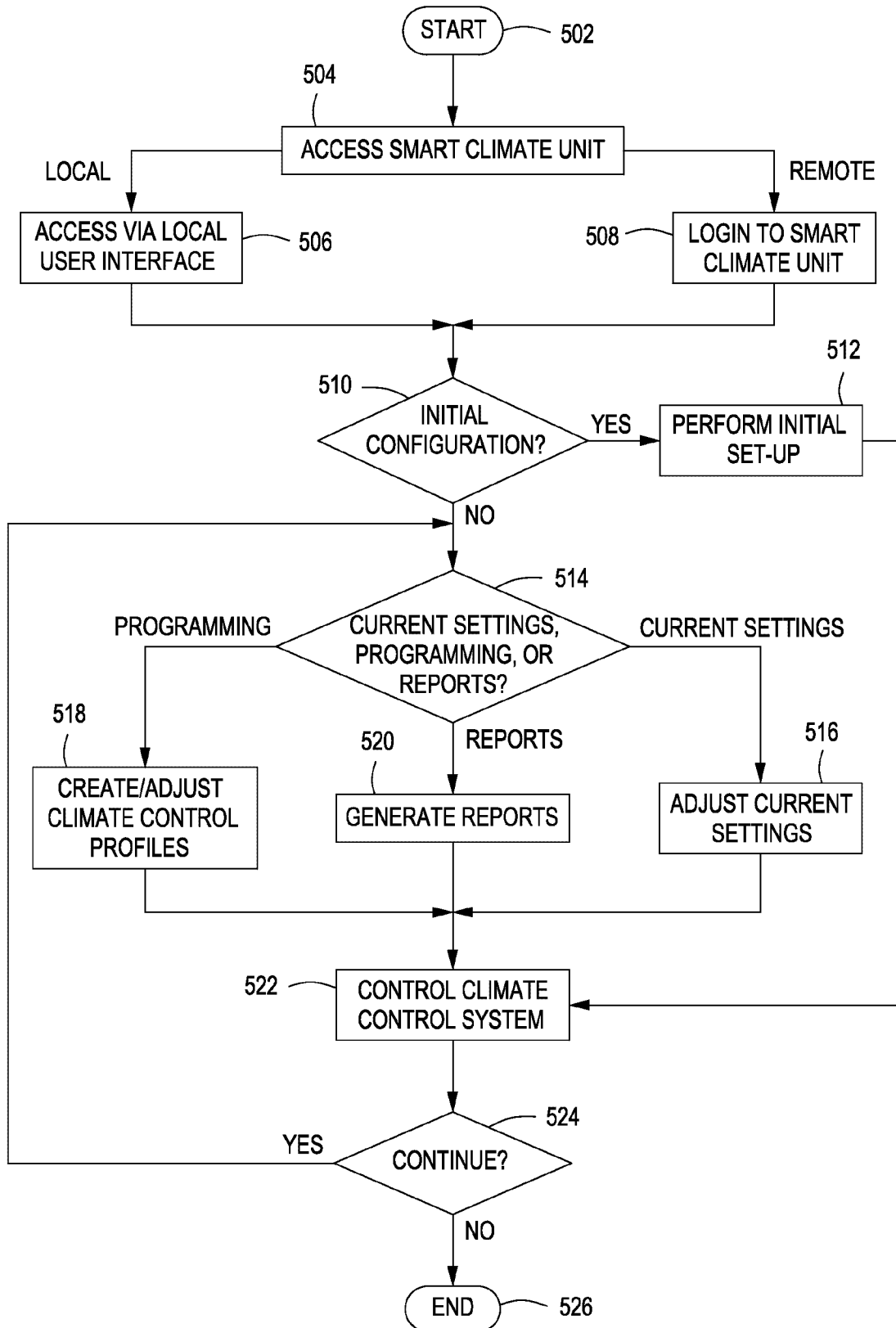

FIG. 5

600

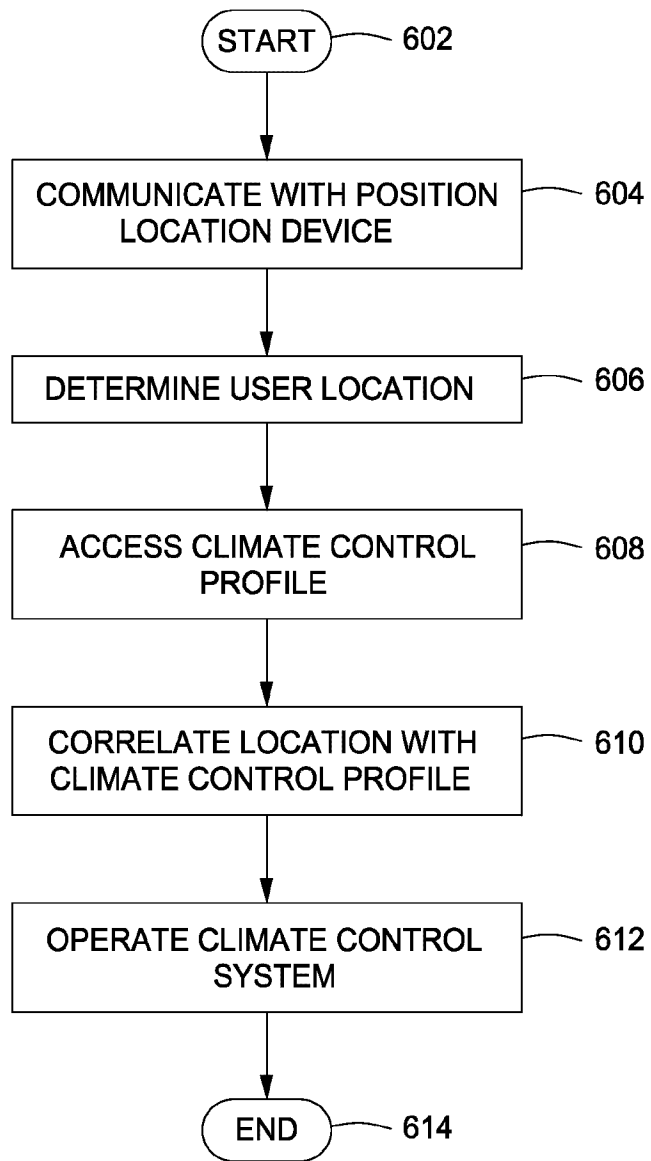

FIG. 6



(51) International Patent Classification:  
G05D 23/19 (2006.01) H02J 3/14 (2006.01)

(74) Agents: ARTZ, John, S. et al.; Dickinson Wright PLLC,  
38525 Woodward Avenue, Suite 2000, Bloomfield Hills,  
MI 48304-5092 (US).

(21) International Application Number:  
PCT/US2010/042589

(81) Designated States (unless otherwise indicated, for every  
kind of national protection available): AI, AG, AL, AM,  
AO, AT, AU, AZ, BA, BB, BG, BH, BR, BW, BY, BZ,  
CA, CH, CL, CN, CO, CR, CU, CZ, DE, DK, DM, DO,  
DZ, EC, EE, EG, ES, FI, GB, GD, GE, GH, GM, GT,  
HN, HR, HU, ID, IL, IN, IS, JP, KE, KG, KM, KN, KP,  
KR, KZ, LA, LC, LK, LR, LS, LT, LU, LY, MA, MD,  
ME, MG, MK, MN, MW, MX, MY, MZ, NA, NG, NI,  
NO, NZ, OM, PE, PG, PH, PL, PT, RO, RS, RU, SC, SD,  
SE, SG, SK, SL, SM, ST, SV, SY, TH, TJ, TM, TN, TR,  
TT, TZ, UA, UG, US, UZ, VC, VN, ZA, ZM, ZW.

(22) International Filing Date:  
20 July 2010 (20.07.2010)

(25) Filing Language: English

(26) Publication Language: English

(30) Priority Data:  
61/226,899 20 July 2009 (20.07.2009) US  
61/227,860 23 July 2009 (23.07.2009) US  
61/235,798 21 August 2009 (21.08.2009) US  
61/255,678 28 October 2009 (28.10.2009) US

(84) Designated States (unless otherwise indicated, for every  
kind of regional protection available): ARIPO (BW, GH,  
GM, KE, LR, LS, MW, MZ, NA, SD, SL, SZ, TZ, UG,  
ZM, ZW), Eurasian (AM, AZ, BY, KG, KZ, MD, RU, TJ,  
TM), European (AL, AT, BE, BG, CH, CY, CZ, DE, DK,  
EE, ES, FI, FR, GB, GR, HR, HU, IE, IS, IT, LT, LU,  
LV, MC, MK, MT, NL, NO, PL, PT, RO, SE, SI, SK,  
SM, TR), OAPI (BF, BJ, CF, CG, CI, CM, GA, GN, GQ,  
GW, ML, MR, NE, SN, TD, TG).

(71) Applicant (for all designated States except US): AL-  
LURE ENERGY, INC. [US/US]; 2003 S. Lamar Boul-  
vard, Suite 9, Austin, TX 78704 (US).

(72) Inventors; and

(75) Inventors/Applicants (for US only): IMES, Kevin, R.  
[US/US]; 7309 Tamaqua Lane, Austin, TX 78739 (US).  
HOLLISTER, James [US/US]; 2006 Chaparral Drive,  
Round Rock, TX 78681 (US).

Published:

— with international search report (Art. 21(3))

[Continued on next page]

(54) Title: ENERGY MANAGEMENT SYSTEM AND METHOD

WO 2011/011404 A1

FIG. 6

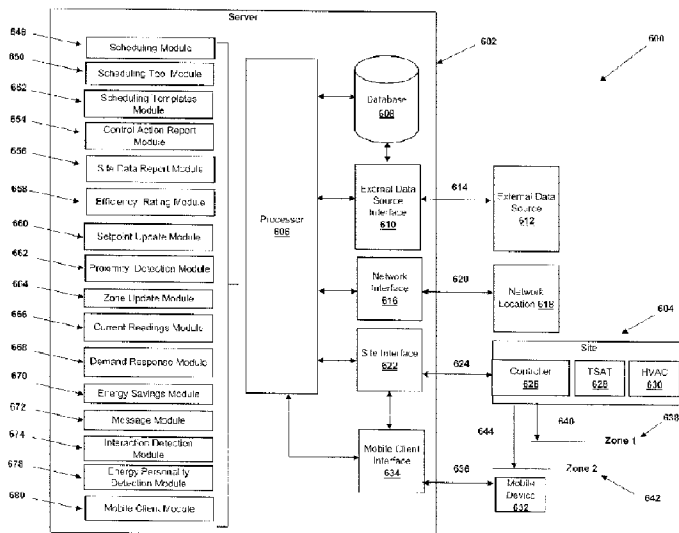

(57) Abstract: A home energy management system includes a database configured to store site report data received from a plurality of residential sites using a wireless home energy network at each site. Each residential site includes a thermostat accessible to the wireless home energy network. A processor is operably coupled to the database and configured to access the site report data and detect a current temperature set-point of the thermostat at a first residential site; detect a first seasonal profile of the thermostat; detect a current operating mode of a HVAC system operably coupled to the thermostat; and determine a thermostat schedule of the thermostat using the first seasonal profile and the current operating mode of the HVAC system.

- *before the expiration of the time limit for amending the claims and to be republished in the event of receipt of amendments (Rule 48.2(h))*

## **ENERGY MANAGEMENT SYSTEM AND METHOD**

### **CROSS REFERENCE TO RELATED APPLICATIONS**

[0001] The present application claims benefit of United States Provisional Patent Application Serial No. 61/255,678 entitled a "Proximity Based Home Energy Management System and Method", filed on October 28, 2009, and United States Provisional Patent Application Serial No. 61/235,798 entitled an "Alternative Energy Asset Management System with Intelligent Data Framework Capabilities, filed on August 21, 2009, and United States Provisional Patent Application Serial No. 61/226,899 entitled a "Congestion Detection, Curtailment, Storage, and Dispatch Module," filed on July 20, 2009, and United States Provisional Patent Application Serial No. 61/227,860 entitled a " Congestion Detection, Curtailment, Storage, and Dispatch Module," filed on July 23, 2009.

### **Field of the Disclosure**

[0002] This disclosure relates generally to home systems, and more particularly to an energy management system and method.

### **BACKGROUND**

[0003] Current energy management systems take a passive role to residential energy management. For example, consumers lack energy awareness and are typically left with having to evaluate a monthly bill to determine how much energy was consumed. Additionally, consumers lack transparency into what the leading causes of energy consumption are at their residences. Some utility companies are providing energy display only technologies that will allow consumers to see what the current price of energy may be. However, such displays take a passive role to conservation, and leaving it up to the consumer to manually curtail their use.

[0004] In certain regions, information infrastructure is lacking to enable utility companies and customers to access real-time energy consumption. For example, some regions have smart meters that are capable measuring and reporting consumption data. However, there is a lack of communication and analytical infrastructure to allow utility companies to analyze future demand and schedule energy production. For example, some utilities are providing demand response systems that react to load levels, and force curtailment on residential, industrial, and commercial customers. Such programs have not been well received as they typically inconvenience the end user.

### **BRIEF DESCRIPTION OF THE DRAWINGS**

[0005] It will be appreciated that for simplicity and clarity of illustration, elements illustrated in the Figures have not necessarily been drawn to scale. For example, the dimensions of some of the elements are exaggerated relative to other elements. Embodiments incorporating teachings of the present disclosure are shown and described with respect to the drawings presented herein, in which:

[0006] FIG. 1 illustrates a block diagram of an energy management system and energy transmission system according to an aspect of the disclosure;

[0007] FIG. 2 illustrates a energy management system operable to manage energy at a site according to an aspect of the disclosure;

[0008] FIG. 3 illustrates a flow diagram of a method of managing energy at a site according to an aspect of the disclosure;

[0009] FIG. 4 illustrates a block diagram of a controller according to an aspect of the disclosure;

[0010] FIG. 5A illustrates a block diagram of a mobile device operable to be used with an energy management system according to another aspect of the disclosure;

[0011] FIG. 5B illustrates a block diagram of an energy management user interface according to another aspect of the disclosure;

[0012] FIG. 6 illustrates a block diagram of an energy management system according to another aspect of the disclosure;

[0013] FIG. 7 illustrates an energy management user interface according to an aspect of the disclosure;

[0014] FIG. 8 illustrates an energy management system interface operable to report energy usage and savings information according to a further aspect of the disclosure;

[0015] FIG. 9 illustrates an energy management system interface operable to access and edit user and site information according to a further aspect of the disclosure;

[0016] FIG. 10 illustrates an energy management scheduling user interface operable to schedule energy use at a residential site according to a further aspect of the disclosure;

[0017] FIG. 11 illustrates a wireless thermostat user interface operable according to an aspect of the disclosure;

[0018] FIG. 12 illustrates a block diagram of a wireless thermostat according to a further aspect of the disclosure;

[0019] FIG. 13 illustrates a block diagram of an energy network bridge according to a further aspect of the disclosure;

[0020] FIG. 14 illustrates a block diagram of a demand response system according to a further aspect of the disclosure;

[0021] FIG. 15 illustrates a block diagram of an aggregate demand schedule system according to a further aspect of the disclosure; and



[0022] FIG. 16 illustrates a flow diagram of a method of managing energy use at a residence according to a further aspect of the disclosure.

[0023] The use of the same reference symbols in different drawings indicates similar or identical items.

### **DETAILED DESCRIPTION OF DRAWINGS**

[0024] The following description in combination with the Figures is provided to assist in understanding the teachings disclosed herein. The following discussion will focus on specific implementations and embodiments of the teachings. This focus is provided to assist in describing the teachings and should not be interpreted as a limitation on the scope or applicability of the teachings. However, other teachings can certainly be utilized in this application. The teachings can also be utilized in other applications and with several different types of architectures such as distributed computing architectures, client/server architectures, or middleware server architectures and associated components.

[0025] Devices or programs that are in communication with one another need not be in continuous communication with each other unless expressly specified otherwise. In addition, devices or programs that are in communication with one another may communicate directly or indirectly through one or more intermediaries.

[0026] Embodiments discussed below describe, in part, distributed computing solutions that manage all or part of a communicative interaction between network elements. In this context, a communicative interaction may be intending to send information, sending information, requesting information, receiving information, receiving a request for information, or any combination thereof. As such, a communicative interaction could be unidirectional, bidirectional, multi-directional, or any combination thereof. In some circumstances, a communicative interaction could be relatively complex and involve two or more network elements. For example, a communicative interaction may be "a

conversation" or series of related communications between a client and a server – each network element sending and receiving information to and from the other. The communicative interaction between the network elements is not necessarily limited to only one specific form. A network element may be a node, a piece of hardware, software, firmware, middleware, another component of a computing system, or any combination thereof.

[0027] For purposes of this disclosure, an energy management system, network device, or any combination thereof can include any instrumentality or aggregate of instrumentalities operable to compute, classify, process, transmit, receive, retrieve, originate, switch, store, display, manifest, detect, record, reproduce, handle, or utilize any form of information, intelligence, or data for business, scientific, control, entertainment, or other purposes. For example, an energy management system, network device, or any combination thereof can include any combination of a personal computer, a PDA, a consumer electronic device, a media device, a smart phone, a cellular or mobile phone, a smart utility meter, an advanced metering infrastructure, a smart energy device, an energy display device, a home automation controller, an energy hub, a smart energy gateway, a set-top box, a digital media subscriber system, a cable modem, a fiber optic enabled communications device, a media gateway, a home media management system, a network server or storage device, an energy substation, a vehicle charging station, a renewable energy production device, a renewable energy control device, an energy storage management system, a smart appliance, an HVAC system, a water pump, a heat pump, a hot water heater, a thermostat, an energy controller, an irrigation system, a lighting system, an alarm system, a smart power outlet, an energy detection device, a power measurement device, a power measurement unit (PMU), an air handler, a wireless air damper, a humidity control system, a heat and motion sensing device, a smart power outlet, a switch router, wireless router, or other network communication device, or any other suitable device or system, and can vary in size, shape, performance, functionality, and price.

[0028] According to an aspect, an energy management system can include memory, one or more processing resources or controllers such as a central processing unit (CPU) or hardware or software control logic. Additional components of the energy management system can include one or more storage devices, one or more wireless, wired or any combination thereof of communications ports to communicate with external devices as well as various input and output (I/O) devices, such as a keyboard, a mouse, pointers, controllers, and display devices. The energy management system can also include one or more buses operable to transmit communications between the various hardware components, and can communicate using wireline communication data buses, wireless network communication, or any combination thereof.

[0029] As used herein, a wireless energy network can include various types and variants of wireless communication configurable to manage energy at a site, including associated protocols or enhancements thereto including, but not limited to, any combination or portion of, IEEE 802.15-based wireless communication, Zigbee communication, INSETEON communication, X10 communication protocol, Z-Wave communication, Bluetooth communication, WIFI communication, IEEE 802.11-based communication, WiMAX communication, IEEE 802.16-based communication, various proprietary wireless communications, or any combination thereof.

[0030] As described herein, a flow charted technique, method, or algorithm may be described in a series of sequential actions. Unless expressly stated to the contrary, the sequence of the actions and the party performing the actions may be freely changed without departing from the scope of the teachings. Actions may be added, deleted, or altered in several ways. Similarly, the actions may be re-ordered or looped. Further, although processes, methods, algorithms or the like may be described in a sequential order, such processes, methods, algorithms, or any combination thereof may be operable to be performed in alternative orders. Further, some actions within a process, method, or algorithm may be performed simultaneously during at least a point in time (e.g., actions

performed in parallel), can also be performed in whole, in part, or any combination thereof.

**[0031]** As used herein, the terms "comprises," "comprising," "includes," "including," "has," "having" or any other variation thereof, are intended to cover a non-exclusive inclusion. For example, a process, method, article, system, or apparatus that comprises a list of features is not necessarily limited only to those features but may include other features not expressly listed or inherent to such process, method, article, system, or apparatus. Further, unless expressly stated to the contrary, "or" refers to an inclusive-or and not to an exclusive-or. For example, a condition A or B is satisfied by any one of the following: A is true (or present) and B is false (or not present), A is false (or not present) and B is true (or present), and both A and B are true (or present).

**[0032]** Also, the use of "a" or "an" is employed to describe elements and components described herein. This is done merely for convenience and to give a general sense of the scope of the invention. This description should be read to include one or at least one and the singular also includes the plural, or vice versa, unless it is clear that it is meant otherwise. For example, when a single device is described herein, more than one device may be used in place of a single device. Similarly, where more than one device is described herein, a single device may be substituted for that one device.

**[0033]** Unless otherwise defined, all technical and scientific terms used herein have the same meaning as commonly understood by one of ordinary skill in the art to which this invention belongs. Although methods and materials similar or equivalent to those described herein can be used in the practice or testing of embodiments of the present invention, suitable methods and materials are described below. All publications, patent applications, patents, and other references mentioned herein are incorporated by reference in their entirety, unless a particular passage is cited. In case of conflict, the present specification, including definitions, will control. In addition, the materials, methods, and examples are illustrative only and not intended to be limiting.

[0034] To the extent not described herein, many details regarding specific materials, processing acts, and circuits are conventional and may be found in textbooks and other sources within the computing, electronics, and software arts.

[0035] In accordance with an aspect of the disclosure, an energy management system is disclosed. The energy management system can include a database configured to store site report data received from a plurality of residential sites using a wireless home energy network at each site. According to an aspect, each residential site can include a thermostat accessible to the wireless home energy network. The energy management system can also include a processor operably coupled to the database and configured to access the site report data, detect a current temperature set-point of the thermostat at a first residential site, and detect a first seasonal profile of the thermostat. The processor can also detect a current operating mode of a HVAC system operably coupled to the thermostat, and determine a thermostat schedule of the thermostat using the first seasonal profile and the current operating mode of the HVAC system.

[0036] FIG. 1 illustrates a block diagram of an energy management system, illustrated generally at 100, according to an aspect of the disclosure. Energy management system 100 can include an energy source 102 configured to generate energy that can be coupled to an energy transmission system 104 to satisfy a load or demand at a first site 106, second site 108, third site 110, or any combination thereof. Energy transmission system 104 can be configured to be coupled to one or more of first site 106, second site 108, third site 110, or any combination thereof.

[0037] According to an aspect, first site 106 can include a distributed energy generation (DEG) asset 112. DEG asset 112 can include various types of energy producing assets such as a natural gas generator, fuel cell generator, solar array, solar concentrator, wind turbine generator, battery array, electric vehicle, hydro-power generator, any type of

generator, or any combination thereof capable of outputting energy to energy transmission system 104.

**[0038]** According to a further aspect, second site 108 can include a virtual capacity generation (VCG) asset 114. VCG 114 can include an energy consumption device configured to reduce energy consumption or load placed on energy transmission system 104 during various periods. For example, VCG asset 108 can include equipment located a commercial facility, industrial facility and the like. According to another aspect, second site 102 can include a retail center having energy consuming devices that can be managed to reduce energy consumption. In other forms, second site 108 can include a residential site having VCG assets that include energy consuming devices such as an HVAC system, heat pump, hot water heater, lighting systems, entertainments systems, refrigerators, or any type of electricity consuming device or system, or any combination thereof. According to a further aspect, third site 110 can include a combination of a assets such as DEG asset 116 and a VCG asset 118.

**[0039]** According to another aspect, first site 106 can be coupled to server 120 using an Internet or broadband connection 122. Second site 108 can be coupled to server 120 using a second Internet or broadband connection 124. Third site 110 can be coupled to server 120 using a third Internet or broadband connection 126. Various other types of connections can also be deployed by energy management system 100 as needed or desired.

**[0040]** According to another aspect, portions or combinations of energy transmission system 104 can be used within one or more markets such as ERCOT, Southwest Power Pool (SPP), California Independent system operator (CAISO), Western Electric Coordinating Council (WECC), other grids or markets, future national or regional grids, operators, councils, or any combination or portions thereof can be accessed using energy management system 100.

[0041] According to a further aspect, energy management system 100 can utilize energy management information (EMI) to manage energy production, consumption, curtailment, load shedding, purchase decisions, demand response decisions, or any combination thereof. For example, EMI can include any combination of data sources such as real-time congestion data, energy transmission line operating conditions, synchrophasor data, firm owned alternative energy generator operating status, non-firm owned alternative energy generator operating status, locational marginal pricing data, congestion revenue rights data, energy storage capacity, stored energy output capacity, real time energy pricing data, historical energy pricing data, real time nodal demand data, historical nodal demand data, real time zonal demand data, historical zonal demand data, external market demand data, historical external market demand data, nodal price data, real time energy price data, real time energy demand data, historical energy demand data, historical energy price data, firm owned alternative energy generator data, non-firm owned alternative energy generator data, est. firm owned alternative energy generator output schedule, estimated non-firm owned alternative energy generator output schedule, macro environmental data, micro environmental data, real-time grid congestion data, historical grid congestion data, renewable energy credit information, carbon credit cap and trade pricing information, fixed and variable costs for operating alternative energy generators, production tax credit (PTC) pricing information, investment tax credit (ITC) information, federal grant information, credit-to-grant comparison analysis data, PTC to ITC analysis data, interest / finance data for alternative energy generators, asset depreciation schedules, available solar and wind output capacity, distributed energy production scheduling data, feed-in tariff data, baseline energy generator data, load utilization data, transmission efficiency data, congestion right revenue data, priority dispatch data, federal renewable portfolio standard (RPS) data, state renewable portfolio standard (RPS) data, net-metering data, current or forecasted % coal production data, current or forecasted % natural gas production data, current or forecasted % green house gas production data, current or future coal pricing data, current or future natural gas pricing data, current or future oil pricing data, current or

future energy transmission pricing data, forecasted transmission price setting events, virtual capacity data, historical site performance data, seasonal weather and performance data, aggregate scheduling demand data, collaborative demand response data, historical device consumption data, forecasted device consumption data, or any combination thereof.

[0042] FIG. 2 illustrates an energy management system, illustrated generally at 200 and configured to be used at a site 202 according to an aspect of the disclosure. Site 202 can include a residential site, and industrial site, a manufacturing site, a commercial site, or any combination thereof. According to an aspect, energy management system 200 can include a server 204 located at a remote location that can be communicatively coupled to a network 206. According to a further aspect, site 202 can include a controller 216 capable of connecting to a wireless thermostat ('TSTAT') 208, an associated mobile device 210, one or more smart appliances 212, a distributed energy generating asset 214, or any combination thereof. In a form, controller 216 can establish a wireless energy network 242 using a wireless communication described herein. Various combinations of networks and variants thereof can also be deployed by controller 216 to establish wireless energy network 242.

[0043] According to a further aspect, mobile device 210 can communicate with controller 216 using a WIFI or 802.11 based communication, Bluetooth communication, Zigbee communication, or various other wireless communication, or any combination thereof. According to a further aspect, mobile device 210 can communicate with an information network 240 using a subscriber based wireless data communication network such as a 3G network, 4G network, EDGE network, a cellular network, WiMAX, other wireless data communication, or any combination thereof. According to a further aspect, site 202 can include a gateway 218 configured as a broadband gateway such as a DSL gateway, cable system gateway, fiber optic gateway, or any combination thereof.

[0044] According to another aspect, energy management system 200 can include an advanced metering infrastructure (AMI) gateway 242 configured to communicate with a



smart metering device 250. Smart metering device 250 can include a utility or power company owned metering device and can be configured to communicate using a wireless network such as a cellular network, a mesh network, WiMAX network, or any combination thereof. According to an aspect, controller 216 can communicate with AMI gateway 242 using an AMI network 248 communicated by AMI gateway 242.

**[0045]** According to a further aspect, energy management system 200 can include server 204 configurable to include various energy management logic, modules, interfaces, database sources, or various combinations thereof to manage energy use at site 200. Server 204 can also include a processor 222 that can be configured as multiple processors having one or more processing cores as needed or desired, one or more databases 224 that can be internal or external to server 204, and memory 226 configurable to store data. According to an aspect, server 204 can be located in a single location however multiple locations, and server configurations including cloud computing, distributed computing, dedicated computing, or any combination thereof can be deployed. According to an aspect, controller 216 can include portions or all of server 204 and can deploy some or all of the capabilities of server 204.

**[0046]** According to another aspect, server 204 can include a site interface 220 operable to be coupled to network 206 and gateway 218 to communicate data between site 202 and server 204. Server 204 can also include a mobile client interface 226 that can be coupled to a wireless telecommunications communication gateway such as a WAP gateway and the like. According to an aspect, mobile client interface 226 can communicate with one or more mobile devices 210, using information network 240 or another data network provided by a wireless telecommunications provider. Mobile client interface 226, mobile device 210, an information network 240, or various combinations thereof can include secure connection capabilities such as SSL connections or other carrier supported secure connection capabilities. Server 204 can also include an energy price monitor 228, a demand response module 230, an efficiency rating module 232, a proximity detection

module 234, a scheduling module 236, an energy savings module 238, a messaging module 240, or any combination thereof.

[0047] According to an aspect, energy price monitor 228 can be deployed by processor 222 and can access EMI stored within database 224 or a remote data source to monitor energy pricing of site 202.

[0048] According to an aspect, demand response module 230 can be deployed by processor 222 and can access EMI stored within database 224 or a remote data source to manage demand response preferences and capabilities of site 202.

[0049] According to an aspect, efficiency rating module 232 can be deployed by processor 222 and can access EMI stored within database 224 or a remote data source to determine an efficiency rating, thermal response, virtual capacity capabilities, performance data, or various other of site 202.

[0050] According to an aspect, proximity detection module 234 can be deployed by processor 222 and can access EMI stored within database 224 or a remote data source to detect a location of mobile device 210 relative to site 202, and modify operating conditions of site 202 based on a proximity of mobile device 210 to site 202.

[0051] According to an aspect, scheduling module 236 can be deployed by processor 222 and can access EMI stored within database 224 or a remote data source to schedule energy use or operations of one or more energy consuming devices at site 202.

[0052] According to an aspect, energy savings module 238 can be deployed by processor 222 and can access EMI stored within database 224 or a remote data source to determine a past or forecasted energy savings of site 202. In a form, server 204 can include user account login information at a utility company or energy provider that can enable a user to gain access to meter data. As such, energy savings module 238 can pull EMI data stored at a third party website, and output past or forecasted energy savings of site 202.

[0053] According to an aspect, messaging module 240 can be deployed by processor 222 and can access EMI stored within database 224 or a remote data source to communicate messages. For example, messaging module 240 can use an email address, mobile device identifier, SMS gateway data, network device identifier data, IP address of controller 216, IP address of gateway 218, IP address of AMI gateway 242, or any combination thereof to communicate messages or other energy management information.

[0054] According to a further aspect, energy management system 200 and controller 216 can access consumption data at site 202 using AMI gateway 242. For example, controller 216 can include a wireless communication module (not expressly illustrated in FIG. 2) such as a Zigbee communication module (e.g. 802.15.4), WIFI module, Bluetooth module or various other wireless modules, or any combination thereof. Controller 216 can include one or more profiles stored within a memory device (not expressly illustrated in FIG. 2) configured to include data that will enable controller 216 to join AMI gateway 242. For example, a profile can include various attributes to initiate or establish communication using one or more security levels as needed or desired.

[0055] According to a further aspect, energy management system 200 can be used with an energy management application accessible or deployed by mobile device 210 or other computing device. For example, the energy management application can be used to control TSTAT 208, one or more smart appliances 212 or various other devices at site 202. A user can access the energy management application using mobile device 210 or other computing device and read the current settings, operating conditions, or various other types of energy management information associated with site 202. For example, a user can view if TSTAT 208 and an associated HVAC system (not expressly illustrated in FIG. 2) is on or off, a mode such as heat, A/C, or fan, or any combination thereof. In other forms, the user can use the energy management application to access multiple thermostats or zones at site 202. Although the energy management application has been described in the context of accessing TSTAT 208, it should be understood that other network devices,

smart appliances, lighting systems, or any other energy consuming or network accessible device or any combination thereof can be accessed using the energy management application.

[0056] According to a further aspect, mobile device 210 can include a mobile device application that can upload location data to server 204, controller 216, TSTAT 210, smart appliances 212, various other devices capable of receiving location data, or any combination thereof. For example, in a particular form mobile device 210 can report a current location using a location application program interface (API) of mobile device 210, and can upload location data to server 204 using mobile client interface 226. Server 204 can then deploy proximity detection module 234 to determine whether one or more operating conditions should be altered at site 202. For example, proximity detection module 234 can include rules based logic to determine if an operating condition of a resource at site 202 should be altered. For example, if a user is greater than two miles away from site 202, and is moving away from site 202, server 204 can generate a control action report to be communicated to site 202. For example, a control action report can include adjusting TSTAT 208 up a specific number of degrees relative based on the distance and direction a user may be from site 202.

[0057] According to a particular aspect, a user may have previously established an upper setting limit a user would like an internal temperature to reach at site 202 without having an associated HVAC unit turning on. The upper setting limit can be sent to TSTAT 208 based on how far a user may be from site 202. A lower limit can be established for a heating unit as well. These limits can be entered using mobile device 210, a web-based user interface, or any combination thereof.

[0058] According to another aspect, server 204 can characterize site 202 to determine operating characteristics and performance data of site 202 and associated energy consuming devices at site 202. For example, server 204 can use efficiency rating module 232 to monitor performance data at site 202. Performance data can include measured

performance data detected by controller 216, performance specifications of an energy consuming device that can be based on a model number or other identification data of the device, the size or square footage of site 202, efficiency improvements or specifications of site 202, various other EMI data, or any combination thereof. As performance of an energy consuming device may be detected, an energy alert can be sent using messaging module 240. In another form, an energy alert can be sent to a third party to initiate a service call at site 202. For example, one or more third parties may subscribe to a service to buy leads based on an energy consuming devices performance eroding. Server 204 can include a lead generation module (not expressly illustrated in FIG. 2) that can be communicated using messaging module 240 to a subscriber such as a service company, appliance provider, and the like.

[0059] In another form, performance data can be used to determine when to adjust an operating condition of an energy consuming device based on a schedule, proximal location of the user and mobile device, in response to a demand response event, in response to a consumer setting of a desired operating condition based on an energy savings mode (e.g. low, med, high), or any combination thereof.

[0060] According to a particular aspect, controller 216 can be configured as a plug-device that can be plugged directly to a wall socket or other power receptacle and can include various components (not expressly shown in FIG. 2). Controller 216 can also include a network interface or Ethernet port, one or more USB interfaces or mini-USB interfaces, an SDIO slot, additional data or plug interfaces, or any combination thereof. Controller 216 can include an internal or external AC, DC, AC to DC converter power module, or any combination thereof to power controller 216. According to an aspect, controller 216 can be provided as a small form factor unit to allow for easy installation, use, and discretionary placement. For example, controller 216 can include a plug computer based on Marvell Corporation's Kirkwood ® microprocessor, Part Number 6281 and associated components. In another form, controller 216 can include a plug computer including

specifications described in “Sheeva Plug Development Kit Reference Design”, version 1.1, and previous versions which are herein incorporated by reference. Other processors having various other speeds and supporting components can also be used. According to an aspect, controller 216 can include various buses that can be used to install one or more wireless modules. For example, controller 216 can include a UART bus interface that can be used to interface a Zigbee module, WIFI module, Bluetooth Module, various other modules or combinations thereof. Various other buses can also be used including but not limited to a USB bus, a SPI bus, an SDIO bus, a mini-USB bus, or any combination thereof. Controller 216 can include buses that can be located internal or external to a housing of controller 216.

[0061] According to an aspect, energy management system 200 can include one or more network devices, such as TSTAT 208, smart appliances 212, or various other network devices installed at a residential site such as a home or residence. Controller 216 can establish a wireless energy network 242 capable of communicating with a network device at site 202. Energy management system 200 can also include server 204 disposed remotely from site 202 and capable of generating a control action report to control the network device. Controller 216 can also be located at site 202 including a residential site. Controller 202 can be in communication with server 204. According to an aspect, controller 202 can establish initiate a plurality of operating status requests of the network device, and receive device data in response to at least one of the operating status requests. Controller 202 can further generate a site report including the device data, and initiate a communication of the site report to server 204. During the communication of the site report from controller 202 to server 204, controller 202 can detect an availability of a control action report at server 202 in conjunction with the communication of the site report. As such, a secure connection can be initiated from site 202 to communicate site reports and receive control action reports without having to have server 204 initiate a communication with site 202.

[0062] According to another aspect, server 202 can generate control action report prior to a site report upload, in association with a site report upload, or any combinations thereof. For example, one or more control action reports can be generated and queued in advance of a site report upload. In other forms, a control action report can be generated during a site report upload. In yet another form, a control action report can be generated in response to information uploaded within the site report. As such, various combinations of control action report generation techniques can be deployed as needed or desired.

[0063] According to an aspect, energy management system 200 can be used to generate a control action report in response to a distance mobile client 210 may be from site 202. For example, site 202 can include a network device, such as TSTAT 208, joined to wireless energy network 242. According to an aspect, controller 216 can be configured to establish wireless energy network 242 using a wireless mesh network and initiate a plurality of operating status requests. For example, controller 216 can access TSTAT 208 using wireless energy network 242 at a first operating status request interval. Controller 216 can be used to generate a site report that can include device data of TSTAT 208 at a site report interval. According to an aspect, a site report interval can be the same interval as the first operating status request interval. In other forms, each interval can be different. For example, the first operating status report request interval can be set to thirty seconds and the site report interval can be set to sixty seconds. As such, two cycles of data can be acquired. Various combinations of intervals can be used as desired.

[0064] According to a further aspect, controller 216 can initiate a communication of site report to a remote server such as server 204 using gateway 218. For example, gateway 218 can include a residential broadband connection 206 capable of establishing a secure gateway connection between site 202 and server 204 using a public communication network. According to an aspect, residential broadband connection 206 does not include a cellular communications based network.

[0065] In another form, control data can be provided in response to a detection of a travel direction and a distance between mobile device 210 having location reporting device, and site 202. For example, as a user of mobile device 210 is moving away from site 202, server 204 can detect a direction and distance mobile device 210 may be from residential site 202. Server 204 can then determine if a control action should be generated. For example, as mobile device 210 moves away from residential site 202, TSTAT 208 setting can be adjusted up during a warm or summer season (or down during a cold or winter season) to reduce energy consumption. Other network devices can also be adjusted as needed or desired.

[0066] According to a further aspect, energy management system 200 can use energy pricing monitor 228 to generate a control action report. For example, energy pricing monitor 228 can be configured to detect energy pricing within an energy market, and initiate curtailing use of a network device, such as TSTAT 208, smart appliance 212, other network devices at site 202, or any combination thereof. For example, energy pricing monitor 228 can output a control action report in response to an unfavorable pricing condition, and further upon the detection of a travel direction and a distance between mobile device 210 and site 202. In another form, energy pricing monitor 228 can also initiate use of one or more network devices at site 202 in response to a favorable pricing condition, and a detection of a travel direction and a distance between mobile device 210 and residential site 202. In this manner, a user's travel direction, distance, and current energy pricing within a market can be used to determine how energy consumption can occur at site 202.

[0067] According to a further aspect, energy management system 200 can also use demand response module 230 to detect a demand response condition and respond accordingly. For example, demand response module 230 can be used to detect a grid condition favorable to a demand response event and detect a profile preference setting of an user or site manager of site 202. For example, a user or site manager can set a profile



to always participate, not participate, or have a request sent to collaborate on whether to participate. Other profile settings can also be used such as determining an economic or monetary value to a user or site manager if participating in a demand response event. For example, a favorable grid condition can include an increase in the price of energy due to an undersupply of energy within an energy transmission system or market (not expressly illustrated in FIG. 2). In another form, a favorable condition can include an oversupply of energy purchased by an energy provider of site 202. Additionally, a high demand period can be detected and the oversupply of energy can be increased using a demand response event. In another form, a favorable grid condition can include a time interval when transmission pricing to use an energy transmission system may be determined. As such, an energy provider would receive an economic benefit from reducing load when the transmission rate or rate for using transmission lines would be determined. Various combinations of favorable grid conditions can be detected as needed or desired in association with determining a demand response event to curtail energy use at site 202.

[0068] According to an aspect, energy management system 200 can use demand response module 230 configured to detect an energy capacity of site 202 having a residence. For example, demand response module 230 can detect a grid condition favorable to a demand response event, and can also detect a preference of an resident or owner of the residence to participate in demand response events. Demand response module 230 can also determine an energy capacity of site 202 using historical device consumption data received in a site report, and forecasted device consumption data. Control data can then be generated to alter an operating condition of the network device in response to the grid condition and the preference of the owner and the energy capacity of site 202.

[0069] According to a further aspect, server 204 can determine an energy capacity of site 202 using device data received in association with site reports received from site 202. For example, site report data can be used with efficiency rating module 232 to determine a virtual generation capacity or energy reduction capacity of site 202. Upon detecting an

available capacity, demand response module 230 can output a curtailment action to be used within a control action report to be communicated to site 202. For example, a curtailment action can include an updated control data to alter a current operating condition of one or more network devices connected to wireless energy network 242 at site 202.

**[0070]** According to a further aspect, controller 216 can be configured to detect a new set-point value within a control action report, and identify TSTAT 208 to be adjusted to the new set-point value. In some forms, multiple wireless thermostats can be accessed via wireless energy network 242 and adjusted as desired. Controller 216 can communicate a different set-point values to each of the wireless thermostats. Controller 216 can initiate an outputting of new set-point values to TSTAT 208 and others using wireless energy network 242.

**[0071]** According to an aspect, energy management system 200 can use proximity detection module 234 to detect a distance mobile device 210 may be from site 202 including a residential site. For example, proximity detection module 234 can access location data stored within database 224 and provided by mobile device 210 using mobile client interface 226. Proximity detection module 234 can further detect mobile device 210 within a first zone (e.g. less than one (1) mile from the site, less than three (3) miles from site, greater than five (5) miles from site, etc.). Proximity detection module can further detect a current thermostat setting of TSTAT 208, and an indoor temperature detected at site 202 and communicated within a site data report communicated from site 202. Proximity detection module 234 can then determine a percentage adjustment to adjust a current setting of TSTAT 208, and output the percentage adjustment as a new set-point value to be used within a control action report. For example, if mobile device 210 can be detect as being greater than three (3) miles from site 202, TSTAT 208 can be adjusted to within 75% of the maximum setting in a summer season, or minimum setting in a winter season. As such, a site 202 can be managed based on a user's proximity to a site, which

zone a user may be located in, and current seasonal schedule or setting being used at a site 202.

[0072] According to another aspect, energy management system 200 can include TSTAT 208 configured as a wireless thermostat capable of joining wireless energy network 242 operable as a wireless home energy network. According to an aspect, TSTAT 208 can be configured to not include an enabled local programming schedule configured to control an HVAC system of site 202. For example, TSTAT 208 can include sufficient memory to store a set-point value, but may be not include scheduling capabilities at TSTAT 208. As such, a simplified user interface of TSTAT 208 can be deployed. For example, if TSTAT 208 includes a scheduling feature, energy management system 200 can be used to disable the scheduling feature located at TSTAT 208. As such, TSTAT 208 can be considered a non-programmable thermostat capable of connecting to wireless energy network 242, and set-point values or other control actions can be received using wireless energy network 242. In this manner, scheduling use of TSTAT 208 can be provided using on-line or web application based scheduling tool.

[0073] According to a further aspect, controller 216 can be further configured to initiate joining TSTAT 208 to wireless energy network 242 using a unique identifier of TSTAT 208. A unique identifier of TSTAT 208 can be received from server 204 and a local schedule and or scheduling capabilities of TSTAT 208 can be disabled. In this manner, an overall design complexity of a thermostat can be reduced and scheduling capabilities can be provided using a schedule created within a network environment and output by controller 216, server 204, mobile device 210, or any combination of sources capable of providing schedule information or control action data to TSTAT 208.

[0074] According to another aspect, energy management system 200 can also use scheduling module 236 to schedule use of a network device located at site 202 and capable of connecting to wireless energy network 242. Additionally, multiple user schedules can be stored within database 224 and used by site 202. For example, scheduling module 236

can be used to detect a first user schedule accessible to controller 216. The first user schedule can include a first schedule event configured to alter an operating condition of a network device such as TSTAT 208, smart appliance 212, or other energy consuming network devices. According to an aspect, the first user schedule can be operably linked to mobile device 210 having a location detection device. The first user schedule can be used or not used based on a distance mobile device 210 may be from residence 202. In this manner, as user returns to residential site 202, a user schedule can be activated and used.

**[0075]** According to another aspect, energy management system 200 can include a second user schedule accessible to controller 216. For example, a second user schedule can include scheduling data to schedule a second schedule event configured to alter an operating condition of a network device at site 202. The second user schedule can be operably linked to a second mobile device having a location reporting device (not expressly illustrated in FIG. 2). For example, the second user schedule can be used or not used based on a distance a second mobile device may be from site 202. In another form, mobile device 210 may not be located at site 202, but a second mobile device may located be at site 202. In this form, a second user schedule may be based on detecting the second mobile device located at site 202. According to an aspect, the second user schedule can be disabled when the second user leaves the site 202 and a proximity mode can be enabled. According to a further aspect, a second user schedule may not be operably linked to any mobile device. As such, controller 216 can use a second user's schedule to schedule events in response to a detection of mobile device 210 being a distance away from residential site 202. In this manner, multiple user schedules and proximity control of energy use can be deployed at a common site.

**[0076]** According to an aspect, energy management system 200 can also include controller 242 capable of detecting advanced metering infrastructure (AMI) wireless network 248 output by smart metering device 250. For example, smart metering device 250 can include, or can be coupled to, AMI / Gateway 242 capable of outputting AMI wireless

network 248. In other forms, smart metering device 250 can be configured to output AMI wireless network 248 directly.

[0077] According to another aspect, controller 216 can be configured with a communication interface (not expressly illustrated in FIG. 2) to enable joining AMI wireless network 248. In this manner, controller 216 can gain access to AMI wireless network 248 to receive AMI data. In a further aspect, controller 216 can use the AMI data to alter an operating condition of a network device at site 202, output AMI data using a display of a network device, communicate AMI data to server 204, or any combination thereof. According to a further aspect, controller 216 can communicate the AMI data with site report data as a site report to server 204. As such, AMI data and site report data can be used at server 204.

[0078] According to a further aspect, controller 216 can connect to AMI wireless network 248 at a first security level, and alter an operating condition of a network device connected to wireless energy network 242 at a second security level. According to an aspect, wireless energy network 242 can be deployed at the same security level as AMI wireless network 248, can be deployed at a different security level than AMI wireless network 248, or any combination thereof.

[0079] According to a further aspect, a user or site profile can be used to enable use of control actions initiated or received by AMI wireless network 248. For example, a site manager or user can establish a profile setting to enable or disable a utility company to alter an operating condition of a network device at a residence. As such, controller 216 can access a profile setting prior to connecting to AMI wireless network 248, enabling use of a control action received using the AMI wireless network 248, or any combination thereof. In other forms, controller 216 can access server 204 to detect profile settings.

[0080] According to another aspect, energy management system 200 can also include controller 216 configured to communicate using a Zigbee network and a WIFI network.

For example, controller 216 can include a ZigBee enabled communication device (not expressly illustrated in FIG. 2) capable of initiating wireless energy network 242 at site 202 that includes a residential site. Controller 242 can also include a WIFI enabled communication device (not expressly illustrated in FIG. 2) capable of initiating WIFI network 244 operable to be coupled to mobile device 210 that may be WIFI enabled, or other WIFI enabled devices, systems, or any combination thereof.

[0081] According to a further aspect, controller 216 using WIFI network 244 can be used to alter an operating condition at site 202 in response to detecting mobile device establishing or losing a WIFI connection to WIFI network 244. For example, a user schedule can be enabled when a WIFI connection of mobile device 210 can be detected, and an operating condition of one or more network devices connected to wireless energy network 242. As mobile device 210 leaves site 202, an operating condition of one or more network devices can be altered upon a detection of a WIFI connection of mobile device 210 to WIFI network 244 being lost.

[0082] According to an aspect, mobile device 210 can communicate with controller 216 to access site data, site reports, control action data, AMI data, or various other types of EMI data available using WIFI network 244. According to an aspect, mobile device 210 can initiate control actions, control action reports, or combinations thereof that can alter an operating condition of a network device coupled to wireless energy network 242. According to a further aspect,

[0083] According to another aspect, controller 216 configured with a WIFI communication device can enable a connection to a home computer system, laptop computer, Netbook, home server, IPAD®, home automation system, router, or other WIFI enabled system or devices (not expressly illustrated in FIG. 2), or any combination thereof. For example, a user can use an IPAD to access controller 216. Using WIFI network 244 and wireless energy network 242, a user can receive operating status information, initiate control actions of network devices, schedule energy use, or various

other energy management activities. In some forms, controller 216 may not have access to network 206. Controller 216 can include portions or all of the capabilities of server 204 to schedule energy use, generate scheduling data, access site data, generate control action data, or any combination thereof. As such, in some instances network 206 may not be established (e.g. in a new construction site, etc.), or if a network failure or an absence of network availability occurs, a user can access network devices at site 202 and manage energy use.

[0084] According to another aspect, controller 216 can detect when mobile device 210 connects to WIFI network 244 and alter an operating condition of a network device coupled to wireless energy network 242. For example, as mobile device 210 moves or transitions away from site 202, controller 216 can detect a signal loss and alter an operating condition at site 202. According to an aspect, controller 216 can include control action data to be used upon detecting a signal loss. In other forms, controller 216 can report the signal loss to server 204 within, or external to a site report. Server 204 can then determine a control action (if any) in response to a reporting of the WIFI signal being lost.

[0085] According to a further aspect, server 204 can initiate a text message using messaging module 240 to be sent to mobile device 210. User of mobile device 210 can then view the text message and respond to alter an operating condition at site 202. For example, a user can place site 202 in proximity mode which will enable an energy efficiency schedule associated with the user. In other forms, a user can access an energy management application accessible to mobile device 210 and alter an operating condition at site 202. Various combinations of messaging communications (e.g. SMS text, email, social network messaging, social network postings, etc.), message content, and various combinations thereof can be used to inform a user of mobile device 210 that an operating condition can be altered in response to mobile device 210 not being connected to a WIFI signal at site 202, a detection of mobile device 210 being a distance from site 202 using location detection, or any combination thereof.

[0086] According to another aspect, controller 216 can also connect to mobile device 210 using WIFI network 244 and communicate information using mobile device 210 and information network 240. For example, mobile device 210 can connect to information network 240 which can be a wireless subscriber based information network. Mobile device 210 can receive energy management information from an information source accessible to information network 240. According to an aspect, mobile device 210 can include a mobile energy management application that can be used to access server 204 or other information source(s). Mobile device 210 can be used to upload information such as a site report, network device data, operating statuses, or various other types of information that can be obtained at site 202 using wireless energy network 242. According to a further aspect, mobile device 210 can receive information such as control action reports, control data, environmental data, scheduling data, user profile data, network device profile data, Zigbee based profile data, WIFI data, configuration data, network device data updates or firmware updates, controller data updates or firmware updates, or various other types of FMI data or any combination thereof that can be communicated to mobile device 210 using information network 240. Mobile device 210 can then communicate received information to controller 216 using WIFI network 244. Controller 216 can use the received information to manage energy use at site 202.

[0087] According to a further aspect, controller 216 can be configured to request profile data, profile updates, network device updates, or any combination thereof of a network device using WIFI network 244, wireless AMI network 248, network 206, or any combination thereof. For example, controller 216 can detect a Zigbee enabled network device at site 202. Controller 216 can identify unique identifier of the Zigbee enabled network device, and request a profile of the Zigbee enabled network using WIFI network 244. For example, mobile device 210 can request a Zigbee profile using information network 240. In another form, a home computer, laptop computer, IPAD® etc. can request the Zigbee profile using network 206. In another form, controller 216 can access



wireless AMI network 248 to request a Zigbee profile. As such, controller 216 can be configured to request profile data, profile updates, network device updates, various other types of information to manage network device, or any combination thereof of a network device using one or more networks accessible to controller 216.

[0088] According to a further aspect, controller 216 can be incorporated into a network device. For example, controller 216 and TSTAT 208 can be combined into the same unit. Controller 216 can also include an 802.15.4 based wireless communication device (not expressly shown in FIG. 2) operable to establish wireless energy network 242. Controller 216 can also include an 802.11 based wireless communication device (not expressly shown in FIG. 2) operable to communicate with mobile device 210. Using the 802.11 based wireless communication device, controller 216 can communicate with gateway 218 having a residential broadband wireless router capable of establishing an 802.11 based wireless communication network at site 202. In this manner, combining controller 216 and TSTAT 208 can lead to a reduction in the number of separate devices deployed at site 202.

[0089] According to a further aspect, controller 216 can include a processor (not expressly illustrated in FIG. 2) configured to deploy a web server capable of enabling web services. For example, controller 216 can connect to WIFI network 244 and a computer system at site 202. The computer system can include a browser configured to access an IP address of the web server of controller 216 to manage one or more network devices coupled to wireless energy network 242. In a particular form, controller 216 can include a scheduling tool configured to be output by the web server and accessible using WIFI network 244. According to a further aspect, controller 216 can be coupled to mobile device 210 and controller 216 can be configured to enable access to a subscriber based wireless information network 240 using a connection to the 802.11 based wireless communication device of controller 216.

[0090] FIG 3 illustrates a method of managing energy at a site according to an aspect of the disclosure. Portions or all of the method of FIG. 3 can be used with portions or all of the energy management systems, devices, or apparatuses disclosed herein, or any other type of system, controller, device, module, processor, or any combination thereof, operable to employ all, or portions of, the method of FIG. 3. Additionally, the method can be embodied in various types of encoded logic including software, firmware, hardware, or other forms of digital storage mediums, computer readable mediums, or logic, or any combination thereof, operable to provide all, or portions, of the method of FIG. 3.

[0091] The method begins generally at block 300. At decision block 302, the method detects whether an energy network has been established. For example, a wireless energy network can be established and can include one or more networks that can be used to manage energy use at a site. According to an aspect, a wireless energy network can be established using a wireless enabled controller located at a residence. At decision block 302, a detection of an energy network, AMI enabled network, WIFI enabled network, Zigbee enabled network, WiMAX network, or any other type of energy network, or any combination thereof can be detected. If at decision block 302, one or more networks may not be detected, the method can proceed to decision block 304. At decision block 304, the method can detect if there is an AMI network available. If at decision block 304 there is an AMI network available, the network can proceed to block 306 and the AMI network can be joined. For example, the AMI network can include a specific protocol and security level to establish communication or allow a joining of the network. For example, the AMI network may require an encryption key-based security that can require specific keys, certificates, etc. to enable access. According to another aspect, the AMI network may include a smart grid based security described in Smart Grid standards. As such, various combinations of joining the AMI network can be deployed. Upon joining the AMI network, the method can proceed to decision block 308.

[0092] In some forms, an AMI network may be available and the method can be modified to determine whether to join the AMI network. If at decision block 304, an AMI network may not be detected (or may not be joined), the method can proceed to decision block 308. At decision block 308, the method can detect if a WIFI network (e.g. 802.11 based network) may be available. If a WIFI network is not detected or is not available, the method can proceed to block 310 and a WIFI network can be established. For example, a controller, network device, smart appliance, or various other types of energy consuming devices can include a WIFI communication device capable of initiating a WIFI network. As such, at block 310 a WIFI network can be established and the method can proceed to block 312. If at decision block 308 a WIFI network exists, or if a WIFI network should not be established, the method can proceed to block 312. In some forms, an additional WIFI network can be established at block 310 and the method can be modified to allow a bridging between the two WIFI networks.

[0093] According to an aspect, at block 312 an energy network can be established to manage one or more network devices. For example, an energy network can include a wireless energy network that is based on a Smart Grid standards and protocols such as a Zigbee based protocol. Various other types of communication can also be used to establish an energy network. An energy network can be established by outputting a wireless network at a site to enable a network device to join the energy network.

[0094] Upon establishing an energy network, the method can proceed to block 314 a network device capable of connecting to the energy network can be detected. For example, a network device can include a Zigbee enabled communication device capable of joining a Zigbee enabled energy network. A unique identifier of the network device can be detected and a profile can be obtained at block 316. In some forms, a unique identifier can be previously obtained by a controller deploying the energy network. For example, a unique identifier can be obtained from a server accessible to a controller, via a WIFI or other network accessible to a controller, or any combination thereof. In other forms, an

external information source can be capable of providing a unique identifier, or a list of unique identifiers to identify a valid network device that can be joined to the energy network. A controller can then use the unique identifier, and the profile, to establish or join the network device to the energy network.

[0095] In another form, a profile of a network device may not be immediately available, or may have been revised. As such, a profile can be obtained using a WIFI network, an AMI network, an Internet or broadband network, or any combination thereof. For example, a unique identifier, a model number, a serial number, a device class identifier, or any combination thereof that can be communicated to an external source or information network to obtain a profile can be used. A profile can then be identified and used to join the network device to the energy network.

[0096] According to a further aspect, obtaining a profile at block 316 can include initiating a request using a controller and an information network accessible to a mobile device capable of communicating with a WIFI network at a site. For example, a profile can be provided by connecting a mobile device to a wireless information network such as a 3G data network, 4G data network, or other subscriber based wireless information network. The mobile device and then communicate the profile to the controller using the WIFI network at the site. The controller can then receive the profile and use at least a portion of the profile within the energy network.

[0097] According to an aspect, upon obtaining a profile, the method can proceed to block 318 and the network device can be joined to the energy network. For example, the network device can be joined at a security level that is different than required by an AMI network, or other secure network. In some forms, the network device can be joined to multiple networks or combination of networks while joined to the energy network. In other forms, the network device can be joined to only the energy network. In still other forms, an AMI network connection can be established to enable an AMI network to access the network device, and the network device can unjoin or disconnect the AMI network and

join the energy network. In another form, information received from the AMI network can be used to alter an operating condition of the network device using the energy network. Various other permutations of joining a network device to an energy network or other networks can also be realized as needed or desired.

**[0098]** According to a further aspect, a network device can join the energy network using a standardized profile, such as a Zigbee profile. In addition, a network device can be joined using a profile modifier that can extend the functionality of the Zigbee profile associated with a specific network device. For example, a controller establishing the energy network can access profile modifiers to enhance use of a specific network device.

**[0099]** According to a further aspect, an AMI network can be joined during a period of time, and then the energy network can be joined during a separate time period. As such, various combinations of joining a network device to one or more networks can be used as needed or desired to manage energy use of a network device. Additionally, the method can be modified to join additional network devices to one or more networks as needed or desired. Upon joining one or more network devices, the method can proceed to block 320 and then to decision block 322.

**[00100]** At decision block 322, the method can detect whether a proximity mode associated with a site and energy network is enabled or disabled. For example, proximity mode can include associating a mobile device with a residential site, and automatically controlling a network device based on detecting a location the mobile device may be from the residential site. One or more mobile devices associated with a site can include a location reporting device capable of outputting a location report. The location reporting device can use various technologies to report location including GPS, GPRS, cell tower triangulation, or various other location reporting technologies. In another form, a location reporting device of a mobile device can also include a WIFI radio capable of being connected to a WIFI network. As such, a mobile device can be connected to a WIFI

network at the site using a WIFI connection, and as a WIFI connection is established or lost, a proximity mode can be enabled and disabled accordingly.

**[00101]** According to an aspect, at block 322 if proximity mode is enabled, the method can proceed to block 344 as described below. If at decision block 322 proximity mode may not be enabled, the method can proceed to decision block 324 to detect if a user schedule is available. For example, a user schedule can include an event schedule to control one or more network devices. According to an aspect, one or more user's can create a schedule that can be accessed by a controller, and used to control one or more wireless thermostats or other network devices that can be joined to the energy network. According to a further aspect, a user schedule can be linked to a mobile device of the user. In some forms, the mobile device can include a location detection device configured to report locations of the mobile device.

**[00102]** According to an aspect, if a user schedule may not be detected, the method can proceed to block 356 and an event can be identified. For example, an event can include one or more programmed events that can be created and accessed at a specific time, date, period, or other to alter an operating condition of a network device. For example, a user may not have provided a user schedule to schedule energy use of a hot water system at a residence. As such, a default schedule can be accessed to identify an event and schedule or manage use of the hot water heater. For example, an event can include decreasing a hot water heater ten (10) degrees at midnight. Another event can include increasing a hot water heater fifteen (15) degrees at five (5) A.M. In another form, a network device can include a wireless thermostat that can be used to control an HVAC system based on a time of day or other attribute. For example, a weather forecast can be determined, and an event can be scheduled to adjust a wireless thermostat accessible to the energy network. Various other environmental conditions, grid conditions, user profiles, device profiles, energy pricing, or any combination of energy management information can be used to schedule or create an event.

**[00103]** Upon identifying an event, the method can proceed to decision block 326 and detect whether to schedule the event. For example, if an event is configured to be scheduled at a specific time of day, the method can detect the event at decision block 326. If an event may not be detected, the method can proceed to decision block 322 and repeats.

**[00104]** According to an aspect, if at decision block 326 an event should be scheduled, the method can proceed to block 328 and the event can be scheduled. For example, a network device can be identified, an operating condition to be altered can be identified, a time of day to alter the operating condition can be identified, a period of time to alter an operating condition can be identified, a device profile can be used, or any combination of data that can be used to schedule an event can be used. According to another aspect, the method can include initiating a scheduled event at block 328 using a portion of a programming schedule stored within a memory of the controller associated with the energy network. For example, portions of event data can be communicated from a remote server to the controller, and used with a programming schedule stored within the controller to schedule an event. In this manner, one or more sources can be used alone or in combination to schedule events.

**[00105]** According to a further aspect, upon scheduling the event, the method can proceed to block 330 and a control action can be communicated to a network device. For example, a control action can include control action data or device data sufficient to alter an operating condition of a network device. In some forms, data formatted according to a standard profile, such as a Zigbee Home Automation profile, Zigbee Energy Profile, and the like. In other forms, control action data can include a device identifier, a message format to output a message, a parameter or feature of a network device to alter, an updated set-point or operating condition of the network device, a network or security key, a date and time, or any combination thereof.

**[00106]** According to an aspect, the method can proceed to block 332 and the control action can be output to the energy network as an outgoing message and received by the network device as an incoming message. For example, the network device can detect the outgoing message communicated within the energy network using a unique identifier of the network device.

**[00107]** At block 334, upon the network device receiving the incoming message, a control action can be extracted from the incoming message and the operating condition at the network device can be altered using the control action data. For example, an dishwasher may be turned on, a clothes washer or dryer turned on, lights within a home can be altered, a thermostat can be adjusted, a hot water heater can be adjusted, or various other types of control actions can be initiated as needed or desired.

**[00108]** At block 336, network device data can be obtained from the network device using the energy network. For example, a network device can receive a request to output operating status information as network device data to the energy network. In other forms, the network device can be enabled to periodically publish status information to the energy network and received by the controller. Upon outputting the network device data, the method can then proceed to block 338 and a site report can be generated. For example, a site report can include network device data received from one or more network devices accessible to the home energy network. Site report data can be stored locally to the controller, and processed to confirm an updating of the control action. The site report data can be stored within a site report and communicated to a remote server configurable to receive and process the site report data within a site report. According to an aspect, a site report can be communicated to a remote server configurable to receive site reports from the controller using a broadband connection initiated by the controller. Other forms of communication can also be used to communicate a site report as needed or desired. Upon generating a site report, the method can proceed to decision block 302.



**[00109]** According to an aspect, if at decision block 322 proximity detection may be enabled, the method can proceed to block 344 and a location report can be received. For example, a location report can include location data output from a location reporting device such as a mobile device. In other forms, a location report can be generated in response to a detection that a mobile device having a WIFI radio may be within range, or out of range, of the WIFI network at the site. As such, the method can be used to alter an operating condition of the network device using the energy network in response to detecting the location reporting device establishing or losing a WIFI connection to the WIFI network.

**[00110]** According to an aspect, the method can proceed to decision block 346 and can detect if a location change has occurred. If a location change has not occurred, the method can proceed to block 348 and detects whether to alter an operating condition. If an operating condition of one or more network devices may not be altered, the method can proceed to block 350, and to block 322.

**[00111]** According to another aspect, if at decision block 346 a location change may be detected, the method can proceed to block 350 and detects a distance a location reporting device may be from an associated site. The method can then proceed to block 352 and detects the direction of the mobile device. For example, if the distance has increased from a previous location reported, the method can detect that a user may be moving away from a site. In other forms, a detected direction can include moving toward a site, moving away from a site, or not moving at all.

**[00112]** Upon detecting a direction, the method can proceed to decision block 348 and detects whether to alter an operating condition of a network device. For example, in addition to detecting a distance and direction a user may be from a residence, various other types of information can also be used to alter an operating condition. For example, data such as real time velocity data, average velocity data, estimated length of time a user may

take to return to a site, thermostat scheduling data, network device scheduling data, site report data, real-time weather condition data, traffic condition data, user driving pattern data, daily driving pattern data, GPS mapping data, home energy efficiency ratings, demand response data, curtailment data, energy pricing data, grid condition data, various other types of EMI, or any combination thereof.

**[00113]** Upon detecting an operating condition to alter, the method can proceed to block 354 and initiates a control action. For example, a server remote to a site can be used to generate a control action that can be included within a control action report and communicated to the controller at the site. In a form, the control action report can be communicated in association with an upload of a site report. According to another aspect, a control action can be generated by the controller. For example, a location and direction of a mobile device can be identified and communicated to the controller. The controller can then determine whether to generate a control action using the location data and direction data, and possible other data as needed or desired. The method can then proceed to block 328 as generally described above. If at decision block 348 an operating condition of a network device should not be altered, the method can proceed to block 350 and to block 322.

**[00114]** According to an aspect, the method can be provided to detect a distance between the location reporting device and the site using a previously stored location of the residence and a new location of the location reporting device. At decision block 354 altering an operating condition can include altering an operating condition of the network device in response to detecting the location reporting device is travelling away from the residence. Further, altering an operating condition of the network device in response to detecting the location reporting device is travelling toward the residence.

**[00115]** According to another aspect, the method can be provided to detect a location reporting device at a first distance at block 350, and at decision block 348 initiate a control action. As the location reporting device may be detected at a second distance, a

second control action can be initiated. For example, a control action can include setting a first temperature set-point of a thermostat in response to detecting the first distance. The method can further be provided to detect the location reporting device at a second distance different from the first distance, and set the temperature set-point to a second value.

**[00116]** According to a further aspect, the method can be modified to detect an upper and lower thermostat set-point limits of a network device. For example, an upper set-point limit can include a maximum a temperature that should be reached within a site during a warm season. A set-point of a thermostat can then be determined by determining the difference between a previous set-point and the maximum set-point. In some forms, a percentage adjustment, such as 30%, 50%, 75%, etc. of the resulting difference between a maximum set-point and a base set point can be used to determine a new set-point. For example, if a thermostat is set to seventy (70) degrees and has a maximum set-point of eighty (80) degrees, the delta between the two being ten (10) degrees. A new set-point can then be generated by multiplying this delta by a percentage, such as 50%, and adding it to the current set point. In this example, a new setting of seventy five (75) degrees would be the resulting set-point. In other forms, the method can use the maximum and minimum set-points, resulting or current set-points, in association with a time of day, a distance or distances a user may be from a site, or various other data that can be used to determine a set-point using maximum and minimum set-point values.

**[00117]** FIG. 4 illustrates a block diagram of an energy management apparatus, illustrated generally as controller 400, according to an aspect of the disclosure. Controller 400 can include a processor 402 and memory 404 configurable to store data. Memory 404 can be configured as on-board memory of processor 402, or in other forms can also include expandable memory such as DDR memory, Flash Memory, EPROM, ROM, or various other forms, or any combination thereof generally illustrated as memory 404.

**[00118]** According to an aspect, controller 400 can include buses 406, 408, 410 configured to couple data and signals to various components within controller 400.

Although illustrated as multiple buses 406, 408, 410, controller 400 can include a single bus, multiple buses, or any combination thereof. Various types of bus configurations can be used as needed or desired including, but not limited to, any combination or portion of a serial bus, a parallel bus, a serial – parallel bus, a universal serial bus, industry standard bus, controller area network bus, a serial peripheral bus, a universal asynchronous receiver transmitter bus, a control bus, standard digital input output bus, or any combination thereof.

**[00119]** According to an aspect, controller 400 can also include a communication interface 430, an information network interface 416, an external bus interface 420, an application program interface 440, or any combination thereof configurable to be coupled to one or more of buses 406, 408, 410 or any combination thereof. According to an aspect, any combination of interfaces 430, 416, 420, 440 can be configured in any combination of hardware, software, or firmware, and can include any combination or portion of a serial bus interface, a parallel bus interface, a serial – parallel bus interface, a universal serial bus interface, industry standard bus interface, controller area network bus interface, a serial peripheral interface, a universal asynchronous receiver transmitter interface, a control bus interface, standard digital input output interface, or any combination thereof.

**[00120]** According to a further aspect, controller 400 can also include a power supply 412 capable of providing power to controller 400. Power supply 412 can be an internal power supply and in other forms can be provided external to controller 400. Controller 400 can also include a broadband device 414 configured to be coupled to a broadband network. For example, broadband device can include an Ethernet communication module, a Cable or coaxial-based communication module, and can include communication logic to receive and transmit data between controller 400 and an information network such as a LAN, WAN, local network, the Internet, and the like.

Broadband device 414 can include TCP/IP communication capabilities and can also be security enabled to transmit SSL data between controller 400 and an information network.

**[00121]** According to a further aspect, controller 400 can also include an information network interface 416, a wireless information network device 418, and an external bus interface 420. Controller 400 can also include a Zigbee enabled communication device 422, a WIFI device 424, an Advanced Metering Infrastructure device 426, a support and updates module 428, and a communication interface 430. Controller 400 can also include an operating system 450 that can be executed by processor 402.

**[00122]** According to an aspect, controller 400 can be configured to use any type or combination of wireline or wireless communication to manage energy use at a site, including, but not limited to, power-line communication, wire line communication, wireless communication, Zigbee based communication, INSETEON based communication, X10 based communication, Z-Wave based communication, WiMAX based communication, Bluetooth based communication, WIFI based communication, 802.11-based communication, 802.15-based communication, 802.16-based communication, proprietary communication, other communications described herein, or any combination thereof.

**[00123]** According to a further aspect, controller 400 can include a network device profile module 432, a security module 434, a controller module 436, and a proximity detection module 438. Controller 400 can also include device profiles 442, user profiles 444, home profiles 446, and profile modifiers 448. One or more of the modules, profiles, or any combination thereof can be provided as encoded logic such as a ROM, PROM, EPROM, EEPROM, or various combinations thereof and accessible to processor 402 as needed or desired. In other forms, one or more of the modules, profiles, or any combination thereof can be stored within a memory device such as memory 404, within a

removable flash drive (not expressly illustrated in FIG. 4), an external data storage device (not expressly illustrated in FIG. 4), or any combination thereof.

**[00124]** According to further aspect, controller 400 can include processor 402 operable to manage energy use at a site. Processor 400 can be configured to convert an incoming message received from a wireless energy network (not expressly illustrated in FIG. 4) into XML enabled output data. Processor 400 can also format an outgoing message to be output to a wireless energy network using XML enabled input data. According to an aspect, XML enabled input data includes a network device identifier of a network device accessible using a wireless energy network. Controller 400 can also include communication interface 430 configurable to enable access to communication device, such as Zigbee device 422, WIFI device 424, AMI device 426, or any other device accessible to controller 400 and having access to a wireless energy network. According to an aspect, communication interface 430 can be configured to detect an outgoing message formatted by processor 402 and configure the outgoing message to a message bus format that can be coupled to bus 408 and a communication device such as Zigbee device 422. For example, outgoing message can include network device data configured to be output to a wireless energy network, but processed into a message bus format prior to outputting to a communication device. Communication interface 430 can then convert the outgoing message from a message bus format to a format that can be output by a specific communication device. For example, if the outgoing message was intended to be output using WIFI device 424, communication interface can detect that the message was to be sent on a WIFI network and can convert the outgoing message from a message bus format to a WIFI device format. Communication interface 430 can then output the WIFI device formatted message to WIFI device 424.

**[00125]** According to a further aspect, communication interface 430 can be configured to detect an incoming message received from a wireless energy network using a communication device such as Zigbee device 422, WIFI device 424, AMI device 426, or

any other device accessible to controller 400 and having access to a wireless energy network. Incoming message can include incoming network device data received from a network device. Communication interface 430 can convert an incoming message from a communication device format to access an incoming network device data received from a network device, and output the incoming network device data using a message bus format that can be used by processor 402.

**[00126]** According to another aspect, controller 400 can include a wireless data module, such as Zigbee device 422, WIFI device 424, AMI device 426, or any other device accessible to controller 400 and having access to a wireless energy network. A wireless data module can be accessible to processor 402 and configured to generate profile data to be used with an outgoing message. For example, processor 402 can access network device profile module 434 and use a network device profile of a network device accessible to the wireless energy network to output a message receivable by a specific network device. Network device data can be formatted using a network device profile of a specific network type of the wireless energy network. In some forms, a network device profile may not include information sufficient to output network device data. As such, profile modifiers 448 can be provided and can include profile modification data of the network device not available within the network device profiles 442 that can be used to communicate with a network device coupled to an energy network accessible to controller 400.

**[00127]** For example, device profiles 442 can include a Zigbee thermostat device profile having home automation profile data and smart energy profile data. Profile modification data 448 can be used to access additional profile information to format an outgoing Zigbee message and access a Zigbee enabled thermostat coupled to a wireless energy network accessible to controller 400. In this manner, additional features and functionality that may not exist within Zigbee profile standards can be accessed by using

profile modifier data 448. As such, functionality of a Zigbee enabled device can be expanded beyond a standard Zigbee profile.

**[00128]** According to another aspect, controller 400 can include a first user profile stored within user profiles 444 and accessible to processor 402. For example, a first user profile can include a first time schedule to operate a network device and a control setting to control the network device. User profiles 444 can also include a first user identifier to identify a first user and can also include a network device identifier to identify the network device to control or alter.

**[00129]** According to another aspect, controller 400 can include a second user profile within user profiles 444 and accessible to processor 402 that is different than the first user profile. A second user profile can include a second time schedule to operate a network device and at least one control setting to control the network device. The second user profile can also include a second user identifier to identify the second user and a network device identifier to identify the network device.

**[00130]** According to a further aspect, processor 402 can determine when to use a first user profile or a second user profile. For example, processor 402 can access user profiles 444 to detecting the user profiles, and initiate outputting an outgoing message using the first user schedule or the second user schedule. Processor 402 can then be used to monitor when to alter the operating condition provided by the first user schedule, to an operating condition of a second user schedule. In this manner, multiple user schedules can be used by controller 400 to control a network device.

**[00131]** According to a further aspect, processor 402 can be used to detect an input to a network device as a user schedule is being used, and store a new setting of the network device in association with the deployed user schedule. For example, processor 402 can detect a current user profile being used, and further detect an interaction with a network device during use of a first user schedule. Upon detecting an interaction,



processor 402 can initiate an update to the first user profile in response to detecting the interaction.

**[00132]** According to an aspect, processor 402 can be used to convert data received using broadband device 414 to a format that can be output to a wireless energy network. Also, processor 402 can also be configured to convert data received from the wireless energy network to a format that can be used by broadband device 414. For example, processor 402 can include a Linux enabled processor configured to convert an incoming message received from Zigbee device 422 to an XML enabled output data. Additionally, processor 402 can format XML enabled input data received from broadband device 414 to an outgoing Zigbee message that can be output using Zigbee device 422.

**[00133]** According to a further aspect, controller 400 can be configured as a server and can deploy several processes of applications that can be used, including, but not limited to Ubuntu Version 9.04, Java SE Version 6, "lighttpd HTTP Server", Servlets, FastCGI, Apache log4j, Eclipse, Apache Ant, or any equivalent operating environments or software, or any combination thereof.

**[00134]** According to an aspect, processor 402 using a Java operating environment can initiate generation of a Java output object using XML enabled input data received from broadband device 414. The Java output object can include network device data of a ZigBee enabled network device accessible to a wireless energy network and Zigbee device 422. Processor 402 can further initiate generation of XML enabled output data from an incoming message received from Zigbee device 422 using a Java input object configured to accesses network device data using a network device profile stored within device profiles 422, and a profile modifiers 448 as needed or desired.

**[00135]** According to an aspect, controller 400 can use communication interface 430 and API 440 to enable access to ZigBee device 422 operably coupled to bus 408 and accessible to API 440. As such API 440 can be used by processor 402 during use of one

or more modules to access Zigbee device 422, WIFI device 424, AMI device, 426 or any combination thereof to communicate network data using a wireless energy network. As such, processor 402 can make API calls to API 440 to access various functions of one or more communication devices 422, 424, 426.

**[00136]** According to another aspect, controller 400, can be used to coordinate a wireless energy network, and use data within the wireless energy network that was received from an external information source accessible to controller 400. For example, broadband device 414 can be coupled to an information network. Broadband device 414 can further be coupled to information network interface 416 operable to access external data sources that can be communicatively coupled to broadband device 414. Controller 400 can initiate coordinating a wireless energy network, and initiate outputting XML enabled output data as site report data to information network interface 416 to be communicated to an external data source using broadband device 414. Site report data can include a portion or representation of network device data received by Zigbee device 422, or other device accessing the wireless energy network. According to an aspect, controller 400 can also receive control action report data using broadband device 414. For example, control action report data can include XML enabled input data that can be output as network device data using the wireless energy network.

**[00137]** According to a further aspect, controller 400 can be configured to access a wireless energy network at more than one security level. For example, processor 402 can use security module 434 configured to initiate supporting coordinating a wireless energy network at a first security level and enable access to a network device at a first security level. For example, processor 402 can initiate receipt of an incoming message using Zigbee device 422 at the first security level. Upon gaining access and communicating device data, processor 402 can disconnect the network device. In another form, security module 434 and processor 402 can then initiate access to a second network device at a second security level using Zigbee device 422, and enable access to the second network

device using the second security level. Processor 402 can initiate receipt of a second incoming message at the second security level, and upon receipt of device data disable access to the second network device. As such, controller 400 can use a single Zigbee device 422 to access multiple network devices using more than one security level.

**[00138]** According to an aspect, controller 400 can be used to access more than one wireless energy network. For example, processor 402 can initiate using a first wireless communication device, such as Zigbee device 422, to coordinate a first wireless energy network. Processor 402 can also initiate using a second wireless communication device, such as a second Zigbee device (not expressly illustrated in FIG. 4), or other wireless device, to coordinate a second wireless energy network. As such, processor 402 can access one or more network devices coupled to one or more wireless energy networks. According to another aspect, a second Zigbee device, or other wireless device can be used to join a second wireless energy network instead of coordinating the second wireless energy network. For example, the second wireless energy network can include an advanced metering infrastructure (AMI) enabled network operably associated with an AMI enabled smart meter. AMI device 426 can include a second ZigBee device, or other wireless communication device, capable of joining an AMI enabled network of an AMI enabled smart meter (not expressly illustrated in FIG. 4). As such, smart meter data can be accessed by controller 400 as needed or desired. For example, AMI data or smart meter data can be obtained on a periodic basis and communicated in association with a site report having network device data. As such, broadband device 414, wireless information network device 418, or other information network devices can be used to site report data that can include AMI data acquired using controller 400.

**[00139]** According to another aspect, controller 400 can use AMI device 426 to access an AMI enabled smart meter to alter an operating condition of a network device accessible to controller 400 using Zigbee device 422. For example, AMI device 426 can include an advanced metering infrastructure (AMI) enabled interface capable of initiating

access to an AMI enabled smart meter. Controller 400 can use AMI device 426 to receive AMI data from an AMI enabled smart meter. Processor 402 can be used to initiate altering an operating condition of a network device in response to detecting AMI data received from the AMI enabled smart meter. Processor 402 can further be used to detect a smart energy control request output by an AMI enabled smart meter, and initiate using the smart energy control request at the network device.

**[00140]** In some forms, a control request may be obviated by controller 400 by not allowing an AMI initiated control request to be enabled. For example, processor 402 can access home profiles 446 and determine whether a control action initiated by an AMI enabled smart meter should be enabled or disabled. As such, controller 400 can be used to monitor control actions being output by an AMI enabled smart meter or other utility provided system, and alter the request as desired. For example, a user may create a home profile 446 that would not allow for a curtailment action of a network device. In other forms, home profile 446 may enable a curtailment action over a period or schedule, and disable a curtailment action over another period or schedule. As such, controller 400 can determine a valid period or schedule to enable and disable a curtailment action initiated by an AMI enabled smart meter.

**[00141]** According to a further aspect, controller 400 can reset an operating condition in the event an AMI enabled smart meter alters an operating condition of a network device. For example, an AMI enabled smart meter may be able to control a network device. Controller 400 can monitor an operating condition of the network device, and in the event an operating condition has been altered to a setting that is not scheduled by controller 400, controller 400 can respond to the operating condition by notifying a user, or automatically altering the operating condition to a preferred setting.

**[00142]** According to another aspect, controller 400 can be used to access an information network outside of the wireless home energy network. For example, information network interface 416 can be configured to access an information network

using broadband device 414, wireless information network device 418, external bus interface 420, or any combination thereof. According to an aspect, wireless information network device 418 can include a subscriber based network device, or in other forms can include a WIFI network access device, or various combinations thereof. According to an aspect, wireless information network device 418 can include WIFI device 424 that can be used to access an information network. As such, WIFI device 424 can be used to access an information network, an wireless energy network, a local wireless information network, or any combination thereof.

**[00143]** According to an aspect, controller 400 can use WIFI device 424 to be coupled to a WIFI enabled communication device such as a mobile device, smart phone, home computer, laptop computer, Netbook, or any other WIFI enabled device capable of connecting to a WIFI network. Communication interface 430 and processor 402 can be used to enable a WIFI enabled communication device to access network device data, site data, or any combination of data accessible using the wireless energy network. Control actions can also be requested using the WIFI enabled communication device and connection to control a network device coupled to the wireless energy network accessible by controller 400. For example, a mobile device access a WIFI network can be used to access a wireless energy network having a network device. In other forms, controller 400 can include a web server capable of communicating web services that can be accessed by a mobile device (or other system or device), via a web based environment. For example, controller 400 can output portions or all of a graphical user interface as described in FIGs. 7-10 herein, or other graphical user interfaces that can be output by a web server. As such, a user having a WIFI enable communication device can be coupled to controller 400 using WIFI device 424 and monitor, create and manage operating conditions, home profiles, user profiles, device profiles, user schedules, proximity detection, demand response preferences, energy savings preferences, other control settings, view site data, or any combination thereof. Other settings and operating conditions can be accessed, monitored, or managed as needed or desired.

**[00144]** According to another aspect, controller 400 can include proximity detection module 438 that can be accessed by processor 402 to enable and disable proximity control at a site. For example, proximity detection module 438 and processor can be used to detect a distance between a mobile device having a location reporting device and the site. Processor 402 can be used to identify a current operating condition of a network device, and identify an updated operating condition of the network device in response to the detected distance. Processor 402 can be used to initiate generation of an outgoing message to include an updated operating condition in response to the distance. According to a further aspect, controller 400 can be configured to receive location data using an information network having a server configured to communicate location data associated with a mobile device having a location reporting device that is associated with a site. Location data can be stored within memory 404 and used to monitor a distance and direction between a site and the mobile device. As such, controller 400 can initiate control actions using the location data, and the location data need not be stored in a server remotely located to a site. Various control actions can be generated using various types of conditions including detecting a distance, determining a control zone having a distance or interval, travel pattern of a mobile device, monitoring current and future weather data, monitoring real-time traffic data, monitoring energy pricing data, monitoring home efficiency data, or using any combination of energy management information in association with providing proximity control of a site.

**[00145]** According to an aspect, controller 400 can include a plug computer employing a Linux based server configured to manage energy use at a site. For example, controller 400 can include a Java enabled processor as processor 402, memory 404 configured to store incoming and outgoing wireless energy network messages, Zigbee device 422 capable of accessing a wireless energy network, and information network interface 416 capable of initiating communication with an information network. Controller 400 can also include communication interface 430 operably coupled to bus 408

and Zigbee device 422 coupled to bus 408. Through utilizing a Java enabled processor and Linux operating system, controller 400 can deploy a web server (not expressly illustrated in FIG. 4) and a Java environment to handle and convert XML data received using a web server into Java objects that can be used to communicate network device data and various other types of data.

**[00146]** For example, processor 400 can be used to convert an incoming message received from a wireless energy network using the Zigbee device 422 into XML enabled output data. Processor 402 can format an outgoing message to be output to a wireless energy network using XML enabled input data that includes a network device identifier of a network device accessible using a wireless energy network. Communication interface 430 can be configured to detect the outgoing message formatted by processor 402 to be output using the wireless energy network, and configure the outgoing message to a message bus format to be output to communication bus 408. In some forms, the outgoing message can include network device data configured to be output to a wireless energy network. Communication interface 430 can further detect an incoming message received from a wireless energy network that includes incoming network device data. Communication interface 430 can be used to convert the incoming message accessed from bus 408 from the message bus format to detect incoming network device data that can be output to processor 402. Processor 402 can then be used to generate site data including the network device data, and a site report that can be communicated using information network interface 416.

**[00147]** FIG. 5A illustrates a block diagram of a mobile device, generally illustrated at 500, according to an aspect of the disclosure. Mobile device 500 can be configured as a smart phone or handheld computer, tablet, and the like such as an I-Phone® device, a Blackberry® device, an Android® device, an iPad® or various other devices or systems. Mobile device 500 can include a processor 502, a memory 504, an I/O device 506 such as a keypad, touch screen, function buttons, a mini qwerty board, or any other type of input

device capable providing control of mobile device 500 or any combination thereof. I/O devices 506 can also include a speaker for outputting sound, and a microphone for detecting sound. Mobile device 500 can also include a display 508 such as color LCD display, touch screen display, or any combination thereof. According to a further aspect, one of more of I/O devices 506 can be displayed within display 508 having touch screen capabilities, such as selectable GUI elements that can be used to control features, functions, or various other application of mobile device 500. As such, mobile device 500 can be configured to use numerous applications that output graphical elements configurable to control mobile device 500 and applications accessible by mobile device 500.

**[00148]** According to a further aspect, mobile device 500 can also include an energy management application 510 accessible to processor 502 and configured to enable a user to manage energy use of at a site in a mobile environment. Mobile device 500 can also include a location reporting device 515, such as GPS technology, cell tower location technology, triangulation technology or any combination thereof. Portions of location reporting device 515 can be located within mobile device 500 however in other forms, a wireless network can include functionality that can be selectively accessed to detect a location of mobile device 500.

**[00149]** According to a further aspect, mobile device 500 can also include a network interface 514 configurable to enable access to a WIFI device 516, a Bluetooth device 518, a ZigBee device 520, or any combinations thereof. According to a further aspect, mobile device 500 can also include a wireless data network device 522 that can be configured with one or more RF radios capable of connecting to one or more wireless networks such as a 3G network, 4G network, PCS network, EDGE network, cellular network, or any combination thereof.

**[00150]** As illustrated in FIG. 5B, mobile device 500 can also include an energy management user interface 530 capable of being displayed within display 508. Energy



management user interface 530 can include a user information section 532 that can display various types of user data such as a location of a site being managed, an energy provider providing energy to the site being managed, an energy personality of the user based on the user's interaction with energy use at the residential site, or various other types of user profile information.

**[00151]** According to a further aspect, energy management user interface 530 can include a current readings section 534 configured to display a current readings and operating conditions of a site. For example, current readings can include a current inside temperature, outside temperature, proximity setting, energy alert setting, savings rate, status of network devices being managed such as lights, HVAC system, hot water heater system, sprinkler system, refrigerator system, washing machine system, distributed energy generation system such as a solar array, battery storage device, fuel cell, wind turbine generator, or any combination thereof. Other network devices can also be managed as needed or desired. Current readings section 534 can include a selectable graphical element that can be selected to access additional site information. Site information displayed within current readings 534 can be accessed from a remote server capable of managing or storing site reports that include site data and device data. In other forms, site information, current reading, operating conditions, or any combination thereof can be accessed using a WIFI device 516 of mobile device 500.

**[00152]** According to a further aspect, energy management user interface 530 can include a current settings section configured to enable a user to alter an operating condition of a network device being managed. For example, current settings section 536 can include current setting of one or more thermostats at a site, settings of any other network device being managed at a site. Current settings section 536 can also include general settings to manage a site. For example, a general setting can include a proximity detection setting, a demand response setting, an energy alerts settings, a savings setting, schedules, calendars, events, a vacation setting to enable a vacation schedule, or any other

type of setting that can be used to manage energy consumption or network devices at a site, or any combination thereof. Current settings section 536 can also include a graphical element that can be selected to access additional settings as needed or desired.

**[00153]** According to a further aspect, energy management user interface 530 can include a current savings section 538 configured to enable a user to access energy savings information and adjust as needed or desired. For example, an energy savings amount obtained at a site can be realized. A user may also be able to access an energy saving selector (not expressly illustrated in FIG. 5B) to modify an energy savings level. For example, a user can change a savings level to low, medium, high, or various other savings metrics. According to another aspect, a user may access a vacation mode (not expressly illustrated in FIG. 5B) and alter an operating condition of a site by selecting a vacation mode using mobile device 500. As such, various energy savings settings can be selected as needed or desired.

**[00154]** According to a further aspect, mobile device 500 can provide proximity updates, site report requests, site control commands, configuration data, settings, scheduling data, text messages such as SMS, MMS and others, and various other types of information or data or any combination thereof that can be used with an energy management system. According to another aspect, mobile device 500 may not have full functionality or capabilities of a smart phone or other device capable of running an application. For example, a mobile device such as a cell phone may not be capable of loading an application such as an energy management application. However, the mobile device may have sufficient functionality to allow an energy management system to contact the mobile device. For example, an adverse operating condition may be detected at a site (e.g. temperature set-point of thermostat is out of range, lights are left on, etc.). As such, the energy management system can identify the mobile device and send a message, such as a text message, an email message, or any combination thereof, capable of being received and displayed by the mobile device. In some forms, a user can receive the

message and respond to the message, enabling the user to control the operating condition of the network device at the site. For example, the user can respond to the message via a text message, an email message, or another messaging application accessible to the mobile device. As such, a mobile device that may not be able to run energy management application 510 can be used to control an operating condition at an associated site.

**[00155]** During operation, a user can access operating status and generate control actions to control a network device (not expressly illustrated in FIG. 5A or 5B) at a site. For example, mobile device can receive and send messages, such as text messages, HTTP enabled messages, XML enabled messages, email messages, data, or any combination thereof. For example, if an outside temperature at a site is increasing or forecasted to increase, and the price of energy is increasing or scheduled to increase, mobile device 500 can receive a message to inform the user of the condition. The user can respond to the message as desired. In other forms, a suggestion can be sent to the user. For example, a suggestion to increase a thermostat or indoor temperature by three degrees can be received by mobile device 500. Upon receiving the message, the user can respond to the message using a text or other messaging technology. In other forms, a user can access energy management application 510 and initiate a control action to adjust the thermostat to different set-point. In this manner, a user can become aware of a current operating or forecasted condition in a mobile environment, and respond as needed or desired.

**[00156]** According to another aspect, mobile device 500 can include a portion or all of energy management application 510 running in the background, in the foreground, or any combination thereof. According to an aspect, energy management application 510 can be launched automatically when a message or energy alert may be received by mobile device 500.

**[00157]** According to a further aspect, energy management application 510 can be operable to work with an energy management system to update a control action field within a database. For example, mobile device 500 and energy management application

510 can initiate updating a control field within a database to identify a control action. Energy management application 510 can further update a new set-point within the database. As such, an energy management system can generate a control action report or data during a site upload. In this manner, a user of mobile device 500 can update control setting using a remote server or energy management system, and control actions can be generated to alter an operating condition at a site.

**[00158]** According to another aspect, energy management application 510 can output recommendation settings of a network device to the user. For example, a user can select a low savings, medium savings, or a high savings at a residential site using current settings 536. A user can select a savings level, and mobile device 500 can communicate a message to an energy management system associated with the site and mobile device 500 to generate a control action to alter an operating condition at a site based on a savings level setting. For example, an energy management system can calculate new settings of one or more network devices, intervals to set the network devices, start and stop times, and the like. In some instances, settings can be determined based on a forecasted weather, forecasted energy pricing, forecasted energy availability, proximity of mobile device 500 from a site, or various other types of data. Settings can be stored within a database and control actions can be initiated as needed or desired.

**[00159]** According to a further aspect, an energy alert message received by mobile device 500 can be used to alter or display an energy status icon, alter an application icon, alter a status within a social network, or various combinations thereof. For example, a user can then select the energy status icon using mobile device 500 and an associated application can be presented to a user to allow a user to alter an operating condition as desired. In some forms, a user's election to reduce energy consumption during peak times or other times can be fed into their social network as an energy savings message or update. A user's energy personality can also be output from mobile device or associated web service to be updated within a social network as needed or desired.

**[00160]** According to a further aspect, mobile device 500 can include proximity detection module 524 operably associated with energy management application 510 and location reporting device 512. Proximity detection module 524 can be provided as a part of energy management application 510, location reporting device 512, may be provided as a separate module, or any combination thereof. According to an aspect, proximity detection module 524 can be used with location reporting device 512 to detect a distance mobile device 500 may be from an associated site. For example, proximity detection module 524 can be operated as a background process that periodically requests a location from location reporting device 512. Location reporting device 512 can use various location reporting methods (e.g. GPS, triangulation, etc.) to detect a current location, and an associated API of location reporting device 512. According to an aspect, proximity detection module 524 can request an accuracy of a location to be provided by location reporting device 512, and a response time. For example, if a GPS signal may not be available to mobile device 500, location reporting device 512 can be requested by proximity detection module 524 to detect a location using a triangulation technique or other technique within 500 milliseconds. In another form, proximity detection module 524 can alter reporting parameters of location reporting device 512 in response to a relative location mobile device 500 may be from an associated site. For example, mobile device 500 may be greater than five (5) miles from an associated site, and location reporting device 524 can alter a distance accuracy, response time, method used, or various other location reporting parameters that can be selected.

**[00161]** According to another aspect, proximity detection module 524 can be used to initiate altering an operating condition of an associated site in response to a location of mobile device 500. For example, proximity detection module 524 can be used to detect mobile device 500 being greater than two miles away from an associated site, and a direction that is moving away from an associated site. Proximity detection module 524 can output a location and direction to energy management application 510, and energy

management application 510 can detect whether to initiate a control action at an associated site.

**[00162]** According to a further aspect, proximity detection module 524 can be used to detect a location at a modifiable interval (e.g. one (1) minute, five (5) minutes, etc.) to reduce the amount battery drain or power consumption of mobile device 500. For example, as mobile device 500 may be moving away from an associated site, and an interval to access location data using location reporting device 512 can be increased (e.g. set from one (1) minute to three (3) minutes). In another form, as mobile device 500 moves closer to an associated site, proximity detection module 524 request at location from location reporting device 512 at a shorter interval ( e.g. set from five (5) minutes to (1) minute). Various combinations of intervals can be deployed as needed or desired. In other forms, energy pricing at a period of time can also be used to alter reporting of a location reporting device 512. Various other combinations of using data to alter reporting of a location can also be used as needed or desired to reduce battery consumption or other operating conditions of mobile device 500.

**[00163]** According to a further aspect, proximity detection module 524, energy management application 510, or another portion of mobile device 500, or any combination thereof can be used as an energy management system. For example, an energy management system, such as energy management system 200 illustrated in FIG. 2, energy management system 600 illustrated in FIG. 6, an energy management system located at a site, hosted within a network, a apparatus or device capable of energy management, or any combination thereof can be used. According to an aspect, an energy management system can receive location data reported by location reporting device 512, and alter an operating condition of mobile device 500 based on a relative location mobile device 500 may be from an associated site. As such, an energy management system can be used to alter an operating condition of mobile device 500.

**[00164]** According to another aspect, sampling of location reporting device 512 can be updated using energy management application 510, an energy server operably associated with mobile device 500, or any combination thereof. For example, mobile device 500 can be detected by an energy management system as being between three and five miles from a site. An energy management system or application can further detect mobile device 500 travelling away from an associated site. As such, access to location reporting device 512 can be reduced thereby reducing energy consumption of mobile device 500.

**[00165]** According to a further aspect, a user of mobile device 500 may enter a building where a location based signal, such as a GPS signal, may not be able to be accessed or have limited access. As such, a sampling interval of location reporting device 512 may be altered to conserve energy. Upon a user exiting a building and a location of mobile device 500 being detected, a sampling interval can be returned to a previous value or a new value as needed or desired. According to further aspect, a sampling interval can be sent to mobile device 500 from another source such as an energy management system. In other forms, updated sampling intervals can be stored within mobile device 500 and accessed as needed or desired. In other forms, a distance from a site, a sampling interval, direction, or various combinations of data can be communicated to mobile device 500 to be used to alter access to location reporting device 512.

**[00166]** According to another aspect, mobile device 500 can include software trap routines to be used when a location may go undetected. For example, energy management application 510 can use proximity detection module 524 that accesses location reporting device 512 to obtain a location. However, if a location is not obtained, or invalid, or any combination thereof, a software trap routine can be used to keep the proximity module, or background process from exiting. In this manner, energy management application 510 and various modules, associated processes, or any combination thereof can be

continuously run without having to receive valid location data, and terminating the background process.

**[00167]** According to a further aspect, mobile device 500 can incorporate various portions or functionality of energy management system 200, controller 300, energy management system 600, wireless thermostat 1200, or various other systems, apparatuses, modules, GUI's or any combination thereof described herein as needed or desired to manage energy use in a mobile environment using mobile device 500. Additionally, mobile device 500 can use various types of data accessible to mobile device 500 including, but not limited to EMI data disclosed herein. According to an aspect, an application icon (not expressly illustrated in FIG. 5B) can be provided in a association with energy management application 510. For example, an icon can be used to access energy management application 510 can in some forms, can be altered to display energy consumption information, settings information or various other types of information without a user having to launch energy management application 510. For example, energy management application 510 can alter text information (e.g. device settings, current readings, lights on/off, etc.). An example can include displaying a current thermostat setting of a thermostat at a site, altering a color of an icon based on an energy savings or consumption level, alter a color based on proximity information, display a current temperature within a site, or various combinations thereof. As such, a user need not launch an energy management application 510 to EMI data associated with a site.

**[00168]** FIG. 6 illustrates a block diagram of an energy management system, generally illustrated at 600, according to another aspect of the disclosure. Energy management system 600 can include a server 602 operable to be coupled a site 604. Server 602 can include a processor 606 and a database 608. Server 602 can include an external data source interface 610 that can be coupled to an external data source 612 using a network connection 614. External data source 612 can include one or more data sources capable of providing access to EMI data, various other types of data, or any combination



thereof. According to a further aspect, external data source 612 can also include third party sources. For example, an external data source 612 can include subscription based, non-subscription based, or any combination thereof of data having weather conditions, traffic conditions, grid operating conditions, wholesale energy prices, real-time energy pricing, dynamic pricing information, fixed pricing information, forecasted energy pricing, forecasted energy consumption, forecasted energy production, alternative energy production, distributed alternative energy production, zonal demand or operating conditions, nodal demand or operating conditions, or other EMI data that can be accessed using a third party.

**[00169]** According to a further aspect, server 602 can also include a network interface 616 that can be coupled to a network location 618 using a network connection 620. Network location 618 can be used to access to HMI data, various other types of data, or any combination thereof. Server 602 can also use network interface 620 to access a public network, a private network, a semi-private network or any combination thereof. According to an aspect, network interface 616 can include a network communication device (not expressly illustrated in FIG. 6) and a web server operable to enable access to the Internet or other communication network. Server 602 can also include a site interface 622 that can be coupled to site 604 using a network connection 624 operable to be coupled to a home controller 626. According to an aspect, site interface 622 can be realized as a web services based application configured to receive information initiated by site 604.

**[00170]** According to an aspect, site 604 can also include a wireless thermostat, TSTAT 628, operably coupled to NVAC system, IIVAC 630. Site 604 can further include a mobile device 632 associated with site 604. Mobile device 632 can be coupled to a mobile client interface 634, such as a WAP or other mobile device gateway capable of communicating using a mobile information network 636. According to an aspect, energy management system 600 can be operably to provide a first zone 638 having a first distance 640, and a second zone 642 having a second distance 642. First zone 638 and second zone

642 can be used to control TSTAT 628 and IIVAC 630. For example, first zone 638 and second zone 642 can be provided as a boundary that can be determined in various ways to control one or more energy consuming devices at site 604.

**[00171]** According to another aspect, server 602 and processor 606 can include one or more processors having one or more core processors. Server 602 can also use any combination of software modules, firmware, encoded logic, or any combination thereof to manage energy use. For example, server 602 can use a scheduling module 648, a scheduling tool module 650, a scheduling templates module 652, a control action report module 654, a site data report module 656, an efficiency rating module 658, a set-point update module 660, a proximity detection module 662, a zone update module 664, a current readings module 666, a demand response module 668, an energy savings module 670, a message module 672, an interaction detection module 674, an energy personality module 678, or any combination thereof.

**[00172]** According to an aspect, database 608 can be configured to store HMI data, control action data, site report data or any combination thereof. For example, database 608 can store data received from one or more residential sites associated with server 602. For example, site 604 can access TSTAT 628 using a wireless energy network deployed at site 604. Processor 606 can be configured to access site report data stored within database 608. Processor 606 can detect a current temperature set-point within the site data and an associated date and time of TSTAT 628 at site 604. Processor 606 can detect a current temperature reading at site 604, and can further detect seasonal settings stored within database 608. For example, a seasonal profile can include seasonal settings that can include settings of a winter schedule, a summer schedule, or various combinations of seasons and settings. According to an aspect, processor 606 can detect a current operating mode of IIVAC 630 operably coupled to TSTAT 628, and determine a thermostat schedule to be used with TSTAT 628. For example, if IIVAC 630 may be in an A/C mode, a summer profile, schedule and the like can be deployed which can include

temperature settings that can be different than a winter profile. For example, scheduling module 648 can be used to determine a date, a time or time interval, thermostat setting, operating mode, or any combination thereof, and store a schedule within database 608.

**[00173]** According to another aspect, server 602 can also generate control action reports using control action report module 654. For example, processor 606 can initiate generation of a control action report to communicate to site 604. A control action report can be generated in various ways with various types of data and settings to control an operating environment at site 604. For example, a control action report can be generated by setting a control action field within database 608.

**[00174]** According to a further aspect, energy management system 600 can use seasonal settings to control HVAC 630. For example, energy management system 600 can detect an operating mode of HVAV 630 and alter a set-point in using the detected operating mode and an associated seasonal profile. For example, an updated temperature set-point can include a value between a current temperature set-point and a minimum seasonal set-point in response to the current operating mode of HVAC 630 being in a heating mode. An updated temperature set-point can also have a value between a current temperature set-point and a maximum seasonal set-point in response to the current operating mode of HVAC 630 being in a cooling mode. Server 602 can generate a control action report that can also include settings or data generated in response to an efficiency rating of site 604, an estimated time period to generate an updated temperature reading, an updated temperature set-point, a current energy price, and a future energy price or any combination thereof.

**[00175]** According to another aspect, server 602 can be used to generate a control action report using proximity detection module 662. For example, processor 606 can detect a distance between a location reporting device, such as mobile device 632 and site 604. Processor 606 can further detect a zone, such as first zone 638, second zone 642 or additional zones as desired. Using a detected zone, processor 606 can initiate generation

of a control action report to be communicated to site 604 in response to a current zone. In this manner, various network devices (not expressly illustrated in FIG. 6) at site 604 can be automatically controlled on a zone by zone basis as mobile device 632 moves away from, or towards, site 604.

**[00176]** According to another aspect, one or more of the zones 638, 642, additional zones (not expressly illustrated in FIG. 6), or any combination thereof can be updated automatically using updated conditions. For example, processor 606 can use a zone update module 664 on a periodic basis to update zones using various types of data. For example, processor 606 can detect an efficiency rating of site 604, detect an external temperature at site 604 from an external data source 612 or other sources, determine a real-time travel time between mobile device 632 having location reporting capabilities and site 604. Processor 606 can modify distance 640, 644, or any combination thereof. For example, an efficiency rating of site 604, external temperature at site 604, estimated real-time travel time to or from site 604, various other EMI, or any combination thereof can be used. Although illustrated as being sequential, zones 638, 642 can be modified independently, together, or any combination thereof.

**[00177]** According to another aspect, server 602 can use proximity detection module 662 to detect when mobile device 632 may be moving away from site 604, and adjust IIVAC 630 using thermostat 628. For example, processor 606 can detect mobile device 632 moving away from site 604. Processor 606 can further detect a percentage change value associated with a current zone, and further detect a base set-point of TSTAT 628. Processor 606 can further determine a difference between the base set-point, and a minimum seasonal set-point in response to a current operating mode of the IIVAC 630. For example, if the IIVAC 630 is in a heating mode a percentage change can be determined to adjust use of a heating unit.

**[00178]** According to a further aspect, server 602 can determine a difference between a base set-point and a maximum seasonal set-point in response to a current

operating mode of the HVAC being in a cooling mode. As such, processor 606 can determine an updated thermostat set-point as a percent change based on the determined difference. Processor 606 can initiate generation of a control action report including an updated thermostat set-point to be used at site 604.

**[00179]** According to another aspect, server 602 can be used to generate an aggregated demand schedule. For example, processor 606 can determine energy demand of a plurality of residences in a region using scheduling module 648. For example, processor 606 can identify a group of residential sites within a specified region (not expressly illustrated in FIG. 6) and access thermostat schedules of each of the residential sites within the group. Processor 606 can also aggregate scheduling data using thermostat schedules, and initiate an outputting of the aggregated scheduling data. Aggregated scheduling data can include time intervals, settings, etc. and in some forms can also include an estimate of energy consumption based on an efficiency rating of residential sites, consumption profiles, location data, or various other site attributes that can be used to calculate an aggregated demand. According to an aspect, aggregated data can be used to forecast load, energy production, virtual capacity, demand response capacity, grid congestion, or any combination of grid attributes that can use aggregated scheduling data.

**[00180]** According to another aspect, energy management system 600 can also include a web services enabled scheduling tool to schedule energy use at a residential site. For example, processor 606 can use scheduling tool module 650 to generate a web based or network based graphical user interface that includes a scheduling tool. FIG 8A-D illustrate examples of a web services enabled scheduling tool and user interfaces that can be output using scheduling tool module 650. For example, processor 606 can output a thermostat selector configurable to enable selection of one or more wireless thermostats located at site 604. An event scheduler operably associated with the thermostat selector and configurable to enable a user to graphically select a utilization schedule of the one or more wireless thermostats can also be output by processor 606. Processor 606 can also be

used to update a utilization schedule to include a time of day and temperature setting. Scheduling tool module 650 can be used to control the one or more network devices that can include wireless thermostats, smart appliances and the like. Scheduling tool module 650 can be used to output an energy savings preference selector configured to graphically modify the utilization schedule, and display a resulting energy savings, a weather forecasting tool, and various other types of tools or scheduling features to assist in managing or scheduling use of a network device.

**[00181]** According to another aspect, server 602 can also use interaction detection module 674 to detect when a user may alter an operating mode of a network device. For example, interaction detection module 674 can detect when a user may adjust a thermostat at a specific time of the day, and suggest a modification of a utilization schedule to a user during a user access to scheduling tool output using scheduling tool module 650. A user can then elect to have the utilization schedule updated to include the suggestion as needed or desired.

**[00182]** According to another aspect, server 602 and scheduling tool module 650 can be used to enable additional features and functions. For example, a scheduling tool can be used to display a proximity control selector configured to enable and disable proximity control of a residential site, a demand response selector configured to enable and disable participation in demand response event, a vacation mode selector to enable and disable a vacation schedule, an auto update selector configured to enable an automatic update of the utilization schedule in response to a detection of a user interaction with the one or more network device, or various other controls that can be used to manage energy use at a site, or any combination thereof.

**[00183]** According to another aspect, server 602 and scheduling tool module 650 can be used to enable and disable demand response capabilities. For example, a scheduling tool can be used to provide a demand response selector (not expressly illustrated in FIG. 6) operable to be displayed with a scheduling tool. A demand response selector

can include several settings such as an always participate selection configured to always enable a curtailment of an HVAC system in response to a demand response event, a never participate selection configured to not allow a curtailment of the HVAC system in response to a demand response event, a request participation selection configured to initiate a communication, such as an email, text message, instant message, social network message, or various combinations thereof to the user to request participation in a demand response event. A demand response selector can be operably associated with demand response module 668 to initiate demand response inquiries, analyses, and deployments.

**[00184]** According to another aspect, server 602 can also use scheduling template module 652 to generate utilization templates that a user can access and modify to schedule energy use. For example, a plurality of energy templates can be accessed by a scheduling tool. Templates can include a predetermined utilization schedule selectable by the user based on a user's scheduling profile. A selected predetermined utilization schedule can be modifiable by a user using a scheduling tool module 650, and saved as needed or desired. According to an aspect, server 602 can output an on-line questionnaire or survey that a user can participate in to determine an energy template to use.

**[00185]** According to a further aspect, server 602 can also use energy personality detection module 678 to detect an interaction profile of a user. For example, a user may be an urban professional having a long work commute which may result in a first portion of a utilization schedule. Upon arriving at a residential site, a user may interact with their thermostat to which will result in a different portion of a utilization schedule. For example, a user may like an indoor temperature to be colder when going to bed. As such, a personality of the user while away and while at home can be used to automatically generate a user's schedule. According to another aspect, an energy personality indicia or character can be generated and output with a user's on-line scheduling tool, within a user's social network, or any combination thereof. For example, processor 606 can detect an interaction of a user with a wireless thermostat, and display of an energy personality

indicia in response to the interaction. A user can then enable or disable display of the energy personality indicia within a social network such as Facebook®, MySpace®, etc.. In other forms, processor 606 can be used to modify the indicia based on an overall energy savings a user has accomplished at their residential site. For example, processor 606 can use energy savings module 670 to determine an energy savings of the individual and alter the energy personality indicia accordingly. In another form, a user can set up a messaging service or account using Twitter ® and the like to output energy savings updates to a subscriber base in response to an energy saving initiate, participating in demand response events, alter energy use, or various other forms. According to a further aspect, a Twitter ® account or other messaging service can be used on a community basis to inform a group of individuals of energy management events. For example, an “energy action day” or “energy alerts” can be posted using a Twitter ® account to subscribers and a subscriber can curtail energy use using energy management system 600 or various other energy management systems as needed or desired. Other forms of messaging or any combination thereof can be used as needed or desired.

**[00186]** According to another aspect, server 602 can be used to determine a sample size of residential sites and corresponding schedules to forecast energy consumption over an interval. For example, processor 606 can be used to determine a random sample size of residential sites in connection with estimating an energy consumption of a specific region such as a zip code, street or series of streets, substations supporting residential sites, node-to-node, or any combination thereof or other methods of determining a region. Upon identifying a sample size of a region, residential sites can be identified within the region. For example, processor 606 can then determine associated thermostat schedules of residential sites within the specified region using scheduling module 648. Server 602 can output thermostat scheduling data of the plurality of sites in connection with scheduling or forecasting energy use.



**[00187]** According to another aspect, server 602 can also be used to enable a demand response initiated at site 604. For example, processor 606 can use demand response module 668 to detect an enabled demand response setting of site 604. Processor 606 can further detect a demand response event condition and enable a curtailment action of HVAC 630 if a user of site 604 has selected participation in a demand response event. An energy reduction capacity of site 604 can be determined using efficiency rating module 658, scheduling module 648, proximity detection module 662, or various other modules, data sources, or any combination thereof.

**[00188]** According to another aspect, server 602 can also use demand response module 668 to contact individuals prior to curtailing energy use at site 604. For example, processor 606 can initiate a demand response event request communication to communicate to the users of a plurality of sites. Processor 606 can detect a user response level to participate in a demand response event, and enable a curtailment of a corresponding HVAC system or other energy consuming devices at a site of a user electing to participate in the demand response event. In this manner, user's may not be forced to participate in demand response events but can have real-time election capabilities to participate as needed or desired.

**[00189]** According to an aspect, server 602 can send a text message that includes a request to participate in a demand response event. In some forms, a text message can include an agreement to pay the user to participate in a demand response event. Payment can take various forms such as credits, cash, rewards, points, contribution to education funds, discounts on energy rates, or any combination thereof. Server 602 can receive a response from using mobile client interface 634 and process the response using message module 672 to determine a desire to participate or not.

**[00190]** According to another aspect, server 602 can be used with scheduling module 648 to determine an aggregate capacity to reduce energy consumption. For

example, processor 606 can be used to identify a group of residences within the plurality of residences and determine an energy reduction capacity of each of the residences within the group using an efficiency rating of each of the residences within the group. Upon determining an efficiency rating of each residence, processor 606 can detect other data to be used to determine an available capacity. For example, current weather conditions at each residential site can be detected, a user's energy schedule or thermostat schedule can be used, a response to text messages or emails electing to participate can be determined, grid conditions can be used, or any combination thereof. Upon estimating an available capacity, an aggregate energy reduction capacity based on the energy reduction capacity of each of the residences within the group can be determined.

**[00191]** According to another aspect, server 602 can use an aggregate energy reduction capacity in association with an auction. For example, processor 606 can initiate an auction of virtual energy capacity to retail energy providers electing to bid an available energy capacity. In other forms, a third party can host an auction and energy management system 600 can output an available capacity in association with an upcoming auction event, peak demand period, transmission rate determination period, or any combination thereof. For example, processor 606 can initiate an auction process to sell the aggregate energy reduction capacity to a third party, and detect a sale of the aggregate energy reduction capacity in connection with the auction process. Upon a sale occurring, processor 606 can initiate a curtailment of an HVAC system, other energy consuming devices, or any combination thereof, at each of the residences within the group.

**[00192]** According to another aspect, energy management system 600 can include mobile client interface 634 operable to be coupled to mobile device 632 associated with site 604. For example, mobile client interface 634 can include a WAP gateway or other mobile client gateway to enable server 602 access to mobile device 632. Mobile client interface 634 can be provided as a part of server 602, however in other forms, portions or all of mobile client interface 634 can be provided by a specific wireless network provider.

As such, mobile client interface 634 can be configured to communicate with a specific carrier having a WAP gateway. Mobile client interface 634 can be used to communicate EMI or control data between WAP gateway and server 602 using any combination wireless or terrestrial communication technologies. Additionally, WAP gateway can also include logic or modules that can provide mobile device users access to EMI data or control data generated by mobile device 632, server 602, energy management system 600, or any portions and combinations thereof.

**[00193]** According to an aspect, mobile client interface 632 can receive a site readings request of site 604 from mobile device 632. For example, processor 606 can detect the site reading request and initiate access to database 608 to retrieve site report data of site 604. Processor 606 can format the site report data as mobile device data, and output the mobile device data to mobile device 632 using mobile device network 636.

**[00194]** According to another aspect, mobile client interface 634 can receive a request from mobile device 632 to modify a current temperature set-point of HVAC system 630. For example, processor 606 can process a received request from mobile device 632 and initiate generation of a control report using control action report module 654. The control action report can include a reference to an updated temperature set-point communicated from mobile device 632 to mobile client interface 634. Processor 606 can set a variable or field within database 608 to alter a set-point. Upon site 604 initiating access to server 602, processor 606 can access a variable or field associated with site 604, and generate a control action report or control data to be communicated to site 604 using site interface 622. As such, upon a temperature set-point being updated at site 604, home controller 626 can communicate a control action confirmation data, site report, status information, or various combinations thereof to confirm the updated temperature set-point. Processor 606 can output a confirmation of the updated temperature set-point to the mobile client interface 634 upon receiving a confirmation, and can output an updated temperature set-point to mobile device 632.

**[00195]** According to another aspect, mobile device 632 can be used to enable and disable operating modes of one or more network devices located at site 604. For example, mobile device 632 can include a mobile application loaded on mobile device 632 that can be used to control settings at site 604. FIG. 5A and B illustrate examples of energy management application and functionality that can be used by mobile device 632 although other applications and functions can also be deployed using mobile device 632 as needed or desire. According to another aspect, mobile device 632 can access a web based application associated with server 602 using a web browser of mobile device 632 to enable and disable operating modes or conditions at site 602. For example, mobile device 632 can alter a proximity setting, alter one or more environmental control zones, access current readings, modify a vacation setting, modify energy use schedules, or various other operating modes or data associated with controlling or maintaining operating modes of network devices located at site 604 as needed or desired.

**[00196]** According to another aspect, energy management system 600, can be used to send messages to mobile device 632 in connection with an altered operating condition at site 634. For example, processor 606 can access site data received from site 604, and further detect a manual input condition provided at TSTAT 628. For example, a user may have decreased a temperature set-point of TSTAT 628. Processor 606 can detect whether a user is at home using location data received from mobile device 632 and proximity detection module 660. Upon detecting the condition, processor 606 can determine if it should initiate a text message indicating the manual input condition. For example, processor 606 can use message module 672 to format and output a text message indicating the condition change of TSTAT 628, and output the text message using mobile client interface 634. A user can then alter the condition using mobile device 632 as desired. In other forms, an email message or other electronic message can also be sent to a user. For example, a message can be displayed within a window of a computer system associated with the user. In other forms, a text message can be sent to multiple mobile devices

associated with site 604. Various other combinations of alerting a user of site 604 of a manual change to an operating condition can be used as needed or desired.

**[00197]** FIG. 7 illustrates an energy management user interface (EMUI), illustrated generally at 700, according to an aspect of the disclosure. In some forms, EMUI 700 can be accessed using a mobile device, desktop computer, Netbook, laptop computer, smart phone, a energy display device, a smart thermostat, a home automation control terminal, and iPad ® or any combination of devices capable of displaying energy management user interfaces.

**[00198]** According to an aspect, EMUI 700 can include a user information section 702 configured to display one or more user names 704, a residential site address 706, a mobile phone number 708 associated with residential site address 706. User information section 702 can further display a current energy provider 710 associated with residential site address 705, and a current best rate 712 of a third party energy provider available at residential site address 706. An advertisement 714 section can also be displayed, and an edit details link 716 can be displayed to enable a user to access, edit, modify, delete, manage, etc. information displayed within user information section 702. FIG 9 described herein includes an example of a user interface that can be used to edit user information displayed within user information section 702. User information section 702 can also display an energy personality 740 associated with hers name 704. Energy personality 740 can also be linked to one or more social networks as needed or desired.

**[00199]** According to a further aspect, a current readings section 718 can be displayed within EMUI 700. Current readings section 718 can include, for example, a current date and time section 720 with a current inside temperature and outside temperature at a residential site. Current readings section 718 can further include a current thermostat set-point 722 of a thermostat located at a residential site. More than one thermostat can be deployed at a residential site and current thermostat set-point 722 can include references such as “Main”, “2”, “3” or some other indicia configured to enable

access to current thermostat readings of multiple thermostats at a residential site. A user can also modify the name or number of a thermostat, zone, etc. using an edit feature of thermostat set-point 722.

**[00200]** According to a further aspect, a current readings section 718 can also include an energy savings level 724 configured to indicate a savings level that relates to current thermostat set-point 722. For example, as current thermostat set-point 722 is set to a low set-point, an air conditioner unit may run more frequently and cause a low energy savings. As such, a visual indication of an energy savings can be displayed in association with a current set-point giving a user feedback on energy consumption based on a thermostat set point. In some forms, a user can adjust a thermostat set-point up or down, and an energy savings level can be altered in near real-time based on the users selection. For example, various programming languages such as DHTML, AJAX, Flash, HTML 5, and the like can be used to show a near real-time update of one or more fields within EMUI 700.

**[00201]** According to a further aspect, EMUI 700 can also include a demand response notification selector 726 configured to enable participation in demand response events, disable participation in demand response events, and enable a text message (or other messages) to be sent to a user to request participation in a demand response event. According to a further aspect, EMUI 700 can also include a proximity detection selector 728 configured to enable proximity detection of one or more mobile devices associated with a residential site.

**[00202]** According to another aspect, EMUI 700 can also include an energy usage / savings section 730 that can display a current annual savings 732, a current monthly savings 734, a demand response savings 736, and a view more data link 738. According to an aspect, view more data link 738 can be operably associated with accessing portions or all of EMUI 800 described in FIG. 8.

**[00203]** FIG. 8 illustrates an energy management user interface operable to report energy usage and savings information, illustrated generally as EMUI 800, according to a further aspect of the disclosure. According to an aspect, EMUI 800 can include an energy usage / savings section 802, operable to display a current annual savings 804, a current monthly savings 808, and a current demand response savings 808 realized by a user participating in demand response events. EMUI 800 can also include an estimated annual savings section 810, a managed vs. unmanaged energy consumption graph 812, and a comparative consumption graph 814. According to an aspect, a user can select a comparison graph that includes a community graph configured to compare a user's energy consumption to others in a residential community, a state comparison graph configured to compare a user's energy consumption to others within a state, and a national graph configured to compare a user's energy consumption to a current national average.

**[00204]** According to a further aspect, EMUI 800 can also include a daily usage graph 816 configured to indicate energy consumption and savings on an hour-by-hour basis. For example, if a user selects a medium energy savings settings, daily usage graph can display a daily savings in dollars, KWh or any combination thereof. Daily usage graph 816 can further include a graph indicated what the consumption would have been if energy use was left unmanaged. According to a further aspect, daily usage graph 816 can also include a day selector 818 configured to enable a user to select a day of the week to view energy consumption and savings.

**[00205]** According to another aspect, EMUI 800 can also include a monthly usage and savings graph section 820 configurable to output monthly energy usage and savings information of each day of the month. For example, a monthly graph can include a daily, weekly, or other pairing bar graph configured to display a monthly energy usage and savings at a residential site. A user can navigate between a month using month selector 822 and a specific month's consumption and savings graph can be displayed. In some instances, only a portion of a specific month's data may be available to be displayed. As

such, only a portion of a graph may be displayed as desired. According to a further aspect, monthly usage and savings graph section 820 can also include an link to access annual savings as needed or desired.

**[00206]** According to another aspect, EMUI 800 can further be used to access and display performance data of an adjacent home, a similar sized home, one or more of the same or similar energy consuming devices (e.g. HVAC, hot water heater, other smart appliances), or any combination thereof. EMUI 800 can compare performance of each of the other residences and devices, and provide feedback to a user about the user's relative performance. For example, EMUI 800 can output a visual indication of power consumed, such as a graph, chart, etc. In other forms, a comparable residential site can also be displayed using EMUI 800. For example, a same or similar sized home can be used as a baseline comparison.

**[00207]** In other forms, EMUI 800 can be used to enable a user access to energy efficient devices and systems, and a user can forecast energy reduction and savings through use of an energy efficient system. As such, energy consuming devices that may be introduced and have a greater efficiency rating can be identified and communicated to a consumer. According to another form, EMUI 800 can display a click-through or micro-site to allow a user to access third party product energy efficient offerings. In other forms, EMUI 800 can enable access to a "green energy" marketplace that will enable a user to review energy efficient products and services. Such products and services can be selected by a user and associated XML data, meta data, and the like can be fed into EMUI 800. EMUI 800 can be configured to use the third party data and refresh data displayed within EMUI 800 to display an estimated saving if used at the user's residential site. As such, EMUI 800 can determine an estimate of what energy savings may be for their residential site, allowing a user to make an informed purchase decision. For example, a user may wish to add a solar array or other type of energy producing system to their residential site. EMUI 800 can be used to estimate the amount of energy that may be saved based on a



user's actual historical energy use. As such, a payback period associated with purchasing can be displayed to a consumer.

**[00208]** FIG. 9 illustrates an energy management user interface (EMUI) operable to access and edit user and site information, illustrated generally at 900, according to a further aspect of the disclosure. EMUI 900 can include a user profile 902 configured to display and enable a user to edit changes to user information. User profile 902 can include a user selector 904 configurable to add and remove user's associate with a site, a user name field 906, an energy personality type field and/or indicia 908, a social network selector 910, a residential site address 912, and a mobile number 914 associated with a residential site address 912. According to a further aspect, user profile 902 can also include an energy text message alert selector 916, a proximity detection selector 918, and a current HVAC provider information field 920.

**[00209]** According to an aspect, user selector 904 can be configured to enable a user to select a user data to edit. For example, multiple users can be associated with a residential site and a user's information can be accessed by selecting user selector 904. In other forms, a user can log into a web site or other application and may only be able to have limited access to user specific data associated with a residential site. According to another aspect, user information selector 904 can be used to add additional users to be associated with a residential site. As such, a master user or administrator login can form (not expressly illustrated in FIG. 9) can be provided to manage user information. In some aspects, a user profile 902 can include pre-populated information to reduce the amount of information a user may need to input. Additionally, information associated with the residential site can be accessed and used with the additional user as needed or desired.

**[00210]** According to a further aspect, EMUI 900 can also include an energy provider section 922 which can include retail, utility, or third party energy information. For example, a current energy provider can be displayed and a current energy rate and plan currently being used can also be displayed. Energy provider section 922 can also

indicate a best rate plan at a current provider, and a best local rate available through another provider. Energy provider section 922 can also include a savings calculator element 934 capable of initiating a savings calculation of the residential site using a best available rate of a current provider, other providers, or any combination thereof. Savings calculator element 9434 can also use historical site data, scheduling data of the residential site, forecasted energy consumption, future energy pricing, or various other EMI or any combination thereof to determine annual savings. Site consumption can then be used to determine what an overall cost of energy would be when using a given rate plan. Other intervals (e.g. monthly, weekly, daily, etc.) can also be calculated as needed or desired. As such, a user can identify a plan that would align with usage habits and scheduling data at a residential site.

**[00211]** According to a further aspect of the disclosure, EMUI 900 can also include a user posting and reviews section 924. User posting and reviews section 926 can include a content selector 926 capable of selecting energy blogs, green energy reviews, markets and the like. For example, as a user selects 'My Energy Blogs,' a list of energy blog titles can be displayed including a user energy blog 928 configured to enable a user to edit and publish their own energy blog. A user can publish their energy blog to an energy blog websites, social networks, third party sites, content providers, or any combination thereof. A third party energy blog 930 can also be listed within user posting and reviews section 926 allowing third party bloggers, articles, content providers, RSS feeds, Twitter ® Feeds, or any combination thereof, to provide content. According to an aspect, a user can add a blog, news feed, social network, Twitter ® account, etc. to user posting and reviews section 926 as desired. User selector within user posting and reviews section 924 can allow a user can to select between user content associated with a site and read/write/access privileges can be enabled and disabled accordingly.

**[00212]** According to a further aspect, user posting and reviews section 926 can also include a 'Green Energy Reviews' section configured to review energy saving products,

environmentally friendly products, green energy producing systems, or any combination thereof. User posting and reviews section 926 can also include a 'Markets' section configured to enable a user to access green energy product websites or marketplaces having green energy products. For example, a marketplace can be used to consolidate available green energy products, such as smart appliances, and further identify third party pricing and websites selling green energy products. As such, a user can read reviews of new energy saving products and access the energy products using user posting and reviews section 926. In some instances, EMUI 900 can be used to enable E-commerce between a posting site within markets section, green energy reviews section, retail energy providers, etc. allowing a firm hosting EMUI 900 to be paid a portion of revenue resulting from a sale.

**[00213]** FIG. 10 illustrates an energy management user interface (EMUI) operable to schedule energy use at a residential site, illustrated generally as EMUI 1000 according to a further aspect of the disclosure. EMUI 1000 may be illustrated in association with managing one or more user schedules, thermostats, HVAC systems, zones, sites or any combination thereof. In other forms, EMUI 1000 can be modified to schedule energy use of various energy consumption devices at a site as needed or desired. Additionally, portions or all of EMUI 1000 can be accessed using a computer system capable of accessing the Internet, can be configured as mobile application that can be used with a smart phone or handheld computer, tablet, and the like such as an I-Phone® device, a Blackberry® device, an Android® device, an iPad® or various other devices or systems, or any combination thereof.

**[00214]** According to an aspect, EMUI 1000 includes a thermostat display 1002 configured to enable a user to adjust a temperature of one or more thermostats located at a residential site. Thermostat display 1002 can include a date and time display, a thermostat selector 1004, and a thermostat controller 1006. EMUI 1000 can also include a savings selector 1008 configured to enable a user to select a low savings level, a medium savings

level, or a high savings level. Savings selector 1008 can be operably associated with an estimated savings display 1010 and a scheduling tool 1012. For example, a user can select a low savings using savings selector 1008 and an estimated savings can be calculated and displayed within estimated savings display 1010. According to a further aspect, a user can select a savings level using savings selector 1008. As such, resulting thermostat settings can be displayed within scheduling tool 1012 thereby providing a user a visual indication of a resulting temperature setting. According to a further aspect, savings selector 1008 can also be operably associated with scheduling tool 1012 to display more than one temperature setting at a time. For example, a low savings may result in a temperature setting of sixty-five degrees, a medium savings may result in a temperature setting of sixty-eight degrees, and a high savings level may result in a temperature setting of seventy-four degrees. Various combinations of values and display techniques can be used as needed or desired.

**[00215]** According to a further aspect, scheduling tool 1012 can include a seasonal schedule capable of allowing a user to schedule energy use based on a season (e.g. spring, summer, fall, winter). For example, a first site may be located in a hot climate and a second site may be located in a cold climate. As such, an air conditioner may be used more frequently during the summer months in a hot climate and can be associated with a schedule being displayed. A user can select between a seasonal schedule using scheduling tool 1012, and a schedule can be updated accordingly to display a winter schedule. Various other seasonal schedules can be added and removed as needed or desired. In other forms, scheduling tool 1012 can be used to access a current operating mode of an HVAC system and display a seasonal schedule in response to detecting an operating mode. For example, if an HVAC system may be operating in a heat mode, a winter schedule can be displayed. Other seasonal schedules can also be displayed within scheduling tool 1012 as needed or desired.

**[00216]** According to a further aspect, scheduling tool 1012 can include a current inside and outside temperature display 1014, and a schedule selector 1016 capable of displaying a user schedule of a first user, a second user, a vacation schedule, or any combination of schedules. For example, a user may use scheduling tool 1012 to schedule energy use at multiple sites. As such, scheduling tool can display a second site associated with a specific user. Additional schedules can be added as needed or desired, and access privileges also can be set by a current user using user information profile such as user profile 902 illustrated in FIG. 9 or any other privileges or logic capable of setting access privileges.

**[00217]** According to a further aspect, scheduling tool 1012 can also include a weekly schedule display section 1018, and a time span display section 1020 configured within a schedule 1022. Weekly schedule display 1018 can also be configured to show current dates or a series of dates, and can further include forecasted weather conditions of each day. A user can navigate to another week by selecting tab 1024 configurable to enable a subsequent weekly schedule to be displayed as desired. According to further aspect, schedule 1022 includes a plurality of cells generally illustrated at scheduled events 1026 that can be modified as desired to schedule energy use. Schedule events 1026 can include a time interval and setting of a network device, such as a thermostat, being scheduled. A cell can also include an indicator, such as 'adapt?' indicator 1028 to identify an auto-schedule suggestion detected by an energy management system operably associated with EMUI 1000. For example, when a user may be at a site, a user may desire to have a temperature decreased to seventy eight degrees on Saturday prior to nine (9) P.M. As such, an auto-schedule suggestion can be detected and an adapt? indicator 1028 can be displayed to enable a user to have a schedule adapted automatically. Adaption suggestions can be provided to users in other ways and need not be limited to being displaying within schedule 1022.

**[00218]** According to a further aspect, EMUI 1000 can also provide access to view templates selector 1030 that can be used to schedule energy use. For example, view templates selector 1030 can be used to display predetermined schedules within scheduling tool 1012. A user can then modify portions of a selected template to their preference as needed or desired. In other forms, a series of questions can be asked to a user to determine a template to display. For example, scheduling tool 1012 can enable access to a short questionnaire to detect a user's day-to-day schedule. For example, a user can be an urban professional, a housewife, a single parent, a soccer mom, an empty nester, or various other demographics. As such, EMUI 1000 can be adapted to hide scheduling tool 1012 until a survey or series of questions is completed, and then display a resulting schedule within scheduling tool 1012.

**[00219]** According to a further aspect, EMUI 1000 can be adapted to display a list of selectable templates and can allow a user to select and display each template. Upon identifying a template, a user can then save an identified template as a user schedule. In some forms, a user's site location can be determined in advance and templates can be generated based on a location of a site (e.g. warm climate vs. cold climate). As such, view templates can be generated based on a site profile, a user profile, user characteristics, site data, or various other types of data capable of being used to generate a template that can be used by a user.

**[00220]** According to a further aspect, scheduling tool 1012 can also include an add additional time span selector 1034 configured to enable a user to add an additional time span within time span display section 1020. Scheduling tool 1012 can also include a view additional time slot selector 1032 configured to enable a user to scroll to additional time slots that may be output using scheduling tool 1012. For example, a user can select additional time slot selector 1032 and scheduling tool 1012 can be updated to display scheduled events of each day simultaneously. In this manner, a user can scroll additional time slots and days of the week as needed or desired.

**[00221]** According to a further aspect, EMUI 1000 can also include a proximity detection selector 1036. For example, a user may enable proximity detection using proximity detection selector 1036, and energy use at a site may be altered based on a users distance to the site. A user's mobile device number can be associated with a site and can allow a user to enable and disable proximity detection selector 1036. In some forms, proximity detection selector 1036 can be hidden, displayed, selectable, or any combination thereof in response to a user having a mobile device capable of being detected when a user is at or away from a site.

**[00222]** According to another aspect, EMUI 1000 can a energy alert text message selector 1038 configured to enable a text message to be sent to a user's mobile device. For example, during a high energy use day, an energy action day may be identified and a utility company or other entity may publish a warning indicating that a high energy use day may be occurring. As such, a user can receive a text message indicating the situation. In some forms, a can respond to the text message and alter their energy use schedule. For example, a user can respond to a request to alter their energy savings setting from a medium to a high. As such, scheduling tool 1012 can be modified to initiate a high energy savings schedule at a user's site. In other forms, energy alert text message selector 1038 can be used to enable a user to receive demand response requests via a text message. For example, a demand response request can include a requested time interval, new temperature setting, estimated savings, other demand response data, or any combination thereof within a text message. A user can then respond to the text message to participate, not participate, partially participate, or any combination thereof. Upon responding, a user's schedule can be modified as needed or desired.

**[00223]** According to a further aspect, EMUI 1000 can also include a vacation mode settings 1040 to enable a user to initiate use of a vacation mode or schedule. For example, vacation mode settings 1040 can include a vacation mode selector 1042 to turn a vacation mode on or off. Vacation mode settings can also include a schedule leave date

selector 1044 and a schedule return date selector 1046. A calendar (not expressly illustrated in FIG. 10) can be displayed to enable a user to select an interval of dates when they will be on vacation. As such, reduced energy use can be realized by altering a temperature setting. For example, a schedule can be increased to a high energy saving mode in association with the vacation mode being selected. In other forms, a user may have input or selected a vacation schedule to be used when vacation mode may be selected. Various combinations can be used as needed or desired.

**[00224]** During use, upon a user accessing EMUI 1000, EMUI 1000 can display a current date and time, and can further highlight a current cell within scheduling tool 1012 that corresponds to a current data and time. A user can select a thermostat to adjust using thermostat selector 1004, and a schedule of a selected thermostat can be displayed within scheduling tool 1012. A user can adjust a current set-point using thermostat controller 1006, and a corresponding temperature within a current cell can be adjusted accordingly. In another form, a user can select a cell to be modified. For example, a user may want to modify a temperature setting or scheduled event set for 'Tuesday, between eight (8) A.M and five (5) P.M. As such, a user can select the appropriate cell and further adjust a temperature up or down using thermostat controller 1006. A new setting can be displayed within the selected cell. According to a further aspect, a user can use savings selector 1008 to adjust a savings to be realized on a specific day. As such, a resulting temperature setting can be displayed within a selected cell.

**[00225]** In other forms, a user can select a time span cell to adjust. For example, a user can modify a current time span cell by selecting a specific cell. Upon selection of a specific cell, scheduling tool 1012 can highlight which cells may be affected by modifying a time interval. A user can then modify an interval accordingly as needed or desired.

**[00226]** According to a further aspect, a user can select a day of the week to modify. For example, a user can select 'MON' and a background color can be altered to indicated that each of the MON cells can be modified. In a form, a user can update each cell as



desired, can alter one or more, or all MON cells using savings selector 1008 as needed or desired.

**[00227]** According to another aspect, EMUI 1000 can be used to activate a one or more schedules. For example, a first user schedule can be activated over a period of time and then a second user schedule can be activated over another period of time. A user can also activate a vacation schedule that include an scheduled events to optimize energy savings when nobody is present at a site. In other forms, a first user schedule can be compared to a second user schedule, and events at a site can be scheduled accordingly. For example, a first user schedule may be active during an evening time and may override a second user schedule. In other forms, a second user schedule may be activated in the morning to accommodate an individual that may remain at home during the day. As such, EMUI 1000 can be used to generate multiple schedules to automatically control energy use at a site as needed or desired.

**[00228]** According to an aspect, portions or all of EMUI 1000 can be provided as a hosted application that can allow a user to access site reports, historical consumption data, real-time consumption data, operating status of energy consuming devices, control interface to control energy consuming devices, a scheduling interface to schedule utilization and consumption of energy, an inventory tool that will show real-time and historic energy consumption of each energy consumption device within the home, or any combination thereof.

**[00229]** According to a further aspect, portions of all of EMUI 1000 can include a user interface that can report a current operating condition, and can further include control logic capable of providing a user access to a smart appliance or control system at a site. For example, if a demand response condition may be detected within an energy transmission system, EMUI 1000 can be used to output the condition to a user. A user can then alter an operating status of one or more energy consuming devices at a site.

**[00230]** According to another aspect, a site can include multiple users that can access and control settings at a site using EMUI 1000. Additionally, a site can include multiple thermostats that can be managed remotely and controlled by a user. For example, a thermostat in the upper portion of a home can be displayed via a web browser or application on an mobile device such as a Blackberry®, I-Phone®, Android®, I-Pad® and the like. A user can select a thermostat using thermostat selector 1004, and adjust the thermostat to a first setting. In some forms, the thermostat settings may have a different effect on the actual temperature within various portions of the home. As such, a user may want to select the desired temperature within at a site, and EMUI 1000 can be used to calculate thermostat settings to achieve the desired temperature. In another form, EMUI 1000 can be used with an energy management system such as energy management system 600 in FIG. 6, or other systems. A thermal response of a zone, room, site, or any portion thereof can be determined and setting of one or more thermostats can be automatically determined to achieve a desired temperature.

**[00231]** In other forms, EMUI 1000 can be used in association with various types of EMI data. For example, various EMI data such as current and forecasted weather data, grid conditions, real-time pricing data, grid congestions conditions, forecasted demand, or any combination thereof of EMI data can be used to determine a setting recommendation that a user can select. In this manner, a user's lifestyle and preferences can be aligned with the real-time and forecasted conditions allowing a user to make informed energy consumption decisions.

**[00232]** FIG. 11 illustrates a diagram of a network device, illustrated generally as wireless thermostat 1100, according to an aspect of the disclosure. Wireless thermostat 1100 can be used in association with an energy management system, mobile device, energy management user interface, or various other devices, systems, or any combination thereof.

**[00233]** Wireless thermostat 1100 can include a outside temperature display 1102, a weather forecast display 1104, and an inside temperature display 1106. Wireless thermostat 1100 can also include a thermostat setting display 1108, a temperature increase input 1110, and a temperature decrease input 1112. Various type of display technology having single color, multicolor, or any combination thereof can be used with wireless thermostat 1100, including, but not limited to LED displays, TFT displays, OLED displays, LCD displays, flexible lighting displays, or any combination thereof.

**[00234]** According to an aspect, wireless thermostat 1100 can also include a mode switch 1114 and indicators 1116 configured to identify a mode. For example, mode switch 1114 can be placed off, heat mode, air condition model, or fan mode. An associated indicator above each mode within setting display 1116 can be illuminated in connection with an operating mode setting. In other forms, indicators 1116 can be placed behind an associated text and illuminated to indicate a current mode. For example, wireless thermostat 1100 can include a thin material that can allow a backlight, such as LED lighting to illuminate and show text. In another form, mode switch 1114 can include a push button or toggle switch to enable a back light to display and select a mode. Various other input and display methods or combinations thereof can be used.

**[00235]** According to a further aspect, wireless thermostat 1100 can also include a smart thermostat settings 1118. Smart thermostat settings 1118 can be programmable settings that can display a proximity mode 1122, a vacation mode 1124, and a smart energy mode 1126. Smart thermostat settings 1118 can be displayed based on a capability of a site, a current operating mode of wireless thermostat 1100, a setting within a energy management user interface such as EMUI 1100 and the like, an operating mode of a mobile device, a location of a mobile device, an operating mode of another network device accessible to an energy network, or various other combinations of operating modes or settings accessible to wireless thermostat 1118. For example, a user may want to activate proximity detection to control wireless thermostat 1100 (and possible other network

devices) using proximity mode 1122. As such, a user can activate proximity mode accordingly. In other forms, a user may be going on vacation and can activate vacation mode 1122. In another form, a user may activate a smart energy mode 1126, and an energy schedule provided by EMUI 1100, associated settings, and the like can be deployed.

**[00236]** According to another aspect, wireless thermostat 1100 can include a housing 1130 can having a material that can detect when a user touches wireless thermostat 1100. For example, housing 1130 can be operably coupled to a heat sensor, capacitive sensor, and the like configured to detect when a user touches a portion of housing 1130. Upon detecting a user contacting housing 1130, one or more displays or indicators of wireless thermostat 1100 may illuminate. In this manner, energy consumed by wireless thermostat 1100 can be realized by changing one or more displays from a sleep state to a display state. According to a further aspect, a portion or all of housing 1130 can include a material such as a concealing material that can include characteristics such as transparency, translucency, semi-transparency, semi-translucency, opaqueness, other types of light altering material, or any combination thereof capable of hiding one or more displays or indicators of wireless thermostat 1100. For example, a backlight or LED can illuminate at a surface of wireless thermostat 1100 giving an appearance of having the display at or near a front surface of housing 1130. As such, housing 1130 with a concealing material can be mounted on a wall or other location without having readings or settings persistently being displayed using a display or other indicators.

**[00237]** According to an aspect, temperature control mechanisms 1110 and 1112 can include a mechanism (not expressly illustrated in FIG. 11) that can allow housing 1130 to rock or shift left and right as a user contacts mechanisms 1110 or 1112. Other orientations can also be used. For example, wireless thermostat 1100 can mounted to a wall surface (not expressly illustrated in FIG. 11), and a user can contact a temperature increase mechanism 1110. Housing 1130 would rock slightly to the right. In another

form, at least a portion of housing 1130 can include a switch mechanism similar to a mouse of a computer system that provides a clicking sound or a mechanical feedback when temperature control mechanisms 1110 or 1112 are engaged or touched. As such, a user can realize a visual change of display 1108, and can further be provided a mechanical feedback of a switching mechanism upon activation of a switching mechanism. Various other orientations to rotate housing (e.g. up/down, left/right, etc.) can be realized as needed or desired.

**[00238]** FIG. 12 illustrates a block diagram of a network device, illustrated generally as a wireless thermostat 1200, according to another aspect of the disclosure. Wireless thermostat 1200 be used with wireless thermostat 1100 illustrated in FIG. 11 above or various other devices, systems, or any combination thereof described herein. Wireless thermostat 1200 can include a temperature and humidity sensors 1202, and one or more I/O devices 1204 to allow a user to provide an input to wireless thermostat 1200. For example, I/O device 1204 can enable a user can to select a mode (e.g. off, A/C, Heat, Fan, etc.), a smart energy mode (e.g. proximity, vacation, smart schedule, etc.), or various other features or combinations of features. Wireless thermostat 1200 can also include a power interface 1206, and a bus interface 1208. Wireless thermostat 1200 can also include a processor or controller 1210, and one or more control relays 1212 to control a remote unit such as an HVAC unit, heat pump, other appliances, or any combination thereof.

**[00239]** According to a further aspect, wireless thermostat 1200 can also include a one or more wireless devices 1214 capable of communicating with one or more associated wireless networks, a memory 1216, and a display interface 1218. Display interface 1218 can be configured to engage one or more LCD displays, touch screens, one or more LEDs, or various other display technologies illustrated generally as display 1222. Wireless thermostat 1200 can also include a precision measurement unit (PMU) 1220 configured to measure consumed by an associated network device, and a profile module 1224 that can

include network protocol configuration data, user profile data, device data, seasonal profile data, or various other types of data that can be accessed during use of wireless thermostat 1200. According to an aspect, wireless thermostat 1200 is a non-programmable thermostat that does not include an enabled programmable thermostat scheduling feature accessible by a user engaging wireless thermostat 1200. As such, a limited amount of scheduling functionality is needed or desired within wireless thermostat 1200 and a user can use a scheduling tool such as EMUI 1000 or various other features provided herein to enable and disable use of wireless thermostat 1200.

**[00240]** FIG. 13 includes a block diagram of an energy management system, illustrated generally at 1300, according to a further aspect of the disclosure. Energy management system 1300 can be deployed at residential site 1302 and can include an energy management apparatus or controller 1302. Controller 1302 can include portions or all of controller 400 described in FIG. 4 or any other type of system, device, apparatus, or any combination thereof capable of deploying controller 1302.

**[00241]** According to an aspect, controller 1302 can include an application program interface 1306 operably coupled to a processor or logic (not expressly illustrated in FIG. 13) of controller 1302. Controller 1302 can include a communication interface 1306 a wireless device 1308 configured to access a first network 1314, a wireless device 1310 configured to access a second network 1318, and a wireless device 1312 configured to access a third network 1322. Controller 1302 can also include a network device 1330 such as an Ethernet or other wireline communication device capable of access an information network such as a LAN, WAN, the Internet, and the like.

**[00242]** According to a further aspect, first network 1314 can be communicatively coupled to a smart meter / AMI device 1316. According to another aspect, second network 1318 can be communicatively coupled to a wireless thermostat (TSTAT) 1320. According to a further aspect, third network 1322 can be coupled to a mobile device 1324. According to an aspect, mobile device 1324 can include a smart phone device such as a

Blackberry®, I-Phone®, Android ® and the like, a laptop computer system, a Netbook, an iPad®, or any other type of mobile device.

**[00243]** During use, controller 1302 can be used to communicate information from various networks to a wireless energy network to manage one or more network device connected to a wireless energy network. For example, second network 1318 can be configured as a wireless energy network capable of enabling communication with a network device such as TSTAT 1320. Information can be received from information network 1332, and processed by controller 1302 and output to TSTAT 1320 using API 1306 and communication interface 1306. In other forms, information can be communicated from mobile device 1324 to controller 1302 using third network 1322 that may be different from second network 1318. Controller 1302 can detect information communicated from mobile device 1324 and output information to TSTAT 1320 using second network 1318 to TSTAT 1320. As such, controller 1302 can provide a network bridge to enable information communicated between various different types of networks.

**[00244]** According to an aspect, controller 1302 can include application program interface 1306 configured to use at least a portion of an incoming message communicated from an information network, an information network, a utility network or any combination thereof. For example, an incoming message can include at least a portion of a user energy management schedule. Controller 1302 can initiate altering use of a resource in response to detecting a portion of the first user energy management schedule. For example, a schedule can include altering a thermostat, lights, smart appliances, etc. Communication interface 1306 can further be operably coupled to application program interface 1306 and configured to communicate information using a wireless device.

**[00245]** For example, communication interface 1306 can communicate with wireless device 1310 capable of accessing a second network 1318 operable as a wireless energy network. Although illustrated as a single communication interface, communication interface can be provided as multiple communication interfaces, a single communication

interface, as a multi-network communications interface, or any combination thereof. As such, multiple networks can be accessed and communicated with as needed or desired. For example, wireless device 1312 can be configured to communicate using a WIFI enable communication protocol and wireless device 1310 can be configured to communicate using a Zigbee enabled communication protocol.

**[00246]** According to an aspect, controller 1302 can include wireless device 1312 configured as a WIFI enabled communication device operably coupled communication interface 1306 and third network 1322 operable as a WIFI network. Application program interface 1306 can be configured to receive an energy management schedule communicated using an incoming message received from third network 1322 as an incoming WIFI message. As such, an energy management schedule or other EMI data can be communicated from a WIFI enabled device, such as mobile device 1324 or other devices. Controller 1302 can then use application program interface 1306 to process the energy management schedule and initiate control actions to a network device accessible to an energy network.

**[00247]** According to another aspect, controller 1302 can receive a first energy management schedule using a first network, and receive a second energy management schedule using a second network. For example, a first energy schedule can be received using network device 1330 and can include a first user energy schedule data. A second energy schedule can be received using third network 1322 operable as a WIFI network. For example, a user of mobile device 1324 can provide scheduling data, control data, or various other energy management scheduling data. Controller 1302 can then use portions of each schedule as needed or desired, and initiate control actions using second network 1318 operable as a wireless home energy network. For example, second network 1318 can be configured as a Zigbee enabled network. As such, multiple networks having scheduling information can be accessed and scheduling data of multiple users can be used to control network devices accessible to an energy network.



**[00248]** According to an aspect, controller 1302 can include output control actions that have been received from more than one network to control a network device accessible to an energy network. For example, wireless device 1312 can be configured to receive control action data from third network 1322 operable as a WIFI enabled network. Control action data can be provided in association with a first user schedule using mobile device 1324. Controller 1302 can further receive a second control action data from associated with a second user schedule, such as a utility schedule. Second control action data or a second user energy management schedule can be communicated using first network 1314 configured as an AMI enabled network and smart meter / AMI interface 1316. Controller 1302 can then detect whether to use the second control action prior to the first control action.

**[00249]** According to another aspect, control action data of multiple user schedules can be communicated using communication interface 1306 provided as multiple communication interfaces. For example, wireless device 1312 can include a communication interface accessible to application program interface 1306. Additionally, wireless device 1310 can include a communication interface accessible to application program interface 1306. As such multiple communication interfaces can be deployed to communicate control action data of one or more user energy management schedule.

**[00250]** According to a further aspect, application program interface 1306 can be used to initiate use of a first control action of a first user energy management schedule prior to using a first control action of a second user energy management schedule prior to the first user energy management schedule. For example, a second user energy management schedule can include one or more control action that can have a higher priority that a first user energy management schedule. As such, controller 1302 and application program interface 1306 can initiate a control action as needed or desired based on a priority.

**[00251]** According to a further aspect, controller 1302 can initiate a control action or energy management schedule in response to a distance an associated mobile device 1324 may be from site 1304. For example, a first user energy management schedule may be deployed as a first user having mobile device 1324 may be located at or near site 1302. As mobile device 1324 moves away from site 1302 (e.g. one mile, three miles, etc.), a second user energy management schedule can be initiated and used by controller 1302. In this manner, proximity detection of mobile device 1324 can be used to initiate a second user energy schedule.

**[00252]** According to another aspect, mobile device 1324 can output scheduling data, control action data, energy management data, and the like using third network 1322 configured as a WIFI enabled network. For example, mobile device 1324 can include a application or scheduling logic capable of initiating a user energy management schedule. Mobile device 1324 can encode or output control action data, and communicate the control action data, scheduling data, and the like using a WIFI protocol and messaging format.

**[00253]** According to an aspect, controller 1302 can include detect when mobile device 1324 may be connected to third network 1322 and modify operation of a network device accessible to controller 1302. For example, mobile device 1324 can be coupled to third network 1322 operable as a WIFI network, or other network capable of being deployed at site 1304. As mobile device 1324 moves away from site 1304 and a network connection to third network 1322 may be altered, controller 1302 can detect a change in connectivity (e.g. weak signal, signal is lost, connection switches to another hub, station, controller, and the like) to third network 1322, a connection status of wireless device 1312 can be output to communication interface 1306 and accessed by application program interface 1306. As such, controller 1302 can detect whether to alter use of a resource or network device accessible to controller 1302. For example, mobile device 1324 may be connected to third network 1322 using a WIFI connection. As a WIFI connection is

altered, controller 1302 can initiate altering an operating condition of a resources such as TSTAT 1320, one or more wireless devices 1308, 1310, 1312, or various other resources accessible to controller 1302. For example, if a second user may be located at site 1304, a second user energy management schedule that may be different from the first user energy management schedule can be deployed. For example, a first portion of a second energy management schedule of a second user can be enabled in response to the operating status of the resource,

**[00254]** According to another aspect, wireless device 1312 that may have been configured to be coupled to third network 1322 can be placed in a reduced operating condition to save power consumed by controller 1302. In another form, proximity detection of mobile device 1324 can be initiated to detect a location of mobile device 1324 when a WIFI connection or other connection is altered. Additionally, mobile device 1324 may also alter an operating condition by disabling a WIFI connection to third network 1322. Mobile device 1324 can also initiate location reporting of mobile device 1324, and controller 1302 can alter an operating condition of a network device or resource in response to mobile device 1324 being at a distance from site 1304.

**[00255]** According to another aspect, mobile device 1324 may be configured to enable access to TSTAT 1320 using a network connection 1330 that can include one or more wireless communication protocols. For example, a network device such as TSTAT 1320 can be coupled to mobile device 1324 using a WIFI connection, Bluetooth connection, or various other forms of wireless communication. Upon connecting to TSTAT 1320, mobile device 1324 can be used to alter an operating condition of TSTAT 1320. As such, mobile device 1324 having energy management capabilities can be used to alter an operating condition of TSTAT 1320, various other network devices at site 1304, or any combination thereof. For example, mobile device 1324 can include an energy management scheduling tool, such as portions or all of EMUI 1000 described in FIG. 10, to provide control inputs and scheduling data directly to TSTAT 1320. As such, controller

1302 may not be available to output control actions (e.g. a network connection may be lost, etc.), or mobile device 1324 may have priority over controller 1302 to provide control inputs or energy managing scheduling information to TSTAT 1320.

**[00256]** According to a further aspect, TSTAT 1320 can receive an input and communicate status information, operating conditions, control actions, or any combination thereof to a network resource, controller 1302, mobile device 1423, smart meter / AMI 1316, or any other device, system, or apparatus, or any combination thereof. According to an aspect, TSTAT 1302 can detect is a user altered an operating condition (e.g. change mode, altered smart energy settings, etc.) and can communicate an operating status change. In another form, TSTAT 1320 can alter an operating status of another network device in response to an input to TSTAT 1320. For example, a user may place TSTAT 1320 in a vacation operating mode. As such, TSTAT 1320 can output an updated status to another network device, controller 1302, mobile device 1324, or other network devices. For example, a second TSTAT may be located at site 1304 (not expressly illustrated in FIG 13), and placed in a vacation operating mode using a signal output by TSTAT 1320. In other forms, controller 1302, mobile device 1324, or any combination thereof can be used to alter the operating condition of the second TSTAT as needed or desired.

**[00257]** FIG. 14 illustrates a collaborative demand response system (CDRS), illustrated generally at 1400, according to an aspect of the disclosure. CDRS 1400 can include a server 1402 operably coupled to an information source such as a database 1404. According to a further aspect, server 1402 can include portions or all of server 602 illustrated in FIG. 6, or any other server capable of being deployed with CDRS 1400. According to further aspect, database 1404 can include site data 1406, user profile data 140, performance data 1410, or various other types of EMI data that can be used in association with CDRS 1400 as needed or desired. According to another aspect, CDRS 1400 can also include access to one or more external data source 1412. CDRS 1400 can

also interface with an energy buyer / auction 1414 capable of buying available capacity of CDRS 1400.

**[00258]** According to a further aspect, CDRS 1402 can include a monitor 1416, a client interface 1418, and a site interface 1420. According to an aspect, client interface 1418 can be coupled to a first mobile device 1422, a second mobile device 1424, a client system 1426, or any combination thereof. For example, client interface 1418 can be configured as a mobile client interface operable to communicate information using a mobile network. In other forms, client interface 1418 can be coupled to a client system 1426 using an information network such as the Internet.

**[00259]** According to another aspect, CDRS 1402 can include site interface 1420 configured to interface with multiple sites. For example, site interface 1420 can be operably associated with first site 1428 and mobile device 1422. In other forms, site interface 1420 can be operably associated with second site 1430 and mobile device 1424. Site interface 1420 can also be operably associated with third site 1423 and client system 1426. Various other combinations can also be used with CDRS 1400.

**[00260]** During use, CDRS 1400 can be used to determine a desire by an owner of a site to participate in a demand response event. Server 1402 and monitor 1416 can detect a current or future demand response initiative to be deployed at a specific time. Server 1402 can detect an availability of capacity in a specific region, and initiate an inquiry with a site owner, user, administrator, etc. According to an aspect, a text message, email message or other form of electronic or wireless messaging can be initiated to detect a desire by a user to participate. Server 1402 can access site data 106 associated with a specific site to detect if a user may have a default setting to participate. In other forms, a user may have set a preference to be contacted via email or text message. As such, server 1402 can initiate a message and detect a desire by one or more users to participate.

**[00261]** According to a further aspect, server 1402 can access performance data of each site elected to participate in a demand response event. For example, historical site data of a site can be stored within database 1404, and performance of a participating site can be determined as performance data 1410. According to an aspect, other EMI data can be accessed from database 1404, external data source 1412, or any combination thereof and used to determine performance of a site. For example, current and future weather conditions can be used to determine performance of a site. Taking weather conditions into consideration, along with a thermal response or characteristic of a site, a capacity to reduce energy can be determined on a site by site basis. The overall or aggregate capacity and desire to participate can be sold to a third party, monetized by an owner of CDRS 1400, or any combination thereof.

**[00262]** FIG. 15 illustrates a demand scheduling system (DSS), illustrated generally at 1500, according to an aspect of the disclosure. DSS 1500 can include a server 1502 operably coupled to an information source such as a database 1504. According to a further aspect, server 1502 can include portions or all of server 602 illustrated in FIG. 6, or any other server capable of being deployed with DDS 1500. According to an aspect, database 1504 can include site data 1506, site schedule data 1508, performance data 1510, or various other types of EMI data that can be used in association with DSS 1500 as needed or desired. According to another aspect, DSS 1500 can also include access to one or more external data sources 1512. DSS 1500 can also interface with an utility company, COOP, retail energy provider, or various other energy providers, or any combination thereof, using one or more utility schedule interface 1514. According to an aspect, utility scheduling interface 1514 can be a standard interface however in other forms, utility scheduling interface 1514 can include a custom interface configurable to engage an existing energy company's information network, infrastructure, database, or various other components that can be used by an energy provider to access DDS 1500.

**[00263]** According to a further aspect, DSS 1502 can include an aggregate demand module 1516, a client interface 1518, a site interface 1520, or any combination thereof. According to an aspect, client interface 1518 can be coupled to a first mobile device 1522, a second mobile device 1524, a client system 1526, or any combination thereof. For example, client interface 1518 can be configured as a mobile client interface operable to communicate information using a mobile network. In other forms, client interface 1518 can be coupled to a client system 1526 using an information network such as the Internet.

**[00264]** According to another aspect, DSS 1502 can include site interface 1520 configured to interface with multiple sites. For example, site interface 1520 can be operably associated with a first site 1528 that can be associated with mobile device 1522. In other forms, site interface 1520 can be operably associated with a second site 1530 and mobile device 1524. Site interface 1520 can also be operably associated with third site 1532 and client system 1526. Various other combinations can also be used with DSS 1502.

**[00265]** During use, server 1502 can use EMI data to forecast energy use at sites 1528, 1530, and 1532. For example, each site can include site schedule data 1508 stored within database 1504. For example, EMUI 1000 or another scheduling tool can be used to schedule energy use at a site. Site 1508 schedule data can be used to determine what energy use may be on a site-by-site basis. An aggregate demand of a specific region, zip code, substation, grid location, etc. can also be detected. Aggregate demand module 1516 can then detect what an aggregate level of demand and scheduled demand can then be communicated to a utility company as needed or desired. In this manner, scheduling data that may not have been traditionally accessible on a site by site basis can be used to detect energy demand and schedule energy production. For example, residential sites traditionally use non-programmable and programmable thermostats that do not allow for determining schedules on a site by site basis. DSS 1500 can enable access to scheduling data of each residential site to determine an aggregate demand schedule.

**[00266]** According to an aspect, server 1502 can access performance data of each site to determine scheduled energy demand. For example, historical site data of a site can be stored within database 1504, and performance of a participating site can be determined as performance data 1510. According to an aspect, other EMI data can be accessed from database 1504, external data source 1512, or any combination thereof and used to determine performance of a site. For example, current and future weather conditions can be used to determine performance of a site. Taking weather conditions into consideration, along with a thermal response or characteristic of a site, a capacity to reduce energy can be determined on a site by site basis. The overall or aggregate demand can be used by the owner of DSS 1500 or communicated to a third party on a contractual basis as needed or desired.

**[00267]** FIG 16 illustrates a method of managing energy at a site according to an aspect of the disclosure. Portions or all of the method of FIG. 16 can be used with portions or all of the energy management systems, devices, or apparatuses disclosed herein, or any other type of system, controller, device, module, processor, or any combination thereof, operable to employ all, or portions of, the method of FIG. 16. Additionally, the method can be embodied in various types of encoded logic including software, firmware, hardware, or other forms of digital storage mediums, computer readable mediums, or logic, or any combination thereof, operable to provide all, or portions, of the method of FIG. 16.

**[00268]** The method begins generally at block 1600. At block 1602, an acquisition interval to acquire network device data can be detected. For example, network device data can be acquired using a wireless energy network having one or more network devices accessible to the wireless energy network. For example, a wireless energy network can include various types of wireless networks configured to communicate information to manage energy use of a network devices accessible to the wireless network. For example, a wireless energy network can include one or more of any combination or portion of, IEEE



802.15-based wireless communication, Zigbee communication, INSETEON communication, X10 communication protocol, Z-Wave communication, Bluetooth communication, WIFI communication, IEEE 802.11-based communication, WiMAX communication, IEEE 802.16-based communication, various proprietary wireless communications, or any combination thereof.

**[00269]** At decision block 1604, the method can detect whether an acquisition interval may be updated. For example, an acquisition interval can be set to a first interval (such as 1 minute, 2 minutes, 10 minutes etc.), and can then be altered to another interval. According to an aspect, an acquisition interval can be altered in response to a distance a mobile device may be from a site. For example, as a user moves away from a site, an acquisition interval can be increased (e.g. changed from 1 minute to 3 minutes). Similarly, as a mobile device move towards a site, an acquisition interval can be decreased (e.g. changed from 3 minutes to 1 minute). Various combinations of intervals can be used as needed or desired. If at decision block 1604 an acquisition interval has been updated, the method can proceed to block 1606 and an updated interval can be obtained. If at decision block 1604 an acquisition interval has not been changed, the method can proceed to block 1608.

**[00270]** According to an aspect, at block 1608, device data can be acquired. For example, device data can be obtained by sending a request to one or more network devices joined to a wireless energy network. For example, multiple devices can be accessed at an acquisition interval to obtain device data. Device data can be provided in various forms and types of information. According to an aspect, device data can include a device identifier, a network identifier, operation data, security data, various other types of data that can be used to manage energy use, or any combination thereof. According to a further aspect, device data can be formatted based on a wireless communication protocol (e.g. Zigbee, WIFI, WiMax, etc.) being deployed as the wireless energy network.

**[00271]** According to another aspect, the method can be modified to detect an availability of one or more network devices. For example, a first network device may be accessible to a wireless energy network and may use a first device profile to communicate information using the wireless energy network. Additionally, a second network device may be accessible to the wireless energy network and may use a second device profile that may be different from the first.

**[00272]** Upon acquiring device data from one or more network devices, the device data can be translated at step 1610. For example, the device data may be formatted using a device profile, communication protocol, or various other formats to communicate device data using a wireless energy network. At block 1610, device data can be translated into another format to use by another system, process, device, etc. other than the wireless energy network. For example, Zigbee formatted data can be translated into XML encoded data. According to another aspect, device data can be translated to a data object, such as a Java object and the like. Various other translations can also be used.

**[00273]** The method can then proceed to block 1612 and a report interval can be detected. According to an aspect, a report interval can include an interval that may be the same as the acquisition interval, greater than the acquisition interval, or less than the acquisition interval. According to a particular aspect, the report interval can be twice as long as the acquisition interval. As such, exact timing of when to acquire device data can be obviated as at least one data acquisition may be available to generate a report.

**[00274]** At decision block 1614, if a report interval should not be updated, the method can proceed to block 1618 as described below. If a report interval should be updated, the method can proceed to block 1616 and an updated report interval may be obtained. According to an aspect, a report interval can be provided using a data acquisition interval. For example, a report interval can be updated in association with an acquisition interval being updated. In other forms, a report interval can be provided and

updated without an acquisition interval being updated. Various combinations of updating a report interval, acquisition interval, or any combination thereof can be used. Upon updating a report interval, the method can proceed to block 1618.

**[00275]** According to an aspect, at block 1618 report data can be generated. For example, report data can include data that can be provided within a site report and can be formatted in various ways. For example, report data can include a XML encoded data, Java objects, textual data or various combinations thereof. According to an aspect, network device data can be converted to a binary representation. For example, to reduce the amount of information to be communicated, a binary representation can include one or more binary bits within a data field that can represent portions or all of the network device data. According to a further aspect, report data can be stored on a device basis until a site report can be generated.

**[00276]** Upon generating report data, the method can proceed to block 1620 and generates a site report. For example, a site report can include data received from one or more network devices. In another form, site report data can include data from another source, device, network, or any combination thereof capable of providing data that can be used within a site report. For example, a home controller may include a data and time setting based on a current time zone. A network device may not have a current or updated date and time stamp provided with the network device data. As such, a current date and time stamp can be provided with the site report data. In other forms, data obtained from another source (e.g. WIFI network, AMI network, WiMax network, etc.) can be provided within a site report. For example, a site report can include network device data that includes a thermostat or HVAC system being placed in an 'on' condition. Additionally, an AMI network can be accessed to detect a current energy consumption level, rate, price, savings or various other types of information that can be provided using an AMI network. The AMI network data can be combined with the network device data within a site report. As such, subsequent processing of site reports can include additional information that can

be processed into a site report to manage and report energy use at a site. Other types and combinations of EMI data from various network locations can be included within a site report as needed or desired.

**[00277]** Upon generating a site report, the method can proceed to block 1622 and a network connection can be initiated. For example, a rested web services approach to making a network connection can be deployed to realize increased network security at a site. For example, a home controller can be used to initiate a network connection using a LAN, broadband network, wireless data network, WiMax network, WIFI network, or various other networks or combinations of networks. A specific network location can be accessed on a secure basis using SSL or other encryption methods. At decision block 1624, if a network may not be available, the method can proceed to block 1626 and store the site report until the network may become available. The method can then proceed to block 1608 as described herein. If at decision block 1624 a network location may be available, the method can proceed to block 1630 and initiates a transfer of a site report. According to an aspect, if multiple site reports are available, the method can initiate a transfer of the multiple site reports.

**[00278]** Upon initiating transfer of the site reports, the method can proceed to block 1632 and can initiate processing site report data at a network location. For example, a network location can include a server configured to process site report data and store site report data within a database. Additional processing of the data can be realized as needed or desired. For example, server 602 described in FIG. 6 includes several modules that can be used to process site report data.

**[00279]** Upon initiating processor of site report data, the method can processed to decision block 1634 to detect if a control action may be available. For example, a control action field or flag associated with a specific site and one or more network devices can be provided within a database or other storage location. In another form, one or more binary values can be used to indicate if control action data be available. If control action may be

available, the method can proceed to block 1636 and a control action can be received. For example, a control action can be communicated during a session and can include one or more actions associated with a network device accessible at a site. According to an aspect, a control action can be encoded based on a profile,(e.g. Zigbee Profile, Smart Energy Profile, Home Automation, etc.). In other forms, a control action can be formatted as XML encoded data, HTML encoded data, proprietary data format, or any combination thereof.

**[00280]** Upon receiving a control action at block 1636, or if a control action may not be available, the method can proceed to decision block 1638 and detects if an interval should be updated. For example, a acquisition interval, report interval, or any combination thereof can be available. If an interval should be updated, the method can proceed to block 1640 and one or more intervals can be received and updated. According to an aspect, if an interval may be updated, an update flag can be set to indicate a new or updated interval can be used. In other forms, a current interval field can be updated with a new interval value. If at decision block 1638, an interval may not be updated, the method can proceed to decision block 1642 as described below.

**[00281]** According to an aspect, at decision block 1642 the method can detect if an update may be available. For example, an update can include one or more new or updated profiles that can be used at a site in association with an energy network. In another form, a software or firmware update can be available to update a network device, home controller, or various other systems, apparatuses, methods, devices, or any combination thereof that can be used at a site. If an update may be available, the method can proceed to block 1644 and a method can be received and processed at block 1646 as needed or desired. According to an aspect, an update may be available at another network location. As such, the method can be modified to include an update available flag or data, and another network location can be accessed to receive an update. If at decision block 1642

an update may not be available, the method can proceed to block 1648 as needed or desired.

**[00282]** According to an aspect, at block 1648, the method can disconnect from a network location and proceed to block 1650. If a control action may have been received, the method can processor the control action data, and proceed to block 1652 to detect a control action within the control action data. According to an aspect, a control action can include various combinations of actions such as obtaining or reading an operating status or value of one or more network device attributes, altering an operating condition of network device, updating an operating schedule of a network device, or various other control actions as needed or desired. In another form, control action data can be stored within a memory and deployed based on a schedule. As such, a period of time (e.g. twelve hours, twenty four hours, etc.) can be stored and deployed in the event of a information network failure at a site.

**[00283]** Upon detecting control action data, the method can proceed to block 1654 and can process control action data. For example, if control action data should be stored, the method can store control action data and deploy at a later time. In another form, control action data can be processed into a format that can be used to output network device data. For example, control action data can be processed into one or more JAVA objects, XML files, or other formats to include a received control action data of a specific device. According to an aspect, a network device can include a specific profile to access features of a network device. As such, control action data can be processed based on a specific profile.

**[00284]** Upon processing control action data, the method can proceed to block 1656 and the processed control action data can be generated into network device data. For example, a network may be deployed to provide an energy network at a site. As such, a protocol to communicate device data as network device data can be deployed. In other forms, a communication device can be coupled to a USB port, UART port, SPI port, other

buses, or combinations thereof. As such, control action data can be formatted into a format that can be communicated using a specific bus having a wireless network device or module coupled to a bus. For example, for example. At block 1656 network device data can be formatted to be communicated using a USB bus having Zigbee communication module coupled to the USB bus. In other forms, a network device, such as a wireless WIFI device can be coupled to a UART bus and accessed to output control action data. Upon generating network device data, the method can proceed to block 1658 and the network device data can be output to a communication module that can output the control action data to the network device. The method can then proceed to block 1660, and to block 1602 as needed or desired.

**[00285]** According to another aspect, the present disclosure and include an installation system and method configured to install a system at a site. For example, FIG. 6 described herein includes controller 626 and thermostat 628 installed at a site 604. Installation can include controller 626 including a serial number (not expressly illustrated in FIG. 6), or other unique identifier. Thermostat 628 can also include a serial number (not expressly illustrated in FIG. 6) or other unique identifier. Upon a user or agent installing controller 626, an identifier of controller 626, thermostat 628, or any combination thereof, can be communicated to server 602 to authenticate site 604 and enable energy management at site 604.

**[00286]** According to another aspect, an installation can include controller 626 requesting a list of valid identifiers of one or more network devices that can be installed at site 604. For example, controller 626 can receive a list of one or more valid network devices that may be installed at site 604, and can validate one or more installed devices. For example, controller 626 can detect a network device accessible using an energy network deployed at site 604. A network device can communicate an identifier and controller 626 can detect whether the communicated identifier may be within the list communicated by server 602. As such, an agent that may have an inventory of network

devices, controllers, or any combination thereof can install a controller and a network device without having to determine a valid serial number.

**[00287]** According to a further aspect, an installation can include using a mobile device including installation logic, one or more applications, settings, or any combination thereof. For example, mobile device 632 illustrated in FIG. 6 or other mobile devices or systems can be used to install portions or all of an energy management system at site 604. For example, a user can deploy an energy management application on mobile device 632 and can input a serial number or other identifier to into an energy management application. In this manner, a user may modify network devices installed at site 604 by for example, adding new devices, updating new devices, deleting current devices, receiving software updates using a serial number of an installed device, or various combinations thereof. According to a further aspect, an installation, settings, and the like can include prompting a user to use a GPS location in connection with an installation and site 604. As such, a user need not type in an address and can just select a current location to associate mobile device 632 and site 604.

**[00288]** According to another aspect, an installation can include using RFID, bar code, network scan, or various other hands-free identification processes. For example, mobile device 632 can include an energy management application that can include an installation or set-up that includes reading a bar code label of controller 626, TSTAT 628, various other network devices, or any combination thereof. For example, a user can scan a barcode that can include a unique identifier of controller 626, TSTAT 628, or any combinations thereof. According to an aspect, a bar code label can be affixed to a portion of a housing (not expressly illustrated in FIG. 6). In other forms, a bar code can be accessed using a display, such as a display of TSAT 626 or other network devices or systems that can display one or more bar codes (e.g. outputting multiple at a single system, network device, installation sheet or stickers, etc.). Upon a user scanning a bar code label, the installation process can use a network connection, such as WIFI or other wireless data



networks to communicate unique data and authenticate a system. An server, such as server 602 can authenticate the data and activate a user's account. According to an aspect, a user can also set a location using a current GPS location of mobile device 632 at site 604. In this manner, an installation process that can include authenticating or activating software on a mobile device, a home controller, a network device, and a server account can be coordinated in an efficient manner thereby reducing the need to have an installation technician or other third party activate an account. Various combinations of associating devices, systems, controllers, mobile devices, etc. can be used to activate portions or all of an energy network using hands-free RF, optical scanning devices, or any combination thereof. According to a further aspect, an installation can be modified to allow a third party technician install a system and can include scanning one or more bar codes that may be affixed to a network device, controller, etc. In other forms, a third party technician can scan bar code labels or other devices and affix the labels to a device, controller, system, etc. in association with an installation. As such, inventory management can also be maintained in association with installing a controller, network device, system, etc.

**[00289]** Note that not all of the activities described above in the general description or the examples are required, that a portion of a specific activity may not be required, and that one or more further activities may be performed in addition to those described. Still further, the order in which activities are listed are not necessarily the order in which they are performed.

**[00290]** The specification and illustrations of the embodiments described herein are intended to provide a general understanding of the structure of the various embodiments. The specification and illustrations are not intended to serve as an exhaustive and comprehensive description of all of the elements and features of apparatus and systems that use the structures or methods described herein. Many other embodiments may be apparent to those of skill in the art upon reviewing the disclosure. Other embodiments may be used and derived from the disclosure, such that a structural substitution, logical

substitution, or another change may be made without departing from the scope of the disclosure. Accordingly, the disclosure is to be regarded as illustrative rather than restrictive.

**[00291]** Certain features are, for clarity, described herein in the context of separate embodiments, may also be provided in combination in a single embodiment. Conversely, various features that are, for brevity, described in the context of a single embodiment, may also be provided separately or in any sub combination. Further, reference to values stated in ranges includes each and every value within that range.

**[00292]** Benefits, other advantages, and solutions to problems have been described above with regard to specific embodiments. However, the benefits, advantages, solutions to problems, and any feature(s) that may cause any benefit, advantage, or solution to occur or become more pronounced are not to be construed as a critical, required, or essential feature of any or all the claims.

**[00293]** The above-disclosed subject matter is to be considered illustrative, and not restrictive, and the appended claims are intended to cover any and all such modifications, enhancements, and other embodiments that fall within the scope of the present invention. Thus, to the maximum extent allowed by law, the scope of the present invention is to be determined by the broadest permissible interpretation of the following claims and their equivalents, and shall not be restricted or limited by the foregoing detailed description.

**[00294]** Although only a few exemplary embodiments have been described in detail above, those skilled in the art will readily appreciate that many modifications are possible in the exemplary embodiments without materially departing from the novel teachings and advantages of the embodiments of the present disclosure. Accordingly, all such modifications are intended to be included within the scope of the embodiments of the present disclosure as defined in the following claims. In the claims, means-plus-function

clauses are intended to cover the structures described herein as performing the recited function and not only structural equivalents, but also equivalent structures.

**WHAT IS CLAIMED IS:**

## 1. An energy management system comprising:

a database configured to store site report data received from a plurality of residential sites using a wireless home energy network at each site, wherein each residential site includes a thermostat accessible to the wireless home energy network;

a processor operably coupled to the database and configured to access the site report data and:

detect a current temperature set-point of the thermostat at a first residential site;

detect a first seasonal profile of the thermostat;

detect a current operating mode of a HVAC system operably coupled to the thermostat; and

determine a thermostat schedule of the thermostat using the first seasonal profile and the current operating mode of the HVAC system.

## 2. The energy management system of claim 1, wherein:

the processor is further configured to detect a second seasonal profile of the thermostat;

the first seasonal profile includes at least a minimum seasonal setting;

the second seasonal profile includes at least a maximum seasonal setting;

the processor is further configured to initiate generation of a control action report to communicate to the first residential site, wherein the control action report is generated using one or more of:

an updated temperature set-point having a value between the current temperature set-point and the minimum seasonal set-point in response to the current operating mode of the HVAC being in a heating mode;

an updated temperature set-point having a value between the current temperature set-point and the maximum seasonal set-point in response to the current operating mode of the HVAC being in a cooling mode;

an efficiency rating of the first residential site;

an estimated time period to generate an updated temperature reading an updated temperature set-point;

a current energy price; and

a future energy price.

3. The energy management system of claim 1, wherein the processor is further configured to:

detect a distance between a location reporting device and the first residential site;

detect a current zone from a plurality of zones operably associated with the first residential site using the distance; and

initiate generation of a control action report to be communicated to the first residential site using the current zone.

4. The energy management system of claim 3, further comprising the processor configured to:

detect an efficiency rating of the first residential site;

detect an external temperature at the first residential site;

determine a real-time travel time between the location reporting device and the residential site; and

modify a distance range of the plurality of zones using one or more of:

the efficiency rating;

the external temperature; and

the real-time travel time.

5. The energy management system of claim 3, wherein the processor is further configured to:

detect the location reporting device moving away from the first residential site;

detect a percentage change value associated with the current zone;

detect a base set-point of the wireless thermostat of the first residential site;

determine a difference between the base set-point and a minimum seasonal set-point in response to the current operating mode of the HVAC being in a heating mode;

determine a difference between the base set-point and a maximum seasonal set-point in response to the current operating mode of the HVAC being in a cooling mode;

determine an updated thermostat set-point as a percent change based on the determined difference and the current operating mode of the HVAC; and

output the updated thermostat set-point to be used within the control action report.

6. The energy management system of claim 3, wherein the processor is further configured to:

detect the location reporting device moving toward the first residential site;

detect the current zone and a percentage change value associated with the current zone;

determine a difference between the base set-point and a minimum seasonal set-point in response to the current operating mode of the HVAC being in a heating mode;

determine a difference between the base set-point and a maximum seasonal set-point in response to the current operating mode of the HVAC being in a cooling mode;

and

determine an updated thermostat set-point as a percent change based on the difference and the current operating mode of the HVAC; and

output the updated thermostat set-point to be used within the control action report.

7. The energy management system of claim 1, wherein the processor is further configured to:

identify a group of residential sites within a specified region;

access thermostat schedules of each of the residential sites within the group;

aggregate scheduling data using the thermostat schedules; and

initiate an outputting of the aggregated scheduling data.

8. The energy management system of claim 1, further comprising a web services enabled scheduling tool configured to provide a user access to schedule energy use at a first residential site using a web based graphical user interface, wherein the scheduling tool includes:

a thermostat selector configurable to enable selection of one or more wireless thermostats located at the first residential site;

an event scheduler operably associated with the thermostat selector and configurable to enable the user to graphically select a utilization schedule of the one or more wireless thermostats;

wherein the utilization schedule includes a time of day and temperature setting capabilities to control the one or more wireless thermostats; and

an energy savings preference selector configured to graphically modify the utilization schedule and display a resulting energy savings.

9. The energy management system of claim 8, wherein the processor is further configured to:

detect a user interaction with the wireless thermostat;

suggest a modification of the utilization schedule to the user during a user access to the scheduling tool; and

modify the utilization schedule to include the suggestion in response to the user validating the modification.

10. The energy management system of claim 8, wherein the scheduling tool further comprises:

a proximity control selector configured to enable and disable proximity control of the first residential site;

a demand response selector configured to enable and disable participation in demand response event; and

an auto update selector configured to enable an automatic update of the utilization schedule in response to a detection of a user interaction with the one or more wireless thermostats.

11. The energy management system of claim 8, further comprising a demand response selector operable to be displayed with the scheduling tool, wherein the demand response selector includes:

an always participate selection configured to always enable a curtailment of the HVAC system at the first residential site in response to a demand response event;

a never participate selection configured to not allow a curtailment of the HVAC system at the first residential site in response to a demand response event; and

a request participation selection configured to initiate a communication to the user to request participation in a demand response event.

12. The energy management system of claim 8, further comprising:

a plurality of energy templates accessible using the scheduling tool, wherein each template includes a predetermined utilization schedule selectable by the user based on a user's scheduling profile;

wherein the predetermined utilization schedule is modifiable by the user with the scheduling tool; and

an energy personality detection module configured to:



detect an interaction of the user with the wireless thermostat;  
display of an energy personality indicia in response to the interaction; and  
enable the user to display the energy personality indicia within a social network.

13. The energy management system of claim 1, further comprising the processor configured to:

determine a random sample size of residential sites in connection with estimating an energy consumption of a specific region;

accessing a plurality of thermostat schedules within the specified region based on the random sample size; and

output thermostat scheduling data of the plurality of thermostat schedules in connection with forecasting production.

14. The energy management system of claim 1, further comprising the processor configured to:

detect an enabled demand response setting of the first residential site;

detect a demand response event condition; and

enable a curtailment action of a corresponding HVAC system at the first residential site.

15. The energy management system of claim 1, further comprising the processor configured to:

initiate a demand response event request communication to the users of the plurality of residences;

detect a user response level to participate in a demand response event; and

enable a curtailment of a corresponding HVAC system at the residential sites of the users electing to participate in the demand response event.

16. The energy management system of claim 1, further comprising the processor configured to:

identify a group of residences within the plurality of residences;

determine an energy reduction capacity of each of the residences within the group using an efficiency rating of each of the residences within the group; and

estimate an aggregate energy reduction capacity based on the energy reduction capacity of each of the residences within the group.

17. The energy management system of claim 16, further comprising the processor configured to:

initiate an auction process to sell the aggregate energy reduction capacity to a third party;

detect a sale of the aggregate energy reduction capacity in connection with the auction process; and

initiate a curtailment of the HVAC system at each of the residences within the group.

18. The energy management system of claim 1, further comprising a mobile client module configured to be operably coupled to a mobile device associated with the first residential site, wherein the mobile client module is configured to:

receive a site readings request of the first residential site from the first mobile device;

access the database to retrieve site report data of the first residential site;

format the accessed site report data as mobile device data;

output the mobile device data to the first mobile device using a mobile device network;

receive a request from the mobile device to modify a current temperature set-point of the HVAC system at the first residential site;

initiate generation of a control report including an updated temperature set-point input using the mobile device; and

output a confirmation of the updated temperature set-point.

19. The energy management system of claim 18, wherein the mobile client module is further configured to:

enable access to a proximity setting of the first residential site;

detect multiple control zones at the first residential site;

detect a corresponding wireless thermostat of each of the multiple control zones;

output mobile device data to the mobile device indicating a current reading within each zone;

wherein the current reading is acquired from the site data;

enable access to the corresponding wireless thermostat of each zone; and

enable the mobile device control of the corresponding wireless thermostat.

20. The energy management system of claim 18, further comprising the processor further configured to:

detect a manual input condition to the wireless thermostat at the first residential site;

identify a mobile device associated with the first residential site;

initiate a text message indicating the manual input condition; and

enable a user to alter the manual input condition using the mobile device.

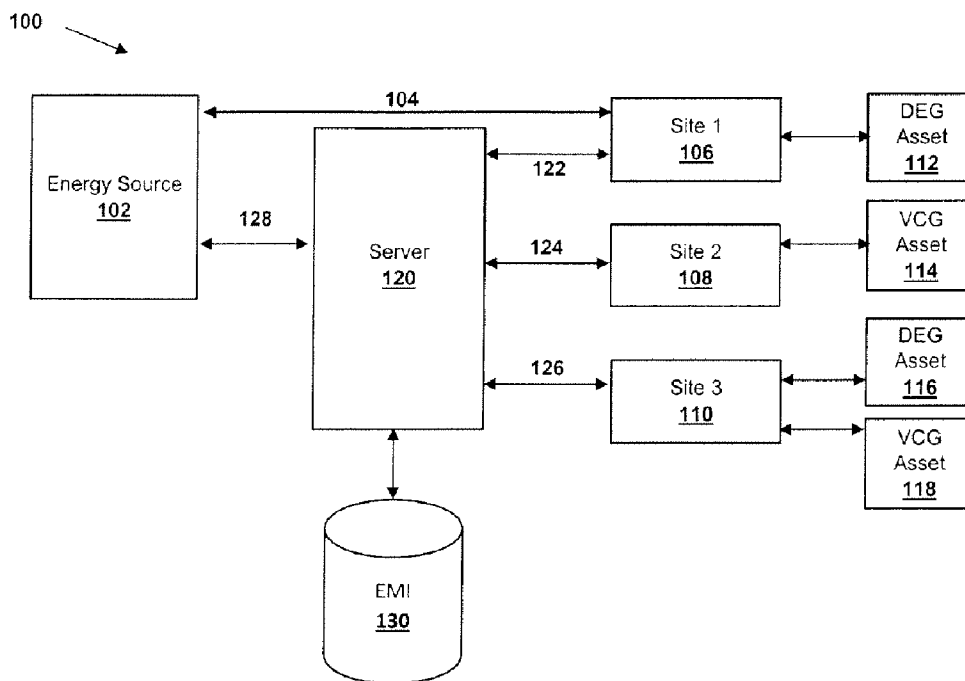

FIG. 1

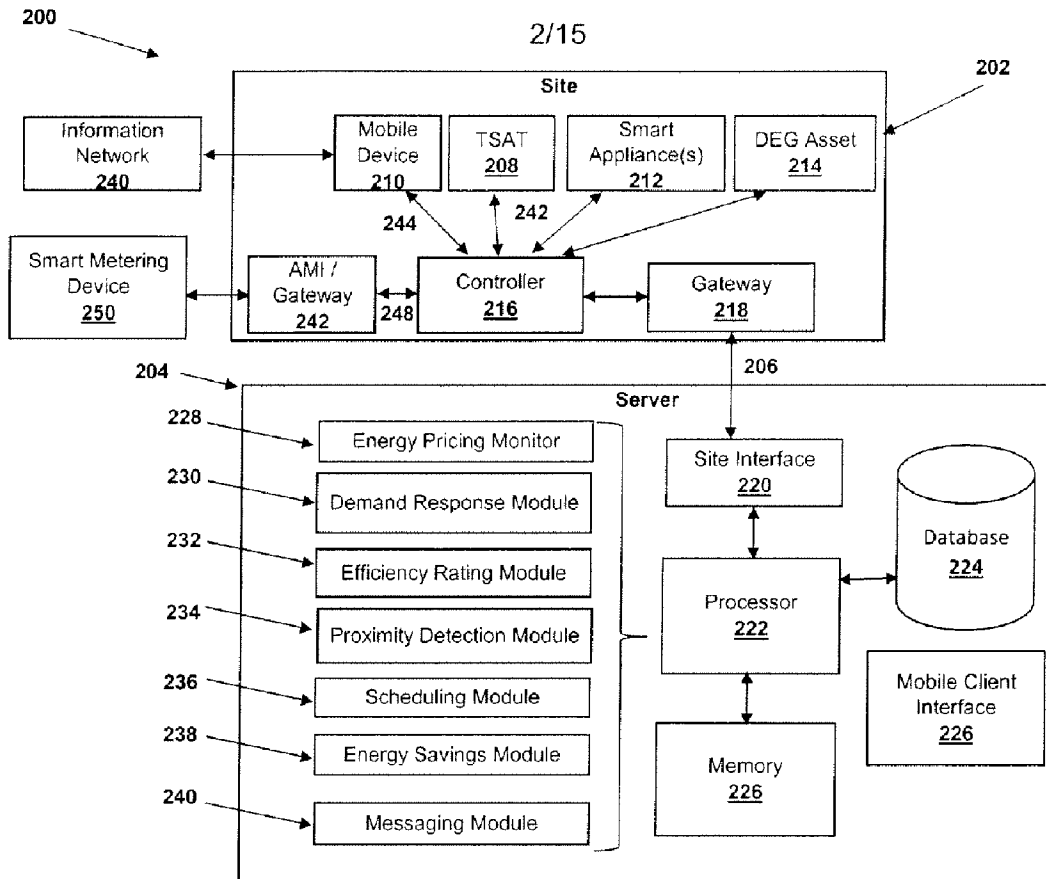

FIG. 2

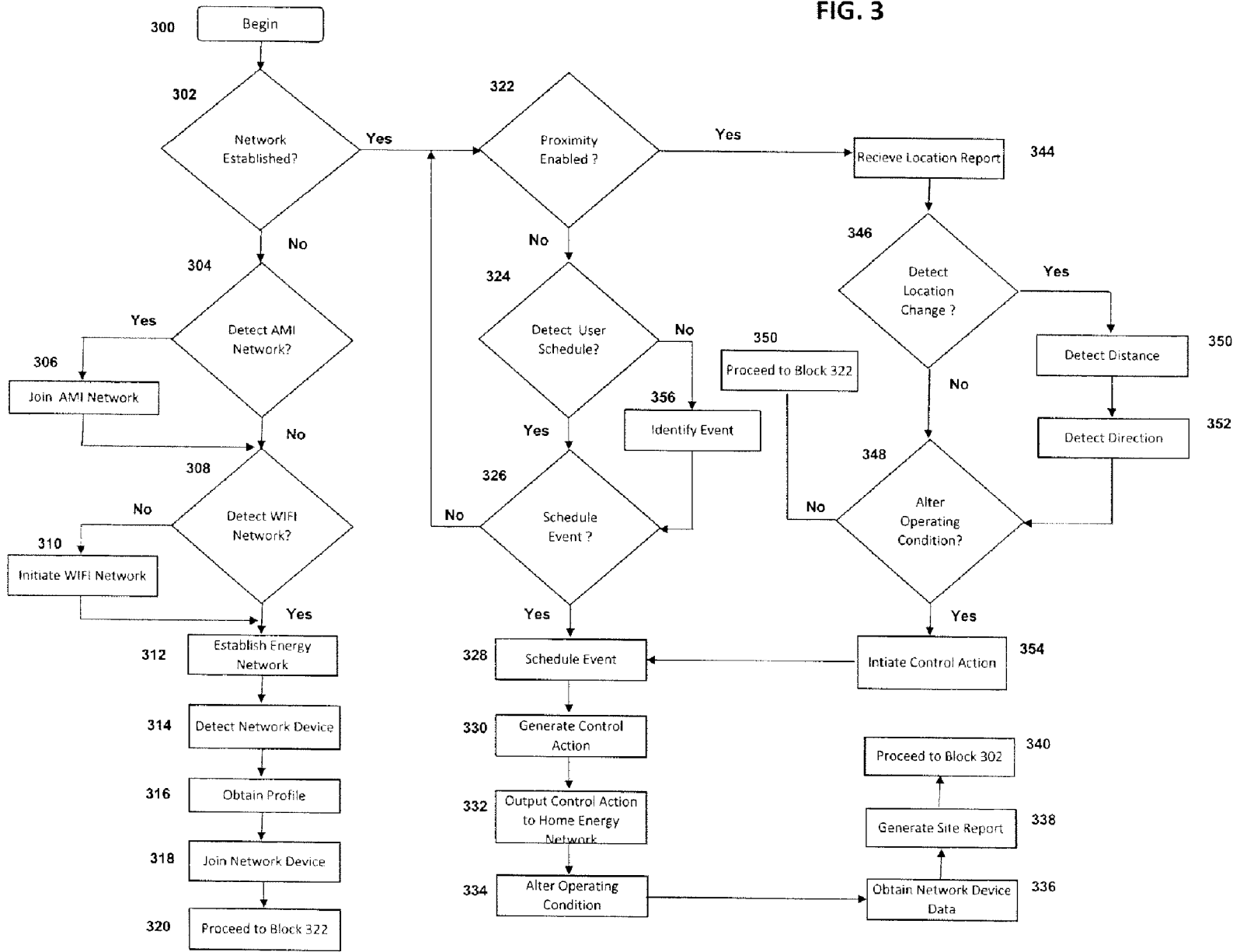

FIG. 3

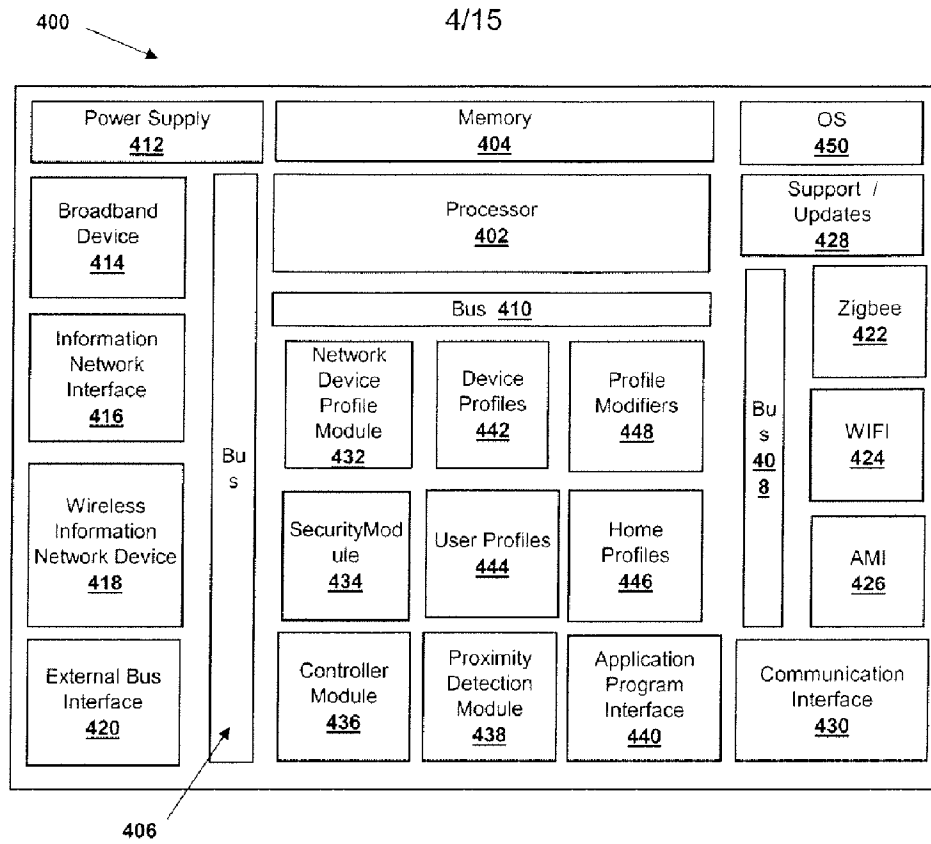

FIG. 4

FIG. 5A

500

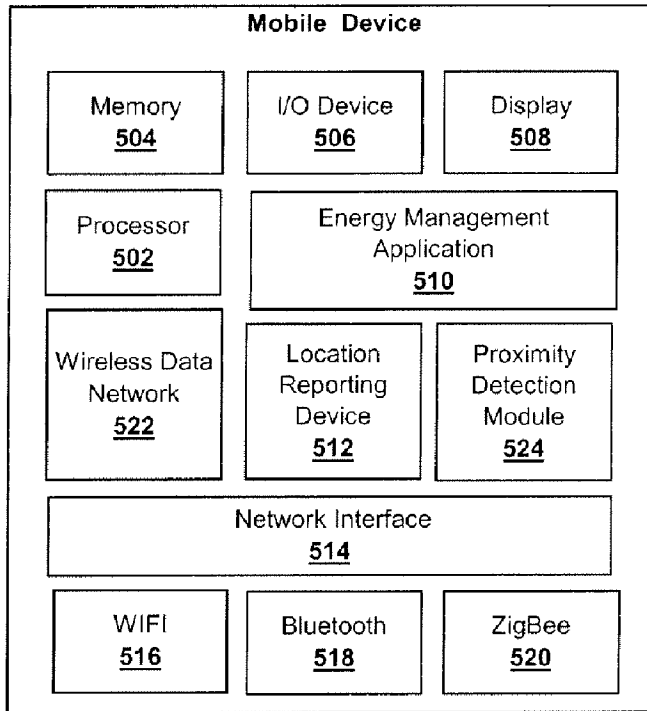

FIG. 5B

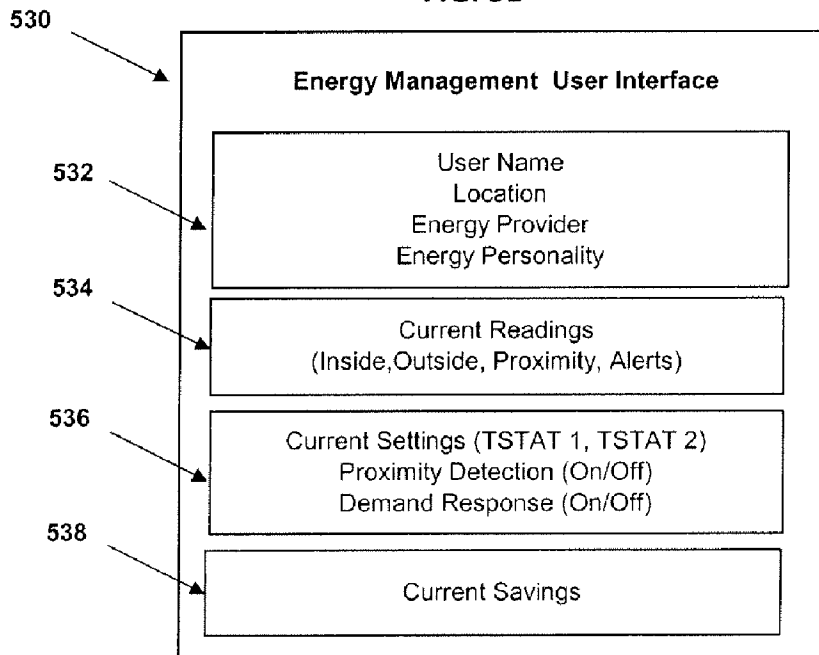
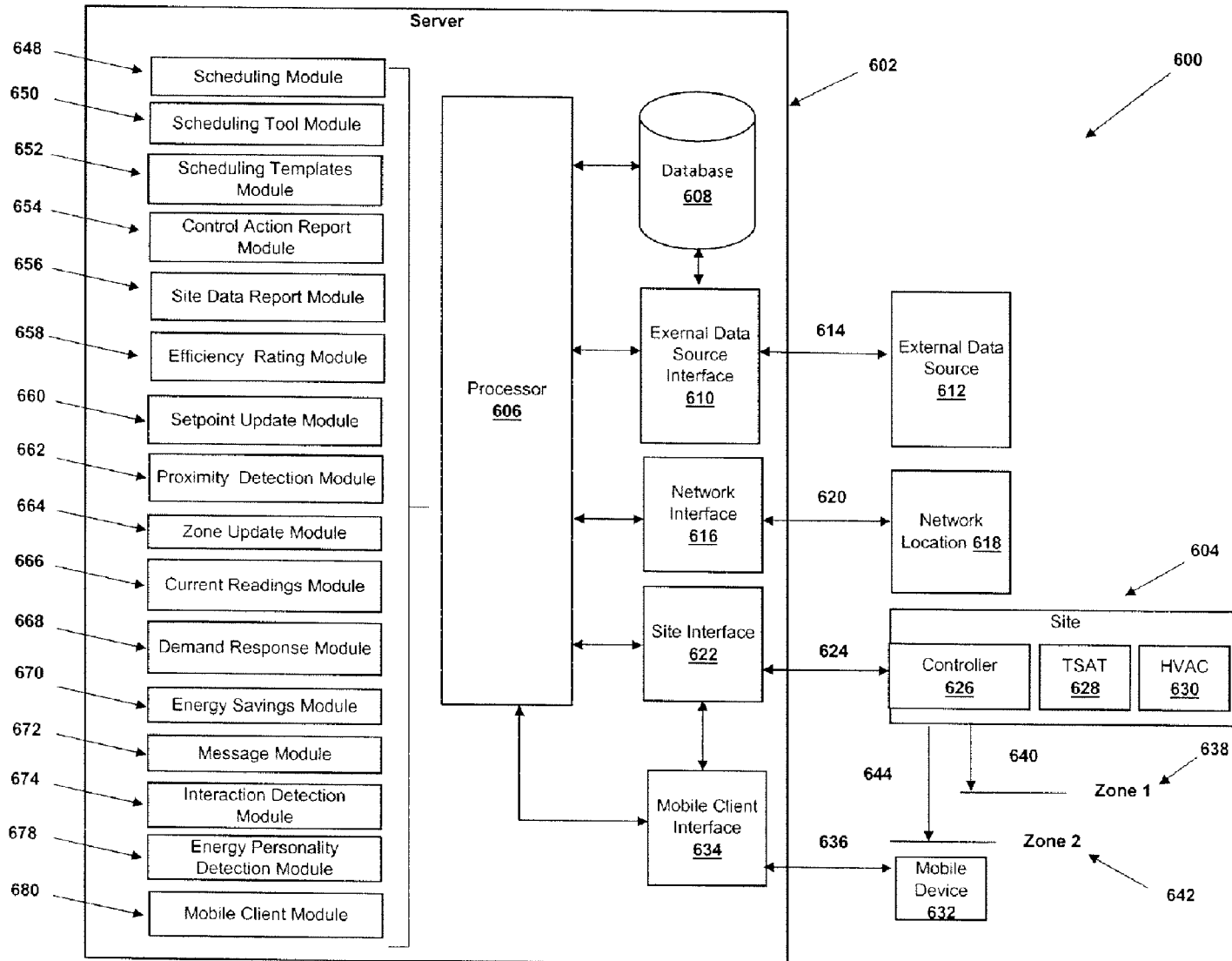



FIG. 6



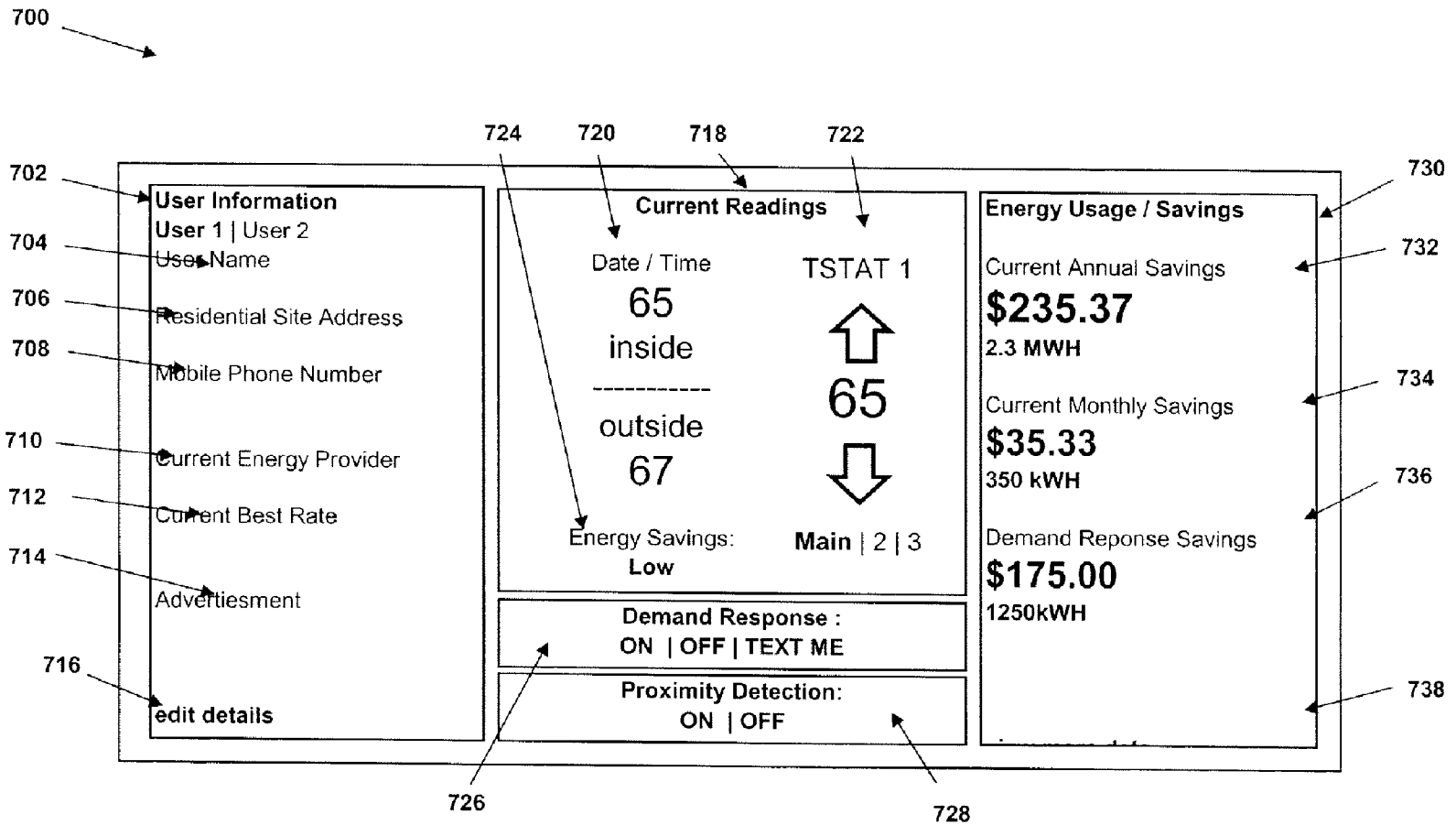

FIG. 7

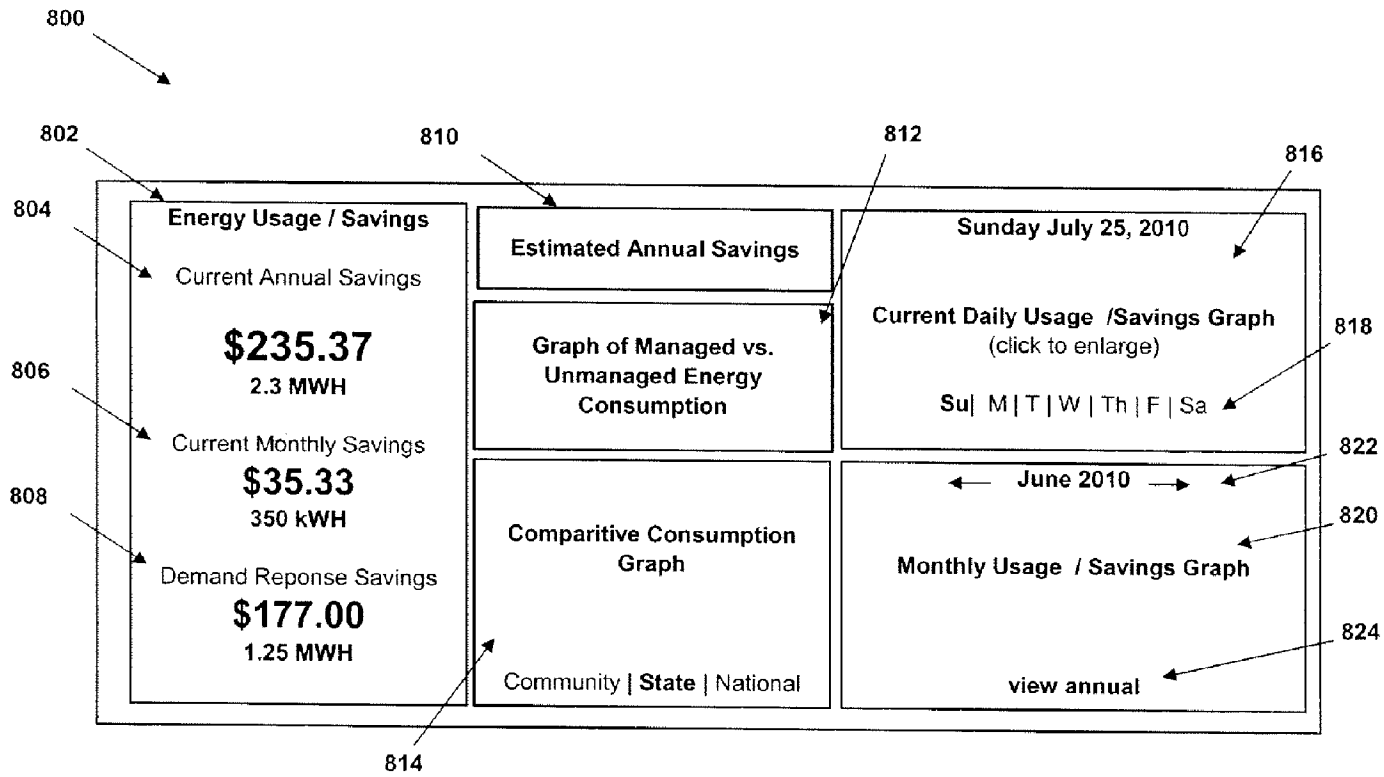

FIG. 8

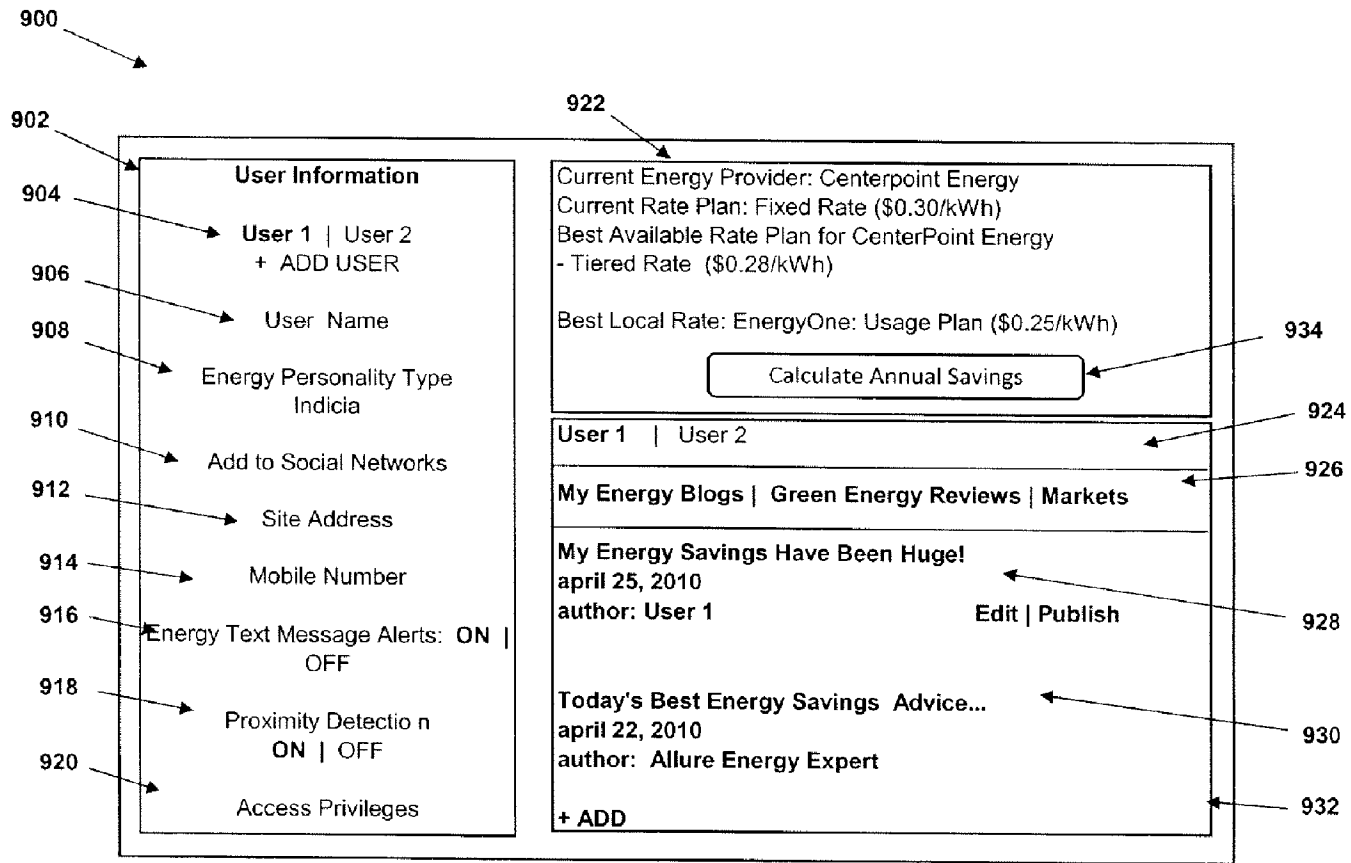

FIG. 9

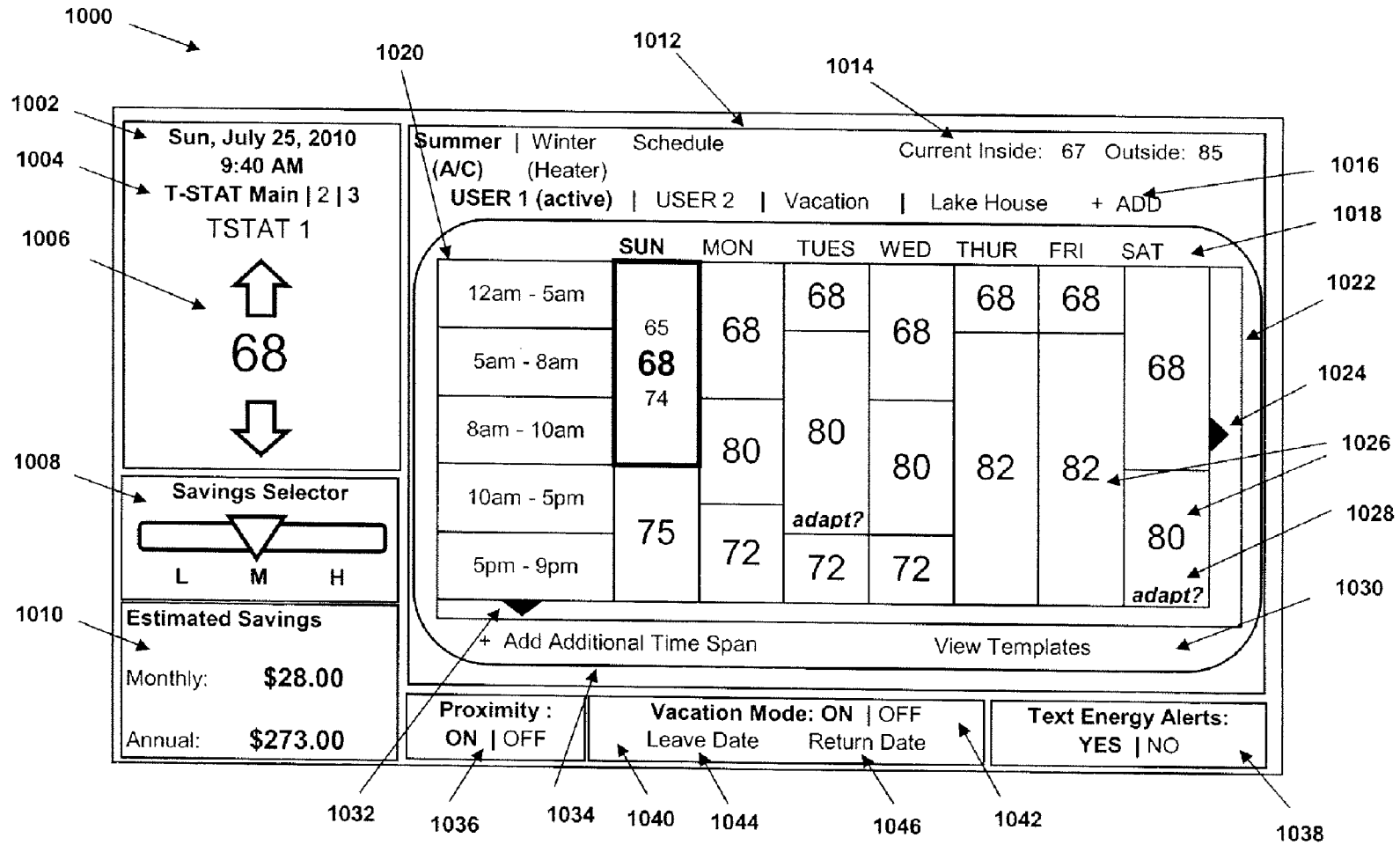

FIG. 10

11/15

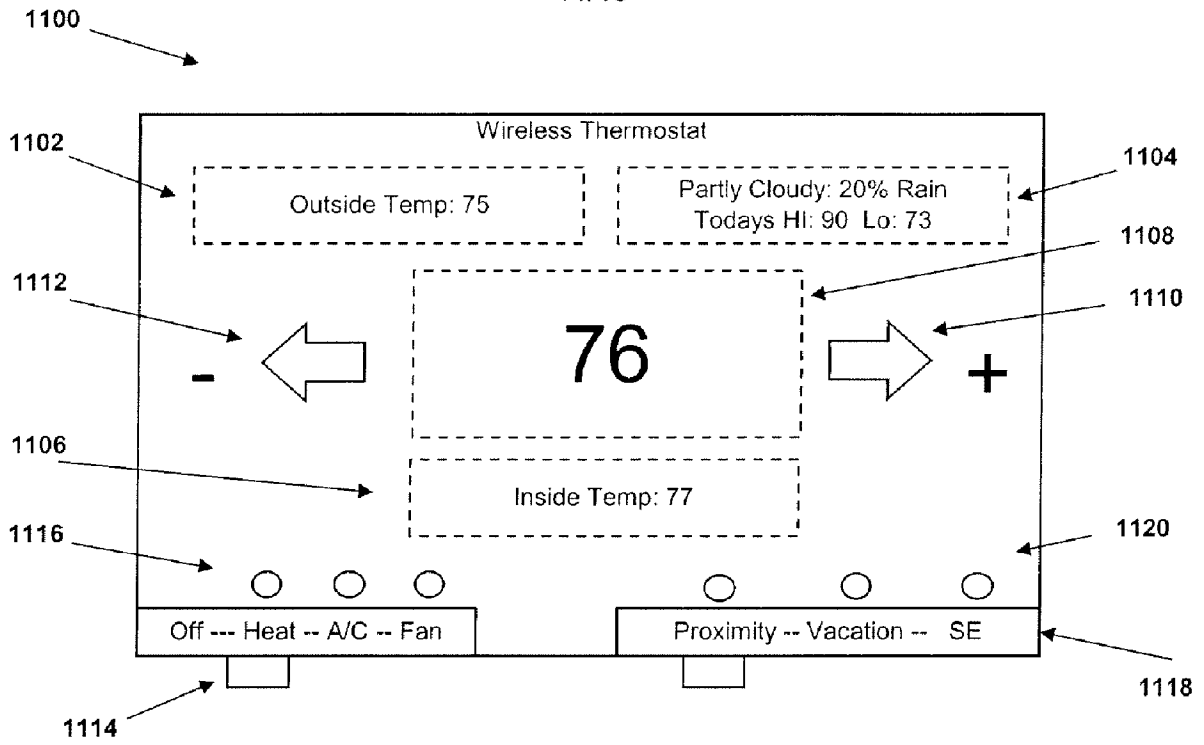

FIG. 11

1200

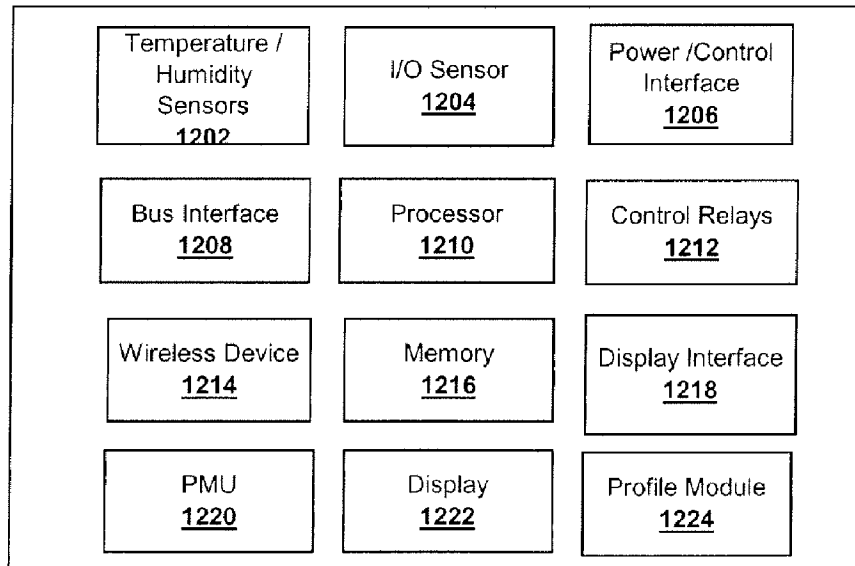

FIG. 12

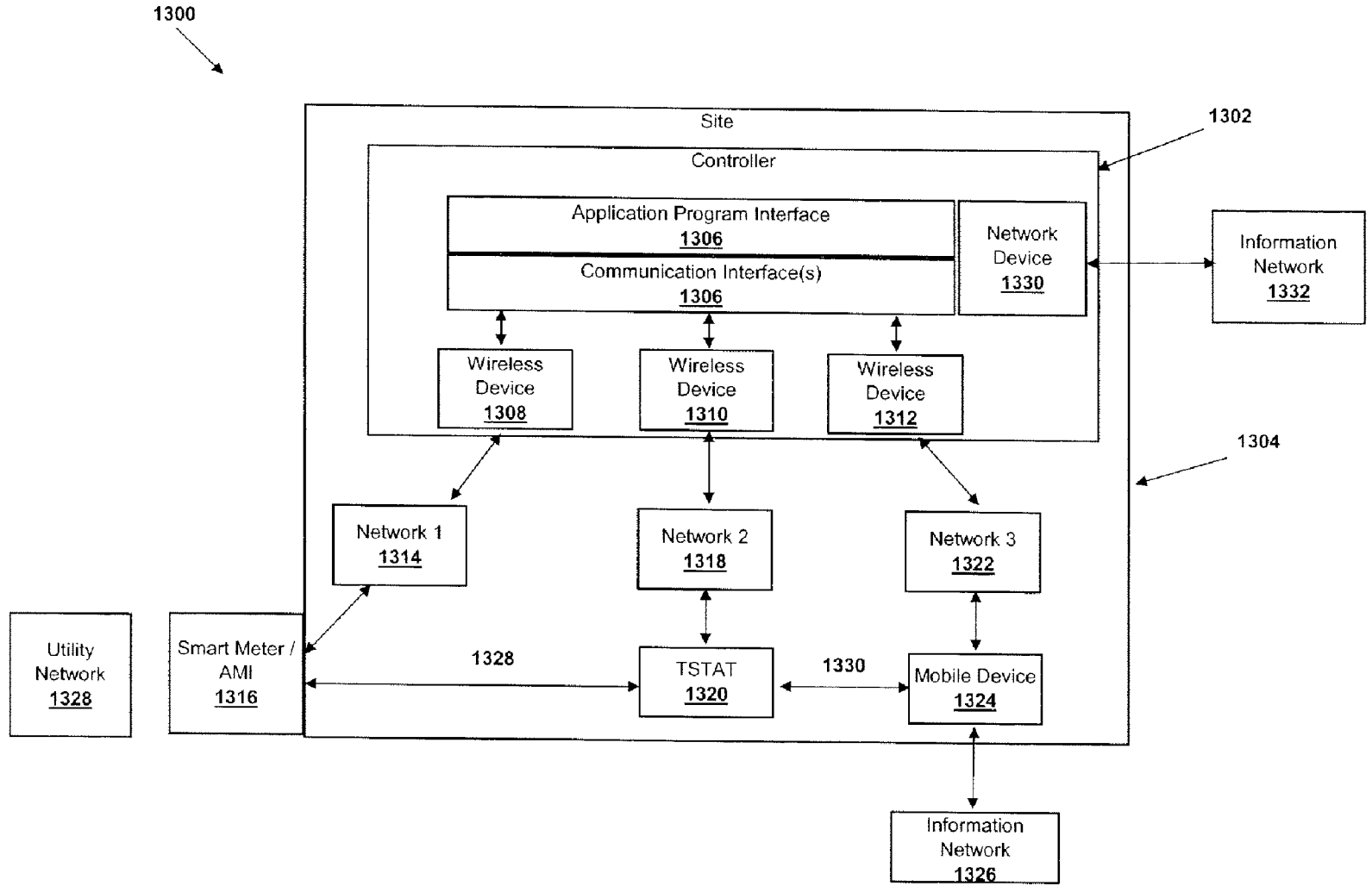

FIG. 13

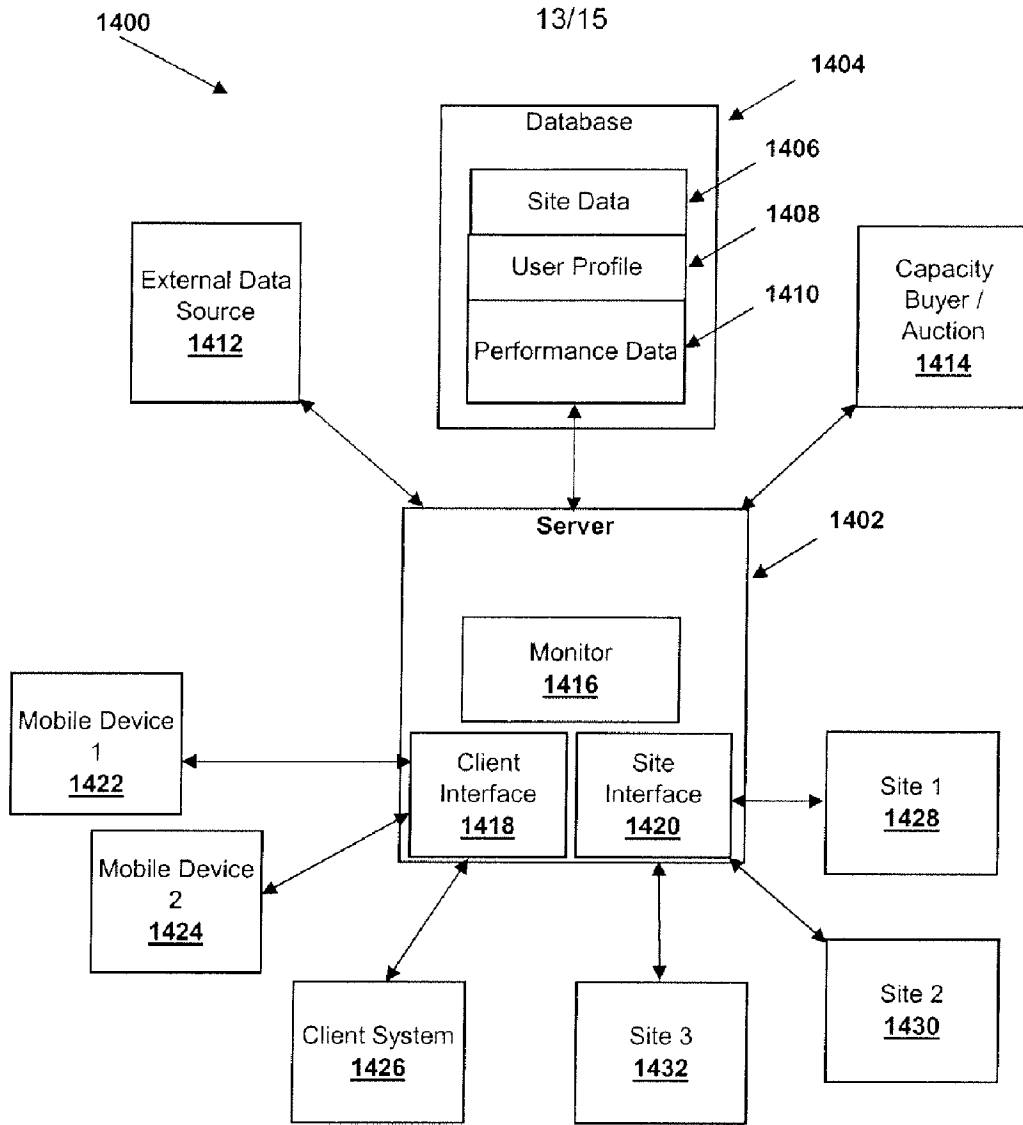

FIG. 14



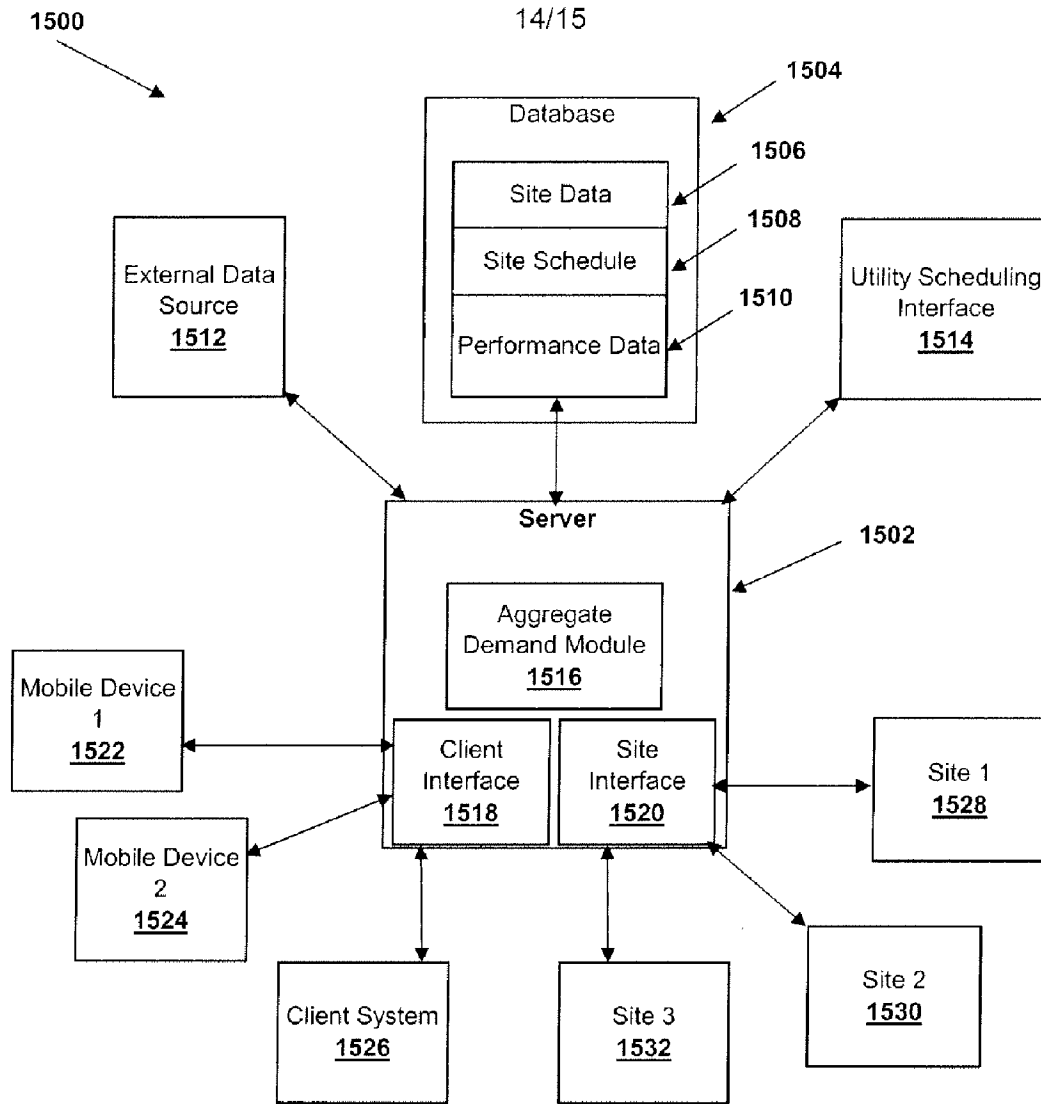

FIG. 15

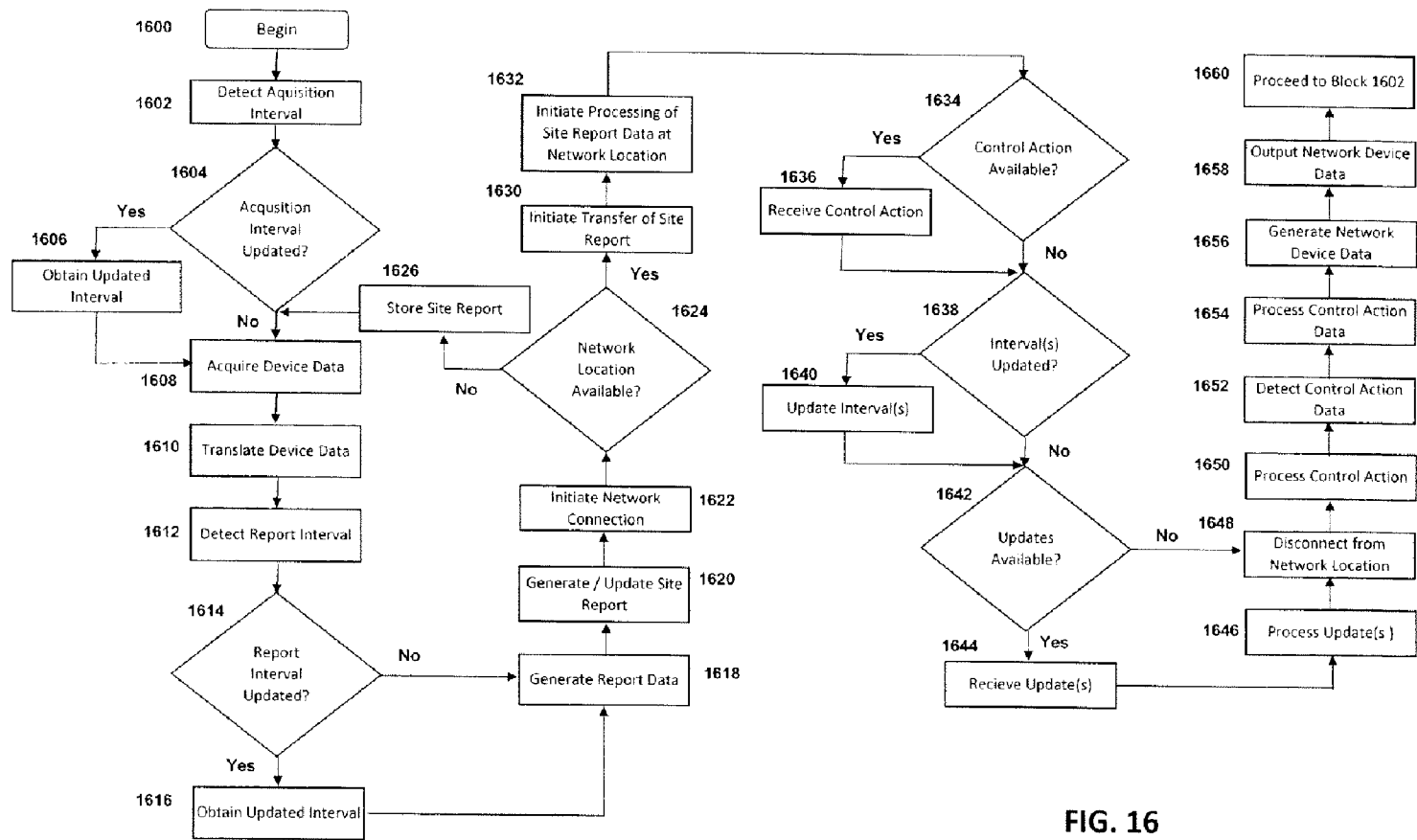

FIG. 16

**INTERNATIONAL SEARCH REPORT**

International application No  
PCT/US2010/042589

**A. CLASSIFICATION OF SUBJECT MATTER**  
INV. G05D23/19 H02J3/14  
ADD.

According to International Patent Classification (IPC) or to both national classification and IPC

**B. FIELDS SEARCHED**

Minimum documentation searched (classification system followed by classification symbols)  
G05D H02J H04L G05B F24F

Documentation searched other than minimum documentation to the extent that such documents are included in the fields searched

Electronic data base consulted during the international search (name of data base and, where practical, search terms used)

EPO-Internal, WPI Data

**C. DOCUMENTS CONSIDERED TO BE RELEVANT**

Category*	Citation of document, with indication, where appropriate, of the relevant passages	Relevant to claim No.
X	US 2007/043477 A1 (EHLERS GREGORY A [US] ET AL) 22 February 2007 (2007-02-22)	1,2,7-20
Y	paragraphs [0002], [0057] - [0164], [0223] - [0358]; figures 1, 3, 4, 5	3-6
Y	WO 2009/034720 A1 (MITSUBISHI ELECTRIC CORP [JP]) 19 March 2009 (2009-03-19) paragraphs [0038] - [0041]; figure 7 & EP 2 189 803 A1 (MITSUBISHI ELECTRIC CORP [JP]) 26 May 2010 (2010-05-26) paragraphs [0038] - [0041]; figure 7	3-6
X	US 2004/034484 A1 (SOLOMITA MICHAEL V [US] ET AL) 19 February 2004 (2004-02-19)	1
Y	paragraphs [0037] - [0049], [0055],	3-6
A	[0056], [0063]; figures 1,2,6,11	2,7-20

Further documents are listed in the continuation of Box C.

See patent family annex.

\* Special categories of cited documents :

- "A" document defining the general state of the art which is not considered to be of particular relevance
- "E" earlier document but published on or after the international filing date
- "L" document which may throw doubts on priority claim(s) or which is cited to establish the publication date of another citation or other special reason (as specified)
- "O" document referring to an oral disclosure, use, exhibition or other means
- "P" document published prior to the international filing date but later than the priority date claimed

- "T" later document published after the international filing date or priority date and not in conflict with the application but cited to understand the principle or theory underlying the invention
- "X" document of particular relevance; the claimed invention cannot be considered novel or cannot be considered to involve an inventive step when the document is taken alone
- "Y" document of particular relevance; the claimed invention cannot be considered to involve an inventive step when the document is combined with one or more other such documents, such combination being obvious to a person skilled in the art.
- "&" document member of the same patent family

Date of the actual completion of the international search

15 November 2010

Date of mailing of the international search report

22/11/2010

Name and mailing address of the ISA/

European Patent Office, P.B. 5818 Patentlaan 2  
NL - 2280 HV Rijswijk  
Tel. (+31-70) 340-2040,  
Fax: (+31-70) 340-3016

Authorized officer

Vañó Gea, Joaquín

# INTERNATIONAL SEARCH REPORT

International application No.

PCT/US2010/042589

Box No. IV Text of the abstract (Continuation of item 5 of the first sheet)

A home energy management system includes a database configured to store site report data received from a plurality of residential sites using a wireless home energy network at each site. Each residential site includes a thermostat accessible to the wireless home energy network. A processor is operably coupled to the database and configured to access the site report data and detect a current temperature set-point of the thermostat at a first residential site; detect a first seasonal profile of the thermostat; detect a current operating mode of a HVAC system operably coupled to the thermostat; and determine a thermostat schedule of the thermostat using the first seasonal profile and the current operating mode of the HVAC system.

# INTERNATIONAL SEARCH REPORT

information on patent family members

International application No

PCT/US2010/042589

Patent document cited in search report	Publication date	Patent family member(s)	Publication date
US 2007043477	A1	22-02-2007	NONE
WO 2009034720	A1	19-03-2009	CN 101802642 A 11-08-2010 EP 2189803 A1 26-05-2010 US 2010225540 A1 09-09-2010
US 2004034484	A1	19-02-2004	NONE

## Electronic Patent Application Fee Transmittal

<b>Application Number:</b>	15002791
<b>Filing Date:</b>	21-Jan-2016
<b>Title of Invention:</b>	SYSTEM AND METHOD FOR USING A WIRELESS DEVICE AS A SENSOR FOR AN ENERGY MANAGEMENT SYSTEM
<b>First Named Inventor/Applicant Name:</b>	John Douglas Steinberg
<b>Filer:</b>	John R. King/Amy Durrant
<b>Attorney Docket Number:</b>	EFACT.011C2

Filed as Small Entity

**Filing Fees for Utility under 35 USC 111(a)**

Description	Fee Code	Quantity	Amount	Sub-Total in USD(\$)
<b>Basic Filing:</b>				
<b>Pages:</b>				
<b>Claims:</b>				
<b>Miscellaneous-Filing:</b>				
<b>Petition:</b>				
<b>Patent-Appeals-and-Interference:</b>				
<b>Post-Allowance-and-Post-Issuance:</b>				
<b>Extension-of-Time:</b>				

Description	Fee Code	Quantity	Amount	Sub-Total in USD(\$)
<b>Miscellaneous:</b>				
SUBMISSION- INFORMATION DISCLOSURE STMT	2806	1	120	120
<b>Total in USD (\$)</b>				<b>120</b>

## Electronic Acknowledgement Receipt

<b>EFS ID:</b>	32627641
<b>Application Number:</b>	15002791
<b>International Application Number:</b>	
<b>Confirmation Number:</b>	4939
<b>Title of Invention:</b>	SYSTEM AND METHOD FOR USING A WIRELESS DEVICE AS A SENSOR FOR AN ENERGY MANAGEMENT SYSTEM
<b>First Named Inventor/Applicant Name:</b>	John Douglas Steinberg
<b>Customer Number:</b>	20995
<b>Filer:</b>	John R. King/Imran Ahmed
<b>Filer Authorized By:</b>	John R. King
<b>Attorney Docket Number:</b>	EFACT.011C2
<b>Receipt Date:</b>	15-MAY-2018
<b>Filing Date:</b>	21-JAN-2016
<b>Time Stamp:</b>	14:11:51
<b>Application Type:</b>	Utility under 35 USC 111(a)

### Payment information:

Submitted with Payment	yes
Payment Type	CARD
Payment was successfully received in RAM	\$120
RAM confirmation Number	051618INTEFSW14125000
Deposit Account	111410
Authorized User	Imran Ahmed

The Director of the USPTO is hereby authorized to charge indicated fees and credit any overpayment as follows:

37 CFR 1.16 (National application filing, search, and examination fees)

37 CFR 1.17 (Patent application and reexamination processing fees)



--	--	--	--	--	--

**File Listing:**

Document Number	Document Description	File Name	File Size(Bytes)/ Message Digest	Multi Part /.zip	Pages (if appl.)
1		EFACT-011C2_response.pdf	477781	yes	13
			3d61deeda046d09185305d79bb62129469560762		

Multipart Description/PDF files in .zip description			
Document Description	Start	End	
Amendment/Req. Reconsideration-After Non-Final Reject	1	1	
Claims	2	4	
Applicant Arguments/Remarks Made in an Amendment	5	13	

**Warnings:**

**Information:**

2		EFACT-011C2_ids.pdf	125966	yes	4
			d169c2660d66cd77bb0fe8025cde44f2e35e2a75		

Multipart Description/PDF files in .zip description			
Document Description	Start	End	
Transmittal Letter	1	2	
Information Disclosure Statement (IDS) Form (SB08)	3	4	

**Warnings:**

**Information:**

3	Foreign Reference	EFACT-011C2_REF32.pdf	1124518	no	18
			9a012eb32bc812f959c28d9c7765e941ba437d38		

**Warnings:**

**Information:**

4	Foreign Reference	EFACT-011C2_REF33.pdf	405324	no	11
			7fab2f6f08c09880b76d0cf096d33c61d0b97727		
<b>Warnings:</b>					
<b>Information:</b>					
5	Foreign Reference	EFACT-011C2_REF34.pdf	1631614	no	47
			db9002a72df68e86f3538c60a70a001590bf5be9		
<b>Warnings:</b>					
<b>Information:</b>					
6	Foreign Reference	EFACT-011C2_REF35.pdf	609131	no	15
			50eba3636587ddcb91546c172f4d62594e2b31d8		
<b>Warnings:</b>					
<b>Information:</b>					
7	Foreign Reference	EFACT-011C2_REF36.pdf	1097570	no	26
			abd9cad16ad008b0ea7b56dd92249cc529badd6e		
<b>Warnings:</b>					
<b>Information:</b>					
8	Foreign Reference	EFACT-011C2_REF37.pdf	5353402	no	138
			532f76a49fc54b91cf3c10be2314e278c5ba42e9		
<b>Warnings:</b>					
<b>Information:</b>					
9	Non Patent Literature	EFACT-011C2_REF38.pdf	321555	no	6
			fb2ab8226548f996c9b1b6c998df7a7be77b3def		
<b>Warnings:</b>					
<b>Information:</b>					
10	Non Patent Literature	EFACT-011C2_REF39.pdf	1046345	no	11
			c958721c4ae725acd072e6d5fa5f62f0fdcc3dd		
<b>Warnings:</b>					
<b>Information:</b>					

11	Non Patent Literature	EFACT-011C2_REF40.pdf	509679	no	15
			741168924f6d23db99143031072883d8f86e2d16		
<b>Warnings:</b>					
<b>Information:</b>					
12	Non Patent Literature	EFACT-011C2_REF41.pdf	159594	no	3
			191269d95aeec3524d285c25283658526671dd6f		
<b>Warnings:</b>					
<b>Information:</b>					
13	Non Patent Literature	EFACT-011C2_REF42.pdf	218653	no	7
			1f73c96f3c1b649f04a75d995a334f4b9271edba		
<b>Warnings:</b>					
<b>Information:</b>					
14	Fee Worksheet (SB06)	fee-info.pdf	30547	no	2
			54109ca78cfe10f6883b5935029ff73edc6f1363		
<b>Warnings:</b>					
<b>Information:</b>					
<b>Total Files Size (in bytes):</b>				13111679	
<p><b>This Acknowledgement Receipt evidences receipt on the noted date by the USPTO of the indicated documents, characterized by the applicant, and including page counts, where applicable. It serves as evidence of receipt similar to a Post Card, as described in MPEP 503.</b></p> <p><b><u>New Applications Under 35 U.S.C. 111</u></b>  <b>If a new application is being filed and the application includes the necessary components for a filing date (see 37 CFR 1.53(b)-(d) and MPEP 506), a Filing Receipt (37 CFR 1.54) will be issued in due course and the date shown on this Acknowledgement Receipt will establish the filing date of the application.</b></p> <p><b><u>National Stage of an International Application under 35 U.S.C. 371</u></b>  <b>If a timely submission to enter the national stage of an international application is compliant with the conditions of 35 U.S.C. 371 and other applicable requirements a Form PCT/DO/EO/903 indicating acceptance of the application as a national stage submission under 35 U.S.C. 371 will be issued in addition to the Filing Receipt, in due course.</b></p> <p><b><u>New International Application Filed with the USPTO as a Receiving Office</u></b>  <b>If a new international application is being filed and the international application includes the necessary components for an international filing date (see PCT Article 11 and MPEP 1810), a Notification of the International Application Number and of the International Filing Date (Form PCT/RO/105) will be issued in due course, subject to prescriptions concerning national security, and the date shown on this Acknowledgement Receipt will establish the international filing date of the application.</b></p>					

Under the Paperwork Reduction Act of 1995, no persons are required to respond to a collection of information unless it displays a valid OMB control number.

<b>PATENT APPLICATION FEE DETERMINATION RECORD</b> Substitute for Form PTO-875	Application or Docket Number <b>15/002,791</b>	Filing Date <b>01/21/2016</b>	<input type="checkbox"/> To be Mailed
---	---	----------------------------------	---------------------------------------

ENTITY:  LARGE  SMALL  MICRO

**APPLICATION AS FILED – PART I**

	(Column 1)	(Column 2)		RATE (\$)	FEE (\$)
FOR	NUMBER FILED	NUMBER EXTRA			
<input type="checkbox"/> BASIC FEE <small>(37 CFR 1.16(a), (b), or (c))</small>	N/A	N/A		N/A	
<input type="checkbox"/> SEARCH FEE <small>(37 CFR 1.16(k), (l), or (m))</small>	N/A	N/A		N/A	
<input type="checkbox"/> EXAMINATION FEE <small>(37 CFR 1.16(o), (p), or (q))</small>	N/A	N/A		N/A	
TOTAL CLAIMS <small>(37 CFR 1.16(i))</small>	minus 20 =	*	X \$	=	
INDEPENDENT CLAIMS <small>(37 CFR 1.16(h))</small>	minus 3 =	*	X \$	=	
<input type="checkbox"/> APPLICATION SIZE FEE <small>(37 CFR 1.16(s))</small>	If the specification and drawings exceed 100 sheets of paper, the application size fee due is \$310 (\$155 for small entity) for each additional 50 sheets or fraction thereof. See 35 U.S.C. 41(a)(1)(G) and 37 CFR 1.16(s).				
<input type="checkbox"/> MULTIPLE DEPENDENT CLAIM PRESENT <small>(37 CFR 1.16(j))</small>					
* If the difference in column 1 is less than zero, enter "0" in column 2.			TOTAL		

**APPLICATION AS AMENDED – PART II**

	(Column 1)	(Column 2)	(Column 3)	(Column 3)		RATE (\$)	ADDITIONAL FEE (\$)
<b>AMENDMENT</b>	<b>05/15/2018</b>	CLAIMS REMAINING AFTER AMENDMENT	HIGHEST NUMBER PREVIOUSLY PAID FOR	PRESENT EXTRA			
	Total <small>(37 CFR 1.16(i))</small>	* 18	Minus	** 20	= 0	X \$50 =	0
	Independent <small>(37 CFR 1.16(h))</small>	* 2	Minus	***3	= 0	X \$230 =	0
	<input type="checkbox"/> Application Size Fee <small>(37 CFR 1.16(s))</small>						
	<input type="checkbox"/> FIRST PRESENTATION OF MULTIPLE DEPENDENT CLAIM <small>(37 CFR 1.16(j))</small>						
			TOTAL ADD'L FEE			<b>0</b>	

	(Column 1)	(Column 2)	(Column 3)	(Column 3)		RATE (\$)	ADDITIONAL FEE (\$)
<b>AMENDMENT</b>		CLAIMS REMAINING AFTER AMENDMENT	HIGHEST NUMBER PREVIOUSLY PAID FOR	PRESENT EXTRA			
	Total <small>(37 CFR 1.16(i))</small>	*	Minus	**	=	X \$	=
	Independent <small>(37 CFR 1.16(h))</small>	*	Minus	***	=	X \$	=
	<input type="checkbox"/> Application Size Fee <small>(37 CFR 1.16(s))</small>						
	<input type="checkbox"/> FIRST PRESENTATION OF MULTIPLE DEPENDENT CLAIM <small>(37 CFR 1.16(j))</small>						
			TOTAL ADD'L FEE				

\* If the entry in column 1 is less than the entry in column 2, write "0" in column 3.  
 \*\* If the "Highest Number Previously Paid For" IN THIS SPACE is less than 20, enter "20".  
 \*\*\* If the "Highest Number Previously Paid For" IN THIS SPACE is less than 3, enter "3".

SLIE  
 NINA RATANAVONG

The "Highest Number Previously Paid For" (Total or Independent) is the highest number found in the appropriate box in column 1.

This collection of information is required by 37 CFR 1.16. The information is required to obtain or retain a benefit by the public which is to file (and by the USPTO to process) an application. Confidentiality is governed by 35 U.S.C. 122 and 37 CFR 1.14. This collection is estimated to take 12 minutes to complete, including gathering, preparing, and submitting the completed application form to the USPTO. Time will vary depending upon the individual case. Any comments on the amount of time you require to complete this form and/or suggestions for reducing this burden, should be sent to the Chief Information Officer, U.S. Patent and Trademark Office, U.S. Department of Commerce, P.O. Box 1450, Alexandria, VA 22313-1450. DO NOT SEND FEES OR COMPLETED FORMS TO THIS ADDRESS. **SEND TO: Commissioner for Patents, P.O. Box 1450, Alexandria, VA 22313-1450.**

If you need assistance in completing the form, call 1-800-PTO-9199 and select option 2.

## Bibliographic Data

Application No: 15002791

Foreign Priority claimed:  Yes  No

35 USC 119 (a-d) conditions met:  Yes  No

Met After Allowance

Verified and Acknowledged:

/AJAY OJHA/

Examiner's Signature

Initials

Title:

SYSTEM AND METHOD FOR USING A WIRELESS DEVICE AS  
A SENSOR FOR AN ENERGY MANAGEMENT SYSTEM

---

FILING or 371(c) DATE	CLASS	GROUP ART UNIT	ATTORNEY DOCKET NO.
01/21/2016	700	2824	EFACT.011C2
<b>RULE</b>			

### APPLICANTS

EcoFactor, Inc., Redwood City, CA, UNITED STATES

### INVENTORS

John Douglas Steinberg, Millbrae, CA, UNITED STATES

### CONTINUING DATA

This application is a CON of 13470074 05/11/2012 PAT 9244470

13470074 is a CON of 12502064 07/13/2009 PAT 8180492

12502064 has PRO of 61134714 07/14/2008

### FOREIGN APPLICATIONS

### IF REQUIRED, FOREIGN LICENSE GRANTED\*\*

02/04/2016

### STATE OR COUNTRY

UNITED STATES

### ADDRESS

KNOBBE MARTENS OLSON & BEAR LLP

2040 MAIN STREET

FOURTEENTH FLOOR

IRVINE, CA 92614

UNITED STATES

### FILING FEE RECEIVED

\$800

<b>Search Notes</b> 	<b>Application/Control No.</b> 15/002,791	<b>Applicant(s)/Patent Under Reexamination</b> Steinberg, John Douglas
	<b>Examiner</b> AJAY OJHA	<b>Art Unit</b> 2824

CPC - Searched*		
Symbol	Date	Examiner
F24F11/006; F24F11/70; F24F11/62; F24F11/30; G05B15/02; G06N7/005; G05D23/1902; F24F11/56; F24F2120/12; F24F2120/10; F24F11/63; F24F11/46; F24F2120/20; F24F2140/60; F24F2120/14	02/13/2018	AO

CPC Combination Sets - Searched*		
Symbol	Date	Examiner

US Classification - Searched*			
Class	Subclass	Date	Examiner

\* See search history printout included with this form or the SEARCH NOTES box below to determine the scope of the search.

Search Notes		
Search Notes	Date	Examiner
Inventor, assignee, classification and text search. See search history.	02/13/2018	AO

Interference Search			
US Class/CPC Symbol	US Subclass/CPC Group	Date	Examiner

/AJAY OJHA/ Examiner, Art Unit 2824	
--	--

PTO/SB/08 Equivalent

<b>INFORMATION DISCLOSURE STATEMENT BY APPLICANT</b>	Application No.	15/002791	
	Filing Date	January 21, 2016	
	First Named Inventor	John Douglas Steinberg	
	Art Unit	3744	
<i>(Multiple sheets used when necessary)</i>		Examiner	Unknown
SHEET 1 OF 1		Attorney Docket No.	EFACT.011C2

U.S. PATENT DOCUMENTS					
Examiner Initials	Cite No.	Document Number <i>Number - Kind Code (if known)</i> Example: 1,234,567 B1	Publication Date MM-DD-YYYY	Name	Pages, Columns, Lines Where Relevant Passages or Relevant Figures Appear
	1	9,244,470 (EFACT.011C1)	01/26/2016	Steinberg	
	2	9,279,594 (EFACT.008C1)	03/08/2016	Steinberg	
	3	2006/0283965	12/21/2006	Mueller et al.	
	4	2008/0083234	04/10/2008	Krebs et al.	
	5	2016/0061474 (EFACT.010C2)	03/03/2016	Cheung et al.	

FOREIGN PATENT DOCUMENTS						
Examiner Initials	Cite No.	Foreign Patent Document <i>Country Code-Number-Kind Code</i> Example: JP 1234567 A1	Publication Date MM-DD-YYYY	Name	Pages, Columns, Lines Where Relevant Passages or Relevant Figures Appear	T <sup>1</sup>

NON PATENT LITERATURE DOCUMENTS			
Examiner Initials	Cite No.	Include name of the author (in CAPITAL LETTERS), title of the article (when appropriate), title of the item (book, magazine, journal, serial, symposium, catalog, etc.), date, page(s), volume-issue number(s), publisher, city and/or country where published.	T <sup>1</sup>
	6	Raji, "Smart Networks for Control", IEEE Spectrum, June 1994.	

22913753:ad  
031516

Examiner Signature /AJAY OJHA/ (02/07/2018)	Date Considered 02/07/2018
---	----------------------------

\*Examiner: Initial if reference considered, whether or not citation is in conformance with MPEP 609. Draw line through citation if not in conformance and not considered. Include copy of this form with next communication to applicant.

T<sup>1</sup> - Place a check mark in this area when an English language Translation is attached.

ALL REFERENCES CONSIDERED EXCEPT WHERE LINED THROUGH. /A.O./

**EAST Search History****EAST Search History (Prior Art)**

Ref #	Hits	Search Query	DBs	Default Operator	Plurals	Time Stamp
S1	149	((("STEINBERG") near3 ("John")).INV.	US-PGPUB; USPAT; USOCR	OR	ON	2018/02/07 09:39
S2	78	("EcoFactor").AS,AANM.	US-PGPUB; USPAT; USOCR; FPRS; EPO; IBM_TDB	OR	ON	2018/02/07 09:40
S3	46883	(F24F11/006; F24F11/70; F24F11/62; F24F11/30; G05B15/02; G06N7/005; G05D23/1902; F24F11/56; F24F2120/12; F24F2120/10; F24F11/63; F24F11/46; F24F2120/20; F24F2140/60; F24F2120/14).cpc.	US-PGPUB; USPAT; USOCR; FPRS; EPO; IBM_TDB	OR	ON	2018/02/07 10:02
S4	3	(S1 S2) AND (HVAC AND temperature AND user\$1 AND wireless).CLM.	US-PGPUB; USPAT; USOCR; FPRS; EPO; IBM_TDB	OR	ON	2018/02/07 10:03
S5	15	("9244470")	US-PGPUB; USPAT; USOCR; FPRS; EPO; IBM_TDB	OR	ON	2018/02/07 10:11
S6	9	("9244470")	USPAT	OR	ON	2018/02/07 10:12
S7	25	("20040117330"   "20090065596"   "20150025691"   "6700224"   "20130173064"   "20040133314"   "5348074"   "7869907"   "8850348"   "9057649"   "20140316581"   "20150120235"   "7206670"   "20130178985").PN.	US-PGPUB; USPAT; USOCR; FPRS; EPO; IBM_TDB	OR	ON	2018/02/07 18:05
S8	4	("20080281472" "20090065596")	US-PGPUB; USPAT; USOCR; FPRS; EPO; IBM_TDB	OR	ON	2018/02/07 18:12

**EAST Search History (Interference)**

&lt;This search history is empty&gt;

**2/13/2018 5:48:45 PM****C:\Users\aojha\Documents\EAST\Workspaces\15002791.wsp**



**Notice of References Cited**

Application/Control No.  
15/002,791

Applicant(s)/Patent Under  
Reexamination  
Steinberg, John Douglas

Examiner  
AJAY OJHA

Art Unit  
2824

Page 1 of 1

**U.S. PATENT DOCUMENTS**

*		Document Number Country Code-Number-Kind Code	Date MM-YYYY	Name	CPC Classification	US Classification
*	A	US-20090065596-A1	03-2009	Seem; John E.	F24F11/30	236/51
	B					
	C					
	D					
	E					
	F					
	G					
	H					
	I					
	J					
	K					
	L					
	M					

**FOREIGN PATENT DOCUMENTS**

*		Document Number Country Code-Number-Kind Code	Date MM-YYYY	Country	Name	CPC Classification
	N					
	O					
	P					
	Q					
	R					
	S					
	T					

**NON-PATENT DOCUMENTS**

*		Include as applicable: Author, Title Date, Publisher, Edition or Volume, Pertinent Pages)
	U	
	V	
	W	
	X	

\*A copy of this reference is not being furnished with this Office action. (See MPEP § 707.05(a).)  
Dates in MM-YYYY format are publication dates. Classifications may be US or foreign.



UNITED STATES PATENT AND TRADEMARK OFFICE

UNITED STATES DEPARTMENT OF COMMERCE
United States Patent and Trademark Office
Address: COMMISSIONER FOR PATENTS
P.O. Box 1450
Alexandria, Virginia 22313-1450
www.uspto.gov

Table with 5 columns: APPLICATION NO., FILING DATE, FIRST NAMED INVENTOR, ATTORNEY DOCKET NO., CONFIRMATION NO. Includes application details for 15/002,791 and associated examiner and notification information.

Please find below and/or attached an Office communication concerning this application or proceeding.

The time period for reply, if any, is set in the attached communication.

Notice of the Office communication was sent electronically on above-indicated "Notification Date" to the following e-mail address(es):

efiling@knobbe.com
jayna.cartee@knobbe.com



## DETAILED ACTION

### *General Remarks*

1. The present application is being examined under the pre-AIA first to invent provisions.
2. In the event the determination of the status of the application as subject to AIA 35 U.S.C. 102 and 103 (or as subject to pre-AIA 35 U.S.C. 102 and 103) is incorrect, any correction of the statutory basis for the rejection will not be considered a new ground of rejection if the prior art relied upon, and the rationale supporting the rejection, would be the same under either status.
3. When responding to this office action, applicants are advised to provide the examiner with line numbers and page numbers in the application and/or references cited to assist the examiner in locating appropriate paragraphs.
4. Per MPEP 2111 and 2111.01, the claims are given their broadest reasonable interpretation and the words of the claims are given their plain meaning consistent with the specification without importing claim limitations from the specification.
5. Applicants seeking an interview with the examiner, including **WebEx Video Conferencing**, are encouraged to fill out the online Automated Interview Request (AIR) form (<http://www.uspto.gov/patent/uspto-automated-interview-request-air-form.html>). See MPEP §502.03, §713.01(II) and Interview Practice for additional details.
6. Status of claim(s) *to be treated* in this office action:
  - a. Independent: 1 and 10.
  - b. Pending: 1-18.

### **IDS**

7. Applicant's IDS(s) submitted on 01/21/2016, 03/18/2016 and 01/19/2017

has/have been considered and made of record.

### **Double Patenting**

The nonstatutory double patenting rejection is based on a judicially created doctrine grounded in public policy (a policy reflected in the statute) so as to prevent the unjustified or improper timewise extension of the "right to exclude" granted by a patent and to prevent possible harassment by multiple assignees. A nonstatutory double patenting rejection is appropriate where the conflicting claims are not identical, but at least one examined application claim is not patentably distinct from the reference claim(s) because the examined application claim is either anticipated by, or would have been obvious over, the reference claim(s). See, e.g., *In re Berg*, 140 F.3d 1428, 46 USPQ2d 1226 (Fed. Cir. 1998); *In re Goodman*, 11 F.3d 1046, 29 USPQ2d 2010 (Fed. Cir. 1993); *In re Longi*, 759 F.2d 887, 225 USPQ 645 (Fed. Cir. 1985); *In re Van Ornum*, 686 F.2d 937, 214 USPQ 761 (CCPA 1982); *In re Vogel*, 422 F.2d 438, 164 USPQ 619 (CCPA 1970); *In re Thorington*, 418 F.2d 528, 163 USPQ 644 (CCPA 1969).

A timely filed terminal disclaimer in compliance with 37 CFR 1.321(c) or 1.321(d) may be used to overcome an actual or provisional rejection based on nonstatutory double patenting provided the reference application or patent either is shown to be commonly owned with the examined application, or claims an invention made as a result of activities undertaken within the scope of a joint research agreement. See MPEP § 717.02 for applications subject to examination under the first inventor to file provisions of the AIA as explained in MPEP § 2159. See MPEP §§ 706.02(I)(1) - 706.02(I)(3) for applications not subject to examination under the first inventor to file provisions of the AIA. A terminal disclaimer must be signed in compliance with 37 CFR 1.321(b).

The USPTO Internet website contains terminal disclaimer forms which may be used. Please visit [www.uspto.gov/patent/patents-forms](http://www.uspto.gov/patent/patents-forms). The filing date of the application in which the form is filed determines what form (e.g., PTO/SB/25, PTO/SB/26, PTO/AIA/25, or PTO/AIA/26) should be used. A web-based eTerminal Disclaimer may be filled out completely online using web-screens. An eTerminal Disclaimer that meets all requirements is auto-processed and approved immediately upon submission. For more information about eTerminal Disclaimers, refer to [www.uspto.gov/patents/process/file/efs/guidance/eTD-info-I.jsp](http://www.uspto.gov/patents/process/file/efs/guidance/eTD-info-I.jsp).

8. **Claims 1-18 rejected on the ground of nonstatutory double patenting as being unpatentable over claims 1-18 of U.S. Patent No. 9,244,470 (" '470 Patent").**

**Although the claims at issue are not identical, they are not patentably distinct from each other as disclosed in the table below.**

<b>Instant Application Claim(s)</b>	<b>'470 Patent Claim(s)</b>
<b>1. A method for varying temperature setpoints for an HVAC system comprising: storing at least a first</b>	<b>1. A method for varying temperature setpoints for a heating ventilation and air conditioning (HVAC) system</b>

**HVAC temperature setpoint and at least a second HVAC temperature setpoint; monitoring an activity status of at least one wireless device associated with one or more occupants of said structure, wherein said wireless device comprises a graphic user interface, wherein use of said wireless device comprises at least one of cursor movement, keystrokes or other user interface actions intended to alter a state of said wireless device; determining a probability that the specific activity status of said wireless device is associated with the use of said wireless device by a specific occupant or occupants of said structure; determining whether a current HVAC temperature setpoint associated with said HVAC system is set to said first HVAC temperature setpoint or said second temperature setpoint; prompting said one or more users, wherein said prompting sends a message to said wireless device recommending a change to said current HVAC temperature setpoint for said HVAC system; in response to said prompting, receiving input from said one or more users; and keeping said current HVAC temperature setpoint based upon said input from said one or more users.**

**comprising: storing at least a first HVAC temperature setpoint associated with a structure that is deemed to be non-occupied and at least a second HVAC temperature setpoint associated with said structure deemed to be occupied; monitoring an activity status of at least one wireless device associated with one or more occupants of said structure, wherein said wireless device comprises a graphic user interface, wherein use of said wireless device comprises at least one of cursor movement, keystrokes or other user interface actions intended to alter a state of said wireless device; determining a probability that specific audio and/or video content being reproduced by said wireless device is associated with the use of said wireless device by at least one specific occupant of said structure; determining whether a current HVAC temperature setpoint associated with said HVAC system is set to said first HVAC temperature setpoint or said second temperature setpoint; determining that said at least one specific occupant has previously indicated a preference that input be obtained before automatically changing said current HVAC temperature setpoint in response to said activity status; prompting said at least one specific occupant based on said determining that said input should be obtained, wherein said prompting sends a message to said wireless device recommending a change to said current HVAC temperature setpoint for said HVAC system; in response to said prompting, receiving said input from said at least one specific occupant; and keeping said current HVAC**

	<p><b>temperature setpoint based upon said input from said at least one specific occupant.</b></p>
<p>2-9</p>	<p>2-9</p>
<p><b>10. A system for altering the setpoint on a thermostat for space conditioning of a structure comprising: at least one thermostat having at least a first temperature setpoint and at least a second temperature setpoint; at least one wireless device associated with one or more occupants of said structure, wherein said wireless device comprises a graphic user interface, wherein use of said wireless device comprises at least one of cursor movement, keystrokes or other user interface actions intended to alter a state of said wireless device; an application comprising one or more computer processors that receives data regarding an activity status of said wireless device and whether said thermostat is set to said first temperature setpoint, said application determining a probability that the specific activity status of said wireless device is associated with the use of said wireless device by a specific occupant or occupants of said structure; said application prompting said one or more users wherein said application provides electronic notice to one or more of said users of said wireless device that said thermostat is set to one of said first temperature setpoint or said second temperature setpoint; and wherein said application in response to said prompting, receives input from said one or more users; and wherein said</b></p>	<p><b>10. A system for altering the setpoint on a thermostat for space conditioning of a structure comprising: at least one thermostat having at least a first temperature setpoint associated with a non-occupied structure, and at least a second temperature setpoint associated with the presence of one or more occupants in said structure; at least one wireless device associated with said one or more occupants of said structure, wherein said wireless device comprises a graphic user interface, wherein use of said wireless device comprises at least one of cursor movement, keystrokes or other user interface actions intended to alter a state of said wireless device; an application comprising one or more computer processors in communication with a storage medium comprising computer accessible memory, the application receives data regarding an activity status of said wireless device and whether said thermostat is set to said first temperature setpoint that indicates said structure is not occupied, said application determining a probability that specific audio and/or video content being reproduced by said wireless device is associated with the use of said wireless device by at least one specific occupant of said structure; said application determining that said at least one specific occupant has previously indicated a preference that input be</b></p>

<p><b>current temperature setpoint is set based upon said input from said one or more users.</b></p>	<p>obtained before automatically changing a current HVAC temperature setpoint in response to said activity status of said wireless device; <b>said application prompting said at least one specific occupant based on said determining that said input should be obtained, wherein said application provides electronic notice to said at least one specific occupant of said wireless device that said thermostat is set for a non-occupied structure and whether to keep said first temperature setpoint or change to said second temperature setpoint; and wherein said application in response to said prompting, receives said input from said at least one specific occupant; and wherein said current temperature setpoint is set based upon said input from said at least one specific occupant.</b></p>
11-18	11-18

This is a non-provisional double patenting rejection.

***Claim Rejections - 35 USC § 103***

9. The following is a quotation of pre-AIA 35 U.S.C. 103(a) which forms the basis for all obviousness rejections set forth in this Office action:

(a) A patent may not be obtained though the invention is not identically disclosed or described as set forth in section 102 of this title, if the differences between the subject matter sought to be patented and the prior art are such that the subject matter as a whole would have been obvious at the time the invention was made to a person having ordinary skill in the art to which said subject matter pertains. Patentability shall not be negated by the manner in which the invention was made.



10. **Claim(s) 1-18 is/are rejected under AIA 35 U.S.C. 103 as being unpatentable over US 2008/0281472 (hereinafter "Podgorny") in view of Seem et al. US 2009/0065596 (hereinafter "Seem").**

**Re: Independent Claim 1**, Podgorny discloses a method for varying temperature setpoints for an HVAC system (Podgorny abstract) comprising:

storing at least a first HVAC temperature setpoint (Podgorny ¶¶ [0092] and [0019] "user preferences stored" in occupied/non-occupied) and at least a second HVAC temperature setpoint (Podgorny ¶¶ [0009] and [0019] describe occupancy and non-occupancy and ¶ [0092] describe storing temperature setpoints and table 2 occupancy and high/low, min/max temperature setting fields);

monitoring an activity status of at least one wireless device (Podgorny FIG. 2 element 508 wireless device) associated with one or more occupants of said structure (Podgorny ¶ [0083] "detects the presence of the user in the Environmental Zone" which means monitoring an activity status of at least one wireless device associated with one or more occupants of said structure), wherein said wireless device comprises a graphic user interface (Podgorny ¶ [0027] "graphical user interface" and ¶¶ [0067], [0080]), wherein use of said wireless device comprises at least one of cursor movement, keystrokes or other user interface actions intended to alter a state of said wireless device (Podgorny ¶ [0083] "keyboard activity monitoring");

determining a probability that the specific activity status of said wireless device (Podgorny ¶ [0093] "identifying the person and transferring his/her environmental preferences to the proper cubicle, together with the person's VoIP phone number" and ¶

[0005]) is associated with the use of said wireless device by a specific occupant or occupants of said structure (Podgorny abstract "autonomous process control" is automatic and "occupancy sensor that recognizes the presence");

determining whether a current HVAC temperature setpoint associated with said HVAC system is set to said first HVAC temperature setpoint or said second temperature setpoint (Podgorny ¶ [0021] "maintain the environmental parameters temperature" which examiner interpreted that to maintain temperature it determine HVAC temperature setpoint associated with HVAC system and ¶¶ [0008], [0029]-[0030] and [0063]);

Podgorny fails to disclose:

prompting said one or more users, wherein said prompting sends a message to said wireless device recommending a change to said current HVAC temperature setpoint for said HVAC system;

in response to said prompting, receiving input from said one or more users; and keeping said current HVAC temperature setpoint based upon said input from said one or more users.

Seem discloses:

prompting said one or more users (Seem ¶ [0062] "user to specify any number of personal comfort settings" which means prompting said one or more users based on said determining that said one or more of said user's input should be obtained and ¶ [0065]), wherein said prompting sends a message to said wireless device recommending a change to said current HVAC temperature setpoint for said HVAC system (Seem Figs. 8-9 and ¶ [0065] "prompting by the user interface" which means

prompting sends a message to said wireless device recommending a change to said current HVAC temperature setpoint for said HVAC system);

in response to said prompting, receiving input from said one or more users (Seem ¶ [0065] "process 800 to adjust a building automation system setting" which means in response to said prompting, receiving input from said one or more users); and

keeping said current HVAC temperature setpoint based upon said input from said one or more users (Seem Fig. 11 element 1120 "adjust HVAC for normal conditions" which examiner interpreted as current setting based on the input from users and paragraph 0070).

Podgorny and Seem disclose home automation and HVAC control system. Seem discloses message communication to various wireless devices including personal wireless devices. It would have been obvious to a person of ordinary skill in the art before the effective filing date of the claimed invention, to modify the above HVAC control system, as taught by Podgorny, and incorporating the sending wireless messages, as taught by Seem in order to improve control of environmental conditions to reflecting individual preferences, as suggested by Seem (Seem ¶ [0003]).

**Re: Independent Claim 10**, Podgorny discloses a system for altering the setpoint on a thermostat for space conditioning of a structure (Podgorny Figs. 1 and 22) comprising:

at least one thermostat having at least a first temperature setpoint (Podgorny ¶¶ [0092] and [0019] "user preferences stored" in occupied/non-occupied) and at least a second temperature setpoint (Podgorny ¶¶ [0009] and [0019] describe occupancy and

non-occupancy and ¶ [0092] describe storing temperature setpoints and table 2 occupancy and high/low, min/max temperature setting fields);

at least one wireless device (Podgorny FIG. 2 element 508 wireless device) associated with one or more occupants of said structure (Podgorny ¶ [0083] "detects the presence of the user in the Environmental Zone" which means monitoring an activity status of at least one wireless device associated with one or more occupants of said structure), wherein said wireless device comprises a graphic user interface (Podgorny ¶ [0027] "graphical user interface" and ¶¶ [0067], [0080]), wherein use of said wireless device comprises at least one of cursor movement, keystrokes or other user interface actions intended to alter a state of said wireless device (Podgorny ¶ [0083] "keyboard activity monitoring");

an application comprising one or more computer processors that receives data regarding an activity status of said wireless device (Podgorny ¶ [0059] "status monitoring and data collection") and whether said thermostat is set to said first temperature setpoint (Podgorny ¶ [0089] "occupancy sensor shuts the system down when users are away from their workstations" which means thermostat is set to said first temperature setpoint that indicates said structure is not occupied and ¶¶ [0009] and [0019]), said application determining a probability that the specific activity status of said wireless device is associated with the use of said wireless device (Podgorny ¶ [0093] "identifying the person and transferring his/her environmental preferences to the proper cubicle, together with the person's VoIP phone number" and Podgorny ¶ [0005]) by a specific occupant or occupants of said structure (Podgorny abstract "autonomous process control" is automatic and "occupancy sensor that recognizes the presence");

Podgorny fails to disclose:

said application prompting said one or more users wherein said application provides electronic notice to one or more of said users of said wireless device that said thermostat is set to one of said first temperature setpoint or said second temperature setpoint; and

wherein said application in response to said prompting, receives input from said one or more users; and

wherein said current temperature setpoint is set based upon said input from said one or more users.

Seem discloses:

said application prompting said one or more users wherein said application provides electronic notice to one or more of said users of said wireless device that said thermostat (Podgorny ¶ [0062] “user to specify any number of personal comfort settings” which means prompting said one or more users based on said determining that said one or more of said user's input should be obtained and ¶ [0065]) is set to one of said first temperature setpoint or said second temperature setpoint (Podgorny Figs. 8-9 and ¶ [0065] “prompting by the user interface” which means prompting sends a message to said wireless device recommending a change to said current HVAC temperature setpoint for said HVAC system); and

wherein said application in response to said prompting, receives input from said one or more users (Podgorny ¶ [0065] “process 800 to adjust a building automation system setting” which means in response to said prompting, receiving input from said one or more users); and

wherein said current temperature setpoint is set based upon said input from said one or more users (Podgorny Fig. 11 element 1120 "adjust HVAC for normal conditions" which examiner interpreted as current setting based on the input from users and ¶ [0070]).

Podgorny and Seem disclose home automation and HVAC control system. Seem discloses message communication to various wireless devices including personal wireless devices. It would have been obvious to a person of ordinary skill in the art before the effective filing date of the claimed invention, to modify the above HVAC control system, as taught by Podgorny, and incorporating the sending wireless messages, as taught by Seem in order to improve control of environmental conditions to reflecting individual preferences, as suggested by Seem (Seem ¶ [0003]).

**Re: Claims 2 and 11,** Podgorny and Seem discloses all the limitations of claims 1 or 10 on which these claims depend. They further disclose:

wherein said wireless device is a remote control (Seem ¶ [0067] "remote control 1006 may be configured to wirelessly communicate" and Fig. 10 which means wireless device is a remote control and ¶ [0043] describes "portable wireless device 306" which is a wireless device and it is a remote control).

**Re: Claims 3 and 12,** Podgorny and Seem discloses all the limitations of claims 1 or 10 on which these claims depend. They further disclose:

wherein said wireless device is a wireless phone (Seem ¶ [0043] “cell phone, PDA, or any other device with transmitting capability”, here “cell phone is a wireless phone”, which means wireless device is a wireless phone).

**Re: Claims 4 and 13**, Podgorny and Seem discloses all the limitations of claims 3 or 12 on which these claims depend. They further disclose:

wherein said wireless phone is connected to a cellular network (Podgorny ¶ [0005] “ wireless converged networks” which means wireless phone is connected to a cellular network).

**Re: Claims 5 and 14**, Podgorny and Seem discloses all the limitations of claims 1 or 10 on which these claims depend. They further disclose:

wherein said wireless device is a tablet computer (Seem Figs. 2, 3 and ¶¶ [0029]-[0032], [0043] disclose multiple portable device, e.g. 104 construed as a tablet and 306)

**Re: Claims 6 and 15**, Podgorny and Seem discloses all the limitations of claims 1 or 10 on which these claims depend. They further disclose:

wherein said first and second HVAC temperature setpoints are stored in a database associated with a remote server (Seem ¶ [0008] “ server computer further includes a processing circuit for accessing a memory device storing the program code” and “program code for adjusting the building automation” which examiner interpreted that it a remote server and first and second HVAC temperature setpoints are stored in a database associated with the remote server and Fig. 2 element 130 is the “server”).

**Re: Claims 7 and 16,** Podgorny and Seem discloses all the limitations of claims 1 or 10 on which these claims depend. They further disclose:

in which said wireless device communicates with a remote server (Seem ¶ [0032] “140 configured to accept a signal or input from various portable wireless devices” and Fig. 2 shows that wireless devices are communicating with a server, element 130 of Fig. 2 is a “server” and elements 502, 506 and 508 of Fig. 2 are “wireless device”).

**Re: Claims 8 and 17,** Podgorny and Seem discloses all the limitations of claims 1 or 10 on which these claims depend. They further disclose:

further comprising adjusting said current HVAC temperature setpoint with a remote computer (Podgorny abstract, the user controlling "over the internet" at a remote computer and Seem at et. ¶ [0026], [0029] and Fig. 2 describe same limitations).

**Re: Claims 9 and 18,** Podgorny and Seem discloses all the limitations of claims 1 or 10 on which these claims depend. They further disclose:

in which said first HVAC temperature setpoint is varied automatically based on said input from said one or more users (Podgorny abstract" autonomous process control and interaction with system users", which means first HVAC temperature setpoint is varied automatically (autonomous) based on said input from one or more users).



### ***Conclusion***

11. Any inquiry concerning this communication or earlier communications from the examiner should be directed to AJAY OJHA whose telephone number is (571)272-8936. The examiner can normally be reached on M-F, 7:30AM to 5:00PM (EST).

If attempts to reach the examiner by telephone are unsuccessful, the examiner's supervisor, Richard Elms can be reached on 571-272-1869. The fax phone number for the organization where this application or proceeding is assigned is 571-273-8300.

12. Information regarding the status of an application may be obtained from the Patent Application Information Retrieval (PAIR) system. Status information for published applications may be obtained from either Private PAIR or Public PAIR. Status information for unpublished applications is available through Private PAIR only. For more information about the PAIR system, see <http://pair-direct.uspto.gov>. Should you have questions on access to the Private PAIR system, contact the Electronic Business Center (EBC) at 866-217-9197 (toll-free). If you would like assistance from a USPTO Customer Service Representative or access to the automated information system, call 800-786-9199 (IN USA OR CANADA) or 571-272-1000.

/AJAY OJHA/  
Examiner, Art Unit 2824  
[ajay.ojha@uspto.gov](mailto:ajay.ojha@uspto.gov)

<b><i>Index of Claims</i></b> 	<b>Application/Control No.</b> 15/002,791	<b>Applicant(s)/Patent Under Reexamination</b> Steinberg, John Douglas
	<b>Examiner</b> AJAY OJHA	<b>Art Unit</b> 2824

✓	<b>Rejected</b>
=	<b>Allowed</b>

-	<b>Cancelled</b>
÷	<b>Restricted</b>

N	<b>Non-Elected</b>
I	<b>Interference</b>

A	<b>Appeal</b>
O	<b>Objected</b>

CLAIMS									
<input type="checkbox"/> Claims renumbered in the same order as presented by applicant <input type="checkbox"/> CPA <input type="checkbox"/> T.D. <input type="checkbox"/> R.1.47									
CLAIM		DATE							
Final	Original	02/13/2018							
	1	✓							
	2	✓							
	3	✓							
	4	✓							
	5	✓							
	6	✓							
	7	✓							
	8	✓							
	9	✓							
	10	✓							
	11	✓							
	12	✓							
	13	✓							
	14	✓							
	15	✓							
	16	✓							
	17	✓							
	18	✓							

<b>INFORMATION DISCLOSURE STATEMENT BY APPLICANT</b>	Application No.	15/002791
	Filing Date	January 21, 2016
	First Named Inventor	John Douglas Steinberg
	Art Unit	3744
<i>(Multiple sheets used when necessary)</i>	Examiner	Unknown
SHEET 1 OF 2	Attorney Docket No.	EFACT.011C2

U.S. PATENT DOCUMENTS					
Examiner Initials	Cite No.	Document Number <i>Number - Kind Code (if known)</i> Example: 1,234,567 B1	Publication Date MM-DD-YYYY	Name	Pages, Columns, Lines Where Relevant Passages or Relevant Figures Appear
	1	4,451,879	05/29/1984	Welch et al.	
	2	4,675,828	06/23/1987	Winston	
	3	4,897,798	01/30/1990	Cler	
	4	5,279,458	01/18/1994	Dewolf et al.	
	5	7,590,469	09/15/2009	Grohman	
	6	8,428,782	04/23/2013	Imes	
	7	2004/0065095	04/08/2004	Osborne et al.	
	8	2009/0188985	07/30/2009	Scharing et al.	
	9	2012/0186774	07/26/2012	Matsuoka et al.	
	10	2014/0058567	02/27/2014	Matsuoka et al.	
	11	2015/0142180	05/21/2015	Matsuoka et al.	
	12	2016/0091219 (EFACT.007C2)	03/31/2016	Steinberg et al.	
	13	2016/0097557 (EFACT.013C4)	04/07/2016	Steinberg	
	14	2016/0238270	08/18/2016	Steinberg	
	15	2016/0258822	09/08/2016	Steinberg et al.	
	16	2016/0363337	12/15/2016	Steinberg et al.	

FOREIGN PATENT DOCUMENTS						
Examiner Initials	Cite No.	Foreign Patent Document <i>Country Code-Number-Kind Code</i> Example: JP 1234567 A1	Publication Date MM-DD-YYYY	Name	Pages, Columns, Lines Where Relevant Passages or Relevant Figures Appear	T <sup>1</sup>

NON PATENT LITERATURE DOCUMENTS			
Examiner Initials	Cite No.	Include name of the author (in CAPITAL LETTERS), title of the article (when appropriate), title of the item (book, magazine, journal, serial, symposium, catalog, etc.), date, page(s), volume-issue number(s), publisher, city and/or country where published.	T <sup>1</sup>
	17	CHENG et al., "Smart Sensors Enable Smart Air Conditioning Control", Sensors 2014, ISSN 1424-8220, June 24, 2014, 25 pages.	
	18	GUNES et al., "Improving Energy Efficiency and Thermal Comfort of Smart Buildings with HVAC Systems in the Presence of Sensor Faults", IEEE, August 24-26, 2015, 6 pages.	
	19	SIMMINI et al., Energy Efficient Control and Fault Detection for HVAC Systems, Univ. of Padova, XXVI Series, 2014, 144 pages.	

Examiner Signature	Date Considered
--------------------	-----------------

\***Examiner:** Initial if reference considered, whether or not citation is in conformance with MPEP 609. Draw line through citation if not in conformance and not considered. Include copy of this form with next communication to applicant.

T<sup>1</sup> - Place a check mark in this area when an English language Translation is attached.

0395  
**ALL REFERENCES CONSIDERED EXCEPT WHERE LINED THROUGH. /A.O./**

<b>INFORMATION DISCLOSURE STATEMENT BY APPLICANT</b>	Application No.	15/002791
	Filing Date	January 21, 2016
	First Named Inventor	John Douglas Steinberg
	Art Unit	3744
<i>(Multiple sheets used when necessary)</i>	Examiner	Unknown
SHEET 2 OF 2	Attorney Docket No.	EFACT.011C2

NON PATENT LITERATURE DOCUMENTS			
Examiner Initials	Cite No.	Include name of the author (in CAPITAL LETTERS), title of the article (when appropriate), title of the item (book, magazine, journal, serial, symposium, catalog, etc.), date, page(s), volume-issue number(s), publisher, city and/or country where published.	T <sup>1</sup>
	20	SKLAVOUNOS, "Detection of Abnormal Situations and Energy Efficiency Control in Heating Ventilation and Air Conditioning (HVAC) Systems", Brunel University thesis, September 2015, 151 pages.	
	21	Extended Search Report for European Application No. 13804057.1 dated June 1, 2016 (EFACT.014EP).	

25047481

Examiner Signature <b>/AJAY OJHA/ (02/07/2018)</b>	Date Considered <b>02/07/2018</b>
<p><b>*Examiner:</b> Initial if reference considered, whether or not citation is in conformance with MPEP 609. Draw line through citation if not in conformance and not considered. Include copy of this form with next communication to applicant.</p>	

T<sup>1</sup> - Place a check mark in this area when an English language Translation is attached.

0396

**ALL REFERENCES CONSIDERED EXCEPT WHERE LINED THROUGH. /A.O./**

PTO/SB/08 Equivalent

<b>INFORMATION DISCLOSURE STATEMENT BY APPLICANT</b>	Application No.	Unknown	
	Filing Date	Herewith	
	First Named Inventor	John Douglas Steinberg	
	Art Unit	Unknown	
(Multiple sheets used when necessary)		Examiner	Unknown
SHEET 1 OF 10		Attorney Docket No.	EFACT.011C2

U.S. PATENT DOCUMENTS					
Examiner Initials	Cite No.	Document Number Number - Kind Code (if known) Example: 1,234,567 B1	Publication Date MM-DD-YYYY	Name	Pages, Columns, Lines Where Relevant Passages or Relevant Figures Appear
	1	H2176	12/05/2006	Meyer et al.	
	2	12/805705	06/10/2010	Crabtree	
	3	13/470074	08/30/2012	Steinberg	
	4	13/523697	06/14/2012	Hublou et al.	
	5	13/725447	06/06/2013	Steinberg	
	6	13/729401	12/28/2012	Sloop	
	7	13/852577	03/28/2013	Steinberg et al.	
	8	13/858710	09/05/2013	Steinberg et al.	
	9	13/861189	04/11/2013	Steinberg et al.	
	10	14/082,675 (EFACT.007C1)	11/18/2003	Steinberg et al.	
	11	14/283,762	04/28/2014	Steinberg	
	12	14/285,384	05/22/2014	Steinberg, et al.	
	13	14/292,377	05/30/2014	Steinberg	
	14	14/491,554	09/19/2014	Steinberg	
	15	14/527,433	10/29/2014	Steinberg, et al.	
	16	14/731,221	06/04/2015	Steinberg, et al.	
	17	D 646,990	10/18/2011	Rhodes	
	18	D 659,560	05/15/2012	Rhodes	
	19	D 673,467	01/01/2013	Lee et al.	
	20	D 705,095 (EFACT.015DA)	05/20/2014	Steinberg et al.	
	21	4,136,732	01/30/1979	Demaray et al.	
	22	4,341,345	07/27/1982	Hammer et al.	
	23	4,403,644	09/13/1983	Hebert	
	24	4,475,685	10/09/1984	Grimado et al.	
	25	4,655,279	04/07/1987	Harmon	
	26	4,674,027	06/16/1987	Beckey	
	27	5,124,502	06/23/1992	Nelson et al.	
	28	5,244,146	09/14/1993	Jefferson et al.	

Examiner Signature	Date Considered
--------------------	-----------------

\*Examiner: Initial if reference considered, whether or not citation is in conformance with MPEP 609. Draw line through citation if not in conformance and not considered. Include copy of this form with next communication to applicant.

T<sup>1</sup> - Place a check mark in this area when an English language Translation is attached.

0397

**ALL REFERENCES CONSIDERED EXCEPT WHERE LINED THROUGH. /A.O./**

PTO/SB/08 Equivalent

<b>INFORMATION DISCLOSURE STATEMENT BY APPLICANT</b>	Application No.	Unknown	
	Filing Date	Herewith	
	First Named Inventor	John Douglas Steinberg	
	Art Unit	Unknown	
(Multiple sheets used when necessary)		Examiner	Unknown
SHEET 2 OF 10		Attorney Docket No.	EFACT.011C2

U.S. PATENT DOCUMENTS					
Examiner Initials	Cite No.	Document Number Number - Kind Code (if known) Example: 1,234,567 B1	Publication Date MM-DD-YYYY	Name	Pages, Columns, Lines Where Relevant Passages or Relevant Figures Appear
	29	5,270,952	12/14/1993	Adams et al.	
	30	5,314,004	05/24/1994	Strand et al.	
	31	5,348,078	09/20/1994	Dushane et al.	
	32	5,462,225	10/31/1995	Massara et al.	
	33	5,544,036	08/06/1996	Brown et al.	
	34	5,555,927	09/17/1996	Shah	
	35	5,572,438	11/05/1996	Ehlers et al.	
	36	5,682,949	11/04/1997	Ratcliffe et al.	
	37	5,717,609	02/10/1998	Packa et al.	
	38	5,725,148	03/10/1998	Hartman	
	39	5,729,474	03/17/1998	Hildebrand et al.	
	40	5,818,347	10/06/1998	Dolan et al.	
	41	5,977,964	11/02/1999	Williams et al.	
	42	6,079,626	06/27/2000	Hartman	
	43	6,115,713	09/05/2000	Pascucci et al.	
	44	6,145,751	11/14/2000	Ahmed	
	45	6,178,362	01/23/2001	Woolard et al.	
	46	6,260,765	07/17/2001	Natale et al.	
	47	6,241,156	06/05/2001	Kline et al.	
	48	6,351,693	02/26/2002	Monie	
	49	6,400,956	06/02/2002	Richton	
	50	6,400,996	06/04/2002	Hoffberg et al.	
	51	6,437,692	08/20/2002	Pelite et al.	
	52	6,478,233	11/12/2002	Shah	
	53	6,480,803	11/12/2002	Pierret et al.	
	54	6,483,906	11/19/2002	Lggulden et al.	
	55	6,536,675	03/25/2003	Pesko et al.	
	56	6,542,076	04/01/2003	Joao	
	57	6,549,130	04/15/2003	Joao	

Examiner Signature	Date Considered
--------------------	-----------------

\*Examiner: Initial if reference considered, whether or not citation is in conformance with MPEP 609. Draw line through citation if not in conformance and not considered. Include copy of this form with next communication to applicant.

T<sup>1</sup> - Place a check mark in this area when an English language Translation is attached.

ALL REFERENCES CONSIDERED EXCEPT WHERE LINED THROUGH. /A.O./

PTO/SB/08 Equivalent

<b>INFORMATION DISCLOSURE STATEMENT BY APPLICANT</b>	Application No.	Unknown	
	Filing Date	Herewith	
	First Named Inventor	John Douglas Steinberg	
	Art Unit	Unknown	
(Multiple sheets used when necessary)		Examiner	Unknown
SHEET 3 OF 10		Attorney Docket No.	EFACT.011C2

U.S. PATENT DOCUMENTS					
Examiner Initials	Cite No.	Document Number Number - Kind Code (if known) Example: 1,234,567 B1	Publication Date MM-DD-YYYY	Name	Pages, Columns, Lines Where Relevant Passages or Relevant Figures Appear
	58	6,574,537	06/02/2003	Kipersztok et al.	
	59	6,580,950	06/17/2003	Johnson	
	60	6,594,825	07/15/2003	Goldschmidtli et al.	
	61	6,595,430	07/22/2003	Shah	
	62	6,598,056	07/22/2003	Hull et al.	
	63	6,619,555	09/16/2003	Rosen	
	64	6,622,097	09/16/2003	Hunter	
	65	6,622,115	09/16/2003	Brown et al.	
	66	6,622,925	09/23/2003	Carner et al.	
	67	6,622,926	09/23/2003	Sartain et al.	
	68	6,628,997	09/30/2003	Fox et al.	
	69	6,633,823	10/14/2003	Bartone et al.	
	70	6,643,567	11/04/2003	Kolk et al.	
	71	6,644,098	11/11/2003	Cardinale et al.	
	72	6,671,586	12/30/2003	Davis et al.	
	73	6,695,218	02/24/2004	Fleckenstein	
	74	6,700,224	03/02/2004	Biskup, Sr.,	
	75	6,726,113	04/27/2004	Guo	
	76	6,731,992	05/04/2004	Ziegler	
	77	6,734,806	05/11/2004	Cratsley	
	78	6,772,052	08/03/2004	Amundsen	
	79	6,785,592	08/31/2004	Smith	
	80	6,785,630	08/31/2004	Kolk	
	81	6,786,421	09/07/2004	Rosen	
	82	6,789,739	09/14/2004	Rosen	
	83	6,853,959	02/08/2005	Ikeda et al.	
	84	6,868,293	03/15/2005	Schurr	
	85	6,868,319	03/15/2005	Kipersztok et al.	
	86	6,882,712	04/19/2005	Iggulden et al.	

Examiner Signature	Date Considered
<p><b>*Examiner:</b> Initial if reference considered, whether or not citation is in conformance with MPEP 609. Draw line through citation if not in conformance and not considered. Include copy of this form with next communication to applicant.</p>	

T<sup>1</sup> - Place a check mark in this area when an English language Translation is attached.

0399

**ALL REFERENCES CONSIDERED EXCEPT WHERE LINED THROUGH. /A.O./**

PTO/SB/08 Equivalent

<b>INFORMATION DISCLOSURE STATEMENT BY APPLICANT</b>	Application No.	Unknown	
	Filing Date	Herewith	
	First Named Inventor	John Douglas Steinberg	
	Art Unit	Unknown	
(Multiple sheets used when necessary)		Examiner	Unknown
SHEET 4 OF 10		Attorney Docket No.	EFACT.011C2

U.S. PATENT DOCUMENTS					
Examiner Initials	Cite No.	Document Number Number - Kind Code (if known) Example: 1,234,567 B1	Publication Date MM-DD-YYYY	Name	Pages, Columns, Lines Where Relevant Passages or Relevant Figures Appear
	87	6,889,908	05/10/2005	Crippen et al.	
	88	6,891,838	05/10/2005	Petite et al.	
	89	6,912,429	06/28/2005	Bilger	
	90	6,991,029	01/31/2006	Orfield et al.	
	91	7,009,493	03/07/2006	Howard	
	92	7,031,880	04/18/2006	Seem et al.	
	93	7,039,532	05/02/2006	Hunter	
	94	7,061,393	06/13/2006	Buckingham et al.	
	95	7,089,088	08/08/2006	Terry et al.	
	96	7,130,719	10/31/2006	Ehlers et al.	
	97	7,130,832	10/31/2006	Bannai et al.	
	98	7,167,079	01/23/2007	Smyth et al.	
	99	7,187,986	03/06/2007	Johnson et al.	
	100	7,205,892	04/17/2007	Luebke et al.	
	101	7,206,670	04/17/2007	Pimputkar, et al.	
	102	7,215,746	05/08/2007	Iggulden et al.	
	103	7,216,015	05/08/2007	Poth Robert J.	
	104	7,231,424	06/11/2007	Bodin et al.	
	105	7,232,075	06/19/2007	Rosen	
	106	7,242,988	07/10/2007	Hoffberg et al.	
	107	7,260,823	08/21/2007	Schlack et al.	
	108	7,356,384	04/08/2008	Gull et al.	
	109	7,476,020	01/13/2009	Zufferey et al.	
	110	7,483,964	01/27/2009	Jackson et al.	
	111	7,644,869	01/12/2010	Hoglund et al.	
	112	7,702,424	04/20/2010	Cannon et al.	
	113	7,758,729	07/20/2010	DeWhitt	
	114	7,784,704	08/31/2010	Harter	
	115	7,848,900 (EFACT.005A)	12/07/2010	Steinberg et al.	

Examiner Signature	Date Considered
--------------------	-----------------

\*Examiner: Initial if reference considered, whether or not citation is in conformance with MPEP 609. Draw line through citation if not in conformance and not considered. Include copy of this form with next communication to applicant.

T<sup>1</sup> - Place a check mark in this area when an English language Translation is attached.

ALL REFERENCES CONSIDERED EXCEPT WHERE LINED THROUGH. /A.O./



PTO/SB/08 Equivalent

<b>INFORMATION DISCLOSURE STATEMENT BY APPLICANT</b>	Application No.	Unknown	
	Filing Date	Herewith	
	First Named Inventor	John Douglas Steinberg	
	Art Unit	Unknown	
(Multiple sheets used when necessary)		Examiner	Unknown
SHEET 5 OF 10		Attorney Docket No.	EFACT.011C2

U.S. PATENT DOCUMENTS					
Examiner Initials	Cite No.	Document Number Number - Kind Code (if known) Example: 1,234,567 B1	Publication Date MM-DD-YYYY	Name	Pages, Columns, Lines Where Relevant Passages or Relevant Figures Appear
	116	7,869,904	01/11/2011	Cannon et al.	
	117	7,894,943	02/22/2011	Sloup et al.	
	118	7,908,116 (EFACT.004A)	03/15/2011	Steinberg et al.	
	119	7,908,117 (EFACT.003A)	03/15/2011	Steinberg et al.	
	120	8,010,237 (EFACT.010A)	08/30/2011	Cheung Leo et al.	
	121	8,019,567 (EFACT.006A)	09/13/2011	Steinberg et al.	
	122	8,090,477 (EFACT.013A)	01/03/2012	Steinberg	
	123	8,131,497 (EFACT.005C1)	03/06/2012	Steinberg et al.	
	124	8,131,506 (EFACT.004C1)	03/06/2012	Steinberg et al.	
	125	8,180,492 (EFACT.011A)	05/15/2012	Steinberg	
	126	8,340,826 (EFACT.013C1)	12/25/2012	Steinberg et al.	
	127	8,412,488 (EFACT.004C2)	04/02/2013	Steinberg et al.	
	128	8,423,322 (EFACT.006C1)	04/16/2013	Steinberg et al.	
	129	8,428,785	04/23/2013	Boucher et al.	
	130	8,457,797	06/04/2013	Imes et al.	
	131	8,498,753 (EFACT.009A)	07/30/2013	Steinberg et al.	
	132	8,556,188 (EFACT.012A)	10/15/2013	Steinberg	
	133	8,596,550 (EFACT.007A)	12/03/2013	Steinberg et al.	
	134	8,712,590 (EFACT.013C2)	04/29/2014	Steinberg	
	135	8,738,327 (EFACT.004C3)	05/27/2014	Steinberg, et al.	
	136	8,740,100 (EFACT.008A)	06/03/2014	Steinberg	
	137	8,751,186 (EFACT.005C3)	06/10/2014	Steinberg, et al.	
	138	8,840,033 (EFACT.012C1)	09/23/2014	Steinberg	
	139	8,850,348	09/30/2014	Fadell et al.	

Examiner Signature	Date Considered
--------------------	-----------------

\*Examiner: Initial if reference considered, whether or not citation is in conformance with MPEP 609. Draw line through citation if not in conformance and not considered. Include copy of this form with next communication to applicant.

T<sup>1</sup> - Place a check mark in this area when an English language Translation is attached.

ALL REFERENCES CONSIDERED EXCEPT WHERE LINED THROUGH. /A.O./

PTO/SB/08 Equivalent

<b>INFORMATION DISCLOSURE STATEMENT BY APPLICANT</b>	Application No.	Unknown	
	Filing Date	Herewith	
	First Named Inventor	John Douglas Steinberg	
	Art Unit	Unknown	
(Multiple sheets used when necessary)		Examiner	Unknown
SHEET 6 OF 10		Attorney Docket No.	EFACT.011C2

U.S. PATENT DOCUMENTS					
Examiner Initials	Cite No.	Document Number Number - Kind Code (if known) Example: 1,234,567 B1	Publication Date MM-DD-YYYY	Name	Pages, Columns, Lines Where Relevant Passages or Relevant Figures Appear
	140	8,886,488 (EFACT.006C2)	11/11/2014	Steinberg, et al.	
	141	9,057,649 (EFACT.006C2)	06/16/2015	Steinberg, et al.	
	142	9,134,710 (EFACT.010C1)	09/15/2015	Cheung et al.	
	143	9,194,597 (EFACT.007C1)	11/24/2015	Steinberg, et al.	
	144	2003/0040934	02/27/2003	Skidmore et al.	
	145	2004/0176880	09/09/2004	Obradovich et al.	
	146	2005/0222889	10/06/2005	Lai et al.	
	147	2005/0288822	12/29/2005	Rayburn	
	148	2006/0045105	03/02/2006	Dobosz et al.	
	149	2006/0214014	09/28/2006	Bash et al.	
	150	2007/0043477	02/22/2007	Elhers et al.	
	151	2007/0045431	03/03/2007	Chapman et al.	
	152	2007/0146126	06/28/2007	Wang	
	153	2008/0083234	04/10/2008	Krebs et al.	
	154	2008/0198549	08/21/2008	Rasmussen et al.	
	155	2008/0281472	11/13/2008	Podgorny et al.	
	156	2009/0052859	02/26/2009	Greenberger et al.	
	157	2009/0099699	04/16/2009	Steinberg et al.	
	158	2009/0125151	05/14/2009	Steinberg et al.	
	159	2009/0240381	09/24/2009	Lane	
	160	2009/0281667	11/12/2009	Masui et al.	
	161	2010/0019052	01/28/2010	Yip	
	162	2010/0070086	03/18/2010	Harrod et al.	
	163	2010/0070089	03/18/2010	Harrod et al.	
	164	2010/0070093	03/18/2010	Harrod et al.	
	165	2010/0156608	06/24/2010	BAE et al.	
	166	2010/0162285	06/24/2010	Cohen et al.	
	167	2010/0211224	08/19/2010	Keeling et al.	

Examiner Signature	Date Considered
--------------------	-----------------

\*Examiner: Initial if reference considered, whether or not citation is in conformance with MPEP 609. Draw line through citation if not in conformance and not considered. Include copy of this form with next communication to applicant.

T<sup>1</sup> - Place a check mark in this area when an English language Translation is attached.

ALL REFERENCES CONSIDERED EXCEPT WHERE LINED THROUGH. /A.O./

PTO/SB/08 Equivalent

<b>INFORMATION DISCLOSURE STATEMENT BY APPLICANT</b>	Application No.	Unknown	
	Filing Date	Herewith	
	First Named Inventor	John Douglas Steinberg	
	Art Unit	Unknown	
<i>(Multiple sheets used when necessary)</i>		Examiner	Unknown
SHEET 7 OF 10		Attorney Docket No.	EFACT.011C2

U.S. PATENT DOCUMENTS					
Examiner Initials	Cite No.	Document Number Number - Kind Code (if known) Example: 1,234,567 B1	Publication Date MM-DD-YYYY	Name	Pages, Columns, Lines Where Relevant Passages or Relevant Figures Appear
	168	2010/0235004	09/16/2010	Thind	
	169	2010/0289643	11/18/2010	Trundle et al.	
	170	2010/0318227	12/16/2010	Steinberg et al.	
	171	2011/0031323	02/10/2011	Nold et al.	
	172	2011/0046792	02/24/2011	Imes et al.	
	173	2011/0046798	02/24/2011	Imes et al.	
	174	2011/0046799	02/24/2011	Imes et al.	
	175	2011/0046800	02/24/2011	Imes et al.	
	176	2011/0046801	02/24/2011	Imes et al.	
	177	2011/0051823	03/03/2011	Imes et al.	
	178	2011/0054699	03/03/2011	Imes et al.	
	179	2011/0054710	03/03/2011	Imes et al.	
	180	2011/0173542	07/14/2011	Imes et al.	
	181	2011/0202185	08/18/2011	Imes et al.	
	182	2011/0214060	09/01/2011	Imes et al.	
	183	2011/0224838	09/15/2011	Imes et al.	
	184	2011/0246898	10/06/2011	Imes et al.	
	185	2011/0253796	10/20/2011	Posa et al.	
	186	2011/0290893	12/01/2011	Steinberg	
	187	2011/0307101	12/15/2011	Imes et al.	
	188	2012/0023225	01/26/2012	Imes et al.	
	189	2012/0046859	02/23/2012	Imes et al.	
	190	2012/0064923	03/15/2012	Imes et al.	
	191	2012/0065935	03/15/2012	Steinberg et al.	
	192	2012/0072033	03/22/2012	Imes et al.	
	193	2012/0086562	04/12/2012	Steinberg	
	194	2012/0093141	04/19/2012	Imes et al.	
	195	2012/0101637	04/26/2012	Imes et al.	
	196	2012/0135759	05/31/2012	Imes et al.	

Examiner Signature	Date Considered
--------------------	-----------------

\*Examiner: Initial if reference considered, whether or not citation is in conformance with MPEP 609. Draw line through citation if not in conformance and not considered. Include copy of this form with next communication to applicant.

T<sup>1</sup> - Place a check mark in this area when an English language Translation is attached.

ALL REFERENCES CONSIDERED EXCEPT WHERE LINED THROUGH. /A.O./

PTO/SB/08 Equivalent

<b>INFORMATION DISCLOSURE STATEMENT BY APPLICANT</b>	Application No.	Unknown	
	Filing Date	Herewith	
	First Named Inventor	John Douglas Steinberg	
	Art Unit	Unknown	
<i>(Multiple sheets used when necessary)</i>		Examiner	Unknown
SHEET 8 OF 10		Attorney Docket No.	EFACT.011C2

U.S. PATENT DOCUMENTS					
Examiner Initials	Cite No.	Document Number Number - Kind Code (if known) Example: 1,234,567 B1	Publication Date MM-DD-YYYY	Name	Pages, Columns, Lines Where Relevant Passages or Relevant Figures Appear
	197	2012/0215725	08/23/2012	Imes et al.	
	198	2012/0221151 (EFACT.011C1)	08/30/2012	Steinberg	
	199	2012/0221718	08/30/2012	Imes et al.	
	200	2012/0252430	10/04/2012	Imes et al.	
	201	2012/0324119	12/20/2012	Imes et al.	
	202	2013/0053054	02/28/2013	Lovitt et al.	
	203	2013/0054758	02/28/2013	Imes et al.	
	204	2013/0054863	02/28/2013	Imes et al.	
	205	2013/0060387	03/07/2013	Imes et al.	
	206	2013/0144453	06/06/2013	Subbloie	
	207	2013/0167035	06/27/2013	Imes et al.	
	208	2013/0173064	07/04/2013	Fadell et al.	
	209	2013/0178985	07/11/2013	Lombard et al.	
	210	2013/0226502 (EFACT.006C2)	08/29/2013	Steinberg, et al.	
	211	2013/0310989 (EFACT.009C1)	11/21/2013	Steinberg et al.	
	212	2013/0338837 (EFACT.014A)	12/19/2013	Hublou et al.	
	213	2014/0039690 (EFACT.012C1)	02/06/2014	Steinberg	
	214	2014/0229018 (EFACT.013C3)	08/20/2014	Steinberg	
	215	2014/0316581	10/26/2014	Fadell et al.	
	216	2015/0021405 (EFACT.008C1)	01/22/2015	Steinberg	
	217	2015/0025691	01/22/2015	Fadell et al.	
	218	2015/0043615 (EFACT.004C4)	02/12/2015	Steinberg et al.	
	219	2015/0120235 (EFACT.005C4)	04/30/2015	Steinberg et al.	
	220	2015/0168001 (EFACT.012C2)	06/18/2015	Steinberg	

Examiner Signature	Date Considered
<p><b>*Examiner:</b> Initial if reference considered, whether or not citation is in conformance with MPEP 609. Draw line through citation if not in conformance and not considered. Include copy of this form with next communication to applicant.</p>	

T<sup>1</sup> - Place a check mark in this area when an English language Translation is attached.

ALL REFERENCES CONSIDERED EXCEPT WHERE LINED THROUGH. /A.O./

PTO/SB/08 Equivalent

<b>INFORMATION DISCLOSURE STATEMENT BY APPLICANT</b>	Application No.	Unknown	
	Filing Date	Herewith	
	First Named Inventor	John Douglas Steinberg	
	Art Unit	Unknown	
(Multiple sheets used when necessary)		Examiner	Unknown
SHEET 9 OF 10		Attorney Docket No.	EFACT.011C2

**FOREIGN PATENT DOCUMENTS**

Examiner Initials	Cite No.	Foreign Patent Document Country Code-Number-Kind Code Example: JP 1234567 A1	Publication Date MM-DD-YYYY	Name	Pages, Columns, Lines Where Relevant Passages or Relevant Figures Appear	T <sup>1</sup>
	221	EP 0415747 A2	03/06/1991	Shaw et al.		
	222	JP 05-189659	07/30/1993	Hitachi Bill Shisetsu Eng. KK.		
	223	JP 2010-038377	02/18/2010	Mitsubishi Heavy Ind. Ltd.		
	224	JP 2010-286218	12/24/2010	Mitsubishi Heavy Ind. Ltd.		
	225	KR 10-1994-0011902	06/22/1994	Koryo Digital Elect. Co.		
	226	KR 10-1999-0070368	09/15/1999	Samsung Electronics Co. Ltd.		
	227	KR 10-2000-0059532	10/05/2000	Dang Hae System Co.		
	228	WO 2005/098331 A1	10/20/2005	Zip Ind Aust Pty Ltd.		
	229	WO 2011/149600 (EFACT.012WO)	12/01/2011	EcoFactor, Inc.		
	230	WO 2012/024534 (EFACT.013WO)	02/23/2012	EcoFactor, Inc.		
	231	WO 2013/187996	12/19/2013	EcoFactor, Inc.		

**NON PATENT LITERATURE DOCUMENTS**

Examiner Initials	Cite No.	Include name of the author (in CAPITAL LETTERS), title of the article (when appropriate), title of the item (book, magazine, journal, serial, symposium, catalog, etc.), date, page(s), volume-issue number(s), publisher, city and/or country where published.	T <sup>1</sup>
	232	ARENS, et al., "How Ambient Intelligence Will Improve Habitability and Energy Efficiency in Buildings", 2005, research paper, Center for the Built Environment, Controls and Information Technology.	
	233	Bourhan, et al., "Cynamic model of an HVAC system for control analysis", Elsevier 2004.	
	234	Brush, et al., Preheat - Controlling Home Heating with Occupancy Prediction, 2013.	
	235	Comverge SuperStat Flyer, prior to June 28, 2007.	
	236	Control4 Wireless Thermostat Brochure, 2006.	
	237	Cooper Power Systems Web Page, 2000-2009.	
	238	Emerson Climate Technologies, "Network Thermostat for E2 Building Controller Installation and Operation Manual", 2007.	
	239	Enernoc Web Page, 2004-2009.	

Examiner Signature	Date Considered
<p>*Examiner: Initial if reference considered, whether or not citation is in conformance with MPEP 609. Draw line through citation if not in conformance and not considered. Include copy of this form with next communication to applicant.</p>	

T<sup>1</sup> - Place a check mark in this area when an English language Translation is attached.

**ALL REFERENCES CONSIDERED EXCEPT WHERE LINED THROUGH. /A.O./**

<b>INFORMATION DISCLOSURE STATEMENT BY APPLICANT</b>	Application No.	Unknown
	Filing Date	Herewith
	First Named Inventor	John Douglas Steinberg
	Art Unit	Unknown
<i>(Multiple sheets used when necessary)</i>	Examiner	Unknown
SHEET 10 OF 10	Attorney Docket No.	EFACT.011C2

NON PATENT LITERATURE DOCUMENTS			
Examiner initials	Cite No.	Include name of the author (in CAPITAL LETTERS), title of the article (when appropriate), title of the item (book, magazine, journal, serial, symposium, catalog, etc.), date, page(s), volume-issue number(s), publisher, city and/or country where published.	T <sup>1</sup>
	240	Enerwise Website, 1999-2009.	
	241	Gupta, Adding GPS-Control to Traditional Thermostats: An Exploration of Potential Energy Savings and Design Challenges, MIT, 2009.	
	242	Gupta, et al., A Persuasive GPS-Controlled Thermostat System, MIT, 2008.	
	243	Honeywell Programmable Thermostat Owner's Guide, www.honeywell.com/yourhome, 2004.	
	244	Honeywell, "W7600/W7620 Controller Reference Manual, HW0021207, October, 1992.	
	245	Johnson Controls, "T600HCx-3 Single-Stage Thermostats", 2006.	
	246	JOHNSON CONTROLS, Touch4 building automation system brochure, 2007.	
	247	KILICOTTE, et al., "Dynamic Controls for Energy Efficiency and Demand Response: Framework Concepts and a New Construction Study Case in New York", Proceedings of the 2006 ACEEE Summer Study of Energy Efficiency in Buildings, Pacific Grove, CA, August 13-18, 2006	
	248	Krumm, et al., Learning Time-Based Presence Probabilities, June 2011.	
	249	LIN, et al., "Multi-Sensor Single-Actuator Control of HVAC Systems", 2002.	
	250	PIER, Southern California Edison, Demand Responsive Control of Air Conditioning via Programmable Communicating Thermostats Draft Report, February 14, 2006.	
	251	Proliphix Thermostat Brochure, prior to June 2007.	
	252	Scott, et al., Home Heating Using GPS-Based Arrival Prediction, 2010.	
	253	WANG, et al., "Opportunities to Save Energy and Improve Comfort by Using Wireless Sensor Networks in Buildings," (2003), Center for Environmental Design Research.	
	254	WETTER, et al., A comparison of deterministic and probabilistic optimization algorithms for nonsmooth simulation-based optimization, Building and Environment 39, 2004, Pages 989-999.	
	255	International Search Report and Written Opinion for PCT/US2013/035726 (EFACT.014WO), dated 08/06/2013.	
	256	Written Opinion and Search Report for PCT/US2011/032537, dated 12/12/11 (our reference EFACT.012WO).	
	257	International Preliminary Report on Patentability in PCT/US2013/035726 dated 12/16/2014 (EFACT.014WO).	

22519965:ad  
012116

Examiner Signature <b>/AJAY OJHA/ (02/07/2018)</b>	Date Considered <b>02/07/2018</b>
*Examiner: Initial if reference considered, whether or not citation is in conformance with MPEP 609. Draw line through citation if not in conformance and not considered. Include copy of this form with next communication to applicant.	

T<sup>1</sup> - Place a check mark in this area when an English language Translation is attached.

0406

**ALL REFERENCES CONSIDERED EXCEPT WHERE LINED THROUGH. /A.O./**

**RESPONSE TO INFORMATIONAL NOTICE**

First Inventor	: John Douglas Steinberg
App. No.	: 15/002,791
Filed	: January 21, 2016
For	: SYSTEM AND METHOD FOR USING A WIRELESS DEVICE AS A SENSOR FOR AN ENERGY MANAGEMENT SYSTEM
Art Unit	: 3744
Conf No.	: 4939

**Commissioner for Patents  
P.O. Box 1450  
Alexandria, VA 22313-1450**

Dear Sir:

The above-captioned application was filed without a Declaration and/or Substitute Statement. Enclosed in compliance with 37 CFR 1.53(f) are the following.

- (X) Declaration for:  
    John Douglas Steinberg
- (X) Information Disclosure Statement.

Dated: January 19, 2017

By: John R. King/  
John R. King  
Registration No. 34,362  
Attorney of Record  
Customer No. 20,995  
(949) 760-0404

25047624

Under the Paperwork Reduction Act of 1995, no persons are required to respond to a collection of information unless it displays a valid OMB control number.

**DECLARATION (37 CFR 1.63) FOR UTILITY OR DESIGN APPLICATION USING AN APPLICATION DATA SHEET (37 CFR 1.76)**

<b>Title of Invention</b>	<b>SYSTEM AND METHOD FOR USING A WIRELESS DEVICE AS A SENSOR FOR AN ENERGY MANAGEMENT SYSTEM</b>
---------------------------	--

As the below named inventor, I hereby declare that:

This declaration is directed to:  The attached application, or  
 United States application or PCT international application number 15/002791  
filed on January 21, 2016

The above-identified application was made or authorized to be made by me.

I believe that I am the original inventor or an original joint inventor of a claimed invention in the application.

I hereby acknowledge that any willful false statement made in this declaration is punishable under 18 U.S.C. 1001 by fine or imprisonment of not more than five (5) years, or both.

**WARNING:**

Petitioner/applicant is cautioned to avoid submitting personal information in documents filed in a patent application that may contribute to identity theft. Personal information such as social security numbers, bank account numbers, or credit card numbers (other than a check or credit card authorization form PTO-2038 submitted for payment purposes) is never required by the USPTO to support a petition or an application. If this type of personal information is included in documents submitted to the USPTO, petitioners/applicants should consider redacting such personal information from the documents before submitting them to the USPTO. Petitioner/applicant is advised that the record of a patent application is available to the public after publication of the application (unless a non-publication request in compliance with 37 CFR 1.213(a) is made in the application) or issuance of a patent. Furthermore, the record from an abandoned application may also be available to the public if the application is referenced in a published application or an issued patent (see 37 CFR 1.14). Checks and credit card authorization forms PTO-2038 submitted for payment purposes are not retained in the application file and therefore are not publicly available.

LEGAL NAME OF INVENTOR

Inventor: John Douglas Steinberg Date (Optional): \_\_\_\_\_

Signature: 

Note: An application data sheet (PTO/SB/14 or equivalent), including naming the entire inventive entity, must accompany this form or must have been previously filed. Use an additional PTO/AIA/01 form for each additional inventor.

This collection of information is required by 35 U.S.C. 115 and 37 CFR 1.63. The information is required to obtain or retain a benefit by the public which is to file (and by the USPTO to process) an application. Confidentiality is governed by 35 U.S.C. 122 and 37 CFR 1.11 and 1.14. This collection is estimated to take 1 minute to complete, including gathering, preparing, and submitting the completed application form to the USPTO. Time will vary depending upon the individual case. Any comments on the amount of time you require to complete this form and/or suggestions for reducing this burden, should be sent to the Chief Information Officer, U.S. Patent and Trademark Office, U.S. Department of Commerce, P.O. Box 1450, Alexandria, VA 22313-1450. DO NOT SEND FEES OR COMPLETED FORMS TO THIS ADDRESS. SEND TO: Commissioner for Patents, P.O. Box 1450, Alexandria, VA 22313-1450.

If you need assistance in completing the form, call 1-800-PTO-9199 and select option 2.



**INFORMATION DISCLOSURE STATEMENT**

First Inventor : John Douglas Steinberg  
App. No. : 15/002,791  
Filed : January 21, 2016  
For : SYSTEM AND METHOD FOR USING A WIRELESS DEVICE AS A  
SENSOR FOR AN ENERGY MANAGEMENT SYSTEM  
Examiner : Unknown  
Art Unit : 3744  
Conf. No. : 4939

Commissioner for Patents  
P.O. Box 1450  
Alexandria, VA 22313-1450

**References and Listing**

Pursuant to 37 CFR 1.56, an Information Disclosure Statement listing references is provided herewith. Copies of any listed foreign and non-patent literature references are being submitted.

**No Disclaimers**

To the extent that anything in the Information Disclosure Statement or the listed references could be construed as a disclaimer of any subject matter supported by the present application, Applicant hereby rescinds and retracts such disclaimer.

**Timing of Disclosure**

This Information Disclosure Statement is being filed before the receipt of a First Office Action on the merits, and presumably no fee is required. If a First Office Action on the merits was mailed before the mailing date of this Statement, the Commissioner is authorized to charge the fee set forth in 37 CFR 1.17(p) to Deposit Account No. 11-1410.

Respectfully submitted,  
KNOBBE, MARTENS, OLSON & BEAR, LLP

Dated: January 19, 2017

By: John R. King/  
John R. King  
Registration No. 34,362  
Attorney of Record  
Customer No. 20,995  
(949) 760-0404

<b>INFORMATION DISCLOSURE STATEMENT BY APPLICANT</b>	Application No.	15/002791
	Filing Date	January 21, 2016
	First Named Inventor	John Douglas Steinberg
	Art Unit	3744
<i>(Multiple sheets used when necessary)</i>	Examiner	Unknown
SHEET 1 OF 2	Attorney Docket No.	EFACT.011C2

<b>U.S. PATENT DOCUMENTS</b>					
Examiner Initials	Cite No.	Document Number <i>Number - Kind Code (if known)</i> Example: 1,234,567 B1	Publication Date MM-DD-YYYY	Name	Pages, Columns, Lines Where Relevant Passages or Relevant Figures Appear
	1	4,451,879	05/29/1984	Welch et al.	
	2	4,675,828	06/23/1987	Winston	
	3	4,897,798	01/30/1990	Cler	
	4	5,279,458	01/18/1994	Dewolf et al.	
	5	7,590,469	09/15/2009	Grohman	
	6	8,428,782	04/23/2013	Imes	
	7	2004/0065095	04/08/2004	Osborne et al.	
	8	2009/0188985	07/30/2009	Scharing et al.	
	9	2012/0186774	07/26/2012	Matsuoka et al.	
	10	2014/0058567	02/27/2014	Matsuoka et al.	
	11	2015/0142180	05/21/2015	Matsuoka et al.	
	12	2016/0091219 (EFACT.007C2)	03/31/2016	Steinberg et al.	
	13	2016/0097557 (EFACT.013C4)	04/07/2016	Steinberg	
	14	2016/0238270	08/18/2016	Steinberg	
	15	2016/0258822	09/08/2016	Steinberg et al.	
	16	2016/0363337	12/15/2016	Steinberg et al.	

<b>FOREIGN PATENT DOCUMENTS</b>						
Examiner Initials	Cite No.	Foreign Patent Document <i>Country Code-Number-Kind Code</i> Example: JP 1234567 A1	Publication Date MM-DD-YYYY	Name	Pages, Columns, Lines Where Relevant Passages or Relevant Figures Appear	T <sup>1</sup>

<b>NON PATENT LITERATURE DOCUMENTS</b>			
Examiner Initials	Cite No.	Include name of the author (in CAPITAL LETTERS), title of the article (when appropriate), title of the item (book, magazine, journal, serial, symposium, catalog, etc.), date, page(s), volume-issue number(s), publisher, city and/or country where published.	T <sup>1</sup>
	17	CHENG et al., "Smart Sensors Enable Smart Air Conditioning Control", Sensors 2014, ISSN 1424-8220, June 24, 2014, 25 pages.	
	18	GUNES et al., "Improving Energy Efficiency and Thermal Comfort of Smart Buildings with HVAC Systems in the Presence of Sensor Faults", IEEE, August 24-26, 2015, 6 pages.	
	19	SIMMINI et al., Energy Efficient Control and Fault Detection for HVAC Systems, Univ. of Padova, XXVI Series, 2014, 144 pages.	

Examiner Signature	Date Considered
* <b>Examiner:</b> Initial if reference considered, whether or not citation is in conformance with MPEP 609. Draw line through citation if not in conformance and not considered. Include copy of this form with next communication to applicant.	

T<sup>1</sup> - Place a check mark in this area when an English language Translation is attached.

<b>INFORMATION DISCLOSURE STATEMENT BY APPLICANT</b>	Application No.	15/002791
	Filing Date	January 21, 2016
	First Named Inventor	John Douglas Steinberg
	Art Unit	3744
<i>(Multiple sheets used when necessary)</i>	Examiner	Unknown
SHEET 2 OF 2	Attorney Docket No.	EFACT.011C2

**NON PATENT LITERATURE DOCUMENTS**

Examiner Initials	Cite No.	Include name of the author (in CAPITAL LETTERS), title of the article (when appropriate), title of the item (book, magazine, journal, serial, symposium, catalog, etc.), date, page(s), volume-issue number(s), publisher, city and/or country where published.	T <sup>1</sup>
	<b>20</b>	SKLAVOUNOS, "Detection of Abnormal Situations and Energy Efficiency Control in Heating Ventilation and Air Conditioning (HVAC) Systems", Brunel University thesis, September 2015, 151 pages.	
	<b>21</b>	Extended Search Report for European Application No. 13804057.1 dated June 1, 2016 (EFACT.014EP).	

25047481

Examiner Signature	Date Considered
<p><b>*Examiner:</b> Initial if reference considered, whether or not citation is in conformance with MPEP 609. Draw line through citation if not in conformance and not considered. Include copy of this form with next communication to applicant.</p>	

T<sup>1</sup> - Place a check mark in this area when an English language Translation is attached.

## Electronic Acknowledgement Receipt

<b>EFS ID:</b>	28106285
<b>Application Number:</b>	15002791
<b>International Application Number:</b>	
<b>Confirmation Number:</b>	4939
<b>Title of Invention:</b>	SYSTEM AND METHOD FOR USING A WIRELESS DEVICE AS A SENSOR FOR AN ENERGY MANAGEMENT SYSTEM
<b>First Named Inventor/Applicant Name:</b>	John Douglas Steinberg
<b>Customer Number:</b>	20995
<b>Filer:</b>	John R. King/Gustavo Lopez
<b>Filer Authorized By:</b>	John R. King
<b>Attorney Docket Number:</b>	EFACT.011C2
<b>Receipt Date:</b>	19-JAN-2017
<b>Filing Date:</b>	21-JAN-2016
<b>Time Stamp:</b>	13:33:21
<b>Application Type:</b>	Utility under 35 USC 111(a)

### Payment information:

Submitted with Payment	no
------------------------	----

### File Listing:

Document Number	Document Description	File Name	File Size(Bytes)/ Message Digest	Multi Part /.zip	Pages (if appl.)
1	Applicant Response to Pre-Exam Formalities Notice	EFACT-011C2_response.pdf	14476 <small>36162c8d3012da4f86cf562bf0f54e845d0a0b89</small>	no	1

### Warnings:

0412

<b>Information:</b>					
2	Oath or Declaration filed	EFACT-011C2_declaration.pdf	86085	no	1
			7cc485dfb6e6bedcd17655b5e1d57337b972e844		
<b>Warnings:</b>					
<b>Information:</b>					
3		EFACT-011C2_IDS.pdf	105875	yes	3
			ec59b1833d634beb0f27f1a619246b60f181e8b		
	<b>Multipart Description/PDF files in .zip description</b>				
	<b>Document Description</b>		<b>Start</b>	<b>End</b>	
	Transmittal Letter		1	1	
	Information Disclosure Statement (IDS) Form (SB08)		2	3	
<b>Warnings:</b>					
<b>Information:</b>					
4	Non Patent Literature	EFACT-011C2_ref17.pdf	1850599	no	25
			ac71790384d863039870dc8c90c1714f8c90eeaf		
<b>Warnings:</b>					
<b>Information:</b>					
5	Non Patent Literature	EFACT-011C2_ref18.pdf	673767	no	6
			d567de5ab4c62e039c84b74a9a4926d8703932f		
<b>Warnings:</b>					
<b>Information:</b>					
6	Non Patent Literature	EFACT-011C2_ref19.pdf	4809309	no	144
			059e6eb38b6737d9f4bfcbb7fa5114247f752cbb		
<b>Warnings:</b>					
<b>Information:</b>					
7	Non Patent Literature	EFACT-011C2_ref20.pdf	5299725	no	151
			572efe3f761fbfa1abef967f7da31839c5af6eebe		
<b>Warnings:</b>					
<b>Information:</b>					

8	Non Patent Literature	EFACT-011C2_ref21.pdf	197869	no	7
			13c6b789e111d68997b7a86354b4fc6d404a8a3c		

**Warnings:**

**Information:**

<b>Total Files Size (in bytes):</b>	13037705
-------------------------------------	----------

**This Acknowledgement Receipt evidences receipt on the noted date by the USPTO of the indicated documents, characterized by the applicant, and including page counts, where applicable. It serves as evidence of receipt similar to a Post Card, as described in MPEP 503.**

**New Applications Under 35 U.S.C. 111**

**If a new application is being filed and the application includes the necessary components for a filing date (see 37 CFR 1.53(b)-(d) and MPEP 506), a Filing Receipt (37 CFR 1.54) will be issued in due course and the date shown on this Acknowledgement Receipt will establish the filing date of the application.**

**National Stage of an International Application under 35 U.S.C. 371**

**If a timely submission to enter the national stage of an international application is compliant with the conditions of 35 U.S.C. 371 and other applicable requirements a Form PCT/DO/EO/903 indicating acceptance of the application as a national stage submission under 35 U.S.C. 371 will be issued in addition to the Filing Receipt, in due course.**

**New International Application Filed with the USPTO as a Receiving Office**

**If a new international application is being filed and the international application includes the necessary components for an international filing date (see PCT Article 11 and MPEP 1810), a Notification of the International Application Number and of the International Filing Date (Form PCT/RO/105) will be issued in due course, subject to prescriptions concerning national security, and the date shown on this Acknowledgement Receipt will establish the international filing date of the application.**



UNITED STATES PATENT AND TRADEMARK OFFICE

UNITED STATES DEPARTMENT OF COMMERCE
United States Patent and Trademark Office
Address: COMMISSIONER FOR PATENTS
P.O. Box 1450
Alexandria, Virginia 22313-1450
www.uspto.gov

Table with 4 columns: APPLICATION NUMBER (15/002,791), FILING OR 371(C) DATE (01/21/2016), FIRST NAMED APPLICANT (John Douglas Steinberg), ATTY. DOCKET NO./TITLE (EFACT.011C2)

CONFIRMATION NO. 4939

PUBLICATION NOTICE

20995
KNOBBE MARTENS OLSON & BEAR LLP
2040 MAIN STREET
FOURTEENTH FLOOR
IRVINE, CA 92614



Title: SYSTEM AND METHOD FOR USING A WIRELESS DEVICE AS A SENSOR FOR AN ENERGY MANAGEMENT SYSTEM

Publication No. US-2016-0138822-A1

Publication Date: 05/19/2016

NOTICE OF PUBLICATION OF APPLICATION

The above-identified application will be electronically published as a patent application publication pursuant to 37 CFR 1.211, et seq. The patent application publication number and publication date are set forth above.

The publication may be accessed through the USPTO's publically available Searchable Databases via the Internet at www.uspto.gov. The direct link to access the publication is currently http://www.uspto.gov/patft/.

The publication process established by the Office does not provide for mailing a copy of the publication to applicant. A copy of the publication may be obtained from the Office upon payment of the appropriate fee set forth in 37 CFR 1.19(a)(1). Orders for copies of patent application publications are handled by the USPTO's Office of Public Records. The Office of Public Records can be reached by telephone at (703) 308-9726 or (800) 972-6382, by facsimile at (703) 305-8759, by mail addressed to the United States Patent and Trademark Office, Office of Public Records, Alexandria, VA 22313-1450 or via the Internet.

In addition, information on the status of the application, including the mailing date of Office actions and the dates of receipt of correspondence filed in the Office, may also be accessed via the Internet through the Patent Electronic Business Center at www.uspto.gov using the public side of the Patent Application Information and Retrieval (PAIR) system. The direct link to access this status information is currently http://pair.uspto.gov/. Prior to publication, such status information is confidential and may only be obtained by applicant using the private side of PAIR.

Further assistance in electronically accessing the publication, or about PAIR, is available by calling the Patent Electronic Business Center at 1-866-217-9197.

Office of Data Management, Application Assistance Unit (571) 272-4000, or (571) 272-4200, or 1-888-786-0101



UNITED STATES PATENT AND TRADEMARK OFFICE

UNITED STATES DEPARTMENT OF COMMERCE  
United States Patent and Trademark Office  
Address: COMMISSIONER FOR PATENTS  
P.O. Box 1450  
Alexandria, Virginia 22313-1450  
www.uspto.gov

APPLICATION NUMBER	FILING OR 371(C) DATE	FIRST NAMED APPLICANT	ATTY. DOCKET NO./TITLE
15/002,791	01/21/2016	John Douglas Steinberg	EFACT.011C2

**CONFIRMATION NO. 4939**

**POA ACCEPTANCE LETTER**

20995  
KNOBBE MARTENS OLSON & BEAR LLP  
2040 MAIN STREET  
FOURTEENTH FLOOR  
IRVINE, CA 92614



Date Mailed: 03/30/2016

**NOTICE OF ACCEPTANCE OF POWER OF ATTORNEY**

This is in response to the Power of Attorney filed 03/18/2016.

The Power of Attorney in this application is accepted. Correspondence in this application will be mailed to the above address as provided by 37 CFR 1.33.

Questions about the contents of this notice and the requirements it sets forth should be directed to the Office of Data Management, Application Assistance Unit, at (571) 272-4000 or (571) 272-4200 or 1-888-786-0101.

/tnguyen/



Under the Paperwork Reduction Act of 1995, no persons are required to respond to a collection of information unless it displays a valid OMB control number.

## TRANSMITTAL FOR POWER OF ATTORNEY TO ONE OR MORE REGISTERED PRACTITIONERS

NOTE: This form is to be submitted with the Power of Attorney by Applicant form (PTO/AIA/82B) to identify the application to which the Power of Attorney is directed, in accordance with 37 CFR 1.5, unless the application number and filing date are identified in the Power of Attorney by Applicant form. If neither form PTO/AIA/82A nor form PTO/AIA82B identifies the application to which the Power of Attorney is directed, the Power of Attorney will not be recognized in the application.

Application Number	15/002791
Filing Date	January 21, 2016
First Named Inventor	John Douglas Steinberg
Title	SYSTEM AND METHOD FOR USING A WIRELESS DEVICE AS A SENSOR FOR AN ENERGY MANAGEMENT SYSTEM
Art Unit	3744
Examiner Name	Unknown
Attorney Docket Number	EFACT.011C2

### SIGNATURE of Applicant or Patent Practitioner

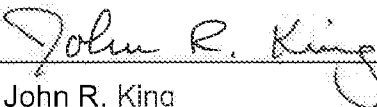
Signature		Date (Optional)	
Name	John R. King	Registration Number	34,362
Title (if Applicant is a juristic entity)	Attorney		
Applicant Name (if Applicant is a juristic entity)	EcoFactor, Inc.		

**NOTE:** This form must be signed in accordance with 37 CFR 1.33. See 37 CFR 1.4(d) for signature requirements and certifications. If more than one applicant, use multiple forms.

\*Total of 1 forms are submitted.

This collection of information is required by 37 CFR 1.131, 1.32, and 1.33. The information is required to obtain or retain a benefit by the public which is to file (and by the USPTO to process) an application. Confidentiality is governed by 35 U.S.C. 122 and 37 CFR 1.11 and 1.14. This collection is estimated to take 3 minutes to complete, including gathering, preparing, and submitting the completed application form to the USPTO. Time will vary depending upon the individual case. Any comments on the amount of time you require to complete this form and/or suggestions for reducing this burden, should be sent to the Chief Information Officer, U.S. Patent and Trademark Office, U.S. Department of Commerce, P.O. Box 1450, Alexandria, VA 22313-1450. DO NOT SEND FEES OR COMPLETED FORMS TO THIS ADDRESS. SEND TO: Commissioner for Patents, P.O. Box 1450, Alexandria, VA 22313-1450.

*If you need assistance in completing the form, call 1-800 PTO-9199 and select option 2.*

## POWER OF ATTORNEY BY APPLICANT

I hereby revoke all previous powers of attorney given in the application identified in either the attached transmittal letter or the boxes below.

Application Number	Filing Date

(Note: The boxes above may be left blank if information is provided on form PTO/AIA/82A.)

I hereby appoint the Patent Practitioner(s) associated with the following Customer Number as my/our attorney(s) or agent(s), and to transact all business in the United States Patent and Trademark Office connected therewith for the application referenced in the attached transmittal letter (form PTO/AIA/82A) or identified above:

20995

OR

I hereby appoint Practitioner(s) named in the attached list (form PTO/AIA/82C) as my/our attorney(s) or agent(s), and to transact all business in the United States Patent and Trademark Office connected therewith for the patent application referenced in the attached transmittal letter (form PTO/AIA/82A) or identified above. (Note: Complete form PTO/AIA/82C.)

**Please recognize or change the correspondence address for the application identified in the attached transmittal letter or the boxes above to:**

The address associated with the above-mentioned Customer Number

OR

The address associated with Customer Number:

OR

Firm or Individual Name			
Address			
City	State	Zip	
Country			
Telephone	Email		

I am the Applicant (if the Applicant is a juristic entity, list the Applicant name in the box):

EcoFactor, Inc.

- Inventor or Joint Inventor (title not required below)
- Legal Representative of a Deceased or Legally Incapacitated Inventor (title not required below)
- Assignee or Person to Whom the Inventor is Under an Obligation to Assign (provide signer's title if applicant is a juristic entity)
- Person Who Otherwise Shows Sufficient Proprietary Interest (e.g., a petition under 37 CFR 1.46(b)(2) was granted in the application or is concurrently being filed with this document) (provide signer's title if applicant is a juristic entity)

**SIGNATURE of Applicant for Patent**

The undersigned (whose title is supplied below) is authorized to act on behalf of the applicant (e.g., where the applicant is a juristic entity).

Signature	Date (Optional) <span style="font-family: cursive;">11/7/13</span>
Name	John Douglas Steinberg
Title	EVP of Business Development

**NOTE:** Signature - This form must be signed by the applicant in accordance with 37 CFR 1.33. See 37 CFR 1.4 for signature requirements and certifications. If more than one applicant, use multiple forms.

Total of 1 forms are submitted.

**INFORMATION DISCLOSURE STATEMENT**

First Inventor	: John Douglas Steinberg
App. No.	: 15/002,791
Filed	: January 21, 2016
For	: SYSTEM AND METHOD FOR USING A WIRELESS DEVICE AS A SENSOR FOR AN ENERGY MANAGEMENT SYSTEM
Examiner	: Unknown
Art Unit	: 3744
Conf. No.	: 4939

Commissioner for Patents  
P.O. Box 1450  
Alexandria, VA 22313-1450

**References and Listing**

Pursuant to 37 CFR 1.56, an Information Disclosure Statement listing references is provided herewith. Listed references are of record in U.S. Patent Application No. 13/470,074, filed May 11, 2012, which is the parent of this continuation application, and is relied upon for an earlier filing date under 35 USC 120. Copies of the references are not submitted pursuant to 37 CFR 1.98(d).

**No Disclaimers**

To the extent that anything in the Information Disclosure Statement or the listed references could be construed as a disclaimer of any subject matter supported by the present application, Applicant hereby rescinds and retracts such disclaimer.

**Timing of Disclosure**

This Information Disclosure Statement is being filed before the receipt of a First Office Action on the merits, and presumably no fee is required. If a First Office Action on the merits was mailed before the mailing date of this Statement, the Commissioner

Application No.: 15/002,791  
Filing Date: January 21, 2016

is authorized to charge the fee set forth in 37 CFR 1.17(p) to Deposit Account No. 11-1410.

Respectfully submitted,  
KNOBBE, MARTENS, OLSON & BEAR, LLP

Dated: 3-18-2016

By: John R. King  
John R. King  
Registration No. 34,362  
Attorney of Record  
Customer No. 20,995  
(949) 760-0404

22913836:ad  
031516

<b>INFORMATION DISCLOSURE STATEMENT BY APPLICANT</b>	Application No.	15/002791	
	Filing Date	January 21, 2016	
	First Named Inventor	John Douglas Steinberg	
	Art Unit	3744	
<i>(Multiple sheets used when necessary)</i>		Examiner	Unknown
SHEET 1 OF 1		Attorney Docket No.	EFACT.011C2

U.S. PATENT DOCUMENTS					
Examiner Initials	Cite No.	Document Number <i>Number - Kind Code (if known)</i> Example: 1,234,567 B1	Publication Date MM-DD-YYYY	Name	Pages, Columns, Lines Where Relevant Passages or Relevant Figures Appear
	1	9,244,470 (EFACT.011C1)	01/26/2016	Steinberg	
	2	9,279,594 (EFACT.008C1)	03/08/2016	Steinberg	
	3	2006/0283965	12/21/2006	Mueller et al.	
	4	2008/0083234	04/10/2008	Krebs et al.	
	5	2016/0061474 (EFACT.010C2)	03/03/2016	Cheung et al.	

FOREIGN PATENT DOCUMENTS						
Examiner Initials	Cite No.	Foreign Patent Document <i>Country Code-Number-Kind Code</i> Example: JP 1234567 A1	Publication Date MM-DD-YYYY	Name	Pages, Columns, Lines Where Relevant Passages or Relevant Figures Appear	T <sup>1</sup>

NON PATENT LITERATURE DOCUMENTS			
Examiner Initials	Cite No.	Include name of the author (in CAPITAL LETTERS), title of the article (when appropriate), title of the item (book, magazine, journal, serial, symposium, catalog, etc.), date, page(s), volume-issue number(s), publisher, city and/or country where published.	T <sup>1</sup>
	6	Raji, "Smart Networks for Control", IEEE Spectrum, June 1994.	

22913753:ad  
031516

Examiner Signature	Date Considered
--------------------	-----------------

\***Examiner:** Initial if reference considered, whether or not citation is in conformance with MPEP 609. Draw line through citation if not in conformance and not considered. Include copy of this form with next communication to applicant.

T<sup>1</sup> - Place a check mark in this area when an English language Translation is attached.

## Electronic Acknowledgement Receipt

<b>EFS ID:</b>	25238640
<b>Application Number:</b>	15002791
<b>International Application Number:</b>	
<b>Confirmation Number:</b>	4939
<b>Title of Invention:</b>	SYSTEM AND METHOD FOR USING A WIRELESS DEVICE AS A SENSOR FOR AN ENERGY MANAGEMENT SYSTEM
<b>First Named Inventor/Applicant Name:</b>	John Douglas Steinberg
<b>Customer Number:</b>	20995
<b>Filer:</b>	John R. King/Kevin Kraus
<b>Filer Authorized By:</b>	John R. King
<b>Attorney Docket Number:</b>	EFACT.011C2
<b>Receipt Date:</b>	18-MAR-2016
<b>Filing Date:</b>	21-JAN-2016
<b>Time Stamp:</b>	14:06:12
<b>Application Type:</b>	Utility under 35 USC 111(a)

### Payment information:

Submitted with Payment	no
------------------------	----

### File Listing:

Document Number	Document Description	File Name	File Size(Bytes)/ Message Digest	Multi Part /.zip	Pages (if appl.)
1	Transmittal Letter	EFACT-011C2_transmittal.pdf	68649 bd17c0dc19e3bdfb1a8235015586d733cb71c10f	no	1

### Warnings:

### Information:

0422

2	Miscellaneous Incoming Letter	EFACT-011C2_rescission.pdf	109435 e0402f1788776516d461ea3c55ded0cb863b7681	no	2
<b>Warnings:</b>					
<b>Information:</b>					
3	Power of Attorney	EFACT-011C2_POA.pdf	285435 83d1d7ca6e5403001ec89d3786e2518ce103bcc	no	2
<b>Warnings:</b>					
<b>Information:</b>					
4		EFACT-011C2_IDS.pdf	150026 a97926b1dc3fef408da0b1656a3276a2c5bbbeb3	yes	3
	<b>Multipart Description/PDF files in .zip description</b>				
	<b>Document Description</b>		<b>Start</b>	<b>End</b>	
	Transmittal Letter		1	2	
	Information Disclosure Statement (IDS) Form (SB08)		3	3	
<b>Warnings:</b>					
<b>Information:</b>					
<b>Total Files Size (in bytes):</b>				613545	
<p><b>This Acknowledgement Receipt evidences receipt on the noted date by the USPTO of the indicated documents, characterized by the applicant, and including page counts, where applicable. It serves as evidence of receipt similar to a Post Card, as described in MPEP 503.</b></p> <p><b><u>New Applications Under 35 U.S.C. 111</u></b>  <b>If a new application is being filed and the application includes the necessary components for a filing date (see 37 CFR 1.53(b)-(d) and MPEP 506), a Filing Receipt (37 CFR 1.54) will be issued in due course and the date shown on this Acknowledgement Receipt will establish the filing date of the application.</b></p> <p><b><u>National Stage of an International Application under 35 U.S.C. 371</u></b>  <b>If a timely submission to enter the national stage of an international application is compliant with the conditions of 35 U.S.C. 371 and other applicable requirements a Form PCT/DO/EO/903 indicating acceptance of the application as a national stage submission under 35 U.S.C. 371 will be issued in addition to the Filing Receipt, in due course.</b></p> <p><b><u>New International Application Filed with the USPTO as a Receiving Office</u></b>  <b>If a new international application is being filed and the international application includes the necessary components for an international filing date (see PCT Article 11 and MPEP 1810), a Notification of the International Application Number and of the International Filing Date (Form PCT/RO/105) will be issued in due course, subject to prescriptions concerning national security, and the date shown on this Acknowledgement Receipt will establish the international filing date of the application.</b></p>					

Please Direct All Correspondence to Customer Number 20,995

**TRANSMITTAL LETTER**

Inventor : John Douglas Steinberg  
App. No. : 15/002,791  
Filed : January 21, 2016  
For : SYSTEM AND METHOD FOR  
USING A WIRELESS DEVICE AS A  
SENSOR FOR AN ENERGY  
MANAGEMENT SYSTEM  
Art Unit : 3744  
Conf No. : 4939

**Mail Stop Missing Parts  
Commissioner for Patents  
P.O. Box 1450  
Alexandria, VA 22313-1450**

Dear Sir:

Enclosed are the following.

- (X) Rescission of Any Prior Disclaimers and Request to Revisit Art.
- (X) Power of Attorney by Applicant.
- (X) Information Disclosure Statement.

The present application qualifies for small entity status under 37 CFR § 1.27.

The Commissioner is hereby authorized to charge any additional fees which may be required, now or in the future, or credit any overpayment, to Account No. 11-1410.

Dated: 3-18-2016

By: John R. King

John R. King  
Registration No. 34,362  
Attorney of Record  
Customer No. 20,995  
(949) 760-0404



---

**IN THE UNITED STATES PATENT AND TRADEMARK OFFICE**

Applicant	:	John Douglas Steinberg
App. No.	:	15/002,791
Filed	:	January 21, 2016
For	:	SYSTEM AND METHOD FOR USING A WIRELESS DEVICE AS A SENSOR FOR AN ENERGY MANAGEMENT SYSTEM
Examiner	:	Unknown
GAU	:	3744
Conf. No.	:	4939

---

**RESCISSION OF ANY PRIOR DISCLAIMERS AND REQUEST TO REVISIT ART**

Commissioner for Patents  
P.O. Box 1450  
Alexandria, VA 22313-1450

Dear Sir:

The claims of the present application are different and possibly broader in scope than any pending claims in any related application or issued claims in any related patent. In particular, in the parent application, U.S. Patent Application No. 12/502,064, now U.S. Patent No. 8,180,492, issued May 15, 2012; and U.S. Patent Application No. 13/470,074, now U.S. Patent No. 9,244,470, issued January 26, 2016; Applicant amended claims and/or presented arguments in view of at least U.S. Patent No. 5,977,964; U.S. Publication Nos. 2008/0281472; and 2009/0065596; article "Opportunities to Save Energy and Improve Comfort by Using Wireless Sensor Networks in Buildings" by Wang, et al. and manuals from Johnson Controls (T600HCx-3 Single-Stage Thermostats Installation Instructions T600HCN-3) and Emerson Climate Technologies (Network Thermostat for E2 Building Controller Installation and Operation Manual 2007)

To the extent that any amendments or characterizations of the scope of any claim or referenced art could be construed as a disclaimer of any subject matter

supported by the present disclosure, Applicant hereby rescinds and retracts such disclaimer. Accordingly, the above-listed references, or other listed or referenced art may need to be re-visited.

In addition, reviewers of this or any parent, child or related prosecution history shall not reasonably infer that Applicant has made any disclaimers or disavowals of any subject matter supported by the present application.

Respectfully submitted,  
KNOBBE, MARTENS, OLSON & BEAR, LLP

Dated: 3-18-2016

By: John R. King  
John R. King  
Registration No. 34,362  
Attorney of Record  
Customer No. 20,995  
(949) 760-0404

**PATENT APPLICATION FEE DETERMINATION RECORD**

Substitute for Form PTO-875

Application or Docket Number  
15/002,791

**APPLICATION AS FILED - PART I**

(Column 1) (Column 2)

FOR	NUMBER FILED	NUMBER EXTRA
BASIC FEE (37 CFR 1.16(a), (b), or (c))	N/A	N/A
SEARCH FEE (37 CFR 1.16(k), (l), or (m))	N/A	N/A
EXAMINATION FEE (37 CFR 1.16(o), (p), or (q))	N/A	N/A
TOTAL CLAIMS (37 CFR 1.16(j))	18 minus 20 = *	*
INDEPENDENT CLAIMS (37 CFR 1.16(h))	2 minus 3 = *	*
APPLICATION SIZE FEE (37 CFR 1.16(s))	If the specification and drawings exceed 100 sheets of paper, the application size fee due is \$310 (\$155 for small entity) for each additional 50 sheets or fraction thereof. See 35 U.S.C. 41(a)(1)(G) and 37 CFR 1.16(s).	
MULTIPLE DEPENDENT CLAIM PRESENT (37 CFR 1.16(j))		

\* If the difference in column 1 is less than zero, enter "0" in column 2.

**SMALL ENTITY**

RATE(\$)	FEE(\$)
N/A	70
N/A	300
N/A	360
x 40 =	0.00
x 210 =	0.00
	0.00
	0.00
<b>TOTAL</b>	<b>730</b>

**OR OTHER THAN SMALL ENTITY**

RATE(\$)	FEE(\$)
N/A	
N/A	
N/A	
<b>TOTAL</b>	

**APPLICATION AS AMENDED - PART II**

(Column 1) (Column 2) (Column 3)

AMENDMENT A	CLAIMS REMAINING AFTER AMENDMENT	HIGHEST NUMBER PREVIOUSLY PAID FOR	PRESENT EXTRA
	Total (37 CFR 1.16(i))	* Minus **	=
Independent (37 CFR 1.16(h))	* Minus ***	=	
Application Size Fee (37 CFR 1.16(s))			
FIRST PRESENTATION OF MULTIPLE DEPENDENT CLAIM (37 CFR 1.16(j))			

**SMALL ENTITY**

RATE(\$)	ADDITIONAL FEE(\$)
x =	
x =	
<b>TOTAL ADD'L FEE</b>	

**OR OTHER THAN SMALL ENTITY**

RATE(\$)	ADDITIONAL FEE(\$)
x =	
x =	
<b>TOTAL ADD'L FEE</b>	

(Column 1) (Column 2) (Column 3)

AMENDMENT B	CLAIMS REMAINING AFTER AMENDMENT	HIGHEST NUMBER PREVIOUSLY PAID FOR	PRESENT EXTRA
	Total (37 CFR 1.16(i))	* Minus **	=
Independent (37 CFR 1.16(h))	* Minus ***	=	
Application Size Fee (37 CFR 1.16(s))			
FIRST PRESENTATION OF MULTIPLE DEPENDENT CLAIM (37 CFR 1.16(j))			

**SMALL ENTITY**

RATE(\$)	ADDITIONAL FEE(\$)
x =	
x =	
<b>TOTAL ADD'L FEE</b>	

**OR OTHER THAN SMALL ENTITY**

RATE(\$)	ADDITIONAL FEE(\$)
x =	
x =	
<b>TOTAL ADD'L FEE</b>	

\* If the entry in column 1 is less than the entry in column 2, write "0" in column 3.  
 \*\* If the "Highest Number Previously Paid For" IN THIS SPACE is less than 20, enter "20".  
 \*\*\* If the "Highest Number Previously Paid For" IN THIS SPACE is less than 3, enter "3".  
 The "Highest Number Previously Paid For" (Total or Independent) is the highest found in the appropriate box in column 1.



UNITED STATES PATENT AND TRADEMARK OFFICE

UNITED STATES DEPARTMENT OF COMMERCE
United States Patent and Trademark Office
Address: COMMISSIONER FOR PATENTS
P.O. Box 1450
Alexandria, Virginia 22313-1450
www.uspto.gov

Table with 4 columns: APPLICATION NUMBER (15/002,791), FILING OR 371(C) DATE (01/21/2016), FIRST NAMED APPLICANT (John Douglas Steinberg), ATTY. DOCKET NO./TITLE (EFACT.011C2)

CONFIRMATION NO. 4939

INFORMAL NOTICE



20995
KNOBBE MARTENS OLSON & BEAR LLP
2040 MAIN STREET
FOURTEENTH FLOOR
IRVINE, CA 92614

Date Mailed: 02/08/2016

INFORMATIONAL NOTICE TO APPLICANT

Applicant is notified that the above-identified application contains the deficiencies noted below. No period for reply is set forth in this notice for correction of these deficiencies. However, if a deficiency relates to the inventor's oath or declaration, the applicant must file an oath or declaration in compliance with 37 CFR 1.63, or a substitute statement in compliance with 37 CFR 1.64, executed by or with respect to each actual inventor no later than the expiration of the time period set in the "Notice of Allowability" to avoid abandonment. See 37 CFR 1.53(f).

The item(s) indicated below are also required and should be submitted with any reply to this notice to avoid further processing delays.

- A properly executed inventor's oath or declaration has not been received for the following inventor(s): John Douglas Steinberg

Questions about the contents of this notice and the requirements it sets forth should be directed to the Office of Data Management, Application Assistance Unit, at (571) 272-4000 or (571) 272-4200 or 1-888-786-0101.

/hchin/



UNITED STATES PATENT AND TRADEMARK OFFICE

UNITED STATES DEPARTMENT OF COMMERCE
United States Patent and Trademark Office
Address: COMMISSIONER FOR PATENTS
P.O. Box 1450
Alexandria, Virginia 22313-1450
www.uspto.gov

Table with 7 columns: APPLICATION NUMBER, FILING or 371(c) DATE, GRP ART UNIT, FIL FEE REC'D, ATTY. DOCKET NO, TOT CLAIMS, IND CLAIMS. Row 1: 15/002,791, 01/21/2016, 3744, 800, EFACT.011C2, 18, 2

CONFIRMATION NO. 4939

FILING RECEIPT

20995
KNOBBE MARTENS OLSON & BEAR LLP
2040 MAIN STREET
FOURTEENTH FLOOR
IRVINE, CA 92614



Date Mailed: 02/08/2016

Receipt is acknowledged of this non-provisional patent application. The application will be taken up for examination in due course. Applicant will be notified as to the results of the examination. Any correspondence concerning the application must include the following identification information: the U.S. APPLICATION NUMBER, FILING DATE, NAME OF APPLICANT, and TITLE OF INVENTION. Fees transmitted by check or draft are subject to collection. Please verify the accuracy of the data presented on this receipt. If an error is noted on this Filing Receipt, please submit a written request for a Filing Receipt Correction. Please provide a copy of this Filing Receipt with the changes noted thereon. If you received a "Notice to File Missing Parts" for this application, please submit any corrections to this Filing Receipt with your reply to the Notice. When the USPTO processes the reply to the Notice, the USPTO will generate another Filing Receipt incorporating the requested corrections

Inventor(s) John Douglas Steinberg, Millbrae, CA;

Applicant(s) EcoFactor, Inc., Redwood City, CA;

Power of Attorney: None

Domestic Priority data as claimed by applicant

This application is a CON of 13/470,074 05/11/2012 PAT 9244470
which is a CON of 12/502,064 07/13/2009 PAT 8180492
which claims benefit of 61/134,714 07/14/2008

Foreign Applications for which priority is claimed (You may be eligible to benefit from the Patent Prosecution Highway program at the USPTO. Please see http://www.uspto.gov for more information.) - None.

Foreign application information must be provided in an Application Data Sheet in order to constitute a claim to foreign priority. See 37 CFR 1.55 and 1.76.

Permission to Access Application via Priority Document Exchange: Yes

Permission to Access Search Results: No

Applicant may provide or rescind an authorization for access using Form PTO/SB/39 or Form PTO/SB/69 as appropriate.

If Required, Foreign Filing License Granted: 02/04/2016

The country code and number of your priority application, to be used for filing abroad under the Paris Convention, is **US 15/002,791**

**Projected Publication Date:** 05/19/2016

**Non-Publication Request:** No

**Early Publication Request:** No

**\*\* SMALL ENTITY \*\***

**Title**

SYSTEM AND METHOD FOR USING A WIRELESS DEVICE AS A SENSOR FOR AN ENERGY MANAGEMENT SYSTEM

**Preliminary Class**

236

**Statement under 37 CFR 1.55 or 1.78 for AIA (First Inventor to File) Transition Applications:** No

### **PROTECTING YOUR INVENTION OUTSIDE THE UNITED STATES**

Since the rights granted by a U.S. patent extend only throughout the territory of the United States and have no effect in a foreign country, an inventor who wishes patent protection in another country must apply for a patent in a specific country or in regional patent offices. Applicants may wish to consider the filing of an international application under the Patent Cooperation Treaty (PCT). An international (PCT) application generally has the same effect as a regular national patent application in each PCT-member country. The PCT process **simplifies** the filing of patent applications on the same invention in member countries, but **does not result** in a grant of "an international patent" and does not eliminate the need of applicants to file additional documents and fees in countries where patent protection is desired.

Almost every country has its own patent law, and a person desiring a patent in a particular country must make an application for patent in that country in accordance with its particular laws. Since the laws of many countries differ in various respects from the patent law of the United States, applicants are advised to seek guidance from specific foreign countries to ensure that patent rights are not lost prematurely.

Applicants also are advised that in the case of inventions made in the United States, the Director of the USPTO must issue a license before applicants can apply for a patent in a foreign country. The filing of a U.S. patent application serves as a request for a foreign filing license. The application's filing receipt contains further information and guidance as to the status of applicant's license for foreign filing.

Applicants may wish to consult the USPTO booklet, "General Information Concerning Patents" (specifically, the section entitled "Treaties and Foreign Patents") for more information on timeframes and deadlines for filing foreign patent applications. The guide is available either by contacting the USPTO Contact Center at 800-786-9199, or it can be viewed on the USPTO website at <http://www.uspto.gov/web/offices/pac/doc/general/index.html>.

For information on preventing theft of your intellectual property (patents, trademarks and copyrights), you may wish to consult the U.S. Government website, <http://www.stopfakes.gov>. Part of a Department of Commerce initiative, this website includes self-help "toolkits" giving innovators guidance on how to protect intellectual property in specific countries such as China, Korea and Mexico. For questions regarding patent enforcement issues, applicants may call the U.S. Government hotline at 1-866-999-HALT (1-866-999-4258).

**LICENSE FOR FOREIGN FILING UNDER**  
**Title 35, United States Code, Section 184**  
**Title 37, Code of Federal Regulations, 5.11 & 5.15**

**GRANTED**

The applicant has been granted a license under 35 U.S.C. 184, if the phrase "IF REQUIRED, FOREIGN FILING LICENSE GRANTED" followed by a date appears on this form. Such licenses are issued in all applications where the conditions for issuance of a license have been met, regardless of whether or not a license may be required as set forth in 37 CFR 5.15. The scope and limitations of this license are set forth in 37 CFR 5.15(a) unless an earlier license has been issued under 37 CFR 5.15(b). The license is subject to revocation upon written notification. The date indicated is the effective date of the license, unless an earlier license of similar scope has been granted under 37 CFR 5.13 or 5.14.

This license is to be retained by the licensee and may be used at any time on or after the effective date thereof unless it is revoked. This license is automatically transferred to any related applications(s) filed under 37 CFR 1.53(d). This license is not retroactive.

The grant of a license does not in any way lessen the responsibility of a licensee for the security of the subject matter as imposed by any Government contract or the provisions of existing laws relating to espionage and the national security or the export of technical data. Licensees should apprise themselves of current regulations especially with respect to certain countries, of other agencies, particularly the Office of Defense Trade Controls, Department of State (with respect to Arms, Munitions and Implements of War (22 CFR 121-128)); the Bureau of Industry and Security, Department of Commerce (15 CFR parts 730-774); the Office of Foreign Assets Control, Department of Treasury (31 CFR Parts 500+) and the Department of Energy.

**NOT GRANTED**

No license under 35 U.S.C. 184 has been granted at this time, if the phrase "IF REQUIRED, FOREIGN FILING LICENSE GRANTED" DOES NOT appear on this form. Applicant may still petition for a license under 37 CFR 5.12, if a license is desired before the expiration of 6 months from the filing date of the application. If 6 months has lapsed from the filing date of this application and the licensee has not received any indication of a secrecy order under 35 U.S.C. 181, the licensee may foreign file the application pursuant to 37 CFR 5.15(b).

---

***SelectUSA***

The United States represents the largest, most dynamic marketplace in the world and is an unparalleled location for business investment, innovation, and commercialization of new technologies. The U.S. offers tremendous resources and advantages for those who invest and manufacture goods here. Through SelectUSA, our nation works to promote and facilitate business investment. SelectUSA provides information assistance to the international investor community; serves as an ombudsman for existing and potential investors; advocates on behalf of U.S. cities, states, and regions competing for global investment; and counsels U.S. economic development organizations on investment attraction best practices. To learn more about why the United States is the best country in the world to develop technology, manufacture products, deliver services, and grow your business, visit <http://www.SelectUSA.gov> or call +1-202-482-6800.

<b>INFORMATION DISCLOSURE STATEMENT BY APPLICANT</b>	Application No.	Unknown	
	Filing Date	Herewith	
	First Named Inventor	John Douglas Steinberg	
	Art Unit	Unknown	
<i>(Multiple sheets used when necessary)</i>		Examiner	Unknown
SHEET 1 OF 10		Attorney Docket No.	EFACT.011C2

U.S. PATENT DOCUMENTS					
Examiner Initials	Cite No.	Document Number Number - Kind Code (if known) Example: 1,234,567 B1	Publication Date MM-DD-YYYY	Name	Pages, Columns, Lines Where Relevant Passages or Relevant Figures Appear
	1	H2176	12/05/2006	Meyer et al.	
	2	12/805705	06/10/2010	Crabtree	
	3	13/470074	08/30/2012	Steinberg	
	4	13/523697	06/14/2012	Hublou et al.	
	5	13/725447	06/06/2013	Steinberg	
	6	13/729401	12/28/2012	Sloop	
	7	13/852577	03/28/2013	Steinberg et al.	
	8	13/858710	09/05/2013	Steinberg et al.	
	9	13/861189	04/11/2013	Steinberg et al.	
	10	14/082,675 (EFACT.007C1)	11/18/2003	Steinberg et al.	
	11	14/263,762	04/28/2014	Steinberg	
	12	14/285,384	05/22/2014	Steinberg, et al.	
	13	14/292,377	05/30/2014	Steinberg	
	14	14/491,554	09/19/2014	Steinberg	
	15	14/527,433	10/29/2014	Steinberg, et al.	
	16	14/731,221	06/04/2015	Steinberg, et al.	
	17	D 646,990	10/18/2011	Rhodes	
	18	D 659,560	05/15/2012	Rhodes	
	19	D 673,467	01/01/2013	Lee et al.	
	20	D 705,095 (EFACT.015DA)	05/20/2014	Steinberg et al.	
	21	4,136,732	01/30/1979	Demaray et al.	
	22	4,341,345	07/27/1982	Hammer et al.	
	23	4,403,644	09/13/1983	Hebert	
	24	4,475,685	10/09/1984	Grimado et al.	
	25	4,655,279	04/07/1987	Harmon	
	26	4,674,027	06/16/1987	Beckey	
	27	5,124,502	06/23/1992	Nelson et al.	
	28	5,244,146	09/14/1993	Jefferson et al.	

Examiner Signature	Date Considered
<p><b>*Examiner:</b> Initial if reference considered, whether or not citation is in conformance with MPEP 609. Draw line through citation if not in conformance and not considered. Include copy of this form with next communication to applicant.</p>	

T<sup>1</sup> - Place a check mark in this area when an English language Translation is attached.



<b>INFORMATION DISCLOSURE STATEMENT BY APPLICANT</b>	Application No.	Unknown
	Filing Date	Herewith
	First Named Inventor	John Douglas Steinberg
	Art Unit	Unknown
<i>(Multiple sheets used when necessary)</i>	Examiner	Unknown
SHEET 2 OF 10	Attorney Docket No.	BFACT.011C2

U.S. PATENT DOCUMENTS					
Examiner Initials	Cite No.	Document Number Number - Kind Code (if known) Example: 1,234,567 B1	Publication Date MM-DD-YYYY	Name	Pages, Columns, Lines Where Relevant Passages or Relevant Figures Appear
	29	5,270,952	12/14/1993	Adams et al.	
	30	5,314,004	05/24/1994	Strand et al.	
	31	5,348,078	09/20/1994	Dushane et al.	
	32	5,462,225	10/31/1995	Massara et al.	
	33	5,544,036	08/06/1996	Brown et al.	
	34	5,555,927	09/17/1996	Shah	
	35	5,572,438	11/05/1996	Ehlers et al.	
	36	5,682,949	11/04/1997	Ratcliffe et al.	
	37	5,717,609	02/10/1998	Packa et al.	
	38	5,725,148	03/10/1998	Hartman	
	39	5,729,474	03/17/1998	Hildebrand et al.	
	40	5,818,347	10/06/1998	Dolan et al.	
	41	5,977,964	11/02/1999	Williams et al.	
	42	6,079,626	06/27/2000	Hartman	
	43	6,115,713	09/05/2000	Pascucci et al.	
	44	6,145,751	11/14/2000	Ahmed	
	45	6,178,362	01/23/2001	Woolard et al.	
	46	6,260,765	07/17/2001	Natale et al.	
	47	6,241,156	06/05/2001	Kline et al.	
	48	6,351,693	02/26/2002	Monie	
	49	6,400,956	06/02/2002	Richton	
	50	6,400,996	06/04/2002	Hoffberg et al.	
	51	6,437,692	08/20/2002	Pelite et al.	
	52	6,478,233	11/12/2002	Shah	
	53	6,480,803	11/12/2002	Pierret et al.	
	54	6,483,906	11/19/2002	Lggulden et al.	
	55	6,536,675	03/25/2003	Pesko et al.	
	56	6,542,076	04/01/2003	Joao	
	57	6,549,130	04/15/2003	Joao	

Examiner Signature	Date Considered
<p><b>*Examiner:</b> Initial if reference considered, whether or not citation is in conformance with MPEP 609. Draw line through citation if not in conformance and not considered. Include copy of this form with next communication to applicant.</p>	

T<sup>1</sup> - Place a check mark in this area when an English language Translation is attached.

<b>INFORMATION DISCLOSURE STATEMENT BY APPLICANT</b>	Application No.	Unknown	
	Filing Date	Herewith	
	First Named Inventor	John Douglas Steinberg	
	Art Unit	Unknown	
<i>(Multiple sheets used when necessary)</i>		Examiner	Unknown
SHEET 3 OF 10		Attorney Docket No.	EFACT.011C2

U.S. PATENT DOCUMENTS					
Examiner Initials	Cite No.	Document Number Number - Kind Code (if known) Example: 1,234,567 B1	Publication Date MM-DD-YYYY	Name	Pages, Columns, Lines Where Relevant Passages or Relevant Figures Appear
	58	6,574,537	06/02/2003	Kipersztok et al.	
	59	6,580,950	06/17/2003	Johnson	
	60	6,594,825	07/15/2003	Goldschmidtliki et al.	
	61	6,595,430	07/22/2003	Shah	
	62	6,598,056	07/22/2003	Hull et al.	
	63	6,619,555	09/16/2003	Rosen	
	64	6,622,097	09/16/2003	Hunter	
	65	6,622,115	09/16/2003	Brown et al.	
	66	6,622,925	09/23/2003	Carner et al.	
	67	6,622,926	09/23/2003	Sartain et al.	
	68	6,628,997	09/30/2003	Fox et al.	
	69	6,633,823	10/14/2003	Bartone et al.	
	70	6,643,567	11/04/2003	Kolk et al.	
	71	6,644,098	11/11/2003	Cardinale et al.	
	72	6,671,586	12/30/2003	Davis et al.	
	73	6,695,218	02/24/2004	Fleckenstein	
	74	6,700,224	03/02/2004	Biskup, Sr.,	
	75	6,726,113	04/27/2004	Guo	
	76	6,731,992	05/04/2004	Ziegler	
	77	6,734,806	05/11/2004	Cratsley	
	78	6,772,052	08/03/2004	Amundsen	
	79	6,785,592	08/31/2004	Smith	
	80	6,785,630	08/31/2004	Kolk	
	81	6,786,421	09/07/2004	Rosen	
	82	6,789,739	09/14/2004	Rosen	
	83	6,853,959	02/08/2005	Ikeda et al.	
	84	6,868,293	03/15/2005	Schurr	
	85	6,868,319	03/15/2005	Kipersztok et al.	
	86	6,882,712	04/19/2005	Iggulden et al.	

Examiner Signature	Date Considered
<p><b>*Examiner:</b> Initial if reference considered, whether or not citation is in conformance with MPEP 609. Draw line through citation if not in conformance and not considered. Include copy of this form with next communication to applicant.</p>	

T<sup>1</sup> - Place a check mark in this area when an English language Translation is attached.

<b>INFORMATION DISCLOSURE STATEMENT BY APPLICANT</b>	Application No.	Unknown
	Filing Date	Herewith
	First Named Inventor	John Douglas Steinberg
	Art Unit	Unknown
<i>(Multiple sheets used when necessary)</i>	Examiner	Unknown
SHEET 4 OF 10	Attorney Docket No.	EFACT.011C2

U.S. PATENT DOCUMENTS					
Examiner Initials	Cite No.	Document Number Number - Kind Code (if known) Example: 1,234,567 B1	Publication Date MM-DD-YYYY	Name	Pages, Columns, Lines Where Relevant Passages or Relevant Figures Appear
	87	6,889,908	05/10/2005	Crippen et al.	
	88	6,891,838	05/10/2005	Petite et al.	
	89	6,912,429	06/28/2005	Bilger	
	90	6,991,029	01/31/2006	Orfield et al.	
	91	7,009,493	03/07/2006	Howard	
	92	7,031,880	04/18/2006	Seem et al.	
	93	7,039,532	05/02/2006	Hunter	
	94	7,061,393	06/13/2006	Buckingham et al.	
	95	7,089,088	08/08/2006	Terry et al.	
	96	7,130,719	10/31/2006	Ehlers et al.	
	97	7,130,832	10/31/2006	Bannai et al.	
	98	7,167,079	01/23/2007	Smyth et al.	
	99	7,187,986	03/06/2007	Johnson et al.	
	100	7,205,892	04/17/2007	Luebke et al.	
	101	7,206,670	04/17/2007	Pimputkar, et al.	
	102	7,215,746	05/08/2007	Iggulden et al.	
	103	7,216,015	05/08/2007	Poth Robert J.	
	104	7,231,424	06/11/2007	Bodin et al.	
	105	7,232,075	06/19/2007	Rosen	
	106	7,242,988	07/10/2007	Hoffberg et al.	
	107	7,260,823	08/21/2007	Schlack et al.	
	108	7,356,384	04/08/2008	Gull et al.	
	109	7,476,020	01/13/2009	Zufferey et al.	
	110	7,483,964	01/27/2009	Jackson et al.	
	111	7,644,869	01/12/2010	Hoglund et al.	
	112	7,702,424	04/20/2010	Cannon et al.	
	113	7,758,729	07/20/2010	DeWhitt	
	114	7,784,704	08/31/2010	Harter	
	115	7,848,900 (EFACT.005A)	12/07/2010	Steinberg et al.	

Examiner Signature	Date Considered
<p>*Examiner: Initial if reference considered, whether or not citation is in conformance with MPEP 609. Draw line through citation if not in conformance and not considered. Include copy of this form with next communication to applicant.</p>	

T<sup>1</sup> - Place a check mark in this area when an English language Translation is attached.

<b>INFORMATION DISCLOSURE STATEMENT BY APPLICANT</b>	Application No.	Unknown	
	Filing Date	Herewith	
	First Named Inventor	John Douglas Steinberg	
	Art Unit	Unknown	
<i>(Multiple sheets used when necessary)</i>		Examiner	Unknown
SHEET 5 OF 10		Attorney Docket No.	EFACT.011C2

U.S. PATENT DOCUMENTS					
Examiner Initials	Cite No.	Document Number Number - Kind Code (if known) Example: 1,234,567 B1	Publication Date MM-DD-YYYY	Name	Pages, Columns, Lines Where Relevant Passages or Relevant Figures Appear
	116	7,869,904	01/11/2011	Cannon et al.	
	117	7,894,943	02/22/2011	Sloup et al.	
	118	7,908,116 (EFACT.004A)	03/15/2011	Steinberg et al.	
	119	7,908,117 (EFACT.003A)	03/15/2011	Steinberg et al.	
	120	8,010,237 (EFACT.010A)	08/30/2011	Cheung Leo et al.	
	121	8,019,567 (EFACT.006A)	09/13/2011	Steinberg et al.	
	122	8,090,477 (EFACT.013A)	01/03/2012	Steinberg	
	123	8,131,497 (EFACT.005C1)	03/06/2012	Steinberg et al.	
	124	8,131,506 (EFACT.004C1)	03/06/2012	Steinberg et al.	
	125	8,180,492 (EFACT.011A)	05/15/2012	Steinberg	
	126	8,340,826 (EFACT.013C1)	12/25/2012	Steinberg et al.	
	127	8,412,488 (EFACT.004C2)	04/02/2013	Steinberg et al.	
	128	8,423,322 (EFACT.006C1)	04/16/2013	Steinberg et al.	
	129	8,428,785	04/23/2013	Boucher et al.	
	130	8,457,797	06/04/2013	Imes et al.	
	131	8,498,753 (EFACT.009A)	07/30/2013	Steinberg et al.	
	132	8,556,188 (EFACT.012A)	10/15/2013	Steinberg	
	133	8,596,550 (EFACT.007A)	12/03/2013	Steinberg et al.	
	134	8,712,590 (EFACT.013C2)	04/29/2014	Steinberg	
	135	8,738,327 (EFACT.004C3)	05/27/2014	Steinberg, et al.	
	136	8,740,100 (EFACT.008A)	06/03/2014	Steinberg	
	137	8,751,186 (EFACT.005C3)	06/10/2014	Steinberg, et al.	
	138	8,840,033 (EFACT.012C1)	09/23/2014	Steinberg	
	139	8,850,348	09/30/2014	Fadell et al.	

Examiner Signature	Date Considered
*Examiner: Initial if reference considered, whether or not citation is in conformance with MPEP 609. Draw line through citation if not in conformance and not considered. Include copy of this form with next communication to applicant.	

T<sup>1</sup> - Place a check mark in this area when an English language Translation is attached.

<b>INFORMATION DISCLOSURE STATEMENT BY APPLICANT</b>	Application No.	Unknown	
	Filing Date	Herewith	
	First Named Inventor	John Douglas Steinberg	
	Art Unit	Unknown	
<i>(Multiple sheets used when necessary)</i>		Examiner	Unknown
SHEET 6 OF 10		Attorney Docket No.	EFACT.011C2

U.S. PATENT DOCUMENTS					
Examiner Initials	Cite No.	Document Number Number - Kind Code (if known) Example: 1,234,567 B1	Publication Date MM-DD-YYYY	Name	Pages, Columns, Lines Where Relevant Passages or Relevant Figures Appear
	140	8,886,488 (EFACT.005C2)	11/11/2014	Steinberg, et al.	
	141	9,057,649 (EFACT.006C2)	06/16/2015	Steinberg, et al.	
	142	9,134,710 (EFACT.010C1)	09/15/2015	Cheung et al.	
	143	9,194,597 (EFACT.007C1)	11/24/2015	Steinberg, et al.	
	144	2003/0040934	02/27/2003	Skidmore et al.	
	145	2004/0176880	09/09/2004	Obradovich et al.	
	146	2005/0222889	10/06/2005	Lai et al.	
	147	2005/0288822	12/29/2005	Rayburn	
	148	2006/0045105	03/02/2006	Dobosz et al.	
	149	2006/0214014	09/28/2006	Bash et al.	
	150	2007/0043477	02/22/2007	Elhers et al.	
	151	2007/0045431	03/03/2007	Chapman et al.	
	152	2007/0146126	06/28/2007	Wang	
	153	2008/0083234	04/10/2008	Krebs et al.	
	154	2008/0198549	08/21/2008	Rasmussen et al.	
	155	2008/0281472	11/13/2008	Podgorny et al.	
	156	2009/0052859	02/26/2009	Greenberger et al.	
	157	2009/0099699	04/16/2009	Steinberg et al.	
	158	2009/0125151	05/14/2009	Steinberg et al.	
	159	2009/0240381	09/24/2009	Lane	
	160	2009/0281667	11/12/2009	Masui et al.	
	161	2010/0019052	01/28/2010	Yip	
	162	2010/0070086	03/18/2010	Harrod et al.	
	163	2010/0070089	03/18/2010	Harrod et al.	
	164	2010/0070093	03/18/2010	Harrod et al.	
	165	2010/0156608	06/24/2010	BAE et al.	
	166	2010/0162285	06/24/2010	Cohen et al.	
	167	2010/0211224	08/19/2010	Keeling et al.	

Examiner Signature	Date Considered
<p><b>*Examiner:</b> Initial if reference considered, whether or not citation is in conformance with MPEP 609. Draw line through citation if not in conformance and not considered. Include copy of this form with next communication to applicant.</p>	

T<sup>1</sup> - Place a check mark in this area when an English language Translation is attached.

<b>INFORMATION DISCLOSURE STATEMENT BY APPLICANT</b>	Application No.	Unknown
	Filing Date	Herewith
	First Named Inventor	John Douglas Steinberg
	Art Unit	Unknown
<i>(Multiple sheets used when necessary)</i>	Examiner	Unknown
SHEET 7 OF 10	Attorney Docket No.	EFACT.011C2

U.S. PATENT DOCUMENTS					
Examiner Initials	Cite No.	Document Number Number - Kind Code (if known) Example: 1,234,567 B1	Publication Date MM-DD-YYYY	Name	Pages, Columns, Lines Where Relevant Passages or Relevant Figures Appear
	168	2010/0235004	09/16/2010	Thind	
	169	2010/0289643	11/18/2010	Trundle et al.	
	170	2010/0318227	12/16/2010	Steinberg et al.	
	171	2011/0031323	02/10/2011	Nold et al.	
	172	2011/0046792	02/24/2011	Imes et al.	
	173	2011/0046798	02/24/2011	Imes et al.	
	174	2011/0046799	02/24/2011	Imes et al.	
	175	2011/0046800	02/24/2011	Imes et al.	
	176	2011/0046801	02/24/2011	Imes et al.	
	177	2011/0051823	03/03/2011	Imes et al.	
	178	2011/0054699	03/03/2011	Imes et al.	
	179	2011/0054710	03/03/2011	Imes et al.	
	180	2011/0173542	07/14/2011	Imes et al.	
	181	2011/0202185	08/18/2011	Imes et al.	
	182	2011/0214060	09/01/2011	Imes et al.	
	183	2011/0224838	09/15/2011	Imes et al.	
	184	2011/0246898	10/06/2011	Imes et al.	
	185	2011/0253796	10/20/2011	Posa et al.	
	186	2011/0290893	12/01/2011	Steinberg	
	187	2011/0307101	12/15/2011	Imes et al.	
	188	2012/0023225	01/26/2012	Imes et al.	
	189	2012/0046859	02/23/2012	Imes et al.	
	190	2012/0064923	03/15/2012	Imes et al.	
	191	2012/0065935	03/15/2012	Steinberg et al.	
	192	2012/0072033	03/22/2012	Imes et al.	
	193	2012/0086562	04/12/2012	Steinberg	
	194	2012/0093141	04/19/2012	Imes et al.	
	195	2012/0101637	04/26/2012	Imes et al.	
	196	2012/0135759	05/31/2012	Imes et al.	

Examiner Signature	Date Considered
<p><b>*Examiner:</b> Initial if reference considered, whether or not citation is in conformance with MPEP 609. Draw line through citation if not in conformance and not considered. Include copy of this form with next communication to applicant.</p>	

T<sup>1</sup> - Place a check mark in this area when an English language Translation is attached.

<b>INFORMATION DISCLOSURE STATEMENT BY APPLICANT</b>	Application No.	Unknown
	Filing Date	Herewith
	First Named Inventor	John Douglas Steinberg
	Art Unit	Unknown
<i>(Multiple sheets used when necessary)</i>	Examiner	Unknown
SHEET 8 OF 10	Attorney Docket No.	EFACT.011C2

U.S. PATENT DOCUMENTS					
Examiner Initials	Cite No.	Document Number Number - Kind Code (if known) Example: 1,234,567 B1	Publication Date MM-DD-YYYY	Name	Pages, Columns, Lines Where Relevant Passages or Relevant Figures Appear
	197	2012/0215725	08/23/2012	Imes et al.	
	198	2012/0221151 (EFACT.011C1)	08/30/2012	Steinberg	
	199	2012/0221718	08/30/2012	Imes et al.	
	200	2012/0252430	10/04/2012	Imes et al.	
	201	2012/0324119	12/20/2012	Imes et al.	
	202	2013/0053054	02/28/2013	Lovitt et al.	
	203	2013/0054758	02/28/2013	Imes et al.	
	204	2013/0054863	02/28/2013	Imes et al.	
	205	2013/0060387	03/07/2013	Imes et al.	
	206	2013/0144453	06/06/2013	Subbloie	
	207	2013/0167035	06/27/2013	Imes et al.	
	208	2013/0173064	07/04/2013	Fadell et al.	
	209	2013/0178985	07/11/2013	Lombard et al.	
	210	2013/0226502 (EFACT.006C2)	08/29/2013	Steinberg, et al.	
	211	2013/0310989 (EFACT.009C1)	11/21/2013	Steinberg et al.	
	212	2013/0338837 (EFACT.014A)	12/19/2013	Hublou et al.	
	213	2014/0039690 (EFACT.012C1)	02/06/2014	Steinberg	
	214	2014/0229018 (EFACT.013C3)	08/20/2014	Steinberg	
	215	2014/0316581	10/26/2014	Fadell et al.	
	216	2015/0021405 (EFACT.008C1)	01/22/2015	Steinberg	
	217	2015/0025691	01/22/2015	Fadell et al.	
	218	2015/0043615 (EFACT.004C4)	02/12/2015	Steinberg et al.	
	219	2015/0120235 (EFACT.005C4)	04/30/2015	Steinberg et al.	
	220	2015/0168001 (EFACT.012C2)	06/18/2015	Steinberg	

Examiner Signature	Date Considered
<p><b>*Examiner:</b> Initial if reference considered, whether or not citation is in conformance with MPEP 609. Draw line through citation if not in conformance and not considered. Include copy of this form with next communication to applicant.</p>	

T<sup>1</sup> - Place a check mark in this area when an English language Translation is attached.

<b>INFORMATION DISCLOSURE STATEMENT BY APPLICANT</b>	Application No.	Unknown	
	Filing Date	Herewith	
	First Named Inventor	John Douglas Steinberg	
	Art Unit	Unknown	
<i>(Multiple sheets used when necessary)</i>		Examiner	Unknown
SHEET 9 OF 10		Attorney Docket No.	EFACT.011C2

**FOREIGN PATENT DOCUMENTS**

Examiner Initials	Cite No.	Foreign Patent Document Country Code-Number-Kind Code Example: JP 1234567 A1	Publication Date MM-DD-YYYY	Name	Pages, Columns, Lines Where Relevant Passages or Relevant Figures Appear	T <sup>1</sup>
	221	EP 0415747 A2	03/06/1991	Shaw et al.		
	222	JP 05-189659	07/30/1993	Hitachi Bill Shisetsu Eng. KK.		
	223	JP 2010-038377	02/18/2010	Mitsubishi Heavy Ind. Ltd.		
	224	JP 2010-286218	12/24/2010	Mitsubishi Heavy Ind. Ltd.		
	225	KR 10-1994-0011902	06/22/1994	Koryo Digital Elect. Co.		
	226	KR 10-1999-0070368	09/15/1999	Samsung Electronics Co. Ltd.		
	227	KR 10-2000-0059532	10/05/2000	Dang Hae System Co.		
	228	WO 2005/098331 A1	10/20/2005	Zip Ind Aust Pty Ltd.		
	229	WO 2011/149600 (EFACT.012WO)	12/01/2011	EcoFactor, Inc.		
	230	WO 2012/024534 (EFACT.013WO)	02/23/2012	EcoFactor, Inc.		
	231	WO 2013/187996	12/19/2013	EcoFactor, Inc.		

**NON PATENT LITERATURE DOCUMENTS**

Examiner Initials	Cite No.	Include name of the author (in CAPITAL LETTERS), title of the article (when appropriate), title of the item (book, magazine, journal, serial, symposium, catalog, etc.), date, page(s), volume-issue number(s), publisher, city and/or country where published.	T <sup>1</sup>
	232	ARENS, et al., "How Ambient Intelligence Will Improve Habitability and Energy Efficiency in Buildings", 2005, research paper, Center for the Built Environment, Controls and Information Technology.	
	233	Bourhan, et al., "Cynamic model of an HVAC system for control analysis", Elsevier 2004.	
	234	Brush, et al., Preheat – Controlling Home Heating with Occupancy Prediction, 2013.	
	235	Comverge SuperStat Flyer, prior to June 28, 2007.	
	236	Control4 Wireless Thermostat Brochure, 2006.	
	237	Cooper Power Systems Web Page, 2000-2009.	
	238	Emerson Climate Technologies, "Network Thermostat for E2 Building Controller Installation and Operation Manual", 2007.	
	239	Enernoc Web Page, 2004-2009.	

Examiner Signature	Date Considered
*Examiner: Initial if reference considered, whether or not citation is in conformance with MPEP 609. Draw line through citation if not in conformance and not considered. Include copy of this form with next communication to applicant.	

T<sup>1</sup> - Place a check mark in this area when an English language Translation is attached.



<b>INFORMATION DISCLOSURE STATEMENT BY APPLICANT</b>	Application No.	Unknown
	Filing Date	Herewith
	First Named Inventor	John Douglas Steinberg
	Art Unit	Unknown
<i>(Multiple sheets used when necessary)</i>	Examiner	Unknown
SHEET 10 OF 10	Attorney Docket No.	EFACT.011C2

**NON PATENT LITERATURE DOCUMENTS**

Examiner Initials	Cite No.	Include name of the author (in CAPITAL LETTERS), title of the article (when appropriate), title of the item (book, magazine, journal, serial, symposium, catalog, etc.), date, page(s), volume-issue number(s), publisher, city and/or country where published.	T <sup>1</sup>
	240	Enerwise Website, 1999-2009.	
	241	Gupta, Adding GPS-Control to Traditional Thermostats: An Exploration of Potential Energy Savings and Design Challenges, MIT, 2009.	
	242	Gupta, et al., A Persuasive GPS-Controlled Thermostat System, MIT, 2008.	
	243	Honeywell Programmable Thermostat Owner's Guide, www.honeywell.com/yourhome, 2004.	
	244	Honeywell, "W7600/W7620 Controller Reference Manual, HW0021207, October, 1992.	
	245	Johnson Controls, "T600HCx-3 Single-Stage Thermostats", 2006.	
	246	JOHNSON CONTROLS, Touch4 building automation system brochure, 2007.	
	247	KILICOTTE, et al., "Dynamic Controls for Energy Efficiency and Demand Response: Framework Concepts and a New Construction Study Case in New York", Proceedings of the 2006 ACEEE Summer Study of Energy Efficiency in Buildings, Pacific Grove, CA, August 13-18, 2006	
	248	Krumm, et al., Learning Time-Based Presence Probabilities, June 2011.	
	249	LIN, et al., "Multi-Sensor Single-Actuator Control of HVAC Systems", 2002.	
	250	PIER, Southern California Edison, Demand Responsive Control of Air Conditioning via Programmable Communicating Thermostats Draft Report, February 14, 2006.	
	251	Proliphix Thermostat Brochure, prior to June 2007.	
	252	Scott, et al., Home Heating Using GPS-Based Arrival Prediction, 2010.	
	253	WANG, et al., "Opportunities to Save Energy and Improve Comfort by Using Wireless Sensor Networks in Buildings," (2003), Center for Environmental Design Research.	
	254	WETTER, et al., A comparison of deterministic and probabilistic optimization algorithms for nonsmooth simulation-based optimization, Building and Environment 39, 2004, Pages 989-999.	
	255	International Search Report and Written Opinion for PCT/US2013/035726 (EFACT.014WO), dated 08/06/2013.	
	256	Written Opinion and Search Report for PCT/US2011/032537, dated 12/12/11 (our reference EFACT.012WO).	
	257	International Preliminary Report on Patentability in PCT/US2013/035726 dated 12/16/2014 (EFACT.014WO).	

22519965:ad  
012116

Examiner Signature	Date Considered
*Examiner: Initial if reference considered, whether or not citation is in conformance with MPEP 609. Draw line through citation if not in conformance and not considered. Include copy of this form with next communication to applicant.	

T<sup>1</sup> - Place a check mark in this area when an English language Translation is attached.

## Electronic Patent Application Fee Transmittal

<b>Application Number:</b>	
<b>Filing Date:</b>	
<b>Title of Invention:</b>	SYSTEM AND METHOD FOR USING A WIRELESS DEVICE AS A SENSOR FOR AN ENERGY MANAGEMENT SYSTEM
<b>First Named Inventor/Applicant Name:</b>	John Douglas Steinberg
<b>Filer:</b>	John R. King/Amy Durrant
<b>Attorney Docket Number:</b>	EFACT.011C2

Filed as Small Entity

### Filing Fees for Utility under 35 USC 111(a)

Description	Fee Code	Quantity	Amount	Sub-Total in USD(\$)
<b>Basic Filing:</b>				
Utility filing Fee (Electronic filing)	4011	1	70	70
Utility Search Fee	2111	1	300	300
Utility Examination Fee	2311	1	360	360

**Pages:**

**Claims:**

### Miscellaneous-Filing:

Late Filing Fee for Oath or Declaration	2051	1	70	70
---	------	---	----	----

**Petition:**

0442

Description	Fee Code	Quantity	Amount	Sub-Total in USD(\$)
<b>Patent-Appeals-and-Interference:</b>				
<b>Post-Allowance-and-Post-Issuance:</b>				
<b>Extension-of-Time:</b>				
<b>Miscellaneous:</b>				
<b>Total in USD (\$)</b>				<b>800</b>

## Electronic Acknowledgement Receipt

<b>EFS ID:</b>	24685303
<b>Application Number:</b>	15002791
<b>International Application Number:</b>	
<b>Confirmation Number:</b>	4939
<b>Title of Invention:</b>	SYSTEM AND METHOD FOR USING A WIRELESS DEVICE AS A SENSOR FOR AN ENERGY MANAGEMENT SYSTEM
<b>First Named Inventor/Applicant Name:</b>	John Douglas Steinberg
<b>Customer Number:</b>	20995
<b>Filer:</b>	John R. King/Gustavo Lopez
<b>Filer Authorized By:</b>	John R. King
<b>Attorney Docket Number:</b>	EFACT.011C2
<b>Receipt Date:</b>	21-JAN-2016
<b>Filing Date:</b>	
<b>Time Stamp:</b>	14:19:33
<b>Application Type:</b>	Utility under 35 USC 111(a)

### Payment information:

Submitted with Payment	yes
Payment Type	Credit Card
Payment was successfully received in RAM	\$800
RAM confirmation Number	558
Deposit Account	
Authorized User	

The Director of the USPTO is hereby authorized to charge indicated fees and credit any overpayment as follows:

<b>File Listing:</b>					
<b>Document Number</b>	<b>Document Description</b>	<b>File Name</b>	<b>File Size(Bytes)/ Message Digest</b>	<b>Multi Part /.zip</b>	<b>Pages (if appl.)</b>
1	Application Data Sheet	EFACT-011C2_ADS.pdf	1561279 e81d0c3c60873c7132ef0ad8bd71859b318ad24	no	7
<b>Warnings:</b>					
<b>Information:</b>					
2		EFACT-011C2_specification.pdf	863993 21b3e55693b2420bf5db3b46a06c2db79c165b02	yes	16
	<b>Multipart Description/PDF files in .zip description</b>				
	<b>Document Description</b>		<b>Start</b>	<b>End</b>	
	Specification		1	12	
	Claims		13	15	
	Abstract		16	16	
<b>Warnings:</b>					
<b>Information:</b>					
3	Drawings-only black and white line drawings	EFACT-011C2_drawings.pdf	158721 f3ec8292ed09c8be08e43a790f2aca6f5a9b258c	no	8
<b>Warnings:</b>					
<b>Information:</b>					
4		EFACT-011C2_IDS.pdf	896841 1d1fe1072884761f68407394687742e323b8d13f	yes	12
	<b>Multipart Description/PDF files in .zip description</b>				
	<b>Document Description</b>		<b>Start</b>	<b>End</b>	
	Transmittal Letter		1	2	
Information Disclosure Statement (IDS) Form (SB08)		3	12		
<b>Warnings:</b>					
<b>Information:</b>					

5	Fee Worksheet (SB06)	fee-info.pdf	36920 03645762ffe510bec6225c43a3cd100cbab86c57	no	2
---	----------------------	--------------	---	----	---

**Warnings:**

**Information:**

<b>Total Files Size (in bytes):</b>	3517754
-------------------------------------	---------

**This Acknowledgement Receipt evidences receipt on the noted date by the USPTO of the indicated documents, characterized by the applicant, and including page counts, where applicable. It serves as evidence of receipt similar to a Post Card, as described in MPEP 503.**

**New Applications Under 35 U.S.C. 111**

**If a new application is being filed and the application includes the necessary components for a filing date (see 37 CFR 1.53(b)-(d) and MPEP 506), a Filing Receipt (37 CFR 1.54) will be issued in due course and the date shown on this Acknowledgement Receipt will establish the filing date of the application.**

**National Stage of an International Application under 35 U.S.C. 371**

**If a timely submission to enter the national stage of an international application is compliant with the conditions of 35 U.S.C. 371 and other applicable requirements a Form PCT/DO/EO/903 indicating acceptance of the application as a national stage submission under 35 U.S.C. 371 will be issued in addition to the Filing Receipt, in due course.**

**New International Application Filed with the USPTO as a Receiving Office**

**If a new international application is being filed and the international application includes the necessary components for an international filing date (see PCT Article 11 and MPEP 1810), a Notification of the International Application Number and of the International Filing Date (Form PCT/RO/105) will be issued in due course, subject to prescriptions concerning national security, and the date shown on this Acknowledgement Receipt will establish the international filing date of the application.**

Under the Paperwork Reduction Act of 1995, no persons are required to respond to a collection of information unless it contains a valid OMB control number.

<b>Application Data Sheet 37 CFR 1.76</b>		Attorney Docket Number	EFACT.011C2
		Application Number	
Title of Invention	SYSTEM AND METHOD FOR USING A WIRELESS DEVICE AS A SENSOR FOR AN ENERGY MANAGEMENT SYSTEM		
The application data sheet is part of the provisional or nonprovisional application for which it is being submitted. The following form contains the bibliographic data arranged in a format specified by the United States Patent and Trademark Office as outlined in 37 CFR 1.76. This document may be completed electronically and submitted to the Office in electronic format using the Electronic Filing System (EFS) or the document may be printed and included in a paper filed application.			

## Secrecy Order 37 CFR 5.2

<input type="checkbox"/>	Portions or all of the application associated with this Application Data Sheet may fall under a Secrecy Order pursuant to 37 CFR 5.2 (Paper filers only. Applications that fall under Secrecy Order may not be filed electronically.)
--------------------------	---

## Inventor Information:

Inventor	1				Remove
Legal Name					
Prefix	Given Name	Middle Name	Family Name	Suffix	
	John	Douglas	Steinberg		
Residence Information (Select One) • US Residency    Non US Residency    Active US Military Service					
City	Millbrae	State/Province	CA	Country of Residence	US
Mailing Address of Inventor:					
Address 1	873 Hacienda Way				
Address 2					
City	Millbrae	State/Province	CA		
Postal Code	94030	Country	US		
All Inventors Must Be Listed - Additional Inventor Information blocks may be generated within this form by selecting the Add button.					Add

## Correspondence Information:

Enter either Customer Number or complete the Correspondence Information section below. For further information see 37 CFR 1.33(a).			
<input type="checkbox"/> An Address is being provided for the correspondence information of this application.			
Customer Number	20995		
Email Address	efiling@knobbe.com	Add Email	Remove Email

## Application Information:

Title of the Invention	SYSTEM AND METHOD FOR USING A WIRELESS DEVICE AS A SENSOR FOR AN ENERGY MANAGEMENT SYSTEM		
Attorney Docket Number	EFACT.011C2	Small Entity Status Claimed	<input checked="" type="checkbox"/>
Application Type	Nonprovisional		
Subject Matter	Utility		
Total Number of Drawing Sheets (if any)	8	Suggested Figure for Publication (if any)	

## Filing By Reference :

<b>Application Data Sheet 37 CFR 1.76</b>	Attorney Docket Number	EFACT.011C2
	Application Number	
Title of Invention	SYSTEM AND METHOD FOR USING A WIRELESS DEVICE AS A SENSOR FOR AN ENERGY MANAGEMENT SYSTEM	

Only complete this section when filing an application by reference under 35 U.S.C. 111(c) and 37 CFR 1.57(a). Do not complete this section if application papers including a specification and any drawings are being filed. Any domestic benefit or foreign priority information must be provided in the appropriate section(s) below (i.e., "Domestic Benefit/National Stage Information" and "Foreign Priority Information").

For the purposes of a filing date under 37 CFR 1.53(b), the description and any drawings of the present application are replaced by this reference to the previously filed application, subject to conditions and requirements of 37 CFR 1.57(a).

Application number of the previously filed application	Filing date (YYYY-MM-DD)	Intellectual Property Authority or Country

### Publication Information:

Request Early Publication (Fee required at time of Request 37 CFR 1.219)

**Request Not to Publish.** I hereby request that the attached application not be published under 35 U.S.C. 122(b) and certify that the invention disclosed in the attached application **has not and will not** be the subject of an application filed in another country, or under a multilateral international agreement, that requires publication at eighteen months after filing.

### Representative Information:

Representative information should be provided for all practitioners having a power of attorney in the application. Providing this information in the Application Data Sheet does not constitute a power of attorney in the application (see 37 CFR 1.32). Either enter Customer Number or complete the Representative Name section below. If both sections are completed the customer number will be used for the Representative Information during processing.

Please Select One:	<input checked="" type="radio"/> Customer Number	US Patent Practitioner	<input type="radio"/> Limited Recognition (37 CFR 11.9)
Customer Number	20995		

### Domestic Benefit/National Stage Information:

This section allows for the applicant to either claim benefit under 35 U.S.C. 119(e), 120, 121, or 365(c) or indicate National Stage entry from a PCT application. Providing this information in the application data sheet constitutes the specific reference required by 35 U.S.C. 119(e) or 120, and 37 CFR 1.78.

When referring to the current application, please leave the application number blank.

Prior Application Status	Pending					Remove
Application Number	Continuity Type	Prior Application Number	Filing Date (YYYY-MM-DD)			
	Continuation of	13/470074	2012-05-11			
Prior Application Status	Patented					Remove
Application Number	Continuity Type	Prior Application Number	Filing Date (YYYY-MM-DD)	Patent Number	Issue Date (YYYY-MM-DD)	
13/470074	Continuation of	12/502064	2009-07-13	8180492	2012-05-15	
Prior Application Status	Expired	0448				Remove



Under the Paperwork Reduction Act of 1995, no persons are required to respond to a collection of information unless it contains a valid OMB control number.

<b>Application Data Sheet 37 CFR 1.76</b>		Attorney Docket Number	EFACT.011C2	
		Application Number		
Title of Invention	SYSTEM AND METHOD FOR USING A WIRELESS DEVICE AS A SENSOR FOR AN ENERGY MANAGEMENT SYSTEM			
Application Number	Continuity Type	Prior Application Number	Filing Date (YYYY-MM-DD)	
12/502064	Claims benefit of provisional <input type="button" value="v"/>	61/134714	2008-07-14	
Additional Domestic Benefit/National Stage Data may be generated within this form by selecting the <b>Add</b> button.				<input type="button" value="Add"/>

### Foreign Priority Information:

This section allows for the applicant to claim priority to a foreign application. Providing this information in the application data sheet constitutes the claim for priority as required by 35 U.S.C. 119(b) and 37 CFR 1.55(d). When priority is claimed to a foreign application that is eligible for retrieval under the priority document exchange program (PDX)<sup>i</sup> the information will be used by the Office to automatically attempt retrieval pursuant to 37 CFR 1.55(h)(1) and (2). Under the PDX program, applicant bears the ultimate responsibility for ensuring that a copy of the foreign application is received by the Office from the participating foreign intellectual property office, or a certified copy of the foreign priority application is filed, within the time period specified in 37 CFR 1.55(g)(1).

<input type="button" value="Remove"/>			
Application Number	Country <sup>i</sup>	Filing Date (YYYY-MM-DD)	Access Code <sup>i</sup> (if applicable)
Additional Foreign Priority Data may be generated within this form by selecting the <b>Add</b> button.			
<input type="button" value="Add"/>			

### Statement under 37 CFR 1.55 or 1.78 for AIA (First Inventor to File) Transition Applications

This application (1) claims priority to or the benefit of an application filed before March 16, 2013 and (2) also contains, or contained at any time, a claim to a claimed invention that has an effective filing date on or after March 16, 2013.

NOTE: By providing this statement under 37 CFR 1.55 or 1.78, this application, with a filing date on or after March 16, 2013, will be examined under the first inventor to file provisions of the AIA.

### Authorization to Permit Access:

Authorization to Permit Access to the Instant Application by the Participating Offices

Under the Paperwork Reduction Act of 1995, no persons are required to respond to a collection of information unless it contains a valid OMB control number.

<b>Application Data Sheet 37 CFR 1.76</b>	Attorney Docket Number	EFACT.011C2
	Application Number	
Title of Invention	SYSTEM AND METHOD FOR USING A WIRELESS DEVICE AS A SENSOR FOR AN ENERGY MANAGEMENT SYSTEM	

If checked, the undersigned hereby grants the USPTO authority to provide the European Patent Office (EPO), the Japan Patent Office (JPO), the Korean Intellectual Property Office (KIPO), the World Intellectual Property Office (WIPO), and any other intellectual property offices in which a foreign application claiming priority to the instant patent application is filed access to the instant patent application. See 37 CFR 1.14(c) and (h). This box should not be checked if the applicant does not wish the EPO, JPO, KIPO, WIPO, or other intellectual property office in which a foreign application claiming priority to the instant patent application is filed to have access to the instant patent application.

In accordance with 37 CFR 1.14(h)(3), access will be provided to a copy of the instant patent application with respect to: 1) the instant patent application-as-filed; 2) any foreign application to which the instant patent application claims priority under 35 U.S.C. 119(a)-(d) if a copy of the foreign application that satisfies the certified copy requirement of 37 CFR 1.55 has been filed in the instant patent application; and 3) any U.S. application-as-filed from which benefit is sought in the instant patent application.

In accordance with 37 CFR 1.14(c), access may be provided to information concerning the date of filing this Authorization.

## Applicant Information:

Providing assignment information in this section does not substitute for compliance with any requirement of part 3 of Title 37 of CFR to have an assignment recorded by the Office.			
<b>Applicant</b>	1	<input type="button" value="Remove"/>	
If the applicant is the inventor (or the remaining joint inventor or inventors under 37 CFR 1.45), this section should not be completed. The information to be provided in this section is the name and address of the legal representative who is the applicant under 37 CFR 1.43; or the name and address of the assignee, person to whom the inventor is under an obligation to assign the invention, or person who otherwise shows sufficient proprietary interest in the matter who is the applicant under 37 CFR 1.46. If the applicant is an applicant under 37 CFR 1.46 (assignee, person to whom the inventor is obligated to assign, or person who otherwise shows sufficient proprietary interest) together with one or more joint inventors, then the joint inventor or inventors who are also the applicant should be identified in this section.			
<input type="button" value="Clear"/>			
<input checked="" type="radio"/> Assignee	Legal Representative under 35 U.S.C. 117	Joint Inventor	
Person to whom the inventor is obligated to assign.		Person who shows sufficient proprietary interest	
If applicant is the legal representative, indicate the authority to file the patent application, the inventor is:			
<input type="button" value="Clear"/>			
Name of the Deceased or Legally Incapacitated Inventor :			
If the Applicant is an Organization check here. <input checked="" type="checkbox"/>			
Organization Name	EcoFactor, Inc.		
<b>Mailing Address Information For Applicant:</b>			
Address 1	1450 Veteran's Boulevard		
Address 2	Suite 100		
City	Redwood City	State/Province	CA
Country	US	Postal Code	94063
Phone Number		Fax Number	

0450

Under the Paperwork Reduction Act of 1995, no persons are required to respond to a collection of information unless it contains a valid OMB control number.

<b>Application Data Sheet 37 CFR 1.76</b>	Attorney Docket Number	EFACT.011C2
	Application Number	
Title of Invention	SYSTEM AND METHOD FOR USING A WIRELESS DEVICE AS A SENSOR FOR AN ENERGY MANAGEMENT SYSTEM	
Email Address		
Additional Applicant Data may be generated within this form by selecting the Add button.		<input type="button" value="Add"/>

## Assignee Information including Non-Applicant Assignee Information:

Providing assignment information in this section does not substitute for compliance with any requirement of part 3 of Title 37 of CFR to have an assignment recorded by the Office.

<b>Assignee</b>	1			
Complete this section if assignee information, including non-applicant assignee information, is desired to be included on the patent application publication. An assignee-applicant identified in the "Applicant Information" section will appear on the patent application publication as an applicant. For an assignee-applicant, complete this section only if identification as an assignee is also desired on the patent application publication.				
				<input type="button" value="Remove"/>
If the Assignee or Non-Applicant Assignee is an Organization check here.				<input type="checkbox"/>
Prefix	Given Name	Middle Name	Family Name	Suffix
<b>Mailing Address Information For Assignee including Non-Applicant Assignee:</b>				
Address 1				
Address 2				
City		State/Province		
Country <sup>i</sup>		Postal Code		
Phone Number		Fax Number		
Email Address				
Additional Assignee or Non-Applicant Assignee Data may be generated within this form by selecting the Add button.				<input type="button" value="Add"/>

## Signature:

NOTE: This form must be signed in accordance with 37 CFR 1.33. See 37 CFR 1.4 for signature requirements and certifications.					
Signature	/John R. King/			Date (YYYY-MM-DD)	2016-01-21
First Name	John	Last Name	King	Registration Number	34362
Additional Signature may be generated within this form by selecting the Add button.					<input type="button" value="Add"/>

Under the Paperwork Reduction Act of 1995, no persons are required to respond to a collection of information unless it contains a valid OMB control number.

<b>Application Data Sheet 37 CFR 1.76</b>	Attorney Docket Number	EFACT.011C2
	Application Number	
Title of Invention	SYSTEM AND METHOD FOR USING A WIRELESS DEVICE AS A SENSOR FOR AN ENERGY MANAGEMENT SYSTEM	

This collection of information is required by 37 CFR 1.76. The information is required to obtain or retain a benefit by the public which is to file (and by the USPTO to process) an application. Confidentiality is governed by 35 U.S.C. 122 and 37 CFR 1.14. This collection is estimated to take 23 minutes to complete, including gathering, preparing, and submitting the completed application data sheet form to the USPTO. Time will vary depending upon the individual case. Any comments on the amount of time you require to complete this form and/or suggestions for reducing this burden, should be sent to the Chief Information Officer, U.S. Patent and Trademark Office, U.S. Department of Commerce, P.O. Box 1450, Alexandria, VA 22313-1450. DO NOT SEND FEES OR COMPLETED FORMS TO THIS ADDRESS. **SEND TO: Commissioner for Patents, P.O. Box 1450, Alexandria, VA 22313-1450.**

## Privacy Act Statement

The Privacy Act of 1974 (P.L. 93-579) requires that you be given certain information in connection with your submission of the attached form related to a patent application or patent. Accordingly, pursuant to the requirements of the Act, please be advised that: (1) the general authority for the collection of this information is 35 U.S.C. 2(b)(2); (2) furnishing of the information solicited is voluntary; and (3) the principal purpose for which the information is used by the U.S. Patent and Trademark Office is to process and/or examine your submission related to a patent application or patent. If you do not furnish the requested information, the U.S. Patent and Trademark Office may not be able to process and/or examine your submission, which may result in termination of proceedings or abandonment of the application or expiration of the patent.

The information provided by you in this form will be subject to the following routine uses:

1. The information on this form will be treated confidentially to the extent allowed under the Freedom of Information Act (5 U.S.C. 552) and the Privacy Act (5 U.S.C. 552a). Records from this system of records may be disclosed to the Department of Justice to determine whether the Freedom of Information Act requires disclosure of these records.
2. A record from this system of records may be disclosed, as a routine use, in the course of presenting evidence to a court, magistrate, or administrative tribunal, including disclosures to opposing counsel in the course of settlement negotiations.
3. A record in this system of records may be disclosed, as a routine use, to a Member of Congress submitting a request involving an individual, to whom the record pertains, when the individual has requested assistance from the Member with respect to the subject matter of the record.
4. A record in this system of records may be disclosed, as a routine use, to a contractor of the Agency having need for the information in order to perform a contract. Recipients of information shall be required to comply with the requirements of the Privacy Act of 1974, as amended, pursuant to 5 U.S.C. 552a(m).
5. A record related to an International Application filed under the Patent Cooperation Treaty in this system of records may be disclosed, as a routine use, to the International Bureau of the World Intellectual Property Organization, pursuant to the Patent Cooperation Treaty.
6. A record in this system of records may be disclosed, as a routine use, to another federal agency for purposes of National Security review (35 U.S.C. 181) and for review pursuant to the Atomic Energy Act (42 U.S.C. 218(c)).
7. A record from this system of records may be disclosed, as a routine use, to the Administrator, General Services, or his/her designee, during an inspection of records conducted by GSA as part of that agency's responsibility to recommend improvements in records management practices and programs, under authority of 44 U.S.C. 2904 and 2906. Such disclosure shall be made in accordance with the GSA regulations governing inspection of records for this purpose, and any other relevant (i.e., GSA or Commerce) directive. Such disclosure shall not be used to make determinations about individuals.
8. A record from this system of records may be disclosed, as a routine use, to the public after either publication of the application pursuant to 35 U.S.C. 122(b) or issuance of a patent pursuant to 35 U.S.C. 151. Further, a record may be disclosed, subject to the limitations of 37 CFR 1.14, as a routine use, to the public if the record was filed in an application which became abandoned or in which the proceedings were terminated and which application is referenced by either a published application, an application open to public inspections or an issued patent.
9. A record from this system of records may be disclosed, as a routine use, to a Federal, State, or local law enforcement agency, if the USPTO becomes aware of a violation or potential violation of law or regulation.

SYSTEM AND METHOD FOR USING A WIRELESS DEVICE AS A SENSOR FOR  
AN ENERGY MANAGEMENT SYSTEM

RELATED APPLICATIONS

**[0001]** Any and all applications for which a foreign or domestic priority claim is identified in the Application Data Sheet, or any correction thereto, are hereby incorporated by reference into this application under 37 CFR 1.57.

BACKGROUND OF THE INVENTION

Field of the Invention

**[0002]** This invention relates to the use of thermostatic HVAC and other energy management controls that are connected to a computer network. More specifically, the present invention pertains to the use of user interactions with an interface such as a personal computer or an Internet-enabled television as signal related to occupancy to inform an energy management system.

**[0003]** Heating and cooling systems for buildings (heating, ventilation and cooling, or HVAC systems) have been controlled for decades by thermostats. At the most basic level, a thermostat includes a means to allow a user to set a desired temperature, a means to sense actual temperature, and a means to signal the heating and/or cooling devices to turn on or off in order to try to change the actual temperature to equal the desired temperature. The most basic versions of thermostats use components such as a coiled bi-metallic spring to measure actual temperature and a mercury switch that opens or completes a circuit when the spring coils or uncoils with temperature changes. More recently, electronic digital thermostats have become prevalent. These thermostats use solid-state devices such as thermistors or thermal diodes to measure temperature, and microprocessor-based circuitry to control the switch and to store and operate based upon user-determined protocols for temperature vs. time.

**[0004]** These programmable thermostats generally offer a very restrictive user interface, limited by the cost of the devices, the limited real estate of the small wall-mounted boxes, and the inability to take into account more than two variables: the desired temperature set by the user, and the ambient temperature sensed by the thermostat. Users can generally only set one series of commands per day, and in order to change one parameter (e.g., to change the late-night temperature) the user often has to cycle through several other parameters by repeatedly pressing one or two buttons.

**[0005]** Because the interface of programmable thermostats is so poor, the significant theoretical savings that are possible with them (sometimes cited as 25% of heating and cooling costs) are rarely realized. In practice, studies have found that more than 50% of users never program their thermostats at all. Significant percentages of the thermostats that are programmed are programmed sub-optimally, in part because, once programmed, people tend to not to re-invest the time needed to change the settings very often.

**[0006]** A second problem with standard programmable thermostats is that they represent only a small evolutionary step beyond the first, purely mechanical thermostats. Like the first thermostats, they only have two input signals - ambient temperature and the preset desired temperature. The entire advance with programmable thermostats is that they can shift between multiple present temperatures at different times without real-time involvement of a human being.

**[0007]** Because most thermostats control HVAC systems that do not offer infinitely variable output, traditional thermostats are designed to permit the temperature as seen by the thermostat to vary above and below the setpoint to prevent the HVAC system from constantly and rapidly cycling on and off, which is inefficient and harmful to the HVAC system. The temperature range in which the thermostat allows the controlled environment to drift is known as both the dead zone and, more formally, the hysteresis zone. The hysteresis zone is frequently set at +/- 1 degree Fahrenheit. Thus if the setpoint is 68 degrees, in the heating context the thermostat will allow the inside temperature to fall to 67 degrees before turning the heating system on, and will allow it to rise to 69 degrees before turning it off again.

**[0008]** As energy prices rise, more attention is being paid to ways of reducing energy consumption. Because energy consumption is directly proportional to setpoint - that is, the further a given setpoint diverges from the balance point (the inside temperature assuming no HVAC activity) in a given house under given conditions, the higher energy consumption will be to maintain temperature at that setpoint), energy will be saved by virtually any strategy that over a given time frame lowers the average heating setpoint or raises the cooling setpoint. Conventional programmable thermostats allow homeowners to save money and energy by pre-programming setpoint changes based upon comfort or schedule. For example, in the summer, allowing the setpoint to rise by several degrees (or even shutting off the air conditioner) when the home is unoccupied will generally save significantly on energy. But such thermostats have proven to be only minimally effective in practice. Because they have such primitive user interfaces, they are difficult to program, and so many users never bother at all, or set them up once and do not alter the programming even if their schedules change.

**[0009]** In the hotel industry, the heating and cooling decisions made in hundred or even thousands of individual rooms with independently controlled HVAC systems are aggregated into a single energy bill, so hotel owners and managers are sensitive to energy consumption by those systems. Hotel guests often turn the air conditioner to a low temperature setting and then leave the room for hours at a time, thereby wasting considerable energy. An approach commonly used outside of the United States to combat this problem is to use a keycard to control the HVAC system, such that guests place the keycard into a slot mounted on the wall near the door of the room which then triggers the lights and HVAC system to power up, and turn them off when the guest removes the card upon leaving the room. However, because most hotels give each guest two cards, it is easy to simply leave the extra card in the slot, thus defeating the purpose of the system. Recently, systems have been introduced in which a motion sensor is connected to the control circuitry for the HVAC system. If no motion is detected in the room for some predetermined interval, the system concludes that the room is unoccupied, and turns off or alters the setpoint of the HVAC system to a more economical level. When the motion sensor



detects motion (which is assumed to coincide with the return of the guest), the HVAC system resets to the guest's chosen setting.

**[0010]** Adding occupancy detection capability to residential HVAC systems could also add considerable value in the form of energy savings without significant tradeoff in terms of comfort. But the systems used in hotels do not easily transfer to the single-family residential context. Hotel rooms tend to be small enough that a single motion sensor is sufficient to determine with a high degree of accuracy whether or not the room is occupied. A single motion sensor in the average home today would have limited value because there are likely to be many places one or more people could be home and active yet invisible to the motion sensor. The most economical way to include a motion sensor in a traditional programmable thermostat would be to build it into the thermostat itself. But thermostats are generally located in hallways, and thus are unlikely to be exposed to the areas where people tend to spend their time. Wiring a home with multiple motion sensors in order to maximize the chances of detecting occupants would involve considerable expense, both for the sensors themselves and for the considerable cost of installation, especially in the retrofit market. Yet if control is ceded to a single-sensor system that cannot reliably detect presence, the resulting errors would likely lead the homeowner to reject the system.

**[0011]** It would thus be desirable to provide a system that could detect occupancy without requiring the installation of additional hardware; that could accurately detect occupancy regardless of which room in the house is occupied, and could optimize energy consumption based upon dynamic and individually configurable heuristics.

#### SUMMARY OF THE INVENTION

**[0012]** In one embodiment, the invention comprises a thermostat attached to an HVAC system, a local network connecting the thermostat to a larger network such as the Internet, and one or more computers attached to the network, and a server in bi-directional communication with a plurality of such thermostats and computers. The server pairs each thermostat with one or more computers or other

consumer electronic devices which are determined to be associated with the home in which the thermostat is located. The server logs the ambient temperature sensed by each thermostat vs. time and the signals sent by the thermostats to their HVAC systems. The server also monitors and logs activity on the computers or other consumer electronic devices associated with each thermostat. Based on the activity patterns evidenced by keystrokes, cursor movement or other inputs, or lack thereof, the server instructs the thermostat to change temperature settings between those optimized for occupied and unoccupied states.

**[0013]** At least one embodiment of the invention comprises the steps of determining whether one or more networked electronic devices inside a structure are in use; determining whether said use of said networked electronic devices indicates occupancy of said structure; and adjusting the temperature setpoint on a thermostatic controller for an HVAC system for said structure based upon whether or not said structure is deemed to be occupied.

**[0014]** At least one embodiment of the invention comprises at least one said thermostat having at least one temperature setting associated with the presence of one or more occupants in said structure, and at least one temperature setting associated with the absence of occupants in said structure; one or more electronic devices having at least a user interface; where said electronic devices and said thermostat are connected to a network; where said setpoint on said thermostat is adjusted between said temperature setting associated with the presence of one or more occupants in said structure and said temperature setting associated with the absence of occupants in said structure based upon the use of said user interface for said electronic device.

#### BRIEF DESCRIPTION OF THE DRAWINGS

**[0015]** Figure 1 shows an example of an overall environment in which an embodiment of the invention may be used.

**[0016]** Figure 2 shows a high-level illustration of the architecture of a network showing the relationship between the major elements of one embodiment of the subject invention.

**[0017]** Figure 3 shows an embodiment of the website to be used as part of the subject invention.

**[0018]** Figure 4 shows a high-level schematic of the thermostat used as part of the subject invention.

**[0019]** Figure 5 shows one embodiment of the database structure used as part of the subject invention.

**[0020]** Figure 6 shows the browser as seen on the display of the computer used as part of the subject invention.

**[0021]** Figure 7 is a flowchart showing the steps involved in the operation of one embodiment of the subject invention.

**[0022]** Figure 8 is a flowchart that shows how the invention can be used to select different HVAC settings based upon its ability to identify which of multiple potential occupants is using the computer attached to the system.

#### DETAILED DESCRIPTION OF THE PREFERRED EMBODIMENT

**[0023]** **Figure 1** shows an example of an overall environment 100 in which an embodiment of the invention may be used. The environment 100 includes an interactive communication network 102 with computers 104 connected thereto. Also connected to network 102 are one or more server computers 106, which store information and make the information available to computers 104. The network 102 allows communication between and among the computers 104 and 106.

**[0024]** Presently preferred network 102 comprises a collection of interconnected public and/or private networks that are linked to together by a set of standard protocols to form a distributed network. While network 102 is intended to refer to what is now commonly referred to as the Internet, it is also intended to encompass variations which may be made in the future, including changes additions to existing standard protocols.

**[0025]** When a user of the subject invention wishes to access information on network 102, the user initiates connection from his computer 104. For example, the user invokes a browser, which executes on computer 104. The browser, in turn,

establishes a communication link with network 102. Once connected to network 102, the user can direct the browser to access information on server 106.

**[0026]** One popular part of the Internet is the World Wide Web. The World Wide Web contains a large number of computers 104 and servers 106, which store HyperText Markup Language (HTML) documents capable of displaying graphical and textual information. HTML is a standard coding convention and set of codes for attaching presentation and linking attributes to informational content within documents.

**[0027]** The servers 106 that provide offerings on the World Wide Web are typically called websites. A website is often defined by an Internet address that has an associated electronic page. Generally, an electronic page is a document that organizes the presentation of text graphical images, audio and video.

**[0028]** In addition to the Internet, the network 102 can comprise a wide variety of interactive communication media. For example, network 102 can include local area networks, interactive television networks, telephone networks, wireless data systems, two-way cable systems, and the like.

**[0029]** In one embodiment, computers 104 and servers 106 are conventional computers that are equipped with communications hardware such as modem or a network interface card. The computers include processors such as those sold by Intel and AMD. Other processors may also be used, including general-purpose processors, multi-chip processors, embedded processors and the like.

**[0030]** Computers 104 can also be handheld and wireless devices such as personal digital assistants (PDAs), cellular telephones and other devices capable of accessing the network. Computers 104 can also be microprocessor- controlled home entertainment equipment including advanced televisions, televisions paired with home entertainment/media centers, and wireless remote controls.

**[0031]** Computers 104 may utilize a browser configured to interact with the World Wide Web. Such browsers may include Microsoft Explorer, Mozilla, Firefox, Opera or Safari. They may also include browsers or similar software used on handheld, home entertainment and wireless devices. The storage medium may comprise any method of storing information. It may comprise random access

memory (RAM), electronically erasable programmable read only memory (EEPROM), read only memory (ROM), hard disk, floppy disk, CD-ROM, optical memory, or other method of storing data. Computers 104 and 106 may use an operating system such as Microsoft Windows, Apple Mac OS, Linux, Unix or the like. Computers 106 may include a range of devices that provide information, sound, graphics and text, and may use a variety of operating systems and software optimized for distribution of content via networks.

**[0032]** **Figure 2** illustrates in further detail the architecture of the specific components connected to network 102 showing the relationship between the major elements of one embodiment of the subject invention. Attached to the network are thermostats 108 and computers 104 of various users. Connected to thermostats 108 are HVAC units 110. The HVAC units may be conventional air conditioners, heat pumps, or other devices for transferring heat into or out of a building. Each user is connected to the server 106 via wired or wireless connection such as Ethernet or a wireless protocol such as IEEE 802.11, a gateway 112 that connects the computer and thermostat to the Internet via a broadband connection such as a digital subscriber line (DSL) or other form of broadband connection to the World Wide Web. Server 106 contains the content to be served as web pages and viewed by computers 104, as well as databases containing information used by the servers.

**[0033]** In the currently preferred embodiment, the website 200 includes a number of components accessible to the user, as shown in **Figure 3**. Those components may include a means to enter temperature settings 202, a means to enter information about the user's home 204, a means to enter the user's electricity bills 206, means to calculate energy savings that could result from various thermostat-setting strategies 208, and means to enable and choose between various arrangements 210 for demand reduction with their electric utility provider as intermediated by the demand reduction service provider.

**[0034]** **Figure 4** shows a high-level block diagram of thermostat 108 used as part of the subject invention. Thermostat 108 includes temperature sensing means 252, which may be a thermistor, thermal diode or other means commonly used in the design of electronic thermostats. It includes a microprocessor 254,

memory 256, a display 258, a power source 260, a relay 262, which turns the HVAC system on and off in response to a signal from the microprocessor, and contacts by which the relay is connected to the wires that lead to the HVAC system. To allow the thermostat to communicate bi-directionally with the computer network, the thermostat also includes means 264 to connect the thermostat to a local computer or to a wireless network. Such means could be in the form of Ethernet, wireless protocols such as IEEE 802.11, IEEE 802.15.4, Bluetooth, cellular systems such as CDMA, GSM and GPRS, or other wireless protocols. The thermostat 250 may also include controls 266 allowing users to change settings directly at the thermostat, but such controls are not necessary to allow the thermostat to function.

**[0035]** The data used to generate the content delivered in the form of the website is stored on one or more servers 106 within one or more databases. As shown in **Figure 5**, the overall database structure 300 may include temperature database 400, thermostat settings database 500, energy bill database 600, HVAC hardware database 700, weather database 800, user database 900, transaction database 1000, product and service database 1100 and such other databases as may be needed to support these and additional features.

**[0036]** The website 200 will allow users of connected thermostats 250 to create personal accounts. Each user's account will store information in database 900, which tracks various attributes relative to users of the site. Such attributes may include the make and model of the specific HVAC equipment in the user's home; the age and square footage of the home, the solar orientation of the home, the location of the thermostat in the home, the user's preferred temperature settings, whether the user is a participant in a demand reduction program, etc.

**[0037]** As shown in Figure 3, the website 200 will permit thermostat users to perform through the web browser substantially all of the programming functions traditionally performed directly at the physical thermostat, such as temperature set points, the time at which the thermostat should be at each set point, etc. Preferably the website will also allow users to accomplish more advanced tasks such as allow users to program in vacation settings for times when the HVAC system may be turned off or run at more economical settings, and set macros that will allow

changing the settings of the temperature for all periods with a single gesture such as a mouse click.

**[0038]** **Figure 6** represents the screen of a computer or other device 104 using a graphical user interface connected to the Internet. The screen shows that a browser 1200 is displayed on computer 104. In one embodiment, a background application installed on computer 104 detects activity by a user of the computer, such as cursor movement, keystrokes or otherwise, and signals the application running on server 106 that activity has been detected. Server 106 may then, depending on context, (a) transmit a signal to thermostat 108 changing setpoint because occupancy has been detected at a time when the system did not expect occupancy; (b) signal the background application running on computer 104 to trigger a software routine that instantiates a pop-up window 1202 that asks the user if the server should change the current setpoint, alter the overall programming of the system based upon a new occupancy pattern, etc. The user can respond by clicking the cursor on "yes" button 1204 or "No" button 1206. Equivalent means of signalling activity may be employed with interactive television programming, gaming systems, etc.

**[0039]** **Figure 7** represents a flowchart showing the steps involved in the operation of one embodiment of the subject invention. In step 1302, computer 104 transmits a message to server 106 via the Internet indicating that there is user activity on computer 104. This activity can be in the form of keystrokes, cursor movement, input via a television remote control, etc. In step 1304 the application queries database 300 to retrieve setting information for the HVAC system. In step 1306 the application determines whether the current HVAC program is intended to apply when the home is occupied or unoccupied. If the HVAC settings then in effect are intended to apply for an occupied home, then the application terminates for a specified interval. If the HVAC settings then in effect are intended to apply when the home is unoccupied, then in step 1308 the application will retrieve from database 300 the user's specific preferences for how to handle this situation. If the user has previously specified (at the time that the program was initially set up or subsequently modified) that the user prefers that the system automatically change settings under

such circumstances, the application then proceeds to step 1316, in which it changes the programmed setpoint for the thermostat to the setting intended for the house when occupied. If the user has previously specified that the application should not make such changes without further user input, then in step 1310 the application transmits a command to computer 104 directing the browser to display a message informing the user that the current setting assumes an unoccupied house and asking the user in step 1312 to choose whether to either keep the current settings or revert to the pre-selected setting for an occupied home. If the user selects to retain the current setting, then in step 1314 the application will write to database 300 the fact that the users has so elected and terminate. If the user elects to change the setting, then in step 1316 the application transmits the revised setpoint to the thermostat. In step 1314 the application writes the updated setting information to database 300.

**[0040] Figure 8** is a flowchart that shows how the invention can be used to select different HVAC settings based upon its ability to identify which of multiple potential occupants is using the computer attached to the system. In step 1402 computer 104 transmits to server 106 information regarding the type of activity detected on computer 104. Such information could include the specific program or channel being watched if, for example, computer 104 is used to watch television. The information matching, for example, TV channel 7 at 4:00 PM on a given date to specific content may be made by referring to Internet-based or other widely available scheduling sources for such content. In step 1404 server 106 retrieves from database 300 previously logged data regarding viewed programs. In step 1406 server 106 retrieves previously stored data regarding the residents of the house. For example, upon initiating the service, one or more users may have filled out online questionnaires sharing their age, gender, schedules, viewing preferences, etc. In step 1408, server 106 compares the received information about user activity to previously stored information retrieved from database 300 about the occupants and their viewing preferences. For example, if computer 104 indicates to server 106 that the computer is being used to watch golf, the server may conclude that an adult male is watching; if computer 104 indicates that it is being used to watch children's



programming, server 106 may conclude that a child is watching. In step 1410 the server transmits a query to the user in order to verify the match, asking, in effect, "Is that you. Bob?" In step 1412, based upon the user's response, the application determines whether the correct user has been identified. If the answer is no, then the application proceeds to step 1416. If the answer is yes, then in step 1414 the application retrieves the temperature settings for the identified occupant. In step 1416 the application writes to database 300 the programming information and information regarding matching of users to that programming.

**[0041]** In an alternative embodiment, the application running on computer 104 may respond to general user inputs (that is, inputs not specifically intended to instantiate communication with the remote server) by querying the user whether a given action should be taken. For example, in a system in which the computer 104 is a web-enabled television or web-enabled set-top device connected to a television as a display, software running on computer 104 detects user activity, and transmits a message indicating such activity to server 106. The trigger for this signal may be general, such as changing channels or adjusting volume with the remote control or a power-on event. Upon receipt by server 104 of this trigger, server 104 transmits instructions to computer 104 causing it to display a dialog box asking the user whether the user wishes to change HVAC settings.

WHAT IS CLAIMED IS:

1. A method for varying temperature setpoints for an HVAC system comprising:

storing at least a first HVAC temperature setpoint and at least a second HVAC temperature setpoint;

monitoring an activity status of at least one wireless device associated with one or more occupants of said structure, wherein said wireless device comprises a graphic user interface, wherein use of said wireless device comprises at least one of cursor movement, keystrokes or other user interface actions intended to alter a state of said wireless device;

determining a probability that the specific activity status of said wireless device is associated with the use of said wireless device by a specific occupant or occupants of said structure;

determining whether a current HVAC temperature setpoint associated with said HVAC system is set to said first HVAC temperature setpoint or said second temperature setpoint;

prompting said one or more users, wherein said prompting sends a message to said wireless device recommending a change to said current HVAC temperature setpoint for said HVAC system;

in response to said prompting, receiving input from said one or more users; and

keeping said current HVAC temperature setpoint based upon said input from said one or more users.

2. The method of Claim 1 wherein said wireless device is a remote control.

3. The method of Claim 1 wherein said wireless device is a wireless phone.

4. The method of Claim 3 wherein said wireless phone is connected to a cellular network.

5. The method of Claim 1 wherein said wireless device is a tablet computer.

6. The method of Claim 1 wherein said first and second HVAC temperature setpoints are stored in a database associated with a remote server.

7. The method of Claim 1 in which said wireless device communicates with a remote server.

8. The method of Claim 1 further comprising adjusting said current HVAC temperature setpoint with a remote computer.

9. The method of Claim 1 in which said first HVAC temperature setpoint is varied automatically based on said input from said one or more users.

10. A system for altering the setpoint on a thermostat for space conditioning of a structure comprising:

at least one thermostat having at least a first temperature setpoint and at least a second temperature setpoint;

at least one wireless device associated with one or more occupants of said structure, wherein said wireless device comprises a graphic user interface, wherein use of said wireless device comprises at least one of cursor movement, keystrokes or other user interface actions intended to alter a state of said wireless device;

an application comprising one or more computer processors that receives data regarding an activity status of said wireless device and whether said thermostat is set to said first temperature setpoint,

said application determining a probability that the specific activity status of said wireless device is associated with the use of said wireless device by a specific occupant or occupants of said structure;

said application prompting said one or more users wherein said application provides electronic notice to one or more of said users of said wireless device that said thermostat is set to one of said first temperature setpoint or said second temperature setpoint; and

wherein said application in response to said prompting, receives input from said one or more users; and

wherein said current temperature setpoint is set based upon said input from said one or more users.

11. The system of Claim 10 wherein said wireless device is a remote controller.

12. The system of Claim 10 wherein said wireless device is a wireless phone.

13. The system of Claim 12 wherein said wireless phone is connected to a cellular network.

14. The system of Claim 10 said wireless device is a tablet computer.

15. The system of Claim 10 wherein said first and second temperature setpoints are stored in a database associated with a remote server.

16. The system of Claim 10 wherein said wireless device communicates with a remote server.

17. The system of Claim 10 further comprising a remote computer that varies said first temperature setpoint.

18. The system of Claim 10 in which said first temperature setpoint is varied automatically based on said input from said one or more users.

# SYSTEM AND METHOD FOR USING A WIRELESS DEVICE AS A SENSOR FOR AN ENERGY MANAGEMENT SYSTEM

## ABSTRACT OF THE DISCLOSURE

The invention comprises systems and methods for detecting the use of networked consumer electronics devices as indications of occupancy of a structure for purposes of automatically adjusting the temperature setpoint on a thermostatic HVAC control. At least one thermostat is located inside a structure and is used to control an HVAC system in the structure. At least one networked electronic device is used to indicate the state of occupancy of the structure. The state of occupancy is used to alter the setpoint on the thermostatic HVAC control to reduce unneeded conditioning of unoccupied spaces.

22511033  
012016

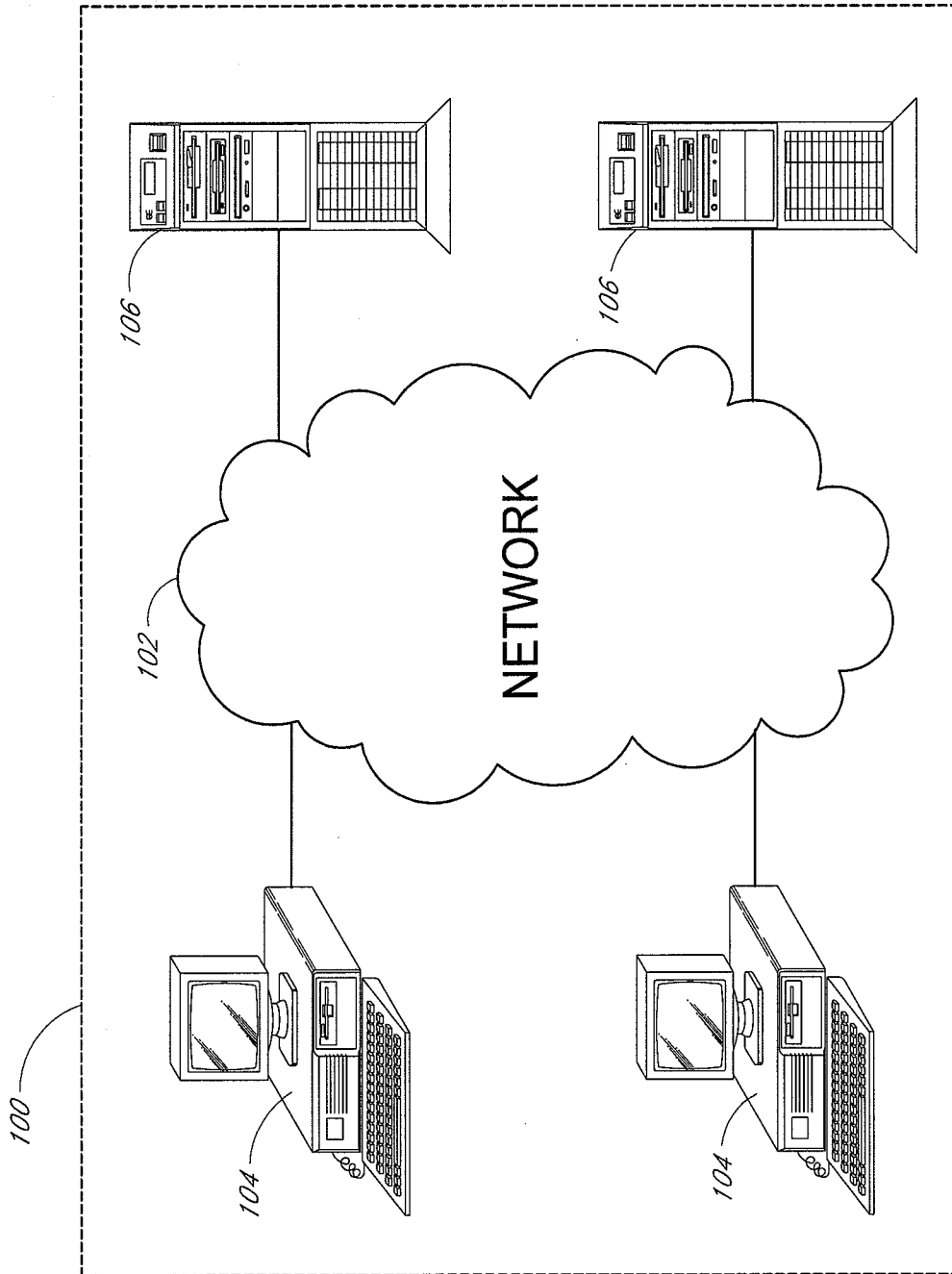

FIG. 1

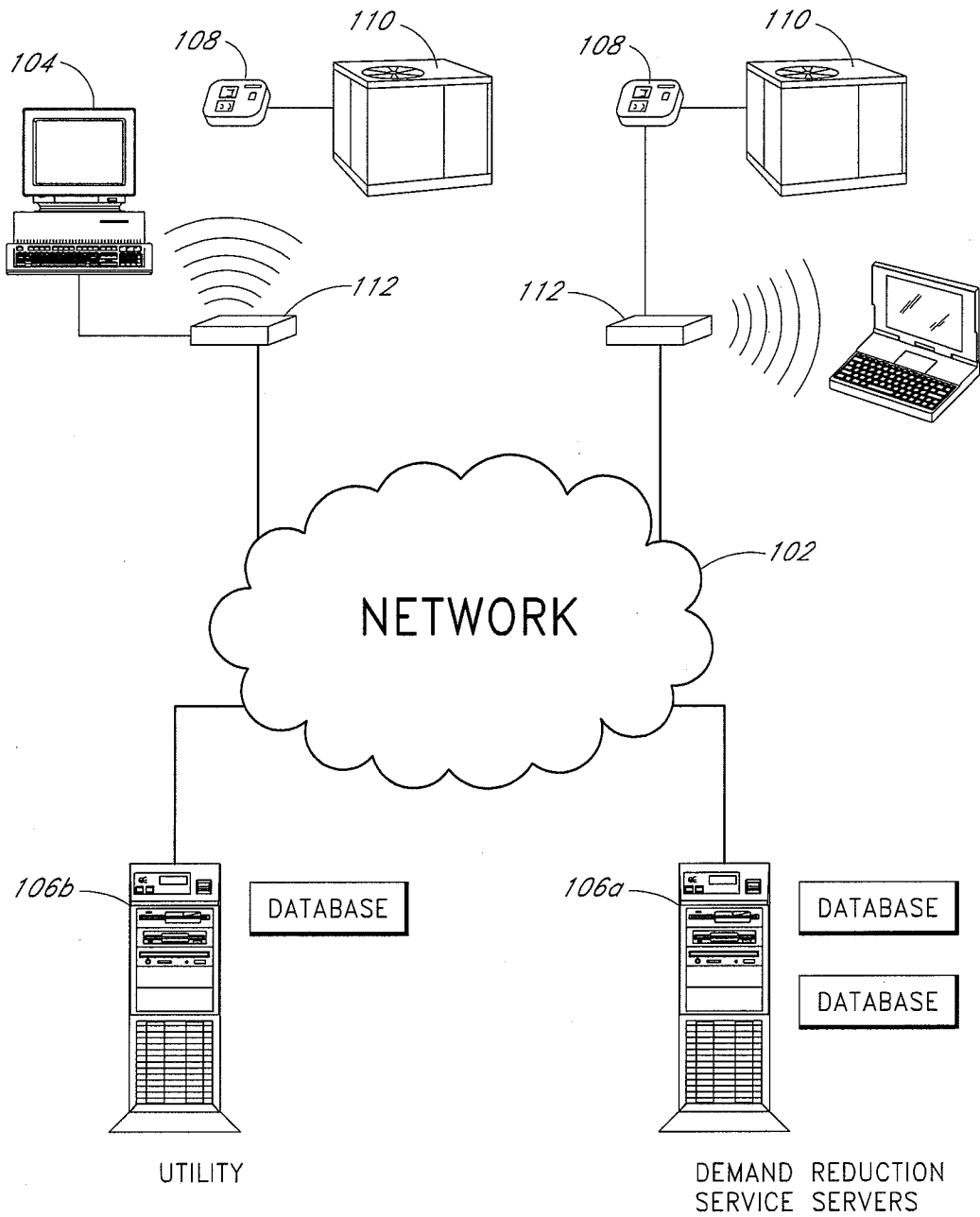

FIG. 2

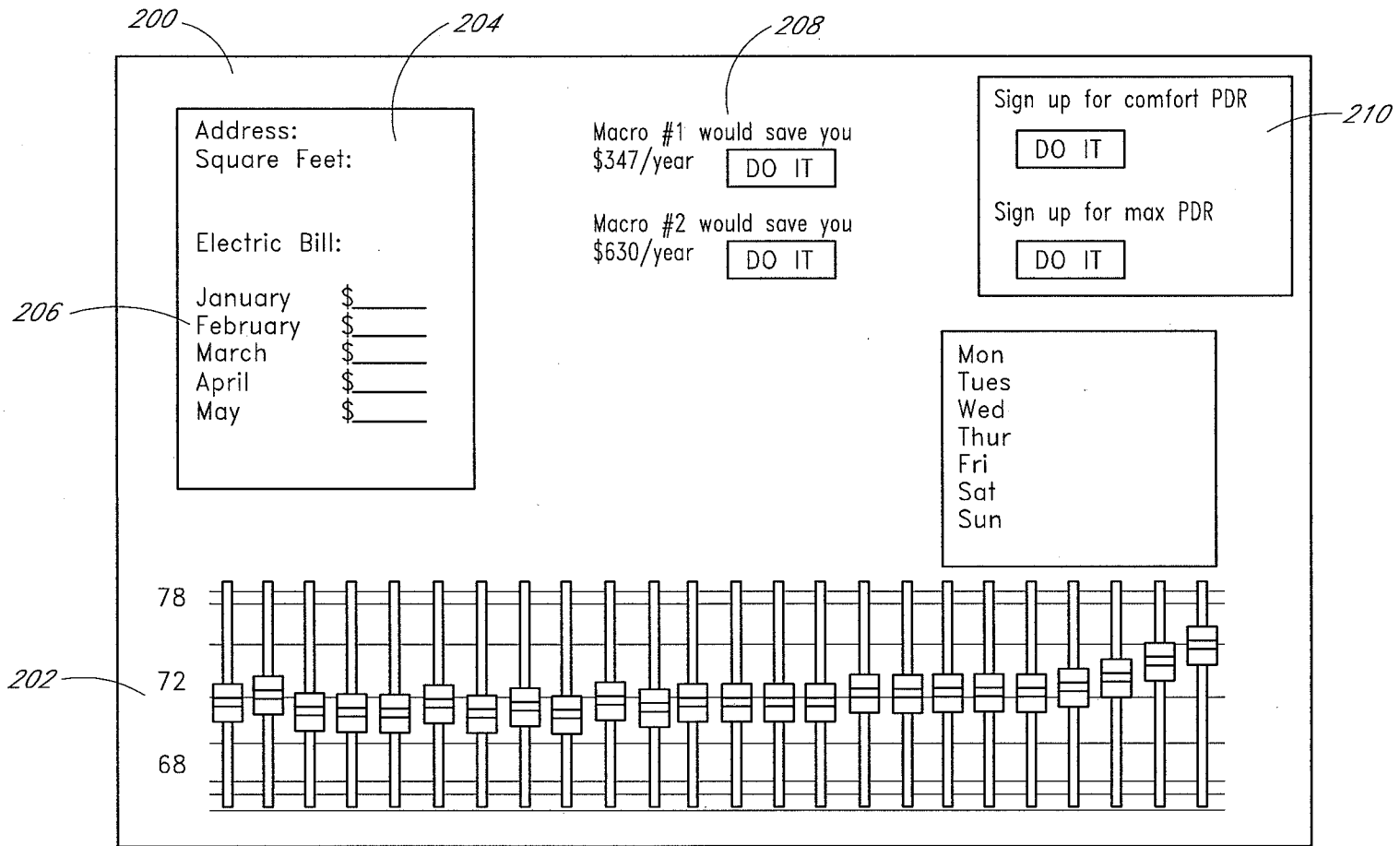

FIG. 3



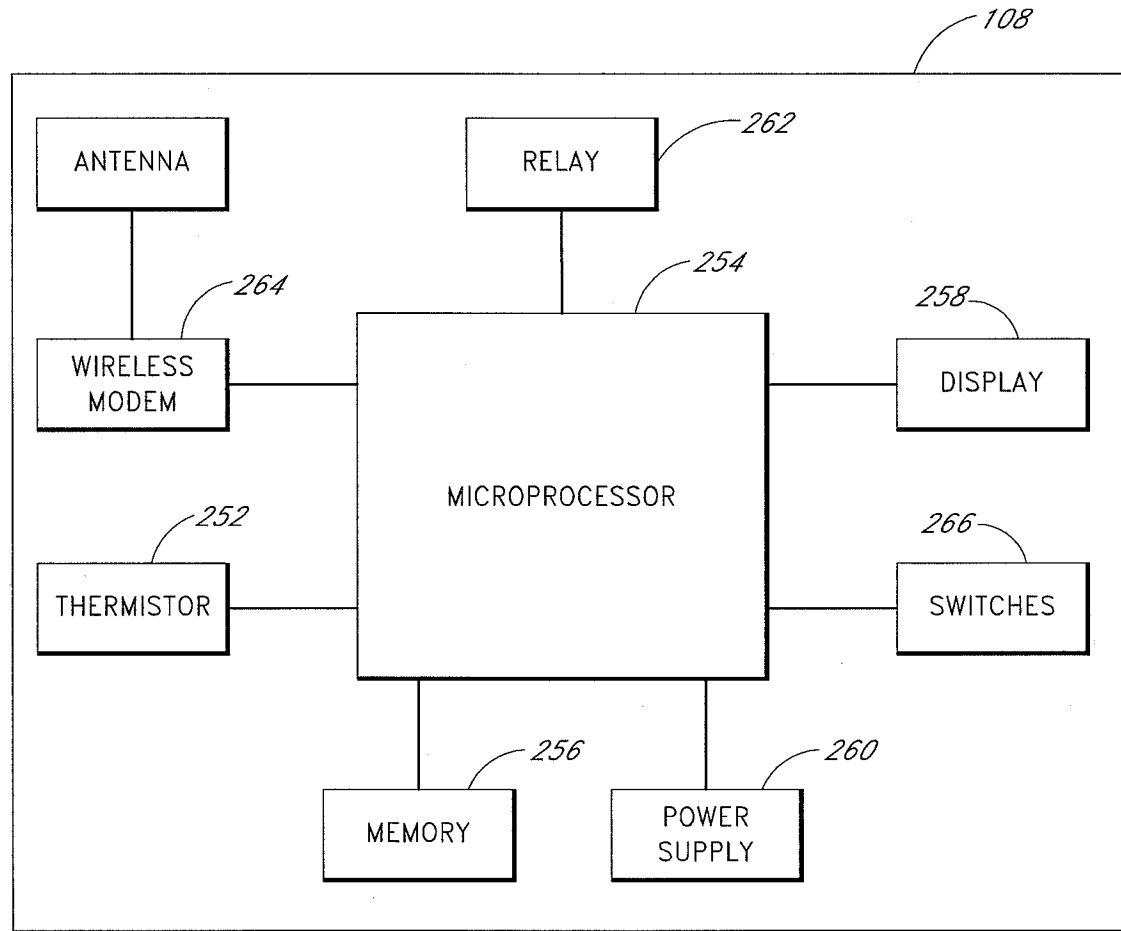
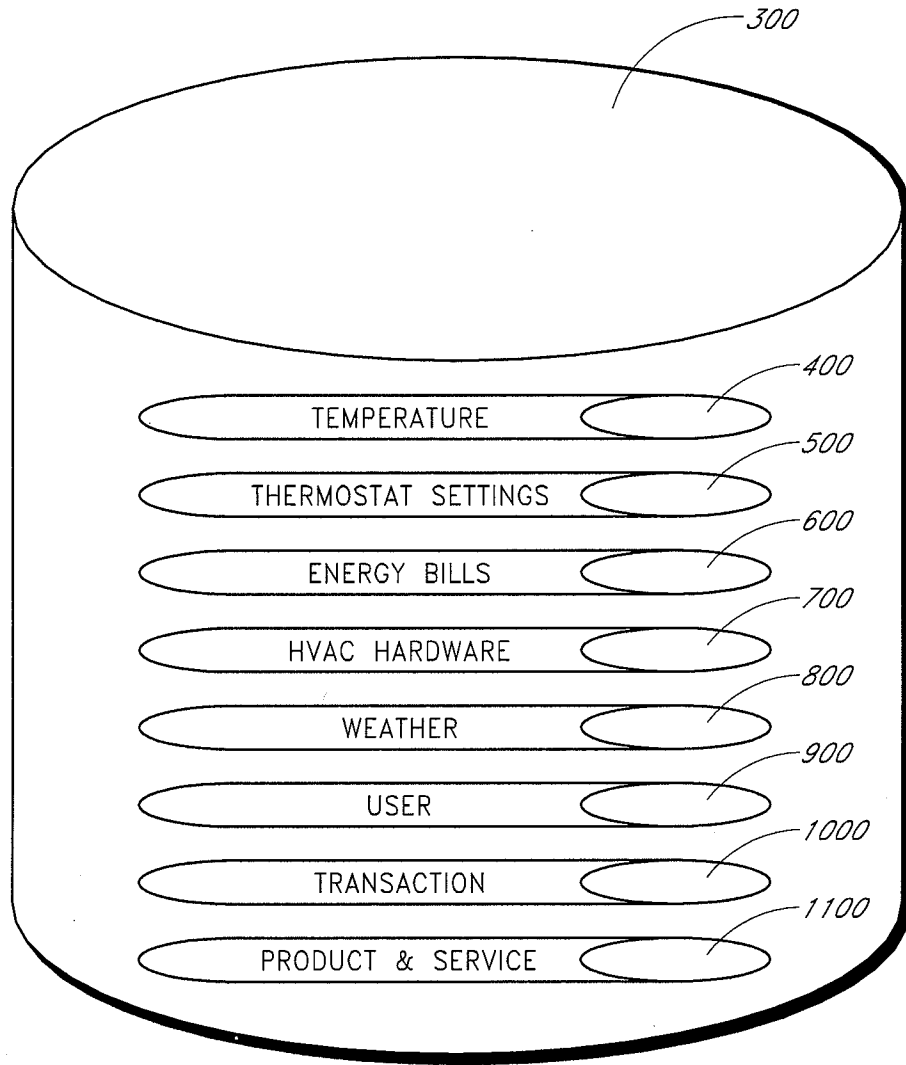
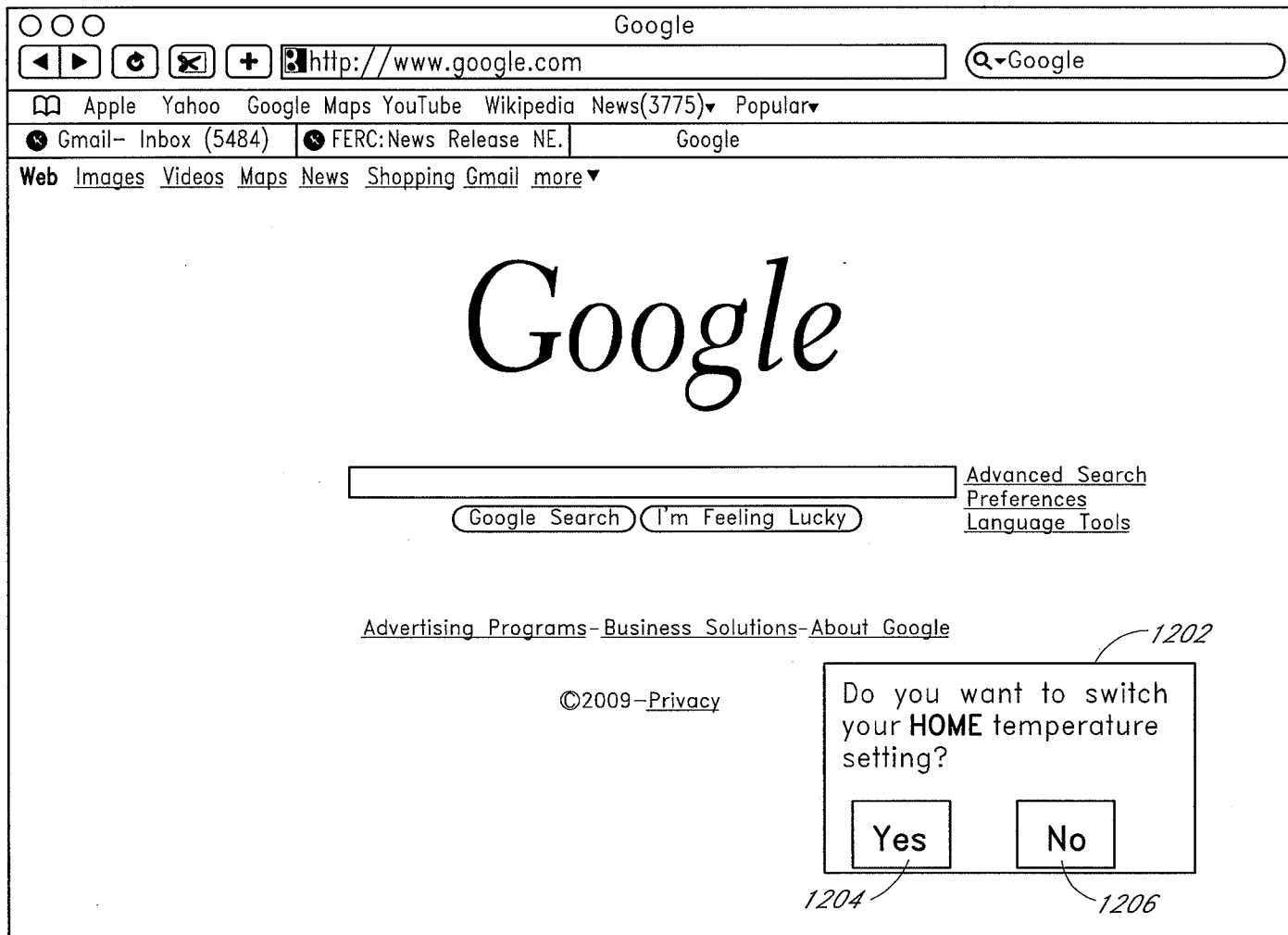

FIG. 4



*FIG. 5*



0475

6/8

FIG. 6

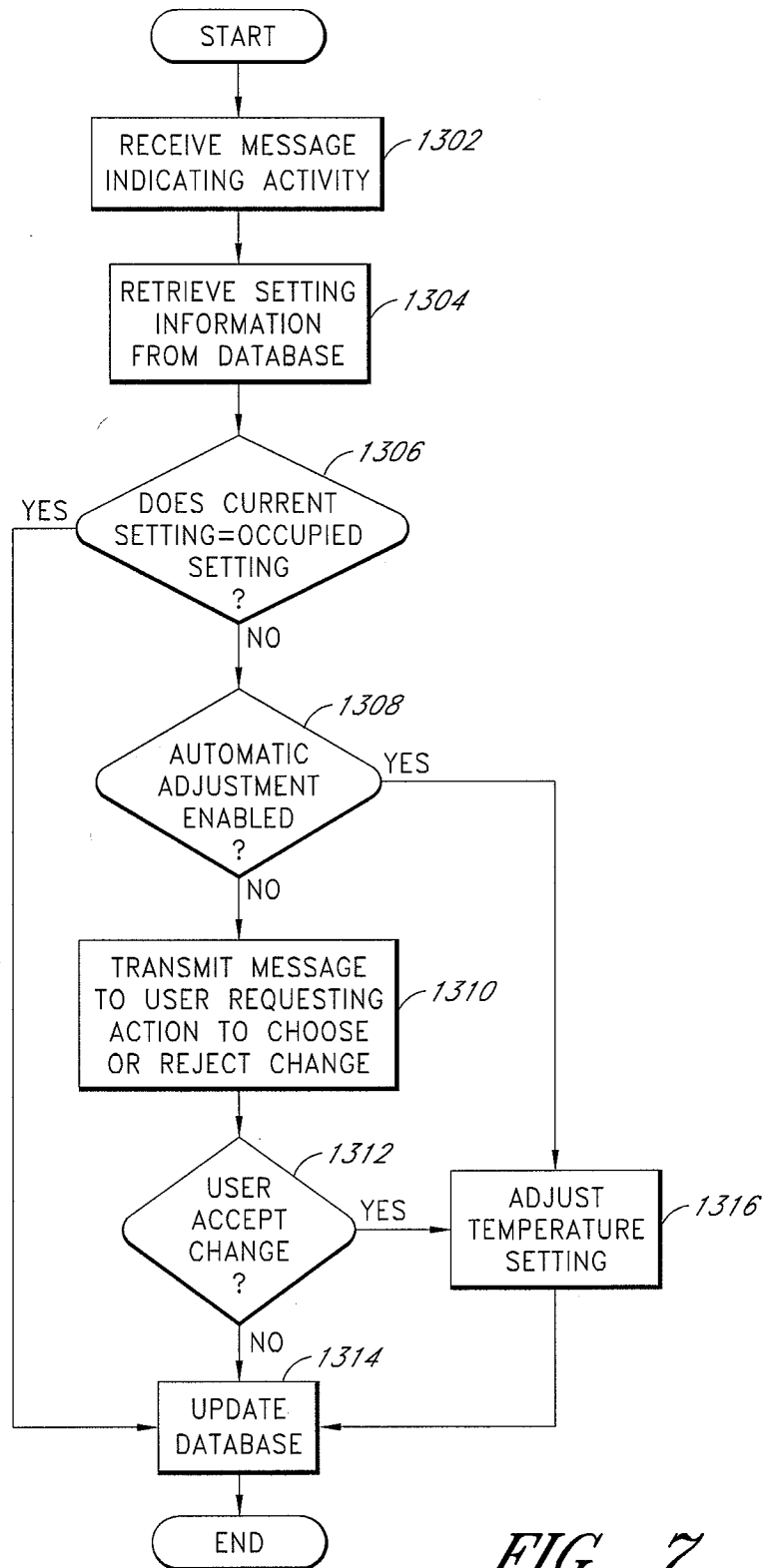
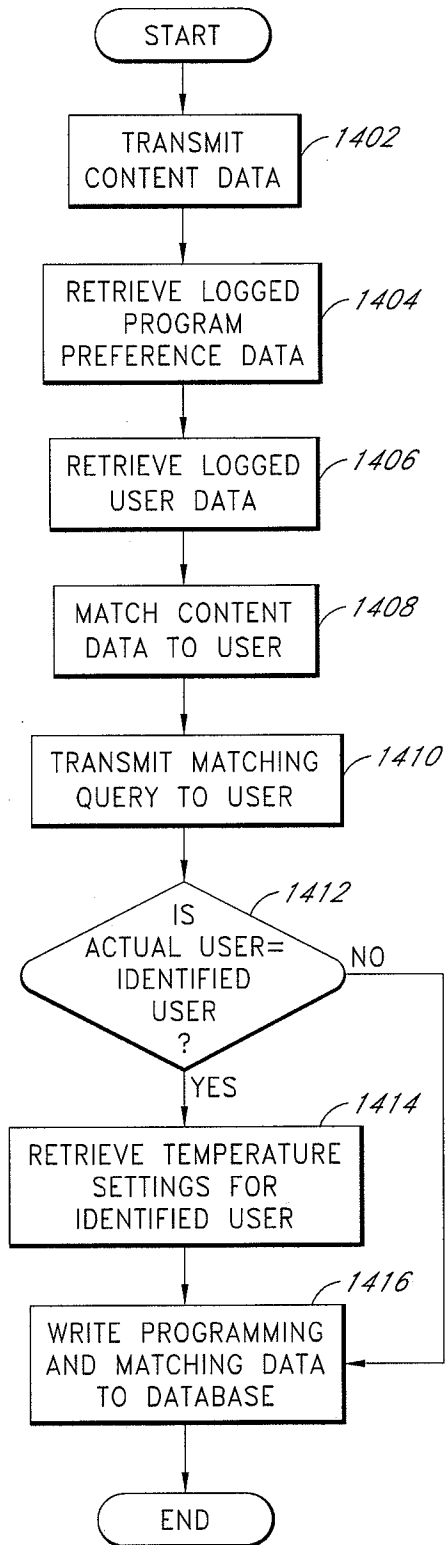

FIG. 7

*FIG. 8*

**INFORMATION DISCLOSURE STATEMENT**

Inventor	:	John Douglas Steinberg
App. No.	:	Unknown
Filed	:	Herewith
For	:	SYSTEM AND METHOD FOR USING A WIRELESS DEVICE AS A SENSOR FOR AN ENERGY MANAGEMENT SYSTEM
Examiner	:	Unknown
Art Unit	:	Unknown
Conf. No.	:	Unknown

Commissioner for Patents  
P.O. Box 1450  
Alexandria, VA 22313-1450

**References and Listing**

Pursuant to 37 CFR 1.56, an Information Disclosure Statement listing references is provided herewith. Listed references are of record in U.S. Patent Application No. 13/470,074, filed May 11, 2012, which is the parent of this continuation application, and is relied upon for an earlier filing date under 35 USC 120. Copies of the references are not submitted pursuant to 37 CFR 1.98(d).

**No Disclaimers**

To the extent that anything in the Information Disclosure Statement or the listed references could be construed as a disclaimer of any subject matter supported by the present application, Applicant hereby rescinds and retracts such disclaimer.

**Timing of Disclosure**

This Information Disclosure Statement is being filed within three months of the filing date or date of national phase entry, with an RCE or before receipt of a First Office Action after an RCE, and no fee is believed to be required.

**Application No.: Unknown**  
**Filing Date: Herewith**

The Commissioner is hereby authorized to charge any additional fees which may be required, or credit any overpayment, to Account No. 11-1410.

Respectfully submitted,  
KNOBBE, MARTENS, OLSON & BEAR, LLP

Dated: January 21, 2016

By: John R. King  
John R. King  
Registration No. 34,362  
Attorney of Record  
Customer No. 20,995  
(949) 760-0404

22520319:ad  
012116