



UNITED STATES PATENT AND TRADEMARK OFFICE

UNITED STATES DEPARTMENT OF COMMERCE
United States Patent and Trademark Office
Address: COMMISSIONER FOR PATENTS
P.O. Box 1450
Alexandria, Virginia 22313-1450
www.uspto.gov

Table with 5 columns: APPLICATION NO., FILING DATE, FIRST NAMED INVENTOR, ATTORNEY DOCKET NO., CONFIRMATION NO.
90/014,679 02/12/2021 10534382 024115 6590

20995 7590 03/09/2021
KNOBBE MARTENS OLSON & BEAR LLP
2040 MAIN STREET
FOURTEENTH FLOOR
IRVINE, CA 92614

EXAMINER

HUGHES, DEANDRA M

Table with 2 columns: ART UNIT, PAPER NUMBER

3992

Table with 2 columns: MAIL DATE, DELIVERY MODE

03/09/2021

PAPER

Please find below and/or attached an Office communication concerning this application or proceeding.

The time period for reply, if any, is set in the attached communication.



UNITED STATES PATENT AND TRADEMARK OFFICE

Commissioner for Patents
United States Patent and Trademark Office
P.O. Box 1450
Alexandria, VA 22313-1450
www.uspto.gov

DO NOT USE IN PALM PRINTER

(THIRD PARTY REQUESTER'S CORRESPONDENCE ADDRESS)

SUGHRUE MION, PLLC
2000 PENNSYLVANIA AVENUE, N.W.
SUITE 900
WASHINGTON, DC 20006

***EX PARTE* REEXAMINATION COMMUNICATION TRANSMITTAL FORM**

REEXAMINATION CONTROL NO. 90/014,679 .

PATENT UNDER REEXAMINATION 10534382 .

ART UNIT 3992 .

Enclosed is a copy of the latest communication from the United States Patent and Trademark Office in the above identified *ex parte* reexamination proceeding (37 CFR 1.550(f)).

Where this copy is supplied after the reply by requester, 37 CFR 1.535, or the time for filing a reply has passed, no submission on behalf of the *ex parte* reexamination requester will be acknowledged or considered (37 CFR 1.550(g)).

Order Granting Request For Ex Parte Reexamination	Control No. 90/014,679	Patent Under Reexamination 10534382	
	Examiner DEANDRA M HUGHES	Art Unit 3992	AIA (FITF) Status No

--The MAILING DATE of this communication appears on the cover sheet with the correspondence address--

The request for *ex parte* reexamination filed 02/12/2021 has been considered and a determination has been made. An identification of the claims, the references relied upon, and the rationale supporting the determination are attached.

Attachments: a) PTO-892, b) PTO/SB/08, c) Other: _____

1. The request for *ex parte* reexamination is GRANTED.

RESPONSE TIMES ARE SET AS FOLLOWS:

For Patent Owner's Statement (Optional): TWO MONTHS from the mailing date of this communication (37 CFR 1.530 (b)). **EXTENSIONS OF TIME ARE GOVERNED BY 37 CFR 1.550(c).**

For Requester's Reply (optional): TWO MONTHS from the **date of service** of any timely filed Patent Owner's Statement (37 CFR 1.535). **NO EXTENSION OF THIS TIME PERIOD IS PERMITTED.** If Patent Owner does not file a timely statement under 37 CFR 1.530(b), then no reply by requester is permitted.

/D.M.H/ Reexamination Specialist, Art Unit 399	/CHARLES R CRAVER/ Primary Examiner, Art Unit 3992	
---	---	--

cc:Requester (if third party requester)

ORDER GRANTING REQUEST FOR *EX PARTE* REEXAMINATION

Acknowledgements

1. This is an order granting *Ex Parte* Reexamination of claims 1-20 of U.S. Patent No. 10,534,382, (“‘382 Patent”) issued January 14, 2020 and filed on April 3, 2019 as U.S. Application No. 16/374,085 (“085 Application”), titled “SYSTEM AND METHOD FOR USING A WIRELESS DEVICE AS A SENSOR FOR AN ENERGY MANAGEMENT SYSTEM.”

2. The ‘382 Patent issued with claims 1-20 (“Patented Claims”) and claims 1 and 17 are independent claims. Thus, claims 1-20 are grouped as follows:

- Claims 1-16; and
- Claims 17-20.

3. Examiners find the ‘382 Patent is a subject of a Request for *Inter Partes* Review in IPR2021-00054 filed on October 22, 2020.

4. Examiners do not any previous *Ex parte* reexaminations, supplemental examinations, or certificates of correction for the ‘382 Patent.

5. The ‘382 Patent was filed on April 3, 2019 with the earliest possible effective filing date of July 14, 2008 because of the priority claim to Provisional Application No. 61/134,714 filed on July 14, 2008.

6. Examiners find the following notice of pending litigation (see Request, pg. 3).

III. NOTICE OF PENDING LITIGATION

The '382 Patent is the subject of four patent infringement lawsuits by the assignee of record, EcoFactor, which may affect, or be affected by, a decision in this proceeding: *EcoFactor, Inc. v. Google LLC*, Case No. 6:20-cv-00075-ADA (W.D. Tex., filed Jan. 31, 2020); *EcoFactor, Inc. v. Ecobee, Inc.*, Case No. 6:20-cv-00078-ADA (W.D. Tex., filed Jan. 31, 2020); *EcoFactor, Inc. v. Vivint, Inc.*, Case No. 6:20-cv-00080-ADA (W.D. Tex., filed Jan. 31, 2020); *EcoFactor, Inc. v. Alarm.com Inc.*, 1:20-cv-11007-LTS (D. Mass., filed May 26, 2020).¹

EcoFactor has asserted four patents against Petitioner in the Massachusetts litigation: U.S. Patent Nos. 8,738,327, 8,412,488, 8,180,492 and the '382 Patent.

The '382 Patent is also the subject of a Request for *Inter Partes* Review in IPR2021-00054, which was filed by Google LLC on October 22, 2020.

¹ On December 9, 2020, the Court issued preliminary claim constructions in the Western District of Texas actions. In relevant part, the Court construed the term "measurement" in the claims of the '382 Patent to have its plain and ordinary meaning. Ex. F at 3. No other terms from the '382 Patent claims were construed by the Court.

Patents/Printed Publications

7. The following prior patents/printed publications are alleged to present an SNQ as to claims 1-20:

- US 2009/0302994A1 to Rhee et al. published Jan. 15, 2004 and field on June 10, 2008 (hereafter “Rhee”);
- US 8,020,777 to Kates issued September 20, 2011 and filed on January 29, 2007 (hereafter “Kates”);
- US 8,239,922 to Sullivan et al. issued on August 7, 2012 and filed on August 27, 2007 (hereafter “Sullivan”).

Proposed Substantial New Questions of Patentability (“SNQs”)

8. The request proposed the following SNQs (see Request pg. 8);

- (1) Rhee anticipates or makes obvious claims 1-20;
- (2) Rhee and Sullivan make obvious claims 7-9 and 15-16.
- (3) Rhee and Kates make obvious claims 1-20;
- (4) Rhee, Sullivan, and Kates make obvious claims 7-9 and 15-16.

Basis of the Substantial New Question of Patentability

9. Under MPEP §2242, for a substantial new question (“SNQ”) of patentability to be present, it is only necessary that: (A) the prior art patents and/or printed publications raise a substantial question of patentability regarding at least one claim, i.e., the teaching of the (prior art) patents and printed publications is such that a reasonable examiner would consider the teaching to be important in deciding whether or not the claim is patentable; and (B) the same question of patentability as to the claim has not been decided by the Office in an earlier concluded examination or review of the patent, raised to or by the Office in a pending reexamination or supplemental examination of

Art Unit: 3992

the patent, or decided in a final holding of invalidity (after all appeals) by a federal court in a decision on the merits involving the claim.

In this case, Examiners find the basis of the SNQ is 'a HVAC system where: (1) temperature set points corresponding to building occupancy are set via the Internet; and (2) the memory storing historical values of the building temperature and the outdoor temperature is located remotely from the processors of the HVAC system' for the following reasons.

Examiners find the '382 Patent is directed to a system and method for using a wireless device as sensor for an energy management system (see title).

Examiners find the '382 Patent specification describes the prior art as including programmable thermostats with restrictive user interfaces that allows the thermostat to drift in a temperature range dependent upon a relationship between the inside and outside temperatures (see background of the invention; col.1:40-42 and col.2:1-25).

Examiners find the '382 Patent specification describes the prior art as including managing HVAC systems as function of occupancy via the use of keycard controls and/or motion sensor controls (see col.5:35-59).

Examiners find the independent claims of the '382 Patent are directed to, *inter alia*,

- “a first data... includes a measurement of at least one characteristic of the building,”
- “a second data... received via the Internet,”
- “a first temperature set point... when the building is occupied,”
- “a second temperature set point... when the building is unoccupied,”
- “receive commands through the Internet by way of a remote interface on a mobile... to adjust the set points,”

- ‘send user-specific data through the Internet...about the HVAC system,’
- ‘controlling the HVAC system based on the determination the building is occupied/unoccupied,’
- ‘a memory that is located remotely from the processors of the HVAC system,’
- “the memory is configured to store historical values of the first data and the second data.”

Examiners find the original claims of the ‘382 Patent were rejected over US2008/0281472 (“Podgorny”) and US2005/0270151 (“Winick”) in the prosecution of the ‘085 Application.

Examiners find the claims were put into allowance with amendments that recite that the one or more processors include a processor “located remotely from the memory and is not electrically connected to the memory” and that the memory “is configured to store historical values of the first data and the second data” (see the ‘085 Application, Claim Amendment and Remarks filed August 2, 2019).

Examiners find the ‘382 Patent describes the first data is the current temperature of the building and the second data is the outdoor temperature of the building (see ‘382 Patent claim 17).

Because (1) it was known to one of ordinary skill in the art to control HVAC temperature set points as a function of occupancy where occupancy is determined via the use of keycard or a motion sensor and (2) the ‘382 Patent claims were placed in condition for allowance by adding limitations pertaining to the location of the memory (i.e., the memory that stores the historical building and outside temperatures) with respect to the location of the processors of the HVAC system, Examiners find these teachings important in determining the patentability of the ‘382 Patent claims.

Thus, Examiners find a reasonable Examiner would find a prior art teaching of ‘a HVAC system where: (1) temperature set points corresponding to building occupancy are set via the Internet and (2) the memory storing historical values of the building temperature and the outdoor temperature is located remotely from the processors of the HVAC system’ to be important in deciding whether the claims of the ‘382 Patent are patentable.

Order for Ex Parte Reexamination

10. A SNQ over Rhee, alone or in combination, has been proposed as to claims 1-20 (see Request, pg. 8).

Examiners find Rhee was filed on June 10, 2008, which is before the earliest possible effective filing date of the ‘382 Patent, which is July 14, 2008.

Examiners find Rhee was not previously considered because the art considered in the ‘085 Application was Podgorny and Winick.

Examiners find Rhee discloses an HVAC system with different temperature set points for when the building is occupied/unoccupied (see e.g., Table 1).

Examiners find Rhee discloses an energy management system (fig. 1A, #50) that includes the Internet (#52) and a wireless gateway (#53) and wireless controller (fig. 1B, #110) for managing the HVAC system as function of energy data comprising the building temperature, outside temperature (see ¶[0040]), and historical energy data (see ¶[0057]).

Examiners find Rhee discloses using a cellular phone network connected to a wireless controller (fig. 1B, #110) to manage energy devices (see ¶[0047]).

Because Rhee discloses using the Internet to manage temperature set points of an HVAC system as a function of building occupancy and historical energy data (e.g., building and outside temperatures), a reasonable Examiner would consider the disclosures of Rhee, alone or in combination with either Sullivan or Kate, to be important in deciding whether or not the '382 Patent claims are patentable irrespective of Rhee's specific disclosure of where the memory storing the historical temperature values is located.

Thus, Rhee is a prior art teaching that meets the basis of the SNQ, which is 'a HVAC system where: (1) temperature set points corresponding to building occupancy are set via the Internet and (2) the memory storing historical values of the building temperature and the outdoor temperature is located remotely from the processors of the HVAC system.'

Order

11. For the above reasons, the request for *Ex Parte* Reexamination of claims 1-20 over Rhee, alone or in combination with another prior art reference of record, is GRANTED.

Conclusion

12. A shortened statutory period for response to this action is set to expire **2 months** from the mailing date of this action.

Extensions of time under 37 CFR 1.136(a) do not apply in reexamination proceedings. The provisions of 37 CFR 1.136 apply only to "an applicant" and not to parties in a reexamination proceeding. Further, in 35 U.S.C. 305 and in 37 CFR

Art Unit: 3992

1.550(a), it is required that reexamination proceedings “will be conducted with special dispatch within the Office.”

Extensions of time in reexamination proceedings are provided for in 37 CFR 1.550(c). A request for extension of time must specify the requested period of extension and it must be accompanied by the petition fee set forth in 37 CFR 1.17(g). Any request for an extension in a third party requested ex parte reexamination must be filed on or before the day on which action by the patent owner is due, and the mere filing of a request will not effect any extension of time. A request for an extension of time in a third party requested ex parte reexamination will be granted only for sufficient cause, and for a reasonable time specified. Any request for extension in a patent owner requested ex parte reexamination (including reexamination ordered under 35 U.S.C. 257) for up to two months from the time period set in the Office action must be filed no later than two months from the expiration of the time period set in the Office action. A request for an extension in a patent owner requested ex parte reexamination for more than two months from the time period set in the Office action must be filed on or before the day on which action by the patent owner is due, and the mere filing of a request for an extension for more than two months will not effect the extension. The time for taking action in a patent owner requested ex parte reexamination will not be extended for more than two months from the time period set in the Office action in the absence of sufficient cause or for more than a reasonable time.

The filing of a timely first response to this final rejection will be construed as including a request to extend the shortened statutory period for an additional two

Art Unit: 3992

months. In no event, however, will the statutory period for response expire later than SIX MONTHS from the mailing date of the final action. See MPEP § 2265.

13. Correspondence

All correspondence relating to this *ex parte* reexamination proceeding should be directed as follows:

By U.S. Postal Service Mail to:

Mail Stop *Ex Parte* Reexam
ATTN: Central Reexamination Unit
Commissioner for Patents
P.O. Box 1450
Alexandria, VA 22313-1450

By FAX to:

(571) 273-9900
Central Reexamination Unit

By hand to:

Customer Service Window
Randolph Building
401 Dulany St.

Signed:

/DEANDRA M HUGHES/
Reexamination Specialist, Art Unit 3992

Conferees:

/CHARLES R CRAVER/
Primary Examiner, Art Unit 3992
/M.F/
Supervisory Patent Examiner, Art Unit 3992

IN THE UNITED STATES PATENT AND TRADEMARK OFFICE

Inventors: John Douglas Steinberg)
)
Patent No: 10,534,382)
)
Date of Patent: January 14, 2020)
)
Title: SYSTEM AND METHOD)
FOR USING A WIRELESS)
DEVICE AS A SENSOR FOR)
AN ENERGY)
MANAGEMENT SYSTEM)
)
Filed: April 3, 2019)
)

Mail Stop “*Ex Parte* Reexam”
Attn: Central Reexamination Unit
Commissioner for Patents
P.O. Box 1450
Alexandria, VA 22313-1450

REQUEST FOR REEXAMINATION OF U.S. PATENT 10,534,382

TABLE OF CONTENTS

I.	CLAIMS FOR WHICH REEXAMINATION IS REQUESTED	1
II.	REQUIRED CERTIFICATIONS.....	2
III.	NOTICE OF PENDING LITIGATION.....	3
IV.	SUMMARY OF THE '382 PATENT	4
	A. Brief Description of the '382 Patent	4
	B. Summary of the Prosecution History of the '382 Patent	5
V.	CITATION OF PRIOR ART	6
VI.	STATEMENT POINTING OUT SUBSTANTIAL NEW QUESTIONS OF PATENTABILITY ("SNQP")	8
	A. Summary of Proposed Rejections	8
	B. SNQP 1: Claims 1-20 are anticipated by or rendered obvious by Rhee.....	9
	1. Overview of Rhee.	9
	2. Rhee disclosed all elements of independent claims 1 and 17.	9
	3. Rhee disclosed the dependent limitations of claim 2 (which depends from claim 1).	50
	4. Rhee disclosed the dependent limitations of claim 3 (which depends from claim 1).	52
	5. Rhee disclosed the dependent limitations of claim 4 (which depends from claims 1 and 2).	54
	6. Rhee disclosed the dependent limitations of claim 5 (which depends from claims 1, 2, and 4).	55
	7. Rhee disclosed the dependent limitations of claim 6 (which depends from claims 1, 2, and 4).	57
	8. Rhee disclosed the dependent limitations of claim 7 (which depends from claim 1).	61
	9. Rhee disclosed the dependent limitations of claim 8 (which depends from claims 1 and 7).	66

10.	Rhee disclosed all elements of dependent claim 9 (which depends from claims 1 and 7).	68
11.	Rhee disclosed the dependent limitations of claim 10 (which depends from claims 1, 2 and 4).	71
12.	Rhee discloses all elements of dependent claim 11 (which depends from claim 1).	75
13.	Rhee disclosed all elements of dependent claim 12 (which depends from claim 1).	77
14.	Rhee disclosed all elements of dependent claim 13 (which depends from claim 1).	78
15.	Rhee disclosed all elements of dependent claim 14 (which depends from claim 1).	79
16.	Rhee disclosed all elements of claim 15 (which depends from claims 1 and 7).	81
17.	Rhee disclosed all elements of claim 16 (which depends from claims 1 and 7).	83
18.	Rhee disclosed the dependent limitations of claim 18 (which depends from claim 17).	87
19.	Rhee disclosed all elements of dependent claim 19 (which depends from claim 1) and dependent claim 20 (which depends from claim 17).	88
C.	SNQP 2: Claims 7-9 and 15-16 are rendered obvious by Rhee in view of Sullivan.	94
1.	Overview of Sullivan.	94
2.	Sullivan disclosed the dependent limitations of claim 7 (which depends from claim 1).	95
3.	Sullivan disclosed the dependent limitations of claim 8 (which depends from claims 1 and 7).	101
4.	Sullivan disclosed all elements of dependent claim 9 (which depends from claims 1 and 7).	106
5.	Sullivan disclosed all elements of claim 15 (which depends from claims 1 and 7).	109
6.	Sullivan disclosed all elements of claim 16 (which depends from claims 1 and 7).	114

7.	Motivation to combine Rhee and Sullivan	116
D.	SNQP 3: Claims 1-20 are rendered obvious by Rhee in view of Kates.	117
1.	Overview of Kates.	117
2.	Kates disclosed processors that determined “whether the building is occupied or unoccupied” based at least in part on “third data from a motion sensor” and controlled the HVAC system to heat or cool the building at an operation temperature based on the determination.	119
3.	Motivation to combine Rhee and Kates.....	132
E.	SNQP 4: Claims 7-9 and 15-16 are rendered obvious by Rhee in view of Kates and Sullivan.	133
VII.	CONCLUSION	133

EXHIBITS

Exhibit	Description
A	U.S. Patent No. 10,534,382 (the “’382 Patent”)
B	File History of the ’382 Patent
C	U.S. Patent Pub. No. 2009/0302994 (“Rhee”)
D	U.S. Patent No. 8,020,777 (“Kates”)
E	U.S. Patent No. 8,239,922 (“Sullivan”)
F	Western District of Texas Preliminary Claim Constructions (Dec. 9, 2020)
G	Declaration of Tajana Šimunić Rosing, Ph.D.
H	File History of U.S. Appl. No. 15/002,791
I	File History of U.S. Appl. No. 13/470,074
J	File History of U.S. Appl. No. 12/502,064
K	File History of U.S. Provisional Appl. No. 61/134,714
L	Terminal Disclaimer for the ’382 Patent

Pursuant to 35 U.S.C. §§ 302-307 and 37 C.F.R. § 1.510, Alarm.com Incorporated (“Alarm.com”) respectfully requests *ex parte* reexamination of claims 1-20 of U.S. Patent No. 10,534,382 (Exhibit A, the “’382 Patent”), which was filed on April 3, 2019, issued on January 14, 2020 to EcoFactor, Inc. (“EcoFactor” or “Patent Owner”), and is currently assigned to EcoFactor according to the United States Patent and Trademark Office (the “Office”) assignment records.

As set forth in detail below, U.S. Patent Pub. No. 2009/0302994 (“Rhee”), alone or in combination with other references, raises substantial new questions of patentability of claims 1-20 of the ’382 Patent.

I. CLAIMS FOR WHICH REEXAMINATION IS REQUESTED

Pursuant to 35 U.S.C. § 303 and 37 C.F.R. § 1.510, the following prior art references raise substantial new questions of patentability (“SNQP”) concerning claims 1-20 of the ’382 Patent:

U.S. Patent Pub. No. 2009/0302994 (“Rhee”)

U.S. Patent No. 8,020,777 (“Kates”)

U.S. Patent No. 8,239,922 (“Sullivan”)

Pursuant to 37 C.F.R. § 1.510(b)(3), copies of Rhee, Kates and Sullivan are attached hereto as Exhibits C-E, respectively.

In particular, pursuant to 37 U.S.C. § 1.510(b)(1), Alarm.com identifies the following references that raise a SNQP concerning claims 1-20 of the ’382 Patent.

SNQP No.	Claim(s)	Basis for Rejection
1	1-20	Anticipated by Rhee and/or obvious in view of Rhee and the knowledge of a POSITA
2	7-9, 15-16	Obvious in view of Rhee, Sullivan and the knowledge of a POSITA
3	1-20	Obvious in view of Rhee, Kates and the knowledge of a POSITA
4	7-9, 15-16	Obvious in view of Rhee, Sullivan, Kates and the knowledge of a POSITA

II. REQUIRED CERTIFICATIONS

Submitted herewith is the fee set forth in 37 C.F.R. § 1.510 and 37 C.F.R. § 1.20(c)(1).

Pursuant to 37 C.F.R. § 1.510(b)(5), the attached Certificate of Service indicates that a copy of this Request has been served on Patent Owner at the following address of the attorney of record for Patent Owner, in accordance with 37 C.F.R. § 1.33(c):

EcoFactor, Inc.
Knobbe Martens Olson & Bear LLP
2040 Main Street, 14th Floor
Irvine, CA 92614

As required by 37 C.F.R. § 1.510(b)(6), Alarm.com certifies that the statutory estoppel provisions of 35 U.S.C. § 315(e)(1) and 35 U.S.C. § 325(e)(1) do not prohibit Alarm.com from filing this *ex parte* reexamination request.

III. NOTICE OF PENDING LITIGATION

The '382 Patent is the subject of four patent infringement lawsuits by the assignee of record, EcoFactor, which may affect, or be affected by, a decision in this proceeding: *EcoFactor, Inc. v. Google LLC*, Case No. 6:20-cv-00075-ADA (W.D. Tex., filed Jan. 31, 2020); *EcoFactor, Inc. v. Ecobee, Inc.*, Case No. 6:20-cv-00078-ADA (W.D. Tex., filed Jan. 31, 2020); *EcoFactor, Inc. v. Vivint, Inc.*, Case No. 6:20-cv-00080-ADA (W.D. Tex., filed Jan. 31, 2020); *EcoFactor, Inc. v. Alarm.com Inc.*, 1:20-cv-11007-LTS (D. Mass., filed May 26, 2020).¹

EcoFactor has asserted four patents against Petitioner in the Massachusetts litigation: U.S. Patent Nos. 8,738,327, 8,412,488, 8,180,492 and the '382 Patent.

The '382 Patent is also the subject of a Request for *Inter Partes* Review in IPR2021-00054, which was filed by Google LLC on October 22, 2020.

¹ On December 9, 2020, the Court issued preliminary claim constructions in the Western District of Texas actions. In relevant part, the Court construed the term “measurement” in the claims of the '382 Patent to have its plain and ordinary meaning. Ex. F at 3. No other terms from the '382 Patent claims were construed by the Court.

IV. SUMMARY OF THE '382 PATENT

A. Brief Description of the '382 Patent

The '382 Patent is directed to systems and methods for “thermostatic HVAC and other energy management controls that are connected to a computer network”.

Ex. A at 1:16-19. Specifically, the '382 Patent relates to the use of user interactions with an interface such as a personal computer as a signal related to occupancy to inform an energy management system. *Id.* at 1:16-23.

The '382 Patent states that energy consumption by an HVAC system is directly proportional to the setpoint (*i.e.*, the desired temperature set on a thermostat). *Id.* at 2:15-24. Therefore, allowing the setpoint to rise by several degrees in the summer during periods when the home is unoccupied can result in reduced energy consumption and greater cost savings. *Id.* at 2:24-34. The '382 Patent explains that it would be desirable to provide a system that could accurately detect occupancy and control the HVAC system accordingly. *Id.* at 3:15-20. For example, the '382 Patent contemplates detecting occupancy based on a user's activity patterns on certain “computers or other consumer electronic devices”. *Id.* at 3:24-41.

Claim 1 of the '382 Patent is directed to a system for controlling an HVAC system at a user's building comprising one more processors with circuitry and code designed to execute instructions that, among other things, receives data, commands

and user-specific information, and controls an HVAC system based on a determination as to whether the building is occupied or unoccupied. *Id.* at cl. 1.

B. Summary of the Prosecution History of the '382 Patent

The '382 Patent issued from U.S. Pat. App. No. 16/374,085 (the "'085 Application"), which also claimed the benefit of U.S. Pat. App. Nos. 15/002,791 (filed Jan. 21, 2016), 13/470,074 (filed May 11, 2012), 12/502,064 (filed July 13, 2009) and 61/134,714 (filed July 14, 2008). Ex. B at B.210.

In an office action dated May 8, 2019, the Examiner rejected all pending claims under 35 U.S.C. § 103 on the basis of U.S. Patent Pub. Nos. 2008/0281472 ("Podgorny") and 2010/0308119 ("Steinberg"). *Id.* at B.167-79. In that same office action, the Examiner also rejected claims 1-19 on the ground of non-statutory double patenting over U.S. Patent Nos. 10,289,131, 9,244,470 and 8,180,492, and rejected claims 19-20 under 35 U.S.C. § 112 ¶ 2. *Id.* at B.160-67. In response, Applicants submitted a terminal disclaimer and requested that the double patenting rejection be withdrawn. *Id.* at B.126. Applicants also amended claim 19 to address the § 112 rejection, and argued that the § 103 rejection should be withdrawn because Steinberg was not prior art. *Id.* at B.127-28.

In an office action dated July 17, 2019, the Examiner again rejected all pending claims under § 103 on the basis of Podgorny and U.S. Patent Pub. No. 2005/0270151 ("Winick"). *Id.* at B.84-96. In that same office action, the

Request for *Ex Parte* Reexamination
U.S. Patent No. 10,534,382

Examiner also rejected claims 13, 16 and 20 under § 112 ¶ 2. *Id.* at B.083. In response, on April 3, 2019, Applicant amended the claims to all recite (or depend from a claim that recites) that the one or more processors include a processor “located remotely from the memory and is not electrically connected to the memory” and that the memory “is configured to store historical values of the first data and second data”. *Id.* at B.049-54. On September 4, 2019, the Examiner allowed the claims as amended, finding that those limitations were not disclosed in the prior art. *Id.* at B.013-21.

The terminal disclaimer for the '382 Patent is attached as Exhibit L.

V. CITATION OF PRIOR ART

Reexamination is requested in light of the following prior art references:

1. U.S. Patent Pub. No. 2009/0302994 (“Rhee”). The application for Rhee was filed on June 10, 2008 and it was published on December 10, 2009. Rhee was not cited as a reference in the prosecution of the '382 Patent. A copy of Rhee is attached as Exhibit C.
2. U.S. Patent No. 8,020,777 (“Kates”). The application for Kates was filed on January 29, 2007 and the patent was issued on September 20, 2011. Kates was not cited as a reference in the prosecution of the '382 Patent. A copy of Kates is attached as Exhibit D.
3. U.S. Patent No. 8,239,922 (“Sullivan”). The application for Sullivan

Request for *Ex Parte* Reexamination
U.S. Patent No. 10,534,382

was filed on August 27, 2007 and the patent was issued on August 7, 2012.

Sullivan was not cited as a reference in the prosecution of the '382 Patent, although a similar reference, U.S. Patent Pub. No. 2009/0057426, was cited. Ex. B at B.201. A copy of Sullivan is attached as Exhibit E.

The '382 Patent is subject to the prior art requirements of the Leahy-Smith America Invents Act, Pub. L. 112-29, 125 Stat. 284 (2011) ("AIA").² Each of the above references is prior art to the '382 Patent under the AIA, 35 U.S.C. §

² To be subject to the AIA, the patent must meet the requirements of Section 3(n)(1) of the AIA. The '382 Patent meets these requirements at least because claims 19 and 20 have an effective filing date after March 16, 2013. Claims 19 and 20 the '382 Patent were added by amendment in 2019 (after March 16, 2013) without any written description support in the application. Ex. B at B.054. Nor does any application to which the '382 Patent claims priority provide written description for claims 19 or 20. For example, claim 20 requires that the processors control the HVAC system based at least in part on historical values of measurements of the temperature of the building (first data) and outdoor temperatures received from the Internet (second data). Neither the application that resulted in the '382 Patent nor any of the earlier applications incorporated therein contain any teaching of this limitation. *See* Exs. B, H-K.

102(a)(2) (2018), because they were filed before the earliest possible effective filing date for the claims of the '382 Patent, July 14, 2008. They would also be prior art to the '382 Patent under pre-AIA 35 U.S.C. § 102(e)(1) (2006) (for Rhee) and 35 U.S.C. § 102(e)(2) (2006) (for Kates and Sullivan).

VI. STATEMENT POINTING OUT SUBSTANTIAL NEW QUESTIONS OF PATENTABILITY (“SNQP”)

A. Summary of Proposed Rejections

Pursuant to 37 C.F.R. § 1510(b)(1), Alarm.com sets forth a statement raising an SNQP regarding all claims of the '382 Patent based on Rhee or based on Rhee in combination with Kates and/or Sullivan.

SNQP 1 sets forth a proposed rejection of claims 1-20 under 35 U.S.C. § 102 and/or 35 U.S.C. § 103 in view of Rhee.

SNQP 2 sets forth a proposed rejection of claims 7-9 and 15-16 under 35 U.S.C. § 103 in view of Rhee and Sullivan.

SNQP 3 sets forth a proposed rejection of claims 1-20 under 35 U.S.C. § 103 in view of Rhee and Kates.

SNQP 4 sets forth a proposed rejection of claims 7-9 and 15-16 under 35 U.S.C. § 103 in view of Rhee, Sullivan and Kates.

B. SNQP 1: Claims 1-20 are anticipated by or rendered obvious by Rhee.

SNQP 1 addresses all claims in view of Rhee. Alarm.com submits that Rhee disclosed all elements of claims 1-20 to a POSITA. However, to the extent that Rhee alone is found not to anticipate any of claims 1-20, Alarm.com submits that the differences would have been obvious. Further explanation of obviousness with respect to certain claim limitations is found below and also in the Declaration of Tajana Šimunić Rosing, Ph.D, submitted as Exhibit G to this Request.

1. Overview of Rhee.

Rhee is directed to energy management systems and methods that include at least one wireless controller in communication with a management server, which manage energy devices (*e.g.*, HVAC systems) based on an energy profile. Ex. C. at Abstract, [0003].

2. Rhee disclosed all elements of independent claims 1 and 17.

(a) Rhee disclosed a management server with a memory and one or more processors.

All challenged claims require a system comprising “a memory” and “one or more processors with circuitry and code designed to execute instructions”. Rhee disclosed these limitations. Ex. G at ¶¶ 59-67.

Rhee disclosed a “management server” as a component of the HVAC control system. The management server managed energy-consuming devices (including

HVAC systems such as air conditioners and heaters). Ex. C at [0037]-[0038]. As disclosed by Rhee, the management server was implemented as one or more computers containing one or more processors, memory for storage of instructions and data, along with circuitry. *Id.* at [0104]-[0107]. This fact would also have been obvious as computer servers containing processors and utilizing memory were well known in the art in 2008. Ex. G at ¶ 60. Rhee also disclosed “wireless controllers” that contained processors and could be included among the claimed “one or more processors” because they worked jointly with the management server to manage the system. *Id.* at [0037]; [0103]-[0107]; Ex. G at ¶ 66.

- (b) Rhee disclosed the management server received “first data from at least one sensor” that included a “measurement of the current temperature of the building”.

Claim 1 requires that the “one or more processors” “receive a first data from at least one sensor” that “includes a measurement of at least one characteristic of the building”. Claims 4 through 6 and claims 17, 18 and 20 require that the first data include “a measurement of the current temperature of the building by the sensor”. Rhee disclosed the “first data” limitations, including the more narrow requirement of claims 4-6, 17, 18 and 20 that the first data include a measurement of the current temperature of the building. Ex. G at ¶¶ 68-70, 115-117.

Rhee disclosed that the wireless controller at the building transmitted

“energy data” to the management server. Ex. C at [0047]-[0048]. This energy data included “environmental data”, which included measurements of the inside temperature of the building. *Id.* at [0057]; [0016]; [0040]; [0042]. Figure 4 of Rhee illustrates how the inside temperature of the building (as well as other characteristics of the building) was measured using a temperature sensor and transmitted via a wireless gateway to the management server. *Id.* at [0074]-[0075]; [0079]. Rhee’s disclosures indicated that the data received by the management server included inside temperature measured by a temperature sensor in the building, as well as other characteristics of the building. Ex. G at ¶¶ 69-70.

- (c) Rhee disclosed the management server received “second data from a network connection” that comprised a “measurement of the current outdoor temperature” that was “collected from a source external to the building”.

All challenged claims require that the “one or more processors” “receive a second data from a network connection” that “is received via the Internet” and that the second data is “collected from a source external to the building”. Claim 5, which depends from claim 1, further requires that the second data “comprises a measurement of the current outdoor temperature”. Claims 17, 18 and 20 similarly require that the second data “comprises outdoor temperature”. Rhee disclosed the “second data” limitations, including the more narrow requirement of claims 5, 17, 18 and 20 that the second data comprise a measurement of the current outdoor

temperature. Ex. G at ¶¶ 71-73, 118-120.

Rhee disclosed that the wireless controller at the building transmitted “energy data” to the management server. Ex. C at [0047]-[0048]. This energy data included “environmental data”, which included measurements of the temperature outside the building. *Id.* at [0057]; [0016]; [0040]; [0042]. The management server received this data from a connection to the Internet (which was a network). *Id.* at [0040]; [0045]. Rhee further disclosed that the outside temperature was measured by a temperature sensor “placed outside the building”. *Id.* at [0079]. The outside temperature measurements were used by the analysis module, which was part of the management server. *Id.* at [0067] (“[T]he analysis module 226 creates a [sic] energy report for the current inputted by the HVAC unit versus the average temperature outside of the building as recorded by a temperature sensor over the course of the past ten years.”). Rhee’s disclosures indicated that the data received by the management server via its Internet connection included outside temperature measurements collected by a temperature sensor outside of and hence external to the building. Ex. G at ¶¶ 72-73.

- (d) Rhee disclosed the management server received a temperature setpoint to use when a building was occupied and a second temperature setpoint to use when a building was unoccupied.

All challenged claims require the one or more processors receive a first

temperature setpoint “corresponding to a desired temperature setting when the building is occupied” and a second temperature setpoint “corresponding to a desired temperature setting when the building is unoccupied”. Rhee disclosed these limitations. Ex. G at ¶¶ 74-77.

Rhee disclosed that the management server maintained an “energy profile” which contained, among other things, a first temperature setpoint that corresponded to a desired temperature for when the building was occupied, and a second temperature setpoint that corresponded to a desired temperature when the building was unoccupied. *See* Ex. C at [0052] & Table 2; [0056]. Figure 6A provides examples of the two temperature setpoints:

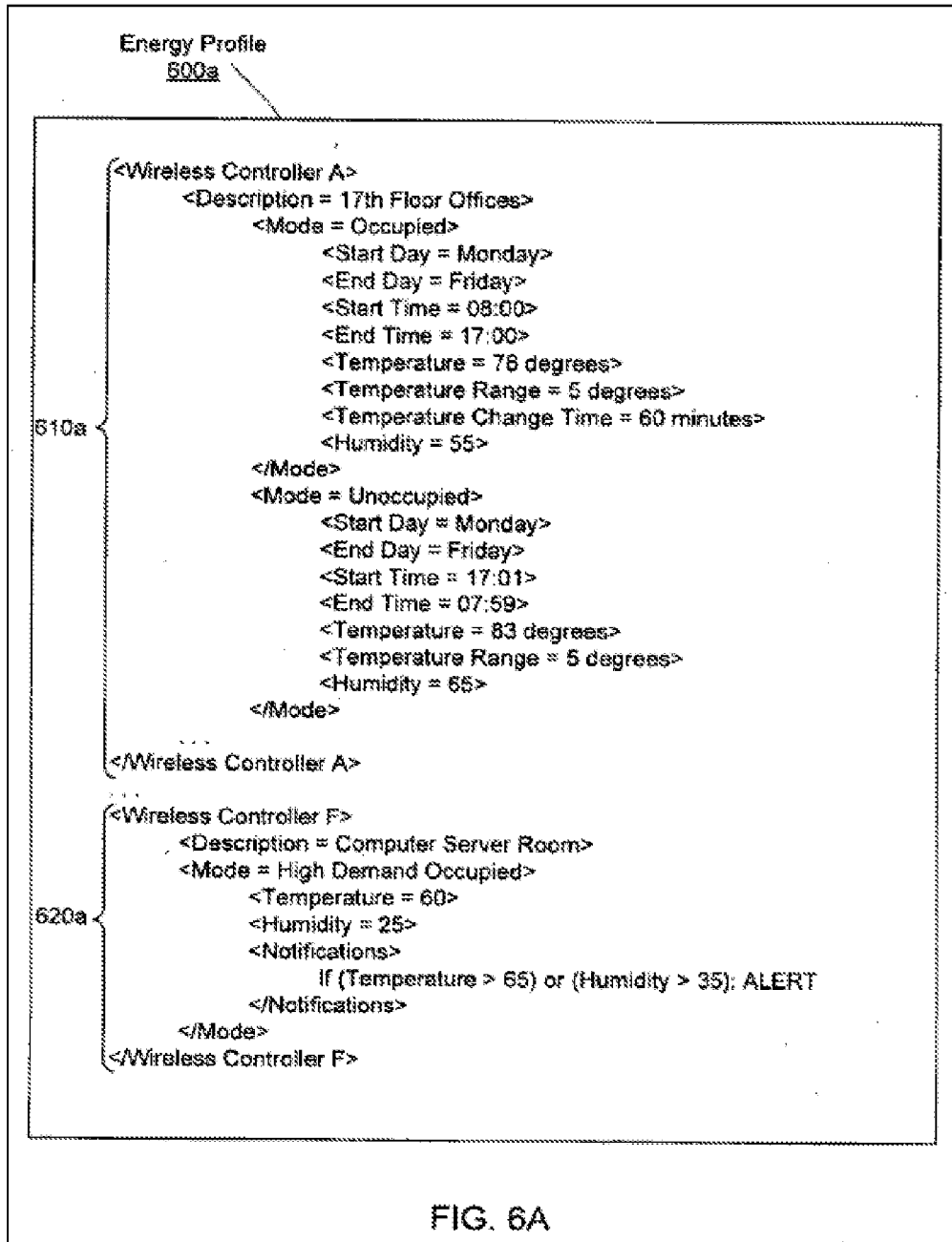

Rhee disclosed that the temperature setpoints in the energy profile could be modified by a user using a client module. Ex. C at [0056]. The client module was a user interface to the management server and could communicate with the management server over the a network connection. *Id.* at [0045]. Therefore, a

POSITA would appreciate that the management server *received* modifications to the desired temperature setpoints for when the building was occupied and unoccupied over a network connection from the client module. Ex. G at ¶¶ 76-77.

- (e) Rhee disclosed the management server received commands through the Internet from a remote interface on a mobile, wireless device.

All challenged claims require that the one or more processors “receive commands through the Internet by way of a remote interface on a mobile, wireless device running software application code” that “allow[s] the user to adjust temperature setpoints for the HVAC system”. Rhee discloses this limitation. Ex. G at ¶¶ 78-80.

Rhee disclosed a client module that provided a user interface to “remotely control” the management server. Ex. C at [0056]. The client module contained a transmitting device for transmitting commands to the management server via the Internet. *Id.* at [0045] & Fig. 1B; [0056]. The transmitting device of the client module was disclosed to include mobile devices such as cellular phones that communicated wirelessly. *Id.* at [0113]. A POSITA would have appreciated that the client module included mobile wireless devices such as cellular phones running software application code, such as a web browser, that sent commands to the management server to control system. Ex. G at ¶¶ 79-80. Furthermore, the client

module allowed the user to adjust the temperature setpoints stored in the management server's energy profile. Ex C. at [0056].

- (f) Rhee disclosed the management server sent user-specific data through the Internet to a remote interface on a mobile, wireless device.

All challenged claims require that the one or more processors “send user-specific data through the Internet” that “user-specific information about the building and HVAC system is generated based at least in part on the user-specific data” and that “user-specific information is configured to be presented on a user interface on a mobile, wireless device running software application code”. Rhee discloses these limitations. Ex. G at ¶¶ 81-87.

As explained above, Rhee disclosed a client module, including a cellular phone, that communicated with the management server via the Internet. Rhee disclosed that access via the client module was controlled by a “username/password” or “other type of authentication mechanism”. Ex. C at [0056]. A POSITA would have understood such a system to provide information specific to the user who was authenticated, and only such information as that user was authorized to access. Ex. G at ¶ 83. For example, the management server could support multiple users associated with different building systems. A POSITA would have understood that a user would see data only for the particular building (or buildings) which they were allowed to access. Ex. G at ¶ 84.

Furthermore, the client module would present information based on the user-specific data it received, for example by displaying charts or analysis reports that the user was authorized to access on a web page. *Id.* at [0056]; [0110]; [0113]. This user-specific information concerned the HVAC system and building, such as energy consumption conditions for the HVAC system, the energy profile for the user, and the network status. *Id.* at [0056]. Additionally, “depending on their access level”, the user would be presented with the option to modify the energy profile (*e.g.*, temperature setpoints). *Id.*

A POSITA would have understood from Rhee’s disclosure that the server sent user-specific data to a cellular phone so that a user could view user-specific information about the system on a remote user interface (*e.g.*, a web browser).

Ex. G at ¶ 87.

- (g) Rhee disclosed that the management server determined whether the building was occupied or unoccupied and controlled the system based on whether the building was occupied or unoccupied.

Claim 1 requires that the one or more processors “determine whether the building is occupied and unoccupied and based on that determination, to control the HVAC system to provide heating or cooling to the building at an operational temperature”. Claim 17 requires that the one or more processors “control the HVAC system based on the determination that the building is occupied to provide

heating or cooling to the building effective to reach the first temperature setpoint for the building corresponding to a desired temperature setting when the building is occupied”. Rhee disclosed these limitations. Ex. G at ¶¶ 88-94, 197-201.

Rhee disclosed that the system could determine whether the building was occupied or unoccupied based on a schedule or based on occupancy sensors. Ex. C [0052]; [0097]; Table 2 & Table 8.

TABLE 8

<u>Exemplary Operational Modes</u>				
Mode	Description	Temperature	Range	Trigger
Occupied	Full occupancy	Energy profile control or local thermostat	Set per comfort range (e.g., ± 3 degrees)	Schedule, occupancy sensors or exit of Override mode
Unoccupied	Empty	Local thermostat disabled	Disabled	Schedule or occupancy sensors
Override	Manual control	Local thermostat within energy profile	Wider comfort range (e.g., ± 5 degrees)	Override button
Maintenance	Manual control	Local thermostat with time limit	Maintenance control range (e.g., ± 10 degrees)	Override button
Demand Response	Full occupancy during peak energy consumption	Energy profile control	Disabled	Energy requirements from the electrical grid
Optimal Generation Source	Energy source availability	Energy profile control	Depends on generation source	Energy source availability
Transition	HVAC transition from heating to cooling, etc.	Energy profile control and/or other factors	Not applicable	Schedule, outside temperature, weather forecast, and/or statistical data

The schedule allowed a user to specify time periods when the building would be occupied and time periods when it would be unoccupied. *Id.* at [0088] & Fig. 6A.

TABLE 2

<u>Exemplary Office HVAC Energy Profile.</u>					
Mode	Start Time	End Time	Days	Temperature	Range
Ramp-Up	7:00 am	7:59 am	Weekdays	70	± 3
Occupied	8:00 am	5:00 pm	Weekdays	73	± 3
Unoccupied	5:01 pm	6:59 am	Weekdays	65	± 3
Unoccupied			Weekend	65	± 3

This could be done via the client module sending the schedule information to the management server. *Id.* at [0056]. A second method was to use one or more occupancy sensors located in the building to directly detect whether occupants were present or not. *E.g., id.* at [0097]; [0102] & Table 8. In either case, the system controlled the temperature of the building according to the occupancy status and the desired temperatures specified for each mode specified in the energy profile. *Id.* Rhee disclosed that the management server could manage (e.g., control) an energy device (e.g., the HVAC system) independently, or jointly with the wireless controllers. *Id.* at [0037]. Thus, a POSITA would have understood that Rhee disclosed determining whether the building was occupied or unoccupied and controlled the HVAC system to provide heating or cooling to the building at

an operational temperature based on that determination. Ex. G at ¶ 92. A POSITA would understand that the temperature setpoints in the energy profile would cause the disclosed system to control the HVAC system to provide heating or cooling to the building until the specified temperature was reached. *Id.*

- (h) Rhee disclosed the management server determined “whether the building is occupied or unoccupied” based at least in part on “third data from a motion sensor”.

Claim 17 and its dependent claims 18 and 20 require that the “one or more processors” “receive a third data from a motion sensor” that is used to “determine whether the building is occupied or unoccupied”. Claim 10 similarly requires that the “determination of whether the building is occupied or unoccupied by one or more processors” be “based on a third data received from a motion sensor”. Rhee disclosed this limitation. Ex. G at ¶¶ 149-153.

Rhee disclosed a management server that received data from a wireless controller. Ex. C at [0048]. The wireless controller can be connected to any number of sensors or alarms, including “a motion detector”. *Id.* at [0083] & Fig. 4. This sensor data was transmitted to and received by the management server. *Id.* at [0101]-[0102]. Rhee disclosed that an “energy profile” may utilize different “operational modes”, including an “occupied” and “unoccupied modes”, both of which can be triggered by “occupancy sensors”. *Id.* at [0097] & Table 8 (“[O]ccupancy sensors”); *see also* Fig. 9 & [0102] (wireless controller and control

module manage HVAC system based on “energy profile and/or the sensor data”). A POSITA would have understood the “occupancy sensors” to refer at least to the wireless motion sensors Ex. G at ¶¶ 198-201; *see also id.* at ¶ 90. The motion sensor data received by the management server was the claimed “third data”. Rhee’s disclosures thus taught that the management server received motion sensor data to determine the occupancy of a building.

- (i) Rhee disclosed a first processor that was located remotely from the memory that communicated with the memory.

Claim 1 requires that the one or more processors include a “first processor” “which is located remotely from the memory and is not electrically connected to the memory” that “communicate[s] with the memory”. Rhee disclosed these limitations. Ex. G at ¶¶ 96-104.

As explained above, Rhee disclosed a management server with processors, any of which would be a “first processor”. Rhee also disclosed a memory in the form of a “storage module” used by the management server to store data including the energy profile and energy data. Ex. C at [0060]. Rhee further disclosed that the storage module could be a “secured SQL database” that “can be located remotely from the management server”. *Id.* at [0070]. A POSITA would have appreciated from Rhee’s disclosure that the management server would not be electrically connected to a remotely located SQL database, as each would be separate

computers with independent electrical circuitry and power supplies. Ex. G at ¶ 98.

The processors of the management server would communicate remotely with the SQL database. Ex. C at [0070]. Thus Rhee disclosed a first processor that was remote from, and not electrically connected to, a memory, where the processor communicated remotely with that memory. Ex. G at ¶¶ 96-100.

- (j) Rhee disclosed a memory that stored historical values of the first and second data.

Claim 1 requires that the “memory is configured to store historical values of the first data and the second data”. Rhee discloses this limitation. Ex. G at ¶¶ 105-108.

As explained above, the management server received measurements of inside temperature (first data) and outside temperature (second data), which were part of the energy data received by the management server. Rhee disclosed that the storage module of the management server stored the energy data. This data was stored over time for use by other components of Rhee’s system, such as displaying a report showing “past indoor and outdoor temperatures”. Ex. C at [0066]; *see also* [0057] (“[E]nvironmental data” can include “inside temperature” and “outside temperature”); [0067] (“As another example, the analysis module 226 creates a [sic] energy savings report based on past indoor and outdoor temperatures.”). A

POSITA would have appreciated that the past values for the indoor and outdoor temperature stored in the storage module were historical values. Ex. G at ¶ 102.

* * *

Claim 1 was anticipated by and/or would have been obvious in view of Rhee as shown in the following claim chart.³

Claim 1	Rhee
1. A system for controlling an HVAC system at a user's building, the system comprising:	<p>“The energy management system 100 further includes a wireless repeater 118, a management server 120, a wireless gateway 130, a network 140, and a client module 150. In one embodiment, <i>the wireless controller 110e manages (e.g., controls, directs, monitors, etc.) an energy device 160 (e.g., heater, air conditioner, lights, windmill, etc.)</i>. The wireless repeater 118 forwards and/or routes communications between wireless controller D 110d and wireless controller C 110c via the wireless mesh network thereby extending the range of the wireless mesh network 170. The wireless gateway 130 connects the wireless mesh network 170 to the management server 120 via the network 140. The management server 120 communicates with the wireless controllers 110 via the network 140 (e.g., the internet) and the wireless gateway 130 and transmits part or all of an energy profile to one or more of the wireless controllers 110. The management server 120 also receives energy data from the wireless controllers 110. The client module 150 includes an interface utilized to manage the management server 120 directly or remotely via the network 140.” Ex. C at [0045].</p>

³ All emphasis in the quoted text of the claim charts has been added to the original.

Claim 1	Rhee
	<p>“The energy management system 100 can be, for example, <i>utilized in a building</i> and/or a group of buildings (e.g., campus, office complex, global office complex, city wide campus, etc.).” <i>Id.</i> at [0046].</p> <p>“As a further example, <i>the wireless controller C 110c manages heating, ventilating, and air conditioning (HVAC) for the office complex.</i> The wireless controller C 110c can manage the HVAC units for the office complex utilizing a wired connection, a wireless connection, and/or a pneumatic controlled connection. The wireless controller C 110c includes a different part of the energy profile for the office complex (i.e., office HVAC energy profile). The office HVAC energy profile includes information as illustrated in Table 2.” <i>Id.</i> at [0052].</p>
[a] a memory; and	<p>“In other examples, <i>the storage module 228 stores the energy data, the modifications to the energy profile, and/or the energy profile utilizing a database.</i> For example, the storage module 228 stores the energy data, the modification to the energy profile, and/or the energy profile in a secured SQL database. The database can be, for example, accessed by the client module 150 and/or the management server 220. In other embodiments, the storage module 228 can be located remotely from the management server 220.” <i>Id.</i> at [0070].</p>
[b] one or more processors with circuitry and code designed to execute instructions;	<p>“The wireless controller E 110e communicates the monitored energy data to the management server 120 via the wireless mesh network 170 and the network 140. <i>The management server 120 manages one or more parts of an energy profile based on the energy data, preferences, and/or other information associated with the energy management system 100 (e.g., building holidays, occupancy vacation, weather, power demands, etc.).</i> The energy profile is utilized to distribute the intelligence of the energy management system 100 across the wireless controllers 110 and the</p>

Claim 1	Rhee
	<p>management server 120. For example, each wireless controller 110 can independently and autonomously manage the energy device 160 based on the energy profile or parts thereof and/or the energy data. An advantage of distributing the intelligence allows for easy deployment and adoption of the energy management system 100 since both the wireless controller 110 and the management server 120 manage the energy policy compliance and optimization.” <i>Id.</i> at [0048].</p> <p>“The above-described systems and methods can be implemented in digital electronic circuitry, in computer hardware, firmware, and/or software. The implementation can be as a computer program product. The implementation can, for example, be in a machine-readable storage device, for execution by, or to control the operation of, data processing apparatus. <i>The implementation can, for example, be a programmable processor, a computer, and/or multiple computers.</i>” <i>Id.</i> at [0104].</p> <p>“<i>Method steps can be performed by one or more programmable processors executing a computer program to perform functions of the invention by operating on input data and generating output. Method steps can also be performed by and an apparatus can be implemented as special purpose logic circuitry. The circuitry can, for example, be a FPGA (field programmable gate array) and/or an ASIC (application specific integrated circuit). Modules, subroutines, and software agents can refer to portions of the computer program, the processor, the special circuitry, software, and/or hardware that implements that functionality.</i>” <i>Id.</i> at [0106].</p> <p>“Processors suitable for the execution of a computer program include, by way of example, both general and</p>

Claim 1	Rhee
	<p>special purpose microprocessors, and any one or more processors of any kind of digital computer. <i>Generally, a processor receives instructions and data from a read-only memory or a random access memory or both.</i> The essential elements of a computer are a processor for executing instructions and one or more memory devices for storing instructions and data. Generally, a computer can include, can be operatively coupled to receive data from and/or transfer data to one or more mass storage devices for storing data (e.g., magnetic, magneto-optical disks, or optical disks).” <i>Id.</i> at [0107].</p>
<p>[c] the one or more processors with circuitry and code designed to execute instructions to receive a first data from at least one sensor, wherein the first data from the at least one sensor includes a measurement of at least one characteristic of the building;</p>	<p>“FIG. 9 is a flowchart 900 illustrating management and monitoring of energy devices 460 and 462 by a wireless controller 410 utilizing an energy profile and sensor data as illustrated by FIG. 4. The network interface module 416 receives (910) energy profile modifications from the management server 120 of FIG. 1B and communicates the energy profile modifications to the control module 414. <i>The control module 414 receives (920) sensor data from the temperature sensor 466 and the humidity sensor 468.</i> The control module 414 manages (930) the energy devices (in this example, the air conditioning unit 460 and the humidifier/de-humidifier unit 462) based on the energy profile and/or the sensor data. <i>The control module 414 receives (940) energy data from the energy devices 460 and 462 and sensor data from the sensors 466 and 468 and transmits (950) the energy data and the sensor data to the management sever 120 via the network interface module 416.</i> The network interface module 416 continues to receive (910) energy profile modifications from the management server 120.” <i>Id.</i> at [0102].</p>

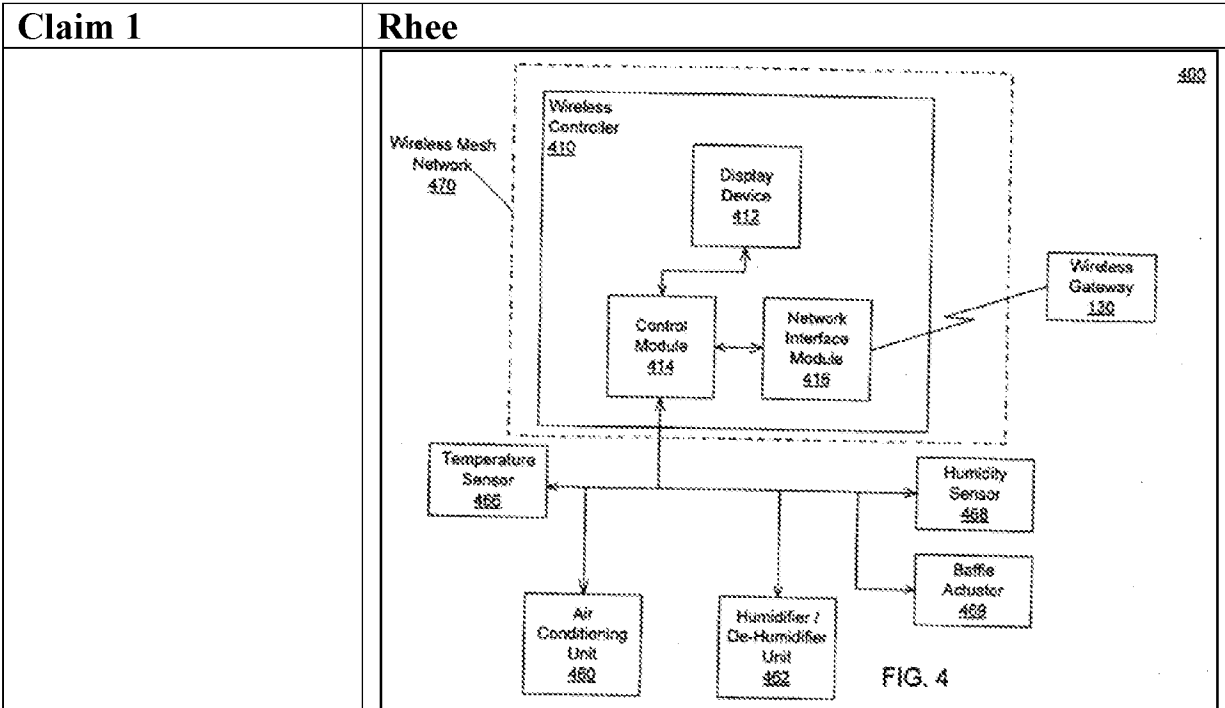

Claim 1	Rhee
<p>[d] the one or more processors with circuitry and code designed to execute instructions to receive a second data from a network connection, wherein the second data from the network connection is collected from a source external to the building, wherein the second data from the network connection is received via the Internet;</p>	<p>power level, and/or any other type of data associated with energy generation.” <i>Id.</i> at [0057].</p> <p>“FIG. 9 is a flowchart 900 illustrating management and monitoring of energy devices 460 and 462 by a wireless controller 410 utilizing an energy profile and sensor data as illustrated by FIG. 4. The network interface module 416 receives (910) energy profile modifications from the management server 120 of FIG. 1B and communicates the energy profile modifications to the control module 414. <i>The control module 414 receives (920) sensor data from the temperature sensor 466 and the humidity sensor 468. The control module 414 manages (930) the energy devices (in this example, the air conditioning unit 460 and the humidifier/de-humidifier unit 462) based on the energy profile and/or the sensor data. The control module 414 receives (940) energy data from the energy devices 460 and 462 and sensor data from the sensors 466 and 468 and transmits (950) the energy data and the sensor data to the management sever 120 via the network interface module 416. The network interface module 416 continues to receive (910) energy profile modifications from the management server 120.”</i> <i>Id.</i> at [0102].</p> <p>“Referring to FIG. 1A, an energy management system 50 is depicted. The energy management system 50 is associated with a building 51 or a series of buildings (e.g., a second building 51', an office complex, a school campus, global offices, commonly-owned buildings, commonly-managed buildings, etc.). The energy management system 50 includes the internet 52, a wireless gateway 53, a wireless repeater 54, a wireless controller A 55a, a wireless controller B 55b, a wireless actuator 57, a wireless sensor 58, and energy devices 59. The building 51 includes a plurality of rooms (e.g., room A 56a and room B 56b). The energy management system 50 is interconnected via a wireless mesh network.</p>

Claim 1	Rhee
	<p><i>The wireless gateway 53 connects the wireless mesh network with a management server (not shown) via the internet 52. The wireless repeater 54 extends the range of the wireless mesh network by forwarding and/or routing communications between the wireless controllers 55a and 55b, the wireless sensor 58 and/or the wireless actuator 57. The wireless controllers A 55a and B 55b are associated with the rooms A 56a and B 56b, respectfully. The wireless actuator 57 actuates and/or deactuates energy devices and/or any other type of device (e.g., mechanical device, electrical device, etc.). The wireless sensor 58 provide energy data to the wireless controllers A 55a and B 55b and/or the management server.” Id. at [0040].</i></p> <p>Referring to FIG. 1B, an energy management system 100 includes wireless controllers 110a, 110b, 110C, 110d, 110e . . . 110n (generally 110) in a wireless mesh network 170. The energy management system 100 further includes a wireless repeater 118, a management server 120, a wireless gateway 130, a network 140, and a client module 150. In one embodiment, the wireless controller 110e manages (e.g., controls, directs, monitors, etc.) an energy device 160 (e.g., heater, air conditioner, lights, windmill, etc.). The wireless repeater 118 forwards and/or routes communications between wireless controller D 110d and wireless controller C 110c via the wireless mesh network thereby extending the range of the wireless mesh network 170. <i>The wireless gateway 130 connects the wireless mesh network 170 to the management server 120 via the network 140. The management server 120 communicates with the wireless controllers 110 via the network 140 (e.g., the internet) and the wireless gateway 130 and transmits part or all of an energy profile to one or more of the wireless controllers 110. The management server 120 also receives energy data from the wireless controllers 110. The client module 150 includes an</i></p>

Claim 1

Rhee

interface utilized to manage the management server 120 directly or remotely via the network 140.” *Id.* at [0045].

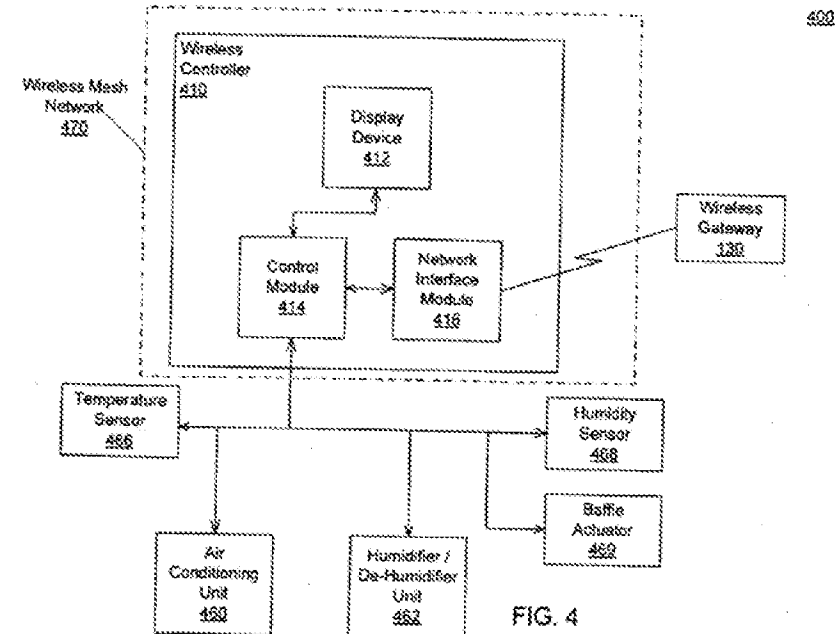
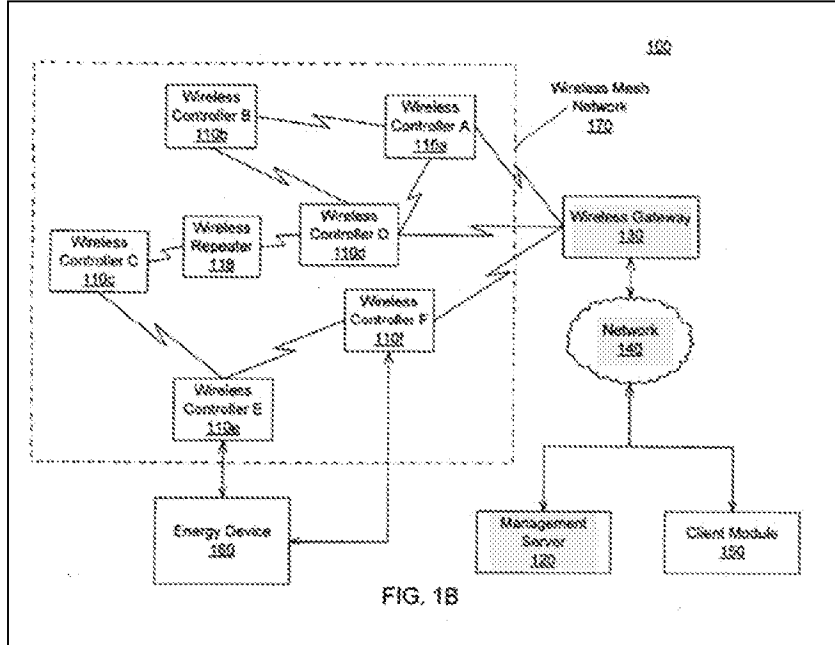

“In some examples, the energy data includes energy consumption data, environmental data, energy generation data, and/or any other type of data

Claim 1	Rhee																														
	<p><i>associated with building management (e.g., direction of windows on the building, prevailing wind, insulation type, oil tank level, propane tank level, alert information, etc.). ... The environmental data can include, for example, outside temperature, inside temperature, outside humidity, inside humidity, rainfall, sunlight coverage, environmental costs of different types of energy (e.g., cost of one kilowatt of wind power, greenhouse gas emissions for one kilowatt of coal power, etc.), and/or any other data associated with the environment.” Id. at [0057].</i></p> <p>“In other examples, the temperature sensor 466 and/or the humidity sensor 468 are utilized to record and/or analyze data regarding the building and/or the environment. <i>For example, the temperature sensor 466 is placed outside of the building to determine the outside temperature so that the energy profile can be modified based on the weather.” Id. at [0079].</i></p>																														
<p>[e] the one or more processors with circuitry and code designed to execute instructions to receive a first temperature setpoint for the building corresponding to a desired temperature setting when the building is occupied, and a second temperature setpoint for the building corresponding to a desired temperature setting when the</p>	<p>“As a further example, the wireless controller C 110c manages heating, ventilating, and air conditioning (HVAC) for the office complex. The wireless controller C 110c can manage the HVAC units for the office complex utilizing a wired connection, a wireless connection, and/or a pneumatic controlled connection. The wireless controller C 110c includes a different part of the energy profile for the office complex (i.e., office HVAC energy profile). The office HVAC energy profile includes information as illustrated in Table 2.” <i>Id. at [0052].</i></p> <div data-bbox="576 1585 1388 1879" style="border: 1px solid black; padding: 10px; margin: 10px auto; width: fit-content;"> <p style="text-align: center;">TABLE 2</p> <p style="text-align: center;"><u>Exemplary Office HVAC Energy Profile.</u></p> <table border="1" style="width: 100%; border-collapse: collapse;"> <thead> <tr> <th style="text-align: left;">Mode</th> <th style="text-align: left;">Start Time</th> <th style="text-align: left;">End Time</th> <th style="text-align: left;">Days</th> <th style="text-align: left;">Temperature</th> <th style="text-align: left;">Range</th> </tr> </thead> <tbody> <tr> <td>Ramp-Up</td> <td>7:00 am</td> <td>7:59 am</td> <td>Weekdays</td> <td>70</td> <td>±3</td> </tr> <tr> <td>Occupied</td> <td>8:00 am</td> <td>5:00 pm</td> <td>Weekdays</td> <td>73</td> <td>±3</td> </tr> <tr> <td>Unoccupied</td> <td>5:01 pm</td> <td>6:59 am</td> <td>Weekdays</td> <td>65</td> <td>±3</td> </tr> <tr> <td>Unoccupied</td> <td></td> <td></td> <td>Weekend</td> <td>65</td> <td>±3</td> </tr> </tbody> </table> </div>	Mode	Start Time	End Time	Days	Temperature	Range	Ramp-Up	7:00 am	7:59 am	Weekdays	70	±3	Occupied	8:00 am	5:00 pm	Weekdays	73	±3	Unoccupied	5:01 pm	6:59 am	Weekdays	65	±3	Unoccupied			Weekend	65	±3
Mode	Start Time	End Time	Days	Temperature	Range																										
Ramp-Up	7:00 am	7:59 am	Weekdays	70	±3																										
Occupied	8:00 am	5:00 pm	Weekdays	73	±3																										
Unoccupied	5:01 pm	6:59 am	Weekdays	65	±3																										
Unoccupied			Weekend	65	±3																										

Claim 1	Rhee
building is unoccupied;	<p>“The wireless controller C 110c manages the heating, ventilating, and air conditioning units for the office complex based on the office HVAC energy profile (i.e., part of the energy profile for the office complex). In these examples, Tables 1 and 2 are parts of an energy profile for the office complex.” <i>Id.</i> at [0052].</p> <p>“FIGS. 6A and 6B illustrate that different parts of the same building can have different settings and/or modes.” <i>Id.</i> at [0093]. <i>See also</i> Figs. 6A & 6B.</p> <p>“In other examples, the energy profile utilizes different operational modes to optimize the energy use under certain conditions. For example, as illustrated in Table 7 above, the classrooms have an Occupied mode and an Unoccupied mode. When the lights are in Occupied mode, then the lights are on and when the lights are in Unoccupied mode, then the lights are off. The automatic and uniform application of the mode utilizing the energy profile advantageously enables the optimally regulation of energy consumption under particular conditions in order to minimize waist. Table 8 illustrates different operational modes in the context of a HVAC unit. Although Table 8 illustrates the different operational modes in the context of a HVAC unit, the different operational modes can be utilized for any type of energy device.” <i>Id.</i> at [0097].</p>

Claim 1	Rhee																																								
	<p style="text-align: center;">TABLE 8</p> <p style="text-align: center;"><u>Exemplary Operational Modes</u></p> <table border="1" style="width: 100%; border-collapse: collapse;"> <thead> <tr> <th style="text-align: left;">Mode</th> <th style="text-align: left;">Description</th> <th style="text-align: left;">Temperature</th> <th style="text-align: left;">Range</th> <th style="text-align: left;">Trigger</th> </tr> </thead> <tbody> <tr> <td>Occupied</td> <td>Full occupancy</td> <td>Energy profile control or local thermostat</td> <td>Set per comfort range (e.g., ±3 degrees)</td> <td>Schedule, occupancy sensors or exit of Override mode</td> </tr> <tr> <td>Unoccupied</td> <td>Empty</td> <td>Local thermostat disabled</td> <td>Disabled</td> <td>Schedule or occupancy sensors</td> </tr> <tr> <td>Override</td> <td>Manual control</td> <td>Local thermostat within energy profile</td> <td>Wider comfort range (e.g., ±5 degrees)</td> <td>Override button</td> </tr> <tr> <td>Maintenance</td> <td>Manual control</td> <td>Local thermostat with time limit</td> <td>Maintenance control range (e.g., ±10 degrees)</td> <td>Override button</td> </tr> <tr> <td>Demand Response</td> <td>Full occupancy during peak energy consumption</td> <td>Energy profile control</td> <td>Disabled</td> <td>Energy requirements from the electrical grid</td> </tr> <tr> <td>Optimal Generation Source Transition</td> <td>Energy source availability</td> <td>Energy profile control</td> <td>Depends on generation source</td> <td>Energy source availability</td> </tr> <tr> <td></td> <td>HVAC transition from heating to cooling, etc.</td> <td>Energy profile control and/or other factors</td> <td>Not applicable</td> <td>Schedule, outside temperature, weather forecast, and/or statistical data</td> </tr> </tbody> </table>	Mode	Description	Temperature	Range	Trigger	Occupied	Full occupancy	Energy profile control or local thermostat	Set per comfort range (e.g., ±3 degrees)	Schedule, occupancy sensors or exit of Override mode	Unoccupied	Empty	Local thermostat disabled	Disabled	Schedule or occupancy sensors	Override	Manual control	Local thermostat within energy profile	Wider comfort range (e.g., ±5 degrees)	Override button	Maintenance	Manual control	Local thermostat with time limit	Maintenance control range (e.g., ±10 degrees)	Override button	Demand Response	Full occupancy during peak energy consumption	Energy profile control	Disabled	Energy requirements from the electrical grid	Optimal Generation Source Transition	Energy source availability	Energy profile control	Depends on generation source	Energy source availability		HVAC transition from heating to cooling, etc.	Energy profile control and/or other factors	Not applicable	Schedule, outside temperature, weather forecast, and/or statistical data
Mode	Description	Temperature	Range	Trigger																																					
Occupied	Full occupancy	Energy profile control or local thermostat	Set per comfort range (e.g., ±3 degrees)	Schedule, occupancy sensors or exit of Override mode																																					
Unoccupied	Empty	Local thermostat disabled	Disabled	Schedule or occupancy sensors																																					
Override	Manual control	Local thermostat within energy profile	Wider comfort range (e.g., ±5 degrees)	Override button																																					
Maintenance	Manual control	Local thermostat with time limit	Maintenance control range (e.g., ±10 degrees)	Override button																																					
Demand Response	Full occupancy during peak energy consumption	Energy profile control	Disabled	Energy requirements from the electrical grid																																					
Optimal Generation Source Transition	Energy source availability	Energy profile control	Depends on generation source	Energy source availability																																					
	HVAC transition from heating to cooling, etc.	Energy profile control and/or other factors	Not applicable	Schedule, outside temperature, weather forecast, and/or statistical data																																					
<p>[f] the one or more processors with circuitry and code designed to execute instructions to receive commands through the Internet by way of a remote interface on a mobile, wireless device running software application code; wherein the interface is configured to allow the user to adjust temperature setpoints for the HVAC system;</p>	<p>“In other examples, <i>the client module 150 includes a web-based interface utilized to manage the management server 120 and/or the wireless controllers 110 via the network 140. A user and/or an administrator can, for example, access the client module 150 utilizing a transmitting device (e.g., laptop computer with a web browser) and remotely control the system 100.</i> The user and/or the administrator can remotely control the system 100 by directly communicating with the wireless controls 110 or by communicating with the management server 120. The client module 150 can control access via various granular levels of access utilizing a username/password and/or any other type of authentication/authorization mechanism. For example, the user utilizing the client module 150 via the transmitting device can monitor current energy consumption conditions and the wireless mesh network 170 status. The user can also view historical trending charts and analysis reports created by the management server 120. <i>As another example, the user, depending on their access level, can modify the energy</i></p>																																								

Claim 1	Rhee
	<p><i>profile (e.g., modify temperature set points for the modes and the schedules). Although FIG. 1B illustrates the client module 150 separate from the management server 120, the client module 150 can be integrated into the management server 120.” Id. at [0056]</i></p> <p><i>“The transmitting device can include, for example, a computer, a computer with a browser device, a telephone, an IP phone, a mobile device (e.g., cellular phone, personal digital assistant (PDA) device, laptop computer, electronic mail device), and/or other communication devices. The browser device includes, for example, a computer (e.g., desktop computer, laptop computer) with a world wide web browser (e.g., Microsoft® Internet Explorer® available from Microsoft Corporation, Mozilla® Firefox available from Mozilla Corporation). The mobile computing device includes, for example, a personal digital assistant (PDA).” Id. at [0113].</i></p> <p><i>“The front-end component can, for example, be a client computer having a graphical user interface, a Web browser through which a user can interact with an example implementation, and/or other graphical user interfaces for a transmitting device. The components of the system can be interconnected by any form or medium of digital data communication (e.g., a communication network).</i></p> <p><i>The system can include clients and servers. A client and a server are generally remote from each other and typically interact through a communication network. The relationship of client and server arises by virtue of computer programs running on the respective computers and having a client-server relationship to each other.” Id. at [0110-0111].</i></p> <p><i>“Examples of communication networks include wired networks, wireless networks, packet-based networks,</i></p>

Claim 1	Rhee
	<p><i>and/or circuit-based networks. Packet-based networks can include, for example, the Internet, a carrier internet protocol (IP) network (e.g., local area network (LAN), wide area network (WAN), campus area network (CAN), metropolitan area network (MAN), home area network (HAN)), a private IP network, an IP private branch exchange (IPBX), a wireless network (e.g., radio access network (RAN), 802.11 network, 802.16 network, general packet radio service (GPRS) network, HiperLAN), and/or other packet-based networks. Circuit-based networks can include, for example, the public switched telephone network (PSTN), a private branch exchange (PBX), a wireless network (e.g., RAN, bluetooth, code-division multiple access (CDMA) network, time division multiple access (TDMA) network, global system for mobile communications (GSM) network), and/or other circuit-based networks.”</i> <i>Id.</i> at [0112].</p>
<p>[g] the one or more processors with circuitry and code designed to execute instructions to send user-specific data through the Internet, wherein user-specific information about the building and HVAC system is generated based at least in part on the user-specific data, wherein the user-specific information is configured to be presented on a user interface on a mobile, wireless device running software</p>	<p>“In other examples, the client module 150 includes a web-based interface utilized to manage the management server 120 and/or the wireless controllers 110 via the network 140. A user and/or an administrator can, for example, access the client module 150 utilizing a transmitting device (e.g., laptop computer with a web browser) and remotely control the system 100. The user and/or the administrator can remotely control the system 100 by directly communicating with the wireless controls 110 or by communicating with the management server 120. <i>The client module 150 can control access via various granular levels of access utilizing a username/password and/or any other type of authentication/authorization mechanism. For example, the user utilizing the client module 150 via the transmitting device can monitor current energy consumption conditions and the wireless mesh network 170 status. The user can also view historical trending charts and analysis reports created by the management server 120.</i> As another example, the user,</p>

Claim 1	Rhee
<p>application code via the Internet;</p>	<p>depending on their access level, can modify the energy profile (e.g., modify temperature set points for the modes and the schedules). Although FIG. 1B illustrates the client module 150 separate from the management server 120, the client module 150 can be integrated into the management server 120.” <i>Id.</i> at [0056]. <i>See also</i> [0066]; [0103].</p>
<p>[h] the one or more processors with circuitry and code designed to execute instructions to determine whether the building is occupied or unoccupied, and based on that determination, to control the HVAC system to provide heating or cooling to the building at an operational temperature;</p>	<p>“<i>In other examples, the energy profile utilizes different operational modes to optimize the energy use under certain conditions. For example, as illustrated in Table 7 above, the classrooms have an Occupied mode and an Unoccupied mode. When the lights are in Occupied mode, then the lights are on and when the lights are in Unoccupied mode, then the lights are off. The automatic and uniform application of the mode utilizing the energy profile advantageously enables the optimally regulation of energy consumption under particular conditions in order to minimize waist. Table 8 illustrates different operational modes in the context of a HVAC unit. Although Table 8 illustrates the different operational modes in the context of a HVAC unit, the different operational modes can be utilized for any type of energy device.</i>” <i>Id.</i> at [0097].</p>

Claim 1

Rhee

TABLE 8

Exemplary Operational Modes

Mode	Description	Temperature	Range	Trigger
Occupied	Full occupancy	Energy profile control or local thermostat	Set per comfort range (e.g., ± 3 degrees)	Schedule, occupancy sensors or exit of Override mode
Unoccupied	Empty	Local thermostat disabled	Disabled	Schedule or occupancy sensors
Override	Manual control	Local thermostat within energy profile	Wider comfort range (e.g., ± 5 degrees)	Override button
Maintenance	Manual control	Local thermostat with time limit	Maintenance control range (e.g., ± 10 degrees)	Override button
Demand Response	Full occupancy during peak energy consumption	Energy profile control	Disabled	Energy requirements from the electrical grid
Optimal Generation Source Transition	Energy source availability HVAC transition from heating to cooling, etc.	Energy profile control and/or other factors	Depends on generation source Not applicable	Energy source availability Schedule, outside temperature, weather forecast, and/or statistical data

TABLE 2

Exemplary Office HVAC Energy Profile

Mode	Start Time	End Time	Days	Temperature	Range
Ramp-Up	7:00 am	7:59 am	Weekdays	70	± 3
Occupied	8:00 am	5:00 pm	Weekdays	73	± 3
Unoccupied	5:01 pm	6:59 am	Weekdays	65	± 3
Unoccupied			Weekend	65	± 3

Claim 1

Rhee

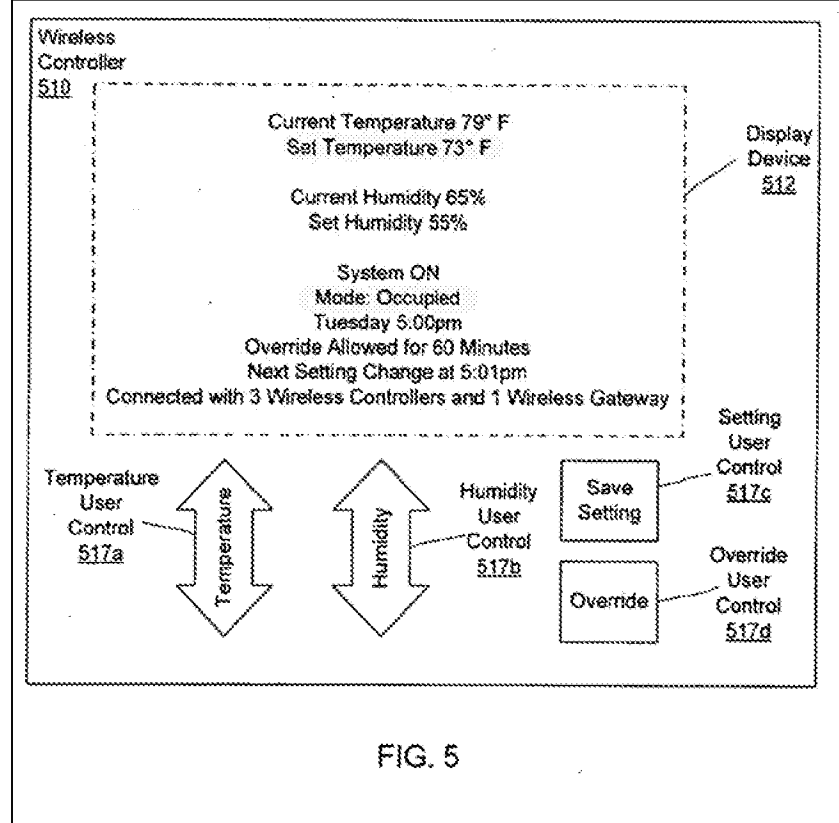

FIG. 5

“The wireless controller E 110e communicates the monitored energy data to the management server 120 via the wireless mesh network 170 and the network 140. The management server 120 manages one or more parts of an energy profile based on the energy data, preferences, and/or other information associated with the energy management system 100 (e.g., building holidays, occupancy vacation, weather, power demands, etc.). The energy profile is utilized to distribute the intelligence of the energy management system 100 across the wireless controllers 110 and the management server 120. For example, each wireless controller 110 can independently and autonomously manage the energy device 160 based on the energy profile or parts thereof and/or the energy data. An advantage of distributing the intelligence allows for easy deployment and adoption of the energy management system 100 since both the wireless

Claim 1	Rhee
	<p>controller 110 and the management server 120 manage the energy policy compliance and optimization.” <i>Id.</i> at [0048].</p> <p>“Generally, the system and method for energy management is reducing the overall energy costs related to energy devices (e.g., air conditioners, lights, fans, etc.). The management of the energy devices can provide a cost-effective solution to energy management by maximizing the effective use of energy-producing devices (e.g., generators, windmills, solar panels, etc.) and minimizing energy use of energy-consuming devices (e.g., air conditioners, heaters, lights, etc.). <i>The management of the energy devices can be performed jointly and independently by a management server and wireless controllers.</i></p> <p>“<i>The management server and the wireless controllers jointly manage an energy profile (e.g., activate the lights at 8:00 am and turn off the lights at 5:00 pm, use solar power from 8:00 am to 12:00 pm, etc.) for the energy devices. The joint management of the energy profile can advantageously provide centralized management of the energy profile while still allowing individualized management of certain features (e.g., temperature ranges, temperature overrides, etc.). The wireless controllers can independently manage the energy devices based on the energy profile which advantageously allows the wireless controllers to operate based on the energy profile without interaction from the management server.</i>” <i>Id.</i> at [0037-0038].</p> <p>“<i>FIG. 9 is a flowchart 900 illustrating management and monitoring of energy devices 460 and 462 by a wireless controller 410 utilizing an energy profile and sensor data as illustrated by FIG. 4. The network interface module 416 receives (910) energy profile modifications from the management server 120 of FIG. 1B and</i></p>

Claim 1	Rhee
	<p>communicates the energy profile modifications to the control module 414. The control module 414 receives (920) sensor data from the temperature sensor 466 and the humidity sensor 468. <i>The control module 414 manages (930) the energy devices (in this example, the air conditioning unit 460 and the humidifier/dehumidifier unit 462) based on the energy profile and/or the sensor data. The control module 414 receives (940) energy data from the energy devices 460 and 462 and sensor data from the sensors 466 and 468 and transmits (950) the energy data and the sensor data to the management sever 120 via the network interface module 416. The network interface module 416 continues to receive (910) energy profile modifications from the management server 120.</i>” <i>Id.</i> at [0102].</p>
<p>[i] wherein the one or more processors comprises a first processor with circuitry and code designed to execute instructions, which is located remotely from the memory and is not electrically connected to the memory;</p>	<p>“Referring to FIG. 2, an energy management system 200 includes a management server 220, a network 140, a wireless gateway 130, and a wireless controller 210 configured in a wireless mesh network 270. The management server 220 communicates via the network 140 to the wireless gateway 130. <i>The management server 220 includes a communication module 222, a profile module 224, an analysis module 226, and a storage module 228.</i> The communication module 222 monitors and receives energy data from the wireless controller 210 via the wireless gateway 130 and the network 140. The profile module 224 manages the energy profile and transmits part or all of the energy profile to the wireless controller 210 via the network 140 and the wireless gateway 130. The analysis module 226 analyzes the energy data received by the communication module 222 and creates modifications to the energy profile managed by the profile module 224. <i>The storage module 228 stores the energy data, the modifications to</i></p>

Claim 1	Rhee
	<p><i>the energy profile, and/or the energy profile.” Id. at [0060].</i></p> <p>“In other examples, the storage module 228 stores the energy data, the modifications to the energy profile, and/or the energy profile utilizing a database. For example, the storage module 228 stores the energy data, the modification to the energy profile, and/or the energy profile in a secured SQL database. The database can be, for example, accessed by the client module 150 and/or the management server 220. <i>In other embodiments, the storage module 228 can be located remotely from the management server 220.” Id. at [0070].</i></p>
<p>[j] the first processor with circuitry and code designed to execute instructions to communicate with the memory;</p>	<p>“In other examples, the storage module 228 stores the energy data, the modifications to the energy profile, and/or the energy profile utilizing a database. For example, the storage module 228 stores the energy data, the modification to the energy profile, and/or the energy profile in a secured SQL database. <i>The database can be, for example, accessed by the client module 150 and/or the management server 220.</i> In other embodiments, the storage module 228 can be located remotely from the management server 220.” <i>Id. at [0070].</i></p> <p>“Processors suitable for the execution of a computer program include, by way of example, both general and special purpose microprocessors, and any one or more processors of any kind of digital computer. <i>Generally, a processor receives instructions and data from a read-only memory or a random access memory or both. The essential elements of a computer are a processor for executing instructions and one or more memory devices for storing instructions and data.</i> Generally, a computer can include, can be operatively coupled to receive data from and/or transfer data to one or more mass storage devices for storing data (e.g., magnetic, magneto-optical disks, or optical disks).” <i>Id. at [0107].</i></p>

Claim 1	Rhee
[k] wherein the memory is configured to store historical values of the first data and second data.	<p>“In other examples, <i>the storage module 228 stores the energy data</i>, the modifications to the energy profile, and/or the energy profile utilizing a database. For example, the storage module 228 stores the energy data, the modification to the energy profile, and/or the energy profile in a secured SQL database. The database can be, for example, accessed by the client module 150 and/or the management server 220. In other embodiments, the storage module 228 can be located remotely from the management server 220.” Rhee at [0070].</p> <p>“<i>In some examples, the energy data includes energy consumption data, environmental data, energy generation data, and/or any other type of data associated with building management (e.g., direction of windows on the building, prevailing wind, insulation type, oil tank level, propane tank level, alert information, etc.). The energy consumption data can include, for example, energy used by the energy device 160, energy saved by the energy device 160, further energy use by the energy device 160, proposed energy use by the energy device 160, cost of different types of energy, and/or any other type of data associated with the consumption of energy. The environmental data can include, for example, outside temperature, inside temperature, outside humidity, inside humidity, rainfall, sunlight coverage, environmental costs of different types of energy (e.g., cost of one kilowatt of wind power, greenhouse gas emissions for one kilowatt of coal power, etc.), and/or any other data associated with the environment. The energy generation data can include, for example, alternative energy generation level (e.g., solar power generation, wind power generation, etc.), grid power level, and/or any other type of data associated with energy generation.</i>” <i>Id.</i> at [0057].</p> <p>“<i>In some examples, the analysis module 226 accesses energy data (e.g., current energy consumption data,</i></p>

Claim 1	Rhee
	<p><i>past energy consumption data, environmental data, etc.) stored on the storage module 228 to create charts and/or reports regarding past, present, and/or future energy use for the system 200. The charts and/or reports can include, for example, a future energy savings chart/report (e.g., how much will be saved by the energy management system 200, how much can be saved by switching from a HVAC unit to another HVAC unit, etc.), a present energy chart/report (e.g., present use of alternative energy generation, present energy use of lights, etc.), a past energy chart/report (e.g., past use of alternative energy generation, past energy use of HVAC units, past indoor and outdoor temperatures, etc.) and/or any other type of chart/report associated with the energy management system 200 (e.g., use of energy by a type of energy device at one building compares to the use of energy of the same energy device at other buildings, energy devices operating at or below optimal efficiency, etc.).</i></p> <p><i>For example, the analysis module 226 creates a energy report for the current inputted by the HVAC unit versus the average temperature outside of the building as recorded by a temperature sensor over the course of the past ten years. As another example, the analysis module 226 creates a time chart for the time between when the Occupied mode is activated until when individual rooms in a zone (e.g., all of the classrooms in a building) reach the set temperature. The time chart can be utilized by the analysis module 226 to modify the energy profile and/or can be utilized by the administrator to determine if the energy unit (e.g., HVAC unit) is underperforming, requires maintenance, and/or if any other issues exist for the rooms. As another example, the analysis module 226 creates a energy savings report based on past indoor and outdoor temperatures. The energy savings report can include, for example, the energy saved by the energy management</i></p>

Claim 1	Rhee
	system 200 (e.g., 15% of hearing energy was saved due to the energy management system 200 during the last two months; 25% of cooling energy was saved last quarter by optimized temperature ranges, etc.).” <i>Id.</i> at [0066-0067].

* * *

Claim 17 was anticipated by and/or would have been obvious in view of Rhee as shown in the following claim chart.

Claim 17	Rhee
17. A system for controlling an HVAC system at a user’s building, the system comprising:	<i>See supra</i> claim 1 claim chart.
[a] a memory; and	<i>See supra</i> claim 1 claim chart at element 1[a].
[b] one or more processors with circuitry and code designed to execute instructions;	<i>See supra</i> claim 1 claim chart at element 1[b].
[c] the one or more processors with circuitry and code designed to execute instructions to receive a first data from at least one sensor, wherein the first data from the at least one sensor includes a measurement of the current temperature of the building by the sensor;	<i>See supra</i> claim 1 claim chart at element 1[c]; claim 4 claim chart.
[d] the one or more	<i>See supra</i> claim 1 claim chart at element 1[d]; claim

Claim 17	Rhee
<p>processors with circuitry and code designed to execute instructions to receive a second data from a network connection, wherein the second data from the network connection is collected from a source external to the building and comprises outdoor temperature, wherein the second data from the network connection is received via the Internet;</p>	<p>5 claim chart.</p>
<p>[e] the one or more processors with circuitry and code designed to execute instructions to receive a first temperature setpoint for the building corresponding to a desired temperature setting when the building is occupied, and a second temperature setpoint for the building corresponding to a desired temperature setting when the building is unoccupied;</p>	<p><i>See supra</i> claim 1 claim chart at element 1[e].</p>
<p>[f] the one or more processors with circuitry and code designed to execute instructions to receive commands through the Internet by</p>	<p><i>See supra</i> claim 1 claim chart at claim 1[f].</p>

Claim 17	Rhee
<p>way of a remote interface on a mobile, wireless device running software application code; wherein the interface is configured to allow the user to adjust temperature setpoints for the HVAC system;</p>	
<p>[g] the one or more processors with circuitry and code designed to execute instructions to send user-specific data through the Internet, wherein user-specific information about the building and HVAC system is generated based at least in part on the user-specific data, wherein the user-specific information is configured to be presented on a user interface via on mobile, wireless device running software application code via the Internet;</p>	<p><i>See supra</i> claim 1 claim chart at element 1[g].</p>
<p>[h] the one or more processors with circuitry and code designed to execute instructions to receive a third data from a motion sensor, and is further configured to determine whether the building is occupied or unoccupied based at least</p>	<p><i>See infra</i> claim 10 claim chart and elements 10[pre]-10[a].</p>

Claim 17	Rhee
in part on the third data;	
<p>[i] the one or more processors with circuitry and code designed to execute instructions to control the HVAC system based on the determination that the building is occupied to provide heating or cooling to the building effective to reach the first temperature setpoint for the building corresponding to a desired temperature setting when the building is occupied;</p>	<p>“Each wireless controller 110 manages at least one energy device based on one or more parts of an energy profile. An advantage to the management of energy devices by the wireless controller 110 is that each individual wireless controller 110 can implement and enforce the appropriate energy management policy that can effectively manage energy consumption. In one embodiment, the wireless controller E 110e manages the energy device 160. The wireless controller E 110e can, for example, manage the energy device 160 directly by utilizing a wired connection (e.g., serial connection, ethernet connection, fiber optic connection, etc.) and/or wireless connection (e.g., wireless personal area network, cellular phone network, etc.) between the energy device 160 and the wireless controller E 110e. The wireless controller E 110e can, for example, monitor the energy device 160 indirectly by utilizing one or more sensors (not shown).” Ex. C at [0047]</p> <p>“The wireless controller E 110e communicates the monitored energy data to the management server 120 via the wireless mesh network 170 and the network 140. The management server 120 manages one or more parts of an energy profile based on the energy data, preferences, and/or other information associated with the energy management system 100 (e.g., building holidays, occupancy vacation, weather, power demands, etc.). The energy profile is utilized to distribute the intelligence of the energy management system 100 across the wireless controllers 110 and the management server 120. For example, each wireless controller 110 can independently and autonomously manage the energy device 160 based on the energy profile or parts thereof and/or the energy data. An advantage of</p>

Claim 17

Rhee

distributing the intelligence allows for easy deployment and adoption of the energy management system 100 since both the wireless controller 110 and the management server 120 manage the energy policy compliance and optimization.” *Id.* at [0048].

“As a further example, the wireless controller C 110c manages heating, ventilating, and air conditioning (HVAC) for the office complex. The wireless controller C 110c can manage the HVAC units for the office complex utilizing a wired connection, a wireless connection, and/or a pneumatic controlled connection. The wireless controller C 110c includes a different part of the energy profile for the office complex (i.e., office HVAC energy profile). The office HVAC energy profile includes information as illustrated in Table 2.” *Id.* at [0052].

Mode	Start Time	End Time	Days	Temperature	Range
Ramp-Up	7:00 am	7:59 am	Weekdays	70	±3
Occupied	8:00 am	5:59 pm	Weekdays	73	±3
Unoccupied	5:01 pm	6:59 am	Weekdays	65	±3
Unoccupied			Weekend	65	±3

“Each wireless controller A 55a and B 55b manages the energy devices 59 associated with the respective room based on an energy profile and/or energy data (e.g., environmental data, energy consumption data, energy generation data, etc.). *For example, the wireless controller A 55a directs the heating unit (i.e., one of the energy devices 59) to activate and heat the room A 56a.* As part of the heating of the room A 56a, the wireless controller A 55a directs the wireless actuator 57 to actuate a baffle and a fan to force a limited amount of outside air into room A

Claim 17

Rhee

55a.” *Id.* at [0041].

“In other examples, the energy profile utilizes different operational modes to optimize the energy use under certain conditions. For example, as illustrated in Table 7 above, the classrooms have an Occupied mode and an Unoccupied mode. When the lights are in Occupied mode, then the lights are on and when the lights are in Unoccupied mode, then the lights are off. The automatic and uniform application of the mode utilizing the energy profile advantageously enables the optimally regulation of energy consumption under particular conditions in order to minimize waist. Table 8 illustrates different operational modes in the context of a HVAC unit. Although Table 8 illustrates the different operational modes in the context of a HVAC unit, the different operational modes can be utilized for any type of energy device.” *Id.* at [0097].

TABLE 8

Exemplary Operational Modes

Mode	Description	Temperature	Range	Trigger
Occupied	Full occupancy	Energy profile control or local thermostat	Set per comfort range (e.g., ±3 degrees)	Schedule, occupancy sensor or exit of Override mode
Unoccupied	Empty	Local thermostat disabled	Disabled	Schedule or occupancy sensor
Override	Manual control	Local thermostat within energy profile	Wider comfort range (e.g., ±5 degrees)	Override button
Maintenance	Manual control	Local thermostat with time limit	Maintenance control range (e.g., ±10 degrees)	Override button
Demand Response	Full occupancy during peak energy consumption	Energy profile control	Disabled	Energy requirements from the electrical grid
Optimal Generation Source Transition	Energy source availability HVAC transition from heating to cooling, etc.	Energy profile control and/or other factors	Depends on generation source Not applicable	Energy source availability Schedule, outside temperature, weather forecast, and/or statistical data

[j] wherein the one or

See supra claim 1 claim chart at element 1[i].

Claim 17	Rhee
more processors comprises a first processor with circuitry and code designed to execute instructions, which is located remotely from the memory and is not electrically connected to the memory;	
[k] the first processor with circuitry and code designed to execute instructions to communicate with the memory;	<i>See supra</i> claim 1 claim chart at element 1 [j].
[l] wherein the memory is configured to store historical values of the first data and second data.	<i>See supra</i> claim 1 claim chart at element 1 [k].

3. Rhee disclosed the dependent limitations of claim 2 (which depends from claim 1).

Claim 2 requires that “the operational temperature is the second temperature setpoint for the building corresponding to a desired temperature setting when the building is unoccupied, in the event the one or more processors with circuitry and code designed to execute instructions determines that the building is unoccupied.”

Rhee disclosed these limitations. Ex. G at ¶¶ 109-111.

As explained above, Rhee disclosed that the system was able to determine that the building was unoccupied based on a schedule or occupancy sensor. (*See supra* Section VI.B.2(g).)

Rhee further disclosed that the system could control the HVAC system to implement a setpoint corresponding to a desired temperature when the building is unoccupied based on the determination that the building is unoccupied.

TABLE 2

Exemplary Office HVAC Energy Profile.

Mode	Start Time	End Time	Days	Temperature	Range
Ramp-Up	7:00 am	7:59 am	Weekdays	70	±3
Occupied	8:00 am	5:00 pm	Weekdays	73	±3
Unoccupied	5:01 pm	6:59 am	Weekdays	65	±3
Unoccupied			Weekend	65	±3

As explained above, the system controlled the temperature of the building based on whether the building was unoccupied and the desired “unoccupied” temperatures specified in the energy profile. (*See supra* Section VI.B.2(g).)

* * *

Claim 2 was anticipated by and/or would have been obvious in view of Rhee as shown in the following claim chart.

Claim 2	Rhee
2. The system of claim 1:	<i>See supra</i> claim 1 claim chart.

Claim 2	Rhee
[a] wherein the operational temperature is the second temperature setpoint for the building corresponding to a desired temperature setting when the building is unoccupied, in the event the one or more processors with circuitry and code designed to execute instructions determines that the building is unoccupied.	<i>See supra</i> claim 1 claim chart at element 1[h].

4. Rhee disclosed the dependent limitations of claim 3 (which depends from claim 1).

Claim 3 requires that “the operational temperature is the first temperature setpoint for the building corresponding to a desired temperature setting when the building is occupied, in the event the one or more processors with circuitry and code designed to execute instructions determines that the building is occupied.”

Rhee disclosed these limitations. Ex. G at ¶¶ 109-111.

As explained above, Rhee disclosed that the system was able to determine that the building was occupied based on a schedule or occupancy sensor. (*See supra* Section VI.B.2(g).)

Rhee further disclosed that the system could control the HVAC system to implement a setpoint corresponding to a desired temperature when the building is unoccupied based on the determination that the building is occupied.

TABLE 2

<u>Exemplary Office HVAC Energy Profile.</u>					
Mode	Start Time	End Time	Days	Temperature	Range
Ramp-Up	7:00 am	7:59 am	Weekdays	70	±3
Occupied	8:00 am	5:00 pm	Weekdays	73	±3
Unoccupied	5:01 pm	6:59 am	Weekdays	65	±3
Unoccupied			Weekend	65	±3

As explained above, the system controlled the temperature of the building based on whether the building was occupied and the desired “occupied” temperatures specified in the energy profile. (*See supra* Section VI.B.2(g).)

* * *

Claim 3 was anticipated by and/or would have been obvious in view of Rhee as shown in the following claim chart.

Claim 3	Rhee
3. The system of claim 1:	<i>See supra</i> claim 1 claim chart.
[a] wherein the operational temperature is the first temperature setpoint for the building corresponding to a desired temperature setting when the building	<i>See supra</i> claim 1 claim chart at element 1[h].

Claim 3	Rhee
is occupied, in the event the one or more processors with circuitry and code designed to execute instructions determines that the building is occupied.	

5. Rhee disclosed the dependent limitations of claim 4 (which depends from claims 1 and 2).

Claim 4 requires that the “first data from the at least one sensor comprises a measurement of the current temperature of the building by the sensor”. Rhee disclosed this limitation. Ex. G at ¶¶ 115-117.

As explained above, Rhee disclosed that the wireless controller at the building transmitted “energy data” to the management server. Ex. C at [0047]-[0048]. This energy data included “environmental data”, which included measurements of the inside temperature of the building. *Id.* at [0057]; [0016]; [0040]; [0042]. Figure 4 of Rhee illustrates how the inside temperature of the building (as well as other characteristics) was measured using a temperature sensor and transmitted via a wireless gateway to the management server. *Id.* at [0074]-[0075]; [0079]. Rhee’s disclosures indicated that the data received by the management server included inside temperature measured by a temperature sensor

in the building, as well as other characteristics of the building. Ex. G at ¶ 116.

(*See supra* Section VI.B.2(b).)

* * *

Claim 4 was anticipated by and/or would have been obvious in view of Rhee as shown in the following claim chart.

Claim 4	Rhee
4. The system of claim 2:	<i>See supra</i> claim 1 claim chart; claim 2 claim chart.
[a] wherein the first data from the at least one sensor comprises a measurement of the current temperature of the building by the sensor.	<i>See supra</i> claim 1 claim chart at element 1[c].

6. Rhee disclosed the dependent limitations of claim 5 (which depends from claims 1, 2, and 4).

Claim 5 requires that the “the second data from the network connection comprises a measurement of the current outdoor temperature”. Rhee disclosed this limitation. Ex. G at ¶¶ 118-120.

As explained above, Rhee disclosed that the wireless controller at the building transmitted “energy data” to the management server. Ex. C at [0047]-[0048]. This energy data included “environmental data”, which included measurements of the outside temperature of the building. *Id.* at [0057]; [0016]; [0040]; [0042]. The management server received this data from a connection to the

Internet (which was a network). *Id.* at [0040]; [0045]. Rhee further disclosed that the outside temperature was measured by a temperature sensor “placed outside the building”. *Id.* at [0079]. The outside temperature measurements were used by the analysis module, which was part of the management server. *Id.* at [0067] (“[T]he analysis module 226 creates a [sic] energy report for the current inputted by the HVAC unit versus the average temperature outside of the building as recorded by a temperature sensor over the course of the past ten years.”). Rhee’s disclosures indicated that the data received by the management server via its Internet connection included outside temperature measurements collected by a temperature sensor outside of and hence external to the building. Ex. G at ¶ 119. (*See supra* Section VI.B.2(c).)

* * *

Claim 5 was anticipated by and/or would have been obvious in view of Rhee as shown in the following claim chart.

Claim 5	Rhee
5. The system of claim 4:	<i>See supra</i> claim 1 claim chart; claim 2 claim chart; claim 4 claim chart.
[a] wherein the second data from the network connection comprises a measurement of the current outdoor temperature.	<i>See supra</i> claim 1 claim chart at element 1[d].

7. Rhee disclosed the dependent limitations of claim 6 (which depends from claims 1, 2, and 4).

Claim 6 requires that the “one or more processors with circuitry and code designed to execute instructions queries the user to confirm whether to change to a different temperature setpoint after determining whether the building is occupied or unoccupied”. Rhee disclosed this limitation. Ex. G at ¶¶ 121-126.

As explained above in Sections VI.B.2(g) and VI.B.3-4, Rhee disclosed that the system could be configured to implement specific temperature setpoints based on certain triggers, including based on the determination of whether the building is occupied or unoccupied. Rhee further disclosed querying the user to confirm whether to change a setpoint. Ex. C at [0078] (“For example, the user requests the control module 414 to decrease the temperature from 68° to 66°. The control module 414 further queries the user to ensure that the user desires to decrease the temperature based on the energy costs”). In other words, Rhee’s system would determine temperature setpoints based on a profile and occupancy determinations. *See id.* at Table 8. The user could then request changes in temperature or override the system-determined setpoints. *Id.* at [0085]. The system would then query the user to confirm those changes. *Id.* at [0078].

A POSITA would appreciate that Rhee disclosed each step in the claimed sequence of events: (1) determine whether the building is occupied or unoccupied;

then (2) query the user to confirm whether to change to a different setpoint. A POSITA would further appreciate that Rhee’s step of querying the user meets this limitation, and the fact that Rhee also disclosed an *additional* step of checking energy costs does not change that fact. Ex. G at ¶ 123.

Alternatively, it would have been obvious to modify the system described in Rhee to query the user to confirm any automatic change of setpoint, since the change would affect both the user’s comfort and their energy costs, and the system’s determination of occupancy based on a sensor or schedule may not always accurately reflect the true occupancy status. *Id.* at ¶ 125.

* * *

Claim 6 was anticipated by and/or would have been obvious in view of Rhee as shown in the following claim chart.

Claim 6	Rhee
6. The system of claim 4:	<i>See supra</i> claim 1 claim chart; claim 2 claim chart; claim 4 claim chart.
[a] wherein the one or more processors with circuitry and code designed to execute instructions queries the user to confirm whether to change to a different temperature setpoint after determining whether the building is occupied or unoccupied.	<i>See supra</i> claim 1 claim chart at element 1[h]; claim 2 claim chart at element 2[a]; claim 3 claim chart at element 3[a]. “In some examples, the wireless controller operates autonomously based on the one or more parts of the energy profile. <i>The control module allows for manual user control of the wireless controller.</i> The control module stores the one or more parts of the energy profile. The wireless controller routes and/or forwards communications via a wireless mesh network.” Ex. C at [0022].

Claim 6	Rhee
	<p>“The network interface module 416 receives part or all of an energy profile via the wireless mesh network 470 from the wireless gateway 130. The part or all of the energy profile is communicated from the network interface module 416 to the control module 414. <i>The control module 414 manages the air conditioner unit 460 and the humidifier/de-humidifier unit 462 based on part or all of the energy profile and/or on data received from temperature sensor 466 and humidity sensor 468.</i> The display device 412 provides visual (e.g., flashing lights, color, intensities, text, graphics, etc.), audio (e.g., bells, tones, tunes, voice, etc.), and/or tactile communication to users of the wireless controller 410. In other embodiments, the display device 412 provides advertisements, local information (e.g., town meetings, baseball game information, etc.), national information, and/or any other type of information communicated by a visual, audio, and/or tactile communication.” <i>Id.</i> at [0076].</p> <p>“In some examples, the control module 414 determines the cost of utilizing the air conditioning unit 460 based on the energy costs of the energy source (e.g., line power). The control module 414 can utilize the display device 412 to communicate the energy costs to the user. <i>For example, the user requests the control module 414 to decrease the temperature from 68° to 66°. The control module 414 further queries the user to ensure that the user desires to decrease the temperature based on the energy costs (e.g., ten dollars per day, etc.) and/or environmental costs (e.g., four pounds of carbon dioxide produced, etc.). In other words, the control module 414 requires the user to confirm the request for the energy device after communicating the</i></p>

Claim 6	Rhee
	<p><i>energy costs and/or environmental costs of the user's request.” Ex. C at [0078].</i></p> <p>“FIG. 5 shows an example of a wireless controller 510 providing thermostat functions. <i>The wireless controller 510 includes a display device 512, a temperature user control 517a, a humidity user control 517b, a setting user control 517c, and an override user control 517d. A user can adjust the temperature and humidity levels of the room serviced by wireless controller 510 via the temperature user control 517a and the humidity user control 517b, respectively, within the limits of all or part of the energy profile. The user can override the settings as defined by the energy profile by utilizing the override user control 517d. The override user control 517d can be used to temporarily (e.g., sixty minutes, one day, etc.) override the mode settings. The user can also save the updated setting and/or request that the updated setting be saved by utilizing the setting user control 517c. An advantage of utilizing the user controls is that the energy management system 100 is easy to use and is similar to existing user controls for energy systems and thus more efficient to use and learn by the user (i.e., better user compliance for energy management). It should be noted that existing thermostat devices can be utilized in conjunction with the wireless controller 510 to reduce the cost of retrofitting the energy management system 500.” Id. at [0085].</i></p>

Claim 6	Rhee																																											
	<p style="text-align: center;">TABLE 8</p> <hr/> <p style="text-align: center;"><i>Essential Operational Modes</i></p> <hr/> <table border="1"> <thead> <tr> <th>Mode</th> <th>Description</th> <th>Temperature</th> <th>Range</th> <th>Trigger</th> </tr> </thead> <tbody> <tr> <td>Occupied</td> <td>Full occupancy</td> <td>Energy profile control or local thermostat</td> <td>Set per comfort range (e.g., ±5 degrees)</td> <td>Schedule, occupancy sensors or exit of Override mode</td> </tr> <tr> <td>Unoccupied</td> <td>Empty</td> <td>Local thermostat disabled</td> <td>Disabled</td> <td>Schedule or occupancy sensors</td> </tr> <tr> <td>Override</td> <td>Manual control</td> <td>Local thermostat with no energy profile</td> <td>Wider comfort range (e.g., ±5 degrees)</td> <td>Override button</td> </tr> <tr> <td>Maintenance</td> <td>Manual control</td> <td>Local thermostat with time limit</td> <td>Maintenance control range (e.g., ±10 degrees)</td> <td>Override button</td> </tr> <tr> <td>Demand Response</td> <td>Full occupancy during peak energy consumption</td> <td>Energy profile control</td> <td>Disabled</td> <td>Energy requirements from the electrical grid</td> </tr> <tr> <td>Optimal Generation Source Transition</td> <td>Energy source scalability</td> <td>Energy profile control</td> <td>Depends on generation source</td> <td>Energy source availability</td> </tr> <tr> <td></td> <td>HVAC transition from heating to cooling, etc.</td> <td>Energy profile control and/or other factors</td> <td>Not applicable</td> <td>Schedule, outside temperature, weather forecast, and/or statistical data</td> </tr> </tbody> </table> <hr/>				Mode	Description	Temperature	Range	Trigger	Occupied	Full occupancy	Energy profile control or local thermostat	Set per comfort range (e.g., ±5 degrees)	Schedule, occupancy sensors or exit of Override mode	Unoccupied	Empty	Local thermostat disabled	Disabled	Schedule or occupancy sensors	Override	Manual control	Local thermostat with no energy profile	Wider comfort range (e.g., ±5 degrees)	Override button	Maintenance	Manual control	Local thermostat with time limit	Maintenance control range (e.g., ±10 degrees)	Override button	Demand Response	Full occupancy during peak energy consumption	Energy profile control	Disabled	Energy requirements from the electrical grid	Optimal Generation Source Transition	Energy source scalability	Energy profile control	Depends on generation source	Energy source availability		HVAC transition from heating to cooling, etc.	Energy profile control and/or other factors	Not applicable	Schedule, outside temperature, weather forecast, and/or statistical data
Mode	Description	Temperature	Range	Trigger																																								
Occupied	Full occupancy	Energy profile control or local thermostat	Set per comfort range (e.g., ±5 degrees)	Schedule, occupancy sensors or exit of Override mode																																								
Unoccupied	Empty	Local thermostat disabled	Disabled	Schedule or occupancy sensors																																								
Override	Manual control	Local thermostat with no energy profile	Wider comfort range (e.g., ±5 degrees)	Override button																																								
Maintenance	Manual control	Local thermostat with time limit	Maintenance control range (e.g., ±10 degrees)	Override button																																								
Demand Response	Full occupancy during peak energy consumption	Energy profile control	Disabled	Energy requirements from the electrical grid																																								
Optimal Generation Source Transition	Energy source scalability	Energy profile control	Depends on generation source	Energy source availability																																								
	HVAC transition from heating to cooling, etc.	Energy profile control and/or other factors	Not applicable	Schedule, outside temperature, weather forecast, and/or statistical data																																								

8. Rhee disclosed the dependent limitations of claim 7 (which depends from claim 1).

Claim 7 requires that the “one or more processors with circuitry and code designed to execute instructions receives at least one setting of the HVAC system.” Rhee disclosed this limitation. Ex. G at ¶¶ 127-132.

Rhee disclosed that the wireless controller of the building receives at least one setting of the HVAC system. For example, Figure 5 shows the wireless controller displaying numerous settings of the HVAC system, including system status (*i.e.*, “on” or “off”), system mode (“occupied” or “unoccupied”), current temperature setpoint, and scheduled setting changes (“Next **Setting** Change at

5:01pm”) (emphasis added). *See also* Ex. C at [0085]-[0086]. A POSITA would recognize that HVAC system status, mode, setpoint, and scheduled changes are settings of the HVAC system. Ex. G at ¶ 128. Rhee further discloses that the wireless controller transmits data, including energy data and energy consumption data to the management server. Ex. C at [0060]. This data includes settings for the HVAC system, including at least mode and temperature setpoints. *Id.* at Table 4. A POSITA would understand from these disclosures that the management server received settings of the HVAC system, including the temperature setpoint, the mode, and the system status (“on” or “off”). Ex. G at ¶ 129. These settings would be needed so that the user could manage the system and the wireless controller using the web-based interface. Ex. C at [0056]; Ex. G at ¶ 129. Further, Rhee disclosed that current and past energy data was used in the management server’s analysis module. Ex. C at [0066]. It would also have been obvious to a POSITA that the management server processors received energy data including HVAC settings, so that the data could be stored, used in the analysis module, and made available to the user through the client module. Ex. G at ¶ 130.

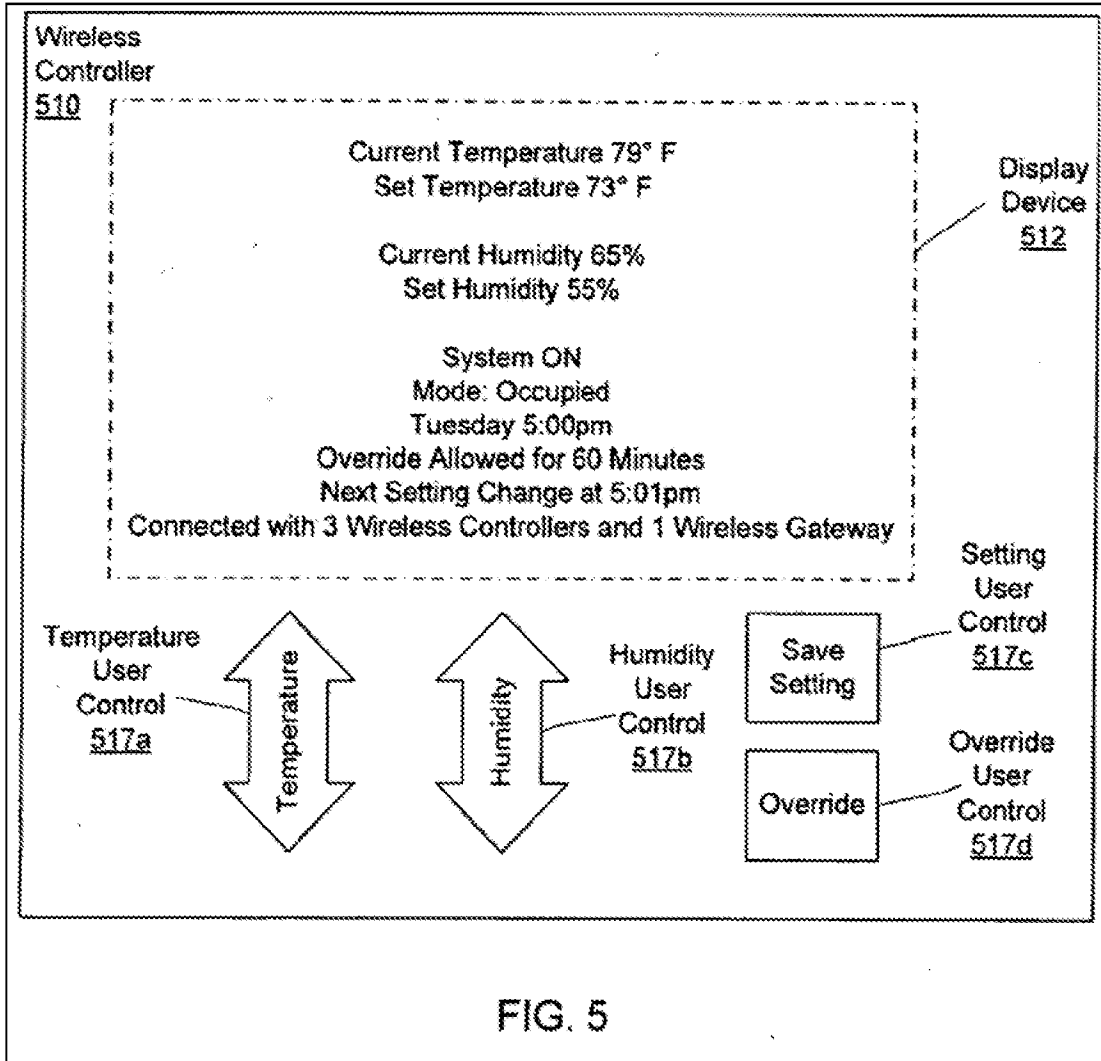

* * *

Claim 7 was anticipated by and/or would have been obvious in view of Rhee as shown in the following claim chart.

Claim 7	Rhee
7. The system of claim 1:	<i>See supra</i> claim 1 claim chart.
[a] wherein the one or more processors with circuitry and code designed to execute instructions receives at least one setting	<i>“FIG. 5 shows an example of a wireless controller 510 providing thermostat functions. The wireless controller 510 includes a display device 512, a temperature user control 517a, a humidity user control 517b, a setting user control 517c, and an</i>

Claim 7	Rhee
of the HVAC system.	<p><i>override user control 517d.</i> A user can adjust the temperature and humidity levels of the room serviced by wireless controller 510 via the temperature user control 517a and the humidity user control 517b, respectively, within the limits of all or part of the energy profile. <i>The user can override the settings as defined by the energy profile by utilizing the override user control 517d. The override user control 517d can be used to temporarily (e.g., sixty minutes, one day, etc.) override the mode settings. The user can also save the updated setting and/or request that the updated setting be saved by utilizing the setting user control 517c.</i> An advantage of utilizing the user controls is that the energy management system 100 is easy to use and is similar to existing user controls for energy systems and thus more efficient to use and learn by the user (i.e., better user compliance for energy management). It should be noted that existing thermostat devices can be utilized in conjunction with the wireless controller 510 to reduce the cost of retrofitting the energy management system 500.</p> <p>For example, the wireless controller 510 is utilizing the HVAC energy profile as illustrated in Table 2 to manage the operation of a HVAC unit. <i>As illustrated by the display device 512, the set temperature for the controller based on the Occupied mode is 73 degrees. However the current temperature is 79 degrees. As such, the HVAC system is currently activated (i.e., ON). As illustrated by the display device 512, the next mode change is at 5:01 pm (in this example, the mode change is from Occupied to Unoccupied). The user can override the Occupied mode setting by adjusting the temperature utilizing the temperature user control 517 a.</i> As illustrated in Table 3, at 7:00</p>

Claim 7

Rhee

am on Tuesday morning, the user overrode the Ramp-Up mode setting and increased the temperature from 70 degrees to 73 degrees. In addition, the redundant connection oriented design of the wireless mesh network 170 is illustrated in the display device 512 via the wireless connection with three other wireless controllers and one wireless gateway (e.g., wireless controller D 110d of FIG. 1B).” Ex. C at [0085]-[0086].

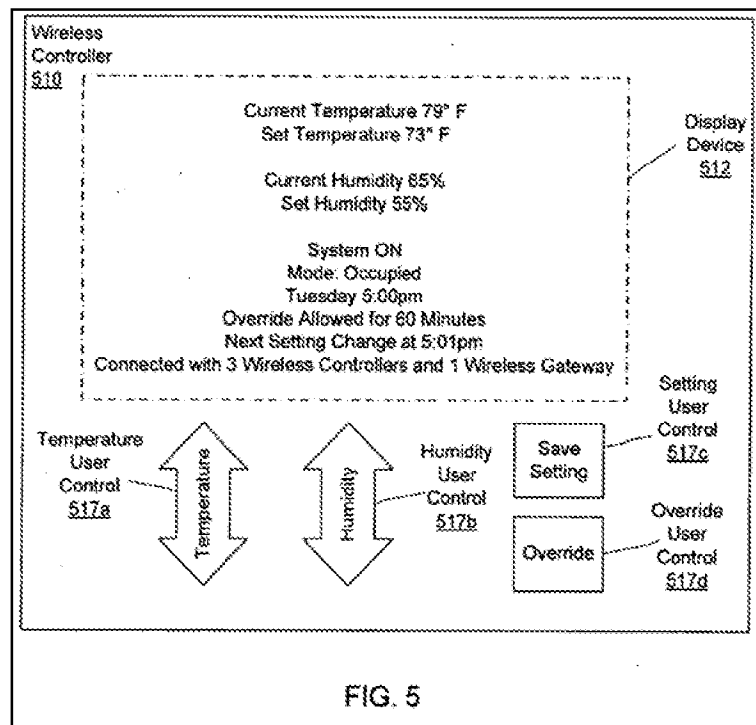

Id. at Fig. 5.

9. Rhee disclosed the dependent limitations of claim 8 (which depends from claims 1 and 7).

Claim 8 requires that the “the at least one setting of the HVAC system comprises whether the HVAC system is currently on or off.” Rhee disclosed this limitation. Ex. G at ¶¶ 135-138.

As explained above in Section VI.B.8, Rhee disclosed that the wireless controller of the building receives whether the HVAC system is currently on or off. For example, Figure 5 shows the wireless controller displaying numerous settings of the HVAC system, including whether the HVAC system is on or off. *See also* Ex. C at [0085]-[0086] (“As illustrated by the display device 512, the set temperature for the controller based on the Occupied mode is 73 degrees. However the current temperature is 79 degrees. As such, the HVAC system is currently activated (i.e., ON)”). A POSITA would have further appreciated that the management server and client module would also receive the setting, so that a user could manage the system, including the management server and the wireless controller through the client module. *Id.* at [0056]; Ex. G at ¶¶ 136-38.

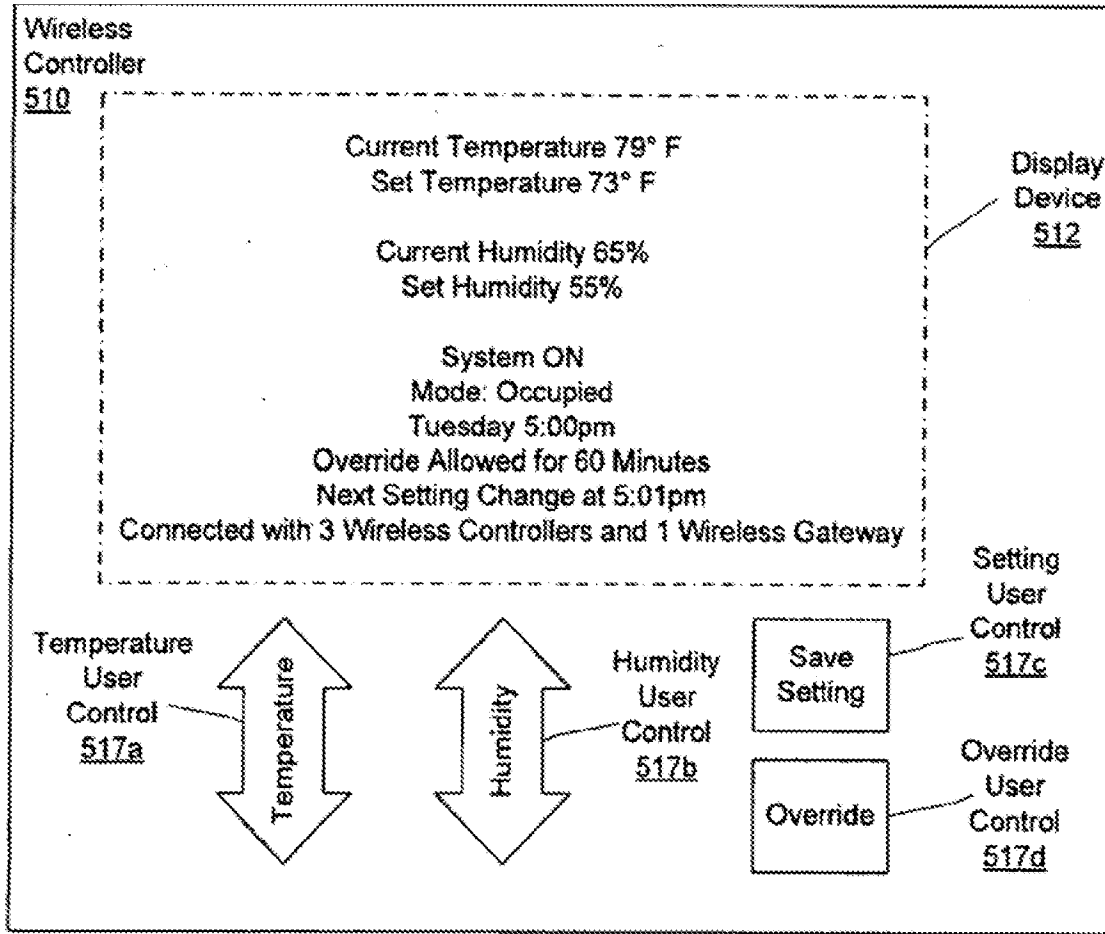

FIG. 5

* * *

Claim 8 was anticipated by and/or would have been obvious in view of Rhee as shown in the following claim chart.

Claim 8	Rhee
8. The system of claim 7:	<i>See supra</i> claim 1 claim chart; claim 7 claim chart.
[a] wherein the at least one setting of the HVAC system comprises whether the HVAC system is currently on or off.	<i>See supra</i> claim 7 claim chart at element 7[a].

10. Rhee disclosed all elements of dependent claim 9 (which depends from claims 1 and 7).

Claim 9 requires that the “the at least one setting of the HVAC system comprises whether the HVAC system is operating in a cooling mode or a heating mode.” Rhee disclosed this limitation. Ex. G at ¶¶ 142-145.

Rhee disclosed that the system will “transition” the HVAC system “from heating to cooling” based on the schedule, outside temperature, weather forecast, and other triggers. Ex. C at Table 8; *see also id.* at [0041] (the wireless controller “directs the heating unit (i.e., one of the energy devices 59) to activate and heat the room”). A POSITA would have therefore understood that the management server receives and manages the HVAC system’s mode as part of the energy profile. Ex. G at ¶ 143.

TABLE 8

<u>Exemplary Operational Modes</u>				
Mode	Description	Temperature	Range	Trigger
Occupied	Full occupancy	Energy profile control or local thermostat	Set per comfort range (e.g., ± 3 degrees)	Schedule, occupancy sensors or exit of Override mode
Unoccupied	Empty	Local thermostat disabled	Disabled	Schedule or occupancy sensors
Override	Manual control	Local thermostat within energy profile	Wider comfort range (e.g., ± 5 degrees)	Override button
Maintenance	Manual control	Local thermostat with time limit	Maintenance control range (e.g., ± 10 degrees)	Override button
Demand Response	Full occupancy during peak energy consumption	Energy profile control	Disabled	Energy requirements from the electrical grid
Optimal Generation Source	Energy source availability	Energy profile control	Depends on generation source	Energy source availability
Transition	HVAC transition from heating to cooling, etc.	Energy profile control and/or other factors	Not applicable	Schedule, outside temperature, weather forecast, and/or statistical data

A POSITA would have further appreciated that the management server and client module would also receive the setting, so that a user could manage the system, including the management server and the wireless controller through the client module. Ex. G at ¶ 144.

* * *

Claim 9 was anticipated by and/or would have been obvious in view of Rhee as shown in the following claim chart.

Claim 9	Rhee
9. The system of	<i>See supra</i> claim 1 claim chart; claim 7 claim chart.

Claim 9	Rhee																																													
claim 7:																																														
<p>[a] wherein the at least one setting of the HVAC system comprises whether the HVAC system is operating in a cooling mode or a heating mode.</p>	<p><i>See supra</i> claim 7 claim chart at element 7[a];</p> <p style="text-align: center;">TABLE 8</p> <hr/> <table border="1" style="width: 100%; border-collapse: collapse;"> <thead> <tr> <th colspan="5" style="text-align: center;"><u>Exemplary Operational Modes</u></th> </tr> <tr> <th style="text-align: left;">Mode</th> <th style="text-align: left;">Description</th> <th style="text-align: left;">Temperature</th> <th style="text-align: left;">Range</th> <th style="text-align: left;">Trigger</th> </tr> </thead> <tbody> <tr> <td>Occupied</td> <td>Full occupancy</td> <td>Energy profile control or local thermostat</td> <td>Set per comfort range (e.g., ± 3 degrees)</td> <td>Schedule, occupancy sensors or exit of Override mode</td> </tr> <tr> <td>Unoccupied</td> <td>Empty</td> <td>Local thermostat disabled</td> <td>Disabled</td> <td>Schedule or occupancy sensors</td> </tr> <tr> <td>Override</td> <td>Manual control</td> <td>Local thermostat within energy profile</td> <td>Wider comfort range (e.g., ± 5 degrees)</td> <td>Override button</td> </tr> <tr> <td>Maintenance</td> <td>Manual control</td> <td>Local thermostat with time limit</td> <td>Maintenance control range (e.g., ± 10 degrees)</td> <td>Override button</td> </tr> <tr> <td>Demand Response</td> <td>Full occupancy during peak energy consumption</td> <td>Energy profile control</td> <td>Disabled</td> <td>Energy requirements from the electrical grid</td> </tr> <tr> <td>Optimal Generation Source</td> <td>Energy source availability</td> <td>Energy profile control</td> <td>Depends on generation source</td> <td>Energy source availability</td> </tr> <tr> <td>Transition</td> <td>HVAC transition from heating to cooling, etc.</td> <td>Energy profile control and/or other factors</td> <td>Not applicable</td> <td>Schedule, outside temperature, weather forecast, and/or statistical data</td> </tr> </tbody> </table> <hr/> <p>“Each wireless controller A55a and B 55b manages the energy devices 59 associated with the respective room based on an energy profile and/or energy data (e.g., environmental data, energy consumption data, energy generation data, etc.). <i>For example, the wireless controller A55a directs the heating unit (i.e., one of the energy devices 59) to activate and heat the room A56a. As part of the heating of the room A 56a, the wireless controller A55a directs the wireless actuator 57 to actuate a baffle and a fan to force a limited amount of outside air into room A55a.</i>” <i>Id.</i> at [0041].</p>	<u>Exemplary Operational Modes</u>					Mode	Description	Temperature	Range	Trigger	Occupied	Full occupancy	Energy profile control or local thermostat	Set per comfort range (e.g., ± 3 degrees)	Schedule, occupancy sensors or exit of Override mode	Unoccupied	Empty	Local thermostat disabled	Disabled	Schedule or occupancy sensors	Override	Manual control	Local thermostat within energy profile	Wider comfort range (e.g., ± 5 degrees)	Override button	Maintenance	Manual control	Local thermostat with time limit	Maintenance control range (e.g., ± 10 degrees)	Override button	Demand Response	Full occupancy during peak energy consumption	Energy profile control	Disabled	Energy requirements from the electrical grid	Optimal Generation Source	Energy source availability	Energy profile control	Depends on generation source	Energy source availability	Transition	HVAC transition from heating to cooling, etc.	Energy profile control and/or other factors	Not applicable	Schedule, outside temperature, weather forecast, and/or statistical data
<u>Exemplary Operational Modes</u>																																														
Mode	Description	Temperature	Range	Trigger																																										
Occupied	Full occupancy	Energy profile control or local thermostat	Set per comfort range (e.g., ± 3 degrees)	Schedule, occupancy sensors or exit of Override mode																																										
Unoccupied	Empty	Local thermostat disabled	Disabled	Schedule or occupancy sensors																																										
Override	Manual control	Local thermostat within energy profile	Wider comfort range (e.g., ± 5 degrees)	Override button																																										
Maintenance	Manual control	Local thermostat with time limit	Maintenance control range (e.g., ± 10 degrees)	Override button																																										
Demand Response	Full occupancy during peak energy consumption	Energy profile control	Disabled	Energy requirements from the electrical grid																																										
Optimal Generation Source	Energy source availability	Energy profile control	Depends on generation source	Energy source availability																																										
Transition	HVAC transition from heating to cooling, etc.	Energy profile control and/or other factors	Not applicable	Schedule, outside temperature, weather forecast, and/or statistical data																																										

11. Rhee disclosed the dependent limitations of claim 10 (which depends from claims 1, 2 and 4).

Claim 10 requires that the “determination of whether the building is occupied or unoccupied by one or more processors” be “based on a third data received from a motion sensor”. Rhee disclosed this limitation. Ex. G at ¶¶ 149-153.

Rhee disclosed a management server that received data from a wireless controller. Ex. C at [0048]. The wireless controller can be connected to any number of sensors or alarms, including “a motion detector”. *Id.* at [0083] & Fig. 4. This sensor data was transmitted to and received by the management server. *Id.* at [0101]. Rhee disclosed that an occupancy determination may be part of the “energy profile”. *Id.* at [0097] & Table 8. An “energy profile” may utilize different “operational modes”, including “occupied” and “unoccupied modes”, both of which can be triggered by “occupancy sensors”. *Id.*; *see also id.* at [0083]; Fig. 9 & [0102] (wireless controller and control module manage HVAC system based on “energy profile and/or the sensor data”). A POSITA would have understood the “occupancy sensors” to refer at least to the wireless motion sensors. Ex. G at ¶ 152. The motion sensor data received by the management server was the claimed “third data”. Rhee’s disclosures thus indicated that the management

server received motion sensor data to determine the occupancy of a building or structure.

* * *

Claim 10 was anticipated by and/or would have been obvious in view of Rhee as shown in the following claim chart.

Claim 10	Rhee
10. The system of claim 4:	<i>See supra</i> claim 1 claim chart; claim 2 claim chart; claim 4 claim chart.
[a] wherein the determination of whether the building is occupied or unoccupied by the one or more processors is based on a third data received from a motion sensor.	<p>“Although FIG. 4 illustrates the temperature sensor 466 and the humidity sensor 468, the energy management system 400 can include any type of sensor and/or alarm. The sensor can include a flow meter (e.g., water meter, gas meter, etc.), a power meter, a current meter, a battery meter, a pulse meter (e.g., network pulse, a human/animal pulse, etc.), a input/output node (e.g., monitor analog input/output, monitor digital input/output, etc.), a light sensor, a <i>motion detector</i>, a proximity sensor, a heat sensor, a network sensor, and/or any other type of sensor. The sensor can measure the environmental level of the particles of the materials and/or gases. The alarm can include an audible alarm, a flashing alarm, an automated telephone alert, an email alert, and/or any other type of alarm.” Ex. C at [0083].</p> <p>“In other examples, the energy profile utilizes different operational modes to optimize the energy use under certain conditions. For example, as illustrated in Table 7 above, the classrooms have an Occupied mode and an Unoccupied mode. When the lights are in Occupied mode, then the lights are on and when the lights are in Unoccupied mode, then the lights are off. The automatic and uniform</p>

Claim 10	Rhee
	<p>application of the mode utilizing the energy profile advantageously enables the optimally regulation of energy consumption under particular conditions in order to minimize waist. <i>Table 8 illustrates different operational modes in the context of a HVAC unit. Although Table 8 illustrates the different operational modes in the context of a HVAC unit, the different operational modes can be utilized for any type of energy device. The operational modes can be utilized for any type of energy device to allow for the operation of the energy device.</i> For example, in the demand response mode, the energy profile for the lighting can be configured to turn off half of the lighting in a grocery store to conserve energy consumption. As another example, in optimal generation mode, the wireless controller controlling the energy producing devices (e.g., electrical grid power, wind generator, etc.) changes the input power to the system 100 based on the current sensor data that a cheaper energy producing device is available (in this example, change the energy producing device from electrical grid power to the wind generator).” <i>Id.</i> at [0097].</p>

Claim 10

Rhee

TABLE 8				
Exemplary Operational Modes				
Mode	Description	Temperature	Range	Trigger
Occupied	Full occupancy	Energy profile control or local thermostat	Set per comfort range (e.g., ±3 degrees)	Schedule, occupancy sensors or exit of Override mode
Unoccupied	Empty	Local thermostat disabled	Disabled	Schedule or occupancy sensors
Override	Manual control	Local thermostat within energy profile	Wider comfort range (e.g., ±5 degrees)	Override button
Maintenance	Manual control	Local thermostat with time limit	Maintenance control range (e.g., ±10 degrees)	Override button
Demand Response	Full occupancy during peak energy consumption	Energy profile control	Disabled	Energy requirements from the electrical grid
Optimal Generation Source Transition	Energy source availability HVAC transition from heating to cooling, etc.	Energy profile control and/or other factors	Depends on generation source Not applicable	Energy source availability Schedule, outside temperature, weather forecast, and/or statistical data

“FIG. 9 is a flowchart 900 illustrating management and monitoring of energy devices 460 and 462 by a wireless controller 410 utilizing an energy profile and sensor data as illustrated by FIG. 4. The network interface module 416 receives (910) energy profile modifications from the management server 120 of FIG. 1B and communicates the energy profile modifications to the control module 414. The control module 414 receives (920) sensor data from the temperature sensor 466 and the humidity sensor 468. The control module 414 manages (930) the energy devices (in this example, the air conditioning unit 460 and the humidifier/de-humidifier unit 462) based on the energy profile and/or the sensor data. The control module 414 receives (940) energy data from the energy devices 460 and 462 and sensor data from the sensors 466 and 468 and transmits (950) the energy data and the sensor data to the management sever 120 via the network interface module 416. The network interface

Claim 10	Rhee
	<i>module 416 continues to receive (910) energy profile modifications from the management server 120.” Id. at [0102].</i>

12. Rhee discloses all elements of dependent claim 11 (which depends from claim 1).

Claim 11 requires that the “the network connection is based on the IEEE 802.11 wireless protocol.” Rhee discloses this limitation. Ex. G at ¶¶ 155-157.

As explained above in Section VI.B.2(c). Rhee disclosed the “one or more processors” receiving “a second data from a network connection” that “is received via the internet”. In describing how the described systems could be implemented, Rhee disclosed that “[t]he components of the system can be interconnected by” a “communication networks” may include a “802.11 network”. Ex. C at [0111]-[0112]. A POSITA would have recognized that a “802.11 network” refers to a network connection based on the IEEE 802.11 wireless protocol. Ex. G at ¶ 156.

* * *

Claim 11 was anticipated by and/or would have been obvious in view of Rhee as shown in the following claim chart.

Claim 11	Rhee
11. The system of claim 1:	<i>See supra</i> claim 1 claim chart.
[a] wherein the network connection is based on the	<i>See supra</i> claim 1 claim chart at element 1[d].

Claim 11	Rhee
IEEE 802.11 wireless protocol.	<p><i>“The above described techniques can be implemented in a distributed computing system that includes a back-end component. The back-end component can, for example, be a data server, a middleware component, and/or an application server. The above described techniques can be implemented in a distributing computing system that includes a front-end component. The front-end component can, for example, be a client computer having a graphical user inter face, a Web browser through which a user can interact with an example implementation, and/or other graphical user inter faces for a transmitting device. The components of the system can be interconnected by any form or medium of digital data communication (e.g., a communication network).</i></p> <p>The system can include clients and servers. A client and a server are generally remote from each other and typically interact through a communication network. The relationship of client and server arises by virtue of computer programs running on the respective computers and having a client-server relationship to each other.</p> <p><i>Examples of communication networks include wired networks, wireless networks, packet-based networks, and/or circuit-based networks. Packet-based networks can include, for example, the Internet, a carrier internet protocol (IP) network (e.g., local area network (LAN), wide area network (WAN), campus area network (CAN), metropolitan area network (MAN), home area network (HAN)), a private IP network, an IP private branch exchange (IPBX), a wireless network (e.g., radio access network (RAN), 802.11 network, 802.16 network, general packet radio service (GPRS) network, HiperLAN), and/or other packet-based networks.</i></p>

Claim 11	Rhee
	Circuit-based networks can include, for example, the public switched telephone network (PSTN), a private branch exchange (PBX), a wireless network (e.g., RAN, bluetooth, code-division multiple access (CDMA) network, time division multiple access (TDMA) network, global system for mobile communications (GSM) network), and/or other circuit-based networks.” Ex. C at [0110]-[0112].

13. Rhee disclosed all elements of dependent claim 12 (which depends from claim 1.

Claim 12 requires that the “determination of whether the building is occupied or unoccupied by [sic] is performed by the first processor”. Rhee disclosed this limitation. Ex. G at ¶¶ 158-161.

As explained above in Sections VI.B.2(a) and VI.B.2(i), Rhee disclosed a management server that was implemented was one or more computers containing one or more processors, any of which would be a “first processor”. As explained above in Sections VI.B.2(d), VI.B.3, and VI.B.4, the management server determined whether the building is occupied or unoccupied.

* * *

Claim 12 was anticipated by and/or would have been obvious in view of Rhee as shown in the following claim chart.

Claim 12	Rhee
12. The system of claim 1:	<i>See supra</i> claim 1 claim chart.

Claim 12	Rhee
[a] wherein the determination of whether the building is occupied or unoccupied by is performed by the first processor.	<i>See supra</i> claim 1 claim chart at elements 1[pre]-[b], 1[e], 1[h], 1[j].

14. Rhee disclosed all elements of dependent claim 13 (which depends from claim 1).

Claim 13 requires that the “the controlling of the HVAC system to provide heating or cooling to the building at an operational temperature is performed by the first processor”. Rhee disclosed this limitation. Ex. G at ¶¶ 163-166.

As explained above in Sections VI.B.2(a) and VI.B.2(i), Rhee disclosed a management server that was implemented as one or more computers containing one or more processors, any of which would be a “first processor”. As explained above in Sections VI.B.2(e) and VI.B.2(g), the management server controlled the HVAC system to provide heating or cooling to the building at an operational temperature.

* * *

Claim 13 was anticipated by and/or would have been obvious in view of Rhee as shown in the following claim chart.

Claim 13	Rhee
13. The system of claim 1:	<i>See supra</i> claim 1 claim chart.

Claim 13	Rhee
[a] wherein the controlling of the HVAC system to provide heating or cooling to the building at an operational temperature is performed by the first processor.	<i>See supra</i> claim 1 claim chart at elements 1[pre]-[b], 1[f], 1[h], and 1[i].

15. Rhee disclosed all elements of dependent claim 14 (which depends from claim 1).

Claim 14 requires that the “first data from the at least one sensor is provided by a sensor that is not electrically connected to the first processor”. Rhee disclosed this limitation. Ex. G at ¶¶ 168-170.

Rhee disclosed an energy management system comprising, among other things, “a wireless controller” and “a wireless sensor”. The disclosed wireless controller and wireless sensor are in communication with one another, and to other components of the system, including the management server, by way of a “wireless mesh network”. Ex. C at [0040]. A POSITA would have understood that sensor data communicated over this wireless mesh network was provided by a sensor that is “not electrically connected to the first processor”, because the wireless sensor was not physically connected to the management server. Ex. G at ¶ 169.

* * *

Claim 14 was anticipated by and/or would have been obvious in view of Rhee as shown in the following claim chart.

Claim 14	Rhee
14. The system of claim 1:	<i>See supra</i> claim 1 claim chart.
[a] wherein the first data from the at least one sensor is provided by a sensor that is not electrically connected to the first processor.	<p>“Referring to FIG. 1A, an energy management system 50 is depicted. The energy management system 50 is associated with a building 51 or a series of buildings (e.g., a second building 51", an office complex, a school campus, global offices, commonly-owned buildings, commonly-managed buildings, etc.). <i>The energy management system 50 includes the internet 52, a wireless gateway 53, a wireless repeater 54, a wireless controller A55a, a wireless controller B55b, a wireless actuator 57, a wireless sensor 58, and energy devices 59. The building 51 includes a plurality of rooms (e.g., room A 56a and room B 56b). The energy management system 50 is interconnected via a wireless mesh network. The wireless gateway 53 connects the wireless mesh network with a management server (not shown) via the internet 52. The wireless repeater 54 extends the range of the wireless mesh network by forwarding and/or routing communications between the wireless controllers 55a and 55b, the wireless sensor 58 and/or the wireless actuator 57. The wireless controllers A55a and B 55b are associated with the rooms. A 56a and B 56b, respectfully. The wireless actuator 57 actuates and/or deactuates energy devices and/or any other type of device (e.g., mechanical device, electrical device, etc.). The wireless sensor 58 provide energy data to the wireless controllers A 55a and B 55b and/or the management server.”</i> Ex. C at [0040].</p> <p><i>“In some embodiments, the wireless controllers A 55a and B 55b can communicate with each other</i></p>

Claim 14	Rhee
	<i>via the wireless mesh network. For example, the wireless sensor 58 transmits temperature data to the wireless controller A 55a via wireless controller B55b and the wireless mesh network. In other words, the wireless sensor 58 transmits the temperature data to the wireless controller A 55a via the wireless mesh network through the following devices: the wireless sensor 58, a first wireless repeater, wireless controller B 55b, a second wireless repeater, a third wireless repeater, and then the wireless controller A 55a.” Id. at [0042].</i>

16. Rhee disclosed all elements of claim 15 (which depends from claims 1 and 7).

Claim 15 requires that the “interface is configured to allow the user to turn the HVAC system on or off”. Rhee disclosed this limitation. Ex. G at ¶¶ 171-174.

As explained above in Sections VI.B.2(d)-(g), Rhee disclosed that the management server could receive commands from the client module. Rhee disclosed that, using the client module, the user could “control the system”, including by modifying temperature setpoints and schedules. Ex. C at [0056]. Rhee also disclosed that the temperature setpoints determined whether the HVAC system was “on” or “off”. *Id.* at [0085]-[0086]. A POSITA would have appreciated that the user could turn the HVAC system on or off at least by adjusting the temperature setpoints using the interface of the client module. Ex. G at ¶ 173. It would also have been obvious that Rhee disclosed an interface

configured to allow the user to turn the HVAC system on or off. *See id.* Rhee disclosed that a “wireless controller 510” provided “thermostat functions”, which as understood by a POSITA would conventionally have included an on/off functionality. Ex. C at [0085]. Rhee also disclosed that “existing thermostat devices” could be utilized. *Id.* A POSITA would have known that such “existing thermostat devices” conventionally included on/off functionality. Ex. G at ¶ 173.

* * *

Claim 15 was anticipated by and/or would have been obvious in view of Rhee as shown in the following claim chart.

Claim 15	Rhee
15. The system of claim 7: [a] wherein the interface is configured to allow the user to turn the HVAC system on or off.	<i>See supra</i> claim 1 claim chart; claim 7 claim chart. <i>See supra</i> claim 1 claim chart at 1[pre], 1[f], 1[h], 1[j]. <i>“FIG. 5 shows an example of a wireless controller 510 providing thermostat functions. The wireless controller 510 includes a display device 512, a temperature user control 517a, a humidity user control 517b, a setting user control 517c, and an override user control 517d. A user can adjust the temperature and humidity levels of the room serviced by wireless controller 510 via the temperature user control 517a and the humidity user control 517b, respectively, within the limits of all or part of the energy profile. The user can override the settings as defined by the energy profile by utilizing the override user control 517d. The override user control 517d can be used to temporarily (e.g., sixty minutes, one day, etc.) override the mode settings. The user can also save</i>

Claim 15	Rhee
	the updated setting and/or request that the updated setting be saved by utilizing the setting user control 517c. An advantage of utilizing the user controls is that the energy management system 100 is easy to use and is similar to existing user controls for energy systems and thus more efficient to use and learn by the user (i.e., better user compliance for energy management). <i>It should be noted that existing thermostat devices can be utilized in conjunction with the wireless controller 510 to reduce the cost of retrofitting the energy management system 500.</i> Ex. C at [0085].

17. Rhee disclosed all elements of claim 16 (which depends from claims 1 and 7).

Claim 16 required that the “interface is configured to allow the user to input that the building is currently unoccupied”. Rhee disclosed this limitation. Ex. G at ¶¶ 179-185.

As explained above in Sections VI.B.2(d)-(g), Rhee disclosed that the management server could receive commands from the client module. Rhee disclosed that, using the client module, the user could “control the system”, including by modifying temperature setpoints and schedules. Ex. C at [0056]. Rhee also disclosed that unoccupancy can be triggered by the schedule. *Id.* at Table 8. Therefore a user could modify the scheduled start of “unoccupied” mode to the current time, and thereby change the current mode to “unoccupied”.

It would have been understood by a POSITA that being able to modify schedules meant that the client module was configured to allow the user to input that the building is currently unoccupied. Moreover, it would have been obvious to a POSITA that the ability to “control” the system entailed being able to input that the building is currently unoccupied. Ex. G at ¶ 182.

Additionally, Rhee disclosed that the user can override the settings as defined by the energy profile by utilizing the override user control. Ex. C at [0085]. This override user control could be used to temporarily override mode settings. *Id.* And as explained above, “occupied” and “unoccupied” were each “modes” in the energy profile. *See id.* at Table 8. This override feature thus allowed users to input that the building is currently unoccupied. Ex. G at ¶¶ 183-84.

* * *

Claim 16 was anticipated by and/or would have been obvious in view of Rhee as shown in the following claim chart.

Claim 16	Rhee
16. The system of claim 7: [a] wherein the interface is configured to allow the user to input that the building is currently unoccupied.	<p><i>See supra</i> claim 1 claim chart; claim 7 claim chart.</p> <p><i>See supra</i> claim 1 claim chart at 1[pre], 1[f], 1[h], 1[j].</p> <p>“FIG. 5 shows an example of a wireless controller 510 providing thermostat functions. The wireless controller 510 includes a display device 512, a temperature user control 517a, a humidity user</p>

Claim 16	Rhee
	<p>control 517b, a setting user control 517c, and an override user control 517d. A user can adjust the temperature and humidity levels of the room serviced by wireless controller 510 via the temperature user control 517a and the humidity user control 517b, respectively, within the limits of all or part of the energy profile. <i>The user can override the settings as defined by the energy profile by utilizing the override user control 517d. The override user control 517d can be used to temporarily (e.g., sixty minutes, one day, etc.) override the mode settings. The user can also save the updated setting and/or request that the updated setting be saved by utilizing the setting user control 517c.</i> An advantage of utilizing the user controls is that the energy management system 100 is easy to use and is similar to existing user controls for energy systems and thus more efficient to use and learn by the user (i.e., better user compliance for energy management). It should be noted that existing thermostat devices can be utilized in conjunction with the wireless controller 510 to reduce the cost of retrofitting the energy management system 500.” Ex. C at [0085].</p>

Claim 16

Rhee

TABLE 8

Exemplary Operational Modes

Mode	Description	Temperature	Range	Trigger
Occupied	Full occupancy	Energy profile control or local thermostat	Set per comfort range (e.g., ±3 degrees)	Schedule, occupancy sensors or exit of Override mode
Unoccupied	Empty	Local thermostat disabled	Disabled	Schedule or occupancy sensors
Override	Manual control	Local thermostat within energy profile	Wider comfort range (e.g., ±5 degrees)	Override button
Maintenance	Manual control	Local thermostat with time limit	Maintenance control range (e.g., ±10 degrees)	Override button
Demand Response	Full occupancy during peak energy consumption	Energy profile control	Disabled	Energy requirements from the electrical grid
Optimal Generation Source Transition	Energy source availability HVAC transition from heating to cooling, etc.	Energy profile control and/or other factors	Depends on generation source Not applicable	Energy source availability Schedule, outside temperature, weather forecast, and/or statistical data

“In other examples, the client module 150 includes a web-based interface utilized to manage the management server 120 and/or the wireless controllers 110 via the network 140. A user and/or an administrator can, for example, access the client module 150 utilizing a transmitting device (e.g., laptop computer with a web browser) and remotely control the system 100. The user and/or the administrator can remotely control the system 100 by directly communicating with the wireless controls 110 or by communicating with the management server 120. The client module 150 can control access via various granular levels of access utilizing a user name/password and/or any other type of authentication/authorization mechanism. For example, the user utilizing the client module 150 via the transmitting device can monitor current energy consumption conditions and the wireless mesh network 170 status. The user can also view historical trending charts and analysis reports

Claim 16	Rhee
	<p>created by the management server 120. <i>As another example, the user, depending on their access level, can modify the energy profile (e.g., modify temperature set points for the modes and the schedules).</i> Although FIG. 1B illustrates the client module 150 separate from the management server 120, the client module 150 can be integrated into the management server 120.” <i>Id.</i> at [0056].</p>

18. Rhee disclosed the dependent limitations of claim 18 (which depends from claim 17).

Claim 18 requires that the “first data from the at least one sensor is provided by a sensor that is not electrically connected to the first processor”. As discussed above in regard to claim 14, Rhee disclosed this limitation. Ex. G at ¶¶ 206-208.

Rhee disclosed an energy management system comprising, among other things, “a wireless controller” and “a wireless sensor”. The disclosed wireless controller and wireless sensor are connected to one another, and to other components of the system, including the management server which included a “first processor”, by way of a “wireless mesh network”. Ex. C at [0040]. A POSITA would have thus understood that sensor data provided over this wireless mesh network would have been provided by a sensor that is “not electrically connected to the first processor”. Ex. G at ¶ 207.

* * *

Claim 18 was anticipated by and/or would have been obvious in view of Rhee as shown in the following claim chart.

Claim 18	Rhee
18. The system of claim 17	<i>See supra</i> claim 17 claim chart.
[a] wherein the first data from the at least one sensor is provided by a sensor that is not electrically connected to the first processor.	<i>See supra</i> claim 14 claim chart at element 14[a].

19. Rhee disclosed all elements of dependent claim 19 (which depends from claim 1) and dependent claim 20 (which depends from claim 17).

Claims 19 and 20 require the one or more processors to control “the HVAC system to provide heating or cooling to the building at an operational temperature based at least in part on the historical values of the first and second data”. Rhee disclosed this limitation. Ex. G at ¶¶ 209-215.

Rhee disclosed a system that included an “analysis module” which could access “energy data” stored on the storage module in order to create charts and reports regarding past, present or future energy usage. Ex. C at [0066]. The analysis module was capable of integrating information like the temperature outside the building and the temperature inside a room, then using the information to devise a modification to the energy profile. *Id.* at [0067]. When the analysis

module concluded that a modification was in order, the “profile module” modified the energy profile and transmitted the modified profile to the wireless controllers, which effectuated the profile. *Id.* at [0098]-[0099]. Figure 7, reproduced below, illustrates the process by which the energy profile was adjusted:

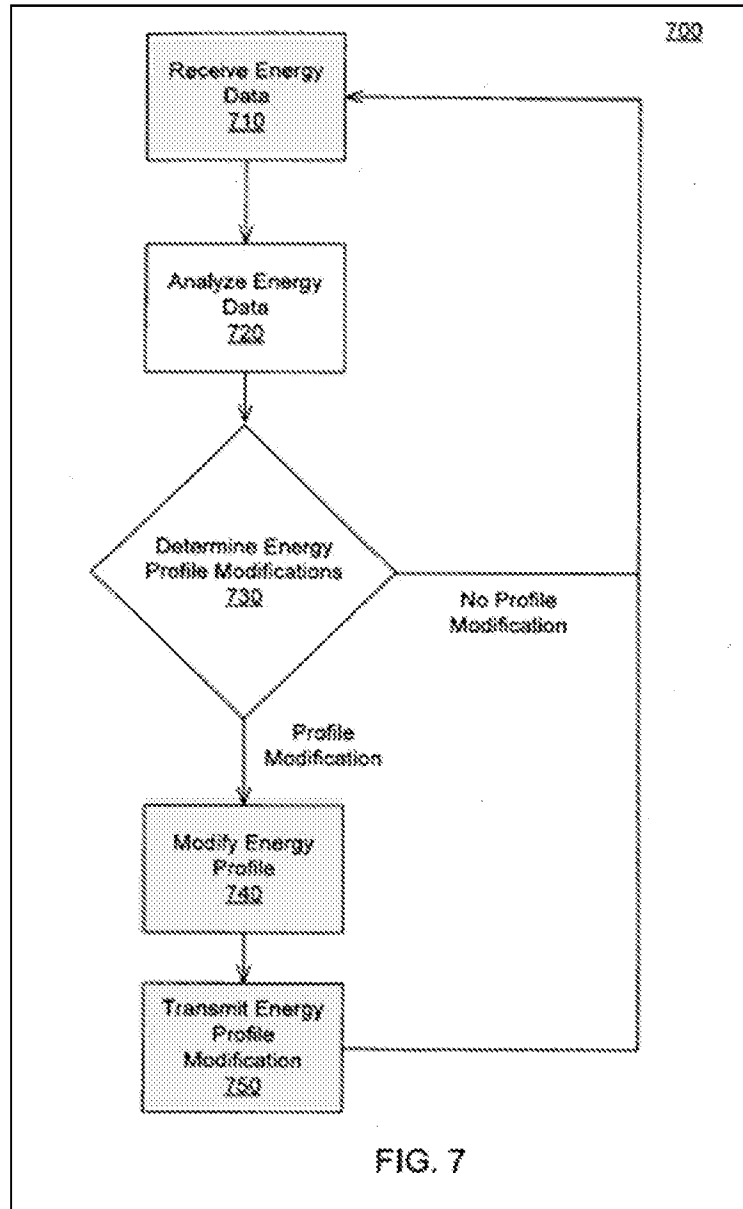

The “energy data”, described in Figure 7, could include “environmental data”. *Id.* at [0066]. Environmental data, in turn, could include measurements of “outside temperature” and “inside temperature” (among others). *Id.* at [0057]. Thus, Rhee disclosed controlling an HVAC system using energy profiles with operational temperatures based on at least in part historical values. Alternatively, it would have been obvious that Rhee disclosed a system wherein one or more processors controlled the HVAC system to provide heating or cooling a building to an operational temperature based on historical values of inside and outside temperature. Ex. G at ¶ 211.

* * *

Claim 19 was anticipated by and/or would have been obvious in view of Rhee as shown in the following claim chart.

Claim 19	Rhee
19. The system of claim 1	<i>See supra</i> claim 1 claim chart.
[a] wherein the one or more processors with circuitry and code designed to execute instructions controls the HVAC system to provide heating or cooling to the building at an operational temperature based at least in part on the historical values of the first and second data.	“In some examples, <i>the analysis module 226 accesses energy data (e.g., current energy consumption data, past energy consumption data, environmental data, etc.) stored on the storage module 228 to create charts and/or reports regarding past, present, and/or future energy use for the system 200. The charts and/or reports can include, for example, a future energy savings chart/report (e.g., how much will be saved by the energy management system 200, how much can be saved by switching from a HVAC unit to another HVAC unit, etc.), a present energy chart/report (e.g., present use of alternative energy generation,</i>

Claim 19	Rhee
	<p>present energy use of lights, etc.), a past energy chart/report (e.g., past use of alternative energy generation, past energy use of HVAC units, past indoor and outdoor temperatures, etc.) and/or any other type of chart/report associated with the energy management system 200 (e.g., use of energy by a type of energy device at one building compares to the use of energy of the same energy device at other buildings, energy devices operating at or below optimal efficiency, etc.).” Ex. C at [0066].</p> <p>“For example, the analysis module 226 creates a energy report for the current inputted by the HVAC unit versus the average temperature outside of the building as recorded by a temperature sensor over the course of the past ten years. As another example, the analysis module 226 creates a time chart for the time between when the Occupied mode is activated until when individual rooms in a zone (e.g., all of the classrooms in a building) reach the set temperature. <i>The time chart can be utilized by the analysis module 226 to modify the energy profile and/or can be utilized by the administrator to determine if the energy unit (e.g., HVAC unit) is underperforming, requires maintenance, and/or if any other issues exist for the rooms. As another example, the analysis module 226 creates a energy savings report based on past indoor and outdoor temperatures. The energy savings report can include, for example, the energy saved by the energy management system 200 (e.g., 15% of heating energy was saved due to the energy management system 200 during the last two months; 25% of cooling energy was saved last quarter by optimized temperature ranges, etc.).” Id. at [0067].</i></p>

Claim 19	Rhee
	<p>“FIG. 7 is a flowchart 700 illustrating management of wireless controllers 210 by a management server 220 utilizing an energy profile and energy data as illustrated by FIG. 2. The communication module 222 of the management server 220 receives (710) energy data from the wireless controller 210 via the wireless mesh network 270, the wireless gateway 130, and the network 140. <i>The analysis module 226 analyzes (720) the energy data and determines (730) if any modifications are needed for the energy profile.</i> If energy profile modifications are not needed, then the communication module 222 continues receiving (710) energy data from the wireless controller 210.” <i>Id.</i> at [0098].</p> <p>“<i>If energy profile modifications are needed, then the analysis module 226 communicates the modifications to the profile module 224. The profile module 224 modifies (740) the energy profile based on the modifications to the energy profile and/or other parameters (e.g., weather information, user preferences, building preferences, etc.). The profile module 224 transmits (750) the modified energy profile to the wireless controller 210 and the communication module 222 continues to receive (710) energy data.</i>” <i>Id.</i> at [0099].</p> <p>“In other examples, <i>the storage module 228 stores the energy data, the modifications to the energy profile, and/or the energy profile utilizing a database. For example, the storage module 228 stores the energy data, the modification to the energy profile, and/or the energy profile in a secured SQL database. The database can be, for example, accessed by the client module 150 and/or the management server 220. In other embodiments, the storage module 228 can be located remotely from the management server 220.</i>” <i>Id.</i> at [0070].</p>

Claim 19	Rhee
	<p>“In some examples, the <i>energy data includes</i> energy consumption data, <i>environmental data</i>, energy generation data, and/or any other type of data associated with building management (e.g., direction of windows on the building, prevailing wind, insulation type, oil tank level, propane tank level, alert information, etc.). The energy consumption data can include, for example, energy used by the energy device 160, energy saved by the energy device 160, further energy use by the energy device 160, proposed energy use by the energy device 160, cost of different types of energy, and/or any other type of data associated with the consumption of energy. <i>The environmental data can include, for example, outside temperature, inside temperature, outside humidity, inside humidity, rainfall, sunlight coverage, environmental costs of different types of energy (e.g., cost of one kilowatt of wind power, greenhouse gas emissions for one kilowatt of coal power, etc.), and/or any other data associated with the environment. The energy generation data can include, for example, alternative energy generation level (e.g., solar power generation, wind power generation, etc.), grid power level, and/or any other type of data associated with energy generation.</i>” <i>Id.</i> at [0057].</p>

* * *

Claim 20 was anticipated by and/or would have been obvious in view of Rhee as shown in the following claim chart.

Claim 20	Rhee
20. The system of claim 17	<i>See supra</i> claim 17 claim chart.

Claim 20	Rhee
[a] wherein the one or more processors with circuitry and code designed to execute instructions controls the HVAC system to provide heating or cooling to the building at an operational temperature based at least in part on the historical values of the first and second data.	<i>See supra</i> claim 19 claim chart at element 19[a].

C. SNQP 2: Claims 7-9 and 15-16 are rendered obvious by Rhee in view of Sullivan.

SNQP 2 presents an additional ground of invalidity with respect to claims 7-9 and 15-16. To the extent Rhee is found not to disclose any of the dependent claim limitations of these claims, the limitations were disclosed by Sullivan. It would have been obvious to incorporate Sullivan’s teachings as set forth below.

1. Overview of Sullivan.

Sullivan is directed to a remote control system for an HVAC system, which uses a web-based interface. Ex. E at 1:40-45. Sullivan taught a Building Control Appliance (“BCA”), which was analogous to Rhee’s management server, that controlled one or more HVAC systems in a building, and enabled users to remotely control the systems through a web-based user interface accessible over the Internet. *See infra*. Sullivan disclosed that the BCA was in communication with Thermostats, which were analogous to Rhee’s wireless controllers.

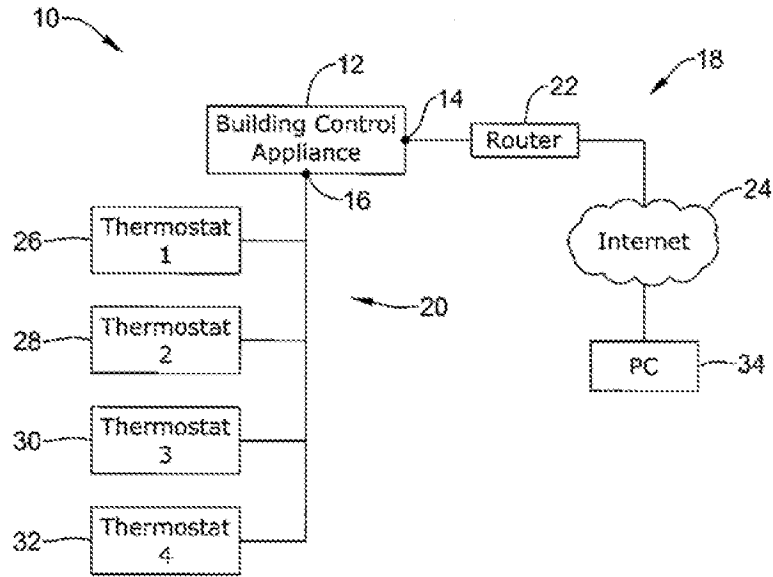

Figure 1

2. Sullivan disclosed the dependent limitations of claim 7 (which depends from claim 1).

Claim 7 requires that the “one or more processors with circuitry and code designed to execute instructions receives at least one setting of the HVAC system.” Sullivan disclosed this limitation. Ex. G at ¶¶ 133-134.

Sullivan disclosed that the BCA received at least one setting of an HVAC system. In particular, Sullivan expressly disclosed that the system displayed to the user HVAC settings including “a current operating mode of HVAC equipment”, “a lockout status of HVAC equipment” and “a fan switch status of HVAC

equipment". Ex. E at 5:19-6:7 & Fig. 3C. These were displayed to the user on a web page.

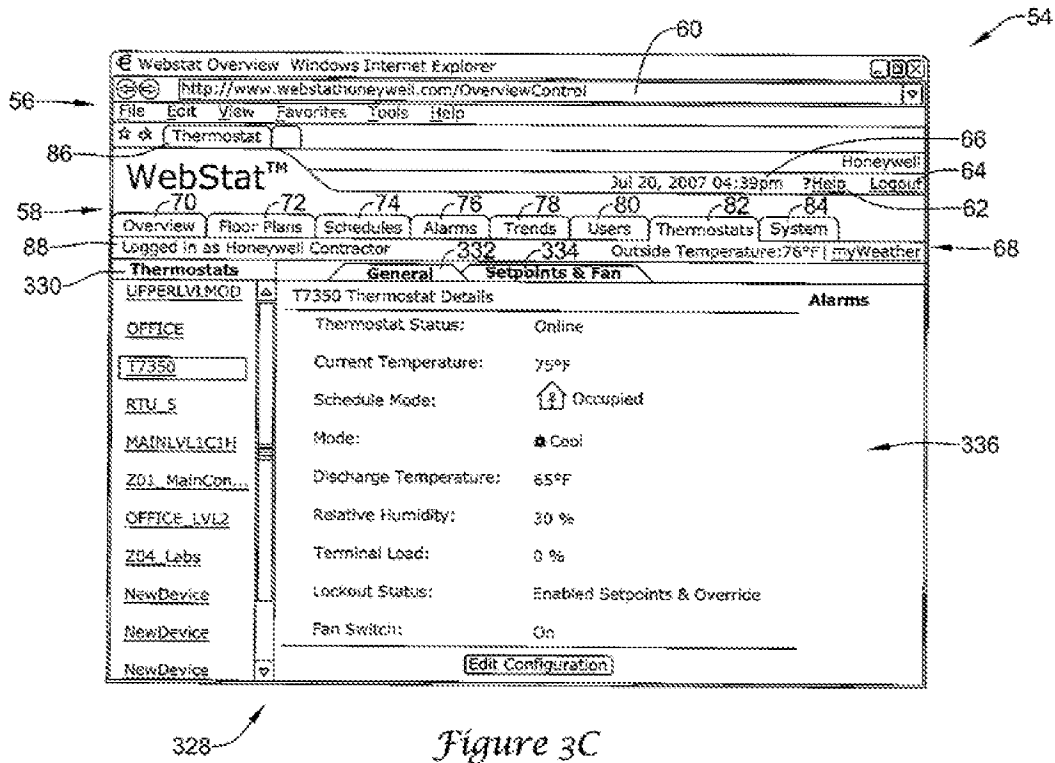

A POSITA would appreciate that the current values of these HVAC settings were reported to the BCA directly or indirectly from an HVAC system, as Sullivan disclosed (*id.* at 7:16-23), and thus were received by the processors in the BCA. Ex. G at ¶ 134. Additionally, the BCA could receive HVAC settings transmitted by the user. Ex. E at 12:4-17. For example, the user could change the operating mode of the HVAC system and the fan switch, as shown below. *Id.* at 11:61-12:17.

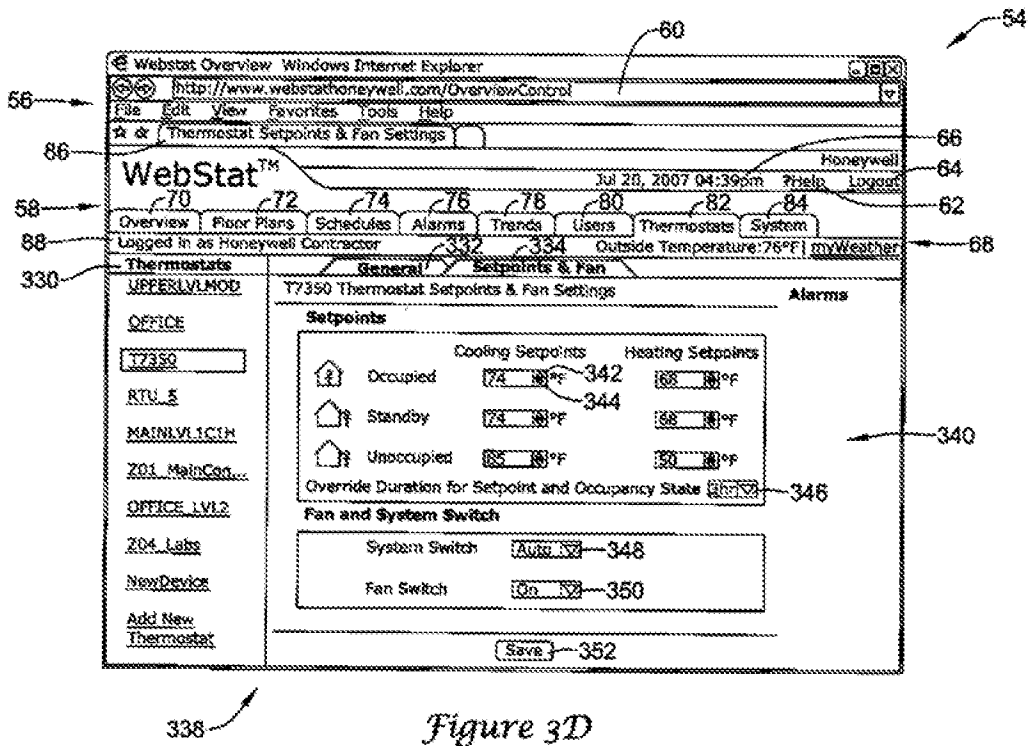

Figure 3D

It would have been obvious to modify Rhee to incorporate Sullivan's teachings of allowing users to view and modify settings of an HVAC system, including the HVAC operating mode, given Rhee's teachings of the use of a remote web interface for control of an HVAC system. Ex. G at ¶ 134. A POSITA would understand that the processors of the web server receive the settings in order to display them to the user, and in order to allow the user to change them. *Id.*

* * *

Claim 7 would have been obvious in view of Rhee in combination with Sullivan as shown in the following claim chart.

Claim 7	Rhee and Sullivan
7. The system of claim 1:	<i>See supra</i> SNQP 1 claim 1 claim chart.
[a] wherein the one or more processors with circuitry and code designed to execute instructions receives at least one setting of the HVAC system.	<p><i>See supra</i> SNQP 1 claim 7[a] claim chart.</p> <p>“Controller 36 may maintain monitoring information, status information, set point information, alarming information, trending information and/or configuration information, and the user rights privileges control, at least in part, what information can be or is displayed and/or changed via web server 38.” Ex. E at 7:10-15.</p> <p>“In some cases, building control appliance 12 may be adapted to be coupled, either directly or indirectly, to an HVAC system, and web server 38 may be adapted to provide one or more web pages via first port 14 that allow information related to the HVAC system to be assigned and unassigned to the user rights privileges. In some cases, at least some of the users of building control appliance 12 are assigned user rights privileges.” <i>Id.</i> at 7:16-23.</p> <p><i>“A variety of information may be displayed on the summary web page. Examples of information include but are not limited to one or more of a thermostat identifier for one or more of the thermostats, a current inside temperature reported by one or more of the thermostats, a current outside temperature, a current set point for one or more of the thermostats, a schedule related parameter for one or more of the thermostats, a humidity related parameter that is reported by one or more of the thermostats, a current operating mode of HVAC equipment that is connected to one or more of the thermostats, an alarm related parameter for one or more of the thermostats, a discharge air temperature of HVAC equipment that is connected to one or more of the thermostats, a plenum related</i></p>

Claim 7	Rhee and Sullivan
	<p>pressure of HVAC equipment that is connected to one or more of the thermostats, <i>a relay output related parameter of HVAC equipment that is connected to one or more of the thermostats, a lockout status of HVAC equipment that is connected to one or more of the thermostats; a fan switch status of HVAC equipment that is connected to one or more of the thermostats, a throttle range of HVAC equipment that is connected to one or more of the thermostats, an integral time of the control algorithm used to control the HVAC equipment that is connected to one or more of the thermostats, a derivative time of the control algorithm used to control the HVAC equipment that is connected to one or more of the thermostats, and an anticipator authority of the control algorithm used to control the HVAC equipment that is connected to one or more of the thermostats. These are only examples, and it is contemplated that any suitable information may be included on the summary web page, as desired.</i>” <i>Id.</i> at 5:35-64.</p> <p>“In FIG. 3D, it can be seen that web page 338 includes a pane 340 that includes information regarding setpoint and fan information for thermostat 316 (T7350). In particular, pane 340 displays cooling and heating temperature set points for one or more time periods such as occupied, unoccupied and standby. For example, pane 340 includes an up arrow 342 and a down arrow 344 that may be used to alter the cooling set point temperature during the occupied time period. Pane 340 includes a pull-down menu 346 that may be used to alter a schedule override duration. Pane 340 also includes settings pertaining to a fan switch and a system switch. <i>In particular, pane 340 includes a pull-down menu 348 that may be used to alter a setting such as Auto, cool, heat</i></p>

Claim 7	Rhee and Sullivan
	<p>and the like for the system switch as well as a pull-down menu 350 that may be used to set the fan switch to either On or Auto. A Save button 352 permits a user to save any changes that they have made to the parameters displayed within web page 352. In some instances, the Save button 352 may be omitted, and web server 38 (FIG. 2) may ask a user if changes should be saved if any parameter values or settings were altered and if the user attempts to exit a particular web page by, for example, selecting another tab within navigation bar 58. Alternatively, the changes may automatically be saved.” <i>Id.</i> at 11:61-12:17.</p> <p style="text-align: center;">Figure 3C</p>

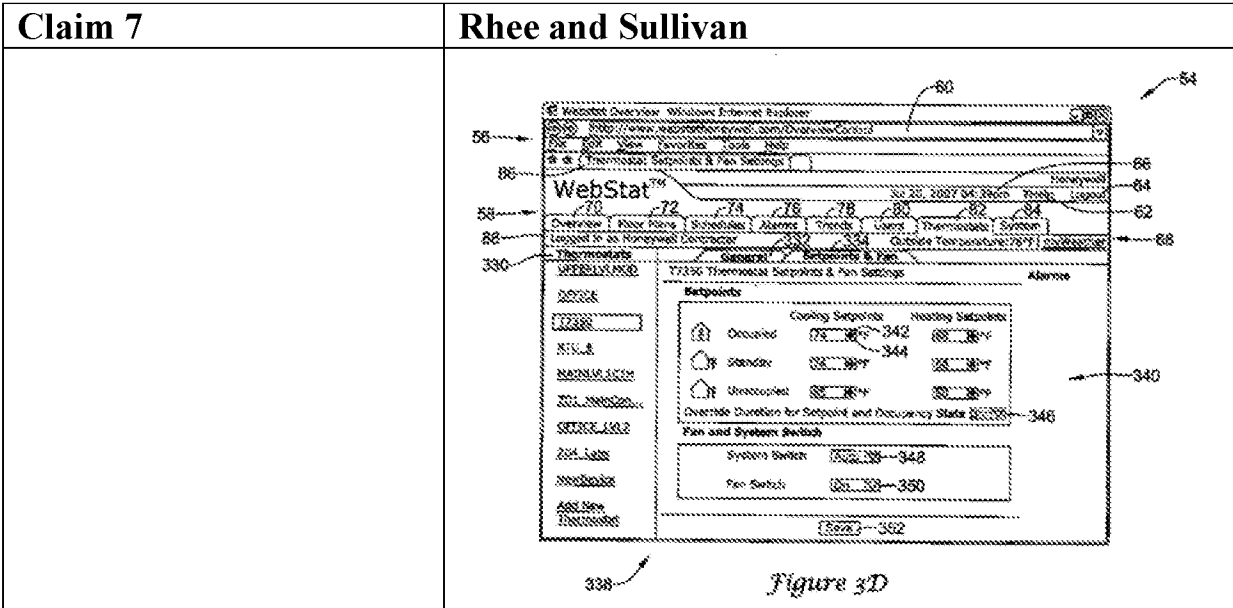

3. Sullivan disclosed the dependent limitations of claim 8 (which depends from claims 1 and 7).

Claim 8 requires that the “the at least one setting of the HVAC system comprises whether the HVAC system is currently on or off.” Sullivan disclosed this limitation. Ex. G at ¶¶ 139-141.

As explained above in Section VI.C.2 Sullivan disclosed that the BCA received whether the HVAC system is currently on or off. For example, Figure 3C shows the web summary screen indicating the mode of HVAC system is currently “❄️ Cool” which is a setting showing the HVAC system is on.

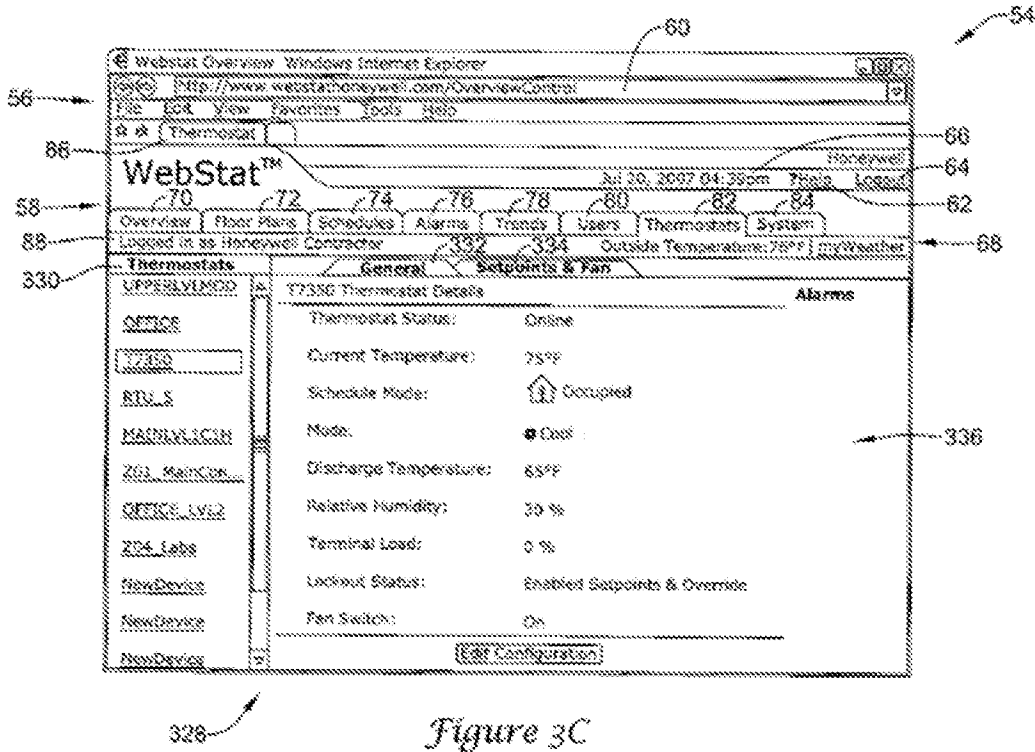

Figure 3C

Figure 9B shows the same web page indicating the mode of the HVAC system is currently “Off”.

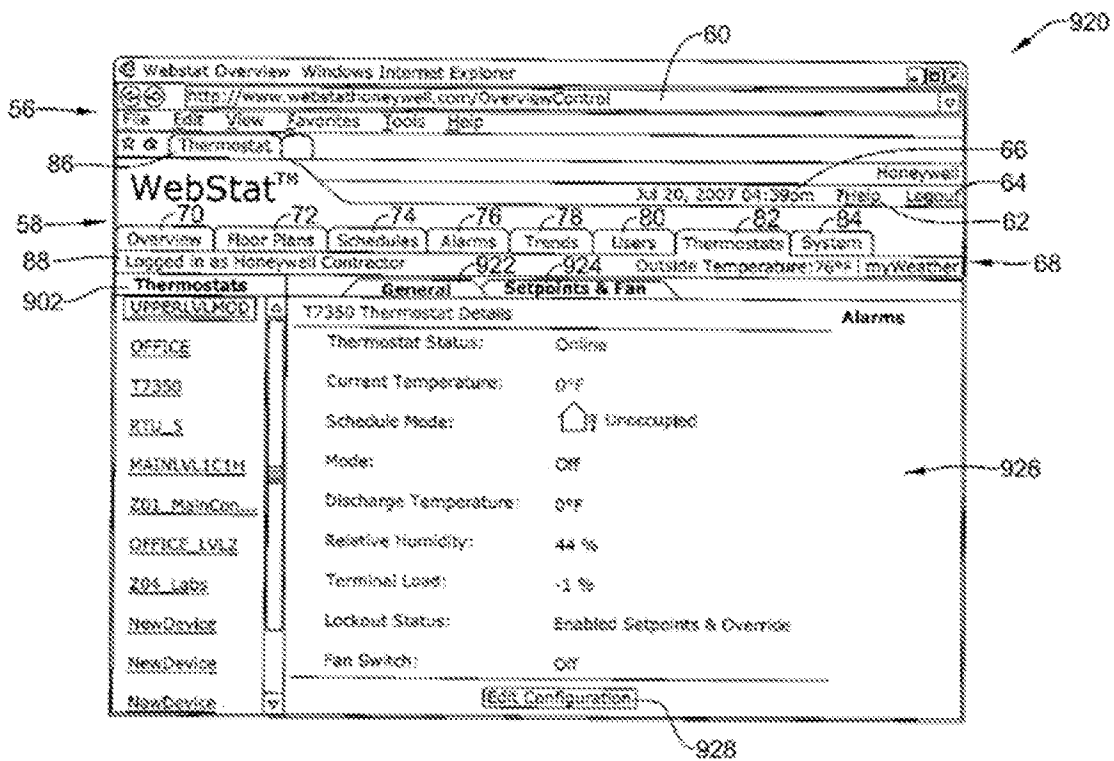

Figure 9B

Figure 3D shows a pull-down menu 348 that serves as a “system switch” to alter a setting such as “[a]uto, cool, heat, and the like”. Ex. E at 12:4-11. Auto, cool and heat are modes in which the HVAC system is “on”. As shown in Figures 3C and 9B, the mode settings also included “off”. Thus, a POSITA would have appreciated that Sullivan disclosed a system that received an HVAC setting of “on” or “off”. Ex. G at ¶ 140.

It would have been obvious to modify Rhee to incorporate Sullivan’s teachings of allowing users to view and modify the on/off setting of an HVAC system, given Rhee’s teachings of the use of a remote web interface for control of an HVAC system. *Id.* at ¶ 141. A POSITA would understand that the processors

of the web server would receive a setting indicating whether the HVAC system was on or off, in order to display the setting to the user and to allow the user to change the setting. *Id.*

* * *

Claim 8 would have been obvious in view of Rhee in combination with Sullivan as shown in the following claim chart.

Claim 8	Rhee and Sullivan
8. The system of claim 7:	<i>See supra</i> SNQP 1 claim 1 claim chart; SNQP 2 claim 7 claim chart .
[a] wherein the at least one setting of the HVAC system comprises whether the HVAC system is currently on or off.	<p><i>See supra</i> SNQP 2 claim 7 claim chart at element 7[a].</p> <p>“Pane 340 also includes settings pertaining to a fan Switch and a system switch. In particular, pane 340 includes a pull-down menu 348 that may be used to alter a setting such as Auto, cool, heat and the like for the system switch as well as a pull-down menu 350 that may be used to set the fan switch to either On or Auto. A Save button 352 permits a user to save any changes that they have made to the parameters displayed within web page 352. In some instances, the Save button 352 may be omitted, and web server 38 (FIG. 2) may ask a user if changes should be saved if any parameter values or settings were altered and if the user attempts to exit a particular web page by, for example, selecting another tab within navigation bar 58. Alternatively, the changes may automatically be saved.”</p> <p>Ex. E at 12:4-17; <i>see also id.</i> at Figs. 3C, 3D, 9B.</p>

Claim 8

Rhee and Sullivan

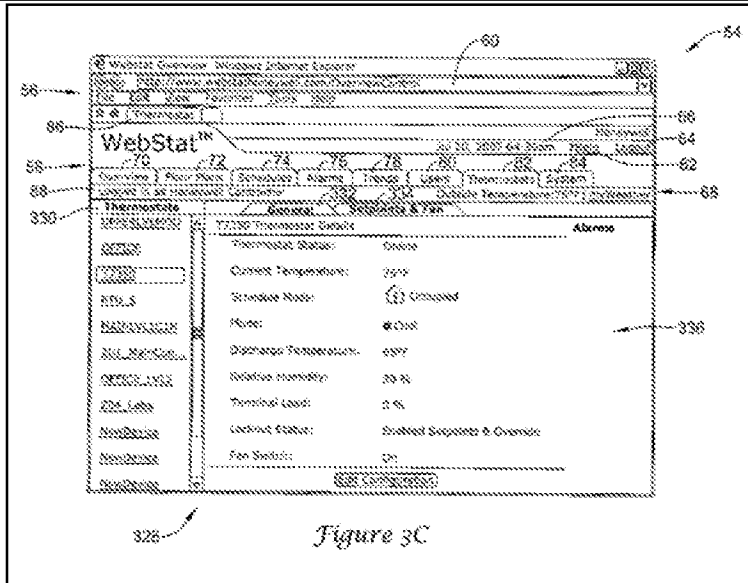

Figure 3C

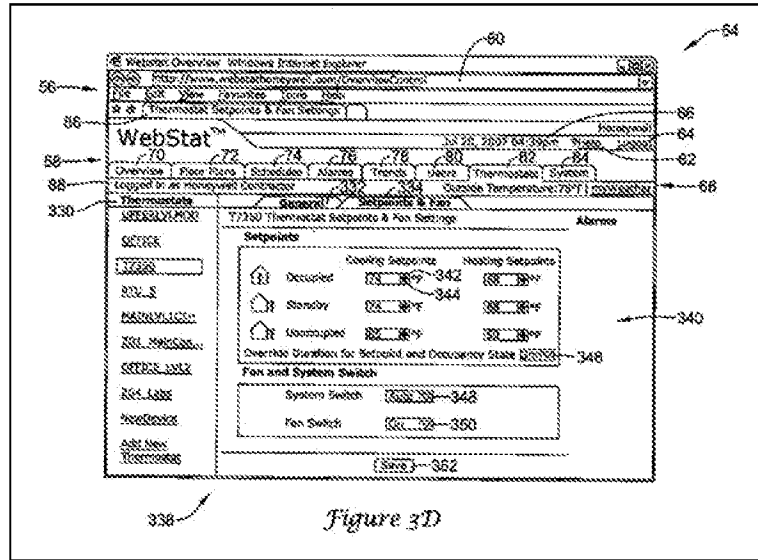
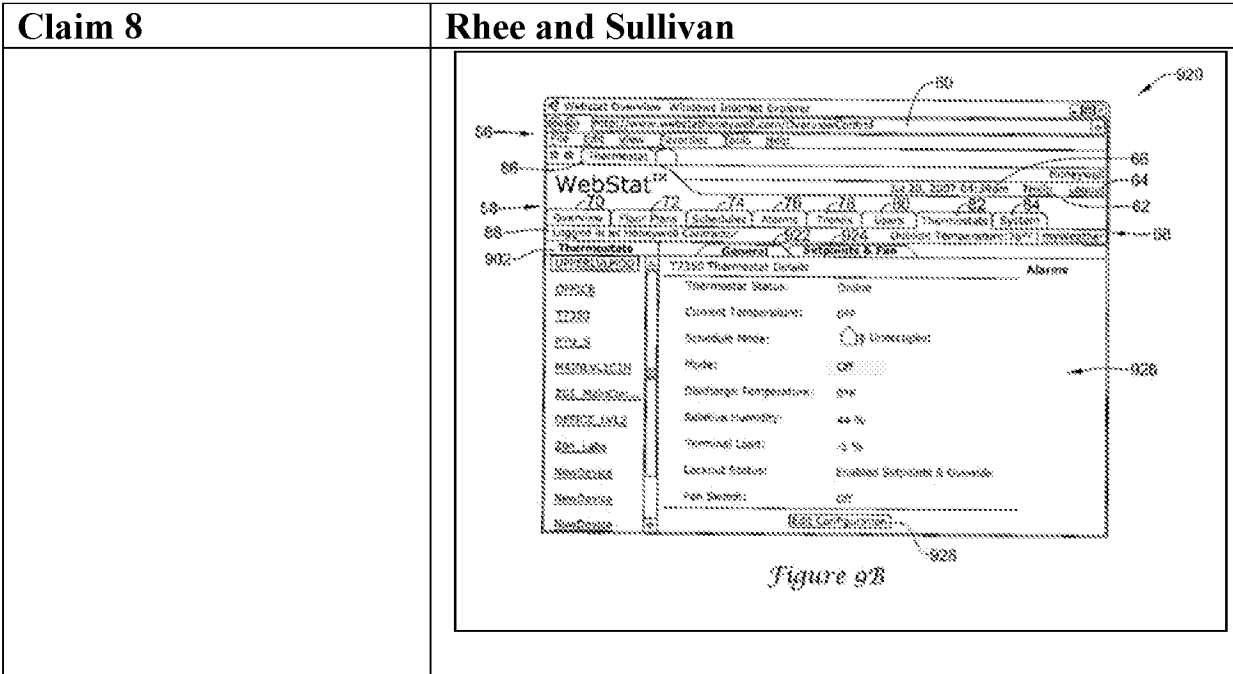

Figure 3D



4. Sullivan disclosed all elements of dependent claim 9 (which depends from claims 1 and 7).

Claim 9 requires that the “the at least one setting of the HVAC system comprises whether the HVAC system is operating in a cooling mode or a heating mode.” Sullivan disclosed this limitation. Ex. G at ¶¶ 146-148.

As explained above in Section VI.C.2-3, Sullivan displayed the mode of the HVAC system which, as a POSITA would appreciate would indicate if the HVAC system was currently operating in a cooling mode or a heating mode: “Setpoints column 306 may include one or more icons for each thermostat, indicating the operational status of corresponding HVAC equipment. For example, a snowflake icon may be displayed if air conditioning equipment is operating, or perhaps a

flame icon may be displayed if heating equipment is operating.” Ex. E at 10:50-59; Ex. G at ¶ 147-48.

It would have been obvious to modify Rhee to incorporate Sullivan’s teachings of allowing users to view and modify the cooling/heating setting of an HVAC system, given Rhee’s teachings of the use of a remote web interface for control of an HVAC system. Ex. G at ¶ 148. A POSITA would understand that the processors of the web server would receive a setting indicating whether the HVAC system was in heating or cooling mode, in order to display the setting to the user and to allow the user to change the setting. *Id.*

* * *

Claim 9 would have been obvious in view of Rhee in combination with Sullivan as shown in the following claim chart.

Claim 9	Rhee and Sullivan
9. The system of claim 7:	<i>See supra</i> SNQP 1 claim 1 claim chart; SNQP 2 claim 7 claim chart.
[a] wherein the at least one setting of the HVAC system comprises whether the HVAC system is operating in a cooling mode or a heating mode.	<i>See supra</i> SNQP 2 claim 8 claim chart at element 8[a]. “Setpoints column 306 may provide a columnar list of current temperature set points as well as equipment status for each of the corresponding thermostats within Thermostat column 302. If the HVAC equipment controlled by a particular thermostat is operating, <i>Setpoints column 306 may include one or more icons for each thermostat, indicating the operational status of corresponding HVAC equipment. For example, a snowflake icon</i>

Claim 9	Rhee and Sullivan
	<p><i>may be displayed if air conditioning equipment is operating, or perhaps a flame icon may be displayed if heating equipment is operating.” Ex. E at 10:50-59.</i></p> <p>“A variety of information may be displayed on the summary web page. Examples of information include but are not limited to one or more of a thermostat identifier for one or more of the thermostats, a current inside temperature reported by one or more of the thermostats, a current outside temperature, a current set point for one or more of the thermostats, a schedule related parameter for one or more of the thermostats, a humidity related parameter that is reported by one or more of the thermostats, <i>a current operating mode of HVAC equipment that is connected to one or more of the thermostats</i>, an alarm related parameter for one or more of the thermostats, a discharge air temperature of HVAC equipment that is connected to one or more of the thermostats, a plenum related pressure of HVAC equipment that is connected to one or more of the thermostats, a relay output related parameter of HVAC equipment that is connected to one or more of the thermostats, a lockout status of HVAC equipment that is connected to one or more of the thermostats; a fan switch status of HVAC equipment that is connected to one or more of the thermostats, a throttle range of HVAC equipment that is connected to one or more of the thermostats, an integral time of the control algorithm used to control the HVAC equipment that is connected to one or more of the thermostats, a derivative time of the control algorithm used to control the HVAC equipment that is connected to one or more of the thermostats, and an anticipator authority of the control algorithm used to control the HVAC equipment that is</p>

Claim 9	Rhee and Sullivan
	<p>connected to one or more of the thermostats. These are only examples, and it is contemplated that any suitable information may be included on the summary web page, as desired.” <i>Id.</i> at 5:35-64.</p> <p>“Pane 340 also includes settings pertaining to a fan Switch and a system switch. In particular, pane 340 includes a pull-down menu 348 that may be used to alter a setting such as Auto, cool, heat and the like for the system switch as well as a pull-down menu 350 that may be used to set the fan switch to either On or Auto. A Save button 352 permits a user to save any changes that they have made to the parameters displayed within web page 352. In some instances, the Save button 352 may be omitted, and web server 38 (FIG. 2) may ask a user if changes should be saved if any parameter values or settings were altered and if the user attempts to exit a particular web page by, for example, selecting another tab within navigation bar 58. Alternatively, the changes may automatically be saved.” <i>Id.</i> at 12:4-17; <i>see also id.</i> at Figs. 3C, 3D, 9B.</p>

5. Sullivan disclosed all elements of claim 15 (which depends from claims 1 and 7).

Claim 15 requires that the “interface is configured to allow the user to turn the HVAC system on or off”. Sullivan disclosed this limitation. Ex. G at ¶¶ 175-178.

As with the management server in Rhee, Sullivan disclosed that the BCA could send commands to control an HVAC system. In particular, a user could

cause the BCA to alter the mode of an HVAC system (which controlled whether it was off or on) via a web page:

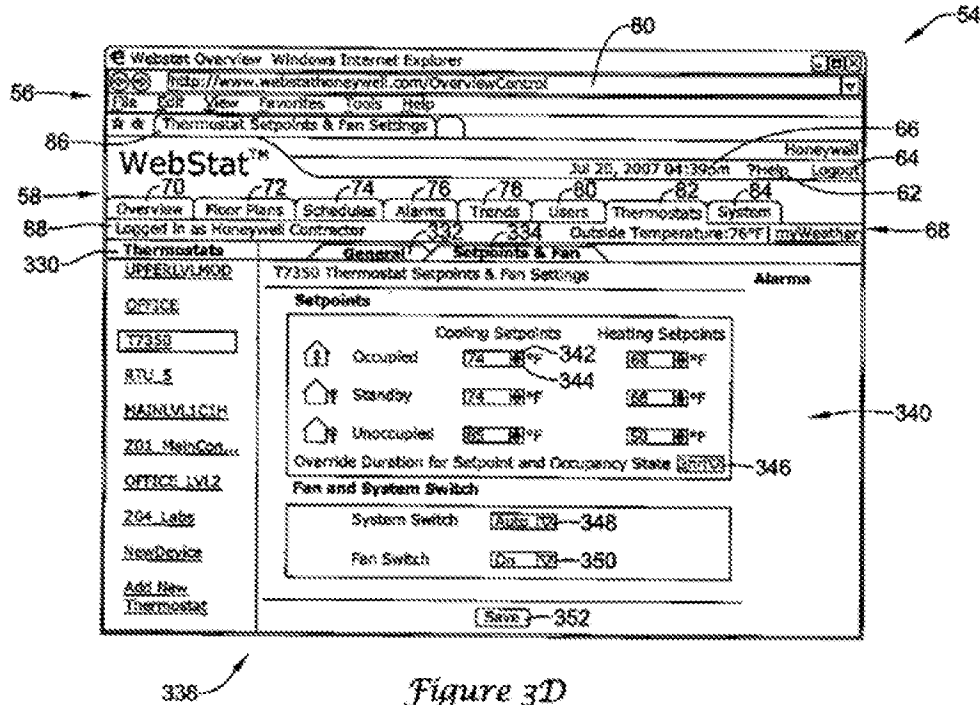

Figure 3D shows a pull-down menu 348 that serves as a “system switch” to alter a setting such as “[a]uto, cool, heat, and the like”. Ex. E at 12:4-11. Auto, cool and heat are modes in which the HVAC system is “on”. As shown in Figures 3C and 9B, the mode settings also included “off”. Thus, a POSITA would have appreciated that Sullivan disclosed a system in which a interface was configured to allow the user turn the HVAC system of “on” or “off”. Ex. G at ¶¶ 173-77.

Moreover, POSITA would have understood that the HVAC system could be turned on an off by adjusting the system switch between “off” (meaning the HVAC system is to be turned off, or “Auto”, “Cool” or “Heat” (meaning the HVAC

system is to be turned on). *Id.* It would have been obvious to modify Rhee to incorporate Sullivan’s teachings of allowing users to modify the on/off setting of an HVAC system through the client module’s web interface, given Rhee’s teachings that the user can control the system through its web interface, and the fact that turning an HVAC on or off was basic functionality in any HVAC control system. *Id.* at 178.

* * *

Claim 15 would have been obvious in view of Rhee in combination with Sullivan as shown in the following claim chart.

Claim 15	Rhee and Sullivan
15. The system of claim 7:	<i>See supra</i> SNQP 1 claim 1 claim chart; SNQP 2 claim 7 claim chart.
[a] wherein the interface is configured to allow the user to turn the HVAC system on or off.	“In FIG. 3D, it can be seen that web page 338 includes a pane 340 that includes information regarding setpoint and fan information for thermostat 316 (T7350). In particular, pane 340 displays cooling and heating temperature set points for one or more time periods such as occupied, unoccupied and standby. For example, pane 340 includes an up arrow 342 and a down arrow 344 that may be used to alter the cooling set point temperature during the occupied time period. Pane 340 includes a pull-down menu 346 that may be used to alter a schedule override duration. Pane 340 also includes settings pertaining to a fan switch and a system switch. <i>In particular, pane 340 includes a pull-down menu 348 that may be used to alter a setting such as Auto, cool, heat and the like for the system switch as well as a pull-down menu 350 that may be used to set the fan</i>

Claim 15

Rhee and Sullivan

switch to either On or Auto. A Save button 352 permits a user to save any changes that they have made to the parameters displayed within web page 352. In some instances, the Save button 352 may be omitted, and web server 38 (FIG. 2) may ask a user if changes should be saved if any parameter values or settings were altered and if the user attempts to exit a particular web page by, for example, selecting another tab within navigation bar 58. Alternatively, the changes may automatically be saved.” Ex. E at 11:61-12:17.

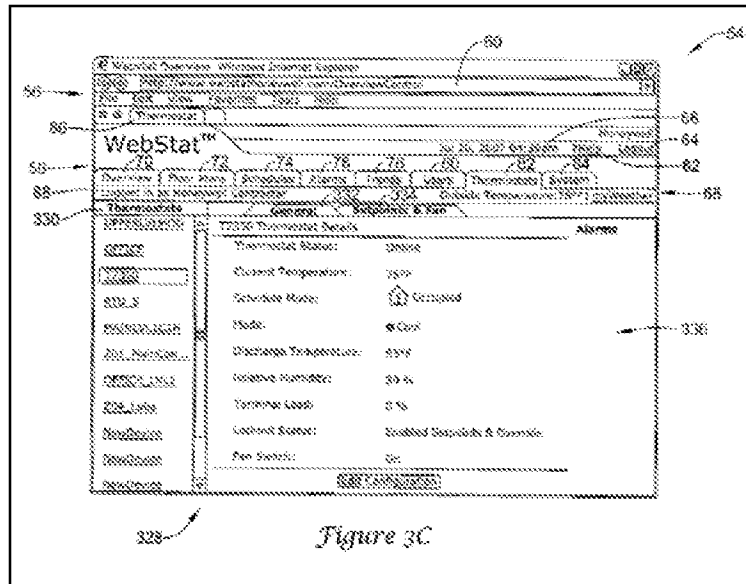

Claim 15

Rhee and Sullivan

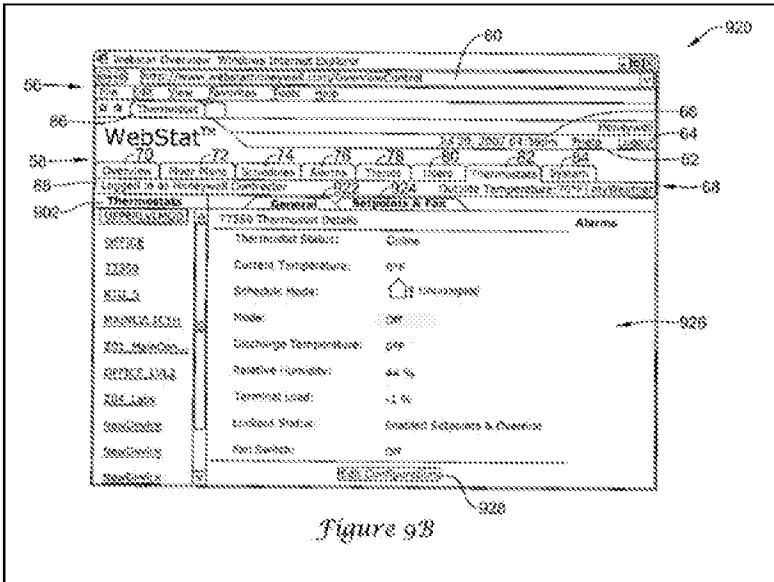
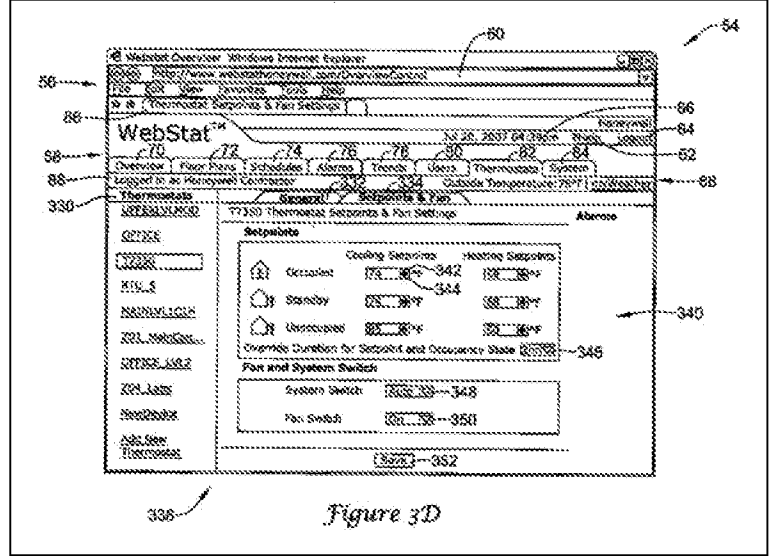

6. Sullivan disclosed all elements of claim 16 (which depends from claims 1 and 7).

Claim 16 required that the “interface is configured to allow the user to input that the building is currently unoccupied”. Sullivan disclosed this limitation. Ex. G at ¶¶ 186-187.

As explained above in Section VI.B.7, Rhee taught allowing the user to override the current occupancy mode. Sullivan provided an exemplary interface for doing so via a pull-down menu in a web interface as shown in Figure 3E.

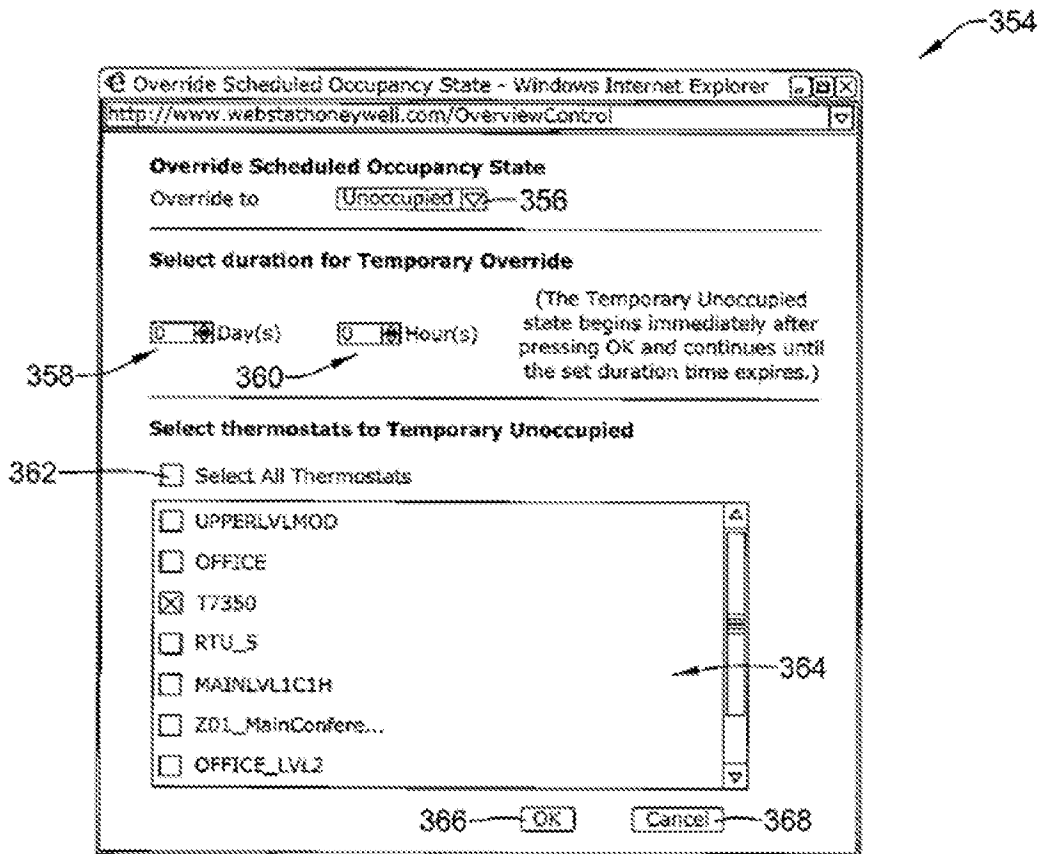

Figure 3E

It would have been obvious to combine Sullivan’s teaching of allowing a user to input that the system is currently unoccupied via a web page with Rhee’s web interface to allow for remote control of the HVAC system. Ex. G at ¶ 187.

* * *

Claim 16 would have been obvious in view of Rhee in combination with Sullivan as shown in the following claim chart.

Claim 16	Rhee and Sullivan
16. The system of claim 7:	<i>See supra</i> SNQP 1 claim 1 claim chart; claim 7 claim chart.
[a] wherein the interface is configured to allow the user to input that the building is currently unoccupied.	<i>See supra</i> SNQP 1 claim 1 claim chart at 1[pre], 1[f], 1[h], 1[j]. “Returning briefly to FIG. 3B, if a user clicks on override button 326, web server 38 (FIG. 2) may provide web page 354, as seen in FIG. 3E. Web page 354 may be simpler in appearance than web page 54 (FIG. 3B) and may in some instances be a pop-up page that floats atop web page 54. Web page 354 includes a pull-down menu 356, which permits a user to determine how to override the current status of a particular thermostat. <i>For example, if the current status is occupied, a user may override the current status by changing it to unoccupied.</i> A length of the override period may be set using pull-down menu 358, which may be used to set a number of days and/or pull-down menu 360, which may be used to set a number of hours.” Ex. E at 12:18-30.

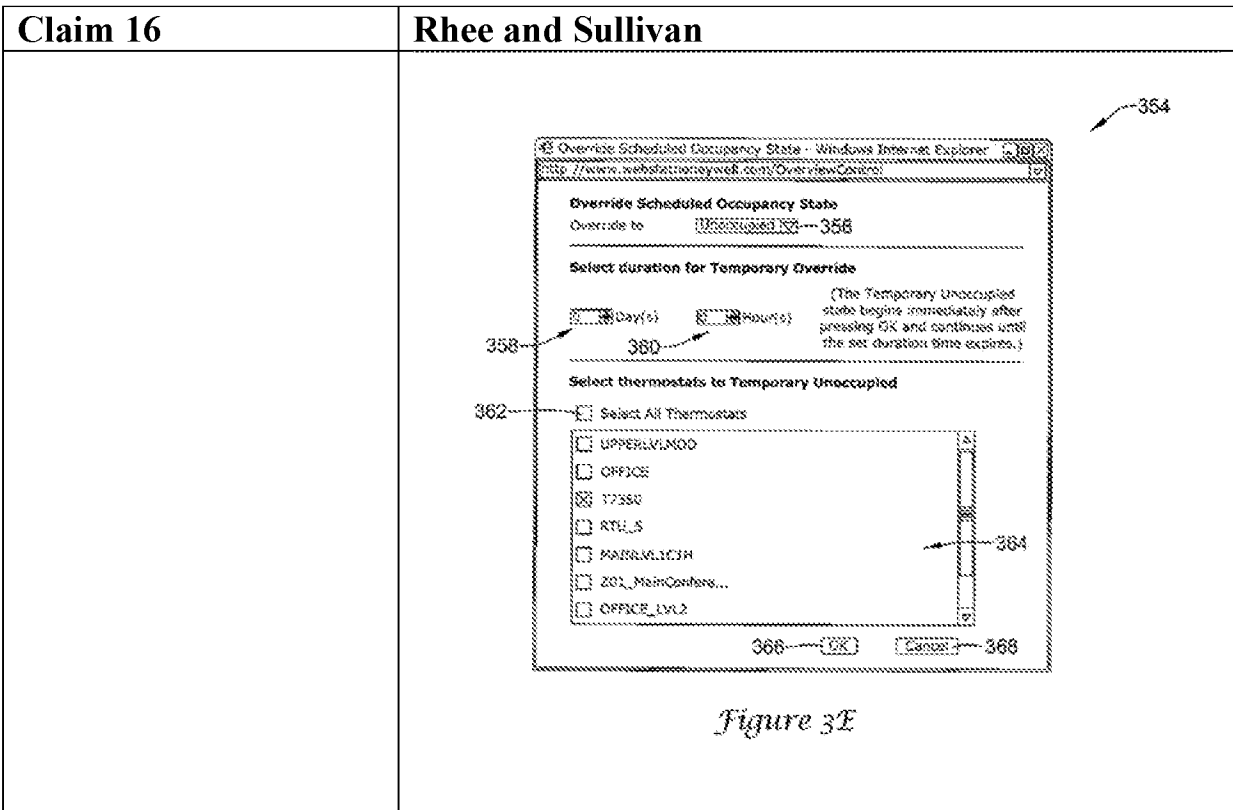

7. Motivation to combine Rhee and Sullivan

A POSITA would have been motivated to combine Sullivan with Rhee because both were analogous systems, directed to remotely managing and controlling an HVAC system in a building remotely through a web-based user interface. Ex. C at [0037]; [0040]; [0056]; Ex. E at 1:40-52. Both had similar architectures, comprising a web server accessible over the Internet that was in communication with controllers at a building. Ex. C at Fig. 1B; Ex. E at Fig. 1. Both disclosed sensors that measured inside and outside temperature and reported that data to a server. Ex. C at Fig. 4A & [0102]; Ex. E at 7:51-53, 8:44-63.

Moreover, as explained above, Rhee disclosed receiving settings of an HVAC system and control of those settings from a mobile device using a web-based interface. Sullivan provided further detail, including exemplary web pages for the display and modification of HVAC settings. A POSITA would look to Sullivan to understand what HVAC settings Rhee's management server could receive from devices in a building to store and display to users, and receive from users to send to devices in a building to affect operations of the devices. Ex. G at ¶¶ 54-55, 148. Web page user interfaces were well known in the art, and it would be straightforward to apply Sullivan's teachings to the web-based client interface of Rhee to meet the limitations of claims 7-9, 15 and 16 of the '382 Patent. *Id.* at 55.

D. SNQP 3: Claims 1-20 are rendered obvious by Rhee in view of Kates.

SNQP 3 presents an additional ground of invalidity with respect to claims 1-20 in view of both Kates and Rhee. Kates discloses additional details concerning determining occupancy based on an occupant sensor, and it would have been obvious to incorporate these teachings into Rhee, as set forth below.

1. Overview of Kates.

Kates is directed to a system and method for heating and cooling a home or commercial structure. Ex. D at 1:7-9. In an embodiment of Kates, a central

system communicates with thermostats and an HVAC system to provide heating and cooling. *Id.* at Fig. 8 & 8:62-9:3.

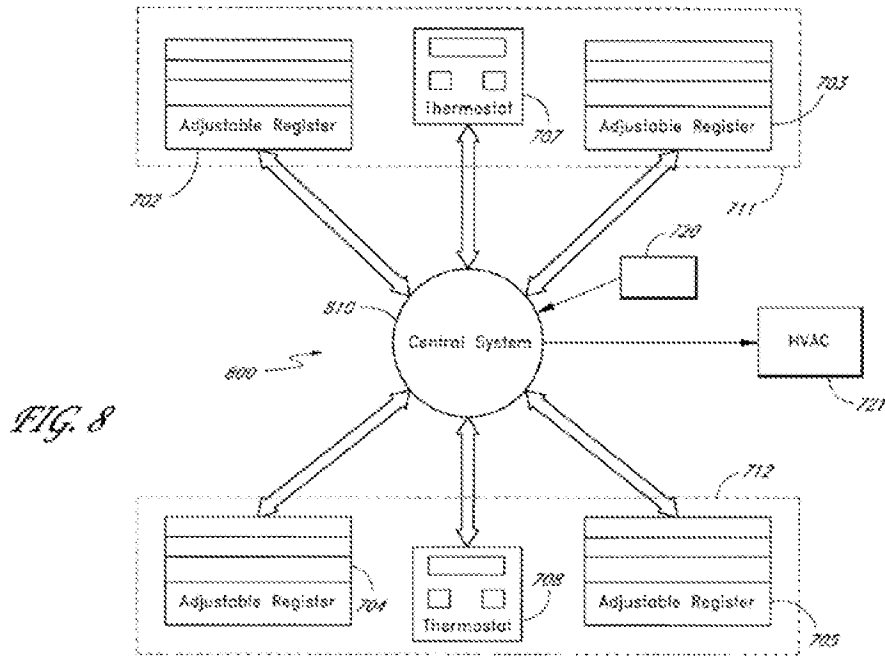

A further embodiment implemented using the architecture of Figure 8 is depicted in Figure 12. In Figure 12, occupant sensor 1201 is provided to controller 1101, and can be, for example, an “infrared sensor, motion sensor, ultrasonic sensor, etc.” *Id.* at 10:10-34.

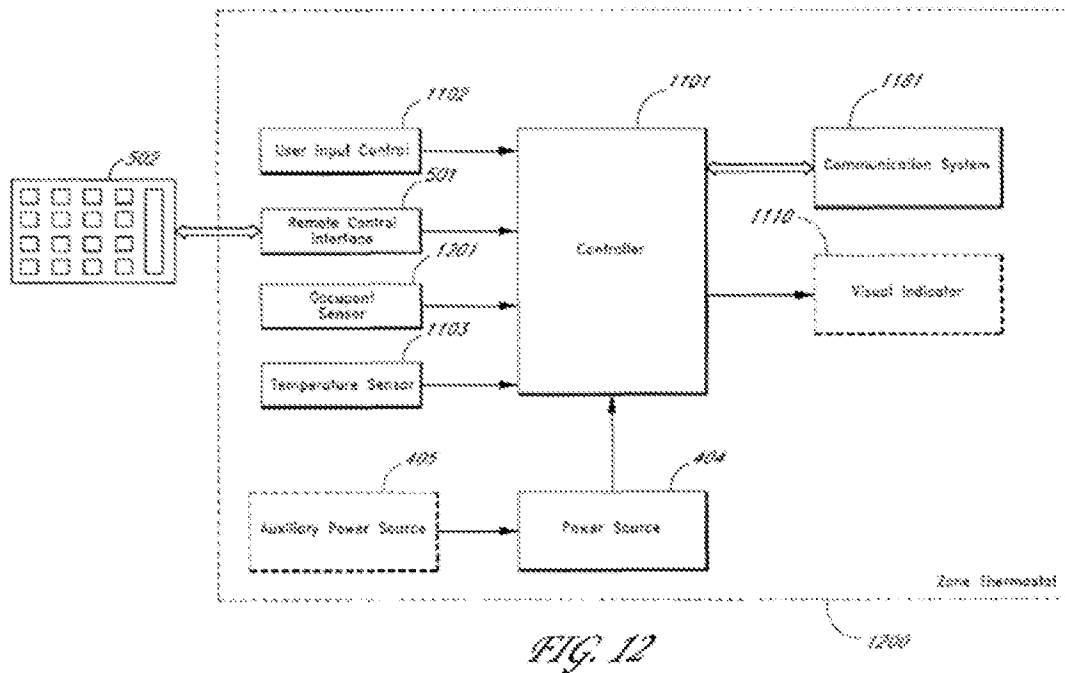

Kates teaches the use of occupant sensors to determine whether a zone in the building is occupied (*id.* at 10:18-24) and the central system changes the temperature setpoint according to whether a zone is occupied or unoccupied (*id.* at 10:28-33).

2. Kates disclosed processors that determined “whether the building is occupied or unoccupied” based at least in part on “third data from a motion sensor” and controlled the HVAC system to heat or cool the building at an operation temperature based on the determination.

Claim 1 and its dependent claims require that the one or more processors “determine whether the building is occupied and unoccupied and based on that

determination, to control the HVAC system to provide heating or cooling to the building at an operational temperature”. Its dependent claim 10 similarly requires that the “determination of whether the building is occupied or unoccupied by one or more processors” be “based on a third data received from a motion sensor”.

Claim 12, which depends from claim 1, requires that the “determination of whether the building is occupied or unoccupied is performed by the first processor”. Claim 17 and its dependent claims 18 and 20 require that the “one or more processors” “receive a third data from a motion sensor” that is used to “determine whether the building is occupied or unoccupied”. Rhee disclosed these limitations as explained with respect to SQNP 1. However, to the extent Rhee is considered insufficient, Kates also disclosed the limitations. Ex. G at ¶¶ 95, 154, 162, 167, 202.

Kates disclosed a central system, which a POSITA would understand from Kates’s disclosures to be a computer system including processors that executed instructions to control the system. Ex. G at ¶ 51; Ex. D at 10:43-51. The central system determined temperature setpoints for an HVAC system based on a determination whether a zone was occupied or unoccupied. Ex. D at 10:28-33. Kates further taught that an occupant sensor, such as a motion sensor, could be used to determine when a zone was occupied or unoccupied. *Id.* at 10:18:21. The central system of Kates used the determination of whether the zone was occupied

or unoccupied to control the operational temperature of the HVAC system by changing the temperature setpoint. *Id.* at 10:28-33.

Given Rhee's teachings of its management server receiving data from sensors, including a motion detector, and determining occupancy based on an occupancy sensor, it would be have been obvious to combine Rhee with Kates's teaching of using a motion sensor to determine occupancy and to control the HVAC system based on that determination. Ex. G at ¶ 95.

* * *

Claim 1 would have been obvious in view of Rhee in combination with Kates as shown in the following claim chart.

Claim 1	Rhee and Kates
1. A system for controlling an HVAC system at a user's building, the system comprising:	<i>See supra</i> SNQP 1 claim 1 claim chart at element 1[pre].
[a] a memory; and	<i>See supra</i> SNQP 1 claim 1 claim chart at element 1[a].
[b] one or more processors with circuitry and code designed to execute instructions;	<i>See supra</i> SNQP 1 claim 1 claim chart at element 1[b].
[c] the one or more processors with circuitry and code designed to execute instructions to receive a first data from at least one sensor, wherein the first data from the at least one sensor includes a	<i>See supra</i> SNQP 1 claim 1 claim chart at element 1[c].

Claim 1	Rhee and Kates
measurement of at least one characteristic of the building;	
[d] the one or more processors with circuitry and code designed to execute instructions to receive a second data from a network connection, wherein the second data from the network connection is collected from a source external to the building, wherein the second data from the network connection is received via the Internet;	<i>See supra</i> SNQP 1 claim 1 claim chart at element 1[d].
[e] the one or more processors with circuitry and code designed to execute instructions to receive a first temperature setpoint for the building corresponding to a desired temperature setting when the building is occupied, and a second temperature setpoint for the building corresponding to a desired temperature setting when the building is unoccupied;	<i>See supra</i> SNQP 1 claim 1 claim chart at element 1[e].
[f] the one or more processors with circuitry and code designed to execute instructions to receive commands through the Internet by way of a remote interface on a mobile, wireless device running software application code; wherein the interface is configured to allow the user to adjust temperature setpoints for the HVAC system;	<i>See supra</i> SNQP 1 claim 1 claim chart at element 1[f].

Claim 1	Rhee and Kates
<p>[g] the one or more processors with circuitry and code designed to execute instructions to send user-specific data through the Internet, wherein user-specific information about the building and HVAC system is generated based at least in part on the user-specific data, wherein the user-specific information is configured to be presented on a user interface on a mobile, wireless device running software application code via the Internet;</p>	<p><i>See supra</i> SNQP 1 claim 1 claim chart at element 1[g].</p>
<p>[h] the one or more processors with circuitry and code designed to execute instructions to determine whether the building is occupied or unoccupied, and based on that determination, to control the HVAC system to provide heating or cooling to the building at an operational temperature;</p>	<p><i>See supra</i> SNQP 1 claim 1 claim chart at element 1[h].</p> <p><i>“In one embodiment, an occupant sensor 1201 is provided to the controller 1101. The occupant sensor 1201, such as, for example, an infrared sensor, motion sensor, ultrasonic sensor, etc. senses when the zone is occupied. The occupants can program the zone thermostat 1201 to bring the zone to different temperatures when the zone is occupied and when the zone is empty. In one embodiment, the occupants can program the zoned thermostat 1201 to bring the zone to different temperatures depending on the time of day, the time of year, the type of room (e.g. bedroom, kitchen, etc.), and/or whether the room is occupied or empty. In one embodiment, a group of zones are combined into a composite zone (e.g., a group of zones</i></p>

Claim 1	Rhee and Kates
	<p>such as an entire house, an entire floor, an entire wing, etc.) and <i>the central system 710, 810, 910 changes the temperature setpoints of the various zones according to whether the composite zone is empty or occupied.</i>” Ex. D at 10:18-33.</p> <p>“<i>In one embodiment, the zone control functions of the blocks 710, 810, 910 are provided by a computer program running on a control system processor, and the control system processor interfaces with personal computer to provide the console 1300 on the personal computer. In one embodiment, the zone control functions of the blocks 710, 810, 910 are provided by a computer program running on a control system processor provided to a hardware console 1300. In one embodiment, the occupants can use the Internet, telephone, cellular telephone, pager, etc. to remotely access the central system to control the temperature, priority, etc. of one or more zones.</i>” <i>Id.</i> at 10:43-54.</p>
<p>[i] wherein the one or more processors comprises a first processor with circuitry and code designed to execute instructions, which is located remotely from the memory and is not electrically connected to the memory;</p>	<p><i>See supra</i> SNQP 1 claim 1 claim chart at element 1[i].</p>

Claim 1	Rhee and Kates
[j] the first processor with circuitry and code designed to execute instructions to communicate with the memory;	<i>See supra</i> SNQP 1 claim 1 claim chart at element 1[j].
[k] wherein the memory is configured to store historical values of the first data and second data.	<i>See supra</i> SNQP 1 claim 1 claim chart at element 1[k].

Further, claims 2-9, 11, 13-16 and 19, which depend from claim 1, would have been obvious in view of Rhee and Kates, because Rhee disclosed the dependent limitations or at least rendered them obvious as explained above for SNQP 1.

Claim 10 would have been obvious in view of Rhee in combination with Kates as shown in the following claim chart.

* * *

Claim 10	Rhee and Kates
10. The system of claim 4:	<i>See supra</i> SNQP 1 claim 1 claim charts; SNQP 1 claim 2 claim chart; SNQP 1 claim 4 claim chart.
[a] wherein the determination of whether the building is occupied or unoccupied by the one or more processors is based on a third data received from a motion sensor.	<i>See supra</i> SNQP 1 claim 10 claim chart. <i>“In one embodiment, an occupant sensor 1201 is provided to the controller 1101. The occupant sensor 1201, such as, for example, an infrared sensor, motion sensor, ultrasonic sensor, etc. senses when the zone is occupied. The occupants can program the zone thermostat 1201 to bring the zone to different temperatures when the zone is occupied and when the zone is empty. In one</i>

Claim 10	Rhee and Kates
	<p>embodiment, the occupants can program the zoned thermostat 1201 to bring the zone to different temperatures depending on the time of day, the time of year, the type of room (e.g. bedroom, kitchen, etc.), and/or whether the room is occupied or empty. In one embodiment, a group of zones are combined into a composite zone (e.g., a group of zones such as an entire house, an entire floor, an entire wing, etc.) and <i>the central system 710, 810, 910 changes the temperature setpoints of the various zones according to whether the composite zone is empty or occupied.</i>” Ex. D 10:18-33.</p>

Claim 12 was obvious in view of Rhee in combination with Kates as shown in the following claim chart.

* * *

Claim 12	Rhee
12. The system of claim 1:	<i>See supra</i> SNQP 1 claim 1 claim chart.
[a] wherein the determination of whether the building is occupied or unoccupied by is performed by the first processor.	<p><i>See supra</i> SNQP 1 claim 12 claim chart.</p> <p><i>“In one embodiment, an occupant sensor 1201 is provided to the controller 1101. The occupant sensor 1201, such as, for example, an infrared sensor, motion sensor, ultrasonic sensor, etc. senses when the zone is occupied. The occupants can program the zone thermostat 1201 to bring the zone to different temperatures when the zone is occupied and when the zone is empty. In one embodiment, the occupants can program the zoned thermostat 1201 to bring the zone to different temperatures depending on the time of day, the time of year, the type of room (e.g. bedroom,</i></p>

Claim 12	Rhee
	kitchen, etc.), and/or whether the room is occupied or empty. In one embodiment, a group of zones are combined into a composite zone (e.g., a group of zones such as an entire house, an entire floor, an entire wing, etc.) and <i>the central system 710, 810, 910 changes the temperature setpoints of the various zones according to whether the composite zone is empty or occupied.</i> ” Ex. D 10:18-33.

Claim 17 would have been obvious in view of Rhee in combination with Kates as shown in the following claim chart.

* * *

Claim 17	Rhee and Kates
17. A system for controlling an HVAC system at a user’s building, the system comprising:	<i>See supra</i> SNQP 1 claim 1 claim chart at element 1[pre].
[a] a memory; and	<i>See supra</i> SNQP 1 claim 1 claim chart at element 1[a].
[b] one or more processors with circuitry and code designed to execute instructions;	<i>See supra</i> SNQP 1 claim 1 claim chart at element 1[b].
[c] the one or more processors with circuitry and code designed to execute instructions to receive a first data from at least one sensor, wherein the first data from the at	<i>See supra</i> SNQP 1 claim 1 claim chart at element 1[c]; SNQP 1 claim 4 claim chart.

Request for *Ex Parte* Reexamination
 U.S. Patent No. 10,534,382

Claim 17	Rhee and Kates
<p>least one sensor includes a measurement of the current temperature of the building by the sensor;</p>	
<p>[d] the one or more processors with circuitry and code designed to execute instructions to receive a second data from a network connection, wherein the second data from the network connection is collected from a source external to the building and comprises outdoor temperature, wherein the second data from the network connection is received via the Internet;</p>	<p><i>See supra</i> SNQP 1 claim 1 claim chart at element 1[d]; SNQP 1 claim 5 claim chart.</p>
<p>[e] the one or more processors with circuitry and code designed to execute instructions to receive a first temperature setpoint for the building corresponding to a desired temperature setting when the building is occupied, and a second temperature setpoint for the building corresponding to a desired temperature setting when the building is unoccupied;</p>	<p><i>See supra</i> SNQP 1 claim 1 claim chart at element 1[e].</p>

Claim 17	Rhee and Kates
<p>[f] the one or more processors with circuitry and code designed to execute instructions to receive commands through the Internet by way of a remote interface on a mobile, wireless device running software application code; wherein the interface is configured to allow the user to adjust temperature setpoints for the HVAC system;</p>	<p><i>See supra</i> SNQP 1 claim 1 claim chart at claim 1[f].</p>
<p>[g] the one or more processors with circuitry and code designed to execute instructions to send user-specific data through the Internet, wherein user-specific information about the building and HVAC system is generated based at least in part on the user-specific data, wherein the user-specific information is configured to be presented on a user interface via on mobile, wireless device running software application code via the Internet;</p>	<p><i>See supra</i> SNQP 1 claim 1 claim chart at element 1[g].</p>
<p>[h] the one or more processors with circuitry and code designed to</p>	<p><i>See supra</i> claim 10 claim chart for Rhee and Kates.</p>

Claim 17	Rhee and Kates
<p>execute instructions to receive a third data from a motion sensor, and is further configured to determine whether the building is occupied or unoccupied based at least in part on the third data;</p>	
<p>[i] the one or more processors with circuitry and code designed to execute instructions to control the HVAC system based on the determination that the building is occupied to provide heating or cooling to the building effective to reach the first temperature setpoint for the building corresponding to a desired temperature setting when the building is occupied;</p>	<p><i>See supra</i> SNQP 1 claim 17 claim chart at element 17[i].</p> <p><i>“In one embodiment, an occupant sensor 1201 is provided to the controller 1101. The occupant sensor 1201, such as, for example, an infrared sensor, motion sensor, ultrasonic sensor, etc. senses when the zone is occupied. The occupants can program the zone thermostat 1201 to bring the zone to different temperatures when the zone is occupied and when the zone is empty. In one embodiment, the occupants can program the zoned thermostat 1201 to bring the zone to different temperatures depending on the time of day, the time of year, the type of room (e.g. bedroom, kitchen, etc.), and/or whether the room is occupied or empty. In one embodiment, a group of zones are combined into a composite zone (e.g., a group of zones such as an entire house, an entire floor, an entire wing, etc.) and the central system 710, 810, 910 changes the temperature setpoints of the various zones according to whether the composite zone is empty or occupied.”</i> <i>Ex. D at 10:18-33.</i></p> <p><i>“In one embodiment, the zone control functions of the blocks 710, 810, 910 are provided by a computer program running on a control system processor, and the control system processor</i></p>

Claim 17	Rhee and Kates
	<p>interfaces with personal computer to provide the console 1300 on the personal computer. In one embodiment, the zone control functions of the blocks 710, 810, 910 are provided by a computer program running on a control system processor provided to a hardware console 1300. In one embodiment, the occupants can use the Internet, telephone, cellular telephone, pager, etc. to remotely access the central system to control the temperature, priority, etc. of one or more zones.” <i>Id.</i> at 10:43-54.</p>
<p>[j] wherein the one or more processors comprises a first processor with circuitry and code designed to execute instructions, which is located remotely from the memory and is not electrically connected to the memory;</p>	<p><i>See supra</i> SNQP 1 claim 1 claim chart at element 1[i].</p>
<p>[k] the first processor with circuitry and code designed to execute instructions to communicate with the memory;</p>	<p><i>See supra</i> SNQP 1 claim 1 claim chart at element 1[j].</p>
<p>[l] wherein the memory is configured to store historical values of the first data and second data.</p>	<p><i>See supra</i> SNQP 1 claim 1 claim chart at element 1[k].</p>

Further, claims 18 and 20 which depend from claim 17, would have been obvious in view of Rhee and Kates, because Rhee disclosed the dependent limitations or at least rendered them obvious as explained above for SNQP 1.

3. Motivation to combine Rhee and Kates

A POSITA would have been motivated to combine Kates with Rhee because both were analogous systems, directed to controlling an HVAC system in a building. Ex. C at [0037]; [0040]; [0056]; Ex. D at 2:3-7, 2:56-67. Both had similar architectures, comprising controller devices that communicated wirelessly with a central computer. Ex. C at Fig. 1B; Ex. D at Figs. 7A-B, 8, 9; 2:45-57. Both systems also disclosed remote control of the system via the Internet. Ex. C at [0045]; Ex. D at 10:51-54. Both systems included occupancy sensors that detected occupancy which was used to control the operational temperature of an HVAC system. Ex. C at Tbl. 8, [0097]; Ex. D at 10:18-23.

Rhee teaches controlling an HVAC system (including its temperature setpoint) by means of occupancy sensors. Kates provides further explanation about how occupancy sensors, including motion sensors, can be used to determine occupancy and control an HVAC system. It would have been obvious to look to Kates's teachings in this respect given both references were directed to HVAC control systems, and used occupancy sensors as inputs for controlling the HVAC system. Ex. G at ¶ 53.

E. SNQP 4: Claims 7-9 and 15-16 are rendered obvious by Rhee in view of Kates and Sullivan.

SNQP 3, addresses all claims in view of Rhee in combination with Kates. If SNQP 3 is found insufficient to establish the obviousness of claims 7-9 and 15-16, Rhee and Kates can further be combined with Sullivan as discussed in SNQP 2 above. Rhee in view of Kates renders claims 1-20 obvious, as discussed in SNQP 3 above. Sullivan further teaches the dependent limitations of claims 7-9 and 15-16. Rhee in view of Kates and Rhee's client module in view of the exemplary web-page interfaces of Sullivan would render claims 7-9 and 15-16 obvious, as well for the reasons previously discussed with respect to SNQP 2.

VII. CONCLUSION

For the above reasons, Alarm.com respectfully submits that claims 1-20 of the '382 Patent should be reexamined and declared unpatentable based on the substantial new questions of patentability presented in this Request.

Respectfully submitted,

Dated: February 12, 2021

/David P. Emery/
David P. Emery
Registration No. 55,154