

UNITED STATES PATENT AND TRADEMARK OFFICE

BEFORE THE PATENT TRIAL AND APPEAL BOARD

APPLE INC.

Petitioner,

v.

MASIMO CORPORATION,

Patent Owner.

Case IPR2020-01737
U.S. Patent 10,709,366

DECLARATION OF VIJAY K. MADISETTI, PH.D.

<p>Masimo Ex. 2004 Apple v. Masimo IPR2020-01737</p>

TABLE OF CONTENTS

I.	QUALIFICATIONS	1
II.	MATERIALS CONSIDERED	8
III.	UNDERSTANDING OF PATENT LAW	10
	A. Level Of Ordinary Skill In The Art.....	10
	B. Claim Construction	11
	C. Obviousness.....	12
IV.	INTRODUCTION TO MASIMO’S ’366 PATENT.....	13
	A. The ’366 Patent	13
	B. Introduction To The Independent Claims Of The ’366 Patent	14
V.	THE PETITION’S PROPOSED COMBINATIONS.....	16
VI.	LEVEL OF ORDINARY SKILL IN THE ART	16
VII.	FOUNDATIONS 1-2 DO NOT ESTABLISH OBVIOUSNESS	18
	A. Introduction To Ground 1	18
	1. Ohsaki Discloses A Pulse Rate Sensor With A Single Emitter And A Single Detector That Must Be Arranged Linearly On The Back Side Of The Wrist	18
	2. The Shape Of Ohsaki’s Board	20
	3. Aizawa Discloses A Circular Pulse Sensor	22
	4. Ground 1’s Motivation To Add Ohsaki And Aizawa To The Proposed Combination.....	24

5.	Dr. Kenny’s Proposed Addition Of Mendelson 2003 to Ground 1	27
6.	Dr. Kenny’s Further Addition of Goldsmith to Ground 1	29
B.	A POSITA Would Not Have Been Motivated To Combine Ohsaki’s Board With Aizawa’s Sensor	30
1.	A POSITA Would Have Understood That Ohsaki’s Rectangular Board Would Not Work With Aizawa’s Circular Sensor Arrangement	31
2.	A POSITA Would Have Understood That Ohsaki’s Board Would Have Been Detrimental In Combination With Aizawa’s Sensor Because Ohsaki’s Board “Has A Tendency To Slip” At Aizawa’s Measurement Location On The Palm Side Of The Wrist, Near The Artery.....	40
3.	A POSITA Would Not Have Been Motivated To Reduce The Measured Optical Signal By Adding A Convex Lens/Protrusion To Aizawa’s Sensor.....	55
4.	A POSITA Would Not Have Selected A Convex Cover To Protect The Sensor’s Optical Elements.....	64
C.	Dr. Kenny’s Modification Of Aizawa’s Detector Arrangement Based On Mendelson 2003 Changes Aizawa’s Principle Of Operation And Produces An Inferior Sensor.....	66
1.	Dr. Kenny’s Proposed Combination Changes Aizawa’s Principle Of Operation And Eliminates A Feature Aizawa Repeatedly Identifies As Important	68

2.	Dr. Kenny’s Proposed Modification Would Result In Increased Power Consumption Compared To Aizawa’s Existing Embodiment	71
3.	Mendelson 2003 Teaches Against Using Its Particular Detector Arrangement, Which Was Designed For Performing Experiments, For An Actual Monitoring Device	74
D.	Goldsmith Does Not Address The Deficiencies In Dr. Kenny’s Proposed Combination Of Aizawa, Ohsaki, and Mendelson 2003	78
E.	The Challenged Dependent Claims Are Nonobvious Over Ground 1	79
F.	Ground 2 Fails For The Same Reasons As Ground 1	79
VIII.	OATH	82

I, Vijay K. Madiseti, Ph.D., declare as follows:

1. I have been retained by counsel for Patent Owner Masimo Corporation (“Masimo”) as an independent expert witness in this proceeding. I have been asked to provide my opinions regarding the Petition in this action and the declaration offered by Thomas W. Kenny, Ph.D., (Ex. 1003) challenging the patentability of claims 1-27 of U.S. Patent No. 10,709,366 (“the ’366 Patent”). I am being compensated at my usual and customary rate for the time I spend working on this proceeding, and my compensation is not affected by its outcome.

I. QUALIFICATIONS

2. My qualifications are set forth in my curriculum vitae, a copy of which is included as Exhibit 2005. A summary of my qualifications follows.

3. I am a professor in Electrical and Computer Engineering at the Georgia Institute of Technology (“Georgia Tech”). I have worked in the area of digital signal processing, wireless communications, computer engineering, integrated circuit design, and software engineering for over 25 years, and have authored, co-authored, or edited several books and numerous peer-reviewed technical papers in these area.

4. I obtained my Ph.D. in Electrical Engineering and Computer Science at the University of California, Berkeley, in 1989. While there, I received the

Demetri Angelakos Outstanding Graduate Student Award and the IEEE/ACM Ira M. Kay Memorial Paper Prize.

5. I joined Georgia Tech in the Fall of 1989 and am now a tenured full professor in Electrical and Computer Engineering. Among other things, I have been active in the areas of digital signal processing, wireless communications, integrated circuit design (analog & digital), system-level design methodologies and tools, and software engineering. I have been the principal investigator (“PI”) or co-PI in several active research programs in these areas, including DARPA’s Rapid Prototyping of Application Specific Signal Processors, the State of Georgia’s Yamacraw Initiative, the United States Army’s Federated Sensors Laboratory Program, and the United States Air Force Electronics Parts Obsolescence Initiative. I have received an IBM Faculty Award and NSF’s Research Initiation Award. I have been awarded the 2006 Frederick Emmons Terman Medal by the American Society of Engineering Education for contributions to Electrical Engineering, including authoring a widely used textbook in the design of VLSI digital signal processors.

6. During the past 20 years at Georgia Tech, I have created and taught undergraduate and graduate courses in hardware and software design for signal processing, computer engineering (software and hardware systems), computer engineering and wireless communication circuits.

7. I have been involved in research and technology in the area of digital signal processing since the late 1980s, and I am the Editor-in-Chief of the CRC Press's 3-volume Digital Signal Processing Handbook (1998, 2010).

8. I have founded three companies in the areas of signal processing, embedded software, military chipsets involving imaging technology, and software for computing and communications systems. I have supervised Ph.D. dissertations of over twenty engineers in the areas of computer engineering, signal processing, communications, rapid prototyping, and system-level design methodology.

9. I have designed several specialized computer and communication systems over the past two decades at Georgia Tech for tasks such as wireless audio and video processing and protocol processing for portable platforms, such as cell phones and PDAs. I have designed systems that are efficient in view of performance, size, weight, area, and thermal considerations. I have developed courses and classes for industry on these topics, and many of my lectures in advanced computer system design, developed under the sponsorship of the United States Department of Defense in the late 1990s, are available for educational use at <http://www.eda.org/rassp> and have been used by several U.S. and international universities as part of their course work. Some of my recent publications in the area of design of computer engineering and wireless communications systems and associated protocols are listed in Exhibit 2005.

10. In the mid 2006-2007 timeframe, I collaborated with Professor John Scharf and his colleagues at Emory Healthcare system in developing FFT-based pulse oximetry system prototypes on FPGAs, which extended technologies developed by Prof. Scharf and his colleagues from the 1996 time frame (*See* T. Rusch, R. Sankar, J. Scharf, “Signal Processing Methods for Pulse Oximetry”, *Comput. Bio. Med.*, Vol. 26, No. 2, 1996). Some of my more recent publications in the area of biological signal processing and bioinformatics are listed in my CV and include, A. Bahga, V. Madiseti, “Healthcare Data Integration and Informatics in the Cloud”, *IEEE Computer*, Vol. 48, Issue 2, 2015, and “Cloud-Based Information Integration Informatics Framework for Healthcare Applications”, *IEEE Computer*, Issue 99, 2013. In addition to my signal processing experience specific to pulse oximetry, I also have experience in developing systems for other physiological signals. Beginning in the early 1990s, I worked, in particular, with ECG/EKG signals, and, in general, with biomedical signals and systems.

11. In addition to my signal processing experience specific to pulse oximetry, I also have experience in developing algorithms and systems for other physiological signals. I worked with ECG/EKG signals in particular, and biomedical signals and systems in general, beginning in the early 1990s. In particular, I worked with graduate student Dr. Shahram Famorzadeh, in 1990 and 1991, to analyze and apply pattern recognition (a category of signal processing

algorithms that is based on correlation with a set of templates) to ECG/EKG waveforms to identify physiological conditions.

12. I have experience with biomedical signals and devices in the field of speech and image processing since the late 1980s. I worked on deconvolution algorithms to recover the state of the system based on observed measurements of the physiological signals in the 1993-1998 time-frame. These signal processing techniques can be applied to pulse oximetry signals, and I have been working with these techniques since the mid-1980s.

13. I have studied, researched and published in the area of adaptive filter signal processing for noise reduction and signal prediction, using correlation-based approaches since the mid-1980s, both in the time-domain and frequency domain, and also to ray-tracing applications, such as Seismic Migration for oil and shale gas exploration. See for instance, V. Madiseti & D. Messerschmitt, Dynamically Reduced Complexity Implementation of Echo Cancellers, IEEE International Conference on Speech, Acoustics and Signal Processing, ICASSP 1986, Tokyo, Japan, and M. Romdhane and V. Madiseti, "All-Digital Oversampled Front-End Sensors" IEEE Signal Processing Letters, Vol 3, Issue 2, 1996, and "LMSGEN: A Prototyping Environment for Programmable Adaptive Digital Filters in VLSI", VLSI Signal processing, pp. 33-42, 1994.

14. Deconvolution of symmetric (seismic) and asymmetric (pulse oximetry) signals has gained much importance in the past two decades, and some of my early work on “Homomorphic Deconvolution of Bandpass Signals” in IEEE Transactions on Signal Processing, October 1997, established several new methods for deconvolution of such signals that had several advantages of robustness, increased accuracy, and simplicity.

15. In the past decade I have authored several peer-reviewed papers in the area of computer systems, instruments, and software design, and these include:

- V. Madiseti, et al., “The Georgia Tech Digital Signal Multiprocessor, IEEE Transactions on Signal Processing, Vol. 41, No. 7, July 1993.
- V. Madiseti et al., “Rapid Prototyping on the Georgia Tech Digital Signal Multiprocessor”, IEEE Transactions on Signal Processing, Vol. 42, March 1994.
- V. Madiseti, “Reengineering legacy embedded systems”, IEEE Design & Test of Computers, Vol. 16, Vol. 2, 1999.
- V. Madiseti et al., “Virtual Prototyping of Embedded Microcontroller-based DSP Systems”, IEEE Micro, Vol. 15, Issue 5, 1995.

- V. Madisetti, et al., “Incorporating Cost Modeling in Embedded-System Design”, IEEE Design & Test of Computers, Vol. 14, Issue 3, 1997.
- V. Madisetti, et al., “Conceptual Prototyping of Scalable Embedded DSP Systems”, IEEE Design & Test of Computers, Vol. 13, Issue 3, 1996.
- V. Madisetti, “Electronic System, Platform & Package Codesign,” IEEE Design & Test of Computers, Vol. 23, Issue 3, June 2006.
- V. Madisetti, et al., “A Dynamic Resource Management and Scheduling Environment for Embedded Multimedia and Communications Platforms”, IEEE Embedded Systems Letters, Vol. 3, Issue 1, 2011.

16. I have been active in the areas of signal processing systems and mobile device communication systems for several years, and some of my publications in this area include “Frequency Dependent Space-Interleaving of MIMO OFDM Systems” Proc. of IEEE Radio and Wireless Conference (RAWCON '03), 2003, “Embedded Alamouti Space Time Codes for High Rate and Low Decoding Complexity”, Proc. IEEE Asilomar Conf. on Signals, Systems, and Computers, 2008; and “Asymmetric Golden Codes for Fast Decoding in Time Varying Channels”, Wireless Personal Communications (2011).

II. MATERIALS CONSIDERED

17. Below is a listing of documents and materials that I considered and reviewed in connection with providing this declaration. In forming my opinions, I considered those materials as well as anything cited or discussed in this declaration.

Exhibit	Description
1001	U.S. Patent No. 10,709,366 (“’366 Patent”)
1002	File History for the ’366 Patent
1003	Declaration of Dr. Thomas W. Kenny
1004	Curriculum Vitae of Dr. Thomas W. Kenny
1006	U.S. Pub. No. 2002/0188210 (“Aizawa”)
1007	JP 2006-296564 (“Inokawa”)
1008	Certified English Translation of Inokawa and Translator’s Declaration
1009	U.S. Pat. No. 7,088,040 (“Ducharme”)
1010	U.S. Pat. No. 6,198,951 (“Kosuda”)
1014	U.S. Pub. No. 2001/0056243 (“Ohsaki”)
1015	“Design and Evaluation of a New Reflectance Pulse Oximeter Sensor,” Y. Mendelson et al., Medical Instrumentation, Vol. 22, No. 4, 1988; pp. 167-173 (“Mendelson 1988”)
1016	“A Wearable Reflectance Pulse Oximeter for Remote Physiological Monitoring,” Y. Mendelson et al.; Proceedings of the 28th IEEE EMBS Annual International Conference, 2006; pp. 912-915 (“Mendelson 2006”)
1017	“Noninvasive Pulse Oximetry Utilizing Skin Reflectance Photoplethysmography,” Y. Mendelson, et al.; IEEE Transactions on Biomedical Engineering, Vol. 35, No. 10, October 1988; pp. 798-805 (“Mendelson-IEEE-1988”)

Exhibit	Description
1018	“Acrylic: Strong, stiff, clear plastic available in a variety of brilliant colors,” available at https://www.curbellplastics.com/Research-Solutions/Materials/Acrylic
1019	U.S. Pat. No. 7,031,728 (“Beyer”)
1020	U.S. Pat. No. 7,092,735 (“Osann, Jr.”)
1021	U.S. Pat. No. 6,415,166 (“Van Hoy”)
1024	“Measurement Site and Photodetector Size Considerations in Optimizing Power Consumption of a Wearable Reflectance Pulse Oximeter,” Y. Mendelson, et al.; Proceedings of the 25th IEEE EMBS Annual International Conference, 2003; pp. 3016-3019 (“Mendelson 2003”)
1025	U.S. Pat. No. 6,801,799 (“Mendelson ’799”)
1027	U.S. Pub. No. 2007/0093786 (“Goldsmith”)
1029	Wikipedia: The Free Encyclopedia, “Universal asynchronous receiver-transmitter” at https://en.wikipedia.org/wiki/Universal_asynchronous_receiver-transmitter , last accessed 08/27/2020
1042	U.S. Pat. No. 7,230,227 (“Wilcken”)
1047	U.S. Pat. No. 4,941,236 (“Sherman”)
2006	Deposition Transcript of Dr. Thomas W. Kenny in <i>Apple Inc. v. Masimo Corp.</i> , IPR2020-01520, IPR2020-01537, IPR2020-01539 (April 22, 2021)
2007	Deposition Transcript of Dr. Thomas W. Kenny in <i>Apple Inc. v. Masimo Corp.</i> , IPR2020-01520, IPR2020-01537, IPR2020-01539 (April 23, 2021)
2010	Frank H. Netter, M.D., Section VI Upper Limb, Atlas of Human Anatomy (2003), Third Edition (“Netter”)
2019	Petition for <i>Inter Partes</i> Review IPR2020-01520
2020	Declaration of Dr. Thomas W. Kenny in <i>Apple Inc. v. Masimo Corp.</i> , IPR2020-01520

Exhibit	Description
2026	Deposition Transcript of Dr. Thomas W. Kenny in <i>Apple Inc. v. Masimo Corp.</i> , IPR2020-01716, IPR2020-01733, IPR2020-01737 (July 16, 2021)
Paper 2	Petition for <i>Inter Partes</i> Review IPR2020-01737
Paper 7	Decision Granting Institution of <i>Inter Partes</i> Review IPR2020-01737

III. UNDERSTANDING OF PATENT LAW

18. I am not an attorney and will not be offering legal conclusions. However, I have been informed of several principles concerning the legal issues relevant to analyzing the challenges to the claims of the '366 Patent, and I used these principles in arriving at my conclusions.

A. Level Of Ordinary Skill In The Art

19. I understand that certain issues in an IPR, such as claim construction and whether a claim is invalid as obvious, are assessed from the view of a hypothetical person of ordinary skill in the relevant art at the time of the invention. I understand there are multiple factors relevant to determining the level of ordinary skill in the art, including (1) the level of education and experience of persons working in the field at the time of the invention; (2) the sophistication of the technology; (3) the types of problems encountered in the field; and (4) the prior art solutions to those problems. I understand that this hypothetical person of

ordinary skill is presumed to have had knowledge from the teachings of the prior art.

20. I understand that Apple Inc. (“Apple” or “Petitioner”) and its Declarant Dr. Kenny have set forth the following definition for a person of ordinary skill in the art (“POSITA”): “someone with a working knowledge of physiological monitoring technologies. The person would have had a Bachelor of Science degree in an academic discipline emphasizing the design of electrical, computer, or software technologies, in combination with training or at least one to two years of related work experience with capture and processing of data or information, including but not limited to physiological monitoring technologies. Alternatively, the person could have also had a Master of Science degree in a relevant academic discipline with less than a year of related work experience in the same discipline.” Ex. 1003 ¶21. I discuss the asserted level of skill further below, in Section VI of this declaration.

B. Claim Construction

21. I understand that claim construction in an IPR is a legal question for the Board to decide. I also understand, however, that in construing claim terms, the Board asks what the terms would mean to a person of ordinary skill in the relevant art in view of the disclosures in the patent and the prosecution history of the patent. I understand that the Board may also consider external evidence, such

as dictionaries. In general, however, I understand that claim terms are given the ordinary and customary meaning one of ordinary skill in the relevant art would apply to them in the context of the patent at the time the patent was filed.

22. I understand that Apple did not identify any terms for construction. I have given the claim terms their plain and ordinary meaning in my analysis.

C. Obviousness

23. I understand that a patent claim is invalid under the patent law, 35 U.S.C. § 103, if, at the time the claimed invention was made, the differences between the prior art and the claimed invention as a whole would have been obvious to a person of ordinary skill in the art. I understand that the following facts are considered in determining whether a claimed invention is invalid as obvious in view of the prior art: (1) the scope and content of the prior art; (2) the level of ordinary skill in the art; and (3) the differences, if any, between the claimed invention and the prior art.

24. I also understand there are additional considerations that may be used in evaluating whether a claimed invention is obvious. These include whether the claimed invention was the result of (a) a teaching, suggestion, or motivation in the prior art that would have led one of ordinary skill to modify the prior art to arrive at the claimed invention; (b) a combination of prior art elements combined according to known methods to yield predictable results; (c) a simple substitution

of one known element for another to obtain a predictable result; (d) the use of a known technique to improve similar things in the same way; (e) applying a known technique to a known thing ready for improvement to yield predictable results; (f) choosing from a finite number of identified, predictable solutions, with a reasonable expectation of success; (g) known work in one field of endeavor prompting variations of it for use in either the same field or a different one based on design incentives or other market forces if the variations are predictable to one of ordinary skill in the art.

25. I have applied this understanding in my analysis.

26. I understand that Dr. Kenny carried out his analysis of patentability as of July 3, 2008. Ex. 1003 ¶¶16, 23. I likewise carry out my analysis of patentability as of July 3, 2008. I do not offer any opinions regarding priority in this declaration.

IV. INTRODUCTION TO MASIMO'S '366 PATENT

A. The '366 Patent

27. Masimo's U.S. Patent No. 10,709,366 ("366 Patent") is generally directed to optical physiological parameter measurement devices that use a combination of different design elements and improve optical detection efficiency. Masimo's claims are directed, in part, to physiological parameter measurement devices with multiple photodiodes, multiple data streams, and a protrusion that

together dramatically enhance the effectiveness of the physiological sensor device. These different pieces work together. For example, the protrusion can thin out the measurement site, which results in less light attenuation by the measured tissue. Ex. 1001 7:48-51. The protruding surface can also increase the area from which attenuated light can be measured. Ex. 1001 7:51-53. The multiple detectors allow for measurement averaging, which can reduce errors due to variations in the path of the light passing through the tissue. Ex. 1001 9:7-16; *see also* 3:1-9, 4:16-27. The '366 Patent explains that using multiple detectors and multiple data streams will improve the signal-to-noise ratio. Ex. 1001 34:21-24. These different components work together and provide greater noise cancellation and an order of magnitude increase in signal strength. Ex. 1001 9:7-16, 20:14-30; *see also* 2:62-3:24, 4:16-27.

B. Introduction To The Independent Claims Of The '366 Patent

28. The '366 Patent has three independent claims: claims 1, 14, and 27.

Claim 1 generally illustrates the claimed features. Claim 1 reads as follows:

1. A noninvasive physiological parameter measurement device adapted to be worn by a wearer, the noninvasive physiological parameter measurement device comprising:

one or more light emitters;

a substrate having a surface;

a first set of photodiodes arranged on the surface and spaced apart from each other, wherein:

the first set of photodiodes comprises at least four photodiodes,
and

the photodiodes of the first set of photodiodes are connected to one another in parallel to provide a first signal stream responsive to light from at least one of the one or more light emitters attenuated by body tissue;

a second set of photodiodes arranged on the surface and spaced apart from each other, wherein:

the second set of photodiodes comprises at least four photodiodes,

the photodiodes of the second set of photodiodes are connected to one another in parallel to provide a second signal stream responsive to light from at least one of the one or more light emitters attenuated by body tissue, and

at least one of the first signal stream or the second signal stream includes information usable to determine a physiological parameter of a wearer of the noninvasive physiological parameter measurement device;

a wall extending from the surface and configured to surround at least the first and second sets of photodiodes; and

a cover arranged to cover at least a portion of the surface of the substrate, wherein the cover comprises a protrusion that extends over all of the photodiodes of the first and second sets of photodiodes arranged on the surface, and wherein the cover is further configured to cover the wall.

V. THE PETITIONER'S PROPOSED COMBINATIONS

29. Petitioner presents two grounds. Ground 1 combines Aizawa (Ex. 1006), Ohsaki (Ex. 1014), Mendelson 2003 (Ex. 1024), and Goldsmith (Ex. 1027). Pet. 1-2. Ground 1 challenges claims 1-12 and 14-27. Ground 2 is a combination of five references that challenges dependent claim 13. Ground 2 adds Sherman (Ex. 1047) to the combination of Aizawa, Ohsaki, Mendelson 2003, and Goldsmith. Pet. 1-2.

VI. LEVEL OF ORDINARY SKILL IN THE ART

30. Petitioner asserts that a POSITA “would have been a person with a working knowledge of physiological monitoring technologies. The person would have had a Bachelor of Science degree in an academic discipline emphasizing the design of electrical, computer, or software technologies, in combination with training or at least one to two years of related work experience with capture and

processing of data or information, including but not limited to physiological monitoring technologies.” Pet. 3. Alternatively, Petitioner asserts a POSITA could have “a Master of Science degree in a relevant academic discipline with less than a year of related work experience in the same discipline.” Pet. 3.

31. Dr. Kenny states that he applies a similar level of skill in his analysis stating that “one of ordinary skill in the art relating to, and at the time of, the invention of the ’366 patent would have been someone with a working knowledge of physiological monitoring technologies. The person would have had a Bachelor of Science degree in an academic discipline emphasizing the design of electrical, computer, or software technologies, in combination with training or at least one to two years of related work experience with capture and processing of data or information, including but not limited to physiological monitoring technologies. Alternatively, the person could have also had a Master of Science degree in a relevant academic discipline with less than a year of related work experience in the same discipline.” Ex. 1003 ¶21.

32. I note that the asserted level of skill (1) requires no coursework, training or experience with optics or optical physiological monitors; (2) requires no coursework, training or experience in physiology; and (3) focuses on data processing and not sensor design. In responding to Dr. Kenny’s opinions in this proceeding, I apply Dr. Kenny’s and Petitioner’s asserted level of skill.

33. In addition, as noted above, I understand that Dr. Kenny carried out his analysis of patentability as of July 3, 2008. Ex. 1003 ¶¶16, 23. In responding to Dr. Kenny’s opinions, I also apply the July 3, 2008 date in my analysis. I do not offer any opinions regarding priority in this declaration.

VII. GROUNDS 1-2 DO NOT ESTABLISH OBVIOUSNESS

A. Introduction To Ground 1

34. Dr. Kenny’s combination for Ground 1 combines four references: Ohsaki, Aizawa, Mendelson 2003, and Goldsmith. Ex. 1003 ¶¶66-210.

1. Ohsaki Discloses A Pulse Rate Sensor With A Single Emitter And A Single Detector That Must Be Arranged Linearly On The Back Side Of The Wrist

35. Ohsaki is directed to a pulse rate sensor with a single emitter (*e.g.*, an LED) and a single detector that are positioned linearly, side-by-side, under a translucent “board.” *See, e.g.*, Ex. 1014 Abstract, Fig. 2, ¶[0019]. Ohsaki explains that the linearly arranged detector and emitter (shown in the figures below) likewise results in a longitudinal rectangular shape and directionality, which Ohsaki explains is important for its benefit of reducing slipping when placed against the backhand side of the wrist. *See* Ex. 1014 ¶[0019] (If longitudinal direction “agrees with the circumferential direction of the user’s wrist 4, it has a tendency to slip off. Therefore it is desirable that the detecting element 2 is arranged so that its longitudinal direction agrees with the longitudinal direction of the user’s arm.”). Ohsaki includes a “dedicated belt” 10 that “fix[es]

the detecting element 2 on the user's wrist 4 in this way"—in a longitudinal direction up-and-down the user's wrist. Ex. 1014 ¶[0019]. Ohsaki consistently states that its sensor “is worn on the back side of a user's wrist corresponding to the back of the user's hand.” Ex. 1014 Abstract; *see also id.* Title, ¶¶ [0008], [0009], [0016], [0024]. Figure 1 of Ohsaki (below left) is a cross section of the device when “worn on the back side of the user's wrist 4 corresponding to the back of the user's hand in the similar manner as a wristwatch is normally worn.” Ex. 1014 ¶[0016], Fig. 1.

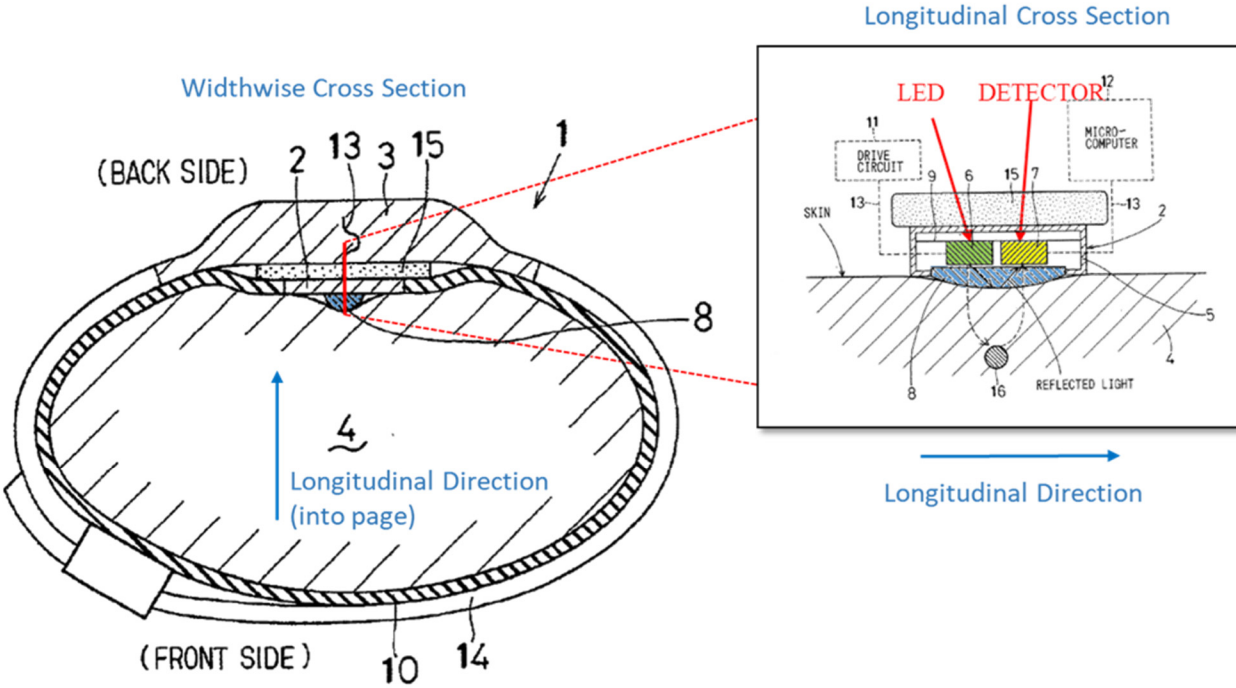

Ohsaki Fig. 1 (left), showing the cross-sectional view of Ohsaki's sensor in the circumferential direction (across the wrist) and Fig. 2 (right) showing the cross-sectional view of Ohsaki's sensor in the longitudinal direction (up-and-down arm)

2. The Shape Of Ohsaki's Board

36. Ohsaki shows two cross-sectional views of its board that a POSITA would have considered together to confirm that the board is rectangular. Ohsaki Figure 2 (below left) illustrates the “long” side of Ohsaki’s detector element (2) that extends from left to right in Ohsaki’s Figure 2, and is shown in the cross section as positioned in the longitudinal direction (up-and-down the arm) on a user’s wrist. Ex. 1014 ¶[0019].

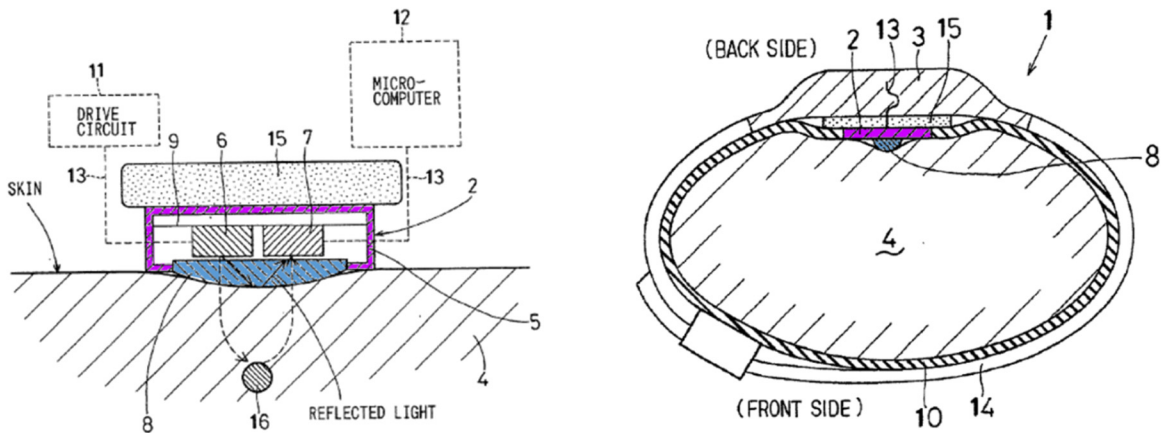

Ohsaki (Ex. 1014) Fig. 2 (left, showing long direction of the detecting element (2), pointing up-and-down the arm) & Fig. 1 (right, showing short direction of the detecting element (2), in the circumferential direction of the wrist) depict different cross-sections (color added)

(Purple: detecting element (2)/package (5); Blue: translucent board (8))

37. Figure 2 (shown above left) illustrates that Ohsaki’s board (8, in blue) is nearly as long as the entire length of the package (5, in purple) in the direction of detecting element’s (2) “long” side. Ohsaki explains that its “detecting element” includes the “package 5, a light emitting element 6 (e.g., LED), a light

receiving element 7 (e.g., PD), and a translucent board 8.” Ex. 1014 ¶[0017]. Figure 1 (shown above right) illustrates the “short” side of Ohsaki’s detecting element (2), which extends from left to right on the page in Figure 1 and shows the cross-section in the circumferential direction of the sensor on (around) the user’s wrist. Ex. 1014 ¶¶[0012], [0019]. As shown in Ohsaki’s Figure 1 (shown above right), the board’s length (8, blue) is narrower (approximately one third the size) than the detecting element’s length (2, purple) in the circumferential direction.

38. Ohsaki’s figures and description would have thus indicated to a POSITA that the board (8) has a long rectangular shape with a pronounced longitudinal directionality, and thus is much longer than it is wide. Ex. 1014 ¶¶[0012], [0017], [0019], Figs. 1, 2. Based on Ohsaki’s disclosure, a POSITA would have understood that the top-down view of Ohsaki’s sensor’s “detecting element”, including the package, board, and emitter and detector, would look approximately like the figure below:

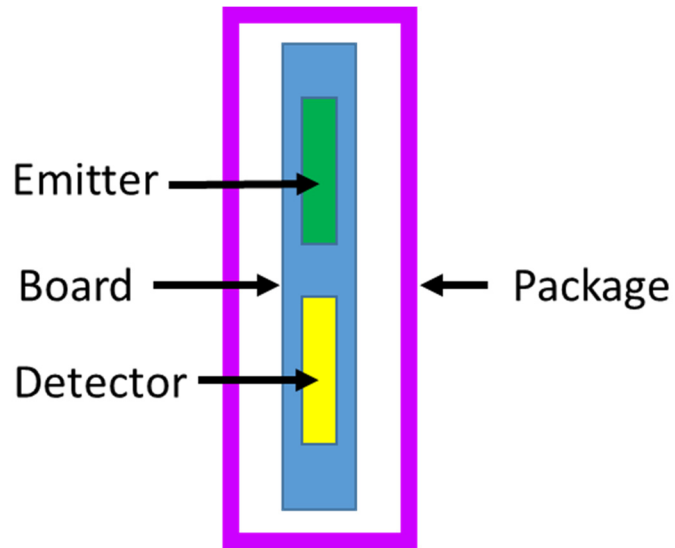

Drawing based on Ohsaki's disclosure, including Figs. 1 and 2 (Ex. 1014), illustrating the rectangular shape of Ohsaki's board and package/detecting element. The long direction of Ohsaki's sensor aligns with the longitudinal direction of the arm. Ex. 1014 ¶[0019].

39. This rectangular shape reflects the rest of Ohsaki's disclosure, which indicates that the sensor has a longitudinal direction, and that to prevent slipping the longitudinal (long) aspect of the sensor's shape must be aligned with the longitudinal direction (long direction) of the user's arm. Ex. 1014 ¶[0019]. Thus, a POSITA reading Ohsaki would have appreciated that Ohsaki discloses a long, rectangular shape for its sensor, as well as the board (8).

3. Aizawa Discloses A Circular Pulse Sensor

40. Aizawa discloses a sensor with four periphery-located photodetectors (22) around a single centrally located LED (21). Ex. 1006 Abstract, Fig. 1B.

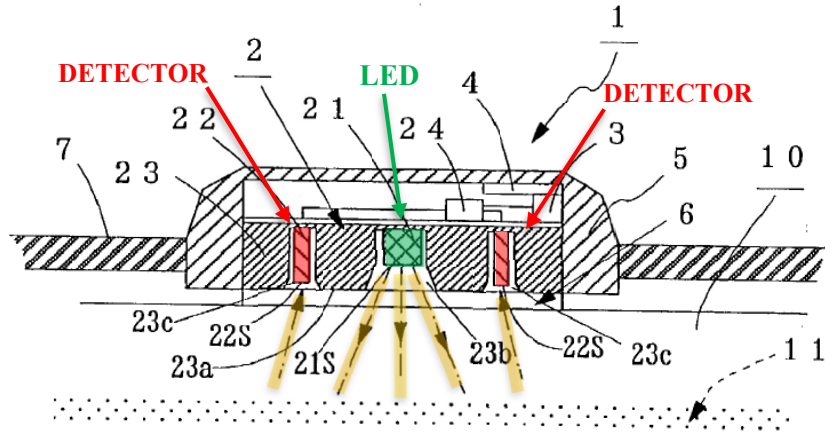

Aizawa Fig. 1B (cross-sectional view, color added)

FIG. 1 (a)

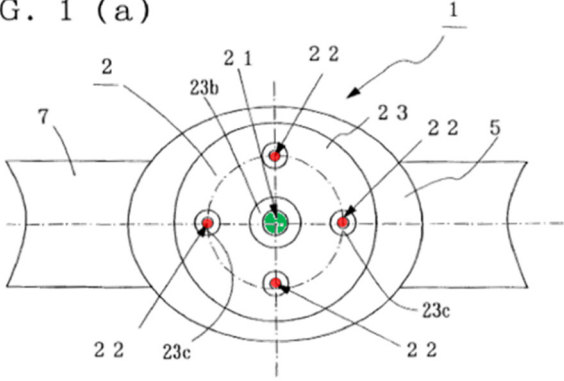

- | <u>Aizawa's Features</u> | |
|--------------------------|---------------------------------------|
| • | Green: central LED (21) |
| • | Red: peripheral detectors (22) |

Aizawa Fig. 1A (top-down view, color added)

41. Aizawa's sensor is constructed with multiple detectors which are arrayed around a single LED. Aizawa uses this configuration in order to ensure at least one detector is near the measurement site, which improves measurement consistency. Ex. 1006 ¶[0027]. Aizawa specifies that its sensor takes measurements "on the inner side of [the] wrist." Ex. 1006 ¶[0026]. As shown in Figure 2 of Aizawa, the "inner side" of the wrist is the palm side of the wrist. Ex. 1006 Fig. 2. Aizawa explains that its sensor "is fastened such that the acrylic

transparent plate 6 becomes close to the artery 11 of the wrist 10.” Ex. 1006 ¶[0026]. Aizawa explains that its circular arrangement is used because as long as “one of the photodetectors 22 is located near the artery 11,” it is “possible to detect a pulse wave accurately.” Ex. 1006 ¶¶[0026]-[0027], Fig. 2. Aizawa includes a flat transparent plate (6), which Aizawa indicates improves adhesion between the detector and the wrist. Ex. 1006 ¶[0030]. Aizawa states that its flat adhesive acrylic plate improves the detection efficiency of a pulse wave. Ex. 1006 ¶[0030]. Aizawa does not indicate that its sensor uses a lens.

4. Ground 1’s Motivation To Add Ohsaki And Aizawa To The Proposed Combination

42. Ground 1 is a four-reference combination with Ohsaki, Aizawa, Mendelson 2003, and Goldsmith. For the combination of Ohsaki and Aizawa (as modified by Mendelson 2003), Dr. Kenny asserts that a POSITA would have added Ohsaki’s translucent board, designed for a linear sensor, to Aizawa’s circular sensor. Ex. 1003 ¶79. Dr. Kenny identifies the following motivations: “a POSITA would have found it obvious to modify the sensor’s flat cover ([below] left) to include a lens/protrusion ([below] right), similar to Ohsaki’s translucent board 8, so as to improve adhesion between the user’s wrist and the sensor’s surface, improve detection efficiency, and protect the elements within the sensor housing.” Ex. 1003 ¶79. Dr. Kenny’s illustration of the result of the combination of Ohsaki, Aizawa, and Mendelson 2003 is shown below (although

the below figure includes two LEDs, in other places Dr. Kenny’s proposed structure only includes a single LED).

FIG. 1 (b)

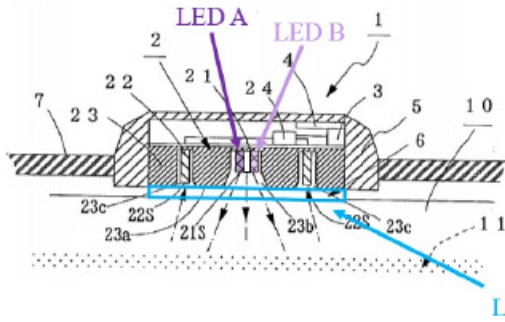
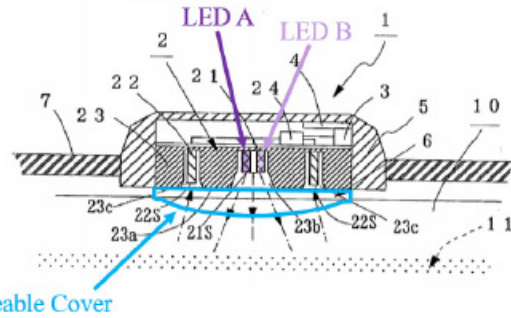

FIG. 1 (b)



Dr. Kenny’s illustration showing the alleged result of the combination of Ohsaki, Aizawa, and Mendelson 2003 (Ex. 1003 ¶79)

43. Dr. Kenny does not explain whether the modification of Aizawa to introduce a “lens/protrusion...similar to Ohsaki’s translucent board” (Ex. 1003 ¶79) means that Ohsaki’s longitudinal board is simply placed over Aizawa, or whether it is changed to be circular to match Aizawa’s shape and detector arrangement.

44. In addition, Dr. Kenny cites another reference, Inokawa (Ex. 1007, translation at Ex. 1008) as providing a “further rationale for a POSITA to modify Aizawa to include a cover comprising a protruding convex surface.” Ex. 1003 ¶81. Unlike Aizawa, however, Inokawa uses a convex lens (27) that focuses light from periphery LEDs to a single detector (25) in the center. Ex. 1008 ¶[0058], Fig. 2. Inokawa’s arrangement is shown below:

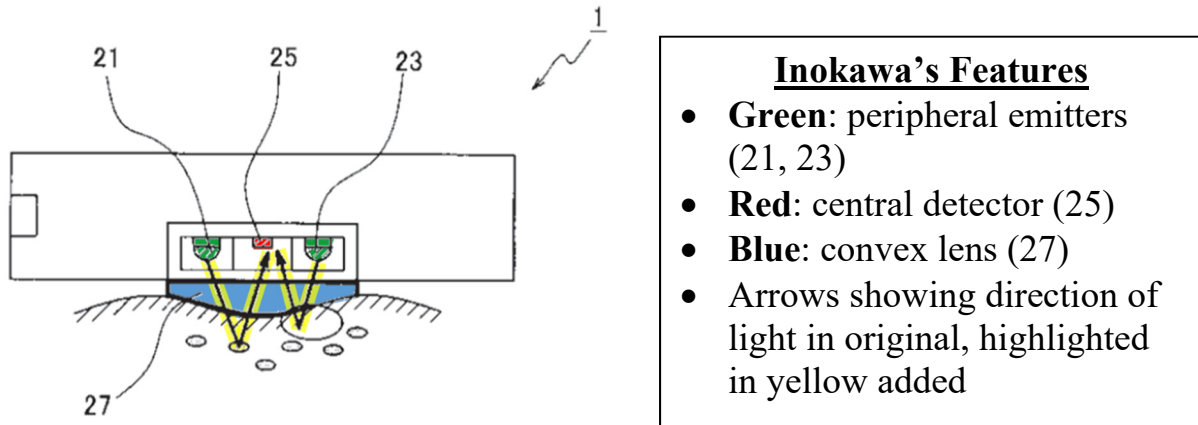

Inokawa Fig. 2 (color added)

45. As shown in the figure above, Inokawa illustrates light reflecting off the body and passing through the lens, and directed to a centrally located detector. Ex. 1008 ¶[0058]. Thus, Inokawa's convex lens focuses incoming light away from the periphery and towards the sensor's center, where the detector is located. See Ex. 1008 ¶[0015] ("This lens makes it possible to increase the light-gathering ability of the LED as well as to protect the LED or PD."). Despite the different emitter/detector positioning in Inokawa's sensor as compared to Aizawa's sensor, Dr. Kenny asserts that "POSITA would have understood that adding a protruded convex surface to Aizawa would have the additional benefit of increasing light collection efficiency, which would in turn lead to an improved signal-to-noise ratio and more reliable pulse detection." Ex. 1003 ¶82. Dr. Kenny states: "The lens of Inokawa provides precisely such an additional benefit to Aizawa's device

by refracting/concentrating incoming light signals reflected by the blood.” Ex. 1003 ¶82.

5. Dr. Kenny’s Proposed Addition Of Mendelson 2003 to Ground 1

46. The claims require a first set of at least four photodiodes that are connected to one another in parallel to provide a first signal stream, and a second set of at least four photodiodes that are connected to one another in parallel to provide a second signal stream. *See, e.g.*, Ex. 1001 claims 1, 14, 27. Dr. Kenny proposes adding a third reference, Mendelson 2003 (Ex. 1024), to the proposed combination. Mendelson 2003 is a test system that was used to study the relative impact of widening the overall active area of a photodetector. Ex. 1024 at 2. Mendelson 2003 uses a detector configuration with two rings of detectors, with each ring individually connected in parallel, to compare the signal difference for different sets of photodiodes. Ex. 1024 at 2. Mendelson 2003 explains that the detected light intensity decreases as the distance from the central LEDs increases. Ex. 1024 at 4. Mendelson 2003 recommends combining all photodetectors together into a single signal “to simulate a single large PD area.” Ex. 1024 at 4. Mendelson 2003’s conclusion from its experiments is that a sensor should use a single large photodetector. *See* Ex. 1024 at 4 (“[E]xperiments revealed that battery longevity could be extended considerably by employing a wide annular PD and limiting SpO₂ measurement to the forehead region.”).

47. Aizawa does not use detectors that are connected in parallel or positioned in multiple rings around an emitter. Instead, Aizawa repeatedly discusses the benefits of a single symmetrical ring of detectors that should not be connected in parallel. Ex. 1006 ¶¶[0009], [0023], [0027], [0029], [0032], [0036]. Aizawa explains that monitoring individual detectors disposed on a concentric circle ensures that “one of the photodetectors 22 is located near the artery 11” for measurements, thereby allowing detection even after sensor displacement. Ex. 1006 ¶[0027], [0032]. Aizawa does not use multiple rings of detectors connected in parallel. Instead, as illustrated below, Aizawa indicates that additional detectors should be added to the same circle, which preserves the system’s symmetry. Ex. 1006 Figs. 1A, 4A, 4B.

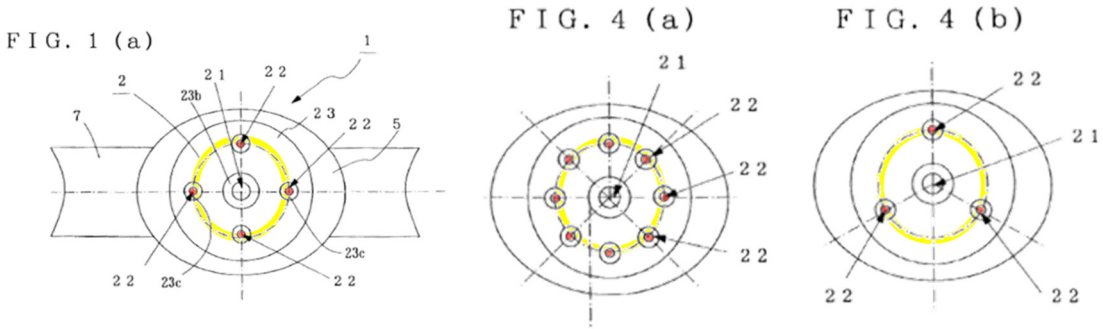

Aizawa’s Detector Arrangements (Ex. 1006, detectors highlighted in red, Aizawa’s single concentric circle highlighted in yellow)

48. Dr. Kenny asserts that another ring of detectors “would in turn allow Aizawa’s wrist-based device to have a longer battery life.” Ex. 1003 ¶72. Dr. Kenny’s proposed combination (Ex. 1003 ¶73) includes eight detectors, with an

added outer ring of detectors near the periphery of the device and farther from the emitter as compared to Aizawa’s original design:

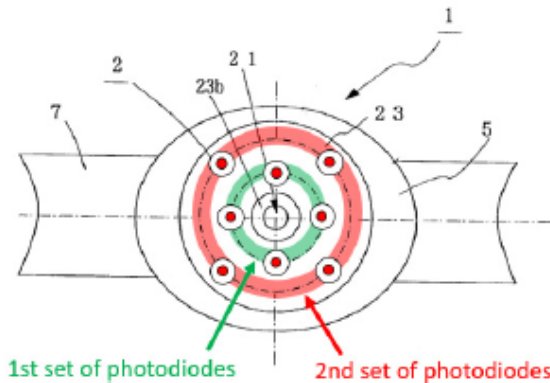

Dr. Kenny’s illustration of his combination (Ex. 1003 ¶73)

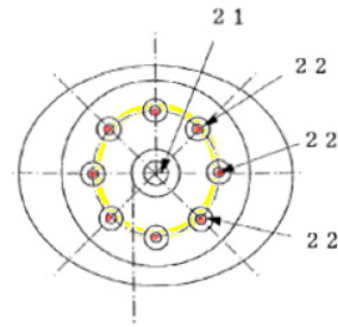

Aizawa’s illustrated detector arrangement (Ex. 1006 Fig. 4A)

49. In contrast to Dr. Kenny’s dual-ring structure, Aizawa’s disclosed 8-detector structure (above right) is symmetrical, with all detectors the same distance from the central LED. Ex. 1006 Fig. 4A. Aizawa also states its 8-detector structure “improve[s] detection efficiency.” Ex. 1006 ¶[0032]. Thus, Dr. Kenny’s proposed combination (1) eliminates Aizawa’s symmetry, (2) discards Aizawa’s existing 8-detector embodiment, and (3) adds detectors farther from the central emitter at a location that receives relatively less light than Aizawa’s existing 8-detector embodiment.

6. Dr. Kenny’s Further Addition of Goldsmith to Ground 1

50. Dr. Kenny adds a fourth reference, Goldsmith (Ex. 1027), to the proposed combination. Ex. 1003 ¶¶85-93. Dr. Kenny asserts a “POSITA would have found it obvious to incorporate Aizawa’s wrist-worn pulse wave sensor with

(i) two rings of photodiodes each connected in parallel (as per Mendelson-2003) and (ii) a protruding convex surface (as per Ohsaki) into Goldsmith's integrated wrist-worn watch controller device that includes, among its various features, a touch screen, network interface, and storage device." Ex. 1003 ¶¶88. Dr. Kenny does not state that Goldsmith cures the deficiencies in the proposed combination of Aizawa, Ohsaki, and Mendelson 2003.

B. A POSITA Would Not Have Been Motivated To Combine Ohsaki's Board With Aizawa's Sensor

51. Dr. Kenny asserts that a POSITA would have modified Aizawa's flat adhesive acrylic plate "to include a lens/protrusion...similar to Ohsaki's translucent board 8, so as to improve adhesion between the user's wrist and the sensor's surface, improve detection efficiency, and protect the elements within the sensor housing." Ex. 1003 ¶¶79; *see also* ¶¶76. As discussed in detail below, Dr. Kenny does not establish that any of these three motivations are present in the cited art, or that they would have motivated a POSITA to create Masimo's invention.

52. As I discuss below, a POSITA would have understood that Ohsaki's rectangular board would be incompatible with Aizawa's circular sensor arrangement, which undermines any motivation to improve adhesion of Aizawa's circular sensor to the user's tissue by adding a lens/protrusion similar to Ohsaki's rectangular board. Second, a POSITA would have understood that to obtain a

benefit from Ohsaki's rectangular board, the sensor must be position on the backhand side of the wrist, which is far from the radial and ulnar arteries that are found on the palm side of the wrist, where Aizawa's sensor takes its pulse measurements. Finally, a POSITA would have believed that adding a convex-shaped cover to Aizawa's sensor would have a detrimental optical impact by directing light away from Aizawa's peripherally located detectors, resulting in reduced signal strength and decreased detection efficiency. Further a POSTIA would not have selected a convex shape for protecting Aizawa's sensor components because of the complications and problems associated with adding a convex surface to Aizawa's flat plate.

1. **A POSITA Would Have Understood That Ohsaki's Rectangular Board Would Not Work With Aizawa's Circular Sensor Arrangement**
 - a) **Modifying Ohsaki's Rectangular Board Would Eliminate The Limited Advantage Of Reduced Slipping Taught By Ohsaki**

53. Dr. Kenny's combination changes Ohsaki's structure and eliminates the longitudinal shape that gives Ohsaki's rectangular board the ability to fit within the user's anatomy and prevent slipping. Ex. 1003 ¶79; Ex. 1014 ¶[0019]. Dr. Kenny's illustrated combination changes Ohsaki's rectangular board (discussed in Sections VII.A.1-2, above) and makes it circular so that it can cover Aizawa's holder 23 (which Dr. Kenny outlined in purple in the figure below):

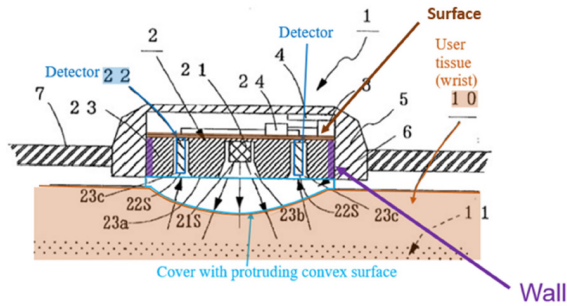

Dr. Kenny’s illustration of the combination of Ohsaki, Aizawa, Mendelson 2003, and Goldsmith (Ex. 1003 ¶114)

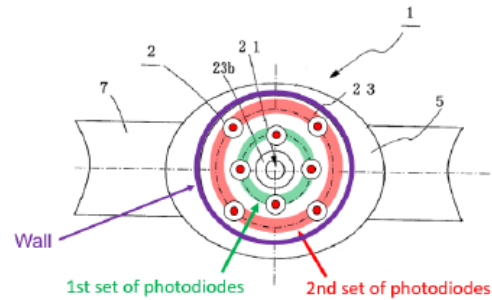

Dr. Kenny’s illustration of Aizawa’s modified circular sensor (Ex. 1003 ¶112)

54. Dr. Kenny asserts that a POSITA would have been motivated to add Ohsaki’s rectangular board to Aizawa’s circular sensor to improve adhesion. Ex. 1003 ¶79; *see also, e.g.*, ¶¶76, 80. As an initial point, Ohsaki does not specifically discuss improving adhesion, and instead refers to a particular configuration that prevents slipping and various other configurations that have a tendency to slip. Ex. 1014 ¶¶[0006], [0010], [0019], [0023], [0025]. Dr. Kenny equates Ohsaki’s disclosure of a convex surface that prevents slippage with “improv[ing] adhesion.” Ex. 1003 ¶79 (citing Ex. 1014 ¶[0025]). But Dr. Kenny’s proposed modification eliminates the longitudinal shape that Ohsaki identifies as an important part of reducing slipping. Ex. 1014 ¶[0019].

55. Ohsaki places its linear, longitudinal sensor on the backhand side of a user’s wrist to avoid interacting with bones in the wrist. *See* Ex. 1014 ¶¶[0006] (discussing need to avoid pressing on “two bones (the radius and the ulna)”), [0024] (“the radius and the ulna inside the user’s wrist 4 are not pressed”); *see*

also, e.g., ¶¶[0023]-[0024], Abstract, Title, Fig. 1 (Ohsaki device worn on back side of wrist). As illustrated below (left), the forearm bones (the radius and ulna) on the arm’s backhand (or watch) side create a longitudinal opening at the junction between the wrist and forearm with no muscle insertions. Ex. 2010 at 49 (Plate 434). The radius and ulna, against which Ohsaki warns against pressing (Ex. 1014 ¶¶[0006], [0024]), are on either side of this longitudinal opening.

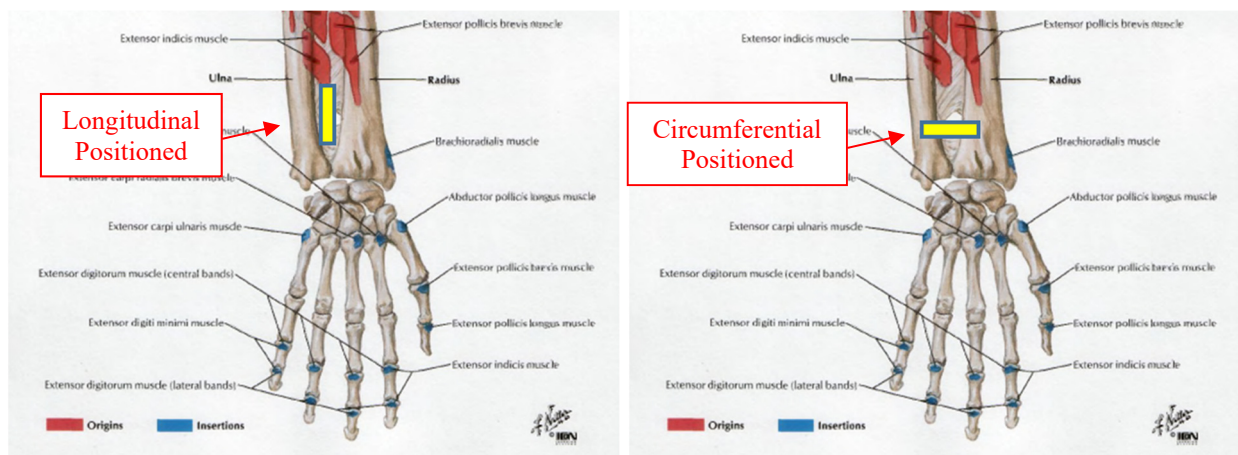

Anatomical drawing of the back side (posterior) of the hand, wrist, and forearm (partial view from Ex. 2010 at 49 (Plate 434))

Left: Conceptual view of how a rectangular sensor that is positioned in longitudinal direction on the wrist/forearm can avoid the radius and ulna

Right: Conceptual view of how the same rectangular sensor placed in the circumferential direction on wrist/forearm interacts with the radius and ulna

56. Ohsaki indicates that its sensor’s longitudinal direction needs to be aligned with the longitudinal direction of the longitudinal opening of the user’s arm to prevent slipping. Ex. 1014 ¶¶[0019]. If the sensor’s longitudinal direction is aligned with the circumferential direction of the user’s wrist, the undesirable result is “a tendency [for Ohsaki’s sensor] to slip off.” Ex. 1014 ¶¶[0019]. As

illustrated above (right), a rectangular structure like Ohsaki's sensor and board that is aligned with the circumferential direction of the user's wrist undesirably interacts with the radius and ulna, which Ohsaki warns against. Ex. 1014 ¶¶[0006], [0024]. In contrast, a rectangular structure aligned with the longitudinal direction of the user's wrist can avoid pressing against the radius and ulna.

57. Thus, a POSITA would have understood that changing the shape of Ohsaki's rectangular board to circular would not preserve its ability to prevent slipping. Instead, if Ohsaki's rectangular board were changed into a circular shape, a POSITA would have believed it would have resulted in slipping, and thus eliminated the advantage of Ohsaki's board. This is because a circular shape extends equally in all directions, including in the circumferential direction of the user's wrist, which Ohsaki explains results in slipping. Ex. 1014 ¶[0019]. As a result, a circular shape cannot be placed in a longitudinal direction and thus cannot align with the longitudinal direction of the user's wrist, as taught by Ohsaki. As illustrated below, unlike a longitudinal sensor, a symmetrical circular shape (with a diameter equal to the long side of the rectangle, below left) would not fit within the user's anatomy in a way that it could avoid undesirably pressing against the user's radius and ulna, which Ohsaki cautioned against.

Ohsaki's Longitudinal Teachings

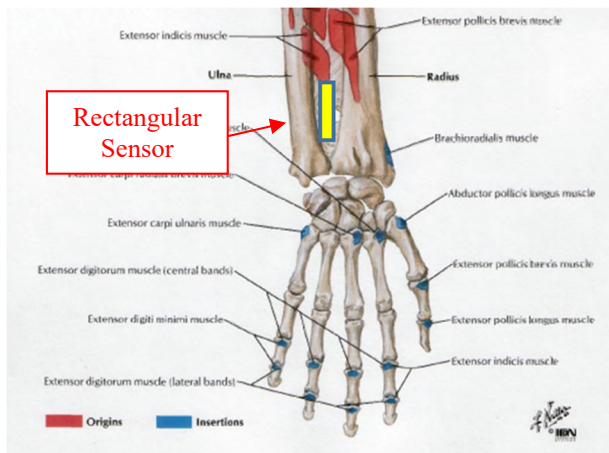

Dr. Kenny's Proposed Combination

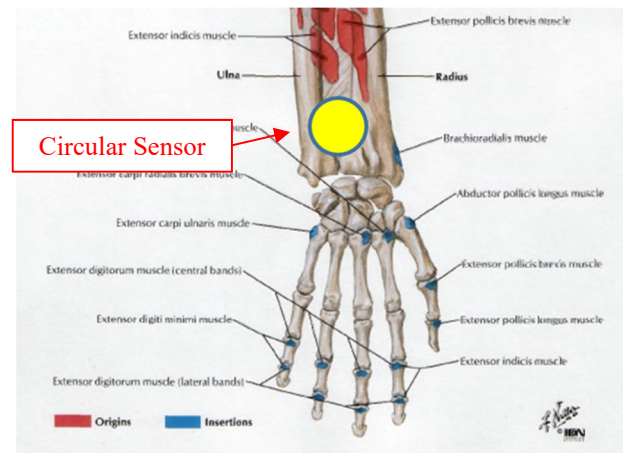

Anatomical drawing of the back side (posterior) of the hand, wrist, and forearm (partial view from Ex. 2010 at 49 (Plate 434))

Left: Conceptual view of how a rectangular sensor that is positioned in longitudinal direction on the wrist/forearm can avoid the radius and ulna

Right: Conceptual view of how a circular sensor with the same diameter as the length of the rectangular board interacts with the radius and ulna

58. Because a symmetrical circular shape will press on the user's arm in all directions, it will interact with the user's bone structure. Ohsaki teaches that such interactions with the user's anatomy are undesirable and result in slipping. Ex. 1014 ¶¶[0006], [0023]-[0024].

59. Dr. Kenny did not discuss Ohsaki's disclosure that when Ohsaki's rectangular sensor was placed in one orientation (up-and-down the arm), it helped prevent slipping. Ex. 1014 ¶[0019]. Dr. Kenny also did not discuss Ohsaki's explanation that rotating the sensor 90 degrees, such that the long direction points in the circumferential direction of the user's wrist, the sensor "has a tendency to slip." Ex. 1014 ¶[0019]; see Ex. 1003 ¶¶58-59, 76-84.

60. In my opinion, a POSITA would have understood that Ohsaki does not include a generalized teaching that any convex surface would prevent slipping. Ohsaki's explanation that rotating a sensor positioned on the back of the wrist 90 degrees results in "a tendency to slip off," would have confirmed for a POSITA that any benefit for reduced slipping stemming from Ohsaki's convex rectangular board was very specific and limited. Ex. 1014 ¶[0019]. A POSITA would have further understood that Ohsaki's use of a "dedicated belt" to keep the long side of the rectangular detecting element pointing up and down the arm indicated that this particular positioning was important. Ex. 1014 ¶[0019]. Further confirming the limited nature of any benefits taught in Ohsaki, Ohsaki teaches its convex board placed on the palm side (front side) of the wrist "has a tendency to slip off the detecting position" and does not prevent slipping. Ex. 1014 ¶¶[0023]-[0024], Figs. 3A-3B. While Ohsaki explains a particular sensor orientation can prevent slipping on the back of the wrist, Ex. 1014 ¶[0019], it does not indicate that a different orientation would help prevent slipping on the palm side of the wrist. In addition, Ohsaki repeatedly emphasizes that its sensor must be placed on the backhand side of the wrist: Ohsaki explains its "pulse wave sensor is worn on the back side of the user's wrist" and its "detecting element is attached on the back side of the user's wrist..." Ex. 1014 ¶¶[0008]-[0009]; *see also, e.g.*, Title,

Abstract, ¶¶[0016], [0024]; *see also* ¶[0030] (single sentence identifying back side of user's forearm, which is connected to the wrist).

61. As a result, a POSITA would not have been motivated to eliminate the longitudinal shape that Ohsaki asserts helps prevent slipping. Ex. 1014 ¶[0019]. Indeed, Ohsaki underscores the unsuitability of the proposed combination, explaining that many sensor positions and orientations are ineffective. Ex. 1014 ¶¶[0019], [0023]-[0024]. Beyond the illustrated longitudinal shape (Ex. 1014 ¶[0019], Figs. 1-2) Ohsaki has no details or explanation that a POSITA could use to implement its board into other devices, other shapes, or other measurement locations. Ohsaki indicates that only one shape (rectangular), one position (back side of the wrist, discussed further below), and one orientation (up-and-down the arm) prevent slipping. Ex. 1014 ¶¶[0019], [0023]-[0025]. Ohsaki emphasizes that its benefit occurs only when the sensor has a longitudinal shape and is on the wrist's back side, in the anatomically appropriate orientation. Ex. 1014 ¶¶[0019], [0023]-[0024].

62. A POSITA would not have been motivated to change the shape of Ohsaki's rectangular board to combine it with Aizawa's circular sensor because a POSITA would have understood that changing Ohsaki's rectangular board into a circular shape would eliminate Ohsaki's benefit of preventing slipping.

b) **To The Extent Dr. Kenny Seeks To Raise A New Argument, A POSITA Would Not Have Been Motivated To Add A Rectangular Board To Aizawa's Circular Detector**

63. Dr. Kenny illustrates his proposed combination (Ex. 1003 ¶¶112, 114) with a circular cover over Aizawa's circular housing. But then Dr. Kenny still asserts that the POSITA "would have found it obvious to modify the [Aizawa] sensor's flat cover...to include a lens/protrusion...similar to Ohsaki's translucent board 8." Ex. 1003 ¶79.

64. To the extent Dr. Kenny seeks to argue that a POSITA would use Ohsaki's rectangular board in conjunction with Aizawa's circular sensor, this would disrupt Aizawa's circular sensor's symmetry, and any such argument is not supported. Aizawa distinguishes its symmetric array of peripheral detectors from linear sensors, such as Ohsaki's side-by-side emitter/detector configuration, explaining the "photodetectors [are] disposed around the light emitting diode and not linearly." Ex. 1006 ¶[0009]; *see also* ¶¶[0027], [0036]. Aizawa indicates this circular symmetry is beneficial because, unlike linear sensors, "[e]ven when the attachment position of the sensor is dislocated, a pulse wave can be detected accurately." Ex. 1006 ¶[0009]; *see also* ¶¶[0012], [0027], [0029], [0032], [0033].

65. Even assuming one could design a longitudinal structure that both covers all of Aizawa's circularly arranged detectors and also still avoids the user's physiology, applying Ohsaki's rectangular board to Aizawa's circular sensor

would result in undesirable asymmetrical pressure and inconsistent contact at the peripheral edge where Aizawa's detectors are located. Ohsaki illustrates the differential pressure created by its convex board. Ex. 1014 Figs. 1, 2. Figures 1 and 2 show that the center of the board exerts the greatest pressure and pushes into the skin, causing distention. Ex. 1014 Figs. 1, 2.

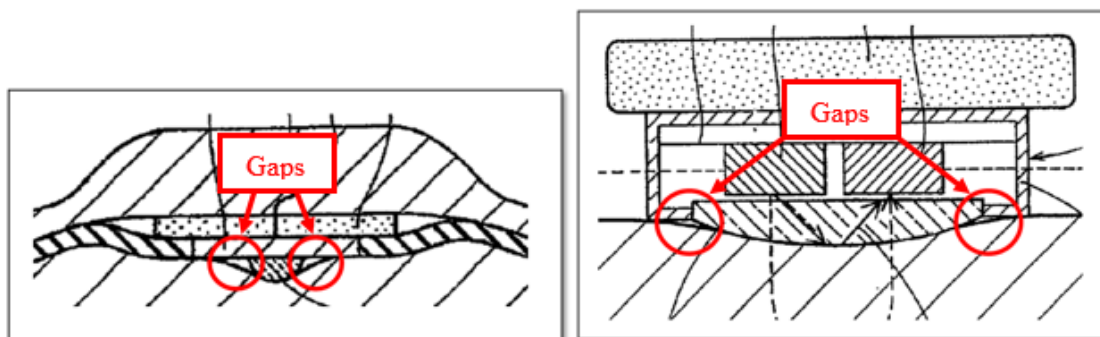

Magnified partial view of Ohsaki Figs. 1 (left) and 2 (right) with red circles annotating air gaps formed by Ohsaki's convex board

66. Placing such a cover over Aizawa's circular, peripherally arrayed detectors may also create air gaps over some or all of Aizawa's peripherally arrayed detectors, but not others, which could result in degraded or inconsistent optical signals. A POSITA would have believed that Ohsaki's rectangular board would result in a substantially different optical environment for Aizawa's various detectors based on the redirection of light away from some detectors and towards others. A longitudinal shape might also cover some detectors completely and leave other detectors mostly uncovered. Disrupting Aizawa's circular symmetry with Ohsaki's rectangular board runs counter to Aizawa's disclosure. Ex. 1006

¶[0009]; *see also* ¶¶[0012], [0027], [0029], [0032], [0033]. A POSITA would not have been motivated to make such a change.

2. **A POSITA Would Have Understood That Ohsaki’s Board Would Have Been Detrimental In Combination With Aizawa’s Sensor Because Ohsaki’s Board “Has A Tendency To Slip” At Aizawa’s Measurement Location On The Palm Side Of The Wrist, Near The Artery**

67. Dr. Kenny asserts that it would have been obvious to modify Aizawa’s “flat cover...to include a lens/protrusion...similar to Ohsaki’s translucent board 8.” Ex. 1003 ¶79. Dr. Kenny asserts this modification would “improve adhesion.” Ex. 1003 ¶79. But Ohsaki indicates a convex surface only prevents slipping on the back (i.e., watch) side of the wrist in a specific orientation, but tends to slip when used in different locations or orientations. *See* Sections VII.A.1-2, VII.B.1, above. In contrast, a POSITA would have understood that Aizawa requires its sensor to be positioned on the palm side of the wrist, where its sensor measures light reflected from an artery (e.g. the radial or ulnar arteries). Ex. 1006 ¶¶[0002], [0007], [0009], [0026], [0027], [0036], Fig. 2. A POSITA seeking to improve Aizawa would not incorporate a feature that only improves adhesion at a measurement location away from the radial and ulnar arteries on the palm side of the wrist.

a) **Aizawa's Flat Acrylic Plate Improves Adhesion On The Palm Side Of The Wrist**

68. Aizawa (Fig. 2 below) discloses a sensor used on the palm side of the wrist. Aizawa's sensor uses a flat acrylic cover with a circular array of multiple detectors surrounding a single LED. Aizawa explains its sensor functions by "irradiating the artery of the wrist" and is thus shown worn on the palm side of the wrist, which is close to the large radial and ulnar arteries. Ex. 1006 ¶[0002]; see also ¶¶[0007], [0009], [0026], [0027], [0036], Fig. 2. Aizawa illustrates its sensor's positioning on the palm side, described by Aizawa as the "inner side," of the user's wrist. Ex. 1006 Fig. 2, ¶[0026]. Aizawa explains: "As shown in FIG. 2, a subject carries the above pulse rate detector 1 on the inner side of his/her wrist 10 with a belt 7 in such a manner that the light emitting face 21s of the light emitting diode 21 faces down (on the wrist 10 side)." Ex. 1006 ¶[0026].

FIG. 2

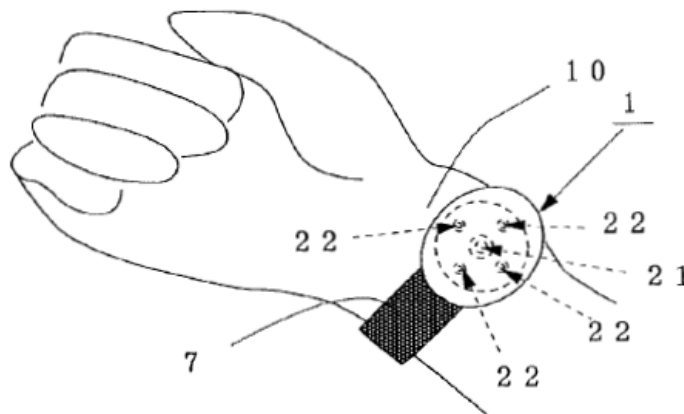

Aizawa's palm-side sensor positioning
on the palm side of the wrist (Ex. 1006 Fig. 2, ¶[0026])

69. As illustrated in Aizawa Figure 2, Aizawa’s sensor takes measurements from the palm side of the wrist, near the artery. As shown below, the ulnar and radial arteries are near the surface on the palm side of the wrist, and Aizawa’s figure shows its sensor positioned towards the thumb side of the wrist, which corresponds to the location of the radial artery. Ex. 2010 at 44 (Plate 429) (showing radial and ulnar arteries in superficial layer of the anterior (palm side) of wrist); *see also* 71 (Plate 456) (showing arteries on palm side of upper limb).

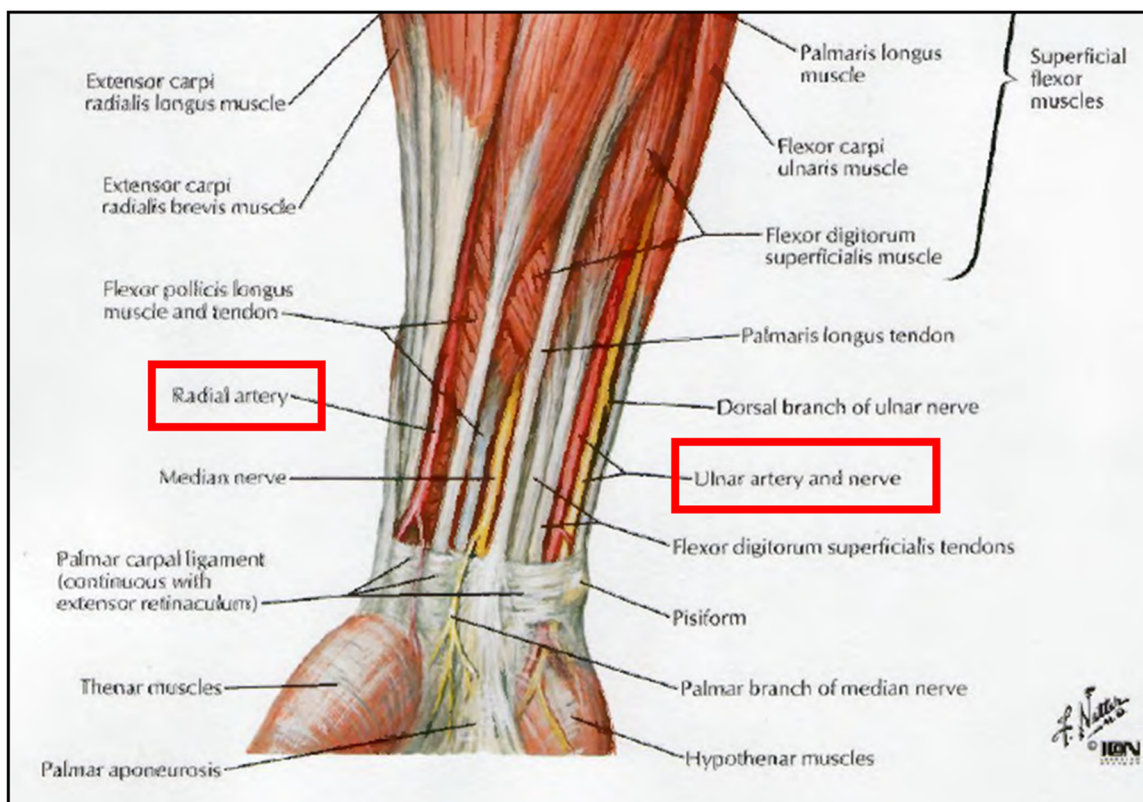

Superficial layer of palm side (anterior) forearm and wrist, showing that the radial and ulnar arteries are close to the surface (partial view) Ex. 2010 at 44 (Plate 429), annotated

70. In contrast, as shown in the figure below, the radial and ulnar arteries are not near the surface of the wrist and forearm's back side.

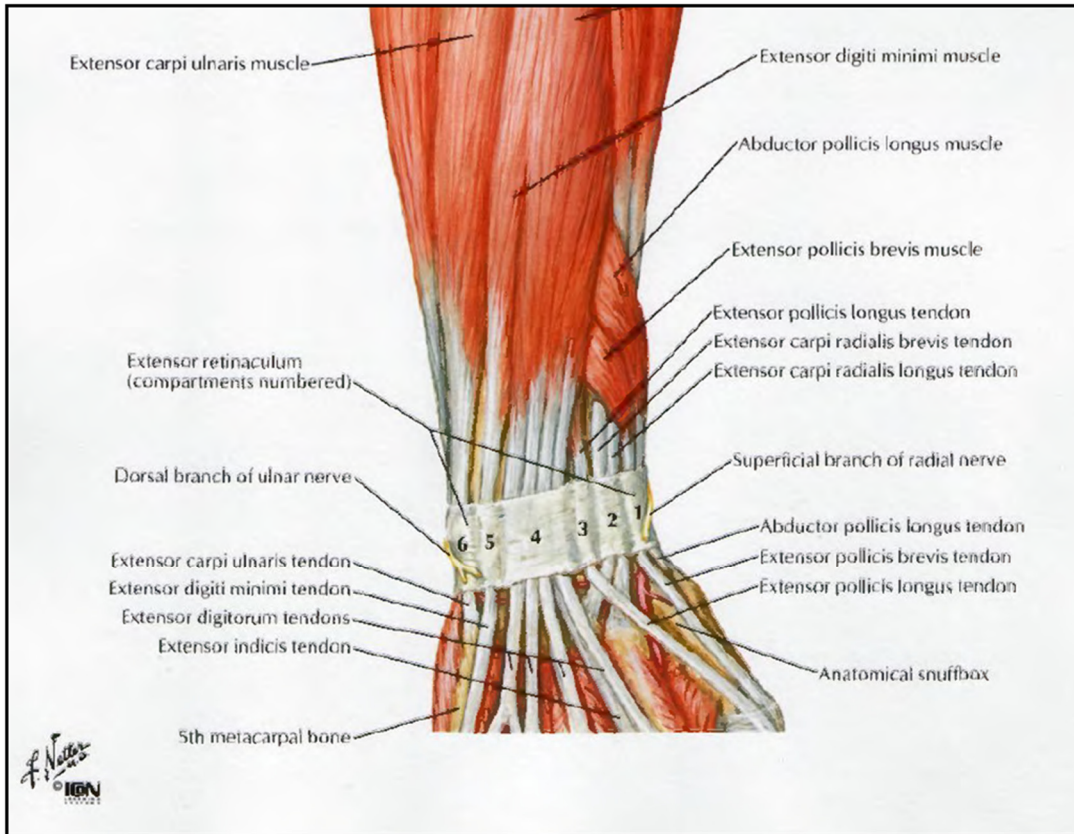

Superficial layer of back side (posterior) of forearm and wrist
(partial view) Ex. 2010 at 42 (Plate 427)

71. Thus, a POSITA would have understood that Aizawa teaches its wrist-worn sensor is used on the palm side of the wrist and measures an optical signal from an artery, and thus should be positioned above, *e.g.*, the radial artery as shown in Aizawa Figure 2's sensor placement. Aizawa repeatedly confirms the positioning at "the artery of the wrist," explaining:

- Its sensor functions by “irradiating the artery of the wrist with light.” Ex. 1006 ¶[0002].
- Its sensor detects “light output from a light emitting diode and reflected from the artery of a wrist of a subject.” Ex. 1006 ¶[0009].
- That a belt fastens its sensor so “the acrylic transparent plate 6 becomes close to the artery 11 of the wrist 10.” Ex. 1006 ¶[0026].
- That the light detected by its sensor’s photodiodes “is reflected by a red corpuscle running through the artery 11 of the wrist 10.” Ex. 1006 ¶[0027].
- That “the present invention...is constituted such that light output from a light emitting diode and reflected from the artery of the wrist....” Ex. 1006 ¶[0036].

72. As shown in the illustration below (left), Aizawa’s sensor places detectors (red) symmetrically in a concentric circle around an emitter (green). Ex. 1006 Fig. 1A. Aizawa protects these optical components, which are in cavities, with a flat acrylic transparent plate (blue, below, right) placed on the top of the holder (23). Ex. 1006 ¶[0023], Fig. 1B; *see also* ¶[0024] (emitters and detectors “stored in cavities”).

FIG. 1 (a)

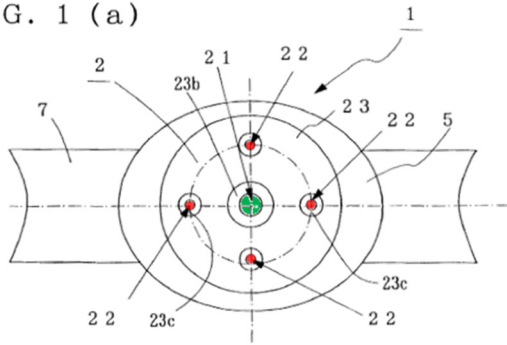

Aizawa Fig. 1A (top view)
Red: detectors; Green: emitter

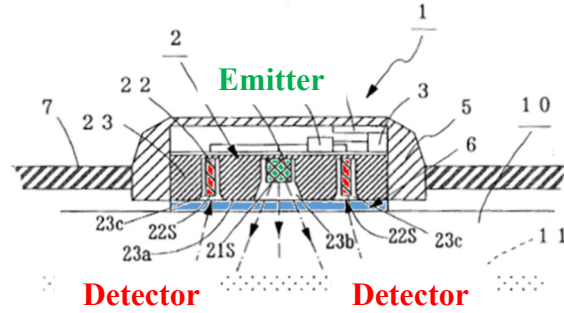

Aizawa Fig. 1B (cross-section)
Red: detectors; Green: emitter,
Blue: flat plate

73. Aizawa repeatedly teaches that its flat acrylic plate beneficially improves adhesion to the measurement site at the palm side of the wrist, explaining:

- “[A] transparent plate-like member is provided on a portion including at least the light emitting face and the light receiving faces of the contact face. This makes it possible to improve adhesion between the sensor and the wrist and thereby further improve the detection efficiency of pulse waves.” Ex. 1006 ¶[0013].
- “[T]he above belt 7 is fastened such that the acrylic transparent plate 6 becomes close to the artery 11 of the wrist 10. Thereby, adhesion between the wrist 10 and the pulse rate detector 1 is improved.” Ex. 1006 ¶[0026].
- “Since the acrylic transparent plate 6 is provided on the detection face 23a of the holder 23, adhesion between the pulse rate detector 1 and the wrist 10

can be improved, thereby further improving the detection efficiency of a pulse wave.” Ex. 1006 ¶[0030].

- “In the above embodiment, the acrylic transparent plate 6 is provided on the detection face 23a of the holder 23 to improve adhesion to the wrist 10.” Ex. 1006 ¶[0034].

74. Thus, a POSITA reading Aizawa’s disclosure as a whole would have understood that Aizawa requires that its sensor take measurements on the palm side of the wrist, near an artery (e.g., the radial artery, based on the sensor positioning in Ex. 1006 Fig. 2). A POSITA would have further understood based on Aizawa’s disclosure that the flat acrylic plate used in Aizawa’s sensor improves adhesion between the sensor and skin on the palm side of the wrist. *See, e.g.,* Ex 1006 ¶¶[0013], [0026], [0030], [0034]. Thus, for these reasons a POSITA would not have been motivated to modify Aizawa’s flat plate, which improves adhesion on the palm side of the wrist where Aizawa’s sensor is used, based on the teachings of Ohsaki’s convex board.

b) Ohsaki’s Convex Board Has “A Tendency To Slip” When Positioned On The Palm Side Of The Wrist

75. In contrast to Aizawa, Ohsaki discloses a pulse rate sensor with a single emitter (e.g., an LED) and a single detector disposed linearly, side-by-side, under a translucent board. Ex. 1014 Fig. 2, ¶[0017]. Ohsaki’s linearly arranged

detector and emitter (below) results in a longitudinal directionality that contributes to Ohsaki's stated benefit of reducing slipping. Ex. 1014 ¶[0019].

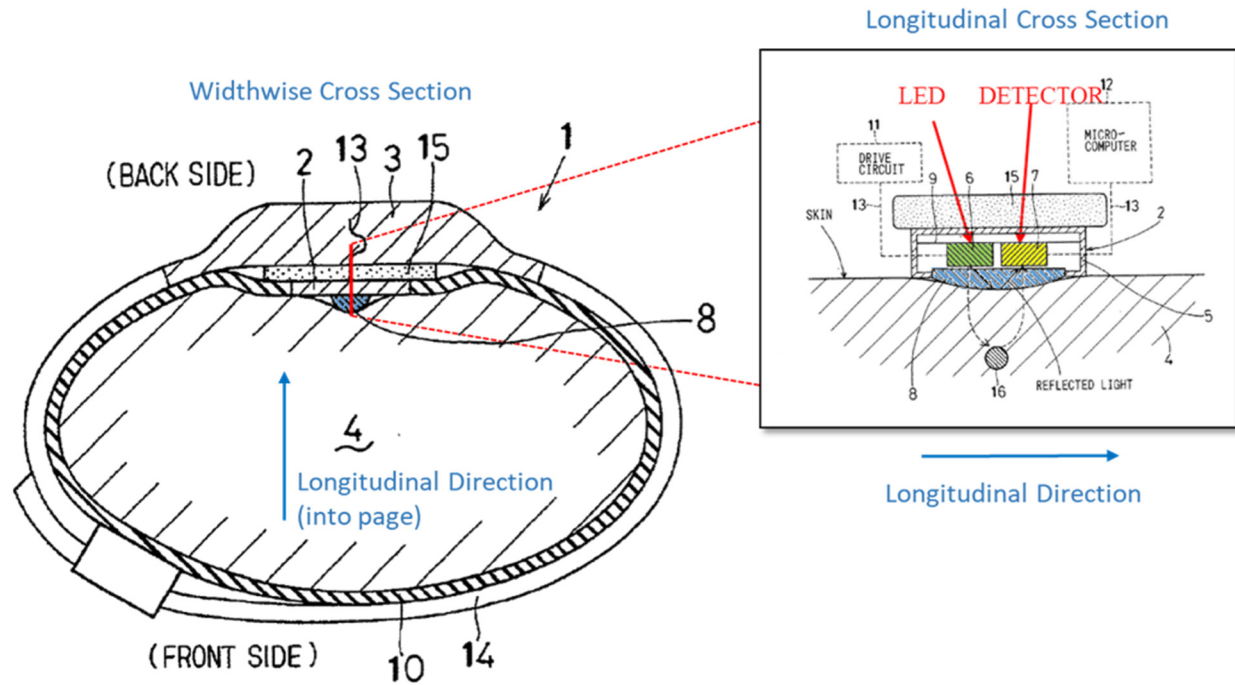

Ohsaki Fig. 1 (left), showing the cross-sectional view of Ohsaki's sensor in the circumferential direction (across the wrist) and Fig. 2 (right) showing the cross-sectional view of Ohsaki's sensor in the longitudinal direction (up-and-down arm)

76. Ohsaki's sensor prevents slipping when it is positioned on the backhand side of the wrist, but only if its longitudinal (long) direction points up and down the user's arm. See, e.g., Ex. 1014 ¶¶[0019], [0024]. In contrast, Ohsaki reports that its sensor "has a tendency to slip off" when it is turned 90 degrees on the back side of the user's wrist (resulting in the sensor's long side pointing across the user's wrist). Ex. 1014 ¶[0019]. Ohsaki also reports that its sensor "has a tendency to slip" if positioned on the palm side (which Ohsaki calls the "front side") of the user's wrist. See, e.g., Ex. 1014 ¶[0023], Figs. 3A-3B.

77. Ohsaki illustrates the “tendency to slip” on the palm side (“front side”) of the wrist using the pulse wave measurements shown in Figures 3A-3B (below). Ex. 1014 ¶¶[0023]-[0024].

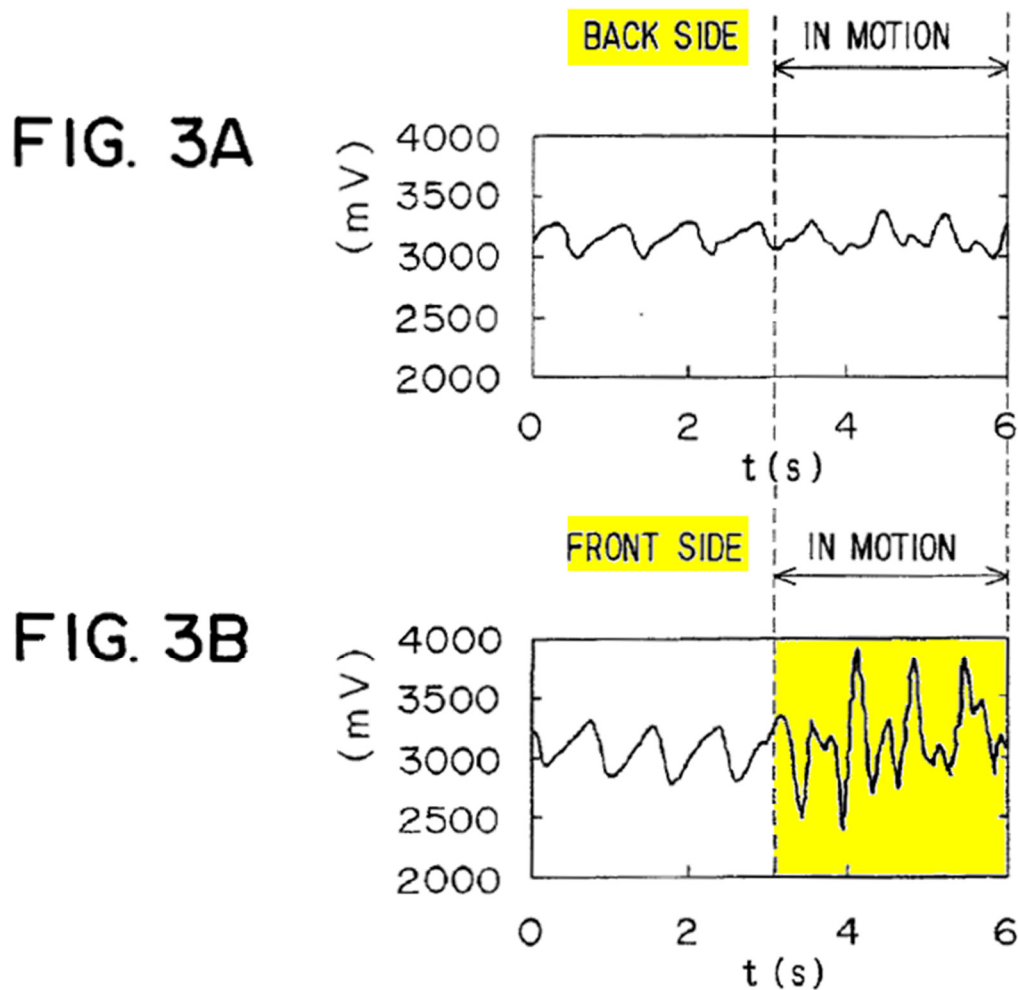

Ohsaki Figs. 3A-3B illustrating the tendency of its convex board “to slip” when positioned on the front side (palm side) of the wrist (highlighting added to show change in signal with motion on palm side of wrist)

78. Ohsaki explains that for measurements taken on the palm side of the wrist, “when the user is in motion, the detected pulse wave is adversely affected by the movement of the user’s wrist....” Ex. 1014 ¶[0023]. This “adverse” result

identified by Ohsaki corresponds to the irregular pattern shown in Figure 3B, compared to the pattern of measurements from the back side of the wrist shown in Figure 3A. For measurements using a convex board on the back side of the wrist, Ohsaki explains Figure 3A shows “the pulse wave is detected stably without being affected by the movement of the user’s wrist...” Ex. 1014 ¶[0024].

79. Dr. Kenny does not cite or discuss Ohsaki’s Figures 3A-3B when discussing the motivation for modifying Aizawa’s palm-side sensor with a lens/protrusion similar to Ohsaki’s board. Ex. 1003 ¶¶76-84; *see also* ¶¶114-115. Instead, Dr. Kenny discusses Ohsaki’s Figures 4A-4B, which compares measurements using a sensor with a convex surface or a flat surface on the back (i.e., watch) side of the wrist. Ex. 1003 ¶¶77-78.

FIG. 4A

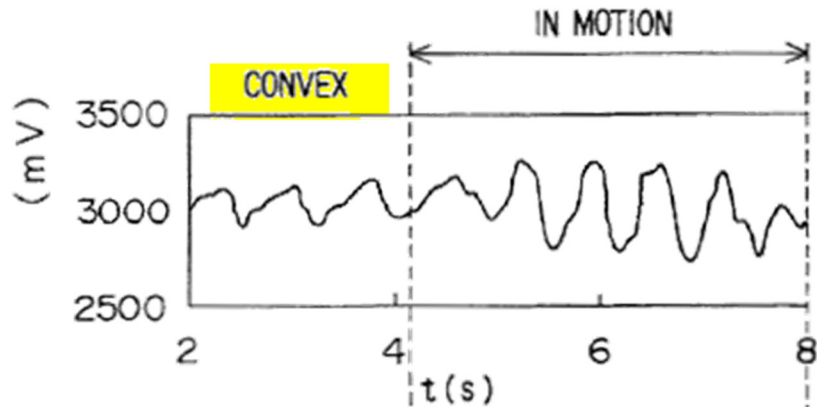
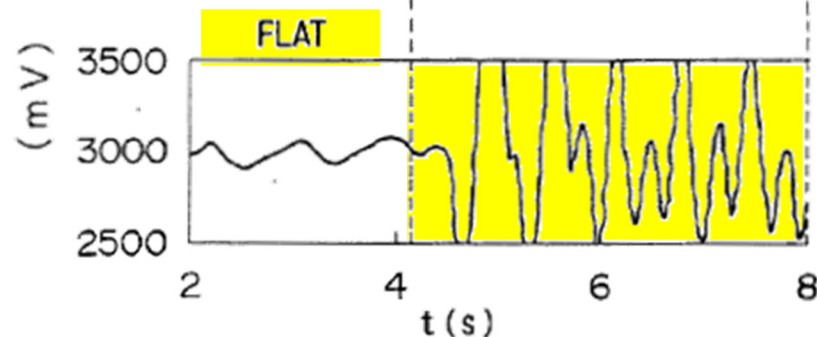

FIG. 4B



Ohsaki Figs. 4A-4B comparing convex and flat surfaces for measurements taken from the back side of the wrist (color added)

80. Ohsaki states that Figure 4B shows that when measurements taken from the back side of the wrist using a sensor with a *flat* surface, “the detected pulse wave is adversely affected by the movement of the user’s wrist.” Ex. 1014 ¶[0025]. Ohsaki also indicates that a board with a *convex* surface prevents “slip[ping] off the detecting position” on the back side of the wrist, as shown in Figure 4A. Ex. 1014 ¶[0025]; see also ¶¶[0023]-[0024] (comparing tendency to slip on front and back side of wrist). Figure 4A, which illustrates Ohsaki’s convex sensor placed on the back side of the wrist, contrasts with the measurements shown in Figure 3B (which illustrates a convex surface slips on the palm side of

the wrist). Figure 4A is consistent with Figure 3A (which illustrates a convex surface has comparatively less motion signal on the back side of the wrist). Taken together, A POSITA would have understood that Ohsaki's convex surface may prevent slipping on the back side of the wrist, if it is positioned appropriately (e.g., in the correct orientation with the long side up-and-down the wrist). Ex. 1014 ¶¶[0019], [0023]-[0025], Figs. 3A-3B, 4A-4B.

81. The rest of Ohsaki's disclosure recognizes the limitations on any benefit derived from its convex surface. Ohsaki repeatedly specifies that its sensor "is worn on the back side of a user's wrist corresponding to the back of the user's hand." Ex. 1014 Abstract; *see also* Title ("Wristwatch-Type Human Pulse Wave Sensor Attached On Back Side Of User's Wrist"), ¶[0008] (The "sensor according to the present invention...is worn on the back side of the user's wrist corresponding to the back of the user's hand."), ¶[0009] ("attached on the back side of the user's wrist by a dedicated belt"), ¶[0016] ("worn on the back side of the user's wrist"), ¶[0024] ("[T]he detecting element 2 is stably fixed to the detecting position of the user's wrist" when arranged on the back side of the user's wrist 4.). The only other possible location mentioned for placement of Ohsaki's sensor is "the back side of the user's forearm," which is adjacent to the wrist. Ex. 1014 ¶¶[0016], [0030]. Thus, in my opinion, for these reasons a POSITA would

not have been motivated to use Ohsaki's longitudinal board, which is designed to be worn on the back of a user's wrist, with Aizawa's palm-side sensor.

c) **A POSITA Would Not Have Been Motivated To Eliminate The Identified Benefits Of Aizawa's Flat Adhesive Acrylic Plate By Including A Lens/Protrusion Similar To Ohsaki's Board**

82. Dr. Kenny asserts that a POSITA would have been motivated to modify Aizawa's flat adhesive acrylic plate "to include a lens/protrusion (right), similar to Ohsaki's translucent board 8, so as to improve adhesion between the user's wrist and the sensor's surface, improve detection efficiency, and protect the elements within the sensor housing." Ex. 1003 ¶79. But a POSITA motivated to improve Aizawa's palm-side sensor would not have been motivated to add Ohsaki's convex board. As discussed above, Ohsaki teaches a POSITA that its convex board only provides advantages on the back side of the wrist, in a particular orientation. Ex. 1014 ¶¶[0019], [0025]. Ohsaki further teaches that on the palm side (front side) of the wrist, a sensor with a convex board, "has a tendency to slip off the detecting position of the user's wrist." Ex. 1014 ¶[0023], Figs. 3A-3B.

83. As discussed above, Aizawa teaches that a flat acrylic plate improves adhesion between the sensor and skin on the palm side of the wrist. See Sections VII.A.3, VII.B.2.a, above. Taken individually and together, both Ohsaki and Aizawa undermine Dr. Kenny's proposed addition of a convex lens/protrusion

similar to Ohsaki’s translucent board to Aizawa’s palm-side sensor to improve adhesion. Ex. 1003 ¶79. This is because, as explained above (Sections VII.B.2.a-b): (1) Aizawa teaches a *flat* acrylic plate *improves* adhesion on the wrist’s *palm* side; (2) Ohsaki teaches a *convex* board “has a tendency to *slip*” on the wrist’s *palm* side. As a result a POSITA reading Aizawa and Ohsaki would have affirmatively avoided modifying Aizawa’s flat acrylic plate—which is taught to improve adhesion at Aizawa’s sensor location on the palm side of the wrist—with a convex lens/protrusion similar to Ohsaki’s convex board because Ohsaki’s convex board is taught to slip on the palm side of the wrist where Aizawa’s sensor is positioned. The table below summarizes these teachings.

	Front (Palm) Side	Back Side
Flat	Flat acrylic plate improves adhesion Ex. 1006 (Aizawa) ¶[0013]; <i>see also</i> ¶¶[0026], [0030], [0034], Fig. 1B (Aizawa’s sensor)	Tends to slip Ex. 1014 (Ohsaki) ¶[0025], Figs. 4A-4B
Convex	Tends to slip Ex. 1014 (Ohsaki) ¶[0023], Figs. 3A-3B	Rectangular convex board prevents slipping Ex. 1014 (Ohsaki) ¶¶[0024]- [0025], Figs. 4A-4B (Ohsaki’s sensor)

84. Dr. Kenny only considers Ohsaki’s discussion of the impact of a convex versus flat surface on the back side of the wrist. *See, e.g.*, Ex. 1003 ¶¶76-84. But a POSITA would have understood that Ohsaki’s discussion regarding the

back side of the wrist has little relevance to Aizawa's sensor, which is used on the palm side of the wrist, near the artery. Ex. 1006 ¶[0002]; *see also* ¶¶[0007], [0009], [0026], [0027], [0036], Fig. 2; *see also* Ex. 2010 at 44-45 (Plate 429-430) (showing radial and ulnar arteries in superficial layer of the anterior (palm side) of wrist); *compare* 71 (Plate 427) (showing arteries on palm-side of upper limb). Indeed, arteries are shown near the surface on the palm side of the wrist. Ex. 2010 at 44 (Plate 429) (showing radial and ulnar arteries in superficial layer of the anterior (palm side) of wrist); *compare* at 42 (Plate 427) (showing no radial and ulnar arteries near the surface of the back side (backhand side) of forearm and wrist). Because Aizawa specifies its sensor takes measurements from an artery on the wrist's palm side, a POSITA would have looked to Ohsaki's teachings regarding the impact of its convex surface when used on the palm side ("front side") of the wrist when considering whether to combine it with Aizawa. In particular, a POSITA would have looked to Ohsaki's guidance that a convex lens/protrusion used on the wrist's palm side "has a tendency to slip." Ex. 1014 ¶[0023], Figs. 3A-3B. A POSITA would have found this teaching of Ohsaki, which corresponds to Aizawa's actual measurement location, much more relevant than Ohsaki's discussion of what features are required for a sensor on the back side of the wrist (e.g., longitudinal directionality in the same direction as the arm, a convex surface).

85. Based on Aizawa’s teaching that a flat acrylic plate improves adhesion on the palm side of the wrist, and Ohsaki’s teaching that a convex surface tends to slip on the palm side of the wrist, a POSITA would have come to the opposite conclusion from Dr. Kenny: that modifying Aizawa’s “flat cover...to include a lens/protrusion...similar to Ohsaki’s translucent board 8” would *not* “improve adhesion.” *See, e.g.*, Ex. 1003 ¶¶79. As discussed above in this section, as well as Section VII.B.2, above, generally, Aizawa and Ohsaki, individually and together rebut Dr. Kenny’s assertion that incorporating Ohsaki’s convex surface is simply improving Aizawa’s transparent plate 6 that has a flat surface “to improve adhesion between the user’s wrist and the sensor’s surface.” Ex. 1003 ¶¶79. Thus, in my opinion, a POSITA would not have been motivated to modify Aizawa’s flat acrylic plate, which improves adhesion at the measurement site on the palm side of the wrist, to include a convex lens/protrusion similar to Ohsaki’s board, which tends to slip at the measurement site on the palm side of the wrist.

3. **A POSITA Would Not Have Been Motivated To Reduce The Measured Optical Signal By Adding A Convex Lens/Protrusion To Aizawa’s Sensor**

86. Dr. Kenny’s proposed combination is also problematic because Dr. Kenny detrimentally modifies Aizawa’s flat cover to include a convex “lens/protrusion” positioned over peripheral detectors surrounding a centrally located emitter. Ex. 1003 ¶¶79, 114-115. As discussed below, a POSITA would

have understood that a convex “lens/protrusion” would direct light away from the detectors and thus result in decreased light collection and optical signal strength at the peripheral detectors — not increased signal strength as Dr. Kenny asserts. *See* Ex. 1003 ¶77 (arguing that the convex surface of the translucent board of Ohsaki “increases the strength of the signals”).

a) **A POSITA Would Have Understood That A Convex Cover Directs Light To The Center Of The Sensor**

87. Petitioner and Dr. Kenny both admit that a convex cover condenses light passing through it towards the center of the sensor and away from the periphery. Petitioner and Dr. Kenny both illustrated this phenomenon in a petition filed against a related patent. In the Petition in IPR2020-01520 (Ex. 2019), Petitioner explained that a convex cover redirects light coming into the convex surface towards the center, as shown in Petitioner’s figure below:

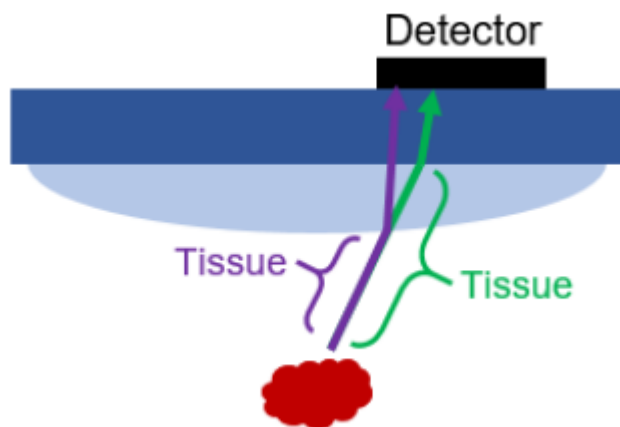

Petitioner’s illustration from a related IPR showing that light hitting a convex surface is directed more centrally than light hitting a flat surface (Ex. 2019 at 45)

88. In his declaration in IPR2020-01520 (Ex. 2020), Dr. Kenny likewise confirmed that when using a convex surface, “the incoming light is ‘condensed’ toward the center.” *See, e.g.*, Ex. 2020 at 69-70 (¶119); *see generally* Ex. 2020 69-71 (¶¶118-120), 115-117 (¶¶199-201). Dr. Kenny included the same illustration as Petitioner, which shows light passing through a convex surface is directed more towards the center, as compared to a flat surface. *See, e.g.*, Ex. 2020 at 69-71 (¶118-120).

89. The '366 Patent also confirms these admissions that a convex surface condenses light away from the periphery and towards the sensor's center. Figure 14B (below) “illustrates how light from emitters (not shown) can be focused by the protrusion 605 onto detectors.” Ex. 1001 36:3-6. “When the light rays 1420 enter the protrusion 605, the protrusion 605 acts as a lens to refract the rays into rays 1422.” Ex. 1001 36:13-15. As shown by Figure 14B of the '366 Patent, the convex shape directs light from the periphery toward the center. Ex. 1001 Fig. 14B.

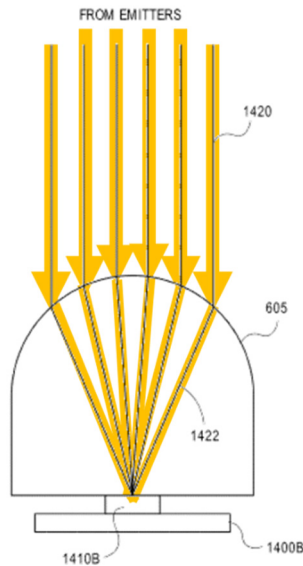

Illustration from the '366 Patent at issue, showing that light hitting a convex surface is directed towards the center
 '366 Patent (Ex. 1001) Fig. 14B (highlighting added to show direction of light)

90. Accordingly, Petitioner, Dr. Kenny, and the '366 Patent all support that a POSITA would have understood that a convex lens/protrusion would direct incoming light towards the center of the sensor, as compared to a flat surface. In my opinion, a POSITA would have believed that light passing through a convex surface would have been directed to a more central location as compared to light passing through a flat surface. This would have been viewed as a detrimental result because, as discussed in the next section below, Aizawa's detectors are at the periphery of the sensor.

b) **A POSITA Would Not Have Been Motivated To Direct Light Away From Aizawa's Detectors**

91. Dr. Kenny asserts that a POSITA would have been motivated to modify Aizawa's flat adhesive acrylic plate with "a lens/protrusion" for improved

detection efficiency. Ex. 1003 ¶79. As illustrated below, Aizawa has peripherally located detectors (in red, below left) and a centrally located emitter (in green, below left) under a flat acrylic adhesive plate (in blue, below left). Ex. 1006 Fig. 1B; *see also, e.g.,* ¶¶[0009], [0026]-[0027], [0033], [0036]. Dr. Kenny’s combination introduces a convex “lens/protrusion” (in blue, below right) over Aizawa’s peripherally located detectors and centrally located light source (*see, e.g.,* Ex. 1003 ¶79):

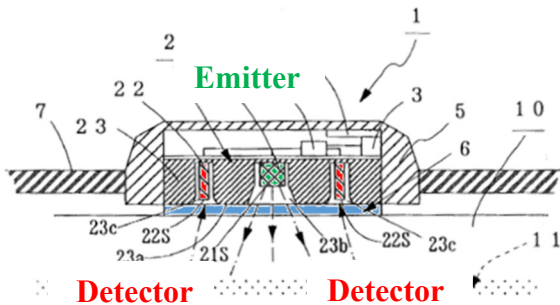

Aizawa Fig. 1B (cross-section)
 Red: detectors; Green: emitter,
 Blue: flat plate

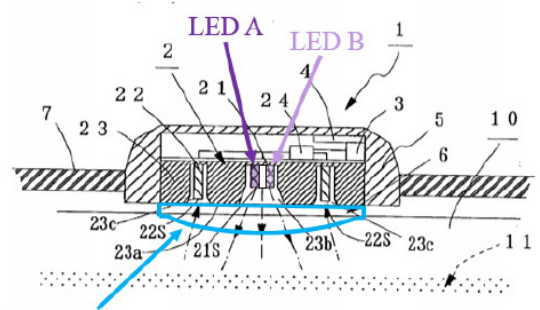

Dr. Kenny’s proposed modifications
 (Ex. 1003 ¶79)

Aizawa (Ex. 1006 Fig. 2) (color added) (left) versus
 Dr. Kenny’s proposed combination (Ex. 1003 ¶79) (right)

92. Dr. Kenny asserts that Ohsaki’s board “increases the strength of the signals obtainable by Ohsaki’s sensor.” Ex. 1003 ¶77. However, as discussed above (Section VII.B.3.a), a POSITA would have believed that adding a convex lens/protrusion to Aizawa’s flat adhesive acrylic plate would direct light away from the combination’s detectors that are located on the periphery. Aizawa

illustrates that the light reaching Aizawa’s detectors must travel from the center emitter to the outer periphery of the detectors. Ex. 1006 Fig. 1B, ¶[0027]. Aizawa shows the light path as leaving a single centrally located emitter, passing through the body, and reflecting back to periphery-located detectors (light must travel from the center emitter to the outer periphery to the detectors. Ex. 1006 Fig. 1B, ¶[0027]):

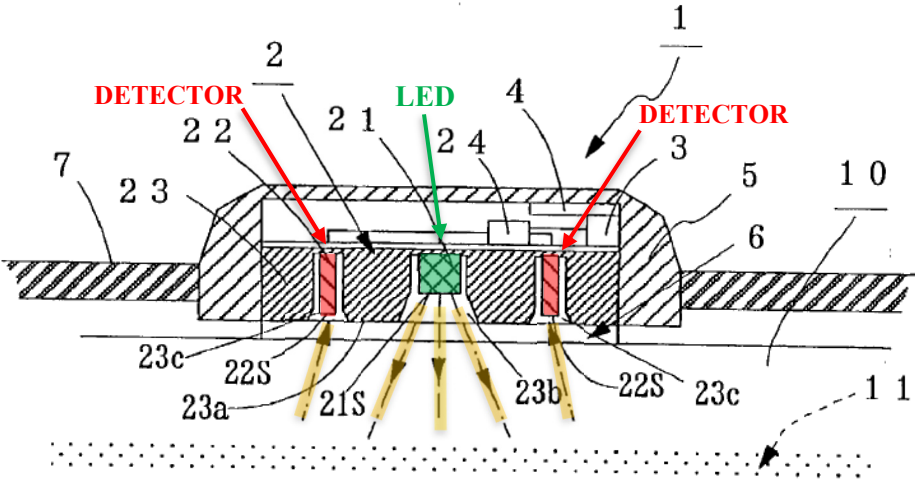

Aizawa Fig. 1B (cross-sectional view, color added)

93. Because of the configuration of Aizawa’s sensor, with its central emitter and peripheral detectors, and the illustrated light path that requires light from the central emitter to reach the peripheral detectors, a POSITA would have understood that a change directing light to a more central location would decrease the optical signal at Aizawa’s peripheral detectors. Ex. 1006 ¶¶[0026], [0030] (discussing benefits of Aizawa’s flat “plate”). Because a POSITA would have believed that adding a convex lens/protrusion would have redirected light to a

more central location as compared to Aizawa's flat adhesive acrylic plate, a POSITA would have concluded that Dr. Kenny's proposed modification would decrease light-collection efficiency at Aizawa's peripheral detectors. Thus, I disagree with Dr. Kenny that a POSITA would have been motivated to modify Aizawa's flat plate to add a lens/protrusion similar to Ohsaki's translucent board based on the belief that it would have improved detection efficiency or otherwise increased signal strength. Ex. 1003 ¶¶79. As discussed above (Section VII.B.3.a) Dr. Kenny, the Petitioner, and the '366 Patent all support that a POSITA would have believed that adding a convex lens/protrusion would result in the light gathered and refracted to a more central location, and thus away from Aizawa's peripheral detectors, as compared to Aizawa's existing flat plate.

94. In addition, the addition of a convex lens/protrusion similar to Ohsaki's is particularly problematic because both Aizawa and Dr. Kenny's illustration of his combination include small detectors with small openings surrounded by a large amount of opaque material. Ex. 1006 Figs. 1A, 1B, 2; *see, also, e.g.*, Ex. 1003 ¶¶79, 94-98, 100, 112-114 (Dr. Kenny's illustrations). Aizawa's top-down view confirms the detectors' small size. Ex. 1006 Fig. 1A.

FIG. 1 (a)

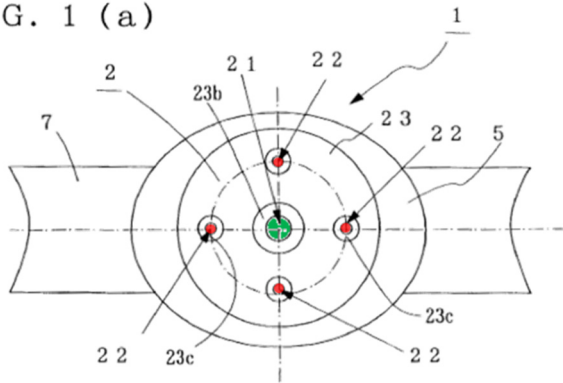

Aizawa's Features

- **Green:** central emitter (21)
- **Red:** peripheral detectors (22)

Aizawa's sensor, showing small detectors (Ex. 1006 Fig. 1A, color added)

95. Thus, Dr. Kenny provides no evidence that a POSITA would have expected a convex lens/protrusion similar to Ohsaki's board to improve detection efficiency at Aizawa's peripheral detectors and increase signal strength. Ex. 1003 ¶¶77, 79. Instead, as explained above (Section VII.B.3.a), a POSITA would have expected that changing Aizawa's flat acrylic plate to a convex lens/protrusion similar to Ohsaki's board would reduce the amount of light gathered and refracted to Aizawa's peripheral detectors. The optical changes resulting from modifying Aizawa's flat surface to include a convex lens/protrusion similar to Ohsaki's board are thus another reason why a POSITA would not have been motivated to make that change.

96. Finally, Dr. Kenny relies on Inokawa for motivation to modify Aizawa's flat surface. Ex. 1003 ¶¶81-84. Dr. Kenny states that Inokawa would provide a "further rationale" (Ex. 1003 ¶81) to add the proposed a "lens/protrusion" (Ex. 1003 ¶79) to Aizawa. Dr. Kenny states that Inokawa

demonstrates “the additional benefit of increasing light collection efficiency, which would in turn lead to an improved signal-to-noise and more reliable pulse detection,” based on “refracting/concentrating incoming light signals reflected by the blood.” Ex. 1003 ¶82. Unlike Aizawa’s circular ring of detectors around a central emitter, Inokawa’s sensor is a linear sensor that uses a convex lens (27) to focus light from LEDs (21, 23) positioned on the periphery of the sensor to a single detector (25) in the center. Ex. 1008 ¶[0058], Fig. 2; *see also id.* ¶[0015] (“This lens makes it possible to increase the light-gathering ability of the LED as well as to protect the LED or PD.”).

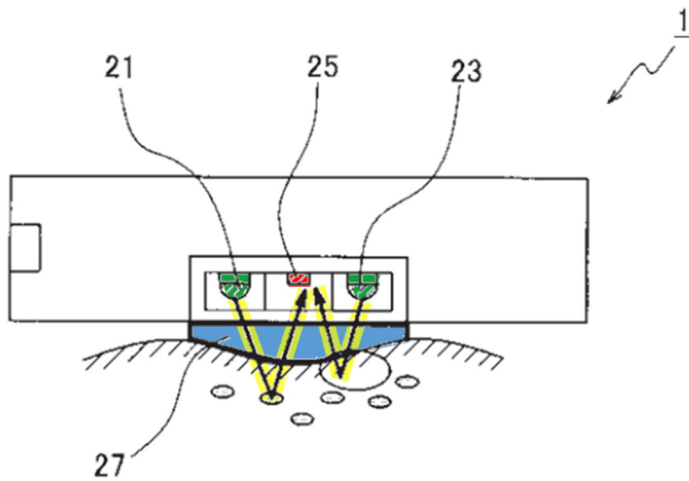

Inokawa’s Features

- **Green:** peripheral emitters (21, 23)
- **Red:** central detector (25)
- **Blue:** convex lens (27)
- Arrows showing the direction of light in original, highlighting in yellow added

Inokawa Fig. 2 (color added)

97. As illustrated above, Inokawa’s linear detector-emitter configuration is different from Aizawa’s circular detector arrangement. In Inokawa’s sensor, light from Inokawa’s periphery-located LEDs will reflect off the body and pass through the lens, which directs incoming light to the centrally located detector.

Ex. 1008 ¶[0058]. Inokawa’s convex surface thus concentrates incoming light towards the sensor’s center, where the detector is located, and away from the periphery. In contrast, Aizawa’s detectors are not located at the center—they surround the central emitter. Inokawa would thus have further demonstrated to a POSITA that the proposed combination would decrease light gathering at Aizawa’s peripheral detectors, which is the opposite of Dr. Kenny’s motivation to combine. Ex. 1003 ¶82.

4. A POSITA Would Not Have Selected A Convex Cover To Protect The Sensor’s Optical Elements

98. Dr. Kenny also asserts that a POSITA would have been motivated “to modify the [Aizawa] sensor’s flat cover...to include a lens/protrusion...similar to Ohsaki’s translucent board 8, so as to...protect the elements within the sensor housing.” Ex. 1003 ¶79. As illustrated below, Aizawa already includes a flat adhesive acrylic plate (blue) that protects the elements (emitter, detectors) within the sensor housing. Ex. 1006 Fig. 1B; *see also, e.g.*, ¶¶[0023]-[0026], [0030]. Thus, in my opinion, a POSITA would not have been motivated to modify Aizawa’s existing flat adhesive acrylic plate to add a convex lens/protrusion similar to Ohsaki’s board for protection because a POSITA would have understood that Aizawa’s flat cover already protects the sensor’s components. Ex. 1006 Fig. 1B; *see also, e.g.*, ¶¶[0023]-[0026], [0030]. Dr. Kenny asserts that the convex lens/protrusion “protect[s] the elements within the sensor housing” (Ex.

1003 ¶79) but does not explain why that protection would be any different from Aizawa’s flat plate without the modification. Thus, in my opinion, a POSITA would not have been motivated to change the shape of Aizawa’s flat acrylic plate based on the desire to protect the optical elements, because a POSITA would have understood that Aizawa’s flat plate already provided that benefit. Indeed, based on the problems discussed above (Sections VII.B.1-3), a POSITA would have been wary of changing the shape of Aizawa’s flat plate to include a convex lens/protrusion like Ohsaki’s board.

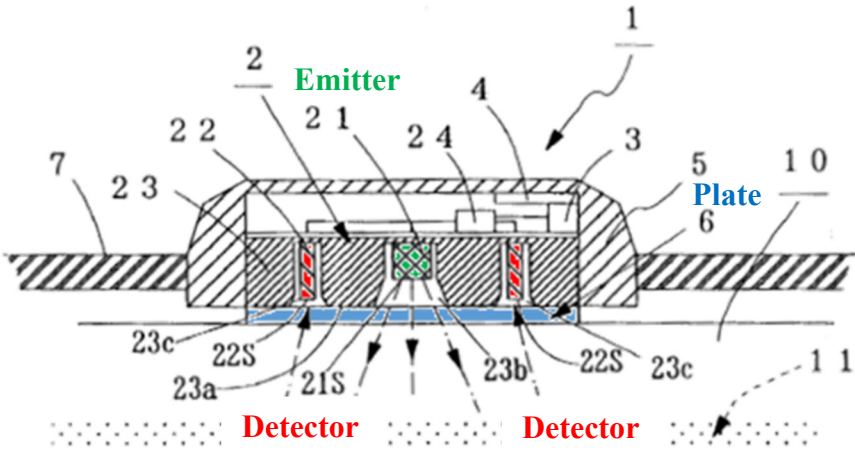

Aizawa Fig. 1B (cross-section) (color added)

99. In addition, a POSITA would have believed that Aizawa’s flat cover would be a better choice to provide better protection than a convex surface because, as taught by Inokawa, a flat surface would be less prone to scratches than a convex surface. Ex. 1008 ¶[0106]. Likewise, as discussed above (Section VII.B.2), Aizawa teaches that its flat surface improves adhesion and detection

efficiency for measurements at the palm side of the wrist, next to the artery. *See* Ex. 1006 ¶[0013] (“[A] transparent plate-like member...makes it possible to improve adhesion between the sensor and the wrist and thereby further improve the detection efficiency of pulse waves.”). In contrast, Ohsaki teaches a convex surface at Aizawa’s detection location “has a tendency to slip.” Ex. 1014 ¶[0023]. Thus, in my opinion, there would have been no reason for a POSITA to modify Aizawa’s flat adhesive acrylic plate, which already protects the elements within the sensor housing and does not introduce the complications and concerns arising from a convex shape.

C. Dr. Kenny’s Modification Of Aizawa’s Detector Arrangement Based On Mendelson 2003 Changes Aizawa’s Principle Of Operation And Produces An Inferior Sensor

100. Every claim of the ’366 Patent requires: (1) a first set of at least four photodiodes that are connected to one another in parallel to provide a first signal stream and (2) a second set of at least four photodiodes that are connected to one another in parallel to provide a second signal stream. *See, e.g.*, Ex. 1001 claims 1, 14, and 27. Dr. Kenny admits that “Aizawa does not expressly teach a second set of photodiodes that are connected to one another in parallel to provide a second signal stream.” Ex. 1003 ¶69. Dr. Kenny asserts that Mendelson 2003 would have led a POSITA to change Aizawa’s single detector ring into two rings, with the detectors of each of those individual rings connected in parallel. Ex. 1003

¶69. Dr. Kenny asserts that a POSITA would have believed that his proposed modification would advance “Aizawa’s goal of improving detection efficiency through increased power savings.” Ex. 1003 ¶69.

101. Dr. Kenny ignores differences between Aizawa and Mendelson 2003 that would have discouraged a POSITA from making the changes that Dr. Kenny proposes. First, a POSITA would have understood that Dr. Kenny’s two-ring modification changes Aizawa’s principle of operation and eliminates Aizawa’s ability to individually monitor pulse using any individual detector, which is a feature that Aizawa repeatedly cites as beneficial. *See* Section VII.C.1, below. Second, a POSITA would have understood that the proposed two ring modification, which adds an “outer” ring, would have resulted in relatively less optical signal and an inferior power consumption as compared to Aizawa’s single-ring detector structure. *See* Section VII.C.2, below. Third, a POSITA would have understood that Mendelson 2003’s detector configuration was used to carry out specific experiments comparing optical signals at different distances from an emitter, and would not have provided the postulated benefits cited by Dr. Kenny. Instead, a POSITA would have credited Mendelson 2003’s statement that when creating a sensor, the sensor should use a single signal stream, and not two different signal streams as claimed. *See* Section VII.C.3, below.

1. **Dr. Kenny's Proposed Combination Changes Aizawa's Principle Of Operation And Eliminates A Feature Aizawa Repeatedly Identifies As Important**

102. Aizawa's sensor monitors different individual detector signals and calculates pulse rate based on each individual photodetector signal. *See* Ex. 1006 ¶[0028] (citing Figure 3 and explaining the pulse rate calculation for "the photodetector"); *see also* ¶¶[0019] ("diagram of a pulse wave which is the output of a photodetector") (emphasis added), [0023], [0028] ("amplifying the outputs of the photodetectors," and "comput[ing] the number of outputs above the threshold value per unit time so as to calculate a pulse rate"). A POSITA would thus understand that Aizawa measures the individual signal from each individual photodetector, and does not measure an aggregated signal from detectors connected in parallel. Ex. 1006 ¶¶[0019], [0023], [0028], Fig. 3. Aizawa repeatedly indicates that measuring pulse using a single detector's output helps avoid problems stemming from sensor dislocation. Ex. 1006 ¶¶[0027]-[0029], [0032], [0036]; *see also* ¶[0007] (discussing prior art where if the "position is dislocated, no output can be obtained"). Aizawa also emphasizes that the detectors, irrespective of the number of detectors, "should be disposed around the light emitting diode 21 on a circle concentric to the light emitting diode 21 to detect a pulse wave." Ex. 1006 ¶[0032].

103. Dr. Kenny does not account for these aspects of Aizawa’s sensor design. Ex. 1003 ¶¶67-75. Instead, Dr. Kenny asserts that Mendelson 2003 would have “advance[ed] Aizawa’s goal of improving detection efficiency through increased power savings.” Ex. 1003 ¶69. Dr. Kenny asserts: “By using Mendelson-2003’s power-saving (*i.e.*, efficiency-enhancing) PD configuration, the power consumption of a wrist-based pulse sensing device as in Aizawa can be reduced through use of a less bright and, hence, lower power-consuming LED. This would in turn allow Aizawa’s wrist-based device to have a longer battery life.” Ex. 1003 ¶72. As shown below, Dr. Kenny’s combination adds “an additional ring of detectors to Aizawa, as per the teachings of Mendelson-2003,” resulting in eight total detectors. Ex. 1003 ¶73.

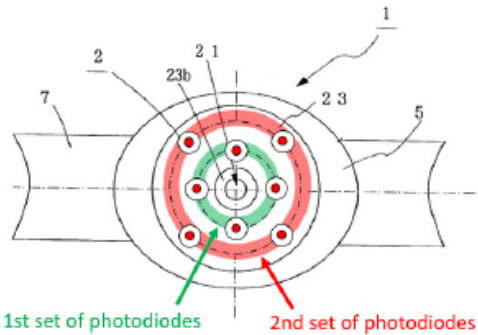

Dr. Kenny’s illustration of the combination (Ex. 1003 ¶73)

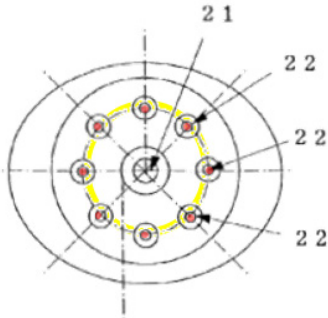

Aizawa’s illustrated detector arrangement (Ex. 1006 Fig. 4A)

104. Dr. Kenny’s modification to Aizawa thus uses Mendelson 2003’s two-ring testing system to modify Aizawa’s individual detector sensor and change it into a dual-ring arrangement with one combined output signal for all four inner ring detectors and one combined output signal for all four outer ring detectors.

This modification changes the operation of Aizawa's pulse sensor and eliminates the functionality of monitoring pulse via individual detector signals, which Aizawa repeatedly cites as helping address problems related to sensor displacement. Ex. 1006 ¶¶[0027]-[0029], [0032], [0036].

105. Dr. Kenny nevertheless acknowledges that his proposed modification, with Aizawa's photodiodes connected in parallel, would "thereby form, essentially, a single continuous detector." Ex. 1003 ¶102. In my opinion, Dr. Kenny incorrectly believes that Aizawa "is in effect trying to mimic" "a single, large detector." Ex. 1003 ¶102. As I explain above, Aizawa does not attempt "to mimic" a single large detector. Instead, Aizawa explains it is beneficial to monitor individual detector signals as a way to help address sensor displacement. *See, e.g.*, Ex. 1006 ¶¶[0027]-[0029], [0032], [0036]. Combining all of the Aizawa detectors in parallel undermines Aizawa's approach because with parallel connected detectors, the sensor can no longer monitor the individual detector signals. Dr. Kenny thus does not note the importance of the individual detector signals in reaching Aizawa's goal. A POSITA would not have changed Aizawa's principle of operation, which uses a circular array of individual detector signals to help address sensor displacement, by eliminating Aizawa's individual detector monitoring.

2. **Dr. Kenny's Proposed Modification Would Result In Increased Power Consumption Compared To Aizawa's Existing Embodiment**

106. Dr. Kenny's motivation for changing the operation of Aizawa's detectors is that adding another ring of detectors would "further advanc[e] Aizawa's goal of improving detection efficiency through increased power savings." Ex. 1003 ¶69. Mendelson 2003, however, explains that any improvements in power savings are the result of increasing the number of peripheral detectors and thus the overall detector area, as opposed to the specific two-ring structure itself. *See* Ex. 1024 at 2 (discussing "increasing the overall size of the PD" and "widening the overall active area of the PD").

107. Dr. Kenny, however, proposes increasing the number of detectors in Aizawa's sensor from four to eight, with the four additional detectors added in an outer ring. Ex. 1003 ¶73. This change discounts Aizawa's existing eight-detector embodiment, which places all eight detectors within a single symmetric ring around the emitter. Ex. 1006 ¶[0032], Fig. 4A. Aizawa states that its eight-detector embodiment "further improve[s] detection efficiency." Ex. 1006 ¶[0032], Fig. 4A.

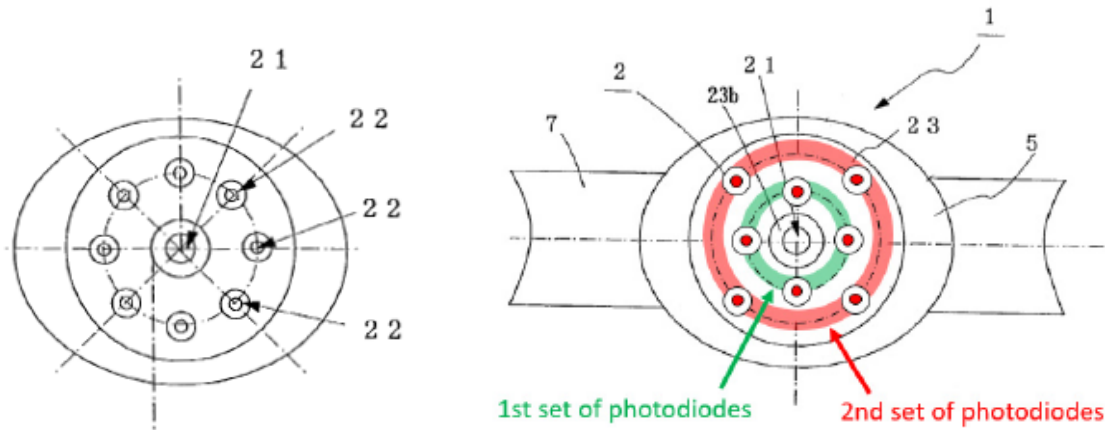

Aizawa Fig. 4A Dr. Kenny's Proposed Combination (Ex. 1003 ¶¶73)

108. Dr. Kenny does not give a plausible reason why a POSITA would have been motivated to modify Aizawa's structure and add a second ring of four detectors that is farther from the emitter. Dr. Kenny's suggestion is contrary to Aizawa's illustrated embodiment, which demonstrates that eight detectors readily fit into the existing ring, and assumes adding a second ring of four detectors that is farther from the emitter would have some benefit. Ex. 1003 ¶¶72-75. But Mendelson 2003 adds a second ring of detectors farther away from the emitter because there is no room for more detectors in the existing ring. Ex. 1024 Fig. 1. The proposed new "outer" ring of detectors is not needed in Aizawa, and a POSITA would have understood that Dr. Kenny's new outer ring would have received substantially lower light intensity and required relatively greater power consumption to use than additional detectors added to the "inner" ring. See Ex. 1024 at 4 (stating optical signal "is inversely related to the separation distance between the PD and the LEDs" and outer ring detectors require LEDs

“significantly higher currents”). A POSITA would have believed the proposed modification would result in greater power consumption as compared to Aizawa’s existing 8-detector structure, all placed on the inner ring closer to the detector. This is particularly true because Dr. Kenny also proposes adding a convex cover that would direct light away from the outer ring of periphery-located detectors. *See* Sections VII.B.1-3, above. A POSITA motivated to achieve improved power savings—Dr. Kenny’s stated motivation for his modification (Ex. 1003 ¶72)—would not have added an outer ring of detectors to Aizawa, and instead would have added detectors to Aizawa’s existing ring as disclosed in Aizawa’s already disclosed 8-detector embodiment that positions all eight detectors in a single concentric circle.

109. Dr. Kenny’s proposed modification thus changes Aizawa’s structure in a way that Mendelson 2003 itself indicates would result in relatively worse power consumption (Ex. 1024 at 4) compared to Aizawa’s existing configuration. In my opinion, a POSITA seeking to increase the number of detectors would have implemented Aizawa’s existing eight detector arrangement, and not come up with an entirely new configuration with multiple rings of detectors.

3. **Mendelson 2003 Teaches Against Using Its Particular Detector Arrangement, Which Was Designed For Performing Experiments, For An Actual Monitoring Device**

110. Dr. Kenny asserts that a POSITA would have found it obvious to connect “multiple photodiodes together in parallel” to obtain “a larger total current akin to what would be generated from a single, large detector, which is what the ring of detectors in Aizawa is in effect trying to mimic.” Ex. 1003 ¶102. As discussed above, I disagree that Aizawa was “trying to mimic” a single large detector, and Dr. Kenny’s proposed change eliminates Aizawa’s principle of operation of monitoring individual detector signals to address problems related to sensor displacement.

111. In addition, Dr. Kenny does not explain why a POSITA “trying to mimic” a “single, large detector” would have instead created two different sets of photodiodes, with each individual set of photodiodes connected in parallel, as required by the claims. Even applying Dr. Kenny’s reasoning, his proposed combination would be “trying to mimic” two detectors—not a “single, large detector.” Dr. Kenny asserts Mendelson 2003 teaches “wiring two rings of photodiodes such that each ring/set of detectors ‘were wired in parallel’ to be a routine and conventional design choice.” Ex. 1003 ¶103. But Mendelson 2003 does not indicate two rings, each wired in parallel, was routine or conventional. Instead, Mendelson 2003 uses its particular configuration because it carried out

specific experiments comparing light intensity and LED drive currents for detectors arranged different distances from the central emitters. Ex. 1024 at 4. To take those individual measurement for comparison, each ring was wired in parallel. Ex. 1024 at 4. In practice, however, Mendelson 2003 teaches no benefits for this arrangement and instead states it “combin[ed] both PD sets to simulate a single large PD area,” and notes “battery longevity could be extended considerably by employing a wide annular PD”—not two different signal streams from two different parallel-connected rings. Ex. 1024 at 4.

112. Dr. Kenny speculates that a POSITA would be motivated to create two different signal streams by the possibility that “monitoring each signal stream (from each ring of detectors) separately allows the system to determine when the sensor device is so severely located that its position should be adjusted” and “can help detect ‘movement/breathing artifacts.’” Ex. 1003 ¶104. Dr. Kenny also refers generally to “various advantages during research, testing, and/or calibration.” Ex. 1003 ¶104. But Mendelson 2003 does not include any of these additional “motivations” as a reason to use a two ring structure in a monitoring device in any situation beyond the specific set of experiments reported in Mendelson 2003. Instead, Dr. Kenny points to a different reference, Mendelson ’799, which is not part of the combination. Ex. 1003 ¶104 (discussing Ex. 1025).

113. Dr. Kenny's use of Mendelson '799 makes no sense in the context of either Mendelson 2003 or his proposed combination. First, Mendelson '799's approach requires at least three different emitters operating at three different wavelengths. See Ex. 1025 13:19-30 (explaining use of W₁, W₂, and W₃), 11:65-67 ("three ratios (AC/DC) computed separately for each of the three wavelengths, namely W₁, W₂ and W₃"). In contrast, both Aizawa and Dr. Kenny's combination use one emitter and one wavelength of light. Ex. 1006 ¶[0010] ("a near infrared LED"); Ex. 1003 ¶95. Aizawa's single wavelength emitter cannot implement Dr. Kenny's alleged "multiple benefits" (Ex. 1003 ¶104), and therefore would not have motivated a POSITA. Any potential benefits stemming from Mendelson '799's three-wavelength approach are irrelevant to Aizawa and Dr. Kenny's proposed combination.

114. Dr. Kenny incorrectly suggests that Mendelson '799's inner ring of detectors and outer ring of detectors produce "two separate signal streams." Ex. 1003 ¶104. Mendelson '799 does not produce an individual signal stream for each ring, and warns against "summing the individual intensities of each photodetector and using the resulting value." Ex. 1025 12:39-44. Instead, Mendelson '799 uses signals "obtained from each of the discrete photodiodes individually" so that it can "selectively disregard" readings from individual photodiodes. Ex. 1025 12:37-13:7. Mendelson '799's benefit cited by Dr. Kenny

thus requires individual detector signals—not detectors connected in parallel as in Mendelson 2003 and in Dr. Kenny’s proposed combination. In my opinion, Mendelson ’799 would have dissuaded a POSITA from using Mendelson 2003’s parallel-connected detector configuration because it would eliminate Mendelson ’799’s cited benefit, which is derived from individual photodiode signals, by eliminating the ability to extract individual photodiode signals and analyze them individually.

115. Dr. Kenny also indicates that the proposed combination’s second ring introduces signal processing problems requiring even more redesign for Aizawa’s sensor. Ex. 1003 ¶¶105-106. Dr. Kenny offers the opinion that a POSITA would have “found it obvious, in some implementations, to keep each ring separately wired and connected to its own amplifier.” Ex. 1003 ¶106. Dr. Kenny suggests this further modification of an additional amplifier because “the inner ring is likely to produce far greater currents compared to the outer ring due to the above-noted exponential relationship between detected light intensity and distance from the LED.” Ex. 1003 ¶106. Dr. Kenny indicates this creates problems because the resulting different magnitude signals are not comparable without additional processing. Ex. 1003 ¶106. Without these further modifications, Dr. Kenny states, “signals detected by the near/first sets of detectors may drown out the weaker signals coming from the far/second sets of detectors, thereby diminishing

the enhanced sensitivity and collection efficiency achieved through the widened detection area.” Ex. 1003 ¶106. As discussed above (Section VII.C.2), however, the weaker signals at the outer ring are why a POSITA would have used Aizawa’s existing single ring embodiment with eight detectors and not a new, worse performing two ring arrangement.

116. Even if a POSITA did add a second ring of detectors, Mendelson 2003 itself undermines the notion that a POSITA would have kept the first and second ring of detectors separate and then made an additional modification to separately amplify the aggregated signals. Instead, Mendelson 2003 explains it “combin[ed] both PD sets to simulate *a single* large PD area” and notes “battery longevity could be extended considerably by employing *a* wide annular PD.” Ex. 1024 at 4 (emphasis added).

117. Thus, in my opinion, a POSITA would not have modified Aizawa based on Mendelson 2003 in the way proposed by Dr. Kenny.

D. Goldsmith Does Not Address The Deficiencies In Dr. Kenny’s Proposed Combination Of Aizawa, Ohsaki, and Mendelson 2003

118. Dr. Kenny’s combination also includes a fourth reference, Goldsmith. Ex. 1003 ¶¶85-93. Dr. Kenny states a “POSITA would have found it obvious to incorporate Aizawa’s wrist-worn pulse wave sensor with (i) two rings of photodiodes each connected in parallel (as per Mendelson-2003) and (ii) a protruding convex surface (as per Ohsaki) into Goldsmith’s integrated wrist-worn

watch controller device that includes, among its various features, a touch screen, network interface, and storage device.” Ex. 1003 ¶88. However, Dr. Kenny does not assert that Goldsmith cures the deficiencies in the proposed combination of Aizawa, Ohsaki, and Mendelson 2003. Thus, Dr. Kenny has not shown that claims 1, 14, and 27 are obvious in view of Aizawa, Ohsaki, Mendelson 2003, and Goldsmith.

E. The Challenged Dependent Claims Are Nonobvious Over Ground 1

119. As discussed above, in my opinion claims 1, 14, and 27 would not have been obvious over the cited references of Ground 1. In addition, in my opinion, the dependent claims would be nonobvious for at least the same reasons. *See* Sections VII.A-D, above.

F. Ground 2 Fails For The Same Reasons As Ground 1

120. Ground 2 only addresses dependent claim 13 and does not fix the deficiencies in Ground 1. Dependent claim 13 is thus nonobvious for the same reasons as explained with respect to Ground 1. Moreover, for the reasons discussed below, dependent claim 13 is non-obvious for additional reasons.

121. Ground 2 adds Sherman (Ex. 1047) to the proposed combination of Aizawa, Ohsaki, Mendelson 2003, and Goldsmith. Ex. 1003 ¶¶211-216. Dr. Kenny relies on Sherman for its discussion of a magnetic connector. Ex. 1003 ¶¶212, 214. Ohsaki, however, already includes a series of dedicated belts

designed to exert a specific pressure on the user's wrist. See Ex. 1014 ¶[0018] (“The belt...may be made from elastic material so that regular pressure is applied to the user's wrist....Therefore it is desirable that the pressure applied to the user's wrist...is limited to 5-15 mmHg.”). Ohsaki explains that this set of belts, used in conjunction with the sensor, “prevent[s] that light reflected by the surface of the skin or disturbance light from the outside penetrates the translucent board.” Ex. 1014 ¶[0018]. Ohsaki also requires a cushion “such as a sponge or gel” that, in combination with its system of belts, helps prevent sensor motion. Ex. 1014 ¶¶[0021], [0026].

122. A POSITA thus would have understood that any advantage from Ohsaki's convex board would also require Ohsaki's specific attachment arrangement, including multiple belts made from specific material and a cushion to prevent movement. These features are absent from Sherman. Indeed, Dr. Kenny does not explain how Sherman would have allowed consistent attachment of a sensor to the wrist at “5-15 mmHg,” as required by Ohsaki. Ex. 1014 ¶[0018]. In my opinion, a POSITA would not have been motivated to incorporate Sherman's attachment mechanism, which is designed for holding a wristwatch, and does not discuss any of the concerns involved with positioning an optical sensor. Ex. 1011 (Abstract: “A strap for holding a wristwatch...”); *see also* Ex. 1006 ¶[0026] (“the above belt 7 is fastened such that the acrylic transparent plate

6 becomes close to the artery 11 of the wrist 10”); Ex. 1014 ¶[0019] (“The dedicated belt 10 is attached to the detecting element 2 so that it can fix the detecting element 2 on the user’s wrist 4 in this way.”).

VIII. OATH

123. I declare that all statements made herein of my own knowledge are true and that all statements made on information and belief are believed to be true; and further that these statements were made with the knowledge that willful false statements and the like so made are punishable by fine or imprisonment, or both, under Section 1001 of Title 18 of the United States Code.

Dated: 8/12/21 By: Vijay K Madiseti
Vijay K. Madiseti, Ph.D