



(12) **United States Patent**
Kosuda et al.

(10) **Patent No.:** **US 6,198,951 B1**
(45) **Date of Patent:** **Mar. 6, 2001**

(54) **REFLECTION PHOTODETECTOR AND BIOLOGICAL INFORMATION MEASURING INSTRUMENT**

5,431,170	*	7/1995	Matthews	600/323
5,524,617	*	6/1996	Mannheimer	600/323
5,645,060	*	7/1997	Yorkey	600/323
5,830,137	*	11/1998	Scharf	600/323

(75) Inventors: **Tsukasa Kosuda**; **Yutaka Kondo**, both of Matsumoto; **Hajime Kurihara**; **Norimitsu Baba**, both of Shimosuwa-machi, all of (JP)

FOREIGN PATENT DOCUMENTS

50-16180	12/1975	(JP)	.
60-135029	7/1985	(JP)	.
3-129107	12/1991	(JP)	.
5-506802	10/1993	(JP)	.
7-88092	4/1995	(JP)	.
7-155312	6/1995	(JP)	.
7-308299	11/1995	(JP)	.
9-114955	5/1997	(JP)	.
9-299342	11/1997	(JP)	.

(73) Assignee: **Seiko Epson Corporation**, Tokyo (JP)

(*) Notice: Subject to any disclaimer, the term of this patent is extended or adjusted under 35 U.S.C. 154(b) by 0 days.

(21) Appl. No.: **09/297,438**

* cited by examiner

(22) PCT Filed: **Sep. 4, 1998**

Primary Examiner—John P. Lacyk
(74) *Attorney, Agent, or Firm*—Michael T. Gabrik

(86) PCT No.: **PCT/JP98/03972**

§ 371 Date: **Apr. 30, 1999**

(57) **ABSTRACT**

§ 102(e) Date: **Apr. 30, 1999**

(87) PCT Pub. No.: **WO99/12469**

PCT Pub. Date: **Mar. 18, 1999**

When emitted light from LED 31 is incident on photodiodes 32 and 33 with luminance Pa and Pb, currents ia and ib are generated according to luminance Pa and Pb. When outside light is incident through the finger tissues on photodiodes 32 and 33 with luminance Pc, current ic is produced. The current i1 (=ia+ic) generated by photodiode 32, and the current i2 (=ib-ic) generated by photodiode 33, are added at node X, and the current ic corresponding to outside light is thus cancelled. In addition, photodiodes 32 and 33 are disposed at different distances from LED 31. As a result, the current flowing to opamp 34 is current ia corresponding to luminance Pa because luminance Pb is extremely low. The opamp 34 then applies a current voltage conversion to generate pulse wave signal Vm.

(30) **Foreign Application Priority Data**

Sep. 5, 1997	(JP)	9-241426
Nov. 11, 1997	(JP)	9-308913

(51) **Int. Cl.⁷** **A61B 5/00**

(52) **U.S. Cl.** **600/323**

(58) **Field of Search** 600/322, 323, 600/336, 310, 316, 330, 340, 344

(56) **References Cited**

U.S. PATENT DOCUMENTS

5,285,784	*	2/1994	Secker	600/323
-----------	---	--------	--------	---------

19 Claims, 27 Drawing Sheets

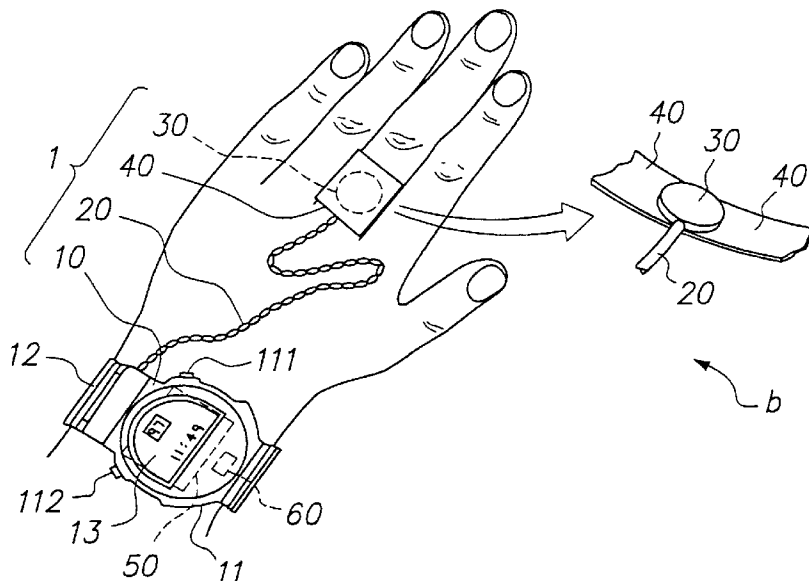

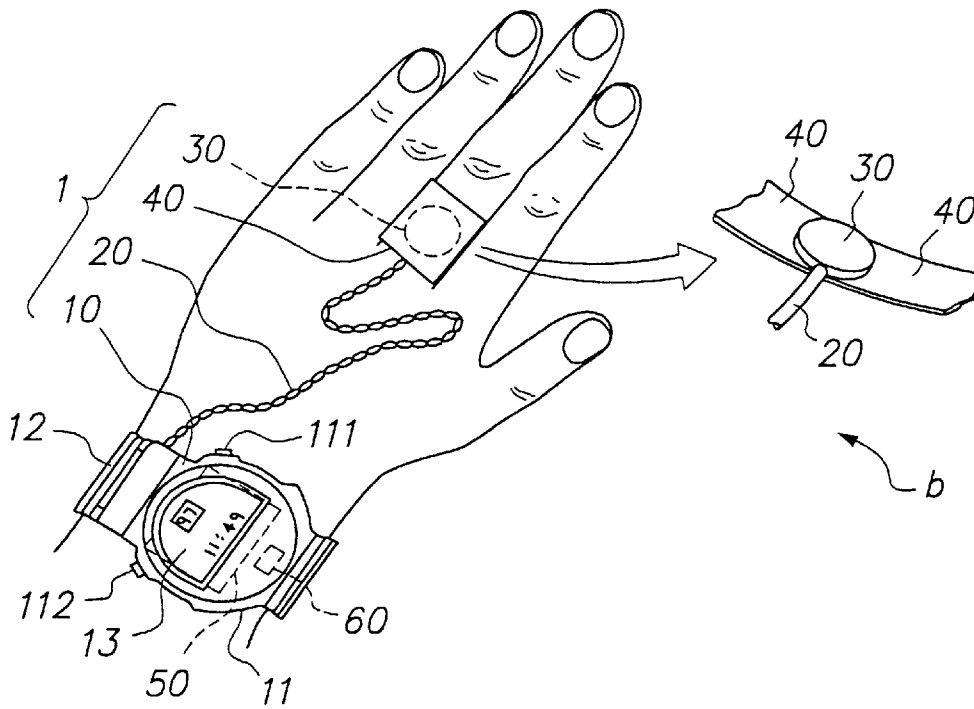

FIG. 1

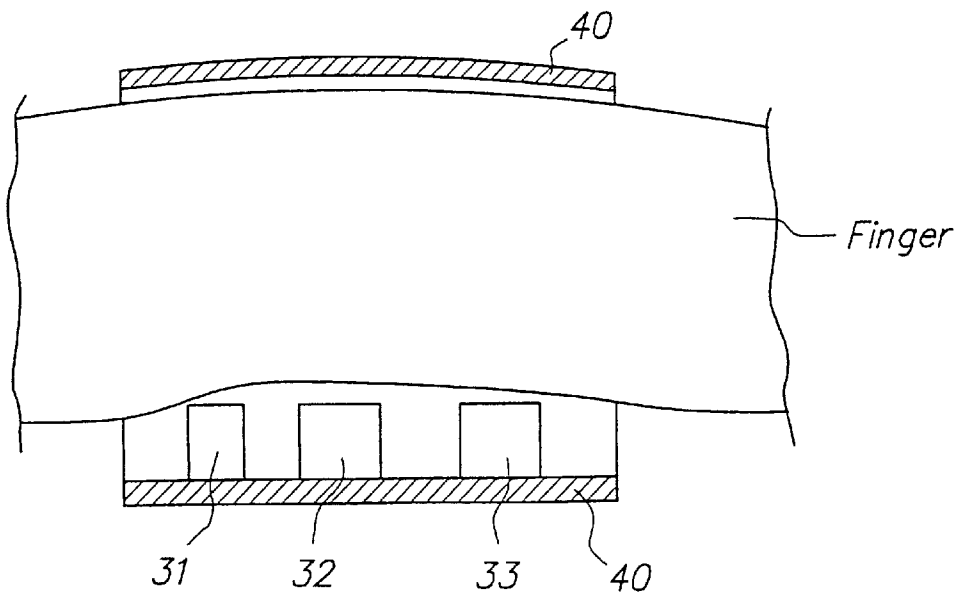

FIG. 2

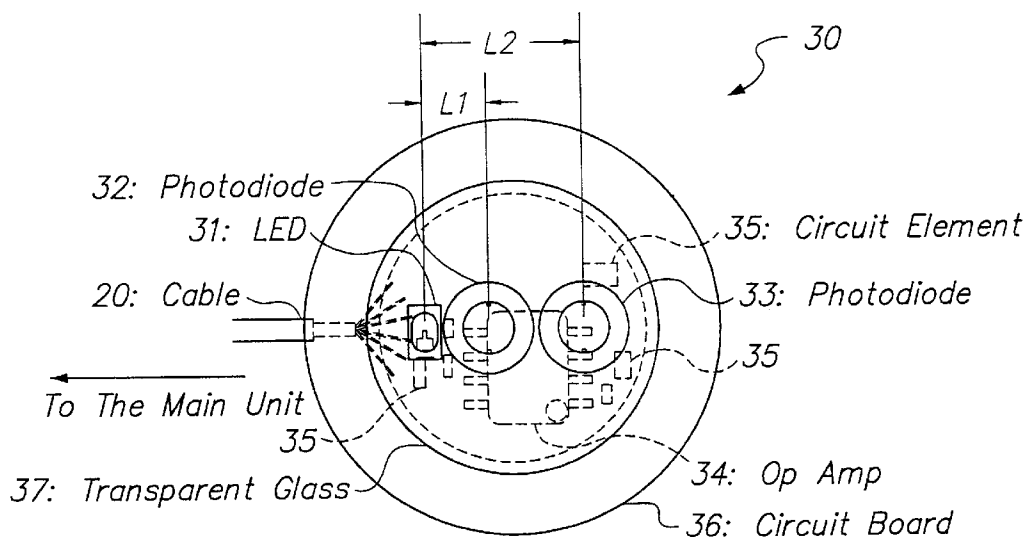

FIG. 3

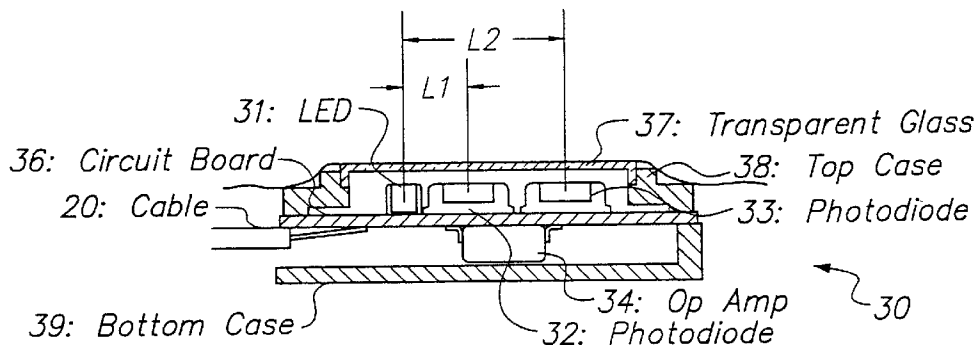

FIG. 4

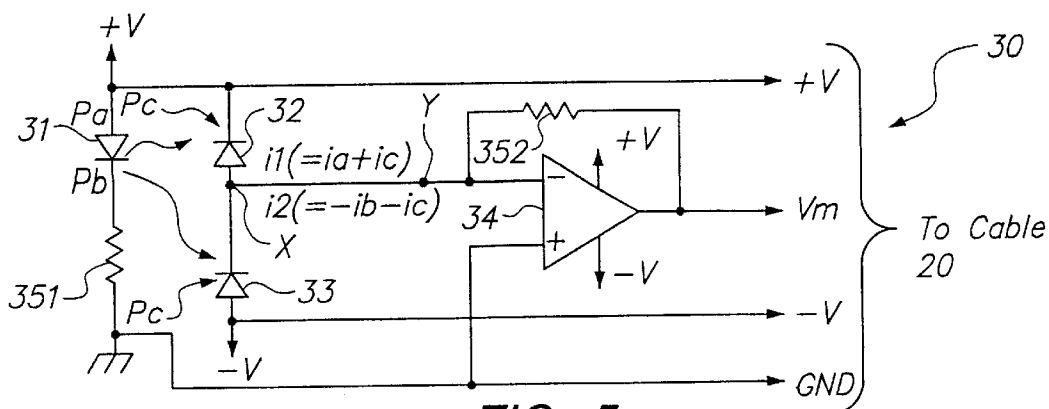

FIG. 5

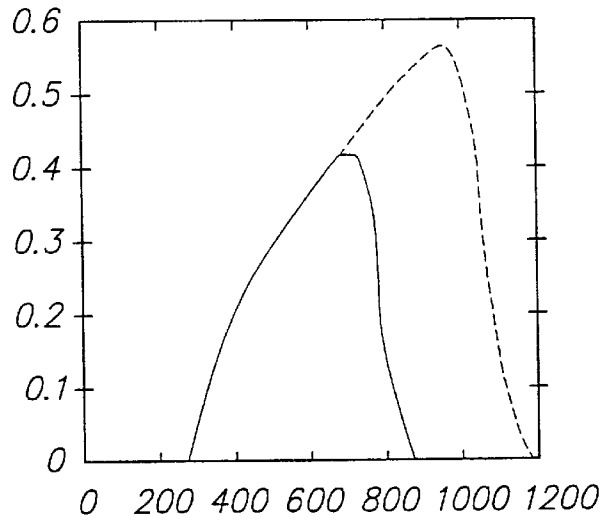

FIG. 6

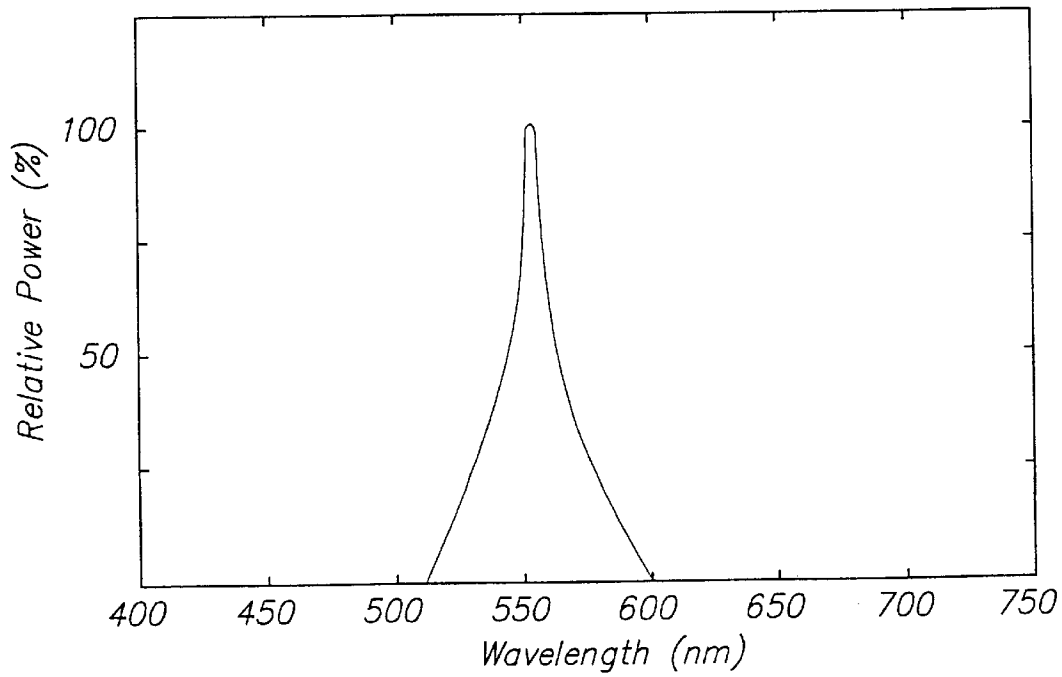

FIG. 7

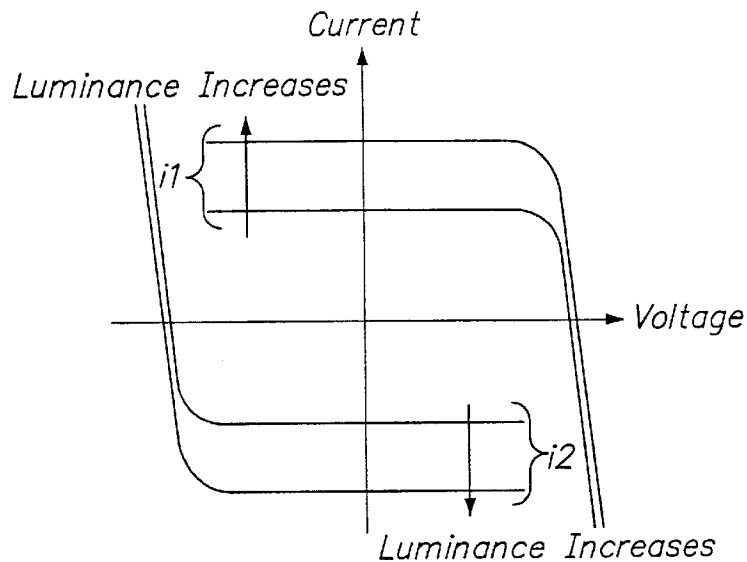

FIG. 8

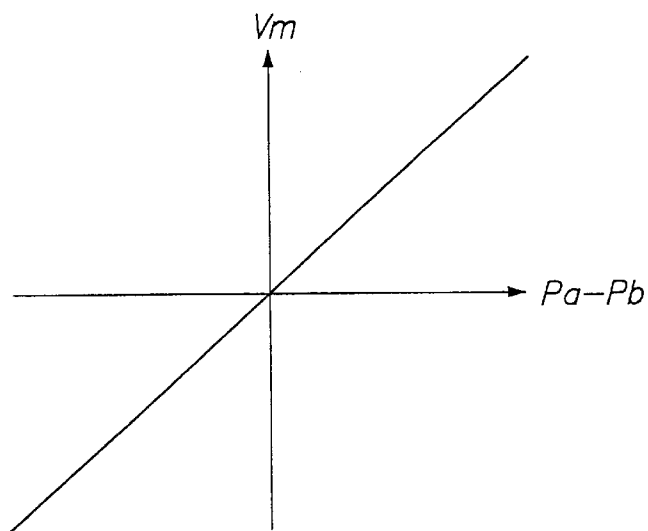

FIG. 9

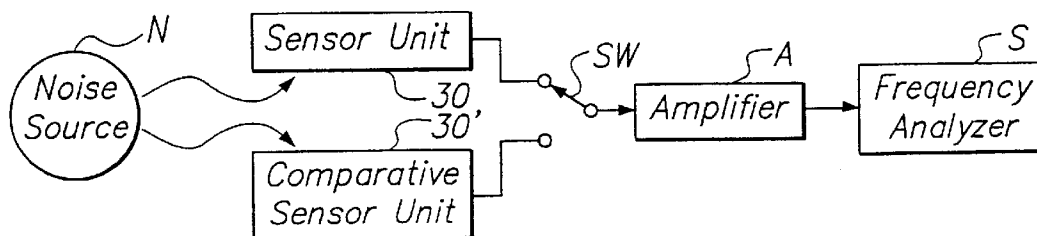

FIG. 12

Explore Litigation Insights

Docket Alarm provides insights to develop a more informed litigation strategy and the peace of mind of knowing you're on top of things.

Real-Time Litigation Alerts



Keep your litigation team up-to-date with **real-time alerts** and advanced team management tools built for the enterprise, all while greatly reducing PACER spend.

Our comprehensive service means we can handle Federal, State, and Administrative courts across the country.

Advanced Docket Research



With over 230 million records, Docket Alarm's cloud-native docket research platform finds what other services can't. Coverage includes Federal, State, plus PTAB, TTAB, ITC and NLRB decisions, all in one place.

Identify arguments that have been successful in the past with full text, pinpoint searching. Link to case law cited within any court document via Fastcase.

Analytics At Your Fingertips



Learn what happened the last time a particular judge, opposing counsel or company faced cases similar to yours.

Advanced out-of-the-box PTAB and TTAB analytics are always at your fingertips.

API

Docket Alarm offers a powerful API (application programming interface) to developers that want to integrate case filings into their apps.

LAW FIRMS

Build custom dashboards for your attorneys and clients with live data direct from the court.

Automate many repetitive legal tasks like conflict checks, document management, and marketing.

FINANCIAL INSTITUTIONS

Litigation and bankruptcy checks for companies and debtors.

E-DISCOVERY AND LEGAL VENDORS

Sync your system to PACER to automate legal marketing.