

**REQUEST FOR CERTIFICATE OF CORRECTION**

First Inventor	:	Ammar Al-Ali
App. No.	:	16/226249
Filed	:	December 19, 2018
Patent No.	:	10,470,695
Issue Date	:	November 12, 2019
Title	:	ADVANCED PULSE OXIMETRY SENSOR
Conf. No.	:	1002

Commissioner for Patents  
Office of Data Management  
**Attention:** Certificates of Correction Branch  
P.O. Box 1450  
Alexandria, VA 22313-1450

Dear Commissioner:

Enclosed for filing is a Certificate of Correction in connection with the above-identified patent.

Some of the errors cited in the Certificate of Correction appear to have been incurred through the fault of the PTO (see 35 USC § 254, 37 CFR § 1.322, and MPEP § 1480). However, because this may not apply to each item in the Certificate of Correction, the \$150 fee under 37 CFR § 1.20(a) is submitted herewith. Please charge any additional fees to our Deposit Account No. 11-1410.

Respectfully submitted,

KNOBBE, MARTENS, OLSON & BEAR, LLP

Dated: August 10, 2020

By:           /Jarom Kesler/            
Jarom D. Kesler  
Registration No. 57,046  
Registered Practitioner  
(949) 760-0404

33262661

**UNITED STATES PATENT AND TRADEMARK OFFICE  
CERTIFICATE OF CORRECTION**

**PATENT NO.** : 10,470,695  
**APPLICATION NO.** : 16/226249  
**ISSUE DATE** : November 12, 2019  
**INVENTOR(S)** : Ammar Al-Ali

Page 1 of 1

It is certified that an error appears or errors appear in the above-identified patent and that said Letters Patent is hereby corrected as shown below:

- On Page 9, Column 1, Item (56), Line 30, under U.S. Patent Documents, delete “Ai” and insert --Al--.
- On Page 9, Column 1, Item (56), Line 35, under U.S. Patent Documents, delete “Ai” and insert --Al--.
- On Page 9, Column 1, Item (56), Line 39, under U.S. Patent Documents, delete “Ai” and insert --Al--.
- On Page 9, Column 2, Item (56), Line 6, under U.S. Patent Documents, delete “Ai” and insert --Al--.
- On Page 9, Column 2, Item (56), Line 8, under U.S. Patent Documents, delete “Ai” and insert --Al--.
- On Page 9, Column 2, Item (56), Line 9, under U.S. Patent Documents, delete “Ai” and insert --Al--.
- On Page 9, Column 2, Item (56), Line 10, under U.S. Patent Documents, delete “Ai” and insert --Al--.
- On Page 9, Column 2, Item (56), Line 11, under U.S. Patent Documents, delete “Ai” and insert --Al--.
- On Page 9, Column 2, Item (56), Line 12, under U.S. Patent Documents, delete “Ai” and insert --Al--.
- On Page 9, Column 2, Item (56), Line 13, under U.S. Patent Documents, delete “Ai” and insert --Al--.
- On Page 9, Column 2, Item (56), Line 14, under U.S. Patent Documents, delete “Ai” and insert --Al--.
- On Page 9, Column 2, Item (56), Line 15, under U.S. Patent Documents, delete “Ai” and insert --Al--.
- On Page 9, Column 2, Item (56), Line 16, under U.S. Patent Documents, delete “Ai” and insert --Al--.
- On Sheet 7 of 7, FIG. 8, Reference Number 810, Line 2 (Approx.), delete “PROCESSOR” and insert --PROCESSOR--.
- In Column 1, Line 39, delete “ $\mu_{a,\lambda}$ ” and insert -- $\mu_{a,\lambda}$ --.
- In Column 1, Line 42 (Approx.), delete “ $\mu_{a,\lambda}$ ” and insert -- $\mu_{a,\lambda}$ --.
- In Column 7, Line 52, delete “(also” and insert --also--.
- In Column 8, Line 1, delete “Gaussian” and insert --Gaussian--.
- In Column 12, Line 37, delete “light emitting” and insert --light-emitting--.

**MAILING ADDRESS OF SENDER:**

Jarom D. Kesler  
KNOBBE, MARTENS, OLSON & BEAR, LLP  
2040 Main Street, 14<sup>th</sup> Floor  
Irvine, California 92614

DOCKET NO. MAS.1007C1

## Electronic Patent Application Fee Transmittal

<b>Application Number:</b>	16226249			
<b>Filing Date:</b>	19-Dec-2018			
<b>Title of Invention:</b>	ADVANCED PULSE OXIMETRY SENSOR			
<b>First Named Inventor/Applicant Name:</b>	Ammar Al-Ali			
<b>Filer:</b>	Jarom D. Kesler/Lorraine Yoo Lin			
<b>Attorney Docket Number:</b>	MAS.1007C1			
Filed as Large Entity				
<b>Filing Fees for Utility under 35 USC 111(a)</b>				
<b>Description</b>	<b>Fee Code</b>	<b>Quantity</b>	<b>Amount</b>	<b>Sub-Total in USD(\$)</b>
<b>Basic Filing:</b>				
<b>Pages:</b>				
<b>Claims:</b>				
<b>Miscellaneous-Filing:</b>				
<b>Petition:</b>				
<b>Patent-Appeals-and-Interference:</b>				
<b>Post-Allowance-and-Post-Issuance:</b>				
CERTIFICATE OF CORRECTION	1811	1	150	150

Description	Fee Code	Quantity	Amount	Sub-Total in USD(\$)
<b>Extension-of-Time:</b>				
<b>Miscellaneous:</b>				
<b>Total in USD (\$)</b>				<b>150</b>



## Electronic Acknowledgement Receipt

<b>EFS ID:</b>	40237895
<b>Application Number:</b>	16226249
<b>International Application Number:</b>	
<b>Confirmation Number:</b>	1002
<b>Title of Invention:</b>	ADVANCED PULSE OXIMETRY SENSOR
<b>First Named Inventor/Applicant Name:</b>	Ammar Al-Ali
<b>Customer Number:</b>	64735
<b>Filer:</b>	Jarom D. Kesler/Elizabeth Rutherford
<b>Filer Authorized By:</b>	Jarom D. Kesler
<b>Attorney Docket Number:</b>	MAS.1007C1
<b>Receipt Date:</b>	10-AUG-2020
<b>Filing Date:</b>	19-DEC-2018
<b>Time Stamp:</b>	14:43:20
<b>Application Type:</b>	Utility under 35 USC 111(a)

### Payment information:

Submitted with Payment	yes
Payment Type	CARD
Payment was successfully received in RAM	\$150
RAM confirmation Number	E202080E43460435
Deposit Account	111410
Authorized User	Elizabeth Rutherford

The Director of the USPTO is hereby authorized to charge indicated fees and credit any overpayment as follows:

37 CFR 1.16 (National application filing, search, and examination fees)

37 CFR 1.17 (Patent application and reexamination processing fees)

--	--	--	--	--	--

**File Listing:**

Document Number	Document Description	File Name	File Size(Bytes)/ Message Digest	Multi Part /.zip	Pages (if appl.)
1	Request for Certificate of Correction	1007C1.pdf	36064	no	2
			6627fefe4404999932ca0ace6a8903afb7065675		

**Warnings:**

**Information:**

2	Fee Worksheet (SB06)	fee-info.pdf	30127	no	2
			c253164ccce834a799f3210e325ac76d51047ed7		

**Warnings:**

**Information:**

<b>Total Files Size (in bytes):</b>	66191
-------------------------------------	-------

**This Acknowledgement Receipt evidences receipt on the noted date by the USPTO of the indicated documents, characterized by the applicant, and including page counts, where applicable. It serves as evidence of receipt similar to a Post Card, as described in MPEP 503.**

**New Applications Under 35 U.S.C. 111**

**If a new application is being filed and the application includes the necessary components for a filing date (see 37 CFR 1.53(b)-(d) and MPEP 506), a Filing Receipt (37 CFR 1.54) will be issued in due course and the date shown on this Acknowledgement Receipt will establish the filing date of the application.**

**National Stage of an International Application under 35 U.S.C. 371**

**If a timely submission to enter the national stage of an international application is compliant with the conditions of 35 U.S.C. 371 and other applicable requirements a Form PCT/DO/EO/903 indicating acceptance of the application as a national stage submission under 35 U.S.C. 371 will be issued in addition to the Filing Receipt, in due course.**

**New International Application Filed with the USPTO as a Receiving Office**

**If a new international application is being filed and the international application includes the necessary components for an international filing date (see PCT Article 11 and MPEP 1810), a Notification of the International Application Number and of the International Filing Date (Form PCT/RO/105) will be issued in due course, subject to prescriptions concerning national security, and the date shown on this Acknowledgement Receipt will establish the international filing date of the application.**



UNITED STATES PATENT AND TRADEMARK OFFICE

UNITED STATES DEPARTMENT OF COMMERCE
United States Patent and Trademark Office
Address: COMMISSIONER FOR PATENTS
P.O. Box 1450
Alexandria, Virginia 22313-1450
www.uspto.gov

Table with 5 columns: APPLICATION NO., ISSUE DATE, PATENT NO., ATTORNEY DOCKET NO., CONFIRMATION NO.
Row 1: 16/226,249, 11/12/2019, 10470695, MAS.1007C1, 1002

64735 7590 10/23/2019
KNOBBE, MARTENS, OLSON & BEAR, LLP
MASIMO CORPORATION (MASIMO)
2040 MAIN STREET
FOURTEENTH FLOOR
IRVINE, CA 92614

ISSUE NOTIFICATION

The projected patent number and issue date are specified above.

Determination of Patent Term Adjustment under 35 U.S.C. 154 (b)
(application filed on or after May 29, 2000)

The Patent Term Adjustment is 0 day(s). Any patent to issue from the above-identified application will include an indication of the adjustment on the front page.

If a Continued Prosecution Application (CPA) was filed in the above-identified application, the filing date that determines Patent Term Adjustment is the filing date of the most recent CPA.

Applicant will be able to obtain more detailed information by accessing the Patent Application Information Retrieval (PAIR) WEB site (http://pair.uspto.gov).

Any questions regarding the Patent Term Extension or Adjustment determination should be directed to the Office of Patent Legal Administration at (571)-272-7702. Questions relating to issue and publication fee payments should be directed to the Application Assistance Unit (AAU) of the Office of Data Management (ODM) at (571)-272-4200.

APPLICANT(s) (Please see PAIR WEB site http://pair.uspto.gov for additional applicants):

Ammar Al-Ali, San Juan Capistrano, CA;
MASIMO CORPORATION, Irvine, CA;

The United States represents the largest, most dynamic marketplace in the world and is an unparalleled location for business investment, innovation, and commercialization of new technologies. The USA offers tremendous resources and advantages for those who invest and manufacture goods here. Through SelectUSA, our nation works to encourage and facilitate business investment. To learn more about why the USA is the best country in the world to develop technology, manufacture products, and grow your business, visit SelectUSA.gov.



# United States Patent and Trademark Office

*Office of the Chief Financial Officer*

Document Code:WFEE

User :C46472

Sale Accounting Date:10/02/2019

---

Sale Item Reference Number	Effective Date
16226249	09/30/2019

Document Number	Fee Code	Fee Code Description	Amount Paid	Payment Method
I201902841092646	1501	UTILITY APPL ISSUE FEE	\$1,000.00	Salea

**PART B - FEE(S) TRANSMITTAL**

Complete and send this form, together with applicable fee(s), by mail or fax, or via EFS-Web.

By mail, send to: Mail Stop ISSUE FEE  
Commissioner for Patents  
P.O. Box 1450  
Alexandria, Virginia 22313-1450

By fax, send to: (571)-273-2885

**INSTRUCTIONS:** This form should be used for transmitting the ISSUE FEE and PUBLICATION FEE (if required). Blocks 1 through 5 should be completed where appropriate. All further correspondence including the Patent, advance orders and notification of maintenance fees will be mailed to the current correspondence address as indicated unless corrected below or directed otherwise in Block 1, by (a) specifying a new correspondence address; and/or (b) indicating a separate "FEE ADDRESS" for maintenance fee notifications.

CURRENT CORRESPONDENCE ADDRESS (Note: Use Block 1 for any change of address)

64735 7590 09/27/2019  
KNOBBE, MARTENS, OLSON & BEAR, LLP  
MASIMO CORPORATION (MASIMO)  
2040 MAIN STREET  
FOURTEENTH FLOOR  
IRVINE, CA 92614

Note: A certificate of mailing can only be used for domestic mailings of the Fee(s) Transmittal. This certificate cannot be used for any other accompanying papers. Each additional paper, such as an assignment or formal drawing, must have its own certificate of mailing or transmission.

**Certificate of Mailing or Transmission**

I hereby certify that this Fee(s) Transmittal is being deposited with the United States Postal Service with sufficient postage for first class mail in an envelope addressed to the Mail Stop ISSUE FEE address above, or being transmitted to the USPTO via EFS-Web or by facsimile to (571) 273-2885, on the date below.

(Typed or printed name)
(Signature)
(Date)

APPLICATION NO.	FILING DATE	FIRST NAMED INVENTOR	ATTORNEY DOCKET NO.	CONFIRMATION NO.
16/226,249	12/19/2018	Ammar Al-Ali	MAS.1007C1	1002

TITLE OF INVENTION: ADVANCED PULSE OXIMETRY SENSOR

APPLN. TYPE	ENTITY STATUS	ISSUE FEE DUE	PUBLICATION FEE DUE	PREV. PAID ISSUE FEE	TOTAL FEE(S) DUE	DATE DUE
nonprovisional	UNDISCOUNTED	\$1000	\$0.00	\$1000.00	\$0	12/27/2019

EXAMINER	ART UNIT	CLASS-SUBCLASS
FARDANESH, MARJAN	3791	600-323000

1. Change of correspondence address or indication of "Fee Address" (37 CFR 1.363).

- Change of correspondence address (or Change of Correspondence Address form PTO/SB/122) attached.
- "Fee Address" indication (or "Fee Address" Indication form PTO/SB/47; Rev 03-09 or more recent) attached. **Use of a Customer Number is required.**

2. For printing on the patent front page, list

- (1) The names of up to 3 registered patent attorneys or agents OR, alternatively,  
(2) The name of a single firm (having as a member a registered attorney or agent) and the names of up to 2 registered patent attorneys or agents. If no name is listed, no name will be printed.

- 1 Knobbe, Martens,  
2 Olson & Bear, LLP  
3 \_\_\_\_\_

3. ASSIGNEE NAME AND RESIDENCE DATA TO BE PRINTED ON THE PATENT (print or type)

PLEASE NOTE: Unless an assignee is identified below, no assignee data will appear on the patent. If an assignee is identified below, the document must have been previously recorded, or filed for recordation, as set forth in 37 CFR 3.11 and 37 CFR 3.81(a). Completion of this form is NOT a substitute for filing an assignment.

(A) NAME OF ASSIGNEE

(B) RESIDENCE: (CITY and STATE OR COUNTRY)

**Masimo Corporation**

**Irvine, CA**

Please check the appropriate assignee category or categories (will not be printed on the patent):  Individual  Corporation or other private group entity  Government

4a. Fees submitted:  Issue Fee  Publication Fee (if required)  Advance Order - # of Copies \_\_\_\_\_

4b. Method of Payment: (Please first reapply any previously paid fee shown above)

Electronic Payment via EFS-Web  Enclosed check  Non-electronic payment by credit card (Attach form PTO-2038)

The Director is hereby authorized to charge the required fee(s), any deficiency, or credit any overpayment to Deposit Account No. **11-1410**

5. Change in Entity Status (from status indicated above)

- Applicant certifying micro entity status. See 37 CFR 1.29
- Applicant asserting small entity status. See 37 CFR 1.27
- Applicant changing to regular undiscounted fee status.

**NOTE:** Absent a valid certification of Micro Entity Status (see forms PTO/SB/15A and 15B), issue fee payment in the micro entity amount will not be accepted at the risk of application abandonment.  
**NOTE:** If the application was previously under micro entity status, checking this box will be taken to be a notification of loss of entitlement to micro entity status.  
**NOTE:** Checking this box will be taken to be a notification of loss of entitlement to small or micro entity status, as applicable.

**NOTE:** This form must be signed in accordance with 37 CFR 1.31 and 1.33. See 37 CFR 1.4 for signature requirements and certifications.

Authorized Signature /Aaron S. Johnson/ Date September 30, 2019  
Typed or printed name Aaron S. Johnson Registration No. 74,164

## Electronic Acknowledgement Receipt

<b>EFS ID:</b>	37315738
<b>Application Number:</b>	16226249
<b>International Application Number:</b>	
<b>Confirmation Number:</b>	1002
<b>Title of Invention:</b>	ADVANCED PULSE OXIMETRY SENSOR
<b>First Named Inventor/Applicant Name:</b>	Ammar Al-Ali
<b>Customer Number:</b>	64735
<b>Filer:</b>	Aaron Samuel Johnson/ThuyQuyen Nguyen
<b>Filer Authorized By:</b>	Aaron Samuel Johnson
<b>Attorney Docket Number:</b>	MAS.1007C1
<b>Receipt Date:</b>	30-SEP-2019
<b>Filing Date:</b>	19-DEC-2018
<b>Time Stamp:</b>	18:51:49
<b>Application Type:</b>	Utility under 35 USC 111(a)

### Payment information:

Submitted with Payment	no
------------------------	----

### File Listing:

Document Number	Document Description	File Name	File Size(Bytes)/ Message Digest	Multi Part /.zip	Pages (if appl.)
1	Issue Fee Payment (PTO-85B)	ISSUE-FEE_MAS1007C1.PDF	217542 bfd066f2fac10d43db28f17c88efe8b7d2c9bae3	no	1

### Warnings:

<b>Information:</b>	
<b>Total Files Size (in bytes):</b>	217542
<p><b>This Acknowledgement Receipt evidences receipt on the noted date by the USPTO of the indicated documents, characterized by the applicant, and including page counts, where applicable. It serves as evidence of receipt similar to a Post Card, as described in MPEP 503.</b></p> <p><b><u>New Applications Under 35 U.S.C. 111</u></b>  <b>If a new application is being filed and the application includes the necessary components for a filing date (see 37 CFR 1.53(b)-(d) and MPEP 506), a Filing Receipt (37 CFR 1.54) will be issued in due course and the date shown on this Acknowledgement Receipt will establish the filing date of the application.</b></p> <p><b><u>National Stage of an International Application under 35 U.S.C. 371</u></b>  <b>If a timely submission to enter the national stage of an international application is compliant with the conditions of 35 U.S.C. 371 and other applicable requirements a Form PCT/DO/EO/903 indicating acceptance of the application as a national stage submission under 35 U.S.C. 371 will be issued in addition to the Filing Receipt, in due course.</b></p> <p><b><u>New International Application Filed with the USPTO as a Receiving Office</u></b>  <b>If a new international application is being filed and the international application includes the necessary components for an international filing date (see PCT Article 11 and MPEP 1810), a Notification of the International Application Number and of the International Filing Date (Form PCT/RO/105) will be issued in due course, subject to prescriptions concerning national security, and the date shown on this Acknowledgement Receipt will establish the international filing date of the application.</b></p>	

**Best Available Copy**  
**PART B FEE(S) TRANSMITTAL**

Complete and send this form, together with applicable fee(s), by mail or fax, or via EFS-Web.

By mail, send to: Mail Stop ISSUE FEE  
Commissioner for Patents  
P.O. Box 1450  
Alexandria, Virginia 22313-1450

By fax, send to: (571)-273-2885

**INSTRUCTIONS:** This form should be used for transmitting the ISSUE FEE and PUBLICATION FEE (if required). Blocks 1 through 5 should be completed where appropriate. All further correspondence including the Patent, advance orders and notification of maintenance fees will be mailed to the current correspondence address as indicated unless corrected below or directed otherwise in Block 1, by (a) specifying a new correspondence address; and/or (b) indicating a separate "FEE ADDRESS" for maintenance fee notifications.

CURRENT CORRESPONDENCE ADDRESS (Note: Use Block 1 for any change of address)

64735 7590 09/27/2019  
KNOBBE, MARTENS, OLSON & BEAR, LLP  
MASIMO CORPORATION (MASIMO)  
2040 MAIN STREET  
FOURTEENTH FLOOR  
IRVINE, CA 92614



Note: A certificate of mailing can only be used for domestic mailings of the Fee(s) Transmittal. This certificate cannot be used for any other accompanying papers. Each additional paper, such as an assignment or formal drawing, must have its own certificate of mailing or transmission.

**Certificate of Mailing or Transmission**

I hereby certify that this Fee(s) Transmittal is being deposited with the United States Postal Service with sufficient postage for first class mail in an envelope addressed to the Mail Stop ISSUE FEE address above, or being transmitted to the USPTO via EFS-Web or by facsimile to (571) 273-2885, on the date below.

_____	(Typed or printed name)
_____	(Signature)
_____	(Date)

APPLICATION NO.	FILING DATE	FIRST NAMED INVENTOR	ATTORNEY DOCKET NO.	CONFIRMATION NO.
16/226,249	12/19/2018	Ammar Al-Ali	MAS.1007C1	1002

TITLE OF INVENTION: ADVANCED PULSE OXIMETRY SENSOR

APPLN. TYPE	ENTITY STATUS	ISSUE FEE DUE	PUBLICATION FEE DUE	PREV. PAID ISSUE FEE	TOTAL FEE(S) DUE	DATE DUE
nonprovisional	UNDISCOUNTED	\$1000	\$0.00	\$1000.00	\$0	12/27/2019

EXAMINER	ART UNIT	CLASS-SUBCLASS
FARDANESH, MARJAN	3791	600-323000

1. Change of correspondence address or indication of "Fee Address" (37 CFR 1.363).

Change of correspondence address (or Change of Correspondence Address form PTO/SB/122) attached.

"Fee Address" indication (or "Fee Address" Indication form PTO/SB/47; Rev 03-09 or more recent) attached. Use of a Customer Number is required.

2. For printing on the patent front page, list

(1) The names of up to 3 registered patent attorneys or agents OR, alternatively,

(2) The name of a single firm (having as a member a registered attorney or agent) and the names of up to 2 registered patent attorneys or agents. If no name is listed, no name will be printed.

1 Knobbe, Martens,

2 Olson & Bear, LLP

3 \_\_\_\_\_

3. ASSIGNEE NAME AND RESIDENCE DATA TO BE PRINTED ON THE PATENT (print or type)

PLEASE NOTE: Unless an assignee is identified below, no assignee data will appear on the patent. If an assignee is identified below, the document must have been previously recorded, or filed for recordation, as set forth in 37 CFR 3.11 and 37 CFR 3.81(a). Completion of this form is NOT a substitute for filing an assignment.

(A) NAME OF ASSIGNEE: Masimo Corporation

(B) RESIDENCE: (CITY and STATE OR COUNTRY) Irvine, CA

Please check the appropriate assignee category or categories (will not be printed on the patent):  Individual  Corporation or other private group entity  Government

4a. Fees submitted:  Issue Fee  Publication Fee (if required)  Advance Order - # of Copies \_\_\_\_\_

4b. Method of Payment: (Please first reapply any previously paid fee shown above)

Electronic Payment via EFS-Web  Enclosed check  Non-electronic payment by credit card (Attach form PTO-2038)

The Director is hereby authorized to charge the required fee(s), any deficiency, or credit any overpayment to Deposit Account No. 11-1410

5. Change in Entity Status (from status indicated above)

Applicant certifying micro entity status. See 37 CFR 1.29

Applicant asserting small entity status. See 37 CFR 1.27

Applicant changing to regular undiscounted fee status.

**NOTE:** Absent a valid certification of Micro Entity Status (see forms PTO/SB/15A and 15B), issue fee payment in the micro entity amount will not be accepted at the risk of application abandonment.

**NOTE:** If the application was previously under micro entity status, checking this box will be taken to be a notification of loss of entitlement to micro entity status.

**NOTE:** Checking this box will be taken to be a notification of loss of entitlement to small or micro entity status, as applicable.

NOTE: This form must be signed in accordance with 37 CFR 1.31 and 1.33. See 37 CFR 1.4 for signature requirements and certifications.

Authorized Signature /Aaron S. Johnson/ Date September 30, 2019

Typed or printed name Aaron S. Johnson Registration No. 74,164





UNITED STATES PATENT AND TRADEMARK OFFICE

UNITED STATES DEPARTMENT OF COMMERCE
United States Patent and Trademark Office
Address: COMMISSIONER FOR PATENTS
P.O. Box 1450
Alexandria, Virginia 22313-1450
www.uspto.gov

NOTICE OF ALLOWANCE AND FEE(S) DUE

64735 7590 09/27/2019
KNOBBE, MARTENS, OLSON & BEAR, LLP
MASIMO CORPORATION (MASIMO)
2040 MAIN STREET
FOURTEENTH FLOOR
IRVINE, CA 92614

EXAMINER
FARDANESH, MARJAN

ART UNIT PAPER NUMBER

3791

DATE MAILED: 09/27/2019

Table with 5 columns: APPLICATION NO., FILING DATE, FIRST NAMED INVENTOR, ATTORNEY DOCKET NO., CONFIRMATION NO.
16/226,249 12/19/2018 Ammar Al-Ali MAS.1007C1 1002

TITLE OF INVENTION: ADVANCED PULSE OXIMETRY SENSOR

Table with 7 columns: APPLN. TYPE, ENTITY STATUS, ISSUE FEE DUE, PUBLICATION FEE DUE, PREV. PAID ISSUE FEE, TOTAL FEE(S) DUE, DATE DUE
nonprovisional UNDISCOUNTED \$1000 \$0.00 \$1000.00 \$0 12/27/2019

THE APPLICATION IDENTIFIED ABOVE HAS BEEN EXAMINED AND IS ALLOWED FOR ISSUANCE AS A PATENT. PROSECUTION ON THE MERITS IS CLOSED. THIS NOTICE OF ALLOWANCE IS NOT A GRANT OF PATENT RIGHTS. THIS APPLICATION IS SUBJECT TO WITHDRAWAL FROM ISSUE AT THE INITIATIVE OF THE OFFICE OR UPON PETITION BY THE APPLICANT. SEE 37 CFR 1.313 AND MPEP 1308.

THE ISSUE FEE AND PUBLICATION FEE (IF REQUIRED) MUST BE PAID WITHIN THREE MONTHS FROM THE MAILING DATE OF THIS NOTICE OR THIS APPLICATION SHALL BE REGARDED AS ABANDONED. THIS STATUTORY PERIOD CANNOT BE EXTENDED. SEE 35 U.S.C. 151. THE ISSUE FEE DUE INDICATED ABOVE DOES NOT REFLECT A CREDIT FOR ANY PREVIOUSLY PAID ISSUE FEE IN THIS APPLICATION. IF AN ISSUE FEE HAS PREVIOUSLY BEEN PAID IN THIS APPLICATION (AS SHOWN ABOVE), THE RETURN OF PART B OF THIS FORM WILL BE CONSIDERED A REQUEST TO REAPPLY THE PREVIOUSLY PAID ISSUE FEE TOWARD THE ISSUE FEE NOW DUE.

HOW TO REPLY TO THIS NOTICE:

I. Review the ENTITY STATUS shown above. If the ENTITY STATUS is shown as SMALL or MICRO, verify whether entitlement to that entity status still applies.

If the ENTITY STATUS is the same as shown above, pay the TOTAL FEE(S) DUE shown above.

If the ENTITY STATUS is changed from that shown above, on PART B - FEE(S) TRANSMITTAL, complete section number 5 titled "Change in Entity Status (from status indicated above)".

For purposes of this notice, small entity fees are 1/2 the amount of undiscounted fees, and micro entity fees are 1/2 the amount of small entity fees.

II. PART B - FEE(S) TRANSMITTAL, or its equivalent, must be completed and returned to the United States Patent and Trademark Office (USPTO) with your ISSUE FEE and PUBLICATION FEE (if required). If you are charging the fee(s) to your deposit account, section "4b" of Part B - Fee(s) Transmittal should be completed and an extra copy of the form should be submitted. If an equivalent of Part B is filed, a request to reapply a previously paid issue fee must be clearly made, and delays in processing may occur due to the difficulty in recognizing the paper as an equivalent of Part B.

III. All communications regarding this application must give the application number. Please direct all communications prior to issuance to Mail Stop ISSUE FEE unless advised to the contrary.

IMPORTANT REMINDER: Maintenance fees are due in utility patents issuing on applications filed on or after Dec. 12, 1980. It is patentee's responsibility to ensure timely payment of maintenance fees when due. More information is available at www.uspto.gov/PatentMaintenanceFees.

**PART B - FEE(S) TRANSMITTAL**

Complete and send this form, together with applicable fee(s), by mail or fax, or via EFS-Web.

By mail, send to: Mail Stop ISSUE FEE  
 Commissioner for Patents  
 P.O. Box 1450  
 Alexandria, Virginia 22313-1450

By fax, send to: (571)-273-2885

**INSTRUCTIONS:** This form should be used for transmitting the ISSUE FEE and PUBLICATION FEE (if required). Blocks 1 through 5 should be completed where appropriate. All further correspondence including the Patent, advance orders and notification of maintenance fees will be mailed to the current correspondence address as indicated unless corrected below or directed otherwise in Block 1, by (a) specifying a new correspondence address; and/or (b) indicating a separate "FEE ADDRESS" for maintenance fee notifications.

CURRENT CORRESPONDENCE ADDRESS (Note: Use Block 1 for any change of address)

64735 7590 09/27/2019  
**KNOBBE, MARTENS, OLSON & BEAR, LLP**  
**MASIMO CORPORATION (MASIMO)**  
 2040 MAIN STREET  
 FOURTEENTH FLOOR  
 IRVINE, CA 92614

Note: A certificate of mailing can only be used for domestic mailings of the Fee(s) Transmittal. This certificate cannot be used for any other accompanying papers. Each additional paper, such as an assignment or formal drawing, must have its own certificate of mailing or transmission.

**Certificate of Mailing or Transmission**

I hereby certify that this Fee(s) Transmittal is being deposited with the United States Postal Service with sufficient postage for first class mail in an envelope addressed to the Mail Stop ISSUE FEE address above, or being transmitted to the USPTO via EFS-Web or by facsimile to (571) 273-2885, on the date below.

_____ (Typed or printed name)
_____ (Signature)
_____ (Date)

APPLICATION NO.	FILING DATE	FIRST NAMED INVENTOR	ATTORNEY DOCKET NO.	CONFIRMATION NO.
16/226,249	12/19/2018	Ammar Al-Ali	MAS.1007C1	1002

TITLE OF INVENTION: ADVANCED PULSE OXIMETRY SENSOR

APPLN. TYPE	ENTITY STATUS	ISSUE FEE DUE	PUBLICATION FEE DUE	PREV. PAID ISSUE FEE	TOTAL FEE(S) DUE	DATE DUE
nonprovisional	UNDISCOUNTED	\$1000	\$0.00	\$1000.00	\$0	12/27/2019

EXAMINER	ART UNIT	CLASS-SUBCLASS
FARDANESH, MARJAN	3791	600-323000

<p>1. Change of correspondence address or indication of "Fee Address" (37 CFR 1.363).</p> <p><input type="checkbox"/> Change of correspondence address (or Change of Correspondence Address form PTO/SB/122) attached.</p> <p><input type="checkbox"/> "Fee Address" indication (or "Fee Address" Indication form PTO/SB/47; Rev 03-09 or more recent) attached. <b>Use of a Customer Number is required.</b></p>	<p>2. For printing on the patent front page, list</p> <p>(1) The names of up to 3 registered patent attorneys or agents OR, alternatively, _____ 1</p> <p>(2) The name of a single firm (having as a member a registered attorney or agent) and the names of up to 2 registered patent attorneys or agents. If no name is listed, no name will be printed. _____ 2</p> <p>_____ 3</p>
---	---

3. ASSIGNEE NAME AND RESIDENCE DATA TO BE PRINTED ON THE PATENT (print or type)

PLEASE NOTE: Unless an assignee is identified below, no assignee data will appear on the patent. If an assignee is identified below, the document must have been previously recorded, or filed for recordation, as set forth in 37 CFR 3.11 and 37 CFR 3.81(a). Completion of this form is NOT a substitute for filing an assignment.

(A) NAME OF ASSIGNEE \_\_\_\_\_ (B) RESIDENCE: (CITY and STATE OR COUNTRY) \_\_\_\_\_

Please check the appropriate assignee category or categories (will not be printed on the patent):  Individual  Corporation or other private group entity  Government

4a. Fees submitted:  Issue Fee  Publication Fee (if required)  Advance Order - # of Copies \_\_\_\_\_

4b. Method of Payment: (Please first reapply any previously paid fee shown above)

Electronic Payment via EFS-Web  Enclosed check  Non-electronic payment by credit card (Attach form PTO-2038)

The Director is hereby authorized to charge the required fee(s), any deficiency, or credit any overpayment to Deposit Account No. \_\_\_\_\_

5. Change in Entity Status (from status indicated above)

Applicant certifying micro entity status. See 37 CFR 1.29

Applicant asserting small entity status. See 37 CFR 1.27

Applicant changing to regular undiscounted fee status.

**NOTE:** Absent a valid certification of Micro Entity Status (see forms PTO/SB/15A and 15B), issue fee payment in the micro entity amount will not be accepted at the risk of application abandonment.

**NOTE:** If the application was previously under micro entity status, checking this box will be taken to be a notification of loss of entitlement to micro entity status.

**NOTE:** Checking this box will be taken to be a notification of loss of entitlement to small or micro entity status, as applicable.

**NOTE:** This form must be signed in accordance with 37 CFR 1.31 and 1.33. See 37 CFR 1.4 for signature requirements and certifications.

Authorized Signature \_\_\_\_\_ Date \_\_\_\_\_

Typed or printed name \_\_\_\_\_ Registration No. \_\_\_\_\_



UNITED STATES PATENT AND TRADEMARK OFFICE

UNITED STATES DEPARTMENT OF COMMERCE
United States Patent and Trademark Office
Address: COMMISSIONER FOR PATENTS
P.O. Box 1450
Alexandria, Virginia 22313-1450
www.uspto.gov

Table with 5 columns: APPLICATION NO., FILING DATE, FIRST NAMED INVENTOR, ATTORNEY DOCKET NO., CONFIRMATION NO. Includes application details for Ammar Al-Ali and attorney information for Knobbe, Martens, Olson & Bear, LLP.

Determination of Patent Term Adjustment under 35 U.S.C. 154 (b)
(Applications filed on or after May 29, 2000)

The Office has discontinued providing a Patent Term Adjustment (PTA) calculation with the Notice of Allowance.

Section 1(h)(2) of the AIA Technical Corrections Act amended 35 U.S.C. 154(b)(3)(B)(i) to eliminate the requirement that the Office provide a patent term adjustment determination with the notice of allowance. See Revisions to Patent Term Adjustment, 78 Fed. Reg. 19416, 19417 (Apr. 1, 2013). Therefore, the Office is no longer providing an initial patent term adjustment determination with the notice of allowance. The Office will continue to provide a patent term adjustment determination with the Issue Notification Letter that is mailed to applicant approximately three weeks prior to the issue date of the patent, and will include the patent term adjustment on the patent. Any request for reconsideration of the patent term adjustment determination (or reinstatement of patent term adjustment) should follow the process outlined in 37 CFR 1.705.

Any questions regarding the Patent Term Extension or Adjustment determination should be directed to the Office of Patent Legal Administration at (571)-272-7702. Questions relating to issue and publication fee payments should be directed to the Customer Service Center of the Office of Patent Publication at 1-(888)-786-0101 or (571)-272-4200.

## OMB Clearance and PRA Burden Statement for PTOL-85 Part B

The Paperwork Reduction Act (PRA) of 1995 requires Federal agencies to obtain Office of Management and Budget approval before requesting most types of information from the public. When OMB approves an agency request to collect information from the public, OMB (i) provides a valid OMB Control Number and expiration date for the agency to display on the instrument that will be used to collect the information and (ii) requires the agency to inform the public about the OMB Control Number's legal significance in accordance with 5 CFR 1320.5(b).

The information collected by PTOL-85 Part B is required by 37 CFR 1.311. The information is required to obtain or retain a benefit by the public which is to file (and by the USPTO to process) an application. Confidentiality is governed by 35 U.S.C. 122 and 37 CFR 1.14. This collection is estimated to take 30 minutes to complete, including gathering, preparing, and submitting the completed application form to the USPTO. Time will vary depending upon the individual case. Any comments on the amount of time you require to complete this form and/or suggestions for reducing this burden, should be sent to the Chief Information Officer, U.S. Patent and Trademark Office, U.S. Department of Commerce, P.O. Box 1450, Alexandria, Virginia 22313-1450. DO NOT SEND FEES OR COMPLETED FORMS TO THIS ADDRESS. SEND TO: Commissioner for Patents, P.O. Box 1450, Alexandria, Virginia 22313-1450. Under the Paperwork Reduction Act of 1995, no persons are required to respond to a collection of information unless it displays a valid OMB control number.

### Privacy Act Statement

**The Privacy Act of 1974 (P.L. 93-579)** requires that you be given certain information in connection with your submission of the attached form related to a patent application or patent. Accordingly, pursuant to the requirements of the Act, please be advised that: (1) the general authority for the collection of this information is 35 U.S.C. 2(b)(2); (2) furnishing of the information solicited is voluntary; and (3) the principal purpose for which the information is used by the U.S. Patent and Trademark Office is to process and/or examine your submission related to a patent application or patent. If you do not furnish the requested information, the U.S. Patent and Trademark Office may not be able to process and/or examine your submission, which may result in termination of proceedings or abandonment of the application or expiration of the patent.

The information provided by you in this form will be subject to the following routine uses:

1. The information on this form will be treated confidentially to the extent allowed under the Freedom of Information Act (5 U.S.C. 552) and the Privacy Act (5 U.S.C. 552a). Records from this system of records may be disclosed to the Department of Justice to determine whether disclosure of these records is required by the Freedom of Information Act.
2. A record from this system of records may be disclosed, as a routine use, in the course of presenting evidence to a court, magistrate, or administrative tribunal, including disclosures to opposing counsel in the course of settlement negotiations.
3. A record in this system of records may be disclosed, as a routine use, to a Member of Congress submitting a request involving an individual, to whom the record pertains, when the individual has requested assistance from the Member with respect to the subject matter of the record.
4. A record in this system of records may be disclosed, as a routine use, to a contractor of the Agency having need for the information in order to perform a contract. Recipients of information shall be required to comply with the requirements of the Privacy Act of 1974, as amended, pursuant to 5 U.S.C. 552a(m).
5. A record related to an International Application filed under the Patent Cooperation Treaty in this system of records may be disclosed, as a routine use, to the International Bureau of the World Intellectual Property Organization, pursuant to the Patent Cooperation Treaty.
6. A record in this system of records may be disclosed, as a routine use, to another federal agency for purposes of National Security review (35 U.S.C. 181) and for review pursuant to the Atomic Energy Act (42 U.S.C. 218(c)).
7. A record from this system of records may be disclosed, as a routine use, to the Administrator, General Services, or his/her designee, during an inspection of records conducted by GSA as part of that agency's responsibility to recommend improvements in records management practices and programs, under authority of 44 U.S.C. 2904 and 2906. Such disclosure shall be made in accordance with the GSA regulations governing inspection of records for this purpose, and any other relevant (i.e., GSA or Commerce) directive. Such disclosure shall not be used to make determinations about individuals.
8. A record from this system of records may be disclosed, as a routine use, to the public after either publication of the application pursuant to 35 U.S.C. 122(b) or issuance of a patent pursuant to 35 U.S.C. 151. Further, a record may be disclosed, subject to the limitations of 37 CFR 1.14, as a routine use, to the public if the record was filed in an application which became abandoned or in which the proceedings were terminated and which application is referenced by either a published application, an application open to public inspection or an issued patent.
9. A record from this system of records may be disclosed, as a routine use, to a Federal, State, or local law enforcement agency, if the USPTO becomes aware of a violation or potential violation of law or regulation.

<b>Notice of Allowability</b>	<b>Application No.</b> 16/226,249	<b>Applicant(s)</b> Al-Ali, Ammar	
	<b>Examiner</b> MARJAN FARDANESH	<b>Art Unit</b> 3791	<b>AIA (FITF) Status</b> Yes

**-- The MAILING DATE of this communication appears on the cover sheet with the correspondence address--**

All claims being allowable, PROSECUTION ON THE MERITS IS (OR REMAINS) CLOSED in this application. If not included herewith (or previously mailed), a Notice of Allowance (PTOL-85) or other appropriate communication will be mailed in due course. **THIS NOTICE OF ALLOWABILITY IS NOT A GRANT OF PATENT RIGHTS.** This application is subject to withdrawal from issue at the initiative of the Office or upon petition by the applicant. See 37 CFR 1.313 and MPEP 1308.

- 1.  This communication is responsive to IDS filed on 08/15/2019.  
 A declaration(s)/affidavit(s) under **37 CFR 1.130(b)** was/were filed on \_\_\_\_\_.
- 2.  An election was made by the applicant in response to a restriction requirement set forth during the interview on \_\_\_\_\_; the restriction requirement and election have been incorporated into this action.
- 3.  The allowed claim(s) is/are 57-64,67-70,72-74,77-78,81-83,85 and 87-95. As a result of the allowed claim(s), you may be eligible to benefit from the **Patent Prosecution Highway** program at a participating intellectual property office for the corresponding application. For more information, please see [http://www.uspto.gov/patents/init\\_events/pph/index.jsp](http://www.uspto.gov/patents/init_events/pph/index.jsp) or send an inquiry to **PPHfeedback@uspto.gov**.
- 4.  Acknowledgment is made of a claim for foreign priority under 35 U.S.C. § 119(a)-(d) or (f).

**Certified copies:**

- a)  All      b)  Some      \*c)  None of the:
  - 1.  Certified copies of the priority documents have been received.
  - 2.  Certified copies of the priority documents have been received in Application No. \_\_\_\_\_.
  - 3.  Copies of the certified copies of the priority documents have been received in this national stage application from the International Bureau (PCT Rule 17.2(a)).

\* Certified copies not received: \_\_\_\_\_.

Applicant has THREE MONTHS FROM THE "MAILING DATE" of this communication to file a reply complying with the requirements noted below. Failure to timely comply will result in ABANDONMENT of this application.  
**THIS THREE-MONTH PERIOD IS NOT EXTENDABLE.**

- 5.  CORRECTED DRAWINGS (as "replacement sheets") must be submitted.  
 including changes required by the attached Examiner's Amendment / Comment or in the Office action of Paper No./Mail Date \_\_\_\_\_.
- Identifying indicia such as the application number (see 37 CFR 1.84(c)) should be written on the drawings in the front (not the back) of each sheet. Replacement sheet(s) should be labeled as such in the header according to 37 CFR 1.121(d).**
- 6.  DEPOSIT OF and/or INFORMATION about the deposit of BIOLOGICAL MATERIAL must be submitted. Note the attached Examiner's comment regarding REQUIREMENT FOR THE DEPOSIT OF BIOLOGICAL MATERIAL.

**Attachment(s)**

- 1.  Notice of References Cited (PTO-892)
- 2.  Information Disclosure Statements (PTO/SB/08),  
Paper No./Mail Date 08/15/2019.
- 3.  Examiner's Comment Regarding Requirement for Deposit of Biological Material \_\_\_\_\_.
- 4.  Interview Summary (PTO-413),  
Paper No./Mail Date. \_\_\_\_\_.
- 5.  Examiner's Amendment/Comment
- 6.  Examiner's Statement of Reasons for Allowance
- 7.  Other \_\_\_\_\_.

/MARJAN FARDANESH/  
Examiner, Art Unit 3791

/ERIC F WINAKUR/  
Primary Examiner, Art Unit 3791

***Notice of Pre-AIA or AIA Status***

1. The present application, filed on or after March 16, 2013, is being examined under the first inventor to file provisions of the AIA.
2. The IDS filed on 08/15/2019 was fully considered and entered. Claims 57-64,67-70,72-74,77-78,81-83,85,87-95 are allowable for the reasons of record.

***Conclusion***

3. Any inquiry concerning this communication or earlier communications from the examiner should be directed to MARJAN FARDANESH whose telephone number is (571)270-5508. The examiner can normally be reached on Monday-Friday 9:00-17:00.

Examiner interviews are available via telephone, in-person, and video conferencing using a USPTO supplied web-based collaboration tool. To schedule an interview, applicant is encouraged to use the USPTO Automated Interview Request (AIR) at <http://www.uspto.gov/interviewpractice>.

If attempts to reach the examiner by telephone are unsuccessful, the examiner's supervisor, Patricia Mallari can be reached on (571)272-4729. The fax phone number for the organization where this application or proceeding is assigned is 571-273-8300.

Information regarding the status of an application may be obtained from the Patent Application Information Retrieval (PAIR) system. Status information for published applications may be obtained from either Private PAIR or Public PAIR. Status information for unpublished applications is available through Private PAIR only. For more information about the PAIR system, see <http://pair-direct.uspto.gov>. Should you have questions on access to the Private PAIR system, contact the Electronic Business Center (EBC) at 866-217-9197 (toll-free). If you would like assistance from a

Application/Control Number: 16/226,249  
Art Unit: 3791

Page 3

USPTO Customer Service Representative or access to the automated information system, call 800-786-9199 (IN USA OR CANADA) or 571-272-1000.

/ERIC F WINAKUR/  
Primary Examiner, Art Unit 3791

/MARJAN FARDANESH/  
Examiner, Art Unit 3791

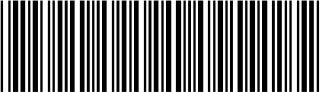
<b>Issue Classification</b> 	<b>Application/Control No.</b> 16/226,249	<b>Applicant(s)/Patent Under Reexamination</b> Al-Ali, Ammar
	<b>Examiner</b> MARJAN FARDANESH	<b>Art Unit</b> 3791

CPC						
Symbol				Type	Version	
A61B	/	5	/	14552	F	2013-01-01
A61B	/	5	/	6826	I	2013-01-01
A61B	/	5	/	0002	I	2013-01-01
A61B	/	5	/	02416	I	2013-01-01
A61B	/	5	/	14532	I	2013-01-01
A61B	/	5	/	14546	I	2013-01-01
A61B	/	5	/	4875	I	2013-01-01
A61B	/	5	/	7278	I	2013-01-01
A61B	/	5	/	742	I	2013-01-01
A61B	/	2562	/	04	A	2013-01-01

CPC Combination Sets				
Symbol	Type	Set	Ranking	Version

/MARJAN FARDANESH/ Examiner, Art Unit 3791 (Assistant Examiner)	11 September 2019 (Date)	<b>Total Claims Allowed:</b> 30	
/ERIC F WINAKUR/ Primary Examiner, Art Unit 3791 (Primary Examiner)	11 September 2019 (Date)	O.G. Print Claim(s) 1	O.G. Print Figure 7



<b>Issue Classification</b> 	<b>Application/Control No.</b> 16/226,249	<b>Applicant(s)/Patent Under Reexamination</b> Al-Ali, Ammar
	<b>Examiner</b> MARJAN FARDANESH	<b>Art Unit</b> 3791

<b>INTERNATIONAL CLASSIFICATION</b>			
<b>CLAIMED</b>			
A61B		5	1455
<b>NON-CLAIMED</b>			

<b>US ORIGINAL CLASSIFICATION</b>	
<b>CLASS</b>	<b>SUBCLASS</b>
600	310

<b>CROSS REFERENCES(S)</b>					
<b>CLASS</b>	<b>SUBCLASS (ONE SUBCLASS PER BLOCK)</b>				

/MARJAN FARDANESH/ Examiner, Art Unit 3791 (Assistant Examiner)	11 September 2019 (Date)	<b>Total Claims Allowed:</b> 30	
/ERIC F WINAKUR/ Primary Examiner, Art Unit 3791 (Primary Examiner)	11 September 2019 (Date)	O.G. Print Claim(s) 1	O.G. Print Figure 7

<b>Issue Classification</b> 	<b>Application/Control No.</b> 16/226,249	<b>Applicant(s)/Patent Under Reexamination</b> Al-Ali, Ammar
	<b>Examiner</b> MARJAN FARDANESH	<b>Art Unit</b> 3791

Claims renumbered in the same order as presented by applicant  
  CPA  
  T.D.  
  R.1.47

CLAIMS															
Final	Original	Final	Original	Final	Original	Final	Original	Final	Original	Final	Original	Final	Original	Final	Original
1	57		66		75		84	28	93						
2	58	9	67		76	24	85	29	94						
3	59	10	68	19	77		86	30	95						
4	60	11	69	20	78	25	87								
5	61	12	70		79	26	88								
6	62		71		80	27	89								
7	63	13	72	21	81	16	90								
8	64	14	73	22	82	17	91								
	65	15	74	23	83	18	92								

/MARJAN FARDANESH/ Examiner, Art Unit 3791 (Assistant Examiner)	11 September 2019 (Date)	<b>Total Claims Allowed:</b> 30	
/ERIC F WINAKUR/ Primary Examiner, Art Unit 3791 (Primary Examiner)	11 September 2019 (Date)	O.G. Print Claim(s) 1	O.G. Print Figure 7

<b><i>Search Notes</i></b> 	<b>Application/Control No.</b> 16/226,249	<b>Applicant(s)/Patent Under Reexamination</b> Al-Ali, Ammar
	<b>Examiner</b> MARJAN FARDANESH	<b>Art Unit</b> 3791

<b>CPC - Searched*</b>		
<b>Symbol</b>	<b>Date</b>	<b>Examiner</b>
EAST-See search history printout	03/04/2019	/mf/
EAST-See search history printout	07/19/2019	/mf/
EAST-See search history printout	09/11/2019	/mf/

<b>CPC Combination Sets - Searched*</b>		
<b>Symbol</b>	<b>Date</b>	<b>Examiner</b>

<b>US Classification - Searched*</b>			
<b>Class</b>	<b>Subclass</b>	<b>Date</b>	<b>Examiner</b>

\* See search history printout included with this form or the SEARCH NOTES box below to determine the scope of the search.

<b>Search Notes</b>		
<b>Search Notes</b>	<b>Date</b>	<b>Examiner</b>
PALM-inventor name search	03/04/2019	/mf/

<b>Interference Search</b>			
<b>US Class/CPC Symbol</b>	<b>US Subclass/CPC Group</b>	<b>Date</b>	<b>Examiner</b>
EAST-	See search history printout	07/19/2019	/mf/
EAST-	See search history printout	09/11/2019	/mf/

/MARJAN FARDANESH/ Examiner, Art Unit 3791	
---	--

## EAST Search History

## EAST Search History (Prior Art)

Ref #	Hits	Search Query	DBs	Default Operator	Plurals	Time Stamp
S1	6	((("5513649") or ("7286871") or ("8538512") or ("20070167858") or ("20160157779") or ("20050288954")).PN.	US-PGPUB; USPAT; USOCR	OR	OFF	2019/09/09 07:24
S2	1	(sweat) with subtract\$4 with EEG and A61B5/0006.cpc.	US-PGPUB; USPAT	OR	ON	2019/09/09 07:32
S3	2	(sweat) with subtract\$4 with EEG and A61B5/\$.cpc.	US-PGPUB; USPAT	OR	ON	2019/09/09 07:41
S4	0	(sweat) adj2 subtract\$4 and A61B5/0006.cpc.	US-PGPUB; USPAT	OR	ON	2019/09/09 07:42
S5	1	(sweat) with subtract\$4 and A61B5/0006.cpc.	US-PGPUB; USPAT	OR	ON	2019/09/09 07:42
S6	4	(sweat) adj artifact and A61B5/0006.cpc.	US-PGPUB; USPAT	OR	ON	2019/09/09 07:46
S7	1	"15782874"	US-PGPUB; USPAT	OR	ON	2019/09/09 08:17
S8	0	pulse and lee with rang.in.	US-PGPUB; USPAT	OR	ON	2019/09/09 09:50
S9	10	lee with rang.in.	US-PGPUB; USPAT	OR	ON	2019/09/09 09:50
S10	373	meridian.asn.	US-PGPUB; USPAT	OR	ON	2019/09/09 09:52
S11	1537586	meridian.asn. ans pulse	US-PGPUB; USPAT	OR	ON	2019/09/09 09:52
S12	32	meridian.asn. and pulse	US-PGPUB; USPAT	OR	ON	2019/09/09 09:52
S13	2008	park.in. and stiffness	US-PGPUB; USPAT	OR	ON	2019/09/09 09:53
S14	0	park.in. and sarterial	US-PGPUB; USPAT	OR	ON	2019/09/09 09:53
S15	1	("20130324859").PN.	US-PGPUB; USPAT; USOCR	OR	OFF	2019/09/09 09:53

## EAST Search History

S16	1	normal adj notch and transient adj notch	US-PGPUB; USPAT	OR	ON	2019/09/09 10:00
S17	143	normal adj notch	US-PGPUB; USPAT	OR	ON	2019/09/09 10:00
S18	38	normal adj notch and pulse	US-PGPUB; USPAT	OR	ON	2019/09/09 10:01
S19	1	normal adj notch and pulse and A61B5/7278.cpc.	US-PGPUB; USPAT	OR	ON	2019/09/09 10:01
S20	533	notch and pulse and A61B5/7278.cpc.	US-PGPUB; USPAT	OR	ON	2019/09/09 10:01
S21	226	notch and pulse and peak\$4 and A61B5/7278.cpc.	US-PGPUB; USPAT	OR	ON	2019/09/09 10:02
S22	51	notch and pulse and peak\$4 and trough and A61B5/7278.cpc.	US-PGPUB; USPAT	OR	ON	2019/09/09 10:02
S23	4228	notch and pulse and peak\$4 and trough and systolic and A61B5/7278.cpc.	US-PGPUB; USPAT	OR	ON	2019/09/09 10:03
S24	35	notch and pulse and peak\$4 and trough and systolic and A61B5/7278.cpc.	US-PGPUB; USPAT	OR	ON	2019/09/09 10:03
S25	5585	notch and pulse and peak\$4 and trough and systolic and onset ] and A61B5/7278.cpc.	US-PGPUB; USPAT	OR	ON	2019/09/09 10:04
S26	21	notch and pulse and peak\$4 and trough and systolic and onset and A61B5/7278.cpc.	US-PGPUB; USPAT	OR	ON	2019/09/09 10:04
S27	21	notch and pulse and peak\$4 and trough and systolic and onset and A61B5/7278.cpc. and (normal transient dicrotic)	US-PGPUB; USPAT	OR	ON	2019/09/09 10:05
S28	4	notch and pulse and peak\$4 and trough and systolic and onset and A61B5/7278.cpc. and (normal transient dicrotic) and classif\$5	US-PGPUB; USPAT	OR	ON	2019/09/09 10:05
S29	1	("20100317940").PN.	US-PGPUB; USPAT; USOCR	OR	OFF	2019/09/09 12:56
S30	5	((("20100317940") or ("20020011568") or ("8175668") or ("4770536") or ("4443107"))).PN.	US-PGPUB; USPAT; USOCR	OR	OFF	2019/09/09 12:57
S31	26	("4114604"   "4623248"   "4776340"   "4809697"   "4944299"   "5048524"   "5061632"   "5149503"   "5282466"   "6064474"   "6103197"   "6144444"   "6181958"   "6275734"   "6711425"   "6714805"   "7029628").PN. OR ("8175668").URPN.	US-PGPUB; USPAT; USOCR	OR	OFF	2019/09/09 13:03
S32	1	("20100041969").PN.	US-PGPUB;	OR	OFF	2019/09/09 13:05

EAST Search History

			USPAT; USOCR			
S33	1	"15581803"	US- PGPUB; USPAT	OR	OFF	2019/09/09 14:36
S34	1	"16312080"	US- PGPUB; USPAT	OR	OFF	2019/09/09 14:54
S35	1	"15850755"	US- PGPUB; USPAT	OR	OFF	2019/09/09 15:12
S36	313	fardanesh.xa.	US- PGPUB; USPAT	OR	OFF	2019/09/09 15:13
S37	920	( "20010021803"   "20010051767"   "20020026109"   "20020028990"   "20020038078"   "20020042558"   "20020068859"   "20020128544"   "20020133067"   "20020156354"   "20020173706"   "20020173709"   "20020190863"   "20020198442"   "20030018243"   "20030036690"   "20030045785"   "20030073889"   "20030073890"   "20030100840"   "20030132495"   "20030135099"   "20030162414"   "20030171662"   "20030176776"   "20030181799"   "20030187337"   "20030195402"   "20030197679"   "20030212316"   "20030225323"   "20030225337"   "20030236452"   "20030236647"   "20040006261"   "20040010188"   "20040024297"   "20040024326"   "20040034293"   "20040039272"   "20040039273"   "20040054269"   "20040054291"   "20040059209"   "20040059210"   "20040064020"   "20040068164"   "20040087846"   "20040092805"   "20040097797"   "20040098009"   "20040107065"   "20040116788"   "20040116789"   "20040117891"   "20040122300"   "20040122302"   "20040133087"   "20040133088"   "20040138538"   "20040138540"   "20040143172"   "20040147821"   "20040147822"   "20040147823"   "20040147824"   "20040152965"   "20040158134"   "20040158135"   "20040162472"   "20040171920"   "20040171948"   "20040176671"   "20040181133"   "20040181134"   "20040186358"   "20040199063"   "20040204636"   "20040204637"   "20040204638"   "20040204639"   "20040204865"   "20040210146"   "20040215069"   "20040230107"   "20040230108"   "20040236196"   "20040242980"   "20040249252"   "20040257557"   "20040260161"   "20040267103"   "20040267104").PN. OR ("20040267140"   "20050004479"   "20050010092"	US- PGPUB; USPAT; USOCR	OR	OFF	2019/09/09 15:27

"20050020887"	"20050020894"
"20050033128"	"20050033129"
"20050043599"	"20050043600"
"20050049468"	"20050049470"
"20050049471"	"20050075550"
"20050113651"	"20050163412"
"20050177034"	"20050197548"
"20050228248"	"20050267346"
"20050277819"	"20050283059"
"20060058594"	"20060084852"
"20060089547"	"20060106294"
"20060195028"	"20060211929"
"20060224058"	"20060229509"
"20060247501"	"20060258921"
"20070032710"	"20070032712"
"20070032715"	"20070060809"
"20070073126"	"20070129613"
"20070135694"	"20070282178"
"20080071154"	"20080081966"
"20080108887"	"20080139906"
"20080177163"	"20080188727"
"20080234560"	"20080242958"
"20090110356"	"3721813"   "4586513"
"4603700"	"4621643"   "4653498"
"4685464"	"4694833"   "4697593"
"4700708"	"4714080"   "4714341"
"4759369"	"4770179"   "4773422"
"4776339"	"4781195"   "4796636"
"4800495"	"4800885"   "4802486"
"4805623"	"4807630"   "4807631"
"4819646"	"4819752"   "4824242"
"4825872"	"4825879"   "4830014"
"4832484"	"4846183"   "4848901"
"4854699"	"4859056"   "4859057"
"4863265"	"4865038"   "4867557"
"4869253"	"4869254"   "4880304"
"4883055"	"4883353"   "4890619"
"4892101"	"4901238"   "4908762"
"4911167"	"4913150"   "4926867"
"4927264"	"4928692"   "4934372"
"4938218"	"4942877"   "4948248"
"4955379"	"4960126"   "4964408"
"4971062"	"4974591". PN. OR
("5007423"   "5025791"   "5028787"	
"5040539"	"5054488"   "5055671"
"5058588"	"5065749"   "5066859"
"5069213"	"5078136"   "5084327"
"5088493"	"5090410"   "5094239"
"5094240"	"5099841"   "5099842"
"5104623"	"5109849"   "5111817"
"5113861"	"5125403"   "5127406"
"5131391"	"5140989"   "5152296"
"5154175"	"5158082"   "5170786"
"5188108"	"5190038"   "5193542"
"5193543"	"5203329"   "5209230"
"5213099"	"5216598"   "5217012"
"5217013"	"5218962"   "5224478"
"5226417"	"5228440"   "5237994"
"5239185"	"5246002"   "5246003"
"5247931"	"5247932"   "5249576"
"5253645"	"5253646"   "5259381"
"5259761"	"5263244"   "5267562"
"5267563"	"5273036"   "5275159"
"5279295"	"5285783"   "5285784"

"5287853"	"5291884"	"5297548"
"5299120"	"5299570"	"5309908"
"5311865"	"5313940"	"5323776"
"5329922"	"5337744"	"5339810"
"5343818"	"5343869"	"5348003"
"5348004"	"5349519"	"5349952"
"5349953"	"5351685"	"5353799"
"5355880"	"5355882"	"5361758"
"5365066"	"5368025"	"5368026"
"5368224"	"5372136"	"5377675"
"5385143"	"5387122"	"5390670"
"5392777"	"5398680"	"5402777"
"5411023"	"5411024"	"5413099"
"5413100"	"5413101"	"5413102"
"5417207"	"5421329"	"5425360"
"5425362"	"5427093"	"5429128"
"5429129"	"5431159"	"5431170"
"5437275"	"5438986"	"5448991"
"5452717"	"5465714"	"5469845"
"5482034"	"5482036"	"5483646"
"5485847"	"5490505".PN. OR	
("5490523"	"5491299"	"5494032"
"5497771"	"5499627"	"5503148"
"5505199"	"5507286"	"5517988"
"5520177"	"5521851"	"5522388"
"5524617"	"5529064"	"5533507"
"5551423"	"5551424"	"5553614"
"5553615"	"5555882"	"5558096"
"5560355"	"5564417"	"5575284"
"5575285"	"5577500"	"5582169"
"5584296"	"5588425"	"5588427"
"5590652"	"5595176"	"5596986"
"5611337"	"5617852"	"5619992"
"5625201"	"5626140"	"5630413"
"5632272"	"5632273"	"5634459"
"5638593"	"5638818"	"5645060"
"5645440"	"5660567"	"5662105"
"5662106"	"5666952"	"5671529"
"5673692"	"5673693"	"5676139"
"5676141"	"5678544"	"5680857"
"5685299"	"5685301"	"5687719"
"5687722"	"5692503"	"5692505"
"5709205"	"5713355"	"5724967"
"5727547"	"5731582"	"5743260"
"5743263"	"5746206"	"5746697"
"5752914"	"5755226"	"5758644"
"5760910"	"5766125"	"5766127"
"5769785"	"5772587"	"5774213"
"5776058"	"5776059"	"5779630"
"5779631"	"5782237"	"5782756"
"5782757"	"5782758"	"5786592"
"5790729"	"5792052"	"5795292"
"5797841"	"5800348"	"5800349"
"5803910"	"5807246"	"5807247"
"5807248"	"5810723"	"5810724"
"5813980"	"5817008"	"5817009"
"5817010"	"5818985"	"5820550"
"5823950"	"5823952"	"5827182"
"5830135"	"5830136"	"5830137"
"5839439"	"5842979"	"5842981"
"5842982"	"5846190"	"5851178"
"5851179"	"5853364"	"5860919"
"5865736"	"5871442".PN. OR	
("5879294"	"5885213"	"5890929"



"5891021"	"5891022"	"5891024"
"5891025"	"5891026"	"5902235"
"5910108"	"5911690"	"5912656"
"5913819"	"5916154"	"5916155"
"5919133"	"5919134"	"5920263"
"5921921"	"5922607"	"5924979"
"5924980"	"5924982"	"5924985"
"5934277"	"5934925"	"5940182"
"5954644"	"5960610"	"5961450"
"5961452"	"5964701"	"5971930"
"5978691"	"5978693"	"5983122"
"5987343"	"5991648"	"5995855"
"5995856"	"5995858"	"5995859"
"5997343"	"5999834"	"6002952"
"6005658"	"6006120"	"6011985"
"6011986"	"6014576"	"6018673"
"6018674"	"6022321"	"6023541"
"6026312"	"6026314"	"6031603"
"6035223"	"6036642"	"6041247"
"6044283"	"6047201"	"6061584"
"6064898"	"6064899"	"6067462"
"6073038"	"6078833"	"6081735"
"6081742"	"6083157"	"6083172"
"6088607"	"6094592"	"6095974"
"6104938"	"6112107"	"6113541"
"6115621"	"6122535"	"6133994"
"6135952"	"6144444"	"6144867"
"6144868"	"6149481"	"6150951"
"6151107"	"6151518"	"6152754"
"6154667"	"6157850"	"6163175"
"6163715"	"6165005"	"6173196"
"6178343"	"6181958"	"6181959"
"6184521"	"6188470"	"6192260"
"6195575"	"6198951"	"6206830"
"6213952"	"6217523"	"6222189"
"6226539"	"6226540"	"6229856"
"6230035"	"6233470"	"6236871"
"6236872"	"6240305"	"6253097"
"6253098"	"6256523"	"6256524"
"6261236"	"6263221"	"6263222"
"6263223"	"6266546")	PN. OR
("6266547"	"6272363"	"6278522"
"6280213"	"6280381"	"6285894"
"6285895"	"6285896"	"6298252"
"6308089"	"6321100"	"6330468"
"6334065"	"6339715"	"6343223"
"6343224"	"6349228"	"6351658"
"6353750"	"6356774"	"6360113"
"6360114"	"6361501"	"6363269"
"6370408"	"6370409"	"6374129"
"6377829"	"6381479"	"6381480"
"6385471"	"6385821"	"6388240"
"6393310"	"6397091"	"6397092"
"6397093"	"6400971"	"6400972"
"6402690"	"6408198"	"6411832"
"6411833"	"6419671"	"6421549"
"6430423"	"6430513"	"6430525"
"6434408"	"6438399"	"6449501"
"6453183"	"6453184"	"6456862"
"6461305"	"6463310"	"6463311"
"6466808"	"6466809"	"6470199"
"6470200"	"6480729"	"6490466"
"6496711"	"6498942"	"6501974"
"6501975"	"6505060"	"6505061"

"6505133"	"6510329"	"6510331"
"6512937"	"6515273"	"6519484"
"6519486"	"6519487"	"6525386"
"6526300"	"6526301"	"6541756"
"6542764"	"6546267"	"6553241"
"6553242"	"6553243"	"6556852"
"6560470"	"6564077"	"6564088"
"6571113"	"6571114"	"6574491"
"6580086"	"6584336"	"6587703"
"6587704"	"6589172"	"6591122"
"6591123"	"6594511"	"6594512"
"6594513"	"6597931"	"6597933"
"6600940"	"6606510"	"6606511"
"6606512"	"6615064"	"6615065"
"6618602"	"6622034"	"6628975"
"6631281"	"6643530"	"6643531"
"6647279"	"6647280"	"6650917"
"6650918"	"6654621"	"6654622"
"6654623"	"6654624").PN. OR	
("6658276"	"6658277"	"6662033"
"6665551"	"6668182"	"6668183"
"6671526"	"6671528"	"6671530"
"6671531"	"6671532"	"6675031"
"6678543"	"6681126"	"6681128"
"6681454"	"6684090"	"6684091"
"6694160"	"6697653"	"6697655"
"6697656"	"6697658"	"6699194"
"6699199"	"6701170"	"6702752"
"6707257"	"6708049"	"6709402"
"6711424"	"6711425"	"6714803"
"6714804"	"6714805"	"6719686"
"6719705"	"6720734"	"6721584"
"6721585"	"6725074"	"6725075"
"6731963"	"6731967"	"6735459"
"6745060"	"6745061"	"6748253"
"6748254"	"6754515"	"6754516"
"6760607"	"6760609"	"6760610"
"6763255"	"6763256"	"6770028"
"6771994"	"6773397"	"6778923"
"6780158"	"6792300"	"6793654"
"6801797"	"6801798"	"6801799"
"6801802"	"6802812"	"6805673"
"6810277"	"6813511"	"6816741"
"6819950"	"6822564"	"6825619"
"6826419"	"6829496"	"6830711"
"6836329"	"6836679"	"6839579"
"6839580"	"6839582"	"6839659"
"6842635"	"6845256"	"6850787"
"6850788"	"6850789"	"6861639"
"6862091"	"6863652"	"6865407"
"6879850"	"6882874"	"6889153"
"6898452"	"6909912"	"6912413"
"6916289"	"6920345"	"6931269"
"6934570"	"6939307"	"6941162"
"6947781"	"6950687"	"6963767"
"6971580"	"6983178"	"6985763"
"6985764"	"6990426"	"6992751"
"6992772"	"6993371"	"6993372"
"6996427"	"7003338"	"7003339"
"7006855"	"7006856"	"7010341"
"7016715"	"7020507").PN. OR	
("7024233"	"7024235"	"7025728"
"7027849"	"7027850"	"7035697"
"7039449"	"7043289"	"7047054"

		"7047055"   "7047056"   "7060035"   "7062307"   "7067893"   "7072701"   "7072702"   "7079880"   "7085597"   "7096052"   "7096054"   "7107088"   "7113815"   "7123950"   "7127278"   "7130671"   "7130672"   "7132641"   "7133711"   "7139599"   "7142901"   "7162288"   "7171065"   "7190987"   "7198778"   "7209775"   "7215984"   "7225006"   "7236811"   "7236881"   "7248910"   "7254433"   "7254434"   "7263395"   "7272426"   "7280858"   "7283242"   "7295866"   "7305262"   "7313425"   "7313426"   "7313427"   "7315753"   "7319894"   "7332784"   "7341560"   "7346378"   "7355688"   "7356365"   "7376454"   "7415298"   "7424317"   "8162503"   "D393830"   "H001039"   "RE33643"   "RE35122"   "RE36000"   "RE38476"   "RE38492").PN. OR ("8577434").URPN.				
S38	1	("20170281074").PN.	US- PGPUB; USPAT; USOCR	OR	OFF	2019/09/09 15:35
S39	1	("20070057004").PN.	US- PGPUB; USPAT; USOCR	OR	OFF	2019/09/09 15:59
S40	3	"15958620" and oxide and absorption	US- PGPUB; USPAT	OR	OFF	2019/09/10 10:10
S41	6483	(UV ultraviolet) same wavelength\$1 and A61B5/\$.cpc.	US- PGPUB; USPAT	OR	OFF	2019/09/10 10:14
S42	1771	(UV ultraviolet) same wavelength\$1 and A61B5/1455\$.cpc.	US- PGPUB; USPAT	OR	OFF	2019/09/10 10:14
S43	837	("380" "390" "400" "410") adj nm and A61B5/1455\$.cpc.	US- PGPUB; USPAT	OR	OFF	2019/09/10 10:28
S44	222	("380" "390") adj nm and A61B5/1455\$.cpc.	US- PGPUB; USPAT	OR	OFF	2019/09/10 10:37
S45	1	("9743864").PN.	US- PGPUB; USPAT; USOCR	OR	OFF	2019/09/10 13:04
S46	29	("20020007113"   "20030225321"   "20030233036"   "20050154269"   "20060134004"   "20060200013"   "20080269580"   "20100234704"   "20110105868"   "3958560"   "5009230"   "5433197"   "5535743"   "5820557"   "5835215"   "5879294"   "6083158"   "6152875"   "6166807"   "6181957"   "6226089"   "6424850"   "6836337"   "6999808"   "7167736"   "7627357"   "7653424"   "7769419"   "RE40316").PN. OR ("9743864").URPN.	US- PGPUB; USPAT; USOCR	OR	OFF	2019/09/10 13:05

EAST Search History

S47	1	("5638816").PN.	US-PGPUB; USPAT; USOCR	OR	OFF	2019/09/10 13:07
S48	2	((("20140051955") or ("20140371601")).PN.	US-PGPUB; USPAT; USOCR	OR	OFF	2019/09/10 14:01
S49	324	reflectance same transmittance and A61B5/\$.cpc. and (energiz\$4 driv\$4) with light	US-PGPUB; USPAT	OR	ON	2019/09/10 14:38
S50	26	("4114604"   "4623248"   "4776340"   "4809697"   "4944299"   "5048524"   "5061632"   "5149503"   "5282466"   "6064474"   "6103197"   "6144444"   "6181958"   "6275734"   "6711425"   "6714805"   "7029628").PN. OR ("8175668").URPN.	US-PGPUB; USPAT; USOCR	OR	OFF	2019/09/10 14:45
S51	16	("20060287589"   "20070060807"   "20070078309"   "20070100218"   "20070100219"   "20070129613"   "20080106792"   "20080108886"   "20090275841"   "20090326346"   "20100026995"   "20100030040"   "20100331640"   "5817007").PN. OR ("8798702").URPN.	US-PGPUB; USPAT; USOCR	OR	OFF	2019/09/10 14:53
S52	139	("5074309"   "5151590"   "5348002"   "5348003"   "5579001"   "5702284"   "5786592").PN. OR ("6403944").URPN.	US-PGPUB; USPAT; USOCR	OR	OFF	2019/09/10 14:54
S53	35	reflectance same transmittance same switch\$4 and A61B5/\$.cpc.	US-PGPUB; USPAT	OR	ON	2019/09/10 14:55
S54	920	("20010021803"   "20010051767"   "20020026109"   "20020028990"   "20020038078"   "20020042558"   "20020068859"   "20020128544"   "20020133067"   "20020156354"   "20020173706"   "20020173709"   "20020190863"   "20020198442"   "20030018243"   "20030036690"   "20030045785"   "20030073889"   "20030073890"   "20030100840"   "20030132495"   "20030135099"   "20030162414"   "20030171662"   "20030176776"   "20030181799"   "20030187337"   "20030195402"   "20030197679"   "20030212316"   "20030225323"   "20030225337"   "20030236452"   "20030236647"   "20040006261"   "20040010188"   "20040024297"   "20040024326"   "20040034293"   "20040039272"   "20040039273"   "20040054269"   "20040054291"   "20040059209"   "20040059210"   "20040064020"   "20040068164"   "20040087846"   "20040092805"   "20040097797"   "20040098009"   "20040107065"   "20040116788"   "20040116789"   "20040117891"   "20040122300"   "20040122302"   "20040133087"	US-PGPUB; USPAT; USOCR	OR	OFF	2019/09/10 14:58

"20040133088"	"20040138538"
"20040138540"	"20040143172"
"20040147821"	"20040147822"
"20040147823"	"20040147824"
"20040152965"	"20040158134"
"20040158135"	"20040162472"
"20040171920"	"20040171948"
"20040176671"	"20040181133"
"20040181134"	"20040186358"
"20040199063"	"20040204636"
"20040204637"	"20040204638"
"20040204639"	"20040204865"
"20040210146"	"20040215069"
"20040230107"	"20040230108"
"20040236196"	"20040242980"
"20040249252"	"20040257557"
"20040260161"	"20040267103"
"20040267104".PN. OR ("20040267140"	
"20050004479"	"20050010092"
"20050020887"	"20050020894"
"20050033128"	"20050033129"
"20050043599"	"20050043600"
"20050049470"	"20050049471"
"20050065417"	"20050075550"
"20050101848"	"20050113651"
"20050177034"	"20050192488"
"20050197548"	"20050228248"
"20050277819"	"20050283059"
"20060025660"	"20060030762"
"20060030763"	"20060030764"
"20060030765"	"20060058594"
"20060084852"	"20060089547"
"20060106294"	"20060161054"
"20060195028"	"20060200018"
"20060211925"	"20060211932"
"20060217604"	"20060217605"
"20060217606"	"20060217607"
"20060217608"	"20060224058"
"20060229510"	"20060229511"
"20060247501"	"20060258921"
"20060258926"	"20060276700"
"20070032710"	"20070032712"
"20070032715"	"20070043269"
"20070043270"	"20070043271"
"20070043272"	"20070043273"
"20070043274"	"20070043275"
"20070043276"	"20070043277"
"20070043278"	"20070043279"
"20070043280"	"20070043282"
"20070073116"	"20070073121"
"20070073125"	"20070073126"
"20070073127"	"20070073128"
"20070088207"	"20070100220"
"20070123756"	"20070244376"
"20080039701"	"20080081969"
"20080081970"	"20080088467"
"20080221413"	"20080221462"
"20080287757"	"20110015507"
"3721813"	"4586513"   "4603700"
"4621643"	"4653498"   "4685464"
"4694833"	"4697593"   "4700708"
"4714080"	"4714341"   "4759369"
"4770179"	"4773422"   "4776339"
"4781195"	"4796636").PN. OR

"4800495"	"4800885"	"4802486"
"4805623"	"4807630"	"4807631"
"4819646"	"4819752"	"4824242"
"4825872"	"4825879"	"4830014"
"4832484"	"4846183"	"4848901"
"4854699"	"4859056"	"4859057"
"4863265"	"4865038"	"4867557"
"4869253"	"4869254"	"4880304"
"4883055"	"4883353"	"4890619"
"4892101"	"4901238"	"4908762"
"4911167"	"4913150"	"4926867"
"4927264"	"4928692"	"4934372"
"4938218"	"4942877"	"4948248"
"4955379"	"4960126"	"4964408"
"4971062"	"4974591"	"5007423"
"5025791"	"5028787"	"5035243"
"5040539"	"5054488"	"5055671"
"5058588"	"5065749"	"5066859"
"5069213"	"5078136"	"5084327"
"5088493"	"5090410"	"5094239"
"5094240"	"5099841"	"5099842"
"5104623"	"5109849"	"5111817"
"5113861"	"5125403"	"5127406"
"5131391"	"5140989"	"5152296"
"5154175"	"5158082"	"5170786"
"5188108"	"5190038"	"5193542"
"5193543"	"5203329"	"5209230"
"5213099"	"5216598"	"5217012"
"5217013"	"5218962"	"5224478"
"5226417"	"5228440"	"5237994"
"5239185"	"5246002"	"5246003"
"5247931"	"5247932"	"5249576"
"5253645"	"5253646"	"5259381"
"5259761"	"5263244"	"5267562"
"5267563"	"5273036"	"5275159"
"5279295"	"5285783"	"5285784"
"5287853"	"5291884"	"5297548"
"5299120"	"5299570"	"5309908"
"5311865"	"5313940"	"5323776"
"5329922"	"5337744"	"5339810"
"5343818"	"5343869"	"5348003"
"5348004"	"5349519".PN. OR	
("5349952"	"5349953"	"5351685"
"5353799"	"5355880"	"5355882"
"5361758"	"5365066"	"5368025"
"5368026"	"5368224"	"5372136"
"5377675"	"5385143"	"5387122"
"5390670"	"5392777"	"5398680"
"5402777"	"5411023"	"5411024"
"5413099"	"5413100"	"5413101"
"5413102"	"5417207"	"5421329"
"5425360"	"5425362"	"5427093"
"5429128"	"5429129"	"5431159"
"5431170"	"5437275"	"5438986"
"5448991"	"5452717"	"5465714"
"5469845"	"5474065"	"5482034"
"5482036"	"5483646"	"5485847"
"5490505"	"5490523"	"5491299"
"5494032"	"5497771"	"5499627"
"5503148"	"5505199"	"5507286"
"5511546"	"5517988"	"5520177"
"5521851"	"5522388"	"5524617"
"5529064"	"5533507"	"5551423"
"5551424"	"5553614"	"5553615"

"5555882"	"5558096"	"5560355"
"5564417"	"5575284"	"5575285"
"5577500"	"5582169"	"5584296"
"5588425"	"5588427"	"5590652"
"5595176"	"5596986"	"5611337"
"5617852"	"5619992"	"5626140"
"5630413"	"5632272"	"5632273"
"5634459"	"5638593"	"5638818"
"5645060"	"5645440"	"5660567"
"5662105"	"5662106"	"5666952"
"5671529"	"5673692"	"5673693"
"5676139"	"5676141"	"5678544"
"5680857"	"5685299"	"5685301"
"5687719"	"5687722"	"5692503"
"5692505"	"5709205"	"5713355"
"5724967"	"5727547"	"5731582"
"5743260"	"5743263"	"5746206"
"5746697"	"5752914"	"5755226"
"5758644"	"5760910"	"5766125"
"5766127"	"5769785".PN. OR	
("5772587"	"5774213"	"5776058"
"5776059"	"5779630"	"5779631"
"5782237"	"5782756"	"5782757"
"5782758"	"5786592"	"5790729"
"5792052"	"5795292"	"5797841"
"5800348"	"5800349"	"5803910"
"5807246"	"5807247"	"5807248"
"5810723"	"5810724"	"5813980"
"5817008"	"5817009"	"5817010"
"5818985"	"5820550"	"5823950"
"5823952"	"5827182"	"5830135"
"5830136"	"5830137"	"5839439"
"5842979"	"5842981"	"5842982"
"5846190"	"5851178"	"5851179"
"5853364"	"5860919"	"5865736"
"5871442"	"5879294"	"5885213"
"5890929"	"5891021"	"5891022"
"5891024"	"5891025"	"5891026"
"5902235"	"5910108"	"5911690"
"5912656"	"5913819"	"5916154"
"5916155"	"5919133"	"5919134"
"5920263"	"5921921"	"5922607"
"5924979"	"5924980"	"5924982"
"5924985"	"5934277"	"5934925"
"5940182"	"5954644"	"5960610"
"5961450"	"5961452"	"5964701"
"5971930"	"5978691"	"5978693"
"5983122"	"5987343"	"5991648"
"5995855"	"5995856"	"5995858"
"5995859"	"5997343"	"5999834"
"6002952"	"6005658"	"6006120"
"6011985"	"6011986"	"6014576"
"6018673"	"6018674"	"6022321"
"6023541"	"6026312"	"6026314"
"6031603"	"6035223"	"6036642"
"6041247"	"6044283"	"6047201"
"6061584"	"6064898"	"6064899"
"6067462"	"6073038"	"6078833"
"6081735"	"6081742"	"6083157"
"6083172"	"6088607"	"6094592"
"6095974"	"6104938"	"6112107"
"6113541"	"6115621".PN. OR	
("6122535"	"6133994"	"6135952"
"6144444"	"6144867"	"6144868"

"6149481"	"6150951"	"6151107"
"6151518"	"6152754"	"6154667"
"6157850"	"6163715"	"6165005"
"6173196"	"6178343"	"6181958"
"6181959"	"6184521"	"6188470"
"6192260"	"6195575"	"6198951"
"6206830"	"6213952"	"6217523"
"6222189"	"6226539"	"6226540"
"6229856"	"6230035"	"6233470"
"6236871"	"6236872"	"6240305"
"6253097"	"6253098"	"6256523"
"6256524"	"6261236"	"6263221"
"6263222"	"6263223"	"6266546"
"6266547"	"6272363"	"6278522"
"6280213"	"6280381"	"6285894"
"6285895"	"6285896"	"6298252"
"6308089"	"6321100"	"6330468"
"6334065"	"6339715"	"6343223"
"6343224"	"6349228"	"6351658"
"6353569"	"6353750"	"6356774"
"6360113"	"6360114"	"6361501"
"6363269"	"6370408"	"6370409"
"6374129"	"6377829"	"6381479"
"6381480"	"6385471"	"6385821"
"6388240"	"6393310"	"6397091"
"6397092"	"6397093"	"6400971"
"6400972"	"6402690"	"6408198"
"6411832"	"6411833"	"6419671"
"6421549"	"6430423"	"6430513"
"6430525"	"6434408"	"6438399"
"6449501"	"6453183"	"6453184"
"6456862"	"6461305"	"6463310"
"6463311"	"6466808"	"6466809"
"6470199"	"6470200"	"6480729"
"6490466"	"6496711"	"6498942"
"6501974"	"6501975"	"6505060"
"6505061"	"6505133"	"6510329"
"6510331"	"6512937"	"6515273"
"6519484"	"6519486"	"6519487"
"6525386"	"6526300".PN. OR	
("6526301"	"6541756"	"6542764"
"6546267"	"6553241"	"6553242"
"6553243"	"6556852"	"6560470"
"6564077"	"6564088"	"6571113"
"6571114"	"6574491"	"6580086"
"6584336"	"6587703"	"6587704"
"6589172"	"6591122"	"6591123"
"6594511"	"6594512"	"6594513"
"6597931"	"6597933"	"6600940"
"6606510"	"6606511"	"6606512"
"6615064"	"6615065"	"6618602"
"6622034"	"6628975"	"6631281"
"6643530"	"6643531"	"6647279"
"6647280"	"6650917"	"6650918"
"6654621"	"6654622"	"6654623"
"6654624"	"6658276"	"6658277"
"6662033"	"6665551"	"6668182"
"6668183"	"6671526"	"6671528"
"6671530"	"6671531"	"6671532"
"6675031"	"6678543"	"6681126"
"6681128"	"6681454"	"6684090"
"6684091"	"6694160"	"6697653"
"6697655"	"6697656"	"6697658"
"6699194"	"6699199"	"6701170"



		"6702752"   "6707257"   "6708049"   "6709402"   "6711424"   "6711425"   "6714803"   "6714804"   "6714805"   "6719686"   "6719705"   "6720734"   "6721584"   "6721585"   "6725074"   "6725075"   "6731963"   "6731967"   "6735459"   "6745060"   "6745061"   "6748253"   "6748254"   "6754515"   "6754516"   "6760607"   "6760609"   "6760610"   "6763255"   "6763256"   "6770028"   "6771994"   "6773397"   "6778923"   "6780158"   "6791689"   "6792300"   "6793654"   "6801797"   "6801798"   "6801799"   "6801802"   "6802812"   "6805673"   "6810277"   "6813511"   "6816741"   "6819950"   "6822564"   "6825619"   "6826419"   "6829496"   "6830711").PN. OR ("6836679"   "6839579"   "6839580"   "6839582"   "6839659"   "6842635"   "6845256"   "6850787"   "6850788"   "6850789"   "6861639"   "6863652"   "6865407"   "6879850"   "6882874"   "6889153"   "6898452"   "6909912"   "6912413"   "6916289"   "6920345"   "6931269"   "6934570"   "6939307"   "6941162"   "6947781"   "6950687"   "6963767"   "6971580"   "6979812"   "6983178"   "6985763"   "6985764"   "6990426"   "6992751"   "6992772"   "6993371"   "6993372"   "6996427"   "6999904"   "7003338"   "7003339"   "7006855"   "7006856"   "7016715"   "7020507"   "7024233"   "7024235"   "7025728"   "7027849"   "7027850"   "7035697"   "7039449"   "7043289"   "7047055"   "7047056"   "7048687"   "7060035"   "7062307"   "7067893"   "7072701"   "7072702"   "7079880"   "7085597"   "7096052"   "7096054"   "7107088"   "7113815"   "7123950"   "7127278"   "7130671"   "7132641"   "7133711"   "7139599"   "7142901"   "7162288"   "7190987"   "7198778"   "7209775"   "7215984"   "7225006"   "7236811"   "7248910"   "7254433"   "7254434"   "7263395"   "7272425"   "7272426"   "7280858"   "7295866"   "7305262"   "7315753"   "7371981"   "7392074"   "7428432"   "7438683"   "D393830"   "H001039"   "RE33643"   "RE35122"   "RE36000"   "RE38476"   "RE38492").PN. OR ("8417310").URPN.				
S55	157	("4700708"   "4796636"   "5057695"   "5139025"   "5188108"   "5218962"   "5226417"   "5277181"   "5285783"   "5297548"   "5372135").PN. OR ("5524617").URPN.	US- PGPUB; USPAT; USOCR	OR	OFF	2019/09/10 15:05
S56	171	("4305398"   "4446871"   "4463762"   "4603700"   "4714080").PN. OR ("4854699").URPN.	US- PGPUB; USPAT; USOCR	OR	OFF	2019/09/10 15:07
S57	1389	reflectance with transmittance and	US-	OR	ON	2019/09/10

		A61B5/\$.cpc.	PGPUB; USPAT			15:08
S58	58	reflectance with transmittance with (switch\$4 select\$4 choos\$4 chos\$4) and A61B5/\$.cpc.	US- PGPUB; USPAT	OR	ON	2019/09/10 15:08
S59	203	("3463142"   "3638640"   "3958560"   "4014321"   "4169676"   "4202339"   "4223680"   "4350163"   "4408880"   "4655225"   "4704029"   "4714080"   "4785814"   "4796636"   "4840179"   "4854699"   "4882492"   "4901728"   "4975581"   "5007423"   "5054487"   "5070874"   "5086229").PN. OR ("5222495").URPN.	US- PGPUB; USPAT; USOCR	OR	OFF	2019/09/10 15:12
S60	35	reflectance with transmittance same plurality and (driv\$4 energiz\$4) and A61B5/\$.cpc.	US- PGPUB; USPAT	OR	ON	2019/09/10 15:13
S61	314	("4766551"   "4901728"   "4975581"   "5009230"   "5028787"   "5068536"   "5070874"   "5077476"   "5086229"   "5119819"   "5121338"   "5137023"   "5139023"   "5140985"   "5204532"   "5206701"   "5223714"   "5223715"   "5242602"   "5243546"   "5252829"   "5258825"   "5267151"   "5267152"   "5299138"   "5307263"   "5313941"   "5343044"   "5348002"   "5348003"   "5349188"   "5349189"   "5360972"   "5361758"   "5362307"   "5370114"   "5379238"   "5379764"   "5383452"   "5433197"   "5435309"   "5446681"   "5456252"   "5459317"   "5459677"   "5481476"   "5498875"   "5512751"   "5515847"   "5551422"   "5568400"   "5576544"   "5582168"   "5602755"   "5606164"   "5610836"   "5615672"   "5638816"   "5641962"   "5655530"   "5657754"   "5666956"   "5668373"   "5668374"   "5672875"   "5676143"   "5680320"   "5680321"   "5692504"   "5706208"   "5710630"   "5712481"   "5712797"   "5730714"   "5740073"   "5743262"   "5747806"   "5750994"   "5752512"   "5771891"   "5782755"   "5788632"   "5798526"   "5822219"   "5823951"   "5823966"   "5830132"   "5830133"   "5840020"   "5841523"   "5857462"   "5890489"   "5896198"   "5900634"   "5910109"   "5933792"   "5935062"   "5945676"   "5946128"   "5946640"   "5968760"   "5985120"   "6006119"   "6012019"   "6014577"   "6026314"   "6040578"   "6049082"   "6061582"   "6064065"   "6064897"   "6066847"   "6067463"   "6070128"   "6087182"   "6087662"   "6091843"   "6110522"   "6114699"   "6115673"   "6124134"   "6137108"   "6151517"   "6157041"   "6159255").PN. OR ("6161028"   "6181957"   "6219565"   "6236047"   "6309884").PN. OR ("6675030").URPN.	US- PGPUB; USPAT; USOCR	OR	OFF	2019/09/10 15:48

EAST Search History

S62	902	"10039080"   "10055121"   "10066970"   "10076257"   "10078052"   "10258265"   "10258266"   "20020099279"   "20060005944"   "20060025659"   "20060076473"   "20070149864"   "20070238955"   "20070293792"   "20080130232"   "20080139908"   "20090030327"   "20090043180"   "20090129102"   "20090247984"   "20090259114"   "20090275844"   "20090306487"   "20100004518"   "20100030040"   "20100217102"   "20110001605"   "20110004082"   "20110082711"   "20110105854"   "20110105865"   "20110208015"   "20110213212"   "20110230733"   "20110237911"   "20120059267"   "20120179006"   "20120209082"   "20120209084"   "20120227739"   "20120283524"   "20120296178"   "20120319816"   "20120330112"   "20130023775"   "20130041591"   "20130045685"   "20130046204"   "20130060147"   "20130096405"   "20130096936"   "20130190581"   "20130197328"   "20130211214"   "20130243021"   "20130253334"   "20130296672"   "20130317370"   "20130324808"   "20130331670"   "20130338461"   "20140012100"   "20140034353"   "20140051953"   "20140058230"   "20140066783"   "20140077956"   "20140081100"   "20140081175"   "20140094667"   "20140100434"   "20140114199"   "20140120564"   "20140121482"   "20140121483"   "20140127137"   "20140129702"   "20140135588"   "20140142401"   "20140155712"   "20140163344"   "20140163402"   "20140166076"   "20140171146"   "20140171763"   "20140180038"   "20140180154"   "20140194709"   "20140194711"   "20140194766"   "20140206963"   "20140213864"   "20140243627"   "20140266790"   "20140275808").PN. OR ("20140275835"   "20140275871"   "20140275872"   "20140275881"   "20140288400"   "20140296664"   "20140303520"   "20140316228"   "20140323825"   "20140330092"   "20140330098"   "20140330099"   "20140333440"   "20140336481"   "20140343436"   "20150018650"   "20150173671"   "20150255001"   "20150281424"   "20150318100"   "20150351697"   "20150351704"   "20150359429"   "20150366472"   "20150366507"   "20150374298"   "20150380875"   "20160000362"   "20160007930"   "20160019360"   "20160023245"   "20160029932"   "20160029933"   "20160038045"   "20160045118"	US- PGPUB; USPAT; USOCR	OR	OFF	2019/09/10 15:51
-----	-----	--	----------------------------------	----	-----	---------------------

"20160051157" | "20160051158" |  
"20160051205" | "20160058302" |  
"20160058309" | "20160058312" |  
"20160058338" | "20160058347" |  
"20160058356" | "20160058370" |  
"20160066823" | "20160066824" |  
"20160066879" | "20160071392" |  
"20160072429" | "20160073967" |  
"20160081552" | "20160095543" |  
"20160095548" | "20160103598" |  
"20160113527" | "20160143548" |  
"20160154950" | "20160157780" |  
"20160166183" | "20160166210" |  
"20160192869" | "20160196388" |  
"20160197436" | "20160213281" |  
"20160213309" | "20160256058" |  
"20160256082" | "20160267238" |  
"20160287181" | "20160296173" |  
"20160296174" | "20160310027" |  
"20160378069" | "20160378071" |  
"20170007183" | "20170010858" |  
"20170074897" | "20170084133" |  
"20170086689" | "20170086742" |  
"20170086743" | "20170094450" |  
"20170164884" | "20170248446" |  
"20170273619" | "20170281024" |  
"20170293727" | "20170325698" |  
"20170325744" | "20170340209" |  
"20170340219" | "20170347885").PN. OR  
("20170354332" | "20170354795" |  
"20170358239" | "20170358240" |  
"20170358242" | "20170360306" |  
"20170366657" | "20180014781" |  
"20180025287" | "20180042556" |  
"20180049694" | "20180050235" |  
"20180055375" | "20180055390" |  
"20180055439" | "20180056129" |  
"20180078151" | "20180078182" |  
"20180110469" | "20180153418" |  
"20180164853" | "20180196514" |  
"20180228414" | "20180238734" |  
"20180279956" | "20190104973" |  
"20190110719" | "3910701" | "4114604" |  
"4258719" | "4267844" | "4438338" |  
"4444471" | "4653498" | "4655225" |  
"4684245" | "4709413" | "4755676" |  
"4781195" | "4805623" | "4880304" |  
"4960128" | "4964408" | "5028787" |  
"5035243" | "5041187" | "5043820" |  
"5069213" | "5069214" | "5077476" |  
"5086229" | "5099842" | "5122925" |  
"5131391" | "5137023" | "5159929" |  
"5163438" | "5222295" | "5222495" |  
"5222496" | "5249576" | "5250342" |  
"5278627" | "5297548" | "5319355" |  
"5337744" | "5337745" | "5341805" |  
"5362966" | "5377676" | "5427093" |  
"5431170" | "5437275" | "5441054" |  
"5452717" | "5456252" | "5479934" |  
"5482034" | "5482036" | "5490505" |  
"5490506" | "5494043" | "5511546" |  
"5533511" | "5534851" | "5551422" |  
"5553615" | "5553616" | "5561275" |  
"5562002" | "5590649" | "5601079" |

"5602924"	"5625458"	"5632272"
"5638816"	"5638818"	"5645440"
"5676143"	"5685299"	"5743262"
"5750927"	"5752914"	"5758644"
"5760910"	"5766131"	"5769785"
"5782757"	"5785659"	"5791347"
"5792052"	"5810734"	"5823950"
"5826885"	"5830131"	"5833618").PN.
OR ("5851178"	"5860919"	"5890929"
"5902235"	"5903357"	"5904654"
"5919134"	"5934925"	"5940182"
"5957840"	"5995855"	"5997343"
"6002952"	"6011986"	"6027452"
"6036642"	"6045509"	"6049727"
"6067462"	"6081735"	"6088607"
"6110522"	"6124597"	"6128521"
"6129675"	"6144866"	"6144868"
"6151516"	"6152754"	"6157850"
"6165005"	"6172743"	"6181958"
"6184521"	"6206830"	"6223063"
"6229856"	"6232609"	"6236872"
"6241683"	"6253097"	"6256523"
"6263222"	"6278522"	"6278889"
"6280213"	"6285896"	"6301493"
"6317627"	"6321100"	"6325761"
"6334065"	"6343223"	"6343224"
"6345194"	"6349228"	"6353750"
"6360113"	"6360114"	"6360115"
"6368283"	"6371921"	"6377829"
"6388240"	"6397091"	"6430437"
"6430525"	"6463311"	"6470199"
"6501975"	"6505059"	"6515273"
"6519487"	"6522521"	"6525386"
"6526300"	"6541756"	"6542764"
"6580086"	"6584336"	"6595316"
"6597932"	"6597933"	"6606509"
"6606511"	"6632181"	"6636759"
"6639668"	"6639867"	"6640116"
"6643530"	"6650917"	"6654624"
"6658276"	"6661161"	"6668185"
"6671531"	"6678543"	"6681133"
"6684090"	"6684091"	"6697656"
"6697657"	"6697658"	"6699194"
"6714804"	"6721582"	"6721585"
"6725075"	"6728560"	"6735459"
"6745060"	"6748254"	"6760607"
"6770028"	"6771994"	"6792300"
"6813511"	"6816010"	"6816241"
"6816741"	"6822564"	"6826419"
"6830711"	"6850787").PN.	OR
("6850788"	"6852083"	"6861639"
"6898452"	"6912413"	"6920345"
"6931268"	"6934570"	"6939305"
"6943348"	"6950687"	"6961598"
"6970792"	"6979812"	"6985764"
"6993371"	"6995400"	"6996427"
"6999904"	"7003338"	"7003339"
"7015451"	"7024233"	"7026619"
"7027849"	"7030749"	"7039449"
"7041060"	"7044918"	"7047054"
"7067893"	"7092757"	"7096052"
"7096054"	"7113815"	"7132641"
"7142901"	"7149561"	"7186966"
"7190261"	"7215984"	"7215986"

"7221971"	"7225006"	"7225007"
"7230227"	"7239905"	"7245953"
"7254429"	"7254431"	"7254433"
"7254434"	"7272425"	"7274955"
"7280858"	"7289835"	"7292883"
"7295866"	"7328053"	"7332784"
"7340287"	"7341559"	"7343186"
"7355512"	"7356365"	"7365923"
"7371981"	"7373193"	"7373194"
"7376453"	"7377794"	"7377899"
"7383070"	"7395189"	"7415297"
"7428432"	"7438683"	"7440787"
"7454240"	"7467002"	"7469157"
"7471969"	"7471971"	"7483729"
"7483730"	"7489958"	"7496391"
"7496393"	"7499741"	"7499835"
"7500950"	"7509153"	"7509154"
"7509494"	"7510849"	"7519327"
"7526328"	"7530942"	"7530949"
"7530955"	"7563110"	"7596398"
"7601123"	"7606606"	"7618375"
"7647083"	"7657294"	"7657295"
"7657296"	"7726209"	"7729733"
"7734320"	"7761127"	"7761128"
"7764982"	"7791155"	"7801581"
"7809418"	"7822452"	"7844313"
"7844314"	"7844315"	"7862523"
"7865222"	"7873497".PN. OR	
("7880606"	"7880626"	"7891355"
"7894868"	"7899506"	"7899507"
"7899518"	"7904132"	"7909772"
"7910875"	"7919713"	"7937128"
"7937129"	"7937130"	"7941199"
"7951086"	"7957780"	"7962188"
"7962190"	"7976472"	"7988637"
"7990382"	"7991446"	"8000761"
"8008088"	"8019400"	"8028701"
"8029765"	"8036728"	"8044998"
"8046040"	"8046041"	"8046042"
"8048040"	"8050728"	"8118620"
"8126528"	"8126531"	"8128572"
"8130105"	"8145287"	"8150487"
"8175672"	"8180420"	"8182443"
"8185180"	"8190223"	"8190227"
"8203438"	"8203704"	"8219170"
"8224411"	"8228181"	"8229532"
"8229533"	"8233955"	"8244325"
"8255026"	"8255027"	"8255028"
"8260577"	"8265723"	"8274360"
"8289130"	"8301217"	"8306596"
"8310336"	"8315683"	"8332006"
"8337403"	"8346330"	"8353842"
"8355766"	"8359080"	"8364223"
"8364226"	"8364389"	"8374665"
"8380272"	"8385995"	"8385996"
"8388353"	"8399822"	"8401602"
"8405608"	"8414499"	"8418524"
"8421022"	"8423106"	"8428674"
"8428967"	"8430817"	"8437825"
"8455290"	"8457703"	"8457707"
"8463349"	"8466286"	"8471713"
"8473020"	"8483787"	"8489364"
"8498684"	"8504128"	"8509867"
"8515509"	"8523781"	"8529301"

"8532727"	"8532728"	"8547209"
"8548548"	"8548549"	"8548550"
"8560032"	"8560034"	"8570167"
"8570503"	"8571617"	"8571618"
"8571619"	"8577431"	"8581732"
"8584345"	"8588880").	PN. OR
("8600467"	"8602971"	"8606342"
"8615290"	"8626255"	"8630691"
"8634889"	"8641631"	"8652060"
"8655004"	"8663107"	"8666468"
"8667967"	"8670811"	"8670814"
"8676286"	"8682407"	"8688183"
"8690799"	"8700111"	"8700112"
"8702627"	"8706179"	"8712494"
"8715206"	"8718735"	"8718737"
"8718738"	"8720249"	"8721541"
"8721542"	"8723677"	"8740792"
"8754776"	"8755535"	"8755856"
"8755872"	"8760517"	"8761850"
"8764671"	"8768423"	"8771204"
"8777634"	"8781543"	"8781544"
"8781549"	"8788003"	"8790268"
"8801613"	"8821397"	"8821415"
"8830449"	"8831700"	"8840549"
"8847740"	"8849365"	"8852094"
"8852994"	"8868147"	"8868150"
"8870792"	"8886271"	"8888539"
"8888708"	"8892180"	"8897847"
"8909310"	"8911377"	"8912909"
"8920317"	"8921699"	"8922382"
"8929964"	"8942777"	"8948834"
"8948835"	"8965471"	"8983564"
"8989831"	"8996085"	"8998809"
"9028429"	"9037207"	"9060721"
"9066666"	"9066680"	"9072437"
"9072474"	"9078560"	"9081889"
"9084569"	"9095316"	"9106038"
"9107625"	"9107626"	"9113831"
"9113832"	"9119595"	"9131881"
"9131882"	"9131883"	"9131917"
"9138180"	"9138182"	"9138192"
"9142117"	"9153112"	"9153121"
"9161696"	"9161713"	"9167995"
"9176141"	"9186102"	"9192312"
"9192329"	"9192351"	"9195385"
"9210566"	"9211072"	"9211095"
"9218454"	"9226696"	"9241662"
"9245668"	"9259185").	PN. OR
("9267572"	"9277880"	"9289167"
"9295421"	"9307928"	"9311382"
"9323894"	"9326712"	"9333316"
"9339220"	"9341565"	"9351673"
"9351675"	"9357665"	"9364181"
"9368671"	"9370325"	"9370326"
"9370335"	"9375185"	"9386953"
"9386961"	"9392945"	"9397448"
"9489081"	"9497534"	"9526430"
"9553625"	"9591975"	"9593969"
"9651405"	"9668676"	"9668680"
"9699546"	"9716937"	"9717425"
"9723997"	"9781984"	"9838775"
"9848823"	"9866671"	"9867575"
"9898049"	"9918646"	"9952095"
"D326715"	"D353195"	"D353196"

		"D356870"   "D359546"   "D361840"   "D362063"   "D363120"   "D378414"   "D390666"   "D393830"   "D403070"   "D414870"   "D452012"   "D455834"   "D463561"   "D481459"   "D502655"   "D508862"   "D510625"   "D514461"   "D535031"   "D537164"   "D547454"   "D549830"   "D550364"   "D551350"   "D553248"   "D554263"   "D562985"   "D566282"   "D567125"   "D569001"   "D569521"   "D587657"   "D603966"   "D606659"   "D609193"   "D614305"   "D621516"   "D692145"   "D755392"   "RE37922"   "RE38476"   "RE38492"   "RE39672"   "RE41317"   "RE41912"   "RE42753"   "RE43169"   "RE43860"   "RE44823"   "RE44875").PN. OR ("10376190").URPN.				
S63	183	reflectance with transmittance and winakur.xp.	US-PGPUB; USPAT	OR	ON	2019/09/10 16:00
S64	14	(energiz\$4 energis\$4 activat\$4) with (light LED diode) same (select\$4 choos\$4 switch\$4) with (reflectance transmittance reflect\$4 transmit\$4) and winakur.xp.	US-PGPUB; USPAT	OR	ON	2019/09/10 16:08
S65	352	(energiz\$4 energis\$4 activat\$4) with (light LED diode) same (select\$4 choos\$4 switch\$4) with (reflectance transmittance reflect\$4 transmit\$4) and A61 B5/\$.cpc.	US-PGPUB; USPAT	OR	ON	2019/09/10 16:12
S66	34	(energiz\$4 energis\$4 activat\$4) with (light LED diode) with set with plurality and A61 B5/\$.cpc.	US-PGPUB; USPAT	OR	ON	2019/09/10 16:33
S67	34	(energiz\$4 energis\$4 activat\$4) with (light LED diode) with first adj set and A61 B5/\$.cpc.	US-PGPUB; USPAT	OR	ON	2019/09/10 16:36
S68	24	S67 not S66	US-PGPUB; USPAT	OR	ON	2019/09/10 16:37
S69	2	"13423705"	US-PGPUB; USPAT	OR	ON	2019/09/10 16:40
S70	5	((("20060270920") or ("3638640") or ("8414499") or ("3638640") or ("8418499") or ("9597021")).PN.	US-PGPUB; USPAT; USOCR	OR	OFF	2019/09/10 16:43

**EAST Search History (Interference)**

< This search history is empty >

9/ 11/ 2019 11:19:56 AM

C:\Users\mfardanesh\Documents\EAST\Workspaces\16312080.wsp



PTO/SB/08 Equivalent

<b>INFORMATION DISCLOSURE STATEMENT BY APPLICANT</b>	Application No.	16/226249	
	Filing Date	December 19, 2018	
	First Named Inventor	Ammar Al-Ali	
	Art Unit	3791	
<i>(Multiple sheets used when necessary)</i>		Examiner	Fardanesh, Marjan
SHEET 1 OF 1		Attorney Docket No.	MAS.1007C1

U.S. PATENT DOCUMENTS					
Examiner Initials	Cite No.	Document Number <i>Number - Kind Code (if known)</i> Example: 1,234,567 B1	Publication Date MM-DD-YYYY	Name	Pages, Columns, Lines Where Relevant Passages or Relevant Figures Appear
	1	5,099,842	03-31-1992	Mannheimer et al.	
	2	5,601,079	02-11-1997	Wong et al.	
	3	6,223,063	04-24-2001	Chaiken et al.	
	4	2002/0042558	04-11-2002	Mendelson	

FOREIGN PATENT DOCUMENTS						
Examiner Initials	Cite No.	Foreign Patent Document <i>Country Code-Number-Kind Code</i> Example: JP 1234567 A1	Publication Date MM-DD-YYYY	Name	Pages, Columns, Lines Where Relevant Passages or Relevant Figures Appear	T <sup>1</sup>
	5	WO 02/028274	04-11-2002	CYBRO MEDICAL LTD.		

NON PATENT LITERATURE DOCUMENTS			
Examiner Initials	Cite No.	Include name of the author (in CAPITAL LETTERS), title of the article (when appropriate), title of the item (book, magazine, journal, serial, symposium, catalog, etc.), date, page(s), volume-issue number(s), publisher, city and/or country where published.	T <sup>1</sup>
	6	Konig, V. et al., "REFLECTANCE PULSE OXIMETRY - PRINCIPLES AND OBSTETRIC APPLICATION IN THE ZURICH SYSTEM," J Clin Monit 1998; 14: 403-412.	

31137798

Examiner Signature	/MARJAN FARDANESH/	Date Considered	09/06/2019
<p><b>*Examiner:</b> Initial if reference considered, whether or not citation is in conformance with MPEP 609. Draw line through citation if not in conformance and not considered. Include copy of this form with next communication to applicant.</p>			

~~ALL REFERENCES CONSIDERED EXCEPT WHERE LINED THROUGH. /M.F./~~  
T<sup>1</sup> - Place a check mark in this area when an English language Translation is attached.

Doc code: RCEX

Doc description: Request for Continued Examination (RCE)

PTO/SB/30EFS (02-18)

Approved for use through 11/30/2020. OMB 0651-0031

U.S. Patent and Trademark Office; U.S. DEPARTMENT OF COMMERCE

Under the Paperwork Reduction Act of 1995, no persons are required to respond to a collection of information unless it contains a valid OMB control number.

### REQUEST FOR CONTINUED EXAMINATION(RCE)TRANSMITTAL (Submitted Only via EFS-Web)

Application Number	16226249	Filing Date	2018-12-19	Docket Number (if applicable)	MAS.1007C1	Art Unit	3791
First Named Inventor	Al-Ali, Ammar			Examiner Name	Fardanesh, Marjan		

**This is a Request for Continued Examination (RCE) under 37 CFR 1.114 of the above-identified application.**  
 Request for Continued Examination (RCE) practice under 37 CFR 1.114 does not apply to any utility or plant application filed prior to June 8, 1995, or to any design application. The Instruction Sheet for this form is located at WWW.USPTO.GOV

#### SUBMISSION REQUIRED UNDER 37 CFR 1.114

Note: If the RCE is proper, any previously filed unentered amendments and amendments enclosed with the RCE will be entered in the order in which they were filed unless applicant instructs otherwise. If applicant does not wish to have any previously filed unentered amendment(s) entered, applicant must request non-entry of such amendment(s).

Previously submitted. If a final Office action is outstanding, any amendments filed after the final Office action may be considered as a submission even if this box is not checked.

Consider the arguments in the Appeal Brief or Reply Brief previously filed on \_\_\_\_\_

Other \_\_\_\_\_

Enclosed

Amendment/Reply

Information Disclosure Statement (IDS)

Affidavit(s)/ Declaration(s)

Other \_\_\_\_\_

#### MISCELLANEOUS

Suspension of action on the above-identified application is requested under 37 CFR 1.103(c) for a period of months \_\_\_\_\_  
 (Period of suspension shall not exceed 3 months; Fee under 37 CFR 1.17(i) required)

Other \_\_\_\_\_

#### FEES

**The RCE fee under 37 CFR 1.17(e) is required by 37 CFR 1.114 when the RCE is filed.**

The Director is hereby authorized to charge any underpayment of fees, or credit any overpayments, to  
 Deposit Account No

#### SIGNATURE OF APPLICANT, ATTORNEY, OR AGENT REQUIRED

Patent Practitioner Signature

Applicant Signature

Doc code: RCEX

Doc description: Request for Continued Examination (RCE)

PTO/SB/30EFS (02-18)

Approved for use through 11/30/2020. OMB 0651-0031

U.S. Patent and Trademark Office; U.S. DEPARTMENT OF COMMERCE

Under the Paperwork Reduction Act of 1995, no persons are required to respond to a collection of information unless it contains a valid OMB control number.

Signature of Registered U.S. Patent Practitioner			
Signature	Aaron S. Johnson/	Date (YYYY-MM-DD)	2019-08-15
Name	Aaron S. Johnson	Registration Number	74164

This collection of information is required by 37 CFR 1.114. The information is required to obtain or retain a benefit by the public which is to file (and by the USPTO to process) an application. Confidentiality is governed by 35 U.S.C. 122 and 37 CFR 1.11 and 1.14. This collection is estimated to take 12 minutes to complete, including gathering, preparing, and submitting the completed application form to the USPTO. Time will vary depending upon the individual case. Any comments on the amount of time you require to complete this form and/or suggestions for reducing this burden, should be sent to the Chief Information Officer, U.S. Patent and Trademark Office, U.S. Department of Commerce, P.O. Box 1450, Alexandria, VA 22313-1450.

*If you need assistance in completing the form, call 1-800-PTO-9199 and select option 2.*

## Privacy Act Statement

The Privacy Act of 1974 (P.L. 93-579) requires that you be given certain information in connection with your submission of the attached form related to a patent application or patent. Accordingly, pursuant to the requirements of the Act, please be advised that: (1) the general authority for the collection of this information is 35 U.S.C. 2(b)(2); (2) furnishing of the information solicited is voluntary; and (3) the principal purpose for which the information is used by the U.S. Patent and Trademark Office is to process and/or examine your submission related to a patent application or patent. If you do not furnish the requested information, the U.S. Patent and Trademark Office may not be able to process and/or examine your submission, which may result in termination of proceedings or abandonment of the application or expiration of the patent.

The information provided by you in this form will be subject to the following routine uses:

1. The information on this form will be treated confidentially to the extent allowed under the Freedom of Information Act (5 U.S.C. 552) and the Privacy Act (5 U.S.C. 552a). Records from this system of records may be disclosed to the Department of Justice to determine whether the Freedom of Information Act requires disclosure of these records.
2. A record from this system of records may be disclosed, as a routine use, in the course of presenting evidence to a court, magistrate, or administrative tribunal, including disclosures to opposing counsel in the course of settlement negotiations.
3. A record in this system of records may be disclosed, as a routine use, to a Member of Congress submitting a request involving an individual, to whom the record pertains, when the individual has requested assistance from the Member with respect to the subject matter of the record.
4. A record in this system of records may be disclosed, as a routine use, to a contractor of the Agency having need for the information in order to perform a contract. Recipients of information shall be required to comply with the requirements of the Privacy Act of 1974, as amended, pursuant to 5 U.S.C. 552a(m).
5. A record related to an International Application filed under the Patent Cooperation Treaty in this system of records may be disclosed, as a routine use, to the International Bureau of the World Intellectual Property Organization, pursuant to the Patent Cooperation Treaty.
6. A record in this system of records may be disclosed, as a routine use, to another federal agency for purposes of National Security review (35 U.S.C. 181) and for review pursuant to the Atomic Energy Act (42 U.S.C. 218(c)).
7. A record from this system of records may be disclosed, as a routine use, to the Administrator, General Services, or his/her designee, during an inspection of records conducted by GSA as part of that agency's responsibility to recommend improvements in records management practices and programs, under authority of 44 U.S.C. 2904 and 2906. Such disclosure shall be made in accordance with the GSA regulations governing inspection of records for this purpose, and any other relevant (i.e., GSA or Commerce) directive. Such disclosure shall not be used to make determinations about individuals.
8. A record from this system of records may be disclosed, as a routine use, to the public after either publication of the application pursuant to 35 U.S.C. 122(b) or issuance of a patent pursuant to 35 U.S.C. 151. Further, a record may be disclosed, subject to the limitations of 37 CFR 1.14, as a routine use, to the public if the record was filed in an application which became abandoned or in which the proceedings were terminated and which application is referenced by either a published application, an application open to public inspections or an issued patent.
9. A record from this system of records may be disclosed, as a routine use, to a Federal, State, or local law enforcement agency, if the USPTO becomes aware of a violation or potential violation of law or regulation.

---

**INFORMATION DISCLOSURE STATEMENT**

First Inventor :	Ammar Al-Ali
App. No. :	16/226249
Filed :	December 19, 2018
For :	ADVANCED PULSE OXIMETRY SENSOR
Examiner :	Fardanesh, Marjan
Art Unit :	3791
Conf. No. :	1002

**Mail Stop RCE**

Commissioner for Patents  
P.O. Box 1450  
Alexandria, VA 22313-1450

**References and Listing**

Pursuant to 37 CFR 1.56, an Information Disclosure Statement listing references is provided herewith. Copies of any listed foreign and non-patent literature references are being submitted.

**No Disclaimers**

To the extent that anything in the Information Disclosure Statement or the listed references could be construed as a disclaimer of any subject matter supported by the present application, Applicant hereby rescinds and retracts such disclaimer.

**Timing of Disclosure**

This Information Disclosure Statement is being filed within three months of the filing date or date of national phase entry, with an RCE or before receipt of a First Office Action after an RCE, and no fee is believed to be required.

**Application No.: 16/226249**  
**Filing Date: December 19, 2018**

The Commissioner is hereby authorized to charge any additional fees which may be required, or credit any overpayment, to Account No. 11-1410.

Respectfully submitted,  
KNOBBE, MARTENS, OLSON & BEAR, LLP

Dated: August 15, 2019

By: /Aaron S. Johnson/  
Aaron S. Johnson  
Registration No. 74,164  
Registered Practitioner  
Customer No. 64735  
(949) 760-0404

IDS

31137842

<b>INFORMATION DISCLOSURE STATEMENT BY APPLICANT</b>	Application No.	16/226249
	Filing Date	December 19, 2018
	First Named Inventor	Ammar Al-Ali
	Art Unit	3791
<i>(Multiple sheets used when necessary)</i>	Examiner	Fardanesh, Marjan
SHEET 1 OF 1	Attorney Docket No.	MAS.1007C1

<b>U.S. PATENT DOCUMENTS</b>					
Examiner Initials	Cite No.	Document Number <i>Number - Kind Code (if known)</i> Example: 1,234,567 B1	Publication Date MM-DD-YYYY	Name	Pages, Columns, Lines Where Relevant Passages or Relevant Figures Appear
	1	5,099,842	03-31-1992	Mannheimer et al.	
	2	5,601,079	02-11-1997	Wong et al.	
	3	6,223,063	04-24-2001	Chaiken et al.	
	4	2002/0042558	04-11-2002	Mendelson	

<b>FOREIGN PATENT DOCUMENTS</b>						
Examiner Initials	Cite No.	Foreign Patent Document <i>Country Code-Number-Kind Code</i> Example: JP 1234567 A1	Publication Date MM-DD-YYYY	Name	Pages, Columns, Lines Where Relevant Passages or Relevant Figures Appear	T <sup>1</sup>
	5	WO 02/028274	04-11-2002	CYBRO MEDICAL LTD.		

<b>NON PATENT LITERATURE DOCUMENTS</b>			
Examiner Initials	Cite No.	Include name of the author (in CAPITAL LETTERS), title of the article (when appropriate), title of the item (book, magazine, journal, serial, symposium, catalog, etc.), date, page(s), volume-issue number(s), publisher, city and/or country where published.	T <sup>1</sup>
	6	Konig, V. et al., "REFLECTANCE PULSE OXIMETRY - PRINCIPLES AND OBSTETRIC APPLICATION IN THE ZURICH SYSTEM," J Clin Monit 1998; 14: 403-412.	

31137798

Examiner Signature	Date Considered
<p><b>*Examiner:</b> Initial if reference considered, whether or not citation is in conformance with MPEP 609. Draw line through citation if not in conformance and not considered. Include copy of this form with next communication to applicant.</p>	

T<sup>1</sup> - Place a check mark in this area when an English language Translation is attached.

(12) INTERNATIONAL APPLICATION PUBLISHED UNDER THE PATENT COOPERATION TREATY (PCT)

(19) World Intellectual Property Organization  
International Bureau



(43) International Publication Date  
11 April 2002 (11.04.2002)

PCT

(10) International Publication Number  
WO 02/28274 A1

- (51) International Patent Classification<sup>7</sup>: A61B 5/00
- (21) International Application Number: PCT/US01/26642
- (22) International Filing Date: 27 August 2001 (27.08.2001)
- (25) Filing Language: English
- (26) Publication Language: English
- (30) Priority Data:  
138884 5 October 2000 (05.10.2000) IL
- (71) Applicant (for all designated States except US): CYBRO MEDICAL LTD. [IL/IL]; Matam Building 30, 31905 Haifa (IL).
- (72) Inventor; and
- (75) Inventor/Applicant (for US only): MENDELSON, Yizhak [US/US]; 31 Whisper Drive, Worcester, MA 01609 (US).
- (74) Agents: YEE, James, R. et al.; Howard & Howard Attorneys, P.C., Suite 101, The Pinehurst Office Center, 39400 Woodward Avenue, Bloomfield Hills, MI 48304-5151 (US).
- (81) Designated States (national): AE, AG, AL, AM, AT, AU, AZ, BA, BB, BG, BR, BY, BZ, CA, CH, CN, CO, CR, CU, CZ, DE, DK, DM, DZ, EC, EE, ES, FI, GB, GD, GE, GH, GM, HR, HU, ID, IL, IN, IS, JP, KE, KG, KP, KR, KZ, LC, LK, LR, LS, LT, LU, LV, MA, MD, MG, MK, MN, MW, MX, MZ, NO, NZ, PL, PT, RO, RU, SD, SE, SG, SI, SK, SL, TJ, TM, TR, TT, TZ, UA, UG, US, UZ, VN, YU, ZA, ZW.
- (84) Designated States (regional): ARIPO patent (GH, GM, KE, LS, MW, MZ, SD, SL, SZ, TZ, UG, ZW), Eurasian patent (AM, AZ, BY, KG, KZ, MD, RU, TJ, TM), European patent (AT, BE, CH, CY, DE, DK, ES, FI, FR, GB, GR, IE, IT, LU, MC, NL, PT, SE, TR), OAPI patent (BF, BJ, CF, CG, CI, CM, GA, GN, GQ, GW, ML, MR, NE, SN, TD, TG).
- Published:**  
— with international search report  
— before the expiration of the time limit for amending the claims and to be republished in the event of receipt of amendments
- For two-letter codes and other abbreviations, refer to the "Guidance Notes on Codes and Abbreviations" appearing at the beginning of each regular issue of the PCT Gazette.*



WO 02/28274 A1

(54) Title: A PULSE OXIMETER AND A METHOD OF ITS OPERATION

(57) Abstract: A sensor for use in an optical measurement device and a method for non-invasive measurement of a blood parameter. The sensor includes sensor housing, a source of radiation coupled to the housing, and a detector assembly coupled to the housing. The source of radiation is adapted to emit radiation at predetermined frequencies. The detector assembly is adapted to detect reflected radiation at least one predetermined frequency and to generate respective signals. The signals are use to determine the parameter of the blood.



## A PULSE OXIMETER AND A METHOD OF ITS OPERATION

### BACKGROUND OF THE INVENTION

#### Field of the Invention

5 This invention is generally in the field of pulse oximetry, and relates to a sensor for use in a pulse oximeter, and a method for the pulse oximeter operation.

#### Background of the Invention

10 Oximetry is based on spectrophotometric measurements of changes in the color of blood, enabling the non-invasive determination of oxygen saturation in the patient's blood. Generally, oximetry is based on the fact that the optical property of blood in the visible (between 500 and 700nm) and near-infrared (between 700 and 1000nm) spectra depends strongly on the amount of oxygen in blood.

15 Referring to Fig. 1, there is illustrated a hemoglobin spectra measured by oximetry based techniques. Graphs G1 and G2 correspond, respectively, to reduced hemoglobin, or deoxyhemoglobin (Hb), and oxygenated hemoglobin, or oxyhemoglobin (HbO<sub>2</sub>), spectra. As shown, deoxyhemoglobin (Hb) has a higher optical extinction (i.e., absorbs more light) in the red region of spectrum around 660nm, as compared to that of oxyhemoglobin (HbO<sub>2</sub>). On the other hand, in the near-infrared 20 region of the spectrum around 940nm, the optical absorption by deoxyhemoglobin (Hb) is lower than the optical absorption of oxyhemoglobin (HbO<sub>2</sub>).

25 Prior art non-invasive optical sensors for measuring arterial oxyhemoglobin saturation (SaO<sub>2</sub>) by a pulse oximeter (termed SpO<sub>2</sub>) are typically comprised of a pair of small and inexpensive light emitting diodes (LEDs), and a single highly sensitive silicon photodetector. A red (R) LED centered on a peak emission wavelength around 660nm and an infrared (IR) LED centered on a peak emission wavelength around 940nm are used as light sources.

30 Pulse oximetry relies on the detection of a photoplethysmographic signal caused by variations in the quantity of arterial blood associated with periodic contraction and relaxation of a patient's heart. The magnitude of this signal depends on

the amount of blood ejected from the heart into the peripheral vascular bed with each systolic cycle, the optical absorption of the blood, absorption by skin and tissue components, and the specific wavelengths that are used to illuminate the tissue. SaO<sub>2</sub> is determined by computing the relative magnitudes of the R and IR photoplethysmograms. Electronic circuits inside the pulse oximeter separate the R and IR photoplethysmograms into their respective pulsatile (AC) and non-pulsatile (DC) signal components. An algorithm inside the pulse oximeter performs a mathematical normalization by which the time-varying AC signal at each wavelength is divided by the corresponding time-invariant DC component which results mainly from the light absorbed and scattered by the bloodless tissue, residual arterial blood when the heart is in diastole, venous blood and skin pigmentation.

Since it is assumed that the AC portion results only from the arterial blood component, this scaling process provides a normalized R/IR ratio (i.e., the ratio of AC/DC values corresponding to R- and IR-spectrum wavelengths, respectively), which is highly dependent on SaO<sub>2</sub>, but is largely independent of the volume of arterial blood entering the tissue during systole, skin pigmentation, skin thickness and vascular structure. Hence, the instrument does not need to be re-calibrated for measurements on different patients. Typical calibration of a pulse oximeter is illustrated in Fig. 2 by presenting the empirical relationship between SaO<sub>2</sub> and the normalized R/IR ratio, which is programmed by the pulse oximeters' manufacturers.

Pulse oximeters are of two kinds operating, respectively, in transmission and reflection modes. In transmission-mode pulse oximetry, an optical sensor for measuring SaO<sub>2</sub> is usually attached across a fingertip, foot or earlobe, such that the tissue is sandwiched between the light source and the photodetector.

In reflection-mode or backscatter type pulse oximetry, as shown in Fig. 3, the LEDs and photodetector are both mounted side-by-side next to each other on the same planar substrate. This arrangement allows for measuring SaO<sub>2</sub> from multiple convenient locations on the body (e.g. the head, torso, or upper limbs), where conventional transmission-mode measurements are not feasible. For this reason, non-invasive reflectance pulse oximetry has recently become an important new clinical technique

with potential benefits in fetal and neonatal monitoring. Using reflectance oximetry to monitor SaO<sub>2</sub> in the fetus during labor, where the only accessible location is the fetal scalp or cheeks, or on the chest in infants with low peripheral perfusion, provides several more convenient locations for sensor attachment.

5           Reflection pulse oximetry, while being based on similar spectrophotometric principles as the transmission one, is more challenging to perform and has unique problems that can not always be solved by solutions suitable for solving the problems associated with the transmission-mode pulse oximetry. Generally, comparing transmission and reflection pulse oximetry, the problems associated with reflection  
10 pulse oximetry consist of the following:

          In reflection pulse oximetry, the pulsatile AC signals are generally very small and, depending on sensor configuration and placement, have larger DC components as compared to those of transmission pulse oximetry. As illustrated in Fig. 4, in addition to the optical absorption and reflection due to blood, the DC signal of the R and IR  
15 photoplethysmograms in reflection pulse oximetry can be adversely affected by strong reflections from a bone. This problem becomes more apparent when applying measurements at such body locations as the forehead and the scalp, or when the sensor is mounted on the chest over the ribcage. Similarly, variations in contact pressure between the sensor and the skin can cause larger errors in reflection pulse oximetry (as  
20 compared to transmission pulse oximetry) since some of the blood near the superficial layers of the skin may be normally displaced away from the sensor housing towards deeper subcutaneous structures. Consequently, the highly reflective bloodless tissue compartment near the surface of the skin can cause large errors even at body locations where the bone is located too far away to influence the incident light generated by the  
25 sensor.

          Another problem with currently available reflectance sensors is the potential for specular reflection caused by the superficial layers of the skin, when an air gap exists between the sensor and the skin, or by direct shunting of light between the LEDs and the photodetector through a thin layer of fluid which may be due to excessive  
30 sweating or from amniotic fluid present during delivery.

It is important to keep in mind the two fundamental assumptions underlying the conventional dual-wavelength pulse oximetry, which are as follows:

(1) the path of light rays with different illuminating wavelengths in tissue are substantially equal and, therefore, cancel each other; and (2) each light source  
5 illuminates the same pulsatile change in arterial blood volume.

Furthermore, the correlation between optical measurements and tissue absorptions in pulse oximetry are based on the fundamental assumption that light propagation is determined primarily by absorbance due to Lambert-Beer's law neglecting multiple scattering effects in biological tissues. In practice, however, the  
10 optical paths of different wavelengths in biological tissues is known to vary more in reflectance oximetry compared to transmission oximetry, since it strongly depends on the light scattering properties of the illuminated tissue and sensor mounting.

Several human validation studies, backed by animal investigations, have suggested that uncontrollable physiological and physical parameters can cause large  
15 variations in the calibration curve of reflectance pulse oximeters primarily at low oxygen saturation values below 70%. It was observed that the accuracy of pulse oximeters in clinical use might be adversely affected by a number of physiological parameters when measurements are made from sensors attached to the forehead, chest, or the buttock area. While the exact sources of these variations are not fully understood,  
20 it is generally believed that there are a few physiological and anatomical factors that may be the major source of these errors. It is also well known for example that changes in the ratio of blood to bloodless tissue volumes may occur through venous congestion, vasoconstriction/vasodilatation, or through mechanical pressure exerted by the sensor on the skin.

25 Additionally, the empirically derived calibration curve of a pulse oximeter can be altered by the effects of contact pressure exerted by the probe on the skin. This is associated with the following. The light paths in reflectance oximetry are not well defined (as compared to transmission oximetry), and thus may differ between the red and infrared wavelengths. Furthermore, the forehead and scalp areas consist of a  
30 relatively thin subcutaneous layer with the cranium bone underneath, while the tissue

of other anatomical structures, such as the buttock and limbs, consists of a much thicker layer of skin and subcutaneous tissues without a nearby bony support that acts as a strong light reflector.

Several in vivo and in vitro studies have confirmed that uncontrollable  
5 physiological and physical parameters (e.g., different amounts of contact pressure applied by the sensor on the skin, variation in the ratio of bloodless tissue-to-blood content, or site-to-site variations) can often cause large errors in the oxygen saturation readings of a pulse oximeter, which are normally derived based on a single internally-programmed calibration curve. The relevant in vivo studies are disclosed in the  
10 following publications:

1. Dassel, et al., "Effect of location of the sensor on reflectance pulse oximetry", *British Journal of Obstetrics and Gynecology*, vol. 104, pp. 910-916, (1997);
2. Dassel, et al., "Reflectance pulse oximetry at the forehead of newborns: The influence of varying pressure on the probe", *Journal of Clinical Monitoring*, vol. 12, pp.  
15 421-428, (1996).]

The relevant in vitro studies are disclosed, for example in the following publication:

3. Edrich et al., "Fetal pulse oximetry: influence of tissue blood content and hemoglobin concentration in a new in-vitro model", *European Journal of Obstetrics and  
20 Gynecology and Reproductive Biology*, vol. 72, suppl. 1, pp. S29-S34, (1997).

Improved sensors for application in dual-wavelength reflectance pulse oximetry have been developed. As disclosed in the following publication: Mendelson, et al., "Noninvasive pulse oximetry utilizing skin reflectance photoplethysmography", *IEEE Transactions on Biomedical Engineering*, vol. 35, no. 10, pp. 798-805 (1988), the  
25 total amount of backscattered light that can be detected by a reflectance sensor is directly proportional to the number of photodetectors placed around the LEDs. Additional improvements in signal-to-noise ratio were achieved by increasing the active area of the photodetector and optimizing the separation distance between the light sources and photodetectors.

Another approach is based on the use of a sensor having six photodiodes arranged symmetrically around the LEDs that is disclosed in the following publications:

4. Mendelson, et al., "Design and evaluation of a new reflectance pulse oximeter sensor", *Medical Instrumentation*, vol. 22, no. 4, pp. 167-173 (1988); and

5. Mendelson, et al., "Skin reflectance pulse oximetry: in vivo measurements from the forearm and calf", *Journal of Clinical Monitoring*, vol. 7, pp. 7-12, (1991).

According to this approach, in order to maximize the fraction of backscattered light collected by the sensor, the currents from all six photodiodes are summed electronically by internal circuitry in the pulse oximeter. This configuration essentially  
10 creates a large area photodetector made of six discrete photodiodes connected in parallel to produce a single current that is proportional to the amount of light backscattered from the skin. Several studies showed that this sensor configuration could be used successfully to accurately measure SaO<sub>2</sub> from the forehead, forearm and the calf on humans. However, this sensor requires a means for heating the skin in order to increase  
15 local blood flow, which has practical limitations since it could cause skin burns.

Yet another prototype reflectance sensor is based on eight dual-wavelength LEDs and a single photodiode, and is disclosed in the following publication: Takatani et al., "Experimental and clinical evaluation of a noninvasive reflectance pulse oximeter sensor", *Journal of Clinical Monitoring*, vol. 8, pp. 257-266 (1992). Here, four R and  
20 four IR LEDs are spaced at 90-degree intervals around the substrate and at an equal radial distance from the photodiode.

A similar sensor configuration based on six photodetectors mounted in the center of the sensor around the LEDs is disclosed in the following publication: Konig, et al., "Reflectance pulse oximetry – principles and obstetric application in the Zurich system", *Journal of Clinical Monitoring*, vol. 14, pp. 403-412 (1998).  
25

According to the techniques disclosed in all of the above publications, only LEDs of two wavelengths, R and IR, are used as light sources, and the computation of SaO<sub>2</sub> is based on reflection photoplethysmograms measured by a single photodetector, regardless of whether one or multiple photodiodes chips are used to construct the  
30 sensor. This is because of the fact that the individual signals from the photodetector

elements are all summed together electronically inside the pulse oximeter. Furthermore, while a radially-symmetric photodetector array can help to maximize the detection of backscattered light from the skin and minimize differences from local tissue inhomogeneity, human and animal studies confirmed that this configuration can not  
5 completely eliminate errors caused by pressure differences and site-to-site variations.

The use of a nominal dual-wavelength pair of 735/890nm was suggested as providing the best choice for optimizing accuracy, as well as sensitivity in dual-wavelength reflectance pulse oximetry, in US 5,782,237 and 5,421,329. This approach minimizes the effects of tissue heterogeneity and enables to obtain a balance in path  
10 length changes arising from perturbations in tissue absorbance. This is disclosed in the following publications:

6. Mannheimer at al., "Physio-optical considerations in the design of fetal pulse oximetry sensors", European Journal of Obstetrics and Gynecology and Reproductive Biology, vol. 72, suppl. 1, pp. S9-S19, (1997); and
- 15 7. Mannheimer at al., "Wavelength selection for low-saturation pulse oximetry", IEEE Transactions on Biomedical Engineering, vol. 44, no. 3, pp. 48-158 (1997)].

However, replacing the conventional R wavelength at 660nm, which coincides with the region of the spectrum where the difference between the extinction coefficient  
20 of Hb and HbO<sub>2</sub> is maximal, with a wavelength emitting at 735nm, not only lowers considerably the overall sensitivity of a pulse oximeter, but does not completely eliminate errors due to sensor placement and varying contact pressures.

Pulse oximeter probes of a type comprising three or more LEDs for filtering noise and monitoring other functions, such as carboxyhemoglobin or various indicator  
25 dyes injected into the blood stream, have been developed and are disclosed, for example, in WO 00/32099 and US 5,842,981. The techniques disclosed in these publications are aimed at providing an improved method for direct digital signal formation from input signals produced by the sensor and for filtering noise.

None of the above prior art techniques provides a solution to overcome the  
30 most essential limitation in reflectance pulse oximetry, which requires the automatic

correction of the internal calibration curve from which accurate and reproducible oxygen saturation values are derived, despite variations in contact pressure or site-to-site tissue heterogeneity.

5 In practice, most sensors used in reflection pulse oximetry rely on closely spaced LED wavelengths in order to minimize the differences in the optical path lengths of the different wavelengths. Nevertheless, within the wavelength range required for oximetry, even closely spaced LEDs with closely spaced wavelengths mounted on the same substrate can lead to large random error in the final determination of SaO<sub>2</sub>.

#### 10 SUMMARY OF THE INVENTION AND ADVANTAGES

The object of the invention is to provide a novel sensor design and method that functions to correct the calibration relationship of a reflectance pulse oximeter, and reduce measurement inaccuracies in general. Another object of the invention is to provide a novel sensor and method that functions to correct the calibration relationship  
15 of a reflectance pulse oximeter, and reduce measurement inaccuracies in the lower range of oxygen saturation values (typically below 70%), which is the predominant range in neonatal and fetal applications.

Yet another object of the present invention is to provide automatic correction of the internal calibration curve from which oxygen saturation is derived inside the  
20 oximeter in situations where variations in contact pressure or site-to-site tissue heterogeneity may cause large measurement inaccuracies.

Another object of the invention is to eliminate or reduce the effect of variations in the calibration of a reflectance pulse oximeter between subjects, since perturbations caused by contact pressure remain one of the major sources of errors in  
25 reflectance pulse oximetry. In fetal pulse oximetry, there are additional factors, which must be properly compensated for in order to produce an accurate and reliable measurement of oxygen saturation. For example, the fetal head is usually the presenting part, and is a rather easily accessible location for application of reflectance pulse oximetry. However, uterine contractions can cause large and unpredictable variations  
30 in the pressure exerted on the head and by the sensor on the skin, which can lead to



large errors in the measurement of oxygen saturation by a dual-wavelength reflectance pulse oximeter. Another object of the invention is to provide accurate measurement of oxygen saturation in the fetus during delivery.

The basis for the errors in the oxygen saturation readings of a dual-wavelength pulse oximeter is the fact that, in practical situations, the reflectance sensor applications affect the distribution of blood in the superficial layers of the skin. This is different from an ideal situation, when a reflectance sensor measures light backscattered from a homogenous mixture of blood and bloodless tissue components. Therefore, the R and IR DC signals practically measured by photodetectors contain a relatively larger proportion of light absorbed by and reflected from the bloodless tissue compartments. In these uncontrollable practical situations, the changes caused are normally not compensated for automatically by calculating the normalized R/IR ratio since the AC portions of each photoplethysmogram, and the corresponding DC components, are affected differently by pressure or site-to-site variations. Furthermore, these changes depend not only on wavelength, but depend also on the sensor geometry, and thus cannot be eliminated completely by computing the normalized R/IR ratio, as is typically the case in dual-wavelength pulse oximeters.

The inventor has found that the net result of this nonlinear effect is to cause large variations in the slope of the calibration curves. Consequently, if these variations are not compensated automatically, they will cause large errors in the final computation of SpO<sub>2</sub>, particularly at low oxygen saturation levels normally found in fetal applications.

Another object of the present invention is to compensate for these variations and to provide accurate measurement of oxygen saturation. The invention consists of, in addition to two measurement sessions typically carried out in pulse oximetry based on measurements with two wavelengths centered around the peak emission values of 660nm (red spectrum) and 940nm ± 20nm (IR spectrum), one additional measurement session is carried out with an additional wavelength. At least one additional wavelength is preferably chosen to be substantially in the IR region of the electromagnetic spectrum, i.e., in the NIR-IR spectrum (having the peak emission value above 700nm).

In a preferred embodiment the use of at least three wavelengths enables the calculation of an at least one additional ratio formed by the combination of the two IR wavelengths, which is mostly dependent on changes in contact pressure or site-to-site variations. In a preferred embodiment, slight dependence of the ratio on variations in arterial oxygen saturation that may occur, is easily minimized or eliminated completely, by the proper selection and matching of the peak emission wavelengths and spectral characteristics of the at least two IR-light sources.

Preferably, the selection of the IR wavelengths is based on certain criteria. The IR wavelengths are selected to coincide with the region of the optical absorption curve where HbO<sub>2</sub> absorbs slightly more light than Hb. The IR wavelengths are in the spectral regions where the extinction coefficients of both Hb and HbO<sub>2</sub> are nearly equal and remain relatively constant as a function of wavelength, respectively.

In a preferred embodiment, tracking changes in the ratio formed by the two IR wavelengths, in real-time, permits automatic correction of errors in the normalized ratio obtained from the R-wavelength and each of the IR-wavelengths. The term "ratio" signifies the ratio of two values of AC/DC corresponding to two different wavelengths. This is similar to adding another equation to solve a problem with at least three unknowns (i.e., the relative concentrations of HbO<sub>2</sub> and Hb, which are used to calculate SaO<sub>2</sub>, and the unknown variable fraction of blood-to-tissue volumes that effects the accurate determination of SaO<sub>2</sub>), which otherwise must rely on only two equations in the case of only two wavelengths used in conventional dual-wavelength pulse oximetry. In a preferred embodiment, a third wavelength provides the added ability to compute SaO<sub>2</sub> based on the ratio formed from the R-wavelength and either of the IR-wavelengths. In a preferred embodiment, changes in these ratios are tracked and compared in real-time to determine which ratio produces a more stable or less noisy signal. That ratio is used predominantly for calculating SaO<sub>2</sub>.

The present invention utilizes collection of light reflected from the measurement location at different detection locations arranged along a closed path around light emitting elements, which can be LEDs or laser sources. Preferably, these detection locations are arranged in two concentric rings, the so-called "near" and "far"

rings, around the light emitting elements. This arrangement enables optimal positioning of the detectors for high quality measurements, and enables discrimination between photodetectors receiving “good” information (i.e., AC and DC values which would result in accurate calculations of SpO<sub>2</sub>) and “bad” information (i.e., AC and DC values  
5 which would result in inaccurate calculations of SpO<sub>2</sub>).

There is thus provided according to one aspect of the present invention, a sensor for use in an optical measurement device for non-invasive measurements of blood parameters, the sensor comprising:

(1) a light source for illuminating a measurement location with incident light  
10 of at least three wavelengths, the first wavelength lying in a red (R) spectrum, and the at least second and third wavelengths lying substantially in the infrared (IR) spectrum; and

(2) a detector assembly for detecting light returned from the illuminated location, the detector assembly being arranged so as to define a plurality of detection  
15 locations along at least one closed path around the light source.

The term “closed path” used herein signifies a closed curve, like a ring, ellipse, or polygon, and the like.

The detector assembly is comprised of at least one array of discrete detectors (e.g., photodiodes) accommodated along at least one closed path, or at least one  
20 continuous photodetector defining the closed path.

The term “substantially IR spectrum” used herein signifies a spectrum range including near infrared and infrared regions.

According to another aspect of the present invention, there is provided a pulse oximeter utilizing a sensor constructed as defined above, and a control unit for  
25 operating the sensor and analyzing data generated thereby.

According to yet another aspect of the present invention, there is provided a method for non-invasive determination of a blood parameter, the method comprising the steps of:

illuminating a measurement location with at least three different wavelengths  
30  $\lambda_1$ ,  $\lambda_2$  and  $\lambda_3$ , the first wavelength  $\lambda_1$  lying in a red (R) spectrum, and the at least

second and at least third wavelengths  $\lambda_2$  and  $\lambda_3$  lying substantially in the infrared (IR) spectrum;

detecting light returned from the measurement location at different detection locations and generating data indicative of the detected light, wherein said different  
5 detection locations are arranged so as to define at least one closed path around the measurement location; and

analyzing the generated data and determining the blood parameter.

#### BRIEF DESCRIPTION OF THE DRAWINGS

10 Other advantages of the present invention will be readily appreciated as the same becomes better understood by reference to the following detailed description when considered in connection with the accompanying drawings wherein:

Fig. 1 illustrates hemoglobin spectra as measured by oximetry based techniques;

Fig. 2 illustrates a calibration curve used in pulse oximetry as typically  
15 programmed by the pulse oximeters manufacturers;

Fig. 3 illustrates the relative disposition of light source and detector in reflection-mode or backscatter type pulse oximetry;

Fig. 4 illustrates light propagation in reflection pulse oximetry;

Figs. 5A and 5B illustrate a pulse oximeter reflectance sensor operating under  
20 ideal and practical conditions, respectively;

Fig. 6 illustrates variations of the slopes of calibration curves in reflectance pulse oximetry measurements;

Fig. 7 illustrates an optical sensor according to the invention;

Fig. 8 is a block diagram of the main components of a pulse oximeter utilizing  
25 the sensor of Fig. 7;

Fig. 9 is a flow chart of a selection process used in the signal processing technique according to the invention; and

Figs. 10A to 10C are flow charts of three main steps, respectively, of the signal processing method according to the invention.

30

## DETAILED DESCRIPTION OF THE PREFERRED EMBODIMENT

Referring to the Figures, wherein like numerals indicate like or corresponding parts throughout the several views, Figs. 1 and 2 illustrate typical hemoglobin spectra and calibrations curve utilized in the pulse oximetry measurements.

5           The present invention provides a sensor for use in a reflection-mode or backscatter type pulse oximeter. The relative disposition of light source and detector in the reflection-mode pulse oximeter are illustrated in Fig. 3.

Fig. 4 shows light propagation in the reflection-mode pulse oximeter where, in addition to the optical absorption and reflection due to blood, the DC signal of the R and IR photoplethysmograms can be adversely affected by strong reflections from the bone.

Figs. 5A and 5B illustrate a pulse oximeter reflectance sensor operating under, respectively, ideal and practical conditions. Referring now to Fig. 5A, it is shown that, under ideal conditions, reflectance sensor measures light backscattered from a homogenous mixture of blood and bloodless tissue components. Accordingly, the normalized R/IR ratio in dual-wavelength reflection type pulse oximeters, which relies on proportional changes in the AC and DC components in the photoplethysmograms, only reflect changes in arterial oxygen saturation.

Referring now to Fig. 5B, in practical situations, the sensor applications affect the distribution of blood in the superficial layers of the skin. Accordingly, the R and IR DC signals measured by photodetectors contain a relatively larger proportion of light absorbed by and reflected from the bloodless tissue compartments. As such, the changes in DC signals depend not only on wavelength but also sensor geometry and thus cannot be eliminated completely by computing the normalized R/IR ratio, as is typically the case in dual-wavelength pulse oximeters. The result is large variations in the slope of the calibration curves, as illustrated in Fig. 6. Referring now to Fig. 6, graphs C1, C2 and C3 show three calibration curves, presenting the variation of the slope for oxygen saturation values between 50% and 100%.

Referring to Fig. 7, there is illustrated an optical sensor 10 designed according to the invention aimed at minimizing some of the measurement inaccuracies in a

reflectance pulse oximeter. The sensor 10 comprises such main constructional parts as a light source 12 composed of three closely spaced light emitting elements (e.g., LEDs or laser sources) 12a, 12b and 12c generating light of three different wavelengths, respectively; an array of discrete detectors (e.g., photodiodes), a “far” detector 16 and a “near” detector 18, arranged in two concentric ring-like arrangements (constituting closed paths) surrounding the light emitting elements; and a light shield 14. In the present example, six photodiodes form each ring. All these elements are accommodated in a sensor housing 17. The light shield 14 is positioned between the photodiodes and the light emitting elements, and prevents direct optical coupling between them, thereby maximizing the fraction of backscattered light passing through the arterially perfused vascular tissue in the detected light.

It should be noted that more than three wavelengths can be utilized in the sensor. The actual numbers of wavelengths used as a light source and the number of photodetectors in each ring are not limited and depend only on the electronic circuitry inside the oximeter. The array of discrete photodiodes can be replaced by one or more continuous photodetector rings.

In addition to the R and IR light emitting elements 12a and 12b as used in the conventional pulse oximeter sensors, the sensor 10 incorporates the third, reference, light emitting element 12c, which emits light in the NIR-IR spectrum. Wavelength  $\lambda_1$  and  $\lambda_2$  of the R and IR light emitting elements 12a and 12b are centered, respectively, around the peak emission values of 660nm and 940nm, and wavelength  $\lambda_3$  of the third light emitting element 12c has the peak emission value above 700nm (typically ranging between 800nm and 900nm). In the description below, the light emitting elements 12b and 12c are referred to as two IR light emitting elements, and wavelengths  $\lambda_2$  and  $\lambda_3$  are referred to as two IR wavelengths.

During the operation of the sensor 10, different light emitting elements are selectively operated for illuminating a measurement location (not shown) with different wavelengths. Each of the photodetectors detects reflected light of different wavelengths and generates data indicative of the intensity I of the detected light of different wavelengths.

It should be noted that the sensor can be of a compact design utilizing an integrated circuit manufactured by CMOS technology. This technique is disclosed in a co-pending application assigned to the assignee of the present application. According to this technique, the sensor comprises a package including the light source, a block of two tubular optical waveguides of different diameters concentrically dislocated one inside the other and surrounding the light source, and an integrated circuit plate comprising two ring-like areas of photodiodes positioned concentrically one inside the other. The integrated circuit is also provided with a plurality of printed contact areas and electric conductors intended for mounting the light source thereon, controlling the light source, and transmitting electric signals produced by the photodiodes areas for further processing.

Fig. 8 illustrates a block diagram of a pulse oximeter 20 utilizing the above-described sensor 10. The pulse oximeter typically includes a control unit 21, which is composed of an electronic block 22 including A/D and D/A converters connectable to the sensor 10, a microprocessor 24 for analyzing measured data, and a display 26 for presenting measurement results. The measured data (i.e., electrical output of the sensor 10 indicative of the detected light) is directly processed in the block 22, and the converted signal is further processed by the microprocessor 24. The microprocessor 24 is operated by a suitable software model for analyzing the measured data and utilizing reference data (i.e., calibration curve stored in a memory) to compute the oxygen saturation value, which is then presented on the display 26. The analysis of the measured data utilizes the determination of AC- and DC-components in the detected light for each wavelength,  $\lambda_1$ ,  $\lambda_2$ , and  $\lambda_3$ , respectively, i.e.,  $I_1^{(AC)}$ ,  $I_1^{(DC)}$ ,  $I_2^{(AC)}$ ,  $I_2^{(DC)}$ ,  $I_3^{(AC)}$ , and  $I_3^{(DC)}$ , and the calculation of AC/DC ratio for each wavelength, namely,  $W_1=I_1^{(AC)}/I_1^{(DC)}$ ,  $W_2=I_2^{(AC)}/I_2^{(DC)}$ , and  $W_3=I_3^{(AC)}/I_3^{(DC)}$ , as will be described more specifically further below with reference to Figs. 9 and 10A-10C.

The pulse oximeter 20 with the sensor arrangement shown in Fig. 7 provides the following three possible ratio values:  $W_1/W_2$ ,  $W_1/W_3$  and  $W_2/W_3$ . It should be noted that  $W_1/W_2$  and  $W_1/W_3$  are the ratios that typically have the highest sensitivity to oxygen saturation. This is due to the fact that  $\lambda_1$  is chosen in the red region of the

electromagnetic spectrum, where the changes in the absorption between Hb and HbO<sub>2</sub> are the largest, as described above with reference to Fig. 1. Therefore, in principle, the absorption ratios formed by either wavelength pair  $\lambda_1$  and  $\lambda_2$  or wavelength pair  $\lambda_1$  and  $\lambda_3$  can be used to compute the value of SaO<sub>2</sub>.

5           The inventor conducted extensive human and animal studies, and confirmed that either of the two ratios  $W_1/W_2$  and  $W_1/W_3$  can be affected not only by changes in arterial oxygen saturation, but also by sensor placement and by the amount of pressure applied by the sensor on the skin. Any calculation of SaO<sub>2</sub> based on either of the two ratios  $W_1/W_2$  and  $W_1/W_3$  alone (as normally done in commercially available dual-  
10 wavelength pulse oximeters) could result in significant errors. Furthermore, since at least two wavelengths are necessary for the calculation of arterial oxygen saturation, it is not feasible to self-correct the calibration curve for variations due to contact pressure or site-to-site variations utilizing the same two wavelengths used already to compute SaO<sub>2</sub>.

15           The inventor has found that the third ratio  $W_2/W_3$  formed by the combination of the two IR wavelengths is mostly dependent on changes in contact pressure or site-to-site variations. Furthermore, this ratio can depend, but to a much lesser degree, on variations in arterial oxygen saturation. The dependency on arterial oxygen saturation, however, is easily minimized or eliminated completely, for example by selection and  
20 matching of the peak emission wavelengths and spectral characteristics of the two IR light emitting elements 12b and 12c.

          Generally, the two IR wavelengths  $\lambda_2$  and  $\lambda_3$  are selected to coincide with the region of the optical absorption curve where HbO<sub>2</sub> absorbs slightly more light than Hb, but in the spectral region, respectively, where the extinction coefficients of both Hb and  
25 HbO<sub>2</sub> are nearly equal and remain relatively constant as a function of wavelength. For example, at 940nm and 880nm, the optical extinction coefficients of Hb and HbO<sub>2</sub> are approximately equal to 0.29 and 0.21, respectively. Therefore, ideally, the ratio of  $W_2/W_3$  should be close to 1, except for situations when the AC/DC signals measured from  $\lambda_2$  and  $\lambda_3$  are affected unequally causing the ratio  $W_2/W_3$  to deviate from 1.



Fortunately, variations in the ratio  $W_2/W_3$  mimic changes in the ratios  $W_1/W_2$  and  $W_1/W_3$ , since these ratios are all affected by similar variations in sensor positioning or other uncontrollable factors that normally can cause large errors in the calibration curve from which oxygen saturation is typically derived. Thus, by tracking in real-time  
5 changes in the ratio formed by wavelengths  $\lambda_2$  and  $\lambda_3$ , it is possible to automatically correct for errors in the normalized ratios obtained from wavelengths  $\lambda_1$  and  $\lambda_2$ , or from  $\lambda_1$  and  $\lambda_3$ .

The use of an additional third wavelength in the sensor serves another important function (not available in conventional dual-wavelength pulse oximeters),  
10 which is associated with the following. Reflectance pulse oximeters have to be capable of detecting and relying on the processing of relatively low quality photoplethysmographic signals. Accordingly, electronic or optical noise can cause large inaccuracies in the final computation of  $SaO_2$ . Although the amount of electronic or optical noise pickup from the sensor can be minimized to some extent, it is impossible  
15 to render the signals measured by the pulse oximeter completely noise free. Therefore, pulse oximeters rely on the assumption that any noise picked up during the measurement would be cancelled by calculating the ratio between the R- and IR-light intensities measured by the photodetector. Practically, however, the amount of noise that is superimposed on the R- and IR-photoplethysmograms cannot be cancelled  
20 completely and, thus, can lead to significant errors in the final computation of  $SaO_2$  which, in dual-wavelength pulse oximeters, is based only on the ratio between two wavelengths.

By utilizing a third wavelength, the invention has the added ability to compute  $SaO_2$  based on the ratio formed from either  $W_1/W_2$  or  $W_1/W_3$ . An algorithm utilized in  
25 the pulse oximeter according to the invention has the ability to track and compare in real-time changes between  $W_1/W_2$  and  $W_1/W_3$  to determine which ratio produces a more stable or less noisy signal and selectively choose the best ratio for calculating  $SaO_2$ .

The method according to the invention utilizes the so-called "selection process" as part of the signal processing technique based on the measured data obtained  
30 with the multiple photodetectors. The main steps of the selection process are shown in

Fig. 9 in a self-explanatory manner. Here, the symbol  $i$  corresponds to a single photodetector element in the array of multiple discrete photodetector elements, the term “ $i$ st” signifies the last photodetector element in the array, and the term “DATA” signify three ratios (AC/DC) computed separately for each of the three wavelengths, namely,  
5  $W_1$ ,  $W_2$  and  $W_3$ .

The selection process is associated with the following: Practically, each time one of the light emitting elements is in its operative position (i.e., switched on), all of the photodetectors in the sensor receiving backscattered light from the skin. However, the intensity of the backscattered light measured by each photodetector may be different  
10 from that measured by the other photodetectors, depending on the anatomical structures underneath the sensor and its orientation relative to these structures.

Thus, the selection process is used to discriminate between photodetectors receiving “good” signals (i.e., “good” signal meaning that the calculation of  $SpO_2$  from the pulsating portion of the electro-optic signal (AC) and the constant portion (DC) would result in accurate value) and “bad” signals (i.e., having AC and DC values which would result in inaccurate calculations of  $SpO_2$ ). Accordingly, each data point (i.e., ratio  
15  $W_{1i}$ ,  $W_{2i}$  or  $W_{3i}$  detected at the corresponding  $i^{th}$  detector) is either accepted, if it meets a certain criteria based for example on a certain ratio of AC to DC values (e.g., such that the intensity of AC signal is about 0.05-2.0% of the intensity of DC signal), or rejected.  
20 All of the accepted data points (data from accepted detection locations) are then used to calculate the ratios  $W_1/W_2$ ,  $W_1/W_3$  and  $W_2/W_3$ , and to calculate the  $SpO_2$  value, in conjunction with the signal processing technique, as will be described further below with reference to Figs. 10A-10C.

Besides the use of the third IR-wavelength to compensate for changes in the  
25 internal calibration curve of the pulse oximeter, the pulse oximeter utilizing the sensor according to the invention provides a unique new method to compensate for errors due to sensor positioning and pressure variability. This method is based on multiple photodetector elements, instead of the conventional approach that relies on a single photodetector.

While optical sensors with multiple photodetectors for application in reflectance pulse oximetry have been described before, their main limitation relates to the way the information derived from these photodetectors is processed. Although the primary purpose of utilizing multiple photodetectors is to collect a larger portion of the backscattered light from the skin, practically, summing the individual intensities of each photodetector and using the resulting value to compute  $\text{SaO}_2$  can introduce large errors into the calculations. These errors can be caused, for example, by situations where the sensor is placed over inhomogeneous tissue structures such as when the sensor is mounted on the chest. The case may be such that, when using a continuous photodetector ring to collect the backscattered light, a portion of the photodetector ring lies over a rib, which acts as a strongly reflecting structure that contributes to a strong DC component, and the remaining part of the photodetector is positioned over the intercostals space, where the DC signal is much smaller. In this case, the final calculation of  $\text{SaO}_2$  would be inaccurate, if the current produced by this photodetector is used indiscriminately to compute the DC value before the final computation of  $\text{SaO}_2$  is performed. Therefore, in addition to automatically correcting errors in the calibration curve as outlined above using three different LEDs (one R and two different IR wavelengths), the sensor 10 has the optional ability to track automatically and compare changes in the R/IR ratios obtained from each of the discrete photodiodes individually. For example, if some of either the near or the far photodetectors in the two concentrically arranged arrays detect larger than normal DC signals during the operation of one of the photodiodes compared to the other photodiodes in the sensor, it could be indicative of one of the following situations: the sensor is positioned unevenly, the sensor is partially covering a bony structure, or uneven pressure is exerted by the sensor on the skin causing partial skin "blanching" and therefore the blood-to-bloodless tissue ratio might be too high to allow accurate determination of  $\text{SaO}_2$ . If such a situation is detected, the oximeter has the ability to selectively disregard the readings obtained from the corresponding photodetectors. Otherwise, if the DC and AC signals measured from each photodetector in the array are similar in magnitude, which is an indication that the

sensor is positioned over a homogeneous area on the skin, the final computation of  $SaO_2$  can be based on equal contributions from every photodetector in the array.

Turning now to Figs. 10A, 10B and 10C, there are illustrated three main steps of the signal processing technique utilized in the present invention. Here,  $TH_1$  and  $TH_2$  are two different threshold values (determined experimentally) related respectively to  $W_2/W_3$  and  $(W_1/W_2 - W_1/W_3)$ .

During step 1 (Fig. 10A), measured data generated by the “near” and “far” photodetectors indicative of the detected (backscattered) light of wavelength  $\lambda_2$  and  $\lambda_3$  is analyzed to calculate the two ratios  $W_2/W_3$  (far and near). If one of the calculated ratios (far or near) is not in the range of  $1 \pm TH_1$  ( $TH_1$  is for example 0.1), then this data point is rejected from the  $SpO_2$  calculation, but if both of them are not in the mentioned range, a corresponding alarm is generated indicative of that the sensor position should be adjusted. Only if there are calculated ratios which are in the range of  $1 \pm TH_1$ , they are accepted and the process (data analysis) proceeds by performing step 2.

Step 2 (Fig. 10B) consists of determining whether the quality of each photoplethysmogram is acceptable or not. The quality determination is based on the relative magnitude of each AC component compared to its corresponding DC component. If the quality is not acceptable (e.g., the signal shape detected by any detector varies within a time frame of the measurement session, which may for example be 3.5 sec), the data point is rejected and a corresponding alarm signal is generated. If the AC/DC ratio of  $W_1$ ,  $W_2$  and  $W_3$  are within an acceptable range, the respective data point is accepted, and the process proceeds through performing step 3.

In step 3 (Fig. 10C), the measured data is analyzed to calculate ratios  $W_1/W_2$  and  $W_1/W_3$  from data generated by far and near photodetectors, and to calculate the differences  $(W_1/W_2 - W_1/W_3)$ .

In a perfect situation,  $W_1/W_2$  (far) is very close to  $W_1/W_3$  (far), and  $W_1/W_2$  (near) is very close to  $W_1/W_3$  (near). In a practical situation, this condition is not precisely satisfied, but all the ratios are close to each other if the measurement situation is “good”.

Then, the calculated differences are analyzed to determine the values (corresponding to far and near photodetectors) that are accepted and to use them in the SpO<sub>2</sub> calculation. For each detector that satisfied the condition  $ABS(W_1/W_2 - W_1/W_3) < TH_2$ , where ABS signifies the absolute value, its respective data point is  
5 accepted and used to calculate the oxygen saturation value that will be displayed. If the condition is not satisfied, the data point is rejected. If all data points are rejected, another measurement session is carried out.

It should be noted that, although the steps 1-3 above are exemplified with respect to signal detection by both near and far photodetectors, each of these steps can  
10 be implemented by utilizing only one array of detection locations along the closed path. The provision of two such arrays, however, provides higher accuracy of measurements.

## CLAIMS

What is claimed is:

1. A sensor for use in an optical measurement device for non-invasive measurement of a blood parameter, the sensor comprising:
  - 5 (a) a light source for illuminating a measurement location with incident light of at least three wavelengths, the first wavelength  $\lambda_1$  lying in a red (R) spectrum, and the at least second and third wavelengths  $\lambda_2$  and  $\lambda_3$  lying substantially in the infrared (IR) spectrum; and
  - (b) a detector assembly for detecting light returned from the illuminated  
10 location, the detector assembly being arranged so as to define a plurality of detection locations along at least one closed path around the light source.
2. A sensor as set forth in claim 1, for use in a pulse oximeter, the at least second and third wavelengths  $\lambda_2$  and  $\lambda_3$  being selected to coincide with a spectral  
15 region of the optical absorption curve, where HbO<sub>2</sub> absorbs slightly more light than Hb, and where the extinction coefficients of Hb and HbO<sub>2</sub> are nearly equal and remain relatively constant as a function of wavelength.
3. A sensor, as set forth in claim 2, wherein the second wavelength  $\lambda_2$  is in the  
20 IR spectral region around 940nm $\pm$ 20nm, and the third wavelength  $\lambda_3$  is above 700nm.
4. A sensor, as set forth in claim 1, wherein the detector assembly comprises at least one array of detector elements arranged in a spaced-apart relationship along the at least one closed path.  
25
5. A sensor, as set forth in claim 1, wherein the detector assembly comprises at least one ring-shaped detector element.
6. A sensor according to claim 1, wherein the plurality of the detection  
30 locations are arranged along two concentric closed paths around the light source.

7. A sensor, as set forth in claim 6, wherein the detector assembly comprises two arrays of detector elements, the detector elements of each array being arranged in a spaced apart relationship along the corresponding one of the closed paths.

5

8. A sensor, as set forth in claim 6, wherein the detector assembly comprises two concentric ring-shaped detector elements.

9. A sensor, as set forth in claim 1, manufactured by CMOS technology, the sensor comprising a package including said light source, and an integrated circuit plate, which comprises said at least one closed path of the detector assembly positioned around the light source, and a plurality of printed contact areas and electric conductors for mounting the light source thereon, controlling the light source, and transmitting electric signals produced by the detector assembly for further processing.

10

10. A sensor for use in an optical measurement device for non-invasive measurement of a blood parameter, the sensor comprising:

a light source for illuminating a measurement location with incident light of at least three wavelengths, the first wavelength  $\lambda_1$  lying in a red (R) spectrum, and the at least second and third wavelengths  $\lambda_2$  and  $\lambda_3$  lying substantially in the infrared (IR) spectrum; and

20

a detector assembly for detecting light returned from the illuminated location, the detector assembly being arranged so as to define a plurality of detection locations along two concentric closed path around the light source.

25

11. A pulse oximeter comprising a sensor and a control unit for operating the sensor and analyzing data generated thereby, the sensor comprising:

(a) a light source for illuminating a measurement location with incident light of at least three wavelengths, the first wavelength  $\lambda_1$  lying in a red (R) spectrum,

and the at least second and third wavelengths  $\lambda_2$  and  $\lambda_3$  lying substantially in the infrared (IR) spectrum; and

(b) a detector assembly for detecting light returned from the illuminated location, the detector assembly being arranged so as to define a plurality of detection  
5 locations along at least one closed path around the light source.

12. A method for non-invasive determination of a blood parameter, the method comprising the steps of:

(i) illuminating a measurement location with at least three different  
10 wavelengths, a first wavelength  $\lambda_1$  lying in a red (R) spectrum, and at least second and third wavelengths  $\lambda_2$  and  $\lambda_3$  lying substantially in the infrared (IR) spectrum;

(ii) detecting light returned from the measurement location at different detection locations and generating data indicative of the detected light, wherein said different detection locations are arranged so as to define at least one closed path around  
15 the measurement location; and

(iii) analyzing the generated data and determining the blood parameter.

13. The method according to claim 12, wherein the analysis of the generated data comprises the steps of:

20 calculating data indicative of an AC/DC ratio in the light detected at each of the detection locations for the at least three wavelengths;

analyzing the calculated data and determining accepted detection locations to select corresponding AC/DC ratios for each of the at least three wavelengths,  $\lambda_1$ ,  $\lambda_2$  and  $\lambda_3$ ; and

25 utilizing the selected ratios for determining the blood parameter.

14. The method according to claim 13, wherein the determination of the blood parameter comprises the steps of:

30 calculating values of the ratio  $W_2/W_3$  for the accepted detection locations in at least one closed path;



analyzing each of the calculated values to determine whether it satisfies a first predetermined condition, so as to generate a signal indicative of that a sensor position is to be adjusted, if the condition is not satisfied;

5 if the condition is satisfied, determining whether the quality of a photoplethysmogram is acceptable;

if the quality is acceptable, analyzing the selected ratios for calculating ratios  $W_1/W_2$  and  $W_1/W_3$  from the data detected in at least one closed path, and calculating the differences  $ABS(W_1/W_2 - W_1/W_3)$ ; and,

10 analyzing the calculated differences for determining whether each of the differences satisfies a second predetermined condition for determining the blood parameter if the condition is satisfied.

15 15. The method according to claim 14, wherein said first predetermined condition consists of that the calculated value of  $W_2/W_3$  is inside a predetermined range around the value one, said predetermined range being defined by the first threshold value, and the second predetermined condition consists of that the calculated difference  $ABS(W_1/W_2 - W_1/W_3)$  is less than certain, second threshold value.

20 16. A pulse oximeter for detecting a value of a parameter of blood, comprising:  
a sensor housing;

a source of radiation coupled to the housing and being adapted to emit radiation at predetermined frequencies;

25 a detector assembly coupled to the housing and being adapted to detect reflected radiation at first, second, and third frequencies and to generate respective first, second, and third signals, wherein the first, second, and third signals are indicative of a value of the reflected radiation at the respective first, second, and third frequencies; and,

30 a control unit coupled to the detector assembly and adapted to receive the first, second, and third signals, to calculate first, second and third ratios of the first, second, and third signals and to responsively determine the parameter of the blood as a function of the first, second and third ratios.

17. A pulse oximeter, as set forth in claim 16, wherein the control unit is adapted to determine the parameter of the blood as a function of the first and second ratios and a calibration curve.

5

18. A pulse oximeter, as set forth in claim 17, wherein the calibration curve is adjusted as a function of the third ratio.

19. A pulse oximeter, as set forth in claim 16, wherein the first ratio is defined by the first signal divided by the second signal.

10

20. A pulse oximeter, as set forth in claim 16, wherein the second ratio is defined by the first signal divided by the third signal.

21. A pulse oximeter, as set forth in claim 16, wherein the third ratio is defined by the second signal divided by the third signal.

15

22. A pulse oximeter, as set forth in claim 16, wherein the first frequency is in a red frequency range, the second frequency is in a near-infrared frequency range, and the third frequency is in an infrared frequency range.

20

23. A pulse oximeter, as set forth in claim 22, wherein the first ratio is defined by the first signal divided by the second signal, the second ratio is defined by the first signal divided by the third signal, and the third ratio is defined by the second signal divided by the third signal.

25

24. A pulse oximeter, as set forth in claim 16, wherein the control unit is adapted to determine the parameter of the blood as a function of a more stable one of the first and second ratios.

30

25. A pulse oximeter for detecting a value of a parameter of blood, comprising:  
a sensor housing;  
a source of radiation coupled to the housing and being adapted to emit radiation  
at predetermined frequencies;
- 5 a detector assembly coupled to the housing and being adapted to detect reflected  
radiation at first, second, and third frequencies and to generate respective first, second,  
and third signals, wherein the first, second, and third signals are indicative of a value  
of the reflected radiation at the respective first, second, and third frequencies; and,  
a control unit coupled to the detector assembly and being adapted to calculate
- 10 first and second ratios of the first, second, and third signals, wherein the first ratio is  
defined by the first signal divided by the second signal and the second ratio is defined  
by the first signal divided by the third signal, and wherein the control unit is adapted to  
determine the parameter of the blood as a function of a more stable one of the first and  
second ratios.
- 15
26. A pulse oximeter, as set forth in claim 25, wherein the control unit is  
adapted to determine the parameter of the blood as a function of the more stable one of  
the first and second ratios and a calibration curve.
- 20
27. A pulse oximeter, as set forth in claim 26, wherein the calibration curve  
is adjusted as a function of a third ratio.
28. A pulse oximeter, as set forth in claim 27, wherein the third ratio is  
defined by the second signal divided by the third signal.
- 25
29. A pulse oximeter, as set forth in claim 25, wherein the first frequency  
is in a red frequency range, the second frequency is in a near-infrared frequency range,  
and the third frequency is in an infrared frequency range.

30. A pulse oximeter, as set forth in claim 25, wherein the control unit is adapted to track the first and second ratios and determine which one of the first and second ratios is more stable in real-time.

5 31. A pulse oximeter for detecting a value of a parameter of blood, comprising:

a sensor housing;

a source of radiation coupled to the housing and being adapted to emit radiation at predetermined frequencies; and,

10 a plurality of detectors coupled to the housing and being adapted to detect reflected radiation at first, second, and third frequencies and to responsively generate a plurality of first sensor signals indicative of the reflected radiation at the first frequency, a plurality of second sensor signals indicative of the reflected radiation at the second frequency, and a plurality of third sensor signals indicative of the reflected  
15 radiation at the third frequency;

a control unit being coupled to the plurality of detectors and adapted to receive the plurality of first, second and third sensor signals, to analyze the first, second and third sensor signals and determine which of the first, second and third sensor signals are valid and to generate first, second, and third frequency signals as a function of valid  
20 first sensor signals, valid second sensor signals, and valid third sensor signals, respectively and to determine the parameter of the blood as a function of the valid first, second, and third sensor signals.

32. A pulse oximeter, as set forth in claim 31, wherein the control unit is adapted to calculate first, second and third ratios of the valid first, second, and third  
25 signals and to responsively determine the parameter of the blood as a function of the first, second and third ratios.

33. A pulse oximeter, as set forth in claim 32, wherein the control unit is adapted to determine the parameter of the blood as a function of the first and second  
30 ratios and a calibration curve.

34. A pulse oximeter, as set forth in claim 33, wherein the calibration curve is adjusted as a function of the third ratio.

5 35. A pulse oximeter, as set forth in claim 32, wherein the first ratio is defined by the valid first signals divided by the valid second signals.

36. A pulse oximeter, as set forth in claim 32, wherein the second ratio is defined by the valid first signals divided by the valid third signals.

10

37. A pulse oximeter, as set forth in claim 32, wherein the third ratio is defined by the valid second signals divided by the valid third signals.

15 38. A pulse oximeter, as set forth in claim 31, wherein the first frequency is in a red frequency range, the second frequency is in a near-infrared frequency range, and the third frequency is in an infrared frequency range.

39. A pulse oximeter, as set forth in claim 32, wherein the first ratio is defined by the valid first signals divided by the valid second signals, the second ratio is defined by the valid first signals divided by the valid third signals, and the third ratio is defined by the valid second signals divided by the valid third signals.

20

40. A pulse oximeter, as set forth in claim 32, wherein the control unit is adapted to determine the parameter of the blood as a function of a more stable one of the first and second ratios.

25

41. A pulse oximeter, as set forth in claim 31, wherein the plurality of first, second, and third sensor signals having an AC portion and a DC portion.

42. A pulse oximeter, as set forth in claim 41, wherein a sensor signal is valid if it a ratio of the AC portion to the DC portion is within a predetermined range.

30

43. A pulse oximeter, as set forth in claim 42, wherein the predetermined range is 0.05 to 2.0 percent.

5 44. A sensor for use in an optical measurement device for non-invasive measurement of a blood parameter, comprising:

a sensor housing;

a source of radiation coupled to the housing and being adapted to emit radiation at predetermined frequencies;

10 a detector assembly coupled to the housing and being adapted to detect reflected radiation at least one predetermined frequency and to generate respective signals, wherein the detector assembly is ring shaped.

45. A sensor, as set forth in claim 44, wherein the detector assembly  
15 includes a plurality of detectors arranged along a closed loop path.

46. A sensor, as set forth in claim 45, wherein the closed loop path has a circular shape.

20 47. A sensor, as set forth in claim 45, wherein the closed loop path has an elliptical shape.

48. A sensor, as set forth in claim 45, wherein the closed loop path has a polygonal shape.

25 49. A sensor, as set forth in claim 44, wherein the detector assembly includes a continuous photodetector ring.

50. A sensor, as set forth in claim 49, wherein the continuous photodetector ring has a circular shape.

30

51. A sensor, as set forth in claim 49, wherein the continuous photo detector ring has an elliptical shape.

52. A sensor, as set forth in claim 49, wherein the continuous photo detector  
5 ring has a polygonal shape.

53. A sensor, as set forth in claim 44, wherein the detector assembly includes a first plurality of detectors arranged along an inner closed loop path and a second plurality of detectors arranged along an outer closed loop path.

10

54. A sensor, as set forth in claim 53, wherein the inner and outer closed loop paths have a circular shape.

55. A sensor, as set forth in claim 49, wherein the inner and outer closed  
15 loop paths have an elliptical shape.

56. A sensor, as set forth in claim 49, wherein the inner and outer closed loop paths have a polygonal shape.

57. A sensor for use in an optical measurement device for non-invasive  
20 measurement of a blood parameter, comprising:

a sensor housing;

a source of radiation coupled to the housing and being adapted to emit radiation at predetermined frequencies;

a detector assembly coupled to the housing and being adapted to detect reflected  
25 radiation at least one predetermined frequency and to generate respective signals, wherein the detector assembly includes a plurality of pairs of detectors, each pair of detectors including a near detector and a far detector.

58. A sensor, as set forth in claim 57, wherein the near detectors are arranged along an inner closed loop path and the far detectors are arranged along an outer closed loop paths.

5 59. A sensor, as set forth in claim 58, wherein the inner and outer closed loop paths have a circular shape.

60. A sensor, as set forth in claim 58, wherein the inner and outer closed loop paths have an elliptical shape.

10

61. A sensor, as set forth in claim 58, wherein the inner and outer closed loop paths have a polygonal shape.

62. A method for detecting a value of a parameter of blood using a sensor adapted to emit radiation at predetermined frequencies, to detect reflected radiation at first, second, and third frequencies and to generate respective first, second, and third signals, wherein the first, second, and third signals are indicative of a value of the reflected radiation at the respective first, second, and third frequencies, the method including the steps of:

15 20 receiving the first, second, and third signals;  
calculating first, second and third ratios of the first, second, and third signals;  
and,  
responsively determining the parameter of the blood as a function of the first, second and third ratios.

25

63. A method, as set forth in claim 62, wherein the parameter of the blood is determined as a function of the first and second ratios and a calibration curve.

64. A method, as set forth in claim 63, including the step of adjusting the calibration curve as a function of the third ratio.

30



65. A method, as set forth in claim 62, wherein the first ratio is defined by the first signal divided by the second signal.

5 66. A method, as set forth in claim 62, wherein the second ratio is defined by the first signal divided by the third signal.

67. A method, as set forth in claim 62, wherein the third ratio is defined by the second signal divided by the third signal.

10

68. A method, as set forth in claim 62, wherein the first frequency is in a red frequency range, the second frequency is in a near-infrared frequency range, and the third frequency is in an infrared frequency range.

15 69. A method, as set forth in claim 62, wherein the first ratio is defined by the first signal divided by the second signal, the second ratio is defined by the first signal divided by the third signal, and the third ratio is defined by the second signal divided by the third signal.

20 70. A method, as set forth in claim 62, including the step of determining a more stable of the first and second ratios, wherein the parameter of the blood is determined using the more stable one of the first and second ratios.

25 71. A method for detecting a value of a parameter of blood using a sensor adapted to emit radiation at predetermined frequencies, to detect reflected radiation at first, second, and third frequencies and to generate respective first, second, and third signals, wherein the first, second, and third signals are indicative of a value of the reflected radiation at the respective first, second, and third frequencies, the method including the steps of:

30 receiving the first, second and third signals;

calculate first and second ratios of the first, second and third signals, wherein the first ratio is defined by the first signal divided by the second signal and the second ratio is defined by the first signal divided by the third signal; and,

5 determining the parameter of the blood as a function of a more stable one of the first and second ratios.

72. A method, as set forth in claim 71, wherein the parameter of the blood as a function of the more stable one of the first and second ratios and a calibration curve.

10

73. A method, as set forth in claim 72, including the step of adjusted the calibration curve as a function of a third ratio.

74. A method, as set forth in claim 73, wherein the third ratio is defined by  
15 the second signal divided by the third signal.

75. A method, as set forth in claim 71, wherein the first frequency is in a red frequency range, the second frequency is in an infrared frequency range, and the third frequency is in a near-infrared frequency range.

20

76. A method, as set forth in claim 71, including the step of tracking the first and second ratios and determining which one of the first and second ratios is more stable in real-time.

25 77. A method for detecting a value of a parameter of blood using a sensor adapted to emit radiation at predetermined frequencies, to detect reflected radiation at first, second, and third frequencies and to responsively generate a plurality of first sensor signals indicative of the reflected radiation at the first frequency, a plurality of second sensor signals indicative of the reflected radiation at the second frequency, and

a plurality of third sensor signals indicative of the reflected radiation at the third frequency, the method comprising:

receiving the plurality of first, second and third sensor signals;

analyzing the first, second and third sensor signals and determining which of the  
5 first, second and third sensor signals are valid;

generating first, second, and third frequency signals as a function of valid first sensor signals, valid second sensor signals, and valid third sensor signals, respectively;  
and,

determining the parameter of the blood as a function of the valid first, second,  
10 and third sensor signals.

78. A method, as set forth in claim 77, including the step of calculating first, second and third ratios of the first, second, and third valid signals and responsively determining the parameter of the blood as a function of the first, second and third ratios.  
15

79. A method, as set forth in claim 78, wherein the parameter of the blood is determined as a function of the first and second ratios and a calibration curve.

80. A method, as set forth in claim 79, including the step of adjusting the  
20 calibration curve as a function of the third ratio.

81. A method, as set forth in claim 78, wherein the first ratio is defined by the valid first signals divided by the valid second signals.

25 82. A method, as set forth in claim 78, wherein the second ratio is defined by the valid first signals divided by the valid third signals.

83. A method, as set forth in claim 78, wherein the third ratio is defined by the valid second signals divided by the valid third signals.  
30

84. A method, as set forth in claim 78, wherein the first frequency is in a red frequency range, the second frequency is in an infrared frequency range, and the third frequency is in a near-infrared frequency range.

5           85. A method, as set forth in claim 78, wherein the first ratio is defined by the valid first signals divided by the valid second signals, the second ratio is defined by the valid first signals divided by the valid third signals, and the third ratio is defined by the valid second signals divided by the valid third signals.

10           86. A method, as set forth in claim 78, including the step of determining the parameter of the blood as a function of a more stable one of the first and second ratios.

87. A method, as set forth in claim 77, wherein the plurality of first, second, and third sensor signals have an AC portion and a DC portion.

15           88. A method, as set forth in claim 87, wherein a sensor signal is valid if a ratio of the AC portion to the DC portion is within a predetermined range.

89. A method, as set forth in claim 88, wherein the predetermined range is 0.05 to 2.0 percent.

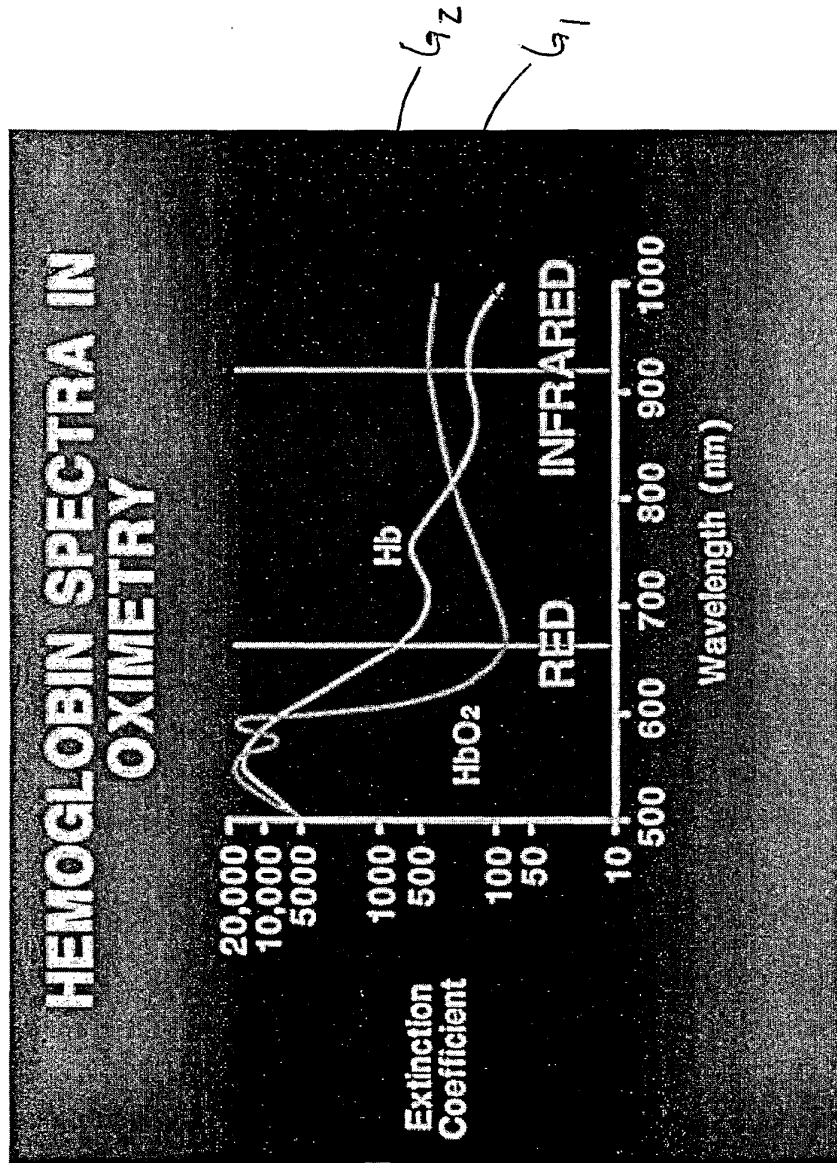

Fig. 1

**CALIBRATION OF A PULSE OXIMETER**

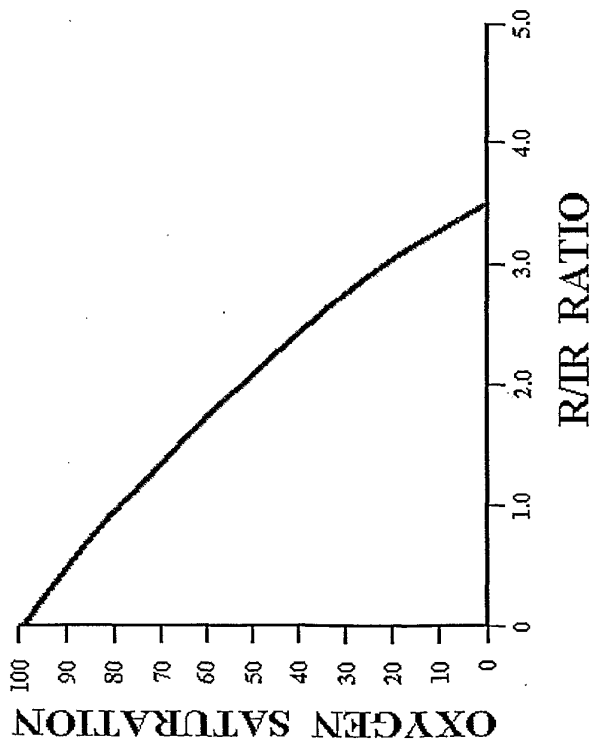

Fig. 2

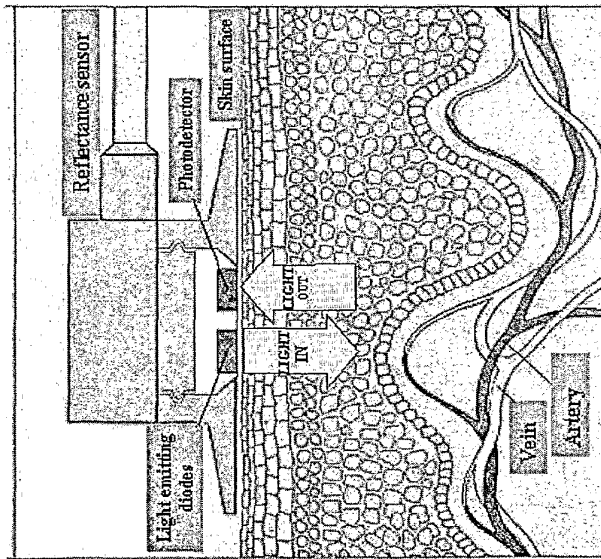

Fig. 3

FOUR DIFFERENT LIGHT PATHS

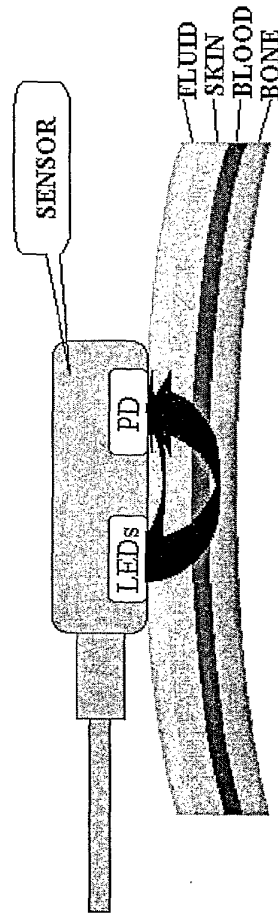
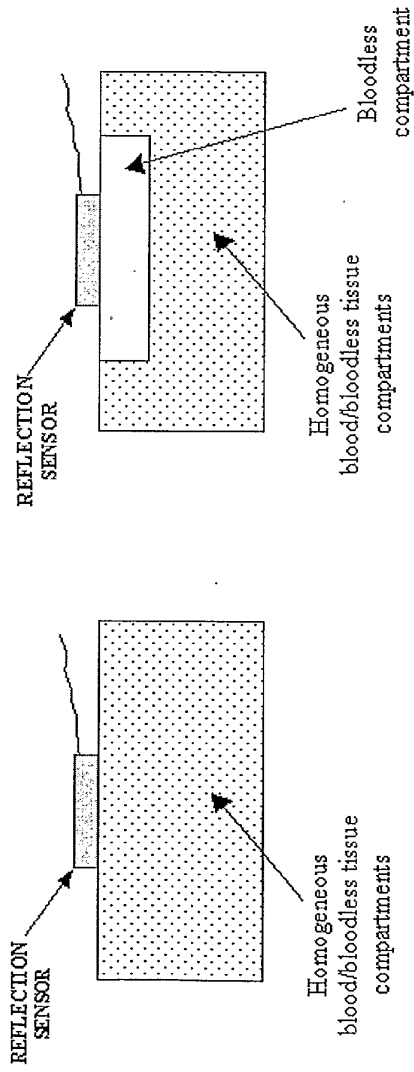

Fig. 4





(b)

(a)

Fig. 5b

Fig. 5a

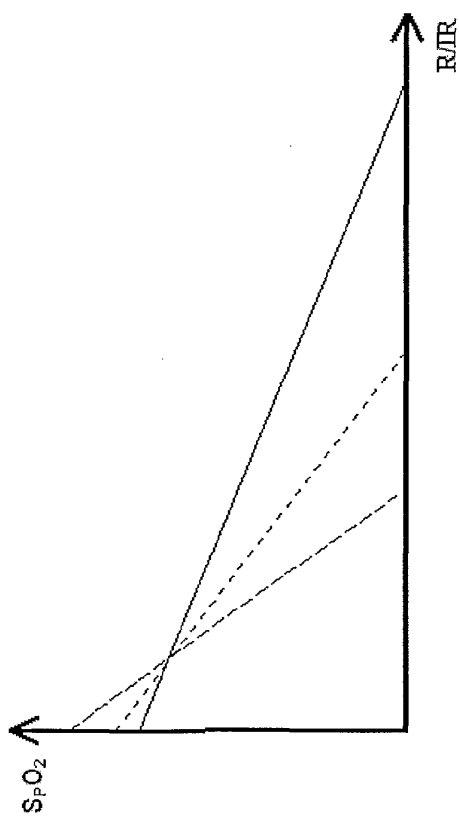

Fig. 6

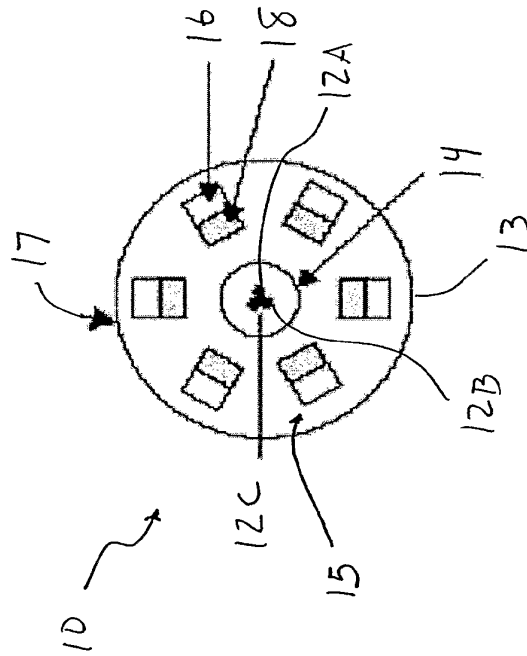

Fig. 7

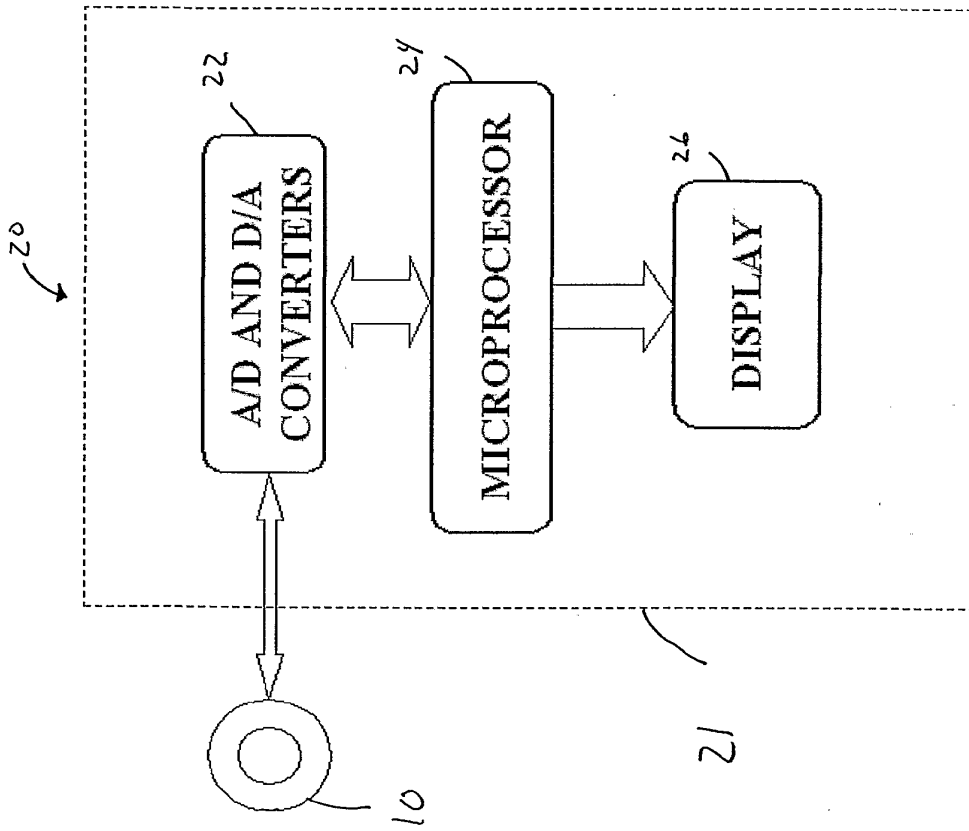

Fig. 8

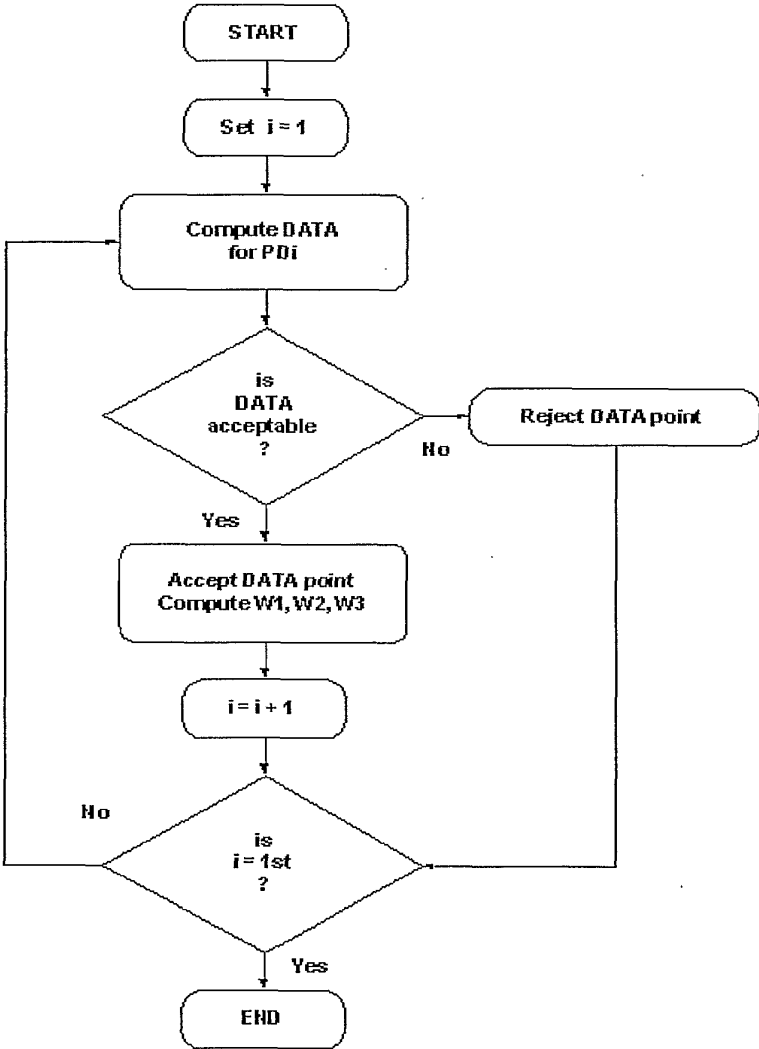

Fig. 9

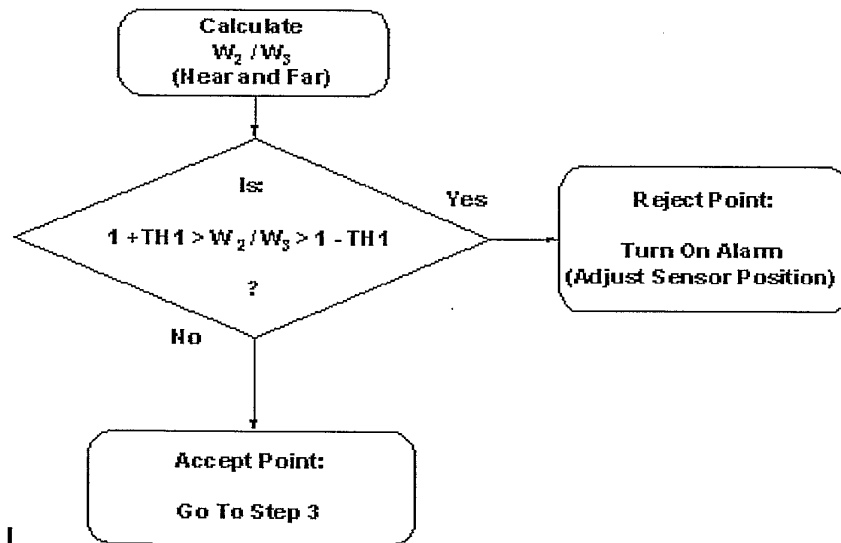

Fig. 10A

**Step 2**

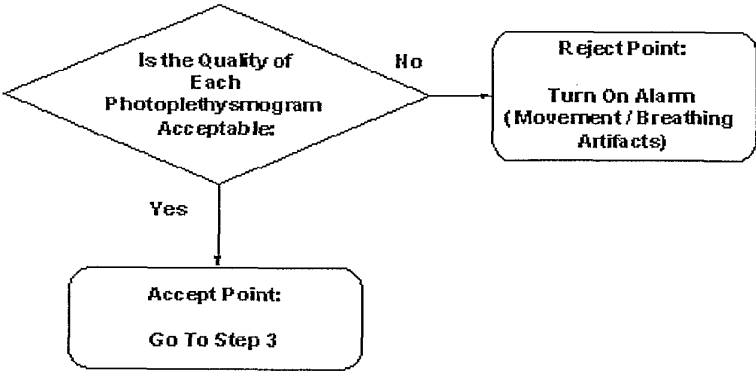

Fig. 10B

Step 3

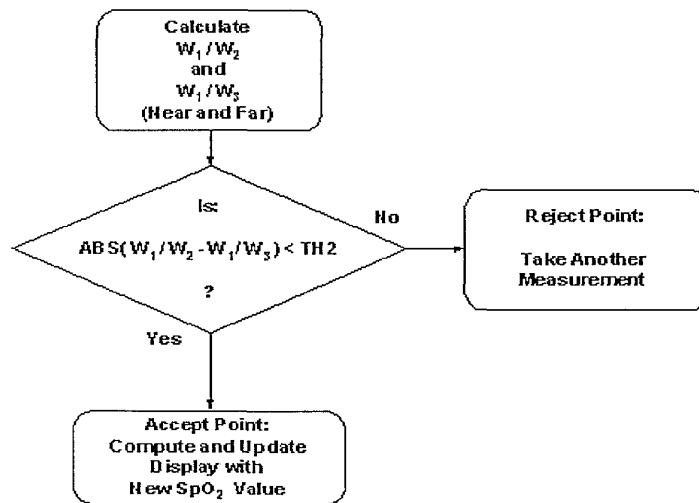

Fig. 10C



INTERNATIONAL SEARCH REPORT

In International Application No  
PCT/US 01/26642

**A. CLASSIFICATION OF SUBJECT MATTER**  
IPC 7 A61B5/00

According to International Patent Classification (IPC) or to both national classification and IPC

**B. FIELDS SEARCHED**  
Minimum documentation searched (classification system followed by classification symbols)  
IPC 7 A61B

Documentation searched other than minimum documentation to the extent that such documents are included in the fields searched

Electronic data base consulted during the international search (name of data base and, where practical, search terms used)  
EPO-Internal

**C. DOCUMENTS CONSIDERED TO BE RELEVANT**

Category °	Citation of document, with indication, where appropriate, of the relevant passages	Relevant to claim No.
X	US 5 385 143 A (AOYAGI) 31 January 1995 (1995-01-31)  the whole document	1, 2, 11, 12, 16-40, 62-86
X	WO 00 32099 A (CRITICARE) 8 June 2000 (2000-06-08) page 5	1, 13, 41, 42, 87, 88
A	WO 96 41566 A (CYBRO) 27 December 1996 (1996-12-27) page 15, line 17 -page 16, line 30	1, 4-8, 10, 44-61

Further documents are listed in the continuation of box C.  Patent family members are listed in annex.

Special categories of cited documents :

\*A\* document defining the general state of the art which is not considered to be of particular relevance  
 \*I\* earlier document but published on or after the international filing date  
 \*I\* document which may throw doubts on priority claim(s) or which is cited to establish the publication date of another citation or other special reason (as specified)  
 \*O\* document referring to an oral disclosure, use, exhibition or other means  
 \*P\* document published prior to the international filing date but later than the priority date claimed

\*T\* later document published after the international filing date or priority date and not in conflict with the application but cited to understand the principle or theory underlying the invention  
 \*X\* document of particular relevance; the claimed invention cannot be considered novel or cannot be considered to involve an inventive step when the document is taken alone  
 \*Y\* document of particular relevance; the claimed invention cannot be considered to involve an inventive step when the document is combined with one or more other such documents, such combination being obvious to a person skilled in the art.  
 \*&\* document member of the same patent family

Date of the actual completion of the international search  14 March 2002	Date of mailing of the international search report  21/03/2002
--	--

Name and mailing address of the ISA European Patent Office, P.B. 5818 Patentlaan 2 NL - 2280 HV Rijswijk Tel. (+31-70) 340-2040, Tx. 31 651 epo nl, Fax: (+31-70) 340-3016	Authorized officer  Lemercier, D
--	--

## INTERNATIONAL SEARCH REPORT

 International Application No  
 PCT/US 01/26642

Patent document cited in search report		Publication date	Patent family member(s)	Publication date
US 5385143	A	31-01-1995	JP 2608828 B2	14-05-1997
			JP 5212016 A	24-08-1993
			JP 2613832 B2	28-05-1997
			JP 6030916 A	08-02-1994
			JP 2608830 B2	14-05-1997
			JP 6030915 A	08-02-1994
WO 0032099	A	08-06-2000	US 6163715 A	19-12-2000
			AU 1839300 A	19-06-2000
			CN 1335756 T	13-02-2002
			EP 1146812 A1	24-10-2001
			WO 0032099 A1	08-06-2000
			US 2001005773 A1	28-06-2001
WO 9641566	A	27-12-1996	IL 114082 A	28-10-1999
			AU 708051 B2	29-07-1999
			AU 5909696 A	09-01-1997
			CA 2221968 A1	27-12-1996
			EP 0957747 A2	24-11-1999
			WO 9641566 A2	27-12-1996
			IL 122515 A	28-10-1999
			JP 11507568 T	06-07-1999
			US 6031603 A	29-02-2000

Electronic Petition Request	<b>PETITION TO WITHDRAW AN APPLICATION FROM ISSUE AFTER PAYMENT OF THE ISSUE FEE UNDER 37 CFR 1.313(c)</b>
Application Number	16226249
Filing Date	19-Dec-2018
First Named Inventor	Ammar Al-Ali
Art Unit	3791
Examiner Name	MARJAN FARDANESH
Attorney Docket Number	MAS.1007C1
Title	ADVANCED PULSE OXIMETRY SENSOR

An application may be withdrawn from issue for further action upon petition by the applicant. To request that the Office withdraw an application from issue, applicant must file a petition under this section including the fee set forth in § 1.17(h) and a showing of good and sufficient reasons why withdrawal of the application from issue is necessary.

APPLICANT HEREBY PETITIONS TO WITHDRAW THIS APPLICATION FROM ISSUE UNDER 37 CFR 1.313(c).

A grantable petition requires the following items:

- (1) Petition fee; and
- (2) One of the following reasons:
  - (a) Unpatentability of one or more claims, which must be accompanied by an unequivocal statement that one or more claims are unpatentable, an amendment to such claim or claims, and an explanation as to how the amendment causes such claim or claims to be patentable;
  - (b) Consideration of a request for continued examination in compliance with § 1.114 (for a utility or plant application only); or
  - (c) Express abandonment of the application. Such express abandonment may be in favor of a continuing application, but not a CPA under 37 CFR 1.53(d).

**Petition Fee**

<input type="radio"/> Small Entity
<input type="radio"/> Micro Entity
<input checked="" type="radio"/> Regular Undiscounted

Reason for withdrawal from issue

- One or more claims are unpatentable
- Consideration of a request for continued examination (RCE) (List of Required Documents and Fees)
- Applicant hereby expressly abandons the instant application (any attorney/agent signing for this reason must have power of attorney pursuant to 37 CFR 1.32(b)).

RCE request, submission, and fee.

I certify, in accordance with 37 CFR 1.4(d)(4) that :  
The RCE request ,submission, and fee have already been filed in the above-identified application on

Are attached.

**THIS PORTION MUST BE COMPLETED BY THE SIGNATORY OR SIGNATORIES**

I certify, in accordance with 37 CFR 1.4(d)(4) that I am:

- An attorney or agent registered to practice before the Patent and Trademark Office who has been given power of attorney in this application.
- An attorney or agent registered to practice before the Patent and Trademark Office, acting in a representative capacity.
- A sole inventor
- A joint inventor; I certify that I am authorized to sign this submission on behalf of all of the inventors as evidenced by the power of attorney in the application
- A joint inventor; all of whom are signing this e-petition

Signature	/Aaron S. Johnson/
Name	Aaron S. Johnson
Registration Number	74164

## Electronic Patent Application Fee Transmittal

<b>Application Number:</b>	16226249			
<b>Filing Date:</b>	19-Dec-2018			
<b>Title of Invention:</b>	ADVANCED PULSE OXIMETRY SENSOR			
<b>First Named Inventor/Applicant Name:</b>	Ammar Al-Ali			
<b>Filer:</b>	Aaron Samuel Johnson/Melissa Ramirez			
<b>Attorney Docket Number:</b>	MAS.1007C1			
Filed as Large Entity				
<b>Filing Fees for Utility under 35 USC 111(a)</b>				
<b>Description</b>	<b>Fee Code</b>	<b>Quantity</b>	<b>Amount</b>	<b>Sub-Total in USD(\$)</b>
<b>Basic Filing:</b>				
PETITION FEE- 37 CFR 1.17(H) (GROUP III)	1464	1	140	140
RCE- 1ST REQUEST	1801	1	1300	1300
<b>Pages:</b>				
<b>Claims:</b>				
<b>Miscellaneous-Filing:</b>				
<b>Petition:</b>				
<b>Patent-Appeals-and-Interference:</b>				

Description	Fee Code	Quantity	Amount	Sub-Total in USD(\$)
<b>Post-Allowance-and-Post-Issuance:</b>				
<b>Extension-of-Time:</b>				
<b>Miscellaneous:</b>				
<b>Total in USD (\$)</b>				<b>1440</b>



## UNITED STATES PATENT AND TRADEMARK OFFICE

---

Commissioner for Patents  
United States Patent and Trademark Office  
P.O. Box 1450  
Alexandria, VA 22313-1450  
[www.uspto.gov](http://www.uspto.gov)

Decision Date : August 15, 2019

In re Application of :

Ammar Al-Ali

DECISION ON PETITION

UNDER CFR 1.313(c)(2)

Application No : 16226249

Filed : 19-Dec-2018

Attorney Docket No : MAS.1007C1

This is an electronic decision on the petition under 37 CFR 1.313(c)(2), filed August 15, 2019 , to withdraw the above-identified application from issue after payment of the issue fee.

The petition is **GRANTED**.

The above-identified application is withdrawn from issue for consideration of a submission under 37 CFR 1.114 (request for continued examination). See 37 CFR 1.313(c)(2).

**Petitioner is advised that the issue fee paid in this application cannot be refunded. If, however, this application is again allowed, petitioner may request that it be applied towards the issue fee required by the new Notice of Allowance.**

Telephone inquiries concerning this decision should be directed to the Patent Electronic Business Center (EBC) at 866-217-9197.

This application file is being referred to Technology Center AU 3791 for processing of the request for continuing examination under 37 CFR 1.114 .

Office of Petitions

## Electronic Acknowledgement Receipt

<b>EFS ID:</b>	36887098
<b>Application Number:</b>	16226249
<b>International Application Number:</b>	
<b>Confirmation Number:</b>	1002
<b>Title of Invention:</b>	ADVANCED PULSE OXIMETRY SENSOR
<b>First Named Inventor/Applicant Name:</b>	Ammar Al-Ali
<b>Customer Number:</b>	64735
<b>Filer:</b>	Aaron Samuel Johnson/Melissa Ramirez
<b>Filer Authorized By:</b>	Aaron Samuel Johnson
<b>Attorney Docket Number:</b>	MAS.1007C1
<b>Receipt Date:</b>	15-AUG-2019
<b>Filing Date:</b>	19-DEC-2018
<b>Time Stamp:</b>	16:06:54
<b>Application Type:</b>	Utility under 35 USC 111(a)

### Payment information:

Submitted with Payment	yes
Payment Type	CARD
Payment was successfully received in RAM	\$1440
RAM confirmation Number	E20198EG06308859
Deposit Account	111410
Authorized User	Melissa Ramirez

The Director of the USPTO is hereby authorized to charge indicated fees and credit any overpayment as follows:

37 CFR 1.16 (National application filing, search, and examination fees)

37 CFR 1.17 (Patent application and reexamination processing fees)



<b>File Listing:</b>					
<b>Document Number</b>	<b>Document Description</b>	<b>File Name</b>	<b>File Size(Bytes)/ Message Digest</b>	<b>Multi Part /.zip</b>	<b>Pages (if appl.)</b>
1	Request for Continued Examination (RCE)	RCE_MAS1007C1.pdf	1349942	no	3
			5ce4f44e415357beb1796e3cc9667c3ba5b608b0		
<b>Warnings:</b>					
<b>Information:</b>					
2		IDS_MAS1007C1.pdf	48683	yes	3
			73ab4846363e73ac20955a226a1277ae1332c591		
	<b>Multipart Description/PDF files in .zip description</b>				
	<b>Document Description</b>		<b>Start</b>	<b>End</b>	
	Transmittal Letter		1	2	
	Information Disclosure Statement (IDS) Form (SB08)		3	3	
<b>Warnings:</b>					
<b>Information:</b>					
3	Foreign Reference	WO2002028274A1.pdf	2353491	no	51
			1628218dfc9ac217b24ac3bd84b882e3111b2f51		
<b>Warnings:</b>					
<b>Information:</b>					
4	Non Patent Literature	KONIG_1998.pdf	242161	no	10
			47173a0504b8c0f7a79d6e0323969cbb3106c04c		
<b>Warnings:</b>					
<b>Information:</b>					
5	Petition automatically granted by EFS	petition-request.pdf	31630	no	2
			f06ee7ecd1cd3d79da85569e3e434a455d43aa9		
<b>Warnings:</b>					
<b>Information:</b>					

6	Fee Worksheet (SB06)	fee-info.pdf	32165  3d6e87dacf9548c83dbf97b7286e2911d145a25	no	2
<b>Warnings:</b>					
<b>Information:</b>					
<b>Total Files Size (in bytes):</b>				4058072	
<p><b>This Acknowledgement Receipt evidences receipt on the noted date by the USPTO of the indicated documents, characterized by the applicant, and including page counts, where applicable. It serves as evidence of receipt similar to a Post Card, as described in MPEP 503.</b></p> <p><b><u>New Applications Under 35 U.S.C. 111</u></b>  <b>If a new application is being filed and the application includes the necessary components for a filing date (see 37 CFR 1.53(b)-(d) and MPEP 506), a Filing Receipt (37 CFR 1.54) will be issued in due course and the date shown on this Acknowledgement Receipt will establish the filing date of the application.</b></p> <p><b><u>National Stage of an International Application under 35 U.S.C. 371</u></b>  <b>If a timely submission to enter the national stage of an international application is compliant with the conditions of 35 U.S.C. 371 and other applicable requirements a Form PCT/DO/EO/903 indicating acceptance of the application as a national stage submission under 35 U.S.C. 371 will be issued in addition to the Filing Receipt, in due course.</b></p> <p><b><u>New International Application Filed with the USPTO as a Receiving Office</u></b>  <b>If a new international application is being filed and the international application includes the necessary components for an international filing date (see PCT Article 11 and MPEP 1810), a Notification of the International Application Number and of the International Filing Date (Form PCT/RO/105) will be issued in due course, subject to prescriptions concerning national security, and the date shown on this Acknowledgement Receipt will establish the international filing date of the application.</b></p>					

PTO/SB/08 Equivalent

<b>INFORMATION DISCLOSURE STATEMENT BY APPLICANT</b>	Application No.	16/226249
	Filing Date	December 19, 2018
	First Named Inventor	Ammar Al-Ali
	Art Unit	3791
(Multiple sheets used when necessary)	Examiner	Fardanesh, Marjan
SHEET 11 OF 12	Attorney Docket No.	MAS.1007C1

U.S. PATENT DOCUMENTS					
Examiner Initials	Cite No.	Document Number Number - Kind Code (if known) Example: 1,234,567 B1	Publication Date MM-DD-YYYY	Name	Pages, Columns, Lines Where Relevant Passages or Relevant Figures Appear
	291	2018/0253947	9/6/2018	Muhsin et al.	
	292	2018/0256087	9/13/2018	Al-Ali et al.	
	293	2018/0256113	9/13/2018	Weber et al.	
	294	2018/0285094	10/4/2018	Housel et al.	
	295	2018/0289325	10/11/2018	Poeze et al.	
	296	2018/0289337	10/11/2018	Al-Ali et al.	
	297	2018/0296161	10/18/2018	Shreim et al.	
	298	2018/0300919	10/18/2018	Muhsin et al.	
	299	2018/0310822	11/1/2018	Indorf et al.	
	300	2018/0310823	11/1/2018	Al-Ali et al.	
	301	2018/0317826	11/8/2018	Muhsin	
	302	2018/0317841	11/8/2018	Novak, Jr.	
	303	2018/0333055	11/22/2018	Lamego et al.	
	304	2018/0333087	<del>11/22/2018</del> 11/2018	Al-Ali	
	305	2019/0000317	1/3/2019	Muhsin et al.	
	306	2019/0000362	1/3/2019	Kiani et al.	
	307	2019/0015023	1/17/2019	Monfre	
	308	2019/0021638	1/24/2019	Al-Ali et al.	
	309	2019/0029574	1/31/2019	Schurman et al.	
	310	2019/0029578	1/31/2019	Al-Ali et al.	
	311	2019/0038143	2/7/2019	Al-Ali	
	312	2019/0058280	2/21/2019	Al-Ali et al.	
	313	2019/0058281	2/21/2019	Al-Ali et al.	
	314	2019/0069813	3/7/2019	Al-Ali	
	315	2019/0069814	3/7/2019	Al-Ali	
	316	2019/0076028	3/14/2019	Al-Ali et al.	
	317	2019/0082979	3/21/2019	Al-Ali et al.	
	318	2019/0090748	3/28/2019	Al-Ali	
	319	2019/0090760	3/28/2019	Kinast et al.	

Change(s) applied to document, /S.D./ 8/9/2019

Examiner Signature /MARJAN FARDANESH/	Date Considered 07/19/2019
<p>*Examiner: Initial if reference considered, whether or not citation is in conformance with MPEP 609. Draw line through citation if not in conformance and not considered. Include copy of this form with next communication to applicant.</p> <p style="text-align: center;"><del>ALL REFERENCES CONSIDERED EXCEPT WHERE LINED THROUGH.</del> /M.F/</p>	

T1 - Place a check mark in this area when an English language Translation is attached.

PTO/SB/08 Equivalent

<b>INFORMATION DISCLOSURE STATEMENT BY APPLICANT</b>	Application No.	Unassigned
	Filing Date	Filed herewith
	First Named Inventor	Ammar Al-Ali
	Art Unit	Unassigned
(Multiple sheets used when necessary)	Examiner	Unassigned
SHEET 27 OF 28	Attorney Docket No.	MAS.1007C1

U.S. PATENT DOCUMENTS					
Examiner Initials	Cite No.	Document Number Number - Kind Code (if known) Example: 1,234,567 B1	Publication Date MM-DD-YYYY	Name	Pages, Columns, Lines Where Relevant Passages or Relevant Figures Appear
	755	2017/0094450	3/30/2017	Tu et al.	
	756	2017/0164884	6/15/2017	Culbert et al.	
	757	2017/0248446	8/31/2017	Gowreesunker et al.	
	758	2017/0273619	9/28/2017	Alvarado et al.	
	759	2017/0281024	10/5/2017	Narasimhan et al.	
	760	2017/0293727	10/12/2017	Klaassen et al.	
	761	2017/0325698	11/16/2017	Allec et al.	
	762	2017/0325744	11/16/2017	Allec et al.	
	763	2017/0340209	11/30/2017	Klaassen et al.	
	764	2017/0340219	11/30/2017	Sullivan et al.	
	765	2017/0347885	12/7/2017	Tan et al.	
	766	2017/0354332	12/14/2017	Lamego	
	767	2017/0354795	12/14/2017	BLAHNIK et al.	
	768	2017/0358239	12/14/2017	Arney et al.	
	769	2017/0358240	12/14/2017	Blahnik et al.	
	770	2017/0358242	12/14/2017	Thompson et al.	
	771	2017/0360306	12/14/2017	Narasimhan et al.	
	772	2017/0366657	12/21/2017	Thompson et al.	
	773	2018/0014781	1/18/2018	Clavelle et al.	
	774	2018/0025287	1/25/2018	Mathew et al.	
	775	2018/0042556	2/15/2018	SHAHPARNIA et al.	
	776	2018/0049694	2/22/2018	Singh Alvarado et al.	
	777	2018/0050235	2/22/2018	Tan et al.	
	778	2018/0055375	3/1/2018	MARTINEZ et al.	
	779	2018/0055439	3/1/2018	Pham et al.	
	780	2018/0056129 <sup>03/2018</sup>	<del>1/1/2018</del>	NARASIMHA RAO et al.	
	781	2018/0078151	3/22/2018	ALLEC et al.	
	782	2018/0078182	3/22/2018	CHEN et al.	
	783	2018/0110469	4/26/2018	MAANI et al.	

Change(s) applied to document, /S.D./ 8/9/2019

Examiner Signature /MARJAN FARDANESH/	Date Considered 02/06/2019
*Examiner: Initial if reference considered, whether or not citation is in conformance with MPEP 609. Draw line through citation if not in conformance and not considered. Include copy of this form with next communication to applicant.	

ALL REFERENCES CONSIDERED EXCEPT WHERE LINED THROUGH. /M.F/

T1 - Place a check mark in this area when an English language Translation is attached.

PTO/SB/08 Equivalent

<b>INFORMATION DISCLOSURE STATEMENT BY APPLICANT</b>	Application No.	Unassigned
	Filing Date	Filed herewith
	First Named Inventor	Ammar Al-Ali
	Art Unit	Unassigned
(Multiple sheets used when necessary)	Examiner	Unassigned
SHEET 12 OF 28	Attorney Docket No.	MAS.1007C1

U.S. PATENT DOCUMENTS					
Examiner Initials	Cite No.	Document Number Number - Kind Code (if known) Example: 1,234,567 B1	Publication Date MM-DD-YYYY	Name	Pages, Columns, Lines Where Relevant Passages or Relevant Figures Appear
	320	8,359,080	1/22/2013	Diab et al.	
	321	8,364,223	1/29/2013	Al-Ali et al.	
	322	8,364,226	1/29/2013	Diab et al.	
	323	8,364,389	1/29/2013	Dorogusker et al.	
	324	8,374,665	2/12/2013	Lamego	
	325	8,385,995	2/26/2013	Al-ali et al.	
	326	8,385,996	2/26/2013	Smith et al.	
	327	8,388,353	3/5/2013	Kiani et la.	
	328	8,399,822	3/19/2013	Al-Ali	
	329	8,401,602	3/19/2013	Kiani	
	330	8,405,608	3/26/2013	Al-Ali et al.	
	331	8,414,499	4/9/2013	Al-Ali et al.	
	332	8,418,524	4/16/2013	Al-Ali	
	333	8,423,106	4/16/2013	Lamego et al.	
	334	8,428,967	4/23/2013	Olsen et al.	
	335	8,430,817	4/30/2013	Al-Ali et al.	
	336	8,437,825	5/7/2013	Dalvi et al.	
	337	8,455,290	6/4/2013	Siskavich	
	338	8,457,703	6/4/2013	Al-Ali	
	339	8,457,707	6/4/2013	Kiani	
	340	8,463,349	6/11/2013	Diab et al.	
	341	8,466,286	6/18/2013	Bellot et al.	
	342	8,471,713	6/25/2013	Poeze et al.	
	343	8,473,020	6/25/2013	Kiani et al.	
	344	8,483,787	7/9/2013	Al-Ali et al.	
	345	8,489,364	7/16/2013	Weber et al.	
	346	8,498,684	07/2013 <del>07/30/2013</del>	Weber et al.	
	347	8,504,128	8/6/2013	Blank et al.	
	348	8,509,867	8/13/2013	Workman et al.	

Change(s) applied to document, /S.D./

8/9/2019

Examiner Signature	/MARJAN FARDANESH/	Date Considered	02/06/2019
<p><b>*Examiner:</b> Initial if reference considered, whether or not citation is in conformance with MPEP 609. Draw line through citation if not in conformance and not considered. Include copy of this form with next communication to applicant.</p>			

~~ALL REFERENCES CONSIDERED EXCEPT WHERE LINED THROUGH. /M.F./~~

T1 - Place a check mark in this area when an English language Translation is attached.

Please Direct All Correspondence to Customer Number 64735

---

**TRANSMITTAL OF DECLARATION**

First Inventor	:	Ammar Al-Ali
App. No.	:	16/226249
Filed	:	December 19, 2018
For	:	ADVANCED PULSE OXIMETRY SENSOR
Art Unit	:	3791
Conf No.	:	1002

**Commissioner for Patents**  
**P.O. Box 1450**  
**Alexandria, VA 22313-1450**

Dear Sir:

The above-captioned application was filed without a Declaration and/or Substitute Statement. Enclosed in compliance with 37 CFR 1.53(f) are the following.

(X) Declaration(s) for:  
Ammar Al-Ali

The Commissioner is hereby authorized to charge any additional fees which may be required, now or in the future, or credit any overpayment, to Account No. 11-1410.

/Aaron S. Johnson/  
Aaron S. Johnson  
Registration No. 74,164  
Registered Practitioner  
Customer No. 64735  
(949) 760-0404

Under the Paperwork Reduction Act of 1995, no persons are required to respond to a collection of information unless it displays a valid OMB control number.

### DECLARATION (37 CFR 1.63) FOR UTILITY OR DESIGN APPLICATION USING AN APPLICATION DATA SHEET (37 CFR 1.76)

Title of Invention: **ADVANCED PULSE OXIMETRY SENSOR**

As the below named inventor, I hereby declare that:  
This declaration is directed to:  The attached application, or  United States application or PCT international application number 15/195199 filed on June 28, 2016

The above-identified application was made or authorized to be made by me.

I believe that I am the original inventor or an original joint inventor of a claimed invention in the application.

I hereby acknowledge that any willful false statement made in this declaration is punishable under 18 U.S.C. 1001 by fine or imprisonment of not more than five (5) years, or both.

#### WARNING:

Petitioner/applicant is cautioned to avoid submitting personal information in documents filed in a patent application that may contribute to identity theft. Personal information such as social security numbers, bank account numbers, or credit card numbers (other than a check or credit card authorization form PTO-2038 submitted for payment purposes) is never required by the USPTO to support a petition or an application. If this type of personal information is included in documents submitted to the USPTO, petitioners/applicants should consider redacting such personal information from the documents before submitting them to the USPTO. Petitioner/applicant is advised that the record of a patent application is available to the public after publication of the application (unless a non-publication request in compliance with 37 CFR 1.213(a) is made in the application) or issuance of a patent. Furthermore, the record from an abandoned application may also be available to the public if the application is referenced in a published application or an issued patent (see 37 CFR 1.14). Checks and credit card authorization forms PTO-2038 submitted for payment purposes are not retained in the application file and therefore are not publicly available.

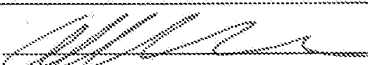
LEGAL NAME OF INVENTOR  
Inventor: Ammar Al-Ali Date (Optional): 8/2/19  
Signature: 

Note: An application data sheet (PTO/SB/14 or equivalent), including naming the entire inventive entity, must accompany this form or must have been previously filed. Use an additional PTO/AIA/01 form for each additional inventor.

This collection of information is required by 35 U.S.C. 115 and 37 CFR 1.63. The information is required to obtain or retain a benefit by the public which is to file (and by the USPTO to process) an application. Confidentiality is governed by 35 U.S.C. 122 and 37 CFR 1.11 and 1.14. This collection is estimated to take 1 minute to complete, including gathering, preparing, and submitting the completed application form to the USPTO. Time will vary depending upon the individual case. Any comments on the amount of time you require to complete this form and/or suggestions for reducing this burden, should be sent to the Chief Information Officer, U.S. Patent and Trademark Office, U.S. Department of Commerce, P.O. Box 1450, Alexandria, VA 22313-1450. DO NOT SEND FEES OR COMPLETED FORMS TO THIS ADDRESS. SEND TO: Commissioner for Patents, P.O. Box 1450, Alexandria, VA 22313-1450.

If you need assistance in completing the form, call 1-800-PTO-9199 and select option 3.

## Electronic Acknowledgement Receipt

<b>EFS ID:</b>	36784542
<b>Application Number:</b>	16226249
<b>International Application Number:</b>	
<b>Confirmation Number:</b>	1002
<b>Title of Invention:</b>	ADVANCED PULSE OXIMETRY SENSOR
<b>First Named Inventor/Applicant Name:</b>	Ammar Al-Ali
<b>Customer Number:</b>	64735
<b>Filer:</b>	Aaron Samuel Johnson/Melissa Ramirez
<b>Filer Authorized By:</b>	Aaron Samuel Johnson
<b>Attorney Docket Number:</b>	MAS.1007C1
<b>Receipt Date:</b>	05-AUG-2019
<b>Filing Date:</b>	19-DEC-2018
<b>Time Stamp:</b>	16:14:38
<b>Application Type:</b>	Utility under 35 USC 111(a)

### Payment information:

Submitted with Payment	no
------------------------	----

### File Listing:

Document Number	Document Description	File Name	File Size(Bytes)/ Message Digest	Multi Part /.zip	Pages (if appl.)
1	Transmittal Letter	TRANSMITTAL_MAS1007C1.pdf	15485 23207c27c8253ba8d514d93212aa19ead65b9628	no	1

### Warnings:



<b>Information:</b>					
2	Oath or Declaration filed	Declaration_MAS1007.PDF	1166962	no	1
			5427ae2c0b8bb118e58af9ee3844b8b6d5102148		
<b>Warnings:</b>					
<b>Information:</b>					
<b>Total Files Size (in bytes):</b>			1182447		
<p><b>This Acknowledgement Receipt evidences receipt on the noted date by the USPTO of the indicated documents, characterized by the applicant, and including page counts, where applicable. It serves as evidence of receipt similar to a Post Card, as described in MPEP 503.</b></p> <p><b><u>New Applications Under 35 U.S.C. 111</u></b>  <b>If a new application is being filed and the application includes the necessary components for a filing date (see 37 CFR 1.53(b)-(d) and MPEP 506), a Filing Receipt (37 CFR 1.54) will be issued in due course and the date shown on this Acknowledgement Receipt will establish the filing date of the application.</b></p> <p><b><u>National Stage of an International Application under 35 U.S.C. 371</u></b>  <b>If a timely submission to enter the national stage of an international application is compliant with the conditions of 35 U.S.C. 371 and other applicable requirements a Form PCT/DO/EO/903 indicating acceptance of the application as a national stage submission under 35 U.S.C. 371 will be issued in addition to the Filing Receipt, in due course.</b></p> <p><b><u>New International Application Filed with the USPTO as a Receiving Office</u></b>  <b>If a new international application is being filed and the international application includes the necessary components for an international filing date (see PCT Article 11 and MPEP 1810), a Notification of the International Application Number and of the International Filing Date (Form PCT/RO/105) will be issued in due course, subject to prescriptions concerning national security, and the date shown on this Acknowledgement Receipt will establish the international filing date of the application.</b></p>					

**PART B - FEE(S) TRANSMITTAL**

Complete and send this form, together with applicable fee(s), by mail or fax, or via EFS-Web.

By mail, send to: Mail Stop ISSUE FEE  
 Commissioner for Patents  
 P.O. Box 1450  
 Alexandria, Virginia 22313-1450

By fax, send to: (571)-273-2885

**INSTRUCTIONS:** This form should be used for transmitting the ISSUE FEE and PUBLICATION FEE (if required). Blocks 1 through 5 should be completed where appropriate. All further correspondence including the Patent, advance orders and notification of maintenance fees will be mailed to the current correspondence address as indicated unless corrected below or directed otherwise in Block 1, by (a) specifying a new correspondence address; and/or (b) indicating a separate "FEE ADDRESS" for maintenance fee notifications.

CURRENT CORRESPONDENCE ADDRESS (Note: Use Block 1 for any change of address)

64735 7590 07/30/2019  
**KNOBBE, MARTENS, OLSON & BEAR, LLP**  
**MASIMO CORPORATION (MASIMO)**  
 2040 MAIN STREET  
 FOURTEENTH FLOOR  
 IRVINE, CA 92614

Note: A certificate of mailing can only be used for domestic mailings of the Fee(s) Transmittal. This certificate cannot be used for any other accompanying papers. Each additional paper, such as an assignment or formal drawing, must have its own certificate of mailing or transmission.

**Certificate of Mailing or Transmission**

I hereby certify that this Fee(s) Transmittal is being deposited with the United States Postal Service with sufficient postage for first class mail in an envelope addressed to the Mail Stop ISSUE FEE address above, or being transmitted to the USPTO via EFS-Web or by facsimile to (571) 273-2885, on the date below.

_____ (Typed or printed name)
_____ (Signature)
_____ (Date)

APPLICATION NO.	FILING DATE	FIRST NAMED INVENTOR	ATTORNEY DOCKET NO.	CONFIRMATION NO.
16/226,249	12/19/2018	Ammar Al-Ali	MAS.1007C1	1002

TITLE OF INVENTION: **ADVANCED PULSE OXIMETRY SENSOR**

APPLN. TYPE	ENTITY STATUS	ISSUE FEE DUE	PUBLICATION FEE DUE	PREV. PAID ISSUE FEE	TOTAL FEE(S) DUE	DATE DUE
nonprovisional	UNDISCOUNTED	\$1000	\$0.00	\$0.00	\$1000	10/30/2019

EXAMINER	ART UNIT	CLASS-SUBCLASS
FARDANESH, MARJAN	3791	600-323000

<p>1. Change of correspondence address or indication of "Fee Address" (37 CFR 1.363).</p> <p><input type="checkbox"/> Change of correspondence address (or Change of Correspondence Address form PTO/SB/122) attached.</p> <p><input type="checkbox"/> "Fee Address" indication (or "Fee Address" Indication form PTO/SB/47; Rev 03-09 or more recent) attached. <b>Use of a Customer Number is required.</b></p>	<p>2. For printing on the patent front page, list</p> <p>(1) The names of up to 3 registered patent attorneys or agents OR, alternatively,</p> <p>(2) The name of a single firm (having as a member a registered attorney or agent) and the names of up to 2 registered patent attorneys or agents. If no name is listed, no name will be printed.</p> <p>1 <u>Knobbe, Martens,</u></p> <p>2 <u>Olson &amp; Bear, LLP</u></p> <p>3 _____</p>
---	--

3. ASSIGNEE NAME AND RESIDENCE DATA TO BE PRINTED ON THE PATENT (print or type)

PLEASE NOTE: Unless an assignee is identified below, no assignee data will appear on the patent. If an assignee is identified below, the document must have been previously recorded, or filed for recordation, as set forth in 37 CFR 3.11 and 37 CFR 3.81(a). Completion of this form is NOT a substitute for filing an assignment.

(A) NAME OF ASSIGNEE **MASIMO CORPORATION**

(B) RESIDENCE: (CITY and STATE OR COUNTRY) **Irvine, CA**

Please check the appropriate assignee category or categories (will not be printed on the patent):  Individual  Corporation or other private group entity  Government

4a. Fees submitted:  Issue Fee  Publication Fee (if required)  Advance Order - # of Copies \_\_\_\_\_

4b. Method of Payment: (Please first reapply any previously paid fee shown above)

Electronic Payment via EFS-Web  Enclosed check  Non-electronic payment by credit card (Attach form PTO-2038)

The Director is hereby authorized to charge the ~~required fee(s)~~ any deficiency, or credit any overpayment to Deposit Account No. **11-1410**

5. **Change in Entity Status** (from status indicated above)

Applicant certifying micro entity status. See 37 CFR 1.29

Applicant asserting small entity status. See 37 CFR 1.27

Applicant changing to regular undiscounted fee status.

**NOTE:** Absent a valid certification of Micro Entity Status (see forms PTO/SB/15A and 15B), issue fee payment in the micro entity amount will not be accepted at the risk of application abandonment.

**NOTE:** If the application was previously under micro entity status, checking this box will be taken to be a notification of loss of entitlement to micro entity status.

**NOTE:** Checking this box will be taken to be a notification of loss of entitlement to small or micro entity status, as applicable.

**NOTE:** This form must be signed in accordance with 37 CFR 1.31 and 1.33. See 37 CFR 1.4 for signature requirements and certifications.

Authorized Signature /Aaron S. Johnson/ Date 8/5/2019

Typed or printed name Aaron S. Johnson Registration No. 74,164

## Electronic Patent Application Fee Transmittal

<b>Application Number:</b>	16226249			
<b>Filing Date:</b>	19-Dec-2018			
<b>Title of Invention:</b>	ADVANCED PULSE OXIMETRY SENSOR			
<b>First Named Inventor/Applicant Name:</b>	Ammar Al-Ali			
<b>Filer:</b>	Aaron Samuel Johnson/Daniel Escajeda			
<b>Attorney Docket Number:</b>	MAS.1007C1			
Filed as Large Entity				
<b>Filing Fees for Utility under 35 USC 111(a)</b>				
<b>Description</b>	<b>Fee Code</b>	<b>Quantity</b>	<b>Amount</b>	<b>Sub-Total in USD(\$)</b>
<b>Basic Filing:</b>				
<b>Pages:</b>				
<b>Claims:</b>				
<b>Miscellaneous-Filing:</b>				
<b>Petition:</b>				
<b>Patent-Appeals-and-Interference:</b>				
<b>Post-Allowance-and-Post-Issuance:</b>				
UTILITY APPL ISSUE FEE	1501	1	1000	1000

Description	Fee Code	Quantity	Amount	Sub-Total in USD(\$)
<b>Extension-of-Time:</b>				
<b>Miscellaneous:</b>				
<b>Total in USD (\$)</b>				<b>1000</b>

## Electronic Acknowledgement Receipt

<b>EFS ID:</b>	36786505
<b>Application Number:</b>	16226249
<b>International Application Number:</b>	
<b>Confirmation Number:</b>	1002
<b>Title of Invention:</b>	ADVANCED PULSE OXIMETRY SENSOR
<b>First Named Inventor/Applicant Name:</b>	Ammar Al-Ali
<b>Customer Number:</b>	64735
<b>Filer:</b>	Aaron Samuel Johnson/Jennifer Neat
<b>Filer Authorized By:</b>	Aaron Samuel Johnson
<b>Attorney Docket Number:</b>	MAS.1007C1
<b>Receipt Date:</b>	05-AUG-2019
<b>Filing Date:</b>	19-DEC-2018
<b>Time Stamp:</b>	19:03:14
<b>Application Type:</b>	Utility under 35 USC 111(a)

### Payment information:

Submitted with Payment	yes
Payment Type	CARD
Payment was successfully received in RAM	\$1000
RAM confirmation Number	E201985J03365661
Deposit Account	111410
Authorized User	Jennifer Neat

The Director of the USPTO is hereby authorized to charge indicated fees and credit any overpayment as follows:

37 CFR 1.16 (National application filing, search, and examination fees)

37 CFR 1.17 (Patent application and reexamination processing fees)

--	--	--	--	--	--

**File Listing:**

Document Number	Document Description	File Name	File Size(Bytes)/ Message Digest	Multi Part /.zip	Pages (if appl.)
1	Issue Fee Payment (PTO-85B)	ISSUE-FEE_MAS1007C1.PDF	216473	no	1
			b635829f9adc94920da07ab5bba0794b3a0d99		

**Warnings:**

**Information:**

2	Fee Worksheet (SB06)	fee-info.pdf	30292	no	2
			8ec6fc7439f3425d5da30960b347eeb227091eb3		

**Warnings:**

**Information:**

<b>Total Files Size (in bytes):</b>	246765
-------------------------------------	--------

**This Acknowledgement Receipt evidences receipt on the noted date by the USPTO of the indicated documents, characterized by the applicant, and including page counts, where applicable. It serves as evidence of receipt similar to a Post Card, as described in MPEP 503.**

**New Applications Under 35 U.S.C. 111**

**If a new application is being filed and the application includes the necessary components for a filing date (see 37 CFR 1.53(b)-(d) and MPEP 506), a Filing Receipt (37 CFR 1.54) will be issued in due course and the date shown on this Acknowledgement Receipt will establish the filing date of the application.**

**National Stage of an International Application under 35 U.S.C. 371**

**If a timely submission to enter the national stage of an international application is compliant with the conditions of 35 U.S.C. 371 and other applicable requirements a Form PCT/DO/EO/903 indicating acceptance of the application as a national stage submission under 35 U.S.C. 371 will be issued in addition to the Filing Receipt, in due course.**

**New International Application Filed with the USPTO as a Receiving Office**

**If a new international application is being filed and the international application includes the necessary components for an international filing date (see PCT Article 11 and MPEP 1810), a Notification of the International Application Number and of the International Filing Date (Form PCT/RO/105) will be issued in due course, subject to prescriptions concerning national security, and the date shown on this Acknowledgement Receipt will establish the international filing date of the application.**



UNITED STATES PATENT AND TRADEMARK OFFICE

UNITED STATES DEPARTMENT OF COMMERCE
United States Patent and Trademark Office
Address: COMMISSIONER FOR PATENTS
P.O. Box 1450
Alexandria, Virginia 22313-1450
www.uspto.gov

NOTICE OF ALLOWANCE AND FEE(S) DUE

64735 7590 07/30/2019
KNOBBE, MARTENS, OLSON & BEAR, LLP
MASIMO CORPORATION (MASIMO)
2040 MAIN STREET
FOURTEENTH FLOOR
IRVINE, CA 92614

EXAMINER
FARDANESH, MARJAN

ART UNIT PAPER NUMBER

3791

DATE MAILED: 07/30/2019

Table with 5 columns: APPLICATION NO., FILING DATE, FIRST NAMED INVENTOR, ATTORNEY DOCKET NO., CONFIRMATION NO.
16/226,249 12/19/2018 Ammar Al-Ali MAS.1007C1 1002

TITLE OF INVENTION: ADVANCED PULSE OXIMETRY SENSOR

Table with 7 columns: APPLN. TYPE, ENTITY STATUS, ISSUE FEE DUE, PUBLICATION FEE DUE, PREV. PAID ISSUE FEE, TOTAL FEE(S) DUE, DATE DUE
nonprovisional UNDISCOUNTED \$1000 \$0.00 \$0.00 \$1000 10/30/2019

THE APPLICATION IDENTIFIED ABOVE HAS BEEN EXAMINED AND IS ALLOWED FOR ISSUANCE AS A PATENT. PROSECUTION ON THE MERITS IS CLOSED. THIS NOTICE OF ALLOWANCE IS NOT A GRANT OF PATENT RIGHTS. THIS APPLICATION IS SUBJECT TO WITHDRAWAL FROM ISSUE AT THE INITIATIVE OF THE OFFICE OR UPON PETITION BY THE APPLICANT. SEE 37 CFR 1.313 AND MPEP 1308.

THE ISSUE FEE AND PUBLICATION FEE (IF REQUIRED) MUST BE PAID WITHIN THREE MONTHS FROM THE MAILING DATE OF THIS NOTICE OR THIS APPLICATION SHALL BE REGARDED AS ABANDONED. THIS STATUTORY PERIOD CANNOT BE EXTENDED. SEE 35 U.S.C. 151. THE ISSUE FEE DUE INDICATED ABOVE DOES NOT REFLECT A CREDIT FOR ANY PREVIOUSLY PAID ISSUE FEE IN THIS APPLICATION. IF AN ISSUE FEE HAS PREVIOUSLY BEEN PAID IN THIS APPLICATION (AS SHOWN ABOVE), THE RETURN OF PART B OF THIS FORM WILL BE CONSIDERED A REQUEST TO REAPPLY THE PREVIOUSLY PAID ISSUE FEE TOWARD THE ISSUE FEE NOW DUE.

HOW TO REPLY TO THIS NOTICE:

I. Review the ENTITY STATUS shown above. If the ENTITY STATUS is shown as SMALL or MICRO, verify whether entitlement to that entity status still applies.

If the ENTITY STATUS is the same as shown above, pay the TOTAL FEE(S) DUE shown above.

If the ENTITY STATUS is changed from that shown above, on PART B - FEE(S) TRANSMITTAL, complete section number 5 titled "Change in Entity Status (from status indicated above)".

For purposes of this notice, small entity fees are 1/2 the amount of undiscounted fees, and micro entity fees are 1/2 the amount of small entity fees.

II. PART B - FEE(S) TRANSMITTAL, or its equivalent, must be completed and returned to the United States Patent and Trademark Office (USPTO) with your ISSUE FEE and PUBLICATION FEE (if required). If you are charging the fee(s) to your deposit account, section "4b" of Part B - Fee(s) Transmittal should be completed and an extra copy of the form should be submitted. If an equivalent of Part B is filed, a request to reapply a previously paid issue fee must be clearly made, and delays in processing may occur due to the difficulty in recognizing the paper as an equivalent of Part B.

III. All communications regarding this application must give the application number. Please direct all communications prior to issuance to Mail Stop ISSUE FEE unless advised to the contrary.

IMPORTANT REMINDER: Maintenance fees are due in utility patents issuing on applications filed on or after Dec. 12, 1980. It is patentee's responsibility to ensure timely payment of maintenance fees when due. More information is available at www.uspto.gov/PatentMaintenanceFees.

**PART B - FEE(S) TRANSMITTAL**

Complete and send this form, together with applicable fee(s), by mail or fax, or via EFS-Web.

By mail, send to: Mail Stop ISSUE FEE  
 Commissioner for Patents  
 P.O. Box 1450  
 Alexandria, Virginia 22313-1450

By fax, send to: (571)-273-2885

**INSTRUCTIONS:** This form should be used for transmitting the ISSUE FEE and PUBLICATION FEE (if required). Blocks 1 through 5 should be completed where appropriate. All further correspondence including the Patent, advance orders and notification of maintenance fees will be mailed to the current correspondence address as indicated unless corrected below or directed otherwise in Block 1, by (a) specifying a new correspondence address; and/or (b) indicating a separate "FEE ADDRESS" for maintenance fee notifications.

CURRENT CORRESPONDENCE ADDRESS (Note: Use Block 1 for any change of address)

64735 7590 07/30/2019  
**KNOBBE, MARTENS, OLSON & BEAR, LLP**  
**MASIMO CORPORATION (MASIMO)**  
 2040 MAIN STREET  
 FOURTEENTH FLOOR  
 IRVINE, CA 92614

Note: A certificate of mailing can only be used for domestic mailings of the Fee(s) Transmittal. This certificate cannot be used for any other accompanying papers. Each additional paper, such as an assignment or formal drawing, must have its own certificate of mailing or transmission.

**Certificate of Mailing or Transmission**

I hereby certify that this Fee(s) Transmittal is being deposited with the United States Postal Service with sufficient postage for first class mail in an envelope addressed to the Mail Stop ISSUE FEE address above, or being transmitted to the USPTO via EFS-Web or by facsimile to (571) 273-2885, on the date below.

_____ (Typed or printed name)
_____ (Signature)
_____ (Date)

APPLICATION NO.	FILING DATE	FIRST NAMED INVENTOR	ATTORNEY DOCKET NO.	CONFIRMATION NO.
16/226,249	12/19/2018	Ammar Al-Ali	MAS.1007C1	1002

TITLE OF INVENTION: ADVANCED PULSE OXIMETRY SENSOR

APPLN. TYPE	ENTITY STATUS	ISSUE FEE DUE	PUBLICATION FEE DUE	PREV. PAID ISSUE FEE	TOTAL FEE(S) DUE	DATE DUE
nonprovisional	UNDISCOUNTED	\$1000	\$0.00	\$0.00	\$1000	10/30/2019

EXAMINER	ART UNIT	CLASS-SUBCLASS
FARDANESH, MARJAN	3791	600-323000

<p>1. Change of correspondence address or indication of "Fee Address" (37 CFR 1.363).</p> <p><input type="checkbox"/> Change of correspondence address (or Change of Correspondence Address form PTO/SB/122) attached.</p> <p><input type="checkbox"/> "Fee Address" indication (or "Fee Address" Indication form PTO/SB/47; Rev 03-09 or more recent) attached. <b>Use of a Customer Number is required.</b></p>	<p>2. For printing on the patent front page, list</p> <p>(1) The names of up to 3 registered patent attorneys or agents OR, alternatively, 1 _____</p> <p>(2) The name of a single firm (having as a member a registered attorney or agent) and the names of up to 2 registered patent attorneys or agents. If no name is listed, no name will be printed. 2 _____</p> <p>3 _____</p>
---	---

3. ASSIGNEE NAME AND RESIDENCE DATA TO BE PRINTED ON THE PATENT (print or type)

PLEASE NOTE: Unless an assignee is identified below, no assignee data will appear on the patent. If an assignee is identified below, the document must have been previously recorded, or filed for recordation, as set forth in 37 CFR 3.11 and 37 CFR 3.81(a). Completion of this form is NOT a substitute for filing an assignment.

(A) NAME OF ASSIGNEE \_\_\_\_\_ (B) RESIDENCE: (CITY and STATE OR COUNTRY) \_\_\_\_\_

Please check the appropriate assignee category or categories (will not be printed on the patent):  Individual  Corporation or other private group entity  Government

4a. Fees submitted:  Issue Fee  Publication Fee (if required)  Advance Order - # of Copies \_\_\_\_\_

4b. Method of Payment: (Please first reapply any previously paid fee shown above)

Electronic Payment via EFS-Web  Enclosed check  Non-electronic payment by credit card (Attach form PTO-2038)

The Director is hereby authorized to charge the required fee(s), any deficiency, or credit any overpayment to Deposit Account No. \_\_\_\_\_

5. Change in Entity Status (from status indicated above)

Applicant certifying micro entity status. See 37 CFR 1.29

Applicant asserting small entity status. See 37 CFR 1.27

Applicant changing to regular undiscounted fee status.

**NOTE:** Absent a valid certification of Micro Entity Status (see forms PTO/SB/15A and 15B), issue fee payment in the micro entity amount will not be accepted at the risk of application abandonment.

**NOTE:** If the application was previously under micro entity status, checking this box will be taken to be a notification of loss of entitlement to micro entity status.

**NOTE:** Checking this box will be taken to be a notification of loss of entitlement to small or micro entity status, as applicable.

**NOTE:** This form must be signed in accordance with 37 CFR 1.31 and 1.33. See 37 CFR 1.4 for signature requirements and certifications.

Authorized Signature \_\_\_\_\_ Date \_\_\_\_\_

Typed or printed name \_\_\_\_\_ Registration No. \_\_\_\_\_





UNITED STATES PATENT AND TRADEMARK OFFICE

UNITED STATES DEPARTMENT OF COMMERCE
United States Patent and Trademark Office
Address: COMMISSIONER FOR PATENTS
P.O. Box 1450
Alexandria, Virginia 22313-1450
www.uspto.gov

Table with 5 columns: APPLICATION NO., FILING DATE, FIRST NAMED INVENTOR, ATTORNEY DOCKET NO., CONFIRMATION NO. Includes application details for Ammar Al-Ali and attorney information for Knobbe, Martens, Olson & Bear, LLP.

Determination of Patent Term Adjustment under 35 U.S.C. 154 (b)
(Applications filed on or after May 29, 2000)

The Office has discontinued providing a Patent Term Adjustment (PTA) calculation with the Notice of Allowance.

Section 1(h)(2) of the AIA Technical Corrections Act amended 35 U.S.C. 154(b)(3)(B)(i) to eliminate the requirement that the Office provide a patent term adjustment determination with the notice of allowance. See Revisions to Patent Term Adjustment, 78 Fed. Reg. 19416, 19417 (Apr. 1, 2013). Therefore, the Office is no longer providing an initial patent term adjustment determination with the notice of allowance. The Office will continue to provide a patent term adjustment determination with the Issue Notification Letter that is mailed to applicant approximately three weeks prior to the issue date of the patent, and will include the patent term adjustment on the patent. Any request for reconsideration of the patent term adjustment determination (or reinstatement of patent term adjustment) should follow the process outlined in 37 CFR 1.705.

Any questions regarding the Patent Term Extension or Adjustment determination should be directed to the Office of Patent Legal Administration at (571)-272-7702. Questions relating to issue and publication fee payments should be directed to the Customer Service Center of the Office of Patent Publication at 1-(888)-786-0101 or (571)-272-4200.

<b><i>Notice Requiring Inventor's Oath or Declaration</i></b>	Application No. 16/226,249	Applicant(s) Ammar Al-Ali	
	Examiner FARDANESH, MARJAN	Art Unit 3791	

This notice is an attachment to the Notice of Allowability (PTOL-37), or the Notice of Allowability For A Design Application (PTOL-37D).

An inventor's oath or declaration in compliance with 37 CFR 1.63 or 1.64 executed by or with respect to each inventor has not yet been submitted.

An oath or declaration in compliance with 37 CFR 1.63, or a substitute statement in compliance with 37 CFR 1.64, executed by or with respect to each inventor (for any inventor for which a compliant oath, declaration, or substitute statement has not yet been submitted) **MUST** be filed no later than the date on which the issue fee is paid. See 35 U.S.C. 115(f). Failure to timely comply will result in ABANDONMENT of this application.

A properly executed inventor's oath to declaration has not been received for the following inventor(s):

If applicant previously filed one or more oaths, declarations, or substitute statements, applicant may have received an informational notice regarding deficiencies therein.

The following deficiencies are noted:

**INFORMAL ACTION PROBLEMS**

- A properly executed inventor's oath or declaration has not been received for the following inventor(s): **Ammar Al-Ali**.

Applicant may submit the inventor's oath or declaration at any time before the Notice of Allowance and Fee(s) Due, PTOL-85, is mailed.

Questions relating to this Notice should be directed to the Application Assistance Unit at 571-272-4200.

## OMB Clearance and PRA Burden Statement for PTOL-85 Part B

The Paperwork Reduction Act (PRA) of 1995 requires Federal agencies to obtain Office of Management and Budget approval before requesting most types of information from the public. When OMB approves an agency request to collect information from the public, OMB (i) provides a valid OMB Control Number and expiration date for the agency to display on the instrument that will be used to collect the information and (ii) requires the agency to inform the public about the OMB Control Number's legal significance in accordance with 5 CFR 1320.5(b).

The information collected by PTOL-85 Part B is required by 37 CFR 1.311. The information is required to obtain or retain a benefit by the public which is to file (and by the USPTO to process) an application. Confidentiality is governed by 35 U.S.C. 122 and 37 CFR 1.14. This collection is estimated to take 30 minutes to complete, including gathering, preparing, and submitting the completed application form to the USPTO. Time will vary depending upon the individual case. Any comments on the amount of time you require to complete this form and/or suggestions for reducing this burden, should be sent to the Chief Information Officer, U.S. Patent and Trademark Office, U.S. Department of Commerce, P.O. Box 1450, Alexandria, Virginia 22313-1450. DO NOT SEND FEES OR COMPLETED FORMS TO THIS ADDRESS. SEND TO: Commissioner for Patents, P.O. Box 1450, Alexandria, Virginia 22313-1450. Under the Paperwork Reduction Act of 1995, no persons are required to respond to a collection of information unless it displays a valid OMB control number.

### Privacy Act Statement

**The Privacy Act of 1974 (P.L. 93-579)** requires that you be given certain information in connection with your submission of the attached form related to a patent application or patent. Accordingly, pursuant to the requirements of the Act, please be advised that: (1) the general authority for the collection of this information is 35 U.S.C. 2(b)(2); (2) furnishing of the information solicited is voluntary; and (3) the principal purpose for which the information is used by the U.S. Patent and Trademark Office is to process and/or examine your submission related to a patent application or patent. If you do not furnish the requested information, the U.S. Patent and Trademark Office may not be able to process and/or examine your submission, which may result in termination of proceedings or abandonment of the application or expiration of the patent.

The information provided by you in this form will be subject to the following routine uses:

1. The information on this form will be treated confidentially to the extent allowed under the Freedom of Information Act (5 U.S.C. 552) and the Privacy Act (5 U.S.C. 552a). Records from this system of records may be disclosed to the Department of Justice to determine whether disclosure of these records is required by the Freedom of Information Act.
2. A record from this system of records may be disclosed, as a routine use, in the course of presenting evidence to a court, magistrate, or administrative tribunal, including disclosures to opposing counsel in the course of settlement negotiations.
3. A record in this system of records may be disclosed, as a routine use, to a Member of Congress submitting a request involving an individual, to whom the record pertains, when the individual has requested assistance from the Member with respect to the subject matter of the record.
4. A record in this system of records may be disclosed, as a routine use, to a contractor of the Agency having need for the information in order to perform a contract. Recipients of information shall be required to comply with the requirements of the Privacy Act of 1974, as amended, pursuant to 5 U.S.C. 552a(m).
5. A record related to an International Application filed under the Patent Cooperation Treaty in this system of records may be disclosed, as a routine use, to the International Bureau of the World Intellectual Property Organization, pursuant to the Patent Cooperation Treaty.
6. A record in this system of records may be disclosed, as a routine use, to another federal agency for purposes of National Security review (35 U.S.C. 181) and for review pursuant to the Atomic Energy Act (42 U.S.C. 218(c)).
7. A record from this system of records may be disclosed, as a routine use, to the Administrator, General Services, or his/her designee, during an inspection of records conducted by GSA as part of that agency's responsibility to recommend improvements in records management practices and programs, under authority of 44 U.S.C. 2904 and 2906. Such disclosure shall be made in accordance with the GSA regulations governing inspection of records for this purpose, and any other relevant (i.e., GSA or Commerce) directive. Such disclosure shall not be used to make determinations about individuals.
8. A record from this system of records may be disclosed, as a routine use, to the public after either publication of the application pursuant to 35 U.S.C. 122(b) or issuance of a patent pursuant to 35 U.S.C. 151. Further, a record may be disclosed, subject to the limitations of 37 CFR 1.14, as a routine use, to the public if the record was filed in an application which became abandoned or in which the proceedings were terminated and which application is referenced by either a published application, an application open to public inspection or an issued patent.
9. A record from this system of records may be disclosed, as a routine use, to a Federal, State, or local law enforcement agency, if the USPTO becomes aware of a violation or potential violation of law or regulation.

<b>Notice of Allowability</b>	<b>Application No.</b> 16/226,249	<b>Applicant(s)</b> Al-Ali et al.	
	<b>Examiner</b> MARJAN FARDANESH	<b>Art Unit</b> 3791	<b>AIA (FITF) Status</b> Yes

**-- The MAILING DATE of this communication appears on the cover sheet with the correspondence address--**

All claims being allowable, PROSECUTION ON THE MERITS IS (OR REMAINS) CLOSED in this application. If not included herewith (or previously mailed), a Notice of Allowance (PTOL-85) or other appropriate communication will be mailed in due course. **THIS NOTICE OF ALLOWABILITY IS NOT A GRANT OF PATENT RIGHTS.** This application is subject to withdrawal from issue at the initiative of the Office or upon petition by the applicant. See 37 CFR 1.313 and MPEP 1308.

1.  This communication is responsive to amendments filed on 07/01/2019.  
 A declaration(s)/affidavit(s) under **37 CFR 1.130(b)** was/were filed on \_\_\_\_\_.
2.  An election was made by the applicant in response to a restriction requirement set forth during the interview on \_\_\_\_\_; the restriction requirement and election have been incorporated into this action.
3.  The allowed claim(s) is/are See Continuation Sheet. As a result of the allowed claim(s), you may be eligible to benefit from the **Patent Prosecution Highway** program at a participating intellectual property office for the corresponding application. For more information, please see [http://www.uspto.gov/patents/init\\_events/pph/index.jsp](http://www.uspto.gov/patents/init_events/pph/index.jsp) or send an inquiry to **PPHfeedback@uspto.gov**.
4.  Acknowledgment is made of a claim for foreign priority under 35 U.S.C. § 119(a)-(d) or (f).  
**Certified copies:**  
a)  All      b)  Some      \*c)  None of the:
  1.  Certified copies of the priority documents have been received.
  2.  Certified copies of the priority documents have been received in Application No. \_\_\_\_\_.
  3.  Copies of the certified copies of the priority documents have been received in this national stage application from the International Bureau (PCT Rule 17.2(a)).
\* Certified copies not received: \_\_\_\_\_.

Applicant has THREE MONTHS FROM THE "MAILING DATE" of this communication to file a reply complying with the requirements noted below. Failure to timely comply will result in ABANDONMENT of this application.  
**THIS THREE-MONTH PERIOD IS NOT EXTENDABLE.**

5.  CORRECTED DRAWINGS (as "replacement sheets") must be submitted.  
 including changes required by the attached Examiner's Amendment / Comment or in the Office action of Paper No./Mail Date \_\_\_\_\_.  
**Identifying indicia such as the application number (see 37 CFR 1.84(c)) should be written on the drawings in the front (not the back) of each sheet. Replacement sheet(s) should be labeled as such in the header according to 37 CFR 1.121(d).**
6.  DEPOSIT OF and/or INFORMATION about the deposit of BIOLOGICAL MATERIAL must be submitted. Note the attached Examiner's comment regarding REQUIREMENT FOR THE DEPOSIT OF BIOLOGICAL MATERIAL.

**Attachment(s)**

- |  |   |
|--|---|
| 1. <input type="checkbox"/> Notice of References Cited (PTO-892)   | 5. <input checked="" type="checkbox"/> Examiner's Amendment/Comment       |
| 2. <input checked="" type="checkbox"/> Information Disclosure Statements (PTO/SB/08),<br>Paper No./Mail Date <u>07/01/2019, 07/19/2019</u> . | 6. <input type="checkbox"/> Examiner's Statement of Reasons for Allowance |
| 3. <input type="checkbox"/> Examiner's Comment Regarding Requirement for Deposit of Biological Material _____.                               | 7. <input type="checkbox"/> Other _____.                                  |
| 4. <input checked="" type="checkbox"/> Interview Summary (PTO-413),<br>Paper No./Mail Date. <u>07/18/2019</u> .                              |   |

/MARJAN FARDANESH/ Examiner, Art Unit 3791	/ERIC F WINAKUR/ Primary Examiner, Art Unit 3791
---	---

Continuation of 3. The allowed claim(s) is/are: 57-64,67-70,72-74,77-78,81-83,85 and 87-95

***Notice of Pre-AIA or AIA Status***

1. The present application, filed on or after March 16, 2013, is being examined under the first inventor to file provisions of the AIA.

**EXAMINER'S AMENDMENT**

2. An examiner's amendment to the record appears below. Should the changes and/or additions be unacceptable to applicant, an amendment may be filed as provided by 37 CFR 1.312. To ensure consideration of such an amendment, it **MUST** be submitted no later than the payment of the issue fee.

Authorization for this examiner's amendment was given in an interview with Mr. Jarom Kesler on 07/18/2019. Applicant agreed to amend the claims, as set forth below, to clarify the relationship between the irradiated tissue portion, detected tissue portion, and the light block.

The application has been amended as follows:

Claim 57 was amended as follows:

57. A wrist-worn physiological monitoring device configured for placement on a user at a tissue measurement site, the device comprising:

a light emission source comprising a plurality of emitters configured to irradiate a ~~circular portion~~ of the tissue measurement site by emitting light towards the tissue measurement site, the tissue measurement site being located on a wrist of the user, the plurality of emitters configured to emit one or more wavelengths;

a plurality of detectors configured to detect the light emitted by the plurality of emitters after attenuation by a circular portion of ~~tissue of the user~~ at the tissue measurement site, the plurality of detectors further configured to output at least one signal responsive to the detected light;

a processor configured to receive the at least one signal responsive to the output and determine a physiological parameter of the user; and

a light block forming an enclosing wall between the light emission source and the plurality of detectors, the light block defining the ~~irradiated~~ circular portion of the tissue measurement site, the light emission source arranged proximate a first side of the enclosing wall and the plurality of detectors arranged proximate a second side of the enclosing wall, the first side being different than the second side,

wherein the enclosing wall prevents at least a portion of light emitted from the light emission source from being detected by the plurality of detectors without attenuation by the tissue, and wherein the plurality of detectors are arranged in an array having a spatial configuration corresponding to the circular portion of the ~~irradiated~~ tissue measurement site.

Claim 67 was amended as follows:

67. A method of measuring a physiological parameter in a user's blood, the method comprising:

irradiating ~~a circular portion of~~ a tissue measurement site by emitting, from a plurality of emitters of a light emission source of a physiological monitoring device, light of one or more wavelengths toward the tissue measurement site, the tissue measurement site located on a wrist of the user;

detecting, with a plurality of detectors, the light emitted by the plurality of emitters of the light emission source after attenuation through a circular portion of tissue of the user at the tissue measurement site; and

providing a cylindrical light block forming an enclosing wall between the light emission source and the plurality of detectors, the light emission source arranged proximate a first side of the enclosing wall and the plurality of detectors arranged proximate a second side of the enclosing wall, the first side being different than the second side, wherein the enclosing wall prevents at least a portion of light emitted from the light emission source from being detected by the plurality of detectors without attenuation by the tissue measurement site, and wherein the plurality of detectors are arranged in an array having a circular spatial configuration, the circular spatial configuration arranged to receive said attenuated light;

outputting, from the plurality of detectors, at least one signal responsive to the detected light;

receiving, by a processor, the outputted at least one signal responsive to the detected light; and processing, by the processor, the received at least one signal responsive to the detected light to determine a physiological parameter.

Claim 77 was amended as follows:

77. A wrist-worn physiological monitoring sensor comprising:

a light emission source comprising a plurality of optical sources configured to irradiate ~~a circular portion of~~ a tissue measurement site by emitting light towards the tissue measurement site on a user, the tissue measurement site located on a wrist of the user, the plurality of optical sources configured to emit one or more wavelengths;



a plurality of detectors configured to detect the light emitted by the plurality of emitters after attenuation by a circular portion of tissue of the user at the tissue measurement site, the plurality of detectors further configured to output at least one signal responsive to the detected light;

a processor configured to receive the outputted at least one signal responsive to the detected light and determine a physiological parameter indicative of a state or trend of wellness of the user; and

a light block forming an enclosing wall between the light emission source and the plurality of detectors, the light emission source arranged proximate a first side of the enclosing wall and the plurality of detectors arranged proximate a second side of the enclosing wall, the first side being different than the second side, the light block forming a light isolation chamber defined by the enclosing wall, wherein the enclosing wall prevents at least a portion of light emitted from the light emission source from being detected by the plurality of detectors without attenuation by the tissue, and wherein the plurality of detectors are arranged in an array having a circular spatial configuration, the circular spatial configuration arranged to receive said attenuated light.

### ***Conclusion***

Any inquiry concerning this communication or earlier communications from the examiner should be directed to MARJAN FARDANESH whose telephone number is (571)270-5508. The examiner can normally be reached on Monday-Friday 9:00-17:00.

Examiner interviews are available via telephone, in-person, and video conferencing using a USPTO supplied web-based collaboration tool. To schedule an

interview, applicant is encouraged to use the USPTO Automated Interview Request (AIR) at <http://www.uspto.gov/interviewpractice>.

If attempts to reach the examiner by telephone are unsuccessful, the examiner's supervisor, Patricia Mallari can be reached on (571)272-4729. The fax phone number for the organization where this application or proceeding is assigned is 571-273-8300.

Information regarding the status of an application may be obtained from the Patent Application Information Retrieval (PAIR) system. Status information for published applications may be obtained from either Private PAIR or Public PAIR. Status information for unpublished applications is available through Private PAIR only. For more information about the PAIR system, see <http://pair-direct.uspto.gov>. Should you have questions on access to the Private PAIR system, contact the Electronic Business Center (EBC) at 866-217-9197 (toll-free). If you would like assistance from a USPTO Customer Service Representative or access to the automated information system, call 800-786-9199 (IN USA OR CANADA) or 571-272-1000.

/ERIC F WINAKUR/  
Primary Examiner, Art Unit 3791

/MARJAN FARDANESH/  
Examiner, Art Unit 3791

<b><i>Applicant-Initiated Interview Summary</i></b>	<b>Application No.</b> 16/226,249	<b>Applicant(s)</b> Al-Ali et al.		
	<b>Examiner</b> MARJAN FARDANESH	<b>Art Unit</b> 3791	<b>AIA (First Inventor to File) Status</b> Yes	<b>Page</b> <b>1 of 2</b>
<p>All participants (applicant, applicants representative, PTO personnel):</p> <p>1. MARJAN FARDANESH (Examiner); Telephonic                      2. Jarom Kesler (Attorney of Record); Telephonic</p> <p>3. Aaron Johnson (Attorney of Record); Telephonic</p> <p><b>Date of Interview:</b> <u>07 May 2019</u></p> <p><b>Claims Discussed:</b> claim 57 was discussed.</p> <p><b>Prior Art Discussed:</b> Hannula and Cui were discussed.</p> <p><b>Amendment proposed:</b> Applicant proposed amendments to capture the subject matter of figure 7 in order to overcome the prior art.</p> <hr/> <p style="text-align: center;"><b>Issues Discussed:</b></p> <p><b>Item(s) under 35 U.S.C. 102:</b> Prior art rejection were discussed and compared to figure 7 of the current application. Applicant will take the discussions into consideration while filing a formal response.</p> <p><b>Item(s) under 35 U.S.C. 103:</b> Prior art rejection were discussed and compared to figure 7 of the current application. Applicant will take the discussions into consideration while filing a formal response.</p> <p><b>Attachment(s):</b> Proposed Amendments,</p>				

/MARJAN FARDANESH/ Examiner, Art Unit 3791	/ERIC F WINAKUR/ Primary Examiner, Art Unit 3791
<p><b>Applicant is reminded that a complete written statement as to the substance of the interview must be made of record in the application file. It is the applicants responsibility to provide the written statement, unless the interview was initiated by the Examiner and the Examiner has indicated that a written summary will be provided. See MPEP 713.04</b></p> <p>Please further see:  MPEP 713.04  Title 37 Code of Federal Regulations (CFR) § 1.133 Interviews, paragraph (b)  37 CFR § 1.2 Business to be transacted in writing</p>	

**Applicant recordation instructions:** The formal written reply to the last Office action must include the substance of the interview. (See MPEP section 713.04). If a reply to the last Office action has already been filed, applicant is given a non-extendable period of the longer of one month or thirty days from this interview date, or the mailing date of this interview summary form, whichever is later, to file a statement of the substance of the interview.

**Examiner recordation instructions:** Examiners must summarize the substance of any interview of record. A complete and proper recordation of the substance of an interview should include the items listed in MPEP 713.04 for complete and proper recordation including the identification of the general thrust of each argument or issue discussed, a general indication of any other pertinent matters discussed regarding patentability and the general results or outcome of the interview, to include an indication as to whether or not agreement was reached on the issues raised.

<b><i>Search Notes</i></b> 	<b>Application/Control No.</b> 16/226,249	<b>Applicant(s)/Patent Under Reexamination</b> Al-Ali et al.
	<b>Examiner</b> MARJAN FARDANESH	<b>Art Unit</b> 3791

CPC - Searched*		
Symbol	Date	Examiner
EAST-See search history printout	03/04/2019	/mf/
EAST-See search history printout	07/19/2019	/mf/

CPC Combination Sets - Searched*		
Symbol	Date	Examiner

US Classification - Searched*			
Class	Subclass	Date	Examiner

\* See search history printout included with this form or the SEARCH NOTES box below to determine the scope of the search.

Search Notes		
Search Notes	Date	Examiner
PALM-inventor name search	03/04/2019	/mf/

Interference Search			
US Class/CPC Symbol	US Subclass/CPC Group	Date	Examiner
EAST-	See search history printout	07/19/2019	/mf/

/MARJAN FARDANESH/ Examiner, Art Unit 3791	
---	--

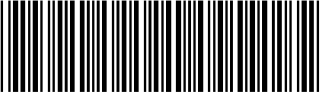
<b>Issue Classification</b> 	<b>Application/Control No.</b> 16/226,249	<b>Applicant(s)/Patent Under Reexamination</b> Al-Ali et al.
	<b>Examiner</b> MARJAN FARDANESH	<b>Art Unit</b> 3791

CPC						
Symbol				Type	Version	
A61B	/	5	/	14552	F	2013-01-01
A61B	/	5	/	6826	I	2013-01-01
A61B	/	5	/	0002	I	2013-01-01
A61B	/	5	/	02416	I	2013-01-01
A61B	/	5	/	14532	I	2013-01-01
A61B	/	5	/	14546	I	2013-01-01
A61B	/	5	/	4875	I	2013-01-01
A61B	/	5	/	7278	I	2013-01-01
A61B	/	5	/	742	I	2013-01-01
A61B	/	2562	/	04	A	2013-01-01

CPC Combination Sets				
Symbol	Type	Set	Ranking	Version

/MARJAN FARDANESH/ Examiner, Art Unit 3791 (Assistant Examiner)	19 July 2019 (Date)	<b>Total Claims Allowed:</b> 30	
/ERIC F WINAKUR/ Primary Examiner, Art Unit 3791 (Primary Examiner)	19 July 2019 (Date)	O.G. Print Claim(s) 1	O.G. Print Figure 7

<b>Issue Classification</b> 	<b>Application/Control No.</b> 16/226,249	<b>Applicant(s)/Patent Under Reexamination</b> Al-Ali et al.
	<b>Examiner</b> MARJAN FARDANESH	<b>Art Unit</b> 3791

<b>INTERNATIONAL CLASSIFICATION</b>			
<b>CLAIMED</b>			
A61B		5	1455
<b>NON-CLAIMED</b>			

<b>US ORIGINAL CLASSIFICATION</b>	
<b>CLASS</b>	<b>SUBCLASS</b>
600	310

<b>CROSS REFERENCES(S)</b>					
<b>CLASS</b>	<b>SUBCLASS (ONE SUBCLASS PER BLOCK)</b>				

/MARJAN FARDANESH/ Examiner, Art Unit 3791 (Assistant Examiner)	19 July 2019 (Date)	<b>Total Claims Allowed:</b> 30	
/ERIC F WINAKUR/ Primary Examiner, Art Unit 3791 (Primary Examiner)	19 July 2019 (Date)	O.G. Print Claim(s) 1	O.G. Print Figure 7

<b>Issue Classification</b> 	<b>Application/Control No.</b> 16/226,249	<b>Applicant(s)/Patent Under Reexamination</b> Al-Ali et al.
	<b>Examiner</b> MARJAN FARDANESH	<b>Art Unit</b> 3791

Claims renumbered in the same order as presented by applicant  
  CPA  
  T.D.  
  R.1.47

CLAIMS															
Final	Original	Final	Original	Final	Original	Final	Original	Final	Original	Final	Original	Final	Original	Final	Original
1	57		66		75		84	28	93						
2	58	9	67		76	24	85	29	94						
3	59	10	68	19	77		86	30	95						
4	60	11	69	20	78	25	87								
5	61	12	70		79	26	88								
6	62		71		80	27	89								
7	63	13	72	21	81	16	90								
8	64	14	73	22	82	17	91								
	65	15	74	23	83	18	92								

/MARJAN FARDANESH/ Examiner, Art Unit 3791 (Assistant Examiner)	19 July 2019 (Date)	<b>Total Claims Allowed:</b> 30	
/ERIC F WINAKUR/ Primary Examiner, Art Unit 3791 (Primary Examiner)	19 July 2019 (Date)	O.G. Print Claim(s) 1	O.G. Print Figure 7



**FOR DISCUSSION PURPOSES ONLY – NOT FOR ENTRY**

**IN THE UNITED STATES PATENT AND TRADEMARK OFFICE**

First : Ammar Al-Ali  
Inventor  
App. Nos. : 16/226249; 15/195199  
Filed : December 19, 2018; June 28, 2016  
For : ADVANCED PULSE OXIMETRY SENSOR  
Examiner : Fardanesh, Marjan  
Art Unit : 3791; 3791  
Conf. No. : 1002; 3453  
Docket : MAS.1007C1; MAS.1007A  
Nos.

**INTERVIEW AGENDA**

**Type:** Telephone

**Date and Time:** May 7, 2019, 2:00PM EST, 11:00AM PST

**Participants:** Examiner Fardanesh and Applicant's representatives Jarom Kesler (Reg. No. 57,046) and Aaron Johnson (Reg. No. 74,164)

- A. Discuss disclosed embodiments and claimed invention**
- B. Review references cited in Office Action**
- C. Discuss differences between references and claimed invention**

**FOR DISCUSSION PURPOSES ONLY – NOT FOR ENTRY**

**PROPOSED CLAIM AMENDMENTS FOR APP. NO. 16/226249**

1-56. **(Cancelled)**

57. **(Currently Amended)** A wrist-worn physiological monitoring device configured for placement on a user at a tissue measurement site, the device comprising:

a light emission source comprising a plurality of emitters configured to irradiate a circular portion of the tissue measurement site by emitting light towards the tissue measurement site, the tissue measurement site being located on a wrist of the user, the plurality of emitters comprising one or more light emitting diodes (LEDs) configured to emit one or more wavelengths, the one or more wavelengths comprising at least an infrared wavelength;

a plurality of detectors configured to detect the light emitted by the plurality of emitters after attenuation by tissue of the user at the tissue measurement site, wherein the plurality of detectors comprise one or more photodiodes, the plurality of detectors further configured to output at least one signal responsive to the detected light;

a processor configured to receive the at least one signal responsive to the output and determine a physiological parameter of the user; and

a light block forming an enclosing wall between the light emission source and the plurality of detectors, the light emission source arranged proximate a first side of the enclosing wall and the plurality of detectors arranged proximate a second side of the enclosing wall, the first side being different than the second side, light emitted from the plurality of emitters at the tissue measurement site and the plurality of detectors when the physiological monitoring device is worn by the user, wherein the enclosing wall prevents at least a portion of light emitted from the light emission source plurality of emitters from being detected by the plurality of detectors without attenuation by the tissue, and wherein the plurality of detectors are arranged in an array having a spatial configuration corresponding to the circular portion of the irradiated tissue measurement site.

58. **(Previously Presented)** The physiological monitoring device of Claim 57, further comprising a display configured to present information related to the determined physiological parameter to the user.

59. **(Previously Presented)** The physiological monitoring device of Claim 58, wherein the display is a touch-screen display.

**FOR DISCUSSION PURPOSES ONLY – NOT FOR ENTRY**

60. **(Previously Presented)** The physiological monitoring device of Claim 57, wherein the enclosing wall of the light block is a circular wall.

61. **(Previously Presented)** The physiological monitoring device of Claim 57, wherein, when the physiological monitoring device is worn by the user at the tissue measurement site, the plurality of emitters are arranged in a reflectance measurement configuration on a first side of the tissue measurement site, and wherein the plurality of detectors are arranged in a reflectance measurement configuration on the first side of the tissue measurement site when the physiological monitoring device is worn by the user.

62. **(Previously Presented)** The physiological monitoring device of Claim 57, further comprising a diffuser which receives, spreads, and emits the spread light, wherein the emitted spread light is directed at the tissue measurement site.

63. **(Currently Amended)** The physiological monitoring device of Claim 57, wherein the light emission source ~~is a plurality of emitters~~ are positioned outside the enclosing wall when the physiological monitoring device is worn by the user at the tissue measurement site, and wherein the plurality of detectors are positioned inside the enclosing wall when the physiological monitoring device is worn by the user at the tissue measurement site.

64. **(Previously Presented)** The physiological monitoring device of Claim 57, wherein the physiological parameter is selected from the group consisting of arterial oxygen saturation, glucose, and pulse rate.

65. **(Cancelled)**

66. **(Cancelled)**

67. **(Currently Amended)** A method of measuring a physiological parameter in a user's blood, the method comprising:

irradiating a circular portion of a tissue measurement site by emitting, from a plurality of emitters of a light emission source of a physiological monitoring device, light of one or more wavelengths toward ~~[[a]]~~the tissue measurement site, the tissue measurement site located on a wrist of the user ~~the plurality of emitters comprise one or more light emitting diodes (LEDs) and the one or more wavelengths comprises at least an infrared wavelength;~~

detecting, with a plurality of detectors, the light emitted by the plurality of emitters of the light emission source after attenuation through tissue of the user at the

**FOR DISCUSSION PURPOSES ONLY – NOT FOR ENTRY**

tissue measurement site, ~~wherein the plurality of detectors comprise one or more photodiodes;~~ and

providing a cylindrical light block forming an enclosing wall between the light emission source and the plurality of detectors, the light emission source arranged proximate a first side of the enclosing wall and the plurality of detectors arranged proximate a second side of the enclosing wall, the first side being different than the second side, light emitted from the plurality of emitters at the tissue measurement site and the plurality of detectors when the physiological monitoring device is worn by the user, wherein the enclosing wall prevents at least a portion of light emitted from the light emission source plurality of emitters from being detected by the plurality of detectors without attenuation by the tissue, and wherein the plurality of detectors are arranged in an array having a circular spatial configuration, the circular spatial configuration arranged to receive said attenuated light;

outputting, from the plurality of detectors, at least one signal responsive to the detected light;

receiving, by a processor, the outputted at least one signal responsive to the detected light; and

processing, by the processor, the received at least one signal responsive to the detected light to determine a physiological parameter.

68. **(Currently Amended)** The method of Claim 67, wherein the light emission source is ~~plurality of emitters are~~ positioned outside the enclosing wall when the physiological monitoring device is worn by the user at the tissue measurement site, and wherein the plurality of detectors are positioned inside the enclosing wall when the physiological monitoring device is worn by the user at the tissue measurement site.

69. **(Previously Presented)** The method of Claim 67, further comprising presenting, with a display of the physiological monitoring device, information related to the determined physiological parameter to the user.

70. **(Previously Presented)** The method of Claim 69, wherein the display is a touch-screen display.

71. **(Cancelled)**

**FOR DISCUSSION PURPOSES ONLY – NOT FOR ENTRY**

72. **(Previously Presented)** The method of Claim 67, wherein when the physiological monitoring device is worn by the user at the tissue measurement site, the plurality of emitters are arranged in a reflectance measurement configuration on a first side of the tissue measurement site, and wherein the plurality of detectors are arranged in a reflectance measurement configuration on the first side of the tissue measurement site when the physiological monitoring device is worn by the user.

73. **(Previously Presented)** The method of Claim 67, further comprising spreading, with a diffuser, the emitted light and emitting the spread light from the diffuser to the tissue measurement site.

74. **(Previously Presented)** The method of Claim 67, wherein the physiological parameter is indicative of at least one of pulse rate, perfusion index, oxygen content, and total hemoglobin.

75. **(Cancelled)**

76. **(Cancelled)**

77. **(Currently Amended)** A wrist-worn physiological monitoring sensor comprising:

a light emission source comprising a plurality of optical sources configured to irradiate a circular portion of a tissue measurement site by emitting light towards [[a]]the tissue measurement site on a user, the tissue measurement site located on a wrist of the user, the plurality of optical sources ~~comprising one or more light emitting diodes (LEDs) configured to emit one or more wavelengths, the one or more wavelengths comprising at least an infrared wavelength;~~

a plurality of detectors configured to detect the light emitted by the plurality of emitters after attenuation by tissue of the user at the tissue measurement site, ~~wherein the plurality of detectors comprise one or more photodiodes,~~ the plurality of detectors further configured to output at least one signal responsive to the detected light;

a processor configured to receive the outputted at least one signal responsive to the detected light and determine a physiological parameter indicative of a state or trend of wellness of the user; and

a light block forming an enclosing wall between the light emission source and the plurality of detectors, the light emission source arranged proximate a first side of the

**FOR DISCUSSION PURPOSES ONLY – NOT FOR ENTRY**

enclosing wall and the plurality of detectors arranged proximate a second side of the enclosing wall, the first side being different than the second side, light emitted from the plurality of emitters at the tissue measurement site and the plurality of detectors when the physiological monitoring sensor is worn by the user, the light block forming a light isolation chamber defined by the enclosing wall, wherein the enclosing wall prevents at least a portion of light emitted from the light emission source plurality of emitters from being detected by the plurality of detectors without attenuation by the tissue, and wherein the plurality of detectors are arranged in an array having a circular spatial configuration, the circular spatial configuration arranged to receive said attenuated light.

78. **(Currently Amended)** The physiological monitoring sensor of Claim 77, wherein the light emission source ~~plurality of optical sources~~ are located outside the enclosing wall when the physiological monitoring sensor is worn by the user at the tissue measurement site, and wherein the plurality of detectors are arranged inside the enclosing wall when the physiological monitoring sensor is worn by the user at the tissue measurement site.

79. **(Cancelled)**

80. **(Cancelled)**

81. **(Previously Presented)** The physiological monitoring sensor of Claim 77, further comprising a diffuser which receives, spreads, and emits the spread light, wherein the emitted spread light is directed at the tissue measurement site.

82. **(Previously Presented)** The physiological monitoring sensor of Claim 77, further comprising a display configured to present information related to the determined physiological parameter to the user.

83. **(Previously Presented)** The physiological monitoring sensor of Claim 82, wherein the display is a touch-screen display.

84. **(Cancelled)**

85. **(Currently Amended)** The physiological monitoring sensor of Claim 77, wherein when the physiological monitoring sensor is worn by the user at the tissue measurement site, the plurality of optical sources ~~emitters~~ are arranged in a reflectance measurement configuration on a first side of the tissue measurement site, and wherein the plurality of detectors are arranged in a reflectance measurement configuration on the first side of the tissue measurement site when the physiological monitoring sensor is worn by the user.

**FOR DISCUSSION PURPOSES ONLY – NOT FOR ENTRY**

86. **(Cancelled)**

87. **(New)** The physiological monitoring device of Claim 57, wherein the plurality of emitters comprise one or more light emitting diodes (LEDs), and wherein the one or more wavelengths comprises at least an infrared wavelength.

88. **(New)** The physiological monitoring device of Claim 57, wherein the plurality of detectors comprise a plurality of photodiodes.

89. **(New)** The physiological monitoring device of Claim 57, further comprising a light concentrator configured to direct the attenuated, reflected light to the plurality of detectors.

90. **(New)** The method of Claim 67, wherein the plurality of emitters comprise one or more light emitting diodes (LEDs), and wherein the one or more wavelengths comprises at least an infrared wavelength.

91. **(New)** The method of Claim 67, wherein the plurality of detectors comprise a plurality of photodiodes.

92. **(New)** The method of Claim 67, further comprising, directing, with a light concentrator, the light emitted by the light emission source after attenuation through tissue of the user at the tissue measurement site to the plurality of detectors.

93. **(New)** The physiological monitoring sensor of Claim 77, wherein the plurality of optical sources comprise one or more light emitting diodes (LEDs), and wherein the one or more wavelengths comprises at least an infrared wavelength.

94. **(New)** The physiological monitoring sensor of Claim 77, wherein the plurality of detectors comprise a plurality of photodiodes.

95. **(New)** The physiological monitoring sensor of Claim 77, further comprising a light concentrator configured to direct the attenuated, reflected light to the plurality of detectors.

PTO/SB/08 Equivalent

<b>INFORMATION DISCLOSURE STATEMENT BY APPLICANT</b>	Application No.	16/226249	
	Filing Date	December 19, 2018	
	First Named Inventor	Ammar Al-Ali	
	Art Unit	3791	
<i>(Multiple sheets used when necessary)</i>		Examiner	Fardanesh, Marjan
SHEET 1 OF 12		Attorney Docket No.	MAS.1007C1

U.S. PATENT DOCUMENTS					
Examiner Initials	Cite No.	Document Number <i>Number - Kind Code (if known)</i> Example: 1,234,567 B1	Publication Date MM-DD-YYYY	Name	Pages, Columns, Lines Where Relevant Passages or Relevant Figures Appear
	1	5,497,771	3/12/1996	Rosenheimer	
	2	6,343,223	1/29/2002	Chin et al.	
	3	5,987,343	11/16/1999	Kinast	
	4	6,308,089	10/23/2001	von der Ruhr et al.	
	5	7,048,687	5/23/2006	Reuss et al.	
	6	8,280,473	10/2/2012	Al-Ali	
	7	9,364,181	6/14/2016	Kiani et al.	
	8	9,368,671	6/14/2016	Wojtczuk et al.	
	9	9,370,325	6/21/2016	Al-Ali et al.	
	10	9,370,326	6/21/2016	McHale et al.	
	11	9,370,335	6/21/2016	Al-ali et al.	
	12	9,375,185	6/28/2016	Ali et al.	
	13	9,386,953	7/12/2016	Al-Ali	
	14	9,386,961	7/12/2016	Al-Ali et al.	
	15	9,392,945	7/19/2016	Al-Ali et al.	
	16	9,397,448	7/19/2016	Al-Ali et al.	
	17	9,408,542	8/9/2016	Kinast et al.	
	18	9,436,645	9/6/2016	Al-Ali et al.	
	19	9,445,759	9/20/2016	Lamego et al.	
	20	9,466,919	10/11/2016	Kiani et al.	
	21	9,474,474	10/25/2016	Lamego et al.	
	22	9,480,422	11/1/2016	Al-Ali	
	23	9,480,435	11/1/2016	Olsen	
	24	9,492,110	11/15/2016	Al-Ali et al.	
	25	9,510,779	12/6/2016	Poeze et al.	
	26	9,517,024	12/13/2016	Kiani et al.	
	27	9,532,722	1/3/2017	Lamego et al.	
	28	9,538,949	1/10/2017	Al-Ali et al.	
	29	9,538,980	1/10/2017	Telfort et al.	

Examiner Signature	/MARJAN FARDANESH/	Date Considered	07/19/2019
<p><b>*Examiner:</b> Initial if reference considered, whether or not citation is in conformance with MPEP 609. Draw line through citation if not in conformance and not considered. Include copy of this form with next communication to applicant.</p>			

~~ALL REFERENCES CONSIDERED EXCEPT WHERE LINED THROUGH. /M.F/~~

T<sup>1</sup> - Place a check mark in this area when an English language Translation is attached.



PTO/SB/08 Equivalent

<b>INFORMATION DISCLOSURE STATEMENT BY APPLICANT</b>	Application No.	16/226249
	Filing Date	December 19, 2018
	First Named Inventor	Ammar Al-Ali
	Art Unit	3791
<i>(Multiple sheets used when necessary)</i>	Examiner	Fardanesh, Marjan
SHEET 2 OF 12	Attorney Docket No.	MAS.1007C1

U.S. PATENT DOCUMENTS					
Examiner Initials	Cite No.	Document Number <i>Number - Kind Code (if known)</i> Example: 1,234,567 B1	Publication Date MM-DD-YYYY	Name	Pages, Columns, Lines Where Relevant Passages or Relevant Figures Appear
	30	9,549,696	1/24/2017	Lamego et al.	
	31	9,554,737	1/31/2017	Schurman et al.	
	32	9,560,996	2/7/2017	Kiani	
	33	9,560,998	2/7/2017	Al-Ali et al.	
	34	9,566,019	2/14/2017	Al-Ali et al.	
	35	9,579,039	2/28/2017	Jansen et al.	
	36	9,591,975	3/14/2017	Dalvi et al.	
	37	9,622,692	4/18/2017	Lamego et al.	
	38	9,622,693	4/18/2017	Diab	
	39	9,636,055	5/2/2017	Al-Ali et al.	
	40	9,636,056	5/2/2017	Al-Ali	
	41	9,649,054	5/16/2017	Lamego et al.	
	42	9,662,052	5/30/2017	Al-Ali et al.	
	43	9,668,679	6/6/2017	Schurman et al	
	44	9,668,680	6/6/2017	Bruinsma et al.	
	45	9,668,703	6/6/2017	Al-Ali	
	46	9,675,286	6/13/2017	Diab	
	47	9,687,160	6/27/2017	Kiani	
	48	9,693,719	7/4/2017	Al-Ali et al.	
	49	9,693,737	7/4/2017	Al-Ali	
	50	9,697,928	7/4/2017	Al-Ali et al.	
	51	9,717,425	8/1/2017	Kiani et al.	
	52	9,717,458	8/1/2017	Lamego et al.	
	53	9,724,016	8/8/2017	Al-Ali et al.	
	54	9,724,024	8/8/2017	Al-Ali	
	55	9,724,025	8/8/2017	Kiani et al.	
	56	9,730,640	8/15/2017	Diab et al.	
	57	9,743,887	8/29/2017	Al-Ali et al.	
	58	9,749,232	8/29/2017	Sampath et al.	

Examiner Signature	/MARJAN FARDANESH/	Date Considered	07/19/2019
<p><b>*Examiner:</b> Initial if reference considered, whether or not citation is in conformance with MPEP 609. Draw line through citation if not in conformance and not considered. Include copy of this form with next communication to applicant.</p>			

~~ALL REFERENCES CONSIDERED EXCEPT WHERE LINED THROUGH.~~ /M.F/

T<sup>1</sup> - Place a check mark in this area when an English language Translation is attached.

PTO/SB/08 Equivalent

<b>INFORMATION DISCLOSURE STATEMENT BY APPLICANT</b>	Application No.	16/226249
	Filing Date	December 19, 2018
	First Named Inventor	Ammar Al-Ali
	Art Unit	3791
<i>(Multiple sheets used when necessary)</i>	Examiner	Fardanesh, Marjan
SHEET 3 OF 12	Attorney Docket No.	MAS.1007C1

U.S. PATENT DOCUMENTS					
Examiner Initials	Cite No.	Document Number <i>Number - Kind Code (if known)</i> Example: 1,234,567 B1	Publication Date MM-DD-YYYY	Name	Pages, Columns, Lines Where Relevant Passages or Relevant Figures Appear
	59	9,750,442	9/5/2017	Olsen	
	60	9,750,443	9/5/2017	Smith et al.	
	61	9,750,461	9/5/2017	Telfort	
	62	9,775,545	10/3/2017	Al-Ali et al.	
	63	9,775,546	10/3/2017	Diab et al.	
	64	9,775,570	10/3/2017	Al-Ali	
	65	9,778,079	10/3/2017	Al-Ali et al.	
	66	9,782,077	10/10/2017	Lamego et al.	
	67	9,782,110	10/10/2017	Kiani	
	68	9,787,568	10/10/2017	Lamego et al.	
	69	9,788,735	10/17/2017	Al-Ali	
	70	9,788,768	10/17/2017	Al-Ali et al.	
	71	9,795,300	10/24/2017	Al-Ali	
	72	9,795,310	10/24/2017	Al-Ali	
	73	9,795,358	10/24/2017	Telfort et al.	
	74	9,795,739	10/24/2017	Al-Ali et al.	
	75	9,801,556	10/31/2017	Kiani	
	76	9,801,588	10/31/2017	Weber et al.	
	77	9,808,188	11/7/2017	Perea et al.	
	78	9,814,418	11/14/2017	Weber et al.	
	79	9,820,691	11/21/2017	Kiani	
	80	9,833,152	12/5/2017	Kiani et al.	
	81	9,833,180	12/5/2017	Shakespeare et al.	
	82	9,839,379	12/12/2017	Al-Ali et al.	
	83	9,839,381	12/12/2017	Weber et al.	
	84	9,847,002	12/19/2017	Kiani et al.	
	85	9,847,749	12/19/2017	Kiani et al.	
	86	9,848,800	12/26/2017	Lee et al.	
	87	9,848,806	12/26/2017	Al-Ali et al.	

Examiner Signature	<u>/MARJAN FARDANESH/</u>	Date Considered	07/19/2019
<p><b>*Examiner:</b> Initial if reference considered, whether or not citation is in conformance with MPEP 609. Draw line through citation if not in conformance and not considered. Include copy of this form with next communication to applicant.</p>			

~~ALL REFERENCES CONSIDERED EXCEPT WHERE LINED THROUGH.~~ /M.F/

T<sup>1</sup> - Place a check mark in this area when an English language Translation is attached.

PTO/SB/08 Equivalent

<b>INFORMATION DISCLOSURE STATEMENT BY APPLICANT</b>	Application No.	16/226249
	Filing Date	December 19, 2018
	First Named Inventor	Ammar Al-Ali
	Art Unit	3791
<i>(Multiple sheets used when necessary)</i>	Examiner	Fardanesh, Marjan
SHEET 4 OF 12	Attorney Docket No.	MAS.1007C1

U.S. PATENT DOCUMENTS					
Examiner Initials	Cite No.	Document Number <i>Number - Kind Code (if known)</i> Example: 1,234,567 B1	Publication Date MM-DD-YYYY	Name	Pages, Columns, Lines Where Relevant Passages or Relevant Figures Appear
	88	9,848,807	12/26/2017	Lamego	
	89	9,861,298	1/9/2018	Eckerbom et al.	
	90	9,861,304	1/9/2018	Al-Ali et al.	
	91	9,861,305	1/9/2018	Weber et al.	
	92	9,867,578	1/16/2018	Al-Ali et al.	
	93	9,872,623	1/23/2018	Al-Ali	
	94	9,876,320	1/23/2018	Coverston et al.	
	95	9,877,650	1/30/2018	Muhsin et al.	
	96	9,877,686	1/30/2018	Al-Ali et al.	
	97	9,891,079	2/13/2018	Dalvi	
	98	9,895,107	2/20/2018	Al-Ali et al.	
	99	9,913,617	3/13/2018	Al-Ali et al.	
	100	9,924,893	3/27/2018	Schurman et al.	
	101	9,924,897	3/27/2018	Abdul-Hafiz	
	102	9,936,917	4/10/2018	Poeze et al.	
	103	9,943,269	4/17/2018	Muhsin et al.	
	104	9,949,676	4/24/2018	Al-Ali	
	105	9,955,937	5/1/2018	Telfort	
	106	9,965,946	5/8/2018	Al-Ali	
	107	9,980,667	5/29/2018	Kiani et al.	
	108	9,986,919	6/5/2018	Lamego et al.	
	109	9,986,952	6/5/2018	Dalvi et al.	
	110	9,989,560	6/5/2018	Poeze et al.	
	111	9,993,207	6/12/2018	Al-Ali et al.	
	112	10,007,758	6/26/2018	Al-Ali et al.	
	113	10,010,276	7/3/2018	Al-Ali et al.	
	114	10,032,002	7/24/2018	Kiani et al.	
	115	10,039,482	8/7/2018	Al-Ali et al.	
	116	10,052,037	8/21/2018	Kinast et al.	

Examiner Signature /MARJAN FARDANESH/	Date Considered 07/19/2019
<p><b>*Examiner:</b> Initial if reference considered, whether or not citation is in conformance with MPEP 609. Draw line through citation if not in conformance and not considered. Include copy of this form with next communication to applicant.</p>	

~~ALL REFERENCES CONSIDERED EXCEPT WHERE LINED THROUGH. /M.F/~~

T<sup>1</sup> - Place a check mark in this area when an English language Translation is attached.

PTO/SB/08 Equivalent

<b>INFORMATION DISCLOSURE STATEMENT BY APPLICANT</b>	Application No.	16/226249	
	Filing Date	December 19, 2018	
	First Named Inventor	Ammar Al-Ali	
	Art Unit	3791	
<i>(Multiple sheets used when necessary)</i>		Examiner	Fardanesh, Marjan
SHEET 5 OF 12		Attorney Docket No.	MAS.1007C1

U.S. PATENT DOCUMENTS					
Examiner Initials	Cite No.	Document Number <i>Number - Kind Code (if known)</i> Example: 1,234,567 B1	Publication Date MM-DD-YYYY	Name	Pages, Columns, Lines Where Relevant Passages or Relevant Figures Appear
	117	10,058,275	8/28/2018	Al-Ali et al.	
	118	10,064,562	9/4/2018	Al-Ali	
	119	10,086,138	10/2/2018	Novak, Jr.	
	120	10,092,200	10/9/2018	Al-Ali et al.	
	121	10,092,249	10/9/2018	Kiani et al.	
	122	10,098,550	10/16/2018	Al-Ali et al.	
	123	10,098,591	10/16/2018	Al-Ali et al.	
	124	10,098,610	10/16/2018	Al-Ali et al.	
	125	10,123,726	11/13/2018	Al-Ali et al.	
	126	10,130,289	11/20/2018	Al-Ali et al.	
	127	10,130,291	11/20/2018	Schurman et al.	
	128	10,149,616	12/11/2018	Al-Ali et al.	
	129	10,154,815	12/18/2018	Al-Ali et al.	
	130	10,159,412	12/25/2018	Lamego et al.	
	131	10,188,296	1/29/2019	Al-Ali et al.	
	132	10,188,331	1/29/2019	Al-Ali et al.	
	133	10,188,348	1/29/2019	Kiani et al.	
	134	10,194,847	2/5/2019	Al-Ali	
	135	10,194,848	2/5/2019	Kiani et al.	
	136	10,201,298	2/12/2019	Al-Ali et al.	
	137	10,205,272	2/12/2019	Kiani et al.	
	138	10,205,291	2/12/2019	Scruggs et al.	
	139	10,213,108	2/26/2019	Al-Ali	
	140	10,219,706	3/5/2019	Al-Ali	
	141	10,219,746	3/5/2019	McHale et al.	
	142	10,226,187	3/12/2019	Al-Ali et al	
	143	10,226,576	3/12/2019	Kiani	
	144	10,231,657	3/19/2019	Al-Ali et al	
	145	10,231,670	3/19/2019	Blank et al.	

Examiner Signature	/MARJAN FARDANESH/	Date Considered	07/19/2019
<p><b>*Examiner:</b> Initial if reference considered, whether or not citation is in conformance with MPEP 609. Draw line through citation if not in conformance and not considered. Include copy of this form with next communication to applicant.</p>			

~~ALL REFERENCES CONSIDERED EXCEPT WHERE LINED THROUGH.~~ /M.F/

T<sup>1</sup> - Place a check mark in this area when an English language Translation is attached.

PTO/SB/08 Equivalent

<b>INFORMATION DISCLOSURE STATEMENT BY APPLICANT</b>	Application No.	16/226249	
	Filing Date	December 19, 2018	
	First Named Inventor	Ammar Al-Ali	
	Art Unit	3791	
<i>(Multiple sheets used when necessary)</i>		Examiner	Fardanesh, Marjan
SHEET 6 OF 12		Attorney Docket No.	MAS.1007C1

U.S. PATENT DOCUMENTS					
Examiner Initials	Cite No.	Document Number <i>Number - Kind Code (if known)</i> Example: 1,234,567 B1	Publication Date MM-DD-YYYY	Name	Pages, Columns, Lines Where Relevant Passages or Relevant Figures Appear
	146	10,231,676	3/19/2019	Al-Ali et al	
	147	10,251,585	4/9/2019	Al-Ali et al.	
	148	10,251,586	4/9/2019	Lamego	
	149	10,255,994	4/9/2019	Sampath et al.	
	150	10,258,265	4/16/2019	Poeze et al.	
	151	10,258,266	4/16/2019	Poeze et al.	
	152	10,271,748	4/30/2019	Al-Ali	
	153	10,278,626	5/7/2019	Schurman et al.	
	154	10,278,648	5/7/2019	Al-Ali et al.	
	155	10,279,247	5/7/2019	Kiani	
	156	10,292,628	5/21/2019	Poeze et al.	
	157	10,292,657	5/21/2019	Abdul-Hafiz et al.	
	158	10,292,664	5/21/2019	Al-Ali	
	159	10,299,708	5/28/2019	Poeze et al.	
	160	10,299,709	5/28/2019	Perea et al.	
	161	10,305,775	5/28/2019	Lamego et al.	
	162	10,307,111	6/4/2019	Muhsin et al.	
	163	10,325,681	6/18/2019	Sampath et al.	
	164	10,327,337	6/18/2019	Triman et al.	
	165	D788,312	5/30/2017	Al-Ali et al.	
	166	D820,865	6/19/2018	Muhsin et al.	
	167	D822,215	7/3/2018	Al-Ali et al.	
	168	D822,216	7/3/2018	Barker et al.	
	169	D833,624	11/13/2018	DeJong et al.	
	170	D835,282	12/4/2018	Barker et al.	
	171	D835,283	12/4/2018	Barker et al.	
	172	D835,284	12/4/2018	Barker et al.	
	173	D835,285	12/4/2018	Barker et al.	
	174	RE47,218	2/5/2019	Ali-Ali	

Examiner Signature /MARJAN FARDANESH/	Date Considered 07/19/2019
<p><b>*Examiner:</b> Initial if reference considered, whether or not citation is in conformance with MPEP 609. Draw line through citation if not in conformance and not considered. Include copy of this form with next communication to applicant.</p> <p style="text-align: center;"><del>ALL REFERENCES CONSIDERED EXCEPT WHERE LINED THROUGH.</del> /M.F/</p>	

T1 - Place a check mark in this area when an English language Translation is attached.

PTO/SB/08 Equivalent

<b>INFORMATION DISCLOSURE STATEMENT BY APPLICANT</b>	Application No.	16/226249
	Filing Date	December 19, 2018
	First Named Inventor	Ammar Al-Ali
	Art Unit	3791
<i>(Multiple sheets used when necessary)</i>	Examiner	Fardanesh, Marjan
SHEET 7 OF 12	Attorney Docket No.	MAS.1007C1

U.S. PATENT DOCUMENTS					
Examiner Initials	Cite No.	Document Number Number - Kind Code (if known) Example: 1,234,567 B1	Publication Date MM-DD-YYYY	Name	Pages, Columns, Lines Where Relevant Passages or Relevant Figures Appear
	175	RE47,244	2/19/2019	Kiani et al.	
	176	RE47,249	2/19/2019	Kiani et al.	
	177	RE47,353	4/16/2019	Kiani et al.	
	178	2004/0054290	3/18/2004	Chance	
	179	2004/0114783	6/17/2004	Spycher et al.	
	180	2006/0161054	7/20/2006	Reuss et al.	
	181	2011/0004106	1/6/2011	Iwamiya et al.	
	182	2011/0085721	4/14/2011	Guyon et al.	
	183	2016/0166182	6/16/2016	Al-Ali et al.	
	184	2016/0166183	6/16/2016	Poeze et al.	
	185	2016/0196388	7/7/2016	Lamego	
	186	2016/0197436	7/7/2016	Barker et al.	
	187	2016/0213281	7/28/2016	Eckerbom, et al.	
	188	2016/0228043	8/11/2016	O'Neil et al.	
	189	2016/0233632	8/11/2016	Scruggs et al.	
	190	2016/0234944	8/11/2016	Schmidt et al.	
	191	2016/0270735	9/22/2016	Diab et al.	
	192	2016/0283665	9/29/2016	Sampath et al.	
	193	2016/0287090	10/6/2016	Al-Ali et al.	
	194	2016/0287786	10/6/2016	Kiani	
	195	2016/0296169	10/13/2016	McHale et al.	
	196	2016/0310052	10/27/2016	Al-Ali et al.	
	197	2016/0314260	10/27/2016	Kiani	
	198	2016/0324488	11/10/2016	Olsen	
	199	2016/0327984	11/10/2016	Al-Ali et al.	
	200	2016/0331332	11/17/2016	Al-Ali	
	201	2016/0367173	12/22/2016	Dalvi et al.	
	202	2017/0000394	1/5/2017	Al-Ali et al.	
	203	2017/0007134	1/12/2017	Al-Ali et al.	

Examiner Signature	<u>/MARJAN FARDANESH/</u>	Date Considered	07/19/2019
<p><b>*Examiner:</b> Initial if reference considered, whether or not citation is in conformance with MPEP 609. Draw line through citation if not in conformance and not considered. Include copy of this form with next communication to applicant.</p>			

~~ALL REFERENCES CONSIDERED EXCEPT WHERE LINED THROUGH. /M.F/~~

T<sup>1</sup> - Place a check mark in this area when an English language Translation is attached.

PTO/SB/08 Equivalent

<b>INFORMATION DISCLOSURE STATEMENT BY APPLICANT</b>	Application No.	16/226249
	Filing Date	December 19, 2018
	First Named Inventor	Ammar Al-Ali
	Art Unit	3791
<i>(Multiple sheets used when necessary)</i>	Examiner	Fardanesh, Marjan
SHEET 8 OF 12	Attorney Docket No.	MAS.1007C1

U.S. PATENT DOCUMENTS					
Examiner Initials	Cite No.	Document Number <i>Number - Kind Code (if known)</i> Example: 1,234,567 B1	Publication Date MM-DD-YYYY	Name	Pages, Columns, Lines Where Relevant Passages or Relevant Figures Appear
	204	2017/0007198	1/12/2017	Al-Ali et al.	
	205	2017/0014083	1/19/2017	Diab et al.	
	206	2017/0014084	1/19/2017	Al-Ali et al.	
	207	2017/0024748	1/26/2017	Haider	
	208	2017/0042488	2/16/2017	Muhsin	
	209	2017/0055851	3/2/2017	Al-Ali	
	210	2017/0055882	3/2/2017	Al-Ali et al.	
	211	2017/0055887	3/2/2017	Al-Ali	
	212	2017/0055896	3/2/2017	Al-Ali et al.	
	213	2017/0079594	3/23/2017	Telfort et al.	
	214	2017/0086723	3/30/2017	Al-Ali et al.	
	215	2017/0143281	5/25/2017	Olsen	
	216	2017/0147774	5/25/2017	Kiani	
	217	2017/0156620	6/8/2017	Al-Ali et al.	
	218	2017/0173632	6/22/2017	Al-Ali	
	219	2017/0187146	6/29/2017	Kiani et al.	
	220	2017/0188919	7/6/2017	Al-Ali et al.	
	221	2017/0196464	7/13/2017	Jansen et al.	
	222	2017/0196470	7/13/2017	Lamego et al.	
	223	2017/0224262	8/10/2017	Al-Ali	
	224	2017/0228516	8/10/2017	Sampath et al.	
	225	2017/0245790	8/31/2017	Al-Ali et al.	
	226	2017/0251974	9/7/2017	Shreim et al.	
	227	2017/0251975	9/7/2017	Shreim et al.	
	228	2017/0258403	9/14/2017	Abdul-Hafiz et al.	
	229	2017/0311851	11/2/2017	Schurman et al.	
	230	2017/0311891	11/2/2017	Kiani et al.	
	231	2017/0325728	11/16/2017	Al-Ali et al.	
	232	2017/0332976	11/23/2017	Al-Ali et al.	

Examiner Signature <u>/MARJAN FARDANESH/</u>	Date Considered <u>07/19/2019</u>
<p><b>*Examiner:</b> Initial if reference considered, whether or not citation is in conformance with MPEP 609. Draw line through citation if not in conformance and not considered. Include copy of this form with next communication to applicant.</p> <p style="text-align: center;"><del>ALL REFERENCES CONSIDERED EXCEPT WHERE LINED THROUGH. /M.F/</del></p>	

T1 - Place a check mark in this area when an English language Translation is attached.

PTO/SB/08 Equivalent

<b>INFORMATION DISCLOSURE STATEMENT BY APPLICANT</b>	Application No.	16/226249
	Filing Date	December 19, 2018
	First Named Inventor	Ammar Al-Ali
	Art Unit	3791
<i>(Multiple sheets used when necessary)</i>	Examiner	Fardanesh, Marjan
SHEET 9 OF 12	Attorney Docket No.	MAS.1007C1

U.S. PATENT DOCUMENTS					
Examiner Initials	Cite No.	Document Number Number - Kind Code (if known) Example: 1,234,567 B1	Publication Date MM-DD-YYYY	Name	Pages, Columns, Lines Where Relevant Passages or Relevant Figures Appear
	233	2017/0340293	11/30/2017	Al-Ali et al.	
	234	2017/0360310	12/21/2017	Kiani et al.	
	235	2017/0367632	12/28/2017	Al-Ali et al.	
	236	2018/0008146	1/11/2018	Al-Ali et al.	
	237	2018/0013562	1/11/2018	Haider et al.	
	238	2018/0014752	1/18/2018	Al-Ali et al.	
	239	2018/0028124	2/1/2018	Al-Ali et al.	
	240	2018/0055385	3/1/2018	Al-Ali	
	241	2018/0055390	3/1/2018	Kiani et al.	
	242	2018/0055430	3/1/2018	Diab et al.	
	243	2018/0064381	3/8/2018	Shakespeare et al.	
	244	2018/0069776	3/8/2018	Lamego et al.	
	245	2018/0070867	3/15/2018	Smith et al.	
	246	2018/0082767	3/22/2018	Al-Ali et al.	
	247	2018/0085068	3/29/2018	Telfort	
	248	2018/0087937	3/29/2018	Al-Ali et al.	
	249	2018/0103874	4/19/2018	Lee et al.	
	250	2018/0103905	4/19/2018	Kiani	
	251	2018/0110478	4/26/2018	Al-Ali	
	252	2018/0116575	5/3/2018	Perea et al.	
	253	2018/0125368	5/10/2018	Lamego et al.	
	254	2018/0125430	5/10/2018	Al-Ali et al.	
	255	2018/0125445	5/10/2018	Telfort et al.	
	256	2018/0130325	5/10/2018	Kiani et al.	
	257	2018/0132769	5/17/2018	Weber et al.	
	258	2018/0132770	5/17/2018	Lamego	
	259	2018/0146901	5/31/2018	Al-Ali et al.	
	260	2018/0146902	5/31/2018	Kiani et al.	
	261	2018/0153442	6/7/2018	Eckerbom, et al.	

Examiner Signature /MARJAN FARDANESH/	Date Considered 07/19/2019
<p><b>*Examiner:</b> Initial if reference considered, whether or not citation is in conformance with MPEP 609. Draw line through citation if not in conformance and not considered. Include copy of this form with next communication to applicant.</p>	

~~ALL REFERENCES CONSIDERED EXCEPT WHERE LINED THROUGH. /M.F/~~

T1 - Place a check mark in this area when an English language Translation is attached.



PTO/SB/08 Equivalent

<b>INFORMATION DISCLOSURE STATEMENT BY APPLICANT</b>	Application No.	16/226249
	Filing Date	December 19, 2018
	First Named Inventor	Ammar Al-Ali
	Art Unit	3791
(Multiple sheets used when necessary)	Examiner	Fardanesh, Marjan
SHEET 10 OF 12	Attorney Docket No.	MAS.1007C1

U.S. PATENT DOCUMENTS					
Examiner Initials	Cite No.	Document Number Number - Kind Code (if known) Example: 1,234,567 B1	Publication Date MM-DD-YYYY	Name	Pages, Columns, Lines Where Relevant Passages or Relevant Figures Appear
	262	2018/0153446	6/7/2018	Kiani	
	263	2018/0153447	6/7/2018	Al-Ali et al.	
	264	2018/0153448	6/7/2018	Weber et al.	
	265	2018/0161499	6/14/2018	Al-Ali et al.	
	266	2018/0168491	6/21/2018	Al-Ali et al.	
	267	2018/0174679	6/21/2018	Sampath et al.	
	268	2018/0174680	6/21/2018	Sampath et al.	
	269	2018/0182484	6/28/2018	Sampath et al.	
	270	2018/0184917	7/5/2018	Kiani	
	271	2018/0192924	7/12/2018	Al-Ali	
	272	2018/0192953	7/12/2018	Shreim et al.	
	273	2018/0192955	7/12/2018	Al-Ali et al.	
	274	2018/0199871	7/19/2018	Pauley et al.	
	275	2018/0206795	7/26/2018	Al-Ali	
	276	2018/0206815	7/26/2018	Telfort	
	277	2018/0213583	7/26/2018	Al-Ali	
	278	2018/0214031	8/2/2018	Kiani et al.	
	279	2018/0214090	8/2/2018	Al-Ali et al.	
	280	2018/0218792	8/2/2018	Muhsin et al.	
	281	2018/0225960	8/9/2018	Al-Ali et al.	
	282	2018/0238718	8/23/2018	Dalvi	
	283	2018/0242853	8/30/2018	Al-Ali	
	284	2018/0242921	8/30/2018	Muhsin et al.	
	285	2018/0242923	8/30/2018	Al-Ali et al.	
	286	2018/0242924	8/30/2018	Barker et al.	
	287	2018/0242926	8/30/2018	Muhsin et al.	
	288	2018/0247353	8/30/2018	Al-Ali et al.	
	289	2018/0247712	8/30/2018	Muhsin et al.	
	290	2018/0249933	9/6/2018	Schurman, et al.	

Examiner Signature /MARJAN FARDANESH/	Date Considered 07/19/2019
<p><b>*Examiner:</b> Initial if reference considered, whether or not citation is in conformance with MPEP 609. Draw line through citation if not in conformance and not considered. Include copy of this form with next communication to applicant.</p> <p style="text-align: center;"><del>ALL REFERENCES CONSIDERED EXCEPT WHERE LINED THROUGH.</del> /M.F/</p>	

T1 - Place a check mark in this area when an English language Translation is attached.

PTO/SB/08 Equivalent

<b>INFORMATION DISCLOSURE STATEMENT BY APPLICANT</b>	Application No.	16/226249
	Filing Date	December 19, 2018
	First Named Inventor	Ammar Al-Ali
	Art Unit	3791
(Multiple sheets used when necessary)	Examiner	Fardanesh, Marjan
SHEET 11 OF 12	Attorney Docket No.	MAS.1007C1

U.S. PATENT DOCUMENTS					
Examiner Initials	Cite No.	Document Number Number - Kind Code (if known) Example: 1,234,567 B1	Publication Date MM-DD-YYYY	Name	Pages, Columns, Lines Where Relevant Passages or Relevant Figures Appear
	291	2018/0253947	9/6/2018	Muhsin et al.	
	292	2018/0256087	9/13/2018	Al-Ali et al.	
	293	2018/0256113	9/13/2018	Weber et al.	
	294	2018/0285094	10/4/2018	Housel et al.	
	295	2018/0289325	10/11/2018	Poeze et al.	
	296	2018/0289337	10/11/2018	Al-Ali et al.	
	297	2018/0296161	10/18/2018	Shreim et al.	
	298	2018/0300919	10/18/2018	Muhsin et al.	
	299	2018/0310822	11/1/2018	Indorf et al.	
	300	2018/0310823	11/1/2018	Al-Ali et al.	
	301	2018/0317826	11/8/2018	Muhsin	
	302	2018/0317841	11/8/2018	Novak, Jr.	
	303	2018/0333055	11/22/2018	Lamego et al.	
	304	2018/0333087	11/22/2019	Al-Ali	
	305	2019/0000317	1/3/2019	Muhsin et al.	
	306	2019/0000362	1/3/2019	Kiani et al.	
	307	2019/0015023	1/17/2019	Monfre	
	308	2019/0021638	1/24/2019	Al-Ali et al.	
	309	2019/0029574	1/31/2019	Schurman et al.	
	310	2019/0029578	1/31/2019	Al-Ali et al.	
	311	2019/0038143	2/7/2019	Al-Ali	
	312	2019/0058280	2/21/2019	Al-Ali et al.	
	313	2019/0058281	2/21/2019	Al-Ali et al.	
	314	2019/0069813	3/7/2019	Al-Ali	
	315	2019/0069814	3/7/2019	Al-Ali	
	316	2019/0076028	3/14/2019	Al-Ali et al.	
	317	2019/0082979	3/21/2019	Al-Ali et al.	
	318	2019/0090748	3/28/2019	Al-Ali	
	319	2019/0090760	3/28/2019	Kinast et al.	

Examiner Signature /MARJAN FARDANESH/	Date Considered 07/19/2019
<p><b>*Examiner:</b> Initial if reference considered, whether or not citation is in conformance with MPEP 609. Draw line through citation if not in conformance and not considered. Include copy of this form with next communication to applicant.</p> <p style="text-align: center;"><del>ALL REFERENCES CONSIDERED EXCEPT WHERE LINED THROUGH.</del> /M.F/</p>	

T<sup>1</sup> - Place a check mark in this area when an English language Translation is attached.

PTO/SB/08 Equivalent

<b>INFORMATION DISCLOSURE STATEMENT BY APPLICANT</b>	Application No.	16/226249
	Filing Date	December 19, 2018
	First Named Inventor	Ammar Al-Ali
	Art Unit	3791
(Multiple sheets used when necessary)	Examiner	Fardanesh, Marjan
SHEET 12 OF 12	Attorney Docket No.	MAS.1007C1

**U.S. PATENT DOCUMENTS**

Examiner Initials	Cite No.	Document Number Number - Kind Code (if known) Example: 1,234,567 B1	Publication Date MM-DD-YYYY	Name	Pages, Columns, Lines Where Relevant Passages or Relevant Figures Appear
	320	2019/0090764	3/28/2019	Al-Ali	
	321	2019/0104973	04-11.2019	Poeze et al.	
	322	2019/0110719	4/18/2019	Poeze et al.	
	323	2019/0117070	4/25/2019	Muhsin et al.	
	324	2019/0117139	4/25/2019	Al-Ali et al.	
	325	2019/0117140	4/25/2019	Al-Ali et al.	
	326	2019/0117141	4/25/2019	Al-Ali	
	327	2019/0117930	4/25/2019	Al-Ali	
	328	2019/0122763	4/25/2019	Sampath et al.	
	329	2019/0133525	5/9/2019	Al-Ali et al.	
	330	2019/0142283	5/16/2019	Lamego et al.	
	331	2019/0142344	5/16/2019	Telfort et al.	
	332	2019/0150800	5/23/2019	Poeze et al.	
	333	2019/0150856	5/23/2019	Kiani et al.	
	334	2019/0167161	6/6/2019	Al-Ali et al.	
	335	2019/0175019	6/13/2019	Al-Ali et al.	
	336	2019/0192076	6/27/2010	McHale et al.	

**FOREIGN PATENT DOCUMENTS**

Examiner Initials	Cite No.	Foreign Patent Document Country Code-Number-Kind Code Example: JP 1234567 A1	Publication Date MM-DD-YYYY	Name	Pages, Columns, Lines Where Relevant Passages or Relevant Figures Appear	T <sup>1</sup>
-------------------	----------	---	--------------------------------	------	--	----------------

**NON PATENT LITERATURE DOCUMENTS**

Examiner Initials	Cite No.	Include name of the author (in CAPITAL LETTERS), title of the article (when appropriate), title of the item (book, magazine, journal, serial, symposium, catalog, etc.), date, page(s), volume-issue number(s), publisher, city and/or country where published.	T <sup>1</sup>
-------------------	----------	---	----------------

30950940

Examiner Signature	/MARJAN FARDANESH/	Date Considered	07/19/2019
--------------------	--------------------	-----------------	------------

**\*Examiner:** Initial if reference considered, whether or not citation is in conformance with MPEP 609. Draw line through citation if not in conformance and not considered. Include copy of this form with next communication to applicant.

~~ALL REFERENCES CONSIDERED EXCEPT WHERE LINED THROUGH. /M.F/~~  
 T<sup>1</sup> - Place a check mark in this area when an English language Translation is attached.

## EAST Search History

## EAST Search History (Prior Art)

Ref #	Hits	Search Query	DBs	Default Operator	Plurals	Time Stamp
L1	1	"15711123" and band	US-PGPUB; USPAT	OR	OFF	2019/07/19 10:06
L2	1	"15711123" and sensor	US-PGPUB; USPAT	OR	OFF	2019/07/19 10:27
L3	0	("2018/0008199").URPN.	USPAT	OR	OFF	2019/07/19 10:33
L4	1	"14108012"	USPAT	OR	OFF	2019/07/19 10:34
L5	13	("20040220485"   "20050049474"   "20100033303"   "20110112793"   "20120179067"   "20120247179"   "20130324860"   "5517987"   "6519487"   "6699199"   "7324841"   "8250796"   "8263986").PN. OR ("10292654").URPN.	US-PGPUB; USPAT; USOCR	OR	OFF	2019/07/19 10:34
L6	45	("3954100"   "4729377"   "5450845"   "5624736"   "5947897"   "6263226"   "6381482").PN. OR ("7324841").URPN.	US-PGPUB; USPAT; USOCR	OR	OFF	2019/07/19 10:38
L7	7	("2011/0112793").URPN.	USPAT	OR	OFF	2019/07/19 10:39
L8	123	("20010027282"   "20040054291"   "20040122302"   "20040221370"   "20040267104"   "20050059869"   "20050070776"   "20050197556"   "20050197579"   "20050283082"   "20060020179"   "20060058690"   "20060074283"   "20060085891"   "20060089547"   "20060189871"   "20060195028"   "20060211922"   "20060211923"   "20060211924"   "20060229509"   "20060241363"   "20060264722"   "20060264723"   "20060264724"   "20060264725"   "20060264726"   "20060264727"   "20060281984"   "20070038050"   "20070073125"   "20070078309"   "20070078311"   "20070083094"   "20070106134"   "20070142717"   "20080216211"   "20080220633"   "20080221463"   "20090171177"   "20100076276"   "20100076282"   "20100081900"   "20100081904"   "20100186211"   "20100186749"   "20100206323"   "20100234706"   "20100249551"   "20100249553"   "20100249554"   "20100249557"   "20100261995"   "20100261996"   "20100298678"   "20100327063"	US-PGPUB; USPAT; USOCR	OR	OFF	2019/07/19 10:41

		"20100331631"   "20110041232"   "20110046464"   "20110077483"   "20110112379"   "20110213226"   "20120071742"   "20120216335"   "20120248985"   "20120253148"   "20120253152"   "20120253159"   "2549836"   "4510938"   "4681413"   "5099842"   "5295490"   "5817008"   "5919133"   "5950245"   "6115621"   "6171258"   "6343223"   "6525386"   "6671531"   "6748254"   "7006855"   "7047055"   "7047056"   "7067893"   "7096052"   "7190986"   "7190987"   "7289837"   "7296305"   "7324841"   "7359741"   "7377794"   "7440788"   "7483731"   "7574245"   "7657294"   "7698909"   "7721349"   "7809420"   "7810359").PN. OR ("7813779"   "7822453"   "7877126"   "7877127"   "7880884"   "7904130"   "7979102"   "8071935"   "8257274"   "8346328"   "8352004"   "8364220").PN. OR ("8852095").URPN.				
L9	11	("2010/0249557").URPN.	USPAT	OR	OFF	2019/07/19 10:47
L18	687	("20010000790"   "20010009398"   "20020013538"   "20020042558"   "20020052539"   "20020084904"   "20020091335"   "20020095092"   "20020103445"   "20020109600"   "20020124295"   "20020139368"   "20020148470"   "20020151929"   "20020156354"   "20020161309"   "20020173706"   "20020173708"   "20030004547"   "20030009119"   "20030009308"   "20030018243"   "20030023140"   "20030036685"   "20030065275"   "20030086156"   "20030120183"   "20030122706"   "20030125616"   "20030135127"   "20030144579"   "20030156288"   "20030176810"   "20030189492"   "20030216728"   "20030225323"   "20040002655"   "20040007585"   "20040030258"   "20040044545"   "20040054287"   "20040054291"   "20040064097"   "20040064165"   "20040082842"   "20040092919"   "20040100784"   "20040102931"   "20040116822"   "20040117891"   "20040144391"   "20040147974"   "20040149282"   "20040163648"   "20040173456"   "20040221370"   "20040230116"   "20040231772"   "20040236207"   "20040236242"   "20040242981"   "20040254490"   "20040254501"   "20040267145"   "20050001728"   "20050020919"   "20050027207"   "20050029432"   "20050041531"   "20050043599"   "20050043763"   "20050049465"   "20050049501"   "20050059869"   "20050070776"   "20050070778"   "20050075550"   "20050080345"	US- PGPUB; USPAT; USOCR	OR	OFF	2019/07/19 10:48

"20050085799"	"20050090754"
"20050096557"	"20050101845"
"20050102167"	"20050113650"
"20050113656"	"20050113703"
"20050114154"	"20050171576"
"20050177063"	"20050182458"
"20050188991"	"20050190068"
"20050197548").PN. OR ("20050206518"	
"20050215847"   "20050215880"	
"20050215947"   "20050216064"	
"20050216199"   "20050222522"	
"20050228234"   "20050228297"	
"20050228299"   "20050231686"	
"20050234312"   "20050234317"	
"20050234518"   "20050240087"	
"20050256523"   "20050261594"	
"20050268916"   "20050277819"	
"20050280531"   "20050283082"	
"20060009685"   "20060009698"	
"20060020181"   "20060030049"	
"20060030767"   "20060036137"	
"20060036179"   "20060047447"	
"20060058593"   "20060058690"	
"20060064133"   "20060064134"	
"20060064142"   "20060064143"	
"20060074283"   "20060074324"	
"20060084848"   "20060084852"	
"20060085227"   "20060095032"	
"20060100496"   "20060100530"	
"20060100618"   "20060122517"	
"20060122520"   "20060124128"	
"20060125623"   "20060132382"	
"20060133362"   "20060142640"	
"20060149132"   "20060149339"	
"20060167351"   "20060173247"	
"20060183980"   "20060184051"	
"20060189859"   "20060195026"	
"20060195027"   "20060195028"	
"20060211929"   "20060211942"	
"20060217604"   "20060217605"	
"20060217606"   "20060217607"	
"20060217608"   "20060224040"	
"20060224326"   "20060224421"	
"20060229510"   "20060229511"	
"20060241358"   "20060241384"	
"20060241510"   "20060247504"	
"20060253010"   "20060253953"	
"20060258922"   "20060264722"	
"20060264723"   "20060264724"	
"20060264725"   "20060264726"	
"20060264727"   "20060264771"	
"20060276700"   "20060276701"	
"20060281984"   "20070032732"	
"20070060808"   "20070073117").PN. OR	
("20070073121"   "20070073123"	
"20070073126"   "20070078316"	
"20070100218"   "20070100219"	
"20070149871"   "20070208233"	
"20070260129"   "20070293746"	
"20080009691"   "20080076988"	
"20080076990"   "20080081967"	
"20080139908"   "20080143080"	
"20080146890"   "20080165017"	
"20080177163"   "20080221413"	

"20080221414"	"20080228053"	
"20080230363"	"4025733"	"4047400"
"4462116"	"4499741"	"4510938"
"4570638"	"4675919"	"4739757"
"4775116"	"4784162"	"4802485"
"4825872"	"4825879"	"4833734"
"4838279"	"4856116"	"4890619"
"4910804"	"4918758"	"4930888"
"4942877"	"4972331"	"4977011"
"4991234"	"4996975"	"5005374"
"5054488"	"5080096"	"5080098"
"5111817"	"5119815"	"5122974"
"5125403"	"5167230"	"5188108"
"5191891"	"5209230"	"5214409"
"5217012"	"5217013"	"5241300"
"5246003"	"5253645"	"5267563"
"5267567"	"5295490"	"5313940"
"5337744"	"5348008"	"5353798"
"5354979"	"5357953"	"5368025"
"5368562"	"5383874"	"5392777"
"5398689"	"5400267"	"5405269"
"5405614"	"5413099"	"5413101"
"5413102"	"5415166"	"5425360"
"5431170"	"5437275"	"5437634"
"5444254"	"5451763"	"5452717"
"5465714"	"5469845"	"5482034"
"5490523"	"5528519"	"5546955"
"5551423"	"5562718"	"5564108"
"5564417"	"5584296"	"5592408"
"5596987"	"5617865"	"5617866"
"5627323"	"5634466"	"5638593"
"5638818"	"5640953"	"5645440"
"5645586"	"5646416")	.PN. OR
("5671750"	"5673708"	"5678544"
"5681285"	"5683434"	"5697363"
"5697367"	"5701894"	"5706820"
"5732475"	"5738612"	"5743856"
"5743857"	"5752913"	"5752920"
"5758644"	"5772601"	"5776058"
"5776071"	"5779631"	"5779639"
"5782757"	"5786592"	"5791347"
"5791348"	"5792052"	"5792058"
"5797841"	"5810724"	"5813980"
"5823012"	"5823952"	"5826277"
"5830136"	"5830137"	"5830148"
"5830149"	"5833602"	"5836887"
"5839439"	"5842981"	"5842982"
"5851179"	"5857974"	"5860932"
"5860957"	"5868133"	"5870626"
"5872713"	"5873821"	"5879294"
"5891021"	"5891026"	"5895359"
"5902235"	"5906581"	"5913819"
"5916154"	"5919133"	"5931790"
"5931791"	"5934925"	"5936539"
"5947905"	"5954053"	"5957850"
"5964701"	"5980464"	"5983129"
"5987343"	"5987351"	"5991648"
"5995077"	"5995855"	"5995856"
"5995857"	"6007492"	"6011986"
"6022320"	"6027453"	"6030351"
"6031603"	"6036651"	"6041247"
"6047201"	"6047203"	"6049958"
"6050951"	"6052619"	"6073038"
"6084380"	"6085752"	"6088607"

"6106780"	"6112107"	"6115621"
"6118382"	"6126614"	"6134459"
"6144868"	"6149481"	"6152754"
"6154667"	"6162188"	"6165173"
"6171258"	"6173196"	"6179786"
"6181959"	"6184521"	"6186953"
"6186954"	"6190325"	"6196974"
"6198952"	"6199550"	"6209144"
"6216021"	"6223063"	"6241680"
"6248083"	"6251076"	"6251080"
"6251081"	"6251113").PN. OR	
("6256523"	"6256524"	"6263221"
"6263223"	"6280213"	"6282450"
"6283922"	"6285895"	"6306076"
"6308089"	"6321100"	"6322516"
"6343223"	"6343224"	"6346886"
"6349228"	"6356774"	"6362622"
"6368282"	"6370411"	"6377829"
"6381480"	"6381481"	"6385486"
"6385821"	"6387092"	"6388240"
"6397091"	"6405075"	"6416471"
"6416474"	"6417774"	"6423010"
"6430423"	"6432050"	"6450168"
"6450957"	"6450981"	"6454708"
"6461305"	"6463310"	"6466809"
"6468241"	"6470199"	"6470279"
"6480762"	"6491638"	"6491639"
"6503087"	"6503204"	"6505061"
"6511478"	"6516289"	"6519487"
"6524257"	"6525386"	"6526309"
"6526970"	"6527725"	"6527726"
"6535765"	"6537220"	"6541756"
"6542081"	"6547742"	"6547743"
"6551252"	"6553242"	"6575902"
"6575904"	"6580086"	"6582371"
"6582374"	"6584356"	"6589171"
"6589183"	"6589189"	"6594513"
"6597933"	"6605038"	"6606993"
"6611793"	"6615065"	"6622034"
"6635048"	"6640116"	"6645154"
"6645155"	"6653557"	"6654622"
"6662033"	"6666860"	"6671531"
"6671545"	"6678543"	"6681454"
"6684091"	"6694160"	"6695806"
"6700497"	"6704601"	"6708048"
"6711425"	"6712767"	"6721585"
"6721602"	"6725075"	"6726327"
"6731963"	"6735459"	"6736759"
"6736786"	"6743173"	"6743202"
"6745061"	"6748254"	"6748262"
"6749567"	"6755789"	"6758808"
"6763255"	"6767330"	"6771994"
"6776758"	"6779257").PN. OR	
("6785568"	"6792300"	"6796946"
"6801799"	"6804543"	"6804558"
"6808496"	"6811538"	"6813511"
"6816741"	"6824520"	"6827688"
"6829003"	"6830711"	"6832987"
"6842722"	"6847294"	"6849074"
"6853304"	"6870479"	"6875176"
"6877511"	"6893400"	"6898299"
"6899682"	"6899684"	"6904124"
"6907284"	"6909912"	"6911027"
"6915167"	"6920345"	"6921198"



		"6923771"   "6923776"   "6930608"   "6934570"   "6934571"   "6936011"   "6938488"   "6939314"   "6943881"   "6944498"   "6952870"   "6955650"   "6965071"   "6971790"   "6979329"   "6985763"   "6985764"   "6990371"   "6993371"   "6995665"   "7001334"   "7017420"   "7018338"   "7019392"   "7020508"   "7024235"   "7027850"   "7027871"   "7033316"   "7039449"   "7041121"   "7047054"   "7047055"   "7047056"   "7048687"   "7052509"   "7054453"   "7054454"   "7063669"   "7067893"   "7072704"   "7079036"   "7081128"   "7085597"   "7087023"   "7089061"   "7096052"   "7096054"   "7097621"   "7107706"   "7108659"   "7112196"   "7113815"   "7122005"   "7125383"   "7127278"   "7132641"   "7136452"   "7158822"   "7160284"   "7161484"   "7164938"   "7167743"   "7171251"   "7179228"   "7181264"   "7181505"   "7190987"   "7192403"   "7197357"   "7198605"   "7204250"   "7214191"   "7218232"   "7220220"   "7222624"   "7224282"   "7225007"   "7229400"   "7245953"   "7248905"   "7248910"   "7254444"   "7255475"   "7257448"   "7263393"   "7270636"   "7280858"   "7289837"   "7297119"   "7303680"   "7313427").PN. OR ("7349726"   "7376454"   "7413305"   "7415298"   "H001039"   "RE36000"   "RE39359").PN. OR ("8257274").URPN.				
L19	269	("4885571"   "5204670"   "5455851"   "5493805"   "5504474"   "5525969"   "5532705"   "5742233"   "5877675"   "5883576"   "5936529"   "6104295"   "6140936"   "6255951").PN. OR ("6346886").URPN.	US- PGPUB; USPAT; USOCR	OR	OFF	2019/07/19 11:04
L20	239	(fiber conduit guide pipe) and (clock watch wristwatch wrist adj watch) and winakur.xp.	US- PGPUB; USPAT; USOCR	OR	OFF	2019/07/19 11:05
L21	57	("1275769"   "2227131"   "2558007"   "2895658"   "3712049"   "4185621"   "4280506"   "4295472"   "4865038"   "4879702"   "4896676"   "5504474"   "5766131"   "5807267"   "5823409"   "5833602"   "5848030"   "RE24502").PN. OR ("6529754").URPN.	US- PGPUB; USPAT; USOCR	OR	OFF	2019/07/19 11:09
L22	5	("20090118622"   "20090287076"   "20100030480"   "7225005").PN. OR ("9763607").URPN.	US- PGPUB; USPAT; USOCR	OR	OFF	2019/07/19 11:16
L23	10	("20050054907"   "20060253010"   "20080004510"   "20140128691"   "20140200423"   "20140332675"   "20140339428"   "20150157261"   "5825488"   "7299080").PN. OR ("9993201").URPN.	US- PGPUB; USPAT; USOCR	OR	OFF	2019/07/19 11:19
L24	24	("20030212316"   "20110098583"	US-	OR	OFF	2019/07/19

		"20120108928"   "20120293410"   "20130064552"   "20130183042"   "20130195273"   "20130274565"   "20130305053"   "20130338470"   "20140131549"   "20140159912"   "20140213863"   "20140243612"   "20140266787"   "20140275871"   "20140275874"   "20140288390"   "5846190"   "6126595"   "7810504"   "8547036"   "8579827"   "8779349").PN. OR ("10076254").URPN.	PGPUB; USPAT; USOCR			11:21
L25	43	("2008/0004510").URPN.	USPAT	OR	OFF	2019/07/19 13:06
S1	9	((("7809441") or ("9364662") or ("20070270675") or ("20090076353") or ("20130131765") or ("20140018644") or ("20140266776") or ("20140316482") or ("20160038743") or ("20160038743")).PN.	US- PGPUB; USPAT; USOCR	OR	OFF	2019/06/12 13:26
S2	1	("2014/0018644").URPN.	USPAT	OR	OFF	2019/06/12 13:27
S3	5	fluorescen\$4 and palti.in. and A61B5/\$.cpc.	US- PGPUB; USPAT	OR	OFF	2019/06/12 13:37
S4	44	palti.in. and A61B5/\$.cpc.	US- PGPUB; USPAT	OR	OFF	2019/06/12 13:37
S5	87	IAS and A61B5/\$.cpc.	US- PGPUB; USPAT	OR	OFF	2019/06/12 13:38
S6	0	"15676847"	US- PGPUB; USPAT	OR	OFF	2019/06/12 15:13
S7	2	((("20020026108") or ("20080146890")).PN.	US- PGPUB; USPAT; USOCR	OR	OFF	2019/06/12 15:51
S8	218	semiconductor with ceramic and A61B5/\$.cpc.	US- PGPUB; USPAT	OR	OFF	2019/06/12 15:56
S9	86	semiconductor with ceramic with substrate and A61B5/\$.cpc.	US- PGPUB; USPAT	OR	OFF	2019/06/12 16:01
S10	1	("20030208113").PN.	US- PGPUB; USPAT; USOCR	OR	OFF	2019/06/12 16:09
S11	1	"15663107"	US- PGPUB; USPAT	OR	OFF	2019/06/13 12:49
S12	1253	threshold with (hyperglycemia hypoglycemia) and A61B5/\$.cpc.	US- PGPUB; USPAT	OR	ON	2019/06/13 14:29
S13	69	threshold with (hyperglycemia hypoglycemia) with compar\$5 and A61B5/\$.cpc.	US- PGPUB; USPAT	OR	ON	2019/06/13 14:29
S14	16	scalar with (activity acceleration) with threshold and A61B5/\$.cpc.	US- PGPUB;	OR	ON	2019/06/14 11:53

			USPAT			
S15	2	"15697311"	US-PGPUB; USPAT	OR	ON	2019/06/17 12:06
S16	16	((("VERIFOOD") near3 ("LTD"))).AS,AANM.	USPAT	OR	OFF	2019/06/17 14:15
S17	42	((("GOLDRING") near3 ("Damian"))).INV.	US-PGPUB; USPAT; USOCR	OR	OFF	2019/06/17 14:15
S18	49	((("VERIFOOD") near3 ("LTD"))).AS,AANM.	US-PGPUB; USPAT	OR	OFF	2019/06/17 14:15
S19	1	((("VERIFOOD") near3 ("LTD"))).AS,AANM. and catheter	US-PGPUB; USPAT	OR	OFF	2019/06/17 14:20
S20	42	((("VERIFOOD") near3 ("LTD"))).AS,AANM. and block\$4	US-PGPUB; USPAT	OR	OFF	2019/06/17 14:23
S21	81	("0679577"   "20020039186"   "20020131047"   "20020163641"   "20020191127"   "20040019462"   "20040136577"   "20050151975"   "20050196046"   "20060086901"   "20060124656"   "20060146315"   "20070230932"   "20080061236"   "20080073510"   "20080137328"   "20080204578"   "20080277625"   "20090201577"   "20100085537"   "20100110442"   "20100128370"   "20100134794"   "20100191493"   "20100201979"   "20100271352"   "20100284005"   "20100309454"   "20110255745"   "20110261252"   "20110318717"   "20120018829"   "20120019819"   "20120053426"   "20120088486"   "20130021611"   "20130155402"   "20140052555"   "20140293091"   "20140320858"   "20150036138"   "20150055132"   "20150204833"   "20150292948"   "20150300879"   "20150369725"   "20160033328"   "5469252"   "6031233"   "6031619"   "6212312"   "6483583"   "7236243"   "7262839"   "7286233"   "7414724"   "7420663"   "7433042"   "7528957"   "7535617"   "7667740"   "7805319"   "7897923"   "7986193"   "8060383"   "8149415"   "8269174"   "8274739"   "8284401"   "8330945"   "8462420"   "8542359"   "8665440"   "9060113"   "9291504"   "9383258").PN. OR ("9562848").URPN.	US-PGPUB; USPAT; USOCR	OR	OFF	2019/06/17 14:24
S22	1485	(tube catheter) same (block\$4 actuator) and (spectroscopy spectrometer) and A61B5/\$.cpc.	US-PGPUB; USPAT; USOCR	OR	ON	2019/06/17 14:27
S23	89	(tube catheter) same (block\$4 actuator) same (spectroscopy spectrometer) and A61B5/\$.cpc.	US-PGPUB; USPAT; USOCR	OR	ON	2019/06/17 14:27

EAST Search History

S24	61	(tube catheter) same (block\$4 actuator) same (spectroscopy spectrometer) and A61B5/\$.cpc. and (fluid urine)	US-PGPUB; USPAT; USOCR	OR	ON	2019/06/17 14:28
S25	1225	(tube catheter) same (block\$4 actuator) and (spectroscopy spectrometer) and A61B5/\$.cpc. and (fluid urine)	US-PGPUB; USPAT; USOCR	OR	ON	2019/06/17 14:29
S26	637	(tube catheter) with (block\$4 actuator) and (spectroscopy spectrometer) and A61B5/\$.cpc. and (fluid urine)	US-PGPUB; USPAT; USOCR	OR	ON	2019/06/17 14:29
S27	158	(tube catheter) with (block\$4 actuator) and (spectroscopy spectrometer) and A61B5/\$.cpc. and (urine)	US-PGPUB; USPAT; USOCR	OR	ON	2019/06/17 14:33
S28	18	(("6069696") or ("6072576") or ("6333501") or ("6441375") or ("6456373") or ("6615142") or ("6639666") or ("6700661") or ("6717669") or ("6836325") or ("6864978") or ("7009702") or ("7038774") or ("7068366") or ("7075643") or ("7084974") or ("7145650") or ("7151600")).PN.	US-PGPUB; USPAT; USOCR	OR	OFF	2019/06/17 14:39
S29	2	(("7158225") or ("7235766")).PN.	US-PGPUB; USPAT; USOCR	OR	OFF	2019/06/17 14:41
S30	21	(("7245372") or ("7248370") or ("7251037") or ("7339665") or ("7426446") or ("7436511") or ("7489396") or ("7528957") or ("7649627") or ("7697136") or ("7767969") or ("7817273") or ("7868296") or ("7876435") or ("7881892") or ("7907282") or ("7929130") or ("7999933") or ("8125633") or ("8144322") or ("8169607")).PN.	US-PGPUB; USPAT; USOCR	OR	OFF	2019/06/17 14:43
S31	21	(("8169608") or ("8247774") or ("8477305") or ("8526002") or ("8593628") or ("8604412") or ("8654327") or ("8675188") or ("8711360") or ("8711362") or ("8735820") or ("8742320") or ("8760645") or ("8773659") or ("8786854") or ("8848187") or ("8862445") or ("8867033") or ("8868387") or ("8873046") or ("8937717")).PN.	US-PGPUB; USPAT; USOCR	OR	OFF	2019/06/17 14:46
S32	21	(("8976357") or ("9030662") or ("9063011") or ("9074933") or ("9128055") or ("9163986") or ("9173508") or ("9182280") or ("9234800") or ("9239264") or ("9297821") or ("9301626") or ("9310564") or ("9383308") or ("9395244") or ("9417180") or ("9448165") or ("9453794") or ("9464934") or ("9464934") or	US-PGPUB; USPAT; USOCR	OR	OFF	2019/06/17 14:48

		("9488468") or ("9488523")).PN.				
S33	19	((("9508765") or ("9518917") or ("9546902") or ("9546904") or ("9557220") or ("9568363") or ("20050117151") or ("20050128477") or ("20060132760") or ("20080265146") or ("20080297791") or ("20090051910") or ("20100165337") or ("20110037975") or ("20130107260") or ("20130182250") or ("20140046630") or ("20140046630") or ("20140168636") or ("20140333932")).PN.	US-PGPUB; USPAT; USOCR	OR	OFF	2019/06/17 14:51
S34	22	((("20150062577") or ("20160103354") or ("20150108333") or ("20150116707") or ("20150119661") or ("20150153225") or ("20150323383") or ("20160018260") or ("20160091369") or ("20160103069") or ("20160223400") or ("20160231171") or ("20160245700") or ("20160258813") or ("20160263910") or ("20160282182") or ("20160299004") or ("20160305820") or ("20160313184") or ("20160334274") or ("20160356646") or ("20160356647")).PN.	US-PGPUB; USPAT; USOCR	OR	OFF	2019/06/17 14:53
S35	2	S33 and (tube catheter)	US-PGPUB; USPAT	OR	OFF	2019/06/17 14:55
S36	0	S28 and S29 and S30 and S31 and S32 and S33 and S34	US-PGPUB; USPAT	OR	OFF	2019/06/17 14:56
S37	3	S28 and (tube catheter) and (spectroscopy spectrometer spectrograph\$4)	US-PGPUB; USPAT	OR	OFF	2019/06/17 15:03
S38	0	S29 and (tube catheter) and (spectroscopy spectrometer spectrograph\$4)	US-PGPUB; USPAT	OR	OFF	2019/06/17 15:04
S39	6	S30 and (tube catheter) and (spectroscopy spectrometer spectrograph\$4)	US-PGPUB; USPAT	OR	OFF	2019/06/17 15:04
S40	7	S31 and (tube catheter) and (spectroscopy spectrometer spectrograph\$4)	US-PGPUB; USPAT	OR	OFF	2019/06/17 15:04
S41	3	S32 and (tube catheter) and (spectroscopy spectrometer spectrograph\$4)	US-PGPUB; USPAT	OR	OFF	2019/06/17 15:04
S42	2	S33 and (tube catheter) and (spectroscopy spectrometer spectrograph\$4)	US-PGPUB; USPAT	OR	OFF	2019/06/17 15:04
S43	5	S34 and (tube catheter) and (spectroscopy spectrometer spectrograph\$4)	US-PGPUB; USPAT	OR	OFF	2019/06/17 15:04
S44	2	S28 and (tube catheter) and (spectroscopy spectrometer spectrograph\$4) and (block\$4 actuat\$4)	US-PGPUB; USPAT	OR	OFF	2019/06/17 15:08
S45	0	S29 and (tube catheter) and (spectroscopy spectrometer spectrograph\$4) and (block\$4 actuat\$4)	US-PGPUB; USPAT	OR	OFF	2019/06/17 15:13
S46	6	S30 and (tube catheter) and (spectroscopy spectrometer	US-PGPUB;	OR	OFF	2019/06/17 15:13

		spectrograph\$4) and (block\$4 actuat\$4)	USPAT			
S47	6	S31 and (tube catheter) and (spectroscopy spectrometer spectrograph\$4) and (block\$4 actuat\$4)	US-PGPUB; USPAT	OR	OFF	2019/06/17 15:14
S48	1	"15660573" and (block\$4 actuat\$4)	US-PGPUB; USPAT	OR	OFF	2019/06/17 15:16
S49	0	S31 and (tube catheter) with (blocker block\$2 actuator actuat\$2) with (urine drain fluid) and (spectroscopy spectrometer spectrograph\$4)	US-PGPUB; USPAT	OR	ON	2019/06/17 15:18
S50	0	S32 and (tube catheter) with (blocker block\$2 actuator actuat\$2) with (urine drain fluid) and (spectroscopy spectrometer spectrograph\$4)	US-PGPUB; USPAT	OR	ON	2019/06/17 15:18
S51	0	S33 and (tube catheter) with (blocker block\$2 actuator actuat\$2) with (urine drain fluid) and (spectroscopy spectrometer spectrograph\$4)	US-PGPUB; USPAT	OR	ON	2019/06/17 15:18
S52	0	S34 and (tube catheter) with (blocker block\$2 actuator actuat\$2) with (urine drain fluid) and (spectroscopy spectrometer spectrograph\$4)	US-PGPUB; USPAT	OR	ON	2019/06/17 15:18
S53	791	(tube catheter) with (blocker block\$2 actuator actuat\$2) with (urine drain fluid) and (spectroscopy spectrometer spectrograph\$4)	US-PGPUB; USPAT	OR	ON	2019/06/17 15:18
S54	179	(tube catheter) with (blocker block\$2 actuator actuat\$2) with (urine drain fluid) and (spectroscopy spectrometer spectrograph\$4) and A61B5/\$.cpc.	US-PGPUB; USPAT	OR	ON	2019/06/17 15:19
S55	95	fardanesh.xa. and (tube catheter)	US-PGPUB; USPAT	OR	ON	2019/06/17 15:31
S56	28	("20020016536"   "20020080368"   "20030084906"   "20040186468"   "20060281992"   "3814081"   "4223680"   "4281645"   "4510938"   "4782819"   "4907876"   "5221255"   "5433216"   "5476434"   "5728092"   "5769791"   "5788647"   "5807261"   "5853005"   "5916153"   "6010453"   "6334064"   "6406431"   "6447462"   "6505074"   "6519487"   "6690958"   "6699175").PN. OR ("8412294"),URPN.	US-PGPUB; USPAT; USOCR	OR	OFF	2019/06/17 15:41
S57	114	("20010016699"   "20010021817"   "20010037079"   "20010041892"   "20020103453"   "20020147423"   "20030009123"   "20030045784"   "20030070969"   "20030097087"   "20030143116"   "20030196949"   "20030210390"   "20030212316"   "20040087845"   "20050094127"   "20060036185"   "20060144776"   "20060226079"   "20060290625"   "20070015963"   "20070100219"   "20070149871"   "20070179433"   "20080081970"   "20080129047"   "20080300570"   "20090054751"   "20090247850"   "20090322861"	US-PGPUB; USPAT; USOCR	OR	OFF	2019/06/17 15:47

		"2010004518"   "20100072280"   "20100110416"   "20100113891"   "20100168531"   "20100298677"   "20110004082"   "20110022077"   "20110160679"   "20120120384"   "20120154789"   "20160296687"   "2357238"   "3507951"   "3580683"   "3728032"   "3740156"   "4243883"   "4444498"   "4759369"   "4784768"   "4936993"   "5073171"   "5126686"   "5171456"   "5222948"   "5231464"   "5247434"   "5312535"   "5351686"   "5366630"   "5372136"   "5456253"   "5458566"   "5476764"   "5670050"   "5674390"   "5676644"   "5729333"   "5730712"   "5762805"   "5769815"   "5779529"   "5792052"   "6018673"   "6069687"   "6090061"   "6284131"   "6284142"   "6510330"   "6554788"   "6654621"   "6746415"   "6784820"   "7018353"   "7241825"   "7247143"   "7671974"   "8133194"   "8287739"   "8315682"   "8328748"   "8333724"   "8517968"   "8518247"   "9002655"   "9212988"   "D206714"   "D212218"   "D270281"   "D335096"   "D409750"   "D518573"   "D623302"   "D625824"   "D630536"   "D654999"   "D684695"   "D684697"   "D698440").PN. OR ("9801993").URPN.				
S58	13	("20010034479"   "20060167405"   "20080097288"   "4215940"   "4830013"   "4989606"   "5249584"   "5453248"   "5462052"   "5871627"   "5944660"   "6144444"   "7018353").PN. OR ("9091660").URPN.	US- PGPUB; USPAT; USOCR	OR	OFF	2019/06/17 15:50
S59	153	(urine urinary) with infection and (spectrometer spectroscopy spectrograph\$4) and A61B5/\$.cpc.	US- PGPUB; USPAT	OR	OFF	2019/06/17 16:15
S60	77	(compress\$4) with (tube catheter) with (stop\$4 prevent\$4) with flow\$4 and (spectroscopy and spectrometer spectrograph\$4)	US- PGPUB; USPAT	OR	ON	2019/06/17 16:34
S61	2	(compress\$4) with (tube catheter) with (stop\$4 prevent\$4) with flow\$4 same (urine urinary) with infection	US- PGPUB; USPAT	OR	ON	2019/06/17 16:42
S62	11	(compress\$4) with (tube catheter) with (stop\$4 prevent\$4) with flow\$4 and (urine urinary) with infection	US- PGPUB; USPAT	OR	ON	2019/06/17 16:43
S67	0	((("2013021153") or ("2014165697") or ("2013035602") or ("2009182216") or ("2009182216") or ("2010251804") or ("2014365142") or ("2014081106")).PN.	US- PGPUB; USPAT; USOCR	OR	OFF	2019/06/18 15:53
S68	7	((("20130021153") or ("20140165697") or ("20130035602") or ("20090182216") or ("20090182216") or ("20100251804") or ("20140365142") or ("20140081106")).PN.	US- PGPUB; USPAT; USOCR	OR	OFF	2019/06/18 15:53
S69	1	"15557319"	US- PGPUB; USPAT	OR	OFF	2019/06/18 16:03

EAST Search History

S70	2	"14745180" and determin\$4 adj dT	US-PGPUB; USPAT	OR	OFF	2019/06/18 17:29
S71	2	"14745180" and determin\$4 with dT	US-PGPUB; USPAT	OR	OFF	2019/06/18 17:29
S72	3	((("5439002") or ("5033471") or ("20150105676")).PN.	US-PGPUB; USPAT; USOCR	OR	OFF	2019/06/19 11:25
S73	6962	A61B5/02\$.cpc. and wrist and (screen display) and pressure	US-PGPUB; USPAT	OR	ON	2019/06/19 11:30
S74	6962	A61B5/02\$.cpc. and wrist and (screen display) and pressure and (cuff press\$4)	US-PGPUB; USPAT	OR	ON	2019/06/19 11:31
S75	2559	A61B5/02\$.cpc. and wrist same (screen display) and pressure and (cuff press\$4)	US-PGPUB; USPAT	OR	ON	2019/06/19 11:31
S76	867	A61B5/02\$.cpc. and wrist same (screen display) same pressure and (cuff press\$4)	US-PGPUB; USPAT	OR	ON	2019/06/19 11:32
S77	867	A61B5/02\$.cpc. and wrist same (screen display) same pressure same (cuff press\$4)	US-PGPUB; USPAT	OR	ON	2019/06/19 11:32
S78	57	A61B5/02\$.cpc. and wrist same (first and second) with (screen display) same pressure same (cuff press\$4)	US-PGPUB; USPAT	OR	ON	2019/06/19 11:32
S79	2	A61B5/02\$.cpc. and (wrist wristwatch wrist adj watch) adj (second two) adj display	US-PGPUB; USPAT	OR	ON	2019/06/19 11:39
S80	783	A61B5/02\$.cpc. and (second two) adj display	US-PGPUB; USPAT	OR	ON	2019/06/19 11:42
S81	3	((("20150378312") or ("20160267310") or ("20150186092")).PN.	US-PGPUB; USPAT; USOCR	OR	OFF	2019/06/19 11:47
S82	1	("20110213212").PN.	US-PGPUB; USPAT; USOCR	OR	OFF	2019/06/19 12:02
S83	1	"14947688"	US-PGPUB; USPAT	OR	OFF	2019/06/19 12:07
S84	2	((("20100137695") or ("20080114280")).PN.	US-PGPUB; USPAT; USOCR	OR	OFF	2019/06/19 13:36
S85	1	"15592451" and processor	US-PGPUB; USPAT	OR	OFF	2019/06/19 14:03
S86	120	(handheld mobile) with alcohol and strap and A61B5/\$.cpc.	US-PGPUB; USPAT	OR	OFF	2019/06/19 20:29
S87	0	(handheld mobile) with alcohol and strap and G01N33/49.cpc.	US-PGPUB; USPAT	OR	OFF	2019/06/19 20:29



## EAST Search History

S88	17	(handheld mobile) with alcohol and strap and A61B5/\$.cpc. and breath	US-PGPUB; USPAT	OR	OFF	2019/06/19 20:34
S89	1	("6853304").PN.	US-PGPUB; USPAT; USOCR	OR	OFF	2019/06/19 20:42
S90	10	alcohol and breath and (inside with mouth) with camera	US-PGPUB; USPAT	OR	OFF	2019/06/19 21:30
S91	10	(identification biometric) with (inside with mouth) with camera	US-PGPUB; USPAT	OR	OFF	2019/06/19 21:34
S92	1	breath and alcohol and (micro adj camera)	US-PGPUB; USPAT	OR	OFF	2019/06/19 21:39
S93	216	breath and alcohol and (camera) with mouth	US-PGPUB; USPAT	OR	OFF	2019/06/19 21:40
S94	216	breath and alcohol and (identification biometric) and (second two) adj camera	US-PGPUB; USPAT	OR	ON	2019/06/19 22:00
S95	232	breath and alcohol and (identification identif\$4 biometric) and (second two) adj camera	US-PGPUB; USPAT	OR	ON	2019/06/19 22:00
S96	1	"15674434" and center	US-PGPUB; USPAT	OR	OFF	2019/06/20 16:59
S97	2	"20130222271"	US-PGPUB; USPAT	OR	OFF	2019/06/20 17:39
S98	4	((("20130271350") or ("20070158376") or ("20130222270") or ("20130222271")).PN.	US-PGPUB; USPAT; USOCR	OR	OFF	2019/06/20 17:41
S99	5	((("20160267310") or ("20150186092") or ("4896676") or ("20150213580") or ("20150182147")).PN.	US-PGPUB; USPAT; USOCR	OR	OFF	2019/06/20 17:45
S100	1	"15674434"	US-PGPUB; USPAT	OR	OFF	2019/06/20 18:19
S101	864	(blood) adj pressure and (cuff) same press\$4 same (artery pulse) same wrist and A61B5/\$.cpc.	US-PGPUB; USPAT	OR	OFF	2019/06/20 21:09
S102	8	((("6216490") or ("4896676") or ("20170367649") or ("20150186092") or ("20150213580") or ("20150182147") or ("20130245391") or ("20070208258")).PN.	US-PGPUB; USPAT; USOCR	OR	OFF	2019/06/20 21:11
S103	3	((("20140371552") or ("20090259407") or ("20110098542")).PN.	US-PGPUB; USPAT; USOCR	OR	OFF	2019/06/21 10:24
S104	5	"14745180"	US-PGPUB; USPAT	OR	OFF	2019/06/21 10:27

## EAST Search History

S105	78	"5900632"	US-PGPUB; USPAT	OR	OFF	2019/06/21 11:18
S106	85	("4429999"   "5040539"   "5070242"   "5075552"   "5191215"   "5313941"   "5360004"   "5361758"   "5370114"   "5372135"   "5372136"   "5383452"   "5451787"   "5461229"   "5471056"   "5473162"   "5515847"   "5666956").PN. OR ("5900632").URPN.	US-PGPUB; USPAT; USOCR	OR	OFF	2019/06/21 11:19
S107	1	"15388672" and hemoglobin and diuretic	US-PGPUB; USPAT; USOCR	OR	OFF	2019/06/21 13:13
S108	1	("5335659").PN.	US-PGPUB; USPAT; USOCR	OR	OFF	2019/06/21 17:58
S109	1	("20150182147").PN.	US-PGPUB; USPAT; USOCR	OR	OFF	2019/06/22 11:30
S110	19	alcohol same temperature with exhaled with breath and A61B5/\$.cpc.	US-PGPUB; USPAT	OR	OFF	2019/06/22 12:34
S111	94	alcohol same temperature with breath and A61B5/\$.cpc.	US-PGPUB; USPAT	OR	OFF	2019/06/22 12:37
S112	75	S111 not S110	US-PGPUB; USPAT	OR	OFF	2019/06/22 12:38
S113	1	"15557319" and temperature	US-PGPUB; USPAT	OR	OFF	2019/06/22 12:45
S114	15	breath with temperature same compar\$4 same threshold and alcohol	US-PGPUB; USPAT	OR	OFF	2019/06/22 12:47
S115	0	"4809810".pn. and refrence and temperature and alcohol	US-PGPUB; USPAT	OR	OFF	2019/06/22 12:57
S116	1	"4809810".pn. and temperature and alcohol	US-PGPUB; USPAT	OR	OFF	2019/06/22 12:57
S117	1	"15557319"	US-PGPUB; USPAT	OR	OFF	2019/06/22 14:08
S118	1	("20120276549").PN.	US-PGPUB; USPAT; USOCR	OR	OFF	2019/06/23 14:21
S119	1	("20020026108").PN.	US-PGPUB; USPAT; USOCR	OR	OFF	2019/06/24 14:09
S120	3268	implant\$4 and substrate with semiconductor with ceramic	US-PGPUB; USPAT	OR	ON	2019/06/24 14:11
S121	122	implant\$4 and substrate with	US-	OR	ON	2019/06/24

		semiconductor with ceramic and A61B5/\$.cpc.	PGPUB; USPAT			14:11
S122	98	implant\$4 and substrate with semiconductor with ceramic and A61B5/\$.cpc. and glucose	US-PGPUB; USPAT	OR	ON	2019/06/24 14:15
S123	2069	EMR and A61B5/\$.cpc.	US-PGPUB; USPAT	OR	OFF	2019/06/26 15:28
S124	1059832	blood aj pressure same (ppg photopleth\$7) same (ECG electrocardio\$4) and A61B5/\$.cpc.	US-PGPUB; USPAT	OR	OFF	2019/06/27 13:41
S125	988	blood adj pressure same (ppg photopleth\$7) same (ECG electrocardio\$4) and A61B5/\$.cpc.	US-PGPUB; USPAT	OR	OFF	2019/06/27 13:41
S126	676	blood adj pressure with (ppg photopleth\$7) same (ECG electrocardio\$4) and A61B5/\$.cpc.	US-PGPUB; USPAT	OR	OFF	2019/06/27 13:41
S127	611	blood adj pressure with (ppg photopleth\$7) with (ECG electrocardio\$4) and A61B5/\$.cpc.	US-PGPUB; USPAT	OR	OFF	2019/06/27 13:42
S128	1	("20120162438").PN.	US-PGPUB; USPAT; USOCR	OR	OFF	2019/06/28 13:35
S129	1	"16195624"	US-PGPUB; USPAT	OR	OFF	2019/07/16 14:35
S130	39	((("3649964") or ("3721233") or ("3736927") or ("3822698") or ("3998213") or ("4019508") or ("4037595") or ("4206644") or ("4233972") or ("4297999") or ("7381267") or ("4425501") or ("4430995") or ("4549542") or ("4588425") or ("4590951") or ("4644947") or ("4765316") or ("4782832") or ("4802485") or ("4829998") or ("4836219") or ("5035239") or ("5046492") or ("5054480") or ("5054484") or ("5104430") or ("5113853") or ("5154168") or ("5273036") or ("5284160") or ("5303701") or ("5318020") or ("5349946") or ("5353788") or ("5372130") or ("20150021535") or ("20160015916") or ("20150367092")).PN.	US-PGPUB; USPAT; USOCR	OR	OFF	2019/07/16 14:49
S131	9	((("HANCOCK") near3 ("MEDICAL") near3 ("INC"))).AS.AANM.	USPAT	OR	OFF	2019/07/16 14:50
S132	57	((("GOFF") near3 ("Thomas") near3 ("G"))).INV.	US-PGPUB; USPAT; USOCR	OR	OFF	2019/07/16 14:51
S133	9	((("CHIANG") near3 ("Kirby"))).INV.	US-PGPUB; USPAT; USOCR	OR	OFF	2019/07/16 14:51
S134	230	("20020078958"   "20020104541"   "20030062045"   "20030079749"	US-PGPUB;	OR	OFF	2019/07/16 14:52

"20040079373"	"20040163648"	USPAT; USOCR
"20040186681"	"20040226562"	
"20050005937"	"20050034724"	
"20050068639"	"20050131288"	
"20050133039"	"20050188991"	
"20060037613"	"20060081250"	
"20060096596"	"20060150973"	
"20060150978"	"20060180149"	
"20060231097"	"20070000493"	
"20070113854"	"20070163592"	
"20070169781"	"20070208269"	
"20070221220"	"20070240716"	
"20070247009"	"20070251527"	
"20070277825"	"20080006275"	
"20080053451"	"20080091090"	
"20080127976"	"20080178879"	
"20080185002"	"20080202527"	
"20080216831"	"20080251079"	
"20080304986"	"20090044810"	
"20090065005"	"20090078255"	
"20090078258"	"20090078259"	
"20090194101"	"20100024811"	
"20100180895"	"20100191076"	
"20100229867"	"20100240982"	
"20100312513"	"20100319687"	
"20110056489"	"20110100366"	
"20110105915"	"20110192400"	
"20110295083"	"20120146251"	
"20120152239"	"20120152255"	
"20120266873"	"20120298099"	
"20120304985"	"20130060098"	
"20130104883"	"20130146054"	
"20130239966"	"20130298908"	
"20130306074"	"20130333701"	
"20140000600"	"20140007881"	
"20140102456"	"20140127996"	
"20140144445"	"20150040908"	
"20150096565"	"20150197378"	
"20160015916"	"3649964"   "3721233"	
"3736927"	"3822698"   "3881198"	
"3998213"	"4019508"   "4233972"	
"4297999"	"4381267"   "4430995"	
"4549542"	"4588425"   "4590951"	
"4644947"	"4765316"   "4782832").PN.	
OR ("4802485"   "4829998"   "4836219"		
"4944310"   "5035239"   "5046492"		
"5054480"   "5054484"   "5104430"		
"5113853"   "5154168"   "5303701"		
"5318020"   "5349946"   "5353788"		
"5372130"   "5394870"   "5461934"		
"5485851"   "5517986"   "5533500"		
"5564124"   "5577496"   "5649533"		
"5657752"   "5769071"   "5928189"		
"5937855"   "5950621"   "5954050"		
"5961447"   "6050262"   "6122773"		
"6135106"   "6179586"   "6213119"		
"6349724"   "6367474"   "6371112"		
"6393617"   "6397845"   "6431171"		
"6435180"   "6435184"   "6513526"		
"6532960"   "6561190"   "6561191"		
"6615831"   "6622311"   "6622726"		
"6634864"   "6694978"   "6705314"		
"6709405"   "6752146"   "6772760"		
"6772762"   "6793629"   "6854465"		

		"6881192"   "6889691"   "6895959"   "6895962"   "6920877"   "6932084"   "6973929"   "6990980"   "7019652"   "7069932"   "7089941"   "7096864"   "7118608"   "7156090"   "7178525"   "7195014"   "7200873"   "7204250"   "7255103"   "7297119"   "7357136"   "7382247"   "7406966"   "7406996"   "7471290"   "7478635"   "7487778"   "7516743"   "7575005"   "7588033"   "7664546"   "7681575"   "7766841"   "7887492"   "7913692"   "7934500"   "7942824"   "7975687"   "8020557"   "8061354"   "8172766"   "8316848"   "8327846"   "8336546"   "8353290"   "8453640"   "8475370"   "8517017"   "8688187"   "8720439"   "8903467"   "8919344"   "8925546"   "D421298"   "D570473"   "D643929"   "D659235"   "D683444"   "D683445"   "D696393"   "D696394"   "D710989"   "D732158"   "D734446"   "D740929").PN. OR ("D740930"   "RE35339").PN. OR ("D776802").URPN.				
S135	30	("20050197550"   "20050228299"   "20070142715"   "20070244378"   "5099842"   "5999834"   "6006120"   "6377829"   "6725075"   "6839585"   "6920345"   "7225007"   "7486977"   "7736310"   "D452318"   "D463561"   "D492783"   "D557423"   "D603966").PN. OR ("D643929").URPN.	US- PGPUB; USPAT; USOCR	OR	OFF	2019/07/16; 14:53
S136	178	("3505993"   "4537197"   "4859057"   "4880304").PN. OR ("5099842").URPN.	US- PGPUB; USPAT; USOCR	OR	OFF	2019/07/16; 14:56
S137	30	("20050197550"   "20050228299"   "20070142715"   "20070244378"   "5099842"   "5999834"   "6006120"   "6377829"   "6725075"   "6839585"   "6920345"   "7225007"   "7486977"   "7736310"   "D452318"   "D463561"   "D492783"   "D557423"   "D603966").PN. OR ("D643929").URPN.	US- PGPUB; USPAT; USOCR	OR	OFF	2019/07/16; 14:58
S138	147	fardanesh.xa. and glucose	US- PGPUB; USPAT; USOCR	OR	OFF	2019/07/16; 15:00
S139	17	("20020072681"   "20020173709"   "4017756"   "4859057"   "5224478"   "5345935"   "6461305").PN. OR ("6839585").URPN.	US- PGPUB; USPAT; USOCR	OR	OFF	2019/07/16; 15:03
S140	6	"15404117" and vasodilator	US- PGPUB; USPAT	OR	OFF	2019/07/16; 19:15
S141	541	vasodilat\$5 with (measur\$5 calculat\$5) and A61B5/\$.cpc.	US- PGPUB; USPAT	OR	OFF	2019/07/16; 19:24
S142	209	vasodilat\$5 with (measur\$5 calculat\$5) with blood and A61B5/\$.cpc.	US- PGPUB; USPAT	OR	OFF	2019/07/16; 19:24

EAST Search History

S143	92	vasodilat\$5 with (measur\$5 calculat\$5) and (ppg photoplethysm\$6) and A61B5/\$.cpc.	US-PGPUB; USPAT	OR	OFF	2019/07/16 19:28
S144	5	((("5830137") or ("5584296") or ("8452364") or ("20030036690") or ("5497771")).PN.	US-PGPUB; USPAT; USOCR	OR	OFF	2019/07/17 13:37
S145	1	"16195624" and instruction\$4	US-PGPUB; USPAT	OR	OFF	2019/07/17 15:14
S146	1	"16226249"	US-PGPUB; USPAT	OR	OFF	2019/07/17 16:22
S147	2	((("5833603") or ("20020026108")).PN.	US-PGPUB; USPAT; USOCR	OR	OFF	2019/07/17 17:41
S148	2794	apnea and accelerometer and A61B5/\$.cpc.	US-PGPUB; USPAT	OR	OFF	2019/07/18 07:48
S149	1543	apnea and (sleep position\$1) same accelerometer and A61B5/\$.cpc.	US-PGPUB; USPAT	OR	OFF	2019/07/18 07:49
S150	481	apnea and (sleep and position\$1) same accelerometer and A61B5/\$.cpc.	US-PGPUB; USPAT	OR	OFF	2019/07/18 07:49
S151	191	apnea and accelerometer and (position\$4 same (PPG photoplethysm\$6)) and A61B5/\$.cpc.	US-PGPUB; USPAT	OR	OFF	2019/07/18 07:51
S152	406	apnea and accelerometer and (position same (PPG photoplethysm\$6 saturation)) and A61B5/\$.cpc.	US-PGPUB; USPAT	OR	ON	2019/07/18 07:54
S153	128	accelerometer and (position same (PPG photoplethysm\$6 saturation)) and A61B5/4818.cpc.	US-PGPUB; USPAT	OR	ON	2019/07/18 08:04
S154	14	correlat\$4 with (oxygen saturation) with position and A61B5/4818.cpc.	US-PGPUB; USPAT	OR	ON	2019/07/18 08:38

**EAST Search History (Interference)**

Ref #	Hits	Search Query	DBs	Default Operator	Plurals	Time Stamp
S63	607	hemoglobin and IVI	US-PGPUB; USPAT	OR	ON	2019/06/17 18:47
S64	582	hemoglobin and IVI and (light intensity)	US-PGPUB; USPAT	OR	ON	2019/06/17 18:47
S65	33	hemoglobin and IVI and (light intensity) and A61B5/\$.cpc.	US-PGPUB; USPAT	OR	ON	2019/06/17 18:48
S66	2	temperature and (heat\$4 cool\$4) and glucose and oscilat\$4 and A61B5/\$.cpc.	US-PGPUB; USPAT	OR	ON	2019/06/18 10:59

7/ 19/ 2019 1:24:37 PM

C:\Users\mfardanesh\Desktop\new.wsp



## Bibliographic Data

Application No: 16/226,249

Foreign Priority claimed:  Yes  No

35 USC 119 (a-d) conditions met:  Yes  No  Met After Allowance

Verified and Acknowledged: /MARJAN FARDANESH/

Examiner's Signature

Initials

Title:

ADVANCED PULSE OXIMETRY SENSOR

---

FILING or 371(c) DATE	CLASS	GROUP ART UNIT	ATTORNEY DOCKET NO.
12/19/2018	600	3791	MAS.1007C1
<b>RULE</b>			

### APPLICANTS

MASIMO CORPORATION, Irvine, CA,

### INVENTORS

Ammar Al-Ali San Juan Capistrano, CA, UNITED STATES

Stephen Scruggs Newport Beach, CA, UNITED STATES

### CONTINUING DATA

This application is a CON of 15195199 06/28/2016

15195199 has PRO of 62188430 07/02/2015

### FOREIGN APPLICATIONS

### IF REQUIRED, FOREIGN LICENSE GRANTED\*\*

01/15/2019

### STATE OR COUNTRY

UNITED STATES

### ADDRESS

KNOBBE, MARTENS, OLSON & BEAR, LLP

MASIMO CORPORATION (MASIMO)

2040 MAIN STREET

FOURTEENTH FLOOR

IRVINE, CA 92614

UNITED STATES

### FILING FEE RECEIVED

\$5,860



PTO/SB/08 Equivalent

<b>INFORMATION DISCLOSURE STATEMENT BY APPLICANT</b>	Application No.	16/226249	
	Filing Date	December 19, 2018	
	First Named Inventor	Ammar Al-Ali	
	Art Unit	3791	
<i>(Multiple sheets used when necessary)</i>		Examiner	Fardanesh, Marjan
SHEET 1 OF 1		Attorney Docket No.	MAS.1007C1

U.S. PATENT DOCUMENTS					
Examiner Initials	Cite No.	Document Number <i>Number - Kind Code (if known)</i> Example: 1,234,567 B1	Publication Date MM-DD-YYYY	Name	Pages, Columns, Lines Where Relevant Passages or Relevant Figures Appear
	1	5,830,137	11-03-1998	Scharf	

FOREIGN PATENT DOCUMENTS						
Examiner Initials	Cite No.	Foreign Patent Document <i>Country Code-Number-Kind Code</i> Example: JP 1234567 A1	Publication Date MM-DD-YYYY	Name	Pages, Columns, Lines Where Relevant Passages or Relevant Figures Appear	T <sup>1</sup>

NON PATENT LITERATURE DOCUMENTS			
Examiner Initials	Cite No.	Include name of the author (in CAPITAL LETTERS), title of the article (when appropriate), title of the item (book, magazine, journal, serial, symposium, catalog, etc.), date, page(s), volume-issue number(s), publisher, city and/or country where published.	T <sup>1</sup>

30349862

Examiner Signature	/MARJAN FARDANESH/	Date Considered	07/18/2019
<p><b>*Examiner:</b> Initial if reference considered, whether or not citation is in conformance with MPEP 609. Draw line through citation if not in conformance and not considered. Include copy of this form with next communication to applicant.</p>			

~~ALL REFERENCES CONSIDERED EXCEPT WHERE LINED THROUGH. /M.F/~~  
T<sup>1</sup> - Place a check mark in this area when an English language Translation is attached.



UNITED STATES PATENT AND TRADEMARK OFFICE

UNITED STATES DEPARTMENT OF COMMERCE
United States Patent and Trademark Office
Address: COMMISSIONER FOR PATENTS
P.O. Box 1450
Alexandria, Virginia 22313-1450
www.uspto.gov

Table with 7 columns: APPLICATION NUMBER, FILING or 371(c) DATE, GRP ART UNIT, FIL FEE REC'D, ATTY DOCKET NO, TOT CLAIMS, IND CLAIMS. Row 1: 16/226,249, 12/19/2018, 3791, 2880, MAS.1007C1, 20, 3

CONFIRMATION NO. 1002
UPDATED FILING RECEIPT

64735
KNOBBE, MARTENS, OLSON & BEAR, LLP
MASIMO CORPORATION (MASIMO)
2040 MAIN STREET
FOURTEENTH FLOOR
IRVINE, CA 92614



Date Mailed: 07/25/2019

Receipt is acknowledged of this non-provisional utility patent application. The application will be taken up for examination in due course. Applicant will be notified as to the results of the examination. Any correspondence concerning the application must include the following identification information: the U.S. APPLICATION NUMBER, FILING DATE, NAME OF FIRST INVENTOR, and TITLE OF INVENTION. Fees transmitted by check or draft are subject to collection.

Please verify the accuracy of the data presented on this receipt. If an error is noted on this Filing Receipt, please submit a written request for a corrected Filing Receipt, including a properly marked-up ADS showing the changes with strike-through for deletions and underlining for additions. If you received a "Notice to File Missing Parts" or other Notice requiring a response for this application, please submit any request for correction to this Filing Receipt with your reply to the Notice. When the USPTO processes the reply to the Notice, the USPTO will generate another Filing Receipt incorporating the requested corrections provided that the request is grantable.

Inventor(s)

Ammar Al-Ali, San Juan Capistrano, CA;

Applicant(s)

MASIMO CORPORATION, Irvine, CA;

Power of Attorney: The patent practitioners associated with Customer Number 64735

Domestic Priority data as claimed by applicant

This application is a CON of 15/195,199 06/28/2016
which claims benefit of 62/188,430 07/02/2015

Foreign Applications for which priority is claimed (You may be eligible to benefit from the Patent Prosecution Highway program at the USPTO. Please see http://www.uspto.gov for more information.) - None.

Foreign application information must be provided in an Application Data Sheet in order to constitute a claim to foreign priority. See 37 CFR 1.55 and 1.76.

Permission to Access Application via Priority Document Exchange: Yes

Permission to Access Search Results: Yes

Applicant may provide or rescind an authorization for access using Form PTO/SB/39 or Form PTO/SB/69 as appropriate.

**Projected Publication Date:** Not Applicable

**Non-Publication Request:** No

**Early Publication Request:** No  
**Title**

ADVANCED PULSE OXIMETRY SENSOR

**Preliminary Class**

600

**Statement under 37 CFR 1.55 or 1.78 for AIA (First Inventor to File) Transition Applications:** No

## **PROTECTING YOUR INVENTION OUTSIDE THE UNITED STATES**

Since the rights granted by a U.S. patent extend only throughout the territory of the United States and have no effect in a foreign country, an inventor who wishes patent protection in another country must apply for a patent in a specific country or in regional patent offices. Applicants may wish to consider the filing of an international application under the Patent Cooperation Treaty (PCT). An international (PCT) application generally has the same effect as a regular national patent application in each PCT-member country. The PCT process **simplifies** the filing of patent applications on the same invention in member countries, but **does not result** in a grant of "an international patent" and does not eliminate the need of applicants to file additional documents and fees in countries where patent protection is desired.

Almost every country has its own patent law, and a person desiring a patent in a particular country must make an application for patent in that country in accordance with its particular laws. Since the laws of many countries differ in various respects from the patent law of the United States, applicants are advised to seek guidance from specific foreign countries to ensure that patent rights are not lost prematurely.

Applicants also are advised that in the case of inventions made in the United States, the Director of the USPTO must issue a license before applicants can apply for a patent in a foreign country. The filing of a U.S. patent application serves as a request for a foreign filing license. The application's filing receipt contains further information and guidance as to the status of applicant's license for foreign filing.

Applicants may wish to consult the USPTO booklet, "General Information Concerning Patents" (specifically, the section entitled "Treaties and Foreign Patents") for more information on timeframes and deadlines for filing foreign patent applications. The guide is available either by contacting the USPTO Contact Center at 800-786-9199, or it can be viewed on the USPTO website at <http://www.uspto.gov/web/offices/pac/doc/general/index.html>.

For information on preventing theft of your intellectual property (patents, trademarks and copyrights), you may wish to consult the U.S. Government website, <http://www.stopfakes.gov>. Part of a Department of Commerce initiative, this website includes self-help "toolkits" giving innovators guidance on how to protect intellectual property in specific countries such as China, Korea and Mexico. For questions regarding patent enforcement issues, applicants may call the U.S. Government hotline at 1-866-999-HALT (1-866-999-4258).

**LICENSE FOR FOREIGN FILING UNDER**  
**Title 35, United States Code, Section 184**  
**Title 37, Code of Federal Regulations, 5.11 & 5.15**

**GRANTED**

The applicant has been granted a license under 35 U.S.C. 184, if the phrase "IF REQUIRED, FOREIGN FILING LICENSE GRANTED" followed by a date appears on this form. Such licenses are issued in all applications where the conditions for issuance of a license have been met, regardless of whether or not a license may be required as set forth in 37 CFR 5.15. The scope and limitations of this license are set forth in 37 CFR 5.15(a) unless an earlier license has been issued under 37 CFR 5.15(b). The license is subject to revocation upon written notification. The date indicated is the effective date of the license, unless an earlier license of similar scope has been granted under 37 CFR 5.13 or 5.14.

This license is to be retained by the licensee and may be used at any time on or after the effective date thereof unless it is revoked. This license is automatically transferred to any related applications(s) filed under 37 CFR 1.53(d). This license is not retroactive.

The grant of a license does not in any way lessen the responsibility of a licensee for the security of the subject matter as imposed by any Government contract or the provisions of existing laws relating to espionage and the national security or the export of technical data. Licensees should apprise themselves of current regulations especially with respect to certain countries, of other agencies, particularly the Office of Defense Trade Controls, Department of State (with respect to Arms, Munitions and Implements of War (22 CFR 121-128)); the Bureau of Industry and Security, Department of Commerce (15 CFR parts 730-774); the Office of Foreign Assets Control, Department of Treasury (31 CFR Parts 500+) and the Department of Energy.

**NOT GRANTED**

No license under 35 U.S.C. 184 has been granted at this time, if the phrase "IF REQUIRED, FOREIGN FILING LICENSE GRANTED" DOES NOT appear on this form. Applicant may still petition for a license under 37 CFR 5.12, if a license is desired before the expiration of 6 months from the filing date of the application. If 6 months has lapsed from the filing date of this application and the licensee has not received any indication of a secrecy order under 35 U.S.C. 181, the licensee may foreign file the application pursuant to 37 CFR 5.15(b).

---

***SelectUSA***

The United States represents the largest, most dynamic marketplace in the world and is an unparalleled location for business investment, innovation, and commercialization of new technologies. The U.S. offers tremendous resources and advantages for those who invest and manufacture goods here. Through SelectUSA, our nation works to promote and facilitate business investment. SelectUSA provides information assistance to the international investor community; serves as an ombudsman for existing and potential investors; advocates on behalf of U.S. cities, states, and regions competing for global investment; and counsels U.S. economic development organizations on investment attraction best practices. To learn more about why the United States is the best country in the world to develop technology, manufacture products, deliver services, and grow your business, visit <http://www.SelectUSA.gov> or call +1-202-482-6800.



UNITED STATES PATENT AND TRADEMARK OFFICE

UNITED STATES DEPARTMENT OF COMMERCE  
United States Patent and Trademark Office  
Address: COMMISSIONER FOR PATENTS  
P.O. Box 1450  
Alexandria, Virginia 22313-1450  
www.uspto.gov

APPLICATION NUMBER	FILING OR 371(C) DATE	FIRST NAMED APPLICANT	ATTY. DOCKET NO./TITLE
16/226,249	12/19/2018	Ammar Al-Ali	MAS.1007C1

**CONFIRMATION NO. 1002**

**37 CFR 1.48 ACKNOWLEDGEMENT LETTER**

64735  
KNOBBE, MARTENS, OLSON & BEAR, LLP  
MASIMO CORPORATION (MASIMO)  
2040 MAIN STREET  
FOURTEENTH FLOOR  
IRVINE, CA 92614



Date Mailed: 07/25/2019

**NOTICE OF ACCEPTANCE OF REQUEST UNDER 37 CFR 1.48(a)**

This is in response to the applicant's request under 37 CFR 1.48(a) submitted on 07/19/2019.

The request under 37 CFR 1.48(a) to correct the inventorship, to correct or update the name of an inventor, or to correct the order of names of joint inventors is accepted.

Questions about the contents of this notice and the requirements it sets forth should be directed to the Office of Data Management, Application Assistance Unit, at (571) 272-4000 or (571) 272-4200 or 1-888-786-0101.

/mmasfaw/

---

Please Direct All Correspondence to Customer Number 64735

---

**IN THE UNITED STATES PATENT AND TRADEMARK OFFICE**

Inventor	: Ammar Al-Ali
App. No	: 16/226,249
Filed	: December 19, 2018
For	: ADVANCED PULSE OXIMETRY SENSOR
Examiner	: Fardanesh, Marjan
Art Unit	: 3791
Conf No.	: 1002

**SUMMARY OF INTERVIEW**

Commissioner for Patents  
P.O. Box 1450  
Alexandria, VA 22313-1450

Dear Commissioner:

A telephonic interview was conducted and attended by Examiner Fardanesh and Applicant's representatives Jarom D. Kesler (Reg. No. 57,046) and Aaron S. Johnson (Reg. No. 74,164) on July 18, 2019. During the interview, proposed claim amendments were discussed to place the application in condition for allowance. Examiner Fardanesh and Applicant's representatives reached an agreement that the pending claims were supported by the written description of the application and that the pending claims were patentably distinct over the prior art of record.

Examiner Fardanesh requested the filing of a Terminal Disclaimer with reference to co-pending Application Serial No. 15/195199. Without commenting on the appropriateness of a Terminal Disclaimer, and solely in the interest of advancing prosecution, Applicant submitted a Terminal Disclaimer on July 18, 2019. Applicant notes that according to M.P.E.P § 804.02, the filing of a terminal disclaimer to obviate a rejection based on nonstatutory obviousness-type double patenting is not an admission regarding the propriety of the rejection. Applicant thanks Examiner Fardanesh for her time and consideration.

**Application No.:** 16/226,249  
**Filing Date:** December 19, 2018

Please charge any additional fees, including any fees for additional extension of time, or credit overpayment to Deposit Account No. 11-1410.

Respectfully submitted,

KNOBBE, MARTENS, OLSON & BEAR, LLP

Dated: July 25, 2019

By: /Aaron S. Johnson/  
Aaron S. Johnson  
Registration No. 74,164  
Registered Practitioner  
Customer No. 64735  
(949) 760-0404

30945431

## Electronic Acknowledgement Receipt

<b>EFS ID:</b>	36691207
<b>Application Number:</b>	16226249
<b>International Application Number:</b>	
<b>Confirmation Number:</b>	1002
<b>Title of Invention:</b>	ADVANCED PULSE OXIMETRY SENSOR
<b>First Named Inventor/Applicant Name:</b>	Ammar Al-Ali
<b>Customer Number:</b>	64735
<b>Filer:</b>	Aaron Samuel Johnson/Evelyn Salcido
<b>Filer Authorized By:</b>	Aaron Samuel Johnson
<b>Attorney Docket Number:</b>	MAS.1007C1
<b>Receipt Date:</b>	25-JUL-2019
<b>Filing Date:</b>	19-DEC-2018
<b>Time Stamp:</b>	18:17:20
<b>Application Type:</b>	Utility under 35 USC 111(a)

### Payment information:

Submitted with Payment	no
------------------------	----

### File Listing:

Document Number	Document Description	File Name	File Size(Bytes)/ Message Digest	Multi Part /.zip	Pages (if appl.)
1	Applicant summary of interview with examiner	Summary_MAS1007C1.pdf	19639 9c20c54ef5c9f5c01a508a807ba65afc47248ec5	no	2

### Warnings:



<b>Information:</b>	
<b>Total Files Size (in bytes):</b>	19639
<p><b>This Acknowledgement Receipt evidences receipt on the noted date by the USPTO of the indicated documents, characterized by the applicant, and including page counts, where applicable. It serves as evidence of receipt similar to a Post Card, as described in MPEP 503.</b></p> <p><b><u>New Applications Under 35 U.S.C. 111</u></b>  <b>If a new application is being filed and the application includes the necessary components for a filing date (see 37 CFR 1.53(b)-(d) and MPEP 506), a Filing Receipt (37 CFR 1.54) will be issued in due course and the date shown on this Acknowledgement Receipt will establish the filing date of the application.</b></p> <p><b><u>National Stage of an International Application under 35 U.S.C. 371</u></b>  <b>If a timely submission to enter the national stage of an international application is compliant with the conditions of 35 U.S.C. 371 and other applicable requirements a Form PCT/DO/EO/903 indicating acceptance of the application as a national stage submission under 35 U.S.C. 371 will be issued in addition to the Filing Receipt, in due course.</b></p> <p><b><u>New International Application Filed with the USPTO as a Receiving Office</u></b>  <b>If a new international application is being filed and the international application includes the necessary components for an international filing date (see PCT Article 11 and MPEP 1810), a Notification of the International Application Number and of the International Filing Date (Form PCT/RO/105) will be issued in due course, subject to prescriptions concerning national security, and the date shown on this Acknowledgement Receipt will establish the international filing date of the application.</b></p>	

<b>PATENT ASSIGNMENT COVER SHEET</b>
--------------------------------------

Electronic Version v1.1  
 Stylesheet Version v1.2

EPAS ID: PAT5634478

<b>SUBMISSION TYPE:</b>	NEW ASSIGNMENT
<b>NATURE OF CONVEYANCE:</b>	ASSIGNMENT
<b>CONVEYING PARTY DATA</b>	
<b>Name</b>	<b>Execution Date</b>
AMMAR AL-ALI	07/19/2019
<b>RECEIVING PARTY DATA</b>	
<b>Name:</b>	MASIMO CORPORATION
<b>Street Address:</b>	52 DISCOVERY
<b>City:</b>	IRVINE
<b>State/Country:</b>	CALIFORNIA
<b>Postal Code:</b>	92618
<b>PROPERTY NUMBERS Total: 2</b>	
<b>Property Type</b>	<b>Number</b>
<b>Application Number:</b>	15195199
<b>Application Number:</b>	16226249
<b>CORRESPONDENCE DATA</b>	
<b>Fax Number:</b>	(949)760-9502
<i>Correspondence will be sent to the e-mail address first; if that is unsuccessful, it will be sent using a fax number, if provided; if that is unsuccessful, it will be sent via US Mail.</i>	
<b>Phone:</b>	9497600404
<b>Email:</b>	efiling@knobbe.com
<b>Correspondent Name:</b>	KNOBBE, MARTENS, OLSON & BEAR, LLP
<b>Address Line 1:</b>	2040 MAIN STREET
<b>Address Line 2:</b>	14TH FLOOR
<b>Address Line 4:</b>	IRVINE, CALIFORNIA 92614
<b>ATTORNEY DOCKET NUMBER:</b>	MAS.1007A/ MAS.1007C1
<b>NAME OF SUBMITTER:</b>	AARON S. JOHNSON
<b>SIGNATURE:</b>	/Aaron S. Johnson/
<b>DATE SIGNED:</b>	07/24/2019
This document serves as an Oath/Declaration (37 CFR 1.63).	
<b>Total Attachments: 3</b>	
source=Executed CDA - MAS.1007A#page1.tif	
source=Executed CDA - MAS.1007A#page2.tif	
source=Executed CDA - MAS.1007A#page3.tif	

**COMBINED DECLARATION & ASSIGNMENT (37 CFR 1.63(e))**

*Application Data Sheet filed previously or concurrently*

**Docket Nos.:** MAS.1007A; MAS.1007C1

Page 1 of 3

**Title:** ADVANCED PULSE OXIMETRY SENSOR

**Inventors:** Ammar Al-Ali

***Declaration***

This Declaration is directed to U.S. Application Nos. **15/195199** and **16/226249**, filed June 28, 2016 and December 19, 2018, respectively, and incorporating any amendments made thereto prior to the signature date of this Declaration.

As a named inventor, I declare that:

The above-identified application was made or authorized to be made by me.

I believe that I am the original inventor or an original joint inventor of a claimed invention in the application.

I hereby acknowledge that any willful false statement made in this declaration is punishable under 18 USC 1001 by fine or imprisonment of not more than five (5) years, or both.

I have reviewed and understand the contents of the above-identified application, including the claims, as amended by any amendment.

I acknowledge the duty to disclose information which is material to patentability as defined in 37 CFR 1.56.

***Assignment from Inventors***

WHEREAS, **above-identified inventors** (individual(s) hereinafter "ASSIGNOR") invented certain new and useful improvements, technology, inventions, developments, ideas, ornamental designs, or discoveries related to **ADVANCED PULSE OXIMETRY SENSOR** (collectively hereinafter referred to as the "Work") for which an application for Letters Patent in the United States (identified above) has been filed or prepared for filing with the United States Patent and Trademark Office (hereinafter the "Application"), and ASSIGNOR desires to assign or confirm assignment of the Work and the Application to the below identified Assignee.

AND WHEREAS, **Masimo Corporation**, with its principal place of business at **52 Discovery, Irvine, California 92618** (hereinafter the "ASSIGNEE"), desires to acquire or confirm ownership of the entire right, title, and interest in and to the Application and the Work.

NOW, THEREFORE, for good and valuable consideration of which receipt is hereby acknowledged, ASSIGNOR hereby acknowledges that ASSIGNOR has sold, assigned, transferred, and set over, and by these presents does hereby sell, assign, transfer, and set over, unto said ASSIGNEE, **its** successors, legal representatives, and assigns, the entire right, title, and interest throughout the world in and to the Application and the Work, including:

all provisional applications relating to the Work and the Application (including but not limited to U.S. Provisional Application No(s). **62/188430**, filed **July 2, 2015** (respectively if plural applications));

all nonprovisional applications claiming priority to aforementioned provisional(s) and/or the Application, including, all divisions, continuations, continuations-in-part, and reissues, and all Letters Patent of the United States which may be granted thereon and all reissues and extensions thereof; and

all rights of priority under International Conventions and any related Letters Patent which may hereafter be granted or filed in any country or countries foreign to the United States, all extensions, renewals, and reissues thereof.

**COMBINED DECLARATION & ASSIGNMENT (37 CFR 1.63(e))**

*Application Data Sheet filed previously or concurrently*

**Docket Nos.:** MAS.1007A; MAS.1007C1

Page 2 of 3

**Title:** ADVANCED PULSE OXIMETRY SENSOR

**Inventors:** Ammar Al-Ali

ASSIGNOR hereby authorizes and requests the Commissioner of Patents of the United States, and any Official of any country or countries foreign to the United States, whose duty it is to issue patents on applications as aforesaid, to issue all related Letters Patent to the ASSIGNEE, **its** successors, legal representatives, and assigns.

AND ASSIGNOR DOES HEREBY sell, assign, transfer, and convey to ASSIGNEE, **its** successors, legal representatives, and assigns all claims for damages and all remedies arising out of any violation of the rights assigned hereby that may have accrued prior to the date of assignment to ASSIGNEE, or may accrue hereafter, including, but not limited to, the right to sue for, collect, and retain damages for past infringements of said Letters Patent before or after issuance.

AND ASSIGNOR DOES HEREBY covenant and agree that ASSIGNOR will: communicate to said ASSIGNEE, **its** successors, legal representatives, and assigns any facts known to ASSIGNOR respecting the Work; testify in any legal proceeding; assist in the preparation of any other Patent Property relating to the Application and the Work or any improvements made thereto; sign/execute all lawful papers; authorize the filing of, execute, and make all rightful oaths and/or declarations in connection with the Application and the Work including any improvements made thereto, any patent applications filed therefrom, and any continuing application filed from any of the aforementioned applications; and generally do everything possible to aid the ASSIGNEE, **its** successors, legal representatives, and assigns, to obtain and enforce proper patent protection for the Work in all countries.

**COMBINED DECLARATION & ASSIGNMENT (37 CFR 1.63(e))**

*Application Data Sheet filed previously or concurrently*

Docket Nos.: MAS.1007A; MAS.1007C1

Page 3 of 3

Title: ADVANCED PULSE OXIMETRY SENSOR

Inventors: Ammar Al-Ali

Legal Name of Inventor: Ammar Al-Ali

IN TESTIMONY WHEREOF, I hereunto set my hand and seal this 19<sup>th</sup> day of JULY, 2019.

Signature: \_\_\_\_\_

A NOTARY PUBLIC OR OTHER OFFICER COMPLETING THIS CERTIFICATE VERIFIES ONLY THE IDENTITY OF THE INDIVIDUAL WHO SIGNED THE DOCUMENT TO WHICH THIS CERTIFICATE IS ATTACHED, AND NOT THE TRUTHFULNESS, ACCURACY, OR VALIDITY OF THAT DOCUMENT.

STATE OF CALIFORNIA

COUNTY OF ORANGE

ss.

On 19 JULY 2019, before me, ELISA M MULET, notary public, personally appeared Ammar Al-Ali who proved to me on the basis of satisfactory evidence to be the person(s) whose name(s) is/~~are~~ subscribed to the within instrument, and acknowledged to me that he/~~she~~/they executed the same in his/~~her~~/their authorized capacity(ies), and that by his/~~her~~/their signature(s) on the instrument the person(s), or the entity upon behalf of which the person(s) acted, executed the instrument.

I certify under PENALTY OF PERJURY under the laws of the State of California that the foregoing paragraph is true and correct.

WITNESS my hand and official seal.

\_\_\_\_\_  
Notary Signature

[SEAL]

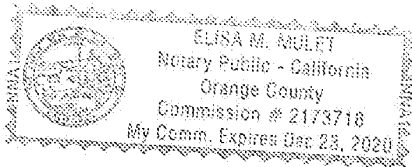

30945203

<b>INFORMATION DISCLOSURE STATEMENT BY APPLICANT</b>	Application No.	16/226249
	Filing Date	December 19, 2018
	First Named Inventor	Ammar Al-Ali
	Art Unit	3791
<i>(Multiple sheets used when necessary)</i>	Examiner	Fardanesh, Marjan
SHEET 1 OF 12	Attorney Docket No.	MAS.1007C1

U.S. PATENT DOCUMENTS					
Examiner Initials	Cite No.	Document Number Number - Kind Code (if known) Example: 1,234,567 B1	Publication Date MM-DD-YYYY	Name	Pages, Columns, Lines Where Relevant Passages or Relevant Figures Appear
	1	5,497,771	3/12/1996	Rosenheimer	
	2	6,343,223	1/29/2002	Chin et al.	
	3	5,987,343	11/16/1999	Kinast	
	4	6,308,089	10/23/2001	von der Ruhr et al.	
	5	7,048,687	5/23/2006	Reuss et al.	
	6	8,280,473	10/2/2012	Al-Ali	
	7	9,364,181	6/14/2016	Kiani et al.	
	8	9,368,671	6/14/2016	Wojtczuk et al.	
	9	9,370,325	6/21/2016	Al-Ali et al.	
	10	9,370,326	6/21/2016	McHale et al.	
	11	9,370,335	6/21/2016	Al-ali et al.	
	12	9,375,185	6/28/2016	Ali et al.	
	13	9,386,953	7/12/2016	Al-Ali	
	14	9,386,961	7/12/2016	Al-Ali et al.	
	15	9,392,945	7/19/2016	Al-Ali et al.	
	16	9,397,448	7/19/2016	Al-Ali et al.	
	17	9,408,542	8/9/2016	Kinast et al.	
	18	9,436,645	9/6/2016	Al-Ali et al.	
	19	9,445,759	9/20/2016	Lamego et al.	
	20	9,466,919	10/11/2016	Kiani et al.	
	21	9,474,474	10/25/2016	Lamego et al.	
	22	9,480,422	11/1/2016	Al-Ali	
	23	9,480,435	11/1/2016	Olsen	
	24	9,492,110	11/15/2016	Al-Ali et al.	
	25	9,510,779	12/6/2016	Poeze et al.	
	26	9,517,024	12/13/2016	Kiani et al.	
	27	9,532,722	1/3/2017	Lamego et al.	
	28	9,538,949	1/10/2017	Al-Ali et al.	
	29	9,538,980	1/10/2017	Telfort et al.	

Examiner Signature	Date Considered
<p><b>*Examiner:</b> Initial if reference considered, whether or not citation is in conformance with MPEP 609. Draw line through citation if not in conformance and not considered. Include copy of this form with next communication to applicant.</p>	

T<sup>1</sup> - Place a check mark in this area when an English language Translation is attached.

<b>INFORMATION DISCLOSURE STATEMENT BY APPLICANT</b>	Application No.	16/226249
	Filing Date	December 19, 2018
	First Named Inventor	Ammar Al-Ali
	Art Unit	3791
<i>(Multiple sheets used when necessary)</i>	Examiner	Fardanesh, Marjan
SHEET 2 OF 12	Attorney Docket No.	MAS.1007C1

<b>U.S. PATENT DOCUMENTS</b>					
Examiner Initials	Cite No.	Document Number <i>Number - Kind Code (if known)</i> Example: 1,234,567 B1	Publication Date MM-DD-YYYY	Name	Pages, Columns, Lines Where Relevant Passages or Relevant Figures Appear
	30	9,549,696	1/24/2017	Lamego et al.	
	31	9,554,737	1/31/2017	Schurman et al.	
	32	9,560,996	2/7/2017	Kiani	
	33	9,560,998	2/7/2017	Al-Ali et al.	
	34	9,566,019	2/14/2017	Al-Ali et al.	
	35	9,579,039	2/28/2017	Jansen et al.	
	36	9,591,975	3/14/2017	Dalvi et al.	
	37	9,622,692	4/18/2017	Lamego et al.	
	38	9,622,693	4/18/2017	Diab	
	39	9,636,055	5/2/2017	Al-Ali et al.	
	40	9,636,056	5/2/2017	Al-Ali	
	41	9,649,054	5/16/2017	Lamego et al.	
	42	9,662,052	5/30/2017	Al-Ali et al.	
	43	9,668,679	6/6/2017	Schurman et al	
	44	9,668,680	6/6/2017	Bruinsma et al.	
	45	9,668,703	6/6/2017	Al-Ali	
	46	9,675,286	6/13/2017	Diab	
	47	9,687,160	6/27/2017	Kiani	
	48	9,693,719	7/4/2017	Al-Ali et al.	
	49	9,693,737	7/4/2017	Al-Ali	
	50	9,697,928	7/4/2017	Al-Ali et al.	
	51	9,717,425	8/1/2017	Kiani et al.	
	52	9,717,458	8/1/2017	Lamego et al.	
	53	9,724,016	8/8/2017	Al-Ali et al.	
	54	9,724,024	8/8/2017	Al-Ali	
	55	9,724,025	8/8/2017	Kiani et al.	
	56	9,730,640	8/15/2017	Diab et al.	
	57	9,743,887	8/29/2017	Al-Ali et al.	
	58	9,749,232	8/29/2017	Sampath et al.	

Examiner Signature	Date Considered
<p><b>*Examiner:</b> Initial if reference considered, whether or not citation is in conformance with MPEP 609. Draw line through citation if not in conformance and not considered. Include copy of this form with next communication to applicant.</p>	

T<sup>1</sup> - Place a check mark in this area when an English language Translation is attached.

<b>INFORMATION DISCLOSURE STATEMENT BY APPLICANT</b>	Application No.	16/226249
	Filing Date	December 19, 2018
	First Named Inventor	Ammar Al-Ali
	Art Unit	3791
<i>(Multiple sheets used when necessary)</i>	Examiner	Fardanesh, Marjan
SHEET 3 OF 12	Attorney Docket No.	MAS.1007C1

U.S. PATENT DOCUMENTS					
Examiner Initials	Cite No.	Document Number <i>Number - Kind Code (if known)</i> Example: 1,234,567 B1	Publication Date MM-DD-YYYY	Name	Pages, Columns, Lines Where Relevant Passages or Relevant Figures Appear
	59	9,750,442	9/5/2017	Olsen	
	60	9,750,443	9/5/2017	Smith et al.	
	61	9,750,461	9/5/2017	Telfort	
	62	9,775,545	10/3/2017	Al-Ali et al.	
	63	9,775,546	10/3/2017	Diab et al.	
	64	9,775,570	10/3/2017	Al-Ali	
	65	9,778,079	10/3/2017	Al-Ali et al.	
	66	9,782,077	10/10/2017	Lamego et al.	
	67	9,782,110	10/10/2017	Kiani	
	68	9,787,568	10/10/2017	Lamego et al.	
	69	9,788,735	10/17/2017	Al-Ali	
	70	9,788,768	10/17/2017	Al-Ali et al.	
	71	9,795,300	10/24/2017	Al-Ali	
	72	9,795,310	10/24/2017	Al-Ali	
	73	9,795,358	10/24/2017	Telfort et al.	
	74	9,795,739	10/24/2017	Al-Ali et al.	
	75	9,801,556	10/31/2017	Kiani	
	76	9,801,588	10/31/2017	Weber et al.	
	77	9,808,188	11/7/2017	Perea et al.	
	78	9,814,418	11/14/2017	Weber et al.	
	79	9,820,691	11/21/2017	Kiani	
	80	9,833,152	12/5/2017	Kiani et al.	
	81	9,833,180	12/5/2017	Shakespeare et al.	
	82	9,839,379	12/12/2017	Al-Ali et al.	
	83	9,839,381	12/12/2017	Weber et al.	
	84	9,847,002	12/19/2017	Kiani et al.	
	85	9,847,749	12/19/2017	Kiani et al.	
	86	9,848,800	12/26/2017	Lee et al.	
	87	9,848,806	12/26/2017	Al-Ali et al.	

Examiner Signature	Date Considered
<p><b>*Examiner:</b> Initial if reference considered, whether or not citation is in conformance with MPEP 609. Draw line through citation if not in conformance and not considered. Include copy of this form with next communication to applicant.</p>	

T<sup>1</sup> - Place a check mark in this area when an English language Translation is attached.



<b>INFORMATION DISCLOSURE STATEMENT BY APPLICANT</b>	Application No.	16/226249
	Filing Date	December 19, 2018
	First Named Inventor	Ammar Al-Ali
	Art Unit	3791
<i>(Multiple sheets used when necessary)</i>	Examiner	Fardanesh, Marjan
SHEET 4 OF 12	Attorney Docket No.	MAS.1007C1

U.S. PATENT DOCUMENTS					
Examiner Initials	Cite No.	Document Number Number - Kind Code (if known) Example: 1,234,567 B1	Publication Date MM-DD-YYYY	Name	Pages, Columns, Lines Where Relevant Passages or Relevant Figures Appear
	88	9,848,807	12/26/2017	Lamego	
	89	9,861,298	1/9/2018	Eckerbom et al.	
	90	9,861,304	1/9/2018	Al-Ali et al.	
	91	9,861,305	1/9/2018	Weber et al.	
	92	9,867,578	1/16/2018	Al-Ali et al.	
	93	9,872,623	1/23/2018	Al-Ali	
	94	9,876,320	1/23/2018	Coverston et al.	
	95	9,877,650	1/30/2018	Muhsin et al.	
	96	9,877,686	1/30/2018	Al-Ali et al.	
	97	9,891,079	2/13/2018	Dalvi	
	98	9,895,107	2/20/2018	Al-Ali et al.	
	99	9,913,617	3/13/2018	Al-Ali et al.	
	100	9,924,893	3/27/2018	Schurman et al.	
	101	9,924,897	3/27/2018	Abdul-Hafiz	
	102	9,936,917	4/10/2018	Poeze et al.	
	103	9,943,269	4/17/2018	Muhsin et al.	
	104	9,949,676	4/24/2018	Al-Ali	
	105	9,955,937	5/1/2018	Telfort	
	106	9,965,946	5/8/2018	Al-Ali	
	107	9,980,667	5/29/2018	Kiani et al.	
	108	9,986,919	6/5/2018	Lamego et al.	
	109	9,986,952	6/5/2018	Dalvi et al.	
	110	9,989,560	6/5/2018	Poeze et al.	
	111	9,993,207	6/12/2018	Al-Ali et al.	
	112	10,007,758	6/26/2018	Al-Ali et al.	
	113	10,010,276	7/3/2018	Al-Ali et al.	
	114	10,032,002	7/24/2018	Kiani et al.	
	115	10,039,482	8/7/2018	Al-Ali et al.	
	116	10,052,037	8/21/2018	Kinast et al.	

Examiner Signature	Date Considered
<p><b>*Examiner:</b> Initial if reference considered, whether or not citation is in conformance with MPEP 609. Draw line through citation if not in conformance and not considered. Include copy of this form with next communication to applicant.</p>	

T<sup>1</sup> - Place a check mark in this area when an English language Translation is attached.

<b>INFORMATION DISCLOSURE STATEMENT BY APPLICANT</b>	Application No.	16/226249
	Filing Date	December 19, 2018
	First Named Inventor	Ammar Al-Ali
	Art Unit	3791
<i>(Multiple sheets used when necessary)</i>	Examiner	Fardanesh, Marjan
SHEET 5 OF 12	Attorney Docket No.	MAS.1007C1

U.S. PATENT DOCUMENTS					
Examiner Initials	Cite No.	Document Number <i>Number - Kind Code (if known)</i> Example: 1,234,567 B1	Publication Date MM-DD-YYYY	Name	Pages, Columns, Lines Where Relevant Passages or Relevant Figures Appear
	117	10,058,275	8/28/2018	Al-Ali et al.	
	118	10,064,562	9/4/2018	Al-Ali	
	119	10,086,138	10/2/2018	Novak, Jr.	
	120	10,092,200	10/9/2018	Al-Ali et al.	
	121	10,092,249	10/9/2018	Kiani et al.	
	122	10,098,550	10/16/2018	Al-Ali et al.	
	123	10,098,591	10/16/2018	Al-Ali et al.	
	124	10,098,610	10/16/2018	Al-Ali et al.	
	125	10,123,726	11/13/2018	Al-Ali et al.	
	126	10,130,289	11/20/2018	Al-Ali et al.	
	127	10,130,291	11/20/2018	Schurman et al.	
	128	10,149,616	12/11/2018	Al-Ali et al.	
	129	10,154,815	12/18/2018	Al-Ali et al.	
	130	10,159,412	12/25/2018	Lamego et al.	
	131	10,188,296	1/29/2019	Al-Ali et al.	
	132	10,188,331	1/29/2019	Al-Ali et al.	
	133	10,188,348	1/29/2019	Kiani et al.	
	134	10,194,847	2/5/2019	Al-Ali	
	135	10,194,848	2/5/2019	Kiani et al.	
	136	10,201,298	2/12/2019	Al-Ali et al.	
	137	10,205,272	2/12/2019	Kiani et al.	
	138	10,205,291	2/12/2019	Scruggs et al.	
	139	10,213,108	2/26/2019	Al-Ali	
	140	10,219,706	3/5/2019	Al-Ali	
	141	10,219,746	3/5/2019	McHale et al.	
	142	10,226,187	3/12/2019	Al-Ali et al	
	143	10,226,576	3/12/2019	Kiani	
	144	10,231,657	3/19/2019	Al-Ali et al	
	145	10,231,670	3/19/2019	Blank et al.	

Examiner Signature	Date Considered
<p><b>*Examiner:</b> Initial if reference considered, whether or not citation is in conformance with MPEP 609. Draw line through citation if not in conformance and not considered. Include copy of this form with next communication to applicant.</p>	

T<sup>1</sup> - Place a check mark in this area when an English language Translation is attached.

<b>INFORMATION DISCLOSURE STATEMENT BY APPLICANT</b>	Application No.	16/226249
	Filing Date	December 19, 2018
	First Named Inventor	Ammar Al-Ali
	Art Unit	3791
<i>(Multiple sheets used when necessary)</i>	Examiner	Fardanesh, Marjan
SHEET 6 OF 12	Attorney Docket No.	MAS.1007C1

U.S. PATENT DOCUMENTS					
Examiner Initials	Cite No.	Document Number <i>Number - Kind Code (if known)</i> Example: 1,234,567 B1	Publication Date MM-DD-YYYY	Name	Pages, Columns, Lines Where Relevant Passages or Relevant Figures Appear
	146	10,231,676	3/19/2019	Al-Ali et al	
	147	10,251,585	4/9/2019	Al-Ali et al.	
	148	10,251,586	4/9/2019	Lamego	
	149	10,255,994	4/9/2019	Sampath et al.	
	150	10,258,265	4/16/2019	Poeze et al.	
	151	10,258,266	4/16/2019	Poeze et al.	
	152	10,271,748	4/30/2019	Al-Ali	
	153	10,278,626	5/7/2019	Schurman et al.	
	154	10,278,648	5/7/2019	Al-Ali et al.	
	155	10,279,247	5/7/2019	Kiani	
	156	10,292,628	5/21/2019	Poeze et al.	
	157	10,292,657	5/21/2019	Abdul-Hafiz et al.	
	158	10,292,664	5/21/2019	Al-Ali	
	159	10,299,708	5/28/2019	Poeze et al.	
	160	10,299,709	5/28/2019	Perea et al.	
	161	10,305,775	5/28/2019	Lamego et al.	
	162	10,307,111	6/4/2019	Muhsin et al.	
	163	10,325,681	6/18/2019	Sampath et al.	
	164	10,327,337	6/18/2019	Triman et al.	
	165	D788,312	5/30/2017	Al-Ali et al.	
	166	D820,865	6/19/2018	Muhsin et al.	
	167	D822,215	7/3/2018	Al-Ali et al.	
	168	D822,216	7/3/2018	Barker et al.	
	169	D833,624	11/13/2018	DeJong et al.	
	170	D835,282	12/4/2018	Barker et al.	
	171	D835,283	12/4/2018	Barker et al.	
	172	D835,284	12/4/2018	Barker et al.	
	173	D835,285	12/4/2018	Barker et al.	
	174	RE47,218	2/5/2019	Ali-Ali	

Examiner Signature	Date Considered
<p><b>*Examiner:</b> Initial if reference considered, whether or not citation is in conformance with MPEP 609. Draw line through citation if not in conformance and not considered. Include copy of this form with next communication to applicant.</p>	

T<sup>1</sup> - Place a check mark in this area when an English language Translation is attached.

<b>INFORMATION DISCLOSURE STATEMENT BY APPLICANT</b>	Application No.	16/226249
	Filing Date	December 19, 2018
	First Named Inventor	Ammar Al-Ali
	Art Unit	3791
<i>(Multiple sheets used when necessary)</i>	Examiner	Fardanesh, Marjan
SHEET 7 OF 12	Attorney Docket No.	MAS.1007C1

U.S. PATENT DOCUMENTS					
Examiner Initials	Cite No.	Document Number <i>Number - Kind Code (if known)</i> Example: 1,234,567 B1	Publication Date MM-DD-YYYY	Name	Pages, Columns, Lines Where Relevant Passages or Relevant Figures Appear
	175	RE47,244	2/19/2019	Kiani et al.	
	176	RE47,249	2/19/2019	Kiani et al.	
	177	RE47,353	4/16/2019	Kiani et al.	
	178	2004/0054290	3/18/2004	Chance	
	179	2004/0114783	6/17/2004	Spycher et al.	
	180	2006/0161054	7/20/2006	Reuss et al.	
	181	2011/0004106	1/6/2011	Iwamiya et al.	
	182	2011/0085721	4/14/2011	Guyon et al.	
	183	2016/0166182	6/16/2016	Al-Ali et al.	
	184	2016/0166183	6/16/2016	Poeze et al.	
	185	2016/0196388	7/7/2016	Lamego	
	186	2016/0197436	7/7/2016	Barker et al.	
	187	2016/0213281	7/28/2016	Eckerbom, et al.	
	188	2016/0228043	8/11/2016	O'Neil et al.	
	189	2016/0233632	8/11/2016	Scruggs et al.	
	190	2016/0234944	8/11/2016	Schmidt et al.	
	191	2016/0270735	9/22/2016	Diab et al.	
	192	2016/0283665	9/29/2016	Sampath et al.	
	193	2016/0287090	10/6/2016	Al-Ali et al.	
	194	2016/0287786	10/6/2016	Kiani	
	195	2016/0296169	10/13/2016	McHale et al.	
	196	2016/0310052	10/27/2016	Al-Ali et al.	
	197	2016/0314260	10/27/2016	Kiani	
	198	2016/0324488	11/10/2016	Olsen	
	199	2016/0327984	11/10/2016	Al-Ali et al.	
	200	2016/0331332	11/17/2016	Al-Ali	
	201	2016/0367173	12/22/2016	Dalvi et al.	
	202	2017/0000394	1/5/2017	Al-Ali et al.	
	203	2017/0007134	1/12/2017	Al-Ali et al.	

Examiner Signature	Date Considered
<p><b>*Examiner:</b> Initial if reference considered, whether or not citation is in conformance with MPEP 609. Draw line through citation if not in conformance and not considered. Include copy of this form with next communication to applicant.</p>	

T<sup>1</sup> - Place a check mark in this area when an English language Translation is attached.

<b>INFORMATION DISCLOSURE STATEMENT BY APPLICANT</b>	Application No.	16/226249
	Filing Date	December 19, 2018
	First Named Inventor	Ammar Al-Ali
	Art Unit	3791
<i>(Multiple sheets used when necessary)</i>	Examiner	Fardanesh, Marjan
SHEET 8 OF 12	Attorney Docket No.	MAS.1007C1

<b>U.S. PATENT DOCUMENTS</b>					
Examiner Initials	Cite No.	Document Number <i>Number - Kind Code (if known)</i> Example: 1,234,567 B1	Publication Date MM-DD-YYYY	Name	Pages, Columns, Lines Where Relevant Passages or Relevant Figures Appear
	204	2017/0007198	1/12/2017	Al-Ali et al.	
	205	2017/0014083	1/19/2017	Diab et al.	
	206	2017/0014084	1/19/2017	Al-Ali et al.	
	207	2017/0024748	1/26/2017	Haider	
	208	2017/0042488	2/16/2017	Muhsin	
	209	2017/0055851	3/2/2017	Al-Ali	
	210	2017/0055882	3/2/2017	Al-Ali et al.	
	211	2017/0055887	3/2/2017	Al-Ali	
	212	2017/0055896	3/2/2017	Al-Ali et al.	
	213	2017/0079594	3/23/2017	Telfort et al.	
	214	2017/0086723	3/30/2017	Al-Ali et al.	
	215	2017/0143281	5/25/2017	Olsen	
	216	2017/0147774	5/25/2017	Kiani	
	217	2017/0156620	6/8/2017	Al-Ali et al.	
	218	2017/0173632	6/22/2017	Al-Ali	
	219	2017/0187146	6/29/2017	Kiani et al.	
	220	2017/0188919	7/6/2017	Al-Ali et al.	
	221	2017/0196464	7/13/2017	Jansen et al.	
	222	2017/0196470	7/13/2017	Lamego et al.	
	223	2017/0224262	8/10/2017	Al-Ali	
	224	2017/0228516	8/10/2017	Sampath et al.	
	225	2017/0245790	8/31/2017	Al-Ali et al.	
	226	2017/0251974	9/7/2017	Shreim et al.	
	227	2017/0251975	9/7/2017	Shreim et al.	
	228	2017/0258403	9/14/2017	Abdul-Hafiz et al.	
	229	2017/0311851	11/2/2017	Schurman et al.	
	230	2017/0311891	11/2/2017	Kiani et al.	
	231	2017/0325728	11/16/2017	Al-Ali et al.	
	232	2017/0332976	11/23/2017	Al-Ali et al.	

Examiner Signature	Date Considered
<p><b>*Examiner:</b> Initial if reference considered, whether or not citation is in conformance with MPEP 609. Draw line through citation if not in conformance and not considered. Include copy of this form with next communication to applicant.</p>	

T<sup>1</sup> - Place a check mark in this area when an English language Translation is attached.

<b>INFORMATION DISCLOSURE STATEMENT BY APPLICANT</b>	Application No.	16/226249
	Filing Date	December 19, 2018
	First Named Inventor	Ammar Al-Ali
	Art Unit	3791
<i>(Multiple sheets used when necessary)</i>	Examiner	Fardanesh, Marjan
SHEET 9 OF 12	Attorney Docket No.	MAS.1007C1

U.S. PATENT DOCUMENTS					
Examiner Initials	Cite No.	Document Number <i>Number - Kind Code (if known)</i> Example: 1,234,567 B1	Publication Date MM-DD-YYYY	Name	Pages, Columns, Lines Where Relevant Passages or Relevant Figures Appear
	233	2017/0340293	11/30/2017	Al-Ali et al.	
	234	2017/0360310	12/21/2017	Kiani et al.	
	235	2017/0367632	12/28/2017	Al-Ali et al.	
	236	2018/0008146	1/11/2018	Al-Ali et al.	
	237	2018/0013562	1/11/2018	Haider et al.	
	238	2018/0014752	1/18/2018	Al-Ali et al.	
	239	2018/0028124	2/1/2018	Al-Ali et al.	
	240	2018/0055385	3/1/2018	Al-Ali	
	241	2018/0055390	3/1/2018	Kiani et al.	
	242	2018/0055430	3/1/2018	Diab et al.	
	243	2018/0064381	3/8/2018	Shakespeare et al.	
	244	2018/0069776	3/8/2018	Lamego et al.	
	245	2018/0070867	3/15/2018	Smith et al.	
	246	2018/0082767	3/22/2018	Al-Ali et al.	
	247	2018/0085068	3/29/2018	Telfort	
	248	2018/0087937	3/29/2018	Al-Ali et al.	
	249	2018/0103874	4/19/2018	Lee et al.	
	250	2018/0103905	4/19/2018	Kiani	
	251	2018/0110478	4/26/2018	Al-Ali	
	252	2018/0116575	5/3/2018	Perea et al.	
	253	2018/0125368	5/10/2018	Lamego et al.	
	254	2018/0125430	5/10/2018	Al-Ali et al.	
	255	2018/0125445	5/10/2018	Telfort et al.	
	256	2018/0130325	5/10/2018	Kiani et al.	
	257	2018/0132769	5/17/2018	Weber et al.	
	258	2018/0132770	5/17/2018	Lamego	
	259	2018/0146901	5/31/2018	Al-Ali et al.	
	260	2018/0146902	5/31/2018	Kiani et al.	
	261	2018/0153442	6/7/2018	Eckerbom, et al.	

Examiner Signature	Date Considered
<p><b>*Examiner:</b> Initial if reference considered, whether or not citation is in conformance with MPEP 609. Draw line through citation if not in conformance and not considered. Include copy of this form with next communication to applicant.</p>	

T<sup>1</sup> - Place a check mark in this area when an English language Translation is attached.

<b>INFORMATION DISCLOSURE STATEMENT BY APPLICANT</b>	Application No.	16/226249
	Filing Date	December 19, 2018
	First Named Inventor	Ammar Al-Ali
	Art Unit	3791
<i>(Multiple sheets used when necessary)</i>	Examiner	Fardanesh, Marjan
SHEET 10 OF 12	Attorney Docket No.	MAS.1007C1

U.S. PATENT DOCUMENTS					
Examiner Initials	Cite No.	Document Number <i>Number - Kind Code (if known)</i> Example: 1,234,567 B1	Publication Date MM-DD-YYYY	Name	Pages, Columns, Lines Where Relevant Passages or Relevant Figures Appear
	262	2018/0153446	6/7/2018	Kiani	
	263	2018/0153447	6/7/2018	Al-Ali et al.	
	264	2018/0153448	6/7/2018	Weber et al.	
	265	2018/0161499	6/14/2018	Al-Ali et al.	
	266	2018/0168491	6/21/2018	Al-Ali et al.	
	267	2018/0174679	6/21/2018	Sampath et al.	
	268	2018/0174680	6/21/2018	Sampath et al.	
	269	2018/0182484	6/28/2018	Sampath et al.	
	270	2018/0184917	7/5/2018	Kiani	
	271	2018/0192924	7/12/2018	Al-Ali	
	272	2018/0192953	7/12/2018	Shreim et al.	
	273	2018/0192955	7/12/2018	Al-Ali et al.	
	274	2018/0199871	7/19/2018	Pauley et al.	
	275	2018/0206795	7/26/2018	Al-Ali	
	276	2018/0206815	7/26/2018	Telfort	
	277	2018/0213583	7/26/2018	Al-Ali	
	278	2018/0214031	8/2/2018	Kiani et al.	
	279	2018/0214090	8/2/2018	Al-Ali et al.	
	280	2018/0218792	8/2/2018	Muhsin et al.	
	281	2018/0225960	8/9/2018	Al-Ali et al.	
	282	2018/0238718	8/23/2018	Dalvi	
	283	2018/0242853	8/30/2018	Al-Ali	
	284	2018/0242921	8/30/2018	Muhsin et al.	
	285	2018/0242923	8/30/2018	Al-Ali et al.	
	286	2018/0242924	8/30/2018	Barker et al.	
	287	2018/0242926	8/30/2018	Muhsin et al.	
	288	2018/0247353	8/30/2018	Al-Ali et al.	
	289	2018/0247712	8/30/2018	Muhsin et al.	
	290	2018/0249933	9/6/2018	Schurman, et al.	

Examiner Signature	Date Considered
<p><b>*Examiner:</b> Initial if reference considered, whether or not citation is in conformance with MPEP 609. Draw line through citation if not in conformance and not considered. Include copy of this form with next communication to applicant.</p>	

T<sup>1</sup> - Place a check mark in this area when an English language Translation is attached.

<b>INFORMATION DISCLOSURE STATEMENT BY APPLICANT</b>	Application No.	16/226249
	Filing Date	December 19, 2018
	First Named Inventor	Ammar Al-Ali
	Art Unit	3791
<i>(Multiple sheets used when necessary)</i>	Examiner	Fardanesh, Marjan
SHEET 11 OF 12	Attorney Docket No.	MAS.1007C1

U.S. PATENT DOCUMENTS					
Examiner Initials	Cite No.	Document Number <i>Number - Kind Code (if known)</i> Example: 1,234,567 B1	Publication Date MM-DD-YYYY	Name	Pages, Columns, Lines Where Relevant Passages or Relevant Figures Appear
	291	2018/0253947	9/6/2018	Muhsin et al.	
	292	2018/0256087	9/13/2018	Al-Ali et al.	
	293	2018/0256113	9/13/2018	Weber et al.	
	294	2018/0285094	10/4/2018	Housel et al.	
	295	2018/0289325	10/11/2018	Poeze et al.	
	296	2018/0289337	10/11/2018	Al-Ali et al.	
	297	2018/0296161	10/18/2018	Shreim et al.	
	298	2018/0300919	10/18/2018	Muhsin et al.	
	299	2018/0310822	11/1/2018	Indorf et al.	
	300	2018/0310823	11/1/2018	Al-Ali et al.	
	301	2018/0317826	11/8/2018	Muhsin	
	302	2018/0317841	11/8/2018	Novak, Jr.	
	303	2018/0333055	11/22/2018	Lamego et al.	
	304	2018/0333087	11/22/2019	Al-Ali	
	305	2019/0000317	1/3/2019	Muhsin et al.	
	306	2019/0000362	1/3/2019	Kiani et al.	
	307	2019/0015023	1/17/2019	Monfre	
	308	2019/0021638	1/24/2019	Al-Ali et al.	
	309	2019/0029574	1/31/2019	Schurman et al.	
	310	2019/0029578	1/31/2019	Al-Ali et al.	
	311	2019/0038143	2/7/2019	Al-Ali	
	312	2019/0058280	2/21/2019	Al-Ali et al.	
	313	2019/0058281	2/21/2019	Al-Ali et al.	
	314	2019/0069813	3/7/2019	Al-Ali	
	315	2019/0069814	3/7/2019	Al-Ali	
	316	2019/0076028	3/14/2019	Al-Ali et al.	
	317	2019/0082979	3/21/2019	Al-Ali et al.	
	318	2019/0090748	3/28/2019	Al-Ali	
	319	2019/0090760	3/28/2019	Kinast et al.	

Examiner Signature	Date Considered
<p><b>*Examiner:</b> Initial if reference considered, whether or not citation is in conformance with MPEP 609. Draw line through citation if not in conformance and not considered. Include copy of this form with next communication to applicant.</p>	

T<sup>1</sup> - Place a check mark in this area when an English language Translation is attached.



<b>INFORMATION DISCLOSURE STATEMENT BY APPLICANT</b>	Application No.	16/226249
	Filing Date	December 19, 2018
	First Named Inventor	Ammar Al-Ali
	Art Unit	3791
<i>(Multiple sheets used when necessary)</i>	Examiner	Fardanesh, Marjan
SHEET 12 OF 12	Attorney Docket No.	MAS.1007C1

<b>U.S. PATENT DOCUMENTS</b>					
Examiner Initials	Cite No.	Document Number <i>Number - Kind Code (if known)</i> Example: 1,234,567 B1	Publication Date MM-DD-YYYY	Name	Pages, Columns, Lines Where Relevant Passages or Relevant Figures Appear
	320	2019/0090764	3/28/2019	Al-Ali	
	321	2019/0104973	04-11-2019	Poeze et al.	
	322	2019/0110719	4/18/2019	Poeze et al.	
	323	2019/0117070	4/25/2019	Muhsin et al.	
	324	2019/0117139	4/25/2019	Al-Ali et al.	
	325	2019/0117140	4/25/2019	Al-Ali et al.	
	326	2019/0117141	4/25/2019	Al-Ali	
	327	2019/0117930	4/25/2019	Al-Ali	
	328	2019/0122763	4/25/2019	Sampath et al.	
	329	2019/0133525	5/9/2019	Al-Ali et al.	
	330	2019/0142283	5/16/2019	Lamego et al.	
	331	2019/0142344	5/16/2019	Telfort et al.	
	332	2019/0150800	5/23/2019	Poeze et al.	
	333	2019/0150856	5/23/2019	Kiani et al.	
	334	2019/0167161	6/6/2019	Al-Ali et al.	
	335	2019/0175019	6/13/2019	Al-Ali et al.	
	336	2019/0192076	6/27/2010	McHale et al.	

<b>FOREIGN PATENT DOCUMENTS</b>						
Examiner Initials	Cite No.	Foreign Patent Document <i>Country Code-Number-Kind Code</i> Example: JP 1234567 A1	Publication Date MM-DD-YYYY	Name	Pages, Columns, Lines Where Relevant Passages or Relevant Figures Appear	T <sup>1</sup>

<b>NON PATENT LITERATURE DOCUMENTS</b>			
Examiner Initials	Cite No.	Include name of the author (in CAPITAL LETTERS), title of the article (when appropriate), title of the item (book, magazine, journal, serial, symposium, catalog, etc.), date, page(s), volume-issue number(s), publisher, city and/or country where published.	T <sup>1</sup>

30950940

Examiner Signature	Date Considered
*Examiner: Initial if reference considered, whether or not citation is in conformance with MPEP 609. Draw line through citation if not in conformance and not considered. Include copy of this form with next communication to applicant.	

T<sup>1</sup> - Place a check mark in this area when an English language Translation is attached.

---

**INFORMATION DISCLOSURE STATEMENT**

First Inventor	:	Ammar Al-Ali
App. No.	:	16/226249
Filed	:	December 19, 2018
For	:	ADVANCED PULSE OXIMETRY SENSOR
Examiner	:	Fardanesh, Marjan
Art Unit	:	3791
Conf. No.	:	1002

Commissioner for Patents  
P.O. Box 1450  
Alexandria, VA 22313-1450

**References and Listing**

Pursuant to 37 CFR 1.56, an Information Disclosure Statement listing references is provided herewith. Copies of any listed foreign and non-patent literature references are being submitted.

**No Disclaimers**

To the extent that anything in the Information Disclosure Statement or the listed references could be construed as a disclaimer of any subject matter supported by the present application, Applicant hereby rescinds and retracts such disclaimer.

**Timing of Disclosure**

This Information Disclosure Statement is being filed after receipt of a First Office Action, but before the mailing date of a Final Action and before the mailing date of a Notice of Allowance.

This Statement is accompanied by the fees set forth in 37 CFR 1.17(p). The Commissioner is hereby authorized to charge any additional fees which may be required or to credit any overpayment to Account No. 11-1410.

Respectfully submitted,  
KNOBBE, MARTENS, OLSON & BEAR, LLP

Dated: July 19, 2019

By: /Aaron S. Johnson/  
Aaron S. Johnson  
Registration No. 74,164  
Registered Practitioner  
Customer No. 64735  
(949) 760-0404

## Electronic Patent Application Fee Transmittal

<b>Application Number:</b>	16226249				
<b>Filing Date:</b>	19-Dec-2018				
<b>Title of Invention:</b>	ADVANCED PULSE OXIMETRY SENSOR				
<b>First Named Inventor/Applicant Name:</b>	Ammar Al-Ali				
<b>Filer:</b>	Aaron Samuel Johnson/Daniel Escajeda				
<b>Attorney Docket Number:</b>	MAS.1007C1				
Filed as Large Entity					
<b>Filing Fees for Utility under 35 USC 111(a)</b>					
<b>Description</b>	<b>Fee Code</b>	<b>Quantity</b>	<b>Amount</b>	<b>Sub-Total in USD(\$)</b>	
<b>Basic Filing:</b>					
<b>Pages:</b>					
<b>Claims:</b>					
<b>Miscellaneous-Filing:</b>					
<b>Petition:</b>					
<b>Patent-Appeals-and-Interference:</b>					
<b>Post-Allowance-and-Post-Issuance:</b>					
<b>Extension-of-Time:</b>					

Description	Fee Code	Quantity	Amount	Sub-Total in USD(\$)
<b>Miscellaneous:</b>				
SUBMISSION- INFORMATION DISCLOSURE STMT	1806	1	240	240
<b>Total in USD (\$)</b>				<b>240</b>

## Electronic Acknowledgement Receipt

<b>EFS ID:</b>	36636368
<b>Application Number:</b>	16226249
<b>International Application Number:</b>	
<b>Confirmation Number:</b>	1002
<b>Title of Invention:</b>	ADVANCED PULSE OXIMETRY SENSOR
<b>First Named Inventor/Applicant Name:</b>	Ammar Al-Ali
<b>Customer Number:</b>	64735
<b>Filer:</b>	Aaron Samuel Johnson/Daniel Escajeda
<b>Filer Authorized By:</b>	Aaron Samuel Johnson
<b>Attorney Docket Number:</b>	MAS.1007C1
<b>Receipt Date:</b>	19-JUL-2019
<b>Filing Date:</b>	19-DEC-2018
<b>Time Stamp:</b>	13:23:52
<b>Application Type:</b>	Utility under 35 USC 111(a)

### Payment information:

Submitted with Payment	yes
Payment Type	CARD
Payment was successfully received in RAM	\$240
RAM confirmation Number	071919INTEFSW13250800
Deposit Account	
Authorized User	

The Director of the USPTO is hereby authorized to charge indicated fees and credit any overpayment as follows:

--	--	--	--	--	--

**File Listing:**

Document Number	Document Description	File Name	File Size(Bytes)/ Message Digest	Multi Part /.zip	Pages (if appl.)
1		IDS_MAS1007C1.pdf	157671	yes	13
			3a3162a75370e7d4ecbf40a717d6fee4d0b2eb97		

Multipart Description/PDF files in .zip description			
Document Description	Start	End	
Information Disclosure Statement (IDS) Form (SB08)	2	13	
Transmittal Letter	1	1	

**Warnings:**

**Information:**

2	Fee Worksheet (SB06)	fee-info.pdf	30470	no	2
			6ab1762475a3900bb6fe5f09c8b26b7309214039		

**Warnings:**

**Information:**

<b>Total Files Size (in bytes):</b>	188141
-------------------------------------	--------

**This Acknowledgement Receipt evidences receipt on the noted date by the USPTO of the indicated documents, characterized by the applicant, and including page counts, where applicable. It serves as evidence of receipt similar to a Post Card, as described in MPEP 503.**

**New Applications Under 35 U.S.C. 111**

**If a new application is being filed and the application includes the necessary components for a filing date (see 37 CFR 1.53(b)-(d) and MPEP 506), a Filing Receipt (37 CFR 1.54) will be issued in due course and the date shown on this Acknowledgement Receipt will establish the filing date of the application.**

**National Stage of an International Application under 35 U.S.C. 371**

**If a timely submission to enter the national stage of an international application is compliant with the conditions of 35 U.S.C. 371 and other applicable requirements a Form PCT/DO/EO/903 indicating acceptance of the application as a national stage submission under 35 U.S.C. 371 will be issued in addition to the Filing Receipt, in due course.**

**New International Application Filed with the USPTO as a Receiving Office**

**If a new international application is being filed and the international application includes the necessary components for an international filing date (see PCT Article 11 and MPEP 1810), a Notification of the International Application Number and of the International Filing Date (Form PCT/RO/105) will be issued in due course, subject to prescriptions concerning national security, and the date shown on this Acknowledgement Receipt will establish the international filing date of the application.**

Doc Code: R48.REQ

Document Description: Request under Rule 48 correcting inventorship

PTO/AIA/40 (04-18)

Approved for use through 11/30/2020. OMB 0651-0031

U.S. Patent and Trademark Office, U.S. DEPARTMENT OF COMMERCE

Under the Paperwork Reduction Act of 1995, no persons are required to respond to a collection of information unless it displays a valid OMB control number.

<b>REQUEST FOR CORRECTION IN A PATENT APPLICATION RELATING TO INVENTORSHIP OR AN INVENTOR NAME, OR ORDER OF NAMES, OTHER THAN IN A REISSUE APPLICATION (37 CFR 1.48)</b>	Application Number	16/226249
	Filing Date	December 19, 2018
	First Named Inventor	Amriar Al-Ali
	Art Unit	3791
	Examiner Name	Fardanesh, Marjan
	Practitioner Docket Number	<b>MAS.1007C1</b>

To: Commissioner for Patents  
P.O. Box 1450  
Alexandria, VA 22313-1450

Applicant hereby requests that the inventorship be corrected or changed, or that the name of the inventor or a joint inventor, or the order of the names of joint inventors, be changed, in the above-identified application. Note: 37 CFR 1.48 applies to any request to correct inventorship filed on or after September 16, 2012, regardless of the application filing date. Do not submit this form after payment of the issue fee or if the application has been patented. See 37 CFR 1.324 for correction of inventorship in a patent.

Please check the applicable box(es) below.

**For a nonprovisional application:**

- 1. This request is to correct or change the inventorship in a **nonprovisional** application (**under 37 CFR 1.48(a)**) and includes:
    - An application data sheet (ADS) in accordance with 37 CFR 1.76(c) with the corrected or updated information shown with markings (e.g., underlining for insertions, strikethrough for deletions). See the Manual of Patent Examining Procedure (MPEP) section 601.05(a) for information about filing an ADS in an application filed on/after September 16, 2012. For information about filing a Supplemental ADS in an application filed before September 16, 2012, see MPEP 601.05(b).
    - The processing fee set forth in 37 CFR 1.17(i). \$ 140
    - An inventor is being added. An inventor's oath or declaration by any actual inventor who has not yet executed an oath or declaration is required (see 37 CFR 1.48(b)). See MPEP 602.01(a) for information about an inventor's oath or declaration for an application filed on/after September 16, 2012 (e.g., form **PTO/AIA/01**). For information about an inventor's oath or declaration for an application filed before September 16, 2012 (e.g., form **PTO/SB/01**), see MPEP 602.01(b).
    - This request is being filed after the first Office action on the merits has been given or mailed (see 37 CFR 1.48(c) and 1.17(d)). Check one of the following:
      - This request to correct or change the inventorship is due solely to the cancellation of claims in the application.
- OR
- The fee set forth in 37 CFR 1.17(d) is due (in addition to the fee set forth in 37 CFR 1.17(i)). \$ 600

[Page 1 of 2]

This collection of information is required by 37 CFR 1.48. The information is required to obtain or retain a benefit by the public which is to file (and by the USPTO to process) an application. Confidentiality is governed by 35 U.S.C. 122 and 37 CFR 1.11 and 1.14. This collection is estimated to take 1 hour to complete, including gathering, preparing, and submitting the completed application form to the USPTO. Time will vary depending upon the individual case. Any comments on the amount of time you require to complete this form and/or suggestions for reducing this burden, should be sent to the Chief Information Officer, U.S. Patent and Trademark Office, U.S. Department of Commerce, P.O. Box 1450, Alexandria, VA 22313-1450. DO NOT SEND FEES OR COMPLETED FORMS TO THIS ADDRESS. **SEND TO: Commissioner for Patents, P.O. Box 1450, Alexandria, VA 22313-1450.**

If you need assistance in completing the form, call 1-800-PTO-9199 and select option 2.

Under the Paperwork Reduction Act of 1995, no persons are required to respond to a collection of information unless it displays a valid OMB control number.

**REQUEST FOR CORRECTION IN A PATENT APPLICATION RELATING TO INVENTORSHIP OR AN INVENTOR NAME, OR ORDER OF NAMES, OTHER THAN IN A REISSUE APPLICATION (37 CFR 1.48)**

2. This request is to correct or update the name of the inventor or a joint inventor, or the order of names of joint inventors, in a **nonprovisional** application (under 37 CFR 1.48(f)) and includes:

An application data sheet in accordance with 37 CFR 1.76(c) identifying the complete inventive entity, including the corrected or updated name of the inventor, or the new order of names shown with markings (e.g., underlining for insertions, strikethrough for deletions). See the MPEP 601.05(a) for information about filing an ADS in an application filed on/after September 16, 2012. For information about filing a Supplemental ADS in an application filed before September 16, 2012, see MPEP 601.05(b).

The processing fee set forth in 37 CFR 1.17(i). \$ \_\_\_\_\_

**For a provisional application:**

This request is to change or correct the inventorship, or correct or update the name of the inventor or a joint inventor, in a **provisional** application (under 37 CFR 1.48(d)) and includes:

Attached hereto is a document that is signed by a party set forth in 37 CFR 1.33(b) and identifies each inventor by his or her legal name, in the preferred order. Note: the document may be an application data sheet in accordance with 37 CFR 1.76(c) that identifies the changes with markings (underlining for insertions, strikethrough for deletions).

The processing fee set forth in 37 CFR 1.17(q). \$ \_\_\_\_\_

**Fee Payment Information:**

Applicant asserts small entity status. See 37 CFR 1.27.

Applicant certifies micro entity status. See 37 CFR 1.29. Form PTO/SB/15A or B or equivalent must either be enclosed or have been submitted previously

A check in the amount of the fee is enclosed.

Payment by credit card. Form PTO-2038 is attached.

The Director is hereby authorized to charge any fees which may be required, or credit any overpayment to Deposit Account No. 11-1410.

Payment made via EFS-Web.

**WARNING: Information on this form may become public. Credit card information should not be included on this form. Provide credit card information and authorization on PTO-2038.**

I am the

Applicant\*       attorney or agent of record       attorney or agent acting under 37 CFR 1.34

Registration number 74164      Registration number \_\_\_\_\_

Signature /Aaron S. Johnson/

Typed or printed name Aaron S. Johnson

Date July 19, 2019

**NOTE:** This form must be signed in accordance with 37 CFR 1.33. See 37 CFR 1.4 for signature requirements and certifications. \*Juristic entities must be represented by a patent practitioner (See 37 CFR 1.31, applicable to any paper filed on or after September 16, 2012 that is presented on behalf of a juristic entity, regardless of application filing date). Submit multiple forms if more than one signature is required, see below\*\*.

\*\* Total of 1 forms are submitted.



## Privacy Act Statement

The **Privacy Act of 1974 (P.L. 93-579)** requires that you be given certain information in connection with your submission of the attached form related to a patent application or patent. Accordingly, pursuant to the requirements of the Act, please be advised that: (1) the general authority for the collection of this information is 35 U.S.C. 2(b)(2); (2) furnishing of the information solicited is voluntary; and (3) the principal purpose for which the information is used by the U.S. Patent and Trademark Office is to process and/or examine your submission related to a patent application or patent. If you do not furnish the requested information, the U.S. Patent and Trademark Office may not be able to process and/or examine your submission, which may result in termination of proceedings or abandonment of the application or expiration of the patent.

The information provided by you in this form will be subject to the following routine uses:

1. The information on this form will be treated confidentially to the extent allowed under the Freedom of Information Act (5 U.S.C. 552) and the Privacy Act (5 U.S.C. 552a). Records from this system of records may be disclosed to the Department of Justice to determine whether disclosure of these records is required by the Freedom of Information Act.
2. A record from this system of records may be disclosed, as a routine use, in the course of presenting evidence to a court, magistrate, or administrative tribunal, including disclosures to opposing counsel in the course of settlement negotiations.
3. A record in this system of records may be disclosed, as a routine use, to a Member of Congress submitting a request involving an individual, to whom the record pertains, when the individual has requested assistance from the Member with respect to the subject matter of the record.
4. A record in this system of records may be disclosed, as a routine use, to a contractor of the Agency having need for the information in order to perform a contract. Recipients of information shall be required to comply with the requirements of the Privacy Act of 1974, as amended, pursuant to 5 U.S.C. 552a(m).
5. A record related to an International Application filed under the Patent Cooperation Treaty in this system of records may be disclosed, as a routine use, to the International Bureau of the World Intellectual Property Organization, pursuant to the Patent Cooperation Treaty.
6. A record in this system of records may be disclosed, as a routine use, to another federal agency for purposes of National Security review (35 U.S.C. 181) and for review pursuant to the Atomic Energy Act (42 U.S.C. 218(c)).
7. A record from this system of records may be disclosed, as a routine use, to the Administrator, General Services, or his/her designee, during an inspection of records conducted by GSA as part of that agency's responsibility to recommend improvements in records management practices and programs, under authority of 44 U.S.C. 2904 and 2906. Such disclosure shall be made in accordance with the GSA regulations governing inspection of records for this purpose, and any other relevant (*i.e.*, GSA or Commerce) directive. Such disclosure shall not be used to make determinations about individuals.
8. A record from this system of records may be disclosed, as a routine use, to the public after either publication of the application pursuant to 35 U.S.C. 122(b) or issuance of a patent pursuant to 35 U.S.C. 151. Further, a record may be disclosed, subject to the limitations of 37 CFR 1.14, as a routine use, to the public if the record was filed in an application which became abandoned or in which the proceedings were terminated and which application is referenced by either a published application, an application open to public inspection or an issued patent.
9. A record from this system of records may be disclosed, as a routine use, to a Federal, State, or local law enforcement agency, if the USPTO becomes aware of a violation or potential violation of law or regulation.

## Electronic Patent Application Fee Transmittal

<b>Application Number:</b>	16226249				
<b>Filing Date:</b>	19-Dec-2018				
<b>Title of Invention:</b>	ADVANCED PULSE OXIMETRY SENSOR				
<b>First Named Inventor/Applicant Name:</b>	Ammar Al-Ali				
<b>Filer:</b>	Aaron Samuel Johnson/Daniel Escajeda				
<b>Attorney Docket Number:</b>	MAS.1007C1				
Filed as Large Entity					
<b>Filing Fees for Utility under 35 USC 111(a)</b>					
<b>Description</b>	<b>Fee Code</b>	<b>Quantity</b>	<b>Amount</b>	<b>Sub-Total in USD(\$)</b>	
<b>Basic Filing:</b>					
<b>Pages:</b>					
<b>Claims:</b>					
<b>Miscellaneous-Filing:</b>					
PROCESSING FEE, EXCEPT PROV. APPLS.	1830	1	140	140	
<b>Petition:</b>					
<b>Patent-Appeals-and-Interference:</b>					
<b>Post-Allowance-and-Post-Issuance:</b>					

Description	Fee Code	Quantity	Amount	Sub-Total in USD(\$)
<b>Extension-of-Time:</b>				
<b>Miscellaneous:</b>				
CORRECTION OF INVENTORSHIP ON MERITS	1819	1	600	600
<b>Total in USD (\$)</b>				<b>740</b>

## Electronic Acknowledgement Receipt

<b>EFS ID:</b>	36637867
<b>Application Number:</b>	16226249
<b>International Application Number:</b>	
<b>Confirmation Number:</b>	1002
<b>Title of Invention:</b>	ADVANCED PULSE OXIMETRY SENSOR
<b>First Named Inventor/Applicant Name:</b>	Ammar Al-Ali
<b>Customer Number:</b>	64735
<b>Filer:</b>	Aaron Samuel Johnson/Jennifer Neat
<b>Filer Authorized By:</b>	Aaron Samuel Johnson
<b>Attorney Docket Number:</b>	MAS.1007C1
<b>Receipt Date:</b>	19-JUL-2019
<b>Filing Date:</b>	19-DEC-2018
<b>Time Stamp:</b>	15:12:04
<b>Application Type:</b>	Utility under 35 USC 111(a)

### Payment information:

Submitted with Payment	yes
Payment Type	CARD
Payment was successfully received in RAM	\$740
RAM confirmation Number	072219INTEFSW15124000
Deposit Account	111410
Authorized User	Jennifer Neat

The Director of the USPTO is hereby authorized to charge indicated fees and credit any overpayment as follows:

37 CFR 1.16 (National application filing, search, and examination fees)

37 CFR 1.17 (Patent application and reexamination processing fees)

--	--	--	--	--	--

**File Listing:**

Document Number	Document Description	File Name	File Size(Bytes)/ Message Digest	Multi Part /.zip	Pages (if appl.)
1	Application Data Sheet	CORR-ADS_MAS1007C1.pdf	35697	no	2
			02f64c428806c04b79ca5d289177fcea6c16403		

**Warnings:**

**Information:**

This is not an USPTO supplied ADS fillable form

2	Request under Rule 48 correcting inventorship	REQUEST_MAS1007C1.pdf	167460	no	3
			987024ad2bb2fd65ed67df6cd920ff308894516		

**Warnings:**

**Information:**

3	Fee Worksheet (SB06)	fee-info.pdf	32197	no	2
			e64f3fba10d3c9aa0c319d78deb9b83b53931cb2		

**Warnings:**

**Information:**

**Total Files Size (in bytes):** 235354

**This Acknowledgement Receipt evidences receipt on the noted date by the USPTO of the indicated documents, characterized by the applicant, and including page counts, where applicable. It serves as evidence of receipt similar to a Post Card, as described in MPEP 503.**

**New Applications Under 35 U.S.C. 111**

**If a new application is being filed and the application includes the necessary components for a filing date (see 37 CFR 1.53(b)-(d) and MPEP 506), a Filing Receipt (37 CFR 1.54) will be issued in due course and the date shown on this Acknowledgement Receipt will establish the filing date of the application.**

**National Stage of an International Application under 35 U.S.C. 371**

**If a timely submission to enter the national stage of an international application is compliant with the conditions of 35 U.S.C. 371 and other applicable requirements a Form PCT/DO/EO/903 indicating acceptance of the application as a national stage submission under 35 U.S.C. 371 will be issued in addition to the Filing Receipt, in due course.**

**New International Application Filed with the USPTO as a Receiving Office**

**If a new international application is being filed and the international application includes the necessary components for an international filing date (see PCT Article 11 and MPEP 1810), a Notification of the International Application Number and of the International Filing Date (Form PCT/RO/105) will be issued in due course, subject to prescriptions concerning national security, and the date shown on this Acknowledgement Receipt will establish the international filing date of the application.**

**APPLICATION DATA SHEET**

**Application Information**

Application Number: 16/226249  
Filing Date: December 19, 2018  
Title: ADVANCED PULSE OXIMETRY SENSOR  
Attorney Docket Number: MAS.1007C1

**Inventor Information 1**

Given Name: Ammar  
Family Name: Al-Ali  
City of Residence: San Juan Capistrano  
State or Prov. of Residence: CA  
Country of Residence: US  
Street: 30312 Via Bella  
City: San Juan Capistrano  
State or Province: CA  
Country: US  
Postal or Zip Code: 92675

**Inventor Information 2**

Given Name: ~~Stephen~~  
Family Name: ~~Scruggs~~  
City of Residence: ~~Newport Beach~~  
State or Prov. of Residence: ~~CA~~  
Country of Residence: ~~US~~  
Street: ~~307 Snug Harbor Road~~  
City: ~~Newport Beach~~  
State or Province: ~~CA~~

Country: US  
Postal or Zip Code: ~~92663~~

**Correspondence Information**

Correspondence Customer Number: 64735  
Phone Number: (949) 760-0404  
Fax Number: (949) 760-9502  
E-Mail Address: [efiling@knobbe.com](mailto:efiling@knobbe.com)

**Representative Information**

Representative Customer Number: 64735

Dated: July 19, 2019

By: Aaron S. Johnson/  
Aaron S. Johnson  
Registration No. 74,164  
Registered Practitioner  
Customer No. 64735  
(949) 760-0404

30951164

<b>Doc Code: DIST.E.FILE</b> <b>Document Description: Electronic Terminal Disclaimer - Filed</b>		PTO/SB/25 U.S. Patent and Trademark Office Department of Commerce
Electronic Petition Request	<b>TERMINAL DISCLAIMER TO OBVIATE A PROVISIONAL DOUBLE PATENTING REJECTION OVER A PENDING "REFERENCE" APPLICATION</b>	
Application Number	16226249	
Filing Date	19-Dec-2018	
First Named Inventor	Ammar Al-Ali	
Attorney Docket Number	MAS.1007C1	
Title of Invention	ADVANCED PULSE OXIMETRY SENSOR	
<input checked="" type="checkbox"/> Filing of terminal disclaimer does not obviate requirement for response under 37 CFR 1.111 to outstanding Office Action  <input checked="" type="checkbox"/> This electronic Terminal Disclaimer is not being used for a Joint Research Agreement.		
Owner	Percent Interest	
Masimo Corporation	100%	
<p>The owner(s) of percent interest listed above in the instant application hereby disclaims, except as provided below, the terminal part of the statutory term of any patent granted on the instant application which would extend beyond the expiration date of the full statutory term of any patent granted on pending reference Application Number(s)</p> <p>15195199 filed on 06/28/2016</p> <p>as the term of any patent granted on said reference application may be shortened by any terminal disclaimer filed prior to the grant of any patent on the pending reference application. The owner hereby agrees that any patent so granted on the instant application shall be enforceable only for and during such period that it and any patent granted on the reference application are commonly owned. This agreement runs with any patent granted on the instant application and is binding upon the grantee, its successors or assigns.</p> <p>In making the above disclaimer, the owner does not disclaim the terminal part of any patent granted on the instant application that would extend to the expiration date of the full statutory term of any patent granted on said reference application, "as the term of any patent granted on said reference application may be shortened by any terminal disclaimer filed prior to the grant of any patent on the pending reference application," in the event that any such patent granted on the pending reference application: expires for failure to pay a maintenance fee, is held unenforceable, is found invalid by a court of competent jurisdiction, is statutorily disclaimed in whole or terminally disclaimed under 37 CFR 1.321, has all claims canceled by a reexamination certificate, is reissued, or is in any manner terminated prior to the expiration of its full statutory term as shortened by any terminal disclaimer filed prior to its grant.</p>		
<input checked="" type="radio"/> Terminal disclaimer fee under 37 CFR 1.20(d) is included with Electronic Terminal Disclaimer request.		



I certify, in accordance with 37 CFR 1.4(d)(4), that the terminal disclaimer fee under 37 CFR 1.20(d) required for this terminal disclaimer has already been paid in the above-identified application.

Applicant claims the following fee status:

- Small Entity
- Micro Entity
- Regular Undiscounted

I hereby declare that all statements made herein of my own knowledge are true and that all statements made on information and belief are believed to be true; and further that these statements were made with the knowledge that willful false statements and the like so made are punishable by fine or imprisonment, or both, under Section 1001 of Title 18 of the United States Code and that such willful false statements may jeopardize the validity of the application or any patent issued thereon.

THIS PORTION MUST BE COMPLETED BY THE SIGNATORY OR SIGNATORIES

I certify, in accordance with 37 CFR 1.4(d)(4) that I am:

- An attorney or agent registered to practice before the Patent and Trademark Office who is of record in this application  
  
Registration Number 74164
- A sole inventor
- A joint inventor; I certify that I am authorized to sign this submission on behalf of all of the inventors as evidenced by the power of attorney in the application
- A joint inventor; all of whom are signing this request

Signature	/Aaron S. Johnson/
Name	Aaron S. Johnson

\*Statement under 37 CFR 3.73(b) is required if terminal disclaimer is signed by the assignee (owner).  
Form PTO/SB/96 may be used for making this certification. See MPEP § 324.

## Electronic Patent Application Fee Transmittal

<b>Application Number:</b>	16226249				
<b>Filing Date:</b>	19-Dec-2018				
<b>Title of Invention:</b>	ADVANCED PULSE OXIMETRY SENSOR				
<b>First Named Inventor/Applicant Name:</b>	Ammar Al-Ali				
<b>Filer:</b>	Aaron Samuel Johnson/Evelyn Salcido				
<b>Attorney Docket Number:</b>	MAS.1007C1				
Filed as Large Entity					
<b>Filing Fees for Utility under 35 USC 111(a)</b>					
<b>Description</b>	<b>Fee Code</b>	<b>Quantity</b>	<b>Amount</b>	<b>Sub-Total in USD(\$)</b>	
<b>Basic Filing:</b>					
STATUTORY OR TERMINAL DISCLAIMER	1814	1	160	160	
<b>Pages:</b>					
<b>Claims:</b>					
<b>Miscellaneous-Filing:</b>					
<b>Petition:</b>					
<b>Patent-Appeals-and-Interference:</b>					
<b>Post-Allowance-and-Post-Issuance:</b>					

Description	Fee Code	Quantity	Amount	Sub-Total in USD(\$)
<b>Extension-of-Time:</b>				
<b>Miscellaneous:</b>				
<b>Total in USD (\$)</b>				<b>160</b>

Doc Code: DISQ.E.FILE  
Document Description: Electronic Terminal Disclaimer – Approved

Application No.: 16226249

Filing Date: 19-Dec-2018

Applicant/Patent under Reexamination: Al-Ali

Electronic Terminal Disclaimer filed on July 18, 2019

APPROVED

**This patent is subject to a terminal disclaimer**

DISAPPROVED

Approved/Disapproved by: Electronic Terminal Disclaimer automatically approved by EFS-Web

U.S. Patent and Trademark Office

## Electronic Acknowledgement Receipt

<b>EFS ID:</b>	36626760
<b>Application Number:</b>	16226249
<b>International Application Number:</b>	
<b>Confirmation Number:</b>	1002
<b>Title of Invention:</b>	ADVANCED PULSE OXIMETRY SENSOR
<b>First Named Inventor/Applicant Name:</b>	Ammar Al-Ali
<b>Customer Number:</b>	64735
<b>Filer:</b>	Aaron Samuel Johnson/Evelyn Salcido
<b>Filer Authorized By:</b>	Aaron Samuel Johnson
<b>Attorney Docket Number:</b>	MAS.1007C1
<b>Receipt Date:</b>	18-JUL-2019
<b>Filing Date:</b>	19-DEC-2018
<b>Time Stamp:</b>	15:56:05
<b>Application Type:</b>	Utility under 35 USC 111(a)

### Payment information:

Submitted with Payment	yes
Payment Type	CARD
Payment was successfully received in RAM	\$160
RAM confirmation Number	071919INTEFSW15555800
Deposit Account	111410
Authorized User	Evelyn Salcido

The Director of the USPTO is hereby authorized to charge indicated fees and credit any overpayment as follows:

37 CFR 1.16 (National application filing, search, and examination fees)

37 CFR 1.17 (Patent application and reexamination processing fees)

--	--	--	--	--	--

**File Listing:**

Document Number	Document Description	File Name	File Size(Bytes)/ Message Digest	Multi Part /.zip	Pages (if appl.)
1	Terminal Disclaimer-Filed (Electronic)	eTerminal-Disclaimer.pdf	34022	no	2
			c7bd665ae2e3d36a449278736bd85784cb4e886b		

**Warnings:**

**Information:**

2	Fee Worksheet (SB06)	fee-info.pdf	30305	no	2
			3042f13ff3047cbe12f8fb019cf1d5d17eed2ce3		

**Warnings:**

**Information:**

<b>Total Files Size (in bytes):</b>	64327
-------------------------------------	-------

**This Acknowledgement Receipt evidences receipt on the noted date by the USPTO of the indicated documents, characterized by the applicant, and including page counts, where applicable. It serves as evidence of receipt similar to a Post Card, as described in MPEP 503.**

**New Applications Under 35 U.S.C. 111**

**If a new application is being filed and the application includes the necessary components for a filing date (see 37 CFR 1.53(b)-(d) and MPEP 506), a Filing Receipt (37 CFR 1.54) will be issued in due course and the date shown on this Acknowledgement Receipt will establish the filing date of the application.**

**National Stage of an International Application under 35 U.S.C. 371**

**If a timely submission to enter the national stage of an international application is compliant with the conditions of 35 U.S.C. 371 and other applicable requirements a Form PCT/DO/EO/903 indicating acceptance of the application as a national stage submission under 35 U.S.C. 371 will be issued in addition to the Filing Receipt, in due course.**

**New International Application Filed with the USPTO as a Receiving Office**

**If a new international application is being filed and the international application includes the necessary components for an international filing date (see PCT Article 11 and MPEP 1810), a Notification of the International Application Number and of the International Filing Date (Form PCT/RO/105) will be issued in due course, subject to prescriptions concerning national security, and the date shown on this Acknowledgement Receipt will establish the international filing date of the application.**

**IN THE UNITED STATES PATENT AND TRADEMARK OFFICE**

First Inventor	:	Ammar Al-Ali
App. No.	:	16/226,249
Filed	:	December 19, 2018
For	:	ADVANCED PULSE OXIMETRY SENSOR
Examiner	:	Fardanesh, Marjan
Art Unit	:	3791
Conf. No.	:	1002

**RESPONSE TO OFFICE ACTION DATED MARCH 29, 2019****Mail Stop Amendment**

Commissioner for Patents  
P.O. Box 1450  
Alexandria, VA 22313-1450

Dear Commissioner:

In response to the Non-final Office Action dated March 29, 2019, please consider the following.

**Amendments to the Specification** begin on page 2 of this paper.

**Amendments to the Claims** are reflected in the listing of claims which begins on page 3 of this paper.

**Amendments to the Drawings** begin on page 10. A “Replacement Sheet” for each sheet of drawings being amended can be found in the Appendix.

**Summary of Interview** begins on page 11 of this paper.

**Remarks** begin on page 12 of this paper.

**Application No.:** 16/226,249  
**Filing Date:** December 19, 2018

### **AMENDMENTS TO THE SPECIFICATION**

Please amend the originally-filed specification as set forth below.

**[0053]** Referring now to FIG. 7B, a top view of the 3D sensor 700 is illustrated with both the emitter 702 and the light blocker cover 707 removed for ease of illustration. The outer ring illustrates the footprint of the light diffuser 704. As light is emitted from the emitter 702 (not shown in FIG. 7B), it is diffused homogenously and directed to the tissue measurement site 102. The light blocker 706 forms the circular wall of a light isolation chamber to keep incident light from being sensed by the detector 710. The light blocker cover 707 blocks incidental light from entering the light isolation chamber from above. The light concentrator ~~710~~708 collects the reflected light from the tissue measurement site 102 and funnels it upward toward the detector 710 at the center of the 3D sensor 700.



Application No.: 16/226,249  
Filing Date: December 19, 2018

### AMENDMENTS TO THE CLAIMS

A complete listing of all claims is presented below with insertions underlined (e.g., insertion), and deletions struck through or in double brackets (e.g., ~~deletion~~ or [[deletion]]).

1-56. **(Cancelled)**

57. **(Currently Amended)** A wrist-worn physiological monitoring device configured for placement on a user at a tissue measurement site, the device comprising:

a light emission source comprising a plurality of emitters configured to irradiate a circular portion of the tissue measurement site by emitting light towards the tissue measurement site, the tissue measurement site being located on a wrist of the user, the plurality of emitters ~~comprising one or more light emitting diodes (LEDs)~~ configured to emit one or more wavelengths, ~~the one or more wavelengths comprising at least an infrared wavelength;~~

a plurality of detectors configured to detect the light emitted by the plurality of emitters after attenuation by tissue of the user at the tissue measurement site, ~~wherein the plurality of detectors comprise one or more photodiodes,~~ the plurality of detectors further configured to output at least one signal responsive to the detected light;

a processor configured to receive the at least one signal responsive to the output and determine a physiological parameter of the user; and

a light block forming an enclosing wall between the light emission source and the plurality of detectors, the light block defining the irradiated circular portion of the tissue measurement site, the light emission source arranged proximate a first side of the enclosing wall and the plurality of detectors arranged proximate a second side of the enclosing wall, the first side being different than the second side,~~light emitted from the plurality of emitters at the tissue measurement site and the plurality of detectors when the physiological monitoring device is worn by the user, wherein the enclosing wall prevents at least a portion of light emitted from the light emission source~~plurality of emitters from being detected by the plurality of detectors without attenuation by the tissue, and wherein the plurality of detectors are arranged in an array having a spatial configuration corresponding to the circular portion of the irradiated tissue measurement site.

**Application No.:** 16/226,249  
**Filing Date:** December 19, 2018

58. **(Previously Presented)** The physiological monitoring device of Claim 57, further comprising a display configured to present information related to the determined physiological parameter to the user.

59. **(Previously Presented)** The physiological monitoring device of Claim 58, wherein the display is a touch-screen display.

60. **(Previously Presented)** The physiological monitoring device of Claim 57, wherein the enclosing wall of the light block is a circular wall.

61. **(Previously Presented)** The physiological monitoring device of Claim 57, wherein, when the physiological monitoring device is worn by the user at the tissue measurement site, the plurality of emitters are arranged in a reflectance measurement configuration on a first side of the tissue measurement site, and wherein the plurality of detectors are arranged in a reflectance measurement configuration on the first side of the tissue measurement site when the physiological monitoring device is worn by the user.

62. **(Previously Presented)** The physiological monitoring device of Claim 57, further comprising a diffuser which receives, spreads, and emits the spread light, wherein the emitted spread light is directed at the tissue measurement site.

63. **(Currently Amended)** The physiological monitoring device of Claim 57, wherein the light emission source ~~is plurality of emitters~~ are positioned outside the enclosing wall when the physiological monitoring device is worn by the user at the tissue measurement site, and wherein the plurality of detectors are positioned inside the enclosing wall when the physiological monitoring device is worn by the user at the tissue measurement site.

64. **(Previously Presented)** The physiological monitoring device of Claim 57, wherein the physiological parameter is selected from the group consisting of arterial oxygen saturation, glucose, and pulse rate.

65. **(Cancelled)**

66. **(Cancelled)**

67. **(Currently Amended)** A method of measuring a physiological parameter in a user's blood, the method comprising:

irradiating a circular portion of a tissue measurement site by emitting, from a plurality of emitters of a light emission source of a physiological monitoring device, light

**Application No.:** 16/226,249  
**Filing Date:** December 19, 2018

of one or more wavelengths toward ~~[[a]]~~the tissue measurement site, the tissue measurement site located on a wrist of the user~~the plurality of emitters comprise one or more light emitting diodes (LEDs) and the one or more wavelengths comprises at least an infrared wavelength;~~

detecting, with a plurality of detectors, the light emitted by the plurality of emitters of the light emission source after attenuation through tissue of the user at the tissue measurement site, ~~wherein the plurality of detectors comprise one or more photodiodes;~~ and

providing a cylindrical light block forming an enclosing wall between the light emission source and the plurality of detectors, the light emission source arranged proximate a first side of the enclosing wall and the plurality of detectors arranged proximate a second side of the enclosing wall, the first side being different than the second side,~~light emitted from the plurality of emitters at the tissue measurement site and the plurality of detectors when the physiological monitoring device is worn by the user,~~ wherein the enclosing wall prevents at least a portion of light emitted from the light emission source~~plurality of emitters~~ from being detected by the plurality of detectors without attenuation by the tissue, and wherein the plurality of detectors are arranged in an array having a circular spatial configuration, the circular spatial configuration arranged to receive said attenuated light;

outputting, from the plurality of detectors, at least one signal responsive to the detected light;

receiving, by a processor, the outputted at least one signal responsive to the detected light; and

processing, by the processor, the received at least one signal responsive to the detected light to determine a physiological parameter.

68. **(Currently Amended)** The method of Claim 67, wherein the light emission source~~plurality of emitters are~~ positioned outside the enclosing wall when the physiological monitoring device is worn by the user at the tissue measurement site, and wherein the plurality of detectors are positioned inside the enclosing wall when the physiological monitoring device is worn by the user at the tissue measurement site.

**Application No.:** 16/226,249  
**Filing Date:** December 19, 2018

69. **(Previously Presented)** The method of Claim 67, further comprising presenting, with a display of the physiological monitoring device, information related to the determined physiological parameter to the user.

70. **(Previously Presented)** The method of Claim 69, wherein the display is a touch-screen display.

71. **(Cancelled)**

72. **(Previously Presented)** The method of Claim 67, wherein when the physiological monitoring device is worn by the user at the tissue measurement site, the plurality of emitters are arranged in a reflectance measurement configuration on a first side of the tissue measurement site, and wherein the plurality of detectors are arranged in a reflectance measurement configuration on the first side of the tissue measurement site when the physiological monitoring device is worn by the user.

73. **(Previously Presented)** The method of Claim 67, further comprising spreading, with a diffuser, the emitted light and emitting the spread light from the diffuser to the tissue measurement site.

74. **(Previously Presented)** The method of Claim 67, wherein the physiological parameter is indicative of at least one of pulse rate, perfusion index, oxygen content, and total hemoglobin.

75. **(Cancelled)**

76. **(Cancelled)**

77. **(Currently Amended)** A wrist-worn physiological monitoring sensor comprising:  
a light emission source comprising a plurality of optical sources configured to irradiate a circular portion of a tissue measurement site by emitting light towards [[a]]the tissue measurement site on a user, the tissue measurement site located on a wrist of the user, the plurality of optical sources ~~comprising one or more light emitting diodes (LEDs) configured to emit one or more wavelengths, the one or more wavelengths comprising at least an infrared wavelength;~~

a plurality of detectors configured to detect the light emitted by the plurality of emitters after attenuation by tissue of the user at the tissue measurement site, ~~wherein the~~

**Application No.:** 16/226,249  
**Filing Date:** December 19, 2018

~~plurality of detectors comprise one or more photodiodes,~~ the plurality of detectors further configured to output at least one signal responsive to the detected light;

a processor configured to receive the outputted at least one signal responsive to the detected light and determine a physiological parameter indicative of a state or trend of wellness of the user; and

a light block forming an enclosing wall between the light emission source and the plurality of detectors, the light emission source arranged proximate a first side of the enclosing wall and the plurality of detectors arranged proximate a second side of the enclosing wall, the first side being different than the second side, light emitted from the plurality of emitters at the tissue measurement site and the plurality of detectors when the physiological monitoring sensor is worn by the user, the light block forming a light isolation chamber defined by the enclosing wall, wherein the enclosing wall prevents at least a portion of light emitted from the light emission source plurality of emitters from being detected by the plurality of detectors without attenuation by the tissue, and wherein the plurality of detectors are arranged in an array having a circular spatial configuration, the circular spatial configuration arranged to receive said attenuated light.

78. **(Currently Amended)** The physiological monitoring sensor of Claim 77, wherein the light emission source is plurality of optical sources are located outside the enclosing wall when the physiological monitoring sensor is worn by the user at the tissue measurement site, and wherein the plurality of detectors are arranged inside the enclosing wall when the physiological monitoring sensor is worn by the user at the tissue measurement site.

79. **(Cancelled)**

80. **(Cancelled)**

81. **(Previously Presented)** The physiological monitoring sensor of Claim 77, further comprising a diffuser which receives, spreads, and emits the spread light, wherein the emitted spread light is directed at the tissue measurement site.

82. **(Previously Presented)** The physiological monitoring sensor of Claim 77, further comprising a display configured to present information related to the determined physiological parameter to the user.

**Application No.:** 16/226,249  
**Filing Date:** December 19, 2018

83. **(Previously Presented)** The physiological monitoring sensor of Claim 82, wherein the display is a touch-screen display.

84. **(Cancelled)**

85. **(Currently Amended)** The physiological monitoring sensor of Claim 77, wherein when the physiological monitoring sensor is worn by the user at the tissue measurement site, the plurality of optical sources~~emitters~~ are arranged in a reflectance measurement configuration on a first side of the tissue measurement site, and wherein the plurality of detectors are arranged in a reflectance measurement configuration on the first side of the tissue measurement site when the physiological monitoring sensor is worn by the user.

86. **(Cancelled)**

87. **(New)** The physiological monitoring device of Claim 57, wherein the plurality of emitters comprise one or more light emitting diodes (LEDs), and wherein the one or more wavelengths comprises at least an infrared wavelength.

88. **(New)** The physiological monitoring device of Claim 57, wherein the plurality of detectors comprise a plurality of photodiodes.

89. **(New)** The physiological monitoring device of Claim 57, further comprising a light concentrator configured to direct the attenuated, reflected light to the plurality of detectors.

90. **(New)** The method of Claim 67, wherein the plurality of emitters comprise one or more light emitting diodes (LEDs), and wherein the one or more wavelengths comprises at least an infrared wavelength.

91. **(New)** The method of Claim 67, wherein the plurality of detectors comprise a plurality of photodiodes.

92. **(New)** The method of Claim 67, further comprising, directing, with a light concentrator, the light emitted by the light emission source after attenuation through tissue of the user at the tissue measurement site to the plurality of detectors.

93. **(New)** The physiological monitoring sensor of Claim 77, wherein the plurality of optical sources comprise one or more light emitting diodes (LEDs), and wherein the one or more wavelengths comprises at least an infrared wavelength.

94. **(New)** The physiological monitoring sensor of Claim 77, wherein the plurality of detectors comprise a plurality of photodiodes.

**Application No.:** 16/226,249  
**Filing Date:** December 19, 2018

95. (New) The physiological monitoring sensor of Claim 77, further comprising a light concentrator configured to direct the attenuated, reflected light to the plurality of detectors.

**Application No.:** 16/226,249  
**Filing Date:** December 19, 2018

**AMENDMENTS TO THE DRAWINGS**

Please replace Figure 7A with the enclosed *Replacement Sheet*.



**Application No.:** 16/226,249  
**Filing Date:** December 19, 2018

## SUMMARY OF INTERVIEW

### Attendees, Date and Type of Interview

The interview was conducted on May 7, 2019 and attended by Examiner Fardanesh and Applicant's representatives Jarom D. Kesler (Reg. No. 57,046) and Aaron S. Johnson (Reg. No. 74,164).

### Exhibits and/or Demonstrations

N/A.

### Identification of Claims Discussed

Claims 57, 67, and 77.

### Identification of Cited/Disclosed Art

- U.S. Patent No. 5,830,137 to Scharf.
- U.S. Patent No. 5,584,296 to Cui et al.
- U.S. Patent No. 8,452,364 to Hannula et al.
- U.S. Patent Pub. No. 2003/0036690 to Geddes et al.
- U.S. Patent No. 5,497,771 to Rosenheimer.

### Proposed Amendments

Amendments as appearing herein.

### Issues Discussed and Results of Interview

Applicant thanks Examiner Fardanesh for taking the time to conduct the Interview. During the interview, the claims were discussed in view of the cited prior art. Examiner Fardanesh acknowledged that the prior art did not teach three or more detectors arranged in a spatial configuration as recited in the claims.

**Application No.:** 16/226,249  
**Filing Date:** December 19, 2018

### REMARKS

This paper is filed in response to the Office Action mailed March 29, 2019 (“Office Action”), in connection with the above-referenced patent application. Claims 57-86 were pending prior to the submission of this paper. Claims 57, 63, 67, 68, 77-78, and 85 have been amended and Claims 65-66, 71, 75-76, 79-80, 84, and 86 have been cancelled without prejudice or disclaimer. Claims 87-95 have been added as new. Thus, Claims 57-64, 67-70, 72-74, 77-78, 81-83, 85, and 87-95 are pending. Applicant respectfully requests allowance of the pending claims in light of the present response.

**A. Information Disclosure Statement**

As discussed during the interview on May 7, 2019 (“Interview”), Applicant is submitting an Information Disclosure Statement (IDS) herewith. The IDS contains a reference that was discussed during the Interview.

**B. Claim Amendment Support**

Claim 57 recites, among other things, a “plurality of detectors” “arranged in an array having a spatial configuration corresponding to the circular portion of the irradiated tissue measurement site.” Claims 67 and 77 recite, among other things, a “plurality of detectors” “arranged in an array having a circular spatial configuration.” Support for these claim amendments can be found throughout the present disclosure. For example, in multiple locations, the originally-filed application discusses providing “a plurality of detectors” in an arrangement “corresponding” to an “irradiated surface area” so as to appropriately capture light attenuated from a tissue measurement site. For example, paragraph [0042] of the originally-filed application states:

The detector 310 can be implemented using one or more photodiodes, phototransistors, or the like. In addition, a plurality of detectors 310 can be arranged in an array with a spatial configuration *corresponding to* the irradiated surface area 206 to capture the attenuated or reflected light from the tissue measurement site.

Originally-filed Specification, para. [0042] (emphasis added). The “irradiated surface area 206” is described in paragraph [0032] of the originally-filed specification, which discussed various exemplary shapes and dimensions that the irradiated surface area can have (for example, a rectangular shape). *See id.*, para. [0032], Figure 2.

As another example, paragraph [0051] of the originally-filed application states:

**Application No.:** 16/226,249  
**Filing Date:** December 19, 2018

The detector 710 can be implemented using one or more photodiodes, phototransistors, or the like. In addition, a plurality of detectors 710 can be arranged in an array with a spatial configuration *corresponding to* the irradiated surface area depicted in FIG. 7B by the light concentrator 708 to capture the reflected light from the tissue measurement site.

*Id.*, para. [0051] (emphasis added). The “irradiated surface area depicted in FIG. 7B by the light concentrator 708” comprises a circular shape. Figure 7B of the Application is shown below.

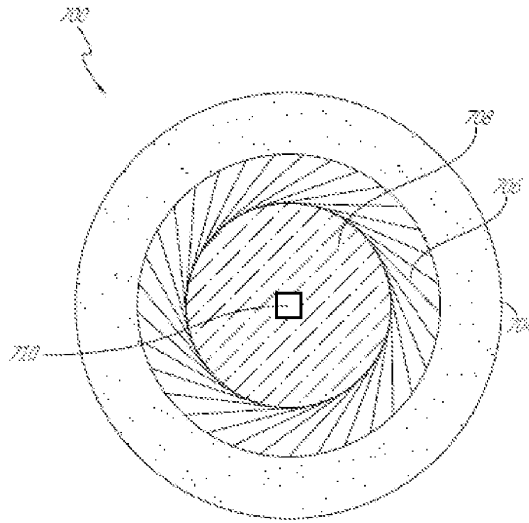

**Figure 7B of Originally-filed Application**

The ordinary meaning of the claim term “correspond” means to “have a close similarity; match or agree almost exactly” or “be analogous or equivalent in character, form, or function” or “represent.” New Oxford American Dictionary, 390 (3rd Edition 2010). Consistent with this exemplary definition and the originally-filed application, the phrase “arranged in an array having a spatial configuration corresponding to the circular portion of the irradiated tissue measurement site” (see Claim 57) would be understood by a person having ordinary skill in the art as requiring a sufficient number of detectors such that, when arranged together in an array, can “match,” “have a close similarity,” or “represent” a “circular portion of the irradiated surface area.” Similarly, the phrase “arranged in an array having a circular spatial configuration” (see Claims 67 and 77) would be understood by a person having ordinary skill in the art as including a sufficient number of detectors such that the array matches or represents a circular shape.

**Application No.:** 16/226,249  
**Filing Date:** December 19, 2018

In order for the claimed “plurality of detectors” to “match” or “represent” a circular shape, the “plurality of detectors” must include sufficient detectors to represent the circular shape. For example, six or more detectors could be arranged in a circular shape and meet the recited limitation. However, two detectors, for example, can only be arranged in a spatial configuration representing a line and three detectors, for example, can only be arranged in a spatial configuration representing a triangle. Thus, when read in view of the originally-filed application, the recited “plurality of detectors” would be understood by a person having ordinary skill in the art as including a sufficient number of detectors to represent the desired geometric shape.

**C. Claim Objections**

The Office Action objected to Claims 65, 75, and 80 and requested amending the term “spacial” to “spatial.” *See* Office Action, p. 2. Applicant has cancelled Claims 65, 75, and 80 without prejudice or disclaimer and respectfully submits that the objections are thereby rendered moot.

**D. Objection to the Drawings**

In the Office Action, the Drawings are objected to under 37 C.F.R. § 1.84(p)(5) because they include the reference character 709 (see Figure 7A) which is not mentioned in the Specification. *See* Office Action, p. 2. Applicant has amended the Drawings as discussed above and respectfully requests that this objection be withdrawn.

**E. Objection to the Specification**

The Office Action objected to the Specification because of a typographical error and requested Applicant to amend “light concentrator 710” to “light concentrator 708” in paragraph [0053]. *See* Office Action, p. 2. Applicant thanks the Examiner for her careful review of the present application and has amended the Specification as shown above. Accordingly, Applicant respectfully requests this objection be withdrawn.

**F. The Pending Claims Are Patentable over the Cited Art**

Claims 57, 58, 60-62, 64-67, 69, 71-77, 79-82 and 84-86 stand rejected under 35 U.S.C. § 102(a)(1) as being anticipated by U.S. Patent No. 5,584,296 to Cui et al. (hereinafter “Cui”). Claims 57, 60-61, 63-68, 71-72, 74-80, 84-86 stand rejected as being unpatentable under 35 U.S.C. § 103 over U.S. Patent No. 8,452,364 to Hannula et al. (“Hannula”) in view of U.S. Patent Pub. No. 2003/0036690 to Geddes et al. (“Geddes”). Applicant respectfully disagrees and

**Application No.:** 16/226,249  
**Filing Date:** December 19, 2018

requests that the rejections of Claims 57-59, 61-64, 67-70, 72-74, 77-78, 81-83, and 85-86 be withdrawn and new Claims 87-95 be allowed for at least the following reasons.

**1. Independent Claim 57**

Amended Claim 57 recites, in part (emphasis added):

a light emission source comprising a plurality of emitters configured to *irradiate a circular portion of the tissue measurement site* by emitting light towards the tissue measurement site, the tissue measurement site being located on a wrist of the user, the plurality of emitters configured to emit one or more wavelengths;

a plurality of detectors configured to detect the light emitted by the plurality of emitters after attenuation by tissue of the user at the tissue measurement site, the plurality of detectors further configured to output at least one signal responsive to the detected light;

a processor configured to receive the at least one signal responsive to the output and determine a physiological parameter of the user; and

a light block forming an enclosing wall between the light emission source and the plurality of detectors, the light block defining the irradiated circular portion of the tissue measurement site, the light emission source arranged proximate a first side of the enclosing wall and the plurality of detectors arranged proximate a second side of the enclosing wall, the first side being different than the second side, wherein the enclosing wall prevents at least a portion of light emitted from the light emission source from being detected by the plurality of detectors without attenuation by the tissue, and *wherein the plurality of detectors are arranged in an array having a spatial configuration corresponding to the circular portion of the irradiated tissue measurement site.*

Applicant respectfully submits that the cited art, alone or in combination, fails to teach or suggest at least the above-recited limitations of Claim 57. For example, as discussed during the Interview, none of the cited art, alone or in combination, teaches or suggests the utilization of more than three detectors arranged in the recited configuration. For at least these reasons, Applicant respectfully requests withdrawal of the rejection of independent Claim 57 and allowance of the claim.

**2. Independent Claim 67**

Amended Claim 67 recites, in part (emphasis added):

*irradiating a circular portion of a tissue measurement site* by emitting, from a plurality of emitters of a light emission source of a physiological monitoring device, light of one or more wavelengths toward the tissue measurement site, the tissue measurement site located on a wrist of the user;

detecting, with a plurality of detectors, the light emitted by the plurality of emitters of the light emission source after attenuation through tissue of the user at the tissue measurement site; and

**Application No.:** 16/226,249  
**Filing Date:** December 19, 2018

providing a cylindrical light block forming an enclosing wall between the light emission source and the plurality of detectors, the light emission source arranged proximate a first side of the enclosing wall and the plurality of detectors arranged proximate a second side of the enclosing wall, the first side being different than the second side, wherein the enclosing wall prevents at least a portion of light emitted from the light emission source from being detected by the plurality of detectors without attenuation by the tissue, and *wherein the plurality of detectors are arranged in an array having a circular spatial configuration, the circular spatial configuration arranged to receive said attenuated light;*

Applicant respectfully submits that the cited art, alone or in combination, fails to teach or suggest at least the above-recited limitations of Claim 67. For example, as discussed during the Interview, none of the cited art, alone or in combination, teaches or suggests the utilization of more than three detectors arranged in the recited configuration. For at least these reasons, Applicant respectfully requests withdrawal of the rejection of independent Claim 67 and allowance of the claim.

**3. Independent Claim 77**

Amended Claim 77 recites, in part (emphasis added):

a light emission source comprising a plurality of optical sources configured to *irradiate a circular portion of a tissue measurement site* by emitting light towards the tissue measurement site on a user, the tissue measurement site located on a wrist of the user, the plurality of optical sources configured to emit one or more wavelengths;

a plurality of detectors configured to detect the light emitted by the plurality of emitters after attenuation by tissue of the user at the tissue measurement site, the plurality of detectors further configured to output at least one signal responsive to the detected light;

a processor configured to receive the outputted at least one signal responsive to the detected light and determine a physiological parameter indicative of a state or trend of wellness of the user; and

a light block forming an enclosing wall between the light emission source and the plurality of detectors, the light emission source arranged proximate a first side of the enclosing wall and the plurality of detectors arranged proximate a second side of the enclosing wall, the first side being different than the second side, the light block forming a light isolation chamber defined by the enclosing wall, wherein the enclosing wall prevents at least a portion of light emitted from the light emission source from being detected by the plurality of detectors without attenuation by the tissue, and *wherein the plurality of detectors are arranged in an array having a circular spatial configuration, the circular spatial configuration arranged to receive said attenuated light.*

Applicant respectfully submits that the cited art, alone or in combination, fails to teach or suggest at least the above-recited limitations of Claim 77. For example, as discussed during the Interview, none of the cited art, alone or in combination, teaches or suggests the utilization of

**Application No.:** 16/226,249  
**Filing Date:** December 19, 2018

more than three detectors arranged in the recited configuration. For at least these reasons, Applicant respectfully requests withdrawal of the rejection of independent Claim 77 and allowance of the claim.

**4. Dependent Claims 58-59, 61-64, 68-70, 72-74, 78, 81-83, and 85**

Claims 58-64, 68-70, 72-74, 78, 81-83, and 85 depend directly or indirectly from Claims 57, 67, or 77 and are thus patentably distinct from the cited art of record for at least the reasons set forth above in regard to Claims 57, 67, or 77. In addition, Applicant notes that these claims, when taken in the context of Claims 57, 67, or 77, set forth a number of recitations not taught, disclosed, or suggested by the cited references, alone or in combination. For at least these additional reasons, Applicant respectfully requests that the rejections of Claims 58-64, 68-70, 72-74, 78, 81-83, and 85 be withdrawn and the claims allowed.

**5. New Claims 87-95**

Claims 87-95 were added in the present paper and our believed to be patentable over the cited art. Accordingly, Applicant respectfully requests that Claims 87-95 be indicated as allowable.

**G. No Disclaimers or Disavowals**

Although the present communication may include alterations to the application or claims, or characterizations of claim scope or referenced art, Applicant is not conceding in this application that previously pending claims are not patentable over the cited references. Rather, any alterations or characterizations are being made to facilitate expeditious prosecution of this application. Applicant reserves the right to pursue at a later date any previously pending or other broader or narrower claims that capture any subject matter supported by the present disclosure, including subject matter found to be specifically disclaimed herein or by any prior prosecution. Accordingly, reviewers of this or any parent, child or related prosecution history shall not reasonably infer that Applicant has made any disclaimers or disavowals of any subject matter supported by the present application.

**Application No.:** 16/226,249  
**Filing Date:** December 19, 2018

Please charge any additional fees, including any fees for additional extension of time, or credit overpayment to Deposit Account No. 11-1410.

Respectfully submitted,

KNOBBE, MARTENS, OLSON & BEAR, LLP

Dated: July 1, 2019

By: /Aaron S. Johnson/  
Aaron S. Johnson  
Registration No. 74,164  
Registered Practitioner  
Customer No. 64735  
(949) 760-0404



**INFORMATION DISCLOSURE STATEMENT**

First Inventor	:	Ammar Al-Ali
App. No.	:	16/226249
Filed	:	December 19, 2018
For	:	ADVANCED PULSE OXIMETRY SENSOR
Examiner	:	Fardanesh, Marjan
Art Unit	:	3791
Conf. No.	:	1002

**Mail Stop Amendment**

Commissioner for Patents  
P.O. Box 1450  
Alexandria, VA 22313-1450

**References and Listing**

Pursuant to 37 CFR 1.56, an Information Disclosure Statement listing references is provided herewith. Copies of any listed foreign and non-patent literature references are being submitted.

**No Disclaimers**

To the extent that anything in the Information Disclosure Statement or the listed references could be construed as a disclaimer of any subject matter supported by the present application, Applicant hereby rescinds and retracts such disclaimer.

**Timing of Disclosure**

This Information Disclosure Statement is being filed after receipt of a First Office Action, but before the mailing date of a Final Action and before the mailing date of a Notice of Allowance.

This Statement is accompanied by the fees set forth in 37 CFR 1.17(p). The Commissioner is hereby authorized to charge any additional fees which may be required or to credit any overpayment to Account No. 11-1410.

Respectfully submitted,

KNOBBE, MARTENS, OLSON & BEAR, LLP

Dated: July 1, 2019

By: /Aaron S. Johnson/  
Aaron S. Johnson  
Registration No. 74,164  
Registered Practitioner  
Customer No. 64735  
(949) 760-0404

<b>INFORMATION DISCLOSURE STATEMENT BY APPLICANT</b>	Application No.	16/226249
	Filing Date	December 19, 2018
	First Named Inventor	Ammar Al-Ali
	Art Unit	3791
<i>(Multiple sheets used when necessary)</i>	Examiner	Fardanesh, Marjan
SHEET 1 OF 1	Attorney Docket No.	MAS.1007C1

<b>U.S. PATENT DOCUMENTS</b>						
Examiner Initials	Cite No.	Document Number <i>Number - Kind Code (if known)</i> Example: 1,234,567 B1	Publication Date MM-DD-YYYY	Name	Pages, Columns, Lines Where Relevant Passages or Relevant Figures Appear	
	1	5,830,137	11-03-1998	Scharf		

<b>FOREIGN PATENT DOCUMENTS</b>						
Examiner Initials	Cite No.	Foreign Patent Document <i>Country Code-Number-Kind Code</i> Example: JP 1234567 A1	Publication Date MM-DD-YYYY	Name	Pages, Columns, Lines Where Relevant Passages or Relevant Figures Appear	T <sup>1</sup>

<b>NON PATENT LITERATURE DOCUMENTS</b>			
Examiner Initials	Cite No.	Include name of the author (in CAPITAL LETTERS), title of the article (when appropriate), title of the item (book, magazine, journal, serial, symposium, catalog, etc.), date, page(s), volume-issue number(s), publisher, city and/or country where published.	T <sup>1</sup>

30349862

Examiner Signature	Date Considered
<p><b>*Examiner:</b> Initial if reference considered, whether or not citation is in conformance with MPEP 609. Draw line through citation if not in conformance and not considered. Include copy of this form with next communication to applicant.</p>	

T<sup>1</sup> - Place a check mark in this area when an English language Translation is attached.

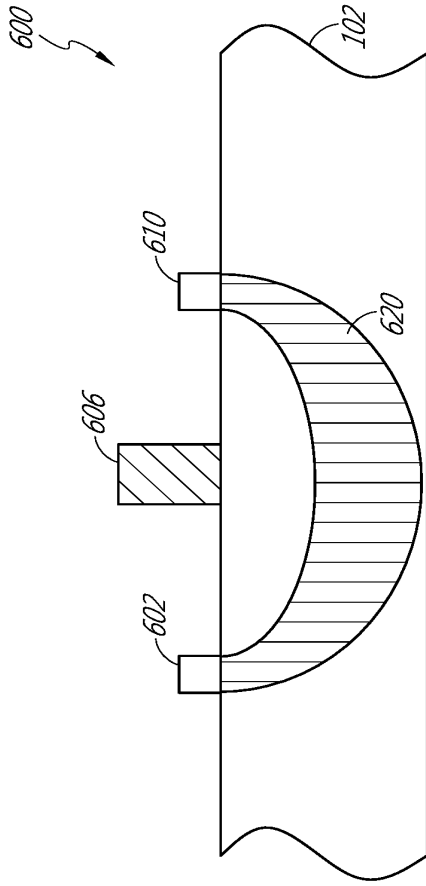

FIG. 6  
(PRIOR ART)

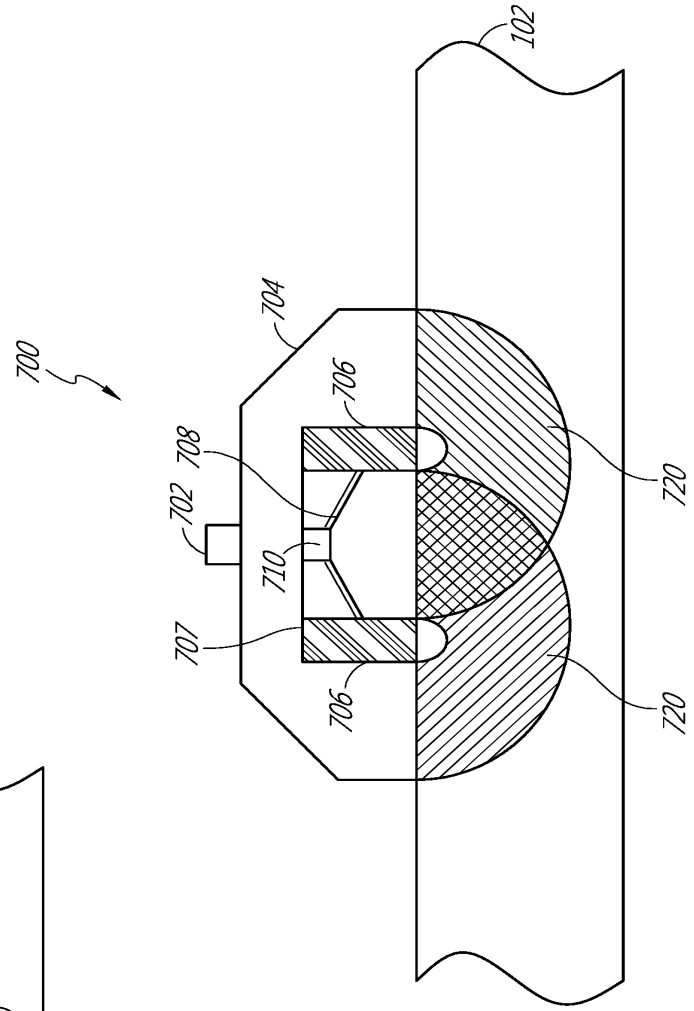

FIG. 7A

## Electronic Patent Application Fee Transmittal

<b>Application Number:</b>	16226249				
<b>Filing Date:</b>	19-Dec-2018				
<b>Title of Invention:</b>	ADVANCED PULSE OXIMETRY SENSOR				
<b>First Named Inventor/Applicant Name:</b>	Ammar Al-Ali				
<b>Filer:</b>	Aaron Samuel Johnson/Daniel Escajeda				
<b>Attorney Docket Number:</b>	MAS.1007C1				
Filed as Large Entity					
<b>Filing Fees for Utility under 35 USC 111(a)</b>					
<b>Description</b>	<b>Fee Code</b>	<b>Quantity</b>	<b>Amount</b>	<b>Sub-Total in USD(\$)</b>	
<b>Basic Filing:</b>					
<b>Pages:</b>					
<b>Claims:</b>					
<b>Miscellaneous-Filing:</b>					
<b>Petition:</b>					
<b>Patent-Appeals-and-Interference:</b>					
<b>Post-Allowance-and-Post-Issuance:</b>					
<b>Extension-of-Time:</b>					

Description	Fee Code	Quantity	Amount	Sub-Total in USD(\$)
<b>Miscellaneous:</b>				
SUBMISSION- INFORMATION DISCLOSURE STMT	1806	1	240	240
<b>Total in USD (\$)</b>				<b>240</b>

## Electronic Acknowledgement Receipt

<b>EFS ID:</b>	36460609
<b>Application Number:</b>	16226249
<b>International Application Number:</b>	
<b>Confirmation Number:</b>	1002
<b>Title of Invention:</b>	ADVANCED PULSE OXIMETRY SENSOR
<b>First Named Inventor/Applicant Name:</b>	Ammar Al-Ali
<b>Customer Number:</b>	64735
<b>Filer:</b>	Aaron Samuel Johnson/Evelyn Salcido
<b>Filer Authorized By:</b>	Aaron Samuel Johnson
<b>Attorney Docket Number:</b>	MAS.1007C1
<b>Receipt Date:</b>	01-JUL-2019
<b>Filing Date:</b>	19-DEC-2018
<b>Time Stamp:</b>	14:39:06
<b>Application Type:</b>	Utility under 35 USC 111(a)

### Payment information:

Submitted with Payment	yes
Payment Type	CARD
Payment was successfully received in RAM	\$240
RAM confirmation Number	070219INTEFSW14394100
Deposit Account	111410
Authorized User	Evelyn Salcido

The Director of the USPTO is hereby authorized to charge indicated fees and credit any overpayment as follows:

37 CFR 1.16 (National application filing, search, and examination fees)

37 CFR 1.17 (Patent application and reexamination processing fees)

<b>File Listing:</b>					
<b>Document Number</b>	<b>Document Description</b>	<b>File Name</b>	<b>File Size(Bytes)/ Message Digest</b>	<b>Multi Part /.zip</b>	<b>Pages (if appl.)</b>
1		OAR_MAS1007C1.pdf	105119 d54bd2461beb11027022825cea10c30a3e4feab9	yes	18
<b>Multipart Description/PDF files in .zip description</b>					
		<b>Document Description</b>	<b>Start</b>	<b>End</b>	
		Amendment/Req. Reconsideration-After Non-Final Reject	1	1	
		Specification	2	2	
		Claims	3	9	
		Drawings-only black and white line drawings	10	10	
		Applicant summary of interview with examiner	11	11	
		Applicant Arguments/Remarks Made in an Amendment	12	18	
<b>Warnings:</b>					
<b>Information:</b>					
2		IDS_MAS1007C1.pdf	44968 4b375a8c8aa60c06cae40512710f462514f4244a	yes	2
<b>Multipart Description/PDF files in .zip description</b>					
		<b>Document Description</b>	<b>Start</b>	<b>End</b>	
		Transmittal Letter	1	1	
		Information Disclosure Statement (IDS) Form (SB08)	2	2	
<b>Warnings:</b>					
<b>Information:</b>					

3	Drawings-only black and white line drawings	REPLACEMENT_MAS1007C1.pdf	62554	no	1
			c4dc3a082ace834b17f69214b4b5672203d73b0a		
<b>Warnings:</b>					
<b>Information:</b>					
4	Fee Worksheet (SB06)	fee-info.pdf	30470	no	2
			dab75d37fcf9d7aac9404760c1292189c0103ae7		
<b>Warnings:</b>					
<b>Information:</b>					
<b>Total Files Size (in bytes):</b>			243111		
<p><b>This Acknowledgement Receipt evidences receipt on the noted date by the USPTO of the indicated documents, characterized by the applicant, and including page counts, where applicable. It serves as evidence of receipt similar to a Post Card, as described in MPEP 503.</b></p> <p><b><u>New Applications Under 35 U.S.C. 111</u></b>  <b>If a new application is being filed and the application includes the necessary components for a filing date (see 37 CFR 1.53(b)-(d) and MPEP 506), a Filing Receipt (37 CFR 1.54) will be issued in due course and the date shown on this Acknowledgement Receipt will establish the filing date of the application.</b></p> <p><b><u>National Stage of an International Application under 35 U.S.C. 371</u></b>  <b>If a timely submission to enter the national stage of an international application is compliant with the conditions of 35 U.S.C. 371 and other applicable requirements a Form PCT/DO/EO/903 indicating acceptance of the application as a national stage submission under 35 U.S.C. 371 will be issued in addition to the Filing Receipt, in due course.</b></p> <p><b><u>New International Application Filed with the USPTO as a Receiving Office</u></b>  <b>If a new international application is being filed and the international application includes the necessary components for an international filing date (see PCT Article 11 and MPEP 1810), a Notification of the International Application Number and of the International Filing Date (Form PCT/RO/105) will be issued in due course, subject to prescriptions concerning national security, and the date shown on this Acknowledgement Receipt will establish the international filing date of the application.</b></p>					



## Electronic Acknowledgement Receipt

<b>EFS ID:</b>	36460609
<b>Application Number:</b>	16226249
<b>International Application Number:</b>	
<b>Confirmation Number:</b>	1002
<b>Title of Invention:</b>	ADVANCED PULSE OXIMETRY SENSOR
<b>First Named Inventor/Applicant Name:</b>	Ammar Al-Ali
<b>Customer Number:</b>	64735
<b>Filer:</b>	Aaron Samuel Johnson/Evelyn Salcido
<b>Filer Authorized By:</b>	Aaron Samuel Johnson
<b>Attorney Docket Number:</b>	MAS.1007C1
<b>Receipt Date:</b>	01-JUL-2019
<b>Filing Date:</b>	19-DEC-2018
<b>Time Stamp:</b>	14:39:06
<b>Application Type:</b>	Utility under 35 USC 111(a)

### Payment information:

Submitted with Payment	yes
Payment Type	CARD
Payment was successfully received in RAM	\$240
RAM confirmation Number	070219INTEFSW14394100
Deposit Account	111410
Authorized User	Evelyn Salcido

The Director of the USPTO is hereby authorized to charge indicated fees and credit any overpayment as follows:

37 CFR 1.16 (National application filing, search, and examination fees)

37 CFR 1.17 (Patent application and reexamination processing fees)

<b>File Listing:</b>					
<b>Document Number</b>	<b>Document Description</b>	<b>File Name</b>	<b>File Size(Bytes)/ Message Digest</b>	<b>Multi Part /.zip</b>	<b>Pages (if appl.)</b>
1		OAR_MAS1007C1.pdf	105119 d54bd2461beb11027022825cea10c30a3e4feab9	yes	18
<b>Multipart Description/PDF files in .zip description</b>					
		<b>Document Description</b>	<b>Start</b>	<b>End</b>	
		Amendment/Req. Reconsideration-After Non-Final Reject	1	1	
		Specification	2	2	
		Claims	3	9	
		Drawings-only black and white line drawings	10	10	
		Applicant summary of interview with examiner	11	11	
		Applicant Arguments/Remarks Made in an Amendment	12	18	
<b>Warnings:</b>					
<b>Information:</b>					
2		IDS_MAS1007C1.pdf	44968 4b375a8c8aa60c06cae40512710f462514f4244a	yes	2
<b>Multipart Description/PDF files in .zip description</b>					
		<b>Document Description</b>	<b>Start</b>	<b>End</b>	
		Transmittal Letter	1	1	
		Information Disclosure Statement (IDS) Form (SB08)	2	2	
<b>Warnings:</b>					
<b>Information:</b>					

3	Drawings-only black and white line drawings	REPLACEMENT_MAS1007C1.pdf	62554	no	1
			c4dc3a082ace834b17f69214b4b5672203d73b0a		
<b>Warnings:</b>					
<b>Information:</b>					
4	Fee Worksheet (SB06)	fee-info.pdf	30470	no	2
			dab75d37fcf9d7aac9404760c1292189c0103ae7		
<b>Warnings:</b>					
<b>Information:</b>					
<b>Total Files Size (in bytes):</b>			243111		
<p><b>This Acknowledgement Receipt evidences receipt on the noted date by the USPTO of the indicated documents, characterized by the applicant, and including page counts, where applicable. It serves as evidence of receipt similar to a Post Card, as described in MPEP 503.</b></p> <p><b><u>New Applications Under 35 U.S.C. 111</u></b>  <b>If a new application is being filed and the application includes the necessary components for a filing date (see 37 CFR 1.53(b)-(d) and MPEP 506), a Filing Receipt (37 CFR 1.54) will be issued in due course and the date shown on this Acknowledgement Receipt will establish the filing date of the application.</b></p> <p><b><u>National Stage of an International Application under 35 U.S.C. 371</u></b>  <b>If a timely submission to enter the national stage of an international application is compliant with the conditions of 35 U.S.C. 371 and other applicable requirements a Form PCT/DO/EO/903 indicating acceptance of the application as a national stage submission under 35 U.S.C. 371 will be issued in addition to the Filing Receipt, in due course.</b></p> <p><b><u>New International Application Filed with the USPTO as a Receiving Office</u></b>  <b>If a new international application is being filed and the international application includes the necessary components for an international filing date (see PCT Article 11 and MPEP 1810), a Notification of the International Application Number and of the International Filing Date (Form PCT/RO/105) will be issued in due course, subject to prescriptions concerning national security, and the date shown on this Acknowledgement Receipt will establish the international filing date of the application.</b></p>					

<b>PATENT APPLICATION FEE DETERMINATION RECORD</b> Substitute for Form PTO-875	Application or Docket Number 16/226,249	Filing Date 12/19/2018	<input type="checkbox"/> To be Mailed
---	--	---------------------------	---------------------------------------

ENTITY:  LARGE  SMALL  MICRO

**APPLICATION AS FILED - PART I**

FOR	(Column 1) NUMBER FILED	(Column 2) NUMBER EXTRA	RATE (\$)	FEE (\$)
<input type="checkbox"/> BASIC FEE (37 CFR 1.16(a), (b), or (c))	N/A	N/A	N/A	
<input type="checkbox"/> SEARCH FEE (37 CFR 1.16(k), (l), or (m))	N/A	N/A	N/A	
<input type="checkbox"/> EXAMINATION FEE (37 CFR 1.16(o), (p), or (q))	N/A	N/A	N/A	
TOTAL CLAIMS (37 CFR 1.16(j))	minus 20 = *		x \$100 =	
INDEPENDENT CLAIMS (37 CFR 1.16(h))	minus 3 = *		x \$460 =	
<input type="checkbox"/> APPLICATION SIZE FEE (37 CFR 1.16(s))	If the specification and drawings exceed 100 sheets of paper, the application size fee due is \$310 (\$155 for small entity) for each additional 50 sheets or fraction thereof. See 35 U.S.C. 41(a)(1)(G) and 37 CFR 1.16(s).			
<input type="checkbox"/> MULTIPLE DEPENDENT CLAIM PRESENT (37 CFR 1.16(j))				
* If the difference in column 1 is less than zero, enter "0" in column 2.				TOTAL

**APPLICATION AS AMENDED - PART II**

	(Column 1)		(Column 2)	(Column 3)	RATE (\$)	ADDITIONAL FEE (\$)
<b>AMENDMENT</b>	07/01/2019		HIGHEST NUMBER PREVIOUSLY PAID FOR	PRESENT EXTRA		
	Total (37 CFR 1.16(i))	* 30	Minus	** 30	= 0	x \$100 = 0
	Independent (37 CFR 1.16(h))	* 3	Minus	*** 3	= 0	x \$460 = 0
	<input type="checkbox"/> Application Size Fee (37 CFR 1.16(s))					
<input type="checkbox"/> FIRST PRESENTATION OF MULTIPLE DEPENDENT CLAIM (37 CFR 1.16(j))						
					TOTAL ADD'L FEE	0
<b>AMENDMENT</b>			HIGHEST NUMBER PREVIOUSLY PAID FOR	PRESENT EXTRA		
	Total (37 CFR 1.16(i))	*	Minus	**	=	x \$0 =
	Independent (37 CFR 1.16(h))	*	Minus	***	=	x \$0 =
	<input type="checkbox"/> Application Size Fee (37 CFR 1.16(s))					
<input type="checkbox"/> FIRST PRESENTATION OF MULTIPLE DEPENDENT CLAIM (37 CFR 1.16(j))						
					TOTAL ADD'L FEE	
* If the entry in column 1 is less than the entry in column 2, write "0" in column 3.					LIE	
** If the "Highest Number Previously Paid For" IN THIS SPACE is less than 20, enter "20".					/TERRY BRYANT/	
*** If the "Highest Number Previously Paid For" IN THIS SPACE is less than 3, enter "3".						
The "Highest Number Previously Paid For" (Total or Independent) is the highest number found in the appropriate box in column 1.						

This collection of information is required by 37 CFR 1.16. The information is required to obtain or retain a benefit by the public which is to file (and by the USPTO to process) an application. Confidentiality is governed by 35 U.S.C. 122 and 37 CFR 1.14. This collection is estimated to take 12 minutes to complete, including gathering, preparing, and submitting the completed application form to the USPTO. Time will vary depending upon the individual case. Any comments on the amount of time you require to complete this form and/or suggestions for reducing this burden, should be sent to the Chief Information Officer, U.S. Patent and Trademark Office, U.S. Department of Commerce, P.O. Box 1450, Alexandria, VA 22313-1450. DO NOT SEND FEES OR COMPLETED FORMS TO THIS ADDRESS. **SEND TO: Commissioner for Patents, P.O. Box 1450, Alexandria, VA 22313-1450.**

*If you need assistance in completing the form, call 1-800-PTO-9199 and select option 2.*



UNITED STATES PATENT AND TRADEMARK OFFICE

UNITED STATES DEPARTMENT OF COMMERCE
United States Patent and Trademark Office
Address: COMMISSIONER FOR PATENTS
P.O. Box 1450
Alexandria, Virginia 22313-1450
www.uspto.gov

Table with 4 columns: APPLICATION NUMBER (16/226,249), FILING OR 371(C) DATE (12/19/2018), FIRST NAMED APPLICANT (Ammar Al-Ali), ATTY. DOCKET NO./TITLE (MAS.1007C1)

CONFIRMATION NO. 1002

PUBLICATION NOTICE

64735
KNOBBE, MARTENS, OLSON & BEAR, LLP
MASIMO CORPORATION (MASIMO)
2040 MAIN STREET
FOURTEENTH FLOOR
IRVINE, CA 92614



Title:ADVANCED PULSE OXIMETRY SENSOR

Publication No.US-2019-0117140-A1

Publication Date:04/25/2019

NOTICE OF PUBLICATION OF APPLICATION

The above-identified application will be electronically published as a patent application publication pursuant to 37 CFR 1.211, et seq. The patent application publication number and publication date are set forth above.

The publication may be accessed through the USPTO's publically available Searchable Databases via the Internet at www.uspto.gov. The direct link to access the publication is currently http://www.uspto.gov/patft/.

The publication process established by the Office does not provide for mailing a copy of the publication to applicant. A copy of the publication may be obtained from the Office upon payment of the appropriate fee set forth in 37 CFR 1.19(a)(1). Orders for copies of patent application publications are handled by the USPTO's Public Records Division. The Public Records Division can be reached by telephone at (571) 272-3150 or (800) 972-6382, by facsimile at (571) 273-3250, by mail addressed to the United States Patent and Trademark Office, Public Records Division, Alexandria, VA 22313-1450 or via the Internet.

In addition, information on the status of the application, including the mailing date of Office actions and the dates of receipt of correspondence filed in the Office, may also be accessed via the Internet through the Patent Electronic Business Center at www.uspto.gov using the public side of the Patent Application Information and Retrieval (PAIR) system. The direct link to access this status information is currently https://portal.uspto.gov/pair/PublicPair. Prior to publication, such status information is confidential and may only be obtained by applicant using the private side of PAIR.

Further assistance in electronically accessing the publication, or about PAIR, is available by calling the Patent Electronic Business Center at 1-866-217-9197.

Office of Data Management, Application Assistance Unit (571) 272-4000, or (571) 272-4200, or 1-888-786-0101



## Privacy Act Statement

The **Privacy Act of 1974 (P.L. 93-579)** requires that you be given certain information in connection with your submission of the attached form related to a patent application or patent. Accordingly, pursuant to the requirements of the Act, please be advised that: (1) the general authority for the collection of this information is 35 U.S.C. 2(b)(2); (2) furnishing of the information solicited is voluntary; and (3) the principal purpose for which the information is used by the U.S. Patent and Trademark Office is to process and/or examine your submission related to a patent application or patent. If you do not furnish the requested information, the U.S. Patent and Trademark Office may not be able to process and/or examine your submission, which may result in termination of proceedings or abandonment of the application or expiration of the patent.

The information provided by you in this form will be subject to the following routine uses:

1. The information on this form will be treated confidentially to the extent allowed under the Freedom of Information Act (5 U.S.C. 552) and the Privacy Act (5 U.S.C. 552a). Records from this system of records may be disclosed to the Department of Justice to determine whether disclosure of these records is required by the Freedom of Information Act.
2. A record from this system of records may be disclosed, as a routine use, in the course of presenting evidence to a court, magistrate, or administrative tribunal, including disclosures to opposing counsel in the course of settlement negotiations.
3. A record in this system of records may be disclosed, as a routine use, to a Member of Congress submitting a request involving an individual, to whom the record pertains, when the individual has requested assistance from the Member with respect to the subject matter of the record.
4. A record in this system of records may be disclosed, as a routine use, to a contractor of the Agency having need for the information in order to perform a contract. Recipients of information shall be required to comply with the requirements of the Privacy Act of 1974, as amended, pursuant to 5 U.S.C. 552a(m).
5. A record related to an International Application filed under the Patent Cooperation Treaty in this system of records may be disclosed, as a routine use, to the International Bureau of the World Intellectual Property Organization, pursuant to the Patent Cooperation Treaty.
6. A record in this system of records may be disclosed, as a routine use, to another federal agency for purposes of National Security review (35 U.S.C. 181) and for review pursuant to the Atomic Energy Act (42 U.S.C. 218(c)).
7. A record from this system of records may be disclosed, as a routine use, to the Administrator, General Services, or his/her designee, during an inspection of records conducted by GSA as part of that agency's responsibility to recommend improvements in records management practices and programs, under authority of 44 U.S.C. 2904 and 2906. Such disclosure shall be made in accordance with the GSA regulations governing inspection of records for this purpose, and any other relevant (*i.e.*, GSA or Commerce) directive. Such disclosure shall not be used to make determinations about individuals.
8. A record from this system of records may be disclosed, as a routine use, to the public after either publication of the application pursuant to 35 U.S.C. 122(b) or issuance of a patent pursuant to 35 U.S.C. 151. Further, a record may be disclosed, subject to the limitations of 37 CFR 1.14, as a routine use, to the public if the record was filed in an application which became abandoned or in which the proceedings were terminated and which application is referenced by either a published application, an application open to public inspection or an issued patent.
9. A record from this system of records may be disclosed, as a routine use, to a Federal, State, or local law enforcement agency, if the USPTO becomes aware of a violation or potential violation of law or regulation.

## Electronic Acknowledgement Receipt

<b>EFS ID:</b>	35764634
<b>Application Number:</b>	16226249
<b>International Application Number:</b>	
<b>Confirmation Number:</b>	1002
<b>Title of Invention:</b>	ADVANCED PULSE OXIMETRY SENSOR
<b>First Named Inventor/Applicant Name:</b>	Ammar Al-Ali
<b>Customer Number:</b>	64735
<b>Filer:</b>	Aaron Samuel Johnson/Imran Ahmed
<b>Filer Authorized By:</b>	Aaron Samuel Johnson
<b>Attorney Docket Number:</b>	MAS.1007C1
<b>Receipt Date:</b>	18-APR-2019
<b>Filing Date:</b>	19-DEC-2018
<b>Time Stamp:</b>	13:42:49
<b>Application Type:</b>	Utility under 35 USC 111(a)

### Payment information:

Submitted with Payment	no
------------------------	----

### File Listing:

Document Number	Document Description	File Name	File Size(Bytes)/ Message Digest	Multi Part /.zip	Pages (if appl.)
1	Internet Communications Authorized	Internet-Comm- Autho_MAS1007C1.pdf	75415 <small>0e279929698a874a027a40f5eba5acfb2c4f180f</small>	no	2

### Warnings:



<b>Information:</b>	
<b>Total Files Size (in bytes):</b>	75415
<p><b>This Acknowledgement Receipt evidences receipt on the noted date by the USPTO of the indicated documents, characterized by the applicant, and including page counts, where applicable. It serves as evidence of receipt similar to a Post Card, as described in MPEP 503.</b></p> <p><b><u>New Applications Under 35 U.S.C. 111</u></b>  <b>If a new application is being filed and the application includes the necessary components for a filing date (see 37 CFR 1.53(b)-(d) and MPEP 506), a Filing Receipt (37 CFR 1.54) will be issued in due course and the date shown on this Acknowledgement Receipt will establish the filing date of the application.</b></p> <p><b><u>National Stage of an International Application under 35 U.S.C. 371</u></b>  <b>If a timely submission to enter the national stage of an international application is compliant with the conditions of 35 U.S.C. 371 and other applicable requirements a Form PCT/DO/EO/903 indicating acceptance of the application as a national stage submission under 35 U.S.C. 371 will be issued in addition to the Filing Receipt, in due course.</b></p> <p><b><u>New International Application Filed with the USPTO as a Receiving Office</u></b>  <b>If a new international application is being filed and the international application includes the necessary components for an international filing date (see PCT Article 11 and MPEP 1810), a Notification of the International Application Number and of the International Filing Date (Form PCT/RO/105) will be issued in due course, subject to prescriptions concerning national security, and the date shown on this Acknowledgement Receipt will establish the international filing date of the application.</b></p>	



UNITED STATES PATENT AND TRADEMARK OFFICE

UNITED STATES DEPARTMENT OF COMMERCE  
**United States Patent and Trademark Office**  
Address: COMMISSIONER FOR PATENTS  
P.O. Box 1450  
Alexandria, Virginia 22313-1450  
www.uspto.gov

APPLICATION NO.	FILING DATE	FIRST NAMED INVENTOR	ATTORNEY DOCKET NO.	CONFIRMATION NO.
16/226,249	12/19/2018	Ammar Al-Ali	MAS.1007C1	1002
64735	7590	03/29/2019	EXAMINER	
KNOBBE, MARTENS, OLSON & BEAR, LLP MASIMO CORPORATION (MASIMO) 2040 MAIN STREET FOURTEENTH FLOOR IRVINE, CA 92614			FARDANESH, MARJAN	
			ART UNIT	PAPER NUMBER
			3791	
			NOTIFICATION DATE	DELIVERY MODE
			03/29/2019	ELECTRONIC

**Please find below and/or attached an Office communication concerning this application or proceeding.**

The time period for reply, if any, is set in the attached communication.

Notice of the Office communication was sent electronically on above-indicated "Notification Date" to the following e-mail address(es):

efiling@knobbe.com  
jayna.cartee@knobbe.com



***Notice of Pre-AIA or AIA Status***

1. The present application, filed on or after March 16, 2013, is being examined under the first inventor to file provisions of the AIA.

***Claim Objections***

2. Claims 65, 75, 80 are objected to because of the following informalities: In line 2, change "spacial" to "spatial". Appropriate correction is required.

***Drawings***

3. The drawings are objected to as failing to comply with 37 CFR 1.84(p)(5) because they include the following reference character(s) not mentioned in the description: reference character 709 in figure 7A not mentioned in the specification. Corrected drawing sheets in compliance with 37 CFR 1.121(d), or amendment to the specification to add the reference character(s) in the description in compliance with 37 CFR 1.121(b) are required in reply to the Office action to avoid abandonment of the application. Any amended replacement drawing sheet should include all of the figures appearing on the immediate prior version of the sheet, even if only one figure is being amended. Each drawing sheet submitted after the filing date of an application must be labeled in the top margin as either "Replacement Sheet" or "New Sheet" pursuant to 37 CFR 1.121(d). If the changes are not accepted by the examiner, the applicant will be notified and informed of any required corrective action in the next Office action. The objection to the drawings will not be held in abeyance.

***Specification***

4. The disclosure is objected to because of the following informalities: In [0053], line 8, Applicant should change "light concentrator 710" to "light concentrator 708".

Appropriate correction is required.

***Claim Rejections - 35 USC § 102***

5. The following is a quotation of the appropriate paragraphs of 35 U.S.C. 102 that form the basis for the rejections under this section made in this Office action:

A person shall be entitled to a patent unless –

(a)(1) the claimed invention was patented, described in a printed publication, or in public use, on sale or otherwise available to the public before the effective filing date of the claimed invention.

6. Claim(s) 57, 58, 60-62, 64-67, 69, 71-77, 79-82, and 84-86 is/are rejected under 35 U.S.C. 102(a)(1) as being anticipated by Cui et al. (USPN 5,584,296).

Regarding claims 57, 67, 77, Cui et al. discloses a wrist-worn physiological monitoring device configured for placement on a user at a tissue measurement site, the device comprising: a plurality of emitters configured to emit light towards the tissue measurement site (elements 36a-b, figures 7, 9-10, Col.11 line 2-Col.12 line 5), the tissue measurement site being located on a wrist of the user (the emitters are configured to irradiate any tissue of the user such a wrist of the user), the plurality of emitters comprising one or more light-emitting diodes (LEDs) configured to emit one or more wavelengths, the one or more wavelengths comprising at least an infrared wavelength (Col.11 line 2-Col.12 line 5); a plurality of detectors configured to detect the light emitted by the plurality of emitters after attenuation by tissue of the user at the tissue measurement site, wherein the plurality of detectors comprise one or more photodiodes, the plurality of detectors further configured to output at least one signal responsive to the detected light (elements 34,32, figures 7, 9-10, Col.11 line 2-Col.12 line 5); a processor configured to receive the at least one signal responsive to the

output and determine a physiological parameter of the user (processor 18, Col.4 lines 26-50); and a light block forming an enclosing wall between the light emitted from the plurality of emitters at the tissue measurement site and the plurality of detectors when the physiological monitoring device is worn by the user, wherein the wall prevents at least a portion of light emitted from the plurality of emitters from being detected by the plurality of detectors without attenuation by the tissue (element 60 figure 10, Col.7 line 50-Col.8 line 43).

Regarding claims 58, 69, 82, Cui et al. discloses a display (element 22) configured to present information related to the determined physiological parameter to the user (Col.4 lines 26-50).

Regarding claims 60, 71, 84, Cui et al. discloses the enclosing wall of the light block is a circular wall (element 60 figure 10 Col.7 line 50-Col.8 line 43).

Regarding claims 61, 72, 85, Cui et al. discloses when the physiological monitoring device is worn by the user at the tissue measurement site, the plurality of emitters are arranged in a reflectance measurement configuration on a first side of the tissue measurement site, and wherein the plurality of detectors are arranged in a reflectance measurement configuration on the first side of the tissue measurement site when the physiological monitoring device is worn by the user (figure 9).

Regarding claims 62, 73,81, Cui et al. discloses a diffuser which receives, spreads, and emits the spread light, wherein the emitted spread light is directed at the tissue measurement site (the inside surface of element 60 a figure 9 acts as a diffuser since it has an optical reflective surface, Col.7 line 50-Col.8 line 43).

Regarding claims 64, 74, 86, Cui et al. discloses the physiological parameter is selected from the group consisting of arterial oxygen saturation, glucose, and pulse rate (Col.2 lines 5-45).

Regarding claims 65, 75, 79, 80, Cui et al. discloses the plurality of detectors are arranged in an array with a spatial configuration corresponding to an irradiated surface area (figure 9).

Regarding claims 66, 76, Cui et al. discloses the irradiated surface area comprises a circular shape (figures 9-10).

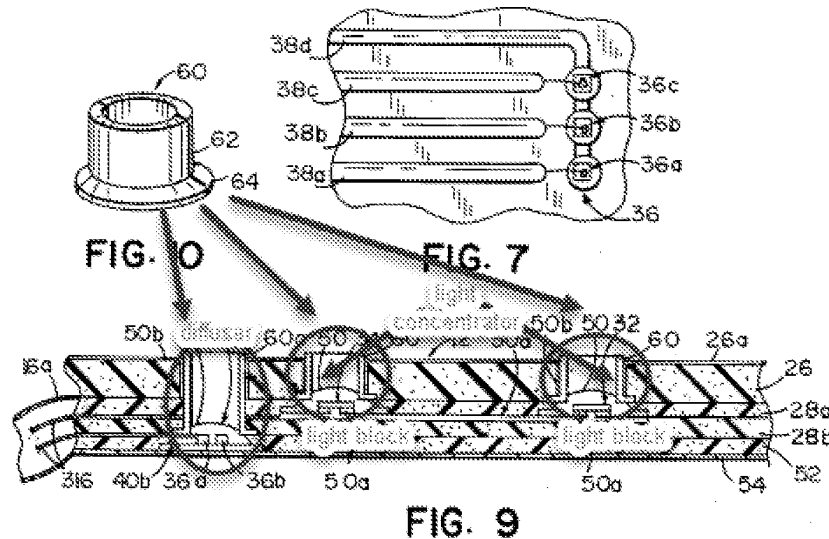

**Claim Rejections - 35 USC § 103**

7. The following is a quotation of 35 U.S.C. 103 which forms the basis for all obviousness rejections set forth in this Office action:

A patent for a claimed invention may not be obtained, notwithstanding that the claimed invention is not identically disclosed as set forth in section 102, if the differences between the claimed invention and the prior art are such that the claimed invention as a whole would have been obvious before the effective filing date of the claimed invention to a person having ordinary skill in the art to which the claimed invention pertains. Patentability shall not be negated by the manner in which the invention was made.

8. Claims 57,60-61, 63-68,71-72, 74-80, 84-86, is/are rejected under 35 U.S.C. 103 as being unpatentable over Hannula et al. (USPN 8,452,364) in view of Geddes et al. (USPN 2003/0036690).

Regarding claims 57, 67, 77, Hannula et al. discloses a wrist-worn physiological monitoring device configured for placement on a user at a tissue measurement site, the device comprising: a plurality of emitters configured to emit light towards the tissue measurement site (elements 18 figure 1B), the tissue measurement site being located on a wrist of the user (the emitters are configured to irradiate any tissue of the user such a wrist of the user), the plurality of emitters comprising one or more light-emitting diodes (Col.4 lines 10-62) configured to emit one or more wavelengths, the one or more wavelengths comprising at least an infrared wavelength (Col.3 lines 50-64); detector (18) configured to detect the light emitted by the plurality of emitters after attenuation by tissue of the user at the tissue measurement site, wherein the detector comprise one or more photodiodes, the plurality of detectors further configured to output at least one signal responsive to the detected light (Col.4 lines 10-62); a processor configured to receive the at least one signal responsive to the output and determine a physiological parameter of the user (Col.8 lines 22-50); and a light block forming an enclosing wall between the light emitted from the plurality of emitters at the tissue measurement site and the plurality of detectors when the physiological monitoring device is worn by the user, wherein the wall prevents at least a portion of light emitted from the plurality of emitters from being detected by the plurality of detectors without attenuation by the tissue (optical barrier 20, Col.4 line 36-Col.5 line 45). While Hannula et al. discloses two emitters and a detector or two detector and an emitter configurations, it fails to disclose



two emitters and two detectors. Geddes et al. discloses that the configuration of two emitters and one detector and the configuration of two detectors and one emitter can be combined resulting in two emitters and two detectors ([0040]). Therefore, it would have been obvious to one of ordinary skill in the art at the time the invention was made before the effective filing date of the claimed invention (AIA) to have modified the configuration of the emitters and detector of Hannula et al. by including two detectors and two emitters, with a reasonable expectation of success, because the prior art teaches two emitters and a detector or two detector and an emitter configurations, as taught by Hannula et al., and since the configuration of two emitters and one detector and the configuration of two detectors and one emitter can be combined resulting in two emitters and two detectors would have been known in the art, as taught by Geddes et al.. The rationale would have been the predictable use of prior art elements according to their established functions. KSR, 550, U.S. at 417.

Regarding claims 60, 71, 84, Hannula et al. discloses the enclosing wall of the light block is a circular wall (optical barrier figures 3A, 5A).

Regarding claims 61, 72, 85, Hannula et al. discloses when the physiological monitoring device is worn by the user at the tissue measurement site, the plurality of emitters are arranged in a reflectance measurement configuration on a first side of the tissue measurement site, and wherein the plurality of detectors are arranged in a reflectance measurement configuration on the first side of the tissue measurement site when the physiological monitoring device is worn by the user (figures 1 and 5).

Regarding claims 63, 68, 78, the combination of Hannula et al. and Geddes et al. discloses the plurality of emitters (elements 18 figure 1B) are positioned outside the

enclosing wall when the physiological monitoring device is worn by the user at the tissue measurement site, and wherein the plurality of detectors (elements 16) are positioned inside the enclosing wall when the physiological monitoring device is worn by the user at the tissue measurement site (figure 1B).

Regarding claims 64, 74, 86, Hannula et al. discloses the physiological parameter is selected from the group consisting of arterial oxygen saturation, glucose, and pulse rate (Col.8 lines 22-50).

Regarding claims 65, 75, 79, 80, the combination of Hannula et al. and Geddes et al discloses the plurality of detectors are arranged in an array with a spatial configuration corresponding to an irradiated surface area (figure 1B).

Regarding claims 66, 76, the combination of Hannula et al. and Geddes et al discloses the irradiated surface area comprises a circular shape (figures 1B, 3A, 5A).

9. Claims 59, 70, 83 is/are rejected under 35 U.S.C. 103 as being unpatentable over Cui et al. (USPN 5,584,296) as applied to claims 58,69, 82 above, and further in view of Swenson et al. (USPN 5,623,925).

Cui et al. fails to disclose that the display is a touch-screen display. Swenson et al. discloses that the computer monitor has touch screen capabilities (Col.4 lines 54-58). Therefore, it would have been obvious to one of ordinary skill in the art at the time the invention was made before the effective filing date of the claimed invention (AIA) to have modified the display of Cui et al. by including touch screen capabilities, with a reasonable expectation of success, because the prior art teaches computer monitor 22 (figure 1), as taught by Cui et al., and since computer monitor with touch screen capabilities would have been known in the art, as taught by Swenson et al.. The

rationale would have been the predictable use of prior art elements according to their established functions. KSR, 550, U.S. at 417.

### ***Conclusion***

10. Any inquiry concerning this communication or earlier communications from the examiner should be directed to MARJAN FARDANESH whose telephone number is (571)270-5508. The examiner can normally be reached on Monday-Friday 9:00-17:00.

Examiner interviews are available via telephone, in-person, and video conferencing using a USPTO supplied web-based collaboration tool. To schedule an interview, applicant is encouraged to use the USPTO Automated Interview Request (AIR) at <http://www.uspto.gov/interviewpractice>.

If attempts to reach the examiner by telephone are unsuccessful, the examiner's supervisor, Patricia Mallari can be reached on (571)272-4729. The fax phone number for the organization where this application or proceeding is assigned is 571-273-8300.

Information regarding the status of an application may be obtained from the Patent Application Information Retrieval (PAIR) system. Status information for published applications may be obtained from either Private PAIR or Public PAIR. Status information for unpublished applications is available through Private PAIR only. For more information about the PAIR system, see <http://pair-direct.uspto.gov>. Should you have questions on access to the Private PAIR system, contact the Electronic Business Center (EBC) at 866-217-9197 (toll-free). If you would like assistance from a

Application/Control Number: 16/226,249  
Art Unit: 3791

Page 10

USPTO Customer Service Representative or access to the automated information system, call 800-786-9199 (IN USA OR CANADA) or 571-272-1000.

/ERIC F WINAKUR/  
Primary Examiner, Art Unit 3791

/MARJAN FARDANESH/  
Examiner, Art Unit 3791

<b>Notice of References Cited</b>	Application/Control No. 16/226,249	Applicant(s)/Patent Under Reexamination Al-Ali et al.	
	Examiner MARJAN FARDANESH	Art Unit 3791	Page 1 of 1

**U.S. PATENT DOCUMENTS**

*		Document Number Country Code-Number-Kind Code	Date MM-YYYY	Name	CPC Classification	US Classification
*	A	US-5584296-A	12-1996	Cui; Weijia	A61B5/14552	356/41
*	B	US-8452364-B2	05-2013	Hannula; Don L.	A61B5/14552	600/322
*	C	US-20030036690-A1	02-2003	Geddes, Leslie A.	A61B5/02233	600/323
*	D	US-5623925-A	04-1997	Swenson; Michael R.	A61B5/0205	600/301
	E					
	F					
	G					
	H					
	I					
	J					
	K					
	L					
	M					

**FOREIGN PATENT DOCUMENTS**

*		Document Number Country Code-Number-Kind Code	Date MM-YYYY	Country	Name	CPC Classification
	N					
	O					
	P					
	Q					
	R					
	S					
	T					

**NON-PATENT DOCUMENTS**

*		Include as applicable: Author, Title Date, Publisher, Edition or Volume, Pertinent Pages)
	U	
	V	
	W	
	X	

\*A copy of this reference is not being furnished with this Office action. (See MPEP § 707.05(a).)  
Dates in MM-YYYY format are publication dates. Classifications may be US or foreign.

<b><i>Search Notes</i></b> 	<b>Application/Control No.</b> 16/226,249	<b>Applicant(s)/Patent Under Reexamination</b> Al-Ali et al.
	<b>Examiner</b> MARJAN FARDANESH	<b>Art Unit</b> 3791

<b>CPC - Searched*</b>		
<b>Symbol</b>	<b>Date</b>	<b>Examiner</b>
EAST-See search history printout	03/04/2019	/mf/

<b>CPC Combination Sets - Searched*</b>		
<b>Symbol</b>	<b>Date</b>	<b>Examiner</b>

<b>US Classification - Searched*</b>			
<b>Class</b>	<b>Subclass</b>	<b>Date</b>	<b>Examiner</b>

\* See search history printout included with this form or the SEARCH NOTES box below to determine the scope of the search.

<b>Search Notes</b>		
<b>Search Notes</b>	<b>Date</b>	<b>Examiner</b>
PALM-inventor name search	03/04/2019	/mf/

<b>Interference Search</b>			
<b>US Class/CPC Symbol</b>	<b>US Subclass/CPC Group</b>	<b>Date</b>	<b>Examiner</b>

/MARJAN FARDANESH/ Examiner, Art Unit 3791	
---	--

<b><i>Index of Claims</i></b> 	<b>Application/Control No.</b> 16/226,249	<b>Applicant(s)/Patent Under Reexamination</b> Al-Ali et al.
	<b>Examiner</b> MARJAN FARDANESH	<b>Art Unit</b> 3791

✓	<b>Rejected</b>
=	<b>Allowed</b>

-	<b>Cancelled</b>
÷	<b>Restricted</b>

N	<b>Non-Elected</b>
I	<b>Interference</b>

A	<b>Appeal</b>
O	<b>Objected</b>

CLAIMS									
<input type="checkbox"/> Claims renumbered in the same order as presented by applicant <input type="checkbox"/> CPA <input type="checkbox"/> T.D. <input type="checkbox"/> R.1.47									
CLAIM		DATE							
Final	Original	03/04/2019							
	57	✓							
	58	✓							
	59	✓							
	60	✓							
	61	✓							
	62	✓							
	63	✓							
	64	✓							
	65	✓							
	66	✓							
	67	✓							
	68	✓							
	69	✓							
	70	✓							
	71	✓							
	72	✓							
	73	✓							
	74	✓							
	75	✓							
	76	✓							
	77	✓							
	78	✓							
	79	✓							
	80	✓							
	81	✓							
	82	✓							
	83	✓							
	84	✓							
	85	✓							
	86	✓							

## EAST Search History

## EAST Search History (Prior Art)

Ref #	Hits	Search Query	DBs	Default Operator	Plurals	Time Stamp
L1	1	("5584296").PN.	USPAT; USOCR	OR	OFF	2019/03/04 11:33
S1	1	JP-2005192879-\$.did.	DERWENT	AND	ON	2011/01/04 11:01
S2	1	"2002111544".pn.	DERWENT	AND	ON	2011/01/04 11:14
S3	2	"2002111544".pn.	US-PGPUB; USPAT; USOCR; FPRS; EPO; JPO; DERWENT; IBM_TDB	AND	ON	2011/01/04 11:14
S4	2	"2005192879".pn.	US-PGPUB; USPAT; USOCR; FPRS; EPO; JPO; DERWENT; IBM_TDB	AND	ON	2011/01/04 11:15
S5	1	"2006509574".pn.	US-PGPUB; USPAT; USOCR; FPRS; EPO; JPO; DERWENT; IBM_TDB	AND	ON	2011/01/04 11:16
S6	2	"20060155174".pn.	US-PGPUB; USPAT; USOCR; FPRS; EPO; JPO; DERWENT; IBM_TDB	AND	ON	2011/01/04 11:18
S7	2	"2002146368".pn.	US-PGPUB; USPAT; USOCR; FPRS; EPO; JPO; DERWENT; IBM_TDB	AND	ON	2011/01/04 11:20
S8	2	"20020146368".pn.	US-PGPUB; USPAT; USOCR; FPRS; EPO; JPO; DERWENT; IBM_TDB	AND	ON	2011/01/04 11:21
S9	0	"2002198470".pn.	US-PGPUB; USPAT	AND	ON	2011/01/04 13:38



## EAST Search History

S10	0	"US 2002198470".pn.	US-PGPUB; USPAT	AND	ON	2011/01/04 13:38
S11	904	whitman.in.	US-PGPUB; USPAT	AND	ON	2011/01/04 13:38
S12	402	whitman michael.in.	US-PGPUB; USPAT	AND	ON	2011/01/04 13:39
S13	139	whitman michael.in. and "2002"	US-PGPUB; USPAT	AND	ON	2011/01/04 13:39
S14	0	whitman michael.in. @pd<="2002"	US-PGPUB; USPAT	AND	ON	2011/01/04 13:39
S15	402	whitman michael.in.	US-PGPUB; USPAT	AND	ON	2011/01/04 13:39
S16	1	"5993378".pn.	US-PGPUB; USPAT	AND	ON	2011/01/04 14:06
S17	0	"2004560166".pn.	US-PGPUB; USPAT	AND	ON	2011/01/04 16:00
S18	0	"2004560166".pn.	US-PGPUB; USPAT	AND	ON	2011/01/04 16:00
S19	0	"2004560166"	US-PGPUB; USPAT; USOCR; FPRS; EPO; JPO; DERWENT; IBM_TDB	AND	ON	2011/01/04 16:00
S20	0	"2004560166".pn.	US-PGPUB; USPAT; USOCR; FPRS; EPO; JPO; DERWENT; IBM_TDB	AND	ON	2011/01/04 16:01
S21	0	JP 2004-560166	US-PGPUB; USPAT; USOCR; FPRS; EPO; JPO; DERWENT; IBM_TDB	AND	ON	2011/01/04 16:01
S22	6	("20020072784"   "20020111544"   "20020132226"   "20020146368"   "20020165444"   "20020198470").PN.	DERWENT	AND	ON	2011/01/04 16:56
S23	3	takizawa.in. and (600/309-310).ccls.	US-PGPUB; USPAT	AND	ON	2011/01/05 11:16
S24	4	kawano.in. and (600/309-310).ccls.	US-PGPUB; USPAT	AND	ON	2011/01/05 11:18
S25	3	uchiyama.in. and (600/309-310).ccls.	US-PGPUB; USPAT	AND	ON	2011/01/05 11:19
S26	2	segawa.in. and (600/309-310).ccls.	US-PGPUB; USPAT	AND	ON	2011/01/05 11:22
S27	3	homan.in. and (600/309-310).ccls.	US-PGPUB; USPAT	AND	ON	2011/01/05 11:24
S28	28	(600/309-310).ccls. and pill	US-PGPUB; USPAT	AND	ON	2011/01/05 11:26
S29	1	"4011538".pn.	US-PGPUB; USPAT	AND	ON	2011/01/05 12:36

S30	1597	(600/309,310,317,345,347,361).ccls. and (heat\$3 or dry\$3)	US-PGPUB; USPAT	AND	ON	2011/01/05 13:09
S31	545	(600/309,310,317,345,347,361).ccls. and (heat\$3 or dry\$3) and (recover\$3 or restore\$3 or reset\$3)	US-PGPUB; USPAT	AND	ON	2011/01/05 13:10
S32	493	(600/309,310,317,345,347,361).ccls. and (heat\$3 or dry\$3) and (recover\$3 or restore\$3 or reset\$3) and sensor	US-PGPUB; USPAT	AND	ON	2011/01/05 13:11
S33	472	(600/309,310,317,345,347,361).ccls. and (heat\$3 or dry\$3) and (recover\$3 or restore\$3 or reset\$3) and sensor and (heat or thermal or temperature)	US-PGPUB; USPAT	AND	ON	2011/01/05 13:12
S34	94	(600/309,310,317,345,347,361).ccls. and (heat\$3 or dry\$3) and (recover\$3 or restore\$3 or reset\$3) and sensor and (heat or thermal or temperature) and usage	US-PGPUB; USPAT	AND	ON	2011/01/05 13:15
S35	87	(600/309,310,317,345,347,361).ccls. and (heat\$3 or dry\$3) and (recover\$3 or restore\$3 or reset\$3) and sensor same (heat or thermal or temperature) and usage	US-PGPUB; USPAT	AND	ON	2011/01/05 13:20
S36	1	(600/309,310,317,345,347,361).ccls. and (heat\$3 or dry\$3) same (recover\$3 or restore\$3 or reset\$3) and sensor same (heat or thermal or temperature) and usage	US-PGPUB; USPAT	AND	ON	2011/01/05 13:21
S37	1	(600/309,310,317,345,347,361).ccls. and (heat\$3 or dry\$3) and (recover\$3 or restore\$3 or reset\$3) and sensor same (heat or thermal or temperature) same usage	US-PGPUB; USPAT	AND	ON	2011/01/05 13:21
S38	87	(600/309,310,317,345,347,361).ccls. and (heat\$3 or dry\$3) and (recover\$3 or restore\$3 or reset\$3) and sensor same (heat or thermal or temperature) and usage	US-PGPUB; USPAT	AND	ON	2011/01/05 13:22
S39	71	(600/309,310,317,345,347,361).ccls. and (heat\$3 and dry\$3) and (recover\$3 or restore\$3 or reset\$3) and sensor same (heat or thermal or temperature) and usage	US-PGPUB; USPAT	AND	ON	2011/01/05 13:38
S40	0	(600/309,310,317,345,347,361).ccls. and (heat\$3 same dry\$3) and (recover\$3 or restore\$3 or reset\$3) and sensor same (heat or thermal or temperature) and usage	US-PGPUB; USPAT	AND	ON	2011/01/05 13:39
S41	71	(600/309,310,317,345,347,361).ccls. and (heat\$3 and dry\$3) and (recover\$3 or restore\$3 or reset\$3) and sensor same (heat or thermal or temperature) and usage	US-PGPUB; USPAT	AND	ON	2011/01/05 13:39
S42	65	emitter same detector same (distance offset) and A61B5/\$.cpc.	US-PGPUB; USPAT; USOCR; FPRS; EPO; JPO; DERWENT; IBM_TDB	AND	ON	2018/12/28 17:00

## EAST Search History

S43	1328	emitter same detector same (distance offset) and A61B5/\$.cpc.	US-PGPUB; USPAT; USOCR; FPRS; EPO; JPO; DERWENT; IBM_TDB	OR	ON	2018/12/28 17:02
S46	1	"20090105564".pn.	US-PGPUB; USPAT	AND	ON	2019/01/02 12:56
S47	7	((("8277384") or ("4743107") or ("20020016533") or ("20140206980") or ("20170209047") or ("20090209834") or ("20120277559")),PN.	US-PGPUB; USPAT; USOCR	OR	OFF	2019/01/02 15:30
S48	1	"15132279"	US-PGPUB; USPAT	OR	OFF	2019/01/02 15:33
S49	11	((("4699376") or ("4583555") or ("8282579") or ("7785232") or ("6436058") or ("8341850") or ("20060064044") or ("20120226199") or ("20080132818") or ("20070043308") or ("20160000369")),PN.	US-PGPUB; USPAT; USOCR	OR	OFF	2019/01/02 17:04
S50	0	"15581656"	US-PGPUB; USPAT	OR	OFF	2019/01/02 17:43
S51	0	"15581656"	US-PGPUB; USPAT	OR	OFF	2019/01/02 17:44
S52	1	"20060064044".pn.	US-PGPUB; USPAT	OR	OFF	2019/01/02 17:48
S53	1	("5833603").PN.	US-PGPUB; USPAT; USOCR	OR	OFF	2019/01/02 19:09
S54	1	("20060249690").PN.	US-PGPUB; USPAT; USOCR	OR	OFF	2019/01/03 13:46
S55	1	("20110133730").PN.	US-PGPUB; USPAT; USOCR	OR	OFF	2019/01/03 13:46
S56	0	"14957840"	US-PGPUB; USPAT	OR	OFF	2019/01/03 13:47
S61	3	((("7941199") or ("8224411") or ("8385996")),PN.	US-PGPUB; USPAT; USOCR	OR	OFF	2019/01/21 14:54
S62	933	(oximetry oximeter) and ratio same AC	US-PGPUB; USPAT	OR	ON	2019/01/21 15:13
S63	426	(oximetry oximeter) and ratio same AC same wavelength\$1	US-PGPUB; USPAT	OR	ON	2019/01/21 15:13
S64	19	newberry.in. and ratio same AC same wavelength\$1	US-PGPUB; USPAT	OR	ON	2019/01/21 15:23
S65	2	newberry.in. and ratio same AC same wavelength\$1.clm.	US-PGPUB; USPAT	OR	ON	2019/01/21 15:24
S66	877	AC same first same second same (spectral spectrum wavelength\$1 pulsating pulsatile pulse) same ratio	US-PGPUB; USPAT	OR	ON	2019/01/22 11:00
S67	110	AC same first same second same (spectral spectrum wavelength\$1 pulsating pulsatile pulse) same ratio and A61B5/\$.cpc.	US-PGPUB; USPAT	OR	ON	2019/01/22 11:01
S68	46	AC same first same second same	US-PGPUB;	OR	ON	2019/01/22

		(spectral spectrum wavelength\$1 pulsating pulsatile pulse) same ratio and (hyperglycemi\$3 diabet\$3 hypoglycemi\$3 glucose)	USPAT			11:23
S69	1	"15958620" and AC and (glucose hyperglycem\$4 hypoglycem\$4) and ratio and compar\$4 and threshold\$1	US-PGPUB; USPAT	OR	ON	2019/01/22 12:19
S70	226	ratio and wavelength and threshold and (alert\$4 alarm\$4) same (hyperglycem\$4 hypoglycem\$4)	US-PGPUB; USPAT	OR	ON	2019/01/22 13:37
S71	23	lambert and threshold with compar\$5 and (alert\$4 alarm\$4) same (hyperglycem\$4 hypoglycem\$4)	US-PGPUB; USPAT	OR	ON	2019/01/22 13:45
S72	19	lambert and AC and threshold same compar\$5 and (alert\$4 alarm\$4) same (hyperglycem\$4 hypoglycem\$4)	US-PGPUB; USPAT	OR	ON	2019/01/22 13:47
S73	20	lambert and AC and threshold and (alert\$4 alarm\$4) same (hyperglycem\$4 hypoglycem\$4)	US-PGPUB; USPAT	OR	ON	2019/01/22 13:51
S74	1	S73 not S72	US-PGPUB; USPAT	OR	ON	2019/01/22 13:51
S75	771	AC and (alert\$4 alarm\$4) same (hyperglycem\$4 hypoglycem\$4)	US-PGPUB; USPAT	OR	ON	2019/01/22 13:52
S76	20	AC and lambert and (alert\$4 alarm\$4) same (hyperglycem\$4 hypoglycem\$4)	US-PGPUB; USPAT	OR	ON	2019/01/22 13:52
S77	1	S76 not S72	US-PGPUB; USPAT	OR	ON	2019/01/22 13:52
S78	204	AC and DC and (alert\$4 alarm\$4) same (hyperglycem\$4 hypoglycem\$4) and A61B5/\$.cpc.	US-PGPUB; USPAT	OR	ON	2019/01/22 13:53
S79	1	newberry.in. and AC same compar\$4 same threshold\$4.clm.	US-PGPUB; USPAT	OR	ON	2019/01/22 14:03
S80	4	newberry.in. and AC.clm.	US-PGPUB; USPAT	OR	ON	2019/01/22 14:03
S81	35060	(LED diode light adj source) same switch\$4 with frequenc\$4	US-PGPUB; USPAT	OR	ON	2019/01/22 14:43
S82	18125	(LED diode light adj source) with switch\$4 with frequenc\$4	US-PGPUB; USPAT	OR	ON	2019/01/22 14:44
S83	385	(LED diode light adj source) with switch\$4 with frequenc\$4 and A61B5/\$.cpc.	US-PGPUB; USPAT	OR	ON	2019/01/22 14:45
S84	271	frequenc\$5 with depend\$5 with switch\$5 and A61B5/\$.cpc.	US-PGPUB; USPAT	OR	ON	2019/01/22 14:52
S85	20	frequenc\$5 with depend\$5 with switch\$5 same (light adj source LED diode) and A61B5/\$.cpc.	US-PGPUB; USPAT	OR	ON	2019/01/22 14:53
S86	1	"13985232" and encapsulat\$5	US-PGPUB; USPAT	OR	ON	2019/01/22 16:22
S87	1	"5217013".pn.	US-PGPUB; USPAT	OR	ON	2019/01/22 16:27
S88	220	("4321930"   "4380240"   "4510938"   "4819752"   "4825879"   "4865038"   "4880304"   "4928691"   "4964408"   "5094240"   "5111817").PN. OR ("5217013").URPN.	US-PGPUB; USPAT; USOCR	OR	OFF	2019/01/22 16:53
S89	1	"20100049018".pn.	US-PGPUB;	OR	OFF	2019/01/22

			USPAT; USOCR			17:01
S90	1	"20090182209".pn.	US-PGPUB; USPAT; USOCR	OR	OFF	2019/01/22 17:22
S91	3	((("20110245686") or ("20020115918") or ("20100252721")).PN.	US-PGPUB; USPAT; USOCR	OR	OFF	2019/01/24 11:10
S92	1	"14773755"	US-PGPUB; USPAT	OR	OFF	2019/01/24 11:18
S93	314	lens same fourier adj transform and A61 B5/\$.cpc.	US-PGPUB; USPAT	OR	ON	2019/01/24 11:43
S94	6	((("20110118571") or ("20070213607") or ("6921366") or ("20160356746") or ("20150005611") or ("7039446")).PN.	US-PGPUB; USPAT; USOCR	OR	OFF	2019/01/29 09:34
S95	1	("5217013").PN.	USPAT; USOCR	OR	OFF	2019/01/29 15:46
S96	1	("20100298678").PN.	US-PGPUB; USPAT; USOCR	OR	OFF	2019/01/29 15:58
S97	0	("145309087").PN.	USPAT; USOCR	OR	OFF	2019/01/29 16:26
S98	0	("14309087").PN.	USPAT; USOCR	OR	OFF	2019/01/29 16:26
S99	1	"14309087"	USPAT	OR	OFF	2019/01/29 16:26
S100	1	"20100073669"	USPAT	OR	OFF	2019/01/29 16:34
S101	2	"20100073669"	US-PGPUB; USPAT	OR	OFF	2019/01/29 16:34
S102	2	"14108012"	US-PGPUB; USPAT	OR	OFF	2019/01/30 11:40
S103	3717	electrical\$5 with conductive\$4 same (copper carbon) and A61 B5/\$.cpc.	US-PGPUB; USPAT	OR	ON	2019/01/30 11:43
S104	254	electrical\$5 with conductive\$4 same (copper carbon) and A61 B5/1455\$.cpc.	US-PGPUB; USPAT	OR	ON	2019/01/30 11:51
S105	532	"6519487"	US-PGPUB; USPAT	OR	ON	2019/01/30 12:38
S106	1	("6519487").PN.	USPAT; USOCR	OR	OFF	2019/01/30 12:38
S107	0	("16030303").PN.	USPAT; USOCR	OR	OFF	2019/01/30 14:52
S108	1	"16030303"	US-PGPUB; USPAT	OR	OFF	2019/01/30 14:53
S109	1	"5217013".pn.	US-PGPUB; USPAT	OR	OFF	2019/01/30 15:01
S110	2	((("20100049018") or ("20090182209")).PN.	US-PGPUB; USPAT; USOCR	OR	OFF	2019/01/30 15:04
S111	1	"13985232"	US-PGPUB; USPAT	OR	OFF	2019/01/30 15:06
S112	1	("20100041969").PN.	US-PGPUB; USPAT; USOCR	OR	OFF	2019/01/30 15:22
S113	51	weighted with subtract\$5 same reference	US-PGPUB;	OR	OFF	2019/01/30

		and A61B5/\$.cpc.	USPAT			15:39
S114	1	("6097975").PN.	USPAT; USOCR	OR	OFF	2019/01/30 15:41
S115	1	("6067463").PN.	USPAT; USOCR	OR	OFF	2019/01/30 15:42
S116	205	weighted same subtract\$5 same reference and A61B5/\$.cpc.	US-PGPUB; USPAT	OR	OFF	2019/01/30 15:49
S117	0	("20090253996").PN.	USPAT; USOCR	OR	OFF	2019/01/30 16:00
S118	1	("20090253996").PN.	US-PGPUB; USPAT; USOCR	OR	OFF	2019/01/30 16:01
S119	1	("20060264727").PN.	US-PGPUB; USPAT; USOCR	OR	OFF	2019/01/30 16:03
S120	2	"14108012"	US-PGPUB; USPAT	OR	OFF	2019/01/30 16:48
S121	7	lee.in. and lifescan.asn.	US-PGPUB; USPAT	OR	OFF	2019/01/30 16:49
S122	0	fardanesh.xa. and lifescan.asn.	US-PGPUB; USPAT	OR	OFF	2019/01/30 16:50
S123	2	((("6097975") or ("6067463"))).PN.	USPAT; USOCR	OR	OFF	2019/01/31 10:43
S124	77	(remov\$4 filter\$4 subtract\$4) with weighted with reference and A61B5/\$.cpc.	US-PGPUB; USPAT	OR	OFF	2019/01/31 10:55
S125	276	(remov\$4 filter\$4 subtract\$4) with weighted same reference and A61B5/\$.cpc.	US-PGPUB; USPAT	OR	OFF	2019/01/31 11:01
S126	199	S125 not S124	US-PGPUB; USPAT	OR	OFF	2019/01/31 11:01
S127	1	("20100073669").PN.	US-PGPUB; USPAT; USOCR	OR	OFF	2019/01/31 12:35
S128	1	"12110994"	USPAT	OR	OFF	2019/01/31 17:54
S129	270	fardanesh.xa.	US-PGPUB; USPAT	OR	ON	2019/01/31 18:39
S130	1	("6067463").PN.	USPAT; USOCR	OR	OFF	2019/01/31 18:53
S131	1	("6097975").PN.	USPAT; USOCR	OR	OFF	2019/01/31 18:53
S132	1	("20130096403").PN.	US-PGPUB; USPAT; USOCR	OR	OFF	2019/02/01 12:30
S133	1	"15166702" and power adj sensor	US-PGPUB; USPAT	OR	OFF	2019/02/01 12:32
S134	3	"13651173"	US-PGPUB; USPAT	OR	OFF	2019/02/01 12:35
S135	1	("20080275317").PN.	US-PGPUB; USPAT; USOCR	OR	OFF	2019/02/01 12:37
S136	10	("20070203448"   "20080027330"   "20090105605"   "20100009328"   "20100298899"   "20110181422"	US-PGPUB; USPAT; USOCR	OR	OFF	2019/02/01 12:38

		"7220220").PN. OR ("8996088").URPN.				
S137	2	((("20020151772") or ("20100202966")).PN.	US-PGPUB; USPAT; USOCR	OR	OFF	2019/02/05 09:24
S138	1	("20140051955").PN.	US-PGPUB; USPAT; USOCR	OR	OFF	2019/02/05 14:14
S139	2	((("20140187883") or ("20110112387")).PN.	US-PGPUB; USPAT; USOCR	OR	OFF	2019/02/05 14:51
S140	1	("9314197").PN.	US-PGPUB; USPAT; USOCR	OR	OFF	2019/02/05 16:01
S141	1	"15606666" and detector and reader	US-PGPUB; USPAT	OR	OFF	2019/02/05 16:13
S142	2	("0569186").PN.	USPAT; USOCR	OR	OFF	2019/02/05 16:19
S143	1	("5569186").PN.	USPAT; USOCR	OR	OFF	2019/02/05 16:19
S145	1	("6561978").PN.	US-PGPUB; USPAT; USOCR	OR	OFF	2019/02/05 16:33
S146	273	fardanesh.xa.	US-PGPUB; USPAT; USOCR	OR	OFF	2019/02/05 16:34
S147	1	("7275437").PN.	USPAT; USOCR	OR	OFF	2019/02/06 11:10
S148	2	((("7827537") or ("7827437")).PN.	USPAT; USOCR	OR	OFF	2019/02/06 11:11
S149	1	("7827543").PN.	USPAT; USOCR	OR	OFF	2019/02/06 11:11
S150	1	("7827547").PN.	USPAT; USOCR	OR	OFF	2019/02/06 11:12
S151	0	holker.in. and "7827"\$	USPAT	OR	OFF	2019/02/06 11:14
S152	21	holker.in.	USPAT	OR	OFF	2019/02/06 11:14
S153	1	("7003336").PN.	USPAT; USOCR	OR	OFF	2019/02/06 12:02
S154	0	((("20060249690") or ("20110133730")).PN.	USPAT; USOCR	OR	OFF	2019/02/06 13:21
S155	2	((("20060249690") or ("20110133730")).PN.	US-PGPUB; USPAT; USOCR	OR	OFF	2019/02/06 13:21
S156	2172	tumor and (probe marker) same (circulation vessel) and A61B5/\$.cpc.	US-PGPUB; USPAT	OR	ON	2019/02/06 14:01
S157	1127	tumor and (probe marker) with (circulation vessel) and A61B5/\$.cpc.	US-PGPUB; USPAT	OR	ON	2019/02/06 14:02
S158	199	tumor same (probe marker) with (circulation vessel) and A61B5/\$.cpc.	US-PGPUB; USPAT	OR	ON	2019/02/06 14:02
S163	1	("9314197").PN.	USPAT; USOCR	OR	OFF	2019/02/06 16:59
S164	1	("20140200423").PN.	US-PGPUB; USPAT; USOCR	OR	OFF	2019/02/06 17:00

EAST Search History

S165	1	("20140051955").PN.	US-PGPUB; USPAT; USOCR	OR	OFF	2019/02/07 13:38
S166	1	("5817012").PN.	US-PGPUB; USPAT; USOCR	OR	OFF	2019/02/07 14:51
S167	1	("20140046149").PN.	US-PGPUB; USPAT; USOCR	OR	OFF	2019/02/07 17:30
S168	1	("4880441").PN.	US-PGPUB; USPAT; USOCR	OR	OFF	2019/02/07 17:31
S169	7	"2003052865"	US-PGPUB; USPAT; USOCR; FPRS; EPO; JPO; DERWENT; IBM_TDB	OR	OFF	2019/02/07 17:32
S170	352	sweat and pump same permeable	US-PGPUB; USPAT; USOCR; FPRS; EPO; JPO; DERWENT; IBM_TDB	OR	OFF	2019/02/07 17:34
S171	78	sweat and pump same permeable same water	US-PGPUB; USPAT; USOCR; FPRS; EPO; JPO; DERWENT; IBM_TDB	OR	OFF	2019/02/07 17:35
S172	61	sweat and pump same permeable same water and sensor	US-PGPUB; USPAT; USOCR; FPRS; EPO; JPO; DERWENT; IBM_TDB	OR	OFF	2019/02/07 17:35
S173	63	sweat and pump same permeable same water and sens\$4	US-PGPUB; USPAT; USOCR; FPRS; EPO; JPO; DERWENT; IBM_TDB	OR	OFF	2019/02/07 17:35
S174	1	("20020151772").PN.	US-PGPUB; USPAT; USOCR	OR	OFF	2019/02/15 14:16
S175	1	("6561978").PN.	US-PGPUB; USPAT; USOCR	OR	OFF	2019/02/15 15:39
S176	852	"4178916"   "4509531"   "4703756"   "5062841"   "5063081"   "5077753"   "5112614"   "5113869"   "5140985"   "5279543"   "5362307"   "5458140"   "5462051"   "5507288"   "5569186"   "5636632"   "5721783"   "5730714"   "5735273"   "5771890"   "5807375"	US-PGPUB; USPAT; USOCR	OR	OFF	2019/02/15 15:47



		"5827183"   "5830132"   "5875186"   "5882300"   "5897033"   "5914701"   "5954685"   "5982297"   "5989409"   "5995860"   "6023629"   "6024699"   "6049727"   "6059736"   "6134461"   "6159147"   "6175752"   "6248067"   "6277067").PN. OR ("6561978").URPN.				
S177	2	"20100081906"	US-PGPUB; USPAT; USOCR	OR	OFF	2019/02/15: 15:55
S178	0	(2002/0019587).CCLS.	USPAT; USOCR	OR	OFF	2019/02/18: 10:26
S179	1	("20020019587").PN.	US-PGPUB; USPAT; USOCR	OR	OFF	2019/02/18: 10:26
S180	2	((("20140148661") or ("5517987")).PN.	US-PGPUB; USPAT; USOCR	OR	OFF	2019/02/19: 09:27
S181	4	((("20130004972") or ("20140353503") or ("20050148834") or ("7133710")).PN.	US-PGPUB; USPAT; USOCR	OR	OFF	2019/02/19: 10:59
S182	6	((("20110118571") or ("20070213607") or ("6921366") or ("20160356746") or ("20150005611") or ("7039446")).PN.	US-PGPUB; USPAT; USOCR	OR	OFF	2019/02/20: 14:21
S183	214	(chang\$5 with speckle with pattern) with (variable vary\$4 coefficient analyte)	US-PGPUB; USPAT	OR	ON	2019/02/20: 14:36
S184	1	("20130079618").PN.	US-PGPUB; USPAT; USOCR	OR	OFF	2019/02/28: 12:07
S185	1	("20150366490").PN.	US-PGPUB; USPAT; USOCR	OR	OFF	2019/02/28: 12:54
S186	2	((("20160007864") or ("20150031970")).PN.	US-PGPUB; USPAT; USOCR	OR	OFF	2019/02/28: 14:42
S187	0	"20160007864".pn. same threshold same (acceler\$6)	US-PGPUB; USPAT	OR	OFF	2019/02/28: 14:46
S188	0	"20150031970".pn. same threshold same (acceler\$6)	US-PGPUB; USPAT	OR	OFF	2019/02/28: 14:46
S189	0	"20150031970".pn. same threshold and (acceler\$6)	US-PGPUB; USPAT	OR	OFF	2019/02/28: 14:46
S190	0	"20160007864".pn. same threshold and (acceler\$6)	US-PGPUB; USPAT	OR	OFF	2019/02/28: 14:46
S191	1	"15581803"	US-PGPUB; USPAT	OR	OFF	2019/02/28: 15:35
S192	824	(shoulder scapula) with motion and A61B5/\$.cpc.	US-PGPUB; USPAT	OR	OFF	2019/02/28: 15:38
S193	23	(shoulder scapula) with motion and A61B5/4576.cpc.	US-PGPUB; USPAT	OR	OFF	2019/02/28: 15:38
S194	0	(shoulder scapula) with motion and eiseman.xa.	US-PGPUB; USPAT	OR	OFF	2019/02/28: 15:39
S195	0	(shoulder scapula) with motion and eiseman.xp.	US-PGPUB; USPAT	OR	OFF	2019/02/28: 15:39
S196	13	(shoulder scapula) with motion and dougherty.xp.	US-PGPUB; USPAT	OR	OFF	2019/02/28: 15:39
S197	2	(shoulder scapula) with motion and	US-PGPUB;	OR	OFF	2019/02/28

		dougherty.xa.	USPAT			15:39
S198	27	(shoulder scapula) with motion and A61B5/742.cpc.	US-PGPUB; USPAT	OR	OFF	2019/02/28 15:45
S199	0	(shoulder scapula) with motion and "minnesota.asn.."	US-PGPUB; USPAT	OR	OFF	2019/02/28 15:47
S200	1	(shoulder scapula) with motion and staker.in.	US-PGPUB; USPAT	OR	OFF	2019/02/28 15:48
S201	1	(shoulder scapula) with motion and ludewig.in.	US-PGPUB; USPAT	OR	OFF	2019/02/28 15:48
S202	0	("2017/0281074").URPN.	USPAT	OR	OFF	2019/02/28 15:48
S203	0	("2017/0281074").URPN.	US-PGPUB; USPAT	OR	OFF	2019/02/28 15:48
S204	0	(shoulder scapula) with motion with sens\$4 same orientation same (3-D 3D three-dimensional dimensional) same (smart-phone (smart adj phone) smartphone)and A61B5/\$.cpc.	US-PGPUB; USPAT	OR	ON	2019/02/28 16:12
S205	2	(shoulder scapula) with motion with sens\$4 and orientation same (3-D 3D three-dimensional dimensional) same (smart-phone (smart adj phone) smartphone)and A61B5/\$.cpc.	US-PGPUB; USPAT	OR	ON	2019/02/28 16:12
S206	15	(shoulder scapula) with motion with sens\$4 and orientation same (3-D 3D three-dimensional dimensional) and (smart-phone (smart adj phone) smartphone)and A61B5/\$.cpc.	US-PGPUB; USPAT	OR	ON	2019/02/28 16:14
S207	1	"14576581"	US-PGPUB; USPAT	OR	ON	2019/02/28 16:18
S208	1	(shoulder scapula) same motion same (3-D 3D three-dimensional dimensional) same (smart-phone (smart adj phone) smartphone)and A61B5/\$.cpc.	US-PGPUB; USPAT	OR	ON	2019/02/28 16:21
S209	1	(shoulder scapula) same (3-D 3D three-dimensional dimensional) same (smart-phone (smart adj phone) smartphone)and A61B5/\$.cpc.	US-PGPUB; USPAT	OR	ON	2019/02/28 16:21
S210	138	(shoulder scapula) same (3-D 3D three-dimensional dimensional) and (smart-phone (smart adj phone) smartphone)and A61B5/\$.cpc.	US-PGPUB; USPAT	OR	ON	2019/02/28 16:22
S211	1	humeral with elevation with arm and A61B5/\$.cpc.	US-PGPUB; USPAT	OR	ON	2019/02/28 16:56
S212	11	humeral with elevation and A61B5/\$.cpc.	US-PGPUB; USPAT	OR	ON	2019/02/28 16:56
S213	1	humeral with elevation and degree with scapula and A61B5/\$.cpc.	US-PGPUB; USPAT	OR	ON	2019/02/28 16:56
S214	1	humeral with elevation same degree and A61B5/\$.cpc.	US-PGPUB; USPAT	OR	ON	2019/02/28 16:57
S215	1	"15195199"	US-PGPUB; USPAT	OR	ON	2019/03/01 14:19
S216	1	"15195199" and ring	US-PGPUB; USPAT	OR	ON	2019/03/01 14:19
S217	3	((("20170007330") or ("20150223941") or ("20160213924")).PN.	US-PGPUB; USPAT;	OR	OFF	2019/03/01 14:54

			USOCR			
S218	277	fardanesh.xa.	US-PGPUB; USPAT	OR	OFF	2019/03/04 08:40
S219	0	"16226249" and wall	US-PGPUB; USPAT	OR	OFF	2019/03/04 09:00
S220	0	"16226249"	US-PGPUB; USPAT	OR	OFF	2019/03/04 09:00
S221	32	"20030139672"   "20040082842"   "20040225206"   "20050267346"   "20060193550"   "20070038126"   "20070060809"   "20080017800"   "20090182209"   "20100004719"   "20100022856"   "20120044484"   "20120253153"   "20130043551"   "4867557"   "4877322"   "4880304"   "5357954"   "5584296"   "5647359"   "6177984"   "6181959"   "6763256"   "6839585"   "6859658"   "6879850"   "7356365"   "7822453"   "8116851"   "8175667"   "8311601"   "8386000").PN. OR ("9883824").URPN.	US-PGPUB; USPAT; USOCR	OR	OFF	2019/03/04 09:13

## EAST Search History (I nterference)

Ref #	Hits	Search Query	DBs	Default Operator	Plurals	Time Stamp
S44	86	emitter same detector same (distance offset).clm. and A61B5/\$.cpc.	USPAT	OR	ON	2018/12/28 17:02
S45	190	emitter same detector same (distance offset).clm. and A61B5/\$.cpc.	US- PGPUB; USPAT	OR	ON	2018/12/28 17:02
S57	1	magnet\$4 same uniform with alignment and hydrogel and magnetometer	US- PGPUB; USPAT	OR	OFF	2019/01/04 15:23
S58	39	magnet\$4 same uniform and hydrogel and magnetometer	US- PGPUB; USPAT	OR	OFF	2019/01/04 15:25
S59	3	magnet\$4 same halbach and hydrogel and magnetometer	US- PGPUB; USPAT	OR	OFF	2019/01/04 15:25
S60	1	"20090316137".pn.	US- PGPUB; USPAT	OR	OFF	2019/01/04 17:00
S159	73	tumor same (probe marker) with (circulation vessel) and A61B5/\$.cpc.	USPAT	OR	ON	2019/02/06 14:04
S160	199	tumor same (probe marker) with (circulation vessel) and A61B5/\$.cpc.	US- PGPUB; USPAT	OR	ON	2019/02/06 14:04
S161	231	tumor same (probe marker) with (circulation vessel vasculature) and A61B5/\$.cpc.	US- PGPUB; USPAT	OR	ON	2019/02/06 14:05
S162	8	tumor same (probe marker) with (circulation vessel vasculature).clm. and A61B5/\$.cpc.	US- PGPUB; USPAT	OR	ON	2019/02/06 14:07

3/ 4/ 2019 12:02:30 PM

C:\Users\mfardanesh\Documents\EAST\Workspaces\~ auto.07102015.115008.wsp



PTO/SB/08 Equivalent

<b>INFORMATION DISCLOSURE STATEMENT BY APPLICANT</b>	Application No.	Unassigned
	Filing Date	Filed herewith
	First Named Inventor	Ammar Al-Ali
	Art Unit	Unassigned
<i>(Multiple sheets used when necessary)</i>	Examiner	Unassigned
SHEET 1 OF 28	Attorney Docket No.	MAS.1007C1

U.S. PATENT DOCUMENTS					
Examiner Initials	Cite No.	Document Number <i>Number - Kind Code (if known)</i> Example: 1,234,567 B1	Publication Date MM-DD-YYYY	Name	Pages, Columns, Lines Where Relevant Passages or Relevant Figures Appear
	1	4,960,128	10/2/1990	Gordon et al.	
	2	4,964,408	10/23/1990	Hink et al.	
	3	5,041,187	8/20/1991	Hink et al.	
	4	5,069,213	12/3/1991	Polczynski	
	5	5,163,438	11/17/1992	Gordon et al.	
	6	5,319,355	6/7/1994	Russek	
	7	5,337,744	8/16/1994	Branigan	
	8	5,341,805	8/30/1994	Stavridi, et al.	
	9	5,377,676	1/3/1995	Vari, et al.	
	10	5,431,170	7/11/1995	Mathews	
	11	5,452,717	9/26/1995	Branigan et al.	
	12	5,456,252	10/10/1995	Vari, et al.	
	13	5,479,934	1/2/1996	Imran	
	14	5,482,036	1/9/1996	Diab et al.	
	15	5,490,505	2/13/1996	Diab et al.	
	16	5,494,043	2/27/1996	O'Sullivan et al.	
	17	5,533,511	7/9/1996	Kaspari et al.	
	18	5,534,851	7/9/1996	Russek	
	19	5,561,275	10/1/1996	Savage, et al.	
	20	5,562,002	10/8/1996	Lalin	
	21	5,590,649	1/7/1997	Caro et al.	
	22	5,602,924	2/11/1997	Durand et al.	
	23	5,632,272	5/27/1997	Diab et al.	
	24	5,638,816	6/17/1997	Kiani-Azarbayjany et al.	
	25	5,638,818	6/17/1997	Diab et al.	
	26	5,645,440	7/8/1997	Tobler et al.	
	27	5,685,299	11/11/1997	Diab et al.	
	28	5,743,262	4/28/1998	Lepper, Jr. et al.	
	29	5,758,644	6/2/1998	Diab et al.	

Examiner Signature /MARJAN FARDANESH/	Date Considered 02/06/2019
<p><b>*Examiner:</b> Initial if reference considered, whether or not citation is in conformance with MPEP 609. Draw line through citation if not in conformance and not considered. Include copy of this form with next communication to applicant.</p>	

~~ALL REFERENCES CONSIDERED EXCEPT WHERE LINED THROUGH.~~ /M.F/

T<sup>1</sup> - Place a check mark in this area when an English language Translation is attached.

PTO/SB/08 Equivalent

<b>INFORMATION DISCLOSURE STATEMENT BY APPLICANT</b>	Application No.	Unassigned
	Filing Date	Filed herewith
	First Named Inventor	Ammar Al-Ali
	Art Unit	Unassigned
<i>(Multiple sheets used when necessary)</i>	Examiner	Unassigned
SHEET 2 OF 28	Attorney Docket No.	MAS.1007C1

U.S. PATENT DOCUMENTS					
Examiner Initials	Cite No.	Document Number <i>Number - Kind Code (if known)</i> Example: 1,234,567 B1	Publication Date MM-DD-YYYY	Name	Pages, Columns, Lines Where Relevant Passages or Relevant Figures Appear
	30	5,760,910	6/2/1998	Lepper, Jr. et al.	
	31	5,769,785	6/23/1998	Diab et al.	
	32	5,782,757	7/21/1998	Diab et al.	
	33	5,785,659	7/28/1998	Caro et al.	
	34	5,791,347	8/11/1998	Flaherty et al.	
	35	5,810,734	9/22/1998	Caro et al.	
	36	5,823,950	10/20/1998	Diab et al.	
	37	5,830,131	11/3/1998	Caro et al.	
	38	5,833,618	11/10/1998	Caro et al.	
	39	5,860,919	1/19/1999	Kiani-Azarbayjany et al.	
	40	5,890,929	4/6/1999	Mills et al.	
	41	5,904,654	5/18/1999	Wohltmann et al.	
	42	5,919,134	7/6/1999	Diab	
	43	5,934,925	8/10/1999	Tobler et al.	
	44	5,940,182	8/17/1999	Lepper, Jr. et al.	
	45	5,995,855	11/30/1999	Kiani et al.	
	46	5,997,343	12/7/1999	Mills et al.	
	47	6,002,952	12/14/1999	Diab et al.	
	48	6,011,986	1/4/2000	Diab et al.	
	49	6,027,452	2/22/2000	Flaherty et al.	
	50	6,036,642	3/14/2000	Diab et al.	
	51	6,045,509	4/4/2000	Caro et al.	
	52	6,067,462	5/23/2000	Diab et al.	
	53	6,081,735	6/27/2000	Diab et al.	
	54	6,088,607	7/11/2000	Diab et al.	
	55	6,110,522	8/29/2000	Lepper, Jr. et al.	
	56	6,124,597	9/26/2000	Shehada	
	57	6,128,521	10/3/2000	Marro et al.	
	58	6,129,675	10/10/2000	Jay	

Examiner Signature / <b>MARJAN FARDANESH</b> /	Date Considered <b>02/06/2019</b>
--	-----------------------------------

**\*Examiner:** Initial if reference considered, whether or not citation is in conformance with MPEP 609. Draw line through citation if not in conformance and not considered. Include copy of this form with next communication to applicant.

~~ALL REFERENCES CONSIDERED EXCEPT WHERE LINED THROUGH.~~ /M.F/

T<sup>1</sup> - Place a check mark in this area when an English language Translation is attached.

PTO/SB/08 Equivalent

<b>INFORMATION DISCLOSURE STATEMENT BY APPLICANT</b>	Application No.	Unassigned
	Filing Date	Filed herewith
	First Named Inventor	Ammar Al-Ali
	Art Unit	Unassigned
<i>(Multiple sheets used when necessary)</i>	Examiner	Unassigned
SHEET 3 OF 28	Attorney Docket No.	MAS.1007C1

U.S. PATENT DOCUMENTS					
Examiner Initials	Cite No.	Document Number <i>Number - Kind Code (if known)</i> Example: 1,234,567 B1	Publication Date MM-DD-YYYY	Name	Pages, Columns, Lines Where Relevant Passages or Relevant Figures Appear
	59	6,144,868	11/7/2000	Parker	
	60	6,151,516	11/21/2000	Kiani-Azarbayjany et al.	
	61	6,152,754	11/28/2000	Gerhardt et al.	
	62	6,157,850	12/5/2000	Diab et al.	
	63	6,165,005	12/26/2000	Mills et al.	
	64	6,184,521	2/6/2001	Coffin, IV et al.	
	65	6,206,830	3/27/2001	Diab et al.	
	66	6,229,856	5/8/2001	Diab et al.	
	67	6,232,609	5/15/2001	Snyder, et al.	
	68	6,236,872	5/22/2001	Diab et al.	
	69	6,241,683	6/5/2001	Macklem, et al.	
	70	6,253,097	6/26/2001	Aronow et al.	
	71	6,256,523	7/3/2001	Diab et al.	
	72	6,263,222	7/17/2001	Diab et al.	
	73	6,278,522	8/21/2001	Lepper, Jr. et al.	
	74	6,280,213	8/28/2001	Tobler et al.	
	75	6,285,896	9/4/2001	Tobler et al.	
	76	6,301,493	10/9/2001	Marro et al.	
	77	6,317,627	11/13/2001	Ennen et al.	
	78	6,321,100	11/20/2001	Parker	
	79	6,325,761	12/4/2001	Jay	
	80	6,334,065	12/25/2001	Al-Ali et al.	
	81	6,343,224	1/29/2002	Parker	
	82	6,349,228	2/19/2002	Kiani et al.	
	83	6,360,114	3/19/2002	Diab et al.	
	84	6,368,283	4/9/2002	Xu, et al.	
	85	6,371,921	4/16/2002	Caro et al.	
	86	6,377,829	4/23/2002	Al-Ali	
	87	6,388,240	5/14/2002	Schulz et al.	

Examiner Signature	/MARJAN FARDANESH/	Date Considered	02/06/2019
<p><b>*Examiner:</b> Initial if reference considered, whether or not citation is in conformance with MPEP 609. Draw line through citation if not in conformance and not considered. Include copy of this form with next communication to applicant.</p>			

~~ALL REFERENCES CONSIDERED EXCEPT WHERE LINED THROUGH. /M.F/~~

T<sup>1</sup> - Place a check mark in this area when an English language Translation is attached.

PTO/SB/08 Equivalent

<b>INFORMATION DISCLOSURE STATEMENT BY APPLICANT</b>	Application No.	Unassigned
	Filing Date	Filed herewith
	First Named Inventor	Ammar Al-Ali
	Art Unit	Unassigned
<i>(Multiple sheets used when necessary)</i>	Examiner	Unassigned
SHEET 4 OF 28	Attorney Docket No.	MAS.1007C1

U.S. PATENT DOCUMENTS					
Examiner Initials	Cite No.	Document Number <i>Number - Kind Code (if known)</i> Example: 1,234,567 B1	Publication Date MM-DD-YYYY	Name	Pages, Columns, Lines Where Relevant Passages or Relevant Figures Appear
	88	6,397,091	5/28/2002	Diab et al.	
	89	6,430,437	8/6/2002	Marro	
	90	6,430,525	8/6/2002	Weber et al.	
	91	6,463,311	10/8/2002	Diab	
	92	6,470,199	10/22/2002	Kopotic et al.	
	93	6,501,975	12/31/2002	Diab et al.	
	94	6,505,059	1/7/2003	Kollias, et al.	
	95	6,515,273	2/4/2003	Al-Ali	
	96	6,519,487	2/11/2003	Parker	
	97	6,525,386	2/25/2003	Mills et al.	
	98	6,526,300	2/25/2003	Kiani et al.	
	99	6,541,756	4/1/2003	Schulz et al.	
	100	6,542,764	4/1/2003	Al-Ali et al.	
	101	6,580,086	6/17/2003	Schulz et al.	
	102	6,584,336	6/24/2003	Ali et al.	
	103	6,595,316	7/22/2003	Cybulski et al.	
	104	6,597,932	7/22/2003	Tian et al.	
	105	6,597,933	7/22/2003	Kiani et al.	
	106	6,606,511	8/12/2003	Ali et al.	
	107	6,632,181	10/14/2003	Flaherty et al.	
	108	6,639,668	10/28/2003	Trepagnier, Pierre	
	109	6,640,116	10/28/2003	Diab	
	110	6,643,530	11/4/2003	Diab et al.	
	111	6,650,917	11/18/2003	Diab et al.	
	112	6,654,624	11/25/2003	Diab et al.	
	113	6,658,276	12/2/2003	Kiani et al.	
	114	6,661,161	12/9/2003	Lanzo et al.	
	115	6,671,531	12/30/2003	Al-Ali et al.	
	116	6,678,543	1/13/2004	Diab et al.	

Examiner Signature	/MARJAN FARDANESH/	Date Considered	02/06/2019
<p><b>*Examiner:</b> Initial if reference considered, whether or not citation is in conformance with MPEP 609. Draw line through citation if not in conformance and not considered. Include copy of this form with next communication to applicant.</p>			

~~ALL REFERENCES CONSIDERED EXCEPT WHERE LINED THROUGH.~~ /M.F/

T<sup>1</sup> - Place a check mark in this area when an English language Translation is attached.



PTO/SB/08 Equivalent

<b>INFORMATION DISCLOSURE STATEMENT BY APPLICANT</b>	Application No.	Unassigned
	Filing Date	Filed herewith
	First Named Inventor	Ammar Al-Ali
	Art Unit	Unassigned
(Multiple sheets used when necessary)	Examiner	Unassigned
SHEET 5 OF 28	Attorney Docket No.	MAS.1007C1

U.S. PATENT DOCUMENTS					
Examiner Initials	Cite No.	Document Number Number - Kind Code (if known) Example: 1,234,567 B1	Publication Date MM-DD-YYYY	Name	Pages, Columns, Lines Where Relevant Passages or Relevant Figures Appear
	117	6,684,090	1/27/2004	Ali et al.	
	118	6,684,091	1/27/2004	Parker	
	119	6,697,656	2/24/2004	Al-Ali	
	120	6,697,657	2/24/2004	Shehada, et al.	
	121	6,697,658	2/24/2004	Al-Ali	
	122	6,699,194	3/2/2004	Diab et al.	
	123	6,714,804	3/30/2004	Al-Ali et al.	
	124	6,721,582	4/13/2004	Trepagnier, et al.	
	125	6,721,585	4/13/2004	Parker	
	126	6,725,075	4/20/2004	Al-Ali	
	127	6,728,560	4/27/2004	Kollias, et al.	
	128	6,735,459	5/11/2004	Parker	
	129	6,745,060	6/1/2004	Diab et al.	
	130	6,760,607	7/6/2004	Al-Ali	
	131	6,770,028	8/3/2004	Ali et al.	
	132	6,771,994	8/3/2004	Kiani et al.	
	133	6,792,300	9/14/2004	Diab et al.	
	134	6,813,511	11/2/2004	Diab et al.	
	135	6,816,741	11/9/2004	Diab	
	136	6,822,564	11/23/2004	Al-Ali	
	137	6,826,419	11/30/2004	Diab et al.	
	138	6,830,711	12/14/2004	Mills et al.	
	139	6,850,787	2/1/2005	Weber et al.	
	140	6,850,788	2/1/2005	Al-Ali	
	141	6,852,083	2/8/2005	Caro et al.	
	142	6,861,639	3/1/2005	Al-Ali	
	143	6,898,452	5/24/2005	Al-Ali et al.	
	144	6,920,345	7/19/2005	Al-Ali et al.	
	145	6,931,268	8/16/2005	Kiani-Azarbayjany et al.	

Examiner Signature <u>/MARJAN FARDANESH/</u>	Date Considered <u>02/06/2019</u>
<p><b>*Examiner:</b> Initial if reference considered, whether or not citation is in conformance with MPEP 609. Draw line through citation if not in conformance and not considered. Include copy of this form with next communication to applicant.</p>	

~~ALL REFERENCES CONSIDERED EXCEPT WHERE LINED THROUGH.~~ /M.F/

T<sup>1</sup> - Place a check mark in this area when an English language Translation is attached.

PTO/SB/08 Equivalent

<b>INFORMATION DISCLOSURE STATEMENT BY APPLICANT</b>	Application No.	Unassigned
	Filing Date	Filed herewith
	First Named Inventor	Ammar Al-Ali
	Art Unit	Unassigned
<i>(Multiple sheets used when necessary)</i>	Examiner	Unassigned
SHEET 6 OF 28	Attorney Docket No.	MAS.1007C1

U.S. PATENT DOCUMENTS					
Examiner Initials	Cite No.	Document Number <i>Number - Kind Code (if known)</i> Example: 1,234,567 B1	Publication Date MM-DD-YYYY	Name	Pages, Columns, Lines Where Relevant Passages or Relevant Figures Appear
	146	6,934,570	8/23/2005	Kiani et al.	
	147	6,939,305	9/6/2005	Flaherty et al.	
	148	6,943,348	9/13/2005	Coffin IV	
	149	6,950,687	9/27/2005	Al-Ali	
	150	6,961,598	11/1/2005	Diab	
	151	6,970,792	11/29/2005	Diab	
	152	6,979,812	12/27/2005	Al-Ali	
	153	6,985,764	1/10/2006	Mason et al.	
	154	6,993,371	1/31/2006	Kiani et al.	
	155	6,996,427	2/7/2006	Ali et al.	
	156	6,999,904	2/14/2006	Weber et al.	
	157	7,003,338	2/21/2006	Weber et al.	
	158	7,003,339	2/21/2006	Diab et al.	
	159	7,015,451	3/21/2006	Dalke et al.	
	160	7,024,233	4/4/2006	Ali et al.	
	161	7,027,849	4/11/2006	Al-Ali	
	162	7,030,749	4/18/2006	Al-Ali	
	163	7,039,449	5/2/2006	Al-Ali	
	164	7,041,060	5/9/2006	Flaherty et al	
	165	7,044,918	5/16/2006	Diab	
	166	7,067,893	6/27/2006	Mills et al.	
	167	7,096,052	8/22/2006	Mason et al.	
	168	7,096,054	8/22/2006	Abdul-Hafiz et al.	
	169	7,132,641	11/7/2006	Schulz et al.	
	170	7,142,901	11/28/2006	Kiani et al.	
	171	7,149,561	12/12/2006	Diab	
	172	7,186,966	3/6/2007	Al-Ali	
	173	7,190,261	3/13/2007	Al-Ali	
	174	7,215,984	5/8/2007	Diab	

Examiner Signature / <b>MARJAN FARDANESH</b> /	Date Considered <b>02/06/2019</b>
<p><b>*Examiner:</b> Initial if reference considered, whether or not citation is in conformance with MPEP 609. Draw line through citation if not in conformance and not considered. Include copy of this form with next communication to applicant.</p>	

~~ALL REFERENCES CONSIDERED EXCEPT WHERE LINED THROUGH.~~ /M.F/

T<sup>1</sup> - Place a check mark in this area when an English language Translation is attached.

PTO/SB/08 Equivalent

<b>INFORMATION DISCLOSURE STATEMENT BY APPLICANT</b>	Application No.	Unassigned
	Filing Date	Filed herewith
	First Named Inventor	Ammar Al-Ali
	Art Unit	Unassigned
(Multiple sheets used when necessary)	Examiner	Unassigned
SHEET 7 OF 28	Attorney Docket No.	MAS.1007C1

U.S. PATENT DOCUMENTS					
Examiner Initials	Cite No.	Document Number Number - Kind Code (if known) Example: 1,234,567 B1	Publication Date MM-DD-YYYY	Name	Pages, Columns, Lines Where Relevant Passages or Relevant Figures Appear
	175	7,215,986	5/8/2007	Diab	
	176	7,221,971	5/22/2007	Diab	
	177	7,225,006	5/29/2007	Al-Ali et al.	
	178	7,225,007	5/29/2007	Al-Ali	
	179	7,239,905	7/3/2007	Kiani-Azarbayjany et al.	
	180	7,245,953	7/17/2007	Parker	
	181	7,254,429	8/7/2007	Schurman et al.	
	182	7,254,431	8/7/2007	Al-Ali	
	183	7,254,433	8/7/2007	Diab et al.	
	184	7,254,434	8/7/2007	Schulz et al.	
	185	7,272,425	9/18/2007	Al-Ali	
	186	7,274,955	9/25/2007	Kiani et al.	
	187	7,280,858	10/9/2007	Al-Ali et al.	
	188	7,289,835	10/30/2007	Mansfield et al.	
	189	7,292,883	11/6/2007	De Felice et al.	
	190	7,295,866	11/13/2007	Al-Ali	
	191	7,328,053	2/5/2008	Diab et al.	
	192	7,332,784	2/19/2008	Mills, et al.	
	193	7,340,287	3/4/2008	Mason et al.	
	194	7,341,559	3/11/2008	Schulz et al.	
	195	7,343,186	3/11/2008	Lamego et al.	
	196	7,355,512	4/8/2008	Al-Ali	
	197	7,356,365	4/8/2008	Schurman	
	198	7,371,981	5/13/2008	Abdul-Hafiz	
	199	7,373,193	5/13/2008	Al-Ali et al.	
	200	7,373,194	5/13/2008	Weber et al.	
	201	7,376,453	5/20/2008	Diab et al.	
	202	7,377,794	5/27/2008	Al Ali et al.	
	203	7,377,899	5/27/2008	Weber et al.	

Examiner Signature	/MARJAN FARDANESH/	Date Considered	02/06/2019
<p><b>*Examiner:</b> Initial if reference considered, whether or not citation is in conformance with MPEP 609. Draw line through citation if not in conformance and not considered. Include copy of this form with next communication to applicant.</p>			

~~ALL REFERENCES CONSIDERED EXCEPT WHERE LINED THROUGH.~~ /M.F/

T<sup>1</sup> - Place a check mark in this area when an English language Translation is attached.

PTO/SB/08 Equivalent

<b>INFORMATION DISCLOSURE STATEMENT BY APPLICANT</b>	Application No.	Unassigned
	Filing Date	Filed herewith
	First Named Inventor	Ammar Al-Ali
	Art Unit	Unassigned
<i>(Multiple sheets used when necessary)</i>	Examiner	Unassigned
SHEET 8 OF 28	Attorney Docket No.	MAS.1007C1

U.S. PATENT DOCUMENTS					
Examiner Initials	Cite No.	Document Number <i>Number - Kind Code (if known)</i> Example: 1,234,567 B1	Publication Date MM-DD-YYYY	Name	Pages, Columns, Lines Where Relevant Passages or Relevant Figures Appear
	204	7,383,070	6/3/2008	Diab et al.	
	205	7,415,297	8/19/2008	Al-Ali et al.	
	206	7,428,432	9/23/2008	Ali et al.	
	207	7,438,683	10/21/2008	Al-Ali et al.	
	208	7,440,787	10/21/2008	Diab	
	209	7,454,240	11/18/2008	Diab et al.	
	210	7,467,002	12/16/2008	Weber et al.	
	211	7,469,157	12/23/2008	Diab et al.	
	212	7,471,969	12/30/2008	Diab et al.	
	213	7,471,971	12/30/2008	Diab et al.	
	214	7,483,729	1/27/2009	Al-Ali et al.	
	215	7,483,730	1/27/2009	Diab et al.	
	216	7,489,958	2/10/2009	Diab et al.	
	217	7,496,391	2/24/2009	Diab et al.	
	218	7,496,393	2/24/2009	Diab et al.	
	219	7,499,741	3/3/2009	Diab et al.	
	220	7,499,835	3/3/2009	Weber et al.	
	221	7,500,950	3/10/2009	Al-Ali et al.	
	222	7,509,154	3/24/2009	Diab et al.	
	223	7,509,494	3/24/2009	Al-Ali	
	224	7,510,849	3/31/2009	Schurman et al.	
	225	7,519,327	4/14/2009	White	
	226	7,526,328	4/28/2009	Diab et al.	
	227	7,530,942	5/12/2009	Diab	
	228	7,530,949	5/12/2009	Al Ali et al.	
	229	7,530,955	5/12/2009	Diab et al.	
	230	7,563,110	7/21/2009	Al-Ali et al.	
	231	7,596,398	9/29/2009	Al-Ali et al.	
	232	7,601,123	10/13/2009	Tweed, et al.	

Examiner Signature <u>  /MARJAN FARDANESH/  </u>	Date Considered <u>  02/06/2019  </u>
<p><b>*Examiner:</b> Initial if reference considered, whether or not citation is in conformance with MPEP 609. Draw line through citation if not in conformance and not considered. Include copy of this form with next communication to applicant.</p>	

~~ALL REFERENCES CONSIDERED EXCEPT WHERE LINED THROUGH.~~ /M.F/

T1 - Place a check mark in this area when an English language Translation is attached.

PTO/SB/08 Equivalent

<b>INFORMATION DISCLOSURE STATEMENT BY APPLICANT</b>	Application No.	Unassigned
	Filing Date	Filed herewith
	First Named Inventor	Ammar Al-Ali
	Art Unit	Unassigned
<i>(Multiple sheets used when necessary)</i>	Examiner	Unassigned
SHEET 9 OF 28	Attorney Docket No.	MAS.1007C1

U.S. PATENT DOCUMENTS					
Examiner Initials	Cite No.	Document Number <i>Number - Kind Code (if known)</i> Example: 1,234,567 B1	Publication Date MM-DD-YYYY	Name	Pages, Columns, Lines Where Relevant Passages or Relevant Figures Appear
	233	7,618,375	11/17/2009	Flaherty	
	234	7,647,083	1/12/2010	Al-Ali et al.	
	235	7,726,209	6/1/2010	Ruotoistenmäki	
	236	7,729,733	6/1/2010	Al-Ali et al.	
	237	7,734,320	6/8/2010	Al-Ali	
	238	7,761,127	7/20/2010	Al-Ali et al.	
	239	7,761,128	7/20/2010	Al-Ali et al.	
	240	7,764,982	7/27/2010	Dalke et al.	
	241	7,791,155	9/7/2010	Diab	
	242	7,801,581	9/21/2010	Diab	
	243	7,822,452	10/26/2010	Schurman et al.	
	244	7,844,313	11/30/2010	Kiani et al.	
	245	7,844,314	11/30/2010	Al-Ali	
	246	7,844,315	11/30/2010	Al-Ali	
	247	7,862,523	1/4/2011	Ruotoistenmaki	
	248	7,865,222	1/4/2011	Weber et al.	
	249	7,873,497	1/18/2011	Weber et al.	
	250	7,880,606	2/1/2011	Al-Ali	
	251	7,880,626	2/1/2011	Al-Ali et al.	
	252	7,891,355	2/22/2011	Al-Ali et al.	
	253	7,894,868	2/22/2011	Al-Ali et al.	
	254	7,899,507	3/1/2011	Al-Ali et al.	
	255	7,899,518	3/1/2011	Trepagnier et al.	
	256	7,904,132	3/8/2011	Weber et al.	
	257	7,909,772	3/22/2011	Popov et al.	
	258	7,910,875	3/22/2011	Al-Ali	
	259	7,919,713	4/5/2011	Al-Ali et al.	
	260	7,937,128	5/3/2011	Al-Ali	
	261	7,937,129	5/3/2011	Mason et al.	

Examiner Signature /MARJAN FARDANESH/	Date Considered 02/06/2019
<p><b>*Examiner:</b> Initial if reference considered, whether or not citation is in conformance with MPEP 609. Draw line through citation if not in conformance and not considered. Include copy of this form with next communication to applicant.</p>	

~~ALL REFERENCES CONSIDERED EXCEPT WHERE LINED THROUGH.~~ /M.F/

T<sup>1</sup> - Place a check mark in this area when an English language Translation is attached.

PTO/SB/08 Equivalent

<b>INFORMATION DISCLOSURE STATEMENT BY APPLICANT</b>  <i>(Multiple sheets used when necessary)</i>	Application No.	Unassigned
	Filing Date	Filed herewith
	First Named Inventor	Ammar Al-Ali
	Art Unit	Unassigned
	Examiner	Unassigned
SHEET 10 OF 28	Attorney Docket No.	MAS.1007C1

U.S. PATENT DOCUMENTS					
Examiner Initials	Cite No.	Document Number <i>Number - Kind Code (if known)</i> Example: 1,234,567 B1	Publication Date MM-DD-YYYY	Name	Pages, Columns, Lines Where Relevant Passages or Relevant Figures Appear
	262	7,937,130	5/3/2011	Diab et al.	
	263	7,941,199	5/10/2011	Kiani	
	264	7,951,086	5/31/2011	Flaherty et al.	
	265	7,957,780	6/7/2011	Lamego et al.	
	266	7,962,188	6/14/2011	Kiani et al.	
	267	7,962,190	6/14/2011	Diab et al.	
	268	7,976,472	7/12/2011	Kiani	
	269	7,988,637	8/2/2011	Diab	
	270	7,990,382	8/2/2011	Kiani	
	271	7,991,446	8/2/2011	Al-Ali et al.	
	272	8,000,761	8/16/2011	Al-Ali	
	273	8,008,088	8/30/2011	Bellott et al.	
	274	8,019,400	9/13/2011	Diab et al.	
	275	8,028,701	10/4/2011	Al-Ali et al.	
	276	8,029,765	10/4/2011	Bellott et al.	
	277	8,036,727	10/11/2011	Schurman et al.	
	278	8,036,728	10/11/2011	Diab et al.	
	279	8,046,040	10/25/2011	Ali et al.	
	280	8,046,041	10/25/2011	Diab et al.	
	281	8,046,042	10/25/2011	Diab et al.	
	282	8,048,040	11/1/2011	Kiani	
	283	8,050,728	11/1/2011	Al-Ali et al.	
	284	8,118,620	2/21/2012	Al-Ali et al.	
	285	8,126,528	2/28/2012	Diab et al.	
	286	8,128,572	3/6/2012	Diab et al.	
	287	8,130,105	3/6/2012	Al-Ali et al.	
	288	8,145,287	3/27/2012	Diab et al.	
	289	8,150,487	4/3/2012	Diab et al.	
	290	8,175,672	5/8/2012	Parker	

Examiner Signature	<u>/MARJAN FARDANESH/</u>	Date Considered	02/06/2019
<p><b>*Examiner:</b> Initial if reference considered, whether or not citation is in conformance with MPEP 609. Draw line through citation if not in conformance and not considered. Include copy of this form with next communication to applicant.</p>			

~~ALL REFERENCES CONSIDERED EXCEPT WHERE LINED THROUGH.~~ /M.F/

T<sup>1</sup> - Place a check mark in this area when an English language Translation is attached.

PTO/SB/08 Equivalent

<b>INFORMATION DISCLOSURE STATEMENT BY APPLICANT</b>	Application No.	Unassigned
	Filing Date	Filed herewith
	First Named Inventor	Ammar Al-Ali
	Art Unit	Unassigned
<i>(Multiple sheets used when necessary)</i>	Examiner	Unassigned
SHEET 11 OF 28	Attorney Docket No.	MAS.1007C1

U.S. PATENT DOCUMENTS					
Examiner Initials	Cite No.	Document Number <i>Number - Kind Code (if known)</i> Example: 1,234,567 B1	Publication Date MM-DD-YYYY	Name	Pages, Columns, Lines Where Relevant Passages or Relevant Figures Appear
	291	8,180,420	5/15/2012	Diab et al.	
	292	8,182,443	5/22/2012	Kiani	
	293	8,185,180	5/22/2012	Diab et al.	
	294	8,190,223	5/29/2012	Al-Ali et al.	
	295	8,190,227	5/29/2012	Diab et al.	
	296	8,203,438	6/19/2012	Kiani et al.	
	297	8,203,704	6/19/2012	Merritt et al.	
	298	8,204,566	6/19/2012	Schurman et al.	
	299	8,219,172	7/10/2012	Schurman et al.	
	300	8,224,411	7/17/2012	Al-Ali et al.	
	301	8,228,181	7/24/2012	Al-Ali	
	302	8,229,533	7/24/2012	Diab et al.	
	303	8,233,955	7/31/2012	Al-Ali et al.	
	304	8,244,325	8/14/2012	Al-Ali et al.	
	305	8,255,026	8/28/2012	Al-Ali	
	306	8,255,027	8/28/2012	Al-Ali et al.	
	307	8,255,028	8/28/2012	Al-Ali et al.	
	308	8,260,577	9/4/2012	Weber et al.	
	309	8,265,723	9/11/2012	McHale et al.	
	310	8,274,360	9/25/2012	Sampath et al.	
	311	8,289,130	10/16/2012	Nakajima et al.	
	312	8,301,217	10/30/2012	Al-Ali et al.	
	313	8,306,596	11/6/2012	Schurman et al.	
	314	8,310,336	11/13/2012	Muhsin et al.	
	315	8,315,683	11/20/2012	Al-Ali et al.	
	316	8,337,403	12/25/2012	Al-Ali et al.	
	317	8,346,330	1/1/2013	Lamego	
	318	8,353,842	1/15/2013	Al-Ali et al.	
	319	8,355,766	1/15/2013	MacNeish, III et al.	

Examiner Signature <u>/MARJAN FARDANESH/</u>	Date Considered <u>02/06/2019</u>
<p><b>*Examiner:</b> Initial if reference considered, whether or not citation is in conformance with MPEP 609. Draw line through citation if not in conformance and not considered. Include copy of this form with next communication to applicant.</p>	

~~ALL REFERENCES CONSIDERED EXCEPT WHERE LINED THROUGH.~~ /M.F/

T<sup>1</sup> - Place a check mark in this area when an English language Translation is attached.

PTO/SB/08 Equivalent

<b>INFORMATION DISCLOSURE STATEMENT BY APPLICANT</b>	Application No.	Unassigned
	Filing Date	Filed herewith
	First Named Inventor	Ammar Al-Ali
	Art Unit	Unassigned
(Multiple sheets used when necessary)	Examiner	Unassigned
SHEET 12 OF 28	Attorney Docket No.	MAS.1007C1

U.S. PATENT DOCUMENTS					
Examiner Initials	Cite No.	Document Number Number - Kind Code (if known) Example: 1,234,567 B1	Publication Date MM-DD-YYYY	Name	Pages, Columns, Lines Where Relevant Passages or Relevant Figures Appear
	320	8,359,080	1/22/2013	Diab et al.	
	321	8,364,223	1/29/2013	Al-Ali et al.	
	322	8,364,226	1/29/2013	Diab et al.	
	323	8,364,389	1/29/2013	Dorogusker et al.	
	324	8,374,665	2/12/2013	Lamego	
	325	8,385,995	2/26/2013	Al-ali et al.	
	326	8,385,996	2/26/2013	Smith et al.	
	327	8,388,353	3/5/2013	Kiani et la.	
	328	8,399,822	3/19/2013	Al-Ali	
	329	8,401,602	3/19/2013	Kiani	
	330	8,405,608	3/26/2013	Al-Ali et al.	
	331	8,414,499	4/9/2013	Al-Ali et al.	
	332	8,418,524	4/16/2013	Al-Ali	
	333	8,423,106	4/16/2013	Lamego et al.	
	334	8,428,967	4/23/2013	Olsen et al.	
	335	8,430,817	4/30/2013	Al-Ali et al.	
	336	8,437,825	5/7/2013	Dalvi et al.	
	337	8,455,290	6/4/2013	Siskavich	
	338	8,457,703	6/4/2013	Al-Ali	
	339	8,457,707	6/4/2013	Kiani	
	340	8,463,349	6/11/2013	Diab et al.	
	341	8,466,286	6/18/2013	Bellot et al.	
	342	8,471,713	6/25/2013	Poeze et al.	
	343	8,473,020	6/25/2013	Kiani et al.	
	344	8,483,787	7/9/2013	Al-Ali et al.	
	345	8,489,364	7/16/2013	Weber et al.	
	346	8,498,684	0730//2013	Weber et al.	
	347	8,504,128	8/6/2013	Blank et al.	
	348	8,509,867	8/13/2013	Workman et al.	

Examiner Signature	/MARJAN FARDANESH/	Date Considered	02/06/2019
<p><b>*Examiner:</b> Initial if reference considered, whether or not citation is in conformance with MPEP 609. Draw line through citation if not in conformance and not considered. Include copy of this form with next communication to applicant.</p>			

~~ALL REFERENCES CONSIDERED EXCEPT WHERE LINED THROUGH.~~ /M.F/

T<sup>1</sup> - Place a check mark in this area when an English language Translation is attached.



PTO/SB/08 Equivalent

<b>INFORMATION DISCLOSURE STATEMENT BY APPLICANT</b>	Application No.	Unassigned
	Filing Date	Filed herewith
	First Named Inventor	Ammar Al-Ali
	Art Unit	Unassigned
<i>(Multiple sheets used when necessary)</i>	Examiner	Unassigned
SHEET 13 OF 28	Attorney Docket No.	MAS.1007C1

U.S. PATENT DOCUMENTS					
Examiner Initials	Cite No.	Document Number <i>Number - Kind Code (if known)</i> Example: 1,234,567 B1	Publication Date MM-DD-YYYY	Name	Pages, Columns, Lines Where Relevant Passages or Relevant Figures Appear
	349	8,515,509	8/20/2013	Bruinsma et al.	
	350	8,523,781	9/3/2013	Al-Ali	
	351	8,529,301	9/10/2013	Al-Ali et al.	
	352	8,532,727	9/10/2013	Ali et al.	
	353	8,532,728	9/10/2013	Diab et al.	
	354	8,547,209	10/1/2013	Kiani et al.	
	355	8,548,548	10/1/2013	Al-Ali	
	356	8,548,549	10/1/2013	Schurman et al.	
	357	8,548,550	10/1/2013	Al-Ali et al.	
	358	8,560,032	10/15/2013	Al-Ali et al.	
	359	8,560,034	10/15/2013	Diab et al.	
	360	8,570,167	10/29/2013	Al-Ali	
	361	8,570,503	10/29/2013	Vo et al.	
	362	8,571,617	10/29/2013	Reichgott et al.	
	363	8,571,618	10/29/2013	Lamego et al.	
	364	8,571,619	10/29/2013	Al-Ali et al.	
	365	8,577,431	11/5/2013	Lamego et al.	
	366	8,581,732	11/12/2013	Al-Ali et al.	
	367	8,584,345	11/19/2013	Al-Ali et al.	
	368	8,588,880	11/19/2013	Abdul-Hafiz et al.	
	369	8,600,467	12/3/2013	Al-Ali et al.	
	370	8,606,342	12/10/2013	Diab	
	371	8,615,290	12/24/2013	Lin et al.	
	372	8,626,255	1/7/2014	Al-Ali et al.	
	373	8,630,691	1/14/2014	Lamego et al.	
	374	8,634,889	1/21/2014	Al-Ali et al.	
	375	8,641,631	2/4/2014	Sierra et al.	
	376	8,652,060	2/18/2014	Al-Ali	
	377	8,655,004	2/18/2014	Prest et al.	

Examiner Signature	/MARJAN FARDANESH/	Date Considered	02/06/2019
<p><b>*Examiner:</b> Initial if reference considered, whether or not citation is in conformance with MPEP 609. Draw line through citation if not in conformance and not considered. Include copy of this form with next communication to applicant.</p>			

~~ALL REFERENCES CONSIDERED EXCEPT WHERE LINED THROUGH.~~ /M.F/

T<sup>1</sup> - Place a check mark in this area when an English language Translation is attached.

PTO/SB/08 Equivalent

<b>INFORMATION DISCLOSURE STATEMENT BY APPLICANT</b>	Application No.	Unassigned
	Filing Date	Filed herewith
	First Named Inventor	Ammar Al-Ali
	Art Unit	Unassigned
<i>(Multiple sheets used when necessary)</i>	Examiner	Unassigned
SHEET 14 OF 28	Attorney Docket No.	MAS.1007C1

U.S. PATENT DOCUMENTS					
Examiner Initials	Cite No.	Document Number <i>Number - Kind Code (if known)</i> Example: 1,234,567 B1	Publication Date MM-DD-YYYY	Name	Pages, Columns, Lines Where Relevant Passages or Relevant Figures Appear
	378	8,663,107	3/4/2014	Kiani	
	379	8,666,468	3/4/2014	Al-Ali	
	380	8,667,967	3/11/2014	Al- Ali et al.	
	381	8,670,811	3/11/2014	O'Reilly	
	382	8,670,814	3/11/2014	Diab et al.	
	383	8,676,286	3/18/2014	Weber et al.	
	384	8,682,407	3/25/2014	Al-Ali	
	385	8,690,799	4/8/2014	Telfort et al.	
	386	8,700,112	4/15/2014	Kiani	
	387	8,702,627	4/22/2014	Telfort et al.	
	388	8,706,179	4/22/2014	Parker	
	389	8,712,494	4/29/2014	MacNeish, III et al.	
	390	8,715,206	5/6/2014	Telfort et al.	
	391	8,718,735	5/6/2014	Lamego et al.	
	392	8,718,737	5/6/2014	Diab et al.	
	393	8,718,738	5/6/2014	Blank et al.	
	394	8,720,249	5/13/2014	Al-Ali	
	395	8,721,541	5/13/2014	Al-Ali et al.	
	396	8,721,542	5/13/2014	Al-Ali et al.	
	397	8,723,677	5/13/2014	Kiani	
	398	8,740,792	6/3/2014	Kiani et al.	
	399	8,754,776	6/17/2014	Poeze et al.	
	400	8,755,535	6/17/2014	Telfort et al.	
	401	8,755,856	6/17/2014	Diab et al.	
	402	8,755,872	6/17/2014	Marinow	
	403	8,760,517	6/24/2014	Sarwar et al.	
	404	8,761,850	6/24/2014	Lamego	
	405	8,764,671	7/1/2014	Kiani	
	406	8,768,423	7/1/2014	Shakespeare et al.	

Examiner Signature <u>  /MARJAN FARDANESH/  </u>	Date Considered <u>  02/06/2019  </u>
<p><b>*Examiner:</b> Initial if reference considered, whether or not citation is in conformance with MPEP 609. Draw line through citation if not in conformance and not considered. Include copy of this form with next communication to applicant.</p>	

~~ALL REFERENCES CONSIDERED EXCEPT WHERE LINED THROUGH.~~ /M.F/

T<sup>1</sup> - Place a check mark in this area when an English language Translation is attached.

PTO/SB/08 Equivalent

<b>INFORMATION DISCLOSURE STATEMENT BY APPLICANT</b>  <i>(Multiple sheets used when necessary)</i>	Application No.	Unassigned
	Filing Date	Filed herewith
	First Named Inventor	Ammar Al-Ali
	Art Unit	Unassigned
	Examiner	Unassigned
SHEET 15 OF 28	Attorney Docket No.	MAS.1007C1

U.S. PATENT DOCUMENTS					
Examiner Initials	Cite No.	Document Number <i>Number - Kind Code (if known)</i> Example: 1,234,567 B1	Publication Date MM-DD-YYYY	Name	Pages, Columns, Lines Where Relevant Passages or Relevant Figures Appear
	407	8,771,204	7/8/2014	Telfort et al.	
	408	8,777,634	7/15/2014	Kiani et al.	
	409	8,781,543	7/15/2014	Diab et al.	
	410	8,781,544	7/15/2014	Al-Ali et al.	
	411	8,781,549	7/15/2014	Al-Ali et al.	
	412	8,788,003	7/22/2014	Schurman et al.	
	413	8,790,268	7/29/2014	Al-Ali	
	414	8,801,613	8/12/2014	Al-Ali et al.	
	415	8,821,397	9/2/2014	Al-Ali et al.	
	416	8,821,415	9/2/2014	Al-Ali et al.	
	417	8,830,449	9/9/2014	Lamego et al.	
	418	8,831,700	9/9/2014	Schurman et al.	
	419	8,840,549	9/23/2014	Al-Ali et al.	
	420	8,845,543	9/30/2014	Diab et al.	
	421	8,847,740	9/30/2014	Kiani et al.	
	422	8,849,365	9/30/2014	Smith et al.	
	423	8,852,094	10/7/2014	Al-Ali et al.	
	424	8,852,994	10/7/2014	Wojtczuk et al.	
	425	8,868,147	10/21/2014	Stippick et al.	
	426	8,868,150	10/21/2014	Al-Ali et al.	
	427	8,870,792	10/28/2014	Al-Ali et al.	
	428	8,886,271	11/11/2014	Kiani et al.	
	429	8,888,539	11/18/2014	Al-Ali et al.	
	430	8,888,708	11/18/2014	Diab et al.	
	431	8,892,180	11/18/2014	Weber et al.	
	432	8,897,847	11/25/2014	Al-Ali	
	433	8,909,310	12/9/2014	Lamego et al.	
	434	8,911,377	12/16/2014	Al-Ali	
	435	8,912,909	12/16/2014	Al-Ali et al.	

Examiner Signature	/MARJAN FARDANESH/	Date Considered	02/06/2019
<p><b>*Examiner:</b> Initial if reference considered, whether or not citation is in conformance with MPEP 609. Draw line through citation if not in conformance and not considered. Include copy of this form with next communication to applicant.</p>			

~~ALL REFERENCES CONSIDERED EXCEPT WHERE LINED THROUGH. /M.F./~~

T<sup>1</sup> - Place a check mark in this area when an English language Translation is attached.

PTO/SB/08 Equivalent

<b>INFORMATION DISCLOSURE STATEMENT BY APPLICANT</b>	Application No.	Unassigned
	Filing Date	Filed herewith
	First Named Inventor	Ammar Al-Ali
	Art Unit	Unassigned
<i>(Multiple sheets used when necessary)</i>	Examiner	Unassigned
SHEET 16 OF 28	Attorney Docket No.	MAS.1007C1

U.S. PATENT DOCUMENTS					
Examiner Initials	Cite No.	Document Number <i>Number - Kind Code (if known)</i> Example: 1,234,567 B1	Publication Date MM-DD-YYYY	Name	Pages, Columns, Lines Where Relevant Passages or Relevant Figures Appear
	436	8,920,317	12/30/2014	Al-Ali et al.	
	437	8,921,699	12/30/2014	Al-Ali et al.	
	438	8,922,382	12/30/2014	Al-Ali et al.	
	439	8,929,964	1/6/2015	Al-Ali et al.	
	440	8,942,777	1/27/2015	Diab et al.	
	441	8,948,834	2/3/2015	Diab et al.	
	442	8,948,835	2/3/2015	Diab	
	443	8,965,471	2/24/2015	Lamego	
	444	8,983,564	3/17/2015	Al-Ali	
	445	8,989,831	3/24/2015	Al-Ali et al.	
	446	8,996,085	3/31/2015	Kiani et al.	
	447	8,998,809	4/7/2015	Kiani	
	448	9,028,429	5/12/2015	Telfort et al.	
	449	9,037,207	5/19/2015	Al-Ali et al.	
	450	9,060,721	6/23/2015	Reichgott et al.	
	451	9,066,666	6/30/2015	Kiani	
	452	9,066,680	6/30/2015	Al-Ali et al.	
	453	9,072,437	7/7/2015	Paalasmaa	
	454	9,072,474	7/7/2015	Al-Ali et al.	
	455	9,078,560	7/14/2015	Schurman et al.	
	456	9,081,889	7/14/2015	Ingrassia, Jr. et al.	
	457	9,084,569	7/21/2015	Weber et al.	
	458	9,095,316	8/4/2015	Welch et al.	
	459	9,106,038	8/11/2015	Telfort et al.	
	460	9,107,625	8/18/2015	Telfort et al.	
	461	9,107,626	8/18/2015	Al-Ali et al.	
	462	9,113,831	8/25/2015	Al-Ali	
	463	9,113,832	8/25/2015	Al-Ali	
	464	9,119,595	9/1/2015	Lamego	

Examiner Signature	<u>/MARJAN FARDANESH/</u>	Date Considered	02/06/2019
<p><b>*Examiner:</b> Initial if reference considered, whether or not citation is in conformance with MPEP 609. Draw line through citation if not in conformance and not considered. Include copy of this form with next communication to applicant.</p>			

~~ALL REFERENCES CONSIDERED EXCEPT WHERE LINED THROUGH. /M.F/~~

T<sup>1</sup> - Place a check mark in this area when an English language Translation is attached.

PTO/SB/08 Equivalent

<b>INFORMATION DISCLOSURE STATEMENT BY APPLICANT</b>	Application No.	Unassigned
	Filing Date	Filed herewith
	First Named Inventor	Ammar Al-Ali
	Art Unit	Unassigned
<i>(Multiple sheets used when necessary)</i>	Examiner	Unassigned
SHEET 17 OF 28	Attorney Docket No.	MAS.1007C1

U.S. PATENT DOCUMENTS					
Examiner Initials	Cite No.	Document Number <i>Number - Kind Code (if known)</i> Example: 1,234,567 B1	Publication Date MM-DD-YYYY	Name	Pages, Columns, Lines Where Relevant Passages or Relevant Figures Appear
	465	9,131,881	9/15/2015	Diab et al.	
	466	9,131,882	9/15/2015	Al-Ali et al.	
	467	9,131,883	9/15/2015	Al-Ali	
	468	9,131,917	9/15/2015	Telfort et al.	
	469	9,138,180	9/22/2015	Coverston et al.	
	470	9,138,182	9/22/2015	Al-Ali et al.	
	471	9,138,192	9/22/2015	Weber et al.	
	472	9,142,117	9/22/2015	Muhsin et al.	
	473	9,153,112	10/6/2015	Kiani et al.	
	474	9,153,121	10/6/2015	Kiani et al.	
	475	9,161,696	10/20/2015	Al-Ali et al.	
	476	9,161,713	10/20/2015	Al-Ali et al.	
	477	9,167,995	10/27/2015	Lamego et al.	
	478	9,176,141	11/3/2015	Al-Ali et al.	
	479	9,186,102	11/17/2015	Bruinsma et al.	
	480	9,192,312	11/24/2015	Al-Ali	
	481	9,192,329	11/24/2015	Al-Ali	
	482	9,192,351	11/24/2015	Telfort et al.	
	483	9,195,385	11/24/2015	Al-Ali et al.	
	484	9,210,566	12/8/2015	Ziemianska et al.	
	485	9,211,072	12/15/2015	Kiani	
	486	9,211,095	12/15/2015	Al-Ali	
	487	9,218,454	12/22/2015	Kiani et al.	
	488	9,226,696	1/5/2016	Kiani	
	489	9,241,662	1/26/2016	Al-Ali et al.	
	490	9,245,668	1/26/2016	Vo et al.	
	491	9,259,185	2/16/2016	Abdul-Hafiz et al.	
	492	9,267,572	2/23/2016	Barker et al.	
	493	9,277,880	3/8/2016	Poeze et al.	

Examiner Signature	/MARJAN FARDANESH/	Date Considered	02/06/2019
<p><b>*Examiner:</b> Initial if reference considered, whether or not citation is in conformance with MPEP 609. Draw line through citation if not in conformance and not considered. Include copy of this form with next communication to applicant.</p>			

~~ALL REFERENCES CONSIDERED EXCEPT WHERE LINED THROUGH. /M.F./~~

T<sup>1</sup> - Place a check mark in this area when an English language Translation is attached.

PTO/SB/08 Equivalent

<b>INFORMATION DISCLOSURE STATEMENT BY APPLICANT</b>	Application No.	Unassigned
	Filing Date	Filed herewith
	First Named Inventor	Ammar Al-Ali
	Art Unit	Unassigned
<i>(Multiple sheets used when necessary)</i>	Examiner	Unassigned
SHEET 18 OF 28	Attorney Docket No.	MAS.1007C1

U.S. PATENT DOCUMENTS					
Examiner Initials	Cite No.	Document Number <i>Number - Kind Code (if known)</i> Example: 1,234,567 B1	Publication Date MM-DD-YYYY	Name	Pages, Columns, Lines Where Relevant Passages or Relevant Figures Appear
	494	9,289,167	3/22/2016	Diab et al.	
	495	9,295,421	3/29/2016	Kiani et al.	
	496	9,307,928	4/12/2016	Al-Ali et al.	
	497	9,311,382	4/12/2016	Varoglu et al.	
	498	9,323,894	4/26/2016	Kiani	
	499	9,326,712	5/3/2016	Kiani	
	500	9,333,316	5/10/2016	Kiani	
	501	9,339,220	5/17/2016	Lamego et al.	
	502	9,341,565	5/17/2016	Lamego et al.	
	503	9,351,673	5/31/2016	Diab et al.	
	504	9,351,675	5/31/2016	Al-Ali et al.	
	505	9,357,665	5/31/2016	Myers et al.	
	506	9,489,081	11/8/2016	Anzures et al.	
	507	9,497,534	11/15/2016	Prest et al.	
	508	9,526,430	12/27/2016	Srinivas et al.	
	509	9,553,625	1/24/2017	Hatanaka et al.	
	510	9,593,969	3/14/2017	King	
	511	9,651,405	5/16/2017	Gowreesunker et al.	
	512	9,668,676	6/6/2017	Culbert	
	513	9,699,546	7/4/2017	Qian et al.	
	514	9,716,937	7/25/2017	Qian et al.	
	515	9,723,997	8/8/2017	Lamego	
	516	9,781,984	10/10/2017	Baranski et al.	
	517	9,838,775	12/5/2017	Qian et al.	
	518	9,848,823	12/26/2017	Raghuram et al.	
	519	9,866,671	1/9/2018	Thompson et al.	
	520	9,867,575	1/16/2018	Maani et al.	
	521	9,898,049	2/20/2018	Myers et al.	
	522	9,918,646	3/20/2018	Singh Alvarado et al.	

Examiner Signature /MARJAN FARDANESH/	Date Considered 02/06/2019
<p><b>*Examiner:</b> Initial if reference considered, whether or not citation is in conformance with MPEP 609. Draw line through citation if not in conformance and not considered. Include copy of this form with next communication to applicant.</p>	

~~ALL REFERENCES CONSIDERED EXCEPT WHERE LINED THROUGH. /M.F/~~  
 T1 - Place a check mark in this area when an English language Translation is attached.

PTO/SB/08 Equivalent

<b>INFORMATION DISCLOSURE STATEMENT BY APPLICANT</b>	Application No.	Unassigned
	Filing Date	Filed herewith
	First Named Inventor	Ammar Al-Ali
	Art Unit	Unassigned
<i>(Multiple sheets used when necessary)</i>	Examiner	Unassigned
SHEET 19 OF 28	Attorney Docket No.	MAS.1007C1

U.S. PATENT DOCUMENTS					
Examiner Initials	Cite No.	Document Number <i>Number - Kind Code (if known)</i> Example: 1,234,567 B1	Publication Date MM-DD-YYYY	Name	Pages, Columns, Lines Where Relevant Passages or Relevant Figures Appear
	523	9,952,095	4/24/2018	Hotelling et al.	
	524	10,039,080	7/31/2018	Miller et al.	
	525	10,055,121	8/21/2018	Chaudhri et al.	
	526	10,066,970	9/4/2018	Gowreesunker et al.	
	527	10,076,257	9/18/2018	Lin et al.	
	528	10,078,052	9/18/2018	Ness et al.	
	529	6,671,526 B1	12/30/2003	Aoyagi et al.	
	530	D353,195	12/6/1994	Savage, et al.	
	531	D353,196	12/6/1994	Savage, et al.	
	532	D359,546	6/20/1995	Savage, et al.	
	533	D361,840	8/29/1995	Savage, et al.	
	534	D362,063	9/5/1995	Savage, et al.	
	535	D363,120	10/10/1995	Savage, et al.	
	536	D393,830	4/28/1998	Tobler et al.	
	537	D554,263	10/30/2007	Al-Ali	
	538	D566,282	4/8/2008	Al-Ali et al.	
	539	D587,657	3/3/2009	Al-Ali et al.	
	540	D606,659	12/22/2009	Kiani et al.	
	541	D609,193	2/2/2010	Al-Ali et al.	
	542	D614,305	4/20/2010	Al-Ali et al.	
	543	D621,516	8/10/2010	Kiani et al.	
	544	D692,145	10/22/2013	Al-Ali et al.	
	545	D755,392	5/3/2016	Hwang et al.	
	546	RE38,476	3/30/2004	Diab et al.	
	547	RE38,492	4/6/2004	Diab et al.	
	548	RE39,672	6/5/2007	Shehada et al.	
	549	RE41,317	5/4/2010	Parker	
	550	RE41,912	11/2/2010	Parker	
	551	RE42,753	9/27/2011	Kiani-Azarbayjany et al.	

Examiner Signature /MARJAN FARDANESH/	Date Considered 02/06/2019
<p><b>*Examiner:</b> Initial if reference considered, whether or not citation is in conformance with MPEP 609. Draw line through citation if not in conformance and not considered. Include copy of this form with next communication to applicant.</p>	

~~ALL REFERENCES CONSIDERED EXCEPT WHERE LINED THROUGH. /M.F./~~

T<sup>1</sup> - Place a check mark in this area when an English language Translation is attached.

PTO/SB/08 Equivalent

<b>INFORMATION DISCLOSURE STATEMENT BY APPLICANT</b>	Application No.	Unassigned
	Filing Date	Filed herewith
	First Named Inventor	Ammar Al-Ali
	Art Unit	Unassigned
<i>(Multiple sheets used when necessary)</i>	Examiner	Unassigned
SHEET 20 OF 28	Attorney Docket No.	MAS.1007C1

U.S. PATENT DOCUMENTS					
Examiner Initials	Cite No.	Document Number <i>Number - Kind Code (if known)</i> Example: 1,234,567 B1	Publication Date MM-DD-YYYY	Name	Pages, Columns, Lines Where Relevant Passages or Relevant Figures Appear
	552	RE43,169	2/7/2012	Parker	
	553	RE43,860	12/11/2012	Parker	
	554	RE44,823	4/1/2014	Parker	
	555	RE44,875	4/29/2014	Kiani et al.	
	556	2005/0277819	12/15/2005	Kiani et al.	
	557	2007/0282478	12/6/2007	Al-Ali et al.	
	558	2008/0030468	2/7/2008	Al-Ali et al.	
	559	2009/0247984	10/1/2009	Lamego et al.	
	560	2009/0275813	11/5/2009	Davis	
	561	2009/0275844	11/5/2009	Al-Ali	
	562	2010/0004518	1/7/2010	Vo et al.	
	563	2010/0030040	2/4/2010	Poeze et al.	
	564	2011/0082711	4/7/2011	Poeze et al.	
	565	2011/0105854	5/5/2011	Kiani et al.	
	566	2011/0125060	5/26/2011	Telfort et al.	
	567	2011/0208015	8/25/2011	Welch et al.	
	568	2011/0213212	9/1/2011	Al-Ali	
	569	2011/0230733	9/22/2011	Al-Ali	
	570	2011/0237969	9/29/2011	Eckerbom et al.	
	571	2011/0288383	11/24/2011	Diab	
	572	2011/0301444	12/8/2011	Al-Ali	
	573	2012/0041316	2/16/2012	Al-Ali et al.	
	574	2012/0046557	2/23/2012	Kiani	
	575	2012/0059267	3/8/2012	Lamego et al.	
	576	2012/0088984	4/12/2012	Al-Ali et al.	
	577	2012/0165629	6/28/2012	Merritt et al.	
	578	2012/0179006	7/12/2012	Jansen et al.	
	579	2012/0209082	8/16/2012	Al-Ali	
	580	2012/0209084	8/16/2012	Olsen et al.	

Examiner Signature /MARJAN FARDANESH/	Date Considered 02/06/2019
<p><b>*Examiner:</b> Initial if reference considered, whether or not citation is in conformance with MPEP 609. Draw line through citation if not in conformance and not considered. Include copy of this form with next communication to applicant.</p>	

~~ALL REFERENCES CONSIDERED EXCEPT WHERE LINED THROUGH. /M.F/~~  
 T<sup>1</sup> - Place a check mark in this area when an English language Translation is attached.



PTO/SB/08 Equivalent

<b>INFORMATION DISCLOSURE STATEMENT BY APPLICANT</b>	Application No.	Unassigned
	Filing Date	Filed herewith
	First Named Inventor	Ammar Al-Ali
	Art Unit	Unassigned
(Multiple sheets used when necessary)	Examiner	Unassigned
SHEET 21 OF 28	Attorney Docket No.	MAS.1007C1

U.S. PATENT DOCUMENTS					
Examiner Initials	Cite No.	Document Number Number - Kind Code (if known) Example: 1,234,567 B1	Publication Date MM-DD-YYYY	Name	Pages, Columns, Lines Where Relevant Passages or Relevant Figures Appear
	581	2012/0283524	11/8/2012	Kiani et al.	
	582	2012/0296178	11/22/2012	Lamego et al.	
	583	2012/0319816	12/20/2012	Al-Ali	
	584	2012/0330112	12/27/2012	Lamego et al.	
	585	2013/0006076	1/3/2013	McHale	
	586	2013/0023775	1/24/2013	Lamego et al.	
	587	2013/0041591	2/14/2013	Lamego	
	588	2013/0046204	2/21/2013	Lamego et al.	
	589	2013/0060147	3/7/2013	Welch et al.	
	590	2013/0096405	4/18/2013	Garfio	
	591	2013/0096936	4/18/2013	Sampath et al.	
	592	2013/0190581	7/25/2013	Al-Ali et al.	
	593	2013/0211214	8/15/2013	Olsen	
	594	2013/0243021	9/19/2013	Siskavich	
	595	2013/0253334	9/26/2013	Al-Ali et al.	
	596	2013/0262730	10/3/2013	Al-Ali et al.	
	597	2013/0267804	10/10/2013	Al-Ali	
	598	2013/0274572	10/17/2013	Al-Ali et al.	
	599	2013/0296672	11/7/2013	O'Neil et al.	
	600	2013/0296713	11/7/2013	Al-Ali et al.	
	601	2013/0317370	11/28/2013	Dalvi et al.	
	602	2013/0324808	12/5/2013	Al-Ali et al.	
	603	2013/0331660	12/12/2013	Al-Ali et al.	
	604	2013/0331670	12/12/2013	Kiani	
	605	2014/0012100	1/9/2014	Al-Ali et al.	
	606	2014/0034353	2/6/2014	Al-Ali et al.	
	607	2014/0051953	2/20/2014	Lamego et al.	
	608	2014/0066783	3/6/2014	Kiani et al.	
	609	2014/0077956	3/20/2014	Sampath et al.	

Examiner Signature	/MARJAN FARDANESH/	Date Considered	02/06/2019
<p><b>*Examiner:</b> Initial if reference considered, whether or not citation is in conformance with MPEP 609. Draw line through citation if not in conformance and not considered. Include copy of this form with next communication to applicant.</p>			

~~ALL REFERENCES CONSIDERED EXCEPT WHERE LINED THROUGH.~~ /M.F/

T<sup>1</sup> - Place a check mark in this area when an English language Translation is attached.

PTO/SB/08 Equivalent

<b>INFORMATION DISCLOSURE STATEMENT BY APPLICANT</b>  <i>(Multiple sheets used when necessary)</i>	Application No.	Unassigned
	Filing Date	Filed herewith
	First Named Inventor	Ammar Al-Ali
	Art Unit	Unassigned
	Examiner	Unassigned
SHEET 22 OF 28	Attorney Docket No.	MAS.1007C1

U.S. PATENT DOCUMENTS					
Examiner Initials	Cite No.	Document Number <i>Number - Kind Code (if known)</i> Example: 1,234,567 B1	Publication Date MM-DD-YYYY	Name	Pages, Columns, Lines Where Relevant Passages or Relevant Figures Appear
	610	2014/0081100	3/20/2014	Muhsin et al.	
	611	2014/0081175	3/20/2014	Telfort	
	612	2014/0094667	4/3/2014	Schurman et al.	
	613	2014/0100434	4/10/2014	Diab et al.	
	614	2014/0114199	4/24/2014	Lamego et al.	
	615	2014/0120564	5/1/2014	Workman et al.	
	616	2014/0121482	5/1/2014	Merritt et al.	
	617	2014/0121483	5/1/2014	Kiani	
	618	2014/0127137	5/8/2014	Bellott et al.	
	619	2014/0129702	5/8/2014	Lamego et al.	
	620	2014/0135588	5/15/2014	Al-Ali et al.	
	621	2014/0142401	5/22/2014	Al-Ali et al.	
	622	2014/0163344	6/12/2014	Al-Ali	
	623	2014/0163402	6/12/2014	Lamego et al.	
	624	2014/0166076	6/19/2014	Kiani et al.	
	625	2014/0171146	6/19/2014	Ma et al.	
	626	2014/0171763	6/19/2014	Diab	
	627	2014/0180038	6/26/2014	Kiani	
	628	2014/0180154	6/26/2014	Sierra et al.	
	629	2014/0180160	6/26/2014	Brown et al.	
	630	2014/0187973	7/3/2014	Brown et al.	
	631	2014/0194766	7/10/2014	Al-Ali et al.	
	632	2014/0206963	7/24/2014	Al-Ali	
	633	2014/0213864	7/31/2014	Abdul-Hafiz et al.	
	634	2014/0266790	9/18/2014	Al-Ali et al.	
	635	2014/0275808	9/18/2014	Poeze et al.	
	636	2014/0275835	9/18/2014	Lamego et al.	
	637	2014/0275871	9/18/2014	Lamego et al.	
	638	2014/0275872	9/18/2014	Merritt et al.	

Examiner Signature /MARJAN FARDANESH/	Date Considered 02/06/2019
<p><b>*Examiner:</b> Initial if reference considered, whether or not citation is in conformance with MPEP 609. Draw line through citation if not in conformance and not considered. Include copy of this form with next communication to applicant.</p>	

~~ALL REFERENCES CONSIDERED EXCEPT WHERE LINED THROUGH. /M.F/~~

T<sup>1</sup> - Place a check mark in this area when an English language Translation is attached.

PTO/SB/08 Equivalent

<b>INFORMATION DISCLOSURE STATEMENT BY APPLICANT</b>	Application No.	Unassigned
	Filing Date	Filed herewith
	First Named Inventor	Ammar Al-Ali
	Art Unit	Unassigned
<i>(Multiple sheets used when necessary)</i>	Examiner	Unassigned
SHEET 23 OF 28	Attorney Docket No.	MAS.1007C1

U.S. PATENT DOCUMENTS					
Examiner Initials	Cite No.	Document Number <i>Number - Kind Code (if known)</i> Example: 1,234,567 B1	Publication Date MM-DD-YYYY	Name	Pages, Columns, Lines Where Relevant Passages or Relevant Figures Appear
	639	2014/0275881	9/18/2014	Lamego et al.	
	640	2014/0276115	9/18/2014	Dalvi et al.	
	641	2014/0288400	9/25/2014	Diab et al.	
	642	2014/0303520	10/9/2014	Telfort et al.	
	643	2014/0316217	10/23/2014	Purdon et al.	
	644	2014/0316218	10/23/2014	Purdon et al.	
	645	2014/0316228	10/23/2014	Blank et al.	
	646	2014/0323825	10/30/2014	Al-Ali et al.	
	647	2014/0323897	10/30/2014	Brown et al.	
	648	2014/0323898	10/30/2014	Purdon et al.	
	649	2014/0330092	11/6/2014	Al-Ali et al.	
	650	2014/0330098	11/6/2014	Merritt et al.	
	651	2014/0330099	11/6/2014	Al-Ali et al.	
	652	2014/0336481	11/13/2014	Shakespeare et al.	
	653	2014/0357966	12/4/2014	Al-Ali et al.	
	654	2014/0371548	12/28/2014	Al-Ali et al.	
	655	2014/0371632	12/18/2014	Al-Ali et al.	
	656	2014/0378784	12/25/2014	Kiani et al.	
	657	2015/0005600	1/1/2015	Blank et al.	
	658	2015/0011907	1/8/2015	Purdon et al.	
	659	2015/0012231	1/8/2015	Poeze et al.	
	660	2015/0018650	1/15/2015	Al-Ali et al.	
	661	2015/0025406	1/22/2015	Al-Ali	
	662	2015/0032029	1/29/2015	Al-Ali et al.	
	663	2015/0038859	2/5/2015	Dalvi et al.	
	664	2015/0045637	2/12/2015	Dalvi	
	665	2015/0045685	2/12/2015	Al-Ali et al.	
	666	2015/0051462	2/19/2015	Olsen	
	667	2015/0080754	3/19/2015	Purdon et al.	

Examiner Signature /MARJAN FARDANESH/	Date Considered 02/06/2019
<p><b>*Examiner:</b> Initial if reference considered, whether or not citation is in conformance with MPEP 609. Draw line through citation if not in conformance and not considered. Include copy of this form with next communication to applicant.</p>	

~~ALL REFERENCES CONSIDERED EXCEPT WHERE LINED THROUGH. /M.F/~~

T<sup>1</sup> - Place a check mark in this area when an English language Translation is attached.

PTO/SB/08 Equivalent

<b>INFORMATION DISCLOSURE STATEMENT BY APPLICANT</b>	Application No.	Unassigned
	Filing Date	Filed herewith
	First Named Inventor	Ammar Al-Ali
	Art Unit	Unassigned
<i>(Multiple sheets used when necessary)</i>	Examiner	Unassigned
SHEET 24 OF 28	Attorney Docket No.	MAS.1007C1

U.S. PATENT DOCUMENTS					
Examiner Initials	Cite No.	Document Number <i>Number - Kind Code (if known)</i> Example: 1,234,567 B1	Publication Date MM-DD-YYYY	Name	Pages, Columns, Lines Where Relevant Passages or Relevant Figures Appear
	668	2015/0087936	3/26/2015	Al-Ali et al.	
	669	2015/0094546	4/2/2015	Al-Ali	
	670	2015/0097701	4/9/2015	Al-Ali et al.	
	671	2015/0099324	4/9/2015	Wojtczuk et al.	
	672	2015/0099950	4/9/2015	Al-Ali et al.	
	673	2015/0099951	4/9/2015	Al-Ali et al.	
	674	2015/0099955	4/9/2015	Al-Ali et al.	
	675	2015/0101844	4/16/2015	Al-Ali et al.	
	676	2015/0106121	4/16/2015	Muhsin et al.	
	677	2015/0112151	4/23/2015	Muhsin et al.	
	678	2015/0116076	4/30/2015	Al-Ali et al.	
	679	2015/0126830	5/7/2015	Schurman et al.	
	680	2015/0133755	5/14/2015	Smith et al.	
	681	2015/0140863	5/21/2015	Al-Ali et al.	
	682	2015/0141781	5/21/2015	Weber et al.	
	683	2015/0165312	6/18/2015	Kiani	
	684	2015/0173671	6/25/2015	Paalasmaa et al.	
	685	2015/0196237	7/16/2015	Lamego	
	686	2015/0201874	7/23/2015	Diab	
	687	2015/0208966	7/30/2015	Al-Ali	
	688	2015/0216459	8/6/2015	Al-Ali et al.	
	689	2015/0230755	8/20/2015	Al-Ali et al.	
	690	2015/0238722	8/27/2015	Al-Ali	
	691	2015/0245773	9/3/2015	Lamego et al.	
	692	2015/0245793	9/2/2015	Al-Ali et al.	
	693	2015/0245794	9/3/2015	Al-Ali	
	694	2015/0255001	9/10/2015	Haughav et al.	
	695	2015/0257689	9/17/2015	Al-Ali et al.	
	696	2015/0272514	10/1/2015	Kiani et al.	

Examiner Signature /MARJAN FARDANESH/	Date Considered 02/06/2019
<p><b>*Examiner:</b> Initial if reference considered, whether or not citation is in conformance with MPEP 609. Draw line through citation if not in conformance and not considered. Include copy of this form with next communication to applicant.</p>	

~~ALL REFERENCES CONSIDERED EXCEPT WHERE LINED THROUGH. /M.F/~~

T<sup>1</sup> - Place a check mark in this area when an English language Translation is attached.

PTO/SB/08 Equivalent

<b>INFORMATION DISCLOSURE STATEMENT BY APPLICANT</b>	Application No.	Unassigned
	Filing Date	Filed herewith
	First Named Inventor	Ammar Al-Ali
	Art Unit	Unassigned
<i>(Multiple sheets used when necessary)</i>	Examiner	Unassigned
SHEET 25 OF 28	Attorney Docket No.	MAS.1007C1

U.S. PATENT DOCUMENTS					
Examiner Initials	Cite No.	Document Number Number - Kind Code (if known) Example: 1,234,567 B1	Publication Date MM-DD-YYYY	Name	Pages, Columns, Lines Where Relevant Passages or Relevant Figures Appear
	697	2015/0281424	10/1/2015	Vock et al.	
	698	2015/0318100	11/5/2015	Rothkopf et al.	
	699	2015/0351697	12/10/2015	Weber et al.	
	700	2015/0351704	12/20/2015	Kiani et al.	
	701	2015/0359429	12/17/2015	Al-Ali et al.	
	702	2015/0366472	12/24/2015	Kiani	
	703	2015/0366507	12/24/2015	Blank	
	704	2015/0374298	12/31/2015	Al-Ali et al.	
	705	2015/0380875	12/31/2015	Coverston et al.	
	706	2016/0000362	1/7/2016	Diab et al.	
	707	2016/0007930	1/14/2016	Weber et al.	
	708	2016/0019360	1/21/2016	PAHWA et al.	
	709	2016/0023245	1/28/2016	Zadesky et al.	
	710	2016/0029932	2/4/2016	Al-Ali	
	711	2016/0029933	2/4/2016	Al-Ali et al.	
	712	2016/0038045	2/11/2016	Shapiro	
	713	2016/0045118	2/18/2016	Kiani	
	714	2016/0051157	2/25/2016	Waydo	
	715	2016/0051158	2/25/2016	Silva	
	716	2016/0051205	2/25/2016	Al-Ali et al.	
	717	2016/0058302	3/3/2016	Raghuram et al.	
	718	2016/0058309	3/3/2016	Han	
	719	2016/0058312	3/3/2016	Han et al.	
	720	2016/0058338	3/3/2016	Schurman et al.	
	721	2016/0058347	3/3/2016	Reichgott et al.	
	722	2016/0058356	3/3/2016	RAGHURAM et al.	
	723	2016/0058370	3/3/2016	RAGHURAM et al.	
	724	2016/0066823	3/10/2016	Kind et al.	
	725	2016/0066824	3/10/2016	Al-Ali et al.	

Examiner Signature	/MARJAN FARDANESH/	Date Considered	02/06/2019
<p><b>*Examiner:</b> Initial if reference considered, whether or not citation is in conformance with MPEP 609. Draw line through citation if not in conformance and not considered. Include copy of this form with next communication to applicant.</p>			

~~ALL REFERENCES CONSIDERED EXCEPT WHERE LINED THROUGH. /M.F/~~

T<sup>1</sup> - Place a check mark in this area when an English language Translation is attached.

PTO/SB/08 Equivalent

<b>INFORMATION DISCLOSURE STATEMENT BY APPLICANT</b>	Application No.	Unassigned
	Filing Date	Filed herewith
	First Named Inventor	Ammar Al-Ali
	Art Unit	Unassigned
(Multiple sheets used when necessary)	Examiner	Unassigned
SHEET 26 OF 28	Attorney Docket No.	MAS.1007C1

U.S. PATENT DOCUMENTS					
Examiner Initials	Cite No.	Document Number Number - Kind Code (if known) Example: 1,234,567 B1	Publication Date MM-DD-YYYY	Name	Pages, Columns, Lines Where Relevant Passages or Relevant Figures Appear
	726	2016/0066879	3/10/2016	Telfort et al.	
	727	2016/0071392	3/10/2016	Hankey et al.	
	728	2016/0072429	3/10/2016	Kiani et al.	
	729	2016/0073967	3/17/2016	Lamego et al.	
	730	2016/0081552	3/24/2016	Wojtczuk et al.	
	731	2016/0095543	4/7/2016	Telfort et al.	
	732	2016/0095548	4/7/2016	Al-Ali et al.	
	733	2016/0103598	4/14/2016	Al-Ali et al.	
	734	2016/0113527	4/28/2016	Al-Ali et al.	
	735	2016/0143548	5/26/2016	Al-Ali	
	736	2016/0154950	6/2/2016	NAKAJIMA et al.	
	737	2016/0157780	6/9/2016	RIMMINEN et al.	
	738	2016/0213309	7/28/2016	SANNHOLM et al.	
	739	2016/0256058	9/8/2016	Pham et al.	
	740	2016/0256082	9/8/2016	Ely et al.	
	741	2016/0267238	9/15/2016	Nag	
	742	2016/0287181	10/6/2016	Han et al.	
	743	2016/0296173	10/13/2016	Culbert	
	744	2016/0296174	10/13/2016	Isikman et al.	
	745	2016/0310027	10/27/2016	Han	
	746	2016/0378069	12/29/2016	Rothkopf	
	747	2016/0378071	12/29/2016	Rothkopf	
	748	2017/0007183	1/12/2017	Dusan et al.	
	749	2017/0010858	1/12/2017	Prest et al.	
	750	2017/0074897	3/16/2017	Mermel et al.	
	751	2017/0084133	3/23/2017	Cardinali et al.	
	752	2017/0086689	3/30/2017	Shui et al.	
	753	2017/0086742	3/30/2017	Harrison-Noonan et al.	
	754	2017/0086743	3/30/2017	Bushnell et al.	

Examiner Signature /MARJAN FARDANESH/	Date Considered 02/06/2019
<p><b>*Examiner:</b> Initial if reference considered, whether or not citation is in conformance with MPEP 609. Draw line through citation if not in conformance and not considered. Include copy of this form with next communication to applicant.</p>	

~~ALL REFERENCES CONSIDERED EXCEPT WHERE LINED THROUGH. /M.F/~~

T<sup>1</sup> - Place a check mark in this area when an English language Translation is attached.

PTO/SB/08 Equivalent

<b>INFORMATION DISCLOSURE STATEMENT BY APPLICANT</b>	Application No.	Unassigned
	Filing Date	Filed herewith
	First Named Inventor	Ammar Al-Ali
	Art Unit	Unassigned
(Multiple sheets used when necessary)	Examiner	Unassigned
SHEET 27 OF 28	Attorney Docket No.	MAS.1007C1

U.S. PATENT DOCUMENTS					
Examiner Initials	Cite No.	Document Number Number - Kind Code (if known) Example: 1,234,567 B1	Publication Date MM-DD-YYYY	Name	Pages, Columns, Lines Where Relevant Passages or Relevant Figures Appear
	755	2017/0094450	3/30/2017	Tu et al.	
	756	2017/0164884	6/15/2017	Culbert et al.	
	757	2017/0248446	8/31/2017	Gowreesunker et al.	
	758	2017/0273619	9/28/2017	Alvarado et al.	
	759	2017/0281024	10/5/2017	Narasimhan et al.	
	760	2017/0293727	10/12/2017	Klaassen et al.	
	761	2017/0325698	11/16/2017	Allec et al.	
	762	2017/0325744	11/16/2017	Allec et al.	
	763	2017/0340209	11/30/2017	Klaassen et al.	
	764	2017/0340219	11/30/2017	Sullivan et al.	
	765	2017/0347885	12/7/2017	Tan et al.	
	766	2017/0354332	12/14/2017	Lamego	
	767	2017/0354795	12/14/2017	BLAHNIK et al.	
	768	2017/0358239	12/14/2017	Arney et al.	
	769	2017/0358240	12/14/2017	Blahnik et al.	
	770	2017/0358242	12/14/2017	Thompson et al.	
	771	2017/0360306	12/14/2017	Narasimhan et al.	
	772	2017/0366657	12/21/2017	Thompson et al.	
	773	2018/0014781	1/18/2018	Clavelle et al.	
	774	2018/0025287	1/25/2018	Mathew et al.	
	775	2018/0042556	2/15/2018	SHAHPARNIA et al.	
	776	2018/0049694	2/22/2018	Singh Alvarado et al.	
	777	2018/0050235	2/22/2018	Tan et al.	
	778	2018/0055375	3/1/2018	MARTINEZ et al.	
	779	2018/0055439	3/1/2018	Pham et al.	
	780	2018/0056129	1/1/2018	NARASIMHA RAO et al.	
	781	2018/0078151	3/22/2018	ALLEC et al.	
	782	2018/0078182	3/22/2018	CHEN et al.	
	783	2018/0110469	4/26/2018	MAANI et al.	

Examiner Signature /MARJAN FARDANESH/	Date Considered 02/06/2019
<p><b>*Examiner:</b> Initial if reference considered, whether or not citation is in conformance with MPEP 609. Draw line through citation if not in conformance and not considered. Include copy of this form with next communication to applicant.</p> <p style="text-align: center;"><del>ALL REFERENCES CONSIDERED EXCEPT WHERE LINED THROUGH. /M.F/</del></p>	

T<sup>1</sup> - Place a check mark in this area when an English language Translation is attached.

PTO/SB/08 Equivalent

<b>INFORMATION DISCLOSURE STATEMENT BY APPLICANT</b>	Application No.	Unassigned
	Filing Date	Filed herewith
	First Named Inventor	Ammar Al-Ali
	Art Unit	Unassigned
<i>(Multiple sheets used when necessary)</i>	Examiner	Unassigned
SHEET 28 OF 28	Attorney Docket No.	MAS.1007C1

U.S. PATENT DOCUMENTS					
Examiner Initials	Cite No.	Document Number <i>Number - Kind Code (if known)</i> Example: 1,234,567 B1	Publication Date MM-DD-YYYY	Name	Pages, Columns, Lines Where Relevant Passages or Relevant Figures Appear
	784	2018/0153418	6/7/2018	SULLIVAN et al.	
	785	2018/0164853	6/14/2018	Myers et al.	
	786	2018/0196514	7/12/2018	ALLEC et al.	
	787	2018/0228414	8/16/2018	SHAO et al.	
	788	2018/0238734	8/23/2018	Hotelling et al.	
	789	2018/0279956	10/4/2018	WAYDO et al.	

FOREIGN PATENT DOCUMENTS						
Examiner Initials	Cite No.	Foreign Patent Document <i>Country Code-Number-Kind Code</i> Example: JP 1234567 A1	Publication Date MM-DD-YYYY	Name	Pages, Columns, Lines Where Relevant Passages or Relevant Figures Appear	T <sup>1</sup>
	790	EP 0781527 A1	7/2/1997	INSTRUMENTARIUM OY		
	791	EP 2277440 A1	1/26/2011	PIONEER CORP		

NON PATENT LITERATURE DOCUMENTS			
Examiner Initials	Cite No.	Include name of the author (in CAPITAL LETTERS), title of the article (when appropriate), title of the item (book, magazine, journal, serial, symposium, catalog, etc.), date, page(s), volume-issue number(s), publisher, city and/or country where published.	T <sup>1</sup>
	792	Written Opinion received in International Application No. PCT/US2016/040190, dated January 2, 2018.	

29627927

Examiner Signature /MARJAN FARDANESH/	Date Considered 02/06/2019
<p><b>*Examiner:</b> Initial if reference considered, whether or not citation is in conformance with MPEP 609. Draw line through citation if not in conformance and not considered. Include copy of this form with next communication to applicant.</p>	

~~ALL REFERENCES CONSIDERED EXCEPT WHERE LINED THROUGH. /M.F./~~  
T<sup>1</sup> - Place a check mark in this area when an English language Translation is attached.



**IN THE UNITED STATES PATENT AND TRADEMARK OFFICE**

First Inventor	:	Ammar Al-Ali
App. No.	:	16/226249
Filed	:	December 19, 2018
For	:	ADVANCED PULSE OXIMETRY SENSOR
Examiner	:	Fardanesh, Marjan
Art Unit	:	3791
Conf. No.	:	1002

**SUPPLEMENTAL PRELIMINARY AMENDMENT**

**Mail Stop Amendment**

Commissioner for Patents  
P.O. Box 1450  
Alexandria, VA 22313-1450

Dear Commissioner:

Prior to examination of the above-identified application, please enter the amendments set forth herein.

**Amendments to the Claims** are reflected in the listing of claims which begins on page 2 of this paper.

**Remarks** begin on page 7 of this paper.

**Application No.:** 16/226249  
**Filing Date:** December 19, 2018

### AMENDMENTS TO THE CLAIMS

1-56. (Cancelled)

57. (New) A wrist-worn physiological monitoring device configured for placement on a user at a tissue measurement site, the device comprising:

a plurality of emitters configured to emit light towards the tissue measurement site, the tissue measurement site being located on a wrist of the user, the plurality of emitters comprising one or more light-emitting diodes (LEDs) configured to emit one or more wavelengths, the one or more wavelengths comprising at least an infrared wavelength;

a plurality of detectors configured to detect the light emitted by the plurality of emitters after attenuation by tissue of the user at the tissue measurement site, wherein the plurality of detectors comprise one or more photodiodes, the plurality of detectors further configured to output at least one signal responsive to the detected light;

a processor configured to receive the at least one signal responsive to the output and determine a physiological parameter of the user; and

a light block forming an enclosing wall between the light emitted from the plurality of emitters at the tissue measurement site and the plurality of detectors when the physiological monitoring device is worn by the user, wherein the wall prevents at least a portion of light emitted from the plurality of emitters from being detected by the plurality of detectors without attenuation by the tissue.

58. (New) The physiological monitoring device of Claim 57, further comprising a display configured to present information related to the determined physiological parameter to the user.

59. (New) The physiological monitoring device of Claim 58, wherein the display is a touch-screen display.

60. (New) The physiological monitoring device of Claim 57, wherein the enclosing wall of the light block is a circular wall.

61. (New) The physiological monitoring device of Claim 57, wherein, when the physiological monitoring device is worn by the user at the tissue measurement site, the plurality of emitters are arranged in a reflectance measurement configuration on a first side of the tissue measurement site, and wherein the plurality of detectors are arranged in a reflectance

**Application No.:** 16/226249  
**Filing Date:** December 19, 2018

measurement configuration on the first side of the tissue measurement site when the physiological monitoring device is worn by the user.

62. (New) The physiological monitoring device of Claim 57, further comprising a diffuser which receives, spreads, and emits the spread light, wherein the emitted spread light is directed at the tissue measurement site.

63. (New) The physiological monitoring device of Claim 57, wherein the plurality of emitters are positioned outside the enclosing wall when the physiological monitoring device is worn by the user at the tissue measurement site, and wherein the plurality of detectors are positioned inside the enclosing wall when the physiological monitoring device is worn by the user at the tissue measurement site.

64. (New) The physiological monitoring device of Claim 57, wherein the physiological parameter is selected from the group consisting of arterial oxygen saturation, glucose, and pulse rate.

65. (New) The physiological monitoring device of Claim 57, wherein the plurality of detectors are arranged in an array with a spacial configuration corresponding to an irradiated surface area.

66. (New) The physiological monitoring device of Claim 65, wherein the irradiated surface area comprises a circular shape.

67. (New) A method of measuring a physiological parameter in a user's blood, the method comprising:

emitting, from a plurality of emitters of a physiological monitoring device, light of one or more wavelengths toward a tissue measurement site located on a wrist of the user, wherein the plurality of emitters comprise one or more light-emitting diodes (LEDs) and the one or more wavelengths comprises at least an infrared wavelength;

detecting, with a plurality of detectors, the light emitted by the plurality of emitters after attenuation through tissue of the user at the tissue measurement site, wherein the plurality of detectors comprise one or more photodiodes; and

providing a light block forming an enclosing wall between the light emitted from the plurality of emitters at the tissue measurement site and the plurality of detectors when the physiological monitoring device is worn by the user, wherein the wall prevents at

**Application No.:** 16/226249  
**Filing Date:** December 19, 2018

least a portion of light emitted from the plurality of emitters from being detected by the plurality of detectors without attenuation by the tissue;

outputting, from the plurality of detectors, at least one signal responsive to the detected light;

receiving, by a processor, the outputted at least one signal responsive to the detected light; and

processing, by the processor, the received at least one signal responsive to the detected light to determine a physiological parameter.

68. (New) The method of Claim 67, wherein the plurality of emitters are positioned outside the enclosing wall when the physiological monitoring device is worn by the user at the tissue measurement site, and wherein the plurality of detectors are positioned inside the enclosing wall when the physiological monitoring device is worn by the user at the tissue measurement site.

69. (New) The method of Claim 67, further comprising presenting, with a display of the physiological monitoring device, information related to the determined physiological parameter to the user.

70. (New) The method of Claim 69, wherein the display is a touch-screen display.

71. (New) The method of Claim 67, wherein the enclosing wall of the light block comprises a circular wall.

72. (New) The method of Claim 67, wherein when the physiological monitoring device is worn by the user at the tissue measurement site, the plurality of emitters are arranged in a reflectance measurement configuration on a first side of the tissue measurement site, and wherein the plurality of detectors are arranged in a reflectance measurement configuration on the first side of the tissue measurement site when the physiological monitoring device is worn by the user.

73. (New) The method of Claim 67, further comprising spreading, with a diffuser, the emitted light and emitting the spread light from the diffuser to the tissue measurement site.

74. (New) The method of Claim 67, wherein the physiological parameter is indicative of at least one of pulse rate, perfusion index, oxygen content, and total hemoglobin.

75. (New) The method of Claim 67, wherein the plurality of detectors are arranged in an array with a spacial configuration corresponding to an irradiated surface area.

**Application No.:** 16/226249  
**Filing Date:** December 19, 2018

76. (New) The method of Claim 75, wherein the irradiated surface area comprises a circular shape.

77. (New) A wrist-worn physiological monitoring sensor comprising:

a plurality of optical sources configured to emit light towards a tissue measurement site on a user, the tissue measurement site located on a wrist of the user, the plurality of optical sources comprising one or more light-emitting diodes (LEDs) configured to emit one or more wavelengths, the one or more wavelengths comprising at least an infrared wavelength;

a plurality of detectors configured to detect the light emitted by the plurality of emitters after attenuation by tissue of the user at the tissue measurement site, wherein the plurality of detectors comprise one or more photodiodes, the plurality of detectors further configured to output at least one signal responsive to the detected light;

a processor configured to receive the outputted at least one signal responsive to the detected light and determine a physiological parameter indicative of a state or trend of wellness of the user; and

a light block forming an enclosing wall between the light emitted from the plurality of emitters at the tissue measurement site and the plurality of detectors when the physiological monitoring sensor is worn by the user, the light block forming a light isolation chamber defined by the enclosing wall, wherein the wall prevents at least a portion of light emitted from the plurality of emitters from being detected by the plurality of detectors without attenuation by the tissue.

78. (New) The physiological monitoring sensor of Claim 77, wherein the plurality of optical sources are located outside the enclosing wall when the physiological monitoring sensor is worn by the user at the tissue measurement site, and wherein the plurality of detectors are arranged inside the enclosing wall when the physiological monitoring sensor is worn by the user at the tissue measurement site.

79. (New) The physiological monitoring sensor of Claim 77, wherein the plurality of detectors are arranged in an array so as to capture the emitted light reflected from the tissue of the user at the tissue measurement site.

**Application No.:** 16/226249  
**Filing Date:** December 19, 2018

80. (New) The physiological monitoring sensor of Claim 77, wherein the plurality of detectors are arranged with a spacial configuration corresponding to an irradiated surface area.

81. (New) The physiological monitoring sensor of Claim 77, further comprising a diffuser which receives, spreads, and emits the spread light, wherein the emitted spread light is directed at the tissue measurement site.

82. (New) The physiological monitoring sensor of Claim 77, further comprising a display configured to present information related to the determined physiological parameter to the user.

83. (New) The physiological monitoring sensor of Claim 82, wherein the display is a touch-screen display.

84. (New) The physiological monitoring sensor of Claim 77, wherein the enclosing wall of the light block is a circular wall.

85. (New) The physiological monitoring sensor of Claim 77, wherein when the physiological monitoring sensor is worn by the user at the tissue measurement site, the plurality of emitters are arranged in a reflectance measurement configuration on a first side of the tissue measurement site, and wherein the plurality of detectors are arranged in a reflectance measurement configuration on the first side of the tissue measurement site when the physiological monitoring sensor is worn by the user.

86. (New) The physiological monitoring sensor of Claim 77, wherein the physiological parameter is selected from the group consisting of arterial oxygen saturation, glucose, and pulse rate.

**Application No.:** 16/226249  
**Filing Date:** December 19, 2018

### REMARKS

Prior to examination, please amend the Claims as shown herein.

#### No Disclaimers or Disavowals

Although the present communication may include alterations to the application or claims, or characterizations of claim scope or referenced art, Applicant is not conceding in this application that previously pending claims are not patentable. Rather, any alterations or characterizations are being made to facilitate expeditious prosecution of this application. Applicant reserves the right to pursue at a later date any previously pending or other broader or narrower claims that capture any subject matter supported by the present disclosure, including subject matter found to be specifically disclaimed herein or by any prior prosecution. Accordingly, reviewers of this or any parent, child or related prosecution history shall not reasonably infer that Applicant has made any disclaimers or disavowals of any subject matter supported by the present application.

Please charge any additional fees, including any fees for additional extension of time, or credit overpayment to Deposit Account No. 11-1410.

Respectfully submitted,

KNOBBE, MARTENS, OLSON & BEAR, LLP

Dated: January 30, 2019

By: /Aaron S. Johnson/  
Aaron S. Johnson  
Registration No. 74,164  
Registered Practitioner  
Customer No. 64735  
(949) 760-0404

29558484

## Electronic Patent Application Fee Transmittal

<b>Application Number:</b>	16226249			
<b>Filing Date:</b>	19-Dec-2018			
<b>Title of Invention:</b>	ADVANCED PULSE OXIMETRY SENSOR			
<b>First Named Inventor/Applicant Name:</b>	Ammar Al-Ali			
<b>Filer:</b>	Aaron Samuel Johnson/Daniel Escajeda			
<b>Attorney Docket Number:</b>	MAS.1007C1			
Filed as Large Entity				
<b>Filing Fees for Utility under 35 USC 111(a)</b>				
<b>Description</b>	<b>Fee Code</b>	<b>Quantity</b>	<b>Amount</b>	<b>Sub-Total in USD(\$)</b>
<b>Basic Filing:</b>				
<b>Pages:</b>				
<b>Claims:</b>				
CLAIMS IN EXCESS OF 20	1202	10	100	1000
<b>Miscellaneous-Filing:</b>				
<b>Petition:</b>				
<b>Patent-Appeals-and-Interference:</b>				
<b>Post-Allowance-and-Post-Issuance:</b>				



Description	Fee Code	Quantity	Amount	Sub-Total in USD(\$)
<b>Extension-of-Time:</b>				
<b>Miscellaneous:</b>				
<b>Total in USD (\$)</b>				<b>1000</b>

## Electronic Acknowledgement Receipt

<b>EFS ID:</b>	35004602
<b>Application Number:</b>	16226249
<b>International Application Number:</b>	
<b>Confirmation Number:</b>	1002
<b>Title of Invention:</b>	ADVANCED PULSE OXIMETRY SENSOR
<b>First Named Inventor/Applicant Name:</b>	Ammar Al-Ali
<b>Customer Number:</b>	64735
<b>Filer:</b>	Aaron Samuel Johnson/Sandra Autry
<b>Filer Authorized By:</b>	Aaron Samuel Johnson
<b>Attorney Docket Number:</b>	MAS.1007C1
<b>Receipt Date:</b>	30-JAN-2019
<b>Filing Date:</b>	19-DEC-2018
<b>Time Stamp:</b>	15:52:20
<b>Application Type:</b>	Utility under 35 USC 111(a)

### Payment information:

Submitted with Payment	yes
Payment Type	CARD
Payment was successfully received in RAM	\$1000
RAM confirmation Number	013119INTEFSW15524801
Deposit Account	111410
Authorized User	Sandra Autry

The Director of the USPTO is hereby authorized to charge indicated fees and credit any overpayment as follows:

37 CFR 1.16 (National application filing, search, and examination fees)

37 CFR 1.17 (Patent application and reexamination processing fees)

<b>File Listing:</b>					
<b>Document Number</b>	<b>Document Description</b>	<b>File Name</b>	<b>File Size(Bytes)/ Message Digest</b>	<b>Multi Part /.zip</b>	<b>Pages (if appl.)</b>
1		SupplementalPrelim_MAS1007 C1.pdf	43063  02d1b89940354061018472f6789653a083a 08fb5	yes	7
<b>Multipart Description/PDF files in .zip description</b>					
		<b>Document Description</b>	<b>Start</b>	<b>End</b>	
		Supplemental Response or Supplemental Amendment	1	1	
		Claims	2	6	
		Applicant Arguments/Remarks Made in an Amendment	7	7	
<b>Warnings:</b>					
<b>Information:</b>					
2	Fee Worksheet (SB06)	fee-info.pdf	30208  b73fa1d795733f74c11eb7b4c3d09336c7d 4c20c	no	2
<b>Warnings:</b>					
<b>Information:</b>					
<b>Total Files Size (in bytes):</b>			73271		

This Acknowledgement Receipt evidences receipt on the noted date by the USPTO of the indicated documents, characterized by the applicant, and including page counts, where applicable. It serves as evidence of receipt similar to a Post Card, as described in MPEP 503.

**New Applications Under 35 U.S.C. 111**

If a new application is being filed and the application includes the necessary components for a filing date (see 37 CFR 1.53(b)-(d) and MPEP 506), a Filing Receipt (37 CFR 1.54) will be issued in due course and the date shown on this Acknowledgement Receipt will establish the filing date of the application.

**National Stage of an International Application under 35 U.S.C. 371**

If a timely submission to enter the national stage of an international application is compliant with the conditions of 35 U.S.C. 371 and other applicable requirements a Form PCT/DO/EO/903 indicating acceptance of the application as a national stage submission under 35 U.S.C. 371 will be issued in addition to the Filing Receipt, in due course.

**New International Application Filed with the USPTO as a Receiving Office**

If a new international application is being filed and the international application includes the necessary components for an international filing date (see PCT Article 11 and MPEP 1810), a Notification of the International Application Number and of the International Filing Date (Form PCT/RO/105) will be issued in due course, subject to prescriptions concerning national security, and the date shown on this Acknowledgement Receipt will establish the international filing date of the application.



UNITED STATES PATENT AND TRADEMARK OFFICE

UNITED STATES DEPARTMENT OF COMMERCE  
**United States Patent and Trademark Office**  
Address: COMMISSIONER FOR PATENTS  
P.O. Box 1450  
Alexandria, Virginia 22313-1450  
www.uspto.gov

APPLICATION NO.	FILING DATE	FIRST NAMED INVENTOR	ATTORNEY DOCKET NO.	CONFIRMATION NO.
16/226,249	12/19/2018	Ammar Al-Ali	MAS.1007C1	1002
64735	7590	01/18/2019	EXAMINER	
KNOBBE, MARTENS, OLSON & BEAR, LLP MASIMO CORPORATION (MASIMO) 2040 MAIN STREET FOURTEENTH FLOOR IRVINE, CA 92614			ART UNIT	PAPER NUMBER
			3791	
			NOTIFICATION DATE	DELIVERY MODE
			01/18/2019	ELECTRONIC

**Please find below and/or attached an Office communication concerning this application or proceeding.**

The time period for reply, if any, is set in the attached communication.

Notice of the Office communication was sent electronically on above-indicated "Notification Date" to the following e-mail address(es):

efiling@knobbe.com  
jayna.cartee@knobbe.com

<b><i>Decision Granting Request for Prioritized Examination (Track I)</i></b>	<b>Application No.</b> 16/226,249	<b>Applicant(s)</b> Al-Ali et al.	
	<b>Examiner</b> BRIAN W BROWN	<b>Art Unit</b> OPET	<b>AIA (First Inventor to File) Status</b> Yes
<p>1. THE REQUEST FILED <u>19 December 2018</u> IS <b>GRANTED</b> .</p> <p>The above-identified application has met the requirements for prioritized examination</p> <p>A. <input checked="" type="checkbox"/> for an original nonprovisional application (Track I).</p> <p>B. <input type="checkbox"/> for an application undergoing continued examination (RCE).</p> <p>2. <b>The above-identified application will undergo prioritized examination.</b> The application will be accorded special status throughout its entire course of prosecution until one of the following occurs:</p> <p>A. filing a <b><u>petition for extension of time</u></b> to extend the time period for filing a reply;</p> <p>B. filing an <b><u>amendment to amend the application to contain more than four independent claims, more than thirty total claims</u></b>, or a multiple dependent claim;</p> <p>C. filing a <b><u>request for continued examination</u></b> ;</p> <p>D. filing a notice of appeal;</p> <p>E. filing a request for suspension of action;</p> <p>F. mailing of a notice of allowance;</p> <p>G. mailing of a final Office action;</p> <p>H. completion of examination as defined in 37 CFR 41.102; or</p> <p>I. abandonment of the application.</p> <p>Telephone inquiries with regard to this decision should be directed to BRIAN BROWN at (571)272-5338. In his/her absence, calls may be directed to Petition Help Desk at (571) 272-3282.</p>			
/BRIAN W BROWN/ Petitions Examiner, OPET			

<b>PATENT APPLICATION FEE DETERMINATION RECORD</b> Substitute for Form PTO-875	Application or Docket Number 16/226,249
---	--

APPLICATION AS FILED - PART I			SMALL ENTITY		OR	OTHER THAN SMALL ENTITY	
	(Column 1)	(Column 2)					
FOR	NUMBER FILED	NUMBER EXTRA	RATE(\$)	FEE(\$)		RATE(\$)	FEE(\$)
BASIC FEE (37 CFR 1.16(a), (b), or (c))	N/A	N/A	N/A			N/A	300
SEARCH FEE (37 CFR 1.16(k), (j), or (m))	N/A	N/A	N/A			N/A	660
EXAMINATION FEE (37 CFR 1.16(o), (p), or (q))	N/A	N/A	N/A			N/A	760
TOTAL CLAIMS (37 CFR 1.16(i))	20	minus 20 = *				x 100 =	0.00
INDEPENDENT CLAIMS (37 CFR 1.16(h))	3	minus 3 = *				x 460 =	0.00
APPLICATION SIZE FEE (37 CFR 1.16(s))	If the specification and drawings exceed 100 sheets of paper, the application size fee due is \$310 (\$155 for small entity) for each additional 50 sheets or fraction thereof. See 35 U.S.C. 41(a)(1)(G) and 37 CFR 1.16(s).						0.00
MULTIPLE DEPENDENT CLAIM PRESENT (37 CFR 1.16(j))							0.00
* If the difference in column 1 is less than zero, enter "0" in column 2.			TOTAL			TOTAL	1720

APPLICATION AS AMENDED - PART II					SMALL ENTITY		OR	OTHER THAN SMALL ENTITY		
	(Column 1)	(Column 2)	(Column 3)							
AMENDMENT A		CLAIMS REMAINING AFTER AMENDMENT	HIGHEST NUMBER PREVIOUSLY PAID FOR	PRESENT EXTRA	RATE(\$)	ADDITIONAL FEE(\$)		RATE(\$)	ADDITIONAL FEE(\$)	
	Total (37 CFR 1.16(i))	*	Minus	**	=			x	=	
	Independent (37 CFR 1.16(h))	*	Minus	***	=			x	=	
	Application Size Fee (37 CFR 1.16(s))									
	FIRST PRESENTATION OF MULTIPLE DEPENDENT CLAIM (37 CFR 1.16(j))									
					TOTAL ADD'L FEE			TOTAL ADD'L FEE		
AMENDMENT B		CLAIMS REMAINING AFTER AMENDMENT	HIGHEST NUMBER PREVIOUSLY PAID FOR	PRESENT EXTRA	RATE(\$)	ADDITIONAL FEE(\$)		RATE(\$)	ADDITIONAL FEE(\$)	
	Total (37 CFR 1.16(i))	*	Minus	**	=			x	=	
	Independent (37 CFR 1.16(h))	*	Minus	***	=			x	=	
	Application Size Fee (37 CFR 1.16(s))									
	FIRST PRESENTATION OF MULTIPLE DEPENDENT CLAIM (37 CFR 1.16(j))									
					TOTAL ADD'L FEE			TOTAL ADD'L FEE		
<p>* If the entry in column 1 is less than the entry in column 2, write "0" in column 3.</p> <p>** If the "Highest Number Previously Paid For" IN THIS SPACE is less than 20, enter "20".</p> <p>*** If the "Highest Number Previously Paid For" IN THIS SPACE is less than 3, enter "3".</p> <p>The "Highest Number Previously Paid For" (Total or Independent) is the highest found in the appropriate box in column 1.</p>										



UNITED STATES PATENT AND TRADEMARK OFFICE

UNITED STATES DEPARTMENT OF COMMERCE
United States Patent and Trademark Office
Address: COMMISSIONER FOR PATENTS
P.O. Box 1450
Alexandria, Virginia 22313-1450
www.uspto.gov

Table with 4 columns: APPLICATION NUMBER (16/226,249), FILING OR 371(C) DATE (12/19/2018), FIRST NAMED APPLICANT (Ammar Al-Ali), ATTY. DOCKET NO./TITLE (MAS.1007C1)

CONFIRMATION NO. 1002

64735
KNOBBE, MARTENS, OLSON & BEAR, LLP
MASIMO CORPORATION (MASIMO)
2040 MAIN STREET
FOURTEENTH FLOOR
IRVINE, CA 92614

INFORMAL NOTICE



Date Mailed: 01/17/2019

INFORMATIONAL NOTICE TO APPLICANT

Applicant is notified that the above-identified application contains the deficiencies noted below. No period for reply is set forth in this notice for correction of these deficiencies. However, if a deficiency relates to the inventor's oath or declaration, the applicant must file an oath or declaration in compliance with 37 CFR 1.63, or a substitute statement in compliance with 37 CFR 1.64, executed by or with respect to each actual inventor no later than the expiration of the time period set in the "Notice of Allowability" to avoid abandonment. See 37 CFR 1.53(f).

The item(s) indicated below are also required and should be submitted with any reply to this notice to avoid further processing delays.

- A properly executed inventor's oath or declaration has not been received for the following inventor(s):
Ammar Al-Ali
Stephen Scruggs

Questions about the contents of this notice and the requirements it sets forth should be directed to the Office of Data Management, Application Assistance Unit, at (571) 272-4000 or (571) 272-4200 or 1-888-786-0101.

/hchin/





UNITED STATES PATENT AND TRADEMARK OFFICE

UNITED STATES DEPARTMENT OF COMMERCE
United States Patent and Trademark Office
Address: COMMISSIONER FOR PATENTS
P.O. Box 1450
Alexandria, Virginia 22313-1450
www.uspto.gov

Table with 7 columns: APPLICATION NUMBER, FILING or 371(c) DATE, GRP ART UNIT, FIL FEE REC'D, ATTY DOCKET NO, TOT CLAIMS, IND CLAIMS. Row 1: 16/226,249, 12/19/2018, 3791, 1880, MAS.1007C1, 20, 3

CONFIRMATION NO. 1002

FILING RECEIPT

64735
KNOBBE, MARTENS, OLSON & BEAR, LLP
MASIMO CORPORATION (MASIMO)
2040 MAIN STREET
FOURTEENTH FLOOR
IRVINE, CA 92614



Date Mailed: 01/17/2019

Receipt is acknowledged of this non-provisional patent application. The application will be taken up for examination in due course. Applicant will be notified as to the results of the examination. Any correspondence concerning the application must include the following identification information: the U.S. APPLICATION NUMBER, FILING DATE, NAME OF APPLICANT, and TITLE OF INVENTION. Fees transmitted by check or draft are subject to collection. Please verify the accuracy of the data presented on this receipt. If an error is noted on this Filing Receipt, please submit a written request for a Filing Receipt Correction. Please provide a copy of this Filing Receipt with the changes noted thereon. If you received a "Notice to File Missing Parts" for this application, please submit any corrections to this Filing Receipt with your reply to the Notice. When the USPTO processes the reply to the Notice, the USPTO will generate another Filing Receipt incorporating the requested corrections

Inventor(s)

Ammar Al-Ali, San Juan Capistrano, CA;
Stephen Scruggs, Newport Beach, CA;

Applicant(s)

MASIMO CORPORATION, Irvine, CA;

Power of Attorney: The patent practitioners associated with Customer Number 64735

Domestic Priority data as claimed by applicant

This application is a CON of 15/195,199 06/28/2016
which claims benefit of 62/188,430 07/02/2015

Foreign Applications for which priority is claimed (You may be eligible to benefit from the Patent Prosecution Highway program at the USPTO. Please see http://www.uspto.gov for more information.) - None.

Foreign application information must be provided in an Application Data Sheet in order to constitute a claim to foreign priority. See 37 CFR 1.55 and 1.76.

Permission to Access Application via Priority Document Exchange: Yes

Permission to Access Search Results: Yes

Applicant may provide or rescind an authorization for access using Form PTO/SB/39 or Form PTO/SB/69 as appropriate.

If Required, Foreign Filing License Granted: 01/15/2019

The country code and number of your priority application, to be used for filing abroad under the Paris Convention, is **US 16/226,249**

**Projected Publication Date:** 04/25/2019

**Non-Publication Request:** No

**Early Publication Request:** No  
**Title**

ADVANCED PULSE OXIMETRY SENSOR

**Preliminary Class**

600

**Statement under 37 CFR 1.55 or 1.78 for AIA (First Inventor to File) Transition Applications:** No

### **PROTECTING YOUR INVENTION OUTSIDE THE UNITED STATES**

Since the rights granted by a U.S. patent extend only throughout the territory of the United States and have no effect in a foreign country, an inventor who wishes patent protection in another country must apply for a patent in a specific country or in regional patent offices. Applicants may wish to consider the filing of an international application under the Patent Cooperation Treaty (PCT). An international (PCT) application generally has the same effect as a regular national patent application in each PCT-member country. The PCT process **simplifies** the filing of patent applications on the same invention in member countries, but **does not result** in a grant of "an international patent" and does not eliminate the need of applicants to file additional documents and fees in countries where patent protection is desired.

Almost every country has its own patent law, and a person desiring a patent in a particular country must make an application for patent in that country in accordance with its particular laws. Since the laws of many countries differ in various respects from the patent law of the United States, applicants are advised to seek guidance from specific foreign countries to ensure that patent rights are not lost prematurely.

Applicants also are advised that in the case of inventions made in the United States, the Director of the USPTO must issue a license before applicants can apply for a patent in a foreign country. The filing of a U.S. patent application serves as a request for a foreign filing license. The application's filing receipt contains further information and guidance as to the status of applicant's license for foreign filing.

Applicants may wish to consult the USPTO booklet, "General Information Concerning Patents" (specifically, the section entitled "Treaties and Foreign Patents") for more information on timeframes and deadlines for filing foreign patent applications. The guide is available either by contacting the USPTO Contact Center at 800-786-9199, or it can be viewed on the USPTO website at <http://www.uspto.gov/web/offices/pac/doc/general/index.html>.

For information on preventing theft of your intellectual property (patents, trademarks and copyrights), you may wish to consult the U.S. Government website, <http://www.stopfakes.gov>. Part of a Department of Commerce initiative, this website includes self-help "toolkits" giving innovators guidance on how to protect intellectual property in specific countries such as China, Korea and Mexico. For questions regarding patent enforcement issues, applicants may call the U.S. Government hotline at 1-866-999-HALT (1-866-999-4258).

**LICENSE FOR FOREIGN FILING UNDER**  
**Title 35, United States Code, Section 184**  
**Title 37, Code of Federal Regulations, 5.11 & 5.15**

**GRANTED**

The applicant has been granted a license under 35 U.S.C. 184, if the phrase "IF REQUIRED, FOREIGN FILING LICENSE GRANTED" followed by a date appears on this form. Such licenses are issued in all applications where the conditions for issuance of a license have been met, regardless of whether or not a license may be required as set forth in 37 CFR 5.15. The scope and limitations of this license are set forth in 37 CFR 5.15(a) unless an earlier license has been issued under 37 CFR 5.15(b). The license is subject to revocation upon written notification. The date indicated is the effective date of the license, unless an earlier license of similar scope has been granted under 37 CFR 5.13 or 5.14.

This license is to be retained by the licensee and may be used at any time on or after the effective date thereof unless it is revoked. This license is automatically transferred to any related applications(s) filed under 37 CFR 1.53(d). This license is not retroactive.

The grant of a license does not in any way lessen the responsibility of a licensee for the security of the subject matter as imposed by any Government contract or the provisions of existing laws relating to espionage and the national security or the export of technical data. Licensees should apprise themselves of current regulations especially with respect to certain countries, of other agencies, particularly the Office of Defense Trade Controls, Department of State (with respect to Arms, Munitions and Implements of War (22 CFR 121-128)); the Bureau of Industry and Security, Department of Commerce (15 CFR parts 730-774); the Office of Foreign Assets Control, Department of Treasury (31 CFR Parts 500+) and the Department of Energy.

**NOT GRANTED**

No license under 35 U.S.C. 184 has been granted at this time, if the phrase "IF REQUIRED, FOREIGN FILING LICENSE GRANTED" DOES NOT appear on this form. Applicant may still petition for a license under 37 CFR 5.12, if a license is desired before the expiration of 6 months from the filing date of the application. If 6 months has lapsed from the filing date of this application and the licensee has not received any indication of a secrecy order under 35 U.S.C. 181, the licensee may foreign file the application pursuant to 37 CFR 5.15(b).

---

***SelectUSA***

The United States represents the largest, most dynamic marketplace in the world and is an unparalleled location for business investment, innovation, and commercialization of new technologies. The U.S. offers tremendous resources and advantages for those who invest and manufacture goods here. Through SelectUSA, our nation works to promote and facilitate business investment. SelectUSA provides information assistance to the international investor community; serves as an ombudsman for existing and potential investors; advocates on behalf of U.S. cities, states, and regions competing for global investment; and counsels U.S. economic development organizations on investment attraction best practices. To learn more about why the United States is the best country in the world to develop technology, manufacture products, deliver services, and grow your business, visit <http://www.SelectUSA.gov> or call +1-202-482-6800.

Docket No.: MAS.1007C1  
App. No.: 16/226,249

December 21, 2018  
Page 1 of 2

Please Direct All Correspondence to Customer Number 64735

---

**RESCISSION OF ANY PRIOR DISCLAIMERS AND REQUEST TO REVISIT ART**

First Inventor	: Ammar Al-Ali
App. No	: 16/226,249
Filed	: December 19, 2018
For	: ADVANCED PULSE OXIMETRY SENSOR
Examiner	: Unassigned
Art Unit	: Unassigned
Conf #	: 1002

Commissioner for Patents  
P.O. Box 1450  
Alexandria, VA 22313-1450

Dear Commissioner:

The claims of the present application are different and possibly broader in scope than the claims pursued in the parent application(s). To the extent any prior amendments or characterizations of the scope of any claim or referenced art could be construed as a disclaimer of any subject matter supported by the present disclosure, Applicant hereby rescinds and retracts such disclaimer. Accordingly, the references previously considered in the parent application(s) may need to be re-visited.

Please charge any additional fees, including any fees for additional extension of time, or credit overpayment to Deposit Account No. 11-1410.

Docket No.: MAS.1007C1  
App. No.: 16/226,249

December 21, 2018  
Page 2 of 2

Please Direct All Correspondence to Customer Number 64735

---

Respectfully submitted,

KNOBBE, MARTENS, OLSON & BEAR, LLP

Dated: December 21, 2018

By: /Aaron S. Johnson/  
Aaron S. Johnson  
Registration No. 74,164  
Registered Practitioner  
Customer No. 64735  
(949) 760-0404

## Electronic Acknowledgement Receipt

<b>EFS ID:</b>	34675367
<b>Application Number:</b>	16226249
<b>International Application Number:</b>	
<b>Confirmation Number:</b>	1002
<b>Title of Invention:</b>	ADVANCED PULSE OXIMETRY SENSOR
<b>First Named Inventor/Applicant Name:</b>	Ammar Al-Ali
<b>Customer Number:</b>	64735
<b>Filer:</b>	Aaron Samuel Johnson/Blake Morgan
<b>Filer Authorized By:</b>	Aaron Samuel Johnson
<b>Attorney Docket Number:</b>	MAS.1007C1
<b>Receipt Date:</b>	21-DEC-2018
<b>Filing Date:</b>	
<b>Time Stamp:</b>	15:53:03
<b>Application Type:</b>	Utility under 35 USC 111(a)

### Payment information:

Submitted with Payment	no
------------------------	----

### File Listing:

Document Number	Document Description	File Name	File Size(Bytes)/ Message Digest	Multi Part /.zip	Pages (if appl.)
1	Miscellaneous Incoming Letter	REQUEST-TO-REVISIT-ART_MAS1007C1.pdf	15830 a11f2536b3ecc61935d526687652bf37c6e11104	no	2

### Warnings:

<b>Information:</b>	
<b>Total Files Size (in bytes):</b>	15830
<p><b>This Acknowledgement Receipt evidences receipt on the noted date by the USPTO of the indicated documents, characterized by the applicant, and including page counts, where applicable. It serves as evidence of receipt similar to a Post Card, as described in MPEP 503.</b></p> <p><b><u>New Applications Under 35 U.S.C. 111</u></b>  <b>If a new application is being filed and the application includes the necessary components for a filing date (see 37 CFR 1.53(b)-(d) and MPEP 506), a Filing Receipt (37 CFR 1.54) will be issued in due course and the date shown on this Acknowledgement Receipt will establish the filing date of the application.</b></p> <p><b><u>National Stage of an International Application under 35 U.S.C. 371</u></b>  <b>If a timely submission to enter the national stage of an international application is compliant with the conditions of 35 U.S.C. 371 and other applicable requirements a Form PCT/DO/EO/903 indicating acceptance of the application as a national stage submission under 35 U.S.C. 371 will be issued in addition to the Filing Receipt, in due course.</b></p> <p><b><u>New International Application Filed with the USPTO as a Receiving Office</u></b>  <b>If a new international application is being filed and the international application includes the necessary components for an international filing date (see PCT Article 11 and MPEP 1810), a Notification of the International Application Number and of the International Filing Date (Form PCT/RO/105) will be issued in due course, subject to prescriptions concerning national security, and the date shown on this Acknowledgement Receipt will establish the international filing date of the application.</b></p>	

**IN THE UNITED STATES PATENT AND TRADEMARK OFFICE**

First Inventor	:	Ammar Al-Ali
App. No.	:	Unassigned
Filed	:	Filed herewith
For	:	ADVANCED PULSE OXIMETRY SENSOR
Examiner	:	Unassigned
Art Unit	:	Unassigned
Conf. No.	:	Unassigned

**PRELIMINARY AMENDMENT**

**Mail Stop Amendment**

Commissioner for Patents  
P.O. Box 1450  
Alexandria, VA 22313-1450

Dear Commissioner:

Prior to examination of the above-identified application, please enter the amendments set forth herein.

**Amendments to the Specification** begin on page 2 of this paper.

**Amendments to the Claims** are reflected in the listing of claims which begins on page 4 of this paper.

**Remarks** begin on page 9 of this paper.



<b>INFORMATION DISCLOSURE STATEMENT BY APPLICANT</b>	Application No.	Unassigned
	Filing Date	Filed herewith
	First Named Inventor	Ammar Al-Ali
	Art Unit	Unassigned
<i>(Multiple sheets used when necessary)</i>	Examiner	Unassigned
SHEET 1 OF 28	Attorney Docket No.	MAS.1007C1

<b>U.S. PATENT DOCUMENTS</b>					
Examiner Initials	Cite No.	Document Number <i>Number - Kind Code (if known)</i> Example: 1,234,567 B1	Publication Date MM-DD-YYYY	Name	Pages, Columns, Lines Where Relevant Passages or Relevant Figures Appear
	1	4,960,128	10/2/1990	Gordon et al.	
	2	4,964,408	10/23/1990	Hink et al.	
	3	5,041,187	8/20/1991	Hink et al.	
	4	5,069,213	12/3/1991	Polczynski	
	5	5,163,438	11/17/1992	Gordon et al.	
	6	5,319,355	6/7/1994	Russek	
	7	5,337,744	8/16/1994	Branigan	
	8	5,341,805	8/30/1994	Stavridi, et al.	
	9	5,377,676	1/3/1995	Vari, et al.	
	10	5,431,170	7/11/1995	Mathews	
	11	5,452,717	9/26/1995	Branigan et al.	
	12	5,456,252	10/10/1995	Vari, et al.	
	13	5,479,934	1/2/1996	Imran	
	14	5,482,036	1/9/1996	Diab et al.	
	15	5,490,505	2/13/1996	Diab et al.	
	16	5,494,043	2/27/1996	O'Sullivan et al.	
	17	5,533,511	7/9/1996	Kaspari et al.	
	18	5,534,851	7/9/1996	Russek	
	19	5,561,275	10/1/1996	Savage, et al.	
	20	5,562,002	10/8/1996	Lalin	
	21	5,590,649	1/7/1997	Caro et al.	
	22	5,602,924	2/11/1997	Durand et al.	
	23	5,632,272	5/27/1997	Diab et al.	
	24	5,638,816	6/17/1997	Kiani-Azarbayjany et al.	
	25	5,638,818	6/17/1997	Diab et al.	
	26	5,645,440	7/8/1997	Tobler et al.	
	27	5,685,299	11/11/1997	Diab et al.	
	28	5,743,262	4/28/1998	Lepper, Jr. et al.	
	29	5,758,644	6/2/1998	Diab et al.	

Examiner Signature	Date Considered
<p><b>*Examiner:</b> Initial if reference considered, whether or not citation is in conformance with MPEP 609. Draw line through citation if not in conformance and not considered. Include copy of this form with next communication to applicant.</p>	

T<sup>1</sup> - Place a check mark in this area when an English language Translation is attached.

<b>INFORMATION DISCLOSURE STATEMENT BY APPLICANT</b>	Application No.	Unassigned
	Filing Date	Filed herewith
	First Named Inventor	Ammar Al-Ali
	Art Unit	Unassigned
<i>(Multiple sheets used when necessary)</i>	Examiner	Unassigned
SHEET 2 OF 28	Attorney Docket No.	MAS.1007C1

<b>U.S. PATENT DOCUMENTS</b>					
Examiner Initials	Cite No.	Document Number <i>Number - Kind Code (if known)</i> Example: 1,234,567 B1	Publication Date MM-DD-YYYY	Name	Pages, Columns, Lines Where Relevant Passages or Relevant Figures Appear
	30	5,760,910	6/2/1998	Lepper, Jr. et al.	
	31	5,769,785	6/23/1998	Diab et al.	
	32	5,782,757	7/21/1998	Diab et al.	
	33	5,785,659	7/28/1998	Caro et al.	
	34	5,791,347	8/11/1998	Flaherty et al.	
	35	5,810,734	9/22/1998	Caro et al.	
	36	5,823,950	10/20/1998	Diab et al.	
	37	5,830,131	11/3/1998	Caro et al.	
	38	5,833,618	11/10/1998	Caro et al.	
	39	5,860,919	1/19/1999	Kiani-Azarbayjany et al.	
	40	5,890,929	4/6/1999	Mills et al.	
	41	5,904,654	5/18/1999	Wohltmann et al.	
	42	5,919,134	7/6/1999	Diab	
	43	5,934,925	8/10/1999	Tobler et al.	
	44	5,940,182	8/17/1999	Lepper, Jr. et al.	
	45	5,995,855	11/30/1999	Kiani et al.	
	46	5,997,343	12/7/1999	Mills et al.	
	47	6,002,952	12/14/1999	Diab et al.	
	48	6,011,986	1/4/2000	Diab et al.	
	49	6,027,452	2/22/2000	Flaherty et al.	
	50	6,036,642	3/14/2000	Diab et al.	
	51	6,045,509	4/4/2000	Caro et al.	
	52	6,067,462	5/23/2000	Diab et al.	
	53	6,081,735	6/27/2000	Diab et al.	
	54	6,088,607	7/11/2000	Diab et al.	
	55	6,110,522	8/29/2000	Lepper, Jr. et al.	
	56	6,124,597	9/26/2000	Shehada	
	57	6,128,521	10/3/2000	Marro et al.	
	58	6,129,675	10/10/2000	Jay	

Examiner Signature	Date Considered
<p><b>*Examiner:</b> Initial if reference considered, whether or not citation is in conformance with MPEP 609. Draw line through citation if not in conformance and not considered. Include copy of this form with next communication to applicant.</p>	

T<sup>1</sup> - Place a check mark in this area when an English language Translation is attached.

<b>INFORMATION DISCLOSURE STATEMENT BY APPLICANT</b>	Application No.	Unassigned
	Filing Date	Filed herewith
	First Named Inventor	Ammar Al-Ali
	Art Unit	Unassigned
<i>(Multiple sheets used when necessary)</i>	Examiner	Unassigned
SHEET 3 OF 28	Attorney Docket No.	MAS.1007C1

U.S. PATENT DOCUMENTS					
Examiner Initials	Cite No.	Document Number <i>Number - Kind Code (if known)</i> Example: 1,234,567 B1	Publication Date MM-DD-YYYY	Name	Pages, Columns, Lines Where Relevant Passages or Relevant Figures Appear
	59	6,144,868	11/7/2000	Parker	
	60	6,151,516	11/21/2000	Kiani-Azarbayjany et al.	
	61	6,152,754	11/28/2000	Gerhardt et al.	
	62	6,157,850	12/5/2000	Diab et al.	
	63	6,165,005	12/26/2000	Mills et al.	
	64	6,184,521	2/6/2001	Coffin, IV et al.	
	65	6,206,830	3/27/2001	Diab et al.	
	66	6,229,856	5/8/2001	Diab et al.	
	67	6,232,609	5/15/2001	Snyder, et al.	
	68	6,236,872	5/22/2001	Diab et al.	
	69	6,241,683	6/5/2001	Macklem, et al.	
	70	6,253,097	6/26/2001	Aronow et al.	
	71	6,256,523	7/3/2001	Diab et al.	
	72	6,263,222	7/17/2001	Diab et al.	
	73	6,278,522	8/21/2001	Lepper, Jr. et al.	
	74	6,280,213	8/28/2001	Tobler et al.	
	75	6,285,896	9/4/2001	Tobler et al.	
	76	6,301,493	10/9/2001	Marro et al.	
	77	6,317,627	11/13/2001	Ennen et al.	
	78	6,321,100	11/20/2001	Parker	
	79	6,325,761	12/4/2001	Jay	
	80	6,334,065	12/25/2001	Al-Ali et al.	
	81	6,343,224	1/29/2002	Parker	
	82	6,349,228	2/19/2002	Kiani et al.	
	83	6,360,114	3/19/2002	Diab et al.	
	84	6,368,283	4/9/2002	Xu, et al.	
	85	6,371,921	4/16/2002	Caro et al.	
	86	6,377,829	4/23/2002	Al-Ali	
	87	6,388,240	5/14/2002	Schulz et al.	

Examiner Signature	Date Considered
<p><b>*Examiner:</b> Initial if reference considered, whether or not citation is in conformance with MPEP 609. Draw line through citation if not in conformance and not considered. Include copy of this form with next communication to applicant.</p>	

T<sup>1</sup> - Place a check mark in this area when an English language Translation is attached.

<b>INFORMATION DISCLOSURE STATEMENT BY APPLICANT</b>	Application No.	Unassigned
	Filing Date	Filed herewith
	First Named Inventor	Ammar Al-Ali
	Art Unit	Unassigned
<i>(Multiple sheets used when necessary)</i>	Examiner	Unassigned
SHEET 4 OF 28	Attorney Docket No.	MAS.1007C1

<b>U.S. PATENT DOCUMENTS</b>					
Examiner Initials	Cite No.	Document Number <i>Number - Kind Code (if known)</i> Example: 1,234,567 B1	Publication Date MM-DD-YYYY	Name	Pages, Columns, Lines Where Relevant Passages or Relevant Figures Appear
	88	6,397,091	5/28/2002	Diab et al.	
	89	6,430,437	8/6/2002	Marro	
	90	6,430,525	8/6/2002	Weber et al.	
	91	6,463,311	10/8/2002	Diab	
	92	6,470,199	10/22/2002	Kopotic et al.	
	93	6,501,975	12/31/2002	Diab et al.	
	94	6,505,059	1/7/2003	Kollias, et al.	
	95	6,515,273	2/4/2003	Al-Ali	
	96	6,519,487	2/11/2003	Parker	
	97	6,525,386	2/25/2003	Mills et al.	
	98	6,526,300	2/25/2003	Kiani et al.	
	99	6,541,756	4/1/2003	Schulz et al.	
	100	6,542,764	4/1/2003	Al-Ali et al.	
	101	6,580,086	6/17/2003	Schulz et al.	
	102	6,584,336	6/24/2003	Ali et al.	
	103	6,595,316	7/22/2003	Cybulski et al.	
	104	6,597,932	7/22/2003	Tian et al.	
	105	6,597,933	7/22/2003	Kiani et al.	
	106	6,606,511	8/12/2003	Ali et al.	
	107	6,632,181	10/14/2003	Flaherty et al.	
	108	6,639,668	10/28/2003	Trepagnier, Pierre	
	109	6,640,116	10/28/2003	Diab	
	110	6,643,530	11/4/2003	Diab et al.	
	111	6,650,917	11/18/2003	Diab et al.	
	112	6,654,624	11/25/2003	Diab et al.	
	113	6,658,276	12/2/2003	Kiani et al.	
	114	6,661,161	12/9/2003	Lanzo et al.	
	115	6,671,531	12/30/2003	Al-Ali et al.	
	116	6,678,543	1/13/2004	Diab et al.	

Examiner Signature	Date Considered
<p><b>*Examiner:</b> Initial if reference considered, whether or not citation is in conformance with MPEP 609. Draw line through citation if not in conformance and not considered. Include copy of this form with next communication to applicant.</p>	

T<sup>1</sup> - Place a check mark in this area when an English language Translation is attached.

<b>INFORMATION DISCLOSURE STATEMENT BY APPLICANT</b>	Application No.	Unassigned
	Filing Date	Filed herewith
	First Named Inventor	Ammar Al-Ali
	Art Unit	Unassigned
<i>(Multiple sheets used when necessary)</i>	Examiner	Unassigned
SHEET 5 OF 28	Attorney Docket No.	MAS.1007C1

U.S. PATENT DOCUMENTS					
Examiner Initials	Cite No.	Document Number <i>Number - Kind Code (if known)</i> Example: 1,234,567 B1	Publication Date MM-DD-YYYY	Name	Pages, Columns, Lines Where Relevant Passages or Relevant Figures Appear
	117	6,684,090	1/27/2004	Ali et al.	
	118	6,684,091	1/27/2004	Parker	
	119	6,697,656	2/24/2004	Al-Ali	
	120	6,697,657	2/24/2004	Shehada, et al.	
	121	6,697,658	2/24/2004	Al-Ali	
	122	6,699,194	3/2/2004	Diab et al.	
	123	6,714,804	3/30/2004	Al-Ali et al.	
	124	6,721,582	4/13/2004	Trepagnier, et al.	
	125	6,721,585	4/13/2004	Parker	
	126	6,725,075	4/20/2004	Al-Ali	
	127	6,728,560	4/27/2004	Kollias, et al.	
	128	6,735,459	5/11/2004	Parker	
	129	6,745,060	6/1/2004	Diab et al.	
	130	6,760,607	7/6/2004	Al-Ali	
	131	6,770,028	8/3/2004	Ali et al.	
	132	6,771,994	8/3/2004	Kiani et al.	
	133	6,792,300	9/14/2004	Diab et al.	
	134	6,813,511	11/2/2004	Diab et al.	
	135	6,816,741	11/9/2004	Diab	
	136	6,822,564	11/23/2004	Al-Ali	
	137	6,826,419	11/30/2004	Diab et al.	
	138	6,830,711	12/14/2004	Mills et al.	
	139	6,850,787	2/1/2005	Weber et al.	
	140	6,850,788	2/1/2005	Al-Ali	
	141	6,852,083	2/8/2005	Caro et al.	
	142	6,861,639	3/1/2005	Al-Ali	
	143	6,898,452	5/24/2005	Al-Ali et al.	
	144	6,920,345	7/19/2005	Al-Ali et al.	
	145	6,931,268	8/16/2005	Kiani-Azarbayjany et al.	

Examiner Signature	Date Considered
<p><b>*Examiner:</b> Initial if reference considered, whether or not citation is in conformance with MPEP 609. Draw line through citation if not in conformance and not considered. Include copy of this form with next communication to applicant.</p>	

T<sup>1</sup> - Place a check mark in this area when an English language Translation is attached.

<b>INFORMATION DISCLOSURE STATEMENT BY APPLICANT</b>	Application No.	Unassigned
	Filing Date	Filed herewith
	First Named Inventor	Ammar Al-Ali
	Art Unit	Unassigned
<i>(Multiple sheets used when necessary)</i>	Examiner	Unassigned
SHEET 6 OF 28	Attorney Docket No.	MAS.1007C1

<b>U.S. PATENT DOCUMENTS</b>					
Examiner Initials	Cite No.	Document Number <i>Number - Kind Code (if known)</i> Example: 1,234,567 B1	Publication Date MM-DD-YYYY	Name	Pages, Columns, Lines Where Relevant Passages or Relevant Figures Appear
	146	6,934,570	8/23/2005	Kiani et al.	
	147	6,939,305	9/6/2005	Flaherty et al.	
	148	6,943,348	9/13/2005	Coffin IV	
	149	6,950,687	9/27/2005	Al-Ali	
	150	6,961,598	11/1/2005	Diab	
	151	6,970,792	11/29/2005	Diab	
	152	6,979,812	12/27/2005	Al-Ali	
	153	6,985,764	1/10/2006	Mason et al.	
	154	6,993,371	1/31/2006	Kiani et al.	
	155	6,996,427	2/7/2006	Ali et al.	
	156	6,999,904	2/14/2006	Weber et al.	
	157	7,003,338	2/21/2006	Weber et al.	
	158	7,003,339	2/21/2006	Diab et al.	
	159	7,015,451	3/21/2006	Dalke et al.	
	160	7,024,233	4/4/2006	Ali et al.	
	161	7,027,849	4/11/2006	Al-Ali	
	162	7,030,749	4/18/2006	Al-Ali	
	163	7,039,449	5/2/2006	Al-Ali	
	164	7,041,060	5/9/2006	Flaherty et al	
	165	7,044,918	5/16/2006	Diab	
	166	7,067,893	6/27/2006	Mills et al.	
	167	7,096,052	8/22/2006	Mason et al.	
	168	7,096,054	8/22/2006	Abdul-Hafiz et al.	
	169	7,132,641	11/7/2006	Schulz et al.	
	170	7,142,901	11/28/2006	Kiani et al.	
	171	7,149,561	12/12/2006	Diab	
	172	7,186,966	3/6/2007	Al-Ali	
	173	7,190,261	3/13/2007	Al-Ali	
	174	7,215,984	5/8/2007	Diab	

Examiner Signature	Date Considered
<p><b>*Examiner:</b> Initial if reference considered, whether or not citation is in conformance with MPEP 609. Draw line through citation if not in conformance and not considered. Include copy of this form with next communication to applicant.</p>	

T<sup>1</sup> - Place a check mark in this area when an English language Translation is attached.

<b>INFORMATION DISCLOSURE STATEMENT BY APPLICANT</b>	Application No.	Unassigned
	Filing Date	Filed herewith
	First Named Inventor	Ammar Al-Ali
	Art Unit	Unassigned
<i>(Multiple sheets used when necessary)</i>	Examiner	Unassigned
SHEET 7 OF 28	Attorney Docket No.	MAS.1007C1

<b>U.S. PATENT DOCUMENTS</b>					
Examiner Initials	Cite No.	Document Number <i>Number - Kind Code (if known)</i> Example: 1,234,567 B1	Publication Date MM-DD-YYYY	Name	Pages, Columns, Lines Where Relevant Passages or Relevant Figures Appear
	175	7,215,986	5/8/2007	Diab	
	176	7,221,971	5/22/2007	Diab	
	177	7,225,006	5/29/2007	Al-Ali et al.	
	178	7,225,007	5/29/2007	Al-Ali	
	179	7,239,905	7/3/2007	Kiani-Azarbayjany et al.	
	180	7,245,953	7/17/2007	Parker	
	181	7,254,429	8/7/2007	Schurman et al.	
	182	7,254,431	8/7/2007	Al-Ali	
	183	7,254,433	8/7/2007	Diab et al.	
	184	7,254,434	8/7/2007	Schulz et al.	
	185	7,272,425	9/18/2007	Al-Ali	
	186	7,274,955	9/25/2007	Kiani et al.	
	187	7,280,858	10/9/2007	Al-Ali et al.	
	188	7,289,835	10/30/2007	Mansfield et al.	
	189	7,292,883	11/6/2007	De Felice et al.	
	190	7,295,866	11/13/2007	Al-Ali	
	191	7,328,053	2/5/2008	Diab et al.	
	192	7,332,784	2/19/2008	Mills, et al.	
	193	7,340,287	3/4/2008	Mason et al.	
	194	7,341,559	3/11/2008	Schulz et al.	
	195	7,343,186	3/11/2008	Lamego et al.	
	196	7,355,512	4/8/2008	Al-Ali	
	197	7,356,365	4/8/2008	Schurman	
	198	7,371,981	5/13/2008	Abdul-Hafiz	
	199	7,373,193	5/13/2008	Al-Ali et al.	
	200	7,373,194	5/13/2008	Weber et al.	
	201	7,376,453	5/20/2008	Diab et al.	
	202	7,377,794	5/27/2008	Al Ali et al.	
	203	7,377,899	5/27/2008	Weber et al.	

Examiner Signature	Date Considered
<p><b>*Examiner:</b> Initial if reference considered, whether or not citation is in conformance with MPEP 609. Draw line through citation if not in conformance and not considered. Include copy of this form with next communication to applicant.</p>	

T<sup>1</sup> - Place a check mark in this area when an English language Translation is attached.

<b>INFORMATION DISCLOSURE STATEMENT BY APPLICANT</b>	Application No.	Unassigned
	Filing Date	Filed herewith
	First Named Inventor	Ammar Al-Ali
	Art Unit	Unassigned
<i>(Multiple sheets used when necessary)</i>	Examiner	Unassigned
SHEET 8 OF 28	Attorney Docket No.	MAS.1007C1

U.S. PATENT DOCUMENTS					
Examiner Initials	Cite No.	Document Number <i>Number - Kind Code (if known)</i> Example: 1,234,567 B1	Publication Date MM-DD-YYYY	Name	Pages, Columns, Lines Where Relevant Passages or Relevant Figures Appear
	204	7,383,070	6/3/2008	Diab et al.	
	205	7,415,297	8/19/2008	Al-Ali et al.	
	206	7,428,432	9/23/2008	Ali et al.	
	207	7,438,683	10/21/2008	Al-Ali et al.	
	208	7,440,787	10/21/2008	Diab	
	209	7,454,240	11/18/2008	Diab et al.	
	210	7,467,002	12/16/2008	Weber et al.	
	211	7,469,157	12/23/2008	Diab et al.	
	212	7,471,969	12/30/2008	Diab et al.	
	213	7,471,971	12/30/2008	Diab et al.	
	214	7,483,729	1/27/2009	Al-Ali et al.	
	215	7,483,730	1/27/2009	Diab et al.	
	216	7,489,958	2/10/2009	Diab et al.	
	217	7,496,391	2/24/2009	Diab et al.	
	218	7,496,393	2/24/2009	Diab et al.	
	219	7,499,741	3/3/2009	Diab et al.	
	220	7,499,835	3/3/2009	Weber et al.	
	221	7,500,950	3/10/2009	Al-Ali et al.	
	222	7,509,154	3/24/2009	Diab et al.	
	223	7,509,494	3/24/2009	Al-Ali	
	224	7,510,849	3/31/2009	Schurman et al.	
	225	7,519,327	4/14/2009	White	
	226	7,526,328	4/28/2009	Diab et al.	
	227	7,530,942	5/12/2009	Diab	
	228	7,530,949	5/12/2009	Al Ali et al.	
	229	7,530,955	5/12/2009	Diab et al.	
	230	7,563,110	7/21/2009	Al-Ali et al.	
	231	7,596,398	9/29/2009	Al-Ali et al.	
	232	7,601,123	10/13/2009	Tweed, et al.	

Examiner Signature	Date Considered
<p><b>*Examiner:</b> Initial if reference considered, whether or not citation is in conformance with MPEP 609. Draw line through citation if not in conformance and not considered. Include copy of this form with next communication to applicant.</p>	

T<sup>1</sup> - Place a check mark in this area when an English language Translation is attached.



<b>INFORMATION DISCLOSURE STATEMENT BY APPLICANT</b>	Application No.	Unassigned
	Filing Date	Filed herewith
	First Named Inventor	Ammar Al-Ali
	Art Unit	Unassigned
<i>(Multiple sheets used when necessary)</i>	Examiner	Unassigned
SHEET 9 OF 28	Attorney Docket No.	MAS.1007C1

<b>U.S. PATENT DOCUMENTS</b>					
Examiner Initials	Cite No.	Document Number <i>Number - Kind Code (if known)</i> Example: 1,234,567 B1	Publication Date MM-DD-YYYY	Name	Pages, Columns, Lines Where Relevant Passages or Relevant Figures Appear
	233	7,618,375	11/17/2009	Flaherty	
	234	7,647,083	1/12/2010	Al-Ali et al.	
	235	7,726,209	6/1/2010	Ruotoistenmäki	
	236	7,729,733	6/1/2010	Al-Ali et al.	
	237	7,734,320	6/8/2010	Al-Ali	
	238	7,761,127	7/20/2010	Al-Ali et al.	
	239	7,761,128	7/20/2010	Al-Ali et al.	
	240	7,764,982	7/27/2010	Dalke et al.	
	241	7,791,155	9/7/2010	Diab	
	242	7,801,581	9/21/2010	Diab	
	243	7,822,452	10/26/2010	Schurman et al.	
	244	7,844,313	11/30/2010	Kiani et al.	
	245	7,844,314	11/30/2010	Al-Ali	
	246	7,844,315	11/30/2010	Al-Ali	
	247	7,862,523	1/4/2011	Ruotoistenmaki	
	248	7,865,222	1/4/2011	Weber et al.	
	249	7,873,497	1/18/2011	Weber et al.	
	250	7,880,606	2/1/2011	Al-Ali	
	251	7,880,626	2/1/2011	Al-Ali et al.	
	252	7,891,355	2/22/2011	Al-Ali et al.	
	253	7,894,868	2/22/2011	Al-Ali et al.	
	254	7,899,507	3/1/2011	Al-Ali et al.	
	255	7,899,518	3/1/2011	Trepagnier et al.	
	256	7,904,132	3/8/2011	Weber et al.	
	257	7,909,772	3/22/2011	Popov et al.	
	258	7,910,875	3/22/2011	Al-Ali	
	259	7,919,713	4/5/2011	Al-Ali et al.	
	260	7,937,128	5/3/2011	Al-Ali	
	261	7,937,129	5/3/2011	Mason et al.	

Examiner Signature	Date Considered
<p><b>*Examiner:</b> Initial if reference considered, whether or not citation is in conformance with MPEP 609. Draw line through citation if not in conformance and not considered. Include copy of this form with next communication to applicant.</p>	

T<sup>1</sup> - Place a check mark in this area when an English language Translation is attached.

<b>INFORMATION DISCLOSURE STATEMENT BY APPLICANT</b>	Application No.	Unassigned
	Filing Date	Filed herewith
	First Named Inventor	Ammar Al-Ali
	Art Unit	Unassigned
<i>(Multiple sheets used when necessary)</i>	Examiner	Unassigned
SHEET 10 OF 28	Attorney Docket No.	MAS.1007C1

<b>U.S. PATENT DOCUMENTS</b>					
Examiner Initials	Cite No.	Document Number <i>Number - Kind Code (if known)</i> Example: 1,234,567 B1	Publication Date MM-DD-YYYY	Name	Pages, Columns, Lines Where Relevant Passages or Relevant Figures Appear
	262	7,937,130	5/3/2011	Diab et al.	
	263	7,941,199	5/10/2011	Kiani	
	264	7,951,086	5/31/2011	Flaherty et al.	
	265	7,957,780	6/7/2011	Lamego et al.	
	266	7,962,188	6/14/2011	Kiani et al.	
	267	7,962,190	6/14/2011	Diab et al.	
	268	7,976,472	7/12/2011	Kiani	
	269	7,988,637	8/2/2011	Diab	
	270	7,990,382	8/2/2011	Kiani	
	271	7,991,446	8/2/2011	Al-Ali et al.	
	272	8,000,761	8/16/2011	Al-Ali	
	273	8,008,088	8/30/2011	Bellott et al.	
	274	8,019,400	9/13/2011	Diab et al.	
	275	8,028,701	10/4/2011	Al-Ali et al.	
	276	8,029,765	10/4/2011	Bellott et al.	
	277	8,036,727	10/11/2011	Schurman et al.	
	278	8,036,728	10/11/2011	Diab et al.	
	279	8,046,040	10/25/2011	Ali et al.	
	280	8,046,041	10/25/2011	Diab et al.	
	281	8,046,042	10/25/2011	Diab et al.	
	282	8,048,040	11/1/2011	Kiani	
	283	8,050,728	11/1/2011	Al-Ali et al.	
	284	8,118,620	2/21/2012	Al-Ali et al.	
	285	8,126,528	2/28/2012	Diab et al.	
	286	8,128,572	3/6/2012	Diab et al.	
	287	8,130,105	3/6/2012	Al-Ali et al.	
	288	8,145,287	3/27/2012	Diab et al.	
	289	8,150,487	4/3/2012	Diab et al.	
	290	8,175,672	5/8/2012	Parker	

Examiner Signature	Date Considered
<p><b>*Examiner:</b> Initial if reference considered, whether or not citation is in conformance with MPEP 609. Draw line through citation if not in conformance and not considered. Include copy of this form with next communication to applicant.</p>	

T<sup>1</sup> - Place a check mark in this area when an English language Translation is attached.

<b>INFORMATION DISCLOSURE STATEMENT BY APPLICANT</b>	Application No.	Unassigned
	Filing Date	Filed herewith
	First Named Inventor	Ammar Al-Ali
	Art Unit	Unassigned
<i>(Multiple sheets used when necessary)</i>	Examiner	Unassigned
SHEET 11 OF 28	Attorney Docket No.	MAS.1007C1

U.S. PATENT DOCUMENTS					
Examiner Initials	Cite No.	Document Number <i>Number - Kind Code (if known)</i> Example: 1,234,567 B1	Publication Date MM-DD-YYYY	Name	Pages, Columns, Lines Where Relevant Passages or Relevant Figures Appear
	291	8,180,420	5/15/2012	Diab et al.	
	292	8,182,443	5/22/2012	Kiani	
	293	8,185,180	5/22/2012	Diab et al.	
	294	8,190,223	5/29/2012	Al-Ali et al.	
	295	8,190,227	5/29/2012	Diab et al.	
	296	8,203,438	6/19/2012	Kiani et al.	
	297	8,203,704	6/19/2012	Merritt et al.	
	298	8,204,566	6/19/2012	Schurman et al.	
	299	8,219,172	7/10/2012	Schurman et al.	
	300	8,224,411	7/17/2012	Al-Ali et al.	
	301	8,228,181	7/24/2012	Al-Ali	
	302	8,229,533	7/24/2012	Diab et al.	
	303	8,233,955	7/31/2012	Al-Ali et al.	
	304	8,244,325	8/14/2012	Al-Ali et al.	
	305	8,255,026	8/28/2012	Al-Ali	
	306	8,255,027	8/28/2012	Al-Ali et al.	
	307	8,255,028	8/28/2012	Al-Ali et al.	
	308	8,260,577	9/4/2012	Weber et al.	
	309	8,265,723	9/11/2012	McHale et al.	
	310	8,274,360	9/25/2012	Sampath et al.	
	311	8,289,130	10/16/2012	Nakajima et al.	
	312	8,301,217	10/30/2012	Al-Ali et al.	
	313	8,306,596	11/6/2012	Schurman et al.	
	314	8,310,336	11/13/2012	Muhsin et al.	
	315	8,315,683	11/20/2012	Al-Ali et al.	
	316	8,337,403	12/25/2012	Al-Ali et al.	
	317	8,346,330	1/1/2013	Lamego	
	318	8,353,842	1/15/2013	Al-Ali et al.	
	319	8,355,766	1/15/2013	MacNeish, III et al.	

Examiner Signature	Date Considered
<p><b>*Examiner:</b> Initial if reference considered, whether or not citation is in conformance with MPEP 609. Draw line through citation if not in conformance and not considered. Include copy of this form with next communication to applicant.</p>	

T<sup>1</sup> - Place a check mark in this area when an English language Translation is attached.

<b>INFORMATION DISCLOSURE STATEMENT BY APPLICANT</b>	Application No.	Unassigned
	Filing Date	Filed herewith
	First Named Inventor	Ammar Al-Ali
	Art Unit	Unassigned
<i>(Multiple sheets used when necessary)</i>	Examiner	Unassigned
SHEET 12 OF 28	Attorney Docket No.	MAS.1007C1

<b>U.S. PATENT DOCUMENTS</b>					
Examiner Initials	Cite No.	Document Number <i>Number - Kind Code (if known)</i> Example: 1,234,567 B1	Publication Date MM-DD-YYYY	Name	Pages, Columns, Lines Where Relevant Passages or Relevant Figures Appear
	320	8,359,080	1/22/2013	Diab et al.	
	321	8,364,223	1/29/2013	Al-Ali et al.	
	322	8,364,226	1/29/2013	Diab et al.	
	323	8,364,389	1/29/2013	Dorogusker et al.	
	324	8,374,665	2/12/2013	Lamego	
	325	8,385,995	2/26/2013	Al-ali et al.	
	326	8,385,996	2/26/2013	Smith et al.	
	327	8,388,353	3/5/2013	Kiani et la.	
	328	8,399,822	3/19/2013	Al-Ali	
	329	8,401,602	3/19/2013	Kiani	
	330	8,405,608	3/26/2013	Al-Ali et al.	
	331	8,414,499	4/9/2013	Al-Ali et al.	
	332	8,418,524	4/16/2013	Al-Ali	
	333	8,423,106	4/16/2013	Lamego et al.	
	334	8,428,967	4/23/2013	Olsen et al.	
	335	8,430,817	4/30/2013	Al-Ali et al.	
	336	8,437,825	5/7/2013	Dalvi et al.	
	337	8,455,290	6/4/2013	Siskavich	
	338	8,457,703	6/4/2013	Al-Ali	
	339	8,457,707	6/4/2013	Kiani	
	340	8,463,349	6/11/2013	Diab et al.	
	341	8,466,286	6/18/2013	Bellot et al.	
	342	8,471,713	6/25/2013	Poeze et al.	
	343	8,473,020	6/25/2013	Kiani et al.	
	344	8,483,787	7/9/2013	Al-Ali et al.	
	345	8,489,364	7/16/2013	Weber et al.	
	346	8,498,684	0730//2013	Weber et al.	
	347	8,504,128	8/6/2013	Blank et al.	
	348	8,509,867	8/13/2013	Workman et al.	

Examiner Signature	Date Considered
<p><b>*Examiner:</b> Initial if reference considered, whether or not citation is in conformance with MPEP 609. Draw line through citation if not in conformance and not considered. Include copy of this form with next communication to applicant.</p>	

T<sup>1</sup> - Place a check mark in this area when an English language Translation is attached.

<b>INFORMATION DISCLOSURE STATEMENT BY APPLICANT</b>	Application No.	Unassigned
	Filing Date	Filed herewith
	First Named Inventor	Ammar Al-Ali
	Art Unit	Unassigned
<i>(Multiple sheets used when necessary)</i>	Examiner	Unassigned
SHEET 13 OF 28	Attorney Docket No.	MAS.1007C1

<b>U.S. PATENT DOCUMENTS</b>					
Examiner Initials	Cite No.	Document Number <i>Number - Kind Code (if known)</i> Example: 1,234,567 B1	Publication Date MM-DD-YYYY	Name	Pages, Columns, Lines Where Relevant Passages or Relevant Figures Appear
	349	8,515,509	8/20/2013	Bruinsma et al.	
	350	8,523,781	9/3/2013	Al-Ali	
	351	8,529,301	9/10/2013	Al-Ali et al.	
	352	8,532,727	9/10/2013	Ali et al.	
	353	8,532,728	9/10/2013	Diab et al.	
	354	8,547,209	10/1/2013	Kiani et al.	
	355	8,548,548	10/1/2013	Al-Ali	
	356	8,548,549	10/1/2013	Schurman et al.	
	357	8,548,550	10/1/2013	Al-Ali et al.	
	358	8,560,032	10/15/2013	Al-Ali et al.	
	359	8,560,034	10/15/2013	Diab et al.	
	360	8,570,167	10/29/2013	Al-Ali	
	361	8,570,503	10/29/2013	Vo et al.	
	362	8,571,617	10/29/2013	Reichgott et al.	
	363	8,571,618	10/29/2013	Lamego et al.	
	364	8,571,619	10/29/2013	Al-Ali et al.	
	365	8,577,431	11/5/2013	Lamego et al.	
	366	8,581,732	11/12/2013	Al-Ali et al.	
	367	8,584,345	11/19/2013	Al-Ali et al.	
	368	8,588,880	11/19/2013	Abdul-Hafiz et al.	
	369	8,600,467	12/3/2013	Al-Ali et al.	
	370	8,606,342	12/10/2013	Diab	
	371	8,615,290	12/24/2013	Lin et al.	
	372	8,626,255	1/7/2014	Al-Ali et al.	
	373	8,630,691	1/14/2014	Lamego et al.	
	374	8,634,889	1/21/2014	Al-Ali et al.	
	375	8,641,631	2/4/2014	Sierra et al.	
	376	8,652,060	2/18/2014	Al-Ali	
	377	8,655,004	2/18/2014	Prest et al.	

Examiner Signature	Date Considered
<p><b>*Examiner:</b> Initial if reference considered, whether or not citation is in conformance with MPEP 609. Draw line through citation if not in conformance and not considered. Include copy of this form with next communication to applicant.</p>	

T<sup>1</sup> - Place a check mark in this area when an English language Translation is attached.

<b>INFORMATION DISCLOSURE STATEMENT BY APPLICANT</b>	Application No.	Unassigned
	Filing Date	Filed herewith
	First Named Inventor	Ammar Al-Ali
	Art Unit	Unassigned
<i>(Multiple sheets used when necessary)</i>	Examiner	Unassigned
SHEET 14 OF 28	Attorney Docket No.	MAS.1007C1

<b>U.S. PATENT DOCUMENTS</b>					
Examiner Initials	Cite No.	Document Number <i>Number - Kind Code (if known)</i> Example: 1,234,567 B1	Publication Date MM-DD-YYYY	Name	Pages, Columns, Lines Where Relevant Passages or Relevant Figures Appear
	378	8,663,107	3/4/2014	Kiani	
	379	8,666,468	3/4/2014	Al-Ali	
	380	8,667,967	3/11/2014	Al- Ali et al.	
	381	8,670,811	3/11/2014	O'Reilly	
	382	8,670,814	3/11/2014	Diab et al.	
	383	8,676,286	3/18/2014	Weber et al.	
	384	8,682,407	3/25/2014	Al-Ali	
	385	8,690,799	4/8/2014	Telfort et al.	
	386	8,700,112	4/15/2014	Kiani	
	387	8,702,627	4/22/2014	Telfort et al.	
	388	8,706,179	4/22/2014	Parker	
	389	8,712,494	4/29/2014	MacNeish, III et al.	
	390	8,715,206	5/6/2014	Telfort et al.	
	391	8,718,735	5/6/2014	Lamego et al.	
	392	8,718,737	5/6/2014	Diab et al.	
	393	8,718,738	5/6/2014	Blank et al.	
	394	8,720,249	5/13/2014	Al-Ali	
	395	8,721,541	5/13/2014	Al-Ali et al.	
	396	8,721,542	5/13/2014	Al-Ali et al.	
	397	8,723,677	5/13/2014	Kiani	
	398	8,740,792	6/3/2014	Kiani et al.	
	399	8,754,776	6/17/2014	Poeze et al.	
	400	8,755,535	6/17/2014	Telfort et al.	
	401	8,755,856	6/17/2014	Diab et al.	
	402	8,755,872	6/17/2014	Marinow	
	403	8,760,517	6/24/2014	Sarwar et al.	
	404	8,761,850	6/24/2014	Lamego	
	405	8,764,671	7/1/2014	Kiani	
	406	8,768,423	7/1/2014	Shakespeare et al.	

Examiner Signature	Date Considered
<p><b>*Examiner:</b> Initial if reference considered, whether or not citation is in conformance with MPEP 609. Draw line through citation if not in conformance and not considered. Include copy of this form with next communication to applicant.</p>	

T<sup>1</sup> - Place a check mark in this area when an English language Translation is attached.

<b>INFORMATION DISCLOSURE STATEMENT BY APPLICANT</b>	Application No.	Unassigned
	Filing Date	Filed herewith
	First Named Inventor	Ammar Al-Ali
	Art Unit	Unassigned
<i>(Multiple sheets used when necessary)</i>	Examiner	Unassigned
SHEET 15 OF 28	Attorney Docket No.	MAS.1007C1

U.S. PATENT DOCUMENTS					
Examiner Initials	Cite No.	Document Number <i>Number - Kind Code (if known)</i> Example: 1,234,567 B1	Publication Date MM-DD-YYYY	Name	Pages, Columns, Lines Where Relevant Passages or Relevant Figures Appear
	407	8,771,204	7/8/2014	Telfort et al.	
	408	8,777,634	7/15/2014	Kiani et al.	
	409	8,781,543	7/15/2014	Diab et al.	
	410	8,781,544	7/15/2014	Al-Ali et al.	
	411	8,781,549	7/15/2014	Al-Ali et al.	
	412	8,788,003	7/22/2014	Schurman et al.	
	413	8,790,268	7/29/2014	Al-Ali	
	414	8,801,613	8/12/2014	Al-Ali et al.	
	415	8,821,397	9/2/2014	Al-Ali et al.	
	416	8,821,415	9/2/2014	Al-Ali et al.	
	417	8,830,449	9/9/2014	Lamego et al.	
	418	8,831,700	9/9/2014	Schurman et al.	
	419	8,840,549	9/23/2014	Al-Ali et al.	
	420	8,845,543	9/30/2014	Diab et al.	
	421	8,847,740	9/30/2014	Kiani et al.	
	422	8,849,365	9/30/2014	Smith et al.	
	423	8,852,094	10/7/2014	Al-Ali et al.	
	424	8,852,994	10/7/2014	Wojtczuk et al.	
	425	8,868,147	10/21/2014	Stippick et al.	
	426	8,868,150	10/21/2014	Al-Ali et al.	
	427	8,870,792	10/28/2014	Al-Ali et al.	
	428	8,886,271	11/11/2014	Kiani et al.	
	429	8,888,539	11/18/2014	Al-Ali et al.	
	430	8,888,708	11/18/2014	Diab et al.	
	431	8,892,180	11/18/2014	Weber et al.	
	432	8,897,847	11/25/2014	Al-Ali	
	433	8,909,310	12/9/2014	Lamego et al.	
	434	8,911,377	12/16/2014	Al-Ali	
	435	8,912,909	12/16/2014	Al-Ali et al.	

Examiner Signature	Date Considered
<p><b>*Examiner:</b> Initial if reference considered, whether or not citation is in conformance with MPEP 609. Draw line through citation if not in conformance and not considered. Include copy of this form with next communication to applicant.</p>	

T<sup>1</sup> - Place a check mark in this area when an English language Translation is attached.

<b>INFORMATION DISCLOSURE STATEMENT BY APPLICANT</b>	Application No.	Unassigned
	Filing Date	Filed herewith
	First Named Inventor	Ammar Al-Ali
	Art Unit	Unassigned
<i>(Multiple sheets used when necessary)</i>	Examiner	Unassigned
SHEET 16 OF 28	Attorney Docket No.	MAS.1007C1

<b>U.S. PATENT DOCUMENTS</b>					
Examiner Initials	Cite No.	Document Number <i>Number - Kind Code (if known)</i> Example: 1,234,567 B1	Publication Date MM-DD-YYYY	Name	Pages, Columns, Lines Where Relevant Passages or Relevant Figures Appear
	436	8,920,317	12/30/2014	Al-Ali et al.	
	437	8,921,699	12/30/2014	Al-Ali et al.	
	438	8,922,382	12/30/2014	Al-Ali et al.	
	439	8,929,964	1/6/2015	Al-Ali et al.	
	440	8,942,777	1/27/2015	Diab et al.	
	441	8,948,834	2/3/2015	Diab et al.	
	442	8,948,835	2/3/2015	Diab	
	443	8,965,471	2/24/2015	Lamego	
	444	8,983,564	3/17/2015	Al-Ali	
	445	8,989,831	3/24/2015	Al-Ali et al.	
	446	8,996,085	3/31/2015	Kiani et al.	
	447	8,998,809	4/7/2015	Kiani	
	448	9,028,429	5/12/2015	Telfort et al.	
	449	9,037,207	5/19/2015	Al-Ali et al.	
	450	9,060,721	6/23/2015	Reichgott et al.	
	451	9,066,666	6/30/2015	Kiani	
	452	9,066,680	6/30/2015	Al-Ali et al.	
	453	9,072,437	7/7/2015	Paalasmaa	
	454	9,072,474	7/7/2015	Al-Ali et al.	
	455	9,078,560	7/14/2015	Schurman et al.	
	456	9,081,889	7/14/2015	Ingrassia, Jr. et al.	
	457	9,084,569	7/21/2015	Weber et al.	
	458	9,095,316	8/4/2015	Welch et al.	
	459	9,106,038	8/11/2015	Telfort et al.	
	460	9,107,625	8/18/2015	Telfort et al.	
	461	9,107,626	8/18/2015	Al-Ali et al.	
	462	9,113,831	8/25/2015	Al-Ali	
	463	9,113,832	8/25/2015	Al-Ali	
	464	9,119,595	9/1/2015	Lamego	

Examiner Signature	Date Considered
<p><b>*Examiner:</b> Initial if reference considered, whether or not citation is in conformance with MPEP 609. Draw line through citation if not in conformance and not considered. Include copy of this form with next communication to applicant.</p>	

T<sup>1</sup> - Place a check mark in this area when an English language Translation is attached.



<b>INFORMATION DISCLOSURE STATEMENT BY APPLICANT</b>	Application No.	Unassigned
	Filing Date	Filed herewith
	First Named Inventor	Ammar Al-Ali
	Art Unit	Unassigned
<i>(Multiple sheets used when necessary)</i>	Examiner	Unassigned
SHEET 17 OF 28	Attorney Docket No.	MAS.1007C1

<b>U.S. PATENT DOCUMENTS</b>					
Examiner Initials	Cite No.	Document Number <i>Number - Kind Code (if known)</i> Example: 1,234,567 B1	Publication Date MM-DD-YYYY	Name	Pages, Columns, Lines Where Relevant Passages or Relevant Figures Appear
	465	9,131,881	9/15/2015	Diab et al.	
	466	9,131,882	9/15/2015	Al-Ali et al.	
	467	9,131,883	9/15/2015	Al-Ali	
	468	9,131,917	9/15/2015	Telfort et al.	
	469	9,138,180	9/22/2015	Coverston et al.	
	470	9,138,182	9/22/2015	Al-Ali et al.	
	471	9,138,192	9/22/2015	Weber et al.	
	472	9,142,117	9/22/2015	Muhsin et al.	
	473	9,153,112	10/6/2015	Kiani et al.	
	474	9,153,121	10/6/2015	Kiani et al.	
	475	9,161,696	10/20/2015	Al-Ali et al.	
	476	9,161,713	10/20/2015	Al-Ali et al.	
	477	9,167,995	10/27/2015	Lamego et al.	
	478	9,176,141	11/3/2015	Al-Ali et al.	
	479	9,186,102	11/17/2015	Bruinsma et al.	
	480	9,192,312	11/24/2015	Al-Ali	
	481	9,192,329	11/24/2015	Al-Ali	
	482	9,192,351	11/24/2015	Telfort et al.	
	483	9,195,385	11/24/2015	Al-Ali et al.	
	484	9,210,566	12/8/2015	Ziemianska et al.	
	485	9,211,072	12/15/2015	Kiani	
	486	9,211,095	12/15/2015	Al-Ali	
	487	9,218,454	12/22/2015	Kiani et al.	
	488	9,226,696	1/5/2016	Kiani	
	489	9,241,662	1/26/2016	Al-Ali et al.	
	490	9,245,668	1/26/2016	Vo et al.	
	491	9,259,185	2/16/2016	Abdul-Hafiz et al.	
	492	9,267,572	2/23/2016	Barker et al.	
	493	9,277,880	3/8/2016	Poeze et al.	

Examiner Signature	Date Considered
<p><b>*Examiner:</b> Initial if reference considered, whether or not citation is in conformance with MPEP 609. Draw line through citation if not in conformance and not considered. Include copy of this form with next communication to applicant.</p>	

T<sup>1</sup> - Place a check mark in this area when an English language Translation is attached.

<b>INFORMATION DISCLOSURE STATEMENT BY APPLICANT</b>	Application No.	Unassigned
	Filing Date	Filed herewith
	First Named Inventor	Ammar Al-Ali
	Art Unit	Unassigned
<i>(Multiple sheets used when necessary)</i>	Examiner	Unassigned
SHEET 18 OF 28	Attorney Docket No.	MAS.1007C1

<b>U.S. PATENT DOCUMENTS</b>					
Examiner Initials	Cite No.	Document Number <i>Number - Kind Code (if known)</i> Example: 1,234,567 B1	Publication Date MM-DD-YYYY	Name	Pages, Columns, Lines Where Relevant Passages or Relevant Figures Appear
	494	9,289,167	3/22/2016	Diab et al.	
	495	9,295,421	3/29/2016	Kiani et al.	
	496	9,307,928	4/12/2016	Al-Ali et al.	
	497	9,311,382	4/12/2016	Varoglu et al.	
	498	9,323,894	4/26/2016	Kiani	
	499	9,326,712	5/3/2016	Kiani	
	500	9,333,316	5/10/2016	Kiani	
	501	9,339,220	5/17/2016	Lamego et al.	
	502	9,341,565	5/17/2016	Lamego et al.	
	503	9,351,673	5/31/2016	Diab et al.	
	504	9,351,675	5/31/2016	Al-Ali et al.	
	505	9,357,665	5/31/2016	Myers et al.	
	506	9,489,081	11/8/2016	Anzures et al.	
	507	9,497,534	11/15/2016	Prest et al.	
	508	9,526,430	12/27/2016	Srinivas et al.	
	509	9,553,625	1/24/2017	Hatanaka et al.	
	510	9,593,969	3/14/2017	King	
	511	9,651,405	5/16/2017	Gowreesunker et al.	
	512	9,668,676	6/6/2017	Culbert	
	513	9,699,546	7/4/2017	Qian et al.	
	514	9,716,937	7/25/2017	Qian et al.	
	515	9,723,997	8/8/2017	Lamego	
	516	9,781,984	10/10/2017	Baranski et al.	
	517	9,838,775	12/5/2017	Qian et al.	
	518	9,848,823	12/26/2017	Raghuram et al.	
	519	9,866,671	1/9/2018	Thompson et al.	
	520	9,867,575	1/16/2018	Maani et al.	
	521	9,898,049	2/20/2018	Myers et al.	
	522	9,918,646	3/20/2018	Singh Alvarado et al.	

Examiner Signature	Date Considered
<p><b>*Examiner:</b> Initial if reference considered, whether or not citation is in conformance with MPEP 609. Draw line through citation if not in conformance and not considered. Include copy of this form with next communication to applicant.</p>	

T<sup>1</sup> - Place a check mark in this area when an English language Translation is attached.

<b>INFORMATION DISCLOSURE STATEMENT BY APPLICANT</b>	Application No.	Unassigned
	Filing Date	Filed herewith
	First Named Inventor	Ammar Al-Ali
	Art Unit	Unassigned
<i>(Multiple sheets used when necessary)</i>	Examiner	Unassigned
SHEET 19 OF 28	Attorney Docket No.	MAS.1007C1

U.S. PATENT DOCUMENTS					
Examiner Initials	Cite No.	Document Number <i>Number - Kind Code (if known)</i> Example: 1,234,567 B1	Publication Date MM-DD-YYYY	Name	Pages, Columns, Lines Where Relevant Passages or Relevant Figures Appear
	523	9,952,095	4/24/2018	Hotelling et al.	
	524	10,039,080	7/31/2018	Miller et al.	
	525	10,055,121	8/21/2018	Chaudhri et al.	
	526	10,066,970	9/4/2018	Gowreesunker et al.	
	527	10,076,257	9/18/2018	Lin et al.	
	528	10,078,052	9/18/2018	Ness et al.	
	529	6,671,526 B1	12/30/2003	Aoyagi et al.	
	530	D353,195	12/6/1994	Savage, et al.	
	531	D353,196	12/6/1994	Savage, et al.	
	532	D359,546	6/20/1995	Savage, et al.	
	533	D361,840	8/29/1995	Savage, et al.	
	534	D362,063	9/5/1995	Savage, et al.	
	535	D363,120	10/10/1995	Savage, et al.	
	536	D393,830	4/28/1998	Tobler et al.	
	537	D554,263	10/30/2007	Al-Ali	
	538	D566,282	4/8/2008	Al-Ali et al.	
	539	D587,657	3/3/2009	Al-Ali et al.	
	540	D606,659	12/22/2009	Kiani et al.	
	541	D609,193	2/2/2010	Al-Ali et al.	
	542	D614,305	4/20/2010	Al-Ali et al.	
	543	D621,516	8/10/2010	Kiani et al.	
	544	D692,145	10/22/2013	Al-Ali et al.	
	545	D755,392	5/3/2016	Hwang et al.	
	546	RE38,476	3/30/2004	Diab et al.	
	547	RE38,492	4/6/2004	Diab et al.	
	548	RE39,672	6/5/2007	Shehada et al.	
	549	RE41,317	5/4/2010	Parker	
	550	RE41,912	11/2/2010	Parker	
	551	RE42,753	9/27/2011	Kiani-Azarbayjany et al.	

Examiner Signature	Date Considered
<p><b>*Examiner:</b> Initial if reference considered, whether or not citation is in conformance with MPEP 609. Draw line through citation if not in conformance and not considered. Include copy of this form with next communication to applicant.</p>	

T<sup>1</sup> - Place a check mark in this area when an English language Translation is attached.

<b>INFORMATION DISCLOSURE STATEMENT BY APPLICANT</b>	Application No.	Unassigned
	Filing Date	Filed herewith
	First Named Inventor	Ammar Al-Ali
	Art Unit	Unassigned
<i>(Multiple sheets used when necessary)</i>	Examiner	Unassigned
SHEET 20 OF 28	Attorney Docket No.	MAS.1007C1

<b>U.S. PATENT DOCUMENTS</b>					
Examiner Initials	Cite No.	Document Number <i>Number - Kind Code (if known)</i> Example: 1,234,567 B1	Publication Date MM-DD-YYYY	Name	Pages, Columns, Lines Where Relevant Passages or Relevant Figures Appear
	552	RE43,169	2/7/2012	Parker	
	553	RE43,860	12/11/2012	Parker	
	554	RE44,823	4/1/2014	Parker	
	555	RE44,875	4/29/2014	Kiani et al.	
	556	2005/0277819	12/15/2005	Kiani et al.	
	557	2007/0282478	12/6/2007	Al-Ali et al.	
	558	2008/0030468	2/7/2008	Al-Ali et al.	
	559	2009/0247984	10/1/2009	Lamego et al.	
	560	2009/0275813	11/5/2009	Davis	
	561	2009/0275844	11/5/2009	Al-Ali	
	562	2010/0004518	1/7/2010	Vo et al.	
	563	2010/0030040	2/4/2010	Poeze et al.	
	564	2011/0082711	4/7/2011	Poeze et al.	
	565	2011/0105854	5/5/2011	Kiani et al.	
	566	2011/0125060	5/26/2011	Telfort et al.	
	567	2011/0208015	8/25/2011	Welch et al.	
	568	2011/0213212	9/1/2011	Al-Ali	
	569	2011/0230733	9/22/2011	Al-Ali	
	570	2011/0237969	9/29/2011	Eckerbom et al.	
	571	2011/0288383	11/24/2011	Diab	
	572	2011/0301444	12/8/2011	Al-Ali	
	573	2012/0041316	2/16/2012	Al-Ali et al.	
	574	2012/0046557	2/23/2012	Kiani	
	575	2012/0059267	3/8/2012	Lamego et al.	
	576	2012/0088984	4/12/2012	Al-Ali et al.	
	577	2012/0165629	6/28/2012	Merritt et al.	
	578	2012/0179006	7/12/2012	Jansen et al.	
	579	2012/0209082	8/16/2012	Al-Ali	
	580	2012/0209084	8/16/2012	Olsen et al.	

Examiner Signature	Date Considered
<p><b>*Examiner:</b> Initial if reference considered, whether or not citation is in conformance with MPEP 609. Draw line through citation if not in conformance and not considered. Include copy of this form with next communication to applicant.</p>	

T<sup>1</sup> - Place a check mark in this area when an English language Translation is attached.

<b>INFORMATION DISCLOSURE STATEMENT BY APPLICANT</b>	Application No.	Unassigned
	Filing Date	Filed herewith
	First Named Inventor	Ammar Al-Ali
	Art Unit	Unassigned
<i>(Multiple sheets used when necessary)</i>	Examiner	Unassigned
SHEET 21 OF 28	Attorney Docket No.	MAS.1007C1

U.S. PATENT DOCUMENTS					
Examiner Initials	Cite No.	Document Number <i>Number - Kind Code (if known)</i> Example: 1,234,567 B1	Publication Date MM-DD-YYYY	Name	Pages, Columns, Lines Where Relevant Passages or Relevant Figures Appear
	581	2012/0283524	11/8/2012	Kiani et al.	
	582	2012/0296178	11/22/2012	Lamego et al.	
	583	2012/0319816	12/20/2012	Al-Ali	
	584	2012/0330112	12/27/2012	Lamego et al.	
	585	2013/0006076	1/3/2013	McHale	
	586	2013/0023775	1/24/2013	Lamego et al.	
	587	2013/0041591	2/14/2013	Lamego	
	588	2013/0046204	2/21/2013	Lamego et al.	
	589	2013/0060147	3/7/2013	Welch et al.	
	590	2013/0096405	4/18/2013	Garfio	
	591	2013/0096936	4/18/2013	Sampath et al.	
	592	2013/0190581	7/25/2013	Al-Ali et al.	
	593	2013/0211214	8/15/2013	Olsen	
	594	2013/0243021	9/19/2013	Siskavich	
	595	2013/0253334	9/26/2013	Al-Ali et al.	
	596	2013/0262730	10/3/2013	Al-Ali et al.	
	597	2013/0267804	10/10/2013	Al-Ali	
	598	2013/0274572	10/17/2013	Al-Ali et al.	
	599	2013/0296672	11/7/2013	O'Neil et al.	
	600	2013/0296713	11/7/2013	Al-Ali et al.	
	601	2013/0317370	11/28/2013	Dalvi et al.	
	602	2013/0324808	12/5/2013	Al-Ali et al.	
	603	2013/0331660	12/12/2013	Al-Ali et al.	
	604	2013/0331670	12/12/2013	Kiani	
	605	2014/0012100	1/9/2014	Al-Ali et al.	
	606	2014/0034353	2/6/2014	Al-Ali et al.	
	607	2014/0051953	2/20/2014	Lamego et al.	
	608	2014/0066783	3/6/2014	Kiani et al.	
	609	2014/0077956	3/20/2014	Sampath et al.	

Examiner Signature	Date Considered
<p><b>*Examiner:</b> Initial if reference considered, whether or not citation is in conformance with MPEP 609. Draw line through citation if not in conformance and not considered. Include copy of this form with next communication to applicant.</p>	

T<sup>1</sup> - Place a check mark in this area when an English language Translation is attached.

<b>INFORMATION DISCLOSURE STATEMENT BY APPLICANT</b>	Application No.	Unassigned
	Filing Date	Filed herewith
	First Named Inventor	Ammar Al-Ali
	Art Unit	Unassigned
<i>(Multiple sheets used when necessary)</i>	Examiner	Unassigned
SHEET 22 OF 28	Attorney Docket No.	MAS.1007C1

<b>U.S. PATENT DOCUMENTS</b>					
Examiner Initials	Cite No.	Document Number <i>Number - Kind Code (if known)</i> Example: 1,234,567 B1	Publication Date MM-DD-YYYY	Name	Pages, Columns, Lines Where Relevant Passages or Relevant Figures Appear
	610	2014/0081100	3/20/2014	Muhsin et al.	
	611	2014/0081175	3/20/2014	Telfort	
	612	2014/0094667	4/3/2014	Schurman et al.	
	613	2014/0100434	4/10/2014	Diab et al.	
	614	2014/0114199	4/24/2014	Lamego et al.	
	615	2014/0120564	5/1/2014	Workman et al.	
	616	2014/0121482	5/1/2014	Merritt et al.	
	617	2014/0121483	5/1/2014	Kiani	
	618	2014/0127137	5/8/2014	Bellott et al.	
	619	2014/0129702	5/8/2014	Lamego et al.	
	620	2014/0135588	5/15/2014	Al-Ali et al.	
	621	2014/0142401	5/22/2014	Al-Ali et al.	
	622	2014/0163344	6/12/2014	Al-Ali	
	623	2014/0163402	6/12/2014	Lamego et al.	
	624	2014/0166076	6/19/2014	Kiani et al.	
	625	2014/0171146	6/19/2014	Ma et al.	
	626	2014/0171763	6/19/2014	Diab	
	627	2014/0180038	6/26/2014	Kiani	
	628	2014/0180154	6/26/2014	Sierra et al.	
	629	2014/0180160	6/26/2014	Brown et al.	
	630	2014/0187973	7/3/2014	Brown et al.	
	631	2014/0194766	7/10/2014	Al-Ali et al.	
	632	2014/0206963	7/24/2014	Al-Ali	
	633	2014/0213864	7/31/2014	Abdul-Hafiz et al.	
	634	2014/0266790	9/18/2014	Al-Ali et al.	
	635	2014/0275808	9/18/2014	Poeze et al.	
	636	2014/0275835	9/18/2014	Lamego et al.	
	637	2014/0275871	9/18/2014	Lamego et al.	
	638	2014/0275872	9/18/2014	Merritt et al.	

Examiner Signature	Date Considered
<p><b>*Examiner:</b> Initial if reference considered, whether or not citation is in conformance with MPEP 609. Draw line through citation if not in conformance and not considered. Include copy of this form with next communication to applicant.</p>	

T<sup>1</sup> - Place a check mark in this area when an English language Translation is attached.

<b>INFORMATION DISCLOSURE STATEMENT BY APPLICANT</b>	Application No.	Unassigned
	Filing Date	Filed herewith
	First Named Inventor	Ammar Al-Ali
	Art Unit	Unassigned
<i>(Multiple sheets used when necessary)</i>	Examiner	Unassigned
SHEET 23 OF 28	Attorney Docket No.	MAS.1007C1

U.S. PATENT DOCUMENTS					
Examiner Initials	Cite No.	Document Number <i>Number - Kind Code (if known)</i> Example: 1,234,567 B1	Publication Date MM-DD-YYYY	Name	Pages, Columns, Lines Where Relevant Passages or Relevant Figures Appear
	639	2014/0275881	9/18/2014	Lamego et al.	
	640	2014/0276115	9/18/2014	Dalvi et al.	
	641	2014/0288400	9/25/2014	Diab et al.	
	642	2014/0303520	10/9/2014	Telfort et al.	
	643	2014/0316217	10/23/2014	Purdon et al.	
	644	2014/0316218	10/23/2014	Purdon et al.	
	645	2014/0316228	10/23/2014	Blank et al.	
	646	2014/0323825	10/30/2014	Al-Ali et al.	
	647	2014/0323897	10/30/2014	Brown et al.	
	648	2014/0323898	10/30/2014	Purdon et al.	
	649	2014/0330092	11/6/2014	Al-Ali et al.	
	650	2014/0330098	11/6/2014	Merritt et al.	
	651	2014/0330099	11/6/2014	Al-Ali et al.	
	652	2014/0336481	11/13/2014	Shakespeare et al.	
	653	2014/0357966	12/4/2014	Al-Ali et al.	
	654	2014/0371548	12/28/2014	Al-Ali et al.	
	655	2014/0371632	12/18/2014	Al-Ali et al.	
	656	2014/0378784	12/25/2014	Kiani et al.	
	657	2015/0005600	1/1/2015	Blank et al.	
	658	2015/0011907	1/8/2015	Purdon et al.	
	659	2015/0012231	1/8/2015	Poeze et al.	
	660	2015/0018650	1/15/2015	Al-Ali et al.	
	661	2015/0025406	1/22/2015	Al-Ali	
	662	2015/0032029	1/29/2015	Al-Ali et al.	
	663	2015/0038859	2/5/2015	Dalvi et al.	
	664	2015/0045637	2/12/2015	Dalvi	
	665	2015/0045685	2/12/2015	Al-Ali et al.	
	666	2015/0051462	2/19/2015	Olsen	
	667	2015/0080754	3/19/2015	Purdon et al.	

Examiner Signature	Date Considered
<p><b>*Examiner:</b> Initial if reference considered, whether or not citation is in conformance with MPEP 609. Draw line through citation if not in conformance and not considered. Include copy of this form with next communication to applicant.</p>	

T<sup>1</sup> - Place a check mark in this area when an English language Translation is attached.

<b>INFORMATION DISCLOSURE STATEMENT BY APPLICANT</b>	Application No.	Unassigned
	Filing Date	Filed herewith
	First Named Inventor	Ammar Al-Ali
	Art Unit	Unassigned
<i>(Multiple sheets used when necessary)</i>	Examiner	Unassigned
SHEET 24 OF 28	Attorney Docket No.	MAS.1007C1

U.S. PATENT DOCUMENTS					
Examiner Initials	Cite No.	Document Number <i>Number - Kind Code (if known)</i> Example: 1,234,567 B1	Publication Date MM-DD-YYYY	Name	Pages, Columns, Lines Where Relevant Passages or Relevant Figures Appear
	668	2015/0087936	3/26/2015	Al-Ali et al.	
	669	2015/0094546	4/2/2015	Al-Ali	
	670	2015/0097701	4/9/2015	Al-Ali et al.	
	671	2015/0099324	4/9/2015	Wojtczuk et al.	
	672	2015/0099950	4/9/2015	Al-Ali et al.	
	673	2015/0099951	4/9/2015	Al-Ali et al.	
	674	2015/0099955	4/9/2015	Al-Ali et al.	
	675	2015/0101844	4/16/2015	Al-Ali et al.	
	676	2015/0106121	4/16/2015	Muhsin et al.	
	677	2015/0112151	4/23/2015	Muhsin et al.	
	678	2015/0116076	4/30/2015	Al-Ali et al.	
	679	2015/0126830	5/7/2015	Schurman et al.	
	680	2015/0133755	5/14/2015	Smith et al.	
	681	2015/0140863	5/21/2015	Al-Ali et al.	
	682	2015/0141781	5/21/2015	Weber et al.	
	683	2015/0165312	6/18/2015	Kiani	
	684	2015/0173671	6/25/2015	Paalasmaa et al.	
	685	2015/0196237	7/16/2015	Lamego	
	686	2015/0201874	7/23/2015	Diab	
	687	2015/0208966	7/30/2015	Al-Ali	
	688	2015/0216459	8/6/2015	Al-Ali et al.	
	689	2015/0230755	8/20/2015	Al-Ali et al.	
	690	2015/0238722	8/27/2015	Al-Ali	
	691	2015/0245773	9/3/2015	Lamego et al.	
	692	2015/0245793	9/2/2015	Al-Ali et al.	
	693	2015/0245794	9/3/2015	Al-Ali	
	694	2015/0255001	9/10/2015	Haughav et al.	
	695	2015/0257689	9/17/2015	Al-Ali et al.	
	696	2015/0272514	10/1/2015	Kiani et al.	

Examiner Signature	Date Considered
<p><b>*Examiner:</b> Initial if reference considered, whether or not citation is in conformance with MPEP 609. Draw line through citation if not in conformance and not considered. Include copy of this form with next communication to applicant.</p>	

T<sup>1</sup> - Place a check mark in this area when an English language Translation is attached.



<b>INFORMATION DISCLOSURE STATEMENT BY APPLICANT</b>	Application No.	Unassigned
	Filing Date	Filed herewith
	First Named Inventor	Ammar Al-Ali
	Art Unit	Unassigned
<i>(Multiple sheets used when necessary)</i>	Examiner	Unassigned
SHEET 25 OF 28	Attorney Docket No.	MAS.1007C1

<b>U.S. PATENT DOCUMENTS</b>					
Examiner Initials	Cite No.	Document Number <i>Number - Kind Code (if known)</i> Example: 1,234,567 B1	Publication Date MM-DD-YYYY	Name	Pages, Columns, Lines Where Relevant Passages or Relevant Figures Appear
	697	2015/0281424	10/1/2015	Vock et al.	
	698	2015/0318100	11/5/2015	Rothkopf et al.	
	699	2015/0351697	12/10/2015	Weber et al.	
	700	2015/0351704	12/20/2015	Kiani et al.	
	701	2015/0359429	12/17/2015	Al-Ali et al.	
	702	2015/0366472	12/24/2015	Kiani	
	703	2015/0366507	12/24/2015	Blank	
	704	2015/0374298	12/31/2015	Al-Ali et al.	
	705	2015/0380875	12/31/2015	Coverston et al.	
	706	2016/0000362	1/7/2016	Diab et al.	
	707	2016/0007930	1/14/2016	Weber et al.	
	708	2016/0019360	1/21/2016	PAHWA et al.	
	709	2016/0023245	1/28/2016	Zadesky et al.	
	710	2016/0029932	2/4/2016	Al-Ali	
	711	2016/0029933	2/4/2016	Al-Ali et al.	
	712	2016/0038045	2/11/2016	Shapiro	
	713	2016/0045118	2/18/2016	Kiani	
	714	2016/0051157	2/25/2016	Waydo	
	715	2016/0051158	2/25/2016	Silva	
	716	2016/0051205	2/25/2016	Al-Ali et al.	
	717	2016/0058302	3/3/2016	Raghuram et al.	
	718	2016/0058309	3/3/2016	Han	
	719	2016/0058312	3/3/2016	Han et al.	
	720	2016/0058338	3/3/2016	Schurman et al.	
	721	2016/0058347	3/3/2016	Reichgott et al.	
	722	2016/0058356	3/3/2016	RAGHURAM et al.	
	723	2016/0058370	3/3/2016	RAGHURAM et al.	
	724	2016/0066823	3/10/2016	Kind et al.	
	725	2016/0066824	3/10/2016	Al-Ali et al.	

Examiner Signature	Date Considered
<p><b>*Examiner:</b> Initial if reference considered, whether or not citation is in conformance with MPEP 609. Draw line through citation if not in conformance and not considered. Include copy of this form with next communication to applicant.</p>	

T<sup>1</sup> - Place a check mark in this area when an English language Translation is attached.

<b>INFORMATION DISCLOSURE STATEMENT BY APPLICANT</b>	Application No.	Unassigned
	Filing Date	Filed herewith
	First Named Inventor	Ammar Al-Ali
	Art Unit	Unassigned
<i>(Multiple sheets used when necessary)</i>	Examiner	Unassigned
SHEET 26 OF 28	Attorney Docket No.	MAS.1007C1

U.S. PATENT DOCUMENTS					
Examiner Initials	Cite No.	Document Number <i>Number - Kind Code (if known)</i> Example: 1,234,567 B1	Publication Date MM-DD-YYYY	Name	Pages, Columns, Lines Where Relevant Passages or Relevant Figures Appear
	726	2016/0066879	3/10/2016	Telfort et al.	
	727	2016/0071392	3/10/2016	Hankey et al.	
	728	2016/0072429	3/10/2016	Kiani et al.	
	729	2016/0073967	3/17/2016	Lamego et al.	
	730	2016/0081552	3/24/2016	Wojtczuk et al.	
	731	2016/0095543	4/7/2016	Telfort et al.	
	732	2016/0095548	4/7/2016	Al-Ali et al.	
	733	2016/0103598	4/14/2016	Al-Ali et al.	
	734	2016/0113527	4/28/2016	Al-Ali et al.	
	735	2016/0143548	5/26/2016	Al-Ali	
	736	2016/0154950	6/2/2016	NAKAJIMA et al.	
	737	2016/0157780	6/9/2016	RIMMINEN et al.	
	738	2016/0213309	7/28/2016	SANNHOLM et al.	
	739	2016/0256058	9/8/2016	Pham et al.	
	740	2016/0256082	9/8/2016	Ely et al.	
	741	2016/0267238	9/15/2016	Nag	
	742	2016/0287181	10/6/2016	Han et al.	
	743	2016/0296173	10/13/2016	Culbert	
	744	2016/0296174	10/13/2016	Isikman et al.	
	745	2016/0310027	10/27/2016	Han	
	746	2016/0378069	12/29/2016	Rothkopf	
	747	2016/0378071	12/29/2016	Rothkopf	
	748	2017/0007183	1/12/2017	Dusan et al.	
	749	2017/0010858	1/12/2017	Prest et al.	
	750	2017/0074897	3/16/2017	Mermel et al.	
	751	2017/0084133	3/23/2017	Cardinali et al.	
	752	2017/0086689	3/30/2017	Shui et al.	
	753	2017/0086742	3/30/2017	Harrison-Noonan et al.	
	754	2017/0086743	3/30/2017	Bushnell et al.	

Examiner Signature	Date Considered
<p><b>*Examiner:</b> Initial if reference considered, whether or not citation is in conformance with MPEP 609. Draw line through citation if not in conformance and not considered. Include copy of this form with next communication to applicant.</p>	

T<sup>1</sup> - Place a check mark in this area when an English language Translation is attached.

<b>INFORMATION DISCLOSURE STATEMENT BY APPLICANT</b>	Application No.	Unassigned
	Filing Date	Filed herewith
	First Named Inventor	Ammar Al-Ali
	Art Unit	Unassigned
<i>(Multiple sheets used when necessary)</i>	Examiner	Unassigned
SHEET 27 OF 28	Attorney Docket No.	MAS.1007C1

<b>U.S. PATENT DOCUMENTS</b>					
Examiner Initials	Cite No.	Document Number <i>Number - Kind Code (if known)</i> Example: 1,234,567 B1	Publication Date MM-DD-YYYY	Name	Pages, Columns, Lines Where Relevant Passages or Relevant Figures Appear
	755	2017/0094450	3/30/2017	Tu et al.	
	756	2017/0164884	6/15/2017	Culbert et al.	
	757	2017/0248446	8/31/2017	Gowreesunker et al.	
	758	2017/0273619	9/28/2017	Alvarado et al.	
	759	2017/0281024	10/5/2017	Narasimhan et al.	
	760	2017/0293727	10/12/2017	Klaassen et al.	
	761	2017/0325698	11/16/2017	Allec et al.	
	762	2017/0325744	11/16/2017	Allec et al.	
	763	2017/0340209	11/30/2017	Klaassen et al.	
	764	2017/0340219	11/30/2017	Sullivan et al.	
	765	2017/0347885	12/7/2017	Tan et al.	
	766	2017/0354332	12/14/2017	Lamego	
	767	2017/0354795	12/14/2017	BLAHNIK et al.	
	768	2017/0358239	12/14/2017	Arney et al.	
	769	2017/0358240	12/14/2017	Blahnik et al.	
	770	2017/0358242	12/14/2017	Thompson et al.	
	771	2017/0360306	12/14/2017	Narasimhan et al.	
	772	2017/0366657	12/21/2017	Thompson et al.	
	773	2018/0014781	1/18/2018	Clavelle et al.	
	774	2018/0025287	1/25/2018	Mathew et al.	
	775	2018/0042556	2/15/2018	SHAHPARNIA et al.	
	776	2018/0049694	2/22/2018	Singh Alvarado et al.	
	777	2018/0050235	2/22/2018	Tan et al.	
	778	2018/0055375	3/1/2018	MARTINEZ et al.	
	779	2018/0055439	3/1/2018	Pham et al.	
	780	2018/0056129	1/1/2018	NARASIMHA RAO et al.	
	781	2018/0078151	3/22/2018	ALLEC et al.	
	782	2018/0078182	3/22/2018	CHEN et al.	
	783	2018/0110469	4/26/2018	MAANI et al.	

Examiner Signature	Date Considered
<p><b>*Examiner:</b> Initial if reference considered, whether or not citation is in conformance with MPEP 609. Draw line through citation if not in conformance and not considered. Include copy of this form with next communication to applicant.</p>	

T<sup>1</sup> - Place a check mark in this area when an English language Translation is attached.

<b>INFORMATION DISCLOSURE STATEMENT BY APPLICANT</b>	Application No.	Unassigned
	Filing Date	Filed herewith
	First Named Inventor	Ammar Al-Ali
	Art Unit	Unassigned
<i>(Multiple sheets used when necessary)</i>	Examiner	Unassigned
SHEET 28 OF 28	Attorney Docket No.	MAS.1007C1

**U.S. PATENT DOCUMENTS**

Examiner Initials	Cite No.	Document Number <i>Number - Kind Code (if known)</i> Example: 1,234,567 B1	Publication Date MM-DD-YYYY	Name	Pages, Columns, Lines Where Relevant Passages or Relevant Figures Appear
	784	2018/0153418	6/7/2018	SULLIVAN et al.	
	785	2018/0164853	6/14/2018	Myers et al.	
	786	2018/0196514	7/12/2018	ALLEC et al.	
	787	2018/0228414	8/16/2018	SHAO et al.	
	788	2018/0238734	8/23/2018	Hotelling et al.	
	789	2018/0279956	10/4/2018	WAYDO et al.	

**FOREIGN PATENT DOCUMENTS**

Examiner Initials	Cite No.	Foreign Patent Document <i>Country Code-Number-Kind Code</i> Example: JP 1234567 A1	Publication Date MM-DD-YYYY	Name	Pages, Columns, Lines Where Relevant Passages or Relevant Figures Appear	T <sup>1</sup>
	790	EP 0781527 A1	7/2/1997	INSTRUMENTARIUM OY		
	791	EP 2277440 A1	1/26/2011	PIONEER CORP		

**NON PATENT LITERATURE DOCUMENTS**

Examiner Initials	Cite No.	Include name of the author (in CAPITAL LETTERS), title of the article (when appropriate), title of the item (book, magazine, journal, serial, symposium, catalog, etc.), date, page(s), volume-issue number(s), publisher, city and/or country where published.	T <sup>1</sup>
	792	Written Opinion received in International Application No. PCT/US2016/040190, dated January 2, 2018.	

29627927

Examiner Signature	Date Considered
*Examiner: Initial if reference considered, whether or not citation is in conformance with MPEP 609. Draw line through citation if not in conformance and not considered. Include copy of this form with next communication to applicant.	

T<sup>1</sup> - Place a check mark in this area when an English language Translation is attached.

---

**INFORMATION DISCLOSURE STATEMENT**

First Inventor :	Ammar Al-Ali
App. No. :	Unassigned
Filed :	Filed herewith
For :	ADVANCED PULSE OXIMETRY SENSOR
Examiner :	Unassigned
Art Unit :	Unassigned
Conf. No. :	Unassigned

---

Commissioner for Patents  
P.O. Box 1450  
Alexandria, VA 22313-1450

**References and Listing**

Pursuant to 37 CFR 1.56, an Information Disclosure Statement listing references is provided herewith. Listed references are of record in U.S. patent application No. 15/195199, filed June 28, 2016, which is the parent of this Utility application, and is relied upon for an earlier filing date under 35 USC 120. Copies of the references are not submitted pursuant to 37 CFR 1.98(d).

**No Disclaimers**

To the extent that anything in the Information Disclosure Statement or the listed references could be construed as a disclaimer of any subject matter supported by the present application, Applicant hereby rescinds and retracts such disclaimer.

**Timing of Disclosure**

This Information Disclosure Statement is being filed within three months of the filing date or date of national phase entry, with an RCE or before receipt of a First Office Action after an RCE, and no fee is believed to be required.

**Application No.: Unassigned**  
**Filing Date: Filed herewith**

The Commissioner is hereby authorized to charge any additional fees which may be required, or credit any overpayment, to Account No. 11-1410.

Respectfully submitted,  
KNOBBE, MARTENS, OLSON & BEAR, LLP

Dated: December 19, 2018

By: /Aaron S. Johnson/  
Aaron S. Johnson  
Registration No. 74,164  
Registered Practitioner  
Customer No. 64735  
(949) 760-0404

29628280

**ADVANCED PULSE OXIMETRY SENSOR**

INCORPORATION BY REFERENCE TO ANY PRIORITY APPLICATIONS

**[0001]** The present application is a continuation of U.S. Patent Application No. 15/195,199 filed June 28, 2016, which claims priority benefit under 35 U.S.C. § 119(e) from U.S. Provisional Application No. 62/188,430, filed July 2, 2015, entitled “Advanced Pulse Oximetry Sensor,” which is incorporated by reference herein. Any and all applications for which a foreign or domestic priority claim is identified in the Application Data Sheet as filed with the present application are hereby incorporated by reference under 37 CFR 1.57.

FIELD OF THE DISCLOSURE

**[0002]** The present disclosure relates to the field of non-invasive optical-based physiological monitoring sensors, and more particularly to systems, devices and methods for improving the non-invasive measurement accuracy of oxygen saturation, among other physiological parameters.

BACKGROUND

**[0003]** Spectroscopy is a common technique for measuring the concentration of organic and some inorganic constituents of a solution. The theoretical basis of this technique is the Beer-Lambert law, which states that the concentration  $c_i$  of an absorbent in solution can be determined by the intensity of light transmitted through the solution, knowing the pathlength  $d_\lambda$ , the intensity of the incident light  $I_{o,\lambda}$ , and the extinction coefficient  $\epsilon_{i,\lambda}$  at a particular wavelength  $\lambda$ .

**[0004]** In generalized form, the Beer-Lambert law is expressed as:

$$I_\lambda = I_{o,\lambda} e^{-d_\lambda \cdot \mu_{a,\lambda}} \tag{1}$$

$$\mu_{a,\lambda} = \sum_{i=1}^n \epsilon_{i,\lambda} \cdot c_i \tag{2}$$

### *Marked-Up Specification*

where  $\mu_{\alpha,\lambda}$  is the bulk absorption coefficient and represents the probability of absorption per unit length. The minimum number of discrete wavelengths that are required to solve equations 1 and 2 is the number of significant absorbers that are present in the solution.

**[0005]** A practical application of this technique is pulse oximetry, which utilizes a noninvasive sensor to measure oxygen saturation and pulse rate, among other physiological parameters. Pulse oximetry relies on a sensor attached externally to the patient to output signals indicative of various physiological parameters, such as a patient's blood constituents and/or analytes, including for example a percent value for arterial oxygen saturation, among other physiological parameters. The sensor has an emitter that transmits optical radiation of one or more wavelengths into a tissue site and a detector that responds to the intensity of the optical radiation after absorption by pulsatile arterial blood flowing within the tissue site. Based upon this response, a processor determines the relative concentrations of oxygenated hemoglobin (HbO<sub>2</sub>) and deoxygenated hemoglobin (Hb) in the blood so as to derive oxygen saturation, which can provide early detection of potentially hazardous decreases in a patient's oxygen supply.

**[0006]** A pulse oximetry system generally includes a patient monitor, a communications medium such as a cable, and/or a physiological sensor having one or more light emitters and a detector, such as one or more light-emitting diodes (LEDs) and a photodetector. The sensor is attached to a tissue site, such as a finger, toe, earlobe, nose, hand, foot, or other site having pulsatile blood flow which can be penetrated by light from the one or more emitters. The detector is responsive to the emitted light after attenuation or reflection by pulsatile blood flowing in the tissue site. The detector outputs a detector signal to the monitor over the communication medium. The monitor processes the signal to provide a numerical readout of physiological parameters such as oxygen saturation (SpO<sub>2</sub>) and/or pulse rate. A pulse oximetry sensor is described in U.S. Patent No. 6,088,607 entitled *Low Noise Optical Probe*; pulse oximetry signal processing is described in U.S. Patent Nos. 6,650,917 and 6,699,194 entitled *Signal Processing Apparatus* and *Signal Processing Apparatus and Method*, respectively; a pulse oximeter monitor is



*Marked-Up Specification*

described in U.S. Patent No. 6,584,336 entitled *Universal/Upgrading Pulse Oximeter*, all of which are assigned to Masimo Corporation, Irvine, CA, and each is incorporated by reference herein in its entirety.

**[0007]** There are many sources of measurement error introduced to pulse oximetry systems. Some such sources of error include the pulse oximetry system's electronic components, including emitters and detectors, as well as chemical and structural physiological differences between patients. Another source of measurement error is the effect of multiple scattering of photons as the photons pass through the patient's tissue (arterial blood) and arrive at the sensor's light detector.

#### SUMMARY

**[0008]** This disclosure describes embodiments of non-invasive methods, devices, and systems for measuring blood constituents, analytes, and/or substances such as, by way of non-limiting example, oxygen, carboxyhemoglobin, methemoglobin, total hemoglobin, glucose, proteins, lipids, a percentage thereof (*e.g.*, saturation), pulse rate, perfusion index, oxygen content, total hemoglobin, Oxygen Reserve Index™ (ORI™) or for measuring many other physiologically relevant patient characteristics. These characteristics can relate to, for example, pulse rate, hydration, trending information and analysis, and the like.

**[0009]** In an embodiment, an optical physiological measurement system includes an emitter configured to emit light of one or more wavelengths. The system also includes a diffuser configured to receive the emitted light, to spread the received light, and to emit the spread light over a larger tissue area than would otherwise be penetrated by the emitter directly emitting light at a tissue measurement site. The tissue measurement site can include, such as, for example, a finger, a wrist, or the like. The system further includes a concentrator configured to receive the spread light after it has been attenuated by or reflected from the tissue measurement site. The concentrator is also configured to collect and concentrate the received light and to emit the concentrated light to a detector. The detector is configured to detect the concentrated light and to transmit a signal indicative of the

*Marked-Up Specification*

detected light. The system also includes a processor configured to receive the transmitted signal indicative of the detected light and to determine, based on an amount of absorption, an analyte of interest, such as, for example, arterial oxygen saturation or other parameter, in the tissue measurement site.

**[0010]** In certain embodiments of the present disclosure, the diffuser comprises glass, ground glass, glass beads, opal glass, or a microlens-based, band-limited, engineered diffuser that can deliver efficient and uniform illumination. In some embodiments the diffuser is further configured to define a surface area shape by which the emitted spread light is distributed onto a surface of the tissue measurement site. The defined surface area shape can include, by way of non-limiting example, a shape that is substantially rectangular, square, circular, oval, or annular, among others.

**[0011]** According to some embodiments, the optical physiological measurement system includes an optical filter having a light-absorbing surface that faces the tissue measurement site. The optical filter also has an opening that is configured to allow the spread light, after being attenuated by the tissue measurement site, to be received by the concentrator. In an embodiment, the opening has dimensions, wherein the dimensions of the opening are similar to the defined surface area shape by which the emitted spread light is distributed onto the surface of the tissue measurement site. In an embodiment, the opening has dimensions that are larger than the defined surface area shape by which the emitted spread light is distributed onto the surface of the tissue measurement site. In other embodiments, the dimensions of the opening in the optical filter are not the same as the diffuser opening, but the dimensions are larger than the detector package.

**[0012]** In other embodiments of the present disclosure, the concentrator comprises glass, ground glass, glass beads, opal glass, or a compound parabolic concentrator. In some embodiments the concentrator comprises a cylindrical structure having a truncated circular conical structure on top. The truncated section is adjacent the detector. The light concentrator is structured to receive the emitted optical radiation, after reflection by the tissue measurement site, and to direct the reflected light to the detector.

*Marked-Up Specification*

**[0013]** In accordance with certain embodiments of the present disclosure, the processor is configured to determine an average level of the light detected by the detector. The average level of light is used to determine a physiological parameter in the tissue measurement site.

**[0014]** According to another embodiment, a method to determine a constituent or analyte in a patient's blood is disclosed. The method includes emitting, from an emitter, light of at least one wavelength; spreading, with a diffuser, the emitted light and emitting the spread light from the diffuser to a tissue measurement site; receiving, by a concentrator, the spread light after the spread light has been attenuated by the tissue measurement site; concentrating, by the concentrator, the received light and emitting the concentrated light from the concentrator to a detector; detecting, with the detector, the emitted concentrated light; transmitting, from the detector, a signal responsive to the detected light; receiving, by a processor, the transmitted signal responsive to the detected light; and processing, by the processor, the received signal responsive to the detected light to determine a physiological parameter.

**[0015]** In some embodiments, the method to determine a constituent or analyte in a patient's blood includes filtering, with a light-absorbing detector filter, scattered portions of the emitted spread light. According to an embodiment, the light-absorbing detector filter is substantially rectangular in shape and has outer dimensions in the range of approximately 1-5 cm in width and approximately 2-8 cm in length, and has an opening through which emitted light may pass, the opening having dimensions in the range of approximately 0.25-3 cm in width and approximately 1-7 cm in length. In another embodiment, the light-absorbing detector filter is substantially square in shape and has outer dimensions in the range of approximately 0.25-10 cm<sup>2</sup>, and has an opening through which emitted light may pass, the opening having dimensions in the range of approximately 0.1-8cm<sup>2</sup>. In yet another embodiment, the light-absorbing detector filter is substantially rectangular in shape and has outer dimensions of approximately 3 cm in width and approximately 6 cm in length, and has an opening through which emitted light may pass, the

*Marked-Up Specification*

opening having dimensions of approximately 1.5 cm in width and approximately 4 cm in length.

**[0016]** In still other embodiments of the method to determine a constituent or analyte in a patient's blood, spreading, with a diffuser, the emitted light and emitting the spread light from the diffuser to a tissue measurement site is performed by at least one of a glass diffuser, a ground glass diffuser, a glass bead diffuser, an opal glass diffuser, and an engineered diffuser. In some embodiments the emitted spread light is emitted with a substantially uniform intensity profile. And in some embodiments, emitting the spread light from the diffuser to the tissue measurement site includes spreading the emitted light so as to define a surface area shape by which the emitted spread light is distributed onto a surface of the tissue measurement site.

**[0017]** According to yet another embodiment, a pulse oximeter is disclosed. The pulse oximeter includes an emitter configured to emit light at one or more wavelengths. The pulse oximeter also includes a diffuser configured to receive the emitted light, to spread the received light, and to emit the spread light directed at a tissue measurement sight. The pulse oximeter also includes a detector configured to detect the emitted spread light after being attenuated by or reflected from the tissue measurement site and to transmit a signal indicative of the detected light. The pulse oximeter also includes a processor configured to receive the transmitted signal and to process the received signal to determine an average absorbance of a blood constituent or analyte in the tissue measurement site over a larger measurement site area than can be performed with a point light source or point detector. In some embodiments, the diffuser is further configured to define a surface area shape by which the emitted spread light is distributed onto a surface of the tissue measurement site, and the detector is further configured to have a detection area corresponding to the defined surface area shape by which the emitted spread light is distributed onto the surface of the tissue measurement site. According to some embodiments, the detector comprises an array of detectors configured to cover the detection area. In still other embodiments, the processor is further configured to determine an average of the detected light.

**[0018]** For purposes of summarizing, certain aspects, advantages and novel features of the disclosure have been described herein. It is to be understood that not necessarily all such advantages can be achieved in accordance with any particular embodiment of the systems, devices and/or methods disclosed herein. Thus, the subject matter of the disclosure herein can be embodied or carried out in a manner that achieves or optimizes one advantage or group of advantages as taught herein without necessarily achieving other advantages as can be taught or suggested herein.

#### BRIEF DESCRIPTION OF THE DRAWINGS

**[0019]** Throughout the drawings, reference numbers can be re-used to indicate correspondence between referenced elements. The drawings are provided to illustrate embodiments of the disclosure described herein and not to limit the scope thereof.

**[0020]** FIG. 1 illustrates a conventional approach to ~~[[2D]]-two-dimensional~~ pulse oximetry in which the emitter is configured to emit optical radiation as a point optical source.

**[0021]** FIG. 2 illustrates the disclosed ~~[[3D]]-three-dimensional~~ approach to pulse oximetry in which the emitted light irradiates a substantially larger volume of tissue as compared to the point source approach described with respect to FIG. 2A ~~FIG. 1~~.

**[0022]** FIG. 3 illustrates schematically a side view of a ~~[[3D]]-three-dimensional~~ pulse oximetry sensor according to an embodiment of the present disclosure.

**[0023]** FIG. 4A is a top view of a portion of a ~~[[3D]]-three-dimensional~~ pulse oximetry sensor according to an embodiment of the present disclosure.

**[0024]** FIG. 4B illustrates the top view of a portion of the ~~[[3D]]-three-dimensional~~ pulse oximetry sensor shown in FIG. 4A, with the addition of a tissue measurement site in operational position.

**[0025]** FIG. 5 illustrates a top view of a ~~[[3D]]-three-dimensional~~ pulse oximetry sensor according to an embodiment of the present disclosure.

**[0026]** FIG. 6 illustrates a conventional [[2D]]-two-dimensional approach to reflective pulse oximetry in which the emitter is configured to emit optical radiation as a point optical source.

**[0027]** FIG. 7A is a simplified schematic side view illustration of a reflective [[3D]]-three-dimensional pulse oximetry sensor according to an embodiment of the present disclosure.

**[0028]** FIG. 7B is a simplified schematic top view illustration of the [[3D]] three-dimensional reflective pulse oximetry sensor of FIG. 7A.

**[0029]** FIG. 8 illustrates a block diagram of an example pulse oximetry system capable of noninvasively measuring one or more blood analytes in a monitored patient, according to an embodiment of the disclosure.

#### DETAILED DESCRIPTION

**[0030]** FIG. 1 illustrates schematically a conventional pulse oximetry sensor having a two-dimensional (2D) approach to pulse oximetry. As illustrated, the emitter 104 is configured to emit optical radiation as a point optical source, *i.e.*, an optical radiation source that has negligible dimensions such that it may be considered as a point. This approach is referred to herein as “two-dimensional” pulse oximetry because it applies a two-dimensional analytical model to the three-dimensional space of the tissue measurement site 102 of the patient. Point optical sources feature a defined, freely selectable, and homogeneous light beam area. Light beams emitted from LED point sources often exhibit a strong focus which can produce a usually sharply-defined and evenly-lit illuminated spot often with high intensity dynamics. Illustratively, when looking at the surface of the tissue measurement site 102 (or “sample tissue”), which in this example is a finger, a small point-like surface area of tissue 204 is irradiated by a point optical source. In some embodiments, the irradiated circular area of the point optical source is in the range between 8 and 150 microns. Illustratively, the emitted point optical source of light enters the tissue measurement site 102 as a point of light. As the light penetrates the depth of the tissue 102, it does so as a line or vector, representing a

two-dimensional construct within a three-dimensional structure, namely the patient's tissue 102.

**[0031]** Use of a point optical source is believed to reduce variability in light pathlength which would lead to more accurate oximetry measurements. However, in practice, photons do not travel in straight paths. Instead, the light particles scatter, bouncing around between various irregular objects (such as, for example, red blood cells) in the patient's blood. Accordingly, photon pathlengths vary depending on, among other things, their particular journeys through and around the tissue at the measurement site 102. This phenomenon is referred to as "multiple scattering." In a study, the effects of multiple scattering were examined by comparing the results of photon diffusion analysis with those obtained using an analysis based on the Beer-Lambert law, which neglects multiple scattering in the determination of light pathlength. The study found that that the difference between the average lengths of the paths traveled by red and infrared photons makes the oximeter's calibration curve (based on measurements obtained from normal subjects) sensitive to the total attenuation coefficients of the tissue in the two wavelength bands used for pulse oximetry, as well as to absorption by the pulsating arterial blood.

**[0032]** FIG. 2 illustrates schematically the disclosed systems, devices, and methods to implement three-dimensional (3D) pulse oximetry in which the emitted light irradiates a larger volume of tissue at the measurement site 102 as compared to the 2D point optical source approach described with respect to FIG. 1. In an embodiment, again looking at the surface of the tissue measurement site 102, the irradiated surface area 206 of the measurement site 102 is substantially rectangular in shape with dimensions in the range of approximately 0.25-3 cm in width and approximately 1-6 cm in length. In another embodiment, the irradiated surface area 206 of the measurement site 102 is substantially rectangular in shape and has dimensions of approximately 1.5 cm in width and approximately 2 cm in length. In another embodiment, the irradiated surface area 206 of the measurement site 102 is substantially rectangular in shape and has dimensions of approximately 0.5 cm in width and approximately 1 cm in length. In another embodiment, the irradiated surface area 206 of the measurement site 102 is substantially rectangular in shape

*Marked-Up Specification*

has dimensions of approximately 1 cm in width and approximately 1.5 cm in length. In yet another embodiment, the irradiated surface area 206 of the measurement site 102 is substantially square in shape and has dimensions in a range of approximately 0.25-9 cm<sup>2</sup>. In certain embodiments, the irradiated surface area 206 of the measurement site 102 is within a range of approximately 0.5-2 cm in width, and approximately 1-4 cm in length. Of course a skilled artisan will appreciate that many other shapes and dimensions of irradiated surface area 206 can be used. Advantageously, by irradiating the tissue measurement site 102 with a surface area 206, the presently disclosed systems, devices, and methods apply a three-dimensional analytical model to the three-dimensional structure being measured, namely, the patient's sample tissue 102.

**[0033]** According to the Beer-Lambert law, the amount of light absorbed by a substance is proportional to the concentration of the light-absorbing substance in the irradiated solution (*i.e.*, arterial blood). Advantageously, by irradiating a larger volume of tissue 102, a larger sample size of light attenuated (or reflected) by the tissue 102 is measured. The larger, 3D sample provides a data set that is more representative of the complete interaction of the emitted light as it passes through the patient's blood as compared to the 2D point source approach described above with respect to FIG. 1. By taking an average of the detected light, as detected over a surface area substantially larger than a single point, the disclosed pulse oximetry systems, devices, and methods will yield a more accurate measurement of the emitted light absorbed by the tissue, which will lead to a more accurate oxygen saturation measurement.

**[0034]** FIG. 3 illustrates schematically a side view of a pulse oximetry 3D sensor 300 according to an embodiment of the present disclosure. In the illustrated embodiment, the 3D sensor 300 irradiates the tissue measurement site 102 and detects the emitted light, after being attenuated by the tissue measurement site 102. In other embodiments, for example, as describe below with respect to FIGS. 7A and 7B, the 3D sensor 300 can be arranged to detect light that is reflected by the tissue measurement site 102. The 3D sensor 300 includes an emitter 302, a light diffuser 304, a light-absorbing detector filter 306, a light concentrator 308, and a detector



310. In some optional embodiments, the 3D sensor 300 further includes a reflector 305. The reflector 305 can be a metallic reflector or other type of reflector. Reflector 305 can be a coating, film, layer or other type of reflector. The reflector 305 can serve as a reflector to prevent emitted light from emitting out of a top portion of the light diffuser 304 such that light from the emitter 302 is directed in the tissue rather than escaping out of a side or top of the light diffuser 304. Additionally, the reflector 305 can prevent ambient light from entering the diffuser 304 which might ultimately cause errors within the detected light. The reflector 305 also prevent light piping that might occur if light from the detector 302 is able to escape from the light diffuser 304 and be piped around a sensor securement mechanism to detector 310 without passing through the patient's tissue 102.

**[0035]** The emitter 302 can serve as the source of optical radiation transmitted towards the tissue measurement site 102. The emitter 302 can include one or more sources of optical radiation, such as LEDs, laser diodes, incandescent bulbs with appropriate frequency-selective filters, combinations of the same, or the like. In an embodiment, the emitter 302 includes sets of optical sources that are capable of emitting visible and near-infrared optical radiation. In some embodiments, the emitter 302 transmits optical radiation of red and infrared wavelengths, at approximately 650 nm and approximately 940 nm, respectively. In some embodiments, the emitter 302 includes a single source optical radiation.

**[0036]** The light diffuser 304 receives the optical radiation emitted from the emitter 302 and spreads the optical radiation over an area, such as the area 206 depicted in FIG. 2. In some embodiments, the light diffuser 304 is a beam shaper that can homogenize the input light beam from the emitter 302, shape the output intensity profile of the received light, and define the way (*e.g.*, the shape or pattern) the emitted light is distributed to the tissue measurement site 102. Examples of materials that can be used to realize the light diffuser 304 include, without limitation, a white surface, glass, ground glass, glass beads, polytetrafluoroethylene (also known as Teflon®, opal glass, and greyed glass, to name a few. Additionally, engineered diffusers can be used to realize the diffuser 304 by providing customized light shaping with respect to intensity and distribution. Such diffusers can, for

*Marked-Up Specification*

example, deliver substantially uniform illumination over a specified target area (such as, for example, irradiated surface area 206) in an energy-efficient manner. Examples of engineered diffusers can include molded plastics with specific shapes, patterns or textures designed to diffuse the emitter light across the entirety of the patient's tissue surface.

**[0037]** Advantageously, the diffuser 304 can receive emitted light in the form of a point optical source and spread the light to fit a desired surface area on a plane defined by the surface of the tissue measurement site 102. In an embodiment, the diffuser 304 is made of ground glass which spreads the emitted light with a Gaussian intensity profile. In another embodiment the diffuser 304 includes glass beads. In some embodiments, the diffuser 304 is constructed so as to diffuse the emitted light in a Lambertian pattern. A Lambertian pattern is one in which the radiation intensity is substantially constant throughout the area of dispersion. One such diffuser 304 is made from opal glass. Opal glass is similar to ground glass, but has one surface coated with a milky white coating to diffuse light evenly. In an embodiment, the diffuser 304 is capable of distributing the emitted light on the surface of a plane (*e.g.*, the surface of the tissue measurement site 102) in a predefined geometry (*e.g.*, a rectangle, square, or circle), and with a substantially uniform intensity profile and energy distribution. In some embodiments, the efficiency, or the amount of light transmitted by the diffuser 304, is greater than 70% of the light emitted by the emitter 302. In some embodiments, the efficiency is greater than 90% of the emitted light. Other optical elements known in the art may be used for the diffuser 304.

**[0038]** In an embodiment, the diffuser 304 has a substantially rectangular shape having dimensions within a range of approximately 0.5-2 cm in width and approximately 1-4 centimeters in length. In another embodiment, the substantially rectangular shape of the diffuser 304 has dimensions of approximately 0.5 cm in width and approximately 1 cm in length. In another embodiment, the diffuser's 304 substantially rectangular shape has dimensions of approximately 1 cm in width and approximately 1.5 cm in length. In yet another embodiment, the diffuser 304 has a

*Marked-Up Specification*

substantially square shape with dimensions in the range of approximately 0.25-10 cm<sup>2</sup>.

**[0039]** The light-absorbing detector filter 306, which is also depicted in FIG. 4A in a top view, is a planar surface having an opening 402 through which the emitted light may pass after being attenuated by the tissue measurement site 102. In the depicted embodiment, the opening 402 is rectangular-shaped, with dimensions substantially similar to the irradiated surface area 206. According to an embodiment, the light-absorbing detector filter is substantially rectangular in shape and has outer dimensions of 4 cm in width and 8 cm in length, and has an opening through which emitted light may pass, the opening having dimensions of 2 cm in width and 5 cm in length. In another embodiment, the light-absorbing detector filter is substantially rectangular in shape and has outer dimensions in the range of 1-3 cm in width and 2-8 cm in length, and has an opening through which emitted light may pass, the opening having dimensions in the range of 0.25-2 cm in width and 1-4 cm in length. In yet another embodiment, the light-absorbing detector filter is substantially rectangular in shape and has outer dimensions of 3 cm in width and 6 cm in length, and has an opening through which emitted light may pass, the opening having dimensions of 1.5 cm in width and 4 cm in length.

**[0040]** The top surface of the light-absorbing filter 306 (facing the tissue measurement site 102 and the emitter 302) is coated with a material that absorbs light, such as, for example, black pigment. Many other types of light-absorbing materials are well known in the art and can be used with the detector filter 306. During operation, light emitted from the emitter 302 can reflect off of the tissue measurement site 102 (or other structures within the 3D sensor 300) to neighboring portions of the 3D sensor 300. If those neighboring portions of the 3D sensor 300 possess reflective surfaces, then the light can reflect back to the tissue measurement site 102, progress through the tissue and arrive at the detector 310. Such multiple scattering can result in detecting photons whose pathlengths are considerably longer than most of the light that is detected, thereby introducing variations in pathlength which will affect the accuracy of the measurements of the pulse oximetry 3D sensor 300. Advantageously, the light-absorbing filter 306

*Marked-Up Specification*

reduces or eliminates the amount of emitted light that is reflected in this manner because it absorbs such reflected light, thereby stopping the chain of scattering events. In certain embodiments, the sensor-facing surfaces of other portions of the 3D sensor 300 are covered in light-absorbing material to further decrease the effect of reflective multiple scattering.

**[0041]** The light concentrator 308 is a structure to receive the emitted optical radiation, after attenuation by the tissue measurement site 102, to collect and concentrate the dispersed optical radiation, and to direct the collected and concentrated optical radiation to the detector 310. In an embodiment, the light concentrator 308 is made of ground glass or glass beads. In some embodiments, the light concentrator 308 includes a compound parabolic concentrator.

**[0042]** As described above with respect to FIG. 1, the detector 310 captures and measures light from the tissue measurement site 102. For example, the detector 310 can capture and measure light transmitted from the emitter 302 that has been attenuated by the tissue in the measurement site 102. The detector 310 can output a detector signal responsive to the light captured or measured. The detector 310 can be implemented using one or more photodiodes, phototransistors, or the like. In addition, a plurality of detectors 310 can be arranged in an array with a spatial configuration corresponding to the irradiated surface area 206 to capture the attenuated or reflected light from the tissue measurement site.

**[0043]** Referring to FIG. 4A, a top view of a portion of the 3D sensor 300 is provided. The light-absorbing detector filter 306 is illustrated having a top surface coated with a light-absorbing material. The light-absorbing material can be a black opaque material or coating or any other dark color or coating configured to absorb light. Additionally, a rectangular opening 402 is positioned relative to the light concentrator 308 (shown in phantom) and the detector 310 such that light may pass through the rectangular opening 402, into the light concentrator 308, and to the detector 310. FIG. 4B illustrates the top view of a portion of the 3D sensor 300 as in FIG. 4A, with the addition of the tissue measurement site 102 in operational position. Accordingly, the rectangular opening 402, the light concentrator 308 and the detector 310 are shown in phantom as being under the tissue measurement site

*Marked-Up Specification*

102. In FIGS. 4A and 4B, the light concentrator 308 is shown to have dimensions significantly larger than the dimensions of the rectangular opening 402. In other embodiments, the dimensions of the light concentrator 308, the rectangular opening 402, and the irradiated surface area 206 are substantially similar.

**[0044]** FIG. 5 illustrates a top view of a 3D pulse oximetry sensor 500 according to an embodiment of the present disclosure. The 3D sensor 500 is configured to be worn on a patient's finger 102. The 3D sensor 500 includes an adhesive substrate 502 having front flaps 504 and rear flaps 506 extending outward from a center portion 508 of the 3D sensor 500. The center portion 508 includes components of the 3D pulse oximetry sensor 300 described with respect to FIGS. 3, 4A and 4B. On the front side of the adhesive substrate 502 the emitter 302 and the light diffuser 304 are positioned. On the rear side of the adhesive substrate 502 the light-absorbent detector filter 306, the light concentrator 308 and the detector 310 are positioned. In use, the patient's finger serving as the tissue measurement site 102 is positioned over the rectangular opening 402 such that when the front portion of the adhesive substrate is folded over on top of the patient's finger 102, the emitter 302 and the light diffuser 304 are aligned with the measurement site 102, the filter 306, the light concentrator 308 and the detector 310. Once alignment is established, the front and rear flaps 504, 506 can be wrapped around the finger measurement site 102 such that the adhesive substrate 502 provides a secure contact between the patient's skin and the 3D sensor 500. Fig. 5 also illustrates an example of a sensor connector cable 510 which is used to connect the 3D sensor 500 to a monitor 809, as described with respect to FIG. 8.

**[0045]** FIG. 6 is a simplified schematic illustration of a conventional, 2D approach to reflective pulse oximetry in which the emitter is configured to emit optical radiation as a point optical source. Reflective pulse oximetry is a method by which the emitter and detector are located on the same side of the tissue measurement site 102. Light is emitted into a tissue measurement site 102 and attenuated. The emitted light passes into the tissue 102 and is then reflected back to the same side of the tissue measurement site 102 as the emitter. As illustrated in FIG. 6, a depicted reflective 2D pulse oximetry sensor 600 includes an emitter 602,

*Marked-Up Specification*

a light block 606, and a detector 610. The light block 606 is necessary because the emitter 602 and the detector 610 are located on the same side of the tissue measurement site 102. Accordingly, the light block 606 prevents incident emitter light, which did not enter the tissue measurement site 102, from arriving at the detector 610. The depicted 2D pulse oximetry sensor 600 is configured to emit light as a point source. As depicted in FIG. 6, a simplified illustration of the light path 620 of the emitted light from the emitter 602, through the tissue measurement site 102, and to the detector 610 is provided. Notably, a point source of light is emitted, and a point source of light is detected. As discussed above with respect to FIG. 1, use of a point optical source can result in substantial measurement error due to pathlength variability resulting from the multiple scatter phenomenon. The sample space provided by a 2D point optical emitter source is not large enough to account for pathlength variability, which will skew measurement results.

**[0046]** FIGS. 7A and 7B are simplified schematic side and top views, respectively, of a 3D reflective pulse oximetry sensor 700 according to an embodiment of the present disclosure. In the illustrated embodiment, the 3D sensor 700 irradiates the tissue measurement site 102 and detects the emitted light that is reflected by the tissue measurement site 102. The 3D sensor 700 can be placed on a portion of the patient's body that has relatively flat surface, such as, for example a wrist, because the emitter 702 and detector 710 are on located the same side of the tissue measurement site 102. The 3D sensor 700 includes an emitter 702, a light diffuser 704, a light block 706, a light concentrator 708, and a detector 710.

**[0047]** As previously described, the emitter 702 can serve as the source of optical radiation transmitted towards the tissue measurement site 102. The emitter 702 can include one or more sources of optical radiation. Such sources of optical radiation can include LEDs, laser diodes, incandescent bulbs with appropriate frequency-selective filters, combinations of the same, or the like. In an embodiment, the emitter 702 includes sets of optical sources that are capable of emitting visible and near-infrared optical radiation. In some embodiments, the emitter 702 transmits optical radiation of red and infrared wavelengths, at approximately 650 nm and

approximately 940 nm, respectively. In some embodiments, the emitter 702 includes a single source of optical radiation.

**[0048]** The light diffuser 704 receives the optical radiation emitted from the emitter 302 and homogeneously spreads the optical radiation over a wide, donut-shaped area, such as the area outlined by the light diffuser 704 as depicted in FIG. 7B. Advantageously, the diffuser 704 can receive emitted light in the form of a 2D point optical source (or any other form) and spread the light to fit the desired surface area on a plane defined by the surface of the tissue measurement site 102. In an embodiment, the diffuser 704 is made of ground glass or glass beads. A skilled artisan will understand that many other materials can be used to make the light diffuser 704.

**[0049]** The light blocker 706 includes an annular ring having a cover portion 707 sized and shaped to form a light isolation chamber for the light concentrator 708 and the detector 710. (For purposes of illustration, the light block cover 707 is not illustrated in FIG. 7B.) The light blocker 706 and the cover 707 can be made of any material that optically isolates the light concentrator 708 and the detector 710. The light isolation chamber formed by the light blocker 706 and cover 708 ensures that the only light detected by the detector 710 is light that is reflected from the tissue measurement site.

**[0050]** The light concentrator 708 is a cylindrical structure with a truncated circular conical structure on top, the truncated section of which is adjacent the detector 710. The light concentrator 708 is structured to receive the emitted optical radiation, after reflection by the tissue measurement site 102, and to direct the reflected light to the detector 710. In an embodiment, the light concentrator 708 is made of ground glass or glass beads. In some embodiments, the light concentrator 708 includes a compound parabolic concentrator.

**[0051]** As previously described, the detector 710 captures and measures light from the tissue measurement site 102. For example, the detector 710 can capture and measure light transmitted from the emitter 702 that has been reflected from the tissue in the measurement site 102. The detector 710 can output a detector signal responsive to the light captured or measured. The detector 710 can be

### *Marked-Up Specification*

implemented using one or more photodiodes, phototransistors, or the like. In addition, a plurality of detectors 710 can be arranged in an array with a spatial configuration corresponding to the irradiated surface area depicted in FIG. 7B by the light concentrator 708 to capture the reflected light from the tissue measurement site.

**[0052]** Advantageously, the light path 720 illustrated in FIG. 7A depicts a substantial sample of reflected light that enter the light isolation chamber formed by the light blocker 706 and cover 707. As previously discussed, the large sample of reflected light (as compared to the reflected light collected using the 2D point optical source approach) provides the opportunity to take an average of the detected light, to derive a more accurate measurement of the emitted light absorbed by the tissue, which will lead to a more accurate oxygen saturation measurement.

**[0053]** Referring now to FIG. 7B, a top view of the 3D sensor 700 is illustrated with both the emitter 702 and the light blocker cover 707 removed for ease of illustration. The outer ring illustrates the footprint of the light diffuser 704. As light is emitted from the emitter 702 (not shown in FIG. 7B), it is diffused homogenously and directed to the tissue measurement site 102. The light blocker 706 forms the circular wall of a light isolation chamber to keep incident light from being sensed by the detector 710. The light blocker cover 707 blocks incidental light from entering the light isolation chamber from above. The light concentrator 710 collects the reflected light from the tissue measurement site 102 and funnels it upward toward the detector 710 at the center of the 3D sensor 700.

**[0054]** FIG. 8 illustrates an example of an optical physiological measurement system 800, which may also be referred to herein as a pulse oximetry system 800. In certain embodiments, the pulse oximetry system 800 noninvasively measures a blood analyte, such as oxygen, carboxyhemoglobin, methemoglobin, total hemoglobin, glucose, proteins, lipids, a percentage thereof (*e.g.*, saturation), pulse rate, perfusion index, oxygen content, total hemoglobin, Oxygen Reserve Index™ (ORI™) or many other physiologically relevant patient characteristics. These characteristics can relate to, for example, pulse rate, hydration, trending information and analysis, and the like. The system 800 can also measure additional blood



analytes and/or other physiological parameters useful in determining a state or trend of wellness of a patient.

**[0055]** The pulse oximetry system 800 can measure analyte concentrations at least in part by detecting optical radiation attenuated by tissue at a measurement site 102. The measurement site 102 can be any location on a patient's body, such as a finger, foot, earlobe, wrist, forehead, or the like.

**[0056]** The pulse oximetry system 800 can include a sensor 801 (or multiple sensors) that is coupled to a processing device or physiological monitor 809. In an embodiment, the sensor 801 and the monitor 809 are integrated together into a single unit. In another embodiment, the sensor 801 and the monitor 809 are separate from each other and communicate with one another in any suitable manner, such as via a wired or wireless connection. The sensor 801 and monitor 809 can be attachable and detachable from each other for the convenience of the user or caregiver, for ease of storage, sterility issues, or the like.

**[0057]** In the depicted embodiment shown in FIG. 8, the sensor 801 includes an emitter 804, a detector 806, and a front-end interface 808. The emitter 804 can serve as the source of optical radiation transmitted towards measurement site 102. The emitter 804 can include one or more sources of optical radiation, such as light emitting diodes (LEDs), laser diodes, incandescent bulbs with appropriate frequency-selective filters, combinations of the same, or the like. In an embodiment, the emitter 804 includes sets of optical sources that are capable of emitting visible and near-infrared optical radiation.

**[0058]** The pulse oximetry system 800 also includes a driver 811 that drives the emitter 804. The driver 111 can be a circuit or the like that is controlled by the monitor 809. For example, the driver 811 can provide pulses of current to the emitter 804. In an embodiment, the driver 811 drives the emitter 804 in a progressive fashion, such as in an alternating manner. The driver 811 can drive the emitter 804 with a series of pulses for some wavelengths that can penetrate tissue relatively well and for other wavelengths that tend to be significantly absorbed in tissue. A wide variety of other driving powers and driving methodologies can be used in various embodiments. The driver 811 can be synchronized with other parts

*Marked-Up Specification*

of the sensor 801 to minimize or reduce jitter in the timing of pulses of optical radiation emitted from the emitter 804. In some embodiments, the driver 811 is capable of driving the emitter 804 to emit optical radiation in a pattern that varies by less than about 10 parts-per-million.

**[0059]** The detector 806 captures and measures light from the tissue measurement site 102. For example, the detector 806 can capture and measure light transmitted from the emitter 804 that has been attenuated or reflected from the tissue at the measurement site 102. The detector 806 can output a detector signal 107 responsive to the light captured and measured. The detector 806 can be implemented using one or more photodiodes, phototransistors, or the like. In some embodiments, a detector 806 is implemented in detector package to capture and measure light from the tissue measurement site 102 of the patient. The detector package can include a photodiode chip mounted to leads and enclosed in an encapsulant. In some embodiments, the dimensions of the detector package are approximately 2 square centimeters. In other embodiments, the dimensions of the detector package are approximately 1.5 centimeters in width and approximately 2 centimeters in length.

**[0060]** The front-end interface 808 provides an interface that adapts the output of the detectors 806, which is responsive to desired physiological parameters. For example, the front-end interface 808 can adapt the signal 807 received from the detector 806 into a form that can be processed by the monitor 809, for example, by a signal processor 810 in the monitor 809. The front-end interface 808 can have its components assembled in the sensor 801, in the monitor 809, in a connecting cabling (if used), in combinations of the same, or the like. The location of the front-end interface 808 can be chosen based on various factors including space desired for components, desired noise reductions or limits, desired heat reductions or limits, and the like.

**[0061]** The front-end interface 808 can be coupled to the detector 806 and to the signal processor 810 using a bus, wire, electrical or optical cable, flex circuit, or some other form of signal connection. The front-end interface 808 can also be at least partially integrated with various components, such as the detectors 806. For

example, the front-end interface 808 can include one or more integrated circuits that are on the same circuit board as the detector 806. Other configurations can also be used.

**[0062]** As shown in FIG. 8, the monitor 909 can include the signal processor 810 and a user interface, such as a display 812. The monitor 809 can also include optional outputs alone or in combination with the display 812, such as a storage device 814 and a network interface 816. In an embodiment, the signal processor 810 includes processing logic that determines measurements for desired analytes based on the signals received from the detector 806. The signal processor 810 can be implemented using one or more microprocessors or sub-processors (*e.g.*, cores), digital signal processors, application specific integrated circuits (ASICs), field programmable gate arrays (FPGAs), combinations of the same, and the like.

**[0063]** The signal processor 810 can provide various signals that control the operation of the sensor 801. For example, the signal processor 810 can provide an emitter control signal to the driver 811. This control signal can be useful in order to synchronize, minimize, or reduce jitter in the timing of pulses emitted from the emitter 804. Accordingly, this control signal can be useful in order to cause optical radiation pulses emitted from the emitter 804 to follow a precise timing and consistent pattern. For example, when a transimpedance-based front-end interface 808 is used, the control signal from the signal processor 810 can provide synchronization with an analog-to-digital converter (ADC) in order to avoid aliasing, cross-talk, and the like. As also shown, an optional memory 813 can be included in the front-end interface 808 and/or in the signal processor 810. This memory 813 can serve as a buffer or storage location for the front-end interface 808 and/or the signal processor 810, among other uses.

**[0064]** The user interface 812 can provide an output, *e.g.*, on a display, for presentation to a user of the pulse oximetry system 800. The user interface 812 can be implemented as a touch-screen display, a liquid crystal display (LCD), an organic LED display, or the like. In alternative embodiments, the pulse oximetry system 800

can be provided without a user interface 812 and can simply provide an output signal to a separate display or system.

**[0065]** The storage device 814 and a network interface 816 represent other optional output connections that can be included in the monitor 809. The storage device 814 can include any computer-readable medium, such as a memory device, hard disk storage, EEPROM, flash drive, or the like. The various software and/or firmware applications can be stored in the storage device 814, which can be executed by the signal processor 810 or another processor of the monitor 809. The network interface 816 can be a serial bus port (RS-232/RS-485), a Universal Serial Bus (USB) port, an Ethernet port, a wireless interface (*e.g.*, WiFi such as any 802.1x interface, including an internal wireless card), or other suitable communication device(s) that allows the monitor 809 to communicate and share data with other devices. The monitor 809 can also include various other components not shown, such as a microprocessor, graphics processor, or controller to output the user interface 812, to control data communications, to compute data trending, or to perform other operations.

**[0066]** Although not shown in the depicted embodiment, the pulse oximetry system 800 can include various other components or can be configured in different ways. For example, the sensor 801 can have both the emitter 804 and detector 806 on the same side of the tissue measurement site 102 and use reflectance to measure analytes.

**[0067]** Although the foregoing disclosure has been described in terms of certain preferred embodiments, many other variations than those described herein will be apparent to those of ordinary skill in the art.

**[0068]** Conditional language used herein, such as, among others, "can," "might," "may," "*e.g.*," and the like, unless specifically stated otherwise, or otherwise understood within the context as used, is generally intended to convey that certain embodiments include, while other embodiments do not include, certain features, elements and/or states. Thus, such conditional language is not generally intended to imply that features, elements and/or states are in any way required for one or more embodiments or that one or more embodiments necessarily include logic for

*Marked-Up Specification*

deciding, with or without author input or prompting, whether these features, elements and/or states are included or are to be performed in any particular embodiment. The terms "comprising," "including," "having," and the like are synonymous and are used inclusively, in an open-ended fashion, and do not exclude additional elements, features, acts, operations, and so forth. Also, the term "or" is used in its inclusive sense (and not in its exclusive sense) so that when used, for example, to connect a list of elements, the term "or" means one, some, or all of the elements in the list. Further, the term "each," as used herein, in addition to having its ordinary meaning, can mean any subset of a set of elements to which the term "each" is applied.

**[0069]** While the above detailed description has shown, described, and pointed out novel features as applied to various embodiments, it will be understood that various omissions, substitutions, and changes in the form and details of the systems, devices or algorithms illustrated can be made without departing from the spirit of the disclosure. As will be recognized, certain embodiments of the disclosure described herein can be embodied within a form that does not provide all of the features and benefits set forth herein, as some features can be used or practiced separately from others.

**[0070]** The term "and/or" herein has its broadest, least limiting meaning which is the disclosure includes A alone, B alone, both A and B together, or A or B alternatively, but does not require both A and B or require one of A or one of B. As used herein, the phrase "at least one of" A, B, "and" C should be construed to mean a logical A or B or C, using a non-exclusive logical or.

**[0071]** The apparatuses and methods described herein may be implemented by one or more computer programs executed by one or more processors. The computer programs include processor-executable instructions that are stored on a non-transitory tangible computer readable medium. The computer programs may also include stored data. Non-limiting examples of the non-transitory tangible computer readable medium are nonvolatile memory, magnetic storage, and optical storage. Although the foregoing disclosure has been described in terms of certain preferred embodiments, other embodiments will be apparent to those of

*Marked-Up Specification*

ordinary skill in the art from the disclosure herein. Additionally, other combinations, omissions, substitutions and modifications will be apparent to the skilled artisan in view of the disclosure herein. Accordingly, the present invention is not intended to be limited by the description of the preferred embodiments, but is to be defined by reference to claims.

**[0072]** Additionally, all publications, patents, and patent applications mentioned in this specification are herein incorporated by reference to the same extent as if each individual publication, patent, or patent application were specifically and individually indicated to be incorporated by reference.

**ADVANCED PULSE OXIMETRY SENSOR**

INCORPORATION BY REFERENCE TO ANY PRIORITY APPLICATIONS

**[0001]** The present application is a continuation of U.S. Patent Application No. 15/195,199 filed June 28, 2016, which claims priority benefit under 35 U.S.C. § 119(e) from U.S. Provisional Application No. 62/188,430, filed July 2, 2015, entitled “Advanced Pulse Oximetry Sensor,” which is incorporated by reference herein. Any and all applications for which a foreign or domestic priority claim is identified in the Application Data Sheet as filed with the present application are hereby incorporated by reference under 37 CFR 1.57.

FIELD OF THE DISCLOSURE

**[0002]** The present disclosure relates to the field of non-invasive optical-based physiological monitoring sensors, and more particularly to systems, devices and methods for improving the non-invasive measurement accuracy of oxygen saturation, among other physiological parameters.

BACKGROUND

**[0003]** Spectroscopy is a common technique for measuring the concentration of organic and some inorganic constituents of a solution. The theoretical basis of this technique is the Beer-Lambert law, which states that the concentration  $c_i$  of an absorbent in solution can be determined by the intensity of light transmitted through the solution, knowing the pathlength  $d_\lambda$ , the intensity of the incident light  $I_{o,\lambda}$ , and the extinction coefficient  $\epsilon_{i,\lambda}$  at a particular wavelength  $\lambda$ .

**[0004]** In generalized form, the Beer-Lambert law is expressed as:

$$I_\lambda = I_{o,\lambda} e^{-d_\lambda \cdot \mu_{a,\lambda}} \tag{1}$$

$$\mu_{a,\lambda} = \sum_{i=1}^n \epsilon_{i,\lambda} \cdot c_i \tag{2}$$

*Clean Specification*

where  $\mu_{\alpha,\lambda}$  is the bulk absorption coefficient and represents the probability of absorption per unit length. The minimum number of discrete wavelengths that are required to solve equations 1 and 2 is the number of significant absorbers that are present in the solution.

**[0005]** A practical application of this technique is pulse oximetry, which utilizes a noninvasive sensor to measure oxygen saturation and pulse rate, among other physiological parameters. Pulse oximetry relies on a sensor attached externally to the patient to output signals indicative of various physiological parameters, such as a patient's blood constituents and/or analytes, including for example a percent value for arterial oxygen saturation, among other physiological parameters. The sensor has an emitter that transmits optical radiation of one or more wavelengths into a tissue site and a detector that responds to the intensity of the optical radiation after absorption by pulsatile arterial blood flowing within the tissue site. Based upon this response, a processor determines the relative concentrations of oxygenated hemoglobin (HbO<sub>2</sub>) and deoxygenated hemoglobin (Hb) in the blood so as to derive oxygen saturation, which can provide early detection of potentially hazardous decreases in a patient's oxygen supply.

**[0006]** A pulse oximetry system generally includes a patient monitor, a communications medium such as a cable, and/or a physiological sensor having one or more light emitters and a detector, such as one or more light-emitting diodes (LEDs) and a photodetector. The sensor is attached to a tissue site, such as a finger, toe, earlobe, nose, hand, foot, or other site having pulsatile blood flow which can be penetrated by light from the one or more emitters. The detector is responsive to the emitted light after attenuation or reflection by pulsatile blood flowing in the tissue site. The detector outputs a detector signal to the monitor over the communication medium. The monitor processes the signal to provide a numerical readout of physiological parameters such as oxygen saturation (SpO<sub>2</sub>) and/or pulse rate. A pulse oximetry sensor is described in U.S. Patent No. 6,088,607 entitled *Low Noise Optical Probe*; pulse oximetry signal processing is described in U.S. Patent Nos. 6,650,917 and 6,699,194 entitled *Signal Processing Apparatus* and *Signal Processing Apparatus and Method*, respectively; a pulse oximeter monitor is



*Clean Specification*

described in U.S. Patent No. 6,584,336 entitled *Universal/Upgrading Pulse Oximeter*, all of which are assigned to Masimo Corporation, Irvine, CA, and each is incorporated by reference herein in its entirety.

**[0007]** There are many sources of measurement error introduced to pulse oximetry systems. Some such sources of error include the pulse oximetry system's electronic components, including emitters and detectors, as well as chemical and structural physiological differences between patients. Another source of measurement error is the effect of multiple scattering of photons as the photons pass through the patient's tissue (arterial blood) and arrive at the sensor's light detector.

SUMMARY

**[0008]** This disclosure describes embodiments of non-invasive methods, devices, and systems for measuring blood constituents, analytes, and/or substances such as, by way of non-limiting example, oxygen, carboxyhemoglobin, methemoglobin, total hemoglobin, glucose, proteins, lipids, a percentage thereof (*e.g.*, saturation), pulse rate, perfusion index, oxygen content, total hemoglobin, Oxygen Reserve Index™ (ORI™) or for measuring many other physiologically relevant patient characteristics. These characteristics can relate to, for example, pulse rate, hydration, trending information and analysis, and the like.

**[0009]** In an embodiment, an optical physiological measurement system includes an emitter configured to emit light of one or more wavelengths. The system also includes a diffuser configured to receive the emitted light, to spread the received light, and to emit the spread light over a larger tissue area than would otherwise be penetrated by the emitter directly emitting light at a tissue measurement site. The tissue measurement site can include, such as, for example, a finger, a wrist, or the like. The system further includes a concentrator configured to receive the spread light after it has been attenuated by or reflected from the tissue measurement site. The concentrator is also configured to collect and concentrate the received light and to emit the concentrated light to a detector. The detector is configured to detect the concentrated light and to transmit a signal indicative of the

detected light. The system also includes a processor configured to receive the transmitted signal indicative of the detected light and to determine, based on an amount of absorption, an analyte of interest, such as, for example, arterial oxygen saturation or other parameter, in the tissue measurement site.

**[0010]** In certain embodiments of the present disclosure, the diffuser comprises glass, ground glass, glass beads, opal glass, or a microlens-based, band-limited, engineered diffuser that can deliver efficient and uniform illumination. In some embodiments the diffuser is further configured to define a surface area shape by which the emitted spread light is distributed onto a surface of the tissue measurement site. The defined surface area shape can include, by way of non-limiting example, a shape that is substantially rectangular, square, circular, oval, or annular, among others.

**[0011]** According to some embodiments, the optical physiological measurement system includes an optical filter having a light-absorbing surface that faces the tissue measurement site. The optical filter also has an opening that is configured to allow the spread light, after being attenuated by the tissue measurement site, to be received by the concentrator. In an embodiment, the opening has dimensions, wherein the dimensions of the opening are similar to the defined surface area shape by which the emitted spread light is distributed onto the surface of the tissue measurement site. In an embodiment, the opening has dimensions that are larger than the defined surface area shape by which the emitted spread light is distributed onto the surface of the tissue measurement site. In other embodiments, the dimensions of the opening in the optical filter are not the same as the diffuser opening, but the dimensions are larger than the detector package.

**[0012]** In other embodiments of the present disclosure, the concentrator comprises glass, ground glass, glass beads, opal glass, or a compound parabolic concentrator. In some embodiments the concentrator comprises a cylindrical structure having a truncated circular conical structure on top. The truncated section is adjacent the detector. The light concentrator is structured to receive the emitted optical radiation, after reflection by the tissue measurement site, and to direct the reflected light to the detector.

**[0013]** In accordance with certain embodiments of the present disclosure, the processor is configured to determine an average level of the light detected by the detector. The average level of light is used to determine a physiological parameter in the tissue measurement site.

**[0014]** According to another embodiment, a method to determine a constituent or analyte in a patient's blood is disclosed. The method includes emitting, from an emitter, light of at least one wavelength; spreading, with a diffuser, the emitted light and emitting the spread light from the diffuser to a tissue measurement site; receiving, by a concentrator, the spread light after the spread light has been attenuated by the tissue measurement site; concentrating, by the concentrator, the received light and emitting the concentrated light from the concentrator to a detector; detecting, with the detector, the emitted concentrated light; transmitting, from the detector, a signal responsive to the detected light; receiving, by a processor, the transmitted signal responsive to the detected light; and processing, by the processor, the received signal responsive to the detected light to determine a physiological parameter.

**[0015]** In some embodiments, the method to determine a constituent or analyte in a patient's blood includes filtering, with a light-absorbing detector filter, scattered portions of the emitted spread light. According to an embodiment, the light-absorbing detector filter is substantially rectangular in shape and has outer dimensions in the range of approximately 1-5 cm in width and approximately 2-8 cm in length, and has an opening through which emitted light may pass, the opening having dimensions in the range of approximately 0.25-3 cm in width and approximately 1-7 cm in length. In another embodiment, the light-absorbing detector filter is substantially square in shape and has outer dimensions in the range of approximately 0.25-10 cm<sup>2</sup>, and has an opening through which emitted light may pass, the opening having dimensions in the range of approximately 0.1-8cm<sup>2</sup>. In yet another embodiment, the light-absorbing detector filter is substantially rectangular in shape and has outer dimensions of approximately 3 cm in width and approximately 6 cm in length, and has an opening through which emitted light may pass, the

*Clean Specification*

opening having dimensions of approximately 1.5 cm in width and approximately 4 cm in length.

**[0016]** In still other embodiments of the method to determine a constituent or analyte in a patient's blood, spreading, with a diffuser, the emitted light and emitting the spread light from the diffuser to a tissue measurement site is performed by at least one of a glass diffuser, a ground glass diffuser, a glass bead diffuser, an opal glass diffuser, and an engineered diffuser. In some embodiments the emitted spread light is emitted with a substantially uniform intensity profile. And in some embodiments, emitting the spread light from the diffuser to the tissue measurement site includes spreading the emitted light so as to define a surface area shape by which the emitted spread light is distributed onto a surface of the tissue measurement site.

**[0017]** According to yet another embodiment, a pulse oximeter is disclosed. The pulse oximeter includes an emitter configured to emit light at one or more wavelengths. The pulse oximeter also includes a diffuser configured to receive the emitted light, to spread the received light, and to emit the spread light directed at a tissue measurement sight. The pulse oximeter also includes a detector configured to detect the emitted spread light after being attenuated by or reflected from the tissue measurement site and to transmit a signal indicative of the detected light. The pulse oximeter also includes a processor configured to receive the transmitted signal and to process the received signal to determine an average absorbance of a blood constituent or analyte in the tissue measurement site over a larger measurement site area than can be performed with a point light source or point detector. In some embodiments, the diffuser is further configured to define a surface area shape by which the emitted spread light is distributed onto a surface of the tissue measurement site, and the detector is further configured to have a detection area corresponding to the defined surface area shape by which the emitted spread light is distributed onto the surface of the tissue measurement site. According to some embodiments, the detector comprises an array of detectors configured to cover the detection area. In still other embodiments, the processor is further configured to determine an average of the detected light.

**[0018]** For purposes of summarizing, certain aspects, advantages and novel features of the disclosure have been described herein. It is to be understood that not necessarily all such advantages can be achieved in accordance with any particular embodiment of the systems, devices and/or methods disclosed herein. Thus, the subject matter of the disclosure herein can be embodied or carried out in a manner that achieves or optimizes one advantage or group of advantages as taught herein without necessarily achieving other advantages as can be taught or suggested herein.

#### BRIEF DESCRIPTION OF THE DRAWINGS

**[0019]** Throughout the drawings, reference numbers can be re-used to indicate correspondence between referenced elements. The drawings are provided to illustrate embodiments of the disclosure described herein and not to limit the scope thereof.

**[0020]** FIG. 1 illustrates a conventional approach to two-dimensional pulse oximetry in which the emitter is configured to emit optical radiation as a point optical source.

**[0021]** FIG. 2 illustrates the disclosed three-dimensional approach to pulse oximetry in which the emitted light irradiates a substantially larger volume of tissue as compared to the point source approach described with respect to FIG. 1.

**[0022]** FIG. 3 illustrates schematically a side view of a three-dimensional pulse oximetry sensor according to an embodiment of the present disclosure.

**[0023]** FIG. 4A is a top view of a portion of a three-dimensional pulse oximetry sensor according to an embodiment of the present disclosure.

**[0024]** FIG. 4B illustrates the top view of a portion of the three-dimensional pulse oximetry sensor shown in FIG. 4A, with the addition of a tissue measurement site in operational position.

**[0025]** FIG. 5 illustrates a top view of a three-dimensional pulse oximetry sensor according to an embodiment of the present disclosure.

**[0026]** FIG. 6 illustrates a conventional two-dimensional approach to reflective pulse oximetry in which the emitter is configured to emit optical radiation as a point optical source.

**[0027]** FIG. 7A is a simplified schematic side view illustration of a reflective three-dimensional pulse oximetry sensor according to an embodiment of the present disclosure.

**[0028]** FIG. 7B is a simplified schematic top view illustration of the three-dimensional reflective pulse oximetry sensor of FIG. 7A.

**[0029]** FIG. 8 illustrates a block diagram of an example pulse oximetry system capable of noninvasively measuring one or more blood analytes in a monitored patient, according to an embodiment of the disclosure.

#### DETAILED DESCRIPTION

**[0030]** FIG. 1 illustrates schematically a conventional pulse oximetry sensor having a two-dimensional (2D) approach to pulse oximetry. As illustrated, the emitter 104 is configured to emit optical radiation as a point optical source, *i.e.*, an optical radiation source that has negligible dimensions such that it may be considered as a point. This approach is referred to herein as “two-dimensional” pulse oximetry because it applies a two-dimensional analytical model to the three-dimensional space of the tissue measurement site 102 of the patient. Point optical sources feature a defined, freely selectable, and homogeneous light beam area. Light beams emitted from LED point sources often exhibit a strong focus which can produce a usually sharply-defined and evenly-lit illuminated spot often with high intensity dynamics. Illustratively, when looking at the surface of the tissue measurement site 102 (or “sample tissue”), which in this example is a finger, a small point-like surface area of tissue 204 is irradiated by a point optical source. In some embodiments, the irradiated circular area of the point optical source is in the range between 8 and 150 microns. Illustratively, the emitted point optical source of light enters the tissue measurement site 102 as a point of light. As the light penetrates the depth of the tissue 102, it does so as a line or vector, representing a

two-dimensional construct within a three-dimensional structure, namely the patient's tissue 102.

**[0031]** Use of a point optical source is believed to reduce variability in light pathlength which would lead to more accurate oximetry measurements. However, in practice, photons do not travel in straight paths. Instead, the light particles scatter, bouncing around between various irregular objects (such as, for example, red blood cells) in the patient's blood. Accordingly, photon pathlengths vary depending on, among other things, their particular journeys through and around the tissue at the measurement site 102. This phenomenon is referred to as "multiple scattering." In a study, the effects of multiple scattering were examined by comparing the results of photon diffusion analysis with those obtained using an analysis based on the Beer-Lambert law, which neglects multiple scattering in the determination of light pathlength. The study found that that the difference between the average lengths of the paths traveled by red and infrared photons makes the oximeter's calibration curve (based on measurements obtained from normal subjects) sensitive to the total attenuation coefficients of the tissue in the two wavelength bands used for pulse oximetry, as well as to absorption by the pulsating arterial blood.

**[0032]** FIG. 2 illustrates schematically the disclosed systems, devices, and methods to implement three-dimensional (3D) pulse oximetry in which the emitted light irradiates a larger volume of tissue at the measurement site 102 as compared to the 2D point optical source approach described with respect to FIG. 1. In an embodiment, again looking at the surface of the tissue measurement site 102, the irradiated surface area 206 of the measurement site 102 is substantially rectangular in shape with dimensions in the range of approximately 0.25-3 cm in width and approximately 1-6 cm in length. In another embodiment, the irradiated surface area 206 of the measurement site 102 is substantially rectangular in shape and has dimensions of approximately 1.5 cm in width and approximately 2 cm in length. In another embodiment, the irradiated surface area 206 of the measurement site 102 is substantially rectangular in shape and has dimensions of approximately 0.5 cm in width and approximately 1 cm in length. In another embodiment, the irradiated surface area 206 of the measurement site 102 is substantially rectangular in shape

*Clean Specification*

has dimensions of approximately 1 cm in width and approximately 1.5 cm in length. In yet another embodiment, the irradiated surface area 206 of the measurement site 102 is substantially square in shape and has dimensions in a range of approximately 0.25-9 cm<sup>2</sup>. In certain embodiments, the irradiated surface area 206 of the measurement site 102 is within a range of approximately 0.5-2 cm in width, and approximately 1-4 cm in length. Of course a skilled artisan will appreciate that many other shapes and dimensions of irradiated surface area 206 can be used. Advantageously, by irradiating the tissue measurement site 102 with a surface area 206, the presently disclosed systems, devices, and methods apply a three-dimensional analytical model to the three-dimensional structure being measured, namely, the patient's sample tissue 102.

**[0033]** According to the Beer-Lambert law, the amount of light absorbed by a substance is proportional to the concentration of the light-absorbing substance in the irradiated solution (*i.e.*, arterial blood). Advantageously, by irradiating a larger volume of tissue 102, a larger sample size of light attenuated (or reflected) by the tissue 102 is measured. The larger, 3D sample provides a data set that is more representative of the complete interaction of the emitted light as it passes through the patient's blood as compared to the 2D point source approach described above with respect to FIG. 1. By taking an average of the detected light, as detected over a surface area substantially larger than a single point, the disclosed pulse oximetry systems, devices, and methods will yield a more accurate measurement of the emitted light absorbed by the tissue, which will lead to a more accurate oxygen saturation measurement.

**[0034]** FIG. 3 illustrates schematically a side view of a pulse oximetry 3D sensor 300 according to an embodiment of the present disclosure. In the illustrated embodiment, the 3D sensor 300 irradiates the tissue measurement site 102 and detects the emitted light, after being attenuated by the tissue measurement site 102. In other embodiments, for example, as describe below with respect to FIGS. 7A and 7B, the 3D sensor 300 can be arranged to detect light that is reflected by the tissue measurement site 102. The 3D sensor 300 includes an emitter 302, a light diffuser 304, a light-absorbing detector filter 306, a light concentrator 308, and a detector



310. In some optional embodiments, the 3D sensor 300 further includes a reflector 305. The reflector 305 can be a metallic reflector or other type of reflector. Reflector 305 can be a coating, film, layer or other type of reflector. The reflector 305 can serve as a reflector to prevent emitted light from emitting out of a top portion of the light diffuser 304 such that light from the emitter 302 is directed in the tissue rather than escaping out of a side or top of the light diffuser 304. Additionally, the reflector 305 can prevent ambient light from entering the diffuser 304 which might ultimately cause errors within the detected light. The reflector 305 also prevent light piping that might occur if light from the detector 302 is able to escape from the light diffuser 304 and be piped around a sensor securement mechanism to detector 310 without passing through the patient's tissue 102.

**[0035]** The emitter 302 can serve as the source of optical radiation transmitted towards the tissue measurement site 102. The emitter 302 can include one or more sources of optical radiation, such as LEDs, laser diodes, incandescent bulbs with appropriate frequency-selective filters, combinations of the same, or the like. In an embodiment, the emitter 302 includes sets of optical sources that are capable of emitting visible and near-infrared optical radiation. In some embodiments, the emitter 302 transmits optical radiation of red and infrared wavelengths, at approximately 650 nm and approximately 940 nm, respectively. In some embodiments, the emitter 302 includes a single source optical radiation.

**[0036]** The light diffuser 304 receives the optical radiation emitted from the emitter 302 and spreads the optical radiation over an area, such as the area 206 depicted in FIG. 2. In some embodiments, the light diffuser 304 is a beam shaper that can homogenize the input light beam from the emitter 302, shape the output intensity profile of the received light, and define the way (*e.g.*, the shape or pattern) the emitted light is distributed to the tissue measurement site 102. Examples of materials that can be used to realize the light diffuser 304 include, without limitation, a white surface, glass, ground glass, glass beads, polytetrafluoroethylene (also known as Teflon®, opal glass, and greyed glass, to name a few. Additionally, engineered diffusers can be used to realize the diffuser 304 by providing customized light shaping with respect to intensity and distribution. Such diffusers can, for

### *Clean Specification*

example, deliver substantially uniform illumination over a specified target area (such as, for example, irradiated surface area 206) in an energy-efficient manner. Examples of engineered diffusers can include molded plastics with specific shapes, patterns or textures designed to diffuse the emitter light across the entirety of the patient's tissue surface.

**[0037]** Advantageously, the diffuser 304 can receive emitted light in the form of a point optical source and spread the light to fit a desired surface area on a plane defined by the surface of the tissue measurement site 102. In an embodiment, the diffuser 304 is made of ground glass which spreads the emitted light with a Gaussian intensity profile. In another embodiment the diffuser 304 includes glass beads. In some embodiments, the diffuser 304 is constructed so as to diffuse the emitted light in a Lambertian pattern. A Lambertian pattern is one in which the radiation intensity is substantially constant throughout the area of dispersion. One such diffuser 304 is made from opal glass. Opal glass is similar to ground glass, but has one surface coated with a milky white coating to diffuse light evenly. In an embodiment, the diffuser 304 is capable of distributing the emitted light on the surface of a plane (*e.g.*, the surface of the tissue measurement site 102) in a predefined geometry (*e.g.*, a rectangle, square, or circle), and with a substantially uniform intensity profile and energy distribution. In some embodiments, the efficiency, or the amount of light transmitted by the diffuser 304, is greater than 70% of the light emitted by the emitter 302. In some embodiments, the efficiency is greater than 90% of the emitted light. Other optical elements known in the art may be used for the diffuser 304.

**[0038]** In an embodiment, the diffuser 304 has a substantially rectangular shape having dimensions within a range of approximately 0.5-2 cm in width and approximately 1-4 centimeters in length. In another embodiment, the substantially rectangular shape of the diffuser 304 has dimensions of approximately 0.5 cm in width and approximately 1 cm in length. In another embodiment, the diffuser's 304 substantially rectangular shape has dimensions of approximately 1 cm in width and approximately 1.5 cm in length. In yet another embodiment, the diffuser 304 has a

*Clean Specification*

substantially square shape with dimensions in the range of approximately 0.25-10 cm<sup>2</sup>.

**[0039]** The light-absorbing detector filter 306, which is also depicted in FIG. 4A in a top view, is a planar surface having an opening 402 through which the emitted light may pass after being attenuated by the tissue measurement site 102. In the depicted embodiment, the opening 402 is rectangular-shaped, with dimensions substantially similar to the irradiated surface area 206. According to an embodiment, the light-absorbing detector filter is substantially rectangular in shape and has outer dimensions of 4 cm in width and 8 cm in length, and has an opening through which emitted light may pass, the opening having dimensions of 2 cm in width and 5 cm in length. In another embodiment, the light-absorbing detector filter is substantially rectangular in shape and has outer dimensions in the range of 1-3 cm in width and 2-8 cm in length, and has an opening through which emitted light may pass, the opening having dimensions in the range of 0.25-2 cm in width and 1-4 cm in length. In yet another embodiment, the light-absorbing detector filter is substantially rectangular in shape and has outer dimensions of 3 cm in width and 6 cm in length, and has an opening through which emitted light may pass, the opening having dimensions of 1.5 cm in width and 4 cm in length.

**[0040]** The top surface of the light-absorbing filter 306 (facing the tissue measurement site 102 and the emitter 302) is coated with a material that absorbs light, such as, for example, black pigment. Many other types of light-absorbing materials are well known in the art and can be used with the detector filter 306. During operation, light emitted from the emitter 302 can reflect off of the tissue measurement site 102 (or other structures within the 3D sensor 300) to neighboring portions of the 3D sensor 300. If those neighboring portions of the 3D sensor 300 possess reflective surfaces, then the light can reflect back to the tissue measurement site 102, progress through the tissue and arrive at the detector 310. Such multiple scattering can result in detecting photons whose pathlengths are considerably longer than most of the light that is detected, thereby introducing variations in pathlength which will affect the accuracy of the measurements of the pulse oximetry 3D sensor 300. Advantageously, the light-absorbing filter 306

reduces or eliminates the amount of emitted light that is reflected in this manner because it absorbs such reflected light, thereby stopping the chain of scattering events. In certain embodiments, the sensor-facing surfaces of other portions of the 3D sensor 300 are covered in light-absorbing material to further decrease the effect of reflective multiple scattering.

**[0041]** The light concentrator 308 is a structure to receive the emitted optical radiation, after attenuation by the tissue measurement site 102, to collect and concentrate the dispersed optical radiation, and to direct the collected and concentrated optical radiation to the detector 310. In an embodiment, the light concentrator 308 is made of ground glass or glass beads. In some embodiments, the light concentrator 308 includes a compound parabolic concentrator.

**[0042]** As described above with respect to FIG. 1, the detector 310 captures and measures light from the tissue measurement site 102. For example, the detector 310 can capture and measure light transmitted from the emitter 302 that has been attenuated by the tissue in the measurement site 102. The detector 310 can output a detector signal responsive to the light captured or measured. The detector 310 can be implemented using one or more photodiodes, phototransistors, or the like. In addition, a plurality of detectors 310 can be arranged in an array with a spatial configuration corresponding to the irradiated surface area 206 to capture the attenuated or reflected light from the tissue measurement site.

**[0043]** Referring to FIG. 4A, a top view of a portion of the 3D sensor 300 is provided. The light-absorbing detector filter 306 is illustrated having a top surface coated with a light-absorbing material. The light-absorbing material can be a black opaque material or coating or any other dark color or coating configured to absorb light. Additionally, a rectangular opening 402 is positioned relative to the light concentrator 308 (shown in phantom) and the detector 310 such that light may pass through the rectangular opening 402, into the light concentrator 308, and to the detector 310. FIG. 4B illustrates the top view of a portion of the 3D sensor 300 as in FIG. 4A, with the addition of the tissue measurement site 102 in operational position. Accordingly, the rectangular opening 402, the light concentrator 308 and the detector 310 are shown in phantom as being under the tissue measurement site

*Clean Specification*

102. In FIGS. 4A and 4B, the light concentrator 308 is shown to have dimensions significantly larger than the dimensions of the rectangular opening 402. In other embodiments, the dimensions of the light concentrator 308, the rectangular opening 402, and the irradiated surface area 206 are substantially similar.

**[0044]** FIG. 5 illustrates a top view of a 3D pulse oximetry sensor 500 according to an embodiment of the present disclosure. The 3D sensor 500 is configured to be worn on a patient's finger 102. The 3D sensor 500 includes an adhesive substrate 502 having front flaps 504 and rear flaps 506 extending outward from a center portion 508 of the 3D sensor 500. The center portion 508 includes components of the 3D pulse oximetry sensor 300 described with respect to FIGS. 3, 4A and 4B. On the front side of the adhesive substrate 502 the emitter 302 and the light diffuser 304 are positioned. On the rear side of the adhesive substrate 502 the light-absorbent detector filter 306, the light concentrator 308 and the detector 310 are positioned. In use, the patient's finger serving as the tissue measurement site 102 is positioned over the rectangular opening 402 such that when the front portion of the adhesive substrate is folded over on top of the patient's finger 102, the emitter 302 and the light diffuser 304 are aligned with the measurement site 102, the filter 306, the light concentrator 308 and the detector 310. Once alignment is established, the front and rear flaps 504, 506 can be wrapped around the finger measurement site 102 such that the adhesive substrate 502 provides a secure contact between the patient's skin and the 3D sensor 500. Fig. 5 also illustrates an example of a sensor connector cable 510 which is used to connect the 3D sensor 500 to a monitor 809, as described with respect to FIG. 8.

**[0045]** FIG. 6 is a simplified schematic illustration of a conventional, 2D approach to reflective pulse oximetry in which the emitter is configured to emit optical radiation as a point optical source. Reflective pulse oximetry is a method by which the emitter and detector are located on the same side of the tissue measurement site 102. Light is emitted into a tissue measurement site 102 and attenuated. The emitted light passes into the tissue 102 and is then reflected back to the same side of the tissue measurement site 102 as the emitter. As illustrated in FIG. 6, a depicted reflective 2D pulse oximetry sensor 600 includes an emitter 602,

a light block 606, and a detector 610. The light block 606 is necessary because the emitter 602 and the detector 610 are located on the same side of the tissue measurement site 102. Accordingly, the light block 606 prevents incident emitter light, which did not enter the tissue measurement site 102, from arriving at the detector 610. The depicted 2D pulse oximetry sensor 600 is configured to emit light as a point source. As depicted in FIG. 6, a simplified illustration of the light path 620 of the emitted light from the emitter 602, through the tissue measurement site 102, and to the detector 610 is provided. Notably, a point source of light is emitted, and a point source of light is detected. As discussed above with respect to FIG. 1, use of a point optical source can result in substantial measurement error due to pathlength variability resulting from the multiple scatter phenomenon. The sample space provided by a 2D point optical emitter source is not large enough to account for pathlength variability, which will skew measurement results.

**[0046]** FIGS. 7A and 7B are simplified schematic side and top views, respectively, of a 3D reflective pulse oximetry sensor 700 according to an embodiment of the present disclosure. In the illustrated embodiment, the 3D sensor 700 irradiates the tissue measurement site 102 and detects the emitted light that is reflected by the tissue measurement site 102. The 3D sensor 700 can be placed on a portion of the patient's body that has relatively flat surface, such as, for example a wrist, because the emitter 702 and detector 710 are on located the same side of the tissue measurement site 102. The 3D sensor 700 includes an emitter 702, a light diffuser 704, a light block 706, a light concentrator 708, and a detector 710.

**[0047]** As previously described, the emitter 702 can serve as the source of optical radiation transmitted towards the tissue measurement site 102. The emitter 702 can include one or more sources of optical radiation. Such sources of optical radiation can include LEDs, laser diodes, incandescent bulbs with appropriate frequency-selective filters, combinations of the same, or the like. In an embodiment, the emitter 702 includes sets of optical sources that are capable of emitting visible and near-infrared optical radiation. In some embodiments, the emitter 702 transmits optical radiation of red and infrared wavelengths, at approximately 650 nm and

approximately 940 nm, respectively. In some embodiments, the emitter 702 includes a single source of optical radiation.

**[0048]** The light diffuser 704 receives the optical radiation emitted from the emitter 302 and homogeneously spreads the optical radiation over a wide, donut-shaped area, such as the area outlined by the light diffuser 704 as depicted in FIG. 7B. Advantageously, the diffuser 704 can receive emitted light in the form of a 2D point optical source (or any other form) and spread the light to fit the desired surface area on a plane defined by the surface of the tissue measurement site 102. In an embodiment, the diffuser 704 is made of ground glass or glass beads. A skilled artisan will understand that many other materials can be used to make the light diffuser 704.

**[0049]** The light blocker 706 includes an annular ring having a cover portion 707 sized and shaped to form a light isolation chamber for the light concentrator 708 and the detector 710. (For purposes of illustration, the light block cover 707 is not illustrated in FIG. 7B.) The light blocker 706 and the cover 707 can be made of any material that optically isolates the light concentrator 708 and the detector 710. The light isolation chamber formed by the light blocker 706 and cover 708 ensures that the only light detected by the detector 710 is light that is reflected from the tissue measurement site.

**[0050]** The light concentrator 708 is a cylindrical structure with a truncated circular conical structure on top, the truncated section of which is adjacent the detector 710. The light concentrator 708 is structured to receive the emitted optical radiation, after reflection by the tissue measurement site 102, and to direct the reflected light to the detector 710. In an embodiment, the light concentrator 708 is made of ground glass or glass beads. In some embodiments, the light concentrator 708 includes a compound parabolic concentrator.

**[0051]** As previously described, the detector 710 captures and measures light from the tissue measurement site 102. For example, the detector 710 can capture and measure light transmitted from the emitter 702 that has been reflected from the tissue in the measurement site 102. The detector 710 can output a detector signal responsive to the light captured or measured. The detector 710 can be

*Clean Specification*

implemented using one or more photodiodes, phototransistors, or the like. In addition, a plurality of detectors 710 can be arranged in an array with a spatial configuration corresponding to the irradiated surface area depicted in FIG. 7B by the light concentrator 708 to capture the reflected light from the tissue measurement site.

**[0052]** Advantageously, the light path 720 illustrated in FIG. 7A depicts a substantial sample of reflected light that enter the light isolation chamber formed by the light blocker 706 and cover 707. As previously discussed, the large sample of reflected light (as compared to the reflected light collected using the 2D point optical source approach) provides the opportunity to take an average of the detected light, to derive a more accurate measurement of the emitted light absorbed by the tissue, which will lead to a more accurate oxygen saturation measurement.

**[0053]** Referring now to FIG. 7B, a top view of the 3D sensor 700 is illustrated with both the emitter 702 and the light blocker cover 707 removed for ease of illustration. The outer ring illustrates the footprint of the light diffuser 704. As light is emitted from the emitter 702 (not shown in FIG. 7B), it is diffused homogeneously and directed to the tissue measurement site 102. The light blocker 706 forms the circular wall of a light isolation chamber to keep incident light from being sensed by the detector 710. The light blocker cover 707 blocks incidental light from entering the light isolation chamber from above. The light concentrator 710 collects the reflected light from the tissue measurement site 102 and funnels it upward toward the detector 710 at the center of the 3D sensor 700.

**[0054]** FIG. 8 illustrates an example of an optical physiological measurement system 800, which may also be referred to herein as a pulse oximetry system 800. In certain embodiments, the pulse oximetry system 800 noninvasively measures a blood analyte, such as oxygen, carboxyhemoglobin, methemoglobin, total hemoglobin, glucose, proteins, lipids, a percentage thereof (*e.g.*, saturation), pulse rate, perfusion index, oxygen content, total hemoglobin, Oxygen Reserve Index™ (ORI™) or many other physiologically relevant patient characteristics. These characteristics can relate to, for example, pulse rate, hydration, trending information and analysis, and the like. The system 800 can also measure additional blood



analytes and/or other physiological parameters useful in determining a state or trend of wellness of a patient.

**[0055]** The pulse oximetry system 800 can measure analyte concentrations at least in part by detecting optical radiation attenuated by tissue at a measurement site 102. The measurement site 102 can be any location on a patient's body, such as a finger, foot, earlobe, wrist, forehead, or the like.

**[0056]** The pulse oximetry system 800 can include a sensor 801 (or multiple sensors) that is coupled to a processing device or physiological monitor 809. In an embodiment, the sensor 801 and the monitor 809 are integrated together into a single unit. In another embodiment, the sensor 801 and the monitor 809 are separate from each other and communicate with one another in any suitable manner, such as via a wired or wireless connection. The sensor 801 and monitor 809 can be attachable and detachable from each other for the convenience of the user or caregiver, for ease of storage, sterility issues, or the like.

**[0057]** In the depicted embodiment shown in FIG. 8, the sensor 801 includes an emitter 804, a detector 806, and a front-end interface 808. The emitter 804 can serve as the source of optical radiation transmitted towards measurement site 102. The emitter 804 can include one or more sources of optical radiation, such as light emitting diodes (LEDs), laser diodes, incandescent bulbs with appropriate frequency-selective filters, combinations of the same, or the like. In an embodiment, the emitter 804 includes sets of optical sources that are capable of emitting visible and near-infrared optical radiation.

**[0058]** The pulse oximetry system 800 also includes a driver 811 that drives the emitter 804. The driver 111 can be a circuit or the like that is controlled by the monitor 809. For example, the driver 811 can provide pulses of current to the emitter 804. In an embodiment, the driver 811 drives the emitter 804 in a progressive fashion, such as in an alternating manner. The driver 811 can drive the emitter 804 with a series of pulses for some wavelengths that can penetrate tissue relatively well and for other wavelengths that tend to be significantly absorbed in tissue. A wide variety of other driving powers and driving methodologies can be used in various embodiments. The driver 811 can be synchronized with other parts

*Clean Specification*

of the sensor 801 to minimize or reduce jitter in the timing of pulses of optical radiation emitted from the emitter 804. In some embodiments, the driver 811 is capable of driving the emitter 804 to emit optical radiation in a pattern that varies by less than about 10 parts-per-million.

**[0059]** The detector 806 captures and measures light from the tissue measurement site 102. For example, the detector 806 can capture and measure light transmitted from the emitter 804 that has been attenuated or reflected from the tissue at the measurement site 102. The detector 806 can output a detector signal 107 responsive to the light captured and measured. The detector 806 can be implemented using one or more photodiodes, phototransistors, or the like. In some embodiments, a detector 806 is implemented in detector package to capture and measure light from the tissue measurement site 102 of the patient. The detector package can include a photodiode chip mounted to leads and enclosed in an encapsulant. In some embodiments, the dimensions of the detector package are approximately 2 square centimeters. In other embodiments, the dimensions of the detector package are approximately 1.5 centimeters in width and approximately 2 centimeters in length.

**[0060]** The front-end interface 808 provides an interface that adapts the output of the detectors 806, which is responsive to desired physiological parameters. For example, the front-end interface 808 can adapt the signal 807 received from the detector 806 into a form that can be processed by the monitor 809, for example, by a signal processor 810 in the monitor 809. The front-end interface 808 can have its components assembled in the sensor 801, in the monitor 809, in a connecting cabling (if used), in combinations of the same, or the like. The location of the front-end interface 808 can be chosen based on various factors including space desired for components, desired noise reductions or limits, desired heat reductions or limits, and the like.

**[0061]** The front-end interface 808 can be coupled to the detector 806 and to the signal processor 810 using a bus, wire, electrical or optical cable, flex circuit, or some other form of signal connection. The front-end interface 808 can also be at least partially integrated with various components, such as the detectors 806. For

example, the front-end interface 808 can include one or more integrated circuits that are on the same circuit board as the detector 806. Other configurations can also be used.

**[0062]** As shown in FIG. 8, the monitor 909 can include the signal processor 810 and a user interface, such as a display 812. The monitor 809 can also include optional outputs alone or in combination with the display 812, such as a storage device 814 and a network interface 816. In an embodiment, the signal processor 810 includes processing logic that determines measurements for desired analytes based on the signals received from the detector 806. The signal processor 810 can be implemented using one or more microprocessors or sub-processors (*e.g.*, cores), digital signal processors, application specific integrated circuits (ASICs), field programmable gate arrays (FPGAs), combinations of the same, and the like.

**[0063]** The signal processor 810 can provide various signals that control the operation of the sensor 801. For example, the signal processor 810 can provide an emitter control signal to the driver 811. This control signal can be useful in order to synchronize, minimize, or reduce jitter in the timing of pulses emitted from the emitter 804. Accordingly, this control signal can be useful in order to cause optical radiation pulses emitted from the emitter 804 to follow a precise timing and consistent pattern. For example, when a transimpedance-based front-end interface 808 is used, the control signal from the signal processor 810 can provide synchronization with an analog-to-digital converter (ADC) in order to avoid aliasing, cross-talk, and the like. As also shown, an optional memory 813 can be included in the front-end interface 808 and/or in the signal processor 810. This memory 813 can serve as a buffer or storage location for the front-end interface 808 and/or the signal processor 810, among other uses.

**[0064]** The user interface 812 can provide an output, *e.g.*, on a display, for presentation to a user of the pulse oximetry system 800. The user interface 812 can be implemented as a touch-screen display, a liquid crystal display (LCD), an organic LED display, or the like. In alternative embodiments, the pulse oximetry system 800

can be provided without a user interface 812 and can simply provide an output signal to a separate display or system.

**[0065]** The storage device 814 and a network interface 816 represent other optional output connections that can be included in the monitor 809. The storage device 814 can include any computer-readable medium, such as a memory device, hard disk storage, EEPROM, flash drive, or the like. The various software and/or firmware applications can be stored in the storage device 814, which can be executed by the signal processor 810 or another processor of the monitor 809. The network interface 816 can be a serial bus port (RS-232/RS-485), a Universal Serial Bus (USB) port, an Ethernet port, a wireless interface (*e.g.*, WiFi such as any 802.1x interface, including an internal wireless card), or other suitable communication device(s) that allows the monitor 809 to communicate and share data with other devices. The monitor 809 can also include various other components not shown, such as a microprocessor, graphics processor, or controller to output the user interface 812, to control data communications, to compute data trending, or to perform other operations.

**[0066]** Although not shown in the depicted embodiment, the pulse oximetry system 800 can include various other components or can be configured in different ways. For example, the sensor 801 can have both the emitter 804 and detector 806 on the same side of the tissue measurement site 102 and use reflectance to measure analytes.

**[0067]** Although the foregoing disclosure has been described in terms of certain preferred embodiments, many other variations than those described herein will be apparent to those of ordinary skill in the art.

**[0068]** Conditional language used herein, such as, among others, "can," "might," "may," "*e.g.*," and the like, unless specifically stated otherwise, or otherwise understood within the context as used, is generally intended to convey that certain embodiments include, while other embodiments do not include, certain features, elements and/or states. Thus, such conditional language is not generally intended to imply that features, elements and/or states are in any way required for one or more embodiments or that one or more embodiments necessarily include logic for

*Clean Specification*

deciding, with or without author input or prompting, whether these features, elements and/or states are included or are to be performed in any particular embodiment. The terms "comprising," "including," "having," and the like are synonymous and are used inclusively, in an open-ended fashion, and do not exclude additional elements, features, acts, operations, and so forth. Also, the term "or" is used in its inclusive sense (and not in its exclusive sense) so that when used, for example, to connect a list of elements, the term "or" means one, some, or all of the elements in the list. Further, the term "each," as used herein, in addition to having its ordinary meaning, can mean any subset of a set of elements to which the term "each" is applied.

**[0069]** While the above detailed description has shown, described, and pointed out novel features as applied to various embodiments, it will be understood that various omissions, substitutions, and changes in the form and details of the systems, devices or algorithms illustrated can be made without departing from the spirit of the disclosure. As will be recognized, certain embodiments of the disclosure described herein can be embodied within a form that does not provide all of the features and benefits set forth herein, as some features can be used or practiced separately from others.

**[0070]** The term "and/or" herein has its broadest, least limiting meaning which is the disclosure includes A alone, B alone, both A and B together, or A or B alternatively, but does not require both A and B or require one of A or one of B. As used herein, the phrase "at least one of" A, B, "and" C should be construed to mean a logical A or B or C, using a non-exclusive logical or.

**[0071]** The apparatuses and methods described herein may be implemented by one or more computer programs executed by one or more processors. The computer programs include processor-executable instructions that are stored on a non-transitory tangible computer readable medium. The computer programs may also include stored data. Non-limiting examples of the non-transitory tangible computer readable medium are nonvolatile memory, magnetic storage, and optical storage. Although the foregoing disclosure has been described in terms of certain preferred embodiments, other embodiments will be apparent to those of

*Clean Specification*

ordinary skill in the art from the disclosure herein. Additionally, other combinations, omissions, substitutions and modifications will be apparent to the skilled artisan in view of the disclosure herein. Accordingly, the present invention is not intended to be limited by the description of the preferred embodiments, but is to be defined by reference to claims.

**[0072]** Additionally, all publications, patents, and patent applications mentioned in this specification are herein incorporated by reference to the same extent as if each individual publication, patent, or patent application were specifically and individually indicated to be incorporated by reference.

## Electronic Patent Application Fee Transmittal

<b>Application Number:</b>					
<b>Filing Date:</b>					
<b>Title of Invention:</b>	ADVANCED PULSE OXIMETRY SENSOR				
<b>First Named Inventor/Applicant Name:</b>	Ammar Al-Ali				
<b>Filer:</b>	Aaron Samuel Johnson/Daniel Escajeda				
<b>Attorney Docket Number:</b>	MAS.1007C1				
Filed as Large Entity					
<b>Filing Fees for Track I Prioritized Examination - Nonprovisional Application under 35 USC 111(a)</b>					
<b>Description</b>	<b>Fee Code</b>	<b>Quantity</b>	<b>Amount</b>	<b>Sub-Total in USD(\$)</b>	
<b>Basic Filing:</b>					
UTILITY APPLICATION FILING	1011	1	300	300	
UTILITY SEARCH FEE	1111	1	660	660	
UTILITY EXAMINATION FEE	1311	1	760	760	
REQUEST FOR PRIORITIZED EXAMINATION	1817	1	4000	4000	
<b>Pages:</b>					
<b>Claims:</b>					
<b>Miscellaneous-Filing:</b>					

Description	Fee Code	Quantity	Amount	Sub-Total in USD(\$)
PUBL. FEE- EARLY, VOLUNTARY, OR NORMAL	1504	1	0	0
PROCESSING FEE, EXCEPT PROV. APPLS.	1830	1	140	140
<b>Petition:</b>				
<b>Patent-Appeals-and-Interference:</b>				
<b>Post-Allowance-and-Post-Issuance:</b>				
<b>Extension-of-Time:</b>				
<b>Miscellaneous:</b>				
<b>Total in USD (\$)</b>				<b>5860</b>



## Electronic Acknowledgement Receipt

<b>EFS ID:</b>	34636172
<b>Application Number:</b>	16226249
<b>International Application Number:</b>	
<b>Confirmation Number:</b>	1002
<b>Title of Invention:</b>	ADVANCED PULSE OXIMETRY SENSOR
<b>First Named Inventor/Applicant Name:</b>	Ammar Al-Ali
<b>Customer Number:</b>	64735
<b>Filer:</b>	Aaron Samuel Johnson/Gustavo Lopez
<b>Filer Authorized By:</b>	Aaron Samuel Johnson
<b>Attorney Docket Number:</b>	MAS.1007C1
<b>Receipt Date:</b>	19-DEC-2018
<b>Filing Date:</b>	
<b>Time Stamp:</b>	18:02:05
<b>Application Type:</b>	Utility under 35 USC 111(a)

### Payment information:

Submitted with Payment	yes
Payment Type	CARD
Payment was successfully received in RAM	\$5860
RAM confirmation Number	122018INTEFSW18031100
Deposit Account	111410
Authorized User	Gustavo Lopez

The Director of the USPTO is hereby authorized to charge indicated fees and credit any overpayment as follows:

37 CFR 1.16 (National application filing, search, and examination fees)

37 CFR 1.17 (Patent application and reexamination processing fees)

<b>File Listing:</b>					
Document Number	Document Description	File Name	File Size(Bytes)/ Message Digest	Multi Part /.zip	Pages (if appl.)
1	TrackOne Request	TrackOneRequest_MAS1007C1.PDF	147678	no	2
			02bc8c0aa972c7779160096ca7092f29cc35021		
<b>Warnings:</b>					
<b>Information:</b>					
2	Application Data Sheet	ADS_MAS1007C1.PDF	1823009	no	8
			a4e8712705c4ca57c92ac89bc3af0aec623468a7		
<b>Warnings:</b>					
<b>Information:</b>					
3	Power of Attorney	POA_MAS1007C1.PDF	453501	no	3
			ee14bf49cf9d697be6aae74682eb768a547af939		
<b>Warnings:</b>					
<b>Information:</b>					
4		Spec_MAS1007C1.pdf	164392	yes	30
			28b5dbd646d840b000fd26fcf504147d670822c6		
	<b>Multipart Description/PDF files in .zip description</b>				
	<b>Document Description</b>		<b>Start</b>	<b>End</b>	
	Abstract		30	30	
	Claims		25	29	
	Specification		1	24	
<b>Warnings:</b>					
<b>Information:</b>					
5	Drawings-only black and white line drawings	Drawings_MAS1007C1.PDF	228624	no	7
			ce66a69576ddc1dd5e49f14da746e9c185e99fe7		

<b>Warnings:</b>					
<b>Information:</b>					
6		Prelim_MAS1007C1.pdf	49321	yes	9
			2cb3e6e912b398821d3facd2d362e8bbc5a fb347		
<b>Multipart Description/PDF files in .zip description</b>					
		<b>Document Description</b>	<b>Start</b>	<b>End</b>	
		Applicant Arguments/Remarks Made in an Amendment	9	9	
		Claims	4	8	
		Specification	2	3	
		Preliminary Amendment	1	1	
<b>Warnings:</b>					
<b>Information:</b>					
7		IDS_MAS1007C1.pdf	290742	yes	30
			79f9b44f3df992b328f89c4afd2e1d23c4a17 a58		
<b>Multipart Description/PDF files in .zip description</b>					
		<b>Document Description</b>	<b>Start</b>	<b>End</b>	
		Information Disclosure Statement (IDS) Form (SB08)	3	30	
		Transmittal Letter	1	2	
<b>Warnings:</b>					
<b>Information:</b>					
8	Specification	marked-Spec_MAS1007C1.pdf	151393	no	24
			44b6ebbe701112d4e5d96b5d41422bf05c bdbe27		
<b>Warnings:</b>					
<b>Information:</b>					
9	Specification	clean-Spec_MAS1007C1.pdf	149858	no	24
			8220852c45c8a7cbad999faf985e2d3a6d8c7 9ee8		
<b>Warnings:</b>					
<b>Information:</b>					

10	Fee Worksheet (SB06)	fee-info.pdf	40200 6f3918ae1f35327d4eecd30de51e10ae5c66d86e3	no	2
<b>Warnings:</b>					
<b>Information:</b>					
<b>Total Files Size (in bytes):</b>				3498718	
<p><b>This Acknowledgement Receipt evidences receipt on the noted date by the USPTO of the indicated documents, characterized by the applicant, and including page counts, where applicable. It serves as evidence of receipt similar to a Post Card, as described in MPEP 503.</b></p> <p><b><u>New Applications Under 35 U.S.C. 111</u></b>  <b>If a new application is being filed and the application includes the necessary components for a filing date (see 37 CFR 1.53(b)-(d) and MPEP 506), a Filing Receipt (37 CFR 1.54) will be issued in due course and the date shown on this Acknowledgement Receipt will establish the filing date of the application.</b></p> <p><b><u>National Stage of an International Application under 35 U.S.C. 371</u></b>  <b>If a timely submission to enter the national stage of an international application is compliant with the conditions of 35 U.S.C. 371 and other applicable requirements a Form PCT/DO/EO/903 indicating acceptance of the application as a national stage submission under 35 U.S.C. 371 will be issued in addition to the Filing Receipt, in due course.</b></p> <p><b><u>New International Application Filed with the USPTO as a Receiving Office</u></b>  <b>If a new international application is being filed and the international application includes the necessary components for an international filing date (see PCT Article 11 and MPEP 1810), a Notification of the International Application Number and of the International Filing Date (Form PCT/RO/105) will be issued in due course, subject to prescriptions concerning national security, and the date shown on this Acknowledgement Receipt will establish the international filing date of the application.</b></p>					

**CERTIFICATION AND REQUEST FOR PRIORITIZED EXAMINATION  
 UNDER 37 CFR 1.102(e)** (Page 1 of 1)

First Named Inventor:	Ammar Al-Ali	Nonprovisional Application Number (if known):	MAS.1007C1
Title of Invention:	ADVANCED PULSE OXIMETRY SENSOR		

**APPLICANT HEREBY CERTIFIES THE FOLLOWING AND REQUESTS PRIORITIZED EXAMINATION FOR THE ABOVE-IDENTIFIED APPLICATION.**

1. The processing fee set forth in 37 CFR 1.17(i)(1) and the prioritized examination fee set forth in 37 CFR 1.17(c) have been filed with the request. The publication fee requirement is met because that fee, set forth in 37 CFR 1.18(d), is currently \$0. The basic filing fee, search fee, and examination fee are filed with the request or have been already been paid. I understand that any required excess claims fees or application size fee must be paid for the application.
2. I understand that the application may not contain, or be amended to contain, more than four independent claims, more than thirty total claims, or any multiple dependent claims, and that any request for an extension of time will cause an outstanding Track I request to be dismissed.
3. The applicable box is checked below:
  - I.  **Original Application (Track One) - Prioritized Examination under § 1.102(e)(1)**
    - i. (a) The application is an original nonprovisional utility application filed under 35 U.S.C. 111(a). This certification and request is being filed with the utility application via EFS-Web.  
 ---OR---
      - (b) The application is an original nonprovisional plant application filed under 35 U.S.C. 111(a). This certification and request is being filed with the plant application in paper.
    - ii. An executed inventor's oath or declaration under 37 CFR 1.63 or 37 CFR 1.64 for each inventor, or the application data sheet meeting the conditions specified in 37 CFR 1.53(f)(3)(i) is filed with the application.
  - II.  **Request for Continued Examination - Prioritized Examination under § 1.102(e)(2)**
    - i. A request for continued examination has been filed with, or prior to, this form.
    - ii. If the application is a utility application, this certification and request is being filed via EFS-Web.
    - iii. The application is an original nonprovisional utility application filed under 35 U.S.C. 111(a), or is a national stage entry under 35 U.S.C. 371.
    - iv. This certification and request is being filed prior to the mailing of a first Office action responsive to the request for continued examination.
    - v. No prior request for continued examination has been granted prioritized examination status under 37 CFR 1.102(e)(2).

Signature /Aaron Johnson/	Date 2018-12-19
Name (Print/Typed) Aaron Johnson	Practitioner Registration Number 74,164

**Note:** This form must be signed in accordance with 37 CFR 1.33. See 37 CFR 1.4(d) for signature requirements and certifications. Submit multiple forms if more than one signature is required.\*

\*Total of 1 forms are submitted.

## Privacy Act Statement

The **Privacy Act of 1974 (P.L. 93-579)** requires that you be given certain information in connection with your submission of the attached form related to a patent application or patent. Accordingly, pursuant to the requirements of the Act, please be advised that: (1) the general authority for the collection of this information is 35 U.S.C. 2(b)(2); (2) furnishing of the information solicited is voluntary; and (3) the principal purpose for which the information is used by the U.S. Patent and Trademark Office is to process and/or examine your submission related to a patent application or patent. If you do not furnish the requested information, the U.S. Patent and Trademark Office may not be able to process and/or examine your submission, which may result in termination of proceedings or abandonment of the application or expiration of the patent.

The information provided by you in this form will be subject to the following routine uses:

1. The information on this form will be treated confidentially to the extent allowed under the Freedom of Information Act (5 U.S.C. 552) and the Privacy Act (5 U.S.C. 552a). Records from this system of records may be disclosed to the Department of Justice to determine whether disclosure of these records is required by the Freedom of Information Act.
2. A record from this system of records may be disclosed, as a routine use, in the course of presenting evidence to a court, magistrate, or administrative tribunal, including disclosures to opposing counsel in the course of settlement negotiations.
3. A record in this system of records may be disclosed, as a routine use, to a Member of Congress submitting a request involving an individual, to whom the record pertains, when the individual has requested assistance from the Member with respect to the subject matter of the record.
4. A record in this system of records may be disclosed, as a routine use, to a contractor of the Agency having need for the information in order to perform a contract. Recipients of information shall be required to comply with the requirements of the Privacy Act of 1974, as amended, pursuant to 5 U.S.C. 552a(m).
5. A record related to an International Application filed under the Patent Cooperation Treaty in this system of records may be disclosed, as a routine use, to the International Bureau of the World Intellectual Property Organization, pursuant to the Patent Cooperation Treaty.
6. A record in this system of records may be disclosed, as a routine use, to another federal agency for purposes of National Security review (35 U.S.C. 181) and for review pursuant to the Atomic Energy Act (42 U.S.C. 218(c)).
7. A record from this system of records may be disclosed, as a routine use, to the Administrator, General Services, or his/her designee, during an inspection of records conducted by GSA as part of that agency's responsibility to recommend improvements in records management practices and programs, under authority of 44 U.S.C. 2904 and 2906. Such disclosure shall be made in accordance with the GSA regulations governing inspection of records for this purpose, and any other relevant (*i.e.*, GSA or Commerce) directive. Such disclosure shall not be used to make determinations about individuals.
8. A record from this system of records may be disclosed, as a routine use, to the public after publication of the application pursuant to 35 U.S.C. 122(b) or issuance of a patent pursuant to 35 U.S.C. 151. Further, a record may be disclosed, subject to the limitations of 37 CFR 1.14, as a routine use, to the public if the record was filed in an application which became abandoned or in which the proceedings were terminated and which application is referenced by either a published application, an application open to public inspection or an issued patent.
9. A record from this system of records may be disclosed, as a routine use, to a Federal, State, or local law enforcement agency, if the USPTO becomes aware of a violation or potential violation of law or regulation.

Under the Paperwork Reduction Act of 1995, no persons are required to respond to a collection of information unless it contains a valid OMB control number.

<b>Application Data Sheet 37 CFR 1.76</b>		Attorney Docket Number	MAS.1007C1
		Application Number	
Title of Invention	ADVANCED PULSE OXIMETRY SENSOR		
The application data sheet is part of the provisional or nonprovisional application for which it is being submitted. The following form contains the bibliographic data arranged in a format specified by the United States Patent and Trademark Office as outlined in 37 CFR 1.76. This document may be completed electronically and submitted to the Office in electronic format using the Electronic Filing System (EFS) or the document may be printed and included in a paper filed application.			

**Secrecy Order 37 CFR 5.2:**

Portions or all of the application associated with this Application Data Sheet may fall under a Secrecy Order pursuant to 37 CFR 5.2 (Paper filers only. Applications that fall under Secrecy Order may not be filed electronically.)

**Inventor Information:**

Inventor	1				Remove	
Legal Name						
Prefix	Given Name	Middle Name	Family Name	Suffix		
	Ammar		Al-Ali			
Residence Information (Select One) <input checked="" type="radio"/> US Residency <input type="radio"/> Non US Residency <input type="radio"/> Active US Military Service						
City	San Juan Capistrano	State/Province	CA	Country of Residence	US	
Mailing Address of Inventor:						
Address 1	80312 Via Bella					
Address 2						
City	San Juan Capistrano	State/Province	CA			
Postal Code	92675	Country	US			
Inventor	2				Remove	
Legal Name						
Prefix	Given Name	Middle Name	Family Name	Suffix		
	Stephen		Scruggs			
Residence Information (Select One) <input checked="" type="radio"/> US Residency <input type="radio"/> Non US Residency <input type="radio"/> Active US Military Service						
City	Newport Beach	State/Province	CA	Country of Residence	US	
Mailing Address of Inventor:						
Address 1	807 Snug Harbor Road					
Address 2						
City	Newport Beach	State/Province	CA			
Postal Code	92663	Country	US			
All Inventors Must Be Listed - Additional Inventor Information blocks may be generated within this form by selecting the Add button.						
Add						

**Correspondence Information:**

Enter either Customer Number or complete the Correspondence Information section below.  
For further information see 37 CFR 1.33(a).

Under the Paperwork Reduction Act of 1995, no persons are required to respond to a collection of information unless it contains a valid OMB control number.

<b>Application Data Sheet 37 CFR 1.76</b>		Attorney Docket Number	MAS.1007C1
		Application Number	
Title of Invention	ADVANCED PULSE OXIMETRY SENSOR		

 An Address is being provided for the correspondence information of this application.

Customer Number	64735		
Email Address	efiling@knobbe.com	<input type="button" value="Add Email"/>	<input type="button" value="Remove Email"/>

### Application Information:

Title of the Invention	ADVANCED PULSE OXIMETRY SENSOR		
Attorney Docket Number	MAS.1007C1	Small Entity Status Claimed	<input type="checkbox"/>
Application Type	Nonprovisional		
Subject Matter	Utility		
Total Number of Drawing Sheets (if any)	7	Suggested Figure for Publication (if any)	

### Filing By Reference:

Only complete this section when filing an application by reference under 35 U.S.C. 111(c) and 37 CFR 1.57(a). Do not complete this section if application papers including a specification and any drawings are being filed. Any domestic benefit or foreign priority information must be provided in the appropriate section(s) below (i.e., "Domestic Benefit/National Stage Information" and "Foreign Priority Information").

For the purposes of a filing date under 37 CFR 1.53(b), the description and any drawings of the present application are replaced by this reference to the previously filed application, subject to conditions and requirements of 37 CFR 1.57(a).

Application number of the previously filed application	Filing date (YYYY-MM-DD)	Intellectual Property Authority or Country

### Publication Information:

 Request Early Publication (Fee required at time of Request 37 CFR 1.219)

**Request Not to Publish.** I hereby request that the attached application not be published under 35 U.S.C. 122(b) and certify that the invention disclosed in the attached application **has not and will not be** the subject of an application filed in another country, or under a multilateral international agreement, that requires publication at eighteen months after filing.

### Representative Information:

Representative information should be provided for all practitioners having a power of attorney in the application. Providing this information in the Application Data Sheet does not constitute a power of attorney in the application (see 37 CFR 1.32). Either enter Customer Number or complete the Representative Name section below. If both sections are completed the customer number will be used for the Representative Information during processing.

Please Select One:	<input checked="" type="radio"/> Customer Number	<input type="radio"/> US Patent Practitioner	<input type="radio"/> Limited Recognition (37 CFR 11.9)
Customer Number	64735		



Under the Paperwork Reduction Act of 1995, no persons are required to respond to a collection of information unless it contains a valid OMB control number.

<b>Application Data Sheet 37 CFR 1.76</b>		Attorney Docket Number	MAS.1007C1
		Application Number	
Title of Invention	ADVANCED PULSE OXIMETRY SENSOR		

### Domestic Benefit/National Stage Information:

This section allows for the applicant to either claim benefit under 35 U.S.C. 119(e), 120, 121, 365(c), or 386(c) or indicate National Stage entry from a PCT application. Providing benefit claim information in the Application Data Sheet constitutes the specific reference required by 35 U.S.C. 119(e) or 120, and 37 CFR 1.78.

When referring to the current application, please leave the "Application Number" field blank.

Prior Application Status	Pending		<input type="button" value="Remove"/>
Application Number	Continuity Type	Prior Application Number	Filing or 371(c) Date (YYYY-MM-DD)
	Continuation of	15/195199	2016-06-28
Prior Application Status	Expired		<input type="button" value="Remove"/>
Application Number	Continuity Type	Prior Application Number	Filing or 371(c) Date (YYYY-MM-DD)
15/195199	Claims benefit of provisional	62/188430	2015-07-02
Additional Domestic Benefit/National Stage Data may be generated within this form by selecting the <b>Add</b> button.			<input type="button" value="Add"/>

### Foreign Priority Information:

This section allows for the applicant to claim priority to a foreign application. Providing this information in the application data sheet constitutes the claim for priority as required by 35 U.S.C. 119(b) and 37 CFR 1.55. When priority is claimed to a foreign application that is eligible for retrieval under the priority document exchange program (PDX)<sup>i</sup> the information will be used by the Office to automatically attempt retrieval pursuant to 37 CFR 1.55(i)(1) and (2). Under the PDX program, applicant bears the ultimate responsibility for ensuring that a copy of the foreign application is received by the Office from the participating foreign intellectual property office, or a certified copy of the foreign priority application is filed, within the time period specified in 37 CFR 1.55(g)(1).

			<input type="button" value="Remove"/>
Application Number	Country <sup>i</sup>	Filing Date (YYYY-MM-DD)	Access Code <sup>i</sup> (if applicable)
Additional Foreign Priority Data may be generated within this form by selecting the <b>Add</b> button.			<input type="button" value="Add"/>

### Statement under 37 CFR 1.55 or 1.78 for AIA (First Inventor to File) Transition Applications

- This application (1) claims priority to or the benefit of an application filed before March 16, 2013 and (2) also contains, or contained at any time, a claim to a claimed invention that has an effective filing date on or after March 16, 2013.
- NOTE: By providing this statement under 37 CFR 1.55 or 1.78, this application, with a filing date on or after March 16, 2013, will be examined under the first inventor to file provisions of the AIA.

<b>Application Data Sheet 37 CFR 1.76</b>		Attorney Docket Number	MAS.1007C1
		Application Number	
Title of Invention	ADVANCED PULSE OXIMETRY SENSOR		

## Authorization or Opt-Out of Authorization to Permit Access:

When this Application Data Sheet is properly signed and filed with the application, applicant has provided written authority to permit a participating foreign intellectual property (IP) office access to the instant application-as-filed (see paragraph A in subsection 1 below) and the European Patent Office (EPO) access to any search results from the instant application (see paragraph B in subsection 1 below).

Should applicant choose not to provide an authorization identified in subsection 1 below, applicant **must opt-out** of the authorization by checking the corresponding box A or B or both in subsection 2 below.

**NOTE:** This section of the Application Data Sheet is **ONLY** reviewed and processed with the **INITIAL** filing of an application. After the initial filing of an application, an Application Data Sheet cannot be used to provide or rescind authorization for access by a foreign IP office(s). Instead, Form PTO/SB/39 or PTO/SB/69 must be used as appropriate.

### 1. Authorization to Permit Access by a Foreign Intellectual Property Office(s)

**A. Priority Document Exchange (PDX)** - Unless box A in subsection 2 (opt-out of authorization) is checked, the undersigned hereby **grants the USPTO authority** to provide the European Patent Office (EPO), the Japan Patent Office (JPO), the Korean Intellectual Property Office (KIPO), the State Intellectual Property Office of the People's Republic of China (SIPO), the World Intellectual Property Organization (WIPO), and any other foreign intellectual property office participating with the USPTO in a bilateral or multilateral priority document exchange agreement in which a foreign application claiming priority to the instant patent application is filed, access to: (1) the instant patent application-as-filed and its related bibliographic data, (2) any foreign or domestic application to which priority or benefit is claimed by the instant application and its related bibliographic data, and (3) the date of filing of this Authorization. See 37 CFR 1.14(h)(1).

**B. Search Results from U.S. Application to EPO** - Unless box B in subsection 2 (opt-out of authorization) is checked, the undersigned hereby **grants the USPTO authority** to provide the EPO access to the bibliographic data and search results from the instant patent application when a European patent application claiming priority to the instant patent application is filed. See 37 CFR 1.14(h)(2).

The applicant is reminded that the EPO's Rule 141(1) EPC (European Patent Convention) requires applicants to submit a copy of search results from the instant application without delay in a European patent application that claims priority to the instant application.

### 2. Opt-Out of Authorizations to Permit Access by a Foreign Intellectual Property Office(s)

A. Applicant **DOES NOT** authorize the USPTO to permit a participating foreign IP office access to the instant application-as-filed. If this box is checked, the USPTO will not be providing a participating foreign IP office with any documents and information identified in subsection 1A above.

B. Applicant **DOES NOT** authorize the USPTO to transmit to the EPO any search results from the instant patent application. If this box is checked, the USPTO will not be providing the EPO with search results from the instant application.

**NOTE:** Once the application has published or is otherwise publicly available, the USPTO may provide access to the application in accordance with 37 CFR 1.14.

Under the Paperwork Reduction Act of 1995, no persons are required to respond to a collection of information unless it contains a valid OMB control number.

<b>Application Data Sheet 37 CFR 1.76</b>		Attorney Docket Number	MAS.1007C1
		Application Number	
Title of Invention	ADVANCED PULSE OXIMETRY SENSOR		

## Applicant Information:

Providing assignment information in this section does not substitute for compliance with any requirement of part 3 of Title 37 of CFR to have an assignment recorded by the Office.

<b>Applicant</b>	1	<input type="button" value="Remove"/>
<p>If the applicant is the inventor (or the remaining joint inventor or inventors under 37 CFR 1.45), this section should not be completed. The information to be provided in this section is the name and address of the legal representative who is the applicant under 37 CFR 1.43; or the name and address of the assignee, person to whom the inventor is under an obligation to assign the invention, or person who otherwise shows sufficient proprietary interest in the matter who is the applicant under 37 CFR 1.46. If the applicant is an applicant under 37 CFR 1.46 (assignee, person to whom the inventor is obligated to assign, or person who otherwise shows sufficient proprietary interest) together with one or more joint inventors, then the joint inventor or inventors who are also the applicant should be identified in this section.</p>		
<input type="button" value="Clear"/>		
<input checked="" type="radio"/> Assignee	Legal Representative under 35 U.S.C. 117	Joint Inventor
Person to whom the inventor is obligated to assign.		Person who shows sufficient proprietary interest
If applicant is the legal representative, indicate the authority to file the patent application, the inventor is:		
<div style="border: 1px solid black; height: 20px; width: 100%;"></div>		
Name of the Deceased or Legally Incapacitated Inventor: <input type="text"/>		
If the Applicant is an Organization check here. <input checked="" type="checkbox"/>		
Organization Name	MASIMO CORPORATION	
<b>Mailing Address Information For Applicant:</b>		
Address 1	52 Discovery	
Address 2		
City	Irvine	State/Province CA
Country	US	Postal Code 92618
Phone Number		Fax Number
Email Address		
Additional Applicant Data may be generated within this form by selecting the Add button. <input type="button" value="Add"/>		

## Assignee Information including Non-Applicant Assignee Information:

Providing assignment information in this section does not substitute for compliance with any requirement of part 3 of Title 37 of CFR to have an assignment recorded by the Office.

Under the Paperwork Reduction Act of 1995, no persons are required to respond to a collection of information unless it contains a valid OMB control number.

<b>Application Data Sheet 37 CFR 1.76</b>		Attorney Docket Number	MAS.1007C1
		Application Number	
Title of Invention	ADVANCED PULSE OXIMETRY SENSOR		

<b>Assignee</b>   1				
Complete this section if assignee information, including non-applicant assignee information, is desired to be included on the patent application publication. An assignee-applicant identified in the "Applicant Information" section will appear on the patent application publication as an applicant. For an assignee-applicant, complete this section only if identification as an assignee is also desired on the patent application publication.				
				<input type="button" value="Remove"/>
If the Assignee or Non-Applicant Assignee is an Organization check here. <input type="checkbox"/>				
Prefix	Given Name	Middle Name	Family Name	Suffix
<b>Mailing Address Information For Assignee including Non-Applicant Assignee:</b>				
Address 1				
Address 2				
City		State/Province		
Country i		Postal Code		
Phone Number		Fax Number		
Email Address				
Additional Assignee or Non-Applicant Assignee Data may be generated within this form by selecting the Add button.				<input type="button" value="Add"/>

**Signature:**

**NOTE:** This Application Data Sheet must be signed in accordance with 37 CFR 1.33(b). **However, if this Application Data Sheet is submitted with the INITIAL filing of the application and either box A or B is not checked in subsection 2 of the "Authorization or Opt-Out of Authorization to Permit Access" section, then this form must also be signed in accordance with 37 CFR 1.14(c).**

This Application Data Sheet **must** be signed by a patent practitioner if one or more of the applicants is a **juristic entity** (e.g., corporation or association). If the applicant is two or more joint inventors, this form must be signed by a patent practitioner, **all** joint inventors who are the applicant, or one or more joint inventor-applicants who have been given power of attorney (e.g., see USPTO Form PTO/AIA/81) on behalf of **all** joint inventor-applicants.

See 37 CFR 1.4(d) for the manner of making signatures and certifications.

<b>Signature</b>	/Aaron S. Johnson/		Date (YYYY-MM-DD)	2018-12-19
First Name	Aaron S.	Last Name	Johnson	Registration Number
				74164
Additional Signature may be generated within this form by selecting the Add button.				<input type="button" value="Add"/>

Under the Paperwork Reduction Act of 1995, no persons are required to respond to a collection of information unless it contains a valid OMB control number.

<b>Application Data Sheet 37 CFR 1.76</b>		Attorney Docket Number	MAS.1007C1
		Application Number	
Title of Invention	ADVANCED PULSE OXIMETRY SENSOR		

This collection of information is required by 37 CFR 1.76. The information is required to obtain or retain a benefit by the public which is to file (and by the USPTO to process) an application. Confidentiality is governed by 35 U.S.C. 122 and 37 CFR 1.14. This collection is estimated to take 23 minutes to complete, including gathering, preparing, and submitting the completed application data sheet form to the USPTO. Time will vary depending upon the individual case. Any comments on the amount of time you require to complete this form and/or suggestions for reducing this burden, should be sent to the Chief Information Officer, U.S. Patent and Trademark Office, U.S. Department of Commerce, P.O. Box 1450, Alexandria, VA 22313-1450. DO NOT SEND FEES OR COMPLETED FORMS TO THIS ADDRESS. **SEND TO: Commissioner for Patents, P.O. Box 1450, Alexandria, VA 22313-1450.**

## Privacy Act Statement

The Privacy Act of 1974 (P.L. 93-579) requires that you be given certain information in connection with your submission of the attached form related to a patent application or patent. Accordingly, pursuant to the requirements of the Act, please be advised that: (1) the general authority for the collection of this information is 35 U.S.C. 2(b)(2); (2) furnishing of the information solicited is voluntary; and (3) the principal purpose for which the information is used by the U.S. Patent and Trademark Office is to process and/or examine your submission related to a patent application or patent. If you do not furnish the requested information, the U.S. Patent and Trademark Office may not be able to process and/or examine your submission, which may result in termination of proceedings or abandonment of the application or expiration of the patent.

The information provided by you in this form will be subject to the following routine uses:

1. The information on this form will be treated confidentially to the extent allowed under the Freedom of Information Act (5 U.S.C. 552) and the Privacy Act (5 U.S.C. 552a). Records from this system of records may be disclosed to the Department of Justice to determine whether the Freedom of Information Act requires disclosure of these records.
2. A record from this system of records may be disclosed, as a routine use, in the course of presenting evidence to a court, magistrate, or administrative tribunal, including disclosures to opposing counsel in the course of settlement negotiations.
3. A record in this system of records may be disclosed, as a routine use, to a Member of Congress submitting a request involving an individual, to whom the record pertains, when the individual has requested assistance from the Member with respect to the subject matter of the record.
4. A record in this system of records may be disclosed, as a routine use, to a contractor of the Agency having need for the information in order to perform a contract. Recipients of information shall be required to comply with the requirements of the Privacy Act of 1974, as amended, pursuant to 5 U.S.C. 552a(m).
5. A record related to an International Application filed under the Patent Cooperation Treaty in this system of records may be disclosed, as a routine use, to the International Bureau of the World Intellectual Property Organization, pursuant to the Patent Cooperation Treaty.
6. A record in this system of records may be disclosed, as a routine use, to another federal agency for purposes of National Security review (35 U.S.C. 181) and for review pursuant to the Atomic Energy Act (42 U.S.C. 218(c)).
7. A record from this system of records may be disclosed, as a routine use, to the Administrator, General Services, or his/her designee, during an inspection of records conducted by GSA as part of that agency's responsibility to recommend improvements in records management practices and programs, under authority of 44 U.S.C. 2904 and 2906. Such disclosure shall be made in accordance with the GSA regulations governing inspection of records for this purpose, and any other relevant (i.e., GSA or Commerce) directive. Such disclosure shall not be used to make determinations about individuals.
8. A record from this system of records may be disclosed, as a routine use, to the public after either publication of the application pursuant to 35 U.S.C. 122(b) or issuance of a patent pursuant to 35 U.S.C. 151. Further, a record may be disclosed, subject to the limitations of 37 CFR 1.14, as a routine use, to the public if the record was filed in an application which became abandoned or in which the proceedings were terminated and which application is referenced by either a published application, an application open to public inspections or an issued patent.
9. A record from this system of records may be disclosed, as a routine use, to a Federal, State, or local law enforcement agency, if the USPTO becomes aware of a violation or potential violation of law or regulation.

## TRANSMITTAL FOR POWER OF ATTORNEY TO ONE OR MORE REGISTERED PRACTITIONERS

NOTE: This form is to be submitted with the Power of Attorney by Applicant form (PTO/AIA/82B) to identify the application to which the Power of Attorney is directed, in accordance with 37 CFR 1.5, unless the application number and filing date are identified in the Power of Attorney by Applicant form. If neither form PTO/AIA/82A nor form PTO/AIA82B identifies the application to which the Power of Attorney is directed, the Power of Attorney will not be recognized in the application.

Application Number	Filed herewith
Filing Date	Filed herewith
First Named Inventor	Ammar Al-Ali
Title	ADVANCED PULSE OXIMETRY SENSOR
Art Unit	Unassigned
Examiner Name	Unassigned
Attorney Docket Number	MAS.1007C1

SIGNATURE of Applicant or Patent Practitioner			
Signature	/Aaron S. Johnson/	Date (Optional)	2018-12-19
Name	Aaron S. Johnson	Registration Number	74164
Title (if Applicant is a juristic entity)			
Applicant Name (if Applicant is a juristic entity)			

**NOTE:** This form must be signed in accordance with 37 CFR 1.33. See 37 CFR 1.4(d) for signature requirements and certifications. If more than one applicant, use multiple forms.

\*Total of 1 forms are submitted.

This collection of information is required by 37 CFR 1.131, 1.32, and 1.33. The information is required to obtain or retain a benefit by the public which is to file (and by the USPTO to process) an application. Confidentiality is governed by 35 U.S.C. 122 and 37 CFR 1.11 and 1.14. This collection is estimated to take 3 minutes to complete, including gathering, preparing, and submitting the completed application form to the USPTO. Time will vary depending upon the individual case. Any comments on the amount of time you require to complete this form and/or suggestions for reducing this burden, should be sent to the Chief Information Officer, U.S. Patent and Trademark Office, U.S. Department of Commerce, P.O. Box 1450, Alexandria, VA 22313-1450. DO NOT SEND FEES OR COMPLETED FORMS TO THIS ADDRESS. **SEND TO: Commissioner for Patents, P.O. Box 1450, Alexandria, VA 22313-1450.**

*If you need assistance in completing the form, call 1-800-PTO-9199 and select option 2.*

# POWER OF ATTORNEY BY APPLICANT

I hereby revoke all previous powers of attorney given in the application identified in the attached transmittal letter.

I hereby appoint Practitioner(s) associated with the following Customer Number as my/our attorney(s) or agent(s), and to transact all business in the United States Patent and Trademark Office connected therewith for the application referenced in the attached transmittal letter (form PTO/AIA/82A or equivalent):

64735

OR

I hereby appoint Practitioner(s) named below as my/our attorney(s) or agent(s), and to transact all business in the United States Patent and Trademark Office connected therewith for the application referenced in the attached transmittal letter (form PTO/AIA/82A or equivalent):

Name	Registration Number	Name	Registration Number

Please recognize or change the correspondence address for the application identified in the attached transmittal letter to:

The address associated with the above-mentioned Customer Number.

OR

The address associated with Customer Number:

OR

Firm or Individual Name

Address

City State Zip

Country

Telephone Email

I am the Applicant:

Inventor or Joint Inventor

Legal Representative of a Deceased or Legally Incapacitated Inventor

Assignee or Person to Whom the Inventor is Under an Obligation to Assign

Person Who Otherwise Shows Sufficient Proprietary Interest (e.g., a petition under 37 CFR 1.46(b)(2) was granted in the application or is concurrently being filed with this document)

**SIGNATURE of Applicant for Patent**

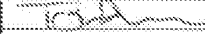
Signature		Date	7/12/13
Name	Thomas McClenahan	Telephone	(949) 297-7000
Title and Company	Executive Vice President and General Counsel, Masimo Corporation		

**NOTE:** Signature - This form must be signed by the applicant in accordance with 37 CFR 1.33. See 37 CFR 1.4 for signature requirements and certifications. Submit multiple forms for more than one signature, see below.

\*Total of 1 forms are submitted.

This collection of information is required by 37 CFR 1.31, 1.32 and 1.33. The information is required to obtain or retain a benefit by the public which is to file (and by the USPTO to process) an application. Confidentiality is governed by 35 U.S.C. 122 and 37 CFR 1.11 and 1.14. This collection is estimated to take 3 minutes to complete, including gathering, preparing, and submitting the completed application form to the USPTO. Time will vary depending upon the individual case. Any comments on the amount of time you require to complete this form and/or suggestions for reducing this burden, should be sent to the Chief Information Officer, U.S. Patent and Trademark Office, U.S. Department of Commerce, P.O. Box 1450, Alexandria, VA 22313-1450. DO NOT SEND FEES OR COMPLETED FORMS TO THIS ADDRESS. SEND TO: Commissioner for Patents, P.O. Box 1450, Alexandria, VA 22313-1450.

*If you need assistance in completing the form, call 1-800-PTO-9199 and select option 2.*



## Privacy Act Statement

The **Privacy Act of 1974 (P.L. 93-579)** requires that you be given certain information in connection with your submission of the attached form related to a patent application or patent. Accordingly, pursuant to the requirements of the Act, please be advised that: (1) the general authority for the collection of this information is 35 U.S.C. 2(b)(2); (2) furnishing of the information solicited is voluntary; and (3) the principal purpose for which the information is used by the U.S. Patent and Trademark Office is to process and/or examine your submission related to a patent application or patent. If you do not furnish the requested information, the U.S. Patent and Trademark Office may not be able to process and/or examine your submission, which may result in termination of proceedings or abandonment of the application or expiration of the patent.

The information provided by you in this form will be subject to the following routine uses:

1. The information on this form will be treated confidentially to the extent allowed under the Freedom of Information Act (5 U.S.C. 552) and the Privacy Act (5 U.S.C. 552a). Records from this system of records may be disclosed to the Department of Justice to determine whether disclosure of these records is required by the Freedom of Information Act.
2. A record from this system of records may be disclosed, as a routine use, in the course of presenting evidence to a court, magistrate, or administrative tribunal, including disclosures to opposing counsel in the course of settlement negotiations.
3. A record in this system of records may be disclosed, as a routine use, to a Member of Congress submitting a request involving an individual, to whom the record pertains, when the individual has requested assistance from the Member with respect to the subject matter of the record.
4. A record in this system of records may be disclosed, as a routine use, to a contractor of the Agency having need for the information in order to perform a contract. Recipients of information shall be required to comply with the requirements of the Privacy Act of 1974, as amended, pursuant to 5 U.S.C. 552a(m).
5. A record related to an International Application filed under the Patent Cooperation Treaty in this system of records may be disclosed, as a routine use, to the International Bureau of the World Intellectual Property Organization, pursuant to the Patent Cooperation Treaty.
6. A record in this system of records may be disclosed, as a routine use, to another federal agency for purposes of National Security review (35 U.S.C. 181) and for review pursuant to the Atomic Energy Act (42 U.S.C. 218(c)).
7. A record from this system of records may be disclosed, as a routine use, to the Administrator, General Services, or his/her designee, during an inspection of records conducted by GSA as part of that agency's responsibility to recommend improvements in records management practices and programs, under authority of 44 U.S.C. 2904 and 2906. Such disclosure shall be made in accordance with the GSA regulations governing inspection of records for this purpose, and any other relevant (*i.e.*, GSA or Commerce) directive. Such disclosure shall not be used to make determinations about individuals.
8. A record from this system of records may be disclosed, as a routine use, to the public after either publication of the application pursuant to 35 U.S.C. 122(b) or issuance of a patent pursuant to 35 U.S.C. 151. Further, a record may be disclosed, subject to the limitations of 37 CFR 1.14, as a routine use, to the public if the record was filed in an application which became abandoned or in which the proceedings were terminated and which application is referenced by either a published application, an application open to public inspection or an issued patent.
9. A record from this system of records may be disclosed, as a routine use, to a Federal, State, or local law enforcement agency, if the USPTO becomes aware of a violation or potential violation of law or regulation.

## ABSTRACT OF THE DISCLOSURE

A non-invasive, optical-based physiological monitoring system is disclosed. One embodiment includes an emitter configured to emit light. A diffuser is configured to receive and spread the emitted light, and to emit the spread light at a tissue measurement site. The system further includes a concentrator configured to receive the spread light after it has been attenuated by or reflected from the tissue measurement site. The concentrator is also configured to collect and concentrate the received light and to emit the concentrated light to a detector. The detector is configured to detect the concentrated light and to transmit a signal representative of the detected light. A processor is configured to receive the transmitted signal and to determine a physiological parameter, such as, for example, arterial oxygen saturation, in the tissue measurement site.

WHAT IS CLAIMED IS:

1. An optical physiological measurement system comprising:
  - an emitter which emits light of a wavelength;
  - a diffuser which receives, spreads and emits the spread light, wherein the emitted spread light is directed at a tissue measurement site of a patient;
  - and
  - a detector configured to detect the emitted light after attenuation by tissue of the patient, the detector further configured to transmit a signal responsive to the detected light.
2. The optical physiological measurement system of Claim 1, further comprising a concentrator which receives the spread light after attenuation by tissue of the patient, concentrates the received spread light and emits the concentrated light in the direction of the detector.
3. The optical physiological measurement system of Claim 1, further comprising a processor configured to receive the transmitted signal responsive to the detected light and to determine a physiological parameter.
4. The optical physiological measurement system of Claim 3, wherein the parameter is arterial oxygen saturation.
5. The optical physiological measurement system of Claim 1, wherein the diffuser comprises at least one of a glass diffuser, ground glass diffuser, a glass bead diffuser, an opal glass diffuser, and an engineered diffuser.
6. The optical physiological measurement system of Claim 1, wherein the diffuser emits the spread light with a substantially uniform intensity profile.
7. The optical physiological measurement system of Claim 1, wherein the diffuser defines a surface area shape by which the emitted spread light is distributed onto a surface of the tissue measurement site.
8. The optical physiological monitor of Claim 7, further comprising a detector filter having a light-absorbing surface facing the tissue measurement site and an opening, the opening having dimensions, wherein the dimensions of the opening are substantially similar to the defined surface area shape by which the emitted spread light is distributed onto the surface of the tissue measurement site.

9. The optical physiological measurement system of Claim 7, wherein the surface area shape is rectangular.

10. The optical physiological measurement system of Claim 9, wherein the rectangular surface area shape has dimensions within a range of approximately 0.25 cm to 3 cm in width and a range of approximately 1 cm to 6 cm in length.

11. The optical physiological measurement system of Claim 9, wherein the rectangular surface area shape has dimensions in the range of approximately 0.1 cm to 2 cm in width and approximately 0.5 cm to 5 cm in length.

12. The optical physiological measurement system of Claim 9, wherein the rectangular surface area shape has dimensions of approximately 1 centimeter in width and approximately 1.5 centimeters in length.

13. The optical physiological measurement system of Claim 7, wherein the surface area shape is square.

14. The optical physiological measurement system of Claim 13, wherein the square surface area shape has dimensions in the range of approximately 0.25 cm<sup>2</sup> to 10 cm<sup>2</sup>.

15. The optical physiological measurement system of Claim 9, further comprising a detector filter comprising a light-absorbing surface facing the tissue measurement site and an opening, the opening having dimensions, wherein the dimensions of the opening are substantially similar to dimensions of the rectangular shape.

16. The optical physiological measurement system of Claim 1, wherein the concentrator comprises at least one of glass, ground glass, glass beads, opal glass, and a compound parabolic concentrator.

17. The optical physiological measurement system of Claim 1, further comprising a detector filter comprising a light-absorbing surface facing the tissue measurement site and an opening, wherein the opening is configured to allow the spread light, after being attenuated by or reflected from the tissue measurement site, to be received by the concentrator.

18. A method to determine a constituent or analyte in a patient's blood, the method comprising:

emitting, from an emitter, light of a wavelength;

spreading, with a diffuser, the emitted light and emitting the spread light from the diffuser to a tissue measurement site, wherein the diffuser spreads the light over a greater area of the tissue measurement site than would otherwise be illuminated by the emitter directly emitting light at a tissue measurement site; and

detecting, with the detector, the emitted concentrated light.

19. The method of Claim 18, further comprising receiving, by a concentrator, the emitted spread light after the spread light has been attenuated by or reflected from the tissue measurement site and concentrating, by the concentrator, the received light and emitting the concentrated light from the concentrator to a detector.

20. The method of Claim 18, further comprising transmitting, from the detector, a signal responsive to the detected light; receiving, by a processor, the transmitted signal responsive to the detected light; and processing, by the processor, the received signal responsive to the detected light to determine a physiological parameter.

21. The method of Claim 18, further comprising filtering, with a light-absorbing detector filter, scattered portions of the emitted spread light.

22. The method of Claim 18, wherein spreading, with a diffuser, the emitted light and emitting the spread light from the diffuser to a tissue measurement site is performed by at least one of a glass diffuser, a glass bead diffuser, an opal glass diffuser, and an engineered diffuser.

23. The method of Claim 18, wherein spreading, with a diffuser, the emitted light and emitting the spread light from the diffuser to a tissue measurement site further comprises spreading the emitted light with a substantially uniform intensity profile.

24. The method of Claim 18, wherein spreading, with a diffuser, the emitted light and emitting the spread light from the diffuser to a tissue measurement site further comprises spreading the emitted light so as to define a surface area

shape by which the emitted spread light is distributed onto a surface of the tissue measurement site.

25. The method of Claim 18, wherein concentrating, by the concentrator, the received light and emitting the concentrated light from the concentrator to a detector is performed by at least one of a glass concentrator, a glass bead concentrator, an opal glass concentrator, and a compound parabolic concentrator.

26. A pulse oximeter sensor comprising:  
an emitter configured to emit light at a wavelength;  
a diffuser configured to receive the emitted light, to spread the received light, and to emit the spread light, wherein the emitted spread light is directed at a tissue measurement site; and  
a detector configured to detect the emitted spread light, the spread light having been attenuated by the tissue measurement site, the detector further configured to output a signal responsive to the detected light.

27. The pulse oximeter sensor of Claim 26, further comprising a concentrator which concentrates the emitted light after it has been attenuated by the tissue measurement site and directs the concentrated light toward the detector.

28. The pulse oximeter sensor of Claim 26, wherein the detector is further configured to output the signal response to the detected light to a processor configured to receive the signal responsive to the detected light and to determine a physiological parameter.

29. The pulse oximeter sensor of Claim 26, wherein the diffuser is further configured to define a surface area shape by which the emitted spread light is distributed onto a surface of the tissue measurement site.

30. The pulse oximeter sensor of Claim 29, wherein the detector is further configured to have a detection area corresponding to the defined surface area shape by which the emitted spread light is distributed onto the surface of the tissue measurement site.

31. The pulse oximeter sensor of Claim 30, wherein the detector further comprises an array of detectors configured to cover the detection area.

32. A pulse oximeter sensor comprising:

an emitter configured to emit light at a wavelength;  
a concentrator which concentrates the emitted light after it has been attenuated by the tissue measurement site; and  
a detector configured to detect the emitted spread, the spread light having been attenuated by or reflected from the tissue measurement site, the detector further configured to output a signal responsive to the detected light.

33. The pulse oximeter sensor of Claim 32, wherein the detector is further configured to transmit the output signal responsive to the detected light to a processor configured to receive the signal responsive to the detected light and to determine a physiological parameter.

34. The pulse oximeter sensor of Claim 32, wherein the concentrator is further configured to define a surface area shape by which the emitted spread light is received from a surface of the tissue measurement site.

35. The pulse oximeter sensor of Claim 34, wherein the concentrator is further configured to have a detection area corresponding to the defined surface area shape by which the emitted spread light is distributed onto the surface of the tissue measurement site.

36. The pulse oximeter sensor of Claim 35, wherein the detector further comprises an array of detectors configured to cover the detection area.

**ADVANCED PULSE OXIMETRY SENSOR**

## INCORPORATION BY REFERENCE TO ANY PRIORITY APPLICATIONS

**[0001]** The present application is a continuation of U.S. Patent Application No. 15/195,199 filed June 28, 2016, which claims priority benefit under 35 U.S.C. § 119(e) from U.S. Provisional Application No. 62/188,430, filed July 2, 2015, entitled “Advanced Pulse Oximetry Sensor,” which is incorporated by reference herein. Any and all applications for which a foreign or domestic priority claim is identified in the Application Data Sheet as filed with the present application are hereby incorporated by reference under 37 CFR 1.57.

## FIELD OF THE DISCLOSURE

**[0002]** The present disclosure relates to the field of non-invasive optical-based physiological monitoring sensors, and more particularly to systems, devices and methods for improving the non-invasive measurement accuracy of oxygen saturation, among other physiological parameters.

## BACKGROUND

**[0003]** Spectroscopy is a common technique for measuring the concentration of organic and some inorganic constituents of a solution. The theoretical basis of this technique is the Beer-Lambert law, which states that the concentration  $c_i$  of an absorbent in solution can be determined by the intensity of light transmitted through the solution, knowing the pathlength  $d_\lambda$ , the intensity of the incident light  $I_{o,\lambda}$ , and the extinction coefficient  $\epsilon_{i,\lambda}$  at a particular wavelength  $\lambda$ .

**[0004]** In generalized form, the Beer-Lambert law is expressed as:

$$I_\lambda = I_{o,\lambda} e^{-d_\lambda \cdot \mu_{a,\lambda}} \quad (1)$$

$$\mu_{a,\lambda} = \sum_{i=1}^n \epsilon_{i,\lambda} \cdot c_i \quad (2)$$



where  $\mu_{\alpha,\lambda}$  is the bulk absorption coefficient and represents the probability of absorption per unit length. The minimum number of discrete wavelengths that are required to solve equations 1 and 2 is the number of significant absorbers that are present in the solution.

**[0005]** A practical application of this technique is pulse oximetry, which utilizes a noninvasive sensor to measure oxygen saturation and pulse rate, among other physiological parameters. Pulse oximetry relies on a sensor attached externally to the patient to output signals indicative of various physiological parameters, such as a patient's blood constituents and/or analytes, including for example a percent value for arterial oxygen saturation, among other physiological parameters. The sensor has an emitter that transmits optical radiation of one or more wavelengths into a tissue site and a detector that responds to the intensity of the optical radiation after absorption by pulsatile arterial blood flowing within the tissue site. Based upon this response, a processor determines the relative concentrations of oxygenated hemoglobin (HbO<sub>2</sub>) and deoxygenated hemoglobin (Hb) in the blood so as to derive oxygen saturation, which can provide early detection of potentially hazardous decreases in a patient's oxygen supply.

**[0006]** A pulse oximetry system generally includes a patient monitor, a communications medium such as a cable, and/or a physiological sensor having one or more light emitters and a detector, such as one or more light-emitting diodes (LEDs) and a photodetector. The sensor is attached to a tissue site, such as a finger, toe, earlobe, nose, hand, foot, or other site having pulsatile blood flow which can be penetrated by light from the one or more emitters. The detector is responsive to the emitted light after attenuation or reflection by pulsatile blood flowing in the tissue site. The detector outputs a detector signal to the monitor over the communication medium. The monitor processes the signal to provide a numerical readout of physiological parameters such as oxygen saturation (SpO<sub>2</sub>) and/or pulse rate. A pulse oximetry sensor is described in U.S. Patent No. 6,088,607 entitled *Low Noise Optical Probe*; pulse oximetry signal processing is described in U.S. Patent Nos. 6,650,917 and 6,699,194 entitled *Signal Processing Apparatus* and *Signal Processing Apparatus and Method*, respectively; a pulse oximeter monitor is

described in U.S. Patent No. 6,584,336 entitled *Universal/Upgrading Pulse Oximeter*, all of which are assigned to Masimo Corporation, Irvine, CA, and each is incorporated by reference herein in its entirety.

**[0007]** There are many sources of measurement error introduced to pulse oximetry systems. Some such sources of error include the pulse oximetry system's electronic components, including emitters and detectors, as well as chemical and structural physiological differences between patients. Another source of measurement error is the effect of multiple scattering of photons as the photons pass through the patient's tissue (arterial blood) and arrive at the sensor's light detector.

#### SUMMARY

**[0008]** This disclosure describes embodiments of non-invasive methods, devices, and systems for measuring blood constituents, analytes, and/or substances such as, by way of non-limiting example, oxygen, carboxyhemoglobin, methemoglobin, total hemoglobin, glucose, proteins, lipids, a percentage thereof (*e.g.*, saturation), pulse rate, perfusion index, oxygen content, total hemoglobin, Oxygen Reserve Index™ (ORI™) or for measuring many other physiologically relevant patient characteristics. These characteristics can relate to, for example, pulse rate, hydration, trending information and analysis, and the like.

**[0009]** In an embodiment, an optical physiological measurement system includes an emitter configured to emit light of one or more wavelengths. The system also includes a diffuser configured to receive the emitted light, to spread the received light, and to emit the spread light over a larger tissue area than would otherwise be penetrated by the emitter directly emitting light at a tissue measurement site. The tissue measurement site can include, such as, for example, a finger, a wrist, or the like. The system further includes a concentrator configured to receive the spread light after it has been attenuated by or reflected from the tissue measurement site. The concentrator is also configured to collect and concentrate the received light and to emit the concentrated light to a detector. The detector is configured to detect the concentrated light and to transmit a signal indicative of the

detected light. The system also includes a processor configured to receive the transmitted signal indicative of the detected light and to determine, based on an amount of absorption, an analyte of interest, such as, for example, arterial oxygen saturation or other parameter, in the tissue measurement site.

**[0010]** In certain embodiments of the present disclosure, the diffuser comprises glass, ground glass, glass beads, opal glass, or a microlens-based, band-limited, engineered diffuser that can deliver efficient and uniform illumination. In some embodiments the diffuser is further configured to define a surface area shape by which the emitted spread light is distributed onto a surface of the tissue measurement site. The defined surface area shape can include, by way of non-limiting example, a shape that is substantially rectangular, square, circular, oval, or annular, among others.

**[0011]** According to some embodiments, the optical physiological measurement system includes an optical filter having a light-absorbing surface that faces the tissue measurement site. The optical filter also has an opening that is configured to allow the spread light, after being attenuated by the tissue measurement site, to be received by the concentrator. In an embodiment, the opening has dimensions, wherein the dimensions of the opening are similar to the defined surface area shape by which the emitted spread light is distributed onto the surface of the tissue measurement site. In an embodiment, the opening has dimensions that are larger than the defined surface area shape by which the emitted spread light is distributed onto the surface of the tissue measurement site. In other embodiments, the dimensions of the opening in the optical filter are not the same as the diffuser opening, but the dimensions are larger than the detector package.

**[0012]** In other embodiments of the present disclosure, the concentrator comprises glass, ground glass, glass beads, opal glass, or a compound parabolic concentrator. In some embodiments the concentrator comprises a cylindrical structure having a truncated circular conical structure on top. The truncated section is adjacent the detector. The light concentrator is structured to receive the emitted optical radiation, after reflection by the tissue measurement site, and to direct the reflected light to the detector.

**[0013]** In accordance with certain embodiments of the present disclosure, the processor is configured to determine an average level of the light detected by the detector. The average level of light is used to determine a physiological parameter in the tissue measurement site.

**[0014]** According to another embodiment, a method to determine a constituent or analyte in a patient's blood is disclosed. The method includes emitting, from an emitter, light of at least one wavelength; spreading, with a diffuser, the emitted light and emitting the spread light from the diffuser to a tissue measurement site; receiving, by a concentrator, the spread light after the spread light has been attenuated by the tissue measurement site; concentrating, by the concentrator, the received light and emitting the concentrated light from the concentrator to a detector; detecting, with the detector, the emitted concentrated light; transmitting, from the detector, a signal responsive to the detected light; receiving, by a processor, the transmitted signal responsive to the detected light; and processing, by the processor, the received signal responsive to the detected light to determine a physiological parameter.

**[0015]** In some embodiments, the method to determine a constituent or analyte in a patient's blood includes filtering, with a light-absorbing detector filter, scattered portions of the emitted spread light. According to an embodiment, the light-absorbing detector filter is substantially rectangular in shape and has outer dimensions in the range of approximately 1-5 cm in width and approximately 2-8 cm in length, and has an opening through which emitted light may pass, the opening having dimensions in the range of approximately 0.25-3 cm in width and approximately 1-7 cm in length. In another embodiment, the light-absorbing detector filter is substantially square in shape and has outer dimensions in the range of approximately 0.25-10 cm<sup>2</sup>, and has an opening through which emitted light may pass, the opening having dimensions in the range of approximately 0.1-8cm<sup>2</sup>. In yet another embodiment, the light-absorbing detector filter is substantially rectangular in shape and has outer dimensions of approximately 3 cm in width and approximately 6 cm in length, and has an opening through which emitted light may pass, the

opening having dimensions of approximately 1.5 cm in width and approximately 4 cm in length.

**[0016]** In still other embodiments of the method to determine a constituent or analyte in a patient's blood, spreading, with a diffuser, the emitted light and emitting the spread light from the diffuser to a tissue measurement site is performed by at least one of a glass diffuser, a ground glass diffuser, a glass bead diffuser, an opal glass diffuser, and an engineered diffuser. In some embodiments the emitted spread light is emitted with a substantially uniform intensity profile. And in some embodiments, emitting the spread light from the diffuser to the tissue measurement site includes spreading the emitted light so as to define a surface area shape by which the emitted spread light is distributed onto a surface of the tissue measurement site.

**[0017]** According to yet another embodiment, a pulse oximeter is disclosed. The pulse oximeter includes an emitter configured to emit light at one or more wavelengths. The pulse oximeter also includes a diffuser configured to receive the emitted light, to spread the received light, and to emit the spread light directed at a tissue measurement sight. The pulse oximeter also includes a detector configured to detect the emitted spread light after being attenuated by or reflected from the tissue measurement site and to transmit a signal indicative of the detected light. The pulse oximeter also includes a processor configured to receive the transmitted signal and to process the received signal to determine an average absorbance of a blood constituent or analyte in the tissue measurement site over a larger measurement site area than can be performed with a point light source or point detector. In some embodiments, the diffuser is further configured to define a surface area shape by which the emitted spread light is distributed onto a surface of the tissue measurement site, and the detector is further configured to have a detection area corresponding to the defined surface area shape by which the emitted spread light is distributed onto the surface of the tissue measurement site. According to some embodiments, the detector comprises an array of detectors configured to cover the detection area. In still other embodiments, the processor is further configured to determine an average of the detected light.

**[0018]** For purposes of summarizing, certain aspects, advantages and novel features of the disclosure have been described herein. It is to be understood that not necessarily all such advantages can be achieved in accordance with any particular embodiment of the systems, devices and/or methods disclosed herein. Thus, the subject matter of the disclosure herein can be embodied or carried out in a manner that achieves or optimizes one advantage or group of advantages as taught herein without necessarily achieving other advantages as can be taught or suggested herein.

#### BRIEF DESCRIPTION OF THE DRAWINGS

**[0019]** Throughout the drawings, reference numbers can be re-used to indicate correspondence between referenced elements. The drawings are provided to illustrate embodiments of the disclosure described herein and not to limit the scope thereof.

**[0020]** FIG. 1 illustrates a conventional approach to 2D pulse oximetry in which the emitter is configured to emit optical radiation as a point optical source.

**[0021]** FIG. 2 illustrates the disclosed 3D approach to pulse oximetry in which the emitted light irradiates a substantially larger volume of tissue as compared to the point source approach described with respect to FIG. 2A.

**[0022]** FIG. 3 illustrates schematically a side view of a 3D pulse oximetry sensor according to an embodiment of the present disclosure.

**[0023]** FIG. 4A is a top view of a portion of a 3D pulse oximetry sensor according to an embodiment of the present disclosure.

**[0024]** FIG. 4B illustrates the top view of a portion of the 3D pulse oximetry sensor shown in FIG. 4A, with the addition of a tissue measurement site in operational position.

**[0025]** FIG. 5 illustrates a top view of a 3D pulse oximetry sensor according to an embodiment of the present disclosure.

**[0026]** FIG. 6 illustrates a conventional 2D approach to reflective pulse oximetry in which the emitter is configured to emit optical radiation as a point optical source.

**[0027]** FIG. 7A is a simplified schematic side view illustration of a reflective 3D pulse oximetry sensor according to an embodiment of the present disclosure.

**[0028]** FIG. 7B is a simplified schematic top view illustration of the 3D reflective pulse oximetry sensor of FIG. 7A.

**[0029]** FIG. 8 illustrates a block diagram of an example pulse oximetry system capable of noninvasively measuring one or more blood analytes in a monitored patient, according to an embodiment of the disclosure.

#### DETAILED DESCRIPTION

**[0030]** FIG. 1 illustrates schematically a conventional pulse oximetry sensor having a two-dimensional (2D) approach to pulse oximetry. As illustrated, the emitter 104 is configured to emit optical radiation as a point optical source, *i.e.*, an optical radiation source that has negligible dimensions such that it may be considered as a point. This approach is referred to herein as “two-dimensional” pulse oximetry because it applies a two-dimensional analytical model to the three-dimensional space of the tissue measurement site 102 of the patient. Point optical sources feature a defined, freely selectable, and homogeneous light beam area. Light beams emitted from LED point sources often exhibit a strong focus which can produce a usually sharply-defined and evenly-lit illuminated spot often with high intensity dynamics. Illustratively, when looking at the surface of the tissue measurement site 102 (or “sample tissue”), which in this example is a finger, a small point-like surface area of tissue 204 is irradiated by a point optical source. In some embodiments, the irradiated circular area of the point optical source is in the range between 8 and 150 microns. Illustratively, the emitted point optical source of light enters the tissue measurement site 102 as a point of light. As the light penetrates the depth of the tissue 102, it does so as a line or vector, representing a two-dimensional construct within a three-dimensional structure, namely the patient’s tissue 102.

**[0031]** Use of a point optical source is believed to reduce variability in light pathlength which would lead to more accurate oximetry measurements. However, in practice, photons do not travel in straight paths. Instead, the light particles scatter,

bouncing around between various irregular objects (such as, for example, red blood cells) in the patient's blood. Accordingly, photon pathlengths vary depending on, among other things, their particular journeys through and around the tissue at the measurement site 102. This phenomenon is referred to as "multiple scattering." In a study, the effects of multiple scattering were examined by comparing the results of photon diffusion analysis with those obtained using an analysis based on the Beer-Lambert law, which neglects multiple scattering in the determination of light pathlength. The study found that that the difference between the average lengths of the paths traveled by red and infrared photons makes the oximeter's calibration curve (based on measurements obtained from normal subjects) sensitive to the total attenuation coefficients of the tissue in the two wavelength bands used for pulse oximetry, as well as to absorption by the pulsating arterial blood.

**[0032]** FIG. 2 illustrates schematically the disclosed systems, devices, and methods to implement three-dimensional (3D) pulse oximetry in which the emitted light irradiates a larger volume of tissue at the measurement site 102 as compared to the 2D point optical source approach described with respect to FIG. 1. In an embodiment, again looking at the surface of the tissue measurement site 102, the irradiated surface area 206 of the measurement site 102 is substantially rectangular in shape with dimensions in the range of approximately 0.25-3 cm in width and approximately 1-6 cm in length. In another embodiment, the irradiated surface area 206 of the measurement site 102 is substantially rectangular in shape and has dimensions of approximately 1.5 cm in width and approximately 2 cm in length. In another embodiment, the irradiated surface area 206 of the measurement site 102 is substantially rectangular in shape and has dimensions of approximately 0.5 cm in width and approximately 1 cm in length. In another embodiment, the irradiated surface area 206 of the measurement site 102 is substantially rectangular in shape has dimensions of approximately 1 cm in width and approximately 1.5 cm in length. In yet another embodiment, the irradiated surface area 206 of the measurement site 102 is substantially square in shape and has dimensions in a range of approximately 0.25-9 cm<sup>2</sup>. In certain embodiments, the irradiated surface area 206 of the measurement site 102 is within a range of approximately 0.5-2 cm in width, and



approximately 1-4 cm in length. Of course a skilled artisan will appreciate that many other shapes and dimensions of irradiated surface area 206 can be used. Advantageously, by irradiating the tissue measurement site 102 with a surface area 206, the presently disclosed systems, devices, and methods apply a three-dimensional analytical model to the three-dimensional structure being measured, namely, the patient's sample tissue 102.

**[0033]** According to the Beer-Lambert law, the amount of light absorbed by a substance is proportional to the concentration of the light-absorbing substance in the irradiated solution (*i.e.*, arterial blood). Advantageously, by irradiating a larger volume of tissue 102, a larger sample size of light attenuated (or reflected) by the tissue 102 is measured. The larger, 3D sample provides a data set that is more representative of the complete interaction of the emitted light as it passes through the patient's blood as compared to the 2D point source approach described above with respect to FIG. 1. By taking an average of the detected light, as detected over a surface area substantially larger than a single point, the disclosed pulse oximetry systems, devices, and methods will yield a more accurate measurement of the emitted light absorbed by the tissue, which will lead to a more accurate oxygen saturation measurement.

**[0034]** FIG. 3 illustrates schematically a side view of a pulse oximetry 3D sensor 300 according to an embodiment of the present disclosure. In the illustrated embodiment, the 3D sensor 300 irradiates the tissue measurement site 102 and detects the emitted light, after being attenuated by the tissue measurement site 102. In other embodiments, for example, as describe below with respect to FIGS. 7A and 7B, the 3D sensor 300 can be arranged to detect light that is reflected by the tissue measurement site 102. The 3D sensor 300 includes an emitter 302, a light diffuser 304, a light-absorbing detector filter 306, a light concentrator 308, and a detector 310. In some optional embodiments, the 3D sensor 300 further includes a reflector 305. The reflector 305 can be a metallic reflector or other type of reflector. Reflector 305 can be a coating, film, layer or other type of reflector. The reflector 305 can serve as a reflector to prevent emitted light from emitting out of a top portion of the light diffuser 304 such that light from the emitter 302 is directed in the

tissue rather than escaping out of a side or top of the light diffuser 304. Additionally, the reflector 305 can prevent ambient light from entering the diffuser 304 which might ultimately cause errors within the detected light. The reflector 305 also prevent light piping that might occur if light from the detector 302 is able to escape from the light diffuser 304 and be piped around a sensor securement mechanism to detector 310 without passing through the patient's tissue 102.

**[0035]** The emitter 302 can serve as the source of optical radiation transmitted towards the tissue measurement site 102. The emitter 302 can include one or more sources of optical radiation, such as LEDs, laser diodes, incandescent bulbs with appropriate frequency-selective filters, combinations of the same, or the like. In an embodiment, the emitter 302 includes sets of optical sources that are capable of emitting visible and near-infrared optical radiation. In some embodiments, the emitter 302 transmits optical radiation of red and infrared wavelengths, at approximately 650 nm and approximately 940 nm, respectively. In some embodiments, the emitter 302 includes a single source optical radiation.

**[0036]** The light diffuser 304 receives the optical radiation emitted from the emitter 302 and spreads the optical radiation over an area, such as the area 206 depicted in FIG. 2. In some embodiments, the light diffuser 304 is a beam shaper that can homogenize the input light beam from the emitter 302, shape the output intensity profile of the received light, and define the way (*e.g.*, the shape or pattern) the emitted light is distributed to the tissue measurement site 102. Examples of materials that can be used to realize the light diffuser 304 include, without limitation, a white surface, glass, ground glass, glass beads, polytetrafluoroethylene (also known as Teflon®, opal glass, and greyed glass, to name a few. Additionally, engineered diffusers can be used to realize the diffuser 304 by providing customized light shaping with respect to intensity and distribution. Such diffusers can, for example, deliver substantially uniform illumination over a specified target area (such as, for example, irradiated surface area 206) in an energy-efficient manner. Examples of engineered diffusers can include molded plastics with specific shapes, patterns or textures designed to diffuse the emitter light across the entirety of the patient's tissue surface.

**[0037]** Advantageously, the diffuser 304 can receive emitted light in the form of a point optical source and spread the light to fit a desired surface area on a plane defined by the surface of the tissue measurement site 102. In an embodiment, the diffuser 304 is made of ground glass which spreads the emitted light with a Gaussian intensity profile. In another embodiment the diffuser 304 includes glass beads. In some embodiments, the diffuser 304 is constructed so as to diffuse the emitted light in a Lambertian pattern. A Lambertian pattern is one in which the radiation intensity is substantially constant throughout the area of dispersion. One such diffuser 304 is made from opal glass. Opal glass is similar to ground glass, but has one surface coated with a milky white coating to diffuse light evenly. In an embodiment, the diffuser 304 is capable of distributing the emitted light on the surface of a plane (*e.g.*, the surface of the tissue measurement site 102) in a predefined geometry (*e.g.*, a rectangle, square, or circle), and with a substantially uniform intensity profile and energy distribution. In some embodiments, the efficiency, or the amount of light transmitted by the diffuser 304, is greater than 70% of the light emitted by the emitter 302. In some embodiments, the efficiency is greater than 90% of the emitted light. Other optical elements known in the art may be used for the diffuser 304.

**[0038]** In an embodiment, the diffuser 304 has a substantially rectangular shape having dimensions within a range of approximately 0.5-2 cm in width and approximately 1-4 centimeters in length. In another embodiment, the substantially rectangular shape of the diffuser 304 has dimensions of approximately 0.5 cm in width and approximately 1 cm in length. In another embodiment, the diffuser's 304 substantially rectangular shape has dimensions of approximately 1 cm in width and approximately 1.5 cm in length. In yet another embodiment, the diffuser 304 has a substantially square shape with dimensions in the range of approximately 0.25-10 cm<sup>2</sup>.

**[0039]** The light-absorbing detector filter 306, which is also depicted in FIG. 4A in a top view, is a planar surface having an opening 402 through which the emitted light may pass after being attenuated by the tissue measurement site 102. In the depicted embodiment, the opening 402 is rectangular-shaped, with

dimensions substantially similar to the irradiated surface area 206. According to an embodiment, the light-absorbing detector filter is substantially rectangular in shape and has outer dimensions of 4 cm in width and 8 cm in length, and has an opening through which emitted light may pass, the opening having dimensions of 2 cm in width and 5 cm in length. In another embodiment, the light-absorbing detector filter is substantially rectangular in shape and has outer dimensions in the range of 1-3 cm in width and 2-8 cm in length, and has an opening through which emitted light may pass, the opening having dimensions in the range of 0.25-2 cm in width and 1-4 cm in length. In yet another embodiment, the light-absorbing detector filter is substantially rectangular in shape and has outer dimensions of 3 cm in width and 6 cm in length, and has an opening through which emitted light may pass, the opening having dimensions of 1.5 cm in width and 4 cm in length.

**[0040]** The top surface of the light-absorbing filter 306 (facing the tissue measurement site 102 and the emitter 302) is coated with a material that absorbs light, such as, for example, black pigment. Many other types of light-absorbing materials are well known in the art and can be used with the detector filter 306. During operation, light emitted from the emitter 302 can reflect off of the tissue measurement site 102 (or other structures within the 3D sensor 300) to neighboring portions of the 3D sensor 300. If those neighboring portions of the 3D sensor 300 possess reflective surfaces, then the light can reflect back to the tissue measurement site 102, progress through the tissue and arrive at the detector 310. Such multiple scattering can result in detecting photons whose pathlengths are considerably longer than most of the light that is detected, thereby introducing variations in pathlength which will affect the accuracy of the measurements of the pulse oximetry 3D sensor 300. Advantageously, the light-absorbing filter 306 reduces or eliminates the amount of emitted light that is reflected in this manner because it absorbs such reflected light, thereby stopping the chain of scattering events. In certain embodiments, the sensor-facing surfaces of other portions of the 3D sensor 300 are covered in light-absorbing material to further decrease the effect of reflective multiple scattering.

**[0041]** The light concentrator 308 is a structure to receive the emitted optical radiation, after attenuation by the tissue measurement site 102, to collect and concentrate the dispersed optical radiation, and to direct the collected and concentrated optical radiation to the detector 310. In an embodiment, the light concentrator 308 is made of ground glass or glass beads. In some embodiments, the light concentrator 308 includes a compound parabolic concentrator.

**[0042]** As described above with respect to FIG. 1, the detector 310 captures and measures light from the tissue measurement site 102. For example, the detector 310 can capture and measure light transmitted from the emitter 302 that has been attenuated by the tissue in the measurement site 102. The detector 310 can output a detector signal responsive to the light captured or measured. The detector 310 can be implemented using one or more photodiodes, phototransistors, or the like. In addition, a plurality of detectors 310 can be arranged in an array with a spatial configuration corresponding to the irradiated surface area 206 to capture the attenuated or reflected light from the tissue measurement site.

**[0043]** Referring to FIG. 4A, a top view of a portion of the 3D sensor 300 is provided. The light-absorbing detector filter 306 is illustrated having a top surface coated with a light-absorbing material. The light-absorbing material can be a black opaque material or coating or any other dark color or coating configured to absorb light. Additionally, a rectangular opening 402 is positioned relative to the light concentrator 308 (shown in phantom) and the detector 310 such that light may pass through the rectangular opening 402, into the light concentrator 308, and to the detector 310. FIG. 4B illustrates the top view of a portion of the 3D sensor 300 as in FIG. 4A, with the addition of the tissue measurement site 102 in operational position. Accordingly, the rectangular opening 402, the light concentrator 308 and the detector 310 are shown in phantom as being under the tissue measurement site 102. In FIGS. 4A and 4B, the light concentrator 308 is shown to have dimensions significantly larger than the dimensions of the rectangular opening 402. In other embodiments, the dimensions of the light concentrator 308, the rectangular opening 402, and the irradiated surface area 206 are substantially similar.

**[0044]** FIG. 5 illustrates a top view of a 3D pulse oximetry sensor 500 according to an embodiment of the present disclosure. The 3D sensor 500 is configured to be worn on a patient's finger 102. The 3D sensor 500 includes an adhesive substrate 502 having front flaps 504 and rear flaps 506 extending outward from a center portion 508 of the 3D sensor 500. The center portion 508 includes components of the 3D pulse oximetry sensor 300 described with respect to FIGS. 3, 4A and 4B. On the front side of the adhesive substrate 502 the emitter 302 and the light diffuser 304 are positioned. On the rear side of the adhesive substrate 502 the light-absorbent detector filter 306, the light concentrator 308 and the detector 310 are positioned. In use, the patient's finger serving as the tissue measurement site 102 is positioned over the rectangular opening 402 such that when the front portion of the adhesive substrate is folded over on top of the patient's finger 102, the emitter 302 and the light diffuser 304 are aligned with the measurement site 102, the filter 306, the light concentrator 308 and the detector 310. Once alignment is established, the front and rear flaps 504, 506 can be wrapped around the finger measurement site 102 such that the adhesive substrate 502 provides a secure contact between the patient's skin and the 3D sensor 500. Fig. 5 also illustrates an example of a sensor connector cable 510 which is used to connect the 3D sensor 500 to a monitor 809, as described with respect to FIG. 8.

**[0045]** FIG. 6 is a simplified schematic illustration of a conventional, 2D approach to reflective pulse oximetry in which the emitter is configured to emit optical radiation as a point optical source. Reflective pulse oximetry is a method by which the emitter and detector are located on the same side of the tissue measurement site 102. Light is emitted into a tissue measurement site 102 and attenuated. The emitted light passes into the tissue 102 and is then reflected back to the same side of the tissue measurement site 102 as the emitter. As illustrated in FIG. 6, a depicted reflective 2D pulse oximetry sensor 600 includes an emitter 602, a light block 606, and a detector 610. The light block 606 is necessary because the emitter 602 and the detector 610 are located on the same side of the tissue measurement site 102. Accordingly, the light block 606 prevents incident emitter light, which did not enter the tissue measurement site 102, from arriving at the

detector 610. The depicted 2D pulse oximetry sensor 600 is configured to emit light as a point source. As depicted in FIG. 6, a simplified illustration of the light path 620 of the emitted light from the emitter 602, through the tissue measurement site 102, and to the detector 610 is provided. Notably, a point source of light is emitted, and a point source of light is detected. As discussed above with respect to FIG. 1, use of a point optical source can result in substantial measurement error due to pathlength variability resulting from the multiple scatter phenomenon. The sample space provided by a 2D point optical emitter source is not large enough to account for pathlength variability, which will skew measurement results.

**[0046]** FIGS. 7A and 7B are simplified schematic side and top views, respectively, of a 3D reflective pulse oximetry sensor 700 according to an embodiment of the present disclosure. In the illustrated embodiment, the 3D sensor 700 irradiates the tissue measurement site 102 and detects the emitted light that is reflected by the tissue measurement site 102. The 3D sensor 700 can be placed on a portion of the patient's body that has relatively flat surface, such as, for example a wrist, because the emitter 702 and detector 710 are on located the same side of the tissue measurement site 102. The 3D sensor 700 includes an emitter 702, a light diffuser 704, a light block 706, a light concentrator 708, and a detector 710.

**[0047]** As previously described, the emitter 702 can serve as the source of optical radiation transmitted towards the tissue measurement site 102. The emitter 702 can include one or more sources of optical radiation. Such sources of optical radiation can include LEDs, laser diodes, incandescent bulbs with appropriate frequency-selective filters, combinations of the same, or the like. In an embodiment, the emitter 702 includes sets of optical sources that are capable of emitting visible and near-infrared optical radiation. In some embodiments, the emitter 702 transmits optical radiation of red and infrared wavelengths, at approximately 650 nm and approximately 940 nm, respectively. In some embodiments, the emitter 702 includes a single source of optical radiation.

**[0048]** The light diffuser 704 receives the optical radiation emitted from the emitter 302 and homogenously spreads the optical radiation over a wide, donut-shaped area, such as the area outlined by the light diffuser 704 as depicted in FIG.

7B. Advantageously, the diffuser 704 can receive emitted light in the form of a 2D point optical source (or any other form) and spread the light to fit the desired surface area on a plane defined by the surface of the tissue measurement site 102. In an embodiment, the diffuser 704 is made of ground glass or glass beads. A skilled artisan will understand that many other materials can be used to make the light diffuser 704.

**[0049]** The light blocker 706 includes an annular ring having a cover portion 707 sized and shaped to form a light isolation chamber for the light concentrator 708 and the detector 710. (For purposes of illustration, the light block cover 707 is not illustrated in FIG. 7B.) The light blocker 706 and the cover 707 can be made of any material that optically isolates the light concentrator 708 and the detector 710. The light isolation chamber formed by the light blocker 706 and cover 707 ensures that the only light detected by the detector 710 is light that is reflected from the tissue measurement site.

**[0050]** The light concentrator 708 is a cylindrical structure with a truncated circular conical structure on top, the truncated section of which is adjacent the detector 710. The light concentrator 708 is structured to receive the emitted optical radiation, after reflection by the tissue measurement site 102, and to direct the reflected light to the detector 710. In an embodiment, the light concentrator 708 is made of ground glass or glass beads. In some embodiments, the light concentrator 708 includes a compound parabolic concentrator.

**[0051]** As previously described, the detector 710 captures and measures light from the tissue measurement site 102. For example, the detector 710 can capture and measure light transmitted from the emitter 702 that has been reflected from the tissue in the measurement site 102. The detector 710 can output a detector signal responsive to the light captured or measured. The detector 710 can be implemented using one or more photodiodes, phototransistors, or the like. In addition, a plurality of detectors 710 can be arranged in an array with a spatial configuration corresponding to the irradiated surface area depicted in FIG. 7B by the light concentrator 708 to capture the reflected light from the tissue measurement site.



**[0052]** Advantageously, the light path 720 illustrated in FIG. 7A depicts a substantial sample of reflected light that enter the light isolation chamber formed by the light blocker 706 and cover 707. As previously discussed, the large sample of reflected light (as compared to the reflected light collected using the 2D point optical source approach) provides the opportunity to take an average of the detected light, to derive a more accurate measurement of the emitted light absorbed by the tissue, which will lead to a more accurate oxygen saturation measurement.

**[0053]** Referring now to FIG. 7B, a top view of the 3D sensor 700 is illustrated with both the emitter 702 and the light blocker cover 707 removed for ease of illustration. The outer ring illustrates the footprint of the light diffuser 704. As light is emitted from the emitter 702 (not shown in FIG. 7B), it is diffused homogenously and directed to the tissue measurement site 102. The light blocker 706 forms the circular wall of a light isolation chamber to keep incident light from being sensed by the detector 710. The light blocker cover 707 blocks incidental light from entering the light isolation chamber from above. The light concentrator 710 collects the reflected light from the tissue measurement site 102 and funnels it upward toward the detector 710 at the center of the 3D sensor 700.

**[0054]** FIG. 8 illustrates an example of an optical physiological measurement system 800, which may also be referred to herein as a pulse oximetry system 800. In certain embodiments, the pulse oximetry system 800 noninvasively measures a blood analyte, such as oxygen, carboxyhemoglobin, methemoglobin, total hemoglobin, glucose, proteins, lipids, a percentage thereof (*e.g.*, saturation), pulse rate, perfusion index, oxygen content, total hemoglobin, Oxygen Reserve Index™ (ORI™) or many other physiologically relevant patient characteristics. These characteristics can relate to, for example, pulse rate, hydration, trending information and analysis, and the like. The system 800 can also measure additional blood analytes and/or other physiological parameters useful in determining a state or trend of wellness of a patient.

**[0055]** The pulse oximetry system 800 can measure analyte concentrations at least in part by detecting optical radiation attenuated by tissue at a

measurement site 102. The measurement site 102 can be any location on a patient's body, such as a finger, foot, earlobe, wrist, forehead, or the like.

**[0056]** The pulse oximetry system 800 can include a sensor 801 (or multiple sensors) that is coupled to a processing device or physiological monitor 809. In an embodiment, the sensor 801 and the monitor 809 are integrated together into a single unit. In another embodiment, the sensor 801 and the monitor 809 are separate from each other and communicate with one another in any suitable manner, such as via a wired or wireless connection. The sensor 801 and monitor 809 can be attachable and detachable from each other for the convenience of the user or caregiver, for ease of storage, sterility issues, or the like.

**[0057]** In the depicted embodiment shown in FIG. 8, the sensor 801 includes an emitter 804, a detector 806, and a front-end interface 808. The emitter 804 can serve as the source of optical radiation transmitted towards measurement site 102. The emitter 804 can include one or more sources of optical radiation, such as light emitting diodes (LEDs), laser diodes, incandescent bulbs with appropriate frequency-selective filters, combinations of the same, or the like. In an embodiment, the emitter 804 includes sets of optical sources that are capable of emitting visible and near-infrared optical radiation.

**[0058]** The pulse oximetry system 800 also includes a driver 811 that drives the emitter 804. The driver 811 can be a circuit or the like that is controlled by the monitor 809. For example, the driver 811 can provide pulses of current to the emitter 804. In an embodiment, the driver 811 drives the emitter 804 in a progressive fashion, such as in an alternating manner. The driver 811 can drive the emitter 804 with a series of pulses for some wavelengths that can penetrate tissue relatively well and for other wavelengths that tend to be significantly absorbed in tissue. A wide variety of other driving powers and driving methodologies can be used in various embodiments. The driver 811 can be synchronized with other parts of the sensor 801 to minimize or reduce jitter in the timing of pulses of optical radiation emitted from the emitter 804. In some embodiments, the driver 811 is capable of driving the emitter 804 to emit optical radiation in a pattern that varies by less than about 10 parts-per-million.

**[0059]** The detector 806 captures and measures light from the tissue measurement site 102. For example, the detector 806 can capture and measure light transmitted from the emitter 804 that has been attenuated or reflected from the tissue at the measurement site 102. The detector 806 can output a detector signal 107 responsive to the light captured and measured. The detector 806 can be implemented using one or more photodiodes, phototransistors, or the like. In some embodiments, a detector 806 is implemented in detector package to capture and measure light from the tissue measurement site 102 of the patient. The detector package can include a photodiode chip mounted to leads and enclosed in an encapsulant. In some embodiments, the dimensions of the detector package are approximately 2 square centimeters. In other embodiments, the dimensions of the detector package are approximately 1.5 centimeters in width and approximately 2 centimeters in length.

**[0060]** The front-end interface 808 provides an interface that adapts the output of the detectors 806, which is responsive to desired physiological parameters. For example, the front-end interface 808 can adapt the signal 807 received from the detector 806 into a form that can be processed by the monitor 809, for example, by a signal processor 810 in the monitor 809. The front-end interface 808 can have its components assembled in the sensor 801, in the monitor 809, in a connecting cabling (if used), in combinations of the same, or the like. The location of the front-end interface 808 can be chosen based on various factors including space desired for components, desired noise reductions or limits, desired heat reductions or limits, and the like.

**[0061]** The front-end interface 808 can be coupled to the detector 806 and to the signal processor 810 using a bus, wire, electrical or optical cable, flex circuit, or some other form of signal connection. The front-end interface 808 can also be at least partially integrated with various components, such as the detectors 806. For example, the front-end interface 808 can include one or more integrated circuits that are on the same circuit board as the detector 806. Other configurations can also be used.

**[0062]** As shown in FIG. 8, the monitor 909 can include the signal processor 810 and a user interface, such as a display 812. The monitor 809 can also include optional outputs alone or in combination with the display 812, such as a storage device 814 and a network interface 816. In an embodiment, the signal processor 810 includes processing logic that determines measurements for desired analytes based on the signals received from the detector 806. The signal processor 810 can be implemented using one or more microprocessors or sub-processors (*e.g.*, cores), digital signal processors, application specific integrated circuits (ASICs), field programmable gate arrays (FPGAs), combinations of the same, and the like.

**[0063]** The signal processor 810 can provide various signals that control the operation of the sensor 801. For example, the signal processor 810 can provide an emitter control signal to the driver 811. This control signal can be useful in order to synchronize, minimize, or reduce jitter in the timing of pulses emitted from the emitter 804. Accordingly, this control signal can be useful in order to cause optical radiation pulses emitted from the emitter 804 to follow a precise timing and consistent pattern. For example, when a transimpedance-based front-end interface 808 is used, the control signal from the signal processor 810 can provide synchronization with an analog-to-digital converter (ADC) in order to avoid aliasing, cross-talk, and the like. As also shown, an optional memory 813 can be included in the front-end interface 808 and/or in the signal processor 810. This memory 813 can serve as a buffer or storage location for the front-end interface 808 and/or the signal processor 810, among other uses.

**[0064]** The user interface 812 can provide an output, *e.g.*, on a display, for presentation to a user of the pulse oximetry system 800. The user interface 812 can be implemented as a touch-screen display, a liquid crystal display (LCD), an organic LED display, or the like. In alternative embodiments, the pulse oximetry system 800 can be provided without a user interface 812 and can simply provide an output signal to a separate display or system.

**[0065]** The storage device 814 and a network interface 816 represent other optional output connections that can be included in the monitor 809. The

storage device 814 can include any computer-readable medium, such as a memory device, hard disk storage, EEPROM, flash drive, or the like. The various software and/or firmware applications can be stored in the storage device 814, which can be executed by the signal processor 810 or another processor of the monitor 809. The network interface 816 can be a serial bus port (RS-232/RS-485), a Universal Serial Bus (USB) port, an Ethernet port, a wireless interface (*e.g.*, WiFi such as any 802.1x interface, including an internal wireless card), or other suitable communication device(s) that allows the monitor 809 to communicate and share data with other devices. The monitor 809 can also include various other components not shown, such as a microprocessor, graphics processor, or controller to output the user interface 812, to control data communications, to compute data trending, or to perform other operations.

**[0066]** Although not shown in the depicted embodiment, the pulse oximetry system 800 can include various other components or can be configured in different ways. For example, the sensor 801 can have both the emitter 804 and detector 806 on the same side of the tissue measurement site 102 and use reflectance to measure analytes.

**[0067]** Although the foregoing disclosure has been described in terms of certain preferred embodiments, many other variations than those described herein will be apparent to those of ordinary skill in the art.

**[0068]** Conditional language used herein, such as, among others, "can," "might," "may," "*e.g.*," and the like, unless specifically stated otherwise, or otherwise understood within the context as used, is generally intended to convey that certain embodiments include, while other embodiments do not include, certain features, elements and/or states. Thus, such conditional language is not generally intended to imply that features, elements and/or states are in any way required for one or more embodiments or that one or more embodiments necessarily include logic for deciding, with or without author input or prompting, whether these features, elements and/or states are included or are to be performed in any particular embodiment. The terms "comprising," "including," "having," and the like are synonymous and are used inclusively, in an open-ended fashion, and do not

exclude additional elements, features, acts, operations, and so forth. Also, the term "or" is used in its inclusive sense (and not in its exclusive sense) so that when used, for example, to connect a list of elements, the term "or" means one, some, or all of the elements in the list. Further, the term "each," as used herein, in addition to having its ordinary meaning, can mean any subset of a set of elements to which the term "each" is applied.

**[0069]** While the above detailed description has shown, described, and pointed out novel features as applied to various embodiments, it will be understood that various omissions, substitutions, and changes in the form and details of the systems, devices or algorithms illustrated can be made without departing from the spirit of the disclosure. As will be recognized, certain embodiments of the disclosure described herein can be embodied within a form that does not provide all of the features and benefits set forth herein, as some features can be used or practiced separately from others.

**[0070]** The term "and/or" herein has its broadest, least limiting meaning which is the disclosure includes A alone, B alone, both A and B together, or A or B alternatively, but does not require both A and B or require one of A or one of B. As used herein, the phrase "at least one of" A, B, "and" C should be construed to mean a logical A or B or C, using a non-exclusive logical or.

**[0071]** The apparatuses and methods described herein may be implemented by one or more computer programs executed by one or more processors. The computer programs include processor-executable instructions that are stored on a non-transitory tangible computer readable medium. The computer programs may also include stored data. Non-limiting examples of the non-transitory tangible computer readable medium are nonvolatile memory, magnetic storage, and optical storage. Although the foregoing disclosure has been described in terms of certain preferred embodiments, other embodiments will be apparent to those of ordinary skill in the art from the disclosure herein. Additionally, other combinations, omissions, substitutions and modifications will be apparent to the skilled artisan in view of the disclosure herein. Accordingly, the present invention is not intended to

be limited by the description of the preferred embodiments, but is to be defined by reference to claims.

**[0072]** Additionally, all publications, patents, and patent applications mentioned in this specification are herein incorporated by reference to the same extent as if each individual publication, patent, or patent application were specifically and individually indicated to be incorporated by reference.

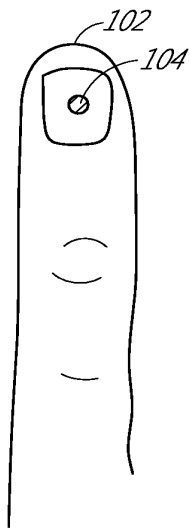

**FIG. 1**  
**(PRIOR ART)**

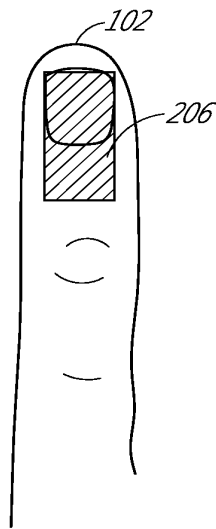

**FIG. 2**

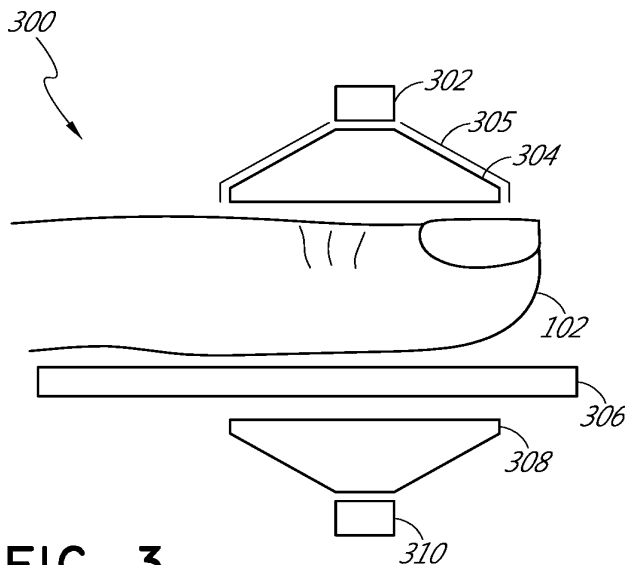

**FIG. 3**



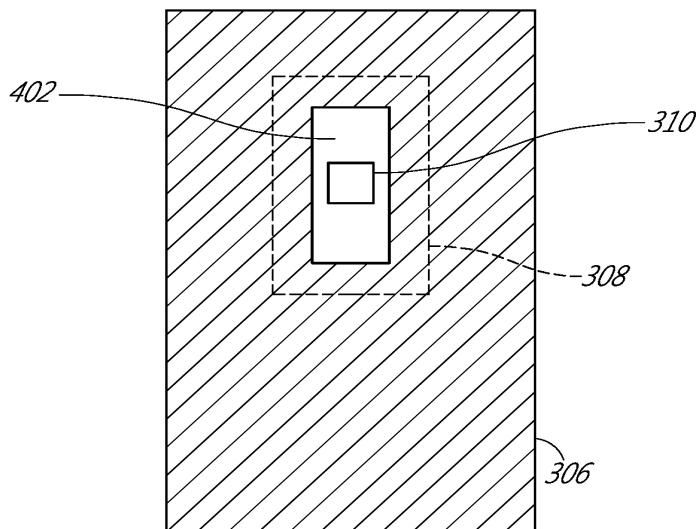

FIG. 4A

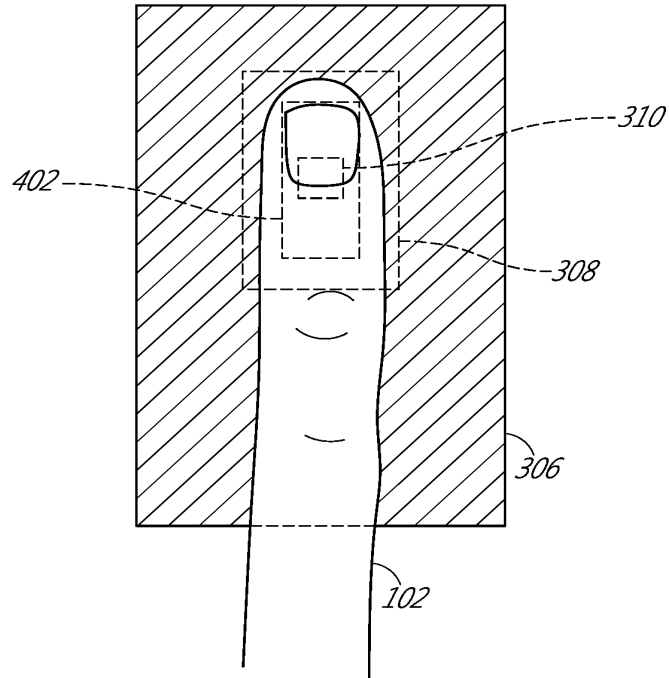

FIG. 4B

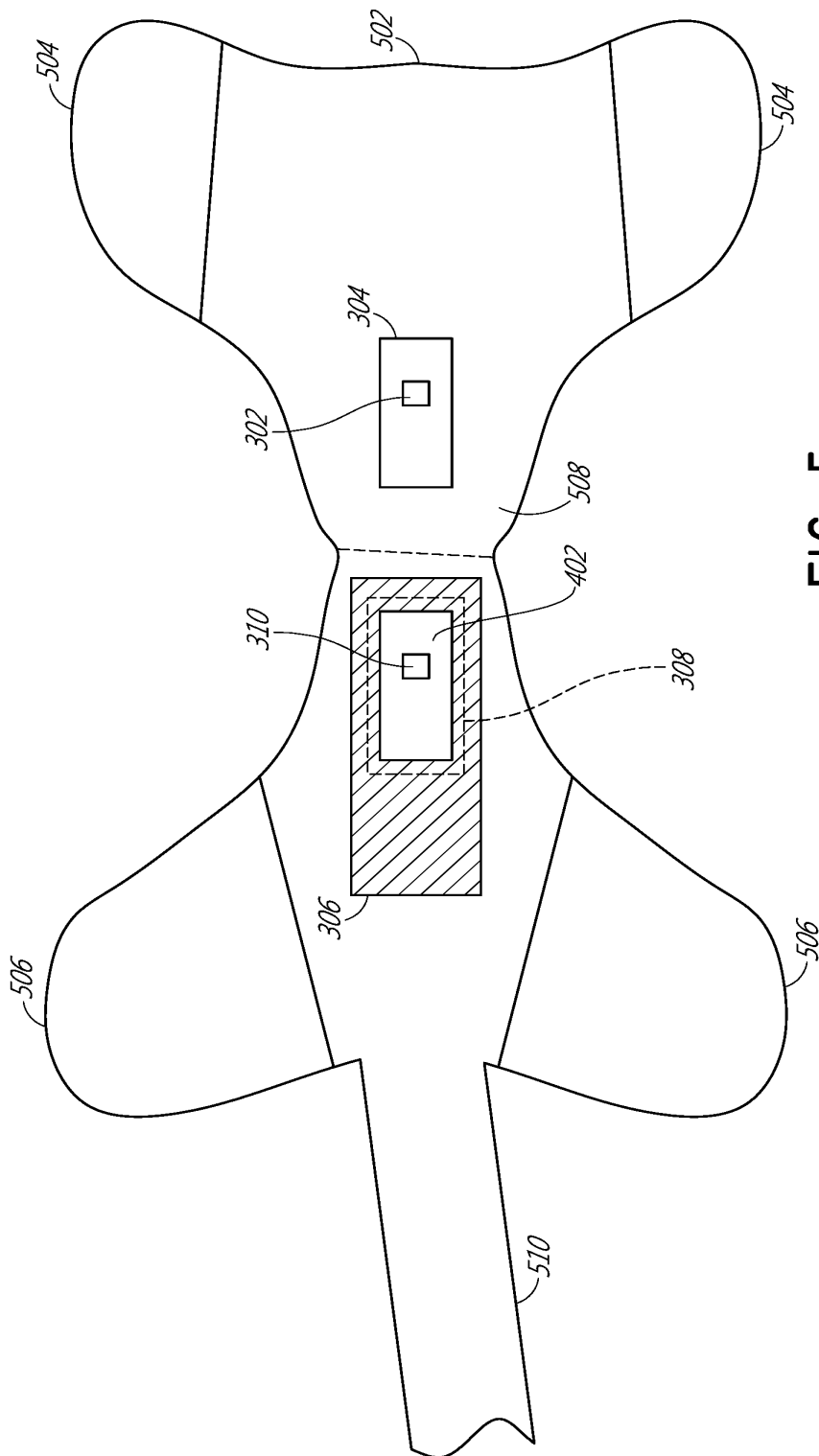

FIG. 5

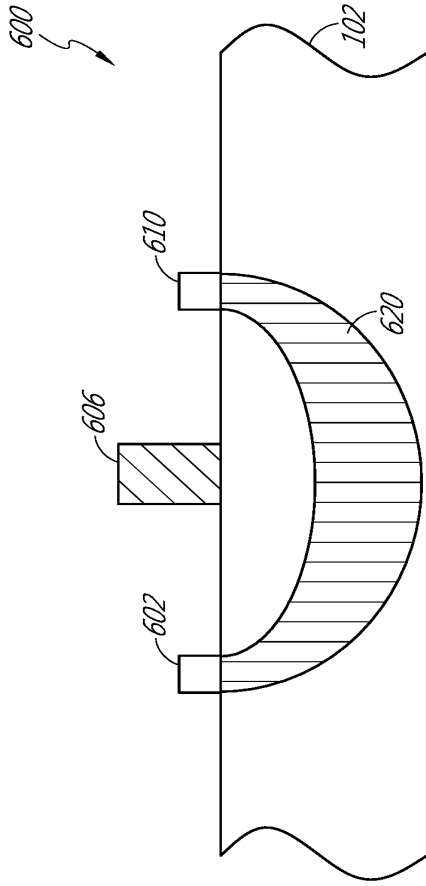

FIG. 6  
(PRIOR ART)

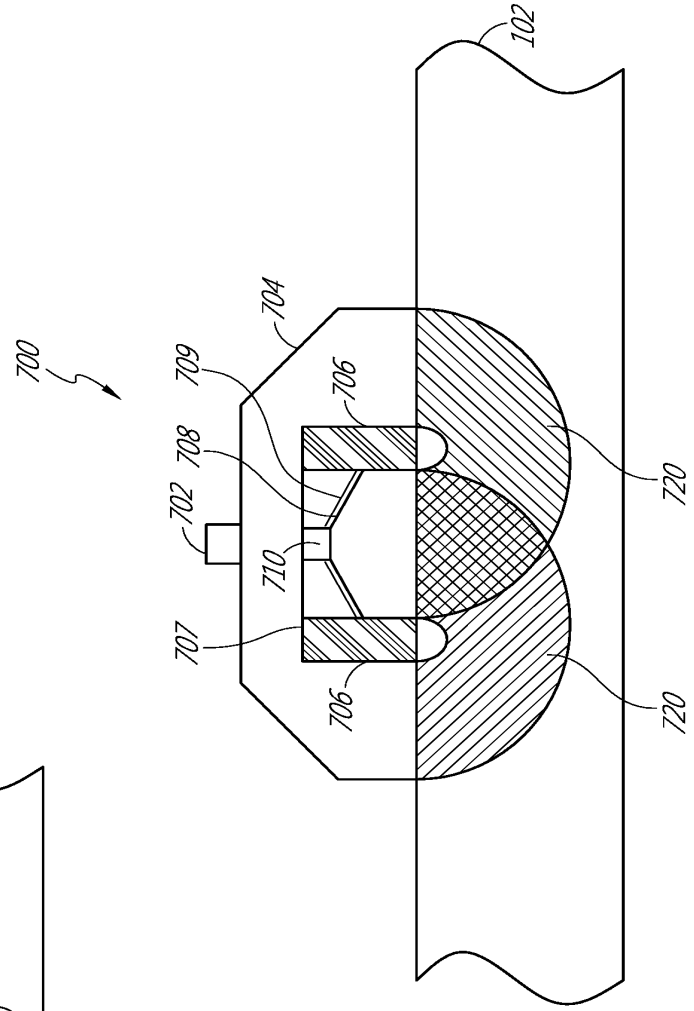

FIG. 7A

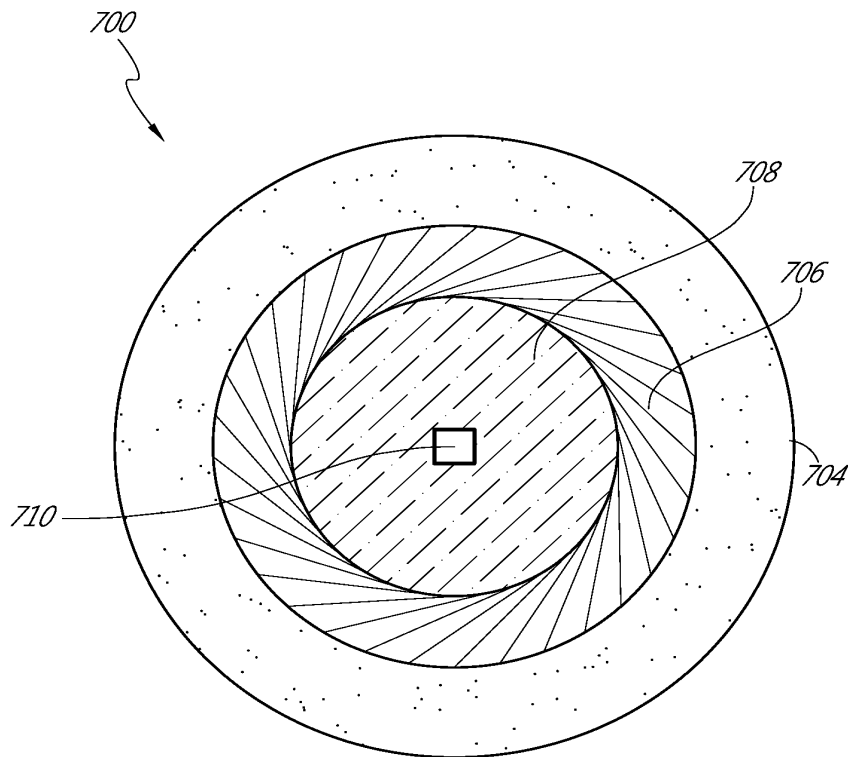

FIG. 7B

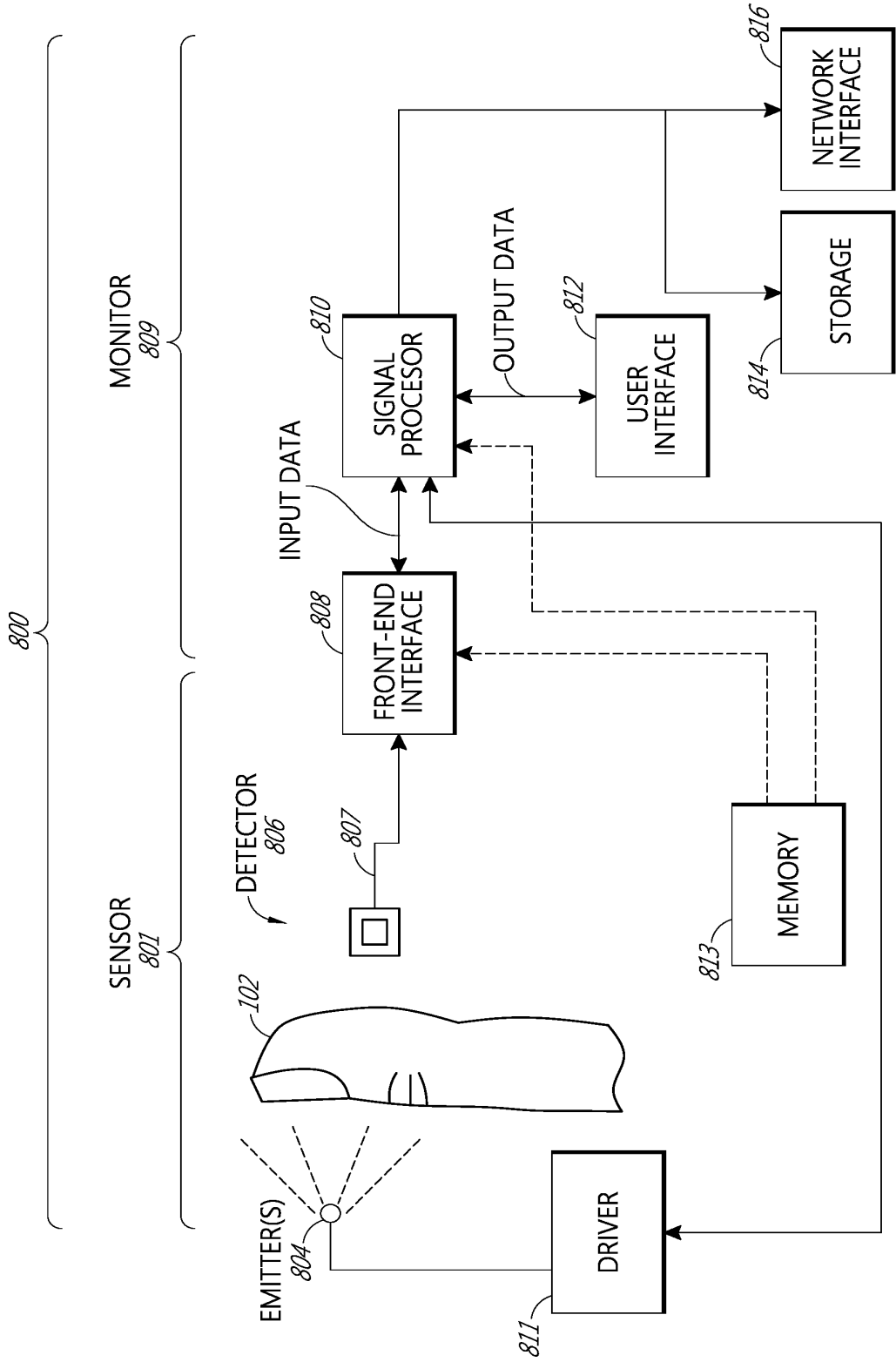

FIG. 8

**Application No.:** Unassigned  
**Filing Date:** Filed herewith

### REMARKS

Prior to examination, please amend the Specification and Claims as shown herein. Accompanying this Amendment is both a marked up and clean version of the specification.

#### No Disclaimers or Disavowals

Although the present communication may include alterations to the application or claims, or characterizations of claim scope or referenced art, Applicant is not conceding in this application that previously pending claims are not patentable. Rather, any alterations or characterizations are being made to facilitate expeditious prosecution of this application. Applicant reserves the right to pursue at a later date any previously pending or other broader or narrower claims that capture any subject matter supported by the present disclosure, including subject matter found to be specifically disclaimed herein or by any prior prosecution. Accordingly, reviewers of this or any parent, child or related prosecution history shall not reasonably infer that Applicant has made any disclaimers or disavowals of any subject matter supported by the present application.

Please charge any additional fees, including any fees for additional extension of time, or credit overpayment to Deposit Account No. 11-1410.

Respectfully submitted,

KNOBBE, MARTENS, OLSON & BEAR, LLP

Dated: December 19, 2018

By: /Aaron S. Johnson/  
Aaron S. Johnson  
Registration No. 74,164  
Registered Practitioner  
Customer No. 64735  
(949) 760-0404

29558484

**Application No.:** Unassigned  
**Filing Date:** Filed herewith

### AMENDMENTS TO THE CLAIMS

A complete listing of all claims is presented below with insertions underlined (e.g., insertion), and deletions struck through or in double brackets (e.g., ~~deletion~~ or [[deletion]]).

1-36. **(Cancelled)**

37. **(New)** A circular-shaped reflective pulse oximetry device configured for placement on a user at a tissue measurement site, the device comprising:

a plurality of emitters configured to emit light towards the tissue measurement site, the tissue measurement site being located on a wrist of the user, wherein pulsatile blood flows within tissue of the user at the tissue measurement site and the light emitted from the plurality of emitters penetrates the pulsatile blood flowing within the tissue when the circular-shaped reflective pulse oximetry device is in use, the plurality of emitters comprising one or more light-emitting diodes (LEDs) configured to emit one or more wavelengths, the one or more wavelengths comprising at least an infrared wavelength, and wherein, when the circular-shaped reflective pulse oximetry device is placed on the user at the tissue measurement site, the plurality of emitters are arranged in a reflectance measurement configuration on a first side of the tissue measurement site;

a plurality of detectors configured to detect the light emitted by the plurality of emitters after attenuation by and reflection from the pulsatile blood flowing through tissue of the user at the tissue measurement site, wherein the plurality of detectors comprise one or more photodiodes, and wherein the plurality of detectors are arranged in a reflectance measurement configuration on the first side of the tissue measurement site when the circular-shaped reflective pulse oximetry device is placed on the user, the plurality of detectors further configured to transmit a signal responsive to the detected light to a processor, the processor configured to receive the transmitted signal responsive to the detected light and determine a physiological parameter indicative of a state or trend of wellness of the user;

a light block comprising a circular wall, wherein the light block is positioned between the emitted light at the tissue measurement site and the plurality of detectors when the circular-shaped reflective pulse oximetry device is placed on the user, the light block forming a light isolation chamber defined by the circular wall, wherein the light



**Application No.:** Unassigned  
**Filing Date:** Filed herewith

isolation chamber reduces an amount of incident light emitted from the plurality of emitters from being detected by the plurality of detectors; and

a display configured to present information related to the determined physiological parameter to the user.

38. (New) The reflective pulse oximetry device of Claim 37, further comprising a diffuser which receives, spreads, and emits the spread light, wherein the emitted spread light is directed at the tissue measurement site.

39. (New) The reflective pulse oximetry device of Claim 37, wherein the plurality of emitters are positioned outside the circular wall when the reflective pulse oximetry device is placed on the user at the tissue measurement site, and wherein the plurality of detectors are positioned inside the circular wall when the reflective pulse oximetry device is placed on the user at the tissue measurement site.

40. (New) The reflective pulse oximetry device of Claim 37, further comprising a concentrator which receives the light after attenuation by tissue of the user, concentrates the received light, and directs the concentrated light toward the plurality of detectors.

41. (New) The reflective pulse oximetry device of Claim 37, wherein the physiological parameter is arterial oxygen saturation.

42. (New) The reflective pulse oximetry sensor of Claim 37, wherein the plurality of detectors are arranged in an array with a spacial configuration corresponding to an irradiated surface area.

43. (New) The reflective pulse oximetry sensor of Claim 42, wherein the irradiated surface area comprises a circular shape.

44. (New) A method of measuring a physiological parameter in a user's blood, the method comprising:

emitting, from a plurality of emitters of a reflective pulse oximetry device, light of one or more wavelengths toward a tissue measurement site comprising pulsatile blood flow, the tissue measurement site located on a lower arm of the user, wherein the light emitted from the plurality of emitters penetrates the pulsatile blood flowing within tissue of the user at the tissue measurement site, and wherein the plurality of emitters comprise one or more light-emitting diodes (LEDs) and the one or more wavelengths comprises at

**Application No.:** Unassigned  
**Filing Date:** Filed herewith

least an infrared wavelength, the plurality of emitters arranged in a reflectance measurement configuration on a first side of the tissue measurement site when the reflective pulse oximetry device is placed on the user at the tissue measurement site;

detecting, with a plurality of detectors, the light emitted by the plurality of emitters after attenuation by and reflection from the pulsatile blood flowing through tissue of the user at the tissue measurement site, wherein the plurality of detectors comprise one or more photodiodes, and wherein the plurality of detectors are arranged in a reflectance measurement configuration on the first side of the tissue measurement site when the reflective pulse oximetry device is placed on the user at the tissue measurement site; and

providing a light block comprising a circular wall, wherein the light block is positioned between the emitted light at the tissue measurement site and the plurality of detectors when the reflective pulse oximetry device is placed on the user, the light block forming a light isolation chamber defined by the circular wall, and wherein the light isolation chamber reduces an amount of incident light emitted from the plurality of emitters from being detected by the plurality of detectors;

transmitting, from the plurality of detectors, a signal responsive to the detected light;

receiving, by a processor, the transmitted signal responsive to the detected light; and

processing, by the processor, the received signal responsive to the detected light to determine a physiological parameter.

45. **(New)** The method of Claim 44, wherein the plurality of emitters are positioned outside the circular wall when the reflective pulse oximetry device is placed on the user at the tissue measurement site, and wherein the plurality of detectors are positioned inside the circular wall when the reflective pulse oximetry device is placed on the user at the tissue measurement site.

46. **(New)** The method of Claim 44, further comprising presenting, with a display of the reflective pulse oximetry device, information related to the determined physiological parameter to the user.

**Application No.:** Unassigned  
**Filing Date:** Filed herewith

47. (New) The reflective pulse oximetry sensor of Claim 44, further comprising spreading, with a diffuser, the emitted light and emitting the spread light from the diffuser to the tissue measurement site.

48. (New) The reflective pulse oximetry sensor of Claim 44, wherein the physiological parameter is indicative of at least one of pulse rate, perfusion index, oxygen content, and total hemoglobin.

49. (New) The reflective pulse oximetry sensor of Claim 44, wherein the plurality of detectors are arranged in an array with a spacial configuration corresponding to an irradiated surface area.

50. (New) The reflective pulse oximetry sensor of Claim 49, wherein the irradiated surface area comprises a circular shape.

51. (New) A reflective pulse oximetry sensor comprising:

a plurality of optical sources configured to emit light towards a tissue measurement site on a user, the tissue measurement site located on a wrist of the user, wherein pulsatile blood flows within tissue of the user at the tissue measurement site and the light emitted from the plurality of optical sources penetrates the pulsatile blood flowing within the tissue when the reflective pulse oximetry device is in use, the plurality of optical sources comprising one or more light-emitting diodes (LEDs) configured to emit one or more wavelengths, the one or more wavelengths comprising at least an infrared wavelength, and wherein, when the reflective pulse oximetry device is placed on the user at the tissue measurement site, the plurality of optical sources are arranged in a reflectance measurement configuration on a first side of the tissue measurement site;

a plurality of detectors configured to detect the light emitted by the plurality of emitters after attenuation by and reflection from the pulsatile blood flowing through tissue of the user at the tissue measurement site, wherein the plurality of detectors comprise one or more photodiodes, and wherein the plurality of detectors are arranged in a reflectance measurement configuration on the first side of the tissue measurement site when the reflective pulse oximetry device is placed on the user, the plurality of detectors further configured to transmit a signal responsive to the detected light to a processor, the processor configured to receive the transmitted signal responsive to the detected light and

**Application No.:** Unassigned  
**Filing Date:** Filed herewith

determine a physiological parameter indicative of a state or trend of wellness of the user;  
and

a light block comprising a circular wall, wherein the light block is positioned between the emitted light at the tissue measurement site and the plurality of detectors when the reflective pulse oximetry device is placed on the user, the light block forming a light isolation chamber defined by the circular wall, wherein the light isolation chamber reduces an amount of incident light emitted from the plurality of emitters from arriving at the plurality of detectors.

52. (New) The reflective pulse oximetry sensor of Claim 51, wherein the plurality of optical sources are user outside the circular wall when the reflective pulse oximetry sensor is placed on the user at the tissue measurement site, and wherein the plurality of detectors are arranged inside the circular wall when the reflective pulse oximetry sensor is placed on the user at the tissue measurement site.

53. (New) The reflective pulse oximetry sensor of Claim 51, wherein the plurality of detectors are arranged in an array so as to capture the emitted light reflected from the tissue of the user at the tissue measurement site.

54. (New) The reflective pulse oximetry sensor of Claim 51, wherein the plurality of detectors are arranged with a spacial configuration corresponding to an irradiated surface area.

55. (New) The reflective pulse oximetry sensor of Claim 51, further comprising a diffuser which receives, spreads, and emits the spread light, wherein the emitted spread light is directed at the tissue measurement site.

56. (New) The reflective pulse oximetry sensor of Claim 51, further comprising a display configured to present information related to the determined physiological parameter to the user.

**Application No.:** Unassigned  
**Filing Date:** Filed herewith

### AMENDMENTS TO THE SPECIFICATION

Please amend the originally filed specification as set forth below.

**Please amend Paragraph [0020] as follows:**

[0020] FIG. 1 illustrates a conventional approach to two-dimensional pulse oximetry in which the emitter is configured to emit optical radiation as a point optical source.

**Please amend Paragraph [0021] as follows:**

[0021] FIG. 2 illustrates the disclosed three-dimensional approach to pulse oximetry in which the emitted light irradiates a substantially larger volume of tissue as compared to the point source approach described with respect to ~~FIG. 2A~~FIG. 1.

**Please amend Paragraph [0022] as follows:**

[0022] FIG. 3 illustrates schematically a side view of a three-dimensional pulse oximetry sensor according to an embodiment of the present disclosure.

**Please amend Paragraph [0023] as follows:**

[0023] FIG. 4A is a top view of a portion of a three-dimensional pulse oximetry sensor according to an embodiment of the present disclosure.

**Please amend Paragraph [0024] as follows:**

[0024] FIG. 4B illustrates the top view of a portion of the three-dimensional pulse oximetry sensor shown in FIG. 4A, with the addition of a tissue measurement site in operational position.

**Please amend Paragraph [0025] as follows:**

[0025] FIG. 5 illustrates a top view of a three-dimensional pulse oximetry sensor according to an embodiment of the present disclosure.

**Application No.:** Unassigned  
**Filing Date:** Filed herewith

**Please amend Paragraph [0026] as follows:**

[0026] FIG. 6 illustrates a conventional two-dimensional approach to reflective pulse oximetry in which the emitter is configured to emit optical radiation as a point optical source.

**Please amend Paragraph [0027] as follows:**

[0027] FIG. 7A is a simplified schematic side view illustration of a reflective three-dimensional pulse oximetry sensor according to an embodiment of the present disclosure.

**Please amend Paragraph [0028] as follows:**

[0028] FIG. 7B is a simplified schematic top view illustration of the three-dimensional reflective pulse oximetry sensor of FIG. 7A.