



- (51) International Patent Classification:
A61B 5/00 (2006.01)
- (21) International Application Number:
PCT/IB2010/054858
- (22) International Filing Date:
27 October 2010 (27.10.2010)
- (25) Filing Language: English
- (26) Publication Language: English
- (30) Priority Data:
09174732.9 2 November 2009 (02.11.2009) EP
- (71) Applicant (for all designated States except US): **KONINKLIJKE PHILIPS ELECTRONICS N.V.** [NL/NL]; Groenewoudseweg 1, NL-5621 BA Eindhoven (NL).
- (72) Inventors; and
- (75) Inventors/Applicants (for US only): **ACKERMANS, Paul, Anton, Josef** [NL/NL]; c/o High Tech Campus Building 44, NL-5656 AE Eindhoven (NL). **KASSIES, Roelf** [NL/NL]; c/o High Tech Campus Building 44, NL-5656 AE Eindhoven (NL).
- (74) Agents: **VAN VELZEN, Maaïke, M.** et al.; High Tech Campus, Building 44, NL-5656 AE Eindhoven (NL).

- (81) Designated States (unless otherwise indicated, for every kind of national protection available): AE, AG, AL, AM, AO, AT, AU, AZ, BA, BB, BG, BH, BR, BW, BY, BZ, CA, CH, CL, CN, CO, CR, CU, CZ, DE, DK, DM, DO, DZ, EC, EE, EG, ES, FI, GB, GD, GE, GH, GM, GT, HN, HR, HU, ID, IL, IN, IS, JP, KE, KG, KM, KN, KP, KR, KZ, LA, LC, LK, LR, LS, LT, LU, LY, MA, MD, ME, MG, MK, MN, MW, MX, MY, MZ, NA, NG, NI, NO, NZ, OM, PE, PG, PH, PL, PT, RO, RS, RU, SC, SD, SE, SG, SK, SL, SM, ST, SV, SY, TH, TJ, TM, TN, TR, TT, TZ, UA, UG, US, UZ, VC, VN, ZA, ZM, ZW.
- (84) Designated States (unless otherwise indicated, for every kind of regional protection available): ARIPO (BW, GH, GM, KE, LR, LS, MW, MZ, NA, SD, SL, SZ, TZ, UG, ZM, ZW), Eurasian (AM, AZ, BY, KG, KZ, MD, RU, TJ, TM), European (AL, AT, BE, BG, CH, CY, CZ, DE, DK, EE, ES, FI, FR, GB, GR, HR, HU, IE, IS, IT, LT, LU, LV, MC, MK, MT, NL, NO, PL, PT, RO, RS, SE, SI, SK, SM, TR), OAPI (BF, BJ, CF, CG, CI, CM, GA, GN, GQ, GW, ML, MR, NE, SN, TD, TG).

Declarations under Rule 4.17:

- as to applicant's entitlement to apply for and be granted a patent (Rule 4.17(ii))

[Continued on next page]

(54) Title: MEDICAL OPTICAL SENSOR

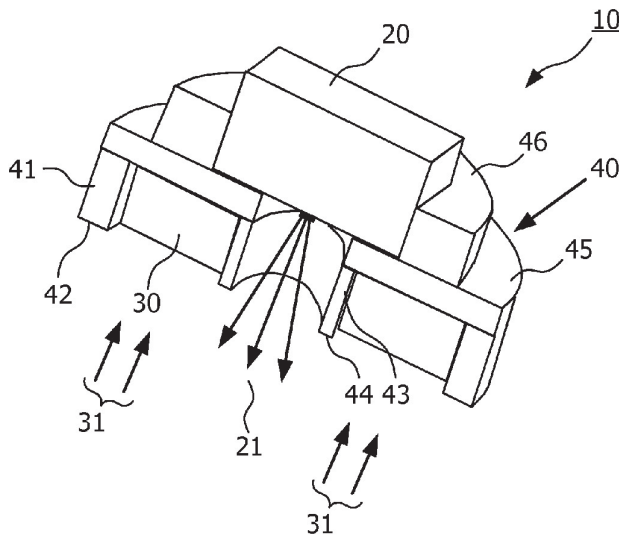

FIG. 1

(57) **Abstract:** The medical optical sensor (10) comprises at least one light emitter (20) for emitting light (21) directed to a part of the skin (50) of a patient and at least one photo-detector (30) for detecting light (31) reflected from the skin (50). A housing (40) for carrying the at least one light emitter (20) and the at least one photo-detector (30) is provided, where the housing (40) has a contact area with the skin (50). The at least one light emitter (20) is positioned within the housing (40) such that emitted light (21) impinges on the skin (50) in a central part of the contact area. The at least one photo-detector (30) is positioned in a peripheral part of the housing (40) such that light reflected (31) from the skin (50) to the outer part of the contact area is detectable by the at least one photo-detector (30).

WO 2011/051888 A2



Published:

- *without international search report and to be republished upon receipt of that report (Rule 48.2(g))*

Medical optical sensor

FIELD OF THE INVENTION

The invention relates to the field of medical sensors, and in particular to the field of medical optical sensors and systems that make use of one or more of these sensors. The invention further relates to methods for measuring the blood oxygenation level by using
5 these sensors.

BACKGROUND OF THE INVENTION

Optical sensors are widely used to determine physiological parameters of patients in medical care. The non-invasive measurement of the oxygen saturation in arterial
10 blood, also called pulse oximetry, is an application of optical medical sensors of particular importance. In pulse oximeters the oxygen saturation in arterial blood (SpO_2), sometimes also referred to as blood oxygenation level, is determined by measuring the absorption of light caused by oxy- (HbO_2) and deoxyhemoglobin (HHb). Usually, the absorption is measured at two different wavelengths where the extinction coefficients of HbO_2 and HHb differ
15 significantly, for example at wavelengths of 660 nanometers (nm) and 940 nm. In addition to measuring the oxygenation level of blood, pulse oximeters also provide a pulse signal for determining a heart rate of a patient.

The light emitter and photo-detector that are used as the light source and the light detector in a pulse oximeter can either be placed opposite of each other for measuring
20 the transmission of light through the skin tissue, or adjacent to each other, measuring the diffuse reflection of light from the skin tissue. Suitable measurement locations are for example finger tips, toes, earlobes and the forehead.

With an increasing integration level of signal processing electronics and the recent advances in wireless transmission technology, wearable pulse oximeters are available
25 that allow measurements to be taken while a patient is free to move around. An example of a wearable pulse oximeter is disclosed in the document US 2009/0240125 A1. The document describes a pulse oximeter that uses an optical sensor of the transmission type. An integrated circuit including signal processing elements required to convert the detected light signals into a pulse oximetry measurement is integrated into a carriage housing of the optical sensor.

In optical measurements on the skin, motion artifacts are a serious point of concern. Movements of a patient could lead to a movement of the sensor with respect to the skin, which, in turn, leads to a change in the optical coupling between the sensor and the skin. Sensor movements can also lead to pressure variations between the sensor and the skin,
5 which could cause perfusion variations in the skin underneath the sensor, resulting in signal artifacts. Furthermore, the signal quality is inherently position sensitive for physiological reasons, for example due to the small size of blood vessels.

It would therefore be advantageous to provide for medical optical sensors and medical optical sensor systems that are less sensitive to motion artifacts.

10

SUMMARY OF THE INVENTION

The present application contemplates a medical optical sensor, a medical optical sensor unit, a medical optical sensor system, and a method of measuring the blood oxygenation level with a medical optical sensor address the abovementioned objects.

15

According to the invention, a medical optical sensor comprises at least one light emitter for emitting light directed to a part of the skin of a patient and at least one photo-detector for detecting light reflected from the skin. A housing for carrying the at least one light emitter and the at least one photo-detector is provided, where the housing has a contact area with the skin. The at least one light emitter is positioned within the housing such that
20 emitted light impinges on the skin in a central part of the contact area. The at least one photo-detector is positioned in a peripheral part of the housing such that light reflected from the skin to the outer part of the contact area is detectable by the at least one photo-detector. This way, a compact and lightweight sensor can be built.

25

In a preferred embodiment, the housing comprises an outer ring and an inner ring. Both rings are concentric to each other. The outer ring has a rim that defines the outer perimeter of the contact area with the skin. The inner ring has a rim that defines the perimeter of the central part of the contact area with the skin. The housing further comprises a base plate for supporting the rings at a side of the rings opposite of the respective rims and wherein the at least one photo-detector is mounted between the outer ring and the inner ring.
30 This way, the light emitter and the photo-detector are arranged concentric to each other in a compact way that allows obtaining a high signal quality.

Further according to the invention, a medical optical sensor unit comprises a plurality of sensors as described above, which are arranged in form of a matrix and are

connected to each other by web members, such that the sensors and the web members form a web-like structure with openings.

Further according to the invention, a medical optical sensor system comprises at least one sensor as described above or at least one sensor unit as described above. The
5 medical optical sensor system furthermore comprises a control unit for operating the sensor or the sensor unit. Flexible electrical connectors are present for connecting the sensor or the sensor unit with the control unit.

Further according to the invention, a method of measuring the blood oxygen level with a medical optical sensor comprises the following steps. Light is emitted by at least
10 one light emitter and directed to a part of a patient's skin. The light is then reflected by the patient's skin and received by at least one photo-detector. Electrical signals from the at least one photo-detector are processed in order to determine an oximetry value.

The basic idea behind all mentioned aspects of the invention is that mechanical forces acting on the sensor which lead to pressure variations between the sensor
15 and the skin or even to a dislocation of the sensor with respect to the skin are minimized. One type of force acting on the sensor is inertial force. Inertial forces result from an acceleration of the inert mass of the sensor. Acceleration of the sensor is unavoidable if a patient moves. For a given acceleration, the force acting on the sensor is proportional to the mass of the sensor. The small and compact design of the medical optical sensor according to the
20 invention allows building a lightweight sensor that accordingly only experiences small acceleration forces and is well suited for wearable systems. Furthermore, the separation of the electronic control unit and the sensor in the medical optical sensor system according to the invention also minimizes the weight of the sensor and thus the acceleration forces that act on the sensor. A coupling of a plurality of sensors to form a sensor unit according to the
25 invention opens the possibility to have a lightweight sensor arrangement with a low position sensitivity, i.e. the performance of the sensor arrangement is less influenced by the position of the sensor on the patient.

Another type of force acting on the sensor arises from the electrical connections use for operating the sensor. The mechanical decoupling of the sensor from the
30 electronic control unit due to the flexible electrical connection furthermore minimizes the forces acting on the sensor.

Advantageous embodiments are provided in the respective dependent claims. Still further advantages and benefits of the present invention will become apparent from and

elucidated with reference to the embodiments described hereinafter in connection with the drawings.

BRIEF DESCRIPTION OF THE DRAWINGS

5 Fig. 1 shows a first embodiment of a medical optical sensor in a three-dimensional sectional schematic drawing;

Fig. 2 shows a second embodiment of a medical optical sensor positioned on a patient's skin in a schematic drawing;

10 Fig. 3 is a schematic illustration of the influence of the lateral separation of a light emitter and a photo-detector on the origin of the detected light in a medical optical sensor;

Fig. 4 shows a first embodiment of a medical optical sensor unit in a schematic drawing seen from above;

15 Fig. 5 shows a side view of a second embodiment of a medical optical sensor unit in a schematic drawing;

Fig. 6 shows a first embodiment of a medical optical sensor system in a sectional schematic drawing; and

Fig. 7 shows a side view a second embodiment of a medical optical sensor system in a sectional schematic drawing.

20

DETAILED DESCRIPTION OF EMBODIMENTS

With reference to Figure 1, a medical optical sensor 10 is shown that comprises a light emitter 20 for emitting light 21, a photo-detector 30 for detecting reflected light 31 and a housing 40 that is basically cylindrical in shape. The housing 40 includes an
25 outer ring 41 having a rim 42 and an inner ring 43 having a rim 44. On the side opposite of the rims 42, 44, the rings 41, 43 are attached to a common base plate 45. On the side opposite of the rings 41, 43, the base plate 45 provides an emitter mount 46 for holding the light emitter 20. The base plate 45 has a central opening that extends the opening of the inner ring through the base plate 45. The opening in the base plate 45 allows emitted light 21 to leave
30 the housing 40 through the inner ring 43. The photo-detector 30 is circular in shape and mounted in the circular groove formed by the base plate 45, the outer ring 41 and the inner ring 42.

The medical optical sensor 10, also abbreviated as sensor 10 in the following, is designed to be attached to the skin with at least the rims 42 and 44 touching the skin. The

emitted light 21 is directed onto the skin and partly penetrates into the skin where it interacts with the skin tissue and in particular with blood vessels contained in the skin. A part of the light leaves the tissue again after one or more scattering events and enters the photo-detector 30 as the reflected light 31. Due to the diffuse reflectance, the area of the skin through which the reflected light 31 leaves the skin is by far larger than the entrance spot of the emitted light 21 on the skin. Since, in first order, the light is scattered isotropically in all directions in the diffuse reflectance process, the area through which the light leaves the skin is essentially circular in shape. The sensor 10 and the circular shaped photo-detector 30 account for this effect, which leads to a high detection efficiency.

10 In the embodiment shown, the rims 42 and 44 are positioned in the same plane. The circularly shaped photo-detector 30 is mounted recessed from this plane in a direction way from the skin. In this configuration, the inner ring 43 shadows the photo-detector 30 from emitted light 21 shining directly onto the photo-detector 30, thereby overwhelming the signal of the reflected light 31 which is much lower in intensity. In an
15 alternative configuration, the photo-detector 30 could also be mounted with its light entrance surface positioned within the plane defined by the rims 42 and 44. In order to protect the light emitter 20 and the photo-detector 30 and in order to have a planar contact area between the sensor 10 and the skin, it is possible to fill the remaining parts of the inner and the outer rings 41 and 43 with a transparent resin. For reasons of biocompatibility and hygiene, a medical-
20 grade resin suitable for medical applications is preferred.

In order to attach the sensor 10 to a patient's skin, a medical-grade optically transparent adhesive can be used. This can either be an adhesive gel or a double-sided adhesive tape. In particular if the sensor 10 does not have a planar contact area for contacting the skin, for example if no resin is used to fill the rings 41 and 43, a gel is suitable to ensure a
25 good optical transition of light between the skin and the light emitter 20 or the photo-detector 30. In all cases, the contact area is defined to be the area that is delimited by the perimeter of the outer ring 41.

The close integration of the light emitter 20 and the photo-detector 30 into the compact housing 40, which can be made with a very light weight by using a one piece
30 extraction molded material, leads to a medical optical sensor 10 that only experiences very small acceleration forces. As a result, the movements of the sensor with respect to the underlying skin are minimized and the signal delivered by the photo-detector 30 is less affected by movement artifacts.

Both light emitter 20 and photo-detector 30 can be semiconductor devices, for example based on silicon (Si), gallium nitride (GaN) or gallium arsenide (GaAs) or a combination thereof. A light emitting diode (LED) or laser diode (LD) can be used as the light emitter 20. The light emitting diode could comprise more than one die, which offers the possibility of emitting light at different wavelengths. Alternatively, the emitter mount 46 of the housing 40 could be designed such that more than one LEDs or LDs could be mounted, either for the option of having light of different wavelengths available, or for the option of providing emitted light 21 at a single wavelength, but with increased power or power density.

A photodiode can be used as the photo-detector 30. As an alternative to the ring shaped circular single photo-detector 30 shown in Fig. 1, a plurality of smaller photo-detectors could be used, for example small photodiodes that are arranged between the inner ring 43 and the outer ring 41. However, a single photo-detector 30, in particular if it fills the available space between the inner and the outer rings 41, 43, would offer the best detection sensitivity.

A typical application of the shown optical medical sensor 10 could be the measurement of the oxygenation level of blood in a pulse oximeter. In this case, a light emitter 20 is used that emits light at two different wavelengths, usually around 660 nm and 940 nm.

Figure 2 shows another embodiment of a medical optical sensor 10. Elements having the same or comparable functions are denoted by the same reference numerals in all figures.

The optical medical sensor 10 of Fig. 2 is attached to a skin 50 of a patient by using a medical transparent adhesive 60, a double-sided transparent adhesive tape in this case. In accordance with the embodiment shown in Fig. 1, the medical optical sensor 10 of Fig. 2 comprises a housing 40 with an outer ring 41 and an inner ring 43 and respective rims 42, 44. It also comprises a light emitter 20 for emitting light 21 impinging on the skin 50 within the vicinity of the inner ring 43. As in the embodiment of Fig. 1, the photo-detector 30 is a single circular shaped photo-detector filling almost the entire available space between the inner ring 43 and the outer ring 41. In contrast to the embodiment shown in Fig. 1, the light emitter 20 is mounted within the ring 43 rather than on top of the base plate 45, thereby reaching a very high level of integration. Both the light emitter 20 and the photo-detector 30 are mounted recessed from the plane defined by the rims 42 and 44. As a result, the inner ring 43 prevents light emitted by the light emitter 20 from shining directly into the photo-detector 30. In the embodiment shown, the light emitter 20 and the photo-detector 30 are embedded

into a transparent medical resin 47. Thus, the resin 47 does not only fill the remaining parts of the inner and the outer rings 41 and 43 to protect the light emitter 20 and the photo-detector 30, but also fixes them. It is possible to mount the light emitter 20 and the photo-detector 30 by this means only.

5 Figures 3A and 3B illustrate the dependence of the origin of the reflected light 31 from the lateral distance between emitted light 21 entering the skin and reflected light 31 emerging from the skin 50. The skin 50 comprises three sub-layers, called epidermis layer 51, dermis layer 52 and fat layer 53. The dermis layer 52 contains a dense network of small blood vessels and is the layer of the main interest for medical optical measurements.

10 In Figs. 3 A and B, r denotes the mean distance between the entrance spot of light 21 entering the skin and the area through which reflected light 31 leaves the skin. A small aperture for the entrance and the exit area is assumed. The vertically hedged u-shaped area schematically indicates the detection volume 32, being the volume of the skin 50, in which one or more scattering events occur for leading light from the entrance aperture to the
15 detection aperture. Accordingly, the detection volume 32 can be regarded as the part of the skin, for which physiological information can be obtained. In the figures, d denotes the depth with respect to the surface of the skin 50 down to which the detection volume reaches.

 Fig. 3A shows the situation for a distance r of approximately 1 mm. It is apparent that the detection volume 32 just overlaps with the upper part of the dermis layer 52.

20 Fig. 3B shows the situation for a distance r of approximately 3 mm. Here, the detection volume 32 just reaches down to the fat layer 53.

 The figures show that a distance r between approximately 1 mm and 3 mm is well suited to perform medical optical measurements of the reflection type, since then the dermis layer 52, which is of major physiological interest, is being sampled. Accordingly, for
25 a sensor 10 with a concentric arrangement of the light emitter 20 and the photo-detector 30, as for example shown in the embodiments of Figs. 1 and 2, an inner ring 43 with a radius of approximately one mm and an outer ring 41 with a radius of approximately 3 mm radius is advantageous.

 Figure 4 shows a schematic drawing of a first embodiment of a medical optical
30 sensor unit 100 seen from above. The medical optical sensor unit 100, also abbreviated as sensor unit 100 in the following, is depicted from a top view with its invisible down side intended to be attached to the skin of a patient.

 The sensor unit 100 comprises a plurality of sensors 10, which are in this embodiment arranged in a regular matrix with a hexagonal lattice structure. Adjacent sensors

10 are connected to each other by web members 110, some of which furthermore have integrated electrical connections 112. For a clear depiction, only some of the mentioned elements carry reference numerals in Fig. 4. The web members 110 are deliberately narrow in order to leave openings 120 between adjacent sensors 10 and the connecting web members
5 110. Through the openings 120, the skin of the patient is partly exposed to the environment, such that an exchange of air and in particular moisture is possible. The web members 110 are in addition recessed from the skin to expose the skin even more and enhance the exchange of air and moisture. The resulting open matrix structure enables a long term and irritation-free use on the patient's skin. At least some of the web members 110 can be made of a flexible
10 material such that the sensor unit 100 easily adapts to the surface structure and to the curvature of the skin.

The type of the sensors 10 used in the sensor unit 100, their number and the geometry of their arrangement of the embodiment shown in Fig. 4 are only exemplary. While the embodiment of Fig. 4 makes use of a cylindrical sensor 10 with concentric light emitter
15 and photo-detector and a circular contact area with the skin, a matrix-like sensor unit 100 could comprise medical optical sensor having a different outline and/or light emitters and photo-detectors that are positioned differently with respect to each other, for example mounted side by side in a rectangular shaped housing. Furthermore, the sensor unit 100 is not limited to medical optical sensors. It is also possible to combine other medical sensors to
20 build a medical optical sensor unit, for example medical electrical sensors like electrodes for use in electroencephalography (EEG) or electrocardiography (ECG).

Sensor units with more or less than the shown number of sensors are conceivable as well. Also other arrangements than the shown hexagonal structure, such as for example linear, triangular, rectangular or quadratic arrangements are possible.

25 By combining a plurality of sensors 10 within the sensor unit 100, measurements can be performed at a number of locations on the skin simultaneously. The derived signals of the plurality of photo-detectors contained in the sensors 10 can be processed further and analyzed in order to receive a maximal signal amplitude and quality. For example, the electrical signals of the photo-detectors could be averaged in order to
30 minimize the position sensitivity that a single sensor inherently shows. This is particularly important for small sized sensors, where a single sensor could be positioned above a spot of the skin with a low perfusion. When averaging the signals derived by the different photo-detectors, a weighting factor could additionally be used to account for the signal quality of the individual single signals. In this way well-positioned photo-detectors that provide a signal

with a high signal-to-noise ratio are preferred over less well-positioned sensors 10 that only provide a signal with a low signal-to-noise ratio.

Figures 5A and 5B each show a section of a second embodiment of a medical optical sensor unit 100. As in the embodiment shown in Fig. 4, a plurality of sensors 10 is provided for, of which two are depicted in the figure. The two adjacent sensors 10 are connected to each other with a web member 110. In contrast to the embodiment shown in Fig. 4, the sensor unit 100 additionally comprises stands 130 that are equal in size to the sensors 10, but do not provide any electrical functioning. The stands 130 are connected to the adjacent sensors 10 by flexible and elastic web members 111. These flexible and elastic web members 111 are slightly slanted such that the stands 130 lie in a plane that is vertically dislocated from the plane in which the sensors 10 are arranged. In this way a corrugated matrix is formed.

Fig. 5A depicts a situation, in which the sensor unit 100 is put on a patient's skin 50 without applying any force to the sensor unit 100. As a result of the corrugation of the matrix, the stands 130 float above the skin 50, which is indicated by a height h larger zero.

Fig. 5B shows a situation, in which an external force directed towards the skin is applied to the stands 130, such that the stands 130 do touch the skin as indicated by a height h equal to zero. Due to the corrugation, the flexible and elastic web members 111 press the shown sensors 10 onto the skin 50. The force applied on the sensor 10 by the flexible and elastic web members 111 is predetermined and can be controlled by using an appropriate material and an appropriate dimensioning for the flexible and elastic web members 111. This makes the applied force an inherent parameter of the device and independent of the way a user applies the device.

As it is the case in the embodiment shown in Fig. 4, also here the type of the sensors 10 used in the sensor unit 100, their number and the geometry of their arrangement is only exemplary. The same holds true for the stands 130. In particular the number and geometry of the stands 130 and the ratio between the number of sensors 10 and stands 130, is not limited to the embodiment shown. Also the sensors 10 and the stands 130 can be of the same shape as in the shown case, but could alternatively also differ in size and shape. Furthermore, stands 130 could be positioned at regular lattice positions of the matrix and, in this sense, replace sensors 10. Alternatively or additionally, stands 130 could be positioned dislocated from regular lattice positions in so called lattice interstitial positions.

Fig. 6 shows a first embodiment of a medical optical sensor system attached to the skin 50 of a patient in a side view.

The system comprises a medical optical sensor unit 100 containing of medical optical sensors 10, two of which are visible in the figure, and web members 110 connection the sensors 10. The system further comprises an electric control unit 70 with a power supply 71 and a wireless transmitter 72 explicitly shown. Further electrical elements, for example for driving the light emitters of the sensor unit 100 and for receiving and processing the electrical signals of the photo-detectors of the sensor unit 100, are not explicitly shown. The control unit 70 and the sensor unit 100 are electrically connected via a flexible electrical connector 80.

The control unit 70 and the sensor unit 100 are individually and separately attached to the skin 50. In both cases, an adhesive could be used for that purpose. Alternatively, only the sensor unit 100 could be attached to the skin 50 by an adhesive, while the control unit 70 is attached to the skin 50 by means of an elastic band.

The flexible electric connector 80 could, for example, be a ribbon cable with very thin stranded wires, or a flexible flat cable with multiple electrical conductors bonded or evaporated on a thin insulating plastic film base. Using thin and flexible materials for the flexible electric connector 80 results in a mechanical decoupling of the sensor unit 100 from the control unit 70. In this way vibrations or dislocations of the relatively heavy control unit 70 are not transferred onto the sensor unit 100, thereby not disturbing the signal quality.

The separation of the control unit 70 and the sensor unit 100 further keeps the inert mass of the sensor unit 100 small compared to systems where the electronics and probably even the power supply unit are integrated into the sensor unit. This is particularly important for systems that use convenient but power-consuming wireless technology for transmitting the measured physiological parameters to a monitor station, or for systems that are designed for a long-term observation of the patient, since in such cases a power supply unit with a sufficient battery capacity and an according heavy weight would have to be provided.

Figure 7 shows a second embodiment of a medical optical system. The system comprises a frame 90 with a round ring-like base and a traverse 91 spanning over the base. The frame 90 is shaped in form of a wristwatch and attachable to the skin 50 of a patient with an elastic band 92, for example an arm wrist. An electric control unit 70, by way of example depicted as a printed connector board (PCB) with a battery as a power supply 71, is rigidly attached to the frame 90. A medical optical sensor 10 is positioned at the center of the frame

90 underneath the traverse 91 and mechanically attached to the traverse 91 by a spring 93. The sensor 10 and the control unit 70 are electrically connected via a flexible electrical connector 80.

In this embodiment, the sensor 10 is pressed onto the skin 50 by a force that is defined by the spring constant of the spring 93 and the geometry of the frame 90. The large supporting surface of the frame 90 on the skin 50 leads to a defined height of the traverse 91 above the skin 50. Accordingly, the sensor 10 is pressed onto the skin 50 with a relatively constant and predetermined force. At the same time, the sensor 10 is mechanically decoupled from the frame 90 and the control unit 70, in particular concerning slight lateral movements of the frame 90 on the skin. As an alternative or in addition to the elastic band 92, the frame 90 could be attached to the skin 50 by a medical grade adhesive. In one embodiment, the adhesive could be transparent and fix the sensor 10 as well as the frame 90. In another embodiment, the adhesive could be provided with a central opening that leaves the vicinity of the sensor 10 on the skin blank and only fixes the frame 90. In the latter case, the adhesive does not have to be transparent.

In all embodiments shown or described in connection with Figs. 6 and 7, one or more sensors 10 could be used in the system, either individually attached to the skin 50 or combined together as one or more sensor units 100.

The sensors used in the system could be medical optical sensors 10 as described in connection with the Figs. 1 and 2. However, the shown separation of the sensors and the control unit, and the mechanical decoupling due to the usage of the flexible electrical connection in the sensor system is also applicable to medical sensors having a different form and/or function than the ones described in connection with Figs. 1 and 2.

While the invention has been illustrated and described in detail in the drawings and the foregoing description, such illustration and description are to be considered illustrative or exemplary only and not restrictive. The invention is not limited to the disclosed embodiments. In particular, combinations of features described in the different embodiments are apparent to those skilled in the art. Any reference signs in the claims should not be construed as limiting the scope of protection.

CLAIMS:

1. A medical optical sensor, comprising
at least one light emitter (20) for emitting light (21) directed to a part of the
skin (50) of a patient;
at least one photo-detector for detecting light reflected (31) from the skin (50);
5 a housing (40) for carrying the at least one light emitter (20) and the at least
one photo-detector (30), the housing having a contact area with the skin (50);
wherein
the at least one light emitter (20) is positioned in the housing (40) such that
emitted light (21) impinges on the skin (50) in a central part of the contact area; and
10 the at least one photo-detector (30) is positioned in a peripheral part of the
housing (40) such that light (31) reflected from the skin (50) to the outer part of the contact
area is detectable by the at least one photo-detector (30).
2. The medical optical sensor as set forth in claim 1, wherein the housing (40)
15 comprises
an outer ring (41) with a rim (42) that defines the outer perimeter of the
contact area with the skin (50);
an inner ring (43) that is concentric with the outer ring (41), the inner ring (43)
having a rim (44) that defines the perimeter of the central part of contact area; and
20 a base plate (45) for supporting the rings (41, 43) at a side of the rings opposite
of the rims (42, 44) and wherein
the at least one photo-detector (30) is mounted between the outer ring (41) and
the inner ring (43).
- 25 3. The medical optical sensor as set forth in claim one of claims 1 or 2, wherein
the at least one photo-detector (30) is a single ring-shaped photo-detector.
4. The medical optical sensor as set forth in one of claims 2 or 3, wherein the
rims (42, 44) of the inner ring (43) and the outer ring (41) are located in a common plane and

wherein the at least one photo-detector (30) is mounted recessed with respect to the common plane.

5. The medical optical sensor as set forth in one of claims 2 to 4, wherein the
5 base plate (45) has an opening in the vicinity of the inner ring (43) and wherein the at least one light emitter (20) is mounted on top of the base plate (45) at a side opposite of the rings (41, 43) such that emitted light (21) passes through the opening and the inner ring (43) onto the skin (50).
- 10 6. The medical optical sensor as set forth in one of claims 1 to 5, wherein the light emitter (20) and the photo-detector (30) are designed for wavelengths that are suited for determining the arterial oxygen saturation and/or heart rate in a pulse oximeter.
7. A medical optical sensor unit, comprising a plurality of medical optical
15 sensors (10) as set forth in one of claims 1 to 6, which are arranged in form of a matrix and are connected to each other by web members (110), such that the sensors (10) and the web members (110) form a web-like structure with openings (120).
8. The medical optical sensor unit as set forth in claim 7, wherein at least two of
20 the web members (110) are flexible.
9. The medical optical sensor unit as set forth in one of claims 7 or 8, which is corrugated in a direction perpendicular to its lateral extension.
- 25 10. The medical optical sensor unit as set forth in claim 9 further comprising stands (130) that are connected to the sensors (10) by flexible and elastic web members (111), wherein a surface of the stands (130) facing the skin (50) is located in a plane that is dislocated from the plane of the contact area of the sensors (10) with the skin (50), such that the sensors (10) are pressed onto the skin (50) with a predetermined force if the stands (130)
30 are in contact with the skin (50).
11. The medical optical sensor unit as set forth in one of claims 7 to 10, wherein electrical connectors (112) for connecting the sensors are integrally formed with the web members (110).

12. A medical optical sensor system, comprising
 at least one sensor (10) as claimed in one of claims 1 to 6 or a sensor unit
(100) as set forth in one of claims 7 to 11; and
5 a control unit (70) for operating the at least one sensor (10) or the sensor unit
(100); and
 flexible electrical connectors (80) for connecting the sensor (10) or the sensor
unit (100) with the control unit (70).
- 10 13. The medical optical sensor system as set forth in claim 12, further comprising
a frame (90), affixable to a skin (50), wherein
 the control unit (70) is directly attached to the frame (90);
 the sensor (10) or the sensor unit (100) is attached to the frame (90) by a
spring (93), such that the sensor (10) or the sensor unit (100) is pressed onto the skin (50)
15 with a predetermined force.
14. A method of measuring blood oxygen a lever with a medical optical sensor
system as set forth in claims 12 or 13 comprising the steps of
 emitting light by at least one light emitter (20) contained in the sensor (10) or
20 the sensor unit (100);
 receiving light by at least one photo-detector (30) contained in the sensor (10)
or the sensor unit (100); and
 processing electrical signals from the at least one photo-detector (30) in order
to determine an oximetry value.
25
15. The method as set forth by claim 14, wherein a sensor unit (100) as set forth in
one of claims 7 to 11 with a plurality of sensors (10) is used and wherein the electrical signals
from the plurality of photo-detectors (30) of the sensors (10) are averaged in the course of
processing the electrical signals.

1/4

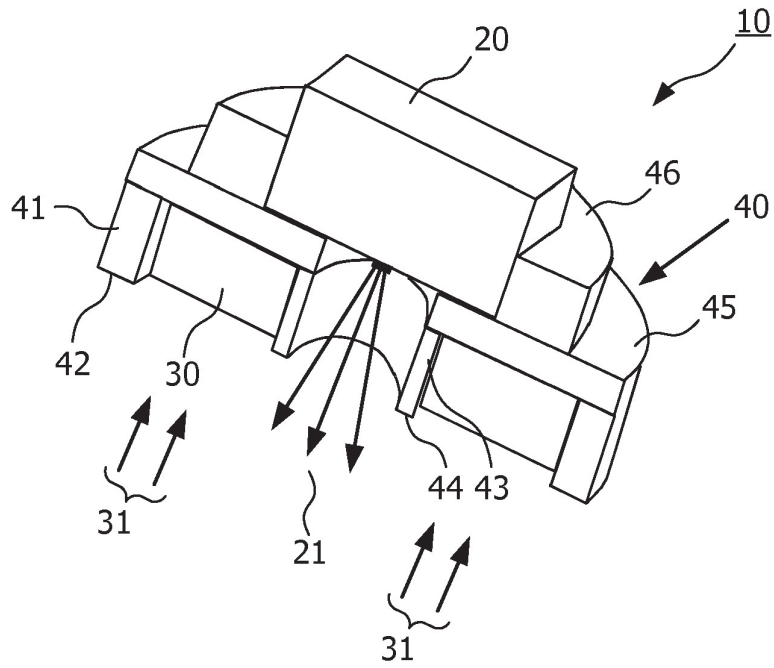

FIG. 1

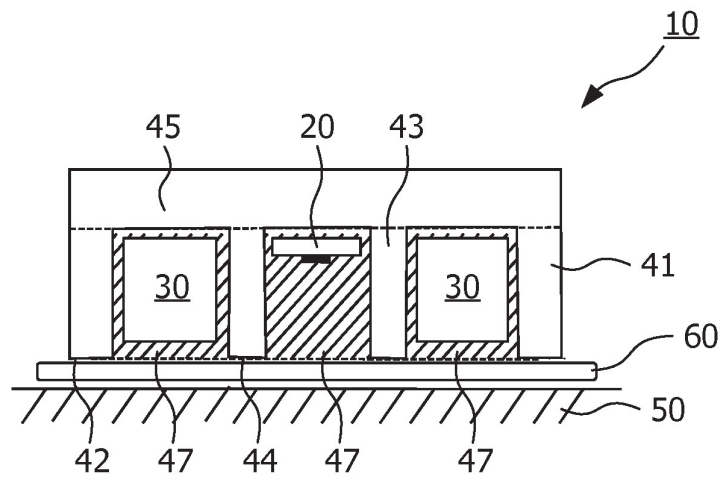

FIG. 2

2/4

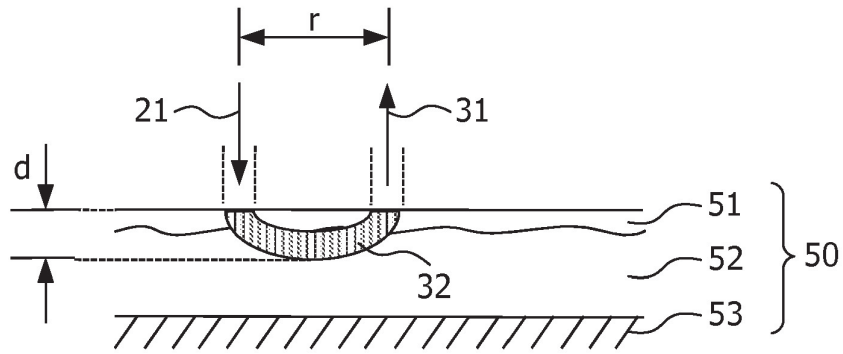

FIG. 3A

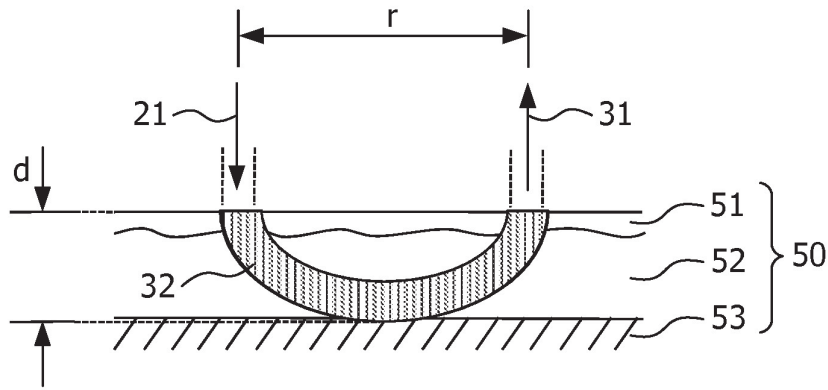

FIG. 3B

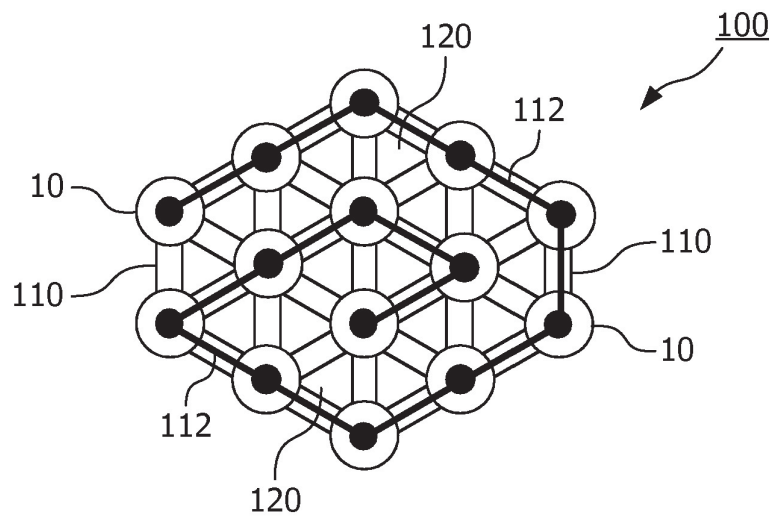

FIG. 4

SUBSTITUTE SHEET (RULE 26)

3/4

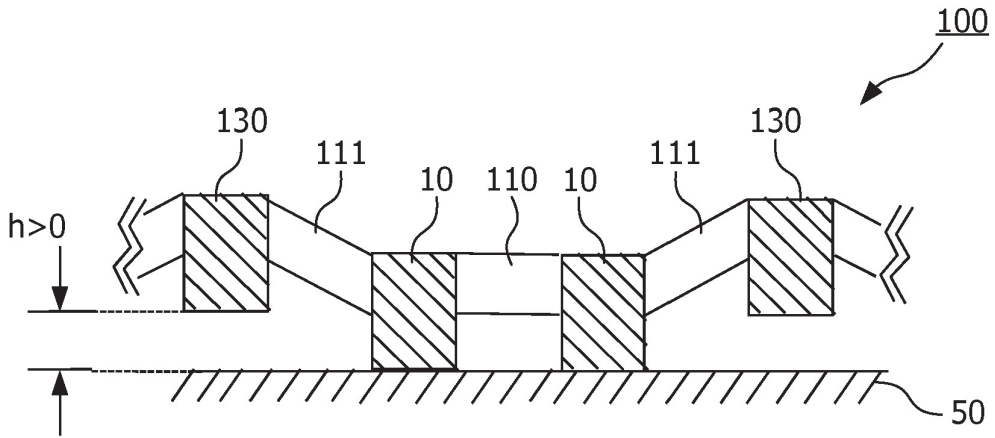

FIG. 5A

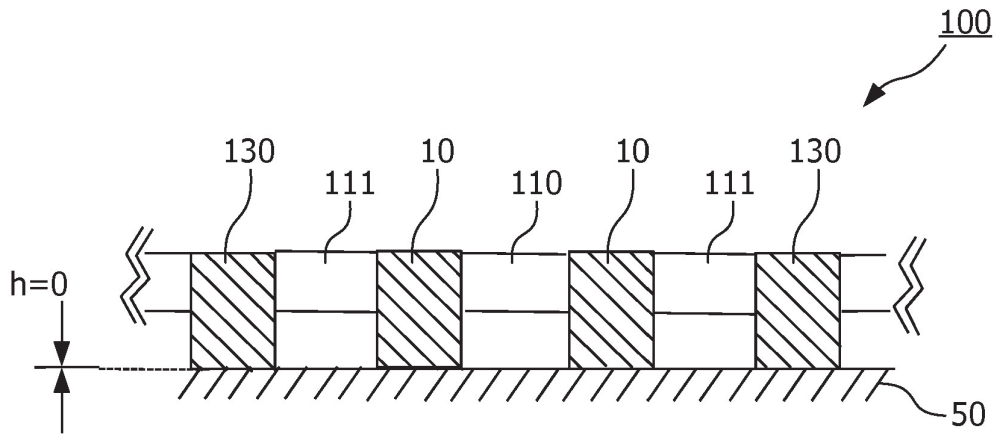

FIG. 5B

4/4

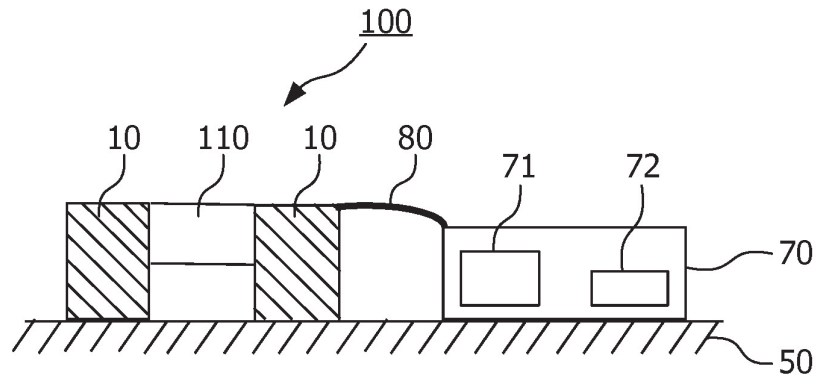

FIG. 6

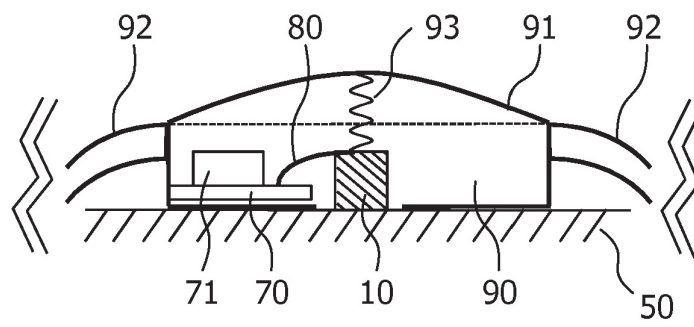

FIG. 7