

(19) Japan Patent Office (JP) (12) JAPANESE UNEXAMINED PATENT APPLICATION PUBLICATION (A)

(11) Patent Application Publication No. JP 2005-270543 (P2005-270543A)

(43) Publication Date: **October 6, 2005 (Heisei 17)**

(51) Int. Cl.⁷ FI Theme Code (Reference)
A61B 5/0245 A61B 5/02 320B 4C017

Examination Request: Not Yet

Total No. of Claims: 15 OL (Total 17 pages)

(21) Application No. JP 2004-91942 (P2004-91942)

(22) Date of Filing March 26, 2004 (Heisei 16)

(Patent Office Note: The following is a registered trademark)

1. Bluetooth

(71) Applicant 000002325
Seiko Instruments, Inc.
1-8 Nakase, Mihama-ku,
Chiba-shi, Chiba-ken

(74) Agent 100079212
Yoshiharu Matsushita,
Patent Attorney

(72) Inventor Susumu Otanagi
c/o Seiko Instruments, Inc.
1-8 Nakase, Mihama-ku,
Chiba-shi, Chiba-ken

(72) Inventor Takashi Nakamura
c/o Seiko Instruments, Inc.
1-8 Nakase, Mihama-ku,
Chiba-shi, Chiba-ken

(72) Inventor Kazuya Maekawa
c/o Seiko Instruments, Inc.
1-8 Nakase, Mihama-ku,
Chiba-shi, Chiba-ken

Continued on last page

(54) [Title of Invention] BIOLOGICAL INFORMATION MEASURING DEVICE

(57) [Abstract]

[Problem] To improve adhesion and wear for a long time without experiencing a feeling of discomfort.

[Resolution Means] To provide a biological information measuring device 1, provided with: a main body 2; a projection part 4 formed by projecting from a lower surface 2a of the main body 2; fixing means 3 for wearing the main body 2 on an arm in a state wherein the lower surface 2a of the main body 2 is directed to a biological body surface side; a biological sensor part 8 having a light emitting part 5 for irradiating light directed to a biological body when in a state contacting the biological body surface, a light receiving part 6 for receiving reflected light from the biological body from among light irradiated by the light emitting part 5 and for generating a biological information signal corresponding to the received light quantity, and contact sensing means 7 for sensing whether the light emitting part 5 and the light receiving part 6 are contacting the biological body surface; and a biological information sensing part for sensing biological information based on the biological information signal and provided on the main body 2; wherein the biological sensor part 8 is disposed on a lower surface 4a of the projection part 4.

[Selected Drawing] FIG. 5

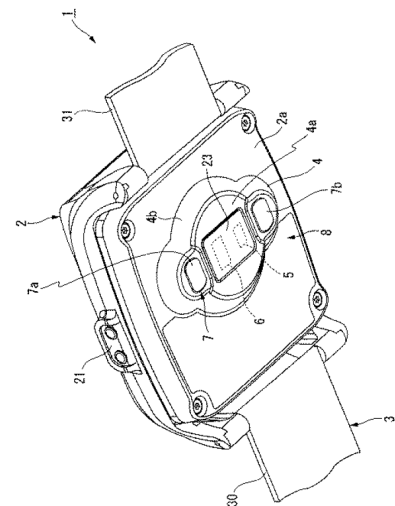

[Scope of Patent Claims]

[Claim 1]

A biological information measuring device, comprising:
a main body;
a projection part formed by projecting from a lower surface of the main body;
fixing means for wearing the main body on an arm in a state wherein the lower surface of the main body is directed to a biological body surface side;
a biological sensor part having a light emitting part for irradiating light directed to a biological body when in a state contacting the biological body surface, a light receiving part for receiving reflected light from the biological body from among light irradiated by the light emitting part and for generating a biological information signal corresponding to the received light quantity, and contact sensing means for sensing whether the light emitting part and the light receiving part are contacting the biological body; and
a biological information sensing part provided on the main body for sensing biological information based on the biological information signal; wherein:
the biological sensor part is disposed on a lower surface of the projection part.

[Claim 2]

The biological information measuring device according to claim 1, wherein:
a convex part is provided at the lower surface of the main body, formed to interpose at least the projection part and project from the lower surface of the main body at a position separated by a predetermined distance from the side surface of the projection part, and
the distance between the lower surface of the convex part and the lower surface of the main body part is set to be the same as or greater than the distance between the lower surface of the projection part and the lower surface of the main body part.

[Claim 3]

The biological information measuring device according to claims 1 or 2, wherein:
the contact sensing means has at least one pair of electrodes and senses whether the light emitting part and the light receiving part are contacting the biological body surface based on the potential difference between the pair of electrodes.

[Claim 4]

The biological information measuring device according to claim 3, wherein:
the pair of electrodes is disposed so as to interpose between the light emitting part and the light receiving part.

[Claim 5]

The biological information measuring device according to any one of claims 1 to 4, further comprising:

a flexible substrate electrically connecting between the biological information sensing part and the light emitting part and the light receiving part, wherein:
the flexible substrate is provided in the main body so as to use its own elasticity to press the light emitting part and the light receiving part directed to the lower surface side of the main body.

[Claim 6]

The biological information measuring device according to any one of claims 1 to 5, further comprising:

a display part for displaying sensed biological information on the upper surface of the main body.

[Claim 7]

The biological information measuring device according to any one of claims 1 to 6, wherein:
the fixing means comprises a first band and a second band which are attached to the main body by the base end side and may be worn on an arm, wherein:

the first band and the second band are disposed to interpose and face the main body and are formed of a stretchable elastic material.

[Claim 8]

The biological information measuring device according to claim 7, wherein:
the biological sensor part is disposed at a position shifted from the center position of the main body to the base end side of the first band or the second band.

[Claim 9]

The biological information measuring device according to any one of claims 1 to 8, further comprising:

a rechargeable battery capable of being charge and charging means for charging power to the rechargeable battery, on the main body.

[Claim 10]

The biological information measuring device according to any one of claims 1 to 9, wherein: the distance between the lower surface of the projection part and the lower surface of the main body is set to 2 to 4 mm.

[Claim 11]

The biological information measuring device according to any one of claims 1 to 10, wherein:

the projection part is formed so that the outer circumference is circular.

[Claim 12]

The biological information measuring device according to claim 11, wherein: the projection part is formed so that the outer edge is a curved surface.

[Claim 13]

The biological information measuring device according to claim 11, wherein: the projection part is formed so as to form a curved surface directed from the center of the lower surface to the outer edge.

[Claim 14]

The biological information measuring device according to any one of claims 11 to 13, wherein:

the diameter of the projection part is set to 20 mm or less.

[Claim 15]

The biological information measuring device according to any one of claims 2 to 14, wherein:

the convex part is provided at a position separated by 8 mm from the side surface of the projection part, and the distance between the lower surface of the projection part and the lower surface of the main body is set to 4 mm.

[Detailed Description of Invention]

[Technical Field]

[0001]

The present invention relates to a biological information measuring device capable of measuring biological information such as pulse rate when in a state of being worn on a wrist (arm).

[Background Art]

[0002]

As interest in health management has increased in recent years, many kinds of biological information measuring devices have been provided, capable of measuring various biological information such as pulse rate while worn on a wrist (arm) or the like (for example, see Patent Literature 1).

[0003]

Among the biological information measuring devices of this kind, for example, one that senses the pulse rate, when in a state when worn on a wrist, irradiates light to a biological body, uses a pulse sensor or the like to receive reflected light — that is, to receive a reflected signal — from blood vessels, extracts a pulse signal corresponding to the pulse from the reflected signal, and calculates the pulse rate. In particular, this is easily used by a user since measurement of the pulse rate may be easily performed while worn on a wrist.

[Patent Literature 1]JP 2001-78973 A (paragraph numbers 0011 to 0031 and FIG. 1 to FIG. 7)

[Disclosure of Invention]

[Problem to Be Solved by Invention]

[0004]

The conventional biological information measuring device described above is generally used while worn on a wrist. However, depending on the movement of a user, when there is muscle movement the thickness (diameter) of the wrist ends up changing, and there is a risk that a gap will open between the biological information measuring device and the biological body surface. Therefore, there is a possibility that adhesion will reduce and accurate biological information cannot be sensed. Furthermore, in order to securely fix the biological information measuring device to a wrist, in the case of fastening with a band for example, a feeling of pressure on the wrist increases and it is difficult to wear the device for a long time.

[0005]

The present invention was created in consideration of such circumstances, and thus an object thereof is to provide a biological information measuring device with improved adhesion and that may be worn for a long time without experiencing a feeling of discomfort.

[Means for Solving Problem]

[0006]

The present invention provides the following means for solving the problem.

[0007]

A biological information measuring device of the present invention is provided with a main body; a projection part formed by projecting from a lower surface of the main body; fixing means for wearing the main body on an arm in a state wherein the lower surface of the main body is directed to a biological body surface side; a biological sensor part having a light emitting part for irradiating light directed to a biological body when in a state contacting the biological body surface, a light receiving part for receiving reflected light from the biological body from among light irradiated by the light emitting part and for generating a biological information signal corresponding to the received light quantity, and contact sensing means for sensing whether the light emitting part and the light receiving part are contacting the biological body; and a biological information sensing part provided on the main body for sensing biological information based on the biological information signal; wherein the biological sensor part is disposed on a lower surface of the projection part.

[0008]

In the biological information measuring device of this invention, after the main body is worn on a wrist (arm) using the fixing means, light is irradiated from the light emitting part directed to the biological body. A part of the irradiated light is absorbed by, for example, hemoglobin or the like in blood vessels, and furthermore, another part of the light is reflected by biological tissue. The light receiving part receives the reflected light and generates a biological information signal, such as a pulse signal corresponding to the received light quantity. Also, biological information sensing means makes it possible to perform sensing of biological information, such as pulse rate, by carrying out predetermined processing of the biological information signal. Furthermore, the contact sensing means makes it possible to perform sensing as to whether the light emitting part and the light receiving part are securely contacting the biological body surface.

[0009]

In particular, when the main body is worn on a wrist using the fixing means, since the projection part projects from the lower surface of the main body, a state is formed wherein the biological body surface and the lower surface of the projection part are easily brought into contact. That is, the adhesion of the biological sensor part is improved. Therefore, it is not necessary to use the fixing means to strongly press (apply pressure to) the main body against the biological body surface as is conventional. Accordingly, even if it is worn for a long time, a feeling of discomfort is not experienced. Furthermore, since the adhesion of the biological sensor part is improved, the light emitting part and the light receiving part are capable of efficiently irradiating and receiving light. Accordingly, sensing of the biological information may be performed with high accuracy.

[0010]

Furthermore, as for the biological information measuring device of the present invention, in the biological information measuring device of the foregoing present invention, a convex part is provided at the lower surface of the main body, formed to interpose at least the projection part and project from the lower surface of the main body at a position separated by a predetermined distance from the side surface of the projection part, and the distance between the lower surface of the convex part and the lower surface of the main body part is set to be the same as or greater than the distance between the lower surface of the projection part and the lower surface of the main body part.

[0011]

In the biological information measuring device of this invention, when the main body is worn on an arm using the fixing means, a state is formed wherein the biological body surface is contacting the lower surface of the

convex part and the lower surface of the projection part. At this time, since the convex part interposes the projection part and projects at a position separated by a predetermined distance from the side surface of the projection part, a state is formed wherein a gap opens between the convex part and the projection part. As a result, the biological body contacts the lower surfaces of the convex part and the projection part when in a state of temporarily entering the gaps on both sides interposing the projection part. Accordingly, adhesion between the biological body surface and the biological sensor part may be more securely maintained.

[0012]

In particular, since the convex part projects from the lower surface of the main body with respect to the projection part by the same height or a greater height, the convex part contacts the biological body surface in the same manner as the projection part or ahead of the projection part. Furthermore, the convex part contacts the biological body surface on an outer side of the projection part. As a result, the biological body surface may be brought into contact with the lower surface of the projection part in the same state and in a stable manner, and contact pressure may be made constant. Accordingly, biological information may be sensed for a long time in a stable manner.

[0013]

Furthermore, as for the biological information measuring device of the present invention, in the biological information measuring device of the foregoing present invention, the contact sensing means has at least one pair of electrodes and senses whether the light emitting part and the light receiving part are contacting the biological body surface based on the potential difference between the pair of electrodes.

[0014]

In the biological information measuring device of this invention, when the main body is worn on an arm, the pair of electrodes contact the biological body surface and discharge is performed through the biological body surface. As a result, potential between the electrodes is reduced. Also, by sensing the potential difference between the pair of electrodes, it is possible to easily and reliably sense whether the light emitting part and the light receiving part are securely contacting the biological body surface. Note that the electrodes may not be a pair; for example, a plurality of electrodes may be provided, and whether contact is being made may be sensed based on the potential difference of these respective electrodes.

[0015]

Furthermore, as for the biological information measuring device of the present invention, in the biological information measuring device of the foregoing present invention, the pair of electrodes is disposed so as to interpose between the light emitting part and the light receiving part.

[0016]

In the biological information measuring device of this invention, since the pair of electrodes is disposed so as to interpose between the light emitting part and the light receiving part, it is possible to sense whether the light emitting part and the light receiving part are contacting the biological body surface with high accuracy.

[0017]

Furthermore, the biological information measuring device of the present invention, in the biological information measuring device of any one of the foregoing present inventions, is provided with a flexible substrate electrically connecting between the biological information sensing part and the light emitting part and the light receiving part, wherein the flexible substrate is provided in the main body so as to use its own elasticity to press the light emitting part and the light receiving part directed to the lower surface side of the main body.

[0018]

In the biological information measuring device of this invention, since the light emitting part and the light receiving part are always pressed to the lower surface side of the main body by the elasticity of the flexible substrate, when the main body is worn on a wrist, a state is formed wherein the light emitting part and the light receiving part are brought close to the biological body surface. Accordingly, irradiation and receiving of light may be performed more efficiently with respect to the biological body, and sensing accuracy of biological information may be improved.

[0019]

Furthermore, the biological information measuring device of the present invention, in the biological information measuring device according to any one of the foregoing present inventions, is provided with a display part for displaying sensed biological information on the upper surface of the main body.

[0020]

In the biological information measuring device of this invention, since the biological information displayed on the display part is easily visible, it is possible to check the sensed biological information whenever necessary, and to check whether the biological information is being correctly sensed, or the like, and thus it is easy and simple to use.

[0021]

Furthermore, as for the biological information measuring device of the present invention, in the biological information measuring device of any one of the foregoing present inventions, the fixing means is provided with a first band and a second band which are attached to the main body by the base end side and may be worn on an arm,

Explore Litigation Insights

Docket Alarm provides insights to develop a more informed litigation strategy and the peace of mind of knowing you're on top of things.

Real-Time Litigation Alerts



Keep your litigation team up-to-date with **real-time alerts** and advanced team management tools built for the enterprise, all while greatly reducing PACER spend.

Our comprehensive service means we can handle Federal, State, and Administrative courts across the country.

Advanced Docket Research



With over 230 million records, Docket Alarm's cloud-native docket research platform finds what other services can't. Coverage includes Federal, State, plus PTAB, TTAB, ITC and NLRB decisions, all in one place.

Identify arguments that have been successful in the past with full text, pinpoint searching. Link to case law cited within any court document via Fastcase.

Analytics At Your Fingertips



Learn what happened the last time a particular judge, opposing counsel or company faced cases similar to yours.

Advanced out-of-the-box PTAB and TTAB analytics are always at your fingertips.

API

Docket Alarm offers a powerful API (application programming interface) to developers that want to integrate case filings into their apps.

LAW FIRMS

Build custom dashboards for your attorneys and clients with live data direct from the court.

Automate many repetitive legal tasks like conflict checks, document management, and marketing.

FINANCIAL INSTITUTIONS

Litigation and bankruptcy checks for companies and debtors.

E-DISCOVERY AND LEGAL VENDORS

Sync your system to PACER to automate legal marketing.