



US005332402A

United States Patent [19]

[11] Patent Number: **5,332,402**

Teitelbaum

[45] Date of Patent: **Jul. 26, 1994**

[54] **PERCUTANEOUSLY-INSERTED CARDIAC VALVE**

[76] Inventor: **George P. Teitelbaum**, 12138 Laurel Terrace Dr., Studio City, Calif. 92604

[21] Appl. No.: **881,969**

[22] Filed: **May 12, 1992**

[51] Int. Cl.⁵ **A61F 2/24**

[52] U.S. Cl. **623/2; 623/900**

[58] Field of Search **623/2, 900**

[56] **References Cited**

U.S. PATENT DOCUMENTS

- 3,626,518 12/1971 Leibinsohn 623/2
- 3,691,567 9/1972 Cromie 623/2
- 3,868,956 3/1975 Alfidi et al. 606/194

- 3,911,502 10/1975 Boretos 623/2
- 4,030,142 6/1977 Wolfe 623/2
- 4,503,569 3/1985 Dotter 604/8 X
- 4,759,758 7/1988 Gabbay 623/2
- 4,994,077 2/1991 Dobben 623/2

Primary Examiner—Randall L. Green
Assistant Examiner—Mary Beth Jones
Attorney, Agent, or Firm—James H. Laughlin, Jr.

[57] **ABSTRACT**

A cardiac valve implanted within the heart is given where a expansible valve maintained in a collapsed form by cold temperature is percutaneously inserted along a releasable guide wire in a cooled sheath and when positioned is expanded by withdrawing the cold temperature.

8 Claims, 2 Drawing Sheets

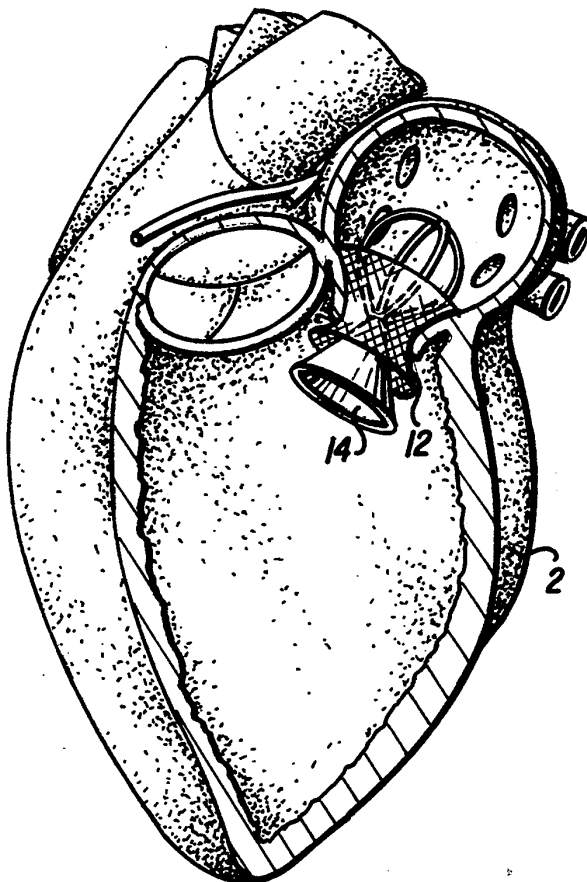

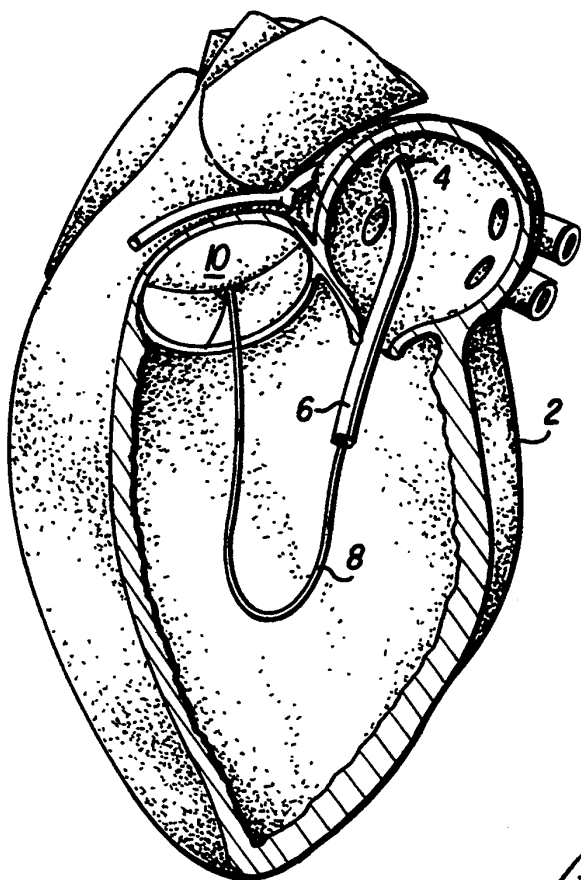

FIG. 1

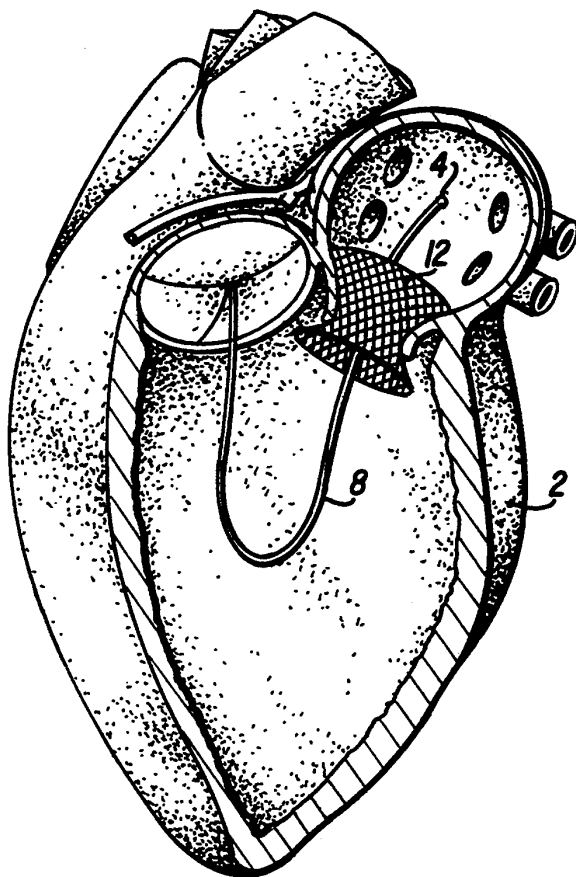

FIG. 2

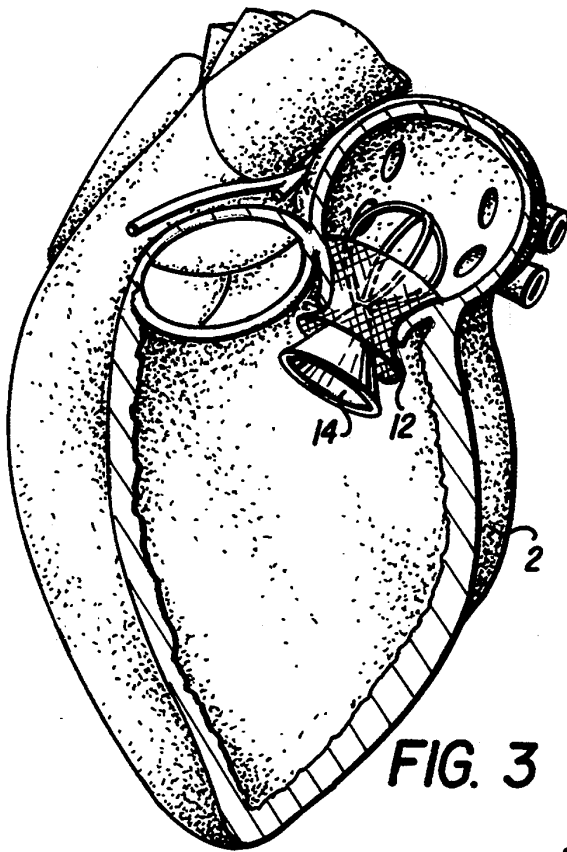

FIG. 3

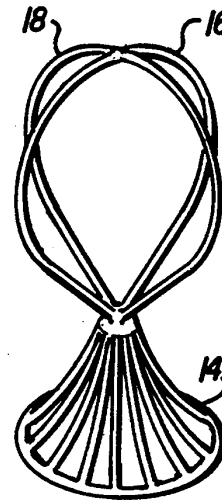

FIG. 4

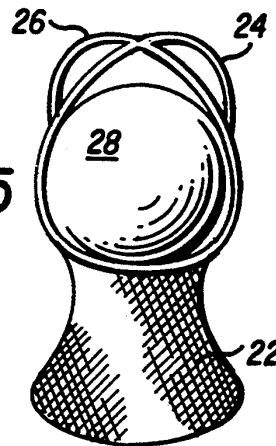

FIG. 5

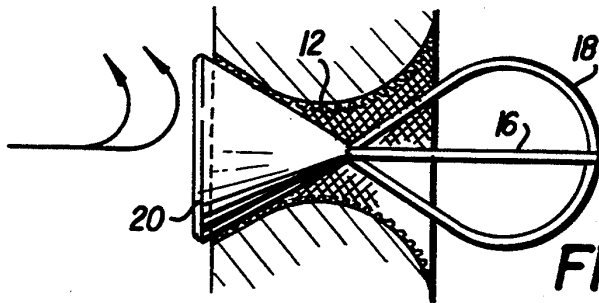

FIG. 4A

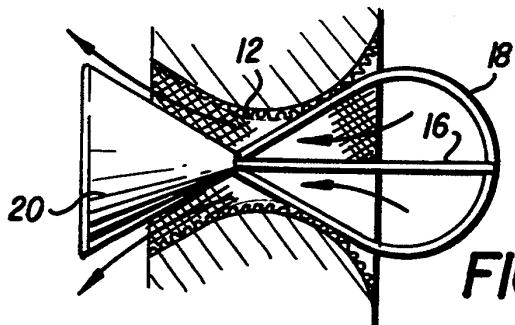

FIG. 4B

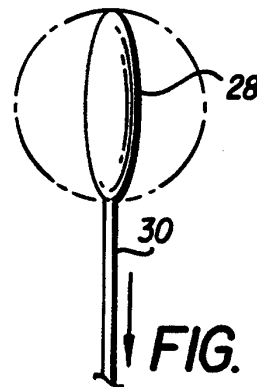

FIG. 6

PERCUTANEOUSLY-INSERTED CARDIAC VALVE

BACKGROUND OF THE INVENTION

1. FIELD OF THE INVENTION

This invention relates to cardiac valvular surgery techniques for replacement of diseased cardiac valves. More particularly, this invention relates to materials and techniques for replacement of diseased mitral valves in humans as well as other animals.

2. PRIOR ART

Cardiac valvular surgery is performed in cases where there is a diminished flow area within a cardiac valve which results in a blockage of normal flow. This blockage leads to cardiac failure. Cardiac valvular surgery may also be required in cases of valvular incompetence in which back flow of blood occurs across a valve that cannot close fully. This is also known as valvular regurgitation. Each of the above conditions are frequently due to rheumatic heart disease. Replacement of stenotic or narrowed cardiac valves and regurgitant or incompetent cardiac valves requires open-heart surgery which utilizes a heart-lung machine.

Expandable devices for implantation have been known by the medical community. These devices include, for example, the so-called recovery metals such as titanium-nickel equiatomic intermetallic compounds which demonstrate mechanical "memory" whereby after being formed into specific shapes, these metals are compressed or otherwise given temporary different shapes for insertion and thereafter, when in place, are expanded whereby their mechanical "memory" of the originally formed shape causes the device to assume its originally formed shape.

Materials which are known for having properties useful in such systems include nickel based alloys such as those described in U.S. Pat. No. 3,174,851. Typically, these materials comprise 52 to 56 percent nickel by weight with the remainder being titanium. An initial shape may be permanently set into such recovery metals by heating them while they are held in the desired configuration. The forming temperature for setting the initial shape into the described titanium-nickel alloy is typically about 930° F. The alloy is then cooled and thereafter deformed plastically to a deformed configuration which can be retained until the alloy is reheated to a transition temperature whereafter the alloy will recover its initial configuration.

Various implantable appliances have been described in the patent literature. For example, U.S. Pat. No. 3,868,956 uses an expandable appliance implanted with a vessel through a catheter involving a positioning device. The positioning device is complex because it requires the use of electrical conductors to heat the expandable appliance to allow it to function. U.S. Pat. No. 4,503,569 positions and expands a graft prosthesis using hot saline.

Generally, the known art applies these techniques to the repair of blood vessels narrowed or occluded by disease.

If a satisfactory means could be devised of replacing diseased cardiac valves percutaneously, many major open-heart surgeries could be avoided.

SUMMARY OF THE INVENTION

This invention generally describes a device that serves as a replacement for a diseased (either stenotic or

regurgitant) cardiac valve. The device is inserted percutaneously via an appropriately sized small sheath, such as, for example, a 14F sheath using the jugular venous routes. The sheath is positioned to extend across the interatrial septum.

The device is fabricated from a "shaped memory" alloy, nitinol, which is composed of nickel and titanium. Nitinol wire is first fashioned into the desired shape for the device and then the device is heat annealed. When the components of the valve are then exposed to ice-cold temperatures, they become very flexible and supple, allowing them to be compressed down and pass easily through the delivery sheath. A cold temperature is maintained within the sheath during delivery to the deployment site by constantly infusing the sheath with an iced saline solution. Once the valve components are exposed to body temperature at the end of the sheath, they instantaneously reassume their predetermined shapes, thus allowing them to function as designed.

The percutaneous cardiac valve has two possible designs, each of which consists of two components. In the first design, one of the components is a meshwork of nitinol wire of approximately 0.008 inch gauge formed into a tubular structure with a minimum central diameter of 20 mm. Away from its central portion, the tubular structure flares markedly at both ends in a trumpet-like configuration. The maximum longitudinal dimension of this component which shall be referred to as the stent or doubly-flared stent is approximately 20 mm. The maximum diameter of the flared ends of the stent is approximately 30 mm. The purpose of the stent is to maintain a semi-rigid patent channel through the diseased cardiac valve following its balloon dilation. The flared ends of the stent maintain the position of this component across the native valve following deployment. The stent contains a thin hydrophilic plastic coating that helps prevent thrombus formation along the inner surface of the stent.

In the second component of the first percutaneous cardiac valve design is referred to as the sliding obturator. At one end of this component are two nitinol wires of 0.038 inch diameter which are fashioned into dual loops a right angles to one another. At the other end these dual wires are connected to an umbrella-shaped structure composed of small, thin slats of nitinol metal covered by silicone rubber with a hydrophilic coating. The dual wires and umbrella structure can be compressed down so as to fit through a 14F delivery sheath with continuous flushing of this sheath with ice-cold heparinized saline. When exposed to body temperature at the end of the delivery sheath, the sliding obturator will expand to its functional size, with a final umbrella diameter of 20-25 mm.

The sliding obturator will be deployed within the expanded stent. The loop formed by the dual wires of the sliding obturator will have sufficient diameter so as not to allow the sliding obturator being carried away by the force of blood flow. The umbrella portion of the sliding obturator will flair out so that its widest diameter will face the interior of the cardiac ventricle. This will allow the sliding obturator to move forward during diastole (relaxation of the heart), thus opening the valve and allowing filling of the ventricle. However, during systole (contraction of the heart), when there is markedly increased intraventricular pressure, the force of blood will act against the open or widest portion of the umbrella pushing back against the flared opening of the

wire mesh stent, thus closing the valve. The sliding obturator will therefore allow blood flow in only one direction.

The second version of the percutaneous cardiac valve is the ball design. In this design, the distal end of the wire mesh stent possesses two curved wires that extend beyond the stent into the ventricle, forming a cage structure that will house a small silicone rubber sphere or ball. The silicone sphere will have a hydrophilic coating to diminish thrombogenicity. The silicone sphere will be introduced deflated attached to the end of an 8F catheter through the same delivery sheath used for the placement of the stent with the distal cage. Once in position within the cage, the sphere will be inflated with a polymer mixture that will have a rapid set-up time (it will harden within minutes). After the sphere has been inflated it will be separated from its delivery catheter and will remain inflated due to a self-sealing valve at its attachment point with the delivery catheter. During diastole (ventricular falling stage), the sphere will be carried forward by blood flow, thus opening the valve. The cage will act to restrict the motion of the sphere, preventing it from being lost within the ventricle. During systole, the sphere will be forced backwards due to markedly increased intraventricular pressure, thus closing the valve. The design of the second version of the percutaneous cardiac valve is similar to the Starr-Edwards cardiac valve which also uses a ball-valve mechanism to allow only one-way flow through the valve.

Both versions of the percutaneous cardiac valve are introduced via the right internal jugular venous approach. Following puncture of this vein, a catheter and needle combination are used to puncture the interatrial septum allowing passage of a guide wire and catheter from the right to the left atrium. The same catheter and guide wire or catheter is then floated with blood flow out the left ventricle and into the thoracic aorta. The transjugular guide wire is then captured by a snare or basket and dragged out through the right or left common femoral artery. In so doing, one will have control over both ends of the guide wire used to introduce the percutaneous cardiac valve. Over this guide wire, a high-pressure balloon catheter is advanced across the diseased mitral valve where it is inflated. Once the valve is fully dilated, the balloon catheter is deflated and replaced with a 14F delivery sheath inserted via the right internal jugular approach. The sheath's tip will be positioned in the left ventricle. The nitinol stent (with or without distal cage) is advanced to the site of the dilated valve by means of a pusher rod. All the while, the delivery sheath is being flushed with cold heparinized saline to keep the stent compressed, soft, and flexible. Once the stent has been pushed to the distal end of the sheath where it bridges the site of the dilated valve, the pusher will be held steady while the sheath is withdrawn, allowing the stent to come into contact with body temperature. This will cause the rapid expansion of the stent and create an adequate flow lumen through the diseased valve.

At this point, either the sliding obturator or the silicone sphere are deployed with the appropriate valve stent. Since both versions of the stent have a hydrophilic silicone coating, when the sliding obturator or silicone sphere come into contact with the stent lumen, they seal or close the valve, preventing backflow of blood.

BRIEF DESCRIPTION OF THE DRAWINGS

FIG. 1 is a cutaway portion of a heart showing the catheter following a guide wire entering through the interatrial septum.

FIG. 2 is a cutaway portion of a heart showing the stent in place along the guide wire after the catheter has been withdrawn from the heart.

FIG. 3 is a cutaway portion of a heart showing the installed cardiac valve, a sliding obturator, positioned within the stent.

FIG. 4 is a perspective view of the sliding obturator of this invention in its expanded and normal form.

FIG. 4A is and FIG. 4B are partial side views of the sliding obturator of FIG. 4 inserted and in use where FIG. 4A shows its position within the stent in systole while FIG. 4B shows its position within the stent in diastole.

FIG. 5 is a perspective view of a different embodiment of this invention, namely, a ball valve and stent design.

FIG. 6 is a view of the ball of the ball valve of FIG. 5 after inflation.

DESCRIPTION OF THE PREFERRED EMBODIMENTS

As noted earlier, cardiac valvular surgery is performed in cases where there is a diminished flow area within a cardiac valve which results in a blockage of normal flow which can lead to cardiac failure. Surgery is often required in cases of valvular incompetence in which back flow of blood occurs across a valve that cannot close fully. Replacement of stenotic and regurgitant cardiac valves can be accomplished in accordance with this invention using percutaneous techniques allowing for avoidance of many major open-heart surgery procedures.

This invention describes a device that serves as a replacement for a diseased stenotic or regurgitant cardiac valve. By this invention, a technique and the devices which serve as a replacement for a stenotic or regurgitant diseased cardiac valves is given. This technique and the devices employed are particularly useful in replacement of diseased mitral valves.

In this invention, compressed devices are inserted percutaneously by way of an appropriately sized sheath using the jugular venous routes and expanded to form new valve mechanisms which provide replacement cardiac valves.

The catheter and delivery sheath of this invention are appropriately sized for use. One such appropriate catheter is a 14F plastic catheter used for delivery and deployment of both stents and the valve structures of this invention. Such a delivery sheath is used in the normal matter and may have a pusher capable of moving a stent or other valve part to its ultimate location in the heart.

With reference to FIG. 1, FIG. 2 and FIG. 3, in the technique and procedure of this invention, the percutaneous cardiac valve is introduced via the right internal jugular venous approach. Following puncture of this vein, a catheter and needle combination (not shown) are used to puncture the interatrial septum 4 allowing passage of a guide wire 8 and catheter 6 from the right to the left atrium. The same catheter and guide wire or catheter is then floated with blood flow out the left ventricle and into the thoracic aorta 10. The transjugular guide wire is then captured by a snare or basket (not shown) and dragged out through the right or left

Explore Litigation Insights

Docket Alarm provides insights to develop a more informed litigation strategy and the peace of mind of knowing you're on top of things.

Real-Time Litigation Alerts



Keep your litigation team up-to-date with **real-time alerts** and advanced team management tools built for the enterprise, all while greatly reducing PACER spend.

Our comprehensive service means we can handle Federal, State, and Administrative courts across the country.

Advanced Docket Research



With over 230 million records, Docket Alarm's cloud-native docket research platform finds what other services can't. Coverage includes Federal, State, plus PTAB, TTAB, ITC and NLRB decisions, all in one place.

Identify arguments that have been successful in the past with full text, pinpoint searching. Link to case law cited within any court document via Fastcase.

Analytics At Your Fingertips



Learn what happened the last time a particular judge, opposing counsel or company faced cases similar to yours.

Advanced out-of-the-box PTAB and TTAB analytics are always at your fingertips.

API

Docket Alarm offers a powerful API (application programming interface) to developers that want to integrate case filings into their apps.

LAW FIRMS

Build custom dashboards for your attorneys and clients with live data direct from the court.

Automate many repetitive legal tasks like conflict checks, document management, and marketing.

FINANCIAL INSTITUTIONS

Litigation and bankruptcy checks for companies and debtors.

E-DISCOVERY AND LEGAL VENDORS

Sync your system to PACER to automate legal marketing.