



US007117867B2

(12) **United States Patent**  
**Cox et al.**

(10) **Patent No.:** **US 7,117,867 B2**  
(45) **Date of Patent:** **\*Oct. 10, 2006**

(54) **AEROSOL GENERATOR AND METHODS OF MAKING AND USING AN AEROSOL GENERATOR**

(75) Inventors: **Kenneth A. Cox**, Midlothian, VA (US); **Timothy Paul Beane**, Richmond, VA (US); **William R. Sweeney**, Richmond, VA (US); **Walter A. Nichols**, Chesterfield, VA (US); **F. Murphy Sprinkel, Jr.**, Richmond, VA (US)

(73) Assignee: **Philip Morris USA**, Richmond, VA (US)

(\*) Notice: Subject to any disclaimer, the term of this patent is extended or adjusted under 35 U.S.C. 154(b) by 9 days.

This patent is subject to a terminal disclaimer.

(21) Appl. No.: **10/438,329**

(22) Filed: **May 15, 2003**

(65) **Prior Publication Data**  
US 2004/0050383 A1 Mar. 18, 2004

**Related U.S. Application Data**  
(63) Continuation of application No. 10/247,776, filed on Sep. 20, 2002, now abandoned, which is a continuation of application No. 09/479,597, filed on Jan. 7, 2000, now Pat. No. 6,516,796, which is a continuation of application No. PCT/US99/24080, which is a continuation of application No. 09/172,023, filed on Oct. 14, 1998, now Pat. No. 6,234,167.

(51) **Int. Cl.**  
**A61M 11/00** (2006.01)  
**A61M 15/00** (2006.01)  
**A61M 16/00** (2006.01)  
**F16K 11/00** (2006.01)

(52) **U.S. Cl.** ..... **128/200.14**; 128/200.18; 128/200.21; 128/203.12; 128/203.21; 128/203.25; 128/203.26

(58) **Field of Classification Search** ..... 128/200.14, 128/200.18, 200.21, 203.12, 203.21, 203.25, 128/203.26

See application file for complete search history.

(56) **References Cited**

U.S. PATENT DOCUMENTS

2,896,856 A	7/1959	Kravits
3,084,698 A	4/1963	Smith
3,157,179 A	11/1964	Paullus et al.
3,162,324 A	12/1964	Houser
3,431,393 A	3/1969	Katsuda
3,486,663 A	12/1969	Humphrey
3,658,059 A	4/1972	Steil
3,716,416 A	2/1973	Adlhart et al.
3,750,961 A	8/1973	Franz
3,847,304 A	11/1974	Cohen
3,859,398 A	1/1975	Havstad
3,902,635 A	9/1975	Jinotti
3,903,883 A	9/1975	Pecina et al.
3,904,083 A	9/1975	Little
3,967,001 A	6/1976	Almaula et al.
3,987,941 A	10/1976	Blessing
3,993,246 A	11/1976	Erb et al.
3,995,371 A	12/1976	O'Keefe
4,042,153 A	8/1977	Callahan et al.
4,060,082 A	11/1977	Lindberg et al.
4,077,542 A	3/1978	Pettersson
4,161,282 A	7/1979	Erb et al.
4,162,501 A	7/1979	Mitchell et al.
4,215,708 A	8/1980	Bron
4,231,492 A	11/1980	Rios
4,258,073 A	3/1981	Payne
4,259,409 A	3/1981	Arnold
4,261,356 A	4/1981	Turner et al.
4,289,003 A	9/1981	Yang
4,291,838 A	9/1981	Williams
4,303,083 A	12/1981	Burruss, Jr.
4,383,171 A	5/1983	Sinha et al.
4,391,308 A	7/1983	Steiner

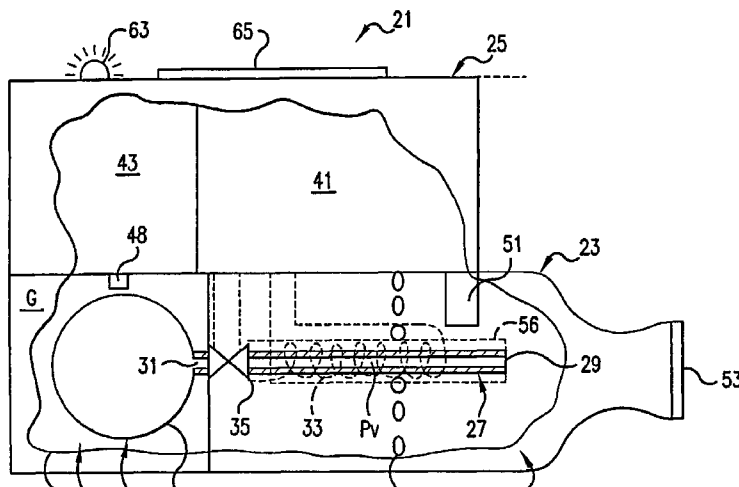

4,395,303 A	7/1983	Weir	5,556,964 A	9/1996	Hofstraat et al.
4,433,797 A	2/1984	Galia	5,564,442 A	10/1996	MacDonald et al.
4,471,892 A	9/1984	Coleman	5,565,677 A	10/1996	Wexler
4,512,341 A	4/1985	Lester	5,575,929 A	11/1996	Yu et al.
4,575,609 A	3/1986	Fassel et al.	5,585,045 A *	12/1996	Heinonen et al. .... 261/72.1
4,627,432 A	12/1986	Newell et al.	5,617,844 A	4/1997	King
4,649,911 A	3/1987	Knight et al.	5,642,728 A	7/1997	Andersson et al.
4,682,010 A	7/1987	Drapeau et al.	5,674,860 A	10/1997	Carling et al.
4,695,625 A	9/1987	Macdonald	5,682,874 A	11/1997	Grabenkort et al.
4,700,657 A	10/1987	Butland	5,730,158 A	3/1998	Collins et al.
4,730,111 A *	3/1988	Vestal et al. .... 250/288	5,743,251 A *	4/1998	Howell et al. .... 128/200.14
4,735,217 A *	4/1988	Gerth et al. .... 131/273	5,755,218 A	5/1998	Johansson et al.
4,744,932 A	5/1988	Browne	5,756,995 A	5/1998	Maswadeh et al.
4,749,778 A	6/1988	Fukuzawa et al.	5,765,724 A	6/1998	Amberg et al.
4,762,995 A	8/1988	Browner et al.	5,813,397 A	9/1998	Goodman et al.
4,776,515 A *	10/1988	Michalchik ..... 239/3	5,823,178 A	10/1998	Lloyd et al.
4,790,305 A	12/1988	Zoltan et al.	5,839,430 A	11/1998	Cama
4,811,731 A	3/1989	Newell et al.	5,855,202 A	1/1999	Andrade
4,819,374 A	4/1989	Gemgnani	5,856,671 A	1/1999	Henion et al.
4,819,834 A	4/1989	Thiel	5,863,652 A	1/1999	Matsumura et al.
4,829,996 A	5/1989	Noakes et al.	5,869,133 A	2/1999	Anthony et al.
4,837,260 A	6/1989	Sato et al.	5,872,010 A	2/1999	Karger et al.
4,848,374 A	7/1989	Chard et al.	5,878,752 A	3/1999	Adams et al.
4,871,115 A	10/1989	Hessey	5,881,714 A	3/1999	Yokoi et al.
4,871,623 A	10/1989	Hoopman et al.	5,906,202 A	5/1999	Schuster et al.
4,877,989 A *	10/1989	Drews et al. .... 310/323.01	5,914,122 A	6/1999	Otterbeck et al.
4,911,157 A	3/1990	Miller	5,932,249 A	8/1999	Gruber et al.
4,922,901 A	5/1990	Brooks et al.	5,932,315 A	8/1999	Lum et al.
4,926,852 A	5/1990	Zoltan et al.	5,934,272 A	8/1999	Lloyd et al.
4,935,624 A *	6/1990	Henion et al. .... 250/288	5,934,273 A	8/1999	Andersson et al.
4,941,483 A	7/1990	Ridings et al.	5,944,025 A	8/1999	Cook et al.
4,947,875 A	8/1990	Brooks et al.	5,954,979 A	9/1999	Counts et al.
4,974,754 A	12/1990	Wirz	5,957,124 A	9/1999	Lloyd et al.
4,982,097 A	1/1991	Slivon et al.	5,970,973 A	10/1999	Gonda et al.
4,992,206 A	2/1991	Waldron	5,970,974 A	10/1999	Van Der Linden et al.
5,021,802 A	6/1991	Allred	5,978,548 A	11/1999	Holmstrand et al.
5,044,565 A	9/1991	Alexander	5,993,633 A	11/1999	Smith et al.
5,056,511 A	10/1991	Ronge	6,014,970 A	1/2000	Ivri et al.
5,060,671 A *	10/1991	Counts et al. .... 131/329	6,053,176 A	4/2000	Adams et al.
5,063,921 A *	11/1991	Howe ..... 128/200.14	6,054,032 A	4/2000	Haddad et al.
5,096,092 A	3/1992	Devine	6,069,214 A	5/2000	McCormick et al.
5,125,441 A	6/1992	Mette	6,069,219 A	5/2000	McCormick et al.
5,133,343 A	7/1992	Johnson et al.	6,070,575 A	6/2000	Gonda et al.
5,134,993 A *	8/1992	van der Linden et al. .... 128/200.14	6,071,428 A	6/2000	Franks et al.
5,135,009 A	8/1992	Müller et al.	6,071,554 A	6/2000	Isomura et al.
5,144,962 A	9/1992	Counts et al.	6,076,522 A	6/2000	Dwivedi et al.
5,151,827 A	9/1992	Ven et al.	6,077,543 A	6/2000	Gordon et al.
5,178,305 A	1/1993	Keller	6,080,721 A	6/2000	Patton
5,184,776 A	2/1993	Minier	6,085,740 A	7/2000	Ivri et al.
5,217,004 A *	6/1993	Blasnik et al. .... 128/200.23	6,085,753 A	7/2000	Gonda et al.
5,226,441 A	7/1993	Dunmire et al.	6,089,228 A	7/2000	Smith et al.
5,228,444 A *	7/1993	Burch ..... 600/431	6,095,153 A	8/2000	Kessler et al.
5,230,445 A	7/1993	Rusnak	6,098,615 A	8/2000	Lloyd et al.
5,231,983 A	8/1993	Matson et al.	6,098,620 A	8/2000	Lloyd et al.
5,259,370 A *	11/1993	Howe ..... 128/200.14	6,103,270 A	8/2000	Johnson et al.
5,284,133 A *	2/1994	Burns et al. .... 128/200.23	6,116,516 A	9/2000	Gañán-Calvo
5,290,540 A	3/1994	Prince et al.	6,116,893 A	9/2000	Peach
5,298,744 A	3/1994	Mimura et al.	6,119,953 A	9/2000	Gañán-Calvo
5,299,565 A	4/1994	Brown	6,123,068 A	9/2000	Lloyd et al.
5,322,057 A	6/1994	Raabe et al.	6,123,936 A	9/2000	Platz et al.
5,327,915 A	7/1994	Porenski et al.	6,131,567 A	10/2000	Gonda et al.
5,342,180 A	8/1994	Daoud	6,131,570 A	10/2000	Schuster et al.
5,342,645 A	8/1994	Eisele et al.	6,136,346 A	10/2000	Eljamal et al.
5,349,946 A *	9/1994	McComb ..... 128/203.17	6,138,668 A	10/2000	Patton et al.
5,395,445 A	3/1995	Bohanan	6,155,268 A	12/2000	Takeuchi
5,421,489 A	6/1995	Holzner, Sr. et al.	6,158,431 A	12/2000	Poole
5,462,597 A	10/1995	Jubran	6,158,676 A	12/2000	Hughes
5,474,059 A *	12/1995	Cooper ..... 128/200.22	6,159,188 A	12/2000	Laibovitz et al.
5,487,378 A *	1/1996	Robertson et al. .... 128/200.16	6,164,630 A	12/2000	Birdsell et al.
5,509,557 A	4/1996	Jimarez et al.	6,165,463 A	12/2000	Platz et al.
			6,167,880 B1	1/2001	Gonda et al.

6,187,214	B1	2/2001	Gañán-Calvo	
6,187,344	B1	2/2001	Eljamal et al.	
6,189,803	B1	2/2001	Gañán-Calvo	
6,192,882	B1	2/2001	Gonda	
6,197,835	B1	3/2001	Gañán-Calvo	
6,205,999	B1 *	3/2001	Ivri et al. ....	128/200.22
6,206,242	B1	3/2001	Amberg et al.	
6,207,135	B1	3/2001	Rössling et al.	
6,223,746	B1	5/2001	Jewett et al.	
6,230,706	B1 *	5/2001	Gonda et al. ....	128/203.12
6,231,851	B1	5/2001	Platz et al.	
6,234,167	B1 *	5/2001	Cox et al. ....	128/200.14
6,234,402	B1	5/2001	Gañán-Calvo	
6,235,177	B1	5/2001	Borland et al.	
6,250,298	B1	6/2001	Gonda et al.	
6,257,233	B1	7/2001	Burr et al.	
6,258,341	B1	7/2001	Foster et al.	
6,263,872	B1	7/2001	Schuster et al.	
6,267,155	B1	7/2001	Parks et al.	
6,275,650	B1	8/2001	Lambert	
6,276,347	B1	8/2001	Hunt	
6,284,525	B1	9/2001	Mathies et al.	
6,288,360	B1	9/2001	Beste	
6,290,685	B1	9/2001	Insley et al.	
6,294,204	B1	9/2001	Rössling et al.	
6,295,986	B1	10/2001	Patel et al.	
6,318,361	B1	11/2001	Sosiak	
6,491,233	B1 *	12/2002	Nichols .....	239/128
6,501,052	B1 *	12/2002	Cox et al. ....	219/486
6,516,796	B1 *	2/2003	Cox et al. ....	128/200.23
6,557,552	B1 *	5/2003	Cox et al. ....	128/203.27
6,766,220	B1 *	7/2004	McRae et al. ....	700/266
6,772,757	B1 *	8/2004	Sprinkel, Jr. ....	128/203.26
6,923,179	B1 *	8/2005	Gupta et al. ....	128/203.17
2001/0032647	A1	10/2001	Schuster et al.	

FOREIGN PATENT DOCUMENTS

BE	354004	A	9/1928
BE	354094		9/1928
DE	1036470		4/1958
EP	358114		3/1990
EP	642802		3/1995
FR	667979		10/1929
HU	168128		2/1976
HU	168128		4/1993
HU	207457		4/1993
HU	P 95034-0		6/1994
HU	216121		4/1999
WO	WO 94/09842		5/1994
WO	WO 97/49441	A	12/1997
WO	98/17131		4/1998
WO	WO 98/17131	A	4/1998

OTHER PUBLICATIONS

Supplementary Partial European Search Report for Appln. No. 999520003.4-2310/US9924080 dated Jun. 22, 2004.

Barry, P.W. et al., "In Vitro Comparison of the Amount of Salbutamol Available for Inhalation From Different Formulations Used with Different Spacer Devices" *Eur Respir J* 1997; 10: 1345-1348.

Hindle, Michael et al., "High Efficiency Aerosol Production Using the Capillary Aerosol Generator" *PharmSci* 1998; 1: (1: suppl) S211.

Hindle, Michael et al., "High Efficiency Fine Particle Generation Using Novel Condensation Technology", *Respiratory Drug Deliv-*

*ery VI* (eds Dalby, R.N., Byron, P.R. & Farr, S.J.) Interpharm Press, Buffalo Grove, IL 1998 pp 97-102.

Hou, Shuguang et al. *Solution Stability of Budendone in Novel Aerosol Formations* Abstract No. 2582, *Solid State Physical Pharmacy*, Nov. 17, 1998, p. S-307.

Morén, Folke "Drug Deposition of Pressurized Inhalation Aerosols I. Influence of Actuator Tube Design" AB Draco (Subsidiary of AB Astra, Sweden) Research and Development Laboratories Pack, S-221 01 Lund (Sweden), *International Journal of Pharmaceutics*, 1 (1978) 205-212.

Newman, Stephen P. et al. "Deposition of Pressurized Suspension Aerosols Inhaled Through Extension Devices<sub>1-3</sub>" *Am Rev Respir Dis* 1981; 124:317-320

Roth, G. et al. High Performance Liquid Chromatographic Determination of Epimers, Impurities, and Content of the Glucocorticoid Budesonide and Preparation of Primary Standard, *Journal of Pharmaceutical Sciences*, vol. 69, No. 7, pp. 766-770, Jul. 1980.

Kousaka et al., Generation of Aerosol Particles by Boiling of Suspensions, *Aerosol Science & Technology*, 1994, pp. 236-240.

Stimuli to the Revision process, *Pharmacopeial Forum*, May-Jun. 1994, pp. 7477-7505, vol. 20, No. 3.

European Communication Pursuant to Article 96(2) EPC dated Dec. 1, 2004 for Application No. 99 952 003.4-2310.

European Communication Pursuant to Article 96(2) EPC dated Sep. 15, 2005 for Application No. 99 952 003.4-2310.

\* cited by examiner

Primary Examiner—Henry Bennett

Assistant Examiner—Nihir Patel

(74) Attorney, Agent, or Firm—Buchanan Ingersoll & Rooney PC

(57)

ABSTRACT

An aerosol generator includes a flow passage having an inlet and an outlet, a heater arranged relative to the flow passage for heating the flow passage, a source of material to be volatilized in communication with the inlet of the flow passage, a valve to open and close communication between the source of material and the inlet of the flow passage, and a pressurization arrangement for causing material in the source of material to be introduced into the flow passage when the valve is in an open position. The aerosol generator further includes a source of power for operating the heater and the valve, and a control device for controlling supply of power from the source of power to the heater and the valve. A metering device in an inhaler includes a pressurized source of medicated fluid and a metering chamber configured to deliver a predetermined volume of fluid to a heated flow passage in the inhaler. The metering chamber can be part of a rotary valve having a bore and a displacement member moveable within the bore from a first position where the fluid is loaded into the bore to a second position where the predetermined volume is ejected out of the bore. Another metering chamber has an elastic portion of a delivery passage in fluid communication with the pressurized source of liquid and the elastic portion of the delivery passage is deformed to eject the predetermined volume.

11 Claims, 15 Drawing Sheets

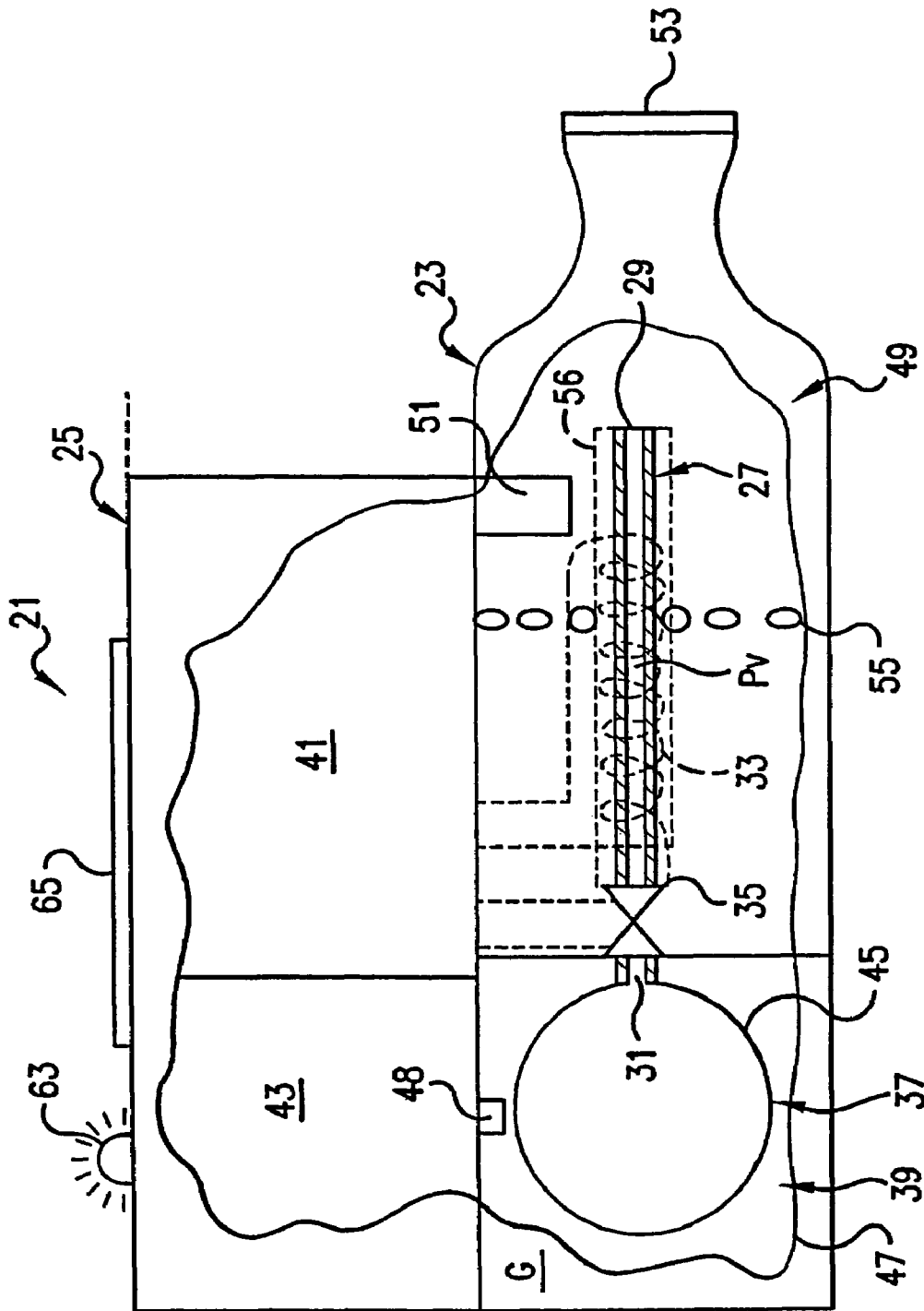

FIG.1

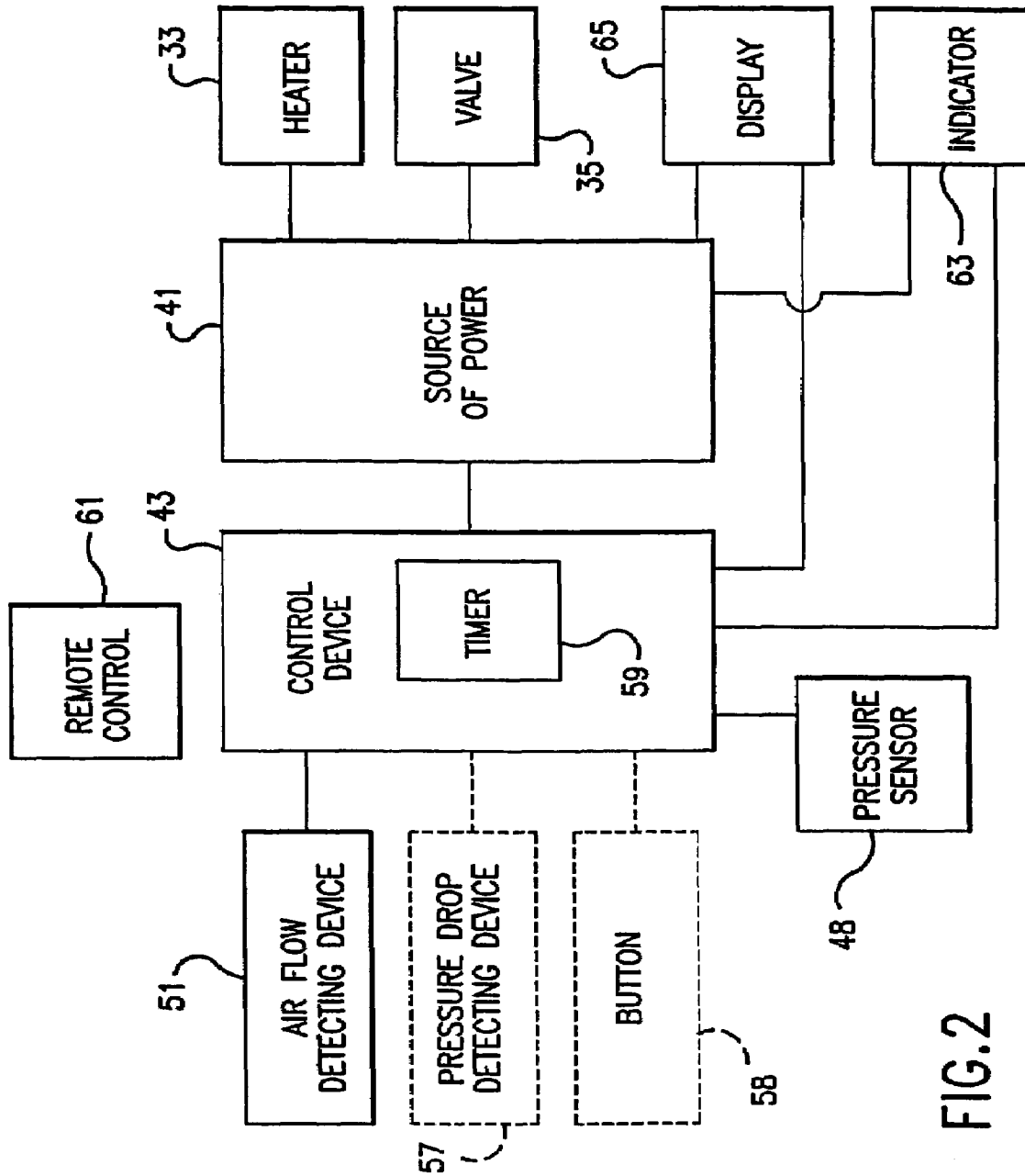

FIG. 2

# Explore Litigation Insights

Docket Alarm provides insights to develop a more informed litigation strategy and the peace of mind of knowing you're on top of things.

## Real-Time Litigation Alerts



Keep your litigation team up-to-date with **real-time alerts** and advanced team management tools built for the enterprise, all while greatly reducing PACER spend.

Our comprehensive service means we can handle Federal, State, and Administrative courts across the country.

## Advanced Docket Research



With over 230 million records, Docket Alarm's cloud-native docket research platform finds what other services can't. Coverage includes Federal, State, plus PTAB, TTAB, ITC and NLRB decisions, all in one place.

Identify arguments that have been successful in the past with full text, pinpoint searching. Link to case law cited within any court document via Fastcase.

## Analytics At Your Fingertips



Learn what happened the last time a particular judge, opposing counsel or company faced cases similar to yours.

Advanced out-of-the-box PTAB and TTAB analytics are always at your fingertips.

## API

Docket Alarm offers a powerful API (application programming interface) to developers that want to integrate case filings into their apps.

## LAW FIRMS

Build custom dashboards for your attorneys and clients with live data direct from the court.

Automate many repetitive legal tasks like conflict checks, document management, and marketing.

## FINANCIAL INSTITUTIONS

Litigation and bankruptcy checks for companies and debtors.

## E-DISCOVERY AND LEGAL VENDORS

Sync your system to PACER to automate legal marketing.