

[54] MICROSURGICAL INSTRUMENT

[76] Inventor: Finn Skjaerpe, Nedreveien 1, Stavanger, Norway, N-4000

[21] Appl. No.: 438,891

[22] PCT Filed: Mar. 12, 1982

[86] PCT No.: PCT/NO82/00014

§ 371 Date: Oct. 29, 1982

§ 102(e) Date: Oct. 29, 1982

[87] PCT Pub. No.: WO82/03168

PCT Pub. Date: Sep. 30, 1982

[30] Foreign Application Priority Data

Mar. 12, 1981 [NO] Norway 810849

[51] Int. Cl.³ A61B 17/32

[52] U.S. Cl. 128/305

[58] Field of Search 128/303 R, 305, 304, 128/303.14, 751, 753, 754, 757; 30/124, 130, 172, 299, 279

[56] References Cited

U.S. PATENT DOCUMENTS

- 1,167,014 1/1916 O'Brien 128/751 X
- 2,133,208 10/1938 Nellis 30/299 X
- 2,668,536 2/1954 Farries et al. 128/305

- 3,185,155 5/1965 Slaten et al. 128/303 R
- 4,315,511 2/1982 Chin 128/304 X

FOREIGN PATENT DOCUMENTS

452338 12/1974 U.S.S.R. 128/305

Primary Examiner—Michael H. Thaler
Attorney, Agent, or Firm—Watson, Cole, Grindle & Watson

[57] ABSTRACT

A microsurgical instrument for performing selective trabeculectomy in surgical treatment of glaucoma includes a flexible probe (A) and a cutting member (C) fixed to the same. The cutting member comprises two knife blades (C1,C2) protruding in different directions from the probe and each providing at least one sharp edge (E1,E2) turned towards a free end of the probe.

The instrument is designed to be pulled between two incisions in the eye wall with the probe foremost through the Canal of Schlemm at the transition between cornea and sclera, thereby cutting away the inner wall of the canal and the corresponding part of the trabecular meshwork located in the canal. The aqueous humour of the eye then gains access to the outer wall of the Canal of Schlemm with its drainage outlets leading out of the eye.

13 Claims, 5 Drawing Figures

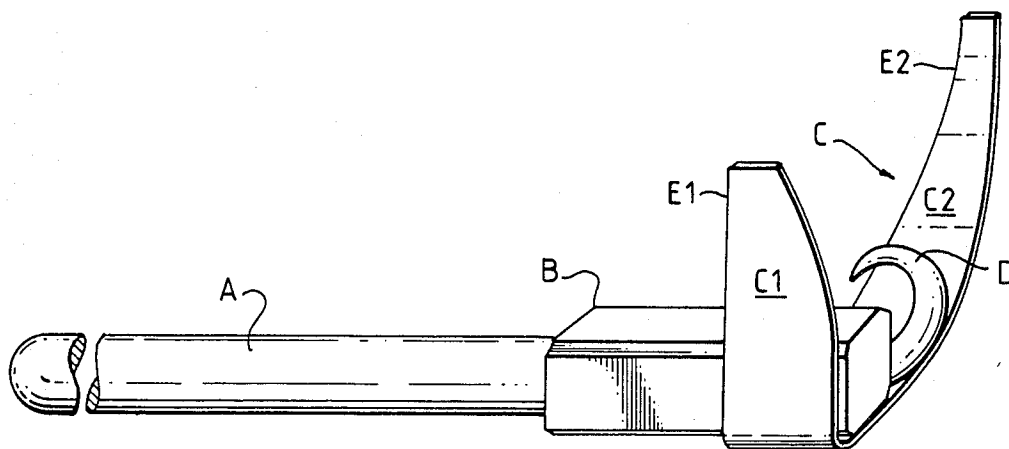

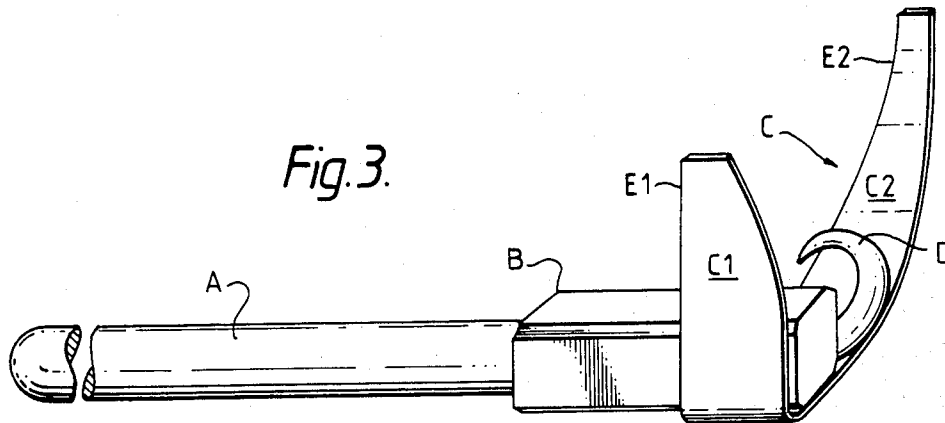
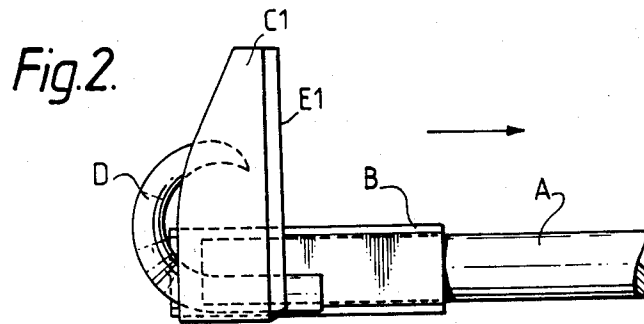
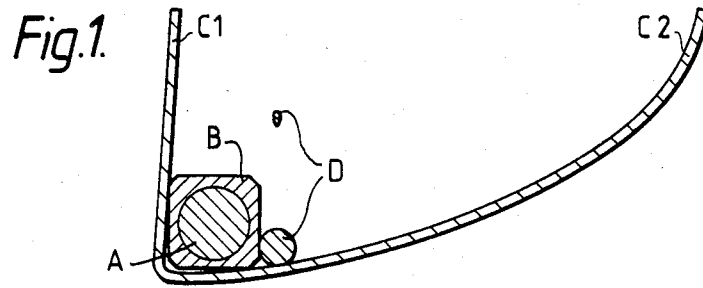

Fig. 4.

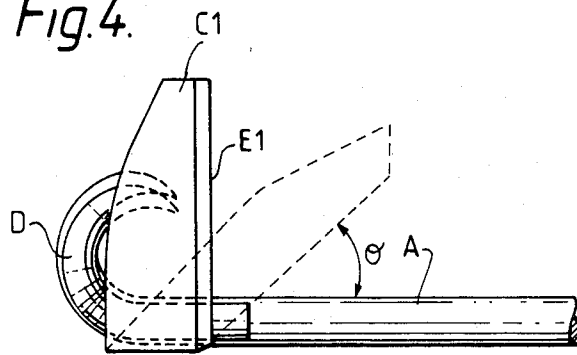
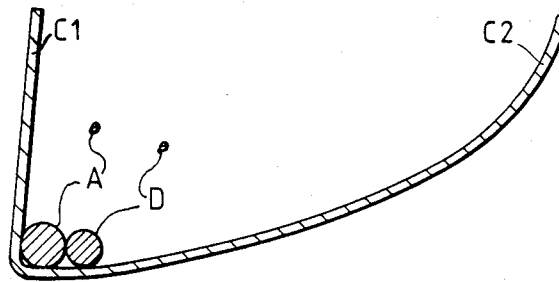
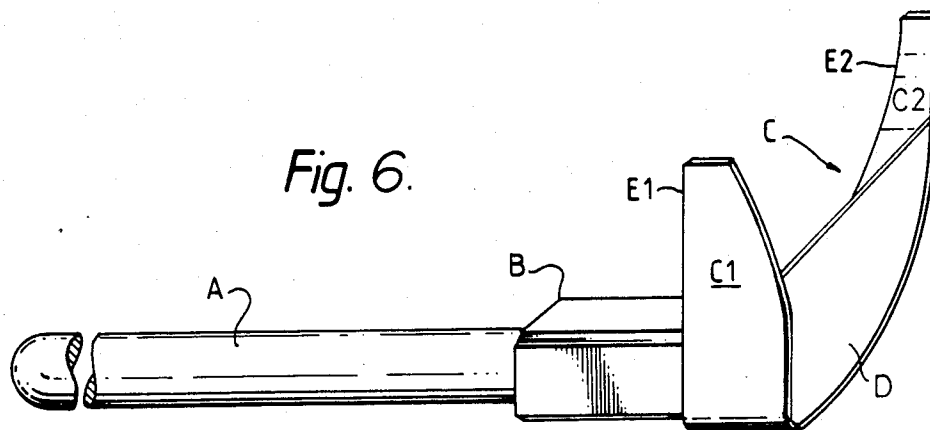

Fig. 5.





MICROSURGICAL INSTRUMENT

BACKGROUND OF THE INVENTION

The present invention relates to a microsurgical cutting instrument to be used in surgical treatment of glaucoma by means of a novel operational procedure, which significantly may be called "selective trabeculectomy".

Glaucoma is an ailment resulting in increased inner pressure in the eyeball. Within the eye, aqueous humor is produced at a fairly constant rate. This liquid is drained out through filterlike tissue (trabecular meshwork) in the area between iris and cornea into a collector canal running circularly along the transition between cornea and sclera (Canal of Schlemm), and from this canal through 20-30 drainage outlets in the eye wall into blood vessels (water veins).

The cause of glaucoma is believed to be a type of "clogging" of the trabecular meshwork, so that the outflow resistance increases. Then, also the pressure increases to allow the same volume of liquid to be drained out per time unit. All treatment aims at reducing the eye pressure. Such treatment is primarily medical, but when this is intolerable and/or insufficient, surgical treatment is used.

The surgical treatment may be subdivided according to three principles, namely:

1. Operations aiming at reduced production of aqueous humour.

2. Fistulizing procedures, i.e., surgical provision of artificial slits in the eye walls through which the liquid may seep out of the eye.

3. Operations on the trabecular meshwork. Existing procedures of this kind are of two types, i.e.:

(a) Approach through the anterior chamber of the eye by means of goniotomy or cautery of the trabecular meshwork with laser beams.

(b) Approach through the Canal of Schlemm. Such approach consists in opening this canal through a radial incision in the eye wall above the canal and insertion of a blunt probe or probe means with a cutting edge (trabeculotome). This instrument is then manipulated in such a way that it tears open or cuts through the trabecular meshwork into the anterior chamber of the eye. With such procedure a narrow slitlike opening is formed through the trabecular meshwork. Such slits exhibit, however, a considerable tendency to close.

SUMMARY OF THE INVENTION

In order to inhibit such closure it is an object of the present invention to provide a microsurgical instrument which through appropriate use may form a permanent opening from the anterior chamber of the eye to the Canal of Schlemm by selective removal of the inner wall of this canal along a certain sector. In this manner the aqueous humour gains direct access to the outer wall of the Canal of Schlemm, which has outlets or drainage canals, so that normal drainage of aqueous humour may be reestablished.

Thus, the invention concerns a microsurgical instrument for performing selective trabeculectomy in surgical treatment of glaucoma, the instrument including flexible probe means and a cutting member fixed to the same. With this background the general inventive feature of the instrument is that the cutting member comprises two knife blades protruding in different directions from the probe and each providing at least one sharp

cutting edge turned towards a free end of the probe means.

This instrument may be called a trabeculectome, as it is designed to be pulled through the Canal of Schlemm along a certain peripheral sector of the eye. By this the inner wall of the canal and the corresponding portion of the 0.1 mm thick trabecular meshwork are cut away.

As indicated, the trabeculectome consists of probe means and a cutting member. The probe means is preferably knob-shaped at the extreme end and made of flexible material, but this still sufficiently rigid to be inserted into and directed through the Canal of Schlemm. The cutting member has a double-cutting knife, the two cutting edges of which are angularly separated to such extent that the issuing V-form fits into the scleral groove in the eye wall, in which the trabecular meshwork is embedded. Advantageously, the cutting member is asymmetrical in such a manner that the knife blade that projects perpendicularly into the anterior chamber towards the iris is short, whereas the blade that projects obliquely into the anterior chamber and forms a small angle with the back side of the cornea is longer. This feature stabilizes the correct position of the knife.

The probe means of the trabeculectome is directed through an incision in the eye wall into and along the Canal of Schlemm, and is pulled out through another incision at a certain distance from the first one. The cutting member of the trabeculectome is pulled after the probe means through the Canal of Schlemm with the two knife edges projecting into the anterior chamber of the eye and thereby cutting away a strip of the trabecular tissue and the inner wall of the Canal of Schlemm which are located between the cutting edges. This tissue strip is preferably removed together with the trabeculectome when it is pulled out through the second incision in the eye wall. Such removal of the tissue strip may be secured by mounting one or more hooks in the angle between the two knife edges in order to catch the cut away strip and carry it out of the eye.

The microsurgical instrument according to the invention allows a surgical procedure which secures a permanent, broad opening between the anterior chamber of the eye and the outlets from the Canal of Schlemm by removing the trabecular meshwork and the inner wall of the canal. Tissue removal together with maintained cell casing on the outer wall of the Canal of Schlemm make a closure of this opening improbable, even after a long period of time.

Experiences with this method up to now suggest a low rate of complications, so that the operational indications probably may be extended. This means that the patients may be operated at an earlier stage and thus expensive and troublesome medical treatment is avoided.

The invention will now be explained in more detail with reference to exemplified embodiments as shown in the accompanying drawings.

DESCRIPTION OF THE DRAWINGS

FIG. 1 shows a first embodiment of the instrument in a cross-section through the cutting member at a right angle to the longitudinal axis of the probe means.

FIG. 2 is a side elevation of the instrument shown in FIG. 1.

FIG. 3 shows the instrument in FIGS. 1 and 2 in perspective view.

Explore Litigation Insights

Docket Alarm provides insights to develop a more informed litigation strategy and the peace of mind of knowing you're on top of things.

Real-Time Litigation Alerts



Keep your litigation team up-to-date with **real-time alerts** and advanced team management tools built for the enterprise, all while greatly reducing PACER spend.

Our comprehensive service means we can handle Federal, State, and Administrative courts across the country.

Advanced Docket Research



With over 230 million records, Docket Alarm's cloud-native docket research platform finds what other services can't. Coverage includes Federal, State, plus PTAB, TTAB, ITC and NLRB decisions, all in one place.

Identify arguments that have been successful in the past with full text, pinpoint searching. Link to case law cited within any court document via Fastcase.

Analytics At Your Fingertips



Learn what happened the last time a particular judge, opposing counsel or company faced cases similar to yours.

Advanced out-of-the-box PTAB and TTAB analytics are always at your fingertips.

API

Docket Alarm offers a powerful API (application programming interface) to developers that want to integrate case filings into their apps.

LAW FIRMS

Build custom dashboards for your attorneys and clients with live data direct from the court.

Automate many repetitive legal tasks like conflict checks, document management, and marketing.

FINANCIAL INSTITUTIONS

Litigation and bankruptcy checks for companies and debtors.

E-DISCOVERY AND LEGAL VENDORS

Sync your system to PACER to automate legal marketing.