

(19) World Intellectual Property Organization  
International Bureau



(43) International Publication Date  
21 October 2004 (21.10.2004)

PCT

(10) International Publication Number  
WO 2004/090853 A1

(51) International Patent Classification<sup>7</sup>: G09G 3/30

(KR). CHAI, Chong-Chul [KR/KR]; 102-2001 Samsung Apt., Singongdeok-dong, Mapo-gu, Seoul 121-765 (KR). CHOI, Joon-Hoo [KR/KR]; 108-303 Samho Apt., Youngcheon-dong, Seodaemun-gu, Seoul 120-768 (KR).

(21) International Application Number:  
PCT/KR2004/000787

(22) International Filing Date: 6 April 2004 (06.04.2004)

(74) Agent: PARK, Young-Woo; 5F., Seil Building, #727-13 Yoksam-dong, Gangnam-gu, Seoul 135-921 (KR).

(25) Filing Language: Korean

(26) Publication Language: English

(30) Priority Data:  
10-2003-0021640 7 April 2003 (07.04.2003) KR  
10-2004-0022553 1 April 2004 (01.04.2004) KR

(81) Designated States (unless otherwise indicated, for every kind of national protection available): AE, AG, AL, AM, AT, AU, AZ, BA, BB, BG, BR, BW, BY, BZ, CA, CH, CN, CO, CR, CU, CZ, DE, DK, DM, DZ, EC, EE, EG, ES, FI, GB, GD, GE, GH, GM, HR, HU, ID, IL, IN, IS, JP, KE, KG, KP, KZ, LC, LK, LR, LS, LT, LU, LV, MA, MD, MG, MK, MN, MW, MX, MZ, NA, NI, NO, NZ, OM, PG, PH, PL, PT, RO, RU, SC, SD, SE, SG, SK, SL, SY, TJ, TM, TN, TR, TT, TZ, UA, UG, US, UZ, VC, VN, YU, ZA, ZM, ZW.

(71) Applicant (for all designated States except US): SAM-SUNG ELECTRONICS CO., LTD. [KR/KR]; 416 Maetan-dong, Yeongtong-gu, Suwon-si, Gyeonggi-do 442-742 (KR).

(72) Inventors; and

(84) Designated States (unless otherwise indicated, for every kind of regional protection available): ARIPO (BW, GH, GM, KE, LS, MW, MZ, SD, SL, SZ, TZ, UG, ZM, ZW), Eurasian (AM, AZ, BY, KG, KZ, MD, RU, TJ, TM), European (AT, BE, BG, CH, CY, CZ, DE, DK, EE, ES, FI, FR, GB, GR, HU, IE, IT, LU, MC, NL, PL, PT, RO, SE, SI, SK,

(75) Inventors/Applicants (for US only): SHIN, Kyoung-Ju [KR/KR]; 102-504 Samjeongseonbi maeul, #289-12, Bora-ri, Giheung-eup, Yongin-si, Gyeonggi-do 449-904 (KR). CHOI, Beohm-Rock [KR/KR]; 112-508 Samsung Apt., Daechi 1-dong, Gangnam-gu, Seoul 135-968

[Continued on next page]

(54) Title: DISPLAY PANEL

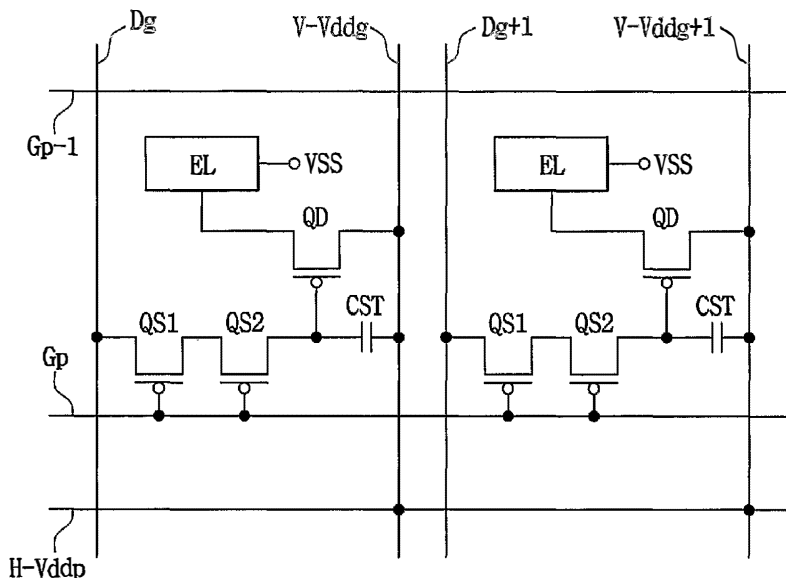

(57) Abstract: In an OLED panel capable of decreasing a cross-talk and an OLED apparatus having the OLED panel, a switching part is formed in a unit pixel defined by a data line and a scan line to control the output of a data signal in response to a scan signal. A current supply line is disposed on at least two sides of the unit pixel to transfer a current. The sides of the unit pixel are disposed adjacent to one another. An organic electro luminescent part generates a light in response to the current. A driving part is disposed between the organic electro luminescent part and the current supply line to control the current in response to the data signal outputted from the switching part. Therefore, the current supply line forms a net shape to decrease a cross-talk.

WO 2004/090853 A1



TR), OAPI (BF, BJ, CF, CG, CI, CM, GA, GN, GQ, GW, ML, MR, NE, SN, TD, TG).

*For two-letter codes and other abbreviations, refer to the "Guidance Notes on Codes and Abbreviations" appearing at the beginning of each regular issue of the PCT Gazette.*

**Published:**

— with international search report

## DISPLAY PANEL

### Technical Field

The present invention relates to a display panel, a method of manufacturing  
5 the display panel and a display apparatus having the display panel. More  
particularly, the present invention relates to a display panel capable of decreasing a  
cross-talk, a method of manufacturing the display panel and a display apparatus  
having the display panel.

### 10 Background Art

A display apparatus may be classified into a cathode ray tube (CRT), a liquid  
crystal display (LCD) apparatus, a plasma display panel (PDP), an organic electro  
luminescent display (OELD) apparatus, etc. A monitor for a computer may  
include the LCD apparatus. The LCD apparatus has low luminance, narrow  
15 viewing angle, etc. The CRT has heavy weight, large volume, etc.

The OELD apparatus has various characteristics, for example, such as low  
cost, high luminance, thin thickness, light weight, etc.

The OELD apparatus generates a light using an electro-luminescence of an  
organic material or polymers. When an electric energy is applied to the organic  
20 material or the polymers, the light is generated through the electro-luminescence.  
Therefore, a backlight may be omitted so that the OELD apparatus has thinner  
thickness and lower cost than the LCD apparatus. In addition, the OELD apparatus  
has wider viewing angle and higher luminance than the LCD apparatus.

FIG. 1 is a circuit diagram showing a pixel of a conventional organic electro  
25 luminescent panel.

Referring to FIG. 1, an organic electro luminescent driving element of the  
conventional organic electro luminescent panel includes a switching transistor (QS),

a storage capacitor (Cst), a driving transistor (QD) and an organic electro luminescent element. Current supply lines (VDD lines) are formed with data lines in a direction that is substantially in parallel with the data line. A pixel is electrically connected to each of the current supply lines (VDD lines). The number  
5 of the pixels is equal to that of scan lines.

The organic electro luminescent display (OELD) apparatus has lower luminance than the cathode ray tube (CRT). An organic electro luminescent display (OELD) apparatus of a passive type has lower luminance than an organic electro luminescent display (OELD) apparatus of an active type. The organic  
10 electro luminescent display (OELD) apparatus of a passive type generates the light when a voltage is applied to one of the scan lines. An active layer of a light emitting cell generates the light in proportion to an amount of a current that is applied to the active layer.

A cross-talk may be formed in a direction that is substantially in parallel  
15 with the current supply lines (VDD lines) while the organic electro luminescent panel is operated.

FIG. 2 is a plan view showing a cross-talk of a conventional organic electro luminescent panel.

Referring to FIG. 2, when a voltage drop of each of the current supply lines  
20 (VDD lines) corresponding to a column A where a white block is not displayed is small and a voltage drop of each of the current supply lines (VDD lines) corresponding to a column B where the white is displayed is large, pixels in the column B, which receive a current from each of the current supply lines (VDD lines) of the column B display a dark gray color.

25 Therefore, pixels disposed adjacent to an upper portion of the white block and a lower portion of the white block display the dark gray color that is darker than that of pixels spaced apart from the white block, thereby forming the cross-talk. In

addition, the voltage drop of each of the current supply lines (VDD lines) increases in proportion to a size of the white block.

Furthermore, a luminance of the pixels disposed adjacent to the upper and lower portions of the white block decreases in proportion to the size of the white  
5 block, therefore forming the cross-talk.

The luminance of the pixels decreases in inverse proportion to a light emitting area, and a change of the luminance in a longitudinal direction is greater than that in the horizontal direction.

## 10 Disclosure

### -Technical Problem

The present invention provides a display panel capable of decreasing a voltage drop and a cross-talk.

The present invention also provides a method of manufacturing the display  
15 panel.

The present invention also provides a display apparatus having the display panel.

### -Technical Solution

The display panel according to an exemplary embodiment of the present  
20 invention includes a data line, a scan line, a switching part, a current supply line, an organic electro luminescent part and a driving part. The data and scan lines transfer a data signal and a scan signal, respectively. The switching part is formed in a unit pixel defined by the data and scan lines to control the output of the data signal in response to the scan signal. The current supply line is disposed on at least  
25 two sides of the unit pixel to transfer a current. The sides of the unit pixel are disposed adjacent to one another. The organic electro luminescent part generates a light in response to the current. The driving part is disposed between the organic

# Explore Litigation Insights

Docket Alarm provides insights to develop a more informed litigation strategy and the peace of mind of knowing you're on top of things.

## Real-Time Litigation Alerts



Keep your litigation team up-to-date with **real-time alerts** and advanced team management tools built for the enterprise, all while greatly reducing PACER spend.

Our comprehensive service means we can handle Federal, State, and Administrative courts across the country.

## Advanced Docket Research



With over 230 million records, Docket Alarm's cloud-native docket research platform finds what other services can't. Coverage includes Federal, State, plus PTAB, TTAB, ITC and NLRB decisions, all in one place.

Identify arguments that have been successful in the past with full text, pinpoint searching. Link to case law cited within any court document via Fastcase.

## Analytics At Your Fingertips



Learn what happened the last time a particular judge, opposing counsel or company faced cases similar to yours.

Advanced out-of-the-box PTAB and TTAB analytics are always at your fingertips.

## API

Docket Alarm offers a powerful API (application programming interface) to developers that want to integrate case filings into their apps.

## LAW FIRMS

Build custom dashboards for your attorneys and clients with live data direct from the court.

Automate many repetitive legal tasks like conflict checks, document management, and marketing.

## FINANCIAL INSTITUTIONS

Litigation and bankruptcy checks for companies and debtors.

## E-DISCOVERY AND LEGAL VENDORS

Sync your system to PACER to automate legal marketing.