

In FIG. 3, 72 is a latch release button, 73 is a coil spring, 74 is a leaf spring, 75 is a latch claw, 76 is a support (A), and 77 is a support (B).

3A shows a state in which the latch mechanism is locked, and FIG. 3B shows a state in which the latch mechanism is opened.

In FIG. 3A, the leaf spring 74 is temporarily hooked on the latch claw 75, and the support (B) is restricted from entering the support (A) 76.

In this state, in FIG. 3A, the interval between the first arm 31 and the second arm 32 is limited from being widened.

That is, it is difficult to drop off the biological information detection apparatus that once sandwiches the living body.

[0064]

Here, as shown in FIG. 3B, when the latch release button 72 is pressed, the leaf spring 74 restrained by the coil spring 73 opens in the direction of the arrow and is released from the latch pawl 75.

When the leaf spring 74 is released from the latch claw 75, the support (B) 77 can enter the support (A) 76.

In this state, in FIG. 3A, the interval between the first arm 31 and the second arm 32 is widened.

That is, it becomes easy to remove the biological information detection apparatus that once sandwiched the living body.

[0065]

As described above, the living body information detecting apparatus of the present invention can adjust the distance between the other ends of the pair of arms by the distance variable mechanism provided on the support shaft, and does not widen the distance between the other ends. Due to the temporarily restricting latch, the sensor attached to the arm can be kept in close contact with the living body, so it can be mounted in an appropriate position with an appropriate contact pressure corresponding to the difference in individual body shape. Thus, the biological information can be detected stably.

[0066]

(Embodiment 3) The biological information detection apparatus according to the present embodiment is an adjustment screw for mounting a sensor or an adjustment screw for mounting a sensor in the above-described biological information detection apparatus. Each of the first arm and the second arm has a function of adjusting one or both of the distance between the surface of the first arm and the surface of the first arm and the distance between the surface of the sensor and the second arm. Or both.

[0067]

FIG. 4A is a front view of a configuration example of the biological information detection apparatus of the present embodiment, and FIG. 4B is a plan view of the configuration example of the biological information detection apparatus of the present embodiment.

In FIG. 4 and the following drawings, some names are not shown in order to avoid complexity of the drawing.

In the configuration example of the biological information detection apparatus shown in FIGS. 4A and 4B, the biological information detection apparatus includes an adjustment screw 42 on the first arm 31 and a sensor 33 mounted on the adjustment screw 42. The case where the space interval of the sensor 33 with which the adjustment screw 42 and the sensor 34 with which the 2nd arm 32 is equipped is adjusted is shown.

In addition, it is arbitrary to provide a rotation mechanism and a latch mechanism.

[0068]

As a mechanism of the adjusting screw 42, a mechanism for adjusting the position of the sensor 33 by rotating the screw and adjusting a distance between the sensor 33 and the sensor 34, or a mechanism for adjusting the position of the sensor 33 by friction and fixing it with a fixing screw. May be used to adjust the distance between the sensor 33 and the sensor 34.

[0069]

As described above, when the biological information detecting device of the present embodiment is attached to the tragus of the auricle, for example, the distance between the sensor 33 and the sensor 34 is adjusted by an adjustment screw in response to individual differences in the shape of the tragus. The sensor 33 and the sensor 34 can be attached to the tragus with an appropriate contact pressure.

[0070]

In the following embodiments, an auricle tragus will be described as an example of the protrusions of the human auricle.

[0071]

(Embodiment 4) FIG. 5 shows an example of mounting the biological information detection device to the auricle.

In FIG. 5, the biological information detection device is attached to the tragus 1 so as to be in contact with both sides, the sensor 33 provided in the first arm 31 is outside the tragus 1, and the sensor 34 provided in the second arm 32 is the tragus 1. It is attached in contact with the inside.

Since a part of the second arm 32 and the sensor 34 are inside the tragus 1, they are indicated by broken lines.

[0072]

As described above, when the biological information detection device according to the present embodiment is worn on both sides of a part of the living body, for example, the tragus 1 of the

auricle, it detects individual differences in the shape of the tragus 1. Then, the position of the sensor 33 and the sensor 34 can be adjusted by the distance variable mechanism 40 or the rotation mechanism 41, and the sensor 33 and the sensor 34 can be attached to the appropriate position of the tragus 1 in an appropriate contact state.

In addition, it is arbitrary to provide a rotation mechanism and a latch mechanism.

[0073]

(Embodiment 5) The biological information detection apparatus of this Embodiment is a case where the above-mentioned biological information detection apparatus is further provided with an ear hook that goes around the root of the auricle.

FIG. 6A shows a configuration example of the biological information detection apparatus of the present embodiment, and FIG. 6B shows a mounting state of the configuration example of the biological information detection apparatus of the present embodiment on the auricle.

In the case of the configuration example of the biological information detection apparatus shown in FIG. 6A, the first arm 31 is provided with an ear hook mechanism 46, and the ear hook mechanism 46 is connected to the auricle as shown in FIG. It has a mechanism that goes around the base of the ear ring 5 from the base, goes around the base of the pinna, and fixes the biological information detecting device to the pinna.

[0074]

The shape of the ear hook may be a ring shape along the pinna.

Alternatively, a structure may be adopted in which the ring goes around along the base of the auricle and the ring is closed by a clasp.

Further, the tightness of the closed ring may be adjusted with a stopper.

[0075]

The material for the ear hook may be a plastic metal, solder alloy, zinc alloy, brass, copper alloy, aluminum alloy, stainless steel, Ni alloy, tin alloy, or shape memory alloy.

The resin system may be plastic, vinyl chloride resin, acrylic resin, ABS resin, MC nylon, fluoro-resin (PTFE), polycarbonate, polypropylene, polyethylene silicone resin, polyurethane resin, or natural rubber.

By selecting such a material, individual differences such as the size of the subject's pinna can be absorbed.

[0076]

As described above, the living body information detection apparatus of the present embodiment further includes the ear hooking mechanism 46 that wraps around the base of the auricle and suspends it on the auricle. Deviation from the tragus position of the device due to the above can be prevented.

For this reason, a biological information detection apparatus is stably fixed to the auricle, and biological information can be detected more stably.

[0077]

It is also possible to make the ear-hooking mechanism detachable from the main body of the biological information apparatus and select an ear-hooking mechanism having a size suitable for the subject.

[0078]

(Embodiment 6) The living body information detection device of this embodiment is the above-described living body information detection device, the cushion provided on the auricle side of the arm arranged on the auricle side of the pair of arms, This is a case of further including a magnet provided on at least one of the arm provided with a cushion and the ear hook, and a

magnet or a magnetic body provided on the other.

[0079]

FIG. 7 is a diagram showing a state in which the biological information detecting device of the present embodiment is attached to the auricle, and the auricle is a cross section by a horizontal plane in the vicinity of the tragus 1 viewed from above the head of the living body. The living body information collecting device is a schematic view showing a state where the living body is attached to the living body as viewed from above the head of the living body, and a combination of both.

In FIG. 7, the cushion 45 is disposed outside the second arm 32, the cushion 45 includes a magnet 47 at a position in contact with the auricle, and the ear hooking mechanism 46 is in a position in contact with the auricle on the back side of the auricle. Is provided with a magnet 48.

[0080]

The magnet 47 and the magnet 48 are on both sides of the pinion 4 of the auricle, and are installed with polarities in which a magnetic force acts on each other. The magnet 47 and the magnet 48 are fixed in contact with the auricle.

[0081]

As described above, by providing the cushion 45, even when the arm of the biological information detection device is formed of a hard material, it can be worn for a long time without causing pain to the subject.

The living body information detection apparatus of the present embodiment further includes a magnet that exerts a magnetic force on the side where the cushion 45 comes into contact with the auricle and the side where the ear hooking mechanism 46 comes into contact with the auricle, and detects living body information. The apparatus can be more comfortably fixed to the auricle and biometric information can be detected more stably.

[0082]

In FIG. 7, two magnets 47 and 48 are used, but one may be a magnet and the other may be a magnetic body.

Further, the magnet 47 or the magnet 48 may be installed inside the cushion 45 or the ear hook mechanism 46, respectively.

[0083]

As described above, the living body information detecting device of the present embodiment is a small and light weight that can be attached to a living body more comfortably at an appropriate position with an appropriate contact pressure corresponding to a difference in individual body shape. Thus, it is possible to detect biological information more stably and continuously.

[0084]

(Embodiment 7) In the biological information detection device of this embodiment, the main body of the biological information detection device described above is attached to one of the left and right pinna of the human body, and the pair of arms and the 1 This is a case that further includes a bridge that connects the auricles to which the pair of arms are not mounted, and a power supply unit that is arranged in the middle of the bridge and drives the sensor.

[0085]

FIG. 8 shows a wearing state of the biological information detection apparatus of the present embodiment.

In FIG. 8, 30 is a biological information detection apparatus, 80 is a bridge | bridging, 82 is a power supply part.

In the configuration example of the biological information detection device shown in FIG. 8, the main body of the biological information detection device described above is attached to one of the left and right pinna of the human body, and the pair of arms and the pair of arms A power supply unit for driving the sensor is arranged on the bridge that connects the auricles to which the sensor is not attached via the back of the human body.

In the case where the pair of arms is provided with a cuff, a pump for supplying and exhausting the cuff together with the power supply unit may be disposed.

[0086]

The cross-linking material may be a plastic metal, solder alloy, zinc alloy, brass, copper alloy, aluminum alloy, stainless steel, Ni alloy, tin alloy, or shape memory alloy.

The resin system may be plastic, vinyl chloride resin, acrylic resin, ABS resin, MC nylon, fluoro-resin (PTFE), polycarbonate, polypropylene, polyethylene silicone resin, or polyurethane resin.

By selecting such a material, individual differences such as the size of the subject's head can be absorbed.

[0087]

It is also possible to make the bridge removable from the biological information device main body and select a bridge having a size suitable for the subject.

It is also possible to make the bridge stretchable so as to match the size of the subject's head.

[0088]

In FIG. 8, the bridge is routed through the back of the head, but may be routed through the top of the head or under the chin.

By arranging the power supply unit on the head, it is possible to easily carry and manage the biological information detection apparatus.

In addition, by disposing the pump on the head, it becomes easier to fix the pipe, and noise can be reduced when detecting biological information.

[0089]

As described above, the biological information detection device can be stably attached to the auricles by providing a bridge across the left and right auricles.

Further, by making the power supply unit separate from the arm side, the arm side can be reduced.

[0090]

(Embodiment 8) The biological information detection apparatus according to the present embodiment is the same as the above-described biological information detection apparatus, as shown in FIGS. 9A and 9B, for example, in the sensor 33 shown in FIG. Instead, a support 57 is provided, a cuff 56 is provided instead of the sensor 34, a light emitting element 61 and a light receiving element 62 are provided in the cuff 56, and the cuff 56 is provided with an air pipe 36 for supplying air.

Here, FIG. 9B is an enlarged view of the support 57 and the cuff 56 in a state where the biological information detecting device of FIG. 9A is attached to the tragus 1, and to avoid the complexity of the drawing, the light emitting element 61 and the light receiving element cuff 62 are not shown in the cuff 56 shown in FIG.

By incorporating the light emitting element and the light receiving element as sensors into the cuff, it is possible to acquire biological information on the living body part pressed by the cuff.

[0091]

9A and 9B, the support 57 is disposed on the first arm 31 and the cuff 56 is disposed on the second arm 32. However, the support 57 is disposed on the second arm 32. The cuff 56 may be

disposed on the first arm 31.

[0092]

The light emitting element 61 and the light receiving element 62 in the cuff 56 shown in FIG. 9B form a reflection type pulse wave detection system to detect a pulse wave.

In the process of detecting the pulse wave as described above, the blood pressure can also be measured by applying pressure to the tragus 1 with the cuff 56.

[0093]

(Embodiment 9) A biological information detection apparatus according to the present embodiment includes a pair of opposed arms, a support shaft that connects the pair of arms at one end of each of the pair of arms, and the support shaft A distance variable mechanism that adjusts the distance between the other ends of the pair of arms, and the other end of at least one arm of the pair of arms on the opposite side of the pair of arms. An attached cuff that presses against the living body, and in a state where air is exhausted from the cuff, an arm to which the cuff is attached or a frame surrounding the periphery of the cuff abuts on the living body, and air is applied to the cuff. The cuff is in contact with the surface of the living body and presses the tragus.

[0094]

FIG. 10 shows a configuration example of the biological information detection apparatus of the present embodiment.

In FIG. 10, 1 is a tragus, 31 is a first arm, 32 is a second arm, 35 is a support shaft, 55 is a cuff, and 56 is a cuff. In FIG. 10, a cuff 55 is disposed inside the tip of the first arm 31 that has an arcuate or bowl shape. Rather than pinching the tragus 1 with the cuff 55, the biological information detecting device is fixed at the position of the tragus surface at the tip of the arm around the cuff 55, and the cuff 55 is supplied with the air to the cuff 55 for the first time. A pressure is applied to the tragus 1 in contact with the surface of 1.

[0095]

With such a configuration, when the cuff is being exhausted, the cuff surface does not come into contact with the tragus surface, so that it is possible to prevent pressure from being applied to a site where biological information is actually obtained. For this reason, it is possible to remove the measurement error factor due to the pressure applied to the surface of the tragus rather than bringing the cuff itself into contact with the tragus from the beginning and fixing the biological information detection device.

[0096]

In FIG. 10, the cuff 55 is disposed on the first arm 31 and the cuff 56 is disposed on the second arm 32, but the same configuration may be adopted even when the cuff is disposed on only one arm, it can. Moreover, in FIG. 10, although the front-end | tip part of the 1st arm 31 or the 2nd arm 32 has become bow shape or bowl shape, it is not limited to these shapes. It is sufficient that the inside of the cylindrical shape, the square cylindrical shape, the cone shape, or the like is hollow. The arm itself is not limited to such a shape. A frame surrounding the cuff may be attached to the arm.

[0097]

As described above, the arm to which the cuff is attached abuts the tragus when air is exhausted from the cuff, and the cuff contacts the tragus surface while air is supplied to the cuff. By using a living body information detection device that compresses the tragus, it is possible to eliminate a measurement error factor due to pressure applied to the cuff.

[0098]

(Embodiment 10) A biological information detection apparatus according to the present embodiment includes a pair of opposed arms, a spindle that connects the pair of arms at one end of the pair of arms, and the spindle A distance variable mechanism that adjusts the distance between the other ends of the pair of arms, and the other end of at least one arm of the pair of arms on the opposite side of the pair of arms. And a cuff for pressing the living body, and at least the cuff is detachable from an arm to which the cuff is attached.

[0099]

FIG. 11A is a front view of a configuration example of the biological information detection apparatus of this embodiment, and FIG. 11B is a plan view of the configuration example of the biological information detection apparatus of the present invention.

11A and 11B, 31 is a first arm, 55 is a cuff, and 86 is a sealing material.

In FIG. 11 (A) and FIG. 11 (B), the cuff can be exchanged by extracting the arm tip provided with the cuff 55 in the direction of the arrow. In the configuration example of the biological information detection apparatus shown in FIGS. 11A and 11B, the arm tip and the arm body are made of rubber so that there is no air leakage from the pipe that supplies and exhausts air to the cuff 55. It is necessary to install a sealing material 86 such as packing or silicon.

[0100]

FIG. 12A is a front view of another configuration example of the biological information detection apparatus of this embodiment, and FIG. 12B is a plan view of another configuration example of the biological information detection apparatus of the present invention. 12A and 12B, 31 is a first arm, 33 is a sensor, 55 is a cuff, and 86 is a sealing material. In FIG. 12A and FIG. 12B, the cuff can be exchanged by extracting the arm tip provided with the cuff 55 in the direction of the arrow. In the case of the configuration example of the biological information detection apparatus shown in FIGS. 12A and 12B, the cuff 55 includes the sensor 33 inside, and thus air is supplied to the cuff 55 including the support base of the sensor 33. It is necessary to attach a sealing material 86 such as rubber packing or silicon between the arm tip and the arm body so that there is no air leakage from the exhaust pipe.

[0101]

The cuff and support mechanism that touches the tragus are easily soiled by wax, sebum, etc., and is subject to wear, so the cuff can be easily removed from the arm by cleaning the cuff. Or replacing it can prevent cuff leakage and reduced permeability. In addition, disposing the cuff and the support mechanism has an advantage that hygiene management becomes easy.

[0102]

(Embodiment 11) A living body information detection apparatus according to an embodiment of the present invention includes a pair of opposed arms, a support shaft that connects the pair of arms at each end of the pair of arms, and the support shaft A distance variable mechanism that adjusts the distance between the other ends of the pair of arms, and the other end of at least one arm of the pair of arms on the opposite side of the pair of arms. And a cuff that presses against the living body, and at least one of the cuffs can change a direction in contact with the living body.

[0103]

FIG. 13 shows a configuration example of the biological information detection apparatus of this embodiment.

In FIG. 13, 31 is a first arm, 35 is a support shaft, 55 is a cuff, 56 is a cuff, and 88 is a cuff rotation mechanism. In FIG. 13, the cuff 55 has a cuff rotation mechanism 88 that can change the direction in which the cuff 55 contacts the tragus. If the first arm 31 is an arm arranged outside the tragus, the cuff 55 comes into contact with the outside of the tragus.

[0104]

Since the cuff 55 that contacts the outside of the tragus has a degree of freedom of rotation, if the distance between the cuffs is adjusted to a length that matches the tragus shape of the subject, the angle of the cuff is strictly Even if it does not adjust, since the rotation angle of the cuff 55 is determined with respect to the tragus so as to follow the tragus shape, the ease of wearing is improved.

[0105]

The cuff rotation mechanism 88 may have a structure that can change the direction of contact with the tragus within one plane, but if the structure that can change the direction of contact with the tragus within two planes, the cuff contacts the tragus. Making it even easier.

[0106]

In FIG. 13, only the cuff 55 disposed on the first arm 31 has a structure capable of changing the direction, but only the cuff 56 disposed on the second arm 32 has a structure capable of changing the direction. Alternatively, both the cuff 55 and the cuff 56 may have a structure capable of changing the direction.

[0107]

As described above, by providing the cuff disposed on the arm with a structure that can change the direction, it is easy to attach the biological information detecting device to the tragus.

In particular, since the cuff 55 that contacts the outside of the tragus has a degree of freedom of rotation, if the distance between the cuffs is adjusted to a length that matches the tragus shape of the subject, the angle of the cuff can be adjusted. Even if it is not strictly adjusted, it becomes easy to attach to the tragus.

[0108]

(Embodiment 12) A biological information detection apparatus according to the present embodiment includes a pair of opposed arms, a support shaft that connects the pair of arms at each end of the pair of arms, and the support shaft A distance variable mechanism that adjusts the distance between the other ends of the pair of arms, and the other end of at least one arm of the pair of arms on the opposite side of the pair of arms. And a cuff that presses against the living body, and at least one of the cuffs can slide in a longitudinal direction of an arm to which the cuff is attached.

[0109]

If the first arm 31 is an arm arranged outside the tragus, the cuff 55 comes into contact with the outside of the tragus.

[0110]

FIG. 14 shows a configuration example of the biological information detection apparatus according to the present embodiment.

In FIG. 14, 31 is a first arm, 35 is a support shaft, 55 is a cuff, 56 is a cuff, and 90 is a cuff slide mechanism.

In FIG. 14, the cuff 55 has a cuff slide mechanism 90 that can slide in the long axis direction of the first arm 31, and by changing the position of the cuff 55, the cuff 55 can be brought into contact with the tragus in an optimal position. .

[0111]

As shown in FIG. 14, when a spring for pulling the cuff 55 to the tip of the first arm 31 is provided, the cuff 55 settles at a stable point when the cuff 55 comes into contact with the tragus.

Further, a spring that extends to press the cuff 55 against the tip of the first arm 31 may be used.

[0112]

Further, in FIG. 14, only the cuff 55 is configured to slide, but only the cuff 56 that contacts the inside of the tragus may be configured to slide, or both the cuff 55 and the cuff 56 may be configured to slide. You may comprise so that it may slide.

[0113]

In FIG. 14, the cuff 55 is merely slid in the longitudinal direction of the first arm. However, if the structure in which the direction of contact with the tragus of the cuff 55 can be changed, the cuff becomes an optimal part of the tragus. It makes it easier to abut.

[0114]

As described above, the distance between the other ends of the pair of arms can be adjusted by the distance variable mechanism provided on the support shaft of the living body information detection apparatus, and the cuff is slid to be arranged at the optimum position on the living body. be able to.

[0115]

(Embodiment 13) A living body information detection apparatus according to the present embodiment includes an ear hook for suspending a body of a living body information detection

apparatus mounted on a human auricle at a root of a human ear, and the ear hook. And a power supply unit for driving the sensor on the head side behind the auricle.

Furthermore, a pump for supplying and exhausting air to the cuff may be provided.

[0116]

FIG. 15 shows a wearing state of the biological information detection apparatus of the present embodiment.

In the configuration example of the biological information detection apparatus shown in FIG. 15, a power supply unit (not shown) for driving the sensor and a pump 84 for supplying and exhausting a cuff (not shown) are arranged in the ear hook mechanism 46.

Further, switches 83 may be arranged.

[0117]

The material and structure of the crosslinking are the same as those described above.

By arranging the power supply unit in the ear hooking mechanism, it is possible to easily carry and manage the biological information detection device. By placing the power supply unit on the ear hook, the burden on the arm can be reduced, and noise due to wiring vibration can be reduced. In addition, by disposing the pump on the head, it becomes easier to fix the pipe, and noise can be reduced when detecting biological information.

[0118]

The biological information detection apparatus according to the present invention can be used for blood pressure measurement, pulse wave measurement, and blood flow measurement for health and beauty.

[0119]

(A) is a front view of the structural example of the biological information detection apparatus of this Embodiment, (B) shows the top view of the structural example of the biological information detection apparatus of this invention.

(A) is a front view of the structural example of the biological information detection apparatus of this Embodiment, (B) shows the top view of the structural example of the biological information detection apparatus of this invention. It is a figure explaining the latch mechanism with which the biometric information detection apparatus of this Embodiment is provided. (A) is a front view of the structural example of the biological information detection apparatus of this Embodiment, (B) shows the top view of the structural example of the biological information detection apparatus of this invention. It is a figure explaining the example of mounting | wearing with the pinna of the biometric information detection apparatus of this Embodiment. (A) shows a configuration example of the biological information detection device of the present embodiment, and (B) shows a mounting state of the configuration example of the biological information detection device of the present embodiment on the auricle. It is a figure which shows the state which mounted | worn the biological information detection apparatus of this Embodiment to the said pinna. It is a figure which shows the mounting state of the biometric information detection apparatus of this Embodiment. (A) shows the example of a structure of the biometric information detection apparatus of this Embodiment, (B) is an enlarged view of the support body and the cuff part of the state which mounted | wore the tragus with the biometric information detection apparatus of (A). It is a figure which shows the structural example of the biometric information detection apparatus of this Embodiment. (A) is a front view of a configuration example of the biological information detection apparatus of the present embodiment, and (B) is a plan view of a configuration example of the biological information detection apparatus of the present invention. (A) is a front view of a configuration example of the biological information detection apparatus of the present embodiment, and (B) is a plan view of a configuration example of the biological information detection apparatus of the present invention. It is a figure which shows the structural example of the biometric information detection apparatus of this Embodiment. It is a figure which shows the structural example of the biometric information detection apparatus of this Embodiment. It is a figure which shows the mounting state of the biometric information detection apparatus of this Embodiment. It is a figure explaining the name of each part of an auricle.

Explanation of symbols

[0120]

DESCRIPTION OF SYMBOLS 1 Tragus 2 Pair of beads 3 Ear concha 4 Pair of rings 5 Ear ring 6 Pair of wheels 7 Ring ring 8 Ear concha cavity 30 Biological information detection device 31 1st arm 32 2nd arm 33 Sensor 34 Sensor 35 Support shaft 36 Air pipe 37 Signal line 40 Distance variable mechanism 41 Rotating mechanism 42 Adjustment screw 45 Cushion 46 Ear hook mechanism 47 Magnet 48 Magnet 55 Cuff 56 Cuff 57 Support body 61 Light emitting element 62 Light receiving element 70 Spring 71 Latch mechanism 72 Latch release button 73 Coil spring 74 Leaf spring 75 Latch tab 76 Support body (A) 77 Support body (B) 80 Bridge 82 Power supply unit 83 Switches 84 Pump 86 Sealing material 88 Cuff rotation mechanism 90 Cuff slide mechanism

(19) 日本国特許庁 (JP)

(12) 公開特許公報 (A)

(11) 特許出願公開番号

特開2006-102164
(P2006-102164A)

(43) 公開日 平成18年4月20日 (2006. 4. 20)

(51) Int. Cl.

A61B 5/0245 (2006.01)

F1

A61B 5/02 S10G

テーマコード (参考)

4C017

審査請求 未請求 請求項の数 18 O L (全 22 頁)

(21) 出願番号 特願2004-293238 (P2004-293238)
(22) 出願日 平成16年10月6日 (2004. 10. 6)

(71) 出願人 000004226
日本電信電話株式会社
東京都千代田区大手町二丁目3番1号
(71) 出願人 000102739
エヌ・ティ・ティ・アドバンステクノロジー株式会社
東京都新宿区西新宿二丁目1番1号
(74) 代理人 100119677
弁理士 岡田 賢治
(72) 発明者 多々良 尚愛
東京都千代田区大手町二丁目3番1号 日本電信電話株式会社内
(72) 発明者 相原 公久
東京都千代田区大手町二丁目3番1号 日本電信電話株式会社内

最終頁に続く

(54) 【発明の名称】 生体情報検出装置

(57) 【要約】

【課題】

血圧測定などの生体組織への加圧が必要な測定においては、振動によるノイズが混入しやすいため正確な脈波、血圧値の測定が困難であり、安定して血圧を測定することが課題であった。また、日常活動の中での測定や常に血圧計を装着した状態で一定間隔や連続して血圧を測定することが困難であるため、生体情報検出装置の保持方法が課題であった。

本発明は上記課題を解決するためになされたもので、装着が容易で、かつ安定して生体情報を検出する生体情報検出装置を提供することを目的とする。

【解決手段】

上記目的を達成するために、本発明に係る生体情報検出装置は、支軸で接続された1対のアームに生体情報検出用のセンサを備え、センサが生体の突起部、特に耳介の耳珠に密着するような構成とした。

【選択図】 図1

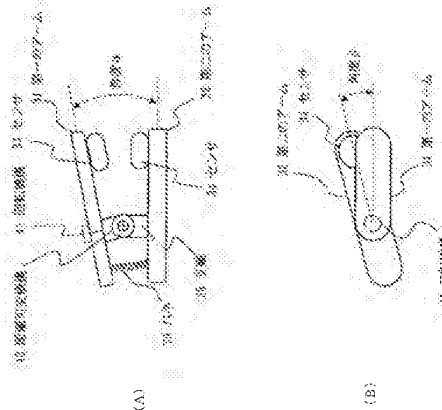

【特許請求の範囲】

【請求項 1】

対向する 1 対のアームと、
前記 1 対のアームのそれぞれの一端で前記 1 対のアームを接続する支軸と、
前記支軸に設けられ、前記 1 対のアームの他端の間隔を調整する距離可変機構と、
前記 1 対のアームのうち少なくとも 1 つのアームの前記他端であって前記 1 対のアームの
対向する側に取り付けられた生体情報を検出するセンサと、
前記 1 対のアームの前記他端の間隔を縮める弾性体と、
を備える生体情報検出装置。

【請求項 2】

対向する 1 対のアームと、
前記 1 対のアームのそれぞれの一端で前記 1 対のアームを接続する支軸と、
前記支軸に設けられ、前記 1 対のアームの他端の間隔を調整する距離可変機構と、
前記 1 対のアームのうち少なくとも 1 つのアームの前記他端であって前記 1 対のアームの
対向する側に取り付けられた生体情報を検出するセンサと、
前記 1 対のアームの前記他端の間隔が広がらないように一時的に制限するラッチと、
を備える生体情報検出装置。

【請求項 3】

前記センサが、前記アームの前記他端を貫通するネジ孔に取り付けられた調整ネジの先
端に搭載されていることを特徴とする請求項 1 又は 2 に記載の生体情報検出装置。

【請求項 4】

前記センサは、出力光を耳介の生体に入射させる発光素子及び前記発光素子からの出力
光が前記生体で散乱した光又は前記生体を透過した光を受光する受光素子であることを特
徴とする請求項 1 から 3 に記載のいずれかの生体情報検出装置。

【請求項 5】

前記センサは、生体に圧力を印加すると共に生体からの圧力を検出するカフであること
を特徴とする請求項 1 から 3 に記載のいずれかの生体情報検出装置。

【請求項 6】

前記 1 対のアームのうち少なくとも 1 つのアームの前記他端であって前記 1 対のアーム
の対向する側に取り付けられた、生体を押圧するカフを備え、前記センサは前記カフに内
蔵されていることを特徴とする請求項 1 から 3 に記載のいずれかの生体情報検出装置。

【請求項 7】

対向する 1 対のアームと、
前記 1 対のアームのそれぞれの一端で前記 1 対のアームを接続する支軸と、
前記支軸に設けられ、前記 1 対のアームの他端の間隔を調整する距離可変機構と、
前記 1 対のアームのうち少なくとも 1 つのアームの前記他端であって前記 1 対のアームの
対向する側に取り付けられた、生体を押圧するカフと、
を備える生体情報検出装置であって、

前記カフから空気が排気されている状態で前記カフの取り付けられたアーム又は前記カ
フの周囲を囲む枠は生体に当接し、前記カフに空気が供給されている状態で前記カフが生
体表面に接して耳珠を圧迫することを特徴とする生体情報検出装置。

【請求項 8】

対向する 1 対のアームと、
前記 1 対のアームのそれぞれの一端で前記 1 対のアームを接続する支軸と、
前記支軸に設けられ、前記 1 対のアームの他端の間隔を調整する距離可変機構と、
前記 1 対のアームのうち少なくとも 1 つのアームの前記他端であって前記 1 対のアームの
対向する側に取り付けられた、生体を押圧するカフと、
を備える生体情報検出装置であって、

少なくとも前記カフが当該カフの取り付けられたアームから着脱可能であることを特徴
とする生体情報検出装置。

10

20

30

40

50

【請求項 9】

対向する 1 対のアームと、
前記 1 対のアームのそれぞれの一端で前記 1 対のアームを接続する支軸と、
前記支軸に設けられ、前記 1 対のアームの他端の間隔を調整する距離可変機構と、
前記 1 対のアームのうち少なくとも 1 つのアームの前記他端であって前記 1 対のアームの
対向する側に取り付けられた、生体を押圧するカフと、
を備える生体情報検出装置であって、
前記カフのうち少なくとも 1 つは、前記生体に当接する方向を可変できることを特徴と
する生体情報検出装置。

【請求項 10】

10

対向する 1 対のアームと、
前記 1 対のアームのそれぞれの一端で前記 1 対のアームを接続する支軸と、
前記支軸に設けられ、前記 1 対のアームの他端の間隔を調整する距離可変機構と、
前記 1 対のアームのうち少なくとも 1 つのアームの前記他端であって前記 1 対のアームの
対向する側に取り付けられた、生体を押圧するカフと、
を備える生体情報検出装置であって、
前記カフのうち少なくとも 1 つは、前記カフの取り付けられたアームの長軸方向にスラ
イドできることを特徴とする生体情報検出装置。

【請求項 11】

前記カフを前記カフの取り付けられたアームの前記他端方向に近づける弾性体を備える
ことを特徴とする請求項 10 に記載の生体情報検出装置。 20

【請求項 12】

前記支軸を中心軸として、前記 1 対のアームのうち少なくとも 1 つのアームを回転させ
る回転機構をさらに備えることを特徴とする請求項 1 から 11 に記載のいずれかの生体情
報検出装置。

【請求項 13】

前記 1 対のアームが、人体の耳介の突起部の一方の側面側に配置されるアーム及び前記
人体の耳介の突起部の他方の側面側に配置されるアームで前記人体の耳介の突起部を挟む
ように構成されていることを特徴とする請求項 1 から 12 に記載のいずれかの生体情報検
出装置。 30

【請求項 14】

前記 1 対のアームが、人体の耳介の突起部としての耳珠の一方の側面側に配置されるア
ーム及び前記人体の耳介の突起部としての耳珠の他方の側面側に配置されるアームで前記
人体の耳介の突起部としての耳珠を挟むように構成されていることを特徴とする請求項 1
3 に記載の生体情報検出装置。

【請求項 15】

人体の耳介の付け根を一周する耳掛を、さらに備えることを特徴とする請求項 13 又は
14 に記載の生体情報検出装置。

【請求項 16】

前記 1 対のアームのうち耳介側に配置されるアームの耳介側に設けたクッションと、
前記クッションを設けた前記アーム及び前記耳掛のうち少なくとも一方に設けた磁石と、
他方に設けた磁石又は磁性体と、
をさらに備えることを特徴とする請求項 15 に記載の生体情報検出装置。 40

【請求項 17】

人体の左右の耳介のうち一方の耳介に装着された前記 1 対のアームと前記 1 対のアーム
の装着されていない他方の耳介とを接続する架橋と、
前記架橋の中間に配置されセンサを駆動する電源部と、
をさらに備えることを特徴とする請求項 1 から 16 に記載のいずれかの生体情報検出装置

【請求項 18】

50

人体の耳介の付け根に懸架するための耳掛と、
当該耳掛けに配置された電源部と、
をさらに備えることを特徴とする請求項1から16に記載の生体情報検出装置。

【発明の詳細な説明】

【技術分野】

【0001】

本発明は、人体の耳介等の生体の一部で生体情報を検出する生体情報検出装置に関するものである。

【背景技術】

【0002】

高齢化が進み、成人の生活習慣病への対応が社会的に大きな課題となっている。特に高血圧に関連する疾患の場合、長期の血圧データの収集が非常に重要である点が認識されている。このような観点から、血圧をはじめとした各種の生体情報の検出装置が開発されている。

【0003】

従来、外耳部で生体情報を検出する装置については、外耳道又は外耳中の他の部位に、挿入され、常時装着する患者モニタ装置がある（例えば、特許文献1参照。）。特許文献1には、動脈の脈波や血流を検出する方法として、発光素子により生体へ照射した照射光が生体の動脈あるいは動脈内の血球により散乱した散乱光を、受光素子により受光し、散乱光から脈波や血流を検出する方法が開示されている。ここで脈拍、脈波、心電、体温、動脈血酸素飽和度、及び血圧などを生体内へ放射した赤外光、可視光の散乱光の受光量から計算できるとしている。

【0004】

また、外耳道又は耳朶に装着する装置としては、無線通信手段を有し、動脈血酸素飽和度センサ、体温センサ、心電センサ、脈波センサを備えている緊急情報装置がある（例えば、特許文献2参照。）。

【0005】

一方、血圧の測定に関しては、血管の脈波波形による血圧測定装置は、他の方式であるカフ振動法や容積補償法などによる血圧測定装置（例えば、非特許文献1参照。）と並んで有力な血圧の測定方法として認められている。

【0006】

なお、本願では、耳介の名称は非特許文献2に、耳介の軟骨の名称は非特許文献3による。

【特許文献1】特開平9-122083

【特許文献2】特開平11-128174

【非特許文献1】山越 憲一、戸川 達男著、「生体センサと計測装置」、日本エム・イー学会編/ME教科書シリーズ A-1、39頁～52頁

【非特許文献2】Sobotta 図説人体解剖学第1巻（監訳者：岡本道雄）、p. 126、（株）医学書院、1996年10月1日発行

【非特許文献3】Sobotta 図説人体解剖学第1巻（監訳者：岡本道雄）、p. 127、（株）医学書院、1996年10月1日発行

【発明の開示】

【発明が解決しようとする課題】

【0007】

血圧測定などの生体組織への加圧が必要な測定においては、振動によるノイズが混入しやすいため正確な脈波、血圧値の測定が困難であり、安定して血圧を測定することが課題であった。また、日常活動の中での測定や常に血圧計を装着した状態で一定間隔や連続して血圧を測定することが困難であるため、生体情報検出装置の保持方法が課題であった。

【0008】

本発明は上記課題を解決するためになされたもので、装着が容易で、かつ安定して生体

情報を検出する生体情報検出装置を提供することを目的とする。

【課題を解決するための手段】

【0009】

上記目的を達成するために、本発明に係る生体情報検出装置は、支軸で接続された1対のアームに生体情報検出用のセンサを備え、センサが生体の突起部、特に耳介の耳珠に密着するような構成とした。

【0010】

具体的には、本発明に係る生体情報検出装置は、対向する1対のアームと、前記1対のアームのそれぞれの一端で前記1対のアームを接続する支軸と、前記支軸に設けられ、前記1対のアームの他端の間隔を調整する距離可変機構と、前記1対のアームのうち少なくとも1つのアームの前記他端であって前記1対のアームの対向する側に取り付けられた生体情報を検出するセンサと、前記1対のアームの前記他端の間隔を縮める弾性体と、を備える。

10

【0011】

支軸に設けられた距離可変機構によって、1対のアームの他端の間隔が調整でき、また、当該他端の間隔を縮める弾性体によって、アームに取り付けられたセンサを生体に密着させることができる。

【0012】

本発明に係る生体情報検出装置は、対向する1対のアームと、前記1対のアームのそれぞれの一端で前記1対のアームを接続する支軸と、前記支軸に設けられ、前記1対のアームの他端の間隔を調整する距離可変機構と、前記1対のアームのうち少なくとも1つのアームの前記他端であって前記1対のアームの対向する側に取り付けられた生体情報を検出するセンサと、前記1対のアームの前記他端の間隔が広がらないように一時的に制限するラッチと、を備える。

20

【0013】

支軸に設けられた距離可変機構によって、1対のアームの他端の間隔が調整でき、また、当該他端の間隔広がらないように一時的に制限するラッチによって、アームに取り付けられたセンサを生体への密着を継続させることができる。

【0014】

本発明に係る生体情報検出装置は、前記センサが、前記アームの前記他端を貫通するネジ孔に取り付けられた調整ネジの先端に搭載されていてもよい。

30

【0015】

調整ネジの先端にセンサを搭載することによって、生体への密着具合を調整することができる。

【0016】

本発明に係る生体情報検出装置では、前記センサが、出力光を耳介の生体に入射させる発光素子及び前記発光素子からの出力光が前記生体で散乱した光又は前記生体を透過した光を受光する受光素子であってもよい。

【0017】

発光素子の出力光を生体に入射させ、生体で散乱した光又は生体を透過した光を受光素子で受光することによって、生体情報を取得することができる。例えば、脈波を検出することができる。

40

【0018】

本発明に係る生体情報検出装置は、前記センサが、生体に圧力を印加すると共に生体からの圧力を検出するカフであってもよい。

【0019】

カフによって生体に圧力を印加しつつ、カフ内の微小な圧力変動を測定することによって生体からの圧脈波を検出することができる。

【0020】

本発明に係る生体情報検出装置は、前記1対のアームのうち少なくとも1つのアームの

50

前記他端であって前記1対のアームの対向する側に取り付けられた、生体を押圧するカフを備え、前記センサは前記カフに内蔵されていてもよい。

【0021】

センサをカフに内蔵することによって、カフの押圧している生体部分での生体情報を取得することができる。また、生体情報検出装置の小型化を図ることができる。

【0022】

本発明に係る生体情報検出装置は、対向する1対のアームと、前記1対のアームのそれぞれの一端で前記1対のアームを接続する支軸と、前記支軸に設けられ、前記1対のアームの他端の間隔を調整する距離可変機構と、前記1対のアームのうち少なくとも1つのアームの前記他端であって前記1対のアームの対向する側に取り付けられた、生体を押圧するカフと、を備え、前記カフから空気が排気されている状態で前記カフの取り付けられたアーム又は前記カフの周囲を開む棒は生体に当接し、前記カフに空気が供給されている状態で前記カフが生体表面に接して耳珠を圧迫することを特徴とする。

10

【0023】

支軸に設けられた距離可変機構によって、1対のアームの他端の間隔が調整でき、またカフ内の与圧を少なくして、与圧による測定誤差要因を除去することができる。

【0024】

本発明に係る生体情報検出装置は、対向する1対のアームと、前記1対のアームのそれぞれの一端で前記1対のアームを接続する支軸と、前記支軸に設けられ、前記1対のアームの他端の間隔を調整する距離可変機構と、前記1対のアームのうち少なくとも1つのアームの前記他端であって前記1対のアームの対向する側に取り付けられた、生体を押圧するカフと、を備え、少なくとも前記カフが当該カフの取り付けられたアームから着脱可能であることを特徴とする。

20

【0025】

支軸に設けられた距離可変機構によって、1対のアームの他端の間隔が調整でき、また汚れたり消耗しやすいカフを交換したり、衛生管理も容易となる。

【0026】

本発明に係る生体情報検出装置は、対向する1対のアームと、前記1対のアームのそれぞれの一端で前記1対のアームを接続する支軸と、前記支軸に設けられ、前記1対のアームの他端の間隔を調整する距離可変機構と、前記1対のアームのうち少なくとも1つのアームの前記他端であって前記1対のアームの対向する側に取り付けられた、生体を押圧するカフと、を備え、前記カフのうち少なくとも1つは、前記生体に当接する方向を可変できることを特徴とする。

30

【0027】

支軸に設けられた距離可変機構によって、1対のアームの他端の間隔が調整でき、またカフの方向が自由になることによって生体への密着度を高めることができる。

【0028】

本発明に係る生体情報検出装置は、対向する1対のアームと、前記1対のアームのそれぞれの一端で前記1対のアームを接続する支軸と、前記支軸に設けられ、前記1対のアームの他端の間隔を調整する距離可変機構と、前記1対のアームのうち少なくとも1つのアームの前記他端であって前記1対のアームの対向する側に取り付けられた、生体を押圧するカフと、を備え、前記カフのうち少なくとも1つは、前記カフの取り付けられたアームの長軸方向にスライドできることを特徴とする。

40

【0029】

支軸に設けられた距離可変機構によって、1対のアームの他端の間隔が調整でき、またカフをスライドさせて、生体の最適な位置に配置することができる。

【0030】

本発明に係る生体情報検出装置は、前記カフを前記カフの取り付けられたアームの前記他端方向に近づける弾性体を備える。

【0031】

50

カフをアームの他端方向に押し付けることによって、カフを生体に密着させることができる。

【0032】

本発明に係る生体情報検出装置は、前記支軸を中心軸として、前記1対のアームのうち少なくとも1つのアームを回転させる回転機構をさらに備えることを特徴とする。

【0033】

生体の形状が複雑な場合であっても、アームの交差する角度を変えることによってカフを生体に密着させることができる。

【0034】

本発明に係る生体情報検出装置は、前記1対のアームが、人体の耳介の突起部の一方の側面側に配置されるアーム及び前記人体の耳介の突起部の他方の側面側に配置されるアームで前記人体の耳介の突起部を挟むように構成されていることを特徴とする。

【0035】

1対のアームで耳介の突起部を挟むことによって、生体情報検出装置を耳介に装着することができる。

【0036】

本発明に係る生体情報検出装置は、前記1対のアームが、人体の耳介の突起部としての耳珠の一方の側面側に配置されるアーム及び前記人体の耳介の突起部としての耳珠の他方の側面側に配置されるアームで前記人体の耳介の突起部としての耳珠を挟むように構成されていることを特徴とする。

【0037】

1対のアームで耳珠を挟むことによって、生体情報検出装置を耳介に装着することができる。

【0038】

本発明に係る生体情報検出装置は、人体の耳介の付け根を一周する耳掛を、さらに備えていることを特徴とする。

【0039】

生体情報検出装置を耳介に安定して装着することができる。

【0040】

本発明に係る生体情報検出装置は、前記1対のアームのうち耳介側に配置されるアームの耳介側に設けたクッションと、前記クッションを設けた前記アーム及び前記耳掛のうち少なくとも一方に設けた磁石と、他方に設けた磁石又は磁性体と、をさらに備えることを特徴とする。

【0041】

クッションを備えることにより生体情報検出装置を長時間にわたって装着することができ、また、耳掛とクッションが磁力で引き合うことにより体動を原因とするノイズを減少させることができる。

【0042】

本発明に係る生体情報検出装置は、人体の左右の耳介のうち一方の耳介に装着された前記1対のアームと前記1対のアームの装着されていない他方の耳介とを接続する架橋と、前記架橋の中間に配置されセンサを駆動する電源部と、をさらに備えることを特徴とする。

【0043】

左右の耳介に跨る架橋を備えることによって生体情報検出装置を安定して耳介に装着することができる。また、電源部をアームと別体とすることにより、アームの軽減化が可能になる。

【0044】

本発明に係る生体情報検出装置は、人体の耳介の付け根に懸架するための耳掛と、当該耳掛けに配置された電源部とを、さらに備えることを特徴とする。

【0045】

耳掛を備えることにより生体情報検出装置を耳介に安定して装着することができ、また耳掛に電源部を配置することによりアームへの負担を軽くし、配線の振動によるノイズを減少させることができる。

【発明の効果】

【0046】

本発明の生体情報検出装置によれば、装着が容易で、かつ安定して生体情報を検出することができる。

【発明を実施するための最良の形態】

【0047】

本発明の生体情報検出装置について添付の図を参照しながら実施の形態を説明する。なお、本発明は以下の実施の形態に限定されるものではない。

【0048】

本願において、「耳珠の内側」とは、図16における耳珠1の耳甲介腔8の側をいう。「耳珠の外側」とは、図16における耳珠1の耳甲介腔8と反対の側をいう。

【0049】

(実施の形態1)

本実施の形態の生体情報検出装置は、対向する1対のアームと、前記1対のアームのそれぞれの一端で前記1対のアームを接続する支軸と、前記支軸に設けられ、前記1対のアームの他端の間隔を調整する距離可変機構と、前記1対のアームのうち少なくとも1つのアームの前記他端であって前記1対のアームの対向する側に取り付けられた生体情報を検出するセンサと、前記1対のアームの前記他端の間隔を縮める弾性体と、を備える。

【0050】

また、前記支軸を中心軸として、前記1対のアームのうち少なくとも1つのアームを回転させる回転機構をさらに備えてもよい。

【0051】

図1(A)に本実施の形態の生体情報検出装置の構成例の正面図、図1(B)に本発明の生体情報検出装置の構成例の平面図を示す。図1(A)、図1(B)に示す生体情報検出装置は、例えば第一のアーム31および第二のアーム32の各々が支軸35に接続される部分、あるいは支軸35に、第一のアーム31と第二のアーム32が互いに対向する他端の間隔を調整する距離可変機構を備える。距離可変機構40は支軸35と第一のアーム31の角度を変化させて図1(A)に示す角度 α を変化させることにより、第一のアーム31と第二のアーム32が互いに対向する面の間隔を調整する機能を有する。

【0052】

ここで、距離可変機構40の角度を可変にする機構としては、支軸35と第一のアーム31の角度をネジにより調整する機構、あるいはフリクションとネジ固定を併用する機構などのいずれでもよい。さらに、第一のアーム31と第二のアーム32が互いに対向する他端の間隔を調整する機構としては、支軸35の長さを伸縮させる機構でもよい。

【0053】

また、図1(A)に示す生体情報検出装置は、第一のアーム31と支軸35の接続部分に、支軸35を軸として、第一のアーム31を回転方向へ移動させる回転機構41を備えており、回転機構41は図1(B)に示す支軸35の軸方向から見た第一のアーム31の方向と第二のアーム32の方向のなす角度 β を可変する機能を有する。なお、回転機構41を備えることは任意である。

【0054】

図1(A)および図1(B)に示す生体情報検出装置の構成例の場合は、第一のアーム31の他端と第二のアーム32の他端の間隔を縮めるパネ70を備えている。

【0055】

図1(A)に示すパネ70は、第一のアーム31の他端と第二のアーム32の他端を縮める方向に働く。例えば、第一のアーム31の一端と第二のアーム32の一端をつまんで、センサ33とセンサ34との間隔を広げておき、生体を挟んだときにパネ70を解放す

ると、バネ 70 の延伸力によりセンサ 33 とセンサ 34 が生体に密着することになる。

【0056】

バネ 70 を支軸 35 よりも他端側に配置するとき、第一のアーム 31 の一端と第二のアーム 32 の一端をつまんで、センサ 33 とセンサ 34 との間隔を広げておき、生体を挟んだときにバネ 70 を解放すると、バネ 70 の引っ張り力によりセンサ 33 とセンサ 34 が生体に密着することになる。

【0057】

ここでは、弾性体としてコイル状のバネを例としたが、コイル状のバネでなくとも、板バネやねじりバネ、空気バネ、ゴム、樹脂等の弾性体であればよい。

【0058】

生体情報検出装置は人体の耳介の突起部の一部、例えば耳介の耳珠の両側にセンサ 33 およびセンサ 34 を接触させて、生体情報を検出する機能を有する。ここで、センサ 33 およびセンサ 34 を耳珠の両側に接触する場合、センサ 33 およびセンサ 34 の間の間隔は距離可変機構 40 により、第一のアーム 31 および第二のアーム 32 の対向する面の距離を変化させることにより、適切な接触状態に調整し、さらに、センサ 33 およびセンサ 34 の接触する位置は回転機構 41 により、図 1 (B) に示す角度 β を変化させることにより、適切な位置に調整する。調整後は、バネ 70 によって、第一のアーム 31 の他端と第二のアーム 32 の他端の間隔を縮める方向に働くので、センサ 33 とセンサ 34 を生体に密着させることができる。

【0059】

以上説明したように、本実施の形態の生体情報検出装置は、支軸に設けられた距離可変機構によって、1 対のアームの他端の間隔が調整でき、当該他端の間隔を縮める弾性体によって、アームに取り付けられたセンサを生体に密着させることができる。また、アームを回転させる回転機構によって、生体の形状が複雑な場合であっても、アームの交差する角度を変えることでカフを生体に密着させることができる。従って、個人の体型の差に対応して適切な接触圧で、適切な位置に装着できる小型軽量で、安定に生体情報を検出することができる。

【0060】

(実施の形態 2)

本実施の形態の生体情報検出装置は、対向する 1 対のアームと、前記 1 対のアームのそれぞれ的一端で前記 1 対のアームを接続する支軸と、前記支軸に設けられ、前記 1 対のアームの他端の間隔を調整する距離可変機構と、前記 1 対のアームのうち少なくとも 1 つのアームの前記他端であって前記 1 対のアームの対向する側に取り付けられた生体情報を検出するセンサと、前記 1 対のアームの前記他端の間隔が広がらないように一時的に制限するラッチと、を備える。

【0061】

図 2 (A) に本実施の形態の生体情報検出装置の構成例の正面図、図 2 (B) に本発明の生体情報検出装置の構成例の平面図を示す。図 2 (A) および図 2 (B) に示す生体情報検出装置の構成例の場合は、第一のアーム 31 の他端と第二のアーム 32 の他端の間隔を縮めるバネ 70 を備え、さらに、第一のアーム 31 の他端と第二のアーム 32 の他端の間隔が広がらないようにラッチ機構 71 も備えている。

【0062】

図 2 (A) に示すバネ 70 は、第一のアーム 31 の一端と第二のアーム 32 の一端を広げる方向に働く。例えば、第一のアーム 31 の一端と第二のアーム 32 の一端をつまんで、センサ 33 とセンサ 34 との間隔を広げておき、生体を挟んだときにバネ 70 を解放すると、センサ 33 とセンサ 34 が生体に密着することになる。ラッチ機構 71 は、センサ 33 とセンサ 34 が生体に密着した状態を維持する。

【0063】

ラッチ機構について、図 3 で説明する。図 3 において、72 はラッチ開放ボタン、73 はコイルバネ、74 は板バネ、75 はラッチ用ツメ、76 は支持体 (A)、77 は支持体

(B)である。図3(A)はラッチ機構がロックされている状態を表し、図3(B)はラッチ機構が開放されている状態を表す。図3(A)において、板バネ74がラッチ用ツメ75に一時的に掛けられ、支持体(B)が支持体(A)76に入り込むことを制限される。この状態は、図3(A)では、第一のアーム31と第二のアーム32の間隔が広がることを制限されることになる。つまり、一度、生体を挟んだ生体情報検出装置が脱落することを困難にする。

【0064】

ここで、図3(B)に示すように、ラッチ開放ボタン72を押すと、コイルバネ73に拘束されていた板バネ74が矢印の方向に開き、ラッチ用のツメ75から開放される。板バネ74がラッチ用のツメ75から開放されると、支持体(A)76に支持体(B)77が入り込むことができる。この状態は、図3(A)では、第一のアーム31と第二のアーム32の間隔が広がることになる。つまり、一度、生体を挟んだ生体情報検出装置が取り外すことが容易になる。

【0065】

以上説明したように、本発明の生体情報検出装置は、支軸に設けられた距離可変機構によって、1対のアームの他端の間隔が調整でき、また、当該他端の間隔広がらないように一時的に制限するラッチによって、アームに取り付けられたセンサを生体への密着を継続させることができるため、個人の体型の差に対応して適切な接触圧で、適切な位置に装着できる小型軽量で、安定に生体情報を検出することができる。

【0066】

(実施の形態3)

本実施の形態の生体情報検出装置は、前述の生体情報検出装置において、センサを搭載する調整ネジあるいはセンサを搭載する調整ネジであって、前記それぞれの調整ネジにより、センサと第一のアームの表面の間隔およびセンサと第二のアームの表面の間隔のいずれか、あるいは両方を調整する機能を有する前記それぞれの調整ネジを、第一のアームあるいは第二のアームのいずれか、あるいは両方に備える場合である。

【0067】

図4(A)に本実施の形態の生体情報検出装置の構成例の正面図、図4(B)に本実施の形態の生体情報検出装置の構成例の平面図を示す。なお、図4および以下の図においては、図面の煩雑さをさけるために、一部の名称の表示を省略している。図4(A)および図4(B)に示す生体情報検出装置の構成例においては、生体情報検出装置は第一のアーム31に調整ネジ42を備え、調整ネジ42にセンサ33を搭載し、調整ネジ42によりセンサ33と、第二のアーム32に備えるセンサ34との間隔を調整する場合を示している。なお、回転機構、ラッチ機構を備えることは任意である。

【0068】

調整ネジ42の機構としては、ネジを回転させることによりセンサ33の位置を調整し、センサ33とセンサ34の間隔を調整する機構、あるいはフリクションによりセンサ33の位置を調整し固定ネジで固定する機構を併用することにより、センサ33とセンサ34の間隔を調整する機構でもよい。

【0069】

以上説明したように、本実施の形態の生体情報検出装置は、例えば耳介の耳珠に装着する場合、耳珠の形状の個人差に対応して、調整ネジによりセンサ33とセンサ34の間隔を細かく調整し、センサ33およびセンサ34を耳珠に適切な接触圧で装着することができる。

【0070】

以下の実施の形態では、人体の耳介の突起部として耳介の耳珠を例として説明する。

【0071】

(実施の形態4)

図5に生体情報検出装置の耳介への装着例を示す。図5において、生体情報検出装置は耳珠1に両側から接するように装着され、第一のアーム31の備えるセンサ33が耳珠1

の外側、第二のアーム 3 2 の備えるセンサ 3 4 が耳珠 1 の内側に接して装着される。第二のアーム 3 2 の一部およびセンサ 3 4 は耳珠 1 の内側にあるので破線で示している。

【0072】

上記のように、本実施の形態の生体情報検出装置は生体の一部、例えば耳介の耳珠 1 の両側に装着して生体情報を検出する場合、耳珠 1 の形状の個人差に対応して、距離可変機構 4 0 又は回転機構 4 1 によりセンサ 3 3 およびセンサ 3 4 の位置を調整し、センサ 3 3 およびセンサ 3 4 を耳珠 1 の適切な位置に、適切な接触状態で装着できる。なお、回転機構、ラッチ機構を備えることは任意である。

【0073】

(実施の形態 5)

本実施の形態の生体情報検出装置は、前述の生体情報検出装置がさらに耳介の付け根を一周する耳掛を備えている場合である。図 6 (A) に本実施の形態の生体情報検出装置の構成例を示し、図 6 (B) に本実施の形態の生体情報検出装置の構成例の前記耳介への装着状態を示す。図 6 (A) に示す生体情報検出装置の構成例の場合、第一のアーム 3 1 は耳掛け機構 4 6 を備えており、耳掛け機構 4 6 は図 6 (B) に示すように前記耳介の付け根から耳輪 5 の裏側へ回りこみ、耳介の付け根を一周して、生体情報検出装置を前記耳介へ固定する機構を有する。

【0074】

耳掛けの形状が耳介に沿ったリング状のものであってもよい。また、耳介の付け根に沿って一周し、留め金によりリングを閉じる構造であってもよい。さらに、閉じたリングをストッパーで締め具合を調節可能にしてもよい。

【0075】

耳掛けの材質としては、可塑性のある金属、半田合金、亜鉛合金、真鍮、銅系合金、アルミ系合金、ステンレススチール、Ni 系合金、Ti 系合金や又、形状記憶合金でもよい。樹脂系としては、プラスチック、塩化ビニル樹脂、アクリル樹脂、ABS 樹脂、MC ナイロン、フッ素樹脂 (PTFE)、ポリカーボネイト、ポリプロピレン、ポリエチレンシリコーン樹脂、ポリウレタン樹脂や又、天然ゴムでもよい。このような材質の選択により被検者の耳介の大きさなどの個人差を吸収することができる。

【0076】

上記のように、本実施の形態の生体情報検出装置はさらに耳介の付け根を一周して耳介に懸架するための耳掛け機構 4 6 を備えているので、装置の自重や被検者の運動に起因する装置の耳珠位置からのズレを防止することができる。このため、生体情報検出装置を前記耳介に安定に固定し、より安定に生体情報を検出できる。

【0077】

また、耳掛け機構を生体情報装置本体から取り外し可能な構造とし、被検者に合ったサイズの耳掛け機構を選択することも可能である。

【0078】

(実施の形態 6)

本実施の形態の生体情報検出装置は、前述の生体情報検出装置において、前記一対のアームのうち耳介側に配置されるアームの耳介側に設けたクッションと、前記クッションを設けた前記アーム及び前記耳掛のうち少なくとも一方に設けた磁石と、他方に設けた磁石又は磁性体と、をさらに備える場合である。

【0079】

図 7 は本実施の形態の生体情報検出装置を前記耳介へ装着した状態を想定して示す図であり、前記耳介は生体の頭部上方から見た耳珠 1 付近における水平面による断面で示し、生体情報収集装置は生体への装着状態を生体の頭部上方から見た図で示し、両者を組み合わせて示した模式図である。図 7 において、クッション 4 5 が第二のアーム 3 2 の外側に配置され、クッション 4 5 は前記耳介と接する位置に磁石 4 7 を備え、耳掛け機構 4 6 は前記耳介の裏側で前記耳介と接する位置に磁石 4 8 を備えている。

【0080】

磁石 47 と磁石 48 は前記耳介の対輪 4 を挟んで両側にあり、互いに磁力が働く極性で設置されており、磁石 47 と磁石 48 は前記耳介に接触して固定される。

【0081】

上記のように、クッション 45 を備えることにより、生体情報検出装置のアームが固い材料で形成されている場合でも、被検者に苦痛を与えることなく長時間の装着が可能となる。また、本実施の形態の生体情報検出装置はさらにクッション 45 が前記耳介に接する側、および耳掛け機構 46 が前記耳介に接する側に互いに磁力が働く磁石をさらに備えており、生体情報検出装置を前記耳介に、より快適に固定し、より安定に生体情報を検出することができる。

【0082】

図 7 では磁石 47 及び磁石 48 の 2 つの磁石を用いているが、一方を磁石とし、他方を磁性体とすることもよい。また、磁石 47 又は磁石 48 をそれぞれクッション 45 又は耳掛け機構 46 の内部に設置してもよい。

【0083】

以上説明したように、本実施の形態の生体情報検出装置は生体の耳珠に、個人の体型の差に対応して適切な接触圧で、適切な位置に、より快適に装着できる小型軽量で、より安定に、連続的に生体情報を検出することができる。

【0084】

(実施の形態 7)

本実施の形態の生体情報検出装置は、前述の生体情報検出装置の本体が人体の左右の耳介のうち一方の耳介に装着され、前記 1 対のアーム及び前記 1 対のアームの装着されていない耳介を接続する架橋と、前記架橋の中間に配置されセンサを駆動する電源部と、をさらに備えている場合である。

【0085】

図 8 に本実施の形態の生体情報検出装置の装着状態を示す。図 8 において、30 は生体情報検出装置、80 は架橋、82 は電源部である。図 8 に示す生体情報検出装置の構成例の場合、前述の生体情報検出装置の本体が人体の左右の耳介のうち一方の耳介に装着され、前記 1 対のアーム及び前記 1 対のアームの装着されていない耳介を人体の後頭部を經由して接続する架橋に、センサを駆動する電源部が配置されている。前記 1 対のアームにカフを備える場合は、電源部と共にカフに給排気するポンプを配置してもよい。

【0086】

架橋の材質としては、可塑性のある金属、半田合金、亜鉛合金、真鍮、銅系合金、アルミ系合金、ステンレススチール、Ni 系合金、すず系合金や又、形状記憶合金でもよい。樹脂系としては、プラスチック、塩化ビニル樹脂、アクリル樹脂、ABS 樹脂、MC ナイロン、フッ素樹脂 (PTFE)、ポリカーボネイト、ポリプロピレン、ポリエチレンシリコーン樹脂、ポリウレタン樹脂でもよい。このような材質の選択により被検者の頭部の大きさなどの個人差を吸収することができる。

【0087】

架橋を生体情報装置本体から取り外し可能な構造とし、被検者に合ったサイズの架橋を選択することも可能である。また、架橋を伸縮自在にして、被検者の頭部のサイズに合わせることも可能である。

【0088】

図 8 では、架橋を後頭部を經由しているが、頭頂部や顎の下を經由してもよい。電源部を頭部に配置することにより、生体情報検出装置の持ち運びや管理を容易にすることができる。また、ポンプを頭部に配置することにより、パイプを固定しやすくなり生体情報の検出に当たって、ノイズを低減することができる。

【0089】

以上説明したように、左右の耳介に跨る架橋を備えることにより生体情報検出装置を安定して耳介に装着することができる。また、電源部をアーム側と別体とすることにより、アーム側の軽減化が可能になる。

10

20

30

40

50

【0090】

(実施の形態8)

本実施の形態の生体情報検出装置は、前述の生体情報検出装置において、図9(A)および図9(B)に示すように、例えば、図1に示すセンサ33に代えて支持体57を備え、センサ34に代えてカフ56を備え、カフ56の中には発光素子61と受光素子62を備え、さらにカフ56は空気を供給する空気パイプ36を備える場合である。ここで、図9(B)は図9(A)の生体情報検出装置を耳珠1に装着した状態の支持体57およびカフ56の部分の拡大図であり、また図面の煩雑さをさけるために、図9(A)に示すカフ56の中には発光素子61および受光素子62を示していない。センサとしての発光素子と受光素子をカフに内蔵することによって、カフの押圧している生体部分での生体情報

10

【0091】

図9(A)、図9(B)では、支持体57を第一のアーム31に、カフ56を第二のアーム32に配置しているが、支持体57を第二のアーム32に、カフ56を第一のアーム31に配置してもよい。

【0092】

図9(B)に示すカフ56の中の発光素子61と受光素子62は反射型の脈波検出系を形成し、脈波を検出する。上記のように脈波を検出する過程において、カフ56で耳珠1に圧力を加えることにより、血圧も測定することができる。

【0093】

(実施の形態9)

本実施の形態の生体情報検出装置は、対向する1対のアームと、前記1対のアームのそれぞれ的一端で前記1対のアームを接続する支軸と、前記支軸に設けられ、前記1対のアームの他端の間隔を調整する距離可変機構と、前記1対のアームのうち少なくとも1つのアームの前記他端であって前記1対のアームの対向する側に取り付けられた、生体を押圧するカフと、を備え、前記カフから空気が排気されている状態で前記カフの取り付けられたアーム又は前記カフの周囲を囲む枠は生体に当接し、前記カフに空気が供給されている状態で前記カフが生体表面に接して耳珠を圧迫する。

20

【0094】

図10に本実施の形態の生体情報検出装置の構成例を示す。図10において、1は耳珠、31は第一のアーム、32は第二のアーム、35は支軸、55はカフ、56はカフである。図10では、弓状又はお椀状になった第一のアーム31の先端部の内部にカフ55が配置されている。カフ55によって耳珠1を挟むのではなく、カフ55の周囲のアームの先端部で耳珠表面位置に生体情報検出装置を固定し、カフ55に空気を供給することによって初めてカフ55が耳珠1の表面に接して、耳珠1に圧力を印加する。

30

【0095】

このような構成とすることにより、カフが排気されている状態ではカフ表面が耳珠表面に接しないことで、実際に生体情報を得ようとする部位に圧力がかかることを防ぐことができる。このため、カフ自体をはじめから耳珠に接触させて生体情報検出装置を固定するよりも、耳珠表面へ与圧がかかることによる測定誤差要因を取り除くことができる。

40

【0096】

図10では、第一のアーム31にカフ55が、第二のアーム32にカフ56が配置されているが、一方のアームにのみカフが配置されている場合でも、同様の構成とすることができる。また、図10では、第一のアーム31又は第二のアーム32の先端部は弓状又はお椀状となっているが、これらの形状には限定されない。円筒形状、角型筒形状、コーン形状等の内部が空洞になっていれば足りる。アーム自体をこのような形状にすることは限定されない。カフの周囲を囲む枠をアームに取り付けたものでもよい。

【0097】

以上説明したように、カフから空気が排気されている状態で前記カフの取り付けられたアームは耳珠に当接し、前記カフに空気が供給されている状態で前記カフが生体表面に接

50

して耳珠を圧迫する生体情報検出装置とすることにより、カフへの与圧による測定誤差要因を除去することができる。

【0098】

(実施の形態10)

本実施の形態の生体情報検出装置は、対向する1対のアームと、前記1対のアームのそれぞれ的一端で前記1対のアームを接続する支軸と、前記支軸に設けられ、前記1対のアームの他端の間隔を調整する距離可変機構と、前記1対のアームのうち少なくとも1つのアームの前記他端であって前記1対のアームの対向する側に取り付けられた、生体を押圧するカフと、を備え、少なくとも前記カフが当該カフの取り付けられたアームから着脱可能である。

10

【0099】

図11(A)に本実施の形態の生体情報検出装置の構成例の正面図、図11(B)に本発明の生体情報検出装置の構成例の平面図を示す。図11(A)、図11(B)において、31は第一のアーム、55はカフ、86はシーリング材である。図11(A)、図11(B)では、カフ55を備えるアーム先端部を矢印の方向に抜き出すことによって、カフを交換することができる。図11(A)、図11(B)に示す生体情報検出装置の構成例の場合、カフ55に空気を給排気するパイプから空気漏れがないように、アーム先端部とアーム本体とは、ゴムパッキングやシリコンなどシーリング材86を装着する必要がある。

【0100】

図12(A)に本実施の形態の生体情報検出装置の他の構成例の正面図、図12(B)に本発明の生体情報検出装置の他の構成例の平面図を示す。図12(A)、図12(B)において、31は第一のアーム、33はセンサ、55はカフ、86はシーリング材である。図12(A)、図12(B)では、カフ55を備えるアーム先端部を矢印の方向に抜き出すことによって、カフを交換することができる。図12(A)、図12(B)に示す生体情報検出装置の構成例の場合、カフ55はセンサ33を内部に備えているので、センサ33の支持台を含めてカフ55に空気を給排気するパイプから空気漏れがないように、アーム先端部とアーム本体とは、ゴムパッキングやシリコンなどシーリング材86を装着する必要がある。

20

【0101】

耳珠に触れるカフや支持機構は、耳垢や皮脂などによって汚れが付きやすく、また磨耗が起きやすいため、カフをアームから着脱可能な構造とすることによって、汚れたり傷ついたカフを簡単に洗浄したり取り替えたりすることによってカフのリークや透過性低減を防止することができる。また、カフや支持機構をディスポーザブルとすることにより、衛生管理が容易になるという利点がある。

30

【0102】

(実施の形態11)

本実施の形態の生体情報検出装置は、対向する1対のアームと、前記1対のアームのそれぞれ的一端で前記1対のアームを接続する支軸と、前記支軸に設けられ、前記1対のアームの他端の間隔を調整する距離可変機構と、前記1対のアームのうち少なくとも1つのアームの前記他端であって前記1対のアームの対向する側に取り付けられた、生体を押圧するカフと、を備え、前記カフのうち少なくとも1つは、前記生体に当接する方向を可変できる。

40

【0103】

図13に本実施の形態の生体情報検出装置の構成例を示す。図13において、31は第一のアーム、35は支軸、55はカフ、56はカフ、88はカフ回転機構である。図13では、カフ55が耳珠に当接する方向を可変できるカフ回転機構88を持つ。第一のアーム31が耳珠の外側に配置されるアームであれば、カフ55が、耳珠の外側に当接することになる。

【0104】

50

耳珠の外側に当接するカフ 5 5 が回転自由度を持つことで、カフ間の距離をある程度、被検者の耳珠形状にあった長さに調節しておけば、カフの角度を厳密に調節しなくても、耳珠形状に沿うようにカフ 5 5 の回転角度が耳珠に対して決まるため、装着の容易性が向上する。

【0105】

カフ回転機構 8 8 は 1 つの面内で耳珠に当接する方向を可変できる構造でもよいが、2 つの面内で耳珠に当接する方向を可変できる構造にすれば、カフが耳珠に当接することをさらに容易にする。

【0106】

また、図 1 3 では、第一のアーム 3 1 に配置されたカフ 5 5 のみに方向を可変できる構造を持たせたが、第二のアーム 3 2 に配置されたカフ 5 6 のみに方向を可変できる構造を持たせてもよいし、カフ 5 5 とカフ 5 6 の両方に方向を可変できる構造を持たせてもよい。

10

【0107】

以上説明したように、アームに配置されたカフに方向を可変できる構造を持たせることにより、生体情報検出装置を耳珠に装着することが容易になる。特に、耳珠の外側に当接するカフ 5 5 が回転自由度を持つことで、カフ間の距離をある程度、被検者の耳珠形状にあった長さに調節しておけば、カフの角度を厳密に調節しなくても、耳珠に装着することが容易になる。

【0108】

(実施の形態 1 2)

本実施の形態の生体情報検出装置は、対向する 1 対のアームと、前記 1 対のアームのそれぞれの一端で前記 1 対のアームを接続する支軸と、前記支軸に設けられ、前記 1 対のアームの他端の間隔を調整する距離可変機構と、前記 1 対のアームのうち少なくとも 1 つのアームの前記他端であって前記 1 対のアームの対向する側に取り付けられた、生体を押圧するカフと、を備え、前記カフのうち少なくとも 1 つは、前記カフの取り付けられたアームの長軸方向にスライドできる。

20

【0109】

第一のアーム 3 1 が耳珠の外側に配置されるアームであれば、カフ 5 5 が、耳珠の外側に当接することになる。

30

【0110】

図 1 4 に本実施の形態の生体情報検出装置の構成例を示す。図 1 4 において、3 1 は第一のアーム、3 5 は支軸、5 5 はカフ、5 6 はカフ、9 0 はカフスライド機構である。図 1 4 では、カフ 5 5 が第一のアーム 3 1 の長軸方向でスライドできるカフスライド機構 9 0 を持ち、カフ 5 5 の位置を変えることによって、カフ 5 5 を耳珠に最適位置に当接させることができる。

【0111】

図 1 4 に示すように、カフ 5 5 を第一のアーム 3 1 の先端部に引っ張るバネをもたせると、カフ 5 5 を耳珠に当接した際にカフ 5 5 が安定点に落ち着くことになる。また、カフ 5 5 を第一のアーム 3 1 の先端部に押し付けるような延伸するバネでもよい。

40

【0112】

また、図 1 4 では、カフ 5 5 のみがスライドするように構成されているが、耳珠の内側に当接するカフ 5 6 のみがスライドするように構成してもよいし、カフ 5 5 とカフ 5 6 の両方がスライドするように構成してもよい。

【0113】

図 1 4 では、カフ 5 5 は第一のアームの長軸方向にスライドさせるだけであるが、さらにカフ 5 5 の耳珠に当接する方向を可変できる構造にすれば、カフが耳珠の最適な部位に当接することを一層容易にする。

【0114】

以上説明したように、生体情報検出装置の支軸に設けられた距離可変機構によって、1

50

対のアームの他端の間隔が調整でき、またカフをスライドさせて、生体の最適な位置に配置することができる。

【0115】

(実施の形態13)

本実施の形態の生体情報検出装置は、人体の耳介に装着された生体情報検出装置の本体に人体の耳介の付け根に懸架するための耳掛と、当該耳掛けの耳介の裏の頭部側にセンサを駆動する電源部と、を備えている場合である。さらに、カフに空気を給排気するポンプを備えてもよい。

【0116】

図15に本実施の形態の生体情報検出装置の装着状態を示す。図15に示す生体情報検出装置の構成例の場合、耳掛け機構46にセンサを駆動する電源部(不図示)やカフ(不図示)に給排気するポンプ84を配置する。また、スイッチ類83を配置してもよい。

【0117】

架橋の材質や構造は前述したものと同様である。

電源部を耳掛け機構に配置することにより、生体情報検出装置の持ち運びや管理を容易にすることができる。耳掛に電源部を配置することによりアームへの負担を軽くし、配線の振動によるノイズを減少させることができる。また、ポンプを頭部に配置することにより、パイプを固定しやすくなり生体情報の検出に当たって、ノイズを低減することができる。

【産業上の利用可能性】

【0118】

本発明に係る生体情報検出装置は、健康や美容のための血圧測定、脈波測定、血流測定に利用することができる。

【図面の簡単な説明】

【0119】

【図1】(A)は本実施の形態の生体情報検出装置の構成例の正面図、(B)は本発明の生体情報検出装置の構成例の平面図を示す。

【図2】(A)は本実施の形態の生体情報検出装置の構成例の正面図、(B)は本発明の生体情報検出装置の構成例の平面図を示す。

【図3】本実施の形態の生体情報検出装置が備えるラッチ機構を説明する図である。

【図4】(A)は本実施の形態の生体情報検出装置の構成例の正面図、(B)は本発明の生体情報検出装置の構成例の平面図を示す。

【図5】本実施の形態の生体情報検出装置の耳介への装着例を説明する図である。

【図6】(A)に本実施の形態の生体情報検出装置の構成例を示し、(B)に本実施の形態の生体情報検出装置の構成例の前記耳介への装着状態を示す。

【図7】本実施の形態の生体情報検出装置を前記耳介へ装着した状態を想定して示す図である。

【図8】本実施の形態の生体情報検出装置の装着状態を示す図である。

【図9】(A)は本実施の形態の生体情報検出装置の構成例を示し、(B)は(A)の生体情報検出装置を耳珠に装着した状態の支持体およびカフの部分の拡大図である。

【図10】本実施の形態の生体情報検出装置の構成例を示す図である。

【図11】(A)に本実施の形態の生体情報検出装置の構成例の正面図、(B)に本発明の生体情報検出装置の構成例の平面図を示す。

【図12】(A)に本実施の形態の生体情報検出装置の構成例の正面図、(B)に本発明の生体情報検出装置の構成例の平面図を示す。

【図13】本実施の形態の生体情報検出装置の構成例を示す図である。

【図14】本実施の形態の生体情報検出装置の構成例を示す図である。

【図15】本実施の形態の生体情報検出装置の装着状態を示す図である。

【図16】耳介の各部の名称を説明する図である。

【符号の説明】

【0120】

1	耳珠	
2	対珠	
3	耳甲介	
4	対輪	
5	耳輪	
6	対輪脚	
7	耳輪脚	
8	耳甲介腔	
30	生体情報検出装置	10
31	第一のアーム	
32	第二のアーム	
33	センサ	
34	センサ	
35	支軸	
36	空気パイプ	
37	信号線	
40	距離可変機構	
41	回転機構	
42	調整ネジ	20
45	クッション	
46	耳掛け機構	
47	磁石	
48	磁石	
55	カフ	
56	カフ	
57	支持体	
61	発光素子	
62	受光素子	
70	バネ	30
71	ラッチ機構	
72	ラッチ開放ボタン	
73	コイルバネ	
74	板バネ	
75	ラッチ用ツメ	
76	支持体 (A)	
77	支持体 (B)	
80	架橋	
82	電源部	
83	スイッチ類	40
84	ポンプ	
86	シーリング材	
88	カフ回転機構	
90	カフスライド機構	

【図 1】

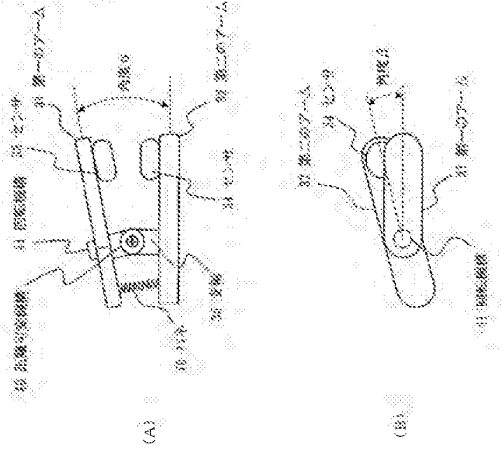

【図 2】

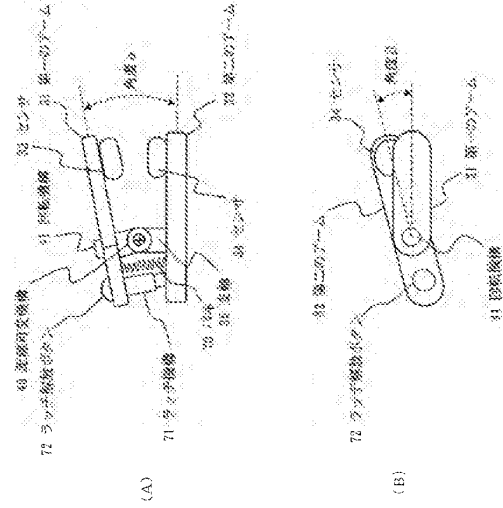

【図 3】

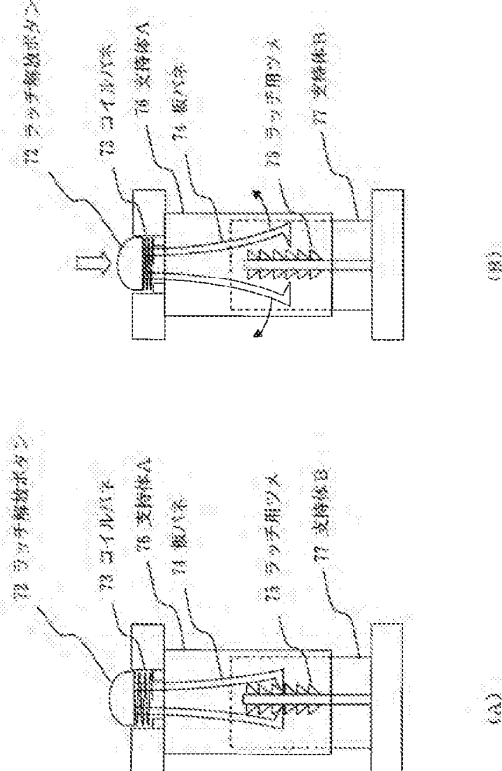

【図 4】

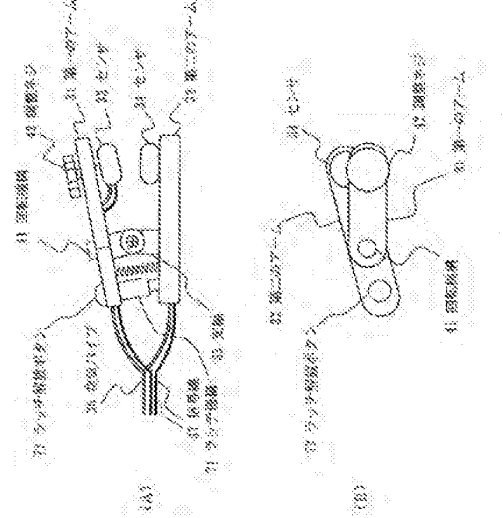

【図 5】

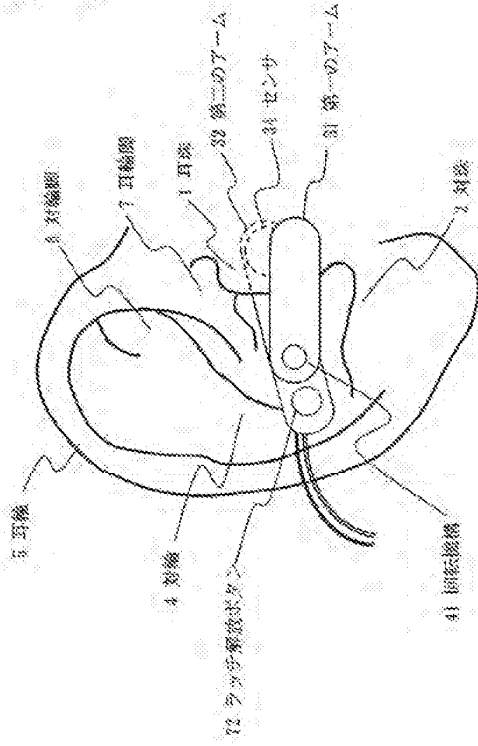

【図 7】

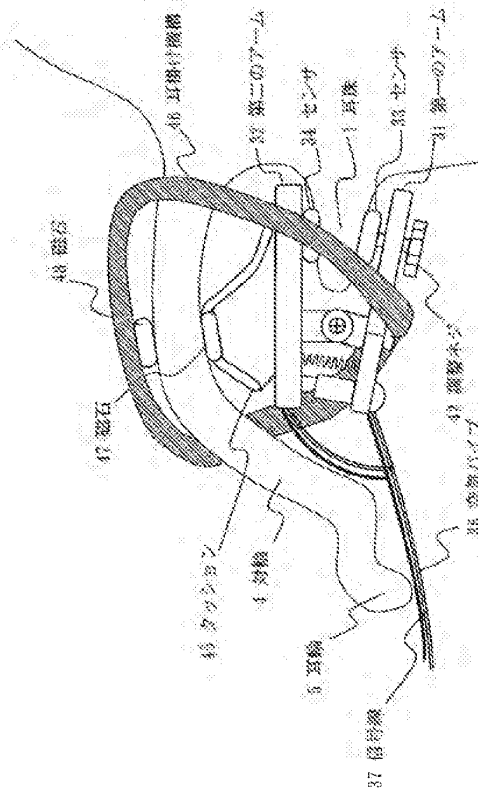

【図 6】

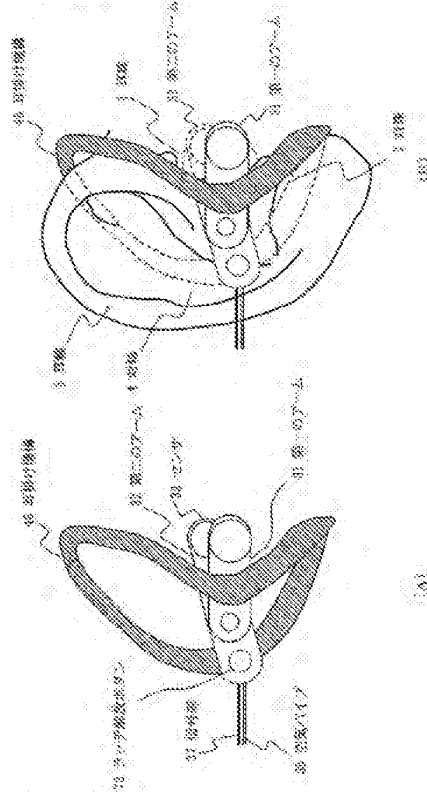

【図 8】

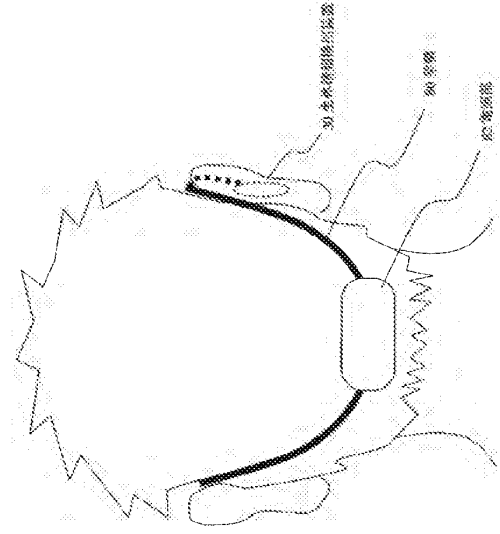

【図13】

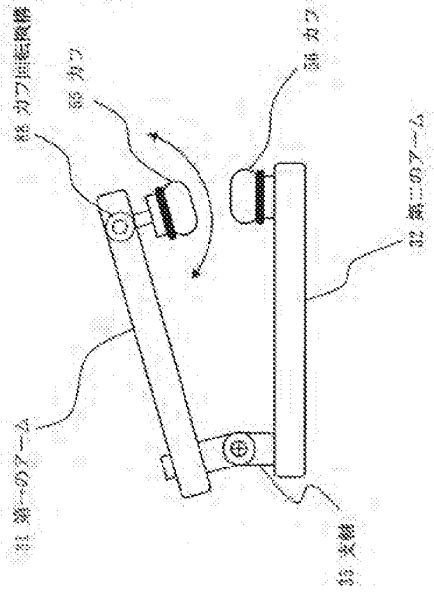

【図14】

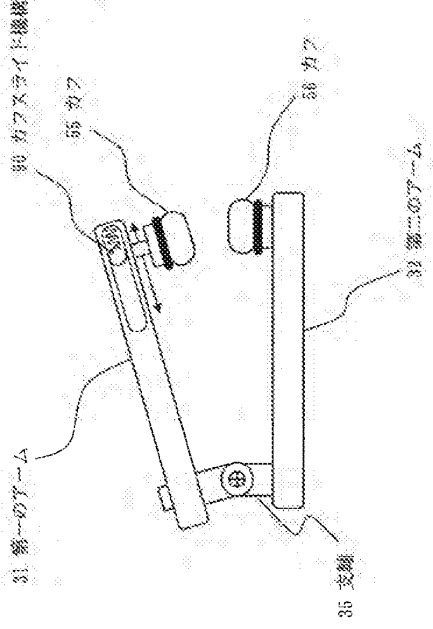

【図15】

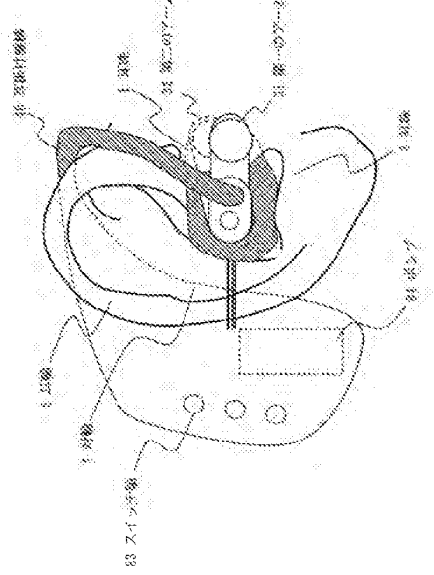

【図16】

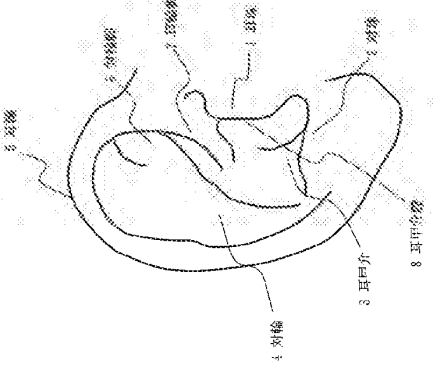

フロントページの続き

- (72)発明者 美野 真司
東京都千代田区大手町二丁目3番1号 日本電信電話株式会社内
- (72)発明者 小泉 弘
東京都千代田区大手町二丁目3番1号 日本電信電話株式会社内
- (72)発明者 林田 尚一
東京都千代田区大手町二丁目3番1号 日本電信電話株式会社内
- (72)発明者 小口 泰介
東京都千代田区大手町二丁目3番1号 日本電信電話株式会社内
- (72)発明者 嶋田 純一
東京都千代田区大手町二丁目3番1号 日本電信電話株式会社内
- (72)発明者 須藤 昭一
東京都千代田区大手町二丁目3番1号 日本電信電話株式会社内
- (72)発明者 枡久保 修
横浜市保土ヶ谷区瀬戸ヶ谷町2-43-108
- (72)発明者 三浦 秀利
東京都新宿区西新宿二丁目1番1号 エヌ・ティ・ティ・アドバンステクノロジー株式会社内
- Fターム(参考) 4C017 AA09 AB08 AC27 AD01 EE01 FF05

Bibliographic Data

Int.Cl.	G16H 50/30 A61B 5/01 A61B 5/0452 A61B 5/02
Published Date	20071119
Registration No.	1007767980000
Registration Date	20071108
Application No.	1020060049063
Application Date	20060530
Unexamined Publication No.	1020070061122
Unexamined Publication Date	20070613
Priority Claims	1020050119914 20051208 KR
Requested Date of Examination	20060530
Agent.	C&S Patent and Law Office
Inventor	PARK,YunKyung LEE,JeunWoo RYOO,DongWan KANG,DongOh KANG,KyuChang LEE,HyungJik PARK,JeEun KO,EunJung JUNG,JoonYoung CHOI,SungGi KIM,YoungSung BAE,ChangSeok
Applicant	Electronics and Telecommunications Research Institute
Rightholder	Electronics and Telecommunications Research Institute

발명의 명칭

건강관리 서비스 제공 시스템 및 그 방법

Title of Invention

method and system for providing health managementservice

요약

본 발명은 사용자의 인체에 부착 가능하며, 종류별의 생체 신호를 감지하는 다수개의 센서를 구비하여, 각 센서에서 감지되는 생체 신호를 무선 통신 방식으로 전송하는 다수의 생체 신호 계측 시스템과, 사용자가 가입하는 종류의 건강관리 서비스를 위한 지침서를 제공하는 건강관리 서버와, 사용자가 휴대 가능하며, 사용자가 가입하는 건강관리 서비스를 제공하기 위한 서비스 프로그램을 구동하고, 각 생체 신호 계측 시스템으로부터 무선 통신 방식으로 수신되는 생체 신호와, 건강관리 서버로부터 수신되는 지침서를 기반으로 건강관리 서비스를 제공하는 휴대용 건강관리 시스템을 포함하는 건강관리 서비스 제공 시스템을 개시함으로써, 사용자에게 보다 효과적인 건강관리 서비스를 제공할 수 있도록 하는 것이다.

건강관리 서비스, 생체 신호 계측 시스템, 휴대용 건강관리 시스템, 건강관리 서버, 계측기 지원 서버

Abstract

The invention provides the effective service for managing health than the user the health management service providing system is disclosed comprising the multiple bio-signal instrumentation systems, which transmits the bio-signal sensed in each sensor with the wireless communication method the user includes multiple sensors sensing the bio-signal of the classification it is attachable to the human body of the user and the health care server, which provides the tutorial in which the user joins for the service for managing health of the kind and the portable health care system which the user is portable ; the user operates the service program for providing the service for managing health in which the user joins ; and provides the service for managing health from each bio-signal instrumentation system to the wireless communication method based on the received bio-signal, and the tutorial received from the health care server.

The service for managing health, the bio-signal instrumentation system, the portable health care system, the health care server, the measuring instrument support server .

대표도면 (Representative drawing)

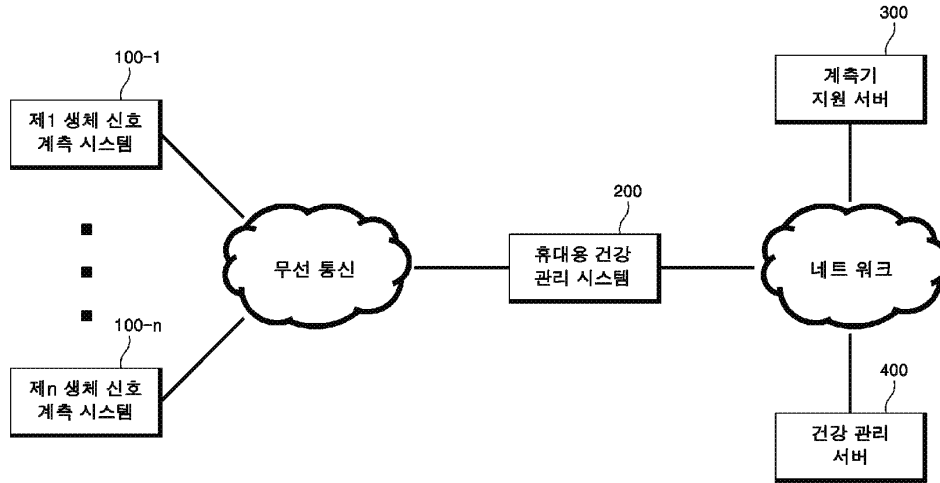

청구의 범위

청구 1항:

사용자의 인체에 부착 가능하며, 종류별의 생체 신호를 감지하는 다수개의 센서를 구비하여, 상기 각 센서에서 감지되는 생체 신호를 무선 통신 방식으로 전송하는 다수의 생체 신호 계측 시스템과, 상기 사용자가 가입하는 종류의 건강관리 서비스를 위한 지침서를 제공하는 건강관리 서버와, 상기 사용자가 휴대 가능하며, 상기 사용자가 가입하는 건강관리 서비스를 제공하기 위한 서비스 프로그램을 구동하고, 상기 각 생체 신호 계측 시스템으로부터 상기 무선 통신 방식으로 수신되는 상기 생체 신호와, 상기 건강관리 서버로부터 수신되는 지침서를 기반으로 상기 건강관리 서비스를 제공하는 휴대용 건강관리 시스템을 포함하는 것을 특징으로 하는 건강관리 서비스 제공 시스템.

청구 2항:

제 1 항에 있어서, 상기 휴대용 건강관리 시스템은, 네트워크를 통해 상기 건강관리 서버에 접속하며, 상기 지침서 및 생체 신호를 기반으로 상기 사용자의 건강 정보를 생성하여 출력하고, 상기 건강 정보 및 상기 생체 신호를 상기 건강관리 서버로 전송함을 특징으로 하는 건강관리 서비스 제공 시스템.

청구 3항:

Scope of Claims

Claim 1:

The multiple bio-signal instrumentation systems, which transmits the bio-signal sensed in each sensor with the wireless communication method the user includes multiple sensors sensing the bio-signal of the classification it is attachable to the human body of the user and the health care server, which provides the tutorial in which the user joins for the service for managing health of the kind and the health management service providing system which the user is portable ; it operates the service program for providing the service for managing health in which the user joins ; and comprises the portable health care system providing the service for managing health from each bio-signal instrumentation system to the wireless communication method based on the received bio-signal, and the tutorial received from the health care server.

Claim 2:

As for claim 1, the health management service providing system which the portable health care system connects to the health care server through the network ; it produces the health information of the user based on the tutorial and bio-signal and it outputs ; and is characterized transmitting the health information and bio-signal with the health care server.

Claim 3:

제 1 항에 있어서, 상기 건강관리 서버는,상기 휴대용 건강관리 시스템으로부터 수신되는 상기 각 종류별 생체 신호와, 상기 가입자의 건강 정보에 따라 상기 지침서를 갱신하여 제공함을 특징으로 하는 건강관리 서비스 제공 시스템.

청구 4항:

제 1 항에 있어서, 상기 센서는,광혈류량(PPG) 센서, 피부전기반사계(GSR) 센서, 심전도(EKG) 센서, 피부온도(SKT) 센서, 피부전기활동(ECG) 센서 또는 가속도(Accelerometer) 센서 중 어느 하나 이상을 포함하는 것을 특징으로 하는 건강관리 서비스 제공 시스템.

청구 5항:

제 1 항에 있어서, 상기 생체 신호 계측 시스템은,상기 사용자의 손가락에 장착할 수 있는 반지형, 손목에 장착할 수 있는 팔찌형 또는 가슴에 장착할 수 있는 가슴띠형 중 적어도 하나의 형태로 구현됨을 특징으로 하는 건강관리 서비스 제공 시스템.

청구 6항:

제 1 항에 있어서, 상기 휴대용 건강관리 시스템이 상기 각 생체 신호 계측 시스템과 상기 무선 통신 방식으로 연동될 수 있는 드라이버 프로그램을 제공하는 계측기 지원 서버를 더 포함하는 것을 특징으로 하는 건강관리 서비스 제공 시스템.

청구 7항:

제 1 항에 있어서, 상기 생체 신호 계측 시스템은,전원이 인가 되어 구동되면, 상기 휴대용 건강관리 시스템으로 고유 식별 정보(URL)를 전송하는 건강관리 서비스 제공 시스템.

청구 8항:

제 6항 또는 제 7항에 있어서, 상기 휴대용 건강관리 시스템은, 상기 생체 신호 계측 시스템으로부터 수신되는 상기 고유 식별 정보에 해당하는 드라이버 프로그램이 설치되어 있는지 여부를 확인하고, 설치되어 있지 않으면, 상기 계측기 지원 서버로 상기 고유 식별 정보에 해당하는 드라이버 프로그램을 요청하고, 상기 계측기 지원 서버로부터 제공되는 상기 드라이버 프로그램을 자동 설치하는 건강관리 서비스 제공 시스템.

청구 9항:

제 1 항에 있어서, 상기 건강관리 서버는,상기 사용자의 건강 정보 또는 생체 신호를 기반으로 의사 또는 전문가에게 상기 지침서의 작성을 문의하여, 상기 지침서를 생성/갱신하고, 상기 지침서를 상기 휴대용 건강관리 시스템으로 제공하는 건강관리 서비스 제공 시스템.

As for claim 1, the health management service providing system renewing the tutorial according to the health information of each classification bio-signal, in which the health care server is received from the portable health care system and subscriber and is characterized by the providing.

Claim 4:

The health management service providing system of claim 1, wherein the sensor comprises any one or greater among the photoplethysmograph (PPG) sensor, the galvanic skin reflex group (GSR) sensor, the electrocardiogram (EKG) sensor, the skin temperature (SKT) sensor, the electrodermal activity (ECG) sensor or the acceleration (Accelerometer) sensor.

Claim 5:

As for claim 1, the health management service providing system which the bio-signal instrumentation system is characterized being implemented among the ring type whom can mount to the user finger, and the wristlet type which can mount to the wrist or the breast band-like which can mount to the breast in the form of at least one.

Claim 6:

As for claim 1, the health management service providing system which further includes the measuring instrument support server in which the portable health care system provides the driver program which can be connected to each bio-signal instrumentation system a nd wireless communication method.

Claim 7:

As for claim 1, the health management service providing system which the power source is applied and the bio-signal instrumentation system is driven ; and transmits the unique identifying information (URL) with the portable health care system.

Claim 8:

As for claim 6 or 7, the installing automatically is the health management service providing system the driver program which confirms whether the portable health care system the driver program corresponding to the unique identifying information received from the bio-signal instrumentation system is installed ; it is not installed ; it requests the driver program corresponding to the unique identifying information as the measuring instrument support server ; and is provided from the measuring instrument support server.

Claim 9:

As for claim 1, the health management service providing system which the health care server asks about the preparation of the tutorial based on the health information or the bio-signal of the user to the doctor or the expert ; it renews the tutorial with the production / ; and provides the tutorial to the portable health care

re system.

청구 10항:

제 1 항에 있어서, 상기 휴대용 건강관리 시스템은, 상기 각 생체 신호 계측 시스템으로부터 동일한 종류의 생체 신호가 다수 개 수신되면, 상기 각 생체 신호 계측 시스템의 센서 신뢰도가 가장 높은 생체 신호를 선택하는 건강관리 서비스 제공 시스템.

Claim 10:

As for claim 1, the health management service providing system wherein the portable health care system chooses the sensor reliability of each bio-signal instrumentation system is the highest bio-signal the bio-signal of the kind is received to the manifoldly that is identical from each bio-signal instrumentation system.

청구 11항:

제 1 항에 있어서, 상기 건강관리 서비스는 건강 진단 서비스, 응급 상황 판단 서비스, 응급 상황 대처 서비스 또는 질병별 건강관리 서비스 중 어느 하나의 건강관리 서비스 제공 시스템.

Claim 11:

As for claim 1, service for managing health. The health management service providing system which is any one of health check service, the emergency determination service, and the emergency management service or the disease service for managing health.

청구 12항:

다수개의 생체 신호 계측 시스템과, 건강관리 서버 및 계측기 지원 서버와 연결되는 휴대용 건강관리 시스템에 있어서, 사용자로부터 기본 건강 정보를 입력받고, 상기 사용자가 상기 건강관리 서버에 접속하여 건강관리 서비스에 가입할 수 있도록 하는 선택부와, 상기 각 생체 신호 계측 시스템으로부터 무선 통신 방식으로 각 종류별 생체 신호를 수신하는 무선 인터페이스부와, 상기 건강관리 서버로부터 네트워크를 통해 지침서 및 서비스 프로그램을 수신하고, 계측기 지원 서버로부터 네트워크를 통해 드라이버 프로그램을 수신하는 네트워크 인터페이스부와, 상기 건강 정보, 지침서 및 생체 신호를 저장하는 저장부와, 상기 서비스 프로그램을 구동하고, 상기 무선 통신 방식으로 수신되는 상기 생체 신호와, 상기 건강관리 서버로부터 수신되는 지침서를 기반으로 상기 사용자가 가입한 건강관리 서비스를 제공하는 제어부를 포함하는 것을 특징으로 하는 휴대용 건강관리 시스템.

Claim 12:

The portable health care system which comprises the multiple bio-signal instrumentation systems, the selecting unit, the RF interface receiving each classification bio-signal from each bio-signal instrumentation system to the wireless communication method, the network interface unit, the storage storing the health information, and the tutorial and bio-signal, the bio-signal, and the control unit providing the service for managing health, and the selecting unit the basis health information is input from the user as to the portable health care system connected to the health care server and measuring instrument support server ; and the user connects to the health care server and joins the service for managing health; the network interface unit receives the tutorial and service program from the health care server through the network ; and receives the driver program from the measuring instrument support server through the network; the bio-signal operates the service program ; and is received to the wireless communication method; and as to the control unit, the user joins based on the tutorial received from the health care server.

청구 13항:

제 12 항에 있어서, 상기 제어부는, 상기 지침서 및 상기 생체 신호를 기반으로 상기 사용자의 건강 정보를 생성하여 출력하고, 상기 생체 신호 및 상기 건강 정보를 상기 건강관리 서버로 주기적으로 또는 실시간적으로 전송함을 특징으로 하는 휴대용 건강관리 시스템.

Claim 13:

As for claim 12, the portable health care system which the control unit produces the health information of the user based on the tutorial and bio-signal and it outputs ; and or is periodically characterized by the bio-signal and health information to the health care server transmitting with the real-time.

청구 14항:

제 12항에 있어서, 상기 제어부는, 접속하는 생체 신호 계측 시스템에 해당하는 드라이버 프로그램이 설치되어 있는지 여부를 확인하고, 설치되어 있지 않으면, 상기 계측기 지원 서버로 상기 드라이버 프로그램을 요청하고, 수신되는 상기 드라이버 프로그램을 자동 설치함을 특징으로 하는 휴대용 건강관리 시스템.

Claim 14:

As for claim 12, the portable health care system wherein the control unit is characterized the installing automatically box the driver program that requests ; and is received the measuring instrument support server the driver program it is not installed it confirms whether the driver program corresponding to the bio-signal instrumentation system connecting is installed or not.

청구 15항:

Claim 15:

건강관리 서버가 사용자로부터 휴대용 건강관리 시스템을 통해 접속하여 건강관리 서비스에 가입 및 기본 건강 정보를 등록받는 단계와, 상기 건강관리 서버가 상기 기본 건강 정보 및 가입한 건강관리 서비스의 종류에 따른 지침서를 작성하여, 상기 휴대용 건강관리 시스템으로 제공하는 단계와, 다수개의 생체 신호 계측 시스템이 상기 사용자의 종류별의 생체 신호를 감지하여 무선 통신 방식으로 상기 휴대용 건강관리 시스템으로 전송하는 단계와, 상기 휴대용 건강관리 시스템이 상기 감지된 생체 신호와 상기 지침서를 기반으로 상기 건강관리 서비스를 제공하는 단계를 포함하는 것을 특징으로 하는 건강관리 서비스 제공 방법.

The health management service providing method comprising preparing the step of subscription and basis health information being registered at the service for managing health the health care server connects from the user through the portable health care system, and the health care server is the tutorial according to the kind of the basis health information and the service for managing health joining to provide the step, of providing to the portable health care system the step of multiple bio-signal instrumentation systems sensing the bio-signal of the classification of the user and transmitting with the wireless communication method with the portable health care system, and the portable health care system is the service for managing health based on the above-mentioned sensed bio-signal and tutorial.

청구 16항:

제 15 항에 있어서, 상기 건강관리 서비스를 제공하는 단계는, 상기 휴대용 건강관리 시스템이 상기 지침서 및 생체 신호를 기반으로 상기 사용자의 건강 정보를 생성하여 출력함을 특징으로 하는 건강관리 서비스 제공 방법.

Claim 16:

As for claim 15, the health management service providing method for being characterized that the portable health care system produces the health information of the user based on the tutorial and bio-signal and the step of providing the service for managing health outputs.

청구 17항:

제 15 항에 있어서, 상기 휴대용 건강관리 시스템이 상기 종류별 생체 신호 및 건강 정보를 상기 건강관리 서버로 전송하는 단계와, 상기 건강관리 서버가 상기 휴대용 건강관리 시스템으로부터 수신되는 상기 각 종류별 생체 신호와, 상기 가입자의 건강 정보에 따라 상기 지침서를 갱신하여 제공하는 단계를 더 포함하는 것을 특징으로 하는 건강관리 서비스 제공 방법.

Claim 17:

As for claim 15, the health management service providing method further including the step that the portable health care system transmits the classification bio-signal and health information with the health care server, each classification bio-signal, and the step of renewing the tutorial according to the health information of the subscriber and providing, and as to each classification bio-signal, the health care server is received from the portable health care system.

청구 18항:

제 15 항에 있어서, 상기 생체 신호는, 광혈류량(PPG) 신호, 피부전기반사계(GSR) 신호, 심전도(EKG) 신호, 피부온도(SK T) 신호, 피부전기활동(ECG) 신호 또는 가속도(Accelerometer) 신호 중 어느 하나 이상을 포함하는 것을 특징으로 하는 건강관리 서비스 제공 방법.

Claim 18:

The health management service providing method of claim 15, wherein the bio-signal comprises any one or greater among the photoplethysmograph (PPG) signal, the galvanic skin reflex group (GSR) signal, the electrocardiogram (EKG) signal, the skin temperature (SKT) signal, the electrodermal activity (ECG) signal or the acceleration (Accelerometer) signal.

청구 19항:

제 15 항에 있어서, 상기 생체 신호 계측 시스템이 전원이 인가되어 구동되면, 상기 휴대용 건강관리 시스템으로 고유 식별 정보(URL)를 전송하는 단계와, 상기 휴대용 건강관리 시스템이 상기 생체 신호 계측 시스템으로부터 수신되는 상기 고유 식별 정보에 해당하는 드라이버 프로그램이 설치되어 있는지 여부를 확인하고, 설치되어 있지 않으면, 상기 계측기 지원 서버로 상기 고유 식별 정보에 해당하는 드라이버 프로그램을 요청하는 단계와, 상기 계측기 지원 서버가 상기 고유 식별 정보에 해당하는 드라이버 프로그램을 전송하는 단계와, 상기 휴대용 건강관리 시스템이 상기 계측기 지원 서버로부터 수신되는 상기 드라이버 프로그램을 자동 설치하는 단계를 더 포함하는 것을 특징으로 하는 건강관리 서비스 제공 방법.

Claim 19:

As for claim 15, the health management service providing method further including the step, and the installing automatically is the step the driver program when the bio-signal instrumentation system confirms acceptance and rejection the driver program corresponding to the step of transmitting the unique identifying information (URL) with the portable health care system, and the unique identifying information in which the portable health care system is received from the bio-signal instrumentation system is installed the power source is applied and it is driven, and the step it is not installed; and of requesting the driver program corresponding to the unique identifying information as the measuring instrument support server., and the measuring instrument support server transmit the driver program corresponding to the unique identifying information, and as to the, the

portable health care system is received from the measuring instrument support server.

청구 20항:

제 15 항에 있어서, 상기 지침서의 작성은, 상기 건강관리 서버가 상기 사용자의 건강 정보 또는 생체 신호를 기반으로 의사 또는 전문가에게 상기 지침서의 작성을 문의하여, 상기 지침서를 생성/갱신함을 특징으로 하는 건강관리 서비스 제공 방법.

Claim 20:

As for claim 15, the health management service providing method the health care server the preparation of the tutorial asks about the preparation of the tutorial based on the health information or the bio-signal of the user to the doctor or the expert ; and for being characterized renewing the tutorial with the production /.

청구 21항:

제 15 항에 있어서, 상기 각 생체 신호 계속 시스템으로부터 동일한 종류의 생체 신호가 다수개 수신되면, 상기 각 생체 신호 계속 시스템의 센서 신뢰도가 가장 높은 생체 신호를 선택하는 단계를 더 포함하는 것을 특징으로 하는 건강관리 서비스 제공 방법.

Claim 21:

As for claim 15, the health management service providing method the same bio-signal of the kind is manifoldly received from each bio-signal instrumentation system ; and further including the step that the sensor reliability of each bio-signal instrumentation system chooses the highest bio-signal.

청구 22항:

제 15 항에 있어서, 상기 건강관리 서비스는 건강 진단 서비스, 응급 상황 판단 서비스, 응급 상황 대처 서비스 또는 질병별 건강관리 서비스 중 적어도 하나를 제공받을 것을 특징으로 하는 건강관리 서비스 제공 방법.

Claim 22:

As for claim 15, service for managing health. The health check service, the emergency determination service, and the emergency management service or the health management service providing method for being characterized receiving at least one among the disease service for managing health.

청구 23항:

다수개의 생체 신호 계속 시스템과, 건강관리 서버 및 계측기 지원 서버와 연결되는 휴대용 건강관리 시스템의 서비스 제공 방법에 있어서, 상기 사용자가 상기 건강관리 서버에 접속하여 건강관리 서비스에 가입하면, 상기 사용자로부터 기본 건강 정보를 등록받는 단계와, 상기 건강관리 서버로부터 상기 기본 건강 정보 및 서비스의 종류에 따른 지침서를 수신하여 저장하고, 서비스 프로그램을 구동하는 단계와, 상기 각 생체 신호 계속 시스템으로부터 무선 통신 방식으로 각 종류별 생체 신호를 수신하는 단계와, 상기 무선 통신 방식으로 수신되는 상기 생체 신호와, 지침서를 기반으로 상기 서비스 프로그램에 따라 건강 정보를 생성하여 출력하는 단계를 포함하는 것을 특징으로 하는 건강관리 서비스 제공 방법.

Claim 23:

The health management service providing method for being characterized comprising receiving the step the user connects to the health care server and it joins the service for managing health as to the service providing method of the portable health care system connected to the multiple bio-signal instrumentation systems, and health care server and measuring instrument support server ; and of the basis health information being registered from the user., and the tutorial according to the kind of the basis health information from the health care server and service to produce and output the step, of operating the service program it stores the step of receiving each classification bio-signal from each bio-signal instrumentation system to the wireless communication method, and the health information according to the service program based on the bio-signal, received to the wireless communication method and tutorial.

청구 24항:

제 23 항에 있어서, 상기 생체 신호 및 상기 건강 정보를 상기 건강관리 서버로 주기적으로 또는 실시간으로 전송하는 단계와, 접속하는 생체 신호 계속 시스템에 해당하는 드라이버 프로그램이 설치되어 있는지 여부를 확인하고, 설치되어 있지 않으면, 상기 계측기 지원 서버로 상기 드라이버 프로그램을 요청하고, 수신되는 상기 드라이버 프로그램을 자동 설치하는 단계를 더 포함하는 것을 특징으로 하는 건강관리 서비스 제공 방법.

Claim 24:

The health management service providing method for being characterized of claim 23, wherein the installing automatically the driver program which or periodically confirms the bio-signal and health information as the health care server whether the driver program corresponding to the step of transmitting with the real-time, and the bio-signal instrumentation system connecting is installed ; it is not installed ; it requests the driver program as the measuring instrument support server ; and is received further include the step.

본 발명은 건강관리 서비스 제공 시스템 및 그 방법에 관한 것이다.

The present invention relates to the health management service providing system and method thereof.

오늘날, 산업화, 컴퓨터 기술의 발전, 이동 수단의 발전 및 환경오염 등과 같은 원인으로 현대인들의 건강 상태가 갈수록 악화되고 있는 현실이며, 소득의 증가로 인하여 건강에 대한 관심의 증가하고 있는 추세이다.

It is the reality when the health condition of the modern peoples over the time gets worse because of the reason including the today, the industrialization, the power generation of the computer technology, the power generation and environmental contamination of the mobile tool etc. and it is the trend increasing of the concern about health due to the increase of the income.

이러한 사용자의 욕구를 충족시키기 위하여 제시된 기존의 건강관리 시스템은 사용자의 생체 신호를 측정하는 생체신호 시스템과, 건강관리 서비스를 제공하는 건강관리 시스템이 상호연동하여 사용자의 생체 신호에 대한 건강 상태만을 통지하는데 그치고 있다.

The bio-signal system, in which the existing health care system which is presented it satisfies the desire of such user measures the bio-signal of the user and the health care system providing the service for managing health mutually work and it notifies only the health condition toward the bio-signal of the user but it stops.

또한, 기존의 건강관리 시스템은 생체 신호를 측정하여, 그 결과 값을 통지하는데 그치고 있음으로, 사용자가 전문적인 지식이 없는 상태에서는 크게 효과를 발휘하지 못하게 된다.

Moreover, the existing health care system measures the bio-signal and consequently the value is notified of but the value stops. In that way the effect is unable to be exhibited in state without the knowledge in which the user is special.

예를 들어, 기존의 건강관리 시스템은 단순히 측정된 생체 신호를 수치 또는 그래프 형태로 사용자에게 제공할 수는 있으나, 현재 건강 상태 또는 측정된 생체 신호에 따른 건강 상태를 명확하게 사용자에게 전송하지 않음으로, 사용자는 현재 자신의 건강 상태에 대하여 명확하게 확인할 수 없으며, 현재 건강 상태에 대한 문제점 및 그 문제를 해소할 수 있는 방법을 인지할 수 없음으로, 단순히 현재 생체 상태만을 사용자에게 알려주는 기능만을 제공할 뿐이다.

For example, the existing health care system can provide the bio-signal which the basic value is measured for the user to the value or the graph type. But it is clear the health condition according to the current health condition or the measured bio-signal is not transmitted to the user. In that way the user specifically cannot confirm the health condition of the current oneself and find the problem and the method for solving the problem about the current health condition cannot be recognized. In that way the user provides only the function of just informing the user of something only the current organism state.

아울러, 기존의 건강관리 시스템은 인체의 상태를 감지하는 생체 신호 측정 시스템과 서버간 근거리에서 유선으로 연결되어야만 서비스를 제공할 수 있는 공간적인 제약이 있으며, 사용자가 새로운 생체 신호 측정 시스템을 이용하고자 하는 경우에는 별도의 설치 과정을 거친 후에야 사용할 수 있는 번거로움이 있다.

And in the short distance between the bio-signal instrumentation system and the server in which the existing health care system senses the state of the human body, it has the spacious obstacle providing the service only when being connected to the streamline and after it passes through the separate installation process in the case to use the bio-signal instrumentation system in which the user is new to be troublesome.

발명의 내용

Summary of Invention

발명의 효과

Effects of the Invention

상기한 바와 같이, 본 발명은 사용자가 자신이 원하는 건강관리 서비스를 선택할 수 있으며, 의사와 같은 전문가의 작성하는 사용자별 개인 건강관리 지침서와, 건강 상태를 기반으로 개인화된 건강관리가 가능할 수 있으며, 사용자의 건강 상태를 측정하

As described above, the present invention has the effect that the user can choose the service for managing health in which oneself wants and *** private health administration tutorial, prepared of the

기 위한 생체 신호 계속 시스템은 반지, 팔찌, 귀걸이와 같은 액세서리 형태로 신체의 각 부분에서 신호를 계속함으로써, 사용자의 착용 상에 불편을 최소화 할 수 있으며, 계속 위치를 분산 배치함은 물론 소형화할 수 있는 효과가 있다. 또한, 사용자가 편의 상 생체 신호 계속 시스템을 추가/변경하는 경우라도 별도의 설치 과정없이 즉시 생체 신호를 계속할 수 있는 효과가 있다.

기술적 과제

따라서 본 발명은 상기와 같은 문제점을 해결하기 위하여 창안된 것으로, 인체의 상태를 감지하여 생체 신호를 제공하는 각종 센서를 액세서리 형태로 분산 배치할 수 있도록 소형화하여 사용자가 착용할 수 있도록 하고, 건강관리 서비스와, 생체 신호 계속 시스템간의 독립성을 제공할 수 있도록 하여 사용자는 원하는 생체 신호 계속 시스템을 착용하여, 원하는 건강관리 서비스를 받을 수 있도록 하는 것이 있다.

또한, 본 발명은 건강관리 서비스를 제공받는 사용자들의 건강 지침을 의사에게 문의하여 적합한 건강 지침을 제공받을 수 있도록 하고, 사용자가 착용하는 생체 신호 계속 시스템의 종류에 따라 별도의 번거로운 설치 과정 없이 실시간으로 서비스를 제공받을 수 있는 건강관리 서비스 제공 시스템 및 그 방법을 제공하는 것에 그 목적이 있다.

발명의 구성 및 작용

상기 목적을 달성하기 위한 본 발명의 일측면에 따른 건강관리 서비스 제공 시스템은, 사용자의 인체에 부착 가능하며, 종류 별의 생체 신호를 감지하는 다수개의 센서를 구비하여, 각 센서에서 감지되는 생체 신호를 무선 통신 방식으로 전송하는 다수의 생체 신호 계속 시스템과, 사용자가 가입하는 종류의 건강관리 서비스를 위한 지침서를 제공하는 건강관리 서버와, 사용자가 휴대 가능하며, 사용자가 가입하는 건강관리 서비스를 제공하기 위한 서비스 프로그램을 구동하고, 각 생체 신호 계속 시스템으로부터 무선 통신 방식으로 수신되는 생체 신호와, 건강관리 서버로부터 수신되는 지침서를 기반으로 건강관리 서비스를 제공하는 휴대용 건강관리 시스템을 포함한다.

본 발명에 따른 휴대용 건강관리 시스템은, 네트워크를 통해 건강관리 서버에 접속하며, 지침서 및 생체 신호를 기반으로 사용자의 건강 정보를 생성하여 출력하고, 건강 정보 및 생체 신호를 건강관리 서버로 전송한다.

expert like the doctor and the health management individualized based on the health condition can be possible and the bio-signal instrumentation system for measuring the health condition of the user measures the signal to the ring, the bracelet, and the accessory-style like the earring in each part of the body. In that way the discomfort can be minimized on the wearing of the user and it can miniaturize as well as the measuring location dispersively is arranged. Moreover, it has the effect that immediately the bio-signal can be measured without the separate installation process in case the user changes the phase bio-signal instrumentation system of the piece with additional /.

Technical Task

Therefore, the invention is invented to solve the above-mentioned problem. And in order to dispersively arrange all kinds of the sensors perceiving the state of the human body and provide the bio-signal to the accessory-style it miniaturizes and the user puts and the independency between the service for managing health, and the bio-signal instrumentation system are provided and the bio-signal instrumentation system in which the user wants is put on and it has to receive the desired service for managing health.

Moreover, the invention provides the health management service providing system which asks about the health needle of the users receiving the service for managing health to the doctor and it receives the suitable health needle and on a real time basis can receive the service according to the kind of the bio-signal instrumentation system which the user puts without the installation process of being troublesome and method thereof it has the purpose.

Structure & Operation of the Invention

The health management service providing system according to one side of the invention for achieving the purpose is attachable to the human body of the user and multiple sensors sensing the bio-signal of the classification are included and the multiple bio-signal instrumentation systems, transmitting the bio-signal sensed in each sensor with the wireless communication method and the health care server, providing the tutorial in which the user joins for the service for managing health of the kind and user are portable and the service program for providing the service for managing health in which the user joins is operated and the portable health care system providing the service for managing health from each bio-signal instrumentation system to the wireless communication method based on the received bio-signal, and the tutorial received from the health care server is implied.

The portable health care system according to the present invention transmits the health information of the user based on the tutorial and bio-signal it connects to the health care server through the network to the health care server the health information and bio-signal it produces.

본 발명에 따른 건강관리 서버는, 휴대용 건강관리 시스템으로 부터 수신되는 각 종류별 생체 신호와, 가입자의 건강 정보에 따라 지침서를 갱신하여 제공한다.

According to the health information of each classification bio-signal, received from the portable health care system and subscriber, the health care server according to the present invention renews and provides the tutorial.

본 발명에 따른 센서는, PPG(photoplethysmogram : 광혈류량) 센서, GSR(galvanic skin reflex : 피부전기반사계) 센서, EKG(Electrokardiogramme : 심전도) 센서, SKT(skin temperature : 피부온도) 센서, ECG(electrodermal activity : 피부전기활동) 센서 또는 가속도(Accelerometer) 센서 중 어느 하나 이상이다.

The sensor according to the present invention is any one or greater among the PPG (photoplethysmogram : photoplethysmograph) sensor, the GSR (the galvanic skin reflex in reflex : galvanic skin reflex group) sensor, the EKG (electrokardiogramme : electrocardiogram) sensor, the SKT (skin temperature : skin temperature) sensor, the ECG (electrodermal activity : electrodermal activity) sensor or the acceleration (Accelerometer) sensor.

본 발명에 따른 생체 신호 계측 시스템은, 사용자의 손가락에 장착할 수 있는 반지형, 손목에 장착할 수 있는 팔찌형 또는 가슴에 장착할 수 있는 가슴띠형 중 어느 하나의 형태로 구현된다.

The bio-signal instrumentation system according to the present invention is frozen but it is implemented among the ring type whom the bio-signal instrumentation system according to the present invention can mount to the user finger, and the wristlet type can mount to the wrist or the breast band-like can mount to the breast in the form of one.

본 발명에 따른 건강관리 서비스 제공 시스템은, 휴대용 건강관리 시스템이 각 생체 신호 계측 시스템과 무선 통신 방식으로 연동될 수 있는 드라이버 프로그램을 제공하는 계측기 지원 서버를 더 포함한다.

The health management service providing system according to the present invention further includes the measuring instrument support server in which the portable health care system provides the driver program which can be connected to each bio-signal instrumentation system and wireless communication method.

본 발명에 따른 생체 신호 계측 시스템은, 전원이 인가되어 구동되면, 휴대용 건강관리 시스템으로 고유 식별 정보(URL)를 전송한다.

If the power source is applied and it is driven it transmits the unique identifying information (URL) with the portable health care system.

본 발명에 따른 휴대용 건강관리 시스템은, 생체 신호 계측 시스템으로부터 수신되는 고유 식별 정보에 해당하는 드라이버 프로그램이 설치되어 있는지 여부를 확인하고, 설치되어 있지 않으면, 계측기 지원 서버로 고유 식별 정보에 해당하는 드라이버 프로그램을 요청하고, 계측기 지원 서버로부터 제공되는 드라이버 프로그램을 자동 설치한다.

As to the portable health care system according to the present invention, it confirms whether the driver program corresponding to the unique identifying information received from the bio-signal instrumentation system is installed and if it is not installed, it requests the driver program corresponding to the unique identifying information as the measuring instrument support server and it automatically sets up the driver program provided from the measuring instrument support server.

본 발명에 따른 건강관리 서버는, 사용자의 건강 정보 또는 생체 신호를 기반으로 의사 또는 전문가에게 지침서의 작성을 문의하여, 지침서를 생성/갱신하고, 지침서를 휴대용 건강관리 시스템으로 제공한다.

The health care server according to the present invention asks about the preparation of the tutorial based on the health information or the bio-signal of the user to the doctor or the expert and it renews the tutorial with the production / and it provides the tutorial to the portable health care system.

본 발명에 따른 휴대용 건강관리 시스템은, 각 생체 신호 계측 시스템으로부터 동일한 종류의 생체 신호가 다수개 수신되면, 각 생체 신호 계측 시스템의 센서 신뢰도가 가장 높은 생체 신호를 선택한다.

As to the portable health care system according to the present invention, if the same bio-signal of the kind is manifoldly received from each bio-signal instrumentation system the sensor reliability of each bio-signal instrumentation system chooses the highest bio-signal.

본 발명에 따른 건강관리 서비스는, 건강 진단 서비스, 응급 상황 판단 서비스, 응급 상황 대처 서비스 또는 질병별 건강관리 서비스 중 어느 하나이다.

The service for managing health according to the present invention is any one of health check service, the emergency determination service, and the emergency management service or the disease service for managing health.

본 발명의 다른 측면에 따른 다수개의 생체 신호 계측 시스템

The multiple bio-signal instrumentation systems

과, 건강관리 서버 및 계측기 지원 서버와 연결되는 휴대용 건강관리 시스템은, 사용자로부터 기본 건강 정보를 입력받고, 사용자가 건강관리 서버에 접속하여 건강관리 서비스에 가입할 수 있도록 하는 선택부와, 각 생체 신호 계측 시스템으로부터 무선 통신 방식으로 각 종류별 생체 신호를 수신하는 무선 인터페이스부와, 건강관리 서버로부터 네트워크를 통해 지침서 및 서비스 프로그램을 수신하고, 계측기 지원 서버로부터 네트워크를 통해 드라이버 프로그램을 수신하는 네트워크 인터페이스부와, 건강 정보, 지침서 및 생체 신호를 저장하는 저장부와, 서비스 프로그램을 구동하고, 무선 통신 방식으로 수신되는 생체 신호와, 건강관리 서버로부터 수신되는 지침서를 기반으로 사용자가 가입한 건강관리 서비스를 제공하는 제어부를 포함한다.

according to the dissimilar side and the portable health care system connected to the health care server and measuring instrument support server of the present invention comprise the selecting unit which the basis health information is input from the user and the user connects to the health care server and joins the service for managing health, the tutorial through the network from the RF interface, receiving each classification bio-signal from each bio-signal instrumentation system to the wireless communication method and health care server and the storage, which stores the network interface unit, receiving the driver program from the measuring instrument support server through the network and health information, and the tutorial and bio-signal it receives the service program and the control unit which operates the service program and provides the service for managing health in which the user joins to the wireless communication method based on the received bio-signal, and the tutorial received from the health care server.

본 발명에 따른 제어부는, 지침서 및 생체 신호를 기반으로 사용자의 건강 정보를 생성하여 출력하고, 생체 신호 및 건강 정보를 건강관리 서버로 주기적으로 또는 실시간적으로 전송한다.

The control unit according to the present invention transmits the health information of the user based on the tutorial and bio-signal to the real-time it produces.

본 발명에 따른 제어부는, 접속하는 생체 신호 계측 시스템에 해당하는 드라이버 프로그램이 설치되어 있는지 여부를 확인하고, 설치되어 있지 않으면, 계측기 지원 서버로 드라이버 프로그램을 요청하고, 수신되는 드라이버 프로그램을 자동 설치한다.

It confirms whether the driver program corresponding to the bio-signal instrumentation system connecting is installed and if it is not installed, it requests the driver program as the measuring instrument support server and it automatically sets up the received driver program.

본 발명의 또 다른 측면에 따른 건강관리 서비스를 제공하는 방법은, 건강관리 서버가 사용자로부터 휴대용 건강관리 시스템을 통해 접속하여 건강관리 서비스에 가입 및 기본 건강 정보를 등록받는 단계와, 건강관리 서버가 기본 건강 정보 및 가입한 건강관리 서비스의 종류에 따른 지침서를 작성하여, 휴대용 건강관리 시스템으로 제공하는 단계와, 다수개의 생체 신호 계측 시스템이 사용자의 종류별의 생체 신호를 감지하여 무선 통신 방식으로 휴대용 건강관리 시스템으로 전송하는 단계와, 휴대용 건강관리 시스템이 감지된 생체 신호와 지침서를 기반으로 건강관리 서비스를 제공하는 단계를 포함한다.

The method for providing the service for managing health according to another side of the present invention on comprises the step of the health care server connecting from the user through the portable health care system and subscription and basis health information being registered at the service for managing health, the health care server is the basis health information and the step it makes the tutorial according to the kind of the service for managing health joining and of providing to the portable health care system, the step of multiple bio-signal instrumentation systems sensing the bio-signal of the classification of the user and transmitting with the wireless communication method with the portable health care system, and the bio-signal. As to the bio-signal, the portable health care system is sensed and the step of providing the service for managing health based on the tutorial.

본 발명에 따른 건강관리 서비스를 제공하는 단계는, 휴대용 건강관리 시스템이 지침서 및 생체 신호를 기반으로 사용자의 건강 정보를 생성하여 출력한다.

The portable health care system produces the health information of the user based on the tutorial and bio-signal and the step of providing the service for managing health according to the present invention outputs.

본 발명에 따른 건강관리 서비스를 제공하는 방법은, 휴대용 건강관리 시스템이 종류별 생체 신호 및 건강 정보를 건강관리 서버로 전송하는 단계와, 건강관리 서버가 휴대용 건강관리 시스템으로부터 수신되는 각 종류별 생체 신호와, 가입자의 건강 정보에 따라 지침서를 갱신하여 제공하는 단계를 더 포함한다.

The method for providing the service for managing health according to the present invention further includes renewing and providing the step that the portable health care system transmits the classification bio-signal and health information with the health care server, and the tutorial according to the health information of each classification bio-signal, in which the health care server is received from the portable health care system and subscriber.

본 발명에 따른 생체 신호는, 광혈류량(PPG : photoplethysmogram) 신호, 피부전기반사계(GSR :galvanic skin reflex) 신호, 심전도(EKG :Electrokardiogramme) 신호, 피부온도(SKT:skin temperature) 신호, 피부전기활동(ECG : electrodermal activity) 신호 또는 가속도(Accelerometer) 신호 중 어느 하나 이상이다.

The bio-signal according to the present invention is any one or greater among the photoplethysmograph (PPG : photoplethysmogram) signal, the galvanic skin reflex group (GSR :galvanic skin reflex) signal, the electrocardiogram (EKG :Electrokardiogramme) signal, the skin temperature (SKT:skin temperature) signal, the electrodermal activity (ECG : electrodermal activity) signal or the acceleration (Accelerometer) signal.

본 발명에 따른 건강관리 서비스를 제공하는 방법은, 생체 신호 계측 시스템이 전원이 인가되어 구동되면, 휴대용 건강관리 시스템으로 고유 식별 정보(URL)를 전송하는 단계와, 휴대용 건강관리 시스템이 생체 신호 계측 시스템으로부터 수신되는 고유 식별 정보에 해당하는 드라이버 프로그램이 설치되어 있는지 여부를 확인하고, 설치되어 있지 않으면, 계측기 지원 서버로 고유 식별 정보에 해당하는 드라이버 프로그램을 요청하는 단계와, 계측기 지원 서버가 고유 식별 정보에 해당하는 드라이버 프로그램을 전송하는 단계와, 휴대용 건강관리 시스템이 계측기 지원 서버로부터 수신되는 드라이버 프로그램을 자동 설치하는 단계를 더 포함한다.

The power source is applied and the bio-signal instrumentation system further includes the step if is driven of transmitting the unique identifying information (URL) with the portable health care system, the step it confirms whether the driver program corresponding to the unique identifying information, the step of transmitting the driver program, and the installing automatically is the step the driver program. As to the step it confirms whether the driver program, the portable health care system is received from the bio-signal instrumentation system is installed and if it is not installed of requesting the driver program corresponding to the unique identifying information as the measuring instrument support server. As to the step of, the measuring instrument support server falls under the unique identifying information. As to the, the portable health care system is received from the measuring instrument support server.

본 발명에 따른 지침서의 작성은, 건강관리 서버가 사용자의 건강 정보 또는 생체 신호를 기반으로 의사 또는 전문가에게 지침서의 작성을 문의하여, 지침서를 생성/갱신한다.

As to the preparation of the tutorial according to the present invention, the health care server asks about the preparation of the tutorial based on the health information or the bio-signal of the user to the doctor or the expert and it renews the tutorial with the production /.

본 발명에 따른 건강관리 서비스를 제공하는 방법은, 각 생체 신호 계측 시스템으로부터 동일한 종류의 생체 신호가 다수개 수신되면, 각 생체 신호 계측 시스템의 센서 신뢰도가 가장 높은 생체 신호를 선택하는 단계를 더 포함한다.

The method for providing the service for managing health according to the present invention further includes choosing the sensor reliability of each bio-signal instrumentation system is the highest bio-signal the same bio-signal of the kind is manifoldly received from each bio-signal instrumentation system.

본 발명의 또 다른 측면에 따른 다수개의 생체 신호 계측 시스템과, 건강관리 서버 및 계측기 지원 서버와 연결되는 휴대용 건강관리 시스템의 서비스 제공 방법은, 사용자가 건강관리 서버에 접속하여 건강관리 서비스에 가입하면, 상기 사용자로부터 기본 건강 정보를 등록받는 단계와, 건강관리 서버로부터 기본 건강 정보 및 서비스의 종류에 따른 지침서를 수신하여 저장하고, 서비스 프로그램을 구동하는 단계와, 각 생체 신호 계측 시스템으로부터 무선 통신 방식으로 각 종류별 생체 신호를 수신하는 단계와, 무선 통신 방식으로 수신되는 생체 신호와, 지침서를 기반으로 서비스 프로그램에 따라 건강 정보를 생성하여 출력하는 단계를 포함한다.

The service providing method of the multiple bio-signal instrumentation systems according to another side and the portable health care system connected to the health care server and measuring instrument support server of the present invention comprise the step if the user connects to the health care server and the user joins the service for managing health , of the basis health information being registered from the user, the basis health information from the health care server and the step it stores and of operating the service program, the step of receiving each classification bio-signal from each bio-signal instrumentation system to the wireless communication method, the bio-signal received to the wireless communication method, and the step of producing the health information based on the tutorial according to the service program and outputting the tutorial according to the kind of the service is received.

본 발명에 따른 휴대용 건강관리 시스템의 서비스 제공 방법은, 생체 신호 및 건강 정보를 건강관리 서버로 주기적으로 또는 실시간적으로 전송하는 단계와, 접속하는 생체 신호 계측 시스템에 해당하는 드라이버 프로그램이 설치되어 있는지 여부를 확인하고, 설치되어 있지 않으면, 계측기 지원 서버로 드라이버 프로그램을 요청하고, 수신되는 드라이버 프로그램을 자동 설치하는 단계를 더 포함한다.

The step or that the service providing method of the portable health care system according to the present invention periodically transmits the bio-signal and health information with the health care server with the real-time, and the installing automatically is the step the driver program further are included. The installing automatically is the step the driver program confirms whether

the driver program corresponding to the bio-signal instrumentation system connecting is installed and if it is not installed it requests the driver program as the measuring instrument support server and is received.

이하 본 발명에 따른 건강관리 서비스 제공 시스템 및 그 방법을 첨부한 도면을 참조하여 상세히 설명한다.

Hereinafter, the health management service providing system and the method thereof according to the invention are particularly illustrated with reference to the attached drawing.

도 1은 본 발명의 바람직한 실시예에 따른 건강관리 서비스 제공 시스템을 설명하기 위한 블록 도면이다.

Figure 1 is a block diagram for illustrating the health management service providing system according to the preferred embodiment of the invention.

도 1을 참조하면, 본 발명에 따른 건강관리 서비스 제공 시스템은, 다수개의 생체 신호 계측 시스템(100)과, 각 생체 신호 계측 시스템(100)과 무선으로 연결되는 휴대용 건강관리 시스템(200)과, 휴대용 건강관리 시스템(200)과 네트워크로 연결되는 계측기 지원 서버(300) 및 건강관리 서버(400)를 포함한다.

Referring to Figure 1, the health management service providing system according to the present invention comprises the multiple bio-signal instrumentation systems (100), and each bio-signal instrumentation system (100) and the measuring instrument support server (300) and the health care server (400) connected to the wirelessly connected portable health care system (200), and a portable health care system (200) and network.

그리고 건강관리 서버(400)는 의사와 같이 건강 관련 정보를 분석하여, 건강관리 지침서를 작성할 수 있는 전문가 또는 전문가 기관과 연동하여, 사용자에게 건강관리 서비스를 제공한다. 즉, 건강관리 서버(400)는 건강관리 서비스에 가입하는 사용자별 건강 정보 및 생체 신호에 따라 각기 다른 건강관리 지침서를 작성하고, 해당 사용자의 휴대용 건강관리 시스템(200)으로 전송하여, 건강관리 서비스를 제공한다.

And the health care server (400) provides the service for managing health about the user it operates with the expert or the specialized agency making the health management tutorial the health related information is analyzed, such as the doctor. That is, the different respectively health management tutorial is prepared according to *** health information and the bio-signal in which the health care server (400) joins the service for managing health and it transmits with the portable health care system (200) of the correspondence user and the service for managing health is provided.

이러한, 건강관리 서비스는 건강 진단 서비스, 응급 상황 판단/대처 서비스, 질병별 건강관리 서비스 등이 될 수 있으며, 예를 들어, 건강 진단 서비스는 사용자의 혈압, 맥박, 체온 등을 분석하여 정상 여부를 판별하는 서비스이며, 사용자가 건강 진단 서비스를 선택하면, 건강관리 서버(400)는 사용자의 혈압, 맥박, 체온 등의 값에 따라 정상 또는 비정상 상태를 파악할 수 있는 건강관리 지침서를 제공하고, 사용자가 선택한 서비스를 제공할 수 있는 서비스 프로그램과 건강관리 지침서들을 함께 제공한다.

The health check service, the emergency determination / management service, the disease service for managing health etc. can become as to the service for managing health, and it is the service which analyzes the blood pressure of the user, pulse, the body temperature etc. and in which for example, the health check service determines normality acceptance and rejection and if the user chooses the health check service the health care server (400) provides the normality or the health management tutorial grasping on the abnormal state according to the value including the blood pressure of the user, pulse, the body temperature etc. and the service program and health management tutorials providing the service selected by the user are provided.

각 생체 신호 계측 시스템(100)은 사용자의 인체 곳곳에 부착 설치되며, 부착되는 센서로부터 감지되는 인체의 생체 신호를 제공한다.

The everywhere each bio-signal instrumentation system (100) is attached and set on the human body of the user and the bio-signal of the human body sensed from the adhered sensor is provided.

그리고 생체 신호 계측 시스템(100)은 무선 통신 방식으로 생체 신호를 휴대용 건강관리 시스템(200)으로 전송할 수 있으며, 이러한 무선 통신 시스템은 적외선 통신 방식, 블루투스(Bluetooth) 통신 방식, 지그비(Zigbee) 통신 방식 또는 전파식별(Radio Frequency Identification) 통신 방식 등이 사용될 수 있다.

And the bio-signal instrumentation system (100) can transmit the bio-signal with the wireless communication method with the portable health care system (200) and such radio communication system the infrared ray communication method, the Bluetooth communication method, the Zigbee communication method or the RFID (Radio Frequency Identification) communication method etc. can be used.

휴대용 건강관리 시스템(200)은 사용자가 휴대 가능하며, 각 생체 신호 계측 시스템(100)으로부터 수신되는 생체 신호들의 특징을 분석하고, 사용자가 선택하는 건강관리 서비스를 제공한다.

The user the portable health care system (200) is portable and the characteristic of the bio-signals received from each bio-signal instrumentation system (100) is analyzed and the service for managing health which the user chooses is provided.

건강관리 서버(400)는 휴대용 건강관리 시스템(200)으로부터 수신되는 생체 신호에 따른 사용자의 건강 관련 정보를 저장하고, 건강 관련 정보를 의사에게 문의하여, 의사가 해당 사용자에게 적합한 건강관리 지침을 작성하면, 의사의 건강관리 지침을 사용자의 휴대용 건강관리 시스템(200)으로 전송한다.

The health care server (400) transmits the health related information of the user according to the bio-signal received from the portable health care system (200) to the portable health care system (200) of the user the health management needle of the doctor the doctor prepares the health management needle which is suitable to the correspondence user it stores and the health related information is asked about to the doctor.

계측기 지원 서버(300)는 사용자가 사용하는 각 생체 신호 계측 시스템(100)들의 계측기 관련 정보 및 처리 프로그램 정보 등과 같은 설치 모듈을 저장하고, 휴대용 건강관리 시스템(200)에 해당 생체 신호 계측 시스템(100)의 설치 모듈을 제공한다.

The measuring instrument support server (300) stores the installation module including the measuring instrument related information and process program information of each bio-signal instrumentation system (100) which the user uses etc. and the installation module of the corresponding bio-signal instrumentation system (100) is provided to the portable health care system (200).

도 2a는 본 발명의 제 1 실시예에 따른 생체 신호 계측 시스템을 설명하기 위한 도면이다.

Figure 2a is a drawing illustrating the bio-signal instrumentation system according to the first preferred embodiment of the invention.

도 2a는 본 발명의 제 1 실시예에 따른 반지형 생체 신호 계측 시스템(100)을 도시한 것으로, 링의 내경면 소정 영역에는 PPG 센서가 부착되고, 외경면의 소정 영역에는 아날로그 처리 모듈(110)이 설치되며, PPG 센서와 아날로그 처리 모듈(110)은 전기적으로 연결된다.

The drawing 2a shows the ring type bio-signal instrumentation system (100) according to the first preferred embodiment of the invention. And in the bore fixed region of the ring, the PPG sensor is adhered and the analog processing module (110) is installed in the fixed region of the diameter surface and the PPG sensor and analog processing module (110) are electrically connected.

사용자가 반지형 생체 신호 계측 시스템(100)을 손가락에 끼우면, 링의 내경면의 광혈류량(이하, PPG이라 칭함) 센서는 손가락의 광 혈류량을 감지하여 PPG 생체 신호를 아날로그 처리 모듈(110)로 전송하고, 아날로그 처리 모듈(110)은 PPG 생체 신호를 무선 통신 방식으로 휴대용 건강관리 시스템(200)에 전송한다.

If the user inserts the ring type bio-signal instrumentation system (100) in finger, photoplethysmograph (it calls because of being less than, and PPG) sensor of the bore of the ring sense the photoplethysmograph of finger and the PPG bio-signal is transmitted with the analog processing module (110) and the analog processing module (110) transmits the PPG bio-signal with the wireless communication method in the portable health care system (200).

그리고 아날로그 처리 모듈(110)은 내부에 전원 공급 장치(예를 들어 배터리)를 구비할 수 있는 공간이 마련되어, 무선 통신 방식으로 PPG 생체 신호를 전송할 수 있도록 한다.

And the space in which the analog processing module (110) can include the power supply device (for example, the battery) in the inside is prepared and the PPG bio-signal is transmitted with the wireless communication method.

도 2b는 본 발명의 제 2 실시예에 따른 생체 신호 계측 시스템을 설명하기 위한 도면이다.

Figure 2b is a drawing illustrating the bio-signal instrumentation system according to the second preferred embodiment of the present invention.

도 2a는 본 발명의 제 2 실시예에 따른 팔찌형 생체 신호 계측 시스템(100#39#)을 도시한 것으로, 링의 외경면에는 피부전기반사계(galvanic skin reflex 이하, GSR라 칭함) 센서, 심전도(Electrokardiogram 이하, EKG라 칭함) 센서, 피부온도(Skin temperature 이하, SKT라 칭함) 센서 등이 부착되며, 내경면에는 피부전기활동(electrodermal activity 이하, ECG라 칭함) 센서, SKT 센서 등이 부착된다.

The drawing 2a shows the wristlet type bio-signal instrumentation system (100') according to the second preferred embodiment of the present invention. And in the diameter surface of the ring, the galvanic skin reflex group (it calls less than the galvanic skin reflex because of being GSR) sensor, the electrocardiogram (it calls less than the Electrocardiogramme because of being EKG) sensor, and the skin temperature (it calls less than t

그리고 링의 외경면에 소정 크기의 기판 상에 GSR 센서, EKG 센서, SKT 센서 등이 부착되며, 생체 신호를 필터링하고, A/D 컨버팅하여 생체 신호를 디지털 방식의 신호로 변환한 이후에 무선 통신 방식으로 휴대용 건강관리 시스템(200)으로 전송하는 디지털 처리 모듈을 구비한다.

또한, 기판 상에는 사용자가 생체 신호를 휴대용 건강관리 시스템(200)으로 전송하는 버튼 및 생체 신호 감지 시작 버튼 등이 설치될 수 있다.

이러한, 팔찌형 생체 신호 계측 시스템(100)은 사용자가 손목에 차게 되면, 내경면에 부착되는 ECG 센서 및 SKT 센서는 ECG 생체 신호 및 SKT 생체 신호를 감지하여 디지털 처리 모듈로 전송하고, 디지털 처리 모듈은 ECG 생체 신호 및 SKT 생체 신호를 휴대용 건강관리 시스템(200)으로 전송한다.

또한, 사용자가 팔찌형 생체 신호 계측 시스템(100)의 외경면에 부착된 GSR 센서, EKG 센서, SKT 센서에 반대 손가락의 끝 부분을 올려놓고, 생체 신호 감지 시작 버튼을 누르면, GSR 센서, EKG 센서, SKT 센서들은 GSR 생체 신호, EKG 생체 신호, SKT 생체 신호를 감지하고, 전송 버튼을 누르면, 디지털 처리 모듈로 전송하고, 디지털 처리 모듈은 휴대용 건강관리 시스템(200)으로 각 생체 신호를 전송한다.

도 2c는 본 발명의 제 3 실시예에 따른 생체 신호 계측 시스템을 설명하기 위한 도면이다.

도 2c는 본 발명의 제 3 실시예에 따른 가슴띠형 생체 신호 계측 시스템(100)을 도시한 것으로, 가슴띠형 생체 신호 계측 시스템은 외측에 인체의 움직임을 감지하는 가속도계(Accelerometer)와 인체 접촉면에 SKT 센서, EKG 센서 등이 부착된다.

가슴띠형 생체 신호 계측 시스템(100)은 소정 구동 전원을 공급하는 배터리와, 외측에 동작 상태를 나타내는 LED(램프)와, 상측면에 전원을 리셋할 수 있는 재시작 버튼과, 하측면에서 전원을 온/오프할 수 있는 전원 버튼을 구비한다.

가속도계, SKT 센서, EKG 센서 및 각 버튼은 기판 상에 구현되어 신호선으로 연결될 수 있으며, 사용자가 선택하는 버튼에 따라 생체 신호 계측 시스템(100)을 전원을 온/오프하거나, 리셋하고, SKT 센서, EKG 센서로부터 수신되는 생체 신호와, 가

the Skin temperature because of being SKT) sensor lamp are adhered and the electrodermal activity (it calls less than the electrodermal activity because of being ECG) sensor, and the SKT sensor lamp are adhered in the bore.

And the GSR sensor on the substrate of the fixed level in the diameter surface of the ring, EKG sensor, and the digital processing module are included. The digital processing module the SKT sensor lamp is adhered and it filters the bio-signal and transmits with the wireless communication method with the portable health care system (200) after it converts into A / D and it converts the bio-signal into the signal of the digital method.

Moreover, the button and bio-signal sensing start button etc. can be installed on the substrate the user transmits the bio-signal with the portable health care system (200).

, and the wristlet type bio-signal instrumentation system (100) transmit the ECG sensor which if the user wears the wrist , is adhered to the bore. And SKT sensor is the ECG bio-signal and SKT bio-signal to the digital processing module is the portable health care system (200) the ECG bio-signal and SKT bio-signal it senses.

Moreover, the user puts the end portion of the opposite finger above the GSR sensor, adhered to the diameter surface of the wristlet type bio-signal instrumentation system (100) the EKG sensor, and the SKT sensor and if the bio-signal sensing start button is pressed , the GSR sensor, the EKG sensor , and SKT sensors sense the GSR bio-signal, the EKG bio-signal, and the SKT bio-signal and if the send button is pressed , the user transmits with the digital processing module and the digital processing module transmits each bio-signal with the portable health care system (200).

Figure 2c is a drawing illustrating the bio-signal instrumentation system according to the third preferred embodiment of the present invention.

The drawing 2c shows the breast band-like bio-signal instrumentation system (100) according to the third preferred embodiment of the present invention. And the SKT sensor, and the EKG sensor lamp are adhered to the accelerometer and the human body contact side in which the breast band-like bio-signal instrumentation system senses the movement of the human body in the outside.

The breast band-like bio-signal instrumentation system (100) includes the battery supplying the predetermined drive power, the LED (lamp) showing the operation state for the outside, the restart button resetting the power source in the upper surface, and the power button. The power button comes the power source from the bottom surface can switch off.

Accelerometer, SKT sensor, the on/off or the SKT sensor the bio-signal instrumentation system (100) according to the button, the bio-signal received from the EKG sensor, and the control means (not illustrated) are i

속도계로부터 수신되는 감지 신호를 무선으로 휴대용 건강관리 시스템(200)으로 전송하는 제어 수단(미도시)을 구비한다.

included. The on/off or the SKT sensor the bio-signal instrumentation system (100) according to the button the EKG sensor and each button are implemented on the substrate and it can be connected to the signal wire and the user chooses. The power source it resets. The control means (not illustrated) wirelessly transmits the sensing signal received from the accelerometer with the portable health care system (200).

도 3은 본 발명의 바람직한 실시예에 따른 휴대용 건강관리 시스템을 설명하기 위한 블록 도면이다.

Figure 3 is a block diagram for illustrating the portable health care system according to the preferred embodiment of the invention.

상기 도 3을 참조하면, 본 발명에 따른 휴대용 건강관리 시스템(200)은 무선 인터페이스부(210)와, 네트워크 인터페이스부(220)와, 출력부(230)와, 선택부(240)와, 저장부(250)와, 제어부(260)를 포함한다.

The above the portable health care system (200) according to the present invention includes with the RF interface (210), with the network interface unit (220), with the output unit (230), with the selecting unit (240), with the storage (250), control unit (260) with reference to 3.

상기 무선 인터페이스부(210)는 각 생체 신호 계측 시스템(100)으로부터 생체 신호를 수신한다.

The RF interface (210) receives the bio-signal from each bio-signal instrumentation system (100).

상기 네트워크 인터페이스부(220)는 네트워크를 통해 계측기 지원 서버(300) 및 건강관리 서버(400)와 접속하며, 계측기 지원 서버(300)로부터 드라이버 프로그램을 수신하고, 건강관리 서버(400)로부터 건강관리 지침서를 수신하고, 생체 신호 및 건강 관련 정보를 건강관리 서버(400)로 전송한다.

The network interface unit (220) transmits the driver program from the measuring instrument support server (300) it connects through the network with the measuring instrument support server (300) and health care server (400) to the health care server (400) the bio-signal and health related information the health management tutorial is received from the health care server (400) it receives.

상기 선택부(240)는 다수개의 키 버튼을 구비하며, 사용자가 서비스를 선택하고, 기본 건강 정보를 입력할 수 있도록 한다.

The selecting unit (240) includes multiple key buttons and the user chooses the service and the basis health information is input.

상기 저장부(250)는 건강관리 서버(400)로부터 수신되는 건강관리 지침서 및 휴대용 건강관리 시스템(200)이 생체 신호를 분석하고, 건강관리 지침서를 기반으로 생성하는 건강 관련 정보를 저장한다.

It stands with the health management bringing and the storage (250) is received from the health care server (400) the portable health care system (200) analyzes the bio-signal and the health related information produced based on the health management tutorial is stored.

상기 제어부(260)는 수신되는 생체 신호를 종류별로 분석하고, 건강관리 지침서와, 분석된 생체 신호를 비교 검토한 이후에 건강 관련 정보를 생성하고, 건강 관련 정보를 출력부(230)로 출력하여 사용자에게 건강관리 서비스를 제공한다. 그리고 제어부(260)는 건강 관련 정보 및 생체 신호를 건강관리 서버(400)로 전송하여, 의사가 건강 관련 정보 및 생체 신호에 따라 건강관리 지침서를 업데이트할 수 있도록 한다.

The control unit (260) provides the health management tutorial, and user the health related information is outputted to the output unit (230) after the analyzed bio-signal is compared and is examined the health related information is produced the received bio-signal is analyzed to the classification with the service for managing health. And the control unit (260) transmits the health related information and bio-signal with the health care server (400) and the doctor updates the health management tutorial according to the health related information and bio-signal.

또한, 생체 신호 계측 시스템(100)을 사용자가 착용하여 전원을 온하면, 생체 신호 계측 시스템(100)은 고유 식별 정보(URL)를 휴대용 건강관리 시스템(200)으로 전송하고, 휴대용 건강관리 시스템(200)의 제어부(260)는 고유 식별 정보에 해당하는 드라이버 프로그램이 설치되어 있는지 여부를 확인한 이후에 설치되어 있지 않으면, 계측기 지원 서버(300)로 접속하

Moreover, the user puts on the bio-signal instrumentation system (100) and on lower-side, and the bio-signal instrumentation system (100) transmit the unique identifying information (URL) the power source with the portable health care system (200) and if the control unit (260) of the portable health care system (2

여, 고유 식별 정보에 상응하는 드라이버 프로그램을 요청하고, 드라이버 프로그램이 수신되면, 수신된 프로그램을 자동으로 설치하여 해당 생체 신호 계속 신호로부터 무선 방식으로 생체 신호를 수신한다.

도 4는 본 발명의 바람직한 실시예에 따른 건강관리 서비스 제공 시스템의 건강관리 서비스 흐름을 설명하기 위한 흐름도이다.

상기 도 4를 참조하면, S100단계에서 사용자는 휴대용 건강관리 시스템(200)을 통해 건강관리 서버(400)에 접속하여 건강관리 서비스에 가입하고, 원하는 건강관리 서비스를 선택하고, 사용자가 입력하는 기본 건강 정보를 전송한다. 즉, 사용자는 먼저 자신이 원하는 서비스를 건강관리 서버(400)에서 선택하고, 건강관리 서버(400)는 사용자가 선택하는 서비스와 서비스들을 수행하는데 필요한 프로그램 정보를 휴대용 건강관리 시스템(200)으로 전송하여 자동 설치되도록 한다.

예를 들어, 건강관리 서버(400)가 건강 진단 서비스, 응급 상황 판단/대처 서비스, 질병별 건강관리 서비스 등을 제공하는 경우, 사용자가 혈압, 맥박, 체온 등의 정상 여부를 판별하는 건강 진단 서비스를 선택하면, 해당 서비스 모듈과 함께 서비스를 구동하는데 필요한 건강관리 지침서들을 함께 제공한다. 이러한 건강 진단 서비스인 경우의 건강관리 지침서는 사용자의 혈압, 맥박, 체온의 정상 여부를 판별할 수 있는 범위 값을 포함할 수 있으며, 이러한 값들은 의사의 판단에 따라 조정되어 조정 시마다 통보되어 서비스에 활용될 수 있다. 그리고 지침서는 사용자가 선택하는 서비스 및 사용자별 건강 상태 또는 병력에 따라 적절하게 구성될 수 있다.

이후, S110단계에서 건강관리 서버(400)는 사용자가 선택하는 서비스에 관련한 서비스 프로그램 정보, 해당 서비스의 지침서를 휴대용 건강관리 시스템(200)으로 전송한다. 이에 따라 휴대용 건강관리 시스템(200)은 수신되는 프로그램 정보 및 지침서를 자동 설치한다.

사용자가 생체 신호 계속 시스템(100)을 인체에 착용하면, S130단계에서 생체 신호 계속 시스템(100)은 고유 식별 정보(드라이버 URL)를 휴대용 건강관리 시스템(200)으로 전송한다.

그러면 S140단계에서 휴대용 건강관리 시스템(200)은 생체

00) confirms whether the driver program corresponding to the unique identifying information is installed or not the power source is not installed the user connects with the measuring instrument support server (300) and the driver program corresponding to the unique identifying information is requested and if the driver program is received the received program is automatically set up and the bio-signal is received from the corresponding bio-signal measurement signal to the radio system.

Figure 4 is a flowchart for illustrating the service for managing health flow of the health management service providing system according to the preferred embodiment of the invention.

In the above is the S100 step with reference to 4, the user connects to the health care server (400) through the portable health care system (200) and the user joins the service for managing health and the desired service for managing health is chosen and the basis health information which the user inputs is transmitted. That is, the user chooses the service in which oneself wants in advance rather than in the health care server (400) and the health care server (400) performs the service and the services which the user chooses but the necessary program information is transmitted with the portable health care system (200) and it is automatically installed.

For example, if the case where the health care server (400) provides the health check service, the emergency determination / management service, the disease service for managing health etc., and the user choose the health check service determining normality acceptance and rejection including the blood pressure, pulse, the body temperature etc. the service is operated with the corresponding service module but necessary health management tutorials are provided. The health management tutorial of the case of being such health check service can include the blood pressure of the user, pulse, and the range value determining normality acceptance and rejection of the body temperature and such values are adjusted upward according to the determination of the doctor and the doctor is reported at the control and it can be used for the service. And according to the service which the user as to the tutorial, chooses and *** health condition or the medical history, it can be appropriately formed.

Then, the health care server (400) in the S110 step transmits the service program information relating to the service which the user chooses, and the tutorial of the target service to the portable health care system (200). Accordingly, the program information and the tutorial in which the portable health care system (200) is received are automatically set up.

The bio-signal instrumentation system (100) in the S130 step the user puts on the bio-signal instrumentation system (100) in the human body transmits the unique identifying information (driver URL) to the portable health care system (200).

And then, in the S140 step, the portable health care

신호 계측 시스템(100)으로부터 수신되는 고유 식별 정보에 따른 드라이버 프로그램이 설치되어 있는지 여부를 확인한다. 그런 다음 S150단계에서 휴대용 건강관리 시스템(200)은 드라이버 프로그램이 설치되어 있지 않으면, 계측기 지원 서버(300)에 접속하고, 해당 생체 신호 계측 시스템(100)의 드라이버 프로그램을 요청한다. 이에 따라 S160단계에서 계측기 지원 서버(300)는 생체 신호 계측 시스템(100)의 고유 식별 정보에 해당하는 드라이버 프로그램을 휴대용 건강관리 시스템(200)으로 전송한다. 그러면 휴대용 건강관리 시스템(200)은 계측기 지원 서버(300)로부터 수신되는 드라이버 프로그램을 자동 설치한다.

한편, 사용자가 건강관리 시스템(200)을 사용하는 중에 새로운 생체 신호 계측 시스템(100)을 추가로 착용한 경우 역시 이와 마찬가지로 생체 신호 계측 시스템(100)으로부터 수신되는 고유 식별 정보에 해당하는 드라이버 프로그램이 설치되어 있지 않으면, 계측기 지원 서버(300)로부터 드라이버 프로그램을 전송받아 자동 설치한다. 또한, 다수의 생체 신호 계측 시스템(100)으로부터 동일한 종류의 생체 신호가 수신되는 경우에는 생체 신호 계측 시스템(100) 중 신뢰도가 높은 생체 신호 계측 시스템(100)으로부터 수신되는 생체 신호를 택일하여 사용할 수 있다.

이후, S170단계에서 각 생체 신호 계측 시스템(100)을 부착된 센서를 통해 감지되는 생체 신호를 휴대용 건강관리 시스템(200)으로 전송한다. 그러면 S180단계에서 휴대용 건강관리 시스템(200)은 건강관리 서버(400)로부터 수신되는 지침서와, 각 생체 신호 계측 시스템(100)으로부터 수신되는 생체 신호를 분석하여 사용자가 선택한 서비스를 제공한다. 예를 들어, 사용자가 건강 진단 서비스를 선택한 경우, 수신되는 생체 신호에 따라 현재 건강 상태가 양호한지, 위험한지 등을 출력하여, 사용자가 건강을 진단할 수 있도록 한다.

그런 다음 S190단계에서 휴대용 건강관리 시스템(200)은 사용자가 선택한 서비스를 제공한 과로 생성되는 각종 건강 관련 정보와 생체 신호 계측 시스템(100)으로부터 수신되는 생체 신호를 건강관리 서버(400)로 전송한다. 이에 따라 S200단계에서 건강관리 서버(400)는 주기적 또는 건강 상태 정보 및 생체 신호가 변경되면, 의사에게 사용자의 건강 상태를 문의하고, 지침서를 갱신하고, S210단계에서 지침서가 갱신되면, 갱신된 지침서를 휴대용 건강관리 시스템(200)으로 전송한다. 즉, 의사는 수시로 자신이 원하는 시간에 건강관리 서버(400)로부터 사용자의 건강 정보를 열람하여 사용자의 건강 상태를 판별하고 필요 시 새로운 지침을 작성하고, 건강관리 서버(400)는 의사가 건강관리 지침서를 변경한 경우, 실시간으로 휴대용 건강관리 시스템에 전송하여 건강관리 지침서가 업데이트되도록 한다.

system (200) confirms whether the driver program according to the unique identifying information received from the bio-signal instrumentation system (100) is installed or not. Next, in the S150 step, if the portable health care system (200) the driver program is not installed it connects to the measuring instrument support server (300) and the driver program of the corresponding bio-signal instrumentation system (100) is requested. Accordingly, the measuring instrument support server (300) in the S160 step transmits the driver program corresponding to the unique identifying information of the bio-signal instrumentation system (100) to the portable health care system (200). And then, the driver program in which the portable health care system (200) is received from the measuring instrument support server (300) is automatically set up.

In the meantime, if putting on the new bio-signal instrumentation system (100) while the user uses the health care system (200) the driver program corresponding to the unique identifying information which also is received from the bio-signal instrumentation system (100) like this is not installed, the driver program is transmitted from the measuring instrument support server (300) and the user establishes. Moreover, in case the same bio-signal of the kind is received from multiple bio-signal instrumentation systems (100) the bio-signal received from the bio-signal instrumentation system (100) in which the reliability is high among the bio-signal instrumentation system (100) is chosen and it can use.

Then, in the S170 step, the bio-signal sensed through the sensor which is attached to each bio-signal instrumentation system (100) via is transmitted with the portable health care system (200). And then, in the S180 step, the portable health care system (200) analyzes the tutorial, received from the health care server (400) and the bio-signal received from each bio-signal instrumentation system (100) and the service selected by the user is provided. For example, in case the user chooses the health check service the current health condition is good according to the received bio-signal whether the user outputs whether it is dangerous and the user makes a diagnosis of health.

Next, the portable health care system (200) in the S190 step transmits the service selected by the user to the health care server (400) all kinds of the health related information generated with the department providing and the bio-signal received from the bio-signal instrumentation system (100). Accordingly, the health care server (400) in the S200 step transmits the health condition of the user to the doctor periodic or the health condition information and bio-signal are changed to the portable health care system (200) the tutorial which asks and it renews the tutorial and if the tutorial is updated in the S210 step, is updated. That is, the doctor provides the health information of the user in time when oneself from time to time wants from the health care server (400) and the health condition of the user is determined and the new needle is prepared in the need and in case the doctor the health care server (400) changes the health management tutorial it transmits in the portable health care system on a real time basis and the health management tutorial is updated.

도 5는 본 발명의 바람직한 실시예에 따른 건강관리 서비스를 제공하는 방법을 설명하기 위한 플로차트 도면이다.

Figure 5 is a flow chart drawing for illustrating the method for providing the service for managing health according to the preferred embodiment of the invention.

상기 도 5를 참조하면, S300단계에서 사용자는 휴대용 건강관리 시스템(200)을 통해 건강관리 서버(400)에 접속하여 서비스에 가입하고, 원하는 서비스를 선택하면서 사용자의 기본 건강 정보를 전송한다.

In the above is the S300 step with reference to 5, the user connects to the health care server (400) through the portable health care system (200) and the user joins the service and while the desired service is chosen the basic health information of the user is transmitted.

S310단계에서 건강관리 서버(400)는 사용자를 등록하고, 해당 사용자의 기본 건강 정보와, 선택한 서비스에 따른 건강관리 지침서를 휴대용 건강관리 시스템(200)으로 전송한다. 즉, 사용자는 자신이 원하는 서비스를 건강관리 서버(400)에서 선택하고, 건강관리 서버(400)는 사용자가 선택하는 서비스와 서비스들을 수행하는데 필요한 프로그램 정보 및 기본 건강 정보에 따른 건강관리 지침서를 휴대용 건강관리 시스템(200)으로 전송한다. 예를 들어, 건강관리 서버(400)가 건강 진단 서비스, 응급 상황 판단/대처 서비스, 질병별 건강관리 서비스 등을 제공하는 경우, 사용자가 혈압, 맥박, 체온 등의 정상 여부를 판별하는 건강 진단 서비스를 선택하면, 해당 서비스 모듈과 함께 서비스를 구동하는데 필요한 건강관리 지침서들을 함께 제공한다.

The health care server (400) in the S310 step transmits the user to the portable health care system (200) the health management tutorial according to the service which it registers and it chooses with the basis health information of the correspondence user. That is, the user transmits the service in which oneself wants to the portable health care system (200) the health management tutorial according to the service which the user selects. The health care server (400) chooses it chooses in the health care server (400) and the necessary program information performing services but and basis health information. For example, if the case where the health care server (400) provides the health check service, the emergency determination / management service, the disease service for managing health etc., and the user choose the health check service determining normality acceptance and rejection including the blood pressure, pulse, the body temperature etc. the service is operated with the corresponding service module but necessary health management tutorials are provided.

S320단계에서 사용자가 생체 신호 계측 시스템(100)을 착용하여 전원을 온하면, 생체 신호 계측 시스템(100)은 고유 식별 정보(URL)를 휴대용 건강관리 시스템(200)으로 전송한다. 그러면 S330단계에서 휴대용 건강관리 시스템(200)은 생체 신호 계측 시스템(100)으로부터 수신되는 고유 식별 정보에 따른 드라이버 프로그램이 설치되어 있는지 여부를 확인한다.

On lower-side the power source, and the bio-signal instrumentation system (100) the user puts on the bio-signal instrumentation system (100) in the S320 step transmit the unique identifying information (URL) to the portable health care system (200). And then, in the S330 step, the portable health care system (200) confirms whether the driver program according to the unique identifying information received from the bio-signal instrumentation system (100) is installed or not.

그런 다음 S340단계에서 휴대용 건강관리 시스템(200)은 드라이버 프로그램이 설치되어 있지 않으면, 계측기 지원 서버(300)에 접속하여, 해당 생체 신호 계측 시스템(100)의 드라이버 프로그램을 요청한다. 그러면 계측기 지원 서버(300)는 생체 신호 계측 시스템(100)의 고유 식별 정보에 해당하는 드라이버 프로그램을 휴대용 건강관리 시스템(200)으로 전송한다.

Next, in the S340 step, if the portable health care system (200) the driver program is not installed, it connects to the measuring instrument support server (300) and the driver program of the corresponding bio-signal instrumentation system (100) is requested. And then, the measuring instrument support server (300) transmits the driver program corresponding to the unique identifying information of the bio-signal instrumentation system (100) to the portable health care system (200).

S350단계에서 휴대용 건강관리 시스템(200)은 계측기 지원 서버(300)로부터 수신되는 드라이버 프로그램을 자동 설치한다.

In the S350 step, the driver program in which the portable health care system (200) is received from the measuring instrument support server (300) is automatically set up.

한편, 사용자가 건강관리 시스템(200)을 사용하는 중에 새로운 생체 신호 계측 시스템(100)을 추가로 착용한 경우 역시 이와 마찬가지로 생체 신호 계측 시스템(100)으로부터 수신되는 고유 식별 정보에 해당하는 드라이버 프로그램이 설치되어 있지 않으면, 계측기 지원 서버(300)로부터 드라이버 프로그램을 전송받아 자동 설치한다.

In the meantime, if putting on the new bio-signal instrumentation system (100) while the user uses the health care system (200) the driver program corresponding to the unique identifying information which also is received from the bio-signal instrumentation system (100) like this is not installed the driver program is transmitted from the measuring instrument support server (300) and the user establishes.

또한, 다수의 생체 신호 계측 시스템(100)으로부터 동일한 종류의 생체 신호가 수신되는 경우에는 생체 신호 계측 시스템(100) 중 신뢰도가 높은 생체 신호 계측 시스템(100)으로부터 수신되는 생체 신호를 택일하여 사용할 수 있다.

Moreover, in case the same bio-signal of the kind is received from multiple bio-signal instrumentation systems (100) the bio-signal received from the bio-signal instrumentation system (100) in which the reliability is high among the bio-signal instrumentation system (100) is chosen and it can use.

S360단계에서 각 생체 신호 계측 시스템(100)은 부착된 센서를 통해 감지되는 생체 신호를 무선 통신 방식으로 휴대용 건강관리 시스템(200)으로 전송한다. 그러면 S370단계에서 휴대용 건강관리 시스템(200)은 건강관리 서버(400)로부터 수신되는 지침서와, 각 생체 신호 계측 시스템(100)으로부터 수신되는 생체 신호를 분석하여, 건강 관련 정보를 생성하고, 건강 관련 정보를 출력하여 사용자가 선택한 건강관리 서비스를 제공한다. 예를 들어, 사용자가 건강 진단 서비스를 선택한 경우, 수신되는 생체 신호에 따라 현재 건강 상태가 양호한지, 위험한지 등을 출력하여, 사용자가 건강을 진단할 수 있도록 한다.

Each bio-signal instrumentation system (100) in the S360 step transmits the bio-signal sensed through the adhered sensor to the wireless communication method the portable health care system (200). And then, in the S370 step, the portable health care system (200) analyzes the tutorial, received from the health care server (400) and the bio-signal received from each bio-signal instrumentation system (100) and the health related information is produced and the health related information is outputted and the service for managing health selected by the user is provided. For example, in case the user chooses the health check service the current health condition is good according to the received bio-signal whether the user outputs whether it is dangerous and the user makes a diagnosis of health.

그런 다음 S380단계에서 휴대용 건강관리 시스템(200)은 사용자가 선택한 서비스를 제공한 결과로 생성되는 각종 건강 관련 정보와 생체 신호 계측 시스템(100)으로부터 수신되는 생체 신호를 건강관리 서버(400)로 전송한다. 이에 따라 S390단계에서 건강관리 서버(400)는 주기적 또는 건강 상태 정보 및 생체 신호가 변경되면, 의사에게 사용자의 건강 상태를 문의하고, 지침서를 갱신하고, 지침서가 갱신되면, 갱신된 지침서를 휴대용 건강관리 시스템(200)으로 전송한다.

Next, the portable health care system (200) in the S380 step transmits the service selected by the user to the health care server (400) all kinds of the health related information which are generated it provides and the bio-signal received from the bio-signal instrumentation system (100). Accordingly, the health care server (400) in the S390 step transmits the health condition of the user to the doctor periodic or the health condition information and bio-signal are changed to the portable health care system (200) the tutorial which asks and it renews the tutorial and if the tutorial is updated, is updated.

즉, 의사는 수시로 자신이 원하는 시간에 건강관리 서버(400)로부터 사용자의 건강 정보를 열람하여 사용자의 건강 상태를 판별하고 필요 시 새로운 지침을 작성하고, 건강관리 서버(400)는 의사가 건강관리 지침서를 변경한 경우, 실시간으로 휴대용 건강관리 시스템에 전송하여 건강관리 지침서가 업데이트되도록 한다.

That is, the doctor peruses the health information of the user in the time when oneself from time to time wants from the health care server (400) and the health condition of the user is determined and the new needle is prepared in the need and in case the doctor the health care server (400) changes the health management tutorial it transmits in the portable health care system on a real time basis and the health management tutorial is updated.

한편, 본 발명의 상세한 설명에서는 구체적인 실시 예에 관하여 설명하였으나, 본 발명의 범위에서 벗어나지 않는 한도 내에서 여러 가지 변형이 가능함은 물론이다. 그러므로 본 발명의 범위는 설명된 실시 예에 국한되어 정해져서는 안되며 후술하는 발명청구의 범위뿐만 아니라 이 발명청구의 범위와 균등한 것들에 의해 정해져야 한다.

In the meantime, in the detailed explanation of the invention, it illustrated for the detailed embodiment. But it is of course that many transformation is possible in figure one. It does not deviate from from the scope of the present invention. Therefore, while being limited to the embodiment in which the scope of the present invention is explained and not being determined it determines with the range of not only the range of the invention demand which will be described later but also this invention demand and the equal things.

도면에 대한 간단한 설명

도 1은 본 발명의 바람직한 실시예에 따른 건강관리 서비스 제공 시스템을 설명하기 위한 블록도,

도 2a는 본 발명의 제 1 실시예에 따른 생체 신호 계측 시스템을 설명하기 위한 도면,

Brief explanation of the drawing

Figure 1 is a block diagram for illustrating the health management service providing system according to the preferred embodiment of the invention

Figure 2a is drawing for illustrating the bio-signal instrumentation system according to the first preferred

도 2b는 본 발명의 제 2 실시예에 따른 생체 신호 계측 시스템을 설명하기 위한 도면,

도 2c는 본 발명의 제 3 실시예에 따른 생체 신호 계측 시스템을 설명하기 위한 도면,

도 3은 본 발명의 바람직한 실시예에 따른 휴대용 건강관리 시스템을 설명하기 위한 블록도,

도 4는 본 발명의 바람직한 실시예에 따른 건강관리 서비스 제공 시스템의 건강관리 서비스 흐름을 설명하기 위한 흐름도,

도 5는 본 발명의 바람직한 실시예에 따른 건강관리 서비스를 제공하는 방법을 설명하기 위한 흐름도.

#60#도면의 주요 부분에 대한 부호의 설명>

100 : 생체 신호 계측 시스템 200 : 휴대용 건강관리 시스템

210 : 무선 인터페이스부 220 : 네트워크 인터페이스부

230 : 출력부 240 : 선택부

250 : 저장부 260 : 제어부

300 : 건강관리 서버 400 : 계측기 지원 서버

embodiment of the invention

Figure 2b is drawing for illustrating the bio-signal instrumentation system according to the second preferred embodiment of the present invention

Figure 2c is drawing for illustrating the bio-signal instrumentation system according to the third preferred embodiment of the present invention

Figure 3 is a block diagram for illustrating the portable health care system according to the preferred embodiment of the invention

Figure 4 is a flowchart for illustrating the service for managing health flow of the health management service providing system according to the preferred embodiment of the invention

Figure 5 is a flowchart for illustrating the method for providing the service for managing health according to the preferred embodiment of the invention.

The description > of the denotation about the main part of the < drawing.

100: bio-signal instrumentation system 200: portable health care system.

210: RF interface 220: network interface unit.

230: output unit 240: selecting unit.

250: storage 260: control unit.

300: health care server 400: measuring instrument support server.

Disclaimer

본 문서는 특허 및 과학기술문헌 전용의 첨단 자동번역 시스템을 이용해 생성되었습니다. 따라서 부분적으로 오역의 가능성이 있으며, 본 문서를 자격을 갖춘 전문 번역가에 의한 번역물을 대신하는 것으로 이용되어서는 안 됩니다. 시스템 및 네트워크의 특성때문에 발생한 오역과 부분 누락, 데이터의 불일치등에 대하여 본원은 법적인 책임을 지지 않습니다. 본 문서는 당사의 사전 동의 없이 권한이 없는 일반 대중을 위해 DB 및 시스템에 저장되어 재생, 복사, 배포될 수 없음을 알려드립니다.

(The document produced by using the high-tech machine translation system for the patent and science & technology literature. Therefore, the document can include the mistranslation, and it should not be used as a translation by a professional translator. We hold no legal liability for inconsistency of mistranslation, partial omission, and data generated by feature of system and network. We would like to inform you that the document cannot be regenerated, copied, and distributed by being stored in DB and system for unauthorized general public without our consent.)



(19)대한민국특허청(KR)
(12) 공개특허공보(A)

(51) Int. Cl. (11) 공개번호 10-2007-0061122
G06F 19/00 (2006.01) (43) 공개일자 2007년06월13일

(21) 출원번호 10-2006-0049063
(22) 출원일자 2006년05월30일
심사청구일자 2006년05월30일

(30) 우선권주장 1020050119914 2005년12월08일 대한민국(KR)

(71) 출원인 한국전자통신연구원
대전 유성구 가정동 161번지

(72) 발명자 박윤경
대전 유성구 신성동 한울아파트 102-1002
이진우
대전 유성구 성북동 86-2
유동완
대전 유성구 송강동 8-2 청솔아파트 511-1301
강동오
대전 유성구 신성동 210-62 203호
강규창
대전 유성구 송강동 한마을아파트 110동 201호
이형직
대전 유성구 송강동 청솔아파트 103동 1502호
박지은
충남 공주시 장기면 금암리 282번지
고은정
전북 무주군 무주읍 808-2
정준영
대전 유성구 노은동 열매마을아파트 903동 802호
최성기
대전 서구 용문동 285-3 덕일한마을아파트 1317호
김영성
서울 서초구 방배2동 975-24호
배창식
대전 서구 월평3동 누리아파트 114-401

(74) 대리인 특허법인 씨엔에스·로고스

전체 청구항 수 : 총 24 항

(54) 건강관리 서비스 제공 시스템 및 그 방법

(57) 요약

본 발명은 사용자의 인체에 부착 가능하며, 종류별의 생체 신호를 감지하는 다수개의 센서를 구비하여, 각 센서에서 감지되는 생체 신호를 무선 통신 방식으로 전송하는 다수의 생체 신호 계측 시스템과, 사용자가 가입하는 종류의 건강관리 서비스를 위한 지침서를 제공하는 건강관리 서버와, 사용자가 휴대 가능하며, 사용자가 가입하는 건강관리 서비스를 제공하기 위한 서비스 프로그램을 구동하고, 각 생체 신호 계측 시스템으로부터 무선 통신 방식으로 수신되는 생체 신호와, 건강관리 서버로부터 수신되는 지침서를 기반으로 건강관리 서비스를 제공하는 휴대용 건강관리 시스템을 포함하는 건강관리 서비스 제공 시스템을 개시함으로써, 사용자에게 보다 효과적인 건강관리 서비스를 제공할 수 있도록 하는 것이다.

도 1

도 1

특허청구의 범위

청구항 1.

사용자의 인체에 부착 가능하며, 종류별의 생체 신호를 감지하는 다수개의 센서를 구비하여, 상기 각 센서에서 감지되는 생체 신호를 무선 통신 방식으로 전송하는 다수의 생체 신호 계측 시스템과,

상기 사용자가 가입하는 종류의 건강관리 서비스를 위한 지침서를 제공하는 건강관리 서버와,

상기 사용자가 휴대 가능하며, 상기 사용자가 가입하는 건강관리 서비스를 제공하기 위한 서비스 프로그램을 구동하고, 상기 각 생체 신호 계측 시스템으로부터 상기 무선 통신 방식으로 수신되는 상기 생체 신호와, 상기 건강관리 서버로부터 수신되는 지침서를 기반으로 상기 건강관리 서비스를 제공하는 휴대용 건강관리 시스템을 포함하는 것을 특징으로 하는 건강관리 서비스 제공 시스템.

청구항 2.

제 1 항에 있어서, 상기 휴대용 건강관리 시스템은,

네트워크를 통해 상기 건강관리 서버에 접속하며, 상기 지침서 및 생체 신호를 기반으로 상기 사용자의 건강 정보를 생성하여 출력하고, 상기 건강 정보 및 상기 생체 신호를 상기 건강관리 서버로 전송함을 특징으로 하는 건강관리 서비스 제공 시스템.

청구항 3.

제 1 항에 있어서, 상기 건강관리 서버는,

상기 휴대용 건강관리 시스템으로부터 수신되는 상기 각 종류별 생체 신호와, 상기 가입자의 건강 정보에 따라 상기 지침서를 갱신하여 제공함을 특징으로 하는 건강관리 서비스 제공 시스템.

청구항 4.

제 1 항에 있어서, 상기 센서는,

광혈류량(PPG) 센서, 피부전기반사계(GSR) 센서, 심전도(EKG) 센서, 피부온도(SKT) 센서, 피부전기활동(ECG) 센서 또는 가속도(Accelerometer) 센서 중 어느 하나 이상을 포함하는 것을 특징으로 하는 건강관리 서비스 제공 시스템.

청구항 5.

제 1 항에 있어서, 상기 생체 신호 계측 시스템은,

상기 사용자의 손가락에 장착할 수 있는 반지형, 손목에 장착할 수 있는 팔찌형 또는 가슴에 장착할 수 있는 가슴띠형 중 적어도 하나의 형태로 구현됨을 특징으로 하는 건강관리 서비스 제공 시스템.

청구항 6.

제 1 항에 있어서,

상기 휴대용 건강관리 시스템이 상기 각 생체 신호 계측 시스템과 상기 무선 통신 방식으로 연동될 수 있는 드라이버 프로그램을 제공하는 계측기 지원 서버를 더 포함하는 것을 특징으로 하는 건강관리 서비스 제공 시스템.

청구항 7.

제 1 항에 있어서, 상기 생체 신호 계측 시스템은,

전원이 인가되어 구동되면, 상기 휴대용 건강관리 시스템으로 고유 식별 정보(URL)를 전송하는 건강관리 서비스 제공 시스템.

청구항 8.

제 6항 또는 제 7항에 있어서, 상기 휴대용 건강관리 시스템은,

상기 생체 신호 계측 시스템으로부터 수신되는 상기 고유 식별 정보에 해당하는 드라이버 프로그램이 설치되어 있는지 여부를 확인하고, 설치되어 있지 않으면, 상기 계측기 지원 서버로 상기 고유 식별 정보에 해당하는 드라이버 프로그램을 요청하고, 상기 계측기 지원 서버로부터 제공되는 상기 드라이버 프로그램을 자동 설치하는 건강관리 서비스 제공 시스템.

청구항 9.

제 1 항에 있어서, 상기 건강관리 서버는,

상기 사용자의 건강 정보 또는 생체 신호를 기반으로 의사 또는 전문가에게 상기 지침서의 작성을 문의하여, 상기 지침서를 생성/갱신하고, 상기 지침서를 상기 휴대용 건강관리 시스템으로 제공하는 건강관리 서비스 제공 시스템.

청구항 10.

제 1 항에 있어서, 상기 휴대용 건강관리 시스템은,

상기 각 생체 신호 계측 시스템으로부터 동일한 종류의 생체 신호가 다수개 수신되면, 상기 각 생체 신호 계측 시스템의 센서 신뢰도가 가장 높은 생체 신호를 선택하는 건강관리 서비스 제공 시스템.

청구항 11.

제 1 항에 있어서, 상기 건강관리 서버는,

건강 진단 서비스, 응급 상황 판단 서비스, 응급 상황 대처 서비스 또는 질병별 건강관리 서비스 중 어느 하나인 건강관리 서비스 제공 시스템.

청구항 12.

다수개의 생체 신호 계측 시스템과, 건강관리 서버 및 계측기 지원 서버와 연결되는 휴대용 건강관리 시스템에 있어서,

사용자로부터 기본 건강 정보를 입력받고, 상기 사용자가 상기 건강관리 서버에 접속하여 건강관리 서비스에 가입할 수 있도록 하는 선택부와,

상기 각 생체 신호 계측 시스템으로부터 무선 통신 방식으로 각 종류별 생체 신호를 수신하는 무선 인터페이스부와,

상기 건강관리 서버로부터 네트워크를 통해 지침서 및 서비스 프로그램을 수신하고, 계측기 지원 서버로부터 네트워크를 통해 드라이버 프로그램을 수신하는 네트워크 인터페이스부와,

상기 건강 정보, 지침서 및 생체 신호를 저장하는 저장부와,

상기 서비스 프로그램을 구동하고, 상기 무선 통신 방식으로 수신되는 상기 생체 신호와, 상기 건강관리 서버로부터 수신되는 지침서를 기반으로 상기 사용자가 가입한 건강관리 서비스를 제공하는 제어부를 포함하는 것을 특징으로 하는 휴대용 건강관리 시스템.

청구항 13.

제 12 항에 있어서, 상기 제어부는,

상기 지침서 및 상기 생체 신호를 기반으로 상기 사용자의 건강 정보를 생성하여 출력하고, 상기 생체 신호 및 상기 건강 정보를 상기 건강관리 서버로 주기적으로 또는 실시간적으로 전송함을 특징으로 하는 휴대용 건강관리 시스템.

청구항 14.

제 12항에 있어서, 상기 제어부는,

접속하는 생체 신호 계측 시스템에 해당하는 드라이버 프로그램이 설치되어 있는지 여부를 확인하고, 설치되어 있지 않으면, 상기 계측기 지원 서버로 상기 드라이버 프로그램을 요청하고, 수신되는 상기 드라이버 프로그램을 자동 설치함을 특징으로 하는 휴대용 건강관리 시스템.

청구항 15.

건강관리 서버가 사용자로부터 휴대용 건강관리 시스템을 통해 접속하여 건강관리 서비스에 가입 및 기본 건강 정보를 등록받는 단계와,

상기 건강관리 서버가 상기 기본 건강 정보 및 가입한 건강관리 서비스의 종류에 따른 지침서를 작성하여, 상기 휴대용 건강관리 시스템으로 제공하는 단계와,

다수개의 생체 신호 계측 시스템이 상기 사용자의 종류별의 생체 신호를 감지하여 무선 통신 방식으로 상기 휴대용 건강관리 시스템으로 전송하는 단계와,

상기 휴대용 건강관리 시스템이 상기 감지된 생체 신호와 상기 지침서를 기반으로 상기 건강관리 서비스를 제공하는 단계를 포함하는 것을 특징으로 하는 건강관리 서비스 제공 방법.

청구항 16.

제 15 항에 있어서, 상기 건강관리 서비스를 제공하는 단계는,

상기 휴대용 건강관리 시스템이 상기 지침서 및 생체 신호를 기반으로 상기 사용자의 건강 정보를 생성하여 출력함을 특징으로 하는 건강관리 서비스 제공 방법.

청구항 17.

제 15 항에 있어서,

상기 휴대용 건강관리 시스템이 상기 종류별 생체 신호 및 건강 정보를 상기 건강관리 서버로 전송하는 단계와,

상기 건강관리 서버가 상기 휴대용 건강관리 시스템으로부터 수신되는 상기 각 종류별 생체 신호와, 상기 가입자의 건강 정보에 따라 상기 지침서를 갱신하여 제공하는 단계를 더 포함하는 것을 특징으로 하는 건강관리 서비스 제공 방법.

청구항 18.

제 15 항에 있어서, 상기 생체 신호는,

광혈류량(PPG) 신호, 피부전기반사계(GSR) 신호, 심전도(EKG) 신호, 피부온도(SKT) 신호, 피부전기활동(ECG) 신호 또는 가속도(Accelerometer) 신호 중 어느 하나 이상을 포함하는 것을 특징으로 하는 건강관리 서비스 제공 방법.

청구항 19.

제 15 항에 있어서,

상기 생체 신호 계측 시스템이 전원이 인가되어 구동되면, 상기 휴대용 건강관리 시스템으로 고유 식별 정보(URL)를 전송하는 단계와,

상기 휴대용 건강관리 시스템이 상기 생체 신호 계측 시스템으로부터 수신되는 상기 고유 식별 정보에 해당하는 드라이버 프로그램이 설치되어 있는지 여부를 확인하고, 설치되어 있지 않으면, 상기 계측기 지원 서버로 상기 고유 식별 정보에 해당하는 드라이버 프로그램을 요청하는 단계와,

상기 계측기 지원 서버가 상기 고유 식별 정보에 해당하는 드라이버 프로그램을 전송하는 단계와,

상기 휴대용 건강관리 시스템이 상기 계측기 지원 서버로부터 수신되는 상기 드라이버 프로그램을 자동 설치하는 단계를 더 포함하는 것을 특징으로 하는 건강관리 서비스 제공 방법.

청구항 20.

제 15 항에 있어서, 상기 지침서의 작성은,

상기 건강관리 서버가 상기 사용자의 건강 정보 또는 생체 신호를 기반으로 의사 또는 전문가에게 상기 지침서의 작성을 문의하여, 상기 지침서를 생성/갱신함을 특징으로 하는 건강관리 서비스 제공 방법.

청구항 21.

제 15 항에 있어서,

상기 각 생체 신호 계측 시스템으로부터 동일한 종류의 생체 신호가 다수개 수신되면, 상기 각 생체 신호 계측 시스템의 센서 신뢰도가 가장 높은 생체 신호를 선택하는 단계를 더 포함하는 것을 특징으로 하는 건강관리 서비스 제공 방법.

청구항 22.

제 15 항에 있어서, 상기 건강관리 서비스는,

건강 진단 서비스, 응급 상황 판단 서비스, 응급 상황 대처 서비스 또는 질병별 건강관리 서비스 중 적어도 하나를 제공받을음을 특징으로 하는 건강관리 서비스 제공 방법.

청구항 23.

다수개의 생체 신호 계측 시스템과, 건강관리 서버 및 계측기 지원 서버와 연결되는 휴대용 건강관리 시스템의 서비스 제공 방법에 있어서,

상기 사용자가 상기 건강관리 서버에 접속하여 건강관리 서비스에 가입하면, 상기 사용자로부터 기본 건강 정보를 등록받는 단계와,

상기 건강관리 서버로부터 상기 기본 건강 정보 및 서비스의 종류에 따른 지침서를 수신하여 저장하고, 서비스 프로그램을 구동하는 단계와,

상기 각 생체 신호 계측 시스템으로부터 무선 통신 방식으로 각 종류별 생체 신호를 수신하는 단계와,

상기 무선 통신 방식으로 수신되는 상기 생체 신호와, 지침서를 기반으로 상기 서비스 프로그램에 따라 건강 정보를 생성하여 출력하는 단계를 포함하는 것을 특징으로 하는 건강관리 서비스 제공 방법.

청구항 24.

제 23 항에 있어서,

상기 생체 신호 및 상기 건강 정보를 상기 건강관리 서버로 주기적으로 또는 실시간적으로 전송하는 단계와,

접속하는 생체 신호 계측 시스템에 해당하는 드라이버 프로그램이 설치되어 있는지 여부를 확인하고, 설치되어 있지 않으면, 상기 계측기 지원 서버로 상기 드라이버 프로그램을 요청하고, 수신되는 상기 드라이버 프로그램을 자동 설치하는 단계를 더 포함하는 것을 특징으로 하는 건강관리 서비스 제공 방법.

명세서

발명의 상세한 설명

발명의 목적

발명이 속하는 기술 및 그 분야의 종래기술

본 발명은 건강관리 서비스 제공 시스템 및 그 방법에 관한 것이다.

오늘날, 산업화, 컴퓨터 기술의 발전, 이동 수단의 발전 및 환경오염 등과 같은 원인으로 현대인들의 건강 상태가 갈수록 악화되고 있는 현실이며, 소득의 증가로 인하여 건강에 대한 관심의 증가하고 있는 추세이다.

이러한 사용자의 욕구를 충족시키기 위하여 제시된 기존의 건강관리 시스템은 사용자의 생체 신호를 계측하는 생체신호 시스템과, 건강관리 서비스를 제공하는 건강관리 시스템이 상호 연동하여 사용자의 생체 신호에 대한 건강 상태만을 통지하는데 그치고 있다.

또한, 기존의 건강관리 시스템은 생체 신호를 계측하여, 그 결과 값을 통지하는데 그치고 있음으로, 사용자가 전문적인 지식이 없는 상태에서는 크게 효과를 발휘하지 못하게 된다.

예를 들어, 기존의 건강관리 시스템은 단순치 계측된 생체 신호를 수치 또는 그래프 형태로 사용자에게 제공할 수는 있으나, 현재 건강 상태 또는 계측된 생체 신호에 따른 건강 상태를 명확하게 사용자에게 전송하지 않음으로, 사용자는 현재 자신의 건강 상태에 대하여 명확하게 확인할 수 없으며, 현재 건강 상태에 대한 문제점 및 그 문제를 해소할 수 있는 방법을 인지할 수 없음으로, 단순히 현재 생체 상태만을 사용자에게 알려주는 기능만을 제공할 뿐이다.

아울러, 기존의 건강관리 시스템은 인체의 상태를 감지하는 생체 신호 계측 시스템과 서버간 근거리에서 유선으로 연결되어야만 서비스를 제공할 수 있는 공간적인 제약이 있으며, 사용자가 새로운 생체 신호 계측 시스템을 이용하고자 하는 경우에는 별도의 설치 과정을 거친 후에야 사용할 수 있는 번거로움이 있다.

발명이 이루고자 하는 기술적 과제

따라서 본 발명은 상기와 같은 문제점을 해결하기 위하여 창안된 것으로, 인체의 상태를 감지하여 생체 신호를 제공하는 각종 센서를 액세서리 형태로 분산 배치할 수 있도록 소형화하여 사용자가 착용할 수 있도록 하고, 건강관리 서비스와, 생체 신호 계측 시스템간의 독립성을 제공할 수 있도록 하여 사용자는 원하는 생체 신호 계측시스템을 착용하여, 원하는 건강관리 서비스를 받을 수 있도록 하는 것이 있다.

또한, 본 발명은 건강관리 서비스를 제공받는 사용자들의 건강 지침을 의사에게 문의하여 적합한 건강 지침을 제공받을 수 있도록 하고, 사용자가 착용하는 생체 신호 계측 시스템의 종류에 따라 별도의 번거로운 설치 과정 없이 실시간으로 서비스를 제공받을 수 있는 건강관리 서비스 제공 시스템 및 그 방법을 제공하는 것에 그 목적이 있다.

발명의 구성

상기 목적을 달성하기 위한 본 발명의 일측면에 따른 건강관리 서비스 제공 시스템은, 사용자의 인체에 부착 가능하며, 종류별의 생체 신호를 감지하는 다수개의 센서를 구비하여, 각 센서에서 감지되는 생체 신호를 무선 통신 방식으로 전송하는 다수의 생체 신호 계측 시스템과, 사용자가 가입하는 종류의 건강관리 서비스를 위한 지침서를 제공하는 건강관리 서버와, 사용자가 휴대 가능하며, 사용자가 가입하는 건강관리 서비스를 제공하기 위한 서비스 프로그램을 구동하고, 각 생체 신호 계측 시스템으로부터 무선 통신 방식으로 수신되는 생체 신호와, 건강관리 서버로부터 수신되는 지침서를 기반으로 건강관리 서비스를 제공하는 휴대용 건강관리 시스템을 포함한다.

본 발명에 따른 휴대용 건강관리 시스템은, 네트워크를 통해 건강관리 서버에 접속하며, 지침서 및 생체 신호를 기반으로 사용자의 건강 정보를 생성하여 출력하고, 건강 정보 및 생체 신호를 건강관리 서버로 전송한다.

본 발명에 따른 건강관리 서버는, 휴대용 건강관리 시스템으로부터 수신되는 각 종류별 생체 신호와, 가입자의 건강 정보에 따라 지침서를 갱신하여 제공한다.

본 발명에 따른 센서는, PPG(photoplethysmogram : 광혈류량) 센서, GSR(galvanic skin reflex : 피부전기반사계) 센서, EKG(Electrokardiogramme : 심전도) 센서, SKT(skin temperature : 피부온도) 센서, ECG(electrodermal activity : 피부전기활동) 센서 또는 가속도(Accelerometer) 센서 중 어느 하나 이상이다.

본 발명에 따른 생체 신호 계측 시스템은, 사용자의 손가락에 장착할 수 있는 반지형, 손목에 장착할 수 있는 팔찌형 또는 가슴에 장착할 수 있는 가슴띠형 중 어느 하나의 형태로 구현된다.

본 발명에 따른 건강관리 서비스 제공 시스템은, 휴대용 건강관리 시스템이 각 생체 신호 계측 시스템과 무선 통신 방식으로 연동될 수 있는 드라이버 프로그램을 제공하는 계측기 지원 서버를 더 포함한다.

본 발명에 따른 생체 신호 계측 시스템은, 전원이 인가되어 구동되면, 휴대용 건강관리 시스템으로 고유 식별 정보(URL)를 전송한다.

본 발명에 따른 휴대용 건강관리 시스템은, 생체 신호 계측 시스템으로부터 수신되는 고유 식별 정보에 해당하는 드라이버 프로그램이 설치되어 있는지 여부를 확인하고, 설치되어 있지 않으면, 계측기 지원 서버로 고유 식별 정보에 해당하는 드라이버 프로그램을 요청하고, 계측기 지원 서버로부터 제공되는 드라이버 프로그램을 자동 설치한다.

본 발명에 따른 건강관리 서버는, 사용자의 건강 정보 또는 생체 신호를 기반으로 의사 또는 전문가에게 지침서의 작성을 문의하여, 지침서를 생성/갱신하고, 지침서를 휴대용 건강관리 시스템으로 제공한다.

본 발명에 따른 휴대용 건강관리 시스템은, 각 생체 신호 계측 시스템으로부터 동일한 종류의 생체 신호가 다수개 수신되면, 각 생체 신호 계측 시스템의 센서 신뢰도가 가장 높은 생체 신호를 선택한다.

본 발명에 따른 건강관리 서비스는, 건강 진단 서비스, 응급 상황 판단 서비스, 응급 상황 대처 서비스 또는 질병별 건강관리 서비스 중 어느 하나이다.

본 발명의 다른 측면에 따른 다수개의 생체 신호 계측 시스템과, 건강관리 서버 및 계측기 지원 서버와 연결되는 휴대용 건강관리 시스템은, 사용자로부터 기본 건강 정보를 입력받고, 사용자가 건강관리 서버에 접속하여 건강관리 서비스에 가입할 수 있도록 하는 선택부와, 각 생체 신호 계측 시스템으로부터 무선 통신 방식으로 각 종류별 생체 신호를 수신하는 무선 인터페이스부와, 건강관리 서버로부터 네트워크를 통해 지침서 및 서비스 프로그램을 수신하고, 계측기 지원 서버로부터 네트워크를 통해 드라이버 프로그램을 수신하는 네트워크 인터페이스부와, 건강 정보, 지침서 및 생체 신호를 저장하는 저장부와, 서비스 프로그램을 구동하고, 무선 통신 방식으로 수신되는 생체 신호와, 건강관리 서버로부터 수신되는 지침서를 기반으로 사용자가 가입한 건강관리 서비스를 제공하는 제어부를 포함한다.

본 발명에 따른 제어부는, 지침서 및 생체 신호를 기반으로 사용자의 건강 정보를 생성하여 출력하고, 생체 신호 및 건강 정보를 건강관리 서버로 주기적으로 또는 실시간적으로 전송한다.

본 발명에 따른 제어부는, 접속하는 생체 신호 계측 시스템에 해당하는 드라이버 프로그램이 설치되어 있는지 여부를 확인하고, 설치되어 있지 않으면, 계측기 지원 서버로 드라이버 프로그램을 요청하고, 수신되는 드라이버 프로그램을 자동 설치한다.

본 발명의 또 다른 측면에 따른 건강관리 서비스를 제공하는 방법은, 건강관리 서버가 사용자로부터 휴대용 건강관리 시스템을 통해 접속하여 건강관리 서비스에 가입 및 기본 건강 정보를 등록받는 단계와, 건강관리 서버가 기본 건강 정보 및 가입한 건강관리 서비스의 종류에 따른 지침서를 작성하여, 휴대용 건강관리 시스템으로 제공하는 단계와, 다수개의 생체 신호 계측 시스템이 사용자의 종류별의 생체 신호를 감지하여 무선 통신 방식으로 휴대용 건강관리 시스템으로 전송하는 단계와, 휴대용 건강관리 시스템이 감지된 생체 신호와 지침서를 기반으로 건강관리 서비스를 제공하는 단계를 포함한다.

본 발명에 따른 건강관리 서비스를 제공하는 단계는, 휴대용 건강관리 시스템이 지침서 및 생체 신호를 기반으로 사용자의 건강 정보를 생성하여 출력한다.

본 발명에 따른 건강관리 서비스를 제공하는 방법은, 휴대용 건강관리 시스템이 종류별 생체 신호 및 건강 정보를 건강관리 서버로 전송하는 단계와, 건강관리 서버가 휴대용 건강관리 시스템으로부터 수신되는 각 종류별 생체 신호와, 가입자의 건강 정보에 따라 지침서를 갱신하여 제공하는 단계를 더 포함한다.

본 발명에 따른 생체 신호는, 광혈류량(PPG : photoplethysmogram) 신호, 피부전기반사계(GSR :galvanic skin reflex) 신호, 심전도(EKG :Electrokardiogramme) 신호, 피부온도(SKT:skin temperature) 신호, 피부전기활동(ECG : electrodermal activity) 신호 또는 가속도(Accelerometer) 신호 중 어느 하나 이상이다.

본 발명에 따른 건강관리 서비스를 제공하는 방법은, 생체 신호 계측 시스템이 전원이 인가되어 구동되면, 휴대용 건강관리 시스템으로 고유 식별 정보(URL)를 전송하는 단계와, 휴대용 건강관리 시스템이 생체 신호 계측 시스템으로부터 수신되는 고유 식별 정보에 해당하는 드라이버 프로그램이 설치되어 있는지 여부를 확인하고, 설치되어 있지 않으면, 계측기 지원 서버로 고유 식별 정보에 해당하는 드라이버 프로그램을 요청하는 단계와, 계측기 지원 서버가 고유 식별 정보에 해당하는 드라이버 프로그램을 전송하는 단계와, 휴대용 건강관리 시스템이 계측기 지원 서버로부터 수신되는 드라이버 프로그램을 자동 설치하는 단계를 더 포함한다.

본 발명에 따른 지침서의 작성은, 건강관리 서버가 사용자의 건강 정보 또는 생체 신호를 기반으로 의사 또는 전문가에게 지침서의 작성을 문의하여, 지침서를 생성/갱신한다.

본 발명에 따른 건강관리 서비스를 제공하는 방법은, 각 생체 신호 계측 시스템으로부터 동일한 종류의 생체 신호가 다수개 수신되면, 각 생체 신호 계측 시스템의 센서 신뢰도가 가장 높은 생체 신호를 선택하는 단계를 더 포함한다.

본 발명의 또 다른 측면에 따른 다수개의 생체 신호 계측 시스템과, 건강관리 서버 및 계측기 지원 서버와 연결되는 휴대용 건강관리 시스템의 서비스 제공 방법은, 사용자가 건강관리 서버에 접속하여 건강관리 서비스에 가입하면, 상기 사용자로부터 기본 건강 정보를 등록받는 단계와, 건강관리 서버로부터 기본 건강 정보 및 서비스의 종류에 따른 지침서를 수신하여 저장하고, 서비스 프로그램을 구동하는 단계와, 각 생체 신호 계측 시스템으로부터 무선 통신 방식으로 각 종류별 생체 신호를 수신하는 단계와, 무선 통신 방식으로 수신되는 생체 신호와, 지침서를 기반으로 서비스 프로그램에 따라 건강 정보를 생성하여 출력하는 단계를 포함한다.

본 발명에 따른 휴대용 건강관리 시스템의 서비스 제공 방법은, 생체 신호 및 건강 정보를 건강관리 서버로 주기적으로 또는 실시간적으로 전송하는 단계와, 접속하는 생체 신호 계측 시스템에 해당하는 드라이버 프로그램이 설치되어 있는지 여부를 확인하고, 설치되어 있지 않으면, 계측기 지원 서버로 드라이버 프로그램을 요청하고, 수신되는 드라이버 프로그램을 자동 설치하는 단계를 더 포함한다.

이하 본 발명에 따른 건강관리 서비스 제공 시스템 및 그 방법을 첨부한 도면을 참조하여 상세히 설명한다.

도 1은 본 발명의 바람직한 실시예에 따른 건강관리 서비스 제공 시스템을 설명하기 위한 블록 도면이다.

도 1을 참조하면, 본 발명에 따른 건강관리 서비스 제공 시스템은, 다수개의 생체 신호 계측 시스템(100)과, 각 생체 신호 계측 시스템(100)과 무선으로 연결되는 휴대용 건강관리 시스템(200)과, 휴대용 건강관리 시스템(200)과 네트워크로 연결되는 계측기 지원 서버(300) 및 건강관리 서버(400)를 포함한다.

그리고 건강관리 서버(400)는 의사와 같이 건강 관련 정보를 분석하여, 건강관리 지침서를 작성할 수 있는 전문가 또는 전문 기관과 연동하여, 사용자에게 대한 건강관리 서비스를 제공한다. 즉, 건강관리 서버(400)는 건강관리 서비스에 가입하는 사용자별 건강 정보 및 생체 신호에 따라 각기 다른 건강관리 지침서를 작성하고, 해당 사용자의 휴대용 건강관리 시스템(200)으로 전송하여, 건강관리 서비스를 제공한다.

이러한, 건강관리 서비스는 건강 진단 서비스, 응급 상황 판단/대처 서비스, 질병별 건강관리 서비스 등이 될 수 있으며, 예를 들어, 건강 진단 서비스는 사용자의 혈압, 맥박, 체온 등을 분석하여 정상 여부를 판별하는 서비스이며, 사용자가 건강 진단 서비스를 선택하면, 건강관리 서버(400)는 사용자의 혈압, 맥박, 체온 등의 값에 따라 정상 또는 비정상 상태를 파악할 수 있는 건강관리 지침서를 제공하고, 사용자가 선택한 서비스를 제공할 수 있는 서비스 프로그램과 건강관리 지침서들을 함께 제공한다.

각 생체 신호 계측 시스템(100)은 사용자의 인체 곳곳에 부착 설치되며, 부착되는 센서로부터 감지되는 인체의 생체 신호를 제공한다.

그리고 생체 신호 계측 시스템(100)은 무선 통신 방식으로 생체 신호를 휴대용 건강관리 시스템(200)으로 전송할 수 있으며, 이러한 무선 통신 시스템은 적외선 통신 방식, 블루투스(Bluetooth) 통신 방식, 지그비(Zigbee) 통신 방식 또는 전파식별(Radio Frequency Identification) 통신 방식 등이 사용될 수 있다.

휴대용 건강관리 시스템(200)은 사용자가 휴대 가능하며, 각 생체 신호 계측 시스템(100)으로부터 수신되는 생체 신호들의 특징을 분석하고, 사용자가 선택하는 건강관리 서비스를 제공한다.

건강관리 서버(400)는 휴대용 건강관리 시스템(200)으로부터 수신되는 생체 신호에 따른 사용자의 건강 관련 정보를 저장하고, 건강 관련 정보를 의사에게 문의하여, 의사가 해당 사용자에게 적합한 건강관리 지침을 작성하면, 의사의 건강관리 지침을 사용자의 휴대용 건강관리 시스템(200)으로 전송한다.

계측기 지원 서버(300)는 사용자가 사용하는 각 생체 신호 계측 시스템(100)들의 계측기 관련 정보 및 처리 프로그램 정보 등과 같은 설치 모듈을 저장하고, 휴대용 건강관리 시스템(200)에 해당 생체 신호 계측 시스템(100)의 설치 모듈을 제공한다.

도 2a는 본 발명의 제 1 실시예에 따른 생체 신호 계측 시스템을 설명하기 위한 도면이다.

도 2a는 본 발명의 제 1 실시예에 따른 반지형 생체 신호 계측 시스템(100)을 도시한 것으로, 링의 내경면 소정 영역에는 PPG 센서가 부착되고, 외경면의 소정 영역에는 아날로그 처리 모듈(110)이 설치되며, PPG 센서와 아날로그 처리 모듈(110)은 전기적으로 연결된다.

사용자가 반지형 생체 신호 계측 시스템(100)을 손가락에 끼우면, 링의 내경면의 광혈류량(이하, PPG이라 칭함) 센서는 손가락의 광 혈류량을 감지하여 PPG 생체 신호를 아날로그 처리 모듈(110)로 전송하고, 아날로그 처리 모듈(110)은 PPG 생체 신호를 무선 통신 방식으로 휴대용 건강관리 시스템(200)에 전송한다.

그리고 아날로그 처리 모듈(110)은 내부에 전원 공급 장치(예를 들어 배터리)를 구비할 수 있는 공간이 마련되어, 무선 통신 방식으로 PPG 생체 신호를 전송할 수 있도록 한다.

도 2b는 본 발명의 제 2 실시예에 따른 생체 신호 계측 시스템을 설명하기 위한 도면이다.

도 2a는 본 발명의 제 2 실시예에 따른 팔찌형 생체 신호 계측 시스템(100')을 도시한 것으로, 링의 외경면에는 피부전기반사계(galvanic skin reflex 이하, GSR라 칭함) 센서, 심전도(Elektrokardiogramme 이하, EKG라 칭함) 센서, 피부온도(Skin temperature 이하, SKT라 칭함) 센서 등이 부착되며, 내경면에는 피부전기활동(electrodermal activity 이하, ECG라 칭함) 센서, SKT 센서 등이 부착된다.

그리고 링의 외경면에 소정 크기의 기관 상에 GSR 센서, EKG 센서, SKT 센서 등이 부착되며, 생체 신호를 필터링하고, A/D 컨버팅하여 생체 신호를 디지털 방식의 신호로 변환한 이후에 무선 통신 방식으로 휴대용 건강관리 시스템(200)으로 전송하는 디지털 처리 모듈을 구비한다.

또한, 기관 상에는 사용자가 생체 신호를 휴대용 건강관리 시스템(200)으로 전송하는 버튼 및 생체 신호 감지 시작 버튼 등이 설치될 수 있다.

이러한, 팔찌형 생체 신호 계측 시스템(100)은 사용자가 손목에 차게 되면, 내경면에 부착되는 ECG 센서 및 SKT 센서는 ECG 생체 신호 및 SKT 생체 신호를 감지하여 디지털 처리 모듈로 전송하고, 디지털 처리 모듈은 ECG 생체 신호 및 SKT 생체 신호를 휴대용 건강관리 시스템(200)으로 전송한다.

또한, 사용자가 팔찌형 생체 신호 계측 시스템(100)의 외경면에 부착된 GSR 센서, EKG 센서, SKT 센서에 반대 손가락의 끝 부분을 올려놓고, 생체 신호 감지 시작 버튼을 누르면, GSR 센서, EKG 센서, SKT 센서들은 GSR 생체 신호, EKG 생체 신호, SKT 생체 신호를 감지하고, 전송 버튼을 누르면, 디지털 처리 모듈로 전송하고, 디지털 처리 모듈은 휴대용 건강관리 시스템(200)으로 각 생체 신호를 전송한다.

도 2c는 본 발명의 제 3 실시예에 따른 생체 신호 계측 시스템을 설명하기 위한 도면이다.

도 2c는 본 발명의 제 3 실시예에 따른 가슴띠형 생체 신호 계측 시스템(100'')을 도시한 것으로, 가슴띠형 생체 신호 계측 시스템은 외측에 인체의 움직임 감지하는 가속도계(Accelerometer)와 인체 접촉면에 SKT 센서, EKG 센서 등이 부착된다.

가슴띠형 생체 신호 계측 시스템(100)은 소정 구동 전원을 공급하는 배터리와, 외측에 동작 상태를 나타내는 LED(램프)와, 상측면에 전원을 리셋할 수 있는 제시작 버튼과, 하측면에서 전원을 온/오프할 수 있는 전원 버튼을 구비한다.

가속도계, SKT 센서, EKG 센서 및 각 버튼은 기관 상에 구현되어 신호선으로 연결될 수 있으며, 사용자가 선택하는 버튼에 따라 생체 신호 계측 시스템(100)을 전원을 온/오프하거나, 리셋하고, SKT 센서, EKG 센서로부터 수신되는 생체 신호와, 가속도계로부터 수신되는 감지 신호를 무선으로 휴대용 건강관리 시스템(200)으로 전송하는 제어 수단(미도시)을 구비한다.

도 3은 본 발명의 바람직한 실시예에 따른 휴대용 건강관리 시스템을 설명하기 위한 블록 도면이다.

상기 도 3을 참조하면, 본 발명에 따른 휴대용 건강관리 시스템(200)은 무선 인터페이스부(210)와, 네트워크 인터페이스부(220)와, 출력부(230)와, 선택부(240)와, 저장부(250)와, 제어부(260)를 포함한다.

상기 무선 인터페이스부(210)는 각 생체 신호 계측 시스템(100)으로부터 생체 신호를 수신한다.

상기 네트워크 인터페이스부(220)는 네트워크를 통해 계측기 지원 서버(300) 및 건강관리 서버(400)와 접속하며, 계측기 지원 서버(300)로부터 드라이버 프로그램을 수신하고, 건강관리 서버(400)로부터 건강관리 지침서를 수신하고, 생체 신호 및 건강 관련 정보를 건강관리 서버(400)로 전송한다.

상기 선택부(240)는 다수개의 키 버튼을 구비하며, 사용자가 서비스를 선택하고, 기본 건강 정보를 입력할 수 있도록 한다.

상기 저장부(250)는 건강관리 서버(400)로부터 수신되는 건강관리 지침서 및 휴대용 건강관리 시스템(200)이 생체 신호를 분석하고, 건강관리 지침서를 기반으로 생성하는 건강 관련 정보를 저장한다.

상기 제어부(260)는 수신되는 생체 신호를 종류별로 분석하고, 건강관리 지침서와, 분석된 생체 신호를 비교 검토한 이후에 건강 관련 정보를 생성하고, 건강 관련 정보를 출력부(230)로 출력하여 사용자에게 건강관리 서비스를 제공한다. 그리고 제어부(260)는 건강 관련 정보 및 생체 신호를 건강관리 서버(400)로 전송하여, 의사가 건강 관련 정보 및 생체 신호에 따라 건강관리 지침서를 업데이트할 수 있도록 한다.

또한, 생체 신호 계측 시스템(100)을 사용자가 착용하여 전원을 온하면, 생체 신호 계측 시스템(100)은 고유 식별 정보(URL)를 휴대용 건강관리 시스템(200)으로 전송하고, 휴대용 건강관리 시스템(200)의 제어부(260)는 고유 식별 정보에 해당하는 드라이버 프로그램이 설치되어 있는지 여부를 확인한 이후에 설치되어 있지 않으면, 계측기 지원 서버(300)로 접속하여, 고유 식별 정보에 상응하는 드라이버 프로그램을 요청하고, 드라이버 프로그램이 수신되면, 수신된 프로그램을 자동으로 설치하여 해당 생체 신호 계측 시스템(100)으로부터 무선 방식으로 생체 신호를 수신한다.

도 4는 본 발명의 바람직한 실시예에 따른 건강관리 서비스 제공 시스템의 건강관리 서비스 흐름을 설명하기 위한 흐름도이다.

상기 도 4를 참조하면, S100단계에서 사용자는 휴대용 건강관리 시스템(200)을 통해 건강관리 서버(400)에 접속하여 건강관리 서비스에 가입하고, 원하는 건강관리 서비스를 선택하고, 사용자가 입력하는 기본 건강 정보를 전송한다. 즉, 사용자는 먼저 자신이 원하는 서비스를 건강관리 서버(400)에서 선택하고, 건강관리 서버(400)는 사용자가 선택하는 서비스와 서비스들을 수행하는데 필요한 프로그램 정보를 휴대용 건강관리 시스템(200)으로 전송하여 자동 설치되도록 한다.

예를 들어, 건강관리 서버(400)가 건강 진단 서비스, 응급 상황 판단/대처 서비스, 질병별 건강관리 서비스 등을 제공하는 경우, 사용자가 혈압, 맥박, 체온 등의 정상 여부를 판별하는 건강 진단 서비스를 선택하면, 해당 서비스 모듈과 함께 서비스를 구동하는데 필요한 건강관리 지침서들을 함께 제공한다. 이러한 건강 진단 서비스인 경우의 건강관리 지침서는 사용자의 혈압, 맥박, 체온의 정상 여부를 판별할 수 있는 범위 값을 포함할 수 있으며, 이러한 값들은 의사의 판단에 따라 조정되어 조정 시마다 통보되어 서비스에 활용될 수 있다. 그리고 지침서는 사용자가 선택하는 서비스 및 사용자별 건강 상태 또는 병력에 따라 적절하게 구성될 수 있다.

이후, S110단계에서 건강관리 서버(400)는 사용자가 선택하는 서비스에 관련한 서비스 프로그램 정보, 해당 서비스의 지침서를 휴대용 건강관리 시스템(200)으로 전송한다. 이에 따라 휴대용 건강관리 시스템(200)은 수신되는 프로그램 정보 및 지침서를 자동 설치한다.

사용자가 생체 신호 계측 시스템(100)을 인체에 착용하면, S130단계에서 생체 신호 계측 시스템(100)은 고유 식별 정보(드라이버 URL)를 휴대용 건강관리 시스템(200)으로 전송한다.

그러면 S140단계에서 휴대용 건강관리 시스템(200)은 생체 신호 계측 시스템(100)으로부터 수신되는 고유 식별 정보에 따른 드라이버 프로그램이 설치되어 있는지 여부를 확인한다. 그런 다음 S150단계에서 휴대용 건강관리 시스템(200)은 드라이버 프로그램이 설치되어 있지 않으면, 계측기 지원 서버(300)에 접속하고, 해당 생체 신호 계측 시스템(100)의 드라이버 프로그램을 요청한다. 이에 따라 S160단계에서 계측기 지원 서버(300)는 생체 신호 계측 시스템(100)의 고유 식별 정보에 해당하는 드라이버 프로그램을 휴대용 건강관리 시스템(200)으로 전송한다. 그러면 휴대용 건강관리 시스템(200)은 계측기 지원 서버(300)로부터 수신되는 드라이버 프로그램을 자동 설치한다.

한편, 사용자가 건강관리 시스템(200)을 사용하는 중에 새로운 생체 신호 계측 시스템(100)을 추가로 착용한 경우 역시 이와 마찬가지로 생체 신호 계측 시스템(100)으로부터 수신되는 고유 식별 정보에 해당하는 드라이버 프로그램이 설치되어 있지 않으면, 계측기 지원 서버(300)로부터 드라이버 프로그램을 전송받아 자동 설치한다. 또한, 다수의 생체 신호 계측 시스템(100)으로부터 동일한 종류의 생체 신호가 수신되는 경우에는 생체 신호 계측 시스템(100) 중 신뢰도가 높은 생체 신호 계측 시스템(100)으로부터 수신되는 생체 신호를 택일하여 사용할 수 있다.

이후, S170단계에서 각 생체 신호 계측 시스템(100)을 부착된 센서를 통해 감지되는 생체 신호를 휴대용 건강관리 시스템(200)으로 전송한다. 그러면 S180단계에서 휴대용 건강관리 시스템(200)은 건강관리 서버(400)로부터 수신되는 지침서와, 각 생체 신호 계측 시스템(100)으로부터 수신되는 생체 신호를 분석하여 사용자가 선택한 서비스를 제공한다. 예를 들어, 사용자가 건강 진단 서비스를 선택한 경우, 수신되는 생체 신호에 따라 현재 건강 상태가 양호한지, 위험한지 등을 출력하여, 사용자가 건강을 진단할 수 있도록 한다.

그런 다음 S190단계에서 휴대용 건강관리 시스템(200)은 사용자가 선택한 서비스를 제공한 과로 생성되는 각종 건강 관련 정보와 생체 신호 계측 시스템(100)으로부터 수신되는 생체 신호를 건강관리 서버(400)로 전송한다. 이에 따라 S200단계에서 건강관리 서버(400)는 주기적 또는 건강 상태 정보 및 생체 신호가 변경되면, 의사에게 사용자의 건강 상태를 문의하고, 지침서를 갱신하고, S210단계에서 지침서가 갱신되면, 갱신된 지침서를 휴대용 건강관리 시스템(200)으로 전송한다. 즉, 의사는 수시로 자신이 원하는 시간에 건강관리 서버(400)로부터 사용자의 건강 정보를 열람하여 사용자의 건강 상태를 판별하고 필요 시 새로운 지침을 작성하고, 건강관리 서버(400)는 의사가 건강관리 지침서를 변경한 경우, 실시간으로 휴대용 건강관리 시스템에 전송하여 건강관리 지침서가 업데이트되도록 한다.

도 5는 본 발명의 바람직한 실시예에 따른 건강관리 서비스를 제공하는 방법을 설명하기 위한 플로차트 도면이다.

상기 도 5를 참조하면, S300단계에서 사용자는 휴대용 건강관리 시스템(200)을 통해 건강관리 서버(400)에 접속하여 서비스에 가입하고, 원하는 서비스를 선택하면서 사용자의 기본 건강 정보를 전송한다.

S310단계에서 건강관리 서버(400)는 사용자를 등록하고, 해당 사용자의 기본 건강 정보와, 선택한 서비스에 따른 건강관리 지침서를 휴대용 건강관리 시스템(200)으로 전송한다. 즉, 사용자는 자신이 원하는 서비스를 건강관리 서버(400)에서 선택하고, 건강관리 서버(400)는 사용자가 선택하는 서비스와 서비스들을 수행하는데 필요한 프로그램 정보 및 기본 건강 정보에 따른 건강관리 지침서를 휴대용 건강관리 시스템(200)으로 전송한다. 예를 들어, 건강관리 서버(400)가 건강 진단 서비스, 응급 상황 판단/대처 서비스, 질병별 건강관리 서비스 등을 제공하는 경우, 사용자가 혈압, 맥박, 체온 등의 정상 여부를 판별하는 건강 진단 서비스를 선택하면, 해당 서비스 모듈과 함께 서비스를 구동하는데 필요한 건강관리 지침서들을 함께 제공한다.

S320단계에서 사용자가 생체 신호 계측 시스템(100)을 착용하여 전원을 온하면, 생체 신호 계측 시스템(100)은 고유 식별 정보(URL)를 휴대용 건강관리 시스템(200)으로 전송한다. 그러면 S330단계에서 휴대용 건강관리 시스템(200)은 생체 신호 계측 시스템(100)으로부터 수신되는 고유 식별 정보에 따른 드라이버 프로그램이 설치되어 있는지 여부를 확인한다.

그런 다음 S340단계에서 휴대용 건강관리 시스템(200)은 드라이버 프로그램이 설치되어 있지 않으면, 계측기 지원 서버(300)에 접속하여, 해당 생체 신호 계측 시스템(100)의 드라이버 프로그램을 요청한다. 그러면 계측기 지원 서버(300)는 생체 신호 계측 시스템(100)의 고유 식별 정보에 해당하는 드라이버 프로그램을 휴대용 건강관리 시스템(200)으로 전송한다.

S350단계에서 휴대용 건강관리 시스템(200)은 계측기 지원 서버(300)로부터 수신되는 드라이버 프로그램을 자동 설치한다.

한편, 사용자가 건강관리 시스템(200)을 사용하는 중에 새로운 생체 신호 계측 시스템(100)을 추가로 착용한 경우 역시 이와 마찬가지로 생체 신호 계측 시스템(100)으로부터 수신되는 고유 식별 정보에 해당하는 드라이버 프로그램이 설치되어 있지 않으면, 계측기 지원 서버(300)로부터 드라이버 프로그램을 전송받아 자동 설치한다.

또한, 다수의 생체 신호 계측 시스템(100)으로부터 동일한 종류의 생체 신호가 수신되는 경우에는 생체 신호 계측 시스템(100) 중 신뢰도가 높은 생체 신호 계측 시스템(100)으로부터 수신되는 생체 신호를 택일하여 사용할 수 있다.

S360단계에서 각 생체 신호 계측 시스템(100)은 부착된 센서를 통해 감지되는 생체 신호를 무선 통신 방식으로 휴대용 건강관리 시스템(200)으로 전송한다. 그러면 S370단계에서 휴대용 건강관리 시스템(200)은 건강관리 서버(400)로부터 수신되는 지침서와, 각 생체 신호 계측 시스템(100)으로부터 수신되는 생체 신호를 분석하여, 건강 관련 정보를 생성하고, 건강 관련 정보를 출력하여 사용자가 선택한 건강관리 서비스를 제공한다. 예를 들어, 사용자가 건강 진단 서비스를 선택한 경우, 수신되는 생체 신호에 따라 현재 건강 상태가 양호한지, 위험한지 등을 출력하여, 사용자가 건강을 진단할 수 있도록 한다.

그런 다음 S380단계에서 휴대용 건강관리 시스템(200)은 사용자가 선택한 서비스를 제공한 결과로 생성되는 각종 건강 관련 정보와 생체 신호 계측 시스템(100)으로부터 수신되는 생체 신호를 건강관리 서버(400)로 전송한다. 이에 따라 S390 단계에서 건강관리 서버(400)는 주기적 또는 건강 상태 정보 및 생체 신호가 변경되면, 의사에게 사용자의 건강 상태를 문의하고, 지침서를 갱신하고, 지침서가 갱신되면, 갱신된 지침서를 휴대용 건강관리 시스템(200)으로 전송한다.

즉, 의사는 수시로 자신이 원하는 시간에 건강관리 서버(400)로부터 사용자의 건강 정보를 열람하여 사용자의 건강 상태를 판별하고 필요 시 새로운 지침을 작성하고, 건강관리 서버(400)는 의사가 건강관리 지침서를 변경한 경우, 실시간으로 휴대용 건강관리 시스템에 전송하여 건강관리 지침서가 업데이트되도록 한다.

한편, 본 발명의 상세한 설명에서는 구체적인 실시 예에 관하여 설명하였으나, 본 발명의 범위에서 벗어나지 않는 한도 내에서 여러 가지 변형이 가능함은 물론이다. 그러므로 본 발명의 범위는 설명된 실시 예에 국한되어 정해져서는 안되며 후술하는 발명청구의 범위뿐 만 아니라 이 발명청구의 범위와 균등한 것들에 의해 정해져야 한다.

발명의 효과

상기한 바와 같이, 본 발명은 사용자가 자신이 원하는 건강관리 서비스를 선택할 수 있으며, 의사와 같은 전문가의 작성하는 사용자별 개인 건강관리 지침서와, 건강 상태를 기반으로 개인화된 건강관리가 가능할 수 있으며, 사용자의 건강 상태를 계측하기 위한 생체 신호 계측 시스템은 반지, 팔찌, 귀걸이와 같은 액세서리 형태로 신체의 각 부분에서 신호를 계측함으로써, 사용자의 착용 상에 불편을 최소화 할 수 있으며, 계측 위치를 분산 배치함은 물론 소형화할 수 있는 효과가 있다. 또한, 사용자가 편의 상 생체 신호 계측 시스템을 추가/변경하는 경우라도 별도의 설치 과정없이 즉시 생체 신호를 계측할 수 있는 효과가 있다.

도면의 간단한 설명

도 1은 본 발명의 바람직한 실시예에 따른 건강관리 서비스 제공 시스템을 설명하기 위한 블록도,

도 2a는 본 발명의 제 1 실시예에 따른 생체 신호 계측 시스템을 설명하기 위한 도면,

도 2b는 본 발명의 제 2 실시예에 따른 생체 신호 계측 시스템을 설명하기 위한 도면,

도 2c는 본 발명의 제 3 실시예에 따른 생체 신호 계측 시스템을 설명하기 위한 도면,

도 3은 본 발명의 바람직한 실시예에 따른 휴대용 건강관리 시스템을 설명하기 위한 블록도,

도 4는 본 발명의 바람직한 실시예에 따른 건강관리 서비스 제공 시스템의 건강관리 서비스 흐름을 설명하기 위한 흐름도,

도 5는 본 발명의 바람직한 실시예에 따른 건강관리 서비스를 제공하는 방법을 설명하기 위한 흐름도.

<도면의 주요 부분에 대한 부호의 설명>

100 : 생체 신호 계속 시스템 200 : 휴대용 건강관리 시스템

210 : 무선 인터페이스부 220 : 네트워크 인터페이스부

230 : 출력부 240 : 선택부

250 : 저장부 260 : 제어부

300 : 건강관리 서버 400 : 계측기 지원 서버

도면

도면1

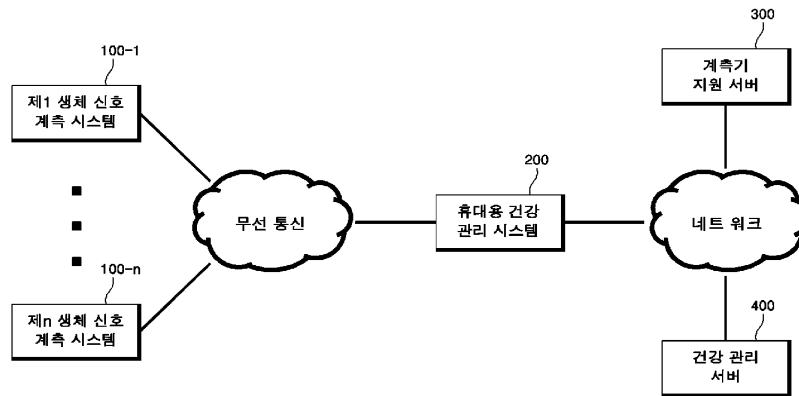

도면2a

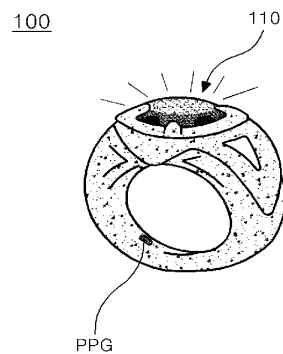

도면 2b

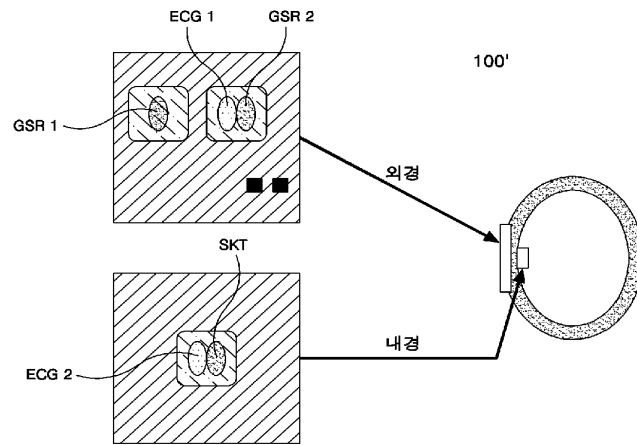

도면 2c

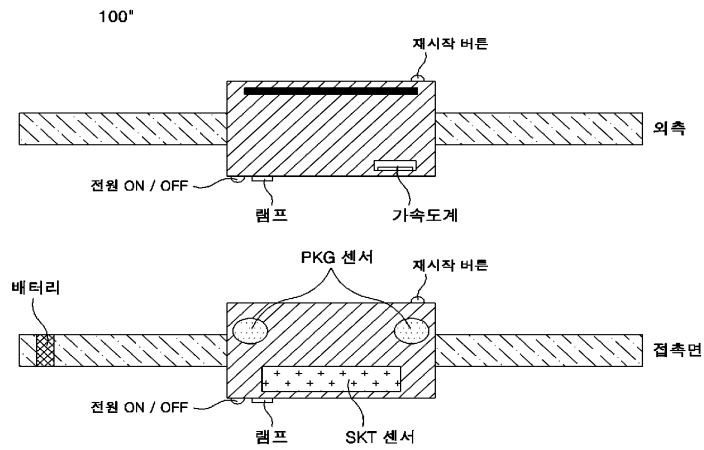

도면3

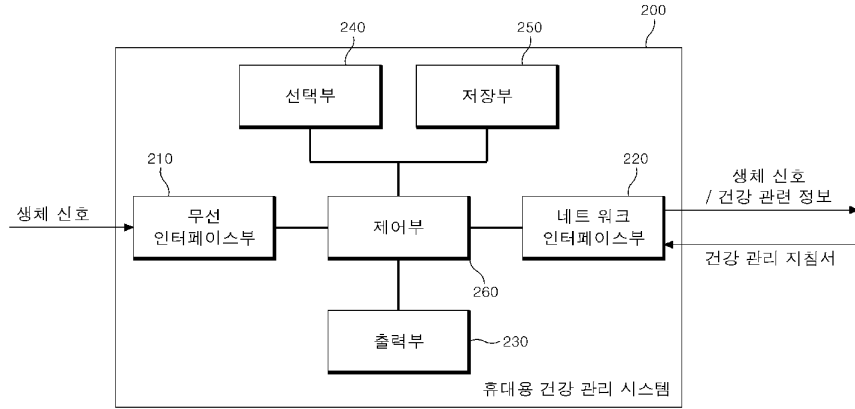

도면4

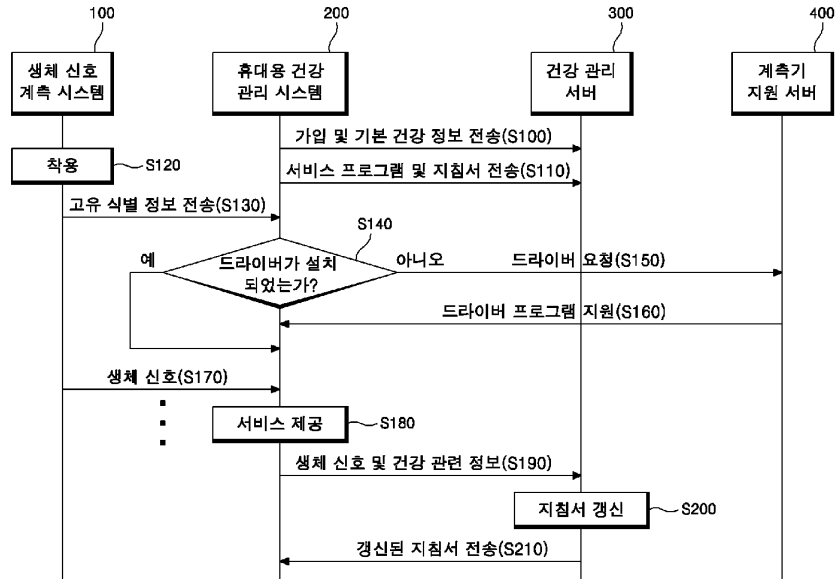

도면5

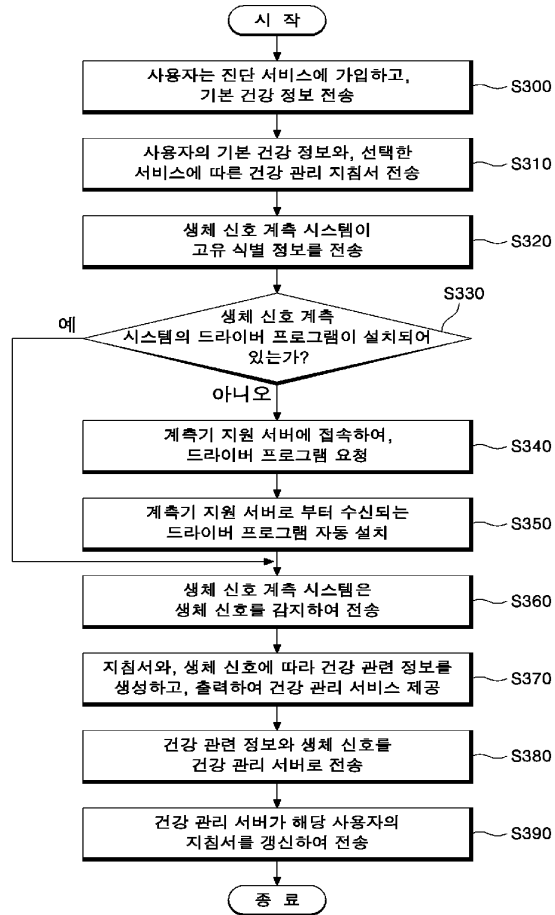

Bibliographic Data

Int.Cl.	A61B 5/00
Published Date	20070906
Registration No.	1007550790000
Registration Date	20070828
Application No.	1020060061157
Application Date	20060630
Requested Date of Examination	20060630
Agent.	Chun Sungjin
Inventor	LEEJongYoun YAMAKOSHIKenichi SHINKunSoo JUNGHyeJin
Applicant	SAMSUNG ELECTRONICS CO., LTD.
Rightholder	SAMSUNG ELECTRONICS CO., LTD.

발명의 명칭

생체 신호 측정 장치

Title of Invention

BIOSIGNAL-MEASURING INSTRUMENT

요약

본 발명에 따른 생체 신호 측정 장치는, 사용자의 손목에 착용되는 팔찌 부재(membrane); 상기 팔찌 부재의 제1 측면에 설치되어 상기 손목의 제1 측면을 지지하는 고정 지지대; 상기 팔찌 부재의 제2 측면에 설치되고, 상기 고정 지지대 방향으로 이동하여 상기 손목의 제2 측면에 밀착되는 이동 지지대; 및 상기 이동 지지대가 이동한 거리를 감지하여 상기 손목의 제1 측면 및 상기 손목의 제2 측면 간의 거리를 산출하고, 상기 산출한 손목의 제1 측면 및 상기 손목의 제2 측면 간의 거리와 선정된(Predetermined) 상수(constant)를 이용하여 상기 손목의 요골 동맥(Radial Artery) 변위(displacement)를 산출하는 정보 제어 수단을 포함하는 것을 특징으로 한다. 맥파, 압력, 생체 신호, 요골 동맥

Abstract

The measuring biological signal apparatus according to the present invention comprises the information control means it is installed at the second side of the bracelet member worn at the wrist of the user the supporter: bracelet member which is installed at the first side of the bracelet member and supports the first side of the wrist and it moves the supporter and it senses the movable support adhering closely to the second side of the wrist and the distance in which the movable support moves and it produces the distance between the second side of the first side of the wrist and the wrist and of producing the radial artery (Radial Artery) displacement of the wrist using the constant chosen with the distance between the second side of the first side of the above-mentioned wrist produced and the wrist (Predetermined). The pulse wave, the pressure, the bio-signal, the radial artery .

대표도면 (Representative drawing)

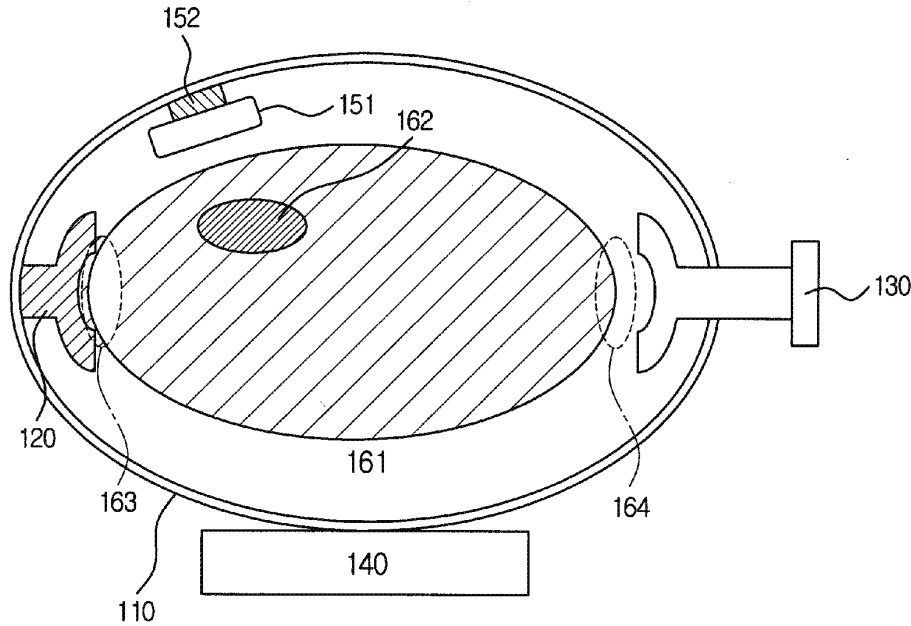

청구의 범위

청구 1항:

사용자의 손목에 착용되는 팔찌 부재(membrane); 상기 팔찌 부재의 제1 측면에 설치되어 상기 손목의 제1 측면을 지지하는 고정 지지대; 상기 팔찌 부재의 제2 측면에 설치되고, 상기 고정 지지대 방향으로 이동하여 상기 손목의 제2 측면에 밀착되는 이동 지지대; 및 상기 이동 지지대가 이동한 거리를 감지하여 상기 손목의 제1 측면 및 상기 손목의 제2 측면 간의 거리를 산출하고, 상기 산출한 손목의 제1 측면 및 상기 손목의 제2 측면 간의 거리와 선정된(Predetermined) 상수(constant)를 이용하여 상기 손목의 요골 동맥(Radial Artery) 변위(displacement)를 산출하는 정보 제어 수단을 포함하는 것을 특징으로 하는 생체 신호 측정 장치

청구 2항:

제1항에 있어서, 상기 선정된 상수값은 0.1 내지 0.2 범위 내의 값으로 설정되는 것을 특징으로 하는 생체 신호 측정 장치.

청구 3항:

제1항에 있어서, 상기 이동 지지대는 소정의 탄성 소자를 포함하고, 상기 탄성 소자의 탄성 운동에 따라 상기 손목의 제2 측면에 밀착되며, 상기 정보 제어 수단은 상기 탄성 소자의 상기 탄성 운동이 수행되기 전의 상기 고정 지지대 및 상기 이동 지지대 간의 거리 및 상기 탄성 운동에 따른 상기 탄성 소자의 변

Scope of Claims

Claim 1:

The measuring biological signal apparatus for comprising: the bracelet member (membrane) worn at the wrist of the user, the supporter, the movable support, and the information control means it senses the distance; the supporter is installed at the first side of the bracelet member and supports the first side of the wrist; the movable support is installed at the second side of the bracelet member; and it moves the supporter and adheres closely to the second side of the wrist; and as to the information control means it senses the distance, the movable support moves and it produces the distance between the second side of the first side of the wrist and the wrist; and of producing the radial artery (Radial Artery) displacement of the wrist using the constant chosen with the distance between the second side of the first side of the above-mentioned wrist produced and the wrist (Predetermined).

Claim 2:

As for claim 1, the measuring biological signal apparatus in which the above-mentioned chosen constant value is set up as the value within 0.1 through 0.2 range.

Claim 3:

The measuring biological signal apparatus of claim 1, wherein the movable support comprises the predetermined resilient element, and the information control means it adheres closely to the second side of the wrist according to the elasticity movement of the resilient element

위를 이용하여 상기 손목의 제1 측면 및 상기 손목의 제2 측면 간의 거리를 산출하는 것을 특징으로 하는 생체 신호 측정 장치.

청구 4항:

제1항에 있어서,상기 이동 지지대는 소정의 볼트 소자를 포함하고, 상기 볼트 소자의 회전 운동에 따라 상기 손목의 제2 측면에 밀착되며,상기 정보 제어 수단은 상기 볼트 소자의 상기 회전 운동이 수행되기 전의 상기 고정 지지대 및 상기 이동 지지대 간의 거리 및 상기 회전 운동에 따른 상기 볼트 소자의 회전수를 이용하여 상기 손목의 제1 측면 및 상기 손목의 제2 측면 간의 거리를 산출하는 것을 특징으로 하는 생체 신호 측정 장치.

청구 5항:

제1항에 있어서,상기 정보 제어 수단은 상기 산출한 손목의 제1 측면 및 상기 손목의 제2 측면 간의 거리와 상기 상수를 서로 곱하여 상기 손목의 요골 동맥 변위를 산출하고,상기 요골 동맥 변위는 상기 손목의 제1 측면으로부터 상기 요골 동맥의 위치까지의 거리인 것을 특징으로 하는 생체 신호 측정 장치.

청구 6항:

제1항에 있어서,상기 팔찌 부재에 설치되고 상기 요골 동맥으로부터 상기 사용자의 생체 신호를 측정하는 센서 수단; 및상기 센서 수단과 연결되어 상기 센서 수단을 이동시키기 위한 센서 구동 수단을 더 포함하고,상기 정보 제어 수단은 상기 산출한 상기 손목의 요골 동맥 변위를 이용하여 상기 센서 구동 수단을 구동하여 상기 센서 수단을 상기 요골 동맥의 위치로 이동시키는 것을 특징으로 하는 생체 신호 측정 장치.

청구 7항:

제6항에 있어서,상기 센서 수단은,상기 요골 동맥으로부터 상기 사용자의 맥파를 측정하는 하나 이상의 맥파 센서;상기 손목으로 각각 적색광 및 적외선을 발진시켜 상기 사용자의 산소 포화도를 측정하는 둘 이상의 발광 소자; 및상기 요골 동맥의 압력을 측정하여 상기 사용자의 혈압을 측정하는 압력 센서를 포함하는 것을 특징으로 하는 생체 신호 측정 장치.

배경기술

본 발명은 생체 신호 측정 장치에 관한 것으로서, 더욱 상세하게는 사용자 손목의 폭 길이를 측정하여 상기 사용자 손목에 위치하는 요골 동맥(Radial Artery)의 위치를 추적하고, 상기 요골 동맥으로부터 상기 사용자의 생체 신호를 측정함으로써, 사용자의 성별, 나이, 체중, 손목 둘레 길이에 상관 없이 누구나 보다 편리하고 정확하게 생체 신호를 측정할 수 있도록 하는 생

nt produces the distance between the second side of the first side of the wrist using the displacement of the resilient element according to the distance between the supporter and the movable support before the elasticity movement of the resilient element is performed and elasticity movement and wrist.

Claim 4:

The measuring biological signal apparatus of claim 1, wherein the movable support comprises the predetermined bolt device, and the information control means it adheres closely to the second side of the wrist according to the rotary motion of the bolt device produces the distance between the second side of the first side of the wrist using the number of rotations of the bolt device according to the distance between the supporter and the movable support before the rotary motion of the bolt device is performed and rotary motion and wrist.

Claim 5:

As for claim 1, the measuring biological signal apparatus in which the information control means multiplies by the distance between the second side of the first side of the above-mentioned wrist produced and the wrist and constant and it produces the radial artery displacement of the wrist ; and the radial artery displacement is the distance to the position of the radial artery from the first side of the wrist.

Claim 6:

As for claim 1, the measuring biological signal apparatus moving to the position of the radial artery the sensor means the information control means operates the sensor driving means using the radial artery displacement of the above-mentioned wrist produced the sensor driving means further is included that is connected to the sensor means of being installed and measuring the bio-signal of the user from the radial artery and sensor means to the bracelet member, for moving the sensor means.

Claim 7:

As for claim 6, the measuring biological signal apparatus comprising two or more light emitting devices, and the pressure sensor measuring the pressure of the radial artery and the blood pressure of the user when the sensor means measures the oxygen saturation of the user the red light and infrared ray are launched respectively to at least one pulse wave sensor: wrist that measures the pulse wave of the user from the radial artery.

Background Art

The invention relates to the measuring biological signal apparatus, and more particularly to the measuring biological signal apparatus it measures the width length of the user wrist and it chases the position of the radial artery positioned in the user wrist and it measures the bio-signal of the user from the radial artery and in that w

체 신호 측정 장치에 관한 것이다.

최근 산업계 전반에 걸쳐 중요시되는 이슈 중 하나인 유비쿼터스 관련 기술은 인간 생활의 모든 분야에 적용될 수 있는데, 특히 근래에는 웰빙(Well-Being) 현상으로 인해 유비쿼터스 헬스 케어(U-HealthCare)가 주목할 만한 기술 분야로 각광 받고 있다. 유비쿼터스 헬스 케어란 인간의 생활 공간 곳곳에 의료 서비스와 관련된 칩이나 센서를 설치함으로써, 모든 사람이 언제 어디서나 자연스럽게 의료 서비스를 제공 받을 수 있도록 하는 유비쿼터스 기술을 의미한다. 이러한 유비쿼터스 헬스 케어에 따르면, 각종 건강진단이나 질병관리, 응급관리, 의사와의 만남 등 병원에서만 이루어지던 의료 행위들이 병원에 가지 않고도 자연스럽게 일상 생활에서 구현될 수 있다.

예를 들어, 당뇨병자의 경우 혈당관리 프로그램이 탑재된 혈당 관리용 허리띠를 착용할 수 있다. 상기 허리띠에 부착된 혈당센서는 수시로 상기 당뇨병자의 혈당을 체크하고 그에 적합한 인슐린 양을 산출할 수 있다. 만일 상기 당뇨병자의 혈당이 급격하게 낮아지거나 높아질 경우, 그 혈당정보를 주치의에게 무선 통신망을 통해 제공할 수 있고, 상기 혈당정보를 제공 받은 주치의는 상기 응급상황에 따른 최적의 처방이나 조치를 취할 수 있다.

이러한 유비쿼터스 헬스 케어의 일환으로 일상 생활에서 누구나 쉽게 자신의 맥파를 측정할 수 있도록 하는 휴대형 맥파 측정 장치가 있다. 상기 휴대형 맥파 측정 장치는 대부분 손목 시계 또는 팔찌의 형태로 구현되어 평상 시 손목에 차고 다니면서 누구나 쉽게 자신의 맥파를 측정할 수 있도록 하고 있다.

일반적으로 손목을 통해 맥파를 측정하는 경우, 상기 맥파는 손목의 요골 동맥(Radial Artery)으로부터 측정될 수 있다. 따라서, 정확한 맥파의 측정을 위해서는 사용자의 요골 동맥의 위치를 정확하게 파악하는 동작이 선행되어야 한다. 그러나, 사람마다 손목의 크기나 둘레가 모두 제각각이어서 사용자마다 손목에서의 요골 동맥 위치는 모두 서로 다르다.

따라서, 종래 기술에 따르면, 사용자마다 그 위치가 서로 다른 요골 동맥의 위치를 파악하기 위해서 사용자가 직접 자신의 요골 동맥 위치로 센서를 이동시키거나, 수군데에서 맥파를 측정 후 가장 정확한 신호가 측정되는 지점을 요골 동맥으로 파악하는 등 많은 불편함과 부정확성이 문제가 되고 있다.

ay for being convenient and it exacts measuring the bio-signal regardless of the sex, the age, the weight, the wrist measurement length of the user than the everybody.

Recently, the ubiquitous relative technique which is one can be applied to all fields of the human life through the whole industrial world among the issue held in high reputation. It is highlighted as the technical field which recently the ubiquitous health care (U-HealthCare) especially pays attention due to the well-being phenomenon. The ubiquitous health care everywhere sets the chip associated with the medical service or the sensor up the living space of human. In that way the ubiquitous technology in which all humans anytime and anywhere naturally receive the medical service the provision is meant. According to such ubiquitous health care, even though it does not go to the medical practice hospital from hospital including all kinds of the health checks or the management of disorders, the emergency administration, the encounter with the doctor etc. it can be naturally implemented in the daily life.

For example, in case of the diabetics patient, the belt for the blood sugar management in which the blood sugar management program is mounted can be put on. The blood sugar sensor adhered to belt from time to time can check the blood sugar of the diabetics patient and the insulin amount which is suitable for that can be produced. When the blood sugar of the diabetics patient is drastically decreased or the blood sugar is enhanced the blood sugar information can be provided the attending personnel with through the wireless communication network and the attending personnel receiving the blood sugar information with provision can take the optimal prescription according to the emergency or the disposition.

In the part of such ubiquitous health care the daily life, it has the hand-held apparatus for measuring pulse for without any difficulties measuring its own pulse wave. While the hand-held apparatus for measuring pulse is mostly implemented in the form of the wrist watch or the bracelet and it wears the wrist in bed and it goes to and from its own pulse wave is without any difficulties measured.

Generally, the case, and the pulse wave of measuring the pulse wave through the wrist can be measured from the radial artery of the wrist. Therefore, for the measurement of the exact pulse wave, the operation of accurately grasping the position of the radial artery of the user has to be preceded. But size or the circumference of the wrist altogether varies at human and the user the radial artery position at the wrist is altogether different from each other.

Therefore, according to prior art, the user moves the sensor to the radial artery position of the direct oneself so that the position locate the different radial artery at the user or the inconvenience and many imprecision become a problem grasping the spot where the signal which is most exact is the pulse wave measured in the number places after doing the measurement by the radial artery.

이러한 종래 기술에 따른 문제점의 지적에 따라, 사용자의 나이, 성별, 손목 크기, 체중 등에 상관 없이 각 사용자의 손목에 위치하는 요골 동맥의 위치를 정확하게 파악하여 상기 사용자의 생체 신호를 상기 요골 동맥으로부터 정확하게 측정할 수 있는 생체 신호 측정 장치의 개발이 요구되고 있다.

발명의 내용

발명의 효과

본 발명의 생체 신호 측정 장치에 따르면, 사용자 손목의 폭 길이를 측정된 후 선정된(Predetermined) 상수(constant)와 곱하여 상기 손목의 요골 동맥 위치를 정확하게 파악하여 상기 사용자의 생체 신호를 상기 요골 동맥으로부터 측정함으로써, 사용자의 신체 조건에 상관 없이 누구나 보다 편리하고 정확하게 자신의 생체 신호를 측정할 수 있도록 하는 효과를 얻을 수 있다.

또한, 본 발명의 생체 신호 측정 장치에 따르면, 요골 동맥으로부터 사용자의 생체 신호를 측정하는 센서 수단에 하나 이상의 광센서, 적외선 및 적외선을 각각 발광하는 둘 이상의 발광 센서, 및 하나 이상의 압력 센서를 구비함으로써, 상기 사용자의 맥파를 측정할 수 있을 뿐만 아니라, 상기 사용자의 산화 및 환원 헤모글로빈의 광 흡수도 차이에 따른 산소 포화도의 측정도 가능하고, 상기 압력 센서를 통해 상기 요골 동맥의 압력을 측정하여 상기 사용자의 혈압 또한 측정할 수 있도록 하는 효과를 얻을 수 있다.

이상과 같이 본 발명은 비록 한정된 실시예와 도면에 의해 설명되었으나, 본 발명은 상기의 실시예에 한정되는 것은 아니며, 이는 본 발명이 속하는 분야에서 통상의 지식을 가진 자라면 이러한 기재로부터 다양한 수정 및 변형이 가능하다. 따라서, 본 발명 사상은 아래에 기재된 특허청구범위에 의해서만 파악되어야 하고, 이의 균등 또는 등가적 변형 모두는 본 발명 사상의 범주에 속한다고 할 것이다.

기술적 과제

본 발명은 상기와 같은 종래 기술을 개선하기 위해 안출된 것으로서, 사용자 손목의 폭 길이를 측정된 후 선정된(Predetermined) 상수(constant)와 곱하여 상기 손목의 요골 동맥 위치를 정확하게 파악하여 상기 사용자의 생체 신호를 상기 요골 동맥으로부터 측정함으로써, 사용자의 신체 조건에 상관 없이 누구나 보다 편리하고 정확하게 자신의 생체 신호를 측정할 수 있도록 하는 생체 신호 측정 장치를 제공하는 것을 목적으로 한다.

According to the indication of the problem according to such prior art, the development of the measuring biological signal apparatus for accurately grasping the position of the radial artery positioned in the wrist of each user to the age, sex, wrist size, the weight etc of the user without the correlation and measuring the bio-signal of the user from the radial artery is requested.

Summary of Invention

Effects of the Invention

According to the measuring biological signal apparatus of the invention, the width length of the user wrist is multiplied by with the constant chosen after doing the measurement (Predetermined) and the radial artery position of the wrist is accurately grasped and the bio-signal of the user is measured from the radial artery. In that way the effect that is convenient and it exactly measures its own bio-signal in the physical condition of the user without the correlation than the everybody can be obtained.

Moreover, according to the measuring biological signal apparatus of the invention, at least one optical sensor in the sensor means of measuring the bio-signal of the user from the radial artery, and two or more light emitting sensors and at least one pressure sensor radiating the red light and infrared ray are included. In that way the pulse wave of the user can be measured. In addition the measurement of the oxygen saturation according to the absorbance difference of the oxidation of the user and reduced hemoglobin are possible and the pressure of the radial artery is measured through the pressure sensor and the effect that it moreover measures the blood pressure of the on-going basis user can be obtained.

As described above, it was explained by the embodiment and drawing in which the invention was restricted. But the invention is not restricted to the embodiment described in the above and if this grows up under the field in which the invention belongs, the correction and the various deformation are possible from such material. Therefore, it has to be grasped by the patent claim in which the invention thought is beneath written and its equality or the equivalent distortion everyone belongs to the category of the invention thought.

Technical Task

The object of the invention is to provide the measuring biological signal apparatus it is devised it improves the above-mentioned prior art and it multiplies by the width length of the user wrist with the constant chosen after doing the measurement (Predetermined) and it accurately grasps the radial artery position of the wrist and it measures the bio-signal of the user from the radial artery and in that way for being convenient and it exactly measuring its own bio-signal in the physical condition of the user without the correlation than the everybody.

또한, 본 발명은 요골 동맥으로부터 사용자의 생체 신호를 측정하는 센서 수단에 하나 이상의 광센서, 적외선 및 적외선을 각각 발광하는 둘 이상의 발광 센서, 및 하나 이상의 압력 센서를 구비함으로써, 상기 사용자의 맥파를 측정할 수 있을 뿐만 아니라, 상기 사용자의 산화 및 환원 헤모글로빈의 광 흡수도 차이에 따른 산소 포화도의 측정도 가능하고, 상기 압력 센서를 통해 상기 요골 동맥의 압력을 측정하여 상기 사용자의 혈압 또한 측정할 수 있도록 하는 생체 신호 측정 장치를 제공하는 것을 목적으로 한다.

Moreover, the object of the invention is to provide the measuring biological signal apparatus it includes at least one optical sensor in the sensor means of measuring the bio-signal of the user from the radial artery, and two or more light emitting sensors and at least one pressure sensor radiating the red light and infrared ray and in that way it can measure the pulse wave of the user and In addition the measurement of the oxygen saturation according to the absorbance difference of the oxidation of the user and reduced hemoglobin are possible and for measuring the pressure of the radial artery through the pressure sensor and moreover measuring the blood pressure of the on-going basis user.

발명의 구성 및 작용

상기의 목적을 이루고 종래기술의 문제점을 해결하기 위하여, 본 발명에 따른 생체 신호 측정 장치는, 사용자의 손목에 착용되는 팔찌 부재(membrane); 상기 팔찌 부재의 제1 측면에 설치되어 상기 손목의 제1 측면을 지지하는 고정 지지대; 상기 팔찌 부재의 제2 측면에 설치되고, 상기 고정 지지대 방향으로 이동하여 상기 손목의 제2 측면에 밀착되는 이동 지지대; 및 상기 이동 지지대가 이동한 거리를 감지하여 상기 손목의 제1 측면 및 상기 손목의 제2 측면 간의 거리를 산출하고, 상기 산출한 손목의 제1 측면 및 상기 손목의 제2 측면 간의 거리와 선정된(Predetermined) 상수(constant)를 이용하여 상기 손목의 요골 동맥(Radial Artery) 변위(displacement)를 산출하는 정보 제어 수단을 포함하는 것을 특징으로 한다.

Structure & Operation of the Invention

The measuring biological signal apparatus according to the present invention it is comprised the purpose described in the above comprises the information control means it is installed at the second side of the bracelet member worn at the wrist of the user the supporter: bracelet member which is installed at the first side of the bracelet member and supports the first side of the wrist and it moves the supporter and it senses the movable support adhering closely to the second side of the wrist and the distance in which the movable support moves and it produces the distance between the second side of the first side of the wrist and the wrist and of producing the radial artery (Radial Artery) displacement of the wrist using the constant chosen with the distance between the second side of the first side of the above-mentioned wrist produced and the wrist (Predetermined).

본 명세서에서 주로 언급되는 맥파란 심장의 물리적인 변화에 근거하여 혈관계와 관맥의 압력과 용적의 변화에 따른 파형을 의미한다. 본 발명에 따른 생체 신호 측정 장치는 사용자의 손목 부위로부터 요골 동맥파를 측정할 수 있다. 상기 생체 신호 측정 장치는 손목 시계 또는 팔찌 등 손목에 착용 가능한 액세서리의 일부 구성으로 구현될 수도 있고, 팔찌 형태의 단일 물품으로 구현될 수도 있다. 본 명세서에서는 설명의 편의상 상기 생체 신호 측정 장치가 팔찌 형태의 단일 물품으로 구현되는 경우를 예로 들어 설명한다.

In this specification, the mainly mentioned pulse wave means the waveform according to the change of the pressure of the vascular system and blood pulse and volume based on the physical change of the heart. The measuring biological signal apparatus according to the present invention can measure the radial artery wave from the wrist part of the user. The measuring biological signal apparatus can be implemented as the some configuration of the wrist watch or the accessory can put in the wrist including the bracelet etc. and it can be implemented as the single item of the bracelet form. It is explained using in that case, for convenience measuring biological signal apparatus of the description is implemented as the single item of the bracelet form in this specification as an example.

이하에서는 첨부된 도면을 참조하여 본 발명의 실시예를 상세히 설명한다.

Hereinafter, the attached embodiment of the invention is particularly illustrated.

도 1은 본 발명의 일 실시예에 따른 생체 신호 측정 장치의 형상 및 구성을 도시한 도면이다.

Figure 1 is a drawing showing the shape of the measuring biological signal apparatus according to a preferred embodiment of the present invention and configuration.

본 발명의 일 실시예에 따른 생체 신호 측정 장치는 팔찌 부재(membrane)(110), 고정 지지대(120), 이동 지지대(130), 정보 제어 수단(140), 센서 수단(151), 및 센서 구동 수단(152)를 포함하여 구성된다.

The measuring biological signal apparatus according to a preferred embodiment of the present invention comprises the bracelet member (membrane) (110), supporter (120), movable support (130), information control means (140), sensor means (151) and sensor driving means (152).

팔찌 부재(110)는 사용자의 손목(161)에 착용 가능한 일반적인 팔찌 형태의 구조물로 구현될 수 있다. 팔찌 부재(110)의 크기는 일반 성인의 손목에 착용 가능한 정도의 크기로 구현될 수 있다.

고정 지지대(120)는 팔찌 부재(110)의 제1 측면에 설치되어 손목(161)의 제1 측면(163)을 지지한다. 즉, 사용자가 팔찌 부재(110)를 손목(161)에 착용하였을 경우, 고정 지지대(120)는 손목(161)의 제1 측면(163)에 접촉되거나 밀착되어 손목(161)을 지지할 수 있다. 예를 들어, 상기 사용자가 팔찌 부재(110)를 왼팔 손목에 착용하였을 경우, 고정 지지대는 상기 왼팔 손목의 왼쪽 측면에 접촉되거나 밀착될 수 있다.

이동 지지대(130)는 팔찌 부재(110)의 제2 측면에 설치되고, 고정 지지대(120) 방향으로 이동하여 손목(161)의 제2 측면(164)에 밀착된다. 즉, 사용자가 팔찌 부재(110)를 손목(161)에 착용하였을 경우, 고정 지지대(120)는 손목(161)의 제1 측면(163)에 접촉되거나 밀착되어 손목(161)을 지지하고, 이동 지지대는 도 1에 도시된 바와 같이 손목(161)의 제2 측면(164)과 소정 거리만큼 이격되어 위치하도록 구현될 수 있다.

이 때, 이동 지지대(130)는 고정 지지대(120) 방향으로 이동하여 손목(161)의 제2 측면(164)에 밀착되어 손목(161)을 지지할 수 있다. 즉, 이동 지지대(130)가 제2 측면(164) 방향으로 이동하여 제2 측면(164)에 밀착됨으로써, 고정 지지대(120) 및 이동 지지대(130)가 손목(161)에 각각 밀착되어 지지할 수 있다.

이동 지지대(130)의 이동 방법으로는 사용자가 이동 지지대(130)를 구동하여 직접 이동시킬 수도 있고, 일반적인 혈압 측정 장치와 같이 사용자가 손목(161)에 팔찌 부재(110)를 착용하는 순간 자동으로 이동하여 손목(161)의 제2 측면(164)에 밀착되도록 구현될 수도 있다.

이동 지지대(130)의 이동 원리로는 스프링 등의 탄성 운동을 이용하는 방법 또는 볼트 수단 등의 회전 운동을 이용하는 방법이 적용될 수 있다.

첫째, 상기 탄성 운동을 이용하는 경우, 이동 지지대(130)는 스프링 등과 같은 소정의 탄성 소자를 포함하여 구성될 수 있다. 이동 지지대(130)는 상기 탄성 소자의 탄성 운동에 따라 손목(160)의 제2 측면(164)에 밀착될 수 있다. 예를 들어, 사용자가 이동 지지대(130)에 압력을 가하는 순간, 상기 탄성 소자의 수축 운동에 따라 이동 지지대(130)는 제2 측면(164)에 밀착될 수 있다.

둘째, 상기 회전 운동을 이용하는 경우, 이동 지지대(130)는

It can be implemented as the structure of the general bracelet form which the bracelet member (110) can wear in the wrist (161) of the user. It can be implemented as the size of the extent that the size of the bracelet member (110) can wear in the wrist of the regular adult.

The supporter (120) is installed at the first side of the bracelet member (110) and the first side (163) of the wrist (161) is supported. That is, when the user put on the bracelet member (110) in the wrist (161) the supporter (120) is contacted with the first side (163) of the wrist (161) or it adheres closely and the wrist (161) can be supported. For example, when the user put on the bracelet member (110) in the left arm wrist the supporter is contacted with the left side of the left arm wrist or it can adhere closely.

The movable support (130) is installed at the second side of the bracelet member (110) and it moves the supporter (120) and it adheres closely to the second side (164) of the wrist (161). That is, when the user put on the bracelet member (110) in the wrist (161) the supporter (120) is contacted with the first side (163) of the wrist (161) or it adheres closely and the wrist (161) is supported and it can be implemented so that the movable support as shown in FIG. 1 locates separately as the second side (164) and prescribed distance of the wrist (161).

Then, the movable support (130) moves the supporter (120) and it adheres closely to the second side (164) of the wrist (161) and the wrist (161) can be supported. That is, the movable support (130) moves the second side (164) and it adheres closely to the second side (164). In that way the supporter (120) and movable support (130) adhere closely to the wrist (161) and it can support.

The user operates the movable support (130) to the transfer method of the movable support (130) and it can let move directly and it can be implemented so that at the moment when the user puts on the bracelet member (110) like the general blood pressure measuring equipment in the wrist (161) the user moves and it adheres closely to the second side (164) of the wrist (161).

The method for using the rotary motion including the method or the voltage shift etc. uses the elasticity movement including the spring etc. as the transfer principle of the movable support (130) can be applied.

First, the case of using the elasticity movement, and the predetermined resilient element including the movable support (130) is the spring etc can be comprised. According to the movable support (130) is the elasticity movement of the resilient element, it can adhere closely to the second side (164) of the wrist (160). For example, at the moment that the user adds the pressure to the movable support (130) the movable support (130) can adhere closely to the second side (164) according to the contraction motion of the resilient element.

Second, the case of using the rotary motion, and the

소정의 볼트 소자를 포함하여 구성될 수 있다. 이동 지지대(130)는 상기 볼트 소자의 회전 운동에 따라 손목(161)의 제2 측면(164)에 밀착될 수 있다. 예를 들어, 상기 사용자가 상기 볼트 수단을 회전시키는 경우, 상기 볼트 수단이 회전함에 따라 이동 지지대(130)는 고정 지지대(120) 방향으로 이동하여 손목(161)의 제2 측면(164)에 밀착될 수 있다.

정보 제어 수단(140)은 이동 지지대(130)가 이동한 거리를 감지하여 손목(161)의 제1 측면(163) 및 제2 측면(163) 간의 거리를 산출한다. 즉, 정보 제어 수단(140)은 이동 지지대(130)가 이동한 거리를 감지함으로써, 손목(161)의 폭 길이를 산출할 수 있다.

정보 제어 수단(140)은 이동 지지대(130)가 이동하기 전, 고정 지지대(120) 및 이동 지지대(130) 간의 거리에서 이동 지지대(130)가 이동한 거리를 차감함으로써, 손목(161)의 상기 폭 길이를 산출할 수 있다.

이동 지지대(130)가 탄성 소자를 포함하여 구현되는 경우, 정보 제어 수단(140)은 이동 지지대(130)가 손목(161)의 제2 측면(164)에 밀착되기 위하여 상기 탄성 소자가 움직인 변위(displacement)를 이용하여 이동 지지대(130)가 이동한 거리를 산출할 수 있다.

또한, 이동 지지대(130)가 볼트 소자를 포함하여 구현되는 경우, 정보 제어 수단(140)은 이동 지지대(130)가 손목(161)의 제2 측면(164)에 밀착되기 위하여 상기 볼트 수단이 회전한 회전수를 이용하여 이동 지지대(130)가 이동한 거리를 산출할 수 있다.

상술한 바와 같이, 이동 지지대(130)가 이동한 거리를 감지하여 손목(161)의 제1 측면(163) 및 제2 측면(163) 간의 거리, 즉, 손목(161)의 폭 길이가 산출되면, 정보 제어 수단(140)은 상기 산출한 손목(161)의 폭 길이와 선정된(Predetermined) 상수(constant)를 이용하여 상기 손목의 요골 동맥(Radial Artery) 변위(displacement)를 산출한다.

상기 상수는 0.1719 또는 0.1492의 값을 갖도록 설정될 수 있다. 본 발명의 실시시예에 따르면, 정보 제어 수단(140)은 상기 상수값과 상기 산출한 제1 측면(163) 및 제2 측면(163) 간의 거리인 손목(161)의 폭 길이를 서로 곱하여 상기 요골 동맥의 변위를 산출할 수 있다. 상기 요골 동맥의 변위는 손목(161)의 제1 측면(163)으로부터의 거리로 설정될 수 있다.

상기 상수값은 소정의 실험을 통해 선정될 수 있다. 이하에서는 도 2 내지 도 4를 참조하여 상기 실험에 따른 상기 상수값의 산

movable support (130) is the predetermined bolt device can be comprised. According to the movable support (130) is the rotary motion of the bolt device, it can adhere closely to the second side (164) of the wrist (161). For example, as the case where the user rotates the voltage shift, and the voltage shift rotate the movable support (130) moves the supporter (120) and it can adhere closely to the second side (164) of the wrist (161).

The information control means (140) senses the distance in which the movable support (130) moves and the distance between the first side (163) of the wrist (161) and the second side (163) is produced. That is, the information control means (140) senses the distance in which the movable support (130) moves. In that way the width length of the wrist (161) can be produced.

Before the information control means (140) the movable support (130) moves. The distance in which the movable support (130) moves is struck a balance in the distance between the movable support (130) and the supporter (120). In that way the width length of the wrist (161) can be produced.

So that the movable support (130) adhere closely to the second side (164) of the wrist (161) the case, and the information control means (140) of the movable support (130) including the resilient element and being implemented can produce the distance in which the movable support (130) moves using the displacement in which the resilient element moves.

Moreover, so that the movable support (130) adhere closely to the second side (164) of the wrist (161) the case, and the information control means (140) of the movable support (130) including the bolt device and being implemented can produce the distance in which the movable support (130) moves using the number of rotations in which the voltage shift rotates.

As described above, if the distance in which the movable support (130) moves is sensed and the distance between the first side (163) of the wrist (161) and the second side (163), in other words, the width length of the wrist (161) are calculated, the radial artery (Radial Artery) displacement of the wrist is produced using the constant in which the information control means (140) is chosen with the width length of the above-mentioned wrist (161) produced (Predetermined).

The constant can be set up in order to have the value of 0.1719 or 0.1492. According to a preferred embodiment of the present invention, the width length of the wrist (161) in which the information control means (140) is the distance between the constant value and the above-mentioned first side (163) produced and the second side (163) is multiplied by and the displacement of the radial artery can be produced. The displacement of the radial artery can be set up as the distance from the first side (163) of the wrist (161).

The constant value can be chosen through the predetermined experiment. Hereinafter, it illustrates for

출 원리에 대하여 설명한다.

도 2는 본 발명의 일 실시예에 따라 수행되는 상수값 산출을 위하여 손목의 요골 동맥을 중심으로 다양한 거리만큼 이격된 위치에서 센서를 통해 측정되는 맥파의 세기를 측정 한 실험 결과를 도시한 도면이다.

손목에 위치하는 요골 동맥의 측정 부위에 따른 맥파 신호의 세기 차이를 비교하기 위하여 도 2의 (a)에 도시된 바와 같이, 요골 동맥을 중심으로 좌우로 각각 2mm 간격만큼 이격된 위치에서 맥파를 측정하는 경우, 도 2의 (b)에 도시된 그래프와 같은 결과를 얻을 수 있다.

상기 실험 결과에 의하면, 요골 동맥의 위치(Center)에서와 상기 요골 동맥으로부터 오른쪽으로 2mm 지점(R2)에서 측정 한 맥파가 최대의 진폭을 갖는 것을 알 수 있다. 또한, 요골 동맥에서 멀리 이격된 지점일수록 맥파의 신호가 작아지는 경향을 보이며 측정 결과가 요골 동맥을 중심으로 대칭을 이루지는 않는다. 따라서, 상기 실험 결과에 의해 요골 동맥을 중심으로 하여 좌측으로 2mm 우측으로 6mm 이내에 센서가 위치하면 보다 정확한 맥파 신호를 측정할 수 있음을 알 수 있다.

도 3은 본 발명의 일 실시예에 따라 수행된 요골 동맥의 위치 측정을 위한 실험의 기준 프로토콜(protocol) 및 상기 실험에 따른 손목의 폭 길이 대 요골 동맥 변위의 비의 결과값을 도시한 도면이다.

상기 상수값의 산출을 위하여, 보다 정량적으로 요골 동맥의 위치를 파악하기 위해 87명의 피검자에서 동맥의 위치를 측정하는 실험을 실시하였다. 한국인은 19명의 남성과 15명의 여성에서, 일본인은 38명의 남성과 6명의 여성에서 그리고 중국인은 5명의 남성과 4명의 여성에서 측정을 실시하였다.

도 3의 (a)에 도시된 바와 같이, 손목 내측의 횡단 주름의 가장 윗 부분을 포지션(position) 1로 설정하고, 상기 포지션 1로부터 2.5cm와 5cm만큼 이격된 손목 내측으로 각각의 위치를 포지션 2 및 포지션 3으로 설정하였다. 또한, C1은 상기 포지션 1에서의 손목 둘레를 의미하고, C2는 상기 포지션 2에서의 손목 둘레를 의미하며, C3는 상기 포지션 3에서의 손목 둘레를 의미한다.

또한, I1은 포지션 1에서 손목의 왼쪽 측면부터 요골 동맥까지의 거리를 의미하고, I2는 포지션 2에서 손목의 왼쪽 측면부터 요골 동맥까지의 거리를 의미하며, I3는 포지션 3에서 손목의 왼쪽 측면부터 요골 동맥까지의 거리를 의미한다. 상기 각각의

the computation principles of the constant value according to the experiment with reference to the figures 2 through 4.

Figure 2 is a drawing showing the experimental result measuring the intensity of the pulse wave measured for the constant value computation performed according to a preferred embodiment of the present invention in the position separated around the radial artery of the wrist as the various distance through the sensor.

In order to compare the intensity difference of the pulse signal according to the measurement position of the radial artery positioned in the wrist, the result illustrated in the position which the respectively is separated from side to side around the radial artery as 2mm gap in the case of measuring the pulse wave, and (b) of fig. 2 like graph can be obtained as shown in (a) of fig. 2.

According to the experimental result, it can know at the position (Center) of the radial artery that the pulse wave measured from the radial artery at the side going up in 2mm spot (R2) has the amplitude of the maximum. Moreover, in the radial artery, while seeing the tendency that the signal of the pulse wave becomes smaller as it is the spot which the far is separated the measurement result is not comprised the symmetry around the radial artery. Therefore, it can know that the more correct pulse signal can be measured with the experimental result centering around the radial artery at the left side if the sensor is positioned to 2mm right side within 6mm.

Figure 3 is a drawing showing the return value of the ratio of the width length large radial artery displacement of the wrist according to the reference Protocol of the experiment for the position location of the radial artery performed according to one room time of the invention and experiment.

The experiment which measured the position of the artery in more than 87 people examinee in order to locate of the radial artery was more quantitatively performed for the computation of the constant value. In the Korean is the female of the male of 19 people and 15 people, Japanese and, Chinese conducted the measurement in the male of 38 people and female of 6 people in the male of 5 people and female of 4 people.

Top was most set up as shown in (a) of fig. 3 of the crossing wrinkle of the wrist inner side as the position 1 and each position was set up as 2.5cm and the wrist inner side located as 5cm from the position 1 as the position 2 and position 3. Moreover, the C1 means the wrist measurement in the position 1 and the C2 means the wrist measurement in the position 2 and the C3 means the wrist measurement in the position 3.

Moreover, in the I1 is the position 1, the distance to the radial artery from the left side of the wrist is meant and the I2 means the distance to the radial artery from the left side of the wrist in the position 2 and the I3 m

포지션에서 손목의 폭(L1, L2, L3)과 손목 왼쪽 측면에서 요골 동맥까지의 거리(I1, I2, I3)의 비(I1/L1, I2/L2, I3/L3)를 산출하는 실험을 수행하였다.

또한, 상기 포지션에서 손목의 폭과 손목 왼쪽 측면에서 요골 동맥까지의 거리의 비(I1/L1, I2/L2, I3/L3)와 손목 둘레(C1, C2, C3)의 상관관계를 산출한 결과, 상관계수가 -0.359로 산출되어 서로 매우 낮은 상관관계를 갖는 것이 입증되었다. 따라서, 손목의 둘레 길이와 손목의 폭에서 요골 동맥의 위치는 서로 무관하다고 설정할 수 있다.

또한, 성별, 나이, 체격 등이 각각 다른 수십명의 피실험자들을 통해 상기 손목의 폭과 손목 왼쪽 측면에서 요골 동맥까지의 거리의 비(I1/L1, I2/L2, I3/L3)를 산출한 결과, 도 2의 (b)와 같은 결과값을 얻을 수 있었다. 즉, 성별에 따른 손목의 폭과 왼쪽 손목의 왼쪽 측면에서 요골 동맥까지의 거리의 비(I1/L1)를 T-test로 비교한 결과, 남성의 평균은 0.17#177#0.04이고 여성의 평균은 0.15#177#0.04으로 산출되어 p-value가 0.053으로 성별에 따른 차이가 없음을 알 수 있다.

따라서, 손목의 둘레와 성별에 영향 받지 않는 손목의 폭 길이와 왼쪽 손목의 왼쪽 측면에서 요골 동맥까지의 거리의 비를 이용하여 요골 동맥 위치를 유추하기 위하여 다음과 같은 과정을 통해 오차를 계산하였다.

- 1) 측정된 87명의 데이터에서 손목의 폭과 왼쪽 손목의 왼쪽 측면에서 요골 동맥까지의 거리의 비(I1/L1)의 평균을 계산
- 2) 이 평균 값에 각 개인의 손목 폭의 길이(L1)를 곱하여 손목 측면에서 요골 동맥까지의 거리(I1_1)의 추정치 계산
- 3) 상기 2)의 과정에서 얻어진 추정치와 실제 손목 왼쪽 측면에서 요골 동맥까지의 거리의 차이를 구함
- 4) 상기 차이의 평균을 구함

도 4는 상술한 실험 과정의 결과를 도시한 도면이다.

상술한 실험 과정의 결과에 따르면 #177#2.24mm의 오차가 산출됨을 알 수 있다. 그러나 상기 #177#2mm의 오차는 도 2에 도시된 실험 결과에서 알 수 있듯이 맥파 신호의 측정 결과에 큰 영향을 미치지 않는다. 따라서 손목의 폭 길이와 왼쪽 손목의 왼쪽 측면에서 요골 동맥까지의 거리의 비(I1/L1)의 평균과 사용자의 손목 폭 길이만 알 수 있다면, 상기 사용자의 왼쪽 손목의 왼쪽 측면에서 요골 동맥까지의 위치를 추정할 수 있다.

ens the distance to the radial artery from the left side of the wrist in the position 3. In each position, the experiment turning out the ratio (I1/L1, I2/L2, I3/L3) of the distance (I1, I2, I3) to the radial artery was performed in the width (L1, L2, L3) and wrist left side of the wrist.

Moreover, in the position, the width and wrist left side of the wrist produced the correlation of the ratio (I1/L1, I2/L2, I3/L3) of the distance to the radial artery and wrist measurement (C1, C2, C3). Then the correlation were proved to the coefficient of correlation be calculated to -0.359 and very have the low correlation. Therefore, in the perimeter of the wrist and the width of the wrist, it can set up that the position of the radial artery has no concern.

Moreover, the ratio (I1/L1, I2/L2, I3/L3) of the distance to the radial artery was produced in the width and wrist left side of the wrist than through the test subjects of the several tens people in which sex, the age, the physique etc. were different. Then the return value like (b) of fig. 2 could be gained. That is, in the left side of the width of the wrist according to sex and left wrist, the ratio (I1/L1) of the distance to the radial artery is compared to the T-test. Then the average of male is 0.17±0.04 and the average of the female is calculated to 0.15±0.04 and the difference according to sex of the p-value can know the none as 0.053.

Therefore, in the width length of the wrist which it does not receive the influence in the circumference and sex of the wrist and left side of the left wrist, the error was calculated through the process as follows in order to analogize the radial artery position using the ratio of the distance to the radial artery.

- 1) The calculation in measured data of 87 people in the left side of the width of the wrist and left wrist the average of the ratio (I1/L1) of the distance to the radial artery.
- 2) The length (L1) of the wrist width of each individual is multiplied this average value by and it calculates the estimate of the distance (I1 1) to the radial artery in the wrist side.
- 3) The difference of distance to the radial artery is actually saved in the wrist left side with the estimate obtained in the process of 2).
- 4) The average of the difference is measured.

Figure 4 is a drawing showing the result of the test process of describing in detail.

According to the result of the test process of describing in detail, it can know that the error of the ±2.24mm is calculated. But it does not affect as seen in the error of the ±2mm is the experimental result illustrated in Figure 2 it is large in the measurement result of the pulse signal. Therefore, in the width length of the wrist and left side of the left wrist, if the wrist width length of the average of the ratio (I1/L1) of the distance

to the radial artery and user can know , the position to the radial artery can be estimated at the left side of the left wrist of the user.

이 때, 손목의 폭 길이와 왼쪽 손목의 왼쪽 측면에서 요골 동맥까지의 거리의 비(I1/L1)의 평균은 지금까지 설명한 실험적으로 얻어진 결과값을 상수처럼 사용할 수 있으므로, 개인의 손목 폭의 길이만 측정하면 사용자의 성별이나 나이, 체형에 상관없이 요골 동맥 위치를 보다 정확하게 추정할 수 있다.

Then, in the width length of the wrist and left side of the left wrist, the return value which the average of the ratio (I1/L1) of the distance to the radial artery so far illustrates and which is experimentally obtained can be used like the constant. Therefore the radial artery position can be more accurately estimated regardless of sex or the age of the user, and figure if it measures the length of the individual wrist width.

다시 도 1에서, 정보 제어 수단(140)은 지금까지 도 2 내지 도 4를 참조하여 설명한 실험 결과에 따라 도출되는 상기 상수값과 상기 산출한 제1 측면(163) 및 제2 측면(163) 간의 거리인 손목(161)의 폭 길이를 서로 곱하여 상기 요골 동맥의 변위를 산출할 수 있다. 상기 요골 동맥의 변위는 상술한 바와 같이 손목(163)의 왼쪽 측면인 제1 위치(163)으로부터 요골 동맥까지의 거리로 설정될 수 있다.

Again, in fig. 1, the width length of the wrist (161) which is the distance between the constant value drawn according to the experimental result that the information control means (140) so far illustrates with reference to the figures 2 through 4 and the above-mentioned first side (163) produced and the second side (163) is multiplied by and the displacement of the radial artery can be produced. As described above, the displacement of the radial artery can be set up as the distance to the radial artery from the first location (163) which is the left side of the wrist (163).

센서 수단(151)은 팔찌 부재(110)에 설치되고, 요골 동맥(162)으로부터 상기 사용자의 생체 신호를 측정한다.

The sensor means (151) is installed at the bracelet member (110) and the bio-signal of the user is measured from the radial artery (162).

또한, 센서 구동 수단(152)은 센서 수단(151)과 연결되어 센서 수단(151)을 이동시킨다. 센서 수단(151)의 이동시키기 위하여 센서 구동 수단(152)은 모터(motor) 부재 등을 포함하여 구현될 수 있다. 또한, 센서 구동 수단(152)의 센서 수단(151) 이동을 위하여 팔찌 부재의 내면에는 소정의 레일(rail) 수단이 설치될 수 있다.

Moreover, the sensor driving means (152) is connected to the sensor means (151) and the sensor means (151) is moved. The sensor driving means (152) can be implemented including the motor absence etc. in order to move of the sensor means (151). Moreover, the predetermined rail means may be installed in the inner surface of the bracelet member for the sensor means (151) movement of the sensor driving means (152).

정보 제어 수단(140)은 상기 산출한 요골 동맥 변위를 이용하여 센서 구동 수단(152)을 구동시켜 센서 수단(151)을 요골 동맥(162)의 위치로 이동시킨다. 이후, 센서 수단(151)을 통해 상기 사용자의 생체 신호를 측정할 수 있다.

The information control means (140) drives the sensor driving means (152) using the above-mentioned radial artery displacement produced and the sensor means (151) is moved to the position of the radial artery (162). Then, the bio-signal of the on-going basis user can be measured through the sensor means (151).

센서 수단은 하나 이상의 센서부를 포함하여 구현될 수 있다. 이는 도 5를 참조하여 상세히 설명한다.

Sensor means include at least one sensor unit and it can be implemented. This particularly illustrates with reference to fig. 5.

도 5는 본 발명의 일 실시예에 따른 센서 수단의 구조를 도시한 도면이다.

Figure 5 is a drawing showing the structure of the sensor means according to a preferred embodiment of the present invention.

도 5에 도시된 바와 같이, 본 발명의 일 실시예에 따른 센서 수단(501)은 4개의 센서부, 즉, 제1 센서부(510), 제2 센서부(520), 제3 센서부(530), 및 제4 센서부(540)를 포함하여 구성될 수 있다. 또한, 각각의 센서부는 하나의 광센서(513 내지 543), 하나의 압력 센서(512 내지 542), 및 두 개의 발광 소자(511 내지 541)를 포함하여 구성될 수 있다.

As shown in FIG. 5, the sensor means (501) according to a preferred embodiment of the present invention can comprise the sensor unit of 4, in other words, the first sensor part (510), second sensor part (520), and the third sensor unit (530) and fourth sensor unit (540). Moreover, each sensor unit can comprise one optical sensor (513 to 543), and one pressure sensor (512 to 542) and two light emitting devices (511 to 541).

광센서(513 내지 543)는 상기 요골 동맥으로부터 상기 사용자의 맥파를 측정할 수 있다. 압력 센서(512 내지 542)는 상기

The optical sensor (513 to 543) can measure the pulse wave of the user from the radial artery. The pressure s

요골 동맥의 압력을 측정하여 상기 사용자의 혈압을 측정할 수 있다. 두 개의 발광 소자(511 내지 541)는 각각 적색광 및 적외선 대역의 파장을 사용하여 산화 및 환원 헤모글로빈이 광 흡수도 차이에 따른 산소 포화도를 측정할 수 있다.

본 발명의 일실시예에 따른 센서 수단(501)은 도 5에 도시된 바와 같이, 가로 방향으로 30mm 및 세로 방향으로 15mm의 길이를 갖도록 설계될 수 있다. 또한, 제1 센서부(510) 및 제4 센서부(540) 간의 가로 거리는 20mm로 설계되고, 세로 거리는 10mm로 설계될 수 있다. 이와 같이, 센서 수단(501)에 하나 이상의 센서부를 설치하여 요골 동맥의 측정 가능 면적을 넓힘으로써, 사용자 별로 나타날 수 있는 요골 동맥의 위치 변화에 따른 오차를 최소화할 수 있는 효과를 기대할 수 있다.

또한, 상술한 바와 같이, 맥파의 측정을 위한 광센서 뿐만 아니라 압력 센서 또는 발광 소자 등을 하나의 센서부에 함께 설치함으로써, 사용자의 맥파 측정뿐만 아니라 요골 동맥 압력 측정에 의한 상기 사용자의 혈압 측정 또는 산소 포화도 등 상기 사용자의 다양한 생체 신호를 동시에 측정할 수 있는 효과를 기대할 수 있다.

지금까지 본 발명에 따른 구체적인 실시예에 관하여 설명하였으나, 본 발명의 범위에서 벗어나지 않는 한도 내에서는 여러 가지 변형이 가능함은 물론이다.

그러므로, 본 발명의 범위는 설명된 실시예에 국한되어 정해져서는 안되며, 후술하는 특허청구의 범위뿐 아니라 이 특허청구의 범위와 균등한 것들에 의해 정해져야 한다.

도면에 대한 간단한 설명

도 1은 본 발명의 일실시예에 따른 생체 신호 측정 장치의 형상 및 구성을 도시한 도면.

도 2는 본 발명의 일실시예에 따라 수행되는 상수값 산출을 위하여 손목의 요골 동맥을 중심으로 다양한 거리만큼 이격된 위치에서 센서를 통해 측정되는 맥파의 세기를 측정한 실험 결과를 도시한 도면.

도 3은 본 발명의 일실시예에 따라 수행된 요골 동맥의 위치 측정을 위한 실험의 기준 프로토콜(protocol) 및 상기 실험에 따른 손목의 폭 길이에 대 요골 동맥 변위의 비의 결과값을 도시한 도면.

도 4는 본 발명의 일실시예에 따른 실험 과정의 결과값 화면을 도시한 도면.

ensor (512 to 542) measures the pressure of the radial artery and the blood pressure of the user can be measured. As to two light emitting devices (511 to 541), oxidation and reduced hemoglobin can measure the oxygen saturation according to the absorbance difference using the wavelength of the infrared ray band and red light.

The sensor means (501) according to a preferred embodiment of the present invention can be designed as shown in 5 to the cross direction to 30mm and length wise in order to have the length of 15mm. Moreover, the width distance between the fourth sensor unit (540) and the first sensor part (510) are designed to 20mm and the longitudinal distance can be designed to 10mm. In this way, at least one sensor unit is set up in the sensor means (501) and the measurable area of the radial artery is broadened. In that way the effect minimizing the error according to the location change of the radial artery which the user especially is able to make an appearance can be expected.

Moreover, as described above, not only the optical sensor for the measurement of the pulse wave but also the pressure sensor or the light emitting device etc. are together set up in one sensor unit. In that way the effect that simultaneously can measure the various bio-signal of the user including the blood pressure measurement of the user by not only the pulse wave measurement of the user but also the radial artery pressure measurement or the oxygen saturation etc. can be expected.

So far, it illustrated for the detailed embodiment according to the present invention. But it is of course that many transformation is possible in figure one. It does not deviate from from the scope of the present invention.

Therefore, it is limited to the embodiment in which the scope of the present invention is explained and it should not be determined and it determines with not only the scope of claims which will be described later but also this scope of claims and the equal things.

Brief explanation of the drawing

Figure 1 is a drawing showing the shape of the measuring biological signal apparatus according to a preferred embodiment of the present invention and configuration.

Figure 2 is a drawing showing the experimental result measuring the intensity of the pulse wave measured for the constant value computation performed according to the preferred embodiment of the present invention in the position separated around the radial artery of the wrist as the various distance through the sensor.

Figure 3 is a drawing showing the return value of the ratio of the width length large radial artery displacement of the wrist according to the reference Protocol of the experiment for the position location of the radial artery performed according to a preferred embodiment of the present invention and experiment.

Figure 4 is a drawing showing the return value screen of the test process according to a preferred embodiment

도 5는 본 발명의 일실시예에 따른 센서 수단의 구조를 도시한 도면.

#60#도면의 주요 부분에 대한 부호의 설명>

110 : 팔찌 부재 120 : 고정 지지대
130 : 이동 지지대 140 : 정보 제어 수단
151 : 센서 수단 152 : 센서 구동 수단
161 : 사용자 손목 162 : 요골 동맥
163 : 손목의 제1 측면 164 : 손목의 제2 측면

nt of the present invention.

Figure 5 is a drawing showing the structure of the sensor means according to a preferred embodiment of the present invention.

The description > of the denotation about the main part of the < drawing.

110: the bracelet member 120: supporter.
130: movable support 140: information control means.
151: sensor means 152: sensor driving means.
161: user wrist 162: radial artery.
163: the first side of the wrist 164: the second side of the wrist.

Disclaimer

본 문서는 특허 및 과학기술문헌 전용의 첨단 자동번역 시스템을 이용해 생성되었습니다. 따라서 부분적으로 오역의 가능성이 있으며, 본 문서를 자격을 갖춘 전문 번역가에 의한 번역물을 대신하는 것으로 이용되어서는 안 됩니다. 시스템 및 네트워크의 특성때문에 발생한 오역과 부분 누락, 데이터의 불일치등에 대하여 본원은 법적인 책임을 지지 않습니다. 본 문서는 당사의 사전 동의 없이 권한이 없는 일반 대중을 위해 DB 및 시스템에 저장되어 재생, 복사, 배포될 수 없음을 알려드립니다.

(The document produced by using the high-tech machine translation system for the patent and science & technology literature. Therefore, the document can include the mistranslation, and it should not be used as a translation by a professional translator. We hold no legal liability for inconsistency of mistranslation, partial omission, and data generated by feature of system and network. We would like to inform you that the document cannot be regenerated, copied, and distributed by being stored in DB and system for unauthorized general public without our consent.)



(19) 대한민국특허청(KR)

(12) 등록특허공보(B1)

(45) 공고일자 2007년09월06일

(11) 등록번호 10-0755079

(24) 등록일자 2007년08월28일

(51) Int. Cl.

A61B 5/00 (2006.01)

(21) 출원번호 10-2006-0061157

(22) 출원일자 2006년06월30일

심사청구일자 2006년06월30일

(56) 선행기술조사문헌

JP17111161 A

(뒷면에 계속)

(73) 특허권자

삼성전자주식회사

경기도 수원시 영통구 매탄동 416

(72) 발명자

이종연

경기도 용인시 기흥구 상갈동 상갈주공 307동 707호

야마코시 켄이치

일본국, 이시카와, 카나자와, 카쿠마-마찌 Nu7

(뒷면에 계속)

(74) 대리인

천성진

전체 청구항 수 : 총 7 항

심사관 : 유창용

(54) 생체 신호 측정 장치

(57) 요약

본 발명에 따른 생체 신호 측정 장치는, 사용자의 손목에 착용되는 팔찌 부재(membrane); 상기 팔찌 부재의 제1 측면에 설치되어 상기 손목의 제1 측면을 지지하는 고정 지지대; 상기 팔찌 부재의 제2 측면에 설치되고, 상기 고정 지지대 방향으로 이동하여 상기 손목의 제2 측면에 밀착되는 이동 지지대; 및 상기 이동 지지대가 이동한 거리를 감지하여 상기 손목의 제1 측면 및 상기 손목의 제2 측면 간의 거리를 산출하고, 상기 산출한 손목의 제1 측면 및 상기 손목의 제2 측면 간의 거리와 선정된(Predetermined) 상수(constant)를 이용하여 상기 손목의 요골 동맥(Radial Artery) 변위(displacement)를 산출하는 정보 제어 수단을 포함하는 것을 특징으로 한다.

도면도 - 도1

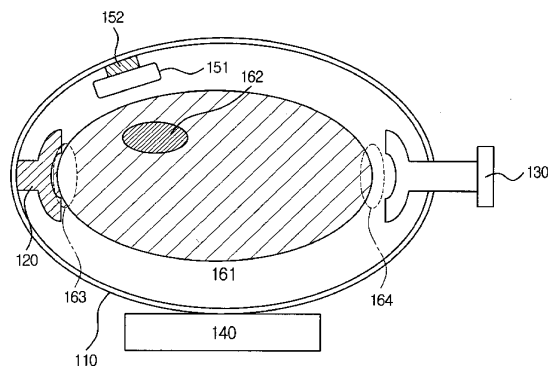

(72) 발명자

신건수

경기도 성남시 분당구 분당동 셋별마을라이프아파트 110동 1107호

정혜진

서울시 마포구 공덕1동 7-58 102호

(56) 선행기술조사문헌

JP17185729 A

JP1641482 A

JP16503280 A

JP14360530 A

JP17511223 A

US 5735800

KR1020070058900 A

특허청구의 범위

청구항 1

사용자의 손목에 착용되는 팔찌 부재(membrane);

상기 팔찌 부재의 제1 측면에 설치되어 상기 손목의 제1 측면을 지지하는 고정 지지대;

상기 팔찌 부재의 제2 측면에 설치되고, 상기 고정 지지대 방향으로 이동하여 상기 손목의 제2 측면에 밀착되는 이동 지지대; 및

상기 이동 지지대가 이동한 거리를 감지하여 상기 손목의 제1 측면 및 상기 손목의 제2 측면 간의 거리를 산출하고, 상기 산출한 손목의 제1 측면 및 상기 손목의 제2 측면 간의 거리와 선정된(Predetermined) 상수(constant)를 이용하여 상기 손목의 요골 동맥(Radial Artery) 변위(displacement)를 산출하는 정보 제어 수단을 포함하는 것을 특징으로 하는 생체 신호 측정 장치

청구항 2

제1항에 있어서,

상기 선정된 상수값은 0.1 내지 0.2 범위 내의 값으로 설정되는 것을 특징으로 하는 생체 신호 측정 장치.

청구항 3

제1항에 있어서,

상기 이동 지지대는 소정의 탄성 소자를 포함하고, 상기 탄성 소자의 탄성 운동에 따라 상기 손목의 제2 측면에 밀착되며,

상기 정보 제어 수단은 상기 탄성 소자의 상기 탄성 운동이 수행되기 전의 상기 고정 지지대 및 상기 이동 지지대 간의 거리 및 상기 탄성 운동에 따른 상기 탄성 소자의 변위를 이용하여 상기 손목의 제1 측면 및 상기 손목의 제2 측면 간의 거리를 산출하는 것을 특징으로 하는 생체 신호 측정 장치.

청구항 4

제1항에 있어서,

상기 이동 지지대는 소정의 볼트 소자를 포함하고, 상기 볼트 소자의 회전 운동에 따라 상기 손목의 제2 측면에 밀착되며,

상기 정보 제어 수단은 상기 볼트 소자의 상기 회전 운동이 수행되기 전의 상기 고정 지지대 및 상기 이동 지지대 간의 거리 및 상기 회전 운동에 따른 상기 볼트 소자의 회전수를 이용하여 상기 손목의 제1 측면 및 상기 손목의 제2 측면 간의 거리를 산출하는 것을 특징으로 하는 생체 신호 측정 장치.

청구항 5

제1항에 있어서,

상기 정보 제어 수단은 상기 산출한 손목의 제1 측면 및 상기 손목의 제2 측면 간의 거리와 상기 상수를 서로 곱하여 상기 손목의 요골 동맥 변위를 산출하고,

상기 요골 동맥 변위는 상기 손목의 제1 측면으로부터 상기 요골 동맥의 위치까지의 거리인 것을 특징으로 하는 생체 신호 측정 장치.

청구항 6

제1항에 있어서,

상기 팔찌 부재에 설치되고 상기 요골 동맥으로부터 상기 사용자의 생체 신호를 측정하는 센서 수단; 및

상기 센서 수단과 연결되어 상기 센서 수단을 이동시키기 위한 센서 구동 수단

을 더 포함하고,

상기 정보 제어 수단은 상기 산출한 상기 손목의 요골 동맥 변위를 이용하여 상기 센서 구동 수단을 구동하여 상기 센서 수단을 상기 요골 동맥의 위치로 이동시키는 것을 특징으로 하는 생체 신호 측정 장치.

청구항 7

제6항에 있어서,

상기 센서 수단은,

상기 요골 동맥으로부터 상기 사용자의 맥파를 측정하는 하나 이상의 맥파 센서;

상기 손목으로 각각 적색광 및 적외선을 발진시켜 상기 사용자의 산소 포화도를 측정하는 둘 이상의 발광 소자; 및

상기 요골 동맥의 압력을 측정하여 상기 사용자의 혈압을 측정하는 압력 센서

를 포함하는 것을 특징으로 하는 생체 신호 측정 장치.

명세서

발명의 상세한 설명

발명의 목적

발명이 속하는 기술 및 그 분야의 종래기술

- <12> 본 발명은 생체 신호 측정 장치에 관한 것으로서, 더욱 상세하게는 사용자 손목의 폭 길이를 측정하여 상기 사용자 손목에 위치하는 요골 동맥(Radial Artery)의 위치를 추적하고, 상기 요골 동맥으로부터 상기 사용자의 생체 신호를 측정함으로써, 사용자의 성별, 나이, 체중, 손목 둘레 길이에 상관 없이 누구나 보다 편리하고 정확하게 생체 신호를 측정할 수 있도록 하는 생체 신호 측정 장치에 관한 것이다.
- <13> 최근 산업계 전반에 걸쳐 중요시되는 이슈 중 하나인 유비쿼터스 관련 기술은 인간 생활의 모든 분야에 적용될 수 있는데, 특히 근래에는 웰빙(Well-Being) 현상으로 인해 유비쿼터스 헬스 케어(U-HealthCare)가 주목할 만한 기술 분야로 각광 받고 있다. 유비쿼터스 헬스 케어란 인간의 생활 공간 곳곳에 의료 서비스와 관련된 칩이나 센서를 설치함으로써, 모든 사람이 언제 어디서나 자연스럽게 의료 서비스를 제공 받을 수 있도록 하는 유비쿼터스 기술을 의미한다. 이러한 유비쿼터스 헬스 케어에 따르면, 각종 건강진단이나 질병관리, 응급관리, 의사와의 만남 등 병원에서만 이루어지던 의료 행위들이 병원에 가지 않고도 자연스럽게 일상 생활에서 구현될 수 있다.
- <14> 예를 들어, 당뇨병자의 경우 혈당관리 프로그램이 탑재된 혈당관리용 허리띠를 착용할 수 있다. 상기 허리띠에 부착된 혈당센서는 수시로 상기 당뇨병자의 혈당을 체크하고 그에 적합한 인슐린 양을 산출할 수 있다. 만일 상기 당뇨병자의 혈당이 급격하게 낮아지거나 높아질 경우, 그 혈당정보를 주치의에게 무선 통신망을 통해 제공할 수 있고, 상기 혈당정보를 제공 받은 주치의는 상기 응급상황에 따른 최적의 처방이나 조치를 취할 수 있다.
- <15> 이러한 유비쿼터스 헬스 케어의 일환으로 일상 생활에서 누구나 쉽게 자신의 맥파를 측정할 수 있도록 하는 휴대형 맥파 측정 장치가 있다. 상기 휴대형 맥파 측정 장치는 대부분 손목 시계 또는 팔찌의 형태로 구현되어 평상 시 손목에 차고 다니면서 누구나 쉽게 자신의 맥파를 측정할 수 있도록 하고 있다.
- <16> 일반적으로 손목을 통해 맥파를 측정하는 경우, 상기 맥파는 손목의 요골 동맥(Radial Artery)으로부터 측정될 수 있다. 따라서, 정확한 맥파의 측정을 위해서는 사용자의 요골 동맥의 위치를 정확하게 파악하는 동작이 선행되어야 한다. 그러나, 사람마다 손목의 크기나 둘레가 모두 제각각이어서 사용자마다 손목에서의 요골 동맥 위치는 모두 서로 다르다.
- <17> 따라서, 종래 기술에 따르면, 사용자마다 그 위치가 서로 다른 요골 동맥의 위치를 파악하기 위해서 사용자가 직접 자신의 요골 동맥 위치로 센서를 이동시키거나, 수군데에서 맥파를 측정한 후 가장 정확한 신호가 측정되는 지점을 요골 동맥으로 파악하는 등 많은 불편함과 부정확성이 문제가 되고 있다.
- <18> 이러한 종래 기술에 따른 문제점의 지적에 따라, 사용자의 나이, 성별, 손목 크기, 체중 등에 상관 없이 각 사

용자의 손목에 위치하는 요골 동맥의 위치를 정확하게 파악하여 상기 사용자의 생체 신호를 상기 요골 동맥으로부터 정확하게 측정할 수 있는 생체 신호 측정 장치의 개발이 요구되고 있다.

발명이 이루고자 하는 기술적 과제

- <19> 본 발명은 상기와 같은 종래 기술을 개선하기 위해 안출된 것으로서, 사용자 손목의 폭 길이를 측정된 후 선정된(Predetermined) 상수(constant)와 곱하여 상기 손목의 요골 동맥 위치를 정확하게 파악하여 상기 사용자의 생체 신호를 상기 요골 동맥으로부터 측정함으로써, 사용자의 신체 조건에 상관 없이 누구나 보다 편리하고 정확하게 자신의 생체 신호를 측정할 수 있도록 하는 생체 신호 측정 장치를 제공하는 것을 목적으로 한다.
- <20> 또한, 본 발명은 요골 동맥으로부터 사용자의 생체 신호를 측정하는 센서 수단에 하나 이상의 광센서, 적외광 및 적외선을 각각 발광하는 둘 이상의 발광 센서, 및 하나 이상의 압력 센서를 구비함으로써, 상기 사용자의 맥파를 측정할 수 있을 뿐만 아니라, 상기 사용자의 산화 및 환원 헤모글로빈의 광 흡수도 차이에 따른 산소 포화도의 측정도 가능하고, 상기 압력 센서를 통해 상기 요골 동맥의 압력을 측정하여 상기 사용자의 혈압 또한 측정할 수 있도록 하는 생체 신호 측정 장치를 제공하는 것을 목적으로 한다.

발명의 구성 및 작용

- <21> 상기의 목적을 이루고 종래기술의 문제점을 해결하기 위하여, 본 발명에 따른 생체 신호 측정 장치는, 사용자의 손목에 착용되는 팔찌 부재(membrane); 상기 팔찌 부재의 제1 측면에 설치되어 상기 손목의 제1 측면을 지지하는 고정 지지대; 상기 팔찌 부재의 제2 측면에 설치되고, 상기 고정 지지대 방향으로 이동하여 상기 손목의 제2 측면에 밀착되는 이동 지지대; 및 상기 이동 지지대가 이동한 거리를 감지하여 상기 손목의 제1 측면 및 상기 손목의 제2 측면 간의 거리를 산출하고, 상기 산출한 손목의 제1 측면 및 상기 손목의 제2 측면 간의 거리와 선정된(Predetermined) 상수(constant)를 이용하여 상기 손목의 요골 동맥(Radial Artery) 변위(displacement)를 산출하는 정보 제어 수단을 포함하는 것을 특징으로 한다.
- <22> 본 명세서에서 주로 언급되는 맥파란 심장의 물리적인 변화에 근거하여 혈관계와 관맥의 압력과 용적의 변화에 따른 파형을 의미한다. 본 발명에 따른 생체 신호 측정 장치는 사용자의 손목 부위로부터 요골 동맥파를 측정할 수 있다. 상기 생체 신호 측정 장치는 손목 시계 또는 팔찌 등 손목에 착용 가능한 액세서리의 일부 구성으로 구현될 수도 있고, 팔찌 형태의 단일 물품으로 구현될 수도 있다. 본 명세서에서는 설명의 편의상 상기 생체 신호 측정 장치가 팔찌 형태의 단일 물품으로 구현되는 경우를 예로 들어 설명한다.
- <23> 이하에서는 첨부된 도면을 참조하여 본 발명의 실시예를 상세히 설명한다.
- <24> 도 1은 본 발명의 일실시예에 따른 생체 신호 측정 장치의 형상 및 구성을 도시한 도면이다.
- <25> 본 발명의 일실시예에 따른 생체 신호 측정 장치는 팔찌 부재(membrane)(110), 고정 지지대(120), 이동 지지대(130), 정보 제어 수단(140), 센서 수단(151), 및 센서 구동 수단(152)를 포함하여 구성된다.
- <26> 팔찌 부재(110)는 사용자의 손목(161)에 착용 가능한 일반적인 팔찌 형태의 구조물로 구현될 수 있다. 팔찌 부재(110)의 크기는 일반 성인의 손목에 착용 가능한 정도의 크기로 구현될 수 있다.
- <27> 고정 지지대(120)는 팔찌 부재(110)의 제1 측면에 설치되어 손목(161)의 제1 측면(163)을 지지한다. 즉, 사용자가 팔찌 부재(110)를 손목(161)에 착용하였을 경우, 고정 지지대(120)는 손목(161)의 제1 측면(163)에 접촉되거나 밀착되어 손목(161)을 지지할 수 있다. 예를 들어, 상기 사용자가 팔찌 부재(110)를 왼팔 손목에 착용하였을 경우, 고정 지지대는 상기 왼팔 손목의 왼쪽 측면에 접촉되거나 밀착될 수 있다.
- <28> 이동 지지대(130)는 팔찌 부재(110)의 제2 측면에 설치되고, 고정 지지대(120) 방향으로 이동하여 손목(161)의 제2 측면(164)에 밀착된다. 즉, 사용자가 팔찌 부재(110)를 손목(161)에 착용하였을 경우, 고정 지지대(120)는 손목(161)의 제1 측면(163)에 접촉되거나 밀착되어 손목(161)을 지지하고, 이동 지지대는 도 1에 도시된 바와 같이 손목(161)의 제2 측면(164)과 소정 거리만큼 이격되어 위치하도록 구현될 수 있다.
- <29> 이 때, 이동 지지대(130)는 고정 지지대(120) 방향으로 이동하여 손목(161)의 제2 측면(164)에 밀착되어 손목(161)을 지지할 수 있다. 즉, 이동 지지대(130)가 제2 측면(164) 방향으로 이동하여 제2 측면(164)에 밀착됨으로써, 고정 지지대(120) 및 이동 지지대(130)가 손목(161)에 각각 밀착되어 지지할 수 있다.
- <30> 이동 지지대(130)의 이동 방법으로는 사용자가 이동 지지대(130)를 구동하여 직접 이동시킬 수도 있고, 일반적인 혈압 측정 장치와 같이 사용자가 손목(161)에 팔찌 부재(110)를 착용하는 순간 자동으로 이동하여 손목(16

1)의 제2 측면(164)에 밀착되도록 구현될 수도 있다.

- <31> 이동 지지대(130)의 이동 원리로는 스프링 등의 탄성 운동을 이용하는 방법 또는 볼트 수단 등의 회전 운동을 이용하는 방법이 적용될 수 있다.
- <32> 첫째, 상기 탄성 운동을 이용하는 경우, 이동 지지대(130)는 스프링 등과 같은 소정의 탄성 소자를 포함하여 구성될 수 있다. 이동 지지대(130)는 상기 탄성 소자의 탄성 운동에 따라 손목(160)의 제2 측면(164)에 밀착될 수 있다. 예를 들어, 사용자가 이동 지지대(130)에 압력을 가하는 순간, 상기 탄성 소자의 수축 운동에 따라 이동 지지대(130)는 제2 측면(164)에 밀착될 수 있다.
- <33> 둘째, 상기 회전 운동을 이용하는 경우, 이동 지지대(130)는 소정의 볼트 소자를 포함하여 구성될 수 있다. 이동 지지대(130)는 상기 볼트 소자의 회전 운동에 따라 손목(161)의 제2 측면(164)에 밀착될 수 있다. 예를 들어, 상기 사용자가 상기 볼트 수단을 회전시키는 경우, 상기 볼트 수단이 회전함에 따라 이동 지지대(130)는 고정 지지대(120) 방향으로 이동하여 손목(161)의 제2 측면(164)에 밀착될 수 있다.
- <34> 정보 제어 수단(140)은 이동 지지대(130)가 이동한 거리를 감지하여 손목(161)의 제1 측면(163) 및 제2 측면(163) 간의 거리를 산출한다. 즉, 정보 제어 수단(140)은 이동 지지대(130)가 이동한 거리를 감지함으로써, 손목(161)의 폭 길이를 산출할 수 있다.
- <35> 정보 제어 수단(140)은 이동 지지대(130)가 이동하기 전, 고정 지지대(120) 및 이동 지지대(130) 간의 거리에서 이동 지지대(130)가 이동한 거리를 차감함으로써, 손목(161)의 상기 폭 길이를 산출할 수 있다.
- <36> 이동 지지대(130)가 탄성 소자를 포함하여 구현되는 경우, 정보 제어 수단(140)은 이동 지지대(130)가 손목(161)의 제2 측면(164)에 밀착되기 위하여 상기 탄성 소자가 움직인 변위(displacement)를 이용하여 이동 지지대(130)가 이동한 거리를 산출할 수 있다.
- <37> 또한, 이동 지지대(130)가 볼트 소자를 포함하여 구현되는 경우, 정보 제어 수단(140)은 이동 지지대(130)가 손목(161)의 제2 측면(164)에 밀착되기 위하여 상기 볼트 수단이 회전한 회전수를 이용하여 이동 지지대(130)가 이동한 거리를 산출할 수 있다.
- <38> 상술한 바와 같이, 이동 지지대(130)가 이동한 거리를 감지하여 손목(161)의 제1 측면(163) 및 제2 측면(163) 간의 거리, 즉, 손목(161)의 폭 길이가 산출되면, 정보 제어 수단(140)은 상기 산출한 손목(161)의 폭 길이와 선정된(Predetermined) 상수(constant)를 이용하여 상기 손목의 요골 동맥(Radial Artery) 변위(displacement)를 산출한다.
- <39> 상기 상수는 0.1719 또는 0.1492의 값을 갖도록 설정될 수 있다. 본 발명의 일실시예에 따르면, 정보 제어 수단(140)은 상기 상수값과 상기 산출한 제1 측면(163) 및 제2 측면(163) 간의 거리인 손목(161)의 폭 길이를 서로 곱하여 상기 요골 동맥의 변위를 산출할 수 있다. 상기 요골 동맥의 변위는 손목(161)의 제1 측면(163)으로부터의 거리로 설정될 수 있다.
- <40> 상기 상수값은 소정의 실험을 통해 선정될 수 있다. 이하에서는 도 2 내지 도 4를 참조하여 상기 실험에 따른 상기 상수값의 산출 원리에 대하여 설명한다.
- <41> 도 2는 본 발명의 일실시예에 따라 수행되는 상수값 산출을 위하여 손목의 요골 동맥을 중심으로 다양한 거리만큼 이격된 위치에서 센서를 통해 측정되는 맥파의 세기를 측정된 실험 결과를 도시한 도면이다.
- <42> 손목에 위치하는 요골 동맥의 측정 부위에 따른 맥파 신호의 세기 차이를 비교하기 위하여 도 2의 (a)에 도시된 바와 같이, 요골 동맥을 중심으로 좌우로 각각 2mm 간격만큼 이격된 위치에서 맥파를 측정하는 경우, 도 2의 (b)에 도시된 그래프와 같은 결과를 얻을 수 있다.
- <43> 상기 실험 결과에 의하면, 요골 동맥의 위치(Center)에서와 상기 요골 동맥으로부터 오른 쪽으로 2mm 지점(R2)에서 측정된 맥파가 최대의 진폭을 갖는 것을 알 수 있다. 또한, 요골 동맥에서 멀리 이격된 지점일수록 맥파의 신호가 작아지는 경향을 보이며 측정 결과가 요골 동맥을 중심으로 대칭을 이루지는 않는다. 따라서, 상기 실험 결과에 의해 요골 동맥을 중심으로 하여 좌측으로 2mm 우측으로 6mm 이내에 센서가 위치하면 보다 정확한 맥파 신호를 측정할 수 있음을 알 수 있다.
- <44> 도 3은 본 발명의 일실시예에 따라 수행된 요골 동맥의 위치 측정을 위한 실험의 기준 프로토콜(protocol) 및 상기 실험에 따른 손목의 폭 길이 대 요골 동맥 변위의 비의 결과값을 도시한 도면이다.

- <45> 상기 상수값의 산출을 위하여, 보다 정량적으로 요골 동맥의 위치를 파악하기 위해 87명의 피검자에서 동맥의 위치를 측정하는 실험을 실시하였다. 한국인은 19명의 남성과 15명의 여성에서, 일본인은 38명의 남성과 6명의 여성에서 그리고 중국인은 5명의 남성과 4명의 여성에서 측정을 실시하였다.
- <46> 도 3의 (a)에 도시된 바와 같이, 손목 내측의 횡단 주름의 가장 윗 부분을 포지션(position) 1로 설정하고, 상기 포지션 1로부터 2.5cm와 5cm만큼 이격된 손목 내측으로 각각의 위치를 포지션 2 및 포지션 3으로 설정하였다. 또한, C1은 상기 포지션 1에서의 손목 둘레를 의미하고, C2는 상기 포지션 2에서의 손목 둘레를 의미하며, C3는 상기 포지션 3에서의 손목 둘레를 의미한다.
- <47> 또한, I1은 포지션 1에서 손목의 왼쪽 측면부터 요골 동맥까지의 거리를 의미하고, I2는 포지션 2에서 손목의 왼쪽 측면부터 요골 동맥까지의 거리를 의미하며, I3는 포지션 3에서 손목의 왼쪽 측면부터 요골 동맥까지의 거리를 의미한다. 상기 각각의 포지션에서 손목의 폭(L1, L2, L3)과 손목 왼쪽 측면에서 요골 동맥까지의 거리(I1, I2, I3)의 비(I1/L1, I2/L2, I3/L3)를 산출하는 실험을 수행하였다.
- <48> 또한, 상기 포지션에서 손목의 폭과 손목 왼쪽 측면에서 요골 동맥까지의 거리의 비(I1/L1, I2/L2, I3/L3)와 손목 둘레(C1, C2, C3)의 상관관계를 산출한 결과, 상관계수가 -0.359로 산출되어 서로 매우 낮은 상관관계를 갖는 것이 입증되었다. 따라서, 손목의 둘레 길이와 손목의 폭에서 요골 동맥의 위치는 서로 무관하다고 설정할 수 있다.
- <49> 또한, 성별, 나이, 체격 등이 각각 다른 수십명의 피실험자들을 통해 상기 손목의 폭과 손목 왼쪽 측면에서 요골 동맥까지의 거리의 비(I1/L1, I2/L2, I3/L3)를 산출한 결과, 도 2의 (b)와 같은 결과값을 얻을 수 있었다. 즉, 성별에 따른 손목의 폭과 왼쪽 손목의 왼쪽 측면에서 요골 동맥까지의 거리의 비(I1/L1)를 T-test로 비교한 결과, 남성의 평균은 0.17 ± 0.04 이고 여성의 평균은 0.15 ± 0.04 으로 산출되어 p-value가 0.053으로 성별에 따른 차이가 없음을 알 수 있다.
- <50> 따라서, 손목의 둘레와 성별에 영향 받지 않는 손목의 폭 길이와 왼쪽 손목의 왼쪽 측면에서 요골 동맥까지의 거리의 비를 이용하여 요골 동맥 위치를 유추하기 위하여 다음과 같은 과정을 통해 오차를 계산하였다.
- <51> 1) 측정된 87명의 데이터에서 손목의 폭과 왼쪽 손목의 왼쪽 측면에서 요골 동맥까지의 거리의 비(I1/L1)의 평균을 계산
- <52> 2) 이 평균 값에 각 개인의 손목 폭의 길이(L1)를 곱하여 손목 측면에서 요골 동맥까지의 거리(I1_1)의 추정치 계산
- <53> 3) 상기 2)의 과정에서 얻어진 추정치와 실제 손목 왼쪽 측면에서 요골 동맥까지의 거리의 차이를 구함
- <54> 4) 상기 차이의 평균을 구함
- <55> 도 4는 상술한 실험 과정의 결과를 도시한 도면이다.
- <56> 상술한 실험 과정의 결과에 따르면 $\pm 2.24\text{mm}$ 의 오차가 산출됨을 알 수 있다. 그러나 상기 $\pm 2\text{mm}$ 의 오차는 도 2에 도시된 실험 결과에서 알 수 있듯이 맥파 신호의 측정 결과에 큰 영향을 미치지 않는다. 따라서 손목의 폭 길이와 왼쪽 손목의 왼쪽 측면에서 요골 동맥까지의 거리의 비(I1/L1)의 평균과 사용자의 손목 폭 길이만 알 수 있다면, 상기 사용자의 왼쪽 손목의 왼쪽 측면에서 요골 동맥까지의 위치를 추정할 수 있다.
- <57> 이 때, 손목의 폭 길이와 왼쪽 손목의 왼쪽 측면에서 요골 동맥까지의 거리의 비(I1/L1)의 평균은 지금까지 설명한 실험적으로 얻어진 결과값을 상수처럼 사용할 수 있으므로, 개인의 손목 폭의 길이만 측정하면 사용자의 성별이나 나이, 체형에 상관없이 요골 동맥 위치를 보다 정확하게 추정할 수 있다.
- <58> 다시 도 1에서, 정보 제어 수단(140)은 지금까지 도 2 내지 도 4를 참조하여 설명한 실험 결과에 따라 도출되는 상기 상수값과 상기 산출한 제1 측면(163) 및 제2 측면(163) 간의 거리인 손목(161)의 폭 길이를 서로 곱하여 상기 요골 동맥의 변위를 산출할 수 있다. 상기 요골 동맥의 변위는 상술한 바와 같이 손목(163)의 왼쪽 측면인 제1 위치(163)으로부터 요골 동맥까지의 거리로 설정될 수 있다.
- <59> 센서 수단(151)은 팔찌 부재(110)에 설치되고, 요골 동맥(162)으로부터 상기 사용자의 생체 신호를 측정한다.
- <60> 또한, 센서 구동 수단(152)은 센서 수단(151)과 연결되어 센서 수단(151)을 이동시킨다. 센서 수단(151)의 이동시키기 위하여 센서 구동 수단(152)은 모터(motor) 부재 등을 포함하여 구현될 수 있다. 또한, 센서 구동 수

단(152)의 센서 수단(151) 이동을 위하여 팔찌 부재의 내면에는 소정의 레일(rail) 수단이 설치될 수 있다.

- <61> 정보 제어 수단(140)은 상기 산출한 요골 동맥 변위를 이용하여 센서 구동 수단(152)을 구동시켜 센서 수단(151)을 요골 동맥(162)의 위치로 이동시킨다. 이후, 센서 수단(151)을 통해 상시 사용자의 생체 신호를 측정할 수 있다.
- <62> 센서 수단은 하나 이상의 센서부를 포함하여 구현될 수 있다. 이는 도 5를 참조하여 상세히 설명한다.
- <63> 도 5는 본 발명의 일실시예에 따른 센서 수단의 구조를 도시한 도면이다.
- <64> 도 5에 도시된 바와 같이, 본 발명의 일실시예에 따른 센서 수단(501)은 4개의 센서부, 즉, 제1 센서부(510), 제2 센서부(520), 제3 센서부(530), 및 제4 센서부(540)를 포함하여 구성될 수 있다. 또한, 각각의 센서부는 하나의 광센서(513 내지 543), 하나의 압력 센서(512 내지 542), 및 두 개의 발광 소자(511 내지 541)를 포함하여 구성될 수 있다.
- <65> 광센서(513 내지 543)는 상기 요골 동맥으로부터 상기 사용자의 맥파를 측정할 수 있다. 압력 센서(512 내지 542)는 상기 요골 동맥의 압력을 측정하여 상기 사용자의 혈압을 측정할 수 있다. 두 개의 발광 소자(511 내지 541)는 각각 적색광 및 적외선 대역의 파장을 사용하여 산화 및 환원 헤모글로빈이 광 흡수도 차이에 따른 산소 포화도를 측정할 수 있다.
- <66> 본 발명의 일실시예에 따른 센서 수단(501)은 도 5에 도시된 바와 같이, 가로 방향으로 30mm 및 세로 방향으로 15mm의 길이를 갖도록 설계될 수 있다. 또한, 제1 센서부(510) 및 제4 센서부(540) 간의 가로 거리는 20mm로 설계되고, 세로 거리는 10mm로 설계될 수 있다. 이와 같이, 센서 수단(501)에 하나 이상의 센서부를 설치하여 요골 동맥의 측정 가능 면적을 넓힘으로써, 사용자 별로 나타날 수 있는 요골 동맥의 위치 변화에 따른 오차를 최소화할 수 있는 효과를 기대할 수 있다.
- <67> 또한, 상술한 바와 같이, 맥파의 측정을 위한 광센서 뿐만 아니라 압력 센서 또는 발광 소자 등을 하나의 센서부에 함께 설치함으로써, 사용자의 맥파 측정뿐만 아니라 요골 동맥 압력 측정에 의한 상기 사용자의 혈압 측정 또는 산소 포화도 등 상기 사용자의 다양한 생체 신호를 동시에 측정할 수 있는 효과를 기대할 수 있다.
- <68> 지금까지 본 발명에 따른 구체적인 실시예에 관하여 설명하였으나, 본 발명의 범위에서 벗어나지 않는 한도 내에서는 여러 가지 변형이 가능함은 물론이다.
- <69> 그러므로, 본 발명의 범위는 설명된 실시예에 국한되어 정해져서는 안되며, 후술하는 특허청구의 범위뿐 아니라 이 특허청구의 범위와 균등한 것들에 의해 정해져야 한다.

발명의 효과

- <70> 본 발명의 생체 신호 측정 장치에 따르면, 사용자 손목의 폭 길이를 측정한 후 선정된(Predetermined) 상수(constant)와 곱하여 상기 손목의 요골 동맥 위치를 정확하게 파악하여 상기 사용자의 생체 신호를 상기 요골 동맥으로부터 측정함으로써, 사용자의 신체 조건에 상관 없이 누구나 보다 편리하고 정확하게 자신의 생체 신호를 측정할 수 있도록 하는 효과를 얻을 수 있다.
- <71> 또한, 본 발명의 생체 신호 측정 장치에 따르면, 요골 동맥으로부터 사용자의 생체 신호를 측정하는 센서 수단에 하나 이상의 광센서, 적색광 및 적외선을 각각 발광하는 둘 이상의 발광 센서, 및 하나 이상의 압력 센서를 구비함으로써, 상기 사용자의 맥파를 측정할 수 있을 뿐만 아니라, 상기 사용자의 산화 및 환원 헤모글로빈의 광 흡수도 차이에 따른 산소 포화도의 측정도 가능하고, 상기 압력 센서를 통해 상기 요골 동맥의 압력을 측정하여 상시 사용자의 혈압 또한 측정할 수 있도록 하는 효과를 얻을 수 있다.
- <72> 이상과 같이 본 발명은 비록 한정된 실시예와 도면에 의해 설명되었으나, 본 발명은 상기의 실시예에 한정되는 것은 아니며, 이는 본 발명이 속하는 분야에서 통상의 지식을 가진 자라면 이러한 기재로부터 다양한 수정 및 변형이 가능하다. 따라서, 본 발명 사상은 아래에 기재된 특허청구범위에 의해서만 파악되어야 하고, 이의 균등 또는 등가적 변형 모두는 본 발명 사상의 범주에 속한다고 할 것이다.

도면의 간단한 설명

- <1> 도 1은 본 발명의 일실시예에 따른 생체 신호 측정 장치의 형상 및 구성을 도시한 도면.
- <2> 도 2는 본 발명의 일실시예에 따라 수행되는 상수값 산출을 위하여 손목의 요골 동맥을 중심으로 다양한 거리만

큼 이격된 위치에서 센서를 통해 측정되는 맥파의 세기를 측정한 실험 결과를 도시한 도면.

- <3> 도 3은 본 발명의 일실시예에 따라 수행된 요골 동맥의 위치 측정을 위한 실험의 기준 프로토콜(protocol) 및 상기 실험에 따른 손목의 폭 길이 대 요골 동맥 변위의 비의 결과값을 도시한 도면.
- <4> 도 4는 본 발명의 일실시예에 따른 실험 과정의 결과값 화면을 도시한 도면.
- <5> 도 5는 본 발명의 일실시예에 따른 센서 수단의 구조를 도시한 도면.
- <6> <도면의 주요 부분에 대한 부호의 설명>
- <7> 110 : 팔찌 부재 120 : 고정 지지대
- <8> 130 : 이동 지지대 140 : 정보 제어 수단
- <9> 151 : 센서 수단 152 : 센서 구동 수단
- <10> 161 : 사용자 손목 162 : 요골 동맥
- <11> 163 : 손목의 제1 측면 164 : 손목의 제2 측면

도면

도면1

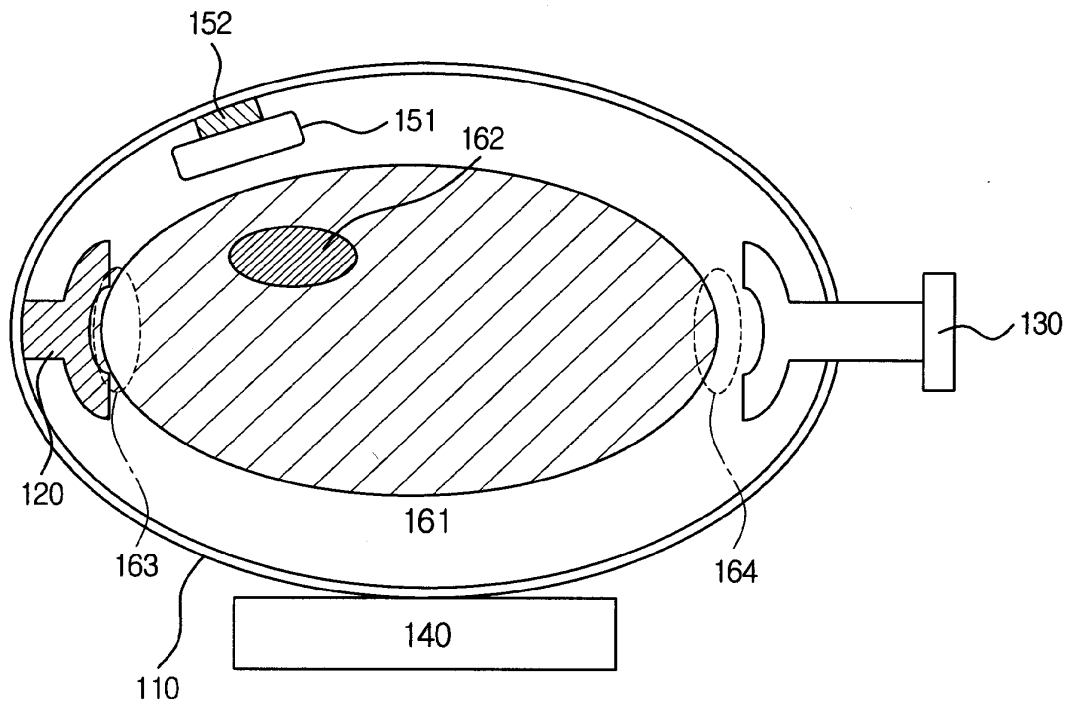

5/22

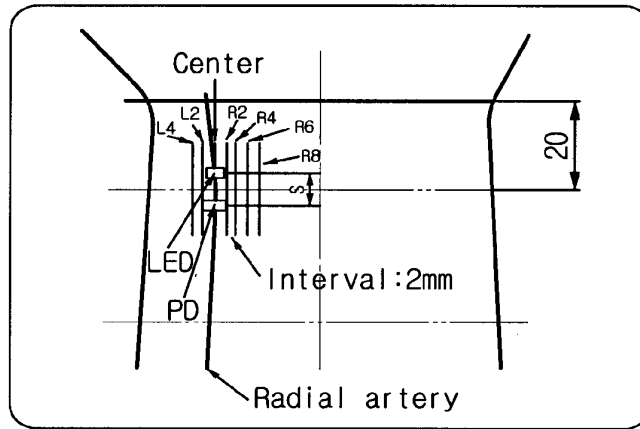

(a)

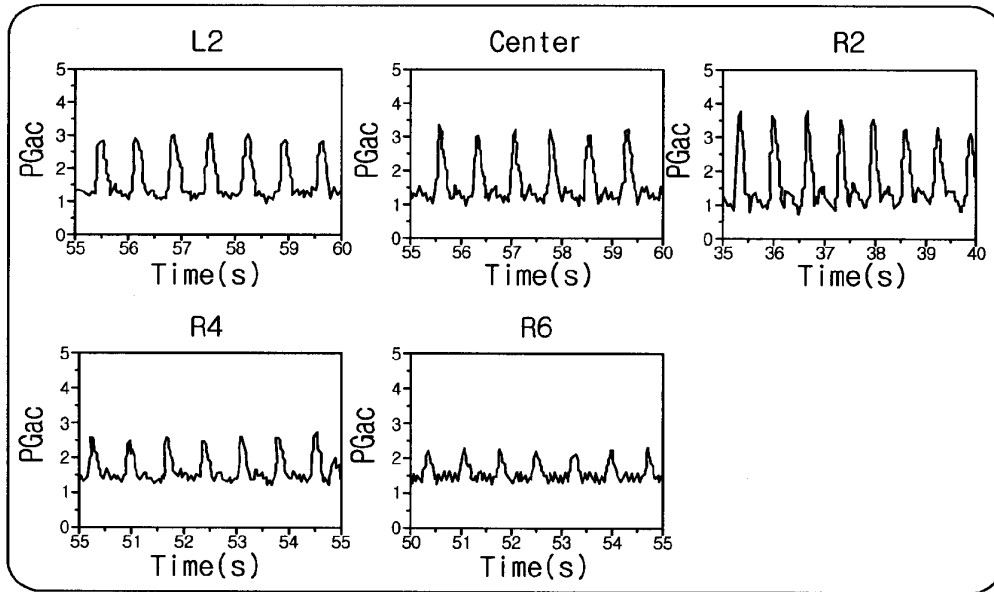

(b)

도면

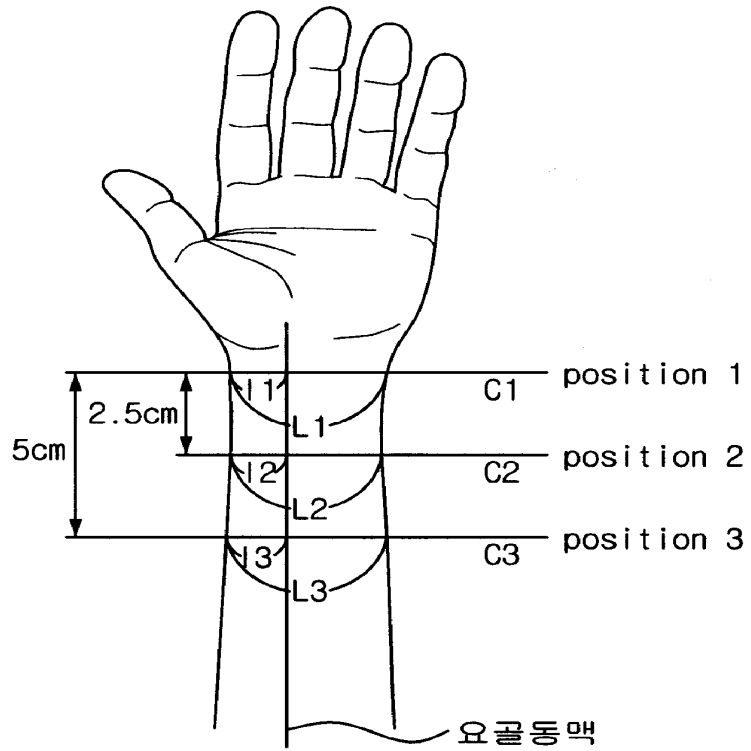

(a)

	N	평균	표준편차
I1/L1 (남성)	57	0.1719	0.0402
I1/L1 (여성)	21	0.1492	0.0454

(b)

도면4

Microsoft Excel - [계산서(1).xls] - [시트1] (N1) * Ratio (G1:A,1)

	H	I	J	K	L	M	N	O	P	Q	R	S
	H1(cm)	I2(cm)	J3(cm)	K1(cm)	L2(cm)	M3(cm)	Ratio (H1:I,1)	Ratio (J2:L,1)	Ratio (K3:M,1)		H_1	SN
2	1	1.9	1.3	6.3	8.9	8.8	0.159	0.217	0.191176		1.0017	0.0
3	0.7	1.1	1	6.1	8.8	8.5	0.175	0.187	0.153846		0.7015	0.0
4	0.9	1.2	1.4	6.3	8.5	8.8	0.143	0.195	0.212121		0.9609	0.0
5	0.8	1.8	1.4	6.3	7.3	7.4	0.127	0.219	0.180189		0.5001	0.0
6	1.2	1	1.2	8.4	8.1	8.4	0.188	0.184	0.1875		1.2032	0.0
7	1.5	1.5	1.1	8.7	7	7.3	0.224	0.229	0.235111		1.5068	0.0
8	0.4	1.4	2	6.4	6.7	7.2	0.141	0.208	0.277778		0.3024	0.0
9	1.5	1.3	1.3	8.9	8.5	8.2	0.217	0.2	0.208877		1.4973	0.0
10	0.8	0.8	0.9	6	5.9	6.1	0.133	0.136	0.147541		0.738	0.1
11	1.6	2.1	2.1	7	7.4	7.5	0.229	0.234	0.23		1.609	0.1
12	0.8	1.3	1.4	6.2	6.5	6.5	0.145	0.2	0.213885		0.889	0.1
13	1.2	1.5	1.7	8.4	8.4	8.5	0.188	0.214	0.257576		1.2032	0.0
14	1.5	1.5	1.6	8.8	8.9	7	0.238	0.232	0.229571		1.598	0.1
15	1.2	1.2	1	6.3	6.4	6.4	0.19	0.188	0.18625		1.157	0.1
16	0.9	1.2	1.2	6.1	6.8	6.3	0.098	0.178	0.176471		0.5978	0.0
17	1.3	1.1	1.2	8.1	8.9	8.4	0.213	0.136	0.20339		1.2883	0.0
18	1.5	1.9	1.9	6.7	6.5	6.8	0.224	0.232	0.279473		1.5068	0.0
19	1.6	1.3	1.3	6.4	6.1	6.1	0.25	0.213	0.218115		1.6	0
20	1	1.4	1.6	6.3	6.9	6.9	0.159	0.206	0.231884		1.0017	0.0
21												
22	1.19	1.23	1	7.77	7.34	7.36	0.15	0.15	0.14		1.1875	0.0
23	1.83	1.32	2.11	6.32	7.01	7.18	0.24	0.28	0.29		1.8608	0.0
24	1.99	1.48	1.94	8.76	8.55	8.69	0.16	0.22	0.2		1.9816	0.0
25	1.11	1.34	0.6	6.28	6.17	6.1	0.18	0.15	0.1		1.1304	0.0
26	1.4	1.45	1.22	8	7.88	7.95	0.18	0.17	0.17		1.44	0
27	0.86	1.42	1.35	7.22	7.09	7.4	0.12	0.16	0.19		0.8664	0.0
28	0.86	1.42	1.19	7.65	6.95	6.83	0.12	0.16	0.17		0.8645	0.0
29												
30												

시트1 / 시트2 / 시트3

시트1

도 95

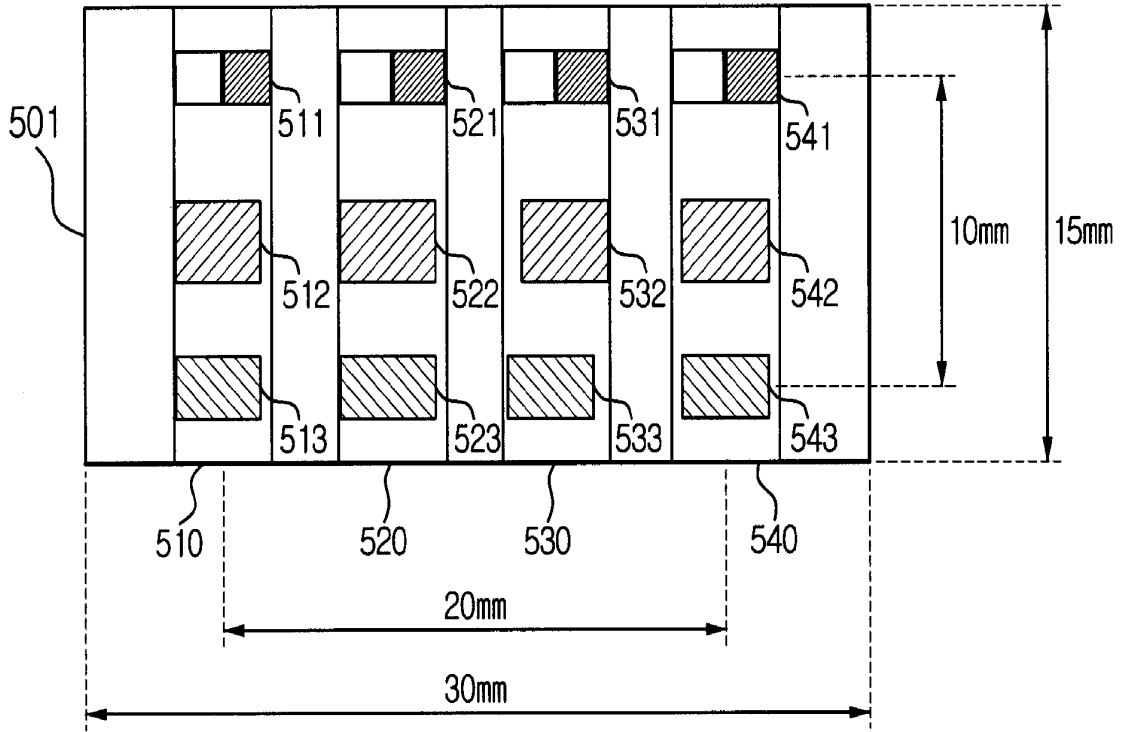

(12) 按照专利合作条约所公布的国际申请

(19) 世界知识产权组织
国际局



(43) 国际公布日
2006年6月15日 (15.06.2006)

PCT

(10) 国际公布号
WO 2006/060949 A1

- (51) 国际专利分类号:
A44C 9/00 (2006.01) G01K 1/14 (2006.01)
A61B 5/16 (2006.01)
- (71) 申请人及
(72) 发明人: 张凤麟(JANG, Fong-Lin) [CN/CN]; 中国台湾省台南市崇学路20巷2号21楼, Taiwan 701 (CN)。
- (21) 国际申请号: PCT/CN2005/002054
- (74) 代理人: 北京维澳专利代理有限公司(WE-ALL PATENT AGENT CO., LTD.); 中国北京市建国门外大街22号赛特广场M层30112室, Beijing 100004 (CN)。
- (22) 国际申请日: 2005年11月30日 (30.11.2005)
- (25) 申请语言: 中文
- (26) 公布语言: 中文
- (30) 优先权:
200420058405.2
2004年12月9日 (09.12.2004) CN
- (81) 指定国 (除另有指明, 要求每一种可提供的国家保护): AE, AG, AL, AM, AT, AU, AZ, BA, BB, BG, BR, BW, BY, BZ, CA, CH, CN, CO, CR, CU, CZ, DE, DK, DM, DZ, EC, EE, EG, ES, FI, GB, GD, GE, GH, GM, HR, HU, ID, IL, IN, IS, JP, KE, KG, KM, KN, KP, KR, KZ, LC, LK, LR, LS, LT, LU, LV, LY, MA, MD,

[见续页]

(54) Title: FINGER TEMPERATURE INDICATING RING

(54) 发明名称: 显示指温的手指佩戴件

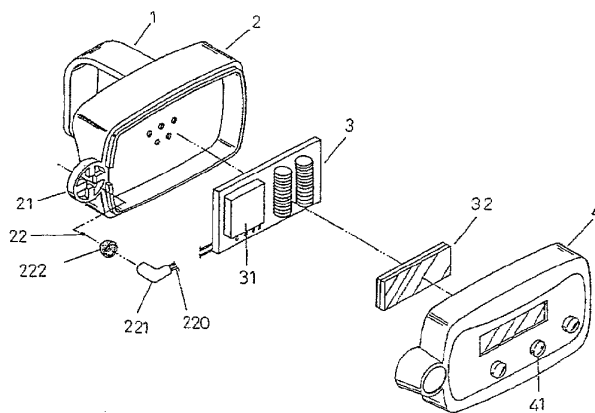

(57) Abstract: A finger temperature indicating ring for wearing around a finger to measure and indicate the finger temperature of the wearer includes a basic carrier, a circuit board, an indicator and other common elements, furthermore, it includes a downward facing pedestal having a temperature sensor which corresponds to the finger skin to measure temperature of the specific location.

(57) 摘要:

一测量并显示手指指温的指环包括载具, 电路板, 显示器和其它常用元件, 还进一步包括一个面朝下的承座, 该承座具有一感温元件, 与手指皮肤对应, 能测量特定区域的温度。

WO 2006/060949 A1



MG, MK, MN, MW, MX, MZ, NA, NG, NI, NO, NZ, OM, PG, PH, PL, PT, RO, RU, SC, SD, SE, SG, SK, SL, SM, SY, TJ, TM, TN, TR, TT, TZ, UA, UG, US, UZ, VC, VN, YU, ZA, ZM, ZW。

CY, CZ, DE, DK, EE, ES, FI, FR, GB, GR, HU, IE, IS, IT, LT, LU, LV, MC, NL, PL, PT, RO, SE, SI, SK, TR), OAPI (BE, BJ, CF, CG, CI, CM, GA, GN, GQ, GW, ML, MR, NE, SN, TD, TG)。

(84) 指定国 (除另有指明, 要求每一种可提供的地区保护): ARIPO (BW, GH, GM, KE, LS, MW, MZ, NA, SD, SL, SZ, TZ, UG, ZM, ZW), 欧亚 (AM, AZ, BY, KG, KZ, MD, RU, TJ, TM), 欧洲 (AT, BE, BG, CH,

本国际公布:

— 包括国际检索报告。

所引用双字母代码及其它缩写符号, 请参考刊登在每期PCT公报期刊起始的“代码及缩写符号简要说明”。

显示指温的手指佩戴件

技术领域

5 本发明系涉及一种手指佩戴件，尤其涉及一种利用感测指温以获得情绪放松与否的临床指标与数据构造的量测指温以感知情绪放松的手指佩戴件。

背景技术

人的身体与心理往往是一体两面而互动的，身体疾病会影响心理，心理不适也会对身体健康有害。而临床上，指温是常用来监测一个人是否放松很敏感的一个指标。
10 当一个人放松时，血管扩张，有较多热量散发到身体表面，因此手脚较温暖，相反地，当人紧张或愤怒时，血管收缩，热量散发到身体表面，因此手脚较冰冷。治疗上医师通常教导病人肌肉放松，并由生理反馈机器显示指温，通过机器了解自己的情绪压力，并予适当的排除。

缘此，本发明者基于多年钻研医疗知识的经验，及研发的动机，由申请号 U.S.
15 Pat. No. 5, 813, 766「感测指温以感知情绪放松的指环」中得到启发。

传统生理反馈机器测量指温的方法，是以胶带或尼龙搭扣固定感温元件，结果容易将手指局部形成压迫，导致指温温度不易上升。因此，即使患者已情绪放松，然而讯号却显示仍属未放松的状态，因此容易产生失真。

又本发明在前案的实际制造与使用过程当中发现尚有改善之处。其指环圈与导温
20 弧杆的连动关系，使得当患者佩戴时不能任意调整紧度，在此情况下，指环圈容易滑动走位而使测量状态不稳定。

再者，感测指温的导温弧杆埋在指环圈的二对称引道，形成密闭，因此纵有指温下降状况，也不容易散热而形成闷热，又导致另一型态的测量失真。

发明内容

25 本发明的目的在于通过提供一种量测指温以感知情绪放松的手指佩戴件，以达到当患者佩戴时可以任意调整紧度，克服了现在指环圈容易滑动走位而使测量状态不稳定的问题。

为实现上述目的，本发明所使用的技术手段在于：

30 量测指温以感知情绪放松的手指佩戴件，主要包括：一个围绕人体手指部表面，内部形成一容室的载具；在载具内设有一个电路板，该电路板上至少包括一计算单元与讯号发出元件，并配合电路板而设一感温元件，与指肤适度对应，且配合计算单元而可侦测温度，并由讯号发出元件提供信息；在所述电路板的一侧面，设有一个设有

多组对应计算单元的功能选择按键的面板：

前述的承座内部设一金属套件，该金属套件端部接合一隔热层，该感温元件由阻绝金属套件导热过大而影响指温精确的隔热层端部裸出；

5 前述的该承座设于载具本体的后部周缘，以使其向外突出载具本体，其开口对应指背；

前述的感温元件为一种利用红外线非接触式的感温特性配合计算单元分析而感测特定区域手指皮肤温度的红外线感测器；

前述的承座开口部位所设的感温元件为一与指肤表面形成适度接触的接触式感温元件。

10 本发明与现有技术相比具有明显的优势和有益效果：

由于该手指配戴件由载具本体的周缘，向外突出载具本体，而形成一开口向下的承座，该承座开口插设一感温元件，以使该感温元件与指肤表面形成适度对应，以侦测特定区域温度的状态，并能固定感温元件。因此：当手指配戴件束紧时，不影响测量部位的血管收缩与血液流通，因此指温上升可随人体自然表现；可以任意调整手指配戴件的松紧度，而不影响感温元件与手指部位的对应。不易产生滑动走位而使测量状态较为稳定；由于感测指温的感温元件在突出载具本体，因此形成开放而容易散热，因此测温纯粹可由指背测得较为精准的数据。

附图概述

20 图 1 为本发明立体分解图；

图 2 为本发明组合立体图；

图 3 为本发明组合平面以及系指部挠曲示意图；

图 4 为本发明接触指背平面示意图；

图 5 为本发明使用状态立体图；

25 图 6 为本发明以 LED 为讯号发出元件的实施例立体图；

图 7 为本发明配合红外线感测器作为感温元件的使用示意图。

本发明的实施方式

下面结合附图对本发明的具体实施例加以说明：

30 以下由图式说明本发明的较佳实施例，以便审查人员进一步了解本案：

请参阅图 1，配合图 2 所示，本发明关于一种量测指温以感知情绪放松的手指配戴件，主要包括：一系指部 1：为围绕人体手指部；一载具 2：设于指部 1 表面，内部形成一容室；一电路板 3：该电路板 3 设于载具 2 内，至少包括一计算单元 31 与讯号

号发出元件 32，请参阅图 4 所示，可由一感温元件 22 与指肤相触，由电路板 3 上计算单元计算指温所传递的讯号值，并由讯号发出元件 32 提供信息；一面板 4：该面板 4 设于电路板 3 一侧面，设有多组对应计算单元 31 的功能选择按键 41；

5 请参阅图 1 配合图 4 所示的实施例：该手指配戴件由载具 2 本体的周缘，向外突出载具本体，而形成一开口向下的承座 21，该承座 21 开口部位设一感温元件 22，以使该感温元件与指肤表面形成适度接触，因为可以按指背依据医学原理，为一较佳的指温量测部位进行轻触指背。以此并能固定感温元件 22。

该感温元件 22 可为一种软性无毒材质并含高导热材质。

10 其中，本发明较佳的实施例是该承座 21 内部设一金属套件 221，以该金属套件 221 可以容纳导线 220，以及对于感温元件 22 有一承载与保护，该金属套件 221 端部接合一隔热层 222，该感温元件 22 由隔热层 222 端部裸出，又可以阻绝金属套件 221 导热过大而影响指温精确。

15 请参阅图 4，配合图 5 所示，当使用者配戴本发明，由于指部 1 上的载具 2 本体的周缘，向外突出载具 2 本体，而形成一开口向下的承座 21 设有感温元件 22，可与指肤相触，经由导线 220，传递至电路板 3 上的计算单元 31 测得因为温度改变所导致的例如电阻的讯号值变化，同时经由计算单元 31 运算，并由讯号发出元件 32 提供信息；该讯号元件可以是，如震动马达、LED、蜂鸣器、液晶屏幕等，图 1、图 2 与图 5 图例为屏幕，图 6 则显示为以 LED 的灯光，甚至可以颜色变化为情绪放松效果的显示为讯号发出元件；且可搭配电脑网络传输技术或无线通讯技术将讯号传递至远端，利用资料处理，由远端医师接收并为诊治。

此外，值得一提的是，由于人体手指的皮肤毛发长短不一，毛发较稀疏、较短者，除可以使用前述的感温元件直接接触测得外，另可配合感温元件如图 7 所示，以一种红外线感测器作为感温元件 22A，利用红外线非接触式的感温特性感测手指皮肤温度。

25 一般物体都会因为本身的温度高低发出不同的红外线能量。温度越高，物体分子就愈加活泼，因此有较高的红外能量发出。因此本发明的感温元件可以利用红外线感测器作为收集物体辐射的红外能量并将能量通过计算单元分析而把能量转化为电信号，电信号经放大并显示为温度读数。

30 最后应说明的是：以上实施例仅用以说明本发明而并非限制本发明所描述的技术方案；因此，尽管本说明书参照上述的各个实施例对本发明已进行了详细的说明，但是，本领域的普通技术人员应当理解，仍然可以对本发明进行修改或等同替换；而一切不脱离实用新型的精神和范围的技术方案及其改进，其均应涵盖在本发明的权利要求范围当中。

权利要求书

1、量测指温以感知情绪放松的手指配戴件，主要包括：一个围绕人体手指部表面，内部形成一容室的载具；在载具内设有一个电路板，该电路板上至少包括一计算
5 单元与讯号发出元件，并配合电路板而设一感温元件，与指肤适度对应，且配合计算单元而可侦测温度，并由讯号发出元件提供信息；在所述电路板的一侧面，设有一个设有多组对应计算单元的功能选择按键的面板：

其特征在于：

10 该手指配戴件由载具本体的周缘，向外突出载具本体，形成一开口向下的承座，该承座开口部位设有一个由载具固定的感温元件，与指肤表面形成适度对应，以侦测特定区域温度的状态。

2. 根据权利要求 1 所述的量测指温以感知情绪放松的手指配戴件，其特征在于：
所述的承座内部设一金属套件，该金属套件端部接合一隔热层，该感温元件由阻绝金属
15 套件导热过大而影响指温精确的隔热层端部裸出。

3. 根据权利要求 1 所述的量测指温以感知情绪放松的手指配戴件，其特征在于：
15 所述的该承座设于载具本体的后部周缘，以使其向外突出载具本体，其开口对应指背。

4. 根据权利要求 1 所述的量测指温以感知情绪放松的手指配戴件，其特征在于：
所述的感温元件为一种利用红外线非接触式的感温特性配合计算单元分析而感测特定
20 区域手指皮肤温度的红外线感测器。

5. 根据权利要求 1 所述的量测指温以感知情绪放松的手指配戴件，其特征在于：
20 所述的承座开口部位所设的感温元件为一与指肤表面形成适度接触的接触式感温元件。



图 1



图 3

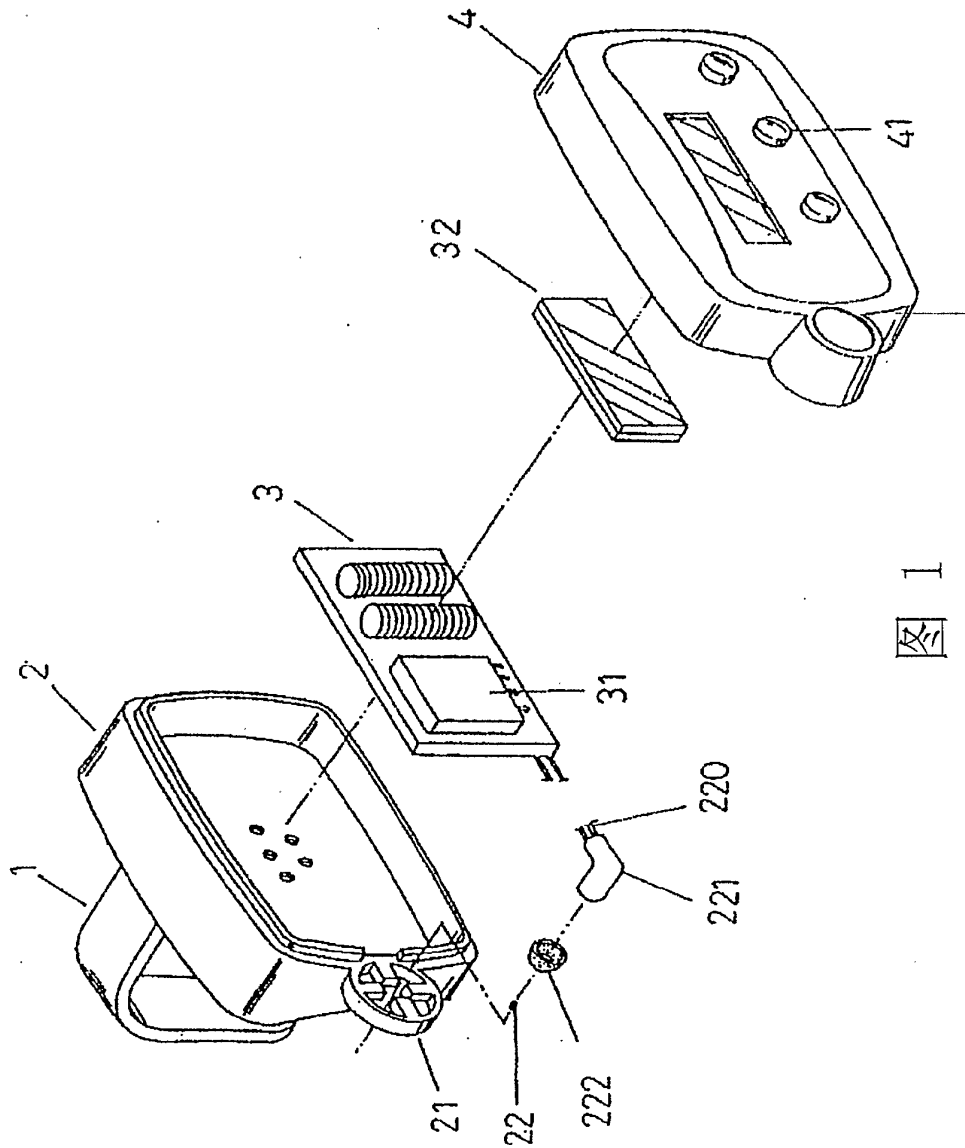

图 2

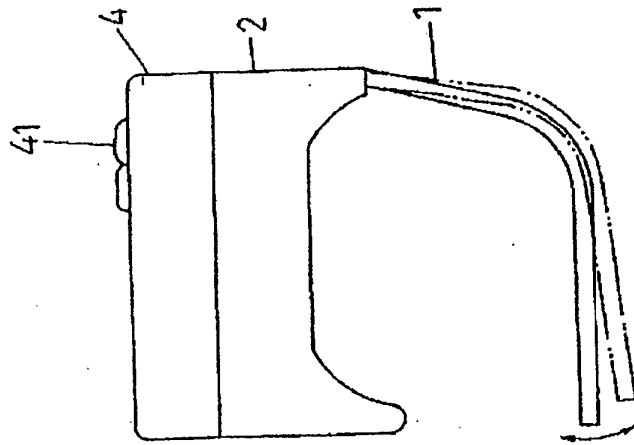

图 4



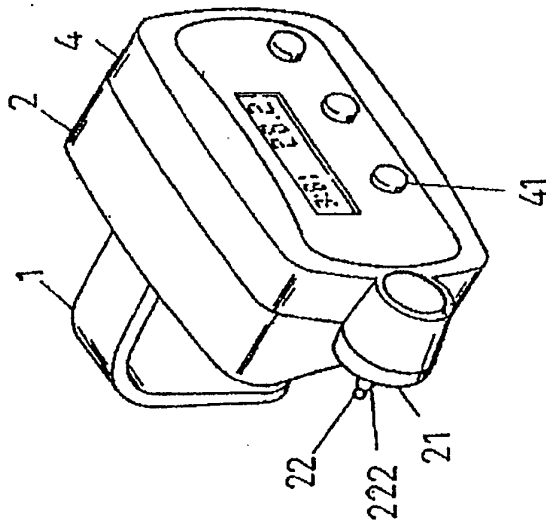

图 6

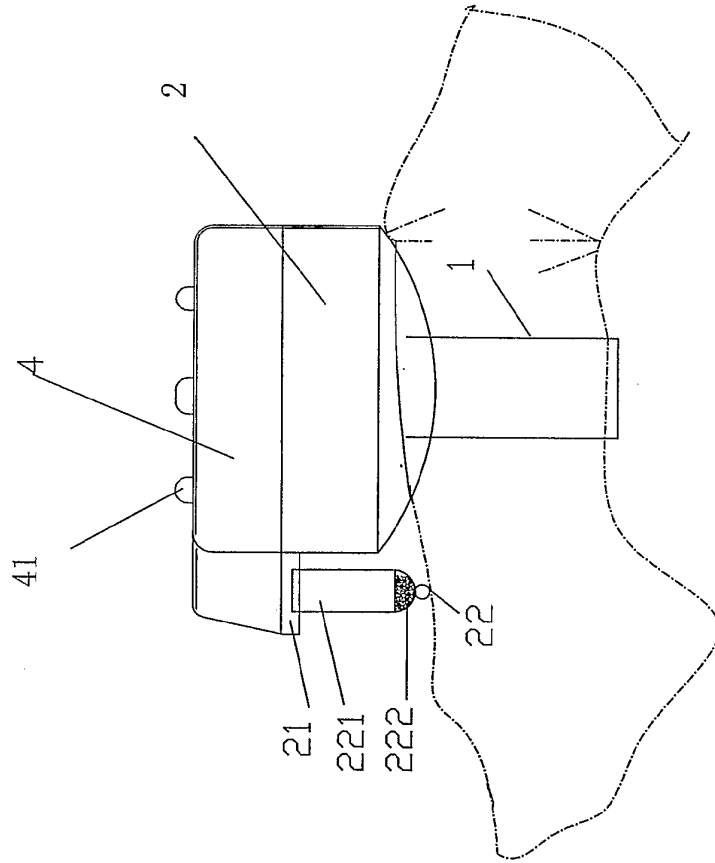
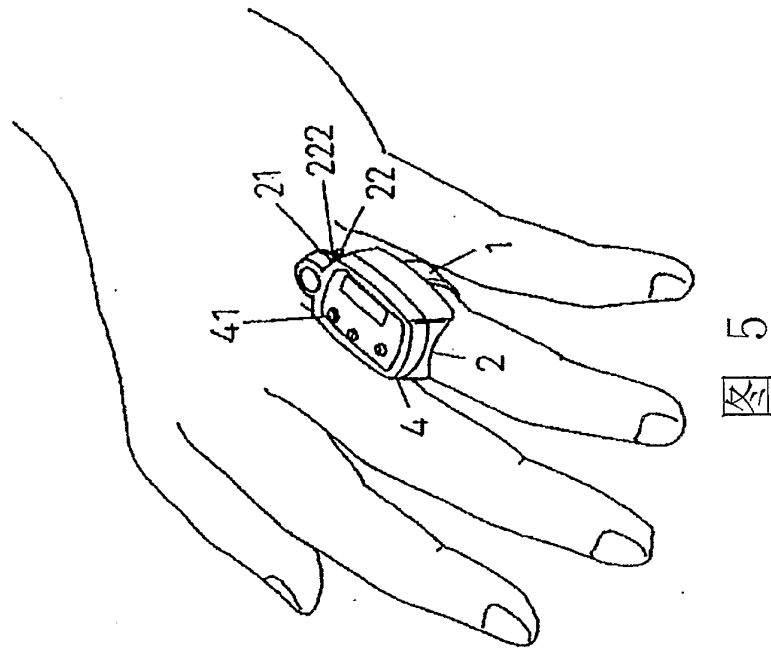

图 7

INTERNATIONAL SEARCH REPORT

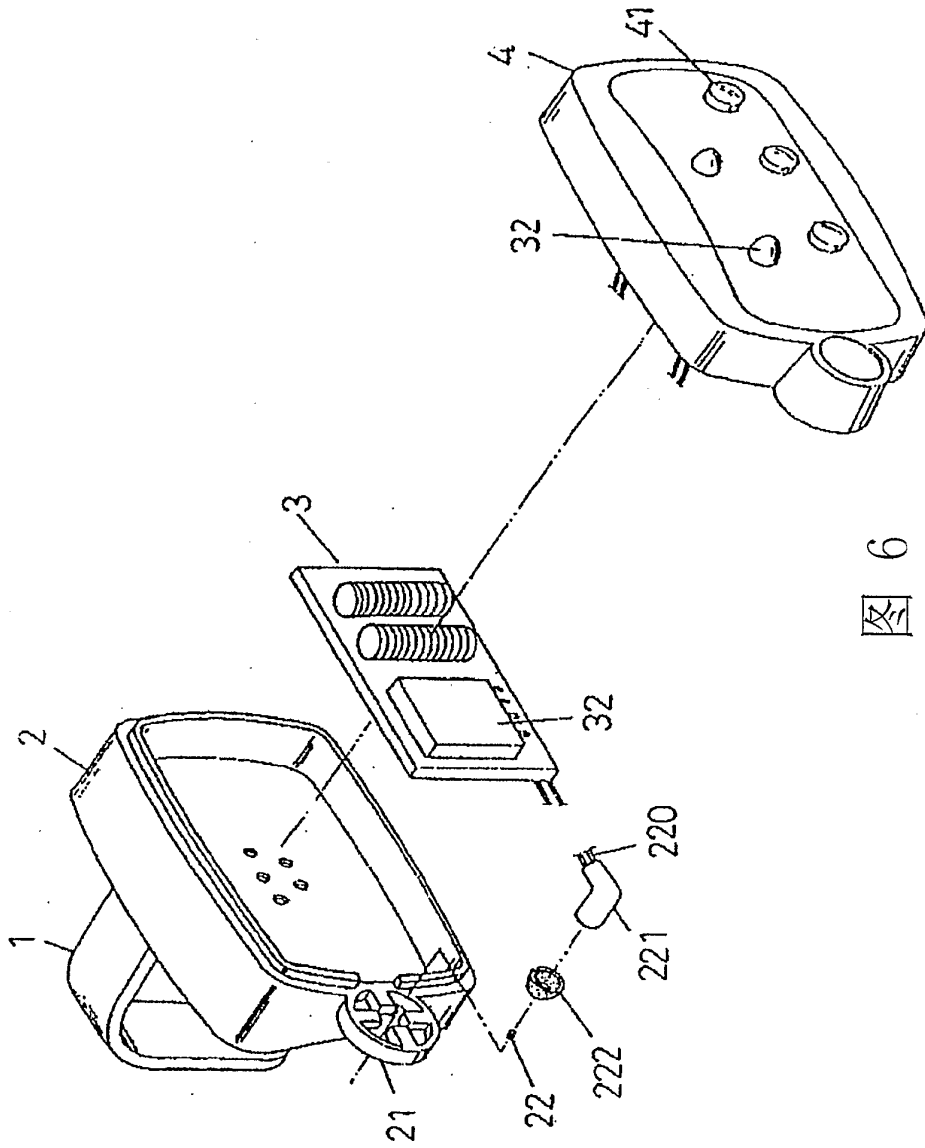
International application No.
PCT/CN2005/002054

A. CLASSIFICATION OF SUBJECT MATTER <p style="text-align: center;">A44C9/00 A61B5/16 G01K1/14</p> <p style="text-align: center;">According to International Patent Classification (IPC) or to both national classification and IPC</p>		
B. FIELDS SEARCHED <p style="text-align: center;">Minimum documentation searched (classification system followed by classification symbols) IPC7:A44C A61B+ G01K+</p> <p style="text-align: center;">Documentation searched other than minimum documentation to the extent that such documents are included in the fields searched Chinese Patent Document:(1985-)</p> <p style="text-align: center;">Electronic data base consulted during the international search (name of data base and, where practicable, search terms used) CNPAT, WPI, EPODOC, PAJ: ring temperature finger</p>		
C. DOCUMENTS CONSIDERED TO BE RELEVANT		
Category*	Citation of document, with indication, where appropriate, of the relevant passages	Relevant to claim No.
A	US5813766A (CHEN Meiyen) 29.Sep. 1998 (29.09.1998) Col.2, line 10 to Col.3, line30, and Fig. 1-3(this document cited in the application)	1-5
A	CN2305166Y (CHEN Meiyen) 27.Jan. 1999 (27.01.1999) page 2,line 8 to page 4, line 6 and Fig. 1-3	1-5
A	US4450843A (Barney et al) 29.May. 1984 (29.05.1984) Col.2, line 26 to page 7, line 66 and Fig. 1-4	1-5
A	US5362966A (Rosenthal et al)08.Nov 1994(08.11.1994)Col. 3, line 22 to Col. 5, line 23 and Fig.1-5	1-5
A	JP57-11633A (NIPPON ELECTRIC CO)21.Jan. 1982(21.01.1982)Col. 2, line 17 to Col. 4,line 15 and Fig. 1-4	1-5
A	GB2200998A (HSIEH FUNG HSING) 17.Aug. 1988 (17.08.1988) page 1,line 23 to page 3, line 28 and Fig. 1-4	1-5
A	CN3092106D (CHEN Meiyen) 02.Dec.1998(02.12.0998) all pictures	1-5
<input type="checkbox"/> Further documents are listed in the continuation of Box C. <input checked="" type="checkbox"/> See patent family annex.		
* Special categories of cited documents:	“T” later document published after the international filing date or priority date and not in conflict with the application but cited to understand the principle or theory underlying the invention	
“A” document defining the general state of the art which is not considered to be of particular relevance	“X” document of particular relevance; the claimed invention cannot be considered novel or cannot be considered to involve an inventive step when the document is taken alone	
“E” earlier application or patent but published on or after the international filing date	“Y” document of particular relevance; the claimed invention cannot be considered to involve an inventive step when the document is combined with one or more other such documents, such combination being obvious to a person skilled in the art	
“L” document which may throw doubts on priority claim (S) or which is cited to establish the publication date of another citation or other special reason (as specified)	“&”document member of the same patent family	
“O” document referring to an oral disclosure, use, exhibition or other means		
“P” document published prior to the international filing date but later than the priority date claimed		
Date of the actual completion of the international search 20.Dec. 2005(12.20.2005)	Date of mailing of the international search report : 2006 05 JAN 2006 09:01	
Name and mailing address of the ISA/CN The State Intellectual Property Office, the P.R.China 6 Xitucheng Rd., Jimen Bridge, Haidian District, Beijing, China 100088 Facsimile No. 86-10-62019451	Authorized officer NI Xiaohong Telephone No. (86-10)62085753	

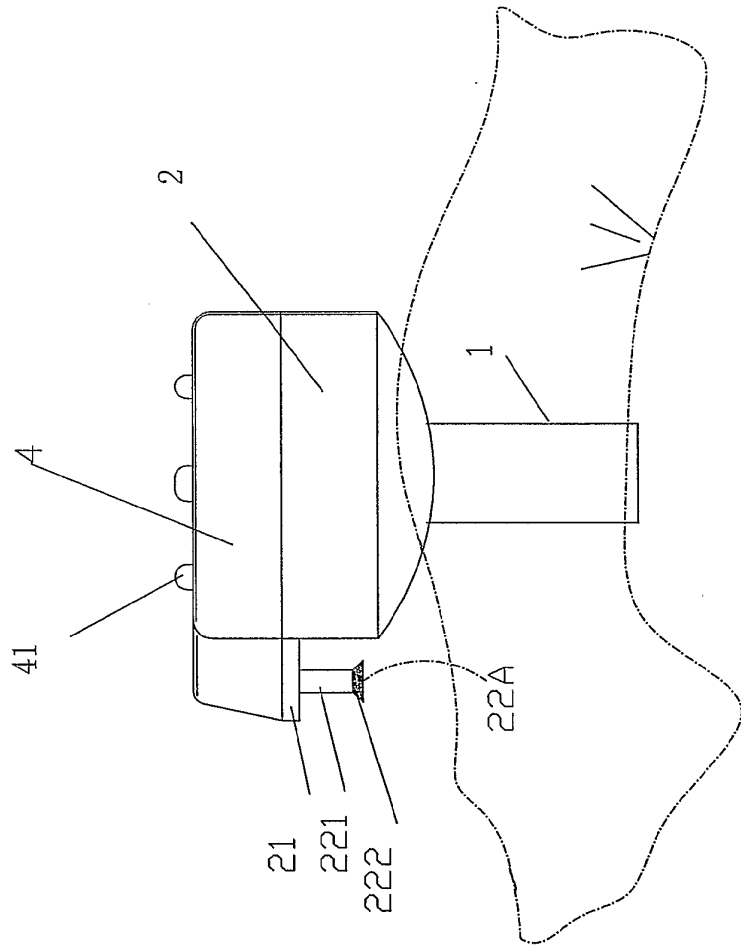
国际检索报告

国际申请号
PCT/CN2005/002054

A. 主题的分类 A44C9/00 A61B5/16 G01K1/14 按照国际专利分类表(IPC)或者同时按照国家分类和 IPC 两种分类		
B. 检索领域 检索的最低限度文献(标明分类系统和分类号) IPC7:A44C+ A61B+ G01K+ 包含在检索领域中的除最低限度文献以外的检索文献 中国专利文献: (1985-)		
在国际检索时查阅的电子数据库(数据库的名称, 和使用的检索词(如使用)) CNPAT: 指环+戒指 温 指 WPI, EPODOC, PAJ: ring temperature finger		
C. 相关文件		
类 型*	引用文件, 必要时, 指明相关段落	相关的权利要求
A	US5813766A (CHEN Meiyen) 29.09 月 1998 (29.09.1998) 说明书第 2 栏第 10 行至第 3 栏第 30 行及附图 1-3(在申请中引证)	1-5
A	CN2305166Y (陈美燕) 27.01 月 1999 (27.01.1999) 说明书第 2 页第 8 行至第 4 页第 6 行及附图 1-3	1-5
A	US4450843A (Barney 等人) 29.05 月 1984 (29.05.1984) 说明书第 2 栏第 26 行至第 7 页第 66 行及附图 1-4	1-5
A	US5362966A (Rosenthal 等人) 08.11 月 1994 (08.11.1994) 说明书第 3 栏第 22 行至 5 栏第 23 行及附图 1-5	1-5
A	JP57-11633A (日本电气株式会社) 21.01 月 1982 (21.01.1982) 说明书第 2 栏第 17 行至第 4 栏第 15 行及附图 1-4	1-5
A	GB2200998A (HSIEH FUNG HSING) 17.08 月 1988 (17.08.1988) 说明书第 1 页第 23 行至第 3 页第 28 行及附图 1-4	1-5
A	CN3092106D (陈美燕) 02.12 月.1998(02.12.0998) 全图	1-5
<input type="checkbox"/> 其余文件在 C 栏的续页中列出。 <input checked="" type="checkbox"/> 见同族专利附件。		
* 引用文件的具体类型: "A" 认为不特别相关的表示了现有技术一般状态的文件 "E" 在国际申请日的当天或之后公布的在先申请或专利 "L" 可能对优先权要求构成怀疑的文件, 或为确定另一篇引用文件的公布日而引用的或者因其他特殊理由而引用的文件 "O" 涉及口头公开、使用、展览或其他方式公开的文件 "P" 公布日先于国际申请日但迟于所要求的优先权日的文件 "T" 在申请日或优先权日之后公布, 与申请不相抵触, 但为了理解发明之理论或原理的在后文件 "X" 特别相关的文件, 单独考虑该文件, 认定要求保护的发明不是新颖的或不具有创造性 "Y" 特别相关的文件, 当该文件与另一篇或者多篇该类文件结合并且这种结合对于本领域技术人员为显而易见时, 要求保护的发明不具有创造性 "&" 同族专利的文件		
国际检索实际完成的日期 20. 12 月 2005 (20.12.2005)		国际检索报告邮寄日期 05. 1 月 2006 (05. 01. 2006)
中华人民共和国国家知识产权局(ISA/CN) 中国北京市海淀区蓟门桥西土城路 6 号 100088 传真号: (86-10)62019451		受权官员 电话号码: (86-10)62085753 

国际检索报告
关于同族专利的信息

国际申请号
PCT/CN2005/002054

检索报告中引用的 专利文件	公布日期	同族专利	公布日期
US5813766A	29.09 月 1998	DE29715113U	30.10 月 1997
		GB2328282A	17.12 月 1999
		FR2767384A3	19.02 月 1999
		CA2213145C	14.11 月 2000
CN2305166Y	27.01 月 1999	无	
US4450843A	29.05 月 1984	无	
US5362966A	08.11 月 1994	无	
JP57-11633A	21.01 月 1982	无	
GB2200998A	17.08 月 1988	无	
CN3092106D	02.12 月.1998	无	

(19) World Intellectual Property Organization
International Bureau



(43) International Publication Date
3 August 2006 (03.08.2006)

PCT

(10) International Publication Number
WO 2006/079862 A2

- (51) International Patent Classification:
A61B 5/00 (2006.01)
- (21) International Application Number:
PCT/HU2006/000010
- (22) International Filing Date: 30 January 2006 (30.01.2006)
- (25) Filing Language: English
- (26) Publication Language: English
- (30) Priority Data:
P0500148 31 January 2005 (31.01.2005) HU
- (71) Applicants and
- (72) Inventors: SÁNTHA, Hunor [HU/HU]; Bajcsy-Zs. u. 1, H-2600 Vác (HU). HARSÁNYI, Gábor [HU/HU]; Zsókavár u. 36, H-1157 Budapest (HU).

CO, CR, CU, CZ, DE, DK, DM, DZ, EC, EE, EG, ES, FI, GB, GD, GE, GH, GM, HR, HU, ID, IL, IN, IS, JP, KE, KG, KM, KN, KP, KR, KZ, LC, LK, LR, LS, LT, LU, LV, LY, MA, MD, MG, MK, MN, MW, MX, MZ, NA, NG, NI, NO, NZ, OM, PG, PH, PL, PT, RO, RU, SC, SD, SE, SG, SK, SL, SM, SY, TJ, TM, TN, TR, TT, TZ, UA, UG, US, UZ, VC, VN, YU, ZA, ZM, ZW.

(84) Designated States (unless otherwise indicated, for every kind of regional protection available): ARIPO (BW, GH, GM, KE, LS, MW, MZ, NA, SD, SL, SZ, TZ, UG, ZM, ZW), Eurasian (AM, AZ, BY, KG, KZ, MD, RU, TJ, TM), European (AT, BE, BG, CH, CY, CZ, DE, DK, EE, ES, FI, FR, GB, GR, HU, IE, IS, IT, LT, LU, LV, MC, NL, PL, PT, RO, SE, SI, SK, TR), OAPI (BF, BJ, CF, CG, CI, CM, GA, GN, GQ, GW, ML, MR, NE, SN, TD, TG).

Declaration under Rule 4.17:
— of inventorship (Rule 4.17(iv))

Published:
— without international search report and to be republished upon receipt of that report

For two-letter codes and other abbreviations, refer to the "Guidance Notes on Codes and Abbreviations" appearing at the beginning of each regular issue of the PCT Gazette.

(74) Agent: MÉSZÁROS, Katalin; Budapest Patent and Trademark Attorneys Ltd., P.O. Box 49, H-1301 Budapest (HU).

(81) Designated States (unless otherwise indicated, for every kind of national protection available): AE, AG, AL, AM, AT, AU, AZ, BA, BB, BG, BR, BW, BY, BZ, CA, CH, CN,

(54) Title: PULSE OXIMETER SENSOR-HEAD, MEASURING SYSTEM AND MEASURING METHOD WITH SAID SENSOR-HEAD, METHOD AND CASING FOR ANCHORING A SENSOR-HEAD

WO 2006/079862 A2

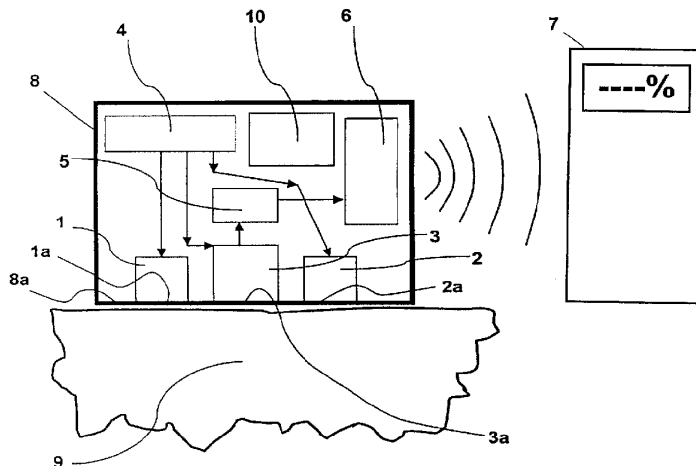

(57) Abstract: The invention is a pulse oximeter sensor-head (8) which is composed of electrical units and comprises at least two light sources (1, 2) of different wavelengths to emit light into the part of the body (9) under examination and a light detector (3) to sense the light either transmitted through or reflected from the part of the body (9) under examination, further comprises a control circuitry (4) connected to each electrical unit or at least to the light sources (1, 2) and the light detector (3), a data collector and A/D dataconverter circuitry (5) connected to the output of the light detector (3), a wireless data communication circuitry (6) connected to the output of the data collector and A/D dataconverter circuitry (5), and a current source (10) to ensure the power supply of

the pulse oximeter sensor-head (8). The invention is also a measuring system comprising said sensor-head (8) and a measuring method with said sensor-head (8). The invention relates also to a method and a casing (11) for anchoring a sensor-head (8) where the sensor-head (8) is fixed mechanically in a bell-jar-like casing (11) by means of structural element (11b) of said casing (11), said casing (11), having an internal air space (12) and a flange (14), is placed together with the sensor-head onto the surface of the body (9) so that the flange (14) together with the surface forms an airtight sealing, and a decrease of pressure is generated in said air space (12) during the process of placing the sensor-head (8) onto the surface of the body (9).

1

PULSE OXIMETER SENSOR-HEAD, MEASURING SYSTEM AND
MEASURING METHOD WITH SAID SENSOR-HEAD, METHOD AND
CASING FOR ANCHORING A SENSOR-HEAD

5 The invention relates to a pulse oximeter sensor-head which is composed of
electrical units, and comprises at least two light sources of different
wavelengths to emit light into the part of the body under examination and a
light detector to sense the light either transmitted through or reflected from the
part of the body under examination. In addition, the invention presented here is
10 a measuring system comprising said sensor-head and a measuring method
performed with said sensor-head. In addition, the invention relates to a method
and a casing for anchoring a sensor-head, particularly according to the
invention. The pulse oximeter sensor-head and measuring system according to
the invention is particularly appropriate to the continuous monitoring of arterial
15 oxygen levels of tissues by attaching it to the surface of the human body, or to
the surface of other living organisms, and is of particular use where currently
available pulse oximeter devices cannot be used. Applications include but are
not confined to, for example, the monitoring of tissue oxygenation of the
presenting part of the fetus through the dilated cervix during parturition and
20 delivery. It can also be used to monitor tissue oxygenation of premature
neonates that are very small in size. A further example is the monitoring of
tissue oxygenation of humans whilst undertaking sporting activities.

The metabolic state of every living substance is particularly characterized by
25 the extent to which it is supplied with oxygen. Since the researches in medical
spectroscopy of the 1940s, it is well known that the extent of oxygenation of
the blood content of living tissues that receive blood circulation can be
determined by photometric methods. This is cited in the work published by
G.A. Millikan: "The oximeter, an instrument for measuring continuously the
30 oxygen saturation of arterial blood in man" (Rev of Scientific Instrument, Vol.
13, pp. 434-444, 1942), namely, blood freshly saturated with oxygen and
transported in the arteries has higher extinction coefficient values in the
infrared wavelength range, whereas blood indigent in oxygen and transported
in the veins has higher extinction coefficient values in the red wavelength
35 range. This phenomenon is caused by the significant difference between the

red infra-red light absorption spectrum of oxyhemoglobin (henceforth HbO_2) which carries 4 oxygen molecules (henceforth O_2) and deoxyhemoglobin (henceforth Hb) which has already released the O_2 molecules.

5 A further development of oximetry was the pulse oximetry method which additionally utilises the principle of pletismography during the oximetry measurement. In this method the ratio of oxygenated and deoxygenated blood content of the arterial blood surplus pumped by each heartbeat into the portion of tissue falling in the optical path can be calculated without knowing the exact
10 optical path length by transmissive or reflective, in fact transfective, spectrometric measurements performed in the aforementioned wavelength ranges on living tissues that receive blood circulation, if the rhythmical changes of the blood content of tissue caused by the pulsation of arteries are taken into account. The physiological parameter to be detected by a pulse oximeter
15 device is called the oxygen saturation index (henceforth SpO_2), because only the ratio of oxygenated hemoglobin molecules (HbO_2) compared to the total hemoglobin content ($\text{Hb} + \text{HbO}_2$) is needed by a physician, since in ordinary situations hemoglobin can only occur in either the oxygenated or the deoxygenated state. In accordance with the description given above the
20 mathematical definition of SpO_2 is: $\text{SpO}_2 = \text{HbO}_2 / (\text{Hb} + \text{HbO}_2)$.

Numerous patents has been filed concerning the topic of pulse oximetry during the recent decades, and several producers use the method of pulse oximetry in their products. The most widespread use of pulse oximetry is the continuous
25 attachment of a finger clip type oximeter to a patient during surgical operation or within intensive care departments in order to non-invasively monitor the metabolic state of the patient.

Knowing the SpO_2 value of a patient is absolutely necessary for the physician
30 in certain decision situations. Since the SpO_2 value can be measured in a non-invasive way, the application of pulse oximetry has no inherent risks. The most typical class of pulse oximeter apparatuses has a central control and data processor device connected through a multiple-core cable to a

transmissive or reflective type measuring head, which has only passive role during the measurement and is directly attached on the individual under examination. The raw measurement data transmitted through the cables from the measuring head are processed, evaluated and displayed by the central device. An apparatus of this type is described in the patent specification US 5,687,719.

There are other known wireless pulse oximeter devices, which include the measurement and the processing and evaluation of measured data plus the displaying of results integrated in one body-attachable device. Such a solution is detailed for instance in the patent specification WO0022980 which describes a relatively small size, finger clip type wireless pulse oximeter. Devices of this type pose the problem that despite the reduced size they are still relatively large, which makes their utilisation impossible in special applications, e.g. monitoring of childbirth. Furthermore, there are other known pulse oximeter systems similar to the aforementioned ones, where results (SpO₂ etc.) acquired after processing the raw measurement data are transmitted through wireless radiofrequency method also to a remote location for telemonitoring purposes. Such a solution is described for instance in the patent specification CA2504252.

The disadvantage of any known solution is that either they comprise cables or their size is relatively large, thus, their utilisation in special application areas is uncomfortable or impossible. If such solutions are utilised the individual under examination is restrained in his motion and his movements falsify the results of the measurements quite often because a sufficiently stable and durable contact between the pulse oximeter device and the living tissue under examination can not be ensured.

The anchoring of the pulse oximeter sensor-head onto the surface of the examined part of the body is a key issue for the feasibility and accuracy of a pulse oximetry measurement. Generally, some kinds of clamping tools or biocompatible adhesive is used in order to anchor the sensor-head. Such a

device is described for instance in the patent specification EP0481612 but other solutions are known as well when the pulse oximeter head is anchored by a suture onto the part of the body under examination e.g. in the patent specification US 5,727,547 or an external vacuum pump sucks out a part of the air from the space between the measuring head of the pulse oximeter and the part of the body to ensure an anchoring, e.g. in the patent specification US 5,497,771. The disadvantage of the former solutions is the possible negative side effects of the invasive anchoring, the disadvantage of the latter solutions using an external vacuum pump is the inherent need for a pipeline which has the same disadvantage as an electrical cable.

The object of the invention is to ensure a wireless pulse oximeter sensor-head, a pulse oximeter measuring system and a measuring method which overcome the aforementioned disadvantages. Furthermore, the object of the invention is to ensure a method and casing for anchoring the sensor-head which overcome the aforementioned disadvantages.

The object is achieved according to our recognition by means of the physical separation of the parts which perform the photometric measurement processes and the digital conversion, that is A/D data conversion of measured data, from the parts which perform processing, analysis and evaluation of measured data as well as the displaying of results; and by means of the fact that we provide a wireless communication between the physically separated devices, that means either radiofrequency or optical datacommunication.

In accordance with the above the invention is a pulse oximeter sensor-head which is composed of electrical units, and said sensor-head comprises at least two light sources of different wavelengths to emit light into part of the body under examination and a light detector to sense (detect) light either transmitted through or reflected from said part of the body, additionally comprises a control circuitry connected to each electrical unit or at least to the light sources and the light detector, further comprises a data collector and A/D dataconverter circuitry connected to the output of the light detector, a wireless data

communication circuitry connected to the output of the data collector and A/D dataconverter circuitry, and a current source to ensure the power supply of the pulse oximeter sensor-head.

5 The current source serving for the power supply of the circuitries of the pulse oximeter sensor-head may be a battery or an accumulator, or preferably a rechargeable accumulator, but in certain cases it may be expedient to ensure the electrical power for the operation by radiation of an external
10 electromagnetic field through inductive coupling into a coil located in the pulse oximeter sensor-head, i.e. the current source is an inductively chargeable power supply in such a case.

For a better exploitation of the possibility for miniaturisation arising from the construction according to the invention all electrical units of the pulse oximeter
15 sensor-head or at least the control circuitry, the data collector and A/D dataconverter circuitry and the wireless data communication circuitry is realised in a single semiconductor chip by means of ASIC (Application Specific Integrated Circuit) technology.

20 In addition, the invention is a measuring system comprising a pulse oximeter sensor-head in which said pulse oximeter sensor-head comprises at least two light sources of different wavelengths to emit light into the part of the body under examination and a light detector to sense the light either transmitted through or reflected from said part of the body and in addition said pulse
25 oximeter sensor-head comprises a control circuitry connected to each electrical unit or at least to the light sources and the light detector, further comprises a data collector and A/D dataconverter circuitry connected to the output of the light detector, a wireless data communication circuitry connected to the output of the data collector and A/D dataconverter circuitry, and a
30 current source to ensure the power supply of the pulse oximeter sensor-head, and in addition the measuring system comprises a receiver device having wireless datacommunication connection with the pulse oximeter sensor-head

located remotely from it and said receiver device comprises dataprocessor and evaluation circuitry plus, if necessary, a displaying circuitry.

5 In a preferred embodiment the connection between the datacommunication circuitry and the receiver device is a wireless radiofrequency connection or a wireless optical connection.

10 In a preferred embodiment the measuring system has additional pulse oximeter sensor-heads, all of which are connected to the same receiver device through wireless connections.

In another preferred embodiment a datastorage and/or measuring command sender circuitry is connected to the dataprocessor and evaluation circuitry.

15 In addition the invention is a measuring method performed with a measuring system comprising a pulse oximeter sensor-head in which said pulse oximeter sensor-head is placed and anchored on the surface of the body, then light at least at two different wavelengths is emitted from light sources into the living tissue and the outgoing light intensities are measured by a light detector,
20 then the measured signals are collected and converted to a digital format by a data collector and A/D dataconverter circuitry, then the signals are transmitted from the pulse oximeter sensor-head by a wireless datacommunication circuitry, and the transmitted digital raw pulse oximetry data are received,
25 processed and evaluated by a receiver device located remotely and maintaining a wireless communication with the pulse oximeter sensor-head, and, if necessary, the results are displayed.

30 The pulse oximeter sensor-head has to be fixed to the surface of the body during the measurement. In a preferred embodiment the contact surface of said pulse oximeter sensor-head is anchored to the surface of the part of the body under examination by a biocompatible adhesive layer.

A further objective of the invention is achieved according to our recognition by means of fixing the pulse oximeter sensor-head in an airtight, bell-jar-like casing comprising an air space in which a decrease of pressure can be realised without using any external means, and the anchoring is achieved by
5 the decrease of pressure in the space closed between the casing of the pulse oximeter sensor-head and the surface, i. e. skin of the part of the body.

In accordance with the above, the invention is also a method for anchoring a sensor-head, particularly but not exclusively, according to the invention so that
10 the sensor-head is fixed mechanically in a bell-jar-like casing by means of structural element of said casing, said casing having an internal air space and a flange, is placed together with the sensor-head onto the surface of the body so that the flange together with said surface creates an airtight sealing and a decrease of pressure is generated in said air space during the process of
15 placing the sensor-head onto the surface of the body.

In a preferred embodiment the wall of the casing is made at least partially of a resilient material, and pressing this resilient wall during the process of placing the sensor-head onto the surface of the body a part of the air content of the air
20 space is pressed out and the flange is pressed against the surface of the body.

In another preferred embodiment the decrease of pressure is created by a micro-vacuum pump fixed in the casing, after the flange is pressed against the surface of the body. Expediently, the micro-vacuum pump is integrated with
25 the pulse oximeter sensor-head and is fabricated by MEMS (Micro Electro-Mechanical System) technology, and in addition a channel and trench system connected to the vacuum pump is realised in the casing which connects said micro-vacuum pump with the contact surface of the sensor-head.

In addition, the invention is a casing for anchoring a sensor-head, particularly but not exclusively, according to the invention, where said casing is bell-jar-like, comprises an internal air space, a flange which can rest against the surface of the body and creates an airtight sealing with it, and comprises a
30

structural element for the mechanical holding of the sensor-head, and the wall of the casing is at least partially made of a resilient material.

5 The pulse oximeter sensor-head of the measuring system according to the invention can be miniaturised to a much higher extent, both in weight and volume, compared to the size of the actually known wearable devices comprising data processor and displaying systems, too, and in addition, no cables restrain the usage of the sensor-head. This measuring system is particularly appropriate to the continuous monitoring of arterial oxygen levels of
10 tissues by attaching it to the surface of the human body, or to the surface of other living organisms, and is of particular use where currently available pulse oximeter devices and their anchoring methods cannot be used. The individual under examination may freely move, since there are no external cables and the size of the pulse oximeter sensor-head is small. By means of the reduced
15 size it becomes feasible to perform pulse oximetry examinations under special circumstances, as well, for instance:

- monitoring of tissue oxygenation of the presenting part of the fetus through the dilated cervix during parturition and delivery,
- monitoring of tissue oxygenation of premature neonates that are very small in
20 size,
- monitoring of tissue oxygenation of humans whilst undertaking sporting activities,
- monitoring of tissue oxygenation of small-size animals during animal tests which require unrestrained motion of the animals etc.

25

The invention will be described hereafter in details by means of preferred embodiments with reference to drawings.

30 Figure 1: Schematic drawing of a preferred embodiment of the pulse oximeter sensor-head and measuring system according to the invention

Figure 2: Cross-sectional drawing of a preferred embodiment of a casing according to the invention for anchoring of the sensor-head

In Figure 1 is shown a measuring system for reflective pulse oximetry measurement, where both the light emitting surfaces 1a and 2a of the light sources 1 and 2 and the light detecting surface 3a of the light detector 3 are on the outer surface of the same side of the sensor-head 8, that is at the contact surface 8a which faces towards the surface of the body 9 when the sensor-head 8 is placed. However, the reflective pulse oximetry measurement is in fact a so-called transreflectance pulse oximetry measurement, since the photons are transmitted into different depths of the tissue before they are reflected or absorbed by it. The light sources 1 and 2 having different wavelengths and the light detector 3, as well, are driven by the control circuitry 4 of the sensor-head 8 attached to the surface of the body 9. The light sources 1, 2 are Light Emitting Diodes (LED) which emit light at wavelengths of 660 nm and 940 nm, respectively. The two LEDs are turned on alternately by the control circuitry 4 for intervals of 150-150 microseconds in such a way that between each interval an intermission of 50 microseconds is made. The light detector 3 is a photodiode having a current generated by the detected photons which current is proportional to the actual light intensity arriving in the photodiode from one of the LEDs after interacting with the tissue, whilst concurrently the other LED is switched off. Through measuring this current the light absorption capability (extinction coefficient) of the transilluminated living tissue at the specific wavelength and during that specific interval can be calculated. The measured values of the current of the photodiodes, as raw pulse oximetry data, are forwarded to the data collector and A/D dataconverter circuitry 5. Numerous known solutions for circuitries published in the scientific literature of electrical engineering are suitable for the data collector and A/D dataconverter circuitry 5. In the preferred embodiment presented here it incorporates a preamplifier, sample and hold circuitries, low and high pass filters, amplifier and a 16 bit A/D converter. The digital raw pulse oximetry data are forwarded from the data collector and A/D dataconverter circuitry 5 to the wireless data communication circuitry 6. By means of the wireless data communication circuitry 6 the digital raw pulse oximetry data are transmitted at radiofrequency to the receiver device 7 by using one of the Industrial - Scientific - Medical (ISM) frequency bands. In this preferred embodiment the wireless data communication circuitry

6 of the standard Blue Tooth Class I. is applied operating at 2,4 GHz of ISM band having a transmission range of 10 m. By means of the data processor and evaluation circuitry and display circuitry of the receiver device 7 the digital raw pulse oximetry data are processed in such a manner that functions are fitted to the measured values of the current of the photodiode and appropriate mathematical operations are performed with these functions, then the actual extinction coefficient corresponding to the wavelengths of 660 nm and 940 nm is calculated, and then the actual SpO₂ value is calculated and displayed. The arrows shown in the figure represent the flow of information in the form of electrical signals. The current source 10 is connected with each unit in order to ensure their power supply. In this embodiment the current source 10 is a 3.3 V Lithium-ion accumulator and for the duration of the measurement the stable anchoring between the sensor-head 8 and the surface of the body 9 is ensured by a biocompatible adhesive layer, not shown in the figure.

15

Figure 2 shows the pulse oximeter sensor-head 8, having two light sources 1, 2, a light detector 3 and further electrical units, is fixed in a casing 11. By means of the casing 11 the sensor-head 8 with its contact surface 8a can be anchored to the surface of the body 9 during the measurement. The casing 11 is bell-jar-like, having an internal air space 12, and comprises a flange 14 which rests against the surface of the body 9 and creates an airtight sealing with it, further has a structural element 11b for the mechanical holding of the sensor-head 8 and a resilient wall 11a which is made of silicone rubber. The structural element 11b and the resilient wall 11a of the casing 11 are fixed to each other in an airtight manner by glue. The air space 12 communicates with the surface of the body 9 through the opening 13.

20

25

In the structural element 11b the sensor-head 8 is embedded in a one step process when said sensor-head 8 is embedded as a whole piece. There is also a possibility to embed the units of the sensor-head 8 separately into the structural element 11b.

30

During the process of placing the sensor-head 8 onto the surface of the body 9 the air content is partially expelled from the air space 12 by means of pressing

the resilient wall 11a, then the 14 flange is pressed against the surface of the body 9 and the resilient wall 11a is released and starts to spring back to its original position, whereby a decrease of pressure is generated in the air space 12 which anchors the sensor-head 8 to the surface of the body 9 for the duration of the measurement.

The invention presented here may be realised in many embodiments different from those described in the examples above but still remaining within the scope and spirit of the present invention, thus, our invention cannot be considered to be restricted to the examples.

12

CLAIMS:

5 1. Pulse oximeter sensor-head which is composed of electrical units and comprises at least two light sources of different wavelengths to emit light into a part of the body under examination and a light detector to sense the light either transmitted through or reflected from said part of the body c h a r a c t e r i -
s e d i n that additionally comprises a control circuitry (4) connected to each electrical unit or at least to the light sources (1,2) and the light detector (3), a data collector and A/D dataconverter circuitry (5) connected to the output of
10 the light detector (3), a wireless data communication circuitry (6) connected to the output of the data collector and A/D dataconverter circuitry (5), and a current source (10) to ensure the power supply of the pulse oximeter sensor-head (8).

15 2. Pulse oximeter sensor-head according to claim 1 c h a r a c t e r i s e d i n that the current source (10) is a battery or an accumulator, more expediently a rechargeable accumulator, or a power supply which is inductively chargeable from outside.

20 3. Pulse oximeter sensor-head according to claim 1 or 2 c h a r a c t e - r i s e d i n that all units of the sensor-head (8) or at least its control circuitry (4), data collector and A/D dataconverter circuitry (5) and wireless data communication circuitry (6) is realised in a single semiconductor chip by means of ASIC technology.

25 4. Measuring system comprising a pulse oximeter sensor-head in which said pulse oximeter sensor-head comprises at least two light sources of different wavelengths to emit light into the part of the body under examination and a light detector to sense the light either transmitted through or reflected from the
30 part of the body under examination c h a r a c t e r i s e d i n that additionally said pulse oximeter sensor-head (8) comprises a control circuitry (4) connected to each electrical unit or at least to the light sources (1,2) and the light detector (3), a data collector and A/D dataconverter circuitry (5)

connected to the output of the light detector (3), a wireless data communication circuitry (6) connected to the output of the data collector and A/D dataconverter circuitry (5), and a current source (10) to ensure the power supply of the pulse oximeter sensor-head (8) and, in addition the measuring system comprises a receiver device (7) having wireless datacommunication connection with the pulse oximeter sensor-head (8) located remotely from it and said receiver device (7) comprises dataprocessor and evaluation circuitry plus, if necessary, a displaying circuitry.

5. Measuring system according to claim 4 characterised in that the connection between the datacommunication circuitry (6) and the receiver device (7) is a wireless radiofrequency connection or a wireless optical connection.

6. Measuring system according to claim 4 characterised in that comprises more pulse oximeter sensor-heads (8), all of them are connected to the same receiver device (7) through wireless connections.

7. Measuring system according to claim 4 characterised in that a datastorage and/or measuring command sender circuitry is connected to the dataprocessor and evaluation circuitry.

8. Measuring method performed with a measuring system comprising a pulse oximeter sensor-head in which the pulse oximeter sensor-head is placed and anchored on the surface of the body, then light at least at two different wavelengths is emitted from light sources into the living tissue and the outcoming light intensities are measured by a light detector characterised in that the measured signals are collected and converted in a digital format by a data collector and A/D dataconverter circuitry (5), then the signals are transmitted from the pulse oximeter sensor-head (8) by a wireless datacommunication circuitry (6), and the transmitted digital raw pulse oximetry data are received, processed and evaluated by a remotely located receiver

device (7) maintaining a wireless communication with the pulse oximeter sensor-head (8), and, if necessary, the results are displayed.

5 9. Measuring method according to claim 8 characterised in that the contact surface (8a) of the sensor-head (8) is anchored to the surface of the body (9) under examination by a biocompatible adhesive layer.

10 10. Method for anchoring a sensor-head particularly according to claim 1, characterised in that the sensor-head (8) is fixed mechanically in a bell-jar-like casing (11) by means of structural element (11b) of said casing (11), said casing (11), having an internal air space (12) and a flange (14), is placed together with the sensor-head onto the surface of the body (9) so that the flange (14) together with said surface forms an airtight sealing, and a decrease of pressure is generated in said air space (12) during the process of placing the sensor-head (8) onto the surface of the body (9).

20 11. Method according to claim 10 characterised in that the wall of the casing (11) is made at least partially of a resilient material, and pressing this resilient wall (11a) during the process of placing the sensor-head (8) onto the surface of the body (9) a part of the air content of the air space (12) is pressed out, and the flange (14) is pressed against the surface of the body (9).

25 12. Method according to claim 10 characterised in that the decrease of pressure is created by a micro-vacuum pump fixed in the casing (11), after the flange (14) is pressed against the surface of the body (9).

30 13. Casing for anchoring a sensor-head, particularly according to claim 1, characterised in that said casing (11) is bell-jar-like, and comprises an internal air space (12), a flange (14) which rests against the surface of the body (9) and creates an airtight sealing with it, further comprises a structural element (11b) for mechanical holding of the sensor-head (8), and the wall of the casing (11) is at least partially made of a resilient material.

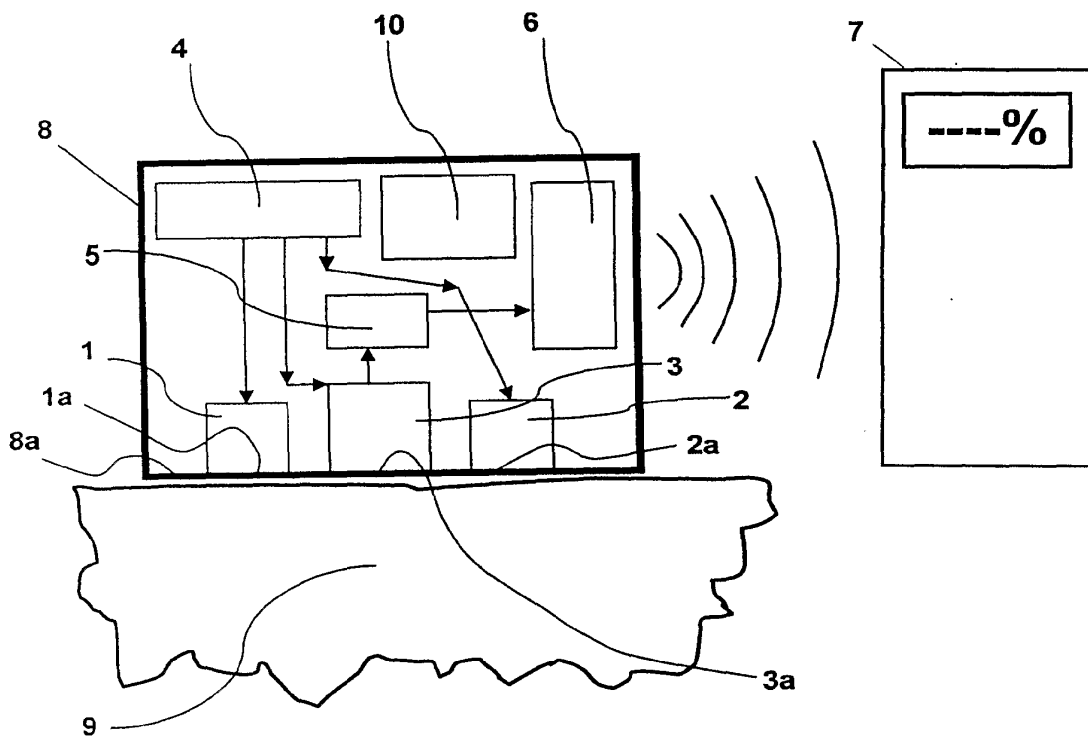

FIG. 1

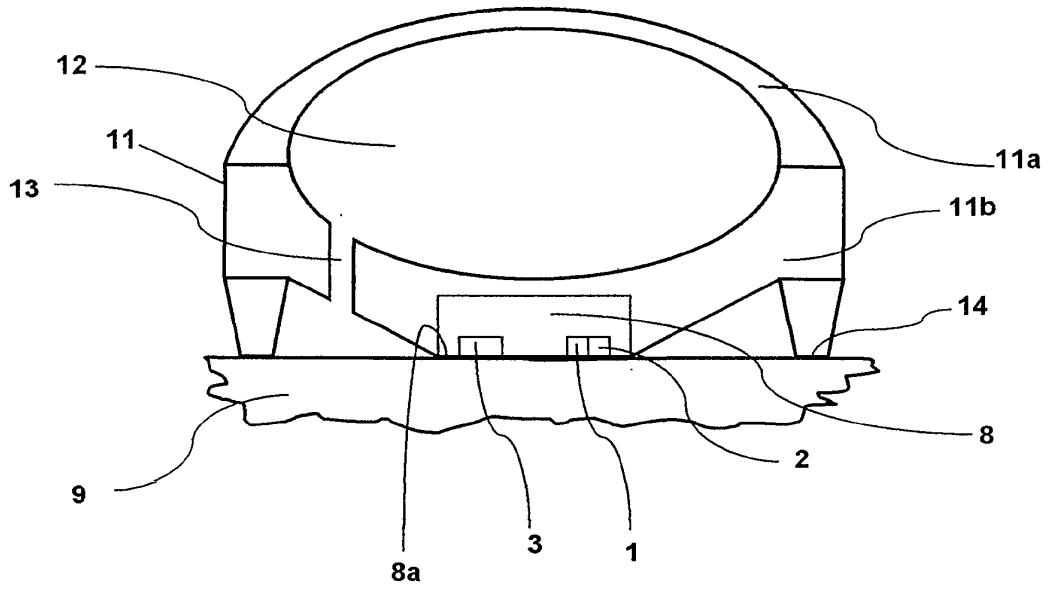

FIG. 2

(12) INTERNATIONAL APPLICATION PUBLISHED UNDER THE PATENT COOPERATION TREATY (PCT)

(19) World Intellectual Property Organization
International Bureau



(43) International Publication Date
31 August 2006 (31.08.2006)

PCT

(10) International Publication Number
WO 2006/090371 A2

- (51) International Patent Classification:
A61B 5/0476 (2006.01)
- (21) International Application Number:
PCT/IL2006/000230
- (22) International Filing Date:
22 February 2006 (22.02.2006)
- (25) Filing Language: English
- (26) Publication Language: English
- (30) Priority Data:
60/654,460 22 February 2005 (22.02.2005) US
- (71) Applicant (for all designated States except US): **SOFTWARE SOLUTIONS LTD.** [GB/GB]; P.o.box 546, 28-30 The Parade, St. Helier, Jersey Je48xy, St. Helier, Jersey Je48xy (VG).
- (72) Inventor; and
- (75) Inventor/Applicant (for US only): **ORBACH, Tuvi** [IL/GB]; 5 Ravenscroft Avenue, London NW11 0SA (GB).
- (74) Agent: **REINHOLD COHN AND PARTNERS**; P.o.box 4060, 61040 Tel Aviv (IL).

- (81) Designated States (unless otherwise indicated, for every kind of national protection available): AE, AG, AL, AM, AT, AU, AZ, BA, BB, BG, BR, BW, BY, BZ, CA, CH, CN, CO, CR, CU, CZ, DE, DK, DM, DZ, EC, EE, EG, ES, FI, GB, GD, GE, GH, GM, HR, HU, ID, IL, IN, IS, JP, KE, KG, KM, KN, KP, KR, KZ, LC, LK, LR, LS, LT, LU, LV, LY, MA, MD, MG, MK, MN, MW, MX, MZ, NA, NG, NI, NO, NZ, OM, PG, PH, PL, PT, RO, RU, SC, SD, SE, SG, SK, SL, SM, SY, TJ, TM, TN, TR, TT, TZ, UA, UG, US, UZ, VC, VN, YU, ZA, ZM, ZW.
- (84) Designated States (unless otherwise indicated, for every kind of regional protection available): ARIPO (BW, GH, GM, KE, LS, MW, MZ, NA, SD, SL, SZ, TZ, UG, ZM, ZW), Eurasian (AM, AZ, BY, KG, KZ, MD, RU, TJ, TM), European (AT, BE, BG, CH, CY, CZ, DE, DK, EE, ES, FI, FR, GB, GR, HU, IE, IS, IT, LT, LU, LV, MC, NL, PL, PT, RO, SE, SI, SK, TR), OAPI (BF, BJ, CF, CG, CI, CM, GA, GN, GQ, GW, ML, MR, NE, SN, TD, TG).

Published:
— without international search report and to be republished upon receipt of that report

For two-letter codes and other abbreviations, refer to the "Guidance Notes on Codes and Abbreviations" appearing at the beginning of each regular issue of the PCT Gazette.

(54) Title: METHODS AND SYSTEMS FOR PHYSIOLOGICAL AND PSYCHO-PHYSIOLOGICAL MONITORING AND USES THEREOF

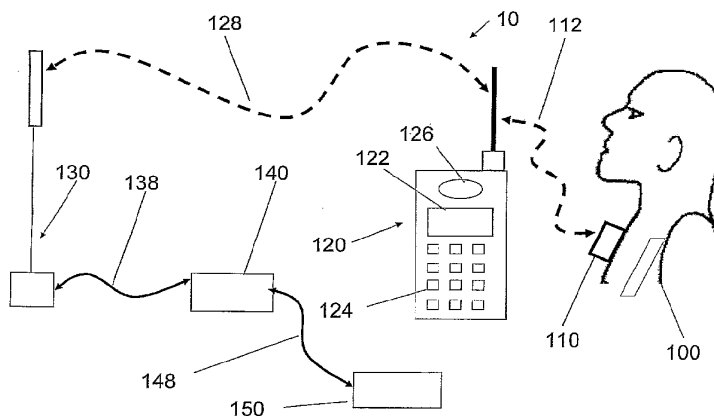

(57) Abstract: The invention provides a system and method for monitoring one or more physiological parameters of a user. The system of the invention includes one or more wearable sensor modules sensing the one or more physiological parameters. One or more transmitters wirelessly transmit signals indicative of values of the one or more physiological parameters to a mobile monitor. The mobile monitor includes a processor processing the signals received from the transmitter in real time using expert knowledge. A device provides one or more indications of results of the processing. The invention also provides wearable mobile sensors for use in the system of the invention. The method of the invention includes obtaining values of the physiological parameters of the user from one or more wearable sensor modules. Signals indicative of values of the one or more physiological parameters are wirelessly transmitted to a mobile monitor. The signals are processed in real time using expert knowledge, and one or more indications of results of the processing are provided to the mobile unit.

WO 2006/090371 A2

- 1 -

**METHODS AND SYSTEMS FOR PHYSIOLOGICAL AND PSYCHO-
PHYSIOLOGICAL MONITORING AND USES THEREOF**

5 FIELD OF THE INVENTION

The present invention is related generally to the field of physiologically monitoring and bio interactive applications.

10 BACKGROUND OF THE INVENTION

Biofeedback has been in use for many years to alleviate and change an individual's negative behavior patterns but existing systems have a number of significant drawbacks: Most current systems are reliant on powerful computers. First
15 of all, they require the user to be trained either by health professionals or complex on-line programmers. Once the user has been trained, they must remember to implement the internal physiological changes in their daily lives. The biofeedback sessions are rarely undertaken on a daily basis and certainly not in real time. This requires the user to remember specific events that occurred days before and recall his exact emotional
20 responses.

US patent 6,026,322; entitled "Biofeedback apparatus for use in therapy"; to Korenman, et al. filed February 6, 1997; discloses an apparatus and a program designed to train the user to control one or more aspects of his or her psycho-physiological state by controlling signals representative of a psycho-physiological
25 parameter of the user, e.g. his galvanic skin resistance, which may be detected by a sensor unit with two contacts on adjacent fingers of a user. The sensor unit can be separate from a receiver unit which is connected to a computer running the program. The disclosed apparatus is described for use in treating patients with a physiological condition, for example, irritable bowel syndrome. In a treatment session, one or more
30 psycho-physiological parameters of the patient are sensed and the sensed parameter

- 2 -

used to alter a display which the patient watches. The display includes a visual or pictorial representation of the physiological condition being treated which changes in appearance in a fashion corresponding to the physiological change desired in the patient.

5 PCT application WO0047110; discloses a method for obtaining continuously and non-invasively one or more parameters relating to the cardiovascular system of a subject, for example: systolic blood pressure, diastolic blood pressure, young modulus of an artery, cardiac output, relative changes in vascular resistance, and relative changes in vascular compliance.

10 US patent 6,067,468; to Korenman, discloses a program, designed to train the user to control one or more aspects of his or her psycho-physiological state. The program is controlled by signals representative of a psycho-physiological parameter of the user, e.g., his galvanic skin resistance which may be detected by a sensor unit with two contacts on adjacent fingers of a user. The sensor unit is separate from a receiver
15 unit which is connected to a computer running the program.

SUMMARY OF THE INVENTION

In its first aspect, the present invention provides portable, cordless, and wearable sensors, for monitoring queries emotional and physiological responses to
20 events as they occur. These results, gathered in real time, may be more effective and relevant to the user than those recreated days later after they occurred, under artificial conditions. The new sensors may utilize mobile phones and other technology to display the user's physiology and emotional state, real-time coaching based on expert knowledge, and to train the user to modify negative behavior patterns.

25 As used herein, the term "*wearable device*" refers to a device that the user can carry with him, for example, under or above his clothing, in his pocket, attached to his clothes, or in his hand.

In its second aspect, the invention provides a system for monitoring a user's emotional and physiological responses to events as they occur.

- 3 -

In another of its aspects, the invention provides methods to analyze the user's state of mind and physiology. In yet another of its aspects, the invention provides applications of the methods and sensors of the invention.

The invention also provides new methods to assess subtle information from this
5 data – such as the user's emotions; new methods of therapy; and new methods of entertainment, based on the interactions with the user's physiology and responses.

Thus, in one of its aspects, the invention provides a system for monitoring one or more physiological parameters of a user comprising:

- 10 (a) one or more wearable sensor modules sensing the one or more physiological parameters;
- (b) one or more transmitters wirelessly transmitting first signals indicative of values of the one or more physiological parameters to a mobile monitor; and
- (c) the mobile monitor, wherein the mobile monitor comprises:
 - 15 a first processor processing the first signals received from the transmitter in real time using expert knowledge; and
 - a device providing one or more indications of results of the processing.

The system of the invention may further comprise a remote server
20 capable of communication with said mobile monitor, the remote server receiving second signals from the mobile monitor, the remote server associated with a viewing station having a second processor, the remote server being configured to perform at least one of the following:

- 25 (a) transmitting the second signals to a viewing station for analysis, the analysis ;
- (b) accessing historical data relating to the subject;
- (c) transmitting the historical data to the viewing station;
- (d) receiving from the viewing station results of the analysis;

- 4 -

- (e) transmitting the results of the analysis to the mobile unit; the analysis being based upon the second signals, and one or more of the historical data, expert knowledge and computerised protocols.

At least one sensor module of the system may comprise at least one
5 sensor selected, for example, from the group comprising:

- (a) An electro dermal activity sensor;
- (b) An electrocardiogram sensor;
- (c) A plethysmograph; and
- (d) A piezoelectric sensor.

10 The system of the invention may comprise at least two sensors selected, for example, from a group comprising:

- (a) an electro dermal activity sensor;
- (b) an electrocardiogram sensor;
- (c) a plethysmograph; and
- 15 (d) a respiration sensor.

The first signals may be transmitted from a sensor module to the mobile monitor, for example, by any one or more of the following protocols:

- (a) Bluetooth;
- (b) WiFi; and
- 20 (c) Wireless Lan;

The mobile monitor may be selected, for example, from the group comprising:

- (a) a cellular phone;
- (b) a personal digital assistant (PDA);
- 25 (c) a pocket PC;
- (d) a mobile audio digital player;
- (e) an iPod,
- (f) an electronic note-book;
- (g) a personal laptop computer;
- 30 (h) a DVD player;

- 5 -

- (i) a hand held video game with wireless communication; and
- (j) a mobile TV.

The mobile unit may be a cellular telephone and communication between the mobile monitor and the remote server may be over a cellular communication network.

The mobile unit may include any one or more of a visual display, one or more speakers, a headphone, and a virtual reality headset.

In another of its aspects, the invention provides a wearable sensor module for use in the system of the invention.

The wearable sensor module may comprise at least one sensor selected, for example, from the group comprising:

- (a) An electro dermal activity sensor;
- (b) An electrocardiogram sensor;
- (c) A plethysmograph; and
- (d) A pizoomagnetic sensor.

The wearable sensor module may comprise at least two sensors selected, for example, from a group comprising:

- (a) an electro dermal activity sensor;
- (b) an electrocardiogram sensor;
- (c) a plethysmograph; and
- (d) a respiration sensor.

The wearable sensor module may comprise a transmitter transmitting signals, for example, by any one or more of the following protocols:

- (a) Bluetooth;
- (b) WiFi; and
- (c) Wireless Lan;

The wearable sensor unit may comprise an electro dermal activity sensor adapted to monitor skin conductivities using at least a 16 bit A to D conversion without the need of manual calibration.

The sensor module may comprise an EDA sensor comprising:

- 6 -

- (a) at least two electrodes adapted to be applied to a skin surface;
- (b) electronic circuitry for measuring a skin resistance across the electrodes and calculating an EDA based upon the resistance using an algorithm in which the EDA does not depend linearly on the resistance.

5

The sensor module may comprise a blood flow sensor comprising:

- (a) a light source adapted to emit light towards a skin surface;
- (b) a light detector adapted to detecting light reflected from the skin surface;
- (c) electronic circuitry for measuring an intensity of the reflected light and controlling an intensity of said light source based upon the intensity of the reflected light.

10

Electronic circuitry in the sensor module may be capable of measuring skin resistance across the electrodes over a range of at least from 50 K Ohm to 12 M Ohm.

15

The first processor of the system of the invention may be configured to calculate from the first signals one or both of a parameter indicative of an arousal state of the user and a parameter indicative of an emotional state of the user.

20

Calculation of a parameter indicative of an arousal state of the user may include calculating a score of a sympathetic and parasympathetic activity of the user using an algorithm based on any one or more of the user's Electro Dermal activity, Heart Rate, EDA variability, and HR variability.

25

The the first processor may be configured to calculate a parameter indicative of an arousal state of the user and to display the parameter indicative of an arousal state of the user on a display associated with the mobile unit as a two-dimensional vector.

30

The first processor may be configured to display on a display associated with the mobile monitor any one or more of the following images: an image indicative of bio-feedback information relating to the user; an image indic

- 7 -

of breathing activity of the user, an image including a graph indicative of an EDA activity of the user, an image including a graph indicative of a heart rate of the user, an image including a graph indicative of a heart rate variability of the user; an image including a graph indicative of an autocorrelation of a heart rate variability of the user; and an image indicative of recommendation to improve the user's psycho-physiological state based on one or both of the user's physiological data and experts' knowledge.

An image indicative of breathing activity may include a bar having a length indicative of the breathing activity. An image indicative of bio-feedback information relating to the user may include one or more parameter target values.

The first processor may be configured to calculate in a calculation based upon the first signals any one or more of the following: a breathing rate of the user; and a heart rate variability of the user. The user's rate of breathing may be calculated and analysis by monitoring changes in the electrical capacitance of the body while the user is breathing.

The system of the invention may further comprise an entertainment system. In this case, the first processor may be configured to determine at least one command based on the first signals and to transmit the at least one command based to the entertainment system. The entertainment system may comprise a third processor configured to perform an action based upon the one or more commands. The action may comprises any one or more of generating an SMS message, controlling a DVD, controlling a computer game, and controlling a "Tamaguchi" animation. The action may comprise processing a user reaction to any one or more of the following: a displayed animated image; a video clip, an audio clip, a multimedia presentation, real-time communication with another human, a question that the user has to answer, and a task that the has to perform.

In another of its aspects, the invention provides a method for monitoring one or more physiological parameters of a user comprising:

- 8 -

- (a) obtaining values of the physiological parameters of the user from one or more wearable sensor modules;
- (b) wirelessly transmitting first signals indicative of values of the one or more physiological parameters to a mobile monitor; and
- 5 (c) processing the first signals received from the transmitter in real time using expert knowledge; and
- (d) providing one or more indications of results of the processing to the mobile unit.

10 The results of the processing may include bio-feedback information of the user.

The method may further comprise transmitting second signals from the mobile monitor to a remote server having an associated viewing station and providing an analysis of the second signals at the viewing station. The viewing station may include one or both of a remote call center and an interactive expert system.

15 The processing may include calculating one or both of a parameter indicative of an arousal state and a parameter indicative of an emotional state of the user. Calculating a parameter indicative of an emotional state of the user may be based upon one or both of a sympathetic activity and parasympathetic activity of the user. Calculating a parameter indicative of an emotional state of the user may be based upon any one or more of an electro dermal activity, a heart rate, an electro dermal activity variability and a heart rate variability.

25 The method of the invention may further comprise a step of displaying on a display associated with the mobile unit one or both of an image indicative of a parameter indicative of an arousal state of the user; and an image indicative of a parameter indicative of emotional state of the user. An image may include one or both of a two-dimensional vector and a color indicative of a parameter.

30 The method of the invention may be used in obtaining respiration information selected from the group comprising duration of the inspiratory phase, and duration of the expiratory phase. The respiratory information m

- 9 -

obtained from audio sounds produced during breathing or speaking. The respiratory information may be obtained by the user indicating the beginning of one or more inspiratory phases and the beginning of one or more expiratory phases of the user's breathing. A breathing rate of the user may be calculated based upon a heart rate variability of the user. The user's rate of breathing may be calculated based upon changes in an electrical skin capacitance of the user while the user is breathing.

The method of the invention may further comprise training the user to increase any one or more of the followings: a duration of the inspiratory phase, a duration of the expiratory phase, and the ratio of the duration of the inspiratory phase to the duration of the expiratory phase.

The method of the invention may further comprise displaying on a display associated with the mobile monitor an image indicative of bio-feedback information, wherein the image includes any one or more of the following: an image indicative of breathing activity, an image including a graph indicative of EDA activity, an image including a graph indicative of heart rate, an image including a graph indicative of heart rate variability and an image including a graph indicative of an autocorrelation of heart rate variability. The analysis of the second signals may include a recommendation for the user to improve a psycho physiological state of the user. The recommendation may be displayed on a display associated with the mobile unit.

The method of the invention may comprise displaying a target value for one or more of the one or more obtained physiological parameters.

The method of the invention may further comprise steps of:

- (a) challenging the user with one or more stimuli;
- (b) monitoring one or more reactions of the user to said one or more stimuli;
- (c) calculating, in a calculation based upon the one or more reactions, at least one parameter selected from the group of: latency time of a

- 10 -

reaction, maximum reaction time, half recovery time, maximum stress, and new baseline stress; and

- (d) providing feedback to the user based on one or more of the calculated parameters.

5 The method of the invention may be used in a method of self behaviour modification comprising any one or more of the methods selected from the group comprising:

- (a) cognitive behavioural therapy (CBT);
(b) visualisation;
10 (c) self hypnosis;
(d) auto suggestion;
(e) mindfulness;
(f) meditation;
(g) emotional intelligence skills;
15 (h) psychological counselling provided over a communications network.

When the method of the invention is used in a method of self behaviour modification the method may further comprise:

- (a) providing the user with an interactive introduction about a specific condition of the user;
20 (b) providing the user interactive questionnaires for self assessment; and
(c) providing the user with one or more interactive sessions selected from the group comprising:

- an interactive session for self training to implement cognitive techniques;
25 interactive sessions for self training to implement behavioural therapy;
interactive sessions for self hypnosis;
interactive sessions for visualisation;
interactive sessions for auto suggestions;
interactive training to acquire and implement life and interpersonal
30 relational skills;

- 11 -

interactive training to improve emotional intelligence skills;
interactive training to find purposes and goals; and
interactive training to plan steps in life.

5 The user may be provided with one or more interactive sessions while
the user is in a deep relaxation state.

Unless otherwise defined, all technical and scientific terms used herein have the
same meaning as commonly understood by one of ordinary skill in the art to which
this invention belongs. Although methods and materials similar or equivalent to those
described herein can be used in the practice or testing of the present invention, suitable
10 methods and materials are described below. In case of conflict, the patent
specification, including definitions, will control. In addition, the materials, methods,
and examples are illustrative only and not intended to be limiting.

BRIEF DESCRIPTION OF THE DRAWINGS

15 An exemplary embodiment of the invention is described in the following
section with respect to the drawings. The same reference numbers are used to
designate the same or related features on different drawings. The drawings are
generally not drawn to scale.

The invention is herein described, by way of example only. With specific
20 reference now to the drawings in detail, it is stressed that the particulars shown are by
way of example and for purposes of illustrative discussion of the preferred
embodiments of the present invention only, and are presented in the cause of
providing what is believed to be the most useful and readily understood description of
the principles and conceptual aspects of the invention. In this regard, no attempt is
25 made to show structural details of the invention in more detail than is necessary for a
fundamental understanding of the invention, the description taken with the drawings
making apparent to those skilled in the art how the several forms of the invention may
be embodied in practice.

30 **Fig. 1** is a physiology monitoring system, according to an exemplary
embodiment of the invention;

- 12 -

Fig. 2 shows a sensor module attached to a user's finger, according to an exemplary embodiment of the invention;

Fig. 3 shows some details of a sensor module, according to an exemplary embodiment of the invention;

5 **Fig. 4** is a schematic representation showing the mental and physiologic states of a person;

Fig. 5a shows a typical electro cardiogram (ECG) of a healthy person;

Fig. 5b shows a typical light reflection optical signal as affected by the blood flow;

10 **Fig. 5c** shows frequency analysis of heart monitoring signal;

Fig. 6a shows a graph of typical heart beat rate vs. time and its correlation to breathing cycle;

Fig. 6b shows frequency analysis of Heart Rate Variability (HRV);

15 **Fig. 7a** shows an exemplary display showing sensors output, according to an exemplary embodiment of the invention;

Fig. 7b shows an exemplary display showing heart beat rate (HR), according to an exemplary embodiment of the invention;

Fig. 7c shows an exemplary display showing Electro Dermal Activity (EDA), according to an exemplary embodiment of the invention;

20 **Fig. 7d** shows an exemplary display showing Heart Rate Variability, demonstrating the breathing cycle, according to an exemplary embodiment of the invention;

Fig. 8 shows an exemplary graph of stimuli induced stress used in a training session, according to an exemplary embodiment of the invention;

25

Fig. 9 schematically shows an electric circuitry of a reflective Photo-Plethysmograph with automatic continual adjustment of the source light intensity in accordance to an exemplary embodiment of the invention;

30 **Fig. 10** shows an improved electronic circuit for EDA monitoring in accordance to an exemplary embodiment of the invention;

- 13 -

Fig. 11 shows an exemplary graph of the relationship between the user's skin resistively and voltage measured by improved electronic circuit for EDA in accordance to an embodiment of the invention; and

Fig. 12 shows an entertainment system according to an aspect of the invention.

5

DETAILED DESCRIPTION OF EXEMPLARY EMBODIMENT

The following detailed description is the best presently contemplated modes of carrying out the present invention. This description is not to be taken in a limiting sense, but is made merely for the purpose of illustrating the general principles in accordance with the present invention. The scope of the present invention is best defined by the appended claims.

10

With reference to the drawings, in Fig. 1 shows a physiological monitoring system **10**, in accordance with an exemplary embodiment of the invention.

15

A sensor module **110** is attached to a user **100**. A communication link **112** is used to transfer data from the module **110** to a mobile monitor **120**. Based on the transferred data the mobile monitor **120** provides visual biofeedback to the user by means of a display **122** and optionally an audio biofeedback to the user by means of speaker **126**. Optionally, a keypad **124** is used to control the operation of the mobile monitor **120**, sensor module **110**, or both. Optionally the user can control the operation using voice recognition methods.

20

Optionally, a communication link **128** is used to connect the mobile monitor **120** to a remote server **140** where in-depth analysis of data obtained by the sensor unit **110** may be done and, optionally, data can be transmitted to an expert or another user. In the exemplary embodiment of Fig. 1, the mobile monitor **130** is a cellular phone, communication link **112** is a Bluetooth link, and communication link **128** is cellular RF link to a cellular base station **130** which is linked to a remote server **140** by a data link **138**.

25

Optionally, an additional data link **148** such as Local Area Network (LAN) or Internet networking or RF cellular link connects the remote server **140** to a viewing

- 14 -

station 150 where a human expert may provide interpretation of the data and transmit recommendations to the user.

Sensor module

Fig. 2 depicts a sensor module 210 that may be used in the system 10 instead of the sensor module 110. The sensor module 210 is in contact with the user's finger 200. The sensor module 210 may be attached to the finger by a strap 212 as shown in Fig. 1, or the sensor module 210 may be shaped to fit over the finger. Alternatively, the finger 200 may simply be applied to the sensor module 210.

Fig. 3 shows a block diagram of a sensor module 310 for use in the system 10 according to an exemplary embodiment of the invention.

In the exemplary embodiment of Fig. 3, Electro Dermal Activity (EDA) at a user's skin surface 300 is monitored by applying at least first electrode 332 and second electrode 334 to the skin surface 300. EDA electronics 330 monitors the skin resistively by applying a very low electric voltage across the first and second electrodes and creating a minute electrical current between the electrodes. EDA electronics 330 generates a digital signal indicative of the skin resistively.

In the exemplary embodiment of Fig 3, blood flow under the skin 300 is monitored by Plethysmograph Electronics 320 which is used for Heart Rate (HR) monitoring. In this exemplary embodiment, a light source 322 illuminates the skin surface 300 with emitted light 324. The intensity of scattered light 326 reflected from the skin and received by light detector 328 depends on the blood flow in the skin. Phethysmograph electronics 320 generates a digital signal indicative of the blood flow and thus may be used to monitor heart activity.

Optionally, one or more additional sensors 372 connected to additional sensor electronics 370 is used to monitor one or more additional physiological signals such as temperature, Electrocardiogram (ECG), blood pressure, etc.

The processor 340 receives digital data from EDA electronics 330, Phjethysmograph electronics 320 and optionally from additional sensor electronics 370 and processes the data according to instructions stored in a memory 342. The memory 342 may be a Read Only Memory (ROM) storing a pre-installed program. a

- 15 -

Random Access Memory (RAM), a non-volatile memory such as flash memory or combination of these types of memory. The processor 340 may store raw or processed data in memory 342 for later use.

Optionally, the sensor module 310 is equipped with an indicator 380. Indicator 5 380 may provide visual or audio indication as to the status of the module such as “on/off”, “low battery”. Additionally or alternatively, indicator 380 may provide visual or audio indication as to the physiological state of the user based on the data from the sensors.

In the exemplary embodiment of Fig. 9, a communication module 350 is used 10 as an interface between the sensor module 310 and mobile monitor 120 (Fig. 1). In this embodiment, a wireless communication link is used. Preferably, communication module 350 supports “blue-tooth” RF bidirectional wireless communication and is connected to antenna 352. Alternatively or additionally, Infra-Red (IR) communication, ultrasonic communication, WIFI communication, or wire 15 communication may be used.

Battery 360 provides power for all the electronics within sensor module 310.

Alternatively or additionally, a wired connection, for example Universal Serial Bus (USB) may be used. In this case, a wired connection may provide power, optionally using electrical isolation such as a transformer which isolates the supplied 20 power for safety, as well as means for data transfer.

The location of the sensor module on the user’s body may depend on the type of physiological data to be acquired by the module and the type of sensor used.

For example, for measuring an EDA signal, the sensor’s electrodes could be placed where the skin resistively changes depending on the person’s stress or arousal 25 level or any minute change in the autonomic nerves system, such as the palm of the hand, fingers wrist or ear lobe.

For measuring blood flow by optical reflectance, the module could be attached to locations where blood vessels are close to the surface such as the wrist, fingertips ear lobe etc, or the forehead to monitor blood flow in the brain.

- 16 -

For measuring cardiac electrical activity (ECG), the sensor may be attached to the user's chest using an adhesive or a strap, alternatively ECG can be monitored by attaching electrodes to two hands.

For temperature sensing, a sensor, which may be external to the sensor module,
5 may be placed in the armpit or ear etc.

Alternatively, sensor may be temporarily touched to the measurement location for the duration of the measurement.

More than one sensor module may be used simultaneously. Two or more sensor modules may acquire the same or different physiological signals and
10 communicate them to the same or different mobile monitors. Optionally, a plurality of sensors may monitor one or plurality of users simultaneously. The sensors may communicate with the same mobile monitor or with different monitors.

The communication link **112** is preferably bidirectional and continues while the sensor module is in operation. In such cases, the sensor module transmits information
15 indicative of the user's physiological state to the mobile monitor for display and processing and receives commands and instructions from said mobile module. Such commands and instruction may control the operation mode of the sensor module. For example, the data sampling rate may be changed by such a command. Additionally or alternatively, data sampling accuracy or range may be changed by such commands.
20 Programs executed by processor **340** may be uploaded and stored in the memory **342**.

Alternatively, the communication link **112** may be unidirectional in which case the sensor module **310** only transmits information to mobile monitor **120**. Optionally, the communication link **112** is intermittent. For example, for saving power and prolong battery life, the communication link may be activated only on demand,
25 when signals detected by the sensor are in specific ranges, for example: above or below thresholds or satisfy other conditions. For example, if the processor **340** detects an anomaly in the acquired physiological signal, it may initiate a data transfer to the mobile monitor. Alert conditions may be set up that trigger such data transfer to the mobile monitor **120**. For example, heart rate may be monitored by the processor **340**
30 to detect anomalous conditions regarding the rate and its Variability such as:]

- 17 -

Rate (HR) too high, HR too low, Heart Rate Variability (HRV) too low. Breathing rate which may be inferred from analysis of HRV as will be demonstrated later, may also be used to trigger data transfer.

Alternatively or additionally, data transfer may be triggered by the mobile
5 monitor.

For example, the mobile monitor **120** may be a laptop computer, The sensor module **310** may acquire and log physiological information, preferably in a compressed form in memory **342**. Such a log may span a duration of several minutes or hours. When the sensor module **310** is in the vicinity of the mobile monitor, the
10 acquired and stored data may be transferred on command initiated automatically or manually.

The data transfer rate may change depending on the operation mode of the sensor module. For example, one or few of HR, EDA ECG and HRV may be relayed to the mobile monitor during normal operation mode, while more or all of the signals
15 are transferred during another mode of operation. Optionally, data is stored in a buffer, for example a cyclic buffer within memory **342** such that data recently acquired is available until over-written. Buffered data may be transferred on demand or initiated by the processor **340** or the mobile monitor.

Instructions and commands may be initiated by the remote server **140** or expert
20 station **150** and relayed to sensor module **110** through mobile monitor **120**. Alternatively, different communication methods may be used for different purposes. For example, data transfer from sensor module **112** to mobile monitor **120** may be achieved by a unidirectional communication such as IR transmission, while reprogramming the sensor module or setting alert parameters may be done while
25 sensor **110** is connected to mobile monitor **120** using a USB cable. It should be apparent that other combinations of communication modes and methods are possible.

Preferably, the sensor module **310** comprises means for monitoring blood flow in the skin **300** using the phethysmograph electronics **320**; light source **322** and light detector **328**. In the preferred embodiment, the light source **322** is a Light Emitting
30 Diode (LED) emitting red or IR light **324**, or a plurality of LEDs transmitting sar

- 18 -

plurality of wavelengths for example both red and IR light. Other light sources may be used such as solid-state diode lasers or Vertical Cavity Surface Emitting Laser (VCSEL). In the preferred embodiment, the light detector 328 is a Silicon photodiode. Optionally, the intensity of the emitted light 324 is not constant. For example, HR electronics 320 may turn off the light to conserve energy or to perform periodic calibration and ambient light subtraction. Additionally or alternatively, the intensity of emitted light 324 may be controlled by plethysmograph electronics 320 to compensate for different skin colors and person to person variations in skin light scattering properties such that reflected light 326 will remain within specific range. This method ensures that the light detector 328 and its associated amplifier and Analog to Digital Converter (ADC) will not be saturated or out of range. Alternatively the light source 322 may be placed on one side of the user's appendage such as finger or ear lobe and the light detector 328 placed on the other side of the appendage. In this case the detector detects the light transmitted through the appendage instead of the reflection light.

Fig. 9 shows some details of exemplary electric circuitry of a reflective photo-plethysmograph 900 with automatic continual adjustment of the source light intensity in accordance to an embodiment of the invention. The circuit is designed to pick up changes in light intensity as blood passes through the capillary bed of a user for example, in the finger. The intensity of reflected light intensity changes in time reflecting the pulsatile action of the heart in the user. The change is converted to a voltage, amplified, filtered and then digitized signal before being passed to a microcontroller 340

The interface sensor comprises an intensity-controlled Opto-transmitter Tx, preferably a red or Infra-red LED and a light receiver Rx preferably a photodiode or a phototransistor and a trans-impedance (current to voltage) amplifier. In the preferred embodiment, the receiver Rx is an integrated component including both photo-detector and amplifier. The signal S1 from the output of the trans-impedance amplifier is feed to one input of a differential amplifier A1 and is also low-pass filtered and taken to a unity-gain buffer amplifier A2 giving output signal S2. Output signal S2 represent the

- 19 -

average level of light falling on the opto-sensor with any pulsatile component removed due to the low pass action of the filter. S2 is then used as the other input to the differential amplifier A1. The output from A1 is low-pass filtered and then fed along with S2 to the differential inputs of an analogue to digital converter AD1 providing a digitized pulse signal to microcontroller 340. Additionally, S2 is used along with a fixed reference voltage V_{ref} slugged comparator A3 whose output controls the intensity of the opto-transmitter Tx. This allows optimal biased input conditions for the receiver by automatic continual adjustment of the source light intensity. The overall effect of the circuit provides for wide variability in ambient light conditions, skin tone of the subject and minimizes unnecessary current drain due to optimal control of the light source. It is possible to replace the photo-plethysmograph with a piezo-electric sensor, which monitors minute changes in blood vessel pressure instead of changes in reflected light.

Another aspect of the invention is a GSR EDA sensor. GSR and EDA have been used for many years to monitor general arousal levels. However, efficacy has been compromised because the difference between skin resistance / impedance of individuals is very high as is the disparity encountered within the same individual experiencing differing emotional and physiological states.

In order to accommodate a wide spectrum of users, current systems are not sensitive enough to diagnose minute changes. One way, used in the art, to overcome this problem is to have two reading sessions monitored by experts: the first reading creates a base line, the second session is done at higher sensitivity centered around the baseline. In the present invention,

- A 16-bit Analog to Digital Converter (ADC) microchip is preferably used to cover a larger range with high sensitivity.
- The electronic circuit, as depicted in Figure 10, is modified to enhance dynamic range.
- Software is used that can automatically monitor both the user's base line and level of sensitivity, and display it to the user in an understandable way.

- 20 -

In contrast to prior art EDA units which use 8-bit or 12 bit ADC, the EDA electronics **330** of the preferred embodiment uses a 16-bit ADC. It was discovered that small temporal changes in skin resistance provide significant physiological information, while the EDA may change over a wide range. Additionally, the large dynamic range reduces or eliminates the need to manually adjust the ADC range or baseline or sensitivity. Since the EDA signal is low bandwidth, high accuracy ADC such as "sigma delta" type may be used.

Optionally, automatic auto ranging and auto scaling may be used. In this method, a baseline may be subtracted from each measurement. The subtracted value may be stored or transmitted to the mobile monitor so that actual values may be restored. Similarly, automatic scaling may be used to re-define the signal change associated with each bit of the ADC. Optionally or additionally, a Logarithmic or other non-linear scaling of acquired data may be used.

Fig. 10 shows an electronic circuit **1000**, for using non-linear scaling for EDA monitoring. The circuit **1000** is designed to pick up very small changes in sweat gland activity reflecting changes in the emotional arousal of the user. The circuit monitors changes in skin resistance level, which are then amplified, filtered and digitized before being passed to the microcontroller **340**.

In one preferred embodiment, the interface consists of a pair of gold plated finger electrodes **1032** and **1034**, etched onto a PCB. The EDA signal has a large dynamic range and there are also very large variations between subjects of base skin resistance level. The electronics comprise a modified constant current source. Operational amplifier A4 tries to maintain the potential at intersection **1100** at voltage V_{ref} , providing a fixed current through the resistor R3. This current is the current flowing through the combination of resistor R1 and the EDA electrodes **1023** and **1034**. The voltage V_x , required to maintain this constant current is measured with respect to reference voltage V_{ref} and digitized by Analog to Digital Converter AD2 after low-pass filtering. Preferably, AD2 is a 16-bit ADC.

The resistance R2 is preferably high, for example ($R2 > 10$ times the normal subject base readings) and during normal operation has no significant effect i

- 21 -

circuit. However for subjects with high levels of basal skin resistance, R2 becomes more significant and the voltage output from A4 is reduced to prevent output saturation. This allows subjects with high base resistance to be measured using the same circuitry with the output measured with a non-constant current.

5 The measured voltage V_x is given by:

$$V_x = \frac{V_{ref} / R3}{1/(R1 + Rx) + 1/ R2}$$

where R1, R2 and R3 are the resistor values. V_{ref} is a reference voltage value, and R_x is the changing resistance of the user's skin appearing between the electrodes.

10 An EDA monitoring device based on the circuitry according to the current invention may be capable of measuring small changes in the skin resistance over a large range, for example from 50 KOhms (50,000 Ohm) to 12 MOhms (12,000,000 Ohm). The exact range may be adjusted by changing the values of the components in said circuitry.

15 Fig. 11 shows an exemplary graph of the relationship between the measured voltage V_x and the user's skin resistivity R_x plotted in arbitrary units on a log-log scale. A linear range is observed near the origin. The plot becomes non-linear for high R_x values.

20 Optionally, the sensor module **310** is equipped with an indicator **380**. Indicator **380** may provide visual or audio indication as to the status of the module or provide one or few of: visual, vibrational, or audio indication as to the physiological state of the user based on the data from the sensors. For example, indicator **380** may be used to alert the user that a physiological signal is out of the predefined range. The alert may be initiated locally by processor **340** or communicated to the sensor module through communication link **112**. Optionally, indicator **380** may be used as biofeedback in a
25 training session as will be detailed later.

The indicator **380** may comprise an LED or a few LEDs optionally of different colors. Optionally, indicator **380** may comprise a speaker providing audio signal to the user. Optionally, indicator **380** may comprise a means to produce vibration such as

- 22 -

PZT buzzer or miniature electric motor so that the alert may be sensed by the user and no one else.

Mobile monitor

In an embodiment of the current invention the sensor module **110** is connected
5 by communication link **112** to a mobile monitor **120**. In one preferred embodiment,
the mobile monitor **120** is a cellular phone or a Personal Digital Assistant (PDA)
equipped with a processor to perform data analysis, memory, a display, Audio output,
input means such as keypad, and microphone and sketchpad and means to
communicate with both sensor module and remote server.

10 Specific programs necessary for interfacing with the sensor module and for
providing feedback to the user may be uploaded by the user. For example, the program
may be loaded into a cellular phone wirelessly in the same way a new game or ring
tone is loaded.

Alternatively, other personal computing devices may be used as mobile
15 monitors, for example a Laptop Personal Computer LPT or a media player such as
Apple iPOD[®], pocket PC or an electronic note-book. Alternatively, a standard PC may
be used if the user wants to execute a training session without moving around or if the
user wants to download data stored in the sensor module periodically or to reprogram
the sensor.

20 The communication range of the sensor module is limited due to its small size
and low battery capacity to few meters or up to almost 100 meters using Bluetooth. In
contrast, the Mobile monitor is equipped with means to connect to a remote server
wirelessly over the cell network, preferably using the Internet. For example, cellular
phone may be connected using one of the cellular data exchange protocols such as
25 GPRS. Other standard and proprietary protocols may be used such a wired connection
to a phone line using a modem or an Asymmetric Digital Subscriber Line (ADSL), a
Local Area Network (LAN) Wireless LAN (WAN), etc.

Remote servers may provide additional processing of the sensor's data, initial
and updating of mobile monitor and sensor module programming, feedback and
30 recommendations to the user, issue alerts to the user or summon rescue teams to a

- 23 -

the user in emergency. Some mobile monitors may be equipped with means to establish their physical location such as Global Positioning System (GPS) which may be used to direct the rescue team to a user in distress such as during cardiac mishap or epilepsy episode.

5 **States of mind**

Reference is now made to Fig. 4 illustrating schematically examples of possible “states of mind” of a user. The vertical axis is the arousal level of the user while the horizontal axis is his emotional state.

Biofeedback and monitoring systems are not designed to analyze emotions.
10 The GSR or EDA sensor reflects arousal level, but the system cannot differentiate between positive arousal – that is when the user is enthusiastic and negative arousal when the user is stressed and angry. The existing methods also cannot differentiate between positive low arousal - when the user is relaxed and meditating, and negative low arousals – when the user is depressed and despondent.

15 Reference is now made to Fig. 4 illustrating schematically examples of possible “states of mind” of a user. The vertical axis is the arousal level of the user while the horizontal axis is his emotional state.

By integrating a sensitive EDA sensor (such as disclosed herein according to the current invention), HRV analysis, and optionally a multimedia display (such as a
20 smart phone , PDA or PC), it is possible not only to analyze the state of the emotions of the user as described in Fig. 4 , but also to train the user to improve his state of emotions and physiology.

For example: the system can have several modes of operation:

a) Baseline calibration: The system automatically determines a base line of the
25 specific user. The base line includes vectors of parameters which will be calculated and recorded during the first interval, including: minimum, maximum and average HR, HRV, FFT (Fast Fourier transform), respiration rate (which can be calculated indirectly or monitored directly), and EDA - max, min, average, variance, number of fluctuation and slope.

- 24 -

b) Calibration using induced state of mind: Preferably, a short time after the base line has been stabilized, the system presents prerecorded triggers. Each trigger is designed to elicit specific emotions in the user. The triggers may be prerecorded scenarios which can cause specific emotional reactions. The preferred methods are multimedia methods, which can be a prerecorded audio visual movie on a smart phone or PC. For a professional system, this can be virtual reality goggles with a real 3D scenario. For a less expensive system, the trigger can be only an audio session using a mobile phone. These triggers or scenarios can be general scenarios which have been tested and validated in the past to create a specific emotional reaction, or can be customized for a specific culture, people or person. For example, a scenario might be an audio visual display of a dentist drill in a tooth, or a car accident for negative arousal; winning a game, or a romantic relationship for a positive arousal; a relaxing nature movie for positive relaxation, and a boring and sad scenario for negative low arousal. Before, during and after each trigger, the system monitors, calculates and records the vectors of parameters as described above and calculates the parameters which are described in Fig. 8 when each trigger start and finish.

c) Calibration using user reported state of mind: The system can ask the users to input their subjective feeling, for example, by using the keyboard of their cell phone (e.g.) if you feel very happy press 9, very sad press 1). By calculating the above vectors and correlating them with the specific triggers, the system is able to differentiate between specific states of emotions and to correlate them with the physiological state of the user. The system can keep those vectors and their correlations to specific emotional states for specific users, and/or for each group of users.

d) Learning mode: The system can incorporate neural network and similar methods to continue learning, using the data from a group of users in the past to predict the emotional state of a specific user in a shorter time using his vector of data as describe above. For example, using this algorithm with a group of people, the system can predict that when a user has a low HRV and at the same time a high skin

- 25 -

conductivity, his emotional state is "*negative stress*", while user with a high HRV and a low skin conductivity is "*relaxed and positive*".

e) Training mode: The system can also train the users first to be more aware of their physiological and emotional state during their daily activities, and, second to
5 acquire better behavioral, physiological and psycho- physiological habits, such as increasing their respiration cycle, and the ratio of expiration to inspiration, increasing their HRV, and learning to relax. , Third, the system can be used to train users to improve their reaction and responses to negative triggers and events during their daily
10 life, and to improve their reactions and performance under pressure. The system can simulate real events and train the user to improve his reaction, performance and behavior. For example while prior art biofeedback systems can be used only in an artificial setting (e.g. the therapist's office) the wireless sensors of the invention can be used during actual important activities, such as driving, playing music, competing in sports, during exams, work interviews, etc.

15 The system of the invention may be calibrated or customized to a specific user. Alternatively, statistical parameters acquired by studying the general population or a specific sub-group of the population may be used. In some embodiments, a remote server receives data from a plurality of users, optionally including information about the user, and uses the information to create a data set used for state of mind analysis.
20 Optionally, parameters extracted from the data set are transmitted to the mobile units of at least some of the users to be used for determination of the state of mind of the users. Optionally, a study group or plurality of study groups of users are used by the service provider in order to create the data set. This real time analysis of the state of mind of the users including their emotional reactions to specific triggers can be used to
25 train the users to improve their performance and also to analyze their reactions to specific events, triggers, products and services.

The users can receive feedback in real time directly from the system by audio-visual feedback in real time, and at the same time the system can transmit the information to an expert or coach who can help them improve their reactions. This can
30 be relevant for health issues –e.g. a child with asthma who can get feedback in

- 26 -

time from the system and/or physician, or an athlete receiving feedback to improve his performance. For training and analysis, it is recommended to record the physiological vectors as described above together with the external situation –e.g. a video of the competition, or a musical performance. In this way, it is possible to find the correlation between the best performance and the physiological vectors, and to train the user to optimize his physiological, emotional and mental performance, using simulation of the event by video or visualization together with the real time feedback of the sensors.

Schematically, the upper section of Fig. 4 is characterized by high arousal state, such as physical or emotional stress. This stress may be a result of vigorous physical activity or by emotional state of anger, aggressiveness, fear, or anxiety. Alternatively, high arousal may be a result of excitement caused by constructive thoughts such as concentrating on performing a task, or feelings of enthusiasm or passion. These two different states are separated by their being on the right (negative emotionally) and left (positive emotionally) sides of the figure respectively.

Similarly, low stress states of mind, schematically symbolized by the lower half of the figure, may be a result of depression or boredom, characterized by low arousal or energy level and negative emotions on the lower right of the figure; or relaxation and self contained pleasure on the lower left side of the figure.

In an embodiment of the invention, the combination of sensors and data processing enable automatic determination of the state of mind of the user and may be used to provide feedback and interactive multimedia training to achieve and maintain the positive state of mind and body.

A high stress state is characterized by a high production of adrenalin hormone associated with high HR. However, high HR by itself cannot separate enthusiasm and passion from anger and anxiety. Positive mental states (left two quadrants of Fig. 4) are associated with secretion of growth hormone and dehydroepiandrosterone (DHEA), and characterized by high heart rate variability (HRV) and high skin resistance. In contrast, negative mental states (right two quadrants of figure 4) are associated with secretion of Cortisol hormone and characterized by

- 27 -

HRV. Additionally, a state of relaxation is characterized by slow, steady breathing with slow exhale periods.

In an exemplary embodiment of the invention the state of mind is characterized by a two component vector: Emotional level: Left- more positive emotions, right- more negative emotions – on the horizontal axis; and Stress level on the vertical axis:
5 Up- more stress, down- less stress.

In some embodiments of the invention a marker, for example an icon is displayed in the coordinates representing the state of mind vector and may be viewed by the user to allow monitoring of his state. The location of the marker may be
10 periodically updated as the state of mind changes.

Alternatively or additionally, color codes may be used to symbolize the state of mind. For example, the horizontal axis may be represented by shades of yellow on the left to black on the right; while the vertical axis may be represented by shades of red on the top and blue on the bottom.

15 The combinations of these colors yields: Orange – representing a passionate mood on the upper left quadrant of the two dimensional scale; Green – representing a relaxed mood on the lower left quadrant; Dark Red - representing an aggressive mood on the upper right quadrant; and Dark Blue - representing depression on the lower left quadrant.

20 The resulting combination color, representative of the state of mind may be displayed on the display 122 of unit 120. For example, the resulting combination color may be used as background for one or some of the graphs as depicted in Figs. 7a to 7d. It should be clear that other color schemes may be used within the general embodiment of the current invention. Such a color representation of state of mind is
25 easy to view and may be intuitively understood by the user without the need to carefully observe the monitor or while performing other mental or physical tasks.

Data processing

In an embodiment of the invention, heart pulses are tracked by data analysis performed by processor 340 within the sensor module.

- 28 -

Fig. 5a shows a typical ECG signal of a healthy person. Three heartbeats are clearly seen separated by time intervals T1 and T2.

Fig. 5b shows a typical optical signal. Three heartbeats are clearly seen separated by time intervals T1 and T2.

5 In an embodiment of the invention, optical signals from detector 328 are analyzed and individual heartbeats are determined.

This can be done by identifying the peaks, minima or zero crossings in the signals, by performing auto correlation or by wavelet analysis.

In one preferred embodiment, local maxima are found in the optical signal.
10 Then, the system checks if this peak is a heartbeat peak or only a local maximum due to noise. This determination may be assisted by performing comparison with signals from previous heartbeats and using, for example, probabilistic, heuristic or fuzzy logic algorithms.

In contrast to standard heart rate monitors which display only an average heart
15 rate, the combination of the electronics and the peak detector – heartbeat recognizer algorithm enables the system to detect, calculate and present more accurately each heartbeat.

A similar analysis may be performed on an ECG signal if available. It is easier to detect accurate peaks in an ECG because the R wave has high amplitude and is
20 sharp. The instantaneous HR is define as $HR(t)=1/T_i$, where $T(i)$ is the duration of heart cycle “i” (T is also known as R-R duration as seen in Fig. 5a), $HR(t)$ is tracked over time (t) and optionally stored in the memory 342. Alternatively, the $T(i)$'s may be stored.

An average HR (AHR) may be calculated by averaging the values of HR over a
25 specific period. A running average may be calculated over a predetermined time window to reduce noise in the signal.

HR Variability (HRV) may be calculated by several methods. One of them is the absolute value of the difference between the AHR and $HR(t)$, and calculating the average of the $HR(t)$ in the specific interval.

- 29 -

Other methods are calculation of the standard deviation or variance of the HR in a specific interval.

Optionally or additionally, spectral analysis of a heart signal may be performed. A computational efficient Fast Fourier Transform (FFT) algorithm is preferably performed to calculate the spectrum.

Fig. 5c shows a typical Fourier spectrum of heart signal. AHR can be inferred from the location of a peak, that is typically located between 0.5 to 3 Hz corresponding to an average heart rate of 30 to 180 beats per minutes. HRV may be inferred from the width of the peak.

A stress level can be inferred from the AHR wherein a high level of stress is characterized by higher than normal AHR. It should be emphasized that "normal" AHR is different for each individual and depends on age and physical stamina. Thus, this level may need to be updated from time to time, for example by measuring and averaging the AHR over an extended duration or by measuring it during a calibration session while the person is in a known state of mind. Similarly, the two ends of each axis may be calibrated during training and calibration sessions, for example: vigorous physical exercises vs. meditation rest or sleep.

Variability in HRV may be assessed from width of the peak in Fig 5c.

It was discovered that heart rate is correlated with the breathing cycle and autonomic nervous system functionality. Fig. 6a shows a typical graph of a healthy person's HR as a function of time during normal breathing cycle. The HR increases during inhalation and decreases during air exhalation.

Breathing monitors known in the art use strain gauge sensors strapped around the chest, or air movement sensors positioned near the person's mouth and nostrils. Using these sensors is cumbersome and uncomfortable. In contrast, an embodiment of the current invention infers the breathing from HR information.

In an embodiment of the invention, values of instantaneous HR(t) determined for example from optical signals or from ECG signals are analyzed and the breathing cycles are determined. This can be done by identifying the peaks, the valleys or zero crossings in the HR sequence, by performing auto correlation or using FFT analy

- 30 -

by wavelet analysis. Each breathing cycle may be analyzed for Breathing Rate (BR), Breathing Depth (BD) and the Ratio of Exhale over Inhale duration (REI). Alternatively or additionally it can be analyzed and presented as two parameters: Inhalation duration and exhalation duration (average duration in seconds).

5 Where: BR per minute is defined as 60 over the duration of the breathing cycle in seconds;

 BD is defined as the Minimum HR subtracted from the maximum HR during the breathing cycle normalized by the AHR, and

 REI is defined as exhale duration divided by inhalation duration.

10 These values may be transmitted to the mobile monitor and optionally stored in the memory 342. Alternatively, the breathing analysis may be done at the mobile monitor.

 The average values of BR, BD and REI (ABR, BD and REI respectively) may be calculated by averaging the values of BR, BD and REI over a specific period. A
15 running average may be calculated over a time window to reduce noise in the signal.

 Optionally or additionally, a spectral analysis of HR or HRV sequence, using a computational efficient Fast Fourier Transform (FFT) algorithm, is performed to calculate the spectrum.

 In some embodiments of the invention, HR(t) is displayed to the user, for
20 example as shown in Figure 7a. A graph of HR(t) may be useful for assessing the ability of the user to quickly adapt to changing circumstances, for example to regain a calm mood after an exciting stimulus.

 An additional method to analyze the data and extract breathing pattern is to perform autocorrelation on the HR(t). Autocorrelation, AC(k) may be defined as the
25 sum over a specific interval $j = \{t-K \text{ to } t\}$ of $HR(j) \cdot HR(j-k)$. In some embodiments of the invention, the autocorrelation function is displayed to the user to assist visualization of the breathing cycle as will be seen in Figure 7d. When breathing is steady, the autocorrelation function exhibits a deep wave pattern with a cycle's length equal to the breathing rate. The depth of the waves of the autocorrelation function is
30 indicative to the depth of the breathing. In contrast, when the user is in agitated state

- 31 -

mind, the breathing is unsteady and may be shallow, causing the autocorrelation function to flatten. The autocorrelation function may be used for calculating the Breathing Rate (BR), the Average Breathing Rate (ABR) and the Breathing Rate Variability (BRV).

5 The Exhalation to Inhalation Ratio (EIR) may be calculated from the graph of Figure 6a by measuring the Exhalation Duration (ED), the Inhale Duration (ID) and calculation $EIR = ED/ID$. Note that the breathing rate BR is given by $1/BD$ wherein the Breathing Duration $BD = ED + ID$. The values of EIR, BD, breathing depth and breathing stability may be assessed from the autocorrelation function, or from an FFT
10 analysis or using other input devices such as a mobile phone or mouse as described below.

Fig. 6b shows a typical FFT spectrum of the HRV. An average breathing rate (ABR) can be inferred from the peak at around 1/10 Hz corresponding to average breathing cycle of 10 seconds. Average breathing depth may be inferred from the
15 height of the peak and Variability in breathing rate from width of the peak.

By analyzing the FFT of the HR and analyzing the EDA over the same period, the balance of the sympathetic and parasympathetic nervous system can be analyzed.

Optionally or additionally, a conventional breathing sensor may be use to provide independent measurement of the breathing cycle. Optionally or additionally,
20 the user may be requested to provide independent measure of the breathing cycle. For example, the user may be asked to use an input device of the mobile monitor, for example an LPT, [define], mouse or keypad, cellular phone keypad, scratchpad of a PDA or any other input device. The user may provide an input at each breathing cycle or provide more information, for example by pressing the "up" key during inhalation
25 and the "down" during exhalation, thus providing information needed to calculate REI independently from the values inferred by HB analysis.

Alternatively or additionally, a microphone may be used as an input device to allow the user to speak an indication or the microphone is placed close to the user's airways to pick up noise caused by air currents during breathing. For example, a
30 headset microphone attached to a cellular phone may be used for sensing the user's

- 32 -

breathing. These methods are simple to implement, do not require a special respiration sensor, and provide important information and feedback to the user.

It was found that during relaxation, a breathing pattern is dominated by regular, slow, deep breathing. This pattern manifests itself by increased amplitude of the peak
5 60 in the curve of Fig 6b. At the same time, due to the increased depth of inhalation, and the stabilization of the breathing rate, the Variability in HR increases, causing the broadening of the peak HRV shown in Fig 6b.

Respiration guide bar

The system may present to the user a respiration guide using any one or more
10 of a graphic bar display, musical cues voice instructions, and/or vibration.. In the graphical bar display, the breathing bar length may vary, for example, in accordance with the user's respiration rate or the duration of the inspiratory or expiratory phase of the respiration cycle. The system can calculate the user's respiration rate and use it as a starting base line, and train him to improve the pace (increase the exhalation period)
15 according to the user's needs, for example, using predetermined instructions that can be overridden by the user or a coach. As another example, the breathing bar length may vary in accordance with the lung volume of the user, increasing in length as the user inhales and decreasing as he exhales. Using an autocorrelation method, the application may anticipate the breathing pattern based on recent berating history. By
20 displaying a delayed image of the breathing pattern, the user may train to slow down his breathing rate. Optionally, the training may be aimed at achieving a predetermined breathing rate goal. Similarly, the breathing depth, as determined by the HRV, may be indicted by the length of the breathing bar. Inspiratory and expiratory phases can easily be followed by the user observing the changing breathing bar. The speaker
25 may be used to give voice indications, encouragement and commands such as: "inhale", "hold breath" or "exhale". Alternatively, the breathing bar may change color according to the phase of the breathing cycle. Alternatively, another type of display, such as an expanding and contracting balloon may be displayed, where the size of the balloon represents the volume of the lungs. Optionally, the user may choose the
30 operation and display mode of the breathing bar.

- 33 -

Display screens

Figs. 7a, 7b, 7c and 7d show exemplary display modes according to different embodiments of the invention.

It should be noted that these exemplary display screens are shown for demonstration purposes as adopted to be viewed on a specific cellular phone. Other display means, for example a PDA, etc, and display designs may be created within the general scope of the current invention.

Fig. 7a shows an exemplary display on a screen 122 of a cellular phone used as mobile monitor 120. On the top of the display screen 122 is an icon driven phone menu 72 that allows the user to access other functions of the cellular phone. In this example, the menu comprises: "incoming call" icon 73a, "address book" icon 73b, "message" icon 73c and it may comprise of other icons. At the bottom of the display screen 122 is a phone status line 86 showing status indicators of the cellular phone, such as "battery level" 81a, "speaker on" 81b, "RF reception level indicator" 81c, etc. Generally, these top and bottom lines are part of the cellular phone system and are not involved with the operation of the mobile unit as physiological monitoring and training.

Some or all functions of the mobile unit, for example cellular phone 120, are available to the user during physiological monitoring. For example, the user may accept an incoming call on the cellular unit. Preferably, physiological data continue to be accepted and logged, to be processed and displayed later. Similarly, the user may access an address book or other information stored in memory of the mobile unit without interruption of physiological data logging.

In the case where the mobile unit 120 is a cellular phone, the data analysis and screen display may be created by an application loaded into the cellular phone memory and executed by the processor within the cellular phone.

The data logged on the mobile unit may be transmitted to a remote server for further analysis. For example data may be sent to via the cellular network using a data exchange protocol such as GSM, GPRS or 3G. Alternatively or additionally, data may

- 34 -

be transferred to a PC or a laptop computer using a cable such as USB cable, Bluetooth RF communication or Infrared (IR) communication.

Below the icon driven phone menu 72 is an application menu 85 that allows the user to access other functions and display modes of the current invention. For example, the user can choose specific tutorial or interactive training. The application menu 75 may allow control of the sensor's mode of operation, for example: starting and stopping data acquisition or data transfer, turning on or off a sensor, determining the sampling rate and accuracy, etc. The user may use the application menu 85 to choose the format of the displayed graphs and data.

The display screen 122 may display breathing bar 77. In the examples herein, breathing bar 77 is in the upper left, below the application menu 75. In the embodiment of Fig. 7a, the graph 80 shows the pulse signal 81 plotted vs. time on the horizontal axis, as measured for example by blood flow in the skin which is monitored by Heart Rate (HR) Electronics 320 within sensor module 210. Preferably, the graph is continuously updated and displays the data in real time. Alternatively, the graph is represents previously logged data.

In the embodiment of Fig. 7a, the graph 90 shows the EDA signal 91 plotted vs. time on the horizontal axis, as measured by the EDA electronics 330 within the sensor module 210. Preferably, the graph is continuously updated and displays the data in real time. Alternatively, said graph may display previously logged data.

The large main graph 50 shows instantaneous HR(t) 51 in units of heart-beats per second on the vertical axis plotted vs. time in minutes on the horizontal axis. Optionally the main graph 50 comprises a navigation icon 54 (shown here in "play" state) used to manipulate the display. For example, the user can "freeze" the display to closely examine a specific time frame. Similarly, the user can perform any or all of the commands "fast forward," "shift up", "shift down", "move back", "zoom in", "zoom out", "smooth" etc. Manipulations performed on the large graph 50 may also effect one or both of the graphs 80 and 90 so as to maintain the synchronization of all the graphs. Alternatively, some of the graphs may show real time data while another graph shows previously logged data.

- 35 -

Target or optimal range zone limits 52a and 52b are marked on the main graph 50 so that the user can easily compare his heart rate to a training goal. The target zone may be colored. For example a central green zone may indicate the goal values, while shades of yellow designate the target zone and shades of red indicate dangerously high or low values. The background color of one or some of the graph may be indicative of the state of mind of the user.

In the embodiment of Fig. 7a, the numerical data on the left 65a shows the instantaneous heart rate $HR(t)$. In this example, the value 61 beats per seconds may also be inferred from the last value of graph 51. Alternatively, numerical data on the left 65a may display the average heart rate over a predetermined time interval.

In the Embodiment of Fig. 7a, the numerical data on the right 65b shows the average heart rate variability as computed from the standard deviation of $HR(t)$ over a time window. Alternatively, numerical data on the right 65b may display data indicative of the difference between the minimum heart rate and maximum heart rate as depicted in Fig. 6a.

Fig. 7b shows another exemplary display on a screen 122 of a cellular phone used as mobile monitor. In this example, graph 90 shows HRV values 93 plotted vs. time on the horizontal axis instead of showing EDA data. The values 93 may be indicative of an autocorrelation function of the HRV.

Fig. 7c shows another exemplary display on a screen of a cellular phone used as mobile monitor. In this embodiment, graph 90 shows HRV values 93 while large graph 50 shows EDA data 91. A navigation icon 54 indicates that the data display is in a "pause" mode..

Fig. 7d shows yet another exemplary display on a screen of a cellular phone used as mobile monitor. In this embodiment, graph 80 shows pulse data 81, graph 90 shows data 51 and graph 50 shows HRVdata 93.

The exemplary screens depicted in Figs. 7a to 7d may be used by a user to assess his physiological state and as a biofeedback device to modify his condition and reactions to daily events. The mobile monitor may be used to display "real-time"

- 36 -

parameters calculated from data recently acquired or may be used to replay a sequence of parameters previously acquired and stored. The date and time at which the data were acquired may be stored and associated with the stored data and is optionally displayed too.

5 The display screens may be flexibly designed to fit the size and type of display of the mobile monitor. Different combinations of signals and parameters may be displayed in various ways such as graphs, colors, pie charts, numerical values, bars, clock-like indicators, alert signals, alphanumeric messages, etc. Static or moving animations may also be displayed according to the interpretation of the physiological data. For example, a happy "*smiley face*" may be displayed when the state of the user is relaxed and sad face when the user is in a state of anxiety. The speed of the motion of the animation may be correlated with vital parameters such as HR or BR. A pulsing heart or breathing lungs may be displayed and animated to follow the cycles of the user. Music and musical tones may also be used as indicators, for example the pitch or intensity may be correlated with HR and BR and the user may train to achieve and maintain low quiet sound.

Training session

Because the EDA sensor as described herein is sensitive to changes in the arousal level of the user, it is possible to calculate several types of scores that reflect changes in the user's responses to different stimuli, including subconscious responses. The stimulus can be, for example, a question, a picture, music, a smell, or multimedia clips such as a short video. The stimulus can be presented/asked by another person or by prerecorded information on the mobile monitor or computer. It can be a message transmitted to the user such as text message or multimedia message on the mobile phone or TV clip or any other stimulus that can affect the user's response consciously or sub-consciously. The system monitors the user's physiology before, during and after the stimulus, and may calculate any one or more of the following parameters: EDA scores, heart scores and state of mind scores.

Fig. 8 shows an EDA graph as an example of a stress response of a user to such a stimulus. From these responses the system can calculate the following

- 37 -

scores:the stimulus (trigger) time, the latency (response time) until the EDA changed, the time to maximum conductivity, the absolute and relative changes in the amplitude before the stimulus (baseline), during the stimulus, and the new base line after a predetermined time following the stimulus, the half recovery time, the full recovery
5 time; the variance and standard deviation of the EDA calculated periodically (such as every one tenth of a second) before during and after the stimulus; calculating a similar parameter based on the variance of the EDA- including the standard deviation and/or variance of the variance of the EDA, and latency, maximum of the variance, half recovery time of the variance, and recovery time of the variance.

10 Trying these scores with many users, it was found that this system can be effective in finding which number a person has chosen or if he is or is not telling the truth, and detecting other information that the user tried to hide. For example, users were asked to choose a number. The mobile phone presents a randomly chosen number, and calculates the parameters described above. The user is instructed to say
15 no to all the numbers. But the system can detect the number that the user had chosen by finding the number with the maximum standard deviation of the variance of the EDA after presenting the chosen number.

In a similar way the system also calculated changes in the pulse, heart rate and heart rate variability of the user during a specific time interval or as a response to a
20 stimulus (heart scores).

In the exemplary embodiment of the invention, the system can monitor and calculate both EDA scores and pulse scores, and present to at least one user a multimedia audio-visual response on the mobile monitor. Therefore it is possible to present different audiovisual clips which represent different moods. The system can
25 also record the user's subjective responses (degree of fear or joy) and calculate the EDA scores and the heart scores simultaneously. This can be used for research, for therapy, for assessment, and for fun. Using these methods it is possible to map at least two dimensions of a user's state of mind; one dimension is arousal or relaxation, and the second dimension is positive or negative – does the user enjoy this state or dislike

- 38 -

it. Fig. 4 shows a two-dimensional array of states of mind. The present invention can be used to map an individual's state of mind in the two-dimensional array.

An additional aspect of the present invention is integration of Computerized Cognitive Behavioral Therapy (CCBT) together with the system of the invention (the sensors, algorithms as described). Several systems have been developed for computerized psychological methods known as CBT. For example, in a Doctorate thesis in Clinical Psychology August 2002, Kings College London UK Dr. Gili Orbach presented a Computerized Cognitive Behavior Therapy (CCBT) program. This is a method and clinical process to train students using a multimedia interactive program over the internet to reduce anxiety, and improve self confidence and results in exams. The CCBT programs can educate the users, explain to them about their thought mistakes, provide them with behavioral advice, etc. By integrating together CCBT, visualization, self hypnosis, and the present invention, including sensors and methods to monitor responses, and interactive multimedia feedback to train them to change their responses, a method and system are created, that can train users to modify their behavioral responses, know themselves better, help them to overcome habits and change themselves in their preferred direction.

Possible uses

When the system of the present invention may be equipped with programmable data processing power and flexible output means, numerous applications and uses may be adopted and used, optionally simultaneously and in combinations. A few exemplary applications will be described below.

Alerts

The system may be programmed to alert the user or someone else when certain conditions occur. Conditions may be assessed, and an alert initiated by any or few of: processor 340 in the sensor module, in the mobile monitor 120, in the server 140 or by the human expert 150.

The system of the invention may generate an alert under predetermined conditions. Heart and breathing alerts may be life saving for patients at risk of heart attack, epilepsy, old or incapacitated people, people with mental disability etc. ^A

- 39 -

may be indicated by any or few of: indicator 380, display 120 and speaker 126. Alternatively or additionally, alerts may be relayed to other locations by any or few of: mobile monitor 120, server 140 or by the human expert 150. For example a medical, law enforcement or rescue team may be informed if the system detects possible behavior abnormality. Data supporting the assessment may be relayed in association with the alert. If it exists, data on identity, health condition such as medical records, and location of the user, for example a GPS reading of the mobile monitor, may also be transferred. Conditions for generating an alert may be related to heart rate for example: HR below or above a predetermined value, abnormal HRV for example HRV below or above a predetermined value or rapidly changing, or indication for arrhythmia. Conditions for alerts may be related to breathing for example: any or more of: HR, BR or ERI below or above a predetermined value, abnormal BR for example BR rapidly changing. Conditions for generating an alert may be related to stress for example: EDA below or above a predetermined value or rapidly changing. Conditions for generating an alert may be related to a combination of signals from multiple sensors.

Training for improving quality of life

The system of the invention may be used for training aimed at modifying his condition. For example, the user may observe his physiological signs and optionally or alternatively the interpretation of these signs to modify his behavior to avoid negative emotions depicted on the right side of Fig. 4. Additionally, the user may train to achieve, strengthen or maintain concentration and enthusiasm depicted in the upper-left quadrant of Fig. 4 by modifying his behavior. Or, the user may train to achieve, strengthen or maintain a state of relaxation as depicted in the lower-left quadrant of Fig. 4.

It has been shown that people are able to achieve these goals by using biofeedback, even though they are not fully aware how they control their emotional and physical states, and thus gain control over involuntarily body activities such as blood pressure, hormone secretion etc. The system of the invention may also be used for training voluntary activity. , For example a user may train to breath at a steady

- 40 -

slow rate optionally achieving deep breathing with low ERI. This type of breathing is known to promote relaxation.

According to another embodiment of the invention, a user known to suffer from episodes of anger or anxiety may use the system in his daily routine. The system may be used to detect early signs of an approaching attack and prompt the user to take
5 measures to mitigate the situation either by taking medication or by mental or physical exercises such as taking deep breaths or by stopping his current activity. A silent alert such as vibration or a concealed alert such as Short Message Service SMS or a "fake" call to a cellular phone may serve to distract the user from the harmful path that may
10 lead to aggressive or an anxiety attack. People suffering from various phobias may also benefit from an alert generated when a stimulus eliciting the phobia is approaching.

When the breathing cycle is followed by both HRV analysis and another means such as breathing sensor or user input, the correlation between HRV and actual
15 breathing cycle may be monitored and the user may train to achieve better synchronization between the two. Generally, inhaling induces sympathetic system response causing arousal and increase of HR while exhaling induces the parasympathetic system response causing relaxation and decrease of HR. Thus, learning to control breathing, an art that currently requires years of studying,
20 meditation or Yoga, may be achieved using the present invention.

According to another embodiment of the invention, the system may be used to record the physical and mental state of the user during his daily routine and correlate its readings to the type of activities performed. For example, times of high stress, high concentration, best performance, or high pleasure may be timed and displayed. The
25 user may compare these times with the activities performed that date, for example, by referring to his diary records. Sensor readings may be integrated with diary records automatically, for example by integrating the software with commercial applications such as Microsoft Outlook®, and displayed on a mobile monitor such as a PDA or LPC.

- 41 -

Additionally or alternatively, the user may use input means on the mobile monitor to input memorandums such as voice or written messages indicating the type of activity he is performing, and his subjective feelings which will be integrated into the log of daily activity and sensor readings. In this way, the user may compare his activities and his subjective feelings to the objective sensor reading. Knowing the activities that induce stress, the user may prepare himself for future repetitions of the same or similar activities, or attempt to avoid them.

According to another embodiment of the invention, the system may be used to record physiological readings during sports training. In contrast to available devices that display only moving AHR, the system of the invention is capable of recording and storing virtually a record of each individual heartbeat and breath. Data compression, large memory capacity in the mobile monitor and mass storage in the remote server enable acquiring and storing these records over long periods of use. Because the sensors are small and transmit the data wirelessly –either using the Bluetooth protocol or the mobile network communication services- an expert coach can view and monitor the physiological parameters, the emotional- arousal states and the performance of the athlete , and coach him in real time to improve his reactions and performance. The data can be also saved for analysis later on. An athlete can also rehearse at his home or office using the invention, with either a multimedia mobile phone or PC or PDA (personal digital device) while he is viewing his performance, and simulating his emotional and physiological conditions, as in a real competition. By using several of the sensors simultaneously (e.g. heart rate, HRV, breathing, EDA EMG), the user learns to tune not only his physiology but also his attitude, arousal level etc, and to achieve his best performance.

According to another embodiment of the invention, the system may be used to record physiological reading while the user is sleeping in order to help identify and possibly correct sleep disorders.

Wearable Biofeedback Tools:

- 42 -

Biofeedback has been in use for many years to alleviate and change an individual's negative behavior patterns but existing systems have a number of significant drawbacks:

1. Hardware, software and information gathering:

- 5
- Most current systems are reliant upon powerful computers
 - They require users to be trained either by health professionals or complex on-line programmers;
 - Once users have been trained they must remember to implement the internal physiological changes in their daily lives;

10

 - The biofeedback sessions are rarely undertaken on a daily basis and not in real time. This requires the user to remember specific events that occurred days before and recall his exact emotional responses.

This invention utilizes portable,, cordless wearable sensors, which enable users to monitor their emotional and physiological responses to events as they occur. These results, gathered in real time, may be more effective and relevant to the user than those
15 recreated days later under completely different conditions. The sensors of the invention utilize mobile phones to display the user's physiology and emotional state.

2. Methodology:

The current method is to train users to modify the underlying physiology
20 related to negative behavior patterns for example,. to reduce muscular tension (EMG), GSR, or electro-dermal activity (EDA) –the main purpose of which is to train users to relax. However, although it is important to train users to relax, two other aspects must also be taken into account for successful treatment:

- Enhancement of emotional health and training to be more positive,
25 enthusiastic and motivated. These states are not reflected in relaxation levels as measured by GSR, EDA or EMG which can give false impressions. For example, a user may display increased physical tension when experiencing positive emotions such as excitement or enthusiasm. Similarly, low levels of physical tension may not necessarily be a positive thing and could represent negative states such as
30 depression or boredom. One example was use of EDA for people suffering :

- 43 -

IBS (irritable bowel syndrome). EDA was found to be very useful for people with high anxiety suffering from diarrhea, but not for depressed people suffered from constipation.

By utilizing two sensors simultaneously, a sensitive EDA sensor and a heart rate monitor for HRV, and by analyzing the changes in specific situations, the system of the invention may be used to monitor and train users not only to relax but also to develop a positive state of mind.

Objective Emotional Monitor:

Another application of the present invention is to monitor emotional reactions by using an objective scale. Although EDA is very sensitive there are disadvantages in monitoring and analyzing emotional reactions using this method:

- EDA levels change between sessions and individuals because of many variables unrelated to a user's emotional state. Therefore EDA levels can only be interpreted as a trend. That is, the user is becoming more relaxed if his skin resistance is increasing above the level when the session began. But the user cannot learn in an objective way how to control his reactions and improve his physiology and performance. The sensor of the invention allows monitoring and real time presentation of changes related to thought and emotion and calculation of parameters that reflect how the user is responding to specific trigger events. By integrating the analysis of the change in the EDA and the Heart Rate and heart rate variability in real-time a scale can be created to enable the user to learn how to improve and monitor his reactions.

Figure 8 shows response to a stimulus (such as PTSD, bullying , phobia). The parameters relating to the response include the amount of time it takes for the user to return to the base line after the stimulus, the amount of time it takes to return to baseline plus half arousal jump, the level of the arousal jump related to specific triggers. By using a mobile sensor, the user can continually monitor and improve his reactions and performance. By adding multimedia instructions the system can be a real

- 44 -

time coach for the user. By transmitting the data in real time using a mobile phone user will be able:

- o To get feedback from a sophisticated expert system on a server almost in real time.
- 5 o to record their reactions to specific situations during the day
- o To receive advice from an expert who can monitor their reaction almost in real time.
- o to modify their reaction and implement this new
- 10 knowledge in their daily behavior while an expert (system or professional caregiver) monitors them.

Integrating CBT and a wearable bio interactive sensor

Existing biofeedback systems use behavioral methods but do not include CBT (Cognitive Behavioral Therapy) training. The system of the invention may integrate

15 computerized CBT, visualization with interactive sensors allowing users to learn not only how to change their physiology but also modify their way of thinking and address negative thought patterns.

New Methods of integrated CEBIT (Cognitive Emotional Behavioral Interactive Therapy). Training utilizing an integrated sensor of the invention allows a

20 user to examine his belief system, his behavior, his unconscious thought processes, emotional and cognitive reactions, and his physiology. It also trains the user to monitor himself, to be aware, listen to his body, his emotions, and his external reactions.

Performance improvement- by using the methods and systems of the invention,

25 and by monitoring their progress, users can learn not only how to modify their health and feel better but also to improve their performance: e.g. exam anxiety, trading, music and singing, sports, relationships, creativity, public speaking etc. The interactive physiology monitoring of the invention can be combined with CBT, and with realtime feedback from the user's performance, to train the user to achieve a

30 predetermined state. This can be applied also to relationships and to happiness lev

- 45 -

Survey and poles

According to another application of the invention, the system may be used to record reactions of viewers to commercials in order to conduct viewer surveys.

Training session

5 Yet another aspect of the invention is to train a user by conducting a training session involving exposing the user to stress inducing stimuli.

Fig. 8 shows a schematic chart of the stress level of a user following a stimulus. The stimulus may be, for example, a phobia caused by an image, for example a picture
10 of a spider to a user suffers from arachnophobia, a disturbing voice message or written phrase. Stress induced by the stimuli may be measured by EDA reading, HR, or a combination of few sensors readings.

In Fig. 8,, the stimulus is given at time ST. At time LT, stress level starts to rise from the Initial Baseline Stress (IBS) after a short latency period in which the user's
15 brain interprets the stimulus. Usually the stress climbs and reaches its Maximum Stress (MS) level at Maximum Reaction Time (MRT), then recovers slowly to the IBS or to a New Baseline Stress (NBS).

Recovery Time (RT) may be defined as the time it takes for the stress level to decrease from MS level to the Half maximum Stress (HS) at the Half Recovery Time
20 (HRT), i.e. $RT = HRT - MRT$, where HS is defined as: $HS = (IBS + MS)/2$. In a training session, the user observes his reactions and learns to minimize one or more of MS, RT and NBS.

A training session may consist of analyzing HR, HRV and changes in EDA using several methods such as neural network software and or wavelet analysis, while
25 presenting to the user specific positive and negative triggers. For example images, video or audio clips. Scenes such as of an accident may be used as negative triggers; while relaxing triggers may be nature scenes. Training may be in a form of interactive games in which the user can win and feel positive; frustrating games or challenges in which the user loses and feels stressed; sexual clips etc;

- 46 -

A "*User psycho-physiological responses profile*" (UPPP) may be created and stored. Using this UPPP, the system can monitor and analyze the user response and state of mind to both real life events (e.g. a meeting with someone, preparing for an exam, receiving a phone call, etc), and or interactive questionnaires, simulation of specific scenarios, etc. These methods can be used for several purposes: to assess the user responses and/or to train the user to improve his responses to specific triggers (such as overcoming a phobia). The system can use the UPPP to drive games and multimedia using the sensors and the user's emotional reaction to drive and navigate the games.

The term "*user*" should be interpreted as encompassing both a male and a female individual, and also to a group of individuals. When there are several users, each one can be monitored with his sensors, or some of them can share sensors, they can either use the same display (for example connected with Bluetooth to the same PC or mobile phone) or each one can have a separate device with their devices configured to communicate with each other. It can also include a plurality users connected through mobile phones or Internet to a center or TV station, watching and sharing one or more images which are transmitted either as broadcast or internet etc to all the users or some of them. In this mode the invention can be used as a new real-time TV show game, or emotional poll, etc.

Entertainment system: Mind Activated Games for Interactive Communication

According to another aspect of the invention, the system may be used for entertainment by providing games and other forms of entertainment.

For example, a person may use the sensor module during a phone conversation or Internet chat with peers. The sensor readings may automatically send SMS or pictorial symbols indicating the user's state of mind and his reactions to the conversation. This can be a basis for emotional based games and communication between a group of users of mobile phones and/or internet and or TV games.

In another example, sensor readings may be used to control devices and appliances such as a DVD or compute, for example, during computer games.

- 47 -

sensor can be added to a remote control, and the content presented to the users can be changed and unfold according to the state of mind of the users who are monitored by the sensors. This can be a basis for a new interactive DVD (or any alternative direct access digital media), for interactive movies, interactive sport, or interactive games, or psychological profiling.

Fig. 12 depicts an entertainment system **1200** according to one embodiment of this aspect of the invention. In the system **1200**, a sensor **1210** is in contact with a user **1201** and is used for monitoring the user's physiological parameters. The Sensor **1210** is in communication with an entertainment system controller **1220**, such as a remote control of a DVD or video game device, through communication link **1212**. Communication link **1212** may be unidirectional or bi-directional. The entertainment system controller **1220** comprises a transmitter **1226** for transmitting commands to the entertainment system **1240** using communication link **1228**. Link **1228** may be unidirectional, for example, IR communication. Optionally, the system controller **1220** comprises of an input means such as keypad **1224**. The sensor **1210** may directly communicate with the entertainment system, and a cable may be used for communicating physiological information or commands.

In accordance with this aspect of the invention, at least one parameter reflecting a state of mind and or body of the players/users is obtained by monitoring one or more parameters indicative of their physiological or psycho-physiological reactions/conditions. The one or more parameters are transmitted to a system that analyses the parameters and calculates one or more scores and uses the calculated scores as input for a process in which audiovisual material (audio and/or visual) is displayed on a screen and/or a physical object (such as remote controlled car) is moved. The content of the audiovisual material, and/or some of the parameters of the movement (e.g. the speed or direction of movement of the remote controlled car) depend on the scores reflecting the state of the user's mind and or body.

The scores, or some information which reflect results of changes in the state of mind and or body of the user or users may be presented directly or indirectly either to the same user / player that is being monitored by the sensor or to another user / player

- 48 -

or to both of them. The users may use information relating to either their own scores / results or the other players' scores / results in order to win or change their reactions / decisions or to guess the other user's feelings or thoughts, or to influence the other user's reactions, or the results of the games / interactive story/ remote controlled toy.

5 Examples of games:

Battleship (submarines). In this a familiar game, two players try to guess and find the location of the opponent player's submarines/ships and "destroy" them, (for example in a 10 by ten array of positions). The present invention may be used to add a new aspect to the game. Before user A
10 "shoots" a torpedo to a specific location (the location "b-4", for example) he can ask the other player 3 questions (e.g. by words or by moving a mouse to specific locations but not clicking it). The questions may be, for example "Do you have submarine in location b-2 or b-4 or c-4?". The user A can see the reaction of the other player as reflected in one of his scores. The other
15 user can respond yes or not and can even lie (high arousal- high bar). User A can use this information to assess where there is a submarine. Thus, a psychological and "mind reading" dimension is added to a game.

a) A group of users, such as teenagers, with mobile phones can send
20 multimedia messages to each other and view pictures and/or a short video of each other. Using this invention we add an emotional dimension to the communication as follows. The scores of the emotional and/or state of mind reaction are also transmitted to the other users, and these scores are used as a basis for games and interactive communication, such as a truth or dare game. The reaction (emotional scores) of a user is transmitted to one or
25 more other users. For example, the scores may be sent to a first user that was the most "aroused" when he or she saw the picture and/or read an MMS message from a particular second user. The first user then has to send a text message to the second user revealing what the first user feels about the second user. While the first user does this, the first user's arousal level can
30 be watched by the second user and/or other users. Thus, either the "system"

- 49 -

and or other users and/or the first user can see if the first user "loves" the second user. In a simple version of this game, a user can see 10 pictures on the screen of his mobile phone or PC or game console and the system can tell him, for example, who he loves, which number he has chosen, or which
5 card he has chosen.

b) Interactive "Tamaguchi" (an electronic pet or animation of a person which the user has to "love" and take care). By incorporating the features of the present invention to this toy, each time that the user is angry
10 and/or anxious, as indicated by the scores obtained from the results monitored by the sensors, the Tamaguchi can feel it and react, be sad, angry, or ill, etc. When the user is calm, relaxed and happy, the Tamaguchi reacts in a positive way, e.g. by smiling, singing, playing, eating etc.

c) In a more advanced version, a user can create a symbolic
15 animated version of himself (a "virtual me" or "Vime") in a mobile phone, PC or game consol. The user and/or other individuals (that have received permission/authority to interact with the user's virtual personality), can interact with this "Virtual me" using a mobile communication device or Internet. An individual may play with the user's virtual personality, for
20 example, by sending the Vime positive and/or negative messages such as that the individual loves the Vime. The "conscious" message is transmitted together with the individual's State of Mind/emotional score and influences the "virtual me". This can be used as games and entertainment but also as adding an emotional dimension and new way of communication and
25 playing, and even virtual "dating".

d) Behavioral skills may be added to the version of the game presented in c) such as how to react and with whom. This can create a psychological/emotional/communication game/community creation. For
30 example, real or imaginary qualities can be added to the Vime and descriptions (physical dimensions, hobbies, area of interest etc); behavioral

- 50 -

rules (*"if a girl with predetermined characteristics and predetermined scores contacts me then send a predetermined response"*). The Vime can have several modes such as a *"live"* mode in which the user is connected, an *"offline"* mode in which the Vime can communicate without the user, a
5 *"receive only"* mode, or a *"sleep"* mode.

e) In another application, the sensors are used as amplifiers of subconscious intuition responses, for example to provide real or fun decision advice. While the user is connected to the sensors, he asks questions and/or is asked questions by the phone, PC or DVD. By watching
10 his scores when he thinks and answers a specific question he can see what his *"intuition"* advises him to do. The system may train the user to tune himself to make a better decision by integration of his or her physiological and psychological states, together with other methods such as logical analysis, systematic planning, scoring etc. (i.e. *"to use his heart and his
15 brain"* together, or to use his analytical mind with his intuition, to combine his *"gut feelings"* with *"objective information"*).

While the invention has been described with reference to certain exemplary embodiments, various modifications will be readily apparent to and may be readily accomplished by persons skilled in the art without departing from the spirit and scope
20 of the above teachings.

It should be understood that features and/or steps described with respect to one embodiment may be used with other embodiments and that not all embodiments of the invention have all of the features and/or steps shown in a particular figure or described with respect to one of the embodiments. Variations of embodiments described will
25 occur to persons of the art.

It is noted that some of the above described embodiments may describe the best mode contemplated by the inventors and therefore include structure, acts or details of structures and acts that may not be essential to the invention and which are described as examples. Structure and acts described herein are replaceable by equivalents which
30 perform the same function, even if the structure or acts are different, as known in

- 51 -

art. Therefore, the scope of the invention is limited only by the elements and limitations as used in the claims. The terms "*comprise*", "*include*" and their conjugates as used herein mean "*include but are not necessarily limited to*".

- 52 -

CLAIMS:

1. A system for monitoring one or more physiological parameters of a user comprising:
 - (a) one or more wearable sensor modules sensing the one or more
5 physiological parameters;
 - (b) one or more transmitters wirelessly transmitting first signals indicative of values of the one or more physiological parameters to a mobile monitor; and
 - (c) the mobile monitor, wherein the mobile monitor comprises:
 - 10 a first processor processing the first signals received from the transmitter in real time using expert knowledge; and
 - a device providing one or more indications of results of the processing.
2. The system according to Claim 1 further comprising a remote server capable of
15 communication with said mobile monitor, the remote server receiving second signals from the mobile monitor, the remote server associated with a viewing station having a second processor, the remote server being configured to perform at least one of the following:
 - (a) transmitting the second signals to a viewing station for analysis, the
20 analysis ;
 - (b) accessing historical data relating to the subject;
 - (c) transmitting the historical data to the viewing station;
 - (d) receiving from the viewing station results of the analysis;
 - (e) transmitting the results of the analysis to the mobile unit; the analysis
25 being based upon the second signals, and one or more of the historical data, expert knowledge and computerised protocols.
3. The system according to Claim 1 wherein at least one sensor module comprises at least one sensor selected from the group comprising:
 - (a) An electro dermal activity sensor;
 - 30 (b) An electrocardiogram sensor;

- 53 -

- (c) A plethysmograph; and
 - (d) A piezoelectric sensor.
4. The system according to Claim 1 comprising at least two sensors selected from a group comprising:
- 5 (a) an electro dermal activity sensor;
- (b) an electrocardiogram sensor;
- (c) a plethysmograph; and
- (d) a respiration sensor.
5. The system according to Claim 1 wherein the first signals are transmitted from a sensor module to the mobile monitor by any one or more of the following protocols:
- 10 (a) Bluetooth;
- (b) WiFi; and
- (c) Wireless Lan;
- 15 6. The system according to Claim 1 wherein said mobile monitor is selected from the group comprising:
- (a) a cellular phone;
- (b) a personal digital assistant (PDA);
- (c) a pocket PC;
- 20 (d) a mobile audio digital player;
- (e) an iPod,
- (f) an electronic note-book;
- (g) a personal laptop computer;
- (h) a DVD player;
- 25 (i) a hand held video game with wireless communication; and
- (j) mobile TV.
7. The system according to Claim 6 wherein the mobile unit is a cellular telephone and communication between the mobile monitor and the remote server is over a cellular communication network.

- 54 -

8. The system according to Claim 1 wherein the mobile unit includes any one or more of a visual display, one or more speakers, a headphone, and a virtual reality headset.
9. A wearable sensor module for use in the system according to Claim 1.
- 5 10. The wearable sensor module according to Claim 9 comprising at least one sensor selected from the group comprising:
- (a) An electro dermal activity sensor;
 - (b) An electrocardiogram sensor;
 - (c) A plethysmograph; and
 - 10 (d) A pizomagnetic sensor.
11. The wearable sensor module according to Claim 10 comprising at least two sensors selected from a group comprising:
- (a) an electro dermal activity sensor;
 - (b) an electrocardiogram sensor;
 - 15 (c) a plethysmograph; and
 - (d) a respiration sensor.
12. The wearable sensor module according to Claim 10 comprising a transmitter transmitting signals by any one or more of the following protocols:
- (a) Bluetooth;
 - 20 (b) WiFi; and
 - (c) Wireless Lan;
13. The wearable sensor unit according to Claim 10 or 11 comprising an electro dermal activity sensor adapted to monitor skin conductivities using at least a 16 bit A to D conversion without the need of manual calibration.
- 25 14. The sensor module according to Claim 10 or 11 comprising an EDA sensor comprising:
- (a) at least two electrodes adapted to be applied to a skin surface;
 - (b) electronic circuitry for measuring a skin resistance across the electrodes and calculating an EDA based upon the resistance using

- 55 -

an algorithm in which the EDA does not depend linearly on the resistance.

15. The sensor module according to Claim 10 or 11 comprising a blood flow sensor comprising:

- 5
- (a) a light source adapted to emit light towards a skin surface;
 - (b) a light detector adapted to detecting light reflected from the skin surface;
 - (c) electronic circuitry for measuring an intensity of the reflected light and controlling an intensity of said light source based upon the
- 10 intensity of the reflected light.

16. The sensor module according to Claim 14, wherein the electronic circuitry capable of measuring skin resistance across the electrodes over a range of at least from 50 K Ohm to 12 M Ohm.

17. The system according to Claim 1 wherein the first processor is configured to calculated from the first signals one or both of a parameter indicative of an arousal state of the user and a parameter indicative of an emotional state of the user.

15

18. The system according to Claim 14 wherein calculation of the parameter indicative of an arousal state of the user includes calculating a score of a sympathetic and parasympathetic activity of the user using an algorithm based on any one or more of the user's Electro Dermal activity, Heart Rate, EDA variability, and HR variability.

20

19. The system according to Claim 14 wherein the first processor is configured to calculate a parameter indicative of an arousal state of the user to display the parameter indicative of an arousal state of the user on a display associated with the mobile unit as a two -dimensional vector.

25

20. The system according to Claim 1 wherein the first processor is configured to display on a display associated with the mobile monitor any one or more of the following images: an image indicative of bio-feedback information relating to the user; an image indicative of breathing activity of the user, an ir

30

- 56 -

5 including a graph indicative of an EDA activity of the user, an image including a graph indicative of a heart rate of the user, an image including a graph indicative of a heart rate variability of the user; an image including a graph indicative of an autocorrelation of a heart rate variability of the user; and an image indicative of recommendation to improve the user's psycho-physiological state based on one or both of the user's physiological data and experts' knowledge.

21. The system according to Claim 17 wherein an image indicative of breathing activity includes a bar having a length indicative of the breathing activity.
- 10 22. The system according to Claim 17 wherein an image indicative of bio-feedback information relating to the user includes one or more parameter target values.
23. The system according to Claim 1 wherein the first processor is configured to calculate in a calculation based upon the first signals any one or more of the following: a breathing rate of the user; and a heart rate variability of the user.
- 15 24. A system according to Claims 23 wherein the user's rate of breathing is calculated and analysis by monitoring changes in the electrical capacitance of the body while the user is breathing.
25. A method for monitoring one or more physiological parameters of a user comprising:
- 20 (a) obtaining values of the physiological parameters of the user from one or more wearable sensor modules;
- (b) wirelessly transmitting first signals indicative of values of the one or more physiological parameters to a mobile monitor; and
- (c) processing the first signals received from the transmitter in real time using expert knowledge; and
- 25 (d) providing one or more indications of results of the processing to the mobile unit.
26. The method according to Claim 25 wherein the results of the processing includes bio-feedback information of the user.

- 57 -

27. The method according to Claim 25 further comprising transmitting second signals from the mobile monitor to a remote server having an associated viewing station and providing an analysis of the second signals at the viewing station.
- 5 28. The method according to Claim 27 wherein the viewing station includes one or both of a remote call center and an interactive expert system.
29. The method according to Claim 25 wherein the processing includes calculating one or both of a parameter indicative of an arousal state and a parameter indicative of an emotional state of the user.
- 10 30. The method according to Claim 29 wherein calculating a parameter indicative of an emotional state of the user is based upon one or both of a sympathetic activity and parasympathetic activity of the user.
31. The method according to claim 30 wherein calculating a parameter indicative of an emotional state of the user is based upon any one or more of an electro dermal activity, a heart rate, an electro dermal activity variability and a heart rate variability.
- 15 32. The method according to Claim 29 further comprising the step of displaying on a display associated with the mobile unit one or both of an image indicative of a parameter indicative of an arousal state of the user; and an image indicative of a parameter indicative of emotional state of the user.
- 20 33. The method according to Claims 32 wherein an image includes one or both of a two-dimensional vector and a color indicative of a parameter.
34. The method according to Claim 25 for use in obtaining respiration information selected from the group comprising duration of the inspiratory phase, and duration of the expiratory phase.
- 25 35. A method according to Claim 34 wherein respiratory information is obtained from audio sounds produced during breathing or speaking.

- 58 -

36. The method according to Claim 34 wherein respiratory information is obtained by the user indicating the beginning of one or more inspiratory phases and the beginning of one or more expiratory phases of the user's breathing.
37. The method according to Claim 34 wherein a breathing rate of the user is calculated based upon a heart rate variability of the user.
38. The method according to Claim 34 wherein the user's rate of breathing is calculated based upon changes in an electrical skin capacitance of the user while the user is breathing.
39. The method according to Claim 34 further comprising training the user to increase any one or more of the followings: a duration of the inspiratory phase, a duration of the expiratory phase, and the ratio of the duration of the inspiratory phase to the duration of the expiratory phase.
40. The method according to Claim 26, further comprising displaying on a display associated with the mobile monitor an image indicative of bio-feedback information, wherein the image includes any one or more of the following: an image indicative of breathing activity, an image including a graph indicative of EDA activity, an image including a graph indicative of heart rate, an image including a graph indicative of heart rate variability and an image including a graph indicative of an autocorrelation of heart rate variability.
41. The method according to Claim 27 wherein the analysis of the second signals includes a recommendation for the user to improve a psycho physiological state of the user.
42. The method according to Claim 41 further comprising displaying the recommendation on a display associated with the mobile unit.
43. The method according to Claim 26 comprising displaying a target value for one or more of the one or more obtained physiological parameters.
44. The method according to Claim 26 comprising displaying on a display associated with the mobile unit a target value for one or more of the one or more obtained physiological parameters.
45. The method according to Claim 26 comprising steps of:

- 59 -

- (a) challenging the user with one or more stimuli;
 - (b) monitoring one or more reactions of the user to said one or more stimuli;
 - (c) calculating, in a calculation based upon the one or more reactions, at least one parameter selected from the group of: latency time of a reaction, maximum reaction time, half recovery time, maximum stress, and new baseline stress; and
 - (d) providing feedback to the user based on one or more of the calculated parameters.
- 5
- 10 **46.** The method according to Claim 25 for use in a method of self behaviour modification comprising any one or more of the methods selected from the group comprising:
- (a) cognitive behavioural therapy (CBT);
 - (b) visualisation;
 - (c) self hypnosis;
 - (d) auto suggestion;
 - (e) mindfulness;
 - (f) meditation;
 - (g) emotional intelligence skills;
 - (h) psychological counselling provided over a communications network.
- 15
- 20 **47.** The method according to Claim 46 further comprising:
- (a) providing the user with an interactive introduction about a specific condition of the user;
 - (b) providing the user interactive questionnaires for self assessment; and
 - (c) providing the user with one or more interactive sessions selected from the group comprising:
 - an interactive session for self training to implement cognitive techniques;
 - interactive sessions for self training to implement behavioural therapy;
 - interactive sessions for self hypnosis;
- 25
- 30

- 60 -

interactive sessions for visualisation;
interactive sessions for auto suggestions;
interactive training to acquire and implement life and interpersonal
relational skills;
5 interactive training to improve emotional intelligence skills;
interactive training to find purposes and goals; and
interactive training to plan steps in life.

48. The method according to Claim 47 wherein the user is provided with one or
more interactive sessions while the user is in a deep relaxation state.

10 49. The system according to Claim 1 further comprising an entertainment system
and wherein the first processor is configured to determine at least one
command based on the first signals and transmitting the at least one command
based to the entertainment system; and wherein the entertainment system
comprises a third processor configured to perform an action based upon the one
15 or more commands.

50. The system according to Claim 49 wherein the action comprises any one or
more of generating an SMS message, controlling a DVD, controlling a
computer game, and controlling a "Tamaguchi" animation.

20 51. The system according to Claim 49 wherein the action comprises processing a
user reaction to any one or more of the following: a displayed animated image;
a video clip, an audio clip, a multimedia presentation, real-time communication
with another human, a question that the user has to answer, and a task that the
has to perform.

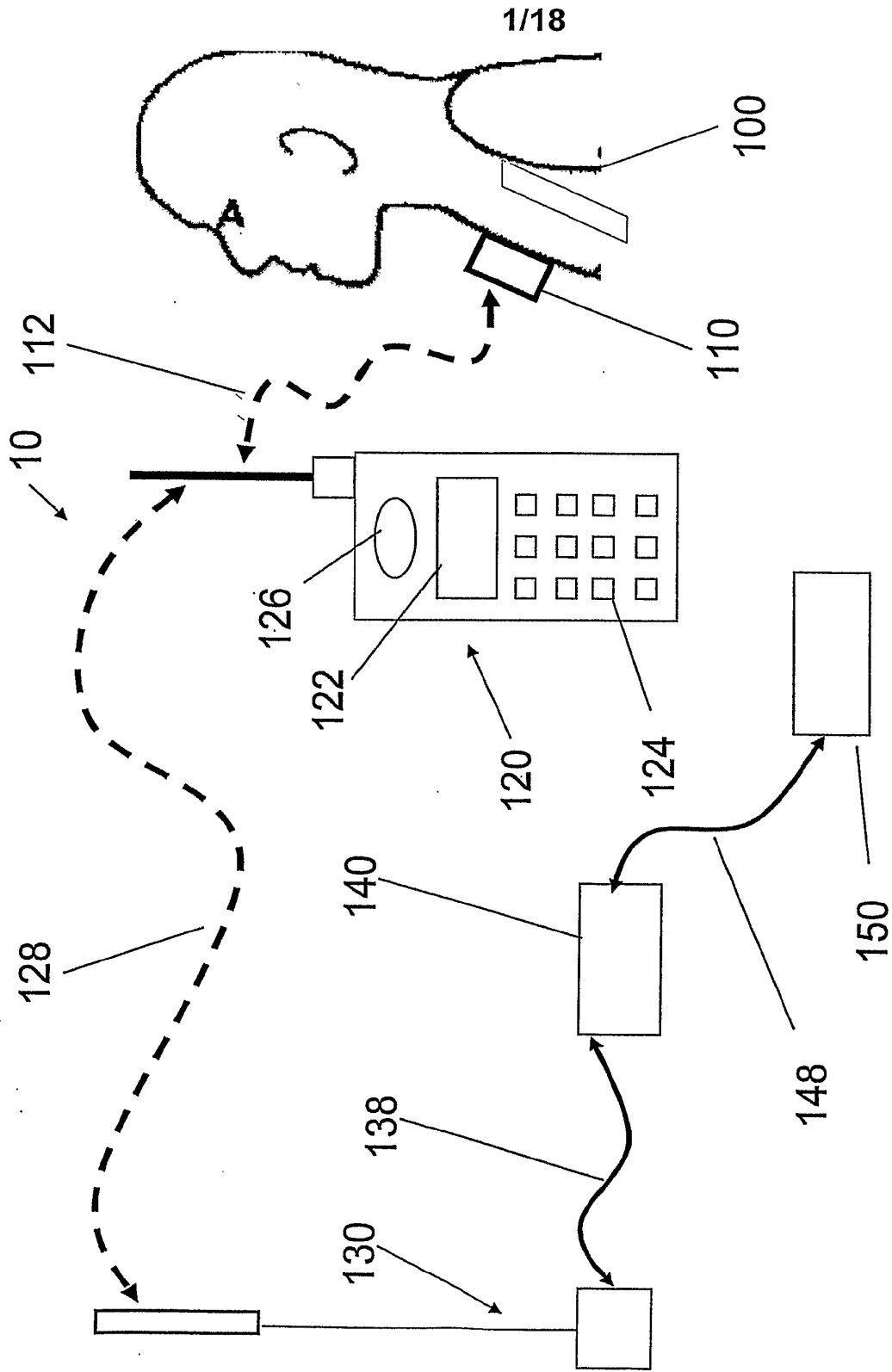

SUBSTITUTE SHEET (RULE 26)

Fig. 1

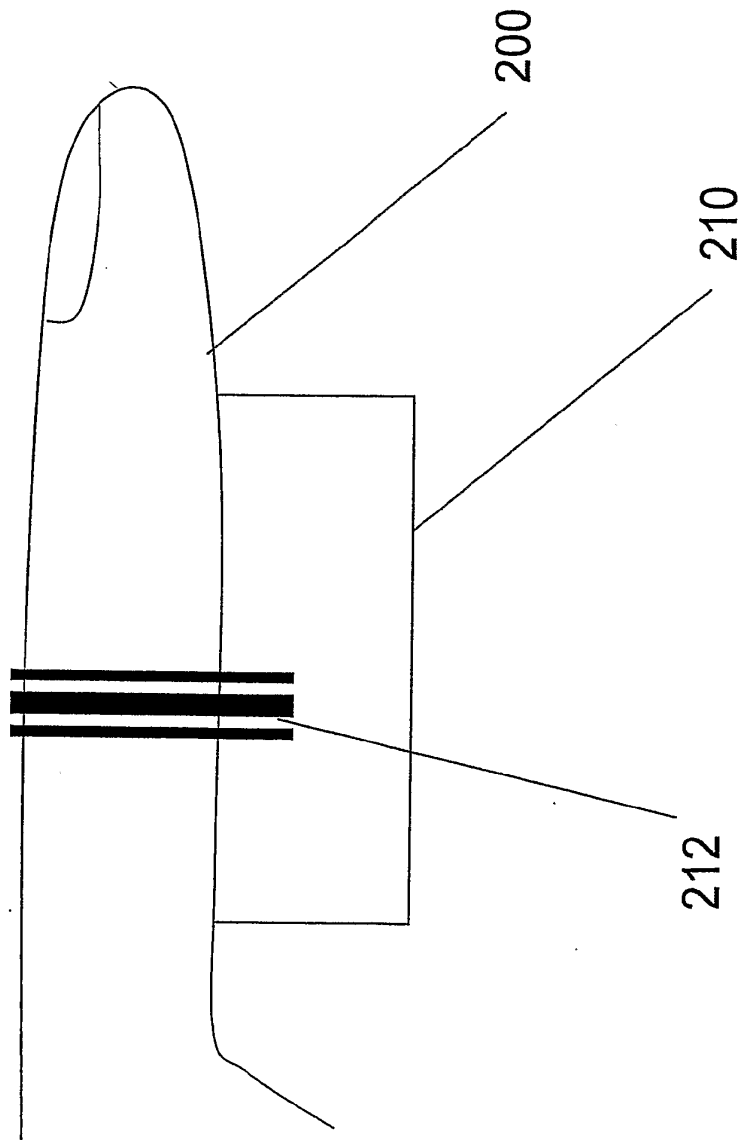

Fig. 2

3/18

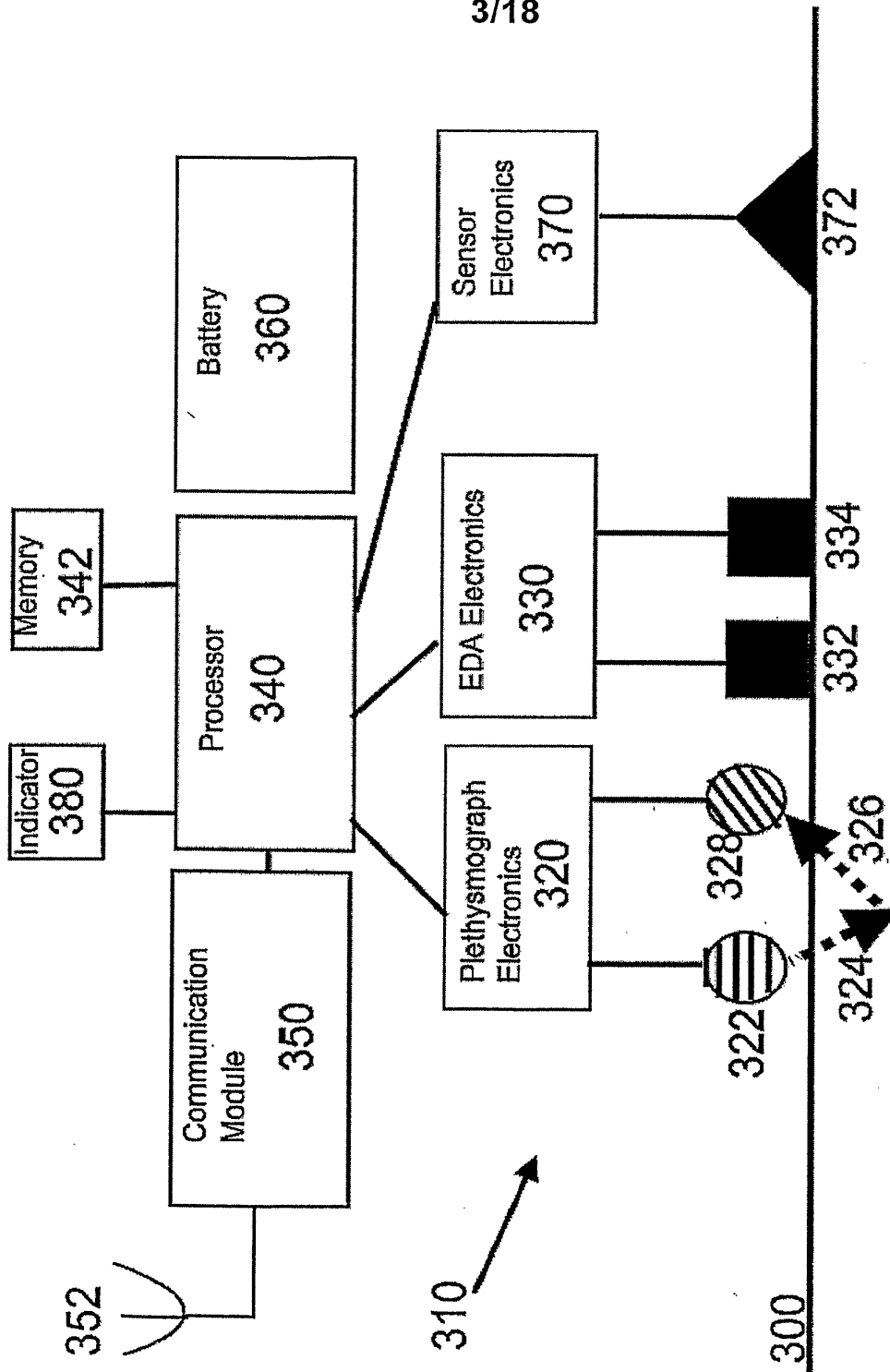

FIG 3

4/18

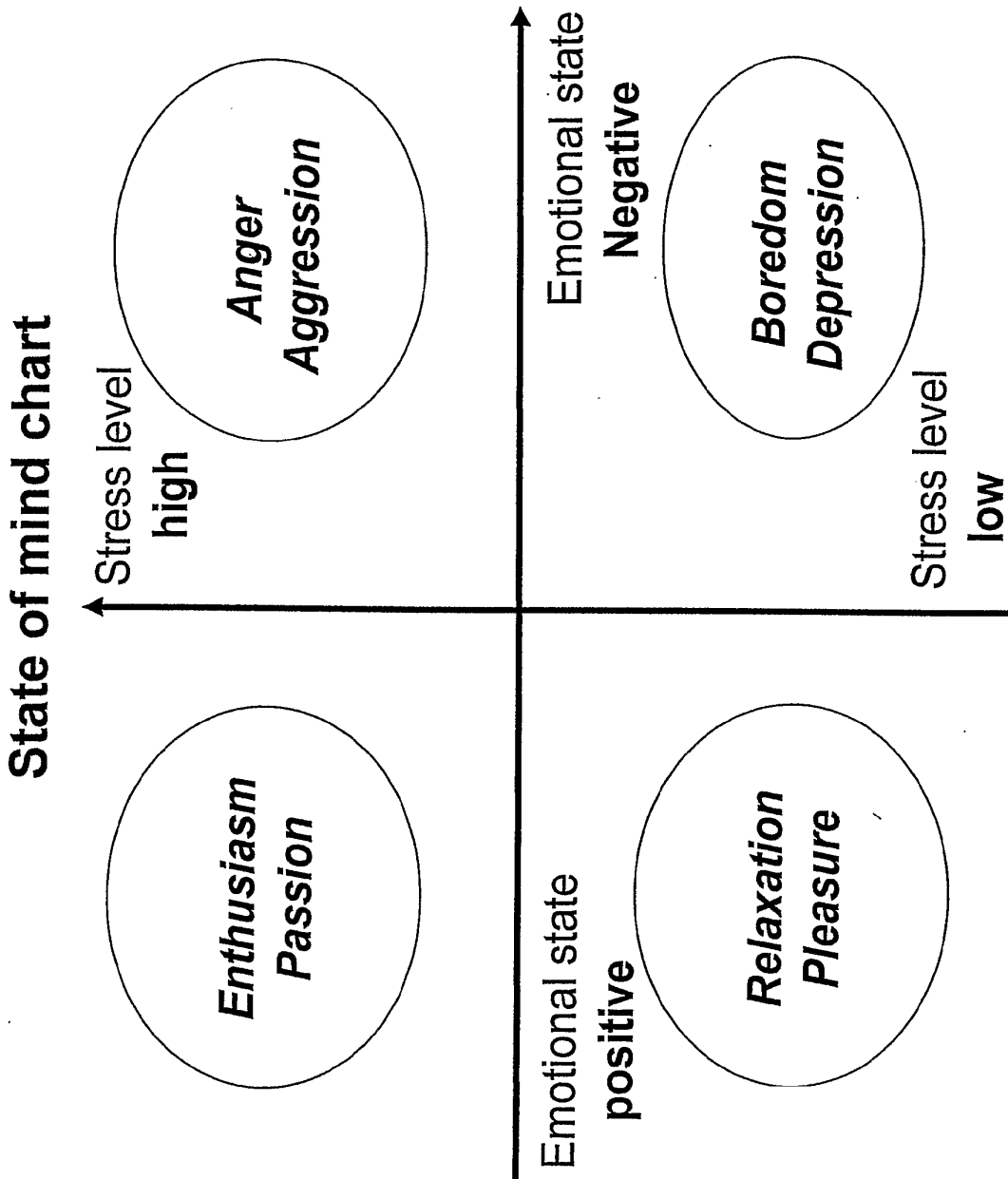

Fig. 4

5/18

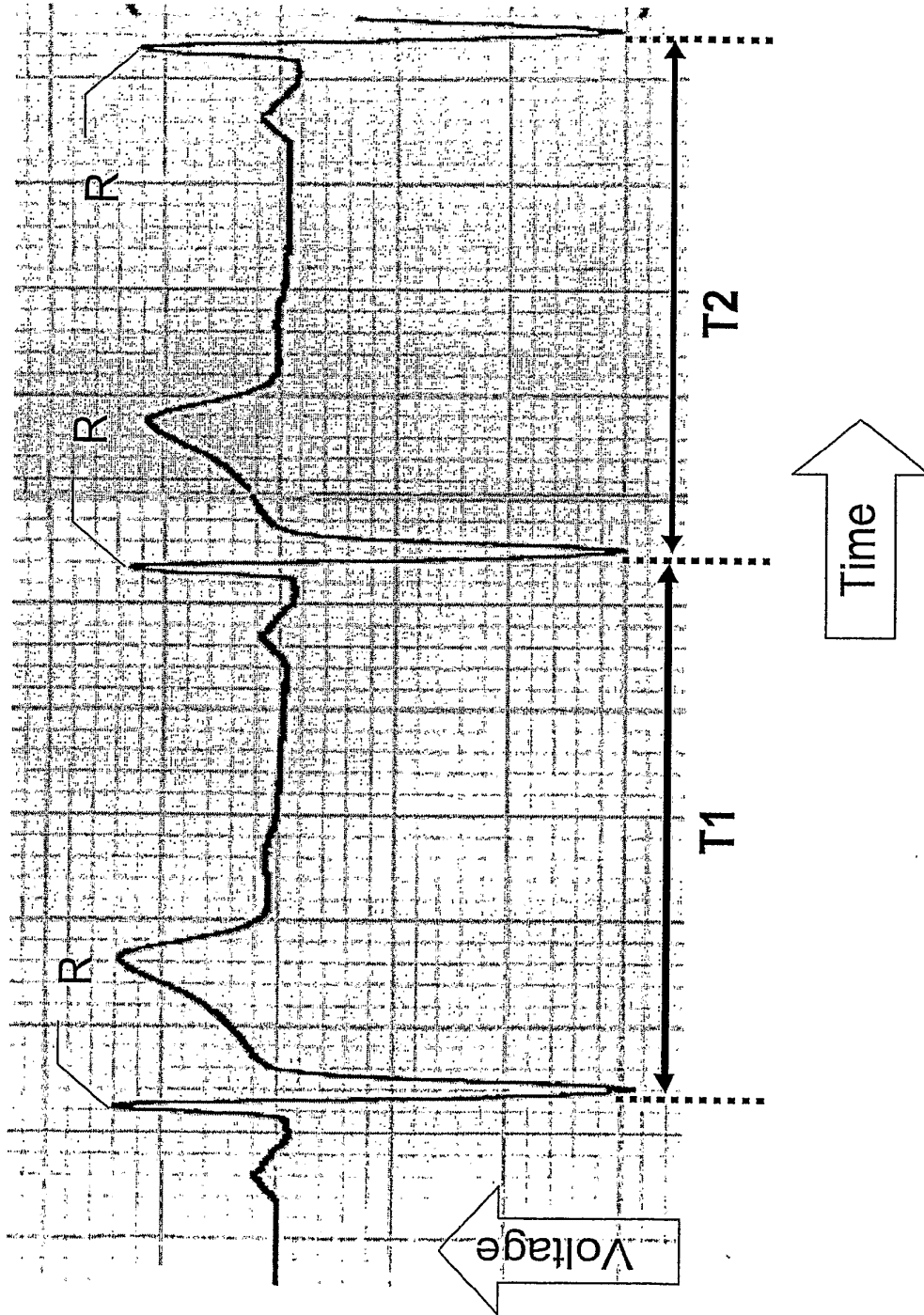

Fig. 5a

6/18

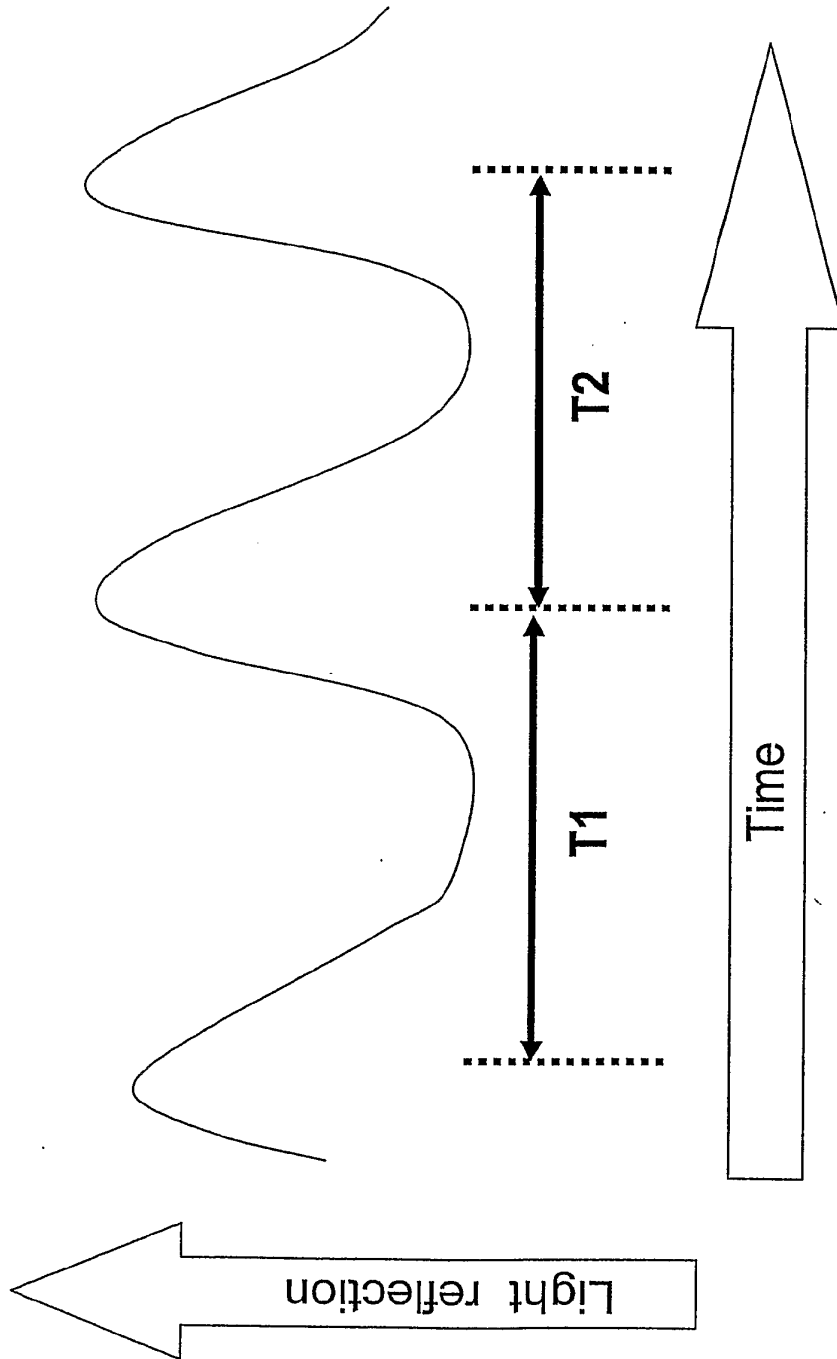

Fig. 5b

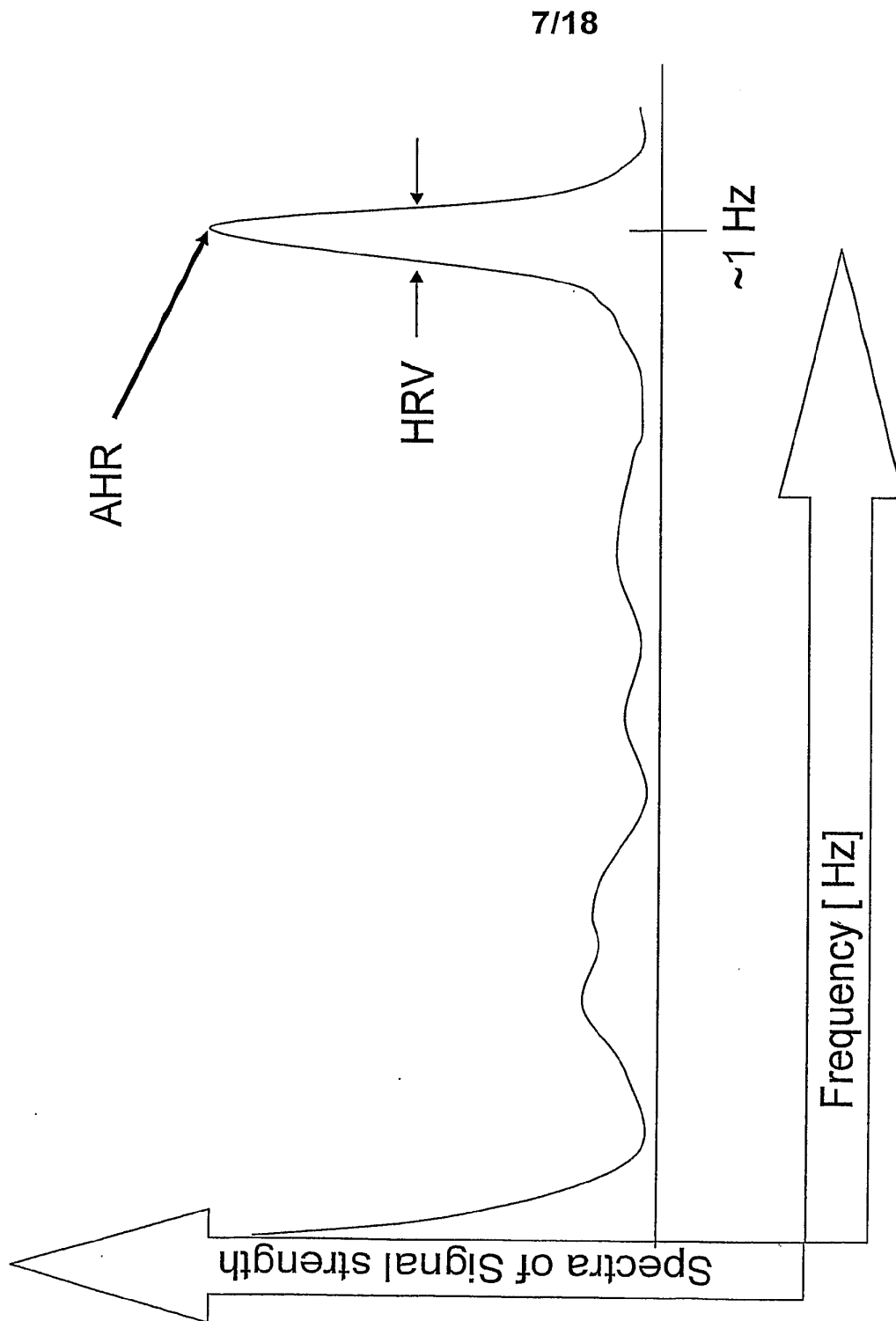

Fig. 5c

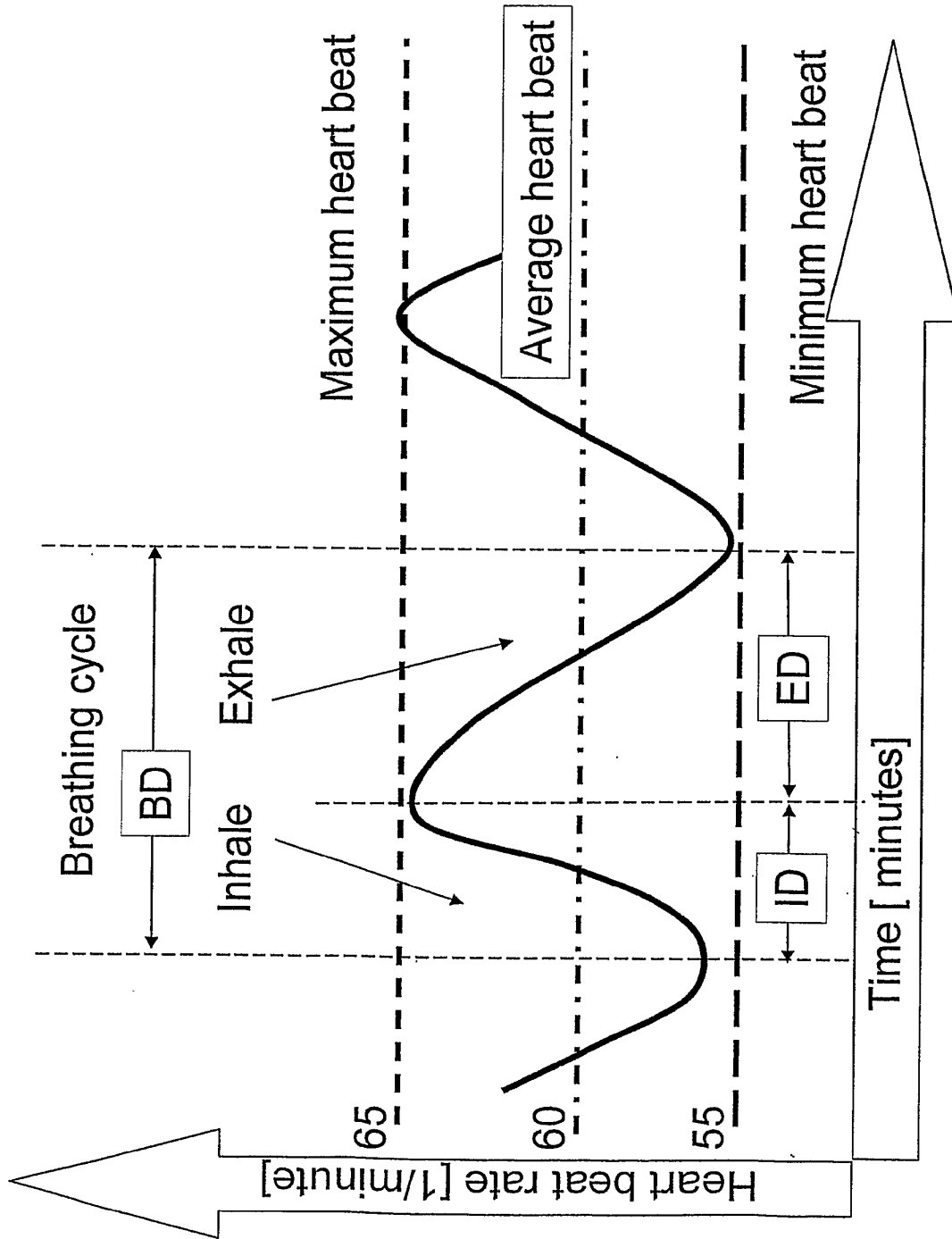

Fig. 6a

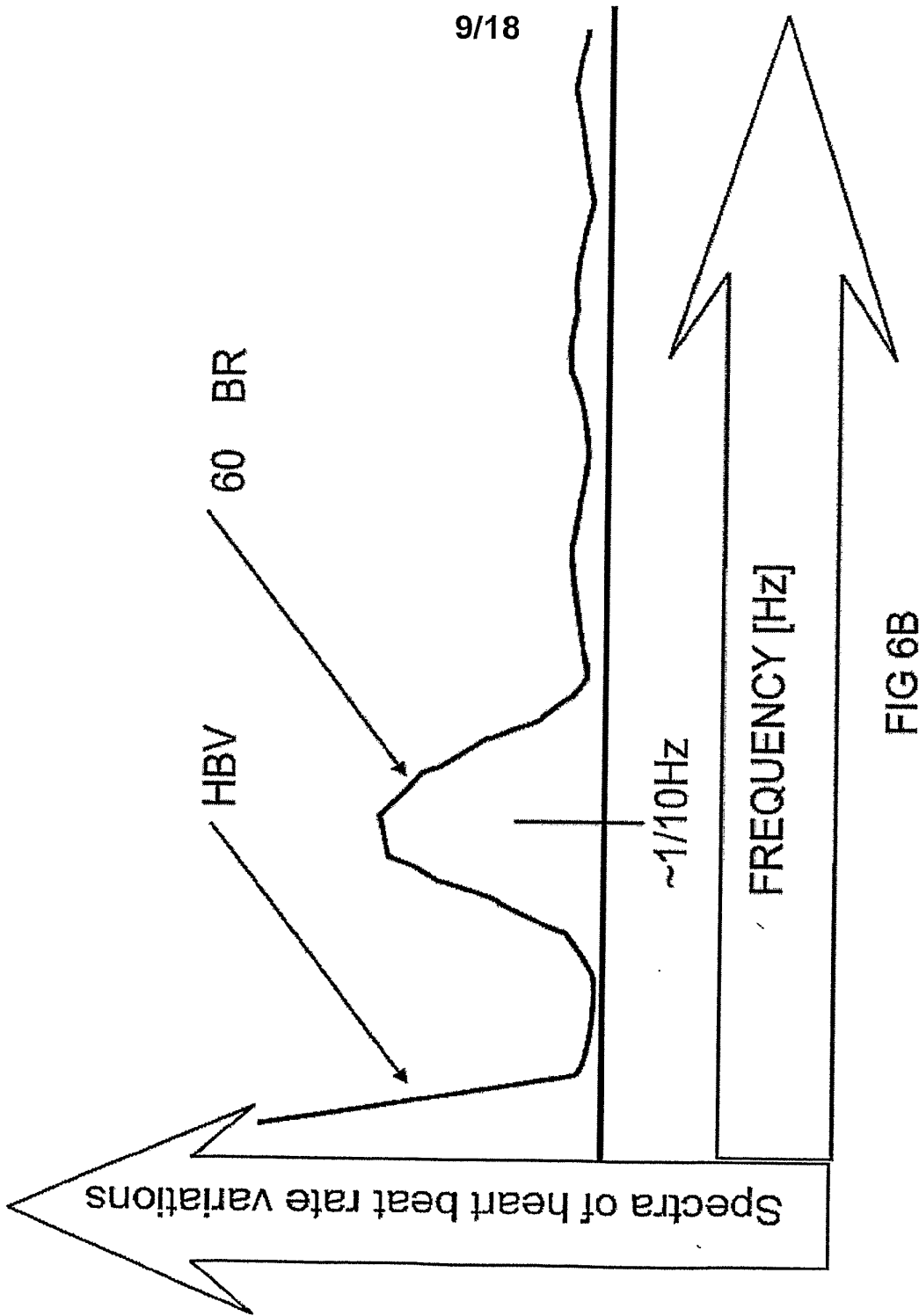

FIG 6B

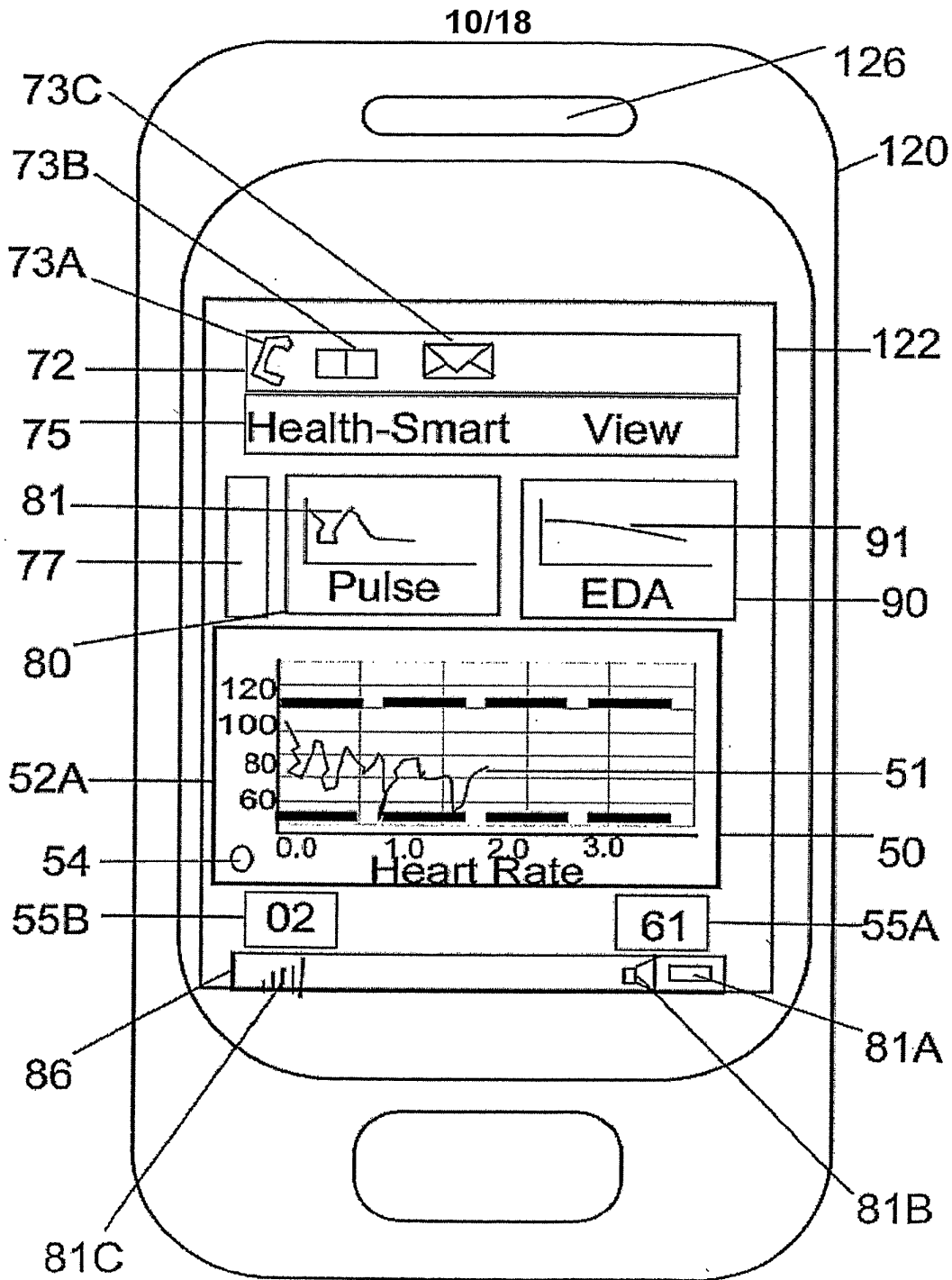

FIG 7A

11/18

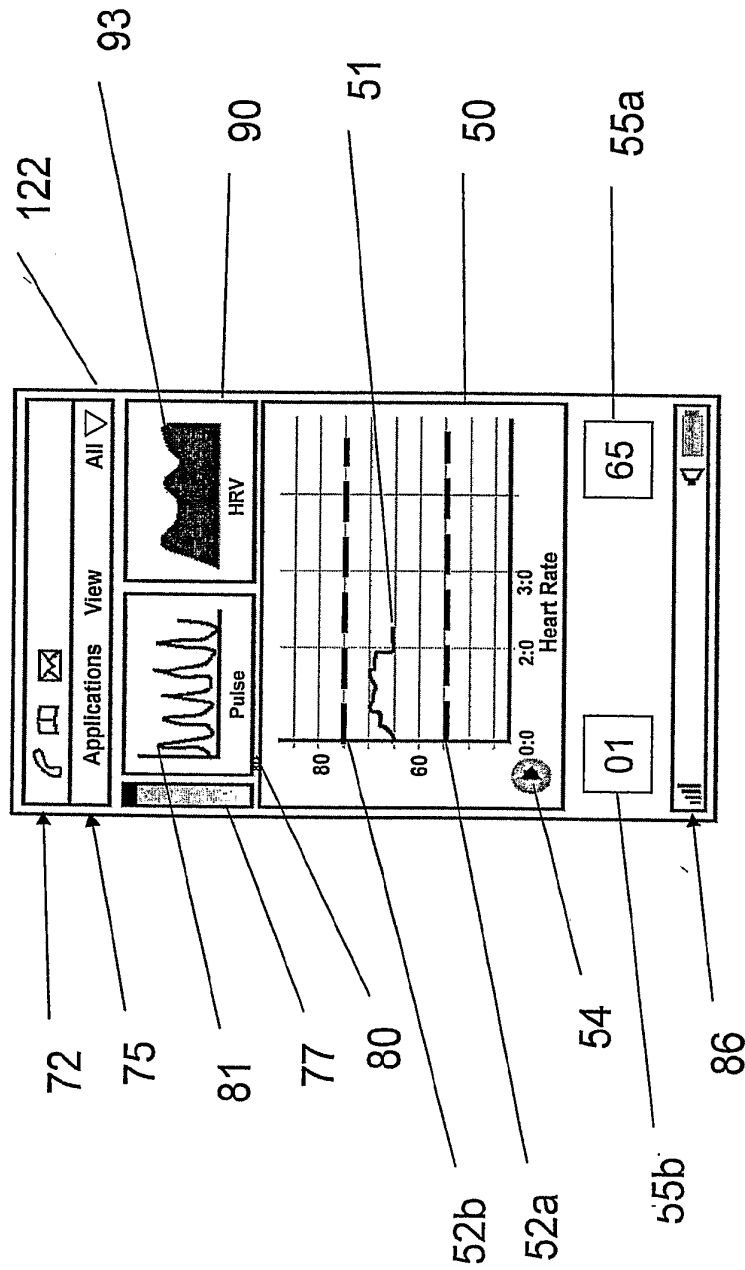

Fig. 7b

SUBSTITUTE SHEET (RULE 26)

12/18

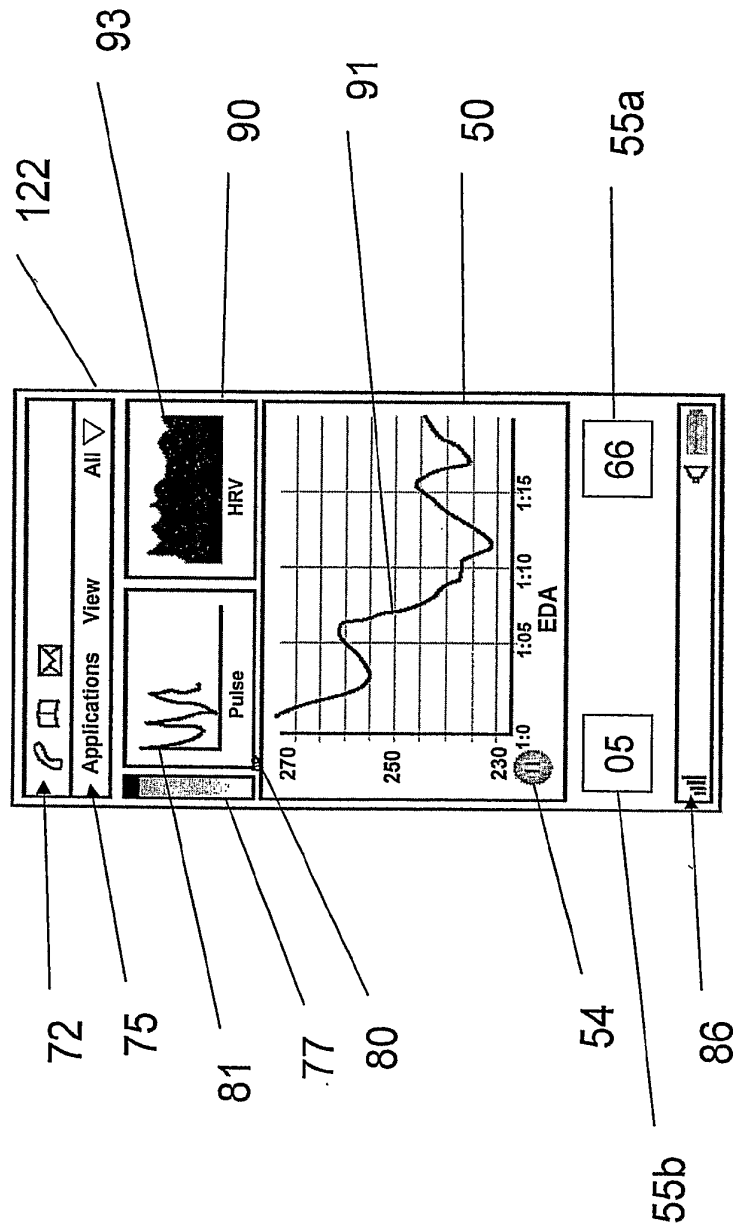

Fig. 7c

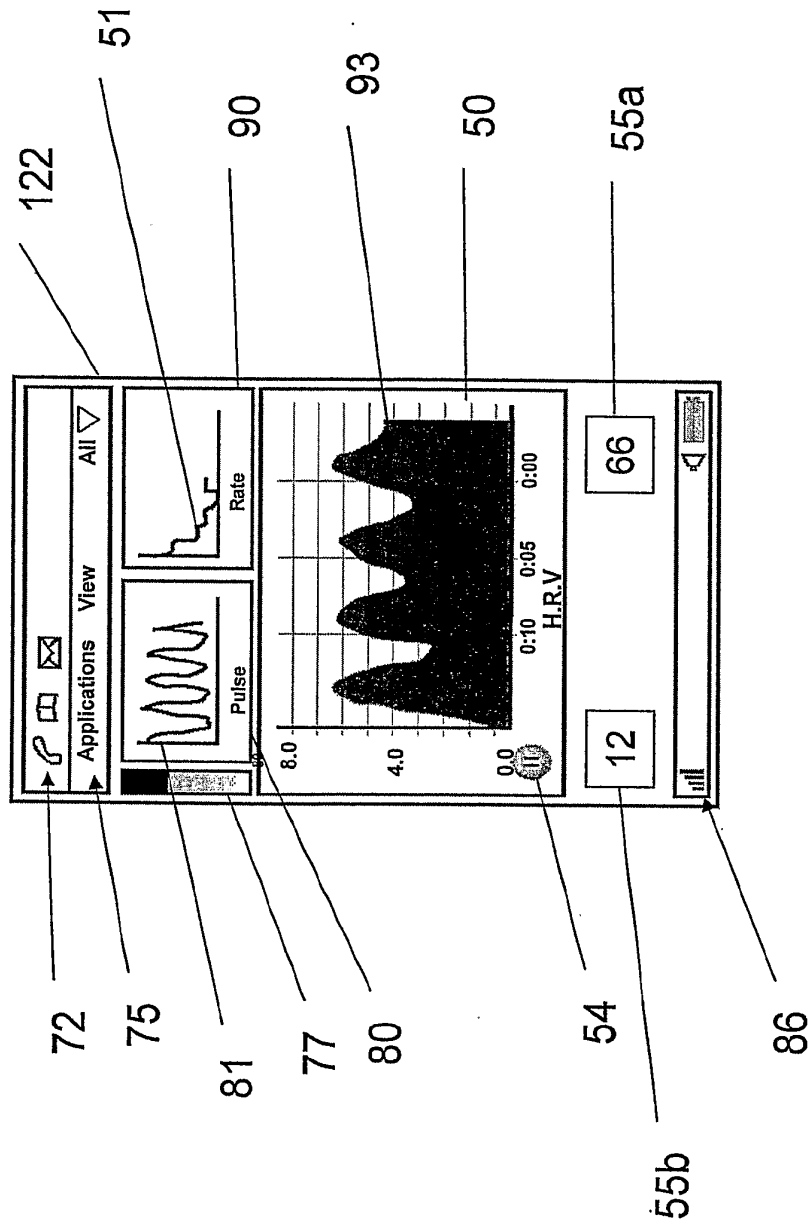

Fig. 7d

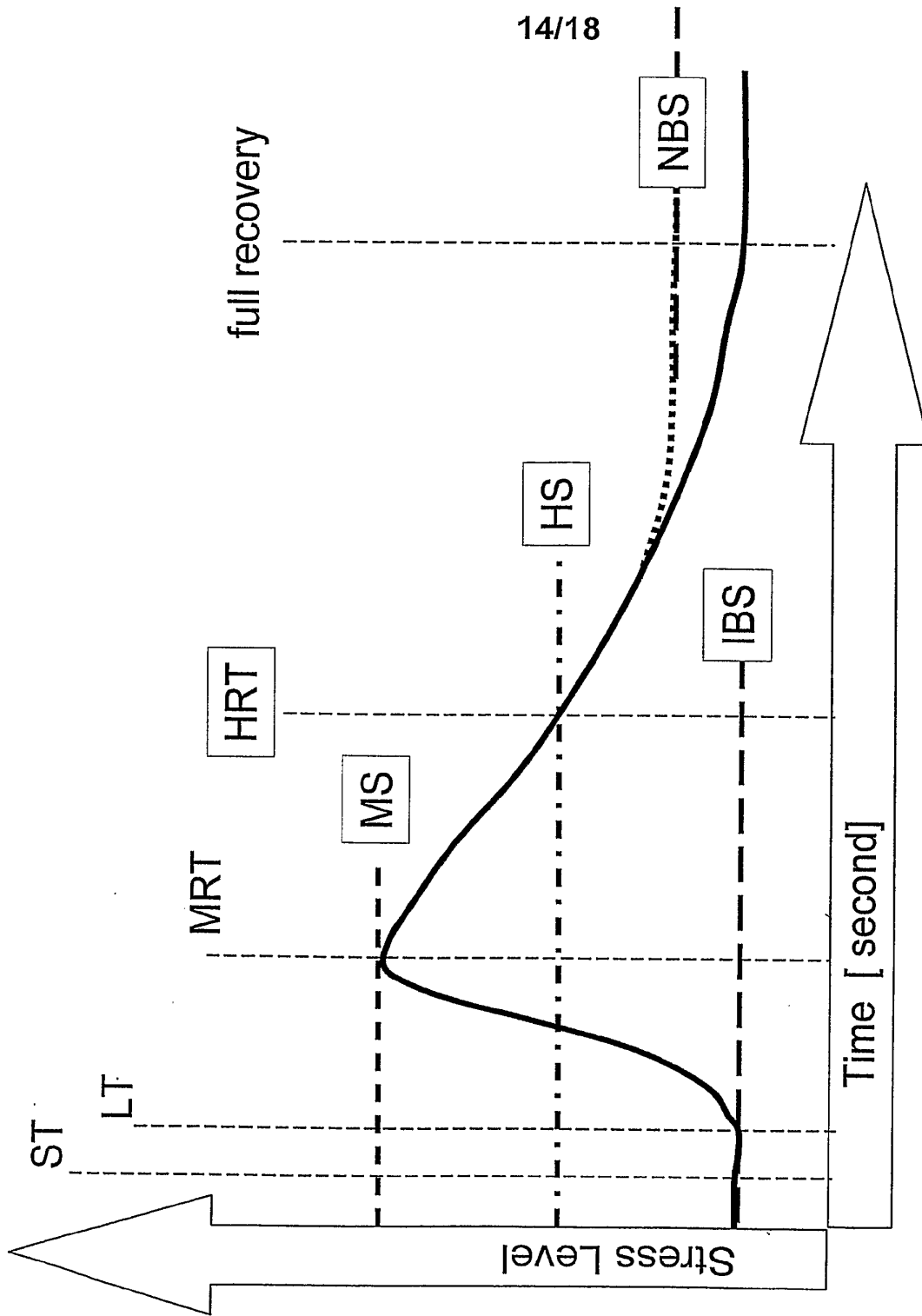

Fig. 8

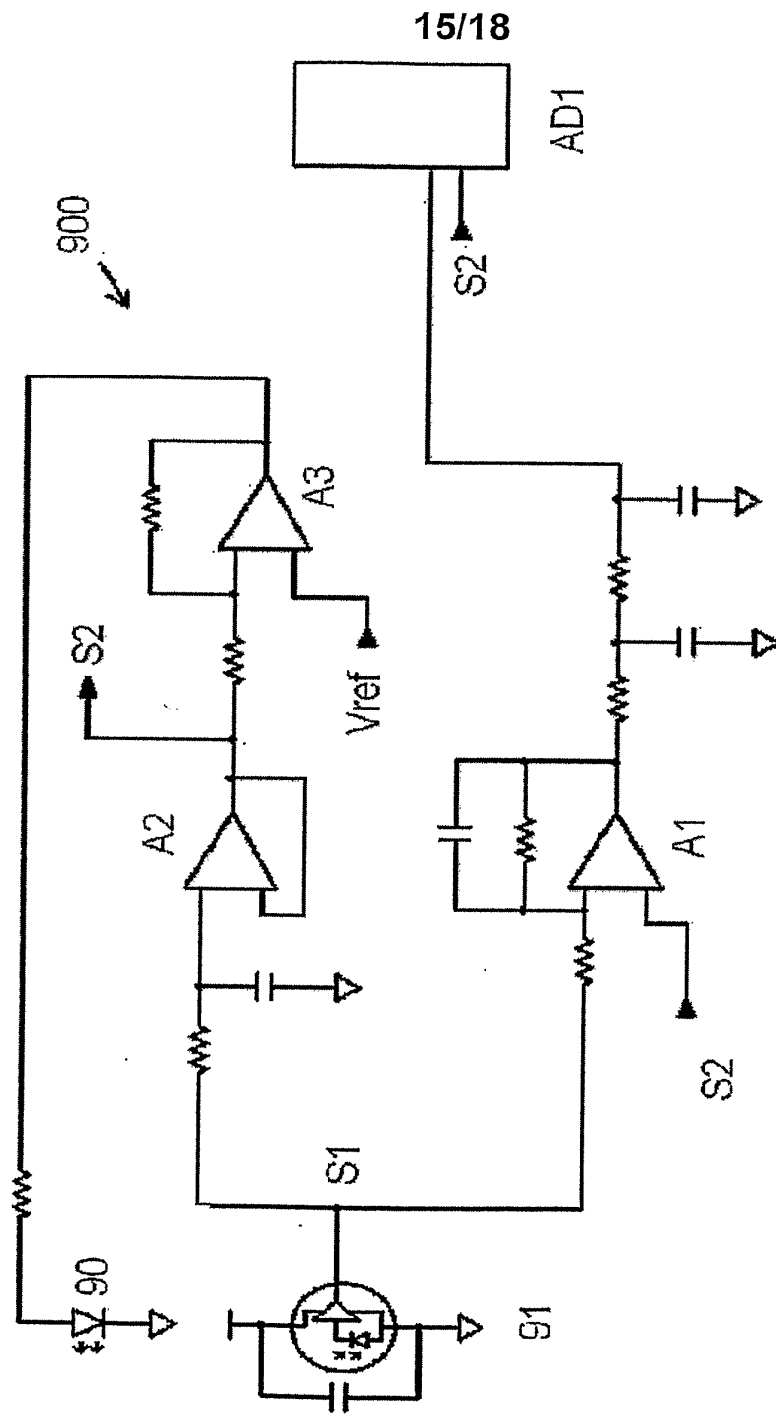

Fig 9

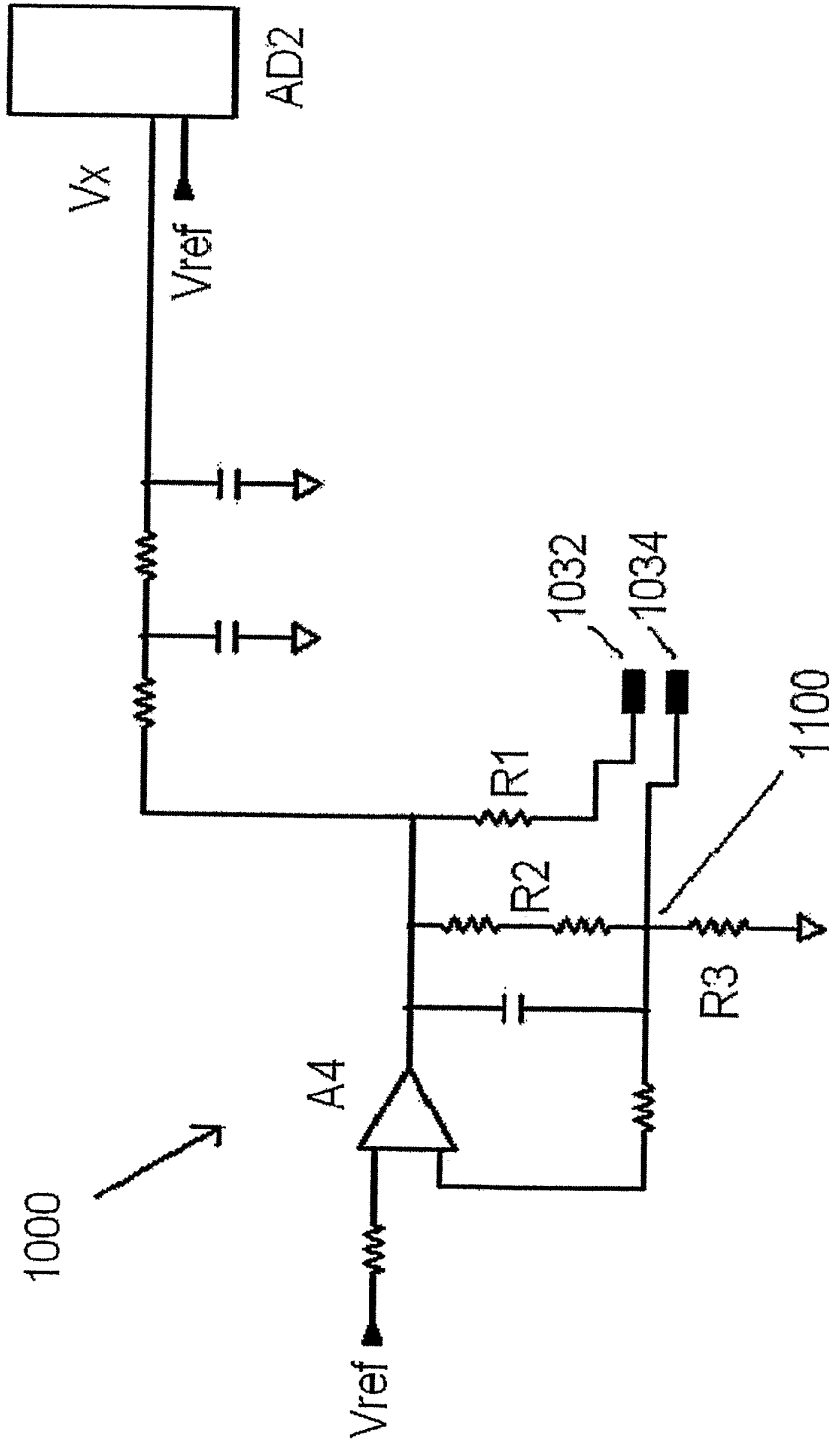

Fig 10

17/18

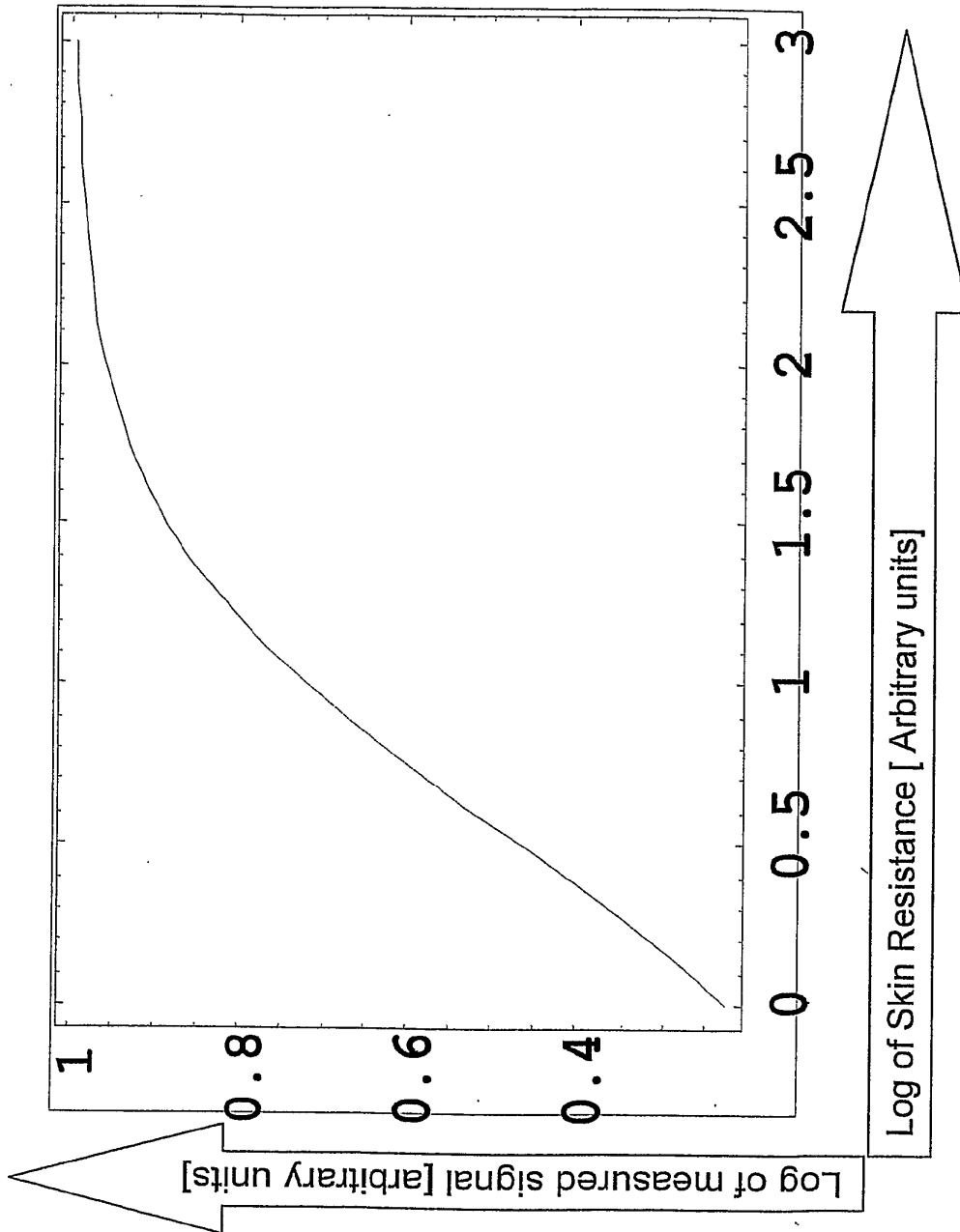

Fig. 11

18/18

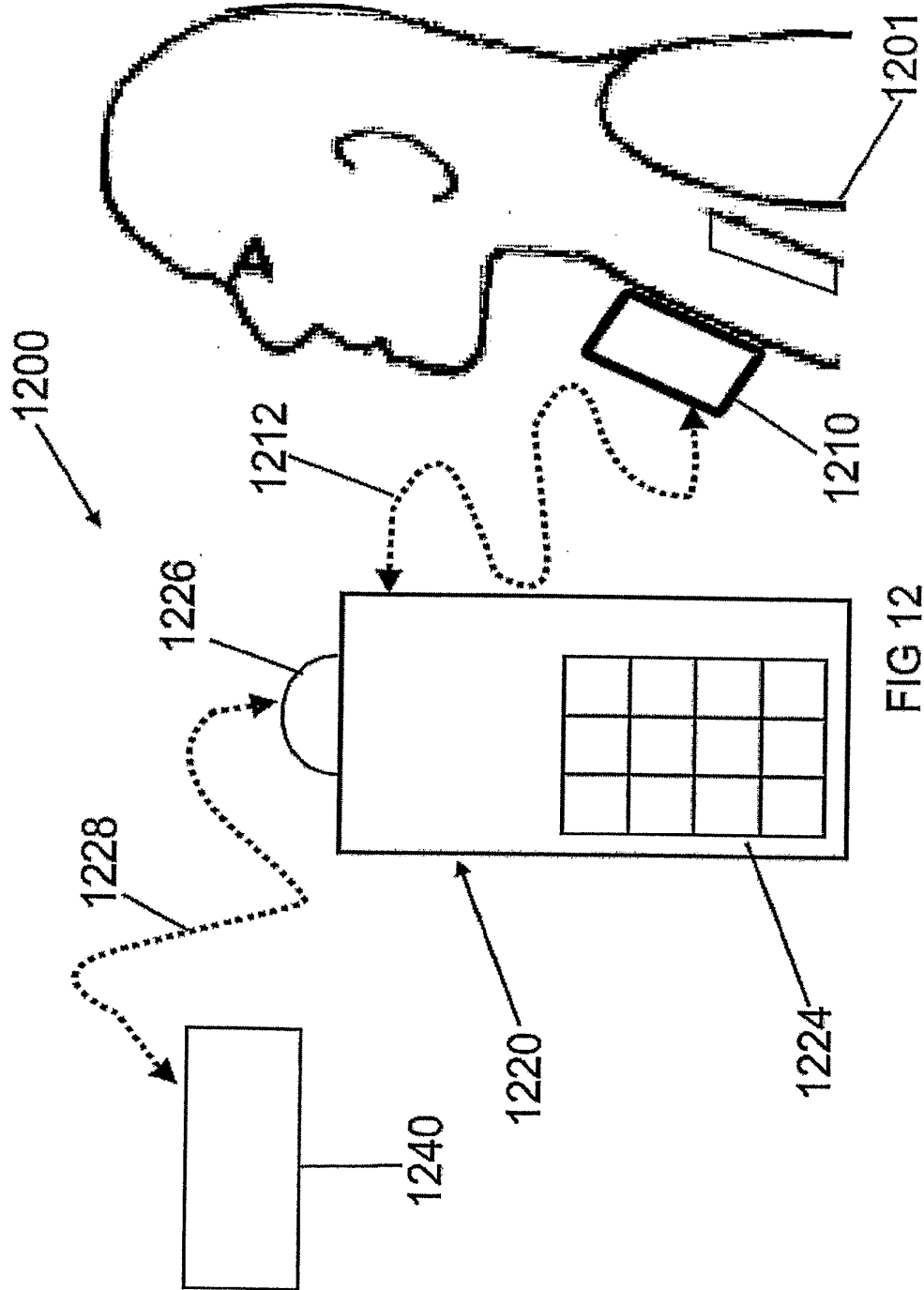

FIG 12

(12) NACH DEM VERTRAG ÜBER DIE INTERNATIONALE ZUSAMMENARBEIT AUF DEM GEBIET DES PATENTWESENS (PCT) VERÖFFENTLICHTE INTERNATIONALE ANMELDUNG

(19) Weltorganisation für geistiges Eigentum
Internationales Büro



(43) Internationales Veröffentlichungsdatum
15. Februar 2007 (15.02.2007)

PCT

(10) Internationale Veröffentlichungsnummer
WO 2007/017266 A2

(51) **Internationale Patentklassifikation:**
A61B 5/0205 (2006.01) A61B 5/053 (2006.01)
A61B 5/0408 (2006.01) A61B 5/00 (2006.01)

(21) **Internationales Aktenzeichen:** PCT/EP2006/007877

(22) **Internationales Anmeldedatum:**
9. August 2006 (09.08.2006)

(25) **Einreichungssprache:** Deutsch

(26) **Veröffentlichungssprache:** Deutsch

(30) **Angaben zur Priorität:**
10 2005 038 035.2 9. August 2005 (09.08.2005) DE
10 2005 043 606.4
9. September 2005 (09.09.2005) DE
10 2005 051 030.2
25. Oktober 2005 (25.10.2005) DE

(71) **Anmelder (für alle Bestimmungsstaaten mit Ausnahme von US): FLORE, Ingo** [DEZDE]; Westfalendamm 280, 44141 Dortmund (DE).

(72) **Erfinder; und**

(75) **Erfinder/Anmelder (nur für US): CHO, Ok, Kyung** [KR/DE]; Im Rosengrund 6, 58239 Schwerte (DE). **KIM, Yoon, Ok** [KR/DE]; Im Rosengrund 6, 58239 Schwerte (DE).

(74) **Anwalt: SCHNEIDERS & BEHRENDT**; Huestrasse 23, 44787 Bochum (DE).

(81) **Bestimmungsstaaten (soweit nicht anders angegeben, für jede verfügbare nationale Schutzrechtsart):** AE, AG, AL, AM, AT, AU, AZ, BA, BB, BG, BR, BW, BY, BZ, CA, CH, CN, CO, CR, CU, CZ, DE, DK, DM, DZ, EC, EE, EG, ES, FI, GB, GD, GE, GH, GM, HN, HR, HU, ID, IL, IN, IS, JP, KE, KG, KM, KN, KP, KR, KZ, LA, LC, LK, LR, LS, LT, LU, LV, LY, MA, MD, MG, MK, MN, MW, MX, MZ, NA, NG, NI, NO, NZ, OM, PG, PH, PL, PT, RO, RS, RU, SC, SD, SE, SG, SK, SL, SM, SY, TJ, TM, TN, TR, TT, TZ, UA, UG, US, UZ, VC, VN, ZA, ZM, ZW.

(84) **Bestimmungsstaaten (soweit nicht anders angegeben, für jede verfügbare regionale Schutzrechtsart):** ARIPO (BW,

[Fortsetzung auf der nächsten Seite]

(54) **Title:** MEDICAL MEASURING DEVICE

(54) **Bezeichnung:** MEDIZINISCHE MESSVORRICHTUNG

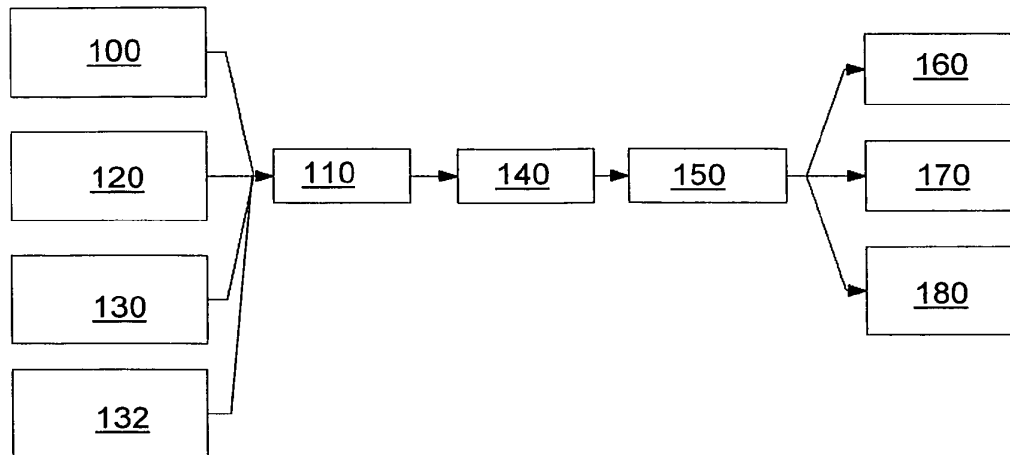

(57) **Abstract:** The invention relates to a measuring device (1) for the non-invasive measurement of physiological parameters. Said measuring device (1) is used to identify and localise illnesses, such as inflammations, tumour diseases or arteriosclerosis, during self-diagnosis. The inventive measuring device (1) comprises at least one optical measuring unit (100) for generating oximetric and/or Plethysmographic measuring Signals, an evaluation unit (140) for processing the measuring Signals, and a unit (120, 130) for recording local tissue parameters, such as fat content, water content and/or circulation of the blood. The evaluation unit (140) is designed in such a way as to determine at least one local metabolism parameter, especially the local oxygen consumption, from the Signals of the optical measuring unit and the tissue parameters. The inventive measuring device (1) also enables the non-invasive determination of the glucose concentration.

[Fortsetzung auf der nächsten Seite]

WO 2007/017266 A2



GH, GM, KE, LS, MW, MZ, NA, SD, SL, SZ, TZ, UG, ZM, ZW), eurasisches (AM, AZ, BY, KG, KZ, MD, RU, TJ, TM), europaisches (AT, BE, BG, CH, CY, CZ, DE, DK, EE, ES, FI, FR, GB, GR, HU, IE, IS, IT, LT, LU, LV, MC, NL, PL, PT, RO, SE, SI, SK, TR), OAPI (BF, BJ, CF, CG, CI, CM, GA, GN, GQ, GW, ML, MR, NE, SN, TD, TG)

Zur Erklärung der Zweibuchstaben Codes und der anderen Abkürzungen wird auf die Erklärungen ("Guidance Notes on Codes and Abbreviations") am Anfang jeder regulären Ausgabe der PCT Gazette verwiesen

Veröffentlicht:

— *ohne internationalen Recherchenbericht und erneut zu veröffentlichen nach Erhalt des Berichts*

(57) Zusammenfassung: Die Erfindung betrifft eine Messvorrichtung (1) zur nicht invasiven Messung von physiologischen Parametern. Die Messvorrichtung (1) ist dazu geeignet, Erkrankungen, wie zum Beispiel Entzündungen, Tumorerkrankungen oder Arteriosklerose, im Wege der Selbstdiagnose zu erkennen und zu lokalisieren. Die Erfindung schlägt eine Messvorrichtung (1) vor mit wenigstens einer optischen Messeinheit (100) zur Erzeugung von oximetrischen und/oder plethysmographischen Messsignalen, einer Auswertungseinheit (140) zur Verarbeitung der Messsignale, und mit einer Einheit (120, 130) zur Erfassung von lokalen Gewebeparametern, wie Fettgehalt, Wassergehalt und/oder Durchblutung, wobei die Auswertungseinheit (140) eingerichtet ist zur Bestimmung wenigstens eines lokalen metabolischen Parameters, insbesondere des lokalen Sauerstoffverbrauchs, aus den Signalen der optischen Messeinheit und den Gewebeparametern. Die Messvorrichtung (1) ermöglicht außerdem die nicht invasive Bestimmung der Glukosekonzentration.

Medizinische Messvorrichtung α

5 Die Erfindung betrifft eine Messvorrichtung zur nicht-invasiven Bestimmung von physiologischen Parametern, mit wenigstens einer optischen Messeinheit zur Erzeugung von oximetrischen und/oder plethysmographischen Messsignalen, und mit einer Auswertungseinheit zur Verarbeitung der Messsignale.

Die Versorgung des Körpergewebes mit Sauerstoff gehört bekanntlich zu den
10 wichtigsten Vitalfunktionen des Menschen. Aus diesem Grund sind oximetrische Diagnosemodalitäten heutzutage von großer Bedeutung in der Medizin. Routinemäßig werden sogenannte Pulsoximeter eingesetzt. Derartige Pulsoximeter umfassen typischerweise zwei Lichtquellen, die rotes bzw. infrarotes Licht unterschiedlicher Wellenlänge in das Körpergewebe einstrahlen.
15 Das Licht wird im Körpergewebe gestreut und teilweise absorbiert. Das gestreute Licht wird schließlich mittels eines Lichtsensors in Form einer geeigneten Photozelle detektiert. Typischerweise verwenden kommerzielle Pulsoximeter zum einen Licht im Wellenlängenbereich von 660 nm. In diesem Bereich ist die Lichtabsorption von Oxihämoglobin und Desoxihämoglobin stark
20 unterschiedlich. Dementsprechend variiert die Intensität des mittels des Photosensors detektierten, gestreuten Lichts in Abhängigkeit davon, wie stark das untersuchte Körpergewebe von sauerstoffreichem, bzw. sauerstoffarmem Blut durchblutet ist. Zum anderen wird üblicherweise Licht im Wellenlängenbereich von 810 nm verwendet. Diese Lichtwellenlänge liegt im
25 sogenannten nahen infraroten Spektralbereich. Die Lichtabsorption von Oxihämoglobin und Desoxihämoglobin ist in diesem Spektralbereich im Wesentlichen gleich. Die bekannten Pulsoximeter sind außerdem in der Lage, ein plethysmographisches Signal, d. h. ein Volumenpulssignal zu erzeugen, das

die während des Herzschlags veränderliche Blutmenge in dem von dem Pulsoximeter erfassten Mikrogefäßsystem wiedergibt (sog. Photoplethysmographie). Bei Verwendung unterschiedlicher Lichtwellenlängen in den oben erwähnten Spektralbereichen kann aus der unterschiedlichen Lichtabsorption auf den Sauerstoffgehalt des Blutes (Sauerstoffsättigung) zurückgeschlossen werden. Die üblichen Pulsoximeter werden entweder an der Fingerspitze eines Patienten oder auch am Ohrläppchen eingesetzt. Es wird dann das Volumenpulssignal aus der Blutperfusion des Mikrogefäßsystems in diesen Bereichen des Körpergewebes erzeugt.

10 Aus der WO 00/69328 A 1 ist ein besonders flexibel einsetzbares oximetrisches Diagnosegerät bekannt. Dieses vorbekannte Gerät ist handführbar ausgebildet, so dass es an beliebigen Messorten am menschlichen Körper eingesetzt werden kann. Das vorbekannte Gerät erlaubt gleichsam ein systematisches Abtasten („Scannen“) des Körpers eines Patienten. Eine Fixierung des
15 Diagnosegerätes - wie bei üblichen Pulsoximetern - kann bei dem aus der genannten Druckschrift bekannten Gerät entfallen.

Die genannte WO 00/69328 A 1 spricht außerdem die Ersetzbarkeit des oximetrischen Diagnosegerätes zur orts aufgelösten Erkennung von Entzündungen, Tumoren und Arterioskleroseerkrankungen im hautoberflächen-
20 nahen Körpergewebe eines Patienten an. Derartige Erkrankungen bewirken eine Veränderung der Durchblutung des Körpergewebes. Durch die orts aufgelöste oximetrische Abtastung des Körpers lassen sich mit dem vorbekannten Gerät Veränderungen der Durchblutung, die auf eine entsprechende Erkrankung hindeuten, erkennen und lokalisieren.

25 Das EKG (Elektrokardiogramm) dürfte die am meisten eingesetzte Untersuchungsmodalität zur Diagnose von Herz-Kreislauf-Erkrankungen sein. Mittels eines EKG-Gerätes werden mit zwei oder mehr EKG-Elektroden elektrische Signale von dem Körper des zu untersuchenden Patienten abgeleitet. Das so gewonnene EKG gibt die bioelektrischen Spannungen, die
30 bei der Erregungsausbreitung und -rückbildung am Herzen entstehen, wieder. Das EKG enthält zahlreiche diagnostisch auswertbare Parameter. Zum Zeitpunkt der Kontraktion des Herzmuskels während eines Herzschlags zeigt

das EKG eine deutliche Spitze, die auch als R-Zacke bezeichnet wird. Weiterhin enthält das EKG die der R-Zacke vorangehende, so genannte P-Welle. Der R-Zacke folgt wiederum die so genannte T-Welle. Die Minima im EKG unmittelbar vor und unmittelbar nach der R-Zacke werden mit Q bzw. S bezeichnet. Für die Herz-Kreislauf-Diagnostik interessante Parameter sind die Dauer der P-Welle sowie die Amplitude der P-Welle, die Dauer des PQ-Intervalls, die Dauer des QRS-Komplexes, die Dauer des QT-Intervalls sowie die Amplitude der T-Welle. Sowohl aus den Absolutwerten der genannten Parameter wie auch aus den Verhältnissen der Parameter kann auf den Gesundheitszustand des Herz-Kreislauf-Systems geschlossen werden. Vorrichtungen und Verfahren zur EKG-Messung sind beispielsweise aus den Druckschriften US 6,331,162 oder US 4,960,126 vorbekannt.

Zur Bestimmung von weiteren physiologischen Parametern, wie z. B. Körperfettgehalt, ist das Prinzip der bioelektrischen Impedanzmessung beispielsweise aus der US 6,714,814 bekannt. Die Zusammensetzung des Körpergewebes kann aber auch optisch bestimmt werden. Das Prinzip der optischen Bestimmung des Körperfettgehalts mittels Infrarotlicht ist beispielsweise in der US 4,928,014 beschrieben.

Der vorliegenden Erfindung liegt die Aufgabe zugrunde, eine Vorrichtung zur nicht-invasiven Bestimmung von physiologischen Parametern bereit zu stellen, die gegenüber dem Stand der Technik verbessert und hinsichtlich ihrer Funktionalität erweitert ist. Insbesondere soll ein Gerät geschaffen werden, das eine möglichst zuverlässige Erkennung und Lokalisierung von Erkrankungen, wie Entzündungen, Tumor- bzw. Krebserkrankungen (Hautkrebs, Melanome) sowie Gefäßerkrankungen, ermöglicht. Außerdem soll optional die Möglichkeit bestehen, mittels des Gerätes die (kardiovaskuläre) Fitness des Benutzers einzuschätzen. Dabei soll das Gerät auch zur Selbstdiagnose genutzt werden können.

Diese Aufgabe löst die Erfindung ausgehend von einer Messvorrichtung der eingangs angegebenen Art dadurch, dass die Auswertungseinheit eingerichtet ist zur Bestimmung wenigstens eines lokalen metabolischen Parameters,

insbesondere des lokalen Sauerstoffverbrauchs, aus den Signalen der optischen Messeinheit.

Kerngedanke der Erfindung ist es, die mittels der optischen Messeinheit gewonnenen oximetrischen und/oder plethysmographischen Messsignale heranzuziehen, um nicht nur - wie z. B. bei den bekannten oximetrischen Diagnosegeräten - die lokale Sauerstoffkonzentration am jeweiligen Messort, sondern insbesondere auch den lokalen Sauerstoffverbrauch als wichtigen Indikator für die lokale metabolische Aktivität zu bestimmen. Erkrankungen können mit der erfindungsgemäßen Messvorrichtung anhand von pathologischen Veränderungen des Metabolismus erkannt und lokalisiert werden.

Gemäß einer bevorzugten Ausgestaltung weist die erfindungsgemäße Messvorrichtung zusätzlich eine Einheit zur Erfassung von lokalen Gewebeparametern, wie Fettgehalt, Wassergehalt und/oder Durchblutung auf, wobei die Auswertungseinheit in diesem Fall eingerichtet ist zur Bestimmung des wenigstens einen lokalischen metabolischen Parameters aus den Signalen der optischen Messeinheit und den Gewebeparametern.

Ein wichtiger lokaler Gewebeparameter im Sinne der Erfindung ist beispielsweise die Durchblutung. Damit sind die durchblutungsbedingten Volumenschwankungen des untersuchten Körpergewebes gemeint. Zur Erfassung der Durchblutung kann die erfindungsgemäße Messvorrichtung insofern mit einer Plethysmographieeinheit herkömmlicher Art (z. B. Photoplethysmograph) ausgestattet sein. Somit kann die optische Messeinheit der erfindungsgemäßen Messvorrichtung gleichzeitig zur Erfassung der lokalen Gewebeparameter genutzt werden.

Die Erfindung basiert u. a. auf der Erkenntnis, dass durch die Kombination der Erfassung von oximetrischen und plethysmographischen Signalen die Möglichkeit eröffnet wird, lokale metabolische Parameter zu bestimmen.

Für die Ermittlung des lokalen Sauerstoffverbrauchs sollte mittels der erfindungsgemäßen Messvorrichtung zusätzlich zur oximetrisch bestimmten

arteriellen Sauerstoffkonzentration auch die kapillare Sauerstoffkonzentration im Gewebe bestimmt werden können. Hierzu muss allerdings die Zusammensetzung des untersuchten Körpergewebes bekannt sein. Entscheidende Parameter sind der lokale Fettgehalt und/oder der Wassergehalt des Körpergewebes. Diese Parameter können beispielsweise mittels bioelektrischer Impedanzmessung erfasst werden. Gemäß einer sinnvollen Ausgestaltung der Erfindung ist eine herkömmliche (optische) Oximetrieinheit mit einer bioelektrischen Impedanzmesseinheit in einem einzigen Gerät kombiniert. Aus den mittels der bioelektrischen Impedanzmesseinheit gewonnenen Messsignalen kann die Zusammensetzung des untersuchten Körpergewebes bestimmt werden. Auf dieser Grundlage kann dann aus den oximetrischen Signalen mittels der Auswertungseinheit der Messvorrichtung die kapillare Sauerstoffsättigung im Gewebe ermittelt werden.

Eine sinnvolle Weiterbildung der erfindungsgemäßen Messvorrichtung sieht vor, dass die bioelektrische Impedanzmesseinheit außerdem zur Erfassung von globalen Gewebeparametern, wie globaler Fettgehalt und/oder globaler Wassergehalt, ausgebildet ist. Hierdurch wird die Funktionalität der erfindungsgemäßen Messvorrichtung erweitert. Die bioelektrische Impedanzmesseinheit der erfindungsgemäßen Messvorrichtung kann derart ausgestaltet sein, dass damit sowohl lokale wie auch globale Gewebeparameter gemessen werden können.

Die Zusammensetzung des Körpergewebes kann mit der erfindungsgemäßen Messvorrichtung auch optisch bestimmt werden. Hierzu kann die Einheit zur Erfassung von lokalen Gewebeparametern eine optische Strahlungsquelle und einen Photosensor umfassen. Das Prinzip der optischen Bestimmung des Körperfettgehalts mittels Infrarotlicht ist aus dem Stand der Technik bekannt.

Gemäß einer vorteilhaften Ausgestaltung umfasst die erfindungsgemäße Vorrichtung einen Wärmesensor zur Bestimmung der lokalen Wärmeproduktion, wobei die Auswertungseinheit zur Bestimmung der lokalen metabolischen Parameter unter Berücksichtigung der Signale des Wärmesensors eingerichtet ist. Vorzugsweise ist mittels des Wärmesensors eine orts-, zeit- und tiefenaufgelöste Wärmemessung am Messort möglich. Anhand des Wärmeaustauschs kann auf die lokale Stoffwechselaktivität zurückgeschlossen

werden. Außerdem ist der Wärmesensor zur Bestimmung der lokalen Durchblutung geeignet. Bezüglich näherer Hintergrundinformationen zur Wärmemessung wird auf die Veröffentlichung von Nitzan et al. verwiesen (Meir Nitzan, Boris Khanokh, „Infrared Radiometry of Thermally Insulated Skin for the Assessment of Skin Blood Flow“, Optical Engineering 33, 1994, No. 9, S. 2953 bis 2956). Insgesamt liefert der Wärmesensor Daten, die mit Vorteil zur Bestimmung von metabolischen Parametern im Sinne der Erfindung genutzt werden können.

Die arterielle Sauerstoffsättigung (SaO_2) und die venöse Sauerstoffsättigung (SvO_2) bestimmen abhängig von der Art des untersuchten Gewebes die kapillare (arteriovenöse) Sauerstoffsättigung (StO_2). Es gilt:

$$K * SvO_2 + (1 - K) * SaO_2 = StO_2,$$

wobei K ein gewebeabhängiger Korrekturfaktor ist, der vom Volumenverhältnis von Arterien zu Venen im untersuchten Gewebe abhängt. Im Mittel liegt dieser Wert etwas unter 0,5. Der für das jeweilige Gewebe maßgebliche Wert kann gemäß der Erfindung durch bioelektrische Impedanzmessung ermittelt werden, um dann aus der obigen Formel die venöse Sauerstoffsättigung zu bestimmen. Mittels Wärmemessung und/oder bioelektrischer Impedanz (Impedanzplethysmographie) kann die Durchblutung V, d. h. die durchblutungsbedingte Volumenschwankung des Gewebes bestimmt werden. Nach der Beziehung

$$VO_2 = V * (SaO_2 - SvO_2)$$

kann dann schließlich der lokale Sauerstoffverbrauch VO_2 berechnet werden, der ein Maß für die metabolische Aktivität am Messort darstellt.

Des Weiteren kann die erfindungsgemäße Messvorrichtung einen optischen Sensor zur orts aufgelösten Bestimmung des Hautkolorits umfassen. Auch anhand von lokalen Verfärbungen der Haut können Erkrankungen, wie zum Beispiel Entzündungen, Melanome usw., detektiert werden.

Durch eine zusätzliche EKG-Einheit zur Erfassung eines EKG-Signals über zwei oder mehr EKG-Elektroden wird der Funktionsumfang der erfindungsgemäßen Messvorrichtung vorteilhaft erweitert. Gemäß der Erfindung werden mittels der Messvorrichtung plethysmographische Signale und EKG-Signale kombiniert erfasst und ausgewertet. Die Auswertungseinheit der Messvorrichtung kann dann mit Vorteil zur Auswertung des zeitlichen Verlaufs der Volumenpulssignale und der EKG-Signale eingerichtet sein. Mittels einer geeigneten Programmsteuerung ist die Auswertungseinheit der erfindungsgemäßen Messvorrichtung dazu in der Lage, die R-Zacken in dem EKG-Signal automatisch zu erkennen. Damit wird automatisch der exakte Zeitpunkt des Herzschlags ermittelt. Weiterhin ist die Auswertungseinheit aufgrund ihrer Programmsteuerung dazu in der Lage, die Maxima in dem Volumenpulssignal zu erkennen. Anhand der Maxima in dem Volumenpulssignal ist der Zeitpunkt des Eintreffens einer bei einem Herzschlag ausgelösten Pulswelle an dem von der Messvorrichtung erfassten peripheren Messort feststellbar. Somit kann schließlich der zeitliche Abstand zwischen einer R-Zacke in dem EKG-Signal und dem darauf folgenden Maximum in dem Volumenpulssignal ermittelt werden. Dieser zeitliche Abstand ist ein Maß für die so genannte Pulswellengeschwindigkeit. Auf der Basis der Pulswellengeschwindigkeit kann einerseits eine Aussage über den Blutdruck getroffen werden. Eine Verkürzung der Pulswellengeschwindigkeit geht nämlich mit einer Erhöhung des Blutdrucks einher, während eine Verlängerung der Pulswellengeschwindigkeit auf eine Blutdruckerniedrigung schließen lässt. Eine exakte Bestimmung des Blutdrucks aus der Pulswellengeschwindigkeit ist allerdings nicht möglich, es können nur Tendenzen angegeben werden. Weiterhin ist die Pulswellengeschwindigkeit von der Dichte des Blutes und insbesondere von der Elastizität der Blutgefäßwandungen (beispielsweise der Aorta) abhängig. Aus der Elastizität der Blutgefäße kann wiederum auf eine ggf. vorliegende Arteriosklerose geschlossen werden. Es können in diese Auswertung auch die Absolutwerte der Herzfrequenz, die Herzfrequenz-Variabilität und entsprechende Arrhythmien des Herzens einbezogen werden. So können automatisch Arrhythmien wie Sinus Tachycardia, Sinus Bradycardia, Sinus Arrest und so genannte Escape Beats festgestellt werden. Anhand des EKG-Signals können außerdem Aussagen über die zeitliche Dauer der Vorhofkontraktion des Herzens bei einem Herzschlag, die zeitliche Dauer der Herzkammerkontraktion sowie die Dauer der Relaxation der Herzkammer usw.

festgestellt werden. Außerdem sind Vordiagnosen bezüglich so genannter Blocks in der Leitung der elektrischen Erregungssignale am Herzen (AV-Block, Bündle Branch-Block usw.) und auch bezüglich Durchblutungsstörungen oder Infarkten möglich. Weitere Irregularitäten im Pulsverlauf sind anhand des
5 Volumenpulssignals feststellbar.

Durch die Kombination der Auswertung des EKG-Signals und des Volumen-
pulssignals bei der automatischen Auswertung ist die erfindungsgemäße
Messvorrichtung zur funktionalen Bewertung des Gefäßsystems des Patienten
selbsttätig in der Lage. Auf der Grundlage der automatisch ausgewerteten
10 Signale kann die erfindungsgemäße Vorrichtung den (globalen) kardiovas-
kulären Zustand oder allgemein die Fitness des Benutzers grob einschätzen und
bei Anzeichen einer Arteriosklerose oder sonstiger Herz-Kreislauf-Probleme ein
entsprechendes Warnsignal oder einen leicht interpretierbaren Fitness- oder
Risikoindikator für den Benutzer der Vorrichtung erzeugen. Somit kann die
15 erfindungsgemäße Messvorrichtung vorteilhaft zur Selbstdiagnose von Herz-
Kreislauf-Erkrankungen verwendet werden.

Besonders vorteilhaft ist die erfindungsgemäße Kombination der vorgenannten
Messverfahren, nämlich der Oximetrie, der bioelektrischen Impedanzmessung
und der Wärmemessung. Mittels der Auswertungseinheit der Vorrichtung
20 können sämtliche Messsignale ausgewertet werden, um daraus die arterielle,
die kapillare und die venöse Sauerstoffsättigung und daraus wiederum die
lokale Stoffwechselaktivität zu bestimmen. Dadurch wird eine hohe Effektivität
und Zuverlässigkeit bei der Erkennung und Lokalisierung von pathologischen
Veränderungen erreicht. Diese wird durch zusätzliche Berücksichtigung des
25 lokalen Hautkolorits noch verbessert. Die zusätzliche EKG-Messung erlaubt, wie
oben ausgeführt, Aussagen bezüglich des Status des Herz-Kreislauf-Systems
des Benutzers. Sämtliche Parameter können mit Vorteil zu einem globalen
Index zusammengefasst werden, der für den Benutzer leicht interpretierbar ist
und ihm einen direkten und fundierten Hinweis auf seinen allgemeinen
30 Gesundheitszustand gibt.

Die Kombination der verschiedenen Messverfahren, die in der
erfindungsgemäßen Messvorrichtung, wie oben beschrieben, zusammengefasst

sind, ist weiterhin vorteilhaft, weil dadurch eine nicht-invasive Messung der Glukosekonzentration möglich ist, wie im Folgenden erläutert wird:

Die erfindungsgemäße Messvorrichtung dient zur Messung und zur Auswertung von Daten, die durch den Stoffwechsel beeinflusst werden. Es leuchtet
5 unmittelbar ein, dass dabei der Energiehaushalt und die Zusammensetzung der von einem Benutzer der Messvorrichtung aufgenommenen Nahrung eine große Rolle spielen. Die Nährstoffe, die am Stoffwechsel beteiligt sind, sind bekanntlich im Wesentlichen Kohlenhydrate, Fette und Eiweiße. Kohlenhydrate werden zur weiteren Verarbeitung in Glukose, Eiweiße in Aminosäuren, und
10 Fette in Fettsäuren umgewandelt. Die Energieträger werden dann wiederum in den Zellen des Körpergewebes zusammen mit Sauerstoff unter Abgabe von Energie zu ATP (Adenosintri-phosphorsäure) umgewandelt. ATP ist der eigentliche körpereigene Energieträger. Die Verwendung von Glukose zur Erzeugung von ATP ist bevorzugt. Wenn die Erzeugung von ATP aus Glukose
15 jedoch (z. B. wegen eines Mangels an Insulin) gehemmt ist, findet stattdessen eine verstärkte Fettsäure-Oxidation statt. Der Sauerstoffverbrauch ist bei diesem Prozess allerdings ein anderer.

Die Reaktion des Metabolismus des menschlichen Körpers auf eine Nahrungsaufnahme hängt, wie zuvor erwähnt, von der Zusammensetzung der
20 Nahrung charakteristisch ab. So reagiert beispielsweise das vaskuläre System des Körpers in Abhängigkeit davon, wie viel Energie der Körper zur Verdauung der aufgenommenen Speisen benötigt. Anhand der mittels der erfindungs-
gemäßen Messvorrichtung bestimmaren Pulswellengeschwindigkeit sowie auch anhand der Blutdruckamplitude und des Pulses lässt sich die Reaktion des
25 Körpers auf die Nahrungsaufnahme bestimmen. Hierzu ist zweckmäßigerweise die Auswertungseinheit der erfindungsgemäßen Messvorrichtung zur Auswertung des zeitlichen Verlaufs der Pulswellengeschwindigkeit und zur Ermittlung der Zusammensetzung von einem Benutzer der Messvorrichtung
aufgenommener Nahrung anhand des zeitlichen Verlaufs der Pulswellen-
30 geschwindigkeit ab dem Zeitpunkt der Nahrungsaufnahme eingerichtet. Die Pulswellengeschwindigkeit, sowie auch die Blutdruckamplitude und der Puls ändern sich, sobald die Nahrungsaufnahme beginnt. Die Maxima und die jeweiligen Zeitpunkte der Maxima sind dabei beeinflusst durch die

Nahrungszusammensetzung. Der Verlauf und die absolute Höhe von Pulswellengeschwindigkeit, Blutdruckamplitude und Puls können herangezogen werden, um mittels der Auswertungseinheit der erfindungsgemäßen Messvorrichtung die Zusammensetzung der aufgenommenen Nahrung zu
5 bestimmen.

Der Metabolismus des menschlichen Körpers ist im Normalzustand, d. h. in Ruhe und in der so genannten thermoneutralen Zone, im Wesentlichen durch den Glukosehaushalt bestimmt. Daher kann die Glukosekonzentration in den Zellen des Körpergewebes in diesen Normalzustand als reine Funktion der
10 Wärmeproduktion und des Sauerstoffverbrauchs beschrieben werden. Es gilt:

$$[\text{Glu}] = f_1(\Delta T, \text{VO}_2),$$

wobei [Glu] für die Glukosekonzentration steht. Die Wärmeproduktion ΔT kann mittels des Wärmesensors der erfindungsgemäßen Messvorrichtung z.B. aus der Differenz zwischen der arteriellen Temperatur und der Temperatur, welche die Hautoberfläche bei perfekter thermischer Isolierung erreichen würde,
15 bestimmt werden ($\Delta T = T_{\text{a}} - T_{\text{A(neutral)}}$). $f_1(\Delta T, \text{VO}_2)$ gibt die funktionale Abhängigkeit der Glukosekonzentration von der Wärmeproduktion und vom Sauerstoffverbrauch an. Der Sauerstoffverbrauch ergibt sich, wie oben beschrieben, aus dem Unterschied zwischen venöser und arterieller Sauerstoffsättigung und der
20 Durchblutung. Zur Bestimmung der Glukosekonzentration während bzw. direkt nach der Nahrungsaufnahme muss jedoch ein Korrekturterm berücksichtigt werden, der den Anteil des Fettstoffwechsels am Energiehaushalt wiedergibt. Es gilt dann:

$$[\text{Glu}] = f_1(\Delta T, \text{VO}_2) + X * f_2(\Delta T, \text{VO}_2)$$

X ist ein Faktor, der nach der Nahrungsaufnahme negativ ist. Dabei hängt X von der Zusammensetzung der aufgenommenen Nahrung ab. Insbesondere ist X davon abhängig, in welchem Verhältnis Fett und Kohlenhydrate am Metabolismus beteiligt sind. Der Faktor X lässt sich, wie oben beschrieben, anhand des zeitlichen Verlaufs der Pulswellengeschwindigkeit bestimmen. X ist
30 0, wenn reine Kohlenhydrate oder direkt Glukose aufgenommen werden. Der

Betrag von X steigt an, je größer der Anteil von Fett an der aufgenommenen Nahrung ist. Zur Bestimmung des Korrekturfaktors X aus dem zeitlichen Verlauf der Pulswellengeschwindigkeit, der Blutdruckamplitude und/oder des Pulses wird normalerweise eine Eichung der erfindungsgemäßen Messvorrichtung zur
 5 Anpassung an den jeweiligen Benutzer der Vorrichtung erforderlich sein. f_2 (ΔT , VO_2) gibt für den Fettstoffwechsel die funktionale Abhängigkeit der Glukosekonzentration von der Wärmeproduktion und vom Sauerstoffverbrauch an.

Die Auswertungseinheit der erfindungsgemäßen Messvorrichtung kann somit
 10 zur Bestimmung der lokalen Glukosekonzentration aus dem lokalen Sauerstoffverbrauch und der lokalen Wärmeproduktion eingerichtet sein. Hierzu muss die Messvorrichtung die geeigneten Messmodalitäten aufweisen. Die Ermittlung des Sauerstoffverbrauchs, kann, wie oben erläutert, durch die Kombination der Oximetrie mit der bioelektrischen Impedanzmessung erfolgen.
 15 Zur Ermittlung der Wärmeproduktion ist dann noch zusätzlich ein geeigneter Wärmesensor erforderlich. Um schließlich die Glukosekonzentration nach dem oben angegebenen funktionalen Zusammenhang berechnen zu können, muss noch der Korrekturfaktor X, beispielsweise aus dem zeitlichen Verlauf der Pulswellengeschwindigkeit, ermittelt werden. Dies kann, wie ebenfalls oben
 20 erläutert, durch kombinierte Messung von EKG-Signalen und plethysmographischen Signalen erfolgen. Zur Bestimmung der Glukosekonzentration sind also zweckmäßigerweise in der erfindungsgemäßen Messvorrichtung ein Pulsoximeter, eine EKG-Einheit, eine bioelektrische Impedanzmeseinheit sowie ein Wärmesensor kombiniert.

25 Die zuvor skizzierte Methode erlaubt zunächst nur eine Bestimmung der intrazellulären Glukosekonzentration. Mit der Blutglukosekonzentration besteht vereinfacht der folgende Zusammenhang:

$$[\text{Glu}]_{\text{zeie}} = a + b \cdot \ln(c \cdot [\text{Glu}]_{\text{BiUt}})$$

Die Konstanten a, b und c hängen von der individuellen Physiologie des
 30 Benutzers der Messvorrichtung ab. Somit kann die Auswertungseinheit der erfindungsgemäßen Messvorrichtung weiterhin eingerichtet sein zur

Bestimmung des Blutglukosespiegels aus der lokalen Glukosekonzentration, wobei von der Physiologie des Benutzers der Messvorrichtung abhängige Parameter berücksichtigt werden müssen. Diese Parameter können durch entsprechende Eichung bestimmt werden, beispielsweise durch Vergleich mit in
5 herkömmlicher Weise invasiv bestimmten Blutglukosewerten.

Die erfindungsgemäße Vorrichtung kann weiterhin eine Datenübertragungs-
schnittstelle umfassen zur Übertragung der mittels der Auswertungseinheit
ermittelten Parameter an einen Personalcomputer (des Arztes), beispielsweise
über das Internet, oder an ein anderes Gerät. Hierbei kann es sich um eine
10 übliche drahtgebundene oder auch um eine drahtlose Schnittstelle
(beispielsweise nach dem DECT-, GSM-, UMTS- oder Bluetooth-Standard)
handeln. Eine Datenübertragung über Infrarotdatenkommunikation oder
Ultraschall ist ebenfalls denkbar.

Eine besonders sinnvolle Ausgestaltung der erfindungsgemäßen Messvor-
richtung ergibt sich, wenn diese eine Speichereinheit zur Speicherung der
mittels der Auswertungseinheit ermittelten Parameter aufweist. Mittels der
Speichereinheit können einerseits der Verlauf einer Erkrankung und
andererseits die Effekte einer entsprechenden Therapie verfolgt und
dokumentiert werden. Andererseits können die in der Speichereinheit
20 abgespeicherten Daten vom behandelnden Arzt ausgelesen und ausgewertet
werden, um eine detaillierte Zustandsdiagnostik durch den Arzt zu ermöglichen.
Sinnvoll ist es weiterhin, wenn die erfindungsgemäße Vorrichtung eine
Diagnoseeinheit zur Bewertung der mittels der Auswertungseinheit ermittelten
Parameter und zur Registrierung von Veränderungen der Parameter in
25 Abhängigkeit vom Messort und von der Messzeit aufweist. Demgemäß hat die
erfindungsgemäße Vorrichtung einen modularen Aufbau. Die Auswertungs-
einheit ist lediglich dafür zuständig, die erfassten Signale auszuwerten, um
daraus die für die Diagnostik erforderlichen Parameter in der oben
beschriebenen Art und Weise zu bestimmen. Diese Parameter werden dann von
30 der Diagnoseeinheit weiter verarbeitet, um daraus Rückschlüsse bezüglich
etwaiger Erkrankungen zu ziehen. Die Diagnoseeinheit ist auch dafür zuständig,
insbesondere bei Verwendung der Messvorrichtung zur Selbstdiagnose durch

einen Benutzer, das Vorliegen einer Erkrankung automatisch zu erkennen und gegebenenfalls ein entsprechendes Warnsignal für den Benutzer zu erzeugen.

Sinnvollerweise ist also die Diagnoseeinheit der erfindungsgemäßen Mess-
vorrichtung zur Bestimmung des Status des Herz-Kreislauf-Systems aus den
5 mittels der Auswertungseinheit ermittelten Parametern eingerichtet. Gemäß
einer besonders vorteilhaften Ausgestaltung der Erfindung ist die Diagnose-
einheit außerdem zur Berechnung eines globalen Fitnessindex auf der Basis
des Status des Herz-Kreislauf-Systems und den (mittels bioelektrischer
Impedanzmessung erfassten) globalen Gewebeparametern eingerichtet. Somit
10 können die globalen Gewebeparameter genutzt werden, um den globalen
Fitnessindex zu erhalten, der besonders aufschlussreich Auskunft über den
momentanen Gesundheitszustand des Benutzers gibt. Zur Bestimmung des
globalen Fitnessindex können sämtliche erfassten Messwerte des Benutzers
einbezogen werden. Gegebenenfalls wird eine Mittelung über einen
15 vorgebbaren Zeitraum durchgeführt. Neben den kardiovaskulären Messwerten
und den globalen Gewebeparametern (globaler Fettgehalt, globaler
Wassergehalt) können auch die lokalen Gewebeparameter sowie die lokalen
metabolischen Parameter (z. B. lokaler Sauerstoffverbrauch) mit berücksichtigt
werden. Das Ergebnis ist dann der globale Fitnessindex als einzelner Wert, der
20 für den Benutzer der Messvorrichtung besonders einfach interpretierbar ist.

Zumindest die optische Messeinheit der erfindungsgemäßen Messvorrichtung
arbeitet auf der Basis von optischen Messverfahren. Aus diesem Grund sollte
die Vorrichtung wenigstens eine Strahlungsquelle zur Bestrahlung des
untersuchten Körpergewebes mit elektromagnetischer Strahlung, und
25 wenigstens einen Strahlungssensor zur Bestimmung der von dem
Körpergewebe gestreuten und/oder transmittierten elektromagnetischen
Strahlung aufweisen. Als Strahlungsquelle kommen übliche Leuchtdioden oder
auch Laserdioden in Frage, die optische Strahlung, d.h. Licht im
entsprechenden Spektralbereich emittieren. Als besonders vorteilhaft hat es sich
30 erwiesen, wenn mit der erfindungsgemäßen Vorrichtung die Strahlungs-
absorption im untersuchten Körpergewebe bei mindestens drei unterschied-
lichen Lichtwellenlängen gemessen wird, um daraus die Sauerstoffkonzentration
des Blutes und die Durchblutung des Gewebes zu bestimmen.

Gemäß einer sinnvollen Ausgestaltung weist die optische Messeinheit der erfindungsgemäßen Messvorrichtung wenigstens zwei Strahlungssensoren zur Detektion der von dem Körpergewebe gestreuten und/oder transmittierten Strahlung auf, wobei die Strahlungssensoren in unterschiedlichem Abstand zur Strahlungsquelle angeordnet sind. Dies eröffnet die Möglichkeit, Rückschlüsse auf die jeweils im Körpergewebe von der Strahlung zurückgelegte Strecke zu ziehen. Auf dieser Basis kann die Sauerstoffkonzentration im Blut und im Gewebe in unterschiedlich tiefen Gewebeschichten untersucht werden. Dabei kann ausgenutzt werden, dass die Messsignale aus den tiefer liegenden Gewebeschichten stärker vom arteriellen Blut beeinflusst sind, während in den oberflächennäheren Regionen die Strahlungsabsorption stärker von dem Blut im kapillaren Gefäßsystem beeinflusst ist.

Vorteilhaft ist eine Ausgestaltung der erfindungsgemäßen Messvorrichtung, bei welcher wenigstens zwei Strahlungsquellen vorgesehen sind, welche unterschiedliche Volumenbereiche des untersuchten Körpergewebes bestrahlen. Hierdurch lässt sich eine differenzielle Messung der Lichtabsorption einfach realisieren. Dies ermöglicht es, Metabolismus-induzierte Änderungen der Durchblutung des untersuchten Körpergewebes mit sauerstoffreichem bzw. sauerstoffarmem Blut zu untersuchen. Dabei wird ausgenutzt, dass sich in Abhängigkeit von der metabolischen Aktivität des Gewebes der lokale Sauerstoffverbrauch verändert. Die Bestimmung des veränderlichen Sauerstoffverbrauchs erlaubt wiederum Rückschlüsse auf den lokalen Energieverbrauch, der mit dem Sauerstoffverbrauch direkt korreliert ist. Besonders interessant ist, dass dies wiederum Rückschlüsse auf den Glukosespiegel zulässt. Somit erlaubt die erfindungsgemäße Messvorrichtung vorteilhafterweise auch eine nicht-invasive Bestimmung des Blutglukosespiegels.

Die zwei Strahlungsquellen der optischen Messeinheit der erfindungsgemäßen Messvorrichtung sollten so ausgelegt sein, dass die von diesen jeweils bestrahlten Volumenbereiche hinsichtlich der Durchblutung mit sauerstoffarmem bzw. sauerstoffreichem Blut unterschiedlich betroffen sind. Dies kann z. B. dadurch erreicht werden, dass die wenigstens zwei Strahlungsquellen unterschiedliche räumliche Abstrahlcharakteristiken haben. So können als Strahlungsquellen z. B. eine Leuchtdiode und ein Laser verwendet werden, die

ähnliche Wellenlängen (z. B. 630 nm und 650 nm) haben. Die beiden Strahlungsquellen unterscheiden sich aber durch den Öffnungswinkel der Abstrahlung. Während z. B. die Leuchtdiode unter einem großen Öffnungswinkel in das untersuchte Körpergewebe einstrahlt, tritt das Licht der Laserdiode unter einem sehr kleinen Öffnungswinkel in das Körpergewebe ein. Dies hat zur Folge, dass mit den beiden Strahlungsquellen unterschiedliche Volumenbereiche des Körpergewebes erfasst werden. Aufgrund des großen Öffnungswinkels wird von der Leuchtdiode ein größerer Volumenbereich der nicht-durchbluteten Epidermis erfasst als von dem Laser. Die undurchblutete Epidermis ist von einer Änderung der Hämoglobinkonzentration praktisch nicht betroffen. Dementsprechend ist die Intensität der von dem Körpergewebe gestreuten und/oder transmittierten Strahlung der Leuchtdiode weniger stark von einer Änderung der Hämoglobinkonzentration abhängig als die Intensität der Strahlung des Lasers. Voraussetzung ist, dass die Wellenlänge der von den beiden Strahlungsquellen jeweils emittierten Strahlung so gewählt wird, dass die Strahlung unterschiedlich stark durch Oxihämoglobin bzw. Desoxihämoglobin absorbiert wird. Die Wellenlänge sollte daher zwischen 600 und 700 nm, vorzugsweise zwischen 630 und 650 nm liegen.

Die Auswertungseinheit der erfindungsgemäßen Messvorrichtung kann mit Vorteil zur Bestimmung des wenigstens einen lokalen metabolischen Parameters aus der von dem Körpergewebe gestreuten und/oder transmittierten Strahlung der beiden Strahlungsquellen ausgebildet sein. Wenn in dem untersuchten Körpergewebe Sauerstoff verbraucht wird, wird Oxihämoglobin in Desoxihämoglobin umgewandelt. Durch einen Vergleich der aus den unterschiedlichen Volumenbereichen des Körpergewebes stammenden Strahlung der beiden Strahlungsquellen kann die Änderung des Konzentrationsverhältnisses von Oxihämoglobin und Desoxihämoglobin festgestellt werden. Hieraus ergibt sich wiederum der lokale Sauerstoffverbrauch und daraus letztlich der Blutglukosespiegel. Somit ist die Auswertungseinheit der erfindungsgemäßen Messvorrichtung sinnvollerweise eingerichtet zur Bestimmung des lokalen Sauerstoffverbrauchs und/oder des Blutglukosespiegels anhand der Intensitäten der von dem Körpergewebe gestreuten und/oder transmittierten Strahlung der beiden Strahlungsquellen.

Gemäß einer besonders vorteilhaften Ausgestaltung sind sämtliche Komponenten der erfindungsgemäßen Messvorrichtung in einem gemeinsamen Gehäuse angeordnet. Dabei weist die Vorrichtung an einem Ende des Gehäuses einen Messkopf mit den benötigten Messsensoren auf. Auf diese
5 Weise ist die Messvorrichtung handführbar und kann, entweder vom Benutzer selbst oder vom behandelnden Arzt, genutzt werden, um den gesamten Körper systematisch auf krankhafte Veränderungen hin zu untersuchen. In das Gehäuse sollte eine Anzeigeeinheit integriert sein, mittels welcher die lokale Sauerstoffkonzentration des Blutes und/oder die gemäß der Erfindung
10 ermittelten lokalen metabolischen Parameter für den Arzt oder den Benutzer anzeigbar sind.

Der Messkopf der erfindungsgemäßen Messvorrichtung umfasst sinnvollerweise wenigstens eine optische Strahlungsquelle und wenigstens zwei Sensoren, die in unterschiedlichem Abstand zur Strahlungsquelle an dem Messkopf
15 angeordnet sind. Mittels der Strahlungsquelle wird Licht bei verschiedenen Lichtwellenlängen erzeugt. Mittels der Sensoren wird die vom untersuchten Körpergewebe zurückgestreute Strahlung gemessen, um aus der Strahlungsabsorption auf die Sauerstoffkonzentration zurückzuschließen. Die in unterschiedlichem Abstand zur Strahlungsquelle angeordneten Sensoren erlauben
20 es, - wie oben erläutert - die Strahlungsabsorption in unterschiedlich tiefen Gewebeschichten zu untersuchen. Dies ermöglicht es, die Sauerstoffkonzentration im Gewebe von der arteriellen Sauerstoffkonzentration zu unterscheiden.

Weiterhin kann der Messkopf der erfindungsgemäßen Messvorrichtung
25 Elektroden zur bioelektrischen Impedanzmessung und zur EKG-Messung umfassen. Für eine Zweipunktmessung kann eine weitere EKG-Elektrode in das Gehäuse der Messvorrichtung integriert sein. Diese weitere EKG-Elektrode kann gleichzeitig zur bioelektrischen Impedanzmessung, nämlich zur Messung von globalen Gewebeparametern, wie globaler Fettgehalt und/oder globaler
30 Wassergehalt, genutzt werden. Die Anordnung der Elektroden ist zweckmäßigerweise so gewählt, dass eine bioelektrische Impedanzmessung von einem Arm des Benutzers zum anderen Arm möglich ist. Außerdem kann in den Messkopf wenigstens ein Wärmesensor zur Bestimmung der über die Haut-

Oberfläche abgegebenen Wärme integriert sein. Besonders praktisch ist es, wenn bei der erfindungsgemäßen Messvorrichtung die für die verschiedenen Messverfahren (Oximetrie, bioelektrische Impedanzmessung, Wärmemessung, EKG, Messung des Hautkolorits) benötigten Messsensoren in einem einzigen Messkopf zusammengefasst sind. Durch diese Ausgestaltung des Messkopfes ist sichergestellt, dass sämtliche Messwerte gleichzeitig an dem jeweils interessierenden Messort erfasst werden.

Die erfindungsgemäße Messvorrichtung kann miniaturisiert ausgebildet sein und kann in einen am Körper eines Benutzers getragenen Gegenstand, wie beispielsweise eine Armbanduhr, ein Brillengestell oder auch ein Kleidungsstück, integriert sein. Es ist dann eine kontinuierliche Überwachung des Gesundheitszustands möglich.

Die Erfindung betrifft weiterhin ein Verfahren zur Erfassung und Auswertung von physiologischen Parametern, wobei

- i 5 - mittels einer optischen Messeinheit oximetrische und/oder plethysmographische Messsignale von Körpergewebe erfasst werden,
- und mittels einer Auswertungseinheit die oximetrischen und plethysmographischen Messsignale verarbeitet werden, und zwar zur Bestimmung des Pulses und/oder der lokalen Sauerstoffkonzentration.

Die der Erfindung zugrunde liegende Aufgabe wird bei einem solchen Verfahren dadurch gelöst, dass mittels der Auswertungseinheit wenigstens ein lokaler metabolischer Parameter, insbesondere der lokale Sauerstoffverbrauch, aus den oximetrischen Signalen bestimmt wird.

Sinnvollerweise werden zusätzlich lokale Gewebeparameter, wie Fettgehalt, Wassergehalt und/oder Durchblutung, erfasst, wobei der wenigstens eine lokale metabolische Parameter aus den oximetrischen Signalen und den lokalen Gewebeparametern bestimmt wird. Die lokalen Gewebeparameter können mittels bioelektrischer Impedanzmessung, optisch oder mittels Wärmemessung erfasst werden. Sinnvoll ist es, zusätzlich die Erfassung eines

EKG-Signals durchzuführen. Mittels der Auswertungseinheit kann ein kardiovaskulärer Parameter aus den plethysmographischen Messsignalen und dem EKG-Signal bestimmt werden. Besonders sinnvoll ist es, wie oben ausgeführt, wenn zusätzlich globale Gewebeparameter, wie Fettgehalt und/oder Wassergehalt, erfasst werden. Es kann dann basierend auf dem mittels der Auswertungseinheit gewonnenen kardiovaskulären Parameter und den globalen Gewebeparametern ein globaler Fitnessindex berechnet werden. Bei einer besonders vorteilhaften Variante des erfindungsgemäßen Verfahrens werden mittels der optischen Messeinheit unterschiedliche Volumenbereiche des untersuchten Körpergewebes bestrahlt, wobei - wie oben beschrieben - der wenigstens eine lokale metabolische Parameter aus der von dem Körpergewebe in den unterschiedlichen Volumenbereichen gestreuten und/oder transmittierten Strahlung bestimmt wird. Hierzu kann die optische Messeinheit wenigstens zwei Strahlungsquellen mit unterschiedlichen räumlichen Abstrahlcharakteristiken umfassen, wobei der lokale Sauerstoffverbrauch und/oder der Blutglukosespiegel anhand der Intensitäten der von dem Körpergewebe gestreuten und/oder transmittierten Strahlung der beiden Strahlungsquellen bestimmt werden, die lokalen Gewebeparameter mittels ortsaufgelöster Wärmemessung erfasst werden.

Außerdem kann bei dem erfindungsgemäßen Verfahren die lokale zelluläre Glukosekonzentration aus dem lokalen Sauerstoffverbrauch und der lokalen Wärmeproduktion bestimmt werden. Die Bestimmung der lokalen Glukosekonzentration sollte - wie oben erläutert - unter Einbeziehung von Daten betreffend die Zusammensetzung von einem Benutzer der Messvorrichtung aufgenommener Nahrung erfolgen. Zur Bestimmung des Blutglukosespiegel aus der lokalen Glukosekonzentration ist es zweckmäßig, von der Physiologie des Benutzers der Messvorrichtung abhängige Parameter zu berücksichtigen.

Ausführungsbeispiele der Erfindung werden im Folgenden unter Bezugnahme auf die Zeichnungen näher erläutert. Es zeigen:

19

	Figur 1	schematische Ansicht der erfindungsgemäßen Messvorrichtung mit vergrößerter Darstellung des Messkopfes;
5	Figur 2	Darstellung der erfindungsgemäßen Vorrichtung anhand eines Blockdiagramms;
	Figur 3	Blockdiagramm-Darstellung der Oximetrie-einheit der erfindungsgemäßen Messvorrichtung;
10	Figur 4	Blockdiagramm-Darstellung der Wärmemesseinheit;
	Figur 5	Blockdiagramm-Darstellung der Impedanzmesseinheit der Messvorrichtung;
	Figur 6	Blockdiagramm-Darstellung der EKG-Einheit der Messvorrichtung;
15	Figur 7	Darstellung der Signalauswertung mittels der erfindungsgemäßen Messvorrichtung;
	Figur 8	schematische Darstellung einer alternativen Anordnung von Strahlungsquellen, Strahlungssensoren und Elektroden zur bioelektrischen Impedanzmessung bei der erfindungsgemäßen Messvorrichtung;
20	Figur 9	Illustration einer Realisierungsmöglichkeit einer erfindungsgemäßen Messvorrichtung mit zwei Strahlungsquellen.

25 In der Figur 1 ist die erfindungsgemäße Messvorrichtung insgesamt mit der Bezugsziffer 1 bezeichnet. Sämtliche Komponenten der Vorrichtung sind in einem gemeinsamen Gehäuse 2 untergebracht, so dass das Gerät per Hand an beliebigen Messorten am Körper eines Benutzers zum Einsatz gebracht werden kann. Am vorderen Ende des Gehäuses 2 ist ein Messkopf 3 angeordnet, in den
30 die verschiedenen Messsensoren der Vorrichtung 1 integriert sind. Diese werden bei der Verwendung der Messvorrichtung 1 auf die Hautoberfläche des

Benutzers am Messort aufgesetzt. Der Messkopf umfasst eine zentral angeordnete Leuchtdiode 4, die dazu in der Lage ist, Licht bei verschiedenen Wellenlängen zu emittieren. Hierzu können beispielsweise verschiedene lichtemittierende Halbleiterelemente in einem gemeinsamen Gehäuse der Leuchtdiode 4 untergebracht sein. Ebenso denkbar ist die Verwendung von Lichtwellenleitern, um das Licht von verschiedenen Lichtquellen an die Unterseite des Messkopfes 3 zu führen. Des Weiteren umfasst der Messkopf 3 insgesamt sechs Photosensoren 5, die in unterschiedlichem Abstand zu der Lichtquelle 4 angeordnet sind. Zwei der Photosensoren 5 sind direkt neben der Lichtquelle 4 angeordnet. Zwei weitere Sensoren 5 befinden sich in einem mittleren Abstand von der Lichtquelle 4, während die zwei verbleibenden Sensoren 5 in maximalem Abstand zur Lichtquelle 4 angeordnet sind. Die unmittelbar neben der Lichtquelle 4 angeordneten Sensoren 5 empfangen hauptsächlich das an den oberen Hautschichten des Benutzers gestreute Licht. Demgegenüber sind die weiter von der Lichtquelle 4 entfernten Sensoren 5 geeignet, die Lichtabsorption in tieferen Gewebeschichten zu messen. Weiterhin ist unmittelbar neben der Lichtquelle 4 ein Wärmesensor 6 vorgesehen. Dadurch ist gewährleistet, dass die Bestimmung der Durchblutung anhand der Wärmemessung am selben Messort erfolgt wie die optische Messung. Außen am Messkopf 3 sind vier Elektroden 7 zur Messung der lokalen bioelektrischen Impedanz vorgesehen. Die Elektroden sind jeweils zweigeteilt und bestehen aus zwei voneinander elektrisch isolierten, separaten Kontaktflächen. Dabei dient jeweils eine der beiden Kontaktflächen zur Aufprägung eines elektrischen Stromes am Messort, während die andere Kontaktfläche zur Spannungsmessung genutzt wird. Auf diese Weise wird sichergestellt, dass die Messergebnisse nicht von den Kontaktwiderständen der Messelektroden beeinflusst sind. Die vier Elektroden 7 können bei der bioelektrischen Impedanzmessung in verschiedenen Kombinationen genutzt werden, um dadurch die Zuverlässigkeit des Messergebnisses zu optimieren. Zumindest eine der Elektroden 7 wird außerdem als EKG-Elektrode einer EKG-Einheit der Messvorrichtung 1 verwendet. In das Gehäuse 2 der Messvorrichtung 1 ist ein LCD-Display 8 als Anzeigeeinheit integriert. Das LCD-Display 8 dient zur Anzeige der lokalen Sauerstoffkonzentration des Blutes. Dabei werden separat die arterielle (SaO_2), die kapillare (StO_2) und die venöse (SvO_2) Sauerstoffsättigung angezeigt. Angezeigt wird weiterhin die ermittelte Herzfrequenz (HR),

der lokal bestimmte Fettgehalt des Gewebes (BF). Schließlich wird noch ein Blutglukosewert (BG) angezeigt. Außerdem ist am Gehäuse 2 ein Ein-/Ausschalter 9 angeordnet, der in üblicher Weise zur Aktivierung bzw. zur Deaktivierung des Gerätes dient. Die Betätigungsfläche des Ein-/Ausschalters 9 bildet außerdem die Kontaktfläche einer weiteren EKG-Elektrode, sodass eine einfache Zweipunktableitung des EKG-Signals des Benutzers der Vorrichtung erfolgen kann. Über die Kontaktfläche ist außerdem eine Arm-zu-Arm-Messung von globalen Gewebeparametern, wie globaler Fettgehalt und/oder globaler Wassergehalt, durch bioelektrische Impedanzmessung möglich.

Die Figur 2 zeigt schematisch den Aufbau der erfindungsgemäßen Messvorrichtung als Blockdiagramm. Die Vorrichtung 1 umfasst eine optische Messeinheit 100 zur optischen Messung der Sauerstoffkonzentration im Blutgefäßsystem des Körpergewebes am jeweiligen Messort. Die mittels der optischen Messeinheit 100 erfassten oximetrischen und plethysmographische Signale werden einer Analyseeinheit 110 zugeführt. Eine weitere wesentliche Komponente der Vorrichtung 1 ist eine Wärmemesseinheit 120 zur Bestimmung der lokalen Wärmeproduktion. Bei der Wärmemesseinheit 120 handelt es sich um einen speziellen Wärmesensor, welcher die jeweils untersuchte Körperstelle isoliert. Diese Stelle kann somit nur noch Wärme durch den Blutstrom aufnehmen oder abgeben. Daher ist es möglich, durch die zeitaufgelöste Messung der Temperatur die Durchblutung und die Wärmeproduktion zu bestimmen. Bei einer starken Durchblutung erreicht die untersuchte Körperstelle in sehr kurzer Zeit ihre maximale Temperatur. Bei geringer Durchblutung dauert dies länger. Zusätzlich kann über die Extrapolation der gemessenen Temperatur auf die arterielle Temperatur geschlossen werden, da die Temperatur am Ort der Messung nur durch die arterielle Temperatur und durch die lokale Wärmeproduktion bestimmt wird. Auch die mittels der Wärmemesseinheit 120 erfassten Messsignale werden der Analyseeinheit 110 zur Weiterverarbeitung zugeführt. Außerdem umfasst die Messvorrichtung 1 eine Impedanzmesseinheit 130, die zur Erfassung von lokalen Gewebeparametern mittels bioelektrischer Impedanzmessung dient. Die Messsignale der Impedanzmesseinheit 130 werden ebenfalls mittels der Analyseeinheit 110 verarbeitet. Schließlich ist gemäß der Erfindung noch eine EKG-Einheit 132 zur Erfassung eines EKG-Signals vorgesehen. Auch die EKG-Einheit 132 ist zur Verarbeitung

der EKG-Signale mit der Analyseeinheit 110 verbunden. Der optischen Messeinheit 100 sind die Lichtquelle 4 sowie die Lichtsensoren 5 des in der Figur 1 dargestellten Messkopfes 3 zugeordnet. Die Wärmemesseinheit 120 ist mit dem Wärmesensor 6 verbunden. Die Impedanzmesseinheit 130 erfasst Messsignale über die Elektroden 7 des Messkopfes 3. Die Analyseeinheit 110 führt eine Vorverarbeitung sämtlicher Messsignale durch. Hierzu durchlaufen die Signale ein Bandpass-Filter, um Störungen im Bereich der Netzfrequenz von 50 bzw. 60 Hz herauszufiltern. Des Weiteren werden die Signale einer Rauschunterdrückung unterzogen. Nach Passieren der Analyseeinheit 110 gelangen die aufbereiteten Signale der optischen Messeinheit 100, der Wärmemesseinheit 120, der Impedanz-Messeinheit 130 und der EKG-Einheit 132 in eine Auswertungseinheit 140. Die Auswertungseinheit 140 ist dafür zuständig, aus den Messsignalen die für die Diagnose wesentlichen Parameter zu berechnen. Aus den zeitabhängig aufgenommenen Messsignalen der Impedanzmesseinheit 130 wird zunächst die Zusammensetzung des untersuchten Körpergewebes (Wassergehalt, Fettgehalt usw.) berechnet. Aus den Signalen der optischen Messeinheit 100 wird die arterielle Sauerstoffsättigung und - unter Zugrundelegung der zuvor auf der Basis der Impedanzmessung ermittelten Gewebeparameter - die kapillare Sauerstoffsättigung berechnet. Weiterhin werden aus den Messsignalen der Wärmemesseinheit 120 und aus den plethysmographischen Daten, die aus der zeitabhängigen Impedanzmessung ableitbar sind, die Durchblutung und die arterielle Temperatur bestimmt. Aus den Signalen der EKG-Einheit 132 und denjenigen der optischen Messeinheit 100 wird die Pulswellengeschwindigkeit bestimmt. Schließlich werden mittels der Auswertungseinheit 140 aus den Ergebnissen sämtlicher zuvor durchgeführter Berechnungen die venöse Sauerstoffsättigung, und daraus weitere metabolische Parameter, insbesondere der lokale Sauerstoffverbrauch und die Glukosekonzentration am Messort berechnet. Die Berechnungsergebnisse werden mittels einer Diagnoseeinheit 150 interpretiert. Die Diagnoseeinheit 150 dient zur Bewertung der mittels der Auswertungseinheit 140 berechneten lokalen metabolischen Parameter. Die Auswertungseinheit 140 und die Diagnoseeinheit 150 sind zur Anzeige der Messresultate mit einer Grafikeinheit 160 verbunden, die ihrerseits die Anzeigeeinheit 8 der Messvorrichtung 1 ansteuert. Die gewonnenen Daten sind in einer Speichereinheit 170 speicherbar, und zwar unter gleichzeitiger Speicherung des

Datums und der Uhrzeit der jeweiligen Messung. Außerdem ist eine Schnittstelleneinheit 180 vorgesehen, die zur Verbindung der Messvorrichtung 1 mit einem Computer oder einem anderen Kommunikationsgerät dient. Über die Schnittstelleneinheit 180 können sämtliche Daten und Parameter, insbesondere auch die in der Speichereinheit 170 gespeicherten Daten und Parameter, an einen nicht näher dargestellten PC eines behandelnden Arztes übertragen werden. Dort können die Daten detaillierter analysiert werden. Insbesondere können über einen längeren Zeitraum mit der Vorrichtung 1 aufgenommene Daten und Parameter auf Veränderungen hin untersucht werden, um daraus Schlussfolgerungen hinsichtlich der Entwicklung einer bestehenden Erkrankung ableiten zu können. Außerdem besteht die Möglichkeit, die erfindungsgemäße Messvorrichtung 1 als bloße Messdatenerfassungs- und -sendeeinheit zu benutzen, wobei die aufgenommenen Signale direkt an den PC des Arztes übertragen werden. Mittels des PCs können die entsprechenden Auswertungen und Berechnungen dann gegebenenfalls schneller und komfortabler durchgeführt werden.

Die Figur 3 illustriert den Aufbau der optischen Messeinheit 100 der erfindungsgemäßen Vorrichtung 1. Die optische Messeinheit 100 umfasst einen Mikrokontroller 190. Bestandteil des Mikrokontrollers 190 ist ein Timing-Generator 200. Dieser erzeugt Steuerungssignale, die einer Modulationseinheit 210 zugeführt werden. Dadurch wird die zeitliche Modulation der Lichtemission der Leuchtdiode 4 gesteuert. Die Leuchtdiode 4 ist über eine Regelungseinheit 220 mit der Modulationseinheit 210 verbunden. Die Intensität des von der Leuchtdiode 4 emittierten Lichtes ist außerdem über eine Leistungssteuerungseinheit 230 anpassbar. Die Leuchtdiode 4 ist dazu in der Lage, Licht bei zumindest drei verschiedenen Wellenlängen zu emittieren. Hierzu sind verschiedene Licht emittierende Halbleiterbauelemente in einem einzigen Gehäuse der Leuchtdiode 4 vereinigt. Mittels des Timing-Generators 200 wird die zeitliche Abfolge der Lichtemission bei den verschiedenen Lichtwellenlängen gesteuert. Die in den Messkopf 3 der Vorrichtung 1 integrierten Photosensoren 5 sind ebenso wie die Leuchtdiode 4 mit dem in der Figur 3 schematisch angedeuteten Körpergewebe 240 des Benutzers in Kontakt. In dem Körpergewebe 240 wird das Licht der Leuchtdiode 4 gestreut und entsprechend der Sauerstoffkonzentration des Blutes, das

das Gewebe 240 durchströmt, absorbiert. Das gestreute Licht wird von den Photosensoren 5 registriert. Der Photostrom jedes Photosensors 5 wird mittels eines Konverters 250 in eine Spannung umgewandelt, mittels eines Verstärkers 260 verstärkt und mittels eines Analog/Digital-Wandlers 270 in digitale Messsignale umgewandelt. Die Digitalsignale werden sodann einem Demodulator 280 zugeführt, der Bestandteil des Mikrokontrollers 190 ist. Der Demodulator 280 separiert die aufgenommenen Messsignale nach den entsprechenden Lichtwellenlängen und nach den unterschiedlichen Entfernungen zwischen den Photosensoren 5 und der Leuchtdiode 4. Schließlich werden die Signale an die Analyseeinheit 110 weitergegeben.

Anhand der Figur 4 wird der Aufbau der Wärmemesseinheit 120 der erfindungsgemäßen Messvorrichtung erläutert. Der Wärmesensor 6, der mit dem Körpergewebe 240 in Berührung ist, weist mehrere nicht näher dargestellte Temperaturmesselemente sowie ein wärmeleitendes Element auf. Sobald der Sensor 6 mit dem Gewebe 240 in Kontakt kommt, beginnt ein Wärmeaustausch. Mittels der Temperaturmesselemente wird die Temperatur an verschiedenen Stellen an dem wärmeleitenden Element des Sensors 6 gemessen. Hieraus kann die in dem Gewebe 240 lokal produzierte Wärme (orts-, zeit- und tiefenaufgelöst) bestimmt werden. Die mittels der Temperaturmesselemente erfassten Signale durchlaufen einen Impedanzwandler 290 sowie einen Verstärker 292 und werden mittels eines Analog/Digital-Wandlers 300 digitalisiert. Die digitalen Messsignale werden sodann der Analyseeinheit 110 zur weiteren Verarbeitung zugeführt. Ein geeigneter Wärmesensor 6 ist beispielsweise in der Veröffentlichung von Ok Kyung Cho et al. (Ok Kyung Cho, Yoon Ok Kim, Hiroshi Mitsumaki, Katsuhiko Kuwa, "Noninvasive Measurement of Glucose by Metabolite Heat Conformation Method", Clinical Chemistry 50, 2004, Nr. 10, S. 1894 bis 1898) beschrieben.

In der Figur 5 ist der Aufbau der Impedanzmesseinheit 130 der erfindungsgemäßen Messvorrichtung 1 dargestellt. Die Impedanzmesseinheit 130 umfasst mehrere Elektroden 7. Über Kontaktflächen T wird dem untersuchten Körpergewebe 240 ein Wechselstrom aufgeprägt, der mittels einer Stromquelle 310 erzeugt wird. Die Stromquelle 310 wird von einem Sinusgenerator 320 angesteuert. Die Frequenz des Wechselstroms variiert zwischen 20 kHz und

100 kHz. Über Kontaktflächen 7" wird eine Spannung als Messsignal am Körpergewebe 240 abgegriffen. Aus dem Verhältnis der gemessenen Spannung zu dem aufgeprägten Strom kann auf die lokale Impedanz des Körpergewebes 240 zurückgeschlossen werden. Hierzu wird die Spannung mittels
5 eines Verstärkers 330 verstärkt und mittels eines Filters 340 gefiltert, um Störsignale zu eliminieren. Wiederum erfolgt eine Digitalisierung mittels eines Analog/Digital-Wandlers 350. Die digitalisierten Messwerte werden wiederum der Analyseeinheit 110 zur weiteren Verarbeitung zugeführt.

Anhand der Figur 6 wird der Aufbau der EKG-Einheit 132 der erfindungsgemäßen Messvorrichtung veranschaulicht. Die EKG-Einheit 132 erfasst ein
10 EKG-Signal über EKG-Elektroden 7' bzw. 7". Es sind dies die Elektroden der Impedanzmesseinheit 130. Die Elektroden 7' und 7" haben also bei dem dargestellten Ausführungsbeispiel eine Doppelfunktion. Für eine brauchbare Zweipunktableitung des EKG-Signals ist eine weitere EKG-Elektrode 9
15 erforderlich, die in ausreichender räumlicher Entfernung von den Elektroden 7' und 7" mit dem Körper des Benutzers in Kontakt kommt. Die EKG-Elektrode 9 bildet bei dem Ausführungsbeispiel gleichzeitig die Bedienfläche des Ein-/Aus-schalters der Messvorrichtung 1. Somit sind sämtliche Elektroden in die Messvorrichtung 1 integriert. Separate, z. B. über Kabel angeschlossene
20 Elektroden sind (für eine einfache Zweipunktableitung des EKG-Signals) nicht zwingend erforderlich. Statt der Bedienfläche des Schalters der Messvorrichtung 1 kann ebenso gut eine zusätzliche Elektrode am Gehäuse 2 der Messvorrichtung 1 angeordnet werden. Das abgeleitete EKG-Signal wird mittels Verstärker 360 und Filter 370 aufbereitet. Nach Passieren eines weiteren
25 Analog/Digital-Wandlers 380 wird das Signal an die Analyseeinheit 110 weitergegeben.

Der Figur 7 ist die Vorgehensweise bei der Ermittlung der physiologischen Parameter gemäß der Erfindung zu entnehmen. Von der optischen Mess-
30 einheit 100 werden mittels Pulsoximetrie ein arterieller Sauerstoffsättigungswert 390, mittels Photoplethysmographie ein Volumenpulssignal 400, und mittels Reflexions-/Absorptionsmessung ein Hautkoloritwert 410 geliefert. Außerdem liefert die optische Messeinheit 100 einen Differenzwert 420 zwischen systolischem und diastolischem Volumenpuls. Mittels der

Wärmemesseinheit 120 wird die Durchblutung 430 ermittelt. Gleichzeitig kann die Durchblutung 430 auch mittels der optischen Messeinheit 100 gewonnen werden. Die Signale der Impedanzmesseinheit 130 ergeben die lokalen Gewebeparameter 440 und ebenfalls den Volumenpuls 400. Die EKG-Einheit 132 liefert Daten 460 über etwaige Arrhythmien und über die Reizleitung am Herzmuskel. Außerdem ist das eigentliche EKG-Signal 470 mit den Zeitpunkten der Herzaktivitäten verfügbar. Auf der Basis der Gewebeparameter 440 und der arteriellen Sauerstoffsättigung 390 wird die kapillare, d. h. die arteriovenöse Sauerstoffsättigung 480 ermittelt. Daraus wird dann wiederum unter Einbeziehung der Gewebeparameter 440 die venöse Sauerstoffsättigung 490 bestimmt. Aus den Herzschlagzeitpunkten 470 und dem zeitlichen Verlauf der Volumenpulssignale 400 lässt sich die Pulswellengeschwindigkeit 500 ermitteln. Aus diesen Daten kann - wie oben im Einzelnen erläutert - die intrazelluläre Glukosekonzentration des Benutzers bestimmt werden. In die Berechnung der Glukosekonzentration wird der lokale Sauerstoffverbrauch 510 einbezogen, der sich aus der Durchblutung 430, der arteriellen Sauerstoffsättigung 390 und der venösen Sauerstoffsättigung 490 ergibt. Einbezogen wird außerdem die mittels der Wärmemesseinheit 120 ermittelte lokale Wärmeproduktion. Zusätzlich kann ein kardiovaskulärer Index aus den Arrhythmien 460, der Pulswellengeschwindigkeit 500 und der Differenz zwischen systolischem und diastolischem Volumenpuls 420 ermittelt werden. Hierbei können weiterhin der Koloritwert 410 und der Körperfettgehalt 440 einbezogen werden.

In der Figur 8 ist eine alternative Sensoranordnung der erfindungsgemäßen Messvorrichtung dargestellt. Ähnlich der Darstellung in der Figur 1 zeigt die Figur 8 eine Ansicht der mit der Haut des Benutzers der Vorrichtung in Kontakt zu bringenden Oberfläche des Messkopfes. Die Darstellung in der Figur 8 ist stark vergrößert. Die von den Sensorelementen beanspruchte Fläche kann nur etwa 0,5 bis 2 cm² betragen.

Bei dem in der Figur 8 dargestellten Ausführungsbeispiel sind zwei Strahlungsquellen 4 und 4' vorgesehen, welche unterschiedliche Volumenbereiche des untersuchten Körpergewebes bestrahlen. Hierzu haben die zwei Strahlungsquellen 4 und 4¹ unterschiedliche räumliche Abstrahlcharakteristiken, nämlich unterschiedliche Abstrahlwinkel. Bei der Strahlungsquelle 4 handelt es sich um

eine Leuchtdiode, während es sich bei der Strahlungsquelle 4¹ um einen Laser, beispielsweise einen so genannten VCSEL-Laser (engl. "vertical cavity surface emitting laser") handelt. Sowohl die Leuchtdiode 4 als auch der Laser 4¹ emittieren Licht mit sehr ähnlicher Wellenlänge (z. B. 630 nm und 650 nm), aber mit unterschiedlichen Öffnungswinkeln (z. B. 25° und 55°). Mit der in der Figur 8 dargestellten Anordnung ist - wie oben beschrieben - eine differenzielle Messung von Metabolismus-induzierten Änderungen des Sauerstoffgehalts im Blut möglich. Hierzu muss die Wellenlänge der von den beiden Strahlungsquellen 4 und 4¹ jeweils emittierten Strahlung in einem Bereich liegen, in welchem das Licht von Oxihämoglobin und Desoxihämoglobin unterschiedlich stark absorbiert wird. Für eine Absolutmessung des Sauerstoffgehalts des Blutes (Sauerstoffsättigung) müssen weitere Strahlungsquellen (in der Figur 8 nicht dargestellt) vorhanden sein, deren Lichtwellenlänge in einem Spektralbereich liegt, in welchem die Lichtabsorption von Oxihämoglobin und Desoxihämoglobin im Wesentlichen gleich ist (so genannter isobektischer Punkt). Das von der Leuchtdiode bzw. von dem Laser emittierte Licht kann mittels entsprechender Lichtleitfasern an die entsprechende Stelle am Messkopf geführt werden. In diesem Fall sind mit den Bezugsziffern 4 und 4¹ in der Figur 8 die entsprechenden Faserenden dargestellt. Es ist möglich, die Leuchtdiode und den Laser so an die entsprechenden Fasern anzukoppeln, dass sie mit dem gewünschten unterschiedlichen Öffnungswinkel in das zu untersuchende Körpergewebe einstrahlen. Dementsprechend werden mit beiden Strahlungsquellen unterschiedliche Volumina des Körpergewebes untersucht. Aufgrund des größeren Öffnungswinkels ist der Anteil der nicht-durchbluteten Epidermis an dem mittels der Leuchtdiode untersuchten Körpergewebe größer als beim Laser. Das im Körpergewebe gestreute und teilweise absorbierte Licht sowohl der Strahlungsquelle 4 als auch der Strahlungsquelle 4¹ wird mittels äquidistant zueinander angeordneten Strahlungssensoren 5 detektiert. Hierbei kann es sich um Fotodioden handeln. Vorzugsweise sind die Fotodioden nicht direkt an der Oberfläche des Messkopfes angeordnet. Stattdessen wird das Licht über Lichtleitfasern den Fotodioden zugeführt. Zur Unterscheidung des Lichtes der Strahlungsquelle 4 von dem Licht der Strahlungsquelle 4¹ können die beiden Lichtquellen 4 und 4¹ unterschiedlich zeitlich moduliert betrieben werden, wobei die mittels der Sensoren 5 detektierten Signale entsprechend demoduliert werden. Alternativ ist es möglich, die Strahlung der beiden Strahlungsquellen 4

und 4' anhand der unterschiedlichen Wellenlänge zu unterscheiden. Die Strahlungsintensität der von den Strahlungsquellen 4 und 4' emittierten Strahlung wird mit der Weglänge beim Durchgang durch das Körpergewebe geschwächt, wobei der Zusammenhang der Intensitätsschwächung mit der Konzentration der absorbierenden Substanz (oxigeniertes Hämoglobin) durch das bekannte Lambert-Beersche Gesetz gegeben ist. Mittels der in der Figur 8 dargestellten äquidistanten Sensoren 5 können die interessierenden Parameter der Intensitätsschwächung mit großer Genauigkeit bestimmt werden, und zwar getrennt für die von den Strahlungsquellen 4 und 4' jeweils erfassten Volumenbereiche des untersuchten Körpergewebes. Die den verschiedenen Strahlungsquellen 4 und 4' zuzuordnenden Parameter der Intensitätsschwächung können mittels der Auswertungseinheit der erfindungsgemäßen Messvorrichtung zueinander in Beziehung gesetzt werden, um auf diese Weise eine differenzielle Messung durchzuführen. Im einfachsten Fall werden aus den Parametern der Intensitätsschwächung der Strahlung der beiden Strahlungsquellen 4 und 4' jeweils Quotienten berechnet. Aus Änderungen dieser Quotienten kann dann auf Änderungen im Metabolismus zurückgeschlossen werden. Steigt beispielsweise nach der Nahrungsaufnahme der Blutglukosespiegel, gelangt (nach einer gewissen zeitlichen Verzögerung) entsprechend mehr Glukose in die Zellen des Körpergewebes und wird dort umgesetzt. Dabei wird Sauerstoff verbraucht. Diesen Sauerstoff erhalten die Zellen über das Blut. Dabei wird aus dem oxigenierten Hämoglobin durch Abgabe von Sauerstoff desoxigeniertes Hämoglobin. Dementsprechend steigt das Verhältnis von desoxigeniertem Hämoglobin zu oxigeniertem an. Aufgrund der unterschiedlichen Öffnungswinkel der Strahlung der Strahlungsquellen 4 und 4' wirken sich die Änderungen der Hämoglobinkonzentration unterschiedlich auf die jeweilige Intensitätsschwächung aus. Somit können aus den Quotienten der Parameter der Intensitätsschwächung Veränderungen der Hämoglobinkonzentration detektiert werden. Dies ermöglicht es, indirekt auf den Sauerstoffverbrauch zurückzuschließen. Da der Sauerstoffverbrauch seinerseits von dem Blutglukosespiegel abhängt, kann mittels der erläuterten differenziellen Messung der Strahlungsabsorption auch der Blutglukosespiegel ermittelt werden. Als sinnvolle Ergänzung wird parallel zur optischen Messung eine Bioimpedanzanalyse durchgeführt, wozu die in der Figur 8 dargestellten Elektroden 7 und 7' vorgesehen sind. Zweck der Bioimpedanzmessung ist vor

5 allem die Bestimmung der lokalen Durchblutung. Diese kann als weiterer Parameter bei der Bestimmung des Sauerstoffverbrauchs und damit auch des Blutglukosespiegels herangezogen werden. Bei dem in der Figur 8 dargestellten Ausführungsbeispiel sind die Elektroden T und T' auf gegenüberliegenden
5 Seiten der Strahlungsquellen 4 und 4' und der Strahlungssensoren 5 angeordnet, um sicherzustellen, dass von der Bioimpedanzmessung und der optischen Messung derselbe Bereich des untersuchten Körpergewebes erfasst ist.

10 Die Figur 9 zeigt eine Möglichkeit auf, zwei Strahlungsquellen 4 und 4' mit unterschiedlicher räumlicher Abstrahlcharakteristik einfach und kostengünstig zu realisieren. Hierzu wird ein einzelnes Strahlung emittierendes Element 10, beispielsweise eine Leuchtdiode, benutzt, deren Licht in eine Lichtleitfaser n eingekoppelt wird. Die Lichtleitfaser ist an einer geeigneten Stelle in zwei
15 Faserzweige aufgespalten. Über den Faserzweig 12 gelangt das Licht direkt in das untersuchte Körpergewebe 240. In dem anderen Faserzweig ist ein zusätzliches optisches Element 13, beispielsweise eine Linse, vorgesehen, beispielsweise um einen kleineren Abstrahlwinkel zu erzielen. Jeder der in der Figur 9 dargestellten Faserzweige bildet somit eine Strahlungsquelle 4 bzw. 4', wie sie in der Figur 8 dargestellt sind.

20

Patentansprüche

1. Messvorrichtung zur nicht-invasiven Bestimmung von physiologischen Parametern, mit wenigstens einer optischen Messeinheit (100) zur Erzeugung von oximetrischen und/oder plethysmographischen Messsignalen, und mit einer Auswertungseinheit (140) zur Verarbeitung der Messsignale,
5
d a d u r c h g e k e n n z e i c h n e t ,
dass die Auswertungseinheit (140) eingerichtet ist zur Bestimmung wenigstens
l o eines lokalen metabolischen Parameters, insbesondere des lokalen Sauerstoffverbrauchs, aus den Signalen der optischen Messeinheit (100).

2. Messvorrichtung nach Anspruch 1, gekennzeichnet durch eine Einheit (120, 130) zur Erfassung von lokalen Gewebeparametern, wie Fettgehalt, Wassergehalt und/oder Durchblutung, wobei die Auswertungseinheit (140) eingerichtet ist zur Bestimmung des wenigstens einen lokalen metabolischen Parameters aus den Signalen der optischen Messeinheit (100) und den Gewebeparametern.
i 5

3. Messvorrichtung nach Anspruch 2, dadurch gekennzeichnet, dass die Einheit zur Erfassung von lokalen Gewebeparametern eine bioelektrische
20 Impedanzmesseinheit (130) umfasst.

4. Messvorrichtung nach Anspruch 3, dadurch gekennzeichnet, dass die bioelektrische Impedanzmesseinheit (130) außerdem zur Erfassung von globalen Gewebeparametern, wie globaler Fettgehalt und/oder globaler Wassergehalt, ausgebildet ist.

5. Messvorrichtung nach einem der Ansprüche 2 bis 4, dadurch gekennzeichnet, dass die Einheit zur Erfassung von lokalen Gewebeparametern eine optische Strahlungsquelle (4) und einen Strahlungssensor (5) umfasst.

5 6. Messvorrichtung nach einem der Ansprüche 2 bis 5, gekennzeichnet, durch einen optischen Sensor zur orts aufgelösten Bestimmung des Hautkolorits.

7. Messvorrichtung nach einem der Ansprüche 2 bis 6, gekennzeichnet durch eine EKG-Einheit (132) zur Erfassung eines EKG-Signals über zwei oder mehr EKG-Elektroden (7, 9), wobei die Auswertungseinheit (140) zur Auswertung des zeitlichen Verlaufs des EKG-Signals eingerichtet ist.

8. Messvorrichtung nach Anspruch 7, dadurch gekennzeichnet, dass die Auswertungseinheit (4) eingerichtet ist zur Auswertung des zeitlichen Verlaufs eines mittels der Vorrichtung erfassten plethysmographischen Signals und/oder zur Bestimmung der Pulswellengeschwindigkeit aus dem zeitlichen Verlauf des EKG-Signals und des plethysmographischen Signals.

9. Messvorrichtung nach Anspruch 8, dadurch gekennzeichnet, dass die Auswertungseinheit (140) eingerichtet ist zur Auswertung des zeitlichen Verlaufs der Pulswellengeschwindigkeit und zur Ermittlung der Zusammensetzung von einem Benutzer der Messvorrichtung aufgenommenen Nahrung anhand des zeitlichen Verlaufs der Pulswellengeschwindigkeit ab dem Zeitpunkt der Nahrungsaufnahme.

10. Messvorrichtung nach einem der Ansprüche 1 bis 9, gekennzeichnet durch einen Wärmesensor (6) zur Bestimmung der lokalen Wärmeproduktion, wobei die Auswertungseinheit (140) zur Bestimmung des wenigstens einen lokalen metabolischen Parameters unter Berücksichtigung der Signale des Wärmesensors (6) eingerichtet ist.

11. Messvorrichtung nach Anspruch 10, dadurch gekennzeichnet, dass die Auswertungseinheit (140) eingerichtet ist zur Bestimmung der lokalen

Glukosekonzentration aus dem lokalen Sauerstoffverbrauch und der lokalen Wärmeproduktion.

12. Messvorrichtung nach Anspruch 11, dadurch gekennzeichnet, dass die Bestimmung der lokalen Glukosekonzentration mittels der
5 Auswertungseinheit (140) unter Einbeziehung von Daten betreffend die Zusammensetzung von einem Benutzer der Messvorrichtung aufgenommener Nahrung erfolgt.

13. Messvorrichtung nach Anspruch 11 oder 12, dadurch gekennzeichnet, dass die Auswertungseinheit (140) weiterhin eingerichtet ist zur
10 Bestimmung des Blutglukosespiegels aus der lokalen Glukosekonzentration, wobei von der Physiologie des Benutzers der Messvorrichtung abhängige Parameter berücksichtigt werden.

14. Messvorrichtung nach einem der Ansprüche 1 bis 13, gekennzeichnet durch eine Speichereinheit (170) zur Speicherung der mittels
15 der Auswertungseinheit (140) ermittelten Parameter.

15. Messvorrichtung nach einem der Ansprüche 1 bis 14, gekennzeichnet durch eine Diagnoseeinheit (150) zur Bewertung der mittels der
Auswertungseinheit (140) ermittelten Parameter und zur Registrierung von
20 Veränderungen der Parameter in Abhängigkeit vom Messort und/oder von der Messzeit.

16. Messvorrichtung nach einem der Ansprüche 1 bis 15, dadurch gekennzeichnet, dass die Diagnoseeinheit (150) eingerichtet ist zur Bestimmung
des Status des Herz-Kreislauf-Systems aus den mittels der Auswertungseinheit (140) ermittelten Parametern.

17. Messvorrichtung nach den Ansprüchen 4 und 16, dadurch gekennzeichnet, dass die Diagnoseeinheit (150) zur Berechnung eines globalen
25 Fitnessindex auf der Basis des Status des Herz-Kreislauf-Systems und den globalen Gewebeparametern eingerichtet ist.

18. Messvorrichtung nach einem der Ansprüche 1 bis 17, dadurch gekennzeichnet, dass die optische Messeinheit (100) wenigstens eine Strahlungsquelle (4) zur Bestrahlung des untersuchten Körpergewebes (240), und wenigstens einen Strahlungssensor (5) zur Detektion der von dem Körpergewebe (240) gestreuten und/oder transmittierten Strahlung aufweist.

19. Messvorrichtung nach Anspruch 14, dadurch gekennzeichnet, dass die optische Messeinheit (100) wenigstens eine Strahlungsquelle (4) zur Bestrahlung des untersuchten Körpergewebes (240), und wenigstens zwei Strahlungssensoren (5) zur Detektion der von dem Körpergewebe (240) gestreuten und/oder transmittierten Strahlung aufweist, wobei die Strahlungssensoren (5) in unterschiedlichem Abstand zur Strahlungsquelle angeordnet sind.

20. Messvorrichtung nach Anspruch 18 oder 19, dadurch gekennzeichnet, dass wenigstens zwei Strahlungsquellen (4, 4') vorgesehen sind, welche unterschiedliche Volumenbereiche des untersuchten Körpergewebes (240) bestrahlen.

21. Messvorrichtung nach Anspruch 20, dadurch gekennzeichnet, dass die wenigstens zwei Strahlungsquellen (4, 4') unterschiedliche räumliche Abstrahlcharakteristiken haben.

22. Messvorrichtung nach Anspruch 20 oder 21, dadurch gekennzeichnet, dass die Auswertungseinheit (140) eingerichtet ist zur Bestimmung des wenigstens einen lokalen metabolischen Parameters aus der von dem Körpergewebe (240) gestreuten und/oder transmittierten Strahlung der beiden Strahlungsquellen (4, 4').

23. Messvorrichtung nach Anspruch 22, dadurch gekennzeichnet, dass die Auswertungseinheit (140) weiterhin eingerichtet ist zur Bestimmung des lokalen Sauerstoffverbrauchs und/oder des Blutglukosespiegels anhand der Intensitäten der von dem Körpergewebe (240) gestreuten und/oder transmittierten Strahlung der beiden Strahlungsquellen (4, 4').

24. Messvorrichtung nach einem der Ansprüche 20 bis 23, dadurch gekennzeichnet, dass die Wellenlänge der von den beiden Strahlungsquellen jeweils emittierten Strahlung im Bereich zwischen 600 und 700 nm, vorzugsweise zwischen 630 und 650 nm, liegt.

5 25. Messvorrichtung nach einem der Ansprüche 18 bis 24, dadurch gekennzeichnet, dass die Strahlungsquellen (4, 4¹) und die Strahlungssensoren (5) an einem Messkopf (3) angeordnet sind.

 26. Messvorrichtung nach Anspruch 21, dadurch gekennzeichnet, dass der Messkopf (3) Elektroden (7) zur bioelektrischen Impedanzmessung umfasst.

l o

 27. Messvorrichtung nach Anspruch 26, dadurch gekennzeichnet, dass wenigstens eine der Elektroden (7) gleichzeitig als EKG-Elektrode ausgebildet ist.

 28. Messvorrichtung nach einem der Ansprüche 25 bis 27, dadurch gekennzeichnet, dass der Messkopf (3) wenigstens einen Wärmesensor (6) umfasst.

i 5

 29. Messvorrichtung nach einem der Ansprüche 25 bis 28, dadurch gekennzeichnet, dass der Messkopf (3) am vorderen Ende eines gemeinsamen Gehäuses (2) angeordnet ist, welches die optische Messeinheit (100) und die Auswertungseinheit (140) aufnimmt, so dass das gesamte Gerät (1) handführbar ausgebildet ist.

20

 30. Messvorrichtung nach den Ansprüchen 27 und 29, dadurch gekennzeichnet, dass das Gehäuse (2) an der Außenseite eine weitere EKG-Elektrode (9) aufweist.

25 31. Messvorrichtung nach Anspruch 30, dadurch gekennzeichnet, dass die weitere EKG-Elektrode (9) gleichzeitig zur bioelektrischen Impedanzmessung ausgebildet ist.

32. Messvorrichtung nach einem der Ansprüche 1 bis 31, gekennzeichnet durch eine Anzeigeeinheit (8) zur Anzeige der lokalen Sauerstoffkonzentration des Blutes und/oder des wenigstens einen lokalen metabolischen Parameters.

5 33. Messvorrichtung nach einem der Ansprüche 1 bis 32, gekennzeichnet durch eine Schnittstelle (180) zur Verbindung der Messvorrichtung (1) mit einem Computer oder einem anderen Gerät.

34. Messvorrichtung nach einem der Ansprüche 1 bis 33, dadurch gekennzeichnet, dass sie miniaturisiert ausgebildet ist und in einen am Körper
10 eines Benutzers getragenen Gegenstand integriert ist.

35. Verfahren zur Erfassung und Auswertung von physiologischen Parametern, insbesondere unter Verwendung einer Messvorrichtung nach einem der Ansprüche 1 bis 34, wobei

- 15 - mittels einer optischen Messeinheit (100) oximetrische und/oder plethysmographische Messsignale von Körpergewebe (240) erfasst werden,
- und mittels einer Auswertungseinheit (140) die oximetrischen und/oder plethysmographischen Messsignale verarbeitet werden, und zwar zur Bestimmung des Pulses und/oder der lokalen
20 Sauerstoffkonzentration,

d a d u r c h g e k e n n z e i c h n e t ,
dass mittels der Auswertungseinheit (140) wenigstens ein lokaler metabolischer Parameter, insbesondere der lokale Sauerstoffverbrauch, aus den oximetrischen Signalen bestimmt wird.

25 36. Verfahren nach Anspruch 35, dadurch gekennzeichnet, dass lokale Gewebeparameter, wie Fettgehalt, Wassergehalt und/oder Durchblutung, erfasst werden, wobei der wenigstens eine lokale metabolische Parameter aus den oximetrischen Signalen und den lokalen Gewebeparametern bestimmt wird.

37. Verfahren nach Anspruch 36, dadurch gekennzeichnet, dass die lokalen Gewebeparameter mittels bioelektrischer Impedanzmessung erfasst werden.

5 38. Verfahren nach Anspruch 36, dadurch gekennzeichnet, dass die lokalen Gewebeparameter optisch erfasst werden.

39. Verfahren nach einem der Ansprüche 35 bis 38, gekennzeichnet durch eine zusätzlich zur Erfassung der oximetrischen Messsignale durchgeführte Erfassung eines EKG-Signals.

10 40. Verfahren nach Anspruch 39, dadurch gekennzeichnet, dass mittels der Auswertungseinheit (140) ein kardiovaskulärer Parameter aus den plethysmographischen Messsignalen und dem EKG-Signal bestimmt wird.

41. Verfahren nach einem der Ansprüche 35 bis 41, gekennzeichnet durch eine Erfassung von globalen Gewebeparametern, wie Fettgehalt und/oder Wassergehalt.

15 42. Verfahren nach den Ansprüchen 40 und 41, dadurch gekennzeichnet, dass basierend auf dem kardiovaskulären Parameter und den globalen Gewebeparametern ein globaler Fitnessindex berechnet wird.

20 43. Verfahren nach einem der Ansprüche 35 bis 42, dadurch gekennzeichnet, dass mittels der optischen Messeinheit (100) unterschiedliche Volumenbereiche des untersuchten Körpergewebes bestrahlt werden, wobei der wenigstens eine lokale metabolische Parameter aus der von dem Körpergewebe (240) in den unterschiedlichen Volumenbereichen gestreuten und/oder transmittierten Strahlung bestimmt wird.

25 44. Verfahren nach Anspruch 43, dadurch gekennzeichnet, dass die optische Messeinheit (100) wenigstens zwei Strahlungsquellen (4, 4') mit unterschiedlichen räumlichen Abstrahlcharakteristiken umfasst, wobei der lokale Sauerstoffverbrauch und/oder der Blutglukosespiegel anhand der Intensitäten

der von dem Körpergewebe (240) gestreuten und/oder transmittierten Strahlung der beiden Strahlungsquellen (4, 4¹) bestimmt wird.

45. Verfahren nach einem der Ansprüche 36 bis 44, dadurch gekennzeichnet, dass die lokalen Gewebeparameter mittels ortsaufgelöster
5 Wärmemessung erfasst werden.

46. Verfahren nach Anspruch 45, dadurch gekennzeichnet, dass die lokale Glukosekonzentration aus dem lokalen Sauerstoffverbrauch und der lokalen Wärmeproduktion bestimmt wird.

47. Verfahren nach Anspruch 46, dadurch gekennzeichnet, dass die
10 Bestimmung der lokalen Glukosekonzentration unter Einbeziehung von Daten betreffend die Zusammensetzung von einem Benutzer der Messvorrichtung aufgenommener Nahrung erfolgt.

48. Verfahren nach Anspruch 46 oder 47, dadurch gekennzeichnet, dass der Blutglukosespiegel aus der lokalen Glukosekonzentration bestimmt
15 wird, wobei von der Physiologie des Benutzers der Messvorrichtung abhängige Parameter berücksichtigt werden.

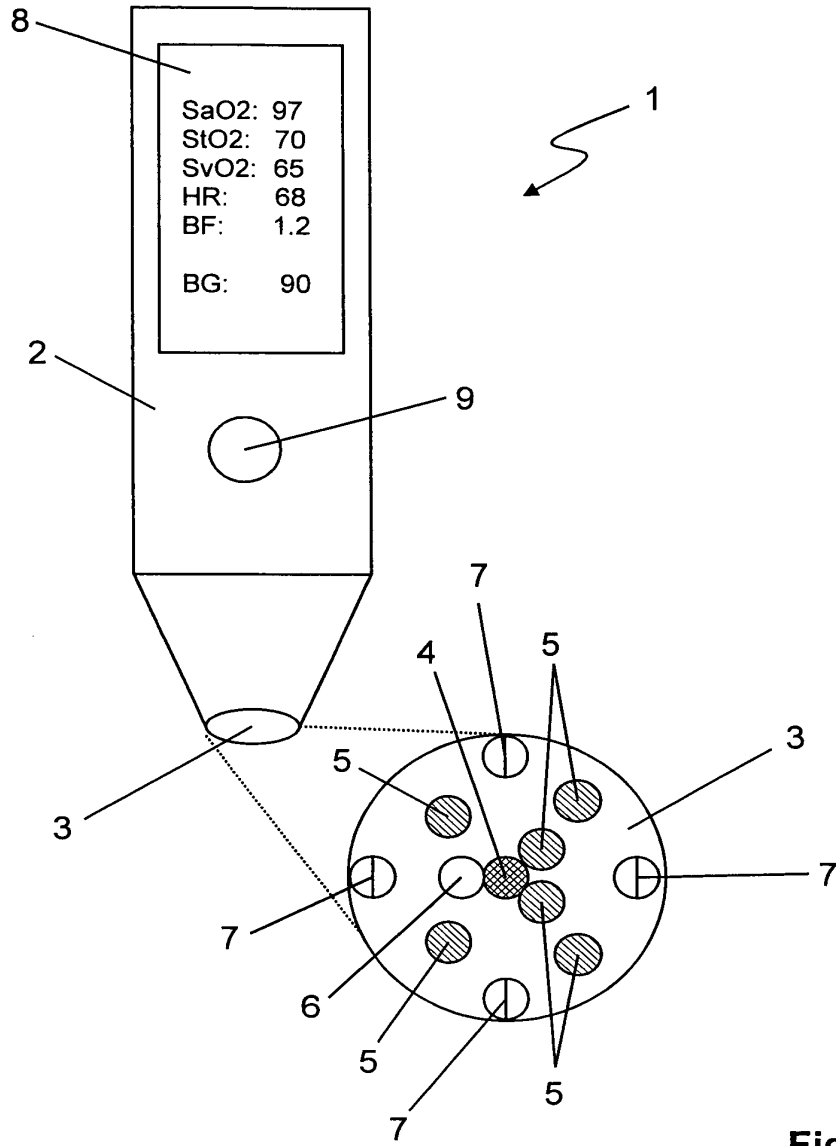

Fig. 1

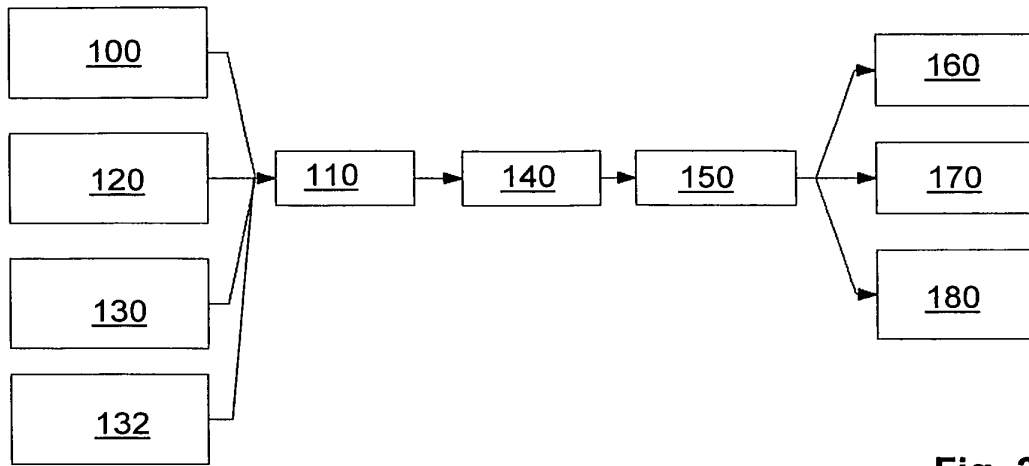

Fig. 2

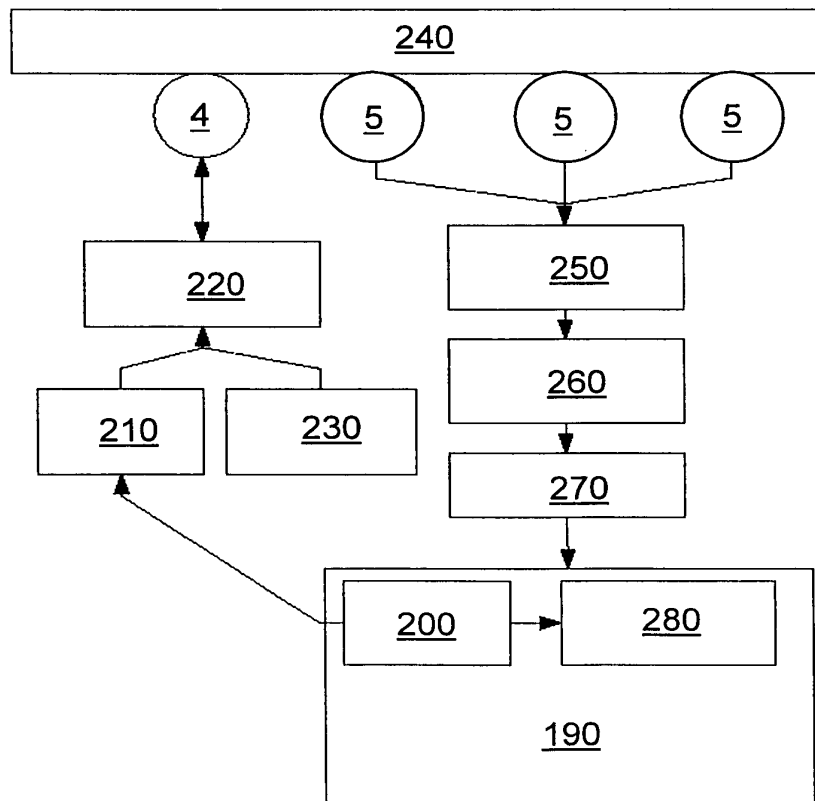

Fig. 3

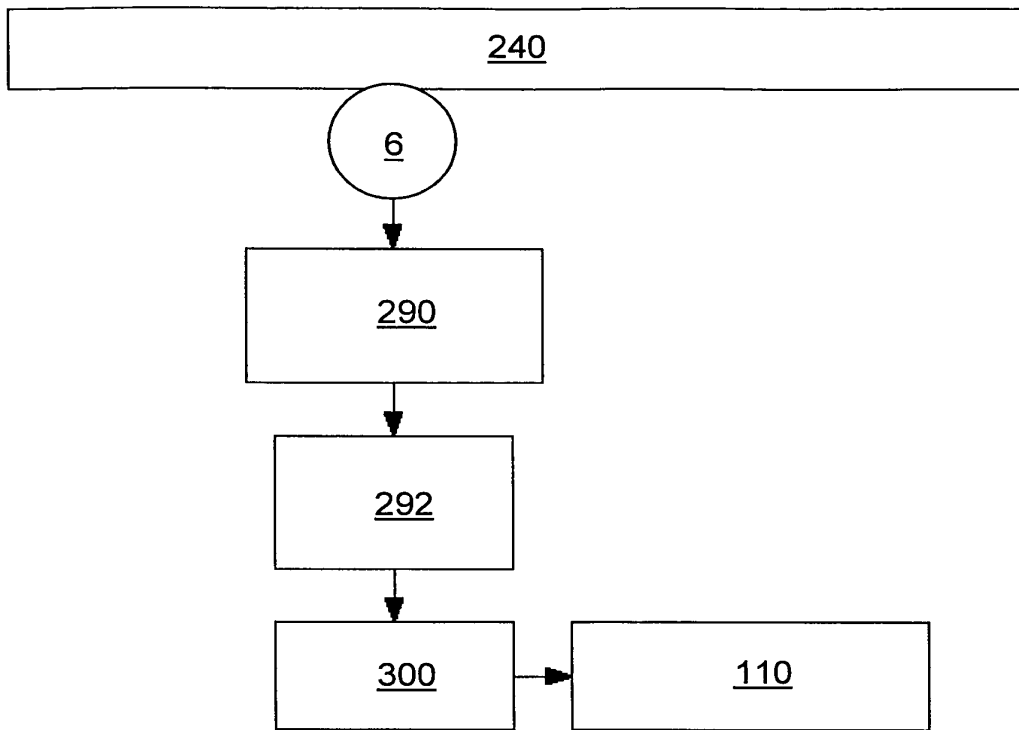

Fig. 4

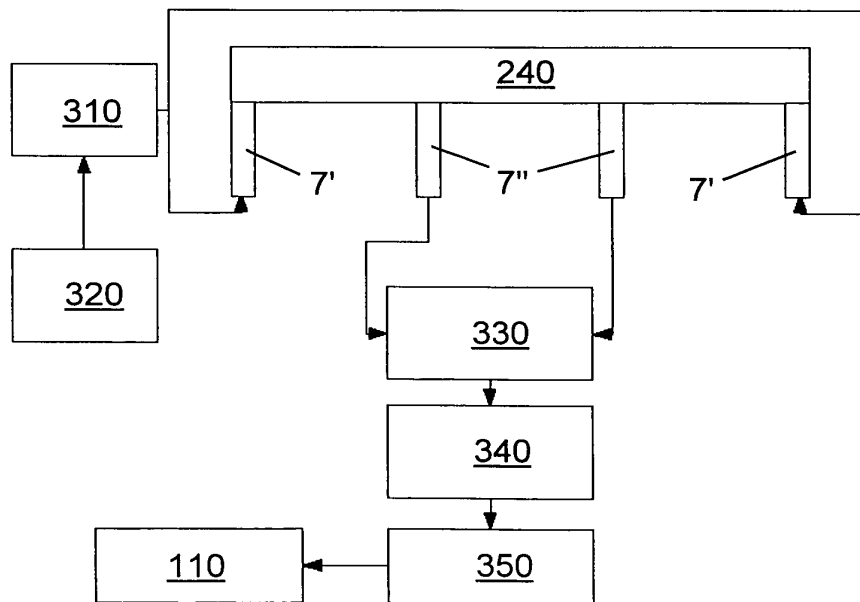

Fig. 5

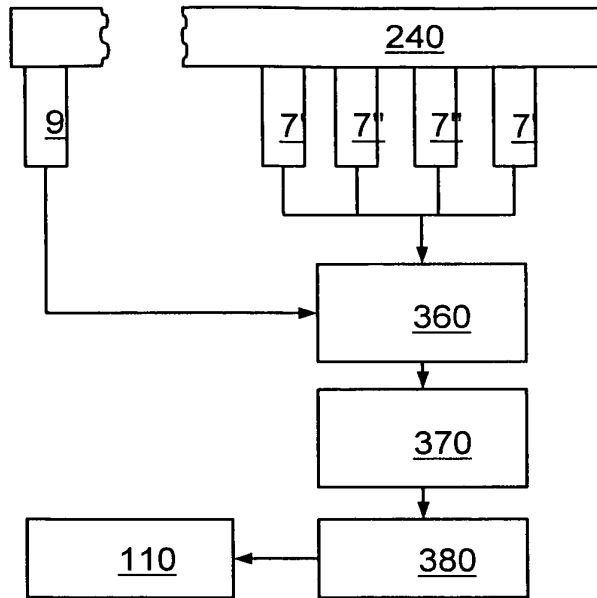

Fig. 6

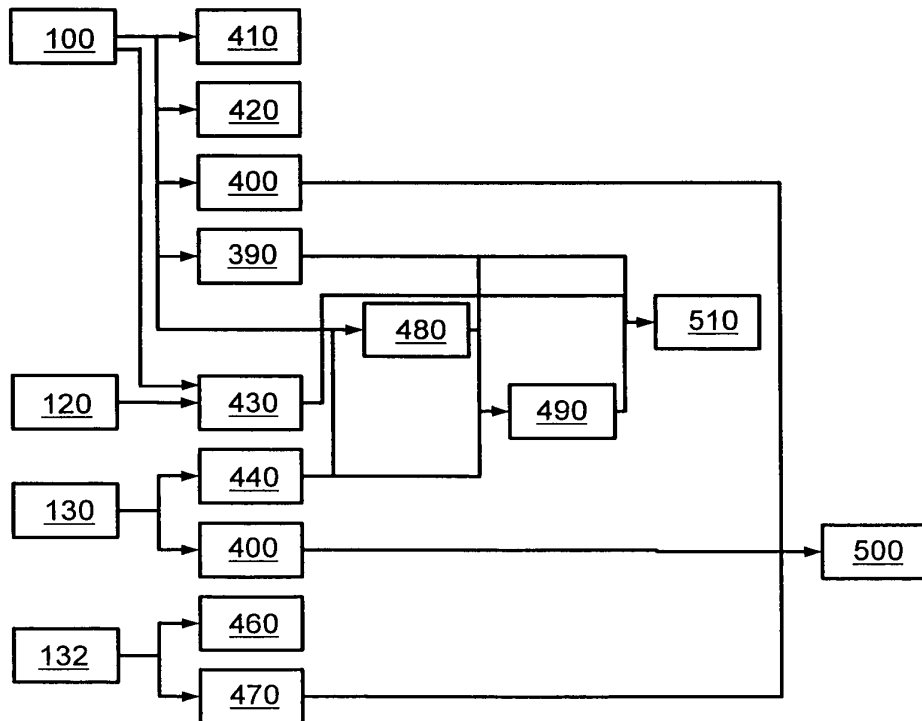

Fig. 7

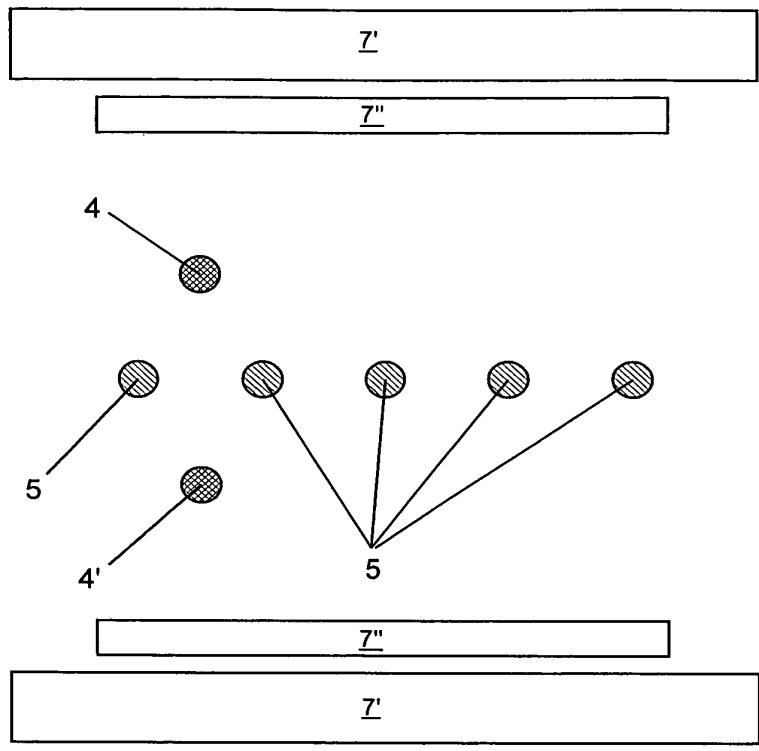

Fig. 8

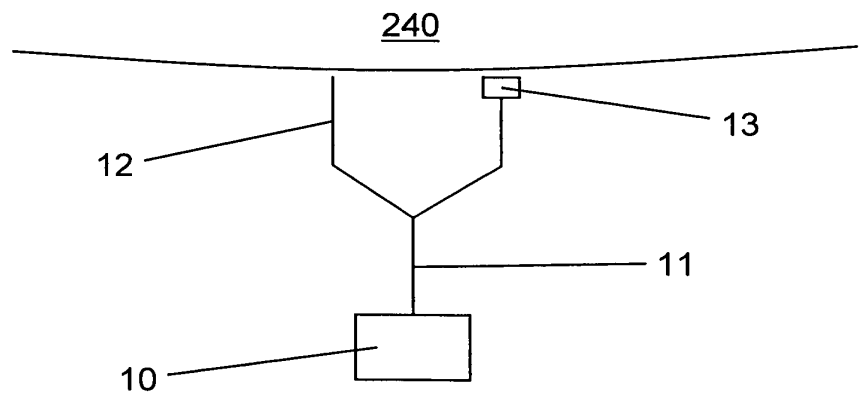

Fig. 9

IN THE UNITED STATES PATENT AND TRADEMARK OFFICE

First Inventor	:	Jeroen Poeze
App. No.	:	16/544713
Filed	:	August 19, 2019
For	:	MULTI-STREAM DATA COLLECTION SYSTEM FOR NONINVASIVE MEASUREMENT OF BLOOD CONSTITUENTS
Examiner	:	Liu, Chu Chuan
Art Unit	:	3791
Conf. No.	:	9381

SUPPLEMENTAL AMENDMENT

Mail Stop Amendment
Commissioner for Patents
P.O. Box 1450
Alexandria, VA 22313-1450

Dear Commissioner:

Please consider the following:

Amendments to the Claims are reflected in the listing of claims which begins on page 2 of this paper.

Remarks begin on page 7 of this paper.

Application No.: 16/544713
Filing Date: August 19, 2019

AMENDMENTS TO THE CLAIMS

1. **(Previously Canceled)**
2. **(Previously Presented)** A physiological measurement system comprising:
 - a physiological sensor device comprising:
 - a plurality of emitters configured to emit light into tissue of a user;
 - at least four detectors, wherein each of the at least four detectors has a corresponding window that allows light to pass through to the detector;
 - a wall that surrounds at least the at least four detectors; and
 - a cover that operably connects to the wall and that is configured to be located between tissue of the user and the at least four detectors when the physiological sensor device is worn by the user, wherein:
 - the cover comprises a single protruding convex surface, and
 - at least a portion of the cover is sufficiently rigid to cause tissue of the user to conform to at least a portion of a shape of the single protruding convex surface when the physiological sensor device is worn by the user;
 - and
 - a handheld computing device in wireless communication with the physiological sensor device, wherein the handheld computing device comprises:
 - one or more processors configured to wirelessly receive one or more signals from the physiological sensor device, the one or more signals responsive to at least a physiological parameter of the user;
 - a touch-screen display configured to provide a user interface, wherein:
 - the user interface is configured to display indicia responsive to measurements of the physiological parameter, and
 - an orientation of the user interface is configurable responsive to a user input; and
 - a storage device configured to at least temporarily store at least the measurements of the physiological parameter.
3. **(Previously Canceled)**
4. **(Previously Presented)** The physiological measurement system of Claim 2, wherein the at least four detectors comprise at least eight detectors.

Application No.: 16/544713
Filing Date: August 19, 2019

5. **(Currently Amended)** The physiological measurement system of Claim 4, wherein at least part of the single protruding convex surface ~~cover~~ is light permeable to provide at least one optical path[[s]] to at least one of the at least four detectors.

6. **(Currently Amended)** The physiological measurement system of Claim 5, wherein the physiological sensor device further comprises:

an at least partially opaque layer blocking one or more optical paths to at least one of the at least four detectors, wherein the at least partially opaque layer comprises the windows that allow light to pass through to the corresponding detectors.

7. **(Previously Presented)** The physiological measurement system of Claim 6, wherein the physiological sensor device further comprises:

a substrate having a first surface, wherein the at least four detectors are arranged on the first surface.

8. **(Previously Presented)** The physiological measurement system of Claim 7, wherein:

the wall surrounds at least the at least four detectors on the first surface,
the wall operably connects to the substrate on one side of the wall, and
the wall operably connects to the cover on an opposing side of the wall.

9. **(Previously Presented)** The physiological measurement system of Claim 8, wherein the wall creates one or more gaps between the first surface of the substrate and a surface of the cover that is interior to the physiological sensor device, and wherein the at least four detectors are positioned on the first surface of the substrate within the one or more gaps.

10. **(Previously Presented)** The physiological measurement system of Claim 8, wherein the substrate, the wall, and the cover together hermetically seal the at least four detectors.

11. **(Previously Presented)** The physiological measurement system of Claim 10, wherein a surface of the handheld computing device positions the touch-screen display.

12. **(Previously Presented)** The physiological measurement system of Claim 11, wherein the physiological parameter comprises at least one of: pulse rate, glucose, oxygen, oxygen saturation, methemoglobin, total hemoglobin, carboxyhemoglobin, or carbon monoxide.

13. **(Previously Presented)** The physiological measurement system of Claim 12, wherein the single protruding convex surface protrudes a height between 1 millimeter and 3 millimeters.

Application No.: 16/544713
Filing Date: August 19, 2019

14. **(Previously Presented)** The physiological measurement system of Claim 13, wherein at least one of the detectors is configured to detect light that has been attenuated by tissue of the user.

15. **(Previously Presented)** The physiological measurement system of Claim 14, wherein the displayed indicia are further responsive to temperature.

16. **(Previously Presented)** The physiological measurement system of Claim 15, wherein a portion of the physiological sensor device comprises one of at least two sizes, the two sizes intended to be appropriate for larger users and smaller users.

17. **(Previously Presented)** The physiological measurement system of Claim 16, wherein the at least four detectors are arranged such that a first detector and a second detector of the least four detectors are arranged across from each other on opposite sides of a central point along a first axis, and a third detector and a fourth detector of the least four detectors are arranged across from each other on opposite sides of the central point along a second axis which is different from the first axis.

18. **(Previously Presented)** The physiological measurement system of Claim 17, wherein the first axis is perpendicular to the second axis, and wherein the first, second, third and fourth detectors form a cross pattern about the central point.

19. **(Previously Presented)** The physiological measurement system of Claim 18, wherein the single protruding convex surface protrudes a height greater than 2 millimeters and less than 3 millimeters.

20. **(Previously Presented)** The physiological measurement system of Claim 19, wherein the attenuated light is reflected by the tissue.

21. **(Previously Presented)** The physiological measurement system of Claim 11, wherein the physiological parameter comprises a state or trend of wellness of the user.

22. **(Currently Amended)** A physiological measurement system comprising:
a physiological sensor device comprising:
a plurality of emitters configured to emit light into tissue of a user;
at least four detectors, wherein each of the at least four detectors has a corresponding window that allows light to pass through to the detector;
a wall that surrounds at least the at least four detectors; and

Application No.: 16/544713
Filing Date: August 19, 2019

a cover comprising a single protruding convex surface, wherein the single protruding convex surface ~~tissue shaper that operably connects to the wall and that~~ is configured to be located between tissue of the user and the at least four detectors when the physiological sensor device is worn by the user, wherein: ~~the tissue shaper comprises a single protruding convex surface, and~~ at least a portion of the single protruding convex surface ~~tissue shaper~~ is sufficiently rigid to cause tissue of the user to conform to at least a portion of a shape of the single protruding convex surface when the physiological sensor device is worn by the user, and wherein the cover operably connects to the wall; and

a handheld computing device in wireless communication with the physiological sensor device.

23. **(Previously Presented)** The physiological measurement system of Claim 22, wherein the handheld computing device comprises:

one or more processors configured to wirelessly receive one or more signals from the physiological sensor device, the one or more signals responsive to at least a physiological parameter of the user;

a touch-screen display configured to provide a user interface, wherein:

the user interface is configured to display indicia responsive to measurements of the physiological parameter, and

an orientation of the user interface is configurable responsive to a user input;

and

a storage device configured to at least temporarily store at least the measurements of the physiological parameter.

24. **(Previously Presented)** The physiological measurement system of Claim 23, wherein the at least four detectors comprise at least eight detectors.

25. **(Currently Amended)** The physiological measurement system of Claim 24, wherein at least part of the single protruding convex surface ~~tissue shaper~~ is light permeable to allow light to reach at least one of ~~provide optical paths to~~ the at least four detectors.

26. **(Previously Canceled)**

27. **(Currently Amended)** The physiological measurement system of Claim 25, wherein the physiological sensor device further comprises:

Application No.: 16/544713
Filing Date: August 19, 2019

an at least partially opaque layer blocking one or more optical paths to at least one of the at least four detectors, wherein the at least partially opaque layer comprises the windows that allow light to pass through to the corresponding detectors.

28. **(Currently Amended)** The physiological measurement system of Claim 27, wherein the physiological sensor device further comprises:

a substrate having a first surface, wherein the at least four detectors are arranged on the first surface, and wherein the wall surrounds at least the at least four detectors on the first surface,

wherein:

the wall operably connects to the substrate on one side of the wall, and
the wall operably connects to the cover-tissue shaper on an opposing side of the wall.

29. **(Previously Presented)** The physiological measurement system of Claim 28, wherein a surface of the handheld computing device positions the touch-screen display.

30. **(Previously Presented)** The physiological measurement system of Claim 29, wherein the physiological parameter comprises at least one of: pulse rate, glucose, oxygen, oxygen saturation, methemoglobin, total hemoglobin, carboxyhemoglobin, carbon monoxide, or a state or trend of wellness of the user.

31. **(Previously Presented)** The physiological measurement system of Claim 30, wherein the single protruding convex surface protrudes a height greater than 2 millimeters and less than 3 millimeters.

Application No.: 16/544713
Filing Date: August 19, 2019

REMARKS

Claims 2, 4-25, and 27-31 were pending. In connection with the request for continued examination filed December 11, 2019, Applicant has amended the claims as recited above. In particular, in the present amendment, Applicant has amended Claims 5-6, 22, and 25, and 27-28 without prejudice or disclaimer of subject matter. Applicant reserves the right to pursue previously pending claims in this or another application (e.g., a continuing application). Accordingly, Claims 2, 4-25, and 27-31 are pending for consideration.

No Disclaimers or Disavowals

Although the present communication may include alterations to the application or claims, or characterizations of claim scope or referenced art, Applicant is not conceding in this application that previously pending claims are not patentable. Rather, any alterations or characterizations are being made to facilitate expeditious prosecution of this application. Applicant reserves the right to pursue at a later date any previously pending or other broader or narrower claims that capture any subject matter supported by the present disclosure, including subject matter found to be specifically disclaimed herein or by any prior prosecution. Accordingly, reviewers of this or any parent, child or related prosecution history shall not reasonably infer that Applicant has made any disclaimers or disavowals of any subject matter supported by the present application.

Co-Pending Applications of Assignee

Applicant wishes to draw the Examiner's attention to the following co-pending applications of the present application's assignee.

Docket No.	Serial No.	Title	Filed
MASCER.002C9	16/449143	MULTI-STREAM DATA COLLECTION SYSTEM FOR NONINVASIVE MEASUREMENT OF BLOOD CONSTITUENTS	06/21/2019
MASCER.002C10	16/534956	MULTI-STREAM DATA COLLECTION SYSTEM FOR NONINVASIVE MEASUREMENT OF BLOOD CONSTITUENTS	08/07/2019
MASCER.002C11	16/534949	MULTI-STREAM DATA COLLECTION SYSTEM FOR NONINVASIVE MEASUREMENT OF BLOOD CONSTITUENTS	08/07/2019

Application No.: 16/544713
Filing Date: August 19, 2019

Docket No.	Serial No.	Title	Filed
MASCER.002C12	16/541987	MULTI-STREAM DATA COLLECTION SYSTEM FOR NONINVASIVE MEASUREMENT OF BLOOD CONSTITUENTS	08/15/2019
MASCER.002C14	16/544755	MULTI-STREAM DATA COLLECTION SYSTEM FOR NONINVASIVE MEASUREMENT OF BLOOD CONSTITUENTS	08/19/2019
MASCER.002C15	16/594980	MULTI-STREAM DATA COLLECTION SYSTEM FOR NONINVASIVE MEASUREMENT OF BLOOD CONSTITUENTS	10/07/2019
MASCER.002C16	16/725478	MULTI-STREAM DATA COLLECTION SYSTEM FOR NONINVASIVE MEASUREMENT OF BLOOD CONSTITUENTS	12/23/2019
MASCER.002C17	16/725292	MULTI-STREAM DATA COLLECTION SYSTEM FOR NONINVASIVE MEASUREMENT OF BLOOD CONSTITUENTS	12/23/2019
MASCER.006C2	15/660743	NOISE SHIELDING FOR A NONINVASIVE DEVICE	07/26/2017

Please charge any additional fees, including any fees for additional extension of time, or credit overpayment to Deposit Account No. 11-1410.

Respectfully submitted,

KNOBBE, MARTENS, OLSON & BEAR, LLP

Dated: December 23, 2019

By: /Scott Cromar/_____
Scott A. Cromar
Registration No. 65,066
Registered Practitioner
Customer No. 64735
(949) 760-0404

31900167

Electronic Acknowledgement Receipt

EFS ID:	38126687
Application Number:	16544713
International Application Number:	
Confirmation Number:	9381
Title of Invention:	MULTI-STREAM DATA COLLECTION SYSTEM FOR NONINVASIVE MEASUREMENT OF BLOOD CONSTITUENTS
First Named Inventor/Applicant Name:	Jeroen Poeze
Customer Number:	64735
Filer:	Scott Cromar/Aimee Kazan
Filer Authorized By:	Scott Cromar
Attorney Docket Number:	MASCER.002C13
Receipt Date:	23-DEC-2019
Filing Date:	19-AUG-2019
Time Stamp:	17:02:38
Application Type:	Utility under 35 USC 111(a)

Payment information:

Submitted with Payment	no
------------------------	----

File Listing:

Document Number	Document Description	File Name	File Size(Bytes)/ Message Digest	Multi Part /.zip	Pages (if appl.)
1		Amd_002C13.pdf	49479 ad33c17c5a18ba38f95dcb33a1397b00e9a01538	yes	8

Multipart Description/PDF files in .zip description		
Document Description	Start	End
Supplemental Response or Supplemental Amendment	1	1
Claims	2	6
Applicant Arguments/Remarks Made in an Amendment	7	8

Warnings:

Information:

Total Files Size (in bytes):	49479
-------------------------------------	-------

This Acknowledgement Receipt evidences receipt on the noted date by the USPTO of the indicated documents, characterized by the applicant, and including page counts, where applicable. It serves as evidence of receipt similar to a Post Card, as described in MPEP 503.

New Applications Under 35 U.S.C. 111

If a new application is being filed and the application includes the necessary components for a filing date (see 37 CFR 1.53(b)-(d) and MPEP 506), a Filing Receipt (37 CFR 1.54) will be issued in due course and the date shown on this Acknowledgement Receipt will establish the filing date of the application.

National Stage of an International Application under 35 U.S.C. 371

If a timely submission to enter the national stage of an international application is compliant with the conditions of 35 U.S.C. 371 and other applicable requirements a Form PCT/DO/EO/903 indicating acceptance of the application as a national stage submission under 35 U.S.C. 371 will be issued in addition to the Filing Receipt, in due course.

New International Application Filed with the USPTO as a Receiving Office

If a new international application is being filed and the international application includes the necessary components for an international filing date (see PCT Article 11 and MPEP 1810), a Notification of the International Application Number and of the International Filing Date (Form PCT/RO/105) will be issued in due course, subject to prescriptions concerning national security, and the date shown on this Acknowledgement Receipt will establish the international filing date of the application.

Application No.: 16/544713
Filing Date: August 19, 2019

References for Examiner Consideration

Applicant wishes to draw the Examiner's attention to, and encourages the Examiner to review, the following co-owned patents and/or applications and their existing and ongoing prosecution history, including without limitation Office Actions, Amendments, Remarks, and any other potentially relevant documents:

Docket No.	Serial No.	Title	Filed
MASCER.002C16	16/725478	MULTI-STREAM DATA COLLECTION SYSTEM FOR NONINVASIVE MEASUREMENT OF BLOOD CONSTITUENTS	12/23/2019
MASCER.002C17	16/725292	MULTI-STREAM DATA COLLECTION SYSTEM FOR NONINVASIVE MEASUREMENT OF BLOOD CONSTITUENTS	12/23/2019

Applicant notes that cited references, office actions, responses and notices of allowance currently exist or will exist with reference to the above-referenced matters. Applicant also understands that the Examiner has access to sophisticated online Patent Office computing systems that provide ready access to the full file histories of these matters including, for example, specifications, drawings, pending claims, cited art, office actions, responses, declarations, and notices of allowance. Rather than submit copies of these file histories, Applicant respectfully requests that the Examiner continue to review these file histories online for past, current, and future information about these matters that may be relevant to examination of the present application. Also, if the Examiner cannot readily access these file histories, Applicant would be pleased to provide any portion of any of the file histories at any time upon specific Examiner request.

No Disclaimers

To the extent that anything in the Information Disclosure Statement or the listed references could be construed as a disclaimer of any subject matter supported by the present application, Applicant hereby rescinds and retracts such disclaimer.

Application No.: 16/544713
Filing Date: August 19, 2019

Timing of Disclosure

This Information Disclosure Statement is being filed with an RCE or before receipt of a First Office Action after an RCE, and no fee is believed to be required.

The Commissioner is hereby authorized to charge any additional fees which may be required, or credit any overpayment, to Account No. 11-1410.

Respectfully submitted,
KNOBBE, MARTENS, OLSON & BEAR, LLP

Dated: December 27, 2019

By: /Scott Cromar/_____
Scott A. Cromar
Registration No. 65,066
Registered Practitioner
Customer No. 64735
(949) 760-0404

31933429

INFORMATION DISCLOSURE STATEMENT BY APPLICANT	Application No.	16/544713
	Filing Date	August 19, 2019
	First Named Inventor	Jeroen Poeze
	Art Unit	3791
<i>(Multiple sheets used when necessary)</i>	Examiner	Liu, Chu Chuan
SHEET 1 OF 6	Attorney Docket No.	MASCER.002C13

U.S. PATENT DOCUMENTS					
Examiner Initials	Cite No.	Document Number <i>Number - Kind Code (if known)</i> Example: 1,234,567 B1	Publication Date MM-DD-YYYY	Name	Pages, Columns, Lines Where Relevant Passages or Relevant Figures Appear
	1	5,228,449	07-20-1993	Christ et al.	
	2	5,333,616	08-02-1994	Mills et al.	
	3	5,431,170	07-11-1995	Mathews	
	4	5,462,051	10-31-1995	Oka et al.	
	5	5,490,523	02-13-1996	Isaacson et al.	
	6	5,564,429	10-15-1996	Bornn et al.	
	7	5,729,203	03-17-1998	Oka et al.	
	8	5,795,300	08-18-1998	Bryars	
	9	5,800,349	09-01-1998	Isaacson et al.	
	10	6,102,856	08-15-2000	Clarence et al.	
	11	6,241,680	06-05-2001	Miwa	
	12	6,356,203	03-12-2002	Halleck et al.	
	13	6,785,568	08-31-2004	Chance	
	14	6,831,266	12-14-2004	Paritsky et al.	
	15	7,227,156	06-05-2007	Colvin, Jr. et al.	
	16	7,740,588	06-22-2010	Sciarra	
	17	7,740,589	06-22-2010	Maschke et al.	
	18	7,869,849	01-11-2011	Ollerdessen et al.	
	19	7,899,510	03-01-2011	Hoarau	
	20	8,071,935	12-06-2011	Besko et al.	
	21	8,280,469	12-02-2012	Baker, Jr.	
	22	8,838,210	09-16-2014	Wood et al.	
	23	10,433,776	10-08-2019	Al-Ali	
	24	10,441,181	10-15-2019	Telfort et al.	
	25	10,448,844	10-22-2019	Al-Ali et al.	
	26	10,448,871	10-22-2019	Al-Ali	
	27	10,456,038	10-29-2019	Lamego et al.	
	28	10,463,284	11-05-2019	Al-Ali et al.	
	29	10,463,340	11-05-2019	Telfort et al.	

Examiner Signature	Date Considered
<p>*Examiner: Initial if reference considered, whether or not citation is in conformance with MPEP 609. Draw line through citation if not in conformance and not considered. Include copy of this form with next communication to applicant.</p>	

T¹ - Place a check mark in this area when an English language Translation is attached.

INFORMATION DISCLOSURE STATEMENT BY APPLICANT	Application No.	16/544713
	Filing Date	August 19, 2019
	First Named Inventor	Jeroen Poeze
	Art Unit	3791
<i>(Multiple sheets used when necessary)</i>	Examiner	Liu, Chu Chuan
SHEET 2 OF 6	Attorney Docket No.	MASCER.002C13

U.S. PATENT DOCUMENTS					
Examiner Initials	Cite No.	Document Number <i>Number - Kind Code (if known)</i> Example: 1,234,567 B1	Publication Date MM-DD-YYYY	Name	Pages, Columns, Lines Where Relevant Passages or Relevant Figures Appear
	30	10,470,695	11-12-2019	Al-Ali	
	31	10,471,159	11-12-2019	Lapotko et al.	
	32	10,478,107	11-19-2019	Kiani et al.	
	33	2009/0177097	07-09-2009	Ma et al.	
	34	2010/0030043	02-04-2010	Kuhn	
	35	2019/0307377	10-10-2019	Perea et al.	
	36	2019/0320906	10-24-2019	Olsen	
	37	2019/0320959	10-24-2019	Al-Ali	
	38	2019/0320988	10-24-2019	Ahmed et al.	
	39	2019/0325722	10-24-2019	Kiani et al.	
	40	2019/0350506	11-21-2019	Al-Ali	
	41	2019/0357812	11-28-2019	Poeze et al.	
	42	2019/0357813	11-28-2019	Poeze et al.	
	43	2019/0365294	12-05-2019	Poeze et al.	
	44	2019/0374135	12-12-2019	Poeze et al.	

FOREIGN PATENT DOCUMENTS						
Examiner Initials	Cite No.	Foreign Patent Document <i>Country Code-Number-Kind Code</i> Example: JP 1234567 A1	Publication Date MM-DD-YYYY	Name	Pages, Columns, Lines Where Relevant Passages or Relevant Figures Appear	T ¹
	45	CN 101484065 B	11-09-2011	Univ Nottingham		X
	46	EP 0630208 A1	12-28-1994	Myllymaeki		
	47	EP 0770349 A1	05-02-1997	Akasaka et al.		
	48	EP 0880936 A2	12-02-1998	Akai		
	49	EP 0985373 A1	03-15-2000	Cvetkovic		X
	50	EP 1124609 B1	08-02-2006	Medtronic Inc		
	51	EP 1875213 A2	01-09-2008	Sensors for Medicine and Science Inc		
	52	EP 2165196 A1	03-24-2010	Siliconfile Technologies Inc		
	53	GB 2243691 A	11-06-1991	Payne et al.		

Examiner Signature	Date Considered
<p>*Examiner: Initial if reference considered, whether or not citation is in conformance with MPEP 609. Draw line through citation if not in conformance and not considered. Include copy of this form with next communication to applicant.</p>	

T¹ - Place a check mark in this area when an English language Translation is attached.

INFORMATION DISCLOSURE STATEMENT BY APPLICANT	Application No.	16/544713
	Filing Date	August 19, 2019
	First Named Inventor	Jeroen Poeze
	Art Unit	3791
<i>(Multiple sheets used when necessary)</i>	Examiner	Liu, Chu Chuan
SHEET 3 OF 6	Attorney Docket No.	MASCER.002C13

FOREIGN PATENT DOCUMENTS

Examiner Initials	Cite No.	Foreign Patent Document <i>Country Code-Number-Kind Code</i> Example: JP 1234567 A1	Publication Date MM-DD-YYYY	Name	Pages, Columns, Lines Where Relevant Passages or Relevant Figures Appear	T ¹
	54	JPH 09257508 A	10-03-1997	Matsushita Electric Works Ltd		X
	55	JPH 10314133 A	12-02-1998	Ido		X
	56	JPH 1170086 A	03-16-1999	Atsukusu KK		X
	57	JP 2919326 B2	07-12-1999	Corporation Miyuki		X
	58	WO 94/23643 A1	10-27-1994	Noninvasive Medical Technology Corporation		
	59	WO 1995/000070 A1	01-05-1995	Increa Oy		
	60	WO 1997/009923 A1	03-20-1997	Medison Co Ltd		
	61	WO 1999/063883 A1	12-16-1999	S P O Medical Equipment Ltd		
	62	WO 2000/028892 A1	05-25-2000	Micromedical Ind Limited		
	63	WO 2008/107238 A1	09-12-2008	Univ Rennes; Univ Bretagne Sud		X

NON PATENT LITERATURE DOCUMENTS

Examiner Initials	Cite No.	Include name of the author (in CAPITAL LETTERS), title of the article (when appropriate), title of the item (book, magazine, journal, serial, symposium, catalog, etc.), date, page(s), volume-issue number(s), publisher, city and/or country where published.	T ¹
	64	L. Grajales <i>et al.</i> , "Wearable multisensor heart rate monitor," International Workshop on Wearable and Implantable Body Sensor Networks (BSN'06), Cambridge, MA, 2006, pp. 4-157.	
	65	N. Townsend, "Pulse Oximetry," Medical Electronics, 2001, pp. 32-42.	
	66	Nonin Medical, Inc., "Operator's Manual – Models 8600F0 and 8600F0M Pulse Oximeters," 2005, 25 pages.	
	67	C. J. Pujary, "Investigation of Photodetector Optimization in Reducing Power Consumption by a Noninvasive Pulse Oximeter Sensor," Worcester Polytechnic Institute, January 16, 2004, 133 pages.	
	68	B. McGarry <i>et al.</i> , "Reflections on a candidate design of the user-interface for a wireless vital-signs monitor," Proceedings of DARE 2000 on Designing Augmented Reality Environments, January 2000, pp. 33-40.	
	69	J. C. D. Conway <i>et al.</i> , "Wearable computer as a multi-parametric monitor for physiological signals," Proceedings IEEE International Symposium on Bio-Informatics and Biomedical Engineering, Arlington, VA, USA, 2000, pp. 236-242.	
	70	J. A. Tamada <i>et al.</i> , "Noninvasive Glucose Monitoring: Comprehensive Clinical Results," JAMA, November 17, 1999, Vol. 282, No. 19, pp.1839-1844.	
	71	B.-H. Yang <i>et al.</i> , "Development of the ring sensor for healthcare automation," Robotics and Autonomous Systems, 2000, pp. 273-281.	

Examiner Signature	Date Considered
*Examiner: Initial if reference considered, whether or not citation is in conformance with MPEP 609. Draw line through citation if not in conformance and not considered. Include copy of this form with next communication to applicant.	

T¹ - Place a check mark in this area when an English language Translation is attached.

INFORMATION DISCLOSURE STATEMENT BY APPLICANT	Application No.	16/544713
	Filing Date	August 19, 2019
	First Named Inventor	Jeroen Poeze
	Art Unit	3791
<i>(Multiple sheets used when necessary)</i>	Examiner	Liu, Chu Chuan
SHEET 4 OF 6	Attorney Docket No.	MASCER.002C13

NON PATENT LITERATURE DOCUMENTS

Examiner Initials	Cite No.	Include name of the author (in CAPITAL LETTERS), title of the article (when appropriate), title of the item (book, magazine, journal, serial, symposium, catalog, etc.), date, page(s), volume-issue number(s), publisher, city and/or country where published.	T ¹
	72	Laukkanen RM et al., "Heart Rate Monitors: State of the Art," Journal of Sports Science, January 1998, pp. S3-S7.	
	73	S. Warren et al., "Designing Smart Health Care Technology into the Home of the Future," Workshops on Future Medical Devices: Home Care Technologies for the 21 st Century, April 1999, 19 pages.	
	74	A. C. M. Dassel <i>et al.</i> , "Reflectance Pulse Oximetry at the Forehead Improves by Pressure on the Probe," Journal of Clinical Monitoring, Vol. 11, No. 4, July 1995, pp. 237-244.	
	75	B-H. Yang <i>et al.</i> , "A Twenty-Four Hour Tele-Nursing System Using a Ringer Sensor," Proceedings of 1998 IEEE International Conference on Robotics and Automation, May 16-20, 1998, 6 pages.	
	76	S. Rhee <i>et al.</i> , "The Ring Sensor: a New Ambulatory Wearable Sensor for Twenty-Four Hour Patient Monitoring," Proceedings of the 20 th Annual International Conference of the IEEE Engineering in Medicine and Biology Society, October 29-November 1 1998, 4 pages.	
	77	S. Rhee <i>et al.</i> , "Design of a Artifact-Free Wearable Plethysmographic Sensor," 21 st Annual International Conference IEEE Engineering in Medicine and Biology Society, October 13-16, 1999, p. 786.	
	78	T. Martin <i>et al.</i> , "Issues in Wearable Computing for Medical Monitoring Applications: A Case Study of a Wearable ECG Monitoring Device," In Proceedings of International Symposium of Wearable Computers (ISWC'00), February 2000, pp. 43-49.	
	79	S. Rhee <i>et al.</i> , "Artifact-Resistant, Power Efficient Design of Finger-Ring Plethysmographic Sensors, Part I: Design and Analysis," 22 nd Annual International Conference IEEE Engineering in Medicine and Biology Society, July 23-28, 2000, pp. 2792-2795.	
	80	C. Pujary <i>et al.</i> , "Photodetector Size Considerations in the Design of a Noninvasive Reflectance Pulse Oximeter for Telemedicine Applications," Proceedings of IEEE Annual Northeast Bioengineering Conference, 2003, pp. 148-149.	
	81	M. Savage <i>et al.</i> , "Optimizing Power Consumption in the Design of a Wearable Wireless Telesensor: Comparison of Pulse Oximeter Modes," Proceedings of IEEE 29 th Annual Nonheust Bioengineering Conference, 2003, pp.150-151.	
	82	A. Tura <i>et al.</i> , "A Wearable Device with Wireless Bluetooth-based Data Transmission," Measurement Science Review, Vol. 3, Sec. 2, 2003, pp. 1-4.	
	83	R. Paradiso, "Wearable Health Care System for Vital Signs Monitoring," In Proceedings of IEEE International Conference on Information Technology Applications in Biomedicine, May 2003, pp. 283-286.	
	84	H.H. Asada <i>et al.</i> , "Mobile Monitoring with Wearable Photoplethysmographic Biosensors," IEEE Engineering in Medicine and Biology Magazine, May/June 2003, pp. 28-40.	
	85	Y. Mendelson <i>et al.</i> , "Minimization of LED Power Consumption in the Design of a Wearable Pulse Oximeter," Proceedings of the IASTED International Conference Biomedical Engineering, June 25-27, 2003, 6 pages.	
	86	Y. Mendelson <i>et al.</i> , "Measurement Site and Photodetector Size Considerations in Optimizing Power Consumption of a Wearable Reflectance Pulse Oximeter," Proceedings of the 25 th Annual International Conference of the IEEE EMBS, September 17-21, 2003, pp. 3016-3019.	
	87	D. Marculescu <i>et al.</i> , "Ready to Ware," IEEE Spectrum, Vol. 40, Issue 10, October 2003, pp. 28-32.	
	88	P. Celka <i>et al.</i> , "Motion Resistant Earphone Located Infrared Based Hearth Rate Measurement Device," In Proceeding of the 2 nd International Conference on Biomedical Engineering, Innsbruck, Austria, February 16-18, 2004, pp. 582-585.	

Examiner Signature	Date Considered
<p>*Examiner: Initial if reference considered, whether or not citation is in conformance with MPEP 609. Draw line through citation if not in conformance and not considered. Include copy of this form with next communication to applicant.</p>	

T¹ - Place a check mark in this area when an English language Translation is attached.

INFORMATION DISCLOSURE STATEMENT BY APPLICANT	Application No.	16/544713
	Filing Date	August 19, 2019
	First Named Inventor	Jeroen Poeze
	Art Unit	3791
<i>(Multiple sheets used when necessary)</i>	Examiner	Liu, Chu Chuan
SHEET 5 OF 6	Attorney Docket No.	MASCER.002C13

NON PATENT LITERATURE DOCUMENTS

Examiner Initials	Cite No.	Include name of the author (in CAPITAL LETTERS), title of the article (when appropriate), title of the item (book, magazine, journal, serial, symposium, catalog, etc.), date, page(s), volume-issue number(s), publisher, city and/or country where published.	T ¹
	89	D. Konstantas <i>et al.</i> , "Mobile Patient Monitoring: The MobiHealth System," In Proceedings of International Conference on Medical and Care Compunetics, NCC'04, February 2004, 8 pages.	
	90	S. Pentland, "Healthwear: Medical Technology Becomes Wearable," IEEE Computer Society, Vol. 37, Issue 5, May 2004, pp. 34-41.	
	91	P. Branche <i>et al.</i> , "Signal Quality and Power Consumption of a New Prototype Reflectance Pulse Oximeter Sensor," Proceeding of the 31th Annual Northeast Bioengineering Conference, Hoboken, NJ, IEEE, 2005, pp. 1-2.	
	92	U. Anliker <i>et al.</i> , "AMON: A Wearable Multiparameter Medical Monitoring and Alert System," IEEE Transactions on Information Technology in Biomedicine, January 2005, pp. 1-11.	
	93	P. T. Gibbs <i>et al.</i> , "Active Motion Artifact Cancellation for Wearable Health Monitoring Sensors Using Collocated MEMS Accelerometers," Proceedings of SPIE Smart Structures and Materials: Sensors and Smart Structures Technologies for Civil, Mechanical, and Aerospace Systems, May 17, 2005, pp. 811-819.	
	94	C. W. Mundt <i>et al.</i> , "A Multiparameter Wearable Physiologic Monitoring System for Space and Terrestrial Applications," IEEE Transactions on Information Technology in Biomedicine, Vol. 9, No. 3, September 2005, pp. 382-391.	
	95	Y. Mendelson <i>et al.</i> , "A Wearable Reflectance Pulse Oximeter for Remote Physiological Monitoring," Proceedings of the 28 th IEEE EMBS Annual International Conference, August 30-September 3, 2006, pp. 912-915.	
	96	B-S. Lin <i>et al.</i> , "RTWPMS: A Real-Time Wireless Physiological Monitoring System," IEEE Transactions on Information Technology in Biomedicine, Vol. 10, No. 4, October 2006, pp. 647-656.	
	97	T. Torfs <i>et al.</i> , "Body-Heat Powered Autonomous Pulse Oximeter," IEEE Sensors 2006, EXCO, October 22-25, 2006, pp. 427-430.	
	98	P.S. Pandian <i>et al.</i> , "Smart Vest: Wearable Multi-Parameter Remote Physiological Monitoring System," Medical Engineering & Physics 30, 2008. pp. 466-477.	
	99	G. Tamannagari, "Power Efficient Design of Finder-Ring Sensor for Patient Monitoring," Master of Science in Electrical Engineering, The University of Texas at San Antonio, College of Engineering, Department of Electrical Engineering, December 2008, 74 pages.	
	100	M. Yamashita <i>et al.</i> , "Development of a Ring-Type Vital Sign Telemeter," Biotelemetry XIII, March 26-31, 1995, pp. 145-150.	
	101	P. Renevey <i>et al.</i> , "Wrist-Located Pulse Detection Using IR Signals, Activity and Nonlinear Artifact Cancellation," Proceedings of the 23 rd Annual EMBS International Conference, October 25-28, 2001, pp. 3030-3033.	
	102	Y. Mendelson <i>et al.</i> , "A Mobile PDA-Based Wireless Pulse Oximeter," Proceedings of the IASTED International Conference Telehealth, July 19-21, 2005, pp. 1-6.	
	103	P. Shaltis <i>et al.</i> , "Novel Design for a Wearable, Rapidly Depolyable, Wireless Noninvasive Triage Sensor," Proceedings of the 2005 IEEE, Engineering in Medicine and Biology 27 th Annual Conference, September 1-4, 2005, pp 3567-3570.	
	104	Y-S. Yan <i>et al.</i> , "An Efficient Motion-Resistant Method for Wearable Pulse Oximeter," IEEE Transactions on Information Technology in Biomedicine, Vol. 12, No. 3, May 2008, pp. 399-405.	
	105	P. C. Branche <i>et al.</i> , "Measurement Reproducibility and Sensor Placement Considerations in Designing a Wearable Pulse Oximeter for Military Applications," IEEE, 2004, pp. 216-217.	

Examiner Signature	Date Considered
<p>*Examiner: Initial if reference considered, whether or not citation is in conformance with MPEP 609. Draw line through citation if not in conformance and not considered. Include copy of this form with next communication to applicant.</p>	

T¹ - Place a check mark in this area when an English language Translation is attached.

INFORMATION DISCLOSURE STATEMENT BY APPLICANT	Application No.	16/544713
	Filing Date	August 19, 2019
	First Named Inventor	Jeroen Poeze
	Art Unit	3791
<i>(Multiple sheets used when necessary)</i>	Examiner	Liu, Chu Chuan
SHEET 6 OF 6	Attorney Docket No.	MASCER.002C13

NON PATENT LITERATURE DOCUMENTS

Examiner Initials	Cite No.	Include name of the author (in CAPITAL LETTERS), title of the article (when appropriate), title of the item (book, magazine, journal, serial, symposium, catalog, etc.), date, page(s), volume-issue number(s), publisher, city and/or country where published.	T ¹
	106	G. Comtois, "A Comparative Evaluation of Adaptive Noise Cancellation Algorithms for Minimizing Motion Artifacts in a Forehead-Mounted Wearable Pulse Oximeter," Proceedings of the 29 th Annual International Conference of the IEEE EMBS, August 23-26, 2007, pp. 1528-1531.	
	107	G. Comtois <i>et al.</i> , "A Noise Reference Input to an Adaptive Filter Algorithm for Signal Processing in a Wearable Pulse Oximeter," IEEE, 2007, pp. 106-107.	
	108	R. P. Drescher <i>et al.</i> , "A New Reflectance Pulse Oximeter Housing to Reduce Contact Pressure Effects," IEEE, 2006, pp. 49-50.	
	109	R. P. Drescher <i>et al.</i> , "Reflectance Forehead Pulse Oximetry: Effects on Contact Pressure During Walking," Proceedings of the 28 th IEEE EMBS Annual International Conference, August 30-September 3, 2006, pp. 3529-3532.	
	110	W. S. Johnston <i>et al.</i> , "Extracting Breathing Rate Information from a Wearable Reflectance Pulse Oximeter Sensor," Proceedings of the 26 th Annual International Conference of the IEEE EMBS, September 1-5, 2004, pp. 5388-5391.	
	111	W. Johnston <i>et al.</i> , "Extracting Heart Rate Variability from a Wearable Reflectance Pulse Oximeter," IEEE, 2005, pp. 1-2.	
	112	W. S. Johnston <i>et al.</i> , "Investigation of Signal Processing Algorithms for an Embedded Microcontroller-Based Wearable Pulse Oximeter," Proceedings of the 28 th IEEE EMBS Annual International Conference, August 30-September 3, 2006, pp. 5888-5891.	
	113	P. Lukowicz <i>et al.</i> , "AMON: A Wearable Medical Computer for High Risk Patient," Proceedings of the 6 th International Symposium on Wearable Computers (ISWC'02), 2002, pp. 1-2.	
	114	P. Lukowicz <i>et al.</i> , "The WearARM Modular, Low-Power Computing Core," IEEE Micro, May-June 2001, pp. 16-28.	
	115	Y. Mendelson <i>et al.</i> , "Accelerometry-Based Adaptive Noise Cancellation for Remote Physiological Monitoring by a Wearable Pulse Oximeter," Proceedings of the 3 rd IASTED International Conference TELEHEALTH, May 31-June 1, 2007, pp. 28-33.	

Examiner Signature	Date Considered
<p>*Examiner: Initial if reference considered, whether or not citation is in conformance with MPEP 609. Draw line through citation if not in conformance and not considered. Include copy of this form with next communication to applicant.</p>	

T¹ - Place a check mark in this area when an English language Translation is attached.

Electronic Acknowledgement Receipt

EFS ID:	38149528
Application Number:	16544713
International Application Number:	
Confirmation Number:	9381
Title of Invention:	MULTI-STREAM DATA COLLECTION SYSTEM FOR NONINVASIVE MEASUREMENT OF BLOOD CONSTITUENTS
First Named Inventor/Applicant Name:	Jeroen Poeze
Customer Number:	64735
Filer:	Scott Cromar/Frances Tsai
Filer Authorized By:	Scott Cromar
Attorney Docket Number:	MASCER.002C13
Receipt Date:	27-DEC-2019
Filing Date:	19-AUG-2019
Time Stamp:	17:45:31
Application Type:	Utility under 35 USC 111(a)

Payment information:

Submitted with Payment	no
------------------------	----

File Listing:

Document Number	Document Description	File Name	File Size(Bytes)/ Message Digest	Multi Part /.zip	Pages (if appl.)
1		IDS_002C13.pdf	88173 6f1581b6f564f6aca3e8240ce0aec46e5a061ce5	yes	9

Multipart Description/PDF files in .zip description		
Document Description	Start	End
Transmittal Letter	1	1
Information Disclosure Statement (IDS) Form (SB08)	2	9
Warnings:		
Information:		
Total Files Size (in bytes):		88173
<p>This Acknowledgement Receipt evidences receipt on the noted date by the USPTO of the indicated documents, characterized by the applicant, and including page counts, where applicable. It serves as evidence of receipt similar to a Post Card, as described in MPEP 503.</p> <p><u>New Applications Under 35 U.S.C. 111</u> If a new application is being filed and the application includes the necessary components for a filing date (see 37 CFR 1.53(b)-(d) and MPEP 506), a Filing Receipt (37 CFR 1.54) will be issued in due course and the date shown on this Acknowledgement Receipt will establish the filing date of the application.</p> <p><u>National Stage of an International Application under 35 U.S.C. 371</u> If a timely submission to enter the national stage of an international application is compliant with the conditions of 35 U.S.C. 371 and other applicable requirements a Form PCT/DO/EO/903 indicating acceptance of the application as a national stage submission under 35 U.S.C. 371 will be issued in addition to the Filing Receipt, in due course.</p> <p><u>New International Application Filed with the USPTO as a Receiving Office</u> If a new international application is being filed and the international application includes the necessary components for an international filing date (see PCT Article 11 and MPEP 1810), a Notification of the International Application Number and of the International Filing Date (Form PCT/RO/105) will be issued in due course, subject to prescriptions concerning national security, and the date shown on this Acknowledgement Receipt will establish the international filing date of the application.</p>		

INFORMATION DISCLOSURE STATEMENT

First Inventor :	Jeroen Poeze
App. No. :	16/544713
Filed :	August 19, 2019
For :	MULTI-STREAM DATA COLLECTION SYSTEM FOR NONINVASIVE MEASUREMENT OF BLOOD CONSTITUENTS
Examiner :	Liu, Chu Chuan
Art Unit :	3791
Conf. No. :	9381

Commissioner for Patents
P.O. Box 1450
Alexandria, VA 22313-1450

References and Listing

Pursuant to 37 CFR 1.56, an Information Disclosure Statement listing references is provided herewith. Listed references are of record in U.S. patent application No. 16/534949, filed August 7, 2019, which is the parent of this continuation application, and is relied upon for an earlier filing date under 35 USC 120. Copies of the references are not submitted pursuant to 37 CFR 1.98(d).

For certain cited non-English patent and/or non-patent references, machine translations of the references (and/or Abstracts) are included, and inclusion is indicated in the last column. Applicant makes no representation as to the accuracy of the English machine translations. If the Examiner would like additional information regarding these references or if anything is unclear, the Examiner is invited to request such information, and Applicant will attempt to comply with any such request.

Pursuant to 37 CFR 1.97(g) and (h), Applicant makes no representation that the information is considered to be material to patentability. Additionally, inclusion on this list is not an admission that any of the cited documents are prior art in this application. Further, Applicant makes no representation regarding the completeness of this list, or that better art does not exist.

INFORMATION DISCLOSURE STATEMENT BY APPLICANT	Application No.	16/544713
	Filing Date	August 19, 2019
	First Named Inventor	Jeroen Poeze
	Art Unit	3791
<i>(Multiple sheets used when necessary)</i>	Examiner	Liu, Chu Chuan
SHEET 1 OF 1	Attorney Docket No.	MASCER.002C13

U.S. PATENT DOCUMENTS

Examiner Initials	Cite No.	Document Number <i>Number - Kind Code (if known)</i> Example: 1,234,567 B1	Publication Date MM-DD-YYYY	Name	Pages, Columns, Lines Where Relevant Passages or Relevant Figures Appear

FOREIGN PATENT DOCUMENTS

Examiner Initials	Cite No.	Foreign Patent Document <i>Country Code-Number-Kind Code</i> Example: JP 1234567 A1	Publication Date MM-DD-YYYY	Name	Pages, Columns, Lines Where Relevant Passages or Relevant Figures Appear	T ¹

NON PATENT LITERATURE DOCUMENTS

Examiner Initials	Cite No.	Include name of the author (in CAPITAL LETTERS), title of the article (when appropriate), title of the item (book, magazine, journal, serial, symposium, catalog, etc.), date, page(s), volume-issue number(s), publisher, city and/or country where published.	T ¹
	1	2020-01-09 Complaint for (1) Patent Infringement (2) Trade Secret Misappropriation and (3) Ownership of Patents and Demand for Jury Trial, Masimo Corporation and Cercacor Laboratories, Inc. v. Apple Inc., Case No. 8:20-cv-00048, 64 pages.	

Examiner Signature	Date Considered
<p>*Examiner: Initial if reference considered, whether or not citation is in conformance with MPEP 609. Draw line through citation if not in conformance and not considered. Include copy of this form with next communication to applicant.</p>	

T¹ - Place a check mark in this area when an English language Translation is attached.

**INFORMATION DISCLOSURE STATEMENT
AND NOTICE OF CONCURRENT LITIGATION**

First Inventor :	Jeroen Poeze
App. No. :	16/544713
Filed :	August 19, 2019
For :	MULTI-STREAM DATA COLLECTION SYSTEM FOR NONINVASIVE MEASUREMENT OF BLOOD CONSTITUENTS
Examiner :	Liu, Chu Chuan
Art Unit :	3791
Conf. No. :	9381

Commissioner for Patents
P.O. Box 1450
Alexandria, VA 22313-1450

References and Listing

Pursuant to 37 CFR 1.56, an Information Disclosure Statement listing references is provided herewith. Copies of any listed foreign and non-patent literature references are being submitted.

Pursuant to 37 CFR 1.97(g) and (h), Applicant makes no representation that the information is considered to be material to patentability. Additionally, inclusion on this list is not an admission that any of the cited documents are prior art in this application. Further, Applicant makes no representation regarding the completeness of this list, or that better art does not exist.

Related Proceedings

Pursuant to M.P.E.P § 2001.06(c), Applicant provides this notification of related litigation proceedings. On January 9, 2020, Applicant, Masimo Corporation, and Cercacor Laboratories, Inc., filed a complaint in the United States Court for the Central District of California (Case No. 8:20-cv-00048) against Apple Inc.. The complaint alleges infringement of U.S. Patent Nos. 10,258,265; 10,258,266; 10,292,628; 10,299,708; 10,376,190; 10,376,191; 10,470,695; 6,771,994; 8,457,703; and 10,433,776. At least U.S. Patent Nos. 10,258,265; 10,258,266; 10,292,628; 10,299,708; 10,376,190; and 10,376,191 share a common priority claim

with the present application. A copy of the complaint in the proceeding is being submitted herewith.

For convenience in reviewing this submission, the following chart is provided showing the pending applications which share at least one common priority claim with each of the asserted patents.

Patent No.	Pending Family Members
10,258,265	16/449143
10,258,266	16/534956
10,292,628	16/534949
10,299,708	16/541987
10,376,190	16/544713
10,376,191	16/544755
	16/594980
	16/725478
	16/725292
10,470,695	16/532061
	16/532065
6,771,994	
8,457,703	15/820082
10,433,776	16/174130

No Disclaimers

To the extent that anything in the Information Disclosure Statement or the listed references could be construed as a disclaimer of any subject matter supported by the present application, Applicant hereby rescinds and retracts such disclaimer.

Timing of Disclosure

This Information Disclosure Statement is being filed with an RCE or before receipt of a First Office Action after an RCE, and no fee is believed to be required.

Docket No.: MASCER.002C13
App. No.: 16/544713

Page 3 of 3

The Commissioner is hereby authorized to charge any additional fees which may be required, or credit any overpayment, to Account No. 11-1410.

Respectfully submitted,

KNOBBE, MARTENS, OLSON & BEAR, LLP

Dated: January 10, 2020

By: /Scott Cromar/ _____
Scott A. Cromar
Registration No. 65,066
Registered Practitioner
(949) 760-0404

32005672

Electronic Acknowledgement Receipt

EFS ID:	38267114
Application Number:	16544713
International Application Number:	
Confirmation Number:	9381
Title of Invention:	MULTI-STREAM DATA COLLECTION SYSTEM FOR NONINVASIVE MEASUREMENT OF BLOOD CONSTITUENTS
First Named Inventor/Applicant Name:	Jeroen Poeze
Customer Number:	64735
Filer:	Scott Cromar/Frances Tsai
Filer Authorized By:	Scott Cromar
Attorney Docket Number:	MASCER.002C13
Receipt Date:	10-JAN-2020
Filing Date:	19-AUG-2019
Time Stamp:	17:38:35
Application Type:	Utility under 35 USC 111(a)

Payment information:

Submitted with Payment	no
------------------------	----

File Listing:

Document Number	Document Description	File Name	File Size(Bytes)/ Message Digest	Multi Part /.zip	Pages (if appl.)
1		IDS_002C13.pdf	48359 9d2748e96b1a137175e0855dee0256d162ed328e	yes	4

Multipart Description/PDF files in .zip description					
Document Description			Start	End	
Information Disclosure Statement (IDS) Form (SB08)			4	4	
Transmittal Letter			1	3	
Warnings:					
Information:					
2	Non Patent Literature	2020-01-09_Complaint.pdf	764129	no	64
			239c5b87904f14e7afdd74bd399a8bfa6ee0698f		
Warnings:					
Information:					
Total Files Size (in bytes):			812488		
<p>This Acknowledgement Receipt evidences receipt on the noted date by the USPTO of the indicated documents, characterized by the applicant, and including page counts, where applicable. It serves as evidence of receipt similar to a Post Card, as described in MPEP 503.</p> <p><u>New Applications Under 35 U.S.C. 111</u> If a new application is being filed and the application includes the necessary components for a filing date (see 37 CFR 1.53(b)-(d) and MPEP 506), a Filing Receipt (37 CFR 1.54) will be issued in due course and the date shown on this Acknowledgement Receipt will establish the filing date of the application.</p> <p><u>National Stage of an International Application under 35 U.S.C. 371</u> If a timely submission to enter the national stage of an international application is compliant with the conditions of 35 U.S.C. 371 and other applicable requirements a Form PCT/DO/EO/903 indicating acceptance of the application as a national stage submission under 35 U.S.C. 371 will be issued in addition to the Filing Receipt, in due course.</p> <p><u>New International Application Filed with the USPTO as a Receiving Office</u> If a new international application is being filed and the international application includes the necessary components for an international filing date (see PCT Article 11 and MPEP 1810), a Notification of the International Application Number and of the International Filing Date (Form PCT/RO/105) will be issued in due course, subject to prescriptions concerning national security, and the date shown on this Acknowledgement Receipt will establish the international filing date of the application.</p>					



UNITED STATES PATENT AND TRADEMARK OFFICE

UNITED STATES DEPARTMENT OF COMMERCE
United States Patent and Trademark Office
Address: COMMISSIONER FOR PATENTS
P.O. Box 1450
Alexandria, Virginia 22313-1450
www.uspto.gov

NOTICE OF ALLOWANCE AND FEE(S) DUE

64735 7590 01/27/2020
KNOBBE, MARTENS, OLSON & BEAR, LLP
MASIMO CORPORATION (MASIMO)
2040 MAIN STREET
FOURTEENTH FLOOR
IRVINE, CA 92614

EXAMINER
LIU, CHU CHUAN

ART UNIT PAPER NUMBER

3791

DATE MAILED: 01/27/2020

Table with 5 columns: APPLICATION NO., FILING DATE, FIRST NAMED INVENTOR, ATTORNEY DOCKET NO., CONFIRMATION NO.
16/544,713 08/19/2019 Jeroen Poeze MASCER.002C13 9381

TITLE OF INVENTION: MULTI-STREAM DATA COLLECTION SYSTEM FOR NONINVASIVE MEASUREMENT OF BLOOD CONSTITUENTS

Table with 7 columns: APPLN. TYPE, ENTITY STATUS, ISSUE FEE DUE, PUBLICATION FEE DUE, PREV. PAID ISSUE FEE, TOTAL FEE(S) DUE, DATE DUE
nonprovisional UNDISCOUNTED \$1000 \$0.00 \$1000.00 \$0 04/27/2020

THE APPLICATION IDENTIFIED ABOVE HAS BEEN EXAMINED AND IS ALLOWED FOR ISSUANCE AS A PATENT. PROSECUTION ON THE MERITS IS CLOSED. THIS NOTICE OF ALLOWANCE IS NOT A GRANT OF PATENT RIGHTS. THIS APPLICATION IS SUBJECT TO WITHDRAWAL FROM ISSUE AT THE INITIATIVE OF THE OFFICE OR UPON PETITION BY THE APPLICANT. SEE 37 CFR 1.313 AND MPEP 1308.

THE ISSUE FEE AND PUBLICATION FEE (IF REQUIRED) MUST BE PAID WITHIN THREE MONTHS FROM THE MAILING DATE OF THIS NOTICE OR THIS APPLICATION SHALL BE REGARDED AS ABANDONED. THIS STATUTORY PERIOD CANNOT BE EXTENDED. SEE 35 U.S.C. 151. THE ISSUE FEE DUE INDICATED ABOVE DOES NOT REFLECT A CREDIT FOR ANY PREVIOUSLY PAID ISSUE FEE IN THIS APPLICATION. IF AN ISSUE FEE HAS PREVIOUSLY BEEN PAID IN THIS APPLICATION (AS SHOWN ABOVE), THE RETURN OF PART B OF THIS FORM WILL BE CONSIDERED A REQUEST TO REAPPLY THE PREVIOUSLY PAID ISSUE FEE TOWARD THE ISSUE FEE NOW DUE.

HOW TO REPLY TO THIS NOTICE:

I. Review the ENTITY STATUS shown above. If the ENTITY STATUS is shown as SMALL or MICRO, verify whether entitlement to that entity status still applies.

If the ENTITY STATUS is the same as shown above, pay the TOTAL FEE(S) DUE shown above.

If the ENTITY STATUS is changed from that shown above, on PART B - FEE(S) TRANSMITTAL, complete section number 5 titled "Change in Entity Status (from status indicated above)".

For purposes of this notice, small entity fees are 1/2 the amount of undiscounted fees, and micro entity fees are 1/2 the amount of small entity fees.

II. PART B - FEE(S) TRANSMITTAL, or its equivalent, must be completed and returned to the United States Patent and Trademark Office (USPTO) with your ISSUE FEE and PUBLICATION FEE (if required). If you are charging the fee(s) to your deposit account, section "4b" of Part B - Fee(s) Transmittal should be completed and an extra copy of the form should be submitted. If an equivalent of Part B is filed, a request to reapply a previously paid issue fee must be clearly made, and delays in processing may occur due to the difficulty in recognizing the paper as an equivalent of Part B.

III. All communications regarding this application must give the application number. Please direct all communications prior to issuance to Mail Stop ISSUE FEE unless advised to the contrary.

IMPORTANT REMINDER: Maintenance fees are due in utility patents issuing on applications filed on or after Dec. 12, 1980. It is patentee's responsibility to ensure timely payment of maintenance fees when due. More information is available at www.uspto.gov/PatentMaintenanceFees.

PART B - FEE(S) TRANSMITTAL

Complete and send this form, together with applicable fee(s), by mail or fax, or via EFS-Web.

By mail, send to: Mail Stop ISSUE FEE
 Commissioner for Patents
 P.O. Box 1450
 Alexandria, Virginia 22313-1450

By fax, send to: (571)-273-2885

INSTRUCTIONS: This form should be used for transmitting the ISSUE FEE and PUBLICATION FEE (if required). Blocks 1 through 5 should be completed where appropriate. All further correspondence including the Patent, advance orders and notification of maintenance fees will be mailed to the current correspondence address as indicated unless corrected below or directed otherwise in Block 1, by (a) specifying a new correspondence address; and/or (b) indicating a separate "FEE ADDRESS" for maintenance fee notifications.

CURRENT CORRESPONDENCE ADDRESS (Note: Use Block 1 for any change of address)

64735 7590 01/27/2020
KNOBBE, MARTENS, OLSON & BEAR, LLP
MASIMO CORPORATION (MASIMO)
 2040 MAIN STREET
 FOURTEENTH FLOOR
 IRVINE, CA 92614

Note: A certificate of mailing can only be used for domestic mailings of the Fee(s) Transmittal. This certificate cannot be used for any other accompanying papers. Each additional paper, such as an assignment or formal drawing, must have its own certificate of mailing or transmission.

Certificate of Mailing or Transmission

I hereby certify that this Fee(s) Transmittal is being deposited with the United States Postal Service with sufficient postage for first class mail in an envelope addressed to the Mail Stop ISSUE FEE address above, or being transmitted to the USPTO via EFS-Web or by facsimile to (571) 273-2885, on the date below.

_____ (Typed or printed name)
_____ (Signature)
_____ (Date)

APPLICATION NO.	FILING DATE	FIRST NAMED INVENTOR	ATTORNEY DOCKET NO.	CONFIRMATION NO.
16/544,713	08/19/2019	Jeroen Poeze	MASCER.002C13	9381

TITLE OF INVENTION: MULTI-STREAM DATA COLLECTION SYSTEM FOR NONINVASIVE MEASUREMENT OF BLOOD CONSTITUENTS

APPLN. TYPE	ENTITY STATUS	ISSUE FEE DUE	PUBLICATION FEE DUE	PREV. PAID ISSUE FEE	TOTAL FEE(S) DUE	DATE DUE
nonprovisional	UNDISCOUNTED	\$1000	\$0.00	\$1000.00	\$0	04/27/2020

EXAMINER	ART UNIT	CLASS-SUBCLASS
LIU, CHU CHUAN	3791	600-310000

<p>1. Change of correspondence address or indication of "Fee Address" (37 CFR 1.363).</p> <p><input type="checkbox"/> Change of correspondence address (or Change of Correspondence Address form PTO/SB/122) attached.</p> <p><input type="checkbox"/> "Fee Address" indication (or "Fee Address" Indication form PTO/SB/47; Rev 03-09 or more recent) attached. Use of a Customer Number is required.</p>	<p>2. For printing on the patent front page, list</p> <p>(1) The names of up to 3 registered patent attorneys or agents OR, alternatively, 1 _____</p> <p>(2) The name of a single firm (having as a member a registered attorney or agent) and the names of up to 2 registered patent attorneys or agents. If no name is listed, no name will be printed. 2 _____</p> <p>3 _____</p>
---	---

3. ASSIGNEE NAME AND RESIDENCE DATA TO BE PRINTED ON THE PATENT (print or type)

PLEASE NOTE: Unless an assignee is identified below, no assignee data will appear on the patent. If an assignee is identified below, the document must have been previously recorded, or filed for recordation, as set forth in 37 CFR 3.11 and 37 CFR 3.81(a). Completion of this form is NOT a substitute for filing an assignment.

(A) NAME OF ASSIGNEE _____ (B) RESIDENCE: (CITY and STATE OR COUNTRY) _____

Please check the appropriate assignee category or categories (will not be printed on the patent): Individual Corporation or other private group entity Government

4a. Fees submitted: Issue Fee Publication Fee (if required) Advance Order - # of Copies _____

4b. Method of Payment: (Please first reapply any previously paid fee shown above)

Electronic Payment via EFS-Web Enclosed check Non-electronic payment by credit card (Attach form PTO-2038)

The Director is hereby authorized to charge the required fee(s), any deficiency, or credit any overpayment to Deposit Account No. _____

5. Change in Entity Status (from status indicated above)

Applicant certifying micro entity status. See 37 CFR 1.29

Applicant asserting small entity status. See 37 CFR 1.27

Applicant changing to regular undiscounted fee status.

NOTE: Absent a valid certification of Micro Entity Status (see forms PTO/SB/15A and 15B), issue fee payment in the micro entity amount will not be accepted at the risk of application abandonment.

NOTE: If the application was previously under micro entity status, checking this box will be taken to be a notification of loss of entitlement to micro entity status.

NOTE: Checking this box will be taken to be a notification of loss of entitlement to small or micro entity status, as applicable.

NOTE: This form must be signed in accordance with 37 CFR 1.31 and 1.33. See 37 CFR 1.4 for signature requirements and certifications.

Authorized Signature _____ Date _____

Typed or printed name _____ Registration No. _____



UNITED STATES PATENT AND TRADEMARK OFFICE

UNITED STATES DEPARTMENT OF COMMERCE
United States Patent and Trademark Office
Address: COMMISSIONER FOR PATENTS
P.O. Box 1450
Alexandria, Virginia 22313-1450
www.uspto.gov

Table with 5 columns: APPLICATION NO., FILING DATE, FIRST NAMED INVENTOR, ATTORNEY DOCKET NO., CONFIRMATION NO.
Row 1: 16/544,713, 08/19/2019, Jeroen Poeze, MASCER.002C13, 9381
Row 2: 64735, 7590, 01/27/2020, EXAMINER, LIU, CHU CHUAN
Row 3: ART UNIT, PAPER NUMBER, 3791
Row 4: DATE MAILED: 01/27/2020

Determination of Patent Term Adjustment under 35 U.S.C. 154 (b)
(Applications filed on or after May 29, 2000)

The Office has discontinued providing a Patent Term Adjustment (PTA) calculation with the Notice of Allowance.

Section 1(h)(2) of the AIA Technical Corrections Act amended 35 U.S.C. 154(b)(3)(B)(i) to eliminate the requirement that the Office provide a patent term adjustment determination with the notice of allowance. See Revisions to Patent Term Adjustment, 78 Fed. Reg. 19416, 19417 (Apr. 1, 2013). Therefore, the Office is no longer providing an initial patent term adjustment determination with the notice of allowance. The Office will continue to provide a patent term adjustment determination with the Issue Notification Letter that is mailed to applicant approximately three weeks prior to the issue date of the patent, and will include the patent term adjustment on the patent. Any request for reconsideration of the patent term adjustment determination (or reinstatement of patent term adjustment) should follow the process outlined in 37 CFR 1.705.

Any questions regarding the Patent Term Extension or Adjustment determination should be directed to the Office of Patent Legal Administration at (571)-272-7702. Questions relating to issue and publication fee payments should be directed to the Customer Service Center of the Office of Patent Publication at 1-(888)-786-0101 or (571)-272-4200.

OMB Clearance and PRA Burden Statement for PTOL-85 Part B

The Paperwork Reduction Act (PRA) of 1995 requires Federal agencies to obtain Office of Management and Budget approval before requesting most types of information from the public. When OMB approves an agency request to collect information from the public, OMB (i) provides a valid OMB Control Number and expiration date for the agency to display on the instrument that will be used to collect the information and (ii) requires the agency to inform the public about the OMB Control Number's legal significance in accordance with 5 CFR 1320.5(b).

The information collected by PTOL-85 Part B is required by 37 CFR 1.311. The information is required to obtain or retain a benefit by the public which is to file (and by the USPTO to process) an application. Confidentiality is governed by 35 U.S.C. 122 and 37 CFR 1.14. This collection is estimated to take 30 minutes to complete, including gathering, preparing, and submitting the completed application form to the USPTO. Time will vary depending upon the individual case. Any comments on the amount of time you require to complete this form and/or suggestions for reducing this burden, should be sent to the Chief Information Officer, U.S. Patent and Trademark Office, U.S. Department of Commerce, P.O. Box 1450, Alexandria, Virginia 22313-1450. DO NOT SEND FEES OR COMPLETED FORMS TO THIS ADDRESS. SEND TO: Commissioner for Patents, P.O. Box 1450, Alexandria, Virginia 22313-1450. Under the Paperwork Reduction Act of 1995, no persons are required to respond to a collection of information unless it displays a valid OMB control number.

Privacy Act Statement

The Privacy Act of 1974 (P.L. 93-579) requires that you be given certain information in connection with your submission of the attached form related to a patent application or patent. Accordingly, pursuant to the requirements of the Act, please be advised that: (1) the general authority for the collection of this information is 35 U.S.C. 2(b)(2); (2) furnishing of the information solicited is voluntary; and (3) the principal purpose for which the information is used by the U.S. Patent and Trademark Office is to process and/or examine your submission related to a patent application or patent. If you do not furnish the requested information, the U.S. Patent and Trademark Office may not be able to process and/or examine your submission, which may result in termination of proceedings or abandonment of the application or expiration of the patent.

The information provided by you in this form will be subject to the following routine uses:

1. The information on this form will be treated confidentially to the extent allowed under the Freedom of Information Act (5 U.S.C. 552) and the Privacy Act (5 U.S.C. 552a). Records from this system of records may be disclosed to the Department of Justice to determine whether disclosure of these records is required by the Freedom of Information Act.
2. A record from this system of records may be disclosed, as a routine use, in the course of presenting evidence to a court, magistrate, or administrative tribunal, including disclosures to opposing counsel in the course of settlement negotiations.
3. A record in this system of records may be disclosed, as a routine use, to a Member of Congress submitting a request involving an individual, to whom the record pertains, when the individual has requested assistance from the Member with respect to the subject matter of the record.
4. A record in this system of records may be disclosed, as a routine use, to a contractor of the Agency having need for the information in order to perform a contract. Recipients of information shall be required to comply with the requirements of the Privacy Act of 1974, as amended, pursuant to 5 U.S.C. 552a(m).
5. A record related to an International Application filed under the Patent Cooperation Treaty in this system of records may be disclosed, as a routine use, to the International Bureau of the World Intellectual Property Organization, pursuant to the Patent Cooperation Treaty.
6. A record in this system of records may be disclosed, as a routine use, to another federal agency for purposes of National Security review (35 U.S.C. 181) and for review pursuant to the Atomic Energy Act (42 U.S.C. 218(c)).
7. A record from this system of records may be disclosed, as a routine use, to the Administrator, General Services, or his/her designee, during an inspection of records conducted by GSA as part of that agency's responsibility to recommend improvements in records management practices and programs, under authority of 44 U.S.C. 2904 and 2906. Such disclosure shall be made in accordance with the GSA regulations governing inspection of records for this purpose, and any other relevant (i.e., GSA or Commerce) directive. Such disclosure shall not be used to make determinations about individuals.
8. A record from this system of records may be disclosed, as a routine use, to the public after either publication of the application pursuant to 35 U.S.C. 122(b) or issuance of a patent pursuant to 35 U.S.C. 151. Further, a record may be disclosed, subject to the limitations of 37 CFR 1.14, as a routine use, to the public if the record was filed in an application which became abandoned or in which the proceedings were terminated and which application is referenced by either a published application, an application open to public inspection or an issued patent.
9. A record from this system of records may be disclosed, as a routine use, to a Federal, State, or local law enforcement agency, if the USPTO becomes aware of a violation or potential violation of law or regulation.

Notice of Allowability	Application No. 16/544,713	Applicant(s) Poeze et al.	
	Examiner CHU CHUAN LIU	Art Unit 3791	AIA (FITF) Status No

-- The MAILING DATE of this communication appears on the cover sheet with the correspondence address--

All claims being allowable, PROSECUTION ON THE MERITS IS (OR REMAINS) CLOSED in this application. If not included herewith (or previously mailed), a Notice of Allowance (PTOL-85) or other appropriate communication will be mailed in due course. **THIS NOTICE OF ALLOWABILITY IS NOT A GRANT OF PATENT RIGHTS.** This application is subject to withdrawal from issue at the initiative of the Office or upon petition by the applicant. See 37 CFR 1.313 and MPEP 1308.

- 1. This communication is responsive to the supplemental amendment filed on 12/23/2019.
 - A declaration(s)/affidavit(s) under **37 CFR 1.130(b)** was/were filed on _____.
- 2. An election was made by the applicant in response to a restriction requirement set forth during the interview on _____; the restriction requirement and election have been incorporated into this action.
- 3. The allowed claim(s) is/are 2,4-25 and 27-31 . As a result of the allowed claim(s), you may be eligible to benefit from the **Patent Prosecution Highway** program at a participating intellectual property office for the corresponding application. For more information , please see http://www.uspto.gov/patents/init_events/pph/index.jsp or send an inquiry to PPHfeedback@uspto.gov.
- 4. Acknowledgment is made of a claim for foreign priority under 35 U.S.C. § 119(a)-(d) or (f).

Certified copies:

- a) All b) Some *c) None of the:
 - 1. Certified copies of the priority documents have been received.
 - 2. Certified copies of the priority documents have been received in Application No. _____ .
 - 3. Copies of the certified copies of the priority documents have been received in this national stage application from the International Bureau (PCT Rule 17.2(a)).

* Certified copies not received: _____ .

Applicant has THREE MONTHS FROM THE "MAILING DATE" of this communication to file a reply complying with the requirements noted below. Failure to timely comply will result in ABANDONMENT of this application.

THIS THREE-MONTH PERIOD IS NOT EXTENDABLE.

- 5. CORRECTED DRAWINGS (as "replacement sheets") must be submitted.
 - including changes required by the attached Examiner's Amendment / Comment or in the Office action of Paper No./Mail Date _____ .

Identifying indicia such as the application number (see 37 CFR 1.84(c)) should be written on the drawings in the front (not the back) of each sheet. Replacement sheet(s) should be labeled as such in the header according to 37 CFR 1.121(d).
- 6. DEPOSIT OF and/or INFORMATION about the deposit of BIOLOGICAL MATERIAL must be submitted. Note the attached Examiner's comment regarding REQUIREMENT FOR THE DEPOSIT OF BIOLOGICAL MATERIAL.

Attachment(s)

- 1. Notice of References Cited (PTO-892)
- 2. Information Disclosure Statements (PTO/SB/08), Paper No./Mail Date 12/11/2019; 12/12/2019; 12/27/2019.
- 3. Examiner's Comment Regarding Requirement for Deposit of Biological Material _____.
- 4. Interview Summary (PTO-413), Paper No./Mail Date. _____.
- 5. Examiner's Amendment/Comment
- 6. Examiner's Statement of Reasons for Allowance
- 7. Other _____.

/CHU CHUAN LIU/ Examiner, Art Unit 3791	/ERIC F WINAKUR/ Primary Examiner, Art Unit 3791
--	---

Allowable Subject Matter

1. Claims 2, 4-25 and 27-31 are allowed.
2. The following is an examiner's statement of reasons for allowance: The IDS filed on 12/11/2019, 12/12/2019 and 12/27/2019 have been considered. The claims remain allowable for the reasons of record. Signed copies of the 1449 are attached for completeness of Applicant's records.

Any comments considered necessary by applicant must be submitted no later than the payment of the issue fee and, to avoid processing delays, should preferably accompany the issue fee. Such submissions should be clearly labeled "Comments on Statement of Reasons for Allowance."

3. Any inquiry concerning this communication or earlier communications from the examiner should be directed to CHU CHUAN LIU whose telephone number is (571)270-5507. The examiner can normally be reached on M-Th (8am-6pm).

Examiner interviews are available via telephone, in-person, and video conferencing using a USPTO supplied web-based collaboration tool. To schedule an interview, applicant is encouraged to use the USPTO Automated Interview Request (AIR) at <http://www.uspto.gov/interviewpractice>.

If attempts to reach the examiner by telephone are unsuccessful, the examiner's supervisor, Jacqueline Cheng can be reached on (571) 272-5596. The fax phone

number for the organization where this application or proceeding is assigned is 571-273-8300.

Information regarding the status of an application may be obtained from the Patent Application Information Retrieval (PAIR) system. Status information for published applications may be obtained from either Private PAIR or Public PAIR. Status information for unpublished applications is available through Private PAIR only. For more information about the PAIR system, see <http://pair-direct.uspto.gov>. Should you have questions on access to the Private PAIR system, contact the Electronic Business Center (EBC) at 866-217-9197 (toll-free). If you would like assistance from a USPTO Customer Service Representative or access to the automated information system, call 800-786-9199 (IN USA OR CANADA) or 571-272-1000.

/ERIC F WINAKUR/
Primary Examiner, Art Unit 3791

/CHU CHUAN LIU/
Examiner, Art Unit 3791

<i>Search Notes</i> 	Application/Control No. 16/544,713	Applicant(s)/Patent Under Reexamination Poeze et al.
	Examiner CHU CHUAN LIU	Art Unit 3791

CPC - Searched*		
Symbol	Date	Examiner
A61B5/1455,14551,14552,14532,6829,6838,6816,6843,14546,6826	09/17/2019	CCL
A61B5/1455,14551,14552,14532,14546,6826,6816,6829,6838 A61B2562/00,04,046,06,063,066	10/16/2019	CCL
A61B5/1455,14551,14552,14532,14546,6826,6816,6829,6838 A61B2562/00,04,046,06,063,066	01/02/2020	CCL

CPC Combination Sets - Searched*		
Symbol	Date	Examiner

US Classification - Searched*			
Class	Subclass	Date	Examiner

* See search history printout included with this form or the SEARCH NOTES box below to determine the scope of the search.

/CHU CHUAN LIU/ Examiner, Art Unit 3791	
--	--

<i>Search Notes</i> 	Application/Control No. 16/544,713	Applicant(s)/Patent Under Reexamination Poeze et al.
	Examiner CHU CHUAN LIU	Art Unit 3791

Search Notes		
Search Notes	Date	Examiner
Inventor Name Search (PALM and EAST)	09/17/2019	CCL
EAST Search (TEXT, USPGPUB, USPAT, CPC) See Search History	09/17/2019	CCL
Google NPL Search	09/17/2019	CCL
Updated EAST Search (TEXT, USPGPUB, USPAT, CPC) See Search History	10/16/2019	CCL
Google NPL Search	10/16/2019	CCL
Allowance consultation with Eric Winakur	10/09/2019	CCL
Updated EAST Search (TEXT, USPGPUB, USPAT, CPC) See Search History	01/02/2020	CCL
Google NPL Search	01/02/2020	CCL
Allowance consultation with Eric Winakur	01/02/2020	CCL

Interference Search			
US Class/CPC Symbol	US Subclass/CPC Group	Date	Examiner
A61B5	1455,14551,14552,14532,14546,6826,6816,6829,6838	10/16/2019	CCL
A61B2562	00,04,046,06,063,066	10/16/2019	CCL
A61B5	1455,14551,14552,14532,14546,6826,6816,6829,6838	01/02/2020	CCL
A61B2562	00,04,046,06,063,066	01/02/2020	CCL

/CHU CHUAN LIU/ Examiner, Art Unit 3791	
--	--

Issue Classification 	Application/Control No. 16/544,713	Applicant(s)/Patent Under Reexamination Poeze et al.
	Examiner CHU CHUAN LIU	Art Unit 3791

CPC						
Symbol					Type	Version
A61B	/	5	/	1455	F	2013-01-01
A61B	/	5	/	14532	I	2013-01-01
A61B	/	5	/	14546	I	2013-01-01
A61B	/	5	/	14552	I	2013-01-01
A61B	/	5	/	6816	I	2013-01-01
A61B	/	5	/	6826	I	2013-01-01
A61B	/	5	/	6838	I	2013-01-01
A61B	/	5	/	6843	I	2013-01-01
A61B	/	5	/	6829	I	2013-01-01
A61B	/	2562	/	146	A	2013-01-01
A61B	/	2562	/	0233	A	2013-01-01
A61B	/	2562	/	04	A	2013-01-01
A61B	/	2562	/	046	A	2013-01-01

CPC Combination Sets				
Symbol	Type	Set	Ranking	Version
/		/		

/CHU CHUAN LIU/ Examiner, Art Unit 3791 (Assistant Examiner)	02 January 2020 (Date)	Total Claims Allowed: 28	
/ERIC F WINAKUR/ Primary Examiner, Art Unit 3791 (Primary Examiner)	02 January 2020 (Date)	O.G. Print Claim(s) 1	O.G. Print Figure 3C

Issue Classification 	Application/Control No. 16/544,713	Applicant(s)/Patent Under Reexamination Poeze et al.
	Examiner CHU CHUAN LIU	Art Unit 3791

INTERNATIONAL CLASSIFICATION			
CLAIMED			
A61B		5	1455
NON-CLAIMED			

US ORIGINAL CLASSIFICATION	
CLASS	SUBCLASS

CROSS REFERENCES(S)					
CLASS	SUBCLASS (ONE SUBCLASS PER BLOCK)				

/CHU CHUAN LIU/ Examiner, Art Unit 3791 (Assistant Examiner)	02 January 2020 (Date)	Total Claims Allowed: 28	
/ERIC F WINAKUR/ Primary Examiner, Art Unit 3791 (Primary Examiner)	02 January 2020 (Date)	O.G. Print Claim(s) 1	O.G. Print Figure 3C

Issue Classification 	Application/Control No. 16/544,713	Applicant(s)/Patent Under Reexamination Poeze et al.
	Examiner CHU CHUAN LIU	Art Unit 3791

Claims renumbered in the same order as presented by applicant
 CPA
 T.D.
 R.1.47

CLAIMS															
Final	Original	Final	Original	Final	Original	Final	Original	Final	Original	Final	Original	Final	Original	Final	Original
	1	8	10	17	19	25	28								
1	2	9	11	18	20	26	29								
	3	10	12	19	21	27	30								
2	4	11	13	20	22	28	31								
3	5	12	14	21	23										
4	6	13	15	22	24										
5	7	14	16	23	25										
6	8	15	17		26										
7	9	16	18	24	27										

/CHU CHUAN LIU/ Examiner, Art Unit 3791 (Assistant Examiner)	02 January 2020 (Date)	Total Claims Allowed: 28	
/ERIC F WINAKUR/ Primary Examiner, Art Unit 3791 (Primary Examiner)	02 January 2020 (Date)	O.G. Print Claim(s) 1	O.G. Print Figure 3C

EAST Search History

EAST Search History (Prior Art)

Ref #	Hits	Search Query	DBs	Default Operator	Plurals	Time Stamp
L13	220	12 and (CCD array beam\$1splitter) same (lens cover protru\$5) same (zone window section)	US-PGPUB; USPAT	OR	ON	2020/01/02 10:45
L12	2566	(CCD array beam\$1splitter) and housing same (lens cover protru\$5) and (A61B5/1455,14551,14552,14532,14546,6826,6816,6829,6838 A61B2562/00,04,046,06,063,066).cpc.	US-PGPUB; USPAT	OR	ON	2020/01/02 10:44
L7	18	transparent with (window\$1 grid permeable) same (photo\$1detector photo\$1diode detector receiver) same (respective\$2 corresponding) same (lens\$2 protru\$5) same (tissue skin finger)	US-PGPUB; USPAT	OR	ON	2020/01/02 10:40
L6	7	("20020029005" "20040054271" "4510938" "5038782" "5497771" "5529065" "6201982").PN. OR ("8244326").URPN.	US-PGPUB; USPAT; USOCR	OR	ON	2020/01/02 10:39
L5	44	("10433776" "10441181" "10448844" "10448871" "10456038" "10463284" "10463340" "10470695" "10471159" "10478107" "20090177097" "20100030043" "20190307377" "20190320906" "20190320959" "20190320988" "20190325722" "20190350506" "20190357812" "20190357813" "20190365294" "20190374135" "5228449" "5333616" "5431170" "5462051" "5490523" "5564429" "5729203" "5795300" "5800349" "6102856" "6241680" "6356203" "6785568" "6831266" "7227156" "7740588" "7740589" "7869849" "7899510" "8071935" "8280469" "8838210").PN.	US-PGPUB; USPAT	OR	ON	2020/01/02 10:03
L4	39	("20030158501" "20040133081" "20050020927" "20050054940" "20050192490" "20060020180" "20060253010" "20060258928" "20070073117" "20070106172" "20070208395" "20070249916" "20070260130" "20080004513" "20080015424" "20080076980" "20080081966" "20080190436" "20080221426" "20080221463" "20090163775" "20090187085" "20090234206" "20090270699" "20100113948" "20100130841" "20100210925" "20110004079" "20150073235" "4825872" "5807247" "5830137" "6202930" "6253097" "6475153" "6491647" "6556852" "6811535" "7060963").PN.	US-PGPUB; USPAT	OR	ON	2020/01/02 10:03
L3	6	("20050116820" "20090247885" "20100305416" "6463187" "8244326" "9700249").PN.	US-PGPUB; USPAT	OR	ON	2020/01/02 10:03
L2	64	touch adj screen with display same user adj interface same orientation and "600".clas.	US-PGPUB; USPAT	OR	ON	2020/01/02 10:02
L1	445	(Poeze near2 Jeroen Lamego near2 Marcelo Merritt near2 Sean Dalvi near2 Cristiano Vo near2 Hung Bruinsma near2 Johannes Lesmana near2 Ferdyan Kiani near4 Massi with Joe Olsen near2 Greg).in.	US-PGPUB; USPAT	OR	ON	2020/01/02 10:01

EAST Search History (Interference)

Ref #	Hits	Search Query	DBs	Default Operator	Plurals	Time Stamp
L11	220	10 and (CCD array beam\$1splitter) same (lens cover protrusion) same (zone window section)	US-PGPUB; USPAT	OR	ON	2020/01/02 10:43
L10	898	9 and (CCD array beam\$1splitter) same (lens cover protrusion) and (A61B5/1455,14551,14552,14532,14546,6826,6816,6829,6838 A61B2562/00,04,046,06,063,066).cpc.	US-PGPUB; USPAT	OR	ON	2020/01/02 10:41
L9	2566	(CCD array beam\$1splitter) and housing same (lens cover protrusion) and (A61B5/1455,14551,14552,14532,14546,6826,6816,6829,6838 A61B2562/00,04,046,06,063,066).cpc.	US-PGPUB; USPAT	OR	ON	2020/01/02 10:40
L8	226	(CCD array beam\$1splitter) and wall same housing same (lens cover protrusion) and (A61B5/1455,14551,14552,14532,14546,6826,6816,6829,6838 A61B2562/00,04,046,06,063,066).cpc.	US-PGPUB; USPAT	OR	ON	2020/01/02 10:40

1/2/2020 11:13:52 AM

C:\Users\cliu\Documents\EAST\Workspaces\16544713.wsp

INFORMATION DISCLOSURE STATEMENT BY APPLICANT	Application No.	16/544713	
	Filing Date	August 19, 2019	
	First Named Inventor	Jeroen Poeze	
	Art Unit	3791	
<i>(Multiple sheets used when necessary)</i>		Examiner	Liu, Chu Chuan
SHEET 1 OF 1		Attorney Docket No.	MASCER.002C13

U.S. PATENT DOCUMENTS					
Examiner Initials	Cite No.	Document Number <i>Number - Kind Code (if known)</i> Example: 1,234,567 B1	Publication Date MM-DD-YYYY	Name	Pages, Columns, Lines Where Relevant Passages or Relevant Figures Appear
	1	6,463,187	10-08-2002	Baruch et al.	
	2	8,244,326	08-14-2012	Ninomiya et al.	
	3	9,700,249	07-11-2017	Johnson et al.	
	4	2005/0116820	06-02-2005	Goldreich	
	5	2009/0247885	10-01-2009	Suzuki et al.	
	6	2010/0305416	12-02-2010	Bedard et al.	

FOREIGN PATENT DOCUMENTS						
Examiner Initials	Cite No.	Foreign Patent Document <i>Country Code-Number-Kind Code</i> Example: JP 1234567 A1	Publication Date MM-DD-YYYY	Name	Pages, Columns, Lines Where Relevant Passages or Relevant Figures Appear	T ¹
	7	JP 2005160641 A	06-23-2005	Denso Corp		X
	8	JP 3741147 B2	02-01-2006	Denso Corp		X
	9	JP 3803351 B2	08-02-2006	Seiko Epson Corp; Seiko Instruments Inc.		X
	10	JP 2007319232 A	12-13-2007	Toshiba Corp		X
	11	WO 2007/004083 A1	01-11-2007	Koninklijke Philips NV		

NON PATENT LITERATURE DOCUMENTS			
Examiner Initials	Cite No.	Include name of the author (in CAPITAL LETTERS), title of the article (when appropriate), title of the item (book, magazine, journal, serial, symposium, catalog, etc.), date, page(s), volume-issue number(s), publisher, city and/or country where published.	T ¹
	12	D. C. Zheng and Y. T. Zhang, "A ring-type device for the noninvasive measurement of arterial blood pressure," Proceedings of the 25th Annual International Conference of the IEEE Engineering in Medicine and Biology Society (IEEE Cat. No.03CH37439), 17-21 September, 2003, Cancun, pp. 3184-3187 Vol.4.	

Examiner Signature	/CHU CHUAN LIU/	Date Considered	01/02/2020
<p>*Examiner: Initial if reference considered, whether or not citation is in conformance with MPEP 609. Draw line through citation if not in conformance and not considered. Include copy of this form with next communication to applicant.</p>			

T¹ - Place a check mark in this area when an English language Translation is attached.

ALL REFERENCES CONSIDERED EXCEPT WHERE LINED THROUGH. /C.L./

Application No.: 16/544713
Filing Date: August 19, 2019

References for Examiner Consideration

Applicant wishes to draw the Examiner's attention to, and encourages the Examiner to review, the following co-owned patents and/or applications and their existing and ongoing prosecution history, including without limitation Office Actions, Amendments, Remarks, and any other potentially relevant documents:

Docket No.	Serial No.	Title	Filed
MASCER.002C16	16/725478	MULTI-STREAM DATA COLLECTION SYSTEM FOR NONINVASIVE MEASUREMENT OF BLOOD CONSTITUENTS	12/23/2019
MASCER.002C17	16/725292	MULTI-STREAM DATA COLLECTION SYSTEM FOR NONINVASIVE MEASUREMENT OF BLOOD CONSTITUENTS	12/23/2019

Applicant notes that cited references, office actions, responses and notices of allowance currently exist or will exist with reference to the above-referenced matters. Applicant also understands that the Examiner has access to sophisticated online Patent Office computing systems that provide ready access to the full file histories of these matters including, for example, specifications, drawings, pending claims, cited art, office actions, responses, declarations, and notices of allowance. Rather than submit copies of these file histories, Applicant respectfully requests that the Examiner continue to review these file histories online for past, current, and future information about these matters that may be relevant to examination of the present application. Also, if the Examiner cannot readily access these file histories, Applicant would be pleased to provide any portion of any of the file histories at any time upon specific Examiner request.

No Disclaimers

To the extent that anything in the Information Disclosure Statement or the listed references could be construed as a disclaimer of any subject matter supported by the present application, Applicant hereby rescinds and retracts such disclaimer.

Application No.: 16/544713
Filing Date: August 19, 2019

Timing of Disclosure

This Information Disclosure Statement is being filed with an RCE or before receipt of a First Office Action after an RCE, and no fee is believed to be required.

The Commissioner is hereby authorized to charge any additional fees which may be required, or credit any overpayment, to Account No. 11-1410.

Respectfully submitted,
KNOBBE, MARTENS, OLSON & BEAR, LLP

Dated: December 27, 2019

By: /Scott Cromar/_____
Scott A. Cromar
Registration No. 65,066
Registered Practitioner
Customer No. 64735
(949) 760-0404

31933429

INFORMATION DISCLOSURE STATEMENT BY APPLICANT	Application No.	16/544713
	Filing Date	August 19, 2019
	First Named Inventor	Jeroen Poeze
	Art Unit	3791
<i>(Multiple sheets used when necessary)</i>	Examiner	Liu, Chu Chuan
SHEET 1 OF 6	Attorney Docket No.	MASCER.002C13

U.S. PATENT DOCUMENTS					
Examiner Initials	Cite No.	Document Number <i>Number - Kind Code (if known)</i> Example: 1,234,567 B1	Publication Date MM-DD-YYYY	Name	Pages, Columns, Lines Where Relevant Passages or Relevant Figures Appear
	1	5,228,449	07-20-1993	Christ et al.	
	2	5,333,616	08-02-1994	Mills et al.	
	3	5,431,170	07-11-1995	Mathews	
	4	5,462,051	10-31-1995	Oka et al.	
	5	5,490,523	02-13-1996	Isaacson et al.	
	6	5,564,429	10-15-1996	Bornn et al.	
	7	5,729,203	03-17-1998	Oka et al.	
	8	5,795,300	08-18-1998	Bryars	
	9	5,800,349	09-01-1998	Isaacson et al.	
	10	6,102,856	08-15-2000	Clarence et al.	
	11	6,241,680	06-05-2001	Miwa	
	12	6,356,203	03-12-2002	Halleck et al.	
	13	6,785,568	08-31-2004	Chance	
	14	6,831,266	12-14-2004	Paritsky et al.	
	15	7,227,156	06-05-2007	Colvin, Jr. et al.	
	16	7,740,588	06-22-2010	Sciarra	
	17	7,740,589	06-22-2010	Maschke et al.	
	18	7,869,849	01-11-2011	Ollerdessen et al.	
	19	7,899,510	03-01-2011	Hoarau	
	20	8,071,935	12-06-2011	Besko et al.	
	21	8,280,469	12-02-2012	Baker, Jr.	
	22	8,838,210	09-16-2014	Wood et al.	
	23	10,433,776	10-08-2019	Al-Ali	
	24	10,441,181	10-15-2019	Telfort et al.	
	25	10,448,844	10-22-2019	Al-Ali et al.	
	26	10,448,871	10-22-2019	Al-Ali	
	27	10,456,038	10-29-2019	Lamego et al.	
	28	10,463,284	11-05-2019	Al-Ali et al.	
	29	10,463,340	11-05-2019	Telfort et al.	

Examiner Signature	Date Considered
<p>*Examiner: Initial if reference considered, whether or not citation is in conformance with MPEP 609. Draw line through citation if not in conformance and not considered. Include copy of this form with next communication to applicant.</p>	

T¹ - Place a check mark in this area when an English language Translation is attached.

ALL REFERENCES CONSIDERED EXCEPT WHERE LINED THROUGH. /C.L./

INFORMATION DISCLOSURE STATEMENT BY APPLICANT	Application No.	16/544713
	Filing Date	August 19, 2019
	First Named Inventor	Jeroen Poeze
	Art Unit	3791
<i>(Multiple sheets used when necessary)</i>	Examiner	Liu, Chu Chuan
SHEET 2 OF 6	Attorney Docket No.	MASCER.002C13

U.S. PATENT DOCUMENTS					
Examiner Initials	Cite No.	Document Number <i>Number - Kind Code (if known)</i> Example: 1,234,567 B1	Publication Date MM-DD-YYYY	Name	Pages, Columns, Lines Where Relevant Passages or Relevant Figures Appear
	30	10,470,695	11-12-2019	Al-Ali	
	31	10,471,159	11-12-2019	Lapotko et al.	
	32	10,478,107	11-19-2019	Kiani et al.	
	33	2009/0177097	07-09-2009	Ma et al.	
	34	2010/0030043	02-04-2010	Kuhn	
	35	2019/0307377	10-10-2019	Perea et al.	
	36	2019/0320906	10-24-2019	Olsen	
	37	2019/0320959	10-24-2019	Al-Ali	
	38	2019/0320988	10-24-2019	Ahmed et al.	
	39	2019/0325722	10-24-2019	Kiani et al.	
	40	2019/0350506	11-21-2019	Al-Ali	
	41	2019/0357812	11-28-2019	Poeze et al.	
	42	2019/0357813	11-28-2019	Poeze et al.	
	43	2019/0365294	12-05-2019	Poeze et al.	
	44	2019/0374135	12-12-2019	Poeze et al.	

FOREIGN PATENT DOCUMENTS						
Examiner Initials	Cite No.	Foreign Patent Document <i>Country Code-Number-Kind Code</i> Example: JP 1234567 A1	Publication Date MM-DD-YYYY	Name	Pages, Columns, Lines Where Relevant Passages or Relevant Figures Appear	T ¹
	45	CN 101484065 B	11-09-2011	Univ Nottingham		X
	46	EP 0630208 A1	12-28-1994	Myllymaeki		
	47	EP 0770349 A1	05-02-1997	Akasaka et al.		
	48	EP 0880936 A2	12-02-1998	Akai		
	49	EP 0985373 A1	03-15-2000	Cvetkovic		X
	50	EP 1124609 B1	08-02-2006	Medtronic Inc		
	51	EP 1875213 A2	01-09-2008	Sensors for Medicine and Science Inc		
	52	EP 2165196 A1	03-24-2010	Siliconfile Technologies Inc		
	53	GB 2243691 A	11-06-1991	Payne et al.		

Examiner Signature	Date Considered
<p>*Examiner: Initial if reference considered, whether or not citation is in conformance with MPEP 609. Draw line through citation if not in conformance and not considered. Include copy of this form with next communication to applicant.</p>	

T¹ - Place a check mark in this area when an English language Translation is attached.

ALL REFERENCES CONSIDERED EXCEPT WHERE LINED THROUGH. /C.L./

INFORMATION DISCLOSURE STATEMENT BY APPLICANT	Application No.	16/544713
	Filing Date	August 19, 2019
	First Named Inventor	Jeroen Poeze
	Art Unit	3791
<i>(Multiple sheets used when necessary)</i>	Examiner	Liu, Chu Chuan
SHEET 3 OF 6	Attorney Docket No.	MASCER.002C13

FOREIGN PATENT DOCUMENTS

Examiner Initials	Cite No.	Foreign Patent Document <i>Country Code-Number-Kind Code</i> Example: JP 1234567 A1	Publication Date MM-DD-YYYY	Name	Pages, Columns, Lines Where Relevant Passages or Relevant Figures Appear	T ¹
	54	JPH 09257508 A	10-03-1997	Matsushita Electric Works Ltd		X
	55	JPH 10314133 A	12-02-1998	Ido		X
	56	JPH 1170086 A	03-16-1999	Atsukusu KK		X
	57	JP 2919326 B2	07-12-1999	Corporation Miyuki		X
	58	WO 94/23643 A1	10-27-1994	Noninvasive Medical Technology Corporation		
	59	WO 1995/000070 A1	01-05-1995	Increa Oy		
	60	WO 1997/009923 A1	03-20-1997	Medison Co Ltd		
	61	WO 1999/063883 A1	12-16-1999	S P O Medical Equipment Ltd		
	62	WO 2000/028892 A1	05-25-2000	Micromedical Ind Limited		
	63	WO 2008/107238 A1	09-12-2008	Univ Rennes; Univ Bretagne Sud		X

NON PATENT LITERATURE DOCUMENTS

Examiner Initials	Cite No.	Include name of the author (in CAPITAL LETTERS), title of the article (when appropriate), title of the item (book, magazine, journal, serial, symposium, catalog, etc.), date, page(s), volume-issue number(s), publisher, city and/or country where published.	T ¹
	64	L. Grajales <i>et al.</i> , "Wearable multisensor heart rate monitor," International Workshop on Wearable and Implantable Body Sensor Networks (BSN'06), Cambridge, MA, 2006, pp. 4-157.	
	65	N. Townsend, "Pulse Oximetry," Medical Electronics, 2001, pp. 32-42.	
	66	Nonin Medical, Inc., "Operator's Manual – Models 8600F0 and 8600F0M Pulse Oximeters," 2005, 25 pages.	
	67	C. J. Pujary, "Investigation of Photodetector Optimization in Reducing Power Consumption by a Noninvasive Pulse Oximeter Sensor," Worcester Polytechnic Institute, January 16, 2004, 133 pages.	
	68	B. McGarry <i>et al.</i> , "Reflections on a candidate design of the user-interface for a wireless vital-signs monitor," Proceedings of DARE 2000 on Designing Augmented Reality Environments, January 2000, pp. 33-40.	
	69	J. C. D. Conway <i>et al.</i> , "Wearable computer as a multi-parametric monitor for physiological signals," Proceedings IEEE International Symposium on Bio-Informatics and Biomedical Engineering, Arlington, VA, USA, 2000, pp. 236-242.	
	70	J. A. Tamada <i>et al.</i> , "Noninvasive Glucose Monitoring: Comprehensive Clinical Results," JAMA, November 17, 1999, Vol. 282, No. 19, pp.1839-1844.	
	71	B.-H. Yang <i>et al.</i> , "Development of the ring sensor for healthcare automation," Robotics and Autonomous Systems, 2000, pp. 273-281.	

Examiner Signature	Date Considered
*Examiner: Initial if reference considered, whether or not citation is in conformance with MPEP 609. Draw line through citation if not in conformance and not considered. Include copy of this form with next communication to applicant.	

T¹ - Place a check mark in this area when an English language Translation is attached.

ALL REFERENCES CONSIDERED EXCEPT WHERE LINED THROUGH. /C.I./

INFORMATION DISCLOSURE STATEMENT BY APPLICANT	Application No.	16/544713
	Filing Date	August 19, 2019
	First Named Inventor	Jeroen Poeze
	Art Unit	3791
<i>(Multiple sheets used when necessary)</i>	Examiner	Liu, Chu Chuan
SHEET 4 OF 6	Attorney Docket No.	MASCER.002C13

NON PATENT LITERATURE DOCUMENTS

Examiner Initials	Cite No.	Include name of the author (in CAPITAL LETTERS), title of the article (when appropriate), title of the item (book, magazine, journal, serial, symposium, catalog, etc.), date, page(s), volume-issue number(s), publisher, city and/or country where published.	T ¹
	72	Laukkanen RM et al., "Heart Rate Monitors: State of the Art," Journal of Sports Science, January 1998, pp. S3-S7.	
	73	S. Warren et al., "Designing Smart Health Care Technology into the Home of the Future," Workshops on Future Medical Devices: Home Care Technologies for the 21 st Century, April 1999, 19 pages.	
	74	A. C. M. Dassel <i>et al.</i> , "Reflectance Pulse Oximetry at the Forehead Improves by Pressure on the Probe," Journal of Clinical Monitoring, Vol. 11, No. 4, July 1995, pp. 237-244.	
	75	B-H. Yang <i>et al.</i> , "A Twenty-Four Hour Tele-Nursing System Using a Ringer Sensor," Proceedings of 1998 IEEE International Conference on Robotics and Automation, May 16-20, 1998, 6 pages.	
	76	S. Rhee <i>et al.</i> , "The Ring Sensor: a New Ambulatory Wearable Sensor for Twenty-Four Hour Patient Monitoring," Proceedings of the 20 th Annual International Conference of the IEEE Engineering in Medicine and Biology Society, October 29-November 1 1998, 4 pages.	
	77	S. Rhee <i>et al.</i> , "Design of a Artifact-Free Wearable Plethysmographic Sensor," 21 st Annual International Conference IEEE Engineering in Medicine and Biology Society, October 13-16, 1999, p. 786.	
	78	T. Martin <i>et al.</i> , "Issues in Wearable Computing for Medical Monitoring Applications: A Case Study of a Wearable ECG Monitoring Device," In Proceedings of International Symposium of Wearable Computers (ISWC'00), February 2000, pp. 43-49.	
	79	S. Rhee <i>et al.</i> , "Artifact-Resistant, Power Efficient Design of Finger-Ring Plethysmographic Sensors, Part I: Design and Analysis," 22 nd Annual International Conference IEEE Engineering in Medicine and Biology Society, July 23-28, 2000, pp. 2792-2795.	
	80	C. Pujary <i>et al.</i> , "Photodetector Size Considerations in the Design of a Noninvasive Reflectance Pulse Oximeter for Telemedicine Applications," Proceedings of IEEE Annual Northeast Bioengineering Conference, 2003, pp. 148-149.	
	81	M. Savage <i>et al.</i> , "Optimizing Power Consumption in the Design of a Wearable Wireless Telesensor: Comparison of Pulse Oximeter Modes," Proceedings of IEEE 29 th Annual Nonheust Bioengineering Conference, 2003, pp.150-151.	
	82	A. Tura <i>et al.</i> , "A Wearable Device with Wireless Bluetooth-based Data Transmission," Measurement Science Review, Vol. 3, Sec. 2, 2003, pp. 1-4.	
	83	R. Paradiso, "Wearable Health Care System for Vital Signs Monitoring," In Proceedings of IEEE International Conference on Information Technology Applications in Biomedicine, May 2003, pp. 283-286.	
	84	H.H. Asada <i>et al.</i> , "Mobile Monitoring with Wearable Photoplethysmographic Biosensors," IEEE Engineering in Medicine and Biology Magazine, May/June 2003, pp. 28-40.	
	85	Y. Mendelson <i>et al.</i> , "Minimization of LED Power Consumption in the Design of a Wearable Pulse Oximeter," Proceedings of the IASTED International Conference Biomedical Engineering, June 25-27, 2003, 6 pages.	
	86	Y. Mendelson <i>et al.</i> , "Measurement Site and Photodetector Size Considerations in Optimizing Power Consumption of a Wearable Reflectance Pulse Oximeter," Proceedings of the 25 th Annual International Conference of the IEEE EMBS, September 17-21, 2003, pp. 3016-3019.	
	87	D. Marculescu <i>et al.</i> , "Ready to Ware," IEEE Spectrum, Vol. 40, Issue 10, October 2003, pp. 28-32.	
	88	P. Celka <i>et al.</i> , "Motion Resistant Earphone Located Infrared Based Hearth Rate Measurement Device," In Proceeding of the 2 nd International Conference on Biomedical Engineering, Innsbruck, Austria, February 16-18, 2004, pp. 582-585.	

Examiner Signature	Date Considered
<p>*Examiner: Initial if reference considered, whether or not citation is in conformance with MPEP 609. Draw line through citation if not in conformance and not considered. Include copy of this form with next communication to applicant.</p>	

T¹ - Place a check mark in this area when an English language Translation is attached.

ALL REFERENCES CONSIDERED EXCEPT WHERE LINED THROUGH. /C.L./

INFORMATION DISCLOSURE STATEMENT BY APPLICANT	Application No.	16/544713
	Filing Date	August 19, 2019
	First Named Inventor	Jeroen Poeze
	Art Unit	3791
<i>(Multiple sheets used when necessary)</i>	Examiner	Liu, Chu Chuan
SHEET 5 OF 6	Attorney Docket No.	MASCER.002C13

NON PATENT LITERATURE DOCUMENTS

Examiner Initials	Cite No.	Include name of the author (in CAPITAL LETTERS), title of the article (when appropriate), title of the item (book, magazine, journal, serial, symposium, catalog, etc.), date, page(s), volume-issue number(s), publisher, city and/or country where published.	T ¹
	89	D. Konstantas <i>et al.</i> , "Mobile Patient Monitoring: The MobiHealth System," In Proceedings of International Conference on Medical and Care Compunetics, NCC'04, February 2004, 8 pages.	
	90	S. Pentland, "Healthwear: Medical Technology Becomes Wearable," IEEE Computer Society, Vol. 37, Issue 5, May 2004, pp. 34-41.	
	91	P. Branche <i>et al.</i> , "Signal Quality and Power Consumption of a New Prototype Reflectance Pulse Oximeter Sensor," Proceeding of the 31th Annual Northeast Bioengineering Conference, Hoboken, NJ, IEEE, 2005, pp. 1-2.	
	92	U. Anliker <i>et al.</i> , "AMON: A Wearable Multiparameter Medical Monitoring and Alert System," IEEE Transactions on Information Technology in Biomedicine, January 2005, pp. 1-11.	
	93	P. T. Gibbs <i>et al.</i> , "Active Motion Artifact Cancellation for Wearable Health Monitoring Sensors Using Collocated MEMS Accelerometers," Proceedings of SPIE Smart Structures and Materials: Sensors and Smart Structures Technologies for Civil, Mechanical, and Aerospace Systems, May 17, 2005, pp. 811-819.	
	94	C. W. Mundt <i>et al.</i> , "A Multiparameter Wearable Physiologic Monitoring System for Space and Terrestrial Applications," IEEE Transactions on Information Technology in Biomedicine, Vol. 9, No. 3, September 2005, pp. 382-391.	
	95	Y. Mendelson <i>et al.</i> , "A Wearable Reflectance Pulse Oximeter for Remote Physiological Monitoring," Proceedings of the 28 th IEEE EMBS Annual International Conference, August 30-September 3, 2006, pp. 912-915.	
	96	B-S. Lin <i>et al.</i> , "RTWPMS: A Real-Time Wireless Physiological Monitoring System," IEEE Transactions on Information Technology in Biomedicine, Vol. 10, No. 4, October 2006, pp. 647-656.	
	97	T. Torfs <i>et al.</i> , "Body-Heat Powered Autonomous Pulse Oximeter," IEEE Sensors 2006, EXCO, October 22-25, 2006, pp. 427-430.	
	98	P.S. Pandian <i>et al.</i> , "Smart Vest: Wearable Multi-Parameter Remote Physiological Monitoring System," Medical Engineering & Physics 30, 2008. pp. 466-477.	
	99	G. Tamannagari, "Power Efficient Design of Finder-Ring Sensor for Patient Monitoring," Master of Science in Electrical Engineering, The University of Texas at San Antonio, College of Engineering, Department of Electrical Engineering, December 2008, 74 pages.	
	100	M. Yamashita <i>et al.</i> , "Development of a Ring-Type Vital Sign Telemeter," Biotelemetry XIII, March 26-31, 1995, pp. 145-150.	
	101	P. Renevey <i>et al.</i> , "Wrist-Located Pulse Detection Using IR Signals, Activity and Nonlinear Artifact Cancellation," Proceedings of the 23 rd Annual EMBS International Conference, October 25-28, 2001, pp. 3030-3033.	
	102	Y. Mendelson <i>et al.</i> , "A Mobile PDA-Based Wireless Pulse Oximeter," Proceedings of the IASTED International Conference Telehealth, July 19-21, 2005, pp. 1-6.	
	103	P. Shaltis <i>et al.</i> , "Novel Design for a Wearable, Rapidly Depolyable, Wireless Noninvasive Triage Sensor," Proceedings of the 2005 IEEE, Engineering in Medicine and Biology 27 th Annual Conference, September 1-4, 2005, pp 3567-3570.	
	104	Y-S. Yan <i>et al.</i> , "An Efficient Motion-Resistant Method for Wearable Pulse Oximeter," IEEE Transactions on Information Technology in Biomedicine, Vol. 12, No. 3, May 2008, pp. 399-405.	
	105	P. C. Branche <i>et al.</i> , "Measurement Reproducibility and Sensor Placement Considerations in Designing a Wearable Pulse Oximeter for Military Applications," IEEE, 2004, pp. 216-217.	

Examiner Signature	Date Considered
<p>*Examiner: Initial if reference considered, whether or not citation is in conformance with MPEP 609. Draw line through citation if not in conformance and not considered. Include copy of this form with next communication to applicant.</p>	

T¹ - Place a check mark in this area when an English language Translation is attached.

ALL REFERENCES CONSIDERED EXCEPT WHERE LINED THROUGH. /C.L./

INFORMATION DISCLOSURE STATEMENT BY APPLICANT	Application No.	16/544713
	Filing Date	August 19, 2019
	First Named Inventor	Jeroen Poeze
	Art Unit	3791
<i>(Multiple sheets used when necessary)</i>	Examiner	Liu, Chu Chuan
SHEET 6 OF 6	Attorney Docket No.	MASCER.002C13

NON PATENT LITERATURE DOCUMENTS

Examiner Initials	Cite No.	Include name of the author (in CAPITAL LETTERS), title of the article (when appropriate), title of the item (book, magazine, journal, serial, symposium, catalog, etc.), date, page(s), volume-issue number(s), publisher, city and/or country where published.	T ¹
	106	G. Comtois, "A Comparative Evaluation of Adaptive Noise Cancellation Algorithms for Minimizing Motion Artifacts in a Forehead-Mounted Wearable Pulse Oximeter," Proceedings of the 29 th Annual International Conference of the IEEE EMBS, August 23-26, 2007, pp. 1528-1531.	
	107	G. Comtois <i>et al.</i> , "A Noise Reference Input to an Adaptive Filter Algorithm for Signal Processing in a Wearable Pulse Oximeter," IEEE, 2007, pp. 106-107.	
	108	R. P. Dresler <i>et al.</i> , "A New Reflectance Pulse Oximeter Housing to Reduce Contact Pressure Effects," IEEE, 2006, pp. 49-50.	
	109	R. P. Dresler <i>et al.</i> , "Reflectance Forehead Pulse Oximetry: Effects on Contact Pressure During Walking," Proceedings of the 28 th IEEE EMBS Annual International Conference, August 30-September 3, 2006, pp. 3529-3532.	
	110	W. S. Johnston <i>et al.</i> , "Extracting Breathing Rate Information from a Wearable Reflectance Pulse Oximeter Sensor," Proceedings of the 26 th Annual International Conference of the IEEE EMBS, September 1-5, 2004, pp. 5388-5391.	
	111	W. Johnston <i>et al.</i> , "Extracting Heart Rate Variability from a Wearable Reflectance Pulse Oximeter," IEEE, 2005, pp. 1-2.	
	112	W. S. Johnston <i>et al.</i> , "Investigation of Signal Processing Algorithms for an Embedded Microcontroller-Based Wearable Pulse Oximeter," Proceedings of the 28 th IEEE EMBS Annual International Conference, August 30-September 3, 2006, pp. 5888-5891.	
	113	P. Lukowicz <i>et al.</i> , "AMON: A Wearable Medical Computer for High Risk Patient," Proceedings of the 6 th International Symposium on Wearable Computers (ISWC'02), 2002, pp. 1-2.	
	114	P. Lukowicz <i>et al.</i> , "The WearARM Modular, Low-Power Computing Core," IEEE Micro, May-June 2001, pp. 16-28.	
	115	Y. Mendelson <i>et al.</i> , "Accelerometry-Based Adaptive Noise Cancellation for Remote Physiological Monitoring by a Wearable Pulse Oximeter," Proceedings of the 3 rd IASTED International Conference TELEHEALTH, May 31-June 1, 2007, pp. 28-33.	

Examiner Signature	/CHU CHUAN LIU/	Date Considered	01/02/2020
<p>*Examiner: Initial if reference considered, whether or not citation is in conformance with MPEP 609. Draw line through citation if not in conformance and not considered. Include copy of this form with next communication to applicant.</p>			

T¹ - Place a check mark in this area when an English language Translation is attached.

ALL REFERENCES CONSIDERED EXCEPT WHERE LINED THROUGH. /C.I./

INFORMATION DISCLOSURE STATEMENT BY APPLICANT	Application No.	16/544713
	Filing Date	August 19, 2019
	First Named Inventor	Jeroen Poeze
	Art Unit	3791
<i>(Multiple sheets used when necessary)</i>	Examiner	Liu, Chu Chuan
SHEET 1 OF 4	Attorney Docket No.	MASCER.002C13

U.S. PATENT DOCUMENTS					
Examiner Initials	Cite No.	Document Number <i>Number - Kind Code (if known)</i> Example: 1,234,567 B1	Publication Date MM-DD-YYYY	Name	Pages, Columns, Lines Where Relevant Passages or Relevant Figures Appear
	1	4,825,872	05-02-1989	Tan et al.	
	2	5,807,247	09-15-1998	Merchant et al.	
	3	5,830,137	11-03-1998	Scharf	
	4	6,202,930	03-20-2001	Plesko	
	5	6,253,097	06-26-2001	Aronow et al.	
	6	6,475,153	11-05-2002	Khair et al.	
	7	6,491,647	12-10-2002	Bridger et al.	
	8	6,556,852	04-29-2003	Schulze et al.	
	9	6,811,535	11-02-2004	Palti et al.	
	10	7,060,963	06-13-2006	Maegawa et al.	
	11	2003/0158501	08-21-2003	Uchida et al.	
	12	2004/0133081	07-08-2004	Teller et al.	
	13	2005/0020927	01-27-2005	Blondeau et al.	
	14	2005/0054940	03-10-2005	Almen	
	15	2005/0192490	09-01-2005	Yamamoto et al.	
	16	2006/0020180	01-26-2006	Al-Ali	
	17	2006/0253010	11-09-2006	Brady et al.	
	18	2006/0258928	11-16-2006	Ortner et al.	
	19	2007/0073117	03-29-2007	Raridan	
	20	2007/0106172	05-10-2007	Abreu	
	21	2007/0208395	09-06-2007	Leclerc et al.	
	22	2007/0249916	10-25-2007	Pesach et al.	
	23	2007/0260130	11-08-2007	Chin	
	24	2008/0004513	01-03-2008	Walker et al.	
	25	2008/0015424	01-17-2008	Bernreuter	
	26	2008/0076980	03-27-2008	Hoarau	
	27	2008/0081966	04-03-2008	Debreczeny	
	28	2008/0190436	08-14-2008	Jaffe et al.	
	29	2008/0221426	09-11-2008	Baker et al.	

Examiner Signature	Date Considered
<p>*Examiner: Initial if reference considered, whether or not citation is in conformance with MPEP 609. Draw line through citation if not in conformance and not considered. Include copy of this form with next communication to applicant.</p>	

T¹ - Place a check mark in this area when an English language Translation is attached.

ALL REFERENCES CONSIDERED EXCEPT WHERE LINED THROUGH. /C.L./

INFORMATION DISCLOSURE STATEMENT BY APPLICANT	Application No.	16/544713
	Filing Date	August 19, 2019
	First Named Inventor	Jeroen Poeze
	Art Unit	3791
<i>(Multiple sheets used when necessary)</i>	Examiner	Liu, Chu Chuan
SHEET 2 OF 4	Attorney Docket No.	MASCER.002C13

U.S. PATENT DOCUMENTS					
Examiner Initials	Cite No.	Document Number <i>Number - Kind Code (if known)</i> Example: 1,234,567 B1	Publication Date MM-DD-YYYY	Name	Pages, Columns, Lines Where Relevant Passages or Relevant Figures Appear
	30	2008/0221463	09-11-2008	Baker	
	31	2009/0163775	06-25-2009	Barrett et al.	
	32	2009/0187085	07-23-2009	Pav	
	33	2009/0234206	09-17-2009	Gaspard et al.	
	34	2009/0270699	10-29-2009	Scholler et al.	
	35	2010/0113948	05-06-2010	Yang et al.	
	36	2010/0130841	05-27-2010	Ozawa et al.	
	37	2010/0210925	08-19-2010	Holley et al.	
	38	2011/0004079	01-06-2011	Al-Ali et al.	
	39	2015/0073235	03-12-2015	Kateraas et al.	

FOREIGN PATENT DOCUMENTS						
Examiner Initials	Cite No.	Foreign Patent Document <i>Country Code-Number-Kind Code</i> Example: JP 1234567 A1	Publication Date MM-DD-YYYY	Name	Pages, Columns, Lines Where Relevant Passages or Relevant Figures Appear	T ¹
	40	CN 1270793 A	10-25-2000	Lu		X
	41	EP 0922432 A1	06-16-1999	Seiko Epson Corp		
	42	EP 1526805 A1	05-04-2005	Healthstats International Pte Ltd		
	43	EP 1860989 A1	12-05-2007	Masimo Laboratories Inc		
	44	EP 1880666 A1	01-23-2008	ETA Manufacture Horlogere Suisse SA		X
	45	JPH 11235320 A	08-31-1999	Seiko Epson Corp		X
	46	JP 2004329406 A	11-25-2004	liguru Kk		X
	47	JP 2005270543 A	10-06-2005	Seiko Instruments Inc.		X
	48	JP 2006102164 A	04-20-2006	Nippon Telegraph & Telephone; NTT Advanced Tech Kk		X
	49	KR 20070061122 A	06-13-2007	Korea Electronics Telecomm		X
	50	KR 100755079 B1	09-06-2007	Samsung Electronics Co Ltd		X

Examiner Signature	Date Considered
<p>*Examiner: Initial if reference considered, whether or not citation is in conformance with MPEP 609. Draw line through citation if not in conformance and not considered. Include copy of this form with next communication to applicant.</p>	

T¹ - Place a check mark in this area when an English language Translation is attached.

ALL REFERENCES CONSIDERED EXCEPT WHERE LINED THROUGH. /C.L./

INFORMATION DISCLOSURE STATEMENT BY APPLICANT	Application No.	16/544713
	Filing Date	August 19, 2019
	First Named Inventor	Jeroen Poeze
	Art Unit	3791
<i>(Multiple sheets used when necessary)</i>	Examiner	Liu, Chu Chuan
SHEET 3 OF 4	Attorney Docket No.	MASCER.002C13

FOREIGN PATENT DOCUMENTS

Examiner Initials	Cite No.	Foreign Patent Document <i>Country Code-Number-Kind Code</i> Example: JP 1234567 A1	Publication Date MM-DD-YYYY	Name	Pages, Columns, Lines Where Relevant Passages or Relevant Figures Appear	T ¹
	51	WO 2006/060949 A1	06-15-2006	Jang		X-Abstract
	52	WO 2006/079862 A2	08-03-2006	Santha et al.		
	53	WO 2006/090371 A2	08-31-2006	Software Solutions Ltd		
	54	WO 2007/017266 A2	02-15-2007	Flore Ingo		

NON PATENT LITERATURE DOCUMENTS

Examiner Initials	Cite No.	Include name of the author (in CAPITAL LETTERS), title of the article (when appropriate), title of the item (book, magazine, journal, serial, symposium, catalog, etc.), date, page(s), volume-issue number(s), publisher, city and/or country where published.	T ¹
	55	Sokwoo Rhee <i>et al.</i> , "Artifact-Resistant Power-Efficient Design of Finger-Ring Plethysmographic Sensors," IEEE Transactions on Biomedical Engineering, July 2001, pp. 795-805, Vol. 48, No. 7.	
	56	L. Xu <i>et al.</i> , "An integrated wrist-worn routine monitoring system for the elderly using BSN," 2008 5th International Summer School and Symposium on Medical Devices and Biosensors, Hong Kong, 2008, pp. 45-48.	
	57	J Kraith <i>et al.</i> , "An optical device to measure blood components by a photoplethysmographic method," Journal of Optics A: Pure and Applied Optics. 7, 2005, pp. S318-S324.	
	58	K. Nakajima <i>et al.</i> , "Monitoring of heart and respiratory rates by photoplethysmography using digital filtering technique," Med. Eng. Phy. Vol. 18, No. 5, pp. 365-372, 1996.	
	59	Russell Drescher, "Wearable Forehead Pulse Oximetry: Minimization of Motion and Pressure Artifacts," May 3, 2006, 93 pages.	
	60	Sonia Maria López Silva <i>et al.</i> , "Near-infrared transmittance pulse oximetry with laser diodes," Journal of Biomedical Optics Vol. 8 No. 3, July 2003, pp. 525-533.	
	61	Fabio Buttussi <i>et al.</i> , "MOPET: A context-aware and user-adaptive wearable system for fitness training," Artificial Intelligence in Medicine 42, 2008, pp. 153-163.	
	62	Stephen A. Mascaro <i>et al.</i> , "Photoplethysmograph Fingernail Sensors for Measuring Finger Forces Without Haptic Obstruction," IEEE Transactions on Robotics and Automation, Vol. 17, No. 5, October 2001, pp. 698-708.	
	63	Stephen A. Mascaro <i>et al.</i> , "Measurement of Finger Posture and Three-Axis Fingertip Touch Force Using Fingernail Sensors," IEEE International Conference on Robotics and Automation, 2002, pp. 1-11.	
	64	Akira Sakane <i>et al.</i> , "Estimating Arterial Wall Impedance using a Plethysmogram," IEEE 2003, pp. 580-585.	
	65	Nuria Oliver <i>et al.</i> , "HealthGear: A Real-time Wearable System for Monitoring and Analyzing Physiological Signals," Proceedings of the International Workshop on Wearable and Implantable Body Sensor Networks 2006 IEEE, pp. 1-4.	
	66	Yuan-Hsiang Lin <i>et al.</i> , "A wireless PDA-based physiological monitoring system for patient transport," IEEE Transactions on Information Technology in Biomedicine, Vol. 8, No. 4, pp. 439-447, Dec. 2004.	
	67	R. Fensli <i>et al.</i> , "A Wireless ECG System for Continuous Event Recording and Communication to a Clinical Alarm Station," Conf Proc IEEE Eng Med Biol Soc, 2004, pp. 1-4.	

Examiner Signature	Date Considered
<p>*Examiner: Initial if reference considered, whether or not citation is in conformance with MPEP 609. Draw line through citation if not in conformance and not considered. Include copy of this form with next communication to applicant.</p>	

T¹ - Place a check mark in this area when an English language Translation is attached.

ALL REFERENCES CONSIDERED EXCEPT WHERE LINED THROUGH. /C.L./

INFORMATION DISCLOSURE STATEMENT BY APPLICANT	Application No.	16/544713
	Filing Date	August 19, 2019
	First Named Inventor	Jeroen Poeze
	Art Unit	3791
<i>(Multiple sheets used when necessary)</i>	Examiner	Liu, Chu Chuan
SHEET 4 OF 4	Attorney Docket No.	MASCER.002C13

NON PATENT LITERATURE DOCUMENTS			
Examiner Initials	Cite No.	Include name of the author (in CAPITAL LETTERS), title of the article (when appropriate), title of the item (book, magazine, journal, serial, symposium, catalog, etc.), date, page(s), volume-issue number(s), publisher, city and/or country where published.	T ¹
	68	E. Higurashi <i>et al.</i> , "An integrated laser blood flowmeter," Journal of Lightwave Technology, Vol. 21, No. 3, pp. 591-595, March 2003.	
	69	T. Kiyokura <i>et al.</i> , "Wearable Laser Blood Flowmeter for Ubiquitous Healthcare Service," 2007 IEEE/LEOS International Conference on Optical MEMS and Nanophotonics, Hualien, 2007, pp. 4-5.	
	70	Takumi Morita <i>et al.</i> , "Integrated Blood Flowmeter Using Micromachining Technology," December 2004, pp. 77-80.	
	71	Eiji Higurashi <i>et al.</i> , "Hybrid integration technologies for optical micro-systems", Proc. SPIE 5604, Optomechatronic Micro/Nano Components, Devices, and Systems, 25 October 2004, pp. 67-73.	

Examiner Signature	/CHU CHUAN LIU/	Date Considered	01/02/2020
<p>*Examiner: Initial if reference considered, whether or not citation is in conformance with MPEP 609. Draw line through citation if not in conformance and not considered. Include copy of this form with next communication to applicant.</p>			

T¹ - Place a check mark in this area when an English language Translation is attached.

ALL REFERENCES CONSIDERED EXCEPT WHERE LINED THROUGH. /C.L./

PART B - FEE(S) TRANSMITTAL

Complete and send this form, together with applicable fee(s), by mail or fax, or via EFS-Web.

By mail, send to: Mail Stop ISSUE FEE
 Commissioner for Patents
 P.O. Box 1450
 Alexandria, Virginia 22313-1450

By fax, send to: (571)-273-2885

INSTRUCTIONS: This form should be used for transmitting the ISSUE FEE and PUBLICATION FEE (if required). Blocks 1 through 5 should be completed where appropriate. All further correspondence including the Patent, advance orders and notification of maintenance fees will be mailed to the current correspondence address as indicated unless corrected below or directed otherwise in Block 1, by (a) specifying a new correspondence address; and/or (b) indicating a separate "FEE ADDRESS" for maintenance fee notifications.

CURRENT CORRESPONDENCE ADDRESS (Note: Use Block 1 for any change of address)

64735 7590 01/27/2020
 KNOBBE, MARTENS, OLSON & BEAR, LLP
 MASIMO CORPORATION (MASIMO)
 2040 MAIN STREET
 FOURTEENTH FLOOR
 IRVINE, CA 92614

Note: A certificate of mailing can only be used for domestic mailings of the Fee(s) Transmittal. This certificate cannot be used for any other accompanying papers. Each additional paper, such as an assignment or formal drawing, must have its own certificate of mailing or transmission.

Certificate of Mailing or Transmission

I hereby certify that this Fee(s) Transmittal is being deposited with the United States Postal Service with sufficient postage for first class mail in an envelope addressed to the Mail Stop ISSUE FEE address above, or being transmitted to the USPTO via EFS-Web or by facsimile to (571) 273-2885, on the date below.

(Typed or printed name)
(Signature)
(Date)

APPLICATION NO.	FILING DATE	FIRST NAMED INVENTOR	ATTORNEY DOCKET NO.	CONFIRMATION NO.
16/544,713	08/19/2019	Jeroen Poeze	MASCER.002C13	9381

TITLE OF INVENTION: MULTI-STREAM DATA COLLECTION SYSTEM FOR NONINVASIVE MEASUREMENT OF BLOOD CONSTITUENTS

APPLN. TYPE	ENTITY STATUS	ISSUE FEE DUE	PUBLICATION FEE DUE	PREV. PAID ISSUE FEE	TOTAL FEE(S) DUE	DATE DUE
nonprovisional	UNDISCOUNTED	\$1000	\$0.00	\$1000.00	\$0	04/27/2020

EXAMINER	ART UNIT	CLASS-SUBCLASS
LIU, CHU CHUAN	3791	600-310000

1. Change of correspondence address or indication of "Fee Address" (37 CFR 1.363).

- Change of correspondence address (or Change of Correspondence Address form PTO/SB/122) attached.
- "Fee Address" indication (or "Fee Address" Indication form PTO/SB/47; Rev 03-09 or more recent) attached. **Use of a Customer Number is required.**

2. For printing on the patent front page, list
 (1) The names of up to 3 registered patent attorneys or agents OR, alternatively,
 (2) The name of a single firm (having as a member a registered attorney or agent) and the names of up to 2 registered patent attorneys or agents. If no name is listed, no name will be printed.

- 1 Knobbe Martens
 2 Olson & Bear LLP
 3 _____

3. ASSIGNEE NAME AND RESIDENCE DATA TO BE PRINTED ON THE PATENT (print or type)

PLEASE NOTE: Unless an assignee is identified below, no assignee data will appear on the patent. If an assignee is identified below, the document must have been previously recorded, or filed for recordation, as set forth in 37 CFR 3.11 and 37 CFR 3.81(a). Completion of this form is NOT a substitute for filing an assignment.

(A) NAME OF ASSIGNEE

(B) RESIDENCE: (CITY and STATE OR COUNTRY)

Masimo Corporation

Irvine, CA

Please check the appropriate assignee category or categories (will not be printed on the patent): Individual Corporation or other private group entity Government

4a. Fees submitted: Issue Fee Publication Fee (if required) Advance Order - # of Copies _____

4b. Method of Payment: (Please first reapply any previously paid fee shown above)

Electronic Payment via EFS-Web Enclosed check Non-electronic payment by credit card (Attach form PTO-2038)

The Director is hereby authorized to charge the required fee(s), any deficiency, or credit any overpayment to Deposit Account No. 11-1410

5. Change in Entity Status (from status indicated above)

- Applicant certifying micro entity status. See 37 CFR 1.29
- Applicant asserting small entity status. See 37 CFR 1.27
- Applicant changing to regular undiscounted fee status.

NOTE: Absent a valid certification of Micro Entity Status (see forms PTO/SB/15A and 15B), issue fee payment in the micro entity amount will not be accepted at the risk of application abandonment.
 NOTE: If the application was previously under micro entity status, checking this box will be taken to be a notification of loss of entitlement to micro entity status.
 NOTE: Checking this box will be taken to be a notification of loss of entitlement to small or micro entity status, as applicable.

NOTE: This form must be signed in accordance with 37 CFR 1.31 and 1.33. See 37 CFR 1.4 for signature requirements and certifications.

Authorized Signature /Scott Cromar/ Date 2020-01-28

Typed or printed name Scott Cromar Registration No. 65066

Please Direct All Correspondence to Customer Number 64735

IN THE UNITED STATES PATENT AND TRADEMARK OFFICE

First Inventor	:	Jeroen Poeze
App. No.	:	16/544713
Filed	:	August 19, 2019
For	:	MULTI-STREAM DATA COLLECTION SYSTEM FOR NONINVASIVE MEASUREMENT OF BLOOD CONSTITUENTS
Examiner	:	Liu, Chu Chuan
Art Unit	:	3791
Conf. No.	:	9381

COMMENTS ON EXAMINER'S STATEMENT OF REASONS FOR ALLOWANCE

Mail Stop Issue Fee

Commissioner for Patents
P.O. Box 1450
Alexandria, VA 22313-1450

Dear Commissioner:

In response to the Examiner's Statement of Reasons for Allowance mailed on January 27, 2020, Applicant respectfully submits the following comments.

Applicant acknowledges the Examiner's statement regarding Allowable Subject Matter and agrees that the claimed subject matter is patentable. To the extent that there is any implication that the patentability of the claims rests on the recitation of a single feature, Applicant respectfully disagrees with the Examiner's Statement because it is the combination of features that makes the claims patentable. Accordingly, Applicant submits that the claims of the present application are allowable because each of the claims recites a combination of features that are not taught or suggested by the prior art. Applicant takes no other positions regarding the Allowable Subject Matter presented by the Examiner other than the positions Applicant may have previously taken during prosecution. Therefore, the Examiner's statement regarding Allowable Subject Matter should not be attributed to Applicant as an indication of the basis for

Applicant's belief that the claims are patentable. Furthermore, Applicant respectfully asserts that there may also be additional reasons for patentability of the claimed subject matter not explicitly stated in this record and Applicant does not waive rights to such arguments by not further addressing such reasons herein.

To the extent that there is any implication that the patentability of dependent claims is only attributable to the limitations in the independent claim from which each depends or that the dependent claims have the same scope as the claims from which they depend, Applicant respectfully disagrees and notes that it is each claim, taken as a whole, that is patentable. For dependent claims, their additional limitations may also provide additional reasons for patentability. Accordingly, Applicant submits that each of the allowed claims is allowable because the prior art does not teach or suggest the combination of features.

Applicant reserves the right to pursue at a later date any previously pending or other broader or narrower claims that capture any subject matter supported by the application's disclosure. Accordingly, reviewers of this or any child or related prosecution history shall not reasonably infer that the Applicant has made any disclaimers, disavowals, or abandonments of any subject matter supported by the present application, and any prior or alleged disclaimers, disavowals, or abandonments are hereby rescinded.

Respectfully submitted,

KNOBBE, MARTENS, OLSON & BEAR, LLP

Dated: January 28, 2020

By: /Scott Cromar/ _____
Scott A. Cromar
Registration No. 65,066
Registered Practitioner
Customer No. 64735
(949) 760-0404

32103600

Electronic Acknowledgement Receipt

EFS ID:	38418419
Application Number:	16544713
International Application Number:	
Confirmation Number:	9381
Title of Invention:	MULTI-STREAM DATA COLLECTION SYSTEM FOR NONINVASIVE MEASUREMENT OF BLOOD CONSTITUENTS
First Named Inventor/Applicant Name:	Jeroen Poeze
Customer Number:	64735
Filer:	Scott Cromar/Kealani Aguon
Filer Authorized By:	Scott Cromar
Attorney Docket Number:	MASCER.002C13
Receipt Date:	28-JAN-2020
Filing Date:	19-AUG-2019
Time Stamp:	14:19:31
Application Type:	Utility under 35 USC 111(a)

Payment information:

Submitted with Payment	no
------------------------	----

File Listing:

Document Number	Document Description	File Name	File Size(Bytes)/ Message Digest	Multi Part /.zip	Pages (if appl.)
1	Issue Fee Payment (PTO-85B)	IssueFee_002C13.pdf	183181 7f446d8874862c037ba59869c2fd33bdbc9a8fd1	no	1

Warnings:

Information:					
2	Post Allowance Communication - Incoming	Comments_002C13.pdf	21533	no	2
			b1203df7c675a291f05acecfb33fd0c24bd6c39		
Warnings:					
Information:					
Total Files Size (in bytes):				204714	
<p>This Acknowledgement Receipt evidences receipt on the noted date by the USPTO of the indicated documents, characterized by the applicant, and including page counts, where applicable. It serves as evidence of receipt similar to a Post Card, as described in MPEP 503.</p> <p><u>New Applications Under 35 U.S.C. 111</u> If a new application is being filed and the application includes the necessary components for a filing date (see 37 CFR 1.53(b)-(d) and MPEP 506), a Filing Receipt (37 CFR 1.54) will be issued in due course and the date shown on this Acknowledgement Receipt will establish the filing date of the application.</p> <p><u>National Stage of an International Application under 35 U.S.C. 371</u> If a timely submission to enter the national stage of an international application is compliant with the conditions of 35 U.S.C. 371 and other applicable requirements a Form PCT/DO/EO/903 indicating acceptance of the application as a national stage submission under 35 U.S.C. 371 will be issued in addition to the Filing Receipt, in due course.</p> <p><u>New International Application Filed with the USPTO as a Receiving Office</u> If a new international application is being filed and the international application includes the necessary components for an international filing date (see PCT Article 11 and MPEP 1810), a Notification of the International Application Number and of the International Filing Date (Form PCT/RO/105) will be issued in due course, subject to prescriptions concerning national security, and the date shown on this Acknowledgement Receipt will establish the international filing date of the application.</p>					

Best Available Copy
PART B FEE(S) TRANSMITTAL

Complete and send this form, together with applicable fee(s), by mail or fax, or via EFS-Web.

By mail, send to: **Mail Stop ISSUE FEE**
Commissioner for Patents
P.O. Box 1450
Alexandria, Virginia 22313-1450

By fax, send to: (571)-273-2885

INSTRUCTIONS: This form should be used for transmitting the ISSUE FEE and PUBLICATION FEE (if required). Blocks 1 through 5 should be completed where appropriate. All further correspondence including the Patent, advance orders and notification of maintenance fees will be mailed to the current correspondence address as indicated unless corrected below or directed otherwise in Block 1, by (a) specifying a new correspondence address; and/or (b) indicating a separate "FEE ADDRESS" for maintenance fee notifications.

CURRENT CORRESPONDENCE ADDRESS (Note: Use Block 1 for any change of address)

64735 7590 01/27/2020
KNOBBE, MARTENS, OLSON & BEAR, LLP
MASIMO CORPORATION (MASIMO)
2040 MAIN STREET
FOURTEENTH FLOOR
IRVINE, CA 92614



Note: A certificate of mailing can only be used for domestic mailings of the Fee(s) Transmittal. This certificate cannot be used for any other accompanying papers. Each additional paper, such as an assignment or formal drawing, must have its own certificate of mailing or transmission.

Certificate of Mailing or Transmission

I hereby certify that this Fee(s) Transmittal is being deposited with the United States Postal Service with sufficient postage for first class mail in an envelope addressed to the Mail Stop ISSUE FEE address above, or being transmitted to the USPTO via EFS-Web or by facsimile to (571) 273-2885, on the date below.

(Typed or printed name)
(Signature)
(Date)

APPLICATION NO.	FILING DATE	FIRST NAMED INVENTOR	ATTORNEY DOCKET NO.	CONFIRMATION NO.
16/544,713	08/19/2019	Jeroen Poeze	MASCER.002C13	9381

TITLE OF INVENTION: MULTI-STREAM DATA COLLECTION SYSTEM FOR NONINVASIVE MEASUREMENT OF BLOOD CONSTITUENTS

APPLN. TYPE	ENTITY STATUS	ISSUE FEE DUE	PUBLICATION FEE DUE	PREV. PAID ISSUE FEE	TOTAL FEE(S) DUE	DATE DUE
nonprovisional	UNDISCOUNTED	\$1000	\$0.00	\$1000.00	\$0	04/27/2020

EXAMINER	ART UNIT	CLASS-SUBCLASS
LIU, CHU CHUAN	3791	600-310000

1. Change of correspondence address or indication of "Fee Address" (37 CFR 1.363).

- Change of correspondence address (or Change of Correspondence Address form PTO/SB/122) attached.
- "Fee Address" indication (or "Fee Address" Indication form PTO/SB/47; Rev 03-09 or more recent) attached. **Use of a Customer Number is required.**

2. For printing on the patent front page, list
(1) The names of up to 3 registered patent attorneys or agents OR, alternatively,
(2) The name of a single firm (having as a member a registered attorney or agent) and the names of up to 2 registered patent attorneys or agents. If no name is listed, no name will be printed.

- 1 Knobbe Martens
2 Olson & Bear LLP
3 _____

3. ASSIGNEE NAME AND RESIDENCE DATA TO BE PRINTED ON THE PATENT (print or type)

PLEASE NOTE: Unless an assignee is identified below, no assignee data will appear on the patent. If an assignee is identified below, the document must have been previously recorded, or filed for recordation, as set forth in 37 CFR 3.11 and 37 CFR 3.81(a). Completion of this form is NOT a substitute for filing an assignment.

(A) NAME OF ASSIGNEE (B) RESIDENCE: (CITY and STATE OR COUNTRY)

Masimo Corporation **Irvine, CA**

Please check the appropriate assignee category or categories (will not be printed on the patent): Individual Corporation or other private group entity Government

4a. Fees submitted: Issue Fee Publication Fee (if required) Advance Order - # of Copies _____

4b. Method of Payment: (Please first reapply any previously paid fee shown above)

Electronic Payment via EFS-Web Enclosed check Non-electronic payment by credit card (Attach form PTO-2038)

The Director is hereby authorized to charge the required fee(s), any deficiency, or credit any overpayment to Deposit Account No. 11-1410

5. Change in Entity Status (from status indicated above)

- Applicant certifying micro entity status. See 37 CFR 1.29
- Applicant asserting small entity status. See 37 CFR 1.27
- Applicant changing to regular undiscounted fee status.

NOTE: Absent a valid certification of Micro Entity Status (see forms PTO/SB/15A and 15B), issue fee payment in the micro entity amount will not be accepted at the risk of application abandonment.
NOTE: If the application was previously under micro entity status, checking this box will be taken to be a notification of loss of entitlement to micro entity status.
NOTE: Checking this box will be taken to be a notification of loss of entitlement to small or micro entity status, as applicable.

NOTE: This form must be signed in accordance with 37 CFR 1.31 and 1.33. See 37 CFR 1.4 for signature requirements and certifications.

Authorized Signature /Scott Cromar/ Date 2020-01-28

Typed or printed name Scott Cromar Registration No. 65066



United States Patent and Trademark Office

Office of the Chief Financial Officer

Document Code:WFEE

User :C44696

Sale Accounting Date:01/29/2020

Sale Item Reference Number	Effective Date
16544713	01/28/2020

Document Number	Fee Code	Fee Code Description	Amount Paid	Payment Method
I20201S018380087	1501	UTILITY APPL ISSUE FEE	\$1,000.00	Salea



UNITED STATES PATENT AND TRADEMARK OFFICE

UNITED STATES DEPARTMENT OF COMMERCE
United States Patent and Trademark Office
Address: COMMISSIONER FOR PATENTS
P.O. Box 1450
Alexandria, Virginia 22313-1450
www.uspto.gov

APPLICATION NO.	FILING DATE	FIRST NAMED INVENTOR	ATTORNEY DOCKET NO.	CONFIRMATION NO.
16/544,713	08/19/2019	Jeroen Poeze	MASCER.002C13	9381
64735	7590	02/12/2020	EXAMINER	
KNOBBE, MARTENS, OLSON & BEAR, LLP MASIMO CORPORATION (MASIMO) 2040 MAIN STREET FOURTEENTH FLOOR IRVINE, CA 92614			LIU, CHU CHUAN	
			ART UNIT	PAPER NUMBER
			3791	
			NOTIFICATION DATE	DELIVERY MODE
			02/12/2020	ELECTRONIC

Please find below and/or attached an Office communication concerning this application or proceeding.

The time period for reply, if any, is set in the attached communication.

Notice of the Office communication was sent electronically on above-indicated "Notification Date" to the following e-mail address(es):

efiling@knobbe.com
jayna.cartee@knobbe.com

Supplemental Notice of Allowability	Application No. 16/544,713	Applicant(s) Poeze et al.	
	Examiner CHU CHUAN LIU	Art Unit 3791	AIA (FITF) Status No

-- The MAILING DATE of this communication appears on the cover sheet with the correspondence address--

All claims being allowable, PROSECUTION ON THE MERITS IS (OR REMAINS) CLOSED in this application. If not included herewith (or previously mailed), a Notice of Allowance (PTOL-85) or other appropriate communication will be mailed in due course. **THIS NOTICE OF ALLOWABILITY IS NOT A GRANT OF PATENT RIGHTS.** This application is subject to withdrawal from issue at the initiative of the Office or upon petition by the applicant. See 37 CFR 1.313 and MPEP 1308.

- 1. This communication is responsive to the IDS filed on 01/10/2020.
 A declaration(s)/affidavit(s) under **37 CFR 1.130(b)** was/were filed on _____.
- 2. An election was made by the applicant in response to a restriction requirement set forth during the interview on _____; the restriction requirement and election have been incorporated into this action.
- 3. The allowed claim(s) is/are 2,4-25 and 27-31 . As a result of the allowed claim(s), you may be eligible to benefit from the **Patent Prosecution Highway** program at a participating intellectual property office for the corresponding application. For more information , please see http://www.uspto.gov/patents/init_events/pph/index.jsp or send an inquiry to PPHfeedback@uspto.gov.
- 4. Acknowledgment is made of a claim for foreign priority under 35 U.S.C. § 119(a)-(d) or (f).

Certified copies:

- a) All b) Some *c) None of the:
 - 1. Certified copies of the priority documents have been received.
 - 2. Certified copies of the priority documents have been received in Application No. _____ .
 - 3. Copies of the certified copies of the priority documents have been received in this national stage application from the International Bureau (PCT Rule 17.2(a)).

* Certified copies not received: _____ .

Applicant has THREE MONTHS FROM THE "MAILING DATE" of this communication to file a reply complying with the requirements noted below. Failure to timely comply will result in ABANDONMENT of this application.

THIS THREE-MONTH PERIOD IS NOT EXTENDABLE.

- 5. CORRECTED DRAWINGS (as "replacement sheets") must be submitted.
 including changes required by the attached Examiner's Amendment / Comment or in the Office action of Paper No./Mail Date _____ .
Identifying indicia such as the application number (see 37 CFR 1.84(c)) should be written on the drawings in the front (not the back) of each sheet. Replacement sheet(s) should be labeled as such in the header according to 37 CFR 1.121(d).
- 6. DEPOSIT OF and/or INFORMATION about the deposit of BIOLOGICAL MATERIAL must be submitted. Note the attached Examiner's comment regarding REQUIREMENT FOR THE DEPOSIT OF BIOLOGICAL MATERIAL.

Attachment(s)

- 1. Notice of References Cited (PTO-892)
- 2. Information Disclosure Statements (PTO/SB/08), Paper No./Mail Date 01/10/2020.
- 3. Examiner's Comment Regarding Requirement for Deposit of Biological Material _____.
- 4. Interview Summary (PTO-413), Paper No./Mail Date. _____.
- 5. Examiner's Amendment/Comment
- 6. Examiner's Statement of Reasons for Allowance
- 7. Other _____.

/ERIC F WINAKUR/ Primary Examiner, Art Unit 3791	/CHU CHUAN LIU/ Examiner, Art Unit 3791
---	--

Allowable Subject Matter

1. Claims 2, 4-25 and 27-31 are allowed.
2. The following is an examiner's statement of reasons for allowance: The IDS filed on 01/10/2020 has been considered. The claims remain allowable for the reasons of record. A signed copy of the 1449 is attached for completeness of Applicant's records.

Any comments considered necessary by applicant must be submitted no later than the payment of the issue fee and, to avoid processing delays, should preferably accompany the issue fee. Such submissions should be clearly labeled "Comments on Statement of Reasons for Allowance."

3. Any inquiry concerning this communication or earlier communications from the examiner should be directed to CHU CHUAN LIU whose telephone number is (571)270-5507. The examiner can normally be reached on M-Th (8am-6pm).

Examiner interviews are available via telephone, in-person, and video conferencing using a USPTO supplied web-based collaboration tool. To schedule an interview, applicant is encouraged to use the USPTO Automated Interview Request (AIR) at <http://www.uspto.gov/interviewpractice>.

If attempts to reach the examiner by telephone are unsuccessful, the examiner's supervisor, Jacqueline Cheng can be reached on (571) 272-5596. The fax phone number for the organization where this application or proceeding is assigned is 571-273-8300.

Information regarding the status of an application may be obtained from the Patent Application Information Retrieval (PAIR) system. Status information for published applications may be obtained from either Private PAIR or Public PAIR. Status information for unpublished applications is available through Private PAIR only. For more information about the PAIR system, see <http://pair-direct.uspto.gov>. Should you have questions on access to the Private PAIR system, contact the Electronic Business Center (EBC) at 866-217-9197 (toll-free). If you would like assistance from a USPTO Customer Service Representative or access to the automated information system, call 800-786-9199 (IN USA OR CANADA) or 571-272-1000.

/ERIC F WINAKUR/
Primary Examiner, Art Unit 3791

/CHU CHUAN LIU/
Examiner, Art Unit 3791

INFORMATION DISCLOSURE STATEMENT BY APPLICANT	Application No.	16/544713
	Filing Date	August 19, 2019
	First Named Inventor	Jeroen Poeze
	Art Unit	3791
<i>(Multiple sheets used when necessary)</i>	Examiner	Liu, Chu Chuan
SHEET 1 OF 1	Attorney Docket No.	MASCER.002C13

U.S. PATENT DOCUMENTS

Examiner Initials	Cite No.	Document Number <i>Number - Kind Code (if known)</i> Example: 1,234,567 B1	Publication Date MM-DD-YYYY	Name	Pages, Columns, Lines Where Relevant Passages or Relevant Figures Appear

FOREIGN PATENT DOCUMENTS

Examiner Initials	Cite No.	Foreign Patent Document <i>Country Code-Number-Kind Code</i> Example: JP 1234567 A1	Publication Date MM-DD-YYYY	Name	Pages, Columns, Lines Where Relevant Passages or Relevant Figures Appear	T ¹

NON PATENT LITERATURE DOCUMENTS

Examiner Initials	Cite No.	Include name of the author (in CAPITAL LETTERS), title of the article (when appropriate), title of the item (book, magazine, journal, serial, symposium, catalog, etc.), date, page(s), volume-issue number(s), publisher, city and/or country where published.	T ¹
	1	2020-01-09 Complaint for (1) Patent Infringement (2) Trade Secret Misappropriation and (3) Ownership of Patents and Demand for Jury Trial, Masimo Corporation and Cercacor Laboratories, Inc. v. Apple Inc., Case No. 8:20-cv-00048, 64 pages.	

Examiner Signature	/CHU CHUAN LIU/	Date Considered	02/03/2020
<p>*Examiner: Initial if reference considered, whether or not citation is in conformance with MPEP 609. Draw line through citation if not in conformance and not considered. Include copy of this form with next communication to applicant.</p>			

T¹ - Place a check mark in this area when an English language Translation is attached.

ALL REFERENCES CONSIDERED EXCEPT WHERE LINED THROUGH. /C.L./



UNITED STATES PATENT AND TRADEMARK OFFICE

UNITED STATES DEPARTMENT OF COMMERCE
United States Patent and Trademark Office
Address: COMMISSIONER FOR PATENTS
P. O. Box 1450
Alexandria, Virginia 22313-1450
www.uspto.gov

Table with 5 columns: APPLICATION NO., ISSUE DATE, PATENT NO., ATTORNEY DOCKET NO., CONFIRMATION NO.
16/544,713 03/17/2020 10588554 MAS CER.002C13 9381

64735 7590 02/26/2020
KNOBBE, MARTENS, OLSON & BEAR, LLP
MASIMO CORPORATION (MASIMO)
2040 MAIN STREET
FOURTEENTH FLOOR
IRVINE, CA 92614

ISSUE NOTIFICATION

The projected patent number and issue date are specified above.

Determination of Patent Term Adjustment under 35 U.S.C. 154 (b)
(application filed on or after May 29, 2000)

The Patent Term Adjustment is 0 day(s). Any patent to issue from the above-identified application will include an indication of the adjustment on the front page.

If a Continued Prosecution Application (CPA) was filed in the above-identified application, the filing date that determines Patent Term Adjustment is the filing date of the most recent CPA.

Applicant will be able to obtain more detailed information by accessing the Patent Application Information Retrieval (PAIR) WEB site (http://pair.uspto.gov).

Any questions regarding the Patent Term Extension or Adjustment determination should be directed to the Office of Patent Legal Administration at (571)-272-7702. Questions relating to issue and publication fee payments should be directed to the Application Assistance Unit (AAU) of the Office of Data Management (ODM) at (571)-272-4200.

APPLICANT(s) (Please see PAIR WEB site http://pair.uspto.gov for additional applicants):

- Masimo Corporation, Irvine, CA;
Jeroen Poeze, Rancho Santa Margarita, CA;
Marcelo Lamego, Cupertino, CA;
Sean Merritt, Lake Forest, CA;
Cristiano Dalvi, Lake Forest, CA;
Hung Vo, Fountain Valley, CA;
Johannes Bruinsma, Opeinde, NETHERLANDS;
Ferdyan Lesmana, Irvine, CA;
Massi Joe E. Kiani, Laguna Niguel, CA;
Greg Olsen, Lake Forest, CA;

The United States represents the largest, most dynamic marketplace in the world and is an unparalleled location for business investment, innovation, and commercialization of new technologies. The USA offers tremendous resources and advantages for those who invest and manufacture goods here. Through SelectUSA, our nation works to encourage and facilitate business investment. To learn more about why the USA is the best country in the world to develop technology, manufacture products, and grow your business, visit SelectUSA.gov.

REQUEST FOR CERTIFICATE OF CORRECTION

First Inventor	:	Jeroen Poeze
App. No.	:	16/544713
Filed	:	August 19, 2019
Patent No.	:	10,588,554
Issue Date	:	March 24, 2020
Title	:	MULTI-STREAM DATA COLLECTION SYSTEM FOR NONINVASIVE MEASUREMENT OF BLOOD CONSTITUENTS
Conf. No.	:	9381

Commissioner for Patents
Office of Data Management
Attention: Certificates of Correction Branch
P.O. Box 1450
Alexandria, VA 22313-1450

Dear Commissioner:

Enclosed for filing is a Certificate of Correction in connection with the above-identified patent.

The Certificate of Correction includes a request to correct typographical errors in the domestic priority application data as printed on the patent grant. The correct domestic priority claim is evidenced by the filing receipt in this application dated August 29, 2019, a copy of which is provided with this request.

Errors cited in the Certificate of Correction appear to have been incurred through the fault of the PTO (see 35 USC § 254, 37 CFR § 1.322, and MPEP § 1480). No fee is believed to be required. Charge to our Deposit Account No. 11-1410 is authorized for any additional or remaining fees.

Respectfully submitted,

KNOBBE, MARTENS, OLSON & BEAR, LLP

Dated: April 29, 2020

By: /Scott Cromar/ _____
Scott A. Cromar
Registration No. 65,066
Registered Practitioner
(949) 760-0404

32706116

**UNITED STATES PATENT AND TRADEMARK OFFICE
CERTIFICATE OF CORRECTION**

PATENT NO. : 10,588,554
APPLICATION NO. : 16/544713
ISSUE DATE : March 24, 2020
INVENTOR(S) : Jeroen Poeze

Page 1 of 1

It is certified that an error appears or errors appear in the above-identified patent and that said Letters Patent is hereby corrected as shown below:

On the Title Page

Item (63), Page 2, Column 1 at Lines 14-15, Related U.S. Application Data, Change “and a continuation-in-part” to --which is a continuation-in-part--.

Item (63), Page 2, Column 1 at Line 21, Related U.S. Application Data, Change “and a continuation-in-part” to --which is a continuation-in-part--.

In the Specification

In Column 29 at Line 14, After “thermistors” delete “(not shown)”.

In Column 38 at Line 22, Change “15008” to --1500B--.

32705925

MAILING ADDRESS OF SENDER:

Scott A. Cromar
KNOBBE, MARTENS, OLSON & BEAR, LLP
2040 Main Street, 14th Floor
Irvine, California 92614

DOCKET NO. MASCER.002C13



UNITED STATES PATENT AND TRADEMARK OFFICE

UNITED STATES DEPARTMENT OF COMMERCE
United States Patent and Trademark Office
Address: COMMISSIONER FOR PATENTS
P.O. Box 1450
Alexandria, Virginia 22313-1450
www.uspto.gov

Table with 7 columns: APPLICATION NUMBER, FILING or 371(c) DATE, GRP ART UNIT, FIL FEE REC'D, ATTY DOCKET NO, TOT CLAIMS, IND CLAIMS. Row 1: 16/544,713, 08/19/2019, 2688, 2120, MAS CER.002C13, 1, 1

CONFIRMATION NO. 9381

FILING RECEIPT

64735
KNOBBE, MARTENS, OLSON & BEAR, LLP
MASIMO CORPORATION (MASIMO)
2040 MAIN STREET
FOURTEENTH FLOOR
IRVINE, CA 92614



Date Mailed: 08/29/2019

Receipt is acknowledged of this non-provisional utility patent application. The application will be taken up for examination in due course. Applicant will be notified as to the results of the examination. Any correspondence concerning the application must include the following identification information: the U.S. APPLICATION NUMBER, FILING DATE, NAME OF FIRST INVENTOR, and TITLE OF INVENTION. Fees transmitted by check or draft are subject to collection.

Please verify the accuracy of the data presented on this receipt. If an error is noted on this Filing Receipt, please submit a written request for a corrected Filing Receipt, including a properly marked-up ADS showing the changes with strike-through for deletions and underlining for additions. If you received a "Notice to File Missing Parts" or other Notice requiring a response for this application, please submit any request for correction to this Filing Receipt with your reply to the Notice. When the USPTO processes the reply to the Notice, the USPTO will generate another Filing Receipt incorporating the requested corrections provided that the request is grantable.

Inventor(s)

- Jeroen Poeze, Rancho Santa Margarita, CA;
Marcelo Lamego, Cupertino, CA;
Sean Merritt, Lake Forest, CA;
Cristiano Dalvi, Lake Forest, CA;
Hung Vo, Fountain Valley, CA;
Johannes Bruinsma, Opeinde, NETHERLANDS;
Ferdyan Lesmana, Irvine, CA;
Massi Joe E. Kiani, Laguna Niguel, CA;
Greg Olsen, Lake Forest, CA;

Applicant(s)

Masimo Corporation, Irvine, CA;

Power of Attorney: The patent practitioners associated with Customer Number 64735

Domestic Priority data as claimed by applicant

This application is a CON of 16/534,949 08/07/2019
which is a CON of 16/409,515 05/10/2019 PAT 10376191
which is a CON of 16/261,326 01/29/2019 PAT 10292628
which is a CON of 16/212,537 12/06/2018 PAT 10258266
which is a CON of 14/981,290 12/28/2015 PAT 10335068
which is a CON of 12/829,352 07/01/2010 PAT 9277880
which is a CON of 12/534,827 08/03/2009 ABN
which claims benefit of 61/086,060 08/04/2008

and claims benefit of 61/086,108 08/04/2008
and claims benefit of 61/086,063 08/04/2008
and claims benefit of 61/086,057 08/04/2008
and claims benefit of 61/091,732 08/25/2008
and said 12/829,352 07/01/2010
is a CIP of 12/497,528 07/02/2009 PAT 8577431
which claims benefit of 61/086,060 08/04/2008
and claims benefit of 61/086,108 08/04/2008
and claims benefit of 61/086,063 08/04/2008
and claims benefit of 61/086,057 08/04/2008
and claims benefit of 61/078,228 07/03/2008
and claims benefit of 61/078,207 07/03/2008
and claims benefit of 61/091,732 08/25/2008
and is a CIP of 29/323,408 08/25/2008 PAT D606659
and is a CIP of 29/323,409 08/25/2008 PAT D621516
and said 12/829,352 07/01/2010
is a CIP of 12/497,523 07/02/2009 PAT 8437825
which claims benefit of 61/086,060 08/04/2008
and claims benefit of 61/086,108 08/04/2008
and claims benefit of 61/086,063 08/04/2008
and claims benefit of 61/086,057 08/04/2008
and claims benefit of 61/078,228 07/03/2008
and claims benefit of 61/078,207 07/03/2008
and claims benefit of 61/091,732 08/25/2008
and is a CIP of 29/323,408 08/25/2008 PAT D606659
and is a CIP of 29/323,409 08/25/2008 PAT D621516

Foreign Applications for which priority is claimed (You may be eligible to benefit from the **Patent Prosecution Highway** program at the USPTO. Please see <http://www.uspto.gov> for more information.) - None.
Foreign application information must be provided in an Application Data Sheet in order to constitute a claim to foreign priority. See 37 CFR 1.55 and 1.76.

Permission to Access Application via Priority Document Exchange: Yes

Permission to Access Search Results: Yes

Applicant may provide or rescind an authorization for access using Form PTO/SB/39 or Form PTO/SB/69 as appropriate.

If Required, Foreign Filing License Granted: 08/28/2019

The country code and number of your priority application, to be used for filing abroad under the Paris Convention, is **US 16/544,713**

Projected Publication Date: 12/05/2019

Non-Publication Request: No

Early Publication Request: No

Title

MULTI-STREAM DATA COLLECTION SYSTEM FOR NONINVASIVE MEASUREMENT OF BLOOD CONSTITUENTS

Preliminary Class

369

Statement under 37 CFR 1.55 or 1.78 for AIA (First Inventor to File) Transition Applications: No

PROTECTING YOUR INVENTION OUTSIDE THE UNITED STATES

Since the rights granted by a U.S. patent extend only throughout the territory of the United States and have no effect in a foreign country, an inventor who wishes patent protection in another country must apply for a patent in a specific country or in regional patent offices. Applicants may wish to consider the filing of an international application under the Patent Cooperation Treaty (PCT). An international (PCT) application generally has the same effect as a regular national patent application in each PCT-member country. The PCT process **simplifies** the filing of patent applications on the same invention in member countries, but **does not result** in a grant of "an international patent" and does not eliminate the need of applicants to file additional documents and fees in countries where patent protection is desired.

Almost every country has its own patent law, and a person desiring a patent in a particular country must make an application for patent in that country in accordance with its particular laws. Since the laws of many countries differ in various respects from the patent law of the United States, applicants are advised to seek guidance from specific foreign countries to ensure that patent rights are not lost prematurely.

Applicants also are advised that in the case of inventions made in the United States, the Director of the USPTO must issue a license before applicants can apply for a patent in a foreign country. The filing of a U.S. patent application serves as a request for a foreign filing license. The application's filing receipt contains further information and guidance as to the status of applicant's license for foreign filing.

Applicants may wish to consult the USPTO booklet, "General Information Concerning Patents" (specifically, the section entitled "Treaties and Foreign Patents") for more information on timeframes and deadlines for filing foreign patent applications. The guide is available either by contacting the USPTO Contact Center at 800-786-9199, or it can be viewed on the USPTO website at <http://www.uspto.gov/web/offices/pac/doc/general/index.html>.

For information on preventing theft of your intellectual property (patents, trademarks and copyrights), you may wish to consult the U.S. Government website, <http://www.stopfakes.gov>. Part of a Department of Commerce initiative, this website includes self-help "toolkits" giving innovators guidance on how to protect intellectual property in specific countries such as China, Korea and Mexico. For questions regarding patent enforcement issues, applicants may call the U.S. Government hotline at 1-866-999-HALT (1-866-999-4258).

LICENSE FOR FOREIGN FILING UNDER
Title 35, United States Code, Section 184
Title 37, Code of Federal Regulations, 5.11 & 5.15

GRANTED

The applicant has been granted a license under 35 U.S.C. 184, if the phrase "IF REQUIRED, FOREIGN FILING LICENSE GRANTED" followed by a date appears on this form. Such licenses are issued in all applications where the conditions for issuance of a license have been met, regardless of whether or not a license may be required as set forth in 37 CFR 5.15. The scope and limitations of this license are set forth in 37 CFR 5.15(a) unless an earlier license has been issued under 37 CFR 5.15(b). The license is subject to revocation upon written notification. The date indicated is the effective date of the license, unless an earlier license of similar scope has been granted under 37 CFR 5.13 or 5.14.

This license is to be retained by the licensee and may be used at any time on or after the effective date thereof unless it is revoked. This license is automatically transferred to any related applications(s) filed under 37 CFR 1.53(d). This license is not retroactive.

The grant of a license does not in any way lessen the responsibility of a licensee for the security of the subject matter as imposed by any Government contract or the provisions of existing laws relating to espionage and the national security or the export of technical data. Licensees should apprise themselves of current regulations especially with respect to certain countries, of other agencies, particularly the Office of Defense Trade Controls, Department of State (with respect to Arms, Munitions and Implements of War (22 CFR 121-128)); the Bureau of Industry and Security, Department of Commerce (15 CFR parts 730-774); the Office of Foreign Assets Control, Department of Treasury (31 CFR Parts 500+) and the Department of Energy.

NOT GRANTED

No license under 35 U.S.C. 184 has been granted at this time, if the phrase "IF REQUIRED, FOREIGN FILING LICENSE GRANTED" DOES NOT appear on this form. Applicant may still petition for a license under 37 CFR 5.12, if a license is desired before the expiration of 6 months from the filing date of the application. If 6 months has lapsed from the filing date of this application and the licensee has not received any indication of a secrecy order under 35 U.S.C. 181, the licensee may foreign file the application pursuant to 37 CFR 5.15(b).

SelectUSA

The United States represents the largest, most dynamic marketplace in the world and is an unparalleled location for business investment, innovation, and commercialization of new technologies. The U.S. offers tremendous resources and advantages for those who invest and manufacture goods here. Through SelectUSA, our nation works to promote and facilitate business investment. SelectUSA provides information assistance to the international investor community; serves as an ombudsman for existing and potential investors; advocates on behalf of U.S. cities, states, and regions competing for global investment; and counsels U.S. economic development organizations on investment attraction best practices. To learn more about why the United States is the best country in the world to develop technology, manufacture products, deliver services, and grow your business, visit <http://www.SelectUSA.gov> or call +1-202-482-6800.

Electronic Acknowledgement Receipt

EFS ID:	39299911
Application Number:	16544713
International Application Number:	
Confirmation Number:	9381
Title of Invention:	MULTI-STREAM DATA COLLECTION SYSTEM FOR NONINVASIVE MEASUREMENT OF BLOOD CONSTITUENTS
First Named Inventor/Applicant Name:	Jeroen Poeze
Customer Number:	64735
Filer:	Scott Cromar/Wendy Castorena
Filer Authorized By:	Scott Cromar
Attorney Docket Number:	MASCER.002C13
Receipt Date:	29-APR-2020
Filing Date:	19-AUG-2019
Time Stamp:	14:28:50
Application Type:	Utility under 35 USC 111(a)

Payment information:

Submitted with Payment	no
------------------------	----

File Listing:

Document Number	Document Description	File Name	File Size(Bytes)/ Message Digest	Multi Part /.zip	Pages (if appl.)
1	Request for Certificate of Correction	CoC_C13.pdf	59104 <small>9f850f4e5c2cc07435608af5160926868f95a eac</small>	no	6

Warnings:

Information:	
Total Files Size (in bytes):	59104
<p>This Acknowledgement Receipt evidences receipt on the noted date by the USPTO of the indicated documents, characterized by the applicant, and including page counts, where applicable. It serves as evidence of receipt similar to a Post Card, as described in MPEP 503.</p> <p><u>New Applications Under 35 U.S.C. 111</u> If a new application is being filed and the application includes the necessary components for a filing date (see 37 CFR 1.53(b)-(d) and MPEP 506), a Filing Receipt (37 CFR 1.54) will be issued in due course and the date shown on this Acknowledgement Receipt will establish the filing date of the application.</p> <p><u>National Stage of an International Application under 35 U.S.C. 371</u> If a timely submission to enter the national stage of an international application is compliant with the conditions of 35 U.S.C. 371 and other applicable requirements a Form PCT/DO/EO/903 indicating acceptance of the application as a national stage submission under 35 U.S.C. 371 will be issued in addition to the Filing Receipt, in due course.</p> <p><u>New International Application Filed with the USPTO as a Receiving Office</u> If a new international application is being filed and the international application includes the necessary components for an international filing date (see PCT Article 11 and MPEP 1810), a Notification of the International Application Number and of the International Filing Date (Form PCT/RO/105) will be issued in due course, subject to prescriptions concerning national security, and the date shown on this Acknowledgement Receipt will establish the international filing date of the application.</p>	



UNITED STATES PATENT AND TRADEMARK OFFICE

UNITED STATES DEPARTMENT OF COMMERCE
United States Patent and Trademark Office
Address: COMMISSIONER FOR PATENTS
P.O. Box 1450
Alexandria, Virginia 22313-1450
www.uspto.gov

Table with 5 columns: APPLICATION NO., FILING DATE, FIRST NAMED INVENTOR, ATTORNEY DOCKET NO., CONFIRMATION NO. Includes details for application 16/544,713, inventor Jeroen Poeze, attorney MAS CER.002C13, examiner LIU, CHU CHUAN, art unit 3791, and notification date 05/11/2020.

Please find below and/or attached an Office communication concerning this application or proceeding.

The time period for reply, if any, is set in the attached communication.

Notice of the Office communication was sent electronically on above-indicated "Notification Date" to the following e-mail address(es):

efiling@knobbe.com
jayna.cartee@knobbe.com



UNITED STATES PATENT AND TRADEMARK OFFICE

Commissioner for Patents
United States Patent and Trademark Office
P.O. Box 1450
Alexandria, VA 22313-1450
www.uspto.gov

Patent No.: 10588554
Issue Date: 03/17/2020
Appl. No.: 16/544,713
Filed: 08/19/2019

PART (A) RESPONSE FOR CERTIFICATES OF CORRECTION

This is a decision on the Certificate of Correction request filed 29 April 2020.

The request for issuance of Certificate of Correction for the above-identified correction(s) under the provisions of 37 CFR 1.322 and/or 1.323 is hereby:

(Check one)

Approved Approved in Part Denied

Comments: _____

PART (B) PETITION UNDER 37 CFR 1.324 OR 37 CFR 1.48

This is a decision on the petition filed _____ to correct inventorship under 37 CFR 1.324.

This is a decision on the request under 37 CFR 1.48, petition filed _____. In view of the fact that the patent has already issued, the request under 37 CFR 1.48 has been treated as a petition to correct inventorship under 37 CFR 1.324.

The petition is hereby: Granted Dismissed

Comment: _____

The patented filed is being forwarded to Certificate of Corrections Branch for issuance of a certificate naming only the actual inventor or inventors.

/JACQUELINE CHENG/
Supervisory Patent Examiner, Art Unit 3791
Technology Center 3700
Phone: (571)272-5596

Certificates of Correction Branch email: CustomerServiceCoC@uspto.gov CoC Central Phone Number: (703) 756-1814

UNITED STATES PATENT AND TRADEMARK OFFICE
CERTIFICATE OF CORRECTION

PATENT NO. : 10,588,554 B2
APPLICATION NO. : 16/544713
DATED : March 17, 2020
INVENTOR(S) : Jeroen Poeze et al.

Page 1 of 1

It is certified that error appears in the above-identified patent and that said Letters Patent is hereby corrected as shown below:

On the Title Page

Item (63), Page 2, Column 1 at Lines 14-15, Related U.S. Application Data, Change “and a continuation-in-part” to --which is a continuation-in-part--.

Item (63), Page 2, Column 1 at Line 21, Related U.S. Application Data, Change “and a continuation-in-part” to --which is a continuation-in-part--.

In the Specification

In Column 29 at Line 14, After “thermistors” delete “(not shown)”.

In Column 38 at Line 22, Change “15008” to --1500B--.

Signed and Sealed this
Second Day of June, 2020

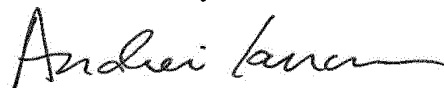

Andrei Iancu
Director of the United States Patent and Trademark Office