

(19) World Intellectual Property Organization  
International Bureau



(43) International Publication Date  
1 November 2007 (01.11.2007)

PCT

(10) International Publication Number  
WO 2007/123424 A1

- (51) International Patent Classification:  
C11B 7/00 (2006.01) A23L 1/48 (2006.01)  
C11B 1/10 (2006.01)
- (21) International Application Number:  
PCT/NZ2007/000087
- (22) International Filing Date: 20 April 2007 (20.04.2007)
- (25) Filing Language: English
- (26) Publication Language: English
- (30) Priority Data:  
546681 20 April 2006 (20.04.2006) NZ
- (71) Applicants and  
(72) Inventors: CATCHPOLE, Owen John, [NZ/NZ]; C/- Industrial Research Limited, Gracefield Research Centre, Gracefield Road, Lower Hutt (NZ). TALLON, Stephen John, [NZ/NZ]; C/- Industrial Research Limited, Gracefield Research Centre, Gracefield Road, Lower Hutt (NZ).
- (74) Agents: ADAMS, Matthew, D et al.; A J Park, 6th Floor Huddart Parker Building, Post Office Square, P O Box 949, Wellington, 6015 (NZ).

(81) Designated States (unless otherwise indicated, for every kind of national protection available): AE, AG, AL, AM, AT, AU, AZ, BA, BB, BG, BH, BR, BW, BY, BZ, CA, CH, CN, CO, CR, CU, CZ, DE, DK, DM, DZ, EC, EE, EG, ES, FI, GB, GD, GE, GH, GM, GT, HN, HR, HU, ID, IL, IN, IS, JP, KE, KG, KM, KN, KP, KR, KZ, LA, LC, LK, LR, LS, LT, LU, LY, MA, MD, MG, MK, MN, MW, MX, MY, MZ, NA, NG, NI, NO, NZ, OM, PG, PH, PL, PT, RO, RS, RU, SC, SD, SE, SG, SK, SL, SM, SV, SY, TJ, TM, TN, TR, TT, TZ, UA, UG, US, UZ, VC, VN, ZA, ZM, ZW.

(84) Designated States (unless otherwise indicated, for every kind of regional protection available): ARIPO (BW, GH, GM, KE, LS, MW, MZ, NA, SD, SL, SZ, TZ, UG, ZM, ZW), Eurasian (AM, AZ, BY, KG, KZ, MD, RU, TJ, TM), European (AT, BE, BG, CH, CY, CZ, DE, DK, EE, ES, FI, FR, GB, GR, HU, IE, IS, IT, LT, LU, LV, MC, MT, NL, PL, PT, RO, SE, SI, SK, TR), OAPI (BF, BJ, CF, CG, CI, CM, GA, GN, GQ, GW, ML, MR, NE, SN, TD, TG).

Published:  
— with international search report

For two-letter codes and other abbreviations, refer to the "Guidance Notes on Codes and Abbreviations" appearing at the beginning of each regular issue of the PCT Gazette.

(54) Title: PROCESS FOR SEPARATING LIPID MATERIALS

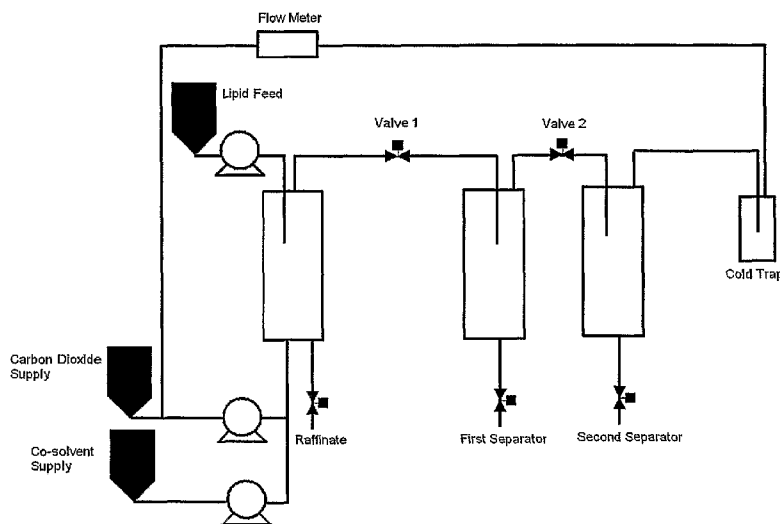

(57) Abstract: The present invention relates to processes for separating a feed material into soluble and insoluble components, by contacting a feed material and a solvent and subsequently separating the solvent containing the soluble components from the insoluble components, wherein the feed material comprises one or more of: at least 1% by mass phosphatidyl serine, at least 1% by mass sphingomyelin, at least 0.3% by mass acylalkylphospholipids and/or plasmalogens, at least 0.5% by mass aminoethylphosphonate and/or other phosphonolipids, at least 1% by mass cardiolipin, and at least 0.3% by mass gangliosides; and wherein the solvent comprises: supercritical or near-critical CO<sub>2</sub>, and a co-solvent comprising one or more C<sub>1</sub>-C<sub>3</sub> monohydric alcohols, and

water, wherein the co-solvent makes up at least 10% by mass of the CO<sub>2</sub>, and the water content of the co-solvent is 0 to 40% by mass. The present invention also relates to processes for separating a feed material into soluble and insoluble components, comprising contacting a feed material and a first solvent and subsequently separating the first solvent containing the first soluble components from the first insoluble components, wherein the feed material comprises one or more of: at least 1% by mass phosphatidyl serine, at least 1% by mass sphingomyelin, at least 0.3% by mass acylalkylphospholipids and/or plasmalogens, at least 0.5% by mass aminoethylphosphonate and/or other phosphonolipids, at least 1% by mass cardiolipin, or at least 0.3% by mass gangliosides; and wherein the first solvent comprises supercritical or near-critical CO<sub>2</sub>. The process then provides contacting the first insoluble components with a second solvent and subsequently separating the second solvent containing the second soluble components from the second insoluble components, wherein the second solvent comprises supercritical or near-critical CO<sub>2</sub>, and a co-solvent comprising one or more C<sub>1</sub>-C<sub>3</sub> monohydric alcohols, and water, wherein the co-solvent makes up at least 10% by mass of the CO<sub>2</sub>, and the water content of the co-solvent is 0 to 40% by mass.

WO 2007/123424 A1

**FIELD OF INVENTION**

5 This invention relates to a separation process. More particularly it relates to a process for separating lipid materials containing phospholipids and/or glycolipids, including for example phosphatidyl serine, gangliosides, cardiolipin, sphingomyelin, plasmalogens, alkylacylphospholipids, phosphonolipids, cerebroside or a combination thereof.

**BACKGROUND**

10

Phospholipids are a major component of all biological membranes, and include phosphoglycerides (phosphatidyl choline (PC), phosphatidyl ethanolamine (PE), phosphatidyl inositol (PI), cardiolipin (CL), phosphatidyl serine (PS)), plasmalogens (PL), phosphonolipids (PP), alkylacylphospholipids (ALP); and sphingolipids such as  
15 sphingomyelin (SM) and ceramide aminoethylphosphonate (CAEP).

Gangliosides are glycolipid components in the cell plasma membrane, which modulate cell signal transductions events. They are implicated as being important in immunology and neurodegenerative disorders. Cerebroside are important components in animal muscle and nerve cell membranes.

20

Both phospholipids and gangliosides are involved in cell signalling events leading to, for example, cell death (apoptosis), cell growth, cell proliferation, and cell differentiation.

25

Reasonable levels of some of these components can be found in milk, soy products, eggs, animal glands and organs, marine animals, plants and other sources. A source of these components is the bovine milk fat globule membrane (MFGM) which is known to contain  
useful quantities of sphingomyelin, ceramides, gangliosides, and phosphatidyl serine.  
Another source of these components is the green-shell mussel, which is known to contain  
useful quantities of plasmalogens, alkylacylphospholipids and ceramide  
aminoethylphosphonate

30

Both phospholipids and gangliosides have been implicated in conferring a number of health benefits including brain health, skin health, eczema treatment, anti-infection, wound healing, gut microbiota modifications, anti-cancer activity, alleviation of arthritis, improvement of

cardiovascular health, and treatment of metabolic syndromes. They can also be used in sports nutrition.

Cardiolipin is an important component of the inner mitochondrial membrane. It is typically present in metabolically active cells of the heart and skeletal muscle. It serves as an  
5 insulator and stabilises the activity of protein complexes important to the electron transport chain.

Existing methods for isolation of these compounds rely on the use of chromatographic techniques, which are slow and costly processes to operate. These techniques can also require the use of solvents that are unsuitable and/or undesirable in products for nutritional  
10 or human use. For example, Palacios and Wang [1] describe a process for extraction of phospholipids from egg yolks using acetone and ethanol extractions, followed by a methanol/chloroform separation. Kang and Row [2] describe a liquid chromatography process for separation of soybean derived PC from PE and PI. This process may be expensive to carry out on an industrial scale, and also uses hexane, methanol, and isopropyl  
15 alcohol as solvents. Kearns et al [3] describe a process for purification of egg yolk derived PC from PE using mixtures of acetonitrile, hydrocarbons, and fluorocarbons. Again, these solvents are undesirable for nutritional or pharmaceutical use.

Supercritical fluid extraction processes using CO<sub>2</sub> are becoming increasingly popular because of a number of processing and consumer benefits. CO<sub>2</sub> can be easily removed from  
20 the final product by reducing the pressure, whereupon the CO<sub>2</sub> reverts to a gaseous state, giving a completely solvent free product. The extract is considered to be more 'natural' than extracts produced using other solvents, and the use of CO<sub>2</sub> in place of conventional organic solvents also confers environmental benefits through reduced organic solvent use. The disadvantage of supercritical CO<sub>2</sub> processing is that the solubility of many compounds in  
25 CO<sub>2</sub> is low, and only neutral lipids can be extracted.

It is known that the use of CO<sub>2</sub> with organic co-solvents such as ethanol allows extraction of some phosphatidyl choline and to a much lesser extent phosphatidyl ethanolamine. For example, Teberikler et al [4] describe a process for extraction of PC from a soybean lecithin. Using 10% ethanol in CO<sub>2</sub> at 60°C they found that PC was easily extracted, while PE and PI  
30 were extracted to a very low extent. Extraction at 12.5 % ethanol at 80°C gave a four-fold increase in solubility of PC. Montanari et al [5] describe a process for extracting phospholipids from soybean flakes. After first extracting neutral lipids using only CO<sub>2</sub> at 320 bar, they found that using 10 % ethanol co-solvent at pressures of 194 to 689 bar resulted in

some extraction of PC, PE, PI, and phosphatidic acid (PA). PC is selectively extracted under some conditions, but at higher temperatures and pressures some extraction of PE and PI was achieved. The pressures required to achieve good extraction were impractically high for industrial application, and the high temperatures used (80°C) could cause polyunsaturated fatty acids to be degraded. Taylor et al [6] describe a process in which soybean flakes are first extracted using only CO<sub>2</sub>, followed by CO<sub>2</sub> with 15% ethanol at 80°C and 665 bar. A mixture of phospholipids is obtained which were fractionated by alumina column. Again, the temperatures and pressures are too high for practical application. In these works, the soybean-derived feed materials do not contain detectable levels of SM, CL, GS or PS.

10 Tanaka and Sakaki [7] describe a method for extracting phospholipids from waste tuna shavings using CO<sub>2</sub> and ethanol as a co-solvent. They describe extraction of DHA-containing phospholipids using 5 % ethanol in CO<sub>2</sub>, and by presoaking the tuna flakes in straight ethanol and then extracting using CO<sub>2</sub>. The phospholipids obtained in this process are not specified and no fractionation of the different phospholipids is described. In addition, 15 the phospholipids fraction makes up a relatively small proportion of the total processed material, requiring use of large pressure vessels to produce a small yield of phospholipids.

Bulley et al [8] describe extraction of frozen egg yolks using CO<sub>2</sub> and 3 % ethanol, and CO<sub>2</sub> with up to 5 % methanol. Higher rates of triglyceride extraction were obtained with the use of the co-solvent. Extraction of small amounts of phospholipids, up to 17% concentration in the extract, was also achieved. Fractionation of the phospholipids is not described. 20

In this specification where reference has been made to patent specifications, other external documents, or other sources of information, this is generally for the purpose of providing a context for discussing the features of the invention. Unless specifically stated otherwise, reference to such external documents or such sources of information is not to be construed as an admission that such documents or such sources of information, in any jurisdiction, are 25 prior art or form part of the common general knowledge in the art.

It is an object of this invention to provide a process for producing a product that contains desirable levels of particular phospholipids and/or gangliosides and/or cerebroside, or at least to offer the public a useful choice.

## SUMMARY OF INVENTION

Accordingly the present invention provides a process for separating a feed material into soluble and insoluble components, comprising:

(a) providing a feed material comprising one or more of:

- 5           (i) at least 1% by mass phosphatidyl serine
- (ii) at least 1% by mass sphingomyelin
- (iii) at least 0.3 % by mass acylalkylphospholipids and/or plasmalogens
- (iv) at least 0.5 % by mass aminoethylphosphonate and/or other phosphonolipids
- (v) at least 1% by mass cardiolipin
- 10           (vi) at least 0.3% by mass gangliosides

(b) providing a solvent comprising:

- (i) supercritical or near-critical CO<sub>2</sub>, and
- (ii) a co-solvent comprising one or more C<sub>1</sub>-C<sub>3</sub> monohydric alcohols, and water

wherein the co-solvent makes up at least 10% by mass of the CO<sub>2</sub>, and the water content  
15 of the co-solvent is 0 to 40 % by mass

(c) contacting the feed material and the solvent and subsequently separating the solvent containing the soluble components from the insoluble components

(d) optionally separating the soluble components and the solvent.

Preferably the feed material comprises greater than 1% phosphatidyl serine. More  
20 preferably the feed material comprises greater than 2% phosphatidyl serine. Most preferably the feed material comprises greater than 5% phosphatidyl serine.

Alternatively the feed material comprises greater than 1% sphingomyelin. More preferably the feed material comprises greater than 5% sphingomyelin. Most preferably the feed material comprises greater than 15% sphingomyelin.

# Explore Litigation Insights

Docket Alarm provides insights to develop a more informed litigation strategy and the peace of mind of knowing you're on top of things.

## Real-Time Litigation Alerts



Keep your litigation team up-to-date with **real-time alerts** and advanced team management tools built for the enterprise, all while greatly reducing PACER spend.

Our comprehensive service means we can handle Federal, State, and Administrative courts across the country.

## Advanced Docket Research



With over 230 million records, Docket Alarm's cloud-native docket research platform finds what other services can't. Coverage includes Federal, State, plus PTAB, TTAB, ITC and NLRB decisions, all in one place.

Identify arguments that have been successful in the past with full text, pinpoint searching. Link to case law cited within any court document via Fastcase.

## Analytics At Your Fingertips



Learn what happened the last time a particular judge, opposing counsel or company faced cases similar to yours.

Advanced out-of-the-box PTAB and TTAB analytics are always at your fingertips.

## API

Docket Alarm offers a powerful API (application programming interface) to developers that want to integrate case filings into their apps.

## LAW FIRMS

Build custom dashboards for your attorneys and clients with live data direct from the court.

Automate many repetitive legal tasks like conflict checks, document management, and marketing.

## FINANCIAL INSTITUTIONS

Litigation and bankruptcy checks for companies and debtors.

## E-DISCOVERY AND LEGAL VENDORS

Sync your system to PACER to automate legal marketing.