

- 16 -

iv) optionally other additives selected from the group consisting of polymers, nutritional components, stabilisers, preservatives, and antioxidants.

The water dispersible concentrate may be utilised in food for human nutrition, or as a supplement administered in a suitable unit dosage form with or without biologically active compounds. It may also be used to prepare lipid aggregates embedded in feed particles to contain nutritional components for feeding fish livestock or fish larvae. Preferably, the water dispersible concentrate is prepared using a purified, waxy phospholipid composition with at least 40 % by weight of PC purified by ethanol extraction of a particulate or powdered marine phospholipid/marine protein, amino acid and minerals composition.

The invention further describes a method to prepare a water dispersible MPL concentrate from MPL compositions obtained by fluid and ethanol extraction.

The invention further provides a method of preparing lipid aggregates which involves dispersing a lipid concentrate (B) comprising:

- i) 25 wt% to 75 wt% of an MPL composition comprising PC or blend of PC and the monoacyl derivative prepared by enzyme hydrolysis in an amount of at least 40 wt% as the major component and minor amounts of other components, including PE, PI, SPM, PS and their monoacyl derivatives,
- ii) 15 wt% to 75 wt% of glycerol or another polyol, or sugar
- iii) 1 wt% to 50 wt% water,
- iv) optionally, other additives selected from the group consisting of polymers, nutritional components, stabilisers, preservatives, and antioxidants;

in water or an aqueous medium for embedment and inclusion in feed particles or addition to food for human consumption.

The fatty acid profile of the phospholipids is characterised by at least 30 wt% of HUFAs, chiefly DHA and EPA based on the total fatty acid content present. Preferably it should comprise between 40 wt% and 60 wt% omega-3 fatty acids.

Hydrophilic medium

Suitable hydrophilic medium are non toxic polyols such as glycerol, propylene glycol, polyglycerols and mixtures thereof. The preferred polyol is glycerol. For human use ethanol may be suitable. Alternative polyols which may be used in place of or in addition to glycerol are aqueous sugar solutions comprising at least 25 wt% of e.g, glucose, sucrose, soluble maltodextrins, or polyhydric alcohols like mannitol and sorbitol etc.

Polymers

Natural gums, particularly sodium alginates which can cross link with Ca^{++} ions are preferred as matrix forming material for the microparticles. Alternative materials are proteins such as gelatine, poly peptides and peptides such as casein and soya proteins.

Stabilisers

These include buffers, osmotic components, antioxidants and anti microbials commonly used in fish feeds and supplements.

For fish feed applications a purified, waxy MPL composition after ethanol treatment, is hydrated in the hydrophilic medium, preferably without using elevated temperatures to prepare a homogeneous water dispersible gel like concentrate. Preferably, permitted antioxidants and preservatives may be added. On mixing with aqueous medium, the concentrates readily disperse into a variety of lipid aggregates below 10 μ average diameter, preferably below 1 μ measured by laser light diffraction. The concentrate further comprising nutritional components and alginates may be embedded in micro particle feed compositions. The amount of MPL concentrate that may be incorporated and embedded in the multicomponent feed composition may be between 10 wt% to 75 wt%, preferably 20 wt% to 40 wt%. After dehydration or lyophilisation (where appropriate) between 25 wt% to 75 wt% of water soluble nutritional components such as protein hydrolysates based on the total phospholipid content may be retained in the microparticles. The high capacity is due to the

- 18 -

unexpected properties of the marine phospholipid concentrates for containment of both water and oil soluble nutritional components in compositions in a destabilising environment like sea water.

It should be understood that the invention also includes MPL compositions wherein the mixture comprises marine diacyl phospholipids and their monoacyl derivatives. The mixture is prepared by enzyme hydrolysis using phospholipase A2 or A1 on a phospholipid substrate which may be either a particulate MPL composition or a waxy composition according to the method described in EP 1011634. The amount of diacyl phospholipid to monoacyl phospholipid in the enzyme hydrolysed MPL composition may be between 1:10 to 20:1.

There is described, characterised and defined marine phospholipid (MPL) compositions which may be used either as such in powder form or for preparing purified waxy lipid compositions which may be used to prepare improved water dispersible MPL concentrates, as nutritional supplements and/or ingredients for functional foods as well as the delivery and containment of nutritional components in multicomponent fish feed compositions. The MPL compositions in powder form and as water dispersible concentrates may be used in unit dosage forms as supplements to supply highly bioavailable omega-3 fatty acids for human use. The dosage forms may also contain biologically active compounds in combination with the MPL compositions. There is also described MPL concentrates comprising standardised and clearly defined phospholipids for embedment in feed microparticles, which are nutritionally essential in larvae feed.

Example 1

A dried marine raw material consisting 1000 g of freeze dried capelin roe with a total lipid content of 35 wt% is extracted in a batch extraction vessel with 40 kg/h carbon dioxide at 300 bar and 40° C for 4 hours to remove 180 g of a clear orange-brown oil containing 18 wt% of cholesterol and cholesterol esters. The particulate MPL composition in the form of a coarse powder which is recovered contains a total lipid content of about 21 wt% , of which the

- 19 -

major proportion (about 17 wt%) is polar phospholipids and 4 wt% are neutral lipids. About 70 wt% of the phospholipids is phosphatidylcholine comprising at least 30 wt% HUFAS. About 70 wt% of the composition is proteinaceous material including about 8 wt% minerals and trace elements. The composition has a mild fishy taste and odour with a peroxide value below 3 and may be used as such or mixed with suitable excipients in functional food applications. A unit dose of 300 mg of the powder may be filled into hard gelatine capsules for oral use as nutritional supplement. The powder may also be converted into tablets. Optionally the MPL composition may contain biologically active compounds

In place of capelin roe, herring or cod roe may be used. An alternative dried starting material that may be used in this example is from krill.

Example 2

820 g of the powder composition from Example 1 is extracted three times successively using a 5 : 1, 3 : 1, and a 2 : 1 ratio of ethanol (containing 6 % of water) to powder to extract the phospholipids. About 160 g of a waxy material comprising phospholipids as the major component with minor amounts of neutral lipids is obtained. A typical purified composition comprises:

Polar lipids:	82 wt%
PC content:	72 wt%
esterified HUFAs:	33 wt% (of PC based on total lipids)
non polar (neutral) lipids:	13 wt%
free fatty acids:	5 wt%
Cholesterol/esters	4 wt%
Iodine value:	112 (range 110 -130)
minerals, (ash)	2 wt%
ethanol:	2.2 wt%
water:	1.9 wt%

- 20 -

The MPL composition may be blended with 50 wt% of an oil which may be a fish oil, vegetable oil or medium chain glyceride such as Miglyol, to prepare a fluid lipophilic composition. Alternatively, it may also be hydrated overnight in glycerol at room temperature to prepare a hydrophilic composition. The liquid compositions may be filled into soft gelatine capsules for oral use or it may be used in fish and larvae feeds as in Example 1.

Example 3

*MPL with 72 wt% PC	50 wt%
Glycerol 90%	50 wt%

*MPL with about 40 % PC may also be used.

The MPL is hydrated overnight in a solution of glycerol at room temperature to prepare a viscous gel like MPL concentrate.

Example 4

The MPL concentrate from Example 3 is mixed with up to 25 wt% lipophilic nutritional components which may be fish triglycerides and anti oxidants such as Vit E, ascorbyl palmitate., t-butylated hydroxytoluene, t-butylated hydroxyanisole, ascorbic acid or ethoxyquin. Additionally 25 wt% to 50 wt% of hydrophilic fish feed components such as fish protein hydrolysates may be added. 2 wt% sodium alginate in aqueous solution may be added to the MPL concentrate as shown in the example. The resultant aqueous suspension of lipid aggregates associated with nutritional components and alginate is used to prepare feed microparticles by cross linking the alginate in the composition in a bath containing Ca ++ ions to prepare microparticles as described in WO0027218. The microparticles are recovered and dried. A typical composition is illustrated below.

*MPL (with about 70 wt% PC)	20.0 wt%
Glycerol (70 %)	10.0 wt%

- 21 -

Water (containing 2% Sod alginate)	19.5 wt%
Fish oil (lipophilic nutritional component)	10.0 wt%
Fish protein hydrolysate (hydrophilic nutritional component)	40.0 wt%
mixed antioxidants (tocopherol, ascorbylpalmitate)	0.5 wt%

* waxy MPL composition with a minimum PC content of about 40 wt% may also be used.

There is described marine phospholipids (MPL) compositions suitable for human, feed and aquaculture purposes comprising a dry composition comprising nutritional components selected from the group consisting of marine phospholipids, marine proteins and amino acid blends obtainable by fluid extraction of a dried marine raw material. The compositions have low amounts of neutral lipids and particularly low amounts of cholesterol and cholesterol esters. They may be used either as such in powder form and for preparing purified MPL compositions by ethanol extraction. Both forms may be used as nutritional supplements, ingredients for functional foods either on their own or in combination with biologically active compounds and to optimise the delivery and containment of nutritional components in multicomponent fish feed compositions.

There is further described a blend of the purified, ethanol extracted MPL compositions mixed with marine, vegetable, microbial or medium chain triglyceride oils to prepare liquid preparations for hard or soft gel encapsulation.

There is further described MPL concentrates comprising purified and clearly defined phospholipid types dispersed in hydrophilic medium which are nutritionally essential in larvae feed. Still further there is described MPL concentrates in unit dosage forms as supplements to supply highly bioavailable omega-3 fatty acids for human use, optionally with biologically active compounds.

CLAIMS:

1. A marine phospholipid (MPL) composition suitable for human, feed or aquaculture applications comprising a dry composition comprising nutritional components selected from the group consisting of marine phospholipids, marine proteins and amino acid blends obtainable by fluid extraction of a dried marine raw material.
2. The composition according to claim 1, wherein the dry composition is present in particulate or powdered form.
3. The composition according to claim 1, wherein the dry composition comprises a major amount of polar and a lower amount of non-polar (neutral) lipids.
4. The composition according to claim 1, wherein the dry composition comprises
 - I) 10 wt% to 30 wt% polar and neutral lipids; and
 - II) 70 wt% to 90 wt% marine proteins and amino acid blends.
5. The composition according to claim 1, wherein the dry composition comprises
 - I) 15 wt% to 30 wt% polar and neutral lipids;
 - II) 70 wt% to 85 wt% marine proteins, amino acid blend and minerals.
6. The composition according to claim 4, wherein the total lipid content consists of 70 wt% to 95 wt% polar lipids and 5 wt% to 30 wt% consist of neutral lipids.
7. The composition according to claim 4, wherein the total lipid content consists of 80 wt% to 95 wt% polar lipids and 5 wt% to 20 wt% consist of neutral lipids.
8. The composition according to claim 4, wherein 40 wt% to 80 wt% of the polar lipids consist of phosphatidylcholine and their monoacyl derivative, wherein said phosphatidylcholine and their monoacyl derivative are esterified with 30 wt% to 60 wt% HUFAs.

- 23 -

9. The composition according to claim 4, wherein 20 wt% to 60 wt% of the polar lipids consist of phospholipids selected from the group consisting of phosphatidyl ethanolamine, phosphatidyl inositol, phosphatidyl serine, sphingomyelin and the monoacyl derivatives thereof.
10. The composition according to claim 4, which is prepared by means of ethanol extraction to achieve a waxy constitution.
11. The composition according to claim 10 comprising
 - i) 70 wt% to 95 wt% of polar and neutral lipids,
 - ii) 5 wt% to 30 wt% of neutral lipids.
12. The composition according to claim 11 blended with 30 wt% to 60 wt% of a fish oil or any other edible neutral oil for use in hard or soft gelatine capsules.
13. A homogeneous water dispersible MPL concentrate comprising,
 - i) 25 wt% to 75 wt% marine phospholipids;
 - ii) 15 wt% to 75 wt% of ethanol or at least one polyol or mixtures thereof
 - iii) water to make 100%; and,
 - iv) optionally further additives selected from the group consisting of polymers, nutritional components, stabilizers, preservatives and antioxidants.
14. A composition according to claims 1, 4, 10 and 11 mixed homogeneously with phospholipids selected from the group consisting of soya, plant, egg, semi-synthetic, enzyme modified phospholipids and optionally biologically active compounds.
15. A method for further processing the MPL composition according to claim 1, which comprises separating the marine proteins and amino acid blends from the dry composition.

- 24 -

16. A method for further processing the water dispersible MPL concentrate according to claim 13, which comprises dispersing the concentrate in water and administering the dispersion to fish and/or larvae.
17. A process for preparing a waxy marine phospholipid (MPL) composition suitable for human or aquaculture applications, which process comprises the step of preparing a dry composition comprising nutritional components selected from the group consisting of marine phospholipids, marine proteins, amino acid and minerals blend by subjecting a dried marine raw material to fluid extraction.
18. A process for preparing a marine phospholipid composition according to claim 1, which comprises preparing the dry composition by subjecting the dried marine raw material to fluid extraction with acetone.
19. A process for preparing a marine phospholipid composition according to claim 1, which process comprises preparing the dry composition by subjecting the dried marine raw material to fluid extraction with supercritical gas.
20. A process for preparing a water dispersible MPL concentrate from an MPL composition involving fluid and ethanol extraction.

INTERNATIONAL SEARCH REPORT

International Application No
PCT/EP 03/13299

A. CLASSIFICATION OF SUBJECT MATTER
 IPC 7 A23K1/18 A23K1/00 A23K1/16 A23D9/013 A23L1/30
 A23L1/305 C11B1/10

According to International Patent Classification (IPC) or to both national classification and IPC

B. FIELDS SEARCHED

Minimum documentation searched (classification system followed by classification symbols)
 IPC 7 A23K A23D A23L C11B

Documentation searched other than minimum documentation to the extent that such documents are included in the fields searched

Electronic data base consulted during the international search (name of data base and, where practical, search terms used)

WPI Data, EPO-Internal, PAJ, FSTA, BIOSIS, MEDLINE

C. DOCUMENTS CONSIDERED TO BE RELEVANT

Category °	Citation of document, with indication, where appropriate, of the relevant passages	Relevant to claim No.
X	DATABASE WPI Section Ch, Week 198611 Derwent Publications Ltd., London, GB; Class B05, AN 1986-074743 XP002276083 & SU 1 175 486 A (ATLANTIC FISHING OCEANOGRAPHY), 30 August 1985 (1985-08-30) abstract ---	1-11, 13-15, 17,20
X	DATABASE WPI Section Ch, Week 199435 Derwent Publications Ltd., London, GB; Class B05, AN 1994-283548 XP002276084 & JP 06 212186 A (AGENCY OF IND SCI & TECHNOLOGY), 2 August 1994 (1994-08-02) abstract --- -/--	1-11, 13-17,19

Further documents are listed in the continuation of box C. Patent family members are listed in annex.

° Special categories of cited documents :

"A" document defining the general state of the art which is not considered to be of particular relevance	"T" later document published after the international filing date or priority date and not in conflict with the application but cited to understand the principle or theory underlying the invention
"E" earlier document but published on or after the international filing date	"X" document of particular relevance; the claimed invention cannot be considered novel or cannot be considered to involve an inventive step when the document is taken alone
"L" document which may throw doubts on priority claim(s) or which is cited to establish the publication date of another citation or other special reason (as specified)	"Y" document of particular relevance; the claimed invention cannot be considered to involve an inventive step when the document is combined with one or more other such documents, such combination being obvious to a person skilled in the art.
"O" document referring to an oral disclosure, use, exhibition or other means	"&" document member of the same patent family
"P" document published prior to the international filing date but later than the priority date claimed	

Date of the actual completion of the international search 5 April 2004	Date of mailing of the international search report 23/04/2004
--	---

Name and mailing address of the ISA European Patent Office, P.B. 5818 Patentlaan 2 NL - 2280 HV Rijswijk Tel. (+31-70) 340-2040, Tx. 31 651 epo nl, Fax: (+31-70) 340-3016	Authorized officer Muller, I
--	--

INTERNATIONAL SEARCH REPORT

International Application No
PCT/EP 03/13299

C.(Continuation) DOCUMENTS CONSIDERED TO BE RELEVANT		
Category °	Citation of document, with indication, where appropriate, of the relevant passages	Relevant to claim No.
X	<p>DATABASE WPI Section Ch, Week 199040 Derwent Publications Ltd., London, GB; Class B04, AN 1990-302732 XP002276087 & JP 02 215351 A (TAIYO FISHERY CO LTD), 28 August 1990 (1990-08-28) abstract & PATENT ABSTRACTS OF JAPAN vol. 014, no. 513 (C-0777), 9 November 1990 (1990-11-09) & JP 02 215351 A (TAIYO FISHERY CO LTD), 28 August 1990 (1990-08-28) abstract</p>	1-11, 13-15, 17,20
X	<p>--- DATABASE WPI Section Ch, Week 199740 Derwent Publications Ltd., London, GB; Class B05, AN 1997-431382 XP002276085 & JP 09 194362 A (BIZEN KASEI KK), 29 July 1997 (1997-07-29) abstract</p>	1-11, 13-15, 17,20
X	<p>--- DATABASE WPI Section Ch, Week 198716 Derwent Publications Ltd., London, GB; Class B05, AN 1987-111742 XP002276086 & JP 62 056497 A (NISSHIN OIL MILLS LTD), 12 March 1987 (1987-03-12) abstract</p>	1-11, 13-15, 17,18
X	<p>--- WO 01 50884 A (HALLDORSSON OLAFUR ;HARALDSSON GUDMUNDUR G (IS); HJALTASON BALDUR) 19 July 2001 (2001-07-19) cited in the application page 4 -page 10; claims 14-22,27-39; examples</p>	1-11,16, 17,20
X	<p>--- US 6 372 460 B1 (BEHRENS PAUL W ET AL) 16 April 2002 (2002-04-16) claims; examples 1,2C,3</p>	1-11, 13-17
X	<p>--- WO 02 092540 A (BANZHAF WULF ;KOHN GERHARD (DE); ABRIL JESUS RUBEN (US); MARTEK BI) 21 November 2002 (2002-11-21) page 8, line 19 -page 9, line 24; example 1</p>	1-11
X	<p>--- US 5 434 183 A (LARSSON-BACKSTROEM CARIN) 18 July 1995 (1995-07-18) column 4, line 33 -column 5, line 24; claims 1-8,16; examples 1,2</p>	1-12

INTERNATIONAL SEARCH REPORT

International Application No
PCT/EP 03/13299

Patent document cited in search report		Publication date	Patent family member(s)	Publication date
SU 1175486	A	30-08-1985	SU 1175486 A1	30-08-1985
JP 6212186	A	02-08-1994	JP 2034924 C JP 7065066 B	28-03-1996 12-07-1995
JP 2215351	A	28-08-1990	JP 2909508 B2	23-06-1999
JP 9194362	A	29-07-1997	NONE	
JP 62056497	A	12-03-1987	JP 1875089 C JP 5086796 B	26-09-1994 14-12-1993
WO 0150884	A	19-07-2001	AU 2394201 A CA 2397216 A1 CN 1400868 T EP 1250058 A1 WO 0150884 A1 JP 2003519501 T NO 20023375 A US 2003124218 A1	24-07-2001 19-07-2001 05-03-2003 23-10-2002 19-07-2001 24-06-2003 21-08-2002 03-07-2003
US 6372460	B1	16-04-2002	US 2002123111 A1 AU 748220 B2 AU 8603498 A EP 0996740 A1 IL 134242 A JP 2001512029 T NO 20000491 A WO 9906585 A1	05-09-2002 30-05-2002 22-02-1999 03-05-2000 24-06-2003 21-08-2001 31-03-2000 11-02-1999
WO 02092540	A	21-11-2002	EP 1392623 A1 WO 02092540 A1	03-03-2004 21-11-2002
US 5434183	A	18-07-1995	AT 216227 T AU 657969 B2 AU 1910192 A CA 2109611 A1 DE 69232564 D1 DE 69232564 T2 EP 0660708 A1 ES 2174833 T3 IE 921477 A1 JP 3387498 B2 JP 6508123 T NZ 242697 A PT 100524 A ,B WO 9221335 A1 SG 64864 A1	15-05-2002 30-03-1995 08-01-1993 10-12-1992 23-05-2002 26-09-2002 05-07-1995 16-11-2002 02-12-1992 17-03-2003 14-09-1994 25-02-1994 31-08-1993 10-12-1992 16-01-2001

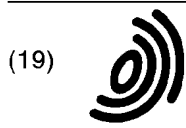

(12) **EUROPEAN PATENT SPECIFICATION**

(45) Date of publication and mention
of the grant of the patent:
07.09.2005 Bulletin 2005/36

(21) Application number: **98904353.4**

(22) Date of filing: **23.02.1998**

(51) Int Cl.7: **A61K 35/78**, A61K 35/12,
A61K 35/56, A01N 61/00,
A01N 63/00, A61K 7/48,
A61P 35/00

(86) International application number:
PCT/IL1998/000085

(87) International publication number:
WO 1998/036761 (27.08.1998 Gazette 1998/34)

(54) **ANTI-PROLIFERATIVE PREPARATIONS**
ANTIPROLIFERATIVE ZUBEREITUNGEN
PREPARATIONS ANTI-PROLIFERATIVES

(84) Designated Contracting States:
DE FR GB

(30) Priority: **23.02.1997 IL 12029197**
23.02.1997 IL 12029297
16.07.1997 IL 12132097

(43) Date of publication of application:
26.01.2000 Bulletin 2000/04

(73) Proprietor: **I.B.R.-Israeli Biotechnology Research
Ltd.**
62301 Tel Aviv (IL)

(72) Inventors:
• **SOUDANT, Etienne**
F-94260 Fresnes (FR)
• **BEZALEL, Lea**
84359 Beer Sheva (IL)
• **ZIV, Meira**
Rehovot 76353 (IL)
• **PERRY, Inon**
62301 Tel Aviv (IL)

(74) Representative: **Desaix, Anne et al**
Ernest Gutmann - Yves Plasseraud S.A.
3, rue Chauveau-Lagarde
75008 Paris (FR)

(56) References cited:
US-A- 5 104 668

- **PATENT ABSTRACTS OF JAPAN vol. 006, no. 191 (C-127), 30 September 1982 & JP 57 102810 A (ISONO JIRO;OTHERS: 01), 26 June 1982,**
- **LEANDRO SASTRE ET AL.: "PURIFICATION AND PROPERTIES OF A POLYADENYLATE POLYMERASE FROM ARTEMIA DORMANT EMBRYOS" BIOCHIMICA ET BIOPHYSICA ACTA, vol. 661, 1981, pages 54-62, XP002064843**
- **P. A. NAGAINIS ET AL.: "EVIDENCE FOR THE PRESENCE OF AN ACID PROTEASE AND PROTEASE INHIBITORS IN DORMANT EMBRYOS OF ARTEMIA SALINA." DEVELOPMENTAL BIOLOGY, vol. 68, no. 1, January 1979, pages 259-270, XP002064844**

Note: Within nine months from the publication of the mention of the grant of the European patent, any person may give notice to the European Patent Office of opposition to the European patent granted. Notice of opposition shall be filed in a written reasoned statement. It shall not be deemed to have been filed until the opposition fee has been paid. (Art. 99(1) European Patent Convention).

Description**FIELD OF THE INVENTION**

5 **[0001]** The present invention concerns extracts of cells or tissue or their supernatants which can inhibit proliferation of cells or tissue. The invention also provides compositions comprising such extracts as well as pharmaceutical, cosmetic and agricultural uses of the compositions and extracts.

BACKGROUND OF THE INVENTION

10 **[0002]** Dormancy is a phenomena which is found in representatives of the plant kingdom as well as the animal kingdom.

[0003] The germination of various grains and seeds comprising the necessary propagation organs is delayed under certain circumstances and yet the grains or seeds are capable of germinating after various periods of time. The period of time in which germination of such seeds may be delayed varies and depends both on intrinsic properties of the seed as well as on the nature and extremity of the environmental conditions. Seeds have been shown to be in dormancy for a few days, a year, several years and even for more than several centuries (as was discovered lately in the case of some nympheaceae and seeds of trees of the Leguminosae family (Shen-Miller, J., *et al.*, *American Journal of Botany*, **82**:1367-1380, 1995)).

20 **[0004]** In some cases, the capability to develop dormancy lies in the embryo envelopes. In such a case, the separation of the envelopes from the embryo, result in its immediate germination.

[0005] In other cases, chemical growth inhibitors capable of preventing germination are present in the embryo itself and thus even a bare embryo may remain dormant (such as in the case of Rosaceae plants such as Kerria, Peach, etc.).

25 **[0006]** In plants, a state of dormancy may be found in the whole plant or in one or more of its parts. Dormant plants are plants which have two main metabolic states in their growth cycle. In their dormant state, the plants' metabolism is extremely low, and the plant growth process is significantly inhibited although differentiation of certain cells may occur. In their active state, the plants' metabolism rate is higher, the cells divide and differentiate and there is significant growth of various parts of the plant. In some cases, the whole plant enters the dormant state. Such is the case in Narcissus plants in which during the dormant state the only remaining viable part is the bulb which is in its dormant state. In other cases, some parts of the plants may be active while other parts may be in dormancy such as, for example, is the case of apple trees.

30 **[0007]** Substances capable of inhibiting germination have also been shown to be present in the juice of fleshy fruits or in other plant organs which produce juice. Examples are tomatoes, grapes, kiwi, watermelon and grapefruit wherein pips present in the fruit do not germinate although their surroundings are suitable for germination due to the water within the fruit.

35 **[0008]** Several plant-derived substances having an effect on cell proliferation have been reported. For example, European Patent Application No. 0351514 describes compositions comprising both naturally derived as well as synthetically prepared sphingolipids which have growth inhibitory activity on various kinds of cells. Another well known plant-derived substance having an anti-mitotic effect on various kinds of human cells is the substance colchicine (Samson, F.E., *A. Rev. Pharmac. Toxic* **16**:143 (1976)). The Narcissus alkaloid, pretazettine, was shown to have a cytotoxic effect on Rausher virus-carrier cells as well as anti-leukemic activity in leukemic mice although the predominant activity of the substance was shown to be an antiviral activity (Furusawa, E. *et al.*, *Chemotherapy*, **26**:36-45, (1980) and Furusawa, E. *et al.*, *Proc. Soc. Exp. Biol. Med.*, **152**:186-191, (1976)). *Ulex europaeus* seed extracts were shown to comprise a non glycoprotein lectin capable of reversibly inhibiting growth of certain lymphocytes as well as to inhibit the growth of various reticulo endothelial tumor cell lines (Pirofsky, B., *et al.*, *Vox-Sang*, **42**:295-303, (1982) and Pirofsky, B., *et al.*, *J. Biol. Response Mod.*, **2**:175-185, (1983)). Root extract of *Panax ginseng* was shown to decrease DNA synthesis measured by [³H]-thymidine incorporation of V 79 Chinese hamster lung cells. Another substance, Narcicla-sine obtained from bulbs of various Narcissus varieties was shown, amongst other of its activities, to inhibit growth of wheat kernel radicals (Ceriotti, G., *et al.*, *Tumors* **53**:359-371 (1967)). Bulbs of *Pancratium littoral* collected in Hawaii were found to contain a product designated pancratistatin capable of inhibiting growth of various neoplastic cell lines *in vitro* (Pettit, G.R., *et al.*, *J. Nat. Prod.* **49**:995-1002 (1986)).

40 **[0009]** The Japanese Patent Application JP 55177865 (Kosugi Kikuo, filed on December 16, 1980) reports the use of an extracted solution from bulbs of cluster-amaryllis of amaryllidaceous plant or narcissus in the preparation of a cosmetic composition to prevent the aging of the skin and the occurrence of the stain caused by the influence of the sunlight, and to exhibit beautifying action.

55 **[0010]** Against this, many plant extracts having an opposite effect on cells, i.e., capable of augmenting their proliferation were also described such as, for example, the methanolic extract from the root of *Scutellaria baicalensis georgi* were shown to significantly augment the cellular activity of fibroblasts (Chung, C.P., *et al.*, *Planta-Med*, **61**:150-153

(1995). Gibberellin-like growth substances were found in six different plant species having bulbs (Staby, G.L., *Hort. Science*, 399-400 (1970)). Several cytokinins which were found in roots that developed from Narcissus bulbs had an effect on bulb growth of the plants in which they were detected (Vanstaden, J.V., *Pflanzenphysiol.*, **86**:323-30 (1978)).

[0011] The phenomena of dormancy may also be found in the animal kingdom, for example, in the small crustacean *Artemia salina* (Finamore and Clegg In: *The Cell Cycle*, Academic Press Ed., 249-278, 1969). The natural environment of this marine crustacea is usually briny ponds. After fertilization, the early stages of development of artemia involve the formation of a blastula which then becomes a gastrula. Under severe environmental conditions such as dehydration (drought), the gastrula is capable of forming a cyst wherein the whole organism enters a dormancy phase. The dormant artemia gastrula (commonly mis-called "artemia eggs") are capable of remaining in their dormant state for many years. When the encysted gastrula are rehydrated, the various metabolic activities of the artemia are resumed and protein synthesis can be seen after about 10 minutes. However, DNA synthesis and cell division are absent until about after 60 hours (Le Gal, Y, In: *Biochimie Marine*, (Ed. Masson) p. 176, 1988).

[0012] Various plant derived compositions (such as retinoic acid (US 5,438,073) and α -hydroxy acids (Ditre, C.M., *et al.*, *J. Am. Acad Dermatol.*, **34**:187-195, 1996)) as well as animal derived extracts have been proposed for use in the cosmetic field for stimulating the proliferation and renewal of epidermal cells. Such compositions were considered to be useful in the cosmetic field where it is accepted that the natural renewal process of epidermis is slowed down with aging. It is believed that removal of the outer surface with simultaneous stimulation of growth of new cells in the inner layers of the epidermis to divide and migrate to the outer surface, will result in skin renewal and in a younger skin appearance. However, it is also known and has been recently shown that the increase in cell division is a crucial factor in converting normal cells into premalignant or malignant cells (Ames, B.N. *et al.*, *Environ. Health Perspect* **101**:35-44 (1993)).

[0013] It is also believed today that normal human and animal cells have a finite capacity to replicate. It has been shown that the number of mitotic events that cultured normal animal cells can undergo appear to be inversely related to the age of the donor from which they were obtained (Hayflick, L., *Clin. Geriatr. Med.*, **1**:15-27, (1985)). It has also been shown that cell cultures obtained from patients with accelerated aging syndromes undergo less replications than cell cultures obtained from age matched control individuals.

GLOSSARY

[0014] The following is the meaning of some terms of which will be used in the text below:

Dormancy - a state in which there is a marked decrease in the metabolic rate of cells or tissues resulting in the inhibition of growth and proliferation of the cells or tissue.

Dormans - substances naturally found in cells or tissue and which are capable of inducing cells or tissue to enter a state of dormancy or of maintaining the dormant state in cells or tissues that have already entered that state. The dormans may be obtained from a variety of plant parts which are capable of entering into a state of dormancy; from juice of various fruits which contain dormans capable of inhibiting germination of seeds within the fruit; from animals which are capable of entering a phase of dormancy in their life cycle, e.g. gastrula of certain crustaceans such as artemia or dafnia; etc. In some cases, the dormans are found within a dormant tissue, e.g. in a dormant seed or in the gastrula of artemia or dafnia; in other cases the dormans are found in a tissue surrounding the dormant tissue or organ, e.g. in a fruit juice surrounding a dormant seed.

Extract - At least one substance obtained by any of a variety of extraction methods known in the art. For example, the extract may be an aqueous extract, a glycolic extract an alcoholic extract, an oily extract, etc. The extract in accordance with the invention is obtained from cells or tissues from a part of a plant or animal capable of entering a state of dormancy. The cells or tissue may be obtained directly from the plant or animal and the extract may then be prepared therefrom. Alternatively, cell cultures may first be prepared from the plant or animal cells or tissues and then the cell cultures may be grown for various periods of time. In order to prepare an extract, the cells are then harvested from the cell cultures, the cells and their growth medium are separated and an extract may be prepared either from the cells themselves or from the growth medium (which will be referred to as "supernatant") which contains substances secreted by the cells into their growth medium. Thus, the "extract" may be obtained directly from plant or animal tissue or from an animal or plant cell or tissue culture.

Dorman extract - an extract obtained from a plant cell or tissue, from fruit or from an animal cell or tissue which comprises dormans.

Enriched dorman preparation (EDP) - a preparation derived from a natural source which comprises dormans in

a concentration larger than that which is found in a natural unprocessed extract. The EDP may be obtained by purification of a natural extract to obtain fractions which contained dormans in the larger concentration, e.g. by various chromatographic techniques, by filtration, etc., as well as by biological means including growing cells or tissue which are capable of producing dormans under conditions in which they produce dormans in relatively large quantities and collecting their secretion products. In order to determine whether a preparation is an enriched dorman preparation, the preparation may be assayed for a specific biological activity associated with dormans, as described below. EDP contains a substantially higher concentration of dormans as compared to the natural preparation, e.g. at least 1.5 folds, preferably 2 folds and typically at least 2.5 folds to the concentration of the dormans in the natural preparation.

Producer cells or producer tissue - cells or tissue which are capable of producing dormans which may thus be extracted therefrom.

Target cells or target tissue - cells or tissue which are contacted with dormans, in accordance with the invention and which thereby enter a state of inhibition of their growth or proliferation or maintain such a state as the result of contact with dormans.

Dorman analog - a substance, typically synthetic, which has a dorman-like activity in that it is capable of inducing dormancy in the same cells or tissue induced to dormancy by the dorman and which, in accordance with the invention, is also capable of inhibiting growth and proliferation of target cells or tissue.

Dorman composition (DC) - a water-soluble extract comprising, as active ingredient, an amount of dorman (e.g. as a dorman extract) or dorman analog effective in inhibiting growth and proliferation of target cells or tissue ("effective amount"). A dorman composition may comprise a naturally derived EDP, a composition comprising synthetic dormans as well as dorman analogs.

Active Extract (AE) - extracts obtained from cells or tissues from a part of a plant or animal capable of entering a state of dormancy during the non dormant state.

SUMMARY OF THE INVENTION

[0015] In accordance with the invention, use is made of a dorman composition. The compositions are used for inhibiting proliferation of cells, particularly cells xenogeneic to the producer cells or tissue. By one preferred embodiment of the invention, the compositions are used in human medicine and cosmetics. In accordance with another embodiment, the compositions are used for controlling plant growth. By yet a further embodiment, the compositions of the invention are used in food preservation.

[0016] By one aspect of the invention there is thus provided a process for producing a water-soluble extract which inhibits proliferation of target cells or target tissue, said process comprising:

- (i) providing producer cells or producer tissue derived from an organism which is xenogeneic to said target cells and which is capable of entering into a dormant state;
- (ii) providing conditions which induce said cells or tissue to enter into a dormant state or, if already in a dormant state, to maintain said dormant state;
- (iii) recovering a water-soluble extract from said cells or tissue or from the medium in which said cells or tissue are incubated; wherein said water-soluble extract displays a cell anti-proliferative activity.

[0017] By one embodiment the composition comprises an enriched dorman preparation (EDP) which, as defined above, comprises dormans in a concentration larger than that which is found in a natural unprocessed extract.

[0018] The producer cells or tissues from which the extract is obtained may be of the same origin as said target cells or tissues but are preferably of a different origin. In accordance with one embodiment of the invention, said target cells or tissue are human cells or tissue and said producer cells or tissue are plant or non human animal cells or tissue. In accordance with another embodiment of the invention, said target cells or tissue are plant cells or tissue.

[0019] In accordance with one preferred embodiment of the invention, the dorman composition is a pharmaceutical or cosmetic composition for inhibiting cell proliferation within the body. In accordance with another embodiment of the invention, said composition is used for inhibiting germination of seeds (being either natural or artificially prepared) or growth of seedlings for the purpose of maintaining seedlings in a dormant state for example during storage. In accordance with a further embodiment of the invention, the dorman composition is used in fresh food preservation.

[0020] By one embodiment, the water-soluble extracts used in accordance with the invention are derived from dor-

mant plants.

[0021] Water-soluble extracts in accordance with the invention obtained from bulbs of dormant plants while in their dormant state are capable of inhibiting the growth of seedlings as well as to inhibit the proliferation of various target cells, including various mammalian cells, e.g. human cells, to a significantly higher extent than preparations obtained under the same conditions from bulbs of the same plant being in their active state. It was also found that dormant compositions obtained from cell cultures prepared from various parts of dormant plants and induced into dormancy are also capable of inhibiting the growth of seedlings as well as to inhibit the proliferation of various cells, including various mammalian cells, e.g. human cells. These DCs, in a wide range of concentrations, had no noticeable toxic effect on the target cells, this being in contrast to most substances which have an anti-proliferating effect.

[0022] In accordance with the invention, any plant capable of entering a dormant state may be used for obtaining an DC. Some non-limiting examples of such plants, as well as the parts of such plants which enter a dormant state (designated "*D-part*") and from which the DC may be obtained, are shown in the following Tables I and II:

Table I

(Bulbs, corms, roots, rhizomes)		
Name	Family	D-part
Allium	Liliaceae	bulbs
Amaryllis belladonna	Amaryllidaceae	bulbs
Anemone	Ranunculaceae	perennials & tuberous or fibrous roots
Babiana	Iridaceae	corms
Brodiaea	Liliaceae	corms
Chionodoxa	Liliaceae	bulbs
Crocus	Iridaceae	corms
Ornithogallum	Liliaceae	bulbs
Cyclamen	Primulaceae	perennials & tuberous roots
Endymion	Liliaceae	bulbs
Arum	Araceae	perennials & Tuberous roots
Freesia	Iridaceae	corms
Fritillaria	Liliaceae	bulbs
Galanthus	Amaryllidaceae	bulbs
Hippeastrum	Amaryllidaceae	bulbs
Hyacinthus	Liliaceae	bulbs
Leek	Liliaceae	bulbs
Ipseion uniflorum	Amaryllidaceae	bulbs
Iris	Iridaceae	bulbs & rhizomes
Ixia	Iridaceae	corms
Leucojum	Amaryllidaceae	bulbs
Lilium	Liliaceae	bulbs
Muscari	Liliaceae	bulbs
Narcissus	Amaryllidaceae	bulbs
Oxalis	Oxalidaceae	bulbs & rhizomes
Paeonia	Paeoniaceae	tuberous perennials
Puschkinia scilloides	Liliaceae	bulbs
Ranunculus	Ranunculaceae	tubers or perennials

EP 0 973 532 B1

Table I (continued)

(Bulbs, corms, roots, rhizomes)		
Name	Family	D-part
Radohypoxis	Hypoxidaceae	bulbs
Rhodophiala	Amaryllidaceae	bulbs
Scilla	Liliaceae	bulbs
Sparaxis	Iridaceae	corms
Raritimum	Liliaceae	bulbs
Triteleia	Amaryllidaceae	corms
Tulipa	Liliaceae	bulbs
Tritonia crocata	Iridaceae	corms
Watsonia pyramidata	Iridaceae	corms
Zantedeschia	Araceae	rhizomes
Begonia	Begoniaceae	rhizomes
Caladium	Araceae	perennials & tuberous roots
Canna	Cannaceae	perennials & tuberous roots
Crocasmia	Iridaceae	corms
Dahlia	Asteraceae	perennials & tuberous roots
Gladiolus	Iridaceae	corms
Gloriosa rothschildiana	Liliaceae	perennials & tuberous roots
Homeria collina	Iridaceae	corms
Hymenocallis	Amaryllidaceae	bulbs
Liatris	Asteraceae	perennials
Polianthes tuberosa	Agavaceae	perennials & tuberous roots
Tigridia pavonia	Iridaceae	bulbs
Zantedeschia	Araceae	rhizomes
Zephyranthes	Amaryllidaceae	bulbs
Colchicum	Liliaceae	corms
Lycoris	Amaryllidaceae	bulbs
Sterenbergia lutea	Amaryllidaceae	bulbs
Pancratium	Liliaceae	bulbs

Table II

(Deciduous fruit trees, shrubs, seeds)		
Name	Family	D-part
Malus - crabapple	Malus	Deciduous & fruit trees & shrubs
Mangifera	Anacardiaceae	Deciduous & fruit trees & shrubs
Peach	Rosaceae	Deciduous & fruit trees & shrubs
Persimmon	Ebenaceae	Deciduous & fruit trees & shrubs
Pistacia chinensis	Anacardiaceae	Deciduous & fruit trees & shrubs

EP 0 973 532 B1

Table II (continued)

(Deciduous fruit trees, shrubs, seeds)		
Name	Family	D-part
Prunus	Rosaceae	Deciduous & fruit trees & shrubs
Fraxinus	Oleaceae	Deciduous & fruit trees & shrubs
Pyrus	Rosaceae	Deciduous & fruit trees & shrubs
Quercus	Fagaceae	Deciduous & fruit trees & shrubs
Salix	Salicaceae	Deciduous & fruit trees & shrubs
Actinidia	Actinidiaceae	Deciduous & fruit trees & shrubs
Akebia quinata	Lardizabalaceae	Deciduous & fruit trees & shrubs
Blueberry	Vitaceae	Deciduous & fruit trees & shrubs
Apple	Rosaceae	Deciduous & fruit trees & shrubs
Aloysia	Verbenaceae	Deciduous & fruit trees & shrubs
Campsis	Bignoniaceae	Deciduous & fruit trees & shrubs
Celastrus	Celastraceae	Deciduous & fruit trees & shrubs
Cellery	Apiaceae	seeds
Clematis	Ranunculaceae	Deciduous & fruit trees & shrubs
Grape	Vitaceae	Deciduous & fruit trees & shrubs
Humulus	Cannabaceae	Deciduous & fruit trees & shrubs
Fig	Moraceae	Deciduous & fruit trees & shrubs
Wisteria	Fabaceae	Deciduous & fruit trees & shrubs
Bean	Fabaceae	Deciduous & fruit trees & shrubs
Lathyrus pea	Fabaceae	Deciduous & fruit trees & shrubs
Tropaeolum	Tropaeolaceae	Deciduous & fruit trees & shrubs
Amelanchier	Rosaceae	Deciduous & fruit trees & shrubs
Cotoneaster	Rosaceae	Deciduous & fruit trees & shrubs
Barberry	Berberadaceae	Deciduous & fruit trees & shrubs
Enkianthus	Ericaceae	Deciduous & fruit trees & shrubs
Eunymus	Celastraceae	Deciduous & fruit trees & shrubs
Kerria japonica	Rosaceae	Deciduous & fruit trees & shrubs
Parsnip	Apiaceae	seeds
Passiflora	Passifloraceae	Deciduous & fruit trees & shrubs
Rhododendron	Ericaceae	Deciduous & fruit trees & shrubs
Acacia	Fabaceae	Deciduous & fruit trees & shrubs
Albizia	Fabaceae	Deciduous & fruit trees & shrubs
Almond	Rosaceae	Deciduous & fruit trees & shrubs
Ampelopsis	Vitaceae	Deciduous & fruit trees & shrubs
Anethum	Apiaceae	seeds
Annona cherimola	Annonaceae	Deciduous & fruit trees & shrubs
Apricot	Rosaceae	Deciduous & fruit trees & shrubs

Table II (continued)

(Deciduous fruit trees, shrubs, seeds)		
Name	Family	D-part
Artemisia	Asteraceae	Deciduous & fruit trees & shrubs
Asparagus	Liliaceae	seeds
Blackberry	Rosaceae	Deciduous & fruit trees & shrubs
Carrot	Apiaceae	seeds
Carya pecan	Juglandaceae	Deciduous & fruit trees & shrubs
Cherry	Rosaceae	Deciduous & fruit trees & shrubs
Corn	Poaceae	seeds
Helianthus	Asteraceae	seeds
Cucumber	Cucurbitaceae	seeds
Filbert	Betulaceae	Deciduous & fruit trees & shrubs
Gooseberry	Saxifragaceae	Deciduous & fruit trees & shrubs
Gourd	Cucurbitaceae	Deciduous & fruit trees & shrubs
Lettuce	Asteraceae	seeds
Melon	Cucurbitaceae	seeds
Okra	Malvaceae	seeds
Onion	Amaryllidaceae	seeds or bulbs
Peanut	Fabaceae	seeds
Pear	Rosaceae	Deciduous & fruit trees & shrubs
Pumpkin	Cucurbitaceae	seeds
Punica garantium	Punicaceae	seeds
Radish	Cruciferae	seeds
Walnut	Juglandaceae	Deciduous & fruit trees & shrubs
Ziziphus jujuba	Rhamanceae	Deciduous & fruit trees & shrubs
Raspberry	Rosaceae	Deciduous & fruit trees & shrubs
Strawberry	Rosaceae	Deciduous & fruit trees & shrubs
Tumip & rutabaga	Cruciferae	Deciduous & fruit trees & shrubs
Malva	Malvaceae	seeds
Verbascum	Scrophulariaceae	seeds
Chenopodium	Chenopodiaceae	seeds
Nelumbo	Nelumbonaceae	seeds
Lupinus	Papilionaceae	seeds

[0023] In accordance with the invention, DC is preferably obtained from plants which are in their dormant state either as a result of the natural process of dormancy or as a result of being externally induced into dormancy by exposure which induce a dormant state e.g. conditions as incubation at a dormancy inducing temperature for a sufficient period of time. The conditions for inducing dormancy in various dormant plants may vary (e.g. the incubation temperature and the duration of the incubation) and are known to a person versed in the art. Thus for example there are plants (such as Narcissus) induced into dormancy by their exposure to relatively high temperatures. Against this, other plants (such as tulip) will be induced into dormancy by their exposure to relatively low temperatures. Other factors such as light, humidity, concentration of various growth factors, etc. may also be used to induce dormancy.

[0024] In accordance with one preferred embodiment of the invention, the DC is obtained from a part of the plant capable of entering dormancy (D-part), e.g. from bulbs. Bulbs induced into their dormant state may either be used immediately for the preparation of DC or, alternatively, may be stored under conditions which maintain a dormant state, e.g. in the case of Narcissus these include high temperature and low humidity. In addition to bulbs, other parts of dormant plants such as combs, roots, seeds, etc., may also be induced into dormancy as explained above and then used for obtaining DC therefrom.

[0025] In accordance with another embodiment of the invention, the dorman extract is obtained from cell cultures which were prepared from any part of a dormant plant (e.g. bulbs) and induced into dormancy. The culture may be obtained by inoculation of bulbs of dormant plants having inflorescence stalk initials into a suitable medium to form callous cultures of the bulb extracts. The cell cultures are typically grown to confluency and very small bulb parts are formed in the cell culture (termed "bulblets"). Induction of a dormant state in the cell cultures or bulblets is obtained by their exposure to conditions which induce dormancy conditions, such as incubation at a dormancy inducing temperature for a sufficient period of time. Dormancy may also be induced *in vitro* by exposing the cell cultures or bulblets to various types of chemical stresses (low or high concentrations of sugar, salts, etc.).

[0026] In addition to bulblets, cell cultures derived from other parts of dormant plants such as combs, roots, seeds, etc., may also be used for obtaining cell culture derived dorman extracts.

[0027] By yet another embodiment, the dorman analogs of the invention may be synthetically prepared by any one by the methods known in the art such as by recombinant DNA techniques, chemical synthesis, combinational chemistry, etc., the dorman analogs maintaining substantially similar characteristics as far as their ability to induce dormancy and inhibit proliferation of target cells of the dormans on which they are based.

[0028] A plant derived DC of the invention is obtained as a water-soluble extract of the plant material. The water-soluble extract may be prepared by homogenizing the plant material and then suspending the homogenate in an aqueous solution.

[0029] In accordance with a further embodiment of the invention, the EDPs are obtained from juice of fruits or other juice producing plant organs. Fruits typically contain dormans which inhibit germination of the seeds and pips while these are within the fruit. Examples of juices from which dormans may be purified are juice of citrus fruits, grapes, tomato, kiwi, etc. The fruit juice may be used as such or alternatively, the dormans can be purified from the fruit juice as explained below.

[0030] In accordance with yet another embodiment of the invention, the dormans are extracted from producer cells originating from animals capable of entering a dormant phase during their life cycle. During the dormant phase, the animals' metabolic rate is lowered to a minimum and there is an arrest in cell proliferation. Examples of such animals are various marine crustacea such as artemia, dafnia and cyclops.

[0031] As explained above with regards to plant derived DC, animal derived DC may also be obtained from animals which are in their dormant state as a result of the natural process of dormancy or as a result of being externally induced into dormancy by exposure to dormancy-inducing conditions such as dehydration (*Artemia salina*) or anoxia (*Artemia franciscana*). The dormans may be extracted from the animal tissue by various methods known *per se*.

[0032] The animal derived DC may be obtained from the animals or their organs as such. Alternatively, cell cultures may first be prepared from the dormant animal, and after maintaining the cells in culture for various periods of time, DC may then be extracted either from the supernatant or by harvesting the cells and/or extracting the DC therefrom.

[0033] The DC of the invention may be purified from the producer cells by a variety of methods known *per se*, for example by chromatography (e.g. TLC, HPLC, ion exchange) by size fractionation (e.g. dialysis, gel filtration), etc.

[0034] In accordance with the invention, it has been realized for the first time that, when administered to an individual, the anti-proliferative activity of said dorman composition may slow down the cell division rate of the cells present in the inner layers of the epidermis.

[0035] Another aspect of the invention is thus the use of said dorman compositions as a cosmetic or dermatological composition useful for the maintenance of the juvenile appearance of an individual's skin or for the treatment of age related skin changes.

[0036] The present invention relates to the use of an effective amount of a water-soluble extract obtained from producer cells or producer tissue or from the medium in which said cells or tissue are incubated, wherein

- (i) said producer cells or producer tissue originate from an organism which is xenogeneic to said individual;
- (ii) said producer cells or producer tissue originate from an organism which can enter into a state of dormancy; and,
- (iii) said water-soluble extract is obtained from producer cell or tissue while in a dormant state,

as a cosmetic composition having an anti-proliferative effect on target cells or tissue of an individual.

[0037] In accordance with this latter aspect of the present invention, a dermatological or cosmetic composition is provided comprising from about 0.0001%, preferably from about 0.001% typically from about 0.01% up to about 5% preferably up to about 1% by weight of dorman extract or dorman analog together with a dermatologically or cosmetically

acceptable carrier.

[0038] The dermatological or cosmetic compositions of the invention may be administered in various forms such as in the form of a balm, an emulsified gel, an aqueous-alcoholic gel, anhydrous gel, an oil in water (O/W) type emulsion, a clear gel, cream containing liposomes, etc.

[0039] The cosmetic or dermatological compositions are typically topically administered. However, it may at times be advantageous to administer the compositions by other administration modes, such as for example, by subcutaneous injections, by orally administered capsules or by iontophoresis (which involves the use of electric fields to increase the penetration of ionic active substances).

[0040] Due to their significant anti-proliferative effect said dormant compositions may also be used for the treatment of various malignancies. The present invention thus relates to the use of an effective amount of a water-soluble extract obtained from producer cells or producer tissue or from the medium in which said cells or tissue are incubated, wherein

- (i) said producer cells or producer tissue originate from an organism which is xenogeneic to said individual;
- (ii) said producer cells or producer tissue originate from an organism which can enter into a state of dormancy; and,
- (iii) said water-soluble extract is obtained from producer cell or tissue while in a dormant state,

for the preparation of a medicament having an anti-proliferative effect on target cells or tissue of an individual.

[0041] As mentioned above, the cell division rate is a significant factor determining the probability of a cell to become a premalignant or malignant cell. In addition, as known, the formation of a benign or malignant tumor is dependent, inter alia, on continuous divisions of the cells forming the tumor. Administration of the dormant compositions to an individual before the formation or at early stages of the formation of a benign or malignant tumor may result in the delay or prevention of the formation of a fully fledged tumor in the treated individual. Administration of said extracts to an individual suffering from a fully fledged benign or malignant tumor may result in the reduction of the tumor load in the treated individual and in the alleviation of the tumor-related symptoms. Said dormant compositions may be effective in the treatment of primary as well as secondary (metastatic) tumors. Said extracts may also be administered in combination with one or more known anti-tumorigenic treatments (e.g. chemotherapeutic agents, radiation, etc.) to achieve a synergistic anti-tumorigenic effect. The doses of said extracts to be administered to an individual as well as the treatment modality will be dependent on characteristics of the treated individual (age, weight, medical history, etc.) as well as on characteristics of the developing or existing tumor (benign or malignant, size, origin, primary or secondary, etc.). In individuals having a high risk of developing a primary or secondary tumor, the dormant compositions may be administered routinely in order to reduce the probability of tumor formation.

[0042] The present invention thus further relates to the use of a composition comprising a dormant extract capable of inhibiting the proliferation of cells, for the administration to an individual having a benign or malignant tumor or being at a high risk of developing a tumor.

[0043] By yet an additional aspect of the invention, dormant compositions may be used to enhance the therapeutic index of chemotherapeutic and radiation treatments. In an individual receiving such treatments, normal dividing cells such as cells of the inner lining of the intestines, cells of hair follicles and hematopoietic cells are also harmed by the chemotherapeutic agents or radiation which are aimed at destroying the malignant cells of which a large percent are dividing cells. By administration of dormant compositions to an individual prior to or together with such treatments, it may be possible to inhibit the proliferation of a significant percent of the normal cells. As a result, toxic side effects due to the influence of the treatments on normal cells may be significantly reduced and when beneficial, higher concentrations of the chemotherapeutic or radiation treatments may be used. In order to facilitate the toxicity reducing effect of the dormant composition, it may at times be administered directly to a needing site, tissue or organ, e.g. onto the skin.

[0044] The present invention thus provides by a further of its aspects, a composition capable of inhibiting the proliferation of cells, for administration to an individual receiving chemotherapeutic or radiation treatments, comprising an effective amount of dormant, dormant extract or dormant analog.

[0045] Other therapeutic applications of the dormant compositions include inhibition of fibrosis, e.g. skin fibrosis, cirrhosis, and others. It should be noted that hitherto, fibrosis, which is an over proliferation of fibroblasts, has been treated by cytotoxic drugs, but with a limited application due to their general non specific toxicity. Inhibition of the fibroblast proliferation by the use of the dormant composition of the invention, provides a viable, less toxic alternative. In a similar manner, the dormant compositions of the invention may also be useful in the treatment of psoriasis which results from over proliferation of keratinocytes. Seborrheic keratosis, papillomas and warts may also be treated by the dormant compositions.

[0046] Another possible application of the dormant composition of the invention is in preservation of organs or tissue prior to their use for transplantation.

[0047] Other applications of said dormant compositions may be, for example, in the treatment of scalp baldness (Alopecia) which is many times one of the phenomena associated with aging of the skin in an individual. In individuals suffering from Alopecia, the life span of scalp hair decreases substantially (e.g. from a life span of about 3 years in a

normal individual to a life span of about one year in an individual suffering from Alopecia). Therefore, decreasing the rate of hair growth in an individual having a high probability of developing Alopecia or in an individual already showing for signs of scalp hair loss, will decrease the extent of such hair loss. Administration of the dormant compositions of the invention to such an individual may result in a partial or complete decrease of the hair loss. For this purpose, the dormant comprising compositions may be administered either topically at the site of scalp hair loss or, alternatively, in other cases may be administered systemically.

[0048] An additional phenomena which may be treated by administration of the dormant comprising compositions of the invention is associated with overgrowth of hair in various parts of an individual's body, such as arms, back, etc. (Hirsutism). Such undesired overgrowth of hair appears many times in aging individuals and, at times, is associated with loss of scalp hair in the same individual. Due to their ability to reduce cell growth, compositions of the invention may be useful in reducing such undesired overgrowth of hair.

[0049] The amount of the dormant comprising compositions to be administered for the above two indications, the administration regimes as well as their mode of application will again depend both on characteristics of the treated individual (age, size, gender, etc.) as well as on parameters associated with the phenomena to be treated (such as the extent of scalp hair loss, the specific body parts in which there is overgrowth of hair, etc.).

[0050] In addition, the dormant composition may be useful as a complementary agent administered in combination with or following hair removal treatments such as, for example, shaving (where said extract may be incorporated in an aftershave solution) or hair stripping (e.g. by wax).

[0051] Another application of the dormant composition may involve its administration to an individual during the period in which a scar is formed, e.g. after an operation in order to decrease scar formation. By slowing down the rate of the healing process in such an individual, the final scar may be much less apparent. In addition, the anti-fibrotic effect of the dormant compositions decreases the formation of cheloids which commonly appear after healing.

[0052] The dormant composition may also be useful for extending the duration of a tan in an individual. Following exposure to the sun, epidermal cells comprise a high concentration of melanin. During skin renewal such melanin comprising cells are shed. By slowing down the cell renewal process in the skin, the dormant composition causes the melanin comprising cells and thus the tan to remain for a longer period of time.

[0053] In addition to inhibiting proliferation of various cells, said dormant compositions are also capable of slowing seed germination and inhibiting growth of various plant seedlings. Following germination of seeds, roots and hypocotyls begin to develop in the seedling. Incubation of the plant seedlings with the dormant composition results in the inhibition of the elongation of the seedling roots and hypocotyls. The dormant compositions may therefore be used for weed control, wherein their administration at an appropriate concentration may result in the inhibition of growth of non desirable weeds while not affecting the growth of the desired plant. In view of the natural origin of the dormant, their administration has no noticeable toxic effect on cells or tissue on which they are induced to act or on the environment. In addition, at times it may be useful to use such compositions for long term storage of seeds and seedlings.

[0054] The present invention thus provides a dormant composition having the activity of slowing and inhibiting the growth of plant seeds and/or seedlings comprising said dormant extract.

[0055] A further application of the dormant composition of the invention is in the preservation of fresh produce, e.g. vegetables, fresh fish eggs, fish shells, etc.

[0056] The invention also provides a process for the preparation of an anti-proliferative composition comprising mixing dormant or DC with a carrier so as to yield an anti-proliferative composition with an anti-proliferative effective amount of dormant in said composition. Such a prepared composition may be used, depending on the nature of the carrier, in therapy, cosmetics, food preservation or agriculture. Such a process for preparing a pharmaceutical or cosmetic composition typically comprises preparing an DC, and mixing it with an appropriate pharmaceutical or cosmetic acceptable carrier, the amount of DC being such so as to yield a final therapeutically or cosmetically (as the case may be) effective amount of dormant in the composition. Also provided is use of dormant or an DC for the preparation of such a pharmaceutical or cosmetic composition.

[0057] As will be appreciated, the various applications of the dormant composition of the invention given above, are examples of a myriad of possible applications of these compositions, all having in common the inhibition of proliferation of target cells.

[0058] In the following, the invention will be illustrated by some non-limiting examples with occasional reference to the figures.

BRIEF DESCRIPTION OF THE FIGURES

[0059]

Fig. 1 is a histogram showing the number of keratinocytes in a cell culture well at different periods of time after their incubation with various concentrations of the DC IBR-1 (obtained from a dormant plant (Fig. 1A) or the AE

IBR-3 (obtained from an active plant) (Fig. 1B). As a control, the cells were incubated with growth medium alone (0 µg/ml of the tested DC or AE). The number of cells in each well was determined by the microculture methylene blue assay (described in Example II) and the dyed culture plates were read at 620 nm.

Fig. 2 is a histogram showing the number of fibroblasts in a microculture at different periods of time after their incubation with various concentrations of the following:

Fig. 2A - cells were incubated with the DC IBR-1 (dormant);

Fig. 2B - cells were incubated with the AE IBR-3 (active).

Fig. 3 is a histogram showing the number of keratinocytes in a microculture at different periods of time after their incubation with various concentrations of the cell culture derived DC IBR-11. As control, the cells were incubated with growth medium only (0 µg/ml DE IBR-11). The number of cells in each well was determined by the microculture methylene blue assay (described in Example II) and the dyed culture plates were read as 620 nm.

Fig. 4 is a histogram showing the number of fibroblasts in a microculture at different periods of time after their incubation with various concentrations of the cell culture derived DC IBR-11.

Fig. 5 is a graphic representation showing the number of cultured mouse bladder carcinoma cells (T24P) in a microculture 72 hours after their incubation with various concentrations of a plant derived DC (IBR-1) (Fig. 5A) or an animal derived DE (IBR-4) (Fig. 5B). The number of cells in each well was determined by the microculture methylene blue assay (described in Example 2) and the dyed culture plates were read at 620 nm.

Fig. 6 is a graphic representation showing the number of mouse bladder carcinoma cells (T50) in a microculture at different periods of time after their incubation with various concentrations of DE IBR-1. The dormin extracts were added at day 1 and day 3 of the cell culture and the number of cells in each well were determined on day 5 of the culture as described in Fig. 5 above. The number of cells in each tested well was determined by using the microculture methylene blue assay as explained in the description of Fig. 1 above and by reading of the dyed microculture plate at 620 nm.

Fig. 7 is a histogram showing the DNA content analysis of keratinocyte incubated with DC IBR-1 for 2 and 5 days (7A and B, respectively) AE IBR-3 (7C and D, respectively) and DC IBR-4 (7E and F, respectively). The analysis was carried out with a FACS, FPAR-Plus (Becton-Dickinson, Inc.) using ethidium bromide. The percent of cells being in the G₁ phase, S phase and G₂+M phase was determined in each cell culture. In addition, the percent of apoptosis (A) in each culture was also determined.

Fig. 8 is a histogram showing the DNA content analysis of fibroblast incubated with DC IBR-1 for 2 and 5 days (Fig. 8A and B), AE IBR-3 (Fig. 8C and D) and DC IBR-4 (Fig. 8E and F). The analysis was carried out as described in Fig. 7 above.

Figs. 9A-9B is a graphic representation showing the UV spectra of bands obtained by separating by thin layer chromatography (TLC) wherein: **Fig. 9A** shows UV spectrum of "band 4" separated by TLC and **Fig. 9B** shows UV spectrum of "band 6" separated by TLC.

Fig. 10 is a graphic representation showing the comparative effect of different treatments on the duration of a tan 5 days and 17 days after administration of the cream on to the tanned area wherein:

A shows the effect of a cream containing 5% IBR-1 on the elongation of the duration of a tan 5 days after administration of the creams.

B shows the same effect as A 17 days after administration of the creams.

C shows the effect on the duration of the tan (shortening) of a cream comprising alpha hydroxy acid (AHA) as compared to the tan without cream 5 days after administration of the creams.

D shows the same effect as C 17 days after administration of the cream.

EXAMPLES

Example I: A: Effect of Narcissus bulb DC prepared from Narcissus field bulbs on growth of cucumber seedlings

(a) Inducing dormancy in Narcissus field bulbs

[0060] Narcissus field bulbs were obtained and subjected to hot water having a temperature of 45°C for 2-4 hours. The bulbs were then either used immediately for the preparation of water soluble extracts or, alternatively, maintained in a dry room at a temperature of 30°C for a maximal period of 8 months after which they were used for the preparation of the plant extract.

(b) Preparation of extracts from Narcissus bulbs

[0061] Active or dormant Narcissus field bulbs (induced into dormancy as explained above) were disinfected in soap water for a period of 1 hour. The bulbs were then cut and homogenized in distilled water (30 sec x 3) using a Homogenizer Ultra-Turbo-turax. The homogenized preparation of the bulbs was then filtrated through a first 0.45 m sterile filter and then through a second 0.22 µm filter and the preparation which was not maintained on the filters was then collected. The concentration is defined as weight of original bulb (gr.) per final extract volume (ml).

(c) The effect of the Narcissus field bulb extracts on growth of cucumber seedlings

(i) Experimental assay:

[0062] Cucumber seeds cv. "Delila", 1994-1995, 95% germination, 99.9% purity were germinated in tap water and then incubated in the dark at 27°C for about 20 hours until root initiation (1-2 mm). Each experimental group comprised Petri dishes which were filled each with 2 mls of DC (IBR-1) originated from dormant Narcissus field bulbs obtained as explained above in various concentrations.

[0063] One layer of filter paper was placed in each of the petri dishes and 10 cucumber seeds, germinated as explained above, were placed on the paper. The petri dishes were incubated for 24 to 72 hours at 26°C to 28°C in the dark.

[0064] The effect of the tested bulb extracts in various concentrations were tested on two parameters of the cucumber seeds:

1. Root elongation
2. Hypocotyl elongation.

[0065] These two parameters were tested every 24 hours after the incubation of the seeds with the tested extract and every 24 hours after that.

(ii) Results:

[0066] As seen in Table 3 below, DC IBR-1 showed sufficient inhibitive activity on the seedlings' growth, as measured by the length of the roots and hypocotyls of seeds which were incubated with DC IBR-1 compared to the length of the same organs incubated with sterile water. The inhibitive activity of DC IBR-1 was dose dependent.

Table 3

Growth of seeds with and without extract:				
Extract source	24 hrs		48 hrs	
	Root (mm)	Hypocotyl (mm)	Root (mm)	Hypocotyl (mm)
Sterile Water	30	2	47	7
DC from Narcissus				
0.2 gr./ml	4	0	4	1
0.1 gr./ml	5	0	5	2
0.05 gr./ml	6	0.5	10	2
0.01 gr./ml	16	1	26	4
0.005 gr./ml	22	2	35	7
0.001 gr./ml	25	2	41	7
Inhibition (%) of seed growth by extracts:				
Extract source	24 hrs		48 hrs	
	Root	Hypocotyl	Root	Hypocotyl
	(% inhibition)		(% inhibition)	
Sterile Water	0	0	0	0
DC from Narcissus				
0.2 gr./ml	87	100	91	86

Table 3 (continued)

Inhibition (%) of seed growth by extracts:				
Extract source	24 hrs		48 hrs	
	Root	Hypocotyl	Root	Hypocotyl
	(% inhibition)		(% inhibition)	
0.1 gr./ml	83	100	89	71
0.05 gr./ml	80	75	79	71
0.01 gr./ml	47	50	45	43
0.005 gr./ml	27	0	25	0
0.001 gr./ml	17	0	13	0

Example I: B: Reversibility of the effect of Narcissus DC on growth of cucumber seedings

(i) Experimental assay:

[0067] (a) The experiment was conducted in an identical manner to that described in I(A) above. The effect of the DC on growth of roots and hypocotyls of cucumber seeds was measured 24 and 72 hours after incubation. 72 hours after incubation, the seeds were washed with sterile distilled water and incubated with sterile distilled water for an additional 72 hours at 27°C in the dark. The length of the roots and hypocotyls of the seeds was measured again 144 hours after the beginning of incubation (72 hours after washing away the DC).

(ii) Results:

[0068] As seen in Table 4 below, after washing away the Narcissus derived DC which had an inhibitive effect on the growth of roots and hypocotyls of cucumber seeds, the roots and hypocotyls began to grow again. Thus, the inhibitive effect of DC was reversible and non toxic. The same effect was apparent at lower concentrations of the DC incubated with the seeds as well (results not shown).

Table 4

Time Extract	24 H		72 H		144 H (72 Hours after washing)	
	Root (mm)	Hypocotyl (mm)	Root (mm)	Hypocotyl (mm)	Root (mm)	Hypocotyl (mm)
Sterile water	44.9	6.5	111.7	17.5	-	-
DC 0.2 gr/ml	2.6	1.5	2.7	6.2	43.3	22.9

Example II: Effect of Narcissus bulb derived DC on proliferation of keratinocytes

(a) Preparation of keratinocyte cultures

[0069] Human keratinocyte cultures were prepared as described in Ben Bassat H., *et al.*, *Plastic and Reconstructive Surgery*, **89**:511, (1992). Generally keratinocyte cultures were initiated from small biopsy specimens (about 1 cm²) of split-thickness skin. The biopsy specimens from healthy donors were obtained under local anesthesia with 1% lidocaine. The biopsy was incubated in trypsin-EDTA at 4°C for 18-20 hours. Thereafter, the epidermis was separated and the epithelium desegregated in trypsin-EDTA to form a single cell suspension. Trypsin 0.125%-EDTA 0.025% in Puck's saline with x10 antibiotics, 1000 U/ml penicillin, 1000 µg/ml streptomycin, 0.0025 µg/ml amphotericin B and 0.4 mg/ml gentamycin were used for these procedures. Trypsin solutions were prepared from trypsin 1:250 strength.

[0070] The cell suspensions prepared as described above, were inoculated at a concentration of 3-6x10⁶ cells into 25 cm² Falcon flasks which were pre-prepared to contain 2x10⁵ lethally irradiated 3T3 mouse fibroblasts as a feeder layer.

[0071] The flasks were incubated at 37°C 10% CO₂ for about 8-10 days until the cultures were about 80% confluent. At this stage, the cells in each flask were released by addition of trypsin 0.25% - EDTA 0.05% (1:1) without antibiotics and the released cells after being washed were inoculated into 96-well microplate at a concentration of 3x10⁴ cells per well without feeder layers in keratinocyte medium (Kmed) according to Rheinwald and Green (Rheinwald T.G. and

Green, H., *Nature*, **265**:421-424 (1988)) to form a secondary culture.

(b) Effect of Narcissus bulb derived DC on the proliferation of keratinocytes

5 (i) Experimental assay:

[0072] Narcissus bulb extracts were obtained as described in Example I(b) above from active and dormant bulbs. The secondary keratinocyte cell cultures seeded in microplates as described above, were further grown in Kmed for a period of 3-4 days. The microplates were then divided into the following main groups:

- 10 (1) keratinocytes which were continuously grown in Kmed;
 (2) keratinocytes grown in Kmed containing the AE IBR-3 prepared from active Narcissus bulbs in several concentrations (from 0.5 µg/ml - 10 µg/ml, each concentration forming a separate experimental group) and
 15 (3) keratinocytes grown in Kmed medium comprising the DC IBR-1 obtained from dormant Narcissus bulbs at various concentrations (0.5 µg/ml - 10 µg/ml each concentration forming a separate experimental group).

[0073] Each experimental group contained 5 wells. The growth medium containing DC IBR-1 or AE IBR-3 was changed every 24 hours for a period of 5 days after which the medium was removed from all of the wells and fresh Kmed medium without any plant extract was added and the cultures were grown in it for an additional 3 days.

20 **[0074]** The effect of the tested DC or AE on the proliferation of the keratinocytes was determined by the number of cells detected in a tested treated well as compared to the number of cells detected in a well in which the cells grew in Kmed medium without any DC or AE.

[0075] The number of cells in each well was determined by the microculture methylene blue assay as follows:

25 **[0076]** Extract treated cultures and controls were fixed in glutaraldehyde, 0.05% final concentration, for 10 mins. at room temperature. After washing, the microplates were stained with methylene blue 1% in 0.1 M borate buffer pH 8.5 for 60 mins. at room temperature. Thereafter the plates were extensively and rigorously washed to remove excess dye and dried. The dye taken up by cells is eluted in 0.1 N HCl for 60 mins, at 37°C, and read at 620 nm.

30 **[0077]** In preliminary titration experiments linear readings were obtained for 1×10^3 to 4×10^4 cells/well. Each point of the growth curve experiments is an average of the reading of 5 wells, since keratinocytes grow in islands and do not form uniform monolayers. The number of average cells in the wells was determined at 2 days, and 5 days after incubation of the keratinocytes with the tested DC or AE as well as at 8 days after incubation (following 3 days growth without the tested extract).

35 (ii) Results:

[0078] As can be seen in Fig. 1A, DC IBR-1 from Narcissus bulbs had a significant inhibitory effect on the proliferation of keratinocytes. The inhibition was apparent from day 5 of the experiment and was dose dependent. Inhibition of the keratinocyte proliferation was apparent at a concentration as low as 0.5 µg/ml but was most significant at a concentration of 10 µg/ml of the DC. The effect was dose dependent (starting at a concentration of 1 µg/ml of the DC and most effective at a concentration of 10 µg/ml of the DC).

40 **[0079]** Against this, as seen in Fig. 1B, AE IBR-3 showed no significant inhibitory effect on the proliferation of keratinocytes.

45 **Example III. Effect of DC obtained from dormant and active Narcissus bulbs on the proliferation of fibroblast in culture**

(a) Preparation of fibroblast cell cultures:

50 **[0080]** Primary fibroblast cell cultures were initiated from small human skin specimens and prepared as described in Example II above regarding preparation of keratinocyte cultures except that the growth medium used was DMEM+ 20% fetal calf serum.

(b) Preparation of DC and AE

55 **[0081]** DC IBR-1 and AE IBR-3 were prepared from dormant and active Narcissus bulbs as described above.

(c) Effect of DC and AE on fibroblast proliferation:

(i) Experimental assay:

5 [0082] The above extracts were added to the fibroblast cultures at various concentrations (1 g-10 g/ml) and the number of fibroblasts in the cultures was determined 2 days, 5 days and 8 days after the addition of the extracts to the cells as described in Example II(a) above.

(ii) Results:

10 [0083] As seen in Fig. 2A, DC IBR-1 had the most significant inhibitory effect on the proliferation of fibroblast in culture. The effect was apparent from day 5 of the experiment and although was dose dependent, the effect was seen at doses as low as 0.5 µg/ml.

15 [0084] As can be seen in Fig. 2B, AE IBR-3 had no inhibitory effect on the proliferation of fibroblasts.

Example IV: Preparation of cosmetic and dermatological compositions comprising DC

[0085] The following are several specific examples of cosmetic and dermatological compositions which may be used in accordance with the invention for administration to an individual.

20

A. *Balm* (topical route):

[0086]

- 25
- Ozokerite 10 gr.
 - Isopropyl palmitate 9 gr.
 - White vaseline 14 gr.
 - Preserving agent 0.2 gr.
 - Antioxidants 0.3 gr.
 - 30 • Perfume 1 gr.
 - DC prepared from bulb extract 0.00001 gr.
 - Liquid paraffin qs 100 gr.

B. *Balm* (topical route):

35

[0087]

- 40
- Ozokerite 19 gr.
 - Liquid purcellin oil 10 gr.
 - White vaseline 15 gr.
 - Preserving agent 0.2 gr.
 - Antioxidant 0.3 gr.
 - DC prepared from bulb extract 0.00002 gr.
 - 45 • Liquid paraffin qs 100 gr.

C. *Emulsified gel of O/W type* (topical route):

[0088]

- 50
- Carbopol® 981 (marketed by Goodrich) 0.6 gr.
 - Volatile silicone oil 3 gr.
 - Purcellin oil 7 gr.
 - Preserving agent 0.3 gr.
 - Ethyl alcohol 15 gr.
 - 55 • Perfume 0.4 gr.
 - Triethanolamine 0.2 gr.
 - DC prepared from bulb extract 0.04 gr.
 - Demineralized water qs 100 gr.

D. *Aqueous-alcoholic gel* (topical route):**[0089]**

- 5 • Carbopol® 981 (marketed by Goodrich) 1 gr.
- Triethanolamine 1 gr.
- 95% Ethanol 60 gr.
- Glycerol 3 gr.
- Propylene glycol 2 gr.
- 10 • DC prepared from bulb extract 5 gr.
- Demineralized water qs 100 gr.

E. *Anhydrous gel* (topical route):15 **[0090]**

- Absolute ethanol 61,1992 gr.
- Hydroxyethyl cellulose 0.8 gr.
- Propylene glycol 25 gr.
- 20 • Polyethylene glycol 12 gr.
- DC prepared from bulb extract 0.0008 g

F. *Emulsion of O/W type* (topical route):25 **[0091]**

- Volatile silicone oil 10 gr.
- Liquid paraffin 6 gr.
- Liquid lanolin 3 gr.
- 30 • Arlacel® 165 (marketed by Atlas) 6 gr.
- Tween® 60 (marketed by Atlas) 2 gr.
- Cetyl alcohol 1.2 gr.
- Stearic acid 2.5 gr.
- Triethanolamine 0.1 gr.
- 35 • Preserving agent 0.3 gr.
- Antioxidants 0.3 gr.
- DC prepared from bulb extract 0.5 gr.
- Demineralized water qs 100 gr.

40 G. *Emulsion of O/W type* (topical route):**[0092]**

- Propylene glycol 2 gr.
- 45 • PEG 400 3 gr.
- Preserving agent 0.3 gr.
- Carbopol® 981 (marketed by Goodrich) 0.2 gr.
- Isopropyl myristate 1 gr.
- Cetyl alcohol 3 gr.
- 50 • Stearic acid 3 gr.
- Glycerol 3 gr.
- Corn oil 2 gr.
- Perfume 0.5 gr.
- DC prepared from bulb extract 0.001 gr.
- 55 • Demineralized water qs 100 gr.

H. *Clear gel* (topical route)**[0093]**

- 5 • Oxyethylenated nonylphenol 5 gr.
- Carbopol® 981 (marketed by Goodrich) 1 gr.
- Ethyl alcohol 30 gr.
- Triethanolamine 0.3 gr.
- Glycerine 3 gr.
- 10 • Perfume 0.3 gr.
- Preserving agent 0.3 gr.
- DC prepared from bulb extract 1 gr.
- Demineralized water qs 100 gr.

15 I. *Cream containing liposomes* (topical route):**[0094]**

- 20 • Cetyl alcohol 4 gr.
- B-sitosterol 4 gr.
- Dicapryl phosphate 0.5 gr.
- Preserving agent 0.3 gr.
- Sunflower oil 35 gr.
- Perfume 0.6 gr.
- 25 • Carbopol® 981 (marketed by Goodrich) 0.2 gr.
- Triethanolamine 0.2 gr.
- Sphingosine 0.05 gr.
- DC prepared from bulb extract 0.2 gr.
- Demineralized water qs 100 gr.

30

J. *Per os composition*:**[0095]**

- 35 • Talc 5 mg
- Aerosil 200 5 mg
- Stearate de Zn 5 mg
- DC prepared from bulb extract 3 mg
- Lactose qs 400 mg

40

K. *Liquid for Iontophoresis*:**[0096]**

- 45 • Benzoate de sodium 2 mg
- Preserving agent 0.15 gr.
- DC prepared from bulb extract 1 gr.
- Water qs 100 gr.

50

L. *Emulsion W/O*:**[0097]**

- 55 • Protegin (marketed by Goldschmidt) 19 gr.
- Vaseline oil 8 gr.
- Glycerine 3 gr.
- DC prepared from bulb extract 1 gr.
- Sulfate de Mg 0.5 gr.

- Perfume 0.8 gr.
- Preserving agent 0.2 gr.
- Water qs 100 gr.

5 **Example V. Extracts prepared from Narcissus Bulblets (cell cultures) on cucumber seedling growth:**

(a) Preparation of Narcissus bulb cell cultures

10 **[0098]** Active Narcissus bulbs from the field having inflorescence stalk initials were used to prepare duplicate inner scale explants. The explants were then inoculated into NR31 medium (NAA/10 μM BA: 5:0.5 μM) to initiate callus cultures. Four to 5 weeks after the initiation of the callus cultures, the cultures were transplanted into NR8 medium (6% sucrose) to form bulblets growth explants. For scaling up of the biomass, half bulblets were transplanted into bulblet column bioreactors with liquid basal media N4 comprising:

15	Murashige & Skoog (Sigma M-5525)	4.33 gr/L
	Myoinositol	100 mg/L
	Adenine sulfate	150 mg/L
	NaH ₂ PO ₄ H ₂ O	345 mg/L
20	NAA	5 μM Agar Type A 7gr/L
	BA	5 μM pH = 5.7
	Pyridoxine	1 mg/L
	Glycine	2 mg/L
25	Nicotinic acid	5 mg/L
	Thiamine HCl	0.5 mg/L
	Sucrose	30 gr/L

for a period of 4 weeks.

30 (b) Preparation of cell culture derived DC

[0099] The plant material prepared as described in (a) above was then shaken for 7-10 days on a gyratory shaker at about 35°C (the column weight per medium was 0.1 gr/ml). Half of the cell cultures were induced into dormancy by their incubation at a high temperature (of about 35°C). The DC prepared from such cultures was designated IBR-11. 35 The remaining cell cultures were maintained in their active state by growing them in regular conditions and the AE prepared from them was designated IBR-10. AE IBR-10 or DC IBR-11 were prepared from the medium free biomass which was washed with water, weighed and homogenized in an ultra-Turbo-turax. The homogenate was suspended and diluted in steril distilled water.

40 **[0100]** (c) Cucumber seeds cv. "*Delila*", 1994-1995, 95% germination, 99.9% purity were germinated in tap water at 27°C in the dark for about 20 hours until root initiation (1-2 mm).

(d) The experimental assay:

45 **[0101]** (i) The effect of the above DC and AE prepared (from Narcissus bulblets on root elongation and hypocotyl elongation of the cucumber seedlings was determined as follows. Each experimental group consisted of petri dishes each containing 10 seeds was incubated with:

1. DC IBR-11 (dormant)
2. AE IBR-10 (active).

[0102] One or two layers of filter paper were placed in each of the petri dishes and 10 cucumber seeds, germinated as explained above, were placed on the filters. The Petri dishes were incubated for 72 hours at 27°C to 30°C in the dark.

[0103] The effect of extracts was tested on two parameters of the cucumber seeds:

1. Root elongation
2. Hypocotyl elongation.

[0104] These two parameters were tested after 72 hours of incubation of the seeds with the extract

(ii) Results:

[0105] As seen in Table 5 below, 72 hours after incubation, DC IBR-11 had a significantly higher inhibition activity on both the root length and hypocotyl length of the seedlings as compared to the effect of AE on the seedlings' growth.

Table 5

	AE (IBR-10)	DC (IBR-11)	% inhibition of DC compared to AE
			$\frac{(AE) - DC}{(AE)} \times 100$
Root length (mm) 72 h	86	31	58%
Hypocotyl (mm) 72 h	81	49	40%

Example VI: Effect of Narcissus bulb cell culture derived DC on proliferation of keratinocytes

(a) Preparation of keratinocyte cultures

[0106] Human keratinocyte cultures were prepared as described in Example II(a) above.

(b) Effect of Narcissus bulblet derived DC on the proliferation of keratinocytes

(i) Experimental assay:

[0107] Narcissus bulb derived cell cultures were obtained as described above and DC IBR-11 was prepared from bulblets induced into dormancy (as is also described above).

[0108] The secondary keratinocyte cell cultures seeded in microplates as described above, were further grown in Kmed for a period of 3-4 days. The microplates were then divided into the following main groups:

- (1) keratinocytes which were continuously grown in Kmed; and
- (2) keratinocytes grown in Kmed containing DC IBR-11 in several concentrations (from 0.5 µg/ml - 10 µg/ml, each concentration forming a separate experimental group).

[0109] Each experimental group contained 5 wells. The growth medium containing DC was changed every 24 hours for a period of 5 days after which the medium was removed from all of the wells and fresh Kmed medium without any plant extract was added and the cultures were grown in it for an additional 3 days.

[0110] The effect of the tested DC on the proliferation of the keratinocytes was determined by the number of cells detected in a tested treated well as compared to the number of cells detected in a well in which the cells grew in Kmed medium without any DC.

[0111] The number of cells in each well was determined by the microculture methylene blue assay as follows:

[0112] Extract treated cultures and controls were fixed in glutaraldehyde, 0.05% final concentration, for 10 mins. at room temperature. After washing, the microplates were stained with methylene blue 1% in 0.1 M borate buffer pH 8.5 for 60 mins. at room temperature. Thereafter the plates were extensively and rigorously washed to remove excess dye and dried. The dye taken up by cells is eluted in 0.1 N HCl for 60 mins. at 37°C, and read at 620 nm.

[0113] In preliminary titration experiments linear readings were obtained for 1x10³ to 4x10⁴ cells/well. Each point of the growth curve experiments is an average of the reading of 5 wells, since keratinocytes grow in islands and do not form uniform monolayers. The number of average cells in the wells was determined at 2 days, and 5 days after incubation of the keratinocytes with the tested DC as well as at 8 days after incubation (following 3 days growth without

the tested extract).

(ii) Results:

5 [0114] As can be seen in Fig. 3, DC EBR-11 showed significant inhibitory activity on the proliferation of keratinocytes in culture.

Example VII. Effect of DC obtained from dormant Narcissus bulblets on the proliferation of fibroblast in culture

10 (a) Preparation of fibroblast cell cultures:

[0115] Primary fibroblast cell cultures were initiated from small human skin specimens and prepared as described in Example II above regarding preparation of keratinocyte cultures except that the growth medium used was DMEM+ 20% fetal calf serum.

15

(b) Preparation of cell cultured DC:

[0116] IBR-11 was prepared from dormant bulblets as described in Example V(b) above.

20 (c) Effect of DC on fibroblast proliferation:

(i) Experimental assay:

25 [0117] The above extracts were added to the fibroblast cultures at various concentrations (1 µg-10 µg/ml) and the number of fibroblasts in the cultures was determined 2 days, 5 days and 8 days after the addition of the extracts to the cells as described in Example V(a) above.

(ii) Results:

30 [0118] As can be seen in Fig. 4, the cell culture derived DC IBR-11 showed inhibitory activity on the proliferation of fibroblasts.

Example VIII. Effect of fruit juice on cucumber seed growth

35 (a) Preparation of fruit juice

[0119] Grapefruit juice was produced from one fresh grapefruit and the produced juice was squeezed and filtrated through cotton cloth and then centrifuged at 10,000 rpm for 10 mins. at room temperature. The supernatant was then used for testing its effect on cucumber seed growth as described below.

40

(b) The effect of grapefruit iuice on growth of cucumber seedlings:

(i) Experimental assay:

45 [0120] Cucumber seeds were prepared as described in Example 1 (c)(i) above. Each experimental group comprised ten Petri dishes which were filled with 1.8 ml of the following:

- (1) dH₂O
- (2) Fruit juice obtained as in (a) above.

50

[0121] One or two layers of filter paper were placed in each of the petri dishes and 10 cucumber seeds, germinated as explained above, were placed on the filters. The petri dishes were incubated at 25°C and the parameters of the cucumber seeds were measured at 24 hours and 72 hours after beginning of incubation.

[0122] The effect of the fruit juice was tested on two parameters of the cucumber seeds:

55

- (1) Root elongation
- (2) Hypocotyl elongation

(ii) Results:

[0123] As seen in Table 6 below, this experiment indicates that the fruit juice comprises inhibitory activity on the growth of cucumber seeds.

Table 6

Treatment	72 hours		72 hours % inhibition	
	Root mm	Hypocotyl mm	Root mm	Hypocotyl mm
dH ₂ O	110	35	-	-
Grapefruit Juice	3	0	97	100

Example IX: Effect of dorman extract obtained from the crustacean *Artemia salina* on cucumber seed growth

(a) Preparation of extracts from Artemia salina:

[0124] The dorman extract designated IBR-4 was obtained by preparing an extract from *Artemia salina*. The *Artemia* "eggs" may be submitted to dehydration or high salt concentration resulting in opening of their shell which is then followed by their grinding. Alternatively, the *Artemia* eggs may be dispensed in 10 ml of water resulting in softening of the shell. Following grinding or softening of the shells, the eggs are then dissolved in one of any of solvents known *per se* (e.g. water) to obtain an extract from them. The extract may be lyophilized (as in this example) or alternatively, used as obtained. An additional method of obtaining the *Artemia* extract may be to dissolve the *Artemia* eggs in water until the prenauplius larvae crawl out of the shells after which the larvae are grounded and an extract obtained therefrom.

(b) The effect of the DC extract from Artemia (IBR-4) on growth of cucumber seedlings:

(i) Experimental assay:

[0125] Cucumber seeds were prepared and seeded into petri dishes as explained in Example 1 above. Each experimental group comprised a petri dish containing 10 cucumber seeds and the results shown below are an average of the parameters measured for the 10 seeds. The petri dishes were grown at 28°C in the dark and the root length and hypocotyl length of the cucumber seeds were measured 24 hours and 48 hours after beginning of incubation with 1.8 ml of one of the following:

- (1) dH₂O
- (2) DC IBR4 at a concentration of 0.02 gr./ml.

(ii) Results:

[0126] As seen in Table 7 below, the *Artemia* dorman extract IBR-4 had a significant inhibitory effect on cucumber seed growth which was apparent already after 24 hours of incubation of the seeds with the DC IBR4 but was most significant 48 hours after incubation (66% inhibition on root growth and 40% inhibition on hypocotyl growth).

5
10
15
20
25
30
35
40
45
50
55

Table 7

Treatment	24 hours		24 hours % Inhibition		48 hours		48 hours % inhibition	
	Root mm	Hypocotyl mm	Root	Hypocotyl	Root mm	Hypocotyl mm	Root	Hypocotyl
dH ₂ O	35	4	0	0	61	10	0	0
IBR4 0.02 gr/ml	20	3	43	25	21	6	66	40

Example X: Effect of a dorman extract from a dormant plant (Narcissus derived IBR-1) and a dorman extract obtained from animals (Artemia derived IBR-4) on proliferation of mouse bladder carcinoma cells

(a) Preparation of the dorman extracts:

[0127] The Narcissus derived plant dorman extract IBR-1 and the Artemia derived animal dorman extract IBR-4 were prepared as explained in the Examples above.

(b) The effect of DC IBR-1 and DC IBR-4 on proliferation of mouse bladder carcinoma cells:

(i) Experimental assay:

[0128] The two experiments were carried out as follows:

[0129] T24P cells (mouse bladder carcinoma cells) (Fig. 5) were plated at a concentration of 5×10^4 cells/well in a microculture well and T50 cells (mouse bladder carcinoma cells) (Fig. 6) were plated at a concentration of 2×10^4 cells per well in a microculture plate and the cells were grown in cell culture medium.

[0130] DC IBR-1 and DC IBR-4 were added to the T24P cell cultures and IBR-1 was added also to the T50 cells at various concentrations (0 g/ml - 25 g/ml) 24 hours after plating of the cells and 48 hours after the beginning of incubation of the cells with the dorman extracts. The number of cells per well were determined 48 hours after the beginning of incubation of the cells with the extracts using the microculture methylene blue assay (described in Example 2 above) and the dyed culture plates were read at 620 nm.

(ii) Results:

[0131] As seen in Figs. 5 and 6, both the plant derived dorman extract as well as the animal derived dorman extract had some inhibitory effect on the proliferation of mouse bladder carcinoma cells T24P (Fig. 5) and T50 (Fig. 6).

Example XI: Inhibition of cucumber seed growth by Grape and Kiwi juice

(a) Preparation of fruit juice

[0132] Grape and Kiwi juices were produced from fresh fruit by blending the fruit in the blender cup for 3 mins. at high speed, filtrating the blend through a cheese cloth and centrifuging it at 6,500 rpm for 10 mins. at room temperature. The supernatant was then used for the experiment at a concentration of 1.2 gr/ml of the grape juice and 1.26 gr/ml of the kiwi juice. The concentration was determined by fruit original weight (gr.) for final volume (v). Several dilutions of each juice were prepared and used for testing on cucumber seed growth.

[0133] Preparation of the cucumber seeds and the experimental assay were carried out as described in Example I (c)(i) above. The length of the roots and hypocotyls were measured 24 and 48 hours after beginning of incubation of the seeds with each of the tested juices or controls at 28°C. As seen in Table 8 below, both the kiwi juice and the grape juice showed a very high percent of inhibition both on growth of cucumber roots as well as on hypocotyls. The most prominent inhibition was seen 48 hours after beginning of incubation wherein both juices inhibited the growth of the cucumber seeds.

Table 8

	24 h		48 h	
	Root % Inhibition	Hypocotyl % Inhibition	Root % Inhibition	Hypocotyl % Inhibition
dH ₂ O	0	0	0	0
Kiwi juice 100 mg/ml	50	100	72	100
Kiwi juice 50 mg/ml	33	67	55	63
Kiwi juice 25 mg/ml	0	67	42	38
Kiwi juice 5 mg/ml	0	0	7	13
Grape juice 100 mg/ml	83	100	88	100
Grape juice 50 mg/ml	40	100	67	63
Grape juice 25 mg/ml	17	67	42	63
Grape juice 5 mg/ml	10	17	20	25

Example XII Cell cycle analysis of cells after incubation with DC

(i) Experimental assay:

[0134] Cell cultures of keratinocytes obtained from healthy human adults and cell cultures of fibroblasts obtained from healthy human skin preparations were incubated with *Narcissus* derived DC (IBR-1), *Narcissus* derived AE (IBR-3) and *Artemia* derived DC (IBR-4) at various concentrations. The DNA content of the cells was analyzed by FACS using ethidium iodide as the fluorescent dye which binds to the DNA (Parks D.R., and Herzenberg, L.A., In: Methods in Cell Biology, Vol. 26, Academic Press, p. 283, 1982). The analysis was carried out on day 2 and 5 after beginning of incubation of the cells with the various extracts and was carried out with FACS FPAR-Plus (Becton-Dickinson, Inc.)

[0135] In addition, the percent apoptosis in each cell culture incubated with the various DC extracts was also determined. In general, apoptosis begins with a strong mitochondrial activation followed by a cellular nuclear degradation. FACS analysis of the above cell cultures enabled also to calculate the percent apoptosis in each cell culture.

(ii) Results:

(a) Effect of DC on the cell cycle of keratinocytes:

[0136] As seen in Fig. 7A and B, and in Fig. 7E and F, both *Narcissus* derived DC and *Artemia* derived DC had an effect on the DNA content of the keratinocytes which showed a decrease in percent of cells being in the G₁ phase and an increase in cells being in the S and G₂+M phases (the effect being evident already on day 2 of the incubation and more apparent on day 5 of the incubation). Against this, as seen in Fig. 7C and D, the effect of the *Narcissus* derived AE (IBR-3) was much less apparent being slightly evident only 5 days after incubation where a decrease in the percent of cells in the G₁ phase was seen with an increase in the percent of cells being in the S phase and a non significant increase in the percent of cells being in the G₂+M phase.

[0137] In addition, the keratinocytes incubated with the *Narcissus* and *Artemia* derived DCs IBR-1 and IBR-4, showed an increase in the percent of apoptosis while no such increase was seen in keratinocytes incubated with *Narcissus* derived AE IBR-3.

(b) Effect of DC on the cell cycle of fibroblasts

[0138] As seen in Fig. 8A and B and Fig. 8E and F, *Narcissus* derived DC (IBR-1) and *Artemia* derived DC (IBR-4) increased the percent of cells being in the S and G₂+M phases (seen mainly five days after beginning of incubation)

as compared to the same cell cultures incubated with water. Against this, as seen in Fig. 8C and D, incubation of the cells with Narcissus derived AE (IBR-3) had no effect. None of the tested extracts increased the percent of apoptosis in the fibroblast cell cultures.

[0139] The effect of the various DCs on the keratinocyte and fibroblast cultures was time and dose dependent.

Example XIII: Effect of DC preparations obtained from bulbs of various plants on growth of germinated cucumber seeds

[0140] (a) Extracts were prepared from bulbs of various plants as described in Example 1 above. The extracted bulbs were in their dormant stage in which no growth tip could be visualized. The extract concentration is defined as original weight of bulb (gr) per final extract volume (ml).

[0141] (b) The effect of extracts on growth of cucumber germinated seeds:

[0142] The experimental assay was carried out as explained in Example 1 above. The effect of the tested bulb extracts on the growth of cucumber seeds was tested 24 hours and 48 hours after beginning of the incubation of the extracts with the seeds.

[0143] The inhibitive effect of the tested extracts was calculated as described in the Examples above.

Results:

[0144] As seen in Table 9 below, most of the extracts showed good inhibitory effect on the growth of the germinated cucumber seeds (up to about 60% inhibition in average). Several of the plants showed very good inhibition activity of about 90% inhibition (e.g. *Pancreatium maritimum*). Several of the extracts showed a low inhibitory effect which may, in some cases, be due to the fact that the bulbs were not in full dormancy.

[0145] The effect of the extracts from *Pancreatium maritimum* and *Hyacinth carnegie* were tested further for their effect on the cucumber seed growth by adding various concentrations of the extracts to the seeds. The results (not shown) showed correlation between the concentration of the added extract and the inhibition effect of the extract on the growth germinated cucumber seeds.

Table 9

Inhibition (%) of seed growth by extracts:					
Extract Source		24 hours		48 hours	
		Root	Hypocotyl	Root	Hypocotyl
		(% inhibition)		(% inhibition)	
<i>Sparaxis</i>	0.52 gr./ml	38	-33	49	39
<i>Hyacinth carnegie</i>	0.40 gr./ml	9	91	94	91
<i>Freesia</i>	0.42 gr./ml	62	18	77	7
<i>Crocus</i>	0.41 gr./ml	48	9	30	37
<i>Ornithogalum arabicum</i>	0.82 gr./ml	52	-18	54	-20
<i>Montbartia</i>	0.64/gr./ml	49	28	63	66
<i>Scilla hyacinthus</i>	1.25 gr./ml	61	0	68	6
<i>Pancreatium maritimum</i>	0.71 gr./ml	90	89	93	96
(-) indicates growth stimulation					

Example XIV: Effect of extracts from Narcissus bulbs on growth of cucumber plants

[0146]

(a) Extracts from dormant Narcissus bulbs were prepared as explained in Example 1 above.

(b) Cucumber seeds were germinated and let grow for three days until they had roots and the hypocotyl of about 4 cm. The plants were then planted in soil and let grow at 23°C in tap water. The plants were divided into the following three groups, each comprising 18 plants:

1. Plants that were irrigated with tap water;
2. Plants that were irrigated with tap water and treated with the Narcissus bulb extract by spraying the extract (5 mg/ml) on the leaves and the growth meristem; and

3. Plants which were irrigated directly with the Narcissus bulb extract (0.2 gr./ml).

[0147] The plants were irrigated every day and following one week of treatment, the plants were taken out of the soil and the effect of each treatment was tested by measuring the length of the roots and stems of each plant.

Results:

[0148] As seen in Table 10 below, application of the dormant Narcissus bulb extract on to cucumber plants both by spraying the extract on the leaves and growth meristem (Group 2) as well as by irrigating the plants with the extract (Group 3) resulted in inhibition of the cucumber plants' growth as compared to their growth with tap water.

Table 10

Effect of dormant Narcissus bulb extract on growth of cucumber plants		
	% inhibition	
Irrigation with:	Root	Stem
(1) Tap water	0	0
(2) Narcissus bulb extract applied on leaves and growth center	21%	25%
(3) Narcissus bulb extract applied with irrigation	30%	21%

Example XV: Effect of Narcissus bulb extract on the growth of different types of seeds

[0149]

- (a) The dormant Narcissus bulb extract was prepared as explained above.
- (b) Several kinds of seeds (tomato, cabbage, melon, water melon, wheat, grass, cucumber, bean, barley, corn and pea) were washed overnight with water and then let germinate for 24 hrs at 30°C in the dark on water soaked filter paper. After 24 hrs, the germinated seeds (20 in each experiment set) were applied to a Petri dish with Watman filter paper soaked with the dormant extract.

[0150] Each group of seeds was divided into the following groups:

- 1. Seeds grown in water (control); and
- 2. Seeds grown with the dormant Narcissus bulb extract.

[0151] Various types of seeds were grown with the water or extract (at several concentrations) as explained in Example 1 above and following incubation, the length of the roots and hypocotyls of each seed was measured every 24 hours, depending on the rate of germination and growth. The inhibition effect of the extract tested and calculated as explained above.

[0152] As seen in Table 11 below, the dormant Narcissus bulb extract effectively inhibited the growth of the above seeds. The inhibition was to different extents.

Table 11

Effect of dormant Narcissus on growth of different types of seeds			
		% Inhibition	
Seed	DC Concentration	Roots	Hypocotyl
Grass	0.02	100	72
Water melon	0.02	42	74
Cabbage	0.02	63	82
Cucumber	0.2	93	76
Cucumber	0.05	70	72

Table 11 (continued)

Effect of dormant Narcissus on growth of different types of seeds			
Seed	DC Concentration	% Inhibition	
		Roots	Hypocotyl
Cucumber	0.02	52	79
Barley	0.2	84	21
Barley	0.05	81	0
Corn	0.2	70	1
Peas	0.2	61	69
Peas	0.05	38	28
Beans	0.2	79	55
Beans	0.05	55	13
Beans	0.02	42	5

Example XVI: Isolation and identification of an active ingredient in the Narcissus bulb extract

[0153] Several grams of powder prepared from active and dormant Narcissus bulbs were extracted with acetone methanol (90:10). The extracts separated using Thin Layer Chromatography (TLC) techniques. The separation was conducted on TLC plates (Silica gel 60 F254 or from Merck). Running conditions were water: n-butanol:acetic acid (5:4:1). The detection method was UV light at 254 nm and 365 nm. The bands resulting from the separation were scraped with the silica from the plate, washed with methanol and dried at 60°C. The bands appearing in the extracts from the active Narcissus bulbs were compared to those in the extracts of the dormant Narcissus bulbs.

Results:

[0154] Comparison of the bands appearing in the two above extracts showed that there was a difference in the expression of two bands (termed "band 4" and "band 6") which appeared at a higher concentration in extracts of the dormant bulbs.

[0155] The UV absorption spectrum of the two bands and their inhibitive activity on germinated cucumber seeds was tested as explained above.

[0156] As seen in Figs. 9A-9B, the UV absorption peak of band 4 was at 288 nm (Fig. 9A) and that of band 6 was at 252 nm (Fig. 9B). As seen in Table 12 below, bands 4 and 6 significantly inhibited the growth of germinated cucumber seeds.

Table 12

Band separated by TLC	4	6
UV spectra (nm) in Methanol	288	252
Inhibition (%) (2 mg. dry purified compound/ml)		
24 hrs		
Hypocotyl	58	58
Root	87	89
48 hours		
Hypocotyl	60	77
Root	90	94

Example XVII: Testing for toxicity of DC obtained from dormant Narcissus bulbs

[0157] The toxicity of DC of the invention was tested using the following methods::

1. Acute Oral Toxicity (Fixed Dose) Test in Rats

[0158] The acute oral toxicological test was based on the protocol, code P/ACU/005, issued at January 1996 by Inveresk Research International (IRI), Tranent, EH33 2NE, Scotland.

2. Ames Test

[0159] *Salmonella typhimurium* mammalian microsome plate incorporation assay was based on Ames B.N., McCann, J., and Yamasaki E., *Mutation Research*, **31**:347-364 (1975).

3. Cytotoxicity

[0160] Cytotoxicity of the extract (5%) of 0.2 gr/ml extract in cosmetic cream, determined by agarose diffusion method was tested by EVIC-CEBA, Bordeaux, France.

4. Irritation potential

[0161] Irritation potential of the product in cream ((5%) of 0.2 gr/ml extract) was determined by means of the HET-CAM test (Chorioallantoic membrane of hen's egg) by EVIC-CEBA, Bordeaux, France.

5. Cutaneous Tolerance

[0162] Cutaneous tolerance of the extract ((5%) of 0.2 gr/ml extract) in cosmetic cream, after repeated application to the skin was assessed by EVIC-CEBA, Bordeaux, France.

Results:

[0163] The results of the toxicity testings using the above methods were as follows:

1. **The Acute Oral Toxicity** (fixed dose) test in rats oral LD 50 > 2000 mg/kg body weight, has no acute harmful effects on both young female and male rats.
2. **Ames test** up to the top-limit dose of 5000 µg/plate, exhibiting no precipitate and no toxicity, did not induce any mutagenic effects on the Ames test.
3. **Irritation potential** in cream ((5%) of 0.2 gr/ml extract). The product was found as a normally irritant for this kind of product.
4. **Cytotoxicity** determination by agarose diffusion method of the product in cream ((5%) of 0.2 gr/ml extract) seems to be low and considered to be low and considered normal for this kind of product.
5. **Cutaneous tolerance** - The clinical assessment of cutaneous tolerance of the extract in cosmetic cream was tested. The product was found very well tolerated by the skin.

Example XVIII The effect of DC on elongation of a tan(a) The assay:

[0164] A cream containing 5% dihydroxyacetone (DHA) was administered on to the forearms of an individual. DHA is a compound capable of coloring the upper layers of the skin which is used in self tanning products. The cream was administered three times until a tan appeared on the forearms.

[0165] The tanned area was then divided into the following three parts, each being treated by administration of a different cream twice a day during 17 days:

1. Treatment with a cream comprising 5% of the DC IBR-1;
2. A cream identical to the one used in (1) above but which does not contain IBR-1;
3. A cream comprising alpha hydroxy acid (AHA) (commercially used for skin treatment); and

[0166] The amount of color on each skin area was measured using a spectro-colorimeter.

[0167] The % effect on elongation of the tan was calculated as:

$$\frac{\text{color of tan of treatment a}}{\text{color of tan with no treatment}} \frac{\text{color of tan after treatment b}}{\text{color of tan with no treatment}} \times 100$$

Results:

5
 [0168] The results of the above experiment can be seen in Fig. 10, which shows the relation between the effect on the duration of the tan of the cream used in 1 above containing the IBR-1 DC as compared to the effect of the cream which contained no IBR-1 (Figs 10A and B) and the relative effect of the cream used in (3) above (comprising AHA) as compared to no cream at all AHA (Figs. 10C and D). As can be seen in Fig. 10A, 5 days after administration of the
 10 creams, the effect of the cream containing IBR-1 on elongation of the tan duration was significantly higher than the effect of the cream which did not contain IBR-1. The effect was even more significant 17 days after administration of the cream as can be seen in Fig. 10B.

[0169] Figs. 10C and D clearly show that the cream used commercially which does not contain IBR-1 had a negative effect on the duration of the tan, i.e. their administration resulted in shorter duration of the tan as compared to no treatment at all. As can also be seen, the cream comprising the AHA shortened the duration of the tan (compared to the duration of the tan with no treatment) 5 days after its administration (Fig. 10C) and 17 days after its administration (Fig. 10D).

[0170] The above results show that a cream comprising DC of the invention, most probably due to its inhibition of proliferation of the skin cells, elongates the duration of a tan. Against this, a cream comprising AHA which is commonly used for skin treatment, most probably due to its stimulation of cell division, shortens the duration of the tan.
 20

Claims

- 25 1. A process for producing a water-soluble extract which inhibits proliferation of target cells or target tissue, said process comprising:
- (i) providing producer cells or producer tissue derived from an organism which is xenogeneic to said target cells and which is capable of entering into a dormant state;
 30
- (ii) providing conditions which induce said cells or tissue to enter into a dormant state or, if already in a dormant state, to maintain said dormant state;
- (iii) recovering a water-soluble extract from said cells or tissue or from the medium in which said cells or tissue are incubated; wherein said water-soluble extract displays a cell anti-proliferative activity.
 35
2. The process according to Claim 1, wherein said water-soluble extract inhibits the growth of seedlings.
3. The process according to Claim 2, wherein said water-soluble extract inhibits the growth of cucumber seedlings.
 40
4. The process according to any one of Claims 1-3, wherein said producer cell or producer tissue is derived from a plant organism.
5. The process according to Claim 4, wherein said producer cells or tissue are obtained from narcissus bulbs.
 45
6. The process according to Claim 4, wherein said water-soluble extract is obtained from fruit.
7. The process according to Claim 4, wherein said producer tissue is a seed.
- 50 8. The process according to any one of claims 1-3, wherein said producer cell or producer tissue is derived from an animal.
9. The process according to Claim 8, wherein said animal is Artemia.
- 55 10. Use of an effective amount of a water-soluble extract obtained from producer cells or producer tissue or from the medium in which said cells or tissue are incubated, for the preparation of a medicament having an anti-proliferative effect on target cells or tissue of an individual wherein

(i) said producer cells or producer tissue originate from an organism which is xenogeneic to said individual;

(ii) said producer cells or producer tissue originate from an organism which can enter into a state of dormancy;
and,

(iii) said water-soluble extract is obtained from producer cell or tissue while in a dormant state.

11. Use according to Claim 10, wherein said xenogeneic organism is a plant.

12. Use according to Claim 11, wherein said producer cells or tissue are obtained from Narcissus bulbs.

13. Use according to Claim 11, wherein said producer tissue is a fruit.

14. Use according to Claim 11, wherein said tissue is a seed.

15. Use according to Claim 10, where said xenogeneic organism is an animal.

16. Use according to Claim 15, wherein said animal is Artemia.

17. Use according to any one of Claims 10-16, wherein said composition is to be administered to an individual having a benign or malignant tumor or being at a high risk of developing a benign or malignant tumor.

18. Use according to any one of Claims 10-16, wherein said composition is intended for use in inhibition of alopecia, inhibition of hirsutism, for reduction of rate of nail growth, in combination with hair treatments for inhibition of scar formation or for the treatment of skin disorders.

19. Use according to any of Claims 10-16 and 18, wherein the composition is to be applied typically onto the individual's skin.

20. Use of an effective amount of a water-soluble extract obtained from producer cells or producer tissue or from the medium in which said cells or tissue are incubated, in a cosmetic composition having an anti-proliferative effect on target cells or tissue of an individual, wherein

(i) said producer cells or producer tissue originate from an organism which is xenogeneic to said individual;

(ii) said producer cells or producer tissue originate from an organism which can enter into a state of dormancy;
and,

(iii) said water-soluble extract is obtained from producer cell or tissue while in a dormant state.

21. Use according to Claim 20, wherein said xenogeneic organism is a plant.

22. Use according to Claim 21, wherein said producer cells or tissue are obtained from Narcissus bulbs.

23. Use according to Claim 21, wherein said producer tissue is a fruit.

24. Use according to Claim 21, wherein said tissue is a seed.

25. Use according to Claim 20, where said xenogeneic organism is an animal.

26. Use according to Claim 25, wherein said animal is Artemia.

27. Use according to any of Claims 20-26, wherein the composition is intended for topical application onto the individual's skin.

28. Use according to Claim 27, wherein said composition is intended for maintaining a juvenile appearance of an individual's skin or for the treatment of age-related phenomena of the skin.

29. Use according to any one of Claims 20-26, for prolonging a sun tan,

30. A method for inhibiting growth of plant seedlings, comprising applying onto the seedlings or their growth media an effective amount of a cell-proliferation inhibiting water-soluble extract which is obtained from producer cells or producer tissue or from the medium in which said cells or tissue were incubated, **characterized in that:**

(i) said producer cells or producer tissue originate from an organism which is xenogeneic to said seedlings;

(ii) said xenogeneic organism is capable of entering into a state of dormancy; and,

(iii) said water-soluble extract is obtained from producer cell or tissue while in a dormant state.

31. A method for reducing rate of seed germination, comprising applying onto the seeds an effective amount of a cell-proliferation inhibiting water-soluble extract obtained from producer cells or producer tissue or from a medium in which said cells or tissue were incubated, **characterized in that:**

(i) said producer cells or producer tissue originate from an organism which is xenogeneic to said seeds;

(ii) said xenogeneic organism is capable of entering into a state of dormancy; and,

(iii) said water-soluble extract is obtained from producer cell or tissue while in a dormant state.

32. A method of preservation of fresh products, comprising applying onto - the fresh products, an effective amount of a cell-proliferation inhibiting water-soluble extract obtained from producer cells or producer tissue or from a medium in which said cells or tissue were incubated, characterized in that:

(i) said producer cells or producer tissue originate from an organism which is xenogeneic to said products;

(ii) said xenogeneic organism is capable of entering into a state of dormancy; and,

(iii) said water soluble extract is obtained from producer cell or tissue while in a dormant state.

Patentansprüche

1. Verfahren zur Herstellung eines wasserlöslichen Extrakts, der die Proliferation von Zielzellen oder Zielgewebe inhibiert, wobei das Verfahren umfasst:

(i) Bereitstellen von Erzeugerzellen oder Erzeugergewebe gewonnen aus einem Organismus, der für die Zielzellen xenogen ist und der in der Lage ist, in einen Ruhezustand einzutreten;

(ii) Bereitstellen von Bedingungen, in die Zellen oder das Gewebe induzieren, in einen Ruhezustand einzutreten oder, wenn sie schon in einem Ruhezustand sind, diesen Ruhezustand beizubehalten;

(iii) Gewinnung eines wasserlöslichen Extrakts aus den Zellen oder dem Gewebe oder aus dem Medium, in dem die Zellen oder das Gewebe inkubiert wurden; worin der wasserlösliche Extrakt eine antiproliferative Aktivität für Zellen aufweist.

2. Verfahren nach Anspruch 1, worin der wasserlösliche Extrakt das Wachstum von Keimlingen inhibiert.

3. Verfahren nach Anspruch 2, worin der wasserlösliche Extrakt das Wachstum von Gurkenkeimlingen inhibiert.

4. Verfahren nach einem der Ansprüche 1-3, worin die Erzeugerzellen oder das Erzeugergewebe von einem Pflanzenorganismus gewonnen wird.

5. Verfahren nach Anspruch 4, worin die Erzeugerzellen oder das Erzeugergewebe von Narzissenzwiebeln erhalten werden.

6. Verfahren nach Anspruch 4, worin der wasserlösliche Extrakt aus Früchten erhalten wird.

7. Verfahren nach Anspruch 4, worin das Erzeugergewebe ein Keim ist.
8. Verfahren nach einem der Ansprüche 1-3, worin die Erzeugerzellen oder das Erzeugergewebe von einem Tier gewonnen wird.
- 5 9. Verfahren nach Anspruch 8, worin das Tier Artemia sind.
10. Verwendung einer wirksamen Menge eines wasserlöslichen Extrakts erhalten aus Erzeugerzellen oder Erzeugergewebe oder aus dem Medium, in dem die Zellen oder das Gewebe inkubiert wurden, für die Herstellung eines Medikaments mit einer antiproliferativen Wirkung auf Zielzellen oder Gewebe eines zu Behandelnden, worin
- 10 (i) die Erzeugerzellen oder das Erzeugergewebe aus einem Organismus stammen, der für den zu Behandelnden xenogen ist;
- 15 (ii) die Erzeugerzellen oder das Erzeugergewebe aus einem Organismus stammen, der in einen Ruhezustand eintreten kann; und
- (iii) der wasserlösliche Extrakt von Erzeugerzellen oder Erzeugergewebe erhalten ist, während sie/es in einem Ruhezustand sind/ist.
11. Verwendung nach Anspruch 10, worin der xenogene Organismus eine Pflanze ist.
- 20 12. Verwendung nach Anspruch 11, worin die Erzeugerzellen oder das -gewebe von Narzissenzwiebeln erhalten sind.
13. Verwendung nach Anspruch 11, worin das Erzeugergewebe eine Frucht ist.
- 25 14. Verwendung nach Anspruch 11, worin das Gewebe ein Keim ist.
15. Verwendung nach Anspruch 10, worin der xenogene Organismus ein Tier ist.
- 30 16. Verwendung nach Anspruch 15, worin das Tier Artemia sind.
17. Verwendung nach einem der Ansprüche 10-16, worin die Zusammensetzung einem zu Behandelnden verabreicht werden soll, der einen benignen oder malignen Tumor aufweist oder ein hohes Risiko hat, einen benignen oder malignen Tumor zu entwickeln.
- 35 18. Verwendung nach einem der Ansprüche 10-16, worin die Zusammensetzung zur Verwendung bei der Inhibierung von Alopezie, Inhibierung von Hirsutismus, zur Reduzierung der Nagelwachstumsrate in Kombination mit Haarbehandlungen zur Inhibierung von Narbenbildung oder zur Behandlung von Hautstörungen vorgesehen ist.
- 40 19. Verwendung nach einem der Ansprüche 10-16 oder 18, worin die Zusammensetzung topisch auf die Haut des zu Behandelnden aufgetragen werden soll.
20. Verwendung einer wirksamen Menge eines wasserlöslichen Extrakts erhalten aus Erzeugerzellen oder Erzeugergewebe oder aus dem Medium, in dem die Zellen oder das Gewebe inkubiert wurden, in einer kosmetischen Zusammensetzung mit einer antiproliferativen Wirkung auf Zielzellen oder Gewebe eines zu Behandelnden,
- 45 (i) die Erzeugerzellen oder das Erzeugergewebe aus einem Organismus stammen, der für den zu Behandelnden xenogen ist;
- (ii) die Erzeugerzellen oder das Erzeugergewebe aus einem Organismus stammen, der in einen Ruhezustand eintreten kann; und
- 50 (iii) der wasserlösliche Extrakt von Erzeugerzellen oder Erzeugergewebe erhalten ist, während sie/es in einem Ruhezustand sind/ist.
21. Verwendung nach Anspruch 20, worin der xenogene Organismus eine Pflanze ist.
- 55 22. Verwendung nach Anspruch 21, worin die Erzeugerzellen oder das -gewebe von Narzissenzwiebeln erhalten sind.
23. Verwendung nach Anspruch 21, worin das Erzeugergewebe eine Frucht ist.

24. Verwendung nach Anspruch 21, worin das Gewebe ein Keim ist.

25. Verwendung nach Anspruch 20, worin der xenogene Organismus ein Tier ist.

5 26. Verwendung nach Anspruch 25, worin das Tier Artemia sind.

27. Verwendung nach einem der Ansprüche 20-26, worin die Zusammensetzung für topische Anwendung auf die Haut eines zu Behandelnden vorgesehen ist.

10 28. Verwendung nach Anspruch 27, worin die Zusammensetzung zur Erhaltung eines jugendlichen Aussehens der Haut eines zu Behandelnden oder für die Behandlung von altersbedingten Phänomenen der Haut vorgesehen ist.

29. Verwendung nach einem der Ansprüche 20-26 zur Verlängerung der Sonnenbräune.

15 30. Verfahren zur Inhibierung des Wachstums von Pflanzenkeimlingen, umfassend Aufbringen auf die Keimlinge oder ihr Wachstumsmedium einer wirksamen Menge eines wasserlöslichen Extrakts, der Zellproliferation inhibiert, der aus Erzeugerkzellen oder Erzeugergewebe oder aus dem Medium, in dem die Zellen oder das Gewebe inkubiert wurden, erhalten ist, **dadurch gekennzeichnet, dass:**

- 20 (i) die Erzeugerkzellen oder das Erzeugergewebe von einem Organismus stammen, der für die Keimlinge xenogen ist;
 (ii) der xenogene Organismus in der Lage ist, in einen Ruhezustand einzutreten; und
 (iii) der wasserlösliche Extrakt von Erzeugerkzellen oder -gewebe erhalten ist, während sie/es in einem Ruhezustand sind/ist.

25 31. Verfahren zur Reduzierung der Keimungsrate, umfassend Aufbringen auf die Keime einer wirksamen Menge eines wasserlöslichen Extrakts, der Zellproliferation inhibiert, der aus Erzeugerkzellen oder Erzeugergewebe oder aus einem Medium, in dem die Zellen oder das Gewebe inkubiert wurden, erhalten ist, **dadurch gekennzeichnet, dass:**

- 30 (i) die Erzeugerkzellen oder das Erzeugergewebe von einem Organismus stammen, der für die Keime xenogen ist; -
 (ii) der xenogene Organismus in der Lage ist, in einen Ruhezustand einzutreten; und
 (iii) der wasserlösliche Extrakt von Erzeugerkzellen oder -gewebe erhalten ist, während sie/es in einem Ruhezustand sind/ist.

35 32. Verfahren zur Konservierung von Frischprodukten, umfassend Aufbringen auf die Frischprodukte einer wirksamen Menge eines wasserlöslichen Extrakts, der Zellproliferation inhibiert, der aus Erzeugerkzellen oder Erzeugergewebe oder aus einem Medium, in dem die Zellen oder das Gewebe inkubiert wurden, erhalten ist, **dadurch gekennzeichnet, dass:**

- 40 (i) die Erzeugerkzellen oder das Erzeugergewebe von einem Organismus stammen, der für die Produkte xenogen ist;
 (ii) der xenogene Organismus in der Lage ist, in einen Ruhezustand einzutreten; und
 (iii) der wasserlösliche Extrakt von Erzeugerkzellen oder -gewebe erhalten ist, während sie/es in einem Ruhezustand sind/ist.

50 Revendications

1. Procédé de production d'un extrait hydrosoluble qui inhibe la prolifération de cellules cibles ou d'un tissu cible, ledit procédé consistant à :

- 55 (i) fournir des cellules productrices ou un tissu producteur issus d'un organisme qui est xénogénique desdites cellules cibles et qui est capable d'entrer dans un état dormant ;
 (ii) fournir des conditions qui amènent lesdites cellules ou ledit tissu à entrer dans un état dormant ou, s'ils sont déjà dans un état dormant, à maintenir ledit état dormant ;
 (iii) récupérer un extrait hydrosoluble à partir desdites cellules ou dudit tissu ou à partir du milieu dans lequel

lesdites cellules ou ledit tissu sont incubés ;

dans lequel ledit extrait hydrosoluble présente une activité anti-proliférative envers des cellules.

- 5 **2.** Procédé selon la revendication 1, dans lequel ledit extrait hydrosoluble inhibe la croissance de semis.
- 3.** Procédé selon la revendication 2, dans lequel ledit extrait hydrosoluble inhibe la croissance de semis de concombre.
- 10 **4.** Procédé selon l'une quelconque des revendications 1 à 3, dans lequel lesdites cellules productrices ou ledit tissu producteur sont issus d'un organisme végétal.
- 5.** Procédé selon la revendication 4, dans lequel lesdites cellules productrices ou ledit tissu producteur sont obtenus à partir de bulbes de narcisse.
- 15 **6.** Procédé selon la revendication 4, dans lequel ledit extrait hydrosoluble est obtenu à partir d'un fruit.
- 7.** Procédé selon la revendication 4, dans lequel ledit tissu producteur est une graine.
- 20 **8.** Procédé selon l'une quelconque des revendications 1 à 3, dans lequel lesdites cellules productrices ou ledit tissu producteur sont issus d'un animal.
- 9.** Procédé selon la revendication 8, dans lequel ledit animal est Artemia.
- 25 **10.** Utilisation d'une quantité efficace d'un extrait hydrosoluble obtenu à partir de cellules productrices ou d'un tissu producteur ou à partir du milieu dans lequel lesdites cellules ou ledit tissu sont incubés, pour la préparation d'un médicament possédant un effet anti-prolifératif sur des cellules ou un tissu cibles d'un individu, dans laquelle :
- (i) lesdites cellules productrices ou ledit tissu producteur proviennent d'un organisme qui est xénogénique dudit individu ;
- 30 (ii) lesdites cellules productrices ou ledit tissu producteur proviennent d'un organisme qui peut entrer dans un état de dormance ; et
- (iii) ledit extrait hydrosoluble est obtenu à partir de cellules productrices ou d'un tissu producteur dans un état dormant.
- 35 **11.** Utilisation selon la revendication 10, dans laquelle ledit organisme xénogénique est une plante.
- 12.** Utilisation selon la revendication 11, dans laquelle lesdites cellules productrices ou ledit tissu producteur sont obtenus à partir de bulbes de narcisse.
- 40 **13.** Utilisation selon la revendication 11, dans laquelle ledit tissu producteur est un fruit.
- 14.** Utilisation selon la revendication 11, dans laquelle ledit tissu est une graine.
- 45 **15.** Utilisation selon la revendication 10, dans laquelle ledit organisme xénogénique est un animal.
- 16.** Utilisation selon la revendication 15, dans laquelle ledit animal est Artemia.
- 50 **17.** Utilisation selon l'une quelconque des revendications 10 à 16, dans laquelle ladite composition doit être administrée à un individu portant une tumeur bénigne ou maligne ou fortement menacé de développer une tumeur bénigne ou maligne.
- 55 **18.** Utilisation selon l'une quelconque des revendications 10 à 16, dans laquelle ladite composition est destinée à être utilisée pour l'inhibition de l'alopecie, l'inhibition de l'hirsutisme, pour la réduction de la vitesse de pousse des ongles, en combinaison avec des traitements capillaires pour l'inhibition de la formation de cicatrices ou pour le traitement de troubles cutanés.
- 19.** Utilisation selon l'une quelconque des revendications 10 à 16 et 18, dans laquelle la composition doit être appliquée

topiquement sur la peau de l'individu.

- 5
20. Utilisation d'une quantité efficace d'un extrait hydrosoluble obtenu à partir de cellules productrices ou d'un tissu producteur ou à partir du milieu dans lequel lesdites cellules ou ledit tissu sont incubés, dans une composition cosmétique possédant un effet anti-prolifératif sur des cellules ou un tissu cibles d'un individu, dans laquelle :
- 10
- (i) lesdites cellules productrices ou ledit tissu producteur proviennent d'un organisme qui est xénogénique dudit individu ;
- (ii) lesdites cellules productrices ou ledit tissu producteur proviennent d'un organisme qui peut entrer dans un état de dormance ; et
- (iii) ledit extrait hydrosoluble est obtenu à partir de cellules productrices ou d'un tissu producteur dans un état dormant.
- 15
21. Utilisation selon la revendication 20, dans laquelle ledit organisme xénogénique est une plante.
22. Utilisation selon la revendication 21, dans laquelle lesdites cellules productrices ou ledit tissu producteur sont obtenus à partir de bulbes de narcisse.
23. Utilisation selon la revendication 21, dans laquelle ledit tissu producteur est un fruit.
- 20
24. Utilisation selon la revendication 21, dans laquelle ledit tissu est une graine.
25. Utilisation selon la revendication 20, dans laquelle ledit organisme xénogénique est un animal.
- 25
26. Utilisation selon la revendication 25, dans laquelle ledit animal est Artemia.
27. Utilisation selon l'une quelconque des revendications 20 à 26, dans laquelle la composition est destinée à une application topique sur la peau de l'individu.
- 30
28. Utilisation selon la revendication 27, dans laquelle ladite composition est destinée à conserver un aspect juvénile à la peau d'un individu ou au traitement de phénomènes cutanés liés à l'âge.
29. Utilisation selon l'une quelconque des revendications 20 à 26, pour prolonger un bronzage.
- 35
30. Procédé d'inhibition de la croissance de semis, consistant à appliquer sur les semis ou leurs milieux de croissance une quantité efficace d'un extrait hydrosoluble inhibant la prolifération cellulaire qui est obtenu à partir de cellules productrices ou d'un tissu producteur ou à partir du milieu dans lequel lesdites cellules ou ledit tissu sont incubés, **caractérisé en ce que** :
- 40
- (i) lesdites cellules productrices ou ledit tissu producteur proviennent d'un organisme qui est xénogénique desdits semis ;
- (ii) ledit organisme xénogénique est capable d'entrer dans un état de dormance ; et
- (iii) ledit extrait hydrosoluble est obtenu à partir de cellules productrices ou d'un tissu producteur dans un état dormant.
- 45
31. Procédé de réduction de la vitesse de germination de graines, consistant à appliquer sur les graines une quantité efficace d'un extrait hydrosoluble inhibant la prolifération cellulaire obtenu à partir de cellules productrices ou d'un tissu producteur ou à partir du milieu dans lequel lesdites cellules ou ledit tissu sont incubés, **caractérisé en ce que** :
- 50
- (i) lesdites cellules productrices ou ledit tissu producteur proviennent d'un organisme qui est xénogénique desdites graines ;
- (ii) ledit organisme xénogénique est capable d'entrer dans un état de dormance ; et
- (iii) ledit extrait hydrosoluble est obtenu à partir de cellules productrices ou d'un tissu producteur dans un état dormant.
- 55
32. Procédé de conservation de produits frais, consistant à appliquer sur les produits frais une quantité efficace d'un extrait hydrosoluble inhibant la prolifération cellulaire obtenu à partir de cellules productrices ou d'un tissu produc-

teur ou à partir du milieu dans lequel lesdites cellules ou ledit tissu sont incubés, **caractérisé en ce que** :

- (i) lesdites cellules productrices ou ledit tissu producteur proviennent d'un organisme qui est xénogénique desdits produits ;
- (ii) ledit organisme xénogénique est capable d'entrer dans un état de dormance ; et
- (iii) ledit extrait hydrosoluble est obtenu à partir de cellules productrices ou d'un tissu producteur dans un état dormant.

5

10

15

20

25

30

35

40

45

50

55

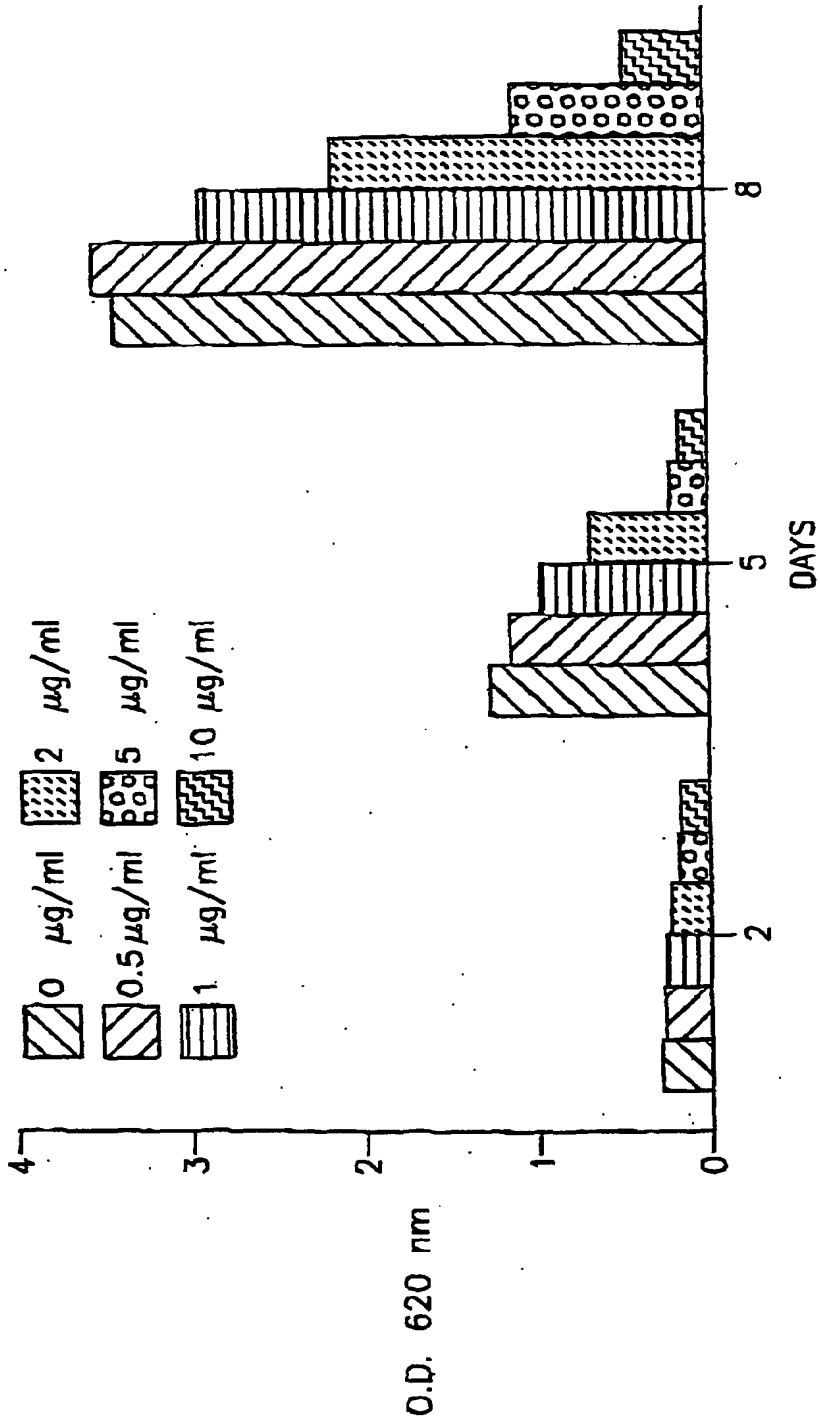

FIG.1A

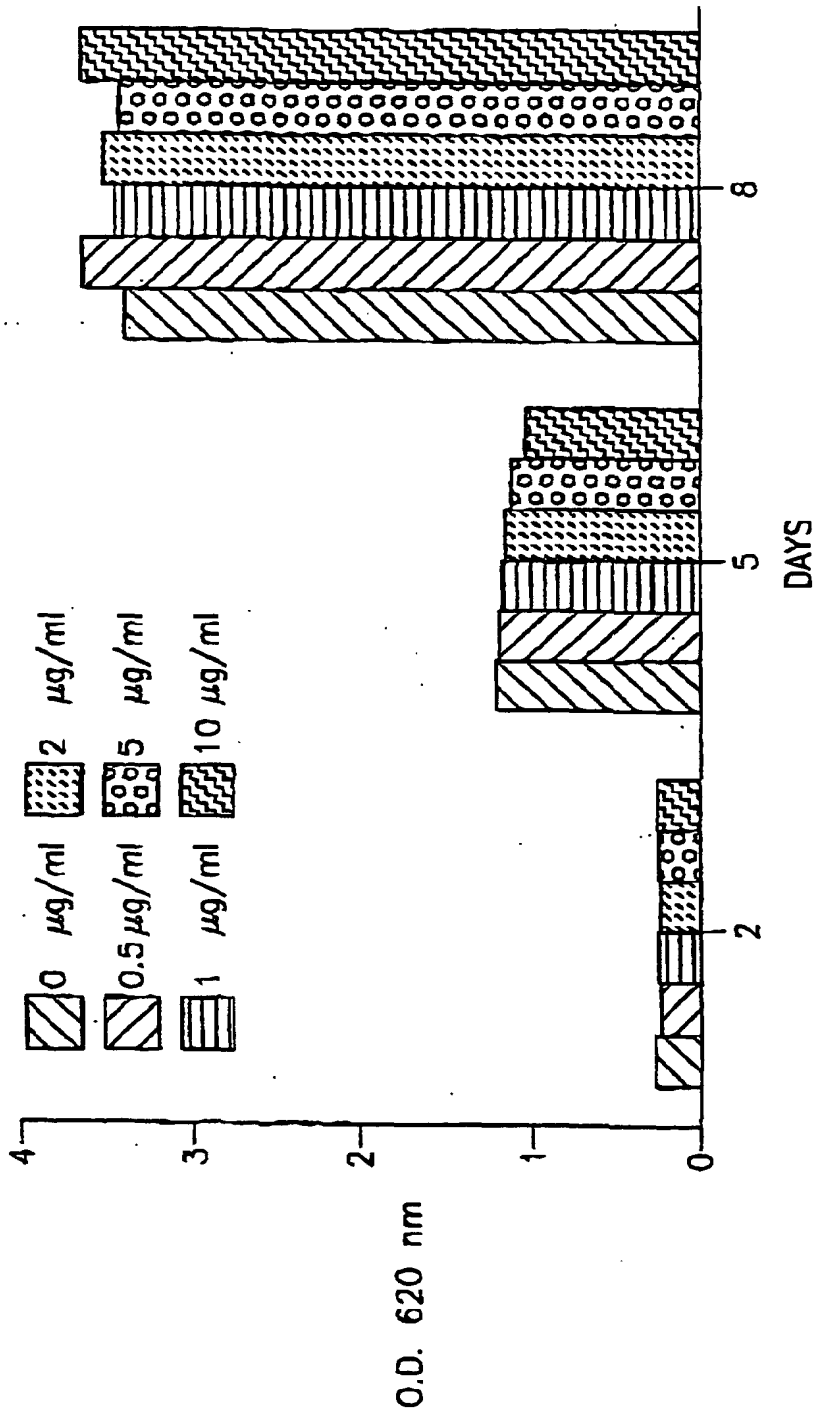

FIG.1B

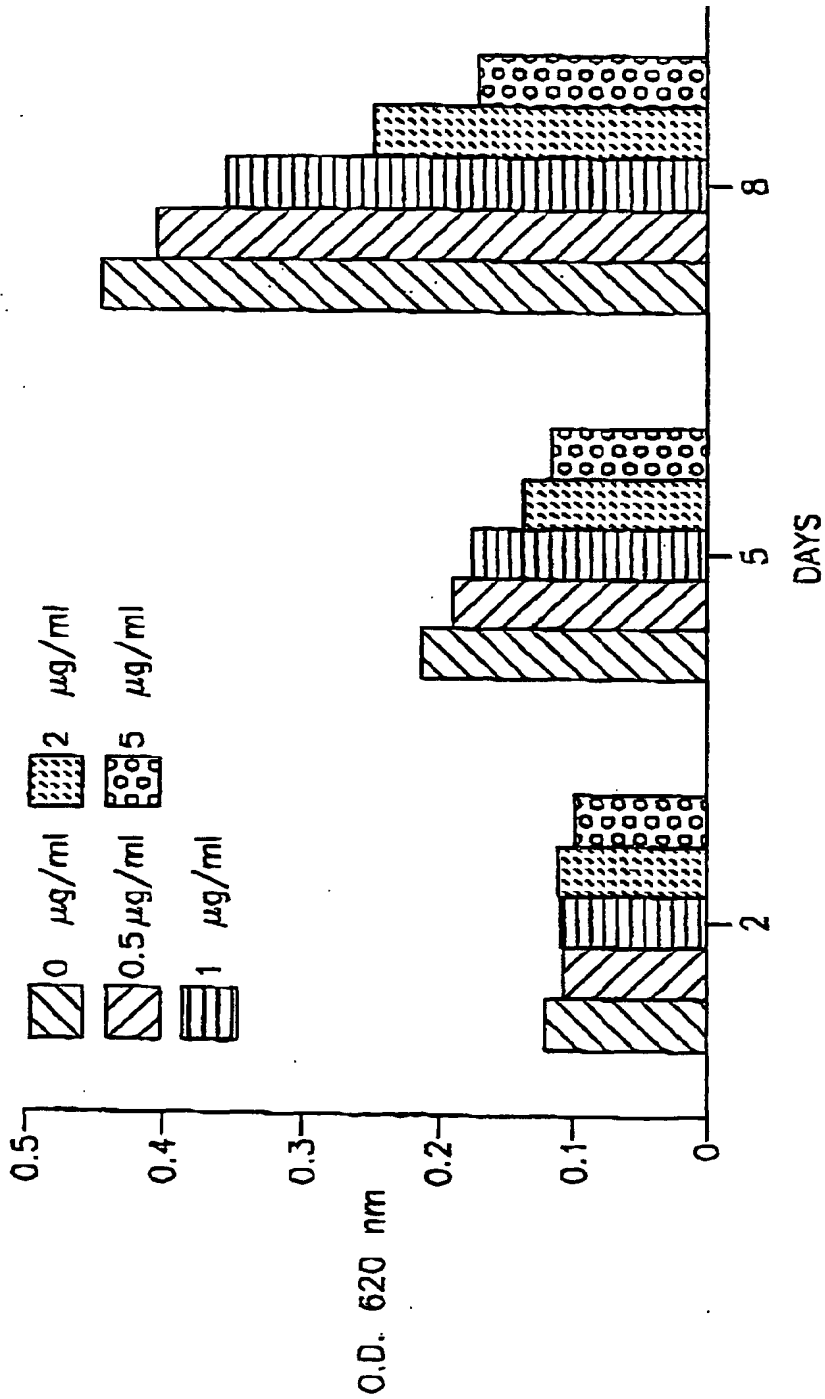

FIG.2A

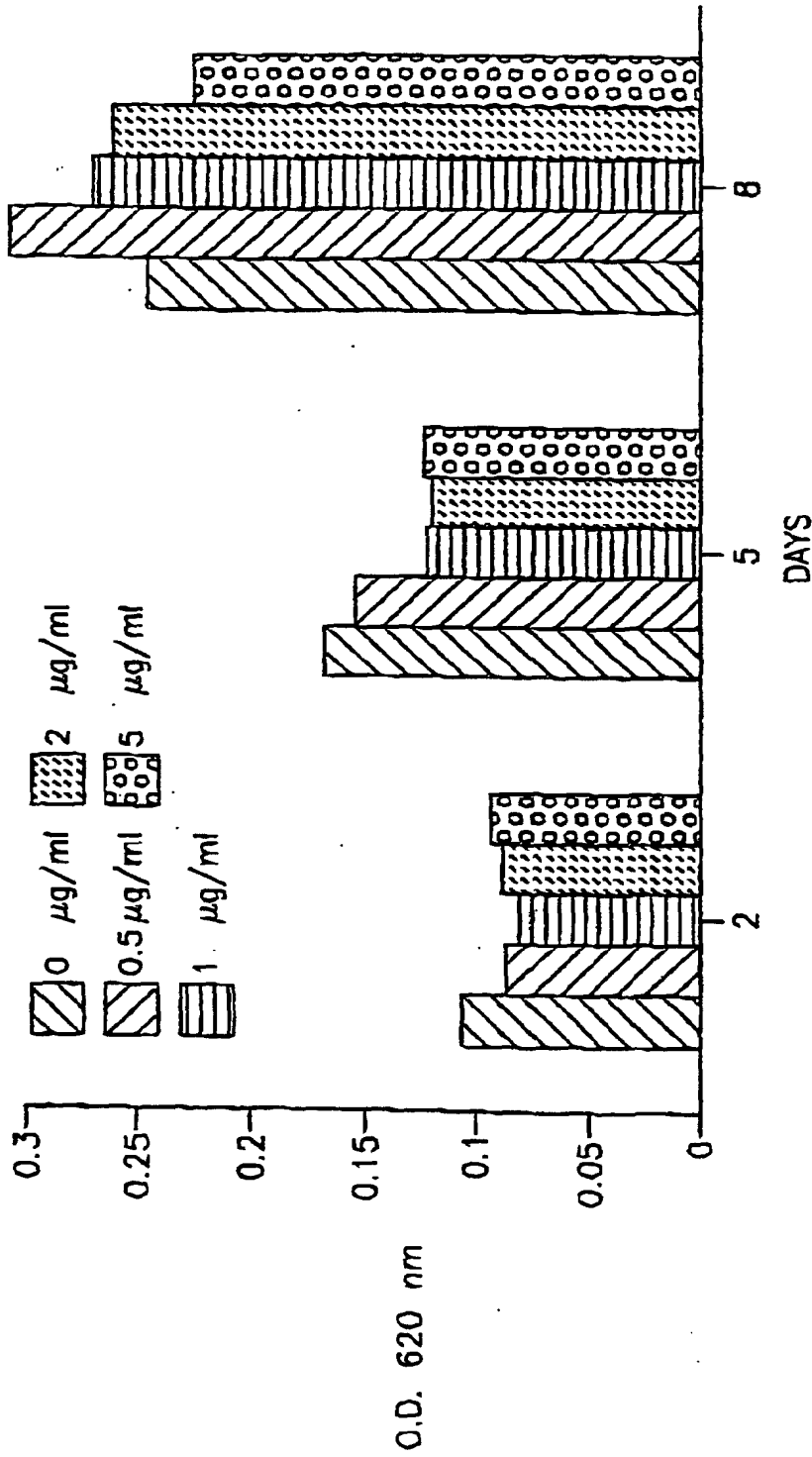

FIG.2B

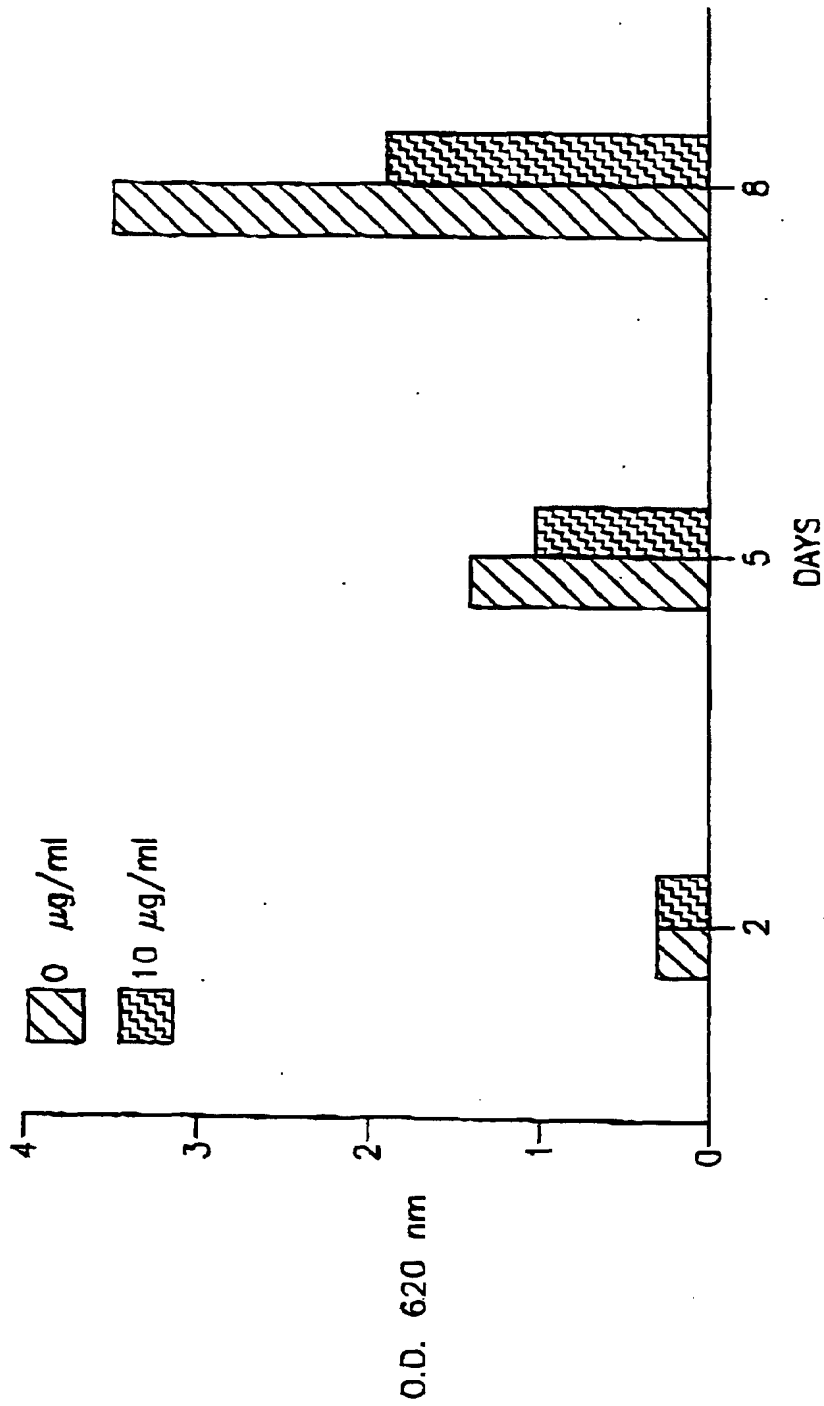

FIG.3

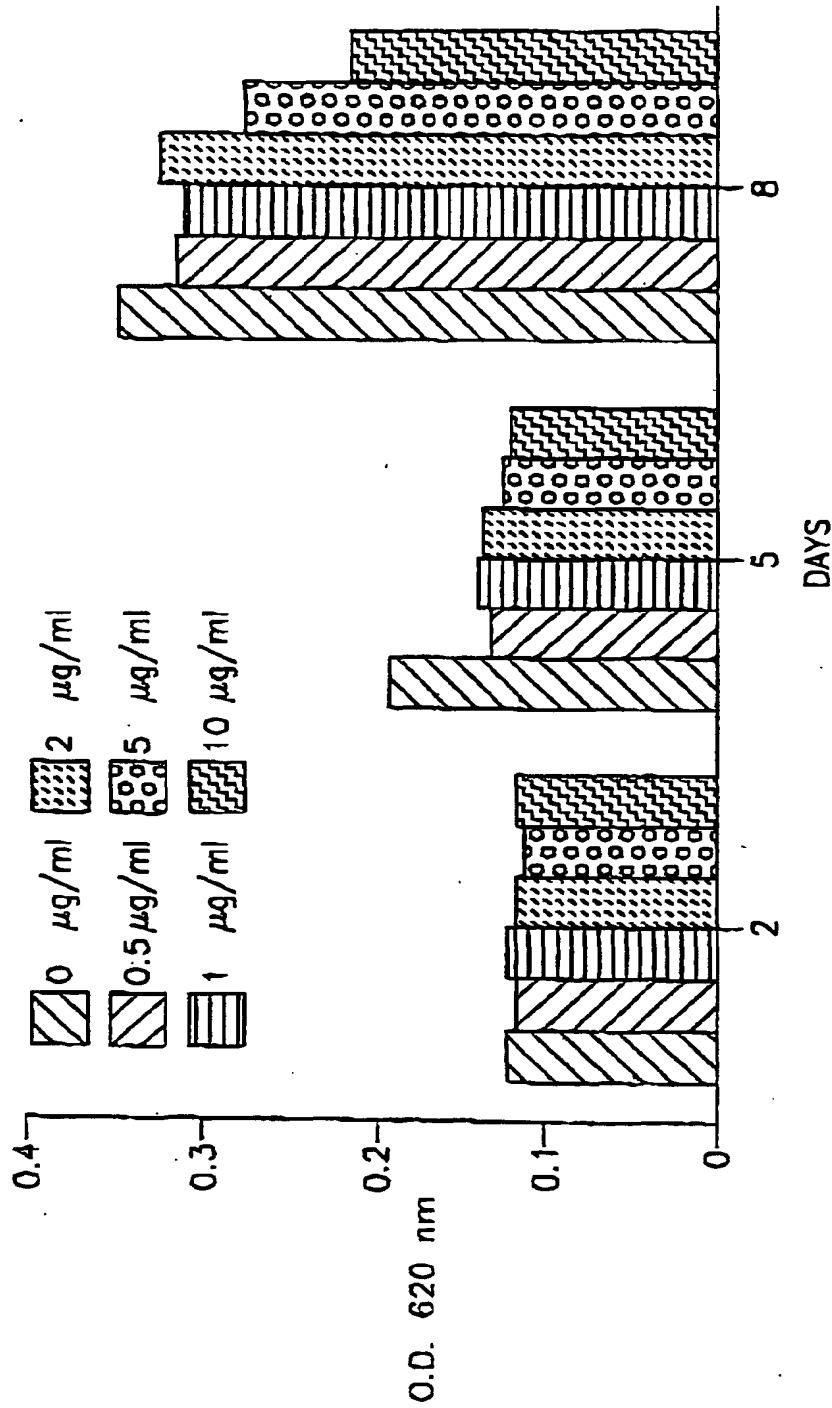

FIG.4

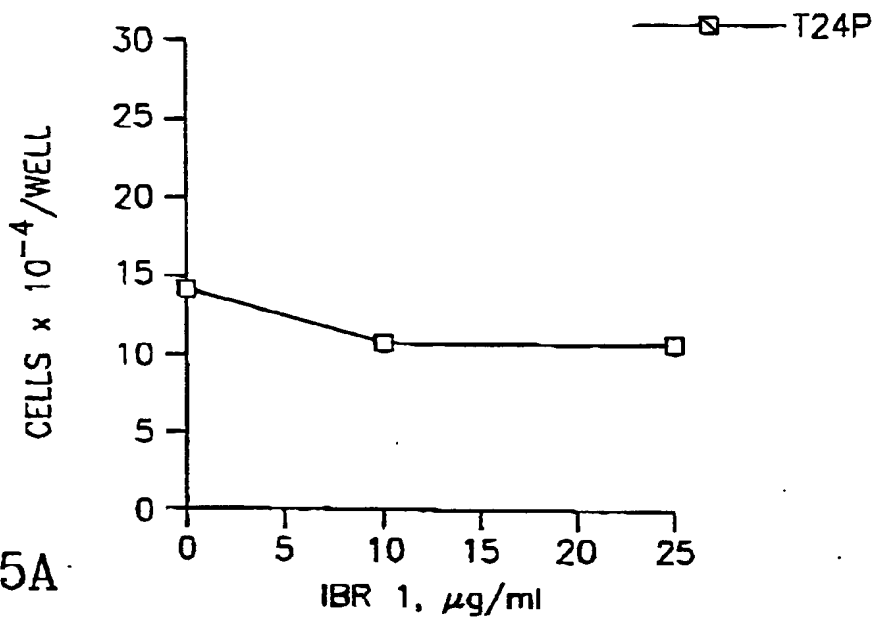

FIG.5A

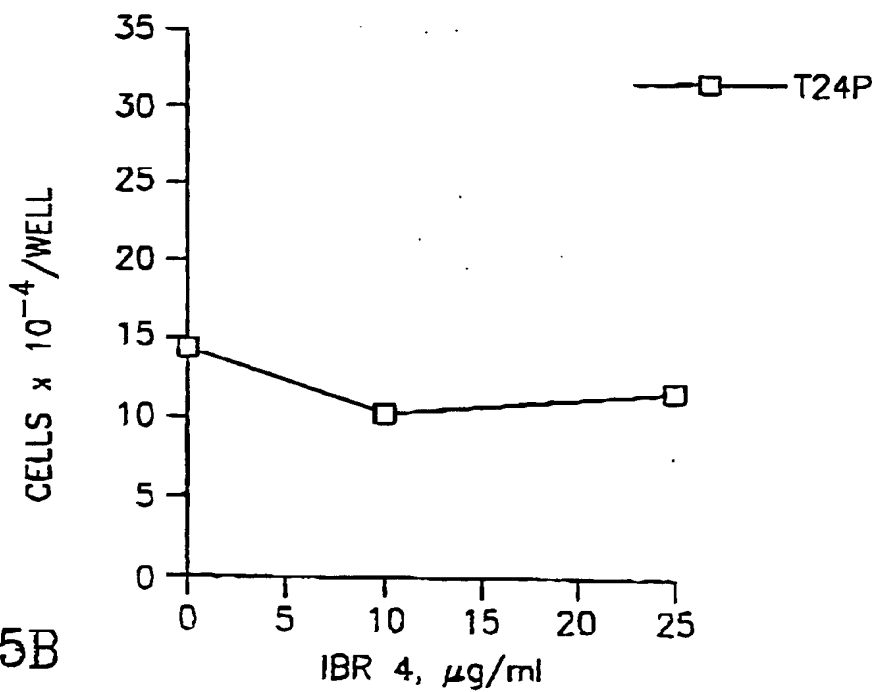

FIG.5B

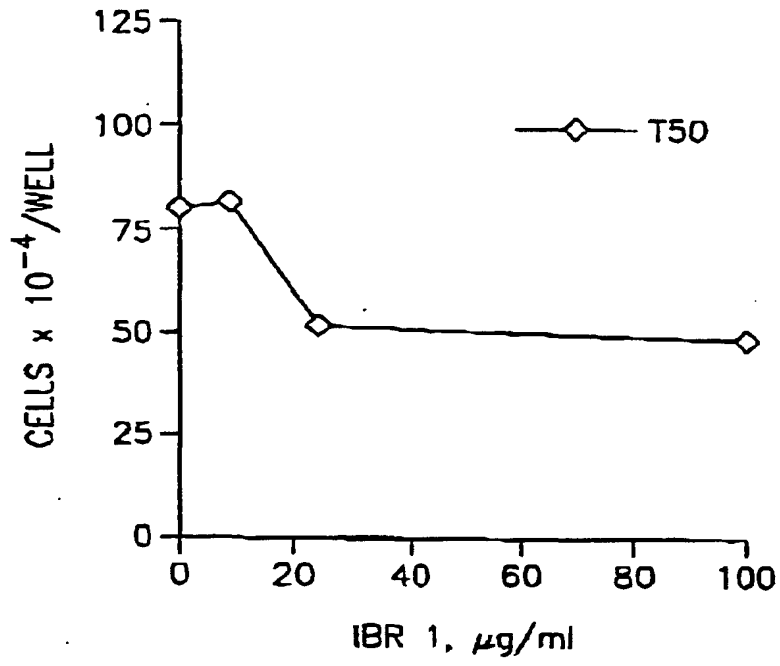

FIG.6

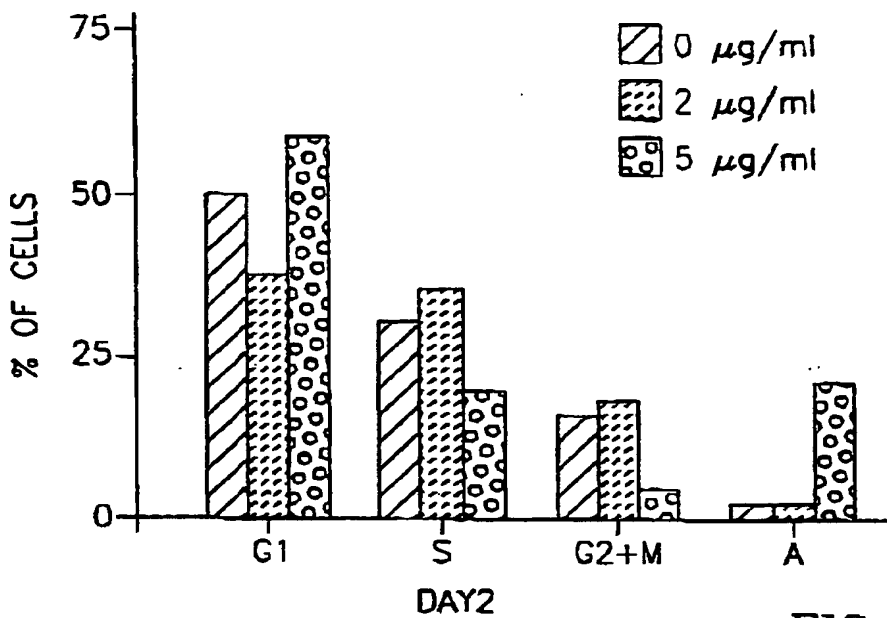

FIG.7A

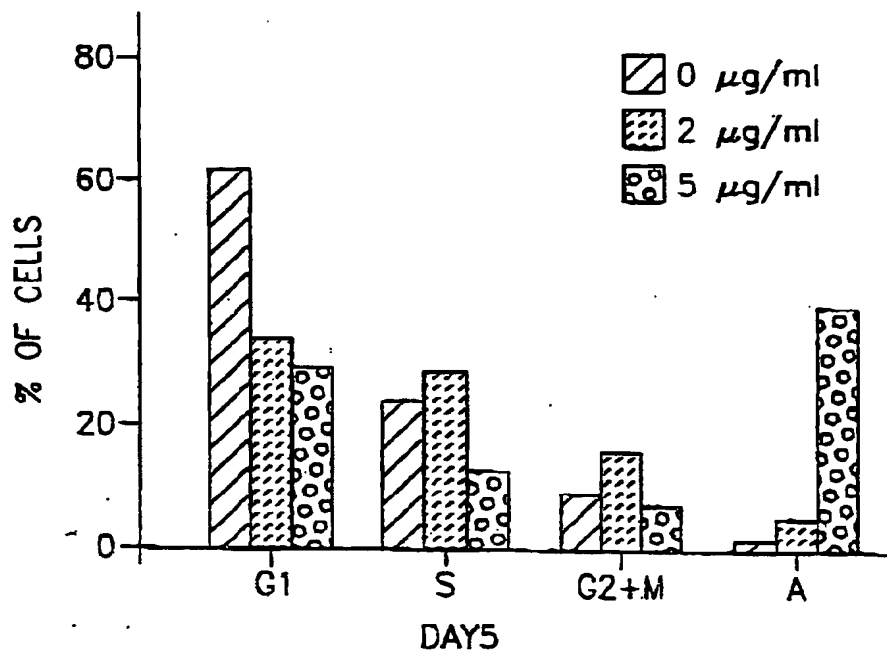

FIG.7B

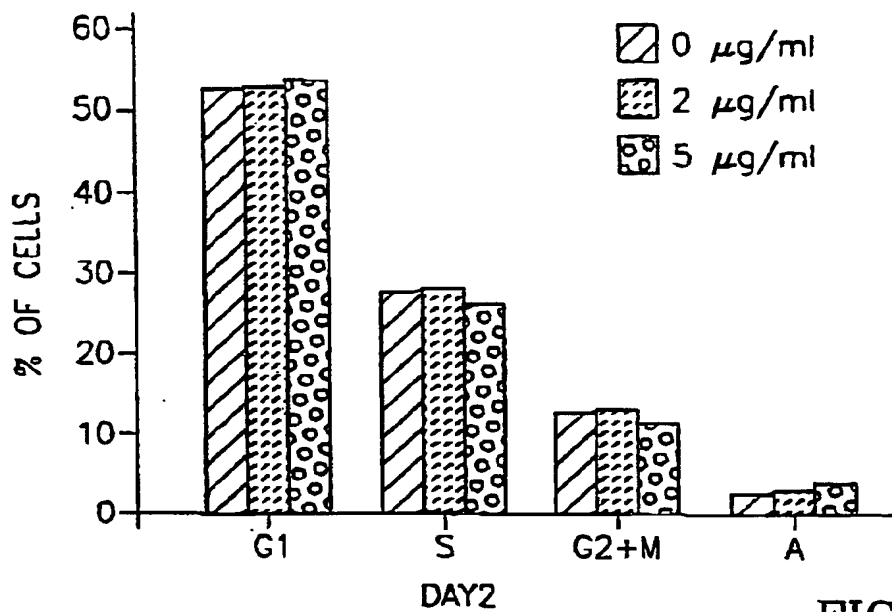

FIG. 7C

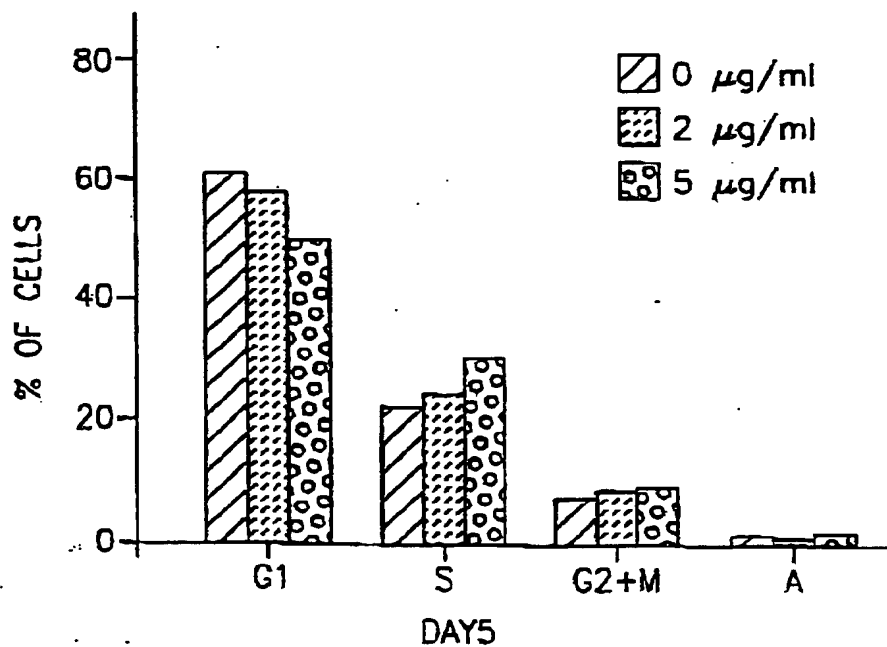

FIG. 7D

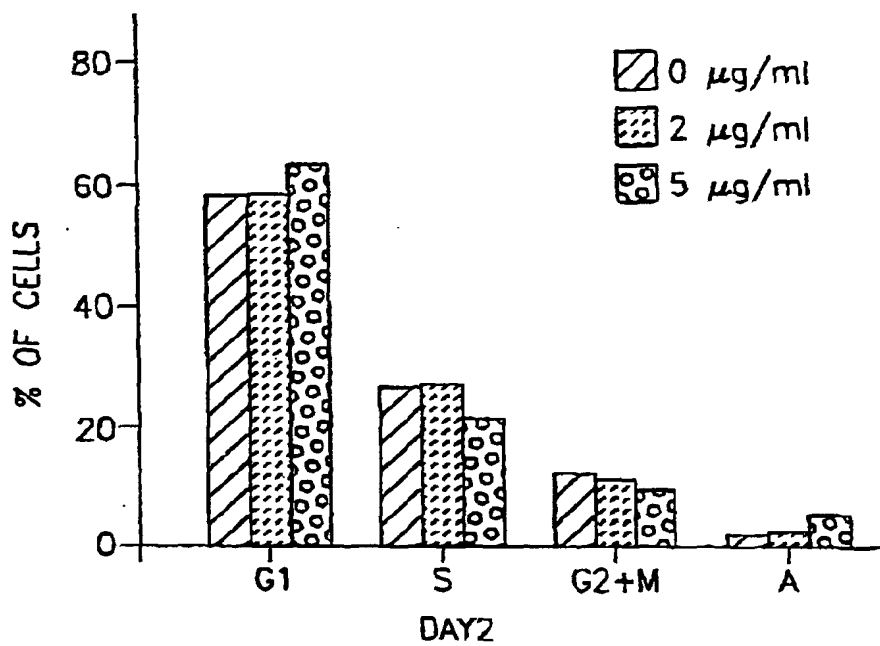

FIG. 7E

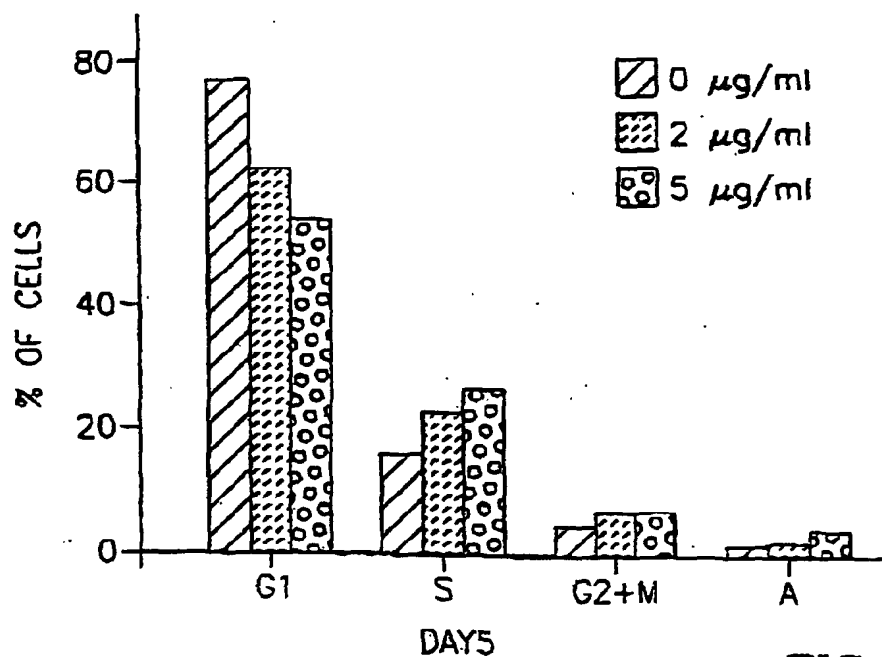
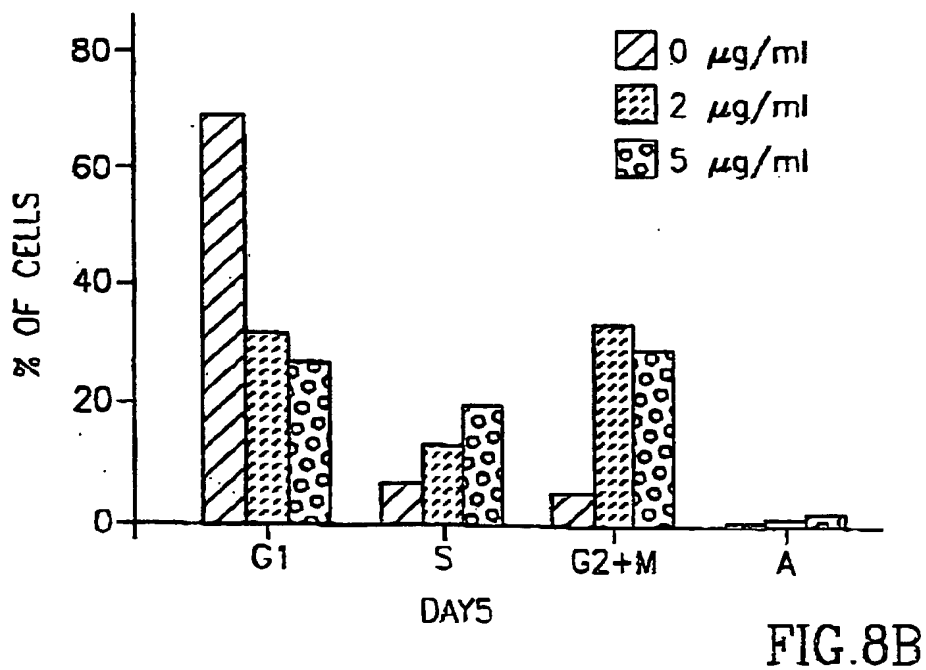
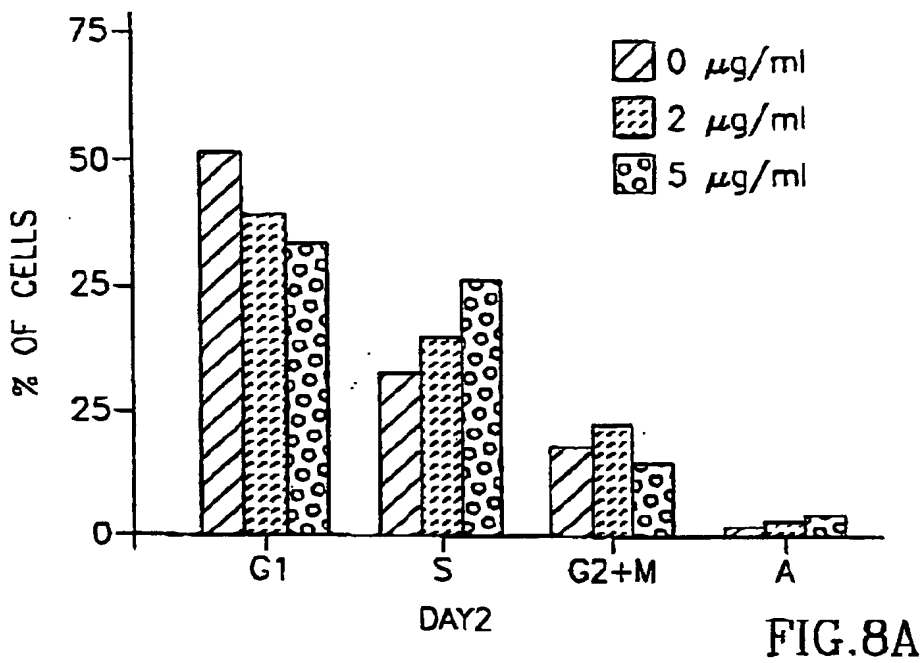

FIG. 7F



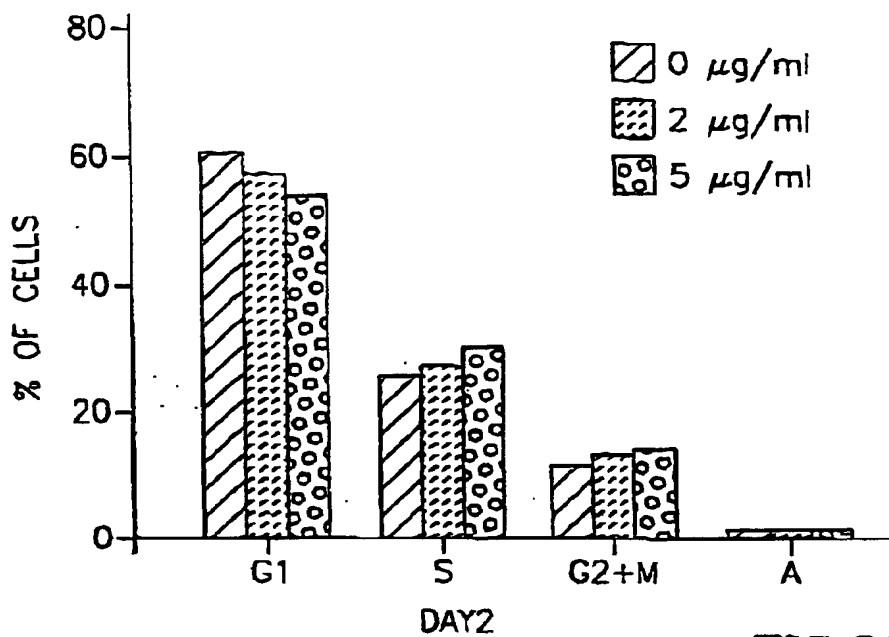

FIG.8C

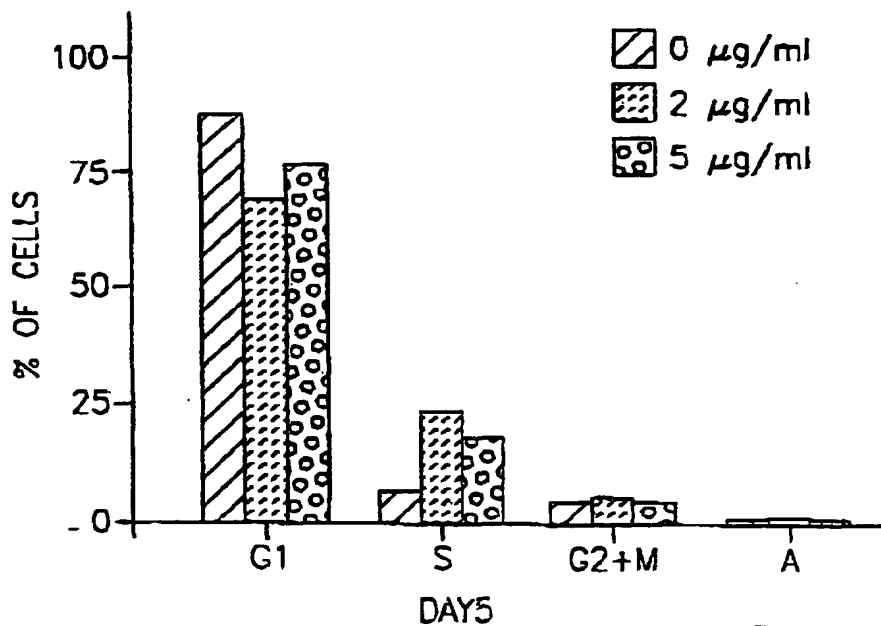

FIG.8D

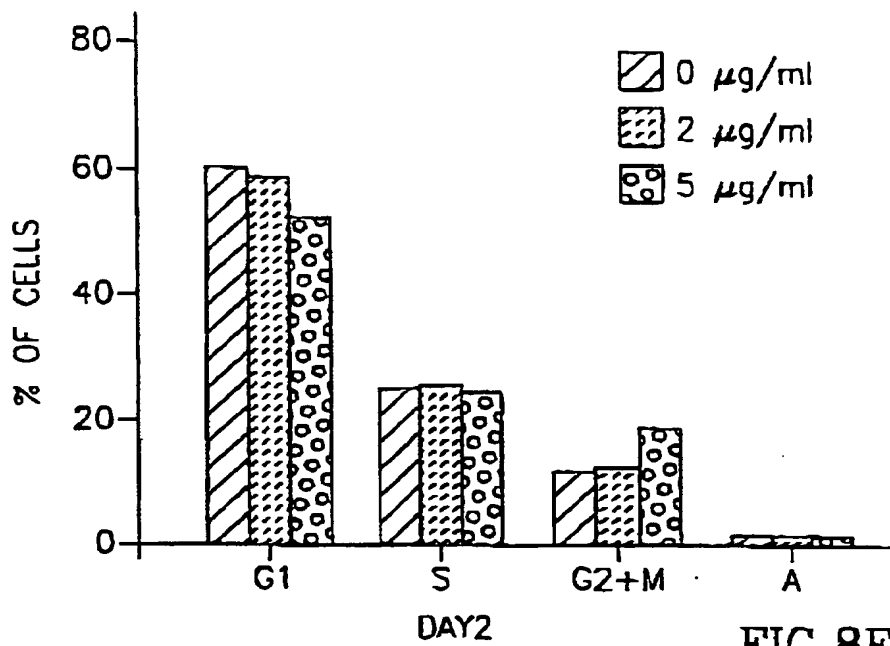

FIG.8E

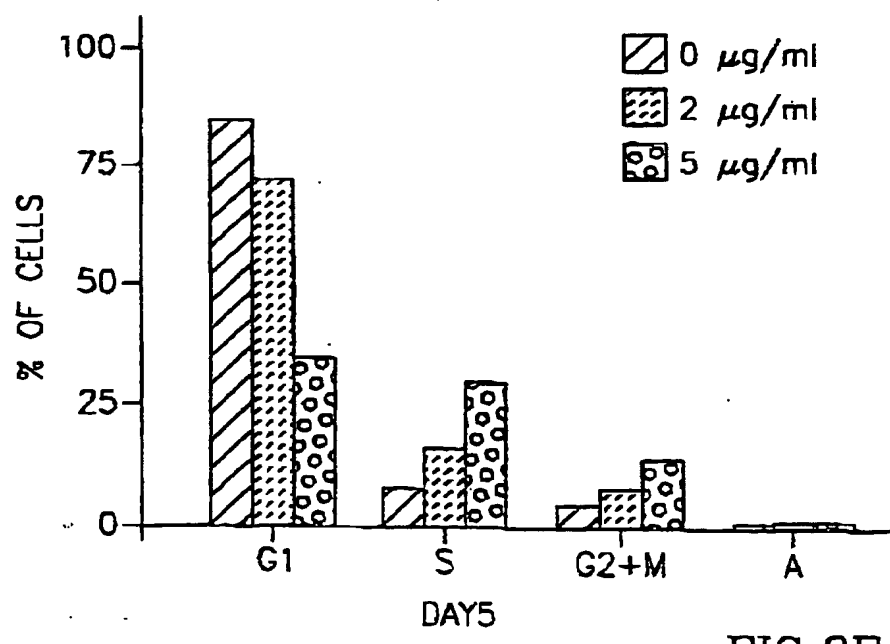

FIG.8F

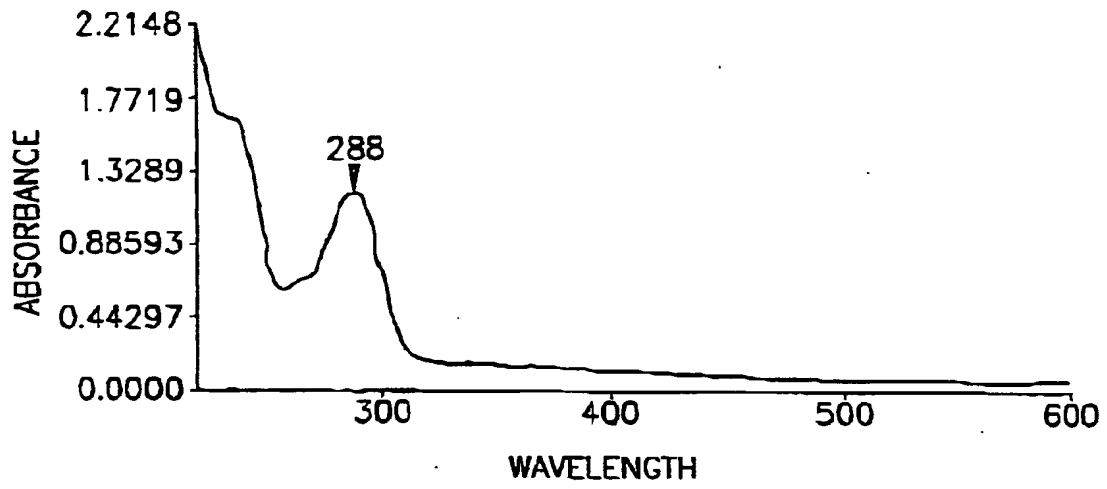

FIG.9 A

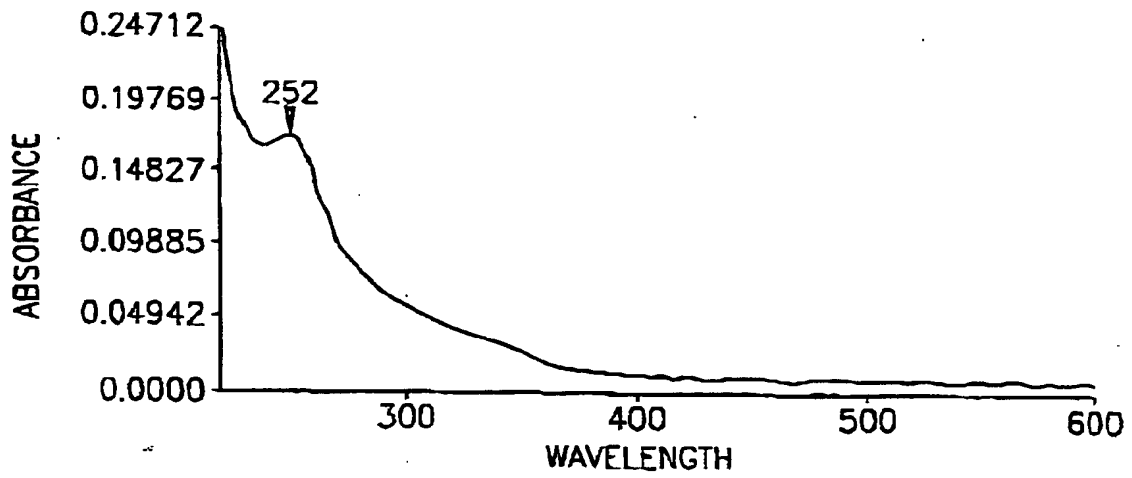

FIG.9 B

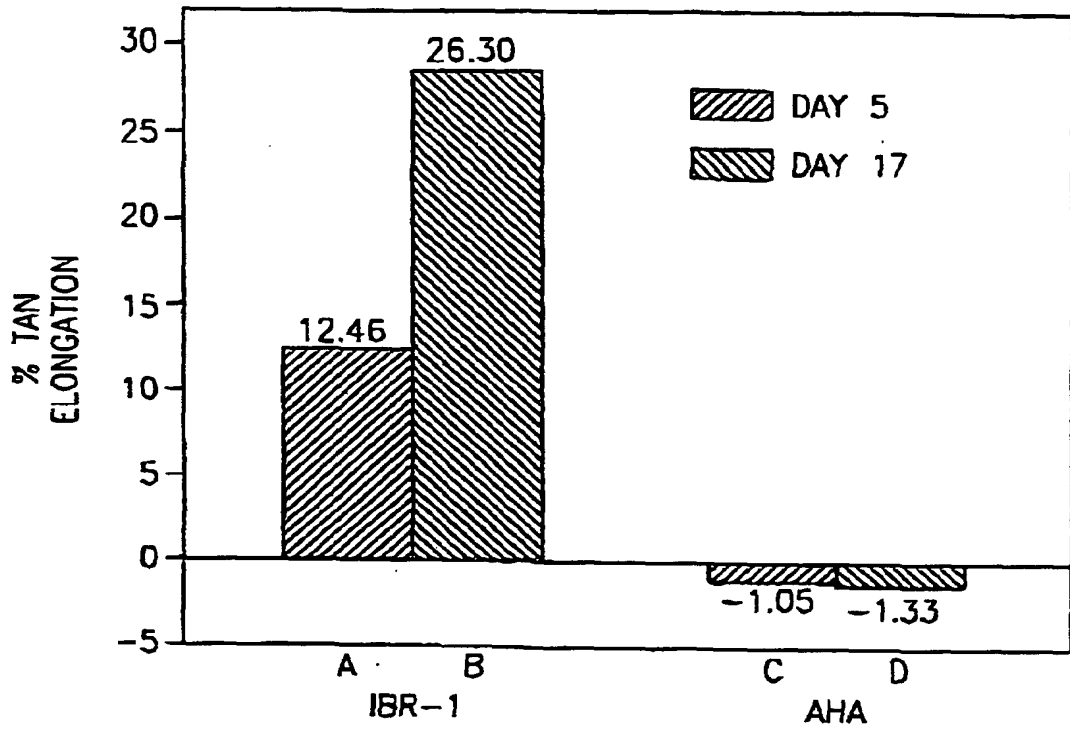

FIG. 10



(11) **EP 1 123 368 B1**

(12) **EUROPEAN PATENT SPECIFICATION**

(45) Date of publication and mention of the grant of the patent:
09.04.2008 Bulletin 2008/15

(51) Int Cl.:
C11B 1/10^(2006.01) C12N 9/64^(2006.01)

(21) Application number: **99952180.0**

(86) International application number:
PCT/CA1999/000987

(22) Date of filing: **21.10.1999**

(87) International publication number:
WO 2000/023546 (27.04.2000 Gazette 2000/17)

(54) **METHOD OF EXTRACTING LIPIDS FROM MARINE AND AQUATIC ANIMAL TISSUES**

VERFAHREN ZUR GEWINNUNG VON LIPIDEN AUS SEE- UND SÜSSWASSERTIERGEWEBEN
PROCEDE D'EXTRACTION DE LIPIDES DES TISSUS D'ANIMAUX MARINS ET AQUATIQUES

(84) Designated Contracting States:
**AT BE CH CY DE DK ES FI FR GB GR IE IT LI LU
MC NL PT SE**

(30) Priority: **21.10.1998 CA 2251265**

(43) Date of publication of application:
16.08.2001 Bulletin 2001/33

(73) Proprietor: **Université de Sherbrooke
Sherbrooke
Québec, J1K 2R1 (CA)**

(72) Inventors:
• **BEAUDOIN, Adrien
Rock Forest, Quebec J1N 1Z7 (CA)**
• **MARTIN, Geneviève
Sherbrooke, Quebec J1H 2N1 (CA)**

(74) Representative: **MacLean, Martin Robert et al
Mathys & Squire
120 Holborn
London EC1N 2SQ (GB)**

(56) References cited:
EP-A2- 0 732 378 WO-A1-84/01715

- **PATENT ABSTRACTS OF JAPAN vol. 1996, no. 12, 26 December 1996 (1996-12-26) -& JP 08 198754 A (YAKULT HONSHA CO LTD), 6 August 1996 (1996-08-06)**

- **DATABASE WPI Section Ch, Week 197845 Derwent Publications Ltd., London, GB; Class C03, AN 1978-80681A XP002129262 -& JP 53 112195 A (NIPPON PAINT CO LTD), 30 September 1978 (1978-09-30)**
- **PATENT ABSTRACTS OF JAPAN vol. 009, no. 160 (C-289), 4 July 1985 (1985-07-04) -& JP 60 035057 A (SANEIKAGAKU KOGYOKK), 22 February 1985 (1985-02-22)**
- **PATENT ABSTRACTS OF JAPAN vol. 016, no. 249 (C-0948), 8 June 1992 (1992-06-08) -& JP 04 057853 A (CHLORINE ENG CORP LTD; OTHERS: 01), 25 February 1992 (1992-02-25)**
- **DATABASE WPI Section Ch, Week 197633 Derwent Publications Ltd., London, GB; Class D13, AN 1976-62648X XP002129263 -& JP 51 076467 A (KYOWA HAKKO KOGYO), 2 July 1976 (1976-07-02)**
- **CHEMICAL ABSTRACTS, vol. 98, no. 21, 23 May 1983 (1983-05-23) Columbus, Ohio, US; abstract no. 177859, RAA, JAN ET AL.: "Isolation of astaxanthin from crayfish or shrimp waste for use as a coloring agent in fish feed" page 531; column 2; XP002129261 -& NO 147 365 B 20 December 1982 (1982-12-20)**
- **PATENT ABSTRACTS OF JAPAN vol. 009, no. 059 (C-270), 15 March 1985 (1985-03-15) -& JP 59 196032 A (FUMIO NISHIKAWA; OTHERS: 02), 7 November 1984 (1984-11-07)**

Note: Within nine months from the publication of the mention of the grant of the European patent, any person may give notice to the European Patent Office of opposition to the European patent granted. Notice of opposition shall be filed in a written reasoned statement. It shall not be deemed to have been filed until the opposition fee has been paid. (Art. 99(1) European Patent Convention).

EP 1 123 368 B1

Description**FIELD OF THE INVENTION**

5 [0001] This invention relates to the extraction of lipid fractions from marine and aquatic animals such as krill, *Calanus*, fish and sea mammals. More specifically, this invention relates to an improved method of extracting lipid fractions by dehydration with solvents and recovering a solid residue rich in active enzymes.

BACKGROUND OF THE INVENTION

10 [0002] Lipid fractions obtained from marine and aquatic animals such as krill, *Calanus*, fish and sea mammals have various applications:

Medical applications

15 [0003] Marine and aquatic animal oils and fractions thereof contain various therapeutic agents. For example, it is reported that various marine and aquatic animal oils have anti-inflammatory properties. Marine and aquatic animal oils are also reported as helpful in reducing the incidence of cardiovascular disease. Also, some marine and aquatic animal oils are reported as suppressing the development of certain forms of lupus and renal diseases. As a further example,
20 krill may be used as a source of enzymes for debridement of ulcers and wounds or to facilitate food digestion. Also marine and aquatic oils contain various antioxidants, which may have potential therapeutic properties.

Nutraceuticals

25 [0004] Considering the beneficial effects of omega-3 fatty acids, oils from krill, *Calanus* and fish could be used as dietary supplements to human diet. These fatty acids are essential for proper development of the brain and the eye. Marine and aquatic animal oils are also rich in liposoluble vitamins A, D and E and carotenoids.

Cosmetics

30 [0005] Various marine and aquatic animal oils are used for the production of moisturizing creams.

Fish farming

35 [0006] Among the lipids found in krill, *Calanus* and fish, high concentrations of fatty acids 20:5 (eicosapentaenoic acid) and 22:6 (docosahexaenoic acid) are present. These fatty acids are essential nutrients and are beneficial as fish feed. Furthermore, these essential nutrients are carried over in human diet by eating the fish grown on such diets.

Animal feed

40 [0007] Animal feed diets rich in omega-3 fatty acids may increase the level of unsaturated fatty acids and decrease cholesterol levels of meat. This property is already exploited in the poultry industry to improve the quality of eggs.

[0008] Various methods for extracting marine and aquatic animal oils are known. For example, it is known to extract fish oil using organic solvents such as hexane and ethanol. It is also known to measure the fat content in fish muscle
45 tissue using solvents such as acetone.

[0009] USP 4,331,695 describes a method using pressurized solvents which are gaseous at room temperature, such as propane, butane or hexane. The extraction is performed at preferred temperatures of 15 to 80 °C on shredded vegetable or finely divided animal products. The extracted oils are then made to precipitate under high pressure and elevated temperatures of 50 to 200 °C. However, hexane is a poor extraction solvent for marine animals such as krill. Furthermore,
50 the high temperatures used in the precipitation step negatively alters the lipids.

[0010] Canadian Patent Application 2,115,571 describes a method for extracting oils from various brown and red algae species. The method provides for example Soxhlet extraction using nearly pure ethanol for 40 hours.

[0011] USP 5,006,281 describes a method for extracting oil from marine and aquatic animals such as fish. The marine and aquatic animal is first treated with an antioxidant compound, finely divided and centrifuged to separate the oil phase from the aqueous phase and solid phase. The oil phase is then further treated with antioxidant to remove undesirable odour or taste.
55

[0012] Canadian Patent 1,098,900 describes a method for extracting oils from krill. The method involves emulsifying fresh or defrosted krill in an aqueous medium. The oil fraction is recovered by centrifugation.

[0013] Folch in the article published in the year 1957 in J. Biol. Chem. 226: 497-509 "A simple method for the isolation and purification of total lipids from animal tissues" proposes an extraction method using chloroform and methanol. This method is not commercially feasible because of the toxicity of the solvents involved.

[0014] Chem Abs. 177859 describes a procedure for extraction of the dye astaxanthine, which is used as a source of colour in salmon fish farming, from shrimp waste or krill, comprising mixing the raw material with triglyceride oil and pressing the raw material to extract the astaxanthine-enriched oil.

[0015] However, prior art processes are generally commercially unfeasible, or provide low quantitative yields.

[0016] The present invention provides a method for extracting total lipid fractions from marine and aquatic animal material, said method comprising the steps of: (a) placing marine and aquatic animal material in a ketone solvent, preferably acetone to achieve extraction of the soluble lipid fraction from said marine and aquatic animal material; (b) separating liquid and solid contents resulting from step (a); (c) recovering a first total lipid rich fraction from the liquid contents of b) by evaporation of the solvent present in the liquid contents; (d) placing said solid contents in an organic solvent selected from the group of solvents consisting of alcohol preferably ethanol, isopropanol or t-butanol, and ester of acetic acid, preferably ethyl acetate, to achieve extraction of the remaining soluble lipid fraction from said marine and aquatic animal material; (e) separating liquid and solid contents resulting from step (d); and (f) recovering a second total lipid rich fraction by evaporation of the solvent from the liquid contents of e).

[0017] Thus, it is an object of the present invention to provide an improved marine and aquatic animal oil extraction method allowing recovery of a valuable lipid fraction and separate recovery of a valuable protein rich solid residue that comprises active enzymes.

[0018] The present invention also provides a method for extracting an astaxanthin-andcanthaxantin-containing total lipid fraction from a marine and aquatic animal material selected from zooplankton and fish, said method comprising the steps of: (a) placing said animal material in a ketone solvent, preferably acetone to achieve an extraction of the soluble lipid fraction from said marine and aquatic animal material; (b) separating liquid and solid contents resulting from step (a); (c) recovering a lipid rich fraction from the liquid contents by evaporation of the solvent present in the liquid contents; whereby an astaxanthin-and-canthaxantin-containing total lipid fraction is obtained.

[0019] The present invention also provides a method for extracting a total lipid fraction from a marine and aquatic animal material selected from zooplankton and fish, said method comprising the steps of: (a) placing said animal material in a solvent mixture comprising acetone and ethanol to achieve an extraction of the soluble lipid fraction from said marine and aquatic animal material; (b) separating liquid and solid contents resulting from step (a); (c) recovering a lipid rich fraction from the liquid contents by evaporation of the solvents present in the liquid contents; whereby a total lipid fraction is obtained.

[0020] The present invention also provides a total krill lipid extract characterized in that it is devoid of toxic solvent and in that the carotenoid content in astaxanthin is 75 µg/g or more and preferably at least about 90 µg/g or more of krill extract, and the carotenoid content in canthaxanthin is 250 µg/g or more and preferably at least about 270 µg/g of krill extract or more.

[0021] The present invention also provides a krill lipid extract characterised in that it is edible, and in that the carotenoid in astaxanthin is 75 µg/g or more and preferably at least about 90 µg/g or more of krill extract, and the carotenoid content in canthaxanthin is 250 µg/g or more and preferably at least about 270 µg/g of krill extract or more.

[0022] Other objects and further scope of applicability of the present invention will become apparent from the detailed description given hereinafter. It should be understood, however, that this detailed description, while indicating preferred embodiments of the invention, is given by way of illustration only, since various changes and modifications within the scope of the invention will become apparent to those skilled in the art.

Figure 1. Gas-liquid chromatography of fatty acids from dry krill (chloroform-methanol)

Figure 2. Gas-liquid chromatography of fatty acids from dry krill (acetone)

Figure 3. Gas-liquid chromatography of fatty acids from frozen krill (acetone)

Figure 4. Gas-liquid chromatography of fatty acids from frozen krill (ethanol)

Figure 5. Gas-liquid chromatography of fatty acids from frozen krill (t-butanol)

Figure 6. Gas-liquid chromatography of fatty acids from frozen krill (ethyl acetate)

Figure 7. Thin-layer chromatography of neutral lipids of *Calanus* sp. and *M. norvegica*

Figure 8. Thin-layer chromatography of neutral lipids of *E. pacifica*

Figure 9. Thin-layer chromatography of neutral lipids of *M. schmitti*

Figure 10. Thin-layer chromatography of neutral lipids of *G. galeus*

Figure 11. Thin-layer chromatography of neutral lipids of Angel Shark

Figure 12. Thin-layer chromatography of phospholipids of *Calanus* sp. and *M. norvegica*

Figure 13. Thin-layer chromatography of phospholipids of *E. pacifica*

- Figure 14. Thin-layer chromatography of phospholipids of *M. schmitti*
 Figure 15. Thin-layer chromatography of phospholipids of *G. galeus*
 Figure 16. Thin-layer chromatography of phospholipids of Angel Shark
 Figure 17. Influence of the volume of acetone on lipid extraction (*E. pacifica*)
 5 Figure 18. Influence of incubation time in acetone on lipid extraction (*E. pacifica*)
 Figure 19. Influence of the volume of ethanol on lipid extraction (*E. pacifica*)
 Figure 20. Influence of incubation time in ethanol on lipid extraction (*T. raschii*)

DETAILED DESCRIPTION OF THE PREFERRED EMBODIMENT

10 **[0023]** Before describing the present invention in detail, it is to be understood that the invention is not limited in its application to the process details described herein. The invention is capable of other embodiments and of being practised in various ways. It is also to be understood that the phraseology or terminology used herein is for the purpose of description and not limitation.

15 **[0024]** The method of the invention comprises suspending freshly collected marine and aquatic material in acetone. Lipids are extracted with a ketone such as acetone. This allows a rapid dehydration of animal tissue and a migration of the lipid fraction to the solvent. The dry residue is a valuable product rich in active enzymes.

20 **[0025]** In a preferred embodiment, the extraction is carried out by successive acetone and alcohol treatments. Preferred alcohols are isopropanol, and *t*-butanol. The alcohol may also be substituted with an ester of acetic acid such as ethyl acetate. The procedure produces two successive lipid fractions and a dry residue enriched in protein, including active enzymes. Recovery of total lipids is comparable to the Folch et al. (1957) procedure reported in the background of the invention. It has been tested with krill, *Calanus*, fish and shark tissues.

25 **[0026]** Surprisingly, it was found that successive extraction treatments as proposed by the present invention has a better yield in lipid extraction than single solvent system extractions. The extraction using two successive solvents which starts with a ketone such as acetone is especially advantageous since the acetone, in effect, dehydrates the animal tissue. Having the animal tissue in dehydrated form greatly facilitates the extraction process with the second solvent, alcohol or an ester of acetic acid such as ethyl acetate.

30 **[0027]** In the case of zooplankton such as krill and *Calanus* and in the case of fish-filleting by-products such as fish viscera, it is noted that extraction with acetone alone may be sufficient to allow a cost-effective recovery of lipid fractions and separate recovery of a dry solid product rich in proteins including active enzymes.

35 **[0028]** The general extraction method of the present invention will now be described. The starting material consisting of freshly harvested and preferably finely divided marine and aquatic animal material is subjected to acetone extraction, for at about two hours and preferably overnight. However extraction time is not critical to the yield of lipid extraction. To facilitate extraction, it is preferable to use particles of less than 5mm in diameter. Extraction is preferably conducted under inert atmosphere and at a temperature in the order of about 5 °C or less.

[0029] Preferably, the beginning of the extraction will be conducted under agitation for about 10 to 40 minutes, preferably 20 minutes. Although extraction time is not critical, it was found that a 2 hour extraction with 6:1 volume ratio of acetone to marine and aquatic animal material is best.

40 **[0030]** The solubilized lipid fractions are separated from the solid material by standard techniques including, for example, filtration, centrifugation or sedimentation. Filtration is preferably used.

[0031] After separation by filtration on an organic solvent resistant filter (metal, glass or paper) the residue is optionally washed with pure acetone, preferably two volumes (original volume of material) to recover yet more lipids. The combined filtrates are evaporated under reduced pressure. Optionally, flash evaporation or spray drying may be used. The water residue obtained after evaporation is allowed to separate from the oil phase (fraction I) at low temperature.

45 **[0032]** The solid residue collected on the filter is suspended and extracted with alcohol, such as ethanol, isopropanol, *t*-butanol or alternatively with ethyl acetate, preferably two volumes (original volume of material). The filtrate is evaporated leaving a second fraction of lipids (identified as fraction II). Although the extraction period is not critical, it was found that an extraction time of about 30 minutes is sufficient at temperatures below about 5 °C.

50 **[0033]** Temperature of the organic solvents, except *t*-butanol, and temperature of the sample are not critical parameters, but it is preferable to be as cold as possible. However, in the case of *t*-butanol which is solid at room temperature, it is important to warm it before using it and to perform the extraction at 25 °C immediately.

Comparative examples

55 **[0034]** To compare the efficiency of the extraction process, a classical technique (Folch et al. 1957) using chloroform and methanol was applied to krill. This method is the reference for measuring efficiency of the extraction process. Another comparison has been made with a technique using hexane as the extraction solvent. Lipid recovery by suspending lipid fractions in small volumes of their original solvents and measuring by gravimetry small aliquots after evaporation.

[0035] For all examples provided herein, the method of the present invention involving acetone extraction followed by extraction with a second solvent (ethyl acetate, for example) gave a translucent oil having appearance and properties more attractive than any oil obtained by the classical technique of Folch et al. (1957).

5 [0036] To analyze lipid composition, 780 µg of each extract was loaded on silica-gel plates and fractionated by thin layer chromatography, TLC (Bowyer et al. 1962) with the following solvents. Neutral lipids: hexane, ethyl ether, acetic acid (90:10:1, v/v) and phospholipids: chloroform, methanol, water (80:25:2, v/v). Fatty acid composition of *E. pacifica* was analyzed by gas liquid chromatography, GLC (Bowyer et al. 1962) including some modifications to the original technique: 2h at 65 °C instead of 1h at 80 °C, three washes with hexane instead of two and no wash with water.

10 [0037] To get rid of traces of organic solvents, lipid fractions I and II are warmed to about 125 °C for about 15 minutes under inert atmosphere.

[0038] Fat was analyzed according to the American Oil Chemist's Society (AOCS). The following criteria have been used to analyze the lipids extracted: saponification and Wijs iodine indexes and moisture-volatile matter levels. Cholesterol content has also been determined by the method of Plummer 1987. The same analyzes and others have been made by an independent laboratory under Professor Robert Ackman's supervision (Canadian Institute of Fisheries Technology, DalTech, Dalhousie University, Halifax, Nova Scotia, Canada). This includes Wijs iodine index, peroxide and anisidine values, lipid class composition, fatty acid composition, free fatty acid FAME, cholesterol, tocopherol, all-*trans* retinol, cholecalciferol, astaxanthin and canthaxanthin contents.

15 [0039] Table 1 shows that higher levels of lipids are extracted from dry krill by acetone followed by ethanol as compared to the classical procedure of Folch et al. (1957).

20 [0040] Table 2 shows the results of lipid extraction from frozen *Euphausia pacifica*, a species of krill from Pacific Ocean. Assuming an eighty percent content of water, the lipid content is comparable to dry krill as shown in Table 1. Isopropanol, *t*-butanol and ethyl acetate, as solvent for the second extraction, give a yield less important than ethanol, but are not necessarily less effective in lipid recovery since ethanol carries more impurities than isopropanol, *t*-butanol or ethyl acetate. Then, they can be used as second solvent after acetone as well. Variations between results from acetone extractions are mainly due to the water-oil separations. These separations are influenced by the quantity of residual acetone in the water-oil solution after acetone evaporation. This quantity of acetone varies from an experiment to another, because the evaporation system used at a small scale is less reproducible (at the industrial scale, the evaporation step will be optimized). Single solvents have also been tested to extract the totality of lipids from krill. This shows that ethyl acetate (1,37% extraction rate), as hexane (0,23% extraction rate) are not good solvents, compared to acetone alone (1,86% extraction rate, and even greater extraction rates with an efficient acetone evaporation system).

25 [0041] One of the main advantages of the procedure is the removal of bacteria from extracts (lipid fraction and solid protein-rich material). Indeed, samples of *E. pacifica* incubated in different ratios of acetone at 4 °C for 112 days have been inoculated on NA medium containing Bacto™ beef extract 0,3%, Bacto™ peptone 0,5% and Bacto™ agar 1,5% (Difco Laboratories, Detroit, USA) then incubated at room temperature or 4 °C for 18 days. No significant bacterial growth was observed at a ratio of 1 volume of acetone per gram of krill. At higher proportions of acetone (2 volumes and 5 volumes), there was no bacterial growth at all, which means that acetone preserves krill samples. Acetone is known as an efficient bactericidal and viricidal agent (Goodman et al. 1980).

30 [0042] Table 3 shows the yield of lipids from *M. norvegica*. The percentage of lipids (3,67%) is comparable to the one obtained with *E. pacifica* (3,11%) shown in Table 2. Variations can be attributable to diet and time (season) of collection, which are different for those two species.

35 [0043] Table 4 shows the influence of grinding on the efficiency of extraction of *M. norvegica* lipids. These extractions were carried out under optimal conditions and show the definite advantage of the procedure over the classical method (4,46 % versus 3,30 %). It also shows that grinding may be an important factor when the species is large (4,46% versus 3,53 %).

40 [0044] Table 5 reports on lipid extraction from *Calanus*. Considerable quantities of lipids were obtained. Some variations in *Calanus* species composition may explain the variations between experiments 1 and 2 (8,22 % and 10,90 % of fresh weight).

45 [0045] Tables 6-8 report the total amount of lipids extracted from fish tissue. The method of the present invention was demonstrated on mackerel, trout and herring. The method was demonstrated on peripheral tissues (mainly muscles) and viscera. Advantageously, the present method would permit the recovery of valuable lipid fractions from parts of fish that are usually wasted after the withdrawal of fillets of the fish. Those fish tissues not used after the transformation of the fish for human consumption could be stored in acetone, and lipids extracted therefrom in accordance with the present invention even if the method Folch [1957] recovers more lipid than our method. Indeed small amounts of lipids from mackerel (0,52% from viscera and 1,45% from tissues) have been extracted by the method of Folch after a first extraction with acetone and ethanol as described in the present invention. Comparative extractions with the method described in the present invention carried out in parallel with the method of Folch on trout and herring show superior recovery with the latter. However, it is noteworthy that the Folch method can not be applied for the recovery of lipids for commercial uses (because of toxicity).

[0046] In Tables 9 to 11, are shown results of lipids extraction from shark liver tissues. There is no marked difference in results between techniques within a species.

[0047] Tables 12 shows some characteristics features of fraction I (acetone) and fraction II (alcohol or ethyl acetate) for krill oil (*e. pacifica*). First, the saponification index of fraction I (130,6) indicates that this fraction contains fatty acids with longer chains, compared to fraction II (185,7). The Wijs iodine index of fraction I shows that this fraction contains high levels of polyunsaturated fatty acids. As compared to olive oil which has an index of 81.1. It explains why fraction I is liquid at room temperature. It is well known that unsaturated fatty acids have a fusion point inferior to the one of their saturated homologues. The same observations are made for fraction II which has a iodine index of 127,2. The fatty acid composition shown in Table 14 corroborates these iodine indexes: fraction I has a high percentage (30,24%) of polyunsaturated fatty acids (pentaenes+hexaenes) and so fraction II (22,98%).

Finally, Table 12 shows also that fraction I is comprised of 10,0% of volatile matter and humidity after evaporation of the solvent. For the same test, the fraction II gives a value of 6.8%. To get rid of traces of solvents, it is important to briefly heat (to about 125°C, for about 15 min) the oil under nitrogen.

[0048] Results on krill oils obtained in accordance with the method of the present invention (fraction I extracted with acetone and fraction II extracted with ethyl acetate) are provided in Tables 12, 13, 14, 15, 16 and 17. It is noteworthy to mention that in Table 17, the carotenoids content was significantly high as measured in terms of two carotenoids namely astaxanthin and canthaxanthin. Indeed, duplicates analyzes revealed values of 92 to 124 µg/g of lipid fraction for astaxanthin and 262 to 734 µg/g for canthaxanthin. Thus, for the purpose of the present invention it may be said that the krill extract comprises astaxanthin at least 75 and preferably at least 90 ug/g of lipid fraction. In the case of canthaxanthin, at least 250 and preferably at least 270 µg/g of lipid fraction. Low values for peroxide and anisidine are advantageous and are due to the presence of high levels of natural antioxidants (astaxanthin and canthaxanthin). These compounds are indicative of favourable pharmaceutical or cosmetological properties of the krill extract whereby high levels of carotenoids indicate excellent transdermal migration characteristics. Thus, krill extract is a good candidate for transdermal delivery of medicines.

[0049] Table 18 shows the best mode of the method in accordance with the present invention for lipid extraction of aquatic animal tissues.

[0050] Table 19 shows that the enzyme activity of the solid fraction is maintained following the method of the present invention. Indeed, the demonstration was completed for solid krill residue obtained after successive acetone and ethyl acetate extraction. Proteolytic activities were measure by the liberation of amino groups by spectrophotometric assay using o-phthaldialdehyde as reagent. Protein concentrations were measured by the Bradford method. Soluble proteins were extracted with water and added to a 10% lactoserum protein concentrate obtained by ultrafiltration. At the end of incubation at 37°C in 50mM potassium phosphate buffer, trichloroacetic acid was added and the amount of NH₂ group was measured the supernatant according to the method of Church et al. [1983, J Dairy Sci 66: 1219-1227].

[0051] Figures 1 to 6 show chromatograms of fatty acid composition of *E. pacifica* lipids. On each of them, high proportions of 20:5 and 22:6 fatty acids (characteristic of marine and aquatic oils) are noticeable and represented by two distinct peaks.

[0052] Variations in lipid patterns of neutral lipids (from Figure 7 to Figure 11) from one species to another are attributable to the differences in food sources. Within a species (*E. pacifica*, for example) there is no marked variation between lipid patterns obtained from different techniques of lipid extraction. Concerning phospholipids (Figure 12 to Figure 16), the opposite is observed: variations are explained by the different extraction processes of lipids since the same species do not lead to the same lipid pattern. Lipids from shark species (extracted by the mentioned methods) and commercial cod-liver oil (sample available from Uniprix drugstores, Province of Québec, Canada) are mainly composed of neutral lipids as opposed to phospholipids.

[0053] The influence of the volume of solvent and incubation time on the efficiency of the acetone to extract lipids from *E. pacifica* is illustrated in Figures 17 and 18, respectively. A ratio of 1:6 (w/v) produced optimal yield with near complete extraction after 2h. The second extraction step has been experimented with ethanol. The volume of this solvent does not appear to be critical since the same yield was obtained with different volumes of ethanol (Figure 19), but incubations time in ethanol should be at least 30 minutes as indicated by the results on Figure 20.

[0054] One of the inventors, Dr. Adrien Beaudoin, has ingested the different lipid fractions of krill. No side effect profile was observed.

[0055] Although the invention has been described above with respect with one specific form, it will be evident to a person skilled in the art that it may be modified and refined in various ways. It is therefore wished to have it understood that the present invention should not be limited in scope, except by the terms of the following claims.

[0056] Demonstration that krill residue, obtained after acetone and ethyl acetate extraction, contains enzyme proteolytic activities. Proteolytic activities were measured by the liberation of amino groups by spectrophotometric assay using o-phthaldialdehyde as reagent. Protein concentrations were measured by the Bradford method.

[0057] The enzyme source was the residue obtained after acetone and ethyl acetate extractions of lipids. Soluble proteins were extracted with water and added to a 10% lactoserum protein concentrate obtained by ultrafiltration.

[0058] At the end of incubation at 37°C in 50 mM potassium phosphate buffer, trichloroacetic acid was added and the amount of NH₃ groups were measured in the supernatant according to Church and al. 1983.

BIBLIOGRAPHY

- 5
- [0059] Bowyer, D.E., Leat, W.M.F., Howard, A.N. and Gresham, G.A. 1962. The determination of the fatty acid composition of serum lipids separated by thin-layer chromatography; and a comparison with column chromatography. BBA. 70: 423-431.
- 10 [0060] Chandrasekar, B., Troyer, D.A., Venkatraman, J.T. and Fernandes, G. 1996. Tissue specific regulation of transforming growth factor beta by omega-3 lipid-rich krill oil in autoimmune murine lupus. Nutr Res. 16(3): 489-503.
- [0061] Christensen, M.S., Hoy, C-E. and Redgrave, T.G. 1994. Lymphatic absorption of n-3 polyunsaturated fatty acids from marine oils with different intramolecular fatty acid distributions. BBA. 1215: 198-204.
- [0062] Church, F.C., Swaisgood, H.E., Porter, D.H. and Catignani, G.L. 1983. Spectrophotometric assay using o-Phthaldialdehyde for determination of proteolysis in milk and isolated milk proteins. J Dairy Sci. 66: 1219-1227.
- 15 [0063] Difco laboratories. 1984. Difco Manual Dehydrated Culture Media and Reagents for Microbiology. 10th ed. Detroit.
- [0064] Folch, J., Lees, M. and Sloane-Stanley, G.H. 1957. A simple method for the isolation and purification of total lipids from animal tissues. J. biol. Chem. 226: 497-509.
- 20 [0065] Goodman Gilman, A., Goodman, L.L. and Gilman, A. 1980. The Pharmacological Basis of Therapeutics. 6th ed. Collier Macmillan Canada Ltd, Toronto.
- [0066] Harwood, H.J. and Geyer, R.P. 1964. Biology Data Book. The Federation of American Societies for Experimental Biology, Washington.
- [0067] Helgren, L., Karlstam, B., Mohr, V. and Vincent, J. 1991. Krill enzymes. A new concept for efficient debridement of necrotic ulcers. Int J Dermatol. 30(2): 102-103
- 25 [0068] Plummer, D.T. 1987. An introduction to practical biochemistry. 3th ed. McGraw-Hill Book Company, London.
- [0069] Rawn, J.D. 1990. Traité de biochimie. De Boeck-Wesmael, Bruxelles.
- [0070] Runge, J.A. and Joly, P. 1994. Rapport sur l'état des invertébrés en 1994: 7:0 Zooplancton (Euphausiacés et Calanus) de l'Estuaire et du Golfe du Saint-Laurent. Sargent, J.R. 1997. Fish oils and human diet. Br J Nutr. 78 Suppl 1: S5-S13.
- 30

TABLE 1. EXTRACTION OF DRY KRILL LIPIDS (*E. pacifica*)

Exp. No.	Technique	Yield (%)	Total (%)	Mean (%) ± s.d.
1-	acetone ^{a)}	8,00		
	ethanol ^{b)}	7,60	15,60	
2-	"	19,70		
	"	6,90	26,60	
3-	"	8,15		
	"	11,20	19,35	
4-	"	6,80		
	"	13,60	20,40	
				20,49±3,95
5-	chlor: MeOH ^{c)}		15,50	
6-	"		14,90	
				15,20±0,30

Determinations in triplicates (variation < 5 %).

a) :Extraction made with a sample-solvent ratio of 1:9 (w/v), no incubation.

b) :Extraction made with a sample-solvent ratio of 1:4 (w/v), incubated 1 night at 4°C, following a first extraction with acetone.

c) : Folch et al. 1957.

TABLE 2. EXTRACTION OF FROZEN KRILL LIPIDS (*E. pacifica*)

Exp. No.	Technique	Yield (%)	Total (%)	Mean (%)± s.d.
1-	acetone ^{a)}	1,17		

EP 1 123 368 B1

(continued)

Exp. No.	Technique	Yield (%)	Total (%)	Mean (%) ± s.d.
	ethanol ^{b)}	1,23	2,40	
5	2- "	3,05		
		1,09	4,14	
	3- "	1,53		
		1,26	2,79	
				3,11 ± 0,91
10	4- acetone ^{a)}	2,45		
	isopropanol ^{b)}	0,70	3,15	
	5- "	1,80		
		0,80	2,60	
15	6- "	1,60		
		0,80	2,40	
				2,72 ± 0,39
	7- acetone ^{a)}	2,15		
	<i>t</i> -butanol ^{c)}	0,47	2,62	
20	8- "	2,11		
		0,40	2,51	
	9- "	2,37		
		0,45	2,82	
				2,65 ± 0,16
25	10- acetone ^{a)}	2,28		
	ethyl acetate ^{b)}	0,21	2,49	
	11- "	1,09		
		0,16	1,25	
30	12- "	2,54		
		0,09	2,63	
				2,12 ± 0,76
	13- combined acetone-ethanol ^{d)}		3,28	
	14- "		3,02	
35	15- "		3,25	
				3,18 ± 0,14
	16- ethyl acetate ^{e)}		1,32	
	17- "		1,49	
40	18- "		1,31	
				1,37 ± 0,10
	19- hexane ^{e)}		0,31	
	20- "		0,18	
45	21- "		0,20	
				0,23 ± 0,07
	22- chlor:MeOH ^{f)}		2,37	
	23- "		2,07	
50	24- "		2,62	

55

EP 1 123 368 B1

(continued)

Exp. No.	Technique	Yield (%)	Total (%)	Mean (%) ± s.d.
				2,35±0.28

5 Determinations in triplicates (variation < 5 %).
 a) :Extraction made with a sample-solvent ratio of 1:6 (wtv), incubated 2 h at 4 °C.
 b) :Extraction made with a sample-solvent ratio of 1:2 (w/v), incubated 30 min at 4 °C, following a first extraction with acetone.
 10 c) :Extraction made with a sample-solvent ratio of 1:2 (w/v), incubated 30 min at 25 °C, following a first extraction with acetone.
 d) :Extraction made with a sample-acetone-ethanol ratio of 1:5:5 (wtv/v), incubated 2 h at 4 °C. e) :Extraction made with a sample-solvent ratio of 1:9 (w/v), incubated 2 h at 4 °C.
 f) Folch et al. 1957.

TABLE 3. EXTRACTION OF FROZEN KRILL LIPIDS(M. norvegica)

Exp. No.	Technique	Yield (%)	Total (%)	Mean (%) ± s.d.
1-	acetone ^{a)}	1,82		
	ethanol ^{b)}	1,82	3,64	
2-	"	1,15		
	"	2,35	3,50	
3-	"	1,68		
	"	2,19	3,87	
				3,67±0,15

15 Determinations in triplicates (variation < 5 %).
 a) :Extraction made with a sample-solvent ratio of 1:9 (w/v), incubated 1 night at 4 °C.
 20 b) :Extraction made with a sample-solvent ratio of 1:4 (w/v), incubated 1 h at 4 °C, following a first extraction with acetone.

TABLE 4. INFLUENCE OF GRINDING ON EXTRACTION OF FROZEN KRILL LIPIDS (M. norvegica)

Exp No.	Technique	Krill around before 1 st extraction	Yield (%)	Total (%)
1-	acetone ^{a)}	yes	3,10	
	ethanol ^{b)}		1,07	4,17
2-	"	no	2,14	
	"		1,39	3,53
3-	"	yes	3,32	
	"		1,14	4,46
4-	chlor : MeOH ^{c)}	yes		3,30
5-	"	yes		3,26

25 Determinations in triplicates (variation < 5 %).
 a) :Extraction made with a sample-solvent ratio of 1:6, incubated 2 h at 4 °C.
 b) :Extraction made with a sample-solvent ratio of 1:2, incubated 30 min at 4 °C, following a first extraction with acetone.
 30 c):Folch et al. 1957.

TABLE 5. EXTRACTION OF FROZEN *Calanus* LIPIDS (*Calanus sip.*)

Exp. No.	Technique	Yield (%)	Total (%)	Mean (%) ± s.d.
1-	acetone ^{a)}	6,18		
	ethanol ^{b)}	2,04	8,22	

EP 1 123 368 B1

(continued)

Exp. No.	Technique	Yield (%)	Total (%)	Mean (%) ± s.d.
2-	"	8,64		
		2,26	10,90	
				9,56 ± 1,34

Determinations in triplicates (variation <: 5 %).

a) :Extraction made with a sample-solvent ratio of 1:9 (w/v), incubated 1 night at 4 °C.

b) :Extraction made with a sample-solvent ratio of 1:4 (w/v), incubated 1 h at 4 °C, following a first extraction with acetone.

TABLE 6 EXTRACTION OF FRESH FISH LIPIDS (Mackerel)

Exp. No.	Technique	Yield (%)	Total (%)
1- viscera	acetone ^{a)}	6,11	
fish 1	ethanol ^{b)}	0,59	6,70
2- tissues	"	3,78	
fish 1	"	0,91	4,69
3- viscera	"	10,46	
fish 2	"	0,57	11,03
4- issues	"	6,65	
fish 2	"	1.41	8,06
5- viscera	"	8,39	
fish 3	"	0,66	9,05
6- tissues	"	5,27	
fish 3	"	0,97	6,24
7- viscera	"	8,47	
fish 4	"	0,69	9,16
8- tissues	"	8,40	
fish 4	"	1,02	9,42
9- viscera	chlor:MeOH ^{c)}		0,52
fish 1			
10- tissues	"		1,45
fish 1			

a) :Extraction made with a sample-solvent ratio of 1:9 (w/v), incubation time: • fish 1 viscera: 4h, fish 1 tissues: 23h • fish 2 viscera: 23h45, fish 2 tissues: 45h30 • fish 3 viscera: 8 days 2h20. fish 3 tissues: 8 days 22h30 • fish 4 viscera: 17 days 23h, fish 4 tissues: 18 days 2h25.

b) :Extraction made with a sample-solvent ratio of 1:4 (w/v), incubated 1 h at 4 °C. following a first extraction with acetone.

c) :Folch et al. 1957, following extractions with acetone, then ethanol.

TABLE 7. EXTRACTION OF FRESH FISH LIPIDS (Trout)

Exp. No.	Technique	Yield (%)	Total (%)
1- viscera	acetone ^{a)}	34,70	
	ethanol ^{b)}	2,18	36,88
2- tissues	"	5,53	
		1,17	6,70

EP 1 123 368 B1

(continued)

Exp. No.	Technique	Yield (%)	Total (%)
3- viscera	chlor:MeOH ^{c)}		39,81
4- tissues	"		14,93

Determinations in triplicates (variation < 5 %).

a) :Extraction made with a sample-solvent ratio of 1:9 (w/v), incubated 1 night at 4 °C.

b) :Extraction made with a sample-solvent ratio of 1:4 (w/v), incubated 1 h at 4 °C, following a first extraction with acetone.

c) : Folch et al. 1957.

TABLE 8. EXTRACTION OF FRESH FISH LIPIDS Herring

Exp. No.	Technique	Yield (%)	Total (%)
1-tissues and viscera	acetone ^{a)}	2,09	
	ethanol ^{b)}	0,68	2,77
2-tissues and viscera	chlor:MeOH ^{c)}		5,95

Determination in triplicates (variation < 5 %).

a) :Extraction made with a sample-solvent ratio of 1:9 (w/v), incubated 1 night at 4 °.

b) :Extraction made with a sample-solvent ratio of 1:4 (w/v), incubated 1 h at 4 °C, following a first extraction with acetone.

c): Folch et al. 1957.

TABLE 9. EXTRACTION OF FRESH SHARK LIVER LIPIDS (M. schmitti)

Exp. No	Technique	Yield (%)	Total (%)
1-	acetone ^{a)}	36,39	
	ethyl acetate ^{b)}	4,48	40,87
2-	ethyl acetate ^{c)}		36,68
3-	chlor : MeOH ^{d)}		41,86

Determinations in triplicates (variations <5 %).

a) :Extraction made with a sample-solvent ratio of 1:9 (w/v), incubated 2h at 4 °C.

b) :Extraction made with a sample-solvent ratio of 1:2 (w/v), incubated 30 min at 4 °C, following a first extraction with acetone.

c) :Extraction made with a sample-solvent ratio of 1 :9 (w/v), incubated 2h at 4 °C.

d) :Folch et al. 1957.

a first extraction with acetone.

c) :Extraction made with a sample-solvent ratio of 1 :9 (w/v), incubated 2h at 4C.

d) :Folch et al. 1957.

TABLE 10. EXTRACTION OF FRESH SHARK LIVER LIPIDS (G. galeus).

Exp. No.	Technique	Yield (%)	Total (%)
1-	acetone ^{a)}	21,39	
	ethyl acetate ^{b)}	5,27	26,66
2-	ethyl acetate ^{c)}		25,89

EP 1 123 368 B1

(continued)

Exp. No.	Technique	Yield (%)	Total (%)
3-	chlor : MeOH ^{d)}		29,99

Determinations in triplicates (variations <5 %).

a):Extraction made with a sample-solvent ratio of 1:9 (w/v), incubated 2h at 4 °C.

b) :Extraction made with a sample-solvent ratio of 1:2 (w/v), incubated 30 min at 4C, following a first extraction with acetone.

c) :Extraction made with a sample-solvent ratio of 1 :9 (w/v), incubated 2h at 4C.

d) :Folch et al. 1957.

TABLE 11. EXTRACTION OF FRESH SHARK LIVER LIPIDS (Angel Shark)

Exp. No.	Technique	Yield (%)	Total (%)
1-	acetone ^{a)}	19,23	
	ethyl acetate ^{b)}	8,98	28,21
2-	ethyl acetate ^{c)}		39,22
3-	chlor : MeOH ^{d)}		39,23

Determinations in triplicates (variations <5 %).

a) : Extraction made with a sample-solvent ratio of 1:9 (w/v), incubated 2h at 4C.

b) :Extraction made with a sample-solvent ratio of 1:2 (w/v), incubated 30 min at 4C, following a first extraction with acetone.

c) :Extraction made with a sample-solvent ratio of 1 :9 (w/v), incubated 2h at 4C.

d):Folch et al. 1957.

TABLE 12. CHARACTERISTICS OF KRILL OIL (*E. pacifica*)

		independent laboratory ^{a)}	handbook ^b
Saponification index			
Fraction I ^{c)}	130,6	--	--
Fraction II ^{d)}	185,7	--	--
Olive oil	192,0 ^{e)}	--	189,7
Wijs iodine index			
Fraction I ^{c)}	185,2	172,5	--
Fraction II ^{d)}	127,2	139,2	--
Olive oil	85,3 ^{e)}	--	81,1
Cholesterol content (%)			
Fraction I ^{c)}	2,1	1,9	--
Fraction II ^{d)}	3,7	3,0	--
Olive oil	0,2 ^{e)}	-	--
Volatile matter and moisture levels (%)			
Fraction I ^{c)}	10,0	--	--
Fraction II ^{d)}	6,8	--	--
Peroxide value (meq peroxide/kg oil)			
Fraction I ^{c)}	--	0,0	--
Fraction II ^{d)}	--	0,0	--
p-Anisidine value (g ⁻¹ absorption)			
Fraction I ^{c)}	--	0,1	--

(continued)

		independent laboratory ^{a)}	handbook ^{b)}
Fraction II ^{d)}	--	5,5	--

5 a): Professor Robert Ackman's laboratory, Canadian Institute of Fisheries Technology, Halifax, Nova Scotia.
b) : Harwood and Geyer 1964.
c) : Extraction made with a sample-acetone ratio of 1:6 (w/v), incubated 2h at 4 °C.
10 d) : Extraction made with a sample-ethyl acetate ratio of 1:2 (w/v), incubated 30 min at 4C, following a first extraction with acetone.
e) : Extra virgin olive oil cold compressed from Bertolli TM.

TABLE 13. LIPID CLASS COMPOSITION OF KRILL OIL (AREA %) (*E. pacifica*)

Triglycerides

Fraction I ^{a)}	19,0±0,7
Fraction II ^{b)}	66.5± 2,3

Hydrocarbons

Fraction I ^{a)}	trace
Fraction II ^{b)}	1,3± 0.1

Free fatty acids

Fraction I ^{a)}	23.7± 1,1
Fraction II ^{b)}	20,3± 0,3

Monoglycerides

Fraction I ^{a)}	1,4± 0,3
Fraction II ^{b)}	0.5± 0,1

Phospholipids or other polar material

Fraction I ^{a)}	54,1 ± 6,1
Fraction II ^{b)}	8,5 ± 1.6

Data from Professor Robert Ackman's laboratory, Canadian Institute of Fisheries Technology, Halifax, Nova Scotia.

a) : Extraction made with a sample-acetone ratio of 1:6 (w/v), incubated 2h at 4 °C.

b) : Extraction made with a sample-ethyl acetate ratio of 1:2 (w/v), incubated 30 min at 4C, following a first extraction with acetone.

TABLE 14. FATTY ACID COMPOSITION OF KRILL OIL (WT/WT%) (*E. pacifica*)

Fatty acids	Fraction I ^{a)}	Fraction II ^{b)}
12 :0	0,0	0,1
13 :0	0,2	0,1
ISO 14 :0	0,4	0,6
14:0	4,2	7,6
ISO 15:0	0,5	0,7
ANT 15:0	0,2	0,2
15:0	0,6	1,0
ISO 16:0	0,2	0,3
ANT 16:0	0,2	0,2
16:0	14,1	21,6
7MH	0,6	0,9
ANT 17:0	0,1	0,3
17:0	2,8	3,7

EP 1 123 368 B1

(continued)

	Fatty acids	Fraction I ^{a)}	Fraction II ^{b)}
	18:0	1,0	1,6
5	20:0	0,1	0,3
	Saturates	25,2	39,2
	14:1	0,4	0,5
	15:1	0,1	0,2
10	16:1 n-7	6,6	7,8
	16:1 n-5	0,6	0,2
	17:1	0,6	0,7
	18:1 n-9	8,0	9,8
	18:1 n-7	4,2	5,6
15	18:1 n-5	0,1	0,1
	20:1 n-9	0,3	0,4
	20:1 n-7	0,3	0,4
	20:1 n-5	0,3	0,4
	22:1 n-11 +13	0,1	0,2
20	Monoenes	21,6	26,3
	16:2 n-6	0,6	1,2
	16:2 n-4	1,3	1,3
25	18:2 n-7	0,1	0,2
	18:2 n-6	2,0	1,8
	18:2 n-4	0,1	0,1
	20:2 NMID	0,2	0,2
	20:2 n-6	0,1	0,1
30	Dienes	4,4	4,9
	16:3n-4	1,4	1,2
	18:3 n-6	0,4	0,3
35	18:3 n-4	0,2	0,2
	18:3 n-3	3,2	3,0
	18:3 n-1	0,1	0,1
	20:3 n-3	0,1	0,1
40	Trienes	5,4	4,9
	16:4 n-3	0,9	0,7
	16:4 n-1	-1,0	0,8
	18:4 n-3	9,2	7,4
45	18:4 n-1	0,1	0,0
	20:4 n-6	0,7	0,5
	20:4 n-3	0,7	0,3
	Tetraenes	12,6	9,7
50	20:5 n-3	17,4	8,6
	21:5 n-3	0,7	0,5
	22:5 n-6	0,2	0,1
	22:5 n-3	0,5	0,3
55	Pentaenes	18,8	9,5
	22:6 n-3 Hexaenes	13,2	6,6

EP 1 123 368 B1

(continued)

Fatty acids	Fraction I ^{a)}	Fraction II ^{b)}
Iodine value calculated	214,8	145,1

5

Data from Professor Robert Ackman's laboratory, Canadian Institute of Fisheries Technology, Halifax, Nova Scotia.

a): Extraction made with a sample-acetone ratio of 1:6 (w/v), incubated 2h at 4°C.

b) : Extraction made with a sample-ethyl acetate ratio of 1:2 (w/v), incubated 30 min at 4°C, following a first extraction with acetone.

10

TABLE 15. KRILL LIPID FREE FATTY ACID FAME (WT/WT%) (*E. pacifica*)

Fatty acids	Fraction I ^{a)}	Fraction II ^{b)}
12:0	0,5	0,1
13:0	0,2	0,0
ISO14:0	0,2	0,2
14:0	1,3	2,6
ISO 15:0	0,3	0,3
ANT 15:0	0,1	0,1
15:0	0,2	0,5
ISO 16:0	0,1	0,2
ANT 16:0	0,2	0,1
16:0	3,3	10,6
7MH	0,6	0,8
ANT 17:0	0,2	0,2
Phytanic	0,2	0,0
17:0	0,5	0,8
18:0	0,2	0,6
20:0	0,3	0,2
22:0	0,0	0,1
Saturates	8,4	17,4
14:1	0,2	0,2
15:1	0,2	0,1
16:1 n-9	0,5	0,0
16:1 n-7	5,2	6,8
16:1 n-5+117:0	0,1	0,1
17:1	0,6	0,7
18:1 n-9	7,0	11,4
18:1 n-7	4,9	9,3
18:1 n-5	0,1	0,3
20:1 n-11	0,2	0,3
20:1 n-9	0,1	0,3
22:1 n-11+13	0,1	0,2
24:1 n-9	0,0	0,1
Monoenes	19,2	29,8
16:2 n-6	0,4	0,9
16:2 n-4	1,2	1,0
18:2 n-7	0,1	0,2
18:2 n-6	2,4	2,6
18:2 n-4	0,1	0,1
20:2 n-6	0,1	0,1

55

EP 1 123 368 B1

(continued)

	Fatty acids	Fraction I ^{a)}	Fraction II ^{b)}
	Dienes	4,3	4,9
5	16:3 n.4+117:1	1,4	0,9
	16:3 n-3+1 18:0	0,2	0,5
	18:3 n-6	0,4	0,3
	18:3 n-4	0,1	0,1
10	18:3 n-3	3,3	3,4
	18:3 n-1	0,1	0,1
	20:3 n-6	0,1	0,1
	20:3 n-3	0,1	0,2
15	Trienes	5,7	5,6
	16:4 n-3	0,6	0,3
	16:4 n-1	1,0	0,6
	18:4 n-3	9,8	6,2
20	18:4 n-1	0,1	0,1
	20:4n-6	1,7	1,4
	20:4 n-3	0,6	0,5
	22:4 n-3	0,3	0,3
25	Tetraenes	14,1	9,4
	18:5 n-3	0,2	0,1
	20:5 n-3	26,4	17,4
	21:5 n-3	0,9	0,6
30	22:5 n-6	0,0	0,1
	22:5 n-3	0,7	0,5
	Pentaenes	28,2	18,7
35	22:6 n-3	20,5	14,4
	Hexaenes	20,5	14,4
	Iodine value calculated	291,6	220,3
40	Data from Professor Robert Ackman's laboratory, Canadian Institute of Fisheries Technology, Halifax. Nova Scotia.		
	^{a)} : Extraction made with a sample-acetone ratio of 1:6 (w/v), incubated 2h at 4C.		
	^{b)} : Extraction made with a sample-ethyl acetate ratio of 1:2 (w/v), incubated 30 min at 4C, following a first extraction with acetone.		
45			

TABLE 16. TOCOPHEROL, ALL-trans RETINOL AND CHOLECALCIFEROL CONTENT IN KRILL OIL (*E. pacifica*)

50	alpha-tocopherol by HPLC (IU) Fraction I ^{a)}	0,01
	Fraction II ^{b)}	0,83
	gamma-tocopherol by HPLC µg/g	
	Fraction I ^{a)}	Tr
55	Fraction II ^{b)}	Tr
	delta-tocopherol by HPLC µg/g	
	Fraction I ^{a)}	N.D.

EP 1 123 368 B1

(continued)

	Fraction II ^{b)} all- <i>trans</i> retinol by HPLC (IU)	N.D.
5	Fraction I ^{a)} Fraction II ^{b)} cholecalciferol by HPLC (IU)	395,57 440,47
10	Fraction I ^{a)} Fraction II ^{b)}	N.D. N.D.

Data from Professor Robert Ackman's laboratory, Canadian Institute of Fisheries Technology, Halifax, Nova Scotia. Data expressed per gram of krill oil.
a): Extraction made with a sample-acetone ratio of 1:6 (w/v), incubated 2h at 4 °C.
b): Extraction made with a sample-ethyl acetate ratio of 1:2 (w/v), incubated 30 min at 4 °C, following a first extraction with acetone.
TR = trace
N.D. = not detected
Conversion: Vitamin alpha-tocopherol mg/g oil x 1,36 = International Unit All-*trans* retinol µg/g + 0,3 = International Unit

TABLE 17. ASTAXANTHIN AND CANTHAXANTHIN CONTENT OF KRILL OIL (*E. pacifica*)

	Astaxanthin (µg/g oil)	
25	Fraction I ^{a)} Fraction II ^{b)}	93.1 121,7
	Canthaxanthin (µg/g oil)	
30	Fraction I ^{a)} Fraction II ^{b)}	270,4 733,0

Data from Professor Robert Ackman's laboratory, Canadian Institute of Fisheries Technology, Halifax, Nova Scotia.
a) : Extraction made with a sample-acetone ratio of 1:6 (w/v), incubated 2h at 4 °C.
b) : Extraction made with a sample-ethyl acetate ratio of 1:2 (w/v), incubated 30 min at 4 °C. following a first extraction with acetone.

TABLE 18. OPTIMAL CONDITIONS FOR LIPID EXTRACTION OF AQUATIC ANIMAL TISSUES (suggested procedure)

STEP	CONDITIONS
Grinding (if particles > 5mm)	4 °C
Lipid extraction	sample-acetone ratio of 1:6 (w/v) 2h (including swirling 20 min) 4 °C
45 Filtration	organic solvent resistant filter under reduced pressure
Washing	sample-acetone ratio of 1:2 (w/v) pure and cold acetone
Filtration	organic solvent resistant filter under reduced pressure
Evaporation	under reduced pressure
Oil-water separation	4 °C
50 Lipid extraction	<u>sample : ethyl acetate</u> ratio of 1:2 (w/v) ^{a)} pure <u>ethylacetate</u> 30 min 30 min 4 °C ^{b)}
Filtration	organic solvent resistant filter under reduced pressure
Evaporation	under reduced pressure

a): Ethanol can be replaced by isopropanol, *t*-butanol or ethyl acetate.
b): 25 °C when using *t*-butanol.

TABLE 19: PROTEOLYTIC ACTIVITY OF KRILL RESIDU USING LACTOSERUM AS THE SUBSTRATE. AT 37° C, PH 7.0 FOR A RATIO ENZYME SUBSTRATE OF 1:43

Time (min)	Amino acids released (μmoles)	Enzymatic rate (μmoles/min)	Specific activity enzymatic (μmoles min/mg*)
15	28.76	1.917	0.164
30	43.74	0.999	0.125
170	98.51	0.322	0.050
255	177.26	0.308	0.060

* total quantity of enzymes in hydrolysis media

Claims

1. A method for extracting total lipid fractions from marine and aquatic animal material, said method comprising the steps of
 - (a) placing marine and aquatic animal material in a ketone solvent, preferably acetone to achieve extraction of the soluble lipid fraction from said marine and aquatic animal material;
 - (b) separating liquid and solid contents resulting from step (a);
 - (c) recovering a first total lipid rich fraction from the liquid contents of b) by evaporation of the solvent present in the liquid contents;
 - (d) placing said solid contents in an organic solvent selected from the group of solvents consisting of alcohol, preferably ethanol, isopropanol or t-butanol, and esters of acetic acid, preferably ethyl acetate, to achieve extraction of the remaining soluble lipid fraction from said marine and aquatic animal material;
 - (e) separating liquid and solid contents resulting from step (d); and
 - (f) recovering a second total lipid rich fraction by evaporation of the solvent from the liquid contents of e).
2. A method according to Claim 1, wherein the extraction of step (a) is conducted under agitation after the animal material has been ground.
3. A method according to any of Claims 1 and 2, wherein the extraction of step (d) is conducted under agitation after the animal material has been ground.
4. A method according to any of Claims 1 to 3, wherein steps (a) and (d) are conducted under inert atmosphere.
5. A method according to any of Claims 1 to 4, wherein steps (b) and (e) are effected by techniques selected from filtration, centrifugation and sedimentation.
6. A method according to any of Claims 1 to 5, wherein steps (c) and (f) are effected by techniques selected from evaporation under reduced pressure, flash evaporation and spray drying.
7. A method according to any of Claims 1 to 6, wherein after step (b) and before step (c), the method additionally comprises the intervening step of washing the solid contents with the solvent and adding the resulting washing solution to the liquid contents of step (b).
8. A method according to any of Claims 1 to 7, wherein after step (e) and before step (f), the method additionally comprises the intervening step of washing the solid contents with the organic solvent selected in step (d).
9. A method according to any of Claims 1 to 8, wherein prior to step (a) the marine and aquatic animal material is finely divided, preferably to an average particle size of 5mm or less.
10. A method according to any of Claims 1 to 9, wherein the organic solvent is selected from the group of solvents consisting of ethanol or isopropanol and esters of acetic acid, preferably ethyl acetate, and wherein said method is

conducted at a temperature of 5°C or less.

11. A method according to any of Claims 1 to 10, wherein said marine and aquatic animal is zooplankton.

5 12. A method according to Claim 11, wherein said zooplankton is krill.

13. A method according to Claim 11, wherein said zooplankton is *Calanus*.

10 14. A method according to any of Claims 1 to 10, wherein said marine and aquatic animal is fish.

15. A method according to any of Claims 1-9, wherein the organic solvent is t-butanol, and wherein said method is conducted at a temperatures of 25°C.

15 16. A method for extracting an astaxanthin-and-canthaxantin-containing total lipid fraction from a marine and aquatic animal material selected from zooplankton and fish, said method comprising the steps of:

(a) placing said animal material in a ketone solvent, preferably acetone to achieve an extraction of the soluble lipid fraction from said marine and aquatic animal material;

(b) separating liquid and solid contents resulting from step (a);

20 (c) recovering a lipid rich fraction from the liquid contents by evaporation of the solvent present in the liquid contents;

whereby an astaxanthin-and-canthaxantin-containing total lipid fraction is obtained.

25 17. A method for extracting a total lipid fraction from a marine and aquatic animal material selected from zooplankton and fish, said method comprising the steps of:

(a) placing said animal material in a solvent mixture comprising acetone and ethanol to achieve an extraction of the soluble lipid fraction from said marine and aquatic animal material;

30 (b) separating liquid and solid contents resulting from step (a);

(c) recovering a lipid rich fraction from the liquid contents by evaporation of the solvents present in the liquid contents;

whereby a total lipid fraction is obtained.

35 18. A method according to Claim 16 or 17, wherein the animal material is krill.

19. A method according to Claim 16 or 18, wherein the animal material is *Calanus*.

40 20. A method as in any of Claims 16 to 19, wherein the extraction of step (a) is conducted under agitation after the animal material has been ground.

21. A method according to any of Claims 16 to 20, wherein step (a) is conducted under inert atmosphere.

45 22. A method according to any of Claims 16 to 21, wherein step (b) is effected by a technique selected from filtration, centrifugation and sedimentation.

23. A method according to any one of Claims 16 to 22, wherein step (c) is effected by a technique selected from vacuum evaporation, flash evaporation and spray drying.

50 24. A method according to any one of Claims 16 to 23, wherein after step (b) and before step (c), the method additionally comprises a step of washing said solid contents with a solvent and adding the resulting washing solution to the liquid contents of step (b).

55 25. A method according to any of Claims 16 to 24, wherein prior to step (a) the marine and aquatic animal material is finely divided, preferably to an average particle size of 5mm or less.

26. A method according to any of Claims 16 to 25, wherein said method is conducted at a temperature of 5°C or less.

27. A method of lipid extraction according to any one of Claims 1 to 26, wherein the resulting solid contents are recovered and consist of a dehydrated residue containing active enzymes.
- 5 28. A total krill lipid extract **characterized in that** it is devoid of toxic solvent and **in that** the carotenoid content in asthaxanthin is 75µg/g or more and preferably at least about 90 µg/g or more of krill extract, and the carotenoid content in canthaxanthin is 250 µg/g or more and preferably at least about 270 µg/g of krill extract or more.
- 10 29. A lipid extract according to Claim 28, obtainable from an aquatic or marine animal by a method according to any of Claims 1-27.
30. Use of a krill lipid extract according to Claim 28 or 29, in an application selected from the group consisting of nutraceuticals, cosmetics, fish farming and animal feeding applications.
- 15 31. Use of a krill lipid extract according to Claim 28 or 29, for the manufacture of a medicament for treating a disease selected from the group consisting of an inflammatory disease, cardiovascular disease, lupus and renal disease.
- 20 32. A krill lipid extract **characterised in that** it is edible, and **in that** the carotenoid content in astaxanthin is 75µg/g or more and preferably at least about 90µg/g or more of krill extract, and the carotenoid content in canthaxanthin is 250µg/g or more and preferably at least about 270µg/g of krill extract or more.
33. A krill lipid extract according to Claim 32, obtainable from an aquatic or marine animal by a method according to any of Claims 1-27.
- 25 34. Use of a krill lipid extract according to Claim 32 or 33, in an application selected from the group consisting of nutraceuticals, cosmetics, fish farming and animal feeding applications.
- 30 35. Use of a krill lipid extract according to Claim 32 or 33, for the manufacture of a medicament for treating a disease selected from the group consisting of an inflammatory disease, cardiovascular disease, lupus and renal disease.

Patentansprüche

- 35 1. Verfahren zum Extrahieren der Gesamtlipidfraktionen von Meeres- und Wassertiermaterial, wobei das Verfahren die folgenden Schritte umfasst:
- (a) das Geben des Meeres- und Wassertiermaterials in ein Ketonlösungsmittel, bevorzugt Aceton, um eine Extraktion der löslichen Lipidfraktion aus dem Meeres- und Wassertiermaterial zu erreichen;
- (b) das Trennen der flüssigen und festen Gehalte, welche aus Schritt (a) resultieren;
- 40 (c) das Gewinnen einer ersten Gesamtlipid-reichen Fraktion aus den flüssigen Gehalten von (b) durch Abdampfen des in den flüssigen Gehalten vorhandenen Lösungsmittels;
- (d) das Geben der festen Gehalte in ein organisches Lösungsmittel, ausgewählt aus der Gruppe von Lösungsmitteln, welche aus Alkohol, bevorzugt Ethanol, Isopropanol oder t-Butanol, und Estern von Essigsäure, bevorzugt Ethylacetat, besteht, um eine Extraktion der verbleibenden löslichen Lipidfraktion von dem Meeres- und Wassertiermaterial zu erreichen;
- 45 (e) das Trennen der flüssigen und festen Gehalte, welche aus Schritt (d) resultieren; und
- (f) das Gewinnen einer zweiten Gesamtlipid-reichen Fraktion durch Abdampfen des Lösungsmittels aus den flüssigen Gehalten von (e).
- 50 2. Verfahren gemäß Anspruch 1, wobei die Extraktion von Schritt (a) unter Bewegung durchgeführt wird, nachdem das Tiermaterial gemahlen wurde.
3. Verfahren gemäß einem der Ansprüche 1 und 2, wobei die Extraktion von Schritt (d) unter Bewegung durchgeführt wird, nachdem das Tiermaterial gemahlen wurde.
- 55 4. Verfahren gemäß einem der Ansprüche 1 bis 3, wobei die Schritte (a) und (d) unter Intertatmosphäre durchgeführt werden.
5. Verfahren gemäß einem der Ansprüche 1 bis 4, wobei die Schritte (b) und (e) durch Techniken, welche aus Filtration,

Zentrifugation und Sedimentation ausgewählt sind, bewirkt werden.

- 5
6. Verfahren gemäß einem der Ansprüche 1 bis 5, wobei die Schritte (c) und (f) durch Techniken, welche aus Verdampfen unter verringertem Druck, Flash-Verdampfen und Sprühtrocknen ausgewählt sind, bewirkt werden.
7. Verfahren gemäß einem der Ansprüche 1 bis 6, wobei das Verfahren nach Schritt (b) und vor Schritt (c) zusätzlich den Zwischenschritt des Waschens der festen Gehalte mit dem Lösungsmittel und des Gebens der resultierenden Waschlösung zu den flüssigen Gehalten von Schritt (b) umfasst.
- 10
8. Verfahren gemäß einem der Ansprüche 1 bis 7, wobei das Verfahren nach Schritt (e) und vor Schritt (f) zusätzlich den Zwischenschritt des Waschens der festen Gehalte mit dem in Schritt (d) ausgewählten organischen Lösungsmittel umfasst.
- 15
9. Verfahren gemäß einem der Ansprüche 1 bis 8, wobei das Meeres- und Wassertiermaterial vor Schritt (a) fein zerteilt wird, bevorzugt in eine mittlere Teilchengröße von 5 mm oder niedriger.
10. Verfahren gemäß einem der Ansprüche 1 bis 9, wobei das organische Lösungsmittel aus der Gruppe von Lösungsmitteln ausgewählt ist, welche aus Ethanol oder Isopropanol und Estern von Essigsäure, bevorzugt Ethylacetat, besteht, und wobei das Verfahren bei einer Temperatur von 5°C oder niedriger durchgeführt wird.
- 20
11. Verfahren gemäß einem der Ansprüche 1 bis 10, wobei das Meeres- und Wassertier Zooplankton ist.
12. Verfahren gemäß Anspruch 11, wobei das Zooplankton Krill ist.
- 25
13. Verfahren gemäß Anspruch 11, wobei das Zooplankton *Calanus* ist.
14. Verfahren gemäß einem der Ansprüche 1 bis 10, wobei das Meeres- und Wassertier Fisch ist.
- 30
15. Verfahren gemäß einem der Ansprüche 1 bis 9, wobei das organische Lösungsmittel t-Butanol ist und wobei das Verfahren bei einer Temperatur von 25°C durchgeführt wird.
- 35
16. Verfahren zum Extrahieren einer Astaxanthin und Canthaxanthin enthaltenden Gesamtlipidfraktion aus einem Meeres- und Wassertiermaterial, welches aus Zooplankton und Fisch ausgewählt ist, wobei das Verfahren die folgenden Schritte umfasst:
- (a) das Geben des Tiermaterials in ein Ketonlösungsmittel, bevorzugt Aceton, um eine Extraktion der löslichen Lipidfraktion aus dem Meeres- und Wassertiermaterial zu erreichen;
- (b) das Trennen der flüssigen und festen Gehalte, welche aus Schritt (a) resultieren;
- (c) das Gewinnen einer Lipid-reichen Fraktion aus den flüssigen Gehalten durch Verdampfen des in den flüssigen Gehalten vorhandenen Lösungsmittels;
- 40
- wobei eine Astaxanthin und Canthaxanthin enthaltende Gesamtlipidfraktion erhalten wird.
- 45
17. Verfahren zum Extrahieren einer Gesamtlipidfraktion aus einem Meeres- und Wassertiermaterial, welches aus Zooplankton und Fisch ausgewählt ist, wobei das Verfahren die folgenden Schritte umfasst:
- (a) das Geben des Tiermaterials in ein Lösungsmittelgemisch, welches Aceton und Ethanol umfasst, um eine Extraktion der löslichen Lipidfraktion aus dem Meeres- und Wassertiermaterial zu erreichen;
- (b) das Trennen der flüssigen und festen Gehalte, welche aus Schritt (a) resultieren;
- (c) das Gewinnen einer Lipid-reichen Fraktion aus den flüssigen Gehalten durch Verdampfen der in den flüssigen Gehalten vorhandenen Lösungsmittel;
- 50
- wobei eine Gesamtlipidfraktion erhalten wird.
- 55
18. Verfahren gemäß Anspruch 16 oder 17, wobei das Tiermaterial Krill ist.
19. Verfahren gemäß Anspruch 16 oder 18, wobei das Tiermaterial *Calanus* ist.

20. Verfahren wie in einem der Ansprüche 16 bis 19, wobei die Extraktion von Schritt (a) unter Bewegung durchgeführt wird, nachdem das Tiermaterial gemahlen wurde.
- 5 21. Verfahren gemäß einem der Ansprüche 16 bis 20, wobei Schritt (a) unter einer Inertatmosphäre durchgeführt wird.
22. Verfahren gemäß einem der Ansprüche 16 bis 21, wobei Schritt (b) durch eine Technik, welche aus Filtration, Zentrifugation und Sedimentation ausgewählt ist, bewirkt wird.
- 10 23. Verfahren gemäß einem der Ansprüche 16 bis 22, wobei Schritt (c) durch eine Technik, welche aus Vakuumverdampfen, Flash-Verdampfen und Sprühtrocknen ausgewählt sind, bewirkt wird.
24. Verfahren gemäß einem der Ansprüche 16 bis 23, wobei das Verfahren nach Schritt (b) und vor Schritt (c) zusätzlich einen Schritt des Waschens der festen Gehalte mit einem Lösungsmittel und des Gebens der resultierenden Waschlösung zu den flüssigen Gehalten von Schritt (b) umfasst.
- 15 25. Verfahren gemäß einem der Ansprüche 16 bis 24, wobei das Meeres- und Wassertiermaterial vor Schritt (a) fein zerteilt wird, bevorzugt in eine mittlere Teilchengröße von 5 mm oder niedriger.
26. Verfahren gemäß einem der Ansprüche 16 bis 25, wobei das Verfahren bei einer Temperatur von 5 °C oder niedriger durchgeführt wird.
- 20 27. Lipidextraktionsverfahren gemäß einem der Ansprüche 1 bis 26, wobei die resultierenden festen Gehalte gewonnen werden und aus einem dehydratisierten Rest, der aktive Enzyme enthält, bestehen.
- 25 28. Krillgesamtlipidextrakt, **dadurch gekennzeichnet, dass** er kein toxisches Lösungsmittel enthält und dass der Carotenoidgehalt in Astaxanthin 75 µg/g oder mehr und bevorzugt mindestens etwa 90 µg/g Krillextrakt oder mehr beträgt und der Carotenoidgehalt in Canthaxanthin 250 µg/g oder mehr und bevorzugt mindestens etwa 270 µg/g Krillextrakt oder mehr beträgt.
- 30 29. Lipidextrakt gemäß Anspruch 28, erhältlich aus einem Wasser- oder Meerestier durch ein Verfahren gemäß einem der Ansprüche 1 bis 27.
31. Verwendung eines Krilllipidextrakts gemäß Anspruch 28 oder 29 in einer Verwendung, welche aus der Gruppe ausgewählt ist, die aus funktionellen Lebensmitteln, Kosmetika, Fischzucht- und Tierfütterungsverwendungen besteht.
- 35 32. Krilllipidextrakt, **dadurch gekennzeichnet, dass** er essbar ist und dass der Carotenoidgehalt in Astaxanthin 75 µg/g oder mehr und bevorzugt mindestens etwa 90 µg/g Krillextrakt oder mehr beträgt und der Carotenoidgehalt in Canthaxanthin 250 µg/g oder mehr und bevorzugt mindestens etwa 270 µg/g Krillextrakt oder mehr beträgt.
- 40 33. Krilllipidextrakt gemäß Anspruch 32, erhältlich aus einem Wasser- oder Meerestier durch ein Verfahren gemäß einem der Ansprüche 1 bis 27.
- 45 34. Verwendung eines Krilllipidextrakts gemäß Anspruch 32 oder 33 in einer Verwendung, welche aus der Gruppe ausgewählt ist, die aus funktionellen Lebensmitteln, Kosmetika, Fischzucht- und Tierfütterungsverwendungen besteht.
- 50 35. Verwendung eines Krilllipidextrakts gemäß Anspruch 32 oder 33 zur Herstellung eines Medikaments zur Behandlung einer Erkrankung, welche aus der Gruppe ausgewählt ist, die aus einer entzündlichen Erkrankung, kardiovaskulären Erkrankung, Lupus und Nierenerkrankung besteht.
- 55

Revendications

1. Procédé pour extraire des fractions lipidiques totales à partir de matériau animal marin et aquatique, ledit procédé comprenant les étapes consistant à :
 - (a) placer le matériau animal marin et aquatique dans un solvant à base de cétone, de préférence l'acétone, pour réaliser l'extraction de la fraction lipidique soluble à partir dudit matériau animal marin et aquatique ;
 - (b) séparer les contenus liquides et solides résultant de l'étape (a) ;
 - (c) récupérer une première fraction riche en lipides totaux à partir des contenus liquides de b) par évaporation du solvant présent dans les contenus liquides ;
 - (d) placer lesdits contenus liquides dans un solvant organique choisi dans le groupe de solvants constitué par un alcool, de préférence l'éthanol, l'isopropanol ou le t-butanol, et les esters d'acide acétique, de préférence l'acétate d'éthyle, pour réaliser l'extraction de la fraction lipidique soluble restante à partir dudit matériau animal marin et aquatique ;
 - (e) séparer les contenus liquides et solides résultant de l'étape (d) ; et
 - (f) récupérer une deuxième fraction riche en lipides totaux par évaporation du solvant à partir des contenus liquides de e).
2. Procédé selon la revendication 1, dans lequel l'extraction de l'étape (a) est effectuée sous agitation après que le matériau animal a été broyé.
3. Procédé selon l'une quelconque des revendications 1 et 2, dans lequel l'extraction de l'étape (d) est effectuée sous agitation après que le matériau animal a été broyé.
4. Procédé selon l'une quelconque des revendications 1 à 3, dans lequel les étapes (a) et (d) sont effectuées dans une atmosphère inerte.
5. Procédé selon l'une quelconque des revendications 1 à 4, dans lequel les étapes (b) et (e) sont effectuées par des techniques choisies parmi la filtration, la centrifugation et la sédimentation.
6. Procédé selon l'une quelconque des revendications 1 à 5, dans lequel les étapes (c) et (f) sont effectuées par des techniques choisies parmi l'évaporation sous pression réduite, l'évaporation sur évaporateur rotatif et le séchage par pulvérisation.
7. Procédé selon l'une quelconque des revendications 1 à 6, dans lequel, après l'étape (b) et avant l'étape (c), le procédé comprend de plus l'étape intermédiaire consistant à laver les contenus solides avec le solvant et à ajouter la solution de lavage résultante aux contenus liquides de l'étape (b).
8. Procédé selon l'une quelconque des revendications 1 à 7, dans lequel, après l'étape (e) et avant l'étape (f), le procédé comprend de plus l'étape intermédiaire consistant à laver les contenus solides avec le solvant organique sélectionné dans l'étape (d).
9. Procédé selon l'une quelconque des revendications 1 à 8, dans lequel, avant l'étape (a), le matériau animal marin et aquatique est finement divisé, de préférence à une granulométrie moyenne de 5 mm ou moins.
10. Procédé selon l'une quelconque des revendications 1 à 9, dans lequel le solvant organique est choisi dans le groupe de solvants constitué par l'éthanol ou l'isopropanol et les esters d'acide acétique, de préférence l'acétate d'éthyle, et lequel procédé est mis en oeuvre à une température de 5°C ou moins.
11. Procédé selon l'une quelconque des revendications 1 à 10, dans lequel ledit animal marin et aquatique est un zooplancton.
12. Procédé selon la revendication 11, dans lequel ledit zooplancton est le krill.
13. Procédé selon la revendication 11, dans lequel ledit zooplancton est *Calanus*.
14. Procédé selon l'une quelconque des revendications 1 à 10, dans lequel ledit animal marin et aquatique est un poisson.

15. Procédé selon l'une quelconque des revendications 1 à 9, dans lequel le solvant organique est le t-butanol, et lequel procédé est mis en oeuvre à une température de 25°C.
- 5 16. Procédé pour extraire une fraction lipidique totale contenant de l'astaxanthine et de la canthaxanthine à partir d'un matériau animal marin et aquatique choisi parmi le zooplancton et le poisson, ledit procédé comprenant les étapes consistant à :
- (a) placer ledit matériau animal dans un solvant à base de cétone, de préférence l'acétone, pour réaliser l'extraction de la fraction lipidique soluble à partir dudit matériau animal marin et aquatique ;
- 10 (b) séparer les contenus liquides et solides résultant de l'étape (a) ;
- (c) récupérer une fraction riche en lipides à partir des contenus liquides par évaporation du solvant présent dans les contenus liquides ;
- grâce à quoi une fraction lipidique totale contenant de l'astaxanthine et de la canthaxanthine est obtenue.
- 15 17. Procédé pour extraire une fraction lipidique totale à partir d'un matériau animal marin et aquatique choisi parmi le zooplancton et le poisson, ledit procédé comprenant les étapes consistant à :
- (a) placer ledit matériau animal dans un mélange de solvants comprenant de l'acétone et de l'éthanol pour réaliser l'extraction de la fraction lipidique soluble à partir dudit matériau animal marin et aquatique ;
- 20 (b) séparer les contenus liquides et solides résultant de l'étape (a) ;
- (c) récupérer une fraction riche en lipides à partir des contenus liquides par évaporation des solvants présents dans les contenus liquides ;
- 25 grâce à quoi une fraction lipidique totale est obtenue.
18. Procédé selon la revendication 16 ou 17, dans lequel le matériau animal est le krill.
19. Procédé selon la revendication 16 ou 18, dans lequel le matériau animal est *Calanus*.
- 30 20. Procédé selon l'une quelconque des revendications 16 à 19, dans lequel l'extraction de l'étape (a) est effectuée sous agitation après que le matériau animal a été broyé.
21. Procédé selon l'une quelconque des revendications 16 à 20, dans lequel l'étape (a) est effectuée dans une atmosphère inerte.
- 35 22. Procédé selon l'une quelconque des revendications 16 à 21, dans lequel l'étape (b) est effectuée par une technique choisie parmi la filtration, la centrifugation et la sédimentation.
- 40 23. Procédé selon l'une quelconque des revendications 16 à 22, dans lequel l'étape (c) est effectuée par une technique choisie parmi l'évaporation sous vide, l'évaporation sur évaporateur rotatif et le séchage par pulvérisation.
24. Procédé selon l'une quelconque des revendications 16 à 23, dans lequel, après l'étape (b) et avant l'étape (c), le procédé comprend de plus l'étape intermédiaire consistant à laver lesdits contenus solides avec le solvant et à ajouter la solution de lavage résultante aux contenus liquides de l'étape (b).
- 45 25. Procédé selon l'une quelconque des revendications 16 à 24, dans lequel, avant l'étape (a), le matériau animal marin et aquatique est finement divisé, de préférence à une granulométrie moyenne de 5 mm ou moins.
- 50 26. Procédé selon l'une quelconque des revendications 16 à 25, lequel procédé est mis en oeuvre à une température de 5°C ou moins.
27. Procédé pour extraire des lipides selon l'une quelconque des revendications 1 à 26, dans lequel les contenus solides résultants sont récupérés et sont constitués d'un résidu déshydraté contenant des enzymes actives.
- 55 28. Extrait lipidique total de krill, **caractérisé en ce qu'il** est exempt de solvant toxique et **en ce que** la teneur en caroténoïde dans l'astaxanthine est de 75 µg/g ou plus et de préférence d'au moins environ 90 µg/g ou plus de l'extrait de krill, et la teneur en caroténoïde dans la canthaxanthine est de 250 µg/g ou plus et de préférence d'au

EP 1 123 368 B1

moins environ 270 µg/g de l'extrait de krill ou plus.

29. Extrait lipidique selon la revendication 28, pouvant être obtenu à partir d'un animal aquatique ou marin par un procédé selon l'une quelconque des revendications 1 à 27.

5

30. Utilisation d'un extrait lipidique de krill selon la revendication 28 ou 29, dans une application choisie dans le groupe constitué par les nutraceutiques, les cosmétiques, l'élevage de poissons et les applications à l'alimentation des poissons.

10

31. Utilisation d'un extrait lipidique de krill selon la revendication 28 ou 29, pour la fabrication d'un médicament destiné à traiter une maladie choisie dans le groupe constitué par une maladie inflammatoire, une maladie cardiovasculaire, un lupus et une maladie rénale.

15

32. Extrait lipidique de krill **caractérisé en ce qu'il** est comestible, et **en ce que** la teneur en caroténoïde dans l'astaxanthine est de 75 µg/g ou plus et de préférence d'au moins environ 90 µg/g ou plus de l'extrait de krill, et la teneur en caroténoïde dans la canthaxanthine est de 250 µg/g ou plus et de préférence d'au moins environ 270 µg/g de l'extrait de krill ou plus.

20

33. Extrait lipidique de krill selon la revendication 32, pouvant être obtenu à partir d'un animal aquatique ou marin par un procédé selon l'une quelconque des revendications 1 à 27.

25

34. Utilisation d'un extrait lipidique de krill selon la revendication 32 ou 33, dans une application choisie dans le groupe constitué par les nutraceutiques, les cosmétiques, l'élevage de poissons et les applications à l'alimentation des poissons.

30

35. Utilisation d'un extrait lipidique de krill selon la revendication 32 ou 33, pour la fabrication d'un médicament destiné à traiter une maladie choisie dans le groupe constitué par une maladie inflammatoire, une maladie cardiovasculaire, un lupus et une maladie rénale.

35

40

45

50

55

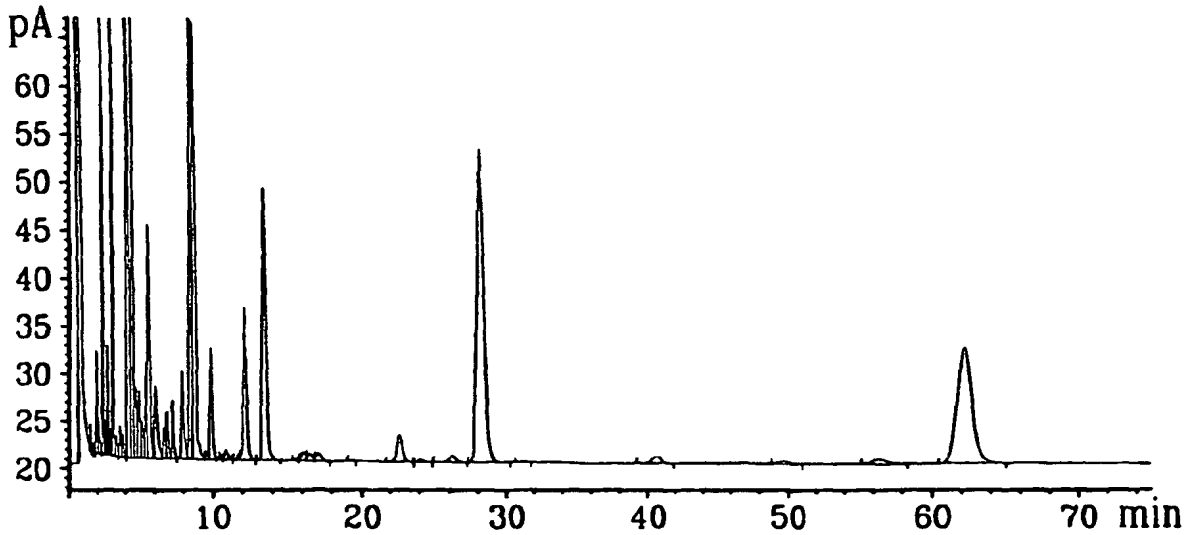

FE-1

1.263		4.521 - 16:1	11.637
1.455 - 12:0		4.684	12.145 - 18:3
1.625		4.891 - 16:1tr	13.458
1.812		5.121	15.626 - 20:0
1.876		5.426	16.045
2.056		5.570	16.482 - 20:1
2.173		6.037	17.017 - 20:1(cis11)
2.331 - 14:0		6.662	19.344 - 20:2
2.505		6.871	22.606 - 20:4(6,10,14,18)
2.591 - 14:1		7.235	24.103
2.682		7.925 - 18:0	26.247
2.802		8.439 - 18:1	28.287
2.855		8.640 - 18:1tr	31.295
3.078 - std 15:0		9.544	40.655
3.309		9.801 - 18:2	49.721
3.586		10.491	56.373
3.810		10.825	62.225
4.176 - 16:0		11.042	



FIG. 2

1.217	3.806	9.786 - 18:2
1.264	4.157 - 16:0	10.484
1.454 - 12:0	4.515 - 16:1	10.813
1.624	4.680	11.590
1.812	4.891 - 16:1tr	12.136 - 18:3
1.876	5.028	13.447
2.055	5.109	15.623 - 20:0
2.171	5.421	16.025
2.330 - 14:0	5.562	16.466 - 20:1
2.505	6.031	17.021 - 20:1 (cis11)
2.591 - 14:1	6.642	22.585 - 20:4 (6,10,14,18)
2.680	6.870	24.100
2.800	7.230	26.217
2.854	7.910 - 18:0	28.241
3.077 - std 15:0	8.419 - 18:1	40.622
3.306	8.622 - 18:1tr	56.417
3.585	9.529	62.086

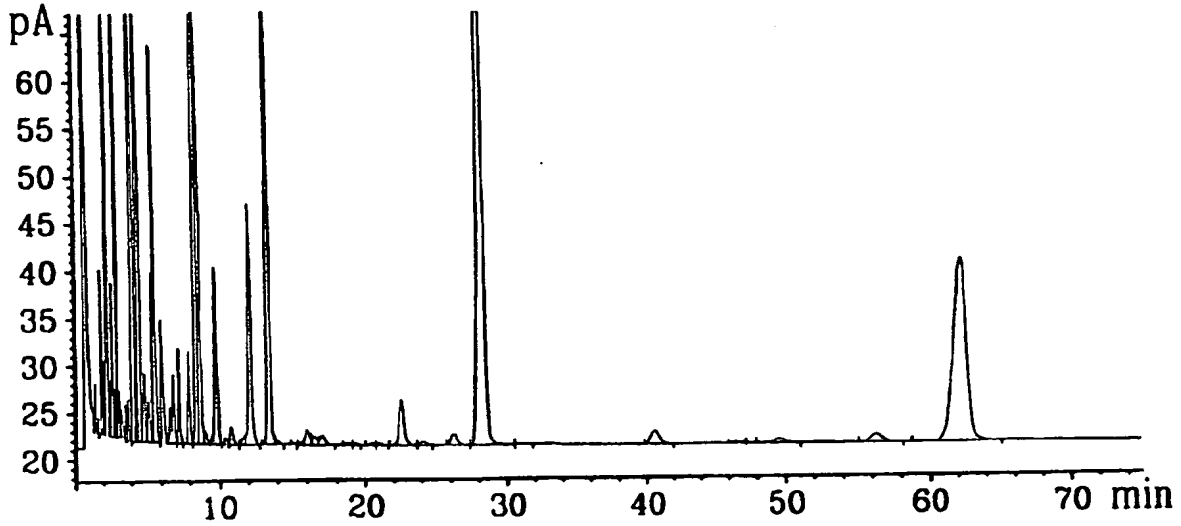

FIG. 3

1.216	4.520 - 16:1	13.457
1.262	4.683	13.943
1.454 - 12:0	4.884 - 16:1tr	15.053
1.624	5.030	15.572 - 20:0
1.811	5.111	16.016
1.875	5.420	16.486 - 20:1
2.016	5.561	16.999 - 20:1(cis11)
2.054	6.031	18.762
2.174	6.642	19.303 - 20:2
2.330 - 14:0	6.868	20.474
2.505	7.226	21.027 - 20:3
2.589 - 14:1	7.908 - 18:0	22.575 - 20:4 (6,10,14,18)
2.679	8.444 - 18:1	24.071
2.799	8.639 - 18:1tr	26.215
2.854	9.005	28.333
2.981	9.536	31.180
3.074 - std 15:0	9.788 - 18:2	40.560
3.304	10.267	46.595
3.580	10.481	49.513
3.804	10.807	56.292
4.169 - 16:0	11.626	62.250
4.296	12.140 - 18:3	

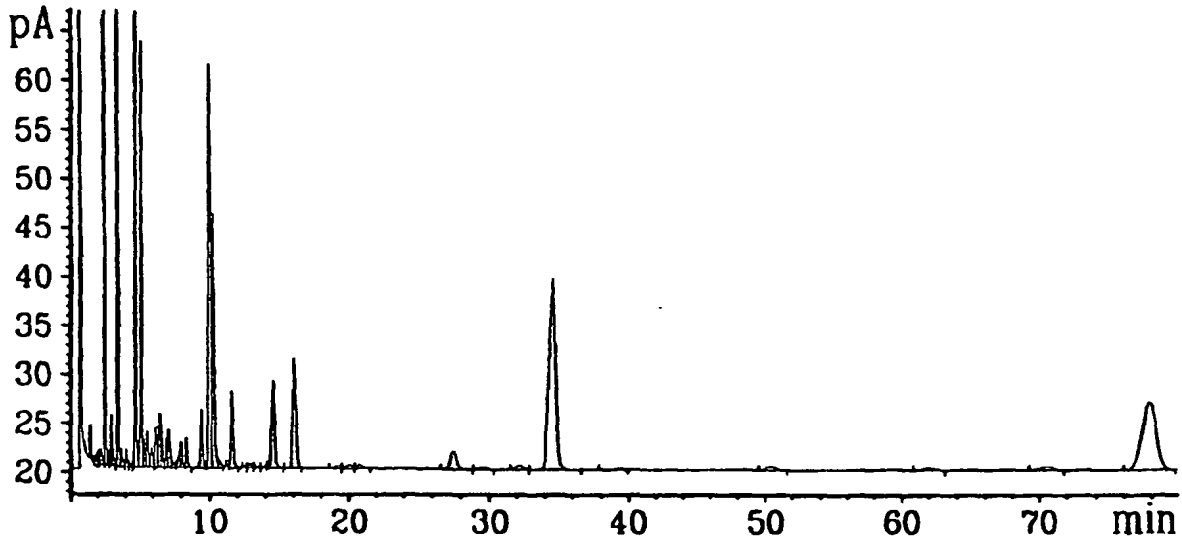

FIG. 4

1.552 - 12:0	5.675 - 16:1tr	12.888
1.749	5.964	13.388
1.968	6.284	14.017
2.095	6.533	14.524 - 18:3
2.262	6.655	16.107
2.485	7.009	19.275 - 20:0
2.582 - 14:0	7.159	20.112 - 20:1 (cis11)
2.784	7.440	20.781 - 20:1
2.886 - 14:1	7.874	27.553
3.004	8.019	29.529
3.145	8.462	32.161
3.478 - std 15:0	9.411 - 18:0	34.614
3.720	10.000 - 18:1	39.240
4.088	10.249 - 18:1tr	50.374
4.325	10.716	61.892
4.793 - 16:0	11.357	70.568
5.196 - 16:1	11.647 - 18:2	77.894
5.406	12.519	

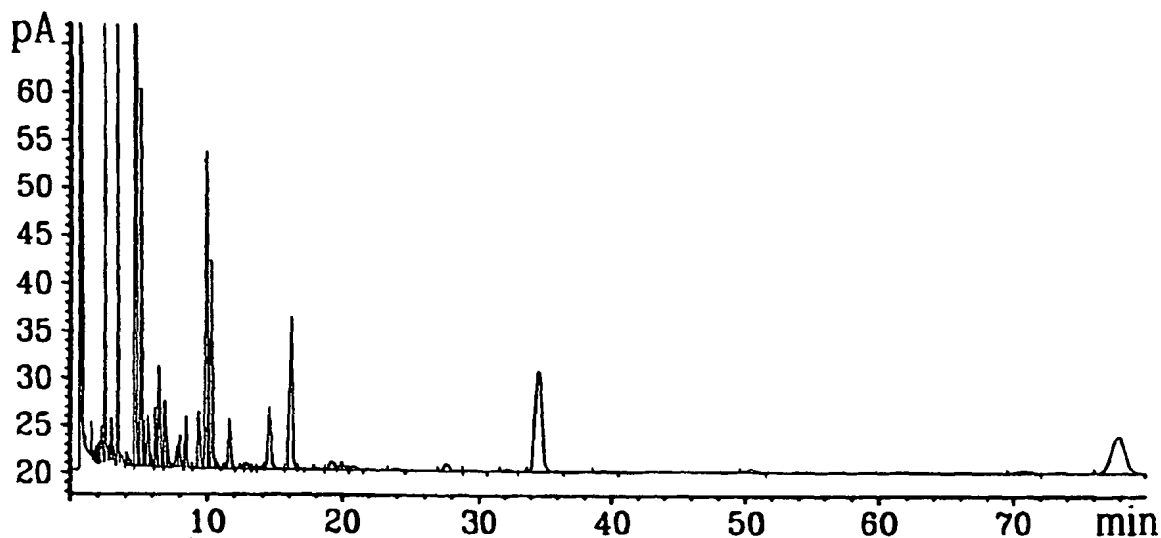
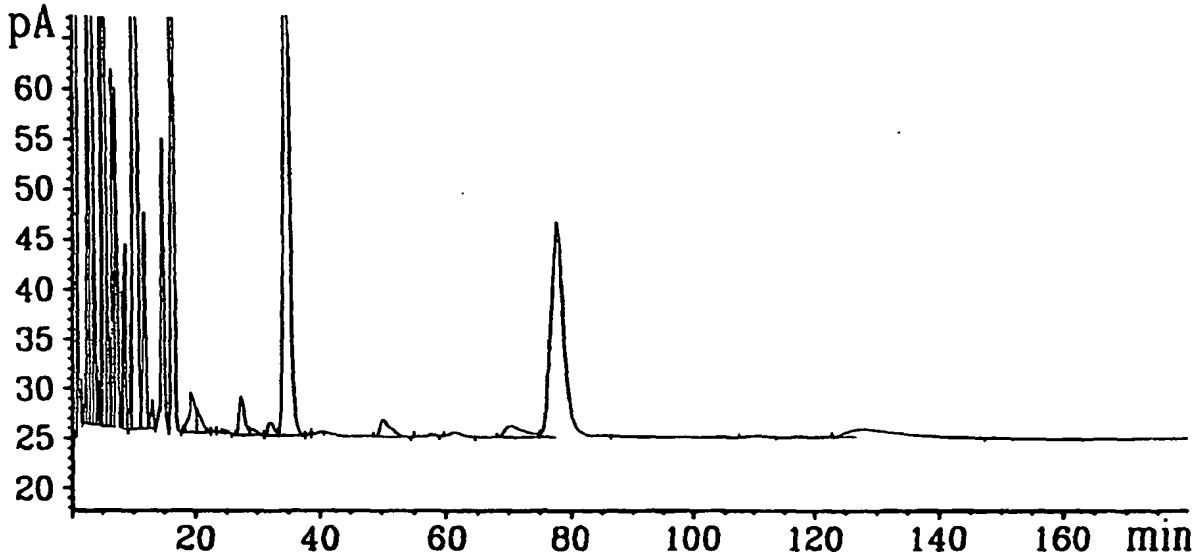

FIG. 5

1.556 - 12:0	5.977	14.540 - 18:3
1.753	6.294	16.133
1.972	6.546	16.805
2.104	7.020	18.131
2.304	7.166	19.154 - 20:0
2.590 - 14:0	7.889	19.875
2.892 - 14:1	8.030	20.099 - 20:1(cis11)
3.012	8.473	20.820 - 20:1
3.153	9.425 - 18:0	23.903
3.485 - std 15:0	10.010 - 18:1	27.583
3.710	10.260 - 18:1tr	29.570
4.096	10.735	32.195
4.203	11.394	34.597
4.333	11.661 - 18:2	39.334
4.800 - 16:0	12.540	50.452
5.206 - 16:1	12.909	70.660
5.417	13.402	77.895 - 24:0
5.711 - 16:1tr	14.010	



7355-6

1.564 - 12:0	8.025	34.677
1.762	8.485	38.373 - 22:0
1.977	9.360 - 18:0	40.163
2.080	9.407	50.157
2.273	10.147 - 18:1tr	57.532
2.591 - 14:0	11.618 - 18:2	61.436
2.887 - 14:1	12.858	70.271
3.008	14.515 - 18:3	77.784 - 24:0
3.470 - std 15:0	16.162	110.694
4.108	18.077	127.696
4.341	19.355 - 20:1	
4.803 - 16:0	20.182 - 20:4 (cis11)	
5.210 - 16:1tr	20.311	
5.683	23.205 - 20:2	
6.292	24.678	
6.514	27.411 - 20:4 (6,10,14,18)	
7.030	29.307	
7.810	31.990	

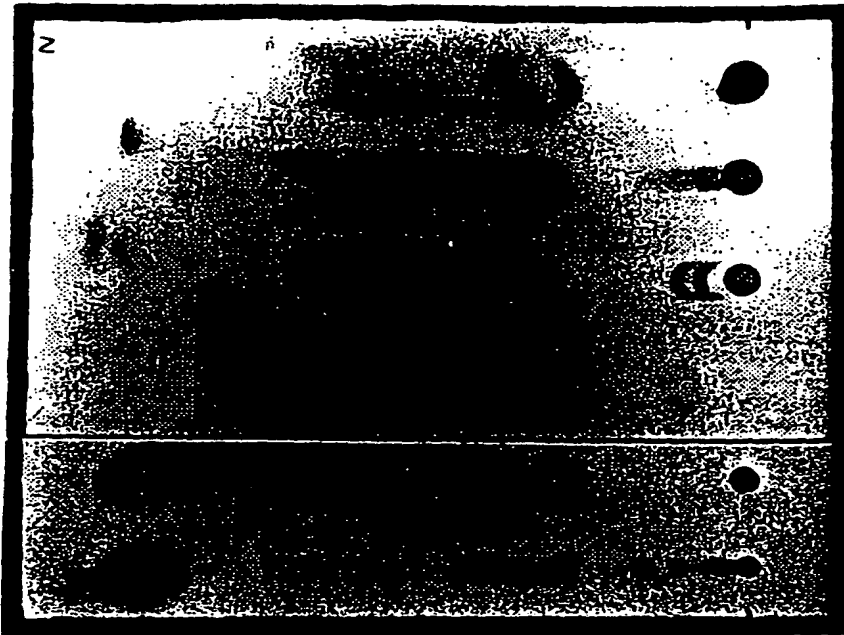

Cholesterol esters

Methyl esters

Triglycerides

Free fatty acids

Cholesterol

Diglycerides

Monoglycerides

Origin

7

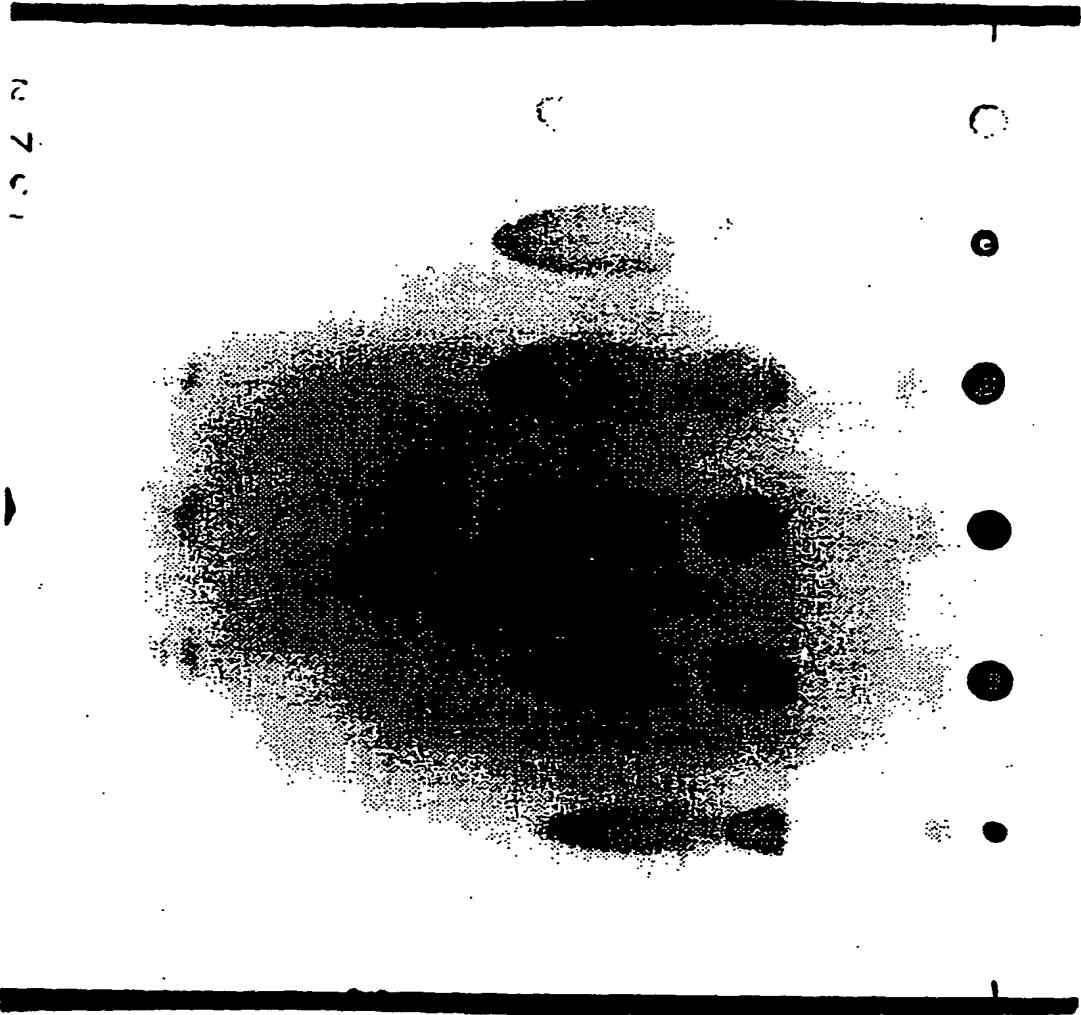

1042

F.F.B.

Cholesterol esters
 Methyl esters

Triglycerides

Free fatty acids
 Cholesterol

Diglycerides

Monoglycerides
 Origin

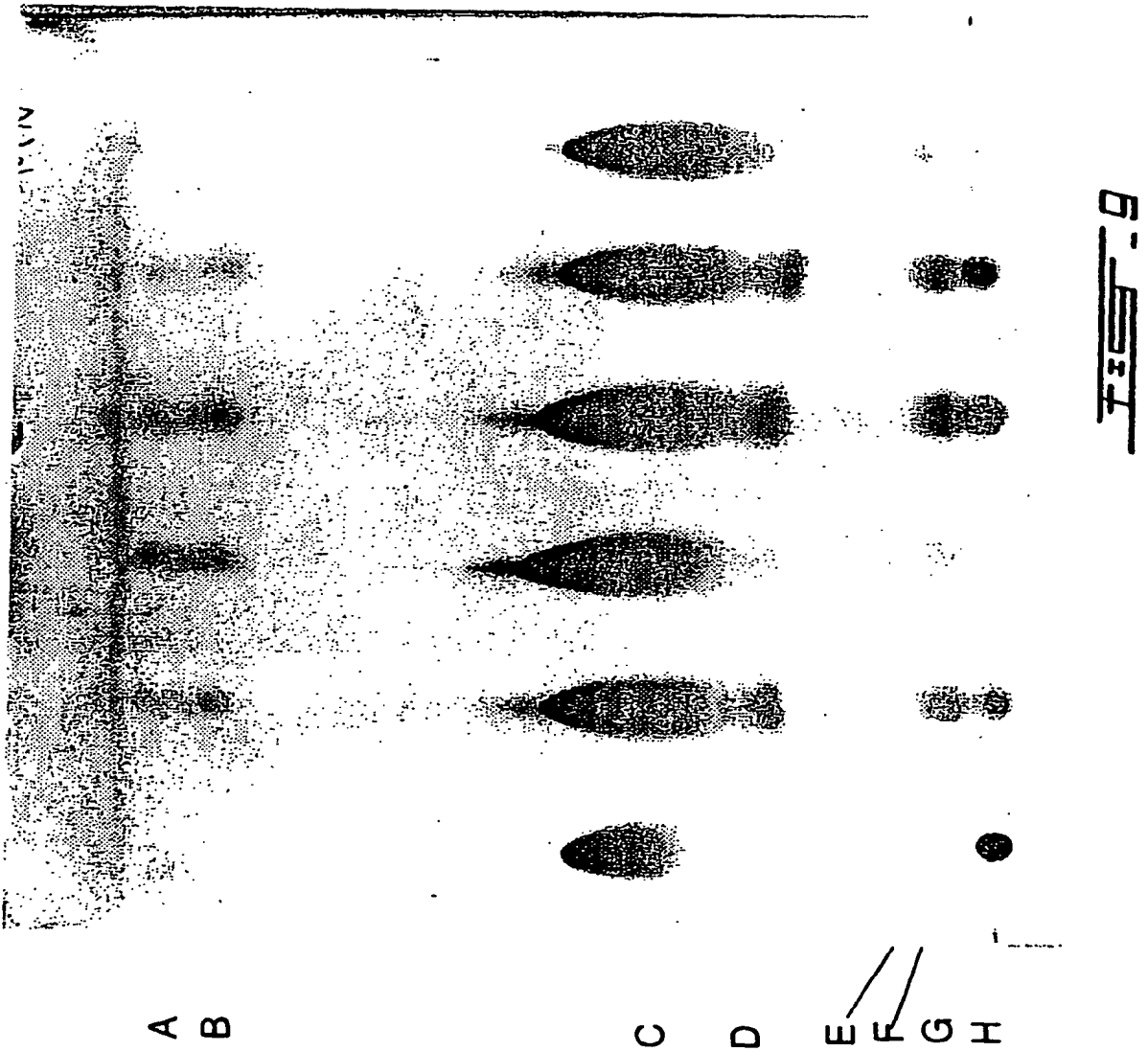

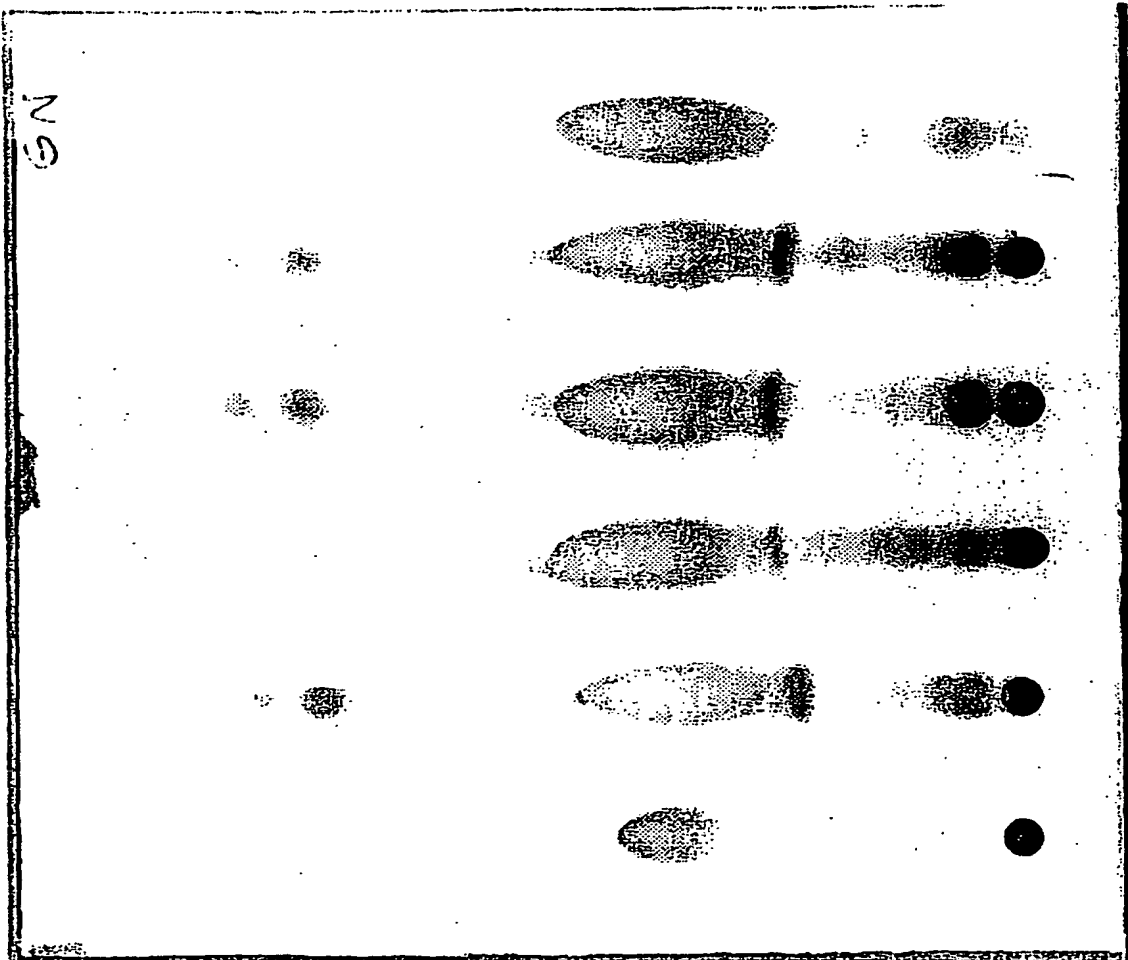

GN

10-11

A

B

C

D

E

F

G

H

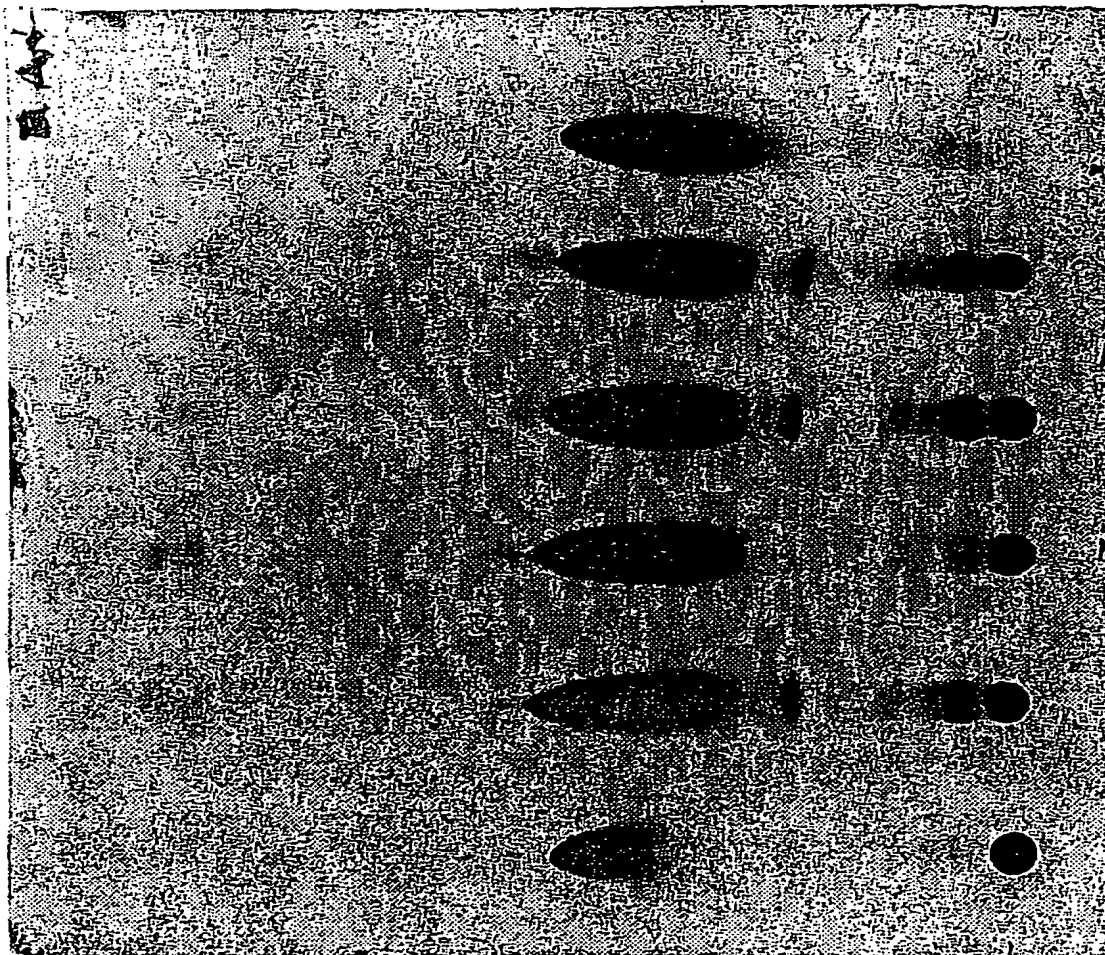

11-11

A B

C

///
D E F G H

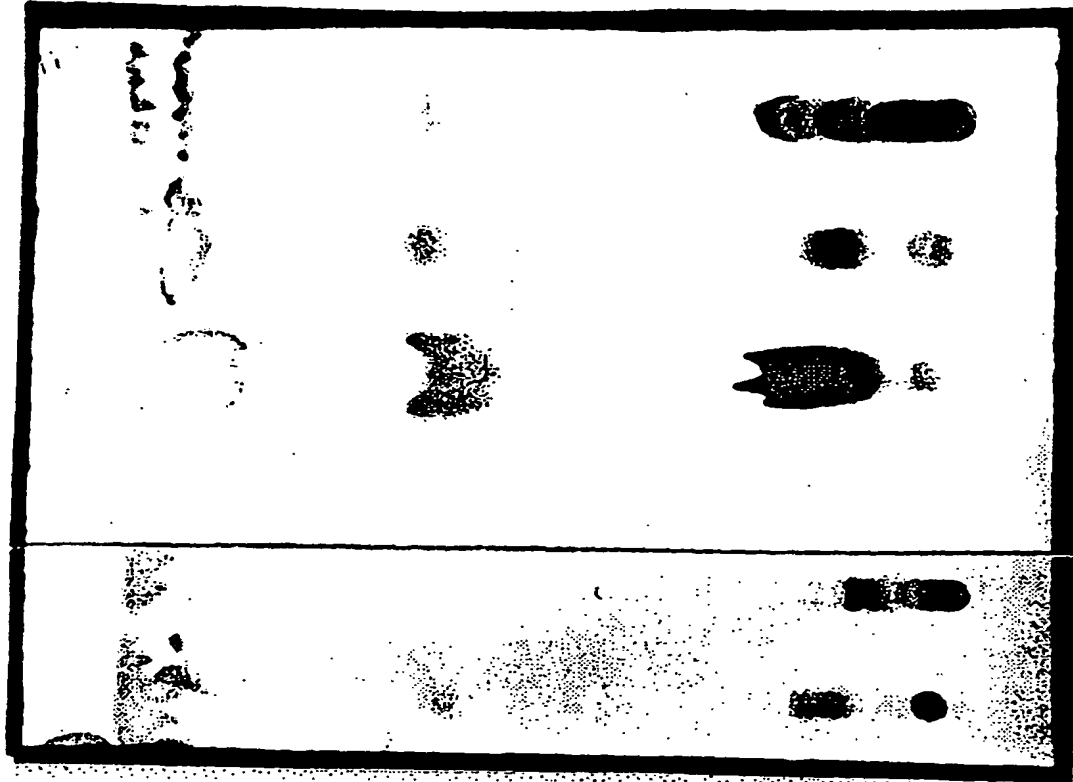

Neutral lipids

Cephalin

Lecithin
Sphingomyelin
Lysolecithin
Origin

1.25

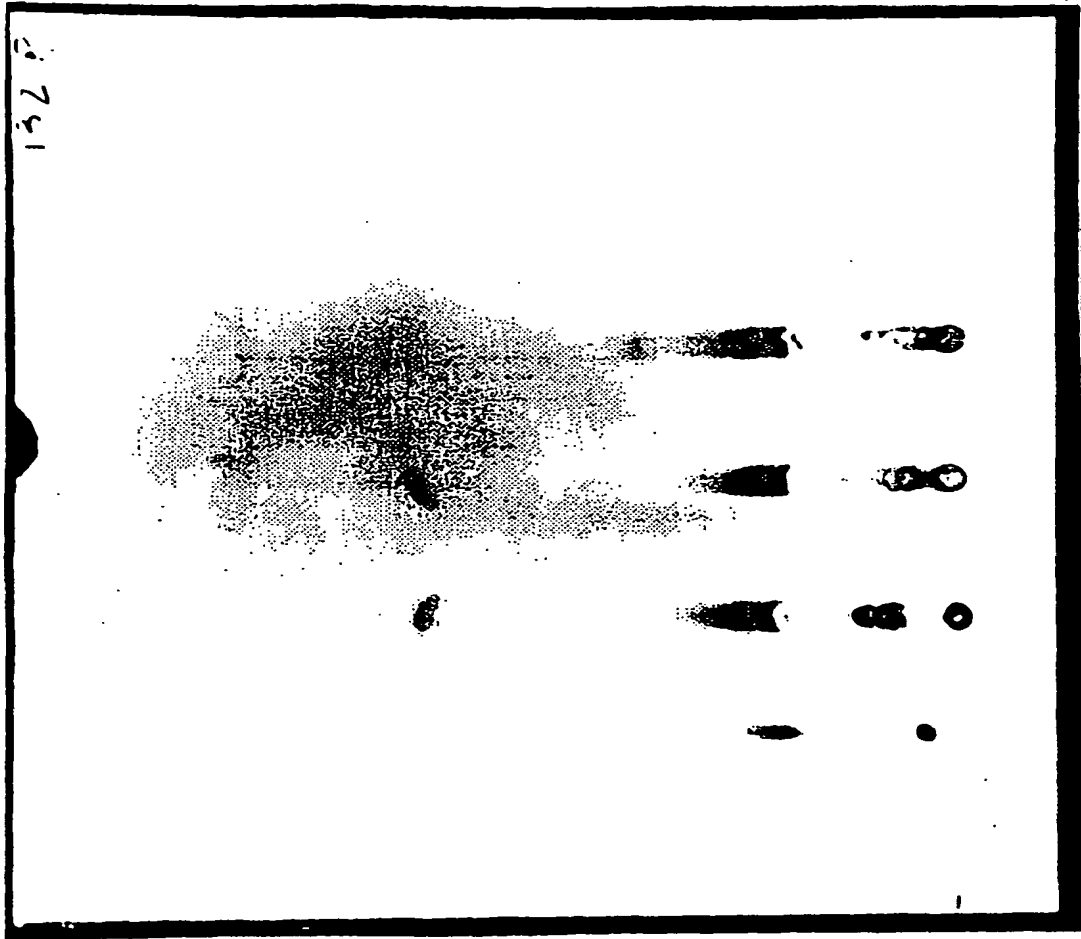

Neutral lipids

Cephalin

Lecithin
Sphingomyelin
Lysolecithin
Origin

132 P

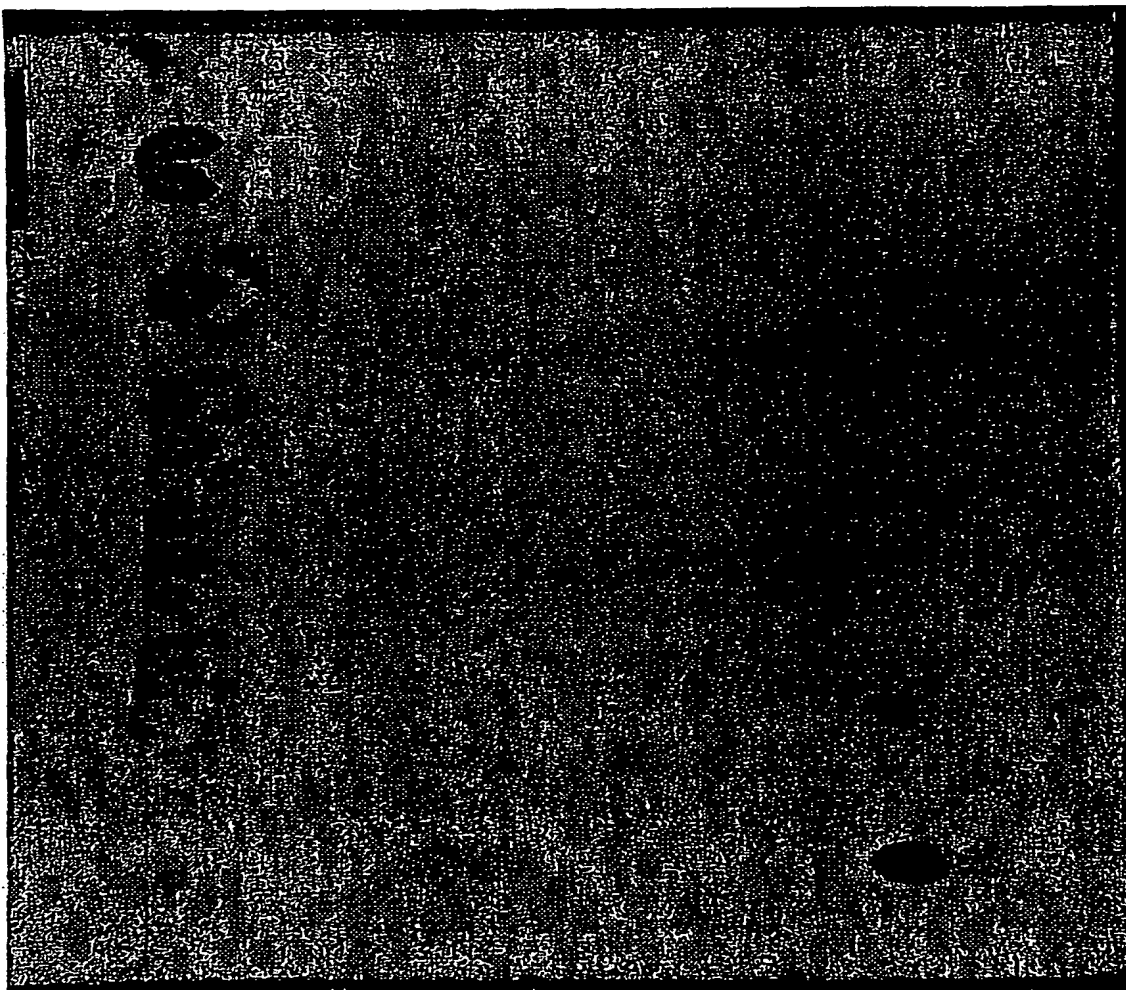

FILE: 14

A

B

///
C D E F

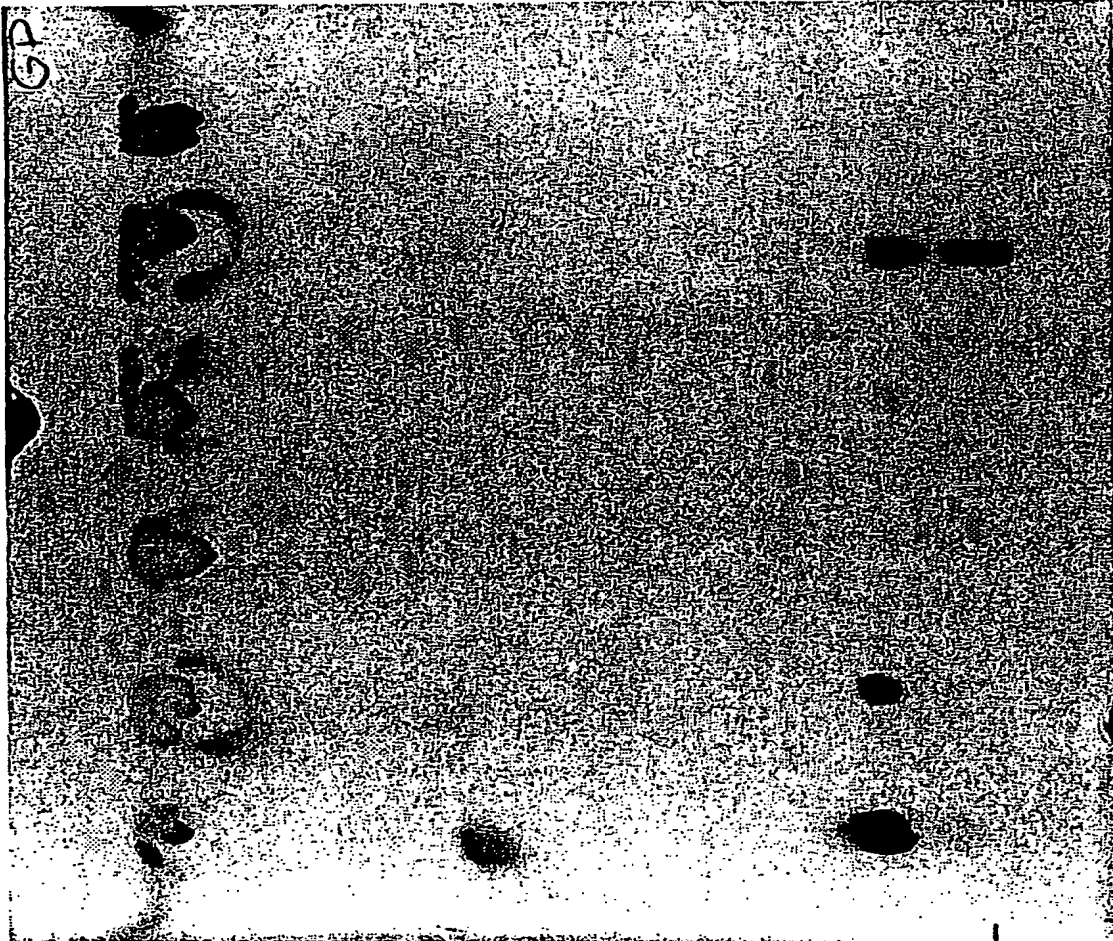

15-138

A

B

|||
C D E F

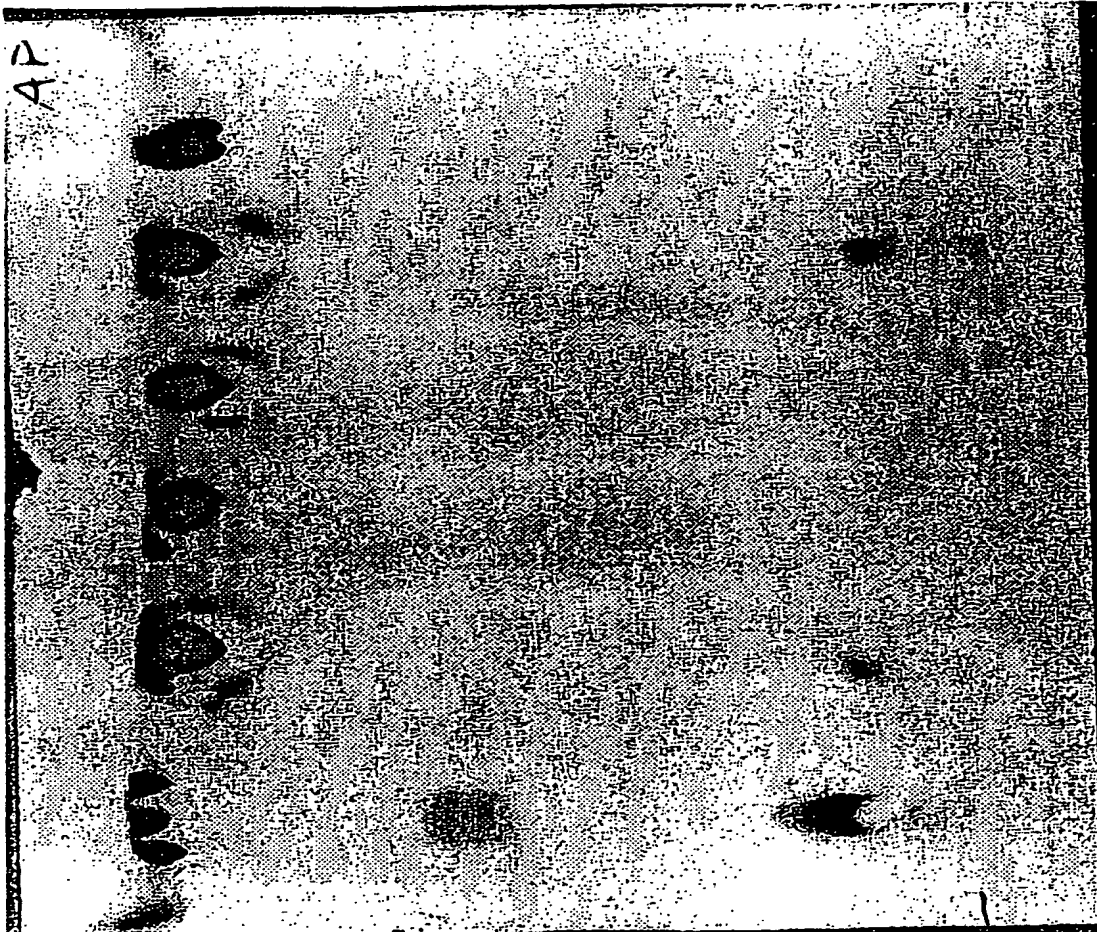

AP

158-16

A

B

C D E F

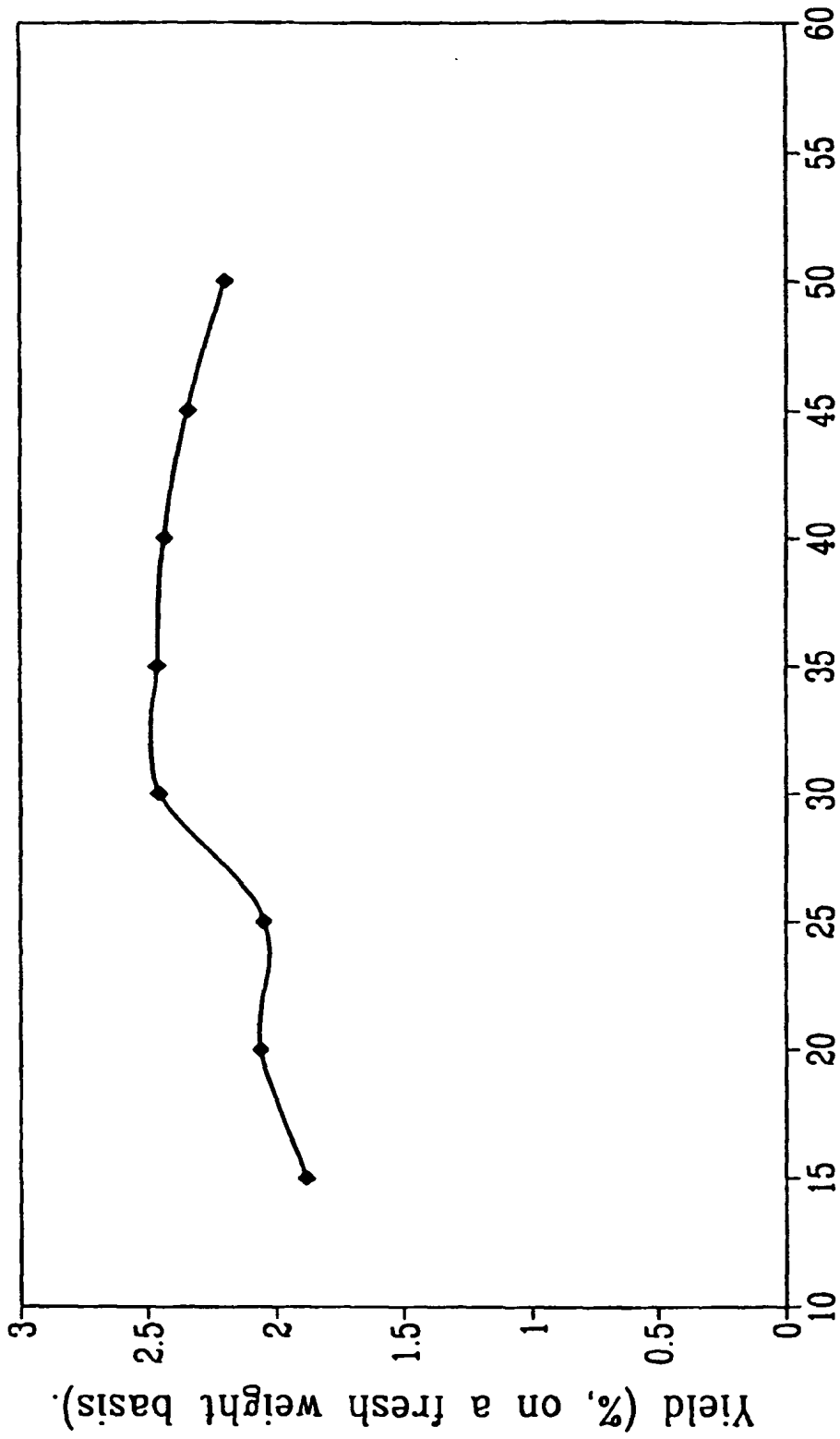

Volume of acetone (mL).

Incubation time of 2 h.

Determinations in triplicates (variation less than 5 %).

FIG. 17

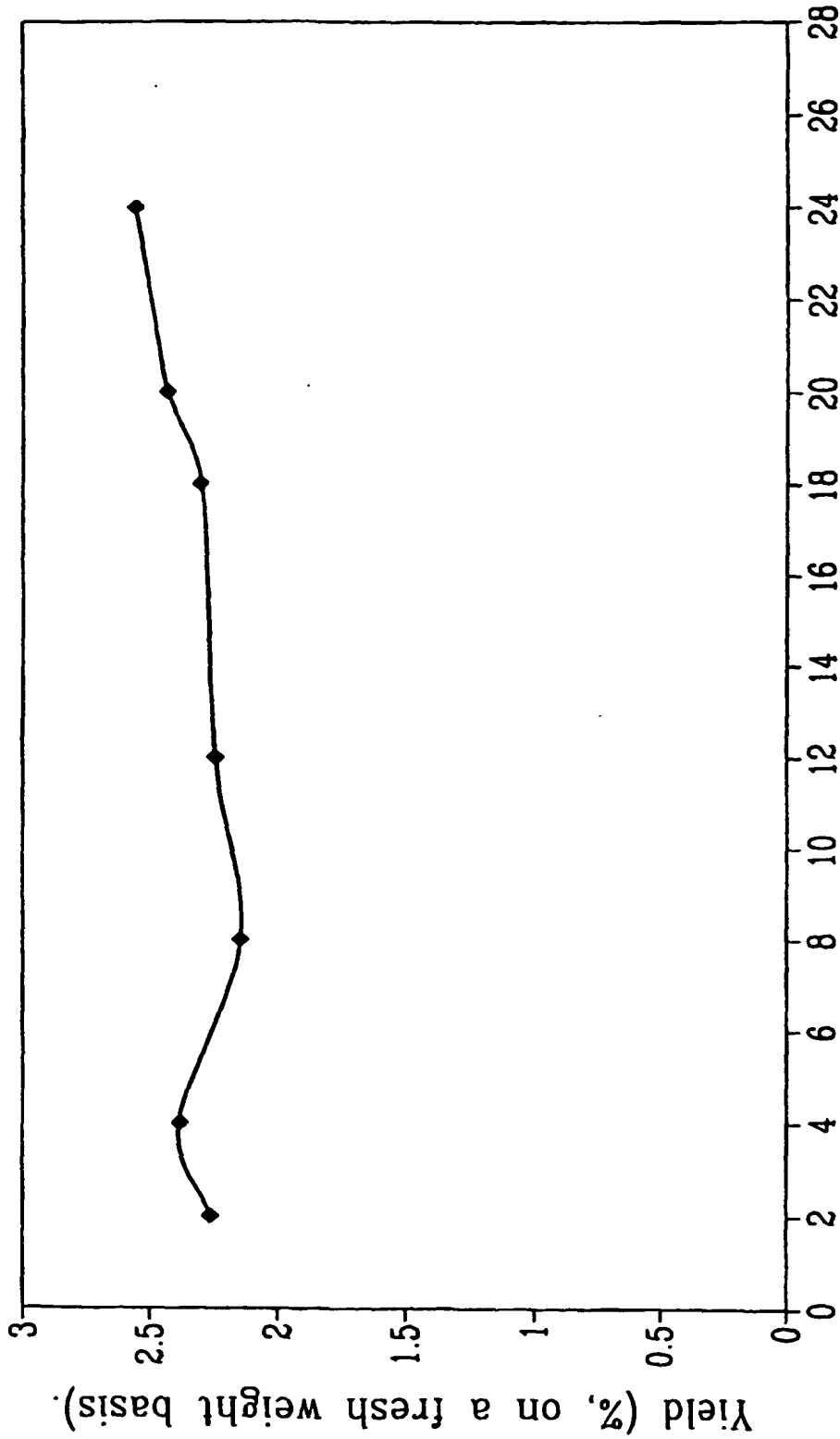

Incubation time in acetone (h).
Sample-acetone ratio of 1:9 (w/v).
Determinations in triplicates (variation less than 5 %).

FIG. 1B

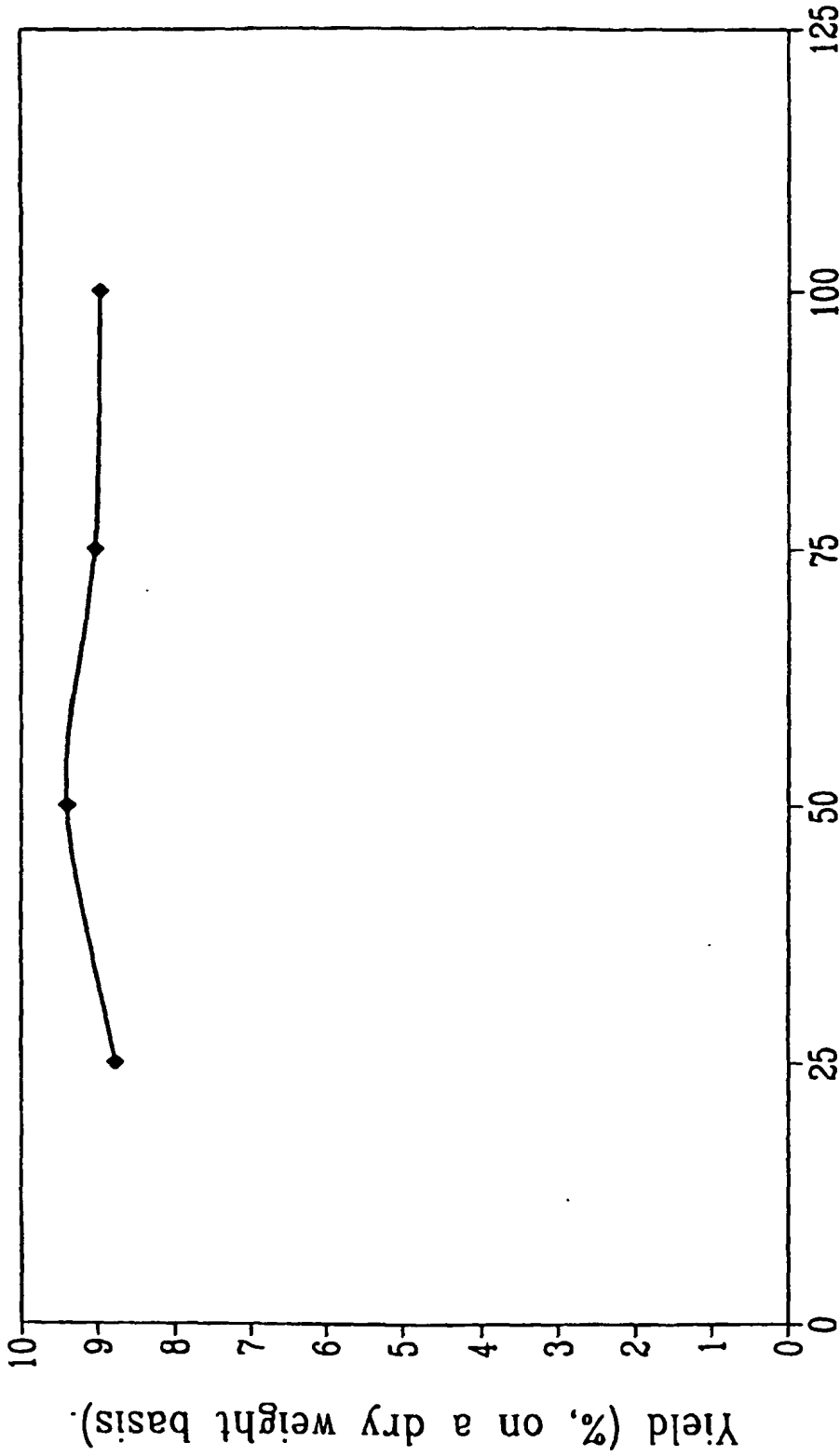

Volume of ethanol (mL).
Incubation time of 30 min.
Determinations in triplicates (variation less than 5 %).

Fig. 19

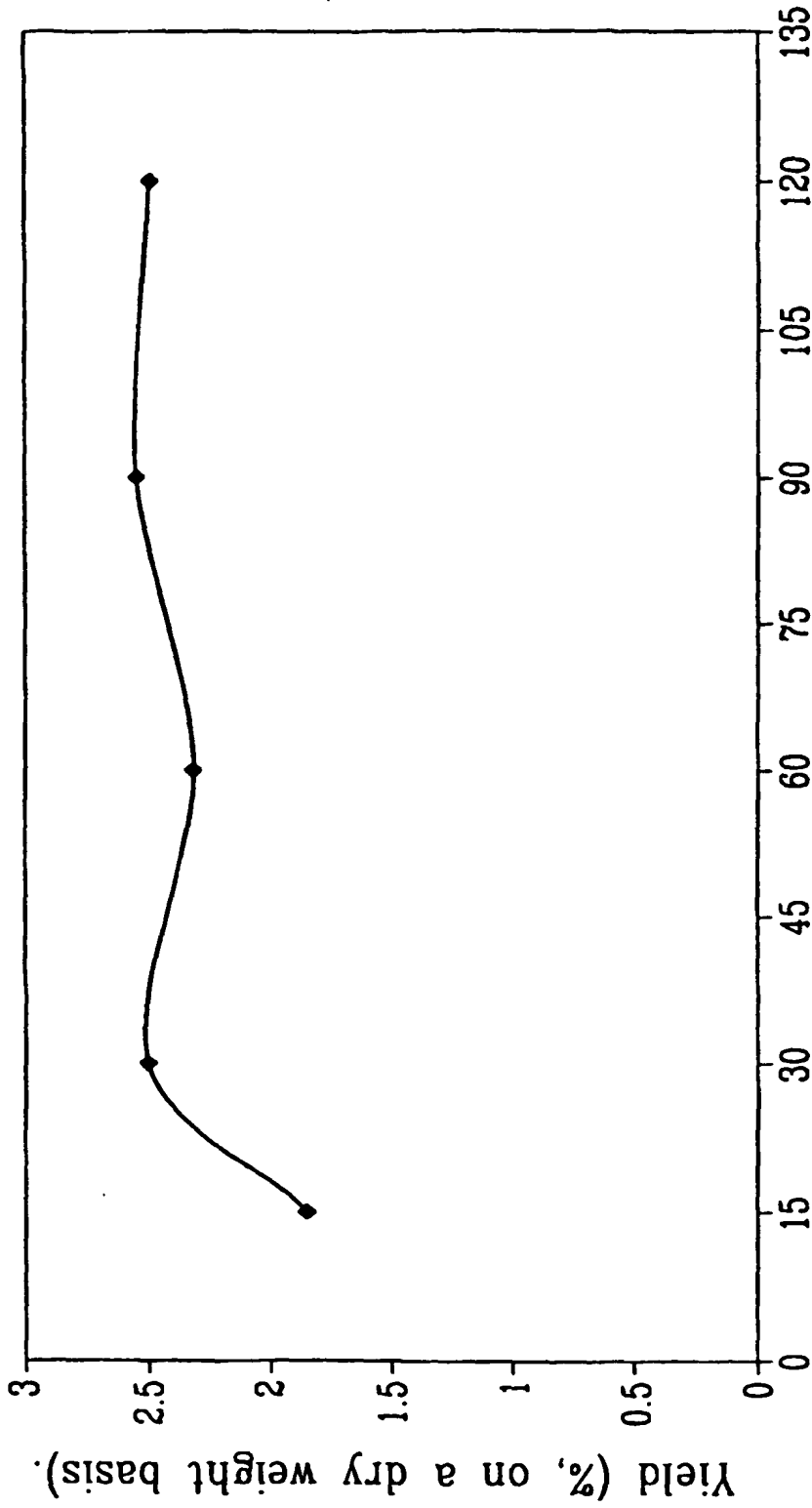

Incubation time in ethanol (min).

Sample-ethanol ratio of 1:4 (w/v).

Determinations in triplicates (variation less than 5 %).

FIG. 20

REFERENCES CITED IN THE DESCRIPTION

This list of references cited by the applicant is for the reader's convenience only. It does not form part of the European patent document. Even though great care has been taken in compiling the references, errors or omissions cannot be excluded and the EPO disclaims all liability in this regard.

Patent documents cited in the description

- US 4331695 A [0009]
- CA 2115571 [0010]
- US 5006281 A [0011]
- CA 1098900 [0012]

Non-patent literature cited in the description

- A simple method for the isolation and purification of total lipids from animal tissues. *J. biol. Chem.*, 1957, vol. 226, 497-509 [0013]
- CHURCH et al. *J Dairy Sci*, 1983, vol. 66, 1219-1227 [0050]
- BOWYER, D.E. ; LEAT, W.M.F. ; HOWARD, A.N. ; GRESHAM, G.A. The determination of the fatty acid composition of serum lipids separated by thin-layer chromatography; and a comparison with column chromatography. *BBA*, 1962, vol. 70, 423-431 [0059]
- CHANDRASEKAR, B. ; TROYER, D.A. ; VENKATRAMAN, J.T. ; FERNANDES, G. Tissue specific regulation of transforming growth factor beta by omega-3 lipid-rich krill oil in autoimmune murine lupus. *Nutr Res.*, 1996, vol. 16 (3), 489-503 [0060]
- CHRISTENSEN, M.S. ; HOY, C-E. ; REDGRAVE, T.G. Lymphatic absorption of n-3 polyunsaturated fatty acids from marine oils with different intramolecular fatty acid distributions. *BBA*, 1994, vol. 1215, 198-204 [0061]
- CHURCH, F.C. ; SWAISGOOD, H.E. ; PORTER, D.H. ; CATIGNANI, G.L. Spectrophotometric assay using o- Phthaldialdehyde for determination of proteolysis in milk and isolated milk proteins. *J Dairy Sci.*, 1983, vol. 66, 1219-1227 [0062]
- Difco laboratories. Difco Manual Dehydrated Culture Media and Reagents for Microbiology. 1984 [0063]
- FOLCH, J. ; LEES, M. ; SLOANE-STANLEY, G.H. A simple method for the isolation and purification of total lipids from animal tissues. *J. biol. Chem.*, 1957, vol. 226, 497-509 [0064]
- GOODMAN GILMAN, A. ; GOODMAN, L.L. ; GILMAN, A. The Pharmacological Basis of Therapeutics. Collier Macmillan Canada Ltd, 1980 [0065]
- Biology Data Book. HARWOOD, H.J. ; GEYER, R.P. The Federation of American Societies for Experimental Biology. 1964 [0066]
- HELLGREN, L. ; KARLSTAM, B. ; MOHR, V. ; VINCENT, J. Krill enzymes. A new concept for efficient debridement of necrotic ulcers. *Int J Dermatol.*, 1991, vol. 30 (2), 102-103 [0067]
- PLUMMER, D.T. An introduction to practical biochemistry. McGraw-Hill Book Company, 1987 [0068]
- RAWN, J.D. *Traité de biochimie*, 1990 [0069]
- RUNGE, J.A. ; JOLY, P. Rapport sur l'état des invertébrés. *Zooplankton (Euphausiacés et Calanus) de l'Estuaire et du Golfe du Saint-Laurent*, 1994, vol. 7, 0 [0070]
- SARGENT, J.R. Fish oils and human diet. *Br J Nutr.*, 1997, vol. 78 (1), S5-S13 [0070]

(19)



(11)

EP 1 292 294 B1

(12)

EUROPEAN PATENT SPECIFICATION

(45) Date of publication and mention of the grant of the patent:
18.03.2009 Bulletin 2009/12

(51) Int Cl.:
A61K 31/215 ^(2006.01) **A61K 31/19** ^(2006.01)
A61K 31/205 ^(2006.01) **A61P 25/28** ^(2006.01)

(21) Application number: **01930965.7**

(86) International application number:
PCT/US2001/013955

(22) Date of filing: **01.05.2001**

(87) International publication number:
WO 2001/082928 (08.11.2001 Gazette 2001/45)

(54) **USE OF MEDIUM CHAIN TRIGLYCERIDES FOR THE TREATMENT AND PREVENTION OF ALZHEIMER'S DISEASE**

VERWENDUNG VON TRIGLYCERIDEN MIT MITTELLANGEN KETTEN ZUR BEHANDLUNG UND VORBEUGUNG DER ALZHEIMERSCHEN ERKRANKUNG

UTILISATION DE TRIGLYCERIDES DE CHAINE MOYENNE POUR TRAITER ET PREVENIR LA MALADIE D'ALZHEIMER

(84) Designated Contracting States:
AT BE CH CY DE DK ES FI FR GB GR IE IT LI LU MC NL PT SE TR

(30) Priority: **01.05.2000 US 200980 P**

(43) Date of publication of application:
19.03.2003 Bulletin 2003/12

(60) Divisional application:
09001380.6

(73) Proprietor: **Accera, Inc.**
Aurora, CO 80014 (US)

(72) Inventor: **HENDERSON, Samuel, T.**
Apt. 203, Bromfield, CO 80020 (US)

(74) Representative: **Clegg, Richard Ian et al**
Mewburn Ellis LLP
33 Gutter Lane
London
EC2V 8AS (GB)

(56) References cited:
WO-A-00/15216 **WO-A-98/41200**

- **PATENT ABSTRACTS OF JAPAN** vol. 1995, no. 01, 28 February 1995 (1995-02-28) & JP 06 287138 A (GREEN CROSS CORP:THE), 11 October 1994 (1994-10-11)

- **COX GERALD F ET AL: "Reversal of severe hypertrophic cardiomyopathy and excellent neuropsychologic outcome in very-long-chain acyl-coenzyme A dehydrogenase deficiency" JOURNAL OF PEDIATRICS, vol. 133, no. 2, August 1998 (1998-08), pages 247-253, XP009025989 ISSN: 0022-3476**
- **THAL L J ET AL: "A 1-YEAR MULTICENTER PLACEBO-CONTROLLED STUDY OF ACETYL-L-CARNITINE IN PATIENTS WITH ALZHEIMER'S DISEASE" NEUROLOGY, LIPPINCOTT WILLIAMS & WILKINS, PHILADELPHIA, US, vol. 47, no. 3, 1 September 1996 (1996-09-01), pages 705-711, XP002039105 ISSN: 0028-3878**
- **KASHIWAYA Y ET AL: "D-beta-hydroxybutyrate prospects neurons in models of Alzheimer's and Parkinson's disease" PROCEEDINGS OF THE NATIONAL ACADEMY OF SCIENCES OF USA, NATIONAL ACADEMY OF SCIENCE. WASHINGTON, US, vol. 97, no. 10, 9 May 2000 (2000-05-09), pages 5440-5444, XP002964865 ISSN: 0027-8424**
- **DATABASE CABA [Online] (COLUMBUS, OHIO, USA) MAK S.C. ET AL.: 'Clinical experience of ketogenic diet on children with refractory epilepsy', XP002961971 Retrieved from STN Database accession no. 1999:136034 & ACTA PAEDIATRICA SINICA vol. 40, no. 2, 1999, pages 97 - 100**

Note: Within nine months of the publication of the mention of the grant of the European patent in the European Patent Bulletin, any person may give notice to the European Patent Office of opposition to that patent, in accordance with the Implementing Regulations. Notice of opposition shall not be deemed to have been filed until the opposition fee has been paid. (Art. 99(1) European Patent Convention).

EP 1 292 294 B1

- **DATABASE MEDLINE [Online] (COLUMBUS, OHIO, USA) BRUNO G. ET AL.: 'Acetyl-L-carnitine in Alzheimer disease: A short-term study on CSF neurotransmitters and neuropeptides', XP002961972 Retrieved from STN Database accession no. 96063810 & ALZHEIMER DISEASE AND ASSOCIATED DISORDERS vol. 9, no. 3, 1995, pages 128 - 131**

Remarks:

The file contains technical information submitted after the application was filed and not included in this specification

Description

FIELD OF THE INVENTION

[0001] This invention relates to the field of therapeutic agents for the treatment of Alzheimer's Disease.

BACKGROUND OF THE INVENTION

[0002] Alzheimer's Disease (AD) is a progressive neurodegenerative disorder, which primarily affects the elderly. There are two forms of AD, early-onset and late-onset. Early-onset AD is rare, strikes susceptible individuals as early as the third decade, and is frequently associated with mutations in a small set of genes. Late onset AD is common, strikes in the seventh or eighth decade, and is a multifactorial disease with many genetic risk factors. Late-onset AD is the leading cause of dementia in persons over the age of 65. An estimated 7-10% of the American population over 65, and up to 40% of the American population greater than 80 years of age is afflicted with AD (McKhann et al., 1984; Evans et al. 1989). Early in the disease, patients experience loss of memory and orientation. As the disease progresses, additional cognitive functions become impaired, until the patient is completely incapacitated. Many theories have been proposed to describe the chain of events that give rise to AD, yet, at time of this application, the cause remains unknown. Currently, no effective prevention or treatment exists for AD. The only drugs to treat AD on the market today, Aricept® and Cognex®, are acetylcholinesterase inhibitors. These drugs do not address the underlying pathology of AD. They merely enhance the effectiveness of those nerve cells still able to function. Since the disease continues, the benefits of these treatments are slight.

[0003] Early-onset cases of AD are rare (~5%), occur before the age of 60 and are frequently associated with mutations in three genes, presenilin1 (PS1), presenilin2 (PS2) and amyloid precursor protein (APP) (for review see Selkoe, 1999). These early-onset AD cases exhibit cognitive decline and neuropathological lesions that are similar to those found in late-onset AD. AD is characterized by the accumulation of neurofibrillar tangles (NFT) and β -amyloid deposits in senile plaques (SP) and cerebral blood vessels. The main constituent of senile plaques is the β -amyloid peptide (A β), which is derived from the APP protein by proteolytic processing. The presenilin proteins may facilitate the cleavage of APP. The A β peptide is amyloidogenic and under certain conditions will form insoluble fibrils. However, the toxicity of A β peptide and fibrils remains controversial. In some cases A β has been shown to be neurotoxic, while others find it to be neurotrophic (for reviews see Selkoe, 1999). The cause of early-onset AD is hypothesized to be accumulation of aggregated proteins in susceptible neurons. Mutations in APP are hypothesized to lead to direct accumulation of fibrillar A β , while mutations in PS 1 or PS2

are proposed to lead to indirect accumulation of A β . How a variety of mutations in PS1 and PS2 lead to increased A β accumulation has not been resolved. Accumulation of aggregated proteins is common to many progressive neurodegenerative disorders, including Amyloid Lateral Sclerosis (ALS) and Huntington's disease (for review see Koo et al., 1999). Evidence suggests that accumulation of aggregated proteins inhibits cellular metabolism and ATP production. Consistent with this observation is the finding that buffering the energy capacity of neurons with creatine will delay the onset of ALS in transgenic mouse models (Klivenyi et al., 1999). Much of the prior art on AD has focused on inhibiting production of or aggregation of A β peptides; such as U.S. Patent No. 5,817,626, U.S. Patent No. 5,854,204, and U.S. Patent No. 5,854,215. Other prior art to treat AD include, U.S. Patent No. 5,385,915 "Treatment of amyloidosis associated with Alzheimer disease using modulators of protein phosphorylation", patent U.S. Patent No. 5,538,983, "Method of treating amyloidosis by modulation of calcium." Attempts to increase neuronal survival by use of nerve growth factors have dealt with either whole cell, gene or protein delivery, such as described in U.S. Patent No. 5,650,148 "Method of grafting genetically modified cells to treat defects, disease or damage of the central nervous system", and U.S. Patent No. 5,936,078 "DNA and protein for the diagnosis and treatment of Alzheimer's disease."

[0004] The vast majority (~95%) of AD cases are late-onset, occurring in the seventh or eighth decade. Late-onset AD is not associated with mutations in APP, PS 1 or PS2, yet exhibits neuropathological lesions and symptoms that are similar to those found in early-onset AD. Since late-onset AD is the most common form, it will be referred to herein as AD, while early-onset AD will be referred to as such. The similar neuropathology and outward symptoms of early-onset and late-onset AD have led to the "amyloid cascade hypothesis of AD" (Selkoe, 1994). This model holds that both early and late onset AD result from accumulation of toxic amyloid deposits. The model speculates that in early onset cases, amyloid accumulates rapidly, while in late onset, amyloid accumulates slowly. Much of the research on prevention and treatment of AD has focused on inhibition of amyloid accumulation. However, the amyloid cascade hypothesis remains controversial. Amyloid deposits may be a marker for the disease and not the cause. Translation of Dr. Alzheimer's original work on the neuropathology of AD, relates that he did not favor the view that senile plaques were causative. He states "These changes are found in the basal ganglia, the medulla, the cerebellum and the spinal cord, although there are no plaques at all in those sites or only isolated ones. So we have to conclude *that the plaques are not the cause of senile dementia but only an accompanying feature of senile involution of the central nervous system.*" The italics are his own (Davis and Chisholm, 1999). Many years of research have not resolved this issue (for review of amyloid hypothesis see Selkoe, 1999, for counter argument see Neve et al.,

1998). Since the present invention addresses the decreased neuronal metabolism associated with AD, it does not rely on the validity of the amyloid cascade hypothesis.

[0005] Several genetic risk factors have been proposed to contribute to the susceptibility to late-onset AD. However, only allelic variation in the lipid transport molecule apolipoprotein E (apoE) has been reproducibly defined as a genetic risk factor for late onset AD. ApoE functions as a ligand in the process of receptor mediated internalization of lipid-rich lipoproteins. These lipoprotein complexes contain phospholipids, triglycerides, cholesterol and lipoproteins. Several well-characterized allelic variations exist at the apoE locus, and are referred to as apoE2, E3 and E4. ApoE4 is associated with an increased risk of AD, while apoE2 and E3 are not. Increasing the dosage of the E4 allele increases the risk of AD, and lowers the age of onset. However, apoE4 is not an invariant cause of AD. Some individuals, who are homozygous for the E4 allele, do not show AD symptoms even into the ninth decade (Beffert et al., 1998).

[0006] A prediction of the observation that apoE4 is associated with AD is that populations with a high prevalence of the E4 allele would also have a high incidence of AD. Yet, the opposite appears to be true. Geographically distinct populations have differing frequencies of apoE alleles. For example, the E4 variant is much more common in Africa versus the UK. In a study of black South Africans and Caucasians from Cambridge England, the apoE4 allele was present in 48% of Black South Africans compared to 20.8% of Caucasians (Loktionov et al, 1999). In fact, the E4 allele is widespread throughout Africa (Zekraoui et al, 1997). Studies on AD are difficult to do in developing countries, but the studies that have been done show a very low incidence of AD in African communities, 1% versus 6% in US populations (Hall et al, 1998). Even more striking is that the normally robust association between AD and apoE4 is absent in African cases (Osuntokun et al, 1995). This suggests that something is different between native Africans, and US citizens, who are largely of European descent. Perhaps the African populations have some other genetic factor that protects them from AD. This is unlikely, since the incidence of AD in a population of African-Americans from Indianapolis, Indiana USA (6.24%) was found to be much higher than an ethnically similar population in Ibadan, Nigeria (1.4%) (Hall et al, 1998). This suggests that the link between apoE4 and AD has some strong environmental component.

[0007] ApoE4 is the ancestral allele, it is most similar to the apoE found in chimpanzees and other primates, while the E2 and E3 alleles arose exclusively in the human lineage, (Hanlon and Rubinsztein, 1995). The changes in apoE were probably brought about by a change in diet in ancestral humans. The E2 and E3 alleles may have arisen in populations as an adaptation to agriculture (Corbo and Scacchi, 1999).

[0008] The metabolism of apoE4 in human circulation is different from the non-AD associated apoE3 allele

(Gregg et al., 1986). The E4 allele is associated with unusually high levels of circulating lipoproteins (Gregg et al., 1986). In particular, the E4 allele results in decreased rates of VLDL clearance, which leads to higher levels of VLDL and LDL particles in the blood (Knouff, et al. 1999). VLDL and LDL particles contain higher levels of triglycerides than HDL particles. The increased levels of circulating VLDL in individuals carrying apoE4 is due to decreased fatty acid utilization caused by preferential binding of apoE4 to chylomicron and VLDL particles. Prior art has suggested that apoE4 contributes to AD due to inefficient delivery of phospholipids to neurons (for review see Beffert et al., 1998). Yet, apoE4 also contributes to decreased triglyceride usage.

[0009] In the central nervous system (CNS), apoE plays a central role in the transportation and redistribution of cholesterol and lipids. The importance of apoE in the brain is highlighted by the absence of other key plasma apolipoproteins such as apoA1 and apoB in the brain (Roheim et al., 1979). ApoE mRNA is found predominantly in astrocytes in the CNS. Astrocytes function as neuronal support cells and can efficiently utilize fatty acids for energy. Since the brain lacks other apolipoproteins, it is uniquely dependent on apoE for lipid transport, including triglycerides. While prior art on apoE's role in AD has focused on phospholipid transport, apoE also delivers free fatty acids in the form of triglycerides to astrocytes. Fatty acids delivered by lipoproteins can be converted to ketone bodies by astrocytes for use as an alternative energy source to glucose. An alternative to the neuronal remodeling hypothesis, is that the preferential binding of apoE4 to VLDL particles prevents efficient astrocyte access to triglycerides. Decreased access to triglycerides results in decreased availability of fatty acids and decreased production of ketone bodies, and hence a decreased alternative energy source for cerebral neurons. This reduction in energy supplies may become critical when glucose metabolism is compromised.

[0010] Metabolism and Alzheimer's Disease At the time of this application, the cause of AD remains unknown, yet a large body of evidence has made it clear that Alzheimer's Disease is associated with decreased neuronal metabolism. In 1984, Blass and Zemcov proposed that AD results from a decreased metabolic rate in subpopulations of cholinergic neurons. However, it has become clear that AD is not restricted to cholinergic systems, but involves many types of transmitter systems, and several discrete brain regions. Positron-emission tomography has revealed poor glucose utilization in the brains of AD patients, and this disturbed metabolism can be detected well before clinical signs of dementia occur (Reiman et al., 1996; Messier and Gagnon, 1996; Hoyer, 1998). Additionally, certain populations of cells, such as somatostatin cells of the cortex in AD brain are smaller, and have reduced Golgi apparatus; both indicating decreased metabolic activity (for review see Swaab et al. 1998). Measurements of the cerebral metabolic rates in healthy versus AD patients demonstrated a 20-40% re-

duction in glucose metabolism in AD patients (Hoyer, 1992). Reduced glucose metabolism results in critically low levels of ATP in AD patients. Also, the severity of decreased metabolism was found to correlate with senile plaque density (Meier-Ruge, et al. 1994).

[0011] Additionally, molecular components of insulin signaling and glucose utilization are impaired in AD patients. Glucose is transported across the blood brain barrier and is used as a major fuel source in the adult brain. Consistent with the high level of glucose utilization, the brains of mammals are well supplied with receptors for insulin and IGF, especially in the areas of the cortex and hippocampus, which are important for learning and memory (Frolich et al., 1998). In patients diagnosed with AD, increased densities of insulin receptor were observed in many brain regions, yet the level of tyrosine kinase activity that normally is associated with the insulin receptor was decreased, both relative to age-matched controls (Frolich et al., 1998). The increased density of receptors represents up-regulation of receptor levels to compensate for decreased receptor activity. Activation of the insulin receptor is known to stimulate phosphatidylinositol-3 kinase (PI3K). PI3K activity is reduced in AD patients (Jolles et al., 1992; Zubenko et al., 1999). Furthermore, the density of the major glucose transporters in the brain, GLUT1 and GLUT3 were found to be 50% of age matched controls (Simpson and Davies 1994). The disturbed glucose metabolism in AD has led to the suggestion that AD may be a form of insulin resistance in the brain, similar to type II diabetes (Hoyer, 1998). Inhibition of insulin receptor activity can be exogenously induced in the brains of rats by intracerebroventricular injection of streptozotocin, a known inhibitor of the insulin receptor. These animals develop progressive defects in learning and memory (Lannert and Hoyer, 1998). While glucose utilization is impaired in brains of AD patients, use of the ketone bodies, beta-hydroxybutyrate and acetoacetate is unaffected (Ogawa et al. 1996).

[0012] The cause of decreased neuronal metabolism in AD remains unknown. Yet, aging may exacerbate the decreased glucose metabolism in AD. Insulin stimulation of glucose uptake is impaired in the elderly, leading to decreased insulin action and increased insulin resistance (for review see Finch and Cohen, 1997). For example, after a glucose load, mean plasma glucose is 10-30% higher in those over 65 than in younger subjects. Hence, genetic risk factors for AD may result in slightly compromised neuronal metabolism in the brain. These defects would only become apparent later in life when glucose metabolism becomes impaired, and thereby contribute to the development of AD. Since the defects in glucose utilization are limited to the brain in AD, the liver is "unaware" of the state of the brain and does not mobilize fatty acids (see Brain Metabolism section below). Without ketone bodies to use as an energy source, the neurons of the AD patient brain slowly and inexorably starve to death.

[0013] Attempts to compensate for reduced cerebral

metabolic rates in AD patients has met with some success. Treatment of AD patients with high doses of glucose and insulin increases cognitive scores (Craft et al., 1996). However, since insulin is a polypeptide and must be transported across the blood brain barrier, delivery to the brain is complicated. Therefore, insulin is administered systemically. Large dose of insulin in the blood stream can lead to hyperinsulinemia, which will cause irregularities in other tissues. Both of these shortcomings make this type of therapy difficult and rife with complications. Accordingly, there remains a need for an agent that may increase the cerebral metabolic rate and subsequently the cognitive abilities of a patient suffering from Alzheimer's disease.

[0014] Brain Metabolism The brain has a very high metabolic rate. For example, it uses 20 percent of the total oxygen consumed in a resting state. Large amounts of ATP are required by neurons of the brain for general cellular functions, maintenance of an electric potential, synthesis of neurotransmitters and synaptic remodeling. Current models propose that under normal physiologic conditions, neurons of the adult human brain depend solely on glucose for energy. Since neurons lack glycogen stores, the brain depends on a continuous supply of glucose from the blood for proper function. Neurons are very specialized and can only efficiently metabolize a few substrates, such as glucose and ketone bodies. This limited metabolic ability makes brain neurons especially vulnerable to changes in energy substrates. Hence, sudden interruption of glucose delivery to the brain results in neuronal damage. Yet, if glucose levels drop gradually, such as during fasting, neurons will begin to metabolize ketone bodies instead of glucose and no neuronal damage will occur.

[0015] Neuronal support cells, glial cells, are much more metabolically diverse and can metabolize many substrates, in particular, glial cells are able to utilize fatty acids for cellular respiration. Neurons of the brain cannot efficiently oxidize fatty acids and hence rely on other cells, such as liver cells and astrocytes to oxidize fatty acids and produce ketone bodies. Ketone bodies are produced from the incomplete oxidation of fatty acids and are used to distribute energy throughout the body when glucose levels are low. In a normal Western diet, rich in carbohydrates, insulin levels are high and fatty acids are not utilized for fuel, hence blood ketone body levels are very low, and fat is stored and not used. Such a scenario explains the prevalence of obesity.

[0016] Current models propose that only during special states, such as neonatal development and periods of starvation, will the brain utilize ketone bodies for fuel. The partial oxidation of fatty acids gives rise to D-beta-hydroxybutyrate (D-3-hydroxybutyrate) and acetoacetate, which together with acetone are collectively called ketone bodies. Neonatal mammals are dependent upon milk for development. The major carbon source in milk is fat (carbohydrates make up less than 12% of the caloric content of milk). The fatty acids in milk are oxidized to

give rise to ketone bodies, which then diffuse into the blood to provide an energy source for development. Numerous studies have shown that the preferred substrates for respiration in the developing mammalian neonatal brain are ketone bodies. Consistent with this observation is the biochemical finding that astrocytes, oligodendrocytes and neurons all have capacity for efficient ketone body metabolism (for review see Edmond, 1992). Yet only astrocytes are capable of efficient oxidation of fatty acids.

[0017] The body normally produces small amounts of ketone bodies. However, because they are rapidly utilized, the concentration of ketone bodies in the blood is very low. Blood ketone body concentrations rise on a low carbohydrate diet, during periods of fasting, and in diabetics. In a low carbohydrate diet, blood glucose levels are low, and pancreatic insulin secretion is not stimulated. This triggers the oxidation of fatty acids for use as a fuel source when glucose is limiting. Similarly, during fasting or starvation, liver glycogen stores are quickly depleted, and fat is mobilized in the form of ketone bodies. Since both a low carbohydrate diet and fasting do not result in a rapid drop of blood glucose levels, the body has time to increase blood ketone levels. The rise in blood ketone bodies provides the brain with an alternative fuel source, and no cellular damage occurs. Since the brain has such high energy demands, the liver oxidizes large amounts of fatty acids until the body becomes literally saturated in ketone bodies. Therefore, when an insufficient source of ketone bodies is coupled with poor glucose utilization severe damage to neurons results. Since glial cells are able to utilize a large variety of substrates they are less susceptible to defects in glucose metabolism than are neurons. This is consistent with the observation that glial cells do not degenerate and die in AD (Mattson, 1998).

[0018] As discussed in the Metabolism and Alzheimer's Disease section, in AD, neurons of the brain are unable to utilize glucose and begin to starve to death. Since the defects are limited to the brain and peripheral glucose metabolism is normal, the body does not increase production of ketone bodies, therefore neurons of the brain slowly starve to death. Accordingly, there remains a need for an energy source for brain cells that exhibit compromised glucose metabolism in AD patients. Compromised glucose metabolism is a hallmark of AD; hence administration of such an agent will prove beneficial to those suffering from AD.

[0019] Medium Chain Triglycerides (MCT) The metabolism of MCT differs from the more common long chain triglycerides (LCT) due to the physical properties of MCT and their corresponding medium chain fatty acids (MCFA). Due to the short chain length of MCFA, they have lower melting temperatures, for example the melting point of MCFA (C8:0) is 16.7 °C, compared with 61.1 °C for the LCFA (C16:0). Hence, MCT and MCFA are liquid at room temperature. MCT are highly ionized at physiological pH, thus they have much greater solubility

in aqueous solutions than LCT. The enhanced solubility and small size of MCT also increases the rate at which fine emulsion particles are formed. These small emulsion particles create increased surface area for action by gastrointestinal lipases. Additionally, medium chain 2-monoglycerides isomerize more rapidly than those of long chain length, allowing for more rapid hydrolysis. Some lipases in the pre-duodenum preferentially hydrolyze MCT to MCFA, which are then partly absorbed directly by stomach mucosa (Hamosh, 1990). Those MCFA which are not absorbed in the stomach, are absorbed directly into the portal vein and not packaged into lipoproteins. LCFA are packaged in chylomicrons and transported via the lymph system, while MCFA are transported via the blood. Since blood transports much more rapidly than lymph, the liver is quickly perfused with MCFA.

[0020] In the liver the major metabolic fate of MCFA is oxidation. The fate of LCFA in the liver is dependent on the metabolic state of the organism. LCFA are transported into the mitochondria for oxidation using carnitine palmitoyltransferase I. When conditions favor fat storage, malonyl-CoA is produced as an intermediate in lipogenesis. Malonyl-CoA allosterically inhibits carnitine palmitoyltransferase I, and thereby inhibits LCFA transport into the mitochondria. This feedback mechanism prevents futile cycles of lipolysis and lipogenesis. MCFA are, to large extent, immune to the regulations that control the oxidation of LCFA. MCFA enter the mitochondria largely without the use of carnitine palmitoyltransferase I, therefore MCFA by-pass this regulatory step and are oxidized regardless of the metabolic state of the organism. Importantly, since MCFA enter the liver rapidly and are quickly oxidized, large amounts of ketone bodies are readily produced from MCFA.

[0021] Numerous patents relate to use of MCT. None of these patents relate to the specific use of MCT for treatment and prevention of Alzheimer's Disease. Patents such as U.S. Patent No. 4,528,197 "Controlled triglyceride nutrition for hypercatabolic mammals" and U.S. Patent No. 4,847,296 "Triglyceride preparations for the prevention of catabolism" relate to the use of MCT to prevent body-wide catabolism that occurs in burns and other serious injuries.

[0022] JP-A-6 287 138 discloses the use of MCT for the treatment of Alzheimer's disease and mainly focuses on the parenteral administration; oral administration is suggested at doses of 100-300g MCT daily given in several divided administrations.

SUMMARY OF THE INVENTION

[0023] The present invention provides for the use of MCT's in the treatment or prevention of dementia of Alzheimer's type comprising administering an effective amount of medium chain triglycerides to a patient in need thereof according to claim 1. Administration is oral. The medium chain triglycerides may be emulsified, and may be coadministered with L-carnitine or a derivative of L-

carnitine.

[0024] The present invention further provides therapeutic agents for the treatment or prevention of dementia of Alzheimer's type.

DETAILED DESCRIPTION OF THE INVENTION

[0025] It is the novel insight of this invention that medium chain triglycerides (MCT) and their associated fatty acids are useful as a treatment and preventative measure for AD patients. MCT are composed of fatty acids with chain lengths of between 5-12 carbons. A diet rich in MCT results in high blood ketone levels. High blood ketone levels will provide an energy source for brain cells that have compromised glucose metabolism via the rapid oxidation of MCFA to ketone bodies.

[0026] The background of this invention supports the present invention in the following ways. (1) Neurons of the brain can use both glucose and ketone bodies for respiration. (2) The neurons of Alzheimer's Disease patients have well documented defects in glucose metabolism. (3) Known genetic risk factors for Alzheimer's Disease are associated with lipid and cholesterol transport, suggesting defects in triglyceride usage may underlie susceptibility to Alzheimer's Disease. (4) A diet rich in MCT will lead to increased levels of blood ketone bodies and thereby provide energy to starving brain neurons. Hence, supplementation of Alzheimer's Disease patients with MCT will restore neuronal metabolism.

[0027] The present invention provides a method of treating or preventing dementia of Alzheimer's type, or other loss of cognitive function caused by reduced neuronal metabolism, comprising administering an effective amount of medium chain triglycerides to a patient in need thereof. Generally, an effective amount is an amount effective to either (1) reduce the symptoms of the disease sought to be treated or (2) induce a pharmacological change relevant to treating the disease sought to be treated. For Alzheimer's Disease, an effective amount includes an amount effective to: increase cognitive scores; slow the progression of dementia; or increase the life expectancy of the affected patient. As used herein, medium chain triglycerides of this invention are represented by the following formula:

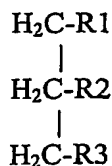

wherein R1, R2 and R3 are fatty acids having 5-12 carbons in the carbon backbone. The structured lipids of this invention may be prepared by any process known in the art, such as direct esterification, rearrangement, fraction-

ation, transesterification, or the like. For example the lipids may be prepared by the rearrangement of a vegetable oil such as coconut oil.

[0028] In a preferred embodiment, the method comprises the use of MCTs wherein R1, R2, and R3 are fatty acids containing a six-carbon backbone (tri-C6:0). Tri-C6:0 MCT are absorbed very rapidly by the gastrointestinal track in a number of model systems (Odle 1997). The high rate of absorption results in rapid perfusion of the liver, and a potent ketogenic response. Additionally, utilization of tri-C6:0 MCT can be increased by emulsification. Emulsification of lipids increases the surface area for action by lipases, resulting in more rapid hydrolysis. Methods for emulsification of these triglycerides are well known to those skilled in the art.

[0029] In another preferred embodiment, the invention comprises the coadministration of emulsified tri-C6:0 MCT and L-carnitine or a derivative of L-carnitine. Slight increases in MCFA oxidation have been noted when MCT are combined with L-carnitine (Odle, 1997). Thus in the present invention emulsified tri-C6:0 MCT are combined with L-carnitine at doses required to increase the utilization of said MCT. The dosage of L-carnitine and MCT will vary according to the condition of the host, method of delivery, and other factors known to those skilled in the art, and will be of sufficient quantity to raise blood ketone levels to a degree required to treat and prevent Alzheimer's Disease. Derivatives of L-carnitine which may be used in the present invention include but are not limited to decanoylcarnitine, hexanoylcarnitine, caproylcarnitine, lauroylcarnitine, octanoylcarnitine, stearoylcarnitine, myristoylcarnitine, acetyl-L-carnitine, O-Acetyl-L-carnitine, and palmitoyl-L-carnitine.

[0030] Therapeutically effective amounts of the therapeutic agents can be any amount or dose sufficient to bring about the desired anti-dementia effect and depend, in part, on the severity and stage of the condition, the size and condition of the patient, as well as other factors readily known to those skilled in the art. The dosages can be given as a single dose, or as several doses, for example, divided over the course of several weeks.

[0031] In one embodiment, the MCT's or fatty acids are administered orally. Oral administration of MCT's and preparations intravenous MCT solutions are well known to those skilled in the art.

[0032] Oral and intravenous administration of MCT or fatty acids result in hyperketonemia. Hyperketonemia results in ketone bodies being utilized for energy in the brain even in the presence of glucose. Additionally, hyperketonemia results in a substantial (39%) increase in cerebral blood flow (Hasselbalch et al. 1996). Hyperketonemia has been reported to reduce cognitive dysfunction associated with systemic hypoglycemia in normal humans (Veneman et al. 1994). Please note that systemic hypoglycemia is distinct from the local defects in glucose metabolism that occur in AD. In another embodiment, the invention provides the subject compounds in the form of one or more prodrugs, which can be meta-

bologically converted to the subject compounds by the recipient host. As used herein, a prodrug is a compound that exhibits pharmacological activity after undergoing a chemical transformation in the body. The said prodrugs will be administered in a dosage required to increase blood ketone bodies to a level required to treat and prevent the occurrence of Alzheimer's Disease. A wide variety of prodrug formulations are known in the art. For example, prodrug bonds may be hydrolyzable, such as esters or anhydrides, or enzymatically biodegradable, such as amides.

[0033] This invention also provides a therapeutic agent for the treatment or prevention of dementia of Alzheimer's type, or other loss of cognitive function caused by reduced neuronal metabolism, comprising medium chain triglycerides. In a preferred embodiment, the therapeutic agent is provided in administratively convenient formulations of the compositions including dosage units incorporated into a variety of containers. Dosages of the MCT are preferably administered in an effective amount, in order to produce ketone body concentrations sufficient to increase the cognitive ability of patients afflicted with AD or other states of reduced neuronal metabolism. For example, for the ketone body D-beta-hydroxybutyrate, blood levels are raised to about 1-10 mM or as measured by urinary excretion in the range of about 5 mg/dL to about 160 mg/dL, although variations will necessarily occur depending on the formulation and host, for example. Effective amount dosages of other MCTs will be apparent to those skilled in the art. Convenient unit dosage containers and/or formulations include tablets, capsules, lozenges, troches, hard candies, nutritional bars, nutritional drinks, metered sprays, creams, and suppositories, among others. The compositions may be combined with a pharmaceutically acceptable excipient such as gelatin, an oil, and/or other pharmaceutically active agent(s). For example, the compositions may be advantageously combined and/or used in combination with other therapeutic or prophylactic agents, different from the subject compounds. In many instances, administration in conjunction with the subject compositions enhances the efficacy of such agents. For example, the compounds may be advantageously used in conjunction with antioxidants, compounds that enhance the efficiency of glucose utilization, and mixtures thereof, (see e.g. Goodman et al. 1996).

[0034] In a preferred embodiment, the invention provides a formulation comprising a mixture of MCT and carnitine to provide elevated blood ketone levels. The nature of such formulations will depend on the duration and route of administration. Such formulations will be in the range of 0.5 g/kg/day to 10 g/kg/day of MCT and 0.5 mg/kg/day to 10 mg/kg/day of carnitine or its derivatives. Variations will necessarily occur depending on the formulation and/or host, for example.

[0035] A particularly preferred formulation comprises a range of 10-500 g of emulsified MCT combined with 10-2000 mg of carnitine. An even more preferred formulation comprises 50 g MCT (95% triC8:0) emulsified with

50 g of mono- and di-glycerides combined with 500 mg of L-carnitine. Such a formulation is well tolerated and induces hyperketonemia for 3-4 hours in healthy human subjects.

[0036] In another embodiment, the invention provides the recipient with a therapeutic agent which enhances endogenous fatty acid metabolism by the recipient. The said therapeutic agent will be administered in a dosage required to increase blood ketone bodies to a level required to treat and prevent the occurrence of Alzheimer's Disease. Ketone bodies are produced continuously by oxidation of fatty acids in tissues that are capable of such oxidation. The major organ for fatty acid oxidation is the liver. Under normal physiological conditions ketone bodies are rapidly utilized and cleared from the blood. Under some conditions, such as starvation or low carbohydrate diet, ketone bodies are produced in excess and accumulate in the blood stream. Compounds that mimic the effect of increasing oxidation of fatty acids will raise ketone body concentration to a level to provide an alternative energy source for neuronal cells with compromised metabolism. Since the efficacy of such compounds derives from their ability to increase fatty acid utilization and raise blood ketone body concentration they are dependent on the embodiments of the present invention.

[0037] From the description above, a number of advantages of the invention for treating and preventing Alzheimer's Disease become evident:

(a) Prior art on AD has largely focused on prevention and clearance of amyloid deposits. The role of these amyloid deposits in AD remains controversial and may only be a marker for some other pathology. The present invention provides a novel route for treatment and prevention of AD based on alleviating the reduced neuronal metabolism associated with AD, and not with aspects of amyloid accumulation.

(b) Current treatments for AD are merely palliative and do not address the reduced neuronal metabolism associated with AD. Ingestion of medium chain triglycerides as a nutritional supplement is a simple method to provide neuronal cells, in which glucose metabolism is compromised, with ketone bodies as a metabolic substrate.

(c) Increase blood levels of ketone bodies can be achieved by a diet rich in medium chain triglycerides.

(d) Medium chain triglycerides can be infused intravenously into patients.

(e) Levels of ketone bodies can be easily measured in urine or blood by commercially available products (i.e. Ketostix®, Bayer, Inc.).

[0038] Accordingly, the reader will see that the use of medium chain triglycerides (MCT) as a treatment and preventative measure of Alzheimer's Disease (AD) provides a novel means of alleviating reduced neuronal metabolism associated with AD. It is the novel and significant insight of the present invention that use of MCT results

in hyperketonemia which will provide increased neuronal metabolism for diseases associated with reduced neuronal metabolism, such as AD. Supplementation with MCT may prove more effective when combined with insulin sensitizing agents such as vanadyl sulfate, chromium picolinate, and vitamin E. Such agents may function to increase glucose utilization in compromised neurons and work synergistically with hyperketonemia. In another example MCT can be combined with compounds that increase the rates of fatty acid utilization such as L-carnitine and its derivatives. Mixtures of such compounds may synergistically increase levels of circulating ketone bodies.

REFERENCES

[0039] Throughout the specification, citations to a number of references have been made. Each of these references is incorporated by reference herein in its entirety. Many of the references are summarized here:

- Beffert, U., Danik, M., Krzywkowski, P., Ramassamy, C., Berrada, F., and Poirier, J. (1998) The neurobiology of apolipoproteins and their receptors in the CNS and Alzheimer's disease. *Brain Res Brain Res Rev* 27:119-42.
- Blass, J. P., and Zemcov, A. (1984) Alzheimer's disease. A metabolic systems degeneration? *Neurochem Pathol* 2:103-14.
- Craft, S., Newcomer, J., Kanne, S., Dagogo-Jack, S., Cryer, P., Sheline, Y., Luby, J., Dagogo-Jack, A., and Alderson, A. (1996) Memory improvement following induced hyperinsulinemia in Alzheimer's disease. *Neurobiol Aging* 17:123-30.
- Corbo, R.M. and Sacchi, R (1999) Apolipoprotein E (APOE) allele distribution in the world. Is APOE*4 a 'thrifty' allele. *Ann Hum Genet* 63:301-10.
- Davis, J. N., and Chisholm, J. C. (1999). Alois Alzheimer and the amyloid debate. *Nature* 400:810.
- Edmond, J. (1992) Energy metabolism in developing brain cells. *Can J Physiol Pharmacol* 70:S118-29.
- Evans, D. A., Funkenstein, H. H., Albert, M. S., Scherr, P. A., Cook, N. R., Chown, M. J., Hebert, L.E., Hennekens, C.H., and Taylor, J. O. (1989) Prevalence of Alzheimer's disease in a community population of older persons. Higher than previously reported. *JAMA* 262:2551-6.
- Finch, C. E., and Cohen, D. M. (1997) Aging, metabolism, and Alzheimer disease: review and hypotheses. *Exp Neurol* 143:82-102.
- Frolich, L., Blum-Degen, D., Bernstein, H. G., Engelsberger, S., Humrich, J., Laufer, S., Muschner, D., Thalheimer, A., Turk, A., Hoyer, S., Zochling, R., Boissl, K. W., Jellinger, K., and Riederer, P. (1998) Brain insulin and insulin receptors in aging and sporadic Alzheimer's disease. *J Neural Transm* 105: 423-38.
- Gregg, R. E., Zech, L. A., Schaefer, E. J., Stark, D.,

Wilson, D., and Brewer, H. B. Jr. (1986). Abnormal in vivo metabolism of apolipoprotein E4 in humans. *J Clin Invest* 78:815-21.

Goodman, L. S., Limbird, L. E., Milinoff, P. B., Gilman, A. G., and Hardman, J. G. (editors). (1996). *The Pharmacological Basis of Therapeutics*, 9.sup.th Ed., McGraw-Hill.

Hall K., Gureje O., Gao S., Ogunniyi A., Hui S.L., Baiyewu O., Unverzagt F.W., Oluwole S., Hendrie H.C. (1998) Risk factors and Alzheimer's disease: a comparative study of two communities. *Aust N Z J Psychiatry* 32:698-706.

Hamosh, M. (1990) In: *Lingual and Gastric Lipases: Their role in fat digestion*. CRC press, Boca Raton, FL.

Hanlon C.S., and Rubinsztein D.C. (1995) Arginine residues at codons 112 and 158 in the apolipoprotein E gene correspond to the ancestral state in humans. *Atherosclerosis* 112:85-90.

Hasselbalch, S. G., Madsen, P. L., Hageman, L. P., Olsen, K. S., Justesen, N., Holm, S., and Paulson, O. B. (1996) Changes in cerebral blood flow and carbohydrate metabolism during acute hyperketonemia. *Am J Physiol* 270:E746-51.

Hoyer, S. (1998) Is sporadic Alzheimer disease the brain type of non-insulin dependent diabetes mellitus? A challenging hypothesis. *J Neural Transm* 105: 415-22.

Hoyer, S. (1992) Oxidative energy metabolism in Alzheimer brain. *Studies in early-onset and late-onset cases*. *Mol Chem Neuropathol* 16:207-24.

Jolles, J., Bothmer, J., Markerink, M., and Ravid, R. (1992) Phosphatidylinositol kinase is reduced in Alzheimer's disease. *J Neurochem* 58:2326-9.

Kolanowski, J., Young, J. B., and Landsberg L. (1994) Stimulatory influence of D(-)-3-hydroxybutyrate feeding on sympathetic nervous system activity in the rat. *Metabolism* 43:180-5.

Klivenyi, P., Ferrante, R. J., Matthews, R. T., Bogdanov, M. B., Klein, A. M., Andreassen, O. A., Mueller, G., Wermer, M., Kaddurah-Daouk, R., and Beal, M. F. (1999) Neuroprotective effects of creatine in a transgenic animal model of amyotrophic lateral sclerosis. *Nat. Med.* 5:347-50.

Koo, E. H., Lansbury, P. T., Jr., and Kelly, J. W. (1999) Amyloid diseases: abnormal protein aggregation in neurodegeneration. *Proc Natl Acad Sci USA*. 96:9989-90.

Knouff, C., Hinsdale, M. E., Mezdour, H., Altenburg, M. K., Watanabe, M., Quarfordt, S.H., Sullivan, P.M., and Maeda, N. (1999) Apo E structure determines VLDL clearance and atherosclerosis risk in mice. *J Clin Invest* 103:1579-86.

Lannert, H., and Hoyer, S. (1998) Intracerebroventricular administration of streptozotocin causes long-term diminutions in learning and memory abilities and in cerebral energy metabolism in adult rats. *Behav Neurosci* 112:199-208.

Loktionov A., Vorster H., O'Neill I.K., Nell T., Bingham S.A., Runswick S.A., Cummings J.H. (1999) Apolipoprotein E and methylenetetrahydrofolate reductase genetic polymorphisms in relation to other risk factors for cardiovascular disease in UK Caucasians and Black South Africans. *Atherosclerosis* 145:125-35.

Mattson, M.P. (1998). Experimental models of Alzheimer's Disease. *Science and Medicine* March/April:16-25.

McKhann, G., Drachman, D., Folstein, M., Katzman, R., Price, D., and Stadlan, E. M. (1984). Clinical diagnosis of Alzheimer's disease: report of the NINCDS-ADRDA Work Group under the auspices of Department of Health and Human Services Task Force on Alzheimer's Disease. *Neurology* 34: 939-44.

Meier-Ruge, W., Bertoni-Freddari, C., and Iwagoff, P. (1994) Changes in brain glucose metabolism as a key to the pathogenesis of Alzheimer's disease. *Gerontology* 40:246-52.

Messier, C., and Gagnon, M. (1996) Glucose regulation and cognitive functions: relation to Alzheimer's disease and diabetes. *Behav Brain Res* 75:1-11.

Neve, R. L., and Robakis, N. K. (1998) Alzheimer's disease: a re-examination of the amyloid hypothesis. *Trends Neurosci* 21:15-9.

Nishimura, M., Yu, G., and St George-Hyslop, P. H. (1999) Biology of presenilins as causative molecules for Alzheimer disease. *Clin Genet* 55:219-25.

Odle, J. (1997) New insights into the utilization of medium-chain triglycerides by the neonate: Observations from a pig model. *J Nutr.* 127:1061-7.

Reiman, E. M., Caselli, R. J., Yun, L. S., Chen, K., Bandy, D., Minoshima, S., Thibodeau, S. N., and Osborne, D. (1996) Preclinical evidence of Alzheimer's disease in persons homozygous for the epsilon 4 allele for apolipoprotein E. *N Engl J Med* 334:752-8.

Ogawa, M., Fukuyama, H., Ouchi, Y., Yamauchi, H., and Kimura, J. (1996) Altered energy metabolism in Alzheimer's disease. *J Neurol Sci* 139:78-82.

Osuntokun B.O., Sahota A., Ogunniyi A.O., Gureje O., Baiyewu O., Adeyinka A., Oluwole S.O., Komolafe O., Hall K.S., Unverzagt F.W., et al (1995) Lack of an association between apolipoprotein E epsilon 4 and Alzheimer's disease in elderly Nigerians. *Ann Neurol* 38:463-5.

Roheim P.S., Carey M., Forte T., and Vega G. L. (1979) Apolipoproteins in human cerebrospinal fluid. *Proc Natl Acad Sci U S A* 76:4646-9.

Selkoe, D. J. (1994) Alzheimer's Disease: A central role for amyloid. *J. Neuropathol. Exp. Neurol.* 53: 438-447.

Selkoe, D. J., (1999) Translating cell biology into therapeutic advances in Alzheimer's disease. *Nature* 399:A23-31.

Simpson, 1. A., and Davies, P. (1994) Reduced glucose transporter concentrations in brains of patients

with Alzheimer's disease: *Ann Neurol* 36:800-1.

Swaab, D. F., Lucassen, P. J., Salehi, A., Scherder, E. J., van Someren, E. J., and Verwer, R. W. (1998) Reduced neuronal activity and reactivation in Alzheimer's disease. *Prog Brain Res* 117:343-77.

Veneman, T., Mitrakou, A., Mokan, M., Cryer, P., and Gerich, J. (1994) Effect of hyperketonemia and hyperlactacidemia on symptoms, cognitive dysfunction, and counterregulatory hormone responses during hypoglycemia in normal humans. *Diabetes* 43:1311-7.

Zekraoui L., Lagarde J.P., Raisonnier A., Gerard N., Aouizerate A., Lucotte G. (1997) High frequency of the apolipoprotein E *4 allele in African pygmies and most of the African populations in sub-Saharan Africa. *Hum Biol* 69:575-81.

Zubenko, G. S., Stiffler, J. S., Hughes, H. B., and Martinez, A. J. (1999) Reductions in brain phosphatidylinositol kinase activities in Alzheimer's disease. *Biol Psychiatry* 45:731-6.

EXAMPLES

[0040] The following example is offered by way of illustration and not by way of limitation.

Example 1: Nutritional drink

[0041] Nutritional drinks are prepared using the following ingredients: emulsified MCT 100 gr/drink, L-carnitine 1 gram/drink, mix of daily vitamins at recommended daily levels, and a variety of flavorings.

Example 2: Additional formulations

[0042] Additional formulations can be in the form of Ready to Drink Beverage, Powdered Beverages, Nutritional drinks, Food Bars, and the like. Formulations for such are clear to those skilled in the art. In the following example, A-C include formulations that are within the scope of the invention, as well as some that are not. D-G are not embodiments of the invention but are useful for understanding the invention.

A. Ready to Drink Beverage Ready to Drink Beverages are prepared using the following ingredients: emulsified MCT 5-100 g/drink, L-carnitine 250-1000 mg/drink, and a variety of flavorings and other ingredients used to increased palatability, stability, etc.

B. Powdered Beverages MCT may be prepared in a dried form, useful for food bars and powdered beverage preparations. A powdered beverage may be formed from the following components: dried emulsified MCT 10-50 g, L-carnitine 250-500 mg, sucrose 8-15 g, maltodextrin 1-5 g, flavorings 0-1 g.

C. Food bar A food bar would consist of: dried emulsified MCT 10-50 g, L-carnitine 250-500 mg, glycerin 1-5 g, corn syrup solids 5-25 g, cocoa 2-7g, coating

15-25 g.

D. Gelatin Capsules Hard gelatin capsules are prepared using the following ingredients: MCT 0.1-1000 mg/capsule, L-carnitine 250-500 mg/capsule, Starch, NF 0-600 mg/capsule; Starch flowable powder 0-600 mg/capsule; Silicone fluid 350 centistokes 0-20 mg/capsule. The ingredients are mixed, passed through a sieve, and filled into capsules.

E. Tablets Tablets are prepared using the following ingredients: MCT 0.1-1000 mg/tablet; L-carnitine 250-500 mg/tablet; Microcrystalline cellulose 20-300 mg/tablet; Starch 0-50 mg/tablet; Magnesium stearate or stearate acid 0-15 mg/tablet; Silicon dioxide, fumed 0-400 mg/tablet; silicon dioxide, colloidal 0-1 mg/tablet, and lactose 0-100 mg/tablet. The ingredients are blended and compressed to form tablets.

F. Suspensions Suspensions are prepared using the following ingredients: 0.1-1000 mg MCT; 250-500 mg L-carnitine; Sodium carboxymethyl cellulose 50-700 mg/5 ml; Sodium benzoate 0-10 mg/5 ml; Purified water 5 ml; and flavor and color agents as needed.

G. Parenteral Solutions A parenteral composition is prepared by stirring 1.5% by weight of MCT and L-carnitine in 10% by volume propylene glycol and water. The solution is made isotonic with sodium chloride and sterilized.

Claims

- 1. Use of an effective amount of medium chain triglyceride for the preparation of a pharmaceutical composition for the treatment or prevention of loss of cognitive function caused by reduced neuronal metabolism in Alzheimer's disease, wherein said treatment or prevention comprises oral administration of a single dose of medium chain triglyceride to a patient such that the blood level of D-beta-hydroxybutyrate in the patient is raised to 1-10mM or patient urinary excretion of D-beta-hydroxybutyrate is in the range 5 mg/dL to 160 mg/dL causing hyperketonemia in the patient resulting in ketone bodies being utilized for energy in the brain in the presence of glucose.
- 2. Use according to claim 1, wherein the pharmaceutical composition further comprises L-carnitine or a derivative of L-carnitine.
- 3. Use according to claim 2, wherein the pharmaceutical composition comprises a dose of medium chain triglycerides of 0.5 g/kg/day to 10 g/kg/day and a dose of L-carnitine or a derivative of L-carnitine of 0.5 mg/kg/day to 10 mg/kg/day.
- 4. Use according to claim 1 or 2, wherein the pharmaceutical composition comprises emulsified medium

chain triglycerides in an amount of between 10 g and 500 g and L-carnitine or a derivative of L-carnitine in an amount of between 10 mg and 2000 mg.

- 5. Use according to any of the preceding claims, wherein the pharmaceutical composition is formulated as a tablet, a capsule, a lozenge, a troche, a hard candy, a nutritional bar, a nutritional drink, a metered spray or a cream.
- 6. Use according to any one of claims 1 to 4, wherein the pharmaceutical composition is formulated as a nutritional drink.
- 7. Use according to any one of claims 1 to 6 wherein the medium chain triglyceride has the formula:

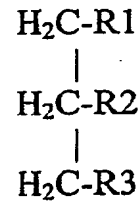

wherein R1, R2 and R3 are fatty acids having 5-12 carbons in the carbon backbone.

- 8. Use according to claim 7 wherein R1, R2 and R3 are fatty acids containing a six carbon backbone.
- 9. Use according to any one of claims 6 to 8 wherein said single dose is 0.5 g/kg/day to 10 g/kg/day medium chain triglyceride.
- 10. A pharmaceutical composition for use in a method of treatment or prevention of loss of cognitive function caused by reduced neuronal metabolism in Alzheimer's disease, wherein said method of treatment or prevention comprises oral administration of a single dose of medium chain triglyceride to a patient such that the blood level of D-beta-hydroxybutyrate in the patient is raised to 1-10mM or patient urinary excretion of D-beta-hydroxybutyrate is in the range 5 mg/dL to 160 mg/dL causing hyperketonemia in the patient resulting in ketone bodies being utilized for energy in the brain in the presence of glucose.

Patentansprüche

- 1. Verwendung einer wirksamen Menge von mittelkettigem Triglycerid zur Herstellung einer pharmazeutischen Zusammensetzung zur Behandlung oder Prävention des Verlustes kognitiver Funktion, der

durch reduzierten neuronalen Metabolismus bei der Alzheimer-Erkrankung hervorgerufen wird, worin die Behandlung oder Prävention die orale Verabreichung einer einzelnen Dosis eines mittelkettigen Triglycerids an einen Patienten umfasst, so dass der Blutspiegel von D-β-Hydroxybutyrat des Patienten auf 1-10 mM ansteigt oder so dass sich die Urin-Exkretion von D-β-Hydroxybutyrat des Patienten im Bereich von 5 mg/dl bis 160 mg/dl befindet, wodurch Hyperketonämie bei dem Patienten hervorgerufen wird, was dazu führt, dass Ketonkörper im Gehirn in Gegenwart von Glukose zur Energiegewinnung verwendet werden.

2. Verwendung nach Anspruch 1, worin die pharmazeutische Zusammensetzung weiters L-Carnitin oder ein Derivat von L-Carnitin umfasst.
3. Verwendung nach Anspruch 2, worin die pharmazeutische Zusammensetzung eine Dosis mittelkettiger Triglyceride von 0,5 g/kg/Tag bis 10 g/kg/Tag sowie eine Dosis L-Carnitin oder eines Derivats von L-Carnitin von 0,5 mg/kg/Tag bis 10 mg/kg/Tag umfasst.
4. Verwendung nach Anspruch 1 oder 2, worin die pharmazeutische Zusammensetzung emulgierte mittelkettige Triglyceride in einer Menge zwischen 10g und 500 g und L-Carnitin oder ein Derivat von L-Carnitin in einer Menge zwischen 10 mg und 2000 mg umfasst.
5. Verwendung nach einem der vorangegangenen Ansprüche, worin die pharmazeutische Zusammensetzung als eine Tablette, eine Kapsel, eine Lutschtablette, eine Pastille, ein Bonbon, ein Nährstoffriegel, ein Nährstoffgetränk, ein Dosier-Spray oder eine Creme formuliert ist.
6. Verwendung nach einem der Ansprüche 1 bis 4, worin die pharmazeutische Zusammensetzung als ein Nährstoffgetränk formuliert ist.
7. Verwendung nach einem der Ansprüche 1 bis 6, worin das mittelkettige Triglycerid folgende Formel aufweist:

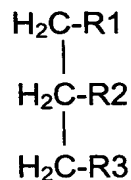

worin R1, R2 und R3 Fettsäuren mit 5-12 Kohlen-

stoffen im Kohlenstoff-Rückgrat sind.

8. Verwendung nach Anspruch 7, worin R1, R2 und R3 Fettsäuren sind, die ein Sechs-Kohlenstoff-Rückgrat enthalten.
9. Verwendung nach einem der Ansprüche 6 bis 8, worin die Einzeldosis 0,5 g/kg/Tag bis 10 g/kg/Tag mittelkettiges Triglycerid beträgt.
10. Pharmazeutische Zusammensetzung zur Verwendung in einem Verfahren zur Behandlung oder Prävention des Verlustes kognitiver Funktion, der durch reduzierten neuronalen Metabolismus bei der Alzheimer-Erkrankung hervorgerufen wird, worin das Behandlungs- oder Präventionsverfahren die orale Verabreichung einer einzelnen Dosis mittelkettigen Triglycerids an einen Patienten umfasst, so dass der Blutspiegel von D-β-Hydroxybutyrat des Patienten auf 1-10 mM ansteigt oder so dass sich die Urin-Exkretion von D-β-Hydroxybutyrat des Patienten im Bereich von 5 mg/dl bis 160 mg/dl befindet, wodurch Hyperketonämie bei dem Patienten hervorgerufen wird, was dazu führt, dass Ketonkörper im Gehirn in Gegenwart von Glukose zur Energiegewinnung verwendet werden.

Revendications

1. Utilisation d'une quantité efficace de triglycérides de chaîne moyenne pour la préparation d'une composition pharmaceutique pour le traitement ou la prévention de la perte de la fonction cognitive provoquée par un métabolisme neuronal réduit dans la maladie de Alzheimer, où ledit traitement ou la prévention comprend l'administration orale d'une seule dose de triglycérides de chaîne moyenne à un patient de telle sorte que le niveau sanguin du D-béta-hydroxybutyrate dans le patient soit relevé à 1-10mM ou bien l'excrétion urinaire du patient de D-béta-hydroxybutyrate est dans la plage de 5 mg/dl à 160 mg/dl en provoquant une cétonémie à des taux pathologiques dans le patient ce qui se traduit par le fait que les corps de cétone sont utilisés pour l'énergie dans le cerveau en présence de glucose.
2. Utilisation selon la revendication 1, où la composition pharmaceutique comprend en outre de la L-carnitine ou un dérivé de la L-carnitine.
3. Utilisation selon la revendication 2, où la composition pharmaceutique comprend une dose de triglycérides de chaîne moyenne de 0,5 g/kg/jour à 10 g/kg/jour et une dose de L-carnitine ou un dérivé de la L-carnitine de 0,5 mg/kg/jour à 10 mg/kg/jour.
4. Utilisation selon la revendication 1 ou 2, où la com-

position pharmaceutique comprend des triglycérides émulsifiés de chaîne moyenne en une quantité entre 10 g et 500 g et de la L-carnitine ou un dérivé de la L-carnitine en une quantité entre 10 mg et 2000 mg.

5

5. Utilisation selon l'une quelconque des revendications précédentes, où la composition pharmaceutique est formulée comme un comprimé, une capsule, une tablette, une pastille, un bonbon dur, une barre nutritionnelle, une boisson nutritionnelle, une pulvérisation dosée ou une crème. 10
6. Utilisation selon l'une quelconque des revendications 1 à 4, où la composition pharmaceutique est formulée comme une boisson nutritionnelle. 15
7. Utilisation selon l'une quelconque des revendications 1 à 6, où les triglycérides de chaîne moyenne ont la formule: 20

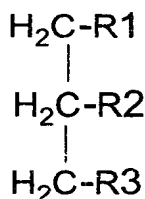

25

30

où R1, R2 et R3 sont des acides gras ayant 5-12 carbones dans l'épine dorsale du carbone.

8. Utilisation selon la revendication 7, où R1, R2 et R3 sont des acides gras contenant une épine dorsale de six carbones. 35
9. Utilisation selon l'une quelconque des revendications 6 à 8, où ladite dose unique est de 0,5 g/kg/jour à 10 g/kg/jour de triglycérides de chaîne moyenne. 40
10. Composition pharmaceutique pour utilisation dans une méthode de traitement ou de prévention de la perte de la fonction cognitive provoquée par un métabolisme neuronal réduit dans la maladie de Alzheimer, où ladite méthode de traitement ou de prévention comprend l'administration orale d'une seule dose de triglycérides de chaîne moyenne à un patient de telle sorte que le niveau sanguin de D-béta-hydroxybutyrate dans le patient est relevé à 1-10mM ou l'excrétion urinaire du patient de D-bét.a-hydroxybutyrate est dans la plage de 5 mg/dl à 160 mg/dl en provoquant une cétonémie à des taux pathologiques dans le patient ce qui se traduit par le fait que les corps de cétone sont utilisés pour l'énergie dans le cerveau en présence de glucose. 45
50
55

REFERENCES CITED IN THE DESCRIPTION

This list of references cited by the applicant is for the reader's convenience only. It does not form part of the European patent document. Even though great care has been taken in compiling the references, errors or omissions cannot be excluded and the EPO disclaims all liability in this regard.

Patent documents cited in the description

- US 5817626 A [0003]
- US 5854204 A [0003]
- US 5854215 A [0003]
- US 5385915 A [0003]
- US 5538983 A [0003]
- US 5650148 A [0003]
- US 5936078 A [0003]
- US 4528197 A [0021]
- US 4847296 A [0021]
- JP 6287138 A [0022]

Non-patent literature cited in the description

- BEFFERT, U. ; DANIK, M. ; KRZYWKOWSKI, P. ; RAMASSAMY, C. ; BERRADA, F. ; POIRIER, J. The neurobiology of apolipoproteins and their receptors in the CNS and Alzheimer's disease. *Brain Res Brain Res Rev*, 1998, vol. 27, 119-42 [0039]
- BLASS, J. P. ; ZEMCOV, A. Alzheimer's disease. A metabolic systems degeneration?. *Neurochem Pathol*, 1984, vol. 2, 103-14 [0039]
- CRAFT, S. ; NEWCOMER, J. ; KANNE, S. ; DAGOGO-JACK, S. ; CRYER, P. ; SHELIN, Y. ; LUBY, J. ; DAGOGO-JACK, A. ; ALDERSON, A. Memory improvement following induced hyperinsulinemia in Alzheimer's disease. *Neurobiol Aging*, 1996, vol. 17, 123-30 [0039]
- CORBO, R.M. ; SACCHI, R. Apolipoprotein E (APOE) allele distribution in the world. Is APOE*4 a 'thrifty' allele. *Ann Hum Genet*, 1999, vol. 63, 301-10 [0039]
- DAVIS, J. N. ; CHISHOLM, J. C. Alois Alzheimer and the amyloid debate. *Nature*, 1999, vol. 400, 810 [0039]
- EDMOND, J. Energy metabolism in developing brain cells. *Can J Physiol Pharmacol*, 1992, vol. 70, 118-29 [0039]
- EVANS, D. A. ; FUNKENSTEIN, H. H. ; ALBERT, M. S. ; SCHERR, P. A. ; COOK, N. R. ; CHOWN, M. J. ; HEBERT, L.E. ; HENNEKENS, C.H. ; TAYLOR, J. O. Prevalence of Alzheimer's disease in a community population of older persons. Higher than previously reported. *JAMA*, 1989, vol. 262, 2551-6 [0039]
- FINCH, C. E. ; COHEN, D. M. Aging, metabolism, and Alzheimer disease: review and hypotheses. *Exp Neurol*, 1997, vol. 143, 82-102 [0039]
- FROLICH, L. ; BLUM-DEGEN, D. ; BERNSTEIN, H. G. ; ENGELSBERGER, S. ; HUMRICH, J. ; LAUFER, S. ; MUSCHNER, D. ; THALHEIMER, A. ; TURK, A. ; HOYER, S. Brain insulin and insulin receptors in aging and sporadic Alzheimer's disease. *J Neural Transm*, 1998, vol. 105, 423-38 [0039]
- GREGG, R. E. ; ZECH, L. A. ; SCHAEFER, E. J. ; STARK, D. ; WILSON, D. ; BREWER, H. B. JR. Abnormal in vivo metabolism of apolipoprotein E4 in humans. *J Clin Invest*, 1986, vol. 78, 815-21 [0039]
- The Pharmacological Basis of Therapeutics. McGraw-Hill, 1996 [0039]
- HALL K. ; GUREJE O. ; GAO S. ; OGUNNIYI A. ; HUI S.L. ; BAIYEWU O. ; UNVERZAGT F.W. ; OLUWOLE S. ; HENDRIE H.C. Risk factors and Alzheimer's disease: a comparative study of two communities. *Aust N Z J Psychiatry*, 1998, vol. 32, 698-706 [0039]
- HAMOSH, M. Lingual and Gastric Lipases: Their role in fat digestion. CRC press, 1990 [0039]
- HANLON C.S. ; RUBINSZTEIN D.C. Arginine residues at codons 112 and 158 in the apolipoprotein E gene correspond to the ancestral state in humans. *Atherosclerosis*, 1995, vol. 112, 85-90 [0039]
- HASSELBALCH, S. G. ; MADSEN, P. L. ; HAGEMAN, L. P. ; OLSEN, K. S. ; JUSTESEN, N. ; HOLM, S. ; PAULSON, O. B. Changes in cerebral blood flow and carbohydrate metabolism during acute hyperketonemia. *Am J Physiol*, 1996, vol. 270, 746-51 [0039]
- HOYER, S. Is sporadic Alzheimer disease the brain type of non-insulin dependent diabetes mellitus? A challenging hypothesis. *J Neural Transm*, 1998, vol. 105, 415-22 [0039]
- HOYER, S. Oxidative energy metabolism in Alzheimer brain. Studies in early-onset and late-onset cases. *Mol Chem Neuropathol*, 1992, vol. 16, 207-24 [0039]
- JOLLES, J. ; BOTHMER, J. ; MARKERINK, M. ; RAVID, R. Phosphatidylinositol kinase is reduced in Alzheimer's disease. *J Neurochem*, 1992, vol. 58, 2326-9 [0039]
- KOLANOWSKI, J. ; YOUNG, J. B. ; LANDSBERG L. Stimulatory influence of D(-)-3-hydroxybutyrate feeding on sympathetic nervous system activity in the rat. *Metabolism*, 1994, vol. 43, 180-5 [0039]

- **KLIVENYI, P. ; FERRANTE, R. J. ; MATTHEWS, R. T. ; BOGDANOV, M. B. ; KLEIN, A. M. ; ANDREASSEN, O. A. ; MUELLER, G. ; WERMER, M. ; KADURAH-DAOUK, R. ; BEAL, M. F.** Neuroprotective effects of creatine in a transgenic animal model of amyotrophic lateral sclerosis. *Nat. Med.*, 1999, vol. 5, 347-50 [0039]
- **KOO, E. H. ; LANSBURY, P. T., JR. ; KELLY, J. W.** Amyloid diseases: abnormal protein aggregation in neurodegeneration. *Proc Natl Acad Sci USA.*, 1999, vol. 96, 9989-90 [0039]
- **KNOUFF, C. ; HINSDALE, M. E. ; MEZDOUR, H. ; ALTENBURG, M. K. ; WATANABE, M. ; QUARFORDT, S.H. ; SULLIVAN, P.M. ; MAEDA, N.** Apo E structure determines VLDL clearance and atherosclerosis risk in mice. *J Clin Invest*, 1999, vol. 103, 1579-86 [0039]
- **LANNERT, H. ; HOYER, S.** Intracerebroventricular administration of streptozotocin causes long-term diminutions in learning and memory abilities and in cerebral energy metabolism in adult rats. *Behav Neurosci*, 1998, vol. 112, 199-208 [0039]
- **LOKTIONOV A. ; VORSTER H. ; O'NEILL I.K. ; NELL T. ; BINGHAM S.A. ; RUNSWICK S.A. ; CUMMINGS J.H.** Apolipoprotein E and methylenetetrahydrofolate reductase genetic polymorphisms in relation to other risk factors for cardiovascular disease in UK Caucasians and Black South Africans. *Atherosclerosis*, 1999, vol. 145, 125-35 [0039]
- **MATTSON, M.P.** Experimental models of Alzheimer's Disease. *Science and Medicine*, March 1998, 16-25 [0039]
- **MCKHANN, G. ; DRACHMAN, D. ; FOLSTEIN, M. ; KATZMAN, R. ; PRICE, D. ; STADLAN, E. M.** Clinical diagnosis of Alzheimer's disease: report of the NINCDS-ADRDA Work Group under the auspices of Department of Health and Human Services Task Force on Alzheimer's Disease. *Neurology*, 1984, vol. 34, 939-44 [0039]
- **MEIER-RUGE, W. ; BERTONI-FREDDARI, C. ; IWANGOFF, P.** Changes in brain glucose metabolism as a key to the pathogenesis of Alzheimer's disease. *Gerontology*, 1994, vol. 40, 246-52 [0039]
- **MESSIER, C. ; GAGNON, M.** Glucose regulation and cognitive functions: relation to Alzheimer's disease and diabetes. *Behav Brain Res*, 1996, vol. 75, 1-11 [0039]
- **NEVE, R. L. ; ROBAKIS, N. K.** Alzheimer's disease: a re-examination of the amyloid hypothesis. *Trends Neurosci*, 1998, vol. 21, 15-9 [0039]
- **NISHIMURA, M. ; YU, G. ; ST GEORGE-HYSLOP, P. H.** Biology of presenilins as causative molecules for Alzheimer disease. *Clin Genet*, 1999, vol. 55, 219-25 [0039]
- **ODLE, J.** New insights into the utilization of medium-chain triglycerides by the neonate: Observations from a pig model. *J Nutr.*, 1997, vol. 127, 1061-7 [0039]
- **REIMAN, E. M. ; CASELLI, R. J. ; YUN, L. S. ; CHEN, K. ; BANDY, D. ; MINOSHIMA, S. ; THIBODEAU, S. N. ; OSBORNE, D.** Preclinical evidence of Alzheimer's disease in persons homozygous for the epsilon 4 allele for apolipoprotein E. *N Engl J Med*, 1996, vol. 334, 752-8 [0039]
- **OGAWA, M. ; FUKUYAMA, H. ; OUCHI, Y. ; YAMAUCHI, H. ; KIMURA, J.** Altered energy metabolism in Alzheimer's disease. *J Neurol Sci*, 1996, vol. 139, 78-82 [0039]
- **OSUNTOKUN B.O. ; SAHOTA A. ; OGUNNIYI A.O. ; GUREJE O. ; BAIYEWU O. ; ADEYINKA A. ; OLUWOLE S.O. ; KOMOLAFE O. ; HALL K.S. ; UNVERZAGT F.W. et al.** Lack of an association between apolipoprotein E epsilon 4 and Alzheimer's disease in elderly Nigerians. *Ann Neurol*, 1995, vol. 38, 463-5 [0039]
- **ROHEIM P.S. ; CAREY M. ; FORTE T. ; VEGA G. L.** Apolipoproteins in human cerebrospinal fluid. *Proc Natl Acad Sci U S A*, 1979, vol. 76, 4646-9 [0039]
- **SELKOE, D. J.** Alzheimer's Disease: A central role for amyloid. *J. Neuropathol. Exp. Neurol.*, 1994, vol. 53, 438-447 [0039]
- **SELKOE, D. J.** Translating cell biology into therapeutic advances in Alzheimer's disease. *Nature*, 1999, vol. 399, 23-31 [0039]
- **SIMPSON, 1. A. ; DAVIES, P.** Reduced glucose transporter concentrations in brains of patients with Alzheimer's disease. *Ann Neurol*, 1994, vol. 36, 800-1 [0039]
- **SWAAB, D. F. ; LUCASSEN, P. J. ; SALEHI, A. ; SCHERDER, E. J. ; VAN SOMEREN, E. J. ; VERWER, R. W.** Reduced neuronal activity and reactivation in Alzheimer's disease. *Prog Brain Res*, 1998, vol. 117, 343-77 [0039]
- **VENEMAN, T. ; MITRAKOU, A. ; MOKAN, M. ; CRYER, P. ; GERICH, J.** Effect of hyperketonemia and hyperlactacidemia on symptoms, cognitive dysfunction, and counterregulatory hormone responses during hypoglycemia in normal humans. *Diabetes*, 1994, vol. 43, 1311-7 [0039]
- **ZEKRAOUI L. ; LAGARDE J.P. ; RAISONNIER A. ; GERARD N. ; AOUIZERATE A. ; LUCOTTE G.** High frequency of the apolipoprotein E *4 allele in African pygmies and most of the African populations in sub-Saharan Africa. *Hum Biol*, 1997, vol. 69, 575-81 [0039]
- **ZUBENKO, G. S. ; STIFFLER, J. S. ; HUGHES, H. B. ; MARTINEZ, A. J.** Reductions in brain phosphatidylinositol kinase activities in Alzheimer's disease. *Biol Psychiatry*, 1999, vol. 45, 731-6 [0039]

(19) World Intellectual Property Organization
International Bureau



(43) International Publication Date
8 November 2001 (08.11.2001)

PCT

(10) International Publication Number
WO 01/82928 A1

- (51) International Patent Classification⁷: **A61K 31/22**, 31/23, 31/215
- (21) International Application Number: PCT/US01/13955
- (22) International Filing Date: 1 May 2001 (01.05.2001)
- (25) Filing Language: English
- (26) Publication Language: English
- (30) Priority Data:
60/200,980 1 May 2000 (01.05.2000) US
- (71) Applicant and
(72) Inventor: **HENDERSON, Samuel, T.** [US/US]; 2110 West 10th Avenue, Apt. 203, Broomfield, CO 80020 (US).
- (74) Agents: **SWANSON, Barry, J.** et al.; Swanson & Bratschun, L.L.C., Suite 330, 1745 Shea Center Drive, Highlands Ranch, CO 80126 (US).
- (81) Designated States (*national*): AE, AG, AL, AM, AT, AU, AZ, BA, BB, BG, BR, BY, BZ, CA, CH, CN, CO, CR, CU, CZ, DE, DK, DM, DZ, EE, ES, FI, GB, GD, GE, GH, GM, HR, HU, ID, IL, IN, IS, JP, KE, KG, KP, KR, KZ, LC, LK, LR, LS, LT, LU, LV, MA, MD, MG, MK, MN, MW, MX, MZ, NO, NZ, PL, PT, RO, RU, SD, SE, SG, SI, SK, SL, TJ, TM, TR, TT, TZ, UA, UG, US, UZ, VN, YU, ZA, ZW.
- (84) Designated States (*regional*): ARIPO patent (GH, GM, KE, LS, MW, MZ, SD, SL, SZ, TZ, UG, ZW), Eurasian patent (AM, AZ, BY, KG, KZ, MD, RU, TJ, TM), European patent (AT, BE, CH, CY, DE, DK, ES, FI, FR, GB, GR, IE, IT, LU, MC, NL, PT, SE, TR), OAPI patent (BF, BJ, CF, CG, CI, CM, GA, GN, GW, ML, MR, NE, SN, TD, TG).
- Published:**
— with international search report
- For two-letter codes and other abbreviations, refer to the "Guidance Notes on Codes and Abbreviations" appearing at the beginning of each regular issue of the PCT Gazette.*



WO 01/82928 A1

(54) Title: USE OF MEDIUM CHAIN TRIGLYCERIDES FOR THE TREATMENT AND PREVENTION OF ALZHEIMER'S DISEASE AND OTHER DISEASES RESULTING FROM REDUCED NEURONAL METABOLISM

(57) Abstract: Methods and compositions for treating or preventing, the occurrence of senile dementia of the Alzheimer's type, or other conditions arising from reduced neuronal metabolism and leading to lessened cognitive function are described. In a preferred embodiment the administration of triglycerides or fatty acids with chain lengths between 5 and 12, to said patient at a level produce an improvement in cognitive ability.

USE OF MEDIUM CHAIN TRIGLYCERIDES FOR THE
TREATMENT AND PREVENTION OF ALZHEIMER'S DISEASE
AND OTHER DISEASES RESULTING FROM REDUCED
NEURONAL METABOLISM

5

FIELD OF THE INVENTION

This invention relates to the field of therapeutic agents for the treatment of Alzheimer's Disease, and other diseases associated with reduced neuronal metabolism.

10

BACKGROUND OF THE INVENTION

Alzheimer's Disease (AD) is a progressive neurodegenerative disorder, which primarily affects the elderly. There are two forms of AD, early-onset and late-onset. Early-onset AD is rare, strikes susceptible individuals as early as the third decade, and is frequently associated with mutations in a small set of genes. Late onset AD is common, strikes in the seventh or eighth decade, and is a multifactorial disease with many genetic risk factors. Late-onset AD is the leading cause of dementia in persons over the age of 65. An estimated 7-10% of the American population over 65, and up to 40% of the American population greater than 80 years of age is afflicted with AD (McKhann et al., 1984; Evans et al. 1989). Early in the disease, patients experience loss of memory and orientation. As the disease progresses, additional cognitive functions become impaired, until the patient is completely incapacitated. Many theories have been proposed to describe the chain of events that give rise to AD, yet, at time of this application, the cause remains unknown. Currently, no effective prevention or treatment exists for AD. The only drugs to treat AD on the market today, Aricept® and Cognex®, are acetylcholinesterase inhibitors. These drugs do not address the underlying pathology of AD. They merely enhance the effectiveness of those nerve cells still able to function. Since the disease continues, the benefits of these treatments are slight.

15

20

25

30

Early-onset cases of AD are rare (~5%), occur before the age of 60 and are frequently associated with mutations in three genes, presenilin1 (PS1), presenilin2 (PS2) and amyloid precursor protein (APP) (for review see Selkoe, 1999). These early-onset AD cases exhibit cognitive decline and neuropathological lesions that are similar to those found in late-onset AD. AD is characterized by the accumulation of neurofibrillar tangles (NFT) and β -amyloid deposits in senile plaques (SP) and cerebral blood vessels. The main constituent of senile plaques is the β -amyloid

35

peptide (A β), which is derived from the APP protein by proteolytic processing. The presenilin proteins may facilitate the cleavage of APP. The A β peptide is amyloidogenic and under certain conditions will form insoluble fibrils. However, the toxicity of A β peptide and fibrils remains controversial. In some cases A β has been shown to be neurotoxic, while others find it to be neurotrophic (for reviews see Selkoe, 1999). The cause of early-onset AD is hypothesized to be accumulation of aggregated proteins in susceptible neurons. Mutations in APP are hypothesized to lead to direct accumulation of fibrillar A β , while mutations in PS1 or PS2 are proposed to lead to indirect accumulation of A β . How a variety of mutations in PS1 and PS2 lead to increased A β accumulation has not been resolved. Accumulation of aggregated proteins is common to many progressive neurodegenerative disorders, including Amyloid Lateral Sclerosis (ALS) and Huntington's disease (for review see Koo et al., 1999). Evidence suggests that accumulation of aggregated proteins inhibits cellular metabolism and ATP production. Consistent with this observation is the finding that buffering the energy capacity of neurons with creatine will delay the onset of ALS in transgenic mouse models (Klivenyi et al., 1999). Much of the prior art on AD has focused on inhibiting production of or aggregation of A β peptides; such as U.S. Patent No. 5,817,626, U.S. Patent No. 5,854,204, and U.S. Patent No. 5,854,215. Other prior art to treat AD include, U.S. Patent No. 5,385,915 "Treatment of amyloidosis associated with Alzheimer disease using modulators of protein phosphorylation", patent U.S. Patent No. 5,538,983, "Method of treating amyloidosis by modulation of calcium." Attempts to increase neuronal survival by use of nerve growth factors have dealt with either whole cell, gene or protein delivery, such as described in U.S. Patent No. 5,650,148 "Method of grafting genetically modified cells to treat defects. disease or damage of the central nervous system". and U.S. Patent No.

both early and late onset AD result from accumulation of toxic amyloid deposits. The model speculates that in early onset cases, amyloid accumulates rapidly, while in late onset, amyloid accumulates slowly. Much of the research on prevention and treatment of AD has focused on inhibition of amyloid accumulation. However, the amyloid cascade hypothesis remains controversial. Amyloid deposits may be a marker for the disease and not the cause. Translation of Dr. Alzheimer's original work on the neuropathology of AD, relates that he did not favor the view that senile plaques were causative. He states "These changes are found in the basal ganglia, the medulla, the cerebellum and the spinal cord, although there are no plaques at all in those sites or only isolated ones. So we have to conclude *that the plaques are not the cause of senile dementia but only an accompanying feature of senile involution of the central nervous system.*" The italics are his own (Davis and Chisholm, 1999). Many years of research have not resolved this issue (for review of amyloid hypothesis see Selkoe, 1999, for counter argument see Neve et al., 1998). Since the present invention addresses the decreased neuronal metabolism associated with AD, it does not rely on the validity of the amyloid cascade hypothesis.

Several genetic risk factors have been proposed to contribute to the susceptibility to late-onset AD. However, only allelic variation in the lipid transport molecule apolipoprotein E (apoE) has been reproducibly defined as a genetic risk factor for late onset AD. ApoE functions as a ligand in the process of receptor mediated internalization of lipid-rich lipoproteins. These lipoprotein complexes contain phospholipids, triglycerides, cholesterol and lipoproteins. Several well-characterized allelic variations exist at the apoE locus, and are referred to as apoE2, E3 and E4. ApoE4 is associated with an increased risk of AD, while apoE2 and E3 are not. Increasing the dosage of the E4 allele increases the risk of AD, and lowers the age of onset. However, apoE4 is not an invariant cause of AD. Some individuals, who are homozygous for the E4 allele, do not show AD symptoms even into the ninth decade (Beffert et al., 1998).

A prediction of the observation that apoE4 is associated with AD is that populations with a high prevalence of the E4 allele would also have a high incidence of AD. Yet, the opposite appears to be true. Geographically distinct populations have differing frequencies of apoE alleles. For example, the E4 variant is much more common in Africa versus the UK. In a study of black South Africans and Caucasians

from Cambridge England, the apoE4 allele was present in 48% of Black South Africans compared to 20.8% of Caucasians (Loktionov et al, 1999). In fact, the E4 allele is widespread throughout Africa (Zekraoui et al, 1997). Studies on AD are difficult to do in developing countries, but the studies that have been done show a very low incidence of AD in African communities, 1% versus 6% in US populations (Hall et al, 1998). Even more striking is that the normally robust association between AD and apoE4 is absent in African cases (Osuntokun et al, 1995). This suggests that something is different between native Africans, and US citizens, who are largely of European descent. Perhaps the African populations have some other genetic factor that protects them from AD. This is unlikely, since the incidence of AD in a population of African-Americans from Indianapolis, Indiana USA (6.24%) was found to be much higher than an ethnically similar population in Ibadan, Nigeria (1.4%) (Hall et al, 1998). This suggests that the link between apoE4 and AD has some strong environmental component.

ApoE4 is the ancestral allele, it is most similar to the apoE found in chimpanzees and other primates, while the E2 and E3 alleles arose exclusively in the human lineage, (Hanlon and Rubinsztein, 1995). The changes in apoE were probably brought about by a change in diet in ancestral humans. The E2 and E3 alleles may have arisen in populations as an adaptation to agriculture (Corbo and Scacchi, 1999).

The metabolism of apoE4 in human circulation is different from the non-AD associated apoE3 allele (Gregg et al., 1986). The E4 allele is associated with unusually high levels of circulating lipoproteins (Gregg et al., 1986). In particular, the E4 allele results in decreased rates of VLDL clearance, which leads to higher levels of VLDL and LDL particles in the blood (Knouff, et al. 1999). VLDL and LDL particles contain higher levels of triglycerides than HDL particles. The increased levels of circulating VLDL in individuals carrying apoE4 is due to decreased fatty acid utilization caused by preferential binding of apoE4 to chylomicron and VLDL particles. Prior art has suggested that apoE4 contributes to AD due to inefficient delivery of phospholipids to neurons (for review see Beffert et al., 1998). Yet, apoE4 also contributes to decreased triglyceride usage.

In the central nervous system (CNS), apoE plays a central role in the transportation and redistribution of cholesterol and lipids. The importance of apoE in the brain is highlighted by the absence of other key plasma apolipoproteins such as

apoA1 and apoB in the brain (Roheim et al., 1979). ApoE mRNA is found predominantly in astrocytes in the CNS. Astrocytes function as neuronal support cells and can efficiently utilize fatty acids for energy. Since the brain lacks other apolipoproteins, it is uniquely dependent on apoE for lipid transport, including 5 triglycerides. While prior art on apoE's role in AD has focused on phospholipid transport, apoE also delivers free fatty acids in the form of triglycerides to astrocytes. Fatty acids delivered by lipoproteins can be converted to ketone bodies by astrocytes for use as an alternative energy source to glucose. An alternative to the neuronal remodeling hypothesis, is that the preferential binding of apoE4 to VLDL particles 10 prevents efficient astrocyte access to triglycerides. Decreased access to triglycerides results in decreased availability of fatty acids and decreased production of ketone bodies, and hence a decreased alternative energy source for cerebral neurons. This reduction in energy supplies may become critical when glucose metabolism in compromised.

15 **Metabolism and Alzheimer's Disease** At the time of this application, the cause of AD remains unknown, yet a large body of evidence has made it clear that Alzheimer's Disease is associated with decreased neuronal metabolism. In 1984, Blass and Zemcov proposed that AD results from a decreased metabolic rate in sub- 20 populations of cholinergic neurons. However, it has become clear that AD is not restricted to cholinergic systems, but involves many types of transmitter systems, and several discrete brain regions. Positron-emission tomography has revealed poor glucose utilization in the brains of AD patients, and this disturbed metabolism can be detected well before clinical signs of dementia occur (Reiman et al., 1996; Messier 25 and Gagnon, 1996; Hoyer, 1998). Additionally, certain populations of cells, such as somatostatin cells of the cortex in AD brain are smaller, and have reduced Golgi apparatus; both indicating decreased metabolic activity (for review see Swaab et al. 1998). Measurements of the cerebral metabolic rates in healthy versus AD patients demonstrated a 20-40% reduction in glucose metabolism in AD patients (Hoyer, 30 1992). Reduced glucose metabolism results in critically low levels of ATP in AD patients. Also, the severity of decreased metabolism was found to correlate with senile plaque density (Meier-Ruge, et al. 1994).

Additionally, molecular components of insulin signaling and glucose utilization are impaired in AD patients. Glucose is transported across the blood brain

barrier and is used as a major fuel source in the adult brain. Consistent with the high level of glucose utilization, the brains of mammals are well supplied with receptors for insulin and IGF, especially in the areas of the cortex and hippocampus, which are important for learning and memory (Frolich et al., 1998). In patients diagnosed with AD, increased densities of insulin receptor were observed in many brain regions, yet the level of tyrosine kinase activity that normally is associated with the insulin receptor was decreased, both relative to age-matched controls (Frolich et al., 1998). The increased density of receptors represents up-regulation of receptor levels to compensate for decreased receptor activity. Activation of the insulin receptor is known to stimulate phosphatidylinositol-3 kinase (PI3K). PI3K activity is reduced in AD patients (Jolles et al., 1992; Zubenko et al., 1999). Furthermore, the density of the major glucose transporters in the brain, GLUT1 and GLUT3 were found to be 50% of age matched controls (Simpson and Davies 1994). The disturbed glucose metabolism in AD has led to the suggestion that AD may be a form of insulin resistance in the brain, similar to type II diabetes (Hoyer, 1998). Inhibition of insulin receptor activity can be exogenously induced in the brains of rats by intracerebroventricular injection of streptozotocin, a known inhibitor of the insulin receptor. These animals develop progressive defects in learning and memory (Lannert and Hoyer, 1998). While glucose utilization is impaired in brains of AD patients, use of the ketone bodies, beta-hydroxybutyrate and acetoacetate is unaffected (Ogawa et al. 1996).

The cause of decreased neuronal metabolism in AD remains unknown. Yet, aging may exacerbate the decreased glucose metabolism in AD. Insulin stimulation of glucose uptake is impaired in the elderly, leading to decreased insulin action and increased insulin resistance (for review see Finch and Cohen, 1997). For example, after a glucose load, mean plasma glucose is 10-30% higher in those over 65 than in younger subjects. Hence, genetic risk factors for AD may result in slightly compromised neuronal metabolism in the brain. These defects would only become apparent later in life when glucose metabolism becomes impaired, and thereby contribute to the development of AD. Since the defects in glucose utilization are limited to the brain in AD, the liver is “unaware” of the state of the brain and does not mobilize fatty acids (see Brain Metabolism section below). Without ketone bodies to

use as an energy source, the neurons of the AD patient brain slowly and inexorably starve to death.

Attempts to compensate for reduced cerebral metabolic rates in AD patients has met with some success. Treatment of AD patients with high doses of glucose and insulin increases cognitive scores (Craft et al., 1996). However, since insulin is a polypeptide and must be transported across the blood brain barrier, delivery to the brain is complicated. Therefore, insulin is administered systemically. Large dose of insulin in the blood stream can lead to hyperinsulinemia, which will cause irregularities in other tissues. Both of these shortcomings make this type of therapy difficult and rife with complications. Accordingly, there remains a need for an agent that may increase the cerebral metabolic rate and subsequently the cognitive abilities of a patient suffering from Alzheimer's disease.

Brain Metabolism The brain has a very high metabolic rate. For example, it uses 20 percent of the total oxygen consumed in a resting state. Large amounts of ATP are required by neurons of the brain for general cellular functions, maintenance of an electric potential, synthesis of neurotransmitters and synaptic remodeling. Current models propose that under normal physiologic conditions, neurons of the adult human brain depend solely on glucose for energy. Since neurons lack glycogen stores, the brain depends on a continuous supply of glucose from the blood for proper function. Neurons are very specialized and can only efficiently metabolize a few substrates, such as glucose and ketone bodies. This limited metabolic ability makes brain neurons especially vulnerable to changes in energy substrates. Hence, sudden interruption of glucose delivery to the brain results in neuronal damage. Yet, if glucose levels drop gradually, such as during fasting, neurons will begin to metabolize ketone bodies instead of glucose and no neuronal damage will occur.

Neuronal support cells, glial cells, are much more metabolically diverse and can metabolize many substrates, in particular, glial cells are able to utilize fatty acids for cellular respiration. Neurons of the brain cannot efficiently oxidize fatty acids and hence rely on other cells, such as liver cells and astrocytes to oxidize fatty acids and produce ketone bodies. Ketone bodies are produced from the incomplete oxidation of fatty acids and are used to distribute energy throughout the body when glucose levels are low. In a normal Western diet, rich in carbohydrates, insulin levels are high and

fatty acids are not utilized for fuel, hence blood ketone body levels are very low, and fat is stored and not used. Such a scenario explains the prevalence of obesity.

Current models propose that only during special states, such as neonatal development and periods of starvation, will the brain utilize ketone bodies for fuel.

5 The partial oxidation of fatty acids gives rise to D-beta-hydroxybutyrate (D-3-hydroxybutyrate) and acetoacetate, which together with acetone are collectively called ketone bodies. Neonatal mammals are dependent upon milk for development. The major carbon source in milk is fat (carbohydrates make up less than 12% of the caloric content of milk). The fatty acids in milk are oxidized to give rise to ketone
10 bodies, which then diffuse into the blood to provide an energy source for development. Numerous studies have shown that the preferred substrates for respiration in the developing mammalian neonatal brain are ketone bodies. Consistent with this observation is the biochemical finding that astrocytes, oligodendrocytes and neurons all have capacity for efficient ketone body metabolism (for review see
15 Edmond, 1992). Yet only astrocytes are capable of efficient oxidation of fatty acids.

The body normally produces small amounts of ketone bodies. However, because they are rapidly utilized, the concentration of ketone bodies in the blood is very low. Blood ketone body concentrations rise on a low carbohydrate diet, during periods of fasting, and in diabetics. In a low carbohydrate diet, blood glucose levels
20 are low, and pancreatic insulin secretion is not stimulated. This triggers the oxidation of fatty acids for use as a fuel source when glucose is limiting. Similarly, during fasting or starvation, liver glycogen stores are quickly depleted, and fat is mobilized in the form of ketone bodies. Since both a low carbohydrate diet and fasting do not result in a rapid drop of blood glucose levels, the body has time to increase blood
25 ketone levels. The rise in blood ketone bodies provides the brain with an alternative fuel source, and no cellular damage occurs. Since the brain has such high energy demands, the liver oxidizes large amounts of fatty acids until the body becomes literally saturated in ketone bodies. Therefore, when an insufficient source of ketone bodies is coupled with poor glucose utilization severe damage to neurons results.
30 Since glial cells are able to utilize a large variety of substrates they are less susceptible to defects in glucose metabolism than are neurons. This is consistent with the observation that glial cells do not degenerate and die in AD (Mattson, 1998).

As discussed in the Metabolism and Alzheimer's Disease section, in AD, neurons of the brain are unable to utilize glucose and begin to starve to death. Since the defects are limited to the brain and peripheral glucose metabolism is normal, the body does not increase production of ketone bodies, therefore neurons of the brain slowly starve to death. Accordingly, there remains a need for an energy source for brain cells that exhibit compromised glucose metabolism in AD patients. Compromised glucose metabolism is a hallmark of AD; hence administration of such an agent will prove beneficial to those suffering from AD.

Medium Chain Triglycerides (MCT) The metabolism of MCT differs from the more common long chain triglycerides (LCT) due to the physical properties of MCT and their corresponding medium chain fatty acids (MCFA). Due to the short chain length of MCFA, they have lower melting temperatures, for example the melting point of MCFA (C8:0) is 16.7 °C, compared with 61.1 °C for the LCFA (C16:0). Hence, MCT and MCFA are liquid at room temperature. MCT are highly ionized at physiological pH, thus they have much greater solubility in aqueous solutions than LCT. The enhanced solubility and small size of MCT also increases the rate at which fine emulsion particles are formed. These small emulsion particles create increased surface area for action by gastrointestinal lipases. Additionally, medium chain 2-monoglycerides isomerize more rapidly than those of long chain length, allowing for more rapid hydrolysis. Some lipases in the pre-duodenum preferentially hydrolyze MCT to MCFA, which are then partly absorbed directly by stomach mucosa (Hamosh, 1990). Those MCFA which are not absorbed in the stomach, are absorbed directly into the portal vein and not packaged into lipoproteins. LCFA are packaged in chylomicrons and transported via the lymph system, while MCFA are transported via the blood. Since blood transports much more rapidly than lymph, the liver is quickly perfused with MCFA.

In the liver the major metabolic fate of MCFA is oxidation. The fate of LCFA in the liver is dependent on the metabolic state of the organism. LCFA are transported into the mitochondria for oxidation using carnitine palmitoyltransferase I. When conditions favor fat storage, malonyl-CoA is produced as an intermediate in lipogenesis. Malonyl-CoA allosterically inhibits carnitine palmitoyltransferase I, and thereby inhibits LCFA transport into the mitochondria. This feedback mechanism prevents futile cycles of lipolysis and lipogenesis. MCFA are, to large extent,

immune to the regulations that control the oxidation of LCFA. MCFA enter the mitochondria largely without the use of carnitine palmitoyltransferase I, therefore MCFA by-pass this regulatory step and are oxidized regardless of the metabolic state of the organism. Importantly, since MCFA enter the liver rapidly and are quickly oxidized, large amounts of ketone bodies are readily produced from MCFA.

Numerous patents relate to use of MCT. None of these patents relate to the specific use of MCT for treatment and prevention of Alzheimer's Disease. Patents such as U.S. Patent No. 4,528,197 "Controlled triglyceride nutrition for hypercatabolic mammals" and U.S. Patent No. 4,847,296 "Triglyceride preparations for the prevention of catabolism" relate to the use of MCT to prevent body-wide catabolism that occurs in burns and other serious injuries. Each patent described herein is incorporated by reference herein in its entirety.

SUMMARY OF THE INVENTION

The present invention provides a method of treating or preventing dementia of Alzheimer's type, or other loss of cognitive function caused by reduced neuronal metabolism, comprising administering an effective amount of medium chain triglycerides to a patient in need thereof. Administration may be oral or intravenous. The medium chain triglycerides may be emulsified, and may be coadministered with L-carnitine or a derivative of L-carnitine.

The present invention also provides a method of treating or preventing dementia of Alzheimer's type, or other loss of cognitive function caused by reduced neuronal metabolism, comprising administering an effective amount of free fatty acids derived from medium chain triglycerides to a patient in need thereof.

The present invention also provides a method of treating or preventing dementia of Alzheimer's type, or other loss of cognitive function caused by reduced neuronal metabolism, comprising administering an effective amount of a medium chain triglyceride prodrug to a patient in need thereof.

The present invention also provides a method of treating or preventing dementia of Alzheimer's type, or other loss of cognitive function caused by reduced neuronal metabolism, comprising administering an effective amount of a therapeutic agent which induces utilization of fatty acids and development of ketosis to a patient in need thereof.

The present invention further provides therapeutic agents for the treatment or prevention of dementia of Alzheimer's type, or other loss of cognitive function caused by reduced neuronal metabolism.

5 DETAILED DESCRIPTION OF THE INVENTION

It is the novel insight of this invention that medium chain triglycerides (MCT) and their associated fatty acids are useful as a treatment and preventative measure for AD patients. MCT are composed of fatty acids with chain lengths of between 5-12 carbons. A diet rich in MCT results in high blood ketone levels. High blood ketone
 10 levels will provide an energy source for brain cells that have compromised glucose metabolism via the rapid oxidation of MCFA to ketone bodies.

The background of this invention supports the present invention in the following ways. (1) Neurons of the brain can use both glucose and ketone bodies for respiration. (2) The neurons of Alzheimer's Disease patients have well documented
 15 defects in glucose metabolism. (3) Known genetic risk factors for Alzheimer's Disease are associated with lipid and cholesterol transport, suggesting defects in triglyceride usage may underlie susceptibility to Alzheimer's Disease. (4) A diet rich in MCT will lead to increased levels of blood ketone bodies and thereby provide energy to starving brain neurons. Hence, supplementation of Alzheimer's Disease
 20 patients with MCT will restore neuronal metabolism.

The present invention provides a method of treating or preventing dementia of Alzheimer's type, or other loss of cognitive function caused by reduced neuronal metabolism, comprising administering an effective amount of medium chain triglycerides to a patient in need thereof. Generally, an effective amount is an amount
 25 effective to either (1) reduce the symptoms of the disease sought to be treated or (2) induce a pharmacological change relevant to treating the disease sought to be treated. For Alzheimer's Disease, an effective amount includes an amount effective to: increase cognitive scores; slow the progression of dementia; or increase the life expectancy of the affected patient. As used herein, medium chain triglycerides of this
 30 invention are represented by the following formula:

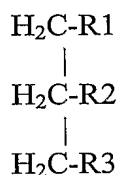

35

wherein R1, R2 and R3 are fatty acids having 5-12 carbons in the carbon backbone. The structured lipids of this invention may be prepared by any process known in the art, such as direct esterification, rearrangement, fractionation, transesterification, or
5 the like. For example the lipids may be prepared by the rearrangement of a vegetable oil such as coconut oil.

In a preferred embodiment, the method comprises the use of MCTs wherein R1, R2, and R3 are fatty acids containing a six-carbon backbone (tri-C6:0). Tri-C6:0 MCT are absorbed very rapidly by the gastrointestinal track in a number of model
10 systems (Odle 1997). The high rate of absorption results in rapid perfusion of the liver, and a potent ketogenic response. Additionally, utilization of tri-C6:0 MCT can be increased by emulsification. Emulsification of lipids increases the surface area for action by lipases, resulting in more rapid hydrolysis. Methods for emulsification of these triglycerides are well known to those skilled in the art.

In another preferred embodiment, the invention provides a method of treating
15 or preventing dementia of Alzheimer's type, or other loss of cognitive function caused by reduced neuronal metabolism, comprising administering an effective amount of free fatty acids, which may be derived from medium chain triglycerides, to a patient in need thereof. Such fatty acids are referred to herein as free medium chain fatty
20 acids, or free fatty acids. Because MCT are metabolized to produce medium chain fatty acids, which are oxidized, the administration of free fatty acids and/or ketone bodies have the same effect as the administration of MCT themselves.

In another preferred embodiment, the invention comprises the
25 coadministration of emulsified tri-C6:0 MCT and L-carnitine or a derivative of L-carnitine. Slight increases in MCFA oxidation have been noted when MCT are combined with L-carnitine (Odle, 1997). Thus in the present invention emulsified tri-C6:0 MCT are combined with L-carnitine at doses required to increase the utilization of said MCT. The dosage of L-carnitine and MCT will vary according to the
30 condition of the host, method of delivery, and other factors known to those skilled in the art, and will be of sufficient quantity to raise blood ketone levels to a degree required to treat and prevent Alzheimer's Disease. Derivatives of L-carnitine which may be used in the present invention include but are not limited to decanoylcarnitine, hexanoylcarnitine, caproylcarnitine, lauroylcarnitine, octanoylcarnitine,

stearoylcarnitine, myristoylcarnitine, acetyl-L-carnitine, O-Acetyl-L-carnitine, and palmitoyl-L-carnitine.

Therapeutically effective amounts of the therapeutic agents can be any amount or dose sufficient to bring about the desired anti-dementia effect and depend, in part, on the severity and stage of the condition, the size and condition of the patient, as well as other factors readily known to those skilled in the art. The dosages can be given as a single dose, or as several doses, for example, divided over the course of several weeks.

In one embodiment, the MCT's or fatty acids are administered orally. In another embodiment, the MCT's are administered intravenously. Oral administration of MCT's and preparations intravenous MCT solutions are well known to those skilled in the art.

Oral and intravenous administration of MCT or fatty acids result in hyperketonemia. Hyperketonemia results in ketone bodies being utilized for energy in the brain even in the presence of glucose. Additionally, hyperketonemia results in a substantial (39%) increase in cerebral blood flow (Hasselbalch et al. 1996). Hyperketonemia has been reported to reduce cognitive dysfunction associated with systemic hypoglycemia in normal humans (Veneman et al. 1994). Please note that systemic hypoglycemia is distinct from the local defects in glucose metabolism that occur in AD. In another embodiment, the invention provides the subject compounds in the form of one or more prodrugs, which can be metabolically converted to the subject compounds by the recipient host. As used herein, a prodrug is a compound that exhibits pharmacological activity after undergoing a chemical transformation in the body. The said prodrugs will be administered in a dosage required to increase blood ketone bodies to a level required to treat and prevent the occurrence of Alzheimer's Disease. A wide variety of prodrug formulations are known in the art. For example, prodrug bonds may be hydrolyzable, such as esters or anhydrides, or enzymatically biodegradable, such as amides.

This invention also provides a therapeutic agent for the treatment or prevention of dementia of Alzheimer's type, or other loss of cognitive function caused by reduced neuronal metabolism, comprising medium chain triglycerides. In a preferred embodiment, the therapeutic agent is provided in administratively convenient formulations of the compositions including dosage units incorporated into

a variety of containers. Dosages of the MCT are preferably administered in an effective amount, in order to produce ketone body concentrations sufficient to increase the cognitive ability of patients afflicted with AD or other states of reduced neuronal metabolism. For example, for the ketone body D-beta-hydroxybutyrate, blood levels are raised to about 1-10 mM or as measured by urinary excretion in the range of about 5 mg/dL to about 160 mg/dL, although variations will necessarily occur depending on the formulation and host, for example. Effective amount dosages of other MCTs will be apparent to those skilled in the art. Convenient unit dosage containers and/or formulations include tablets, capsules, lozenges, troches, hard candies, nutritional bars, nutritional drinks, metered sprays, creams, and suppositories, among others. The compositions may be combined with a pharmaceutically acceptable excipient such as gelatin, an oil, and/or other pharmaceutically active agent(s). For example, the compositions may be advantageously combined and/or used in combination with other therapeutic or prophylactic agents, different from the subject compounds. In many instances, administration in conjunction with the subject compositions enhances the efficacy of such agents. For example, the compounds may be advantageously used in conjunction with antioxidants, compounds that enhance the efficiency of glucose utilization, and mixtures thereof, (see e.g. Goodman et al. 1996).

In a preferred embodiment the human subject is intravenously infused with MCT, MCFA (medium chain fatty acids) and/or ketone bodies directly, to a level required to treat and prevent the occurrence of Alzheimer's Disease. Preparation of intravenous lipid, and ketone body solutions is well known to those skilled in the art.

In a preferred embodiment, the invention provides a formulation comprising a mixture of MCT and carnitine to provide elevated blood ketone levels. The nature of such formulations will depend on the duration and route of administration. Such formulations will be in the range of 0.5 g/kg/day to 10 g/kg/day of MCT and 0.5 mg/kg/day to 10 mg/kg/day of carnitine or its derivatives,. Variations will necessarily occur depending on the formulation and/or host, for example.

A particularly preferred formulation comprises a range of 10-500 g of emulsified MCT combined with 10-2000 mg of carnitine. An even more preferred formulation comprises 50 g MCT (95% triC8:0) emulsified with 50 g of mono- and di-glycerides combined with 500 mg of L-carnitine. Such a formulation is well tolerated and induces hyperketonemia for 3-4 hours in healthy human subjects.

In another embodiment, the invention provides the recipient with a therapeutic agent which enhances endogenous fatty acid metabolism by the recipient. The said therapeutic agent will be administered in a dosage required to increase blood ketone bodies to a level required to treat and prevent the occurrence of Alzheimer's Disease.

5 Ketone bodies are produced continuously by oxidation of fatty acids in tissues that are capable of such oxidation. The major organ for fatty acid oxidation is the liver. Under normal physiological conditions ketone bodies are rapidly utilized and cleared from the blood. Under some conditions, such as starvation or low carbohydrate diet, ketone bodies are produced in excess and accumulate in the blood stream.

10 Compounds that mimic the effect of increasing oxidation of fatty acids will raise ketone body concentration to a level to provide an alternative energy source for neuronal cells with compromised metabolism. Since the efficacy of such compounds derives from their ability to increase fatty acid utilization and raise blood ketone body concentration they are dependent on the embodiments of the present invention.

15 From the description above, a number of advantages of the invention for treating and preventing Alzheimer's Disease become evident:

(a) Prior art on AD has largely focused on prevention and clearance of amyloid deposits. The role of these amyloid deposits in AD remains controversial and may only be a marker for some other pathology. The present invention
20 provides a novel route for treatment and prevention of AD based on alleviating the reduced neuronal metabolism associated with AD, and not with aspects of amyloid accumulation.

(b) Current treatments for AD are merely palliative and do not address the reduced neuronal metabolism associated with AD. Ingestion of medium chain
25 triglycerides as a nutritional supplement is a simple method to provide neuronal cells, in which glucose metabolism is compromised, with ketone bodies as a metabolic substrate.

(c) Increase blood levels of ketone bodies can be achieved by a diet rich in medium chain triglycerides.

30 (d) Medium chain triglycerides can be infused intravenously into patients.

(e) Levels of ketone bodies can be easily measured in urine or blood by commercially available products (i.e. Ketostix®, Bayer, Inc.).

Accordingly, the reader will see that the use of medium chain triglycerides (MCT) or fatty acids as a treatment and preventative measure of Alzheimer's Disease (AD) provides a novel means of alleviating reduced neuronal metabolism associated with AD. It is the novel and significant insight of the present invention that use of MCT results in hyperketonemia which will provide increased neuronal metabolism for diseases associated with reduced neuronal metabolism, such as AD, ALS, Parkinson's Disease and Huntington's Disease. Although the description above contains many specificities, these should not be construed as limiting the scope of the invention but merely as providing illustrations for some of the presently preferred embodiments of this invention. For example, supplementation with MCT may prove more effective when combined with insulin sensitizing agents such as vanadyl sulfate, chromium picolinate, and vitamin E. Such agents may function to increase glucose utilization in compromised neurons and work synergistically with hyperketonemia. In another example MCT can be combined with compounds that increase the rates of fatty acid utilization such as L-carnitine and its derivatives. Mixtures of such compounds may synergistically increase levels of circulating ketone bodies.

Thus the scope of the invention should be determined by the appended claims and their legal equivalents, rather than by the examples given.

20 REFERENCES

Throughout the specification, citations to a number of references have been made. Each of these references is incorporated by reference herein in its entirety. Many of the references are summarized here:

25 Beffert, U., Danik, M., Krzywkowski, P., Ramassamy, C., Berrada, F., and Poirier, J. (1998) The neurobiology of apolipoproteins and their receptors in the CNS and Alzheimer's disease. *Brain Res Brain Res Rev* 27:119-42.

Blass, J. P., and Zemcov, A. (1984) Alzheimer's disease. A metabolic systems degeneration? *Neurochem Pathol* 2:103-14.

30 Craft, S., Newcomer, J., Kanne, S., Dagogo-Jack, S., Cryer, P., Sheline, Y., Luby, J., Dagogo-Jack, A., and Alderson, A. (1996) Memory improvement following induced hyperinsulinemia in Alzheimer's disease. *Neurobiol Aging* 17:123-30.

Corbo, R.M. and Sacchi, R. (1999) Apolipoprotein E (APOE) allele distribution in the world. Is APOE*4 a 'thrifty' allele. *Ann Hum Genet* 63:301-10.

Davis, J. N., and Chisholm, J. C. (1999). Alois Alzheimer and the amyloid debate. *Nature* **400**:810.

Edmond, J. (1992) Energy metabolism in developing brain cells. *Can J Physiol Pharmacol* **70**:S118-29.

5 Evans, D. A., Funkenstein, H. H., Albert, M. S., Scherr, P. A., Cook, N. R., Chown, M. J., Hebert, L.E., Hennekens, C.H., and Taylor, J. O. (1989) Prevalence of Alzheimer's disease in a community population of older persons. Higher than previously reported. *JAMA* **262**:2551-6.

10 Finch, C. E., and Cohen, D. M. (1997) Aging, metabolism, and Alzheimer disease: review and hypotheses. *Exp Neurol* **143**:82-102.

Frolich, L., Blum-Degen, D., Bernstein, H. G., Engelsberger, S., Humrich, J., Laufer, S., Muschner, D., Thalheimer, A., Turk, A., Hoyer, S., Zochling, R., Boissl, K. W., Jellinger, K., and Riederer, P. (1998) Brain insulin and insulin receptors in aging and sporadic Alzheimer's disease. *J Neural Transm* **105**:423-38.

15 Gregg, R. E., Zech, L. A., Schaefer, E. J., Stark, D., Wilson, D., and Brewer, H. B. Jr. (1986). Abnormal in vivo metabolism of apolipoprotein E4 in humans. *J Clin Invest* **78**:815-21.

20 Goodman, L. S., Limbird, L. E., Milinoff, P. B., Gilman, A. G., and Hardman, J. G. (editors). (1996). *The Pharmacological Basis of Therapeutics*, 9.sup.th Ed., McGraw-Hill.

Hall K., Gureje O., Gao S., Ogunniyi A., Hui S.L., Baiyewu O., Unverzagt F.W., Oluwole S., Hendrie H.C. (1998) Risk factors and Alzheimer's disease: a comparative study of two communities. *Aust N Z J Psychiatry* **32**:698-706.

25 Hamosh, M. (1990) In: *Lingual and Gastric Lipases: Their role in fat digestion*. CRC press, Boca Raton, FL.

Hanlon C.S., and Rubinsztein D.C. (1995) Arginine residues at codons 112 and 158 in the apolipoprotein E gene correspond to the ancestral state in humans. *Atherosclerosis* **112**:85-90.

30 Hasselbalch, S. G., Madsen, P. L., Hageman, L. P., Olsen, K. S., Justesen, N., Holm, S., and Paulson, O. B. (1996) Changes in cerebral blood flow and carbohydrate metabolism during acute hyperketonemia. *Am J Physiol* **270**:E746-51.

Hoyer, S. (1998) Is sporadic Alzheimer disease the brain type of non-insulin dependent diabetes mellitus? A challenging hypothesis. *J Neural Transm* **105**:415-22.

Hoyer, S. (1992) Oxidative energy metabolism in Alzheimer brain. Studies in early-onset and late-onset cases. *Mol Chem Neuropathol* **16**:207-24.

Jolles, J., Bothmer, J., Markerink, M., and Ravid, R. (1992) Phosphatidylinositol kinase is reduced in Alzheimer's disease. *J Neurochem* **58**:2326-9.

Kolanowski, J., Young, J. B., and Landsberg L. (1994) Stimulatory influence of D(-)-3-hydroxybutyrate feeding on sympathetic nervous system activity in the rat. *Metabolism* **43**:180-5.

Klivenyi, P., Ferrante, R. J., Matthews, R. T., Bogdanov, M. B., Klein, A. M. Andreassen, O. A., Mueller, G., Wermer, M., Kaddurah-Daouk, R., and Beal, M. F. (1999) Neuroprotective effects of creatine in a transgenic animal model of amyotrophic lateral sclerosis. *Nat. Med.* **5**:347-50.

Koo, E. H., Lansbury, P. T., Jr., and Kelly, J. W. (1999) Amyloid diseases: abnormal protein aggregation in neurodegeneration. *Proc Natl Acad Sci U S A.* **96**:9989-90.

Knouff, C., Hinsdale, M. E., Mezdour, H., Altenburg, M. K., Watanabe, M., Quarfordt, S.H., Sullivan, P.M., and Maeda, N. (1999) Apo E structure determines VLDL clearance and atherosclerosis risk in mice. *J Clin Invest* **103**:1579-86.

Lannert, H., and Hoyer, S. (1998) Intracerebroventricular administration of streptozotocin causes long- term diminutions in learning and memory abilities and in cerebral energy metabolism in adult rats. *Behav Neurosci* **112**:199-208.

Loktionov A., Vorster H., O'Neill I.K., Nell T., Bingham S.A., Runswick S.A., Cummings J.H. (1999) Apolipoprotein E and methylenetetrahydrofolate reductase genetic polymorphisms in relation to other risk factors for cardiovascular disease in UK Caucasians and Black South Africans. *Atherosclerosis* **145**:125-35.

Mattson, M.P. (1998). Experimental models of Alzheimer's Disease. *Science and Medicine* March/April:16-25.

McKhann, G., Drachman, D., Folstein, M., Katzman, R., Price, D., and Stadlan, E. M. (1984). Clinical diagnosis of Alzheimer's disease: report of the NINCDS-ADRDA Work Group under the auspices of Department of Health and Human Services Task Force on Alzheimer's Disease. *Neurology* **34**:939-44.

Meier-Ruge, W., Bertoni-Freddari, C., and Iwangoff, P. (1994) Changes in brain glucose metabolism as a key to the pathogenesis of Alzheimer's disease. *Gerontology* **40**:246-52.

Messier, C., and Gagnon, M. (1996) Glucose regulation and cognitive
5 functions: relation to Alzheimer's disease and diabetes. *Behav Brain Res* **75**:1-11.

Neve, R. L., and Robakis, N. K. (1998) Alzheimer's disease: a re-examination of the amyloid hypothesis. *Trends Neurosci* **21**:15-9.

Nishimura, M., Yu, G., and St George-Hyslop, P. H. (1999) Biology of presenilins as causative molecules for Alzheimer disease. *Clin Genet* **55**:219-25.

10 Odle, J. (1997) New insights into the utilization of medium-chain triglycerides by the neonate: Observations from a pig model. *J Nutr.* **127**:1061-7.

Reiman, E. M., Caselli, R. J., Yun, L. S., Chen, K., Bandy, D., Minoshima, S., Thibodeau, S. N., and Osborne, D. (1996) Preclinical evidence of Alzheimer's disease in persons homozygous for the epsilon 4 allele for apolipoprotein E. *N Engl J Med*
15 **334**:752-8.

Ogawa, M., Fukuyama, H., Ouchi, Y., Yamauchi, H., and Kimura, J. (1996) Altered energy metabolism in Alzheimer's disease. *J Neurol Sci* **139**:78-82.

Osuntokun B.O., Sahota A., Ogunniyi A.O., Gureje O., Baiyewu O., Adeyinka A., Oluwole S.O., Komolafe O., Hall K.S., Unverzagt F.W., et al (1995) Lack of an
20 association between apolipoprotein E epsilon 4 and Alzheimer's disease in elderly Nigerians. *Ann Neurol* **38**:463-5.

Roheim P.S., Carey M., Forte T., and Vega G. L. (1979) Apolipoproteins in human cerebrospinal fluid. *Proc Natl Acad Sci U S A* **76**:4646-9.

Selkoe, D. J. (1994) Alzheimer's Disease: A central role for amyloid. *J. Neuropathol. Exp. Neurol.* **53**:438-447.
25

Selkoe, D. J., (1999) Translating cell biology into therapeutic advances in Alzheimer's disease. *Nature* **399**:A23-31.

Simpson, I. A., and Davies, P. (1994) Reduced glucose transporter concentrations in brains of patients with Alzheimer's disease: *Ann Neurol* **36**:800-1.

30 Swaab, D. F., Lucassen, P. J., Salehi, A., Scherder, E. J., van Someren, E. J., and Verwer, R. W. (1998) Reduced neuronal activity and reactivation in Alzheimer's disease. *Prog Brain Res* **117**:343-77.

Veneman, T., Mitrakou, A., Mogan, M., Cryer, P., and Gerich, J. (1994) Effect of hyperketonemia and hyperlacticacidemia on symptoms, cognitive dysfunction, and counterregulatory hormone responses during hypoglycemia in normal humans.

Diabetes **43**:1311-7.

5 Zekraoui L., Lagarde J.P., Raisonnier A., Gerard N., Aouizerate A., Lucotte G. (1997) High frequency of the apolipoprotein E *4 allele in African pygmies and most of the African populations in sub-Saharan Africa. *Hum Biol* 69:575-81.

Zubenko, G. S., Stiffler, J. S., Hughes, H. B., and Martinez, A. J. (1999) Reductions in brain phosphatidylinositol kinase activities in Alzheimer's disease. *Biol*

10 *Psychiatry* **45**:731-6.

EXAMPLES

The following example is offered by way of illustration and not by way of limitation.

15

Example 1: Nutritional drink

Nutritional drinks are prepared using the following ingredients: emulsified MCT 100 gr/drink, L-carnitine 1 gram/drink, mix of daily vitamins at recommended daily levels, and a variety of flavorings.

20

Example 2: Additional formulations

Additional formulations can be in the form of Ready to Drink Beverage, Powdered Beverages, Nutritional drinks, Food Bars, and the like. Formulations for such are clear to those skilled in the art.

25

A. Ready to Drink Beverage Ready to Drink Beverages are prepared using the following ingredients: emulsified MCT 5-100 g/drink, L-carnitine 250-1000 mg/drink, and a variety of flavorings and other ingredients used to increased palatability, stability, etc.

30

B. Powdered Beverages MCT may be prepared in a dried form, useful for food bars and powdered beverage preparations. A powdered beverage may be formed from the following components: dried emulsified MCT 10-50 g, L-carnitine 250-500 mg, sucrose 8-15 g, maltodextrin 1-5 g, flavorings 0-1 g.

C. Food bar A food bar would consist of: dried emulsified MCT 10-50 g, L-carnitine 250-500 mg, glycerin 1-5 g, corn syrup solids 5-25 g, cocoa 2-7g, coating 15-25 g.

5 D. Gelatin Capsules Hard gelatin capsules are prepared using the following ingredients: MCT 0.1-1000 mg/capsule, L-carnitine 250-500 mg/capsule, Starch, NF 0-600 mg/capsule; Starch flowable powder 0-600 mg/capsule; Silicone fluid 350 centistokes 0-20 mg/capsule. The ingredients are mixed, passed through a sieve, and filled into capsules.

10 E. Tablets Tablets are prepared using the following ingredients: MCT 0.1-1000 mg/tablet; L-carnitine 250-500 mg/tablet; Microcrystalline cellulose 20-300 mg/tablet; Starch 0-50 mg/tablet; Magnesium stearate or stearate acid 0-15 mg/tablet; Silicon dioxide, fumed 0-400 mg/tablet; silicon dioxide, colloidal 0-1 mg/tablet, and lactose 0-100 mg/tablet. The ingredients are blended and compressed to form tablets.

15 F. Suspensions Suspensions are prepared using the following ingredients: 0.1-1000 mg MCT; 250-500 mg L-carnitine; Sodium carboxymethyl cellulose 50-700 mg/5 ml; Sodium benzoate 0-10 mg/5 ml; Purified water 5 ml; and flavor and color agents as needed.

20 G. Parenteral Solutions A parenteral composition is prepared by stirring 1.5% by weight of MCT and L-carnitine in 10% by volume propylene glycol and water. The solution is made isotonic with sodium chloride and sterilized.

CLAIMS

What is claimed is:

1. A method of treating or preventing dementia of Alzheimer's type, or
5 other loss of cognitive function caused by reduced neuronal metabolism, comprising
administering an effective amount of medium chain triglycerides to a patient in need
thereof.
2. The method of Claim 1, wherein said administration is oral.
- 10 3. The method of Claim 1, wherein said administration is intravenous.
4. The method Claim 1, wherein said medium chain triglycerides are
administered medium chain triglycerides are administered at a dose of about 0.5
15 g/kg/day to about 10 g/kg/day.
5. The method of claim 1, further comprising coadministering L-carnitine
or a derivative of L-carnitine.
- 20 6. The method Claim 5, wherein said administration is oral, and said
medium chain triglycerides are administered at a dose of about 0.5 g/kg/day to about
10 g/kg/day and said L-carnitine or said derivative of L-carnitine is administered at a
dose of about 0.5 mg/kg/day to about 10 mg/kg/day.
- 25 7. The method of Claim 1, wherein said medium chain triglycerides are
emulsified.
8. The method of claim 7, further comprising coadministering L-carnitine
or a derivative of L-carnitine.
- 30 9. The method of Claim 8, wherein said emulsified medium chain
triglycerides and L-carnitine or a derivative of L-carnitine are administered in a

formulation comprising 10-500 g emulsified medium chain triglycerides and 10-2000 mg L-carnitine or derivative of L-carnitine.

10. A method of treating or preventing dementia of Alzheimer's type, or
5 other loss of cognitive function caused by reduced neuronal metabolism, comprising administering an effective amount of free medium chain fatty acids.

11. A method of treating or preventing dementia of Alzheimer's type, or
10 other loss of cognitive function caused by reduced neuronal metabolism, comprising administering an effective amount of a medium chain triglyceride prodrug to a patient in need thereof.

12. A method of treating or preventing dementia of Alzheimer's type, or
15 other loss of cognitive function caused by reduced neuronal metabolism, comprising administering an effective amount of a therapeutic agent which induces utilization of fatty acids and development of ketosis to a patient in need thereof.

13. A method of treating or preventing dementia of Alzheimer's type, or
20 other loss of cognitive function caused by reduced neuronal metabolism, comprising coadministering an effective amount of an agent selected from the group consisting of medium chain triglycerides, medium chain fatty acids, and ketone bodies, and L-carnitine or a derivative of L-carnitine to a patient in need thereof.

14. The method of Claim 13, wherein said coadministration is intravenous,
25 and said agent selected from the group consisting of medium chain triglycerides, medium chain fatty acids, and ketone bodies is administered at a dose of about 0.5 g/kg/day to about 10 g/kg/day and said L-carnitine or said derivative of L-carnitine is administered at a dose of about 0.5 mg/kg/day to about 10 mg/kg/day.

15. The method of Claim 13, wherein said agent selected from the group
30 consisting of medium chain triglycerides, medium chain fatty acids, and ketone bodies and L-carnitine or a derivative of L-carnitine are administered in a formulation

comprising 10-500 g of said agent and 10-2000 mg L-carnitine or derivative of L-carnitine.

16. A therapeutic agent for the treatment of prevention or dementia of
5 Alzheimer's type, or other loss of cognitive function caused by reduced neuronal
metabolism comprising medium chain triglycerides.

17. A therapeutic agent for the treatment of prevention or dementia of
10 Alzheimer's type, or other loss of cognitive function caused by reduced neuronal
metabolism comprising free fatty acids derived from medium chain triglycerides .

18. A therapeutic agent for the treatment of prevention or dementia of
Alzheimer's type, or other loss of cognitive function caused by reduced neuronal
metabolism comprising a medium chain triglyceride prodrug.

15

19. A therapeutic agent for the treatment of prevention or dementia of
Alzheimer's type, or other loss of cognitive function caused by reduced neuronal
metabolism comprising an agent which induces utilization of fatty acids and
development of ketosis to a patient in need thereof.

20

INTERNATIONAL SEARCH REPORT

International application No.
PCT/US01/13955

A. CLASSIFICATION OF SUBJECT MATTER

IPC(7) : A61K 31/22, 31/23, 31/215
US CL : 514/529, 546, 551,552

According to International Patent Classification (IPC) or to both national classification and IPC

B. FIELDS SEARCHED

Minimum documentation searched (classification system followed by classification symbols)

U.S. : 514/529, 546, 551, 552

Documentation searched other than minimum documentation to the extent that such documents are included in the fields searched

Electronic data base consulted during the international search (name of data base and, where practicable, search terms used)

REGISTRY, CAPLUS, WPIDS, MEDLINE, CABA, JICST-EPLUS, BIOSIS, BIOTECHNO, DRUGU

C. DOCUMENTS CONSIDERED TO BE RELEVANT

Category*	Citation of document, with indication, where appropriate, of the relevant passages	Relevant to claim No.
A ----- X	Database CABA on STN, (Columbus, OH, USA), No. 991412046, MAK, S.C. ET AL 'Clinical experience of ketogenic diet on children with refractory epilepsy, 'abstract, Acta Paediatrica Sinica, 1999, 40 (2), 97-100.	1-15 ----- 16-19
Y	Database MEDLINE on STN, (Columbus, OH, USA), No. 96063810, BRUNO, G. ET AL. 'Acetyl-L-carnitine in Alzheimer disease: a short-term study on CSF neurotransmitters and neuropeptides,' abstract, Alzheimer Disease And Associated Disorders, Fall 1995, 9 (3), 128-31.	8

Further documents are listed in the continuation of Box C. See patent family annex.

* Special categories of cited documents:	"I"	later document published after the international filing date or priority date and not in conflict with the application but cited to understand the principle or theory underlying the invention
"A" document defining the general state of the art which is not considered to be of particular relevance	"X"	document of particular relevance; the claimed invention cannot be considered novel or cannot be considered to involve an inventive step when the document is taken alone
"E" earlier document published on or after the international filing date	"Y"	document of particular relevance; the claimed invention cannot be considered to involve an inventive step when the document is combined with one or more other such documents, such combination being obvious to a person skilled in the art
"L" document which may throw doubts on priority claim(s) or which is cited to establish the publication date of another citation or other special reason (as specified)	"G"	document member of the same patent family
"O" document referring to an oral disclosure, use, exhibition or other means		
"P" document published prior to the international filing date but later than the priority date claimed		

Date of the actual completion of the international search 25 JUNE 2001	Date of mailing of the international search report 06 AUG 2001
Name and mailing address of the ISA/US Commissioner of Patents and Trademarks Box PCT Washington, D.C. 20231 Facsimile No. (703) 305-3230	Authorized officer REBECCA COOK Telephone No. (703) 308-1235

(19) 世界知的所有権機関
国際事務局



(43) 国際公開日
2003年2月20日 (20.02.2003)

PCT

(10) 国際公開番号
WO 03/013497 A1

- (51) 国際特許分類: A61K 31/202, 31/232, A61P 25/24, 25/28, A23L 1/30, 2/52, A23D 9/00
- (72) 発明者; および
- (75) 発明者/出願人 (米国についてののみ): 秋元 健吾 (AKIMOTO, Kengo) [JP/JP]; 〒618-0001 大阪府 三島郡 島本町 山崎 1-9-5-1 0 0 6 Osaka (JP). 河島 洋 (KAWASHIMA, Hiroshi) [JP/JP]; 〒569-1121 大阪府 高槻市 真上町 6-1 1-1-1 1 3 Osaka (JP). 小野 佳子 (ONO, Yoshiko) [JP/JP]; 〒533-0022 大阪府 大阪市 東淀川区 菅原 1-1 3-1 8-8 0 2 Osaka (JP). 岡市 廣成 (OKAICHI, Hiroshige) [JP/JP]; 〒573-0084 大阪府 枚方市 香里ヶ丘 1 1-2 1-7 Osaka (JP). 岡市 洋子 (OKAICHI, Youko) [JP/JP]; 〒573-0084 大阪府 枚方市 香里ヶ丘 1 1-2 1-7 Osaka (JP).
- (21) 国際出願番号: PCT/JP02/00671
- (22) 国際出願日: 2002年1月29日 (29.01.2002)
- (25) 国際出願の言語: 日本語
- (26) 国際公開の言語: 日本語
- (30) 優先権データ: 特願2001-235519 2001年8月2日 (02.08.2001) JP
- (74) 代理人: 石田 敬, 外 (ISHIDA, Takashi et al.); 〒105-8423 東京都 港区 虎ノ門 三丁目 5番 1号 虎ノ門 3 7 森ビル 青和特許法律事務所 Tokyo (JP).
- (71) 出願人 (米国を除く全ての指定国について): サントリー株式会社 (SUNTORY LIMITED) [JP/JP]; 〒530-8203 大阪府 大阪市 北区 堂島 浜 2丁目 1番 4 0号 Osaka (JP).
- (81) 指定国 (国内): AU, CA, CN, KR, US.

[続葉有]

(54) Title: COMPOSITIONS HAVING EFFECTS OF PREVENTING OR AMELIORATING CONDITIONS OR DISEASES CAUSED BY BRAIN HYPOFUNCTION

(54) 発明の名称: 脳機能の低下に起因する症状あるいは疾患の予防又は改善作用を有する組成物

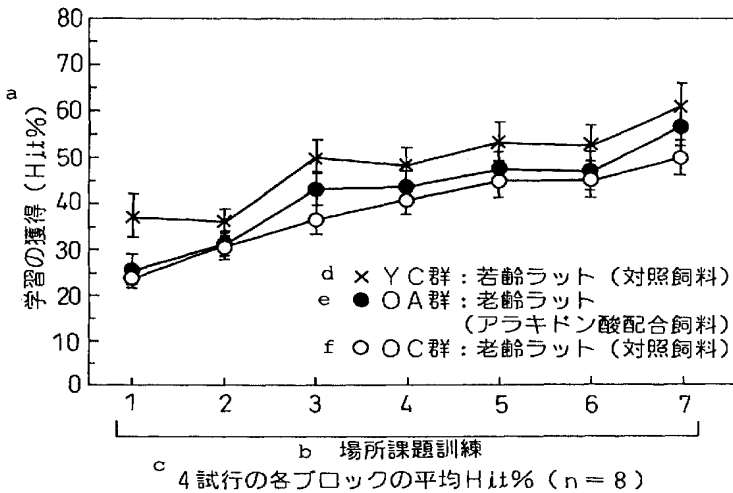

(57) Abstract: It is intended to provide compositions having effects of preventing or ameliorating conditions or diseases caused by brain hypofunction. These compositions contain, as the active ingredient, arachidonic acid and/or compounds having arachidonic acid as a constituting fatty acid, in particular, arachidonic acid alcohol esters, or triglycerides, phospholipids or glycolipids containing arachidonic acid as a part or all of the constituting fatty acid(s) thereof.

- a...ACQUISITION OF LEARNING (HIT%)
- b...SPATIAL TRAINING
- c...AVERAGE HIT% OF 4 TRIALS IN EACH BLOCK (n=8)
- d...YC GROUP: YOUNG RATS (CONTROL FEED)
- e...OA RATS: OLD RAT (ARACHIDONIC ACID-CONTAINING FEED)
- f...OC RATS: (CONTROL FEED)

[続葉有]



WO 03/013497 A1



(84) 指定国 (広域): ヨーロッパ特許 (AT, BE, CH, CY, DE, DK, ES, FI, FR, GB, GR, IE, IT, LU, MC, NL, PT, SE, TR).

— 不利にならない開示又は新規性喪失の例外に関する申立て

規則4.17に規定する申立て:

— すべての指定国のための不利にならない開示又は新規性喪失の例外に関する申立て (規則4.17(v))

2文字コード及び他の略語については、定期発行される各PCTガゼットの巻頭に掲載されている「コードと略語のガイダンスノート」を参照。

添付公開書類:

— 国際調査報告書

(57) 要約:

本発明は脳機能の低下に起因する症状あるいは疾患の予防又は改善作用を有する組成物を提供することを目的とし、前記組成物はアラキドン酸および／又はアラキドン酸を構成脂肪酸とする化合物、特にアラキドン酸のアルコールエステル、構成脂肪酸の一部もしくは全部がアラキドン酸であるトリグリセリド、リン脂質又は糖脂質を有効成分として含有する。

明 細 書

脳機能の低下に起因する症状あるいは疾患の予防又は改善作用を有する組成物

技術分野

本発明は、アラキドン酸及び／又はアラキドン酸を構成脂肪酸とする化合物を有効成分とする、脳機能の低下に起因する症状あるいは疾患の予防又は改善作用を有する組成物及びその製造方法に関するものである。より詳細には、アラキドン酸、アラキドン酸のアルコールエステル並びに構成脂肪酸の一部又は全部がアラキドン酸であるトリグリセリド、リン脂質及び糖脂質の群から選ばれた少なくとも1種を有効成分とする記憶・学習能力の低下、認知能力の低下、感情障害（たとえば、うつ病）、知的障害（たとえば、痴呆、具体的にアルツハイマー型痴呆、脳血管性痴呆）の予防又は改善剤、さらには予防又は改善作用を有する組成物及びその製造方法に関するものである。

背景技術

近年、医療の進歩に伴って急激な高齢化社会に向かっている。それに伴って老人性痴呆者数も増加している。「平成12年度版厚生白書」並びに「痴呆性老人対策検討報告書」によれば、2000年度の痴呆老人は150～160万人であり、65歳以上の痴呆患者は14人に1人に達している。そして、2030年には10人に1人と着実に患者数が増加すると予想されている。老人性痴呆は、進行すると知的機能や感情に障害が起こり、日常生活や社会生活に支障をきたす。老人性痴呆患者の原因別では、脳血管性痴呆、アルツハイマー型痴呆、それら

の混合型に別れ、これら脳疾患の治療に有効な薬剤（脳循環・代謝改善薬、抗痴呆薬）の研究・開発が進められているが、残念ながら、有効な治療薬がないのが現状である。人は歳を重ねるにつれて、脳梗塞がある程度発症するが、痴呆の発症は例えば頭を使うことによって予防することが可能である。このことから、治療のみならず予防を目指した薬剤の開発も十分、可能と考えられる。しかしながら、乳幼児から老人まで手軽に飲用でき、かつ安全であり、脳機能の低下を抑制し、脳機能の低下に起因する症状あるいは疾患を予防し、さらに改善効果を有する薬剤は、これまでのところほとんど開発されていない。

従来から、研究されている脳機能を改善する方法は、脳細胞に栄養を効率良く吸収させて、細胞の働きを活性化する脳エネルギーの代謝を改善する方法（例えば脳内グルコースの上昇など）、脳血行を良くして脳細胞に必要な栄養や酸素を十分に供給しようとする脳循環を改善する方法（例えば、脳血流の増加）、さらに、神経伝達物質を介してシナプス間隙で行われる神経伝達を活性化させる方法（神経伝達物質の前駆体の供給（例えば、コリン、アセチルCoAの補給など）、放出された神経伝達物の変換の阻害（例えば、アセチルコリンエステラーゼ阻害など）、神経伝達物質放出の増加（例えば、アセチルコリン、グルタミン酸の放出増加など）、神経伝達物質受容体の活性化など）、また、神経細胞膜の保護（例えば、抗酸化、膜成分の補給、動脈硬化の予防など）などが検討されている。

このように過去の研究において、脳機能の低下に起因する症状あるいは疾患を予防し、さらに改善効果を有する成分が見いだされているが、現状ではその効果は疑わしく、医薬品においても有効な薬剤が見いだされていない。しかも、食品への適用を考えた場合、天然物由来の成分に限定されるという困難さを有していた。

脳は脂質の塊のような組織であって、例えば、白質においては1/3が、灰白質においては1/4がリン脂質で占められている。脳細胞の各種細胞膜を構成しているリン脂質中の高度不飽和脂肪酸は、アラキドン酸とドコサヘキサエン酸が主である。しかし、これらアラキドン酸とドコサヘキサエン酸は動物体内ではde novo合成できず、直接的あるいは間接的（アラキドン酸、ドコサヘキサエン酸の前駆体となるリノール酸、 α -リノレン酸）に食事から摂取する必要がある。そこで、ドコサヘキサエン酸の学習記憶能力の向上、老人性痴呆症の予防、回復が注目されている。しかし、脳のリン脂質の主要な脂肪酸はドコサヘキサエン酸だけでなく、アラキドン酸も同程度の含有率を占める重要な脂肪酸である。Sonderdegrらは海馬リン脂質中に占めるアラキドン酸の割合が正常な人の12.4質量%に対して、アルツハイマー患者は8.1質量%に有意に減少することを明らかにしている（Lipids 26, 421-425 (1991)）。このようにアラキドン酸が脳の機能維持に重要な役割をはたす可能性を示唆するものの、アラキドン酸の十分な供給源がなかったことから、具体的な実証がなされていなかった。

脳の機能維持にアラキドン酸を利用する発明がいくつか示されている。特開平6-256179号公報記載の「学習能向上剤」は、1,2-ジアシル-sn-グリセロール誘導体を有効成分とする発明であって、2位に結合する種々の高度不飽和脂肪酸が羅列されており、その中のひとつとしてアラキドン酸が示されている。しかし、実施例において具体的に示されているのはドコサヘキサエン酸が結合した1,2-ジアシル-sn-グリセロール誘導体のみであって、アラキドン酸は単に羅列されているに過ぎず、その効果は全く実証されていない。特開平10-101568号公報記載の「脳機能改善及び栄養組成物」においては、新規な脳機能改善剤及びそれを含有する栄養組成物を提供する手

段としてガングリオシドとアラキドン酸の組み合わせが示されている。しかしながら、自然老化ラットでの実験を試験例として示しているものの、試験月齢はわずか13ヶ月齢であって、人間で33歳に相当（ラットの1日は人間では1ヶ月に相当する）する年齢にしか達しておらず、老化モデルの試験とはいえない。また、脳リン脂質中に占めるアラキドン酸の割合あるいはアラキドン酸の量は、この月齢では一般に変化を示さず、また、加齢に起因する脳機能の低下は認められない月齢であることから、アラキドン酸の効果は起こりえないと考えるのが一般的である。実際に試験例ではアラキドン酸単独の効果は評価されておらず、ガングリオシドの効果のアラキドン酸が高めることを示しているに過ぎない。

特開平6-279311号公報記載の「プロテインキナーゼCアイソザイムの活性化剤」においては、細胞内情報伝達で重要な役割を果たすプロテインキナーゼCを活性化し、それに伴う効果として老人性痴呆症治療薬を示している。しかし、活性成分は高度不飽和脂肪酸を構成脂肪酸とするホスファチジルセリン誘導体であり、その高度不飽和脂肪酸のひとつがアラキドン酸である。しかし、実施例において、アラキドン酸の効果はリノール酸、 α -リノレン酸が結合したホスファチジルセリン誘導体と活性に大差なく、アラキドン酸を構成脂肪酸とするホスファチジルセリン誘導体の優位性がなく、アラキドン酸の効果は実証されていない。また、評価は単なる酵素活性の測定によるものであって、脳機能の低下に起因する症状あるいは疾患の予防又は改善効果は何ら明らかにされていない。このように、脳の機能維持にアラキドン酸を利用する発明がいくつか示されているものの、アラキドン酸およびアラキドン酸を構成脂肪酸とする化合物が十分な供給量で存在しなかったことから、動物実験などで真の効果を明らかにすることができず、脂肪酸のひとつとしてアラ

キドン酸を単に記載したに過ぎず、実態は真なる発明とはいえないものであった。

脳の器質的病変に伴う病的な記憶障害で、短期および長期の記憶障害は痴呆の中核をなす症状である。しかし、記憶障害を別の言葉で言い表した物忘れは老年者にもっとも多く認められる訴えのひとつであり、生理的な加齢に伴って、人の学習・記憶力が低下することは各種の研究で指摘されている (Katzman, R. and Terry, R., *The Neurology of Aging*, F.A. Davis, Philadelphia, pp.15-50)。

記憶をそれが形成される時間的経過から見ると、感覚記憶 (sensory memory)、1次記憶 (primary memory) および2次記憶 (secondary memory) に分類される。1次記憶は即時記憶 (immediate memory)、2次記憶は長期記憶 (long-term memory) と呼ばれることもある。短期記憶 (short-term memory) は1次記憶をさす場合と2次記憶にもまたがった学習能力をさす場合がある。感覚記憶は50ミリ秒程度持続する視覚入力があると形成されるが、きわめて不安定でわずか250~500ミリ秒に内に消失してしまう。1次記憶は情報が認知処理される間常に意識されながら保持され、作業記憶 (working memory) としての役割を有する。1次記憶として処理を受けた情報は2次記憶へと転送され長期間保持された後、再び1次記憶を経て回想される。1次記憶の容量はわずか、繰り返し想起し直されない限り20~30秒で消失する。2次記憶は1次記憶で処理された情報の転送 (transfer) と統合強化 (consolidation)、その半永久的な貯蔵 (storage)、さらにその再生 (retrieval) の各段階よりなる。この2次記憶が加齢に伴っていちじるしく障害される。この2次記憶の低下は主として記憶の貯蔵までの段階の障害によるもので、若い頃から貯蔵されていた記憶の再生能力に関して、ほと

んど衰えは認められない。ただし、痴呆患者はこの記憶をも常に侵される。

電気生理的な解析としてアラキドン酸の効果がひとつ明らかとなっている。脳海馬に高頻度刺激を与えるとシナプスが興奮し、その後のシナプス応答が高く持続する現象が知られている。これを海馬LTP（長期増強）と言って、シナプス可塑性のもととなっている現象で、脳機能評価のひとつの指標となっている。BM McGahonらは、22ヶ月齢の老齢ラットに対照飼料あるいはアラキドン酸配合飼料（10mg/ラット/日）で8週間飼育してラット海馬のLTPを測定している（Neurobiol Aging 20, 643（1999））。4ヶ月齢の若齢ラットと比較して老齢ラットの海馬LTPは明らかに低下し、アラキドン酸投与により若齢ラットのレベルまで回復することを示している。しかし、海馬LTPの増強は、記憶のメカニズムから言うと、1次記憶の活性化を示すものであって、記憶の固定に必要な1次記憶から2次記憶への移行の活性化ではない。したがって、記憶の固定は行動薬理試験で明らかにしない限り、効果を実証することはできない。このようにアラキドン酸の効果を電気生理的な指標で評価した例が示されているものの、本発明の脳機能の低下に起因する症状あるいは疾患の予防又は改善にアラキドン酸及び／又はアラキドン酸を構成脂肪酸とする化合物が有効かどうかは明らかにされていない。

したがって、脳機能の低下に起因する症状あるいは疾患を予防し、さらに改善効果を示し、医薬品、さらには食品への適用に優れたより安全な化合物の開発が強く望まれている。

発明の開示

従って本発明は、アラキドン酸及び／又はアラキドン酸を構成脂肪酸とする化合物を有効成分とする、脳機能の低下に起因する症状

あるいは疾患の予防又は改善剤、並びに脳機能の低下に起因する症状あるいは疾患の予防又は改善作用を有する飲食品及びその製造方法を提供しようとするものである。より詳細には、アラキドン酸、アラキドン酸のアルコールエステル並びに構成脂肪酸の一部又は全部がアラキドン酸であるトリグリセリド、リン脂質及び糖脂質の群から選ばれた少なくとも1種を有効成分とする記憶・学習能力の低下、認知能力の低下、感情障害（たとえば、うつ病）、知的障害（たとえば、痴呆、具体的にアルツハイマー型痴呆、脳血管性痴呆）の予防又は改善剤、さらには予防又は改善作用を有する飲食品及びその製造方法を提供しようとするものである。

本発明者等は、アラキドン酸の又はアラキドン酸を構成脂肪酸とする化合物の脳機能の低下に起因する症状あるいは疾患に対する予防又は改善効果を明らかにする目的で鋭意研究した結果、驚くべきことに、20ヶ月齢を超える老齢ラットをモリス型水迷路試験に供し、アラキドン酸又はアラキドン酸を構成脂肪酸とする化合物の効果を行動薬理学的解析で明らかにした。

さらに、本発明者等は、アラキドン酸を20質量%以上含有するトリグリセリドの微生物による工業生産に成功し、本発明の効果試験に供することが可能となり、該トリグリセリドの効果を明らかにした。

さらに、本発明者等は、酵素法により1,3-位に中鎖脂肪酸が、2-位にアラキドン酸が結合したトリグリセリドを含む油脂を製造することに成功し、本発明の効果試験に供することが可能となり、該トリグリセリドの効果を明らかにした。

従って本発明は、アラキドン酸及び／又はアラキドン酸を構成脂肪酸とする化合物を有効成分とする、脳機能の低下に起因する症状あるいは疾患の予防又は改善剤、並びに脳機能の低下に起因する症

状あるいは疾患の予防又は改善作用を有する飲食品及びその製造方法を提供する。より詳細には、アラキドン酸、アラキドン酸のアルコールエステル並びに構成脂肪酸の一部又は全部がアラキドン酸であるトリグリセリド、リン脂質及び糖脂質の群から選ばれた少なくとも1種を有効成分とする記憶・学習能力の低下、認知能力の低下、感情障害（たとえば、うつ病）、知的障害（たとえば、痴呆、具体的にアルツハイマー型痴呆、脳血管性痴呆）の予防又は改善剤、さらには予防又は改善作用を有する飲食品及びその製造方法を提供する。

本発明により、アラキドン酸またはアラキドン酸を構成脂肪酸とする化合物を有効成分とする、脳機能の低下に起因する症状あるいは疾患の予防又は改善剤、並びに脳機能の低下に起因する症状あるいは疾患の予防又は改善作用を有する飲食品及びその製造方法を提供することができ、高齢化社会に向かう人類において特に有用である。

図面の簡単な説明

図1はモリス型水迷路試験に用いる装置の概略説明図を示す。

図2は学習の獲得（Hit%）を説明する。

図3はラットの試行回数に対する学習の獲得（Hit%）を示すグラフである。

図4は学習の獲得の度合いを計るためのプローブテストにおいて、ラットが泳いだ60秒間の軌跡を示す図である。

図5は、学習の獲得の度合いを計るためのプローブテストの結果を示すグラフである。

図6は、学習のパラメータと脳海馬中のアラキドン酸量との相関を求めた結果を示すグラフである。

発明を実施するための最良の形態

本発明は、アラキドン酸及び／又はアラキドン酸を構成脂肪酸とする化合物を有効成分とする、脳機能の低下に起因する症状あるいは疾患の予防又は改善剤、並びに脳機能の低下に起因する症状あるいは疾患の予防又は改善作用を有する飲食品及びその製造方法に関するものである。

本発明の組成物は、脳機能の低下に起因する症状あるいは疾患の予防又は改善作用を有するので、例えば、記憶・学習能力の低下、認知能力の低下、感情障害（例えば、うつ病など）、知的障害（例えば、痴呆であり、具体的にはアルツハイマー型痴呆、脳血管性痴呆）の予防・改善（あるいは治療）などを目的とした飲食品、医薬品、医薬部外品などとして有用である。

より具体的には、本発明の組成物は、加齢に伴う脳機能の低下に起因する症状あるいは疾患の予防又は改善作用を有するもので、記憶・学習能力の低下、認知能力の低下、感情障害（例えば、うつ病など）、知的障害（例えば、痴呆であり、具体的にはアルツハイマー型痴呆、脳血管性痴呆）の予防・改善（あるいは治療）などを目的とした飲食品、医薬品、医薬部外品、さらには、物忘れ予防、ボケ予防、記憶力の維持・向上、集中力の維持・向上、注意力の維持・向上、頭をすっきりさせること、頭が冴えわたること、若返りなどを目的とした飲食品、健康食品、機能性食品、特定保健用食品、老人用食品などとして有用である。

本発明の有効成分としては遊離のアラキドン酸の他に、アラキドン酸を構成脂肪酸とするすべての化合物も利用することができる。アラキドン酸を構成脂肪酸とする化合物には、アラキドン酸塩、例えばカルシウム塩、ナトリウム塩などを挙げることができる。また、アラキドン酸のアルコールエステル、例えばアラキドン酸メチル

エステル、アラキドン酸エチルエステルなどを挙げるができる。また、構成脂肪酸の一部又は全部がアラキドン酸であるトリグリセリド、リン脂質、さらには糖脂質などを利用することができる。

食品への適用を考えた場合、アラキドン酸はトリグリセリドやリン脂質の形態、特にトリグリセリドの形態にすることが望ましい。アラキドン酸を含有するトリグリセリド（構成脂肪酸の一部又は全部がアラキドン酸であるトリグリセリドを含有するトリグリセリドと同義）の自然界の給源はほとんど存在していなかったが、本発明者等によりアラキドン酸を含有するトリグリセリドを工業的に利用することが可能となり、20ヶ月齢を超える老齢ラットをモリス型水迷路試験に供することにより、本発明の有効成分の効果を行動薬理的解析で初めて明らかにし、脳機能の低下に起因する症状あるいは疾患の予防又は改善効果を有することを明確にした。

従って本発明においては、本発明の有効成分である構成脂肪酸の一部又は全部がアラキドン酸であるトリグリセリドを含有するトリグリセリド（アラキドン酸を含有するトリグリセリド）を使用することができる。アラキドン酸を含有するトリグリセリドとしては、トリグリセリドを構成する全脂肪酸のうちアラキドン酸の割合が20質量(W/W)%以上、好ましくは30質量%以上、より好ましくは40質量%以上である油脂（トリグリセリド）が食品に適用する場合には望ましい形態となる。したがって、本発明において、アラキドン酸を含有する油脂（トリグリセリド）を生産する能力を有する微生物を培養して得られたものであればすべて使用することができる。

アラキドン酸を含有する油脂（トリグリセリド）の生産能を有する微生物としては、モルティエレラ (Mortierella) 属、コニディオボラス (Conidiobolus) 属、フィチウム (Pythium) 属、フィトフトラ (Phytophthora) 属、ペニシリウム (Penicillium) 属、

クロドスポリウム (Cladosporium) 属、ムコール (Mucor) 属、フザリウム (Fusarium) 属、アスペルギルス (Aspergillus) 属、ロードトルラ (Rhodotorula) 属、エントモフトラ (Entomophthora) 属、エキノスポランジウム (Echinosporangium) 属、サプロレグニア (Saprolegnia) 属に属する微生物を挙げることができる。モルティエレラ (Mortierella) 属モルティエレラ (Mortierella) 亜属に属する微生物では、例えばモルティエレラ・エロンガタ (Mortierella elongata)、モルティエレラ・エキシグア (Mortierella exigua)、モルティエレラ・フィグロフィラ (Mortierella hygrophila)、モルティエレラ・アルピナ (Mortierella alpina) 等を挙げることができる。具体的にはモルティエレラ・エロンガタ (Mortierella elongata) IF08570、モルティエレラ・エキシグア (Mortierella exigua) IF08571、モルティエレラ・フィグロフィラ (Mortierella hygrophila) IF05941、モルティエレラ・アルピナ (Mortierella alpina) IF08568、ATCC16266、ATCC32221、ATCC42430、CBS219.35、CBS224.37、CBS250.53、CBS343.66、CBS527.72、CBS529.72、CBS608.70、CBS754.68等の菌株を挙げることができる。

これらの菌株はいずれも、大阪市の財団法人醗酵研究所 (IFO)、及び米国のアメリカン・タイプ・カルチャー・コレクション (American Type Culture Collection, ATCC) 及び、Centrralbureau voor Schimmelcultures (CBS) からなんら制限なく入手することができる。また本発明の研究グループが土壌から分離した菌株モルティエレラ・エロンガタSAM0219 (微工研菌寄第8703号) (微工研条寄第1239号) を使用することもできる。

本発明に使用される菌株を培養する為には、その菌株の孢子、菌糸、又は予め培養して得られた前培養液を、液体培地又は固体培地に接種し培養する。液体培地の場合に、炭素源としてはグルコース

、フラクトース、キシロース、サッカロース、マルトース、可溶性デンプン、糖蜜、グリセロール、マンニトール等の一般的に使用されているものが、いずれも使用できるが、これらに限られるものではない。窒素源としてはペプトン、酵母エキス、麦芽エキス、肉エキス、カザミノ酸、コーンステープリカー、大豆タンパク、脱脂ダイズ、綿実カス等の天然窒素源の他に、尿素等の有機窒素源、ならびに硝酸ナトリウム、硝酸アンモニウム、硫酸アンモニウム等の無機窒素源を用いることができる。この他必要に応じリン酸塩、硫酸マグネシウム、硫酸鉄、硫酸銅等の無機塩及びビタミン等も微量栄養源として使用できる。これらの培地成分は微生物の生育を害しない濃度であれば特に制限はない。実用上一般に、炭素源は0.1~40質量(W/V)%、好ましくは1~25質量(W/V)%の濃度とするのが良い。初発の窒素源添加量は0.1~10質量(W/V)%、好ましくは0.1~6質量(W/V)%として、培養途中に窒素源を流加しても構わない。

さらに、培地炭素源濃度を制御することでアラキドン酸を45質量%以上含有する油脂（トリグリセリド）を本発明の有効成分とすることもできる。培養は、培養2~4日目までが菌体増殖期、培養2~4日目以降が油脂蓄積期となる。初発の炭素源濃度は1~8質量%、好ましくは1~4質量%の濃度とし、菌体増殖期および油脂蓄積期の初期の間のみ炭素源を逐次添加し、逐次添加した炭素源の総和は2~20質量%、好ましくは5~15質量%とする。なお、菌体増殖期および油脂蓄積期初期の間での炭素源の逐次添加量は、初発の窒素源濃度に応じて添加し、培養7日目以降、好ましくは培養6日目以降、より好ましくは培養4日目以降の培地中の炭素源濃度を0となるようにすることで、アラキドン酸を45質量%以上含有する油脂（トリグリセリド）を得ることができ本発明の有効成分とすることができる。

アラキドン酸生産菌の培養温度は使用する微生物によりことなる

が、5～40℃、好ましくは20～30℃とし、また20～30℃にて培養して菌体を増殖せしめた後5～20℃にて培養を続けて不飽和脂肪酸を生産せしめることもできる。このような温度管理によっても、生成脂肪酸中の高度不飽和脂肪酸の割合を上昇せしめることができる。培地のpHは4～10、好ましくは5～9として通気攪拌培養、振盪培養、又は静置培養を行う。培養は通常2～30日間、好ましくは5～20日間、より好ましくは5～15日間行う。

さらに、アラキドン酸を含有する油脂（トリグリセリド）中のアラキドン酸の割合を高める手だてとして、培地炭素源濃度を制御する以外に、アラキドン酸含有油脂に選択的加水分解を行ってアラキドン酸高含有油脂を得ることもできる。この選択的加水分解に用いられるリパーゼはトリグリセリドの位置特異性はなく、加水分解活性は二重結合の数に比例して低下するため、高度不飽和脂肪酸以外の脂肪酸のエステル結合が加水分解される。そして、生じたPUFA部分グリセリド間でエステル交換反応が起こるなどして、高度不飽和脂肪酸が高められたトリグリセリドとなる（「Enhancement of Arachidonic: Selective Hydrolysis of a Single-Cell Oil from Mortierella with Candida cylindracea Lipase」 : J. Am. Oil Chem. Soc., 72, 1323-1327 (1998)）。このように、アラキドン酸含有油脂に選択的加水分解を行って得たアラキドン酸を高含有する油脂（トリグリセリド）を本発明の有効成分とすることができる。本発明のアラキドン酸を含有する油脂（トリグリセリド）の全脂肪酸に対するアラキドン酸の割合は、他の脂肪酸の影響を排除する目的で高いほうが望ましいが、高い割合に限定しているわけではなく、実際には、食品に適用する場合にはアラキドン酸の絶対量が問題になる場合もあり、10質量%以上のアラキドン酸を含有する油脂（トリグリセリド）であっても実質的には使用することができる。

さらに、本発明では構成脂肪酸の一部又は全部がアラキドン酸であるトリグリセリドとして、1,3-位に中鎖脂肪酸が、2-位にアラキドン酸が結合したトリグリセリドを使用することができる。また、1,3-位に中鎖脂肪酸が、2-位にアラキドン酸が結合したトリグリセリドを5モル%以上、好ましくは10モル%以上、さらに好ましくは20モル%以上、最も好ましくは30モル%以上含む油脂（トリグリセリド）を使用することができる。上記トリグリセリドの1,3-位に結合する中鎖脂肪酸は、炭素数6～12個を有する脂肪酸から選ばれたものを利用できる。炭素数6～12個を有する脂肪酸として、例えば、カプリル酸又はカプリン酸等を挙げられ、特に1,3-カプリロイル-2-アラキドノイル-グリセロール（以後「8A8」とも称す）が好ましい。

これら、1,3-位に中鎖脂肪酸が、2-位にアラキドン酸が結合したトリグリセリドは、高齢者を対象とした場合には、最適な油脂（トリグリセリド）となる。一般に摂取された油脂（トリグリセリド）は、小腸の中に入ると膵リパーゼで加水分解されるが、この膵リパーゼが1,3-位特異的であり、トリグリセリドの1,3-位が切れて2分子の遊離脂肪酸ができ、同時に1分子の2-モノアシルグリセロール（以後「2-MG」と称す）が生成する。この2-MGは非常に胆汁酸溶解性が高く吸収性が良いため、一般に2-位脂肪酸の方が、吸収性が良いと言われる。また、2-MGは胆汁酸に溶けると界面活性剂的な働きをして、遊離脂肪酸の吸収性を高める働きをする。次に遊離脂肪酸と2-MGはコレステロールやリン脂質等と一緒に胆汁酸複合ミセルを生合成して小腸上皮細胞に取り込まれ、トリアシルグリセロールの再合成が起こり、最終的にはカイロミクロンとしてリンパに放出されていく。ところが、この膵リパーゼの脂肪酸特性は飽和脂肪酸に高く、アラキドン酸は切れにくい特徴を持っている。さらに問題な

のは、膵リパーゼ活性が加齢に伴って低下することから、脳機能の低下に起因する症状および疾患になりやすい高齢者には、1,3-位に中鎖脂肪酸が、2-位にアラキドン酸が結合したトリグリセリドは最適な油脂（トリグリセリド）となる。

1,3-位に中鎖脂肪酸が、2-位にアラキドン酸が結合したトリグリセリドの具体的な製造法のひとつとして、アラキドン酸を含有する油脂（トリグリセリド）及び中鎖脂肪酸の存在下で、トリグリセリドの1,3-位のエステル結合に特異的に作用するリパーゼを作用させることで製造することができる。

原料となる油脂（トリグリセリド）はアラキドン酸を構成脂肪酸とするトリグリセリドであり、トリグリセリドを構成する全脂肪酸に対するアラキドン酸の割合が高い場合には、未反応油脂（原料トリグリセリド並びに1,3-位の脂肪酸のうち一方のみが中鎖脂肪酸となったトリグリセリド）の増加による反応収率の低下を防ぐため、通常酵素反応温度20～30℃より高い、30～50℃、好ましくは40～50℃とする。

トリグリセリドの1,3-位のエステル結合に特異的に作用するリパーゼとして、例えば、リゾプス (Rhizopus) 属、リゾムコール (Rhizomucor) 属、アスペルギルス (Aspergillus) 属などの微生物が産生するもの、ブタ膵臓リパーゼなどを挙げることができる。かかるリパーゼについては、市販のものを用いることができる。例えば、リゾプス・デレマー (Rhizopus delemar) のリパーゼ（田辺製薬（株）製、タリパーゼ）、リゾムコール・ミーハイ (Rhizomucor miehei) のリパーゼ（ノボ・ノルディスク（株）製、リボザイムIM）、アセペルギルス・ニガー (Apergillus niger) のリパーゼ（天野製薬（株）製、リパーゼA）等が挙げられるが、これら酵素に限定しているわけではなく、1,3-位特異的リパーゼであればすべて使用

することができる。

上記リパーゼの使用形態は、反応効率を高める目的で反応温度を30℃以上、好ましくは40℃以上とするため、酵素の耐熱性を付加する目的で固定化担体に固定化したリパーゼを使用することが望ましい。固定化担体として多孔質（ハイポーラス）樹脂であって、約100オングストローム以上の孔径を有するイオン交換樹脂担体、例えばDowex MARATHON WBA（商標、ダウケミカル）等が挙げられる。

固定化担体1に対して、1,3-位特異的リパーゼの水溶液0.5~20倍（質量）に懸濁し、懸濁液に対して2~5倍量の冷アセトン（例えば-80℃）を攪拌しながら徐々に加えて沈殿を形成させる。この沈殿物を減圧下で乾燥させて固定化酵素を調製することができる。さらに簡便な方法では、固定化担体1に対して、0.05~0.4倍量の1,3-位特異的リパーゼを最小限の水に溶解し、攪拌しながら固定化担体を混ぜ合わせ、減圧下で乾燥させて固定化酵素を調製することができる。この操作により約90%のリパーゼが担体に固定化されるが、このままではエステル交換活性は全く示さず、水1~10質量(w/v)%を加えた基質（原料油脂と中鎖脂肪酸）中で、好ましくは水1~3質量%を加えた基質中で前処理することで固定化酵素は最も効率よく活性化することができ製造に供することができる。

酵素の種類によっては、本反応系に加える水分量は極めて重要で、水を含まない場合はエステル交換が進行しにくくなり、また、水分量が多い場合には加水分解が起こり、グリセリドの回収率が低下する（加水分解が起こればジグリセリド、モノグリセリドが生成される）。しかし、この場合、前処理により活性した固定化酵素を使用することで、本反応系に加える水分量は重要ではなくなり、全く水を含まない系でも効率よくエステル交換反応を起こすことができる。さらに酵素剤の種類を選択することで前処理を省略することも

可能である。

このように、耐熱性を有する固定化酵素を使用し、酵素反応温度を上げることで、1,3-位特異的リパーゼの反応性の低いアラキドン酸を含有する油脂（トリグリセリド）においても、反応効率を低下させることなく、1,3-位に中鎖脂肪酸が、2-位にアラキドン酸が結合したトリグリセリドを効率的に製造することができる。

脳機能の低下に起因する症状あるいは疾患の予防又は改善作用を有する飲食品の製造法であっては、アラキドン酸及び／又はアラキドン酸を構成脂肪酸とする化合物を単独で、あるいはアラキドン酸を実質的に含有しない、あるいは含有していても僅かな飲食品原料とともに配合することができる。ここで、僅かな量とは、飲食品原料にアラキドン酸が含まれていたとしても、それを配合した食品組成物を人が摂取しても、後記する本発明の1日当たりのアラキドン酸の摂取量に達しない量を意味する。

特に構成脂肪酸の一部又は全部がアラキドン酸であるトリグリセリドの場合には、油脂（トリグリセリド）の用途に関しては無限の可能性があり、食品、飲料、医薬品、医薬部外品の原料並びに添加物として使用することができる。そして、その使用目的、使用量に関して何ら制限を受けるものではない。

例えば、食品組成物としては、一般食品の他、機能性食品、特定保健用食品、栄養補助食品、未熟児用調製乳、乳児用調製乳、乳児用食品、妊産婦食品又は老人用食品等を挙げることができる。油脂を含む食品例として、肉、魚、またはナッツ等の本来油脂を含む天然食品、スープ等の調理時に油脂を加える食品、ドーナツ等の熱媒体として油脂を用いる食品、バター等の油脂食品、クッキー等の加工時に油脂を加える加工食品、あるいはハードビスケット等の加工仕上げ時に油脂を噴霧または塗布する食品等が挙げられる。さら

に、油脂を含まない、農産食品、醗酵食品、畜産食品、水産食品、または飲料に添加することができる。さらに、機能性食品、医薬品、医薬部外品の形態であっても構わなく、例えば、経腸栄養剤、粉末、顆粒、錠剤、カプセル、トローチ、内服液、懸濁液、乳濁液、シロップ等の加工形態であってもよい。

また本発明の組成物は、本発明の有効成分以外に、一般に飲食品、医薬品または医薬部外品に用いられる各種担体や添加剤を含んでいてよい。特に本発明の有効成分の酸化劣化を防ぐ目的で抗酸化剤を含むことが望ましい。抗酸化剤として、例えば、トコフェロール類、フラボン誘導体、フィロズルシン類、コウジ酸、没食子酸誘導体、カテキン類、フキ酸、ゴシポール、ピラジン誘導体、セサモール、グアヤコール、グアヤク脂、p-クマリン酸、ノールジヒドログアヤテチック酸、ステロール類、テルペン類、核酸塩基類、カロチノイド類、リグナン類などのような天然抗酸化剤およびアスコルビン酸パルミチン酸エステル、アスコルビン酸ステアリン酸エステル、ブチルヒドロキシアニソール (BHA)、ブチルヒドロキシトルエン (BHT)、モノ-tert-ブチルヒドロキノン (TBHQ)、4-ヒドロキシメチル-2,6-ジ-tert-ブチルフェノール (HMBP) に代表されるような合成抗酸化剤を挙げることができる。トコフェロール類では、 α -トコフェロール、 β -トコフェロール、 γ -トコフェロール、 δ -トコフェロール、 ϵ -トコフェロール、 ξ -トコフェロール、 η -トコフェロールおよびトコフェロールエステル (酢酸トコフェロール等) 等を挙げることができる。さらに、カロチノイド類では例えば、 β -カロチン、カンタキサンチン、アスタキサンチン等を挙げることができる。

本発明の組成物は、本発明の有効成分以外に、担体として、各種キャリアー担体、イクステンダー剤、希釈剤、増量剤、分散剤、賦

形剤、結合剤溶媒（例、水、エタノール、植物油）、溶解補助剤、緩衝剤、溶解促進剤、ゲル化剤、懸濁化剤、小麦粉、米粉、でん粉、コーンスターチ、ポリサッカライド、ミルクタンパク質、コラーゲン、米油、レシチンなどが挙げられる。添加剤としては、例えば、ビタミン類、甘味料、有機酸、着色剤、香料、湿化防止剤、ファイバー、電解質、ミネラル、栄養素、抗酸化剤、保存剤、芳香剤、湿潤剤、天然の食物抽出物、野菜抽出物などを挙げるができるが、これらに限定しているわけではない。

アラキドン酸およびアラキドン酸を構成脂肪酸とする化合物の主要成分はアラキドン酸にある。アラキドン酸の1日当たりの食事からの摂取量は関東地区で0.14g、関西地区で0.19~0.20gとの報告があり（脂質栄養学4, 73-82, 1995）、高齢者は油脂の摂取量が低下する点、膵リパーゼ活性が低下する点などから相当量、さらにはそれ以上のアラキドン酸を摂取する必要がある。したがって、本発明のアラキドン酸およびアラキドン酸を構成脂肪酸とする化合物の成人（例えば、体重60kgとして）1日当たりの摂取量は、アラキドン酸量換算として、0.001g~20g、好ましくは0.01g~10g、より好ましくは0.05~5g、最も好ましくは0.1g~2gとする。

本発明の有効成分を実際に飲食品に適用する場合には、食品に配合するアラキドン酸の絶対量も重要となる。ただし、飲食品に配合する絶対量も、配合する飲食品の摂取量によって変化することから、構成脂肪酸の一部又は全部がアラキドン酸であるトリグリセリドを含有するトリグリセリドを食品に配合する場合には、アラキドン酸として0.0003質量%以上、好ましくは0.003質量%以上、より好ましくは0.03質量%以上となるように配合する。さらに、1,3-位に中鎖脂肪酸が、2-位にアラキドン酸が結合したトリグリセリドを含有するトリグリセリドを飲食品に配合する場合には、1,3-位に中鎖脂

肪酸が、2-位にアラキドン酸が結合したトリグリセリドとして0.001質量%以上、好ましくは0.01質量%以上、より好ましくは0.1質量%以上となるように配合する。

本発明の組成物を医薬品として使用する場合、製剤技術分野において慣用の方法、例えば、日本薬局方に記載の方法あるいはそれに準じる方法に従って製造することができる。

本発明の組成物を医薬品として使用する場合、組成物中の有効成分の配合量は、本発明の目的が達成される限り特に限定されず、適宜適当な配合割合で使用が可能である。

本発明の組成物を医薬品として使用する場合、投与単位形態で投与するのが望ましく、特に、経口投与が好ましい。本発明の組成物の投与量は、年齢、体重、症状、投与回数などにより異なるが、例えば、成人（約60kgとして）1日当たり本発明のアラキドン酸およびアラキドン酸を構成脂肪酸とする化合物を、アラキドン酸量換算として、通常約0.001g～20g、好ましくは約0.01g～10g、より好ましくは約0.05～5g、最も好ましくは約0.1g～2gを1日1～3回に分割して投与するのがよい。

脳のリン脂質膜の主要な脂肪酸はアラキドン酸並びにドコサヘキサエン酸であり、バランスを考えた場合、本発明の組成物は、アラキドン酸にドコサヘキサエン酸を組み合わせたことが望ましい。また、脳のリン脂質膜にはエイコサペンタエン酸の割合が非常に低いことから、本発明の組成物には、ほとんどエイコサペンタエン酸を含まないことが望ましい。また、エイコサペンタエン酸をほとんど含まず、しかもアラキドン酸とドコサヘキサエン酸を含有する組成物がより望ましい。そして、アラキドン酸とドコサヘキサエン酸の組み合わせにおいて、アラキドン酸／ドコサヘキサエン酸比（質量）が0.1～15の範囲、好ましくは0.25～10の範囲にあることが望ま

しい。また、アラキドン酸の5分の1（質量比）を超えない量のエイコサペンタエン酸を配合した飲食物が望ましい。

次に、実施例により、本発明をさらに具体的に説明する。しかし、本発明は、下記の実施例に限定されない。

なお飲食品、健康食品、機能性食品、特定保健用食品、老人用食品などの本発明の食品組成物には、該食品組成物及び／又は該食品組成物中の成分が、脳機能の低下に起因する症状あるいは疾患の予防又は改善作用、より具体的には加齢に伴う脳機能の低下に起因する症状あるいは疾患の予防又は改善作用、記憶・学習能力の低下、認知能力の低下、感情障害（例えば、うつ病など）、知的障害（例えば、痴呆であり、具体的にはアルツハイマー型痴呆、脳血管性痴呆）の予防・改善、物忘れ予防、ボケ予防、記憶力の維持・向上、集中力の維持・向上、注意力の維持・向上、頭をすっきりさせること、頭が冴えわたること、若返りなどの作用を有することを該食品組成物の包装用容器及び／又は該食品組成物の販売を促進するためのツール（例えばパンフレット等）に記載又は表示するなどして販売するものも含まれる。

実施例 1

（アラキドン酸を含有するトリグリセリドの製造方法）

アラキドン酸生産菌としてモルティエラ・アルピナ（*Mortierella alpina*）CBS754.68を用いた。グルコース1.8%、脱脂大豆粉3.1%、大豆油0.1%、 KH_2PO_4 0.3%、 Na_2SO_4 0.1%、 $\text{CaCl}_2 \cdot 2\text{H}_2\text{O}$ 0.05%及び $\text{MgCl}_2 \cdot 6\text{H}_2\text{O}$ 0.05%を含む培地6kLを、10kL培養槽に調製し、初発pHを6.0に調整した。前培養液30Lを接種し、温度26°C、通気量 360 m^3 /時間、槽内圧200kPaの条件で8日間の通気攪拌培養を行った。なお、攪拌数は溶存酸素濃度を10~15ppmを維持するように調整した。さらに、グルコース濃度を4日目までは流加法によって培地中の

グルコース濃度が1~2.5%の範囲内となるように、それ以降は0.5~1%を維持した（上記の%は、質量(w/v)%を意味する）。培養終了後、ろ過、乾燥によりアラキドン酸を含有するトリグリセリドを含有する菌体を回収し、得られた菌体からヘキササンで油脂を抽出し、食用油脂の精製工程（脱ガム、脱酸、脱臭、脱色）を経て、アラキドン酸含有トリグリセリド（アラキドン酸はトリグリセリドの任意な位置に結合）150kgを得た。得られた油脂（トリグリセリド）をメチルエステル化し、得られた脂肪酸メチルエステルをガスクロマトグラフィーで分析したところ、全脂肪酸に占めるアラキドン酸の割合は40.84質量%であった。なお、パルミチン酸、ステアリン酸、オレイン酸、リノール酸、 γ -リノレン酸、ジホモ- γ -リノレン酸などが、それぞれ、11.63、7.45、7.73、9.14、2.23、3.27質量%であった。さらに、上記アラキドン酸含有油脂（トリグリセリド）をエチルエステル化し、アラキドン酸エチルエステルを40質量%含む脂肪酸エチルエステル混合物から、定法的高速液体クロマトグラフィーによって、99質量%アラキドン酸エチルエステルを分離・精製した。

実施例 2

（8A8を5モル%以上含有するトリグリセリドの製造）

イオン交換樹脂担体（Dowex MARATHON WBA：ダウケミカル、商標）100gを、Rhizopus delemarリパーゼ12.5%水溶液（タリパーゼ粉末：田辺製薬（株））80mlに懸濁し、減圧下で乾燥させて固定化リパーゼを得た。

次に、実施例1で得たアラキドン酸を40質量%含有するトリグリセリド（TGA40S）80g、カプリル酸160g、上記固定化リパーゼ12g、水4.8 mlを30℃で48時間、攪拌（130rpm）しながら反応させた。反応終了後、反応液を取り除き、活性化された固定化リパーゼを得た

次に、固定化リパーゼ (Rhizopus delemarリパーゼ、担体：Dowe x MARATHON WBA、商標) 10gをジャケット付きガラスカラム (1.8 x 12.5cm、容量31.8ml) に充填し、実施例1で得たTGA40Sとカプリル酸を1:2に混合した混合油脂を一定の流速 (4ml/h) でカラムに流し、連続反応を実施することで、反応油脂を400gを得た。なお、カラム温度は40~41℃とした。得られた反応油脂から未反応のカプリル酸及び遊離の脂肪酸を分子蒸留により取り除き、8A8を含有する油脂 (トリグリセリド) を得た。そして、ガスクロマトグラフィー及び高速液体クロマトグラフィーにより、得られた8A8含有油脂 (トリグリセリド) 中の8A8の割合を調べたところ、31.6モル%であった (なお、8P8、8O8、8L8、8G8、8D8の割合はそれぞれ0.6、7.9、15.1、5.2、4.8モル%であった。トリグリセリドの2-位に結合する脂肪酸P、O、L、G、Dはそれぞれパルミチン酸、オレイン酸、リノール酸、 γ -リノレン酸、ジホモ- γ -リノレン酸を表し、8P8は1,3-カプリロイル-2-パルミトイル-グリセロール、8O8は1,3-カプリロイル-2-オレオイル-グリセロール、8L8は1,3-カプリロイル-2-リノレオイル-グリセロール、8G8は1,3-カプリロイル-2- γ -リノレノイル-グリセロール、8D8は1,3-カプリロイル-2-ジホモ- γ -リノレノイル-グリセロールをいう)。なお、得られた8A8含有油脂 (トリグリセリド) から定法の高速液体クロマトグラフィーによって、96モル% 8A8を分離・精製した。

実施例 3

(モリス型水迷路試験によるTGA40Sの学習能評価)

老齢ラットの実験群として、18ヶ月齢雄性Fischer系ラット16匹を対照飼料群 (8匹：0C群) とTGA40S配合飼料群 (8匹：0A群) の2群に分け、それぞれの群に、表1に示した対照飼料およびSUNT

GA40S配合飼料を与えた。そして、若齢ラットのコントロール群（YC群）として、4ヶ月齢雄性Fischer系ラット8匹に表1に示した対照飼料を与えた（YC群）。なお、TGA40S配合飼料に使用したTGA40Sは実施例1で得たものを使用した。

表1 実験食

	対照飼料 (g)	TGA40S配合飼料 (g)
カゼイン	200	200
DL-メチオニン	3	3
コーンスターチ	150	150
シュクロース	500	500
セルロースパウダー	50	50
コーンオイル	50	45
ミネラル類AIN-76	35	35
ビタミン類AIN-76	10	10
重酒石酸コリン	2	2
ビタミンE	0.05	0.05
TGA40S	0	5

ラット1匹当たりの1日の摂餌量は約20gであるから、TGA40Sのラット1匹当たりの1日の摂取量は0.1gとなる。TGA40Sに結合する全脂肪酸の内、40質量%がアラキドン酸であることから、ラット1匹当たりの1日のアラキドン酸の摂取量は40mgとなる（グリセロール骨格部分の質量については、便宜上無視して計算）。この40mgは人の摂取量に換算すると133mg/60kg/日に相当する。

飼育3ヶ月目（老齢ラットの場合は21ヶ月齢、若齢ラットの場合は7ヶ月齢）の前後でモリス型水迷路学習試験を実施した。モリス型水迷路試験は、水槽（直径120cm、高さ35cm）に墨汁で黒く濁った水を入れ（液面の高さ20cm）、ラットがかろうじて立てるくらいの高さの逃避台（直径11.5cm、高さ19cm）を入れておき（逃避台は水面下にあり、水槽内で泳ぐラットには逃避台は見えない）、学習を行うラットを、この水槽の決められた位置より入れ（出発点）、逃避台まで泳がせる空間認識による学習試験で、記憶を司る脳海馬との関連が認められ、欧米で広く使われている。モリス型水迷路試験に用いる装置の概略説明図を図1に示す。回数をこなすとラットは逃避台の位置を学習していく。ラットの学習は次のようにして行った。すなわち、ラットをモリス型水迷路試験装置の出発点から放し、60秒間経っても、ラットが逃避台に到達できない場合には、ラットを逃避台の上に載せてやることにより、見えない逃避台の位置を学習させた。この学習を1日2回を限度に、2週間続けた。ラットを出発点から放して、出発点から逃避台に向かう±15°の角度の範囲を遊泳した時間の、全遊泳時間に対する割合（Hit%、図2参照）を、学習の指標とした。若齢ラットに比較して、老齢ラットの学習の獲得率は明らかに低下するが、TAG40Sつまりアラキドン酸を与えることで、若齢ラットのレベルに近づき改善した（図3）。図3において、横軸は4試行、すなわち、2日分を1目盛りとして表した。

次に、学習の獲得の度合いを計るため、プローブテストを、前記2週間の学習の翌日、すなわち、15日目に実施した。学習を獲得した後、逃避台を取り去ると、ラットは以前にその逃避台のあった場所を泳ぎまわる。このような逃避台の位置を記憶して、あった場所を泳ぎ回っている時間（水槽を4区画に分けて、逃避台のあった

区画（1/4）にいた時間（秒）で評価）で、学習の獲得の度合いを評価することができる。YC群、0A群および0C群のNo.1とNo.2のラットの遊泳の軌跡を示す（図4）。なお、ラットは個体により出発点を変更して学習させたため、図4における出発点(S) および逃避台のあった区画は、ラットの個体により異なる。また、図5において、target quadrantは、逃避台のあった区画（1/4）を表す。0C群のラット0C-1は明らかに迷走しており、逃避台のあった区画にいたのはわずか2.4秒であった。プローブテストの結果を表2にまとめた。

表2：プローブテストの結果

実験群	逃避台の場所を記憶して、あつた場所を泳いでいる時間 (秒) n = 8	平均±標準偏差 (SD)	標準標準偏差 (S)	t 値	p 値 [t (f ; p) 表より] 自由度 f = n - 1 = 7
0A 群	28.6, 36.6, 14.8, 22.2 22.2, 26.2, 13.0, 21.8	23.20 ± 7.54 ^{ab} *	7.06	3.07	p < 0.05
0C 群	2.4, 30.2, 23.4, 17.4 5.0, 23.0, 30.4, 26.4	19.78 ± 10.79 ^b	10.09	1.25	—
YC 群	27.8, 34.8, 30.6, 33.4 20.8, 23.4, 34.0, 22.6	28.43 ± 5.59 ^a	5.23	6.79	p < 0.001

* a, b は異った文字間で有意差あり (p < 0.05)

表 2 において、

$$t = \frac{\bar{X} - \mu}{\frac{S}{\sqrt{n-1}}}$$

であり、ここで、

\bar{X}

は平均(各群の平均)、 μ は母平均 (15 秒)、 S は標本標準偏差、 SD は平均土標準偏差、 n はデータ数 (各群のデータ数) を表し、 S は、

$$S = \sqrt{\frac{\sum_{i=1}^n (X_i - \bar{X})^2}{n}}$$

を表し、 SD は、

$$SD = \sqrt{\frac{\sum_{i=1}^n (X_i - \bar{X})^2}{n-1}}$$

を表す。

表 2 をグラフで表すと (図 5)、老齡ラットに TGA40S を与えた OA 群については、逃避台のあった区画の滞在時間 (逃避台の場所を記憶して、あった場所を泳いでいる時間) は有意に長いことがわかる。チャンスレベルの 15 秒は、ラットを 60 秒間泳がせて滞在時間を測定しているの、偶然に滞在する可能性を示すものである。棒グラフはラットの逃避台のあった区画の平均滞在時間を示している。

。

次に、モリス型水迷路試験に供したラットから、脳海馬を摘出し、Folch 法にて全脂質を抽出した。そして、薄層クロマトグラフィーで脂質を分画し、リン脂質画分を掻き取って、エタノールとの共

沸で水を除去した後、10%塩酸-メタノールで脂肪酸メチルエステルとして、ガスクロマトグラフィーで分析した。水迷路学習のパラメータ（「逃避台への到達時間（短いほど良い）」「逃避台に向かって泳いでいる割合（Hit%、大きいほど良い）」）と脳海馬中のアラキドン酸量との相関を最小二乗法に基づく一次近似曲線で求めた結果（図6）、逃避台への到達時間では、海馬アラキドン酸量と負の相関（相関係数 $R=-0.38$ ）が、遊泳軌跡のHit%とは正の相関（相関係数 $R=0.32$ ）が認められた。図6において、縦軸は海馬組織1g当たりのアラキドン酸のmgを表す。このように、TGA40Sを与えることで、学習能あるいは認知能力が改善することを初めて明らかにし、その効果はアラキドン酸によることが初めて証明された。

実施例4

（モリス型水迷路試験による8A8の学習能評価）

老齢ラットの実験群として、18ヶ月齢雄性Fischer系ラット20匹を対照飼料群（6匹：0C群）、TGA40S配合飼料群（6匹：0A群）と8A8配合飼料群（8匹：8A8群）の3群に分け、それぞれの群に、表3に示した対照飼料、TGA40S配合飼料及び8A8配合飼料を与えた。そして、若齢ラットの対照群（YC群）として、4ヶ月齢雄性Fischer系ラット8匹に表3に示した対照飼料を与えた。なお、8A8配合飼料に使用した8A8は実施例2で得た96モル% 8A8を使用した。

表 3 実験食

	対照飼料 (g)	TGA40SS配合飼料 (g)	8A8配合飼料 (g)
カゼイン	200	200	200
DL-メチオニン	3	3	3
コーンスターチ	150	150	150
シュクロース	500	500	500
セルロースパウダー	50	50	50
コーンオイル	50	45	45.8
ミネラル類AIN-76	35	35	35
ビタミン類AIN-76	10	10	10
重酒石酸コリン	2	2	2
ビタミンE	0.05	0.05	0.05
TGA40S	0	5	0
8A8	0	0	4.2

ラット1匹の1日当たりの摂餌量は約20gであるから、TGA40Sのラット1匹当たりの1日の摂取量は0.1gとなる。TGA40Sに結合する全脂肪酸の内、40質量%がアラキドン酸であることから、ラット1匹当たりの1日のアラキドン酸の摂取量は40mgとなる（グリセロール骨格部分の質量は便宜上無視して計算）。TGA40Sの分子量は928.5（平均脂肪酸分子量から算出）で、8A8の分子量は628.7となることから、8A8配合飼料群もラット1匹当たりの1日のアラキドン酸の摂取量が40mgになるように、実験食を設計した。

飼育3ヶ月目（老齢ラットの場合は21ヶ月齢、若齢ラットの場合

は7ヶ月齢)の前後でモリス型水迷路学習試験を実施した。

プローブテストを実施した結果、逃避台の位置を記憶して、あった場所を泳ぎ回っている時間(水槽を4区画に分けて、逃避台のあった区画(1/4)にいた時間(秒)で評価)は、YC群、OC群、OA群および8A8群で、それぞれ 28.59 ± 5.44^a 、 13.27 ± 7.89^b 、 22.02 ± 5.35^c および $27.18 \pm 5.10^{a,c}$ となった(数値:平均値±標準偏差、a、b、cは異った文字間に有意差あり($P < 0.05$))。したがって、アラキドン酸を構成脂肪酸とするトリグリセリドを与えることにより、加齢に伴って低下した学習の獲得の度合いが、若齢ラットのレベルに向って、有意に改善された。そして、TGA40Sと8A8の比較では、8A8の方が学習の獲得の度合いが高い傾向を示した。OA群、8A8群いずれも、ラットのアラキドン酸摂取量は同じであることから、8A8の方が吸収されやすいことを示しており、加齢により活性が低下した腓リパーゼに有効であることを実証した。

実施例5

(モリス型水迷路試験による8A8を5%以上含むトリグリセリドの学習能評価)

老齢ラットの実験群として、18ヶ月齢雄性Fischer系ラット20匹を対照飼料群(6匹:OC群)、8A8配合飼料群(6匹:8A8群)と8A8含有油脂配合飼料群(8匹:8A8(32モル%)群)の3群に分け、それぞれの群に、表4に示した対照飼料、8A8配合飼料及び8A8含有油脂配合飼料を与えた。そして、若齢ラットの対照群として、4ヶ月齢雄性Fischer系ラット8匹に表4に示した対照飼料を与えた(YC群)。なお、8A8配合飼料に使用した8A8は実施例2で得た96モル% 8A8を、8A8含有油脂配合飼料に使用した8A8含有油脂(トリグリセリド)は実施例2で得た8A8を31.6モル%含有する油脂(トリグリセリド)を使用した。

表 4 実験食

	対照飼料 (g)	8A8配合飼料 (g)	8A8含有油脂配合飼料 (g)
カゼイン	200	200	200
DL-メチオニン	3	3	3
コーンスターチ	150	150	150
シュクロース	500	500	500
セルロースパウダー	50	50	50
コーンオイル	50	45.8	45.8
ミネラル類AIN-76	35	35	35
ビタミン類AIN-76	10	10	10
重酒石酸コリン	2	2	2
ビタミンE	0.05	0.05	0.05
8A8	0	4.2	0
8A8含有油脂	0	0	4.2

8A8配合飼料は実施例4と同一で、ラット1匹当たりの1日のアラキドン酸の摂取量は40mgとなる。8A8含有油脂（トリグリセリド）配合飼料の場合は、ラット1日当たりのアラキドン酸の摂取量は13.2mgとなる。

飼育3ヶ月目（老齢ラットの場合は21ヶ月齢、若齢ラットの場合は7ヶ月齢）の前後でモリス型水迷路学習試験を実施した。

プローブテストを実施した結果、逃避台の位置を記憶して、あった場所を泳ぎ回っている時間（水槽を4区画に分けて、逃避台のあった区画（1/4）にいた時間（秒）で評価）は、YC群、OC群、8A8群

および8A8(32%モル)群で、それぞれ 27.91 ± 5.93^a 、 13.75 ± 7.74^b 、 27.00 ± 4.65^a および 21.18 ± 4.89^c となった（数値：平均値±標準偏差、a、b、cは異った文字間に有意差あり（ $P < 0.05$ ））。したがって、8A8を5モル%以上含有する油脂（トリグリセリド）を与えることにより、加齢に伴って低下した学習の獲得の度合いが、若齢ラットのレベルに向って、有意に改善された。しかし、8A8配合飼料群より、明らかに獲得の度合いは低値であり、8A8の濃度、さらにはアラキドン酸の濃度に依存することを実証した。

実施例 6

（アラキドン酸を含有する油脂（トリグリセリド）配合カプセルの調製）

ゼラチン100質量部及び食品添加物用グリセリン35質量部に水を加え50～60℃で溶解し、粘度2000cpのゼラチン被膜を調製した。次に実施例1で得たアラキドン酸含有油脂（トリグリセリド）にビタミンE油0.05質量%を混合し、内容物1を調製した。実施例2で得た8A8を32モル%含有する油脂（トリグリセリド）にビタミンE油0.05質量%を配合し、内容物2を調製した。実施例1で得たアラキドン酸含有油脂（トリグリセリド）50質量%と魚油（ツナ油：全脂肪酸に占めるエイコサペンタエン酸およびドコサヘキサエン酸の割合は、それぞれ5.1質量%および26.5質量%）50質量%で混合し、ビタミンE油0.05質量%を混合して内容物3を調製した。実施例1で得たアラキドン酸含有油脂（トリグリセリド）80%と魚油（ツナ油：全脂肪酸に占めるエイコサペンタエン酸およびドコサヘキサエン酸の割合は、それぞれ5.1質量%および26.5質量%）20質量%で混合し、ビタミンE油0.05質量%を混合して内容物4を調製した。これら内容物1から4を用いて、常法によりカプセル成形及び乾燥を行い、1粒当たり180mgの内容物を含有するソフトカプセルを製造した。

実施例 7

(脂肪輸液剤への使用)

実施例 2 で得た 8A8 を 32 モル % 含有する油脂 (トリグリセリド) 400g、精製卵黄レシチン 48g、オレイン酸 20g、グリセリン 100g 及び 0.1N 苛性ソーダ 40ml を加え、ホモジナイザーで分散させたのち、注射用蒸留水を加えて 4 リットルとする。これを高圧噴霧式乳化機にて乳化し、脂質乳液を調製した。該脂質乳液を 200ml ずつプラスチック製バッグに分注したのち、121℃、20 分間、高圧蒸気滅菌処理して脂肪輸液剤とする。

実施例 8

(ジュースへの使用)

β -シクロデキストリン 2g を 20% エタノール水溶液 20ml に添加し、ここにスターラーで攪拌しながら、実施例 1 で得たアラキドン酸含有トリグリセリド (ビタミン E を 0.05 質量% 配合) 100mg を加え、50℃ で 2 時間インキュベートした。室温冷却 (約 1 時間) 後、さらに攪拌を続けながら 4℃ で 10 時間インキュベートした。生成した沈殿を、遠心分離により回収し、n-ヘキサンで洗浄後、凍結乾燥を行い、アラキドン酸含有トリグリセリドを含有するシクロデキストリン包接化合物 1.8g を得た。この粉末 1g をジュース 10L に均一に混ぜ合わせ、アラキドン酸含有トリグリセリドを含有するジュースを調製した。

請 求 の 範 囲

1. アラキドン酸及び／又はアラキドン酸を構成脂肪酸とする化合物を含んで成る、脳機能の低下に起因する症状あるいは疾患の予防又は改善作用を有する組成物。

2. アラキドン酸を構成脂肪酸とする化合物が、アラキドン酸のアルコールエステル又は構成脂肪酸の一部もしくは全部がアラキドン酸である、トリグリセリド、リン脂質もしくは糖脂質である請求項1に記載の組成物。

3. 構成脂肪酸の一部又は全部がアラキドン酸であるトリグリセリドが、1,3-位に中鎖脂肪酸が、2-位にアラキドン酸が結合したトリグリセリドである請求項2に記載の組成物。

4. 中鎖脂肪酸が、炭素数6～12個を有する脂肪酸から選ばれたものである請求項3に記載の組成物。

5. 中鎖脂肪酸が、炭素数8個を有する脂肪酸から選ばれたものである請求項4に記載の組成物。

6. 構成脂肪酸の一部又は全部がアラキドン酸であるトリグリセリドを含有するトリグリセリドを含んで成る、脳機能の低下に起因する症状あるいは疾患の予防又は改善作用を有する組成物。

7. 構成脂肪酸の一部又は全部がアラキドン酸であるトリグリセリドを含有するトリグリセリドの、アラキドン酸の割合が、トリグリセリドを構成する全脂肪酸に対して10質量%以上であることを特徴とする、請求項6に記載の組成物。

8. 構成脂肪酸の一部又は全部がアラキドン酸であるトリグリセリドを含有するトリグリセリドが、モルティエレラ (Mortierella) 属に属する微生物から抽出したものである請求項6又は7に記載の組成物。

9. 構成脂肪酸の一部又は全部がアラキドン酸であるトリグリセリドを含有するトリグリセリドが、エイコサペンタエン酸をほとんど含まないトリグリセリドである請求項6～8のいずれかに記載の組成物。

10. 1,3-位に中鎖脂肪酸が、2-位にアラキドン酸が結合したトリグリセリドを5モル%以上含有するトリグリセリドを含んで成る、脳機能の低下に起因する症状あるいは疾患の予防又は改善作用を有する組成物。

11. 中鎖脂肪酸が、炭素数6～12個を有する脂肪酸から選ばれたものである請求項10に記載の組成物。

12. 中鎖脂肪酸が、炭素数8個を有する脂肪酸から選ばれたものである請求項11に記載の組成物。

13. 脳機能の低下に起因する症状が記憶・学習能力の低下である、請求項1～12のいずれかに記載の組成物。

14. 脳機能の低下に起因する症状が認知能力の低下である、請求項1～12のいずれかに記載の組成物。

15. 脳機能の低下に起因する症状が感情障害又は知的障害である、請求項1～12のいずれかに記載の組成物。

16. 脳機能の低下に起因する疾患がうつ病又は痴呆である、請求項1～12のいずれかに記載の組成物。

17. 痴呆がアルツハイマー型痴呆又は脳血管性痴呆である、請求項16に記載の組成物。

18. 組成物が、食品組成物又は医薬組成物である請求項1～17のいずれかに記載の組成物。

19. 成人1日当たりの摂取量がアラキドン酸量に換算して0.001～20gとなるように、アラキドン酸及び／又はアラキドン酸を構成脂肪酸とする化合物を含んで成る食品組成物。

20. アラキドン酸を構成脂肪酸とする化合物が、アラキドン酸のアルコールエステル又は構成脂肪酸の一部もしくは全部がアラキドン酸である、トリグリセリド、リン脂質もしくは糖脂質である請求項19に記載の食品組成物。

21. 構成脂肪酸の一部又は全部がアラキドン酸であるトリグリセリドが、1,3-位に中鎖脂肪酸が、2-位にアラキドン酸が結合したトリグリセリドである請求項20に記載の食品組成物。

22. 中鎖脂肪酸が、炭素数6～12個を有する脂肪酸から選ばれたものである請求項21に記載の食品組成物。

23. 中鎖脂肪酸が、炭素数8個を有する脂肪酸から選ばれたものである請求項22に記載の組成物。

24. 組成物が1,3-位に中鎖脂肪酸が、2-位にアラキドン酸が結合したトリグリセリドを0.001質量%以上含有することを特徴とする食品組成物。

25. 中鎖脂肪酸が、炭素数6～12個を有する脂肪酸から選ばれたものであることを特徴とする請求項24に記載の食品組成物。

26. 中鎖脂肪酸が、炭素数8個を有する脂肪酸から選ばれたものである請求項25に記載の食品組成物。

27. 食品組成物が、機能性食品、栄養補助食品、特定保健用食品又は老人用食品であることを特徴とする請求項18～26のいずれかに記載の組成物。

28. さらにドコサヘキサエン酸及び／又はドコサヘキサエン酸を構成脂肪酸とする化合物を含んで成る、請求項1～27のいずれかに記載の組成物。

29. ドコサヘキサエン酸を構成脂肪酸とする化合物が、ドコサヘキサエン酸のアルコールエステル又は構成脂肪酸の一部もしくは全部がドコサヘキサエン酸である、トリグリセリド、リン脂質もし

くは糖脂質である請求項28に記載の組成物。

30. 上記アラキドン酸とドコサヘキサエン酸の組み合わせにおいて、アラキドン酸／ドコサヘキサエン酸比（質量）が0.1～15の範囲にあることを特徴とする請求項28又は29に記載の組成物。

31. さらに、組成物中のアラキドン酸に対して、組成物中のエイコサペンタエン酸が、5分の1を超えない量であることを特徴とする請求項1～30のいずれかに記載の組成物。

32. 脳機能の低下に起因する症状あるいは疾患の予防又は改善作用を有する食品組成物の製造法であって、アラキドン酸及び／又はアラキドン酸を構成脂肪酸とする化合物を単独で、あるいはアラキドン酸を実質的に含有しない、あるいは含有していても僅かな量である飲食品原料とともに配合することを特徴とする食品組成物の製造方法。

33. アラキドン酸及び／又はアラキドン酸を構成脂肪酸とする化合物を含んで成る脳機能の低下に起因する症状あるいは疾患の予防又は改善作用を有する食品組成物の販売方法であって、該食品組成物及び／又は該食品組成物中の成分が脳機能の低下に起因する症状あるいは疾患の予防又は改善作用を有することを表示した包装用容器及び／又は販売促進用ツールを用いて販売することを特徴とする脳機能の低下に起因する症状あるいは疾患の予防又は改善作用を有する食品組成物の販売方法。

34. アラキドン酸及び／又はアラキドン酸を構成脂肪酸とする化合物を含んで成る食品組成物であって、該食品組成物及び／又は該食品組成物中の成分が脳機能の低下に起因する症状あるいは疾患の予防又は改善作用を有することを、該食品組成物の包装用容器及び／又は販売促進用ツールに表示して販売することを特徴とする脳機能の低下に起因する症状あるいは疾患の予防又は改善作用を有す

る食品組成物。

Fig.1

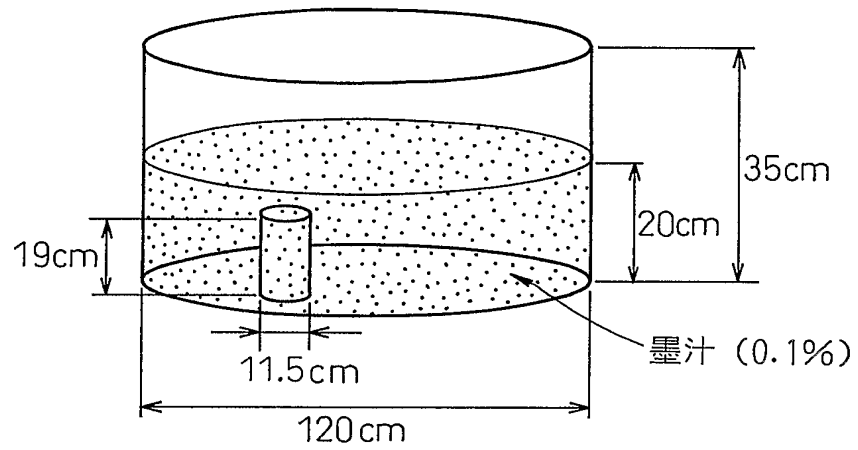

Fig.2

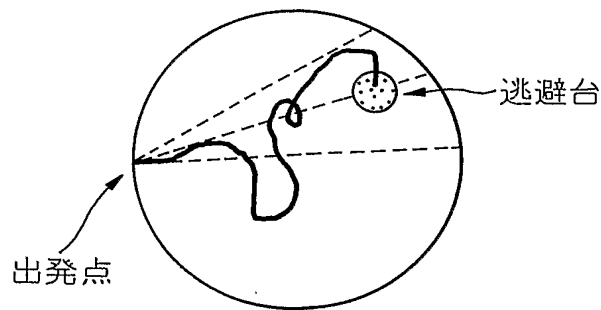

Fig.3

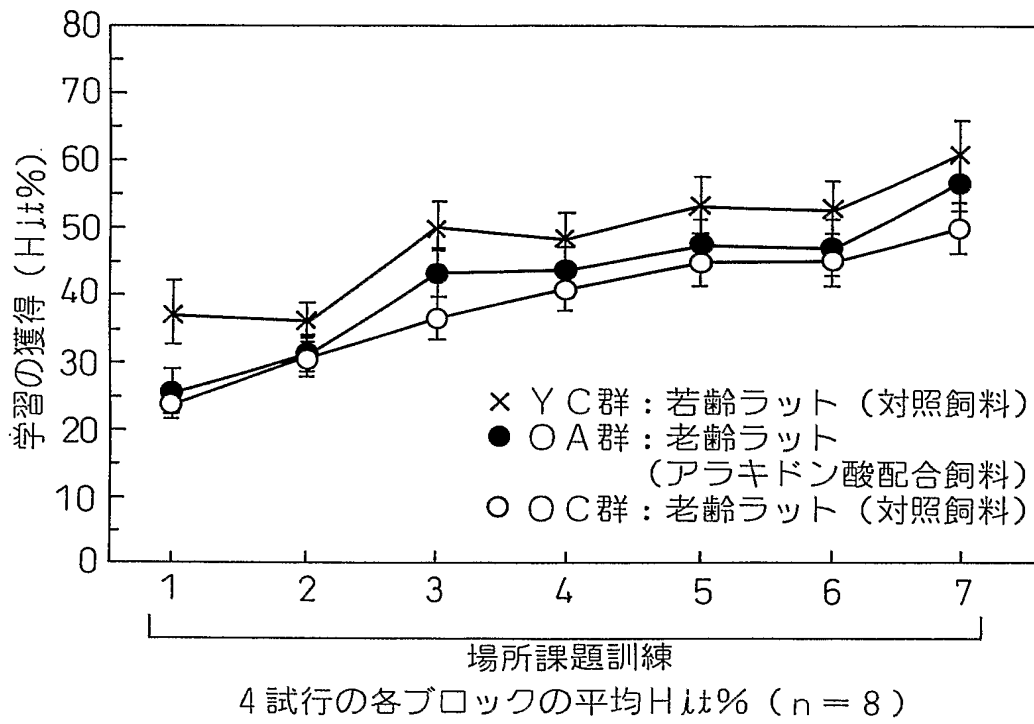
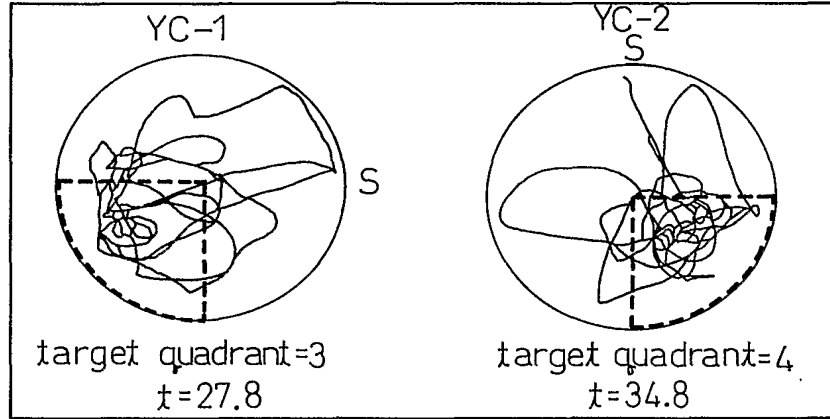
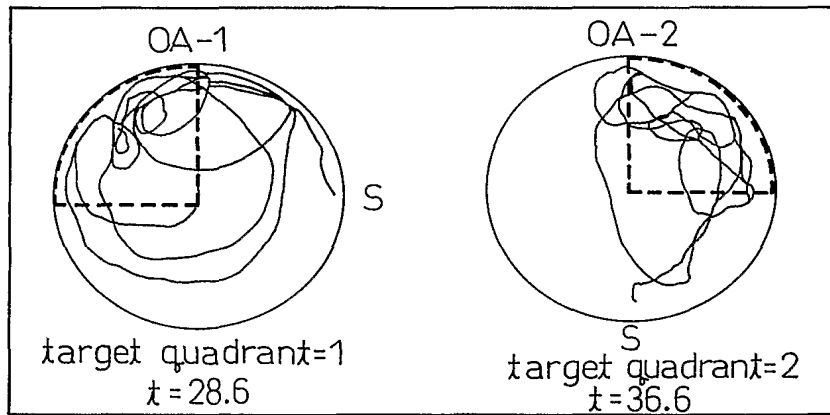

Fig.4

YC群
若齢ラット
(対照飼料)



OA群
老齢ラット
(アラキドン酸飼料)



OC群
老齢ラット
(対照飼料)

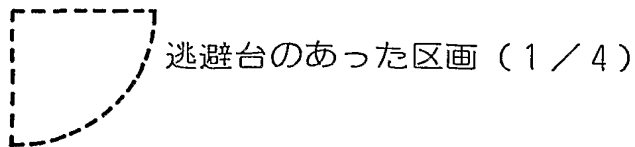
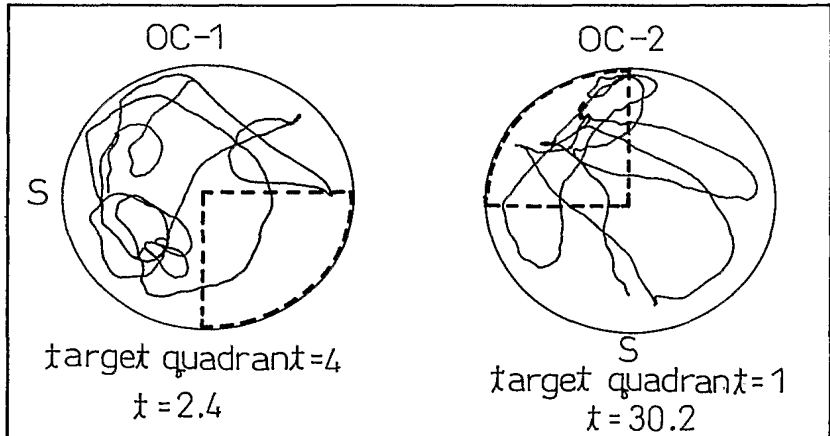

Fig.5

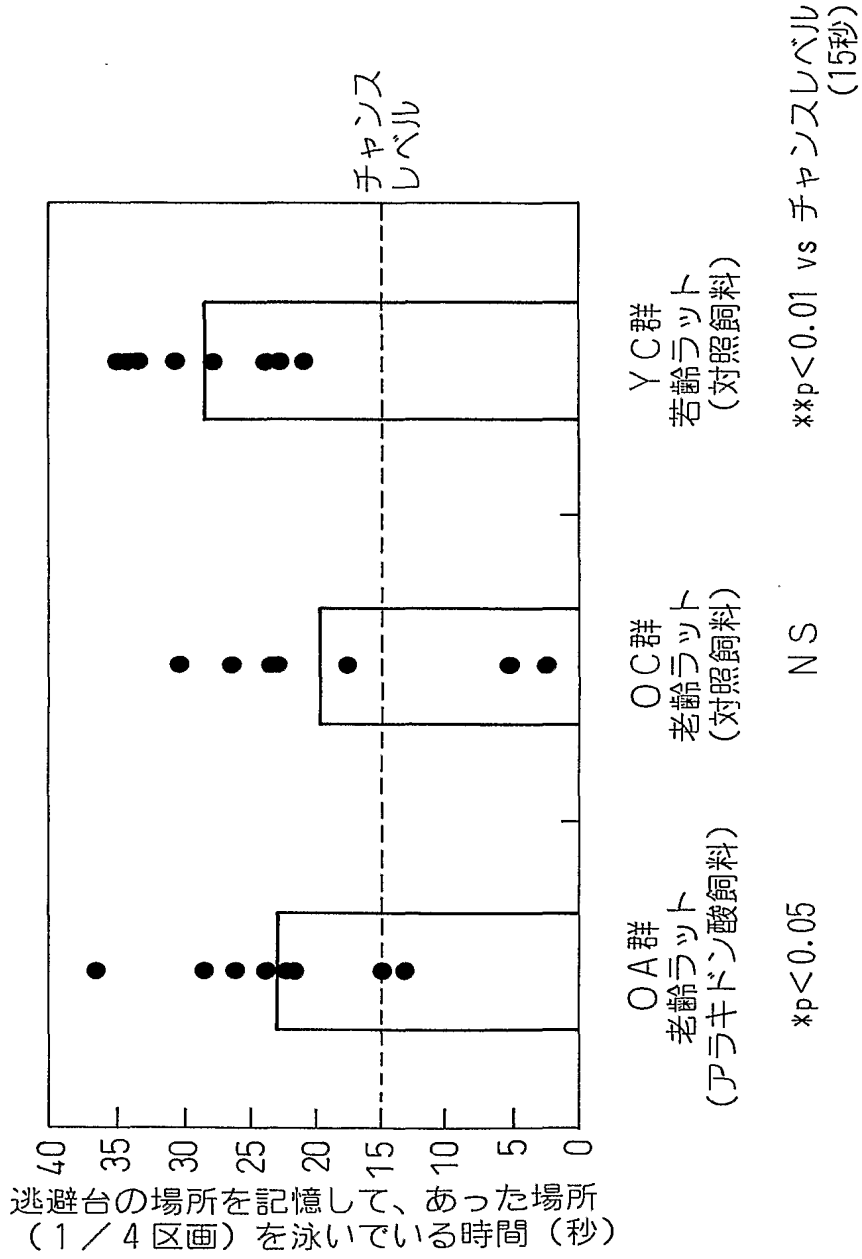
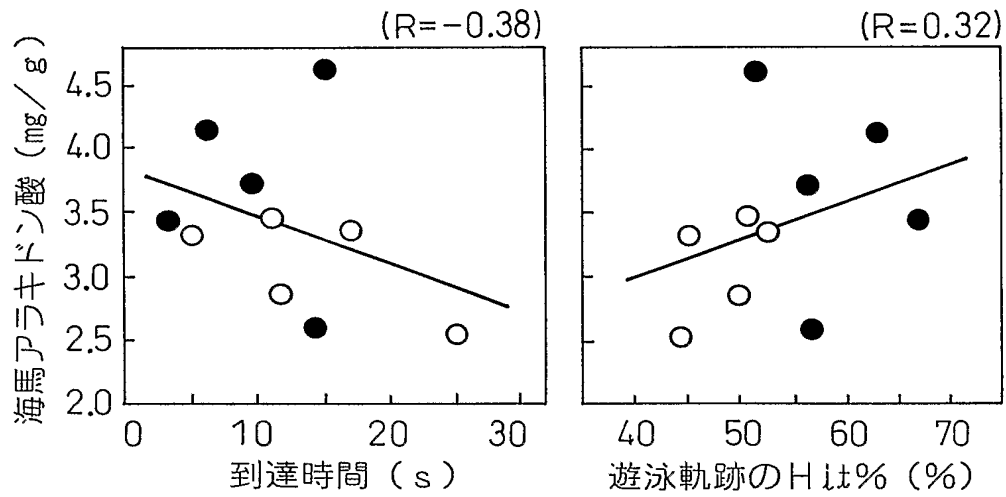

Fig.6



水迷路学習のパラメータ

(● : アラキドン酸群 (n = 5) 、○ : 対照群 (n = 5))

特許協力条約に基づく国際出願願書

K701-PCT

原本（出願用） - 印刷日時 2002年01月29日（29. 01. 2002）火曜日 17時00分51秒

VIII-5-1	不利にならない開示又は新規性喪失の例外に関する申立て 不利にならない開示又は新規性喪失の例外に関する申立て（規則4.17(v)及び51の2.1(a)(v)）	本国際出願に関し、 サントリー株式会社は、本国際出願の請求項に記載された対象が以下のように開示されたことを申し立てる。
VIII-5-1 (i)	開示の種類	その他：インターネットのホームページに掲載
VIII-5-1 (ii)	開示の日付：	2001年07月31日（31. 07. 2001）
VIII-5-1 (iii)	開示の名称：	老齡ラット海馬のシナプス可塑性は、アラキドン酸の摂取によって改善される
VIII-5-1 (iv)	開示の場所：	第24回日本神経科学・第44回日本神経科学合同大会のホームページ http://plaza.umin.ac.jp/~neuro21/ 一般演題プログラム 演題番号PE1-044の抄録
VIII-5-1 (v)	本申立ては、次の指定国のためになされたものである。：	すべての指定国

INTERNATIONAL SEARCH REPORT

International application No.

PCT/JP02/00671

A. CLASSIFICATION OF SUBJECT MATTER

Int.Cl⁷ A61K31/202, 31/232, A61P25/24, 25/28, A23L1/30, 2/52, A23D9/00

B. FIELDS SEARCHED
 According to International Patent Classification (IPC) or to both national classification and IPC

Minimum documentation searched (classification system followed by classification symbols)

Int.Cl⁷ A61K31/202, 31/232, A61P25/24, 25/28, A23L1/30, 2/52, A23D9/00

Documentation searched other than minimum documentation to the extent that such documents are included in the fields searched

Electronic data base consulted during the international search (name of data base and, where practicable, search terms used)
 CAPLUS (STN), MEDLINE (STN), EMBASE (STN)

C. DOCUMENTS CONSIDERED TO BE RELEVANT

Category*	Citation of document, with indication, where appropriate, of the relevant passages	Relevant to claim No.
X	LYNCH M. A. et al., Impaired spatial memory in aged rats is associated with alterations in inositol phospholipid metabolism, Neuroreport, 1994, Vol.5, No.12, pages 1493 to 1497	1-32,34
A	WAINWRIGHT P. E. et al., Water maze performance is unaffected in artificially reared rats fed diets supplemented with arachidonic acid and docosahexaenoic acid, J. Nutr., 1999, Vol.129, No.5, pages 1079 to 1089	1-32,34
A	WAINWRIGHT P. E. et al., Arachidonic acid offsets the effects on mouse brain and behavior of a diet with a low (n-6):(n-3) ratio and very high levels of docosahexaenoic acid, J. Nutr., 1997, Vol.127, No.1, pages 184 to 193	1-32,34

Further documents are listed in the continuation of Box C. See patent family annex.

* Special categories of cited documents:	"I" later document published after the international filing date or priority date and not in conflict with the application but cited to understand the principle or theory underlying the invention
"A" document defining the general state of the art which is not considered to be of particular relevance	"X" document of particular relevance; the claimed invention cannot be considered novel or cannot be considered to involve an inventive step when the document is taken alone
"E" earlier document but published on or after the international filing date	"Y" document of particular relevance; the claimed invention cannot be considered to involve an inventive step when the document is combined with one or more other such documents, such combination being obvious to a person skilled in the art
"L" document which may throw doubts on priority claim(s) or which is cited to establish the publication date of another citation or other special reason (as specified)	"&" document member of the same patent family
"O" document referring to an oral disclosure, use, exhibition or other means	
"P" document published prior to the international filing date but later than the priority date claimed	

Date of the actual completion of the international search 20 March, 2002 (20.03.02)	Date of mailing of the international search report 02 April, 2002 (02.04.02)
--	---

Name and mailing address of the ISA/ Japanese Patent Office	Authorized officer
Facsimile No.	Telephone No.

INTERNATIONAL SEARCH REPORT

International application No.

PCT/JP02/00671

Box I Observations where certain claims were found unsearchable (Continuation of item 1 of first sheet)

This international search report has not been established in respect of certain claims under Article 17(2)(a) for the following reasons:

1. Claims Nos.: 33

because they relate to subject matter not required to be searched by this Authority, namely:

Claim 33 pertains to business activities and thus relates to a subject matter which this International Searching Authority is not required, under the provisions of Article 17(2)(a)(i) of the PCT and Rule 39 (iii) of the Regulations under the PCT, to search.

2. Claims Nos.:

because they relate to parts of the international application that do not comply with the prescribed requirements to such an extent that no meaningful international search can be carried out, specifically:

3. Claims Nos.:

because they are dependent claims and are not drafted in accordance with the second and third sentences of Rule 6.4(a).

Box II Observations where unity of invention is lacking (Continuation of item 2 of first sheet)

This International Searching Authority found multiple inventions in this international application, as follows:

1. As all required additional search fees were timely paid by the applicant, this international search report covers all searchable claims.

2. As all searchable claims could be searched without effort justifying an additional fee, this Authority did not invite payment of any additional fee.

3. As only some of the required additional search fees were timely paid by the applicant, this international search report covers only those claims for which fees were paid, specifically claims Nos.:

4. No required additional search fees were timely paid by the applicant. Consequently, this international search report is restricted to the invention first mentioned in the claims; it is covered by claims Nos.:

Remark on Protest The additional search fees were accompanied by the applicant's protest.

No protest accompanied the payment of additional search fees.

A. 発明の属する分野の分類 (国際特許分類 (IPC))

Int. Cl⁷ A61K31/202, 31/232, A61P25/24, 25/28, A23L1/30, 2/52, A23D9/00

B. 調査を行った分野

調査を行った最小限資料 (国際特許分類 (IPC))

Int. Cl⁷ A61K31/202, 31/232, A61P25/24, 25/28, A23L1/30, 2/52, A23D9/00

最小限資料以外の資料で調査を行った分野に含まれるもの

国際調査で使用した電子データベース (データベースの名称、調査に使用した用語)

CAPLUS (STN), MEDLINE (STN), EMBASE (STN)

C. 関連すると認められる文献

引用文献の カテゴリー*	引用文献名 及び一部の箇所が関連するときは、その関連する箇所の表示	関連する 請求の範囲の番号
X	LYNCH M. A. et al, Impaired spatial memory in aged rats is associated with alterations in inositol phospholipid metabolism, Neuroreport, 1994, Vol.5, No.12, pages 1493 to 1497	1-32, 34
A	WAINWRIGHT P. E. et al, Water maze performance is unaffected in artificially reared rats fed diets supplemented with arachidonic acid and docosahexaenoic acid, J. Nutr., 1999, Vol.129, No.5, pages 1079 to 1089	1-32, 34

C欄の続きにも文献が列挙されている。

パテントファミリーに関する別紙を参照。

* 引用文献のカテゴリー

- 「A」 特に関連のある文献ではなく、一般的技術水準を示すもの
- 「E」 国際出願日前の出願または特許であるが、国際出願日以後に公表されたもの
- 「L」 優先権主張に疑義を提起する文献又は他の文献の発行日若しくは他の特別な理由を確立するために引用する文献 (理由を付す)
- 「O」 口頭による開示、使用、展示等に言及する文献
- 「P」 国際出願日前で、かつ優先権の主張の基礎となる出願

の日の後に公表された文献

- 「T」 国際出願日又は優先日後に公表された文献であって出願と矛盾するものではなく、発明の原理又は理論の理解のために引用するもの
- 「X」 特に関連のある文献であって、当該文献のみで発明の新規性又は進歩性がないと考えられるもの
- 「Y」 特に関連のある文献であって、当該文献と他の1以上の文献との、当業者にとって自明である組合せによって進歩性がないと考えられるもの
- 「&」 同一パテントファミリー文献

国際調査を完了した日 20.03.02

国際調査報告の発送日 02.04.02

国際調査機関の名称及びあて先
 日本国特許庁 (ISA/JP)
 郵便番号100-8915
 東京都千代田区霞が関三丁目4番3号

特許庁審査官 (権限のある職員)
 森井 隆信
 4C 9455
 電話番号 03-3581-1101 内線 3451



C (続き) . 関連すると認められる文献		
引用文献の カテゴリー*	引用文献名 及び一部の箇所が関連するときは、その関連する箇所の表示	関連する 請求の範囲の番号
A	WAINWRIGHT P. E. et al, Arachidonic acid offsets the effects on mouse brain and behavior of a diet with a low (n-6):(n-3) ratio and very high levels of docosahexaenoic acid, J. Nutr., 1997, Vol.127, No.1, pages 184 to 193	1-32, 34

第 I 欄 請求の範囲の一部の調査ができないときの意見 (第 1 ページの 2 の続き)

法第 8 条第 3 項 (PCT 17 条(2)(a)) の規定により、この国際調査報告は次の理由により請求の範囲の一部について作成しなかった。

1. 請求の範囲 33 は、この国際調査機関が調査をすることを要しない対象に係るものである。つまり、
請求の範囲 33 は、事業活動に該当し、PCT 17 条(2)(a)(i) 及び PCT 規則 39 (iii) の規定により、この国際調査機関が調査をすることを要しない対象に係るものである。
2. 請求の範囲 _____ は、有意義な国際調査をすることができる程度まで所定の要件を満たしていない国際出願の部分に係るものである。つまり、
3. 請求の範囲 _____ は、従属請求の範囲であって PCT 規則 6.4(a) の第 2 文及び第 3 文の規定に従って記載されていない。

第 II 欄 発明の単一性が欠如しているときの意見 (第 1 ページの 3 の続き)

次に述べるようにこの国際出願に二以上の発明があるとこの国際調査機関は認めた。

1. 出願人が必要な追加調査手数料をすべて期間内に納付したので、この国際調査報告は、すべての調査可能な請求の範囲について作成した。
2. 追加調査手数料を要求するまでもなく、すべての調査可能な請求の範囲について調査することができたので、追加調査手数料の納付を求めなかった。
3. 出願人が必要な追加調査手数料を一部のみしか期間内に納付しなかったため、この国際調査報告は、手数料の納付のあった次の請求の範囲のみについて作成した。
4. 出願人が必要な追加調査手数料を期間内に納付しなかったため、この国際調査報告は、請求の範囲の最初に記載されている発明に係る次の請求の範囲について作成した。

追加調査手数料の異議の申立てに関する注意

- 追加調査手数料の納付と共に出願人から異議申立てがあった。
 追加調査手数料の納付と共に出願人から異議申立てがなかった。

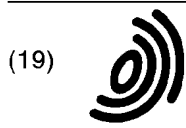

(12) **EUROPEAN PATENT APPLICATION**
published in accordance with Art. 158(3) EPC

(43) Date of publication:
19.05.2004 Bulletin 2004/21

(51) Int Cl.7: **A61K 31/202**, A61K 31/232,
A61P 25/24, A61P 25/28,
A23L 1/30, A23L 2/52,
A23D 9/00

(21) Application number: 02716453.2

(22) Date of filing: 29.01.2002

(86) International application number:
PCT/JP2002/000671

(87) International publication number:
WO 2003/013497 (20.02.2003 Gazette 2003/08)

(84) Designated Contracting States:
AT BE CH CY DE DK ES FI FR GB GR IE IT LI LU
MC NL PT SE TR

- ONO, Yoshiko
Osaka-shi, Osaka 533-0022 (JP)
- OKAICHI, Hiroshige
Hirakata-shi, Osaka 573-0084 (JP)
- OKAICHI, Youko
Hirakata-shi, Osaka 573-0084 (JP)

(30) Priority: 02.08.2001 JP 2001235519

(71) Applicant: SUNTORY LIMITED
Osaka-shi, Osaka 530-8203 (JP)

(74) Representative: Stoner, Gerard Patrick et al
MEWBURN ELLIS
York House
23 Kingsway
London WC2B 6HP (GB)

(72) Inventors:
• AKIMOTO, Kengo
Mishima-gun, Osaka 618-0001 (JP)
• KAWASHIMA, Hiroshi
Takatsuki-shi, Osaka 569-1121 (JP)

(54) **COMPOSITIONS HAVING EFFECTS OF PREVENTING OR AMELIORATING CONDITIONS OR DISEASES CAUSED BY BRAIN HYPOFUNCTION**

(57) The object of the present invention is to provide a composition that has preventive or ameliorative action on symptoms or diseases caused by decreased brain function. This composition contains, as its active ingre-

redient, arachidonic acid and/or a compound having arachidonic acid as a constituent fatty acid and, particularly, an alcohol ester of arachidonic acid or a triglyceride, phospholipid or glycolipid in which all or a portion of the constituent fatty acids are arachidonic acid.

Fig.3

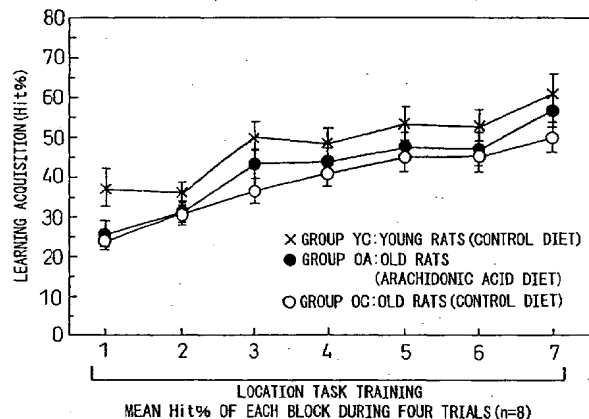

Description

BACKGROUND OF THE INVENTION

5 Technical Field

10 [0001] The present invention relates to a composition, and its production method, that has preventive or ameliorative action on symptoms or diseases caused by decreased brain function, having for its active ingredient arachidonic acid and/or a compound having arachidonic acid as its constituent fatty acid. More particularly, the present invention relates to a preventive or ameliorant for decreased memory or learning ability, decreased cognitive ability, emotional disorders (e.g., depression) and mental disorders (e.g., dementia, and specifically Alzheimer's dementia, and cerebrovascular dementia), a composition that has preventive or ameliorative action and a production method thereof, having for its active ingredient at least one type selected from the group consisting of arachidonic acid, alcohol esters of arachidonic acid, and triglycerides, phospholipids and glycolipids in which a portion or all of the constituent fatty acid is arachidonic acid.

Background Art

20 [0002] There has been a sudden increase in the proportion of elderly persons in society, in recent years, accompanying advances made in the field of medicine. This is resulting in a corresponding increase in the number of persons suffering from senile dementia. According to the "Annual Report on Health and Welfare 1999-2000" and the "Report on the Study of Countermeasures for Elderly Persons with Dementia", the number of elderly suffering from dementia during the 2000 fiscal year was 1.5-1.6 million, and the number of dementia patients age 65 and over reached 1 in 14 persons. The number of these patients is predicted to increase to 1 in 10 persons by 2030. As senile dementia progresses, it causes impairment of mental functions and emotions, eventually causing problems in terms of everyday life and social activities. The causes of senile dementia can be divided into cerebrovascular dementia, Alzheimer's dementia and combinations thereof. Although research and development activities have been conducted on drugs effective for the treatment of these brain disorders (including those that improve cerebral circulation and metabolism as well as those that inhibit dementia), an effective therapeutic drug has yet to be found. Although cerebral infarctions occur to a certain extent as people age, the occurrence of dementia can be prevented by, for example, using the brain. In consideration of this, it is thought to be quite possible to develop drugs targeted at not only treatment, but prevention as well. However, a drug that is safe and can be taken easily by persons ranging from infants to the elderly, inhibits decreases in brain function, prevents symptoms or diseases caused by decreases in brain function and exhibits ameliorative effects has, essentially, not yet been developed.

35 [0003] Research studies have been conducted in the past on methods for improving brain function, examples of which include a method for improving the metabolism of brain energy that activates the functions of cells by allowing brain cells to efficiently absorb nutrients (such as by elevating brain glucose levels), a method for improving cerebral circulation for the purpose of adequately supplying necessary nutrients and oxygen to brain cells by improving cerebral blood flow (such as by increasing cerebral blood flow volume), and a method for activating neurotransmission that takes place in synaptic gaps mediated by neurotransmitters (by supplying precursors of neurotransmitters (e.g., by supplementing with choline or acetyl CoA), inhibiting conversion of released neurotransmitters (e.g., by inhibiting acetylcholinesterase), increasing release of neurotransmitters (e.g., by increasing the release of acetylcholine or glutamic acid) or activating neurotransmitter receptors), and protecting nerve cell membranes (by, for example, antioxidation, supplying membrane components and preventing arteriosclerosis).

45 [0004] During the course of this past research, although ingredients that prevent symptoms or diseases caused by decreased brain function as well as ingredients that have ameliorative effects have been found, their effectiveness remains doubtful at the present time, and an effective drug has yet to be found for use as a pharmaceutical. Moreover, in the case of considering applications to foods, there has also been the additional difficulty of being limited to ingredients of natural origin.

50 [0005] The brain consists of tissue that resembles a mass of lipids. For example, phospholipids account for one-third of the tissue that comprises white matter and one-fourth of the tissue that comprises gray matter. The polyunsaturated fatty acids in the phospholipids that compose the various cell membranes of brain cells consist primarily of arachidonic acid and docosahexaenoic acid. However, this arachidonic acid and docosahexaenoic acid cannot be synthesized de novo by animals, and must be ingested from the diet either directly or indirectly (as linoleic acid and α -linolenic acid that are precursors of arachidonic acid and docosahexaenoic acid).

55 Therefore, attention is being focused on the improvement of learning and memory abilities and the prevention and recovery of senile dementia associated with docosahexaenoic acid. However, among the major fatty acids of phospholipids of the brain, not only docosahexaenoic acid, but also arachidonic acid is an important fatty acid that is present

in roughly the same degree. Sonderdegr, et al. determined that, in contrast to the proportion of arachidonic acid in phospholipids of the hippocampus being 12.4% by weight in normal individuals, that proportion decreases significantly to 8.1% by weight in Alzheimer's patients (Lipids, 26, 421-425, 1991). In this manner, although this suggests that arachidonic acid has the potential for playing an important role in maintaining brain function, concrete evidence has yet to be presented.

[0006] Several inventions have been indicated that utilize arachidonic acid for maintaining brain function. The "learning ability improver" described in Japanese Unexamined Patent Publication No. 6-256179 is an invention that has for its active ingredient a 1,2-diacyl-sn-glycerol derivative, various polyunsaturated fatty acids bound at 2-position are listed, and arachidonic acid is indicated as one of those fatty acids. However, only a 1,2-diacyl-sn-glycerol derivative in which docosahexaenoic acid is bound is specifically indicated in the examples, while arachidonic is listed only without any demonstration of its effect. A novel brain function ameliorant and a combination of ganglioside and arachidonic acid as a means for supplying a nutrient composition that contains the same are indicated in a "brain function ameliorant and nutrient composition" described in Japanese Unexamined Patent Publication No. 10-101568. However, although an experiment using naturally aged rats is indicated as a test example, the age of the rats for testing is only 13 months, which is equivalent to a human age of 33 years (one day for rats is equivalent to one month for humans), thus making it difficult to consider such a test as indicative of an aging model. In addition, the proportion or amount of arachidonic acid in brain phospholipid typically does not exhibit any changes at this age, and since decreases in brain function caused by aging are also not observed at this age, the effects of arachidonic acid would typically be considered to be unlikely to occur. In actuality, the effect of arachidonic acid alone was not evaluated in the test example, and it was merely indicated that arachidonic acid enhances the effect of ganglioside.

[0007] The "protein kinase C isozyme activator" described in Japanese Unexamined Patent Publication No. 6-279311 indicates the activation of protein kinase C, which plays an important role in intracellular information transmission, and a senile dementia therapeutic drug as its accompanying effect. However, the active ingredient is a phosphatidyl serine derivative having polyunsaturated fatty acids as its constituent fatty acids, and one of those polyunsaturated fatty acids is arachidonic acid. In the examples, however, there are no large differences in the effect of arachidonic acid between phosphatidyl serine derivatives bound with linoleic acid and α -linolenic acid, there is no superiority of phosphatidyl serine derivatives having arachidonic acid as a constituent fatty acid, and the effect of arachidonic acid is not demonstrated. In addition, as evaluation consists only of measurement of enzyme activity, preventive or ameliorative effects on symptoms or diseases caused by decreased brain function are not clarified. In this manner, although several inventions have been indicated that utilize arachidonic acid to maintain brain function, since arachidonic acid and compounds having arachidonic acid as a constituent fatty acid were not supplied in adequate amounts, the inventors are unable to identify the true effects in animal experiments and so forth, and merely describe arachidonic acid as one member of a group of fatty acids, thereby preventing them from providing a description of the actual state.

[0008] Short-term and long-term memory loss, which are pathological memory disorders accompanying organic lesions in the brain, are a core symptom of dementia. However, forgetfulness, which is another word for memory disorder, is one of the most frequently observed complaints among the elderly, and decreases in learning and memory abilities in humans accompanying physiological aging has been indicated in various research (Katzman, R. and Terry, R., The Neurology of Aging, F.A. Davis, Philadelphia, pp. 15-50).

[0009] In looking at memory in terms of the passage of time during which memories are formed, memory can be classified into sensory memory, primary memory and secondary memory. Primary memory may also be referred to as immediate memory, while secondary memory may be referred to as long-term memory. Short-term memory may refer to primary memory as well as learning ability that also covers secondary memory. Although sensory memory is formed when there is visual input that persists for about 50 milliseconds, it is extremely unstable and ends up being lost within 250-500 milliseconds. Primary memory is retained while the subject is constantly aware of it during the time information is recognized and processed, and fulfills the role of working memory. After information that has been processed as primary memory is transferred to secondary memory and retained for a long period of time, it is again recalled by way of primary memory. Since primary memory has a very small capacity, it ends up being lost in 20-30 seconds unless it is repeatedly recalled. Secondary memory is composed of each of the steps of transfer of information processed with primary memory, consolidation, its semi-permanent storage and its retrieval. This secondary memory is considerably impaired with aging. Since this decrease in secondary memory is mainly the result of impairment at the stage up to and including memory storage, there is hardly any decline observed with respect to the ability to retrieve memories stored in youth. However, in patients with dementia, this memory is also constantly subject to impairment.

[0010] One of the effects of arachidonic acid has been clearly determined from electrophysiological analysis. A phenomenon is known to occur in which, when stimuli are applied to the hippocampus at a high frequency to excite the synapses, the subsequent synaptic responses are maintained at a high level. This phenomenon is referred to as hippocampus LTP (long-term potentiation). It is based on the reversible nature of synapses and is used as an indicator for assessment of brain function. B.M. McGahon, et al. measured the hippocampus LTP in rats housed for 8 weeks while feeding the animals a control diet or a diet containing arachidonic acid (10 mg/rat/day) using 22-month-old old

rats (Neurobiol. Aging, 20, 643, 1999). In comparison with 4-month-old young rats, the hippocampus LTP levels of the old rats decreased sharply, and demonstrated a recovery to the level of young rats due to administration of arachidonic acid. However, in terms of the memory mechanism, this enhancement of hippocampus LTP indicates activation of primary memory, and not activation of a shift from primary memory to secondary memory required for memory fixation. Thus, effects on memory fixation cannot be verified unless they are clarified in a behavioral pharmacology study. In this manner, although examples of assessing the effects of arachidonic acid using electrophysiological indicators have been indicated, whether or not arachidonic acid and/or compounds having arachidonic acid as a constituent fatty acid of the present invention are effective for the prevention or amelioration of symptoms or diseases caused by decreased brain function has not been determined.

[0011] Thus, there is a strong need to develop pharmaceuticals and safer compounds, superior for application to foods, that prevent and exhibit ameliorative effects on symptoms or diseases caused by decreased brain function.

DISCLOSURE OF THE INVENTION

[0012] Thus, an object of the present invention is to provide a preventive or ameliorant for symptoms or diseases caused by decreased brain function, a food or beverage that has preventive or ameliorative action on symptoms or diseases caused by decreased brain function, and a production method thereof, which have for their active ingredient arachidonic acid and/or a compound having arachidonic acid as a constituent fatty acid. More particularly, an object of the present invention is to provide a preventive or ameliorant for decreased memory or learning ability, decreased cognitive ability, emotional disorders (e.g., depression) and mental disorders (e.g., dementia, and specifically Alzheimer's dementia, and cerebrovascular dementia), a food or beverage having said preventive or ameliorative action, and a production method thereof, which have for their active ingredient at least one type selected from the group consisting of arachidonic acid, alcohol esters of arachidonic acid, and triglycerides, phospholipids and glycolipids in which all or a portion of the constituent fatty acids are arachidonic acid.

[0013] As a result of conducting extensive research for the purpose of determining the preventive or ameliorative effects of arachidonic acid or compounds having arachidonic acid as a constituent fatty acid on symptoms or diseases caused by decreased brain function, the inventors of the present invention unexpectedly determined the effects of arachidonic acid or compounds having arachidonic acid as a constituent fatty acid through a behavioral pathology analysis by using old rats more than 20 months old in a Morris water maze test.

[0014] Moreover, the inventors of the present invention succeeded in industrially producing triglyceride having an arachidonic content of 20% by weight or more using microorganisms, were able to use this for testing the effects of the present invention, and determined the effects of said triglyceride.

[0015] Moreover, the inventors of the present invention also succeeded in producing oils and fats containing triglyceride in which medium-chain fatty acids are bound at 1,3-position and arachidonic acid is bound at 2-position, were able to use this for testing the effects of the present invention, and determined the effects of said triglyceride.

[0016] Thus, the present invention provides a preventive or ameliorant for symptoms or diseases caused by decreased brain function, a food or beverage having preventive or ameliorative action on symptoms or diseases caused by decreased brain function, and a production method thereof, which have for their active ingredient arachidonic acid and/or a compound having arachidonic acid as a constituent fatty acid. More particularly, the present invention provides a preventive or ameliorant for decreased memory or learning ability, decreased cognitive ability, emotional disorders (e.g., depression) and mental disorders (e.g., dementia, and specifically Alzheimer's dementia, and cerebrovascular dementia), a food or beverage having said preventive or ameliorative action, and a production method thereof, which have for their active ingredient at least one type selected from the group consisting of arachidonic acid, alcohol esters of arachidonic acid, and triglycerides, phospholipids and glycolipids in which all or a portion of the constituent fatty acids are arachidonic acid.

[0017] As a result of the present invention, a preventive or ameliorant for symptoms or diseases caused by decreased brain function, a food or beverage having preventive or ameliorative action on symptoms or diseases caused by decreased brain function, and a production method thereof, which have for their active ingredient arachidonic acid and/or a compound having arachidonic acid as a constituent fatty acid, can be provided, and are particularly useful for all humans considering the growing size of the elderly population throughout society.

BRIEF DESCRIPTION OF THE DRAWINGS

[0018]

Fig. 1 is a schematic explanatory drawing of a device used for a Morris water maze test.

Fig. 2 provides an explanation of learning acquisition (Hit%).

Fig. 3 is a graph showing learning acquisition relative to the number of trials made by rats.

Fig. 4 is a drawing showing the paths swam by rats for 60 seconds in a probe test for determining the degree of learning acquisition.

Fig. 5 is a graph showing the results of a probe test for determining the degree of learning acquisition.

Fig. 6 is a graph showing the results of determining the correlation between learning parameters and arachidonic levels in the hippocampus.

BEST MODE FOR CARRYING OUT THE INVENTION

[0019] The present invention relates to a preventive or ameliorant for symptoms or diseases caused by decreased brain function, a food or beverage having preventive or ameliorative action on symptoms or diseases caused by decreased brain function, and a production method thereof, which have for their active ingredient arachidonic acid and/or a compound having arachidonic acid as a constituent fatty acid.

[0020] The composition of the present invention has preventive or ameliorative action on symptoms or diseases caused by decreased brain function, and is useful as a food or beverage, pharmaceutical or over-the-counter drug and so forth for the purpose of prevention and amelioration (or treatment) of decreased memory or learning ability, decreased cognitive ability, emotional disorders (e.g., depression) and mental disorders (e.g., dementia, and specifically Alzheimer's dementia, and cerebrovascular dementia).

[0021] More specifically, the compound of the present invention has preventive or ameliorative action on symptoms or diseases caused by decreased brain function accompanying aging, is useful as a food or beverage, pharmaceutical or over-the-counter drug and so forth for the purpose of prevention and amelioration (or treatment) of decreased memory or learning ability, decreased cognitive ability, emotional disorders (e.g., depression) and mental disorders (e.g., dementia, and specifically Alzheimer's dementia, and cerebrovascular dementia), and is useful as a food or beverage, health food, functional food, food for specified health uses or geriatric food for the purpose preventing forgetfulness, preventing senility, maintaining and improving memory, maintaining and improving concentration, maintaining and improving attentiveness, refreshing the mind, maintaining wakefulness and maintaining youth.

[0022] In addition to free arachidonic acid, all compounds having arachidonic acid as a constituent fatty acid can be used for the active ingredient of the present invention. Examples of compounds having arachidonic acid as a constituent fatty acid include salts of arachidonic acid such as calcium salts and sodium salts. Other examples include alcohol esters of arachidonic acid such as arachidonate methyl ester and arachidonate ethyl ester. In addition, triglycerides, phospholipids and glycolipids in which all or a portion of their constituent fatty acids are arachidonic acid can also be used.

[0023] In the case of considering applications to foods, arachidonic acid is preferably in the form of a triglyceride or phospholipid, and particularly preferably in the form of a triglyceride. Although there are hardly any supply sources in the natural world of triglycerides containing arachidonic acid (synonymous with triglycerides containing triglycerides in which all or a portion of the constituent fatty acids are arachidonic acid), the inventors of the present invention made it possible to industrially utilize triglyceride containing arachidonic acid, and by using old rats more than 20 months old in a Morris water maze test, determined for the first time the effects of the active ingredient of the present invention by behavioral pharmacology analysis, clearly demonstrating that it has preventive or ameliorative action on symptoms or diseases caused by decreased brain function.

[0024] Thus, in the present invention, triglycerides can be used that contain triglycerides in which all or a portion of the constituent fatty acids are arachidonic acid (triglycerides containing arachidonic acid), the active ingredient of the present invention. Oils and fats (triglycerides) in which the proportion of arachidonic acid among all fatty acids that compose the triglyceride is 20% by weight (w/w) or more, preferably 30% by weight or more, and more preferably 40% by weight or more, are the preferable form of triglycerides that contain arachidonic acid in the case of applying to foods. Thus, in the present invention, all triglycerides can be used provided they are obtained by culturing microorganisms having the ability to produce oils and fats (triglycerides) containing arachidonic acid.

[0025] Examples of microorganisms having the ability to produce oils and fats (triglycerides) containing arachidonic acid include microorganisms belonging to the genii Mortierella, Conidiobolus, Pythium, Phytophthora, Penicillium, Cladosporium, Mucor, Fusarium, Aspergillus, Rhodotorula, Entomophthora, Echinozporangium and Saprolegnia. Examples of microorganisms belonging to the genus Mortierella subgenus Mortierella include Mortierella elongata, Mortierella exigua, Mortierella hygrophila and Mortierella alpina. Specific examples of these strains include Mortierella elongata IF08570, Mortierella exigua IF08571, Mortierella hygrophila IF05941 and Mortierella alpina IF08568, ATCC16266, ATCC32221, ATCC42430, CBS219.35, CBS224.37, CBS250.53, CBS343.66, CBS527.72, CBS529.72, CBS608.70 and CBS754.68.

[0026] All of these strains can be acquired without restriction from the Institute for Fermentation (IFO), Osaka, Japan, the American Type Culture Collection (ATCC), USA and the Centraalbureau voor Schimmelcultures (CBS). In addition, the strain Mortierella elongata SAM0219 (NIBH Deposit No. PERM P 8703) (NIBH Deposit No. PERM BP 1239), which was isolated from the soil by the research group of the present invention, can also be used.

[0027] In order to culture the microbial strains used in the present invention, spores or mycelia of that microbial strain or a pre-culture liquid obtained by culturing the microbial strain in advance are inoculated into liquid or solid media. In the case of liquid media, although glucose, fructose, xylose, saccharose, maltose, soluble starch, molasses, glycerol or mannitol are typically used as a carbon source, any of these may be used and there are no restrictions on them. Examples of nitrogen sources that can be used include natural nitrogen sources such as peptones, yeast extract, wheat germ extract, beef extract, casamino acids, cornstarch' stiplica, soybean protein, defatted soybean and cottonseed residue, as well as organic nitrogen sources such as urea, and inorganic nitrogen sources such as sodium nitrate, ammonium nitrate and ammonium sulfate. In addition, inorganic salts such as phosphates, magnesium sulfate, iron sulfate and copper sulfate as well as vitamins and so forth can be used as necessary as trace nutrient sources. There are no particular restrictions on these media ingredients provided they are at a concentration that does not impair microorganism growth. In practical terms, the nitrogen source should typically have a concentration of 0.1-40% by weight (w/v), and preferably 1-25% by weight (w/v). The initial amount of nitrogen source added is typically 0.1-10% by weight (w/v), and preferably 0.1-6% by weight (w/v), and the nitrogen source may be added during the course of culturing.

[0028] Moreover, oils and fats (triglycerides) having an arachidonic acid content of 45% by weight or more can also be used as the active ingredient of the present invention by controlling the concentration of the carbon source in the medium. Culturing consists of an organism growth phase extending from days 2 to 4 of culturing, and an oil or fat accumulation phase extending beyond days 2 to 4 of culturing. The initial concentration of the carbon source should be 1-8% by weight, and preferably 1-4% by weight, the carbon source should be gradually increased only during organism growth phase and early oil or fat accumulation stage, and total amount of the sequentially added carbon source should be 2-20% by weight, and preferably 5-15% by weight. Furthermore, an oil or fat (triglyceride) having an arachidonic acid content of 45% by weight or more can be obtained and used as the active ingredient of the present invention by making the gradually added amount of carbon source added during the organism growth phase and early oil or fat accumulation stage such that the concentration of carbon source in the medium becomes 0 on day 7 of culturing and beyond, preferably on day 6 of culturing and beyond, and more preferably on day 4 of culturing and beyond, by an addition corresponding to the initial concentration of the nitrogen source.

[0029] Although the culturing temperature of arachidonic acid-producing microorganisms varies according to the microorganism used, it should be 5-40°C and preferably 20-30°C, and after growing the microorganisms by culturing at 20-30°C, culturing is continued at 5-20°C to produce unsaturated fatty acid. The proportion of polyunsaturated fatty acids among the fatty acids formed can be increased by controlling the temperature in this manner. The pH of the medium is 4-10, and preferably 5-9, and culturing is carried out by aerated stir culturing, shake culturing or stationary culturing. Culturing is normally carried out for 2-30 days, preferably 5-20 days, and more preferably 5-15 days.

[0030] Moreover, as another means of increasing the proportion of arachidonic acid in an oil or fat (triglyceride) containing arachidonic acid besides controlling the concentration of the carbon source in the medium, oil or fat having a high content of arachidonic acid can also be obtained by selectively hydrolyzing oil or fat containing arachidonic acid. Since the lipase used for this selective hydrolysis does not have position specificity for triglycerides, and the hydrolysis activity decreases in proportion to the number of double bonds, ester bonds of fatty acids other than polyunsaturated fatty acids are hydrolyzed. The resulting triglyceride has an increased polyunsaturated fatty acid content due to the occurrence of a transesterification reaction between the resulting PUFA partial glycerides ("Enhancement of Arachidonic Acid: Selective Hydrolysis of a Single-Cell Oil from *Mortierella* with *Candida cylindracea* Lipase", J. Am. Oil Chem. Soc., 72, 1323-1327 (1998)). In this manner, an oil or fat having a high content of arachidonic acid obtained by carrying out selective hydrolysis on an oil or fat (triglyceride) containing arachidonic acid can be used as the active ingredient of the present invention. Although the proportion of arachidonic acid relative to the total amount of fatty acids of an oil or fat (triglyceride) containing arachidonic acid of the present invention is preferably high for the purpose of eliminating the effects of other fatty acids, it is not limited to a high proportion, but rather, in actuality, in the case of applying to foods, there are cases in which the absolute amount of arachidonic acid may present problems, and even oils and fats (triglycerides) having an arachidonic acid content of 10% by weight or more can substantially be used.

[0031] Moreover, triglycerides in which medium-chain fatty acids are bound at 1,3-position and arachidonic acid is bound at 2-position can also be used as a triglyceride in which all or a portion of the constituent fatty acids are arachidonic acid. In addition, oils and fats (triglycerides) can be used that contain 5 mol% or more, preferably 10 mol% or more, more preferably 20 mol% or more, and most preferably 30 mol% or more of a triglyceride in which medium-chain fatty acids are bound at 1,3-position and arachidonic acid is bound at 2-position. Medium-chain fatty acids selected from fatty acids having 6 to 12 carbon atoms can be used for the medium-chain fatty acids bound at 1,3-position of the aforementioned triglyceride. Examples of fatty acids having 6 to 12 carbon atoms include caprylic acid and capric acid, and 1,3-capryloyl-2-arachidonoyl-glycerol (to be referred to as "8A8") is particularly preferable.

[0032] These triglycerides in which medium-chain fatty acids are bound at 1,3-position and arachidonic acid is bound at 2-position are optimum oils and fats (triglycerides) in the case of being used for the elderly. Although ingested oils and fats (triglycerides) are typically hydrolyzed by pancreatic lipase when they enter the small intestine, this pancreatic

lipase is specific for 1,3-position, enabling 1,3-position of the triglycerides to be severed resulting in the formation of two molecules of free fatty acid, while at the same time forming one molecule of 2-monoacylglycerol (to be referred to as "2-MG"). As this 2-MG is extremely soluble in bile acids and has a high degree of absorption, 2-position fatty acids are typically considered to be easily absorbed. In addition, when 2-MG dissolves in bile acids, it plays the role of a surfactant by acting to increase the absorption of free fatty acids. Next, the free fatty acids and 2-MG biosynthesize bile acid compound micelles together with cholesterol and phospholipids, which are then incorporated into small intestine epithelial cells where the resynthesis of triacylglycerol takes place, after which this is ultimately released into the lymph in the form of chylomicrons. However, this pancreatic lipase is highly specific for saturated fatty acids, thus giving arachidonic acid the characteristic of being resistance to severing by this enzyme. Another problem is that, since pancreatic lipase activity decreases with age, in elderly persons susceptible to symptoms and diseases caused by decreased brain function, triglycerides in which medium-chain fatty acids are bound at 1,3-position and arachidonic acid is bound at 2-position are the optimum type of oils and fats (triglycerides).

[0033] As a concrete example of a method for producing triglyceride in which medium-chain fatty acids are bound at 1,3-position and arachidonic acid is bound at 2-position, such a triglyceride can be produced by allowing lipase, which specifically acts on the ester bonds at 1,3-position of the triglyceride, to act in the presence of oil or fat (triglyceride) containing arachidonic acid and medium-chain fatty acids.

[0034] The oil or fat (triglyceride) serving as the raw material is a triglyceride that has arachidonic acid as a constituent fatty acid, and in the case the proportion of arachidonic acid relative to the total amount of fatty acids that compose the triglyceride is high, because decreases in the reaction yield can be prevented by increasing the unreacted oil or fat (triglyceride in which only the raw material triglyceride or 1,3-position fatty acids have become medium-chain fatty acids), the enzyme reaction temperature is normally higher than 20-30°C, preferably 30-50°C, and more preferably 40-50°C.

[0035] Examples of lipases that can be used which specifically act on the ester bonds at 1,3-position of triglycerides include those produced by microorganisms such as *Rhizopus* species, *Rhizomucor* species and *Aspergillus* species, as well as porcine pancreatic lipase. Commercially available products can also be used for this lipase. Examples of commercially available lipases include, but are not limited to, the lipase of *Rhizopus delemar* (Tanabe Seiyaku, Talipase), and the lipases of *Rhizomucor miehei* (Novo Nordisk, Lipozyme IM) and *Aspergillus niger* (Amano Pharmaceutical, Lipase A), and any lipase can be used provided it is specific for 1,3-position.

[0036] The aforementioned lipase is preferably used in the form of lipase immobilized on a immobilizing support for the purpose of imparting heat resistance to the enzyme since the reaction temperature is 30°C or higher, and preferably 40°C or higher, for the purpose of enhancing reaction efficiency. An ion exchange resin support in the form of a highly porous resin having a pore diameter of about 100 Angstroms or more can be used for the immobilizing support, an example of which is the Dowex Marathon WBA (trade name, Dow Chemical).

[0037] 0.5-20 parts (by weight) of an aqueous solution of 1,3-position-specific type lipase are suspended in 1 part of immobilizing support followed by the gradual addition of 2-5 parts of cold acetone (e.g., -80°C) to the suspension while stirring to form a precipitate. An immobilized enzyme can then be prepared by drying this precipitate under reduced pressure. As an even simpler method, 0.05-0.4 parts of 1,3-position-specific type lipase are dissolved in a minimum of water and mixed with 1 part of immobilizing support while stirring followed by drying under reduced pressure to prepare an immobilized enzyme. Although about 90% of the lipase is immobilized on the support by this procedure, since it does not exhibit any transesterification activity in this state, the immobilized enzyme can be activated most efficiently by pre-treating in a solute (raw material oil or fat and medium-chain fatty acids) to which 1-10% by weight (w/v) of water has been added, and preferably in a solute to which 1-3% by weight of water has been added, followed by use in production.

[0038] Depending on the type of enzyme, the amount of water added to the reaction system is extremely crucial. The transesterification proceeds with difficulty if water is not contained in the reaction system, while hydrolysis occurs if a large amount of water is present, thereby decreasing the triglyceride recovery rate (due to the formation of diglycerides and monoglycerides by hydrolysis). In this case, however, by using an immobilized enzyme that has been activated by the aforementioned pre-treatment, the amount of water added to the reaction system is no longer important, and the transesterification reaction is able to occur efficiently even in the complete absence of water. Moreover, the pre-treatment can be omitted by selecting the type of enzyme agent.

[0039] By using an immobilized enzyme having heat resistance and increasing the enzyme reaction temperature in this manner, triglyceride in which medium-chain fatty acids are bound at 1,3-position and arachidonic acid is bound at 2-position can be efficiently produced without causing a decrease in reaction efficiency even in the case of oils and fats (triglycerides) containing arachidonic acid for which 1,3-position-specific type lipase has a low level of activity.

[0040] In the production of a food or beverage having preventive or ameliorative action on symptoms or diseases caused by decreased brain function, arachidonic acid and/or a compound having arachidonic acid as a constituent fatty acid may be used alone, or it may be blended with a food or beverage raw material substantially free of arachidonic acid or containing only a slight amount of arachidonic acid. Here, a slight amount refers to an amount for which, even

if arachidonic acid is contained in the food or beverage raw material, the food composition in which it is contained does not reach the daily ingested amount of arachidonic acid of the present invention, to be described later, when that food composition is ingested by a person.

5 [0041] In the case of triglycerides in which all or a portion of the constituent fatty acids are arachidonic acid in particular, there are no restrictions on the application of those oils and fats (triglycerides), and they can be used as raw materials or additives of foods, beverages, pharmaceuticals or over-the-counter drugs. These triglycerides are also not subjected to any restrictions on the purpose of their use or the amount used.

10 [0042] Examples of food compositions include not only ordinary foods, but also functional foods, nutritional supplement foods, newborn formulas, infant formulas, baby food, foods to be consumed during pregnancy and geriatric foods. Examples of foods that contain oils and fats include natural foods that inherently contain oils and fats such as meats, fish and nuts, foods to which oils and fats are added during preparation such as soup, foods for which oils and fats are used as a heating medium such as doughnuts, oily foods such as butter, processed foods to which oils and fats are added during processing such as cookies, and foods in which oils and fats are sprayed or coated during final processing such as hard biscuits. Moreover, oils and fats can also be added to agricultural food products, fermented food products, 15 livestock food products, marine food products or beverages that do not contain oils and fats. Moreover, these may also be in the form of functional foods, pharmaceuticals or over-the-counter drugs, examples of which include transintestinal nutrients, powders, granules, tablets, capsules, troches, medicines, suspensions, emulsions, syrups and other processed forms.

20 [0043] Moreover, in addition to the active ingredient of the present invention, the composition of the present invention may also contain various carriers and additives ordinarily used in foods, beverages, pharmaceuticals or over-the-counter drugs. In particular, the composition of the present invention preferably contains an antioxidant for the purpose of preventing oxidative deterioration of the active ingredient of the present invention. Examples of antioxidants include natural antioxidants such as tocopherols, flavone derivatives, phyllozucins, kojic acid, gallic acid derivatives, catechins, butterburic acid, gossypol, pyrazine derivatives, sesamol, guaiacol, guaiac fat, p-coumaric acid, nordihydroguaiaretic acid, sterols, terpenes, nucleic acid bases, carotinoids and lignans, as well as synthetic antioxidants exemplified by such compounds as ascorbic palmitate ester, ascorbic stearate ester, butylhydroxyanisole (BHA), butylhydroxytoluene (BHT), mono-t-butylhydroxyquinone (TBHQ) and 4-hydroxymethyl-2,6-di-t-butylphenol (HMBP). Examples of tocopherols include α -tocopherol, β -tocopherol, γ -tocopherol, δ -tocopherol, ϵ -tocopherol, ζ -tocopherol, η -tocopherol and tocopherol esters (such as tocopherol acetate). Moreover, examples of carotinoids include β -carotene, cantaxanthine and 30 astaxanthine.

[0044] In the composition of the present invention, in addition to the active ingredient of the present invention, examples of carriers include various immobilizing supports, extenders, diluents, thickeners, dispersants, vehicles, binder solvents (such as water, ethanol and vegetable oils), solvent assistants, buffers, solubility promoters, gelling agents, suspension agents, flour, rice flour, starch, cornstarch, polysaccharide, milk protein, collagen, rice oil and lecithin. 35 Examples of additives include, but are not limited to, vitamins, sweeteners, organic acids, colorants, fragrances, moisture prevention agents, fibers, electrolytes, minerals, nutrients, antioxidants, preservatives, aromatics, wetting agents, natural food extracts and vegetable extracts.

[0045] The major pharmacologically active ingredient of arachidonic acid and compound having arachidonic acid as a constituent fatty acid lies in the arachidonic acid. The daily ingested amount of arachidonic acid in the diet is reported to be 0.14 g in the Kanto region and 0.19-0.20 g in the Kansai region (Lipid Nutrition Science, 4, 73-82, 1995). In consideration of the decreased ingestion of oils and fats by the elderly and the decrease in pancreatic lipase activity, elderly persons are required to ingest at least an equivalent amount, and most likely an even greater amount, of arachidonic acid. Thus, the daily ingested amount of the arachidonic acid and compound having arachidonic acid as a constituent fatty acid of the present invention for an adult (for example, body weight: 60 kg) is 0.001-20 g, preferably 45 0.01-10 g, more preferably 0.05-5 g and most preferably 0.1-2 g as arachidonic acid.

[0046] In the case of actually applying the active ingredient of the present invention to foods or beverages, the absolute amount of arachidonic acid blended into the food is important. However, as the absolute amount blended into the food or beverage also varies according to the ingested amount of the food or beverage in which it is blended, in the case of blending triglycerides containing a triglyceride in which all or a portion of the constituent fatty acids are arachidonic acid into a food, they should be blended so that the amount of arachidonic acid is 0.0003% by weight or 50 more, preferably 0.003% by weight or more, and more preferably 0.03% by weight or more. Moreover, in the case of blending triglycerides containing a triglyceride in which medium-chain fatty acids are bound to 1,3-position and arachidonic acid is bound to 2-position into a food or beverage, they should be blended so that the amount of medium-chain fatty acids bound at 1,3-position is 0.001% by weight or more, preferably 0.01% by weight or more, and more preferably 0.1% by weight or more, as triglyceride in which arachidonic acid is bound at 2-position.

55 [0047] In the case of using the composition of the present invention as a pharmaceutical, a pharmaceutical can be produced in accordance methods ordinarily used in the field of pharmaceutical technology, such as methods described in the Japanese Pharmacopoeia or methods conforming thereto.

[0048] In the case of using the composition of the present invention as a pharmaceutical, there are no particular restrictions on the blended amount of active ingredient in the composition provided the object of the present invention is achieved, and it can be used at any suitable blending ratio.

[0049] In the case of using the composition of the present invention as a pharmaceutical, it is preferably administered in a single administration form, and oral administration is particularly preferable. Although the dosage of the composition of the present invention varies according to age, body weight, symptoms, number of administrations and so forth, for example, the daily adult dosage (body weight: approx. 60 kg) of arachidonic acid or a compound having arachidonic acid as a constituent fatty acid of the present invention is normally about 0.001-20 g, preferably about 0.01-10 g, more preferably about 0.05-5 g and most preferably about 0.1-2 g as arachidonic acid, and should be administered by dividing it among one to three administrations per day.

[0050] The major phospholipids of the phospholipid membranes in the brain are arachidonic acid and docosahexaenoic acid, and in the case of considering the balance between the two, the composition of the present invention preferably combines docosahexaenoic acid with arachidonic acid. In addition, as the proportion of eicosapentaenoic acid in the phospholipid membranes of the brain is extremely low, the composition of the present invention preferably contains hardly any eicosapentaenoic acid. In addition, a composition is more preferable that contains hardly any eicosapentaenoic acid but contains arachidonic acid and docosahexaenoic acid. In the combining of the arachidonic acid and docosahexaenoic acid, the ratio of arachidonic acid to docosahexaenoic acid (weight ratio) is within the range of 0.1-15 and preferably within the range of 0.25-10. In addition, a food or beverage is preferable in which the amount of eicosapentaenoic acid does not exceed one-fifth the amount (weight ratio) of arachidonic acid.

[0051] The following provides a more detailed explanation of the present invention through its examples. However, the present invention is not limited to the following examples.

[0052] Furthermore, health foods, functional foods, food for specified health uses, geriatric food and other food compositions of the present invention include those sold without any description or label on packaging container of said food composition and/or a marketing tool (such as a pamphlet) for promoting sales of said food composition indicating that the said food composition and/or ingredients of said food composition have preventive or ameliorative action for symptoms or diseases caused by decreased brain function, and more specifically, preventive or ameliorative action for symptoms or diseases caused by decreased brain function accompanying aging, prevention and amelioration of decreased memory or learning ability, decreased cognitive ability, emotional disorders (e.g., depression) and mental disorders (e.g., dementia, and specifically Alzheimer's dementia and cerebrovascular dementia), prevention of forgetfulness, prevention of senility, maintenance and improvement of memory, maintenance and improvement of concentration, maintenance and improvement of attentiveness, refreshing the mind, maintaining wakefulness and maintaining youth.

Example 1

(Production Method of Triglycerides Containing Arachidonic Acid)

[0053] *Mortierella alpina* CBS754.68 was used for the arachidonic acid-producing microorganism. Six kL of medium containing 1.8% glucose, 3.1% defatted soybean powder, 0.1% soybean oil, 0.3% KH_2PO_4 , 0.1% Na_2SO_4 , 0.05% $\text{CaCl}_2 \cdot 2\text{H}_2\text{O}$ and 0.05% $\text{MgCl}_2 \cdot 6\text{H}_2\text{O}$ were prepared in a 10 kL culturing tank and the initial pH was adjusted to 6.0. After inoculating with 30 L of pre-culture liquid, culturing was carried while aerating by stirring for 8 days under conditions of a temperature of 26°C, air flow rate of 360 m³/hour and tank internal pressure of 200 kPa. Furthermore, the stirring rate was adjusted so as to maintain the dissolved oxygen concentration at 10-15 ppm. Moreover, the glucose concentration was maintained so that the glucose concentration in the medium was within the range of 1-2.5% through day 4 and 0.5-1% after that time (the above percentages refer to w/v%) using the flow addition method. Following completion of culturing, those microorganisms that contain triglycerides containing arachidonic acid were recovered by filtration and drying, and oil or fat was extracted from the resulting microorganisms with hexane followed by an edible oil purification step (degumming, deacidifying, deodorizing and decoloring) to obtain 150 kg of arachidonic acid-containing triglycerides (wherein the arachidonic acid was bound at an arbitrary site of the triglyceride). When the methyl esters were prepared from the resulting oil or fat (triglycerides) by transmethylation and analyzed by gas chromatography, the proportion of arachidonic acid in the total amount of fatty acids was 40.84% by weight. Furthermore, the proportions of palmitic acid, stearic acid, oleic acid, linoleic acid, γ -linolenic acid and dihomo- γ -linolenic acid were 11.63, 7.45, 7.73, 9.14, 2.23 and 3.27% by weight, respectively. Moreover, 99% by weight arachidonic ethyl ester was isolated and purified by the established method of high-performance liquid chromatography from a fatty acid ethyl ester mixture containing 40% by weight of arachidonic ethyl ester, prepared from the aforementioned arachidonic acid containing oil or fat (triglycerides) by transesterification.

Example 2

(Production of Triglycerides Containing 5 mol% or More of 8A8)

5 **[0054]** 100 g of an ion exchange resin support (Dowex Marathon WBA: Dow Chemical, trade name) were suspended in 80 ml of an aqueous solution of 12.5% Rhizopus delemar lipase (Talipase Powder, Tanabe Seiyaku) followed by drying under reduced pressure to obtain immobilized lipase.

[0055] Next, 80 g of the triglycerides obtained in Example 1 containing 40% by weight of arachidonic acid (TGA40S), 160 g of caprylic acid, 12 g of the aforementioned immobilized lipase and 4.8 ml of water were allowed to react for 48 hours at 30°C while stirring (130 rpm). Following completion of the reaction, the reaction solution was removed to obtain activated immobilized lipase.

10 **[0056]** Next, 10 g of immobilized lipase (Rhizopus delemar lipase, support: Dowex Marathon WBA, trade name) were filled into a jacketed glass column (1.8 x 12.5 cm, volume: 31.8 ml), and a mixed oil or fat consisting of the TGA40S obtained in Example 1 and caprylic acid mixed at a ratio of 1:2 was allowed to flow through the column at a constant flow rate (4 ml/h) to allow the reaction to proceed continuously and obtain 400 g of reaction oil or fat. Furthermore, the column temperature was 40-41°C. Unreacted caprylic acid and free fatty acids were removed by molecular distillation to obtain an oil or fat (triglycerides) containing 8A8. When the proportion of 8A8 in the resulting 8A8-containing oil or fat (triglycerides) was investigated by gas chromatography and high-performance liquid chromatography, it was found to be 31.6 mol%. (Furthermore, the proportions of 8P8, 8O8, 8L8, 8G8 and 8D8 were 0.6, 7.9, 15.1, 5.2 and 4.8 mol%, respectively. The fatty acids P, O, L, G and D bound to 2-position of the triglyceride represent palmitic acid, oleic acid, linoleic acid, γ -linolenic acid and dihomo- γ -linolenic acid, respectively, while 8P8 refers to 1,3-capryloyl-2-palmitoyl-glycerol, 8O8 to 1,3-capryloyl-2-oleoyl-glycerol, 8L8 to 1,3-capryloyl-2-linoleoyl-glycerol, 8G8 to 1,3-capryloyl-2- γ -linolenoyl-glycerol and 8D8 to 1,3-capryloyl-2-dihomo- γ -linolenoyl-glycerol.) Furthermore, 96 mol% 8A8 was purified and isolated from the resulting 8A8-containing oil or fat (triglycerides) by the established method of high-performance liquid chromatography.

Example 3

(Evaluation of Learning Ability of TGA40S by a Morris Water Maze Test)

30 **[0057]** For the test groups of old rats, sixteen 18-month-old male Fischer rats were divided into two groups consisting of a control diet group (8 animals, group OC) and a TGA40S diet group (8 animals, group OA), and the control diet and SUNTGA40S diet shown in Table 1 were given to each group, respectively. The control diet shown in Table 1 was given to eight 4-month-old male Fischer rats serving as a control group of young rats (group YC). Furthermore, the TGA40S obtained in Example 1 was used for the TGA40S used in the TGA40S diet.

Table 1

Test Diets		
	Control Diet (g)	TGA40S Diet (g)
Casein	200	200
DL-methionine	3	3
Cornstarch	150	150
Sucrose	500	500
Cellulose powder	50	50
Corn oil	50	45
Mineral AIN-76	35	35
Vitamin AIN-76	10	10
Choline bitartrate	2	2
Vitamin E	0.05	0.05
TGA40S	0	5

[0058] Since the daily ingested amount per rat was about 20 g, the daily ingested amount of TGA40S per rat is 0.1 g. Since 40% by weight of all of the fatty acids bound to TGA40S is arachidonic acid, this means that the daily ingested amount of arachidonic acid per rat is 40 mg (the weight of the glycerol skeleton was ignored to simplify calculations). This 40 mg is equivalent to 133 mg/60 kg/day when converted to the ingested amount for humans.

[0059] A Morris water maze learning test was conducted around the third month of the experiment (age of old rats: 21 months, age of young rats: 7 months). The Morris water maze test is a learning test based on spatial recognition in which water stained black with ink is filled (height of water level: 20 cm) into a water tank (diameter: 120 cm, height: 35 cm), a rat is placed on an escape platform of a size (diameter: 11.5 cm, height: 19 cm) that is just large enough for the rat to stand on (the escape platform is located beneath the surface of the water and cannot be seen by rats swimming in the water tank), the rat on which the learning test is to be performed is placed in the water tank at a predetermined location in the tank (starting point), and then forced to swim to the escape platform. This test is recognized to have a correlation with the hippocampus that governs memory, and is widely used in the US and Europe. As the test is repeated, the rats learn the location of the escape platform. The rats were allowed to learn using the method described below. Namely, after releasing a rat from the starting point of the Morris water maze test apparatus, if the rat was unable to reach the escape platform within 60 seconds, the rat was placed on the escape platform, thereby enabling it to learn the location of the unseen escape platform. This learning process was continued for 2 weeks no more than twice a day. The percentage of the amount of time required to swim from the starting point to the escape platform within an angular deviation range of $\pm 15^\circ$ to the total swimming time (Hit%, see Fig. 2) was used as an indicator of learning. Although the learning acquisition rate of old rats clearly decreases as compared with young rats, as a result of feeding TAG40S, namely arachidonic acid, learning acquisition rate improved to near the level of young rats (Fig. 3). In Fig. 3, each graduation on the scale of the horizontal axis represents four trials, or two days worth of testing.

[0060] Next, in order to determine the degree of learning acquisition, a probe test was conducted on the day after two weeks of the aforementioned learning, namely on day 15. If the escape platform is taken away after the rats have acquired learning, the rats swim around at the location where the escape platform used to be. The time during which the rats swim around at the former location of the escape platform based on the memory of where it used to be (evaluated by dividing the water tank into four quadrants and evaluated as the amount of time (seconds) spent in the quadrant where the escape platform used to be) can be used to evaluate the degree of learning acquisition. The paths swam by the No. 1 and No. 2 rats of the YC group, OA group and OC group are shown (Fig. 4). Furthermore, as the rats were allowed to learn by changing the starting points for individual rats, the starting point (S) and quadrant where the escape platform used to be in Fig. 4 differ according to individual rats. In addition, in Fig. 5, target quadrant indicates the quadrant (1/4) where the escape platform used to be. Rat OC-1 of the OC group was clearly wandered throughout the water tank, and was only in the quadrant where the escape platform used to be for 2.4 seconds. The results of the probe test are summarized in Table 2.

Table 2

Results of Probe Test					
Test Group	Time swimming at location where escape platform used to be as a result of remembering location of escape platform (sec.) n = 8	Mean \pm standard deviation (SD)	Sample standard deviation (S)	t value	p value (from t(f;p) table) degree of freedom f = n - 1 = 7
Group OA	28.6, 36.6, 14.8, 22.2, 22.2, 26.2, 13.0, 21.8	23.20 \pm 7.54 ^{ab*}	7.06	3.07	p<0.05
Group OC	2.4, 30.2, 23.4, 17.4, 5.0, 23.0,	19.78 \pm 10.79 ^b	10.09	1.25	--

* a and b indicate a significant difference between different letters (p<0.05)

Table 2 (continued)

Results of Probe Test					
Test Group	Time swimming at location where escape platform used to be as a result of remembering location of escape platform (sec.) n = 8	Mean ± standard deviation (SD)	Sample standard deviation (S)	t value	p value (from t(f;p) table) degree of freedom f = n - 1 = 7
	30.4, 26.4				
Group YC	27.8, 34.8, 30.6, 33.4, 20.8, 23.4, 34.0, 22.6	28.43 ± 5.59 ^a	5.23	6.79	p < 0.001

[0061] In Table 2,

$$t = \frac{\bar{X} - \mu}{\frac{S}{\sqrt{n - 1}}}$$

where,
 \bar{X}

represents the mean, μ the population mean (15 seconds), S the sample standard deviation, SD the mean ± standard deviation and n the number of data elements (number of data elements of each group), while S represents

$$S = \sqrt{\frac{\sum_{i=1}^n (X_i - \bar{X})^2}{n}}$$

and SD represents

$$SD = \sqrt{\frac{\sum_{i=1}^n (X_i - \bar{X})^2}{n - 1}}$$

[0062] When Table 2 is expressed in the form of a graph (Fig. 5), the amount of time spent in the quadrant where the escape platform used to be by the old rats of group OA given TGA40S (time spent swimming around the location where the escape platform used to be as a result of remembering the location of the escape platform) can be seen to be significantly longer. As the chance level of 15 seconds measures the time spent by allowing the rats to swim for 60 seconds, this also indicates the possibility of the rats spending time in that quadrant by coincidence. The bar graph indicates the mean time spent by rats in the quadrant where the escape platform used to be.

[0063] Next, the hippocampus was excised from those rats used in the Morris water maze test and all of the lipids were extracted using the Folch method. After then fractioning the lipids by thin layer chromatography, scraping off the phospholipid fraction and removing the water by boiling with ethanol, the lipids were analyzed by gas chromatography after converting to fatty acid methyl esters with 10% hydrochloric acid-methanol. As a result of determining the correlation between the water maze learning parameters ("time to reach escape platform (the shorter the better)", "proportion

of time swimming toward escape platform (Hit%, the larger the better)”) and the amount of arachidonic acid in the hippocampus with a primary approximation curve based on the least squares method (Fig. 6), a negative correlation was observed between time to reach escape platform and amount of arachidonic acid in hippocampus (correlation coefficient R = -0.38), while a positive correlation was observed between time to reach escape platform and Hit% of the path swam by the rats (correlation coefficient R = 0.32). In Fig. 6, the vertical axis indicates the amount of arachidonic acid in mg per gram of hippocampus tissue. In this manner, it was shown for the first time that the administration of TGA40S improves learning ability or cognitive ability, and it was also demonstrated for the first time that the effect is due to arachidonic acid.

Example 4

(Evaluation of Learning Ability of 8A8 by a Morris Water Maze Test)

[0064] For the test groups of old rats, twenty 18-month-old male Fischer rats were divided into three groups consisting of a control diet group (6 animals, group OC), a TGA40S diet group (6 animals, group OA) and an 8A8 diet group (8 animals, group 8A8), and the control diet, SUNTGA40S diet and 8A8 diet shown in Table 3 were given to each group, respectively. The control diet shown in Table 3 was given to eight 4-month-old male Fischer rats serving as a control group of young rats (group YC). Furthermore, the 96 mol% 8A8 obtained in Example 2 was used for the 8A8 used in the 8A8 diet.

Table 3

Test Diets			
	Control Diet (g)	TGA40S Diet (g)	8A8 Diet (g)
Casein	200	200	200
DL-methionine	3	3	3
Cornstarch	150	150	150
Sucrose	500	500	500
Cellulose powder	50	50	50
Corn oil	50	45	45.8
Mineral AIN-76	35	35	35
Vitamin AIN-76	10	10	10
Choline bitartrate	2	2	2
Vitamin E	0.05	0.05	0.05
TGA40S	0	5	0
8A8	0	0	4.2

[0065] Since the daily ingested amount per rat was about 20 g, the daily ingested amount of TGA40S per rat is 0.1 g. Since 40% by weight of all of the fatty acids bound to TGA40S is arachidonic acid, this means that the daily ingested amount of arachidonic acid per rat is 40 mg (the weight of the glycerol skeleton was ignored to simplify calculations). Since the molecular weight of TGA40S is 928.5 (calculated from mean fatty acid molecular weight) and the molecular weight of 8A8 is 628.7, the test diet was designed so that the daily ingested amount of arachidonic acid per animal was 40 mg in the 8A8 diet group as well.

[0066] A Morris water maze learning test was conducted around the third month of the experiment (age of old rats: 21 months, age of young rats: 7 months).

[0067] As a result of conducting a probe test, the times spent swimming around the location where the escape platform used to be as a result of remembering the location of the escape platform (evaluated as the amount of time (seconds) spent in the quadrant (1/4) where the escape platform used to be after dividing the water tank into four quadrants) were 28.59±5.44^a, 13.27±7.89^b, 22.02±5.35^c and 27.18±5.10^{ac} (values: mean ± standard deviation, a, b and c indicate a significant difference between different letters (P<0.05)) for group YC, group OC, group OA and group 8A8, respectively. Thus, as a result of administering triglyceride having arachidonic acid as a constituent fatty acid, the

degree of learning acquisition that was decreased due to aging was significantly improved towards the level of young rats. With respect to a comparison between TGA40S and 8A8, 8A8 tended to result in a higher degree of learning acquisition. Since the ingested amounts of arachidonic acid by the rats was the same for both group OA and group 8A8, 8A8 was indicated as being more easily absorbed than TGA40S, and was demonstrated to be effective for pancreatic lipase for which activity has decreased due to aging.

Example 5

(Evaluation of Learning Acquisition of Triglyceride Containing at Least 5% 8A8 by a Morris Water Maze Test)

[0068] For the test groups of old rats, twenty 18-month-old male Fischer rats were divided into three groups consisting of a control diet group (6 animals, group OC), a 8A8 diet group (6 animals, group 8A8) and an 8A8-containing oil or fat diet group (8 animals, group 8A8 (32 mol%)), and the control diet, 8A8 diet and 8A8-containing oil or fat diet shown in Table 4 were given to each group, respectively. The control diet shown in Table 4 was given to eight 4-month-old male Fischer rats serving as a control group of young rats (group YC). Furthermore, the oil or fat (triglycerides) containing 31.6 mol% 8A8 obtained in Example 2 was used for the 8A8-containing oil or fat (triglycerides) used for the 8A8-containing oil or fat diet.

Table 4

Test Diets			
	Control Diet (g)	8A8 diet (g)	8A8-containing oil or fat diet (g)
Casein	200	200	200
DL-methionine	3	3	3
Cornstarch	150	150	150
Sucrose	500	500	500
Cellulose powder	50	50	50
Corn oil	50	45.8	45.8
Mineral AIN-76	35	35	35
Vitamin AIN-76	10	10	10
Choline bitartrate	2	2	2
Vitamin E	0.05	0.05	0.05
8A8	0	4.2	0
8A8-containing oil	0	0	4.2

[0069] The 8A8 diet was the same as that in Example 4, and the daily ingested amount of arachidonic acid per rat was 40 g. In the case of the 8A8-containing oil or fat (triglycerides) diet, the daily ingested amount of arachidonic acid per rat was 13.2 mg.

[0070] A Morris water maze learning test was conducted around the third month of the experiment (age of old rats: 21 months, age of young rats: 7 months).

[0071] As a result of conducting a probe test, the times spent swimming around the location where the escape platform used to be as a result of remembering the location of the escape platform (evaluated as the amount of time (seconds) spent in the quadrant (1/4) where the escape platform used to be after dividing the water tank into four quadrants) were 27.91 ± 5.93^a , 13.75 ± 7.74^b , 27.00 ± 4.65^c and 21.18 ± 4.89^c (values: mean \pm standard deviation, a, b and c indicate a significant difference between different letters ($P < 0.05$)) for group YC, group OC, group 8A8 and group 8A8(32 mol%), respectively. Thus, as a result of administering oil or fat (triglycerides) containing at least 5% 8A8, the degree of learning acquisition that was decreased due to aging was significantly improved towards the level of young rats. However, the degree of acquisition was clearly lower than the 8A8 diet group, demonstrating that the degree of learning acquisition is dependent on the concentration of 8A8, and more specifically, on the concentration of arachidonic acid.

Example 6

(Preparation of Capsules Containing Oil or Fat (Triglycerides) Containing Arachidonic Acid)

5 **[0072]** 100 parts by weight of gelatin and 35 parts by weight of food additive glycerin were dissolved at 50-60°C by addition of water to prepare a gelatin coating having viscosity of 2000 cp. Next, 0.05% by weight of vitamin E oil were mixed into the arachidonic acid-containing oil or fat (triglycerides) obtained in Example 1 to prepare Capsule Contents 1. 0.05% by weight of vitamin E oil were mixed into the oil or fat (triglycerides) containing 32 mol% of 8A8 obtained in
 10 Example 2 to prepare Capsule Contents 2. 50% by weight of the arachidonic acid-containing oil or fat (triglycerides) obtained in Example 1 and 50% by weight of fish oil (tuna oil in which the proportions of eicosapentaenoic acid and docosahexaenoic acid to the total amount of fatty acids were 5.1% by weight and 26.5% by weight, respectively) were mixed followed by mixing in 0.05% by weight of vitamin E oil to prepare Capsule Contents 3. 80% by weight of the arachidonic acid-containing oil or fat (triglycerides) obtained in Example 1 and 20% by weight of fish oil (tuna oil in which the proportions of eicosapentaenoic acids and docosahexaenoic acid to the total amount of fatty acid were 5.1%
 15 by weight and 26.5% by weight, respectively) were mixed followed by mixing in 0.05% by weight of vitamin E oil to prepare Capsule Contents 4. Capsules were formed and dried in accordance with ordinary methods using these Capsule Contents 1 through 4 to produce soft capsules containing 180 mg of contents per capsule.

Example 7

20

(Application to a Fat Infusion Agent)

[0073] After adding 400 g of the oil or fat (triglycerides) containing 32 mol% 8A8 obtained in Example 2, 48 g of purified egg yolk lecithin, 20 g of oleic acid, 100 g of glycerin and 40 ml of 0.1 N sodium hydroxide and dispersing with
 25 a homogenizer, distilled water for injection was added to bring to a volume of 4 liters. This was then emulsified with a high-pressure spraying emulsifier to prepare a lipid latex. After adding 200 ml aliquots of this lipid latex to plastic bags, the plastic bags were sterilized by high-pressure steam for 20 minutes at 121°C to obtain fat infusion agents.

Example 8

30

(Application to a Juice)

[0074] 2 g of β -cyclodextrin were added to 20 ml a 20% aqueous ethanol solution followed by the addition of 100 mg of the arachidonic acid-containing triglycerides (containing 0.05% by weight vitamin E) obtained in Example 1 while
 35 stirring with a stirrer and incubating for 2 hours at 50°C. After being allowed to cool to room temperature (about 1 hour), the mixture was additionally incubated for 10 hours at 4°C while continuing to stir. After recovering the resulting precipitate by centrifugal separation and washing with n-hexane, the product was freeze-dried to obtain 1.8 g of a cyclodextrin inclusion compound containing arachidonic acid-containing triglycerides. 1 g of this powder was then uniformly mixed with 10 L of juice to prepare a juice containing arachidonic acid-containing triglycerides.
 40

Claims

- 45 1. A composition having preventive or ameliorative action on symptoms or diseases caused by decreased brain function comprising arachidonic acid and/or a compound having arachidonic acid as a constituent fatty acid.
2. A composition according to claim 1 wherein, the compound having arachidonic acid as a constituent fatty acid is an alcohol ester of arachidonic acid or a triglyceride, phospholipid or glycolipid in which all or a portion of the constituent fatty acids are arachidonic acid.
 50
3. A composition according to claim 2 wherein, the triglyceride in which all or a portion of the constituent fatty acids are arachidonic acid is a triglyceride in which medium-chain fatty acids are bound to 1,3-position and arachidonic acid is bound to 2-position.
- 55 4. A composition according to claim 3 wherein, the medium-chain fatty acids are selected from fatty acids having 6 to 12 carbon atoms.
5. A composition according to claim 4 wherein, the medium-chain fatty acids are selected from fatty acids having 8

carbon atoms.

- 5 6. A composition having preventive or ameliorative action on symptoms or diseases caused by decreased brain function comprising triglycerides containing triglycerides in which all or a portion of the constituent fatty acids are arachidonic acid.
- 10 7. A composition according to claim 6 wherein, the proportion of arachidonic acid in the triglycerides containing triglycerides in which all or a portion of the constituent fatty acids are arachidonic acid is 10% by weight or more relative to all of the fatty acids that compose the triglycerides.
- 15 8. A composition according to claim 6 or claim 7 wherein, the triglycerides that contains triglycerides in which all or a portion of the constituent fatty acids are arachidonic acid are extracted from a microorganism belonging to the genus Mortierella.
- 20 9. A composition according to any of claims 6 through 8 wherein, the triglycerides containing triglycerides in which all or a portion of the constituent fatty acids are arachidonic acid are triglycerides that are substantially free of eicosapentaenoic acid.
- 25 10. A composition having preventive or ameliorative action on symptoms or diseases caused by decreased brain function comprising triglycerides containing 5 mol% or more of triglycerides in which medium-chain fatty acids are bound to 1,3-position and arachidonic acid is bound to 2-position.
- 30 11. A composition according to claim 10 wherein, the medium-chain fatty acids are selected from fatty acids having 6 to 12 carbon atoms.
- 35 12. A composition according to claim 11 wherein, the medium-chain fatty acids are selected from fatty acids having 8 carbon atoms.
- 40 13. A composition according to any of claims 1 through 12 wherein, the symptom caused by decreased brain function is decreased memory or learning ability.
- 45 14. A composition according to any of claims 1 through 12 wherein, the symptom caused by decreased brain function is decreased cognitive ability.
- 50 15. A composition according to any of claims 1 through 12 wherein, the symptom caused by decreased brain function is an emotional disorder or a mental disorder.
- 55 16. A composition according to any of claims 1 through 12 wherein, the disease caused by decreased brain function is depression or dementia.
17. A composition according to claim 16 wherein, the dementia is Alzheimer's dementia or cerebrovascular dementia.
18. A composition according to any of claims 1 through 17 wherein, the composition is a food composition or a pharmaceutical composition.
19. A food composition comprising arachidonic acid and/or a compound having arachidonic acid as a constituent fatty acid such that the adult daily ingested amount is 0.001-20 g as arachidonic acid.
20. A food composition according to claim 19 wherein, the compound having arachidonic acid as a constituent fatty acid is an alcohol ester of arachidonic acid or a triglyceride, phospholipid or glycolipid in which all or a portion of the constituent fatty acids are arachidonic acid.
21. A food composition according to claim 20 wherein, the triglyceride in which all or a portion of the constituent fatty acids are arachidonic acid is a triglyceride in which medium-chain fatty acids are bound to 1,3-position and arachidonic acid is bound to 2-position.
22. A food composition according to claim 21 wherein, the medium-chain fatty acids are selected from fatty acids having 6 to 12 carbon atoms.

23. A composition according to claim 22 wherein, the medium-chain fatty acids are selected from fatty acids having 8 carbon atoms.
- 5 24. A food composition wherein the composition contains 0.001% by weight of triglyceride in which medium-chain fatty acids are bound to 1,3-position and arachidonic acid is bound to 2-position.
25. A food composition according to claim 24 wherein, the medium-chain fatty acids are selected from fatty acids having 6 to 12 carbon atoms.
- 10 26. A food composition according to claim 25 wherein, the medium-chain fatty acids are selected from fatty acids having 8 carbon atoms.
27. A composition according to any of claims 18 through 26 wherein, the food composition is a functional food, nutritional supplement food, food for specified health uses or geriatric food.
- 15 28. A composition according to any of claims 1 through 27 that additionally comprises docosahexaenoic acid and/or a compound having docosahexaenoic acid as a constituent fatty acid.
- 20 29. A composition according to claim 28 wherein, the compound having docosahexaenoic acid as a constituent fatty acid is an alcohol ester of docosahexaenoic acid or a triglyceride, phospholipid or glycolipid in which all or a portion of the constituent fatty acids are docosahexaenoic acid.
- 25 30. A composition according to claim 28 or claim 29 wherein, the ratio (weight) of arachidonic acid to docosahexaenoic acid in the combination of arachidonic acid and docosahexaenoic acid is within the range of 0.1 to 15.
- 30 31. A composition according to any of claims 1 through 30 wherein, the amount of eicosapentaenoic acid does not exceed one-fifth of the amount of arachidonic acid in the composition.
32. A production method of a food composition having preventive or ameliorative action on symptoms or diseases caused by decreased brain function comprising: blending a food or beverage raw material with arachidonic acid and/or a compound having arachidonic acid as a constituent fatty acid alone, or with a food or beverage raw material that is substantially free of arachidonic acid or only contains a slight amount of arachidonic acid.
- 35 33. A marketing method of a food composition having preventive or ameliorative action on symptoms or diseases caused by decreased brain function that contains arachidonic acid and/or compound having arachidonic acid as a constituent fatty acid, comprising: using a packaging container and/or sales promotional tool which indicates that said food composition and/or ingredient of said food composition has preventive or ameliorative action on symptoms or diseases caused by decreased brain function.
- 40 34. A food composition having preventive or ameliorative action on symptoms or diseases caused by decreased brain function that contains arachidonic acid and/or compound having arachidonic acid as a constituent fatty acid, and is marketed using a packaging container and/or sales promotional tool which indicates that said food composition and/or ingredient of said food composition has preventive or ameliorative action on symptoms or diseases caused by decreased brain function.
- 45
- 50
- 55

Fig.1

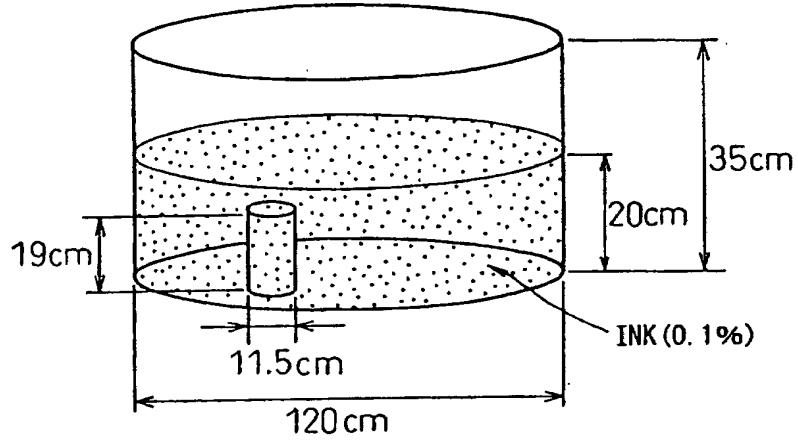

Fig.2

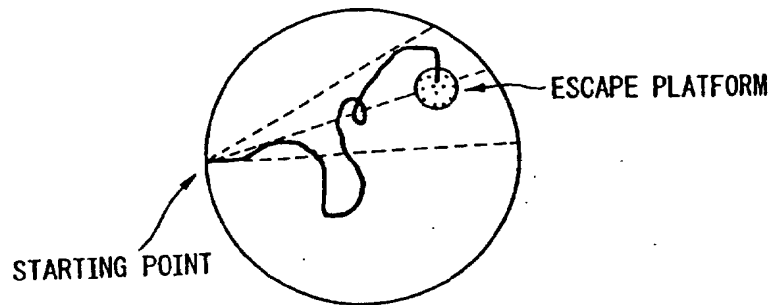

Fig.3

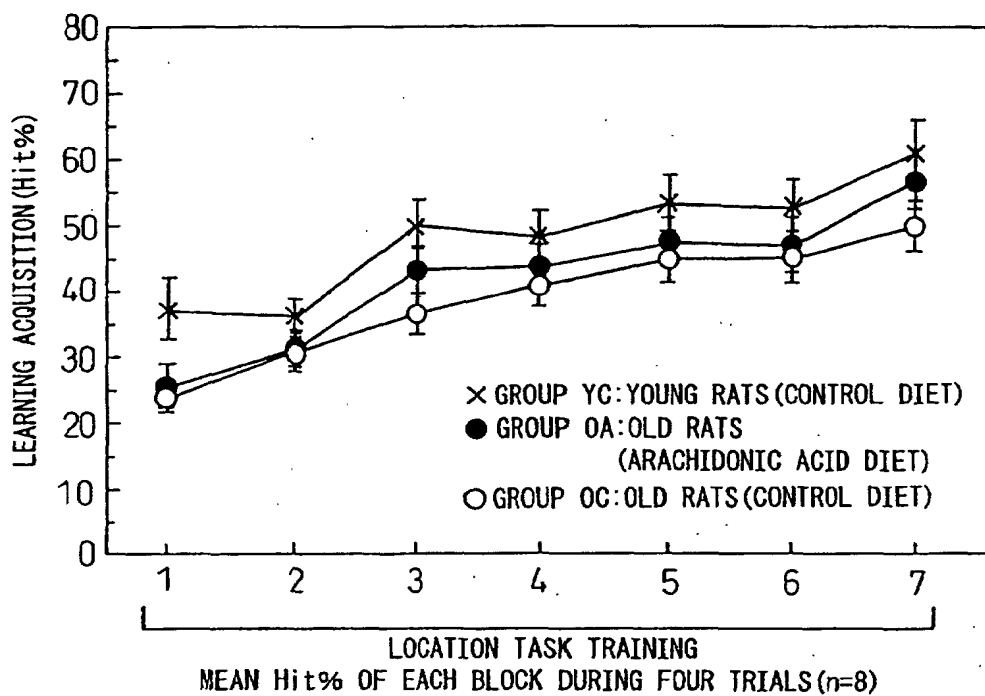
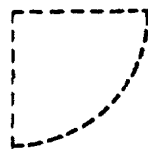
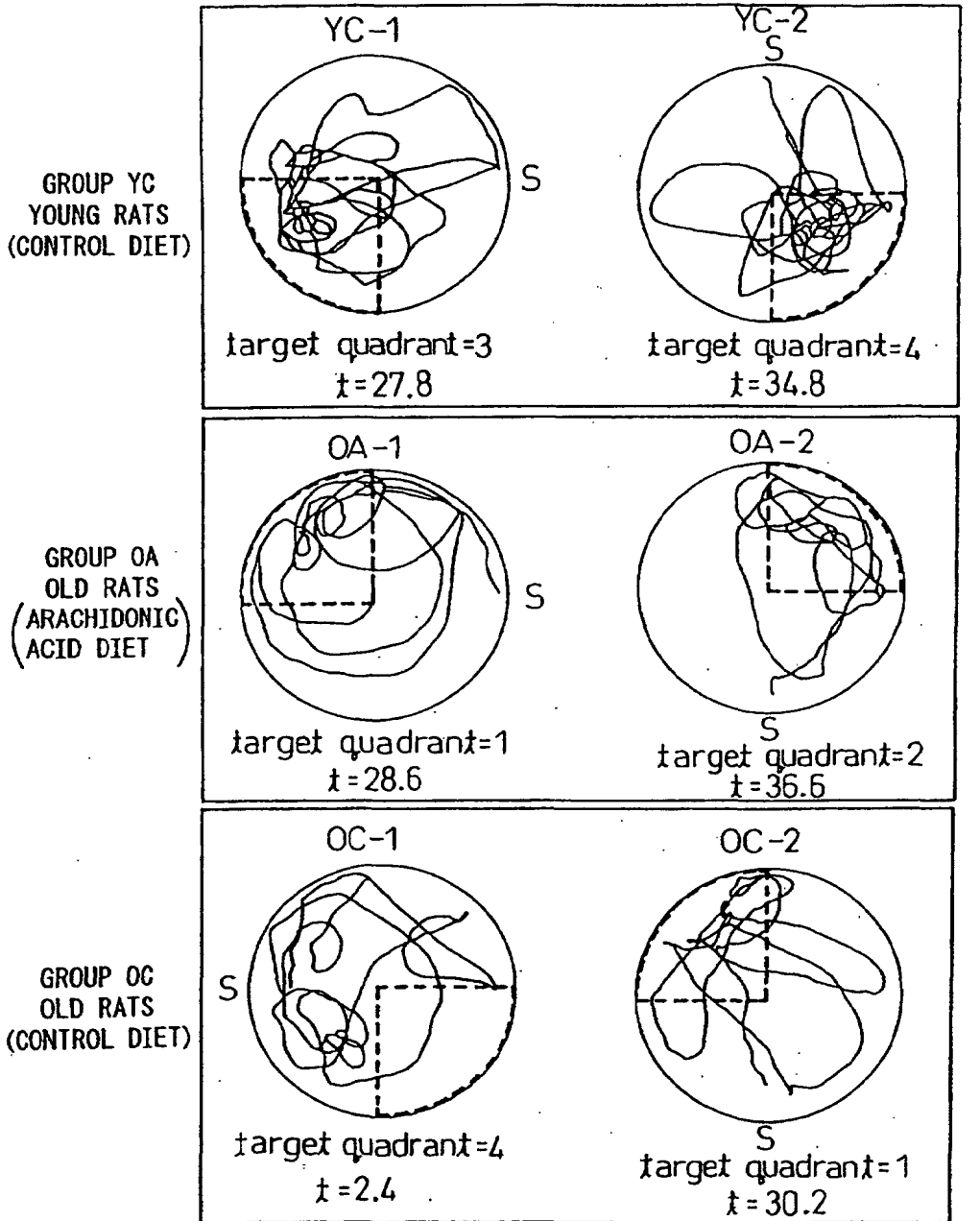

Fig.4



QUADRANT (1/4) WHERE ESCAPE PLATFORM HAD BEEN

Fig.5

