

levels complicates processing, so manufacturers prefer to make as much as possible of the fiber from pure silica.) Both designs are used for single-mode fiber. An alternative used for multimode step-index fiber is a pure silica core clad with a lower index plastic.

As you learned in Chapter 4, the refractive-index profiles of dispersion-shifted fibers are considerably more complex, to provide the extra waveguide dispersion needed to shift the zero-dispersion point to longer wavelengths. So are the profiles of graded-index multimode fibers. The same dopants are used in these more complex fibers as in simple step-index fibers.

Silica Fiber Manufacture

The trickiest stage in the manufacture of fused-silica optical fibers is making the preform from which the fibers are drawn. Several processes have been developed; they share some common features but have important differences.

The crucial common feature is the formation of fluffy fused-silica soot by reacting SiCl_4 (and GeCl_4 , when it is used as a dopant) with oxygen to generate SiO_2 (and GeO_2 if the silica is doped). The crucial variations are in how the soot is deposited and melted into the final preform.

One approach is to deposit the soot on the inside wall of a fused-silica tube, as shown in Figure 6.2. Typically, the tube serves as the outer cladding, onto which an inner cladding layer and the core material are deposited. Variations on the approach are called inside vapor deposition, modified chemical vapor deposition, plasma chemical vapor deposition, and plasma-enhanced chemical vapor deposition. The major differences center on how the reaction zone is heated.

The chemicals react to deposit a fine glass soot, and the waste gas is pumped out to an exhaust. To spread soot along the length of the tube, the reaction zone is moved along the tube. Heating melts the soot, and it condenses into a glass.

Fused-silica preforms can be made by depositing glass soot inside a tube of fused silica, which becomes the cladding.

FIGURE 6.2
Soot deposition inside a fused-silica tube.

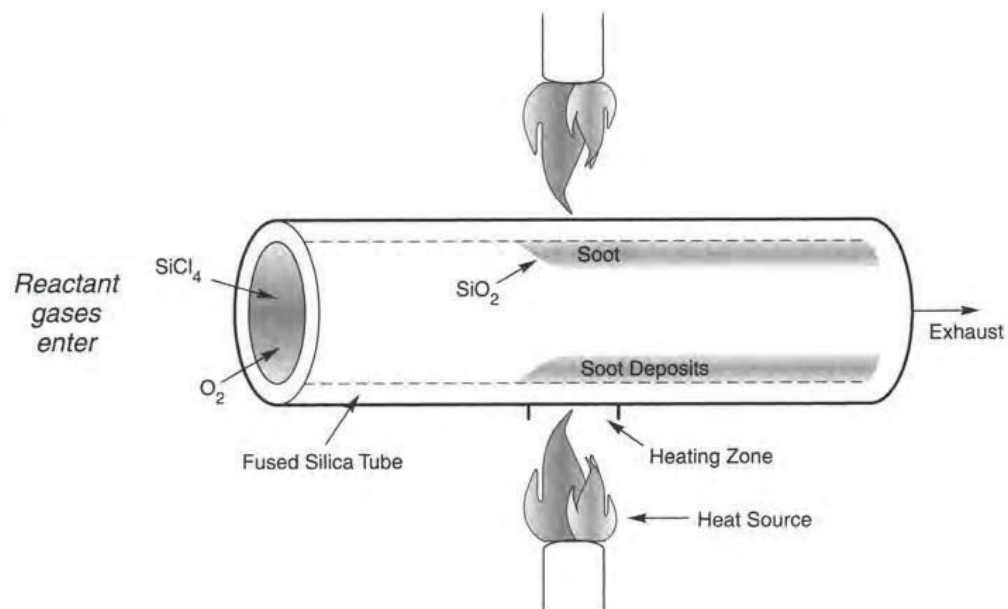

The process can be repeated over and over to deposit many fine layers of slightly different composition, which are needed to grade the refractive index from core to cladding in graded-index fibers. The doping of input gases is changed slightly for each deposition step, producing a series of layers with small steps in the refractive index. Step-index profiles are easier to fabricate, because the whole core has the same doping. A final heating step collapses the tube into a preform.

Another important approach is the outside vapor-deposition process, which deposits soot on the outside of a rotating ceramic rod, as shown in Figure 6.3. The ceramic rod does not become part of the fiber; it is merely a substrate. The glass soot that will become the fiber core is deposited first, then the cladding layers are deposited on top of it. The ceramic core has a different thermal expansion coefficient than the glass layers deposited on top of it, so it slips out easily when the finished assembly is cooled before the glass is sintered to form a preform. The central hole is closed either in making the preform or drawing the fiber.

The third main approach is vapor axial deposition, shown in Figure 6.4. In this case, a rod of pure silica serves as a “seed” for deposition of glass soot on its end rather than on its surface. The initial soot deposited becomes the core. Then more soot is deposited radially outward to become the cladding, and new core material is grown on the end of the preform. Vapor axial deposition does not involve a central hole.

All three processes yield long, glass cylinders or rods called *preforms*. They are essentially fat versions of fibers, composed of a high-index fiber covered with a lower-index cladding. They have the same refractive-index profile as the final fiber.

Preforms also can be made by depositing soot on the outside or on the end of a rod.

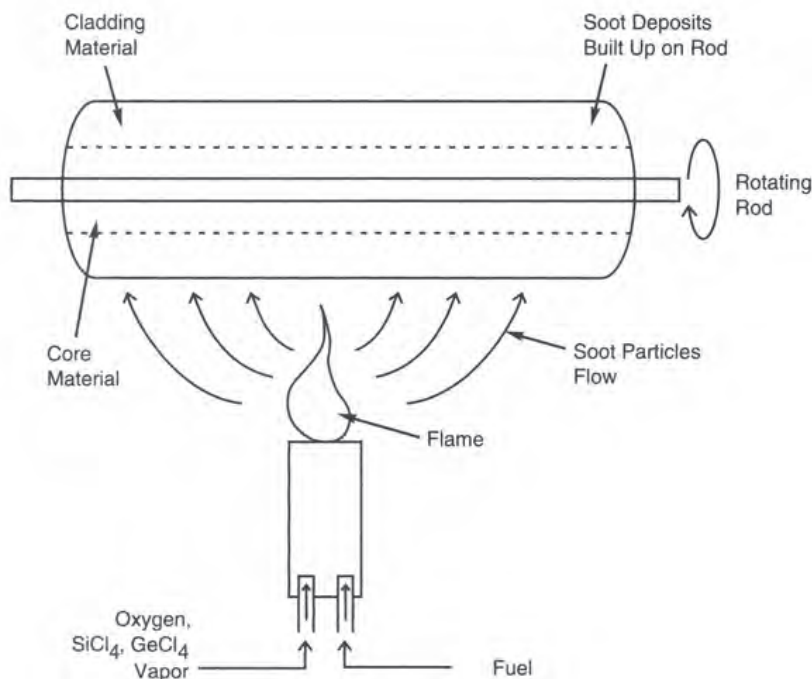
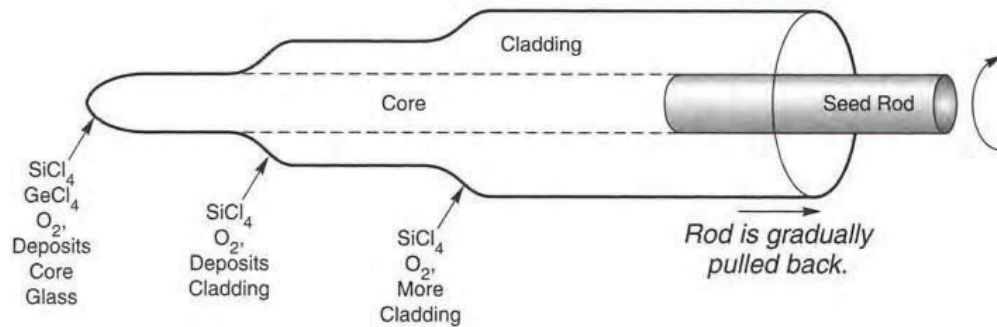

FIGURE 6.3

Outside vapor deposition to make a preform.

FIGURE 6.4

Vapor axial deposition to make a preform.



Drawing Fibers

Fibers are drawn from the bottoms of hot preforms.

Optical fibers are *drawn* from preforms by heating the glass until it softens, then pulling the hot glass away from the preform. This is done in a machine called a *drawing tower*.

Drawing towers typically are a couple of stories high and loom above everything else on the floor of a fiber factory. The preform is mounted vertically at the top, with its bottom end in a furnace that heats the glass to its softening point. Initially a blob of hot glass is pulled from the bottom, stretching out to become the start of the fiber. (This starting segment of the fiber normally is discarded.)

The hot glass thread emerging from the furnace solidifies almost instantaneously as it cools in open air. As shown in Figure 6.5, the bare glass fiber passes through a device that monitors its diameter, then is covered with a protective plastic coating. The end is attached to a rotating drum or spool, which turns steadily, pulling hot glass fiber from the bottom of the preform and winding plastic-coated fiber onto the drum or spool. The actual length of the draw zone is longer than shown in the figure, to allow the fiber to cool and the plastic coating to cure properly.

FIGURE 6.5

Drawing glass fibers from preforms. (Courtesy of Corning Inc.)

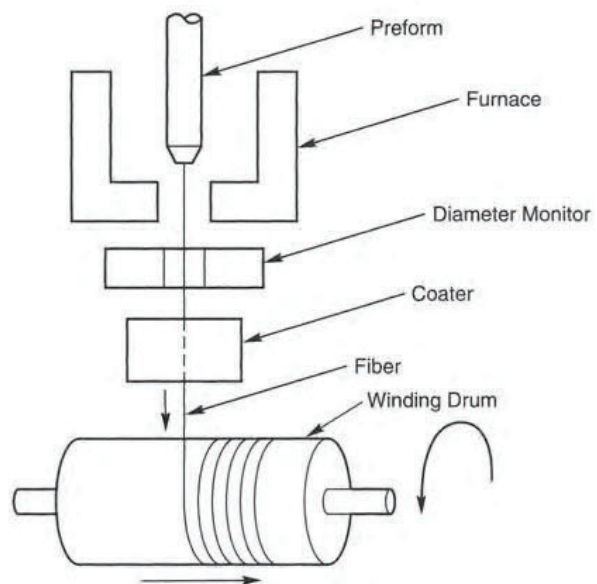

Typically the fiber is drawn at speeds well over a meter per second. A single, large preform can yield over 20 kilometers of fiber; smaller preforms yield a few kilometers. After the fiber is drawn, it is proof tested and wound onto final reels for shipping.

Types of Silica Fibers

Silica is the standard material used for most communication fibers. Except for a few special cases, both core and cladding are made of silica, differentiated by different *doping* levels. Typically the cores contain dopants that increase refractive index above that of pure silica, while the cladding is either pure silica or doped with index-depressing materials such as fluorine, as shown in Figure 6.1 and discussed earlier.

This basic design is used for the single-mode and graded-index multimode fibers used for communications. Figure 6.6 shows typical attenuation curves for a high-quality nonzero dispersion-shifted (ITU G.655) single-mode fiber and a graded-index multimode

All-silica fibers are used for communications.

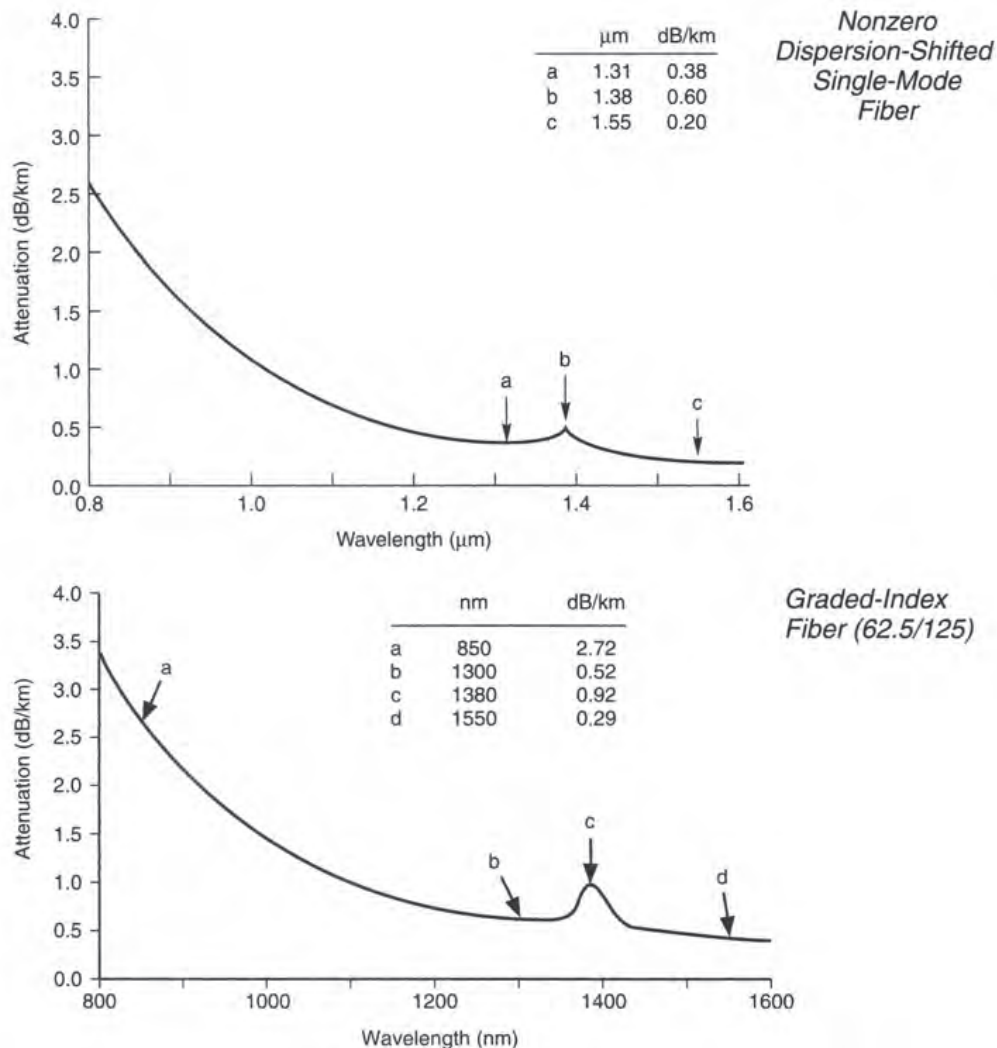

FIGURE 6.6

Attenuation of non-zero dispersion-shifted ITU G.655 fiber (left) and graded-index multimode fiber (below). (Courtesy of Corning Inc.)

fiber. Attenuation for step-index single-mode fiber is slightly lower than for the ITU G.655 fiber, but the difference is not significant and would not show on this scale. Low-water single-mode fibers lack the absorption peak near $1.38\ \mu\text{m}$. A quick comparison shows higher loss for the graded-index fiber, but this is not significant for the short-distance applications in which they are used.

Different designs are used for step-index multimode silica fibers. Typically these fibers have a pure silica core, which is clad either with silica doped to reduce its refractive index or with a plastic having lower refractive index than silica. This approach simplifies the manufacturing process and avoids the need for dopants in cores that are $100\ \mu\text{m}$ or larger. Typically the claddings are thin— $20\ \mu\text{m}$ on a fiber with a $100\text{-}\mu\text{m}$ core and a $140\text{-}\mu\text{m}$ cladding diameter—with a protective plastic coating 50 to $100\ \mu\text{m}$ thick applied over the cladding.

Large-core step-index silica fibers come in a variety of configurations, and typically are used for data transmission, laser beam delivery, or illumination. The oldest type is *plastic-clad silica* (PCS), in which the cladding is a silicone plastic that is fairly easy to strip from the silica core. Easily removed cladding is good for some applications, but bad for others. *Hard-clad silica* (HCS) fibers have a tougher plastic cladding, which makes the fibers more durable. *Silica-clad fibers* can handle higher powers than either type of plastic-clad fiber, an important consideration for fibers delivering high laser powers.

Figure 6.7 shows attenuation for a selection of large-core silica fibers. The values vary depending on the type of cladding and the amount of moisture in the silica core. Fibers made in a low-water environment contain little OH and are more transparent in the near-infrared, while fibers that contain more OH are more transparent in the ultraviolet. (The fibers in Figure 6.7 all have low OH levels, and the plot does not show ultraviolet attenuation.)

Typical core diameters of large-core step-index fibers range from 100 to $1000\ \mu\text{m}$. The smaller fibers may be used for short-distance communication, but the larger fibers are used mostly for illumination. The largest-core fibers can carry considerable power, making them useful for laser-beam delivery, but they are significantly stiffer. For example, the rated continuous

Large-core silica fibers are used for data transmission, laser beam delivery, or illumination.

FIGURE 6.7

Spectral attenuation of various large-core silica fibers. (Courtesy of 3M Specialty Optical Fibers.)

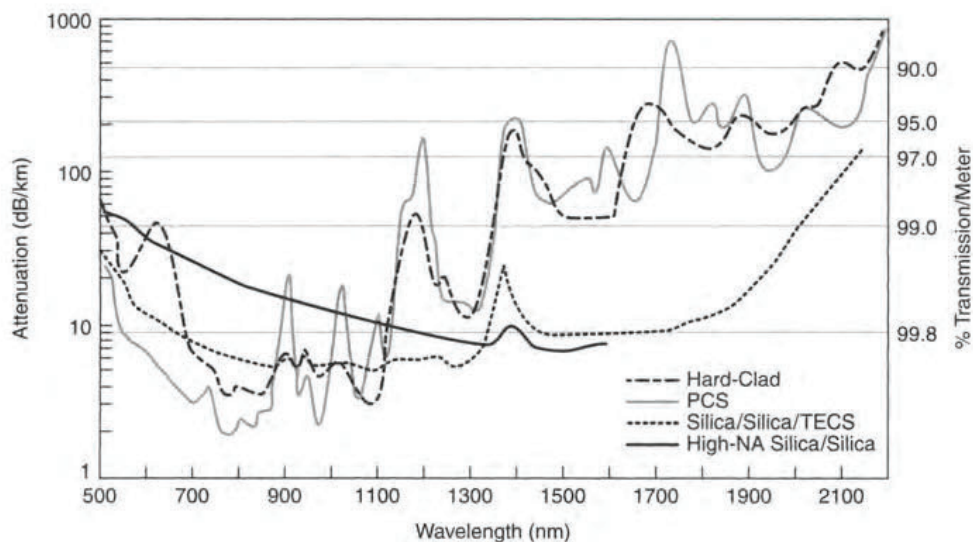

Table 6.1 Characteristics of large-core step-index silica fibers. Bandwidths of fibers with cores over 200 μm generally are unrated because they are very rarely used in communications

Fiber Type	Core/Clad Diameter (μm)	Attenuation at		Bandwidth at 0.82 μm	NA
		0.82 μm			
Silica clad	100/120	5 dB/km	20 MHz-km	0.22	
Hard clad	125/140	20 dB/km	20 MHz-km	0.48	
Plastic-clad, low OH	200/380	6 dB/km	20 MHz-km	0.40	
Plastic-clad, high OH	200/380	12 dB/km	20 MHz-km	0.40	
Silica clad	400/500	12 dB/km	—	0.16	
Hard clad	550/600	12 dB/km	—	0.22	
Silica clad	1000/1250	14 dB/km	—	0.16	
Plastic-clad, low OH	1000/1400	8 dB/km	—	0.40	

power capacity of one family of silica-clad fibers increases from 0.2 kW for 200- μm core fibers to 1.5 kW for 550- μm core fibers, and the rated minimum bend radius increases by a factor of 2.5. Table 6.1 summarizes important optical characteristics of selected fibers.

Although most large-core silica fibers have step-index profiles, some are made with a graded-index core, surrounded by a thin silica cladding and typically a plastic coating and outer buffer layer. Their main application is in delivering high-power laser beams.

Plastic Fibers

Plastic optical fibers have long been a poor relation of glass. Traditionally regarded as inexpensive, flexible, lightweight, and easy to handle, plastic seems to offer some important attractions. These potential advantages can be hard to realize in practice, since silica fibers are reasonably priced and flexible in the small diameters used for telecommunications applications. However, the biggest problem of plastic fibers has been attenuation levels many times that of glass, making commercial types impractical for distances beyond 100 meters.

Years of research have reduced plastic loss considerably, but it still remains far higher than that of glass. The best laboratory plastic fibers have minimum loss around 50 dB/km. At the 650-nm wavelength preferred for communications using red LEDs, commercial plastic fibers have minimum attenuation as low as 150 dB/km. Unlike glass fibers, the loss of plastic fibers is somewhat lower at shorter wavelengths and much higher in the infrared, as shown in Figure 6.8.

For this reason, plastic optical fibers have found only limited applications. One is in flexible bundles for image transmission and illumination, where the light doesn't have to travel far and the flexibility and lower cost of plastic are important. Another application is in short data links, particularly within automobiles, where the ease of handling plastics is a major advantage and the required distances and data rates are small.

Multimode fibers made entirely of plastic have higher loss than silica fibers.

FIGURE 6.8

Attenuation versus wavelength for one commercial PMMA step-index fiber. (Courtesy of Toray Industries Ltd.)

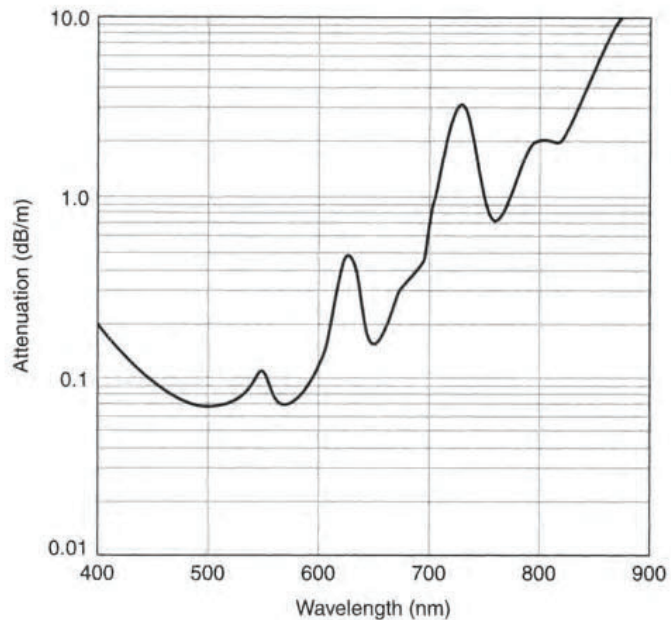

Another important concern with plastic optical fibers is long-term degradation at high operating temperature. Typically plastic fibers cannot be used above 85°C (185°F). This may sound safely above normal room temperature, but it leaves little margin in many environments. The engine compartments of cars, for example, can get considerably hotter. Newer plastics can withstand temperatures to 125°C (257°F), but their optical properties are not as good.

Plastic fibers are made using the same principles as glass fibers. A low-index core surrounds a higher index cladding. The refractive-index difference can be large, so many plastic fibers have large numerical apertures. Commercial plastic fibers are multimode types with large cores. Most are step-index but a few are graded-index. There is little interest in single-mode plastic fibers because the material's high loss makes long-distance transmission impossible.

Step- and Graded-Index Plastic Fibers

Standard step-index plastic fibers have a core of polymethyl methacrylate (PMMA) and a cladding of a lower index polymer, which usually contains fluorine. The differences in refractive index typically are larger than in silica or glass fibers, leading to a large numerical aperture. For example, one commercial plastic fiber designed for short-distance communication has a PMMA core with refractive index of 1.492 and a cladding with index of 1.402, giving an NA of 0.47.

Plastic fibers typically have core diameters from about 85 μm to more than 3 mm (3000 μm). You can find larger light-guiding rods of flexible plastic, which sometimes are called fibers, but it's hard to think of something as thick as a pencil as a "fiber." The smallest fibers typically are used only in bundles, but larger fibers are used individually. Typically the claddings are thin, only a small fraction of overall fiber diameter. Large-core plastic fibers cannot carry optical powers as high as those carried by large-core silica fibers, but

Traditional plastic fibers are made of PMMA, with large step-index cores. They are used in bundles and for short data links.

they are more flexible and less expensive. Plastic fibers with diameters up to around a millimeter are used for some short-distance communication because they are much easier to handle than glass fibers. For example, technicians can splice and connect plastic fibers on site with minimal equipment, instead of the expensive precision equipment required for glass fibers. Figure 6.8 plots attenuation of one PMMA fiber against wavelength, on a scale of decibels per *meter*. The minimum loss, near 500 nm, is equivalent to 70 dB/km, but for communications transmission normally is at the 650-nm wavelength of inexpensive red LEDs. The step-index profile also limits bandwidth, so signals normally are limited to traveling within a building or between adjacent structures.

Graded-index plastic fibers are a recent development because it had been difficult to produce good graded-index profiles in plastic. Typically a preform is heat-treated to make high-index materials diffuse from a fluorinated plastic core and raise the index of lower index plastics in the cladding. This plastic preform is then drawn into fiber, much like glass fibers but at much lower temperatures.

As in silica fibers, the advantage of a graded-index profile is broader transmission bandwidth than step-index fibers. Graded-index plastic fibers with core diameters of 50 to 200 μm can transmit 2.5 Gbit/s over distances of 200 to 500 meters, making them attractive for high-speed local area networks. The fluorinated plastic fibers have attenuation around 60 dB/km over a broad range from about 800 to 1340 nm, allowing operation at the 850 and 1300 nm windows. However, attenuation through the entire range is tens of decibels per kilometer, limiting transmission to much shorter distances than with silica fibers, and the fibers are relatively expensive.

Issues in Developing Plastic Fibers

High attenuation has been a stubborn problem in plastic optical fibers. Bonds between atoms found in plastics—notably carbon-hydrogen and carbon-oxygen bonds—absorb light at visible and near-infrared wavelengths, even in plastics that look transparent to the eye. Fused silica is much more transparent because these bonds are not present in it.

Efforts to reduce loss have concentrated on changing the chemical composition of the plastics. One step is to replace normal hydrogen with the heavier (stable) isotope deuterium, which shifts the absorption peaks of carbon-hydrogen bonds to longer wavelengths. Another step is to use fluorinated plastics instead of standard hydrocarbon plastics, because carbon-fluorine bonds have lower attenuation. Figure 6.9 compares attenuation curves for fibers made of standard hydrogen-based PMMA, deuterated PMMA, and one type of fluorinated plastic between 550 and 850 nm. Loss of the fluorinated plastic remains relatively low at wavelengths to 1.3 μm . However, changing composition raises other issues, including the need for more expensive materials.

Another important issue, mentioned earlier, is the durability of plastics, both over time and under extreme conditions. Plastic fibers generally are more flexible than glass, and are easier to cut and install. They generally work fine in a controlled environment such as an office. However, plastics are not as resistant to heat and sunlight as glass. Temperature limitations have proved a particular problem in areas such as the automotive industry, where equipment installed in the engine compartment must withstand frequent temperature cycling and extremes.

Graded-index profiles can be made in plastic fibers, increasing bandwidth.

Attenuation is a key issue in plastic fibers.

FIGURE 6.9

Attenuation spectra of graded-index plastic fibers made with regular PMMA, a fluorinated plastic, and deuterated PMMA. (Courtesy of Takaaki Ishigure.)

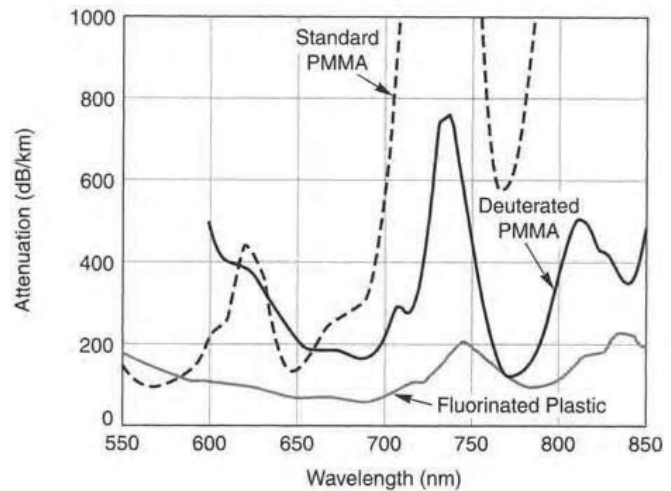

Exotic Fibers and Light Guides

From time to time, you may encounter some unusual optical fibers, light guides, or optical waveguides based on novel materials. They presently play little role in communications, but have other applications.

Liquid-Core Fibers (or Light Guides)

In the very early days of fiber-optic communications, developers desperately seeking low-loss materials turned to liquids. They filled thin silica tubes with tetrachloroethylene, a dry-cleaning fluid that is extremely clear and has a refractive index higher than fused silica. The index difference was adequate to guide light, and developers eventually reduced loss to several decibels per kilometer, very good for the time, and better than current plastics.

Liquid-core fibers were far from a practical communications technology. Filling the tiny capillary tubes took a very long time, but the real problem was thermal expansion. The liquid expanded at a different rate than the tube that held it, so the liquid-core fiber acted like a thermometer, with liquid rising and falling with temperature. If you weren't careful, the liquid could squirt out the ends.

Now larger diameter liquid-core light guides are finding a new life transmitting visible light short distances for illumination. Single liquid-core light guides 2 to 10 mm thick are an alternative to standard illuminating bundles. Using suitable fluids, they have lower attenuation than standard bundle fibers, particularly at green and blue wavelengths. The liquid is housed in a plastic tube rather than glass, so the liquid waveguide is more flexible than a large solid fiber. Because lengths are modest—at most 20 m and typically only a few meters—thermal expansion poses little problem.

Midinfrared Fibers

The extremely low scattering losses expected at wavelengths longer than 1.55 μm prompted interest in those wavelengths for long-distance communications in the 1980s. The

A liquid in a plastic or glass tube can act like a fiber core if its refractive index is higher than the tube.

absorption of silica rises rapidly at longer wavelengths, so developers looked to other materials that are transparent in that region. Theorists hoped that extremely low-loss glass fibers could be made from some of those materials. (Recall that glass is a disordered material, not necessarily made from silica.) If other losses could be avoided, the floor set by scattering loss suggested attenuation might be as low as 0.001 dB/km. Such incredibly low loss would allow extremely long transmission distances without amplifiers or repeaters.

Unfortunately, very low-loss *infrared fibers* have proven exceedingly difficult to make. Purification of the materials is difficult. The raw materials are far more expensive than those for silica fibers. (Despite occasional jokes about desert nations concerning the market on raw materials, silica fibers can't be made from raw sand, as can many glass products.) Infrared materials are harder to pull into fibers because they are much less viscous than silicate glass when molten. The fibers that can be produced are weaker mechanically than silica and suffer other environmental limitations. In short, infrared fibers have been a bust for ultra-long-distance communications.

On the other hand, fibers made from nonsilicate glasses can transmit infrared wavelengths that do not pass through silica fibers. This makes them useful in specialized applications such as infrared instrumentation, although their losses are much larger than the minimum loss of silica fibers at shorter wavelengths.

Fluorozirconate fibers transmit light between 0.4 and 5 μm . Often simply called fluoride fibers, they are made primarily of zirconium fluoride (ZrF_4) and barium fluoride (BaF_2), with some other components added to form a glass compound. The lowest losses for commercial fluorozirconate fibers are about 25 dB/km at 2.6 μm , but loss as low as about 1 dB/km has been reported in the laboratory. A typical transmission curve is shown in Figure 6.10, along with other infrared fibers. Fluoride fibers are vulnerable to excess humidity, so they should be stored and used in low-humidity environments. Fluoride

Fibers made of nonsilica glasses transmit infrared wavelengths, which silica absorbs.

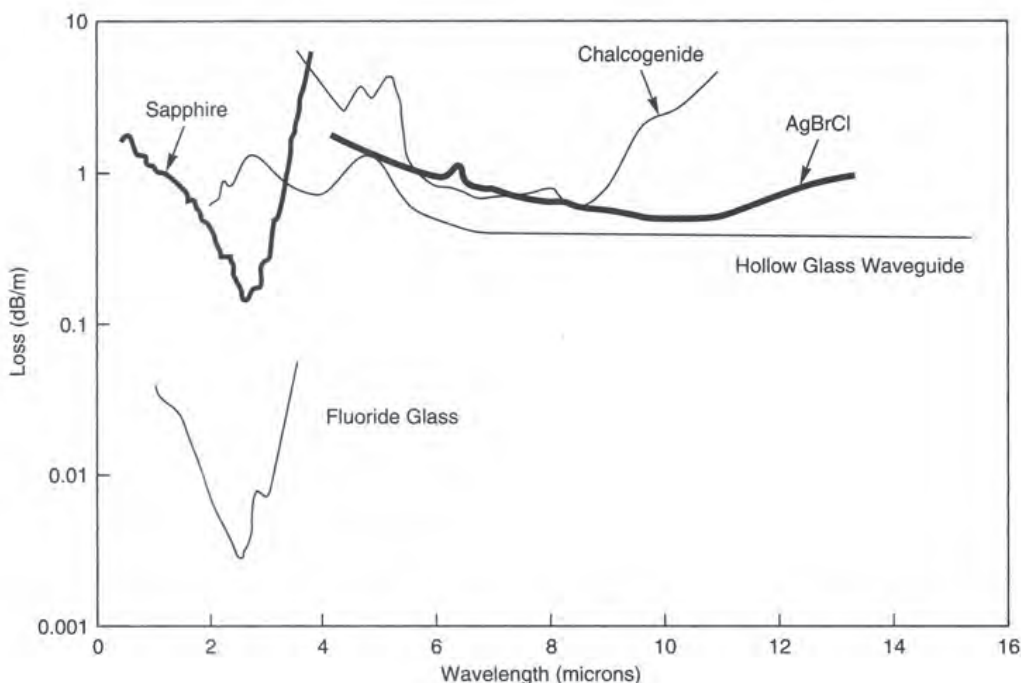

FIGURE 6.10

Attenuation of infrared optical fibers. (Courtesy of James Harrington, Rutgers University)

fibers are used in some fiber amplifiers because of desirable optical characteristics. However, they have a refractive index higher than 2, so they have high reflection from their ends.

Fibers made from silver halide compounds (AgBrCl in Figure 6.10) have useful transmission between about 3 and 16 μm in the infrared. They are not a true glass, but a solid made of many small crystals.

Synthetic crystalline sapphire (Al_2O_3) can be drawn into single-crystal fibers that transmit between 0.5 and 3.1 μm . As Figure 6.10 shows, their loss is higher than fluoride fibers, but the material is much more durable.

Hollow Optical Waveguides

Hollow waveguides can transmit longer infrared wavelengths.

Hollow *optical waveguides* were first developed in the 1960s, after the laser stimulated interest in optical communications. Work on hollow waveguides for the visible and near-infrared stopped shortly after the first low-loss glass fibers were made in the 1970s. However, new types of hollow optical waveguides are being developed for infrared wavelengths longer than a few micrometers. I mention them here because they serve the same purpose as infrared fibers, and compete successfully for some infrared applications. There are two basic types of hollow infrared waveguides, metal and hollow glass.

Hollow metal waveguides are coated inside with a nonconductive dielectric material to make them more reflective. The infrared light bounces along the shiny walls, with high reflectivity limiting loss to about 500 dB/km. That isn't bad considering how many reflections the light undergoes. Many hollow glass waveguides work on the same principle; they have the advantage of very smooth surfaces that give loss as low as 0.5 dB/m with suitable coatings, as shown in Figure 6.10.

Other hollow glass waveguides work on a different principle. At certain wavelengths, some materials have an effective refractive index less than 1. Functionally, that means they absorb those wavelengths strongly, but it also means they can serve as a low-index cladding surrounding a hollow core of air, which at that wavelength has a higher refractive index. Silica glass meets those conditions at wavelengths of 7 to 9.4 μm , and sapphire at 10 to 17 μm . These waveguides are called *attenuating total internal reflection* guides because the fraction of the wave in the cladding is absorbed, so loss is over 1 dB/m. However, hollow sapphire guides can be used at the important 10.6- μm wavelength of carbon dioxide lasers.

Photonic or Microstructured Fibers

Microstructured photonic materials confine light.

A new family of optical fibers, largely in the research stage, relies on internal microstructures to control the propagation of light in ways impossible with conventional fibers. These are often called *photonic fibers*, but also have been called “microstructured” or “holey” fibers because their internal structures typically have holes running along their length.

Figure 6.11 shows how microstructured fibers are made. Hollow glass tubes and solid rods are stacked together with the desired proportions and enclosed in an outer tube. In the design shown, a single solid rod is at the center of the array. Then the glass is fused together and drawn into a fiber. Careful processing produces finished fiber with fine holes running along its length.

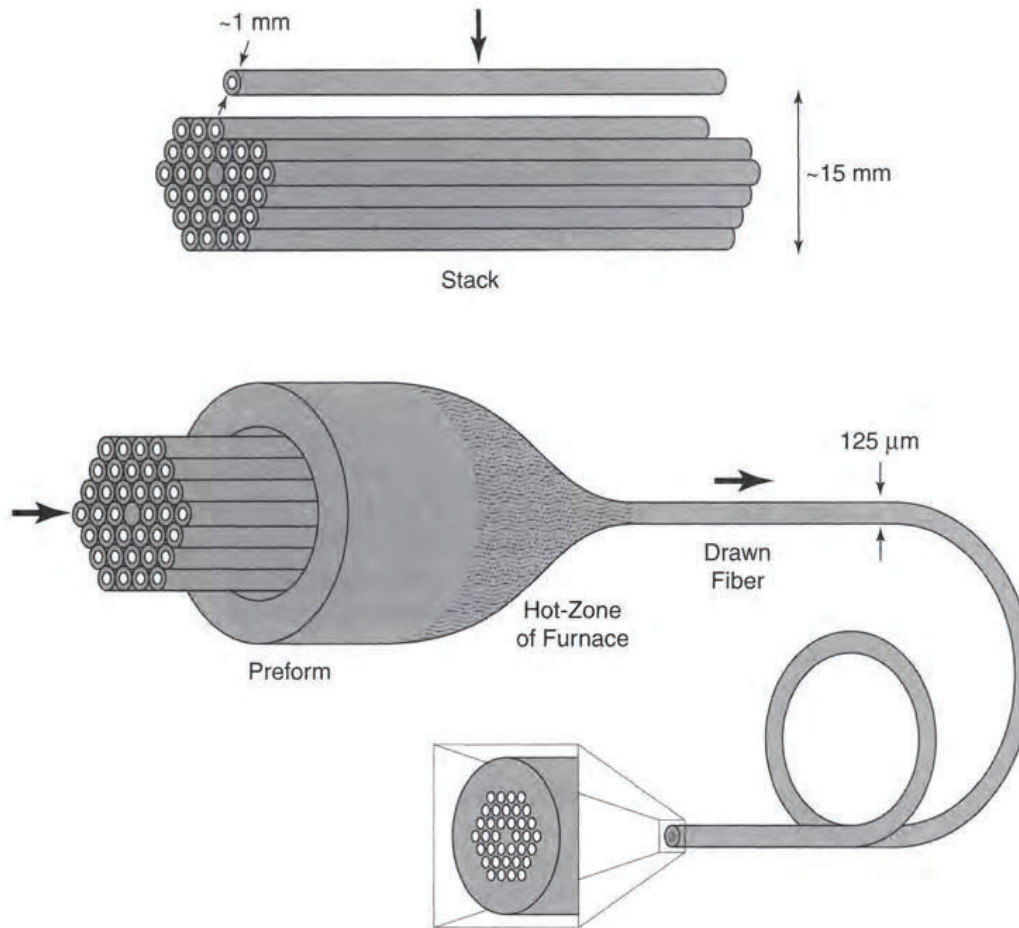
**FIGURE 6.11**

Structure and fabrication of photonic crystal fiber with solid core. (Courtesy of Tim Birks, University of Bath)

Microstructured fibers developed from the phenomenon of the *photonic bandgap*, which arises in materials with internal structures that make it impossible for light to propagate at certain wavelengths. In that sense, the photonic bandgap is analogous to the electronic bandgap, a range of energy levels that electrons can't occupy in semiconductors. Semiconductor bandgaps are used to confine electrons; photonic bandgaps are used to confine the path of light.

The two basic components of a microstructured fiber are a glass matrix and holes containing air (or some other gas or liquid). The relative packing and size of the holes and glass can range from nearly solid glass with a few tiny holes that act as flaws to a thin lattice of glass spread through a volume that is largely air. Specialists divide microstructured fibers into two broad classes, depending on whether the light is confined in a central solid area or within a central hole.

● *Photonic crystal fibers*, like the one shown in Figure 6.11, have a solid core surrounded by a layer containing holes running the length of the fiber. The central solid region is a defect in a sense, because it lacks the holes present in the surrounding microstructure. The microstructured zone is a photonic bandgap material with an average refractive index lower than that of the solid core. That makes photonic crystal

fibers act somewhat like a conventional solid fiber, with a high-index core surrounded by a lower index cladding. However, the light guiding of the structure depends on the size and spacing of the holes, which determine the effective refractive index of the holey cladding layer.

Photonic bandgap fibers confine light in a hollow core.

● *Photonic bandgap fibers* have a hollow core surrounded by a photonic bandgap cladding, which reflects all light at certain wavelengths. In this way, it guides light through the air-filled core, which has a lower refractive index than the surrounding material. Such light guiding is impossible in conventional fibers because the refractive index of air is lower than that of any conventional solid, so these fibers can only be described in terms of photonic bandgaps.

These types of fibers can be designed to have properties impossible in standard fibers. Photonic crystal fibers with a large fraction of the cladding filled with air and small features can confine light in effective mode areas as small as one square micrometer, which is useful for producing nonlinear effects. Large-holed microstructures also can produce high waveguide dispersion for use in dispersion compensation or shifting. Other photonic crystal structures can confine light in a larger core than otherwise possible, reducing nonlinear effects.

Photonic bandgap fibers have received less attention because they are a more recent development, but they offer other possibilities. Guiding light in air should allow very low attenuation and reduce nonlinear effects. It also could allow light transmission at wavelengths where no usable transparent solids are available. Because the photonic bandgap effect is wavelength-dependent, such fibers would guide some wavelengths but not others.

Planar Waveguides

Planar waveguides are thin strips on flat substrates that guide light by total internal reflection.

Planar waveguides work on the same principle of total internal reflection as optical fibers, but they come in a different form. A planar waveguide is a thin layer on the surface of a flat material, which has higher refractive index than the bulk material. Typically the high refractive index is produced by doping the substrate material with something that increases its refractive index. Figure 6.12 shows the basic idea. The boundaries of the doped area form an interface that guides light, like the core-cladding interface in optical fibers. In Figure 6.12, the substrate provides the low-index materials on the sides and bottom, while air is the low-index medium on the top.

An alternative approach is to deposit a layer of high-index material on a lower index substrate. In this case, the waveguide is a raised stripe on the substrate, surrounded by air on top and on the sides, and contacting the substrate only on the bottom. As with the doped waveguide, total internal reflection confines light in the waveguide layer.

From a theoretical standpoint, both types of planar waveguides are *dielectric slab waveguides*. That means they are made of nonconducting (dielectric) materials, and are rectangular in cross section, rather than round like a fiber. The theory of such waveguides is quite well developed.

From a practical standpoint, planar waveguides also have some attractions. The technology for making thin stripes of material on flat substrates has been well developed by the semiconductor electronics industry. The technology can be used with a wide variety

Planar waveguides are used in couplers, lasers, modulators, and switches.

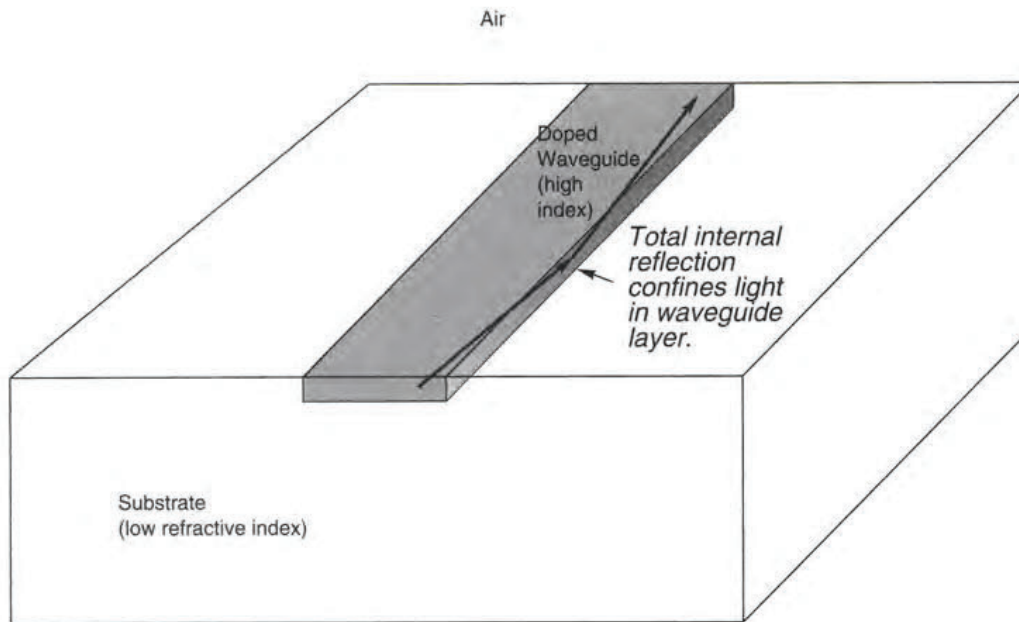
**FIGURE 6.12***Planar waveguide.*

of materials, including silica glass and other compounds as well as semiconductors. Active optical components such as lasers and photodetectors can be made on the semiconductor materials. So can a wide variety of passive optical components, such as demultiplexers and couplers that divide and combine optical signals. That opens the possibility of integrating optical components on a chip.

On the other hand, planar waveguides also suffer serious practical drawbacks. Their attenuation is much higher than optical fibers, so they can't send signals very far. Their flat, wide geometry differs greatly from the round cores of optical fibers, so light is inevitably lost in transferring from a fiber to a waveguide. Such problems limit the uses of planar waveguides.

Nonetheless, planar waveguide devices can manipulate light in many useful ways. Many semiconductor lasers are planar waveguide devices; you'll learn about them in Chapter 9. Other important planar waveguide devices include couplers, modulators, switches, and wavelength division-multiplexing components; you'll learn about them in Chapters 14, 15, and 16.

For now, what's important is to remember what planar waveguides are, that they can guide light like optical fibers, and that they can serve as the basis for a variety of important components.

What Have You Learned?

1. Fiber-optic materials must be transparent and drawable into thin fibers.
2. Glass is a noncrystalline solid. Most glasses are compounds of silica and other oxides. A wide variety of compositions have been developed for various uses.
3. Silica-based glasses have refractive indexes of 1.44 to 1.8, with pure silica among the lowest.

4. Simple glass-clad fibers are made by collapsing a low-index tube onto a high-index rod, called a preform, heating the tip, and drawing fiber from the soft, hot end.
5. Impurities are the main cause of attenuation in standard silica glasses. Synthetic fused silica is the base for communication fibers; it is very clear because impurities are reduced to a part per billion or less.
6. Silica must be doped to form either a high-index core or a low-index cladding for an all-glass fiber. Fluorine can reduce the index of silica; germanium can increase its index.
7. Fused silica preforms are formed by depositing glass soot inside a fused silica tube, on a ceramic rod that is later removed, or on the end of a preform. This soot is melted to make the preform. Fiber is drawn from the bottom of a preform mounted in a drawing tower.
8. Large-core silica fibers are used for illumination and laser beam delivery. They may be clad with doped silica, hard plastic, or soft plastic.
9. All-plastic fibers have attenuation much higher than silica fibers. They are used for image transmission or short-distance communications.
10. Standard plastic fibers are made from PMMA and have step-index profiles. Graded-index plastic fibers are available but are not widely used. Lower-loss plastics are in development, but there are no prospects for reaching the low losses of silica fibers.
11. Silica does not transmit at wavelengths longer than $2\ \mu\text{m}$, so other materials are used in fibers transmitting at longer wavelengths. None of these are as transparent as silica fibers. Hollow waveguides also are used in the infrared.
12. Photonic bandgap materials permit new types of fibers.
13. Planar waveguides are thin layers on flat substrates, which guide light by total internal reflection, like optical fibers.

What's Next?

In Chapter 7, you will learn about special types of fibers including fiber Bragg gratings, fibers used in optical amplifiers, and photonic bandgap fibers.

Further Reading

James Harrington, "Infrared Fiber Review," available at http://irfibers.rutgers.edu/ir_rev_glass.html

Jeff Hecht, "Interest grows in components based on holey fibers," *Laser Focus World* 39, No. 5, 99–105 (May 2003)

Luc B. Jeunhomme, *Single-Mode Fiber Optics: Principles and Applications* (Dekker, 1990)

Donald B. Keck, ed., *Selected Papers on Optical Fiber Technology* (SPIE Milestone Series, Vol. MS38, 1992)

Yasuhiro Koike and Takaaki Ishigure, "Bandwidth and Transmission Distance Achieved by POF," *IECE Transactions Electronics*, Vol. E82-D, No. 98, August 1999, available on the Web at <http://www.ieice.org/eng/index.html>

University of Bath, "Photonic Crystal Fibre," <http://www.bath.ac.uk/Departments/Physics/groups/opto/pcf.html>

Questions to Think About

1. Window glass looks very clear when you look straight through a pane, but when you look into the edge it looks green. What causes this color?
2. Why is it easy to make fibers from glass but impossible to make them from ice, even in Antarctica?
3. What are the main trade-offs in picking dopants for the core and cladding of fused-silica fibers?
4. The large-core step-index fibers listed in Table 6.1 have cores that are nominally pure silica and generally carry higher laser powers than telecommunication fibers. Yet their attenuation is higher than for single-mode telecommunication fibers at the same wavelengths. Why should this happen?
5. How would you compare the advantages of plastic and glass fibers? What are the best features of each? Where might plastic have an advantage?
6. Roughly how many times higher is the minimum loss of plastic fibers than that of glass fibers, measured in dB/km?
7. If you aimed a 1.55- μm laser beam straight up through clear air, about 90% of the light would escape into space, with 10% scattered or absorbed. The atmosphere becomes more tenuous at higher altitudes, so assume that sending a beam into space is equivalent to transmitting it through 10 km of air. What is the equivalent attenuation in dB/km? How does this compare with the best optical fibers at that wavelength? Does that imply a limit on the transparency of hollow photonic bandgap fibers?

Chapter Quiz

1. What is the most essential property of all glass?
 - a. It is a noncrystalline solid.
 - b. It is a crystalline solid.
 - c. It must be transparent.
 - d. It must be made of pure silica.
 - e. It must have a refractive index of 1.5.

2. What type of fiber is drawn from a preform made by fusing a low-index tube onto a higher-index rod?
 - a. step-index single-mode
 - b. graded-index multimode
 - c. dispersion-shifted
 - d. short-distance imaging and illumination
 - e. all of the above
3. What impurity levels are required in fused silica for communications fibers?
 - a. less than 0.1%
 - b. less than 0.001%
 - c. one part per million
 - d. ten parts per billion
 - e. one part per billion
4. What is done to make a depressed-clad fiber?
 - a. The fiber is flattened by rollers to depress it before the cladding is applied.
 - b. The refractive index in the core is depressed by adding germanium.
 - c. The refractive index in the inner part of the cladding is depressed by adding fluorine.
 - d. The fiber is clad with a low-index plastic.
 - e. The entire fiber is made of pure silica because it has the lowest refractive index of any glass.
5. How are preforms for communications fibers made?
 - a. by the rod-in-tube method
 - b. by soot deposition in a fused silica tube
 - c. by soot deposition on the outside of a ceramic rod
 - d. by vapor axial deposition on the end of a rod
 - e. by methods b, c, and d
6. What is *not* used as a cladding for silica fiber?
 - a. silica with refractive index depressed by adding fluorine
 - b. silica with refractive index increased by adding germanium
 - c. hard plastic
 - d. soft plastic
 - e. pure silica cladding on a core doped to have higher refractive index
7. What type of fiber could transmit the highest laser power?
 - a. step-index silica fiber with a 550- μm core
 - b. hard-clad silica fiber with a 100- μm core
 - c. all-plastic fiber with a 1000- μm core

- d. single-mode fiber
 - e. plastic-clad silica fiber with a 200- μm core
- 8.** What is the lowest loss of laboratory all-plastic fibers?
- a. 1 dB/km
 - b. 50 dB/km
 - c. 150 dB/km
 - d. 500 dB/km
 - e. 1 dB/m
- 9.** At what wavelength does PMMA plastic fiber have the lowest loss?
- a. 500 nm
 - b. 650 nm
 - c. 850 nm
 - d. 1.3 μm
 - e. 1.55 μm
- 10.** Why would you use fluorozirconate fibers?
- a. because you couldn't find any other fibers
 - b. because their attenuation is 0.001 dB/km
 - c. to transmit near-infrared wavelengths of 2–5 μm where silica fibers have high loss
 - d. to transmit infrared wavelengths near 10 μm
 - e. to compensate for losses in plastic fibers
- 11.** What types of fibers can be used at wavelengths longer than 2 μm ?
- a. fused silica, fluoride, and silver halide
 - b. plastic, fused silica, and fluoride
 - c. fluoride, chalcogenide, and silver halide
 - d. plastic, fused silica, and chalcogenide
 - e. only plastic-clad silica
- 12.** What is the main advantage of graded-index plastic fiber over other plastic fibers?
- a. higher bandwidth
 - b. uses less plastic
 - c. more flexible
 - d. as clear as graded-index glass fiber
 - e. larger core diameters
- 13.** What is a holey fiber?
- a. a fiber made from a flawed preform that contains tiny air bubbles, which scatter light from the sides
 - b. a fiber that guides light through holes in a plastic with a very low refractive index

- c. a photonic fiber in which the glass contains tiny holes that block light transmission at certain wavelengths
 - d. a theoretical proposal, which has yet to be demonstrated
 - e. another name for a hollow optical waveguide used to transmit the 10.6- μm wavelength of carbon-dioxide lasers
- 14.** In what way is a planar waveguide like an optical fiber?
- a. It guides light through a region of high refractive index by total internal reflection.
 - b. It has attenuation below 0.5 dB/km at 1.3 to 1.6 μm .
 - c. It is a flexible structure.
 - d. It has a plastic coating to protect it from scratches.

Specialty Fibers

About This Chapter

Chapters 4 through 6 covered standard optical fibers whose main function is to guide light over relatively long distances, whether for communications or imaging. Other optical fibers are optimized for a variety of applications, from use in optical components to serving as pigtailed connectors that connect optical devices to standard transmission fibers. This chapter introduces the concept of specialty fibers, then describes important types and how they are used.

The first types covered are made by changing the standard properties of the fiber, such as chromatic dispersion, polarization properties, cladding size, and bending sensitivity. A second group is made by adding materials to the fiber to change its properties, such as light-emitting elements for fiber amplifiers. Fiber Bragg gratings don't fit neatly into these categories because their properties are altered by exposure to ultraviolet light after the fiber is drawn. Some graded-index fibers are made to serve as lenses. Finally, the chapter describes emerging types of special-purpose fibers based on photonic crystal technology. The operation and applications of fiber amplifiers are covered in Chapter 12, and those of fiber Bragg gratings are covered in Chapter 15. Fibers made specifically for sensing are covered in Chapter 29.

What Are "Specialty" Fibers?

In the early days of fiber optics, only a few types of fibers were available, and they were used for everything. Today, some types are mass-produced for signal transmission. However, other fibers have been developed for special-purpose applications that don't require large volumes of fiber. These specialty fibers are produced in smaller quantities, so they are more like clothes made specifically for a sport like winter skiing rather than general-purpose off-the-rack clothing.

Specialty fibers have properties different from those of standard transmission fibers.

There is no standard definition of “specialty” fibers. Standard step-index single-mode fiber, as well as the other transmission fibers described in Chapter 4, are clearly not specialty fibers, although their range of applications is limited. The special fibers doped with erbium for use in optical amplifiers, on the other hand, clearly are specialty fibers. Some other types fall into a hazy zone, such as large-core step-index multimode fibers, which have a limited range of applications. For purposes of this book, we consider most step-index multimode fibers as general-purpose, so they are covered in Chapter 4.

This chapter covers fibers considered to be “specialty” because their properties fall outside the normal range of transmission fibers. These properties are created by tailoring the refractive index profile to meet specific needs, by changing the size of the fiber, by adding materials to the fiber core, or by developing new structures for fiber manufacture.

Dispersion-Compensating Fibers

As you learned in Chapter 5, the total chromatic dispersion in a single fiber is the sum of the waveguide dispersion and the material dispersion, which can have opposite signs and thus offset each other. The zero-dispersion wavelength can be shifted by designing fibers so their waveguide dispersion exactly offsets their material dispersion at one wavelength; but it's neither practical nor desirable for the fiber to have zero dispersion at a broad range of wavelengths. The ideal balance to avoid crosstalk from four-wave mixing is to have local dispersion in the fiber greater than zero, but total dispersion along a fiber-optic route close to zero. This can be accomplished by using two (or more) different types of fibers along the route, with the dispersion in one offsetting the dispersion in the other.

Dispersion-compensating fibers have high negative chromatic dispersion.

One approach is to pick two or more types of standard transmission fibers with different dispersion characteristics and combine them along the transmission route. An alternative is to use special *dispersion-compensating fibers* with high negative chromatic dispersion in the 1550-nm window. These fibers have small cores with a large refractive-index step between core and cladding, as shown in Figure 4.11(f). This design creates high negative material dispersion, so one kilometer of dispersion-compensating fiber can compensate chromatic dispersion in several kilometers (typically 5 km) of standard single-mode fiber. This design also involves trade-offs, because the small core increases nonlinear effects, and the losses are somewhat higher than in standard transmission fibers.

Dispersion-compensating fibers are classed as specialty fibers because they are designed specifically for one purpose: balancing the chromatic dispersion in a transmission line. In practice, they generally are installed in coils at the ends of a transmission line, not in cables along the transmission route. Although dispersion-compensating fibers are part of the transmission path, they are not actually part of the transmission cable, which is a subtle but significant difference. That means their function can be performed by other dispersion-compensating devices. As you will learn later, dispersion compensation is complex because it must be done across a range of wavelengths, not at a single wavelength, so the slope as well as the magnitude of the dispersion is important.

Polarization-Maintaining Fibers

Chapter 4 briefly mentioned that single-mode fibers could be made to maintain polarization by applying an internal stress to them that prevents light from shifting polarization as it does in a radially symmetric fiber. *Polarization-maintaining fibers* are another important type of special-purpose fiber. They are used where polarization is important, such as in couplers, certain modulators, and fiber-optic gyroscopes.

The stress is applied by adding structures across the width of the fiber. Three designs are shown in Figure 7.1. In the PANDA fiber shown in Figure 7.1(a), two stress members are placed within the cladding in the same plane on opposite sides of the fiber core. In the bow-tie fiber shown in Figure 7.1(b), a pair of wedges on opposite sides of the core induce stress in the fiber. A third approach is to grind down both sides of a preform that has a circular boron-doped region surrounding the core. A fiber drawn from the preform is circular, with the boron-doped region stretched into an elliptical stress layer around the core, as shown in Figure 7.1(c). In all three cases the stress produces birefringence in the fiber, with light polarized along the axis of the stress traveling slower (i.e., seeing a higher refractive index) than light polarized in the perpendicular direction. A variety of other designs are possible, but not as widely used.

Polarization-maintaining fibers are used in some advanced transmission systems that remain in the experimental stages; but their main applications are in sensors and optical devices that require polarization control, such as couplers and modulators. The largest-volume use of polarization-maintaining fibers is in coils for the fiber-optic gyroscopes described in Chapter 29.

Polarizing fibers or *single-polarization fibers*, described earlier, guide light in one vertical polarization but not in the other. Polarizing fibers are similar in design to elliptical stress polarization-maintaining fibers, but their internal birefringence is much higher. This causes light in the fundamental mode to leak out of the core through the stressed region. Both polarizations leak out, but one escapes at a shorter wavelength than the other. Between those two wavelengths, the fiber transmits only one polarization and the perpendicular polarization leaks out.

Bend-Insensitive and Coupling Fibers

Standard transmission fibers are optimized for low transmission attenuation. However, the dominant losses in short lengths of fiber arise from coupling light into the core and from leakage at fiber bends. This has led to development of specialty fibers optimized for high coupling efficiency and low bend losses. These specialty fibers are more efficient than standard fibers in short lengths, such as pigtails linking light sources to a fiber.

Fibers can be made bend-insensitive by increasing the core refractive index so the core-cladding index difference is larger than in standard transmission fibers. Recall that the coupling efficiency depends on numerical aperture (NA), which increases with the

Fibers with internal stress maintain polarization of transmitted light.

FIGURE 7.1

Three polarization-maintaining fibers:
 a) the PANDA fiber;
 b) the bow-tie fiber;
 c) drawing a ground preform into a fiber produces an elliptical stress layer.

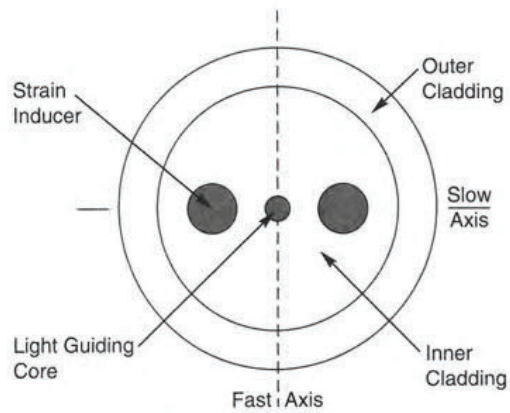
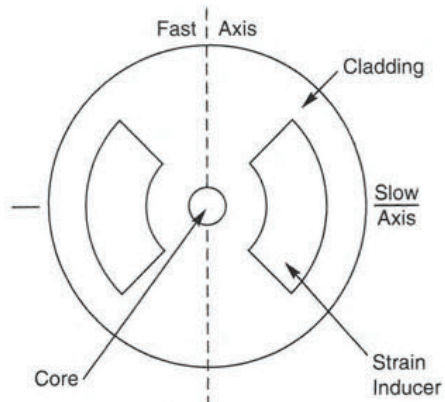
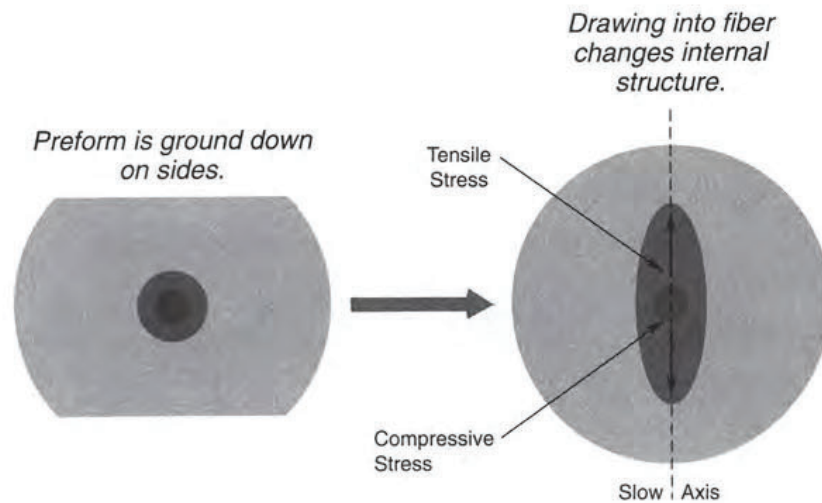
**a. PANDA Fiber Cross-Section****b. Bow-tie Fiber****c. Ground Preform Fiber**

core-cladding index difference. Increasing the core-cladding index difference also increases the confinement angle, which reduces light losses at bends in the fiber. Any increase in attenuation of the fiber is more than offset by the decrease in coupling and bending losses, which are far more important for short fiber segments than for transmission fibers.

These characteristics make bend-insensitive fibers attractive for use in pigtailed, or for short connections inside optical transmitters, receivers, and other devices. Internal space often is at a premium, so a fiber that can bend at a sharper angle increases design flexibility. These features also are useful in making the fused fiber couplers you will learn about in Chapter 14.

Bend-insensitive fibers can be designed for quite specific purposes. Some are metal-clad so they can be soldered into place in opto-electronic packages. Others have tapered cores so they can transfer light from a large-area source or large-core fiber into a smaller-core fiber. Others are made with a flattened core that can transfer light to or from planar optical waveguides more efficiently than standard fibers.

Increasing core index reduces bend sensitivity and increases NA.

Reduced-Cladding Fibers

Reduced-cladding fibers have claddings with outer diameter of 80 μm rather than the usual 125 μm . These fibers have been introduced in the past few years to offer higher packing density and greater flexibility than standard fibers.

As mentioned in Chapter 4, the 125- μm cladding diameter of standard communication fibers was selected to deal with handling problems. Fibers that were much smaller than 125 μm clung to spools and were hard to handle; larger fibers tended to be too stiff and cracked when wound onto spools. The cladding diameter has little impact on the fiber's optical properties. As long as the cladding is at least 20 μm thick, the cladding diameter could be reduced considerably and still confine light in the core. Only single-mode fibers are offered with reduced cladding, so plenty of margin remains. As with standard fibers, a plastic coating is added to protect the outer glass surface and assist handling, which roughly doubles the outer diameter to 165 μm for reduced-cladding fibers.

Fibers with 80- μm cladding diameter are more flexible and compact than standard 125- μm fibers.

A reduction in cladding can significantly reduce the volume occupied by a fiber. For example, if coatings are not considered, a fiber with 80- μm cladding has only 41% of the volume of a 125- μm fiber, as shown in Figure 7.2. With a 165- μm coating, the relative volume of a reduced-cladding fiber increases slightly to about 44%. Reduced cladding is not a major advantage for most transmission cables, but it would allow cables with high fiber counts to pack fibers more densely into the same volume. As you will learn in Chapter 8, this is most important for ribbon cables.

The reduction in cladding diameter can be quite important in coiled fiber devices such as fiber-optic gyroscopes and optical amplifiers, where the coil of fiber occupies a large fraction of the total device volume. The increased flexibility of the smaller fiber also allows tighter winding on a smaller spool.

The increased flexibility of reduced-cladding fiber allows it to be bent to a radius about 40% smaller than a conventional 125- μm fiber, or 3 centimeters compared to the usual 5 cm. In practice, the most important concern is avoiding extra attenuation from sharp bends.

FIGURE 7.2

Reduced-cladding 80- μm fiber compared to standard 125- μm cladding fiber.

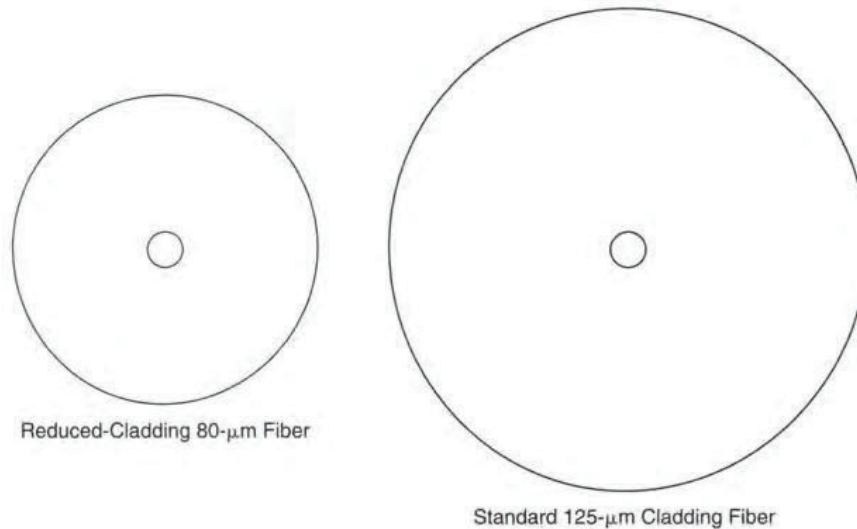

Attenuation losses increase significantly at wavelengths longer than about 1580 nm, so the operating wavelength must also be considered. The tighter bend radius of reduced-cladding fiber can be important in short lengths of fiber used as pigtails or optical jumpers in packaged equipment. Thinner claddings also can be an advantage in fabricating couplers.

Fibers as small as 65- μm cladding and 125- μm coating are being tested to increase packing density and reduce bend diameter. This size is within the limit of cladding design for single-mode fibers, but pushes present fiber-coating technology. Thinner coatings offer less protection for the glass and increase the risk of the coating separating or delaminating from the cladding. This consideration is especially important for polarization-maintaining fiber because external stresses transmitted through the coating and cladding onto the core can affect polarization performance.

One trade-off inevitable with smaller claddings is difficulty in handling the fiber. Stiffness makes the fiber easier to handle, so the flexibility of reduced-cladding fiber increases difficulty of handling. Finer fibers also are harder to feel and to see.

Doped Fibers for Amplifiers and Lasers

Optical fiber amplifiers and fiber lasers are built around fibers in which the cores contain small amounts of elements that can be stimulated to emit light. You'll learn more about fiber lasers and the laser principle in Chapter 9, and more about optical amplifiers in Chapter 12. This section will introduce you to doped fibers and the basic concepts behind their use.

Stimulated Emission and Amplification

Both optical amplifiers and lasers are based on the concept of stimulated emission, a phenomenon in which an atom first absorbs energy, which excites it to an elevated energy level,

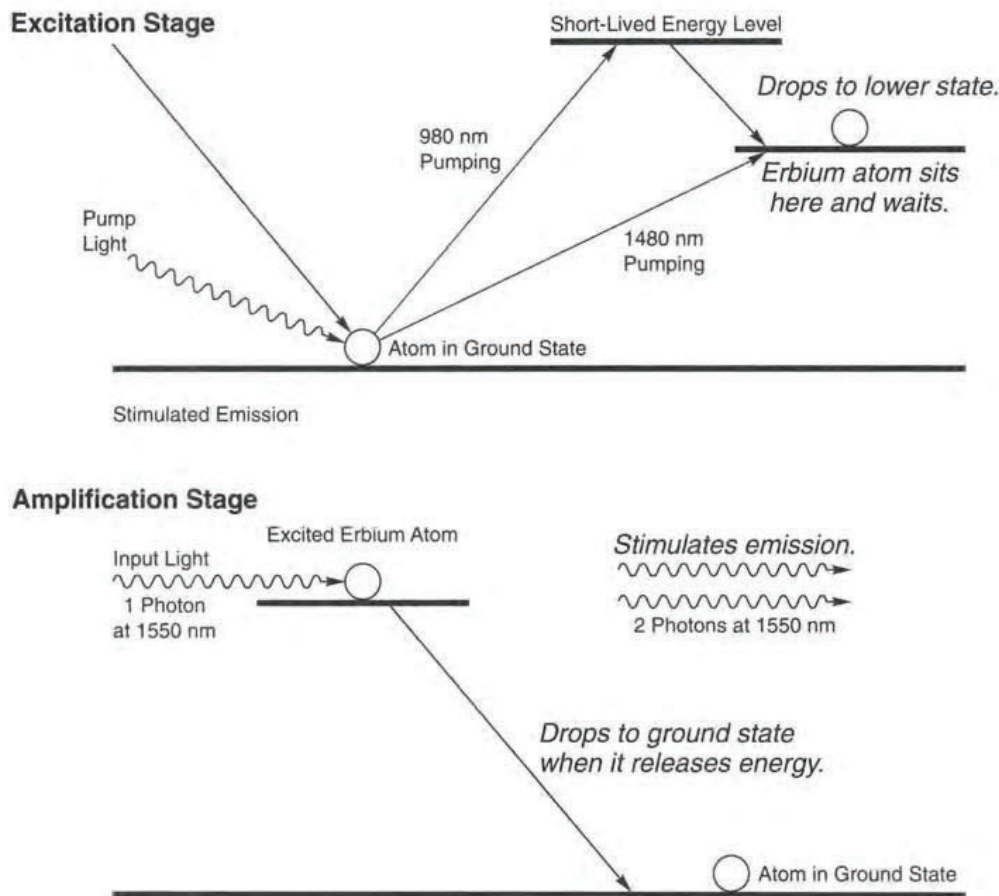
**FIGURE 7.3**

Excitation and amplification in erbium-doped fiber.

then is stimulated to emit some of that energy as light. The physics behind the process are complex, and light is emitted only at certain wavelengths for atoms that are excited in certain ways. For fiber optics, the most important type of optical amplifier is the erbium-doped fiber.

Figure 7.3 shows the process involved. First, the erbium atom absorbs pump energy from a photon at a wavelength of either 980 or 1480 nm, which raises it to a higher energy level. If it absorbs the shorter wavelength, it quickly drops to a lower state, the same one the 1480-nm photon excites it to. The atom sits there with the extra energy for a long time by atomic standards. If nothing happens, it eventually releases the energy as light. However, light of the right wavelength—between 1530 and 1620 nm—can stimulate the erbium atom to release the energy. Critically, the photon released is at exactly the same wavelength, and going in exactly the same direction, as the photon that stimulated the emission. If the input light is an optical signal, the process produces a second photon exactly in phase with the input photon, which amplifies the signal.

To make an optical amplifier, erbium atoms are added to the glass in the core of a simple single-mode optical fiber. For the fiber to amplify light, the core must be illuminated by a laser emitting light at 980 or 1480 nm. The erbium atoms, which absorb this light,

Erbium atoms are added to the fiber core to amplify the 1550-nm band.

are raised to a higher energy level where an optical signal can stimulate them to emit energy. The input light has to be continuous to keep exciting the erbium atoms back to that higher energy level after they release their energy by stimulated emission and drop back down to the ground state. The pump light also should be intense enough to keep most of the erbium atoms in the excited state.

If the pump laser is off, an erbium amplifier absorbs rather than amplifies the signal. The erbium atoms that amplify light in the upper energy level instead absorb light in the lower energy level. Thus an optical amplifier without a pump laser actually blocks the signal rather than transmitting it unamplified.

Types of Fiber Amplifiers

The *erbium-doped fiber amplifier* (EDFA) described so far is the most common type of optical amplifier. The level of erbium doping in the fiber depends on the type of amplifier. It differs for amplifiers working in the C-band at 1530 to 1565 nm, and the L-band at 1570 to 1625 nm, and may also vary depending on the power level and number of channels being amplified.

Other elements chemically similar to erbium are used to make fiber amplifiers for different wavelengths. The processes of pumping and stimulated emission are the same as for erbium, but the pump and amplification wavelengths are different. Praseodymium-doped fibers have been developed for amplification at 1310 nm, but have found few applications. Thulium-doped fibers have been developed for amplification at 1450 to 1500 nm, but also have found few applications. Ytterbium and neodymium have been doped into fiber cores for use in fiber lasers.

Most fiber amplifiers are made of standard silica glass. However, the gain of the amplifier and its strength at various wavelengths depend on the interaction between the light-emitting atoms and the host material, so amplifiers also have used other types of fibers. The fluoride fibers described in Chapter 6 have been used in some fiber amplifiers. Tellurite glasses, based on compounds of tellurium, also can be doped with erbium for amplifiers. Tellurite fibers offer higher gain at the longer-wavelength end of the erbium spectrum, but are not as easy to use as silica fibers.

Dual-Core Fiber for High-Power Lasers

A dual-core structure is used to make fiber lasers that generate a watt or more of continuous optical power. These are high-power lasers, and some versions can reach a kilowatt, an amazing feat for light generated in the core of an optical fiber.

A fiber laser resembles a fiber amplifier, but has mirrors on both ends and has no input signal. The fiber laser is an *oscillator*, in which stimulated emission amplifies light generated internally when some of the excited atoms spontaneously release their energy. The mirrors reflect the light back and forth through the fiber core, with one mirror transmitting a fraction of the light to form a beam. (You'll learn more about lasers in Chapter 9.)

Lasers can be built around single-core fibers, but the dual-core design shown in Figure 7.4 transfers power more efficiently. The inner core has a higher refractive index than the outer

Thulium and praseodymium also are used in fiber amplifiers for other wavelengths.

Dual-core fibers are used in high-power lasers.

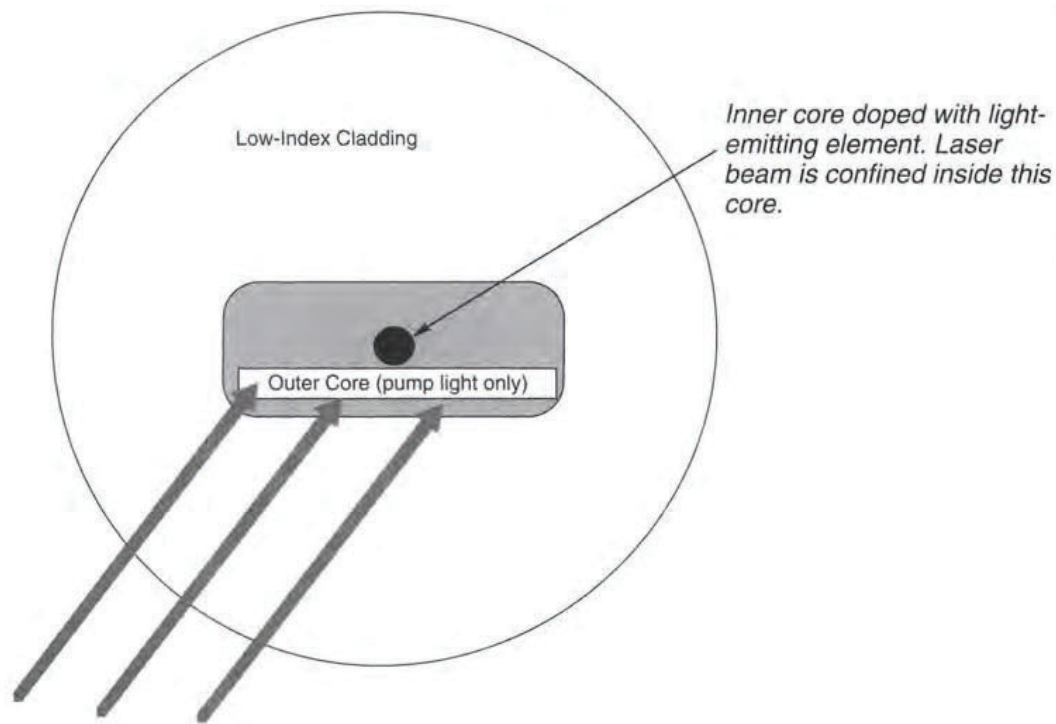
**FIGURE 7.4**

Dual-core fiber for high-power fiber lasers. The outer core guides the pump light so it passes through the inner core, which is doped with light-emitting atoms. Different shapes such as octagons can be used for the outer core.

core, and the outer core, in turn, has a higher index than the cladding. The cladding may be glass or a polymer, as long as its index is lower than that of the outer core. Only the high-index inner core is doped with a light-emitting element. Light from the pump laser is coupled into the large outer core, which is designed to collect light efficiently. The shape of the outer core is not radially symmetric, so total internal reflection sends the pump light on an irregular path. This path takes the pump light through the inner core many times, so it can excite light-emitting atoms efficiently. The highest powers obtained so far have been from fibers doped with ytterbium, which emits at 1120 nm.

Fiber Gratings and Photosensitive Fibers

Fiber gratings and photosensitive fibers might initially seem to be two separate classes of specialty fibers but are actually different aspects of the same thing. Photosensitive fibers are used to make fiber Bragg gratings. Thus the two are treated together here, with the emphasis on what users see, the fiber Bragg grating (which gets its name from the periodic variation of refractive index along its length).

Standard optical fibers have the same refractive index along their entire length, so a slice taken from one part of the fiber looks just like one taken from any other part of the fiber, apart from small imperfections. In a *fiber Bragg grating*, the refractive index rises and falls along its length periodically in a pattern that would look like a uniform wave if you plotted the index variation with distance. (The distance between index peaks is called the

Refractive index varies periodically along a fiber grating.

FIGURE 7.5

Fiber Bragg grating reflects light at wavelengths that match the grating period and transmits other wavelengths.

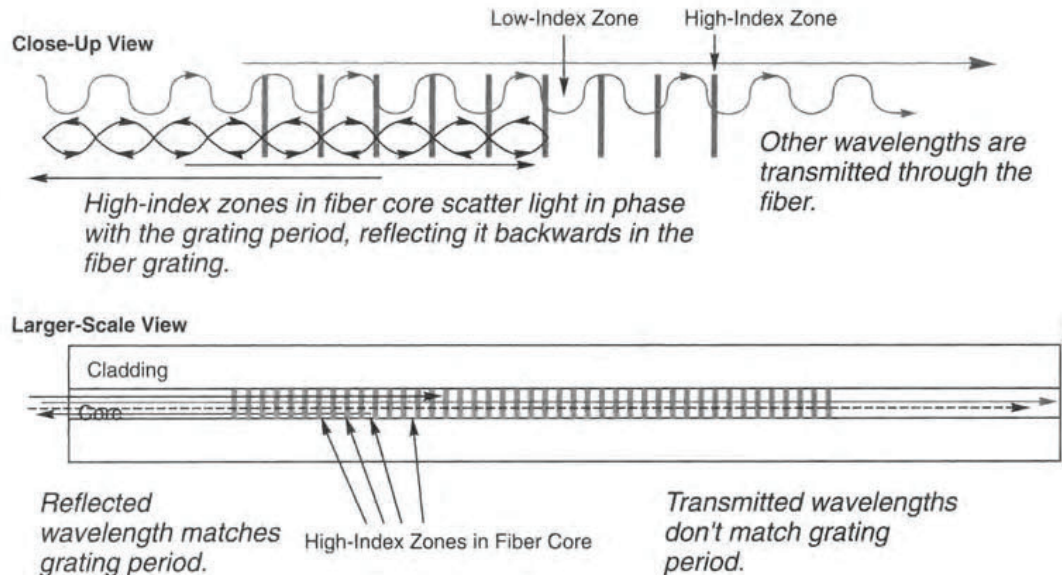

grating period.) These refractive-index variations scatter light back into the fiber at any point where light encounters a refractive index variation.

All wavelengths are scattered by the regularly spaced index variations, which causes the waves to interfere with each other in the fiber. Light at the wavelength that hits each index peak at the same phase experiences constructive interference and is selectively reflected back into the fiber, as shown in Figure 7.5. Light scattered at other wavelengths by the grating elements is out of phase and cancels out by destructive interference.

Fabrication of Fiber Gratings

Fiber Bragg gratings are made by illuminating photosensitive fibers with intense ultraviolet light. The ultraviolet photons break atomic bonds in the germania-doped silica core of a fiber with a composition that makes it particularly sensitive to the light. The fibers may be treated with hydrogen to enhance their response, although manufacturers say that specialty photosensitive fibers do not require hydrogen treatment.

The grating pattern can be created by illuminating the fiber with an ultraviolet laser through a *phase mask*, a thin flat slab of silica with a pattern of fine parallel troughs etched on its bottom, as shown in Figure 7.6. The phase mask diffracts most of the light in two directions, and the light waves interfere to form a pattern of alternating light and dark zones along the length of the fiber. The ultraviolet light breaks bonds in the lighted regions but not in the dark zones. Because of the geometry, the lines in the fiber grating are half as far apart as the lines in the phase mask. The laser wavelength does not affect the line spacing.

Another approach is to split the incoming ultraviolet light into two beams, then recombine them to form an interference pattern that exposes the side of the photosensitive fiber. Like the phase mask, this approach can create short gratings. It also can write gratings

● The grating period selectively reflects one wavelength.

● Ultraviolet illumination changes refractive index in the fiber core.

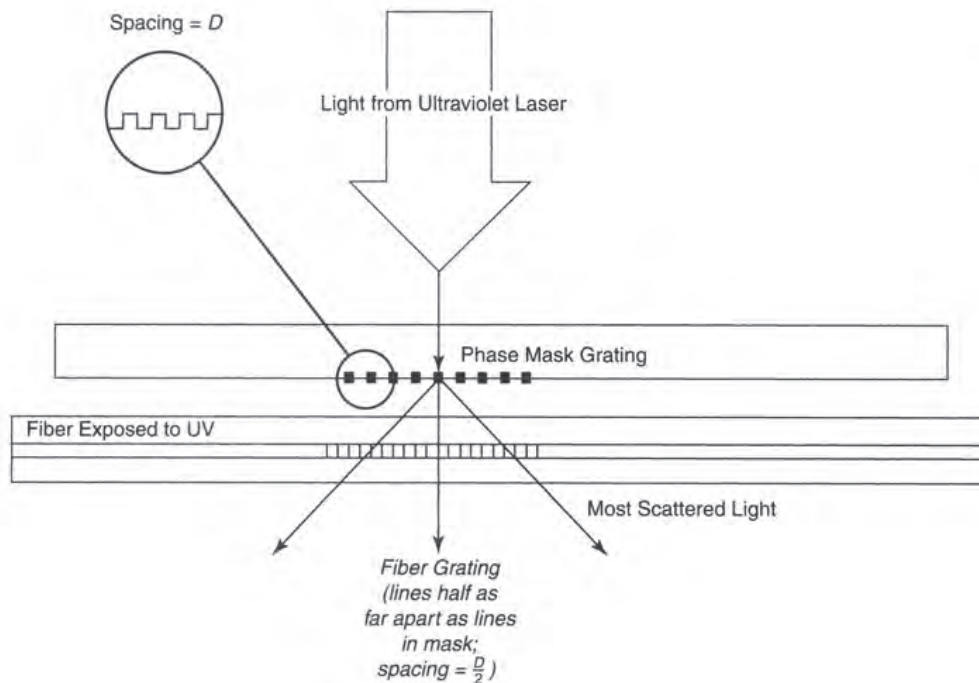
**FIGURE 7.6**

Ultraviolet light forms grating in photosensitive fiber core.

meters long by modulating the ultraviolet light as the fiber is moved relative to the interference pattern.

The amount of change in the refractive index depends on the extent of ultraviolet irradiation, the laser wavelength, the glass composition, and the processing before treatment. Typically, pulsed ultraviolet lasers illuminate the fiber with high intensity for a few minutes, increasing the refractive index of germania-doped silica by a factor of 0.00001 to 0.001. Hydrogen treatment or special processing can increase the sensitivity of the fiber so the index change reaches 1% (0.01), a value larger than the difference between core and cladding index in standard single-mode fibers.

Reflection and Transmission in Fiber Gratings

The wavelength selectively reflected by the grating is twice the period of the grating because the light must go between the grating lines twice: once when it enters, and once when it's reflected. The wavelength in the glass is what counts, which is shorter than the wavelength in air by a factor of the refractive index n . The wavelength λ is normally defined in air, so this means that for a grating spacing of D , the reflected wavelength (measured in air) is

$$\lambda_{\text{reflected}} = 2nD$$

For example, if the grating spacing is $0.500 \mu\text{m}$ and the refractive index is 1.47, the selected wavelength is $1.47 \mu\text{m}$. You also can flip the equation to calculate the grating spacing needed to reflect a particular wavelength if you know the refractive index.

FIGURE 7.7

Reflection and transmission by a fiber grating.

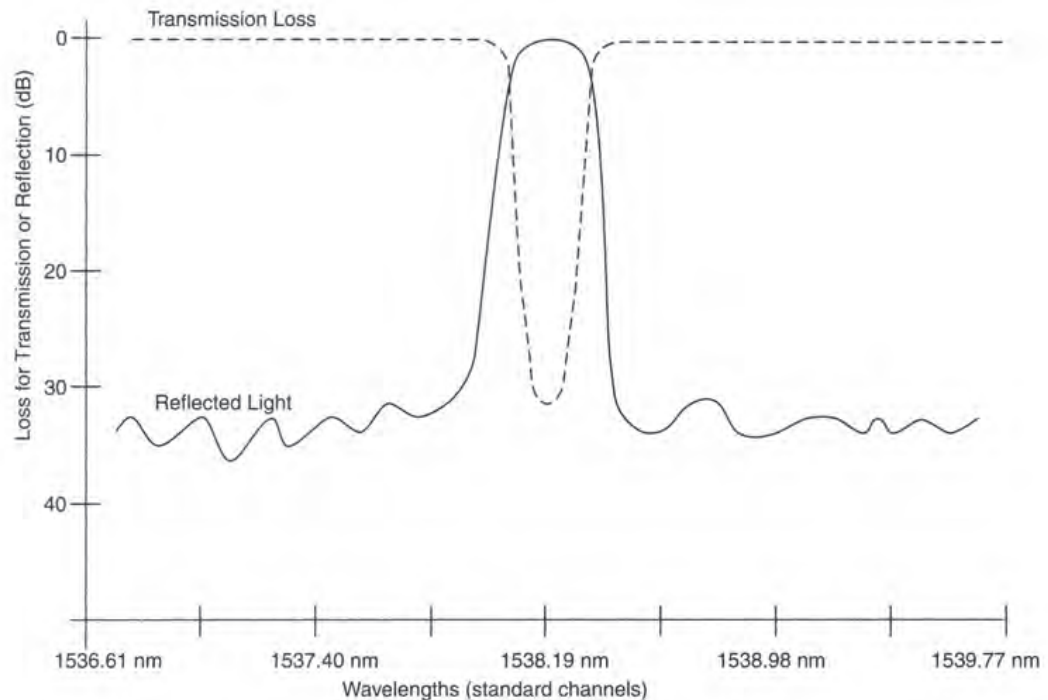

The light reflected back into the fiber at other wavelengths averages out to zero, so the grating transmits it essentially unaffected. This makes a fiber Bragg grating function as a line-reflection filter, selecting a wavelength it reflects while transmitting other wavelengths. Fiber Bragg gratings can be made with peak reflection across a narrow band and very sharp cutoffs on both sides, as shown in Figure 7.7 for peak reflectivity centered at 1538.19 μm . The sharpness of the reflective peak depends on the strength, length, and regularity of the grating. The plot in Figure 7.7, a composite based on typical products, shows how much lower the reflected and transmitted signals are than the input, measured in decibels. The reflected light is 30 dB below the input intensity at wavelengths outside the selected band, which is 100 GHz (0.8 nm) wide. Conversely, virtually all the light at the selected wavelength is reflected, while transmission is 30 dB below the input power.

The variation in reflectivity with wavelength depends on the quality of the grating. Fine, thin, evenly spaced grating lines concentrate reflection at a narrow range of wavelengths. Higher-contrast gratings increase reflectivity and broaden the range of reflected wavelengths. Gratings have been produced that select bands as narrow as 12.5 GHz, about 0.1 nm in the 1550-nm band, with much broader bands also possible.

The grating period can be chirped along the fiber length.

Chirped Gratings and Dispersion Compensation

To select a single wavelength, a fiber grating should have a uniform spacing along its entire length. However, the grating spacing doesn't have to be uniform. It can be "chirped," with

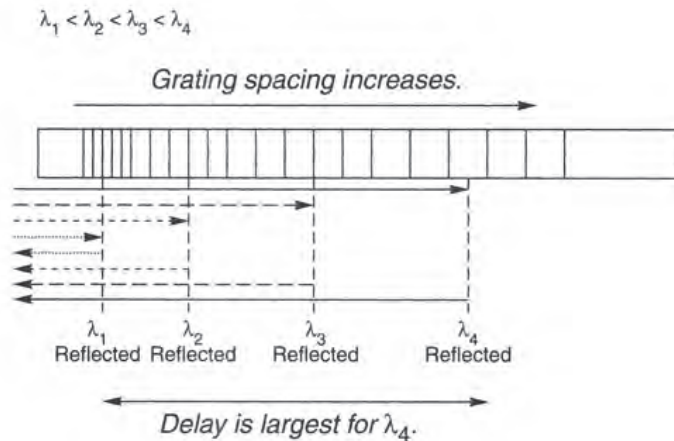
**FIGURE 7.8**

Fiber grating works as a delay line.

spacing changing along the length of the fiber, or with a series of zones of discretely different spacing in successive regions. Such a grating can serve as a wavelength-selective optical delay line, with the wavelengths reflected further along the grating delayed relative to those reflected first. Such a delay line can be used to compensate for chromatic dispersion along the length of a fiber.

Suppose, for example, that the longest wavelengths in a pulse arrived first and the shorter wavelengths arrived last. As shown in Figure 7.8, the grating can be made so segments that reflect different wavelengths are spaced along the fiber. In this case, the longest wavelength, λ_4 , arrives first and is transmitted to the last part of the grating. Thus it has to travel farther than the shortest wavelengths, which arrive last and are reflected by the first part of the grating. Delaying the longest wavelength lets the shortest wavelength catch up, compensating for dispersion.

Fiber gratings don't have to be long to compensate for dispersion. If the average refractive index of the grating was 1.5, it would take only about 10 mm of grating to compensate for 100 ps of dispersion.

Other Fiber-Grating Filters

Spacing and strength of fiber gratings can be adjusted to reflect a broader range of wavelengths, or to reflect a controlled fraction of input light to attenuate certain wavelengths. Some fiber gratings have been designed specifically for sensing.

Important applications of fiber gratings include:

- Mirrors that reflect a narrow range of wavelengths to stabilize a fiber laser that emits at those wavelengths. You'll learn in Chapter 9 how such lasers work.
- Fibers that attenuate light intensity by varying amounts across a range of wavelengths to offset for uneven attenuation or amplification by other components. These fibers are usually called *equalization* filters because they make optical devices perform equivalently across a range of wavelengths.

THINGS TO THINK ABOUT

Separating Wavelengths with Fiber Bragg Gratings

Fiber Bragg gratings separate signals at one wavelength from those at other wavelengths. Yet you've just seen that the fiber grating reflects the wavelength it selects back in the direction it came. The reflected light travels out the input fiber and back toward the light source. You can separate reflected light easily if it goes in some other direction; but how can you separate it if it goes back through the input fiber?

The answer is that you need another device, called an *optical circulator*, described in Chapter 15 and shown in Figure 7.9. An optical circulator acts like a one-way valve that sends light travelling in one direction one way, and light travelling in the opposite direction a different way. It's an ingenious and complex device, and is essential to the practical use of fiber Bragg gratings. Its critical importance is

worth pondering. When fiber Bragg gratings were first introduced for wavelength selection, the people touting them didn't make it clear that they wouldn't work without optical circulators: There was no way you could separate the wavelength you wanted from all the other light going in the other direction. This example is a reminder that you need to check new ideas to make sure people are telling you everything you need to know.

Circulators are not needed for fiber gratings that are used for sensing applications because the system that probes the sensor's response contains a tunable laser source and a wideband spectrum analyzer. This equipment scans the laser wavelength across the spectrum, then records the reflected wavelength for each Bragg grating in the fiber assembly. The system then compares the response to the gratings' reference wavelength to determine the change in temperature or strain in each grating due to the wavelength shift.

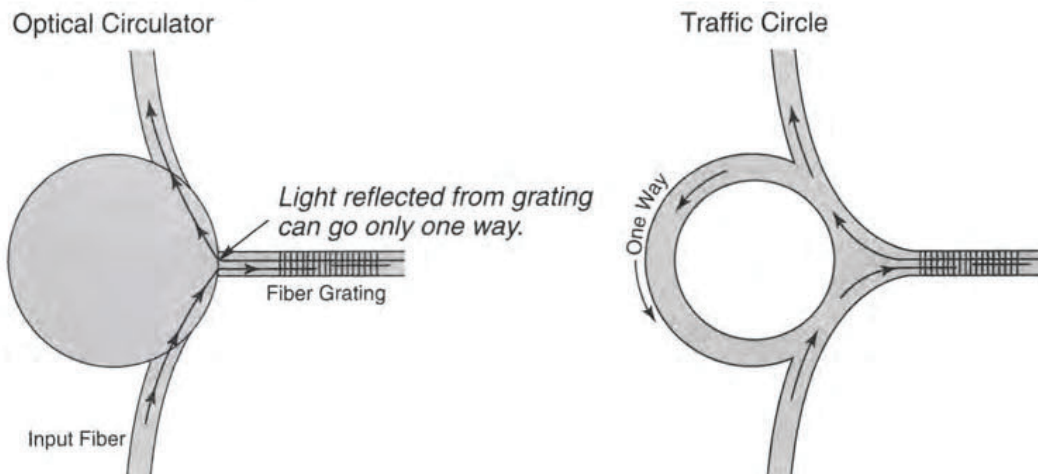

FIGURE 7.9

An optical circulator works like a traffic rotary, preventing light reflected from the fiber grating from going the “wrong way.”

Photonic or "Holey" Fibers

Chapter 6 described the fabrication of photonic fibers in which light guiding depends on internal microstructures. This gives fiber designers more degrees of freedom than are available for conventional fibers, allowing them to make fibers with features that are otherwise impossible. The technology is still evolving, so we will concentrate on key concepts.

Photonic crystal fibers are fibers that guide light in a central solid core surrounded by microstructured material with internal holes, as shown in Figure 7.10. Although the cladding design is based on the photonic bandgap concept, the light guiding also can be viewed in conventional terms; the cladding has a lower refractive index than the solid core, so the guiding mechanism can be interpreted as total internal reflection. The microstructure does allow the core to maintain single-mode transmission at larger diameters than otherwise possible, reducing the fiber's nonlinearity. Conversely, the same principles can be used to make small-core fibers with high nonlinearity. Adjusting cladding properties also can affect chromatic dispersion in the fiber.

Photonic bandgap fibers are similar to photonic crystal fibers, but have a hollow core with lower refractive index than the surrounding cladding. Their operation depends entirely on the presence of a photonic bandgap layer, which cannot transmit light trapped in the hollow core. Because the photonic bandgap material blocks light only at certain wavelengths, a photonic bandgap fiber guides only those wavelengths, not the whole spectrum.

Photonic bandgap fibers guide light in air, not a solid, so they have lower nonlinearity and different dispersion properties than standard fibers. Those properties can be changed by filling the central holes with other gases. The hollow cores can be large or small, and some versions resemble waveguides. Hollow-core waveguides potentially can transmit any wavelength, depending on the design of the photonic bandgap layer.

Photonic fibers are likely to find their first applications as specialty fibers for applications that require high nonlinearity in a fiber. At this writing, photonic fibers are still in development.

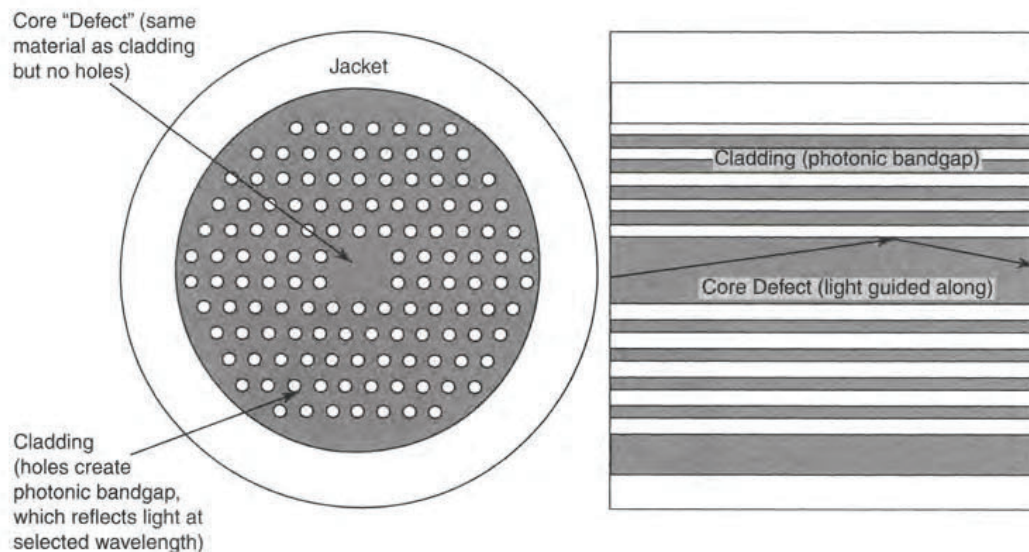

Photonic crystal fibers guide light in a central solid core.

Properties of photonic fibers can be varied over a wide range.

FIGURE 7.10

A photonic crystal fiber guides light in the solid core, which lacks the holes present in the cladding.

FIGURE 7.11

Side-glowing fiber contains material in the core that scatters light out the side, so the fiber glows along its length like a neon tube.

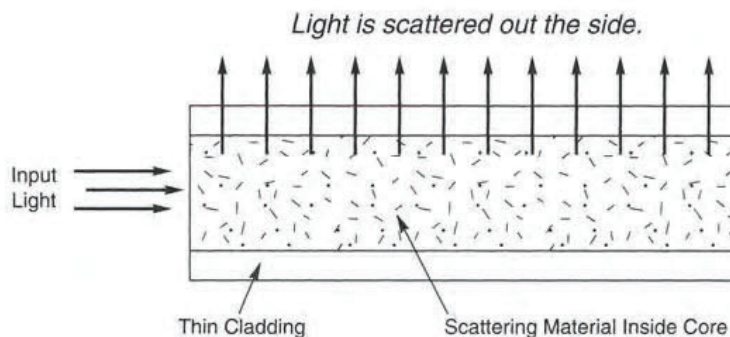

Special Noncommunications Fibers

Side-Glowing Decorative Fibers

Light-scattering material can be added to the cores of optical fibers to create interesting effects for decoration, fabrics, and illumination.

A small amount of scattering is inevitable in all optical fibers that guide light from end to end, but normally it is undetectable. Essentially all the light emerges from the end of the fiber. In decorative objects using standard fibers, such as lamps for Christmas trees, this creates glittering points of light at the fiber tips, with the rest of the fiber emitting no light.

Side-glowing fibers are produced by adding finely divided light-scattering materials to the core of a fiber, as shown in Figure 7.11. Light passing through the core bounces off the material and out the sides, making the length of the fiber glow. The illuminating light, the fiber, or the scattering particles may be colored, and fluorescent materials can be used. In some cases, a side-glowing fiber can look like a neon tube. The cladding normally is thin, and light is scattered so widely that the cladding's presence is not obvious. The length of fiber illuminated depends on the brightness of the source and the degree of scattering.

Side-glowing fibers can be made as thread-like filaments for use in decorative fabrics. These fine fibers can be woven into fabrics, and some artists use them to create fascinating objects, like "The River," by Laurie Carlson, shown in Figure 7.12.

Side-glowing fibers made for architectural decoration are much thicker, sometimes a centimeter or more in diameter. These fibers resemble rods, but retain the core-cladding structure of fibers. They may be made from solid plastic, or contain a liquid core in a hollow plastic tube.

Materials added to the core can scatter light from the sides of decorative fibers.

FIGURE 7.12

"The River," fabric fiber-optic art by Laurie Carlson. (Courtesy of Laurie Carlson)

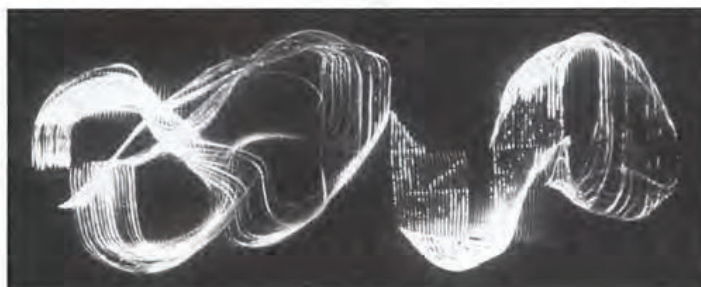

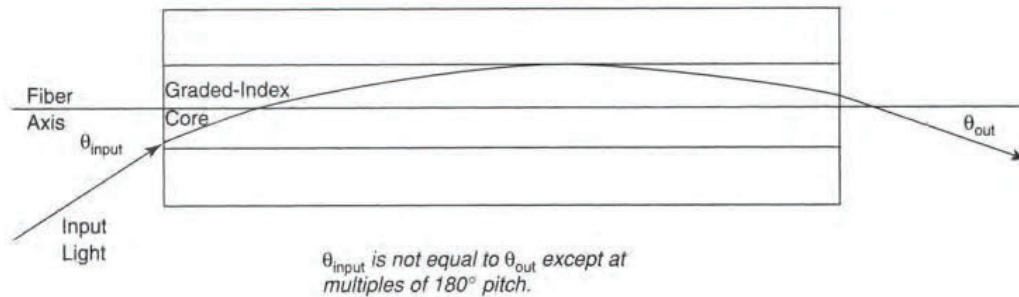

FIGURE 7.13
Graded-index
fiber lens.

Graded-Index Fiber Lenses

Short lengths of graded-index fibers can act as tiny lenses to focus light. These fiber-optic microlenses have limited uses in fiber-optic systems, but have found applications in other systems that manipulate images point by point, such as photocopiers, scanners, and facsimile machines. (These are different from the fiber-optic imaging bundles described in Chapter 30.)

In Chapter 4, you learned that light follows a sinusoidal path through graded-index fiber. In that chapter, you saw a cone of light entering a long graded-index fiber, and light spreading from the end of the fiber in a cone of the same size. Now consider instead the path of an individual light ray through a short segment of graded-index fiber, shown in Figure 7.13.

In a step-index fiber, total internal reflection from the step-index boundary keeps light rays at the same angle to the fiber axis all along the fiber; so the output angle equals the input angle. Graded-index fibers refract light rays, so the angle between the ray and the fiber axis changes constantly as the light bends back and forth following a sinusoidal path. If you cut a graded-index fiber at a point where the light ray has gone through 180° or 360° of the sinusoidal curve, the light emerges at the same angle that it entered. If you cut the fiber at some other point, the light emerges at a different angle, as shown in Figure 7.13. Making light rays emerge at a different angle is equivalent to focusing them with a lens, so a segment of graded-index fiber can serve as a lens.

The key parameter for graded-index fiber lenses (usually sold under the trade name Selfoc™) is the fraction of a full sinusoidal cycle the light has completed before leaving the fiber. That fraction is called the *pitch*. A 0.23-pitch lens, for instance, has gone through 0.23 of a cycle, or 82.8° . The value of the pitch depends on various factors including the refractive-index gradient in the fiber, its core diameter, and the wavelength of the light. Typical graded-index fiber lenses are a few millimeters long, very short by fiber standards.

Graded-index fibers can focus light and act as lenses.

What Have You Learned?

1. Specialty fibers have properties that differ significantly from those of standard transmission fibers and are fine-tuned for specific applications.
2. Dispersion-compensating fibers are made with high waveguide dispersion to give them high negative chromatic dispersion.
3. Polarization-maintaining fibers are made with internal stress that helps them separate the two polarizations of light. They are used in fiber gyroscopes, some components, and some special transmission systems.

4. Fibers made for use in pigtails, couplers, and short connections inside devices have a core with a high refractive index to reduce their sensitivity to bend losses.
5. A high-index core increases numerical aperture, reducing coupling losses.
6. Reduced-cladding fibers have 80- μm cladding diameter, which makes them more flexible and compact than standard 125- μm fibers. The reduced cladding does not affect the optical properties of single-mode fibers.
7. Reduced-cladding fibers are used in fiber gyroscopes and fiber amplifiers, but rarely in cables.
8. Optical amplifiers are built around fibers with single-mode cores that are doped with rare-earth elements such as erbium. These elements produce stimulated emission, which amplifies a weak optical signal.
9. Erbium-doped fiber amplifiers are the most widely used; they amplify in the 1550-nm band. Thulium and praseodymium fiber amplifiers are used for other wavelengths.
10. Dual-core fibers are used to make high-power fiber lasers.
11. Fiber Bragg gratings are periodic variations in refractive index along the length of a fiber that are produced by illuminating a photosensitive fiber with intense ultraviolet light.
12. The refractive-index variations in fiber Bragg gratings scatter light. Interference among the scattered light waves reflects one wavelength while transmitting others through the grating.
13. The wavelength reflected by a fiber grating equals twice the grating spacing multiplied by the refractive index of the fiber.
14. The period of a fiber Bragg grating can be chirped along its length.
15. Photonic fibers can guide light in a solid or a hollow core. Their properties can be adjusted over a wide range, giving high or low nonlinearity and changing chromatic dispersion.
16. Materials added to the core scatter light from the sides of decorative fibers.
17. Short lengths of graded-index fibers can focus light and act as lenses.

What's Next?

In Chapter 8, we move on to learn about the cables that contain optical fibers in communication systems.

Further Reading

University of Bath, "Photonic Crystal Fibre," <http://www.bath.ac.uk/physics/groups/opto/pcf.html>

P. C. Becker et al., *Erbium Fiber Amplifiers: Fundamentals and Technology* (Academic Press, 1999)

- John A. Buck, "Optical Fiber Amplifiers," in Michael Bass, ed., *Handbook of Optics Vol. 4: Fiber Optics and Nonlinear Optics* (McGraw-Hill, 2001)
- Kenneth O. Hill, "Fiber Bragg Gratings," in Michael Bass, ed., *Handbook of Optics Vol. 4: Fiber Optics and Nonlinear Optics* (McGraw-Hill, 2001)
- K. O. Hill and G. Meltz, "Fiber Bragg grating technology fundamentals and overview," *Journal of Lightwave Technology V.15*, 1263–1276 (August 1997)
- Raman Kashyap, *Fiber Bragg Gratings* (Academic Press, 1999)
- Gerd Keiser, *Optical Fiber Communications* (McGraw-Hill, 2000). See Chapter 11 on optical amplifiers.
- J. C. Knight et al., "Photonic crystal fibers: New solutions in fiber optics," *Optics and Photonics News 13*, pp. 26–30 (March 2002)

Questions to Think About

1. Reduced-cladding fibers have outer diameters of 80 μm , but developers have proposed 60- μm claddings. That should not affect optical performance because the claddings would be only about 25 μm thick. What problems might be expected from the smaller diameter?
2. A fiber grating reflects light waves that are in phase with the grating with a wavelength $\lambda = 2nD$, where D is the spacing between the grating lines. This wavelength is the longest that would make exactly one round trip between a pair of grating lines. A wavelength exactly half that value also would be resonant with that grating spacing because exactly two waves would make one round trip. Why isn't this light also reflected?
3. Why is refractive index always measured in air rather than in glass?
4. What's the advantage of doping erbium only in the fiber core?
5. The gain of an erbium-doped fiber varies as a function of wavelength. It is highest from about 1530 to 1565 nm, and lower at longer wavelengths. Recalling how gain is defined, how can you make an erbium-doped fiber amplifier with a high amplification factor at longer wavelengths?
6. Think of a way to demonstrate light scattering from the side of a fiber designed for decorative lighting. Start with a laser pointer.
7. A high-power erbium-doped fiber amplifier has saturated its output at 10 mW/channel for 20 optical channels with 100-GHz spacing. You add 20 more channels at intermediate wavelengths. Assuming the amplifier is so saturated it can't generate any more total output, what is the new output per channel?

Chapter Quiz

1. What creates the grating effect in a fiber grating?
 - a. lines etched on the fiber surface by high-power ultraviolet pulses
 - b. changes in the refractive index of the fiber core induced by ultraviolet light

- c. interference among several modes in a multimode fiber
 - d. variations in glass composition caused by changes in doping during preform fabrication
 - e. optical white magic
- 2.** A grating with period of $0.5\ \mu\text{m}$ is made in a glass fiber with core refractive index of 1.5. What wavelength of light is reflected most strongly?
- a. 1300 nm
 - b. 1500 nm
 - c. 1550 nm
 - d. 1600 nm
 - e. none of the above
- 3.** Which wavelengths are transmitted by the grating in Problem 2?
- a. None; all light is reflected or scattered from the fiber.
 - b. 1300 and 1600 nm only
 - c. 1300, 1500, and 1600 nm
 - d. 1300, 1550, and 1600 nm
 - e. 1300, 1500, and 1550 nm
- 4.** What causes a fiber to maintain the polarization of light transmitted through it?
- a. tension applied along the length of the fiber
 - b. doping of the core with germanium
 - c. stress applied by structures in the fiber cladding
 - d. stress applied by structures inside the fiber core
 - e. Polarization cannot be maintained because the fiber is radially symmetric.
- 5.** How does increasing the refractive index of the core of a fiber make it better for coupling light into fibers?
- a. It reduces attenuation of the glass.
 - b. It increases NA and reduces attenuation of the glass.
 - c. It increases NA and reduces bend sensitivity.
 - d. It decreases NA, bend sensitivity, and attenuation.
 - e. It reduces bend sensitivity and glass attenuation.
- 6.** What determines which wavelengths can be amplified in a fiber amplifier?
- a. the number of modes guided in the fiber
 - b. attenuation of the fiber
 - c. properties of the light-emitting ion doped into the core
 - d. the wavelengths of the pump lasers
 - e. dispersion of the fiber

7. What wavelengths are amplified by an erbium-doped fiber amplifier?
 - a. 980–1480 nm
 - b. 1250–1350 nm
 - c. 1300–1700 nm
 - d. 1470–1530 nm
 - e. 1530–1620 nm
8. Which type of fiber cannot be made in reduced-cladding form?
 - a. graded-index fiber with a 62.5- μm core
 - b. polarization-maintaining fiber
 - c. erbium-doped fiber for amplifiers
 - d. short fiber lengths for pigtails
 - e. standard single-mode fiber
9. Neglecting the weight of the spool and the plastic coating on the fiber, how much can you reduce the weight of a fiber-optic gyroscope by switching from a standard 125- μm fiber to a reduced-cladding fiber?
 - a. 10%
 - b. 35%
 - c. 50%
 - d. 60%
 - e. 90%
10. What can you do with a photonic bandgap fiber that you cannot do with any conventional fiber?
 - a. guide light in a hollow core
 - b. guide light in a solid core
 - c. maintain polarization of the input light
 - d. dope the core with erbium for use in an optical amplifier
 - e. fabricate a fiber grating in the core

Cabling

About This Chapter

Cabling is not glamorous, but it is a necessity for virtually all communication uses of fiber optics. A cable structure protects optical fibers from mechanical damage and environmental degradation, eases handling of the small fibers, and isolates them from mechanical stresses that could occur in installation or operation. The cable makes the critical difference in determining whether optical fibers can transmit signals under the ocean or just within the confines of an environmentally controlled office building.

This chapter discusses the major types of fiber-optic cable you are likely to encounter. You will see what cables do, where and why different types are installed, what cables look like on the inside, how cables are installed, and what happens to fibers in cables.

Cabling Basics

Fiber-optic cables resemble conventional copper cables externally, and they use similar materials and jacketing technology. Polyvinyl chloride (PVC) sheaths are common on both fiber-optic cables and coaxial cables used inside buildings, but fiber cables are often brightly colored, whereas coax usually has a black jacket. Polyethylene (PE) is used to protect both metal and fiber outdoor cables against the environmental rigors of underground burial or aerial installation.

Important differences are hidden inside the cable. Fiber cables do not require the electrical insulation needed to isolate copper wires. Optical cables can be designed without any internal metal elements to produce nonconductive or *all-dielectric cables* that are immune to ground-loop problems and resistant to lightning strikes. Fiber cables usually are smaller because fibers are small and each one has the capacity of many wire pairs.

The mechanical differences between glass fibers and copper wires lead to major differences between optical and metal cables. Pull gently on a fiber, and it stretches lightly then springs back to its original length. Pull a fiber hard enough and it breaks (at a weak

Fibers must be isolated from tension, which can cause breakage or long-term reliability problems.

point or surface flaw). Pull a copper wire, applying less stress than that needed to break the fiber, and the metal stretches by more than 20% and does not spring back to its original length. In mechanical-engineering terms, fiber is elastic because it contracts back to its original length, and copper is inelastic because it stays stretched.

As you learned in Chapter 5, glass fibers are strong. Manufacturers proof-test fibers under stress of 100,000 pounds per square inch, or 0.7 giganewton per square centimeter. (The usual units are thousands of pounds per square inch, kpsi, one of the few cases where Imperial units are widely used in fiber optics.) The test normally is performed as the plastic-coated fiber is wound onto the shipping reel, so weaker fibers should not make it out of the plant.

Although the strength per unit area is very high for glass fibers, you should remember that a strong tug applies a large force per unit area across the small diameter of a fiber. What counts in assessing strength is the cross-section of the glass, not the thicker diameter of the plastic-coated fiber. A standard 125- μm fiber has a cross-sectional area of only 0.000019 square inch (0.00012 square centimeter), so a 2-lb (1-kg) force applied along the fiber corresponds to the 100 kpsi stress test.

Fibers are plastic coated as well as proof-tested; the coating protects the fiber surface from handling damage and environmental moisture. The cable structure isolates the fibers from excessive strain, both during installation and in service, such as when they are hanging from outdoor poles. The cable structure applies tension to strength members that run the length of the cable, either through the center or in another layer, depending on the application. As described later, these strength members may be metallic or nonmetallic.

Reasons for Cabling

Cabling packages optical fibers for protection and ease of handling, and cabled fibers are used for most communication applications. Bare fibers are used in sensors and in a few communication applications such as the fiber-optic guided missile described in Chapter 28. As you will learn later in this chapter, certain fibers can be blown into hollow tubes that guide and protect the fibers. These structures function much like cables and have advantages in some applications.

Ease of Handling

One major reason for cabling fibers is to make them easier to handle both singly and collectively.

Physically, single glass optical fibers resemble monofilament fishing line, except the fibers are stiffer. Protective plastic coatings raise the outer diameter of standard communication fibers to 250–900 μm , making them easier to handle than bare fibers. Reduced-cladding fibers are only 165 μm in diameter with the plastic coating, which makes them hard to handle.

Most communication systems require at least two fibers, each carrying signals in the opposite direction. Generally, multiple fibers follow the same path along much of their routes and are grouped in a single multifiber cable, which serves as a single easy-to-see and easy-to-handle structure. Some of these cables contain dozens of fibers, some hundreds, and the largest cables contain over a thousand fibers.

Cables make fibers easier to handle.

Individual fibers in a multifiber cable usually are color-coded or marked in ways that make them easy to identify. The color-coding is on a thin plastic layer that covers the plastic coating of the fiber. This coding is vital in helping cable installers keep track of connections. Color-coding also makes fibers more visible on a work surface than do clear-plastic coatings.

Cables also serve as mounting points for connectors and other equipment used to interconnect fibers. If you take that function too much for granted, try butting two bare fibers together with your hands and finding some way to hold them together permanently.

Protection from Damaging Forces

Another major goal of cabling is to prevent physical damage to the fiber during installation and use by forces applied intentionally or unintentionally. The two major concerns are stress or tension applied along the length of the cable, and crushing forces applied across the cable's diameter. The ability of cables to withstand these forces varies widely with cable design.

The most severe stresses intentionally applied along the length of a cable come during installation. Many cables are pulled into place through underground ducts outdoors or through conduits within buildings. Pulling gear is attached directly to strength members on cable jackets, isolating the fibers from the force needed to pull the entire cable into place. Aerial cables also may be pulled into place. An alternative approach that reduces stress along the length of the cable is to blow lightweight cables along the length of a duct or conduit.

Cables encounter much less static stress once they are installed, although aerial cables hanging from supports must be able to support their own weight. In cold environments, the cables must also be able to support snow and ice adhering to them.

Static fatigue is a significant issue because glass fibers age very quickly if stretched much. This makes it important to isolate fibers from mechanical loads, so elongation during manufacture and installation is no more than 0.1% to 0.2%.

Cables also can experience short-duration dynamic forces along their lengths. Most of these are unintentional, such as tree limbs falling on aerial cables. Cables can provide reasonable protection against light branches or overweight crows landing on them, but they can be broken by severe shocks. Falling trees and telephone poles snap aerial cables; careless backhoe operators dig up and break underground cables. Even cables inside buildings are vulnerable to damage if someone yanks or trips on them.

Crush resistance is another important cable specification, measuring how well they can withstand force applied from the sides. Requirements differ widely. Ordinary intrabuilding cables are not made to be walked on, but a few have been made for installation under carpets. Deep-sea submarine cables must withstand the pressure of several kilometers of seawater above them.

Cables can be armored to withstand unusual stresses. For example, the portions of submarine cables near shore are armored to protect them against damage from fishing trawlers and boat anchors. Buried cables must withstand a different type of crushing force applied in a small area: the teeth of gophers, who gnaw anything they can get their teeth around. The front teeth of gophers and other rodents grow continually, so they instinctively gnaw on objects they find underground. This is one case where the small size of fiber cables is undesirable, because it makes them just bite-sized for gophers. To prevent such damage,

Cables prevent physical damage to fibers during installation and use.

Crush resistance is how well cables withstand crushing force applied from the side.

cables buried in areas where burrowing rodents live typically are sheathed in steel armor and built to larger sizes than gophers like to munch.

Cables are made stiff to keep fibers from being bent too tightly. This practice also helps prevent fibers from developing tiny microcracks, caused by surface nicks, which can lead to fiber breakage.

Many cables are now designed for quite specific applications, such as within air spaces in buildings or for aerial suspension from poles. Figure 8.1 shows a few representative examples. You'll learn about the structures that make up these cables and their specific applications later in this chapter.

Protection from Environmental Degradation

Cabling also protects fibers from the more gradual degradation caused by the surrounding environment. Cables are designed to withstand specific conditions, making it important to match the cable to the working environment. The utmost care must be taken in the harshest environments.

Cabling helps protect fibers from moisture.

FIGURE 8.1

A sampling of cable designs. (Courtesy of Corning Cable Systems)

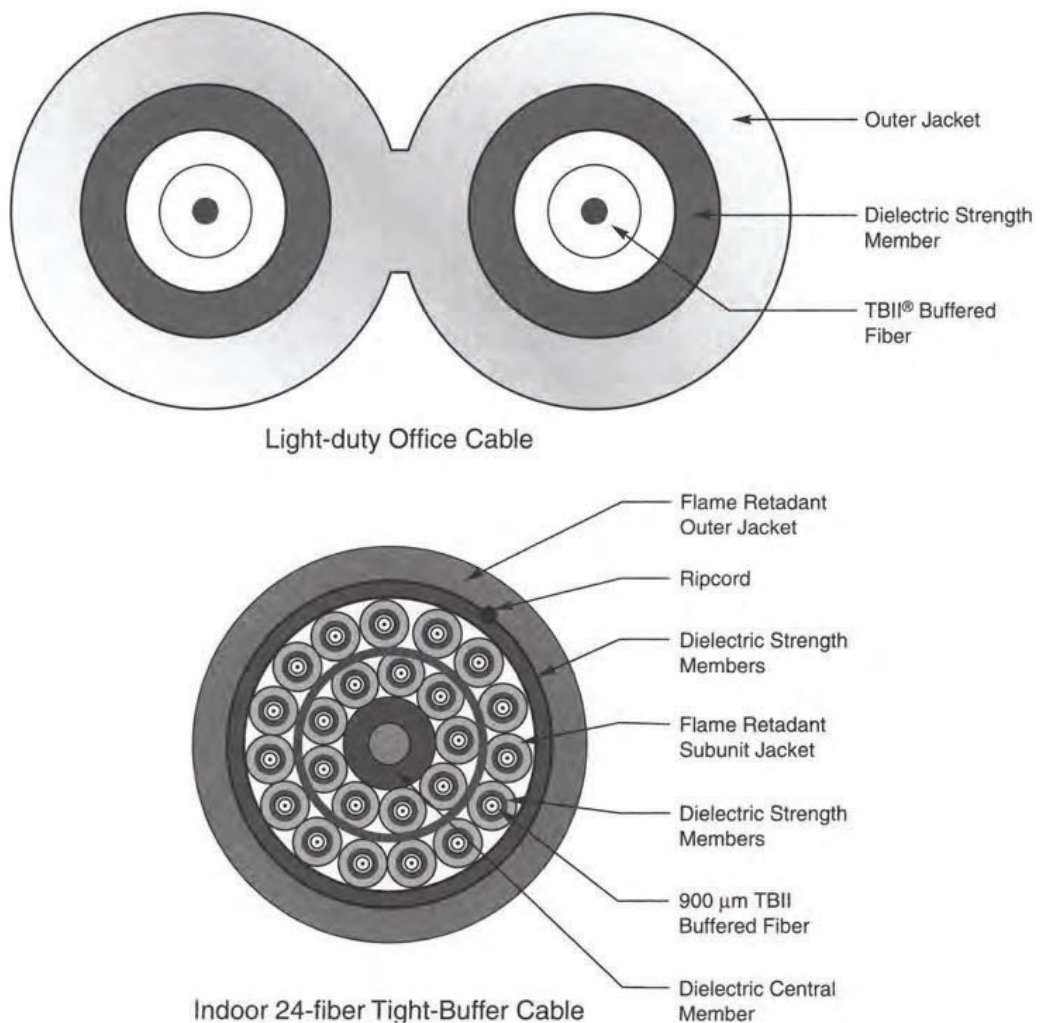
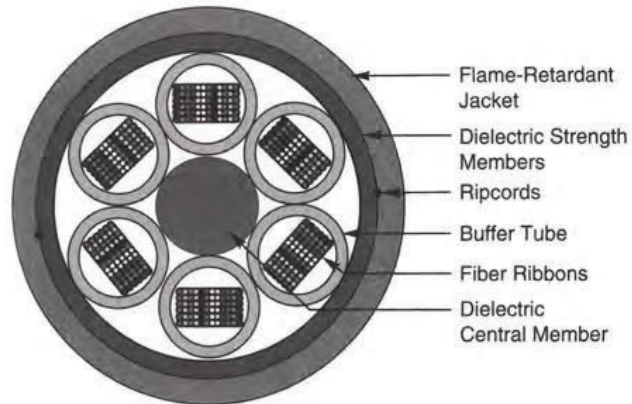
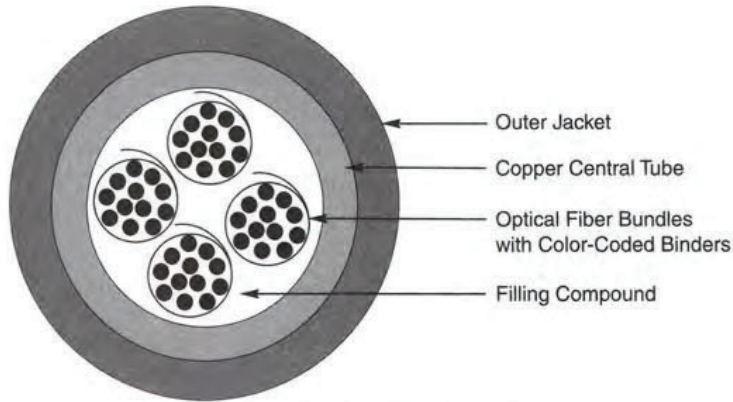

FIGURE 8.1

Continued



432-fiber Ribbon Cable for Indoor Use



Armored Cable for Installation in Roads and Sidewalks

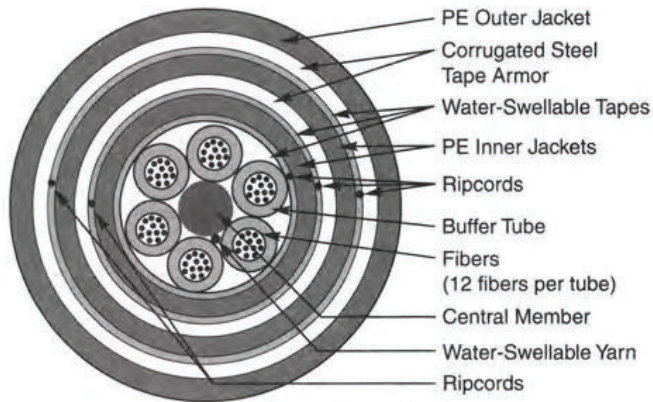

Multi-armored Cable for Direct Burial

Long-term exposure to moisture can degrade fiber strength and optical properties. Most cables designed for an uncontrolled (i.e., outdoor or underground) environment include barriers to keep moisture out. Aerial cables must withstand temperature extremes, from blazing heat on hot, sunny summer days to freezing cold in the winter. The combination of cold and moisture presents an added danger—freezing of moisture inside the cable. Because water expands when it freezes, it can exert forces that produce microbends, increase losses, and even cause microcracks in the fibers.

A significant long-term concern for fibers carrying signals at 1300 to 1650 nm is preventing the accumulation of hydrogen, which as you learned in Chapter 5 has a large absorption peak centered on 1380 nm. Hydrogen is rare in the air, but it can accumulate in a cable that carries electric currents. Electric currents decompose water molecules and some plastics, and the resulting hydrogen gas can diffuse into the glass. Small concentrations of hydrogen can disrupt transmission in the 1350–1450 nm region, and higher concentrations can cause absorption across a broader range. Modern cable designs should avoid hydrogen accumulation.

In all other circumstances, however, fiber undergoes no serious degradation if properly cabled. Nearly three decades have passed since the first fiber-optic systems were installed, and cable design has been greatly refined; but long-term monitoring of some early systems has shown no serious degradation of properly protected fibers.

Types of Cable

● Cables are designed for particular environments.

A single type of fiber may be used in many different environments, but cables are designed for specific requirements. Look through a cable catalog and you'll see a long list of different types of cable, which vary in internal structure and the number of fibers they contain. Cables must meet fire and electrical safety codes, which ban indoor installation of materials that catch fire easily or release toxic gases.

Cable manufacturers use modular design, which they adapt and assemble into cables for particular needs. They have families of cables that can incorporate all the major types of fiber used for communications. They often assemble cables from subunits, such as ribbons, which can contain various numbers of fibers. In short, cable manufacturers build cables to fit customer requirements.

A variety of factors enter into their choices. We'll start by looking at environmental considerations.

Types of Environments

The major types of environments for optical cable can be loosely classified as follows:

- Inside devices (e.g., inside a telephone switching system or computer).
- Intraoffice or horizontal (e.g., across a room, usually to individual terminals or work groups).
- Intrabuilding or riser (e.g., up wiring risers or along elevator shafts between floors in a structure; typically between distribution nodes on each floor that serve multiple users).

- Plenum installations (i.e., through air spaces in a building; must meet special codes).
- Interbuilding or campus links (short exterior connections; link distribution nodes in separate buildings).
- Drop cables, which carry signals from outdoor cables to homes or businesses.
- Blown-fiber cables, in which fibers are blown into previously installed hollow tubes.
- Chemical-resistant cables for industrial environments.
- Temporary light-duty cables (e.g., remote news gathering at sports events).
- Aerial cables (e.g., strung from utility poles outdoors). May be supported by lashing to support wires or other cables.
- All-dielectric self-supporting cables.
- Cables installed in plastic ducts buried underground.
- Direct-burial cables (i.e., laid directly in a trench or plowed into the ground).
- Submarine cables (i.e., submerged in ocean water or sometimes fresh water).
- Instrumentation cables, which may have to meet special requirements (e.g., withstand high temperatures, corrosive vapors, or nuclear radiation).
- Composite cables, which include fibers and copper wires that carry signals (used in buildings). Note the differences from hybrid cables, as follows.
- Hybrid power-fiber cables, which carry electric power (or serve as the ground wire for an electric power system) as well as optical signals.

These categories are not exhaustive or exclusive, and some are deliberately broad and vague. Instrumentation, for example, covers cables used to log data collected while drilling to explore for oil or other minerals. Special cables are needed to withstand the high temperatures and severe physical stresses experienced within deep wells. There is some overlap among categories; composite cables, for example, may also be classed as intraoffice cables.

Cable Design Considerations

A variety of considerations go into cable design, starting with the physical environment and the services being provided. They lead to a wide variety of cable types on the market. The most important considerations are summarized next.

- Intradvice cables should be small, simple, and low in cost, because the device containing them protects the cables.
- Intraoffice and intrabuilding cables must meet the appropriate fire and electrical codes. The National Electric Code (issued by the National Fire Protection Association) covers fiber cables that contain only fibers and

● Cables used inside buildings must meet fire and electrical codes.

Table 8.1 Cable specifications under U.S. National Electric Code

Cable Type	Description	Designation	UL Test
General-purpose (horizontal)—fiber only	Nonconductive optical fiber cable	OFN	Tray/1581
General-purpose (horizontal)—hybrid (fiber/wire)	Conductive optical fiber cable	OFC	Tray/1581
Riser/backbone— fiber only	Nonconductive riser	OFNR	Riser/1666
Riser/backbone— hybrid	Conductive riser	OFCR	Riser/1666
Plenum/overhead— fiber only	Nonconductive plenum	OFNP	Plenum/ NFPA 262
Plenum/overhead— hybrid	Conductive plenum	OFCP	Plenum/ NFPA 262

cables that contain both fibers and copper wires. The primary concern is fire safety, because many cable materials are flammable, and some release toxic gases when they burn. Table 8.1 lists cable types and fire-safety tests specified by Underwriters Laboratories. Outdoor cables that do not meet these requirements can run no more than 50 ft (15 m) within a building before terminating in a cable box or being spliced to an approved indoor cable. Indoor/outdoor cables are available that meet indoor requirements and can withstand outdoor conditions, although they are not as rugged as heavy-duty outdoor cables.

- *Plenum cables* are special intrabuilding cables made for use within air-handling spaces, including the spaces above suspended ceilings, as well as heating and ventilation ducts. They are made of materials that retard the spread of flame, produce little smoke, and protect electronic equipment from damage in fires, called “little smoke, no halogen” (LSNH) materials. (Halogens produce toxins.) Cables meeting the NFPA 262 specification can be run through air spaces without special conduits. The special materials are expensive and are less flexible and less abrasion-resistant than other cable materials, but installation savings and added safety offset the extra cost.
- Fiber count depends on the number of terminals served. Individual terminals may be served by a two-fiber duplex cable that looks like the zip cord used for electric lamps. Other types are round or oval in cross section and the largest contain over a thousand fibers. Multifiber cables often terminate at patch panels or communications “closets” where they connect to cables serving individual terminals.

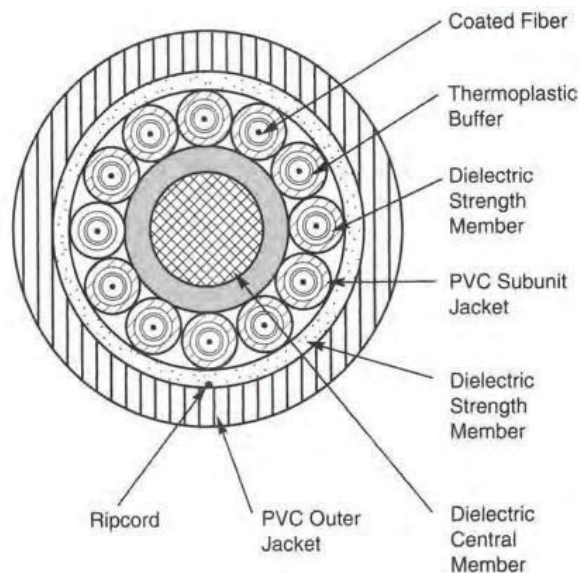
**FIGURE 8.2**

*Breakout cable.
(Courtesy of
Corning Cable
Systems)*

- Breakout or fanout cables are intrabuilding cables in which the fibers are packaged as single- or multifiber subcables. This allows users to divide the cable to serve users with individual fibers, without the need for patch panels. Figure 8.2 shows an example.
- Composite or hybrid cables include both fibers and copper wires to deliver different communication services or communication and power to the same point. For example, the fiber may connect a workstation to a local area network while the wires carry voice telephone service to the same user.
- Temporary light-duty cables are portable and rugged enough to withstand reasonable wear and tear. They may contain only a single fiber (e.g., to carry a video feed from a camera) and should be durable enough to be laid and reused a few times.
- Outdoor cables are designed to survive harsh outdoor conditions. Most are strung from overhead poles, buried directly in the ground, or pulled through underground tubes called ducts, but a few in protected areas are exposed to surface conditions. Most have polyethylene jackets, which keep out moisture and withstand temperature extremes and intense sunlight. However, polyethylene does not meet indoor fire codes, so such cables can run only short distances indoors, typically to equipment bays from which indoor cables fan out.
- Aerial cables are made to be strung from poles outdoors and typically also can be installed in underground ducts. They normally contain multiple fibers, with internal stress members of steel or synthetic yarn that protect the fibers from stress. Figure 8.3 shows two types of aerial installations, which normally use different types of cables. One suspends the cable

● Breakout cables are intrabuilding cables with fibers packaged into subcables.

● Outdoor cables can withstand harsher environments than intrabuilding cables but do not meet the same fire and building codes.

FIGURE 8.3
Aerial cable
installations.

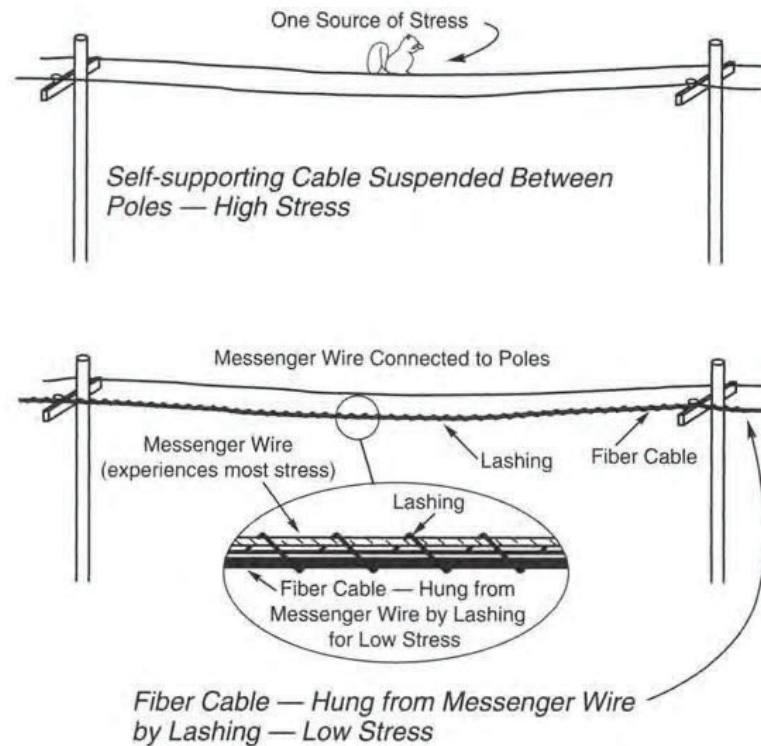

between adjacent poles, supported by internal strength members or by a strength member packaged parallel to the fiber unit, which hangs below in what is called a “figure-8” cable. The other approach is to run a strong “messenger wire” between poles and lash the fiber cable to it by winding a supporting filament around both. Lashing supports the fiber cable at more frequent intervals and reduces the stress applied along its length, which can be large if the only supports are at the poles. Many aerial fiber cables are designed only for lashing, not to withstand the high stress of suspension between poles.

- All-dielectric cables contain no metal elements, either to conduct electricity or to serve as strength members. These cables use nonconductive strength members, such as fiberglass yarns or glass-reinforced plastic (GRP) strength rod. The all-dielectric construction prevents lightning surges and ground-loop problems, so they are widely used outdoors, particularly in lightning-prone areas.
- Armored cables are similar to outdoor cables but include an outer armor layer for mechanical protection and to prevent rodent damage. Steel or all-dielectric central members may be used. They can be installed in ducts or aerially, or directly buried underground (which requires extra protection against the demanding environment of dirt). Normally, the armor is surrounded inside and out with polyethylene layers that protect it from corrosion and cushion the inside from bending damage.

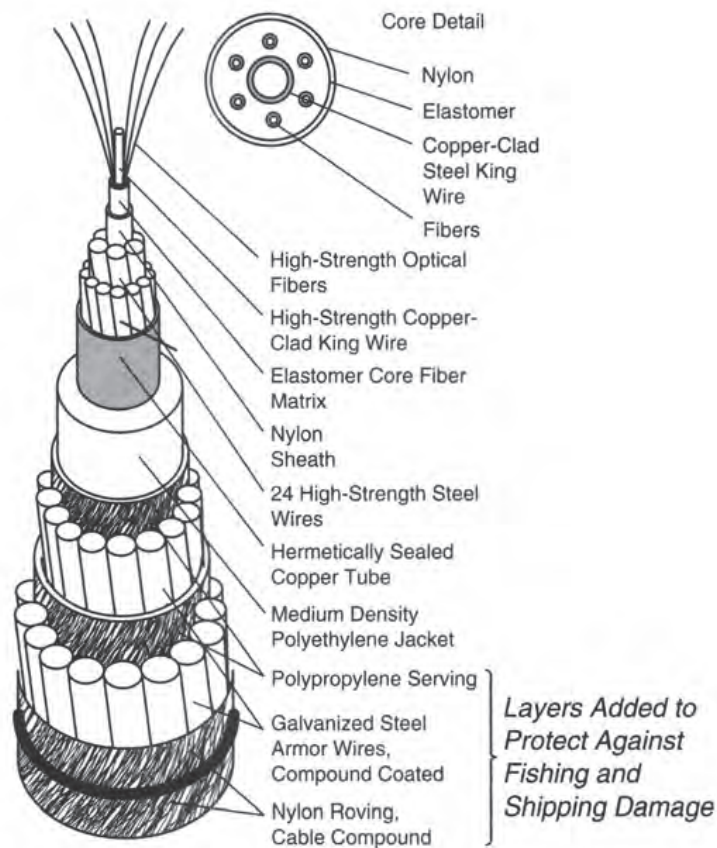

Outside Diameter 51 mm (2.010 in.)

FIGURE 8.4

Fiber-optic submarine cable.
(Courtesy of TyCom Ltd.)

- Submarine cables can operate while submerged in fresh or salt water. Those intended to operate over relatively short distances—no more than a few kilometers—are essentially ruggedized and waterproof versions of direct-burial cables. Cables for long-distance submarine use are more elaborate, as shown in Figure 8.4. Some parts of submarine cables are buried under the floor of the river, lake, or ocean, largely to protect them from damage by fishing trawlers and boat anchors. The multilayer design shown in Figure 8.4 can withstand ocean floor pressures; the outer armor is not needed on the deep-sea bed, where no protection is necessary against fishing trawlers and other boat damage.

Elements of Cable Structure

The diverse variety of fiber-optic cables are built from a common set of structural elements. Individual fibers are housed in one of three different elements—a tight buffer, a loose tube, or a ribbon. These structural elements can house one or more fibers, and they, in turn, are

● All fiber-optic cables are made up of common elements.

grouped together within the cable. The more fibers, the more levels of grouping are likely. Some of these internal assemblies may be called *subcables* or *breakouts* because they can be split from the main cable and strung to another point. Individual fibers within each group may be color coded, with the groups or subcables themselves, in turn, color coded so each fiber can be identified.

Multifiber cables usually are built around central strength members. Sometimes the central strength members are fillers; and sometimes ribbon cables, assembled with flat ribbons stacked in the center of the cable, are surrounded by strength members. Single- and dual-fiber cables typically are surrounded by strength members.

A *jacket* encloses the entire cable structure, sealing it from the environment. *A armor* provides additional mechanical protection, particularly where cables might be exposed to burrowing rodents or mechanical hazards. *Rip cords* embedded in the cable structure can split the jacket to access individual fibers or subcables. Electrical conductors deliver power where needed, or allow one cable to carry both electronic and fiber-optic signals.

Let's look at these structures in more detail.

Fiber Housings

The two fundamental types of fiber housing are rigid jackets and loose tubes, both shown in Figure 8.5. Each type has its own advantages, applications, and variations.

Tightly buffered cables cover plastic-coated fibers with a thick buffer layer of harder plastic, making the fibers easier to handle. These buffered fibers can be packed tightly together in a compact cable structure, an approach widely used indoors. *Ribbon cables* are a variation in which several parallel fibers are encased in a flat outer buffer.

Loose-tube cables leave the plastic-coated fibers loose inside a flexible tube. For outdoor use, the tube usually is filled with a gel that prevents moisture from seeping inside. Multiple fibers can fit inside each tube. The loose-tube structure mechanically isolates the fibers from the cable structure, enabling the cable to handle thermal and other stresses encountered outdoors.

Fibers can be housed in tight buffers or loose tubes.

FIGURE 8.5
Tightly buffered and loose-tube structures for cables.

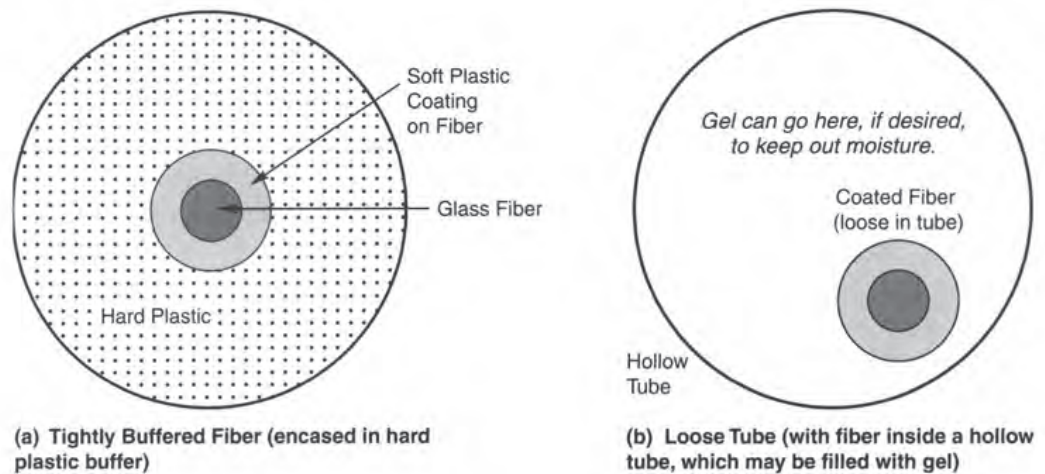

Blown fibers are a variation on the loose-tube design in which the tube is installed first, then fibers are blown along its length. Once the fibers are installed, they function as they would in a loose-tube cable.

Each cable type has its advocates, and the boundaries between their applications are not rigid: Tightly buffered cables can be built for outdoor applications, while loose-tube cables also are made for indoor use.

LOOSE-TUBE CABLE

The simplest loose-tube design contains a single plastic-coated fiber in a long tube, with inner diameter much larger than the fiber diameter. The fiber is installed in a loose helix, so it can move freely inside the tube. This design protects the fiber from stresses applied to the cable structure during installation or service, including the effects of changing temperature, which could cause bending loss or damage the fiber.

There are several variations on the loose-tube approach. Multiple fibers can run through the same tube, either individually or assembled into one or more ribbons. Individual fibers usually are color-coded. The tube does not have to be a physically distinct cylinder running the length of the cable. Alternatives include running grooves along the length of a solid cylinder encased in a larger tube, and pressing corrugated structures together and running fibers through the interstices. The end result is the same; the fiber is isolated from stresses applied to the surrounding cable structure.

Alternatively, fibers can be blown into a previously installed hollow tube that guides them along the cable route. When the fibers are in place, the unit functions as a loose-tube cable. The installation technique is described later.

Moisture-blocking gels can be messy, but they are widely used in outdoor loose-tube cables. Some older cables had similar gels or “grease” around the outside of each tube, filling the interstices of the cable. Cleaning was time-consuming and messy, so dry water-blocking materials are now used between tubes.

Loose-tube cables are preferred for outdoor environments where the cable may be stressed or exposed to moisture. They can be installed from poles, in ducts, or by direct burial. A single tube can contain many fibers, allowing high fiber densities in compact cables. The cables can also be made of flame-retardant materials to meet codes for indoor use, particularly where high fiber counts are needed.

TIGHTLY BUFFERED FIBER

A tightly buffered fiber is encased (after coating) in a plastic layer. The coating is a soft plastic that allows deformation and reduces forces applied to the fiber. The harder outer buffer provides physical protection.

Tight buffering tolerances assure that the fibers are in predictable positions, making it easier to install connectors. The tight-buffer structure creates subunits that can be divided among many terminals, without using patch panels. Tight-buffer cables are smaller for small fiber counts than loose-tube cables, but the ability to pack many fibers into a single loose tube makes that advantage disappear as the fiber count increases.

Loose-tube cables are filled with gels for outdoor use.

Tightly buffered fibers are typically used indoors.

A major advantage of tight-buffered cable for indoor use is its compatibility with materials that meet fire and electrical codes. Although losses may be somewhat higher than in loose-tube cables, indoor transmission distances are short enough that it's not a problem.

RIBBON CABLE

Many parallel fibers can be encased in plastic to form a ribbon around which cables can be built.

The arrangement of fibers in a ribbon cable shown in Figure 8.6 is in some ways a variation on the tightly buffered cable. Each ribbon is made by aligning several coated fibers parallel and touching each other, then coating them with a plastic buffer or jacket to form a single multifiber ribbon. While tightly buffered fibers are individual structures, the ribbon is a unit containing 4 to 36 fibers, which resembles the flat 4-wire cables used for household telephones. Figure 8.6 shows two 12-fiber ribbons stacked on top of each other; up to a dozen ribbons can be stacked to make an extremely dense block of fibers.

Ribbon cables can be used by themselves as the basis of a fiber cable, with a stack of ribbons at the core surrounded by a cable structure. Alternatively, one or more ribbons can be stacked inside loose tubes and assembled into a loose-tube fiber cable. Stacking ribbons can yield very high fiber counts, such as the 864-fiber cable shown in Figure 8.7, made by stacking a dozen 12-fiber ribbons inside each of six loose tubes.

FIGURE 8.6

Fibers in a ribbon cable.

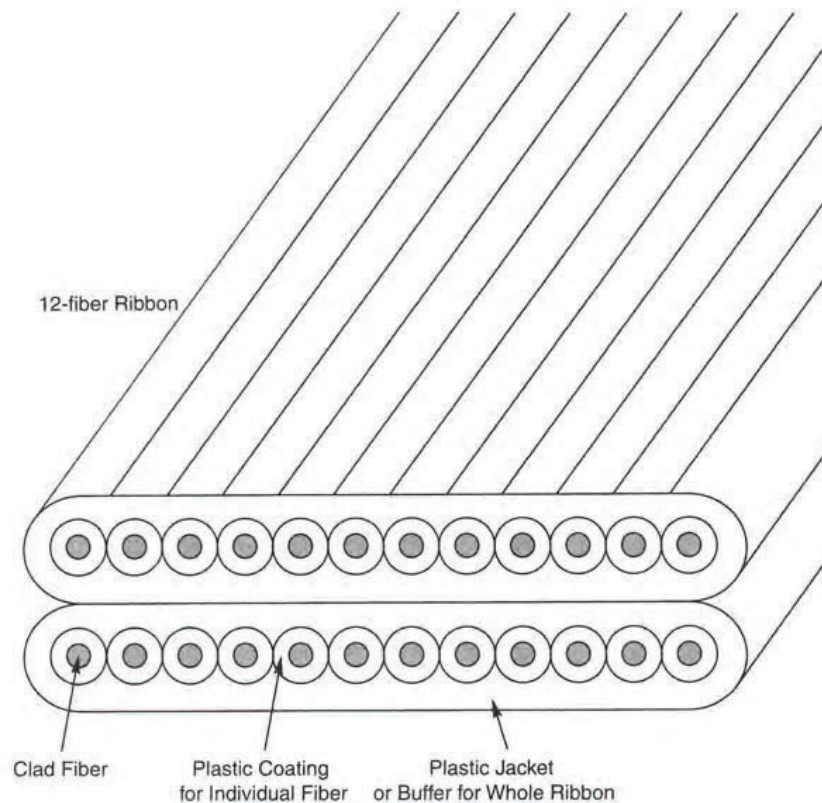

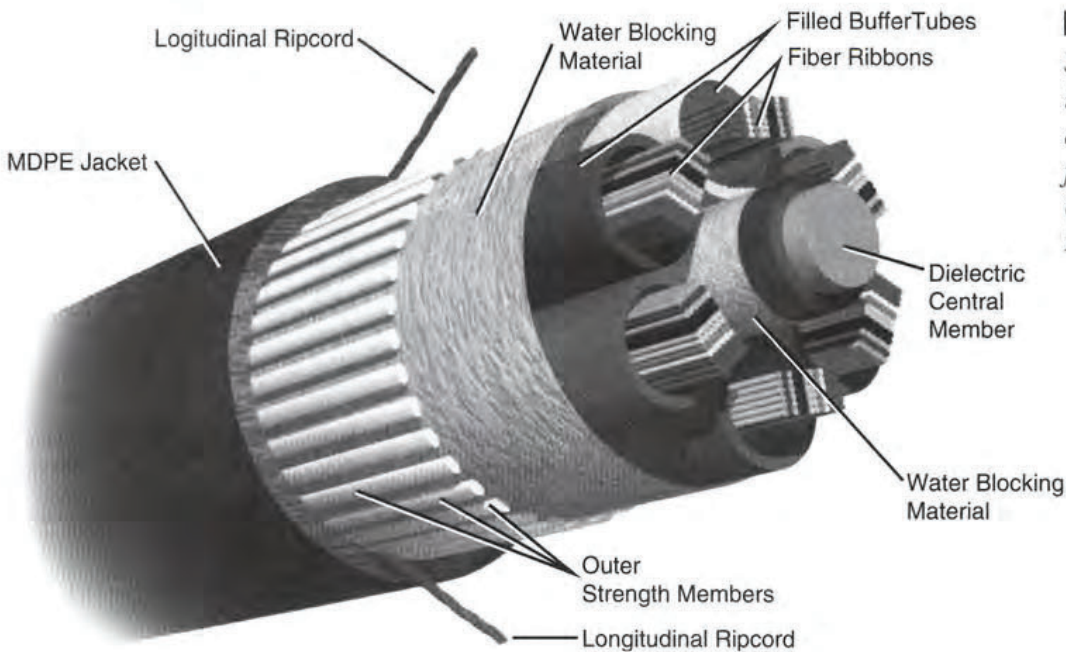
**FIGURE 8.7**

Stacking ribbons inside loose tubes can give very high fiber counts. (Courtesy of Pirelli Cable)

The simple structure makes a ribbon cable easy to splice in the field because each fiber is in a precisely predictable position. Multifiber connectors also can be installed easily on ribbon cables. The ribbons allow very dense packing of fibers, important for some applications. However, installation can cause uneven strain on different fibers in the ribbon, leading to unequal losses and other potential problems.

Fiber Arrangements in Cable

Fibers can be arranged in a cable in many different ways. The simplest cables are round with a single fiber at their center. *Duplex* (two-fiber) cables may either be circular or oval in cross section or be made like electrical zip cord, with two single-fiber structures bonded together along their length, as in Figure 8.1.

The more fibers in the cable, the more complex the structure. One common cable structure has six tightly buffered fibers wound loosely around a central member. The buffered fibers are wound so that they don't experience torsion in the cable. In loose-tube cables, the fiber count can be raised by putting multiple fibers in each tube. Groups of 8 or 12 fibers may also be wound around a central member.

Cables with more fibers are built up of modular structures. For example, a 36-fiber cable can be made from six loose-tube or tightly buffered subcables containing six fibers each, or from three 12-fiber ribbons. A dozen 12-fiber ribbons make a 144-fiber cable. Stacking together 18 loose-tube subcables, each containing a dozen fibers, makes the 216-fiber cable shown in Figure 8.8.

864-fiber cables are in use.

FIGURE 8.8

Modular cable containing 216 fibers, with 12 in each of 18 loose tubes. (Courtesy of Corning Cable Systems)

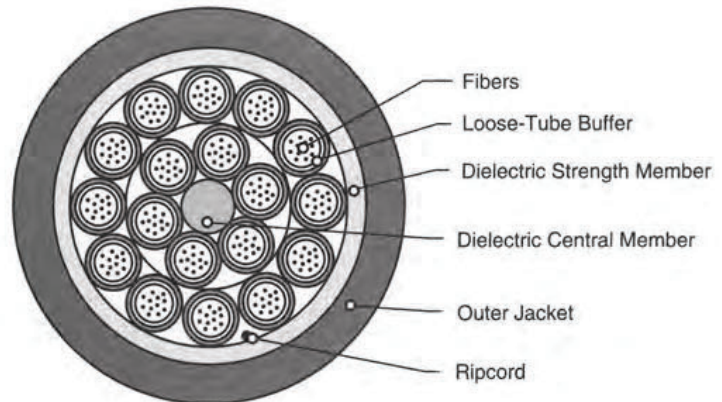

High fiber counts were rare in early installations, but they have become popular as fibers are used to distribute signals to more customers in large metropolitan areas. Cables with several hundred fibers are in use, and manufacturers now offer cables with up to 1,132 fibers.

Cabling Materials

Materials play an important role in cable properties.

The choice of materials plays a crucial role in determining characteristics of a cable. Designers usually face trade-offs among several factors. Fire safety is crucial for indoor cables, particularly those that run through air spaces, because some compounds used in outdoor cables produce toxins or catch fire easily. Moisture resistance and temperature tolerance are critical in most outdoor environments. Aerial cables must survive severe temperature extremes, sunlight, and wind loading; cable pulled through ducts must withstand surface abrasion as well as tension along its length. The major materials used in cabling are as follows:

- Polyethylene: Standard for outdoor cables because it resists moisture, it is stable over a wide temperature range, and resists abrasion. It does not meet indoor fire-safety rules, so only short runs are used indoors to reach service panels.
- Polyvinyl chloride (PVC): The most common material for indoor cables, it is available in different grades for various requirements. It is flexible, fire-retardant, and can be extruded easily during cabling, but it is not as durable or moisture-resistant as polyethylene.
- Polyvinyl difluoride (PVDF): A plastic used for plenum cables, it retards fire better than polyethylene and produces less smoke. It is less flexible and harder to extrude.
- Low smoke-no halogen (LSNH) plastics: Producing little smoke and very low levels of toxic halogen compounds, these materials are safest for cables used in enclosed spaces. These compounds have various names and may not be completely free of halogens (i.e., chlorine, fluorine, and bromine) because halogens reduce the flammability of plastics. These materials also

protect electronic equipment from corrosion and fire damage, but they are expensive and not as durable as PVC.

- High-strength dielectric compounds: Aramid yarn, known by the trade name Kevlar™, was used for dielectric strength members in cables until shortages developed recently. (Kevlar is used in military and police body armor.) Other compounds are now used.

Other Structural Elements

Fibers and their buffers are not the only structural elements of cables. Many—but not all—fiber-optic cables include other components to provide strength and rigidity.

Many cables are built around central members made of steel, fiberglass, or other materials. These run along the center of the cable and provide the rigidity needed to keep it from buckling, as well as a core to build the cable structure around. A central member may be overcoated with plastic or other material to match cable size requirements and to prevent friction with other parts of the cable. Small indoor cables containing few fibers generally lack central members, but they are common in outdoor cables, and in indoor cables with high fiber counts.

The structure containing the fibers surrounds central members in cables that contain central members. Otherwise this structure is at the center of the cable. This structure also contains the supporting structures, such as tubes containing groups of fibers.

Strength members provide tensile strength along the length of cables that are subjected to tension during or after installation. A strength member may be at the core of the cable, or may be a layer between the cable jacket and the fibers, as shown in Figure 8.9. Some cables have both inner and outer strength members. Tension is applied directly to the strength member when a cable is pulled into a duct.

The outer jacket is a plastic layer that covers the cable structure, protecting the fibers from abrasion, moisture, and other damage. Its composition depends on the application.

Underwater and buried cables are among the types that require one or more layers of protecting armor. Typically for buried cables, steel is wound around an inner plastic sheath.

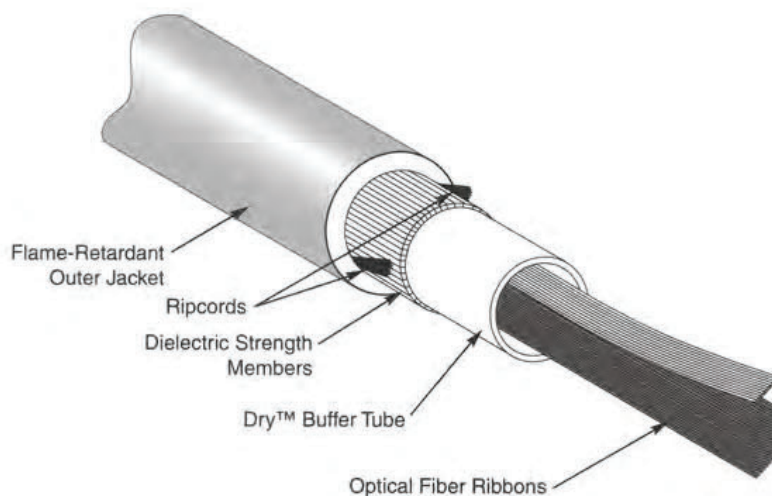

FIGURE 8.9

Strength members are wound around the buffer tube, which holds ribbon fibers in a plenum cable that does not have a central strength member. (Courtesy of Corning Cable Systems)

● Many cables contain central members to make them rigid and strength members to withstand tensile forces.

● Buried and underwater cables require armor.

An outer plastic sheath is then applied over the armor to prevent corrosion. The metal armor helps protect against crushing damage, rocks, and rodents. Underwater cables in shallow waters may have multiple layers to protect against damage from shipping and fishing operations, as shown in Figure 8.4.

Blown-in Fibers

● Fibers can be blown through microducts instead of installing normal cables.

Traditionally, cables are installed as finished units, containing both fibers and protective structures. An alternate approach is to install hollow microducts—typically about 5 mm in diameter—then to blow fibers through them. Forcing air through the microduct carries the fiber along with it, pulling all along its length so it doesn't damage the fiber.

The process uses conventional single- or multimode fibers coated with a blowable coating, designed to be dragged along by air forced through the microducts. The air can carry the coated fibers around bends, and over distances of more than 1000 feet (300 meters), usually within a building or between adjacent buildings.

The use of blown fibers is a two-stage process. The flexible microducts that carry the fibers must be installed first, then the fiber is blown through them. The major attraction is that the fibers need not be blown in at once, and that fibers can be replaced easily, like cables in underground ducts. Thus you could install the microducts when renovating a building, and blow in the fibers later, when you know transmission requirements. If a fiber was damaged, you could pull it out and blow in a replacement. With the proper equipment, fibers can be blown into place very quickly.

From a functional standpoint, blown-in fibers behave like loose-tube cables without a filler in the tubes. Materials used in the plastic tubes are chosen to meet the appropriate fire and electrical codes. While blown fibers are not widely used, the technology is available.

Cable Installation

● Special techniques are used to install different types of cable.

Cable installation is a specialized task, and the detailed procedures are beyond the scope of this book. Most methods for installing optical cables have been adapted from those used for copper cables. Outdoor cables are laid along rights of way leased or owned by telecommunications carriers, such as along a railroad or highway, which are well marked after the cables are installed.

The basic approaches depend on the type of cable being installed.

- Submarine cables are laid from ships built for that purpose. Typically they are buried in a trench dug on the sea floor at depths of less than about 200 meters (600 feet), and laid directly on the ocean floor in deep ocean basins.
- Direct-buried cables normally are laid in a deep, narrow trench dug with a cable plow, which is then covered with dirt.
- Cable ducts are plastic tubes laid in trenches dug for the purpose, then covered over. Duct sizes and flexibility vary; some are only an inch or two and can be wound on large spools; others are a few inches in diameter and rigid. The ducts typically are directly covered by soil, but sometimes

may be encased in concrete to add structural integrity and prevent service disruptions. The ducts are installed without cables inside. Duct routes may be direct between endpoints, or may be routed through a series of underground access points at manholes.

- Cables can be installed in ducts by threading a pull line through the ducts, attaching it to the cable, then pulling the cable through with the pull line. If manholes or other access points are available along the route, cable runs are pulled between them.
- Cables can be blown into place along the length of a duct, just as fibers can be blown into a microduct. As with blown fibers, the air applies force along the length of the cable, minimizing the chance of damage. This technique is easy and has become very popular for outside plant.
- Self-supporting aerial cables may be suspended directly from overhead poles. Other aerial cables can be suspended from messenger wires, strong steel wires strung between poles. If a messenger wire is used, the cable is lashed to it with a special lashing wire running around both the cable and the messenger wire, or sometimes wound around it. This is a common installation for many overhead fiber cables because it minimizes strength requirements.
- Plenum cables are strung through interior air spaces.
- Interior cables may be installed within walls, through cable risers, or elsewhere in buildings. Installation is easiest in new construction. Only special cables designed for installation under carpets should be laid on the floor where people walk.
- Temporary light-duty cables are laid by people carrying mobile equipment that requires a broadband (typically video) connection to a fixed installation.

Cable Changes and Failure

Cabling can cause minor changes in fiber properties, particularly attenuation. The major reason for these changes is microbending, which depends on the fiber's local environment and on stresses applied to it. These stresses generally are negligible for cables in protected or stable environments, such as inside buildings or in buried duct. Aerial cables are subject to the most extreme variations, because they are exposed to conditions from summer sun to winter ice. Repeated heating and cooling can cause microbending because the glass fiber and the cable materials do not expand and contract with temperature at the same rate. Tightly buffered fibers generally are considered more vulnerable to microbending losses, but in well-made cables the differences are quite small.

Telephone companies were very cautious before beginning their massive conversion to fiber-optic cables, conducting extensive tests and field trials to evaluate the reliability of fiber. Engineers were instinctively wary of glass, but many tests have shown that fiber cables are very durable under normal conditions. Although poor installation can damage fibers, fibers or cables rarely fail in properly installed systems unless physical damage occurs.

● Microbending can cause changes in fiber attenuation after cabling.

● Most cable failures are due to physical damage.

Gophers and other burrowing rodents are natural enemies of all buried cables. Their front teeth grow continually, and they instinctively gnaw on anything they can get their incisors around, including cables. Gophers are a serious problem in some areas in the United States, and cables buried in those areas should be armored and otherwise designed to deter gopher attack. The U.S. Fish and Wildlife Service even developed a standardized “gopher test” in which a cable was run through a gopher cage and left in place for seven days to test its resistance to the gnawing rodent. Cables buried in some areas must meet these rodent-proof standards. (Cables containing obsolete fibers are sometimes called “gopher bait” because they are of little use for telecommunications.)

Human activity is responsible for most other damage to buried cables. The archetypical example is a backhoe digging up and breaking a buried cable, an event industry veterans call “backhoe fade.” Construction damage by careless contractors is a serious problem but the subject of some jokes. One telecommunications company runs its long-distance cables alongside natural-gas pipelines, where it posts warnings, which one top manager summarized as “you dig, you die.”

Aerial cables are vulnerable to many other types of damage, from errant cranes to falling branches and heavy loading with ice and snow. All kinds of cables can be—and are—cut by mistake by maintenance crews. Light-duty indoor cables can be damaged by closing doors or windows on them; the fibers can be broken without causing obvious damage to the outside of the cable. Tripping over a cable is not likely to break the cable, but it could snap the fibers inside, or jerk the cable out of a connector at one end. (In general, connectors are the weakest points of short cables.)

Fibers do not always break at the exact point where the cable is damaged. When stressed along their lengths, fibers tend to break at weak points, which may be a short distance away from the obvious damage to the cable. The break points can differ among fibers in a multifiber cable, so you might have to go a ways from the break before you find the ends of all fibers. As with copper cables, physical damage to the cable does not invariably sever fibers.

What Have You Learned?

1. Fibers can break at inherent flaws and develop microcracks under tension, so they must be protected from stretching forces.
2. Cabling packages fibers for protection and easier handling.
3. Cables must resist crushing as well as isolate the fiber from tension along its length.
4. Cables protect fibers from heat, cold, and moisture. The designs chosen vary widely, depending on environmental conditions.
5. Indoor cables must meet fire and electrical safety codes. The major impact of these codes is on composition of the plastics used in the cable structure.
6. Cables can carry from one over 1000 fibers.
7. Important structural elements in a cable are the housing for the fiber, strength members, jacketing, and armor. Armor is used only in certain environments where physical damage is a threat.

8. Outdoor cables may be hung from poles, pulled or blown through ducts, or buried directly in the ground.
9. Fibers can be enclosed in a loose tube, a tight plastic buffer, or a ribbon.
10. The physical arrangement of fibers in the cable depends on the number of fibers and how they are to be distributed in the installation.
11. Much cable damage occurs when a sudden force is applied, such as when a backhoe digs up a buried cable.

What's Next?

In Chapter 9, we will examine the light sources used with fiber-optic cables.

Further Reading

Bob Chomycz, *Fiber Optic Installer's Field Manual* (McGraw-Hill, 2000)

Jim Hayes, *Fiber Optics Technician's Manual* (Delmar, 1996)

Questions to Think About

1. The design of fiber-optic cables evolved from the design of electrical cables for similar applications. What is one common problem with aging electrical cables that does not affect fiber-optic cables?
2. What is one problem with fiber-optic cables *not* present with electronic cables?
3. Why make one cable with 1000 fibers rather than 10 with 100 fibers?
4. A cable weighs 300 kilograms per kilometer, with poles placed 50 meters apart on the road. A flock of twenty 0.5-kilogram crows perch on the cable to watch the scenery. By what percentage do they increase the weight of the cable span?
5. An ice storm coats the cable with a 1-cm layer of ice. Assume for simplicity that the cable is 2 cm in diameter, and that ice weighs 1 gram/cubic centimeter. How much weight does the ice add to a 50-meter span of the cable?
6. What is the main difference between the structures of indoor and outdoor cables?

Chapter Quiz

1. What part of a cable normally bears stress along its length?
 - a. the fiber
 - b. the plastic coating of the fiber

- c. a strength member
 - d. metallic armor
 - e. all of the above
- 2.** Cables cannot protect fibers effectively against
- a. gnawing rodents.
 - b. stresses during cable installation.
 - c. careless excavation.
 - d. static stresses.
 - e. crushing.
- 3.** Light-duty cables are intended for use
- a. within office buildings.
 - b. in underground ducts.
 - c. deep underground where safe from contractors.
 - d. on aerial poles where temperatures are not extreme.
- 4.** The special advantages of plenum cables are what?
- a. They are small enough to fit in air ducts.
 - b. They meet stringent fire codes for running through air spaces.
 - c. They are crush resistant and can run under carpets.
 - d. They have special armor to keep rodents from damaging them.
- 5.** Outdoor cables are *not* used in which of the following situations?
- a. suspended overhead between telephone poles
 - b. tied to a separate messenger wire suspended between overhead poles
 - c. inside air space in office buildings
 - d. pulled through underground ducts
- 6.** A loose-tube cable is
- a. a cable in which fibers are housed in hollow tubes in the cable structure.
 - b. a cable for installation in hollow tubes (ducts) underground.
 - c. cable for installation in indoor air ducts.
 - d. used underwater.
 - e. none of the above
- 7.** Which of the following are usually present in direct-burial cables but *not* in aerial cables?
- a. strength members
 - b. outer jacket
 - c. armor
 - d. fiber housing

8. In what type of cable installation can the cable be blown into place?
 - a. direct burial
 - b. underground duct
 - c. military field systems
 - d. submarine cable
9. The main cause of differences in properties of a fiber before and after cabling is
 - a. microbending.
 - b. temperature within the cable.
 - c. application of forces to the fiber.
 - d. damage during cabling..
10. The most likely cause of failure of cabled fiber is
 - a. hydrogen-induced increases in attenuation.
 - b. corrosion of the fiber by moisture trapped within the cable.
 - c. severe microbending losses.
 - d. physical damage to the cable.

Light Sources

About This Chapter

Fiber-optic systems require light sources that can be modulated with a signal and transfer that optical signal efficiently into a fiber. The two primary types are light-emitting diodes (LEDs) and semiconductor lasers (also called *diode lasers*). This chapter covers important considerations for fiber-optic light sources, the basic principles of LEDs and lasers, and the main types of these light sources used in fiber-optic systems. It also briefly describes fiber lasers.

This chapter will teach you what you should know about lasers and LEDs to work with fiber optics, but it does not cover all types of lasers. Chapter 10 covers how light sources are incorporated into fiber-optic transmitters. Chapter 11 covers receivers, which convert optical signals back to electronic form at the other end of the fiber. Optical amplifiers, which are closely related to diode lasers and fiber lasers, are mentioned in this chapter, but covered in detail in Chapter 12.

Light Source Considerations

The primary light sources for fiber-optic communications are *semiconductor lasers* (often called *laser diodes* or *diode lasers*) and *light-emitting diodes* (LEDs). Fiber-optic light sources must meet several requirements. The wavelength must fall within a window transmitted by the optical fiber being used. The power must be adequate for the signal to reach the receiver or optical amplifier at the other end of the fiber, but not so high that it causes nonlinear effects in the fiber or overloads the receiver. The range of wavelengths should not be so wide that it affects transmission bandwidth. The emitted light must be modulated in some way so it carries a signal, then transferred efficiently into the transmitting fiber.

The same considerations apply to optical amplifiers, which must be matched to the signal wavelengths they are supposed to amplify and designed not to distort input signals.

Wavelength, spectral width, and power are major light-source considerations.

The most widely used optical amplifiers are based on the erbium-doped fibers described in Chapter 7.

The general range of wavelengths a light source can emit depends on its composition. The specific range of wavelengths depends on its structure, and special structures are needed to select narrow ranges of wavelengths or to vary the wavelength.

Let's look in more detail at these important considerations.

Operating Wavelength

Both signal attenuation and pulse dispersion in a fiber depend on operating wavelength. Transmission bands are picked to match windows of low absorption or low dispersion, or to take advantage of inexpensive light sources. The choice depends on the fiber and the application.

Glass fibers are used for telecommunications at wavelengths between about 1280 and 1620 nm. The most common bands are near 1310 nm, the zero-dispersion wavelength of standard single-mode fiber, and at 1530–1565 nm, where fiber attenuation is at a minimum. Many glass-fiber links spanning only a couple of kilometers operate at 780–850 nm, where inexpensive laser sources are available. Plastic fibers have relatively low loss at 650 nm.

Chromatic dispersion depends on the range of wavelengths emitted by the light source, called the *spectral width*. The broader the spectral width, the higher the dispersion and the lower the transmission bandwidth available. Standard LEDs have spectral widths of 30 to 50 nm, so they can only be used over limited distances for low-bandwidth signals. Low-cost diode lasers have spectral widths of 0.5 to 3 nm, as shown in Figure 9.1, so they can be used for higher-speed signals over longer distances. Generally, sending signals at speeds much above 1 Gbit/s over tens of kilometers requires narrow-line or *single-frequency* lasers with spectral widths below 0.01 nm. You'll learn about the differences in structure that lead to these spectral widths later in this chapter.

●
Signal attenuation and bandwidth depend on wavelength.

●
Single-frequency lasers limit chromatic dispersion.

FIGURE 9.1
Comparison of LED and laser spectral widths.

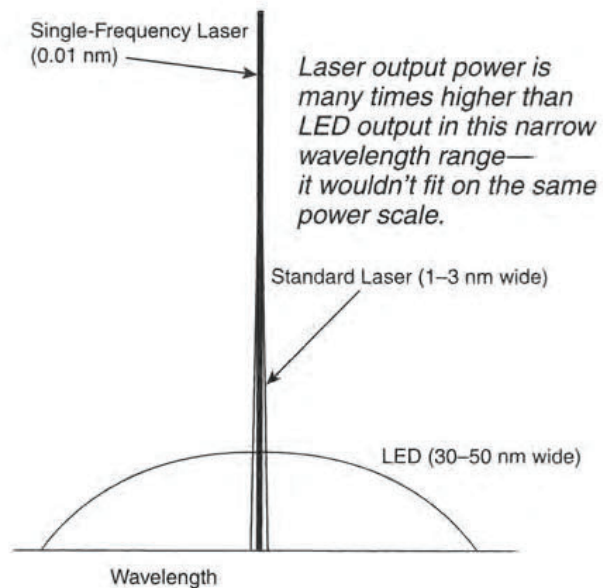

Wavelength-division multiplexing requires light sources that emit light in specific wavelength bands or slots. The light sources must emit a stable narrow band of wavelengths, so they don't drift into adjacent bands. Nominally one source is needed for each optical channel.

Some lasers can be *tuned* to change the wavelengths at which they emit light. This is attractive for systems that require many different wavelengths of laser light because it avoids the need for a different fixed laser at each wavelength. The trade-offs are expense and the need to stabilize the laser to emit at the same wavelength over a long period.

Output Power and Light Coupling

Power from communications light sources can range from more than 100 mW for certain lasers to tens of microwatts for LEDs. Not all that power is useful. For fiber-optic systems, the relevant value is the power delivered into an optical fiber. That power depends on the angle over which light is emitted, the size of the light-emitting area, the alignment of the source and fiber, and the light-collection characteristics of the fiber, as shown in Figure 9.2.

The light intensity is not uniform over the entire angle at which light is emitted but rather falls off with distance from the center. Typical semiconductor lasers emit light that spreads at an angle of 5° to 20° ; the light from LEDs spreads out at larger angles.

Losses of many decibels can easily occur in coupling light from an emitter into a fiber, especially for LEDs with broad emitting areas and wide emitting angles. This makes it important to be sure you know if the power level specified is the output from the device or the light delivered into the fiber.

The output power from semiconductor lasers and LEDs is proportional to the drive current. This allows *direct modulation* of the output light by varying the drive current passing through the device. The alternative is *external modulation* of light from a steady source using a device called a *modulator*, which changes its transparency in response to a separate signal.

Direct modulation is like flicking a light switch off and on, and external modulation is similar to opening and closing a shutter in front of the light. External modulation is more expensive, but gives better performance. A laser operated with a steady drive current has a narrower spectral width than one that is modulated directly.

Diode lasers and LEDs can be modulated directly.

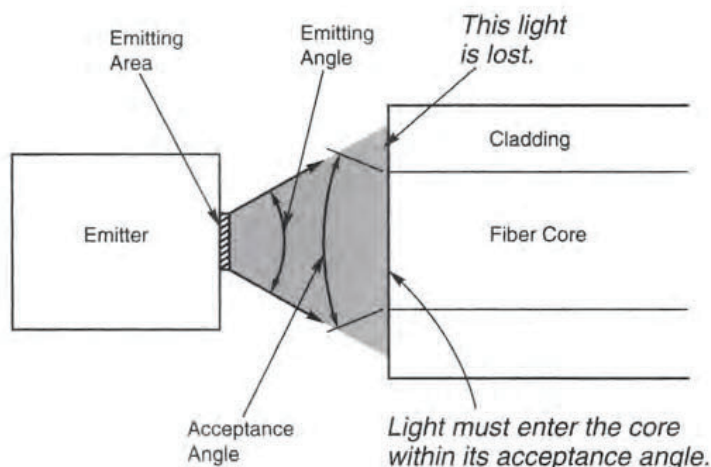

FIGURE 9.2

Light transfer from an emitter into a fiber.

Speed, wavelength, and linearity are critical factors in modulation. Direct modulation is faster for lasers than for LEDs, and external modulation can be even faster. Direct modulation also can affect wavelength because the refractive index of a semiconductor varies with the current passing through it, causing the output wavelength to vary, an effect called *chirp*. Modulation linearity is also important, particularly for analog communications. You will learn about modulation formats in later chapters.

Cost/Performance Trade-offs

As any student of engineering reality would expect, light sources with the most desirable characteristics cost the most. The cheapest light sources are LEDs with slow rise times, large emitting areas, and relatively low output power. Diode lasers with narrow bandwidths in the 1530- to 1620-nm band, where optical fibers have their lowest losses, are the most expensive. The higher-power and narrower-line emission of lasers comes at a marked price premium, with the narrowest-line lasers costing the most. The only real performance advantage of LEDs is generally longer lifetime than some lasers.

LED Sources

An LED emits light when a current flows through it.

The basic concept of a light-emitting diode is shown in Figure 9.3. The diode is made up of two semiconducting regions, each doped with impurities to give it the desired electrical characteristics. The p region is doped with impurities having fewer electrons than atoms they replace in the semiconductor compound, which create “holes” where there is room for electrons in the crystalline lattice. The n region is doped with impurities that donate electrons,

FIGURE 9.3
LED operation.

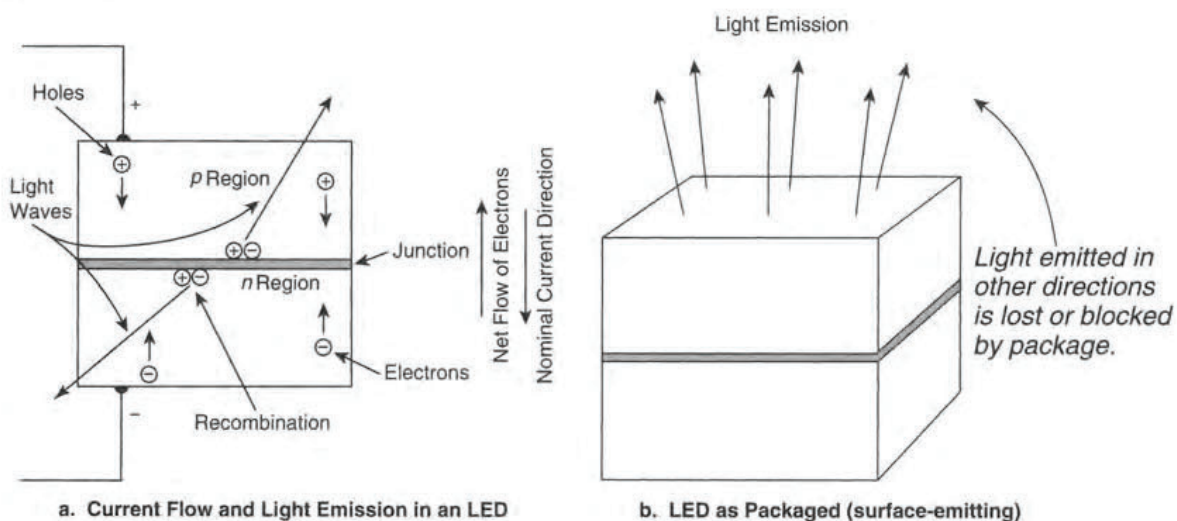

which leave extra electrons floating in the crystalline matrix. Applying a positive voltage to the p region and a negative voltage to the n region causes the electrons and holes to flow toward the junction of the two regions. If the voltage is above a certain (low) level, which depends on the material in the thin *junction layer*, the electrons drop into the holes, releasing energy in a process called *recombination*. As long as that voltage is applied in the same direction, electrons keep flowing through the diode and recombination continues at the junction.

In many semiconductors, notably silicon and germanium, the released energy is dissipated as heat—vibrations of the crystalline lattice. (Light emission from porous silicon is a special case that depends on the microstructure of the silicon crystal.) In other materials, usable in LEDs, the recombination energy is released as a photon of light, which can emerge from the semiconductor material. The most important of these semiconductors, *gallium arsenide* and related materials, are called *III-V* compounds because they are made of elements from the IIIa and Va columns of the periodic table:

IIIa	Va
Aluminum (Al)	Nitrogen (N)
Gallium (Ga)	Phosphorus (P)
Indium (In)	Arsenic (As)
	Antimony (Sb)

A new technology is developing around semiconducting polymers. These are plastics that have the electrical characteristics of semiconductors. (Conventional plastics are insulators, because they bond electrons tightly.) As with their crystalline counterparts, semiconducting plastics can be doped to make p and n materials, and electrical devices, including LEDs, can be made from them.

The wavelength emitted by a semiconductor depends on its internal energy levels. In a pure semiconductor at low temperature, all the electrons are bonded to atoms in the crystalline lattice. As temperature rises, some electrons in this *valence band* jump to a higher-energy *conduction band*, where they are free to move about in the crystal. The valence and conduction bands are separated by a void where no energy levels exist—the band gap that gives semiconductors many of their useful properties.

Exciting an electron from the valence band to the conduction band creates a *hole* in the valence band, an atom that is missing an electron and thus has a positive charge. This hole can move when an electron from another atom replaces the missing electron, leaving a hole in the electron shell of the other atom. The process is repeated in each newly created hole, and so the holes “move” within the crystal. Low levels of electrons and holes exist naturally in semiconductors, but their number can be increased by doping the semiconductor with atoms that create p or n regions where holes or electrons dominate. When an electron drops from the conduction band to the valence band (i.e., when it recombines with a hole), it releases the difference in energy between the two levels, as shown in Figure 9.4.

The band gap between the energy levels—and hence the energy released and the wavelength emitted—depends on the composition of the junction layer of the semiconductor diode. The

The usual LED wavelengths for glass fibers are 820 or 850 nm.

FIGURE 9.4
Semiconductor
energy levels.

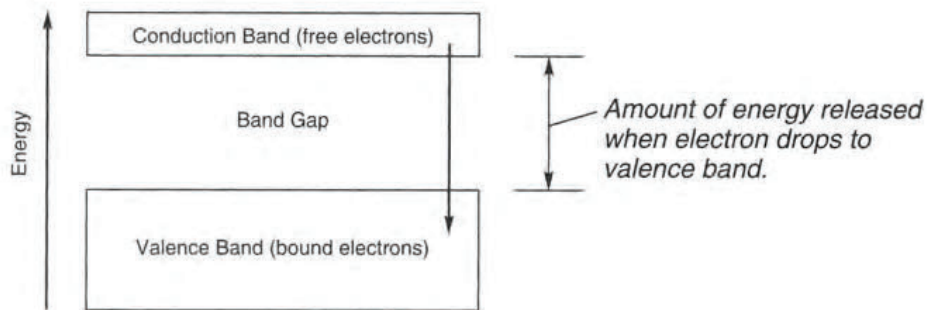

near-infrared LEDs used with short glass-fiber systems have active layers made of *gallium aluminum arsenide* (GaAlAs) or *gallium arsenide* (GaAs). Pure gallium-arsenide LEDs emit near 930 nm. Adding aluminum decreases the drive current requirements and increases the energy gap so light emission is at 750 to 900 nm. Generally only the thin junction layer is made of GaAlAs, with the rest of the diode GaAs, so these devices generally are called GaAs LEDs. The usual LED wavelengths for fiber-optic applications are 820 or 850 nm. At room temperature, the typical 3-dB spectral bandwidth of an 820-nm LED is about 40 nm.

The band-gap energy also can be measured in electron volts, the amount of energy needed to move one electron through an electric field of one volt. With no bias voltage applied, this potential forms at the junction layer, so no light is generated unless a current is flowing through the LED (as you would expect). A forward bias overcomes this potential at the junction layer, allowing current to flow through the LED and generating light at the junction.

LEDs made of other semiconductor compounds emit different wavelengths. Gallium arsenide phosphide (GaAsP) LEDs emitting visible red light around 650 nm are used with plastic fibers, which transmit poorly at GaAlAs wavelengths. GaAsP LEDs are lower in performance than GaAlAs LEDs, but they cost less and are fine for short, low-speed plastic fiber links.

The most important compound for high-performance fiber-optic lasers is *indium gallium arsenide phosphide* (InGaAsP) made of indium, gallium, arsenic, and phosphorus mixed so the number of indium plus gallium atoms equals the number of arsenic plus phosphorus atoms. The resulting compound is written as $\text{In}_x\text{Ga}_{1-x}\text{As}_y\text{P}_{1-y}$, where x is the fraction of indium and y is the fraction of arsenic. These so-called quaternary (four-element) compounds are more complex than ternary (three-element) compounds such as GaAlAs but are needed to produce output at 1200 to 1700 nm. LEDs are rarely used at these wavelengths.

Other LED characteristics depend on device geometry and internal structure. The description of LEDs so far hasn't indicated in which direction they emit light. In fact, simple LEDs emit light in all directions, as shown in Figure 9.3, and are packaged so most emission comes from their surfaces. The light is emitted in a broad cone, with intensity falling off roughly with the cosine of the angle from the normal to the semiconductor junction. (This is called a Lambertian distribution.)

More complex internal structures can concentrate output of *surface-emitting* LEDs in a narrower angle, by such means as confining drive current to a small region of the LED. Such designs typically require that the light emerge through the substrate, which can cause losses. One way to enhance output and make emission more directional is to etch a hole in the substrate to produce what is called a *Burrus diode*, after its inventor Charles A. Burrus of Bell Laboratories. A fiber can be inserted into the hole to collect light directly from the junction layer.

●
Visible LEDs are used with plastic fibers, which transmit poorly in the infrared.

●
InGaAsP emits at 1200 to 1700 nm.

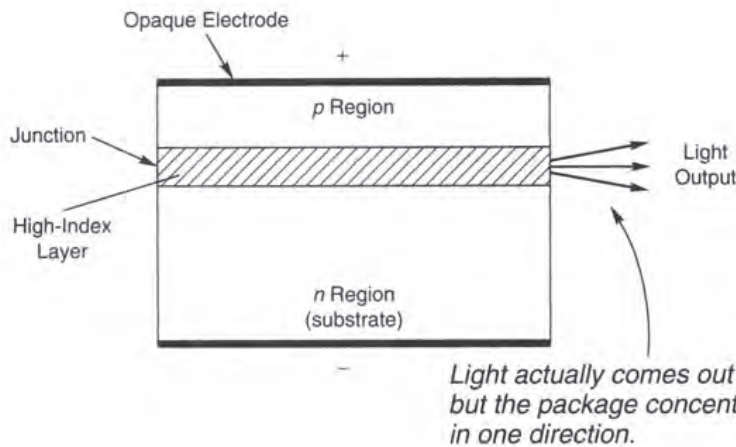
**FIGURE 9.5**

An edge-emitting LED.

A fundamentally different configuration is the *edge-emitting diode*, shown in Figure 9.5. Electrical contacts cover the top and bottom of an edge emitter, so light cannot emerge there. The LED confines light in a thin, narrow stripe in the plane of the *p-n* junction. This is done by giving that stripe a higher refractive index than the surrounding material, a waveguide that functions like an optical fiber, and channels light out both ends where it can be coupled into a fiber. One disadvantage is that this increases the amount of heat the LED must dissipate.

In general, the more complex the LED structure, the brighter and more tightly collimated the emitted light. Shrinking the emitting area and the region through which current passes also decreases rise time and, thus, enhances possible modulation bandwidth. Of course, as with other devices, the greater complexity comes at higher cost. A diode laser goes a step further.

An edge-emitting diode emits light from its ends.

The Laser Principle

LEDs, like the sun, fluorescent lamps, and incandescent bulbs, generate light by a process called *spontaneous emission*. Atoms or molecules accumulate extra energy, then release it on their own accord, without outside stimulation, as they drop from a high-energy state to a lower-energy state. In contrast, lasers use a process called *stimulated emission*, and to understand it we'll take a very quick tour through basic physics.

LEDs generate light by spontaneous emission.

Atoms and Energy Levels

Atoms and molecules can store only certain amounts of energy, occupying discrete states called *energy levels*. When they absorb light, they rise from one energy level to a higher one. When they drop from a higher energy level to a lower one, they release energy. In the jargon of physics, when they make a *transition* between states, they can emit a *photon*, which as you learned earlier is a unit of light energy. (The atoms don't always release energy as light, but we won't worry about these details.)

Nearly 90 years ago, Albert Einstein said an excited atom could release a photon in two different ways. One was spontaneous emission, when the atom drops to a lower energy

●
Laser light is
stimulated
emission.

level on its own. The other was a process that nobody had observed at the time, stimulated emission, which Einstein predicted would occur when a photon triggered the atom to release its energy as a second photon of exactly the same energy as the first in the same direction. If we look at the photons as waves, we find that the second light wave is precisely in phase with the wave that stimulated its emission, making the two waves *coherent*. Coherence organizes light waves, making them act like a troop of soldiers marching in step instead of a crowd spreading in all directions as they leave a stadium.

The laser is based on the growth of stimulated emission in a material. A single photon spontaneously emitted in a transition can stimulate other atoms to release their extra energy as identical photons. If the conditions are just right, this produces a cascade of emission that is all in phase and coherent—a laser beam.

Excitation

The first step in producing stimulated emission is to excite the atoms to a suitable high-energy state. This can be done by passing an electric current through the laser material or illuminating it with light that can excite the atoms.

In a semiconductor laser, the excitation comes from the current passing through the junction layer. When current carriers recombine, the free electron lingers near the hole that captured it before dropping into the valence band. As long as the electron lingers in the conduction band, it can release its energy by either spontaneous or stimulated emission. The same is true for other laser materials.

However, excitation alone is not enough. LEDs are excited, but they don't produce stimulated emission.

Population Inversions

You need photons of the right energy to stimulate emission, and the most likely source of those photons is stimulated emission from atoms dropping from the same energy level. The chance of producing stimulated emission depends on how many atoms are in the upper and lower energy levels. Normally more atoms are in the lower-energy states, so a photon is more likely to be absorbed by an atom in the lower state than to stimulate emission from an atom in the upper state.

To produce a cascade of stimulated emission, you need to have more atoms in the higher energy state than the lower energy state of the transition, a condition called a *population inversion*. Figure 9.6 shows the idea, where the dots represent the number of atoms in each energy level. First, something excites the atoms to a high energy state. Atoms don't stay very long in most high-energy states, releasing their energy quickly, so they drop to a lower state. In this case, they drop into a longer-lived state that is described as *metastable* because atoms stay in it an unusually long time. The atoms linger in this state, called the *upper laser level*, long enough for stimulated emission to occur.

The stimulated emission wouldn't get very far if there were more atoms in the lower level, but in this case the atoms quickly drop down to an even lower state. This sustains a population inversion, which means more atoms in the excited state than in the lower state. But that isn't the whole story.

●
Stimulated
emission requires
a population
inversion.

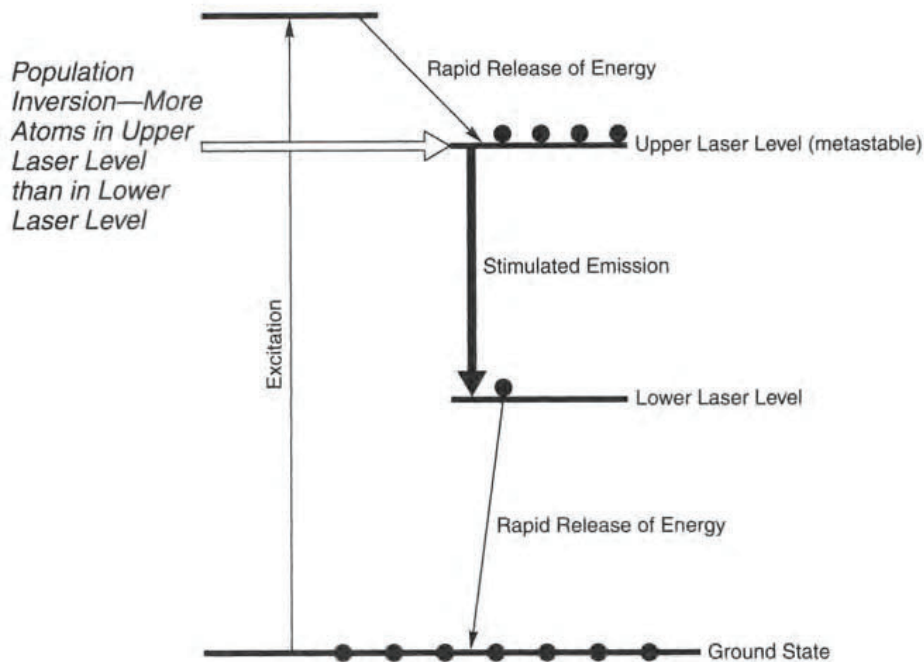
**FIGURE 9.6**

Energy levels and population inversion on a laser transition (**bold arrow**).

Amplification and Oscillation

In the presence of a population inversion, stimulated emission can amplify light at the right wavelength. Figure 9.7 shows the amplification of a weak input signal as it passes through an optical amplifier. Each input photon stimulates the emission of other photons, which in turn can stimulate the emission of others. As a result, the output signal is stronger than the input.

A quantity called *gain* measures increase in signal strength as a signal passes through the amplifier. For example, if the gain is 10% per centimeter and you started with 10 input photons, you would have 11 photons after one centimeter. In general, the power $P(L)$ at a length L along the fiber would be

$$P(L) = P_{\text{input}} (1 + \text{gain})^L$$

as long as the signals are small. (The available power is limited and saturates at some point.) Optical amplifiers have proved invaluable in fiber-optic systems, but they are not lasers.

Stimulated emission amplifies light. Gain measures the amplification.

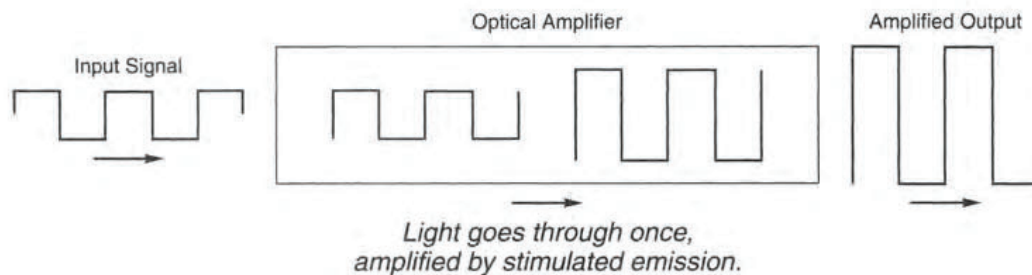
**FIGURE 9.7**

Optical amplification of a weak external signal by stimulated emission.