

# Understanding Fiber Optics

5th edition

Jeff Hecht



*Laser Light Press*

# Understanding Fiber Optics

Fifth edition, revised

Jeff Hecht

*LaserLight Press*

Auburndale, Massachusetts

Hecht, Jeff

Understanding fiber optics / [Jeff Hecht].-5th ed.

p.

cm.

Includes index.

1. Fiber optics.

I. Title.

TA1800.H43 2006

621.36'92-dc22

**Copyright ©2015, 2006, 2002, 1999, 1993, 1987 by  
Jeff Hecht**

**Published by Laser Light Press,  
525 Auburn St., Auburndale, Massachusetts 02466 USA**

**Previously published by Pearson Education, Inc.**

All rights reserved. Printed in the United States of America. This publication protected by Copyright and permission should be obtained from the publisher prior to any prohibited reproduction, storage in a retrieval system, or transmission in any form or by any means, electronic, mechanical, photocopying, recording, or likewise. For information regarding permissions, write to Rights and Permissions Department, Laser Light Press, 525 Auburn St, Auburndale, MA 02466, USA

# Preface to the Laser Light Press Edition

## About This Edition

Except for this preface, the front matter, and the errata that follows, this Laser Light Press edition reprints the fifth edition of *Understanding Fiber Optics* published in 2006 by Pearson Education, Inc. I am planning a sixth edition, but because that will take a while to prepare and with the Pearson edition is no longer available, I am reprinting the fifth through Laser Light Press. It may not cover the cutting edge of fiber optics, but it does cover the fundamentals you need to understand the field.

This edition also is an experiment. I want to see how reducing the book's price will affect sales and make *Understanding Fiber Optics* more accessible to students. Thus Laser Light Press offers a low-cost PDF electronic version and a relatively inexpensive print-on-demand paperback. The many diagrams make an e-reader version more difficult.

Whether you are an instructor, a student or a general reader, I would appreciate your comments and suggestions. If you are teaching a course based on the book, please contact me at [jeff@jeffhecht.com](mailto:jeff@jeffhecht.com) for an instructor's manual. You can find more information on the book's status and on associated material at through <http://www.understandingfiberoptics.com> or through <http://www.jeffhecht.com>.

## About Fiber Optics

Fiber optics has come a long way since I wrote the first edition of *Understanding Fiber Optics* in 1987. Optical-fiber communications was a radical new technology then, used mostly for high-capacity, long-distance transmission of telephone signals. I used a 1200-baud modem to send text messages from my computer through proprietary networks. Today a fiber-optic cable to my home provides a broadband connection to the Internet. A global network of fiber-optic cables links my phone and my computer to every continent except Antarctica, and a new cable is being laid through the Arctic Ocean.

Fiber optics has revolutionized telecommunications in the same way the railroads revolutionized land transportation in the years my great-great-grandfather worked for one. Like the railroad business, the fiber-optic business has had its spectacular booms and busts. The telecommunications bubble brought dreams of riches, but the bust that followed left nightmares of ruin and grim jokes about the stocks of once high-flying companies. Yet the bubble and its aftermath are reminders that fiber optics is a technology that may be too good for its own good. Like the railroads and the Internet, fiber optics was something so good that the stock market wildly overvalued it; and like the Internet, fiber optics will be part of our future.

I wrote the first edition of this book mainly for self-study, but it is now used widely in classroom settings. My goal is to explain principles rather than to detail procedures. When you finish, you should indeed understand fiber optics. You should be able to understand what the field is all about, comprehend what you read in trade journals such as *Lightwave* or *Laser Focus World*, make sense of what people in the field are saying, and explain fiber optics to your Aunt Millie or your niece. You won't be ready to design a brand new system, but you will be literate in the field.



Think of it as Fiber Optics 101, a foundation for your understanding of a growing technology.

To explain the fundamentals of fiber optics, I start with ideas that may seem basic to some readers; the details will follow. To make concepts accessible, I include drawings to show how things work, limit math to simple algebra, and step through some simple calculation to show how they work. I compare fiber optics with other common technologies and highlight similarities and differences. I have organized the book to facilitate cross-referencing and review of concepts, and made a point of adding a thorough index to make its contents accessible. I also include some information on the business side of the technology, and boxes that talk about key issues that the fiber-optics community needs to think about.

The book introduces basic concepts first, then digs deeper into hardware and applications. The chapters are organized as follows:

- The first three chapters are an introduction and overview. Chapter 1 tells how fiber optics are used and how the technology developed. Chapter 2 introduces optics, light, and the concept of light guiding. Chapter 3 introduces other basic concepts of communications and fiber-optic systems. They assume no background in optics or telecommunications.

- Chapters 4 through 8 cover optical fibers, their properties, and how they are assembled into cables. The material is divided into five chapters to make it easier to digest. Chapters 4 through 6 explain the fiber concepts used in the rest of the book. Chapter 7 covers special-purpose fibers used in optical amplifiers and fiber gratings, photonic-crystal or microstructured fibers, and planar waveguides. Chapter 8 is an overview of cabling.

- Chapters 9 to 12 cover laser and LED light sources including diode and fiber lasers, optical transmitters, optical detectors, receivers, optical amplifiers, and electro-optic regenerators. Chapter 12 compares and contrasts the operation of optical amplifiers and electro-optic regenerators.

- Chapters 13 to 16 cover other components. Chapter 13 covers connectors and splices that join fibers. Chapter 14 covers optical couplers and other passive components in simple fiber systems and describes integrated optics. Chapter 15 covers optics that send signals at many separate wavelengths through the same fibers. Chapter 16 covers optical modulation and switching for optical networking.

- Chapter 17 covers fundamentals of optical and fiber-optic measurements and explains the quirks of optical measurements. Chapter 18 describes fiber-optic testing.

- Chapters 19 to 22 cover general principles of fiber communication. Chapter 19 describes fundamental concepts of fiber-optic systems and optical networking and how they work in practice. Chapter 20 describes communication standards. Chapter 21 outlines design of point-to-point single-wavelength systems, with sample calculations, so you can understand their operation. Chapter 22 describes the design of optical networks.

- Chapters 23 to 27 explain how fiber optics fit into networks used for global and regional telephone and Internet transmission, cable television, and data networks. These chapters focus on different levels and aspects of the global network to keep concepts manageable. Chapter 28 covers special systems that don't fit elsewhere, such as networks in cars, military systems, and aircraft.

- The final two chapters describe non-communication applications. Chapter 29 explains the principles and operation of fiber-optic sensors. Chapter 30 covers imaging and illumination with fiber optics.

The glossary at the back of the book gives you quick translations of specialized terms and acronyms.

Appendices tabulate useful information, including values of important physical constants, conversion factors, and a few key formulas. They're all in one place to make them easier to find. They also include an annotated list of resources, in addition to the suggestions for further reading in each chapter. So many resources are available on the Internet that I can't hope to compile a thorough list; I encourage you to use search engines creatively. I welcome your comments, questions, and suggestions at [jeff@jeffhecht.com](mailto:jeff@jeffhecht.com).

## Acknowledgments

Over the years many members of the fiber-optics community have given generously of their time to patiently answer my questions. I owe special thanks to John Jay, Shane Nipple, Craig Kegerise, Jerry Jackson, Eric Udd, Dana McEntire, and Joel Orban for feedback on draft chapters of this edition. Thanks to Kevin Able, Bill Chang, David Charlton, Marc Duchesne, Erich Dzakler, Robert Gallawa, Jim Hayes, Dennis Horwitz, Larry Johnson, Jim Masi, Nick Massa, Mike Pepper, Jim Refi, John Schlager, and Wayne Siddal for help on earlier editions and other material. Thanks to Jeffrey Rankinen, Pennsylvania College of Technology; Richard Windley, FCPI College of Technology; and Dave Whitmore, Champlain College for their helpful reviews. Any errors that remain are my own.

This book draws on a series of articles on optical networking that I wrote for Laser Focus World. I thank Steve Anderson for commissioning and editing them, Carol Settino for ably steering them into print, and the magazine's readers for feedback. I thank the Optical Society of America and SPIE - The International Society for Optical Engineering for inviting me to reach short courses based on *Understanding Fiber Optics*.

I owe special thanks to the editorial and production staff at Pearson Education for their excellent work and their assistance in making this book possible. Thanks also to Lisa Cohen for updating me on the changing world of book publishing.

Jeff Hecht, Auburndale, MA  
March 2015

# Errata

**What have you learned? item 6 on page 35** should read:

Refractive index ( $n$ ) of a material is the speed of light in a vacuum divided by the speed of light in the material. It is always greater than 1.0 at optical wavelengths.

**Figure 14.12 on page 356** does not correctly show the operators performed on light of different polarizations in an optical circulator.

**Figure 15.1 on page 365** should have an \* on  $\lambda_4$  on the right side of the drawing to show that wavelength comes from the local transmitter at the bottom.

**Table A.3 on page 764** should give the value of Planck's constant in J-s (joule-seconds) or eV-s (electronvolt-seconds), not J/s or eV/s. The numerical values are correct, but the units are not.

# Contents

## Chapter 1 An Introduction to Fiber Optics, 1

A Personal View: Ups and Downs, 1 • The Roots of Fiber Optics, 2 • The Very Basics of Communications, 8 • Fiber Terms: Terminology and Units, 12

## Chapter 2 Fundamentals of Fiber-Optic Components, 17

Basics of Optics, 17 • Light Guiding, 26 • Fiber Transmission, 28 • Electro-Optics and Other Components, 33 • Fiber-Optic Applications, 34

## Chapter 3 Fundamentals of Communications, 39

Communications Concepts, 39 • Signals and Formats, 46 • Connectivity, 50 • Communications Services, 54 • The Business of Telecommunications, 58

## Chapter 4 Types of Optical Fibers, 65

Light Guiding, 65 • Step-Index Multimode Fiber, 68 • Modes and Their Effects, 71 • Graded-Index Multimode Fiber, 75 • Single-Mode Fiber, 77 • Dispersion-Shifted Single-Mode Fiber, 80 • Polarization in Single-Mode Fiber, 85 • Other Fiber Types, 87

## Chapter 5 Properties of Optical Fibers, 93

Fiber Attenuation, 93 • Light Collection and Propagation, 99 • Dispersion, 103 • Nonlinear Effects, 115 • Mechanical Properties, 119

## Chapter 6 Fiber Materials, Structure, and Manufacture, 127

Requirements for Making Optical Fibers, 127 • Glass Fibers, 128 • Fused-Silica Fibers, 130

• Plastic Fibers, 137 • Exotic Fibers and Light Guides, 140

## Chapter 7 Specialty Fibers, 151

What Are “Specialty” Fibers?, 151 • Dispersion-Compensating Fibers, 152 • Polarization-Maintaining Fibers, 153 • Bend-Insensitive and Coupling Fibers, 153 • Reduced-Cladding Fibers, 155 • Doped Fibers for Amplifiers and Lasers, 156 • Fiber Gratings and Photosensitive Fibers, 159 • Photonic or “Holey” Fibers, 165 • Special Noncommunications Fibers, 166

## Chapter 8 Cabling, 173

Cabling Basics, 173 • Reasons for Cabling, 174 • Types of Cable, 178 • Elements of Cable Structure, 183 • Cable Installation, 190 • Cable Changes and Failure, 191

## Chapter 9 Light Sources, 197

Light Source Considerations, 197 • LED Sources, 200 • The Laser Principle, 203 • Simple Semiconductor Lasers, 207 • Laser Wavelength, 213 • Fiber Lasers, 219 • Other Solid-State Laser Sources, 221

## Chapter 10 Transmitters, 227

Transmitter Terminology, 227 • Operational Considerations, 228 • Multiplexing, 232 • Modulation, 234 • Single-Channel Transmitter Design, 238 • Sample Transmitters, 241

## Chapter 11 Receivers, 249

Defining Receivers, 249 • Performance Considerations, 258 • Electronic Functions, 265 • Sample Receiver Circuits, 267



## **Chapter 12 Amplification, Regeneration, and Wavelength Conversion, 275**

Amplification and Regeneration, 275  
• System Requirements, 279 • Repeaters and Regenerators, 280 • Optical Amplifiers, 281  
• Erbium-Doped Fiber Amplifiers, 284  
• Other Doped Fiber Amplifiers, 291 • Raman Amplification in Fibers, 292 • Semiconductor Optical Amplifiers, 295 • Optical Regeneration, 299 • Wavelength Conversion, 299

## **Chapter 13 Connectors and Splices, 307**

Applications of Connectors and Splices, 307  
• Fiber-to-Fiber Attenuation, 309 • Internal Reflections, 314 • Mechanical Considerations in Connectors, 315 • Connector Structures, 317 • Standard Connector Types, 320  
• Splicing and Its Applications, 326 • Splicing Issues and Performance, 327 • Types of Splicing, 328

## **Chapter 14 Couplers and Other Passive Components, 339**

Coupler Concepts and Applications, 339  
• Coupler Characteristics, 343 • Coupler Types and Technologies, 347 • Attenuators, 353  
• Optical Isolators, 354 • Optical Circulators, 355

## **Chapter 15 Wavelength-Division Multiplexing Optics, 363**

WDM Requirements, 363 • WDM Systems, 364 • Optical Filters and WDM, 370  
• WDM Technologies, 375 • Building Multiplexers and Demultiplexers, 385

## **Chapter 16 Optical Switches, Modulators, and Other Active Components, 391**

Defining Active Components, 391 • Modulators and Modulation, 392 • Switching in Optical

Networks, 397 • Optical Switching Technologies, 403 • Wavelength Switching and Conversion, 409 • Integrated Optics, 410

## **Chapter 17 Fiber-Optic Measurements, 417**

Basics of Optical Power Measurement, 417  
• Wavelength and Frequency Measurements, 425 • Phase and Interference Measurements, 428 • Polarization Measurements, 430  
• Time and Bandwidth Measurements, 430  
• Signal Quality Measurements, 434  
• Fiber-Specific Measurements, 436

## **Chapter 18 Troubleshooting and Test Equipment, 447**

Fiber-Optic Troubleshooting, 447 • Test and Measurement Instruments, 450  
• Troubleshooting Procedures, 462

## **Chapter 19 System and Optical Networking Concepts, 471**

An Evolving Network, 471 • Telecommunication Network Structure, 473 • Transmission Topologies, 475 • Directing Signals, 481  
• Signal Formats, 483 • Transmission Capacity, 487

## **Chapter 20 Fiber System Standards, 499**

Why Standards Are Needed, 499 • Families of Standards, 501 • Layers of Standards, 502  
• Interchange Standards, 507 • Fiber Transmission Standards, 509 • Current Standards Issues, 513

## **Chapter 21 Single-Channel System Design, 521**

Variables, 521 • Power Budgeting, 523  
• Examples of Loss Budgeting, 528  
• Transmission Capacity Budget, 534  
• Cost/Performance Trade-offs, 541



## **Chapter 22 Optical Networking System Design, 549**

Optical Networking Concepts, 549 • Optical Channel Density, 550 • Operating Ranges of WDM Systems, 555 • Factors in WDM Design, 557 • Optical Amplification and WDM Design, 562 • Switching and Optical Networking, 563 • Design Examples, 566

## **Chapter 23 Global Telecommunications Applications, 573**

Defining Telecommunications, 574 • The Global Telecommunications Network, 577 • Internet Transmission, 582 • Submarine Cables, 585 • Long-Haul Terrestrial Systems, 594 • Types of Long-Distance Services, 598

## **Chapter 24 Regional and Metro Telecommunications, 605**

Defining Regional and Metro Telecommunications, 605 • Regional Distribution, 606 • Regional Telecommunications Networks, 610 • Metro Networks, 612 • Regional/Metro Services and Equipment, 614

## **Chapter 25 Local Telephone or “Access” Networks, 623**

Structure of the Local Phone Network, 623 • Subscriber and Access Services, 630 • Emerging Services and Competing Technologies, 632 • Fiber to the Home or Premises, 636

## **Chapter 26 Internet Access and Local-Area Networks, 651**

Data and Voice Transmission, 651 • The Internet and Its Structure, 654 • Data Transmission Technologies, 660 • Fiber Data-Link Design, 665 • Fiber in Standard Data Networks, 665

## **Chapter 27 Video Transmission, 677**

Video Basics, 677 • Transmission Media, 684 • Cable Television Architecture, 686 • HDTV and Cable, 691 • Other Video Applications, 692

## **Chapter 28 Mobile Fiber-Optic Communications, 699**

Mobile Systems, 699 • Remotely Controlled Robotic Vehicles, 700 • Fibers in Aircraft, 703 • Shipboard Fiber-Optic Networks, 705 • Automotive Fiber Optics, 706

## **Chapter 29 Fiber-Optic Sensors, 713**

Fiber-Sensing Concepts, 713 • Fiber-Optic Probes, 714 • Fiber-Sensing Mechanisms, 716 • Some Fiber Sensor Examples, 719 • Fiber-Optic Gyroscopes, 722 • Smart Skins and Structures, 724

## **Chapter 30 Imaging and Illuminating Fiber Optics, 729**

Basics of Fiber Bundles, 729 • Optics of Bundled Fibers, 734 • Imaging Applications, 737 • Light Piping and Illumination, 740

## **Appendices, 745**

Appendix A: Important Constants, Units, Conversion Factors, and Equations, 745 • Appendix B: Decibels and Equivalents, 749 • Appendix C: Standard Time-Division Multiplexing Rates, 751 • Appendix D: ITU Frequencies and Wavelengths for L- and C-bands, 100-GHz Spacing, 100 Channels, 753 • Appendix E: Laser and Fiber Safety, 755 • Appendix F: Fiber-Optic Resources, 757

## **Glossary, 761**

## **Index, 775**



*This book is dedicated to the memory of Heather Williamson Messenger,  
gifted editor, good friend, and victim of domestic violence.*

# An Introduction to Fiber Optics

## About This Chapter

This chapter is a starting point to look around and see where you're going before you dig into details. The goal is to put fiber optics and communications into context and show how they go together. I start with a personal commentary about the turbulent times of the past several years, then explain the plan for this book. A brief history of fiber optics follows, which introduces some important concepts. Then a brief history of communications explains the need for bandwidth and how fiber optics filled that need, perhaps too well. Finally, I explain some of the terminology of the field to help you in your looking about.

## A Personal View: Ups and Downs

Fiber optics has come a long way in the nearly three decades I've been watching its development. For many years the field grew steadily, with new technology creating new applications, and new applications, in turn, supplying money to develop more new technology. The growth sped out of control in the late 1990s as the Internet fed a seemingly limitless thirst for bandwidth that only optical fibers could provide. The boom turned into a bubble, and the bubble into a bust as I watched in amazement.

We knew the bubble was too good to be true, but none of us wanted it to end. We told ourselves that the communications industry was in better shape than the dot-coms because it had real hardware, not just web sites. Then the industry ran right off a cliff and landed with an ugly splat. We traded grim jokes, noting that we would have done better to invest in cases of beer and return the empties in a state with a bottle-deposit law. Employment dropped nearly as badly. The industry seemed a vast, smoking crater.

Fiber revolutionized telecommunications by supplying tremendous bandwidth.

Fiber-optic technology remains healthy.

That depressing view is as much of an exaggeration as was the euphoric overenthusiasm of the bubble. We'll never see that manic growth again, and that's just as well. But fiber-optic technology remains healthy, with advances continuing at a more sober rate. Fiber optics has become the backbone of the global telecommunications network, giving us instant access to Web sites and telephones around the world. That network continues to reach toward homes and businesses. Cable television companies, telephone companies, Internet providers, and power companies have their own fiber-optic networks. When you use a cell phone, your calls usually go wireless only to the tower, where a fiber-optic cable runs to the backbone telephone network. The demand for bandwidth continues to rise, although there's a lot of surplus fiber in the ground right now.

Fiber revolutionized telecommunications in the twentieth century, just as the railroads revolutionized transportation in the nineteenth century. Overbuilding of railroads caused spectacular busts in the latter half of the nineteenth century, but railroads remained the backbone of the national transportation network until the spread of the interstate highway system in the 1950s and 1960s. Railroads still carry people and freight today—especially in Europe.

The fiber-optic gold rush is over, and the field has had a roller-coaster ride of dramatic ups and downs. We've gained some experience and a few gray hairs in the process, but we've survived. Fiber has carved itself a vital niche in the communications world and will play a growing role around the world as other countries expand their own communications networks. Fiber is here to stay.

## The Roots of Fiber Optics

Fiber optics did not begin as a communications technology. Optical fibers evolved from devices developed to guide light for illumination or displays, and were first used to look inside the human body. Bundles of optical fibers are still used to examine the stomach and the colon because they can reach into otherwise inaccessible areas. It's worth looking at how this idea began—it will teach you the basic ideas of light guiding in a fiber.

### Piping Light

Light normally goes in straight lines, but sometimes we want it to go around corners.

Think of optical fibers as pipes that carry light. Lenses can bend light and mirrors can deflect it, but otherwise light travels in straight lines. The working of optical devices, from our eyes to giant telescopes and sensitive microscopes, depends on light going in straight lines. Yet sometimes it is nice to be able to pipe light around corners and look into inaccessible places. The first steps in that direction were taken in the nineteenth century.

In 1880, William Wheeler, a young engineer from Concord, Massachusetts, filed for a patent on a way to pipe light through buildings. Thomas Edison had already made the first incandescent light bulbs but hadn't gotten all the bugs out. Wheeler wanted to distribute light from an electric arc, a light source that was better developed at the time, but was blindingly bright. He planned to put arc lamps in the basements of buildings and



(No Model.) W. WHEELER. 4 Sheets—Sheet 1.  
 APPARATUS FOR LIGHTING DWELLINGS OR OTHER STRUCTURES.  
 No. 247,229. Patented Sept. 20, 1881.

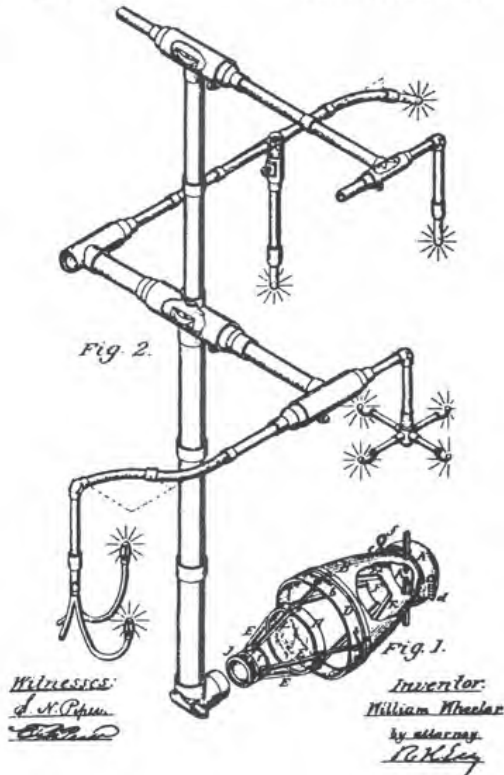

**FIGURE 1.1**

*Wheeler's plan for piping light into rooms (U.S. Patent 247,229).*

distribute the light to distant rooms through a set of pipes coated with a reflective layer inside, as shown in Figure 1.1. Diffusers at the ends of the pipes would spread the light out inside each room.

Wheeler was a solid engineer who became an expert in designing water works. He later founded a successful company that made reflectors for street lamps. His design was logical at the time since air seemed to be a much clearer medium than any known solid. But his light pipes never caught on, and Edison's incandescent bulbs eventually worked much better than arc lamps.

## Total Internal Reflection

Even before Wheeler's time, scientists knew how to trap light inside a solid. A phenomenon called *total internal reflection*, described in Chapter 2, can confine light inside glass or other transparent materials. This phenomenon involves sending light through the material in such a way that it strikes the surface exposed to air at a glancing angle. Then the light is reflected back into the solid. You can see the effect in diamond or cut glass, in which one surface acts like a mirror to reflect light to your eye.

Glassblowers may have been the first to realize this effect could guide light along a bent glass rod, but it wasn't widely recognized until 1841 when a Swiss physicist, Daniel Colladon,

Total internal reflection can guide light along a glass rod or water jet.

**FIGURE 1.2**

*Light guided  
down a water jet.*

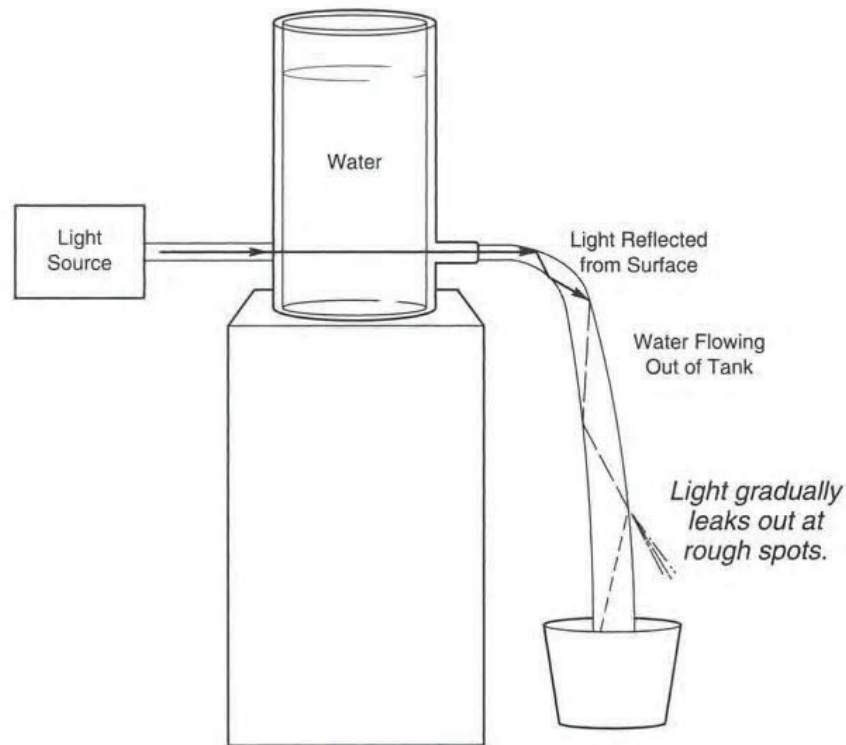

*Light beam becomes more diffuse  
as it passes down the water jet,  
because turbulence breaks up surface.*

adapted the trick for a jet of flowing water in his popular science lectures. Figure 1.2 shows how he directed a bright light down a horizontal pipe leading out of a tank of water. When he opened the spout, water flowed out in a jet and the pull of gravity bent the water jet into a parabolic arc. Total internal reflection trapped the light inside the water jet. The light beam bounced off the top surface, then off the lower surface, until turbulence in the flowing water broke up the beam.

Others borrowed the idea for their own demonstrations. The Paris Opera used it on stage in 1853. The great Victorian exhibitions of the 1880s adapted the idea to make illuminated fountains that fascinated fairgoers who hadn't seen bright artificial lights. But the water jet remained essentially a parlor trick of little practical use.

## Glass Light Guides and Imaging

Inventors soon adapted the idea of guiding light to more practical purposes. By the early 1900s, they had patented a scheme for guiding light through a bent glass rod to illuminate the inside of the mouth for dentistry. This technique was much better than sticking a gas lamp into a patient's mouth, but it was far from perfect. Illuminated tongue depressors followed.

A fine glass fiber is actually a very thin, flexible rod, so it can guide light in the same way. Assemble glass fibers into a *bundle*, and they can carry an image from one end to the other,

An optical fiber  
guides light  
like a very thin  
glass rod.



as you will learn in Chapter 30. Clarence W. Hansell, an American electrical engineer and prolific inventor, was the first to take this logical step and patented the idea in the late 1920s. Hansell thought the bundles could be used for inspecting out-of-the-way places, for medical applications, or even for a facsimile machine.

Heinrich Lamm, a German medical student, made the first image-transmitting bundle in 1930 and was able to photograph the bright filament of a lamp. He combed the fibers to align them, but the bundle didn't work well because it consisted of bare fibers, in which total internal reflection was at the surface exposed to the air. Light can easily leak through that surface if anything touches or scratches it, and the fibers inevitably touched and scratched each other in Lamm's bundle. Light even leaked out at places where fingerprint oil was smudged on the surface.

Neither Hansell nor Lamm got very far. The same problems bedeviled other men who independently invented fiber bundles for imaging in the early 1950s. These men were a Danish inventor, Holger Møller Hansen, two eminent optics professors, Abraham van Heel and Harold H. Hopkins, and Hopkins' student, Narinder Kapany.

Solving the problem required a fresh look at the requirements for total internal reflection. We normally think of it as occurring where light is unable to enter the air, but what really matters is a quantity called the *refractive index*, which you'll learn about in Chapter 2. Total internal reflection can happen when light travelling in one medium tries to enter another medium with a lower refractive index. Air has a much lower refractive index than glass, but the difference does not have to be large. Oils, beeswax, and many plastics have refractive indexes that are higher than air but lower than glass. Coat the glass fiber with one of those materials, and total internal reflection can still occur, but the surface is protected from scratches, fingerprints, and leakage of light into other glass fibers, as shown in Figure 1.3.

Møller Hansen tried coating a fiber with margarine, but the results were impractically messy. Brian O'Brien, a noted American optical physicist, suggested the idea to van Heel, who coated his fibers with plastic and beeswax, which were more practical. In December 1956, Larry Curtiss, an undergraduate student at the University of Michigan, slipped a rod of glass with high refractive index into a tube of glass with lower index and made the first glass-clad fiber.

The technology has been refined considerably since then, but glass-clad fiber remains the most common type. Fiber bundles were the key to making flexible endoscopes, gastroscopes, and colonoscopes to examine the throat, stomach, and colon. Other imaging applications soon emerged, as described in Chapter 30. Fiber bundles are also used for illumination; however, this technology has been largely eclipsed by fiber-optic communications.

## Optical Communications

Optical fibers aren't necessary for optical communications. People have communicated using light since ancient times. The ancient Greeks lit signal fires on hilltops to relay news of the fall of Troy. The first "telegraph" was an optical one, invented by French engineer Claude Chappe in the 1790s. Operators relayed signals from one hilltop telegraph tower to the next by moving semaphore arms. Samuel Morse's electric telegraph put the optical telegraph out of business, but it left behind countless "telegraph hills."

Clad fibers were the key development in making fiber-optic imaging practical.

The first practical application of fiber optics was gastroscopy.

An optical telegraph was invented in the 1790s in France.



**FIGURE 1.3**

*Light cannot leak out of clad fibers if they touch another surface.*

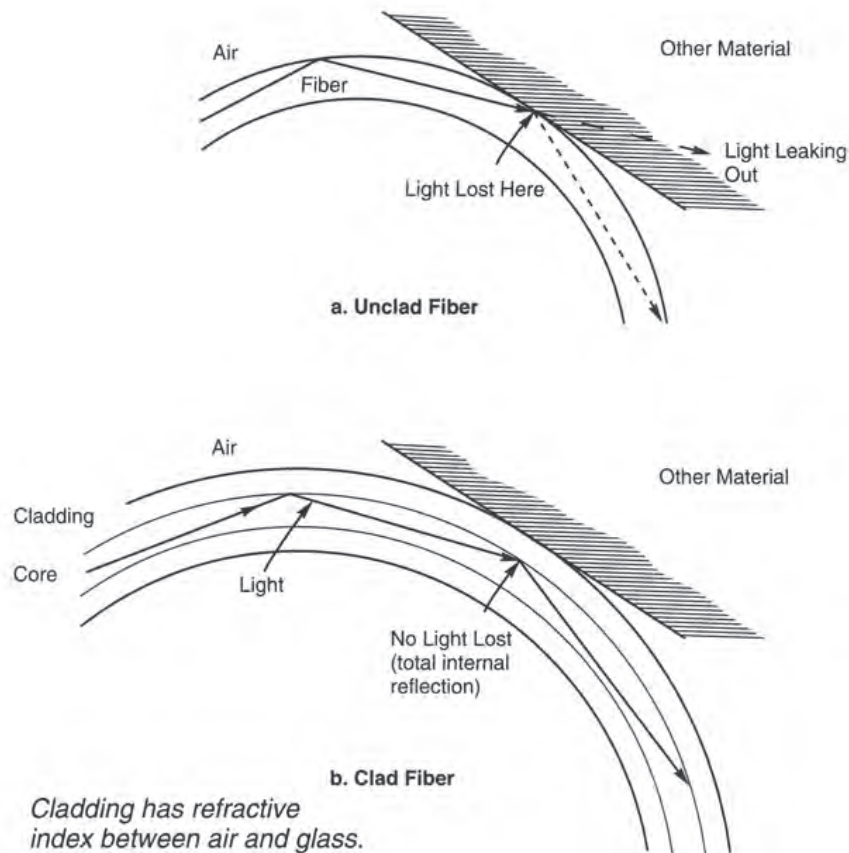

After inventing the telephone, Alexander Graham Bell turned to sending voices through the air on beams of light, demonstrating his “photophone” in 1880. Bell was elated and considered it his greatest invention. The photophone, however, never proved practical, and radio waves eventually provided the means for wireless communications. Other attempts at optical communications followed, but few people took them seriously until Theodore Maiman made the first laser in 1960.

●  
Invention of the laser stimulated interest in optical communications.

The laser generates a tight beam of coherent light at a single pure wavelength. It’s the optical equivalent of the pure carrier frequency that is modulated with a radio or television signal. Its coherence made it very attractive for optical communications, and within a few months Bell Laboratories had made their own laser and used it to send light pulses between two towers 25 miles apart. However, other experiments soon showed that fog, rain, snow, and haze could block signals. Bell Labs tried sending laser beams through hollow light pipes, but they didn’t work well either.

●  
Charles Kao and George Hockham proposed fiber-optic communications.

Optical fibers were available at this time, but they couldn’t send light very far. The clearest fibers used for medical endoscopes lost half of the light they carried after three meters (10 feet). Go 30 meters (100 feet) and just 0.1% of the light remains. That loss was acceptable for examining the stomach through several feet of fiber, but it made optical fiber useless for communications.

Two young engineers at Standard Telecommunications Laboratories in England, Charles K. Kao and George Hockham, took a different approach. Instead of asking how clear was

the best fiber, Kao asked what was the fundamental lower limit on the loss of glass. He and Hockham found that most of the loss in the glass was caused by impurities, not by the glass itself. In 1966, they predicted that a fiber made of highly purified glass would be so clear that 10% of the light entering it would remain after 500 meters (1600 feet). This level of purity sounded unattainable, but a few laboratories around the world tackled the problem.

Kao and Hockham turned out to be too conservative and Robert Maurer, Donald Keck, and Peter Schultz of the Corning Glass Works beat their prediction in 1970. Two years later they had fibers in which 10% of the light remained after 2.5 kilometers (8000 feet). Better fibers followed and in today's best optical fibers 10% of the light remains after passing through 50 kilometers (30 miles) of fiber. That exceptionally low loss lets fibers carry signals much further than copper wires.

## Other Fiber Properties

Long-distance transmission isn't the only thing that matters in communications. It's also important to be able to carry a lot of information, which in the communications world is called *bandwidth*. The more bandwidth, the more information a signal can carry. For reasons we'll explore later, optical signals inherently have a very high bandwidth, which is why the laser first interested communications engineers. Equally important, optical fibers can transmit those signals without seriously limiting their bandwidth. That's not true for copper wires. Electronic devices can generate signals at high frequencies, carrying lots of information, but copper cables tend to attenuate those essential high frequencies, so the signals can't go far.

Telecommunications fibers are made of glass, but they're not as fragile as they sound. Glass is inherently a strong material as long as it's not cracked, but it is brittle in bulk. Communication fibers, however, are flexible because they're relatively thin. Optical fibers are often compared to a human hair. The sizes are close, but fibers are stiffer. On a microscopic scale, a well-made optical fiber is also much smoother than a human hair.

The cross-section of a typical communications fiber is shown in Figure 1.4. The glass fiber itself is 125 micrometers (0.005 inch) thick, with the light-guiding core a central

Optical fibers have very high bandwidth.

Glass fibers are inherently strong, allowing their use in outdoor cables.

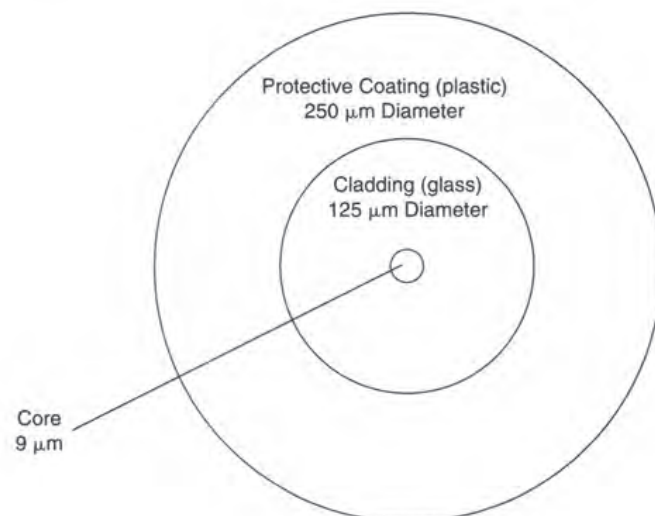

**FIGURE 1.4**  
*Cross-section of a typical communications fiber.*



region about 9  $\mu\text{m}$  in diameter. A plastic *coating* covers the entire fiber, bringing its overall size to 250  $\mu\text{m}$ , or 0.25 mm (about 0.01 inch). These dimensions, like those of other fiber-optic components, are usually given in metric units. The plastic layer protects the fiber surface from scratches and microcracks that could cause it to break. The result is a fiber that's much stronger than you would expect. It's very hard to snap a fiber with your hands, although you can break one if you trip on it while wearing heavy shoes. Communications fiber works perfectly well in cables used in harsh outdoor environments.

Fibers designed for other purposes have different properties, as you will learn in Chapters 4 through 7.

## The Very Basics of Communications

The basic idea of communications is very simple: to transmit information from one point to another. Both the technology and the business of communications are much more complicated, and you should understand a bit about both before you dig deeper into this book. Chapter 3 will give you a more formal introduction to communications, but here you will get some idea of how communications in general, and fiber communications in particular, really work.

### Communications Technology

The word “communications” is used in many different ways. We say we are trying to “communicate” with someone when we convey a message in words. Colleges have “communications” departments that focus on writing and broadcasting, not engineering. Here we're talking about *telecommunications*, which means communications over a distance by means of radio waves, electrical signals, or optical signals.

Today's telecommunications are based on electronic technology. Electronic devices generate and process signals. When you talk on the telephone, circuits in the phone convert your voice to electrical signals. If you're talking on a corded phone, those electrical signals pass along wires into the phone company's network. If you're talking on a cell phone, the phone converts its electrical signals into radio signals and transmits them to a tower, which sends them to the telephone network through wires, optical fibers, or radio links. The Internet and cable television systems work similarly. The networks are vast and complex. You'll learn more about basic concepts in Chapter 3 and learn some details in Chapters 23 through 27.

The optics in a fiber-optic network have to talk with the electronics. The basic idea is shown in Figure 1.5. The input signal drives a light source, modulating its intensity. If the input signal is a series of bits, it turns the light source off and on. In practice, the light source is part of an optical transmitter. The optical transmitter contains electronic circuits that process the signal so it drives the light source properly, but we won't worry about those details now. The light then leaves the source and enters an optical fiber, which carries it to a receiver. The receiver converts the light back to electronic form to drive devices on the other end. We'll cover the details later. This simple example shows transmission between a pair of points. A system that performs that job is often called a *link* between the points. A link that carries digital data is called a *data link*.

Telecommunications  
means  
communications  
over a distance.

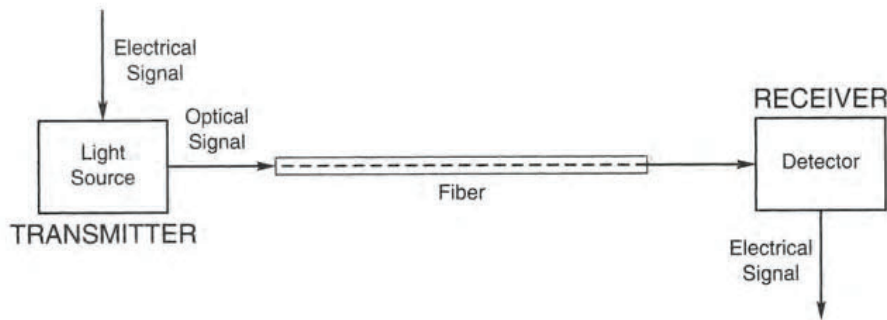
**FIGURE 1.5**

*Elements of a simple fiber-optic system.*

The telecommunications network is considerably more complex and uses different technologies at different levels. Like a network of roads or streams, the telecommunications network starts out small and packs more traffic onto main arteries. Fiber optics are the backbone of these networks, the superhighways that carry the heaviest traffic along the busiest routes. Today, fiber-optic links reach into virtually every community in the United States, although they carry different amounts of traffic. Wireless transmission over radio or microwaves is used for some links, largely for mobile phones and broadcasting from ground antennas or satellites. Plain copper wires and coaxial cables are used for other links. Both copper and wireless usually carry less traffic than fibers.

The basic functions of the telecommunications network are to transmit and distribute information. Think of these two functions as being performed by pipes and switches, as shown in Figure 1.6. The pipes carry information from its source to its destination. The switches direct the information through the proper pipes. The principles are the same whatever the network is, and in some cases, such as broadcast television, there isn't much

The telecommunications network distributes and transmits information.

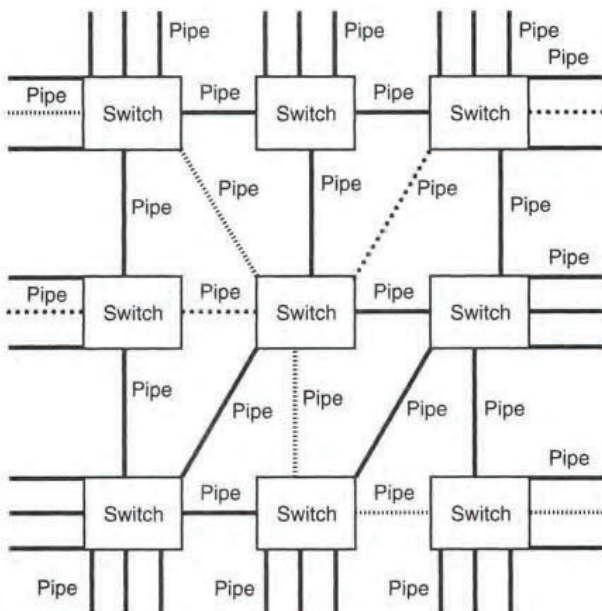
**FIGURE 1.6**

*A communications system consists of pipes that transmit signals and switches that direct them to their destinations.*



switching involved. The same signals go through one big pipe—radio waves transmitted through the air—to everybody.

The pipes are called *transmission media* and include optical fibers, copper wires, satellites, and broadcasts through the atmosphere. The switches direct the signals through particular pipes. As you'll learn later, different networks use different types of switches (often special-purpose computers). Most switches are electronic, but some optical switches have been developed. This book is about fiber optics, so it concentrates mainly on optical systems, although it does describe some electronics.

## The Business of Telecommunications

Telecommunications is a big business with billions of dollars at stake. It used to be a quiet, orderly business run by government agencies or private monopolies that had to comply with detailed sets of rules and regulations. The rules divided their turf. The telephone monopoly couldn't carry video signals, and the cable television monopoly couldn't carry telephone signals. Then governments began to change the rules, new technology arrived on the scene, new competitors appeared, and the picture became very complicated.

Most telecommunications systems today are operated by businesses that make money from charging customers for their services. Their expenses fall into the usual business categories such as providing service, sales, marketing, and overhead. The most important costs in running a network are *operating expense* or "opex" and *capital expense* or "capex." Operating expense covers day-to-day operations, the salaries of equipment operators, technicians and managers, maintenance, and repairs. Some work is done on company sites; other work is done elsewhere and requires sending a technician to a remote site (a "truck roll" in industry jargon). Capital expense is buying and installing new equipment. Network operators can trade one expense off against the other, investing capital expense in an expensive new automated system that automatically performs functions to reduce operating expenses. Government agencies that provide communications services to the public handle their expenses in a similar manner, but they aren't expected to make a profit.

Communications companies decide what equipment to use by estimating how much it will cost and what new revenue it will bring in, and balancing these considerations against other budgetary priorities. The decision process can get quite complex, and installation costs can play a big role. Companies have to pay for rights of way, and construction in downtown urban areas can be extremely expensive. Some of the earliest fiber-optic systems were installed because the small cables fit much better into crowded underground ducts in big cities than did thicker copper cables. The fiber-optic equipment cost more, but the overall project cost less because it didn't require new construction.

The major advantage of fiber has always been its ability to transmit signals at higher speeds and over longer distances than other transmission media. The demand for bandwidth has increased with the steady growth in telephone and video traffic, and the explosive growth in data traffic over the Internet. Engineers steadily increased the volume of data that fiber systems could transmit. The most explosive growth came in the past decade, as a new technique called *wavelength-division multiplexing (WDM)* made it possible to

Major costs are capital expense and operating expense.

Wavelength-division multiplexing sends signals at different wavelengths through one fiber.



transmit separate signals through the same fiber at many wavelengths. WDM multiplies the capacity of individual fibers. The idea is similar to transmitting signals through the air at many separate radio frequencies, which allows many radio and television stations to transmit simultaneously to homes. Developers also began talking about *optical networking*, in which signals would be routed around the country optically without being converted into electronic form.

Eventually investment in fiber optics got out of hand, creating an economic “perfect storm,” which survivors call “the bubble.”

## Understanding the Bubble

The rapid growth of the Internet and the proliferation of dot-com companies started pumping up the bubble in the late 1990s. A number of factors magnified its impact on the telecommunications industry.

For decades, the conventional wisdom of telecommunications engineers had been that you can't have enough bandwidth. Networks are designed around the assumption that everyone is not on the phone at the same time. The long-distance network can't handle all the country's phone lines at once, which is why you sometimes can't get a long-distance line on Mother's Day. As Internet demand started rising, telecommunications carriers installed more fiber to handle the demand. Extra fibers are cheap compared to construction projects, so the carriers added lots of fibers to make sure they had extra capacity in the future. They also planned on using wavelength-division multiplexing to multiply the capacity of every fiber. Nobody thought that they could ever have too much bandwidth.

But nobody fully grasped how fast the Internet was growing. For a brief period around 1996, Internet traffic seemed to be doubling every three months. Worldcom kept quoting that number for years until it became an Internet myth, widely believed although its origins were dubious. Telecommunications carriers looked at that tremendous growth rate and decided they'd need more fibers to handle the projected traffic. They didn't know that in reality Internet traffic was doubling only once every year, a fact hard to ascertain because the traffic was divided among many different carriers.

A gold rush started in technology stocks, focusing on the Internet, as new companies reported fast growth in sales. In reality, many of the numbers were fudged, and others looked deceptively large because they were starting from zero. Market analysts made wild projections of fantastic growth. A few people made fortunes selling promising new companies. Even when the first dot-coms began to fail, telecommunications looked good compared to selling dog food on the Internet, as I heard leading market analyst John Ryan say at a conference.

Venture capitalists kept pumping money into the optical industry. New companies popped up from nowhere. Some had solid ideas, but others seemed to have little more than fancy trade-show booths and a pitch to investors. Yet their valuations kept rising with the growth of the bubble. It was tempting to believe that this growth was real and everyone would get rich.

It wasn't. No one had realized how much market projections or corporate profits had been inflated by wishful thinking and fraud. When the collapse came, it was disastrous. Companies either folded or shrank to shadows of their former selves. Many fibers installed

Bandwidth was traditionally scarce in telecommunications.

The bubble badly hurt telecommunications and fiber optics.



## THINGS TO THINK ABOUT

### The Problem of the Bubble

The bubble created a tremendous amount of paper wealth that largely evaporated in its aftermath and left the telecommunications industry in shambles. Fortunes were made by a few people who sold stock near the peak; many more saw their holdings shrink.

The development of new technology requires investment, and the bubble distorted the entire pattern of investment. Cumulative losses are estimated to be in the hundreds of billions of dollars. Allegations of

fraud abound, going far beyond the handful of criminal charges filed and regulatory actions taken. Both crooks and fools played roles, but we may never know which was more important, nor how we can avoid future bubbles.

The historical parallels with the rise of the railroads during the nineteenth century are striking. You might find it illuminating to read some of the excellent books that chronicle the age of robber barons and the lives of railroad tycoons such as Cornelius Vanderbilt, James J. Hill, Jay Gould, and Jim Fisk.

---

during the bubble remain unused. The industry is still nursing a massive hangover. Troubling questions remain about how telecommunications carriers can make a profit when the price of bandwidth keeps dropping.

Yet telecommunications remains a viable product, and the demand continues to grow. Fiber-optic technology is needed to meet that demand, and to help reduce costs so carriers can make a profit. Unused fibers are likely to be lit in the future as the demand for bandwidth continues to increase. That's why it's important to learn about fiber optics.

### Fiber Terms: Terminology and Units

The appendixes include a glossary, tables listing important units, and other useful data. Many terms are standardized or widely accepted, but others are not. The communications industry is notorious for its many cryptic acronyms and sometimes puzzling buzzwords. I have tried to avoid unclear terms and all but the most widely accepted acronyms. I do use some designations set by international standards organizations, such as types of optical fiber specified by the International Telecommunications Union (ITU), because these labels have specific meanings and are widely used in the industry. Terms are explained the first time they appear. The terminology will continue to evolve as the field grows and changes.

I try to avoid proprietary terms. Many companies develop their own terminology, and different companies often have different names for the same technology. I do use a few trade names or trademarked terms that are widely used or are descriptive; they are capitalized as proper names to reflect their status.

Every writer has their own terminological preferences. I particularly despise meaningless market-speak, such as calling a product or system a "solution," because it tells nothing about what the thing is. I also prefer to spell out whole words rather than resort to acronyms. The latter conviction comes from reading too many specialized magazines that

don't communicate clearly to readers who are not experts in the field. The acronyms I do use are well accepted.

In this introductory chapter, I have used both metric and Imperial units to help you get started. In the rest of the book I give virtually all measurements only in the metric units that are used throughout the telecommunications industry. You should get used to those units. Standard dimensions for most devices—starting with the fiber itself—are quoted in metric units. The American fiber industry uses Imperial units in only a few cases, usually for the lengths of cable runs. Appendix A lists the common metric prefixes for units.

Because this book is published in the United States, it uses standard American spelling such as “meter” and “fiber” with few exceptions. The only important exception is in the “Fibre channel” set of standards for data transmission.

Fiber-optic  
measurements  
are metric.

## What Have You Learned?

1. Fiber optics has revolutionized telecommunications by supplying tremendous bandwidth, which previously was in short supply.
2. Fiber-optic technology remains healthy, but the business has suffered problems.
3. Light normally goes in straight lines, but optical fibers can guide it around corners.
4. Total internal reflection can guide light along a glass rod or water jet. An optical fiber guides light in a manner similar to a very thin glass rod.
5. Clad fibers were crucial in making fiber-optic imaging practical for examining the stomach and colon. The first practical application of fiber optics was gastroscopy.
6. An optical telegraph was invented in the 1790s in France. It was replaced by the electrical telegraph.
7. Optical fibers have very high bandwidth and can transmit signals farther than copper wires.
8. Glass fibers are inherently strong, allowing their use in outdoor cables.
9. Telecommunications means communications over a distance.
10. The telecommunications network is made of “pipes” and “switches” that distribute and transmit information.
11. Wavelength-division multiplexing transmits multiple signals through one fiber at different wavelengths.
12. The telecommunications bubble seriously disrupted the fiber-optics industry.
13. Fiber-optic measurements are made in metric units, although American companies often measure cable lengths in Imperial units (feet or miles).

## What's Next?

In Chapter 2, you'll learn basic principles of physics and optics needed to understand fiber optics. Then you'll learn basic fiber-optic concepts.



## Further Reading

On the evolution of fiber optics:

Jeff Hecht, *City of Light: The Story of Fiber Optics* (Oxford University Press, 1999 and 2004)

On the Internet bubble:

K. G. Coffin and A. M. Odlyzko, "Growth of the Internet," in I. P. Kaminow and T. Li, eds., *Optical Fiber Telecommunications IV B: Systems and Impairments* (Academic Press, 2002), pp. 17–56; available online at <http://www.dtc.umn.edu/~odlyzko/doc/of.internet.growth.pdf>

On the development of communications in general:

Arthur C. Clarke, *How the World Was One: Beyond the Global Village* (Bantam, 1992)

Anton A. Huurdeman, *The Worldwide History of Telecommunications* (Wiley InterScience, 2003)

Irwin Lebow, *Information Highways & Byways: From the Telegraph to the 21st Century* (IEEE Press, 1995)

Laszlo Solymar, *Getting the Message: A History of Communications* (Oxford University Press, 1999)

## Questions to Think About

1. For a bundle of optical fibers to transmit an image, the fibers must be arranged in the same pattern on both ends of the bundle. What limits the size of the smallest details that can be seen?
2. Devise an analogy using common implements found in a kitchen or cafeteria to show how a bundle of fibers transmits an image.
3. Most of the light lost in going through a glass window is reflected at the surface. Ignoring this surface reflection loss, suppose that a one-millimeter-thick window absorbs 1% of the light entering it and transmits 99%. Neglecting reflection, how much light would emerge from a one-meter-thick window?
4. If optical fibers transmit signals so much better than wires, why aren't they used everywhere?
5. During the bubble years, many people in the industry thought Internet traffic was doubling every three months. In reality, it was doubling about every year. How much difference in growth of Internet traffic would this make over a period of five years?
6. Why didn't anybody wonder how long Internet traffic could continue doubling every three months?

## Chapter Quiz

1. Light can be guided around corners best in
  - a. reflective pipes.
  - b. hollow pipes with gas lenses.
  - c. clad optical fibers.
  - d. bare glass fibers.
2. The first practical use of optical fibers was
  - a. in communications via optical telegraph.
  - b. in Alexander Graham Bell's photophone.
  - c. to illuminate flowing jets of water.
  - d. in bundles to examine the inside of the stomach.
3. What is the principal requirement for a cladding on an optical fiber?
  - a. It must have a refractive index lower than the core to produce total internal reflection.
  - b. It must be opaque so light doesn't leak out.
  - c. It must be made of plastic to keep the fiber flexible.
  - d. It must have a refractive index lower than that of air.
4. Flexible bundles of optical fibers can be used to
  - a. examine the inside of the stomach without surgery.
  - b. examine the inside of the colon without surgery.
  - c. illuminate hard-to-reach machinery.
  - d. all of the above
  - e. none of the above
5. A new automated control system costs \$1 million. How much will it have to reduce annual operating expenses if company policy says the payback time has to be no more than four years? (Neglect interest rates.)
  - a. \$100,000
  - b. \$250,000
  - c. \$400,000
  - d. \$500,000
  - e. \$1 million
6. The elements of a fiber-optic data link must include
  - a. light source, receiver, and fiber.
  - b. light source and cable.
  - c. fiber and receiver.

- d. fiber only.
  - e. cable only.
- 7.** You need to install a new cable to handle four years of growth on a transmission route. The traffic now fills one fiber, and traffic is doubling every three months. How many fibers will you need in four years?
- a. 4
  - b. 16
  - c. 128
  - d. 65,536
  - e. over 1 million
- 8.** As in Problem 7, you need to install a new cable to handle four years of growth on a transmission route where traffic is doubling every three months. All the traffic now fits in a signal that requires one wavelength in a fiber that can handle 32 wavelengths with wavelength-division multiplexing. How many fibers will you need to carry that traffic if you fill each one with 32 wavelengths?
- a. 4
  - b. 16
  - c. 128
  - d. 2048
  - e. 65,536
- 9.** Reality has set in, and you realize that traffic is doubling every year. How many fibers would you need if each fiber carried only one signal and the first fiber was already full?
- a. 1
  - b. 4
  - c. 16
  - d. 128
  - e. 2048
- 10.** How many fibers would you need to handle the transmission load in Problem 9 if each fiber could transmit signals at 32 wavelengths?
- a. 1
  - b. 2
  - c. 4
  - d. 16
  - e. can't tell from data given



# Fundamentals of Fiber-Optic Components

## About This Chapter

Fiber optics started as a branch of optics and evolved into a hybrid field that includes electronics and telecommunications. The basic concept behind a fiber is optical, and some single or bundled optical fibers are used as optical components. However, the most common use of fiber optics is in telecommunications, where many concepts originated in electronics and radio communications. Today, signals are converted back and forth between optical and electronic formats as they pass through the global telecommunications network. Fiber-optic transmitters and receivers are opto-electronic devices, part optical and part electronic. To understand fiber-optic communications, you need to learn about three fields: optics, electronics, and telecommunications.

This chapter introduces optical and electronic concepts to lay the groundwork for understanding fiber-optic components. Chapter 3 covers communications systems. Later chapters explain particular devices and systems in more detail.

## Basics of Optics

Optics is the part of physics dealing with light and its interaction with matter. The workings of optical fibers depend on optics, so you need to understand basic optical principles and how light interacts with matter. To prepare you, we will review these principles without going into great detail or length. Some parts of this review may seem unnecessary, but read it anyway because later chapters assume you understand these fundamentals.

From a physical standpoint, you can consider light to be either *electromagnetic waves* or particles called *photons*. This is the famous wave-particle duality of modern physics.



Light can be considered as electromagnetic waves, photons, or rays.

A photon is a quantum of electromagnetic energy.

Both viewpoints are valid and valuable. Optical engineers are concerned with the path that light follows, so they often consider light as *rays* that follow straight lines between or within optical elements, bending only at surfaces.

Each of these viewpoints can be useful at different times. The ray model of light propagation represents how light passes through space and optical devices. Rays are easy to visualize; you can think of them as laser beams drawing straight lines in space. Yet light is not really made up of rays; it's made up of electromagnetic waves or photons. You can learn other things about light by considering it to be waves or photons.

## Electromagnetic Waves and Photons

Viewed as an electromagnetic wave, *light* is composed of electric and magnetic fields, which vary in amplitude as they move through space together at the speed of light, denoted  $c$ . The two fields are perpendicular to each other and to the direction in which the light travels, as shown in Figure 2.1. The amplitude of each field varies *sinusoidally*, like a sine function in trigonometry, rising from zero to a positive peak, going back through zero, hitting a negative peak, then returning to zero. The distance that light travels during that complete cycle is called the *wavelength*. The usual symbol for wavelength is the Greek letter  $\lambda$  (lambda), and that's one symbol you should remember. The number of waves or cycles per second is called the *frequency*, and it's measured in hertz (after Heinrich Hertz, who discovered electromagnetic waves). Frequency usually is denoted by the Greek letter  $\nu$  (nu). Wavelength decreases as frequency increases, and waves can be measured by either.

Many light sources such as red laser pointers emit *continuous* light waves, which oscillate steadily at the same frequency. You can think of them as sine waves that go on for a very long time. Other sources emit pulses of light, and it's useful to think of pulses of light as groups of photons.

A photon is a quantum of electromagnetic energy. It's also a *wave packet*, a series of a few waves that build quickly to a peak amplitude, then fade back to nothing, as shown in

**FIGURE 2.1**  
A light wave consists of electric and magnetic fields.

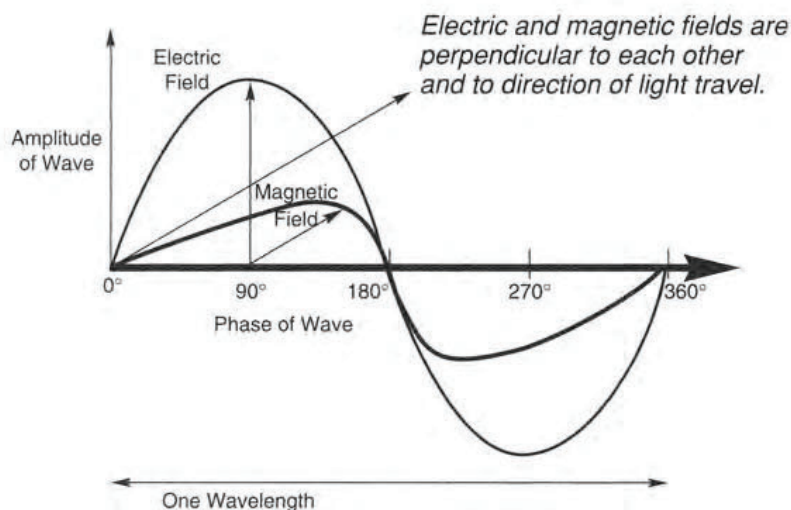

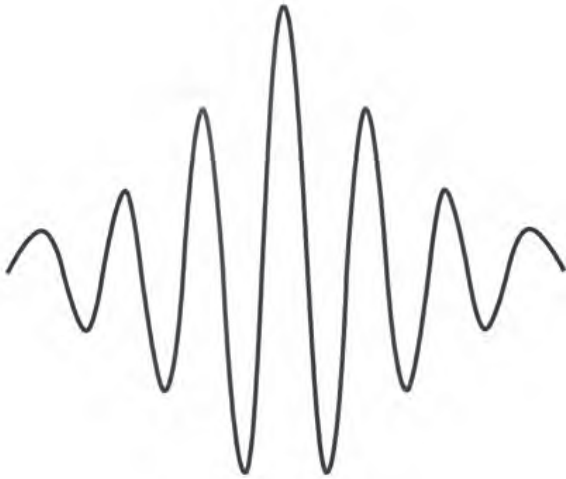
**FIGURE 2.2**

*A single photon is a short packet of waves.*

Figure 2.2. Like a continuous wave, a pulse or wave packet has a wavelength and a frequency, but the wavelength and frequency are not as well defined as for a continuous beam. Thanks to the uncertainty principle, the shorter the pulse, the larger the uncertainty in wavelength.

The amount of energy carried by a single photon depends on the oscillation frequency: The faster the wave oscillates, the higher the energy. A continuous wave is a series of photons, emitted one after the other. Each photon has a unit of energy set by the wavelength or frequency, so the total energy is the number of photons times that photon energy. In wave terms, this is proportional to the wave amplitude squared.

## The Electromagnetic Spectrum

What we call “light” is only a small part of the spectrum of *electromagnetic radiation*. The fundamental nature of all electromagnetic radiation is the same. It can be viewed as photons or waves and travels at the speed of light ( $c$ ), which is approximately 300,000 kilometers per second (km/s), or 180,000 miles per second (mi/s). The difference between radiation in different parts of the electromagnetic spectrum is a quantity that can be measured in several ways: as the length of a wave, as the energy of a photon, or as the oscillation frequency of an electromagnetic field. Figure 2.3 compares these three views.

Each measurement—wavelength, energy, or frequency—has its own characteristic unit. The preferred unit depends on the part of the spectrum. The optics world usually talks in wavelength, which is measured in meters, *micrometers* ( $\mu\text{m}$  or  $10^{-6}$  m), *nanometers* (nm or  $10^{-9}$  m), or sometimes in angstroms ( $1\text{\AA} = 10^{-10}$  m). Don’t even think of wavelength in inches. (If you absolutely have to know,  $1\ \mu\text{m}$  is 0.00003937 in.) Frequency is measured in cycles per second (cps) or hertz (Hz), with megahertz (MHz) meaning a million hertz and gigahertz (GHz) meaning a billion hertz. (The metric system uses the standard prefixes listed in Appendix A to provide different units of length, weight, frequency, and other quantities. The prefix makes a unit a multiple of a standard unit. For example, a millimeter is a thousandth [ $10^{-3}$ ] of a meter, and a kilometer is a thousand [ $10^3$ ] meters.)

The light carried in fiber-optic communications systems can be viewed as either a wave or a particle.



**FIGURE 2.3**

*Electromagnetic spectrum.*

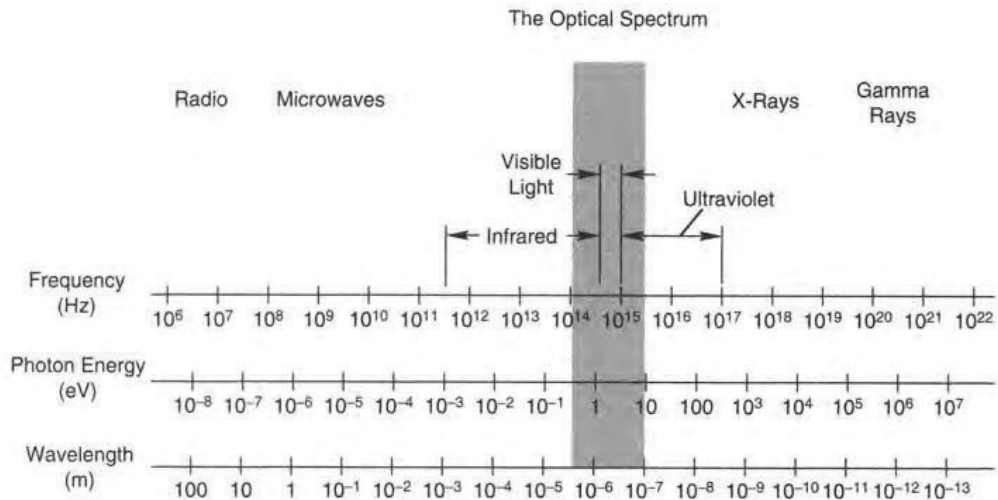

Photon energy can be measured in many ways, but the most convenient here is in electron volts (eV)—the energy that an electron gains in moving through a 1-volt (V) electric field.

All the measurement units shown on the spectrum chart are actually different rulers that measure the same thing. There are simple ways to convert between them. Wavelength is inversely proportional to frequency, according to the formula:

$$\text{wavelength} = \frac{c}{\text{frequency}}$$

or

$$\lambda = \frac{c}{\nu}$$

where  $c$  is the speed of light,  $\lambda$  is wavelength, and  $\nu$  is frequency. To get the right answer, all terms must be measured in the same units. Thus  $c$  must be in meters per second (m/s),  $\lambda$  must be in meters, and frequency must be in hertz (or cycles per second). Plugging in the approximate value of  $c$ , we have a more useful formula for wavelength:

$$\lambda = \frac{3 \times 10^8 \text{ m/s}}{\nu}$$

You can also turn this around to get the frequency if you know the wavelength:

$$\nu = \frac{3 \times 10^8 \text{ m/s}}{\lambda}$$

Not many people talk about photon energy ( $E$ ) in fiber optics, but a value can be gotten from Planck's law, which states:

$$E = h\nu$$

where  $h$  is Planck's constant ( $6.63 \times 10^{-34}$  J-s, or  $4.14 \times 10^{-15}$  eV-s) and  $\nu$  is the frequency. Because most interest in photon energy is in the part of the spectrum measured in wavelength, a more useful formula is

$$E(\text{eV}) = \frac{1.2399}{\lambda(\mu\text{m})}$$

which gives energy in electron volts when wavelength is measured in micrometers ( $\mu\text{m}$ ).

We are mainly interested in a small part of the spectrum shown in Figure 2.3—the optical region, where optical fibers and other optical devices work. That region includes light visible to the human eye at wavelengths of 400 to 700 nm and nearby parts of the infrared and ultraviolet, which have similar properties. Roughly speaking, this means wavelengths of 200 to 20,000 nm (0.2 to 20  $\mu\text{m}$ ).

The wavelengths normally used for communications through silica glass optical fibers are 750 to 1700 nm (0.75 to 1.7  $\mu\text{m}$ ) in the near infrared, where silica is the most transparent. Glass and silica fibers can transmit visible light over shorter distances, and special grades of silica (often called *fused quartz*) can transmit near-ultraviolet light over short distances. Plastic fibers transmit best at visible wavelengths.

Fiber-optic communications systems transmit near-infrared light invisible to the human eye.

## Wave Phase and Interference

One important consequence of the wave nature of light is that light waves have a property called *phase*, which measures the progress of the wave in its cyclical variation in amplitude. Figure 2.1 showed one complete cycle, in which the amplitude of the electric and magnetic fields rises, falls, and returns to the starting point. Light waves from a continuous source repeat this cycle endlessly. Repeating this cycle is like going around a circle, and the phase is measured as an angle between  $0^\circ$  and  $360^\circ$ . The electric and magnetic fields depend on each other, so normally the phase is measured only for the electric field.

Electromagnetic waves combine by adding their amplitudes. If you start with a pair of waves with the same wavelength and amplitude, and the peaks and valleys line up perfectly, their amplitudes add, producing an effect called *constructive interference* (shown in Figure 2.4). However, if the peaks of one wave line up with the valleys of the other wave, the sum of the two intensities at any instant is zero, because one has a positive value and the other has a negative value of the same amount. This case, also shown in Figure 2.4, is known as *destructive interference*. Destructive interference occurs when the two waves are  $180^\circ$  out of phase. With intermediate phase shifts, the combined amplitude is between the peak of constructive interference and the null of destructive interference. (Because the wave repeats indefinitely, we only measure phase shifts within one cycle, between  $0^\circ$  and  $360^\circ$ .)

We normally don't see this interference effect because most light sources radiate light in all directions at a wide range of wavelengths. Turn on two light bulbs in a dark room, and the total intensity is the sum of the two intensities. To see interference you need to combine two identical light waves so their amplitudes add or subtract. You can do this by passing light through a pair of closely spaced slits. Light spreads out from each of the slits,

Light waves add or subtract in amplitude depending on their relative phase.



**FIGURE 2.4**

*Constructive and destructive interference.*

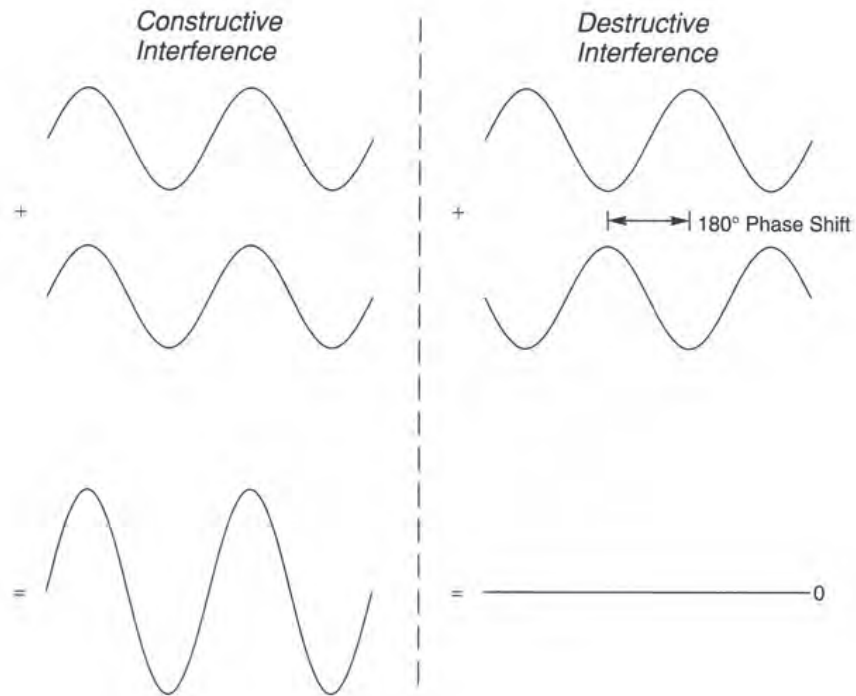

producing a pattern of light and dark regions where the waves interfere constructively and destructively, as shown in Figure 2.5. (The pattern arises because the waves travel slightly different distances from the two slits.)

If you're familiar with the law of conservation of energy, you may wonder where the energy goes when the light waves interfere destructively. The energy doesn't disappear; it's just rearranged in space, appearing where the waves interfere constructively. The total

**FIGURE 2.5**

*Interference of light waves traveling slightly different paths produces bright and dark stripes.*

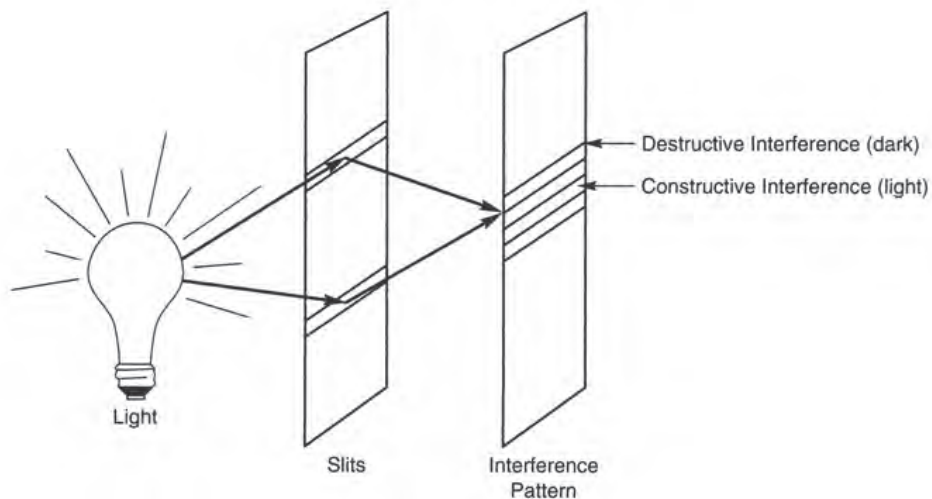

amount of light in the interference pattern is the total passing through the two slits, but it's not spread evenly.

## Refractive Index

The speed of light in a vacuum ( $c$ ) is considered the universal speed limit. Normally nothing travels faster, although sometimes light can go a bit over the speed limit if it carries no information.

Light always travels more slowly through transparent materials than through a vacuum. The speed difference for a material is measured by a number called the *refractive index*, denoted by the letter  $n$  in optics, which equals the speed of light in a vacuum divided by the speed of light in the material:

$$n = \frac{c_{\text{vacuum}}}{c_{\text{material}}}$$

The refractive index of a vacuum equals 1.0 by definition. For normal optical materials, the refractive index is greater than 1.0 in the optical part of the spectrum. (There are some peculiar exceptions you don't need to worry about.) In practice, the refractive index is measured by comparing the speed of light in a material to the speed of light in air rather than in a vacuum. This makes little practical difference because the refractive index of air at normal pressure and temperature is 1.000293.

Light changes speed as it goes from one material into another, such as from air into glass. This causes an effect we call *refraction*. To understand refraction, consider what happens to the peaks of light waves as they enter glass from air, as shown in Figure 2.6. The peaks of the waves line up in air, but when the waves hit the glass at an angle, some of the light enters the glass while the rest remains in the air. The frequency of the wave does not change as the waves slow down in the glass, so the wave takes the same time to complete a cycle, but it doesn't travel as far between peaks in glass as it did in the air. The waves in air continue at the same speed until they reach the surface of the glass, where they also slow down. This process of slowing down bends the path of the light, as you can see in Figure 2.6. The same thing would happen if you braked the wheels on only one side of your car; its path would turn toward the side where the wheels slowed.

Figure 2.6 shows the wave view of light, with a broad *wavefront* passing through the glass. In practice, it's more useful to consider refraction from the ray viewpoint. The bold line in the figure represents the light ray, which bends at the surface of the glass. That ray shows how the path of the light bends as light passes between the two media.

The bending of light at a surface depends on the refractive indexes of the two materials and the *angle of incidence* at the surface. Both the angle of incidence and the *angle of refraction* of the transmitted light are measured from a line perpendicular to the surface called the *normal*. Snell's law describes this bending:

$$n_i \sin I = n_r \sin R$$

where  $n_i$  and  $n_r$  are the refractive indexes of the initial medium and the medium into which the light is refracted, and  $I$  and  $R$  are the angles of incidence and refraction, respectively, as shown in Figure 2.6.

Refractive index is the speed of light in a vacuum divided by the speed of light in a material.

Refraction occurs when light changes speed as it goes between two materials.



**FIGURE 2.6**

*Refraction of light entering glass.*

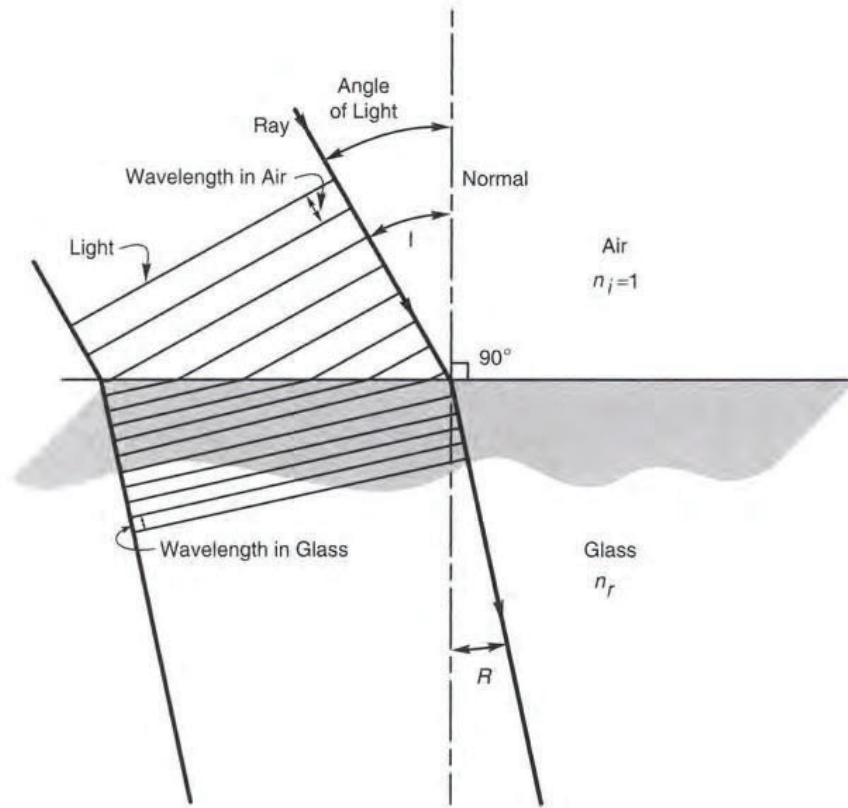

Figure 2.6 shows the standard example of light going from air into glass. The same thing happens in reverse when light emerges into air on the other side of the glass. If the front and rear surfaces of the glass are flat, light emerges at the same angle at which it entered, and the net refraction is zero, as when you look through a flat window. (The light is displaced a little bit, but we usually don't notice that shift.) If one or both surfaces are curved, the light rays emerge at a different angle than when they entered the glass, and you see a net refraction or bending of the light rays, as if you were looking through a lens. Figure 2.7 shows the overall refractive effect.

What does this have to do with fiber optics? Stop and consider what happens when light in a medium with a high refractive index (such as glass) comes to an interface with a medium having a lower refractive index (such as air). If the glass has a refractive index of 1.5 and the air an index of 1.0, the equation becomes

$$1.5 \sin I = 1 \sin R$$

Instead of being bent closer to the normal, as in Figure 2.6, the light is bent farther from it, as in Figure 2.8. This isn't a problem if the angle of incidence is small. For  $I = 30^\circ$ ,  $\sin I = 0.5$ , and  $\sin R = 0.75$ . But a problem does occur when the angle of incidence becomes too steep. For  $I = 60^\circ$ ,  $\sin I = 0.866$ , so Snell's law says that

Total internal reflection occurs when light in a high-index material hits a boundary with a material of lower refractive index at a glancing angle.

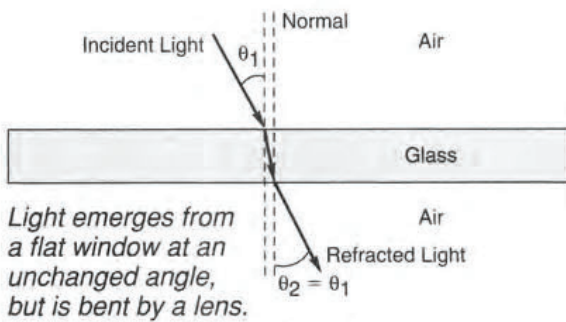

a. Window

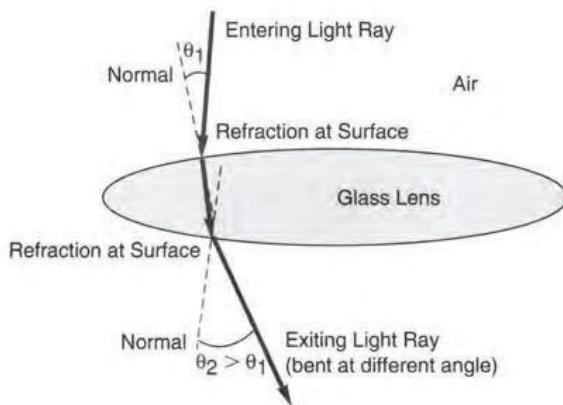

b. Lens

**FIGURE 2.7**

*Refraction through a window and a lens.*

$\sin R = 1.299$ . Your pocket calculator will tell you this is an error. That angle can't exist because the sine can't be greater than 1.0.

Snell's law indicates that refraction can't take place when the angle of incidence is too large, and that's true. Light cannot get out of the glass if the angle of incidence exceeds a value called the critical angle, where the sine of the angle of refraction would equal 1.0. (Recall from trigonometry that the maximum value of the sine is 1.0 at  $90^\circ$ , where the light would be going along the surface.) Instead, total internal reflection bounces the light back into the glass, obeying the law that the angle of incidence equals the angle of reflection, as shown in Figure 2.8. It is this total internal reflection that confines light in optical fibers, at least to a first approximation. As you will see in Chapter 4, the mechanism of light guiding is more complex in modern communication fibers.

The *critical angle* above which total internal reflection takes place,  $\theta_{\text{crit}}$ , can be deduced by turning Snell's law around, to give

$$\theta_{\text{crit}} = \arcsin(n_r/n_i)$$

For the example given, with light trying to emerge from glass with  $n = 1.5$  into air, the critical angle is  $\arcsin(1/1.5)$ , or  $41.8^\circ$ .



**FIGURE 2.8**

Refraction and total internal reflection.

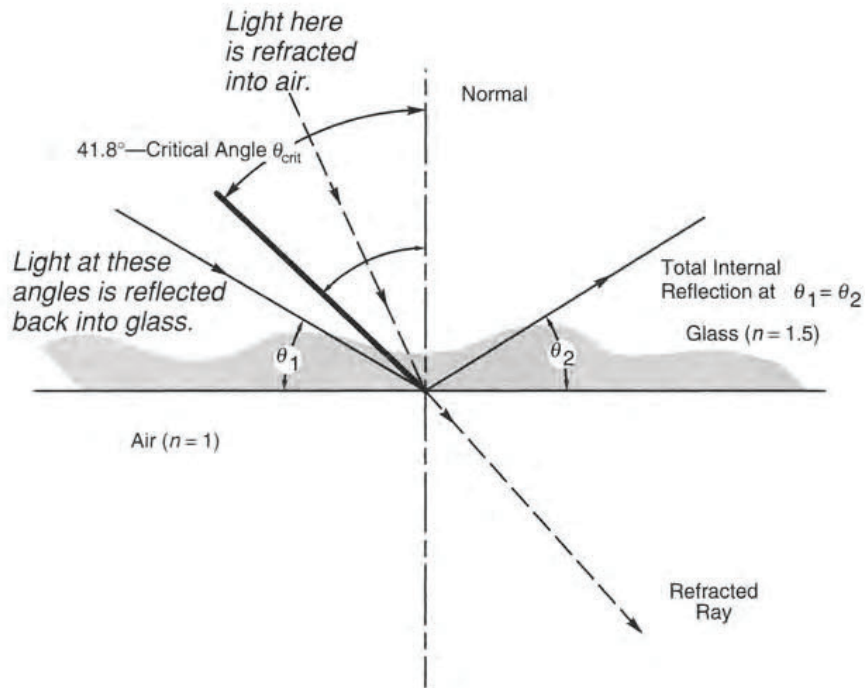

## Light Guiding

Light is guided in the core of an optical fiber by total internal reflection at the boundary.

The two key elements of an optical fiber—from an optical standpoint—are its *core* and *cladding*. The core is the inner part of the fiber, which guides light. The cladding surrounds it completely. The refractive index of the core is higher than that of the cladding, so light in the core that strikes the boundary with the cladding at a glancing angle is confined in the core by total internal reflection, as shown in Figure 2.9.

The difference in refractive index between core and cladding need not be large, and is less than 1% in most telecommunications fibers. For a 1% difference, corresponding to  $n_r/n_i = 0.99$ , the critical angle,  $\theta_{\text{crit}}$ , measured from the normal is about  $82^\circ$ . That means light is confined in the core if it strikes the cladding interface at an angle of  $8^\circ$  or less, as shown in Figure 2.9. The upper limit measured from the interface is called the *confinement angle*,  $\theta_{\text{conf}}$ , of the fiber.

**FIGURE 2.9**

Light guiding in an optical fiber.

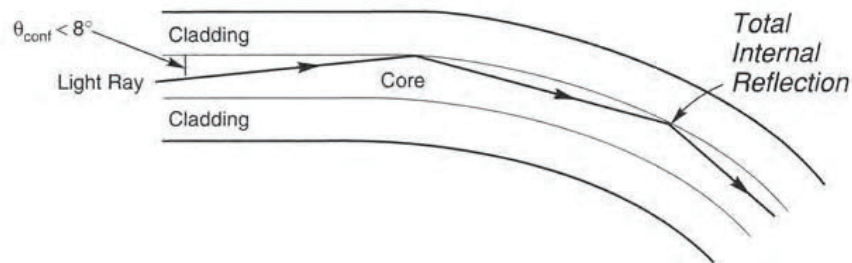

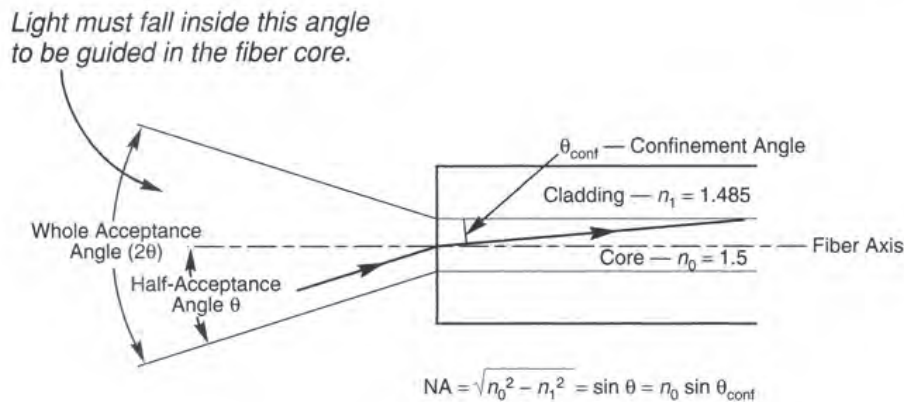
**FIGURE 2.10**

Measuring the acceptance angle.

Another way to look at light guiding in a fiber is to measure the fiber's *acceptance angle*—the angle over which light rays entering the fiber will be guided along its core, shown in Figure 2.10. Because the acceptance angle is measured in air outside the fiber, it differs from the confinement angle in the glass. The acceptance angle normally is measured as *numerical aperture* (NA), which for light entering a fiber from air is approximately

$$NA = \sqrt{(n_0^2 - n_1^2)}$$

where  $n_0$  is the refractive index of the core and  $n_1$  is the index of the cladding. For a fiber with core index of 1.50 and cladding index of 1.485 (a 1% difference),  $NA = 0.21$ . An alternative but equivalent definition is the sine of the half-angle over which the fiber can accept light rays,  $12^\circ$  in this example ( $\theta$  in Figure 2.10). Another alternative definition is  $NA = n_0 \sin \theta_{\text{conf}}$ , where  $\theta_{\text{conf}}$  is the confinement angle in the fiber core ( $8^\circ$  in this example). These angles are measured from a line drawn through the center of the core, called the *fiber axis*.

Note that the half-acceptance angle is larger than the largest glancing angle at which light rays must strike the cladding interface to be reflected, which I said earlier was  $8^\circ$ . What does this mean? Look at Snell's law of refraction again. The difference is the factor  $n_0$ , which is the refractive index of the core glass, or 1.5. As you can see in Figure 2.10, refraction bends a light ray entering the fiber so that it is at a smaller angle to the fiber axis than it was in the air. The sine of the angle inside the glass equals that of the angle outside the glass, divided by the refractive index of the core ( $n_0$ ).

## Light Collection Efficiency

An optical fiber will pick up some light from any light source. You can see this if you point a single large-core fiber at a lightbulb. Look into the other end of the fiber, taking care not to get your eye too close. You should see an illuminated spot in the fiber. That light comes from the bulb, but it's only a tiny fraction of the total the bulb emits. Appendix E describes eye-safety precautions, which are important if you are using a laser source.

Developing ways for small-core fibers to collect light efficiently was an important step in developing practical fiber-optic communications. This includes both collecting light from

The angle over which a fiber accepts light depends on the refractive indexes of the core and cladding.

Light source size and alignment are critical in collecting light in a fiber core.



external sources and transferring light from one fiber to another. *Coupling* light efficiently into the fiber requires both focusing it onto the core and aligning it so it falls within the fiber's acceptance angle. The combination imposes demanding requirements.

Simple optics can focus the light from an ordinary bulb so it forms a narrow beam. You can see the results in a flashlight beam or a searchlight. A careful look reveals that the focusing is not perfect, but the beams are strongly directional. However, focusing a large light source into a narrow beam leaves a large spot that spreads far beyond the fiber core. Large light sources can be focused onto small spots with strong magnifying lenses. You've probably used that trick to burn a hole in paper with focused sunlight. However, that normally leaves the light spreading at too large an angle for the fiber to collect it efficiently.

For communication systems, it's generally more efficient to find a light source that is close to the fiber core in size. Generally these are semiconductor lasers, which emit light from a small spot, or optical-fiber amplifiers, which emit light from a doped core, as described later. Light-emitting diodes (LEDs) can be used with some larger core fibers because they are less expensive and the larger cores can collect more of their light. Larger light sources generally are easier to align with fibers, but their lower intensity delivers less light. Chapter 9 describes light sources in more detail.

Transferring light between fibers requires careful alignment and tight tolerances. Light transfer is most efficient when the ends of two fibers are permanently joined in a splice (described in Chapter 13). Temporary junctions between two fiber ends, made by connectors (also described in Chapter 13) typically have slightly higher losses but allow much greater flexibility in reconfiguring a fiber-optic network. Special devices called *couplers* (described in Chapter 14) are needed to join three or more fiber ends. One of the most important functional differences between fiber-optic and wire communications is that fiber couplers are much harder to make than their metal-wire counterparts.

Losses in transferring signals between wires are so small that they can normally be neglected. This is not so for fiber optics. As you will see in Chapter 21, system designers should account for coupling losses at each connector, coupler, splice, and light source.

## Fiber Transmission

Optical fibers inevitably affect light transmitted through them. The same is true for any material transmitting any kind of signals. You notice these effects most for poor transmitters, like dirty windows or crackling telephone lines. However, they are present even for the tenuous gas dispersed in intergalactic space, which astronomers can spot because it absorbs a tiny fraction of the light passing through it. Generally these effects degrade signals, and if they become large enough, they can make it impossible to receive the signals.

The three principal effects that degrade signals in optical fibers are *attenuation*, *dispersion*, and *crosstalk*. You can see analogous effects when electronic signals go through copper wires or are broadcast as radio or television signals. These effects are critical to the performance of fiber-optic systems, so I will introduce the concepts here before exploring them in more detail in later chapters.

Joining the ends of optical fibers requires careful alignment and tight tolerances.

Transfer losses must be considered in fiber-optic communications systems.

Attenuation, dispersion, and crosstalk can degrade signals transmitted by optical fibers.



## Fiber Attenuation

Attenuation makes signal strength fade with distance. In some cases, such as broadcast radio, distance alone can cause attenuation because signals spread out through space as they travel. As the signal spreads over a larger volume, the intensity drops.

This is not the case in optical fibers, which are *waveguides* that confine light within the core along their entire length. This prevents signals from spreading over a larger volume, but other effects cause different types of attenuation. The three primary effects are *absorption*, *scattering*, and *leakage* of light from the fiber core. You will learn more about these later, but a basic understanding of the concepts will help you now.

Although optical fibers are made of extremely pure glass, they absorb a tiny fraction of the light passing through them. The amount depends on the wavelength and the presence of impurities. Certain impurities cause strong absorption, but even pure silica has some absorption. Every transparent object absorbs a little light but transmits most of the light that enters it; opaque materials transmit a little light a little way inside them, but they absorb (or reflect) most of the incident light.

Atoms within the glass also scatter light. The physics are complex, but the atoms act as if they were tiny reflective particles, like droplets in a fog bank. Scattering reflects light in other directions, so it escapes from the fiber core and is lost from the signal. Like absorption, scattering is inherent in all fiber materials, but generally is small. The amount of scattering increases at shorter wavelengths, so it's higher at visible wavelengths than in the infrared. The physics are the same as for light scattering in the atmosphere, which spreads short-wavelength blue light all over the sky, while allowing longer red wavelengths to reach us as the sun rises and sets.

Light leakage occurs when light escapes from the fiber core into the cladding. It's normally very low unless the fiber is bent sharply, when light can escape by hitting the core-cladding boundary at a steep enough angle to avoid total internal reflection. As you will learn later, fiber installation and the environment can bend fibers in ways that allow light to leak out, but normally this loss is the smallest of the three types. Like leaky plumbing, it's a rare event that indicates something has gone wrong.

Although absorption and scattering are extremely small in optical fibers, total attenuation accumulates when light travels through many kilometers of fiber. Attenuation normally is measured by comparing the strength of the input signal to the output. For example, if 99% of the input light emerges from the other end, a fiber has 1% attenuation.

Attenuation is cumulative, and normally uniform through the entire length of a fiber. Thus every meter of fiber should have the same attenuation as the previous meter. If 99% of the light emerges from the first meter, 99% of that light should emerge from the second meter, and so on. For a 10-meter fiber, the light emerging should be

$$\begin{aligned} \text{Output} &= \text{Input} \times 0.99 \times 0.99 \times 0.99 \times 0.99 \times 0.99 \\ &\quad \times 0.99 \times 0.99 \times 0.99 \times 0.99 \times 0.99 = 0.904 \times \text{Input} \end{aligned}$$

More generally, the output is

$$\text{Output} = \text{Input} \times (\text{transmission/unit length})^{\text{Total length}} = \text{Input} \times (0.99)^{10}$$

Absorption, scattering, and light leakage are the components of fiber attenuation.

Atoms within the fiber scatter light out of the core.

Attenuation of a fiber is the product of the length times the characteristic loss in decibels per kilometer.



These sorts of calculations get messy, so generally attenuation is measured in *decibels* (dB), which are very useful units, although peculiar ones. The decibel is a logarithmic unit measuring the ratio of output to input power. (It is actually a tenth of a unit called a *bel* after Alexander Graham Bell, but that base unit is virtually never used.) Loss in decibels is defined as

$$\text{dB loss} = -10 \times \log_{10} \left( \frac{\text{power out}}{\text{power in}} \right)$$

Thus, if output power is 0.001 of input power, the signal has experienced a 30-dB loss.

The minus sign is added to avoid negative numbers in attenuation measurements. It is not used in systems where the signal level might increase, where the sign of the logarithm indicates if the signal has decreased (minus) or increased (plus).

Each optical fiber has a characteristic attenuation that is measured in decibels per unit length, normally decibels per kilometer. The total attenuation (in decibels) in the fiber equals the characteristic attenuation times the length. To understand why, consider a simple example with a fiber having the relatively high attenuation of 10 dB/km. That is, only 10% of the light that enters the fiber emerges from a 1-km length. If that output light was sent through another kilometer of the same fiber, only 10% of it would emerge (or 1% of the original signal), for a total loss of 20 dB.

As you can see, the decibel scale simplifies calculations of attenuation. It's widely used in electronics and acoustics as well as optics. You'll learn more about decibels later, but you should realize that they are easy to underestimate. Decibels are really exponents, not ordinary numbers. Every additional 10-dB loss reduces the output a factor of 10. A 20-dB loss is a factor of 100 ( $10^{2.0}$ ), a 30-dB loss is a factor of 1000 ( $10^{3.0}$ ), and a 40-dB loss is a factor of 10,000 ( $10^{4.0}$ ). These numbers can get very big very fast. Appendix B gives some comparisons for decibel units, which you may find surprising.

## Bandwidth and Dispersion

Low attenuation alone is not enough to make fibers invaluable for telecommunications. The thick wires that transmit electrical power also have very low loss, but they cannot transmit information at high speeds. Optical fibers are attractive because they combine low loss with high bandwidth to allow high-speed signals to travel over long distances. In a communication system, this becomes high bandwidth, the ability to carry billions of bits per second over many kilometers.

Concepts such as *bandwidth* and *information capacity* are crucial in communications, and the next chapter will tell you more about them. They measure the flow of information through a communication system. For example, television signals have more bandwidth than audio signals. In general, the more bandwidth or information, the better.

The more information you want to transmit, the faster the signal has to vary, and it's the need for rapidly varying signals that can cause problems in transmitting high-bandwidth signals. Different effects limit different types of communications. The number of dots and dashes an old-fashioned electrical telegraph could transmit was limited by how fast one operator could hit the transmitting key and how fast another could write down or relay the incoming signals.

Decibel losses are easy to underestimate; every 10 dB decreases signal strength by a factor of 10.

Optical fibers are unique in transmitting high-speed signals with low attenuation.

Attenuation of copper wires increases with signal frequency.

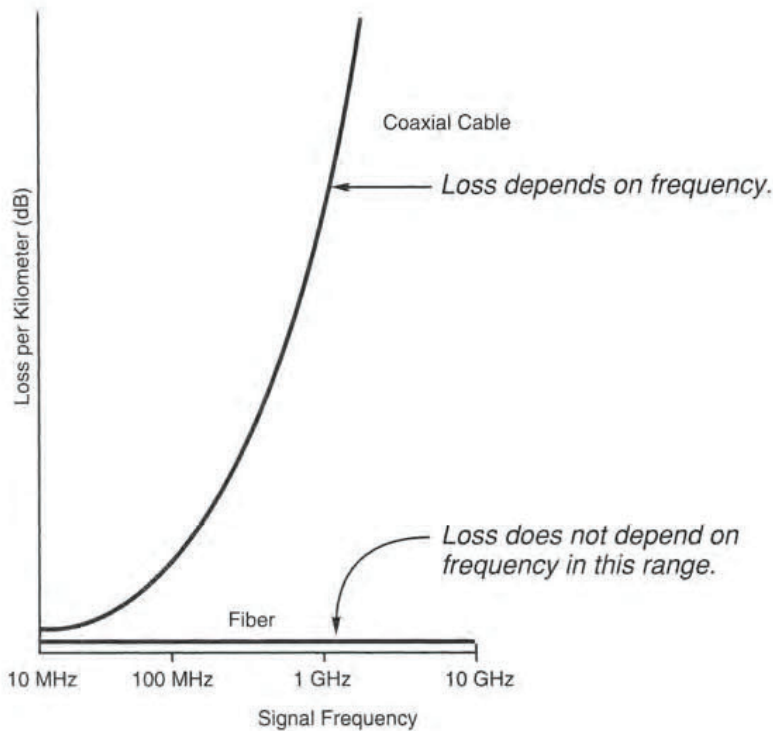
**FIGURE 2.11**

*Loss as a function of frequency.*

The speed limit on electrical wires comes from the nature of electrical currents. Moving electrons induce currents in the copper around them, so the impedance of a wire increases with the speed at which the signal varies. In practice, that means the higher the frequency, the higher the attenuation. Pairs of copper wires have very low attenuation at the extremely low frequencies used for electrical power transmission, 60 Hz in North America and 50 Hz in Europe, and they can carry audio frequencies over reasonable distances, but not television signals. Coaxial cables can transmit higher frequencies, but their attenuation increases sharply with frequency, as shown in Figure 2.11. In contrast, optical fibers have essentially the same attenuation across a wide range of operating frequencies, although dispersion does attenuate high signal frequencies, as described below.

The main limitation on fiber-optic bandwidth is an effect called *dispersion*. It is easiest to visualize if you consider a signal as made up of an instantaneous pulse containing many photons. The photons are not perfectly identical, so they spread out a little as they travel, like a group of race cars on a track. Some spreading occurs because the wavelengths differ slightly, and the refractive index of the glass varies with wavelength. Other spreading comes because the photons may travel slightly different paths through some types of fiber. The effects are small, but like attenuation they accumulate with distance. The farther the pulses travel, the more the photons spread out. If the light travels far enough, the first photons in one pulse catch up with the last photons in the previous pulse, and eventually it's no longer possible to tell the pulses apart, as shown in Figure 2.12. You'll learn more about dispersion in Chapter 5.

Figure 2.12 is an oversimplification in one important aspect: In real fiber-optic systems, digital signals start as boxy square-wave pulses, created by switching a light source on and

Dispersion limits fiber transmission bandwidth.

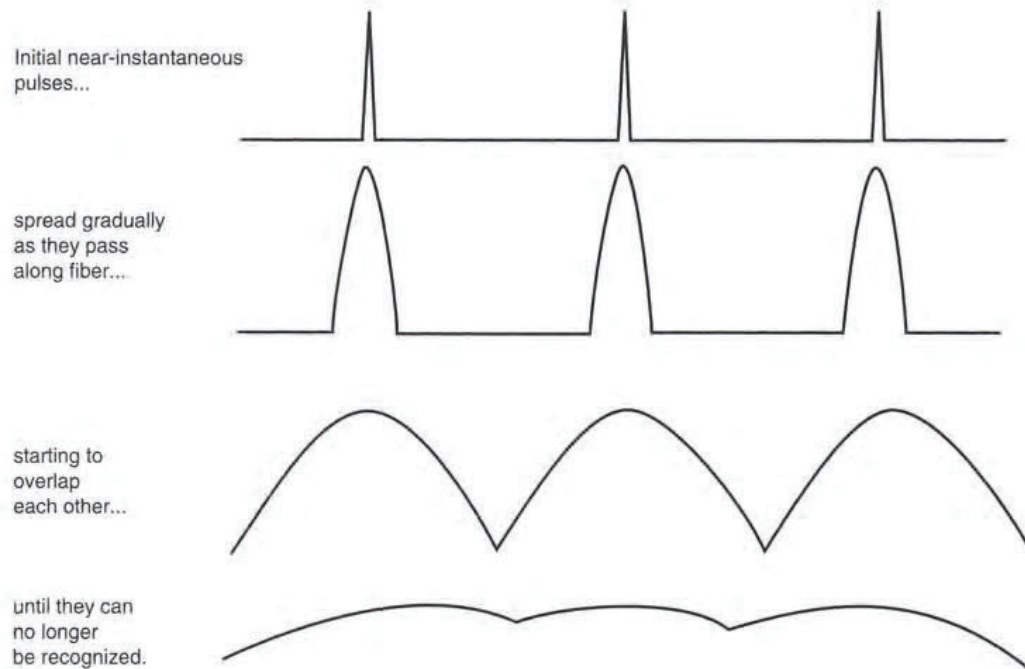

**FIGURE 2.12***Pulse dispersion.*

off very quickly. Gradually the edges round off as some photons get ahead and others fall behind. From a signal-processing standpoint, the sharp edges of a square wave are really signals at frequencies many times higher than the rate at which the pulses are being switched off and on. As the pulse of photons blurs out along the fiber, those high-frequency components are lost. Thus the blurring of sharp square-wave pulses into rounded lumps is really high-frequency attenuation, and optical fibers do have limited transmission bandwidth. But what's important is that the limit for optical fibers is at much higher frequencies than for copper wires.

## Crosstalk and Nonlinear Effects

Crosstalk is the leakage of signals between nominally independent channels.

*Crosstalk* occurs when signals cross the barriers that are supposed to separate them from each other. You have crosstalk on the phone if you hear a radio station or another conversation in the background. The different communication channels—phone lines and radio broadcasts—are supposed to be separate from each other. However, a little bit of one can leak into another channel. There are many reasons for electrical crosstalk. Phone wires can act as antennas to pick up strong radio signals. Currents in one pair of wires can induce signals in another pair running beside them. Sometimes other equipment may transmit signals through the air at the same frequency, so you might hear static on your AM radio when a motor operates nearby.

Fibers are immune to the usual electronic crosstalk. They don't carry electrical currents, and the light inside them is unaffected by nearby currents. You can run fibers along power lines and never hear a thing, although the 60-cycle hum would overwhelm telephone wires.

However, fibers carrying multiple signals or *optical channels* at different wavelengths—an important technique called *wavelength-division multiplexing*—are vulnerable to crosstalk. Nominally, light signals at different wavelengths passing through the same fiber do not interact because no current flows between them. However, like electrical phone signals passing through parallel wires, there can be secondary interactions called *nonlinear effects* because they aren't directly proportional to the strength of a single signal. These nonlinear effects are complex, and are the prime cause of crosstalk. You'll learn more about them in Chapter 5.

Nonlinear interactions between optical channels in the same fiber can cause crosstalk.

## Electro-Optics and Other Components

Electronics play important roles in fiber-optic systems. Because this book is about fiber optics, it doesn't cover electronics in general, but it will cover the electronics used in fiber systems. It assumes only a very general knowledge of electronics.

Many components have both optical and electronic elements, which often are called *electro-optics* or *opto-electronics* to emphasize the connection. Sometimes these components are lumped with optical devices and called *photonics*, a term that originated from the idea of manipulating photons just as electronics manipulate electrons.

These components fall into two very broad categories. One includes devices that convert signals between optical and electronic formats, such as transmitters and receivers. These provide vital connections between fiber-optic systems and other equipment, such as telephones and computers. The second includes devices that manipulate light but are powered or controlled by electronic circuits, such as optical amplifiers that raise the strength of optical signals, and modulators that control the intensity of light passing through them. We'll introduce both types of components briefly here and cover them in more detail later.

Electronics play important roles in fiber-optic equipment.

## Transmitters and Light Sources

Optical *transmitters* convert electronic input signals into the optical signals carried by fiber systems. Electronic circuits take the input electronic signal and process it to modulate light generated by a light source. Typically the light source is a semiconductor laser—often called a *laser diode*—or a *light-emitting diode* (LED). You'll learn more about light sources in Chapter 9 and about transmitters in Chapter 10.

Different types of light sources are used for different applications. Lasers generate higher power and can be modulated at higher speeds, so they transmit faster signals farther than LEDs. The wavelength is chosen to meet requirements for transmission distance and bandwidth. Most transmission is in a band called the *near-infrared*, which is invisible to the human eye. High-speed, long-distance systems use a range of wavelengths from 1530 to 1625 nanometers, where optical fibers have low attenuation and optical amplifiers are readily available. Short high-speed systems use 1310 nanometers, a wavelength at which attenuation is somewhat higher but dispersion is lower. Wavelengths of 750 to 900 nanometers are used for systems spanning no more than a few kilometers. Low-cost systems spanning much shorter distances typically use red LEDs and plastic fibers, which have high attenuation.

Some transmitters include stages that combine or *multiplex* different signals to generate a composite signal containing the information in multiple signals.

Transmitter wavelength depends on the application requirements.



## THINGS TO THINK ABOUT

### Photonics

Newcomers to the world of fiber optics are likely to be confused by the term *photonics*, which is widely used in some circles but ignored in others. The use of this term reflects a confusing and controversial history.

I first heard the term “photonics” about 30 years ago. But it didn’t come into popular use until it was adopted some years later by Bell Labs and one of the industry’s leading trade magazines (formerly called *Optical Spectra*, now *Photonics Spectra*). The idea was for “photonics” to describe devices that manipulate light in the same way that electronics describes things

that manipulate electrons. Because I wrote regularly for a competing magazine, I tended to avoid the word.

Other optical engineers and scientists also showed little enthusiasm, because “photonics” sounded like another word for “optics,” which they felt was a perfectly adequate description of their field. Matters came to a head when a group of leaders attempted to change the name of the Optical Society of America to the Optics and Photonics Society. The members soundly rejected the proposal, and the community remains divided on “photonics.” Some like its modern sound, but others find it unnecessary or obscure and think “optics” is a better description of the field.

●  
A receiver converts an optical signal into electronic form.

### Receivers and Detectors

A *receiver* converts an optical signal into an electrical signal usable by other equipment. The input light signal is directed into a *detector*, which produces a current or voltage proportional to the amount of light illuminating it. Electronic circuits in the receiver amplify that signal and convert it into the format required by electronic equipment at the receiver end of the system. Like transmitters, receivers are designed to operate at specific wavelengths; the usable wavelengths depend on the detector chosen.

The receiver also *demultiplexes* input signals combined at the transmitter, producing separate output signals corresponding to each of the input signals.

### Fiber-Optic Applications

The bulk of this book is about fiber-optic applications in communications, but it’s important to remember that there are other uses for fiber optics. Chapter 29 describes the wide variety of fiber-optic sensors, from gyroscopes that sense rotation to acoustic sensors that pick up faint undersea sounds. Chapter 30 shows how bundles of optical fibers are used for imaging and illumination.

### What Have You Learned?

1. Light is one type of electromagnetic radiation. It is a part of the electromagnetic spectrum with a distinct range of wavelengths, frequencies, and photon energies. Optical wavelengths include the near-ultraviolet, visible, and near-infrared.
2. Light can be viewed as electromagnetic waves, photons, or rays, depending on the situation. Each view has its advantages.

3. A photon is a quantum of electromagnetic energy.
4. Wavelength equals the speed of light divided by the frequency of the wave.
5. Light waves add or subtract in amplitude depending on their relative phase, an effect called *interference*.
6. Refractive index ( $n$ ) is the speed of light in a vacuum divided by the speed of light in the material. It is always less than 1.0 for materials at optical wavelengths.
7. Refraction is the bending of light as it changes speed when entering a new material. It depends on the refractive index of the material and the angle of incidence.
8. Total internal reflection can trap light inside a material that has a higher refractive index than its surroundings. The critical angle for total internal reflection depends on the difference between the two indexes.
9. Total internal reflection guides light along the core of an optical fiber, which has a higher refractive index than the surrounding cladding.
10. Light that falls within the acceptance angle of a fiber is guided in the core. The numerical aperture is the sine of the acceptance angle.
11. Fiber collection efficiency depends on light source size and alignment to the fiber core.
12. Attenuation reduces the amount of light transmitted, reducing transmission distance. It depends on wavelength and occurs because the glass scatters and absorbs light. It is measured in decibels.
13. Dispersion is the spreading out of signal pulses, which limits fiber transmission bandwidth. Optical fibers have much higher bandwidth than copper wires.
14. Both attenuation and dispersion increase with transmission distance.
15. Electronics play important roles in fiber-optic equipment. Opto-electronic or electro-optic devices have both electronic and optical functions.
16. Transmitters convert electronic input signals to optical format by modulating light from an LED or laser.
17. A receiver converts an optical signal into electronic form.

## What's Next?

In Chapter 3, we will look at how fiber-optic systems are used in communications.

## Further Reading

Introductory Level:

J. Warren Blaker and Peter Schaeffer, *Optics: An Introduction for Technicians and Technologists* (Prentice Hall, 2000)

David Falk, Dieter Brill, and David Stork, *Seeing the Light: Optics in Nature, Photography, Color, Vision and Holography* (Harper & Row, 1986)

B. K. Johnson, *Optics and Optical Instruments* (Dover, 1960)



Advanced Treatments:

Eugene Hecht, *Optics*, 4th ed. (Addison-Wesley, 2002)

Francis A. Jenkins and Harvey A. White, *Fundamentals of Optics* (McGraw-Hill, 1976)

## Questions to Think About

1. Interference seems to be a strange effect. The total light intensity from two bulbs is the sum of the two intensities. Yet the light intensity is really the square of the amplitudes, and if the two waves are in phase, you double the amplitude, which when squared means the intensity should be four times the intensity of one bulb. Don't these views contradict each other?
2. One photon is a wave packet that doesn't last very long. A continuous light source emits a steady or continuous wave. How is the continuous light source emitting photons?
3. The sun emits an energy of about  $3.8 \times 10^{33}$  ergs per second. A photon with wavelength of 1.3 micrometers has an energy of about  $1.6 \times 10^{-12}$  erg. If you assume the sun emits all its energy at 1.3  $\mu\text{m}$ , how much attenuation in decibels do you need to reduce the sun's entire output to a single 1.3- $\mu\text{m}$  photon per second?
4. If an entire galaxy contains a billion stars, each one as luminous as the sun, how much attenuation does it take to reduce its entire output to a single 1.3- $\mu\text{m}$  photon per second?
5. Suppose a material has attenuation of 10 dB/m at 1.3 micrometers. How thick a block of the material would you need to reduce the sun's entire output to a single photon as in Problem 3?
6. Medical imaging fiber has attenuation of 1 dB/meter at optical wavelengths. If the attenuation is the same at 1.3  $\mu\text{m}$ , and you don't have to worry about the sun's energy melting the fiber, how long a fiber would reduce the sun's output in Problem 3?
7. Atoms and molecules in the atmosphere scatter light in the same way that atoms in glass scatter light in an optical fiber. The shorter the wavelength in the visible spectrum, the stronger the scattering. Where do you think the sky gets its blue color from and why?
8. Diamond has a refractive index of 2.4. What is its critical angle in air and what does that have to do with its sparkle?

## Chapter Quiz

1. Which of the following is *not* electromagnetic radiation?
  - a. radio waves
  - b. light
  - c. infrared radiation

- d. X-rays
  - e. acoustic waves
- 2.** Optical fibers have minimum loss near  $1.5\ \mu\text{m}$ . What is the frequency that corresponds to that wavelength?
- a. 200 MHz
  - b. 20 GHz
  - c. 200 GHz
  - d. 20 THz
  - e. 200 THz
- 3.** An electron-volt is the energy needed to move an electron across a potential of 1 V. Suppose you could convert all the energy from moving an electron across a potential of 1.5 V into a photon. What would its wavelength be?
- a.  $0.417\ \mu\text{m}$
  - b.  $0.5\ \mu\text{m}$
  - c.  $0.827\ \mu\text{m}$
  - d.  $1.21\ \mu\text{m}$
  - e.  $1.2399\ \mu\text{m}$
- 4.** Light that passes from air into glass is
- a. reflected.
  - b. refracted.
  - c. absorbed.
  - d. scattered.
- 5.** Light is confined within the core of a simple clad optical fiber by
- a. refraction.
  - b. total internal reflection at the outer edge of the cladding.
  - c. total internal reflection at the core-cladding boundary.
  - d. reflection from the fiber's plastic coating.
- 6.** An optical fiber has a core with refractive index of 1.52 and a cladding with index of 1.45. Its numerical aperture is
- a. 0.15.
  - b. 0.20.
  - c. 0.35.
  - d. 0.46.
  - e. 0.70.
- 7.** Zircon has a refractive index of 2.1. What is its critical angle for total internal reflection in air?
- a.  $8^\circ$
  - b.  $25^\circ$



- c.  $32^\circ$
  - d.  $42^\circ$
  - e.  $62^\circ$
- 8.** The output of a 20-km fiber with attenuation of 0.5 dB/km is 0.005 mW. What is the input power to the fiber?
- a. 0.5 mW
  - b. 0.1 mW
  - c. 0.05 mW
  - d. 0.03 mW
  - e. 0.01 mW
- 9.** What fraction of the input power remains after light travels through 100 km of fiber with 0.3 dB/km attenuation?
- a. 0.1%
  - b. 0.5%
  - c. 1%
  - d. 5%
  - e. 10%
- 10.** If a 1-cm glass plate transmits 90% of the light that enters it, how much light will emerge from a 10-cm slab of the same glass? (Neglect surface reflection.)
- a. 0%
  - b. 9%
  - c. 12%
  - d. 35%
  - e. 80%
- 11.** What happens to light that is scattered in an optical fiber?
- a. It escapes from the sides of the fiber.
  - b. Glass atoms absorb its energy.
  - c. Glass atoms store the light and release it later.
  - d. It is reflected back toward the light source.
  - e. It excites acoustic waves in the glass.
- 12.** What effect does dispersion cause?
- a. scattering of light out the sides of the fiber
  - b. stretching of signal pulses that increases with distance
  - c. shrinking of signal pulses that become shorter with distance
  - d. attenuation of signal pulses

# Fundamentals of Communications

## About This Chapter

Communications is the most important application of fiber optics. Optical fibers serve as low-cost, flexible “pipes” that carry signals in environments ranging from climate-controlled office buildings to the ocean bottom. They span distances ranging from a few meters inside an automobile to nearly 10,000 kilometers across the Pacific ocean. They carry signals at speeds up to trillions of bits per second and form the backbone of the global telecommunications network.

To understand these uses of optical fibers, you need to understand the basic concepts behind modern communications. This chapter explains how communications systems function, the types of signals they transmit, the types of services they offer, and how the communications industry works. This chapter also shows you how fiber optics fit in with other communications equipment in the global network.

## Communications Concepts

Communications is the process of conveying information, and the word is used in two distinct senses. One is communication through the use of the written or spoken word by writers, public speakers, broadcasters, and public relations specialists. The other is *telecommunications*, which is sending information over a distance using technology. In this book, I discuss the use of fiber optics in telecommunications, although I usually simply say “communications.”

Many different technologies are used in modern telecommunications. Electrical signals travel through plain copper wires and coaxial cables, also made of copper. Radio and microwave signals travel through the air from antennas on the ground, in

●  
Telecommunications sends signals over a distance by fiber, wire, or radio waves.



aircraft, or in satellites. Beams of light travel through the air or through optical fibers. To learn about these technologies, we'll quickly examine the history of communications.

## A Short History of Communications

The earliest long-distance communications were made by signal fires that relayed simple information. The ancient Greeks relayed news of the fall of Troy by lighting fires on a series of mountain peaks. During the American Revolution, patriots watched the belfry of Boston's Old North Church for signal lamps. These lamps would reveal the path of British troops leaving Boston to seize weapons stored in Concord. Such signals could be seen for miles, but the people sending them had to arrange the signals' meaning in advance. So the patriots knew that one lamp meant the British were leaving Boston by crossing a narrow neck of land leading west; two lamps meant the British were leaving by boat. (Paul Revere was already on his way; the lanterns were used to warn others in case Revere was caught.) The message was vital to the revolution, but it was also simple. The two lanterns conveyed only two bits of information: that the British were coming and that they were crossing the water.

A written letter or a human messenger could carry more information but took time to travel, on foot or by horse. The first system that we might call telecommunications was a series of hilltop towers built in the 1790s by French engineer Claude Chappe. Each tower was in sight of the next and had an operator to relay messages by moving a set of wooden arms. The operator in each tower looked through a telescope to read the message coded by the positions of the arms in the previous tower, recorded the message, then relayed it to the next tower by moving the arms of his own tower. This process continued on down the line to others, as shown in Figure 3.1. Other countries soon adopted Chappe's *optical telegraph*, and it remained in use for decades until it was replaced by Samuel Morse's *electrical telegraph*.

The electrical telegraph sends signals through wires as a series of short and long electrical pulses. Known as Morse code, "dots" and "dashes" represent letters. Each dot or dash is a bit of information. Like the optical telegraph, the electrical telegraph requires operators to relay signals; but wires can carry signals further between operators, and transmission isn't interrupted by darkness or bad weather. Because of these advantages, the electrical telegraph spread across the continents and, in 1866, across the Atlantic. Telegraph wires formed a network running between major cities. Telegraphers received signals and either delivered them locally or relayed them to more distant stations. People did not have home telegraphs; but the stock ticker, a special-purpose telegraph that printed information on stock trades, was available in the stockbrokers' offices.

The first telegraph lines could carry only one message at a time, but inventors soon discovered ways to make them carry two or more signals at once, a process called *multiplexing*. Alexander Graham Bell was trying to invent a new type of multiplexer when he realized that his invention could be used to carry voice. Instead of sending dots and dashes through the wire, Bell modulated an electrical signal that reproduced a speaker's voice. He called his invention the *telephone*. (Bell also invented a device he called the "*photophone*," which modulated the brightness of a beam of light sent through the air, but it never proved practical.)

●  
The optical telegraph relayed messages from hilltop to hilltop 200 years ago.

●  
Multiplexing allowed telegraph lines to carry two or more signals at once.

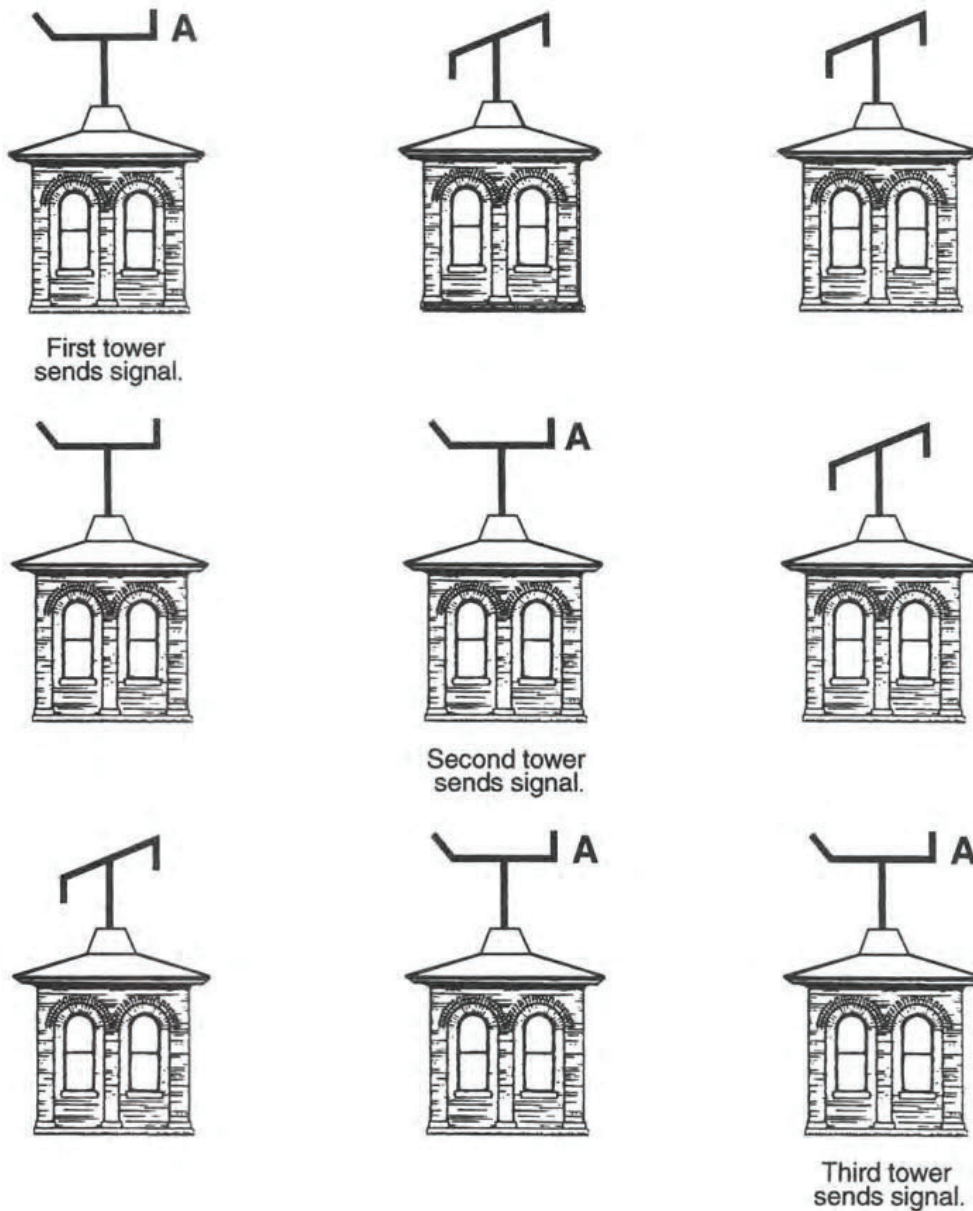
**FIGURE 3.1**

*Relaying messages by moving the arms on an optical telegraph.*

Although many telegraph companies saw no future in the telephone, it soon spread to homes and offices. By the 1890s, dense thickets of telephone wires stretched between poles in downtown areas. The early telephone network differed from the telegraph network because voice signals could not travel as far through wires as the dots and dashes of the telegraph. The telephone worked locally; the telegraph could send signals long distances. Operators and mechanical devices could regenerate telegraph signals when they became weakened by distance; but telephone signals could not be amplified until vacuum tube circuits were developed. Only in 1915 could telephone calls reach across North America,



and not until 1956 did a submarine cable carry telephone conversations under the Atlantic—90 years after the first transatlantic telegraph cable.

Radio communications followed. Guglielmo Marconi showed that radio waves could transmit telegraph signals by a mile in 1896 and steadily increased the distance in the following years. Radio's advantage was that it required no wires, and the British Admiralty saw its potential for communicating with ships at sea. Ships in trouble could transmit pleas for help (most famously the Titanic). Radio telephones followed and in the 1920s became the first way to send voices across the Atlantic. Radio broadcasting began about the same time.

Radio communications began at low frequencies, but improvements in electronic technology opened up higher frequencies. Higher frequencies can carry more information, as we'll see later. Low frequencies of tens or hundreds of kilohertz are fine for voices, but television pictures carry more information and require higher frequencies. Television signals are broadcast at frequencies of tens or hundreds of megahertz, a thousand times higher than the band used for audio-only radio.

High-frequency radio signals and microwaves, which are really higher-frequency radio waves, can multiplex voice or video signals, just as electrical telegraph could carry multiple messages. This led telephone networks to use chains of high-frequency radio and microwave towers to relay signals tens of kilometers, repeating signals in an electronic version of Chappe's optical telegraph. By 1970, satellites were relaying voice and video signals around the world and the telecommunications network had become global. That made it possible to make telephone calls around the world, although the rates were dollars per minute or more. Long-distance calls within the United States cost less, but could still add up to budget-busting bills.

Then fiber-optic communications arrived. When the American long-distance market was opened to competition in the early 1980s, telephone companies built their new national high-capacity backbone lines with optical fiber. The ever-increasing capacity of fiber now far exceeds that of any other telecommunications medium.

This brief history of communications carries a few important lessons. The demand for transmission capacity has increased steadily. Engineers have turned to new technologies to provide more capacity and to send signals over longer distances. Transmission capacity has always been a key limitation. Distance and connectivity are also important. People have friends and family scattered around the world; businesses need to contact people in far-flung places. It's no longer enough to have phones at home and at work; people want mobile phones in their pockets so they can be reached at anytime and anywhere. Let's look at the key concepts of capacity and connectivity.

## Transmission Capacity and Bandwidth

Transmission *capacity* or *bandwidth* tells us how much information a system can carry. Bandwidth has traditionally been in short supply, so communications systems are designed to make the most of it by various means. Depending on what's being transmitted, bandwidth can be measured in various ways, and that requires more explanation.

The telephone is a familiar example that illustrates the principles of transmission capacity. A corded phone is linked to the telephone network by a pair of copper wires, which normally can carry a voice signal several miles. Higher frequencies suffer greater attenuation

Radio moved to higher frequencies as electronics improved.

The demand for transmission capacity has increased steadily.

Bandwidth traditionally has been in short supply.

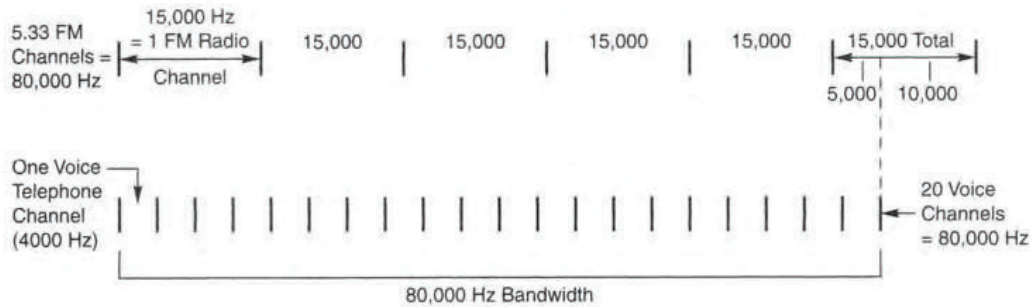

**FIGURE 3.2**

80,000 hertz of bandwidth can carry twenty 4-kHz voice channels, or 5.33 FM radio channels.

than lower frequencies, so phone lines carry frequencies of only 300 to 4000 hertz, much less than the human ear's nominal range of 20 to 20,000 hertz. The high end of this band is reserved for control signals, so the actual bandwidth is about 300 to 3400 hertz. This is enough for intelligible conversation, but not for high-fidelity reproduction. The telephone industry settled on this limit long ago, which means that the nominal bandwidth of a phone line is 4000 hertz. In contrast, FM radio has a bandwidth of 15,000 hertz per channel, which gives it much better fidelity.

Frequency range is one way to measure bandwidth for analog signals, such as voice and music, which vary continuously. Bandwidth also can be measured by the number of standard channels that can fit in the band. For example, a system that can transmit 80,000 hertz, as shown in Figure 3.2, can carry 20 telephone voice channels or 5.33 FM radio channels. In this case, each channel is a distinct signal.

For digital transmission, bandwidth is the number of bits per second passing through the system. (Be aware that computer data storage is measured in *bytes* rather than in bits; one byte contains eight data bits, and may contain extra bits for error correction.) Digital bandwidth also can be measured as the number of standard channels transmitted. For example, a standard analog telephone voice channel can be converted to a digital signal carrying 64,000 bits per second. A digital signal carrying 20 digitized standard voice channels has a nominal line rate of 1,280,000 bits per second or 1.28 megabits per second.

You will note that the digitized bandwidth seems to be higher than the corresponding analog bandwidth. The numbers indeed are larger, but comparing digital and analog capacity is not as simple as comparing the numbers, as you'll see when you learn about analog and digital signals later in this chapter.

## Multiplexing

The builders of electrical telegraphs realized that it costs less to build one high-capacity system that could carry many signals than build several separate systems with lower capacity. This technique, called *multiplexing*, can be used for any type of signal as long as the bandwidth is available. Modern telecommunications systems typically multiplex signals together in three different ways: by frequency, by wavelength, or by time.

● *Frequency-division multiplexing* is the transmission of signals at different frequencies of which radio and television broadcasts are good examples. Each area broadcaster

● Analog bandwidth is measured in frequency range or number of channels.

● Multiplexing combines many signals into one higher-speed signal.



broadcasts signals at a specific frequency or band. Stations are set at standard frequencies, such as 89.7 MHz for an FM radio station or 204 to 210 MHz assigned to channel 12 on the U.S. television dial. Other broadcasters in the region are assigned other frequencies. You tune your radio or television receiver to select one of these frequencies, but all of them are transmitted through the air simultaneously. (For broadcasting, a buffer is usually kept in reserve between adjacent channels, so neither channel 11 nor channel 13 would operate in the same area as channel 12.) Broadcast signals go through the air, but frequency-division multiplexing also works through cable. In fact, frequency-division multiplexing is standard in cable television, where certain frequency bands are reserved for specific video channels, although the frequencies may not match those on the broadcast dial.

- *Wavelength-division multiplexing* is the optical counterpart of frequency-division multiplexing. Separate signals modulate light sources emitting at different wavelengths, just as separate signals modulate radio transmitters broadcasting at different frequencies. Each separate wavelength is an *optical channel*. Light from the separate sources is combined and transmitted through a single optical fiber. Then the wavelengths are separated again, or *demultiplexed*, at the other end, as shown in Figure 3.3. As with frequency-division multiplexing, the wavelengths can be packed closely together, but the signals must not overlap.

- *Time-division multiplexing* combines streams of bits from two or more sources to produce a single stream of bits at a faster rate, as shown in Figure 3.4. For example, four signals at 10 million bits (megabits) per second can be combined to generate one 40-Mbit/s signal. Figure 3.4 shows data bits being interleaved, with one bit from stream A followed by one from stream B, then one from stream C, one from stream D, and finally the next bit from stream A. As you will learn later, other variations on time-division multiplexing may arrange the incoming data bits differently, such as in blocks called *packets*. Note that time-division multiplexing is designed specifically to work with digital signals made of strings of incoming bits.

Note that although demultiplexing may seem to be merely the opposite of multiplexing, separating the combined signals often is a more complex and demanding task than

Time-division multiplexing works only for digital signals.

**FIGURE 3.3**  
*Wavelength-division multiplexing combines signals in one fiber.*

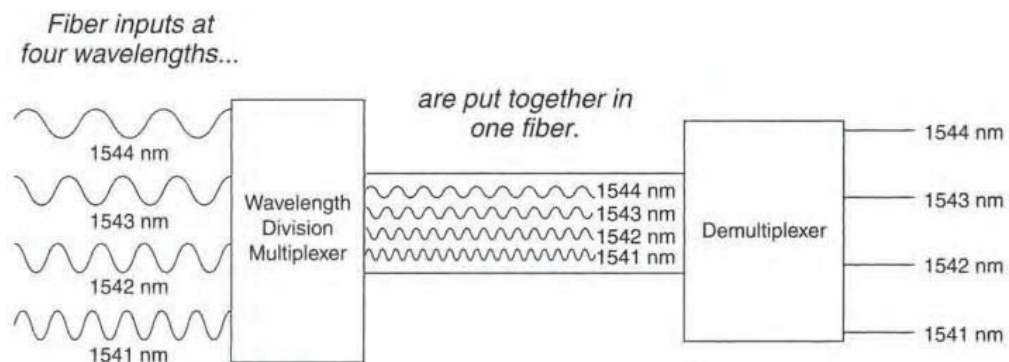

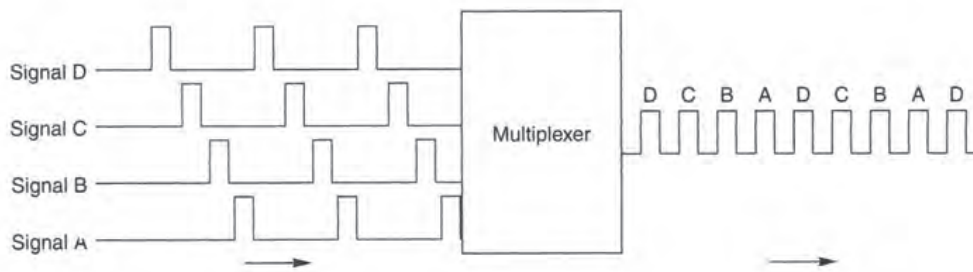
**FIGURE 3.4**

*Time-division multiplexing combines several slow signals into one faster signal.*

multiplexing. Imperfect demultiplexing leaves you with too little of the desired channel, or too many undesired channels scrambling your signal.

## Terminology

In introducing the broad area of communications, we have covered a lot of ground and introduced some terms that have specific meanings in the field. Telecommunications is full of confusing buzzwords, so let's pause to review and explain some important terms before going on to cover the field in more detail.

*Information* is what is communicated. It may be a very simple message confirming receipt of some anticipated message, conveyed by lighting a signal fire. Or it can be a huge and complex message, such as digital files that contain an entire book, an album of music, or a motion picture. Even if the "information" contains something this is not at all informative, such as your least favorite television program; it still counts as information.

A *signal* transmits that information. Signals may take many forms, such as acoustic, electronic, or optical. They may be converted from one form to another, and still contain the same information. For example, when you make a long-distance telephone call, your telephone converts the sound waves from your mouth into an electrical signal. This electrical signal is converted into an optical signal at a telephone switching office, then back to an electronic form at another telephone switching office, and finally back into sound waves at the other person's telephone. Signals are coded in various formats so they can be understood by both the sender and the receiver, as you'll learn in the next section.

A *system* is a collection of equipment that performs a task, such as transmitting a signal. It's also a vague word that can elude precise definition. Systems can contain other systems, sometimes called *subsystems*, and can range in scale from gigantic to tiny. We often speak of the telephone system as one entity that includes all telephone equipment, but it also includes switching systems that direct phone calls to their proper destinations.

*Solution* is a meaningless marketing buzzword. It often functionally means "system," or "something that someone gets paid for selling you."

A *channel* is a distinct signal. An example is the signal from a television station that you select on your dial or remote control. A multiplexed signal may carry many channels. An *optical channel* is a signal carried on one wavelength; a single fiber may carry many optical channels.

*Radio* from a telecommunications standpoint describes frequencies of the electromagnetic spectrum from about 10 kilohertz to 100 gigahertz. Different parts of that spectrum are used for different purposes. Radio waves broadcast both sound (often called simply "radio")

Radio waves have frequencies from 10 kHz to 100 GHz.



**FIGURE 3.5**

Types of copper cables.

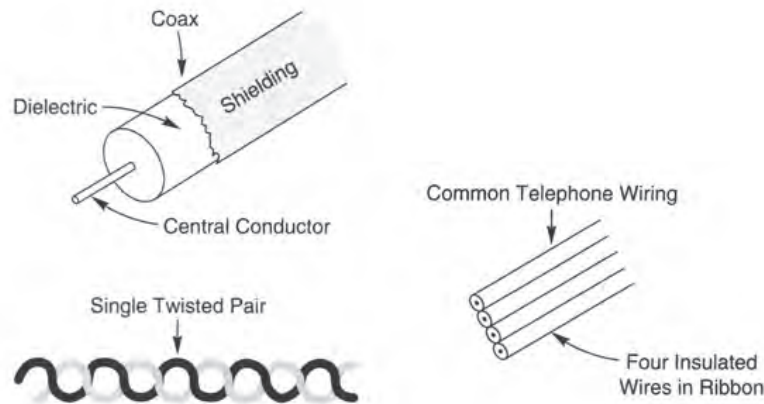

Microwaves have frequencies of 1 to 100 GHz.

and video (television). The radio spectrum is divided into many bands, which carry various services; these bands vary from region to region.

*Microwaves* are high-frequency radio waves ranging from about 1 to 100 GHz, corresponding to wavelengths of 30 centimeters to 3 millimeters. Waves at the upper end of the microwave range and higher sometimes are called *millimeter waves*, because their wavelengths are measured in millimeters. “Microwaves” is an old name, given at a time when radio wavelengths less than a meter were considered short.

*Wireless* literally means “without wires.” In practice, it means sending signals through the air, without a physical connection, to a fixed or mobile terminal such as a cellular telephone or pager. Signals sent by radio waves, microwaves, and visible or infrared light through the air are examples of wireless communications.

*Coaxial cable* is a metal clad cable with a central wire running along its axis. The central wire is surrounded by a nonconductive material called a *dielectric* (usually plastic) and covered by a metal shield, as shown in Figure 3.5. The central wire carries current, and the shield confines the electromagnetic field generated by the current and blocks external electromagnetic fields that could induce noise. Often called *coax*, coaxial cable transmits radio and low-frequency microwave signals. Coax is commonly used for cable television and video signals.

*Twisted pair* is—strictly speaking—a pair of thin insulated copper wires wound around each other in a helical pattern. Twisted pair is the nominal standard for telephone wiring in homes and offices. However, a closer look reveals that telephone wires are often flat strips containing four parallel wires, as shown in Figure 3.5. Only two wires are needed to carry signals for a single phone line. High-performance versions of twisted pair, such as *Category 5 cable*, can carry higher-frequency signals.

*Copper* is the generic term for metal cables, including twisted pair and coax, because most metal cables are made of copper.

“Copper” is the generic term for all metal cables.

## Signals and Formats

Telecommunications signals and their formats are crucial elements in any communications system. The sender and receiver of any message must agree on a format that both can understand. This is true for both one-way communications, like television broadcasts, and

two-way communications, like telephone calls. The transmitter must generate the signal in a format that the receiver can convert to a usable form.

As mentioned earlier, signals can be generated, transmitted, and received in different ways, including sound waves, electrical currents, electronic voltages, and light. We'll start with some very general ideas about telecommunications signals and formats, then consider some specific points important for fiber optics.

## Carriers and Modulation

To understand the basic structure of a telecommunications signal, let's start with a very simple example: an AM radio station. AM stands for *amplitude modulation*, which describes its operation. The radio station is licensed to operate at a specific frequency in a certain location. A radio-frequency oscillator at the station generates a single pure wave that oscillates at the exact frequency specified by the license, such as 980 kHz in the AM band. This pure wave is called the *carrier* because it carries the signal; but it is not a signal because it's only a pure tone that carries no special information.

The input is a signal, which may be an announcer's voice or a piece of music. The sound waves are converted to an electronic signal, which varies in intensity with the volume of the sound wave at any instant. That is, the electrical intensity is proportional to the acoustic intensity. The electronic signal is at the same frequency as the original sound. This is called a *baseband* signal, meaning that the input signal is at its intended frequency.

This baseband signal modulates the amplitude of the carrier wave. For clarity, Figure 3.6 shows a very simple case, where the modulation simply switches the carrier wave on and off, as if sending Morse code. This is the modulated transmitter output. For a real radio station, this would produce an irregular wave that varies with the sound intensity at any instant.

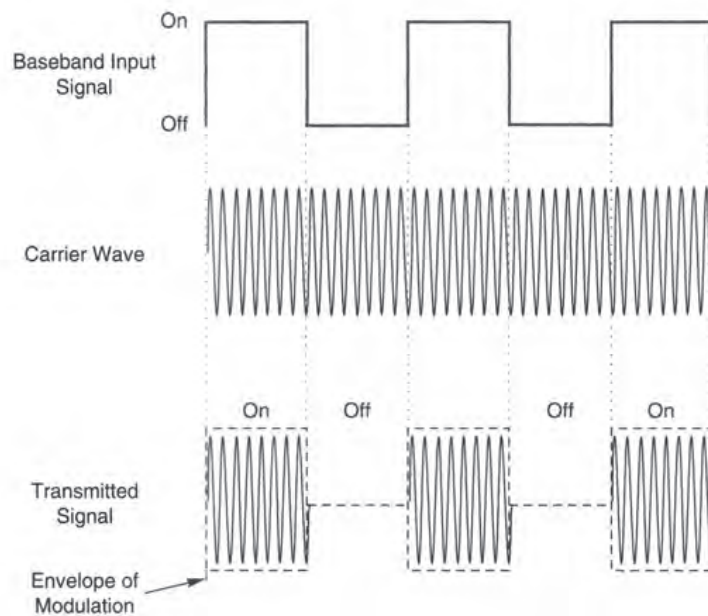

**FIGURE 3.6**  
*Input signal modulates a carrier wave.*

● A telecommunications signal is a modulated carrier wave.

● The carrier wave has a higher frequency than the baseband signal.



Note that the radio carrier frequency is much higher than the highest frequency in the baseband input signal. AM radio stations broadcast at frequencies of 540 to 1700 kHz, well above the 5-kHz upper limit on the baseband audio-frequency signal. This is a common feature in the modulation of carrier frequencies to generate telecommunications signals. The transmitter modulates the carrier with the input audio signal. The receiver *demodulates* the received radio signal, effectively removing the carrier frequency to recover the baseband audio signal.

Another important point is that the transmitter and receiver have to agree on the same format to transmit a signal properly. For a radio station, one part of that format is the carrier frequency. Tune your radio to 680 kHz, and you won't hear a radio station broadcasting at 570 kHz or 890 kHz.

The type of modulation also is critical. AM radio modulates the intensity of the carrier frequency. FM radio uses *frequency modulation*, which modulates the frequency of the carrier signal rather than its intensity. That approach gives a much cleaner signal, as you can easily tell if you compare the sound quality of AM and FM stations. However, you can't decode AM radio with an FM tuner.

The same principles apply in fiber optics. Light waves are the carriers, and their frequencies are much higher than the frequencies of the signals they transmit. Amplitude modulation is standard in commercial fiber-optic systems.

Amplitude modulation is standard in fiber-optic systems.

## Analog and Digital Communications

Communications signals come in two basic types, *analog* and *digital*, as shown in Figure 3.7. The level of an analog signal varies continuously, making it an analog of the variations of the original input. A digital signal transmits a series of bits; if the input signal was analog, the bits represent how that input signal varies. Virtually all practical digital signals are binary codes, which are at either a high level ("on" or "one") or a low level ("off" or "zero"), as shown in Figure 3.7.

Analog and digital formats each have advantages. The older analog technology is more readily compatible with our senses and much existing equipment. Our ears, for example, detect continuous variations in sound level, not merely the presence or absence of sound; likewise our eyes detect levels of brightness, not merely the presence or absence of light.

Digital signals transmit a series of bits. Analog signals vary continuously.

**FIGURE 3.7**  
*Analog and digital signals.*

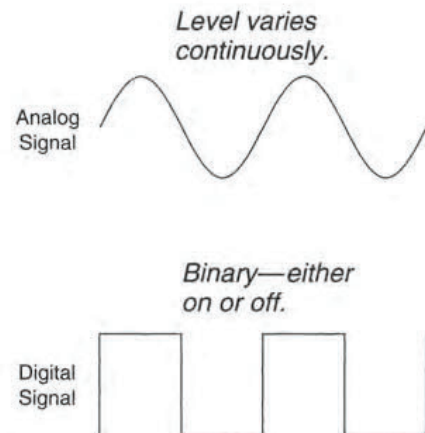

Both audio and video communications traditionally have been in analog format. The wires that serve corded telephones deliver continuously varying analog electronic signals to a standard telephone handset, which converts the incoming electronic signals to continuously varying sound waves. Traditional analog television sets likewise receive analog signals, which they decode to display pictures on the screen.

Digital signals, on the other hand, are easier to process with electronics and optics: It is much simpler and cheaper to produce circuits that detect whether a signal is at a high or low point (on or off) than it is to produce one that can accurately replicate a continuously varying signal. Digital signals also are much less vulnerable to noise and distortion. For an analog device, the output must increase linearly with respect to the input to accurately reproduce an input signal; and once noise gets into an analog signal, it's very hard to remove. In contrast, digital signals don't have to be reproduced accurately; all you need is to be able to tell the ones from the zeroes. It's like the difference between seeing a person across the street clearly enough to identify them (analog), and merely recognizing that someone is across the street (digital).

These advantages are leading engineers to shift increasingly to digital transmission. Recorded music is largely digital, with CDs having replaced phonograph records and audiocassette tapes. Most cellular telephones rely on digital transmission, and the new high-definition television signals are digital. Cable television transmission is a mixture of digital and analog signals. All this technology is possible because signals can readily be converted between analog and digital formats. For example, the telephone network includes circuits that convert the analog electrical signals that replicate your voice to digital form, and other circuits that convert those digital signals back to analog form so you can understand them.

The idea of analog-to-digital conversion is simple, as shown in Figure 3.8. A conversion circuit samples an analog signal at regular intervals, measuring its amplitude at that instant. In the telephone system, the samples are taken 8000 times per second, twice the highest frequency (4000 Hz) that must be reproduced. Each measurement is assigned to one of a number of possible slots that represent different amplitude levels. The amplitude in today's phone systems is described by an eight-bit code, so there are a total of 256

Digital signals are easy to process with electronics and optics.

Analog telephone signals are digitized at 64,000 bits per second.

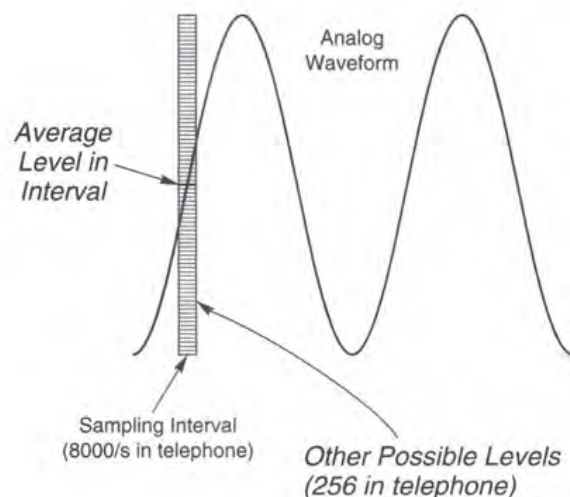

**FIGURE 3.8**

*Digitization of an analog signal.*



possible signal levels. This produces 64,000 bits per second. (Older telephone systems used a seven-bit code for signal amplitude, which gives 128 signal levels and produces 56,000 bits per second.)

Digital-to-analog conversion is straightforward. The circuit sets the signal amplitude at the level measured for each sampling interval, essentially building the analog waveform interval by interval.

Comparing the analog bandwidth of 4000 Hz to the digital bandwidth of 64,000 bits per second suggests another potential disadvantage of digital transmission. Accurate digital reproduction of an analog signal requires sampling at a rate faster than the highest frequency in the analog system. In addition, each sample requires several bits of data, so digital systems seem to require a higher overhead. It isn't that bad in reality, because there is no precise equivalence between analog and digital capacity requirements. Digital systems can tolerate limited bandwidth much better than analog systems because they only need to detect the presence of a pulse, not reproduce its shape accurately. In many cases, the bandwidth needed to carry a digitized version of an analog signal is comparable to the bandwidth needed by the original analog signal.

Fiber optics work well for digital transmission, and initially were mainly used in digital systems. The light sources used with fiber-optic systems are vulnerable to nonlinearities that can distort analog signals at high frequencies, but engineers have succeeded in making highly linear analog fiber systems, which are mainly used to distribute cable television signals.

## Electronic and Optical Signals

At first glance, conversion of signals between optical and electronic formats seems automatic. An electronic signal goes into a transmitter, and an optical signal emerges from the attached optical fiber. Conversely, an optical input to a receiver produces an electronic output. However, the process isn't quite that simple.

In optical devices, the signal is the number of photons, which corresponds to the flow of current. A laser is switched on by increasing the current passing through it; a detector produces a current proportional to the number of photons reaching it.

Electronic signals can be represented in two ways: as a *voltage*, or electrical potential, and as a *current*, or the number of electrons flowing through a circuit. Voltage and current are related, but in practice one or the other is considered the signal, depending on the circuit elements used. Simple circuits can convert a voltage variation to a current variation. Most electronic circuits in optical systems use voltage signals, which must be converted to current variations to drive the optical system. This conversion is not difficult, but you should realize the signals are not exactly equivalent.

## Connectivity

Communications systems provide *connectivity* by transmitting signals from place to place. A critical job of any communications system is to get the signals to the right place. To understand how this is done, we'll divide the parts of a communications system into two basic categories: pipes and switches.

Optical signals are the number of photons. Electrical signals are the current or voltage.

Pipes and switches can represent a communications system.

All receivers get the same signal.

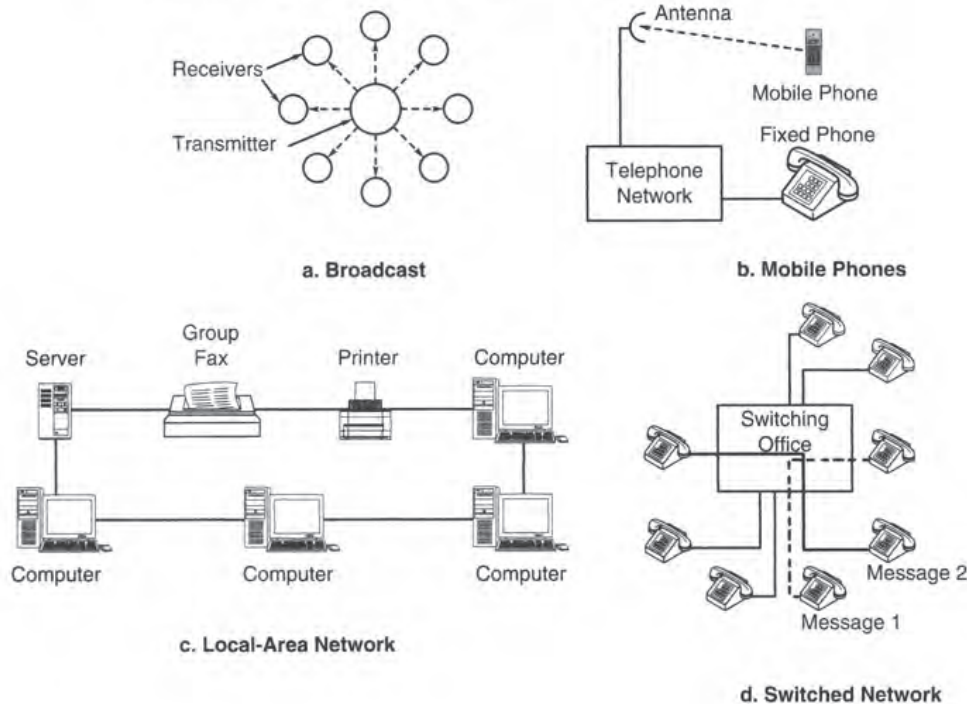

**FIGURE 3.9**

*Some representative communications systems.*

As you saw in Figure 1.6, pipes transmit signals from one point to another. A point-to-point link, such as the one between your personal computer and its keyboard, is an example of a pipe. Switches direct signals arriving from one point to other points; the telephone system, for example, contains many switches to direct calls locally, nationally, or globally. With enough pipes and switches, a communications system can make all the connections you need.

The pipes and switches view of communications is obviously an oversimplification, but it can be useful for understanding the basic designs of communications systems. We'll consider three basic approaches to connectivity: broadcasting, switching, and networking. These approaches are shown in Figure 3.9.

## Broadcasting

A broadcast system sends the same signal to everyone who receives it. In its usual simple form, broadcast transmission is one-way, from the signal source to many individuals. Local radio and television stations are good examples. Their transmitters radiate signals from a main antenna that can be picked up by receivers throughout the local area. Satellite television works the same way; a satellite broadcasts microwaves, which home receivers detect and decode. Broadcasting may not reach everyone within range, because some people don't have antennas, televisions, or satellite television service.

Broadcasting doesn't have to be through the air. Cable television systems broadcast signals through a network of optical fibers and coaxial cables. Most subscribers receive

●  
Broadcasting sends the same signal to all points.



the same signals; but premium channels are broadcast in a scrambled form that can be decoded only by using special equipment. Cable television systems set aside certain channels for two-way service. These channels enable them to provide telephone and broadband data service, and allow customers to order special services, such as pay-per-view programs.

Signals transmitted through the air are not broadcast if only one person or receiver can receive them. For example, cellular telephone conversations are transmitted through the air by local towers, but only the person with the proper cell phone can decode signals directed to that phone. Other phones and antennas working in the same frequency range can pick up the signals, but cannot decode them.

## Switched Systems

●  
A switched system makes temporary connections between points.

A *switched system* makes temporary connections between terminals so they can exchange information. The telephone system is a familiar example. An old-fashioned telephone switchboard made *physical connections* between phones when the operator plugged wires into the jacks. Today, electronic switches in a telephone company switching office perform the same function for local phone calls, completing a circuit that links your telephone to the phone you are calling. These switches also route long-distance calls through a network of other switches that direct them to their destinations.

When these switches make a connection, they dedicate transmission capacity between the two phones for as long as they stay on the line. For a local call, the connection goes through phone wires from your home to the local switching office, then from the switching office through wires to the other caller's phone. For a long-distance call, the switches reserve a *voice channel*, providing room for one phone call on a multiplexed line that carries many separate conversations on multiple voice channels. Once the call is complete, the line is released and can be used for other calls.

The key aspects of a switched system are the following: They make temporary connections, dedicate transmission capacity between a pair of nodes or terminals, and make connections between any pair of terminals attached to the switch. Our example used wired telephones, but cell phones work the same way, except that the signals are transmitted through the air rather than over wires.

## Networking

●  
Networked computers are interconnected so they can communicate with each other.

The word *network* has many meanings. One of these is a specific architecture for connecting computer terminals. A computer network consists of many terminals connected so they can send signals to one another. These connections are always "on," so each terminal can send messages to any other terminal at any time. The signal that carries the message may pass through many terminals, but it is addressed specifically to one terminal, so other terminals cannot read it. (For our purposes, we assume that system security can't be breached.) The permanent connections are like streets on which delivery trucks travel to deliver parcels to your home.

An office *local-area network* (LAN) is a good example of this type of network, as shown in Figure 3.10. A message from one terminal to another may go through the whole network,

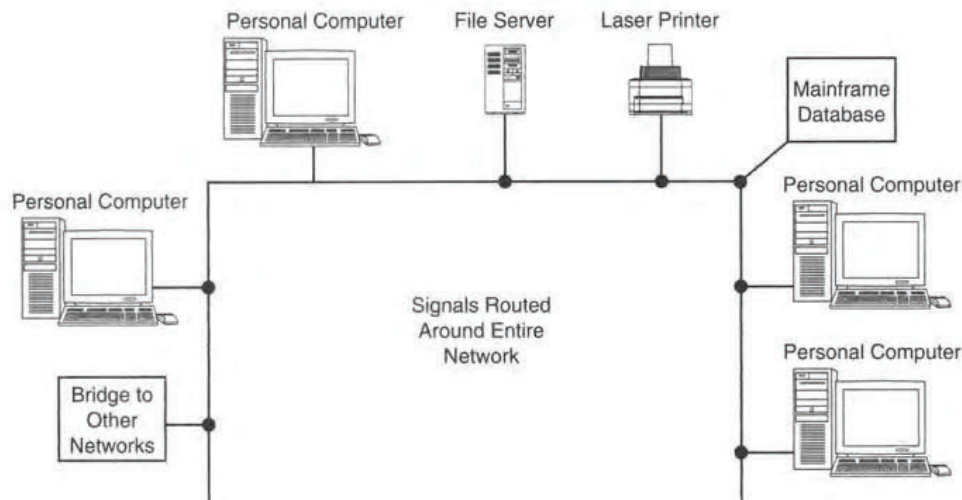

**FIGURE 3.10**  
An office local-area network (LAN).

but the only terminal that receives the message is the one to which it's addressed. The results look superficially like the switched telephone system, but the details differ considerably, as you will see later. Note, for example, that the networking approach does not set aside any transmission capacity to send a particular signal.

Networking lies at the heart of packet switching, which directs messages by a process called *routing*. As you will learn later, routing differs greatly from the type of switching described previously.

## Transmission Media and Switching Technologies

So far, we've largely ignored the media used for pipes and switches. In a general context, the nature of the pipes doesn't matter a lot. Telephone calls made over wired phones and cell phones serve the same purpose, even though they are transmitted and directed in different ways. An office local-area network can be implemented over wires, fiber-optic cables, or wireless links. Cable television does differ significantly from over-the-air broadcast television because it allows two-way transmission, but the differences are largely due to the switches.

Switching technology matters more because it can constrain the system performance. In the early days of the telephone system, switching was done mechanically. Now most switching is done electronically. Electronic switches operate in two different ways: by setting the path that signals will follow (as in making a telephone connection), or by reading the address transmitted with a data message and directing that message to the proper address.

During the bubble, prospects for optical switching created a concept called *optical networking*. The idea was overpromoted, but included an important concept that shouldn't be lost. Because fiber optics have the highest capacity of any current transmission medium, they form the high-capacity core of the modern telecommunications network—the communications equivalent of superhighways in our network of roads and highways. Optically

Switching technology can constrain performance.



switched signals could remain in optical form throughout the high-capacity fiber-optic core of the network. Keeping the signals in optical form would allow them to remain organized in the same way they are arranged for optical transmission, with separate signals carried on different wavelengths in the same fiber. Interest in optical networking evaporated when the bubble ended, but may revive as Internet traffic continues to increase.

## Communications Services

So far we've talked about communications from a general standpoint. Now let's look at specific types of communications services. We won't try to cover everything. Rather, we will concentrate on the types of services most likely to reach modern homes and businesses: voice, video, and data. The three were originally quite distinct services, but have come to converge as different networks offer the same services.

### Telephony

Voice communications, the oldest of the services, is traditionally defined as *telephony* and delivered to subscribers through copper wires. The telephone system is a switched network that offers global connectivity, so you can call any continent from your phone. You can loosely divide the telephone system into a hierarchy of subsystems, shown in simplified form in Figure 3.11.

Your home or business phone is part of the base of the phone network, variously called the *subscriber loop*, the *local loop*, or the *access network*. These links run from individual

Home phones are part of the local loop and connect to a local switching office.

**FIGURE 3.11**  
*Elements of the telephone network.*

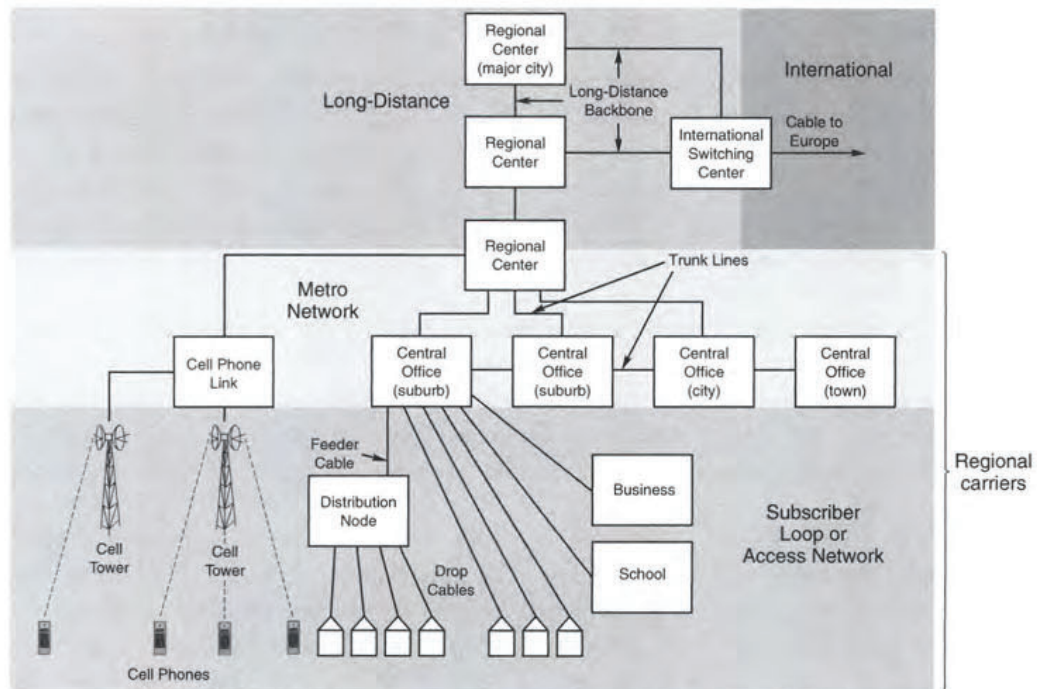

telephones to local telephone switching offices (called *central offices* in the industry). A typical central office serves thousands of homes either directly or through feeder cables that carry signals to neighborhood distribution nodes. Central offices multiplex calls directed outside their local areas on *trunk lines*, which run between central offices, connecting cities, towns, and suburbs in the area. Together with other links between telephone company facilities and large organizations, trunk lines form the *regional* or *metro network* that carries telephone traffic in the area. The access and metro networks—or subscriber loop and regional networks—are the realm of *regional carriers* or *local exchange carriers* that provide services within a region. The best known of these carriers are the *regional Bell operating companies* (RBOCs), sometimes called ILECs for Incumbent Local Exchange Carriers: Bell South, SBC, Verizon, and Qwest. Their smaller competitors, called *competitive local exchange carriers* (CLECs), offer regional telephone services, usually over the phone lines installed by the incumbents. You'll learn more about regional phone networks in Chapter 24 and about local phone networks in Chapter 25.

Many local phone systems also offer broadband Internet access via *digital subscriber line* (DSL). Unlike basic phone service, DSL is always on, so you don't have to dial in as you do with a conventional modem. However, DSL transmission distances are limited, so the service is not available to homes far from the central office.

Long-distance service is a separate business, but is now offered by most of the regional carriers as well as companies that specialize in long-distance service, such as AT&T and MCI. Local and regional service areas are distinguished on the basis of area codes that existed when the original seven Bell operating companies split from AT&T in 1984, so the maps of these areas may look strange today. Long-distance carriers pick up signals at regional nodes and transport them around the country via long-distance backbone systems. These backbone systems, in turn, connect with international systems such as submarine cables running to Europe, Asia, and South America. Although you see only one long-distance carrier on your phone bill, in reality calls may pass through multiple carriers to reach their destination. You'll learn more about the global telephone network in Chapter 23.

Cellular phones, pagers, and satellite phones link to this global telecommunications system. In a sense, the mobile services are like regional phone carriers that distribute signals locally through the air on radio waves rather than through cables. However, they generally provide their own long-distance service, which may be billed at the same rate as local service.

Fiber-optic cables are used throughout the backbone and regional networks, and run to many of the local distribution nodes and cell phone towers shown in Figure 3.11. Large organizations, such as universities and big office buildings, often have direct fiber-optic connections. With a few exceptions, copper lines run from regional distribution nodes to homes and small businesses.

## Cable Television and Video

Cable-television networks now offer telephone service and broadband Internet access in competition with the telephone network. Superficially cable lines resemble telephone lines in that they distribute signals from a central facility (called a *head-end*) to neighborhood nodes and individual homes. However, the network designs differ significantly, reflecting the origins of cable TV.

Optical fibers are the backbone of the global telecommunications network.

Cable TV systems now offer telephone and broadband Internet access.



Sometimes called *CATV* (for Community Antenna TV), cable TV systems originally distributed signals in areas outside the reach of standard broadcast television. A single tall antenna picked up distant broadcasts, and the system distributed the same signal to all subscribers. (It beat having everyone install their own antenna to pick up distant stations.) Cable later offered additional channels from distant “super stations” and from special services distributed by satellite links. Today virtually all cable systems offer two-way services, but their internal architecture differs from that of local telephone systems.

Video signals require much more bandwidth than sound signals, so cable TV systems use coaxial cable to connect to homes. The coax runs from neighborhood distribution nodes, attached via fiber-optic cables to the cable head-ends, which distribute signals in the community. As in the original cable systems, the basic design distributes the same signals to all subscribers in broadcast style. Premium services are transmitted in a coded form that requires special decoders.

Modern cable systems have refined this design by setting aside channels that provide services in addition to broadcast-style video. These channels carry special services to and from individual neighborhood nodes, which distribute them to homes in a networked model. For example, cable modem service is really multiple subscribers sharing the capacity of one cable channel, which functions as a local-area network serving those homes. As in an office network, each subscriber sees only messages addressed to them, not the other data traveling on the network. Cable systems use similar technology to offer telephone service.

Cable TV systems now offer a combination of analog and digital services on separate channels. Digital signals typically are offered at premium rates with the analog services in the basic package. Special cable boxes are needed to receive the digital video signals.

You will learn more about cable TV systems in Chapter 27.

## Data Communications and the Internet

●  
Data communications include local-area networks and the Internet.

Most people think that all data communications goes over the Internet, but that is an illusion arising from the use of personal computers in homes and offices. There are two types of personal links to the Internet: *dial-up* connections made by home modems over ordinary phone lines to companies that provide Internet service, or *broadband* connections using DSL or cable modems. Small businesses also may use these same types of service, but larger businesses use special higher-speed services. Most organizations have internal *local-area networks* (LANs), such as the one shown in Figure 3.10, to transfer data among their own computers, and they use these local-area networks to link to the Internet. (Even home offices may have LANs to link computers to each other, a printer, and a cable modem or DSL.)

Local-area networks typically run within a building or within a campus of buildings that houses a large organization. As you will learn in Chapter 26, small LANs may be linked together to form larger wide-area networks that serve the whole organization. Individual personal computers typically connect over short lengths of special high-quality copper cable made for data transmission; Category 5 cables are widely used. Wireless connections also are possible. Fibers run to individual devices only if they require very high-speed connections; are far from the main network; or are in an environment where copper wires don't work well, such as where heavy machinery generates strong electromagnetic noise.



Backbone wide-area networks that serve large buildings, or links between corporate networks and remote sites or the Internet, typically use fibers. The longer the link and the higher the speed, the more likely fibers are to be used.

Fibers also provide the backbone of the Internet, which functions like the long-distance telephone network. The hardware is essentially the same as that used for long-distance telephone traffic, but the data-transmission protocols are different. You'll learn more about data transmission standards in Chapters 20 and 26.

## Convergence

Voice, video, and data services have evolved considerably during the past decades. Modern versions of these systems strongly resemble each other and can provide similar services, an effect the industry calls *convergence*. The similarities are both more and less than they seem, and deserve a brief explanation.

Both voice and data are transmitted over digital backbone systems, but the hardware and protocols differ in detail. The traditional telephone network is optimized for voice traffic with a separate voice channel reserved for each telephone call. The Internet is optimized for data traffic without fixed channels for separate data streams. Telephone lines have long carried digital data and now data lines can carry voice signals, a scheme called *VoIP* for *Voice over Internet Protocol*. Advocates claim VoIP will replace ordinary phone lines, but it sometimes sounds like a bad cell-phone connection.

Connectivity is essential for both telephone and Internet traffic. You don't want a voice line or an e-mail address that can't connect to the rest of the world's phones and e-mail addresses. Somewhere along the line all voice and data signals must be identified and directed to the right place. Connectivity is not as essential for video, and video feeds to cable TV networks typically are via satellite links, which transmit encoded signals picked up by antennas on the ground. Depending on costs, the video signals may be distributed through fiber in a metropolitan area, but usually they are not transmitted long distances through fiber on the ground.

The distinctions among the various long-distance telecommunications networks are more organizational than physical. In reality, one fiber-optic cable may contain fibers carrying different signals for different organizations. For example, a single fiber might carry telephone traffic at one wavelength and Internet traffic on another. Companies may trade capacity on their cables with other organizations that have excess capacity on different routes.

## Other Communications Services

Voice, video, and Internet data are the three major services of the telecommunications world, but you should be aware of other communications services that fill specific market niches.

- *Broadband fixed wireless* services use microwave antennas to provide broadband service in regions where companies think it would be too expensive to install cables. The idea has been around for a while, but has never caught on widely.
- *Data transmission inside vehicles* is becoming more important as the number of control systems increases. Sometimes fiber is used for vehicle systems because of its

●  
Voice, video, and data services are converging, and can be offered over one network.



broad bandwidth and immunity to electromagnetic interference. Fibers are used in ships, some aircraft, the International Space Station, and some high-end automobiles, as described in Chapter 28.

● *Closed circuit video* transmission is needed for surveillance, monitoring, and broadcasting of sports events. Fibers have high bandwidth, are lightweight, and suffer little interference, so they often are used in these applications.

## The Business of Telecommunications

Understanding telecommunications technology requires learning a little about the business of telecommunications. Telecommunications is a complex industry that involves different companies offering different goods and services. Business considerations have shaped the present network.

### A Very Short History of the Telecommunications Business

● Telephone service was considered a natural monopoly.

Private companies started the telephone industry in the late 1800s, but government agencies became involved as the telephone became a vital service. Governments considered telephone service to be a “natural monopoly” because they felt it only made sense to build a single telephone system to serve all homes and businesses. Through most of the twentieth century, most telephone service outside the United States was run by government post, telephone, and telegraph agencies. In the United States, private telephone service was heavily regulated by state and federal agencies, and most of the nation’s cities were served by a single giant company, AT&T.

This began to change in the late 1970s, as other companies began to offer long-distance service. In 1984, AT&T spun off seven regional operating companies, three of which have since disappeared in mergers. Overseas, telephone agencies were separated from post offices and privatized. Cellular telephone networks emerged in the same period, and now handle a large share of telephone traffic. Cellular service is competitive, with multiple companies offering service across the United States.

The trend in the cable industry is also toward consolidation. Cable TV began as small companies scattered around the country, but is now dominated by a handful of *Multiple System Operators* (MSOs) such as Comcast and Time-Warner. Internet services now are offered by telephone and cable companies, and by other companies including Microsoft, AOL, and Earthlink.

The telecommunications bubble pumped a tremendous amount of money into the industry, which companies used to expand and to buy other companies, often at greatly inflated prices. New companies tried to build “overlay” networks that provided services in competition with existing phone and cable systems, but only a few of them survived the collapse of the bubble. Most of the local “competition” that remains today is based on regulations that require phone companies to lease their transmission lines to other companies that want to provide phone service. Cable companies aren’t required to lease their lines, but sometimes allow other companies to offer broadband service over their cables.

## THINGS TO THINK ABOUT

### Regulations

Telecommunications has always been a regulated industry. Although the changes of recent years have been called “deregulation,” it might be better to call them “changes in regulation.” Governments used to set the prices that carriers could charge. Now they write rules that require carriers to lease their lines to competitors at specified prices and under certain conditions. These regulations assure the public access to essential services at reasonable cost and protect the public from crooks and fools. (The crooks and fools made their presence evident during the bubble years when WorldCom faked its accounts and Enron tried

to create a market for bandwidth trading. Most of us consider access to at least basic telephone service at honest prices to be essential in today’s society.)

What regulations are proper? Does the Federal Communications Commission (FCC) act in the public interest, as its charter specifies? Or do corporate lawyers and lobbyists who contribute generously to political campaigns shape its regulations? FCC policies can’t help but shape the future of the telecommunications industry. Are Congress and the FCC too concerned with promoting corporate profits and issues like preventing copying of digital music and video? These are questions that deserve serious debate.

### Types of Businesses

The telecommunications industry includes distinct types of companies that earn money in different ways. The most important types include the following:

- *Carriers* transmit information over lines that they own or rent. Local and long-distance telephone companies are both carriers, and some companies provide both services. Cable TV systems also function as carriers. They sell transmission service as well as access to networks.
- *Carriers’ carriers* lease capacity on transmission lines they built to carriers and other companies who need service. They don’t retail to individuals or small businesses. They are wholesalers that provide service to other companies.
- *Internet Service Providers* (ISPs) provide Internet access, and related services such as Web hosting and e-mail. They range from giant corporations to small independent companies, and usually are retailers of services.
- *Equipment manufacturers* make hardware and software that they sell to companies and individuals. Their products range from expensive hardware for long-distance networks to desktop cables and modems.
- *Contractors and installers* install hardware for carriers. Many specialize in construction.

### What Have You Learned?

1. Telecommunications sends signals over a distance through such media as optical fibers, copper wires, and radio waves.



2. The optical telegraph was the first form of telecommunications 200 years ago. The electrical telegraph made it obsolete. Telephones followed, then broadcast radio and television.
3. Improvements in electronic technology allowed operation at increasingly higher radio frequencies, which offered more bandwidth for signal transmission.
4. The demand for transmission capacity has increased steadily, and bandwidth has traditionally been in short supply.
5. Analog bandwidth is measured by the frequency range. Digital bandwidth is measured in bits per second.
6. Multiplexing combines many signals into one higher-speed signal. The important types are frequency-division multiplexing, wavelength-division multiplexing, and time-division multiplexing. Time-division multiplexing works only for digital signals.
7. Copper is a general term that includes twisted pair and coaxial cables.
8. Telecommunications systems transmit signals by modulating a carrier wave with a baseband signal. The baseband signal is at a lower frequency than the carrier.
9. Fiber-optic systems use amplitude modulation.
10. Analog signals vary continuously. Digital signals transmit a series of bits. Analog signals can be digitized, then converted back to analog format. Analog telephone signals are digitized at 64,000 bits per second.
11. Electrical signals are current or voltage. Optical signals are the number of photons.
12. A communications system can be viewed as an array of pipes and switches. The pipes carry signals, and the switches direct them.
13. Broadcast communications directs the same signal to many points.
14. A switched system makes temporary connections between terminals. The telephone system is an example.
15. Networking interconnects computers permanently so they can send messages to each other. Each message carries a label so only one computer receives it.
16. The telephone system includes the local loop, which connects subscribers, local switching offices, regional or metro networks, and a long-distance backbone system. Optical fibers provide the backbone.
17. Cable TV systems resemble telephone systems locally. They offer television and broadband Internet access as well as video.
18. Data communications includes local-area networks and the Internet.
19. Convergence is the merging of voice, video, and data services so they can be offered over one network.
20. Telephone service was considered to be a natural monopoly and was run by government agencies or heavily regulated private monopolies. Most countries' telephone networks are now private and regulated differently.

## What's Next?

Now you have a general idea how fiber optics and telecommunications work. The rest of the book will present more details about the technology. Chapters 4 through 7 cover optical fibers and their important features.

## Further Reading

Roger L. Freeman, *Fundamentals of Telecommunications* (Wiley InterScience, 1999)

Gil Held, *Voice and Data Internetworking* (McGraw-Hill, 2000)

Anton A. Huurdeman, *The Worldwide History of Telecommunications* (Wiley InterScience, 2003)

Gary M. Miller, *Modern Electronic Communication* (Prentice Hall, 1999)

Tom Standage, *The Victorian Internet* (Berkeley Books, 1998)

## Questions to Think About

1. How does using a higher-frequency carrier affect the amount of information that can be transmitted?
2. Why does multiplexed transmission of a combined signal cost less than separate transmission of each signal?
3. Computer networks, mobile telephones, and broadcast systems all distribute signals to many terminals. How do these systems differ?
4. Why is frequency-division multiplexing equivalent to wavelength-division multiplexing?
5. The bandwidth of digitized signals measured in bits per second is much higher than the bandwidth of the original analog signal measured in hertz. For example, the analog bandwidth of a phone line is 4000 Hz, but the digitized signal is 64,000 bits per second. Why are these two bandwidths usually equivalent in practice?
6. Why was telephone service considered to be a natural monopoly?
7. Data transmission rates to personal computers have increased from 1200 bits per second with a dial-up modem in 1985 to about 400,000 bits per second with a cable modem or DSL in 2000. If bandwidth keeps increasing at the present rate, how fast will transmission be in 2015?

## Chapter Quiz

1. Which came first?
  - a. electrical telegraph
  - b. optical telegraph