



US005490505A

United States Patent [19]

[11] Patent Number: **5,490,505**

Diab et al.

[45] Date of Patent: **Feb. 13, 1996**

[54] SIGNAL PROCESSING APPARATUS

[75] Inventors: **Mohamed K. Diab; Esmail Kiani-Azarbayjany**, both of Laguna Niguel; **Walter M. Weber**, Dana Point, all of Calif.

[73] Assignee: **Masimo Corporation**, Mission Viejo, Calif.

[21] Appl. No.: **132,812**

[22] Filed: **Oct. 6, 1993**

Related U.S. Application Data

[63] Continuation-in-part of Ser. No. 249,690, May 26, 1994, which is a continuation of Ser. No. 666,060, Mar. 7, 1991, abandoned.

[51] Int. Cl.⁶ **A61B 5/00**

[52] U.S. Cl. **128/633; 356/41**

[58] Field of Search **128/633-634, 128/664-667, 672, 687-688, 716; 356/39-41**

[56] References Cited

U.S. PATENT DOCUMENTS

- 3,647,299 3/1972 Lavallee .
- 3,704,706 12/1972 Herczfeld et al. .
- 4,063,551 12/1977 Sweeny .
- 4,086,915 5/1978 Kofsky et al. .

(List continued on next page.)

OTHER PUBLICATIONS

Harris, Fred et al., "Digital Signal Processing with Efficient Polyphase Recursive All-Pass Filters", International Conference on Signal Processing, Florence, Italy, Sep. 4-6, 1991, 6 pages.

Rabiner, L. et al., *Theory and Application of Digital Signal Processing*, Prentice Hall, Englewood Cliffs, New Jersey 1975, p. 260.

Tremper, Kevin et al., "Pulse Oximetry: Technical Aspects of Machine Design", *Advances in Oxygen Monitoring*, Little, Brown and Comp., Boston, Mass., 1987, pp. 137-153.

Brown, David P., "Evaluation of Pulse Oximeters Using Theoretical Models and Experimental Studies", Master's thesis, University of Washington, Nov. 25, 1987, pp. 1-142.
Cohe, Arnon, "Volume I: Time and Frequency Domains Analysis", *Biomedical Signal Processing*, CRC Press, Inc., Boca Raton, Florida, pp. 152-159.
Severinghaus, John W., "Pulse Oximetry Uses and Limitations", pp. 1-4, ASA Convention, New Orleans, 1989.

(List continued on next page.)

Primary Examiner—Angela D. Sykes
Attorney, Agent, or Firm—Knobbe, Martens, Olson & Bear

[57] ABSTRACT

A signal processor which acquires a first signal, including a first primary signal portion and a first secondary signal portion, and a second signal, including a second primary signal portion and a second secondary signal portion, wherein the first and second primary signal portions are correlated. The signals may be acquired by propagating energy through a medium and measuring an attenuated signal after transmission or reflection. Alternatively, the signals may be acquired by measuring energy generated by the medium. A processor of the present invention generates a primary or secondary reference signal which is a combination, respectively, of only the primary or secondary signal portions. The secondary reference signal is then used to remove the secondary portion of each of the first and second measured signals via a correlation canceler, such as an adaptive noise canceler, preferably of the joint process estimator type. The primary reference signal is used to remove the primary portion of each of the first and second measured signals via a correlation canceler. The processor of the present invention may be employed in conjunction with a correlation canceler in physiological monitors wherein the known properties of energy attenuation through a medium are used to determine physiological characteristics of the medium. Many physiological conditions, such as the pulse, or blood pressure of a patient or the concentration of a constituent in a medium, can be determined from the primary or secondary portions of the signal after other signal portion is removed.

24 Claims, 20 Drawing Sheets

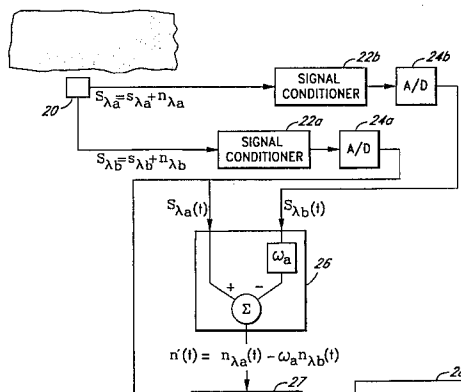

U.S. PATENT DOCUMENTS

4,095,117 6/1978 Nagy .
 4,407,290 10/1983 Wilber .
 4,537,200 8/1985 Widrow .
 4,649,505 3/1987 Zinser, Jr. et al. .
 4,773,422 9/1988 Isaacson et al. .
 4,799,493 1/1989 DuFault .
 4,800,495 1/1989 Smith .
 4,824,242 4/1989 Frick et al. 128/633 X
 4,848,901 7/1989 Hood, Jr. .
 4,860,759 8/1989 Kahn et al. .
 4,863,265 9/1989 Flower et al. .
 4,867,571 9/1989 Frick et al. .
 4,869,253 9/1989 Craig, Jr. et al. .
 4,869,254 9/1989 Stone et al. .
 4,883,353 11/1989 Hausman .
 4,892,101 1/1990 Cheung et al. .
 4,907,594 3/1990 Muz .
 4,911,167 3/1990 Corenman et al. 128/633
 4,927,264 5/1990 Shiga et al. .
 4,928,692 5/1990 Goodman et al. 128/633
 4,948,248 8/1990 Lehman .
 4,955,379 9/1990 Hall .
 4,956,867 9/1990 Zurek et al. .

5,057,695 10/1991 Hiro et al. 128/633 X
 5,273,036 12/1993 Kronberg et al. 128/666 X

OTHER PUBLICATIONS

Mook, G. A., et al. "Spectrophotometric determination of oxygen saturation of blood independent of the presence of indocyanine green", *Cardiovascular Research*, vol. 13, pp. 233-237, 1979.

Neuman, Michael R., "Pulse Oximetry: Physical Principles, Technical Realization and Present Limitations", *Continuous Transcutaneous Monitoring*, Plenum Press, New York, 1987, pp. 135-144.

Mook, G. A., et al., "Wavelength dependency of the spectrophotometric determination of blood oxygen saturation", *Clinical Chemistry Acta*, vol. 26, pp. 170-173, 1969.

Klimasuaskas, Casey, "Neural Nets and Noise Filtering", *Dr. Doob's Journal*, Jan. 1989, p. 32.

Haykin, Simon, *Adaptive Filter Theory*, Prentice Hall, Englewood Cliffs, NJ, 1991.

Widrow, Bernard, *Adaptive Signal Processing*, Prentice Hall, Englewood Cliffs, NJ, 1985.

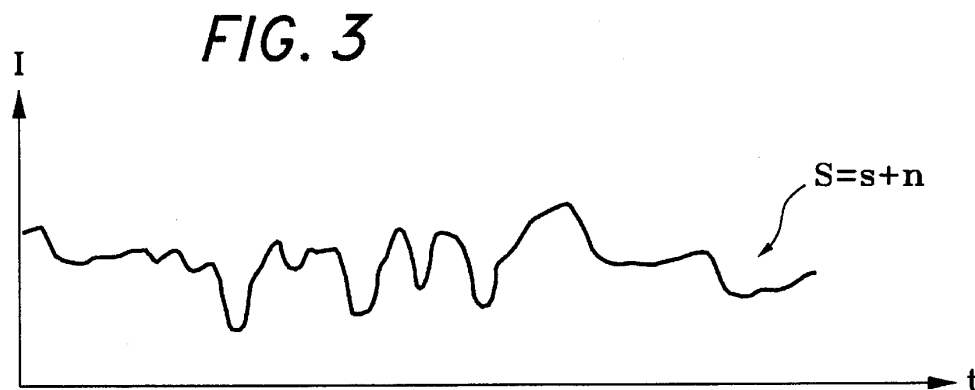
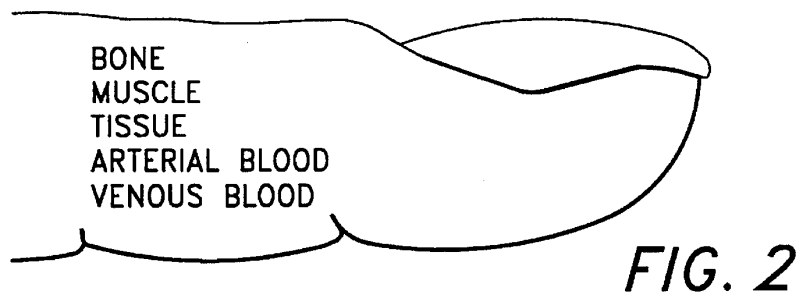
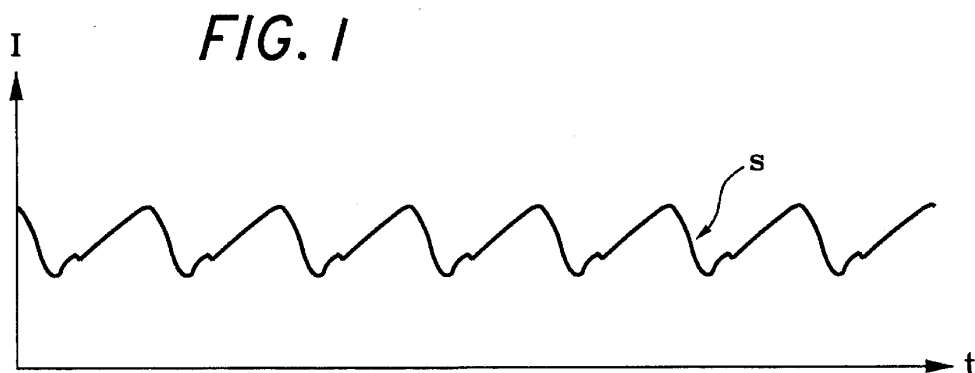

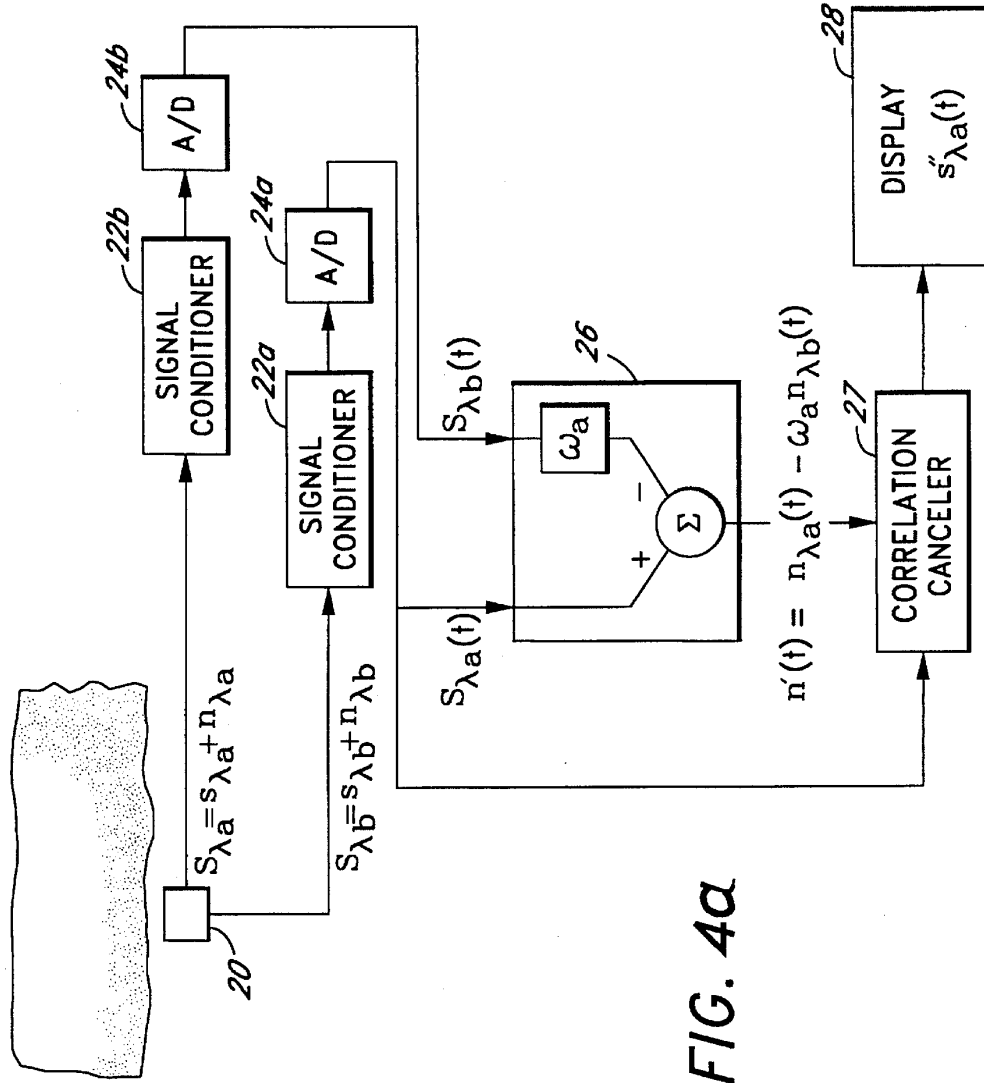

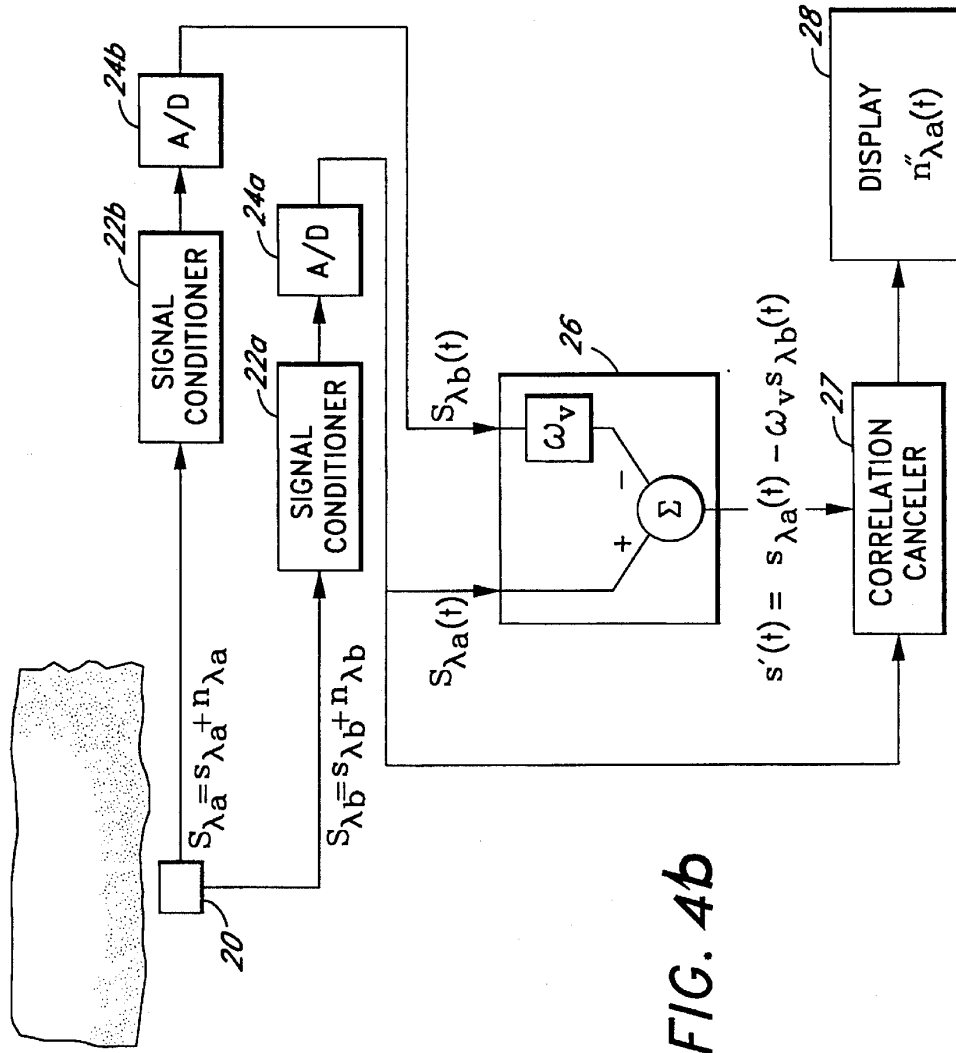

FIG. 4b

Explore Litigation Insights

Docket Alarm provides insights to develop a more informed litigation strategy and the peace of mind of knowing you're on top of things.

Real-Time Litigation Alerts



Keep your litigation team up-to-date with **real-time alerts** and advanced team management tools built for the enterprise, all while greatly reducing PACER spend.

Our comprehensive service means we can handle Federal, State, and Administrative courts across the country.

Advanced Docket Research



With over 230 million records, Docket Alarm's cloud-native docket research platform finds what other services can't. Coverage includes Federal, State, plus PTAB, TTAB, ITC and NLRB decisions, all in one place.

Identify arguments that have been successful in the past with full text, pinpoint searching. Link to case law cited within any court document via Fastcase.

Analytics At Your Fingertips



Learn what happened the last time a particular judge, opposing counsel or company faced cases similar to yours.

Advanced out-of-the-box PTAB and TTAB analytics are always at your fingertips.

API

Docket Alarm offers a powerful API (application programming interface) to developers that want to integrate case filings into their apps.

LAW FIRMS

Build custom dashboards for your attorneys and clients with live data direct from the court.

Automate many repetitive legal tasks like conflict checks, document management, and marketing.

FINANCIAL INSTITUTIONS

Litigation and bankruptcy checks for companies and debtors.

E-DISCOVERY AND LEGAL VENDORS

Sync your system to PACER to automate legal marketing.