

Apple Inc. (Petitioner)
v.
Masimo Corporation (Patent Owner)
Petitioner Demonstratives

Case Nos. IPR2020-01521, -01714, -01715
U.S. Patent Nos. 10,292,628, 10,631,765
Before Hon. Amanda Wieker, Robert Kinder, Josiah Cocks
Administrative Patent Judges

FISH.

Table of Contents

Issue 1: Implementing a Cover with a Protruding Convex Surface	3
1A: The Cover's Protruding Convex Surface would Improve Adhesion and Signal Strength	6
1B: The Cover's Protruding Convex Surface would Enhance Light Gathering Ability	24
1C: The Cover's Protruding Convex Surface would Protect Sensor Elements	42
Issue 2: Adding a Second Emitter to Aizawa	49
Issue 3: Implementing Wireless Communication	59
Issue 4: Guarding against Saturation	68
Issue 5: The Dependent Claims are Obvious	76
Overview of the Challenged '628, and '765 Patents	81
Overview of the Instituted Grounds	89



Issue 1

Implementing a Cover with a Protruding Convex Surface

Case Nos. Case Nos. IPR2020-01521, -01714, -01715
U.S. Patent Nos. 10,292,628, 10,631,765

FISH.

Multiple Advantages would have Motivated the POSITA

Dr. Kenny's Declaration

98. Accordingly, Ohsaki would have motivated a POSITA to add a light permeable protruding convex cover to Mendelson-799's sensor, to improve adhesion between the sensor and the user's tissue, to improve detection efficiency, and to provide additional protection to the elements accommodated within sensor housing 17. APPLE-1009, ¶¶[0015], [0017], [0025], FIGS. 1, 2, 4A, 4B.

IPR2020-01714 APPLE-1003, ¶ 98.

99. In more detail, and as shown below in the section view of the sensor that would have resulted, the POSITA would have added a transparent convex cover to sensor 10, the cover being located over the array of detectors 16 and 18 while also being positioned between tissue of the user and the array of detectors when worn.

APPLE-1012, Abstract, 9:22-10:30, FIG. 8; APPLE-1009, ¶¶[0015], [0017], [0025], FIGS. 1, 2, 4A, 4B; see also APPLE-1008, ¶¶14-15, FIGS. 1, 2. To obtain the advantages described by Ohsaki, the POSITA would have used at least a portion of the protruding convex surface that is rigid to conform tissue of the user to at least a portion of the cover's surface when worn. APPLE-1009, ¶[0025]; see also APPLE-1009, ¶[0030], FIG. 1(b). And, consistent with Ohsaki's configuration, the POSITA would have configured a circumscribing wall in Mendelson-799's sensor to operably connect, on one side, to the planar substrate on which detectors 16 and 18 are arranged and, on an opposite side, to the convex cover. APPLE-1012, Abstract, 9:22-10:30, FIG. 7; APPLE-1009, ¶[0017], FIG. 2.

Mendelson '799

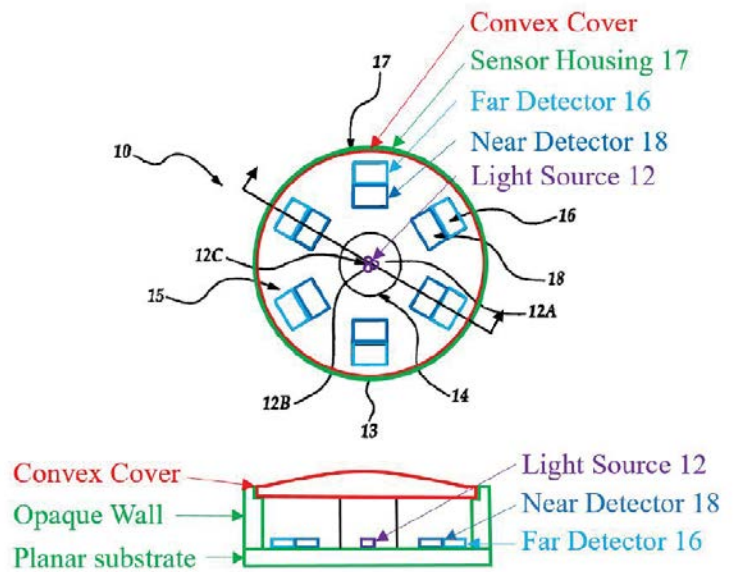

IPR2020-01714 APPLE-1012, FIG. 7 (annotated with additional section view) (APPLE-1003, ¶ 99).

Multiple Advantages would have Motivated the POSITA

Dr. Kenny's Declaration

7. As I explained at length in my first declaration, a "POSITA would have found it obvious to modify the [Aizawa] sensor's flat cover...to include a lens/protrusion...similar to Ohsaki's translucent board 8, so as to [1] improve adhesion between the user's wrist and the sensor's surface, [2] improve detection efficiency, [3] and protect the elements within the sensor housing." APPLE-1003, ¶¶98-102. I further explained that a POSITA would have found it obvious in view

IPR2020-01715 APPLE-1047, ¶ 7.

Aizawa

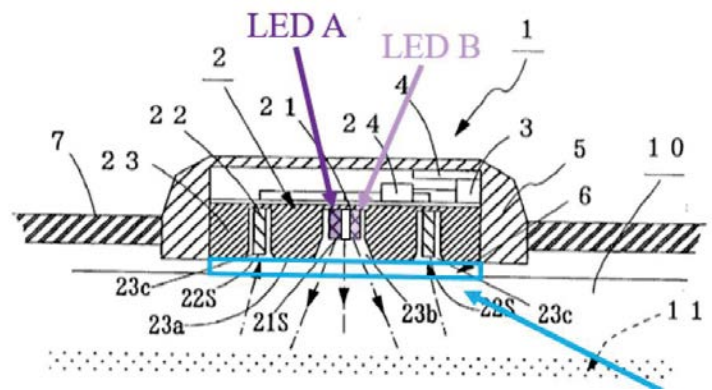

IPR2020-01715 APPLE-1006, FIG. 1(b)
(annotated with flat cover)(APPLE-1003, ¶ 101).

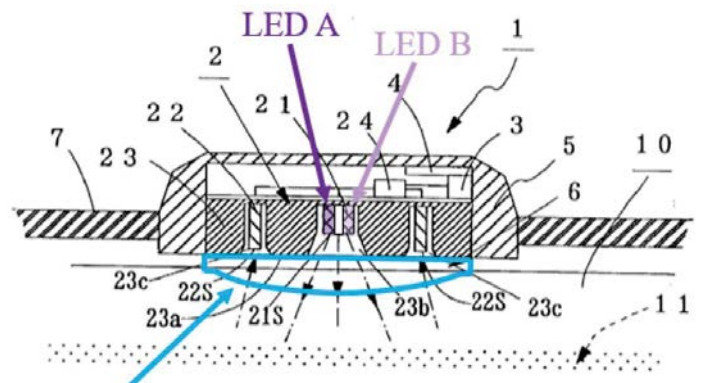

IPR2020-01715 APPLE-1006, FIG. 1(b)
(annotated with protruding cover)(APPLE-1003, ¶ 101). 5

FISH.

Issue 1A

The Cover's Protruding Convex Surface would Improve Adhesion and Signal Strength

FISH.

A POSITA would have Modified Aizawa's Flat Cover

Dr. Kenny's Second Declaration

98. Additionally, I believe that a POSITA would have combined the teachings of Aizawa-Inokawa with the teachings of Ohsaki such that the cover of Aizawa-Inokawa's wrist-worn sensor would include a convex surface, improving adhesion between a subject's wrist and a surface of the sensor. APPLE-1009, ¶[0025] (the convex surface prevents slippage of the detecting element from its position on the subject's wrist, and the convex nature of the surface suppresses the "variation of the amount of the reflected light" that reaches the detecting element).

IPR2020-01715 APPLE-1003, ¶ 98;
see also APPLE-1047, ¶ 7.

Aizawa

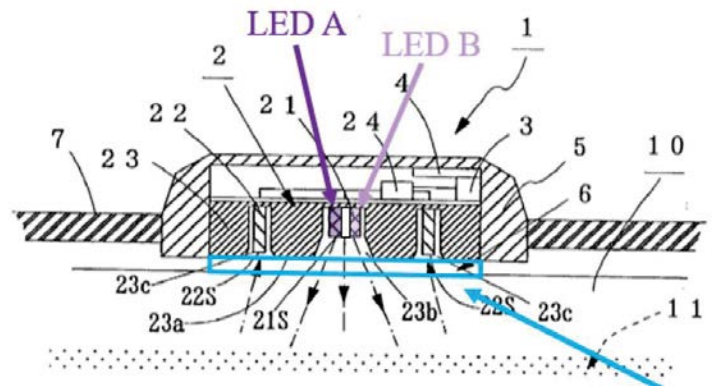

IPR2020-01715 APPLE-1006, FIG. 1(b)
(annotated with flat cover)(APPLE-1003, ¶ 101).

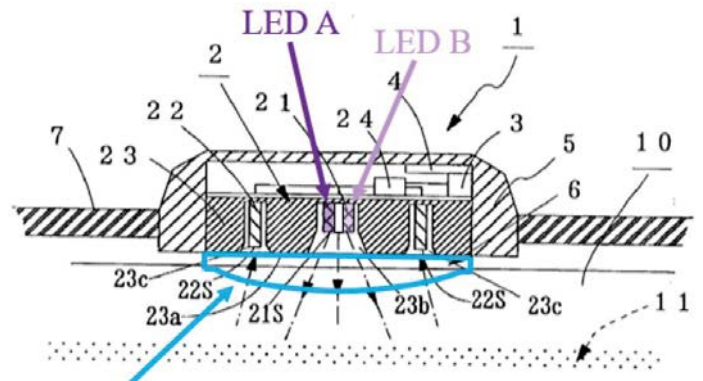

IPR2020-01715 APPLE-1006, FIG. 1(b)
(annotated with protruding cover)(APPLE-1003, ¶ 101). 7

FISH.

Ohsaki Teaches that a Protruding Convex Surface Prevents Slippage and Improves Signal Strength

Dr. Kenny's First Declaration

98. Additionally, I believe that a POSITA would have combined the teachings of Aizawa-Inokawa with the teachings of Ohsaki such that the cover of Aizawa-Inokawa's wrist-worn sensor would include a convex surface, improving adhesion between a subject's wrist and a surface of the sensor. APPLE-1009, ¶[0025] (the convex surface prevents slippage of the detecting element from its position on the subject's wrist, and the convex nature of the surface suppresses the "variation of the amount of the reflected light" that reaches the detecting element).

99. In more detail, Ohsaki describes a "detecting element" that includes "a package 5, a light emitting element 6 (e.g., LED), a light receiving element 7 (e.g., PD), and a translucent board 8." APPLE-1009, ¶[0017]. "The package 5 has an opening and includes a" substrate in the form of "circuit board 9," on which light emitting element 6 and light receiving element 7 are arranged. *Id.* As shown in Ohsaki's FIG. 2, translucent board 8 is arranged such that, when the sensor is worn "on the user's wrist ... the convex surface of the translucent board ... is in intimate contact with the surface of the user's skin"; this contact between the convex surface and the user's skin is said to prevent slippage, which increases the strength of the signals obtainable by Ohsaki's sensor. APPLE-1009, ¶¶[0015], [0017], [0025], FIGS. 1, 2, 4A, 4B.

IPR2020-01715 APPLE-1003, ¶¶ 84-85.

Ohsaki Teaches that a Protruding Convex Surface Prevents Slippage

Ohsaki

[0025] The detecting element 2 is arranged on the user's wrist 4 so that the convex surface of the translucent board 8 is in intimate contact with the surface of the user's skin. Thereby it is prevented that the detecting element 2 slips off the detecting position of the user's wrist 4. If the translucent board 8 has a flat surface, the detected pulse wave is adversely affected by the movement of the user's wrist 4 as shown in FIG. 4B. However, in the case that the translucent board 8 has a convex surface like the present embodiment, the variation of the amount of the reflected light which is emitted from the light emitting element 6 and reaches the light receiving element 7 by being reflected by the surface of the user's skin is suppressed. It is also prevented that noise such as disturbance light from the outside penetrates the translucent board 8. Therefore the pulse wave can be detected without being affected by the movement of the user's wrist 4 as shown in FIG. 4A.

IPR2020-01715 APPLE-1009 ¶ [0025]
 (cited at APPLE-1003, ¶ 98).

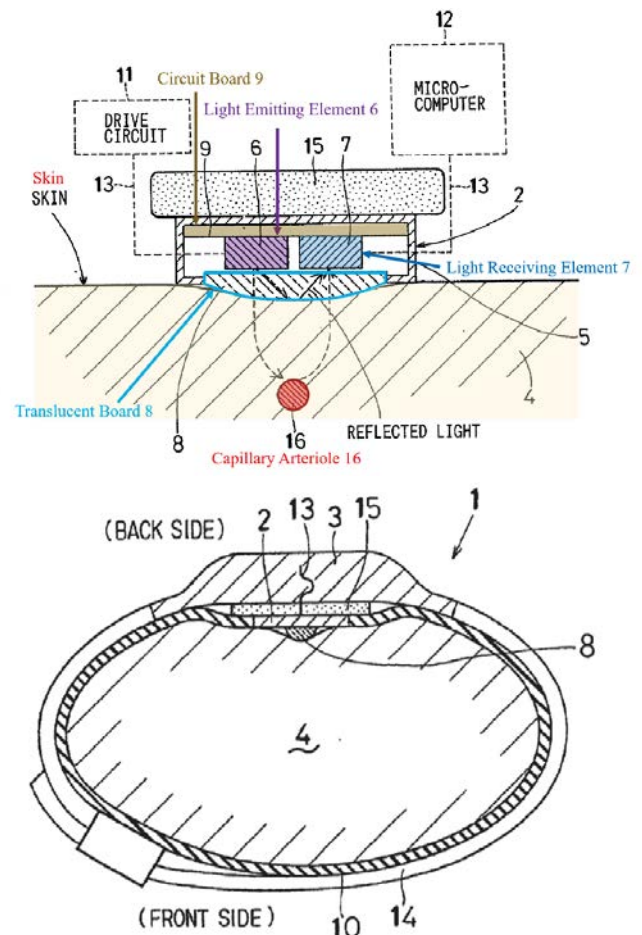

IPR2020-01715 APPLE-1009, FIGS. 1, 2.

Ohsaki Teaches that a Protruding Convex Surface Improves Signal Strength

Ohsaki

[0025] The detecting element 2 is arranged on the user's wrist 4 so that the convex surface of the translucent board 8 is in intimate contact with the surface of the user's skin. Thereby it is prevented that the detecting element 2 slips off the detecting position of the user's wrist 4. If the translucent board 8 has a flat surface, the detected pulse wave is adversely affected by the movement of the user's wrist 4 as shown in FIG. 4B. However, in the case that the translucent board 8 has a convex surface like the present embodiment, the variation of the amount of the reflected light which is emitted from the light emitting element 6 and reaches the light receiving element 7 by being reflected by the surface of the user's skin is suppressed. It is also prevented that noise such as disturbance light from the outside penetrates the translucent board 8. Therefore the pulse wave can be detected without being affected by the movement of the user's wrist 4 as shown in FIG. 4A.

IPR2020-01715 APPLE-1009 ¶ [0025]
 (cited at APPLE-1003, ¶ 98).

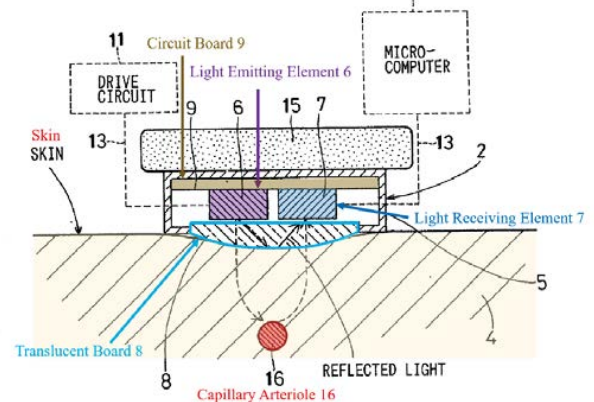
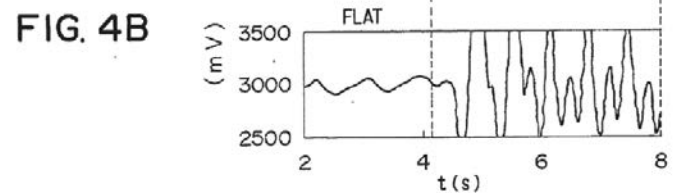
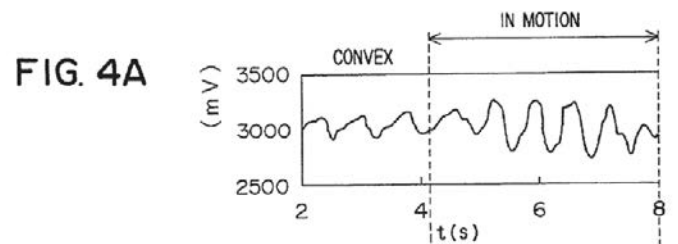

IPR2020-01715 APPLE-1009, FIGS. 2, 4A, 4B.

Aizawa's Modified Cover would have Improved Adhesion and Signal Strength

Dr. Kenny's First Declaration

101. Below, I have shown why the POSITA would have found it obvious to modify the sensor's flat cover (left) to include a lens/protrusion (right), similar to Ohsaki's translucent board 8, so as to improve adhesion between the user's wrist and the sensor's surface, improve detection efficiency, and protect the elements within the sensor housing. APPLE-1009, ¶[0025] (explaining that the convex surface of translucent board 8 prevents slippage of a detecting element from its position on the wrist, and suppresses the "variation of the amount of the reflected light" that reaches the detecting element); APPLE-1024, ¶¶[0033], [0035], FIG. 6 (depicting an LED featuring a convex lens).

IPR2020-01715 APPLE-1003, ¶¶ 101.

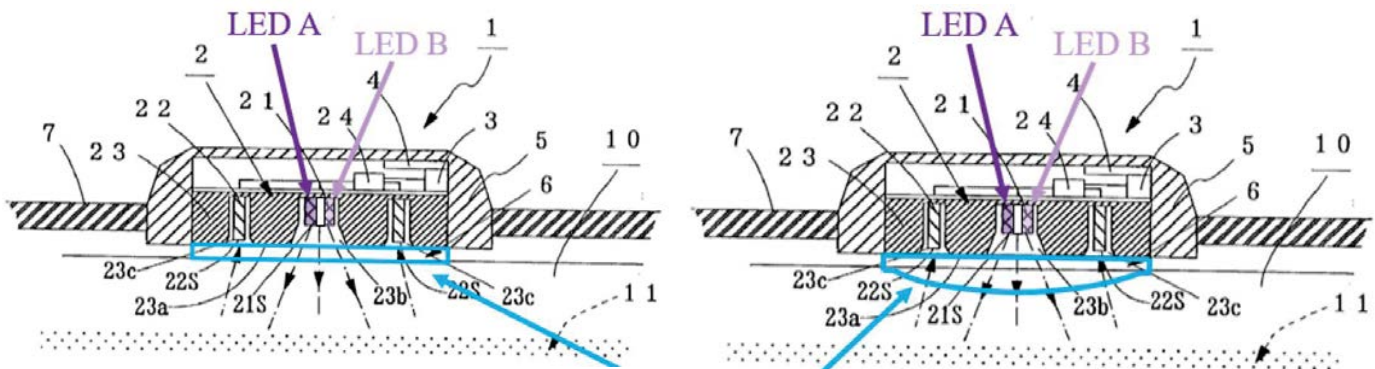

IPR2020-01715 APPLE-1006, FIG. 1(b) (annotated)(APPLE-1003, ¶ 101).

A POSITA would have Incorporated a Cover with a Protrusion into Mendelson '799

Dr. Kenny's First Declaration

98. Accordingly, Ohsaki would have motivated a POSITA to add a light permeable protruding convex cover to Mendelson-799's sensor, to improve adhesion between the sensor and the user's tissue, to improve detection efficiency, and to provide additional protection to the elements accommodated within sensor housing 17. APPLE-1009, ¶¶[0015], [0017], [0025], FIGS. 1, 2, 4A, 4B.

99. In more detail, and as shown below in the section view of the sensor that would have resulted, the POSITA would have added a transparent convex cover to sensor 10, the cover being located over the array of detectors 16 and 18 while also being positioned between tissue of the user and the array of detectors when worn. APPLE-1012, Abstract, 9:22-10:30, FIG. 8; APPLE-1009, ¶¶[0015], [0017], [0025], FIGS. 1, 2, 4A, 4B; *see also* APPLE-1008, ¶¶14-15, FIGS. 1, 2. To obtain

IPR2020-01714 APPLE-1003, ¶¶ 98-99.

Mendelson '799

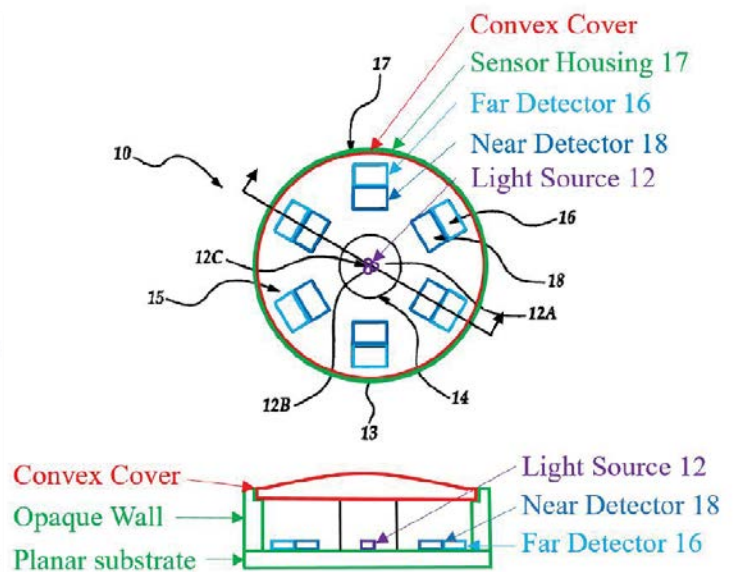

IPR2020-01714 APPLE-1012, FIG. 7
(annotated with additional section view)
(APPLE-1003, ¶ 99).

Masimo Fails to Rebut Dr. Kenny's Testimony

Dr. Kenny's Second Declaration

8. Rather than attempting to rebut my testimony on these points, Masimo and its witness Dr. Madisetti provide arguments that are factually flawed.

9. Specifically, Masimo states that "Ohsaki and Aizawa employ different sensor structures (rectangular versus circular) for different measurement locations (back side versus palm side of the wrist), using different sensor surface shapes (convex versus flat) that are tailored to those specific measurement locations" and then concludes that a POSITA would not "have been motivated to combine these references," and would not have "reasonably expected such a combination to be successful." POR, 1-5. Masimo also argues that "[a]dding another LED complicates Aizawa's sensor and increases power consumption" in addition to "eliminat[ing] the ability to take and display real-time measurements." *Id.*

IPR2020-01715 APPLE-1047, ¶¶ 8-9.

Sensor Structures and Shapes

Dr. Kenny's Second Declaration

10. But Ohsaki nowhere describes its benefits as being limited to a rectangular sensor applied to a particular body location. Also, a POSITA would not have understood those benefits as being so limited. For example, Ohsaki teaches that “the detecting element and the sensor body 3 may be worn on the back side of the user’s forearm” or wrist. Nowhere does Ohsaki teach that its sensor can only be worn on a particular body location. APPLE-1009, [0030], [0008]-[0010], Abstract.

IPR2020-01715 APPLE-1047 ¶ 10.

12. In addition to the above, and as shown in Ohsaki’s FIG. 2 (reproduced below), Ohsaki attributes the prevention of slippage afforded by use of its board (and related improvements in signal quality) to the fact that “*the convex surface of the translucent board...is in intimate contact with the surface of the user’s skin*” when the sensor is worn. APPLE-1003, ¶¶71, 98-102, 159; APPLE-1009, [0015], [0017], [0025], FIGS. 1, 2, 4A, 4B (all emphasis added unless otherwise noted).

IPR2020-01715 APPLE-1047 ¶ 12.

Ohsaki

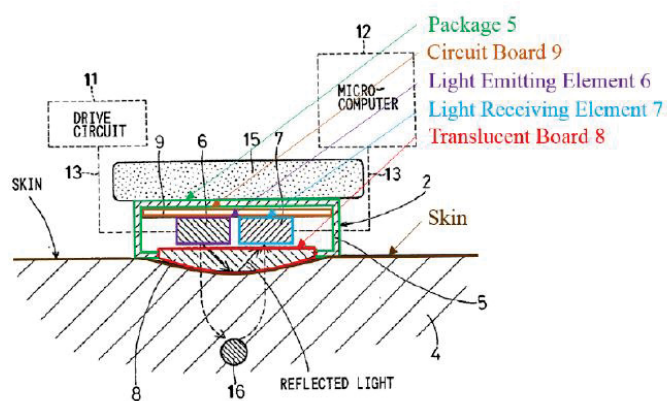

IPR2020-01715 APPLE-1009 FIG. 2 (as annotated at APPLE-1047 ¶ 12).

Sensor Structures and Shapes

Dr. Kenny's Second Declaration

20. Masimo states that it is not the “convex surface” that improves adhesion (*i.e.*, prevents slippage) in Ohsaki, but instead a supposed “longitudinal shape” of “Ohsaki’s translucent board [8].” *See* POR, 20-26. But the cited portion of Ohsaki does not include any reference to board 8. *See* APPLE-1009, [0019]. Instead, Ohsaki associates this “longitudinal” shape to a different component: “detecting element 2.” *See id.* (“it is desirable that the *detecting element 2* is arranged so that *its longitudinal direction* agrees with the longitudinal direction of the user’s arm”).

Ohsaki never describes the “translucent board 8” as “longitudinal,” and nowhere describes that the “translucent board 8” and “detecting element 2” have the same shape. *See generally* APPLE-1009. As illustrated in Ohsaki’s FIG. 2 (reproduced below), translucent board 8 (annotated yellow) is not coextensive with the entire tissue-facing side of detecting element 2 (annotated green).

IPR2020-01715 APPLE-1047 ¶ 20.

Ohsaki

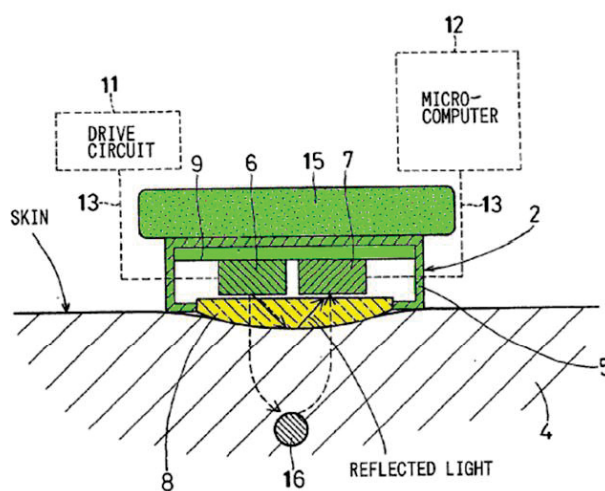

IPR2020-01715 APPLE-1009 FIG. 2
(as annotated at APPLE-1047 ¶ 20).

Sensor Structures and Shapes

Dr. Kenny's Second Declaration

13. Ohsaki's discussion of these benefits does not mention or suggest that they relate to the shape of the exterior edge of Ohsaki's board (whether circular, rectangular, ovoid, or other). Instead, when describing the advantages associated with its board, Ohsaki contrasts a "convex detecting surface" from a "flat detecting surface," and explains that "*if 'the translucent board 8 has a convex surface...variation of the amount of the reflected light...that reaches the light receiving element 7 is suppressed.'*" APPLE-1003, ¶¶100-102; APPLE-1009, [0015], [0025].

IPR2020-01715 APPLE-1047 ¶ 13.

14. From this and related disclosure, a POSITA would have understood that a protruding convex cover would reduce the adverse effects of user movement on signals obtainable by the photodetectors within Aizawa's sensor, which like Ohsaki's light receiving elements, are positioned to detect light reflected from user tissue. APPLE-1003, ¶¶98-102, 154-161; APPLE-1009, [0015], [0017], [0025], FIGS. 1, 2, 4A, 4B; *see also* APPLE-1006, [0012], [0013], [0023], [0024], [0026], [0030], [0034], FIGS. 1(a), 1(b). A POSITA would expect that these benefits would apply to the pulse wave sensor of Aizawa, as well as to other wearable physiological monitors.

IPR2020-01715 APPLE-1047 ¶ 14.

16

FISH.

Sensor Structures and Shapes

Dr. Kenny's Second Declaration

23. Attempting to confirm its false conclusion, Masimo asserts that “*Ohsaki* illustrates two cross-sectional views of its board that confirm it is rectangular.” POR, 15 (citing Ex. 2004, [39]-[42]). Masimo identifies these “two cross-sectional views” as FIGS. 1 and 2, and infers the supposed “rectangular shape” of the translucent board 8 based on FIG. 1 showing the “short” side of the device, and FIG. 2 showing the “long” side of the same device. See POR, 15-17. But, according to Ohsaki, FIG. 2 is “a schematic diagram,” not a cross-sectional view, and Ohsaki never specifies that FIGS. 1 and 2 of Ohsaki are different views of the same device. APPLE-1009, [0013]. Accordingly, nothing in Ohsaki supports Masimo’s inference that the “translucent board 8” *must be* “rectangular” in shape. See, e.g., APPLE-1009, [0013], [0019], [0025], FIG. 2. Further, even if it is possible for the translucent board 8 to be “rectangular,” Ohsaki certainly does not teach or include any disclosure teaching or “*requiring*” this or any other particular shape of the board’s exterior edge. See *id.*

IPR2020-01715 APPLE-1047 ¶ 23.

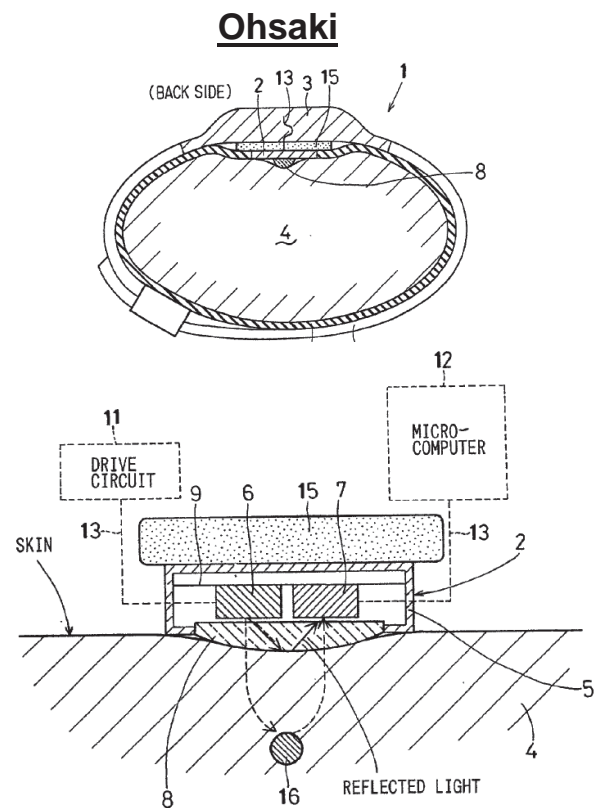

IPR2020-01715 APPLE-1009 FIGS. 1, 2.

Masimo Improperly Relies on Bodily Incorporation

Petitioner's Reply

² Notably, Ohsaki nowhere depicts or describes its cover as rectangular. APPLE-1047, ¶15; APPLE-1009, [0001]-[0030]; FIGS. 1-4B. Even if Ohsaki's cover were understood to be rectangular, "[t]he test for obviousness is not whether the features of a secondary reference may be bodily incorporated into the structure of the primary reference...." *Allied Erecting v. Genesis Attachments*, 825 F.3d 1373, 1381 (Fed. Cir. 2016).

IPR2020-01715 Pap. 21 (Petitioner's Reply), 12.

In addition, as discussed above, even if Ohsaki's translucent board 8 were understood to be rectangular, obviousness does not require "bodily incorporation" of features from one reference into another. *Facebook*, 953 F.3d at 1333. A POSITA, being "a person of ordinary creativity, not an automaton," would have been fully capable of modifying Aizawa to feature a light permeable protruding convex cover to obtain the benefits attributed to such a cover by Ohsaki. *KSR*, 550 U.S. at 418; APPLE-1047, ¶26.

IPR2020-01715 Pap. 21 (Petitioner's Reply), 17.

Measurement Locations

Patent Owner's Response

Ohsaki's translucent board 8." Pet. 33-34. As discussed above, and in more detail below, however, Ohsaki indicates that its sensor's convex board *only* improves adhesion when used on the *back* (i.e., watch) side of the wrist. In contrast, Aizawa *requires* its sensor be positioned on the palm side of the wrist, where it measures light reflected from an artery not accessible on the wrist's back side. Ex. 1006 ¶¶[0002], [0007], [0009], [0026], [0027], [0036], Fig. 2. A POSITA seeking to improve adhesion of Aizawa's sensor would not incorporate a feature that only improves adhesion at a different and unsuitable measurement location. Ex. 2004 ¶66.

IPR2020-01715 Pap. 17 (POR), 27-28.

Dr. Kenny's Second Declaration

10. But Ohsaki nowhere describes its benefits as being limited to a rectangular sensor applied to a particular body location. Also, a POSITA would not have understood those benefits as being so limited. For example, Ohsaki teaches that "the detecting element and the sensor body 3 may be worn on the back side of the user's forearm" or wrist. Nowhere does Ohsaki teach that its sensor can only be worn on a particular body location. APPLE-1009, [0030], [0008]-[0010], Abstract. In its summary of invention and claim preambles, Ohsaki explains that the object of its invention is "to provide a human pulse wave sensor which is capable of detecting the pulse wave *of a human body* stably and has high detection probability." APPLE-1009, [0007], claims 1-8. Thus, Ohsaki's disclosure should not be narrowly understood as applying to a single location or a single embodiment.

IPR2020-01715 APPLE-1047, ¶ 10.

Measurement Locations

Dr. Kenny's Second Declaration

28. Indeed, Ohsaki's claim language reinforces that Ohsaki's description would not have been understood as being that limited. For example, Ohsaki explains that "the detecting element 2...may be worn on the back side of the user's forearm" as one form of modification. APPLE-1009, [0030], [0028] (providing a section titled "[m]odifications"). The gap between the ulna and radius bones at the forearm is even greater than the gap between bones at the wrist, which is already wide enough to easily accommodate a range of sensor sizes and shapes, including circular shapes. In addition, Ohsaki's claim 1 explicitly states that "the detecting element is constructed to be worn on a back side of a user's wrist *or a user's forearm.*" See also APPLE-1009, Claim 2. As another example, Ohsaki's independent claim 5 states that "the detecting element is constructed to be worn on a user's wrist or a user's forearm," *without even mentioning a backside* of the wrist or forearm. See also APPLE-1009, Claims 6-8. A POSITA would have understood this language to directly contradict Masimo's assertion that Ohsaki discloses a "very limited benefit" and that "Ohsaki repeatedly specifies that its sensor 'is worn on the *back side* of a user's wrist corresponding to the back of the user's hand.'" POR, 38. Indeed, from this and related description, a POSITA would have understood that Ohsaki's benefits are provided when the sensor is placed, for example, on either side of the user's wrist or forearm. APPLE-1009, [0025], FIGS. 4A, 4B.

Ohsaki

5. A pulse wave sensor for detecting a pulse wave of a human body comprising:

a detecting element including a light emitting element and a light receiving element; and

a sensor body including a circuit connected to the detecting element via a signal line,

wherein the detecting element is constructed to be worn on a user's wrist or a user's forearm,

wherein the light emitting element and the light receiving element are arranged side by side in a longitudinal direction of the user's arm.

6. A pulse wave sensor as set forth in claim 5, wherein:

the detecting element includes a translucent member which is transparent to light and arranged on the light emitting element and the light receiving element;

the translucent member has a convex surface; and

the translucent member is arranged on the user's wrist or the user's forearm so that the convex surface of the translucent member is in intimate contact with a surface of the user's skin.

IPR2020-01715 APPLE-1009, claims 5, 6.

IPR2020-01715 APPLE-1047, ¶ 28.

20

FISH.

Ohsaki Does Not Limit its Sensor to the Backside of the Wrist

Dr. Kenny's Second Declaration

30. Moreover, even assuming for the sake of argument that a POSITA would have understood Aizawa's sensor as being limited to placement on the palm side of the wrist, and would have understood Ohsaki's sensor's "tendency to slip" when arranged on the front side as informing consideration of Ohsaki's teachings with respect to Aizawa, that *would have further motivated* the POSITA to implement a light permeable convex cover in Aizawa's sensor, to improve detection efficiency of that sensor when placed on the palm side. POR, 28-41; APPLE-1009, [0015], [0017], [0023], [0025], FIGS. 1, 2, 3A, 3B, 4A, 4B.

31. When describing advantages associated with its translucent board, Ohsaki explains with reference to FIGS. 4A and 4B (reproduced below) that "if the translucent board 8 has a flat surface, the detected pulse wave is adversely affected by the movement of the user's wrist," but that if the board "has a convex surface... variation of the amount of the reflected light... that reaches the light receiving element 7 is suppressed." APPLE-1003, ¶¶98, 100; APPLE-1009, [0015], [0017], [0025].

IPR2020-01715 APPLE-1047, ¶¶ 30-31.

Ohsaki

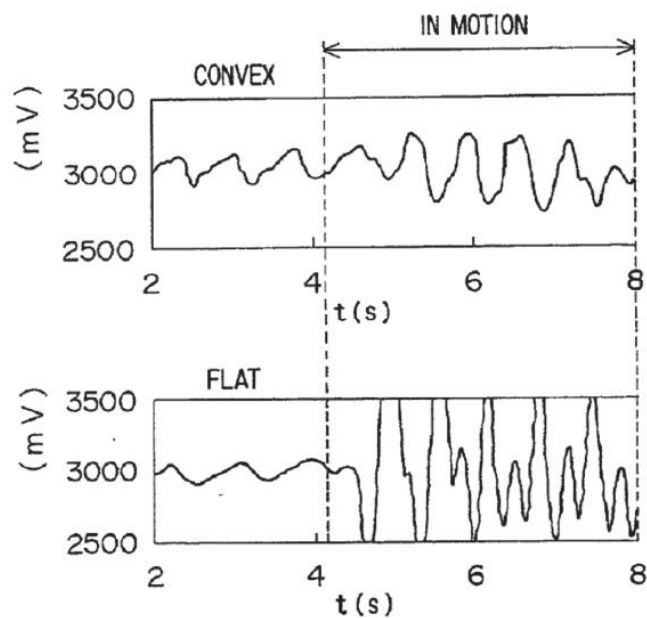

IPR2020-01715 APPLE-1009, FIGS. 4A, 4B.

[0015] FIGS. 4A and 4B are graphs of the pulse wave detected by a pulse wave sensor including a convex detecting surface and the pulse wave detected by a pulse wave sensor including a flat detecting surface, respectively.

IPR2020-01715 APPLE-1009 ¶ [0015].

Ohsaki Does Not Limit its Sensor to the Backside of the Wrist

Dr. Kenny's Second Declaration

32. Contrary to Masimo's arguments, a POSITA would not have understood these benefits of a convex surface over a flat surface to be limited to one side or the other of the user's wrist. APPLE-1009, [0023]-[0025]. Instead, a POSITA would have understood that, by promoting "intimate contact with the surface of the user's skin," a light permeable convex cover would have increased adhesion and reduced slippage of Aizawa's sensor when placed on either side of a user's wrist or forearm, and additionally would have provided improvements in signal quality. APPLE-1009, [0015], [0017], [0025]; FIGS. 1, 2, 4A, 4B, Claims 3-8; *see also* APPLE-1019, 87, 91. Indeed, a POSITA would have known that modifying

IPR2020-01715 APPLE-1047, ¶ 32.

Ohsaki

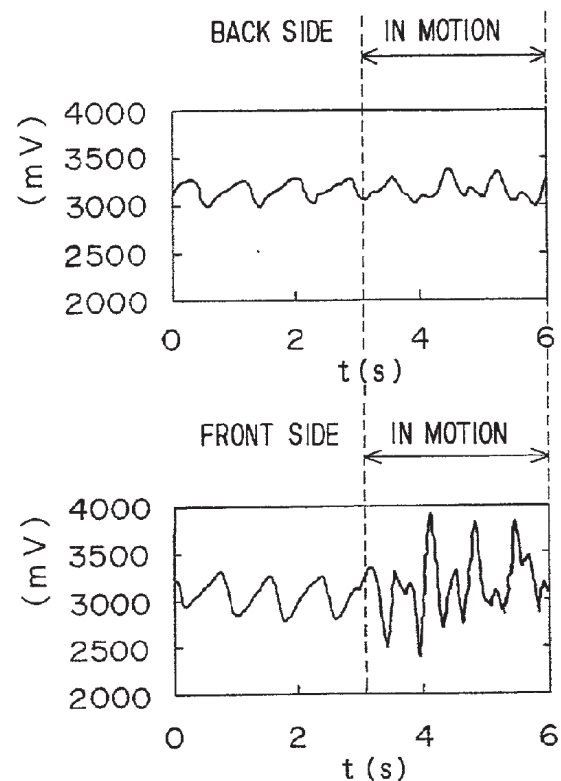

IPR2020-01715 APPLE-1009, FIGS. 3A, 3B.

Reasonable Expectation of Success

Patent Owner's Sur-Reply

Lacking any credible basis to *change* the shape of Ohsaki's board, Petitioner asserts Ohsaki's board has no particular shape. Reply 6-10. Petitioner thus embraces the vague testimony of its declarant, Dr. Kenny, who refused to specify any particular three-dimensional structure for Ohsaki's board or the proposed combination. See, e.g., Ex. 2008 57:19-58:16, 59:18-60:9, 213:17-214:11, 215:8-14. Dr. Kenny testified he did not *know* the shape of Ohsaki's board and that the board could be "circular or square or rectangular." *Id.* 68:21-70:1, 71:7-72:10; Ex. 2027 162:15-20. Petitioner cannot allege Ohsaki's board has *no* geometry while also arguing adding Ohsaki's board is "a known technique to improve similar devices in the same way." Pet. 29.

IPR2020-01714 Pap. 27 (Sur-Reply), 4
(citing Ex. 2027, 162:15-20).

Ex. 2027

Q. Okay. So Ohsaki doesn't tell you anything about the shape of the board, correct?

A. That's correct. It merely says that if the board has a convex surface, it provides these benefits of, of improved adhesion and, and prevention of light from scattering inside.

Ex. 2027, 162:15-20.

And that in view of the references that are part of this combination, that one of ordinary skill in the art would consider combining the sensor of Aizawa with a convex protrusion, such as in Ohsaki, and could carry out that combination in a way that would be able to deliver the benefits being sought.

Ex. 2027, 158:4-10.

Issue 1B

The Cover's Protruding Convex Surface would
Enhance Light-Gathering Ability

FISH.

A POSITA Would Have Modified Aizawa's Flat Cover

Dr. Kenny's Declarations

3. As I previously explained in the Original Declaration, Inokawa *very generally* describes a "lens [that] makes it possible to increase the light-gathering ability" of a reflectance type pulse sensor. APPLE-1008, [0015], [0058], FIG. 2, and, based on this disclosure, a POSITA would have been motivated to incorporate "an Inokawa-like lens into the cover of Aizawa to increase the light collection efficiency...." APPLE-1003, ¶¶91-96. In a significant extrapolation from the very

IPR2020-01521, APPLE-1047, ¶ 3.

97. In more detail, a POSITA would have found it obvious to combine the teachings of Aizawa and Inokawa such that the flat cover (left) of Aizawa is modified to include a lens/protrusion (right) as per Inokawa in order to "increase the light-gathering ability." APPLE-1008, [0015]. Indeed, by positioning a lens above the optical components of Aizawa, as shown below, the modified cover will allow more light to be gathered and refracted toward the light receiving cavities of Aizawa, thereby further increasing the light-gathering ability of Aizawa beyond what is achieved through the tapered cavities. APPLE-1006, [0012], [0024].

IPR2020-01521, APPLE-1003, ¶ 94.

Inokawa

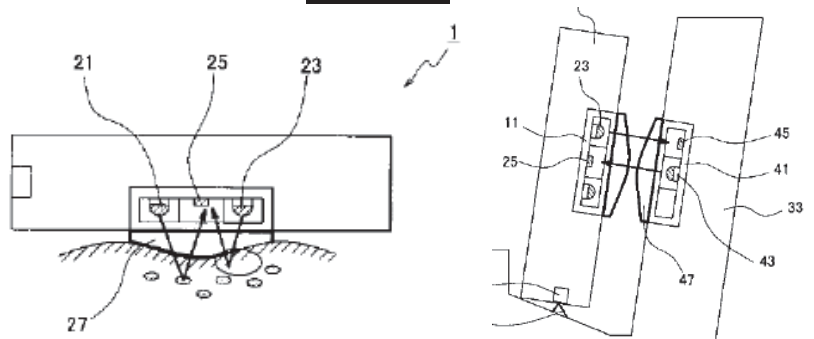

(8) In the invention in Claim 8, a lens is placed on the surface of the sensor-side light-emitting means. This lens makes it possible to increase the light-gathering ability of the LED as well as to protect the LED or PD.

IPR2020-01521, APPLE-1008 FIGS. 2, 3, ¶ [0015].

Aizawa

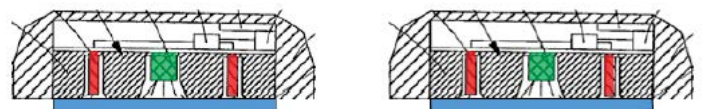

Light permeable cover

IPR2020-01521, APPLE-1006, FIG. 1(b)
(as annotated at APPLE-1003, ¶ 94).

Inokawa's Lens Improves Light-Gathering Ability at All Locations

Dr. Kenny's Declarations

19. As I explained during my deposition, "given the arrangement of the corpuscles as the reflecting objects in the space all around underneath [Inokawa's lens]...there would be some improvement in the light concentration at pretty much all of the locations under the curvature of the lens." Ex. 2006, 164:8-16. As explained further below, this improvement—which a POSITA would understand is what Inokawa is referring to—is based on the convex shape of the lens and application of the most basic of optical concepts, namely Snell's law. Thus, Inokawa's lens "provides an opportunity to capture some light that would otherwise not be captured." *Id.*, 204:21-205:12. In short, Inokawa's lens improves the light-gathering ability of Aizawa's sensor by allowing a larger fraction of the backscattered light to reach the areas covered by the lens. See Ex. 2012, 86, 90; APPLE-1046, 803.

IPR2020-01521, APPLE-1047, ¶ 19.

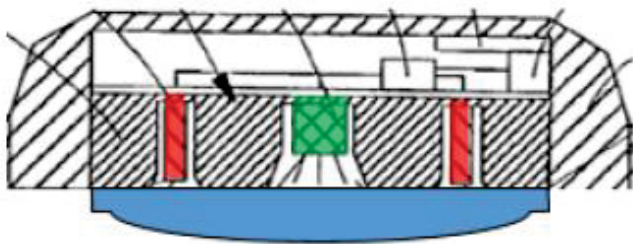

IPR2020-01521, APPLE-1006, FIG. 1(b) (as annotated at APPLE-1047, ¶¶ 20, 21).

Because of the curvature of the lens, the orthogonal lines positioned at the locations of greatest curvature are more generally oriented towards the detector locations. An elementary understanding of Snell's law, and of the lens shape provided in this illustration, would guide a POSITA to understand that a combination of the teachings of Aizawa and Inokawa as presented in my original declaration, would lead to an improvement in the light concentration at the location of the detectors. Very simply, a POSITA familiar with Snell's law and in view of Aizawa and Inokawa would understand that the placement of the curvature in the region near the locations of the detectors would have the effect of improving the light concentration provided by the lens in these regions compared to the case of not having such curvature (*i.e.*, using a flat plate).

IPR2020-01521, APPLE-1047, ¶ 21.

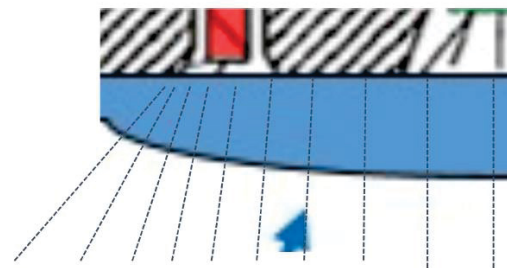

Inokawa's Lens Improves Light-Gathering Ability at All Locations

Ex. 2006

8 Q. How about the, the, the lens in your
9 combination, the figure at the bottom right below
10 Paragraph 97?

11 A. Yeah, I would say there's some, given
12 the arrangement of the corpuscles as the reflecting
13 objects in the space all around underneath that lens,
14 that there would be some improvement in the light
15 concentration at pretty much all of the locations
16 under the curvature of the lens.

IPR2020-01521, Ex. 2006, 164:8-16.

21 Q. So it sounds like there's two
22 considerations here. One is the convex lens in
1 general would direct more light to the center; the
2 other is your testimony that a protruding lens
3 overall would capture more light. Am I capturing
4 your testimony correctly?

5 A. I think one of ordinary skill in the
6 art would appreciate that those are both true,
7 simultaneously, that you have the, the, the general
8 lens-like shape of the convex lens provides
9 refraction which allows additional concentration of
10 light and light-collection efficiency, and that the
11 protrusion provides an opportunity to capture some
12 light that would otherwise not be captured.

IPR2020-01521, Ex. 2006, 204:21-205:12.

Inokawa's Lens Improves Light-Gathering Ability at All Locations

Patent Owner's Response

B. Ground IA Does Not Establish Obviousness

1. A POSITA Would Not Have Been Motivated To Combine Inokawa's Lens With Aizawa's Sensor

- a) Petitioner Admits Inokawa's Lens Directs Light To The Center Of The Sensor

IPR2020-01521, Pap. 15 (POR), 16.

The '628 Patent further confirms that a POSITA would have this understanding. Figure 14B (below) "illustrates how light from emitters (not shown) can be focused by the protrusion 605 onto detectors." Ex. 1001 35:56-57.

IPR2020-01521, Pap. 15 (POR), 18.

Dr. Madisetti's Deposition Transcript

6 A. In certain context, yes. You would,
7 for example, as I describe in my Declaration, as
8 confirmed by Dr. Kenny, if you have a convex surface,
9 a convex surface, light would be, all light reflected
10 or otherwise would be condensed or directed towards
11 the center.

IPR2020-01521, APPLE-1041, 40:6-11.

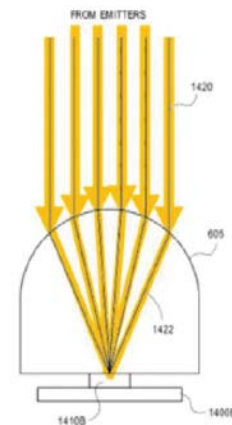

IPR2020-01521, APPLE-1001 FIG. 14B
(as annotated at Pap. 15, 19).

Inokawa's Lens Improves Light-Gathering Ability at All Locations

Dr. Kenny's Second Declaration

26. Patent Owner and Dr. Madisetti's reliance on FIG. 14B for justification of their understanding of Inokawa is severely misplaced. While each of Inokawa, Aizawa, and Mendelson-1988 are directed to a reflectance-type pulse sensor that detects light that has been backscattered from the measurement site, the scenario depicted in FIG. 14B shows a transmittance-type configuration where collimated or nearly-collimated light is "attenuated by body tissue," not backscattered by it. APPLE-1001, 35:62-64. Indeed, FIG. 14I of the '628 patent puts FIG. 14B in proper context, showing how light from the emitters is transmitted through the entire finger/tissue before being received by the detectors on the other side:

IPR2020-01521, APPLE-1047, ¶ 26.

7. As I further show using green arrows below, light emitted from Inokawa's LEDs 21, 23 is backscattered from many locations throughout the measurement site, each scattered return ray propagating towards the lens with a very wide range of positions and orientations before it can go through the lens 27:

IPR2020-01521, APPLE-1047, ¶ 7.

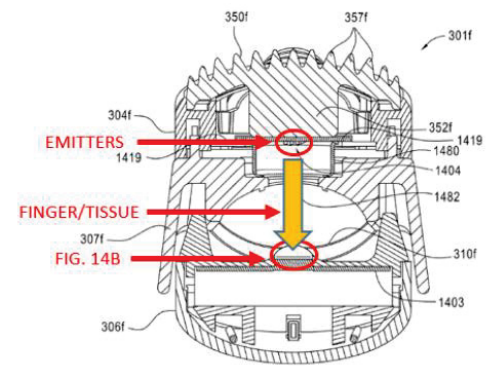
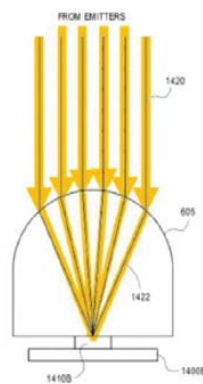

IPR2020-01521, APPLE-1001 FIGS 14B (left) and 14I (right) (as annotated at Pap. 15, 19 and APPLE-1047 ¶ 26).

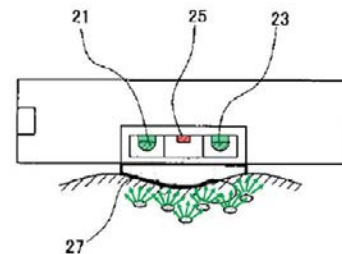

IPR2020-01521, APPLE-1008 FIG. 2 (as annotated at APPLE-1047, ¶ 7).

Inokawa's Lens Improves Light-Gathering Ability at All Locations

Dr. Kenny's Second Declaration

56. Far from *focusing* light to the center as Masimo contends, Ohsaki's convex cover provides at best a slight refracting effect. This effect allows light rays that otherwise would have missed the detection area to instead be directed toward that area as they pass through the interface provided by the cover. This is especially true in configurations like Aizawa's where light detectors are arranged symmetrically about a central light source, so as to enable backscattered light to be detected within a circular active detection area surrounding that source. Ex. 1019, 86, 90. The slight refracting effect is confirmed by the similar indices of refraction between human tissue and a typical cover material (e.g., acrylic). APPLE-1056, 1486; APPLE-1056, 1484.

IPR2020-01715, APPLE-1047, ¶ 56.

37. In contrast, and as explained in more detail below, Dr. Kenny has consistently testified that a POSITA would have understood that a convex cover improves "light concentration at pretty much *all of the locations under the curvature of the lens,*" and for at least that reason would have been motivated to modify Aizawa's sensor to include a convex cover as taught by Ohsaki. Ex. 2006, 164:8-16.

IPR2020-01715, APPLE-1047, ¶ 37.

Ex. 1019 (Webster)

7.2.3 Effect of multiple photodiode arrangement

In a reflectance oximeter, the incident light emitted from the LEDs diffuses through the skin and the back scattered light forms a circular pattern around the LEDs. Thus if we use multiple photodiodes placed symmetrically with respect to the emitter instead of a single photodiode, a large fraction of back scattered light can be detected and therefore larger plethysmograms can be obtained.

To demonstrate this, Mendelson and Ochs (1988) used three photodiodes mounted symmetrically with respect to the red and infrared LEDs; this enabled them to triple the total active area of the photodiode and thus collect a greater fraction of the back scattered light from the skin. The same result can be obtained using a photodiode with three times the area.

IPR2020-01715, APPLE-1019, 90.

Aizawa

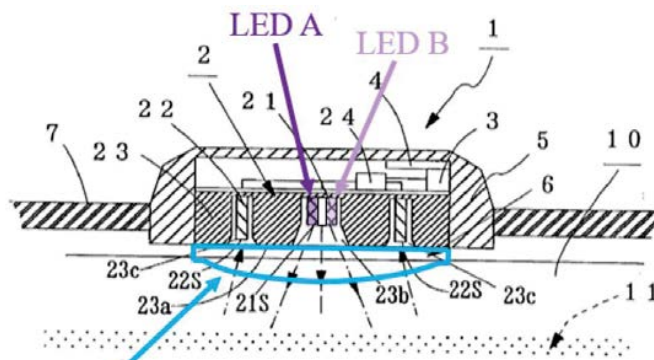

IPR2020-01715 APPLE-1006, FIG. 1(b)
(annotated with protruding cover)(APPLE-1003, ¶ 101).

Masimo Ignores the Behavior of Scattered Light

Patent Owner's Sur-Reply

Even if the theory had merit, however, it would be unavailing because it fails to consider the greater *decrease* in light at the detectors due to light redirection to a *more* central location. See Ex. 2027 19:16-21:8. As Dr. Kenny confirmed, the circle of backscattered light's intensity "*decreases* with the *square of the distance*" between the central emitter and peripheral detectors. Ex. 2027 49:17-50:13, 57:10-22; see also Ex. 1017 at 2 ("The intensity of the backscattered light decreases in direct proportion to the square of the distance between the photodetector and the LEDs"). Thus, any purported signal obtained from light redirected from the sensor's *edge* would be relatively weak and fail to make up for the much greater loss of signal strength when light is redirected away from the detectors and towards a more central position. See *id.*

IPR2020-01715 Pap. 26 (Sur-Reply), 20.

Ex. 2027

Q. So there, there is some light that would have been captured by the detectors that is redirected and no longer hits the detectors; is that correct?

MR. SMITH: Objection; form.

A. So of all of the photons scattered backwards from all of these sites --

Q. Correct.

A. -- and interacting with this curved optical surface that we're calling the lens, some of those rays are diff- -- sorry -- refracted in a way that directs them toward the detectors which otherwise might have missed, and there would be some other rays that would have hit the detectors that are refracted away from the detectors; that's correct.

Ex. 2027, 19:16-20:8.

Masimo Ignores the Behavior of Scattered Light

Patent Owner's Sur-Reply

Even if the theory had merit, however, it would be unavailing because it fails to consider the greater *decrease* in light at the detectors due to light redirection to a *more* central location. See Ex. 2027 19:16-21:8. As Dr. Kenny confirmed, the circle of backscattered light's intensity "*decreases with the square of the distance*" between the central emitter and peripheral detectors. Ex. 2027 49:17-50:13, 57:10-22; see also Ex. 1017 at 2 ("The intensity of the backscattered light decreases in direct proportion to the square of the distance between the photodetector and the LEDs"). Thus, any purported signal obtained from light redirected from the sensor's *edge* would be relatively weak and fail to make up for the much greater loss of signal strength when light is redirected away from the detectors and towards a more central position. See *id.*

IPR2020-01715 Pap. 26 (Sur-Reply), 20.

Ex. 2027

Q. The indication in this figure, "Toward the center," does that indicate the redirection that leads to the detector capturing light that otherwise would have been missed --

MR. SMITH: Objection; form.

Q. -- for a particular ray?

MR. SMITH: Same objection.

A. So just again, reading from Paragraph 42, the "lens' ability to direct light 'toward the center' would allow the detector to capture light that would otherwise have been missed by the detectors, regardless of their location within the sensor device."

Ex. 2027, 19:3-15.

The Principle of Reversibility Confirms Inokawa's Optical Benefits

Dr. Kenny's Second Declaration

principle of reversibility, which comes from the even more fundamental Fermat's principle. APPLE-1049, 87-92, trivially dispels Patent Owner's claim that reversing the LED/detector configuration of Inokawa (as in Aizawa) by placing the detectors around centrally located LEDs would necessarily cause Inokawa's lens to send less light to the detectors, thereby rendering Inokawa's lens ineffective when applied to Aizawa. POR, 15-20. As I noted above, Fermat's principle states that a path taken by a light ray between two points is one that can be traveled in the least time. See APPLE-1052, 87-92; APPLE-1049, 106-111. It is one of the most fundamental concepts in optics (and physics for that matter) and readily explains the principle of reversibility. Simply put, the speed of light is independent of the direction of propagation for these simple materials, which can be represented by an index of refraction. Therefore the shortest path between two points is the same regardless of the direction traveled along the path.

IPR2020-01521, APPLE-1047, ¶ 31.

39. In short, further based on the principle of reversibility, which is an absolute requirement of the simple expression of Snell's law, a POSITA would have understood that both configurations of LEDs and detectors—*i.e.*, with the LED at the center as in Aizawa or with the detector at the center as in Inokawa—would benefit from the enhanced light-gathering ability of an Inokawa-like lens.

IPR2020-01521, APPLE-1047, ¶ 39.

The Principle of Reversibility Confirms Inokawa's Optical Benefits

Dr. Kenny's Second Declaration

33. To illustrate the relevance of this principle, with reference to Patent Owner's annotated version of Inokawa FIG. 2 as shown below, two example ray paths from the LEDs (green) to the detector (red) can be seen. In this case, the rays originate from the peripheral LEDs (green) and arrive at the central detector (red).

IPR2020-01521, APPLE-1047, ¶ 33.

34. Now, by flipping the LED/detector configuration, as in Aizawa, and applying the principle of reversibility, it is readily observed that the two exemplary paths shown above simply reverse their direction—such that any condensing/directing/focusing benefit achieved by Inokawa's lens (blue) under the original configuration would be similarly achieved under the reversed configuration (assuming that other factors are kept constant for ease of comparison):

IPR2020-01521, APPLE-1047, ¶ 34.

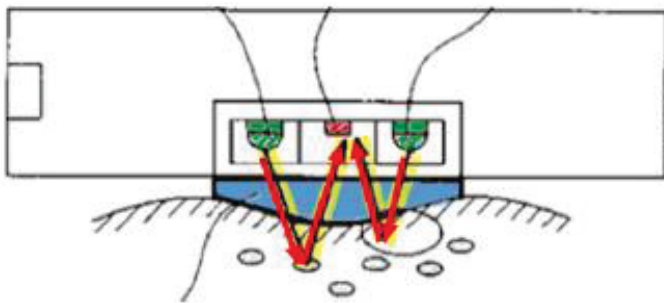

IPR2020-01521, APPLE-1008 FIG. 2
(as annotated at APPLE-1047, ¶ 33).

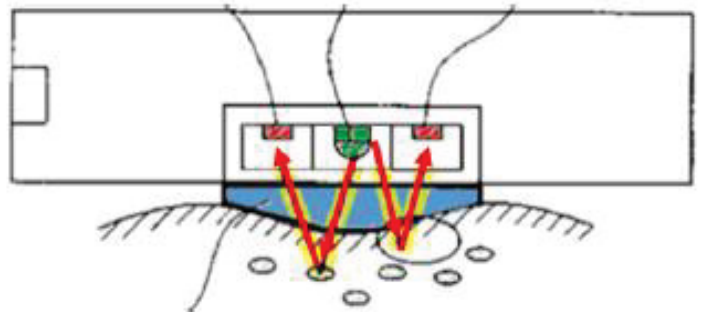

IPR2020-01521, APPLE-1008 FIG. 2
(as annotated at APPLE-1047, ¶ 34).

Masimo Ignores the Principle of Reversibility

Patent Owner's Sur-Reply

"reflected, transmitted, absorbed, and scattered by the skin and other tissues and the blood before it reaches the detector"); Ex. 2027 188:6-17, 29:11-30:7, 31:8-32:3, 38:17-42:6. Petitioner never explains how the principle of reversibility could apply to such "random" scattered and absorbed light.

Indeed, Dr. Kenny testified that "light backscattered from the tissue can go in a large number of possible directions, not any single precise direction." Ex. 2027 17:12-18; *see also id.* 17:19-19:2 (reiterating random path and absorbance), 38:17-40:13, 40:14-42:6 ("Every photon tracing that particular path...would have a potentially different interaction with the tissue and it would be scattered, potentially, in a different direction than the photon arriving before and after it."). In contrast, the principle of reversibility provides that "a ray going from P to S [in one direction] will trace the *same route* as one going from S to P [the opposite direction]" assuming there is *no* absorption or scattering. Ex. 1051 at 51 (illustrating diffuse reflection), 53 (defining principle), 207 (requires no absorption). Dr. Kenny also testified that the principle of reversibility applies to a light ray between two points and admitted it does *not* apply to randomly scattered light in bulk. Ex. 2027 207:9-208:22. In that circumstance, Dr. Kenny merely testified that light "can go" or "could go" along the same path. *Id.* 207:17-209:21, 210:8-211:6. That hardly supports Petitioner's argument that light will necessarily travel the same paths regardless of whether the LEDs and detectors are reversed.

IPR2020-01715 Pap. 26 (Sur-Reply), 17
(citing Ex. 2027, 207:9-208:22).

Ex. 2027

9/18/2021

Apple, Inc. v. Masimo Corp.

Thomas Kenny Jr., Ph.D.

Page 208

1 with the random scattering, even two different
2 photons entering along the same axis are likely to be
3 scattered in, in different exact ways.

4 But the point of the principle is
5 that any particular pathway of any particular photon
6 is -- can be traversed in the opposite direction and
7 that overall, there's no reason that one would expect
8 that swapping the locations of the emitters and the
9 detectors in a system like this would lead to all the
10 light suddenly being directed in the wrong place for
11 success.

12 The light paths are capable of being
13 reversed exactly and that in general, one would
14 expect that light that is likely to go in one
15 direction could go in the exact opposite direction.

16 Q. Fermat's principle, as you stated it,
17 applies to a light ray between two points, correct?

18 A. Yes.

19 Q. It doesn't apply to randomly
20 scattered light in bulk, correct?

21 MR. SMITH: Objection.

22 A. In its simplest form, no --

Ex. 2027, 208:1-22.

FISH.

35

Masimo Ignores the Principle of Reversibility

Ex. 2027

9/18/2021 Apple, Inc. v. Masimo Corp. Thomas Kenny Jr., Ph.D.

Page 208

1 with the random scattering, even two different
2 photons entering along the same axis are likely to be
3 scattered in, in different exact ways.

4 But the point of the principle is
5 that any particular pathway of any particular photon
6 is -- can be traversed in the opposite direction and
7 that overall, there's no reason that one would expect
8 that swapping the locations of the emitters and the
9 detectors in a system like this would lead to all the
10 light suddenly being directed in the wrong place for
11 success.

12 The light paths are capable of being
13 reversed exactly and that in general, one would
14 expect that light that is likely to go in one
15 direction could go in the exact opposite direction.

16 Q. **Fermat's principle, as you stated it,**
17 **applies to a light ray between two points, correct?**

18 A. **Yes.**

19 Q. **It doesn't apply to randomly**
20 **scattered light in bulk, correct?**

21 MR. SMITH: Objection.

22 A. **In its simplest form, no --**

Ex. 2027, 208:1-22 (cited at Pap. 26, 17).

9/18/2021 Apple, Inc. v. Masimo Corp. Thomas Kenny Jr., Ph.D.

Page 209

1 MR. SMITH: Objection; form.

2 A. -- **but one could look at any**
3 **particular randomly scattered path which would be**
4 **little pieces of light paths separated by changes in**
5 **direction with scattering events and the**
6 **reversibility principle applies to all of the pieces**
7 **and, therefore, it applies to the aggregate. Light**
8 **that can go in one direction through this system**
9 **could go in the exact opposite direction along the**
10 **exact same path.**

11 And I think maybe the more important
12 point here is that when we're considering what
13 happens to this light as it encounters this convex
14 surface and is refracted by that surface, it is
15 absolutely the case that the light encountering that,
16 that refractive experience is absolutely able to go
17 in either direction along that path. That's
18 fundamental to the principles that underlie the
19 concepts of refraction. **So if we're concerned with**
20 **the impact of the lens on the system, it's absolutely**
21 **reversible.**

22 Q. Looking at the incoming light, does

Ex. 2027, 209:1-21.

Masimo Ignores the Principle of Reversibility

Patent Owner's Sur-Reply

light in bulk. Ex. 2027 207:9-208:22. In that circumstance, Dr. Kenny merely testified that light "can go" or "could go" along the same path. *Id.* 207:17-209:21, 210:8-211:6. That hardly supports Petitioner's argument that light will necessarily travel the same paths regardless of whether the LEDs and detectors are reversed.

IPR2020-01715 Pap. 26 (Sur-Reply), 17
(citing Ex. 2027, 207:17-209:21).

Ex. 2027

And I think maybe the more important point here is that when we're considering what happens to this light as it encounters this convex surface and is refracted by that surface, **it is absolutely the case that the light** encountering that, that refractive experience **is absolutely able to go in either direction along that path.** That's fundamental to the principles that underlie the concepts of refraction. **So if we're concerned with the impact of the lens on the system, it's absolutely reversible.**

Ex. 2027, 209:11-21.

Masimo Ignores the Principle of Reversibility

Patent Owner's Sur-Reply

The principle of reversibility does not indicate that one could reverse *sensor components* and still obtain the same *benefit* from a convex—as opposed to a flat—surface. As Dr. Kenny testified, the benefit of a convex surface would *not* be “obvious” if one moves the “LEDs and detectors around...” Ex. 2006 86:19-87:6.⁵

IPR2020-01715 Pap. 26 (Sur-Reply), 18-19
(citing Ex. 2006, 86:19-87:6).

Ex. 2006

I think one of ordinary skill in the art would understand that in Inokawa the objective is to concentrate light at the detector, which is in the center axis of the drawing and that the lens is capable of providing that benefit.

If we're going to move the lenses and the LEDs and detectors around and ask different questions, it's -- it isn't so obvious that Inokawa is specifically considering those scenarios. It's a little more hypothetical.

Ex. 2006, 86:19-87:6.

A POSITA would have Modified Mendelson-1988 to Include a Protruding Lens-Like Cover

Dr. Kenny's First Declaration

177. Indeed, as I described above, Inokawa teaches a similarly configured pulse sensor as in Mendelson-1988 but one in which a lens is positioned over the detectors to “increase the light-gathering ability of the LED as well as to protect the LED or [detector].” APPLE-1008, [0015], [0058].

178. Accordingly, a POSITA would have been motivated to incorporate the lens of Inokawa into to cover of Mendelson-1988 in order to increase the light collection efficiency. A POSITA would have been particularly interested in making such a modification because Mendelson-1988 shares a similar goal of maximizing “reflectance photoplethysmographic signals.” APPLE-1015, 173.

The lens of Inokawa provides precisely this benefit to Mendelson-1988’s device by providing a protective cover that further refracts and concentrates the incoming light beams to thereby enhance the light collection efficiency and, by extension, the signal to noise ratio. APPLE-1008, [0015], [0058].

179. Indeed, as illustrated below, the device resulting from this combination of Mendelson-1988 and Inokawa would have modified the flat epoxy cover (left) with a curved one as per Inokawa (right) to thereby “increase the light-gathering ability.” APPLE-1008, [0015].

66. Mendelson-1988 mentions that a user’s forehead provides a good location for placing its sensor because of the region’s alleged “relatively large reflectance photoplethysmographic signals,” but Mendelson-1988’s sensor can certainly be used at other locations as well based on its recognition that “several locations on the body (e.g., forearm, chest, and back)” also allowed the reflectance photoplethysmograms to be detected. *Id.*, 173. Further support for the wider applicability of Mendelson-1988 beyond forehead locations is provided by subsequent work by the same author (Mendelsohn) that recognize, for instance, wrist and forehead regions as convenient alternative locations for a reflectance-type pulse oximeter. *See, e.g.*, APPLE-1024, 3017.

IPR2020-01521, APPLE-1003, ¶ 66.

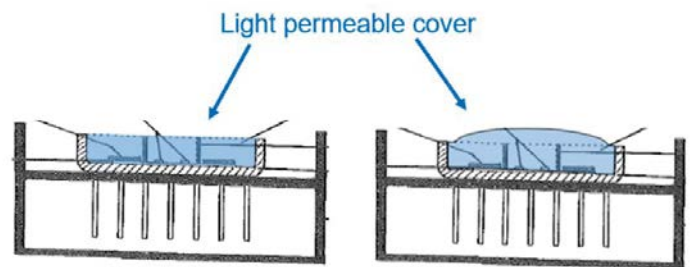

IPR2020-01521, APPLE-1015, FIG 2(B)
(as annotated at APPLE-1003, ¶ 179).

IPR2020-01521, APPLE-1003, ¶¶ 177-179.

A POSITA would have Modified Mendelson-1988 to Include a Protruding Lens-Like Cover

Dr. Kenny's Second Declaration

56. A POSITA would understand the plain meaning of cover to be merely "something that protects, shelters, or guards." APPLE-1050. Both instances of the "light permeable cover" as I previously identified are clearly covers that serve to protect. There is nothing in the specification of the '295 patent itself that suggests that some special meaning is attributed to the term "cover" as used in the patent.

IPR2020-01521, APPLE-1047, ¶ 56.

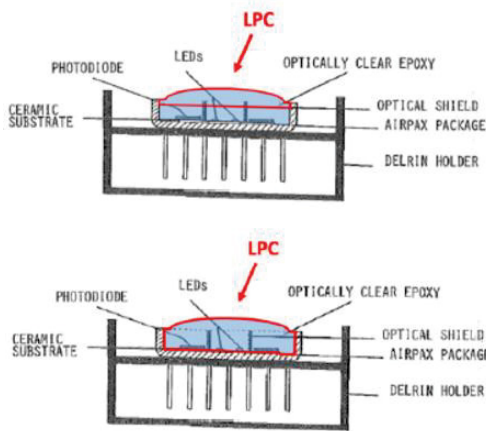

IPR2020-01521, APPLE-1047, ¶ 59.

60. Under plain meaning, both LPCs as identified above are covers that protect the underlying components. Moreover, to the extent the claimed "cover" must be "distinct" from all other components, I previously explained how a POSITA, looking at conventional epoxy processing techniques such as those found in Nishikawa, would have added an additional epoxy lens layer separately on top of the epoxy encapsulation layer underneath, thereby providing a separate and differentiated mass of material to serve as the cover. APPLE-1003, ¶185 (citing to APPLE-1023, [0034]-[0038], FIGS. 5-6).

IPR2020-01521, APPLE-1047, ¶ 60.

62. Despite Patent Owner's assertions, I consistently referred to Nishikawa in my Original Declaration merely as an example among various prior art references of the period that "demonstrate exactly how [a convex] lens shape may be incorporated into a molded cover." APPLE-1003, ¶¶96, 182. That is, Nishikawa merely provides further support for my actual combination (*i.e.*, Mendelson-1988 in view of Inokawa) by demonstrating how the lens of Inokawa may be incorporated in a manufacturing context. APPLE-1003, ¶¶96, 182.

IPR2020-01521, APPLE-1047, ¶ 62.

A POSITA would have Modified Mendelson-1988 to Include a Circular Housing

202. A POSITA would have found it obvious and actually quite routine to use a differently shaped housing, namely a circular one. *Id.* Indeed, using a circular housing having a circular wall, as evidenced by Mendelson-'799, was common practice well before the Critical Date, and there was nothing new or inventive about changing one housing shape for another.

IPR2020-01521, APPLE-1003, ¶ 202.

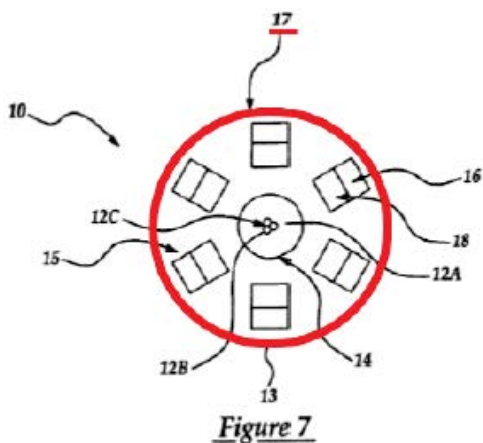

IPR2020-01521, APPLE-1025, FIG. 7.

61. Regarding this feature, I previously explained that there was nothing new or inventive about changing a rectangular housing for a circular one and that a POSITA, among other things because microelectronic packaging as used in Mendelson-1988 comes in various shapes and sizes. APPLE-1003, ¶¶201-202. Patent Owner rebuts this simple change in design by arguing that “[a] POSITA would have no particular motivation to change the shape unless a POSITA perceived some benefit in doing so.” POR, 55-56. But there is nothing in the '628 patent or in the POR that explains how the particular housing shape solves some problem or presents some unexpected result. Rather, a POSITA would have simply recognized that housing shape is a non-inventive feature and that it would have been quite routine to use a differently shaped housing. *See* APPLE-1003, ¶¶201-202. Indeed, given that many other references, such as Mendelson-799 (APPLE-1025), explicitly show the use of circular walls/housings, a POSITA would have found it to be simply a matter of design choice to use a differently shaped walls/housings.

IPR2020-01521, APPLE-1047, ¶ 61.

Issue 1C

The Cover's Protruding Convex Surface would
Protect Sensor Elements

FISH.

A POSITA would have Recognized that a Convex Cover would Protect Sensor Elements

Dr. Kenny's Second Declaration

7. In its POR, Masimo first addresses the "Mendelson '799 and Ohsaki" portion of the full Mendelson '799-Ohsaki-Schulz-Mendelson 2006 combination advanced in Ground 1. As I explained at length in my first declaration, "Ohsaki would have motivated one of ordinary skill to add a light permeable protruding convex cover to Mendelson '799's sensor; to [1] improve adhesion between the sensor and the user's tissue, to [2] improve detection efficiency, and to [3] provide additional protection to the elements accommodated within sensor housing 17."

APPLE-1003, [0098] (citing APPLE-1009, [0015], [0017], [0025], FIGS. 1, 2, 4A, 4B). Rather than attempting to rebut my previous testimony on these points, Masimo offers, through its witness Dr. Madisetti, arguments that are factually flawed and legally irrelevant.

IPR2020-01714 APPLE-1047, ¶ 7.

Mendelson '799

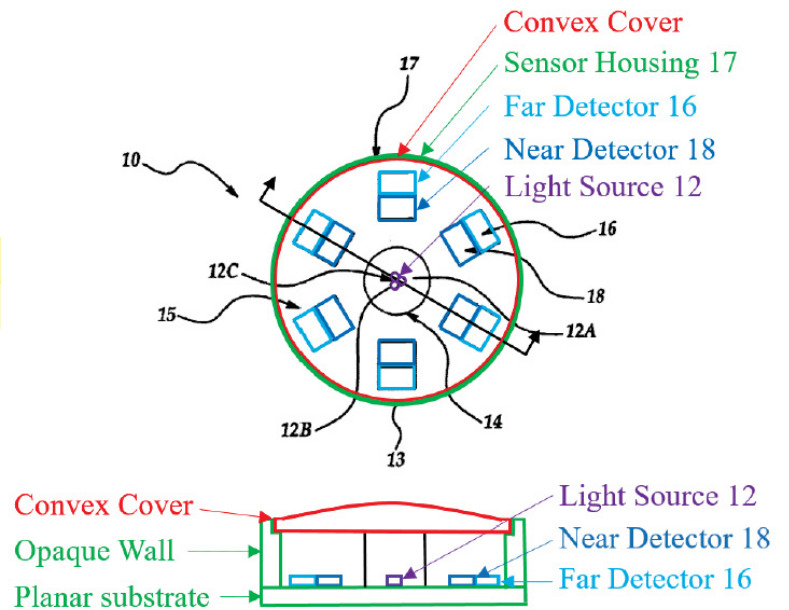

IPR2020-01714 APPLE-1012 FIG. 7
(annotated with additional section view)
(APPLE-1003, ¶ 99).

A Convex Cover would Protect Sensor Elements

Dr. Kenny's First Declaration

92. Mendelson-799 does not describe a cover configured to be located between user tissue and the components accommodated within sensor housing 17 when the sensor is worn, but a POSITA would have recognized that a light permeable cover with a protruding convex surface would improve adhesion between the sensor and the user's tissue, improve detection efficiency, and protect the elements within sensor housing 17. APPLE-1009, ¶¶[0015], [0017], [0025], FIGS. 1, 2, 4A, 4B; APPLE-1008, ¶¶14-15, FIG. 2 (depicting a convex lens that enhances signal strength and protects a LED and photodetector); APPLE-1024, ¶¶[0033], [0035], FIG. 6.

93. Indeed, by the Critical Date, noninvasive optical physiological sensors commonly employed covers. See, e.g., APPLE-1009, ¶¶[0015], [0017], [0025], FIGS. 1, 2, 4A, 4B; APPLE-1006, ¶¶[0012], [0013], [0023], [0024], [0030], FIGS. 1(a), 1(b); APPLE-1008, ¶¶14-15, FIGS. 1, 2.

94. For example, and as described above in Section VI.B, Ohsaki discloses a wrist-worn "pulse wave sensor" that includes a light permeable convex cover – "translucent board 8" – that is configured to be located between user tissue and a detector when the sensor is worn, where the cover comprises a protruding convex

IPR2020-01714 APPLE-1003, ¶¶ 92-94.

Ohsaki

FIG. 1

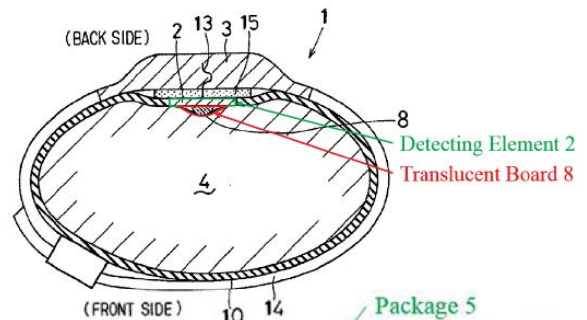
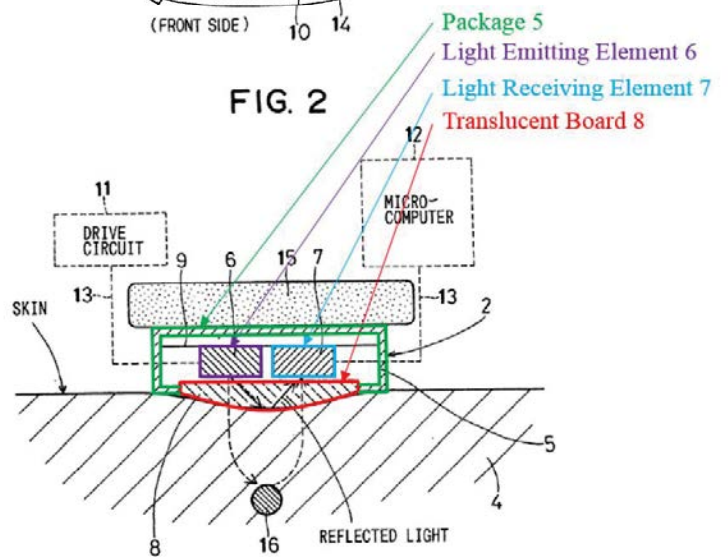

FIG. 2



IPR2020-01714 APPLE-1009, FIGS. 1, 2. 44

A Convex Cover would Protect Sensor Elements

Dr. Kenny's First Declaration

92. Mendelson-799 does not describe a cover configured to be located between user tissue and the components accommodated within sensor housing 17 when the sensor is worn, but a POSITA would have recognized that a light permeable cover with a protruding convex surface would improve adhesion between the sensor and the user's tissue, improve detection efficiency, and protect the elements within sensor housing 17. APPLE-1009, ¶¶[0015], [0017], [0025], FIGS. 1, 2, 4A, 4B; APPLE-1008, ¶¶14-15, FIG. 2 (depicting a convex lens that enhances signal strength and protects a LED and photodetector); APPLE-1024, ¶¶[0033], [0035], FIG. 6.

IPR2020-01714 APPLE-1003, ¶ 92.

Inokawa

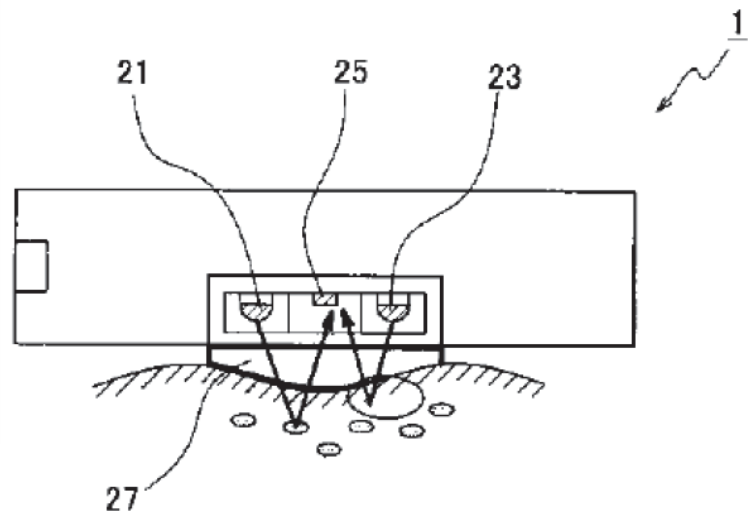

IPR2020-01714, -01715 APPLE-1008, FIG. 2.

(0015)

(8) In the invention in Claim 8, a lens is placed on the surface of the sensor-side light-emitting means. This lens makes it possible to increase the light-gathering ability of the LED as well as to protect the LED or PD.

IPR2020-01714 APPLE-1008, [0015].

Masimo Fails to Rebut that a Convex Cover would Protect Sensor Elements

Patent Owner's Response

c) A POSITA Would Not Have Selected A Convex Cover To Protect The Optical Elements

Petitioner also asserts a POSITA would have been motivated to combine Ohsaki and Mendelson '799 because a convex cover would have protected the optical components. Pet. 27. However, as Dr. Kenny acknowledged in a related proceeding, a convex cover is just one of many different alternatives for protecting the components of a sensor. Ex. 2009 394:18-396:17. For example, as Dr. Kenny acknowledged, a layer of sealing resin could protect the optical elements. *Id.* 395:22-396:4. Dr. Kenny confirmed encapsulation was a "widely used" way of protecting components. *Id.* 395:22-396:8. Other Mendelson references upon which Petitioner relies protect the optical components with a flat layer of epoxy encapsulation. Pet. 13-15 (illustrating Ex. 1017 Fig. 2 and Ex. 1018 Fig. 1); see also Ex. 2004 ¶81.

IPR2020-01714 Pap. 17 (POR), 45-46.

Ex. 2009

Q. Are there other ways a person of ordinary skill in the art could design a sensor to protect the components within?

A. I think by selection of other elements of the package, the housing.

Q. Do you mean that the other elements of the package of the housing could be designed to protect the components on the inside?

A. Yes. For example, you know, if we look at my illustration on below Paragraph 88, I think the combination of the cover and other elements of the housing would be -- could be selected so as to provide that protection.

Q. And what other, what elements of the housing other than the cover are providing protection?

A. Well, in this illustration we have the wall, and the planar substrate together providing protection.

IPR2020-01714 Ex. 2009, 395:3-21 (cited at Pap. 16, 45-46).

Masimo Fails to Rebut that a Convex Cover would Protect Sensor Elements

Mendelson '799

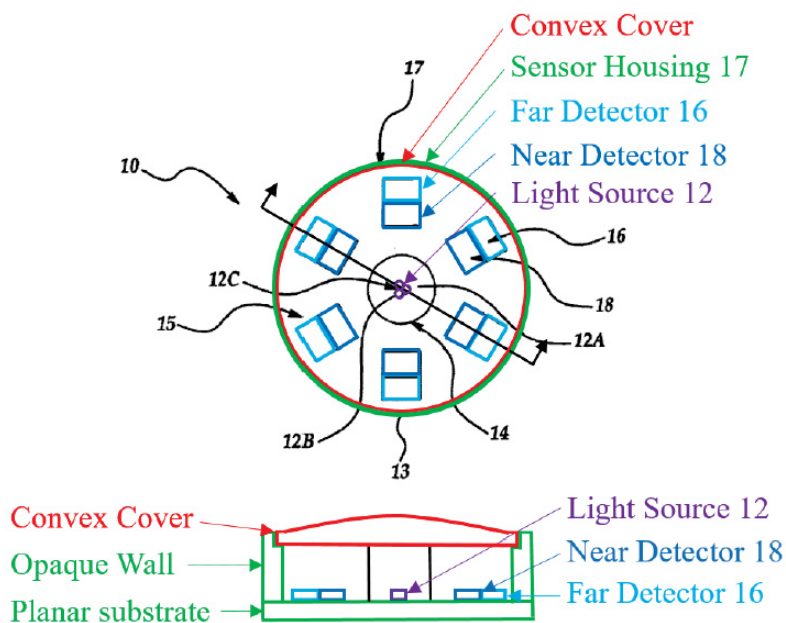

IPR2020-01714 APPLE-1012 FIG. 7
(annotated with additional section view)
(APPLE-1003, ¶ 99).

Ex. 2009

Q. Are there other ways a person of ordinary skill in the art could design a sensor to protect the components within?

A. I think by selection of other elements of the package, the housing.

Q. Do you mean that the other elements of the package of the housing could be designed to protect the components on the inside?

A. Yes. For example, you know, if we look at my illustration on below Paragraph 88, I think the combination of the cover and other elements of the housing would be -- could be selected so as to provide that protection.

Q. And what other, what elements of the housing other than the cover are providing protection?

A. Well, in this illustration we have the wall, and the planar substrate together providing protection.

IPR2020-01714 Ex. 2009, 395:3-21.

A POSITA would have Understood the Multiple Advantages of a Convex Cover to Outweigh Possible Scratching

Patent Owner's Response

Indeed, a POSITA would have understood that a flat cover would provide *better protection* than a convex surface because—as Petitioner's cited art teaches—a flat cover would be less prone to scratches. Ex. 1008 ¶[0106]; Ex. 2004 ¶82. Petitioner's relied-upon references also indicate that a flat surface actually improves adhesion and detection efficiency for more relevant measurement locations such as the wrist's palm side, next to the radial artery. See Ex. 1006 ¶[0013] (“[A] transparent plate-like member...makes it possible to improve adhesion between the sensor and the wrist and thereby further improve the detection efficiency of pulse waves.”); Fig. 2. There would have been no reason for a POSITA to select a convex surface from the many other available options, which provide similar or better protection without the complications and concerns

IPR2020-01714 Pap. 17 (POR), 39

Relevant Case Law

“The fact that the motivating benefit comes at the expense of another benefit, however, should not nullify its use as a basis to modify the disclosure of one reference with the teachings of another.”

Winner Int'l Royalty Corp. v. Wang, 202 F.3d 1340, 1349, n. 8 (Fed. Cir. 2000).

Dr. Kenny's Second Declaration

D. A POSITA would have found the advantages of using a convex cover to outweigh the slight possibility of scratching the cover

49. Masimo claims that “a POSITA would have understood that a flat cover would provide better protection than a convex surface because...it would be less prone to scratches.” POR, 45-47. Even assuming this to be true, one possible disadvantage that competes with the known advantages of applying Ohsaki's teachings to Mendelson-799's sensor would not have negated a POSITA's motivation to combine. In that regard, the POSITA would have understood the *multiple* advantages of a convex cover described in the Petition to outweigh any possibility of scratching (which, at any rate, has nothing whatsoever to do with the protection of optical elements within Mendelson-799's sensor). Moreover, by choosing a suitable material of the protrusion to be scratch-resistant, such as glass, it would have been obvious for a POSITA to achieve both benefits (light gathering and scratch-resistance) at once.

IPR2020-01714 APPLE-1047 ¶ 49.

“[M]ere disclosure of alternative designs does not teach away.”

In re Fulton, 391 F.3d 1195, 1201 (Fed. Cir. 2004).

FISH

Winner Int'l Royalty Corp. v. Wang, 202 F.3d 1340, 1349, n. 8 (Fed. Cir. 2000).

48

Issue 2

Adding a Second Emitter to Aizawa

Case Nos. IPR2020-01521, -01715
U.S. Patent Nos. 10,292,628, 10,631,765

FISH.

Two Emitters would Enable Aizawa to Account for Motion Load

Dr. Kenny's First Declaration

APPLE-1006, ¶[0023]. Aizawa explains that “[t]he arrangement of the light emitting diode 21 and the photodetectors 22 is not limited” to that shown or described in connection with any particular embodiment. APPLE-1006, ¶[0032]. In particular, Aizawa describes arrangements in which multiple light emitting diodes 21 are employed. *Id.*, ¶¶[0032]-[0033].

IPR2020-01715 APPLE-1003, ¶ 79.

80. In my opinion, a POSITA would have combined the teachings of Aizawa and Inokawa such that Aizawa's pulse wave sensor would have been modified to include an additional LED as taught by Inokawa to improve the detected pulse wave by distinguishing between blood flow detection and body movement.

APPLE-1008, ¶(0059) (describing the use of the “S-side green LED 21...to sense the pulse from the light reflected off of the body (e.g., change in the amount of hemoglobin in the capillary artery), while the S-side infrared LED 23 serves to sense body motion from the change in this reflected light”); APPLE-1006, ¶[0006] (recognizing the problem of weak signals from a wearable sensor because the sensor “detects the motion of a red corpuscle...and is easily affected by noise caused by the shaking of the body of the subject), ¶[0028] (describing a device for “computing the amount of motion load” such that the motion can be compensated for).

IPR2020-01715 APPLE-1003, ¶ 80.

Aizawa

[0006] However, although the conventional pulse wave sensor to be attached to the finger or ear is small in size, a signal from the sensor is weak because it detects the motion of a red corpuscle in the capillary and is easily affected by noise caused by the shaking of the body of the subject. Also, as some pressure is applied to the measurement site at the time of detection, the subject cannot carry the detector for a long time when walking or the like.

IPR2020-01715 APPLE-1006, ¶ [0006].

[0028] FIG. 3 schematically shows the waveform of a pulse wave which is the output of the above photodetector 22. The detected pulse wave data is amplified by the drive detection circuit 24 and the amplified pulse wave data is transmitted to the arithmetic circuit 3. The arithmetic circuit 3 has a threshold value and computes the number of outputs above the threshold value per unit time so as to calculate a pulse rate and the transmitter 4 transmits the pulse rate to a display for displaying the above pulse rate data and a device for computing the amount of motion load. Since the output of the above photodetector 22 is generally low, after the output is amplified, the amplified output is converted into a digital signal for the computation of a pulse rate in this embodiment.

IPR2020-01715 APPLE-1006, ¶ [0028]. 51

Two Emitters would Enable Aizawa to Account for Motion Load

Dr. Kenny's First Declaration

80. In my opinion, a POSITA would have combined the teachings of Aizawa and Inokawa such that Aizawa's pulse wave sensor would have been modified to include an additional LED as taught by Inokawa to improve the detected pulse wave by distinguishing between blood flow detection and body movement.

APPLE-1008, ¶(0059) (describing the use of the "S-side green LED 21...to sense the pulse from the light reflected off of the body (e.g., change in the amount of hemoglobin in the capillary artery), while the S-side infrared LED 23 serves to sense body motion from the change in this reflected light"); APPLE-1006, ¶[0006] (recognizing the problem of weak signals from a wearable sensor because the sensor "detects the motion of a red corpuscle...and is easily affected by noise caused by the shaking of the body of the subject), ¶[0028] (describing a device for "computing the amount of motion load" such that the motion can be compensated for).

IPR2020-01715 APPLE-1003, ¶ 80.

110. As explained in Section VII.A, using two LEDs to emit light into the user's tissue at different wavelengths would have been obvious to, for instance, (i)

acquire body motion information for improved pulse detection and/or (ii) more reliably transmit information from the sensor to a base device with less error.

APPLE-1006, Abstract, ¶¶[0002], [0005], [0008]-[0016], [0023], [0027], [0033];

APPLE-1008, ¶¶[0014], [0040], [0058]-[0059], FIGS. 2, 3, 19.

IPR2020-01715 APPLE-1003, ¶ 110.

Inokawa

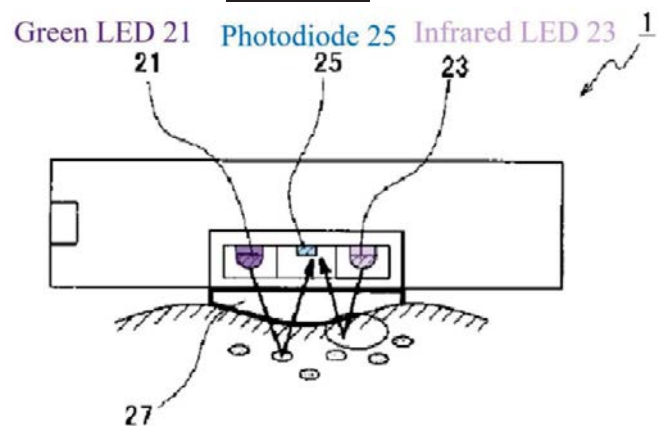

(0014)

(7) In the invention in Claim 7, two or more light-emitting means such as LEDs are provided as the sensor-side light-emitting means.

Accordingly, by transmitting the vital sign information using a plurality of sensor-side light-emitting means, it is possible to transmit efficiently. It is also possible to distinguish between the roles performed by the light-emitting means, e.g. with one means used to transmit vital sign information and another means used to transmit information used to check a checksum or the like. Furthermore, when using sensor-side light-emitting means of various kinds, such as an infrared LED or a green LED, the manner of use can be adjusted according to the properties of each respective means. For example, work can be divided between the various means, with an infrared LED used to detect vital signs and transmit vital sign information, and a green LED used to detect pulse

(0058)

As shown in FIG. 2, the pulse sensor 1 is comprised of a pair of light-emitting elements, i.e. a green light-emitting diode (S-side green LED) 21 and an infrared light-emitting diode (S-side infrared LED) 23, a single photodiode (S-side PD) 25 that receives the reflected light from these, and an S-side lens 27.

(0059)

Among these, the basic function of the S-side green LED 21 is to sense the pulse from the light reflected off of the body (i.e. change in the amount of hemoglobin in the capillary artery), while the S-side infrared LED 23 serves to sense body motion from the change in this reflected light.

APPLE-1008, ¶¶ [0014], [0058]-[0059], FIG. 2.

A POSITA would have Modified Aizawa to Feature Two Emitters to Account for Motion Load

Dr. Kenny's First Declaration

83. It is my opinion that, to obtain the advantages described by Inokawa (e.g., to improve the detected pulse wave by enabling the sensor to distinguish between blood flow detection and body movement, in addition to enabling wireless communication between the sensor and a base station), a POSITA would have been motivated to modify Aizawa's pulse wave sensor to include an additional LED. APPLE-1008, ¶¶[0058]-[0059]; APPLE-1008, ¶¶[0006], [0028].

84. As illustrated below, the Aizawa-Inokawa sensor would have featured two LEDs in place of Aizawa's LED 21.

85. Aizawa-Inokawa would have utilized two LEDs that emit two different wavelengths. Aizawa's LED 21 would have been replaced with two LEDs. In this manner, Aizawa's sensor is improved by using a separate LED to account for motion load that the system already records and accounts for. APPLE-1006, ¶¶[0006], [0028], [0035].

IPR2020-01715 APPLE-1003, ¶¶ 83-85.

Aizawa

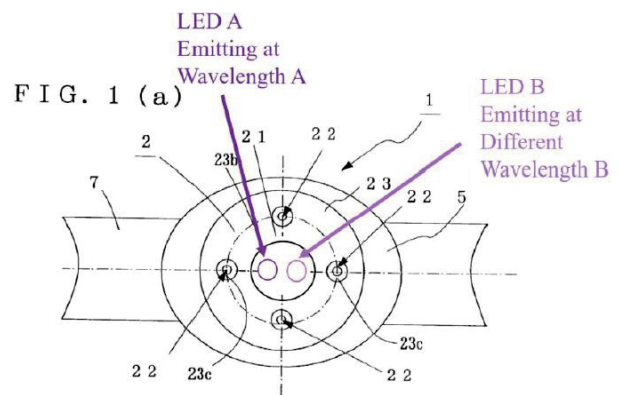

FIG. 1 (a)

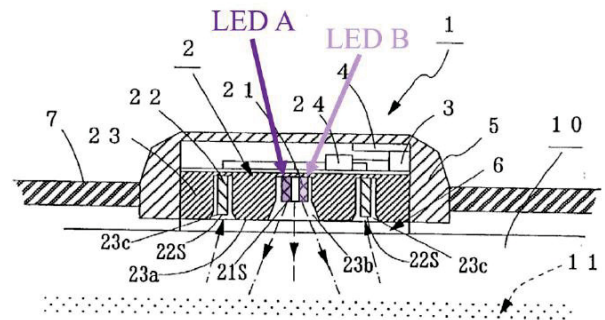

FIG. 1 (b)
IPR2020-01715 APPLE-1006, FIGS. 1(a), 1(b)
(as annotated at APPLE-1003 ¶ 84).

Two Emitters would Enable Wireless Communication

Dr. Kenny's First Declaration

81. I believe that a POSITA would also have looked to Inokawa's disclosure of two LEDs emitting light of different wavelengths, in part, because it provides additional functionality, including that of a wireless communication method.

Inokawa's base device 17 receives, for example, "pulse and body motion" data through "the S-side infrared LED 23 of the pulse sensor 1 and the B-side PD 45 of the base device 17." APPLE-1008, ¶[0076]. The LEDs eliminate the need for "a special wireless communication circuit or a communication cable as previously" and allows "vital sign information to the base device 17 accurately, easily, and without malfunction." *Id.*, ¶[0077]. In other words, the LEDs provided on the sensor can be used not only to detect pulse rate but also to "accurately, easily, and without malfunction" transmit the sensed data to a base station.

IPR2020-01715 APPLE-1003, ¶ 81.

70. With reference to FIG. 19 below, Inokawa teaches that two LEDs, instead of one, improve data transmission accuracy. In particular, Inokawa describes that "the presence of two pairs of light-emitting and light-receiving elements makes it possible to efficiently transmit information," including increasing the "accuracy of data...by transmitting and receiving a checksum signal using, for example, the S-side green LED 165 and the other B-side PD 157." APPLE-1008, ¶¶[0111], [0044], [0048].

IPR2020-01715 APPLE-1003, ¶ 70.

Inokawa

(FIG. 19)

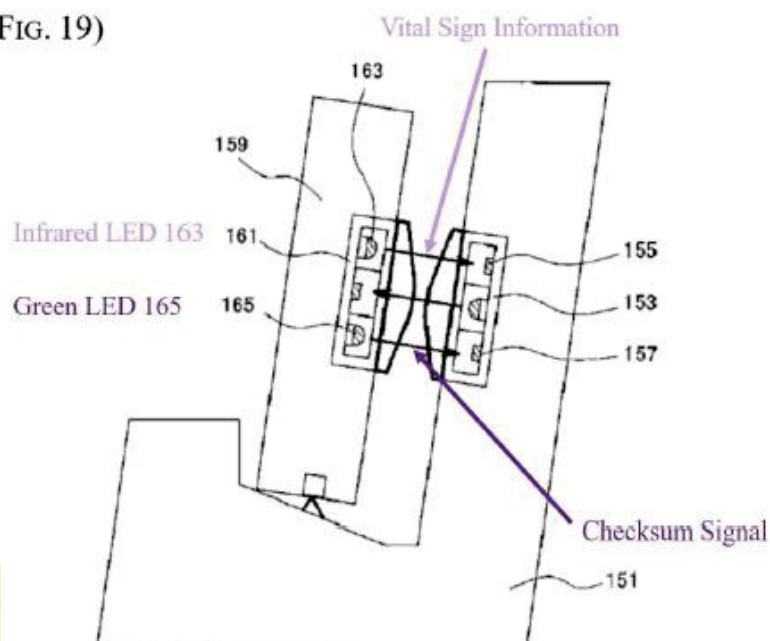

IPR2020-01715 APPLE-1008, FIGS. 1(a), 1(b)
(as annotated at APPLE-1003 ¶ 70).

A POSITA would have Modified Aizawa to Feature Two Emitters to Enable Wireless Communication

Dr. Kenny's First Declaration

81. I believe that a POSITA would also have looked to Inokawa's disclosure of two LEDs emitting light of different wavelengths, in part, because it provides additional functionality, including that of a wireless communication method.

Inokawa's base device 17 receives, for example, "pulse and body motion" data through "the S-side infrared LED 23 of the pulse sensor 1 and the B-side PD 45 of the base device 17." APPLE-1008, ¶[0076]. The LEDs eliminate the need for "a special wireless communication circuit or a communication cable as previously" and allows "vital sign information to the base device 17 accurately, easily, and without malfunction." *Id.*, ¶[0077]. In other words, the LEDs provided on the sensor can be used not only to detect pulse rate but also to "accurately, easily, and without malfunction" transmit the sensed data to a base station.

IPR2020-01715 APPLE-1003, ¶ 81.

70. With reference to FIG. 19 below, Inokawa teaches that two LEDs, instead of one, improve data transmission accuracy. In particular, Inokawa describes that "the presence of two pairs of light-emitting and light-receiving elements makes it possible to efficiently transmit information," including increasing the "accuracy of data...by transmitting and receiving a checksum signal" using, for example, the S-side green LED 165 and the other B-side PD 157." APPLE-1008, ¶[0111], [0044], [0048].

IPR2020-01715 APPLE-1003, ¶ 70.

Aizawa

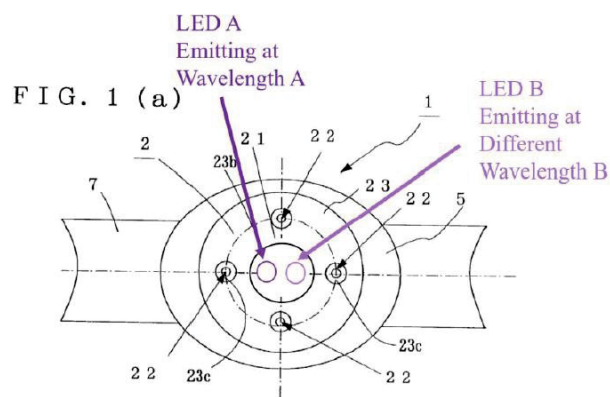
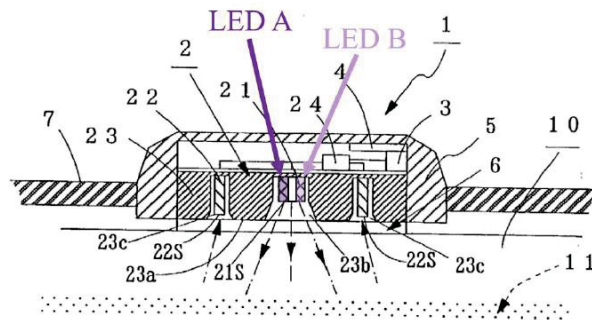

FIG. 1 (b)



IPR2020-01715 APPLE-1006, FIGS. 1(a), 1(b)
(as annotated at APPLE-1003 ¶ 84).

Masimo Fails to Rebut that a POSITA would have Added a Second Emitter to Aizawa to Account for Motion Load

Patent Owner's Response

Petitioner argues Inokawa would have motivated a POSITA to add a second LED to Aizawa's multiple detectors for two reasons, neither of which is persuasive. First, Petitioner argues a second LED would have "improve[d] the detected pulse wave by enabling the sensor to distinguish between blood flow detection and body movement." Pet. 21-22. Petitioner bases its argument on Dr. Kenny's erroneous belief that Aizawa could not calculate a motion wave because Aizawa uses a single LED. Ex. 2007 400:7-401:10. Specifically, Dr. Kenny incorrectly believed Aizawa's sensor attempts to prevent motion rather than account for it. *Id.* 400:7-11. In reality, Aizawa expressly states that it already provides a "device for *computing the amount* of motion load from the pulse rate" based on its measured data. Ex. 1006 ¶[0015]. In fact, Petitioner admits that Aizawa's sensor "already records and accounts for" motion load. Pet. 23; *see also id.* 20 (citing Ex. 1006 ¶[0028] and admitting Aizawa already "describe[s] a device for 'computing the amount of motion load' such that the motion can be compensated for"). Accordingly, Aizawa's sensor *already* includes a means for detecting body movement. Ex. 2004 ¶104. While Petitioner asserts Aizawa's sensor would have been "improved by using a separate LED to account for motion load," Pet. 23, Petitioner's citations do not suggest any alleged improvement. *See* Pet. 20 (citing Ex. 1008 ¶[0059]), 22 (citing Ex. 1008 ¶¶[0058]-[0059]), 43 (citing Ex. 1008 ¶¶[0014], [0040], [0058]-[0059], Figs. 2, 3, 19); Ex. 2004 ¶104.

Dr. Kenny's Second Declaration

70. Masimo, however, suggests that such motivation is flawed because "Aizawa expressly states that it already provides a 'device for *computing the amount* of motion load from the pulse rate.'" POR, 52. Yet while Masimo contends that Aizawa "account[s] for" motion, Aizawa is silent on whether it uses the computed motion load to improve the detection signal. Masimo further fails to rebut that adding a second LED enables the sensor to distinguish between blood flow and body movement. Pet., 20-22; APPLE-1003, ¶¶61-63, 71-72. As I explained during deposition, adding a second LED would allow Aizawa to obtain a more reliable pulse measurement by measuring "pulse rate and motion load during the same time." Ex. 2007, 401:11-402:4. Moreover, having two separate signals allows Aizawa to use "two LEDs...to emit light at different wavelengths" "to detect and record body motion in addition to blood flow." APPLE-1003, ¶¶86-86. Because different wavelengths have different sensitivities to pulse and body motion, collecting two separate signals allows noise arising from body motion to be better isolated and accounted for.

IPR2020-01715 APPLE-1027, ¶ 60.

75. First, although Aizawa explains that its sensor transmits data to an "unshown display," and can be "coupled to devices making use of bio signals," it is silent about how such transmission would be implemented. APPLE-1003, ¶66; APPLE-1006, [0023], [0028], [0035]. As I previously explained, the POSITA "would

IPR2020-01715 APPLE-1027, ¶ 75.

56

IPR2020-01715 Pap. 17 (POR), 51-52.

FISH.

Masimo Fails to Rebut that a POSITA would have Added a Second Emitter to Aizawa to Account for Motion Load

Dr. Kenny's Second Declaration

70. Masimo, however, suggests that such motivation is flawed because “Aizawa expressly states that it already provides a ‘device for *computing* the *amount* of motion load from the pulse rate.’” POR, 52. Yet while Masimo contends that Aizawa “account[s] for” motion, Aizawa is silent on whether it uses the computed motion load to improve the detection signal. Masimo further fails to rebut that adding a second LED enables the sensor to distinguish between blood flow and body movement. Pet., 20-22; APPLE-1003, ¶¶61-63, 71-72. As I explained during deposition, adding a second LED would allow Aizawa to obtain a more reliable pulse measurement by measuring “pulse rate and motion load during the same time.” Ex. 2007, 401:11-402:4. Moreover, having two separate signals allows Aizawa to use “two LEDs...to emit light at different wavelengths” “to detect and record body motion in addition to blood flow.” APPLE-1003, ¶¶86-86. Because different wavelengths have different sensitivities to pulse and body motion, collecting two separate signals allows noise arising from body motion to be better isolated and accounted for.

IPR2020-01715 APPLE-1027, ¶ 70.

Masimo Fails to Rebut that a POSITA would have Added a Second Emitter to Aizawa to Improve Accuracy

Dr. Kenny's Second Declaration

Petition, 15, 19-24; APPLE-1003, ¶70; APPLE-1008, ¶[0111]. That "Aizawa already includes the ability to calculate motion load with its single LED" does not diminish motivation to further improve accuracy based on Inokawa's two-LED implementation. POR, 3; Pet., 19-24; Ex. 2007, 407:7-408:20, 416:5-15.

IPR2020-01715 APPLE-1027, ¶ 71.

Ex. 2007

Q. So you have a picture below Paragraph 81 that shows a base device. You show how additional LED would communicate with the base device. You're relying on an approach for data transmission from Inokawa and saying that would be an additional reason to add LED to Aizawa, correct?

MR. SMITH: Objection; form.

A. So I, I take the combination to include the use of a second LED to transmit data and to provide confirmation of the accuracy of that data, improve data transmission accuracy in particular, without absolutely being bound to the specific details of the base and sensor configuration shown on the bottom of Page 47 or there on the middle of Page 46.

It's one example of how one might use an LED to support data transmission, but it wouldn't absolutely require all of the details of an implementation in order to provide the data transmission.

Ex. 2007, 407:7-408:4.

Issue 3

Implementing Wireless Communication

Case Nos. IPR2020-01521, -01714, -01715
U.S. Patent Nos. 10,292,628, 10,631,765

FISH.

A POSITA would have Enabled Aizawa to Communicate Wirelessly with a Handheld Computing Device

Dr. Kenny's First Declaration

88. When Inokawa's sensor is mounted onto the base station, "vital sign information... such as pulse and body motion, is transmitted to the base device... using the... infrared LED." APPLE-1008, ¶[0076]. The "base device 17 is connected to a PC 59, and information transmitted from the pulse sensor 1 is downloaded to the PC 59 via the base device 17." *Id.*; see also *id.*, ¶¶[0074] ("in

IPR2020-01715 APPLE-1003, ¶ 88.

95. To obtain these and other advantages described by Mendelson-2006, a POSITA would have been motivated to implement Aizawa's pulse wave sensor as part of a physiological measurement system including a handheld computing device, and to enable a physiological sensor device including sensor 1 to communicate wirelessly with the handheld computing device. APPLE-1006, Abstract ("a pulse wave sensor for detecting a pulse wave by detecting light output from a light emitting diode and reflected from the artery of a wrist of a subject"), ¶¶[0002], [0005], [0008]-[0016], [0023] (describing transmitting "pulse rate data to an unshown display"), [0024], [0027]-[0030], [0032]-[0033], FIGS. 1, 2, 3, 4(a); APPLE-1010, 1-4, FIG. 3; see also APPLE-1020, 1-4.

IPR2020-01715 APPLE-1003, ¶ 95.

Inokawa

(FIG. 3) **Pulse Sensor 1**

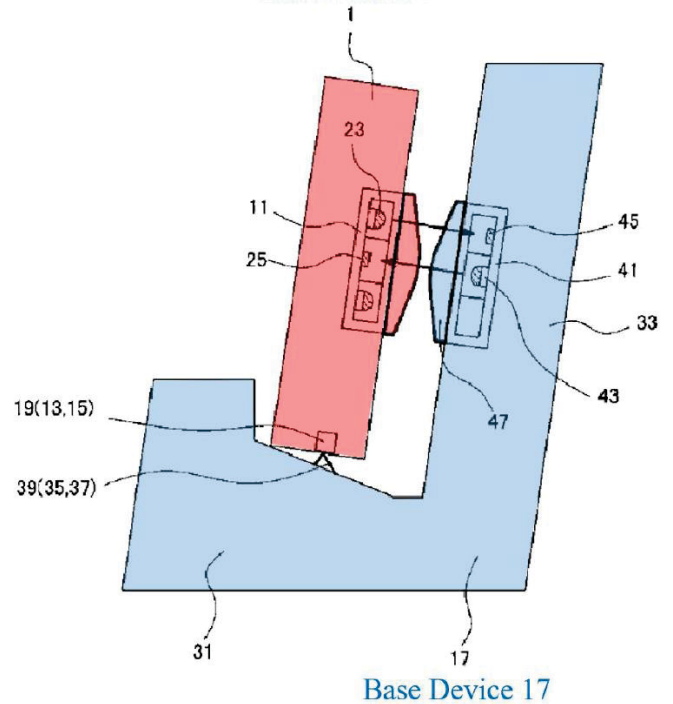

IPR2020-01715 APPLE-1008, FIG. 3 (as annotated at APPLE-1003 ¶ 88).

A POSITA would have Enabled Wireless Communication with a Handheld Computing Device

Dr. Kenny's First Declaration

89. I also think that a POSITA would have also found it obvious to implement the physiological sensor device resulting from the combined teachings of Aizawa, Inokawa, and Ohsaki as part of a physiological measurement system including a handheld computing device, and to enable the physiological sensor device to communicate wirelessly with the handheld computing device. APPLE-1006, Abstract, [0002], [0005], [0008]-[0016], [0023]-[0024], [0027]-[0030], [0032]-[0033], FIGS. 1, 2, 3, 4(a); APPLE-1008, ¶¶ [0002], [0003], [0067], [0074]-[0077]; APPLE-1010, 1-4, FIG. 3.

IPR2020-01715 APPLE-1003, ¶ 89.

90. Indeed, by the '765 Patent's 2008 earliest effective filing date, physiological monitoring devices commonly employed touch-screen displays. For example, Mendelson-2006 describes a "body-worm" pulse oximetry system that includes a sensor module, a receiver module, and a PDA. APPLE-1010, 3. Mendelson-

IPR2020-01715 APPLE-1003, ¶ 90.

Mendelson-2006

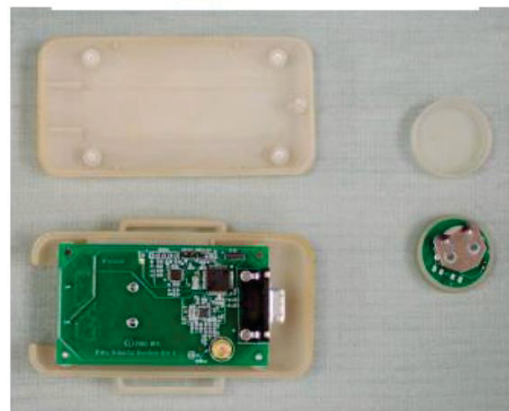
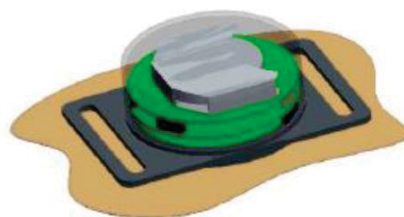

Fig. 1. (Top) Attachment of Sensor Module to the skin; (Bottom) photograph of the Receiver Module (left) and Sensor Module (right).

IPR2020-01715 APPLE-1010, FIG. 1
(as annotated at APPLE-1003 ¶ 73).

Mendelson-2006 Teaches Wireless Communication with a Handheld Computing Device

Dr. Kenny's First Declaration

90. Indeed, by the '765 Patent's 2008 earliest effective filing date, physiological monitoring devices commonly employed touch-screen displays. For example, Mendelson-2006 describes a "body-worn" pulse oximetry system that includes a sensor module, a receiver module, and a PDA. APPLE-1010, 3. Mendelson-2006's system includes a sensor module that transmits signals wirelessly to a PDA through a receiver module. *Id.*, 913, FIGS. 1-3; *see supra* Section VI.D. The PDA provides a low-cost touch screen interface. *Id.*, 3-4; *see also* APPLE-1020, 1-4. In more detail, and as shown in Mendelson-2006's FIG. 3 (reproduced below), the PDA's "simple GUT" is "configured to present ... input and output information to the user" and to allow "easy activation of various functions." *Id.*, 4.

IPR2020-01715 APPLE-1003, ¶ 90.

94. Wireless communication with the handheld PDA is, moreover, said to enable transfer of information pertaining to physiological and wellness parameters such as "SpO₂, HR, body acceleration, and posture information" to the PDA; and, when the PDA is "carried by medics or first responders," this information is said to enhance their ability "to extend more effective medical care, thereby saving the lives of critically injured persons." APPLE-1010, 1-2.

IPR2020-01715 APPLE-1003, ¶ 94.

Mendelson-2006



IPR2020-01715 APPLE-1010, FIG. 3.

A POSITA would have Recognized that Aizawa's LED could be Used for Data Communication to a Computing Device

Dr. Kenny's Second Declaration

78. For example, the POSITA would have found it obvious to implement the “unshown display” of Aizawa’s pulse rate detector as a touch-screen display to provide “a simple GUI” “configured to present...input and output information to the user” in real time, and to allow “easy activation of various functions.” APPLE-1006, [0023]; APPLE-1010, 3; *see also* POR, 59 (describing “eliminat[ing] real time monitoring”); APPLE-1051, [0082]-[0095] (describing a user-worn heart rate monitoring device including “a touchscreen display” that displays data received “from a sensor transmitter on the patient’s skin”), FIG. 9A. Further, the POSITA would have found it obvious to enable Aizawa’s sensor to “accurately, easily, and without malfunction” transmit physiological information to a base station, and would have found it obvious to wirelessly transmit this information from the base station to a PDA featuring a touch-screen display. APPLE-1003, ¶81, 122, 167.

IPR2020-01715, APPLE-1047, ¶ 78.

Inokawa and Mendelson-2006

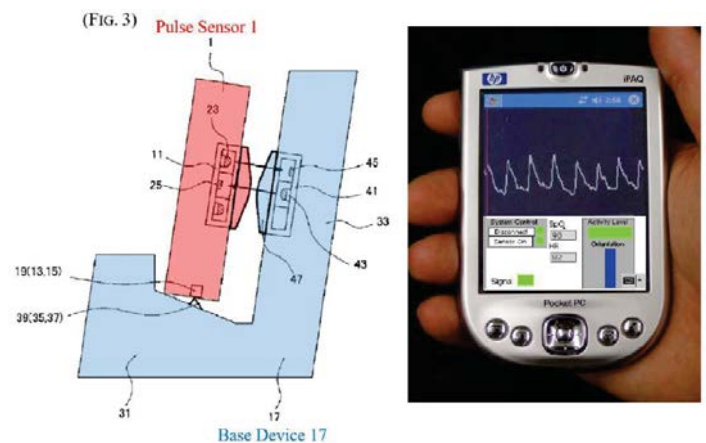

IPR2020-01715 APPLE-1008, FIG. 3;
APPLE-1010, FIG. 3.

Masimo Fails to Address the Motivation to Add Wireless Communication to the Proposed Sensor

Dr. Kenny's Second Declaration

79. And, contrary to Masimo's contention that "Petitioner identifies no valid motivation," I previously testified to several, including: (1) that "[t]he PDA is used 'as a local terminal' and it 'also provides a low-cost touch screen interface'"; (2) that the PDA's "'simple GUI' is 'configured to present...input and output information to the user' and to allow 'easy activation of various functions'"; and (3) that wireless communication with the handheld PDA enables medical personnel to "extend more effective medical care." APPLE-1003, ¶¶93-96; see also APPLE-1010, FIG. 3 (reproduced below)(depicting a "Sample PDA Graphical User Interface"). For at least these reasons, Masimo's arguments fail.

IPR2020-01715, APPLE-1047, ¶ 79.

Mendelson-2006

PDA: The PDA was selected based on size, weight, and power consumption. Furthermore, the ability to carry the user interface with the medic also allows for greater flexibility during deployment. We chose the HP iPAQ h4150 PDA because it can support both 802.11b and Bluetooth™ wireless communication. It contains a modest amount of storage and has sufficient computational resources for the intended application. The use of a PDA as a local terminal also provides a low-cost touch screen interface. The user-friendly touch screen of the PDA offers additional flexibility. It enables multiple controls to occupy the same physical space and the controls appear only when needed. Additionally, a touch screen reduces development cost and time, because no external hardware is required. The data from the wireless-enabled PDA can also be downloaded or streamed to a remote base station via Bluetooth or other wireless communication protocols. The PDA can also serve to temporarily store vital medical information received from the wearable unit.

IPR2020-01715 APPLE-1010, 3.

The GUI was configured to present the input and output information to the user and allows easy activation of various functions.

IPR2020-01715 APPLE-1010, 3-4.

A POSITA would have Recognized that Aizawa's LED could be Used for Data Communication to a Computing Device

Dr. Kenny's Second Declaration

76. More specifically, Inokawa describes that a base station receives information transmitted from a pulse sensor wirelessly via LED, and that the base station transmits signals to a computer, via a network interface. APPLE-1003, ¶¶82-83; APPLE-1008, [0002], [0003], [0067], [0074]-[0077]. Similarly, Mendelson-2006 describes that a receiver module receives information transmitted from a sensor module, and that the receiver module wirelessly transmits signals to a PDA.

77. Thus, contrary to Masimo's contentions, including that "Petitioner's proposed combination frustrates both Aizawa and Mendelson-2006's goal of real-time display of data by requiring a base device," Petitioner's proposed combination does not "eliminate Aizawa's existing transmitter" and then "add back in a separate communications circuit," and does not "eliminate the ability to take and display real-time measurements."¹ POR, 58-59. Rather, "a POSITA would have been motivated to implement Aizawa's pulse wave sensor as part of a physiological measurement system including a handheld computing device, and to enable a physiological sensor device including [Aizawa's] sensor 1 to communicate wirelessly with the handheld computing device." Pet., 28-29; APPLE-1006, [0023] [0028], [0035], APPLE-1010, 1-4, FIGS. 1-3.

IPR2020-01715, APPLE-1047, ¶¶ 76-77.

Inokawa

...base device 17 receives the information transmitted from the pulse sensor 1 by means of the B-side optical device component 41. Note that the base device 17 is connected to a PC 59, and information transmitted from the pulse sensor 1 is downloaded to the PC 59 via the base device 17.

APPLE-1008, [0067]; Pet., 24.

Mendelson-2006

The prototype system, depicted in Fig. 1, consists of a body-worn pulse oximeter that receives and processes the PPG signals measured by a small ($\phi = 22\text{mm}$) and lightweight (4.5g) optical reflectance transducer. The system consists of three units: A Sensor Module, consisting of the optical transducer, a stack of round PCBs, and a coin-cell battery. The information acquired by the Sensor Module is transmitted wirelessly via an RF link over a short range to a body-worn Receiver Module. The data processed by the Receiver Module can be transmitted wirelessly to a PDA.

IPR2020-01715 APPLE-1010, 2.

Masimo Fails to Address the Motivation to Add Wireless Communication to the Proposed Sensor

Dr. Kenny's Second Declaration

74. Rather than attempting to rebut my testimony on these points, Masimo alleges that (1) "Petitioner identifies no valid motivation to add Mendelson 2006 to [its combination]" and that (2) "Petitioner's addition of Mendelson-2006's wireless approach makes no sense given that...Petitioner's combination already replaced Aizawa's wireless transmitter with Inokawa's base station approach." See POR, 58-60 (emphasis omitted). The POR additionally states that Mendelson-2006 "is not a multi-emitter/multi-detector sensor," which is simply irrelevant. POR, 60.

75. First, although Aizawa explains that its sensor transmits data to an "unshown display," and can be "coupled to devices making use of bio signals," it is silent about how such transmission would be implemented. APPLE-1003, ¶66; APPLE-1006, [0023], [0028], [0035]. As I previously explained, the POSITA "would have recognized that Aizawa's LED could have been used for wireless data communication with a personal computer to eliminate problems associated with a physical cable, and, as taught by Inokawa, without requiring a separate RF circuit." APPLE-1003, ¶82; APPLE-1008, [0003], [0067], [0075].

IPR2020-01715, APPLE-1047, ¶¶ 74-75.

Aizawa

to know the quantity of motion. There has recently been proposed a method of estimating a burden on the heart of a person who takes exercise by real-time measuring his/her heart rate at the time of exercise.

[0015] According to a seventh aspect of the present invention, there is provided a pulse rate detector which comprises a transmitter for transmitting the measured pulse rate data to a display for displaying the pulse rate data and a device for computing the amount of motion load from the pulse rate.

In these figures, reference numeral 2 denotes a pulse wave sensor which comprises an LED 21 (to be referred to as "light emitting diode" hereinafter) for emitting light having a wavelength of a near infrared range, four phototransistors 22 (to be referred to as "photodetectors" hereinafter) disposed around the light emitting diode 21 symmetrically on a circle concentric to the light emitting diode 21, a holder 23 for storing the above light emitting diode 21 and the photodetectors 22, and a drive detection circuit 24 for detecting a pulse wave by amplifying the outputs of the photodetectors 22, 3 is an arithmetic circuit for computing a pulse rate from the detected pulse wave data, 4 a transmitter for transmitting the above pulse rate data to an unshown display, 5 an outer casing for storing the above pulse wave sensor 2, the arithmetic circuit 3 and the transmitter 4, 6 an acrylic

IPR2020-01715 APPLE-1008, ¶¶ [0004], [0015], [0023].

A POSITA would have Enabled Mendelson '799 to Communicate Wirelessly with a Handheld Computing Device

Dr. Kenny's First Declaration

150. To obtain these and other advantages described by Mendelson-2006, a POSITA would have found it obvious to wirelessly transmit information or data acquired or processed by a physiological sensor device including sensor 10 and pulse oximeter 20 to a PDA such as the HP iPAQ h4150, using either or both of 802.11b and Bluetooth™. APPLE-1012, Abstract, 8:37-41, 9:22-10:30, FIGS. 7, 8; APPLE-1010, 1-4, FIGS. 1-3; APPLE-1020, 1-4.

IPR2020-01714 APPLE-1003, ¶ 171.

¹Similar to Mendelson-799's sensor 10, which provides "measured data (i.e., electrical output of the sensor 10 indicative of the detected light)" to pulse oximeter 20 for processing, Mendelson-2006's sensor module provides acquired signals to the receiver module for processing. APPLE-1012, 10:22-30, FIG. 8; APPLE-1010, 2.

IPR2020-01714 APPLE-1003, ¶ 114.

Mendelson '799

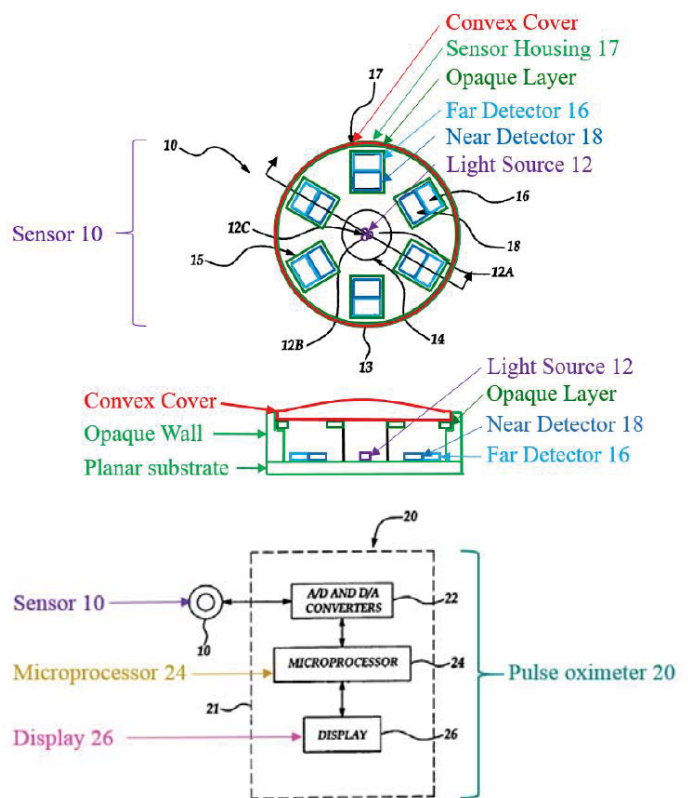

IPR2020-01714 APPLE-1012, FIGS. 7, 8 (as annotated at APPLE-1003 ¶¶ 163, 164).

Issue 4

Guarding against Saturation

Case Nos. IPR2020-01714
U.S. Patent Nos. 10,631,765

FISH.

A POSITA would have Added an Opaque Layer to Mendelson '799's Sensor

Dr. Kenny's First Declaration

103. As explained below, this and related description from Schulz would have motivated a POSITA to add a layer of opaque material to the Mendelson-Ohsaki sensor, and to size windows in the opaque material as appropriate to avoid saturation of each of the sensor's detectors. APPLE-1013, ¶[0073], FIGS. 19A-19C; see also APPLE-1019, 79, 86, 94; APPLE-1006, ¶¶[0012], [0023], [0024], FIGS. 1(a), 1(b).

IPR2020-01714, APPLE-1003, ¶ 221.

Pulse Oximeter Module

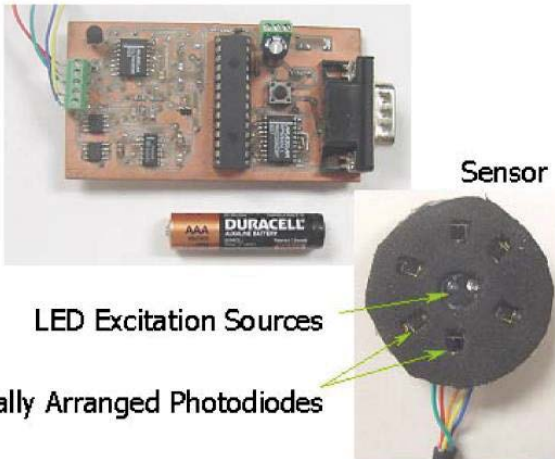

IPR2020-01714, APPLE-1023 (Yao) FIG. 11.

Mendelson '799

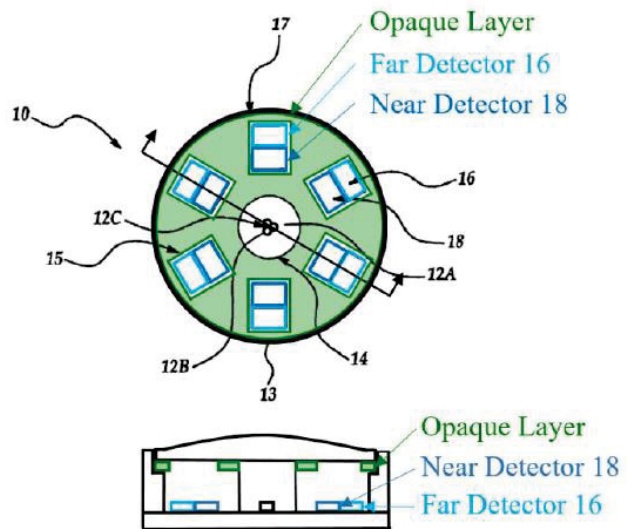

IPR2020-01714, APPLE-1012, FIG. 7 (as annotated at APPLE-1003 ¶ 108).

Schulz Teaches that an Opaque Layer would Shield Detectors from Ambient Light

Dr. Kenny's First Declaration

b. Opaque layer with windows corresponding to detectors

101. A POSITA would have recognized that an opaque circumscribing wall would partially shield Mendelson-799's detectors from ambient light, but would have understood from Schulz that additional measures could be taken to guard against saturation. APPLE-1019, 79, 86, 94.

IPR2020-01714, APPLE-1003, ¶ 101.

105. From Schulz's description, a POSITA would have understood that, in line with textbook recommendations, Schulz's opaque layer limits errors by decreasing the angle of incidence to the photodiode to that enabled by the window included within the layer, and by otherwise preventing ambient light from reaching the photodiode. APPLE-1013, ¶[0073], APPLE-1019, 79-80, 94, FIG. 6.6.

IPR2020-01714, APPLE-1003, ¶ 218.

Schulz

[0073] In an embodiment, a thin sheet of opaque material can be placed inside either housing 1902 or 1903 between the optical components and the inward facing shell 1905 or 1906. The thin sheet of opaque material is located beneath window 1919 or 1924, and a window in the opaque material provides an aperture for transmission of optical energy to or from the tissue site. The opaque material blocks light, and the window in the opaque material can be sized as needed to block the proper amount of light from entering the aperture to, for example, avoid saturation of the light detector. In one

IPR2020-01714, APPLE-1013, ¶ 0073.

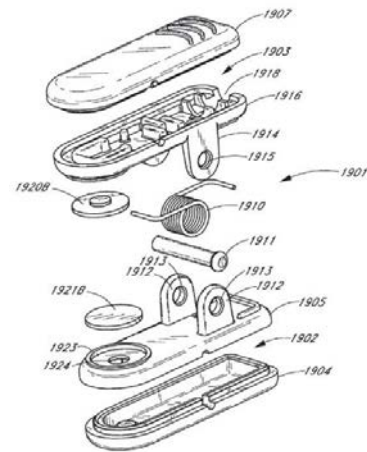

FIG. 19C

IPR2020-01714, APPLE-1013, FIG. 19C
(as annotated at APPLE-1003 ¶ 76).

Schulz Teaches that an Opaque Layer would Shield Detectors from Ambient Light

Dr. Kenny's First Declaration

105. From Schulz's description, a POSITA would have understood that, in line with textbook recommendations, Schulz's opaque layer limits errors by decreasing the angle of incidence to the photodiode to that enabled by the window included within the layer, and by otherwise preventing ambient light from reaching the photodiode. APPLE-1013, ¶[0073], APPLE-1019, 79-80, 94, FIG. 6.6.

106. A POSITA would also have readily understood that Schulz's teachings would apply to pulse oximetry sensors featuring multiple photodiodes and that, in such sensors, errors could be limited through the use of an opaque layer with multiple windows, the windows being configured to decrease the angles of incidence to the photodiodes. APPLE-1013, ¶[0073], APPLE-1019, 79-80, 94, FIG. 6.6; APPLE-1006, ¶¶[0012], [0023], [0024], FIGS. 1(a), 1(b); APPLE-1023,

IPR2020-01714, APPLE-1003, ¶¶ 218-219.

Webster

Since this is a system with an optical interface, it is important to minimize the effects from light other than the optical signals of interest. One way to minimize unwanted light incident upon the detector is to place some type of light filter over the detector. This allows light of wavelengths of interest to pass through the filter but does not allow light of other wavelengths to pass through the filter. For the pulse oximeter to work effectively, most of the light being transmitted from the LEDs must not reach the photodiode unless it has passed through tissue containing arterial blood.

IPR2020-01714, APPLE-1019, 76.

To minimize errors, the pulse oximeter designer must attempt to limit the light reaching the photodiode to that which has traveled through tissue containing arterial blood (Nelcor 1993). This can be accomplished through thoughtful LED/photodiode placement. Light impervious barriers should be placed between LEDs and the photodiode in all areas where the emitted light could reach the photodiode without passing through tissue (New and Corenman 1987). Two additional measures can be taken to ensure this (figure 6.6). One is to decrease the angle of incidence to the photodiode. The second is to coat the housing around the photodiode with a material that does not scatter or reflect light.

IPR2020-01714, APPLE-1019, 79-80.

Ambient light from sources such as sunlight, surgical lamps etc may cause errors in S_aO_2 readings. In order to prevent this, the simple solution is to cover the sensor site with opaque material which can prevent ambient light from reaching the photodiode.

IPR2020-01714, APPLE-1019, 94.

A POSITA would have Modified the Combined Sensor to Guard Against Detector Saturation as taught by Schulz

Patent Owner's Response

In addition, Schulz is generally directed to an ear sensor, which measures light passing through, e.g., the thin earlobe structure. Ex. 1013 Title, Abstract, Fig. 1, ¶¶[0033], [0065]. In contrast, Ohsaki requires that its sensor be used on the backhand side of the wrist. *See, e.g.*, Ex. 1009 Title, Abstract; Section VII.A.1, *supra*, VII.B.1-2, *infra*. Mendelson '799 likewise does not indicate its sensor can be used on the ear and instead *contrasts* its reflectance sensor with transmission sensors attached to an earlobe. Ex. 1012 2:8-13; Ex. 2004 ¶49. Petitioner never accounts for these differences.

IPR2020-01714 Pap. 17 (POR), 20.

Cited Portion of Mendelson '799

Pulse oximeters are of two kinds operating, respectively, in transmission and reflection modes. In transmission-mode pulse oximetry, an optical sensor for measuring SaO₂ is usually attached across a fingertip, foot or earlobe, such that the tissue is sandwiched between the light source and the photodetector.

APPLE-1012, 2:8-13; IPR2020-01714 (cited at POR, 20; APPLE-1027, ¶ 56).

Dr. Kenny's Second Declaration

56. More specifically, Masimo ignores the Petition's robust treatment of the applicability of Schulz's techniques to the Mendelson-Ohsaki sensor, and mischaracterizes Mendelson-799 as "distinguish[ing] its reflectance sensor with transmission sensors attached on an earlobe." POR, 49; Petition, 30-34; APPLE-1003, [0093]-[0101]. But the cited portion of Mendelson-799's background section describes prior art reflectance and transmission sensors, and, contrary to the POR's characterization, does not describe Mendelson's sensor. *See* APPLE-1012, 2:8-13. Further, the cited passage does not "contrast" reflectance and transmission sensors, but merely describes areas of the body to which transmission sensors are "usually attached," specifically the "fingertip, foot or earlobe." APPLE-1012, 2:8-13. The passage contains no indication that these body parts are unsuitable for use with a reflectance sensor, and at least one of the listed body parts (the fingertip) is described as suitable in the '765 patent's description of the prior art. *See id.*; APPLE-1001, 2:6-25.

IPR2020-01714, APPLE-1047, ¶ 56.

A POSITA would have Modified the Combined Sensor to Guard Against Detector Saturation as taught by Schulz

Patent Owner's Response

In addition, Schulz is generally directed to an ear sensor, which measures light passing through, e.g., the thin earlobe structure. Ex. 1013 Title, Abstract, Fig. 1, ¶¶[0033], [0065]. In contrast, Ohsaki requires that its sensor be used on the backhand side of the wrist. *See, e.g.*, Ex. 1009 Title, Abstract; Section VII.A.1, *supra*, VII.B.1-2, *infra*. Mendelson '799 likewise does not indicate its sensor can be used on the ear and instead *contrasts* its reflectance sensor with transmission sensors attached to an earlobe. Ex. 1012 2:8-13; Ex. 2004 ¶49. Petitioner never accounts for these differences.

IPR2020-01714 Pap. 17 (POR), 20.

Dr. Kenny's Second Declaration

57. In fact, Mendelson-799 does not describe its sensor as limited to use in any particular location on the body. *See generally*, APPLE-1012. Indeed, it was well-known before the Critical Date that reflectance probes, like those described in Mendelson-799, could be applied "virtually any place on the human body." APPLE-1018, 88, 87, 91.

IPR2020-01714, APPLE-1047, ¶ 61.

Webster

In reflectance pulse oximetry, the LEDs and the photodiode are placed on the same side of the skin surface as shown in figure 7.2. Normally the reflectance probe is placed on the forehead or temple, but is not restricted to only those two places. Reflectance probes can be used to measure arterial oxygen saturation at virtually any place on the human body where the probe can be placed.

IPR2020-01714, APPLE-1019, 88; Reply, 5.

A POSITA would have Modified the Combined Sensor to Guard Against Detector Saturation as taught by Schulz

Patent Owner's Response

Petitioner admits its combination of Ohsaki and Mendelson '799 does not include "each of the at least four detectors has a corresponding window that allows light to pass through to the detector." Pet. 33-34. Petitioner thus argues that—after combining Ohsaki and Mendelson '799 to increase signal strength—a POSITA would then look to Schulz to *decrease* signal strength by including windows that reduce the amount of incoming light. *Id.* Indeed, Petitioner's sole motivation for adding Schulz is "to guard against saturation." Pet. 30, 33-34. But there is no evidence that detector saturation—an issue associated with high signal strength—was a problem for the Ohsaki or Mendelson '799 sensors. Ex. 2004 ¶83.

IPR2020-01714 Pap. 17 (POR), 47.

Dr. Kenny's Second Declaration

51. Masimo argues that a POSITA would not have been motivated to perform the Mendelson-799-Ohsaki-Schulz combination because "there is no evidence that detector saturation—an issue associated with high signal strength—was a problem for the Ohsaki or Mendelson '799 sensors." POR, 47. This argument ignores the Petitioner's explanation of Schulz's disclosure of the benefits of avoiding detector saturation in pulse oximetry sensors, and the corroborating disclosures from Webster and Yao regarding the desirability of blocking ambient light to improve detection in such sensors. *See* Petition, 30-34; APPLE-1003, [0101]-[0109]. As

IPR2020-01714, APPLE-1047, ¶ 51.

Schulz

from the tissue site. The opaque material blocks light, and the window in the opaque material can be sized as needed to block the proper amount of light from entering the aperture to, for example, avoid saturation of the light detector. In one

IPR2020-01714, APPLE-1013, ¶73
(cited at Pet. 30).

A POSITA would have Modified the Combined Sensor to Guard Against Detector Saturation as taught by Schulz

Dr. Kenny's Second Declaration

53. Masimo further misunderstands or mischaracterizes the teachings of Schulz by its argument that Schulz's features would "make an already weak signal even weaker." POR, 48. Masimo's argument assumes that all light reaching the detectors, including ambient light, represents a useful contribution to the "signal." *See id.* But only light from the LEDs "which has traveled through tissue containing arterial blood" can be used for determination of physiological parameters in pulse oximetry measurements. *See* Petition, 31-34. Therefore, only light from the LEDs that has travelled through tissue represents a "signal" to the sensor. *See id.* Light that has not traveled through tissue containing arterial blood, such as ambient light from the environment, can overwhelm light from the LEDs, and thus represents "noise." APPLE-1052, 25:10-17 (Dr. Madisetti states that "a nonlimiting example of noise could be interference due to light, due to ambient light as an example"). As described in the Petition, the features of Schulz implemented in the Mendelson-Ohsaki-Schulz combination "prevent[] ambient light" (*i.e.*, noise) from reaching the detectors, while allowing light which has traveled through tissue containing arterial blood (*i.e.*, signal) to reach the detectors. *See id.*; Petition 31-34. By blocking noise while allowing signal to reach the detectors, the features of Schulz lead to increased signal-to-noise ratio at the detectors, rather than leading to a "weaker signal" as Masimo alleges.

Dr. Madisetti's Deposition Transcript

15 A. An example of -- again, a nonlimiting
16 example of noise could be interference due to light,
17 due to ambient light as an example, a nonlimiting
18 example.

IPR2020-01714, APPLE-1041, 25:10-17
(cited at Reply, 25).

FISH.

IPR2020-01714, APPLE-1047, ¶ 65.

75

Issue 5

The Dependent Claims are Obvious

Case Nos. Case Nos. IPR2020-01714, -01715
U.S. Patent Nos. 10,631,765

FISH.

'765 Claims 12, 18, and 29 are Obvious

Dr. Kenny's First Declaration

159. The convex cover taught by Ohsaki is designed to be "in intimate contact with the surface of the user's skin," so as to prevent slippage of the detecting element from its position on the user's wrist. APPLE-1009, ¶¶[0009]-[0010], FIG. 2.

160. In incorporating Ohsaki's teachings, a POSITA would have found it obvious that a device designed to fit on a user's wrist would be on the order of millimeters.

See also APPLE-1010, 2 (describing its "optical reflectance transducer" as "small ($\varnothing = 22\text{mm}$)"); see also APPLE-1017, 2 (describing a "standard 24-pin (dimensions: 19 x 19 mm) microelectronic package" for its sensor); APPLE-1041, 9:40-65 (describing a protrusion on a biological measurement device that causes a subject's tissue to deform by a depth of about 2 to 20 mm). Additionally, the POSITA would have taken the user's comfort into consideration—Ohsaki's convex cover, for example, is said to solve the problem of "the user feel[ing] uncomfortable" due to pressure from the device and belt on the user's limbs. APPLE-1009, ¶[0006].

IPR2020-01715 APPLE-1003, ¶¶159-160.

'765 Patent

12. The physiological measurement system of claim 11, wherein the protruding convex surface protrudes a height between 1 millimeter and 3 millimeters.

18. The physiological measurement system of claim 17, wherein the protruding convex surface protrudes a height greater than 2 millimeters and less than 3 millimeters.

29. The physiological measurement system of claim 28, wherein the protruding convex surface protrudes a height greater than 2 millimeters and less than 3 millimeters.

IPR2020-01715 APPLE-1001 ('765 Patent), Claims 12, 18, 29.

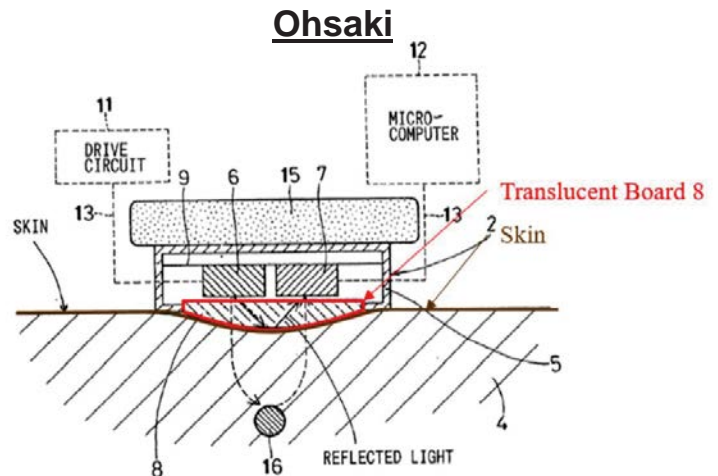

IPR2020-01715 APPLE-1009, FIG. 2 (annotated).

'765 Claims 12, 18, and 29 are Obvious

Kondoh

Also, a protrusion part is preferably provided on the face of the forming part contacting the surface of the organism.

Here, the protrusion part may be provided between the light source part and the light receiving part. In this case, the protrusion part is preferably located at a distance of about 3 to 30 mm from the light source part.

Also, the light source part or/and light receiving part may be provided in the protrusion part.

Here, the protrusion part has preferably a shape such that the organism is deformed so that an area of the surface of the organism having a longitudinal dimension of about 3 to 10 mm and a lateral dimension of 3 to 50 mm is concaved to the depth of about 2 to 20 mm.

Also, there may be a plurality of light source parts or/and light receiving parts.

Also, the apparatus of measuring biological information using light of the present invention preferably has the light source part comprising a first light source part provided at a first predetermined location of the forming part and a second light source part provided at a second predetermined location of the protrusion part, and the light receiving part comprising a first light receiving part provided at a third predetermined location of the forming part opposite to the first predetermined location with the protrusion part therebetween and a second light receiving part provided at a fourth predetermined location of the protrusion.

Mendelson-2006

The prototype system, depicted in Fig. 1, consists of a body-worn pulse oximeter that receives and processes the PPG signals measured by a small ($\phi = 22\text{mm}$) and lightweight (4.5g) optical reflectance transducer. The system consists of three units: A Sensor Module, consisting of the optical transducer, a stack of round PCBs, and a coin-cell battery. The information acquired by the Sensor Module is transmitted wirelessly via an RF link over a short range to a body-worn Receiver Module. The data processed by the Receiver Module can be transmitted wirelessly to a PDA.

IPR2020-01715 APPLE-1010, 2.

Mendelson-1988

The optical reflectance sensor used in this study consists of two red (peak emission wavelength: 660 nm) and two infrared (peak emission wavelength: 930 nm) LED chips (dimensions: 0.3×0.3 mm), and six silicon photodiodes (active area: 2.74×2.74 mm) arranged symmetrically in a hexagonal configuration as shown in Figure 2. To maximize the fraction of backscattered light collected by the sensor, the currents from all six photodiodes were summed. The LEDs and photodiode chips were mounted with conductive epoxy (Epo-tek H31, Epoxy Technology, Inc. Billerica, Massachusetts) on a ceramic substrate (dimensions: $13.2 \times 13.2 \times 0.25$ mm) that was housed in a standard 24-pin (dimensions: 19×19 mm) microelectronic package (AIRPAX, Cambridge, Maryland), which is commonly used for packaging electronic circuits. The optical components were intercon-

IPR2020-01715 APPLE-1017, 2.

'765 Claims 12, 18, and 29 are Obvious

Petitioner Reply

With respect to dependent claims 12, 18, and 29, Masimo attempts to discount that, “when ‘incorporating Ohsaki’s teachings, a POSITA would have found it obvious that a device designed to fit on a user’s wrist would be on the order of millimeters,’ and [that] ‘there would have been a finite range of possible protruding heights, and it would have been obvious to select a protruding height that would have been comfortable to the user.’” POR, 63 (quoting Petition 79). Yet, “[w]hen...there are a finite number of identified, predictable solutions, a person of ordinary skill in the art has good reason to pursue the known options within his or her technical grasp,” and “[i]f this leads to the anticipated success, it is likely the product...of ordinary skill and common sense.” APPLE-1047, ¶81; KSR, 550 U.S. at 398.

Masimo further contends that the sensor size disclosure in Mendelson-2006 and Mendelson-1988 should be overlooked because they are “forehead sensors, not wrist sensors,” but the relied-upon disclosure is irrelevant. POR, 64; APPLE-1047, ¶82. Further, the POSITA is a person of ordinary creativity, not an automaton, and would have been fully capable of applying the cited teachings. See *id.*; KSR, 550 U.S. at 418. Thus, Masimo’s arguments fail.

IPR2020-01715 Pap. 21, 40-41.

Dr. Kenny’s First Declaration

161. It is my conclusion that a POSITA would have found it obvious that in order to provide a comfortable cover featuring a protruding convex surface that prevents slippage, the surface should protrude a height between 1 millimeter and 3 millimeters. Indeed, there would have been a finite range of possible protruding heights, and it would have been obvious to select a protruding height that would have been comfortable to the user.

IPR2020-01715 APPLE-1003, ¶161.

Ohsaki

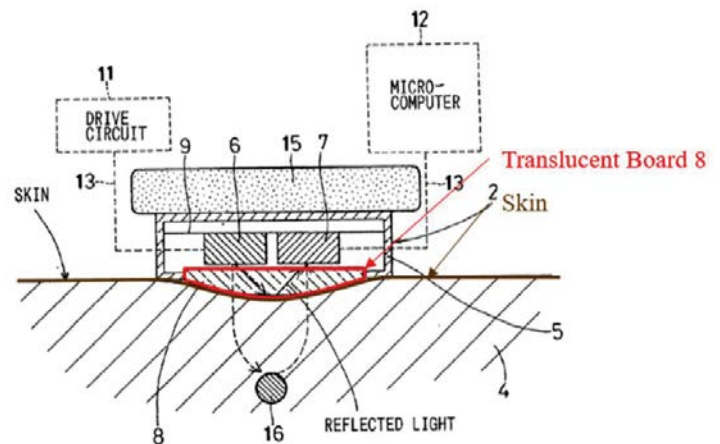

IPR2020-01715 APPLE-1009, FIG. 2 (annotated).

'765 Claims 12, 18, and 29 are Obvious

Patent Owner's Sur-Reply

8. Claims 12, 18, 29

As Masimo explained, the '765 Patent's inventors discovered a convex protrusion between about 1 mm to about 3 mm in height improves "signal strength by about an order of magnitude versus other shapes." Ex. 1001 20:18-22; *see also id.* 20:14-30; Ex. 2004 ¶121; POR 63. Claims 18 and 29 require the protruding convex surface protrude "a height greater than 2 millimeters and less than 3 millimeters." Ex. 1001 Claims 18, 29. No cited art teaches or suggests a cover comprising a protruding convex surface with any claimed height would have been beneficial, as the inventors discovered. POR 63-66; Ex. 2004 ¶¶121-124.

Petitioner's reply cites *KSR* and argues there are a finite number of predictable solutions. Reply 40-41. Not so. According to Dr. Kenny, the protrusion could be many different shapes and heights, e.g., "circular or square or rectangular." Ex. 2008 71:7-72:10. Indeed, Dr. Kenny testified that he does not even know the *shape* of Ohsaki's board or Petitioner's combination, let alone any *dimensions*. POR 65-66; *see, e.g.*, Ex. 2007 333:20-335:4. Petitioner's motivation requires that the convex surface improve adhesion (Reply 8), but Petitioner supplies no evidence that a height greater than 2 millimeters and less than 3 millimeters could accomplish this goal.⁷ Petitioner's own references illustrate various other options, including flat surfaces (Ex. 1006) or encapsulation (Ex. 1017).

IPR2020-01715 Pap. 26, 27-28.

'765 Patent

In an embodiment, the photodetectors can be positioned within or directly beneath the protrusion **305** (see FIG. 3E). In such cases, the mean optical path length from the emitters to the detectors can be reduced and the accuracy of blood analyte measurement can increase. For example, in one embodiment, a convex bump of about 1 mm to about 3 mm in height and about 10 mm² to about 60 mm² was found to help signal strength by about an order of magnitude versus other shapes. Of course other dimensions and sizes can be employed in other embodiments. Depending on the properties desired, the length, width, and height of the protrusion **305** can be selected. In making such determinations, consideration can be made of protrusion's **305** effect on blood flow at the measurement site and mean path length for optical radiation passing through openings **320**, **321**, **322**, and **323**. Patient comfort can also be considered in determining the size and shape of the protrusion.

IPR2020-01715 APPLE-1001 ('765 Patent), 20:14-30.

Overview of the Challenged '628 and '765 Patents

FISH.

'765 Patent Overview



US010631765B1

(12) **United States Patent**
Poeze et al.
 (10) **Patent No.:** US 10,631,765 B1
 (45) **Date of Patent:** *Apr. 28, 2020

(54) **MULTI-STREAM DATA COLLECTION SYSTEM FOR NONINVASIVE MEASUREMENT OF BLOOD CONSTITUENTS**
 (58) **Field of Classification Search**
 CPC A61B 5/1455; A61B 5/14551; A61B 5/14552; A61B 5/14532; A61B 5/14546; (Continued)

(71) Applicant: **Masimo Corporation**, Irvine, CA (US)
 (72) Inventors: **Jeroen Poeze**, Rancho Santa Margarita, CA (US); **Marcelo Lamago Cupertino**, CA (US); **Sean Merritt**, Lake Forest, CA (US); **Cristiano Davi**, Lake Forest, CA (US); **Hung Yu**, Fountain Valley, CA (US); **Johannes Bruijnsma**, Oppeinde (NL); **Ferdyan Lesmana**, Irvine, CA (US); **Massi Joe E. Kiani**, Laguna Niguel, CA (US); **Greg Olsen**, Lake Forest, CA (US)
 (56) **References Cited**
 U.S. PATENT DOCUMENTS
 3,910,791 A 10/1975 Henderson et al.
 4,114,604 A 9/1978 Shaw et al.
 (Continued)
 FOREIGN PATENT DOCUMENTS
 CN 1270793 A 10/2000
 CN 101484063 D 11/2011
 (Continued)

(73) Assignor: **Masimo Corporation**, Irvine, CA (US)
 (*) Notice: Subject to any disclaimer, the term of this patent is extended or adjusted under 35 U.S.C. 154(b) by 0 days.
 This patent is subject to a terminal disclaimer.

(21) Appl. No.: **16/725,478**
 (22) Filed: **Dec. 23, 2019**
 OTHER PUBLICATIONS
 US 8,845,543 B2; 09/2014; Dab et al. (withdrawn)
 (Continued)
 Primary Examiner — Eric F Winakur
 Assistant Examiner — Chu Chuan Liu
 (74) Attorney, Agent, or Firm — Knobbe Martens Olson & Bear LLP

Related U.S. Application Data
 (63) Continuation of application No. 16/534,949, filed on Aug. 7, 2019, which is a continuation of application (Continued)
 (51) **Int. Cl.**
A61B 5/1455 (2006.01)
A61B 5/00 (2006.01)
A61B 5/145 (2006.01)
 (52) **U.S. Cl.**
 CPC **A61B 5/1455** (2013.01); **A61B 5/14532** (2013.01); **A61B 5/14546** (2013.01); (Continued)
 (57) **ABSTRACT**
 The present disclosure relates to noninvasive methods, devices, and systems for measuring various blood constituents or analytes, such as glucose. In an embodiment, a light source comprises LEDs and super-luminescent LEDs. The light source emits light at at least wavelengths of about 1610 nm, about 1640 nm, and about 1665 nm. In an embodiment, the detector comprises a plurality of photodetectors arranged in a special geometry comprising one of a substantially linear substantially equal spaced geometry, a substantially linear substantially non-equal spaced geometry, and a substantially grid geometry.
29 Claims, 65 Drawing Sheets



1 APPLE 1001

- The '765 Patent's earliest effective filing date is July 3, 2008.
- The '553 Patent includes 29 claims, of which claims 1 and 21 are independent.
- Independent claim 1, e.g., recites: "A physiological measurement system comprising ... one or more emitters configured to emit light into tissue of a user ... at least four detectors, wherein each of the at least four detectors has a corresponding window that allows light to pass through to the detector ... a wall ... and a cover ... compris[ing] a protruding convex surface"

FISH IPR2020-01714, APPLE-1001 (U.S. Patent No. 10,631,765) ("765 Patent").

'765 Patent: Background

Dr. Thomas Kenny's Declaration

43. In its background section, the '765 Patent explains that "[t]he standard of care in caregiver environments includes patient monitoring through spectroscopic analysis using, for example, a pulse oximeter," and that "[d]evices capable of spectroscopic analysis generally include a light source(s) transmitting optical radiation into or reflecting off a measurement site, such as, body tissue carrying pulsing blood." *Id.*, 2:5-11. "After attenuation by tissue and fluids of the measurement site, a photo-detection device(s) detects the attenuated light and outputs a detector signal(s) responsive to the detected attenuated light." *Id.*, 2:11-14. "A signal processing device(s)" then "process[es] the detector(s) signal(s) and outputs a measurement indicative of a blood constituent of interest, ... other physiological parameters, or other data or combinations of data useful in determining a state or trend of wellness of a patient." *Id.*, 2:14-20.

IPR2020-01714, APPLE-1003 ¶ 43.

44. In this way, the '765 Patent confirms that prior art "devices capable of spectroscopic analysis" ("for example, a pulse oximeter"), generally included one or more light sources configured to emit light into user tissue, one or more detectors configured to detect light after attenuation by the user's tissue and to output responsive signal(s), and one or more signal processors configured to process signals and to output measurements of physiological parameters. *Id.*, 2:5-20.

IPR2020-01714, APPLE-1003 ¶ 44.

'765 Patent

BACKGROUND

The standard of care in caregiver environments includes patient monitoring through spectroscopic analysis using, for example, a pulse oximeter. Devices capable of spectroscopic analysis generally include a light source(s) transmitting optical radiation into or reflecting off a measurement site, such as, body tissue carrying pulsing blood. After attenuation by tissue and fluids of the measurement site, a photo-detection device(s) detects the attenuated light and outputs a detector signal(s) responsive to the detected attenuated light. A signal processing device(s) process the detector(s) signal(s) and outputs a measurement indicative of a blood constituent of interest, such as glucose, oxygen, met hemoglobin, total hemoglobin, other physiological parameters, or other data or combinations of data useful in determining a state or trend of wellness of a patient.

In noninvasive devices and methods, a sensor is often adapted to position a finger proximate the light source and light detector. For example, noninvasive sensors often include a clothespin-shaped housing that includes a contoured bed conforming generally to the shape of a finger.

IPR2020-01714, APPLE-1001, 2:4-25.

'765 Patent: Brief Description

Dr. Kenny's Declaration

46. In more detail, the exemplary physiological measurement system 100 illustrated by the '765 Patent's FIG. 1 (reproduced below) includes "a sensor 101...that is coupled to a processing device or physiological monitor 109." *Id.*, 5:35-38, 11:47-49.

IPR2020-01714, APPLE-1003 ¶ 46; Pet. 3.

51. From this and related description, a POSITA would have understood that the sensor 201 and monitor 209 together act as components of a physiological sensor device, and that in at least one embodiment that device is part of a larger system including a computer with which the physiological sensor device communicates.

APPLE-1001, 2:38-48, 11:49-57, 16:20-18:28, FIGS. 1, 2A-2D.

52. The sensor included in the physiological sensor device "may include different architectures"; the '765 Patent describes several potential architectures with respect to FIGS. 14A-14I. APPLE-1001, 6:38-49, 35:36-38:20. For example, the '765 Patent's FIG. 14C (reproduced below) illustrates a sensor featuring a "detector submount 1400c...positioned under [a] protrusion 605b in a detector subassembly 1450 illustrated in FIG. 14D" (also reproduced below).

IPR2020-01714, APPLE-1003 ¶¶ 51-52; Pet. 3.

'553 Patent

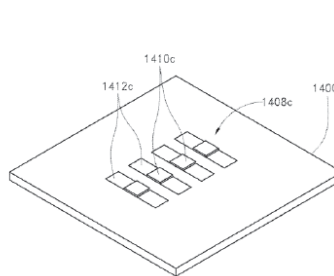
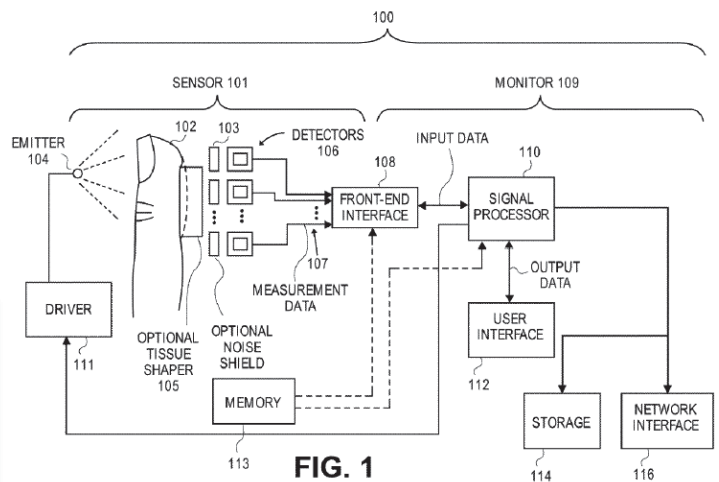

FIG. 14C

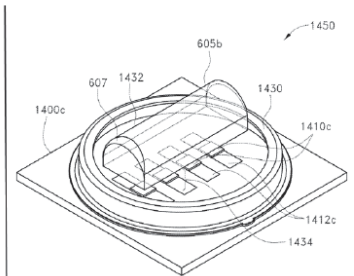

FIG. 14D

IPR2020-01714, APPLE-1001 FIGS. 1, 14C, 14D; Pet. 6-8.

'765 Patent: Brief Description

Dr. Kenny's Declaration

53. As illustrated in FIG. 14D, a housing 1430 including "a transparent cover 1432, upon which the protrusion 605b is disposed" surrounds each of the detectors 1410c. APPLE-1001, 36:30-41. As the '765 Patent explains with respect to earlier embodiments, the "detectors ... can capture and measure light transmitted from [an] emitter ... that has been attenuated or reflected from the tissue in [a] measurement site," and can "output a detector signal ... responsive to the light" *Id.*, 14:3-9. The detectors "can be implemented using one or more photodiodes, phototransistors, or the like," and placement of a protrusion "over the photodiodes" is said to offer multiple benefits; the protrusion may, for example, "penetrate[] into the tissue and reduce[] the path length of the light" *Id.*, 14:3-10, 24:16-35; see also *id.*, 10:61-11:13 ("the system 100 includes an optional tissue thickness

IPR2020-01714, APPLE-1003 ¶ 53.

'553 Patent

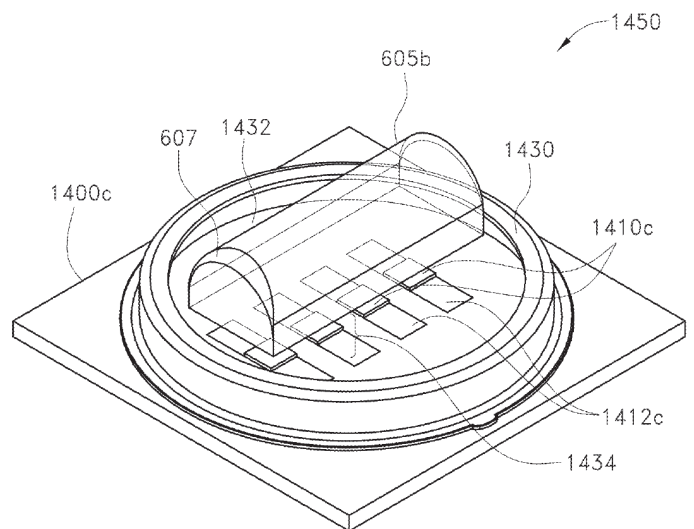

FIG. 14D

IPR2020-01714, APPLE-1001 FIG. 14D; Pet. 8.

'765 Patent: Brief Description

Dr. Kenny's Declaration

41. Prior to the Critical Date of the '765 Patent, numerous products, publications, and patents existed that implemented or described the functionality claimed in the '765 Patent. The methodology of the '765 Patent was therefore well-known in the prior art as of the Critical Date. Further, to the extent there was any problem to be solved in the '765 Patent, it had already been solved in the prior art systems before the Critical Date of the '765 Patent as I discuss below.

IPR2020-01714, APPLE-1003 ¶ 41; Pet. 3.

60. As such, if one of ordinary skill had consulted the '765 Patent for guidance with respect to the specifics of the components that are claimed as being included within the handheld computing device, one of ordinary skill would have instead found generic description of similar components that are included within the physiological sensor device with which the handheld computing device is said to communicate. *Id.*, 15:60-16:11. From this, one of ordinary skill would have understood the claimed "handheld computing device" to be a generic computing device with generic computing components.

IPR2020-01714, APPLE-1003 ¶ 42; Pet. 2.

'765 Patent: Exemplary Claim

'765 Patent

1. A physiological measurement system comprising:
 - a physiological sensor device comprising:
 - one or more emitters configured to emit light into tissue of a user;
 - at least four detectors, wherein each of the at least four detectors has a corresponding window that allows light to pass through to the detector;
 - a wall that surrounds at least the at least four detectors; and
 - a cover comprising a protruding convex surface, wherein the protruding convex surface is above all of the at least four detectors, wherein at least a portion of the protruding convex surface is rigid, and wherein the cover operably connects to the wall; and
 - a handheld computing device in wireless communication with the physiological sensor device, wherein the handheld computing device comprises:
 - one or more processors configured to wirelessly receive one or more signals from the physiological sensor device, the one or more signals responsive to at least a physiological parameter of the user;
 - a touch-screen display configured to provide a user interface, wherein:
 - the user interface is configured to display indicia responsive to measurements of the physiological parameter, and
 - an orientation of the user interface is configurable responsive to a user input; and
 - a storage device configured to at least temporarily store at least the measurements of the physiological parameter.

IPR2020-01714, APPLE-1001 ('765 Patent), 44:50-45:15 (Independent Claim 1).

'628 Patent: Exemplary Claim

'628 Patent

1. A noninvasive optical physiological sensor comprising:
 - a plurality of emitters configured to emit light into tissue of a user;
 - a plurality of detectors configured to detect light that has been attenuated by tissue of the user, wherein the plurality of detectors comprise at least four detectors;
 - a housing configured to house at least the plurality of detectors; and
 - a light permeable cover configured to be located between tissue of the user and the plurality of detectors when the noninvasive optical physiological sensor is worn by the user, wherein the cover comprises an outwardly protruding convex surface configured to cause tissue of the user to conform to at least a portion of the outwardly protruding convex surface when the noninvasive optical physiological sensor is worn by the user and during operation of the noninvasive optical physiological sensor, and wherein the plurality of detectors are configured to receive light passed through the outwardly protruding convex surface after attenuation by tissue of the user.

IPR2020-01521, APPLE-1001 ('628 Patent), 44:35-56 (Independent Claim 1).



Overview of the Instituted Grounds

FISH.

Instituted Aizawa-based Grounds

Ground	Challenged Claim(s)	
	IPR2020-01715	IPR2020-01521
Obvious (§ 103) over Aizawa, Inokawa, Ohsaki, and Mendelson-2006	1-8, 10-13, 15-29	
Obvious (§ 103) over Aizawa, Inokawa, Ohsaki, Mendelson-2006, and Bergey	9	
Obvious (§ 103) over Aizawa, Inokawa, Ohsaki, Mendelson-2006, and Goldsmith	14	
Obvious (§ 103) over Aizawa and Inokawa		1-15, 17, 20-26, 28
Obvious (§ 103) over Aizawa, Inokawa, and Ohsaki		1-15, 17, 20-26, 28
Obvious (§ 103) over Aizawa, Inokawa, Mendelson-2006, and Beyer		18, 19, 29, 30
Obvious (§ 103) over Aizawa, Inokawa, Goldsmith, and Lo		18, 19, 29, 30



Instituted Mendelson '799-based Grounds

Ground	Claim(s) Challenged
	IPR2020-01714
Obvious (§ 103) over Mendelson '799, Ohsaki, Schulz, and Mendelson 2006	1-8, 10-13, 15-16, 20-29
Obvious (§ 103) over Mendelson '799, Ohsaki, Schulz, Mendelson 2006, and Bergey	9
Obvious (§ 103) over Mendelson '799, Ohsaki, Schulz, Mendelson 2006, and Goldsmith	14
Obvious (§ 103) over Mendelson '799, Ohsaki, Schulz, Mendelson 2006, and Aizawa	17-19

Instituted Mendelson-1988-based Grounds

Ground	Claim(s) Challenged
	IPR2020-01521
Obvious (§ 103) over Mendelson-1988 and Inokawa	1-17, 20-28
Obvious (§ 103) over Mendelson-1988, Inokawa, Mendelson-2006, and Beyer	18, 19, 29, 30