



US005961549A

United States Patent [19]

[11] Patent Number: **5,961,549**

Nguyen et al.

[45] Date of Patent: **Oct. 5, 1999**

[54] **MULTI-LEAFLET BIOPROSTHETIC HEART VALVE**

[75] Inventors: **Than Nguyen**, Anaheim; **Hung Ly Lam**, Norco; **Jianbo Zhou**, Irvine; **Carlos M. Romero**, Orange; **Ralph Kafesjian**, Newport Beach; **Xiaoming G. Guo**, Dove Canyon; **Van Le Huynh**, Tustin, all of Calif.

[73] Assignee: **Baxter International Inc.**, Deerfield, Ill.

[21] Appl. No.: **08/833,176**

[22] Filed: **Apr. 3, 1997**

[51] Int. Cl.⁶ **A61F 2/24**

[52] U.S. Cl. **623/2; 623/900**

[58] Field of Search 623/1, 2, 11, 12, 623/66, 13, 900

[56] **References Cited**

U.S. PATENT DOCUMENTS

4,388,735	6/1983	Ionescu et al. .	
4,687,483	8/1987	Fisher et al. .	
5,037,434	8/1991	Lane	623/2
5,376,110	12/1994	Tu et al.	623/12
5,549,666	8/1996	Hata et al.	623/11
5,613,982	3/1997	Goldstein	623/66
5,718,012	2/1998	Cavallaro	623/11

FOREIGN PATENT DOCUMENTS

0133420 2/1985 European Pat. Off. .

OTHER PUBLICATIONS

Sacks, "Biaxial Mechanical Behavior of Fixed Bovine Pericardium", Fifth World Biomaterials Congress, Toronto, Canada, May 29-Jun. 2, 1996.

Simionescu, et al., "Mapping of Glutaraldehyde-Treated Bovine Pericardium and Tissue Selection for Bioprosthetic Heart Valves", *Journal of Biomedical Materials Research*, vol. 27, 697-706, 1993.

Ziopus, et al., "Anisotropic Elasticity and Strength of Glutaraldehyde Fixed Bovine Pericardium for Use in Pericardial Bioprosthetic Valves", *Journal of Biomedical Materials Research*, vol. 28, 49-57, 1994.

Primary Examiner—Mickey Yu

Assistant Examiner—Francis K. Cuddihy

Attorney, Agent, or Firm—Guy L. Cumberbatch

[57] **ABSTRACT**

Heart valve leaflet selection methods and apparatuses which subject individual leaflets to loads and measure the resulting deflection to more reliably group leaflets of similar physical characteristics for later assembly in prosthetic heart valves. The deflection testing may be accomplished using a variety of test set ups which are designed to impart a load on the leaflet which simulates the actual loading within a heart valve. The results from a number of deflection tests are used to categorize individual leaflets, which data can be combined with other data regarding the characteristics of the leaflet to better select leaflets for assembly into a multi-leaflet heart valve. In one embodiment, the deflection test is combined with an intrinsic load test, and leaflets having similar deflection and intrinsic load values used in the same heart valve. One apparatus for testing the leaflets includes a frame for securing the arcuate cusp of the leaflet while the straight coapting edge remains free, to simulate the actual leaflet mounting configuration within the heart valve prosthesis. The frame may include a lower portion having a recess for the leaflet and plurality of receptor holes around the peripheral edge of the recess, and an upper portion having a plurality of needles which extend downward through the leaflet and into the receptor holes and secure the edges of the leaflet.

15 Claims, 9 Drawing Sheets

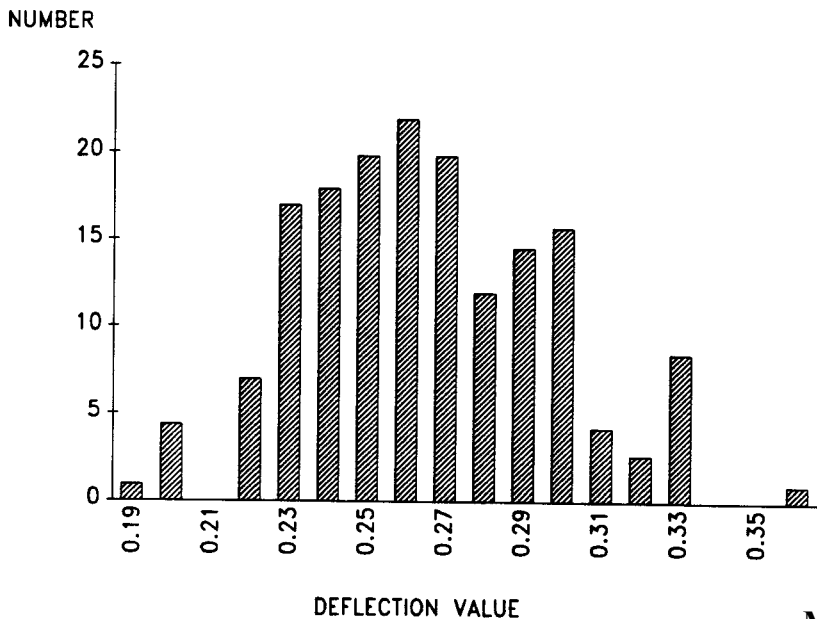

Medtronic Exhibit 1020

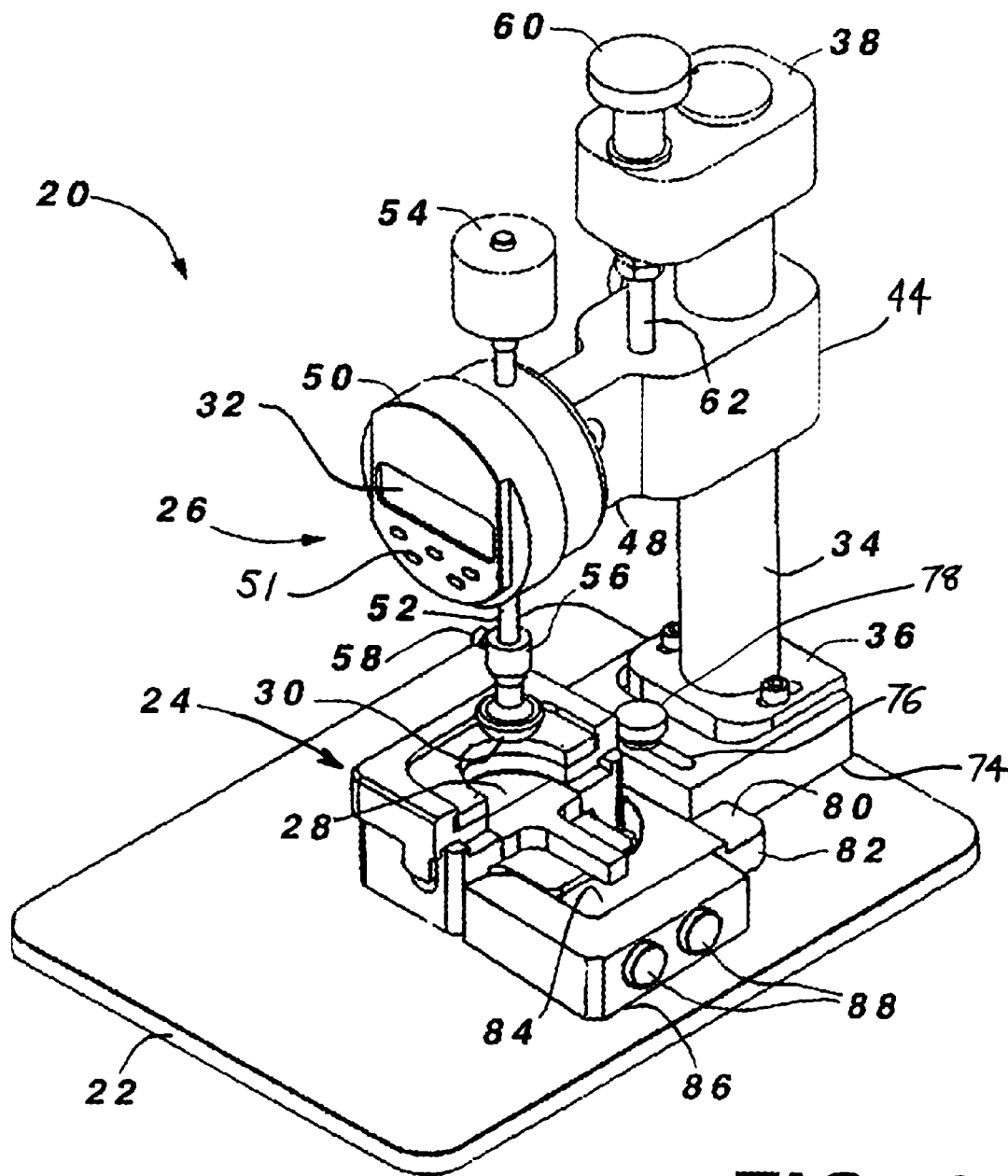

FIG. 1

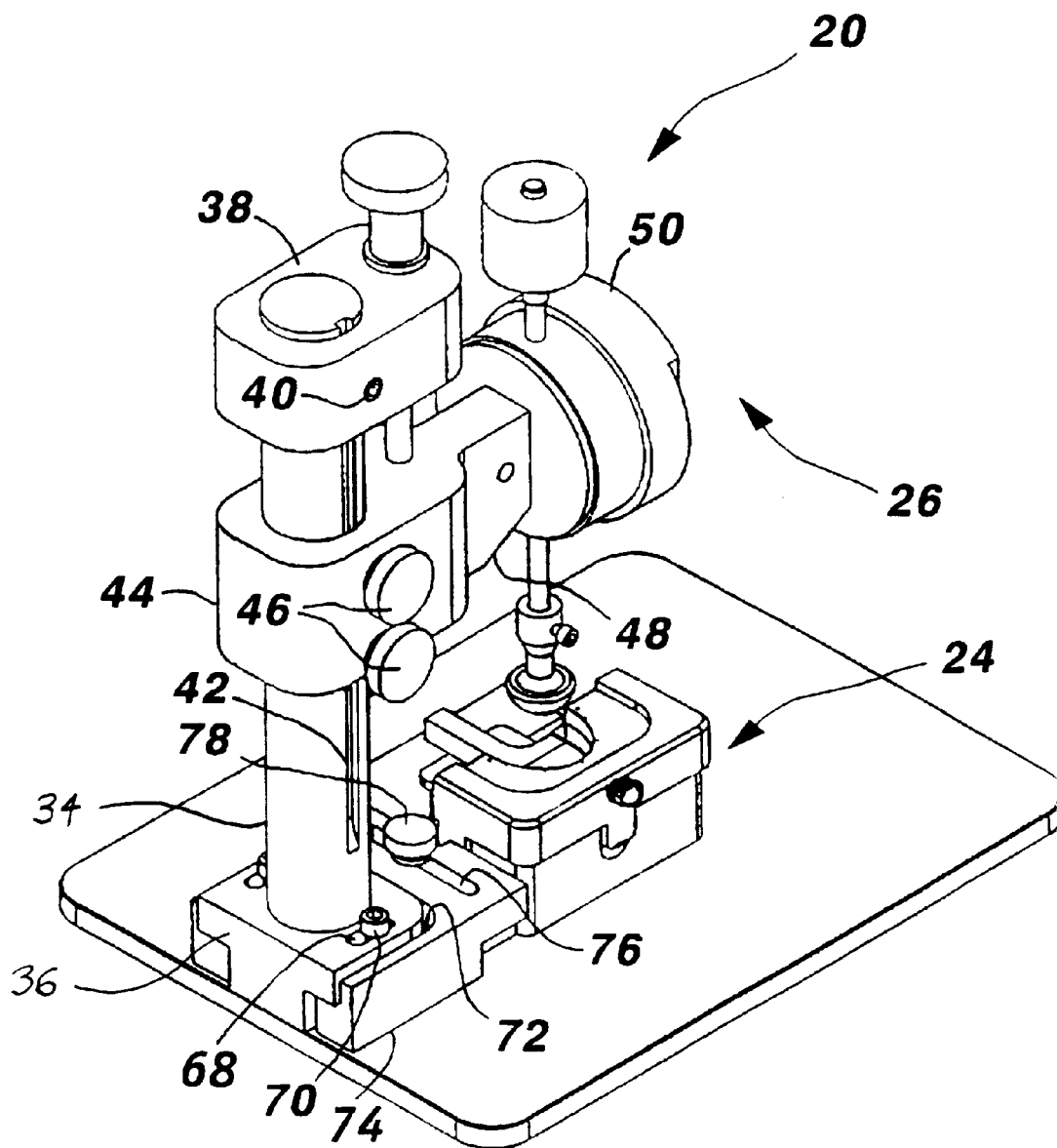

FIG. 2

FIG. 5

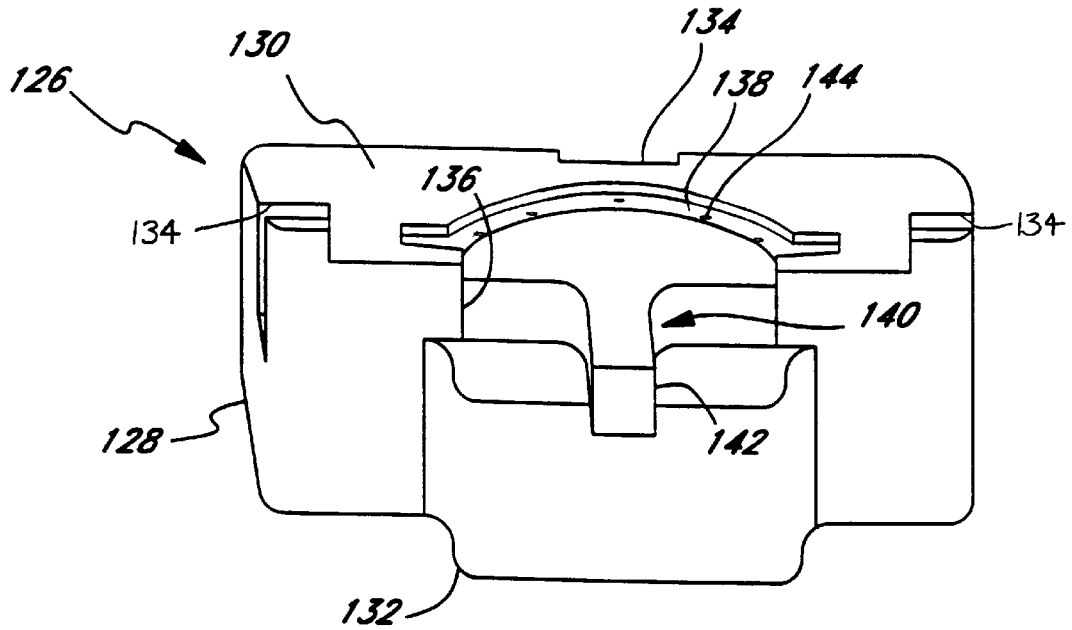
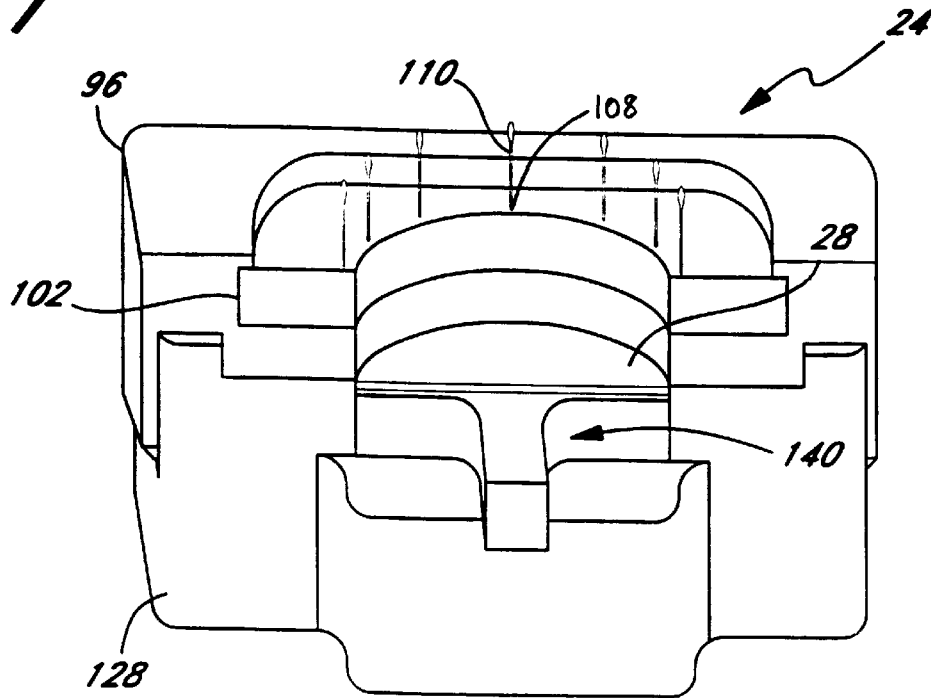

FIG. 7



Explore Litigation Insights

Docket Alarm provides insights to develop a more informed litigation strategy and the peace of mind of knowing you're on top of things.

Real-Time Litigation Alerts



Keep your litigation team up-to-date with **real-time alerts** and advanced team management tools built for the enterprise, all while greatly reducing PACER spend.

Our comprehensive service means we can handle Federal, State, and Administrative courts across the country.

Advanced Docket Research



With over 230 million records, Docket Alarm's cloud-native docket research platform finds what other services can't. Coverage includes Federal, State, plus PTAB, TTAB, ITC and NLRB decisions, all in one place.

Identify arguments that have been successful in the past with full text, pinpoint searching. Link to case law cited within any court document via Fastcase.

Analytics At Your Fingertips



Learn what happened the last time a particular judge, opposing counsel or company faced cases similar to yours.

Advanced out-of-the-box PTAB and TTAB analytics are always at your fingertips.

API

Docket Alarm offers a powerful API (application programming interface) to developers that want to integrate case filings into their apps.

LAW FIRMS

Build custom dashboards for your attorneys and clients with live data direct from the court.

Automate many repetitive legal tasks like conflict checks, document management, and marketing.

FINANCIAL INSTITUTIONS

Litigation and bankruptcy checks for companies and debtors.

E-DISCOVERY AND LEGAL VENDORS

Sync your system to PACER to automate legal marketing.